

MODERN RADIO SERVICING

A Practical Text of the Theory, Construction and Use of Modern Radio Servicing Equipment; the Rapid, Systematic Methods and Technique of Radio Servicing in all its Branches; and Tested Methods of Selling Radio Service Work to the Public.

BY

ALFRED A. GHIRARDI, B.S., E.E.

Author, The Radio Physics Course, Radio Troubleshooters' Handbook, Radio Field Service Data. Contributing Editor, Radio News Magazine. Advisory Editor, Service Magazine. Editorial Consultant Radio & Electronics, Murray Hill Books, Inc. Technical Consultant. Member, Radio Servicemen of America, New York Electrical Society, Radio Club of America, Institute of Radio Engineers, Advertising Club of New York.

706 ILLUSTRATIONS

FIRST EDITION



Reg. U. S. Pat. Off.

12 1 45

TECHNICAL DIVISION

MURRAY HILL BOOKS, INCORPORATED
232 Madison Avenue New York 16, N. Y.



Copyright, 1935
By
MURRAY HILL BOOKS, INC.

*All illustrations and other data in this
book are fully protected by copyright.*

*All rights reserved—no part of this book may be re-
produced in any form, by mimeograph or any other
means, (including translation into Foreign languages)
without express permission in writing from the publisher.*

*No patent liability is assumed with respect
to the use of information contained herein.*

Copyright in Canada and Great Britain and
in all countries subscribing to the Berne
Convention.

LITHO IN U. S. A. BY ELDREDGE CO.
BOUND BY J. J. LITTLE & IVES

**MODERN
RADIO SERVICING**

ANTENNA-GROUND LIGHTNING ARRESTER

NO SHORT WAVE
INTERMITTENT RECEPTION
POOR RECEPTION
LACK OF VOLUME
EXCESSIVE NOISE

5 WAVE TRAP

CODE INTERFERENCE
INTERMITTENT RECEPTION

RADIO FREQUENCY COILS

INTERMEDIATE COILS
INTERMITTENT RECEPTION
POOR SELECTIVITY
LACK OF SENSITIVITY
POOR FIDELITY
FADING

TUNING CONDENSERS

NOISY RECEPTION
DEAD SPOTS
INTERMITTENT RECEPTION
MICROPHONIC HOWLS
CALIBRATION OF DIAL
FADING

RADIO CABINET

RESONANCE
TINNY SOUNDS
RUMBLES

ALIGNMENT OF STAGES

LACK OF SENSITIVITY
POOR TONE QUALITY
OSCILLATION
CODE INTERFERENCE
CALIBRATION OF DIAL
POOR SELECTIVITY

AUDIO TRANSFORMERS

NOISY RECEPTION
NO RECEPTION
REDUCED VOLUME
INTERMITTENT RECEPTION
POOR TONE QUALITY

FILTER CONDENSERS

EXCESS HUM
NO RECEPTION
INTERMITTENT RECEPTION

TUBES

NO RECEPTION
DISTORTION
HUM
LACK OF SENSITIVITY
MICROPHONIC
INTERMITTENT RECEPTION
FADING
NOISY RECEPTION
OSCILLATION

SPEAKER

DISTORTION
TINNY SOUNDS
SCRATCHING - GRATING
EXCESSIVE HUM
INTERMITTENT RECEPTION
NO RECEPTION

BY PASS CONDENSERS

OSCILLATION
POOR TONE QUALITY
INTERMITTENT RECEPTION
FADING
LOSS OF VOLUME
HUM
NOISY RECEPTION
NO RECEPTION

OSCILLATOR

LACK OF SENSITIVITY
EXCESSIVE HISS
DISTORTION
ERRATIC OPERATION
DEAD SPOTS
ON SHORT WAVE
FREQUENCY INSTABILITY
INTERMITTENT OPERATION

POWER TRANSFORMER

NO RECEPTION
INTERMITTENT RECEPTION
EXCESS NOISE
EXCESS HUM

LINE CORD AND PLUG

INTERMITTENT RECEPTION
NO RECEPTION
NOISY RECEPTION

HOUSE WIRING

INTERMITTENT RECEPTION
NO RECEPTION
NOISY RECEPTION

PIPES IN HOUSE

INTERMITTENT RECEPTION
NOISY RECEPTION

ATMOSPHERIC CONDITIONS

FADING
NOISY RECEPTION
DISTORTION
LACK OF SHORT-WAVE RECEPTION

WAVE CHANGE SWITCH

LOSS OF VOLUME
ON SHORT WAVE
INTERMITTENT OPERATION
NO RECEPTION
NOISY RECEPTION
SHORT WAVE DEAD SPOTS
FADING
LOSS OF VOLUME
A V C NOT FUNCTIONING

VOLUME CONTROL

TONE CONTROL
NOISY RECEPTION
NO CONTROL OF VOLUME
NO CONTROL OF TONE
INTERMITTENT RECEPTION
NO RECEPTION
LOSS OF SENSITIVITY
OSCILLATION

RESISTORS

INTERMITTENT RECEPTION
DISTORTION
FADING
NO RECEPTION

LOCAL MACHINERY AND APPLIANCES

NOISY RECEPTION
CLICKS

Frontispiece

Courtesy "RADIO TODAY"

What goes wrong with radio receivers—and why! These are the common troubles which develop in present-day receivers, based on the experience of servicing organizations handling more than 100,000 sets annually. Note that similar "trouble symptoms" may result from several different troubles. The task of locating and repairing these many troubles in all makes and models of receivers, forms the bulk of the radio service man's work.

P R E F A C E

The enthusiastic manner in which the original edition of this book (published under the title "Radio Servicing Course") has been received by students and practicing radio service men is extremely gratifying to the author, and has encouraged him to revise it completely in order to bring it up to date.

During the three years since the first issue was published, progress in the fields of radio tube and receiver development has been extremely rapid and really remarkable—especially when we remember that these years have been perhaps the worst ones in the entire period of economic and financial depression which has enveloped our country. We are now producing what are undoubtedly the most scientific and complicated home receivers ever manufactured in the history of the radio industry. This increased complexity of receiver circuits and tubes has made necessary almost an entirely new technique of radio servicing, and has resulted in the development of new and improved forms of testing equipment. It has also made it absolutely necessary for every radio service man to have a more extensive and adequate knowledge of fundamental electrical and radio principles, modern radio circuit design and servicing methods than has ever been necessary before.

This completely revised and enlarged edition has been written especially to present to every progressive radio service man and student of radio servicing a comprehensive up-to-date guide to the proper methods, correct procedures and latest instruments to employ for the rapid and efficient diagnosis and repair of troubles in both the very latest, and the moderately old, types of radio receivers—in short, a practical means whereby they may learn all about radio servicing as it is practiced today by the most progressive individuals and radio service organizations.

The present book, *Modern Radio Servicing*, is rather an unusual second edition—for second editions are usually reprints with minor changes and additions, whereas this volume is a complete new book from cover to cover—even a more readable style of type has been employed. Most of the material in the first edition was discarded entirely, because it had become obsolete. The urgent necessity for making this drastic change, and the fact that while the first edition required only 182 pages to adequately cover the subject, the present edition contains 1,300 pages, illustrates very forcibly the extent of the far-reaching and important advances which have been made in the industry during this short period of time.

In planning this new volume, the general style of the first issue has been retained, but its scope has been extended considerably. Many additional chapters covering important new topics have been added. Close examination of the Table of Contents on page ix, and even a hasty glance at the various numbered topic headings throughout the book itself will reveal its comprehensive scope.

It is the firm conviction of the author that too much time can never be spent in building a firm foundation by making a thorough study of all basic forms of electrical measuring instruments and radio test equipment. Consequently, the first 17 chapters, which constitute Part 1 of the book, are devoted entirely to a detailed study of all forms of modern radio test equipment. Instructions are given for the construction of testing instruments of all kinds for those service men who prefer to build their own. Much valuable information is also gained through a study of the circuit arrangements and operation of the typical commercial test instruments of all kinds, which are described. It is assumed of course that the reader already possesses a good working knowledge of the fundamentals of electricity and radio before studying from this book.

It has not been assumed that all readers will read this book through in its entirety. Many will read only certain portions which are of particular interest to them, others will use it only for reference purposes. Therefore, there has been no hesitancy

in including cross-references and making slight repetitions where they have been considered to be helpful. An unusually complete index, amply cross-referenced, has been included so that information on any of the many subjects which are contained in the book may be looked up and located quickly.

An unusual departure has been made in that a compilation of a wealth of useful factual service data which is particularly valuable to the service man when he is actually at work in his shop or in the field has been published in a separate manual-size volume entitled "Radio Trouble-Shooter's Handbook". It contains a complete tabulation of the intermediate frequencies of all American superheterodyne receivers; a comprehensive receiver "Case History" section listing the most common symptoms, troubles and their remedies for over 3,300 popular receivers; the answers to the *numerical* review problems which are included at the ends of various chapters of Modern Radio Servicing; and a wealth of data and tables which are extremely useful to every service man in the field. The purchase of this supplemental handbook is optional.

Grateful acknowledgement is again made to the various manufacturers of radio servicing instruments and receivers for the kind spirit of cooperation and helpfulness which they have shown in furnishing the descriptions, circuit data and illustrations of their apparatus. Without their help, the preparation of this book would not have been possible. Acknowledgement is hereby made to the Automobile Trade Journal, Radio Craft, Radio Engineering, Radio News, Radio Retailing and Service magazines for the many helpful ideas which have been obtained from them from time to time. The author is also indebted to the many friends, both in the teaching and radio servicing professions, who have furnished valuable constructive criticism regarding the first edition of the book, and particularly to Messrs. Bertram M. Freed and Louis Martin for their assistance throughout the preparation of the text; to Mr. T. S. Ruggles for his work in putting the chapter, How To Sell Your Service, in its present form; to Mr. Leonard Fischer for his work in the preparation of

PREFACE

the final drawings; to Miss Louise Flanagan for her untiring efforts in reading the proofs and to his wife, Carmen T. Ghirardi, who has been a constant source of inspiration and help throughout the many days and nights during which the manuscript was being prepared.

It is the sincere hope of the author that this book will assist in increasing the popularity of scientific and systematic service methods in the radio servicing profession, and that it will enable both experienced service men and students to better understand not only these methods, but also the equipment required to put them into effect.

ALFRED A. GHIRARDI

NEW YORK CITY,
May, 1935.

PREFACE TO THE FIFTH IMPRESSION

In this fifth impression, a new revised and enlarged Receiving Tube Operating Characteristics and Basing Diagram chart has been added on page 1265. This chart gives important data on 742 receiving tube types that radio servicemen may now encounter in old and recent models of radio receivers.

A. A. G.

April 1943

CONTENTS

| | PAGE |
|---------------|------|
| PREFACE | v |

— PART 1 —

| CHAPTER | | |
|---------|---|-----|
| I | INTRODUCTORY | 1 |
| II | MILLIAMMETERS, AMMETERS & VOLTMETERS | 5 |
| III | METHODS & INSTRUMENTS FOR MEASURING RESISTANCE | 60 |
| IV | HOW TO CONSTRUCT OHMMETERS | 86 |
| V | TYPICAL COMMERCIAL OHMMETERS | 100 |
| VI | CONDENSER TESTERS & CAPACITY METERS | 120 |
| VII | OUTPUT METERS & V.T. VOLTMETERS | 140 |
| VIII | THE TUBE CHECKER | 163 |
| IX | HOW TO CONSTRUCT A MODERN TUBE CHECKER .. | 202 |
| X | TYPICAL COMMERCIAL TUBE CHECKERS | 213 |
| XI | THE VOLTAGE-CURRENT SET ANALYZER | 232 |
| XII | POINT-TO-POINT TESTING | 277 |
| XIII | HOW TO CONSTRUCT A COMPLETE SET ANALYZER.. | 293 |
| XIV | TYPICAL COMMERCIAL SET ANALYZERS | 307 |
| XV | THE SERVICE TEST OSCILLATOR | 332 |
| XVI | HOW TO CONSTRUCT & CALIBRATE A TEST OSCILLATOR | 376 |
| XVII | TYPICAL COMMERCIAL TEST OSCILLATORS | 398 |

— PART 2 —

| | | |
|-------|-------------------------------------|-----|
| XVIII | PRELIMINARY TESTS FOR TROUBLE | 427 |
|-------|-------------------------------------|-----|

CONTENTS

| CHAPTER | PAGE |
|---------|--|
| XIX | PECULIARITIES OF AVC AND QAVC CIRCUITS 441 |
| XX | RECEIVER ANALYSIS BY VOLTAGE-CURRENT TESTS . . 492 |
| XXI | RECEIVER ANALYSIS BY RESISTANCE TESTS 527 |
| XXII | TESTING INDIVIDUAL RADIO COMPONENTS 551 |
| XXIII | OBSCURE TROUBLES NOT REVEALED BY ANALYZERS 601 |
| XXIV | ALIGNING & NEUTRALIZING T-R-F RECEIVERS 682 |
| XXV | ALIGNING & NEUTRALIZING SUPERHETERODYNE RECEIVERS 702 |
| XXVI | REPAIRING INDIVIDUAL RADIO COMPONENTS 793 |

— PART 3 —

| | |
|--------|---|
| XXVII | INSTALLING & SERVICING AUTO-RADIO RECEIVERS 869 |
| XXVIII | SERVICING ALL-WAVE RECEIVERS 985 |
| XXIX | INSTALLING & SERVICING MARINE RADIO RECEIVERS 1022 |
| XXX | REDUCING ELECTRICAL INTERFERENCE 1035 |
| XXXI | HIGH-FIDELITY RECEIVER PROBLEMS 1165 |
| XXXII | HOW TO SELL YOUR SERVICE 1205 |

— PART 4 —

| |
|---|
| APPENDIX—RECEIVING TUBE CHARACTERISTICS & BASING DIAGRAM CHARTS 1265 |
| INDEX 1293 |

PART 1

THEORY AND
CONSTRUCTION OF MODERN
RADIO TEST EQUIPMENT

MODERN RADIO SERVICING

CHAPTER I

INTRODUCTORY

Important and far-reaching changes have taken place in the radio industry during the past few years. The superheterodyne type of receiver has become almost the "standard" American radio set today. However, it is not the simple, straightforward superheterodyne that radio men knew years ago. The development of a large number of new types of tubes has given circuit designers new opportunities for circuit development, and they have responded nobly—perhaps too nobly in some directions. Such features as automatic volume control, tone control, compensated volume control, inter-station noise suppression, tuning indicators, all-wave tuning, high-fidelity reproduction, etc., are all the results of progressive development by circuit designers—features that are almost standard in today's receivers.

Probably the two most important innovations which have been responsible for many new and complex circuit arrangements and changes in set construction are the all-wave tuning features, automatic volume control and high-fidelity reproduction. The complicated switching systems and coil-shields, high-gain amplifier stages, high intermediate frequencies, etc., used in all-wave receivers, have all contributed to the necessity for changes in servicing equipment and technique. The amount of external noise heard with a short-wave receiver is usually far greater than with a broadcast band set, so special noise-reducing antenna systems have been developed for the reduction of this noise in localities where man-made interference is prevalent.

High-fidelity receivers also possess new circuit features, adjustments and peculiarities not found in any previous commercial receivers. These adjustments must be made in certain ways if the results are to resemble the original. When these adjustments, with their consequent complications, are incorporated in all-wave receivers—which combinations are now on the market—the necessity for proper test oscillators, tube testers, and analyzers is apparent.

Data compiled by R. H. Langley and printed in *Service* magazine show that approximately 9,100 different models of radio receivers have been manufactured during the past eleven years; over 1,000 manufacturers have been in business during those eleven years; and there are only about 130 of that 1,000 in business today. With about 1,000 chief engineers incorporating their pet circuit ideas into receivers, and about 22,400,000 radio receivers actually in use in the United States alone at the end of 1935, it is not difficult to understand that the servicing of radio receivers, both old and new, no longer is a simple task, but is one which calls for a highly specialized and up-to-date training, and more than ordinary mechanical and electrical skill.

What do all these new radio devices, almost unthought of in 1930, mean to the radio service man of today—the man who is called upon to locate troubles in, and repair, not only these new complicated receivers but also thousands of the more simple old t-r-f receivers which are still in use? First, it means that the days of the swashbuckling type of service man who tested for voltage with his fingers, and for current with blissful confidence, whose only tools were a soldering iron, a screw driver and a pair of pliers, and who talked glibly of how long he had been servicing radio receivers with nothing more than supreme intuition and a handful of inadequate equipment, are definitely over. A few well-directed questions about the characteristics of automatic volume control circuits, inter-station noise suppressors, linear detection, band-pass tuning circuits, alignment of all-wave receivers, etc., would surely bring to light only the relatively few facts gleaned by actual experience, and any questions touching facts the least bit outside of that experience

would be met by vigorous attempts to change the subject. Mind you, experience in the field is probably the most important asset of the service man, but if it is not coupled with knowledge, understanding, and the desire to learn and keep up to date upon every phase of the radio servicing art, it will not get any service man very far. It is interesting to speculate on how a poorly equipped, unprogressive, "old timer" would attempt to align the tuning circuits of a modern all-wave receiver that has over twenty-two adjustments ahead of the second detector!

A point has now been reached in the radio servicing profession, where the service man who lacks the proper servicing equipment and the broad fundamental knowledge of electrical and radio principles which are necessary today, must either take immediate and serious steps to remedy these deficiencies or be forced out of the profession by unrelenting competition. Modern receivers will prove too much for the abilities of this type of man. New kinds of troubles never encountered in the older types of receivers are commonplace today. Modern radio servicing practice calls for the type of men who have not only the necessary knowledge and equipment to meet today's problems, but who will also have the energy and ambition to keep abreast of all new developments as fast as they are put into use.

The problem of maintaining radio service equipment up to date has always been a troublesome one, due to the many changes which have been made in radio receivers during the development stages of the past few years. The extensive changes in the design of tubes and their terminal arrangements have made obsolete a great deal of tube testing and set-analyzing equipment that service men have paid much money for. The popularization of all-wave receivers, and the necessity for realigning their tuned circuits, has made necessary the use of test oscillators capable of generating test signals of frequencies ranging from 100 to at least 23,000 kc. This means that either more changes must be made in existing test oscillators, or, new ones must be purchased.

New receiver circuit arrangements are making it necessary to employ voltmeters, milliammeters and ohmmeters with wider ranges than has heretofore been necessary, and many old forms

of set analyzers are incapable of giving any real information about the complicated circuit networks in modern receivers.

One of the most surprising things about the servicing profession is the lack of standardization of service practice. No two service men seem to test the same set in the same manner. Some of the systems employed appear ridiculous because of their time-wasting practices, while others seem incorrect because of their failure to show true pictures of circuit conditions. Many of the older routines must be discarded and replaced by new ones which will take care of all new conditions.

The author has kept all of the foregoing problems in mind during the preparation of this book. He has aimed to help not only the experienced service man who desires to bring his knowledge, his servicing methods and his servicing equipment up to date, but also to assist those men who have already gained a broad background knowledge of electrical and radio principles*, and who desire to make a specialized study of radio servicing equipment and methods.

Considerable thought has been given to the arrangement of the material in the book, and the sequence of study. The entire book has been divided into four main parts. The theory, operating instructions, and construction and descriptions of typical commercial units, of all forms of test equipment are considered first, for it is only after all the test equipment is thoroughly understood that its uses and applications can be studied. All necessary data is given for the construction of practical and modern test equipment for those service men who, for various reasons, prefer to make their own. In the second part, the most advanced methods employed in modern practical radio servicing are presented. The third part deals with specialized servicing problems and tested methods of "Selling Service". The fourth contains useful data, and an unusually comprehensive index.

A glance at the Table of Contents will indicate the sequence in greater detail and will reveal the entire plan of study at a glance. The aim throughout has been to take the reader, step by step, from the most elementary considerations to the more complex phases of service work without breaks in continuity.

* The *Radio Physics Course* by Alfred A. Ghirardi was written especially for this phase of radio instruction.

CHAPTER II

MILLIAMMETERS, AMMETERS & VOLTMETERS

2-1. Importance of Electrical Measuring Instruments.—

Since human beings are unable to see, feel, taste, hear or smell electric current directly, but can only observe it by the indirect "effects" it produces, we are forced to employ specially designed instruments for its detection and measurement. These *electrical measuring instruments* are especially necessary in the servicing of radio equipment, since they enable us to test the various circuits and parts in order to obtain quickly all information needed for locating and correcting the various troubles which may arise. Since they form the very backbone of the entire radio servicing art, it is essential that we first understand clearly all about the theory of operation, construction and use of the various forms commonly employed. For this reason, we will first make a detailed and comprehensive study of all forms of modern service instruments—starting with the very simple current and voltage measuring meters and progressing to the more complicated instruments for analyzing and aligning. The circuits of these complicated instruments will be developed in a progressive manner from a consideration of the test operations which they are required to perform, and the basic electrical measuring instruments which are available for making the various measurements required. Studies will also be made of the circuit arrangements employed in typical commercial forms of these instruments, so that the various ideas which manufacturers have developed and incorporated in them may be brought out.

Perhaps the simple instrument used most extensively in radio service work is the *milliammeter*. The milliammeter "movement" forms the basic part of all ammeters, voltmeters, output meters, ohmmeters, circuit testers, etc., used in radio service

work. In order fully to understand its operation and construction, it will be necessary first to review briefly a few of the fundamental principles of electricity and magnetism upon which its operation depends.

2-2. Magnetic Field Around a Straight Conductor.—The first important well-known electrical principle is:

"Whenever a current of electricity flows through a conductor, such as a piece of wire, it always produces a magnetic force, or 'field', around the conductor."

This is illustrated in Fig. 2-1, * and is one of the most important properties of an electric current. This principle may be proved by connecting a short length of thick copper wire across the terminals of one cell of a 6-volt storage battery (or other low-voltage current source) and dipping the wire into some iron filings as shown in Fig. 2-2. The iron is a magnetic substance,

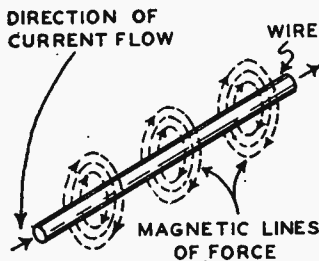

FIG. 2-1.—The magnetic field around the straight current-carrying wire is circular in shape and is represented by the dotted circles. These are called "magnetic whirls". The arrows show their direction.

and the filings will be attracted and cling to the wire, forming little rings around it as long as the current is permitted to flow, proving that a magnetic field is created around the wire by the flow of current. As soon as the current is shut off, the filings drop from the wire, proving that the magnetism disappears.

*Note: All diagrams and other illustrations in this book are numbered according to a convenient Chapter-Figure numbering system. The first number is that of the chapter, and the second is that of the figure. This, Fig. 2-1 means the *first* figure in Chapter II; Fig. 9-14 means the *fourteenth* figure in Chapter IX, etc.

The second important principle regarding magnetism produced by the flow of electric current is:

"The strength of the magnetic field produced at any point is proportioned to the length of the wire and the strength of the current flowing."

This may easily be proved by sending currents of various strengths through the wire and observing how many iron filings are attracted in each case. The stronger the current, the stronger will be the magnetism, and the greater the number of iron filings attracted. The current can be varied by connecting the wire first across one cell, then across two, and finally across all three cells of the storage battery.

2-3. Magnetic Field Around Single-turn Loop.—Since the magnetic lines of force are distributed along the entire length of the straight wire, the magnetic strength at any point is rather

FIG. 2-2.—Iron filings are attracted to the wire by the magnetic field produced around it due to the flow of current through it. When the flow of current is stopped, the iron filings drop off, proving that the magnetism is present only while the current flows.

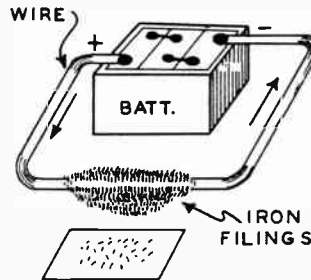

weak. However, if the wire is bent to form a single-turn "loop", all the individual circular magnetic lines of force which surround the wire will pass through the center of the loop, thus creating a stronger, more concentrated magnetic field in the small area there than existed around the wire when it was straight. Consequently, bending the wire in the form of a loop has the effect of greatly increasing the *intensity* of the magnetic effect at the center. However, the *total number* of lines of force in the space around the outside of the loop is the same as the *total number* threading through the inside of the loop.

2-4. Magnetic Field Around a Coil.—By winding a number of these loops, or turns, of wire close together as shown in Fig. 2-4, a solenoid or “coil” is formed. The magnetic fields, or forces, surrounding the individual turns of wire unite to form a

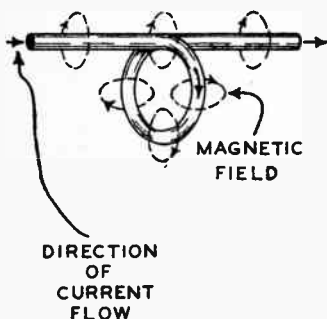

FIG. 2-3. — How the magnetic lines of force arrange themselves around a single-turn loop of wire carrying a current. Notice that they still encircle the wire, but in doing so, they also thread through the inside of the loop.

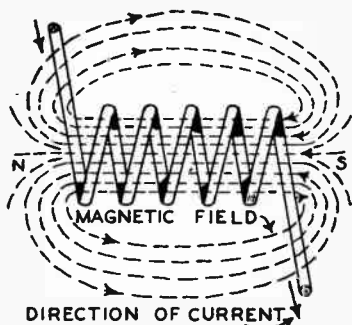

FIG. 2-4. — If the coil is wound with many turns of wire, the magnetic field is stronger, a magnetic pole is produced at each end, and the lines of force take the paths shown by the curved dotted lines.

resultant magnetic field (or force) around, and through, the entire coil—as shown by the curved, dotted lines. The coil really becomes a magnet. A *north* magnetic pole, (*N*) is formed at one end of the coil, and a *south* magnetic pole (*S*) is formed at the other end.

*“The end of the coil from which the magnetic lines of force leave, is called the north pole (*N*), and the end which they enter is called the south (*S*) pole.”*

2-5. Electromagnets.—If an iron core is placed within such a coil, a much better magnetic path is provided for the lines of force and the current will produce a much larger number of them—that is, the *strength* of the magnetic field is greatly

increased. The coil is now called an *electromagnet*. The magnetic strength of an electromagnet depends upon:

1. *Strength of the current (amperes.)*
2. *Number of turns of wire.*
3. *Material, shape and size of the core.*

Experiment: The effect of placing an iron core in a coil of wire may be demonstrated easily by winding a coil of ten or fifteen turns of insulated copper wire on a pencil and then slipping the pencil out of it. Connect the coil to a battery and dip it into iron filings. Notice how many are attracted.

Now slip a large *iron nail* or screw into the coil. Dip the entire unit into the iron filings. Notice how many more filings are attracted now—proving that an iron core in the coil makes the magnetism much more powerful.

The principle demonstrated by this experiment is employed for creating strong magnetic fields—with electromagnets.

2-6. Interaction Between a Coil and Magnetic Poles.—If a current-carrying coil is mounted on pivots and is placed between the poles of a strong permanent magnet, the current flowing through it will produce magnetic poles at its ends, as

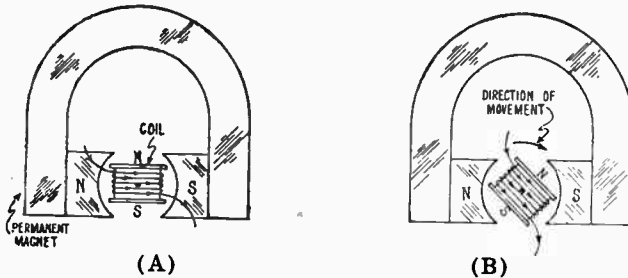

FIG. 2-5.—(A): Arrangement of all of the magnetic poles when a current-carrying coil of wire is placed between the poles of a permanent horseshoe magnet.

(B): How the coil would tend to rotate due to the mutual attraction and repulsion of its magnetic poles and those of the permanent magnet.

shown at (A) of Fig. 2-5. The *N*-pole of the *coil* will be attracted by the *S*-pole, and repelled by the *N*-pole, of the *permanent magnet*. Likewise, the *S*-pole of the *coil* will be attracted by the *N*-, and repelled by the *S*-pole, of the *permanent*

magnet. This will cause the coil to rotate, or deflect, clockwise in the direction of the arrow, as shown at (B).

If a permanent magnet of a fixed strength is used, the force tending to cause the coil to rotate or "deflect" will depend upon the strength of the poles of the coil—which, for any given coil will depend upon *the strength of the current flowing through the coil*. Therefore, an arrangement of this kind, if it be provided with suitable means for indicating the exact amount of deflection of the coil, can be used to measure the strength of the electric current. About 50 years ago, the so-called *Weston "movement"* so widely used today in direct-current measuring instruments, was developed from this basic principle by Dr. Weston.

2-7. The Weston Movement.—The Weston form of d-c meter "movement" is constructed essentially along the basic lines

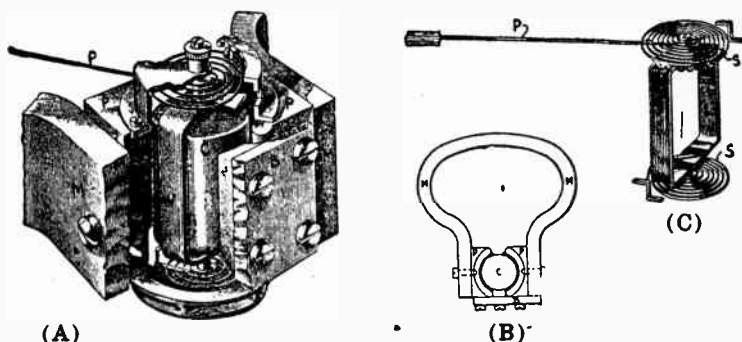

Courtesy Weston Elect. Instr. Corp.

FIG. 2-6.—(A): Assembled Weston d-c meter movement. A portion of the permanent horseshoe magnet has been cut away at the front to reveal the interior.

(B): The permanent magnet *M*, core *C* and pole-pieces *P-P* assembled.

(C): The movable coil, pointer *P*, springs *S*, and pivots assembled.

shown in Fig. 2-5, but has many constructional refinements which make it rugged, accurate, and highly sensitive. An open sectional view showing the construction of a meter movement of

this type is shown at (A) of Fig. 2-6, and a description of it follows:

M-M are the poles of a very strong permanent horse-shoe magnet with soft-iron pole pieces *P-P* between which is mounted the stationary, circular soft-iron core *C* to increase the strength of the magnetic field and make it radial. This is shown at (B). Mounted in the air

FIG. 2-7. — A typical commercial 0-1 d-c milliammeter employing the type of movement shown in Fig. 2-6. Notice the pointer, and the scale graduated and calibrated to indicate directly the number of "milliamperes" of current which are flowing through the movable coil at any time.



Courtesy Weston Elect. Instr. Corp.

gap between the core *C* and pole pieces *P-P*, is the movable coil *W*, consisting of a very light rectangular aluminum form on which are wound many turns of extremely fine insulated copper wire through which the electric current (or a definite fraction of the current) to be measured flows.

This current produces a magnetic pole at each end of the coil. The poles cause a movement of the coil as described in Art. 2-6. The force tending to cause the coil to move is proportional to the strength of the current flowing through the coil. The coil is provided with steel pivots which rest in jewel bearings, so that it may turn freely. The current is conveyed to and from the coil through two light spiral hair-springs which perform two additional important functions.

From this brief description, it is clear that any current through the coil will make it turn to its "maximum position", as long as the friction in the bearings is overcome. By the use of the springs, however, any movement tends to wind up one spring and unwind the other. Hence the coil stops rotating when the force due to the magnetic attraction and repulsion is equal to that stored up in the springs. The greater the current, the greater the force winding and unwinding the springs, and the more the coil will rotate. These springs also perform the function of always returning the coil to a definite zero position after the current is shut off. A pointer is attached to the movable coil to enable its position to be read accurately from a suitably calibrated scale. The assembly of coil and form *L*, springs *S*, and pointer *P* are shown at (C).

A typical 0-1 d-c milliammeter employing this type of movement

is illustrated in Fig. 2-7. Notice the scale markings, and the thin pointer for accurate reading.

2-8. Meter Sensitivity. —The “sensitivity” of a meter movement is determined by the strength of current necessary to cause the pointer to deflect across the full scale of the instrument. This characteristic of a meter movement is expressed in two different ways in practice. When speaking of microammeters, milliammeters, etc., the *sensitivity* of the meter is:

the number of microamperes (or milliamperes) of current which must be sent through the movable coil in order to make the pointer deflect across the full scale.

Thus, a meter having a *sensitivity* of 1 ma. requires a current of 1 ma. for full-scale deflection; etc.

When referring to voltmeters, the sensitivity is usually referred to on the basis of *ohms-per-volt*. This will be explained in detail in Art. 2-20 when studying high-resistance voltmeters.

Recent developments in the design and construction of direct-current instruments have made it possible to build portable meters considerably more sensitive than they were made before. It is not very many years since portable meters having a sensitivity of 1-milliamperere were considered the most sensitive practical instruments available. Now, portable meters have a sensitivity of 50 microamperes—(*twenty* times as sensitive) are commonly used—especially in radio service test instruments. These have been made possible by the use of strong permanent magnets of large cross-section, made of special alloy steels; movable coils wound of copper wire considerably finer than a human hair; extremely short air gaps; and bearings having negligible friction. It is hardly possible to realize that a practical instrument capable of withstanding the rough handling incident to portable use can be constructed so sensitive that a current of only 50 *microamperes* (0.000050 amperes) is able to cause its pointer to move across the full scale (incidentally, instruments even more sensitive than this are available for special requirements).

2-9. Why Shunts are Used in D-C Ammeters. — In order that the entire measuring instrument be made compact, the movable coil must be very small. Also, if it is to be caused to rotate

by the small attractive force of very small currents, it must be light in weight, have very little inertia, and have an appreciable number of turns of wire on it. All of these requirements make it necessary to have the movable coil of very fine insulated wire—wire finer than a human hair is employed for the movable coils of the portable high-sensitivity instruments used in some service work.

It is evident, then, that since the movable coil is made of such fine wire, it cannot carry much current without undue heating, which would damage it. If we want to use a simple meter of this kind to measure the current flowing in a circuit, it is evident that it will have to be connected in *series* with the circuit as shown at (A) of Fig. 2-8. In this case, the *full* current of the circuit will flow through the movable coil. However, wire thin enough to be suitable for movable coils is rarely able to carry more than about 0.05 ampere (50 milliamperes) without overheating. In fact, one large instrument manufacturer uses the arrangement of (A) in Fig. 2-8 only for milliammeters having ranges up to 30 milliamperes. Therefore, if the meter is to be connected into circuits in which more current than this is flowing, either the size of the wire used for the coil must be increased proportionately to take care of the larger current or else only a *definite, known, fraction* of the *total* current of the circuit must be permitted to pass through the movable coil of the instrument.

The *former* arrangement is impracticable, and is not used, for it would result in a heavy, clumsy coil which would cause numerous constructional difficulties (such as impracticable large size, weight, inertia and bearing friction). The *latter* method is the one actually employed to extend the fundamental range of meter "movements", when they are used as milliammeters and ammeters. In practice, the current to be measured is made to divide so that only a definite, known, small part of it flows through the movable coil. The remainder is "shunted" around the coil by means of a low resistance, or *shunt* R_s , connected across it, as shown at (B) of Fig. 2-8.

2-10. How the Meter Operates with a Shunt.— The operation of the meter with a shunt may be explained as follows:

Let us first assume that we connect the meter movement directly in series with the circuit whose current is to be measured—as shown at (A) of Fig. 2-8. Then the only path for the current to flow is through the movable coil of the instrument. If the current being measured is *greater* than the wire of the movable coil can carry safely, a definite part of the current can be “shunted” through the shunt resistor R_s , connected in “shunt” or “parallel” with the movable coil, as shown at (B).

Now, if the shunt resistance R_s is made just equal to the resistance R_m of the movable coil of the meter, then exactly *half* of the total current will flow through the shunt and half will flow through the meter coil. In this case, we simply multiply any reading of the instrument by 2 to determine the *total* current. If we carry this further, and add another, similar shunt as (C), only $\frac{1}{3}$ of the total current will flow through the movable coil (the other $\frac{2}{3}$ flows through the two shunts), and the reading obtained on the instrument scale will have to be multiplied by 3 to determine the “total” current

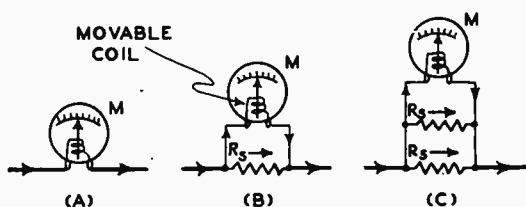

FIG. 2-8.—How shunts are connected in *parallel* with the movable coil of the meter. The shunts carry a definite fraction of the total current to be measured, permitting the use of an ordinary milliammeter movement as an ammeter to measure larger currents than the movable coil is able to carry safely.

flowing in the circuit. We might continue this indefinitely, adding any number of equal shunt resistors in parallel (or using a single shunt of the proper value), and making the *proportion* of the “total” current actually flowing through the meter coil less and less. In this way we can use a simple, light-weight meter movement (employing a movable coil wound with very fine wire), together with the proper shunts, for measuring d-c currents of almost any value. In actual commercial instruments the scale is calibrated to indicate the “total” circuit current *directly*—no multiplication of the meter reading is necessary.

When this type of current-measuring instrument is used to measure “milliamperes”, the meter is called a *milliammeter*. When, by the use of suitable shunts of low resistance, it is made to measure “amperes”, it is called an *ammeter*.

2-11. How to Connect Milliammeters or Ammeters.—It must be remembered that a milliammeter (or an ammeter) must *always* be connected in *series* with the circuit whose current it

is to measure, and never *across* (in parallel with) the circuit, for, since it has a very low resistance, the heavy current which would flow through it if it were connected *across* the circuit would immediately burn out the movable coil and the shunt. The correct way to connect a milliammeter or an ammeter into a circuit

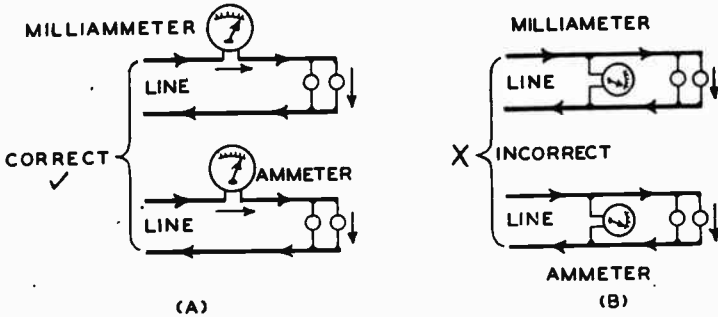
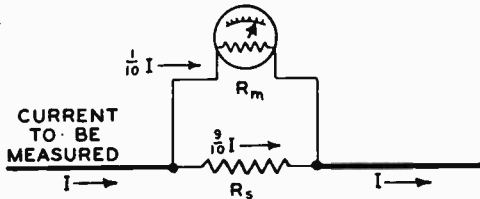

FIG. 2-9.—(A): Correct way to connect (in series) a milliammeter, or an ammeter, in a circuit to measure the current. The total current to be measured should flow *through* the meter and its shunt. (B): Incorrect way to connect a milliammeter or ammeter.

to measure the current flowing, is shown at (A) of Fig. 2-9, the incorrect way is shown at (B).

2-12. Extending Ranges of D-C Ammeters & Milliammeters.—The range of any given d-c milliammeter can be increased by connecting an additional shunt resistor across the terminals of the meter. Radio service men are often obliged to do

FIG. 2-10.—In order to multiply the meter range by 10, a shunt resistance R_s is connected across the meter terminals. The meter resistance is R_m . The shunt must carry 9/10 of the total current, and the meter must carry 1/10 of it. Therefore the shunt resistance must be 1/9 that of the meter resistance.



this when they desire to use a certain meter to measure larger currents than it was designed for.

Suppose that the meter on hand has a range of only 1-ma..

and that a range of 10 ma. (a range 10 times as large), is needed. A shunt must then be connected across the meter. Its value must be such that the *meter* will carry 1/10 (1 milliamper) of the *total* current and the *shunt* will carry 9/10 of it. Now if the shunt is connected across the meter as shown at (B) of Fig. 2-8, then the same voltage must exist across both the meter and the shunt—since they are in parallel. If I is the *total* current flowing through the circuit, it will divide in the two branches as shown in Fig. 2-10. Evidently, the current through the *shunt* ($9/10 I$) is 9 times as large as the current ($1/10 I$) through the *meter*. Therefore, since the current flowing through a circuit is inversely proportional to the resistance, (Ohm's law), for this particular division of current to take place, the resistance of the *shunt* (R_s) must be 1/9 that of the *meter* (R_m). For instance, if the resistance of the 0-1 d-c milliammeter is 27 ohms, the shunt resistance required to make a 0-10 milliammeter of it will be $1/9 \times 27 = 3$ ohms. After this shunt is properly connected, every current reading taken on the scale of the meter must be multiplied by the *multiplying ratio* (10 in this case), to obtain the true current reading.

2-13. How to Calculate the Shunt Resistance Required.—

If the meter resistance R_m , and the desired multiplying ratio n are known, the value of the required shunt resistance R_s in ohms may be found from the formula:

$$R_s = \frac{R_m}{n-1}$$

Using this formula to calculate the shunt resistance required for the range-multiplying case considered at the end of Art. 2-12, we find

$$R_s = \frac{R_m}{n-1} = \frac{27}{10-1} = \frac{27}{9} = 3 \text{ ohms.}$$

which checks with the value found in Art. 2-12.

2-14. Table of Milliammeter Resistance Values.—It is evident that in order to *calculate* the value of shunt resistance required to extend the range of any d-c milliammeter or ammeter, the exact value of the total internal resistance of the meter must be known if the formula given in Art. 2-13 is to be employed. Be-

low will be found, for reference purposes, the *approximate* resistance values of several types of Weston microammeters and milliammeters, and corresponding Jewell meters (these are no longer manufactured, but thousands of them are still in use),

APPROXIMATE INTERNAL RESISTANCES
OF COMMON MICROAMMETERS AND MILLIAMMETERS

| Weston (Model 301) D-C Meters | | | Corresp. Jewell Meters | |
|---|---------------------------------|------------------------------------|---|------------------------------------|
| Range Microamps. D-C | Approx. Resistance (Ohms) | Number of Divisions on Scale | Approx. Resistance (Ohms) | Number of Divisions on Scale |
| 200 | 55 | 40 | 140 | 40 |
| 300 | — | — | 140 | 60 |
| 500 | 55 | 50 | 140 | 50 |
| Milliamps. D-C | | | | |
| 1. | 27 | 50 | 30 | 50 |
| 1.5 | 18 | 75 | 30 | 75 |
| 2. | 18 | 40 | 25 | 40 |
| 3. | 18 | 60 | 20 | 60 |
| 5. | 12 | 50 | 12 | 50 |
| 10. | 8.5 | 50 | 7 | 50 |
| 15. | 3.2 | 75 | 5 | 75 |
| 20. | 1.5 | 40 | — | — |
| 25. | 1.2 | 50 | 3 | 50 |
| 30. | 1.2 | 60 | — | — |
| 50. | 2.0 | 50 | 1.5 | 50 |
| 100. | 1.0 | 50 | 0.75 | 50 |
| 150. | 0.66 | 75 | 0.5 | 75 |
| 200. | 0.5 | 40 | 0.37 | 40 |
| 250. | 0.4 | 50 | — | — |
| 300. | 0.33 | 60 | 0.25 | 60 |
| 500. | 0.2 | 50 | 0.15 | 50 |
| 800. | 0.125 | 40 | — | — |
| 1000. | 0.1 | 50 | — | — |
| Weston (Model 600) High-sensitivity D-C Microammeters | | | Weston (Model 600) A-C Rectifier-Type Microammeters | |
| Range Microamps. D-C | Approx. Resistance (Ohms) | | Range Microamps. | Approx. Resistance (Ohms) |
| 30 | 2000 | | 100 | 3700 |
| 50 | 2000 | | 200 | 2500 |
| 75 | 1750 | | 250 | 2300 |
| 100 | 1300 | | | |
| 200 | 65 | | | |
| 300 | 55 | | | |
| 500 | 30 | | | |

which are familiar to service men. The microammeters and the 0-1 milliammeters are used a great deal by radio servicemen for making home-made ohmmeters and multi-test instruments.

Due to the fact that the resistance values in the table are approximate, if very accurate meter readings are desired, it will be necessary to make up the shunt resistor (or resistors) *by trial* with the actual meter to be used in any case, as described in Art. 2-15. However, for ordinary purposes shunts may be *calculated* from the above values and the formula given in Art. 2-13.

2-15. Making Meter Shunts by Trial. — If the internal resistance of the meter at hand is known only approximately (or is not known at all), or if the required shunt is of some odd resist-

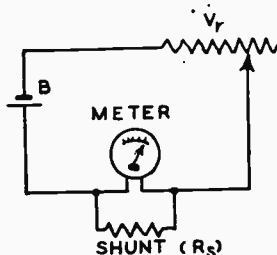

Courtesy Weston Elect. Instr. Corp.

FIG. 2-11.—(Left): Circuit employed for making meter shunts by trial.

(Right): Three shunts for a milliammeter. The one at the left (thick wire) is for the highest current range; that at the right has the highest resistance and is for the lowest current range.

ance value that is not easily obtainable commercially, the exact shunt required for any increase in range may be made by trial in the following way:

Assume that it is desired to extend the range of a 10 ma. meter, whose exact internal resistance is unknown, so that it may be used to read currents up to 50 ma. This means that we wish to multiply the range by 5. We would proceed by connecting a low-voltage battery *B* (a single 1.5 volt dry cell will do), in series with the meter and a variable current-adjusting resistance *Vr*, (about 200 ohms maximum value in this case), as shown at the left of Fig. 2-11. When it is being connected into the circuit, the resistor should be set at *maximum* value, for safety.

Now the current-adjusting resistor should be adjusted carefully until the meter (without a shunt) reads exactly 10 milliamperes (full scale reading). Then the shunt *R*, should be connected directly

across the meter terminals, and its resistance altered (see Art. 2-16) until the meter reads $\frac{1}{5}$ of its previous reading, that is, 2 milliamperes. Under such conditions (with the shunt connected), a reading of 2 milliamperes on the meter would mean that 10 milliamperes were actually flowing through the main circuit. Likewise, full-scale deflection (10 ma.) would indicate a 50 milliampere flow, although the needle pointed only to the 10 milliampere division of the scale. Consequently, in this particular case, whenever the shunt is connected, *any current reading obtained on the meter scale must be multiplied by 5 to find the true current.*

The method outlined above provides a very simple means for making meter shunts accurately and quickly.

2-16. Materials for Shunts.—Meter shunts should be sufficiently large in physical size so that they are able to carry the required current without undue heating (sufficient to insure cool operation), and they must be made of a metal which has a very low temperature coefficient of resistance, so that the value of their resistance does not change appreciably with changes in temperature. Since the resistance of *Manganin* and certain *German-silver* alloys is affected very little by ordinary changes in temperature, they are used extensively for meter shunts. Several shunts for increasing the range of a milliammeter are shown at the right of Fig. 2-11. Notice that the shunt at the left, for the 100-ma. range, is of thicker wire (lower resistance) than the one at the center for the 25 ma. range.

When making a shunt by the method described in Art. 2-15, it is best to start first with a piece of shunt-metal strip or wire of such a size that it has a slightly *lower* resistance than is required. This will be indicated by the fact that when it is connected permanently across the meter terminals, the meter will read *lower* than is desired. The resistance of the shunt can then be *increased* gradually by scraping or filing it carefully at the middle, so as slightly to reduce its cross-section area and thus increase its resistance slightly. This must be continued carefully until the meter reads the correct value.

2-17. Multi-range D-C Milliammeters & Ammeters.—A milliammeter or ammeter need not be limited to the measurement of a single current range. Any single milliammeter "movement" can be made to measure several ranges of current, and thus do the work of several "single-range" meters, by using a number of

suitably-connected shunt resistors—thus making a *multi-range* meter of greater usefulness.

There are several ways of doing this. A number of shunts, having the proper resistance values, may be connected across the meter and controlled by a suitable contact switch, or switches,

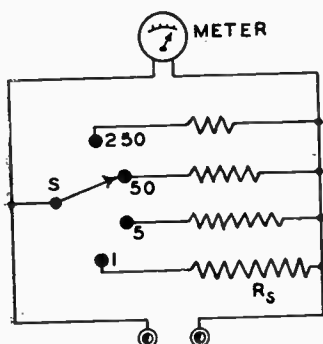

FIG. 2-12.—Multi-range milliammeter, or ammeter, using individual shunt resistors and a range-selector switch *S*.

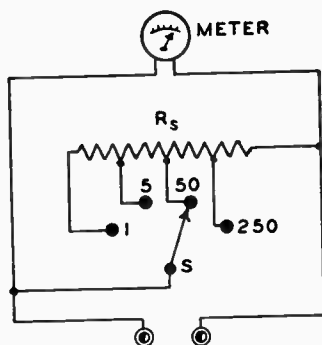

FIG. 2-13.—Multi-range milliammeter or ammeter using a single, tapped shunt resistor and a range-selector switch.

so that the proper value of shunt resistance may be put into the circuit to provide, quickly, any range for which the instrument is designed. One simple arrangement of this kind, in which individual shunts of various resistance values may be selected by a simple range-selector switch *S*, is shown in Fig. 2-12. Another arrangement which employs a tapped shunt resistor instead of individual ones is shown in Fig. 2-13.

Although less costly, a disadvantage of the latter arrangement is that if one of the shunt sections becomes open-circuited in any way, the full current to be measured will flow directly through the meter movement and damage either it or the pointer, when any of the ranges to the left of the "open" section are used. In the system in Fig. 2-12, damage to any one shunt does not affect the operation of the meter on any of the other ranges. The meter ranges are usually marked at the various positions of the range-selector switch.

Another multi-range system which does not require a range-selector switch, is shown in Fig. 2-14. In this instrument, when

the 0-1 range is being used, the circuit is connected to terminals *A* and *B*. Then R_1 and R_2 are in series *with each other* to form the shunt. When the 0-100 range is being used, the circuit is connected to terminals *A* and *C*. By tracing the two paths of flow of the current, it can be seen that resistor R_1 now acts as the shunt, and resistor R_2 is in *series* with the meter movement.

The advantage of the arrangements of Figs. 2-12 and 2-13 over that of Fig. 2-14 is that in the former the external connections to the instrument need not be disturbed when changing from one range to another, while in the latter, one wire of the external circuit must be moved to another terminal on the instrument. For this reason, the arrangement of Fig. 2-12 is used most often in the multi-range current indicators employed in set analyzers, multf-testers, etc., although the others are also used.

Most multi-range meters are designed to have ranges in various multiples of 5, such as 0-1, 0-5, 0-50, 0-250, etc. Multi-range, milliammeters and ammeters are employed extensively in many of the common test instruments used in radio test and service work. Among these, are "circuit testers", "analyzers", tube checkers, "multi-testers", etc.—as we shall see later.

2-18. The D-C Voltmeter. Voltmeters are used for measuring the *electric pressure*, or *voltage*, between two points in an

FIG. 2-14.—Multi-range milliammeter or ammeter providing separate terminals for the different ranges. No range-selector switch is necessary. Two shunt resistors are employed, making two ranges available.

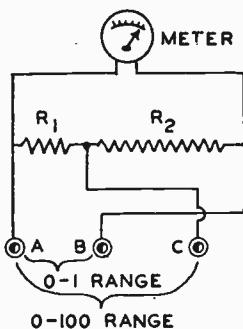

electric circuit. It is the "voltage" which causes an electric current to flow in a conductor. For this reason, it is often called *electrical pressure* since it is analogous to the pressure which causes liquids and gases to flow in suitable pipes or containers.

The measurement of voltage with a voltmeter is based on the fundamental principle that:

"If the 'resistance' of a device is constant, the amount of current that will flow through it is proportional to the 'voltage' that is applied to it."

In other words, if the voltage is doubled, twice as much current flows; if the voltage is tripled, three times as much current flows, etc. This applies strictly to d-c circuits only. In a-c circuits, several other factors such as inductance, capacitance, etc., may also greatly affect the current.

Now, therefore, if a current-measuring instrument is connected *across* a source of voltage, and the resistance of this instrument is of constant value (as it always is), then since $I=E/R$, the current which will flow through it will be directly proportional to the *voltage* across which the instrument is connected. Consequently, instead of marking its scale to indicate the *current* flowing through it, we can calibrate it to indicate directly the *voltage* applied to its terminals, and then use the meter to measure and indicate "voltage". It then becomes a *voltmeter*.

Just how this works out in practice, can be illustrated by the following typical example:

Example: Let us assume that we have a Weston Model 301 d-c milliammeter, having a range of 1 *milliampere*. Suppose we desire to make of it, a d-c voltmeter having a range of 100 *volts*.

Referring to the meter resistance table in Art. 2-14, we find that a 0-1 Weston Model 301 milliammeter has a resistance of 27 ohms. The internal arrangement of this meter is shown in Fig. 2-15. We know that when 1 milliampere of current flows through this meter movement, it will deflect the pointer over the full scale. We desire to make a 100-volt voltmeter of it, that is, when we apply 100 volts to the instrument it must make 1 milliampere of current flow through it and cause the pointer to deflect to the end of the scale (the point now marked "100 volts"). However, we found that the resistance of our milliammeter is only 27 ohms. If we apply 100 volts to it, a current of $I=E/R=100/27=3.7$ amperes, or 3700 milliamperes, will flow through it! Obviously this will not only make the pointer go past the end of the scale and damage itself against the "stop", but it will actually burn out the thin wire of the movable coil as well (remember what was said in Art. 2-9 about the current-carrying capacity of movable coils).

It is clear that we must put something in the meter circuit to limit the current to 1 milliampere when the 100 volts is applied to it, so that the pointer will be deflected merely to the last division on

the scale (now marked in volts up to 100). Naturally, we can limit the current by connecting a resistor R in series with the movable coil—as shown in Fig. 2-16. From Ohm's law $R = E/I$, it is possible to calculate the value of the total resistance which the completed meter must have in order that when 100 volts is applied to it, only 1 milliampere of current (0.001 ampere) will flow through it. This is $R = E/I = 100/0.001 = 100,000$ ohms. Therefore we must connect a resistor R of 100,000 ohms in series with the movable coil as shown in Fig. 2-16 in order to complete our 100-volt range voltmeter. Actually, the total resistance of the meter will now be $100,000 + 27 = 100,027$ ohms. However, the resistance of the meter itself can be disregarded

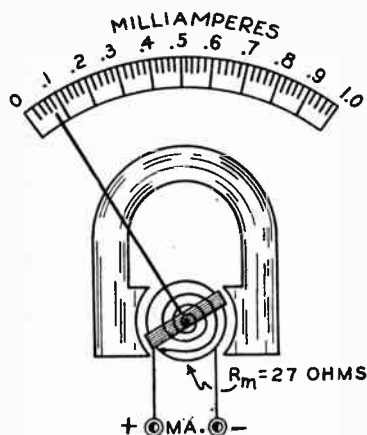

FIG. 2-15.—The internal arrangement of our 1-ma. range milliammeter before converting it into the voltmeter of Fig. 2-16. The resistance R_m of the movable coil, is 27 ohms. The scale is calibrated to read "milliamperes"—up to 1 ma.

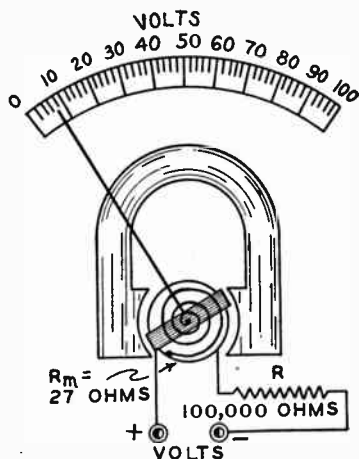

FIG. 2-16.—The general arrangement of the instrument of Fig. 2-15 after a multiplier resistor R has been connected in series with its movable coil. This multiplier determines the range of the meter. The scale is now calibrated to read "volts"—up to 100 volts.

for 27 ohms more in 100,000 would make but slight difference in the accuracy of the voltage reading. Only in cases where extreme precision is necessary and where the voltage to be measured is small need the resistance of the movable coil be considered. A new scale marked in volts up to 100, (see Fig. 2-15) can be made up and put in place of the old "milliampere" scale on the meter.

In the foregoing example, we described how a 100-volt range voltmeter could be made from a 1-ma. milliammeter movement, in order to make clear the idea involved in the construction of voltmeters. Voltmeters of any range can be made from suitable milliammeters in this way. The values of the resistors required

can be calculated by the method illustrated in this typical example. These series resistors are called *multiplier resistors*. Of course, complete voltmeters already equipped with proper multiplier resistors and suitable scales are made by electrical instrument manufacturers. These are the voltmeters usually purchased.

Summing up then, it is evident from the foregoing, that a d-c voltmeter really consists fundamentally of an ordinary d-c milliammeter "movement" connected in series with a suitable "multiplier" resistor. It has a suitably calibrated scale marked to indicate "volts". Since the resistance of the entire instrument is constant, the current flowing through it—and the deflection of the pointer—will be directly proportional to the voltage its terminals are connected to. The scale may be calibrated to indicate the "volts" directly.

2-19. Why High-resistance Voltmeters are Needed—Since the function of a voltmeter is merely to measure the voltage existing across a given circuit, it should not influence in any way the circuit across which it is connected. All voltmeters do not fulfill this requirement. Since the internal circuit of the voltmeter forms a complete path for the flow of current, the voltage across which it is connected will always send some current through it, i.e., the voltmeter will take some current from the circuit. This is really the current which actuates the meter. How much current it takes will depend upon the magnitude of the voltage being measured and the total resistance of the voltmeter itself, since $I = E/R$.

In many voltage measurements made in radio work (especially those in high-resistance circuits in which small currents are flowing), the amount of current which flows through the voltmeter during the measurement is very important, and it is desirable to have it as small as possible if a true indication of the actual voltage existing in the circuit before the voltmeter was connected is to be obtained. If the voltmeter draws so much current from the circuit that the voltage at the terminals of the meter *drops* when it is connected, it is evident that it will not give a true reading of what the voltage of the circuit was before it was connected.

To understand what actually happens in some circuits if the

voltage is measured by a voltmeter which draws an appreciable current (an "ordinary" voltmeter), let us consider a typical case.

Consider (A) of Fig. 2-17. A voltage of 200 volts is being applied across resistors R_1 and R_2 in series. They might be resistors in the plate circuit of a vacuum tube in a radio set. The total resistance (R_1+R_2) of R_1 and R_2 is 20,000 ohms. The current flowing is, therefore, $I=E/R=200/20,000=0.01$ ampere. The voltage actually existing across R_1 (and also across R_2) is $E=I\times R=0.01\times 10,000=100$ volts.

Now suppose we try to measure the voltage across R_1 or R_2 with an ordinary 100-volt range voltmeter—one employing a

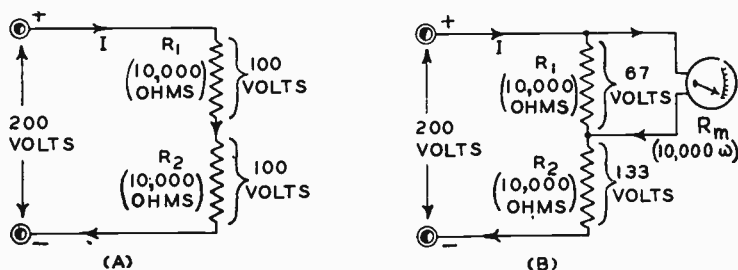

FIG. 2-17.—(A): A typical circuit showing all resistances and voltages before a voltmeter is connected.

(B): The same circuit, showing all resistances and voltages after a voltmeter is connected to read the voltage across R_1 . The voltmeter draws so much current from the circuit, that it alters the voltages across R_1 and R_2 , and therefore gives a false reading.

10 ma basic movement. Obviously, the resistance of this voltmeter is equal to $R_m=E/I=100/0.01=10,000$ ohms. Now, if this voltmeter is connected across R_1 as shown at (B) the total resistance of the circuit will be changed. The combined resistance of R_1 and the voltmeter resistance R_m in parallel is equal to

$$R = \frac{R_1 \times R_m}{R_1 + R_m} = \frac{10,000 \times 10,000}{10,000 + 10,000} = 5,000 \text{ ohms, which, when in series}$$

with resistor R_2 of 10,000 ohms, results in a total circuit resistance R_t of $5000+10,000=15,000$ ohms. The total current now flowing is, then, $I=E/R=200/15,000=0.0133$ ampere. The voltage actually existing across R_2 when the voltmeter is connected across R_1 is $E_2=I\times R_2=0.0133\times 10,000=133$ volts, and that across R_1 and the voltmeter is but $200-133$, or 67 volts!

It is evident that the voltmeter used for this voltage measurement does not give a true indication of the voltage of the circuit—because as soon as it is connected to the circuit, it alters the currents and voltages which previously existed. A change of 100 - 67 (or 33 volts in every 100) occurred in this case. This is a 33% error—far too great to be tolerated in any sort of radio work.

A good working rule to remember when using a voltmeter is that: *the resistance of the voltmeter (its resistance for the particular range employed) should be at least 10 times the resistance of the circuit across which it is connected when making the voltage measurement.* Thus, if in Fig. 2-17, the resistance R_m of the voltmeter employed had been 100,000 ohms, the change in voltage across R_1 when the meter was connected would have been very small, entirely within the limits tolerated in ordinary radio service work. This serves as one practical illustration of the necessity for *high-resistance* voltmeters in radio test work.

2-20. High-resistance Voltmeters. Our discussion of what happens in a typical high-resistance circuit when an ordinary medium-resistance voltmeter is used to measure voltage in it (Art. 2-19) serves to point out the fact that an appreciable error may result if the meter has too low a resistance—or putting it another way, if the meter movement requires too much current to actuate it. What we need is a meter movement that is very "sensitive", that is, one that requires very little actuating current to move its coil and its pointer over full-scale deflection. This is accomplished by making the meter with a very strong special alloy-steel magnet, a short air gap and a movable coil made of many turns of extremely thin wire—wire thinner than a human hair! Since this type of meter movement requires very little current to actuate it, the series multiplier resistance must be of quite high value—thus giving us a voltmeter having a high resistance, that is, a *high-resistance* voltmeter.

At the present time, several forms of high-resistance d-c voltmeters are popular in radio test work. One employs a 1-milliampere basic meter "movement", that is, the needle moves across the full scale when 1 milliamper (0.001 ampere) flows through the movable coil of the instrument. Such a voltmeter has a re-

sistance of $1/0.001=1,000$ ohms per volt of its range, i.e., *1000 ohms-per-volt*. Thus a meter of this kind having a range of 300 volts would have a *total* resistance of $300 \times 1000=300,000$ ohms.

The ohms-per-volt value of a voltmeter is equal to the total resistance of the meter, divided by the maximum voltage marked upon that scale for which this resistance is specified."

This is so, regardless of the voltage that will be applied during any measurement.

A more sensitive form of high-resistance voltmeter which has come into use lately is one employing a 50-microampere

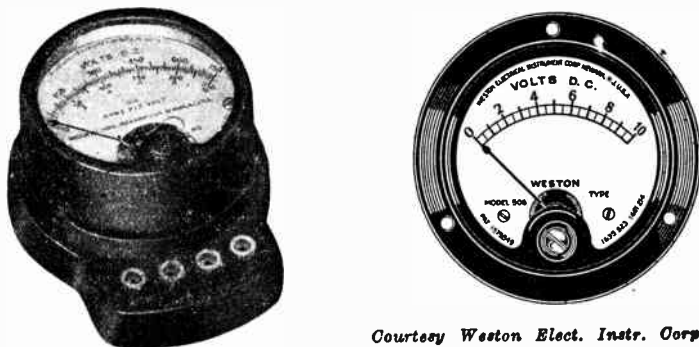

Courtesy Weston Electr. Instr. Corp.

FIG. 2-18.—(Left): A typical miniature, portable, 3-range, 1000-ohms-per-volt voltmeter having ranges of 10; 250 and 750 volts d-c. (Weston Model 489.)

(Right): A 1000-ohms-per-volt panel type voltmeter only 2-inches in diameter. Note the uniform width of the various scale divisions. (Weston Model 506.)

basic meter "movement", that is, one in which the needle moves across the full scale when 50 microamperes (0.00005 ampere) flows through the movable coil. Such a voltmeter has a resistance of $1/0.00005=20,000$ ohms per volt of its range, i.e., 20,000 ohms-per-volt. This meter is *20 times* as sensitive as the 1,000 ohms-per-volt type, and, since its resistance is *20 times* as high, it has only $1/20$ as much effect on the condition of any circuit to which it may be connected. Meters even more sensitive than this are made, but they are not generally for "portable" use.

A typical high-resistance portable voltmeter, which is handy

for voltage measurements in radio receivers and power units, is illustrated at the *left* of Fig. 2-18. It is a 1,000 ohms-per-volt meter having ranges of 10; 250 and 750 volts d-c. The meter at the *right* is a 2-inch diameter d-c panel-type voltmeter, also having a resistance of 1,000 ohms-per-volt. Voltmeters employed in radio service work are also built as integral parts of volt-ohmmeters, circuit testers, set analyzers, etc., as we shall see later.

It should be remembered that it is not possible to make a high-resistance voltmeter (of the same range) from an ordinary low resistance voltmeter simply by connecting additional resistance in series with it, for this would only reduce the current through the meter and reduce the deflection of the pointer proportionately. A high-resistance voltmeter is fundamentally different from a low, or medium-resistance type in that it employs a more "sensitive" basic meter "movement"—one that requires *less current* to deflect its pointer a given amount.

Voltmeters having an ohms-per-volt value as low as 100 are used in ordinary electrical work in which circuits of comparatively low-resistance and carrying fairly large currents are dealt with. In this class of work, the few milliamperes of current taken by the meter does not cause any objectionable error.

2-21. Multi-range Voltmeters.—It is common to construct voltmeters so that they have more than a single range. This

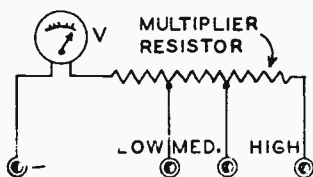

FIG. 2-19.—A d-c voltmeter employing a tapped multiplier resistor, and individual terminals for each range.

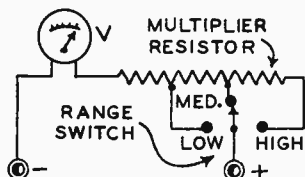

FIG. 2-20.—A d-c voltmeter employing a tapped multiplier resistor and a range-switch for switching from one range to another quickly.

may be done in either of two ways. A single multiplier resistor may be tapped at suitable points, as shown in Fig. 2-19, or, individual resistors of proper values may be connected as shown in Fig. 2-21. The latter arrangement is advantageous, for, if one resistor should become "open-circuited," it will not affect the

operation of the meter on the other ranges, as would be the case in the meter of Fig. 2-19.

In the meter of Fig. 2-19, the terminal at the left serves as the "common" terminal. There is one additional terminal for each range. In order to shift from one range to another, one of

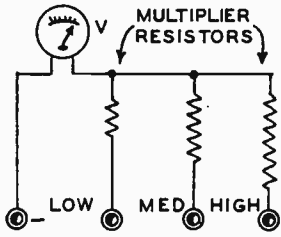

FIG. 2-21.—A d-c voltmeter employing individual multiplier resistors and individual terminals for each range. This arrangement is used in the voltmeter illustrated in Fig. 2-18 (Left).

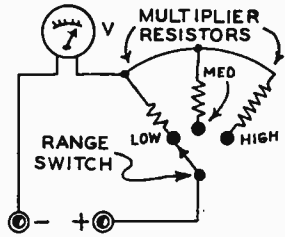

FIG. 2-22.—A d-c voltmeter employing individual multiplier resistors and a range-switch for switching from one range to another quickly.

the wires from the circuit being tested must be shifted from one terminal to another on the instrument. This is objectionable in some test work. To overcome this, the circuit arrangement shown in Fig. 2-20 is often used. Here, a rotary switch is employed as a "range-switch" to select any range—without disturbing the connections from the meter to the circuit under test.

The arrangement shown in Fig. 2-22 is an improvement, for convenience, over that shown in Fig. 2-21. Here, a 3-point range switch enables one to shift quickly from one range to another without disturbing any connections to the voltmeter.

2-22. Extending Ranges of Existing D-C Voltmeters.—

The range of any d-c voltmeter may be increased to any practical value by connecting a "multiplier" resistance, or resistances, in series with the meter, as shown in Fig. 2-23. The value of the "multiplier" resistance can be computed by the following method. The ohms-per-volt value of the voltmeter (which must be known) should be multiplied by the value of the "range" which is to be increased, in order to obtain the total resistance of that particular range of the voltmeter. This product is then multiplied by

the desired multiplier ratio minus 1. This may be expressed by the formula:

$$R_m = R_o \times Range \times (n-1)$$

where R_m = required multiplier resistance in ohms.

R_o = ohms-per-volt value of the meter.

$Range$ = original range of the meter in volts.

n = multiplier ratio.

The use of this formula may be illustrated by the following typical example:

Example: We have a voltmeter with ranges of 5, 50 and 150-volts. Its ohms-per-volt value is 200. The 150-volt range is to be increased to 750 volts. What value of multiplier resistance is required.

Solution: The range is to be multiplied by 750/150, or 5. Therefore, the required multiplier resistance $R_m = R_o \times Range \times (n-1)$

$$= 200 \times 150 \times (5-1) = 30,000 \times (4) = 120,000 \text{ ohms}$$

Each reading taken on the 150-volt scale of the voltmeter must then be multiplied by 5 to obtain the true voltage reading when the multiplier is used.

Where it is desired to obtain a lower range, or ranges, than those for which the meter was originally made, it is necessary to bring out an external lead direct from the lead going to the

COMPLETE VOLTMETER

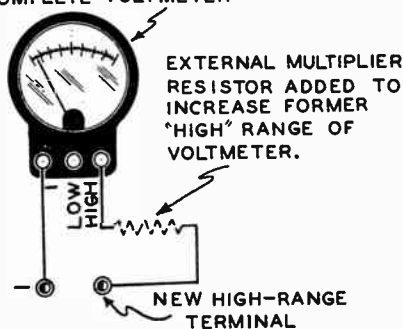

FIG. 2-23.—A suitable external multiplier resistance may be connected to the "HIGH" range terminal of a voltmeter in order to increase its range.

movable coil of the meter, as shown in Fig. 2-24. The proper multiplier resistor for the lower range is then connected in series with this lead, as shown. Any scale reading taken on this new low-range is *divided* by the new multiplier ratio to obtain the true current reading. In most cases, the additional multiplier

resistances will have to be mounted external to the meter—unless there is enough room inside of the meter case for them.

2-23. Making D-C Voltmeters from Milliammeters.—As has already been explained in Art. 2-18, any d-c milliammeter, or microammeter, may be converted easily into a multi-range d-c

FIG. 2-24.—How to obtain a lower range than those for which the voltmeter was designed. A new suitable multiplier resistance is connected directly to the lead going to the movable coil.

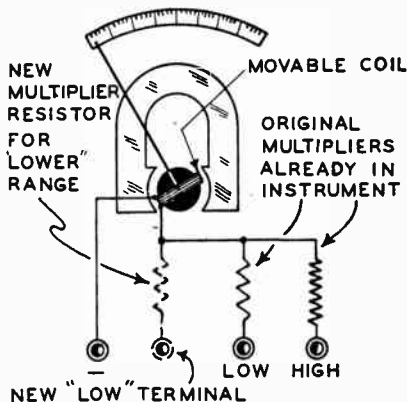

voltmeter by connecting suitable multiplier resistors to it (see Figs. 2-19, 20, 21, 22). Of course, a meter having a full-scale reading of 1 milliampere or less, is preferable to start with, for then it will make a high-resistance voltmeter (see Arts. 2-19 and 2-20).

The proper resistance values to employ for the multiplier resistors may be calculated by Ohm's law. For example: suppose that the meter on hand has a range of 1 milliampere, and it is desired to convert this meter into a voltmeter with a range of 250 volts. In this case, by dividing the desired voltage range (250) by the current consumption of the meter (1 milliampere, or 0.001 amperes), we will obtain a value of 250,000 ohms for the required multiplier resistor. This will result in a voltmeter having a sensitivity of 1000 ohms-per-volt.

As the internal resistance of most d-c microammeters and milliammeters is low, often no higher than 50 or 60 ohms (see table in Art. 2-14), it may be disregarded in computing multiplier resistances for the higher ranges, for it would make but slight difference in the accuracy of the readings. When the meter is

employed to measure low voltages, as 1 or 5 volts, however, its internal resistance value should be considered and subtracted from the value of the *total* resistance, in order to obtain the actual multiplier resistance.

Following is a chart which has been prepared to show, at a glance, the value of multiplier resistances, in ohms, required to make voltmeters, of any of the several ranges specified, from d-c microammeters or milliammeters having common ranges and fairly low resistances.

**MULTIPLIER RESISTORS REQUIRED TO MAKE
VOLTMETERS OUT OF D-C MILLIAMMETERS**

| Ranges of the Microammeters or Milliammeters to be Employed | | | | | | | | | |
|---|---|------------|------------|------------|-------------------------------|------------|----------|----------|----------|
| Voltage Range Desired (Volts) | 100 ua. | 200 ua. | 300 ua. | 500 ua. | 1000 ua. ----- 1 ma. | 1.5 ma. | 2 ma. | 3 ma. | 5 ma. |
| | Required "Multiplier" Resistances in ohms | | | | | | | | |
| 1 | 10,000 | 5,000 | 3,333 | 2,000 | 1,000 | 667 | 500 | 333 | 200 |
| 1.5 | 15,000 | 7,500 | 5,000 | 3,000 | 1,500 | 1,000 | 750 | 500 | 300 |
| 2 | 20,000 | 10,000 | 6,670 | 4,000 | 2,000 | 1,330 | 1,000 | 667 | 400 |
| 3 | 30,000 | 15,000 | 10,000 | 6,000 | 3,000 | 2,000 | 1,500 | 1,000 | 600 |
| 5 | 50,000 | 25,000 | 16,700 | 10,000 | 5,000 | 3,330 | 2,500 | 1,670 | 1,000 |
| 7.5 | 75,000 | 37,500 | 25,000 | 15,000 | 7,500 | 5,000 | 3,750 | 2,500 | 1,500 |
| 10 | 100,000 | 50,000 | 33,300 | 20,000 | 10,000 | 6,670 | 5,000 | 3,330 | 2,000 |
| 15 | 150,000 | 75,000 | 50,000 | 30,000 | 15,000 | 10,000 | 7,500 | 5,000 | 3,000 |
| 30 | 300,000 | 150,000 | 100,000 | 60,000 | 30,000 | 20,000 | 15,000 | 10,000 | 6,000 |
| 50 | 500,000 | 250,000 | 167,000 | 100,000 | 50,000 | 33,300 | 25,000 | 16,700 | 10,000 |
| 100 | 1 Meg. | 500,000 | 333,000 | 200,000 | 100,000 | 66,700 | 50,000 | 33,300 | 20,000 |
| 150 | 1.5 Meg. | 750,000 | 500,000 | 300,000 | 150,000 | 100,000 | 75,000 | 50,000 | 30,000 |
| 300 | 3 Meg. | 1.5 Meg. | 1 Meg. | 600,000 | 300,000 | 200,000 | 150,000 | 100,000 | 60,000 |
| 500 | 5 Meg. | 2.5 Meg. | 1,667,000 | 1 Meg. | 500,000 | 333,000 | 250,000 | 167,000 | 100,000 |
| 1,000 | 10. Meg. | 5 Meg. | 3,333,000 | 2 Meg. | 1 Meg. | 666,000 | 500,000 | 333,000 | 200,000 |

Note: ua.==microamperes, ma.==milliamperes, meg.==megohms.

FIG. 2-25.—Chart showing the exact multiplier resistance (in ohms), to be used to convert any common low-resistance d-c microammeter, or milliammeter, into a d-c voltmeter of any of the several ranges specified.

To illustrate the use of this chart, let it be desired to convert a 1.5-ma. milliammeter into a voltmeter having ranges of 1, 10, 150 and 500 volts. Individual multiplier resistors are to be used, connected as shown in Fig. 2-21. Glancing down the vertical column headed 1.5 ma., we find that for a range of 1 volt, a multiplier resistor of 667 ohms is required; for 10 volts, 6,670

ohms; for 150 volts, 100,000 ohms; for 500 volts, 333,000 ohms.

2-24. Multiplier Resistors for Voltmeters.—The resistors used as “multipliers” to extend the ranges of voltmeters, or to convert milliammeters into voltmeters, should be of the precision type with a tolerance not over 2 per cent, and permanent in value. Some typical resistors made especially for this purpose are shown in Fig. 2-26. It is possible to procure commercial resistors of a high degree of accuracy, having a tolerance of 1 per cent or less, plus or minus. These special wire-wound resistors make it simple to convert meters into multi-range instruments with every assurance that the readings will be as accurate as the original accuracy of the meter movement employed will permit.

2-25. Making a Combination Volt-ammeter.—We have shown (Arts. 2-9, 2-10 and 2-18), that the construction of the



Courtesy Weston Elect. Instru.



Courtesy International Resistor Co.

FIG. 2-26.—Typical precision-type wire-wound multiplier resistors for increasing the ranges of voltmeters—or making voltmeters of any desired ranges from microammeters or milliammeters.

meter movement for a d-c ammeter is exactly the same as that of a d-c microammeter, milliammeter, or voltmeter. The difference between these instruments lies simply in the fact that, in the ammeter, *low-resistances* are connected in *shunt* or *parallel* with the meter movement, whereas, in the voltmeter, *high-resistances* are connected in *series* with it. By using the proper terminal and switching arrangement for the various “shunts” and “multipliers”, it is possible to make a very useful combination instrument which may be used either as a multi-range milliammeter, ammeter, or voltmeter. An ordinary 0-1 d-c milliammeter is used for the “movement”. The schematic diagram showing the connection and values of all resistors required, if a Weston model 301 d-c 0-1 milliammeter is employed (from the table in Art. 2-14 we find its resistance to be 27 ohms), is shown in Fig. 2-27. This

same arrangement, with resistors of suitable values, may be used when some other model or make of instrument is employed. Of course, the resistance of the meter movement must be known first, in any case. The shunt resistors may be calculated by the formula given in Art. 2-13. The multiplier resistors for the voltmeter may be calculated by the method of Art. 2-23, or may be found from the table in Fig. 2-25.

Tracing through the circuit of the instrument shown in Fig. 2-27, we find that when switch *SW-1*, an ordinary S.P.S.T. toggle

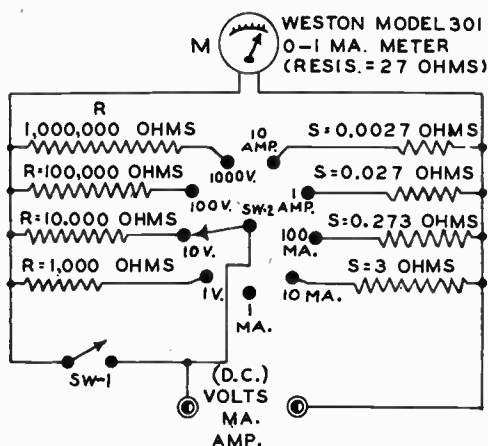

FIG. 2-27.—Complete circuit diagram of a 1-ma. d-c milliammeter arranged to form a multi-range milliammeter, ammeter and voltmeter providing ranges of 1, 10, 100 milliamperes; 1, 10 amperes; 1, 10, 100, 1000 volts.

switch, is closed, the nine-point selector switch *SW-2* may be turned to the right to select any of the shunt resistors *S* in order to convert the meter into a multi-range milliammeter or ammeter. When switch *SW-1* is open, and selector switch *SW-2* is turned to the left, the multiplier resistors *R* are put in series with the meter movement, and therefore convert it into a multi-range voltmeter. Note that the low-range current, and voltage, taps are at the extreme ends of the selector switch. Of course, these ranges may be extended, (or different desired ranges may be obtained) by using shunt and multiplier resistors of different

values, calculated by the methods discussed in the Articles previously mentioned.

By employing a third binding post terminal, and the circuit arrangement shown in Fig. 2-28, the toggle switch *SW-1* of Fig. 2-27 may be eliminated.

An instrument of this kind is very useful in radio test and service work, since one instrument is made to do the work of several meters. As we shall see later, such meters having suit-

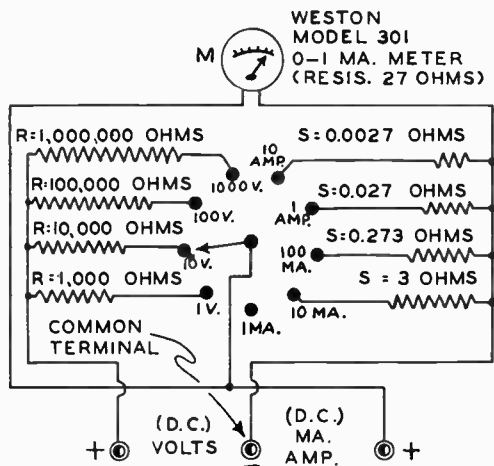

FIG. 2-28.—The same circuit as shown in Fig. 2-27 with the exception that toggle-switch *SW-1* has been eliminated by the addition of another terminal post to the instrument.

able ranges are commonly employed in radio set analyzers.

2-26. Instruments for A-C Measurements. — The milliammeters and voltmeters thus far discussed have been of the d-c movable-coil type, which are employed in direct-current measurements. This type of meter will not function when connected directly in an alternating current circuit, because during one alternation the current flows through the movable coil in one direction, and on the following alternation both the current and the magnetic poles of the movable coil reverse and will, therefore tend to deflect it in the opposite direction. These alternations of the a-c current follow one another so rapidly that the

moving element, in tending to obey one impulse, will almost immediately be caused to be moved in the opposite direction by the next impulse, with the result that the indicating needle will remain practically stationary, trembling slightly at the zero position. Since permanent-magnet instruments cannot be used to measure alternating currents unless a rectifier is used with them (see Art. 2-30), they are generally called *direct current instruments*.

2-27. Movable-Iron Type A-C Instruments.—There are several types of movements used in ordinary commercial a-c instruments. The Weston movable-iron type is one, and it is used primarily for measuring alternating currents and voltages. A detailed description and explanation of its construction follows:

The stationary coil of this form of instrument is wound with a few turns of heavy copper wire when the instrument is to be used as an ammeter. In this case the coil is merely connected in series with the circuit in the usual manner. When the meter is to be used as a voltmeter, a large number of turns of fine wire are wound on the coil, and, connected in series with this coil is an accurately-adjusted high resistance.

As shown in Fig. 2-29, the movable armature *M*, which lies in the center of the coil *C*, consists of a small strip of soft iron,

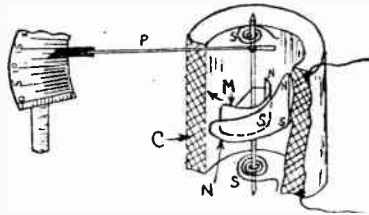

FIG. 2-29.—The movable-iron type movement used in some a-c instruments. The repulsion between the magnetized iron vanes *M* and *N* causes the pointer to move over the scale. A portion of the coil *C* has been cut away in this view to show the interior arrangement of the parts.

semi-circular in shape, secured to a vertical shaft supported so it can turn freely in jewel bearings. The pointer *P* is fastened to the upper end of the shaft and turns with it. A small, loose fitting, thin vane (not shown) is attached to the pointer and moves in a small air compartment. As this vane moves in the

closed air compartment, like a piston in a pump, it provides the damping required to prevent the pointer from oscillating, and thus makes the instrument "dead beat." Close to the movable-iron armature M is secured a stationary wedge-shaped piece of

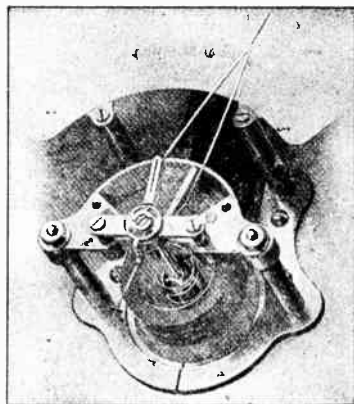

FIG. 2-30.—A "phantom" interior view of the "movement" in a movable-iron type a-c ammeter or voltmeter. This is similar to that shown in Fig. 2-29. Notice the curved iron strips at the center.

Courtesy Weston Elect. Instr. Corp.

curved soft-iron N , with its small end rounded off as shown. This piece of iron is securely held in place, does not move, and has no connection to the movable armature vane M or to the shaft.

When the coil is connected in the circuit, the current flowing through it sets up a magnetic field through its center and both soft-iron vanes become magnetized. The upper edges of each will always have a similar magnetic polarity, and the lower edges will also always have a similar magnetic polarity—when both *upper* edges are *north* poles both *lower* edges are *south* poles, and vice versa. Therefore, there will always be a mutual repulsion between the two upper edges and also between the two lower edges of these soft-iron strips, no matter in which direction the current is flowing through the coil. Consequently, the instrument can be used either in d-c or in a-c circuits. The sidewise repulsion tends to make the movable vane M slide around from the fixed one N , and, in so doing, moves the pointer, against the action of the hair springs, over the graduated scale, and indi-

cates the volts or amperes, depending on whether the instrument is constructed and connected as a voltmeter or as an ammeter. A phantom interior view of a meter of this type is shown in Fig. 2-30. An external view of a small 2-inch diameter voltmeter of this type employed in radio work is shown in Fig. 2-31.

2-28. Disadvantages of Movable-iron A-C Meters.—Since the magnetic field produced by the current flowing through the

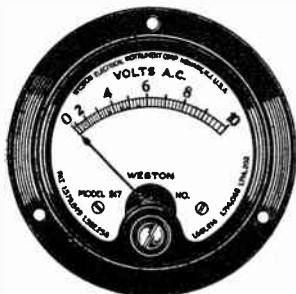

FIG. 2-31.—Exterior view of a small 2-inch diameter a-c voltmeter of the movable-iron type shown in Fig. 2-29. Note the non-uniform scale divisions—crowded at the lower end. (Weston Model 517.)

Courtesy Weston Elect. Instr. Corp.

coils of movable-iron type instruments is located practically all in air, this field is comparatively weak. Consequently, these instruments require more current (usually from 15 to 150 ma.) in the field coil to produce movement of the pointer than the permanent-magnet movable-coil type instruments do. Therefore, they are not as 'sensitive', and are unsuited for the measurement of very weak currents, or the accurate measurement of voltages in circuits where the voltmeter must not draw much current (see Art. 2-19). Consequently they are not employed much in radio service work.

A triple range, portable a-c voltmeter of the movable-iron type is shown in Fig. 2-32. As an example of the low sensitivity inherent in this type of meter let us consider the resistance values of the various ranges of this particular instrument. The ranges are 150, 8 and 4 volts. The corresponding meter resistance values are 10,000, 80 and 40 ohms, respectively. Consequently, on the 150-volt range we have a sensitivity of only $10,000/150=66$ ohms-per-volt! On the 8- and 4-volt ranges, the sensitivity of the meter is very much lower (only 10 ohms-per-volt).

As they have non-uniform scales, with the divisions closely spaced near the bottom and much more "open" near the upper end, as shown in the meter of Fig. 2-31, care should be taken, when instruments of this type are being purchased, that their range be such that the values to be measured come at the "open" part of the scale, rather than near the crowded, lower end, where it is difficult to read the position of the pointer accurately.

The non-uniformity of the scale on the movable-iron type of a-c instrument is due to the fact that the deflection of the pointer is proportional to the *square* of the current flowing. In the d-c movable-coil type instrument, the permanent magnet supplies one of the the two required fields; hence the movement of the coil is directly proportional to the current. In the a-c instrument, the repulsion is proportional to the product of the magnetism in each vane, and, since the *same* current magnetizes *both* vanes, the moving force (and the deflection of the pointer) is proportional to the *square* of the current. Hence, the scale must be marked according to the *square root* of the movements, (i.e., if $d=I^2$, then $I=\sqrt{d}$).

2-29. Extending Ranges of A-C Movable-iron Voltmeters.

—As in the case of the d-c instrument, the a-c meter movement

FIG. 2-32.—A portable triple-range a-c voltmeter of the movable-iron type. Four terminals are provided—one is a common terminal. (Weston Model 528.)



Courtesy Weston Elect. Instr. Corp.

has a certain definite value of internal resistance, and the voltmeter scale may be extended by the use of the resistance form of multiplier. Since the a-c meter requires more current to act-

uate it, the multiplier units must have a higher power rating than those used with d-c meters. The value of the multiplier resistance may be determined in the same manner as was employed in the case with d-c voltmeters (see Art. 2-22). The full-scale reading of the meter in volts should be multiplied by the ohms-per-volt value to find the "total" resistance of the meter. This product is then multiplied by the desired multiplier ratio minus 1 (see Art. 2-22).

2-30. Rectifier Type A-C Instruments.—In the measurement of alternating current or voltage in a radio receiver, it is important

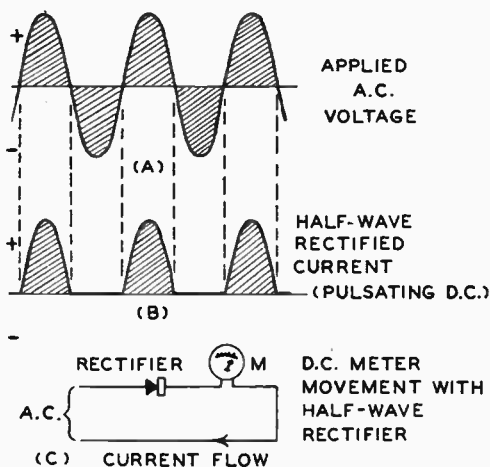

FIG. 2-33.—How a simple half-wave rectifier connected in series with a d-c meter movement in an a-c circuit allows a current to flow in only one direction (d-c current) through the meter, during one-half of every cycle.

ant, in most cases, that the measuring instrument use very little current, or power, for its operation, just as we found was the case with d-c measurements (Art. 2-19). One particular example of this is the measurement of the output signal voltages of radio receivers during the aligning of the tuned stages, etc. If an ordinary movable-iron type a-c voltmeter were connected across the output terminals of a receiver in order to measure the output voltage, it would absorb a comparatively large proportion of the small power available, and the readings obtained would be far

from accurate. Whereas, d-c voltmeters requiring an actuating current of only $\frac{1}{2}$ or 1 milliamperes to secure full-scale deflection are easily obtainable; a-c voltmeters of the movable-iron type usually require in the neighborhood of 5 to 20 milliamperes (depending upon the range) for full-scale deflection, the electrical power consumed by them usually being of the order of several watts!

The advantages of the low current consumption (high sensitivity) of the d-c movable-coil meter movement can be retained for measuring low or high a-c voltages and currents, such as are involved in the output circuits of radio receivers and the high secondary voltages of power transformers, etc., by using a suitable sensitive d-c movement in connection with a copper-oxide type rectifier. The rectifier changes the *alternating current* to *direct current*, which the meter movement is able to measure.

2-31. Operation of the Meter-rectifier.—A *rectifier* is a device which presents a high resistance to the flow of current through it in one direction, and a comparatively low resistance to the flow of current through it in the opposite direction. Therefore, if an alternating voltage (*A*) of Fig. 2-33 is applied to the terminals of a simple rectifier, current can flow through it only in one direction, so the current flowing is a *pulsating direct current*, flowing for half a cycle, only, during each cycle of the applied a-c voltage—as shown at (*B*). A rectifier arrangement of this kind is called a *half-wave rectifier*, since it allows current to flow through the circuit only during *half* of each a-c cycle or wave.

If such a rectifier is connected in series with a d-c meter movement as shown at (*C*), the meter will read only about half of what it should, because only half of each cycle of current flows through it and a d-c meter movement reads the *average* value of the current flowing.

In order to have the meter read the full value, the current must be made to flow through it *in the same direction* during *both halves* of each cycle. This is accomplished by combining two half-wave rectifier circuits (employing four half-wave rectifier units) in a Wheatstone bridge arrangement, as shown at (*C*) of Fig. 2-34. In this case, if an a-c voltage (*A*) is applied to the combination, current flows through the meter in the same

direction during both halves of each cycle, as shown at (B).

The operation of the full-wave rectifier circuit employing four half-wave rectifiers *A, B, C, D*, may be illustrated by the diagrams of Fig. 2-35. The arrow on the rectifier symbol used in the diagrams indicates the direction in which current is able

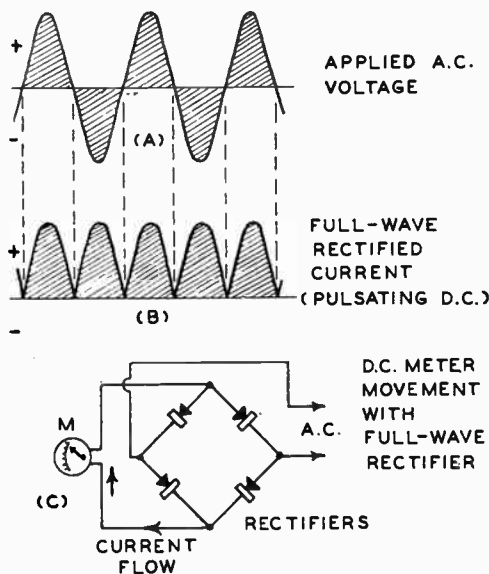

FIG. 2-34.—If the a-c voltage shown at (A) is applied to a full-wave rectifier circuit, current will flow in the same direction during each half cycle—as shown at (B). A full-wave rectifier may be connected to a d-c meter movement, as shown at (C), so that the d-c instrument may be used to measure alternating current or voltage.

to flow through the rectifier. The explanation of the operation of the circuit follows:

The circuit condition existing during those halves of the cycles when the top terminal of the a-c voltage source is *positive*, and the bottom terminal is *negative*, is shown at (A). Starting at the positive terminal of the line, and tracing through the circuit, it will be seen that the current flows *down* through rectifier *C*, *up* through the meter movement *M*, *down* through rectifier *A*, and out of the negative terminal—as shown by the arrows. Rectifiers *B* and *D* do not pass any current during this half cycle. The conditions during the next half cycle are shown at (B). The polarity of the a-c line has now reversed, the lower terminal now being “positive.” The current now

flows down through rectifier *D*, up through the meter movement *M*, down through rectifier *B* and out of the negative terminal—as shown by the arrows. Rectifiers *A* and *C* do not pass any current during this half cycle.

The important point to notice is that even though the direction of the current coming from the a-c line reverses, the rectifier arrangement makes the current flow through the meter movement in the same direction during *both halves* of each cycle. Hence we have here a full-wave rectifier which accomplishes the task of reversing the a-c current during alternate half-cycles so that it flows through our d-c meter movement in the *same* direc-

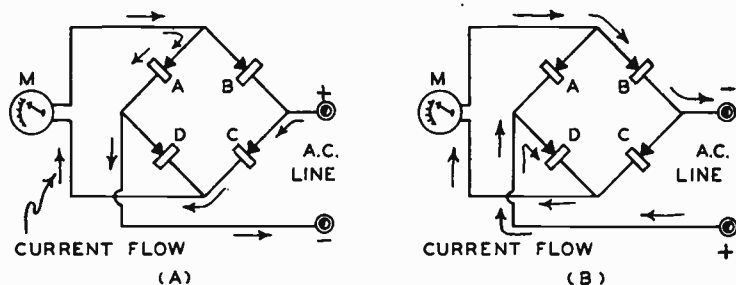

FIG. 2-35.—How a full-wave rectifier operates.

(A): During one half of each cycle, rectifiers *C* and *A* are in operation. Rectifiers *B* and *D* do not operate. Current flows upward through meter movement *M*.

(B): During the other half of each cycle, the a-c line polarity has reversed. Rectifiers *B* and *D* are now in operation. Rectifiers *A* and *C* do not operate. Current again flows upward through meter movement *M*.

tion during each half cycle—and the d-c meter will indicate the *average* value of the full-wave pulsating current.

2-32. Rectifier-type Instruments Really Measure “Average” Values.—Since the output of the rectifier is a pulsating direct current, see (B) of Fig. 2-34, the d-c meter movement will really measure the *average value* of the pulsating rectified current applied to it. Therefore, the meter will indicate the *average value* of the a-c voltage or current, which is equivalent to the maximum or “peak” value $\times 0.635$ (for a sine-wave a-c).

The relation between *peak*, *effective* and *maximum* values of sine-wave alternating currents or voltages is shown by Fig.

2-36. The "peak" value here is taken arbitrarily as 1 volt. The *effective* value is 0.707 of the peak value, and the *average* value (that indicated by *all* d-c meter movements) is 0.635 of the peak value.

The "effective value" of an alternating current is defined as that value of a-c which will produce the same amount of *heat* in a resistor that the same value of non-pulsating direct current will produce. For instance, if the peak value of an alternating current flowing through a resistor is 10 amperes, the effective value is, therefore, $10 \times 0.707 = 7.07$ amperes. A certain amount of heat will be developed by the flow of this current through the resistor. Now if 7.07 amperes of d-c is sent through the same resistor, exactly the same amount of heat will be produced as when the 10 amperes of a-c was sent through it. The "average" value of this same current is $10 \times 0.635 = 6.35$ amperes. This is the value that a copper-oxide rectifier-type ammeter would read.

If a rectifier-type instrument is constructed by the reader by connecting a meter rectifier unit to an ordinary d-c meter movement, he should remember that any reading taken on the original scale of the d-c meter represents the "average" value, or 63.5% of the "peak" value, of the alternating current or volt-

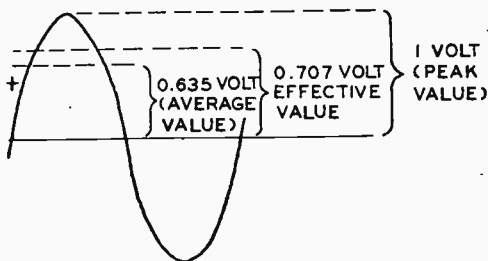

FIG. 2-36.—Sine-wave voltage or current showing the relation between the "peak", "effective", and "average" values of the current or voltage. This graph is drawn approximately to scale.

age being measured. Therefore, all readings taken on the original scale must be multiplied by $0.707/0.635$, or 1.11, to obtain the "effective" value of the a-c. The "effective" value is the one we are usually interested in. It is the value that movable-iron type

a-c instruments indicate, and is the value that we mean when we say that an alternating current or voltage is so many "amperes," or "volts," respectively.

In the rectifier-type instruments which are sold commercially, the scales are already calibrated and marked to indicate

FIG. 2-37.—A typical copper-oxide rectifier-type a-c voltmeter having a resistance of 1000 ohms-per-volt. Notice the almost-uniform scale divisions. (Weston Model 301.)

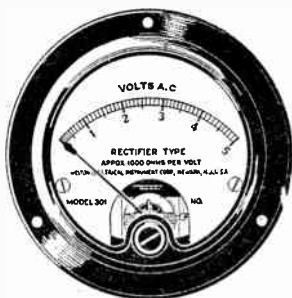

Courtesy Weston Elect. Instr. Corp.

the true "effective" value of the a-c current or voltage being measured, so no correction is necessary. Fig. 2-37 shows a typical meter of this type. Notice that the scale divisions on this meter are practically *uniformly* spaced (similar to those in the d-c voltmeter at the *right* of Fig. 2-18) rather than being of the inconvenient "square law" type (crowded at the lower end as in the movable-iron type meter illustrated in Fig. 2-31). At present, these rectifier-type meters are offered as the only practical means of constructing high-sensitivity a-c voltmeters (particularly of low ranges), and sensitive a-c microammeters and milliammeters. Rectifier type voltmeters having a sensitivity as high as 2,000 ohms-per-volt are now in common use.

2-33. Construction of the Copper-oxide Meter Rectifier.—Several forms of rectifiers have been developed for use in rectifier-type instruments, but the most suitable, simple and inexpensive one yet found for this purpose is the copper-oxide dry-contact form of rectifier. This type of rectifier consists of a disc of copper oxide held in contact with one of copper. It has the property of allowing current to flow easily in a direction *from the copper oxide to the copper*—but not in the reverse

direction. Thus it acts as a rectifier. In Figs. 2-33, 2-34 and 2-35, the copper-oxide discs are represented by the arrow, and the copper by the small rectangle touching it.

The full-wave rectifier units employed in rectifier-type measuring instruments are made with four small copper-oxide discs and four copper discs arranged to form the four arms of a

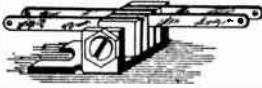

Courtesy Leo Tausig.

FIG. 2-38.—A typical copper-oxide type meter rectifier. It measures only $\frac{1}{4} \times \frac{3}{8}$ inches. The actual circuit connections of a rectifier of this type are shown in Figs. 2-39 and 2-40.

Wheatstone bridge (see Fig. 2-34) and assembled to make a single compact unit measuring less than $\frac{1}{2}$ inch in length. Each set of alternate copper and copper-oxide discs has a resistance of about 500 ohms. A typical commercial unit of this kind is shown in Fig. 2-38. Notice the four projecting lugs for connecting the unit. Two connect to the d-c meter movement, and two connect to the a-c line (see Figs. 2-34, 2-39 and 2-40). The actual circuit connections made to the various elements of the rectifier when it is connected to a d-c milliammeter movement to make a low-range a-c milliammeter (without shunts) is shown in Fig. 2-39. The conventional circuit diagram for this, in which the usual symbols are shown for the various rectifier units, is shown in Fig. 2-40. Trace through each one, and compare them!

2-34. Characteristics of Copper-oxide Type Meter Rectifiers.— Until recent developments and improvements in the design of copper-oxide meter rectifiers were made, resulting in lowering the “capacity” between the elements, these rectifiers could not be employed in meters which were to measure “radio-frequency” currents or voltages. The difficulty was due to the fact that, even though the “rectifying action” did not allow alternating current to pass *through* the “contact” surface of the rectifier elements, alternating current did get into the meter movement because the comparatively high capacity between the elements was sufficiently large to allow current to surge back and forth in the meter circuit due to the “capacity” action of this circuit. In other words, the rectifying surfaces were “by-passed” by the

capacity between the elements. Since the amount of this bypassing depended upon the frequency of the current being measured, the meter was inaccurate for all but small deviations from the frequency for which it was calibrated.

Later developments in rectifier elements have resulted in lowering the capacity between the elements, so that these rectifiers may also be used in r-f meters. Frequency errors introduced by these inherent characteristics of present rectifiers of this type cause the instrument indications, or readings, to *decrease* approximately $\frac{1}{2}$ of 1% for each 1000 cycles up to about 35,000 cycles.

The percentage of error caused by temperature changes is usually not more than 3% at ordinary room temperatures, although it may be higher at temperatures below 60° F. and above

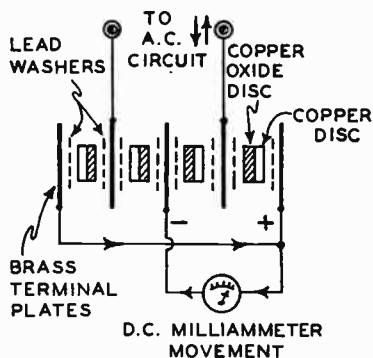

FIG. 2-39.—The actual circuit connections made to the various elements of a copper-oxide full-wave rectifier when it is connected to a d-c milliammeter movement (with no shunt) to make an a-c milliammeter.

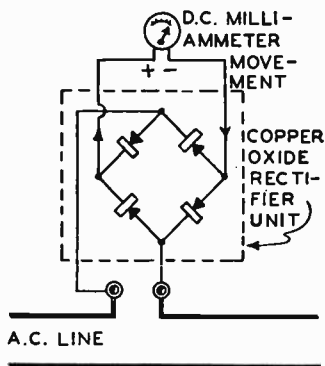

FIG. 2-40 — Conventional circuit diagram for the rectifier type a-c milliammeter arrangement shown in Fig. 2-39. Notice that the *complete* instrument is connected in series with one side of the a-c line.

100° F. Errors may also be caused by any deviation (from a true sine wave) of the wave-form of the current or voltage to be measured. Of course, if accurate measurements are to be made under unusual conditions of frequency, temperature or wave-

form, the proper corrections can be applied to any readings taken.

2-35. Rectifier Type A-C Milliammeters and Voltmeters.

—It was pointed out in Art. 2-30, that by employing a copper-oxide rectifier in conjunction with a sensitive meter, such as a 0-1 milliammeter or a 0-500 microammeter, sensitive instruments with a resistance of 1000 ohms-per-volt or greater may be readily constructed for the measurement of a-c voltages and current.

If current is to be measured with this arrangement, the terminals of the complete instrument should be connected in *series* with one side of the a-c circuit as shown in Fig. 2-40, in

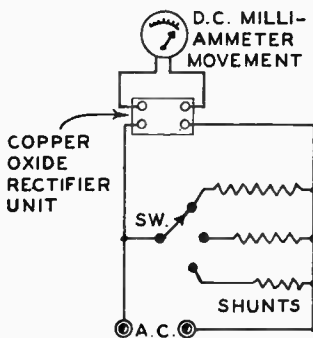

FIG. 2-41.—How a d-c milliammeter movement, a meter rectifier and shunts may be connected together to make a multi-range rectifier type a-c milliammeter.

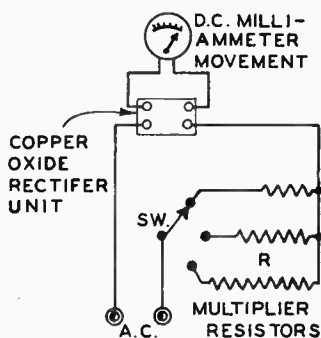

FIG. 2-42.—How a d-c milliammeter movement, a meter rectifier and multiplier resistors may be connected together to make a multi-range rectifier type a-c voltmeter.

the same way that an ordinary milliammeter or ammeter is connected (see Fig. 2-9). A precaution must be observed at this point. Never permit more current to pass through the rectifier than its maximum rating, which in most cases is about 15 ma. Otherwise it will be overheated and become damaged.

If a meter having more than one range is desired, suitable shunt resistors and a range-selector switch may be utilized, as shown in Fig. 2-41, to extend the current ranges. Notice that the shunts are connected on the a-c *line side* of the copper-oxide

rectifier, so that most of the current flows through the shunts and only a small definite fraction of it flows through the rectifier unit and d-c meter movement.

When voltages are to be measured instead of current, the multiplier resistors, R , are connected in series with the a-c input side of the rectifier, as shown in Fig. 2-42. The values of the multiplier resistors are calculated in the same manner as explained in Art. 2-18, or the table in Art. 2-23 may be employed. The resistance of the rectifier is usually neglected when determining the value of multiplier resistance required in any case, for in voltmeters of any appreciable range it forms but a small percentage of the total resistance of the voltmeter.

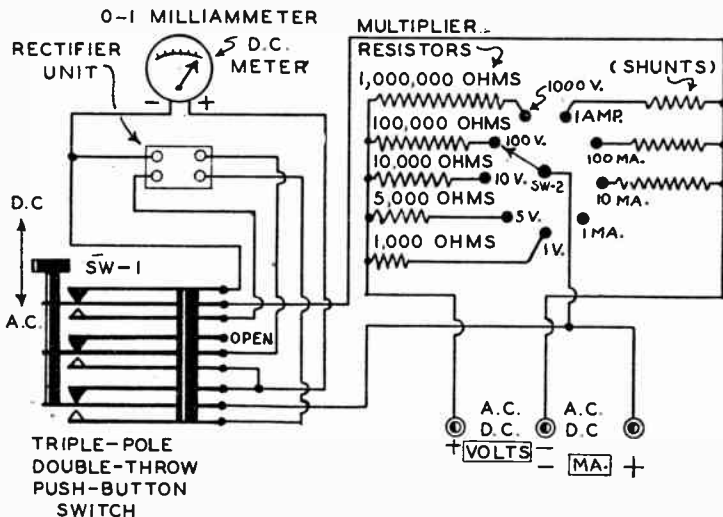

FIG. 2-43.—A handy multi-range a-c and d-c milliammeter, ammeter and voltmeter made from a 0-1 milliamperere d-c meter, a copper-oxide rectifier, and the necessary switches, shunts and multiplier resistors.

All shunts and multiplier resistors used in rectifier type a-c instruments should be non-inductive, wire-wound, precision units, to prevent the introduction of any additional inductance or capacity into the circuit.

2-36. How to Make a Multi-range A-C—D-C Meter.—By

using a suitable terminal and switching arrangement, a 0-1 d-c milliammeter, a copper-oxide meter rectifier and the proper shunt and multiplier resistors, may be combined to form a very useful multi-range a-c—d-c instrument, as shown in Fig. 2-43. The triple-pole double-throw switch *SW-2* is employed to throw the rectifier in and out of the circuit, when measuring either a-c or d-c potentials or currents. The 9-point switch *SW-2* enables the desired voltage or current range desired, to be selected quickly. The ranges available with the particular combination shown, are 1, 5, 10, 100, 1000 volts a-c or d-c; 1, 10, 100 milliamperes and 1 ampere a-c or d-c. All voltage ranges are on the basis of 1000 ohms-per-volt.

Due to the fact that the values of the shunt resistors to be employed depend upon both the exact internal resistance of the particular milliammeter employed, and also upon the resistance of the particular rectifier used, these values were purposely omitted in the circuit diagram of Fig. 2-43. If the resistance of the meter is known accurately, the resistances of the shunts can be calculated by the method already explained in Art. 2-13. If the resistance is not known, the shunts can be made by trial, as explained in Art. 2-15. If the meter is a Weston instrument, its resistance can be found from the table in Art. 2-14, and the shunt resistances may be calculated after this value is known.

It should be remembered (see Art. 2-32) that when a-c currents or voltages are measured with this instrument, any reading obtained on the d-c meter scale will be only 90% of the "effective" value of the a-c current or voltage. Therefore, to obtain the effective values we must multiply the scale readings by 1.11.

2-37. Commercial Rectifier-type A-C Instruments.—Although the simple a-c—d-c instrument described in Art. 2-36 is efficient and useful, many commercial instruments having greater flexibility and accuracy are desirable. In most cases, the a-c correction has been made directly upon the meter scale. Almost all of them also include facilities for resistance measurement, since this useful feature can be added to the instrument at very little additional cost. (Resistance measurements will be discussed at length in Chapter 3). Many of these instruments also incorporate provisions for making capacity and impedance

measurements. Descriptions of several typical commercial instruments of this kind follow.

2-38. Weston Model 301 A-C—D-C Universal Meter Kit.

—This is a practical kit for general measurement work. The instrument furnished with the kit is a Model 301 universal meter, with self-contained d-c ranges of 50 mv., 1 ma., and an a-c range of 5 volts. All voltage readings are on the basis of 1000 ohms-per-volt. A copper-oxide type rectifier is incorporated within

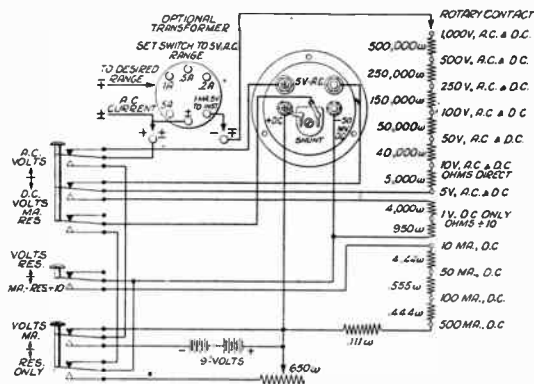

Courtesy Weston Elect. Instr. Corp.

Fig. 2-44.—Schematic circuit diagram of the Weston Model 301 AC-DC Universal Meter Kit. The various parts for use in this meter are shown in Fig. 2-45.

the meter. When the proper resistances and switches furnished with the kit are connected as shown in Fig. 2-44, the following ranges are available: 5, 10, 50, 100, 250, 500, 1,000 volts a-c and d-c; 1 volt d-c; 10, 50, 100, 500 milliamperes d-c; 0-10,000, 0-100,000 ohms. The necessary parts for construction of this instrument are shown in Fig. 2-45. Notice the various shunt resistors mounted on a Bakelite strip at the bottom, and the multiplier resistors wound on spools at the center.

For higher a-c current measurements, a miniature step-down transformer with ranges of 0.2, 0.5, 1, and 5 amperes a-c is obtainable. Its connections may be seen in Fig. 2-44.

The accuracy on d-c measurements is within 2% ; but on a-c, because of the inherent characteristics of the rectifier unit,

the accuracy is within 5%. A reduced facsimile of the interesting instrument scale is shown in Fig. 2-46. Note that the a-c scale divisions do not coincide in position with the corresponding divisions of the d-c scale.

2-39. Shallcross A-C Utility Meter No. 685.—This instrument, shown in Fig. 2-47, is rather unusual, in that it employs a

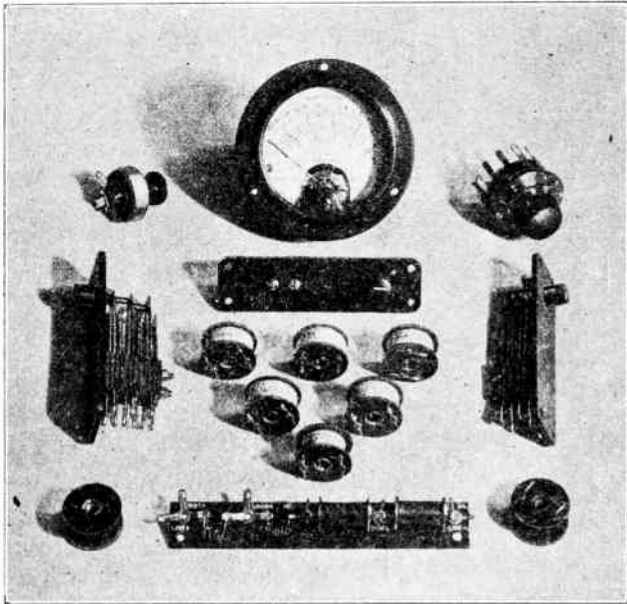

Courtesy Weston Elect. Instr. Corp.

FIG. 2-45.—The various parts for the universal meter of Fig. 2-44 before being assembled and wired. Notice the universal meter at the top, with its various scales. The multiplier resistors are wound on the spools shown at the center. The shunt resistors, assembled on an insulating strip are at the bottom.

1-milliampere, rectifier type a-c meter, connected in a circuit with a double-pole 8-position switch and the proper resistors to provide all essential a-c voltage measurement ranges, and a wide range of impedance measurements, the latter by using the external 110-volt 60-cycle supply. No d-c measurements are provided for. The several meter scales are calibrated to indicate a-c volts, inductance, capacity and resistance. The following

ranges are available on this instrument: 10, 125, 500, 1,000 a-c volts, at 1,000 ohms-per-volt; 0.0005 to 0.1-1-10 mf. capacity (divide meter reading by scale factor marked on face of instrument); 0.5 to 100-1,000-10,000 Henries inductance (multiply

FIG. 2-46.—A reduced reproduction of the instrument scale of the universal meter illustrated in Fig. 2-45. Note the separate a-c and d-c scales; also the "ohms" scale for resistance measurements, at the top.

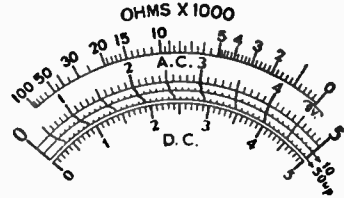

reading by scale factor); 25-50,000-500,000-5,000,000 ohms resistance (multiply reading by scale factor). The schematic circuit of the instrument is shown in Fig. 2-48.

2-40. Triplet Universal A-C—D-C Meter No. 1125.—This instrument is a universal volt-ohm-milliammeter. It employs a



Courtesy Shallex Co. Mfg. Co.

FIG. 2-47. — A-C utility meter which provides for the measurement of a-c voltage, resistance, capacity and inductance. The various ranges are selected by the switch at the center.

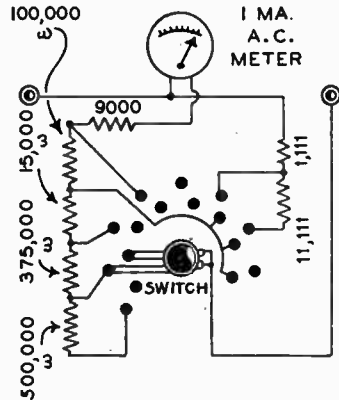
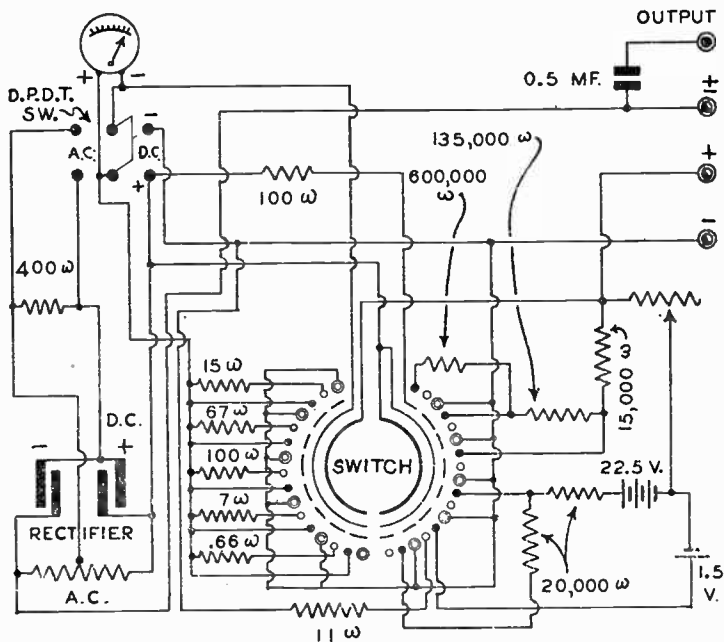

FIG. 2-48.—The circuit arrangement of the a-c utility meter shown in Fig. 2-47. A 1-ma. a-c meter is employed.

sensitive 0-500 d-c microammeter equipped with a copper-oxide rectifier, permitting the accurate measurement of both a-c and d-c currents and potentials. Its circuit diagram is shown in Fig. 2-49. The complete instrument is illustrated in Fig. 2-50. A double-pole double-throw switch marked a-c—d-c enables the meter to be used on either a-c or d-c with equal facility. By the

proper manipulation of the triple-pole, 11-position selector switch, the following voltage and current ranges may be obtained: 15, 150, 750 volts a-c or d-c; 1.5, 15, 150 d-c milliamperes; 15, 150 a-c milliamperes. It is also arranged to meas-



Courtesy Triplett Elect. Instr. Co.

FIG. 2-49.—Circuit arrangement of a typical volt-ohm-milliammeter which employs a 0-500 d-c microammeter equipped with a copper-oxide type rectifier. (Triplett Model 1125.) The complete instrument is shown in Fig. 2-50.

ure resistance in the following ranges: 0-1,500, 1,500,000, 3,000,000, ohms. Resistance measurements are made through the use of a 22.5-volt battery.

The meter scale is divided into 75 divisions. Each division, when reading volts or milliamperes on the 15 scale, represents 0.2 volt or milliampere. Each division when reading volts or milliamperes on the 150 scale represents 2 volts or milliamperes. When reading volts on the 750-volt scale, each division represents 10 volts. As shown in the circuit diagram of the instrument, Fig. 2-49, it may also be utilized as an output meter.

2-41. Meter Accuracy.—How accurate is the meter you are using? The accuracy depends upon the design of the meter, the quality of its parts, the care taken in its construction, the accuracy with which it has been calibrated at the factory and how roughly it has been handled since made. *No commercial type meters are guaranteed to read 100 per cent correctly—only very expensive laboratory-type instruments approach such perfection!* In order to make meters that can be priced within the reach of the average user, accuracy has to be sacrificed somewhat, for, extreme accuracy necessitates more precision and care in the workmanship.

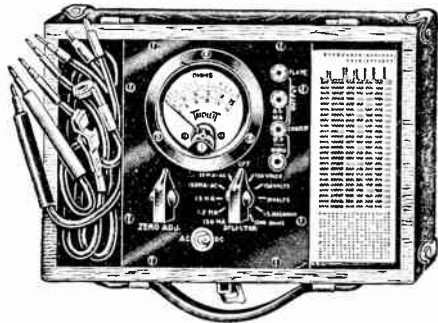

Courtesy Triplett Elect. Instr. Co.

FIG. 2-50.—The volt-ohm-milliammeter whose circuit diagram is shown in Fig. 2-49. The entire instrument is shown here in its carrying case.

It is common practice for instrument manufacturers to make good-quality permanent magnet movable-coil type d-c meters, and movable-iron a-c meters, (of the types used in radio service work) to give readings accurate to within 2%. Good quality a-c rectifier type meters are usually accurate to within only 5% on a-c ranges, due to the inherent properties of the rectifier. For d-c measurements, they may be expected to read accurate to within 2%. It must be mentioned here that accuracies as high as this should not be expected in very low-priced meters, in meters which have been abused, or in meters which are subjected to abnormal temperature or humidity conditions.

When a manufacturer specifies that a certain meter is accurate to, say *within 2%*, what does he mean? He always means that the actual *indication* of the meter itself (not as you may happen to *read* it if you are careless) for any reading within its various ranges is accurate to within 2% of the *full-scale value of the range which is being used*. To make this clear, let us consider the following typical case:

Suppose a certain voltmeter has a 100-volt range (with a uniformly divided scale up to 100 volts), and that its accuracy is stated to be "within 2%". This accuracy rating means, simply, that for any voltage measurement made with this range, the indication of the

meter pointer will be in error not more than ± 2 volts (2% of 100). For instance, if the meter reads 100 volts when a measurement is being made, the *true* voltage might be as much as two volts above (or below) this, i.e. some voltage between 98 and 102. Now if the *reading* happened to be, say, 50 volts instead, the *true* voltage might be as much as 2 volts (still 2% of the full scale value of 100) above or below this, i.e. between 48 and 52 volts. (It is important to note at this point that whereas the possible error in the case of a full-scale reading was 2%, the possible error for the half scale reading of 50 is 2 volts in 50, i.e. 2/50, or 4% of the indicated value—quite an appreciable amount in some work!)

If this same meter had, say a 50 volt range, and a reading of 50 volts was obtained on it, the *true* voltage might be as much as 1 volt (2% of 50) above (or below) this value, i.e., some voltage between 49 and 51 volts. For a *scale reading* of say 20 volts, the true voltage might be some value between 19 and 21 volts, etc. This important point should be remembered; the meter accuracy figure stated by the manufacturer is based on the *full-range value of the particular range used*, and not on the actual value of a reading—except when the reading happens to be the full-scale reading. Although a voltmeter was considered in our illustrative example, the same things hold true for ammeters, milliammeters, etc.

Notice from the foregoing example that the actual possible percentage error is less for readings near the full-range value than for those lower down on the scale. For this reason, greatest accuracy in reading is secured by choosing indicating instruments of such ranges that the largest readable deflections of the pointer are obtained when most usual measurements are made with them.

In those a-c instruments and ohmmeters having scales which are not uniform, the same rule applies. The stated accuracy in *per cent* is based on the *full-scale range*, regardless of what point on the scale the pointer actually is at. However, since the divisions at one end of such scales are very crowded (excepting in rectifier-type a-c meters), such meters should never be read at the crowded part of the range if observational errors are to be avoided and accurate readings are to be obtained.

An apparent mystery which troubles many servicemen and results in numerous unjustified complaints to instrument manufacturers can well be solved at this point. Notice that if a 50-volt voltage is measured with the 100-volt range of the voltmeter we just considered, the reading obtained might be anything between 48 and 52 volts. Let us assume that the accuracy of this range of the meter is definitely $\pm 2\%$. Then the reading will be 52 volts. Now assume that the 50-volt range of the same meter is used to measure this voltage, and that the accuracy of this range is -2% . The reading obtained would then be 50 minus (2% of 50), or 49 volts! Apparently there is something wrong, for when the two ranges of the same meter are connected (in turn) across the same voltage source, two different

voltmeter readings are obtained even though both ranges have an accuracy of 2%. The difference is caused of course, by the fact that the error *in volts* when the 100-volt range is used is + 2% of 100, or 2 volts (plus), whereas the error *in volts* when the 50 volt range is used is—2% of 50, or 1 volt (minus)!

From the foregoing discussions, it appears that for accuracy in any measurement, the range of the meter should be so chosen that the pointer will be deflected to as nearly full-scale position as possible. In the case of a voltmeter, this means as near full-scale as possible; hence, the lowest possible range should be used. But we found in our discussion of the effect of the voltmeter resistance in changing the voltage applied to the voltmeter and indicated by it (Art. 2-19), that the highest possible range should be used, since the meter will then have the greatest possible resistance, and will exert the least effect on the circuit to which it is connected. These two conditions, therefore, are incompatible, so that the choice of range for a voltmeter must depend upon the relative errors in each case. Thus, for high accuracy, if a given voltage can be read using two different ranges of a meter, first use the one giving the larger pointer deflection. Then use the one giving the smaller pointer deflection. If the difference between the two readings is greater than the specified accuracy limit of the instrument, use the range having the highest meter resistance. In general service work, this rule will apply, except when the reading of the meter is close to zero.

To offset this difficulty to some extent, and to provide less error due to voltmeter resistance, meter manufacturers are now making 500- and even 100-microampere meter movements available as standard equipment. Voltmeters using this type instrument have a very high resistance—and a sensitivity of 2,000 or more ohms-per-volt!

Of course, it need hardly be mentioned here that a meter should always be read as carefully and accurately as possible. Look *directly down* at the pointer when reading its position—do not look down at it at an angle. Notice the scale marking carefully, and remember how much each small scale division represents.

REVIEW QUESTIONS AND PROBLEMS

1. Explain how you would prove that a magnetic field always exists around a current-carrying conductor.
2. Draw a diagram showing the magnetic field around a wire through which current is flowing.
3. Indicate how the magnetic field inside, and around, a coil having 6 turns, with current flowing through it, would look if it were visible.

4. Where are the magnetic poles on the coil in Question 3? Mark them on the diagram.
5. Draw a simple sketch and explain the operation of the Weston movable-coil d-c meter movement. Be sure to explain what makes the movable-coil turn when current to be measured is sent through it.
6. State and explain three important functions which the springs in the Weston type meter movement perform.
7. What is the value of the "sensitivity" of a meter movement whose needle deflects over the full scale when a current of 1 milliamperes flows through the moving coil?
8. Since the mechanical construction of the movable coils of a Weston model 301 d-c voltmeter, ammeter and milliammeter are all exactly the same, what, then, is the essential difference between these instruments?
9. What is the function of the shunt in a d-c ammeter?
10. How must a voltmeter always be connected in a circuit? Why?
11. How must an ammeter be connected in a circuit? Why?
12. To illustrate questions 10 and 11, draw a diagram of a 6-volt storage battery connected so as to supply current to the filament of a vacuum tube in series with a 10-ohm rheostat. Indicate how to connect an ammeter in the circuit to measure the current flowing; also indicate the connections of voltmeters to read, (a) the voltage of the battery; (b) the voltage across the tube filament; (c) the voltage drop across the rheostat.
13. A certain 0-1 d-c milliammeter has a resistance of 50 ohms. Calculate the resistances of the shunts required to extend its range to; (a) 10 milliamperes; (b) 50 milliamperes; (c) 1 ampere. What is the multiplying factor which must be applied to the meter scale readings in each case? Draw a diagram showing how you would connect these shunts to the meter so that any one of them could be used at will.
14. A voltmeter having a sensitivity of 1000 ohms-per-volt, has three ranges, 15 volts, 150 volts and 450 volts. What is the value of the series multiplying resistance used for each range? Draw a diagram of the connections. How much current must flow through the movable coil in order to produce full-scale deflection?
15. It is desired to increase the 450 volt range of the voltmeter in Question 14 to 750 volts. (a) Explain just how you would do this. (b) Calculate the values of any additional parts which may be required. (c) Incorporate these changes in the diagram you drew for Question 14. (d) What multiplying factor must be applied to all readings taken on the 150-volt scale when the 750-volt range is being used?
16. It is desired to make a voltmeter having ranges of 5, 150 and 300 volts from a 1 milliamperes meter. (a) Calculate the value of the multiplier resistors required. (b) Draw a diagram showing all of the connections—marking all electrical values on it.
17. State the differences between a low-resistance and a high-resistance voltmeter.
18. Explain by a practical example how a voltmeter having a comparatively low resistance may cause an appreciable change in the voltage of the circuit it is connected across. Show how the use of a high-resistance voltmeter (say 1000 ohms-per-volt) minimizes this trouble.

19. What are the essential requirements of satisfactory meter multiplier resistors? How accurate need their resistance value be?
20. Draw the complete circuit diagram for a combination volt-milliammeter made from a 500 microampere d-c meter. The instrument is to have 4 current ranges and 5 voltage ranges. The connection of all resistors should be shown, but their values need not be calculated.
21. (a) Explain the construction and operation of the movable-iron type a-c ammeter. (b) Why can this type of meter be used to measure either a-c or d-c? (c) What are the objections to its use?
22. What is a rectifier.
23. Draw the circuit diagram, and explain the operation of a full-wave rectifier composed of four half-wave units connected in a Wheatstone bridge arrangement.
24. Define: (a) "half-wave rectification"; (b) full-wave rectification.
25. Explain the general construction and operation of the rectifier type a-c instruments? What are their advantages over the movable-iron type?
26. Explain, by means of a sketch, what is meant by (a) peak value; (b) average value; (c) effective value, of an alternating current or voltage.
27. A sine-wave alternating voltage has a peak value of 300 volts. (a) What is its "average" value? (b) What is its "effective" value?
28. The average value of a sine-wave alternating current is 10 amps. (a) What is its effective value? (b) Which of these values would a commercial rectifier-type a-c ammeter indicate?
29. Draw a diagram showing the method used to connect a meter rectifier to a 0-1 ma. d-c meter of 30 ohms resistance. Also show the multiplier resistances necessary to convert the meter into an a-c—d-c voltmeter with ranges of 10, 50, 500, 1000 volts.
30. Show how shunt resistors should be connected to a d-c meter movement operated with a rectifier, in order to measure 3 ranges of alternating current.
31. A meter scale is divided into 100 divisions, reads up to 1000 volts, and the meter accuracy is 2%. (a) What is the error (in volts) at one-half full-scale reading? (b) At one-quarter full-scale reading? (c) What is the per cent error with respect to the voltage being measured, in each of these cases? (d) Repeat for a 50-division 1000-volt scale.
32. How does the method employed to increase the range of an ammeter or milliammeter differ from that used to increase the range of a voltmeter?
33. Which is more sensitive, a meter having a resistance of 1000 ohms-per-volt, or one having a resistance of 2000 ohms-per-volt?
34. Which meter has the greater sensitivity, one having a range of 10 volts and a resistance of 20,000 ohms, or one having a range of 300 volts and a resistance of 300,000 ohms? Explain!
35. (a) Why are the scale divisions on movable-iron type a-c instruments not uniformly spaced? (b) What is the main objection to such scales?

CHAPTER III

METHODS AND INSTRUMENTS FOR MEASURING RESISTANCE

3-1. Importance of Resistance Measurements. — The measuring, or "checking", of the d-c electrical resistance of the various components of radio receivers forms one of the most important operations in the daily work of every radio service man. Since resistance measurement is so vital, it is essential for service men to have a thorough knowledge of the various methods and instruments employed for this work and to be properly equipped to make resistance tests at any time, either in the shop or in the field. Without this knowledge, the rapid diagnosis and repair of radio receiver troubles, which is always the service man's ultimate goal, cannot be achieved. A few of the common instances in which resistance tests give the service man vital information concerning the condition of a particular component, or the cause of trouble in a receiver, follow:

1. For checking the condition of various resistors—such as "bias" resistors, volume controls, current or voltage-limiting resistors, voltage dividers, etc. The resistance test indicates whether the resistor is still of proper value, or whether it is "open", "grounded", "shorted", etc.
2. For checking the condition of many other receiver components such as tuning coils, condensers, transformer windings, choke coils, loudspeaker windings, etc., by the simple expedient of checking their resistance to find if it is at normal value. These tests are usually made for the purpose of ascertaining whether "short-circuits", "grounds", etc., exist in these components.
3. For indicating and locating possible "short-circuits" and "grounds" between various circuits.
4. When analyzing the receiver by the "point-to-point" method of receiver testing.

In this chapter, we will study the various common ways of measuring resistance, and typical apparatus employed for this work. A detailed study of the actual testing of individual radio parts will be presented in Chap. XXII.

3-2. Range of Resistance Measurements Required.—One important point, which should always be kept in mind, is that the range of resistance measurement required in general radio service work is far greater than in most other branches of electrical work. This is true because the various parts to be checked have resistances ranging anywhere from a fraction of an ohm to several million ohms (*megohms*), depending upon their position and use in the radio circuit (see Chapter XXII). Naturally, the methods of measurement, and the instruments employed, must be able to cover this range satisfactorily.

3-3. Our Study of Resistance Measurement.—While the use of the "ohmmeter", in some form or other, for making resistance measurements has become almost universal among radio men, there are many instances in which a knowledge of resistance measurement by some of the other standard methods is very essential and helpful. For instance, a service man's ohmmeter may become damaged; it may not cover the range for a certain measurement to be made, etc. In cases of this kind, he should be able to make the measurement quickly by some other means. Therefore, we will begin our study of resistance measurement by reviewing several of the common methods for measuring resistances—methods which involve the use of simple instruments that most service men possess. The limitations of these methods of measurement, and the precautions which must be taken when employing them in ordinary radio service work, will be pointed out. Then we will study the ohmmeter. For special, accurate resistance measurements, the "Wheatstone bridge" will be considered. The very useful combination instruments known as "volt-ohmmeters", volt-ohm-milliammeters, etc., will be studied at some length later (in Chapter V).

3-4. Ammeter-voltmeter Method of Measuring Resistance.—One simple method of measuring the electrical resistance of components used in radio equipment—a method which is accurate if done carefully, and which was very widely used before the

perfection and popularization of our present ohmmeters—is known as the “ammeter-voltmeter method”, because it makes use of two common measuring instruments, a d-c ammeter (or milliammeter), and a d-c voltmeter. As shown in Fig. 3-1, the device R , whose resistance is to be measured, is connected in

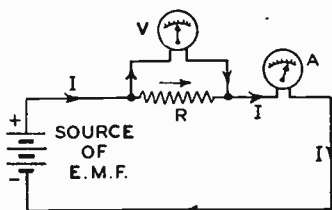

FIG. 3-1.—Preferable circuit arrangement for measuring “low” resistances by the ammeter-voltmeter method. (See also, Fig. 3-2.)

series with a source of steady e.m.f. (such as a $4\frac{1}{2}$ or 6-volt battery) and an ammeter (or milliammeter). Naturally, the voltage of the battery will cause a current to flow through the resistance and the ammeter. The value of the resistance may be calculated by applying Ohm’s law,

$$R = \frac{E}{I}$$

where, R —Resistance in ohms

E —Voltage in volts

I —Current in amperes (or, milliamperes divided by 1000).

Evidently, in order to calculate the value of the resistance R by this formula, both the *voltage* applied to the resistance, and the *current* which it causes to flow, must be known. That is why the voltmeter is connected *across* (in parallel with) the resistance, as shown, to measure the voltage; and the ammeter (or milliammeter) is connected *in series with* the circuit, as shown, to measure the current. The readings of the instruments, when substituted in the formula above, give the value of resistance R . A typical problem, illustrating how the calculations are carried out for resistance measurement by this method, will be considered in the next article.

3-5. Selecting Meter Ranges for Measuring “R” by Amm.-vm.—Of course, the problems of selecting instruments having the proper ranges, and determining how much voltage

must be used for the measurement, etc., must always be considered when measuring resistance by this method. When measuring *low* resistances, one or two dry cells connected in series, a 4½-volt "C" battery, or a 6-volt storage battery, are commonly used as the source of voltage. When *high* resistances are to be measured (unless accurate low-range milliammeters are available for the current measurement), a 45- or 90-volt dry-cell "B" battery, or a 110-volt d-c electric light circuit may be used as a voltage source. The range of the voltmeter to be employed depends entirely upon the voltage source. If it is a 6-volt battery, a 0-10 volt d-c voltmeter will do. If it is a 110-volt line, a 0-150 volt meter is necessary, etc. The range of the current-measuring instrument depends, of course, on the voltage source employed, and the value of the resistance being measured.

One way to settle on this is by first guessing as closely as possible what the approximate value of the resistance to be measured is. Dividing this value into the voltage of the voltage-source gives the approximate current which will flow—and a clue to the meter range required. For instance, suppose it is desired to check the resistance of a volume-control resistor. The service man knows by experience that volume controls of this type are usually of say 1,000 or 1,500 ohms resistance. Also, since the resistance wire is very thin, he cannot send very much current through it during the measurement. Therefore, he decides to use a common 4½-volt "C" battery as the voltage source. Using Ohm's law, $I = E/R$, he finds that approximately $4.5/1,000 = 0.0045$ amperes (4.5 milliamperes) of current will flow during the test. Therefore, he decides to use a milliammeter having a range of 0-5 milliamperes.

When selecting the meters by this "approximate method", one should always be careful to use a meter of *higher* range than is thought necessary, when in doubt. If it is found that the range first selected is too high, a lower range can always be substituted for it. This will prevent possible damage to the meter.

When attempting to measure a resistance by the ammeter-voltmeter method, one must always guard against the danger of burning out the ammeter or milliammeter (unless it is protected by a suitable fuse) if the resistance to be measured happens to be *much lower* than expected perhaps even "short-circuited"). To avoid this danger, the following safer method of selecting the current-meter range may be employed.

Select a *known* resistance having a value such, that when it is connected *alone* in series with the ammeter (or milliammeter) and source of voltage to be used, will allow just enough current to flow through the circuit to produce nearly full scale deflection of the ammeter (or milliammeter). The required resistance of this resistor may easily be calculated by dividing the applied voltage by

the full-scale current value (in *amperes*) of the current-meter range being used. Now connect the resistance to be measured into the circuit in series with this known resistor. This will cause the current-meter reading to decrease. If this reading is now more than *half* the value it was when the *known* resistance was connected in the circuit alone, it shows the resistance to be measured is *less* than the value of the *known* resistor and hence it is not safe to make the final measurement with a current meter of that range, for the pointer will go off scale. A higher current measuring range must be used. A setup of this kind may be conveniently arranged with a switch connected *across* the *known* resistance so as to "short" this resistance out of the circuit quickly as soon as everything is ready for the final *unknown* resistance measurement to be made.

3-6. Precautions Necessary for Accuracy When Measuring "R" by the Amm.-vm. Method.—When measuring a very *high* resistance by the ammeter-voltmeter method, the current flowing through the resistance will necessarily be small, and the voltmeter should always be connected *across both the resistor and the milliammeter*, (as shown in Fig. 3-2) as we shall now see.

If the voltmeter is connected across the resistor only, as shown in Fig. 3-1, the milliammeter, which is employed to measure the small current, indicates the sum of *both the current flowing through the resistor and that flowing through the voltmeter*. Since the resistance *R* is large, the current flowing through it is small. Under these conditions the current flowing through the voltmeter may be almost as great as that through *R* (unless a very high-resistance voltmeter is used, see Art. 2-19). Since the milliammeter reading obtained is really that of these two currents added together, this may cause an appreciable error.

Therefore, when measuring *high* resistances, the connection shown in Fig. 3-2 should always be employed. It is true that in this case the voltmeter measures the sum of the voltage-drops across

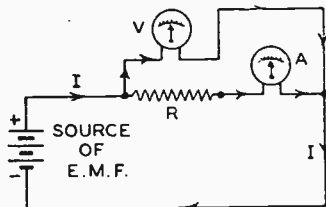
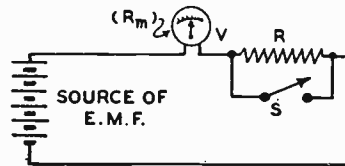

FIG. 3-2.—Preferable circuit arrangement for measuring "high" resistances by the ammeter-voltmeter method. (See also Fig. 3-1.)

both the resistor and the milliammeter, but, since the resistance of the average milliammeter is only from 20 to 50 ohms (see Art. 2-14), adding this to the high resistance to be measured does not affect the result appreciably. Therefore, when the connection shown in Fig. 3-2 is used, the usual formula $R = E/I$ may be employed for calculating the value of the resistance being measured.

When a *low* resistance is to be measured, the circuit arrangement of Fig. 3-1 should be employed. In this case, the current through the resistance will be comparatively large (amperes), and the fact that the ammeter indicates not only the current through the resistance but also the few milliamperes (*thousandths* of an ampere) of current flowing through the voltmeter, results in such a small error that it need not be considered. In this case, a high-range milliammeter, or an ammeter, of proper range

FIG. 3-3.—Circuit arrangement for measuring high resistances with a voltmeter whose total resistance is known.



should be used to measure the current, since it probably will be too large for a low-range milliammeter.

3-7. Voltmeter Method of Measuring Resistance.—If the exact resistance of a voltmeter is known, the meter can be used to measure high resistances fairly accurately. To do this, the voltmeter V , resistance R (whose value is to be measured), switch S , and a battery or other source of e.m.f. (a 90-volt "B" battery, or a 110-volt d-c lighting circuit will do if the voltmeter range is at least 110 volts) are connected as shown in Fig. 3-3.

First, switch S is closed (thereby short-circuiting resistance R out of the circuit), and the voltage of the source of e.m.f. is read on the voltmeter. This is reading E_s . Now switch S is opened, thereby placing unknown resistance R in series with the voltmeter. The voltmeter is read again. This reading is E . Since the instrument scale does not give us the value of the current or the resistance, the value of the unknown resistance R must be calculated by the formula:

$$R = \left(\frac{E_s}{E} - 1 \right) \times R_m$$

where R = Unknown resistance in ohms

E_s = Voltage of the source of e.m.f. (switch closed)

E = Voltage reading with resistance R in series (switch open)

R_m = Resistance of the voltmeter (ohms).

Problem: We are using the 150-volt range of a 0-15, 150, 450-volt voltmeter having a resistance of 1000 ohms-per-volt. When the meter is connected directly across the source of e.m.f., it reads 110 volts. When connected in series with the unknown resistance, it reads 100 volts. What is the value of the unknown resistance?

Solution: The resistance of the voltmeter when the 150-volt range is being used is $150 \times 1000 = 150,000$ ohms (see Art. 2-20). Therefore, the unknown resistance

$$R = \left(\frac{E_1}{E} - 1 \right) R_m = \left(\frac{110}{100} - 1 \right) \times 150,000 \\ = (1.1 - 1) \times 150,000 = 0.1 \times 150,000 = 15,000 \text{ ohms. Ans.}$$

The only information required for measuring resistance by this method is the resistance of the voltmeter. This information may be marked on the meter itself. If the ohms-per-volt value is marked on the meter face, the meter resistance may be found by multiplying the ohms-per-volt value by the *full-scale value of the particular range which is being employed*, as illustrated in the previous example. The two meter readings E_1 and E must be taken always *using the same meter range*, so that the same voltmeter resistance will be in the circuit in both cases.

The "voltmeter method" is not very well adapted to the measurement of very *low* resistances, for then the difference between the two readings is too small to be judged accurately, and an appreciable error results in the measurement. As a matter of fact, since calculation is required to determine the value of the resistance being tested, the voltmeter method is not commonly used for measuring resistance—except when no more suitable apparatus is available. However, if a voltmeter is connected as in Fig. 3-3 (without the switch), it serves as one useful means of checking the "continuity" of radio circuits and parts. This will be studied in detail in Chapter XXII.

3-8. The Wheatstone Bridge Method of Resistance Measurement.—Although resistance values may be checked fairly accurately by any of the more simple methods described in this chapter—the simplest method of all being by means of a direct-reading ohmmeter of proper range (Art 3-11)—there are many instances where more accurate and certain measurement is required. This may be accomplished by using a Wheatstone

bridge—preferably one of the modern forms designed for rapid work.

The ordinary form of Wheatstone bridge consists of suitable resistors connected in a special circuit arrangement in which three resistors of known value form the three sides of a diamond or lozenge circuit, and the resistance to be measured forms the fourth side, as shown in Fig. 3-4. Resistor X is the one whose value is unknown and is to be measured; R is a variable resistor of known value; S and T are also variable resistors of known value, or at least their ratio is known. A sensitive current-indi-

FIG. 3-4.— Simple Wheatstone bridge circuit. X is the resistor whose value is to be measured. S and T are the "ratio-arm" resistors.

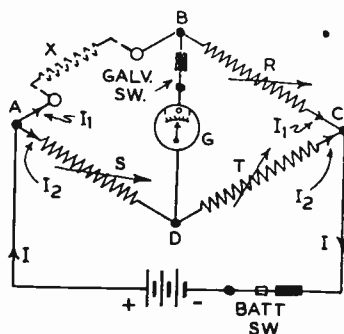

cating meter G is connected across points B - D . A low-voltage battery connected, as shown, to points A and C causes current to flow through the two branches of resistors, in the directions shown by the arrows, when the battery switch is closed.

The value of the resistance X to be measured is found in the following way:

First, resistance X is connected in place and the battery switch is closed. Current flows from the positive terminal of the battery to point A . There it divides, part of it flowing through resistors X and R , the rest flowing through resistors S and T . At C , these two currents combine and flow back to the battery. Now the galvanometer switch is tapped lightly so as to make momentary contact. It will be found that the galvanometer needle indicates a flow of current through the meter. This current flow is caused by the difference of electrical potential which exists between points B and D because of the particular values of resistance which are present in the four arms of the circuit.

It is now necessary to adjust resistors S and T carefully, noticing the meter deflections meanwhile, until the meter reads "zero" when

its switch is held closed—indicating that no current is flowing through it, and that the entire circuit conditions are such that the potentials of points *B* and *D* are equal. This operation is called “balancing the bridge”. When this balanced electrical condition exists in the circuit, it can be shown mathematically that the “product” of resistances *X* and *T* equals the product of resistances *R* and *S*, that is

“The products of the resistances of the opposite arms of a Wheatstone bridge are “equal”, when the bridge is “balanced”.

Thus, *X* times its opposite arm *T*, is equal to *R* times its opposite arm *S*, i.e., $XT = RS$. From this relation we obtain:

$$X = \frac{R \times S}{T}$$

This formula enables us to calculate the value of the unknown resistance *X* from the values which the three other resistors have when the bridge has been “balanced”.

Problem: When the bridge has been “balanced” so that the meter reads “zero”, the values of resistors *R*, *S* and *T* in Fig. 3-4 are 5, 45 and 15 ohms, respectively. What is the value of unknown resistor *X*?

$$\text{Solution: } X = \frac{R \times S}{T} = \frac{5 \times 45}{15} = \frac{225}{15} = 15 \text{ ohms. Ans.}$$

Notice, that in the formula for the Wheatstone bridge, the ratio S/T of the two series resistors *S* and *T* appears. Consequently, it is not necessary for us to know the exact resistance, in ohms, of these two resistors. If we know the ratio of their resistances, we can substitute this number in the formula, directly, for the expression S/T . To illustrate:

Problem: In the previous problem, the resistance of *R* is 5 ohms and the ratio of resistors *S* and *T* is 3. What is the value of the unknown resistance?

$$\text{Solution: } X = R \times \frac{S}{T} = 5 \times 3 = 15 \text{ ohms. Ans.}$$

For this reason resistors *S* and *T* in Fig. 3-4 are commonly referred to as the “ratio resistors” or “ratio arms”, and many commercial Wheatstone bridges are constructed in such a way that their “ratio” (called the “bridge ratio”), and not the individual values of the resistors, is read from the bridge. This not only simplifies the construction of the bridge, but also simplifies and speeds its manipulation and the computation of the value of

resistance being measured, since this resistance is obtained simply by multiplying the value of resistor R by the "bridge ratio." A commercial bridge of this form will be described in Art. 3-10.

The accuracy with which a resistance can be measured by means of a Wheatstone bridge depends upon the accuracy of the ratio arms S and T , the accuracy of the standard resistance S , the sensitivity of the galvanometer G , the relative resistance of all four arms of the bridge, and how accurately the bridge is "balanced". High-grade commercial Wheatstone bridges are made with such precision that it is possible to make resistance measurements accurate to one-tenth of one per cent with them. A bridge of medium accuracy is described in Art. 3-10.

3-9. The Slide-wire Wheatstone Bridge.—Possibly the simplest practical form of Wheatstone bridge is the slide-wire type shown in Fig. 3-5. The letters on this diagram correspond

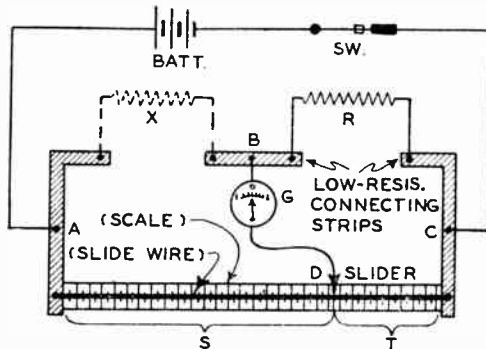

FIG. 3-5.—Simple slide-wire form of Wheatstone bridge. Here, a piece of resistance wire (called the *slide wire*) forms the ratio-arm resistors S and T .

with those in Fig. 3-4. Point D is a sliding contact which can be moved along a straight resistance wire (called the "slide wire"), stretched over a scale. R is a resistance of known value, and X is the resistance to be measured. G is a sensitive current-indicating galvanometer. Slider D is moved along the slide wire until a point is found, for which no perceptible deflection of the galvanometer is obtained when the switch is closed. The ratio S/T is then the ratio of the *length* of the two parts of the resistance wire. This ratio may be used instead of the ratio of the *resistance* of the two parts, since the wire AC is uniform, and therefore

the resistance of parts of it are proportional to the *lengths* of the parts. The rule or scale mounted under the slide wire makes it easy to read lengths S and T when the bridge is balanced.

The same formula derived in Art. 3-8 is used for calculating resistance X , only, instead of substituting in this formula the resistance in "ohms" for S and T , the *lengths* of the slide wire are used instead. The slide wire bridge is very simple and inexpensive, and while it is not readily portable nor extremely accurate, it is capable of quite dependable measurements if care is observed in its construction and use. It is an excellent substitute

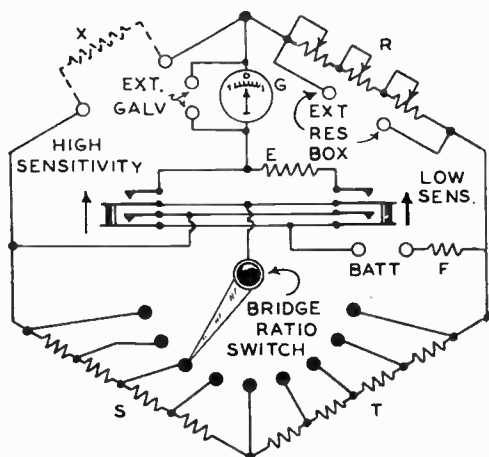

FIG. 3-6. — Schematic circuit diagram of the typical commercial form of Wheatstone bridge shown in Fig. 3-7.

(Courtesy Shalross Mfg. Co.)

for the more expensive commercial forms of Wheatstone bridges, but its limitations should be kept in mind.

3-10. A Typical Commercial Wheatstone Bridge. — The circuit diagram of a typical, fairly compact, commercial form of Wheatstone bridge, designed to permit rapid and accurate measurements of a wide range of resistance is shown in Fig. 3-6. The complete instrument is shown in Fig. 3-7.

This instrument is a direct-reading, decade type of Wheatstone bridge capable of measuring resistances from 0.01 ohms to 11,100,000 ohms (11.1 megohms). As shown in Fig. 3-6, the ratio-arm resistors S - T consist of eight resistor sections to a 9-point switch. Resistor R consists of three decade units (note: *decade* means "in steps of ten"). High-sensitivity Leeds and Northrup galvanometer G is provided with a sensitivity switch which throws resistor E in series with the galvanometer for low sensitivity when the preliminary adjustments are

being made, and cuts the resistor out of the circuit when high sensitivity is desired during the final adjustments. This switch also closes the battery circuit automatically when it is either the "high" or the "low" sensitivity positions. The external battery to be connected to the binding posts marked *BATT.*, in Fig. 3-6, is usually a 4½-volt "C" battery. To obtain the instrument's full high range to 11.1 megohms, a 45-volt battery must be employed. For low-resistance measurements, as little as 1.5 volts may be used. External binding posts are provided to permit the galvanometer *G*, and the decade resistors *R*, to be used independently and externally for other work.

FIG. 3-7.—The Wheatstone bridge whose circuit diagram is shown in Fig. 3-6. Notice the galvanometer at the center, and the ratio dial at the upper left. (Shallcross No. 630.)



Courtesy Shallcross Mfg. Co.

Resistor *F* prevents rapid rundown of the battery should the battery-switch be left in the "on" position for any length of time.

While a radio serviceman can hardly expect to carry an instrument of this kind with him on service calls, because of its bulk and the fact that he has other necessary instruments to take along also, a Wheatstone bridge of this type forms a valuable adjunct to the shop testing equipment of any service man, to be employed whenever accurate resistance measurements are necessary.

3-11. The Ohmmeter for Measuring Resistance. — The "ohmmeter", as the name implies, is an instrument which indicates the resistance of a device or circuit directly in *ohms*, without need for calculations of any sort—just as a voltmeter indicates "volts" directly, etc. The number of ohms may be marked directly on the scale, or may be found by referring the reading of the ohmmeter to an accompanying chart, from which the resistance value in ohms may be read. The chart may be in the form of a curve on graph paper, or in the form of a tabulation—it makes little difference.

A well-designed and properly used ohmmeter is one of the greatest conveniences to effective and rapid radio servicing.

It is no exaggeration to say that the combination voltmeter and ohmmeter are the two most used pieces of test equipment of the radio service man—instruments which he should understand, and learn to use daily.

If we attempt to design the ohmmeter so that a wide range of resistance can be read, errors will be introduced when readings at either the extreme low or the extreme high end of the scale are taken. The error on the low end of the scale is due to the meter inaccuracy, as discussed in Art. 2-41; and the error on the high end of the scale is due to the crowding of the graduations. For these reasons, ohmmeters are usually made with several ranges: those intended for *low*, and those intended for *medium* and *high* resistance measurements.

3-12. Three General Types of Ohmmeters.—A simple ohmmeter consists, essentially, of a milliammeter (or microammeter) and a battery, so connected that when the resistance to be measured is added to the circuit, the reading of the meter indicates the value of this resistance. There are three main types of ohmmeters, differing mainly in the way the resistance to be measured is connected to the meter circuit. They are:

- (1) *The series type.*
- (2) *The "shunt" type.*
- (3) *The combination series and shunt type.*

In the "series" type, the resistance to be measured is connected in *series* with the meter and battery. In the "shunt" type, it is connected in *shunt*, or "parallel", with them. In the "combination type", the instrument circuit is so arranged that it is connected as a "series" type for the high-resistance ranges and as a "shunt" type for the low-resistance ranges—thus using each type of circuit for the range of resistance measurement it is best suited for. We will now study each of those types separately.

3-13. Principle of the "Series" Type Ohmmeter.—If a d-c milliammeter is connected in series with a battery and variable resistor R of suitable value, as shown at (A) of Fig. 3-8, the resistor may be adjusted to produce full-scale reading of the meter M , as shown. Now, if this circuit is arranged with terminals $T-T$, as shown at (B), so that another resistor R_0 can be

connected in *series* with the circuit, the addition of this resistance will cause the current flowing through the circuit to *decrease*—resulting in a lower reading on the meter. The *larger* the value of R_x , the smaller will be the current and the meter reading, that is, there is a definite relation between the value of resistance R_x and the meter reading. Therefore:

instead of calibrating the meter scale to read the milliamperes of current flowing through the circuit, we can calibrate it to read "directly" in "ohms" whatever value of resistance R_x is connected into the circuit.

We can then use the entire instrument to indicate *directly* the value in "ohms" of any resistance R_x (within the range of the instrument) connected to it—that is, the instrument is an *ohm-*

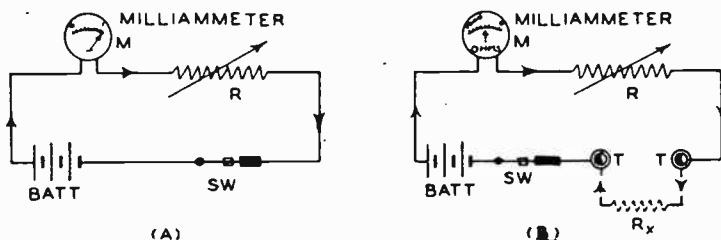

FIG. 3-8.—(A): Fundamental circuit arrangement for a "series" type ohmmeter.

(B): Simple series type ohmmeter with resistance R_x (resistance to be measured) connected in the circuit. The zero-ohms adjusting resistor R is also in series with the circuit.

meter. This is the principle of operation of the series type ohmmeter. Note that in this type, the higher the resistance being measured is, the lower is the meter reading. Therefore, in series ohmmeters, the *left* end of the scale always represents "infinite" resistance (open circuit), and the *right* end represents the lowest resistance of the range—i.e., the *high*-resistance markings are at the *left* and the *low*-resistance markings are at the *right* (just the reverse of usual meter scale markings). The construction of series type ohmmeters, and the calculations pertaining to their design will be considered in detail in Chap. IV.

3-14. The "Zero-ohms" Adjusting Resistor. — In practical ohmmeters, the "current-limiting", or "zero-ohms", adjusting resistor R is made variable, so that when the battery ages and its closed-circuit voltage drops, resistor R can be decreased in value in order to bring the meter reading up to full-scale value when the test terminals $T-T$ are short-circuited ("zero" resistance). This adjustment is usually made every time the instrument is to be used for resistance measurements. In many cases, this resistor is composed of a fixed and a variable resistor in series, as in Fig. 4-1. In this way, fine adjustment is obtained with the variable resistor, since now a given movement of its shaft changes the resistance of the entire circuit by only a small percentage.

Another arrangement for the "zero-ohms", adjusting resistor R is shown in Fig. 3-9. Here it is connected in series with a fixed resistor N of low resistance, and the two of them together are connected in parallel with the meter. A current-limiting resistor P is connected in series with the meter and battery. In this case, when the battery ages, the value of resistor R must be *increased* so that it shunts less of the current away from the meter—thereby making it possible to bring the meter reading up to full-scale value (zero resistance) when the terminals $T-T$ are

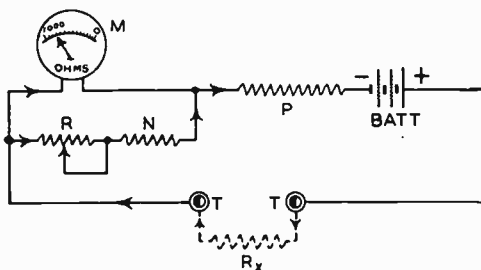
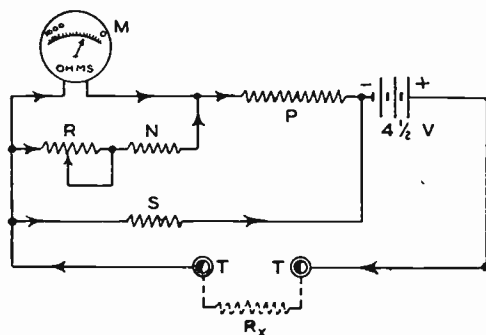

FIG. 3-9. — A simple series type ohmmeter with "zero-ohms" adjusting resistors R and N in parallel with the meter.

touched together ("zero resistance"). As will be seen later, in our study of commercial forms of ohmmeters in Chapter V, this latter arrangement is the one most commonly employed, since it assures a greater degree of ohmmeter accuracy (even after the battery has deteriorated considerably) than that resulting from the use of a variable series resistor for battery voltage compensation.

3-15. Providing Several Ranges for the "Series" Ohmmeter.—It is not practical to design ohmmeters to cover within a single range, the full range of resistance measurement (from a fraction of an ohm to about 3 or 5 megohms) necessary in radio

FIG. 3-10.—The series ohmmeter of Fig. 3-9 with a shunt resistor S added to provide a low range. The arrows show the direction of current flow.



service work. If this is attempted, the graduations at one, or both, ends of the scale are so crowded that accurate readings are impossible. Hence, ohmmeters are made with several separate ranges to cover the wide range of resistance measurement required. Generally speaking, the greater the number of separate ranges the "total" range is split up into, the greater is the accuracy with which resistance values can be read, since now for each range the *total* number of divisions on the scale represents a smaller *range* of resistance. Therefore *each division* now represents less resistance change, and any error made in estimating fractions of a division when taking a reading represents a much smaller error in *ohms* than before.

Let us suppose that the series ohmmeter shown in Fig. 3-9 has a certain range over which resistances can be read accurately from its scale—say 100 to 100,000 ohms. If it were desired to provide a lower range of say 0.1 to 100 ohms, we could connect a shunt resistor S of proper value to shunt the correct proportion of the current away from the meter circuit, as shown in Fig. 3-10. Now, the meter deflection for any value of R_x would be proportionately *smaller* than if this shunt were not connected. Therefore, remembering that in a series ohmmeter the lower the value of resistance being measured, the greater is the meter deflection,

it is evident that we can now accurately measure lower values of resistance than we could before. A still lower range can be provided by connecting another shunt resistor $S1$ in parallel with S , etc. If we bring the ends of these resistors to a switch $SW-1$, we can connect either, or both, of them into the circuit at will, to provide several low ranges, as shown in Fig. 3-11. Typical

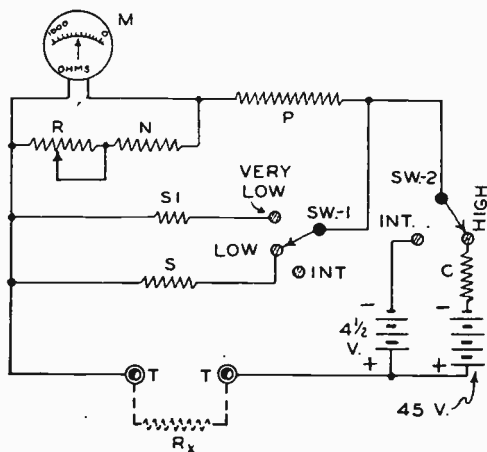

FIG. 3-11. — The series ohmmeter of Fig. 3-10 with two shunt resistors S and $S1$ added. These provide two additional ranges. For high resistances, the 45-volt battery and current-limiting resistor C are put in series with the circuit by switch $SW-2$. This results in an ohmmeter with four ranges.

commercial ohmmeters which employ this system will be studied in Chapter V.

In order to make it possible to measure *higher* resistances than the "intermediate" range of the meter provides for, it is necessary only to increase the battery voltage so as to send the current through the higher resistance. If the intermediate range goes up to, say, 100,000 ohms when a $4\frac{1}{2}$ -volt battery is used, the range can be made ten times as high (1,000,000 ohms) if a battery having ten times as much voltage, i.e., 45 volts, and a current-limiting resistor having ten times as much resistance are used. In Fig. 3-11, we have shown a switch $SW-2$ for connecting either the $4\frac{1}{2}$ -volt, or the 45-volt battery and additional current-limiting resistor C , into the circuit. Obviously, switches $SW-1$ and $SW-2$ can be "ganged" together to provide a single control for the selection of all the ranges of the ohmmeter. Instead of "switching" the 45-volt battery and resistor C into the

circuit, they may be connected externally, between one of the terminals T and one end of the resistor R_x to be measured. This makes switch $SW-2$ unnecessary. When the 45-volt battery is in the circuit, all scale readings should be multiplied by 10.

Complete instructions for making a simple series-type ohmmeter from an ordinary 0-1 milliammeter, including the methods of calibrating the scale, increasing the range, etc., will be found in Chapter IV. In the present chapter we are merely concerned with the principle of operation and main characteristics of series and shunt-type ohmmeters. Descriptions of typical commercial ohmmeters will be found in Chapter V.

3-16. Principle of the "Shunt"-Type Ohmmeter.—The fundamental circuit of the shunt type ohmmeter is simply one containing several parallel or "shunt" resistors with a constant voltage applied. One branch, the meter, indicates its amount of current, and the other branch, the resistor under test, carries the remainder of the full-scale current. Since the reading of the meter therefore depends on the value of the "shunt" resistor connected across it, the scale can be calibrated to indicate the value, in ohms, of this resistor to be measured—instead of indicating the current.

A consideration of Fig. 3-12 will make this clear. Suppose a meter M and battery B to be connected in series as shown at (A). Further suppose that the resistance of the meter is, say, 50 ohms and that the battery has a voltage of 3 volts. If the full-scale range of the meter is 1 ma. (0.001 amp.), then the resistance of the complete circuit must have a value of $R = E/I = 3/0.001 = 3,000$ ohms, for the meter to read full scale. Since the resistance of the meter itself is 50 ohms, the value of R must be $3,000 - 50 = 2,950$ ohms.

Now suppose that the meter is shunted by another resistor R_s of 50 ohms as shown at (B); then if R is 2,950 ohms, the total circuit resistance becomes $2,950 + 25$ (the equivalent resistance of two 50-ohm resistors in parallel), or 2975 ohms. The current flowing from the battery is $I = E/R = 3/2,975 = 0.001008$ ampere, or 1.008 milliamperes (1 ma. is close enough for our purpose). This is very nearly the same current as before, but the important

point is that now only *half* of this current is flowing through the meter, the other half is flowing through the external 50-ohm resistor R_x . The reading of the meter will now be only 0.5 ma.—half as large as before. Therefore, since the meter will always

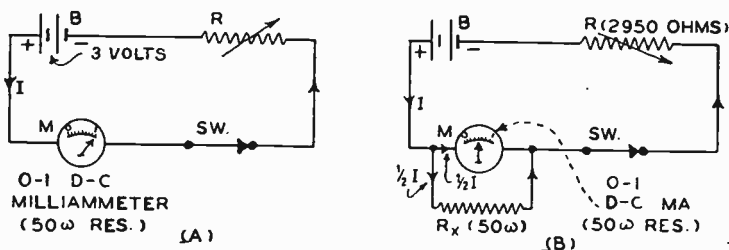

FIG. 3-12.—(A): Simple series-type ohmmeter circuit with a 50-ohm 1-ma. meter.

(B): Simple shunt-type ohmmeter circuit. The resistance R_x to be measured is connected *across* the meter. The current I now divides, part flowing through the meter, and part through R_x .

read 0.5 ma. when a resistance of 50 ohms is connected at R_x , we may mark the 0.5 ma. point on the meter scale, "50 ohms" also.

If, now, a 25-ohm resistor is shunted across the meter at R_x instead, the meter will take only 1/3 of the total line current, and will therefore read 1/3 full scale—or 0.333 ma. Since the meter will always read 0.333 ma. when 25 ohms is connected at R_x , this point on the meter scale may also be marked *25 ohms*.

If the external resistance R_x is made 75 ohms, the meter current will be but 0.6 ma., and the pointer will only go up to the 0.6 mark on the scale. This can therefore be marked *75 ohms*. Following this line of reasoning, then, the milliammeter scale may be calibrated in terms of "ohms of external resistance" (R_x) connected across the meter.

The circuit of a simple "shunt"-type ohmmeter is shown in Fig. 3-13. To operate this type of ohmmeter, R is first adjusted to produce full-scale deflection of the meter (1 ma. in this case), when nothing is connected across output terminals $T-T$ ("open-circuit"). Then the resistor whose value is to be determined is connected across terminals $T-T$, thus shunting it across the meter, and its resistance is read directly on the scale of the meter.

It should be noted that the lower the value of resistance to be measured, the less will be the deflection of the meter, since this resistance presents an additional current-path which shunts current away from the meter. Therefore, the scale on this type of meter has the *low* resistance values at the *left* and the *high* resistance values at the *right*.

When high resistances are being measured, they shunt very little of the current away from the meter, and hence do not cause the pointer to move very much from its full-scale (infinite resistance) position. Hence they cannot be measured accurately. Therefore, in this type of meter, only about 80% of the scale can be used for accurate readings. For instance, for a meter having an internal resistance of 50 ohms, and for a useful scale from divisions 10 to 90, the range of the meter would be from about 5 to 450 ohms.

3-17. Extending the "Low" Range of Shunt-type Ohmmeters. —Of course the lower limit of resistance measurement of a shunt ohmmeter may be made still lower by shunting the meter *inside* of the ohmmeter with a shunt resistor R_s , before the resistor to be measured is connected, as shown in Fig. 3-14. This results in making the meter read *lower* on the scale, for any given value

FIG. 3-13.—A simple shunt-type ohmmeter. R is first adjusted until the meter reads full-scale value when terminals $T-T$ are open. The resistance to be measured is shunted across the meter.

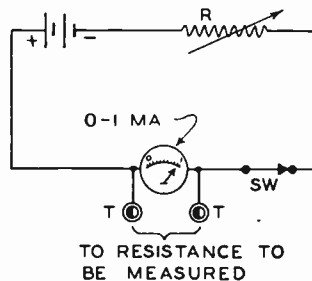

of resistance being measured. When a shunt resistor R_s is employed, resistor R is first adjusted (with terminals $T-T$ open) so that the meter reads full-scale with this shunt connected.

To understand just how much this shunt resistor affects the ohmmeter range, let us suppose that our meter is first arranged as in Fig. 3-13 and that R has been adjusted (with terminals $T-T$

open) to produce full-scale reading. Now suppose that shunt resistor R_s (having a value of, say, 50 ohms) is connected directly across the meter whose resistance is also 50 ohms, as shown in

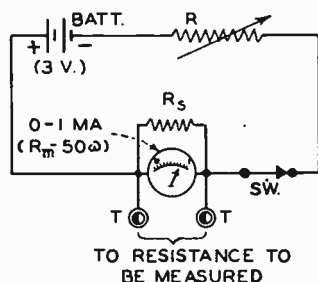

FIG. 3-14.—Here the meter is shunted by shunt resistor R_s , in order to make it possible to measure lower values of resistance.

Fig. 3-14. Since both the meter and shunt resistances are equal in this case, the meter reading will immediately drop to half-scale value. However, if we now decrease resistance R to about half its value, the total current from the battery will be 2 ma. instead of 1 ma., and the meter will read full-scale again. Under these conditions, so far as any external resistance R_x to be measured is concerned, the meter unit now has an effective resistance of 25 ohms (R_s and R_m in parallel). Therefore, any given resistance now connected across terminals T - T causes less lowering of the meter reading than would occur with the previous circuit arrangement, so now it requires a much lower resistance to bring the meter pointer down near the left end of the scale—that is, the ohmmeter is now able to measure, accurately, lower resistances than before. The limits of this new circuit arrangement (using only 80% of the scale) are from about 2.75 to 225 ohms for the particular meter shown. If, as is usually the case in practice, 98% of the scale is graduated, this ohmmeter can measure from about 0.25 to 2,500 ohms, but the end graduations would be rather crowded.

The important point here is that, with a given meter and set of shunts (several R_s resistors), a shunt-type ohmmeter may be designed to measure resistances ranging from a very low value to a fairly high value. This is one important advantage which shunt-type ohmmeters have over the simple series type. Of course,

the various shunts may be selected and connected into the circuit by a switching arrangement in order to produce a practical multi-range ohmmeter.

3-18. Combination "Series"- and "Shunt"-Type Ohmmeters.—The series-type ohmmeter possesses the main advantage of being suited for the measurement of medium and very high resistances. The shunt-type ohmmeter has the advantage of being especially suited to the measurement of very low resistances without drawing a very heavy current from the battery. It is possible to utilize these advantages of each type by arranging the ohmmeter circuit with the proper switches and resistors so that it is connected as a *shunt*-type ohmmeter for measuring very low resistances, and as a *series*-type ohmmeter for measuring medium and high resistances.

3-19. Precautions to Observe When Using Ohmmeters.

—The ohmmeter is one of the most necessary and useful adjuncts to any service man's equipment and is indispensable for the rapid

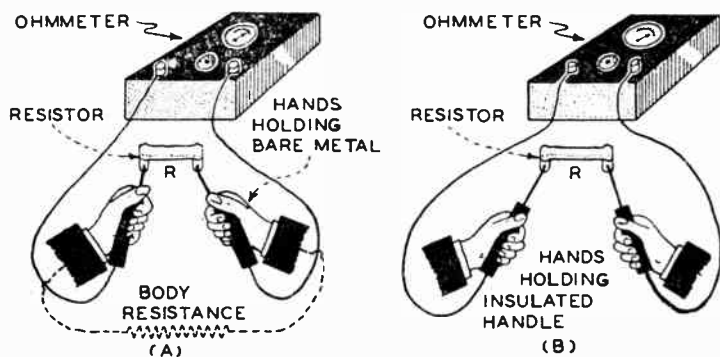

FIG. 3-15.—(A): Incorrect way to hold the test prods when using an ohmmeter. The fingers are touching the bare metal of the test prods, thereby shunting the resistance of the body across them.

(B): Correct way to hold the test prods—by the insulated portion. This insulates them from the body.

determination of resistance values, continuity tests, etc. However, certain precautions must be observed when using ohmmeters if accurate results are to be obtained.

If the bare metal portion of the test prods of an ohmmeter

employing a 0-1 ma. meter, or a more sensitive movement, are held with the hands, as shown at (A) of Fig. 3-15, the meter will not indicate the correct value of any high resistance being measured. Instead, it will give a reading *lower* than the true value. This is due to the fact that the ohmmeter terminals are being "bridged" by the "ohmic" resistance of the human body, which is usually less than 50,000 ohms—especially if the fingers are moist and make good contact. The ohmmeter, then, really indicates the "equivalent resistance" of the body resistance and resistance R in parallel. For this reason it is important to keep the fingers away from the metal of the test prods and the un-insulated parts of the component under test, when making high-resistance measurements. The test prods should be held at the insulated part, as shown at (B).

It is very often found that a resistor whose value in "ohms" is actually marked upon it, or whose value is determined from its color code markings (see "RMA Resistor Color Code" in *Radio Field Service Data & Answer Book Supplement to Modern Radio Servicing*), does not seem to have exactly this resistance when it is measured with an ohmmeter. Whether the deviation is too great for satisfactory operation of the receiver depends entirely upon the particular circuit in which the resistor is employed. For all practical purposes, however, if the "measured value" of the resistance is within 10% plus or minus of the "marked value", it may safely be assumed to be satisfactory unless it is used in a circuit in which the value of the resistance is critical. The subject of tolerances of resistor values will be discussed in greater detail in Chapter XXII, where the testing of individual radio components is considered at length.

Another important precaution to be observed when using ohmmeters is to make certain that the "zero-ohms" adjustment has been checked and set properly in accordance with the instructions of the manufacturer, before any measurements are made. Failure to do this will result in an error in the measurement, if the battery voltage has decreased since the last time this adjustment was made.

Finally, when testing the resistance of a component, be certain that no other component, such as another resistor, a coil, a

leaky condenser, etc., is connected in the circuit in *parallel* with it. If a very leaky condenser or any other closed-circuit object happens to be connected in parallel with a resistor to be measured, as shown in Fig. 3-16, the ohmmeter will read the *combined resistance* of the resistor and the leaky condenser (or other object) in parallel. This causes it to indicate a resistance *lower* than the true value. The mere fact that a condenser is *not*

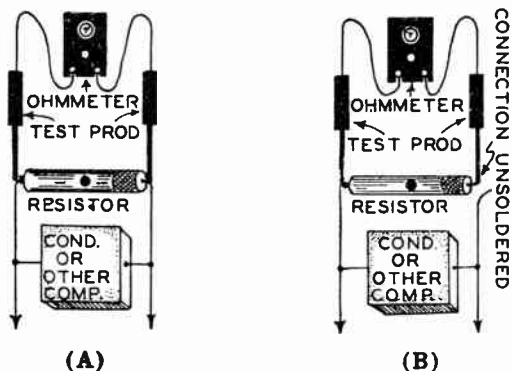

FIG. 3-16.—(A): Incorrect method of checking resistance with an ohmmeter. A leaky condenser (or other component) has been left connected across the resistor whose value is to be measured, thus shunting it and causing the ohmmeter to indicate a lower resistance than the true value.

(B): Correct way. The leaky condenser has been disconnected from the resistor while the resistance is being checked.

supposed to be a resistor does not necessarily mean that it is not *acting* as a resistor. It will act as a resistor if it is "leaky". The best rule to follow is to disconnect one end of the component under test from the receiver circuit it is in (see (B) of Fig. 3-16) before making a resistance measurement—always have one end of the component free, then there can be no circuit to any other possible component in parallel with it.

3-20. The Ohmmeter vs. Other Resistance Measuring Instruments. —Ohmmeters are used more than any of the other instruments described in this chapter, for checking resistances and circuits in radio service work, for the simple reasons that they are compact, accurate enough for the purpose, fairly inex-

pensive and provide rapid measurement without need for any calculations.

The Wheatstone bridge method gives more accurate results than does the ohmmeter. The results are independent of the condition or size of the battery used, but depend almost entirely upon the accuracy of the resistors in the bridge, and its construction. Of course, the Wheatstone bridge is more costly and bulky than the ohmmeter and therefore is not as well suited for portable use. Also, it takes longer to make the measurement and the necessary calculations. For accuracy, though, there can be no doubt as to which instrument must be used—the bridge far surpasses any of the others in accuracy.

REVIEW QUESTIONS AND PROBLEMS

1. Explain how you would measure the value of a rather low resistance by means of a voltmeter and ammeter. Draw a circuit diagram.
2. A filament rheostat is the resistor in Question 1. The voltmeter reads 6 volts, and the ammeter reads 0.5 amperes. Calculate its resistance.
3. The resistance of a "C"-bias resistor is being measured by the ammeter-voltmeter method. The voltmeter reads 6 volts and the milliammeter reads 20 milliamperes. (a) Draw the circuit diagram. (b) Calculate the resistance in ohms.
4. Draw a circuit diagram and explain how you would measure a high resistance roughly, by using a voltmeter and a 110-volt d-c electric light circuit. What range voltmeter is preferable for this measurement?
5. In the measurement of Question 4 the readings of the voltmeter are 110 volts, and 90 volts. The 150-volt range of a 2,000 ohms-per-volt voltmeter is employed. Calculate the value of the resistance being measured.
6. State the advantages of the Wheatstone bridge method of resistance measurement over that of the ohmmeter.
7. Since the Wheatstone bridge is a more precise instrument for resistance measurement than the ohmmeter, why is it not used more than the ohmmeter by radio service men?
8. Draw the circuit diagram of a simple Wheatstone bridge, and label each resistor.
9. (a) Explain in detail how you would go about measuring a resistance with the Wheatstone bridge of Question 8.
(b) Assuming values for the various resistance arms, calculate the value of the unknown resistance.
10. Describe the construction of a slide-wire form of Wheatstone bridge. What advantage does it possess?
11. When the bridge has been balanced during a resistance measurement, it is found that the "bridge ratio" is 150, and the other

known resistor has a value of 95 ohms. Calculate the value of the resistance being measured.

12. Explain the principle of operation of a simple ohmmeter.
13. What is the main limitation of the "ohmmeter method" of resistance measurement?
14. Explain the advantages and disadvantages, if any, of the shunt type of ohmmeter over that of the series circuit type.
15. What are the advantages gained by employing in an ohmmeter a 0-1 ma. milliammeter, instead of one of larger range.
16. Your series ohmmeter now employs a 0-1 ma. milliammeter having a resistance of 27 ohms. The ohmmeter has a range of 0-100,000 ohms. Draw a circuit sketch showing how you would provide (a) a 10,000-ohm range; (b) a 1,000-ohm range.
17. You wish to multiply the original range of the ohmmeter in Question 16 by *ten*. Explain how you would do this.
18. Draw a diagram showing how you would convert a simple, single-range series-type ohmmeter to serve also as a voltmeter having four ranges.
19. Explain two precautions to be observed when using an ohmmeter for high-resistance measurements.
20. Does the ohmmeter indicate a resistance higher, or lower, than the correct amount if the precautions of Question 19 are not observed? Explain why.

CHAPTER IV

HOW TO CONSTRUCT OHMMETERS

4-1. Making Home-constructed Ohmmeters.— Although excellent commercial ohmmeters (see Chap. V) are available at low cost, radio service men often desire to construct their own ohmmeters from meters and resistors that they may have on hand. The construction and calibration of an ohmmeter also forms an excellent project for students of radio servicing. For this reason, some space will be devoted to this subject in this chapter, and the design and construction data for three practical ohmmeters will be given.

The construction and calibration of an ohmmeter are simple, and need not present any serious difficulties to the average experimenter or service man. The meter used should be preferably one of 1-ma. range or lower, although a 2-, 5- or 10-ma. meter may be utilized with less satisfactory results, if necessary. One advantage gained by employing a 1-ma. meter lies in the fact that the drain on the dry-cell battery is very low, namely 1 ma., and the battery will retain its full voltage for a long period of time. In addition, with this type of meter, it is possible to construct an ohmmeter with a range as high as 100,000 ohms, using only a $4\frac{1}{2}$ -volt battery. This cannot be accomplished with milliammeters of higher range—which require more current to make their pointers deflect across the full scale.

4-2. Precaution to Observe when Making Ohmmeters.—One of the chief difficulties encountered when making ohmmeters from published circuit diagrams and miscellaneous parts is to get the desired degree of accuracy in the completed instrument. The final accuracy is the *algebraic* sum of the individual accuracies of the individual parts which have been assembled.

Obviously, if the accumulated errors of these individual parts are appreciable and are all in one sense (all *plus*, or all *minus*), the overall accuracy of the final ohmmeter will be very poor.

Generally speaking, the person who builds instruments of this kind from parts usually has no facilities for testing the device when completed, and must therefore rely on the accuracy of the parts that have been used. It is important, therefore, that the various parts chosen for the assembly of any of the ohmmeters described in this chapter be carefully selected, so that they will produce a completed device that will have a satisfactory accuracy. Resistors should be accurate, and permanent in value. Range-selector switches should be of the type which have low-resistance contacts—especially for the low-resistance ranges—otherwise errors of appreciable magnitude will be introduced into the circuit and the ohmmeter will not repeat itself on these readings.

When connecting shunt resistors into the circuit, care should be taken to place the shunts so that the connections to the meter terminals will be as short and direct as possible. Remember that shunts usually are of low resistance. If much wire is used for connecting them into the circuit, its resistance may be almost as great—or even greater—than that of the shunts. Of course this will seriously impair the accuracy of the instrument on the ranges in which these shunts are used.

4-3. How to Design and Construct a Simple Series-type Ohmmeter.—The design and construction of a simple series-type ohmmeter, having a useful range of approximately 100 to 100,000 ohms, will be considered first. This will be patterned after the common series-ohmmeter circuit shown in (B) of Fig. 3-8. A 0-1 d-c milliammeter is connected in series with a $4\frac{1}{2}$ -volt "C" battery and calibrating resistance R , as shown in Fig. 4-1. The latter is made up of a fixed section $R1$ and a variable section $R2$. As is well known, the internal resistance of a dry-cell battery is not constant, but increases with age and use. This results in an apparent reduction in the terminal voltage of the battery. Therefore, a provision for adjusting the resistance of the ohmmeter circuit is necessary in order to make it possible to adjust the pointer deflection to full-scale when the terminals

$T-T$ (which are usually "test prods") are shorted together—even though the battery voltage may have decreased as much as 25 per cent.

We will now consider the design of this simple ohmmeter. If the terminals $T-T$ are short-circuited ("zero"-resistance), and if the internal resistance R_m of the meter is 27 ohms (a common value for a 1-ma. meter), then the circuit must have a total resistance of $R = E/I = 4.5/0.001 = 4,500$ ohms, to make the pointer deflect over the full scale, i.e., to make 1 milliampere of current

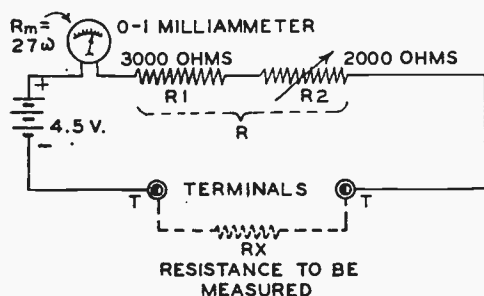

FIG. 4-1.—Circuit diagram of a simple series-type ohmmeter whose design and construction are considered here. A reduced facsimile reproduction of the scale for this meter is shown in Fig. 4-2.

flow through the circuit. Since the 27-ohm internal resistance of the meter represents only six-tenths of one per cent of this total circuit resistance, we can neglect it and say that the value of R must be 4,500 ohms. We can then use a 3,000-ohm fixed resistor for R_1 , and a 2,000-ohm variable resistor for R_2 , as shown. The latter can be set at 1,500-ohm value to meet these circuit conditions. The 1-ma. point on the meter scale can then also be marked "0" ohms.

Now if we imagine a resistor R_x , of say 4,500 ohms to be connected across test terminals $T-T$, only half as much current will flow, and only a half-scale deflection will be produced on the meter. Therefore, on this particular ohmmeter, the 0.5 ma. point on the scale *can also be marked "4,500 ohms"*, for, whenever the instrument is connected to a 4,500-ohm resistor, the meter will read 0.5 ma. Similarly, other points on the scale can be marked with their corresponding resistance values for direct reading.

4-4. Calibrating the "Ohms" Scale of the Series-type Ohmmeter.—The scale of the milliammeter can be calibrated

directly to read "ohms", by actually noticing the meter readings when several accurate resistors of known values are connected, in turn, across test terminals *T-T*. This is the most simple method.

However, such a suitable series of accurate resistors are not usually available for this purpose. In such cases, the exact resistance values of R_x corresponding to any point on the scale, for an ohmmeter of the simple series type shown (in which the meter shows full-scale deflection when the test terminals are short-circuited), can be *calculated* by means of the following formula:

$$R_x = \frac{R(M-m)}{m}$$

Where, R_x = the resistance being measured (ohms)

R = the "calibrating" resistance (in ohms) connected in series with the meter

M = the full-scale range of the meter (milliamperes)

m = the meter reading (ma.) when the resistance R_x is connected to the terminals of the ohmmeter.

Note: This formula neglects the internal resistance of the meter, but this does not introduce serious error since the resistance of a milliammeter is usually very small compared to the resistance R in series with it. However, if the meter is of a type which has appreciable resistance (many high-sensitivity microammeters have a resistance as high as 1,000 ohms or more, as indicated in the table in Art. 2-14), and this resistance is to be taken into account, simply let R in the above formula be equal to the "calibrating" resistance *plus* the internal resistance of the meter movement.

To illustrate the use of the formula, let us consider a typical example:

Example: A 0-1 milliammeter is connected in series with a 4,500-ohm series resistor R , and a $4\frac{1}{2}$ -volt "C" battery, as shown in Fig. 4-1. When the meter reads 0.6 ma., what is the value of the resistance R_x being measured? (Neglect the milliammeter resistance.)

Solution:

$$R_x = \frac{R(M-m)}{m} = \frac{4,500 (1-0.6)}{0.6} = \frac{4,500 \times 0.4}{0.6} = 3,000 \text{ ohms. Ans.}$$

By repeating this calculation for various meter readings, the exact resistance of R_x corresponding to each reading can be de-

terminated quickly, and a complete "ohms" scale or chart can be made for the meter, without actually having to measure a number of accurate resistors of known value. Although the "ohms" calibration may be marked carefully in pencil directly on the meter scale (after removing the meter from the case), it is possible to obtain commercially printed scales of this kind at nominal cost. Of course, an entire new scale may be drawn up by

the constructor on thin Bristol board or stiff paper and fastened to the meter face.

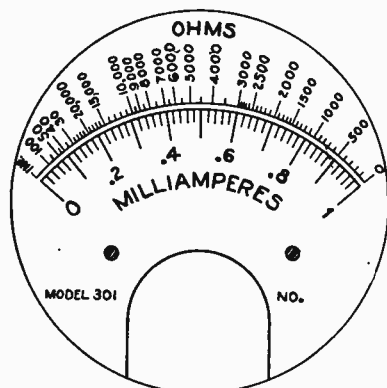

FIG. 4-2.—A typical example of a home made ohmmeter scale. The "ma." scale is at the bottom, and the "ohms" scale is at the top. This scale is suitable for the ohmmeter of Fig. 4-1.

A reduced facsimile of a home-made scale for the ohmmeter of Fig. 4-1 is shown in Fig. 4-2. Notice that the "ohms" divisions are very crowded at the left (high-resistance) end, so accurate measurements cannot be made here. For rough measurements, the useful range of this instrument is approximately from 100 to 100,000 ohms. The "ohms" values on this scale were calculated from the formula given in this article. Of course this range could be increased by employing one of the methods described in Art. 3-15.

It should be remembered that once, each time before the ohmmeter is used, resistor R_2 should be adjusted so the meter reads full-scale (*zero ohms*) when the ohmmeter terminals are touched together.

4-5. How to Construct a Double-range Shunt-type Ohmmeter.—An ohmmeter that will measure lower resistances than the one just described, will now be considered. This ohmmeter is of the "shunt" type (see Art. 3-16) and may be used to measure d-c resistance from $\frac{1}{2}$ ohm to about 50,000 ohms in two

ranges: $\frac{1}{2}$ to 100 ohms, and 100 to 50,000 ohms. It will "maintain its initial calibration even when the battery voltage has decreased as much as 33% due to age. The circuit of this ohmmeter is shown in Fig. 4-3.

Resistor $R1$ is an ordinary wire-wound rheostat with a total resistance of 5,000 ohms, and $R2$ is an accurate wire-wound resistance of 6,000 ohms (accurate to at least 1 per cent). The switch S is closed only when the ohmmeter is put into use, and is open at all other times to prevent a steady drain of current from the battery. A 0-1 ma. d-c meter is employed.

Three terminals are provided, as shown, for connection to the resistance to be measured. Terminals $T1$ and $T2$ are for low-resistance measurements; $T1$ and $T3$ are for high-resistance measurements. Two $4\frac{1}{2}$ -volt dry-cell "C" batteries are employed to furnish the necessary 9 volts of potential.

Resistor $R1$ serves no purpose other than to enable the resistance of the meter circuit to be adjusted so that full-scale deflection ("infinite" resistance on "ohms" scale) is always obtained when all "test terminals" are "open"—even though the voltage of the battery may have decreased to as low as 6 volts due

FIG. 4-3.—The circuit for a double-range shunt-type ohmmeter whose construction is described here.

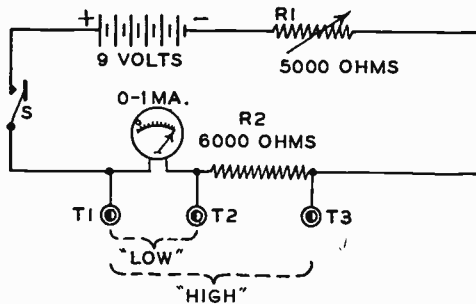

to age. This should always be set for this condition before using the ohmmeter.

If the resistance to be measured is low (between about $\frac{1}{2}$ ohm and about 100 ohms), it should be connected across terminals $T1 - T2$. This connects it in "shunt" with the meter, presenting an additional path for the current to flow through. There-

fore, since the total current now divides and flows through the two parallel paths (the strength of the current in each path varying inversely as the resistance of that path), less current flows through the meter than did before, and the meter deflection is reduced. The *lower* the resistance to be measured is, the *more* the meter deflection is reduced, hence the *low-resistance* end of the scale in this type of ohmmeter is at the *left*.

When terminals *T1 - T3* are used, the shunting effect is *increased* due to the presence of resistor *R2* in the parallel circuit. Hence a readable change in deflection of the meter may be produced with resistances which are too high to produce noticeable change in deflection when connected across *T1 - T2*, i.e., this provides a range for the measurement of higher resistances from about 100 ohms to 50,000 ohms.

4-6. Calibrating the Shunt-type Ohmmeter.—The scales of the ohmmeter described in Art. 4-5 are best calibrated directly in ohms by actually noticing and recording the readings of the meter when a sufficient number of accurate resistors of known value are actually connected in turn to the terminals for both ranges. This is the simplest way of calibrating the "ohms" scale.

If such resistors are not available, the resistance values corresponding to various meter readings when the "low" range is used may be *calculated* fairly closely by means of the formula:

$$R_x = \frac{R_m}{\left(\frac{M}{m}\right) - 1}$$

Where, R_x = the resistance being measured (ohms)

R_m = the internal resistance of the milliammeter (ohms)

M = the full-scale range of the meter (ma.)

m = the meter reading (ma.) when R_x is connected to terminals *T1 - T2*.

To illustrate the use of this formula for the low range (up to about 100 ohms), let us consider a typical example:

Example: A 1-ma. meter having an internal resistance of 27 ohms is employed, and the reading of the meter is 0.2 ma.

when the resistance to be measured is connected to low-range terminals T_1 - T_2 . What is the value of this resistance?

$$\text{Solution: } R_x = \frac{R_m}{\left(\frac{M}{m}\right)^{-1}} = \frac{27}{\left(\frac{1}{0.2}\right)^{-1}} = \frac{27}{5.1} = 6.75 \text{ ohms. Ans.}$$

Likewise, if the meter reading is, say, 0.8 ma., the value of the resistance being measured is 108 ohms, etc.

The foregoing formula cannot be used for calculating the resistance values corresponding to readings on the "high" range, for when the "high" range is used, resistor R_2 is automatically put into the shunted circuit. This alters the circuit conditions in such a way that the formula becomes inapplicable if accurate results are to be obtained.

It will be necessary to make two independent sets of resistance calibrations before the meter can be put into service. They can be marked directly upon the face of the meter in line with each division of the original "milliampere" scale. Otherwise, a new meter scale can be made (see Fig. 4-2 for the general idea), or external reference charts may be prepared. External reference charts upon which each meter reading has to be looked up in order to find the exact resistance value it corresponds to are not very popular among radio service men. The main reasons for this are that the process of referring to the chart for every reading slows up the measurement work considerably and also introduces the possibility of making errors when such reference is made in a hurry. Meters with directly-calibrated scales are much more satisfactory.

Inasmuch as the author has found that the internal resistance of meters such as Weston and Jewell 0-1 milliammeters vary as much as 20 per cent from the *approximate* resistance values given in the chart in Art. 2-14, no definite or accurate calibration values can be supplied here for the "low" range of this ohmmeter, since for this range the values depend entirely upon the exact resistance of the particular meter used. However, upon one ohmmeter constructed in accordance with the circuit of Fig. 4-3, the following readings were obtained for the "low" and the "high" ranges. These may be used as a guide if this ohmmeter is constructed.

| "LOW" RANGE | | "HIGH" RANGE | |
|-----------------|-----------------------|-----------------|-----------------------|
| R_x (ohms) | Meter Reading (ma) | R_x (ohms) | Meter Reading (ma) |
| 0.3 | 0.01 | 62 | 0.01 |
| 0.6 | 0.02 | 123 | 0.04 |
| 5 | 0.16 | 1,160 | 0.87 |
| 6.6 | 0.22 | 1,700 | 0.47 |
| 11 | 0.28 | 2,320 | 0.55 |
| 20 | 0.44 | 5,020 | 0.72 |
| 40 | 0.62 | 9,800 | 0.84 |
| 60 | 0.72 | 15,070 | 0.89 |
| 80 | 0.76 | 19,450 | 0.90 |
| 118 | 0.80 | 24,100 | 0.92 |
| 265 | 0.90 | 32,000 | 0.95 |
| 555 | 0.95 | 38,000 | 0.97 |
| 1,440 | 0.98 | 45,000 | 0.98 |

An examination of these sets of readings reveals an interesting and important characteristic of this type of ohmmeter. At the lower meter readings, the resistance increases fairly slowly with increase of meter reading, and the resistance values may be determined quite accurately. As the "high end" of the scale is approached, the resistance values increase considerably for even small changes in meter deflection, hence the possibility of making a "reading error" is very much greater. If graphs of both sets of readings are plotted on cross-section paper, this characteristic will be revealed even more forcibly.

4-7. How to Extend High-resistance Ranges of Series-type Ohmmeters.—In service work on modern receivers which employ automatic volume control, silent tuning circuits, high-fidelity amplification, etc., it is often necessary to be able to check the value of resistances of quite high value which are used in these circuits. About ten (10) megohms seems to be the maximum resistance encountered in commercial receivers. Five (5) megohm units are fairly common, but it is well to be able to measure resistances as high as 10 megohms even though they are not encountered very often.

Many of the ohmmeters manufactured a few years ago, and many which are sold today, employ a 1-ma. meter, and do not have a range anywhere near as high as this. In order to measure these high resistances with these ohmmeters, it is necessary to

extend their highest range in some way. If the ohmmeter is of the "series" type when the high range is being used (this is the case for most commercial ohmmeters), either a more sensitive meter may be employed, or the voltage may be raised, in order to increase the high-resistance range. Although the simplest method is that of substituting a more sensitive meter for the one already in the ohmmeter, this involves the purchase of a new meter, which is more or less expensive. The only remaining alternative is to employ some external voltage source of much higher voltage than that already incorporated within the voltmeter, and preferably an "even multiple" of it, to make measurements up to 1 or 10 megohms possible.

Of course, if this is done, an additional resistance must also be added in series with the external voltage-supply source. This must be of such value that, when the test prods are shorted together (with the new voltage source connected), the current flowing through the entire circuit is just sufficient to cause full-scale deflection of the meter. The value of this resistor may be calculated by means of Ohm's law in the manner outlined in Art. 4-3. In (B) of Fig. 4-4, and in the following considerations, it will be

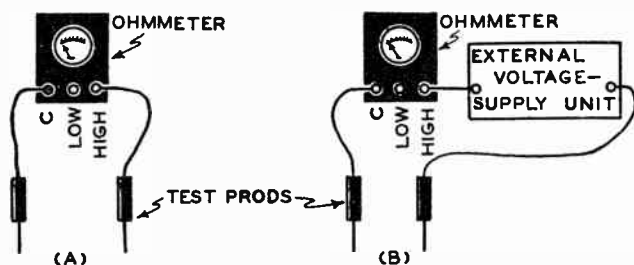

FIG. 4-4.—The high-resistance range of a series-type ohmmeter (A), may be increased by connecting a suitable external voltage source (including the proper resistor) to it as shown at (B).

assumed that this resistor is incorporated with the external voltage supply unit, even though it is not specifically mentioned.

Fig. 4-4 shows how the external voltage source should be connected in most cases. If a 1-ma. meter and a $4\frac{1}{2}$ -volt battery are used in the series ohmmeter, the highest readable range is usually around 100,000 ohms. Therefore an external voltage source of $4\frac{1}{2} \times 10$, or 45 volts, will be necessary to multiply this range by

10, i.e., to extend it to 1,000,000 ohms. Any reading taken on the 100,000-ohm scale must now be multiplied by 10 in order to find the true resistance value. To increase the range to 10 megohms the external voltage source must be capable of supplying $4\frac{1}{2} \times 100 = 450$ volts, etc. Since this external voltage source must be cheap, very compact, and light in weight in order to be practical and portable, the use of batteries for furnishing as high a voltage as this is out of the question.

A suitable line-operated voltage-supply unit which meets these requirements satisfactorily may be constructed from the voltage-supply unit portion of the circuit diagram of Fig. 4-5, and may be connected to the existing ohmmeter as shown at (B) of Fig. 4-4, if the ohmmeter is of the simple series type employing a 1-ma. meter. Instructions for its use will be found in Art. 4-8.

4-8. How to Construct a High-range Ohmmeter—The complete circuit diagram for a high-range ohmmeter which employs a built-in high-voltage supply unit, and which will measure resistances from $\frac{1}{2}$ ohm to 10 megohms (in 3 ranges) even though it uses only a single 0-1 milliammeter, is shown in Fig. 4-5. To make this instrument really universal, provision is also made for the measurement of low and intermediate values of resistance, as well as very high resistances.

As shown in the circuit diagram, the high-voltage supply unit consists of a power transformer *T* and a '201A, '12A or '71A tube connected in a half-wave rectifier circuit. The output is smoothed by the small filter condenser *C*, current-limiting resistor *R3*, and "zero-ohms adjusting" resistor *R4*. It will be seen that the balance of the circuit is identical with that of the double-range shunt-type ohmmeter described in Art. 4-5 and illustrated in Fig. 4-3. This circuit operated by the 9-volt battery is employed for the "LOW" and "INT" ranges of the instrument. For the "HIGH" range, the circuit becomes the "series" type, with the vacuum-tube voltage-supply unit furnishing 450 volts for its operation.

The power transformer *T* may be of the "midget" type, since its output need be but 450 volts, and the only load placed upon both it and the rectifier tube is 1 milliamperes—the full-scale consumption of the meter. The filter condenser *C* has a capacity

of 0.1 mfd. This value is not critical, since it is used only to produce a smoother rectified current flow. Only a condenser with a rated working voltage of over 450 volts should be used, as a breakdown may be disastrous to the power transformer. Resistor $R3$ is a 250,000-ohm unit, and is used with $R4$, a

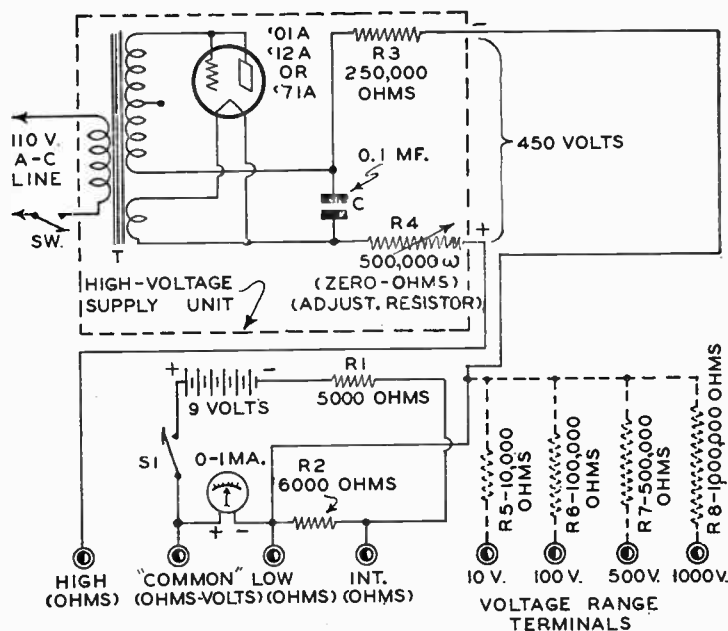

FIG. 4-5.—Circuit diagram of a high-voltage supply unit (within the dotted line rectangle) capable of delivering 450 volts, and an ohmmeter circuit capable of measuring from $\frac{1}{2}$ -ohm to 10 megohms in 4 ranges. If the resistors shown at the right (drawn dotted) are employed, the meter can also be used as a 4-range d-c voltmeter.

500,000-ohm adjustable rheostat, to limit the current flow to the meter. The voltage-supply unit obtains its current from the 110-volt a-c electric light mains.

The "LOW" and "INT" ohmmeter range may be calibrated and operated in the same way as described in Art. 4-6. When high-resistance measurements are to be made, toggle switch $S1$ is first opened, in order to disconnect the 9-volt battery entirely from the circuit. Now the high-voltage supply unit is con-

nected to the a-c line and switched on. Resistor R_4 is then adjusted for full-scale deflection ("zero" resistance), when the "HIGH" ohms and "COMMON" terminals are short-circuited. To calibrate this high-resistance range, a number of accurate comparison resistors may be used, noting the meter reading when each one is tested.

Note: When using the high-resistance range, care should be observed in the handling of the ohmmeter test prods, since high potential exists across them. The bare metal portions should not be touched or held by the hands.

If multiplier resistors R_5 , R_6 , R_7 and R_8 are also provided, as shown in Fig. 4-5, the meter may also be used as a 4-range 1,000 ohms-per-volt d-c voltmeter, thus greatly increasing its usefulness. Of course, in this case, S_1 and the "line switch" for the voltage-supply unit must be left open.

REVIEW QUESTIONS AND PROBLEMS

1. State one advantage gained by using a very sensitive meter in an ohmmeter, instead of employing one that is less sensitive.
2. Explain how the accuracy of the various individual parts of an ohmmeter affect the accuracy of the completed instrument.
3. State 3 precautions which must be taken when constructing an ohmmeter, if the accuracy of the completed instrument is to be kept high.
4. Explain how you would proceed to calibrate the scale of an ohmmeter by means of accurate resistors of known value.
5. What effect has the accuracy of the resistors employed in Ques. 4 upon the accuracy of the final calibration of the ohmmeter.
6. Explain how you would proceed to calibrate the scale of the simple series ohmmeter of Fig. 4-1 by means of calculations performed through the use of a formula.
7. Using the proper formula, perform all the calculations necessary to obtain all the values for the calibration of the "low"-range scale of the ohmmeter of Fig. 4-3 if the internal resistance of the 0-1 milliammeter is 30 ohms, and the calibrating resistance R is 4,000 ohms. Calibration points should be taken at 0.1 ma. intervals along the scale.
8. Explain how you performed the calculations in Problem 7.
9. Draw the complete "milliamperes" and low-range "ohms" scales for the ohmmeter of Problem 7 (see Fig. 4-2 for sample).
10. (a) Explain how the upper resistance-measuring range of a simple series ohmmeter can be increased.

- (b) What determines the "multiplying factor" by which the ohmmeter scale readings must be multiplied in order to find the actual resistance when the range-increase method of (a) is employed?
11. Why is it preferable to make routine resistance tests in radio service work with an ohmmeter rather than with an ammeter and voltmeter or a Wheatstone bridge? Answer this question from the point of view of: (a) number of instruments required for the measurements; (b) rapidity with which the measurements can be made; (c) space occupied by the instruments, and their weight; (d) cost of the instruments required; (e) time required to set them up and connect them for operation.
 12. Explain how the accuracy of the resistance measurements made with an ohmmeter is affected if the battery has deteriorated to such an extent that it is not possible to adjust it to the proper "zero ohms" position before using it.

CHAPTER V

TYPICAL COMMERCIAL OHMMETERS

5-1. Value of Studying Commercial Instruments.—The ohmmeter is such a useful instrument, that many excellent commercial forms have been developed. Most of them provide several convenient ranges for covering the wide range of resistance measurements required in radio service work. Since the circuit and switching arrangements employed by the various manufacturers differ somewhat, it will prove very instructive to study some typical ones in detail. At the same time, very valuable experience will be gained in "breaking down" circuit diagrams. Some circuit diagrams appear rather complicated at first, but are found to be fairly simple when studied systematically and "broken down."

5-2. Ohmmeters, Volt-ohmmeters and Volt-ohm-milliammeters.—After our rather detailed study of milliammeters, ammeters, voltmeters and ohmmeters in the previous chapters, it must be quite evident that it is perfectly possible to use the meter contained in an ohmmeter, as a voltmeter or milliammeter, by the simple expedient of adding suitable switches to cut multipliers and shunts in and out whenever necessary. Such an instrument is then a combination voltmeter, milliammeter and ohmmeter. A variety of voltage ranges may be obtained by using sufficient multiplier resistors; a number of convenient milliammeter ranges may be had by using the proper shunts; and at the same time convenient ohmmeter ranges may be made available. Such combination instruments usually have all the necessary batteries required for ordinary work, self-contained within the instrument case. They are known under various names, such as, "volt-ohm-milliammeters", "multitesters", "combination testers," etc. Special combinations of voltmeters and ohmmeters

only, are called "volt-ohmmeters," and are made in a wide variety of ranges. Although one of these combination instruments costs slightly more than a single corresponding milliammeter, voltmeter or ohmmeter of similar range, they are extremely economical because a single combination instrument will do the work for which a number of separate instruments (at a much greater *total cost*), would be required.

We will now study the circuits and construction of a few typical, interesting ohmmeters, volt-ohmmeters and volt-ohm-milliammeters which have been designed and marketed by commercial test-instrument manufacturers. This study should

FIG. 5-1.—The volt-ohm-milliammeter whose complete circuit diagram is shown in Fig. 5-2. Any one of the various voltage, current and resistance ranges can be selected quickly by the range-selector switch knob at the center.



Courtesy Radio City Products Co.

prove very instructive, and helpful in making ohmmeter circuits clearly understood.

5-3. "Radio City" Model 403A Volt-ohm-milliammeter. —The instrument pictured in Fig. 5-1 is a combination voltmeter, milliammeter and ohmmeter designed especially for radio service work. The voltmeter provides four ranges, the ohmmeter three ranges, and the milliammeter two ranges, as follows: 0-5, 0-50, 0-250, 0-750 volts d-c only; 0-2000, 0-200,000, 0-2,000,000 ohms; also 0-500 microamperes and 0-50 milliamperes, d-c only.

As shown in the schematic circuit diagram in Fig. 5-2, switching is automatically accomplished by means of a triple-pole (arranged in three decks), ten-position selector switch connected to the various resistors and 500-microampere meter *M*.

5-4. "Break-down" Circuit Analysis of the Volt-ohm-milliammeter. — Since the schematic circuit diagram of the foregoing instrument appears more complicated than it really is, it is desirable to "break down" the circuit when studying it, in order

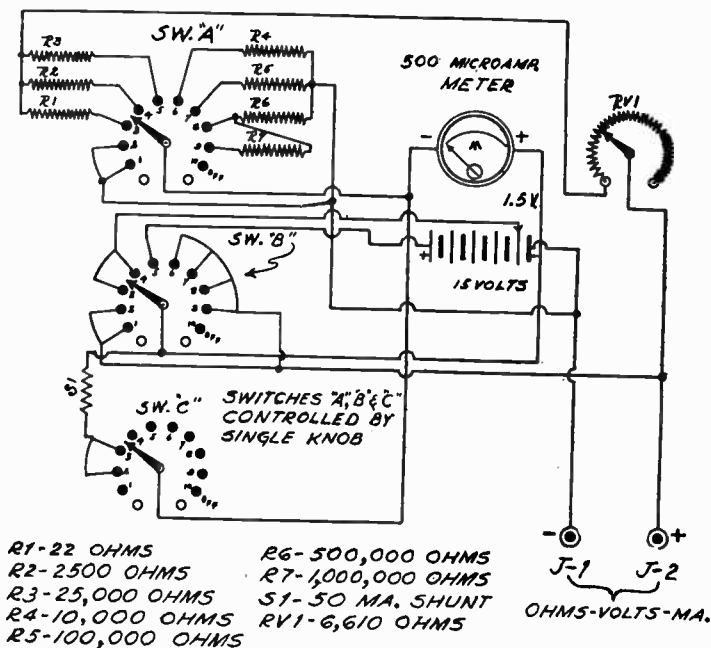

FIG. 5-2.—The schematic circuit diagram of the volt-ohm-milliammeter illustrated in Fig. 5-1. The three sections "A", "B" and "C" of the range-selector switch are here shown independently, with their respective contact points. The "breakdowns" of this circuit for various positions of the switches are shown in Figs. 5-3 to 5-6.

to show what the actual circuit arrangement is for any particular setting of the selector switch. This has been done in Figs. 5-3 to 5-6, in connection with our analysis of this instrument.

Let us suppose that the selector switch has been set to obtain the 500-microampere range—by turning it to the "500-microamp" position. When this is done, the contact arms in switch sections A, B and C (see Fig. 5-2) touch the respective No. 1 contacts. If we carefully trace through the circuit connections for this condition, starting at the instrument "output" ter-

minal *J-1* and finishing at terminal *J-2*, we will find the actual meter circuit to be as shown at (A) of Fig. 5-3. By omitting switches *A* and *B*, this may be simplified down to the simple circuit shown at (B). It can be seen that with the selector switch in this position, the circuit is such that the meter is simply connected directly across the "output" terminals of the instrument, so that its full sensitivity is available.

If now we suppose the selector switch to be set so that the

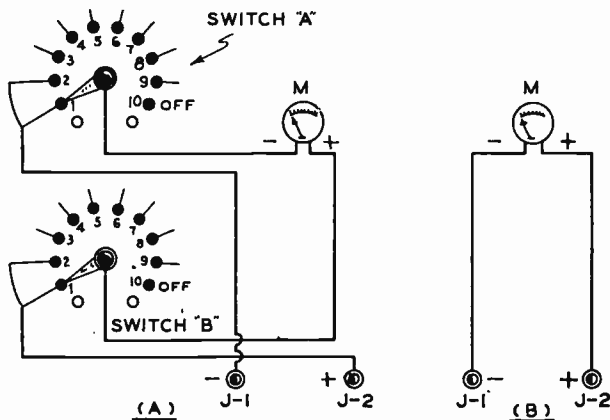

FIG. 5-3.—"Breakdown" of the circuit of Fig. 5-2 when the selector switch *A-B-C* is on contact No. 1. The actual circuit through the switches *A* & *B* (switch *C* is out of the circuit) is shown at (A). The simplified circuit is shown at (B). This places the meter directly across the output terminals, providing the 500-microampere range.

switch arms on switches *A*, *B* and *C* make contact with their respective No. 2 contacts in order to provide the 50-milliampere range, we can trace through the circuit of Fig. 5-2 again, starting at terminal *J-1* and finishing at terminal *J-2*, tracing through that part of the wiring which is now in the meter circuit. This portion of the instrument wiring is shown at (A) of Fig. 5-4. This wiring in more simplified form with the switches omitted from the drawing is shown at (B).

If the selector switch is set so that the switch arms make contact with their respective No. 3 contacts, the meter is automatically connected as an ohmmeter of 0-2,000 ohm range. If we trace through the circuit diagram of Fig. 5-2 and "break it

down" in the same way as before, for this position of the switches, we will find the meter circuit to be as shown at (A) of Fig. 5-5. In this case, we have omitted the intermediate diagram showing the switches. Note that the shunt $S1$ is connected across the meter terminals and that the meter is now connected as a series-type ohmmeter, since the resistance to be measured, when connected to terminals $J-1$ and $J-2$, will be in series with the meter

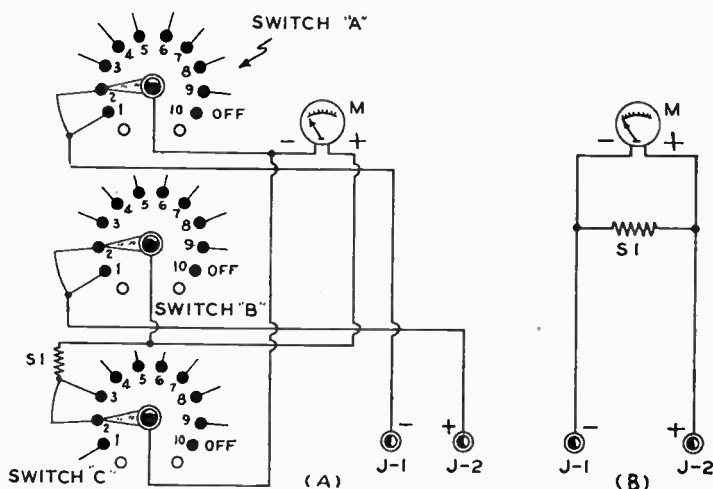

FIG. 5-4.—"Breakdown" of the circuit of Fig. 5-2 when the selector switch $A-B-C$ is on contact No. 2. The actual circuit through the switches is shown at (A). The simplified circuit is shown at (B). This places shunt resistor $S1$ across the meter terminals, providing the 50 milliamp. range.

and battery. The fixed series resistance is $R1$ plus a portion of $RV1$. Resistor $RV1$ becomes the zero-adjusting resistor.

In its fourth position, the selector switch connects in $R2$ and $RV1$ without the meter shunt $S1$. This results in an ohmmeter having the circuit shown at (B) of Fig. 5-5, and having a range of 0-200,000 ohms. In both this, and the previous positions of the switch, only 1.5 volts of the self-contained battery is used.

When the 0-2,000,000 ohm range is selected (contact No. 5 on the switches), the circuit is as shown at (C) of Fig. 5-5. Resistors $R3$ and $RV1$ are now in series with the meter in conjunction with the full 15-volt potential of the battery.

When the selector switch is in positions *No. 6 to No. 9*, inclusive, only sections *A* and *B* are effective, and the circuit ar-

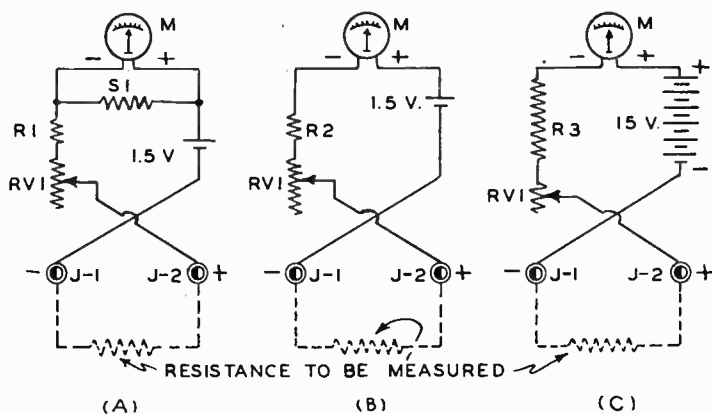

FIG. 5-5.—“Breakdown” of the circuit of Fig. 5-2. The circuit connections for the instrument are shown for the following conditions:

(A). Selector switch is on contacts Nos. 3. This makes it a 0-2,000 ohm ohmmeter.

(B). Selector switch is on contacts Nos. 4. This makes it a 0-200,000 ohm ohmmeter.

(C). Selector switch is on contacts Nos. 5. This makes it a 0-2,000,000 ohm ohmmeter.

range becomes that shown in Fig. 5-6. Here, 6, 7, 8, 9 represent the contacts on switch (A) (see Fig. 5-2 also). The four resistors now become series multiplier resistors, and make the

FIG. 5-6.—“Breakdown” circuit diagram for the meter of Fig. 5-2 when the selector switch is on the “voltmeter” positions. This makes it a voltmeter having four ranges.

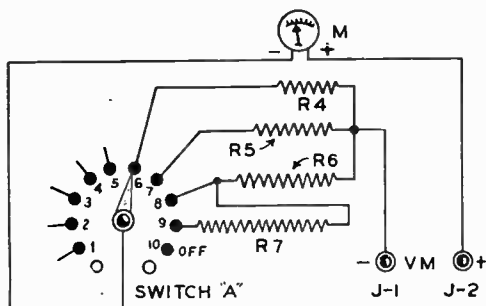

meter a “voltmeter”. With the switch on contact *No. 6*, *R4* is in series with the meter, and it becomes a 0-5 d-c voltmeter.

With the switch on contact *No. 7*, *R 5* is in series, and the range is 0-50 volts. When it is on contact *No. 8*, *R 6* is in series, and the range is 0-250 volts. When it is on contact *No. 9*, *R 6* and *R 7* are in series, and the range is 0-750 volts.

Resistor *RV 1* (see Fig. 5-5) is so constructed, that its resistance is different for different equal parts of its length. At the low ohmmeter ranges, small changes in this resistance produce large changes in the meter reading, and for this reason accurate "zero adjustment" of the instrument prior to using becomes difficult. By winding the resistance element so that it is non-uniform (the change in resistance is slow at one end and rapid at the other), good adjustment is obtained over the entire range of the instrument.

A feature of this particular instrument is that but one pair of tip-jack "output" terminals are used for all the different purposes and ranges of the instrument.

The "break-down" method of circuit analysis which was employed in the detailed study of this instrument should be practiced by servicemen when attempting to find out how test instruments operate, when only a complete circuit diagram of the instrument is available. Through its use, the operation of even



Courtesy Shallcross Mfg. Co.

FIG. 5-7.—A quick-change volt-ohmmeter which provides four voltage ranges and four resistance ranges. Its schematic circuit diagram is shown in Fig. 5-8. (Shallcross volt-ohmmeter No. 681).

the most complicated instruments can be worked out in step-by-step fashion, and understood clearly. It will be found very useful later, for studying the operation of analyzers, test oscillators, tube checkers, etc., from their rather complicated-appearing circuit diagrams.

5-5. "Shallcross" Quick-change Volt-ohmmeter No. 681

—This instrument, designated as a “Quick-change Volt-ohmmeter”, is essentially a simple voltmeter and ohmmeter arranged with a simple switching system to enable any one of four volt-age ranges and four resistance ranges to be selected quickly by

FIG. 5-8.—Schematic circuit diagram of the volt-ohmmeter shown in Fig. 5-7. All ranges are selected by means of the double-pole switch *S*. A facsimile reproduction of the scale of the instrument is shown in Fig. 5-9.

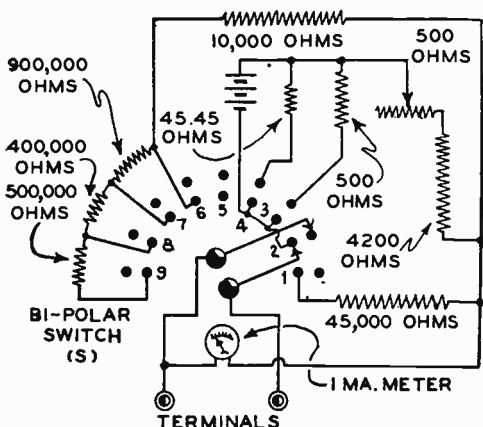

means of a double-pole, nine-position switch *S*. The instrument is illustrated in Fig. 5-7, and its schematic circuit diagram is shown in Fig. 5-8. The operation of this instrument can best be studied by the same “break-down” method that was outlined in Art. 5-4. However, the various individual diagrams will not be given here. The reader will obtain very valuable experience by drawing them for himself—a separate diagram showing the complete circuit connections should be drawn for each position of the switch.

Eight positions of the switch are active. The first, at the extreme right side in Fig. 5-8, makes the instrument an ohmmeter with a maximum range of 3,000,000 ohms, when an external 45-volt “B”-battery is connected in series with the instrument (a 0-1 ma. meter). The scale, shown in Fig. 5-9, is then multiplied by 1,000 to obtain the correct value in ohms, since the lowest ohmmeter range, 3,000 ohms, is engraved on the scale. This position is marked $\times 1,000$, the “ \times ” meaning “multiply by.” For position *No. 2* of the switch, the ohmmeter becomes a simple “series” type with the meter, the 4,200-ohm resistor, the 500-ohm

variable resistor, and the internal battery all in series with the resistor to be measured. For position *No. 3*, the meter, 4,200-ohm resistor, 500-ohm variable resistor and battery are all in series with the resistor to be measured. The 500-ohm fixed resistor is shunted across the first three of these. For switch posi-

FIG. 5-9.—Reduced facsimile reproduction of the scale of the ohmmeter illustrated in Figs. 5-7 and 5-8.



tion *No. 4*, the same arrangement holds, except that the 45.45-ohm resistor is now the shunting resistor. The remaining four positions connect the multipliers in the conventional series fashion to make a voltmeter, the tapped multiplier system being used. Voltage ranges of 0-10, 0-100, 0-500, and 0-1,000 volts are obtained.

Here again, the switching system makes it possible to use



Courtesy Supreme Elect. Instr. Corp.

FIG. 5-10.—A volt-ohmmeter which provides for a wide range of voltage and resistance measurements. Its circuit diagram is shown in Fig. 5-11. (Supreme Model 111.)

but two terminals through which all the facilities of the instrument may be obtained for external use.

5-6 "Supreme" Model 111 Volt-ohmmeter.—The Supreme Model 111 d-c volt-ohmmeter, illustrated in Fig. 5-10, employs a meter with a full-scale deflection of one milliamper. A 7-position selector switch makes it possible to select the following

ohmmeter and voltage ranges: 0-1,000; 0-10,000; 0-100,000; 0-1,000,000 ohms; 5, 25, 125, 250, 500, 1,250 volts d-c at 1,000 ohms-per-volt. The 0-1,000,000 ohm range is obtained by connecting an external 45-volt battery to the binding posts provided for this purpose on the panel of the instrument. All other ohmmeter ranges are operated by the self-contained 4.5-volt battery. For "zero-ohm" adjustments, a 3,600-ohm rheostat is connected

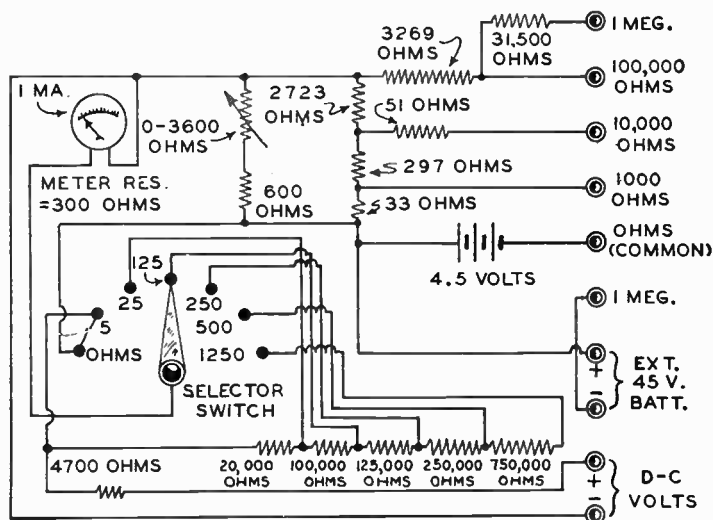

FIG. 5-11.—Schematic circuit diagram of the volt-ohmmeter shown in Fig. 5-10. The ohmmeter section has been redrawn separately in Fig. 5-12.

in series with a 600-ohm resistor across the 300-ohm "movement" of the meter.

From the schematic circuit, Fig. 5-11, it is seen that when the 1,000-ohm-range terminals of the ohmmeter are short-circuited, the battery is connected across 33 ohms of resistance, and these 33 ohms are in series with a 297-ohm and a 2,723-ohm resistor, the combination being across the meter movement (which is also shunted by the zero-adjusting circuit mentioned previously). The battery is connected across different values of resistance for every different voltage range when the terminals are short-circuited for zero adjustment. It is well to trace out

the circuit for every mode of connection thoroughly to understand the instrument. The ohmmeter section has been re-drawn separately to facilitate this, and is reproduced in Fig. 5-12.

The markings of the "ohms" range of the meter, which are direct for the 0-1,000-ohm range, must be multiplied by 10 (by

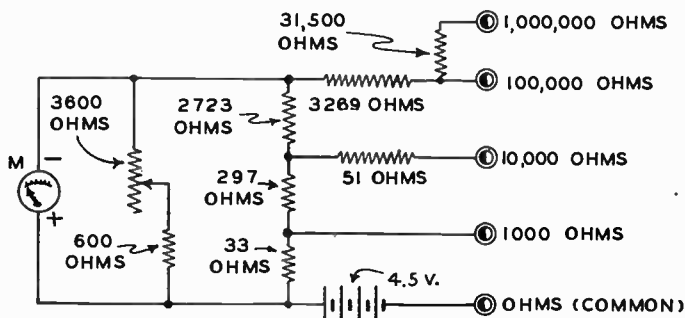

FIG. 5-12.—“Breakdown” of the circuit of the volt-ohmmeter shown in Figs. 5-10 and 5-11 when it is used as an ohmmeter.

adding a zero) for the 0-10,000-ohms range; by 100 (by adding two zeros) for the 0-100,000-ohms range; and by 1,000 (by adding three zeros) for the 0-1,000,000-ohm range. For voltage measurements, the selector switch is rotated to the desired volt-



Courtesy Weston Elect. Instr. Corp.

FIG. 5-13.—A volt-ohmmeter which provides two resistance ranges and four d-c voltage ranges at 1,000 ohms-per-volt. All voltage ranges are brought out at the upper pin jacks. The schematic circuit diagram is shown in Fig. 5-14. (Weston Model 564.)

age range. Only three voltage ranges are marked upon the meter scale, namely 5, 25 and 125 volts. The 250-volt range read-

ings are obtained by multiplying the 25-volt range readings by 10, and the 1,250-volt range readings are obtained by multiplying the 125-volt range readings by 10.

5-7. "Weston" Model 654 Volt-ohmmeter.—This instrument is equipped with a 0-1 milliammeter, whose scale is directly calibrated in two resistance ranges of 0-10,000 and 0-100,000 ohms, and four voltage ranges of 3, 30, 300 and 600 volts, at 1,000 ohms-per-volt. A self-contained 4.5-volt "C" battery provides the necessary potential. As shown by the photograph of Fig.

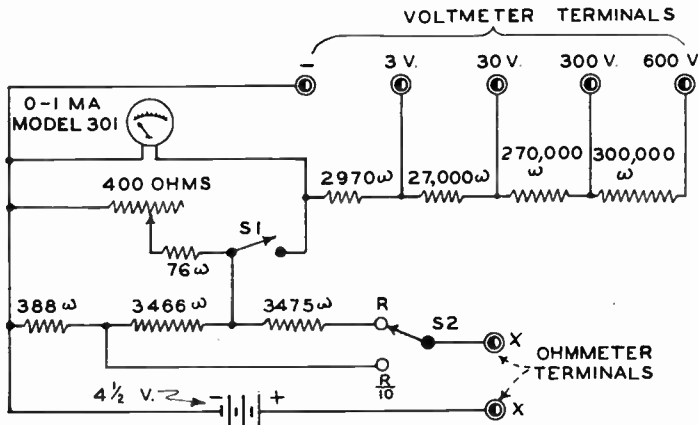

FIG. 5-14.—Schematic circuit diagram of the volt-ohmmeter illustrated in Fig. 5-13.

5-13, all voltage ranges are brought out through the tip-jacks at the top of the instrument panel. Two toggle switches are used, as shown in the circuit diagram of Fig. 5-14. When the first one, *S1*, is closed, the meter becomes an ohmmeter—when it is open, the meter is a voltmeter, with multipliers of the series type. The other switch, *S2*, changes the sensitivity of the meter for the high and low ohmmeter ranges. It does this by altering the connections of the 3,466- and 3,475-ohm resistors in the circuit.

The zero adjustments on the meter are made by means of the 400-ohm rheostat located below it on the panel.

5-8. "Weston" Model 663 Volt-ohm-milliammeter.—Through the use of a 50-microampere meter, a 3-pole 8-position switch, and the necessary multipliers and shunt resistances,

a large number of ranges is made possible with the very interesting model 663, volt-ohm-milliammeter shown in Fig. 5-15. The scale of the indicating instrument is marked 0-1,000 ohms; 0-2.5, 5 and 10 volts and milliamperes. The following ranges, however, are also available: 0-200, 0-1,000, 0-10,000, 0-100,000, 0-1,000,000 and 10,000,000 ohms; 2.5, 10, 100, 250, 500, 1,000 d-c volts at 1,000 ohms-per-volt; and 1, 5, 25, 100 d-c milliamperes. A facsimile reproduction of the meter scale is shown in Fig. 5-16. Notice the scale and the graduations on it.

The schematic circuit diagram of this tester, as drawn in Fig. 5-17, is easy to break down into individual circuits. On position 1 of the 3-section selector switch, the meter is disconnected entirely from the circuit. This is the "off" position. On position 2, the 5,000-ohm fixed and the 15,000-ohm variable resistors are connected in series, and the combination is connected



FIG. 5-15. — A volt-ohm-milliammeter which provides four current ranges, six voltage ranges, and six resistance ranges. All ranges are selected by the selector switch at the bottom. Its schematic circuit diagram is shown in Fig. 5-17. A facsimile reproduction of its scale is shown in Fig. 5-16.

Courtesy Weston Elect. Instr. Corp.

across the meter; the variable resistor provides for "zero-adjustment". At the same time, the ohmmeter terminals are connected in series with one cell (1.5 volts) a 11,500-, a 2,000-, and a 7,500-ohm resistor across the meter movement. Also, a 484-ohm re-

sistor is connected from the positive side of the meter to one of the ohmmeter terminals. This "break-down" is shown in Fig. 5-18. By imagining the switch to be successively in the remaining positions, similar breakdowns of the circuit may be traced.

Although only one resistance range is marked upon the meter scale (0-1,000 ohms), the other 5 ranges are obtained by

FIG. 5-16.—A facsimile reproduction (reduced) of the scale of the volt-ohm-milliammeter shown in Fig. 5-15. Notice the non-uniform "Ohms" scale.

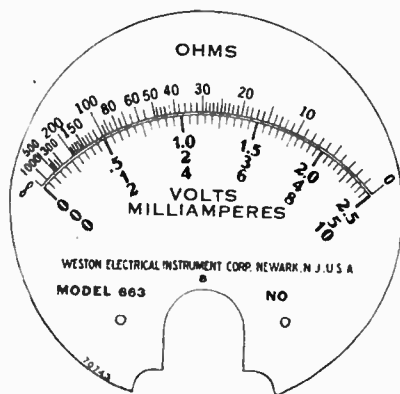

rotating the selector switch to the multiplying or dividing factor mark engraved upon the instrument panel. The instrument will indicate readings below 10 ohms to as low as 0.1 ohm, since the first *calibrated* meter division of this scale is 1.0 ohms. A battery voltage compensator is provided with a control knob marked "Ohmmeter Adjuster." A 1.5-volt battery is used. The 10-megohm range is secured by using the full sensitivity of the meter and 12.5 volts of battery. For the next lower range in resistance, the same sensitivity is maintained using a single dry cell of 1½ volts. The remaining lower ranges are obtained by shunting the meter to obtain various sensitivities.

When the instrument is to be used for the measurement of voltages or current, the selector switch is turned to the desired position and the tip-jacks for the range on the right or left side of the panel are employed. When used as a voltmeter, the meter movement is shunted properly to make a 1-ma. movement out of it. With the proper multiplier resistors, this makes a voltmeter having a sensitivity of 1,000 ohms-per-volt, (see Art. 2-20).

5-9. Combination Testers.—Even those who have but little knowledge of radio service work realize that the service man must have available at all times a number of different test instru-

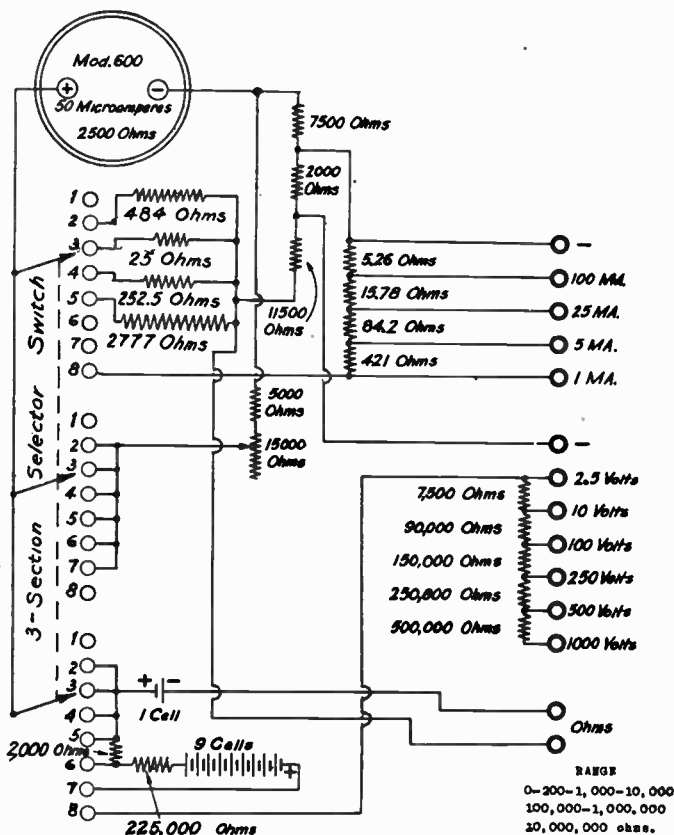
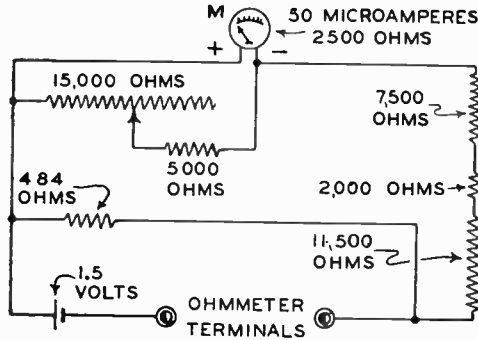

FIG. 5-17.—The schematic circuit diagram of the volt-ohm-milliammeter shown in Fig. 5-15. A 3-section selector switch makes all the necessary circuit changes.

ments—a volt-ohm-milliammeter, a set analyzer, a capacity tester (not essential, but desirable), a tube tester, and the many hand tools required for effecting repairs. Individual instruments are rather unwieldy, so the trend now is to combine as

many individual instruments as possible either into a single carry-

FIG. 5-18.—“Break-down” of the circuit of Fig. 5-17 when the selector switch is in position 2 — making the instrument an ohmmeter.



ing case or into a single instrument. Such instruments are known as combination testers.

Some manufacturers sell each component as a distinct unit — others arrange them into a single case so that they all may be carried together or any one removed at will.

FIG. 5-19.—A combination testing unit incorporating a circuit tester having voltage, current and resistance ranges, and a service test oscillator. The circuit diagram is shown in Figs. 5-20 and 5-21. The circuit diagram of the test oscillator portion is shown in Fig. 17-9. (Philco Model 048.)



Courtesy Philco Radio & Telev. Co.

5-10. The “Philco” Model 048 Combination Tester. — An interesting example of a combination tester is the Model 048 all-purpose tester manufactured by Philco. It has five a-c voltage ranges, five d-c voltage ranges, three d-c milliammeter ranges,

three ohmmeter ranges, five a-c output-meter ranges, a capacity tester, a 105 to 2,000 kc oscillator, and a tube tester, all built into a single case, as shown in Fig. 5-19.

The voltmeter-ohmmeter-milliammeter sections of the tester are of special interest to us at this time. The diagram of this

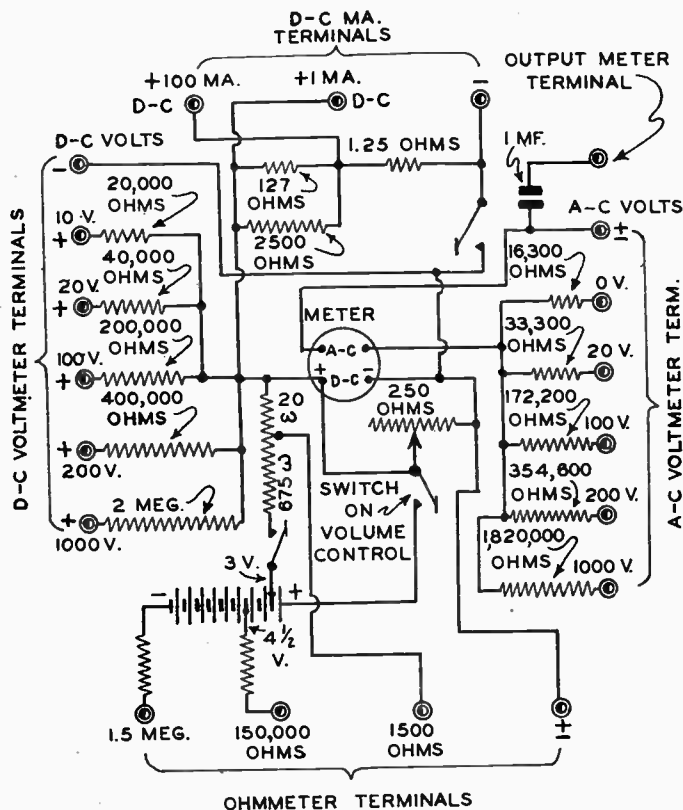

FIG. 5-20.—Schematic circuit diagram of the circuit tester portion of the combination tester illustrated in Fig. 5-19. The ohmmeter section of this tester is drawn separately in Fig. 5-21.

part of the tester is shown in Fig. 5-20. The meter is of the a-c, d-c type, with a built-in rectifier of the copper-oxide type. On the right-hand side of the diagram may be seen the multipliers for the a-c voltage ranges, and, on the left, the multipliers for the

d-c voltage ranges. These connections are perfectly standard and therefore require no comment. The d-c terminals of the meter also connect to the shunts for the d-c milliammeter ranges, and are shown in the upper center part of the diagram.

The ohmmeter section is re-drawn separately in (A) of Fig. 5-21. A 250-ohm rheostat is connected directly across the meter to provide for zero adjustment. The switch $S1$, which is ganged to this rheostat, closes the self-contained battery circuit when the ohmmeter is to be used. With this closed and with $S2$ open

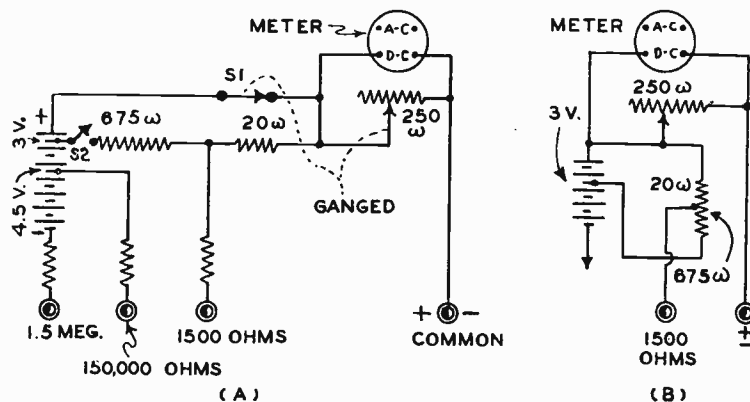

FIG. 5-21.—A “breakdown” circuit diagram of the ohmmeter portion of the tester shown in Fig. 5-20.

(A) Circuit arrangement when the 150,000; and 1,500,000-ohm ranges of the ohmmeter are used.

(B) Circuit arrangement when the 1,500-ohm range is used.

as shown, the 1.5-megohm and 150,000-ohm ranges of the ohmmeter may be used by merely plugging one tip-jack into the proper terminal. However, when the 1500-ohm range is to be used, the switch $S2$ must be closed. If this switch were closed all the time, the 3 volts of the battery would send current through 695 ohms of resistance continuously as long as $S1$ is closed. The circuit of the 1500-ohm range is shown in (B) of the figure. The entire 3 volts is connected across 695 ohms of resistance, but only 20/695, or about 3% of this voltage is made available for this range of the ohmmeter.

It should be noted that the resistance to be measured is

connected in series with the shunted meter and the voltage source, through but 20 ohms of resistance, hence the small energizing potential needed. The circuit diagram of the oscillator section of this compact but versatile tester will be discussed in Chap. XVII.

5-11. "Weston" Combination Tester Assembly. — A typical example of a very complete combination tester assembly is



Courtesy Weston Elect. Instr. Corp.

FIG. 5-22.—A typical example of an unusually complete combination test unit consisting of separate units grouped together in a common carrying case to form a complete radio testing outfit. This assembly contains a volt-ohm-milliammeter, set analyzer, capacity meter, tube checker, test oscillator, and miscellaneous plugs and cables.

illustrated in Fig. 5-22. It consists of a volt-ohm-milliammeter, shown in the lower left corner of the illustration; set analyzer, shown in the lower center; a capacity meter, in the lower right corner; a tube checker in the upper right corner; a test oscillator

in the upper left corner, and various plugs, cables, adapters, etc. in the upper center compartment. The entire assembly is in a carrying case, but any individual instrument may be removed at any time if desired. Such an assembly of test instruments really forms a portable test laboratory, and the wide range of tests and measurements that can be made with it can easily be appreciated.

Of course, other less elaborate combinations are available. One device has a combination a-c, d-c volt-ohm-milliammeter, an output meter and a capacity meter. Still others are only output meters and capacity meters. There is a tendency to accomplish all a-c testing functions (such as output, voltage and capacity measurements) by means of one instrument, and to make all d-c tests by means of another instrument. But if the d-c instrument is equipped with a copper-oxide rectifier, then both a-c and d-c measurements may be made with it.

REVIEW QUESTIONS

1. (a) State two advantages which ohmmeters possess over other forms of resistance measuring instruments. (b) State one limitation which ohmmeters possess.
2. What electrical quantities is a volt-ohm-milliammeter capable of measuring?
3. Trace through the circuit diagram in Fig. 5-8 and break it down, drawing separate simplified diagrams showing the circuit connections which exist for the following positions of the switch: (a) switch in position 1; (b) switch in position 3; (c) switch in position 4; (d) switch in position 9.
4. Explain each circuit drawn in Question 3, and tell what electrical quantity the instrument is able to measure in each case.
5. Trace through the circuit diagram of Fig. 5-12 and explain just what the circuit arrangement is for each ohmmeter range.

CHAPTER VI

CONDENSER TESTERS AND CAPACITY METERS.

6-1. Tests Required by Condensers.—Modern radio receivers employ so many condensers of various types and capacity values that it is only natural that every radio service man should frequently find it necessary to check the condition of one or more condensers which are suspected of being the cause of trouble in a receiver. All the service man ever needs to find out about a suspected condenser is:

1. Whether it is *short-circuited*.
2. Whether it is *open-circuited*.
3. Whether its *leakage* is excessive.
4. Whether its *leakage current* is abnormal (in the case of electrolytic condensers only.)
5. Whether its *capacity* is at *normal* value.

Tests for the first four conditions are probably the most common ones made, since these represent the most frequently occurring troubles in condensers. These tests can be made by the ohmmeter, but the instruments described in this chapter are preferable. A practical detailed discussion of the general methods of making these tests will be reserved for a later chapter (Chap. XXII). In the present chapter, we are interested merely in the *instruments* employed for condenser testing.

6-2. When Measurement of Capacity is Necessary.—Although it might seem at first thought that the radio service man would rarely find it necessary to check the actual capacity value of a condenser, since all the factory-built receivers he encounters are most likely equipped with condensers of proper size, there really are many occasions upon which it is necessary for him to make such measurements.

He may be called upon to service a receiver manufactured years ago—possibly by an obscure manufacturer who has long

since gone out of business—and find that no capacity values or color codes (see RMA Condenser Color Code in *Radio Field Service Data Supplement Book*) are marked on the condensers to identify their value. A circuit diagram with electrical constants may not be available for the set. He can try substituting condensers of various known values in the circuit in place of the suspected condenser, until satisfactory operation of the receiver is obtained, but this is often a time-consuming, and rather inaccurate, way of solving the difficulty. Ability to quickly test the capacity of the condenser proves valuable in cases of this kind—especially if the condenser is of the paper-, or mica-insulated type.

Another instance in which the ability to measure the capacity of condensers is valuable is when unmarked condensers of unknown value are at hand. These may have been salvaged from discarded receivers, bought in a lot for replacement purposes, etc.

There is still another very important instance—one that is not commonly thought of. It is true that the actual *capacity* of a solid-dielectric condenser seldom changes materially when in service, but its *impedance* may. If the condenser happens to have a poorly made internal connection or joint, this introduces resistance *in series* with the flow of current in-and-out of the condenser plates. In some instances this condition may become progressively worse by continued corrosion or oxidation of the joint and the resistance may finally become high enough to materially alter the effectiveness of the condenser as a current-storage device. Since “capacity meters” really measure the *impedance* of condensers, the presence of any such high resistance in a condenser will be revealed immediately by an abnormally high impedance, i.e., by a capacity-meter reading much *lower* than that which would be obtained if the condenser were normal (since the impedance varies *inversely* with the capacity of a condenser, see Art. 6-6). Hence a capacity meter is necessary for this particular trouble.

6-3. Distinction Between “Condenser Testers” and “Capacity Meters”—Before proceeding further with our study of instruments for testing condensers, it will be well to point out a distinction in nomenclature, a distinction between the terms “capacity tester”, “condenser tester”, “condenser an-

alyzer", etc., and *capacity meter*. Strictly speaking, a *capacity tester*, *condenser tester*, or *condenser analyzer* is merely a device which tells whether or not a given condenser is "good", "leaky", "open" or "shorted". A *capacity meter* measures and indicates the effective capacity in microfarads. The former make purely *qualitative* tests, the latter makes a *quantitative* test which may also be interpreted to indicate the qualitative conditions of the condenser. This distinction will be observed in this book and should be kept in mind. We will first study a typical condenser tester and will then proceed to a study of capacity meters.

6-4. Tobe Relaxation-Oscillator Type Condenser Analyzer.

—The circuit diagram of a very novel instrument for testing the *condition* of condensers (not the capacity) is shown in Fig. 6-1. The complete instrument is shown in the illustration of Fig. 6-2. The 110-volt a-c input is stepped up by means of power transformer *T*, and the output is rectified by means of a '01A tube. The output voltage appearing across *A-B* is about 700 volts d-c. The "regulator control" resistor *R₄* permits "splitting" of the voltage adjustments obtained by the various transformer taps and switch *S₄*, and also limits current flow in the event of a "dead short." A neon tube having a very low "striking voltage" (glows with little voltage) is connected in the negative return line, as shown. A "flash-control" condenser, *C₁*, and a number of resistors are connected by means of the "leakage-control switch" *S₅* across the neon tube. The condenser *C_x* to be tested is connected as shown at the right side of the diagram.

Solid dielectric condensers are tested by setting all controls for maximum voltage, connecting the leakage-control switch at position 2, and the condenser under test as shown. When a good condenser is connected at *C_x*, a momentary charging current will flow, which will also charge *C₁* to a potential high enough to ignite the neon lamp. As soon as *C_x* is fully charged, the current stops flowing, condenser *C₁* will discharge through the neon lamp until its voltage falls below the value required to keep the lamp lit; it will then go out. But if *C_x* has a small amount of leakage, as represented in the diagram by the dotted-line resistance *R*, a small current will continue to flow, gradually charging *C₁* again. When a high enough potential is built up, *C₁* dis-

charges through the neon lamp indicator which again flashes. As soon as the voltage of $C1$ falls below the value required to keep the lamp ignited, it will again go out. The continued flow of current at a slow rate through the leakage path will again charge the condenser and the lamp will light again, etc.

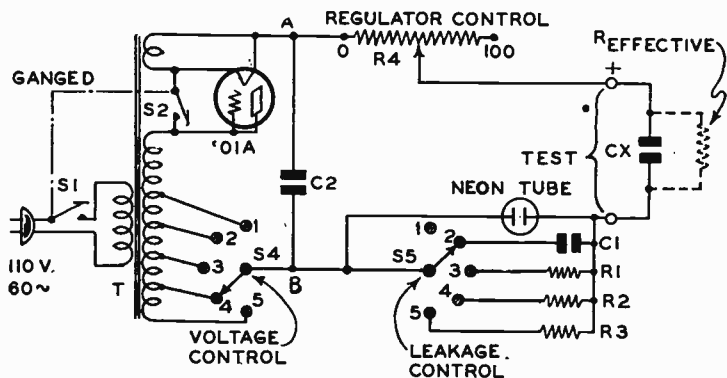

FIG. 6-1.—Schematic circuit diagram of the relaxation-oscillator type condenser analyzer illustrated in Fig. 6-2.

Hence, a fairly good condenser will manifest itself by alternate flashes of the neon lamp, and, in a new, good condenser, the flashes of the lamp may be as much as ten minutes apart. The lower the resistance of the leakage path (the worse the condenser) the more quickly $C1$ charges and discharges, and the more rapidly the lamp will flash. In this manner the "goodness" of a condenser may be estimated by the frequency of the flashes. Poor condensers may flash several times a second. A chart supplied with the instrument indicates permissible rate of flash for good condensers. The reason for the name "relaxation oscillator" is obvious from the theory of operation of the device.

For small values of C_x , say from 0.05 mfd. to 50 mfd., the leakage control switch is set to position 1. This must be done because, for such small capacities, the charging current and leakage currents are too small to charge $C1$ in an appreciable time. The lamp will glow, however, if the condenser is shorted, and it will flash on charge and discharge of the condenser. Under these conditions, the device does not operate as a relaxation oscillator.

Shorted condensers of any value and type will be indicated by a steady glow of the lamp when the leakage-control switch is set in either positions 1, 2, 3, 4 or 5, since a steady current now



Courtesy Tobe Deutschmann Corp.

FIG. 6-2. — The relaxation oscillator type condenser analyzer whose circuit diagram is shown in Fig. 6-1.

flows directly *through* the condenser under test and also through the neon lamp. A condenser of varying capacity is indicated by a change in the flashing rate. Open circuits are shown by the absence of any flash.

Electrolytic condensers are tested with the leakage-control switch in either positions 3, 4 or 5, and the circuit functions merely as an indicator of high leakage current. The controls are set for the rated voltage of the electrolytic condenser under test. As soon as the condenser is connected, a charging current will flow through the resistor connected by the leakage-control switch, and the lamp will glow immediately. But in addition to the charging current, there will be super-imposed the steady current due to the inherent leakage of the electrolytic condenser. This steady current will flow through the leakage-control resistors, causing the neon lamp to remain lit until the leakage current falls low enough so that the voltage across the resistor is lower than the striking voltage of the lamp. In a good condenser, the initial current through the dielectric will be high, but will fall as the voltage applied to the condenser is kept on. It should fall sufficiently for the lamp to remain dark. Too high a leakage current will cause the lamp to remain lighted.

Switch *S*₂, which is ganged to line-switch *S*₁ so that it is

closed when S_2 is opened, is for the purpose of completing the circuit through the rectifier tube so that both condenser C_2 and the condenser under test will discharge automatically through this circuit as soon as the line-switch is flipped to the "off" position, before disconnecting condenser C_2 from the tester. This eliminates any danger of accidental shock to the service man when he removes test clips from the condenser.

6-5. Simple Condenser Test Methods.—A number of other simple condenser test methods which reveal "short" or "open" circuits will be discussed in the section on condenser testing in Chapter XXII. These include ohmmeter tests, neon tube tests, earphone tests, etc.

6-6. Principle of Operation of Capacity Meters. — A simple capacity measuring instrument can be built along the same general lines as the ohmmeter. (Art. 3-13). In this case, however, the reactance of the condenser takes the place of the resistance, a-c of a definite frequency is used for voltage supply

FIG. 6-3. — The fundamental circuit of a simple capacity meter. The a-c milliammeter measures the current flowing through the condenser circuit.

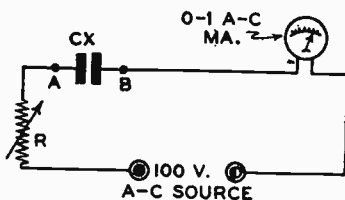

rather than d-c from a battery, and a sensitive a-c meter is employed.

Consider the simple circuit of Fig. 6-3. A condenser whose capacity is to be measured is connected in series with a resistance, an a-c source, and an a-c milliammeter. With points A and B shorted, the resistance R is adjusted so that the a-c meter (a 0-1 ma. d-c meter with a copper-oxide rectifier is convenient for this purpose) reads full scale. When the condenser C_x is connected, its reactance to the flow of current reduces the current and the meter reading. The amount of this reduction depends upon the amount of "opposition" or "reactance" which the condenser offers to the flow of the current through it.

The *reactance* (opposition to a-c current flow) of a condenser may be expressed numerically by the expression

$$X_c = \frac{1}{6.28 \times f \times C}$$

Where, X_c = the capacitive reactance (in ohms).

f = the frequency of the voltage source (in cycles per sec).

C = the capacity of the condenser (in farads).

An inspection of this formula for capacitive reactance reveals that the *larger* the capacity of the condenser, the *lower* is its reactance; likewise, the *smaller* the capacity, the *greater* is the reactance. Hence, in the arrangement of Fig. 6-3, condensers of smaller capacity have higher reactance, allow less current to flow, and so produce lower meter readings than do those of larger capacity. Therefore, since the reading of the meter depends entirely upon the capacity of the condenser, the scale of the meter can be calibrated to indicate the *capacity* of the condenser directly, instead of indicating how much current is flowing. Hence, this simple circuit arrangement can be used for measuring the capacity of condensers, i.e., it is a *capacity meter*—even though it is a very simple one.

6-7. Effect of "High-resistance" and "Leaky" Condensers on Capacity-meter Reading.—Suppose a condenser (whose external terminals are A , B) has a high-resistance joint internally, and is connected to a capacity meter for test, as shown at (A) of Fig. 6-4. The internal resistance of the condenser R_s , then, is in series with the condenser, as shown. Since the effect of this additional resistance is to reduce the amount of current flowing, it is clear that the meter will indicate as though a *smaller* value of capacity were being measured (a smaller deflection will be obtained), since R_s plus the reactance C_s is greater than the reactance of C_s alone.

On the other hand, if the condenser is "leaky", this leakage-path resistance R_s is really between the two sets of plates of the condenser, as shown at (B). Therefore, the meter will indicate as though C_s were *greater* in capacity than it really is, because

R_s and the reactance of C_s in parallel is less than the reactance of C_s alone.

In both these cases the capacity meter may be considered to read condenser *impedance*, rather than reactance alone. Both of

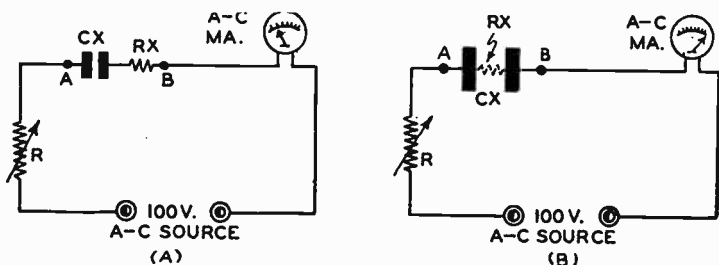

FIG. 6-4.—(A) What happens when a “high-resistance” condenser is connected to a capacity meter. The condenser resistance R_s is in series with the circuit and *reduces* the meter deflection.

(B) What happens when a “leaky” condenser is connected to a capacity meter. The leakage path C_s allows more than normal current to flow through the circuit—resulting in larger than normal meter deflection or “capacity” reading.

these conditions and their effects on the capacity-meter reading should be remembered.

6-8. Calibrating Home-constructed Capacity Meters.—

The calibration of the scale of a home-constructed capacity meter, by the calculation method, is not as simple as is the calibration of an ohmmeter scale. That the calibration of capacity-meter scales is quite involved may be seen from the following typical case.

In the circuit arrangement of Fig. 6-3, in order for the meter to read 1 ma., R must have a value of 100,000 ohms when A and B are short-circuited. For the meter to read half-scale ($\frac{1}{2}$ ma.) the combined *impedance* of C_s and R must be 200,000 ohms. Now, in a-c circuits we cannot add the *reactance* of coils, or condensers, to *resistance* values arithmetically, the way we do with resistances in d-c circuits. The combined opposition to current flow, called *impedance*, of a resistance and a condenser in series is equal to the square root of the sum of the squares of the resistance and reactance. Therefore, in this case $(200,000)^2 = R^2 + X_c^2$, where X_c is the reactance of the condenser. If R is 100,000

ohms, then C_s for a half-scale reading works out to be about 0.00015 mfd. It is evident that the calculation of the capacity values by this method would involve considerable computation if the entire scale of a home-made capacity meter were to be calibrated in this way. This may be avoided by calibrating the scale by connecting various condensers of known values at C_s and noting the reading of the meter in each case.

6-9. How to Construct a Simple Capacity Meter. — Since service men often desire to construct their own test instruments, descriptions of two simple but exceedingly useful capacity meters for home-construction will be presented here. The first one is for testing condensers over a range from 0.001 to 3 mfd. in two ranges, and can be used to test all solid-dielectric type condensers that are within these limits of capacity. In other words, the meter will test for capacity practically every paper type condenser used in the present-day radio receiver, and will also test some of the mica-type condensers to be found in such sets. It cannot be used to test electrolytic condensers. These may be tested by the special capacity meter described in Art. 6-10.

As will be seen from the circuit diagram, the source of voltage is the 110-volt 60-cycle a-c line. The meter used is a 0-1 ma. d-c milliammeter in conjunction with an external copper-oxide rectifier—or a self-contained 0-1 copper-oxide type a-c milliammeter may be employed.

The theory of this capacity test unit, whose schematic circuit diagram is shown in Fig. 6-5, is the simple one of applying a known voltage to the condenser and measuring the amount of current that flows through its circuit. By referring to a previously made calibration chart, the value of the capacity may be read. When the range switch is in either the upper or the lower position, the circuit consists of the voltage source, condenser under test, milliammeter, and resistor R_1 or R_2 , all in series with each other. The meter is shunted by resistor R_3 and R_4 —depending upon the position of the switch.

The two variable shunt resistances R_3 and R_4 are employed to obtain a full-scale reading of the meter when the test terminals are shorted. They are adjusted as follows: with the in-

strument connected to 110 volts a-c and the range switch in the desired position, the high or low zero-adjuster, that has been first turned to its *lowest resistance value*, is increased slowly with the test terminals shorted, until the meter reads full scale.

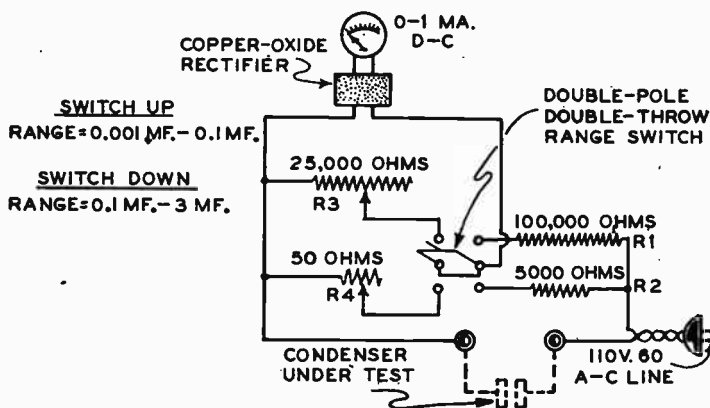

FIG. 6-5.—Schematic circuit diagram of a capacity meter having a range from 0.001 to 3 mfd. This meter tests paper and mica type condensers only.

Resistors R_1 or R_2 need not be accurate, since the instrument must be calibrated by the user after it has been constructed. This may be done most easily by connecting various condensers of known capacities to the instrument and recording the meter reading in each case. A calibration graph can be drawn for these values, so that the capacities corresponding to these or any intermediate meter readings may be found easily at any future time.

6-10. How to Construct a Capacity Meter for Electrolytic Condensers.—It is often necessary or desirable actually to measure the capacity of electrolytic condensers. This problem is not so simple a matter as measuring the capacity of an air dielectric condenser, or of mica or paper-type condensers. Since the capacity meter whose circuit is shown in Fig. 6-6 is simple, does not require costly apparatus, and measures the capacity of this type of condenser accurately, it is desirable for home construction. The circuit and all information pertaining to it are presented here through the courtesy of the *Aerovox Corporation*.

A complete description of it follows:

This capacity meter consists essentially of an a-c step-down transformer developing a secondary voltage of about 6-volts. Across its secondary is placed, in series with a switch, a 0.7 ohm resistor to im-

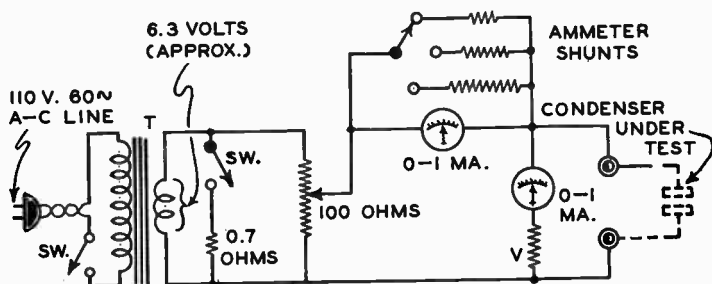

FIG. 6-6.—Schematic circuit diagram of a capacity meter designed especially to measure the capacity of electrolytic condensers. The design of this meter is such that it may be constructed easily by radio service men.

prove the regulation by providing a load for the transformer to work into. The 100-ohm potentiometer permits adjustment of the voltage to be applied to the condenser under test.

The meters are both Weston 1-milliamper a-c meters of the copper-oxide type, one reading voltage and the other milliamperes (1.0 ma. full scale). Various shunts are provided for reducing the sensitivity of the ammeter for measuring condensers of various capacities. In measuring large capacities, the loading resistor across the secondary of the transformer is removed to permit sufficient voltage to be impressed across the capacity. This is necessary due to the poor regulation of the transformer (which may be the type ordinarily used to supply power to light the heaters of 6.3-volt automotive type tubes).

In practice the voltage across the condenser is set at exactly 2.65 volts. Then the reading in milliamperes will be equal to the condenser capacity in microfarads.

The following table gives the values of shunting resistance to be used across the ammeter for various capacity ranges.

AMMETER SHUNTING RESISTORS

| Capacity Range (Mfd.) | Shunt Resist. (Ohms.) | Capacity Range (Mfd.) | Shunt Resist. (Ohms.) |
|-----------------------|-----------------------|-----------------------|-----------------------|
| 10 | 1,149.0 | 3 | 317.2 |
| 100 | 106.7 | 30 | 31.5 |
| 1,000 | 11.55 | 300 | 3.6 |
| 10,000 | 1.05 | 3,000 | 0.34 |

Total voltmeter resistance—5,430 ohms.

All the shunts (except the 1.05- and 0.34-ohm units) are of the variable type—although they are shown as “fixed” resistors in the diagram.

This test instrument will prove very useful in testing electrolytic condensers of practically any capacity and will give reasonably accurate results provided the unit is carefully constructed. Of course, among the most important parts are the shunt resistances across the milliammeter, for the accuracy obtained will depend almost entirely on how carefully these shunt resistors are made. It is desirable that the resistance of the meter used be measured to determine its resistance, although for general service, shunts of the value indicated will be satisfactory.

One of the advantages of this instrument, of course, lies in the fact that the *reading in milliamperes is equal to the capacity in mfd.* That this is true can be seen from the following.

The a-c current in amperes flowing through any condenser having negligible resistance is equal to

$$I = \frac{E}{X_c} = \frac{E}{\frac{1}{2 \times 3.1416 \times f \times C}} = 6.28 \times E \times f \times C$$

Where, E = Applied a-c voltage (volts)

f = Frequency in cycles per second

C = Capacity of the condenser (in farads)

If the frequency is 60 cycles (that of the ordinary a-c electric light circuit), this reduces to

$$I = 6.28 \times E \times 60 \times C = 377 \times E \times C$$

In terms of mfd. and milliamperes, the current is equal to

$$I_{ma.} = 377 \times E \times C_{mfd.} \times 10^{-3}$$

If, now, the scale reading in milliamperes is to be equal to the capacity in mfd.,

$$I_{ma.} = C_{mfd.} \text{ or } \frac{I_{ma.}}{C_{mfd.}} = 1$$

Substituting this in the foregoing equation, we obtain

$$1 = 377 \times E \times 10^{-3}, \text{ or } E = \frac{1}{377 \times 10^{-3}} = \frac{10^3}{377} = \frac{1,000}{377} = 2.65 \text{ volts}$$

The last equation indicates that when the voltage is equal to 2.65 volts then the current in milliamperes is equal to the capacity in mfd., that is, any reading in *milliamperes* on the meter will be equal to the capacity in *mfd.*

This method of measurement is, of course, in error slightly due to the fact that the impedance of a condenser is not exactly determined by its capacity but is determined by its capacity and its internal (series) resistance (see Art. 6-7). However, the error involved is not large and the method therefore is generally satisfactory.

6-11. “Readrite” No. 850 Capacity Meter-Tester.—This

simple, interesting instrument, shown in Fig. 6-7, represents a typical low-priced commercial capacity meter-tester. It is a dual instrument, employing two meters, and is capable of measuring the capacity of solid-dielectric condensers directly, and testing



Courtesy Readrite Meter Works

FIG. 6-7.—A typical inexpensive capacity meter designed to measure the capacity of solid-dielectric condensers and to indicate the condition of electrolytic condensers. Its schematic circuit diagrams are shown in Figs. 6-8 and 6-9. (Readrite Model 850.)

the condition of electrolytic condensers by measuring their leakage current.

One portion of it is employed to read, directly, the capacity of paper- or mica-type condensers in two ranges, from 0.008 to 0.5 mfd. and from 0.25 to 10 mfd. The circuit diagram of this portion of the instrument is shown in Fig. 6-8. It is evident that it is merely a simple series circuit with the 100-140-volt a-c line-supply in series with meter and condenser C_x under test, so that the meter really measures the current flowing in the condenser circuit—which is a function of the *capacity* of the condenser (Art. 6-6). A 100-volt a-c meter is used in making these tests. It is the meter at the right in Fig. 6-7. Line-voltage variations are compensated by the adjustable 3,000-ohm rheostat. This rheostat is first adjusted for full-scale deflection of the meter by

short-circuiting the two test terminals *T-T*. The "HI" range is obtained by flipping the toggle switch *S*. This shunts the 2,500-ohm resistor across the meter, providing a by-pass for a definite proportion of the current.

Electrolytic condensers are tested by measuring their leakage current with the circuit arrangement shown in Fig. 6-9. The me-

FIG. 6-8.—Schematic circuit diagram of the portion of the capacity meter of Fig. 6-7 which is used for testing solid-dielectric condensers from 0.008 to 10 mfd. in two ranges, and indicating their capacity directly.

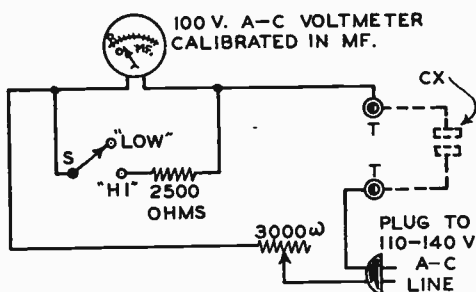

ter employed in this case is a 0-25-100 ma. d-c instrument, also calibrated for a voltage range of 500 volts.

The high voltage necessary for the leakage test of electrolytic condensers may be obtained in either one of the following interesting ways with this instrument.

(1): They may first be removed from the set and tested with a source of voltage supply taken from the plate circuit of a power tube in the set. A convenient plate-voltage connection may be made by clipping the *red* wire (above the d-c meter, see Figs. 6-7 and 6-9) to the power choke circuit, and the *black* wire (also above the d-c meter) to the B-minus of the same plate circuit. The B-terminal is the center-tap of the high-voltage secondary and in many sets is grounded to the chassis. The condenser is connected to the two tip jacks just below the d-c meter. The tip of the spare red wire is placed in the "positive" (+) jack and clipped to the condenser *anode* (center terminal). The spare black wire lead connects in the other jack and is clipped to the can of the condenser. This method may be used for testing either new or used electrolytic condensers which are *not* already installed in any radio set, or for testing set condensers after they have *first* been removed from the set.

(2): To test electrolytic filter condensers *without removing them from the radio set*, the service man may also use the convenient method of applying the high-voltage d-c set power (which in this case is already connected to the condenser to be tested).

To do this, the connection wire to the *anode* of the condenser is removed first. This wire should be clipped to the red wire of the tester (this is the wire with the clip, above the d-c meter). The spare red lead is clipped to the anode terminal of the condenser, putting its tip-jack terminal into the positive (+) tip-jack just below the d-c

meter. No other connections are made to the tester, and the other two black leads are not used.

After test voltage is obtained by either of the connection arrangements just described, the actual test of the electrolytic condenser is carried out as follows: (It will prove instructive for the reader to trace out the complete circuit connections for each position of the 3-section switch).

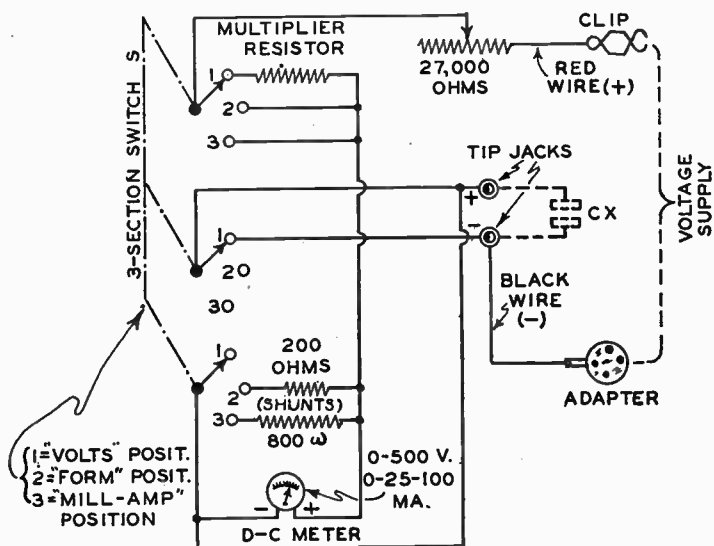

FIG. 6-9.—Schematic circuit diagram of the portion of the capacity meter of Fig. 6-7 which is used for testing electrolytic condensers by measuring their leakage current.

First, the 3-section selector switch *S* is placed in the "VOLTS" position, as shown in the illustration above. This connects the meter directly across the voltage source, with the multiplier resistor and the 27,000-ohm resistor in series. The 27,000-ohm rheostat is now adjusted until the meter reads 300 volts.

The selector switch is now placed in the "FORM" position. This connects the 200-ohm shunt across the meter, so that it now becomes a 100-ma. range milliammeter. The voltage source, 27,000-ohm resistor, meter and condenser under test are now all in series. The "forming" process will start with the meter needle near full-scale and be completed when the needle recedes to zero, or near zero. Electrolytic condensers which are inoperative or leak badly will not form properly. If, after leaving it in the circuit from 10 to 15 minutes, no indi-

cation of forming can be seen, the condenser is judged to be inoperative, and no further tests need be made. New electrolytic condensers, or those which have been out of use for 2 weeks or more, require about 15 minutes time to form properly.

The selector switch is next placed in the "MILL-AMPS" position. This puts the 800-ohm shunt across the meter so it now becomes a 25-ma. milliammeter. Otherwise, the circuit is the same as for the "FORM" position of the switch. The leakage current is now read directly on the low-scale of the meter. A good dry electrolytic filter condenser should show a leakage current of *no more than 0.6 ma. per mfd.* when tested at its normal operating voltage, (see Art. 22-35 in Chapter XXII). Either a higher, or a fluctuating, reading indicates that the condenser is not normal, and should be replaced.

It will be well at this point to correct some erroneous ideas concerning permissible leakage in electrolytic condensers. The limit given above (a maximum of 0.6 ma. per mfd. when tested at normal operating voltage) represents an average figure. The question of how much leakage is permissible in an electrolytic filter condenser depends upon several factors in the design of the receiver. Some receivers require much more complete filtration of the plate and screen supply voltages than others do, in order to provide operation without objectionable hum. In general, receivers which are capable of reproducing the low audio frequencies require more perfect filtering than those which do not. Also in some receivers, the load on the rectifier tube and filter chokes is already so great that additional load caused by excessive leakage in one of the filter condensers may increase the hum greatly.

No provision has been made on this tester for the possibility of the condenser being short-circuited. If a "shorted" condenser should be connected to the instrument, the meter needle will be thrown violently off scale. If this occurs, the selector switch should be set at the "Volts" position immediately, for protection. As such a condenser may cause serious injury to the meter, all condensers should first be checked for a possible short-circuit with an ohmmeter, before applying the leakage test.

6-12. "Weston" Model 664 Capacity Meter.—There are many types of capacity meters available, some incorporating every modern advance known, and enabling very low to very high values of condenser capacities to be measured with a satisfactory degree of accuracy.

The instrument now to be described is designed for a wide range of capacity and a-c voltage measurements, and is very suitable for the requirements of radio servicing. Through the use of a sensitive 250-microampere rectifier-type meter, and a selec-

tor switch to connect the various multiplier and shunt resistors for each range, the following ranges of measurements are possible: 0.0001 to 0.02, 0.01 to 0.2, 0.1 to 2, 1 to 20, and 10 to 200 microfarads: a-c voltmeter ranges of 4, 8, 40, 200, 400, and 800 volts, at 1,000 ohms-per-volt. When any of the low a-c voltage



Courtesy Weston Elect. Instr. Corp.

FIG. 6-10.—A typical commercial capacity meter which is designed to measure a large range of capacity and a-c voltage. Its schematic circuit diagram is shown in Fig. 6-11. (Weston Model 664.)

The instrument is first connected in series with suitable resistance to bring it to 4 volts full scale; it is then shunted as required, for the higher ranges. For measuring electrolytic condensers up to 200 mfd., the instrument is adjusted to 100 ma. and functions at 4 volts a-c tapped from the small power transformer. This low value of a-c voltage does not seem to do any damage to electrolytic condensers, and no polarizing voltage is apparently needed. The scale is shown in Fig. 6-12, and will be seen to be remarkably uniform over a good portion of its length.

The high range to 200 microfarads is obtained by switching to a position marked, " $\times 10$ "; the direct position adjusts the instrument to 10 milliamperes full scale. The position marked, " $\div 10$ ", calibrates the instrument to 1 milliampere, still maintaining the 4 volts. The position marked, " $\div 100$ ", removes the shunts so that the instrument functions at $\frac{1}{4}$ milliampere sensitivity and the 10-volt transformer tap is

ranges are connected (through a series condenser) from the plate of an output tube to ground, they provide a sensitive output meter which can be used when aligning the tuned stages of a radio receiver with an oscillator. The instrument is illustrated in Fig. 6-10. Its complete schematic circuit diagram is shown in Fig. 6-11, and a reduced facsimile of its scale is shown in Fig. 6-12. In view of the extensive service this instrument is capable of rendering, it might well be compared with the Model 663 volt-ohm-milliammeter described in Art. 5-8. Since the measurements made are fundamental, the instruments are not likely to become obsolete.

brought into play. The position, $\div 1,000$, is the highest sensitivity of $\frac{1}{4}$ milliamperes and 100 volts. This is used only for small fixed condensers. With this range it will be noted that the center point on the scale is 0.004 mfd. The first main division is 0.001 mfd. or 1,000 micro-microfarads. This is divided into 10 parts so that the first small

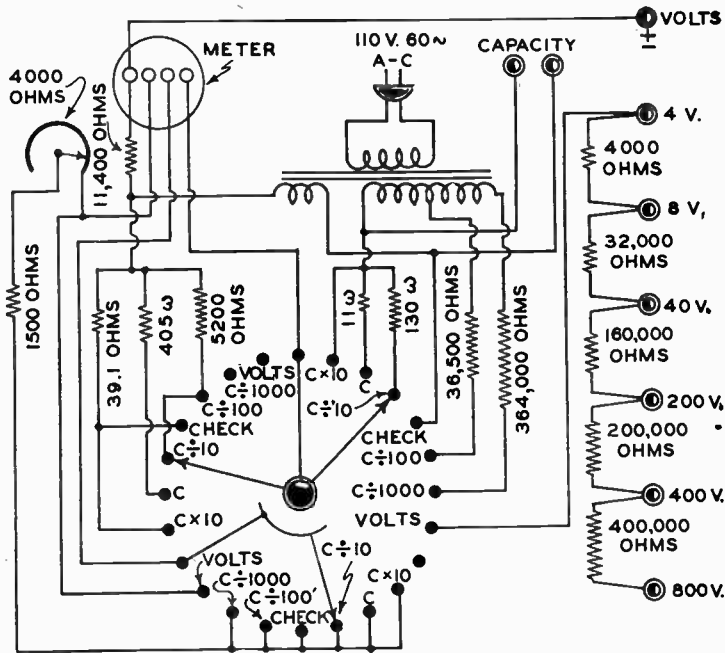

FIG. 6-11.—The schematic circuit diagram of the capacity meter illustrated in Fig. 6-10. Notice the terminals at the right for voltage measurements. Its scale is shown in Fig. 6-12.

division is 100 micro-microfarads. A capacity as small as that of an ordinary 23-plate tuning condenser gives a readable indication.

In general, capacity readings are most accurate when taken between 1 and 10 on the microfarad scale, and the range selected is chosen with this fact in mind.

A-C voltages are measured by turning the switch to the left to the position marked "VOLTS." The test leads are then connected to the voltage jacks for the range desired, and the instrument will read full scale according to the jack markings.

For the measurement of capacity, the instrument is plugged into any convenient 110-volt 60-cycle a-c outlet. The selector switch is then rotated to the "CHECK" position and the "LINE ADJUSTER" is varied until the meter pointer indicates exactly full scale. The test leads are then placed in the "CAPACITY" jacks and the selector

switch is turned to the desired range. The impedance of the condenser being greater than the short-circuit, the meter indicates less than full scale by an amount depending on the capacity of the condenser. Obviously, short-circuited condensers will indicate "full scale" and open-circuited condensers will indicate "zero".

It is interesting to note that in this instrument the manufacturer applies a low a-c voltage for the measurement of high-

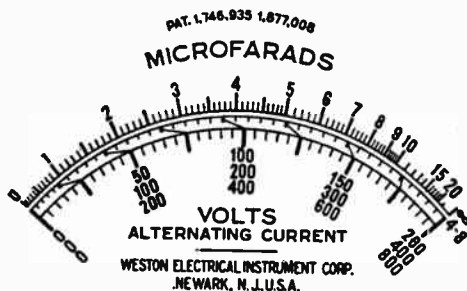

FIG. 6-12.—Reduced facsimile reproduction of the scale of the capacity meter shown in Figs. 6-10 and 6-11. Notice the fairly uniform division spacings.

capacity electrolytic condensers. It is claimed that when an a-c voltage as low as 4 volts is applied to electrolytic condensers under test, it does not seem to do any damage to them—and no polarizing voltage is needed.

REVIEW QUESTIONS AND PROBLEMS

1. State four tests which may be made on an electrolytic filter condenser.
2. Explain what each of the four tests of Prob. 1 would reveal concerning the condition of the condenser.
3. Explain how a measurement of the capacity of a solid dielectric type condenser also reveals whether or not it has an internal high-resistance joint.
4. What is the difference between the function performed by a "capacity meter" and that performed by a "capacity tester"?
5. (a). What is a "relaxation oscillator"?
(b). How does it work?
6. Can a relaxation oscillator be used for testing both electrolytic and solid-dielectric type condensers?
7. How can you tell by means of a relaxation-oscillator type condenser tester when a solid-dielectric type condenser is: (a) normal; (b) "shorted"; (c) "open"; (d) leaky? Explain!
8. Explain the principle of operation used in most portable capacity meters.

9. Explain how you would calibrate the scale of the home-constructed capacity meter described in Art. 6-9, telling just what size "known" condensers you would employ.
10. Draw three separate circuit diagrams showing the simplified circuit which exists in the capacity meter of Fig. 6-9 when the switch S is in; (a) the "VOLTS" position; (b) the "FORM" position; (c) the "MILL-AMP" position.
11. Explain the operation of the individual circuits drawn in Prob. 10.

CHAPTER VII

OUTPUT METERS & VACUUM-TUBE VOLTMETERS

7-1. Why Output Meters are Needed.—When making certain adjustments or tests upon radio receivers and amplifiers, it is often necessary to know exactly how much output the receiver, or amplifier, is producing—that is, a *quantitative* indication of the output is required. Possibly the most common instance of this occurs during the alignment of the tuned stages of t-r-f and superheterodyne receivers (see Chapters XXIV and XXV). In this work, the person doing the aligning changes the settings of the trimmer adjustments one at a time, in the proper sequence, stopping in each case when the receiver output has been brought up to a maximum value (“peaked”). Naturally, he must have some accurate way of telling when the receiver output is *maximum*, so that he can leave the trimmer adjustment fixed at this point.

At first thought, one might suppose that it would be possible to judge accurately just when the output of a receiver, or an amplifier, has been brought up to the maximum value, simply by listening to the sound issuing from the loudspeaker, as shown in Fig. 7-1, and judging by ear when it is loudest. While it is possible to do this, the results are not very accurate, for the simple reason that the human ear cannot accurately detect small changes in the loudness of a sound. Because of this, it is possible to vary considerably the settings of the individual “trimmer” adjustments on most receivers before any noticeable change results in the loudness of the sound from the loudspeaker. Obviously, this would not produce very accurate alignment. What is needed is some sensitive meter or indicating device (as shown in Fig.

7-2), which will produce an easily detectable change in reading for very small changes in receiver output. Several forms of instruments of this kind have been developed, and will be studied. All of them come under the general heading of "output meters".

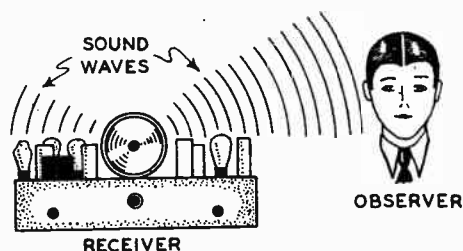
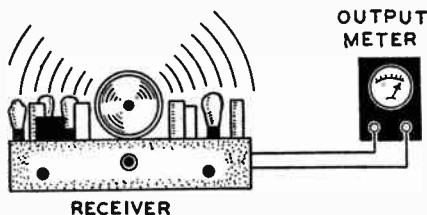

FIG. 7-1.—The "ear" method of judging the intensity of the output of a radio receiver or amplifier. This is an inaccurate method, for the human ear is relatively insensitive to small changes in the loudness of a sound.

They really indicate the *signal voltage* output of the receiver or amplifier to which they are connected.

Output meters find another very important use in public address systems where they are employed to indicate the output of the amplifiers so that the operator may maintain the output constant at some desired level during operation. When used for

FIG. 7-2.—Judging the intensity of the output accurately by means of a suitable form of "output meter".



this purpose, their scales are calibrated in "decibels", and they are often called "power level meters" (see Fig. 7-5).

7-2. Choice of Instrument for "Meter-type" Output Meters.—Since the purpose of an output meter is merely to measure or indicate *voltage*, it is natural that we should expect to use a voltage-measuring meter for this purpose. Indeed, "meter-type" output meters form the most common class of output meters used by radio service men.* We shall first study their construction, before considering such other forms as crystal-detector

*NOTE: Another important form of output indicator, the Cathode-ray Oscilloscope, will be described in detail in the last half of Chapter XXV. This gives a *visual picture* of the receiver output.

output meters, tube-rectifier type output meters, vacuum-tube voltmeters and cathode-ray oscilloscopes (see Chapter XXV).

Since the voltage to be measured in the output circuit of an audio amplifier, or radio receiver, consists of rapid pulsations at audio frequencies, an ordinary d-c meter cannot be utilized (see Art. 2-26). The movable-iron type a-c voltmeter is also unsuited for this purpose, because the voltages and power involved are of quite small magnitude and this type of meter would absorb a comparatively large proportion (see Art. 2-28) of the small power available, since too much current is required for the operation of the meter in this type

of circuit. In addition, the low-frequency movable-iron type a-c meter cannot be employed to accurately measure voltages whose frequencies lie in the audio range; furthermore, its low-resistance usually disturbs, appreciably, the total resistance of the circuit to which it is connected.

It is apparent that the output meter must not only be capable of accurately measuring audio-frequency a-c voltages, but must consume very little current itself. To meet these requirements, the "meter type" of output meter employs a copper-oxide

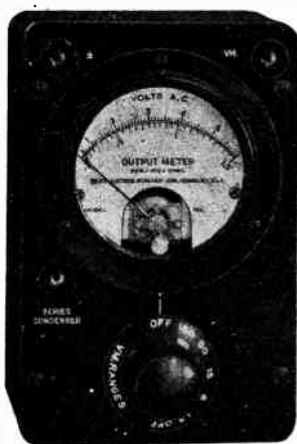

Courtesy Weston Elect. Instr. Corp.

FIG. 7-3.—A typical "meter type" output meter. Its circuit diagram is shown in Fig. 7-4. (Weston Model 571.)

rectifier-type a-c voltmeter. This type of voltmeter, as explained in Arts. 2-30 and 2-35, retains the advantages of a sensitive d-c movable-coil instrument for measuring low a-c voltages and currents (such as are present in radio receiver output circuits) by employing a copper-oxide type rectifier to rectify the a-c, and measuring the resulting rectified current with a sensitive movable-coil type d-c meter whose energy consumption is very low.

7-3. Typical "Meter-type" Output Meters.—The con-

struction of "meter-type" output meters is so simple, that all the knowledge we need to have about them can be gained from a study of the circuit diagrams and descriptions of the following typical commercial copper-oxide type meters of this kind. Be-

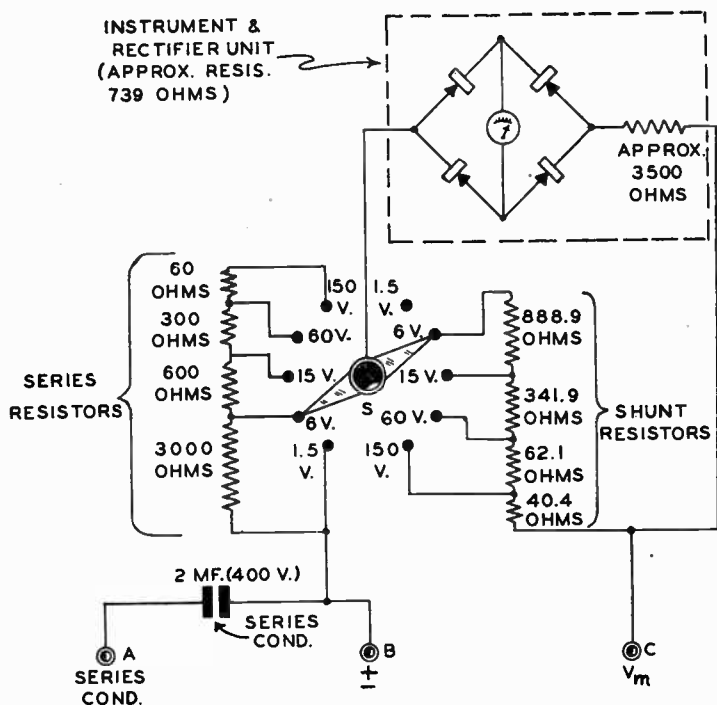

FIG. 7-4.—The schematic circuit diagram of the output meter illustrated in Fig. 7-3. Five voltage ranges may be selected by the knob which controls the selector switch *S*. The impedance remains constant at 4,000 ohms.

sides these separate units, output meters are built-in as integral parts of some commercial test oscillators and set analyzers.

Weston Model 571 Output Meter: This instrument consists essentially of a five-range copper-oxide rectifier-type voltmeter enclosed in a bakelite case, as shown in Fig. 7-3. Its circuit diagram is shown in Fig. 7-4. Voltage ranges of 1.5, 6, 15, 60, and 150 volts are obtained by the dual-selector switch *S*. As one side of this switch connects less and less resistance in

shunt with the instrument movement and rectifier unit to provide the higher voltage ranges, the other side simultaneously, and automatically, adds the proper amount of resistance in *series* with the instrument. These shunt and series resistance steps are so proportioned, that the total impedance of the meter (between terminals *B* and *C*) remains constant at 4,000 ohms, no matter which range of the instrument is being used. All the resistances



Courtesy Weston Elect. Instr. Corp.

FIG. 7-5. — A typical power level meter and voltmeter. The scale is calibrated to read the voltage, and also the power level in decibels. Its schematic circuit diagram is shown in Fig. 7-7. (Weston Model 695.)

are non-inductively wound. Thus, the complete output meter presents a constant non-inductive load of 4,000 ohms to any circuit to which it may be connected, regardless of which voltage range is being used.

Since the impedance of the instrument is constant for all ranges, and the output voltage is measured and indicated on the scale directly, it is an easy matter to calculate the actual *power* output of the radio receiver or amplifier to which the output meter may be connected. Since the meter presents a constant non-inductive load of 4,000 ohms, we have:

$$P = E \times I = E \times \frac{E}{R} = \frac{E^2}{R} = \frac{E^2}{4,000}$$

where P =power in watts.

E =voltage reading on the meter.

This simple method of calculating the power is often very convenient.

As will be seen from Fig. 7-4, the meter is also provided with a self-contained 2-mfd. condenser, which automatically connects in series with the circuit when terminals *A-C* are used.

The use of this condenser will be explained in Art. 7-5 when the methods of connecting output meters are considered.

Weston Model 695 Power Level Meter and Voltmeter:
This instrument, shown in Fig. 7-5, is a combined voltmeter and

FIG. 7-6.—Facsimile reproduction of the multi-range voltage and decibel scale of the meter illustrated in Fig. 7-5.

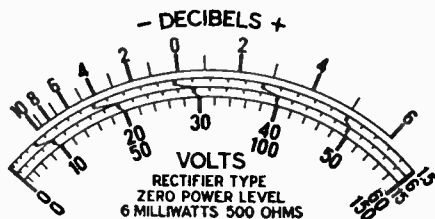

output meter designed especially for power level measurements on both radio receivers and sound amplifier equipment when the readings are desired in decibels. Its schematic circuit dia-

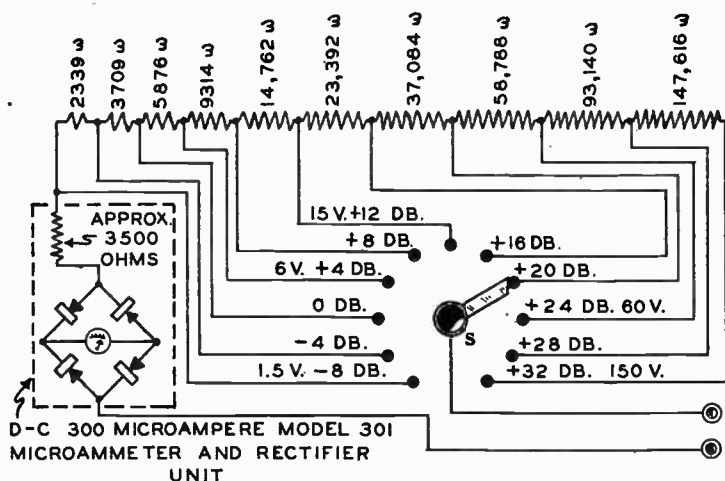

FIG. 7-7.—The schematic circuit diagram of the power level meter illustrated in Fig. 7-7.

gram is shown in Fig. 7-7. A facsimile of its multi-range scale is reproduced in Fig. 7-6.

An inspection of the circuit diagram shows that the meter consists essentially of a copper-oxide rectifier-type multiple-range voltmeter. It provides voltage ranges of 1.5, 6, 16, 60 and

150 volts and -8 , -4 , 0 , $+4$, $+8$, $+12$, $+16$, $+20$, $+24$, $+28$ and $+32$ decibels, selected by means of a marked dial-switch. Its resistance is 2,667 ohms-per-volt, or 4,000 ohms *total* on its lowest range, and 400,000 ohms *total* on its highest range when used as a voltmeter.

As a power level meter, the instrument, which is bridged across the load, is calibrated to read directly the power level in *decibels* above or below 6 milliwatts for a 500-ohm load—or a total spread of 56 DB. A chart on the back of the instrument is furnished to give the corrections to be made to the decibel readings if loads of any resistance from 5 to 50,000 ohms are used, considering 6 milliwatts as the zero power level. All of the resistances in the meter are non-inductively wound.

7-4. Uses for Output-Meters. — Since the copper-oxide meter type output meter is accurate over the usual range of audio frequencies, it is very useful for measuring the signal voltage output; computing the power output of radio receivers; determining the gain or amplification when “lining up”, “neutralizing” or “aligning” the r-f or i-f stages of radio receivers; comparing the amplification produced by several radio tubes; measuring the comparative selectivity of r-f tuners; determining the amplification produced by an amplifier or radio receiver when a known calibrated input voltage is applied to the input of the amplifier or receiver; observing the period or per cent of fading; to set or keep the volume of public address or sound projection equipment at an approximately constant level, etc. Of course, the output meters which have their scales calibrated directly in decibels instead of volts have a distinct advantage in power-level measurements.

7-5. How to Connect “Meter-type” Output Meters. — In order to use a “meter-type” output meter for indicating the signal output when making adjustments or tests upon a radio receiver, the output meter may be connected to the receiver in any one of several ways, depending upon the type of output stage and the type of loud speaker in the receiver. Each of the various common arrangements will be considered in turn.

(1). **Single-tube Output Stage Feeding Dynamic Speaker:** Where a dynamic speaker is employed, there are two common circuit arrangements: either the receiver uses a single-tube output, or it uses two

output tubes in push-pull. The single-tube output arrangement will be considered first.

Perhaps the most convenient place to connect the output meter, in this case, is *directly across* the terminals of either the voice coil or the secondary terminals of the output transformer (whichever are most accessible). However, this arrangement will give a rather low reading on the output meter, and changes in output signal voltage are not easily noted.

A much greater deflection may be obtained by connecting the output meter from the "plate" terminal of the output tube to "ground", in series with a condenser, as shown in Fig. 7-8. The deflection will

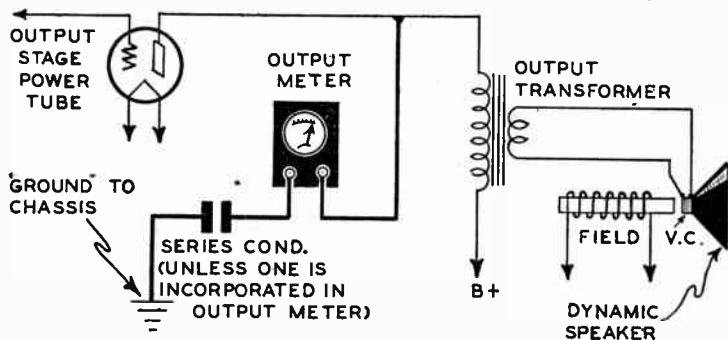

FIG. 7-8.—How an output meter may be connected to a receiver which employs a single-tube power output stage and a dynamic loud speaker.

be almost 20 times as large as when it is connected across a low-impedance voice coil. (The exact increase depends upon the ratio of the output transformer windings). The series condenser, which may be of any value between about 0.1 mfd. and 2 mfd., prevents direct current from flowing through the output meter, and permits only the alternating, or pulsating, component of the signal voltage to be measured. Most commercial output meters already contain a built-in series condenser (see Fig. 7-4) for this mode of application.

The connection of Fig. 7-8 may be made by turning the receiver chassis upside down, and connecting a wire from the output meter to the "plate" terminal of the power tube socket. Instead of disturbing the chassis, an ordinary "plate-lead adapter" may be utilized to make connection to the "plate" prong of the power tube. In this case, the power tube is first removed from its socket, and the tube prongs are placed into this adapter—the lead of which is connected to one terminal of the output meter. Now the tube (with the adapter on) is inserted back into its socket. Then the other terminal of the output meter is connected properly. The circuit connections are again the same as shown in Fig. 7-8.

(2). **Push-pull Output Stage Feeding Dynamic Speaker:** In the case of receivers employing a push-pull output stage, the output meter may be connected directly across the terminals of the voice coil or the secondary terminals of the output transformer (whichever are

most accessible), as shown in Fig. 7-9. However, as explained in the previous section, this arrangement will give a rather low reading on the output meter and changes in the output signal voltage are not easily noted.

The output meter may also be connected across the "plate" terminals of both output tubes, by slipping a "plate-lead" adapter over

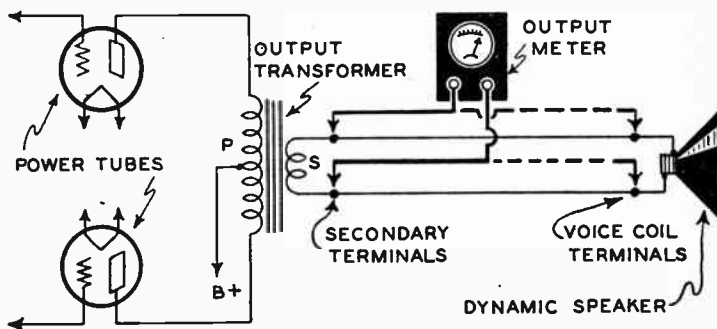

FIG. 7-9.—One possible way of connecting an output meter when the receiver employs a push-pull output stage. The arrangement shown in Fig. 7-10 is preferable to this one, however.

the "plate" pins of each of the push-pull tubes, but the deflection will not be very great.

A much greater deflection will be obtained by connecting the output meter from the "plate" terminal of either of the output tubes, to "ground" through the series condenser (which may already be incorporated in the output meter), as shown in Fig. 7-10.

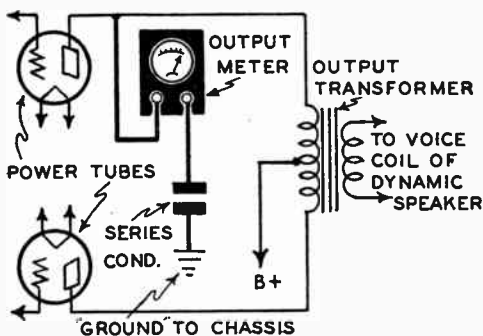

FIG. 7-10.—Preferable way of connecting an output meter when the receiver employs a push-pull output stage.

(3). **Single-tube Output Feeding Directly into Magnetic Type Speaker:** If output indications are desired on receivers in which a single-tube output stage feeds directly into a magnetic type loud speaker (without any coupling device between), the output meter (with a 2-mfd. series condenser) should be connected directly across the terminals of the speaker, as shown in Fig. 7-11. This is per-

missible since the magnetic speaker usually has a high impedance—around 4,000 ohms.

(4). **Single-tube Output Feeding Magnetic Speaker Through Coupler:** In many receivers in which magnetic speakers are employed, a coupling device, which may be in the form of an output transformer, or a choke-condenser filter, is connected between the out-

FIG. 7-11. — How an output meter should be connected in cases where a single power output tube feeds a magnetic speaker without a coupling device between them.

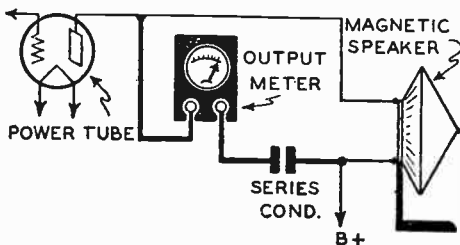

put tube and the magnetic speaker, to prevent the direct plate current from passing through the windings of the speaker. In cases of this kind, it is best to connect the output meter (in series with its 2-mfd. blocking condenser), from the "plate" terminal of the output tube to "ground". The arrangement to be employed when an output transformer is used in the receiver is shown at (A) in Fig. 7-12. When the receiver has a choke-condenser speaker filter, the arrangement shown at (B) is used.

(5). **Push-pull Output Stage Feeding Magnetic Type Speaker:** When a receiver has a push-pull output stage feeding into a magnetic

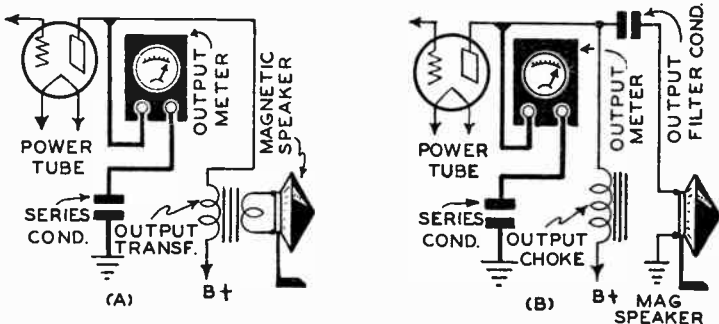

FIG. 7-12.—(A). How an output meter should be connected in a receiver having a single output tube feeding into a magnetic speaker through an output transformer.

(B). How the output meter should be connected if the receiver employs a condenser type output filter.

speaker, the output meter should be connected in the same way as was recommended for case (2), see Fig. 7-10.

Loud Speaker Color Code: In order to facilitate the tracing of connections to dynamic speakers in receivers employing the RMA standard dynamic speaker color code, this color code should be studied.

It will be found in the author's *Radio Trouble-Shooter's Handbook*.

Most meter-type output meters are made with a constant impedance of 4,000 ohms because the standard loud speaker (or output transformer primary impedance when the speaker is connected across the secondary), is the radio receiver output impedance during normal operation, and is also approximately 4,000 ohms in many cases.

In cases where the required output impedance of the tube is greater than 4,000 ohms, additional resistance should be connected in series with the output meter in order to bring the total load impedance to that required by the tube. Thus, a certain tube may require 7,000 ohms load; then 3,000 ohms must be connected in series with the output meter.

7-6. Crystal-detector Output Meters. — So far as most audio output comparative measurements which he may make are concerned, the radio service man is interested in the *relative* output signal intensity rather than in the exact numerical values of voltage or power output. For this type of work, it is not really essential that the output meter be of the calibrated, copper-oxide rectifier type, although a numerical calibration is convenient.

It is possible to construct a fairly good, inexpensive indicating instrument, to be used as an output meter for determining arbitrary values or changes in signal voltage during "aligning", etc.,

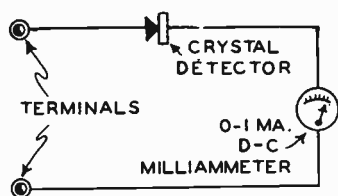

FIG. 7-13.—A simple output meter consisting of a crystal detector and a 0-1 d-c milliammeter.

by connecting a 0-1 ma. d-c milliammeter in *series* with a crystal detector, preferably of the "fixed" carborundum type, as shown in Fig. 7-13. The crystal detector rectifies the a-c so that the current flowing through the d-c meter is unidirectional.

The terminals of the combination may be connected directly across the voice coil of the dynamic speaker in the receiver, or across the secondary winding of the output transformer (see Fig.

7-9). When it is possible to disconnect the output transformer, or where the loud speaker is of the magnetic type, the crystal-detector output meter may be coupled to the output circuit of the receiver, as shown in Fig. 7-14, by means of its own coupling transformer, to prevent excessive current from damaging the

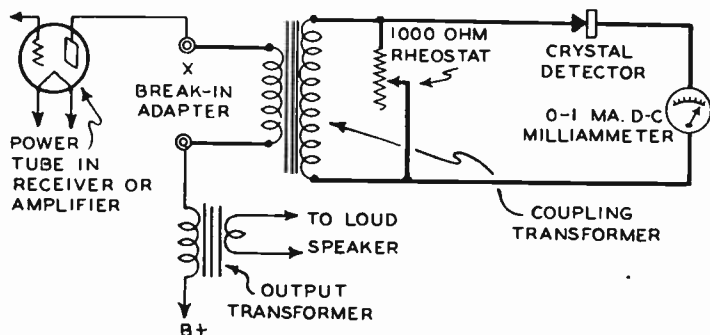

FIG. 7-14.—A coupling transformer and current-limiting resistor have been added to the simple crystal detector output meter of Fig. 7-13. A break-in adapter is used to break into the plate circuit of the output tube of the receiver.

crystal. A 1,000-ohm rheostat is shown shunted across the secondary of the transformer, to keep the signal indications within the range of the meter—preferably near the center of the scale.

By employing a "plate circuit break-in adapter", neither the output transformer nor magnetic speaker wires need be disturbed. The output tube, or one of the push-pull output tubes, is removed from its socket and placed into the adapter which has been inserted into the tube socket. The terminals of the instrument are connected to the adapter terminals, as shown. The crystal rectifies the a-c signal voltage present in the secondary circuit of the transformer, just as it rectifies a radio signal, so that the current flowing through the d-c meter is unidirectional and will cause the d-c meter to read "average" values.

Another crystal-detector output meter arrangement is shown in Fig. 7-15. Here, a 0-1 ma. d-c milliammeter is employed as a 1,000 ohms-per-volt voltmeter (by means of the series multiplier resistors) with ranges of $\frac{1}{4}$, $\frac{1}{2}$, 1, and 5 volts.

Although the crystal-detector type output meter is compara-

tively simple and inexpensive to construct, several disadvantages are encountered because of the inherent characteristics of the crystal. The varying sensitivity of the crystal makes frequent adjustments necessary, which interferes with stable operation. This instability prevents the instrument from maintaining its

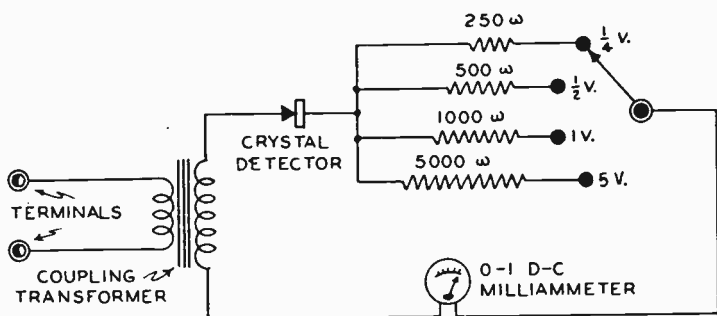

FIG. 7-15.—A crystal detector type output meter in which a 0-1 d-c milliammeter is employed as a low-range d-c voltmeter.

calibration for any appreciable length of time. However, despite the fact that the crystal contact is liable to oxidize at relatively low current values and is generally unstable, this type of output meter is more than satisfactory when used to indicate when an output is maximum, or changing, etc.

7-7. A Tube-Rectifier Type Output Meter. — The output meters discussed thus far have made use of the rectifying action of the copper-oxide disc rectifier and the crystal detector, so that a sensitive d-c milliammeter could be employed for measuring the low output signal voltage of a radio receiver or amplifier. A third method utilizes the rectifying ability of a three-element vacuum tube, connected in a circuit with a 0-1 ma. d-c milliammeter, as shown in Fig. 7-16.

In this case, the milliammeter reads the current rectified by the tube, which functions as a two-element detector. The meter deflection caused by the rectified current depends upon the value of signal voltage impressed upon the terminals *A-B* of the instrument. The purpose of the filament rheostat *R₁* is to keep the output indications within the range of the meter scale. The vari-

able resistance R_2 , provides a control against overload, and serves to increase the voltage-measuring capacity of the device.

To obtain greater output signal indications, the instrument may be connected directly in the plate circuit of an output tube in the receiver or amplifier under test, through the use of a

FIG. 7-16.—A simple tube-rectifier type of output meter.

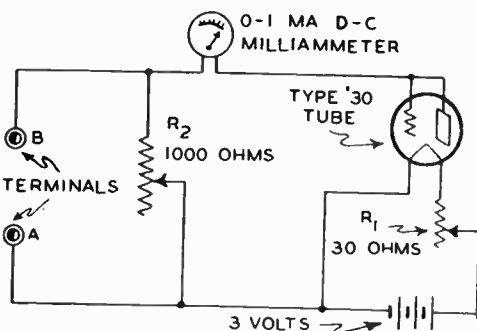

“plate circuit break-in adapter”, as shown in Fig. 7-17, instead of across the voice coil or output transformer secondary winding of the dynamic speaker in the receiver.

Because of its stability, the tube-rectifier type output meter

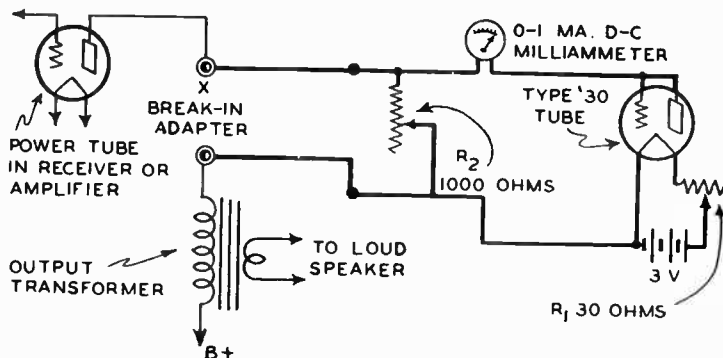

FIG. 7-17.—A tube rectifier type output meter connected into the plate circuit of one of the output tubes of a receiver or amplifier by means of a break-in adapter.

lends itself more readily to more accurate calibration than the crystal detector type. Calibrations may be made by applying known a-c voltages across the input terminals. It is also wise

to check the filament voltage by means of a separate or built-in voltmeter to be certain that it is the same at all times. Any change in filament voltage will shift the calibration of the instrument, the amount of shift depending upon the amount of change in filament voltage.

7-8. A Neon-Tube Type Output Indicator.—Both the circuit diagram and an illustration of an unusual type of output indicator designed especially to furnish a visual indication of the *relative* output of a receiver when its tuned stages are being aligned, are shown in Fig. 7-18. This instrument, which is compact and portable, consists of a tapped step-up transformer T_1 , having a ratio of 80 to 1, a potentiometer R_1 , a neon glow lamp and three binding posts for connecting the transformer to the output of the receiver. Three input impedances, 0.6-ohm from



Courtesy RCA Victor Co.

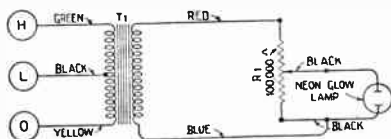

FIG. 7-18.—(Left). An output indicator which employs a neon glow lamp to give a visual indication of receiver output. (RCA Victor Type TMV-121-A.)

(Right). The circuit diagram of this instrument.

H to L , 1.5-ohms from O to L and 4-ohms from O to H , are available. These make it possible to match the impedance of the instrument to the impedance of the voice-coil winding of the speaker transformers in most receivers which employ dynamic speakers.

The signal voltage fed to the primary of transformer T_1 by the receiver is stepped up by the transformer. Any fractional part, or all, of this voltage may be selected by the potentiometer and applied to the neon lamp. Since its brightness varies with the applied voltage, it serves as a visual indicator of the relative output signal strength of the receiver. The glow lamp, which

has a "striking" voltage of 50-60 volts, is very sensitive, following variations in signal frequency and intensity. Naturally, this provides a very sensitive indicator for adjusting "trimmer" capacitors to their optimum position.

The instrument is used by connecting it directly across the voice-coil winding of the loud speaker transformer—either with the voice-coil connected or disconnected.

7-9. The Vacuum-Tube Voltmeter. — A vacuum-tube voltmeter is a type of voltmeter which employs one or more vacuum tubes for measuring voltages applied to its terminals. The two most important characteristics which make the vacuum-tube voltmeter extremely useful in radio service work are:

1. When properly designed and constructed, a V.T. voltmeter can be calibrated at 60 cycles and used thereafter at all frequencies from approximately *40 cycles up through the standard receiver short-wave ranges.*
2. If the V.T. voltmeter is built without a resistance-type voltage divider in its input circuit, it presents practically an infinite resistance across the circuit whose voltage is to be measured. It may therefore be considered to have practically *infinite ohms-per-volt sensitivity* and consumes practically no current from the circuit under test.

The first characteristic makes the v-t voltmeter particularly useful for measuring the gain-per-stage (or overall gain) of either the r-f, i-f, or a-f amplifiers of receivers, because it will register correctly on any of these frequencies. Intermittent operation, poor alignment, etc., of each individual r-f or i-f stage may also be checked.

The second characteristic makes the V.T. voltmeter especially useful for checking the voltages in avc circuits—as we shall see in Art. 7-13.

7-10. Principle of Operation of the V. T. Voltmeter.—The principle of operation of one common form of V.T. voltmeter is similar to that of the three-element "biased detector" so widely used in modern radio receivers, and is as follows:

The voltage to be measured is applied across the grid-cathode

circuit of the tube, which is biased like a detector (see Fig. 7-20). The *positive* excursions of the applied voltage cause the plate current to *increase*, whereas the *negative* excursions cause it to *decrease* because of the curvature of the E_g-I_p characteristic of the tube. The result is that the net value of the d-c plate current changes by an amount which is a measure of the voltage being measured. This plate current change is read upon a milliammeter in the plate circuit. The milliammeter may be cali-

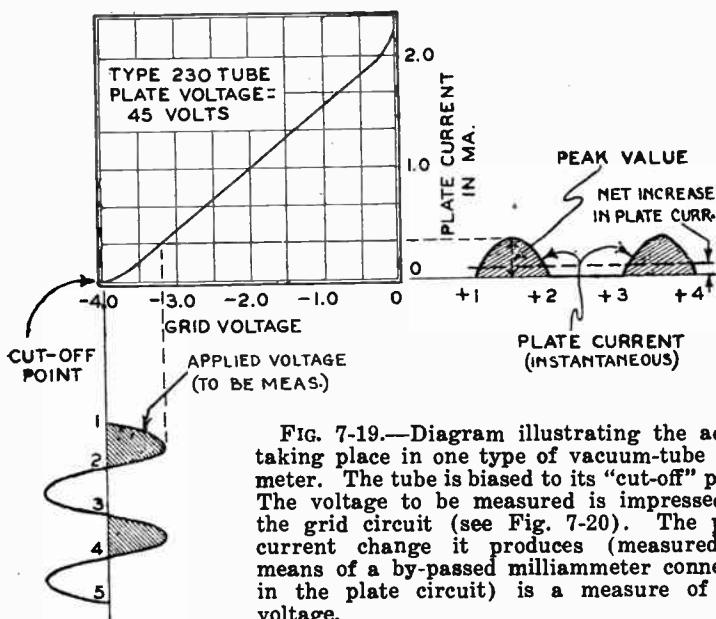

FIG. 7-19.—Diagram illustrating the action taking place in one type of vacuum-tube voltmeter. The tube is biased to its "cut-off" point. The voltage to be measured is impressed on the grid circuit (see Fig. 7-20). The plate current change it produces (measured by means of a by-passed milliammeter connected in the plate circuit) is a measure of this voltage.

brated directly to read the *voltage* being measured. The plate circuit milliammeter must be thoroughly by-passed to all fluctuating currents (see Fig. 7-21).

The behavior of a V.T. voltmeter depends greatly upon exactly which part of the tube characteristic is selected as the normal operating point. If the grid bias and plate voltage are such that the plate current is allowed to flow continuously, the *change in plate current* is very nearly proportional to the *square of the*

effective value of the voltage being measured. If the grid bias is such that the tube operates substantially at the cut-off point (see Fig. 7-19), the negative half cycles are entirely suppressed and the change in plate current will be very nearly proportional to the *effective value of the positive half cycles.* If the grid bias is still more negative, the change in plate current is determined

FIG. 7-20.—Circuit diagram of a simple vacuum-tube voltmeter.

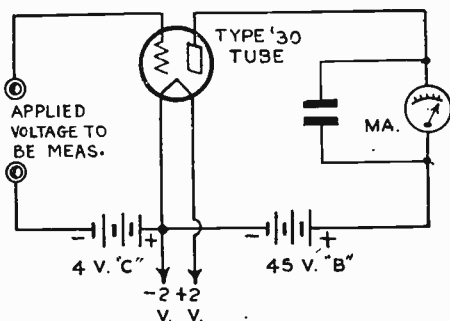

by the *peaks of the positive half cycles*, and what is substantially a *peak* voltmeter results.

7-11. How to Construct a V.T. Voltmeter.—In order to be suitable for measurements in radio service work, a V.T. voltmeter should meet several important requirements: *first*, it should be able to measure both low and fairly high voltages; *second*, it should be rugged; *third*, it should be portable; *fourth*, it should be economical to operate (line operation is desirable); and *fifth*, its calibration should hold over reasonably long periods of time.

A practical instrument that meets most of the above requirements is shown diagrammatically in Fig. 7-21. It consists of a type '30 tube connected in the simple circuit shown: The 2-volts applied to the filament must be maintained by adjusting the 20-ohm filament resistor. The plate circuit has a resistor of about 9000 ohms (see below) in series with a 0-2 ma. meter. The grid bias is about 4.5 volts negative, which may be obtained from a standard battery. The drain from the "B" supply is never more than 2 ma., hence small batteries may be used to advantage. Switch 1 is used to shut the "A" battery off and turn it on;

SW-2 controls the equivalent of a voltmeter multiplier (to be explained); and *SW-3* short-circuits a small fixed condenser.

This voltmeter, with the switch *SW-2* at position 7, must be adjusted so that the plate meter reads full scale when the grid voltage is zero; the adjustment being made by varying the size of the plate resistor (it is shown here as 9000 ohms, but values as high as 13,00 ohms are necessary in some cases) and keeping the tap switch at position 7.

After the meter has been adjusted for full-scale reading with the tap-switch in position 7, it will likely be found that it does not read exactly zero for any other position of the switch, (when no voltage is applied to the "INPUT" terminals). This small residual current always flows and may be "bucked out" if desired. However, for the general run of service work, it is not necessary to do this. The adjustment becomes complicated and has little significance, except for accurate work. If the zero reading is very small—about a division or two—the zero setting of the meter may be changed to bring the reading to zero.

The maximum voltage that may be applied to the "input" terminals of this voltmeter is 22.5 volts *peak*, for, by means of the potentiometer shown, a known fraction of the input voltage may be applied to the grid of the tube. For instance, with the tap on position 4, only $\frac{2}{5}$, or 0.4, of the "input" voltage is actually applied to the tube. For any position of the potentiometer tap, the meter reading must be multiplied by a definite "multiplying factor". These factors are:

| <i>Tap</i> | <i>Multiplying Factor</i> |
|------------|---------------------------|
| 1 | 1.00 |
| 2 | 1.25 |
| 3 | 1.66 |
| 4 | 2.50 |
| 5 | 5.00 |

This means that the peak value of the maximum voltage that may be read is 22.5 volts a-c, or 22.5 volts d-c. The range may be extended further to almost any extent by employing a different suitable potentiometer arrangement.

The input resistance of the voltmeter is 1 megohm. This

value may not be sufficiently high to prevent disturbing all a-c circuits to which it may be connected in service work. The impedance is constant for any position of the potentiometer.

7-12. **Calibrating the V.T. Voltmeter.** — Calibration of the voltmeter described in Art. 7-11 may be effected by the simple arrangement shown in Fig. 7-22. A small 6- or 10-volt battery

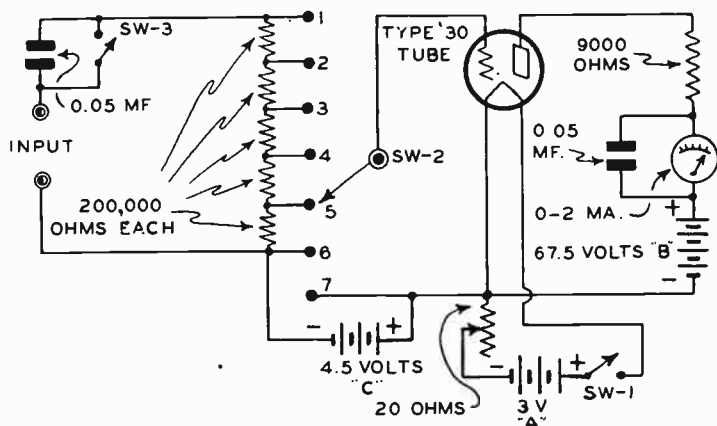

FIG. 7-21.—Schematic circuit diagram of an easily constructed V.T. voltmeter for use by radio service men.

B is connected to a reversing switch, as shown. The switch connects to a potentiometer *P* having a value of about 1,000 ohms, and a d-c voltmeter capable of reading the voltage of *B* is connected from the arm of the potentiometer to one end. The two terminals of this arrangement (with the d-c voltmeter) are then connected to the input terminals of the V.T. voltmeter.

The arm of *P* is set for, say, a 0.25-volt reading on *V*; the arm of the potentiometer in the V.T. voltmeter is set on position 1; *SW-3* is closed; and the plate meter reading noted. The reversing switch is thrown to the other side and the reading of the plate meter again noted. These two readings are subtracted, and the difference is to be taken as the reading of the plate meter for an input peak voltage of 0.25. The same procedure is followed for input voltages, in steps of 0.25 volt, until 4.5 volts are reached. If the V.T. voltmeter has been built and adjusted

according to specifications, there will be but a very small change in the reading of the plate meter for one position of the reversing switch, and so this operation may be dispensed with.

The calibration obtained will correspond to the *peak* values of sine wave input voltages. Each voltage reading on voltmeter *V* should be multiplied by 0.7 to obtain the *effective* value.

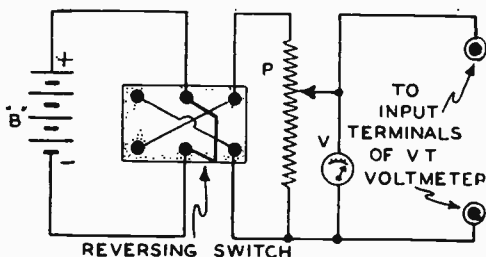

FIG. 7-22.—Circuit arrangement for calibrating the V.T. voltmeter of Fig. 7-21.

This V.T. voltmeter can be used to measure either a-c or d-c voltages whenever a voltmeter that draws little or no current is needed. The calibration obtained by the method described in Art. 7-12 will be valid for all frequencies (within a tolerable percent for service work) within the audio band, and should give excellent comparative readings in r-f measurements. Even though the calibration may not hold exactly for the higher frequencies, it at least enables us to know the *order* of the voltage—whether it is near 5, or 10, or 15 volts, etc.

Note: When measuring a-c voltages, switch *SW-3* (Fig. 7-21) should be left open; it should be closed when making d-c voltage measurements.

7-13. Uses for V.T. Voltmeters.—Now that stable, line-operated V.T. voltmeters are available, it is almost certain that they will become much more popular among radio service men for the types of receiver voltage measurements for which they possess definite advantages over the more ordinary forms of voltmeters.

A vacuum-tube voltmeter is useful for checking the gain-per-stage (or overall gain) of either the r-f, i-f, or a-f amplifiers in receivers. A suitable oscillator is employed to feed a signal to the input of any particular stage to be checked. The V.T. voltmeter is used for measuring both the voltage across the stage *input* and

that across the stage output, so that the *gain* may be determined. Intermittent operation, poor alignment, etc., of each individual r-f or i-f stage of a receiver can also be checked in this way..

The voltages existing across some parts of avc circuits (most of which have resistances of over 1 megohm) may easily be upset as much as 50% if even a 2,000 ohms-per-volt movable-coil type voltmeter is used to check them (see Arts. 2-19 and 2-20). This is due to the current (even though it is very small) which this type of voltmeter draws. Because it has almost an infinite input impedance and therefore draws no current from the voltage source, the V.T. voltmeter (without input voltage divider) may be used for checking these voltages (as well as any other low voltages in the receiver) without causing any such changes. It is also useful for checking grid voltages, plate voltages in detectors and resistance-coupled amplifiers, etc.

The V.T. voltmeter can measure current (indirectly) too. Merely connect it across a small, *known* resistance which is connected in series with the circuit whose current is to be measured. If the voltage-drop across this resistance, as read by the V.T. voltmeter, is divided by the value of the resistance, the value of the current flowing (in *amperes*) is obtained.

Power outputs of radio receivers may also be measured with surprising accuracy. Connect the V.T. voltmeter across the voice coil of the speaker and note the voltage so read with a given station tuned in. Although the reading will vary with the modulations of the signal, maximum, average, or minimum readings may be taken. Dividing the "square" of this voltage reading, by the resistance of the voice coil, gives the power output in watts. In a similar manner, the voltage, or power, of any "residual hum" may be determined, and adjustments in the placement of power pack equipment or changes in the filter system may then be made until the meter reads lowest.

7-14. Comparison of the Copper-oxide and Vacuum-Tube Type Voltmeters.—A comparison of these two types of a-c voltmeters cannot be made fairly unless the use for which they are intended is known. For accurate measurement of high-frequency voltages and for an extremely high-resistance device, the V.T. voltmeter is best. On the other hand, the high first cost, the care which must be exercised in handling and the cost of upkeep (however small) may be detrimental factors which may limit its usefulness in some cases. The copper-oxide type voltmeter is small, light, rugged, is usually not as accurate as a good

V.T. voltmeter, cannot be connected in many circuits without disturbing the circuit, and cannot be used at high frequencies. Each, therefore, has certain advantages and disadvantages which must be considered in any case where the question of their relative advantages is raised.

REVIEW QUESTIONS

1. What is the output meter used for in radio service work, and why is it necessary?
2. Can a d-c meter or a movable-iron type a-c meter be employed in place of an output meter? Explain!
3. What precaution must be observed when connecting an output meter of the copper-oxide type from the plate of one of the output tubes to ground?
4. Mention three different types of output meters and explain the principle of operation of each. Draw sketches to illustrate.
5. How would you connect an output meter to measure the output of a receiver employing a push-pull output stage feeding into a dynamic speaker? Illustrate with a sketch.
6. Explain the advantages of the copper-oxide type output meter. Mention some of its uses.
7. What is the purpose of the series condenser in an output meter? What may occur if it is not employed?
8. State the disadvantages, if any, of the crystal detector output meter.
9. What is a vacuum tube voltmeter? What are its advantages? Disadvantages?
10. Upon what principle does the vacuum-tube voltmeter operate? Draw a circuit of a simple vacuum-tube voltmeter.
11. How would you calibrate a vacuum-tube voltmeter? How would you make it read "effective" values?

CHAPTER VIII

THE TUBE CHECKER

8-1. Need for Tube Testing.—Analyses by competent authorities show that inoperative tubes are by far the most frequent cause of "dead" receivers or unsatisfactory operation. Tubes become poor after they have given their normal amount of service, or when, because of misuse or faulty manufacture, their characteristics change. Tube failure is so common in radio service work that the tubes are usually the first parts of a receiver that are tested by the average service man. (Note that we consider the vacuum tube as an inherent part of the receiver just as we do a transformer or a socket. A receiver *per se* is merely an assembly of apparatus, and can serve no useful purpose unless it is equipped with the proper tubes.)

It is quite essential, therefore, that means be available for testing radio tubes accurately, swiftly, and without recourse to computation. Devices which satisfy these requirements are variously known as *tube checkers*, *tube testers*, or *tube sellers*. They all attempt to do the same thing—indicate the condition of the tube insofar as that condition affects radio reception. Their physical construction depends upon the degree of portability desired. Those intended for store use are large, with large indicating meters readable at a distance, and are commonly known as *counter models*; those intended to be part of the service man's kit are known simply as *portable models*. In many cases, the circuits of both types of instruments of any one manufacturer are identical; the instruments differ only in size and weight.

8-2. The Replacement Test for Tubes. — The necessity for comparing tubes of the same type under standardized conditions cannot be underestimated. A few people maintain

that the best test for a tube is simply to replace it in the receiver with another of the same type. If the signals increase in strength, then the original tube is poor; if they remain the same, the original tube is good. They maintain that this test is simple, and has the distinct advantage that the tube is being "tested" under actual operating conditions and in the receiver in which it is used. Perhaps there is an excuse for this test when no other means are available for determining the worth of a tube. If the tubes in a receiver must be tested, and if no tester is at hand, then the logical thing to do is to replace those in the receiver with other tubes, one by one, each known to be good. However, every radio service man should be equipped to test tubes satisfactorily with suitable instruments. These make it unnecessary to carry around a good tube of every type for test purposes, and give a more accurate test of the condition of the tubes—especially for receivers using AVC—as we shall now see.

8-3. Disadvantages of the Replacement Test.—The ordinary "replacement test" was satisfactory when tubes and circuits were simple, and when small differences in the characteristics of two tubes manifested themselves by noticeably different signal strength. But today, the design of many circuits is such that a tube may be poor enough to be replaced, and yet it will not be detected by this test until a relatively weak signal is tuned in. Receivers are now equipped with automatic volume controls, which vary the sensitivity of the r-f and/or i-f portions of the set as the intensity of the signal varies. Thus, on a loud local signal, the sensitivity of the receiver automatically decreases, and a poor tube in the r-f or i-f portion of the receiver will not manifest itself. Even if it is replaced with a normal tube, the increased signal strength so obtained automatically causes the sensitivity of the set to decrease to the point where the output is the same as when the poor tube was in use. In such receivers, then, the "replacement test" is utterly useless. Furthermore, the types of tubes used in the r-f portion of the receiver are not the same as those used in the a-f section, where the replacement test has some, though few, merits.

If a tuning meter is used in the receiver, or if the receiver be tuned to such a weak signal that the automatic volume control

does not act (under which conditions the sensitivity of the receiver is at maximum), then a poor tube will be shown up by weak and sometimes distorted signals. The deflection of the tuning meter is an indication of the signal strength reaching the second detector in a superheterodyne, and hence, though the audio output remains constant, the reading of the meter will change when a good tube is substituted for a poor one. Hence it also serves to show up a poor tube.

However, comparatively few receivers are equipped with tuning meters, and it is rare that a properly weak signal can be found. Then, too, the signal must be weak for the particular receiver under test, which means that every receiver requires a different degree of signal weakness for every location of the receiver. The degree of required weakness depends upon the sensitivity of the receiver and the amount of AVC used; the greater the sensitivity and the more the AVC the less the required signal.

It is quite apparent from these remarks that the service man, whose time is an important element, is in no position to spend his time guessing about the weaknesses of signals and the sometimes dubious readings of some tuning meters. Furthermore, if tubes in both the r-f and a-f parts of the set are poor, he has no recourse but to provide himself with a device that will tell him the condition of a tube without the necessity for having special signals or special receivers. He must have a device that works independently of the receiver itself, and upon which he can rely with complete confidence. It is the purpose of this, and the following two chapters, to present a comprehensive study of tube checkers for accomplishing this task satisfactorily.

8-4. Structures of Modern Tubes.—Before discussing the different practical tests that may be applied to a tube to indicate its worth, it might be well to review briefly the different structures used in modern tubes and to point out the salient features of each electrode arrangement.* With this knowledge at hand, it is relatively easy to understand the connections of the various grids and plates in some of the modern combina-

*Note: For a more detailed and comprehensive treatment of the subject of vacuum tubes, consult the *Radio Physics Course*, by Alfred A. Ghirardi. (Radio & Technical Pub. Co., N. Y. C.)

tion tubes; for, to understand the operation of a tube tester, the connections of the elements inside the tube being tested must be known.

DIODE
TUBE
Structure.

8-5. Diodes and Triodes.—The simplest type of radio tube is the *diode*, so called because it consists of a filament, or heater, and a single plate. The filament or heater emits electrons which are collected by the plate whenever the plate is positive; no electrons are collected when the plate is negative. The arrangement of the elements in such a tube is illustrated in (A) and (B) of Fig. 8-1. This type of tube is used almost exclusively for power rectifiers (*filament type*, with few exceptions) and for signal detection (*heater type*). This type of rectifier is the "half-wave" type. Two plates may be incorporated, as shown at (C) and (D), to obtain "full-wave" rectification.

A single "grid" in a filament-type diode makes the tube a *triode*, as shown at (E), and the tube is still a triode if the emitter of electrons (simply called the *emitter*) is equipped with a cathode, as in (F). Note that this latter structure has four elements, although only three are actively concerned with the electron flow (the heater is used solely for heating the cathode), hence the name "triode" still persists.

8-6. Multi-grid Tubes.—At (G) is shown a filament type *tetrode*, or four-element tube. $G1$ is the control-grid. The additional grid $G2$ is inserted to reduce the capacity existing between the control-grid and plate of a triode, and is maintained at a potential equal to or less than that of the plate in the usual connection (except when used as a dynatron). This structure gives high gain at very low power output, and is employed mainly in tubes to be used as r-f or i-f amplifiers and sometimes in detectors. For a-c operation, the emitter may be of the indirect-heater, or "cathode" type, as shown at (H).

Still more amplification may be secured by inserting another grid $G3$ (the suppressor grid) between $G2$ and P , as shown at (I). This gives us the pentode (5-electrode) type tubes. This type of structure is in common use at this time. In the indirect-heater form of this tube the connection of this grid $G3$ is brought out to a separate prong in the base, as shown at (I). This makes it possible to connect it (outside the tube) to the cathode when

used in the normal way as an r-f or i-f amplifier. For certain special control work, its potential can be maintained either above or below that of the cathode. In filament-type forms of

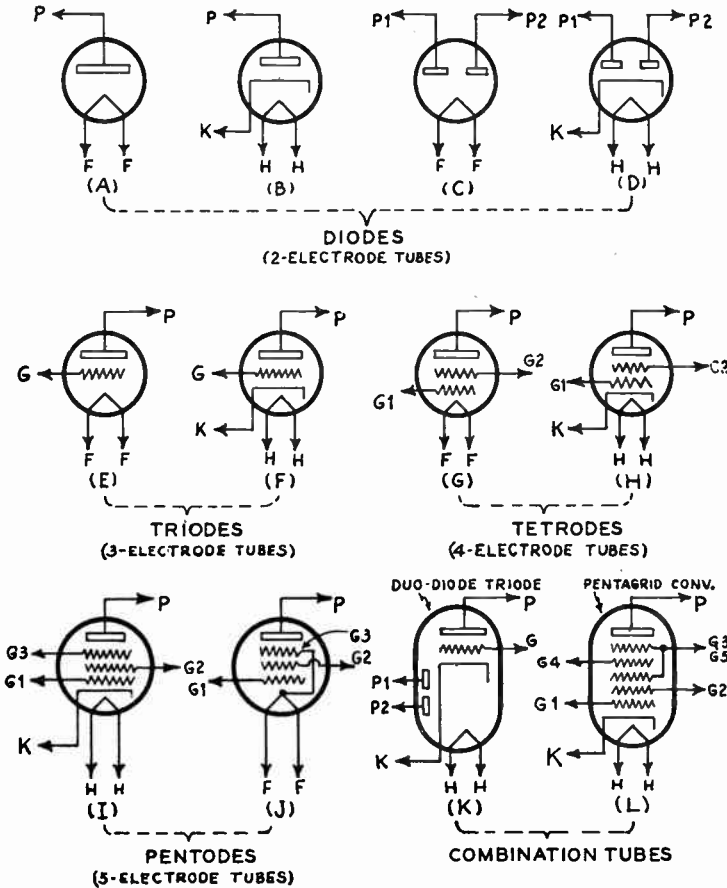

FIG. 8-1.—Some of the electrode arrangements employed in modern radio tubes, starting with the simple diode (2-electrode) tube at (A), progressing to the pentode (5-electrode) tubes at (I) and (J) and the combination tubes at (K) and (L).

tubes, the suppressor grid *G*₃ is already connected (inside the tube) to the center of the filament—as shown at (J).

8-7. Combination Tubes. — Almost any combination of these structures may be built into a single glass envelope and

properly called a single tube. For example, as shown in (K), the double diode plates of (C) and (D) and the triode of (F) are united to form a single unit. A typical "multi-unit", or combination tube employing this arrangement is the '55, and it is known as a *duo-diode triode*. The same structure with slightly different characteristics is used in the '75 and '85 tubes. The diode section of the tube is placed directly below the triode section. It is independent of it, and functions just as if the triode were not present. In fact, two separate tubes could be used instead, with substantially the same results.

Pentodes and triodes, pentodes and diodes, two separate triodes, etc., have been built into a single tube and are used for a variety of special purposes. Such combinations lead to names such as *duplex-diode pentode*, etc. A complete chart giving a list of these tubes and their socket terminal connections will be found in the Appendix at the back of this book.

Another class of combination, or multiple-unit, tubes combines features of the previous classes. Typical of this class are the 2A7 and the 6A7 pentagrid converter types. These are tubes having an unusually large number of electrodes (seven exclusive of the heater), all of which affect *the same electron stream* and yet perform two operations (oscillator and mixer for superheterodyne circuits) *independently* but *simultaneously*. The electrode arrangement in these tubes is shown at (L) of Fig. 8-1.

8-8. A Satisfactory Test for Tubes.—Just what constitutes the "best" method of testing a tube to determine its general condition has been the subject of much discussion, with the result that there are many differences of opinion. However, there is a definite tendency among engineers to standardize on two main methods of test to judge the condition of amplifier tubes. The first is called an *emission test*, and the second type, a *mutual conductance** test. The emission test is the only practical test for rectifier tubes; they are tested entirely by it.

Both the emission test and the mutual conductance test will be discussed first. Then, miscellaneous tests for cathode-heater

*Note: The term "mutual conductance," though universally used, has been changed by the Standardization Committee of *the Institute of Radio Engineers* to *transconductance*. Both terms will be used interchangeably in this book.

leakage, "shorts" between the tube electrodes, etc., will be explained. Finally, the circuit for a complete simple tube checker will be developed step by step, and adapters will be described. Complete instructions for making a modern tube checker are presented in Chapter IX, and commercial tube checkers are described in Chapter X.

8-9. The Emission Test for Tubes.—If normal voltage is applied to the filament or heater of a 2-element radio tube, electrons will be emitted, and these electrons can be collected by a positively charged plate situated close to the emitter. If the

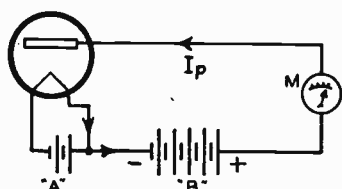

FIG. 8-2.— Circuit arrangement for a simple emission test on a 2-electrode tube (diode).

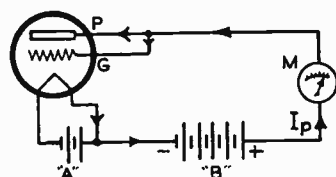

FIG. 8-3.— Circuit arrangement for making an emission test on a 3-electrode tube (triode).

voltage applied to the plate is made high enough, *all* the electrons emitted by the filament can be attracted to the plate at the same rate as they are emitted. Then the plate current flowing will be a measure of the number of electrons being emitted. If this plate current is compared to the *normal emission* for the particular tube under test, the condition of the emitter may be determined. This is the fundamental basis of the so-called *emission test*, and a simple circuit arrangement for it is illustrated diagrammatically in Fig. 8-2.

If the tube is of the three-element type, then the grid must be connected directly to the plate, as shown in Fig 8-3. Under these conditions, both the grid and plate attract the electrons being emitted from the filament, and the meter *M* reads the total of both currents. Note that the grid is at the same potential as the plate. This means that the grid current is greater than the plate current because it is closer to the filament than the plate. If the grid current is too large, it may cause the grid to become red hot; and, if there is a small trace

of gas in the tube, the excessive current may ionize it (break it up into positive and negative charges), causing an abnormally large current to flow and ruining what might otherwise have been a good, serviceable tube.

These facts make several precautions necessary when making an emission test on a triode. First, the milliammeter *M*, in the plate circuit, must be large enough to safely handle the expected current. Second, be certain that the grid of the tube can withstand the heat caused by the grid current flow. Third, do not attempt to conduct an emission test on indirect-heater tubes (cathode types). If too much current (electrons) is drawn from the cathode of an indirect-heater tube by having both the plate and grid at a high positive potential, the emission action in the cathode increases at such an enormous rate that the cathode becomes damaged very easily and quickly.

Theoretically, if the tube has more than one grid, all the grids, too, should be connected to the plate; and, as in the case of the triode, the meter will read the sum of the plate current and all the grid currents.

8-10. Advantages and Disadvantages of the Emission Test.—The emission test is based on the fact that when a tube has operated for its normal span of life (about 1,000 hours), the electron emission begins to drop, and continues to drop until it becomes too small for practical use.

Since rectifier tubes contain only an electron emitter and one or more plates, they must be tested by the emission-test method. All rectifier tubes, and the diode sections of duplex-diode tubes, are tested simply by testing their emission in this way—even though the same tube checker may check other types of tubes by the grid-shift method. Rectifier tube testing is simple and presents no special problems; the proper a-c potential is applied between the anode and cathode and the plate current is read. If it is below normal, the tube is rejected. Little more will be said about the testing of diode, or rectifier tubes.

The emission test reveals the condition of the electron emitter in amplifier tubes, but it does not consider any other faults that the tube may have. It does not take into consideration

the fact that a slight amount of gas ionized by the plate current may cause a higher plate-current reading to be obtained than would be the case if there were no gas ionization, that is, when in reality the reading should be below normal because of low emission. In short, the emission test does not test a tube under conditions simulating those found in actual practice. However, the emission of a tube is an important factor which cannot be neglected. Low emission manifests itself in a manner similar to the shifting of grid bias. Low emission is like making the bias more negative; high emission is similar to making the bias less negative. In this manner only does an emission test simulate operating conditions.

8-11. Emission Test on Cathode-type Tubes.—The fact that emission tests on cathode-type amplifier tubes cannot be made with normal operating voltage because of the high plate currents resulting is no detriment in itself. In practice, the voltage applied to the plate and grid can be made low enough so that the plate-circuit current in a normal tube will not be excessive. And if the emission tester is to test a wide variety of tubes with widely different plate currents, then means must be made available for adjusting the plate voltages on the tubes so that the currents are not excessive and so they all will fall within the range of a single meter.

The circuit diagram of a typical emission tester may be represented essentially as shown in Fig. 8-3. Of course, the necessary switching facilities to reduce the plate current, etc., could be added. Also, in commercial designs, the finished instrument works directly from the a-c supply line. A-c is supplied to the plate and filament or heater, and the d-c milliammeter reads the average value of the plate-circuit current, as does the d-c instrument of a copper-oxide type meter (see Art. 2-32). (Plate current flows only during one-half of each cycle, since the grid and plate are negative during the other half cycle.)

8-12. Calibration of an Emission Tester.—The calibration of such an instrument involves the testing of a number of good tubes of each type. The readings of the meter M for each tube type are recorded and averaged. This average is taken as "good" for the particular type tube. From additional tests

with "fair" and "poor" tubes, arbitrary limits are set between which a tube is said to be good. From still more tests with "poor" and "fair" tubes, the limits between which a tube is "fair" can be determined. All readings below the lower limit of "fair", for a particular tube type, are "poor". The calibration cannot be "computed" by means of a formula with any degree of success; the only calibration method is that of actually testing different tubes whose condition is known. A chart is then compiled with the meter reading limits for every type of tube and is consulted whenever a test is made with the tester.

8-13. Effect of Gas and Emission Test.—A small amount of gas in a tube may make its operation totally unsatisfactory. If a tube contains gas, and if the emission is fairly large, this gas becomes ionized, the positive charges traveling through the tube to the nearest negative electrode and the electron (the negative particles) traveling to the plate. This motion of the charges is, in reality, *plate current*; and, if there is sufficient gas present, this current (composite of the normal plate current and the gas current) may be sufficiently large to damage the tube by overheating of the elements.

In modern tubes the gas content is so small that danger of overheating because of ionization is small; it is possible, though, that the characteristics of the tube may change. When the tube is operating in the receiver and the grid bias is small, a little ionization may cause grid current to flow, which reduces the input resistance of the tube, causing weak signals, broad tuning (if in an r-f amplifier) and distortion (if in an audio amplifier). It is well to be able to test a tube for gas content.

8-14. Testing for Gas.—If the grid current is very small with the bias near zero, then the tube may be assumed to have a negligible amount of gas. This is the principle upon which the typical gas-test indicator works. Consider the circuit (*A*) of Fig. 8-4. A simple triode is connected to batteries and a meter, as shown. The plate current is a certain amount, depending upon the tube type and the voltages. Assume that *C* is a small battery, perhaps 1.5 volts. If the tube is gassy, current will flow in the grid circuit; the direction of flow would be from grid to filament, or from filament to grid, depending upon the potential

of the grid, the gas pressure, the tube structure, and the potentials applied to the other electrodes. For our purpose, it makes little difference which way the current flows, so long as the fact that grid current flows is recognized.

If a resistor R is connected in series with the grid circuit, as shown at (B) of the figure, then this grid current will flow through R and develop a voltage across it. This voltage then acts either with, or against, the voltage C (depending upon the direction of flow of the grid current). In either case, the voltage developed across R alters the grid bias voltage, resulting in a change in the

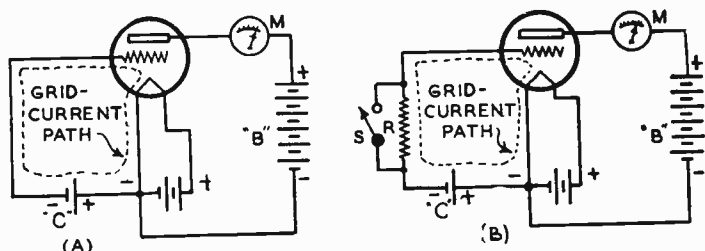

FIG. 8-4.—Action of the circuit arrangement employed to make a "gas" test on a vacuum tube.

plate current—which will be indicated by M . If there were no gas, there would be no ionization, no grid current, no drop across R , and hence no change in plate current. R is usually made about 500,000 ohms, and a switch is placed across it, S in the diagram. If opening and closing this switch produces little or no change in plate current, then there is little or no gas present.

The gas indicator, then, is nothing more than a series grid resistor with a switch across it. Changes in potential across this resistor manifest themselves by changes in the plate current.

8-15. The Mutual Conductance (Grid-Shift) Test. — A more satisfactory method of testing an amplifier tube is to place it in a circuit that more nearly simulates the circuit conditions in an actual receiver, and determine its property as an amplifier. The *mutual conductance*, or *grid-shift*, test most nearly fulfills this condition.

Any amplifier tube functions because a change in its grid voltage causes a change in its plate current. The greater the change in plate current produced by a given change in potential

applied to the grid, the better the tube is as an amplifier or detector, other tube constants remaining the same. Therefore, since the worth of a given type of tube as an amplifier depends upon how much plate current change will be produced by a given grid voltage change, this can be made the basis of a method of amplifier tube testing. This is, in fact, the basis of the *grid-shift* method for testing amplifier tubes.

As the important "amplifying" property of the tube depends on how much *plate current* change is caused by a given *grid voltage* change, by comparing these values we obtain a "figure of merit" which is known as the *mutual conductance* (represented by the symbol G_m). This conductance ratio is called *mutual* because it expresses a mutual relationship between a quantity pertaining to the plate circuit and a related quantity pertaining to the grid circuit. It is called *conductance* because it is the ratio of a "current" to a "voltage" (remember that *resistance* is the ratio of a "voltage" to a "current"). Since conductance is the opposite of resistance, it is expressed in *mhos* (*mho* is *ohm* spelled backward).

Of course, the *plate impedance* and *amplification factor* of the tube are important, but, since the "mutual conductance" of a tube is equal to the ratio of these other two constants, any change in either one is bound to affect the mutual conductance. Therefore, if the mutual conductance of a tube is found to be normal, it indicates that both the plate impedance and amplification factor are also normal, so these need not be tested separately. While the mutual conductance is not a complete indication of the comparative merits of tubes of different types, it is a positive indication of merit among tubes of the same type.

The fundamental definition of mutual conductance is the basis of operation of the grid-shift method of tube testing. *Mutual conductance, G_m , equals the change in plate current (in amps) divided by that change in grid voltage (in volts) causing the plate-current change—with the plate voltage held constant.*

Keeping this definition in mind, we will now see how the mutual conductance of a tube can be measured by the simple circuit arrangement shown in Fig. 8-5. The tube is connected as shown, with provision to read the plate current by means of d-c milliam-

meter M . The grid is connected to an adjustable source of voltage, the value of which at any time can be read on d-c voltmeter V .

Suppose the arm of P to be adjusted so that the grid voltage, as read on V , is 1.5 volts "positive", at which time the plate current meter reads 4.0 ma. Then P is varied until another convenient grid voltage is obtained, say 2.75 volts "positive", at

FIG. 8-5. — Elementary circuit arrangement for determining the mutual conductance of a tube.

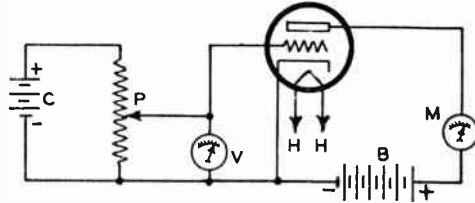

which time the plate current meter reads 7.4 ma. The mutual conductance of this tube then is,

$$G_m = \frac{\text{change in plate current produced (in amperes)}}{\text{change in grid voltage producing it (in volts)}}$$

$$= \frac{0.0074 - 0.004}{2.75 - 1.50} = \frac{0.0034}{1.25} = 0.00272 \text{ mhos.}$$

Mutual conductance is measured in *mhos*. The mutual conductance of radio tubes is so small, however, that one-millionth part of a mho, the *micromho*, is the unit universally employed for expressing the G_m of radio tubes. To convert mhos into micromhos, simply move the decimal point *six* places to the *right*, i.e., multiply by 1,000,000. The G_m of the tube just tested is, then, 0.00272 *mhos*, or 2720 *micromhos*.

Naturally, the general method just described can be used for measuring the mutual conductance of any type of amplifier tube — provided of course, the circuit arrangement of Fig. 8-5 is altered properly to meet the conditions imposed by the particular electrode arrangement which the tube employs (see Fig. 8-1), and the practical field conditions under which tubes are usually tested by the service man. Practical circuits for making this measurement rapidly on all commercial types of tubes employed in radio receivers will now be developed and described in detail.

8-16. "Relative" Mutual Conductance Satisfactory. — While the mutual-conductance testing arrangement described in Art. 8-15 gives the information required, it is not really satisfac-

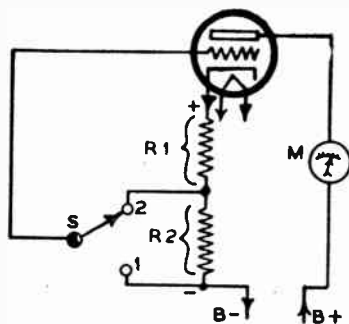

FIG. 8-6. — One method of shifting the grid bias in a tube tester. The switch enables either the voltage drop across $R1$, or that across both $R1$ and $R2$, to be applied to the grid of the tube at will.

tory for rapid testing of tubes, due to the fact that a computation is required for each test.

This computation of the actual mutual conductance for every tube tested by this system is really unnecessary. If we change the grid voltage by a definite fixed amount for each type of tube every time, all we need to notice is how much change in plate current is produced by this grid voltage change. Knowing beforehand (by having previously prepared charts giving the "plate current change" limits obtained for known "good", "fair" and "poor" tubes which have actually been tested) just how much plate current change is obtained in a "good" tube, a "fair" tube and a "poor" tube of the same type, and tested under these same conditions, we can quickly judge which classification the tube being tested falls into—without need for computation of any kind. Hence, only the plate current readings (which really give us the *relative values* of mutual conductance) are necessary, and they give us all the information we need.

From previously prepared charts (or calibrations directly on the tube checker) which specify the normal change in plate current reading for every type of amplifier tube manufactured, the relative "goodness" of any tube under test may be quickly ascertained in this way. Commercial tube checkers employ this idea. However, it must be remembered that a table or chart showing

the minimum allowable *differences* in plate current for various type tubes when the grid-shift test is employed, can only be used with the particular make and model of tube tester it was prepared for.

8-17. Methods of Changing Grid Bias.—In commercial tube testers, which are almost always a-c operated, the bias is often shifted by changing the voltage drop developed across a resistor placed in the cathode circuit, somewhat as shown in Fig. 8-6. This eliminates the need for using a battery for the grid-bias voltage. With *S* in position 1, the voltage drop across both *R1* and *R2* is applied to the tube as a negative grid bias; with *S* in position 2, only *R1* contributes to the bias, so the plate current increases. If *R1* equals *R2*, then the bias voltage may be halved by merely throwing the switch.

Another method of shifting the bias, shown at (A) of Fig. 8-7, is similar, except that *S* connects the grid to different portions of the filament winding. When the switch is in position 1, as shown, the grid connects directly to the cathode, and it is at zero

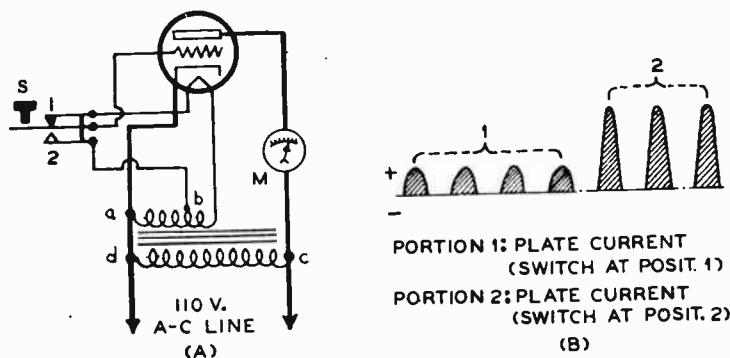

FIG. 8-7.—(A) Another method of shifting the grid bias in a tube tester. The bias is shifted by employing either "zero" bias (switch on Contact 1), or the voltage between *a-b* as a grid bias voltage. Point *d* may be considered as *B* minus, and point *c* as *B* plus. Contact 1 is connected to both the cathode and the filament.

(B) Portion 1 shows the plate current when switch *S* is in position 1. Portion 2 shows it when the switch is in position 2.

potential. A certain plate current flows. Since a-c voltage is applied to the plate, the plate current is a pulsating half-wave rectified current, as shown at portion 1 of (B). The d-c plate

milliammeter reads the *average* value of the plate current (see Art. 2-32).

When *S* is in position 2, the grid connects to point *b* on the filament transformer secondary, and on the half cycles when the plate is positive, the potential of the grid is *positive* with respect to that of the cathode, by an amount equal to the voltage developed in the portion of the winding from *a* to *b*. This causes the plate current to increase, as is shown by portion 2 of (*B*), by an amount dependent upon the mutual conductance of the tube. The deflection of the meter *M* increases, of course. We need not consider the half cycles when the plate is *negative*, since no plate current flows then.

One important point must be kept in mind when a tube tester employing the latter method of grid-bias shift is constructed. The windings of the transformer must be so connected that the polarity of the tap *b* on the filament winding is the same at every instant as that of end *c* of the primary winding (which connects

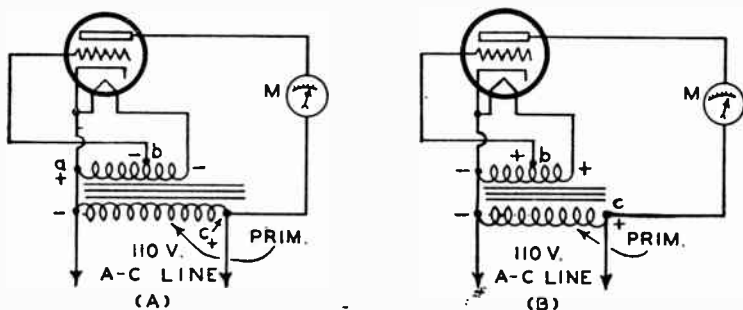

FIG. 8-8.—(A) Incorrect transformer connections for grid shift test method of Fig. 8-7. The instantaneous polarities of the grid and plate are opposite, so they oppose each other's action on the plate current.

(B) Correct transformer connections. Here, the instantaneous polarities of both the grid and plate are always similar.

to the plate of the tube). What happens if this polarity relation is not observed may be understood from a consideration of the illustrations of Fig. 8-8.

At (A) we have a simplified sketch of the circuit conditions (when switch *S* of Fig. 8-7 is in position 2) if the transformer is connected so that the polarity relations are *not* correct. Notice that at the instants when the plate is *positive* with respect to the cathode, tap *b* and the grid of the tube are *negative* with respect to it.

Let us see what happens during *each half cycle* that the plate is "positive". As the plate becomes more and more *positive*, the grid becomes more and more *negative*, so that its effect on the plate current is just opposite to that of the plate. Therefore, the plate current will either increase a small amount, remain the same, or actually decrease, depending upon the value of the plate voltage, the grid voltage and the mutual conductance of the tube (i.e., upon how much relative control the grid and the plate voltages have on the electron flow of the particular tube). Therefore, with the circuit arrangement of (A) the result on the plate current reading is uncertain.

If the circuit is arranged the correct way as shown at (B), both point *b* (and the grid) will be "positive" every time the plate is positive. Therefore, the grid and plate aid each other, and the plate current *increases*. The tube really will act as a half-wave rectifier, plate current flowing only during the "positive" half of each cycle.

Since the plate current is a half-wave rectified current, the d-c milliammeter will indicate the *average* value of the plate current.

8-18. Grid-Shift Test Usually Sufficient.—Both the "emission" and "grid-shift" testing methods are in common use.

The emission test is employed in many tube testers of the direct-reading type, called "English-reading" testers by some manufacturers. In some so-called English-reading testers, especially when they are designed for counter use (one is described in Art. 10-9), the instruments are compensated in various ways, irrespective of the basic circuit, so that the meter will indicate a definite value for a good tube, regardless of the type. The meter usually has sectors marked "Good", "Fair", "Reject", etc. This makes the test simple, and, since the customer sees his tubes tested, it eliminates the necessity for his understanding the significance of definite milliamperere readings and the necessity for subtraction when the grid-shift test is used.

Either the "emission" test or the "grid-shift" test give an indication of the condition of an amplifier tube, although the grid-shift test will report more defects than the emission test will. The grid-shift test checks the mutual conductance of the tube, which is a measure of its amplifying properties. It also reveals low emission, since the *initial* and *final* readings of the meter will be lower than normal (although their *difference* might be the same) in a tube of low emission. Usually, however, low emission is revealed in a mutual conductance test by a small "difference reading." A larger "difference reading" than normal is somewhat rare and is usually due to a shifting of the position of the grid with respect to the filament—the filament may sag so that it is closer

to the grid than it should be. The grid then controls the electron flow more than normal. This closer spacing therefore increases the G_m of the tube, but it is not desirable, because of the greater possibility of a "short" occurring between the grid and filament due to the very small clearance between them.

As will be shown in Chapter XIII, many set analyzers are equipped with facilities to shift the bias of tubes under test (using the voltages of the receiver under test), in order to obtain some idea of the worth of the tube in the analyzer. The one trouble with this system is that the result shown by the test is valid only if all the voltages in the receiver are normal. And since the voltages in different receivers of different manufacturers are not the same, comparative readings cannot be obtained.

8-19. Calibrating the Grid-Shift Tester.—In the grid-shift tube tester, as in the emission type, the initial calibration of the tester cannot be made by computation. A number of tubes known to be "good" within practical limits are tested, and the "difference readings" noted. The same procedure is followed for a number of tubes known to be "fair" and for another lot known to be "poor". A chart is then prepared showing what the shift in reading should be for a "normal" tube. This is repeated for every type of tube to be tested. Of course, commercial tube checkers are calibrated at the factory by the manufacturer when made.

8-20. Cathode-Heater Leakage Test.—When an indirect-heater tube becomes noisy, it is almost a positive indication that a leakage path is present between "the cathode" and the "heater". This is the most common and most important of the leakage conditions found in service. The most practical test method for disclosing such leakage consists of observing the plate current reading for the tube when operated with the cathode connected to both B-minus and the heater. Now if the cathode circuit is opened, by disconnecting the cathode, the plate current reading will be "zero" if there is no cathode-heater leakage. If there is any such leakage, the plate circuit will still be continuous, completing its path through this leakage path, and a definite value of plate current will still be indicated by the meter.

Figure 8-9 shows the circuit of a typical cathode-heater leak-

age testing arrangement. The primary P of filament transformer T connects to a 110-volt a-c source. The secondary of this transformer is tapped to secure all different filament voltages required. The plate voltage employed for the tube testing is the supply voltage (the voltage drop across the primary). One side of the primary connects through a resistor R (used to limit the plate

FIG. 8-9.—A typical circuit arrangement employed in tube checkers for making cathode-heater leakage tests.

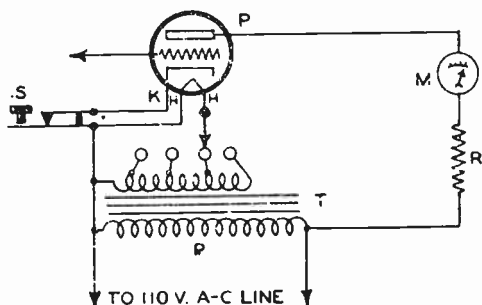

current) and meter M , to the plate of the tube in the socket—a 4-electrode tube in this case. The other end of the primary connects to one side of the filament transformer, to the heater, and to one side of a switch S . The cathode is connected to this same side of the primary through this switch.

Suppose, under the conditions shown, the tube receives normal heater voltage. With the switch closed, as shown, the d-c milliammeter M will read the "average" plate current (since the plate current in this case is a pulsating d-c). If the switch is depressed, the cathode of the tube becomes disconnected from one end of the test-voltage source, and the plate current should drop to zero, since its path has been opened at this point.

A good tube with no leakage will be noted by a zero reading of the meter when S is depressed. If there is a leakage path between the cathode and heater, there will be a complete circuit, and a plate current flowing from the plate to the cathode, then *through the leakage path* to the heater, and thence to the left terminal of the transformer, etc. The meter will indicate the value of this plate current flowing. It will be lower than normal, to be sure, unless there is a direct short-circuit between the cathode and the heater, in which case, the plate current reading will be

the same as it was when the "leakage test" switch was "open".

8-21. Testing for "Shorts" Between Tube Electrodes.—In addition to the foregoing tests, it is essential to know if any of the electrodes of the tube are short-circuited to one another. If such a short-circuit should exist, there is a possibility of burning out the meter because of excessive current. A simple switching circuit that will connect in a small six-volt lamp, or neon bulb, instead of the meter is sufficient. By switching in the *lamp* before the *meter* is connected, excessive currents due to short-circuited elements will be indicated by the lamp. The lamp remains dark if no elements are "shorted".

The number of shorted elements that can be shown by the lamp depends entirely upon the design of the tester. Usually one or two elements, the most frequent offenders, can be indicated. This makes little difference, though, because the purpose of the lamp is to indicate excessive plate current, regardless of which element in the tube is short-circuited; and so long as the plate current is normal, the rest of the tube test may be performed with the meter in the circuit.

An interesting point arises here in connection with tube testing. None of the usual "short" tests that are made on a tube tell which element is causing the trouble. For all practical purposes that knowledge is not important. As long as the tube tester indicates definitely that there is a "short" somewhere, the tube will be discarded and the tester has served its purpose.

8-22. Effect of Line-Voltage Variations Upon Tube Checkers.—Unless some form of line-voltage indicator and compensating adjustments are incorporated in the tube checker, the readings will be seriously affected by line-voltage variations which are encountered in normal practice. If the line voltage is above normal, higher voltages than normal will be applied to the tube under test, and of course the meter readings will be affected correspondingly, so that they are not reliable indicators of the condition of the tube. The same is true if the voltage is too low.

To remedy this condition, provision should be made for measuring the line voltage, and for adjusting the voltages applied to the tubes. In some checkers, the line voltage can be read on the same meter used for the tube test. This feature will be studied

in connection with the commercial tube checkers described in Chapter X.

Line voltage variations are usually compensated for by providing the primary winding of the transformer in the tube checker with taps, so that the proper tap may be selected to provide the correct voltages to the tube under test, even though the line voltage may be above, or below, normal. This feature will also be pointed out in the commercial tube checkers which are described in Chapter X.

8-23. Development of Tube Checker Circuits.—With all of the foregoing tests to be made on a tube, the final circuit of a modern tube checker becomes quite complex, especially to the lay service man. It will be best, therefore, to develop first, step by step, the circuit of a simple tube tester. It should be emphasized that the circuits shown are not intended for constructional purposes—the circuit of such a tester will be described in the next chapter—but merely to show the manner in which the complete circuit of a tube tester is developed step-by-step from the fundamental tube testing ideas which have been presented here.

8-24. Step-by-step Development of a “Grid-Shift” Tube Checker Circuit.—Fig. 8-10 shows a fundamental arrangement which may be used for the testing of 3-electrode tubes. It is

FIG. 8-10.—Fundamental grid-shift type battery-operated tube tester capable of testing 3-electrode tubes only.

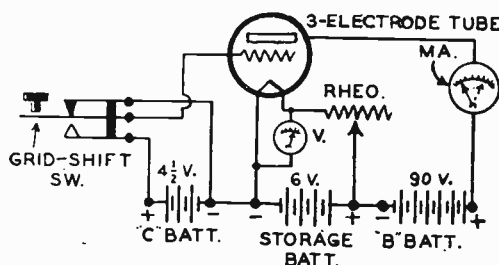

simple, and employs batteries for its operation. A “static” mutual conductance test is obtained by comparing the plate-current reading for the two positions of the grid-test switch (which is usually a S.P.D.T. push-button switch) first in normal position, and second with the switch button pressed. The

latter position changes the "zero" bias impressed on the tube, to a "positive" bias of 4.5 volts (the potential of the "C" battery), causing an increase in the plate current of the tube. This change in plate current may be referred to a chart, previously prepared by testing a number of tubes. The rheostat and voltmeter in the filament circuit serve to adjust the "A"-battery voltage to that required for the tube under test. With this set-up it is impossible to test 5-prong, indirect-heater type tubes. This makes it necessary to add a 5-prong socket to the tester, as shown in Fig. 8-11.*

The disadvantages of these circuit arrangements are apparent. As far as portability is concerned, the apparatus is impractical because of the size and weight of the batteries required. Also, in order that the accompanying "plate-current-change limits" chart be accurate, the battery potentials must be maintained within certain limits, necessitating frequent renewal or re-charging. To overcome these objections, the tube tester may be designed for 110-volt a-c line operation, as shown in Fig. 8-12.

This line-operated tester employs a 7.5-volt filament transformer, with a rheostat and a-c voltmeter, so that the proper

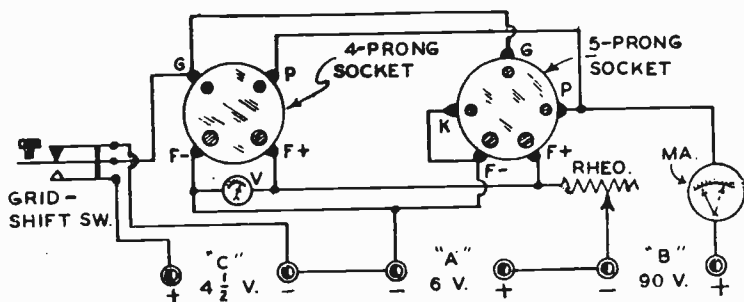

FIG. 8-11.—Here, a 5-prong socket has been added to the tester of Fig. 8-10. This makes it possible to test both 3- and 4-electrode tubes.

filament or heater voltage can be impressed on the tube. The "B" batteries are eliminated by using the line voltage as the source of plate potential. Although the meter in the plate circuit

*NOTE: In both this tester, and others shown in this book, 8-prong sockets may be added in the same way in order to make it possible to test "metal" tubes.

of the tube under test is a d-c instrument, readings are obtained because the tube is acting as a rectifier, and the meter reads the "average" value of the pulsating rectified plate current. Instead of using a 4.5-volt battery to secure the necessary "grid potential change", this potential change is obtained by

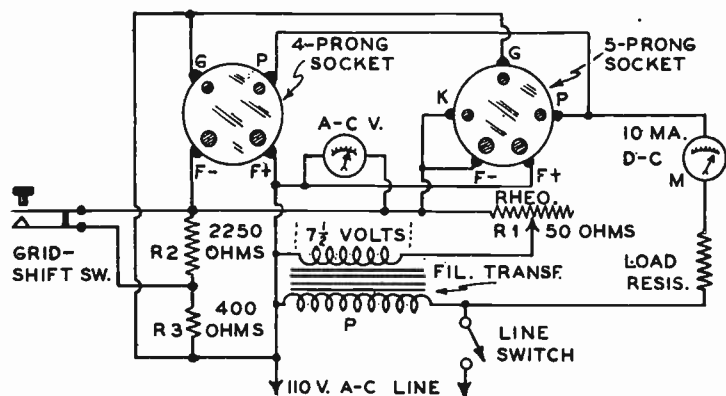

FIG. 8-12.—The tube checker of Fig. 8-11 arranged for operation from the 110-volt a-c line. All batteries have been eliminated in order to provide greater portability and freedom from battery replacement troubles.

short-circuiting part R_2 of the grid-bias resistor $R_2 + R_3$, with the switch marked "grid-shift". The grid-bias voltage is obtained automatically from the fall of potential across R_2 and R_3 , caused by the flow through them of the plate current of the tube being tested. As mentioned, when the "grid-shift" switch is pressed, R_2 is short-circuited, thereby *reducing* the grid-bias and causing an *increase* in the plate current reading.

8-25. Further Refinements in the Simple Tube Checker.

—Even the tube checker of the form shown in Fig. 8-12 is too crude and clumsy. The next step in the development involves the elimination of the filament rheostat and voltmeter. This is accomplished by employing a tapped filament transformer to supply the necessary filament and heater voltages required by the different tubes. By means of a simple tap-switch, any of these voltages can be applied to either tube socket, as shown in Fig. 8-13. In this circuit, the method of obtaining the "grid-shift" voltage involves the use of a portion, or all, of the trans-

former secondary voltage as previously described in Art. 8-17, (and shown in Fig. 8-7). Notice that when the "grid-shift test" switch button is pressed, the grids are connected to the 5-volt tap on the filament winding.

8-26. Providing for Rectifier Tube Tests. — The tube checker developed thus far can test the type '81 tube, and *one plate* of the type '80 tube, by the "emission method," if some

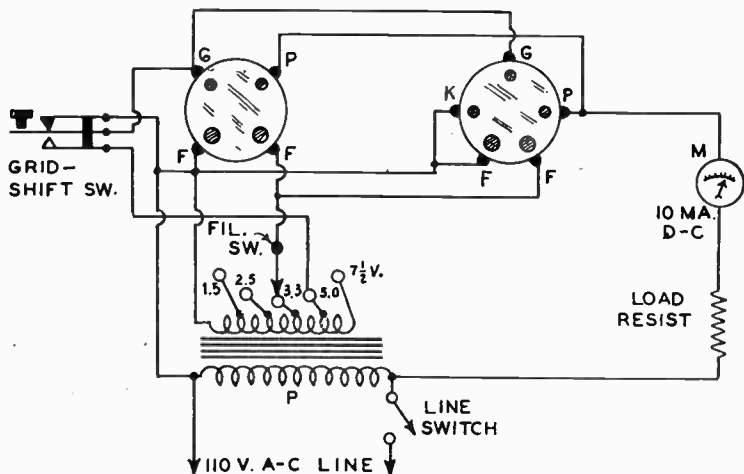

FIG. 8-13.—The tube checker circuit arrangement of Fig. 8-12 further refined by employing a tapped filament winding and the grid bias shift method previously shown in Fig. 8-7.

means are provided whereby the low range 0-10 millimeter can be made to read higher values of plate current. This may be accomplished by the addition of a meter shunt, which is connected across the meter in series with a S.P.S.T. push-button switch which is arranged to *close* the circuit when in its normal position, as shown in Fig. 8-14. The shunt is switched out of the circuit by pressing the switch button, when reading low values of plate current.

It is also necessary to provide some suitable method for checking the emission of the *second plate* of the '80 rectifier tube, and also for detecting short-circuits or leakage between the cathode and heater of indirect-heater tubes. Both of these tests are incorporated into our tube checker by employing another socket,

a S.P.D.T. push-button switch, and a S.P.S.T. push-button switch, as shown in Fig. 8-14. The first switch is so connected that the milliammeter can be inserted in either the plate or the grid lead of the 4-prong '80 socket. Cathode-heater leakage is checked by opening the cathode circuit and observing the meter reading. Since, as previously explained, the cathode is the plate-return of indirect-heater tubes, no plate current should be ob-

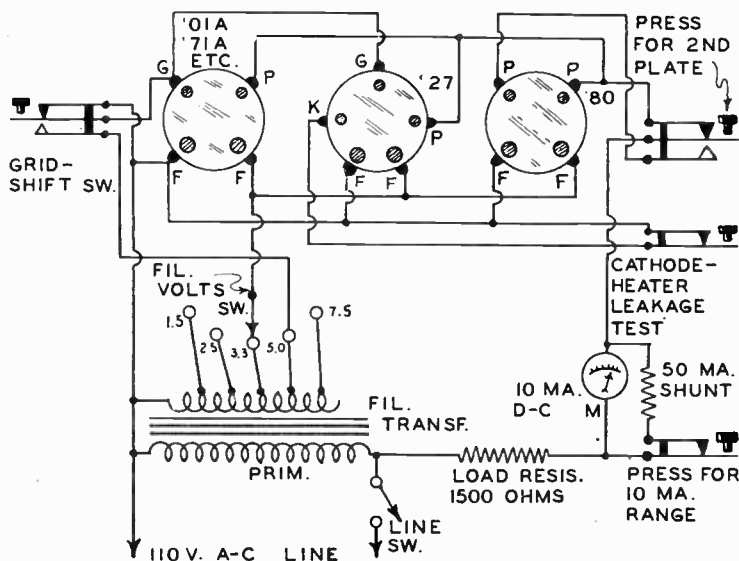

FIG. 8-14.—The tube checker circuit of Fig. 8-13 with additional improvements. A meter shunt and switch, as well as an additional tube socket and plate switch have been added to enable rectifier tubes to be tested. A cathode-heater leakage test switch has also been added.

tained when this switch is pressed. Any reading of the milliammeter indicates cathode-heater leakage.

8-27. Providing for Tetrode and Pentode Tube Tests.

—The 4-prong screen-grid tube, the pentode tube, and the 5-prong screen-grid tube require an additional 4-prong, and two 5-prong sockets. These sockets are incorporated into the tube checker shown in Fig. 8-15. The circuit is essentially that of Fig. 8-14, except for the additional sockets. The screen grids connect directly to the plates, so that the tubes are tested exactly as though they were triodes. The additional sockets required by

tetrodes and pentodes are merely for the purpose of connecting the screen grids to the plates, and the control-grids to clips as shown. For the testing of triple-grid tubes having 6 and 7 prongs, three additional sockets must be added, as shown in Fig.

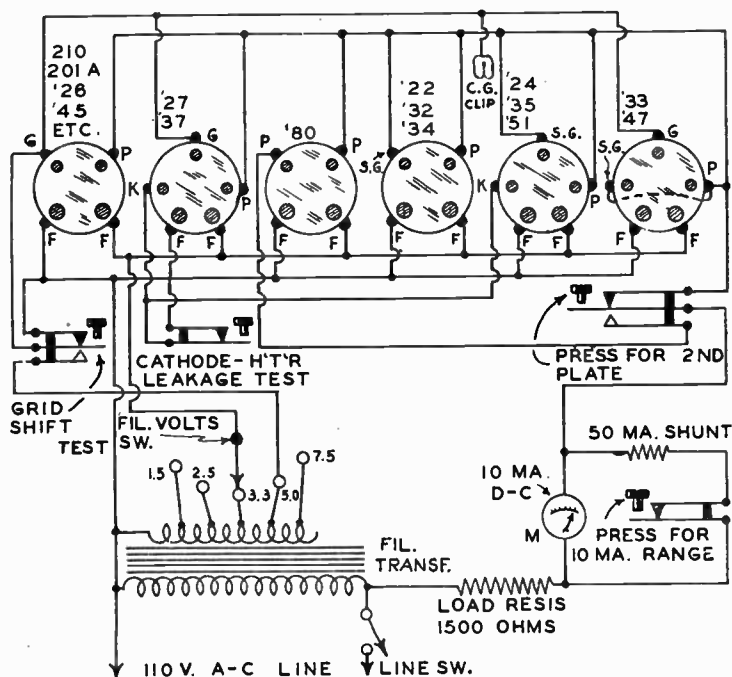

FIG. 8-15.—The tube checker circuit of Fig. 8-14 is here provided with additional sockets so that tetrodes and pentodes may also be tested.

8-16. The important thing to be noted here is that these multi-element tubes are tested as though they are triodes.

8-28. Providing for Testing of Combination Tubes. — In spite of the fact that our tester is now fairly complete, it cannot test many of the combination tubes now in common use. More sockets could be added, requiring perhaps 20 to 30 in all, but portability and weight would be sacrificed. Adapters could be employed, but they require a considerable amount of storage space, are generally considered a hindrance when they are not

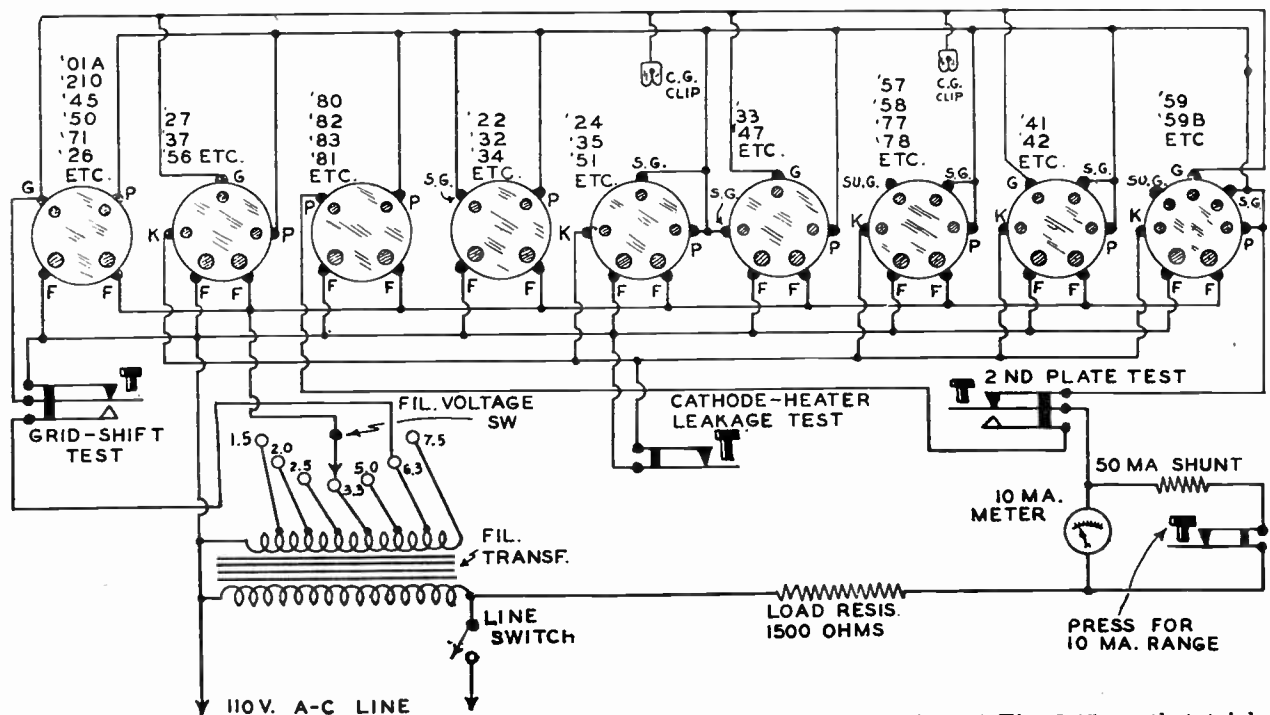

FIG. 8-16.—Here three additional sockets have been added to the tube checker of Fig. 8-15, so that triple-grid tubes may also be tested. This circuit diagram is that of the finished tube checker designed in our step-by-step development.

needed, and are usually found to be missing when required.

Fortunately, however, combination sockets are available—sockets which can accommodate 4- and 6-prong tubes, 4-, 5-, and 6-prong tubes, 6- and 7-prong tubes, etc. By properly combining a number of these sockets, an up-to-date tube tester can be made requiring perhaps one or two adapters for special cases. Such a tube tester, suitable for home construction, will be described in Chapter IX.

8-29. Using Adapters to Modernize Tube Checkers. — Many service men own tube checkers that are out of date, and are therefore unable to test many of the new tubes now in common use. The more serious deficiencies of these obsolete tube checkers may be classified as follows:

- (1) Lack of required new sockets to accommodate the new tube bases and prong arrangements.
- (2) Lack of proper circuits to apply required test voltages to the various elements, and to provide proper inter-connection of different tube elements when necessary.
- (3) Lack of proper filament-supply voltages to operate all types of tubes.

To modernize such testers, adapters must be used with them, unless there is sufficient space available on the tester panel for the addition of more tube sockets and the service man is able to make the necessary wiring changes in the checker. This is not usually practical.

Although it cannot be denied that the ease and speed with which tubes can be tested are reduced when a large number of adapters must be employed, still there are many men who, for one reason or another, do not wish to replace these obsolete test instruments. Usually, the use of adapters for testing the new tubes is the only practical solution to this problem. A number of adapters designed especially for this purpose will now be described. Of course it is impossible to describe every type of adapter here, because of the limited space available. We shall try, however, to present here the fundamental ideas involved in the design of the more commonly used ones. With this knowledge at hand, the reader should be able to understand or work out for himself the arrangements required for any others.

8-30. How to Make Tube Adapters.—Some of the adapters now to be described are available commercially, but they can easily be made up at practically no cost by the service man, if he desires, by using the bases from discarded tubes and small tube sockets that can be fitted into the tube bases. Small

FIG. 8-17.—A suggested arrangement for home-made adapters. The wafer type socket is fastened to the discarded tube base by means of the long machine screw and nut through the center.

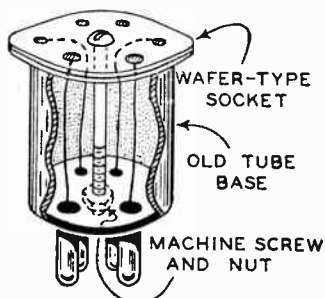

wafer type or button type sockets may be employed and held in position by a long machine screw passing through the center of the socket to the bottom of the tube base, as shown in Fig 8-17. Short insulated wires are connected in the proper order between the hollow pins on the tube base and the tube socket

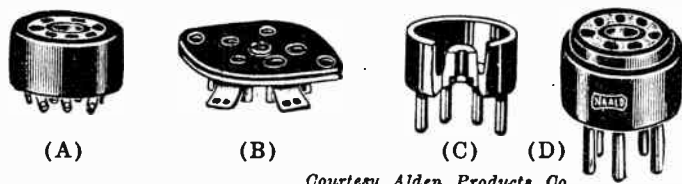

Courtesy Alden Products Co.

FIG. 8-18.—Several commercial components for tube adapters. (A) A "button" type tube socket. (B) A "wafer" type tube socket. (C) Cut-away view of a moulded adapter base. (D) A complete adapter designed to make it possible to test certain 7-prong tubes in 5-hole tube tester sockets.

terminals before assembling. Of course, other mechanical arrangements than that shown here will undoubtedly suggest themselves.

In Fig. 8-18 several typical commercially available adapter components are shown. At (A) we have a button type socket. At (B) is a wafer type socket. At (C) is a cut-away

view of a moulded adapter base which can be obtained with any number of prongs. The recessed portion at the top is designed to take the button-type socket of (A). A complete adapter designed to make it possible to test 2A7 and 2B7 tubes in the '24 socket of a tube tester, and test 6A7, 6B7, 6C7, 6D7, 6E7 and 6F7 tubes in the '36 type socket of the tester, is shown at (D). Notice that it takes a 7-prong tube at the top, and its bottom fits into a 5-prong socket.

Various typical connection arrangements for common "adapting" conditions will now be studied, and the diagrams* showing the exact connections required between the base prongs and the socket contacts of the necessary adapters will be given.

*Note: In order to derive the greatest benefit from this study, the reader is urged to consult repeatedly, the *Tube Base Connection Chart* which will be found in the *Appendix* at the back of this book. He should study the electrode, and socket-terminal, arrangements of each of the tubes discussed, as well as the terminal arrangements of the tube-checker socket to be used in each case. In this way, a clear idea will be obtained concerning the circuit connections the adapter must perform.

In the diagrams of Figs. 8-19 to 8-26 inclusive, the *prongs* of the adapters have been labelled with the old-style terminal markings H, K, P, G (denoting Heater, Cathode, Plate, and Grid, respectively)

CLIP TO CONTROL-GRID
CAP ON TUBE.

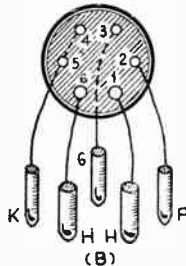
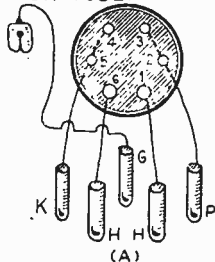

FIG. 8-19.—(A) Wiring of an adapter for testing the 57, 58, 77, 78, 6C6, 6D6, etc. tubes in the '27 or '37 sockets of tube checkers. (B) Adapter for testing the 57, 58, 6C6, 6D6, etc., in the '24 or '36 sockets. (C) A commercial adapter of this type. Notice the flexible lead and clip for connecting to the control-grid cap on the tube.

since these are the ones which are likely to be found on the tube sockets of the old tube checkers into which they must be inserted. The terminals of the *socket* portions of these adapters have been labelled 1, 2, 3, 4, 5, 6 in accordance with the newer RMA standard tube pin marking system, which is employed on the Tube Base Con-

8-31. Adapters for Testing Triple-grid Tubes.—When the tube checker comes already equipped for testing type '27 or '37 tubes, the adapter shown at (A) of Fig. 8-19 may be used for testing type '57, '58, '77, '78, etc., triple-grid 6-prong heater-type

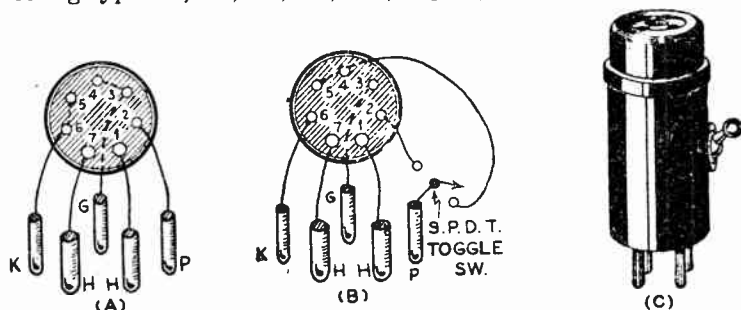

FIG. 8-20.—(A) Wiring of an adapter suitable for testing the 2A7, 6A7, 6D7, 6E7, etc., tubes in a '24 or '36 socket of a tube checker. (B) Wiring of an adapter for testing the 2B7 and 6B7 tubes in a '24 or '36 socket. (C) A typical commercial adapter of this general type. Notice the toggle switch at the side.

tubes. This adapter is made up of a 6-hole socket (at the top) wired properly, as shown, to a 5-prong tube base (bottom). The control-grid clip and lead are connected to the "grid" prong of the base, as shown.

If the tube checker already has facilities for testing '24 or '36 type tubes, the adapter shown at (B) may be constructed instead, since the necessary lead and clip which connect to the control-grid cap on top of the tube are already incorporated in the tester.

8-32. Adapters for Testing "Combination Tubes."—The adapter shown at (A) of Fig. 8-20 is constructed with a 7-hole socket and a 5-prong base for use in a '24 or '36 socket of a tube checker when 2A7, 6A7, 6D7, 6E7, and similar type tubes are to be tested. Should it be desired to test the type 2B7 and 6B7 tubes, the adapter shown at (B) must be employed.

A 7-hole socket and 5-prong base is used here, but a small S.P.D.T. toggle switch must be fixed to the side of the tube base to make possible the individual testing of the diode and pentode portions of the tube. This adapter should be used in either the '24 or '36 socket of the tube checker.

nection Chart referred to above, and which will be found on all the newer sockets which may be used for these adapters.

An adapter suitable for checking the type 55, 75, 85, 2A6 and similar type tubes in the '27 or '37 socket of a tube checker is shown at (A) of Fig 8-21. This adapter is constructed with a 6-hole socket and a 5-prong tube base with a small S.P.D.T. toggle

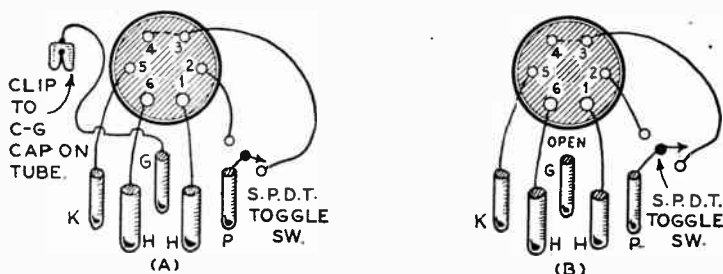

FIG. 8-21.—(A) Wiring of an adapter for testing the 55, 75, 85, and 2A6 tubes in the '27 or '37 socket of a tube checker. (B) Wiring of an adapter for testing the 55, 75, 85, and 2A6 tubes in a '24 or '36 socket of a tube checker.

gle switch at the side for testing the diode and triode portions of the tube separately. If the tube checker is equipped for testing type '24 and '36 tubes, the control-grid lead and clip may be dispensed with by assembling the adapter shown at (B).

The type '53 twin-triode amplifier tube may be tested in the

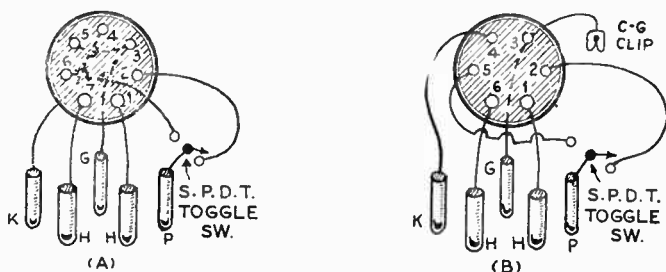
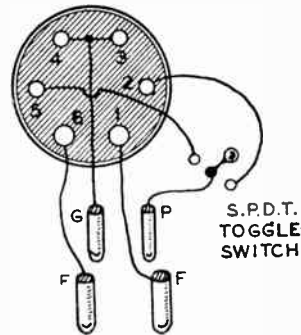

FIG. 8-22.—(A) Wiring of an adapter for testing the 53 tube in the '27 socket of a tube checker. (B) Adapter for testing the '79 tube in the '37 socket of a tube checker.

'27 socket of any tube checker with the adapter shown at (A) of Fig. 8-22. In this adapter, a S.P.D.T. toggle switch must be employed so that a test of each plate of the tube may be made separately. A similar adapter shown at (B) may be constructed

for testing the '79 twin-triode amplifier tube, in the '37 socket of a tube checker. A S.P.D.T. toggle switch must be installed on the side of the tube base of the adapter, as shown. This enables each plate circuit of the tube to be tested separately.

FIG. 8-23.—An adapter for testing the '19 tube in the '45 socket of a tube checker.



The type '19 B twin-triode class B amplifier tube may be checked in the '45 socket of a tube tester by using the adapter shown in Fig. 8-23. This adapter is also equipped with a S.P.D.T. toggle switch mounted on its side. This switch enables each plate circuit of the tube to be tested separately.

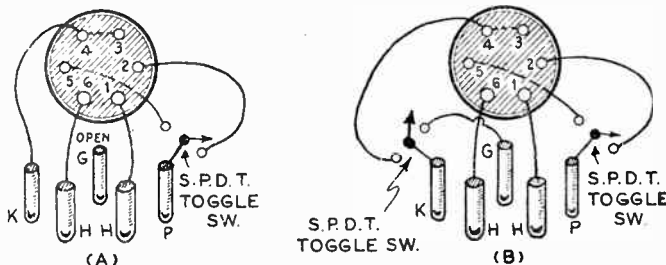

FIG. 8-24.—(A) Wiring of an adapter for testing 25Z5 tubes in the '27 socket of a tube tester able to supply 25 volts to the filament. (B) A single adapter for testing both the '19 and 25Z5 tubes. Two switches are employed.

8-33. Adapters for Testing Tubes with High-Voltage Filaments. —A number of recent tubes have filaments designed to operate on higher voltages than were used in the older types of tubes—higher than the filament voltage which most of the older

tube checkers will supply. When these tubes are to be tested in old tube checkers, the proper filament voltage must usually be supplied by some external source, and adapters must be used. Two convenient combination external voltage source and adapter units for this purpose will be described in Arts. 8-35 and 8-36.

If the tube checker is able to supply the necessary 25-volt potential for the filament, the adapter shown at (A) of Fig. 8-24 may be constructed for testing the 25Z5 voltage-doubler tube in an old tube checker. A S.P.D.T. toggle switch is incorporated

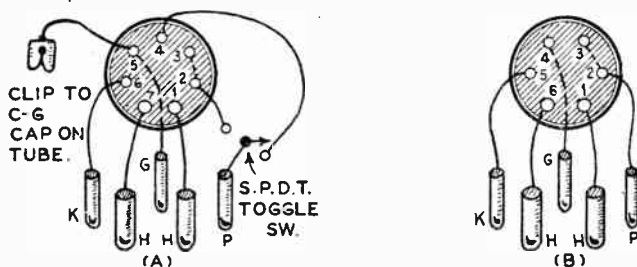

Fig. 8-25.—(A) Wiring of an adapter for testing the 6F7 tube in the '37 socket of a tube checker. (B) Adapter for testing the 41 and 42 tubes in the '37 socket.

for testing each plate circuit separately. If the correct filament voltage is available, the adapter should be used in any test socket of the tube checker which has its plate and cathode terminals in the conventional 5-prong position shown.

If desired, a single adapter may be constructed for testing both the '19 and 25Z5 tubes, as shown at (B) of Fig. 8-24. Here, two S.P.D.T. toggle switches must be installed, one on each side of the adapter, so that each plate circuit may be tested separately, and the grids and cathodes connected to their correct terminals. The adapter is placed in the '27 socket for the tester, for the '19 tube; but the 25Z5 requires a filament voltage of 25 volts (see Art. 8-35).

The adapter shown in (B) of Fig. 8-25 may be employed to test the '43 power amplifier pentode if 25 volts is available for the filament.

8-34. Miscellaneous Adapters.—The type 6F7 tube may be

tested in the '37 socket of a tube checker by means of the adapter shown at (A) of Fig. 8-25. The S.P.D.T. toggle-switch enables each section of the tube to be tested in turn. The adapter shown at (B) permits the testing of power amplifier pentode tubes, such as the '41 and '42, in the '37 socket of any tube checker.

The 6Z5 may be tested in the '37 socket of a tube checker by means of the adapter shown at (A) of Fig. 8-26. A toggle switch is provided on the side of the adapter so that each plate circuit of the tube may be tested separately. The adapter

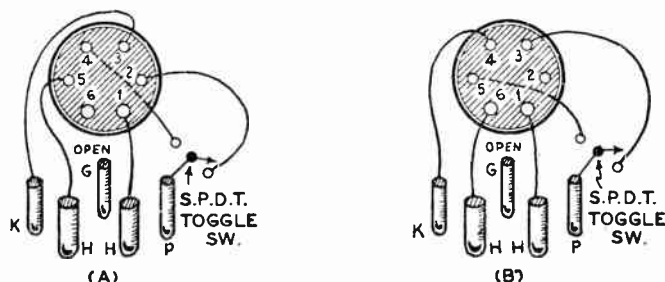

FIG. 8-26.—(A) Wiring of an adapter for testing 6Z5 tubes in the '37 socket of a tube checker. (B) An adapter for testing 6Y5 tubes in the '37 socket of a tube checker.

shown at (B) may be used to test the 6Y5 rectifier in the '37 socket of the tube checker. Both plate circuits may be tested separately by means of the toggle switch.

Many more tube adapter circuits could be described here, but it is felt that those already presented will give the reader sufficient knowledge of this subject to enable him to understand what adapters are, how they may be constructed and how they may be devised to perform any desired function.

8-35. "Na-ald" 950 T R Adapter for Testing Tubes with High-Voltage Filaments.—In Art. 8-33, the testing of several 25-volt filament tubes in old-type tube testers was described. Obviously, very old tube checkers were not designed to supply this high filament voltage. Of course, a new filament transformer capable of delivering the required voltages could be built into the old tube checker, but this is usually a rather complicated (and often impracticable) task, and is not often advisable.

The problem has been solved by one manufacturer of adapters, with the unit shown in Fig. 8-27. It is an adapter containing a built-in filament transformer and switch, and not only provides the necessary high filament voltages, but makes it possible for old tube checkers to test these tubes as well. This adapter is plugged into the '24 socket of the tube tester. Its transformer primary obtains its current (at 2.5 volts) from the heater prongs of the socket. Its secondary is designed to deliver 10, 13, 14, 15, 25 or 30 volts (these are not all shown in the diagram of Fig. 8-28) to the filament of the tube under test, so that it makes



Courtesy Alden Products Co.

FIG. 8-27. — A tube-checking adapter which enables tubes with high-voltage filaments to be checked. It has a self-contained step-up transformer—see Fig. 8-28. (Na-ald 950TR adapter.)

possible the testing of all high-voltage filament type tubes. Thus, it enables the old tube checker to test these tubes.

As is evident from Fig. 8-27, this adapter has composite 4-5-6 prong sockets, i.e., sockets made to take four, five and six-prong tubes. Each is identified by a letter referred to in the direction chart on the bottom of the adapter. It makes it possible to test all high-voltage filament tubes such as the 12Z3, 14, 17, 18, 25Z3, 25Z5 (each plate), 43, 48, 96, 262A, 272A, A22, A26, A28, A30, A32, A40, A48, AE, HZ50, RA1, S01, etc. Its schematic circuit diagram is shown in Fig. 8-28.

8-36. "Radio City" Model 205 Super Multidapter. — A very comprehensive tube testing adapter, which possesses several unusual features and is designed to be used in conjunction with any obsolete tube checker, is illustrated in Fig. 8-29. Its circuit diagram is shown in Fig. 8-30. It aims to eliminate the usual deficiencies of obsolete testers, and is designed to bring them up to date at normal cost. It also supplies correct filament voltages (up to 30 volts) for all of the high-voltage-filament type tubes.

An unusual feature of this adapter is that it causes *all* tubes to be tested as *triodes*, since the triode test circuit is the fundamental test circuit of almost all obsolete tube checkers. A description of its essential important features follows:

The 4-prong plug (shown at the lower left) of the cable is inserted into the '01A socket of the old tester. The tube to be tested

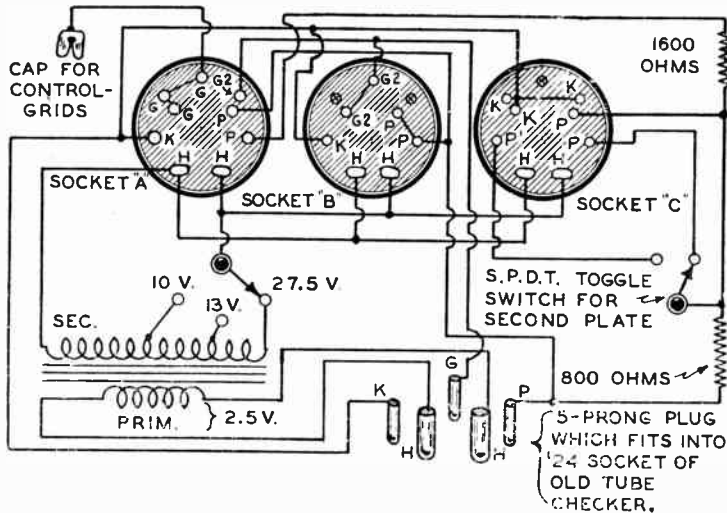

FIG. 8-28.—Schematic circuit diagram of the special tube-checking adapter illustrated in Fig. 8-27. Notice the step-up transformer for stepping up the low filament voltage supplied by the tube checker, to the higher filament voltage required by some types of tubes.

is inserted into the proper tube socket of the adapter (it has a total of 5 sockets, as can be seen in the illustration of Fig. 8-29).

When tubes having filaments designed to operate on 2.5, 3.3, 5 or 7.5 volts are being tested, switch *SW2* is set at contact *X*. This connects the tube filament circuit directly into the filament circuit of the tube checker; the tube checker supplies the correct filament voltage. When testing tubes requiring filament voltages which the old tube checker cannot supply, this switch is placed at the proper voltage tap on the secondary of transformer *T1*. The 5-volt primary of this transformer is now energized from the filament terminals of the '01A socket in the tube checker, and its secondary delivers the proper filament voltage to the tube under test. This transformer winding is designed to deliver as high as approximately 30 volts to the filament.

Resistor *R1* is connected into the plate circuit by pressing switch



Courtesy Radio City Products Co.

FIG. 8-29.—The tube testing adapter unit whose circuit diagram is shown in Fig. 8-30. (Super-multidapter Model 205.)

SW1, and serves to reduce the plate current to a safe value when the meter on the old tester goes off scale in cases when some of the newer high-plate-current tubes are being tested.

Four flexible cords *P*, *P*, *G*, *K* (see Fig. 8-30) with miniature plugs, permit every possible inter-connection of the elements, involving plates, grids, screens and cathodes, to be made easily and quickly, by inserting them properly into the tip-jacks *J1*, *J2*, etc., provided on the panel.

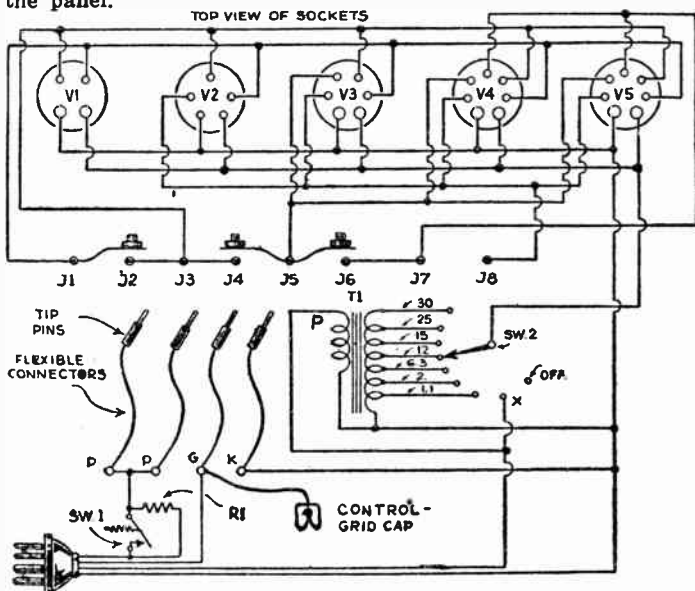

FIG. 8-30.—Schematic circuit diagram of the tube testing adapter illustrated in Fig. 8-29. The transformer *T1* steps up the filament voltage supplied by the old-style tube checker to the proper values required by all types of modern tubes.

8-37. Dynamic Mutual Conductance Tube Test.—The common “grid-shift” method of mutual conductance testing (Art. 8-15), whereby the grid potential is shifted by a d-c voltage, is really a test made under “static” conditions and imposes limitations not encountered in the “dynamic” mutual conductance test. The latter method is superior to the “static” test in that a-c voltage (instead of d-c voltage) is applied to the grid for grid shift. Thus, the tube is tested under conditions which approximate actual operating conditions. The alternating component of the plate current is read by means of an a-c ammeter of the dynamometer type. Commercial tube testers employing this method of testing are available.

8-38. **The Power Output Type Tube Test.**—The *power output type tube test* probably gives the best correlation between test results and actual *operating* performance of a tube.

In the power output test for Class A operation of tubes, a-c voltage is applied to the grid of the tube. When this is done, the a-c output voltage developed across a load impedance in the plate circuit is measured. From this, the output power is calculated.

In the power output test for Class B operation of tubes, while an a-c voltage is applied to the grid of the tube, the current in the plate circuit is read on a d-c milliammeter. The power output of the tube is approximately equal to:

$$\text{Power Output (watts)} = \frac{(\text{d-c current in Amps.})^2 \times \text{Load resist. in ohms}}{0.405}$$

and may be calculated by this relation. Commercial checkers employing this power output test method are available.

REVIEW QUESTIONS

1. What is the difference between the type of test provided for in the usual "counter type" tube checker, and the tube testing arrangement provided in a portable set-analyzer?
2. What is the advantage, if any, of the former for testing tubes?
3. State two reasons why the "replacement test" for tubes is not a satisfactory test under modern set conditions.
4. Draw a sketch showing all of the electrodes, in their proper relative positions, in a pentode tube. Explain the function of each electrode.
5. What test is applied to rectifier tubes to determine their condition? Explain!
6. What is meant by an "English-reading" tube tester? Explain!
7. Explain in your own words, just what is meant by the "mutual-conductance" of an "amplifier tube".
8. Why is the mutual-conductance test good for amplifier tubes?
9. What is the fundamental principle of operation of mutual-conductance type tube testers? What are their advantages over emission testers?
10. What two methods are employed in tube checkers to obtain plate-current changes?
11. Draw a simple sketch illustrating one of these methods, and explain it.
12. In the sketch drawn to answer the preceding question, show the usual method employed to perform a cathode-heater leakage test.
13. What are the advantages of using tube adapters with an obsolete tube checker? What are the disadvantages?
14. Your tube checker can test a type '37 tube. Draw a diagram of an adapter that would enable the testing of a 6Y5 tube using this same socket.
15. Draw a sketch of an adapter for testing the 6F7 tube in the '37 socket of a tube checker.
16. What filament voltage provisions must your tube checker have for testing both the type 48 and 25Z3 tubes?

CHAPTER IX

HOW TO CONSTRUCT A MODERN TUBE CHECKER

9-1. Introduction.—In spite of the great number of excellent commercial tube checkers which are available, many service men prefer to build their own instruments, either because of the personal satisfaction obtained thereby, or for reasons of economy. In any event, it is certain that a service man will have a good idea of the limitations of his instrument if he has constructed it himself. The one difficulty involved is that of calibration of the finished instrument. A great variety of "good" tubes are required for this calibration, and each tube must be tested carefully. If the proper variety is available, good calibration is simply a matter of time and patience. If it is impossible to secure the proper number and class of tubes of each type, the instrument may be used only for comparative purposes—the change in plate-current reading of a similar tube in the set (a tube known to be good), is compared to the change in reading of the tube under test.

For those interested in constructing their own tube checkers, the design and construction data for a modern, practical instrument is presented in this chapter. This instrument makes practical use of the "grid-shift" method of amplifier tube testing studied in the preceding chapter.

9-2. Which Tubes the Checker Will Test.—It is natural to suppose that before considering the construction of any tube checker, the reader will desire to know just which types of tubes the checker will be able to test. This instrument is capable of testing all of the tubes (approximately 150 different types) listed in the chart of Art. 9-19. Its circuit arrangement is so flexible that it is probable that it can also be adapted to test most of the later types of tubes which may be marketed in the future.*

*NOTE: See footnote at bottom of page 212.

9-3. Two Possible Socket Arrangements Considered.—

Before deciding upon the exact design of the checker, described in this chapter, two possible arrangements were considered. Either a multi-contact multi-gang switch could be employed with individual 4-, 5-, 6- and 7-prong sockets, or, a larger number of individual sockets could be used to accommodate all the tubes, without this complicated switching arrangement and wiring. The first design would require rather complicated wiring and a fairly expensive switch not readily obtainable by individual constructors. The use of a number of individual sockets would eliminate these difficulties. Therefore, the latter arrangement was adapted. Since "composite" type tube sockets for 4-, 5- and 6-prong, 5-, 6- and 7-prong, and 5- and 7-prong tubes can be procured easily and at small cost, the tube checker was designed with *12 sockets, enabling over 150 different types of tubes to be tested.* The circuit diagram of the complete tube checker is shown in Fig. 9-1. A suggested layout for its front panel is shown in Fig. 9-2.

9-4. How Amplifier and Rectifier Tubes are Checked.—

Amplifier tubes are tested by means of the grid-shift method, which indicates their "relative" mutual conductance. The mutual conductance is determined by changing the bias on the grid of the tube by a definite amount (always 7.5 volts), so that an accurate "tube condition" chart may be prepared. Because of probable differences in the parts which may be used in the construction of this instrument, and the possibility of variations in line voltage, etc., no chart of plate-current limits is given here. After the checker is completed, several tubes of *each type*, which are known to be "perfect", "fair" and "poor", respectively, should be tested, and the plate-current change obtained for each of them should be noted and recorded, so that a complete chart (see Art. 9-19) may be prepared and used for all future tests.

The circuit has been arranged to provide comparatively large changes in plate current reading, so that the relative mutual conductance (see Art. 8-15) of any amplifying tube may be determined quickly and easily. Both sections, or plates, of rectifier tubes and combination tubes may be tested. Rectifier

tubes are tested for "plate emission". Cathode-heater leakage tests, a test for "short-circuited" elements, and a "gas test" can also be made.

9-5. Meter Ranges Available.—The meter employed in the tube checker is a 10 ma. d-c milliammeter. This range was selected so that a large deflection would be obtained when testing most detector and amplifier tubes. For power amplifiers and rectifiers, and for those tubes which have a high plate current, the fundamental range of the meter is extended to 50 ma. by means of a 50-ma. shunt. This shunt is normally connected across the meter so that the 50-ma. range is the one normally obtained, but by means of the normally closed-circuited S.P.S.T. push-button switch *S3*, it may be removed quickly from the circuit to obtain the lower range. This arrangement serves as a protection for the meter.

9-6. Filament Transformer and Switches.—All heater and filament voltages are supplied by a small, tapped filament transformer, *T*, providing voltages of 1.5, 2.0, 2.5, 3.3, 5.0, 6.3, 7.5, 15.0, 25.0 and 30 volts. Any *one* of these voltages may be impressed upon *all* of the test sockets through the 12 point tap-switch *S1*, so that tubes of like characteristics or electrode arrangement (but of different filament or heater rating), may be tested in the same socket. This system also reduces the possibility of a tube being burned out accidentally because of insertion in the wrong socket, since the voltage at each socket is the same at any one setting of the switch. These filament voltages are also brought out to a pair of pin-jacks located on the side of the panel, permitting external, overhead-heater type tubes to be tested by means of an adapter. These pin-jacks also provide a convenient outlet for the low-voltage a-c, which may be utilized in conjunction with an a-c milliammeter or voltmeter, for checking high capacities (see Arts. 6-5 and 6-6).

The primary of the transformer is tapped for 105-, 115-, and 125-volt operation, permitting, by means of the S.P.T.T. toggle-switch *S-11*, the making of tube tests under constantly similar filament-voltage conditions, even though the usual variations in line voltage may be encountered. Of course the "plate" voltages will vary with any line-voltage variations. Since this type

of switch has a "neutral" position, it also serves as an "off-on" line switch.

9-7. How "Short-Circuit", "Leakage" and "Gas" tests are made.—A "short-circuit" test has been incorporated in the checker to prevent damage to the milliammeter in the event that a tube having two or more elements short-circuited together is inserted. Before a tube is plugged into any of the test sockets, the S.P.D.T. toggle-switch $S5$ should be thrown into the "short" test position. The small 6-volt pilot light bulb will light up if the elements of a tube are short-circuited to such an extent that the meter might become damaged. This flash of the bulb serves as an instantaneous warning.

A separate cathode-heater leakage test is provided by means of the closed-circuit S.P.S.T. push-button switch $S12$. Because of its position in the cathode circuit, the meter reading should drop to zero immediately, when this switch is depressed. If any deflection is obtained, it indicates that there is either a leakage path or a "dead short" between the cathode and the heater of the tube.

Control-grid-to-cathode (or to filament) short-circuits will be indicated, when the "grid test" switch button is pressed, by *no* change in the meter reading.

A "gas" test is provided by the 500,000-ohm resistance $R3$ in the grid circuit. This resistance is shunted by a closed-circuit S.P.S.T. push-button switch, $S6$, and is normally short-circuited by this switch. When the switch-button is pressed, the presence of gas will be indicated by a change in plate current, due to the voltage-drop across the high resistance. This voltage-drop is caused by the grid current which flows if the tube is "gassy".

9-8. Testing Rectifiers and Combination Push-pull Tubes.—The second section of dual-purpose, or push-pull, tubes and the second plate of rectifier tubes are checked by means of the S.P.D.T. push-button switch $S2$. Each diode of duo-diode type tubes is given an individual test as a rectifier by pressing the S.P.D.T. push-button switches $S9$ and $S10$. At the same time, however, it is necessary to press the "second plate" switch, $S2$, in order to disconnect the regular plate element from the circuit and connect the diode section of the tube to the meter.

9-9. **Types of Sockets Employed.**—As will be seen from the circuit diagram of Fig. 9-1, only 12 test sockets are employed in the instrument.* Ten of these are of the "composite" type. These were used purposely to reduce the number of different sockets to a minimum, and to provide for the testing of future types of tubes whose characteristics may be such as to permit their being tested in one of the twelve sockets.

Three of the composite sockets are of the 4-5-6-prong type. Typical sockets of this kind are illustrated at (A) of Fig. 9-3. These sockets have 9 contacts, only the filament contacts being common. A composite 5- and 7-prong socket, pictured at (B), is employed for testing 5- and 7-prong pentode tubes, such as the 46, 47 and 59. This socket has eight contacts, all being common except the No. 4 contact of the 5-prong and the No. 6 contact of the 7-prong portions. Two composite 5-6-7-prong sockets are also used. One is pictured at (C). Of the remaining six sockets; four are of the composite 7-prong type for both small and medium 7-prong tubes, pictured at (D). The other two are standard 6-prong sockets. A suggested panel layout for the entire checker is shown in Fig. 9-2.

9-10. **What Socket No. 1 Tests.**—The first socket, No. 1 in our tube checker (see Fig. 9-1), is a composite 4-5-6-prong type for testing all triode amplifiers such as the 01A, 26, 45, 27, 56 etc.; pentode amplifiers, such as the 41, 42, 48, LA, etc.; and all half-wave cathode type rectifiers, such as the 1, 1V, 6Z3, 12A3, AD, etc. When these rectifier tubes are tested, a cathode-leakage indication will be obtained only when the "gas test" button is pressed. Because of the presence of the 500,000-ohm resistor *R3*, a zero reading should not be expected.

9-11. **What Socket No. 2 Tests.**—Socket No. 2 is also a composite 4-5-6-prong type. Here, almost every tube of screen grid construction such as the 22, 32, 24, 35, 51, 57, 58, 77, 78, 6C6, 6D6, etc., may be checked.

9-12. **What Socket No. 3 Tests.**—Socket No. 3 is a composite 5- and 7-prong unit described previously for the testing of pentode tubes such as the 59, 59B, 47, types, etc., and dual grid

*NOTE: Additional 8-prong sockets may be added for testing "metal" tubes.

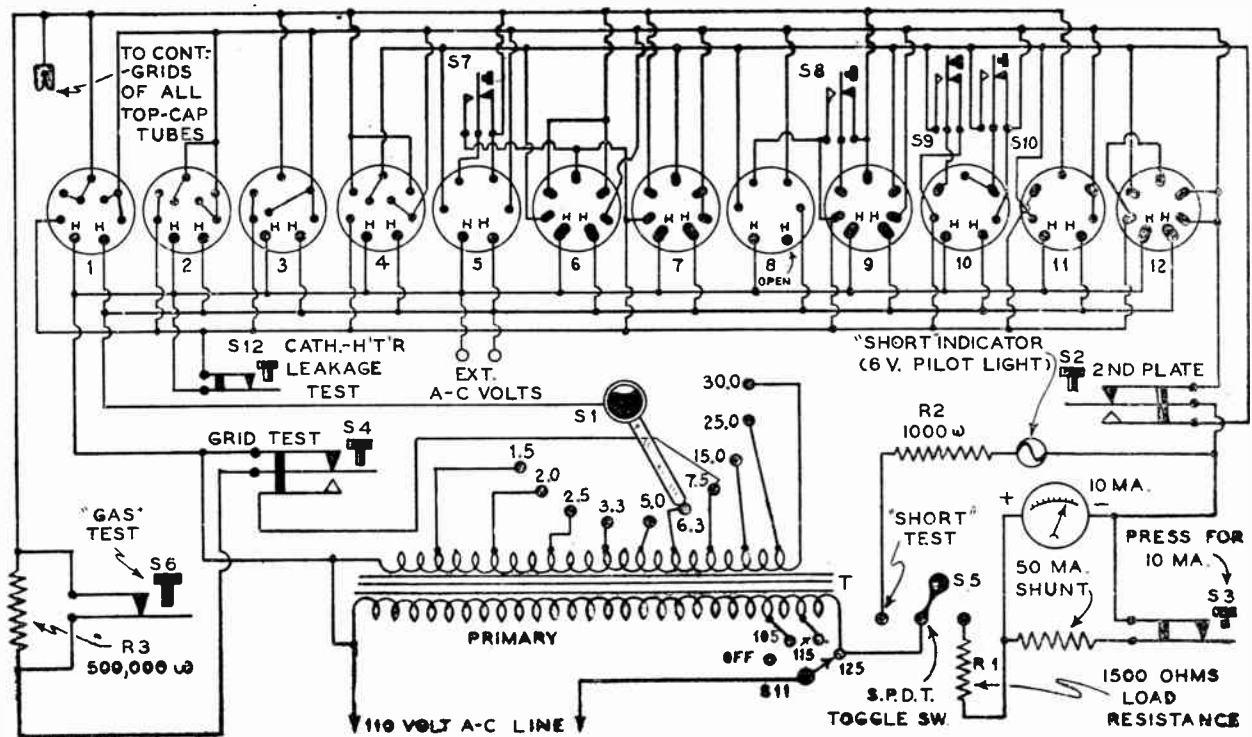

FIG. 9-1.—The complete schematic circuit diagram of the tube checker described in this chapter. The panel layout is shown in Fig. 9-2.

amplifier tubes such as the 46, 49, 52, LA, etc.

9-13. What Socket No. 4 Tests.—This is the last of the composite 4-5-6-prong test sockets. This socket will also be used a great deal, since full-wave rectifying tubes, such as the 80, 82, etc.; twin grid detector tubes, such as the 29, 69 and 70; duplex diode tubes such as the G2, G4, Wunderlich B, etc., may be tested in it.

9-14. What Socket No. 5 Tests.—A 6-prong socket is employed as our fifth test socket for testing the dual tubes type 19 and 79, and the voltage-doubler 25Z5. The S.P.D.T. switch S7 is connected in this circuit. This switch should be pressed only when testing the type '79 tube. Unless this is done, no plate current change will be noted when the "grid test" button is pressed. To test for cathode leakage in the 25Z5, the "gas test" button must be used, just as in the case with half-wave cathode-type rectifiers. A "zero" reading, however, should not be expected.

9-15. What Sockets Nos. 6, 7, 8, 9 Test.—The type 53 push-pull output tube is tested in socket *No. 6*, a composite 7-prong socket. Socket *No. 7* is a 7-prong composite type for the testing of 2F7 and 6F7 tubes. Socket *No. 8* is a standard 6-prong socket for testing the 6Z5 and 12Z5 tubes. It should be noted that one "heater" terminal of this socket is left unconnected. Socket *No. 9* is also a 7-prong composite type for testing the 2B6 push-pull output tube. Because the input cathode of the 2B6 tube is tied internally to the output grid, it is necessary to depress the S.P.D.T. switch S8, and the "second plate" switch, when the *input* portion of this tube is being checked. Leakage between the input cathode and heater is read by pressing both S8 and the regular "leakage" button.

9-16. What Socket No. 10 Tests.—This is a composite 5-6-7-prong socket for testing the pentagrid converters 2A7, 6A7, 6D7, 6E7, etc., and duo-diode amplifiers such as the 55, 75, 85, 2B7, 6B7, etc. Diode current for each diode is checked by first pressing switch S9 and then switch S10, while holding down the "second plate" switch button.

9-17. What Socket No. 11 Tests.—This is a 5-6-7-prong composite type socket for testing the 12A5 and 6Y5 tubes. The

latter tube is a rectifier employed in many automobile radio receivers.

9-18. What Socket No. 12 Tests.—The twelfth and final socket of our tube checker is a composite 7-prong type for testing the 12A7 tube. This tube is a combination pentode amplifier and half-wave cathode-type rectifier. Provisions for testing

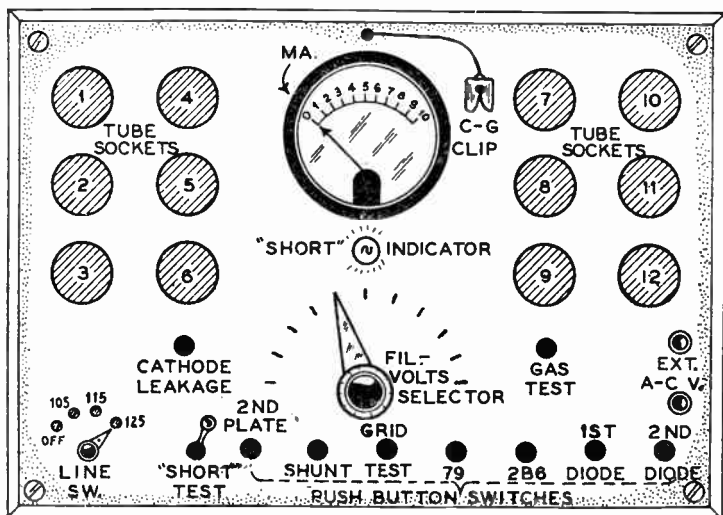

Fig. 9-2.—A suggested front panel layout for the tube checker of Fig. 9-1.

this tube were included because it has been used in small midget receivers, thousands of which are in use, and it may be used in more receivers in the future.

9-19. Test Chart for the Tube Checker.—For the reasons already explained in Art. 9-4, a complete test chart for the tube checker will not be given here. However, a list of the tubes which may be checked, filament switch setting, and the number of the particular socket which each tube must be inserted into for test is given herewith. The tube type numbers are arranged numerically and alphabetically in Column 1. The second column indicates the setting of the filament switch *S1*. In most cases, the voltage indicated is correct for that type tube, but since no 3-volt, 12.5-volt, or 14-volt taps are available on the power trans-

TEST CHART FOR TUBE CHECKER SHOWN IN FIG. 9-1

| <i>Tube Type</i> | <i>Set Fil. Sw. at (Volts)</i> | <i>Use Socket No.</i> | <i>Tube Type</i> | <i>Set Fil. Sw. at (Volts)</i> | <i>Use Socket No.</i> |
|------------------|--------------------------------|-----------------------|------------------|--------------------------------|-----------------------|
| '00A | 5.0 | 1 | 55 | 2.5 | 10 |
| '01A | 5.0 | 1 | 56 | 2.5 | 1 |
| '01AA | 5.0 | 1 | 56A | 6.3 | 1 |
| 1 | 6.3 | 1 | 57 | 2.5 | 2 |
| 1V | 6.3 | 1 | 57A | 6.3 | 2 |
| 10 | 7.5 | 1 | 57AS | 6.3 | 2 |
| 12 | 5.0 | 1 | 58 | 2.5 | 2 |
| 12A | 5.0 | 1 | 58A | 6.3 | 2 |
| 13 | 5.0 | 4 | 58AS | 6.3 | 2 |
| 14 | 15.0 | 2 | 59 | 2.5 | 3 |
| 15 | 2.0 | 2 | 59B | 2.5 | 3 |
| 16 | 7.5 | 4 | 64 | 6.3 | 2 |
| 17 | 15.0 | 1 | 64A | 6.3 | 2 |
| 18 | 15.0 | 1 | 65 | 6.3 | 2 |
| 19 | 2.0 | 5 | 65A | 6.3 | 2 |
| 20 | 3.3 | 1 | 67 | 6.3 | 1 |
| 22 | 3.3 | 2 | 67A | 6.3 | 1 |
| 24 | 2.5 | 2 | 68 | 6.3 | 2 |
| 24A | 2.5 | 2 | 68A | 6.3 | 2 |
| 26 | 1.5 | 1 | 69 | 6.3 | 4 |
| 27 | 2.5 | 1 | 70 | 6.3 | 4 |
| 29 | 2.0 | 4 | 71 | 5.0 | 1 |
| 30 | 2.0 | 1 | 71A | 5.0 | 1 |
| 31 | 2.0 | 1 | 75 | 6.3 | 10 |
| 32 | 2.0 | 2 | 76 | 6.3 | 1 |
| 33 | 2.0 | 3 | 77 | 6.3 | 2 |
| 34 | 2.0 | 2 | 78 | 6.3 | 2 |
| 35 | 2.5 | 2 | 79 | 6.3 | 5 |
| 36 | 6.3 | 2 | 80 | 5.0 | 4 |
| 36A | 6.3 | 2 | 80M | 5.0 | 4 |
| 37 | 6.3 | 1 | 81 | 7.5 | 4 |
| 37A | 6.3 | 1 | 81M | 7.5 | 4 |
| 38 | 6.3 | 2 | 82 | 2.5 | 4 |
| 38A | 6.3 | 2 | 83 | 5.0 | 4 |
| 39 | 6.3 | 2 | 83V | 5.0 | 4 |
| 39A | 6.3 | 2 | 84 | 6.3 | 4 |
| 40 | 5.0 | 1 | 85 | 6.3 | 10 |
| 41 | 6.3 | 1 | 89 | 6.3 | 1 |
| 42 | 6.3 | 1 | 90 | 2.5 | 4 |
| 43 | 25.0 | 1 | 92 | 6.3 | 4 |
| 44 | 6.3 | 2 | 95 | 2.5 | 1 |
| 45 | 2.5 | 1 | 98 | 6.3 | 4 |
| 46 | 2.5 | 3 | 182 | 5.0 | 1 |
| 47 | 2.5 | 3 | 182B | 5.0 | 1 |
| 48 | 30.0 | 1 | 183 | 5.0 | 1 |
| 49 | 2.0 | 3 | 482A | 5.0 | 1 |
| 50 | 7.5 | 1 | 482B | 5.0 | 1 |
| 51 | 2.5 | 2 | 483 | 5.0 | 1 |
| 52 | 6.3 | 3 | 484 | 3.3 | 1 |
| 53 | 2.5 | 6 | 484A | 3.3 | 1 |

TEST CHART (CONT'D.)

| Tube Type | Set Fil. Sw. at (Volts) | Use Socket No. | Tube Type | Set Fil. Sw. at (Volts) | Use Socket No. |
|-----------|-------------------------|----------------|------------|-------------------------|----------------|
| 485 | 3.3 | 1 | Wunderlich | | |
| 486 | 3.3 | 1 | B | 2.5 | 4 |
| 585 | 7.5 | 1 | Wunderlich | | |
| 586 | 7.5 | 1 | BB | 6.3 | 4 |
| 686 | 7.5 | 1 | 1A6 | 2.0 | 2 |
| 864 | 1.5 | 1 | 1C6 | 2.0 | 2 |
| A22 | 15.0 | 2 | 2A3 | 2.5 | 1 |
| A26 | 15.0 | 1 | 2A5 | 2.5 | 1 |
| A28 | 15.0 | 1 | 2A6 | 2.5 | 10 |
| A30 | 15.0 | 1 | 2A7 | 2.5 | 10 |
| A32 | 15.0 | 1 | 2B6 | 2.5 | 9 |
| A40 | 15.0 | 1 | 2B7 | 2.5 | 10 |
| A48 | 15.0 | 1 | 2F7 | 2.5 | 7 |
| AD | 6.3 | 1 | 5Z3 | 5.0 | 4 |
| AE | 15.0 | 1 | 6A4 | 6.3 | 3 |
| AF | 2.5 | 4 | 6A7 | 6.3 | 10 |
| AG | 5.0 | 4 | 6B7 | 6.3 | 10 |
| G2 | 2.5 | 4 | 6C6 | 6.3 | 2 |
| G2S | 2.5 | 4 | 6C7 | 6.3 | 10 |
| G4 | 2.5 | 4 | 6D6 | 6.3 | 2 |
| G4S | 2.5 | 4 | 6D7 | 6.3 | 10 |
| G84 | 2.5 | 4 | 6E7 | 6.3 | 10 |
| GA | 5.0 | 3 | 6F7 | 6.3 | 7 |
| HZ50 | 15.0 | 1 | 6Y5 | 6.3 | 11 |
| KR1 | 6.3 | 1 | 6Z3 | 6.3 | 1 |
| KR2 | 5.0 | 1 | 6Z4 | 6.3 | 4 |
| KR5 | 6.3 | 3 | 6Z5 | 15.0 | 8 |
| KR25 | 2.5 | 1 | 12A5 | 15.0 | 11 |
| LA | 5.0 | 3 | 12A7 | 15.0 | 12 |
| PA | 6.3 | 1 | 12Z3 | 15.0 | 1 |
| PZ | 2.5 | 3 | 12Z5 | 15.0 | 8 |
| PZH | 6.3 | 1 | 25Z3 | 25.0 | 1 |
| RA1 | 15.0 | 1 | 25Z5 | 25.0 | 5 |
| S01 | 15.0 | 1 | | | |

former, the nearest voltage to that required has been used. Three-volt tubes are tested on 3.3 volts; 12.5-volt and 14-volt



Courtesy Alden Products Co.

FIG. 9-3.—Typical “composite” type tube sockets. A 4-5-6 prong socket is shown at (A); a 5-7 prong socket is at (B); a 5-6-7 prong socket is shown at (C); a 7-7 prong socket is at (D).

tubes are tested on 15 volts. The application of this excessive

voltage for the minute or two required for the test will cause no damage to the tube. Of course, it should not be applied too long.

9-20. **Parts Required for the Tube Checker.**—The parts used in the construction of this tube checker should all be of high grade and selected with some care. There are no special parts used, and all may be readily secured. Following is a list of parts required:*

- 1 panel and case
- 1 10-ma. milliammeter
- 1 50 ma. shunt for the milliammeter

12 sockets:

- 3—4-5-6-prong composite
- 2—5-6-7-prong composite
- 1—5-7-prong composite
- 4—7-7-prong composite
- 2—6-prong (standard)

12 switches:

- 1—12-point tap-switch (*S1*)
- 6—S.P.D.T. push-button type switches (*S2, S4, S7, S8, S9, S10*)
- 3—S.P.S.T. push-button "closed" type (*S3, S6, S12*)
- 1—S.P.D.T. toggle switch (*S5*)
- 1—S.P.D.T. toggle switch (*S11*)

- 1—filament transformer, 1.5, 2.0, 2.5, 3.3, 5.0, 6.3, 7.5, 15.0, 25.0, 30.0 volts; primary tapped at 105, 115, 125 volts.
- 1—1,500-ohm wire-wound resistor (25 watts) (*R1*)
- 1—1,000-ohm wire-wound resistor (25 watts) (*R2*)
- 1—500,000-ohm carbon resistor (*R3*)
- 1—pilot-light socket
- 1—6 V. pilot light
- 2—tip-jacks
- 1—control-grid clip and lead
- Miscellaneous wire, solder, screws, nuts, etc.

*NOTE: Eight-prong sockets may be added and wired into the circuit properly in order to make it possible to test all "metal" type tubes having the standard "Octal" type base or standard adapters obtainable for this purpose may be used with the tube checker when these tubes are to be checked.

CHAPTER X

TYPICAL COMMERCIAL TUBE CHECKERS

10-1. Introduction.—The descriptions of the commercial tube checkers presented in this chapter are intended to illustrate actual design features rather than to provide additional data for home-construction purposes. A study of these data will show the various methods of test used. Some designs, especially for counter models, use the familiar emission test; others use the more appropriate mutual conductance test. As explained in Chapter VIII, both tests have their merits, and choice depends mainly upon individual opinion.

While the author has endeavored to describe the latest testers available, a few tube checkers one or more years old have been included purposely in order to illustrate some unique and instructive principles of design. The descriptions are arranged in alphabetical order according to manufacturers, for convenient reference.*

10-2. "Confidence" Model C Tube Checker.—The Confidence Model C Tube Checker, shown in Fig. 10-1, has been designed to test all receiving tubes without the use of adapters. Many new tests may be added without any changes, because blank switch positions are provided for special tubes which may be introduced in the future.

The instrument is manufactured in several types for portable or store use. The 18 sockets with which it is equipped allow the elements to be tested as in a radio receiver. Tubes having more than one working element, such as the 2A6, can be tested separately. These tests are distinguished by abbreviated markings on the tube chart.

When the selector is pointed to any number on the panel, every socket gets the same filament voltage simultaneously, thus

*NOTE: The tube checkers described in this chapter may be adapted for testing all "octal-base" all-metal type tubes if the "standard" adapters available for this purpose are used with them.

eliminating the possibility of any injury to a tube by placing it in a wrong socket. Fifty-five fixed shunts cover the complete range of currents of the tubes tested.

An interesting feature of the design of this tester is that each tube is tested with a fixed bias, and plate voltage is applied through a transformer having relatively high regulation. This combination is so adjusted that the tube is operated at a straight part of its plate-current grid-voltage characteristic, so that the swing of the meter pointer from either side of normal is proportional to the change in plate impedance, or emission, from normal. Hence, the swing of the needle is proportional to the amount of "poorness" of the tube.

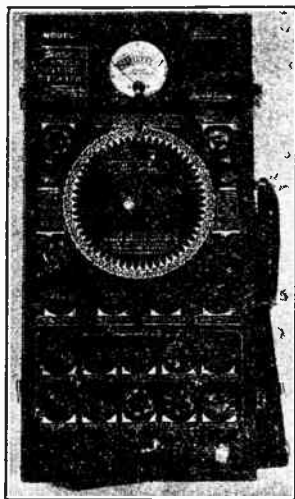

Courtesy Apparatus Design Co.

FIG. 10-1.—The Confidence Model C tube tester. Note the large number of sockets employed.

Line-voltage conditions are adjusted by turning the selector knob to *V* before placing a tube in one of the sockets. The meter needle is adjusted to the single line drawn on the meter scale, by rotating the small *Adjust Line* knob in the upper right-hand corner of the instrument panel.

Any short-circuit from plate or screen-grid to grid, cathode, filament, suppressor, etc., will automatically light the *Short* indicator lamp brightly. Some of the high-plate-current type tubes will cause a slight glow in the indicator lamp when they are being tested. This is caused by heavy drain and is not to be confused with the bright light occasioned by a short-circuited

tube. Small 2.5- and 6-volt dial or pilot lights may be tested by inserting them in their respective sockets located in the panel above the large selector knob. The setting of this knob does not affect these tests.

A movable-coil type meter indicates the results of the test, and registers the worth of the tube as either *Bad* or *Good* on a colored scale ("English Reading Scale").

10-3. Confidence "Special" Tube Seller.—The Confidence Special, shown in Fig. 10-2, is a portable instrument which tests over 130 types of radio tubes, including special Arcturus, Kellogg, Kenrad, Majestic, Sparton and Wunderlich types (as listed and arranged numerically on the tube chart supplied) without the use of adapters (Kellogg excepted).

The principle of test is the same as that employed in the Model C Tube Checker. The movable-coil type meter is protected against possible injury by a shorted tube by means of a pilot lamp, which indicates short-circuits from plate or screen grid to any other element.

A separate cathode-to-heater short test is also included by means of a push-button located to the left of the large selector switch.

Blank switch positions are provided for special tubes which might be introduced in the future. Each diode plate as well as the pentode and triode sections of dual-purpose tubes are tested independently. The condition of any tube is indicated by the colored meter scale as *Bad* or *Good*. Line-voltage variations are compensated for through the use of a 19-tap primary; hence this tester can operate from line voltages from 100 to 130 volts.

10-4. "Dependable" Model 303A Tube Checker.—This tube tester has several features which distinguish it from others

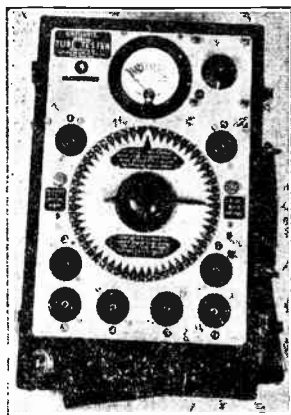

Courtesy Apparatus Design Co.

FIG. 10-2.—The Confidence special tube tester. Note the unique selector dial at the center.

of the same type. The numbers of all the tube types which it is capable of testing are etched on the front panel of the instrument. Thus, to test a certain tube, the main selector-switch, shown in the illustration of the instrument in Fig. 10-3, is set to the column of numbers in which the tube type appears, the

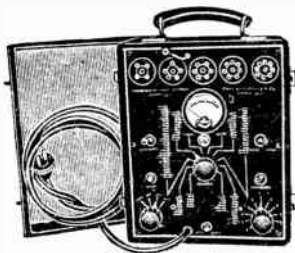

FIG. 10-3. — “Dependable” Model 303A tube checker. The schematic circuit diagram of this instrument is shown in Fig. 10-4.

Courtesy Radio City Products Co.

filament selector switch is rotated to the proper terminal, also etched in the column of tube types, and the test is made.

This instrument is equipped to make short-circuit tests, gas tests, and mutual-conductance tests by means of the grid-shift

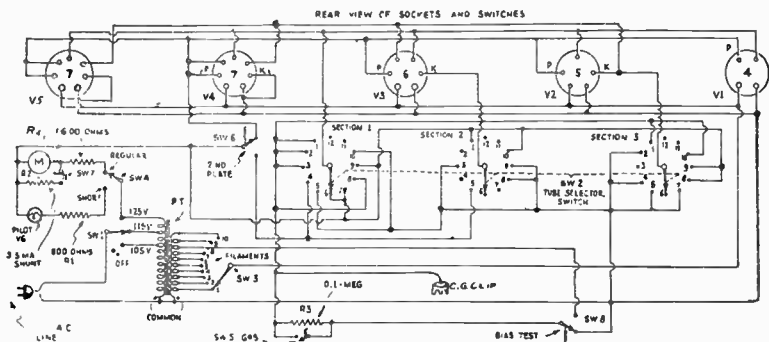

FIG. 10-4.—Schematic circuit diagram of the tube checker illustrated in Fig. 10-3.

method. A tap, No. 8, on the filament transformer connects directly to one side of the *Bias Test* switch, as shown in the schematic circuit diagram of Fig. 10-4.

Line voltage is adjusted by setting another switch to the 105-, 115-, or 125-volt positions, depending upon the voltage of the line, which must be known. The “gas” test is made

by short-circuiting a 0.1-megohm resistor connected in the grid-return lead of the transformer. The "short-circuit" test is made by connecting an 18-volt pilot light and a 900-ohm resistor in place of the meter. Excessive current is indicated by the lighting of the lamp.

Only five sockets are used to test all tubes—a 4-, 5-, 6- and two 7-prong types. The tube to be tested is merely placed in the one socket in which it will fit—all 4-prong tubes in the 4-prong socket, all 5-prong tubes in the 5-prong socket, etc.

The use of this tester involves two operations. First, the tube to be tested is inserted in the proper socket and tested for short-circuits, gas, etc. Then the *Bias-Test* switch is thrown, and the reading noted. The difference between this reading and the one obtained before throwing the switch is the *relative* mutual conductance of the tube. The correct value for any particular tube is indicated on a chart furnished in the cover of the instrument. It should be noted that this instrument follows closely the test procedures discussed in Chapter VIII.



Courtesy Radio City Products Co.

FIG. 10-5.—Dependable Model 304 tube tester. This is a direct-reading tester of the emission-test type. Its schematic circuit diagram is shown in Fig. 10-6.

10-5. "Dependable" Model 304 Tube Checker.—Figures 10-5 and 10-6 show, respectively, the photograph and schematic circuit diagram of this tester. In contrast to previous types of this manufacturer, this one is of the direct-reading type (English reading). This feature obviates the necessity for referring to external charts for the determination of the worth of the tube under test. The instrument scale is calibrated directly to indicate whether the tube is *Good*, *Bad*, or *Questionable*.

In contrast to the model 303A, this instrument operates on the emission principle—the meter in the plate circuit indicates the average plate current. Furthermore, since a-c is used on the plate of the tube under test, the indications of the meter also depend upon the *plate conductance* (plate current change divided by plate voltage change).

In almost all types of emission testers, it is essential that the voltage applied to the tube be accurate within close limits, else the direct-reading scale will be inaccurate. For this reason a

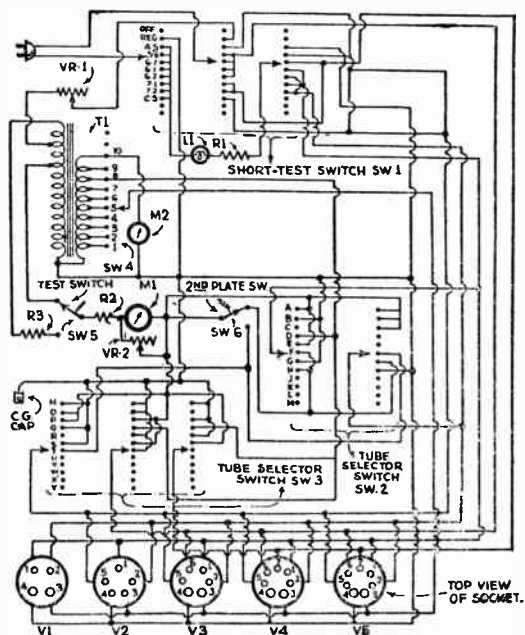

FIG. 10-6. — Schematic circuit diagram of the tube tester illustrated in Fig. 10-5.

second meter, M_2 , is permanently connected across the secondary of the filament transformer. A resistance, $VR-1$, in the primary circuit varies the applied voltage until the meter reads the proper value, indicated by a single line on the meter scale. This meter has a maximum voltage range of 35 volts, and is connected across the 25-volt winding of the secondary.

A "short" and "leakage" indicator is incorporated in the tester, and is operated by means of the switch $SW1$. This

switch, when rotated, indicates a direct short or leakage between any two elements. The neon lamp *L1* glows brightly for a direct short, and lights moderately for leakage. The rating of this lamp is but 1/25 watt, and it will indicate leakage up to 2,000,000 ohms. Eight different combinations for indicating inter-element shorts and leaks are available with this switch.

The two selector switches *SW2* and *SW3* are used for testing purposes. *SW2* has twelve positions, *A* to *M* (the letter *I* is not used), and *SW3* has twelve position, *N* to *Y*. A separate tabulation shows the setting of these switches for each tube to be tested. The instrument is made in both portable and

FIG. 10-7.—The Franklin Model H-33 tube checker. Its schematic circuit diagram is shown in Fig. 10-8.



Courtesy Franklin Radio Products Corp.

counter type models to meet the requirements of both field work and store use.

10-6. "Franklin" Model H-33 Tube Checker.—This tube checker, shown in Fig. 10-7, is a portable instrument for use on 110-volt, 60-cycle lines. Eight sockets are mounted on the instrument panel to accommodate all the tubes tested. A combination meter is employed, with ranges of 0-500 volts, 0-10 ma. and 0-50 ma. The schematic circuit diagram is shown in Fig. 10-8.

When checking a tube with this tester, it is important that the tube be inserted in the socket having the proper filament voltage. The two toggle switches on the top of the panel control the filament voltages applied to the 4-, 5-, 6- and 7-prong

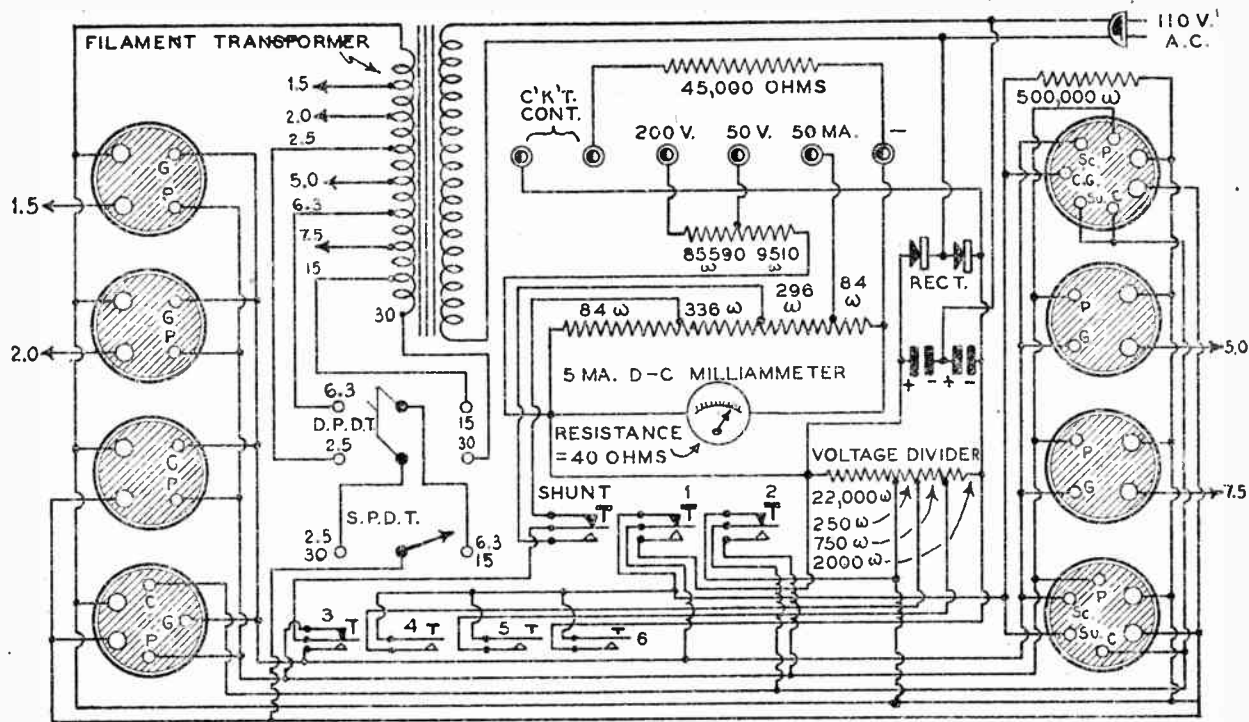

FIG. 10-8.—Schematic circuit diagram of the tube checker illustrated in Fig. 10-7.

sockets. By properly setting the switches, 2.5, 6.3, 15, and 30 volts are available at the sockets. Tubes of the 1.5-, 2.0-, 5.0- and 7.5-volt types are checked in the sockets so marked. 5-, 6- and 7-prong tubes of the two-volt series are tested in the 2.5 volt position, and 3.3-volt tubes are tested in the same manner. Tubes with a filament rating of 25 volts are checked in the 30-volt position, and 12.5- and 14-volt tubes are checked in the 15-volt position.

By pressing a switch button, the second-plate reading of full-wave rectifiers may be obtained. The usual type of test has been provided for determining cathode-heater leakage. The button marked "*Press for 10 ma.*" is a shunt release for the 50 ma. scale. When this button is pressed, the full-scale deflection of the meter is 10 ma.

An interesting feature of this tester is that the high-voltage (plate) circuit employs a copper-oxide rectifier and filter so that d-c is impressed on the tubes. In order that each type of tube may be tested with the proper voltages, a resistance-type voltage-divider network is used.

In addition to checking tubes, the H-33 tube checker has facilities for measuring circuit continuity. The voltage for the ohmmeter is supplied by the self-contained rectifier which delivers approximately 200 volts. A separate chart is used to determine the value of resistance measured.

The same 200 volts used for the ohmmeter is available for external use also. Thus, the instrument has provisions for obtaining 200 and 50 volts at separate terminals. The 50-ma. meter range is also available, as shown on the schematic circuit diagram of Fig. 10-8.

10-7. "Readrite" Model 421-422 Tube Checkers.—The distinct feature of this tester (both testers are the same electrically) is the fact that it is of the "English-reading" type and works on the mutual conductance principle. The instrument is shown in Fig. 10-9 and the schematic circuit diagram in Fig. 10-10. The instrument has two selector switches, one for heater tubes and one for filament types, a separate line meter for checking the voltage of the line, and twelve tube sockets.

Its operation is as follows. The tube number is noted, and the selector switch marked 1, 2, 3, etc., is set to the proper position indicated by a chart supplied with the instrument. The second selector switch marked A, B, C, is also set to the required position as indicated on the same chart. The tube is placed in the designated socket and the toggle switch is thrown on. The line-voltage rheostat is then adjusted until the line-meter pointer reaches a single line ruled on the scale of the meter. After the tube has heated, the reading of the meter is noted and the test button is pressed. A "good" tube will be indicated by the deflec-

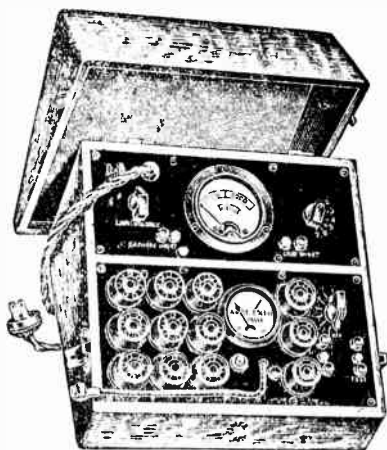

Courtesy Readrite Meter Works

FIG. 10-9. — Readrite Model 421-422 tube checkers. Notice the direct-reading scale of the meter which indicates the condition of the tube in terms of *good* and *poor*.

tion of the pointer on the *dark green* portion of the shaded scale. "Poor" tubes will indicate on the *dark red* portion of the scale.

The cathode-heater leakage test used is similar to that explained in Art. 8-20—no reading of the meter when the leakage button is pressed indicates no leakage. The test for grid short-circuits involves the use of the same meter used for indicating the condition of the tube. If pressing the "short" button brings the meter reading down to, but not quite, zero, the tube is not shorted; if the meter reading remains unchanged, the tube is shorted. The system used for this test may be determined from a study of the circuit diagram.

10-8. "Supreme" Model 65 Tube Testing Power Unit.—The Supreme Model 65, shown in Fig. 10-11 is unusual in that

it is essentially a complete tube checker without the meter, but is provided with two terminals for connecting any suitable milliammeter to check plate current readings. A double range milliammeter of 10 and 100 milliamperes may be used.

An individual socket is provided for 4-, 5-, 6- and 7-prong tubes. It is unnecessary to match each particular type of tube with a special socket. A large 7-hole to small 7-pin adapter is provided for testing all large-bias 7-prong tubes. A multi-section rotary selector switch is used for making proper circuit

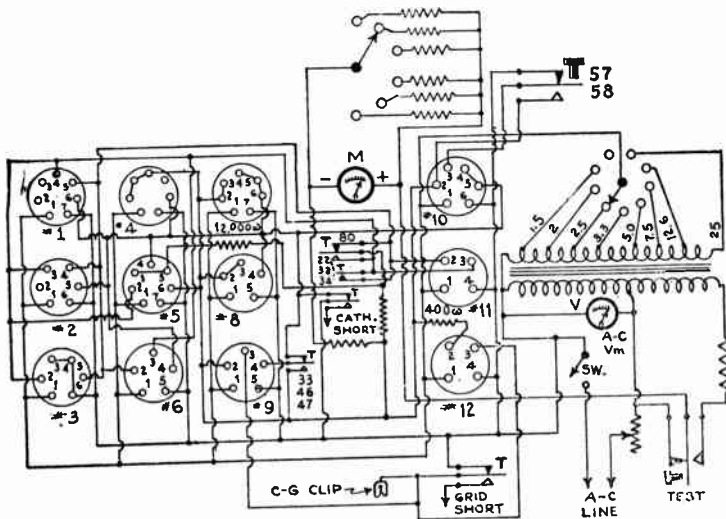

FIG. 10-10.—Schematic circuit diagram of the tube checker illustrated in Fig. 10-9.

connections to the five sockets for the various arrangements and elements within the different tubes. One position on the switch is left open for possible changes in arrangement of these elements on future tubes. The schematic circuit diagram is shown in Fig. 10-12.

Proper filament and heater voltages are supplied from the transformer through the rotary selector switch to the sockets. These voltages are also brought to a pair of pin jacks on the panel, making it possible to test the external heater types of tubes and to provide a group of low voltages which are often

convenient to use on the test bench for one purpose or another. When the rotary selector switch is placed in a certain position, voltage from an external transformer can be placed on the sockets of the power unit through the *FIL-HTR VOLTAGE* pin jacks. These features make it possible to test certain future tubes whose filament voltages may be other than those shown. The mutual conductance method of testing is employed.

An automatic "short" test is provided, which eliminates the necessity of first inserting the tube in a special socket for the indication of shorted elements. A resistor in the plate circuit prevents damage to the milliammeter in the event of a short-circuited tube. A means of determining whether or not the cathode and heater are either partly or totally shorted together is indicated in the "short" test. A "gas" test is provided by the usual arrangement of inserting a high resistance in the grid circuit, as discussed in Art. 8-13.

The instrument is operated by connecting a suitable milliammeter to the plate-current pin jacks, observing the proper polarity. This milliammeter should have a range higher than the sum of the two values (for the particular tube under test) shown in the columns on the chart supplied.

A cathode-heater short is revealed by pressing the *K-H Leakage* button. If the plate milliammeter drops to 0 when



Courtesy Supreme Instr. Corp.

FIG. 10-11. — Supreme Model 65 tube testing power unit. Its schematic circuit diagram is shown in Fig. 10-12.

this button is pressed, the cathode and heater are free from each other. Control-grid-to-cathode short-circuits will result in no change in plate current when the "*Grid Shift*" button is pressed. Plate-to-cathode (or filament), and control-grid-to-plate short-circuits will cause the meter needle to vibrate about the 0 position when the "grid shift" button is pressed.

10-9. "Supreme" Model 85 Tube Checker.—This versa-

tile tube checker, shown in Fig. 10-13, is designed to provide a portable tester by which the quality of a tube may be indicated

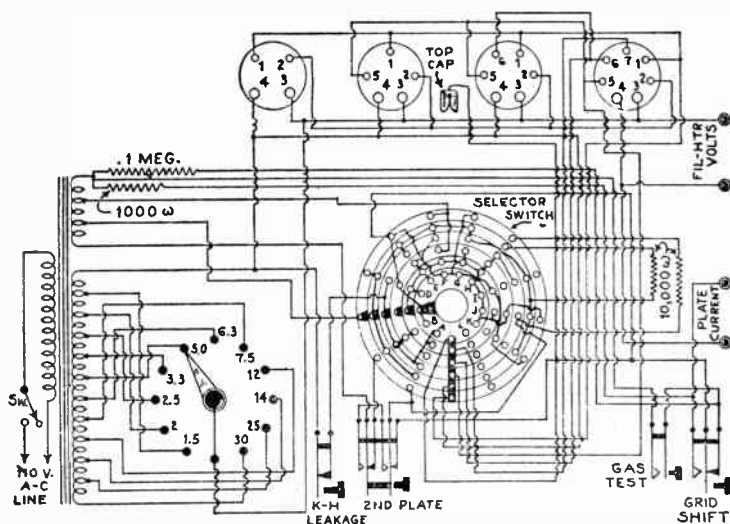

FIG. 10-12.—Schematic circuit diagram of the tube checker illustrated in Fig. 10-11. Note the intricate selector switch at the center.

FIG. 10-13.—Supreme Model 85 tube checker. Note the direct-reading meter at the center. The neon glow lamp reveals leakages or short-circuits. See Fig. 10-14 for the schematic circuit diagram of this tester.



Courtesy Supreme Instr. Corp.

in terms of *Good* or *Bad*, and by which leakage or short-circuits between any elements of a tube may be determined. A new circuit is used in which the various types of tubes act as

Push-button type switches are provided whereby any one element may be checked for leakage or short-circuit to any other element. According to the manufacturer, the neon lamp is superior to a meter for leakage indications because of the inherent mechanical inertia of meter movements, which does not enable them to respond to short, intermittent leakage currents.

This tube checker is provided with a tapped primary transformer for adjustments to any a-c line voltage between 98 and



FIG. 10-15. -- Weston Model 681 counter type tube checker. Notice the unusually large direct reading meter, the clear and simple layout of its scale.

Courtesy Weston Elect. Instr. Corp.

125 volts. The manufacturers prefer the tapped primary to the resistive method of voltage compensation because of their claim that the latter introduces uncontrollable variations of input voltage during test operations. The adjustment of this tester remains practically constant under varying tube loads, so that the pointer does not have to be re-set for each tube. Rectification of the meter current is accomplished by means of a type '01A tube, which is self-contained in a protected position under the panel. As shown by the diagram in Fig. 10-14, the plate impedance of the tube under test is connected in series with the meter.

One of the features of this instrument is the use of only four sockets. All tubes are tested in any one of these sockets, regardless of the internal arrangement or placement of the tube elements, which determine the push-button switch to be operated. If a button other than the correct one is pressed, nothing

happens. The meter needle will not move forward, as the meter will read only when the correct button is pressed.

A list of all popular tubes is verichromed on the panel around the "Tube Selector", and a chart of all tubes, with printed instructions, is fitted into the detachable cover of the carrying

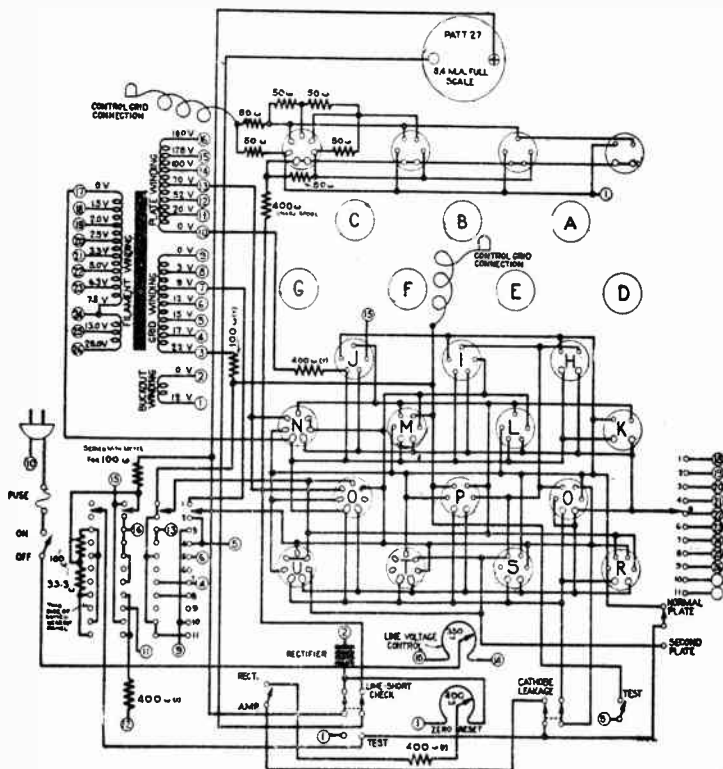

FIG. 10-16.—Schematic circuit diagram of the counter type tube checker illustrated in Fig. 10-15.

case. The operating procedure is also verichromed around the controls on the panel.

10-10. "Weston" Model 681 Counter Tube Checker. — This tester is a typical example of a modern "tube seller." It is designed specifically for counter use, where the customer can easily see how his tubes are being tested. A large 9-inch meter, with all necessary markings on its scale, facilitates its use.

The tester is equipped with twenty-five different sockets and the usual array of switches to enable the proper tests to be made. The scale is divided into a series of colored arcs, lettered for rapid reference to the instruction sheet. Short-circuited tubes are indicated on the scale in a large area marked *Shorted*. The instrument is also equipped to make leakage tests by the method discussed in Art. 8-20.

Tests of tubes are made by the mutual conductance method. A feature of the instrument is that proper plate, filament, screen, and control-grid voltages are applied to the tube during test. Compare this with the many other testers that test tubes as triodes.

Individual tests are made on all combination tubes, and the sockets are color-coded to facilitate locating the proper socket. Of the twenty-five sockets on the panel, seven are spares, installed for future tubes to be designed; thus, only eighteen of the sockets are for present use.

The instrument is shown in Fig. 10-15 and its schematic circuit diagram is shown in Fig. 10-16.

10-11. **Weston Model 682 Tube Checker.**—This instrument, shown in Fig. 10-17, has been designed to be employed either for portable or for counter use, depending upon the type of case used. The meter employed is the familiar model 301, and is divided into two colored sections, green and red, marked *Good* and *Bad*, respectively.

As shown in the schematic circuit, Fig. 10-18, the *total emission* method of testing is used. The manufacturers of this device favor this form of test for small checkers on direct-reading instruments. The line voltage is adjusted *after* the tube is in the socket and heated. This is indicated on the meter by a single line drawn through the center of the scale.

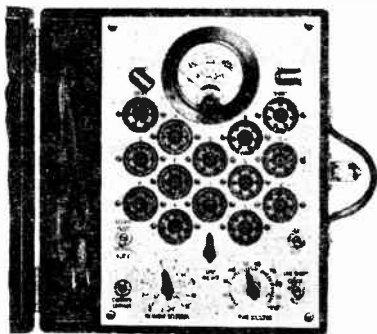

Courtesy Weston Elect. Instr. Corp.

FIG. 10-17.—Weston Model 682 tube checker shown here in its portable carrying case. Its schematic circuit diagram is shown in Fig. 10-18.

Cathode-heater leakage, and short-circuit tests, are available in the usual form, the short-circuit being indicated on the same meter used for determining the worth of the tube.

The chart presented in Fig. 10-19 shows the various sockets into which the tubes that can be tested are inserted, and also

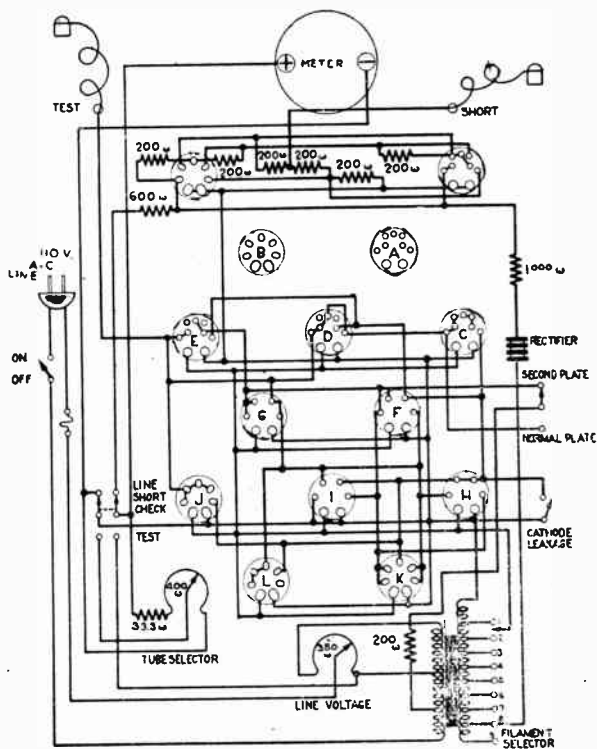

FIG. 10-18.—Schematic circuit diagram of the "emission" type tube checker illustrated in Fig. 10-17.

lists the equivalent tubes—tubes which may be considered equivalent for purposes of test on this particular instrument. This information is extremely useful for reference purposes.

An interesting application of the use of a single d-c meter to check the a-c line voltage is shown in the schematic diagram. When the *Line Check* switch is thrown for use, the d-c meter is connected, in series with 1,600-ohms of resistance and the rectifier, across almost all of the transformer secondary—the

winding supplying the filament. The meter reading is then adjusted by the 350-ohm potentiometer labeled *Line Voltage*. The outside terminals of the 400-ohm potentiometer labeled *Tube Selector* are always across the meter; but when the same switch is thrown to the "test" position, the arm of this poten-

| | | | | | | | | | | | | | | | | | |
|---------------|----|----|-----|-----|----|-----|----|----|----|----|-----|----|----|-----|----|----|----|
| Tube Type | 1 | 1V | 00A | 01A | 10 | 12A | 14 | 15 | 17 | 18 | *19 | 20 | 22 | 24A | 26 | 27 | 29 |
| Fil. Selector | 6 | 6 | 5 | 5 | 7 | 5 | 8 | 2 | 8 | 8 | 2 | 4 | 4 | 3 | 1 | 3 | 3 |
| Tube Selector | 47 | 46 | 30 | 37 | 42 | 40 | 42 | 31 | 42 | 41 | 39 | 27 | 30 | 38 | 40 | 40 | 43 |
| Socket | D | C | C | C | C | C | C | C | C | C | G | C | C | C | C | C | C |

| | | | | | | | | | | | | | | | | | | |
|---------------|----|----|----|----|----|----|----|----|----|----|----|----|----|----|----|----|----|----|
| Tube Type | 30 | 31 | 32 | 33 | 34 | 35 | 36 | 37 | 38 | 39 | 40 | 41 | 42 | 43 | 45 | 46 | 47 | 48 |
| Fil. Selector | 2 | 2 | 2 | 2 | 3 | 6 | 6 | 6 | 6 | 6 | 5 | 6 | 6 | 9 | 3 | 3 | 3 | 9 |
| Tube Selector | 33 | 37 | 37 | 39 | 37 | 40 | 42 | 42 | 42 | 41 | 39 | 42 | 44 | 46 | 44 | 44 | 41 | 47 |
| Socket | C | C | C | D | C | C | C | C | C | C | C | C | C | C | C | D | D | C |

| | | | | | | | | | | | | | | | | | |
|---------------|----|----|----|-----|----|----|----|----|----|----|-----|----|----|----|----|-----|-----|
| Tube Type | 49 | 50 | 52 | *53 | 55 | 56 | 57 | 58 | 59 | 69 | 71A | 75 | 76 | 77 | 78 | *79 | *80 |
| Fil. Selector | 2 | 7 | 6 | 3 | 3 | 3 | 3 | 3 | 3 | 6 | 5 | 6 | 6 | 6 | 6 | 6 | 5 |
| Tube Selector | 40 | 41 | 44 | 46 | 41 | 44 | 45 | 44 | 44 | 43 | 43 | 44 | 45 | 44 | 43 | 44 | 38 |
| Socket | D | C | D | K | E | C | C | C | J | C | C | E | C | C | C | F | E |

| | | | | | | | | | | | | | | |
|---------------|----|-----|-----|------|-----|----|----|----|-----|-----|-----|------|-----|-----|
| Tube Type | 81 | *82 | *83 | *83V | *84 | 85 | 89 | 99 | 1A6 | 1C6 | 2A3 | 2A3H | 2A5 | 2A6 |
| Fil. Selector | 7 | 3 | 5 | 5 | 6 | 6 | 6 | 4 | 2 | 2 | 3 | 3 | 3 | 3 |
| Tube Selector | 36 | 48 | 48 | 48 | 45 | 41 | 43 | 9 | 30 | 36 | 47 | 46 | 43 | 43 |
| Socket | D | E | E | E | E | E | C | C | C | C | C | C | C | E |

| | | | | | | | | | | | | | |
|---------------|-----|-----|-----|------|-----|-----|-----|-----|-----|-----|-----|------|------|
| Tube Type | 2A7 | 2B6 | 2B7 | *5Z3 | 6A4 | 6A7 | 6B7 | 6C7 | 6D7 | 6E7 | 6F7 | *6Y5 | *6Z5 |
| Fil. Selector | 3 | 3 | 3 | 5 | 6 | 6 | 6 | 6 | 6 | 6 | 6 | 6 | 6 |
| Tube Selector | 45 | 44 | 41 | 43 | 43 | 44 | 41 | 44 | 45 | 44 | 42 | 47 | 45 |
| Socket | J | J | J | E | D | J | J | J | J | J | J | I | I |

| | | | | | | | | | | | | |
|---------------|------|------|------|-------|------|-------|------|-----|-----|-----|-----|------|
| Tube Type | 12A5 | 12A7 | 12Z3 | *12Z5 | 25Z3 | *25Z5 | 182B | 183 | 485 | 950 | KR2 | *G-4 |
| Fil. Selector | 8 | 8 | 8 | 8 | 9 | 9 | 9 | 5 | 4 | 2 | 5 | 3 |
| Tube Selector | 43 | 43 | 47 | 46 | 47 | 47 | 42 | 42 | 37 | 38 | 17 | 20 |
| Socket | L | L | D | I | D | H | C | C | C | D | D | E |

*CATHODE LEAKAGE: While taking TEST reading, pull cathode leakage switch. Pointer should come back to Green Arrow.

*Manipulate NORMAL PLATE—SECOND PLATE switch for second plate reading.

THE FOLLOWING HAVE EQUIVALENT TEST READINGS:

| | | | | | |
|------------|----------|-------------|-------------|------------|------------------|
| 01AA = 01A | 67 = 37 | 95 = 2A5 | 951 = 32 | AF = 82 | P-861 = 84 |
| 27HM = 56 | 68 = 38 | 98 = 84 | 6C6 = 77 | AG = 83 | PZ = 47 |
| 44 = 39 | 80M = 83 | 482A = 71A | 6D6 = 78 | C-2 = G-4 | PZH = 2A5 |
| 51 = 35 | 81M = 81 | 482B = 182B | 6Z3 = 1 | G85-S = 85 | Wunderlich = 29 |
| 57AS = 77 | 82V = 82 | 483 = 183 | 6Z4 = 84 | KR1 = 1 | Wund. Auto. = 69 |
| 58AS = 78 | 88 = 83 | 484 = 485 | 14Z3 = 12Z3 | KR5 = 6A4 | |
| 64 = 36 | 90 = 29 | 585 = 50 | 986 = 83 | KR23 = 2A5 | |
| 65 = 39 | 92 = 69 | 586 = 50 | AD = 1 | LA = 6A4 | |

FIG. 10-19.—Operating chart for the Weston Model 682 tube checker. This chart specifies the correct settings of the *Fil. Selector Switch*, *Tube Selector Sw.*, and *Tube Socket* for every type of tube which can be tested by the checker. The tabulation at the bottom specifies the tubes which may be considered as being equivalent, (for test purposes).

tiometer connects to B—, so that the amount of shunt across the meter depends upon the position of the arm. The correct setting for this arm for any type of tube to be tested is specified in the chart of Fig. 10-19 (which accompanies the tube checker).

CHAPTER XI

THE VOLTAGE-CURRENT SET ANALYZER

11-1. Choice of a Method of Set Testing.—When a radio receiver becomes inoperative or does not function properly, it is usually because of the failure of one or more of the tubes or because of trouble in one of the parts or circuits of the receiver proper. The service man's task is to determine the location and nature of the trouble in the most direct and rapid way possible, and to make such replacements or repairs as may be necessary to put the receiver back into proper operating condition. The element of time is important to both the service man and the customer, since service work is usually charged for on a time basis. Consequently, every effort has been made to develop methods and instruments which speed-up radio service work by making it possible to locate troubles in even the most complicated modern receivers in a very short time.

Unfortunately, there is no single standard, or "best" method (or system), of locating and diagnosing trouble in all radio receivers. That such a method can be evolved is questionable, because of the wide variation between the circuits and construction of the receivers manufactured from year to year and the differences in the more common troubles which occur in them. However, there are several methods or systems of diagnosis which are in common use. Each has its own advantageous features and its enthusiastic supporters who are always prepared to argue in favor of their own pet system and the limitations of all others. Regardless of the method employed, there is one common objective—that of making rapid and efficient location and determination of troubles in radio receivers possible.

It is not the purpose of this book to take sides in any controversy concerning service methods. Instead, its aim is to pre-

sent for the reader, in as clear a manner as possible, practical information concerning all the common test methods which are being employed by the most progressive service organizations today, so that the reader may be well informed and better able to adapt any of these methods to his own work as the occasion arises—consistent with his own ideas and the particular test equipment he has available.

Every experienced radio service man knows that there are cases where satisfactory diagnosis can best be made with a plug- and cable voltage-current type analyzer; there are other cases in modern receivers where this type of analyzer is not able to make tests at all points and reveal certain troubles. In such cases, point-to-point resistance tests are best. In still other cases, combinations of these methods are required, etc. Consequently, it is felt that the expert service man should be acquainted with all the methods and the test instruments necessary to put them into practice, so that he can employ whichever one is best suited to the set and circuit conditions at any time. In this chapter, we will study the voltage-and-current analyzer method of diagnosis; the others will be considered in later chapters.

11-2. Preliminary Check of the Tubes. — When testing any radio receiver for the location and cause of trouble which may be making it totally inoperative or else operating unsatisfactorily, a considerable amount of information may be obtained by first testing the individual tubes for either "emission" or "mutual conductance" (also called trans-conductance), by the methods explained in Chapter VIII. In many instances, this test will reveal one or more faulty tubes. In such cases, it is only necessary to replace each faulty tube with a good one of the same type in order to obtain normal receiver operation.

11-3. Trouble-Shooting by Testing Individual Components.—If the tubes all check satisfactorily, the trouble must be looked for elsewhere in the receiver. Of course, at this point the service man could remove the receiver chassis from the set cabinet and proceed to isolate and test each individual part in it by means of an ohmmeter, capacity meter, etc., until the inoperative part was found. This method would probably unearth the trouble eventually, but modern receiver circuits are so com

plex and so many individual components are used in them, that it would take a great deal of time to test every one in a set thoroughly. Fortunately, it is not necessary to hunt for trouble in this time-consuming, tedious way: There are other methods which usually locate the trouble much more directly and quickly. The voltage-current analysis method is one of these, and will be considered now. Another, the point-to-point resistance method, will be described in Chapter XII.

11-4. The Voltage-Current Method of Receiver Analysis.—In most modern receivers, it is quite difficult, and undesirable from the point of view of the time required, to isolate and test directly all the various resistors, condensers, transformers, etc., in a receiver in order to locate trouble. Instead of doing this, informative tests can be made at the tube sockets (usually extended to a point outside the receiver for convenience).

Every radio receiving tube has either three, four, five, six, or more external circuits, depending upon its type (see Arts. 8-4, 8-5, 8-6 and 8-7). For instance, if it is a direct-heater 3-electrode tube, it has a filament, a grid and a plate. If it is an indirect-heater type 3-electrode tube, it has a heater, a cathode, a grid and a plate. An indirect-heater type screen grid tube has a heater, cathode, control grid, screen grid and plate, etc., (see Fig. 8-1). Furthermore, the number of external circuits depends upon how many of the tube elements within the tube have connections which are brought out to its base pins. For instance, in the case of a 2A7 pentagrid converter tube, a 6-element tube, there are seven external circuits to consider. In the 2A5 power amplifier pentode, a 5-element tube, there are five external circuits.

At any rate, in almost all receivers, the main circuits go more or less directly to the tube socket terminals, which are easily reached for test work. The "voltage-current analysis" method of set testing is based upon the idea that:

trouble occurring in any circuit associated with one of the tubes in the receiver will cause a change in the voltage existing at one or more of the tube prongs, or a change in the current flowing in at least one of the tube circuits.

Therefore, in this method, the receiver is *analyzed* by carefully measuring the voltages existing at all of the tube socket terminals and measuring the currents flowing in some of the tube circuits. These readings are compared with a chart which specifies the correct voltages and currents for the particular make and model of receiver under test. To the well-informed service man, any reading which deviates greatly from the normal value furnishes a clue to the *location* of the particular circuit in which the trouble exists. In fact, in many cases a correct interpretation of the readings will also indicate the exact *nature* of the trouble. Keeping this in mind, it is evident that it is possible to analyze the various circuits of most receivers by testing the voltages, and most of the currents, existing at the terminals of the tube sockets.

A very important point must be emphasized here. The voltmeter and milliammeter readings do not in themselves indicate where the trouble lies. They are merely tools which the service man must use in order to help him to *localize* the trouble. No voltmeter or milliammeter reading ever solved a problem or located trouble in radio service work. The service man must solve it, the meter readings are merely important aids to him in his reasoning. From the readings obtained, and his own knowledge of receiver circuits, troubles, etc., he must deduce the location of the trouble. In many cases, this must be accomplished by a considerable amount of trial and error.

After the offending circuit has been definitely localized, an analysis of it is made by applying the necessary continuity tests, capacity tests, resistance measurements, etc., to the various individual parts in it, in order to locate the offending component, connection, etc. These tests, and the instruments for making them, have already been studied, and will be studied further in Chapter XXII. The proper remedy is then applied. Thus there are really three main steps to this method of radio receiver testing. They are:

1. *The voltage-current analysis at the tube socket terminals of the entire receiver and consequent localization of the trouble to some particular offending circuit.*

2. *Testing of the various components and wiring in the offending circuit.*
3. *Repair or replacement of the inoperative part (or other correction of trouble).*

These tests are usually applied in the order listed here.

11-5. Typical Voltage-Current Analysis with Individual Meters.—To illustrate how receiver circuits may be analyzed by the voltage-current method, let us consider the typical screen-grid r-f amplifier stage shown in Fig. 11-1. The general method

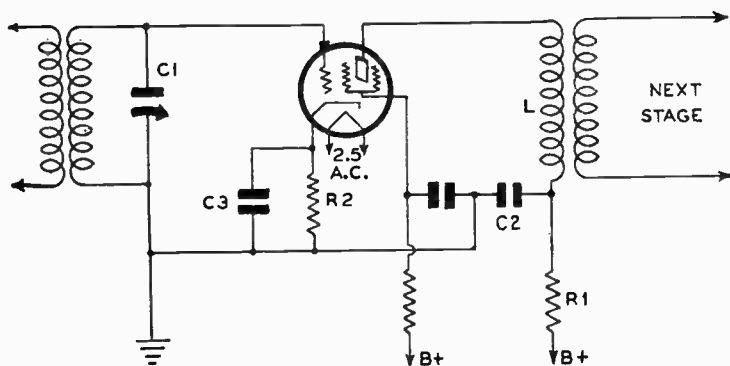

FIG. 11-1.—A typical screen-grid r-f amplifier stage with by-pass condensers, bias resistor, and voltage-dropping resistors connected in their proper places. The connections of all the separate meters required for a complete voltage-current analysis of this stage are illustrated in Fig. 11-2.

of analyzing the circuits of this tube may be duplicated for any other stage in the receiver. In the control-grid circuit of the tube is the secondary of the preceding r-f transformer, with the tuning condenser $C1$. In the plate circuit is the primary L of the next r-f transformer; one end of the primary is connected to the plate of the tube and the other end is connected to the plate filter system consisting of the resistance $R1$ and the by-pass condenser $C2$. The other end of the resistance $R1$ connects to that terminal of the plate-supply unit which supplies plate voltage to the other r-f amplifier tubes.

Of course, in a complete receiver, several tubes comprise the complete radio-frequency amplifier, but the circuits of each individual tube are similar to the one shown here. If the tube is

an audio amplifier, there would be audio transformers, chokes, or resistors, in place of the r-f transformers and variable condensers. In the intermediate-frequency amplifier of a superheterodyne receiver, i-f transformers would be used. Slight variations from this fundamental circuit will be found; but, if this normal arrangement is kept in mind, it will make circuit testing a simple task. The early receivers used 3-element tubes in the radio-frequency stages. The circuits of these older receivers are essentially the same as those used now, except for the added cathode, screen-grid and suppressor-grid elements and circuits which the present-day receivers have.

To check the voltages appearing in the various circuits, individual voltmeters may be used. For battery and d-c electric receivers, only one voltmeter is required for this work; but for a-c operated receivers, both a d-c voltmeter and an a-c voltmeter are necessary. A single combination a-c—d-c voltmeter, of the copper-oxide rectifier type already described, is commonly used for this purpose, since the one meter will read both a-c and d-c voltages. An a-c meter of this type is illustrated in Fig. 2-37. The meter should have a resistance of 1,000 ohms or more per volt. It should have d-c ranges of 0-10, 0-250, and 0-750 volts, and a-c ranges of 0-4, 0-8 and 0-150 volts. Since it has a high sensitivity, its current consumption is low, and it does not materially affect the voltages existing in the circuits it is connected to. The two lowest scales are for reading the filament voltages of a-c type tubes. The 150-volt scale is used for checking the a-c power line voltage. A d-c milliammeter also will be required.

We will now consider the use of individual test instruments merely to develop the method of analyzing circuits; later, we will show how the modern set analyzer performs all of these functions in a rapid, simple manner with one or two multi-range instruments and proper switches.

To measure the voltages and currents at the tube socket in the circuit of Fig. 11-1, the meters must be connected in the various positions across the different tube socket terminals, or in series with the circuits, as shown in Fig. 11-2. With the a-c meter connected across the heater terminals, *K-L*, the meter indicates the *heater* voltage. To check the *plate* voltage, the

d-c voltmeter is connected between point *H* the cathode, and point *F*, the plate. All voltages, except the heating voltage, in an indirect-heater type tube are usually referred to the *cathode* as the reference terminal. This is taken as the point of lowest potential in the tube. All voltages in a direct-heater type tube are usually referred to the negative terminal of the filament when the filament is heated with direct current; if heated from an a-c source, either filament terminal may serve as the reference point. The *screen-grid* circuit is checked by connecting the voltmeter from *H* to *M*. Screen current and plate current are measured by the insertion of the milliammeter (of suitable range) in the screen circuit *M* and plate circuit *F*, as shown on the diagram. The *control-grid* circuit can be checked by connecting the voltmeter across *H* and *J* (the cap on the tube). An examination of the diagram shows that this voltage is the grid-bias voltage drop across the grid-bias resistor *R2*. With the voltmeter connected from *H* to *K*, the meter will read the cathode-heater voltage.

If the correct voltage reading is obtained between cathode and plate, it indicates that whatever is connected in the plate circuit of the tube (in this case, it is the primary winding *L* of a transformer) is not open-circuited, although there is the possibility of it being short-circuited; it also indicates that the "B" voltage supply is operating. If no reading is obtained between points *H* and *F*, then either there is no "B" voltage or something in series with the B+ line is open. The test should then be made between *H* and *E*. If a reading is obtained here, it indicates that an open-circuit exists in the transformer winding connected in the plate circuit between *F* and *E*. If no reading is obtained, a test should be made between *F* and the "B" voltage supply. Voltage here will indicate an open resistor *R1*; if no reading is obtained, the meter should be connected between points *F* and *D*. (*D* will usually be grounded to the frame of the chassis.) If a reading is now obtained, it indicates that an open-circuit exists in the grid-bias resistor *R2*.

Two things should be noted: first, the meter readings *merely give a clue* to the location of the trouble; and second, the meter may have to be connected to a number of points before the

actual circuit and component causing the trouble is located.

This simple test procedure would have to be repeated at the socket of every tube until the one at which an improper voltage exists is located. The particular circuit can then be traced, and the individual components tested for open-circuits, short-circuits, etc., by the methods to be described in Chapter XXII. If the

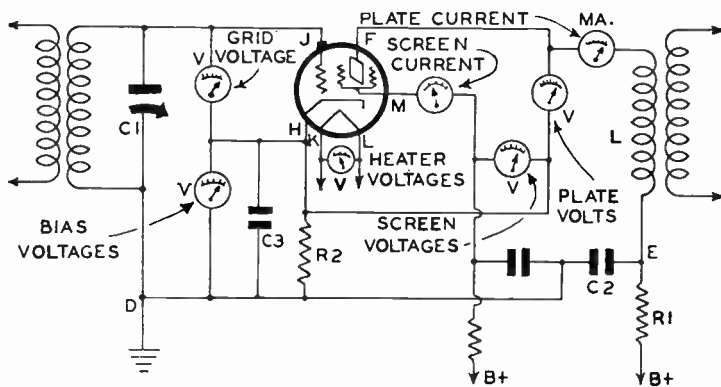

FIG. 11-2.—The principle of voltage-current receiver analysis is illustrated here by indicating where individual meters would have to be connected in the typical screen-grid r-f amplifier stage of Fig. 11-1 in order to check all the important currents and voltages existing at the tube socket terminals.

plate and grid voltages on all the tubes are found to be low, the power-supply unit circuits may be suspected and should be checked.

11-6. Principle of the Voltage-Current Set Analyzer.—

The procedure just outlined indicates in a general way how the circuits of each tube in the receiver may be analyzed to locate the particular circuit in which trouble exists. The equipment which we discussed, however, has one serious objectionable feature which makes it impracticable for use in efficient modern test work. When receivers were constructed with all tube sockets mounted on an open baseboard with every connection easily accessible, this method of testing was suitable. Modern receivers, however, are constructed with the tube sockets, resistors, wiring and most condensers mounted underneath the chassis. Coils, transformers, and chokes are mounted in shield cans, with their

connections accessible only from below the chassis deck. Testing by the method just outlined, therefore, would necessitate the complete removal of the chassis from the cabinet for every service job, and the testing at the tube socket terminals with the set in an inverted or upright position, which is rather awkward, inconvenient and wasteful of time.

Since all tests are made at the tube socket terminals, it is clear that the test manipulations may be greatly facilitated and

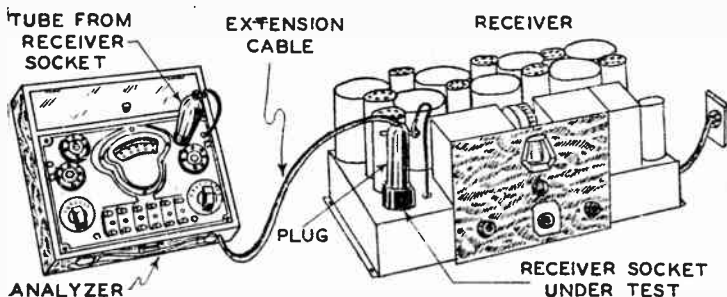

FIG. 11-3.—Pictorial representation of the fundamental idea involved in set analyzers. The circuits which normally terminate at any tube socket in the receiver may be extended conveniently by means of a plug and cable to a similar tube socket placed outside of the receiver (in the analyzer), and means provided whereby a meter, or meters, can be quickly connected to these extended circuits for test purposes. The tube removed from the receiver socket under test is placed in the socket of the analyzer, as shown.

speeded up by bringing all of the circuits of the socket and the tube to be tested to an *external* tube socket located outside of the receiver chassis and cabinet. Into this external socket is placed the tube taken from the receiver socket under test. This may be done conveniently by employing a dummy plug, exactly like the base of the vacuum tube. The prongs of this plug fit in the holes of the socket, and wires connect from each of the prongs to the external sockets. These wires are in the form of a cable, and serve merely to extend the connections of the socket in the set to the external socket. The tube, therefore, must be placed in the external socket. This fundamental arrangement is illustrated in Fig. 11-12. The idea is illustrated pictorially in Fig. 11-3.

Once the socket is outside the set, it is a simple matter to

measure the voltages and currents. It is not possible to make all the measurements that could be made if the receiver were removed from the cabinet and turned up-side-down, but a sufficient number can be made in such a comparatively short time that the cable and external socket idea has been universally adopted.

This is the fundamental principle of the radio set analyzer or tester:

It is nothing more than a means whereby the circuits which normally terminate at each tube socket in a radio receiver may be conveniently extended to a similar tube socket placed outside the receiver (in the analyzer) and means provided whereby a meter, or meters, can be quickly connected to these extended circuits in any order for test purposes.

The problem of supplying meters for making all of the measurements required in the testing of modern radio receivers has been met in several ways. One arrangement employs a separate meter for every circuit which may be subject to test. A glance at Fig. 11-2 will reveal that a large number of meters is required when this "individual-meter" arrangement is used, making the analyzer bulky and expensive. The most popular analyzers employ one or two multi-range meters with suitable switching arrangements to enable them to be connected quickly and properly to make all the voltage and current measurements required.

There is nothing fundamentally complicated about an analyzer. True, the switching systems are not simple—nor are they extremely complex. It merely requires a little patience to trace out the connections for any setting of the various switches. That, however, is not the important thing. The one thing to know when using an analyzer is what the meter is reading, regardless of the mechanical means used to get that reading. The service man must know exactly where the meter is connected, and approximately what the meter *should* read, if everything is normal. The service man solves the problem; the analyzer merely leads the way.

There are many different designs of set analyzers. Naturally, each designer and manufacturer has his own individual ideas regarding the ranges the voltmeters and milliammeters should

have, the types of switches to be used, and the mode of connection of the switches in the circuit in order to provide the greatest ease, speed and flexibility. These variations, however, may be regarded as merely incidental to the main problem, which involves *getting the circuit out of the receiver to an external point where the connections are available for easy measurement*. This is the main purpose of the set analyzer.

11-7. Development of a Set Analyzer.—In order to make clear what goes on in a commercial voltage-current analyzer when the various buttons are pressed and switches turned, we will show the development of the circuit of a simple analyzer, step by step, until quite a flexible testing system is obtained. The circuit to be developed is not exactly that employed in all analyzers; it is, though, *the basic circuit* around which modern voltage-current type set analyzers are designed. An attempt will be made to cover only the general principles involved; the descriptions of typical commercial set analyzers presented in Chapter XIV will supply the details.

11-8. The Meter-Switching System.—The use of many individual meters for measuring the different voltages and currents of a tube circuit increases the cost of construction, makes operation decidedly unwieldy, and the analyzer extremely bulky and heavy. Since a milliammeter must be employed in the analyzer, and since the basic movement of all d-c ammeters and voltmeters is a milliammeter, a single sensitive current-measuring instrument may be adapted for the measurement of all d-c voltages and currents by utilizing a properly designed arrangement to connect suitable shunt and multiplier resistances to it. This will be considered in detail in Art. 11-15. If a copper-oxide rectifier type instrument is employed, a-c voltages and currents may be measured as well.

In order to make all the voltage and current measurements required, using but one or two meters, means must be provided for connecting the meters with their proper shunts or multipliers into (or across) the various receiver networks. Many modern analyzers even employ the same meter as an ohmmeter and/or continuity meter, and as a capacity and inductance meter. By means of carefully designed switching arrangements connected

to the meters, sockets and plug of the analyzer, many circuit testing combinations are made possible.

The actual mechanical means employed by manufacturers of test equipment to meet these switching requirements naturally varies; each manufacturer employing methods which he believes will offer the greatest ease, speed, flexibility, simplicity, safety, freedom from obsolescence, etc., at the price. Of course, every method has certain advantages and disadvantages.

There are three fundamental methods (or combinations of them) actually employed for connecting the meter quickly across the various tube socket terminals for voltage-current analysis. They are:

1. The *test prod* and *pin jack* method.
2. The *push button switch* method.
3. The *rotary switch* method.

At first glance, the meter-connection arrangements used in set analyzers may appear rather complicated; but a systematic study of the main types of pin jacks, push button switches and rotary switches employed, together with their circuits, will greatly assist the reader to become familiar with them. A study of these will now be made.

11-9. Pin-Jack Meter Connection System for Analyzer.

—In analyzers employing the pin-jack system for connecting the meter to the various terminals of the tube socket, two separate leads are connected to the terminals of the meter, as shown in the pictorial sketch of Fig. 11-4. The free ends of these leads are brought out above the surface of the panel and terminate in plugs or test prods. The leads coming through the analyzer cable (from the circuits of the receiver tube socket under test) terminate in the pin jacks (see (B) of Fig. 11-5) of row B on the analyzer panel. From the pin jacks of row A these circuits continue to their respective terminals on the analyzer tube socket. By means of this arrangement, all of the receiver tube socket circuits are extended (through the plug and cable) to the analyzer tube socket. The *voltage* across any two of these circuits may be checked by merely touching the meter test prods (see (A) of Fig. 11-5) to those pin jacks which are connected to these circuits. The *current* flowing in any circuit may be measured by inserting the meter test prods into the A and B pin

jacks of that particular circuit. When this is done, the jumper contact *S* opens automatically thereby breaking the normal circuit between the pin jacks. This causes all of the current to flow through the meter which is now bridging the jacks.

Of course the various meter ranges, etc., may be selected by properly connecting to the meter the various shunts, multipliers, etc. by means of rotary switches, push-button switches, toggle

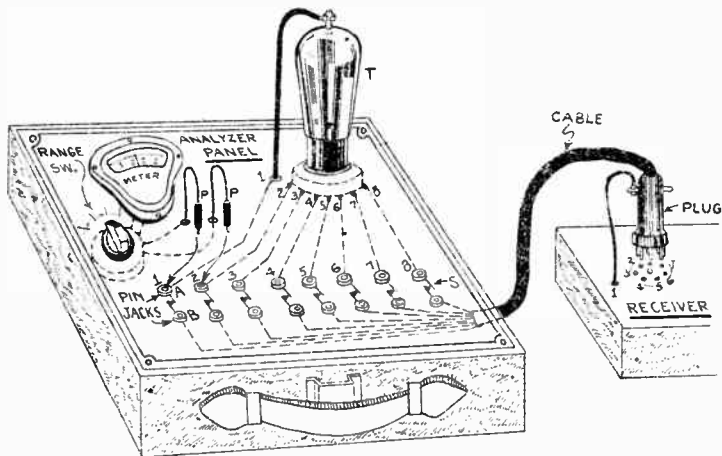

FIG. 11-4.—Pictorial representation of the fundamental idea involved in a simple set analyzer employing the pin jack system for connecting the meter to the various terminals of the tube socket under analysis. *T* is the tube taken from the socket under test in the receiver. The dummy plug has been inserted in the receiver socket in its place. To make the various voltage and current tests, the test prods, *P-P*, from the meter are inserted in the proper pin jacks—one row (*A*) of which connects to the various terminals of the tube socket in the analyzer, the other row (*B*) of which connect to the various circuits of the tube socket in the receiver (by means of the dummy plug and cable). This is not to be considered a complete analyzer by any means, it merely serves to illustrate one simple test prod and pin-jack connection arrangement which may be employed for connecting the meter to any of the tube circuits at will.

switches, or pin jacks, depending upon the preferences of the designer. Rotary switches and push-button switches are the most popular for this purpose.

The main advantage of the pin jack system of connecting the meter to the various tube socket circuits lies in its extreme flex-

ibility because of the many test combinations possible. As new tubes with new electrode arrangements are developed and used in radio receivers, their circuits can still be checked if this system is employed in the analyzer. This makes the analyzer less liable to become obsolete. The most serious disadvantages of the system are that it is not as rapid as the switch methods (which will be described), because of the time required to transfer the two meter leads from one pair of pin jacks to another. Also, because of the many combinations possible, errors are apt to be made by inserting the leads into the wrong pin jacks when working hurriedly.

11-10. Use of Switches for Meter Switching in Analyzers.

—Instead of using the pin-jack system of Fig. 11-4 for connecting the meter to the various terminals of the tube socket, switches may be employed to accomplish this task. Since several types of

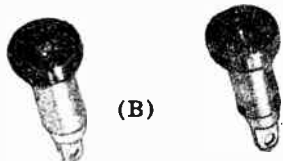
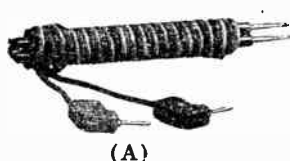

Courtesy Weston Elect. Instr. Corp.

FIG. 11-5.—(A) A pair of test leads (rolled up) with insulated straight prods at one end and elbow prods at the lower end.

(B) A pair of pin jacks having insulated tops to prevent accidental contact with the test leads.

switches, commonly used in radio servicing instruments, are employed for this purpose, it will be well to review their construction briefly before proceeding further.

11-11. Knife Switches.—Most service men are probably familiar with the different types of *knife* switches commonly employed in radio and electrical work. A few of the more common forms are illustrated in Fig. 11-6. They are as follows:

- (a) single-pole single-throw (S.P.S.T.)
- (b) single-pole double-throw (S.P.D.T.)
- (c) double-pole single-throw (D.P.S.T.)
- (d) double-pole double-throw (D.P.D.T.)
- (e) triple-pole single-throw (T.P.S.T.)
- (f) triple-pole double-throw (T.P.D.T.)

While knife switches are simple and perfectly satisfactory from an electrical standpoint, they are seldom used in set analyzers, because they require too much space for mounting and manipulation, and their un-insulated blades expose the operator to possible accidental contact with the circuits.

11-12. Push-Button Switches. — Since the switches employed in radio test equipment are not usually called upon to

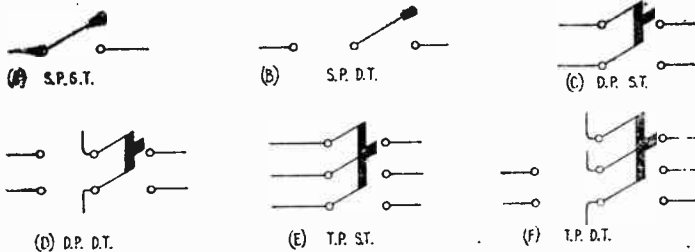

FIG. 11-6.—The common knife switches used extensively in electrical work. These contact arrangements can also be obtained in push-button type switches (see Fig. 11-8).

carry large currents, they are constructed in another form which is more compact, is equally satisfactory electrically, and does not have exposed live parts. The mechanical arrangement employed does not affect the electrical function of the switch in any way, and it provides a means whereby the exposed switch



Courtesy Weston Elect. Instr. Corp.

FIG. 11-7.—(A) A typical multiple-circuit push-button type switch employed in set analyzers because of its compactness, ability to control a number of circuits and construction which permits it to be mounted under the panel and operated above the panel by a slight pressure of the finger.

(B) A typical S.P.S.T. push-button switch which opens and closes a single circuit.

contact surfaces may be placed beneath the panel of the analyzer, thus preventing an excessive accumulation of dust and cor-

rosion on them—and preventing trouble due to the poor contact which would result. This very popular form of switch is called the *push-button* switch, and is used extensively in set analyzers. It consists of two or more blades made of low-resistance spring material such as brass or phosphor bronze, and suitable contact points arranged to be brought together (or released) by light pressure on a button of insulating material which projects through the panel. A typical multi-blade switch of this kind, suitable for controlling a number of circuits, is shown at (A) of Fig. 11-7. A typical single-contact push-button switch employed extensively for opening and closing a single circuit is shown at (B). Push-button switches are made in *locking* and *non-locking* forms. In the former, the button and contacts may be “locked” down after they are depressed, thus keeping them in that position after the finger is removed. This is a very useful

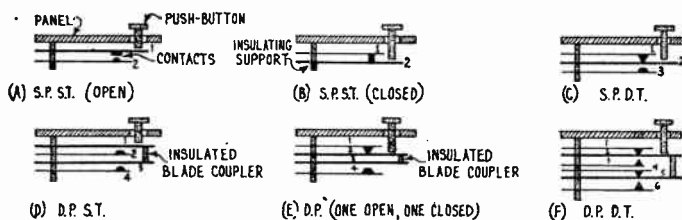

FIG. 11-8.—Several contact arrangements employed in push-button type switches. These switches can be constructed more compactly than the knife switches of Fig. 11-6, and are therefore more desirable for use in radio set analyzers.

feature in some applications. In the non-locking type, the button and contacts release as soon as the finger is removed.

Several blade and contact arrangements employed in push-button switches are shown in Fig. 11-8. A *single-pole single-throw* switch is shown at (A). It has two blades, each having a contact point. When the push-button above the panel is pressed, blade 1 is pushed down so that its contact piece engages, or makes contact with, that of blade 2. This switch is of the *open-circuit* type because it is *open* unless the button is pressed down. On the other hand, it is possible to arrange the blades as shown at (B), so that when the button is pressed, the long blade 2 is pushed *away* from blade 1, thus *breaking* the circuit. This

is called a *closed-circuit* switch. By combining these two blade and contact arrangements as shown at (C), a *single-pole double-throw* switch results. Pressing the button opens the contact between blades 1 and 2, and simultaneously closes the contact between blades 2 and 3. An arrangement whereby two open-circuit single-pole single-throw switches are combined to form a double-pole single-throw switch is shown at (D). This arrangement may be extended to as many poles as desired. The two movable arms are coupled by means of a strip of insulating material; this insulated coupling causes simultaneous "make" and "break" of both circuits.

The switch at (E), composed of two S.P.S.T. units (one of the open-circuit and the other of the closed-circuit type) is useful when one circuit is to be *opened* and another circuit is to be *closed* at the same time. Two S.P.D.T. switches with the long blades coupled as shown at (F) constitute a D.P.D.T. switch. Building up the switch with three S.P.D.T. switches results in a T.P.D.T. combination. Instead of employing two open-circuit S.P.S.T. switches as shown at (D), two closed-circuited S.P.S.T.

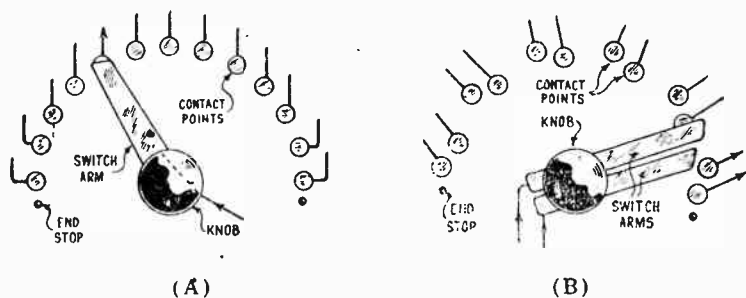
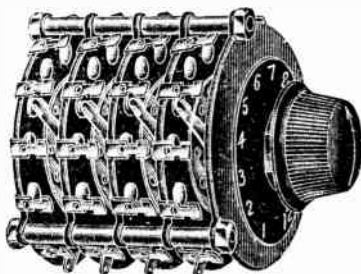

FIG. 11-9.—(A) A single-arm tap switch with 13 contact points. (B) A bi-polar (double circuit) tap switch with 6 pairs of contacts. Each arm really touches only its own set of contacts when it is rotated.

switches may be combined to construct a D.P.S.T. switch which will *open* two circuits (instead of *closing* two circuits) when the button is pressed. By properly combining these fundamental switch blade and contact arrangements, any desired switching function may be performed by the mere pressing of a button.

11-13. "Tap" or "Rotary" Switches.—There is another form of switch which is valuable for some applications in analyzers. This is called a *rotary tap switch*. Tap switches consist of one or more arms of spring metal, such as brass or phosphor bronze, arranged to be rotated over two or more contact

FIG. 11-10.—A typical 4-deck tap switch. The contact arm for each deck may be seen along a line between the No. 4 and No. 5 on the dial plate. Rotation of the single knob turns all of the contact arms simultaneously.



Courtesy Radio City Products Co.

points by means of a knob, dial or pointer. A simple rotary tap switch is illustrated at (A) of Fig. 11-9. This type of switch is usually employed where *one* side of a circuit is to be switched to *any one side* of several circuits in turn. An adaptation of the simple tap switch is the bi-polar tap switch shown at (B). This is generally used for switching *both* sides of a circuit to *both sides* of any of several circuits. The bi-polar tap switch is used extensively in most modern set analyzers and makes possible the application of a single d-c meter to measure all d-c voltages and currents in any tube circuit. By incorporating a copper-oxide type rectifier, the same meter may also be made to read a-c voltages.

These tap, or *rotary switches* can be obtained with any number of contact points and any number of rotating arms, each insulated from the other. A typical commercial 4-deck switch of this kind is illustrated in Fig. 11-10. It can be seen from the illustration that this unit is composed of four decks—it has four individual tap switches coupled together. Note that the switch is so designed that the entire switch mechanism may be mounted below the panel with only a knob or pointer above the panel. An engraved plate shows the position of the rotating arms at any setting.

11-14. Toggle Switches.—Another form of switch fre-

quently employed in set analyzers and other electrical equipment is the *toggle* switch. The most common type is the single-pole single-throw switch, used for "making" and "breaking" any individual circuit. The toggle switch is obtainable with different contact arrangements. A single-pole double-throw toggle switch is illustrated at (A) of Fig. 11-11. A single-pole triple-throw



Courtesy Weston Elect. Instr. Corp.

FIG. 11-11.—(A) A typical single-pole double-throw toggle switch.

(B) A typical single-pole triple-throw toggle switch. Note the extreme compactness of these switches.

toggle switch is shown at (B). Double-pole single-throw, and double-pole double-throw types may also be procured. They serve the same purposes as the push-button type switches shown at (E) and (F) of Fig. 11-8. They *open* one or two circuits while *closing* one or two others. The toggle form of switch is desirable from the point of view of compactness and has the additional advantage that all its contact parts are enclosed.

11-15. Step-By-Step Development of a Typical Set Analyzer Employing Switches.—To understand more easily the circuit arrangement of a complete modern voltage-current type set analyzer employing switches for properly connecting the meter to the various terminals of the tube socket under analysis, it will be well to trace, progressively, its development from a simple testing arrangement—step by step. We will start with a simple analyzer capable of testing the various circuits terminating at the socket of a simple 3-electrode type tube, such as was commonly used in the older receivers, and then add to it, step-by-step, suitable provisions for making the necessary tests for modern tubes having more complicated electrode and circuit arrangements.

Checking the Voltages:

Since, in the early receivers which employ 3-electrode 4-prong tubes, the plate voltage is seldom over 180 volts and the filament current is d-c, all that is necessary to measure the d-c voltages existing at the various terminals of the tube is a single

4-prong socket connected to a cable and dummy plug, a d-c voltmeter and a single-arm contact switch used in conjunction with the meter—all arranged in a manner somewhat as shown in Fig. 11-12. After the tube has been inserted into the socket of the analyzer, and the dummy plug has been inserted into that receiver socket made vacant by the tube, the plate voltage (voltage, between the *plate* and *filament* terminals of the socket), is read on the meter by placing the switch on contact Z. When the switch is placed on contact Y, the filament voltage is read; and, with the switch on contact X, the grid-bias voltage is read. This is substantially the connection of the modern analyzer when measuring grid, filament, and plate voltages.

However, when measuring the grid voltage, the meter will read "backwards," or reversed, since the grid of an amplifier tube is always maintained negative with respect to its filament, and in this test the *negative* grid is being connected to the *positive* terminals of the meter. It is therefore, necessary to

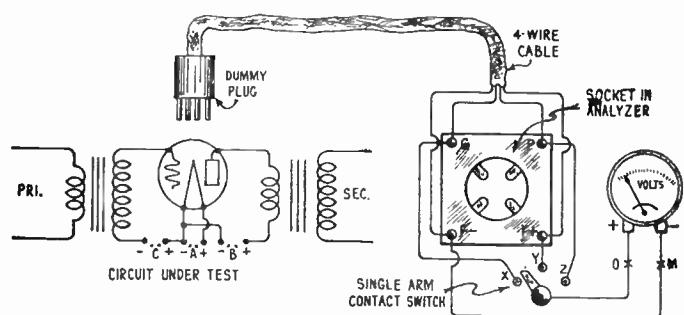

FIG. 11-12.—Here a voltmeter is used with a single-arm contact switch for checking the grid, plate and filament voltages at the terminals of the 4-prong tube socket in the simple analyzer.

employ a double-pole double-throw switching arrangement in the meter circuit, as shown at (A) of Fig. 11-13, to reverse the polarity of the meter for the grid-voltage reading so that the meter pointer will deflect in the proper direction (over its scale). Upon tracing this circuit diagram, it will be found that, when the switch-button is depressed, the long blades 1 and 2 reverse the connections to the meter. This switch is also

necessary in cases where a *reversed* filament-voltage reading is obtained—for instance, in receivers which have their tube filaments connected in *series* with each other.

Since the d-c filament voltage is 6.3 volts or less, it is difficult to accurately read the small deflection which is obtained when a meter range of 0-150 volts or higher (which is necessary for reading the plate voltage) is used. Therefore, we must employ

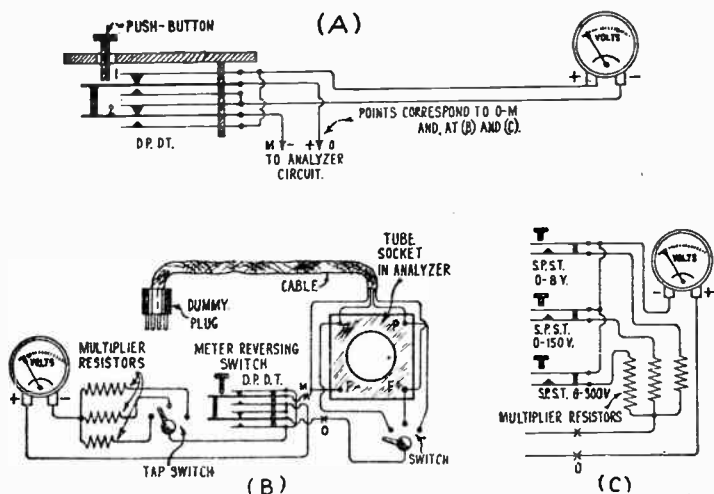

FIG. 11-13.—Progressive study of the voltage-current analyzer and the switching arrangements.

(A) A D.P.D.T. push-button switch is connected to the voltmeter for reversing its connections when checking negative grid voltages, etc.

(B) Here a tap-switch has been added to the voltmeter to make possible the rapid selection of any of its ranges. The analyzer of Fig. 11-12 is shown here with the voltmeter-reversing switch and multi-range voltmeter features added.

(C) Single-pole push-button switches may be employed in the circuits of the voltmeter multiplier, as shown here, to provide rapid range selection.

a multi-range voltmeter having a low range of about 8 volts for filament-voltage measurement, and suitable higher ranges for other tests. The circuit arrangement of such a voltmeter, with its various multiplier resistors and a tap-switch for selecting the ranges, is shown together with the reversing switch and the

rest of the analyzer at (B). The switch used to select the various ranges of the voltmeter may be either a single-arm tap-switch as shown in (B), or a number of single-pole single-throw push-button switches connected as shown at (C). The latter arrangement enables any voltmeter range to be selected by merely pressing the proper push button. In this way, it is possible to check all the d-c voltages of the tube circuit, regardless of the magnitude of the voltage, or the polarity.

Checking the Currents: It is also important to check the plate

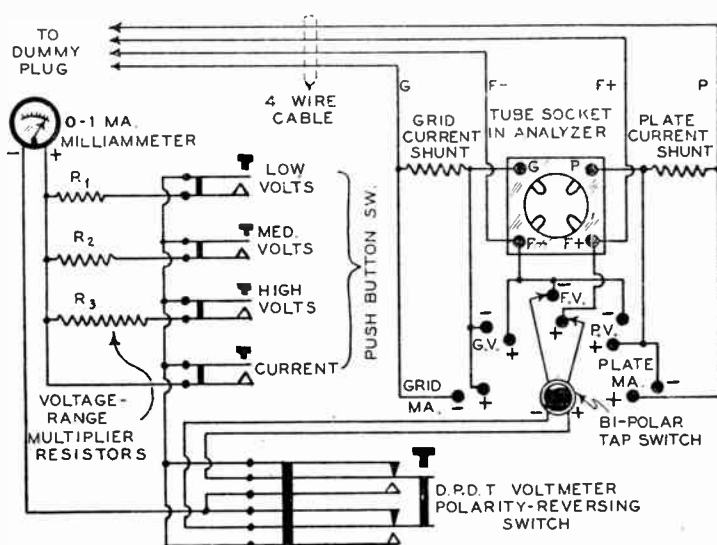

FIG. 11-14.—The circuit arrangement of (B) in Fig. 11-13, altered with a bi-polar tap switch employed to connect the meter to the different circuits of the tube. The meter is provided with shunts and a current switch for checking the plate and grid currents. The voltmeter range multiplier resistances are R_1 , R_2 and R_3 .

and grid currents of the tube. This can only be done by breaking into the plate and grid circuits and inserting a milliammeter of proper range, depending upon the type of tube to be tested. This means that an additional milliammeter must be used unless the single meter employed in our analyzer is a low-range milli-

ammeter with the proper multiplier and shunt resistors to enable it to measure both voltage and low current. In order to make possible the use of a single meter for both voltage and current measurements, it is necessary to modify the arrangement shown at (B) of Fig. 11-13, by wiring into the circuit a bi-polar switch to connect the milliammeter to the different circuits of the tube, as shown in Fig. 11-14. In this circuit, the use of the bi-polar switch enables the checking of the grid voltage without the necessity of employing the polarity-reversing switch which was used in Fig. 11-13. However, this switch is retained, since it is necessary when checking the screen-grid voltage in screen-grid tubes.

By tracing the meter connections for each position of the tap switch, it can be seen that instead of breaking into the plate and grid circuits to connect the meter for current readings, the milliammeter shunt resistors are permanently connected in the grid and plate circuits of the tube. This arrangement eliminates two switches that might ordinarily be required to perform this function if this arrangement were not employed. The presence of these shunt resistors in the grid and plate circuits of the tube has no effect upon the grid and plate voltage readings, as their resistances are very low. For instance, when a 0-1 ma. meter is used, the 10-ma. shunt has a resistance of approximately 3 ohms, and the 100-ma. shunt a fraction of an ohm. Consequently, the voltage drop across these resistors is too small to bother about.

Review of the Analyzer Circuit Thus Far Developed:

In order to more clearly understand the operation of the analyzer which we have built up thus far, let us trace the particular parts and wiring that are in operation when the selector switch is set at each position. The simplified circuits which exist for each position of the switch are shown in Fig. 11-15. As can be seen from (A) of Fig. 11-15, when the bi-polar, or "selector", switch is set at the *F.V.* (filament voltage) position, the meter is connected directly across the filament terminals of the test socket when any one of the *voltage-range* push-button switches are pressed. The advantage of connecting the voltage range multiplier resistors, R_1 , R_2 , R_3 to push-button switches, as

shown, is to prevent possible injury to the meter, which might occur if the tap-switch arrangement illustrated at (B) of Fig. 11-13 were employed. In the latter case, the voltage range tap-switch must first be set at the proper position before setting the bi-polar selector switch at any of its voltage-reading positions,

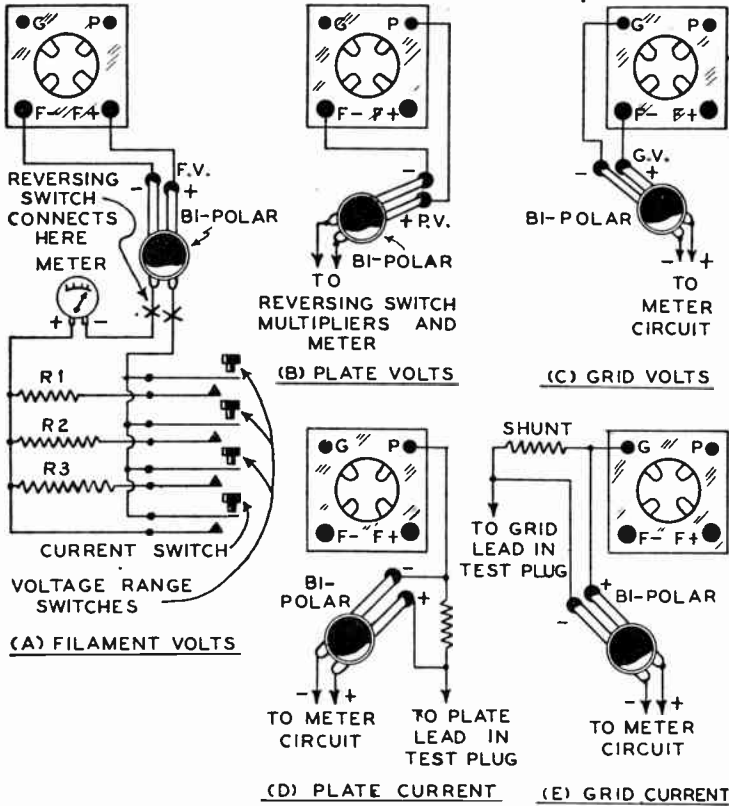

FIG. 11-15.—“Breakdown” of the meter circuits which exist for each position of the bi-polar selector switch in Fig. 11-14.

otherwise, the voltmeter range switch might happen to be set for the *low* voltage range when a *high* plate voltage is to be checked. Naturally, the application of the high voltage to the meter would damage it.

With the selector switch in the *P.V.* (plate voltage) position

the circuit of the analyzer would appear as pictured at (B) of Fig. 11-15. The circuit for the *G.V.* (grid voltage) setting of the bi-polar switch is shown at (C). For plate- or grid-current measurements, the milliammeter is connected across the shunt resistors inserted in the plate and grid circuits of the tube, without

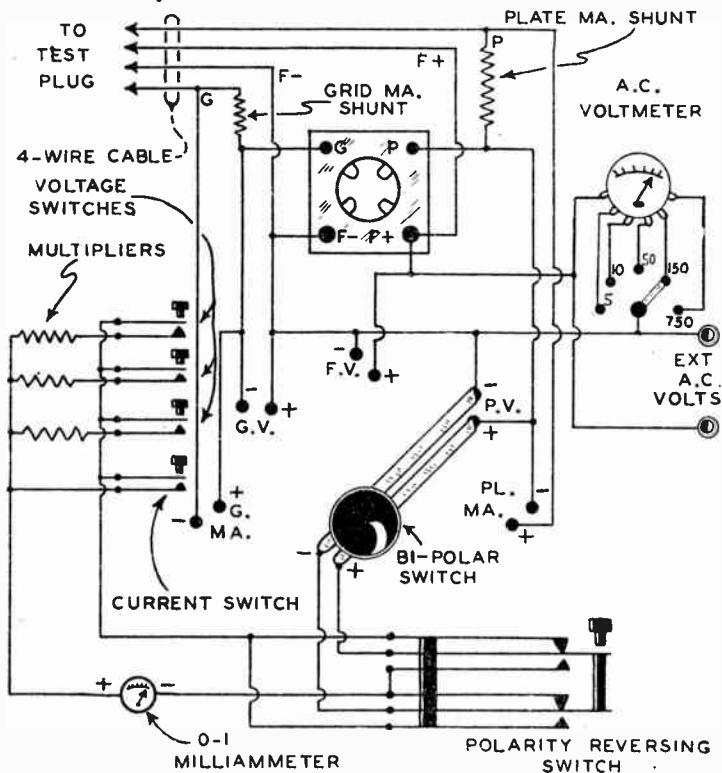

FIG. 11-16.—Here an a-c voltmeter has been added to our analyzer for checking a-c filament voltages and line voltage. The tap-switch shown at the upper right selects its various ranges.

any multiplier resistors or switches, as shown at (D) and (E), after the "current" push button is pressed.

Checking A-C Filament Voltages:

The almost universal use of a-c tubes makes it necessary that the analyzer be capable of checking a-c filament voltages. This

requires the use of an a-c voltmeter with at least three ranges, possibly 5, 10 and 50 volts. If this meter also has a range of 150 volts, it can be employed for the measurement of a-c line voltages; if the range of the meter is as high as 750 volts, then the output voltage of the high-voltage secondary of the power transformer can also be checked. By connecting such an a-c voltmeter to the filament circuit by means of a five point tap-switch,

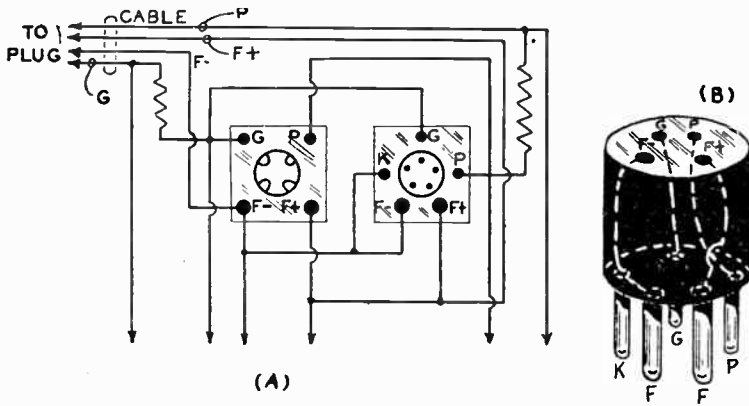

FIG. 11-17.—(A) How a 5-prong socket is added to our analyzer to make it possible to analyze the circuits leading to 5-prong tubes in receivers.

(B) A 4-hole 5-prong adapter to be used at the end of the 4-prong dummy plug when the circuits to a 5-prong tube are to be tested. The internal connections are shown dotted. Note that the K, and one F terminal are connected together.

as shown in Fig. 11-16, it is possible to measure all a-c filament voltages.

Checking Indirect-Heater Type Tube Circuits:

Indirect-heater type 5-prong tubes are employed in many receivers, so it is necessary to modify our analyzer design to accommodate this type of tube. This means that a 5-prong socket must be incorporated in the analyzer and connected into its circuit as shown at (A) of Fig. 11-17. The 4-prong cable plug must then be provided with a removable 5-prong adapter, pictured at (B), to be used when the circuits to a 5-prong tube are to be tested. This analyzer circuit arrangement is satisfactory

so long as the UY, or type 227, tube is employed as a "grid-leak" type detector with the cathode element connected to ground potential; but, when this tube is employed as a "power"

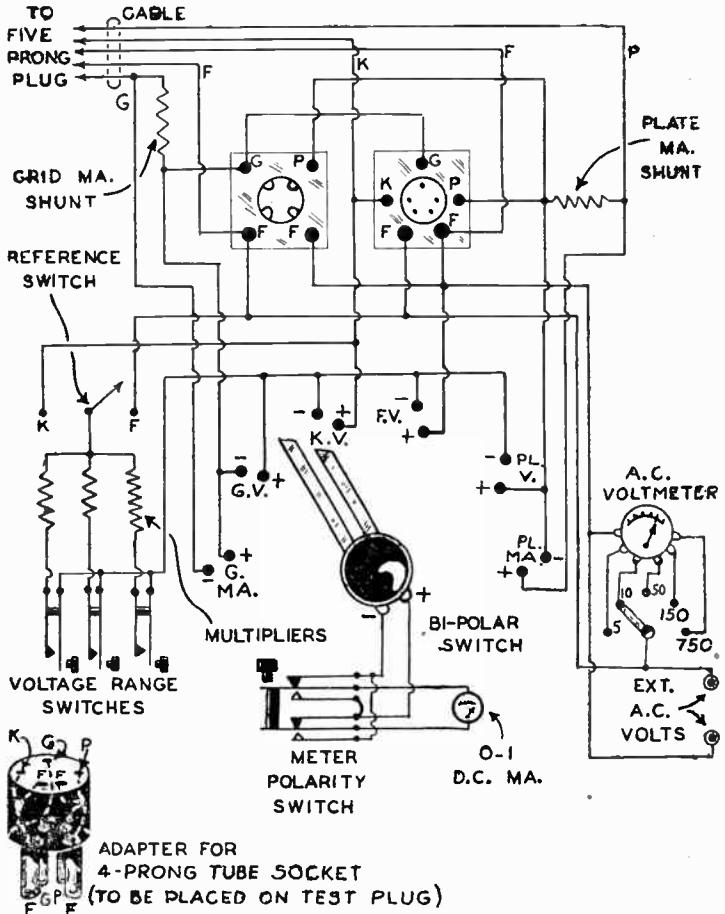

FIG. 11-18.—In this circuit, provisions have been made to measure the various voltages with reference to either the cathode or the filament. A 5-prong test plug is now used on the cable.

detector or as an i-f or a-f amplifier, which uses require a "bias voltage" between *cathode* and *ground*, some arrangement must be devised to measure this cathode voltage and all other voltages,

with respect to the cathode. This again necessitates several changes: another position must be added to the bi-polar switch

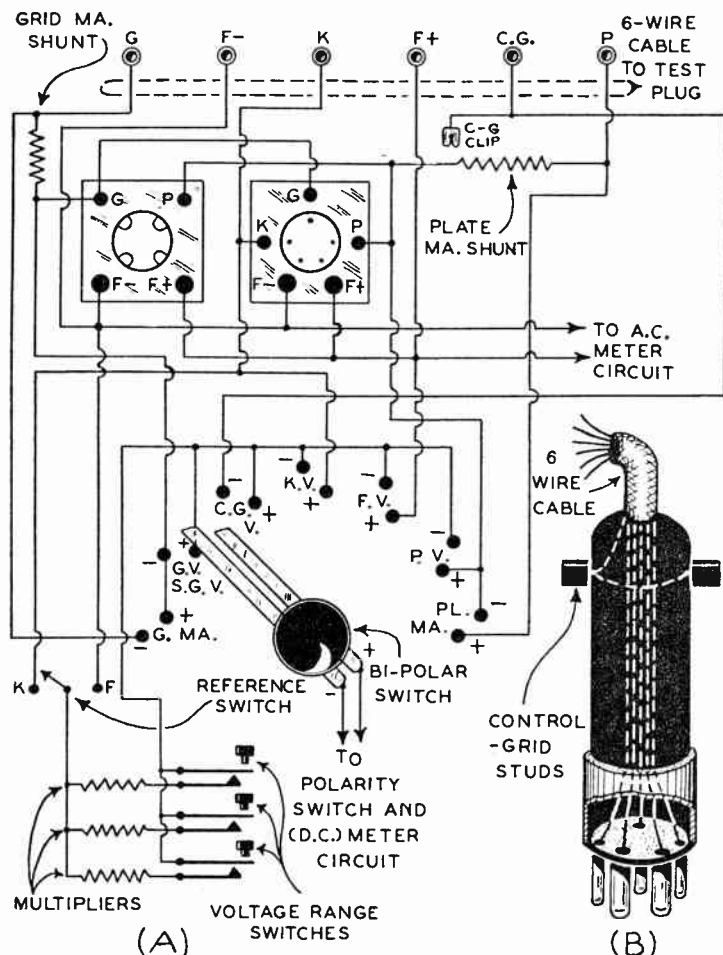

FIG. 11-19.—(A) Analyzer circuit after provisions have been made for measuring the control-grid voltage of screen grid tubes.

(B) The analyzer dummy plug showing the studs for connection to the control-grid clips in the receiver. The plug is shown cut-away at the bottom to reveal the internal connections to the prongs.

to measure the cathode voltage, $K.V.$; a five-wire cable and 5-prong test plug must be used; and a single-pole double-throw

"reference" switch must be added so that grid and plate voltages can be referred either to the cathode or to the filament, respectively, for 5- or 4-prong tubes, as shown in Fig. 11-18. Since a 5-wire cable and 5-prong test plug are now used, the adapter shown at the lower left is necessary when checking the circuits to 4-prong tubes. Notice that it has 5 holes and 4 prongs.

Checking Screen-Grid Tube Circuits:

In its present state, our analyzer can only make voltage and current measurements on unscreened tubes, regardless of whether they are of the a-c or d-c type. If screen-grid tube circuits are to be tested, means must be included for the measurement of screen voltage and current. But the control-grid element in the screen grid tube is not connected in the same relative position on the socket as the control-grid on unscreened tubes—it connects to a special metal cap on top of the tube. What is normally the *control-grid* prong in unscreened tubes is the *screen-grid* prong in screen-grid tubes.

Another position must therefore be added to the bi-polar selector switch to measure the control-grid voltage, as shown in the circuit at (A) of Fig. 11-19. These changes make necessary a 6-wire cable to the dummy-plug. One of these wires (for the control-grid circuit) must be provided with a clip at the "analyzer end" for clipping to the control-grid cap of the tube. At the dummy-plug end, it must be provided with studs, so that the control-grid lead in the receiver may be clipped on to these studs for contact. The position of these studs on the plug is shown at (B). It can be seen from (A) that, when the bi-polar switch is set at the *C.G.* position, the control-grid voltage of screen-grid tubes can be read; and that, with the switch in the *G.V.-S.G.V.* position, the control-grid voltage of other tubes, as well as the screen-grid voltage of screen-grid tubes, can be checked. When measuring screen-grid voltage in this position, however, the meter-reversing switch must be pressed in order to obtain a reading of correct polarity.

Use of Separate Meter Shunts:

The checking of the voltages and currents existing at the socket terminals of the many different types of tubes employed in radio receivers requires extreme flexibility in the design of the

switching system—the very foundation of any analyzer. Plate and screen currents vary within wide limits, so that, if our analyzer is to be as useful as possible, we must discard the fixed shunt system and use separate shunts, any one of which may be thrown into use by merely pressing the proper “current” button. A typical double-shunt switching system making use of two

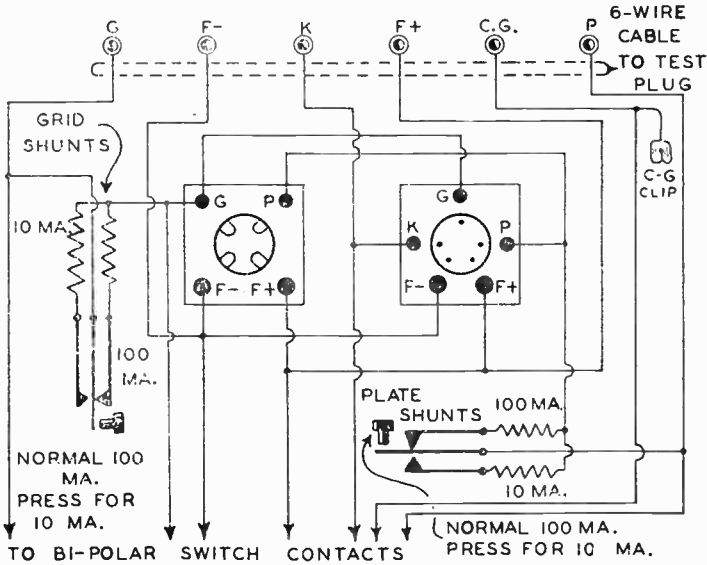

FIG. 11-20.—A double-shunt switching system which makes use of two S.P.D.T. switches for providing two current ranges for grid current and screen current measurement.

S.P.D.T. switches is illustrated in Fig. 11-20. The analyzer now is satisfactory even when the voltages and currents at the socket terminals of output pentodes (5-prong tubes) are being checked, since the only difference between the base connections on these tubes and UY-type tubes is in the location of the “cathode” prong. In the pentode tube, the prong which would normally be the “cathode” prong is connected to the “screen-grid” element within the tube instead (see Figs. 5A and 5B on page 1272). Hence, the screen-grid voltage of a filament-type pentode tube can be read with our analyzer by placing the selector switch in the “cathode volts” (K.V.) position, pressing

the proper voltage-range switch, and reading the meter.

Testing Tubes and Measuring Resistance with the Analyzer:

Aside from being able to measure the various voltage and current values existing at the tube socket terminals, the analyzer may also be used to test tubes, although a separate tube checker will give more satisfactory results because of the probability that the voltages applied to the tube will be more near the proper values. A satisfactory method for determining the worth of a tube is by checking its mutual conductance (see Arts. 8-8

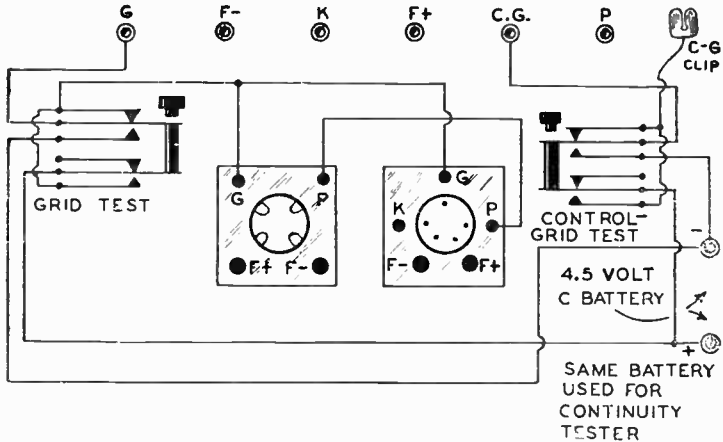

FIG. 11-21.—Circuit arrangement for incorporating a grid-shift test for testing tubes in the set analyzer.

and 8-15) by the "grid-shift" test. Invariably, this is done by noting the change in plate current when a small 3- or 4½-volt battery is switched into the grid circuit of the tube under test in order to alter the grid voltage. By incorporating two double-pole double-throw switches and a small 4½-volt battery into the developed analyzer, as shown in Fig. 11-21, it is possible to obtain a rough check on the mutual conductance of the tubes. It is interesting to note that thousands of analyzers of this form have been built and have rendered excellent service. The same tube-testing battery may also be used to provide ohmmeter facilities, the scale of the meter being calibrated to read "ohms". The circuit arrangement for this feature is shown in Fig. 11-22. The switching arrangement may also be arranged to provide for

the measurement of *external* voltage, current, and resistance. (The testing of radio receivers by means of the voltage-current analyzer will be discussed in detail in Chapter XX).

Testing 6- and 7-Prong Tube Circuits with the Analyzer:

All that remains to bring our voltage-current analyzer up to date is to incorporate facilities for testing the circuits of six- and seven-prong tubes. Two methods are available for doing this: first, the analyzer circuit may be re-designed to accommodate two new sockets; and second, the present sockets and the analyzer plug may be used with *adapters* (see Arts. 8-29 to 8-34).

The first method, of course, is preferable. It obviates the necessity for having numerous adapters, and results in a clean-

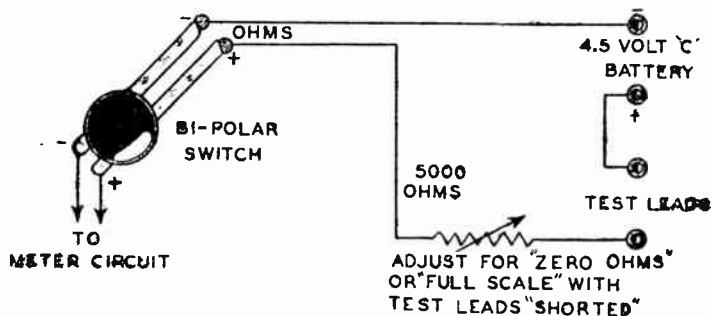

FIG. 11-22.—Circuit arrangement for using the meter in the analyzer as a "series" type ohmmeter.

cut analyzer with a minimum of extraneous parts. Since the plug should be of the six-prong type, 4-, 5-, and 7-prong adapters are required to make it universal. In many cases, the plug is equipped with seven prongs, and 7-to-6, 7-to-5, and 7-to-4 prong adapters are used.

The second method of attack has the distinct advantage of circuit simplicity and is the method that will be followed here. The thousands of owners of similar types of analyzers will thus appreciate the reason for the use of adapters and, what is more important, a logical method of modernizing present analyzers of this general type will be presented for use when additional new tube types appear. Then, too, it is the purpose of this chapter to stress only the *general construction* of set analyzers, not to

explain the many different types of switching systems. Once the general scheme has been learned, changes may be made by the individual himself in order to meet any special requirement.

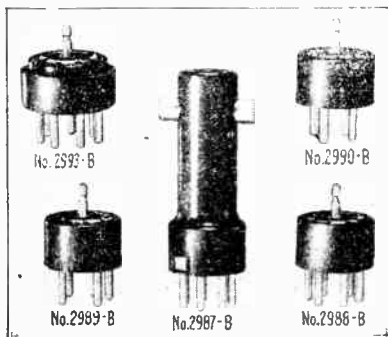

FIG. 11-23.— Seven-prong analyzer dummy plug and four adapters for adapting it to 6-, 5-, 4- and 7 (large base)-hole sockets. See Fig. 11-24 for the internal wiring of these adapters. Notice the control-grid studs on the dummy plug.

Courtesy The Radio Products Co.

A typical 7-prong dummy plug is illustrated in Fig. 11-23 with the requisite 7-to-6, 7-to-5, and 7-to-4 prong adapters and a 7-to-7 prong adapter for large base seven-hole sockets.

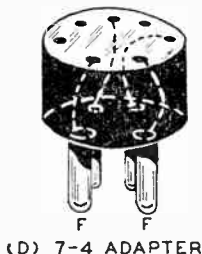
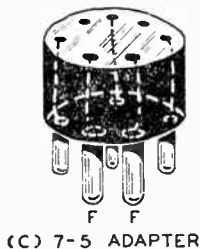
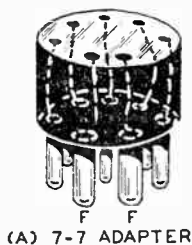

FIG. 11-24.—Internal wiring of the four analyzer adapters illustrated in Fig. 11-23.

The internal wiring of these adapters is depicted in Fig. 11-24. Of course, an 8 wire cable must be used.

11-16. Modernizing Old Set Analyzers with Adapters.—

Many service men now own voltage-current type set analyzers that are able to test the circuits of screen-grid and pentode tubes. By employing suitable adapters, most of these analyzers can

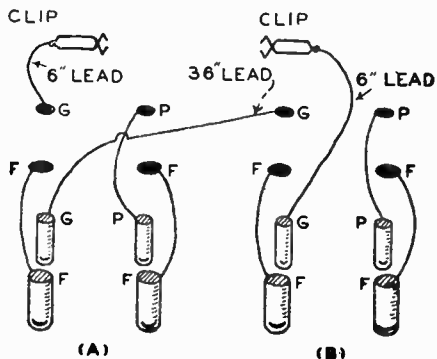
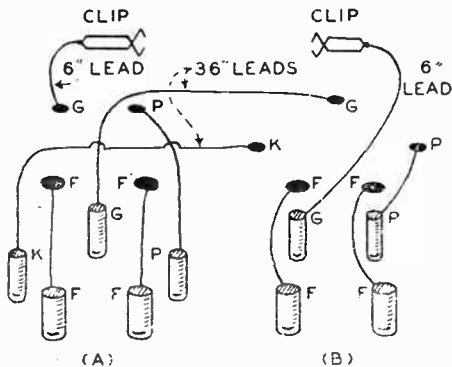

FIG. 11-25.—Two-part adapter for analyzing the circuits to '22, '32, and '34 type tubes when the analyzer is equipped with a 4-prong test plug and a 4-wire cable.

be modernized for the testing of all the new tubes and their circuits. In some instances, it will not be possible to analyze each individual circuit of a tube, but the principal measurements may be made and the tube may be tested for its mutual conductance. Several of these adapters will now be described. The design of an analyzer determines the number of adapters required

FIG. 11-26.—Two-part adapter for analyzing the circuits to '24, '35, '36, '38, '39, '44 and '51 type tubes when the analyzer is equipped with a 4-prong test plug and a 4-wire cable.



for modernization. In the following sections, therefore, several of the more common designs, including the one developed in Art. 11-15, will be considered.

11-17. Adapters for Analyzers having 4-Prong Test Plugs and 4-Wire Cables.—If the analyzer is equipped only with a

4-prong test plug and a 4-hole socket, the combination adapter illustrated in Fig. 11-25 may be used for testing 4-prong screen-grid tubes of the '22, '32, and '34 types without the need for 5- to 4- or 4- to 5-prong adapters.* With 5-prong screen-grid tubes of the '24, '35, '36, '38, '39, '44 and '51 types, however, the combination adapter shown in Fig. 11-26 must be employed.

FIG. 11-27.—Two-part adapter for analyzing the circuits to '33, '46, '47, '49, etc., tubes with an analyzer equipped with a 4-prong test plug and 4-wire cable.

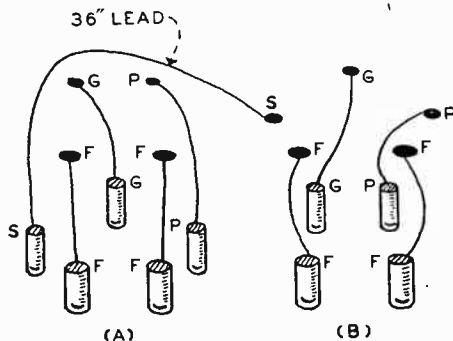

These tubes may be tested and all their circuits, excepting the screen-grid and cathode circuits, may be analyzed with this adapter.

If the analyzer employs a 4-prong test plug and a 4-hole socket, output pentode tubes may be tested with the combination adapter illustrated in Fig. 11-27.

For analyzers that are equipped with 4-prong test plugs and 4-hole sockets, the 6-prong tubes and circuits may be analyzed by employing the combination adapter shown in Fig. 11-28. With this adapter, however, no check on cathode or screen voltage can be made. As can be seen, this adapter consists of two sections, each with two clips. Tubes of the '55, '57, '58, '75, '77, '78, '85, '89, 6C6 and 6D6 types are tested by placing section (A) of the adapter on the test plug and inserting section (B) into the analyzer socket. Clips Nos. 1 and 3 are connected together, clip No. 4 is connected to the control-grid lead of the stage in the receiver to be analyzed. With this arrangement, it is possible to obtain a test of the tube and an analysis of plate

*NOTE: In the abbreviations 4- to 5-, 6- to 7-, 7- to 4-, etc., the first numeral refers to the number of holes in the adapter. The second numeral refers to the number of prongs on the adapter.

voltage, plate current, control-grid voltage, cathode voltage and heater voltage. The measurement of control-grid current may also be made if the analyzer is capable of performing this test (usually designated as "grid current" with triode tubes). In the case of 6-prong tubes, such as the '18, '41, '42, '43, '48, and PZH, clip No. 1 is connected to clip No. 2, and clip No. 3 to clip No. 4. All circuits may be analyzed, except the screen circuit.

11-18. **Adapters for Analyzers having 5-Prong Test Plugs and 5-Wire Cables.** — When the set analyzer comes already equipped with a 5-prong test plug and a 5-wire cable, a 5- to 4-prong adapter is usually supplied with the plug for the testing of 4-prong tubes and their circuits. If the analyzer does not contain a 4-hole socket (only a 5), a 4- to 5-prong adapter is always furnished so that 4-prong tubes may be inserted into the analyzer. In the 4- to 5-prong adapter, the cathode terminal is tied to one of the heater terminals, but in the 5- to 4-prong adapter, the cathode circuit is open.

By employing the combination adapter shown in Fig. 11-29, '22, '32, and '34 type 4-prong *screen-grid* tubes and their circuits may be analyzed. As may be seen from the illustration, this

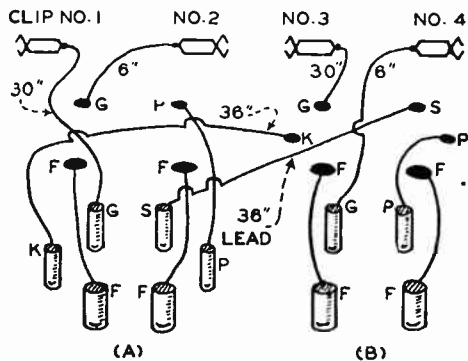

FIG. 11-28.—Two-part adapter for analyzing the circuits to '55, '57, '58, '77, '78, etc., and '18, '41, '42, '43, '48, PZH, etc., tubes when the analyzer is equipped with a 4-prong plug and a 4-wire cable.

device consists of two adapters, one of which (A) is placed on the 5-prong test plug. Then the usual 5- to 4-prong adapter supplied with the analyzer is inserted on this adapter. The other one (B) is inserted into the analyzer socket if a 5-hole test socket has been provided, and the usual 4- to 5-prong

adapter supplied with the analyzer is inserted into this one. In this way, 4-prong screen grid tubes may be inserted into this latter adapter for test, and their circuits analyzed. The clip on section (A) of the adapter is fastened to the control-grid lead of the stage in the receiver that is to be analyzed, and the clip on section (B) is fastened to the control-grid cap of the tube that has been inserted in the analyzer. In this way, the tube may be tested in the conventional manner and an analysis of all its circuits made, except for the screen-grid circuit.

By employing the combination adapter of Fig. 11-29, screen-grid tubes of the '24, '36, '38, '39, '41 and '51 types (5-prong screen-grid tubes) may also be tested, and all their circuits analyzed except the screen-grid circuit. The same procedure described in the preceding paragraphs is followed, but, in this case,

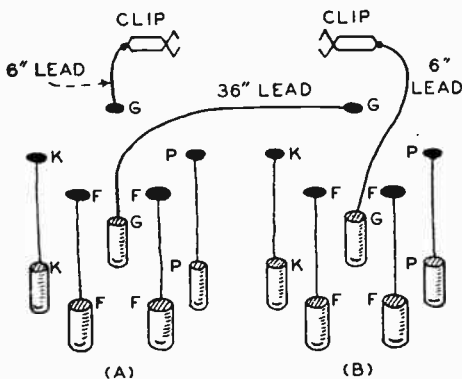

FIG. 11-29.—Two-part adapter for analyzing the circuits to '22, '32, '34, '24, '36 and '51 tube when the analyzer is equipped with a 5-prong plug and a 5-wire cable.

the 5- to 4-prong and 4- to 5-prong adapters are not used. Section (A) of the adapter is placed directly on the 5-prong test plug and the clip is fastened to the control-grid lead in the receiver. Section (B) is inserted into the 5-hole socket of the analyzer and its clip fastened to the control-grid cap of the tube.

The testing of output pentode tubes such as the '33, '46, '47, 'GA, 'LA, and 'PZ and their circuits with analyzers equipped with 5-prong test plugs and 5-hole sockets should not present any difficulties, and an adapter is unnecessary unless the analyzer has not been designed to measure high values of cathode voltage. As has been explained previously, the only difference between the base prong connections of pentode tubes and other

5-prong tubes is in what is normally the "cathode" prong. In the pentode, this prong connects to the screen-grid element of the tube. When the range of the analyzer is limited only to

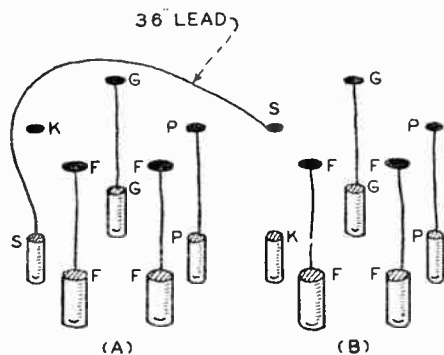
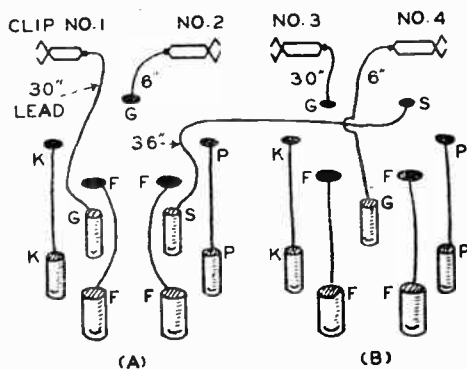

FIG. 11-30.—Two-part adapter for analyzing the circuits to '33, '46, '47, '49, etc., tubes when the analyzer is equipped with a 5-prong test plug and a 5-wire cable.

low cathode voltage measurements, or to none at all, as is the case with some old testers, the combination adapter shown in Fig. 11-30 may be used. Section (A) of the adapter is placed on the test plug and section (B) is inserted in the analyzer

FIG. 11-31.—Two-part adapter for analyzing the circuits to '55, '57, '58, '75, '77, '78, etc., tubes, and the '18, '42, '43, '48, PZH, etc. tubes when the analyzer is equipped with a 5-prong test plug and a 5-wire cable.



socket. With this adapter, then, the screen-grid circuit of pentode tubes cannot be analyzed.

The testing of 6-prong tubes and their circuits with an analyzer provided with a 5-prong test plug, 5-hole socket and a 5-wire cable, is accomplished with another combination adapter such as is shown in Fig. 11-31. This combination adapter is

similar to that seen in Fig. 11-27, except for the 36-inch lead for the cathode circuit. The tubes which can be tested, and the testing procedure, are the same as outlined for this other adapter.

When the testing of 7-prong tubes and their circuits with an analyzer equipped with a 5-prong test plug and 5-wire cable is

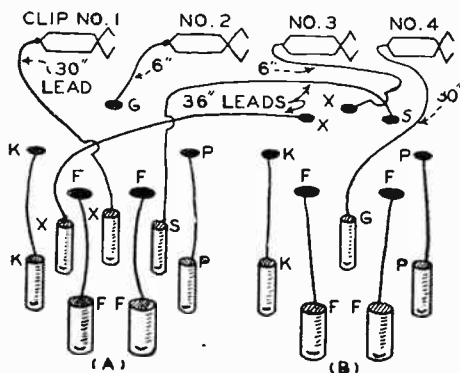

FIG. 11-32.—Two-part adapter for analyzing the circuits of 2A7, 2B7, 6D7, 6E7 and '59, 57B types of tubes when the analyzer is equipped with a 5-prong test plug and a 5-wire cable.

desired, the combination adapter shown in Fig. 11-32 should be used. Tubes of the types 2A7, 2B7, 6A7, 6D7 and 6E7 are tested by placing section (A) of the adapter on the test plug and inserting section (B) into the analyzer socket. Clip No. 1 is connected to clip No. 3, clip No. 2 is connected to the control-grid lead in the receiver, and clip No. 4 is fastened to the control-grid cap of the tube under test. With this arrangement, plate voltage, plate current, cathode voltage, control-grid voltage, and heater voltage may be measured, and the tube may be tested for "mutual conductance." In testing 7-prong tubes such as the '59 and '59B, clip No. 1 is connected to clip No. 2, and clip No. 3 is connected to clip No. 4. All circuits may be analyzed but the suppressor- and screen-grid circuits.

11-19. Adapters for Analyzers having 5-Prong Test Plugs and 6-Wire Cables.—If the analyzer has been designed for the testing of 5-prong screen-grid tubes, with facilities for measuring screen voltage and current, the adapter necessary for testing 6-prong tube circuits, (shown in Fig. 11-33) is not very complicated. The test plugs on these analyzers are provided with a stud on the test plug to which the control-grid lead in the receiver

is connected. This stud is connected to the control-grid terminal or lead on the analyzer through a 6-wire cable with which the test plug is equipped.

The combination adapter pictured in Fig. 11-33 is composed of two sections, each provided with an external lead terminating in a spring clip. In testing 6-prong tubes such as the '55, '57, '58, '75, '77, '78, '85, '89, 6C6 and 6D6, clip No. 1 of section (A) of the combination adapter which fits on the analyzer plug is connected to clip No. 2 of section (B) which is inserted into the analyzer 5-hole socket. The control-grid lead in the receiver is connected to the stud on the test plug, and the analyzer control-grid lead is fastened to the top control-grid cap of the tube under test. With this arrangement, an analysis of all circuits except the suppressor-grid circuit may be made. When the circuits of 6-prong tubes such as the '18, '41, '42, '43, '48 and PZH are to be analyzed, section (A) of the adapter is placed on the test plug and section (B) is inserted in the analyzer. In this case, however, clip No. 1 is fastened to the

FIG. 11-33.—Adapter for analyzing the circuits to '55, '57, '58, '75, '77, '78, etc., tubes, and to '18, '41, '42, '43, '48, PZH, etc., tubes when the analyzer is equipped with a 5-prong plug and 6-wire cable.

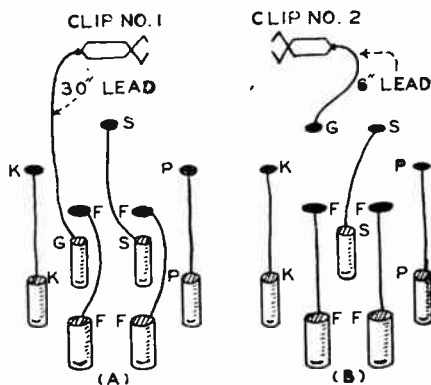

control-grid stud of the test plug and clip No. 2 is attached to the control-grid cap of the tube in the analyzer. This latter procedure makes the testing of all circuits possible.

Analysis of 7-prong tube circuits with a set analyzer equipped with a 5-prong test plug and 5-hole socket is difficult, since the internal elements of the various 7-prong tubes are not connected

to the base pins in any systematic or definite manner. For example, the type '53 tube, a double output triode mounted in a single glass envelope with a common cathode sleeve and employed in Class B amplification, has one plate connected to the conventional plate prong and the other plate connected to the conventional cathode prong. The 2B6, also a twin tube, but utilized as a Class A amplifier, has one plate connected to the conventional plate prong and the second plate connected to the conventional screen-grid prong. Thus, in these two cases, it would be necessary to test the emission (plate current) of both plates to determine the value of the tube as an amplifier.

For this reason, and because of the fact that old test equipment is usually not designed to measure cathode and screen-grid current, testing of the '53, 2B6 and other tubes whose base pins are unconventionally connected requires that too many complicated adapters be used. Where the analyzer is provided with a 5-prong test plug with control-grid stud (6-wire cable), and the testing of screen-grid tubes is possible, the situation is less serious. In the case of analyzers not equipped for the analysis of screen-grid tubes, rewiring the set analyzer to accommodate these tubes is suggested, since this method is simpler and much less expensive than employing an array of complex test adapters. The rewiring would involve the installation of an additional switch or two (*see Testing 6- and 7-prong tube circuits with the analyzer*, in Art. 11-15), a test plug with a control-grid stud connection, a control-grid connection on the analyzer to connect to the control-grid cap of screen-grid tubes, and a 6-wire cable in place of the 5-wire cable formerly used. In some instances, extra switches are not needed, as many set analyzers are provided with bi-polar or selector switches having one or more spare blank positions which may be used for such contingencies.

Analysis of 7-prong tube circuits with set testers employing a 5-prong test plug having a control-grid stud for the testing of 5-prong screen tubes (6-wire cable), requires the combination adapter shown in Fig. 11-34. When 7-prong tubes of the types 2A7, 2B7, 6A7, 6B7, 6D7 and 6E are encountered, section (A) of the adapter is fitted on the test plug, section (B) is inserted

into the analyzer socket, and clip No. 1 is connected to clip No. 2. The control-grid lead in the receiver is fastened to the stud on the test plug, and the control-grid lead in the analyzer is placed upon the top cap of the tube under test. An analysis of plate voltage, plate current, screen voltage, screen current, cathode voltage, control-grid voltage and heater voltage may

FIG. 11-34.—Two-part adapter for analyzing the circuits to 2A7, 2B7, 6A7, 6B7, 6D7, 6E, etc. tubes, and '59, '59B, etc. tubes when the analyzer is equipped with a 5-prong test plug and 6-wire cable.

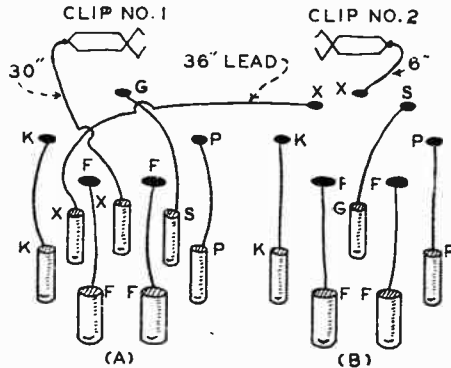

be made with this adapter. In the case of the types '59 and 59B 7-prong tubes, clip No. 1 is attached to the test plug stud, and clip No. 2 is connected to the control-grid lead of the analyzer. With this arrangement, the tube may be tested, and all circuits (except the suppressor-grid circuit) may be analyzed.

11-20. Adapters for Analyzers having 6-prong Test Plugs and 7-Wire Cables.—The testing of 7-prong tubes and circuits with an analyzer employing a 6-prong test plug and 7-wire cable, (and designed for the testing of 6-prong tubes and circuits) requires the two simple test adapters, shown in Fig. 11-35. One of them (A) is placed on the test plug and the other one (B) is inserted into the analyzer socket. With tubes such as the 2A7, 2B7, 6A7, 6B7, 6D7 and 6E7, clip No. 1 is connected to clip No. 2. All circuits but the anode plate or first diode plate may be analyzed, as seen in the illustration, by attaching the control-grid lead in the receiver to the test plug stud and the control-grid lead in the analyzer to the top cap of the tube. With the '59 and '59B tubes, clip No. 1 is connected to the test plug

stud and clip No. 2 is fastened to the analyzer control-grid lead. With this arrangement, all the circuits may be analyzed.

11-21. Advantages of Modern Analyzers.—It is clear that the use of an analyzer equipped to handle the latest tubes with the least number of adapters has very decided advantages over the use of an old analyzer modernized with a large number of adapters. However, the cost of many of the older analyzers was quite high, and service men having them may not want to discard them. The adapters described here will be suitable for such cases. In the following chapter, point-to-point analyzers capable of making resistance, voltage and current analyses of re-

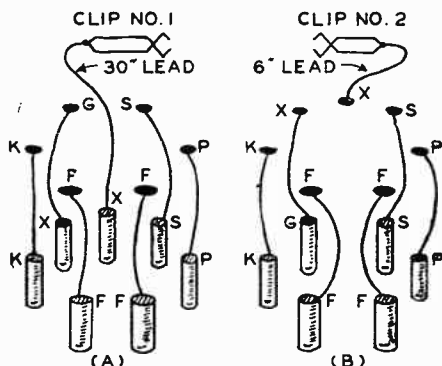

FIG. 11-35.—Adapter for analyzing the circuits to 2A7, 2B7, 6A7, 6B7, 6D7, 6E7, etc., tubes, and '59, '59B tubes when the analyzer is equipped with a 6-prong test plug and 7-wire cable.

ceivers, will be studied. In Chapter XIII, constructional details of a modern set analyzer suitable for home construction and capable of checking resistance, current and voltage in a receiver will be presented. In Chapter XIV, the circuit arrangements of several representative modern commercial set analyzers will be studied in detail. Interesting and instructive circuit details which they possess will be pointed out.

11-22. Use of the Voltage-Current Analyzer in Receiver Testing. — The analysis of radio receivers by means of the voltage-current analyzer will be considered in detail in Chapter XX.

REVIEW QUESTIONS

1. What is the main function of the radio set analyzer or tester? Explain fully.

2. What is the advantage of using a set analyzer or tester instead of checking the various voltages and currents directly at the terminals of the tube sockets of the receiver with a suitable voltmeter and milliammeter?
3. Explain briefly the idea of the set analyzer. Draw a single sketch illustrating its principle of operation.
4. Show by a simple clear sketch how individual meters would have to be connected to make the necessary voltage and current tests in a socket-analysis test of a type '58 tube used in the r-f amplifier stage of a superheterodyne receiver. (See Tube, and Tube Socket Connection Charts in the *Appendix*).
5. Explain the advantages of employing meter-switching and meter-range multiplying systems in radio set analyzers.
6. What is a push-button switch? What inherent advantages, if any, does this type of switch possess?
7. Draw a sketch of a push-button type switch which will close three circuits when the button is pressed down, and will open all of these circuits and close two separate ones when the button is released. Explain its construction and operation.
8. What is a bi-polar switch? How does this type of switch differ from a push-button switch? What can it do that neither a knife switch nor a push-button switch can do?
9. Why is it necessary to provide a means for reversing the meter connections in a set analyzer? Draw a simple sketch showing the connections of a push-button switch capable of accomplishing the reversal of the meter polarity (showing the meter circuit also).
10. For what tests is an a-c voltmeter used in a set analyzer?
11. Describe, with the aid of a sketch, the pin-jack system used for connecting the meter to the various tube circuits in some set analyzers. What are its advantages and disadvantages?
12. What is meant by a "locking" type push-button switch?
13. Explain the value of incorporating a grid current test into the analyzer. Draw a simple sketch showing clearly how this is done.
14. By means of a diagram, show clearly how tubes may be tested for mutual conductance by the "grid-shift" method, in the set analyzer. Explain the advantages and disadvantages of making this test in the set analyzer instead of with a separate tube checker.
15. Your analyzer is equipped for the testing of 5-prong tubes such as the '27 type. Draw a diagram of a simple test adapter that would provide a means for testing a type '44 tube and making an analysis of its circuits with your set analyzer. Explain the test procedure to be followed. (See the Tube and Tube Socket Connection Charts in the *Appendix* at the rear of this book.)
16. With the same analyzer mentioned in the preceding question, you wish to analyze the circuits of a type 59B tube. Draw a diagram showing the adapter required for this purpose.
17. What are the advantages of test adapters? Mention briefly several instances when test adapters are impractical.

18. Draw clear sketches showing the socket connections of the '37, '77, 6A7, '69 and '75 tubes (looking down on top of the socket). Explain the value of knowing the socket terminal connections of the various tubes when making an analysis with a set analyzer.
19. To indicate proper operating conditions, is it necessary that the voltage-current analysis should show the various voltages and currents existing at the tube socket terminals to be practically identical with the values shown on the manufacturer's chart for that particular receiver? State the reasons for your answer.
20. What difference would it make if the tube taken from the receiver under test were not plugged into the analyzer during the analysis of the circuits leading to that tube? Explain!
21. In your opinion, what is the difference between an "inoperative" receiver and a "defective" receiver.
22. Discuss two general methods of modernizing existing set analyzers. What are the advantages of each method?

CHAPTER XII

POINT-TO-POINT TESTING

12-1. **Limitations of Voltage-Current Analyzer Method of Testing.**—The method of voltage-current receiver analysis described in Chapter XI is based upon the fact that defects in a receiver will manifest themselves by incorrect voltages and currents at the tube sockets. Open plate circuits will result in zero plate voltages and plate current; open grid circuit cause zero grid voltage and current (regardless of which grid circuit is considered); open cathode circuits will result in zero grid and plate voltages because the cathode circuit is common to both the grid and plate circuits.

Incorrect voltages at a certain tube socket are indications of probable short-circuits, high-resistance grounds, etc., in the circuits leading to this particular tube socket. However, it should be clearly understood that this method of analysis of current and voltage at the tube sockets merely serves to point out the stage in trouble and gives a general picture of what may be the specific difficulty. Modern radio receivers, however, are becoming increasingly complex, with their involved circuit networks, and abnormal current or voltage readings at the tube sockets may be frequently caused by any of several defects which cannot be analyzed from such readings only. The voltage-current type of set analyzer merely extends the connections of the tube socket of the set to an external tube socket outside the set; it does not necessarily enable the operator to determine exactly which part of the circuit leading to the tube socket is at fault. In most cases where complicated receiver circuits are encountered, the receiver must be removed from the cabinet in order to make all the additional tests which may be necessary to locate the particular part which is at fault and which must be either repaired (if repair is possible and advisable), or replaced.

Then, too, there are many receiver circuits with high-resistance de-coupling filters in the grid and plate circuits. These are used to localize and segregate the r-f or i-f currents to the particular stage to which they belong, thus preventing interstage coupling. Unless it employs a very high-resistance voltmeter for checking the voltages, the grid or plate voltages as read by the usual voltage analyzer will be so incorrect that it is impossible to tell if the plate or grid circuit is normal or not. While the larger set manufacturers list the actual voltages (as read by a meter of certain sensitivity) which exist at the various tube terminals, this information is not always available, in which case the service man is at a loss to know if the considerably decreased grid or plate voltage readings he obtains are normal or not.

The avc circuits in modern superheterodyne receivers present typical examples of these conditions. Checking the voltages in many parts of these circuits with an ordinary voltmeter is quite senseless because the circuits contain such high resistances (over 1 megohm) that the comparatively low resistance of the voltmeter (which really shunts the circuit under measurement) causes a comparatively large change in the voltage. Therefore, an erroneous reading is obtained. This means that unless a vacuum-tube voltmeter (which has a very high input impedance and therefore draws little or no current from the voltage source) is used for checking these voltages, *resistance* tests on the individual units in the circuits must be made instead. The value of each resistor in the circuits suspected must be checked with the ohmmeter and then compared with the correct value specified by the manufacturer. Examination of the manufacturers' voltage analysis charts for many receivers shows that they completely omit all grid voltage readings which must be read either across (or through) very high-resistance circuits.

12-2. Definite Conditions for Satisfactory Voltage-current Analysis.—The comparison of the voltage readings obtained by means of a voltage-current type analyzer, and those specified by the set manufacturer, involves certain definite conditions which must be fulfilled if the readings taken by the service man are to have any important significance. First, the line

voltage must be the same as that specified by the manufacturer; this involves measurement of the line voltage and the adjustment of its value—by some means or other—to that specified by the manufacturer who supplies the voltage data. In many large cities, the line voltage is fairly constant and little or no adjustment is required. But in smaller communities, it is not uncommon to have the line voltage vary from 90 to 125 volts, depending upon the time of day, the season of the year (in industrial sections), and the capacity of the power plant. A rise in voltage from 90 to 125 volts is an increase of nearly 40%. If the effects of such variations are considered along with the errors caused by erroneous readings of the voltmeter because of its resistance, it takes the knowledge gained by years of experience to make an accurate guess as to whether the voltage readings obtained are correct or not—and guessing should be avoided whenever possible.

Second, the tubes used must be in good condition. In general, tubes with low emission give rise to an increase in all voltages applied to the tubes, because the load on the B-power supply unit is below normal. And in extreme cases, this increased voltage due to the poor regulation of the power supply may compensate for some other defect which ordinarily might decrease the tubes' voltages. Under these conditions, the voltage analysis can hardly reveal the trouble unless good tubes are used.

Third, the voltage analysis method can be used only when the fault of the receiver is such that no additional harm can be done by leaving the set turned on during the time it takes to complete the test. It may take ten minutes or so to make plate- and grid-voltage measurements on five or six tubes with an analyzer, and during this time several other components may be damaged. For instance, a short-circuited bleeder resistor may burn out a rectifier tube or a power transformer, if the receiver is allowed to remain connected to the line.

12-3. Resistance Method of Trouble Analysis.—From the foregoing comments, it is clear that any method of analysis that is independent of line voltage conditions, trouble with the receiver, or condition of the tubes, is helpful in localizing the faults in a radio receiver. A *resistance analysis* fulfills these requirements. This analysis is made with the receiver turned off.

It will be noted that the voltage between two points, and the current flowing between these points, may be determined by the voltage-current analyzer, and that the quotient of the two is the resistance between the two points across which the voltmeter is connected. This idea is illustrated in Fig. 12-1. A voltmeter is connected between the plate and cathode, and a milliammeter is inserted in the plate circuit to read the plate current. The voltmeter reading multiplied by 1,000 and divided by the milliammeter reading, gives the resistance (in ohms) between the plate and cathode.

But there is no need to take two instrument readings and perform a calculation in order to obtain the resistance. An ohm-

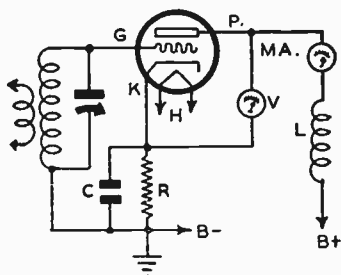

FIG. 12-1.—Checking the resistance between the plate and cathode in a simple radio circuit by means of a milliammeter and a voltmeter.

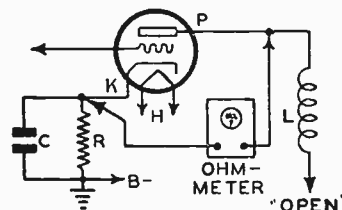

FIG. 12-2.—Checking the resistance between the plate and cathode in a simple radio circuit by means of an ohmmeter.

meter can just as well be connected in place of the voltmeter, as shown in Fig. 12-2; provided the tube is removed from its socket and the set is turned off. The ohmmeter will then indicate the resistance directly, which may be compared to the value as stated by the manufacturer. Note that this method does not involve any unstable conditions due to the power line voltage or the tube. Furthermore, and most important of all, the *presence of the ohmmeter cannot disturb the resistance of the path between the plate and cathode*, although the voltmeter does disturb the voltage between plate and cathode when a voltage test is made.

In a similar manner, the resistance between grid and cathode, grid and plate, plate and high-voltage lead (in *any* circuit) can

be measured conveniently, the only requirement being an ohmmeter that can measure resistances within the range from a fraction of an ohm to several million ohms. Such ohmmeters are readily available (see Chapter V).

12-4. Point-to-Point Resistance Measurement. — This measurement of the resistance between various points in radio receivers has come to be known as *point-to-point resistance measurement*. The name is derived from the fact that the method of test involves the measurement of the resistance from *any one* point to *any other* desired point that may be accessible. The physical means by which this is accomplished will be discussed later in this chapter, but suffice it to say here that the advantages of this system are many, though it cannot entirely replace the voltage-current method.

In the usual case, the resistance is measured from *one* fixed point to *any other* point in the circuit, the one fixed point being called the *common reference point*. The reason for this reference point is apparent when it is realized that in most cases the service man must compare the resistance values he finds by measurement with the values specified by the manufacturer. In order that these measurements may be made under exactly the same conditions, the chassis of the receiver is commonly considered as the reference point for all resistance measurements. It should be emphasized that the "cathode" is not necessarily the *proper* reference point for all receivers. Any point in the circuit that the service man thinks will help him solve the problem is the proper point; but when definite readings are to be compared with manufacturers' data, the reference point must be obviously the same as that used by the manufacturer, and it is usually the chassis.

As a result of the rapid development and widespread use of multi-element tubes, the so-called "free reference point" method of set analysis has become an essential feature of modern set analyzers. By this method the voltage or resistance across any two socket terminals, or the current in any tube circuit, may be tested through the analyzer cable. Although modern tube and receiver design imposes limitations on the use of this method for some voltage and current measurements, its usefulness for the general run of radio service work is unquestioned.

12-5. A Typical Point-to-Point Resistance Analysis. — Consider the simple portion of a radio circuit shown in Fig. 12-3. A power transformer T , is connected to a rectifier tube R which, in turn, feeds a tube P , as shown. This tube is of the screen-grid variety. The high-voltage lead is point A , chassis is point B , cathode is C , the screen grid is connected to point D , and the full output of the rectifier is taken at E for plate voltage. The

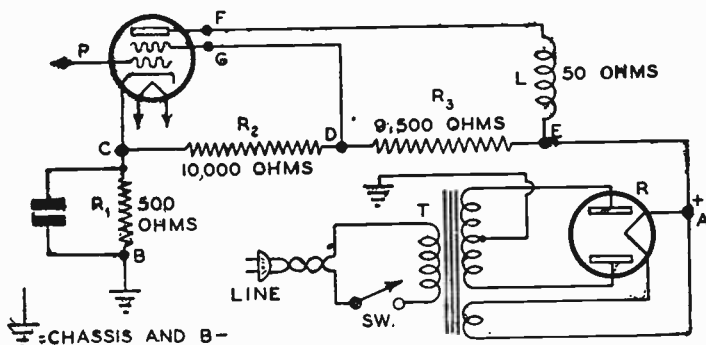

FIG. 12-3.—A typical circuit associated with a tube in a radio receiver. This may be analyzed easily by point-to-point resistance measurements made between the reference points indicated by the heavy dots.

9,500-ohm resistor drops the plate voltage to that required by the screen grid, and the 10,000-ohm "bleeder" resistor completes the circuit to ground through the 500-ohm grid bias resistor. When the receiver is in normal operating condition, the current through this 500-ohm resistor is the sum of the plate and screen currents of the tube plus that through the 10,000-ohm "bleeder" resistor R_2 . In order to prepare the circuit for a complete point-to-point resistance analysis, the tube P is removed from its socket, and the a-c line plug is removed from the line receptacle. This makes the set "dead."

Measurement of resistance from point F to point A with a suitable ohmmeter should give a reading of 50 ohms under normal conditions. Such a reading, or one very close to it, indicates that the plate coil L is neither shorted or open, but is normal in every respect. Note that this test cannot be made with a voltage analysis, since the resistance of this coil is so low that, even if

it were partially, or completely, shorted, the plate voltage reading would hardly be affected. Measurement of the resistance between points *F* and *D* should indicate a resistance of 9,550 ohms, the sum of the resistances of R_2 and *L*. It may not be possible to read exactly 9,550 ohms on the ohmmeter; but, since it is known that *L* is normal, the reading should be slightly greater than 9,500 ohms. Then, too, the actual value of a resistance is seldom the same as the marked value, but the difference is usually within 10%, and, if the reading of the ohmmeter is within this limit, then it can be considered normal.

Measurement of the resistance between *F* and *C* should result in a reading of 19,550 ohms, the sum of the resistances of R_2 , R_3 and *L*. Finally, the resistance between *F* and *B* should give a reading of 20,050 ohms, the sum of the resistances of R_1 , R_2 , R_3 and *L*. If these tests indicate the resistances to be normal, then all of the resistors shown in the diagram are normal.

But it may not be possible to get at points *D* and *E* in order to make the above measurements in the order specified, unless the chassis is removed from the cabinet. If this is the case, exactly the same information can be secured by measuring between other points in the circuit. For instance, one prod of the ohmmeter can be inserted in the proper "filament" hole of the rectifier socket (the tube is removed first), to obtain point *A*, and the other prod may be inserted in the "plate" hole of the socket of tube *P*, to obtain point *F*. The reading of 50 ohms should then be obtained, which checks the condition of the coil *L*. The measurement of the resistance between "chassis" and point *A* will check the total resistance of the circuit between *B* and *A*, and an additional check of the individual resistors may be made by measuring the resistance between points *A-G* and *A-C*. In order to obtain the resistance of R_2 , 9,500 ohms (the resistance of R_2) must be subtracted from the *A-C* reading.

When checking resistance by this latter method, it should be noted that point *A*, the high-voltage line, is used as the reference point. The check may be repeated by using "chassis" as one terminal for all tests, and measuring between point *B*, which is "chassis", to *C*, *G* and *F*. By the simple process of subtraction, the resistance of any of the components may be determined.

12-6. Development of a Practical Point-to-Point Resistance Tester.—It is interesting to know that points *A*, *B*, *C*, *F* and *G* are readily accessible from the sockets and chassis of the set, and that by means of an ohmmeter and a little mental arithmetic the resistance value of the component parts may be determined and their condition checked in most cases *without the necessity for removing the set from the cabinet*. Of course, the circuit diagram of connections and the normal resistance values of the individual parts must be at hand.

Those who have had some experience with radio receivers will realize that it is very inconvenient in many cases to probe inside the receiver cabinet and explore the set chassis in order to find the proper socket hole in which to insert one of the ohmmeter test prods. To eliminate the necessity for doing this, point-to-point resistance testers or analyzers are built exactly the same as voltage analyzers—a plug and cable extends the leads from the socket to be analyzed to a suitable switch which connects to the ohmmeter, and the measurements can be made rapidly and easily outside of the set cabinet.

Figure 12-4 shows a simple circuit arrangement illustrating how a plug and 10-wire cable may be employed to extend the various circuits from a typical tube socket and the chassis to a switch *S* and an ohmmeter, so that point-to-point resistance measurements may be made from a point outside the set cabinet. Seven of the wires of the cable connect to the prongs of a plug, similar to a voltage-analyzer plug, which fits into the socket to be analyzed. Suitable adapters may be necessary if the socket to be analyzed is of the 4-, 5-, or 6-prong variety, of course. The top view of a 7-hole socket is shown in this case.* One of the wires connects the “chassis clip” *J*, to one side of the ohmmeter. Another wire connects to the control-grid stud *B*, on the plug handle. The control-grid clip and lead from the set are clipped to this stud. The tenth wire connects to a test prod *A*, for connecting to any desired circuit point in the receiver which may not be covered by the cable and plug. The other end of the cable

*Note: It should be understood at this point that all point-to-point testers shown here may easily be provided with “standard” plugs and sockets (or “adapters”) for testing tubes having 8-pin “octal” bases.

connects to the ten terminals of a rotary switch *S*. The contacts of this switch have been lettered to correspond with the terminals of the socket under test. The end switch-contact *J* connects to the "chassis clip" wire of the cable and also to one side of the ohmmeter. By rotating the switch to any particular tap, the resistance between the top grid cap terminal—or any socket terminal—and the chassis (to which the "chassis clip" is attached) may be determined.

The main difficulty with the system shown in Fig. 12-4 is

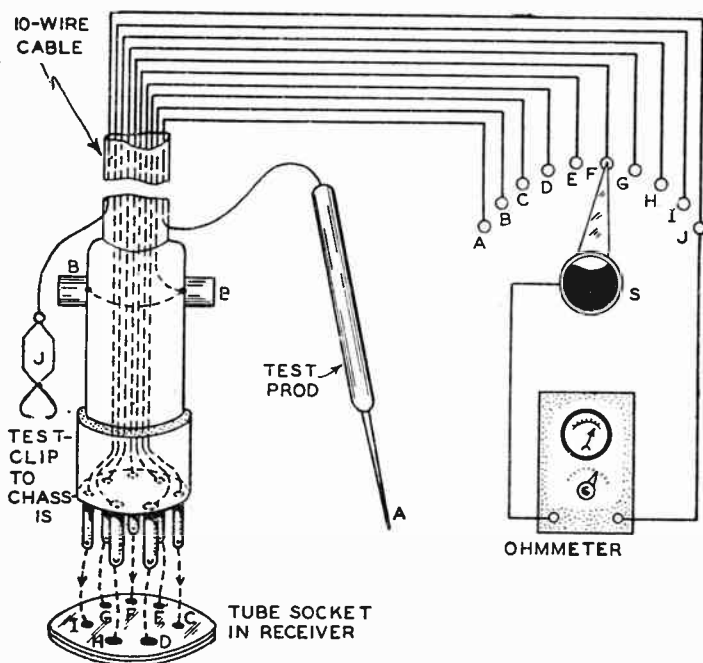

FIG. 12-4.—A resistance testing arrangement in which a switch *S* and a 10-wire cable are used to connect the ohmmeter to the various circuits terminating at a tube socket in the receiver, so that point-to-point resistance measurements may be made from a point outside the radio receiver cabinet. In this particular arrangement the possible number of measurements that can be made is limited by the fact that one side of the ohmmeter is "tied" to the chassis of the set, thus making the chassis the "reference point" for all the resistance measurements.

that the chassis must be used as the "reference point" for all resistance measurements. However, it may be changed to the

"free reference point" arrangement shown in the diagram of Fig. 12-5 to facilitate measurements between *any* terminal of the socket (or "chassis"), to any other terminal of the socket (or to chassis). The system used is simple. The analyzer plug leads connect to two switches, S_1 and S_2 , instead of one. The arms of these switches connect to the two terminals of the ohmmeter. By simply rotating either arm, the resistance between any two points determined by the setting of the switches can be measured. Note particularly that no precautions need be taken when manipulating the switches. It is impossible to damage the ohmmeter with

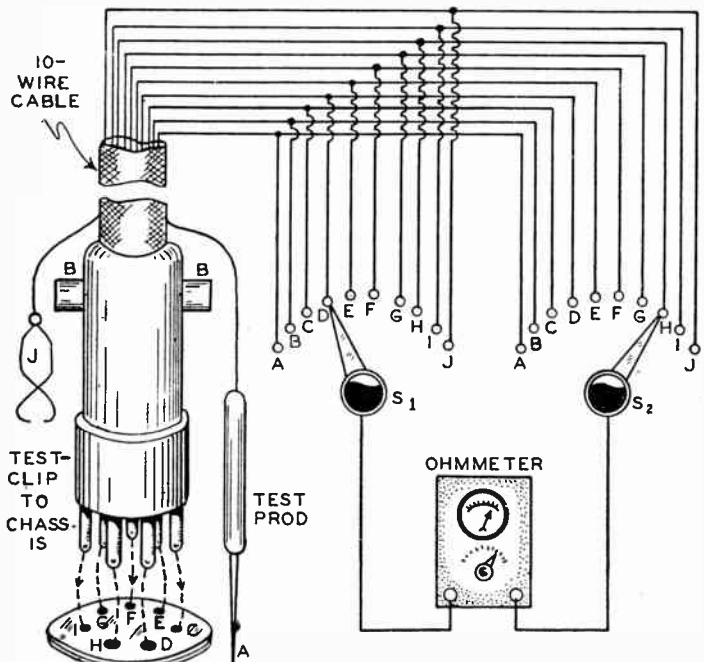

FIG. 12-5.—The point-to-point resistance analyzer of Fig. 12-4 is shown here in improved form with one switch added so that resistance measurements may be made between any two terminals of a socket, or any two points in the wiring of the receiver. This is the "free reference point" system.

any conceivable switch combination used. This is in direct contradistinction to the case of the voltage-current type analyzer, which must be set to the proper range before testing, in order to prevent possible damage to the meter.

12-7. The Dual-plug Type Point-to-Point Resistance Analyzer.—Up to this point, our resistance analyzer is capable of making measurements between any two terminals of a given socket and the “chassis”. But this may not be sufficient in some cases. It may be necessary to know the resistance *between any terminal of one socket and any terminal of any other socket in the set*. To make such measurements possible, two cables are

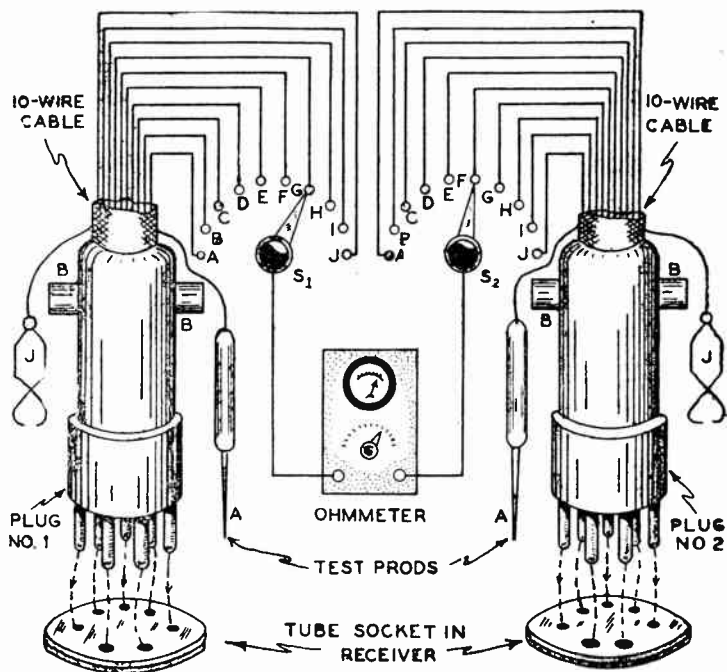

FIG. 12-6.—Circuit arrangement of a dual-plug type resistance analyzer. Two switches, dummy plugs, and cables are employed, so that the resistance between any terminal in one tube socket and any other terminal of any other tube socket in the receiver may be checked.

required, one for each socket in the set. The connections for such an arrangement are shown in Fig. 12-6.

Two plugs are used, as shown. Each of the plugs connect to a set of taps, and the arms of the tap switch connect to the ohmmeter. One plug is inserted in one tube socket and the second plug is inserted into the other tube socket. It makes no differ-

ence which is which, because any socket terminal of any plug may be used as the reference point by simply turning the tap switch to the particular terminal of the particular socket which has been chosen as the "reference point". Readings are then obtained by turning the other tap switch to the various points. The resistance between each of these points and the one established as the reference point can then be read on the ohmmeter.

While this dual-plug arrangement gives extreme flexibility, there seems to be a general feeling among experienced service men that the one-plug system is quite sufficient, and that, once the knack of reasoning "resistance-wise" has been attained, the single-plug arrangement meets all requirements.

12-8. The Combination Point-to-Point Resistance-voltage Analyzer.—From the foregoing discussion, it is clear that the typical resistance analyzer consists of a plug- and cable-arrangement, a set of simple switches and an ohmmeter. With this arrangement, point-to-point resistance measurements may be made. For 4-, 5-, or 6-prong sockets, simple adapters are placed on the plug, in a manner similar to the practice employed with voltage-current analyzers. It should be noted that there are no sockets on the resistance analyzers discussed thus far, because the tubes are not used in resistance measurements.

Suppose the ohmmeter in Fig. 12-5 is replaced by a voltmeter, all the tubes are placed in the receiver, and the power is turned on. The voltmeter will now measure the voltage between any two points of a socket, provided that the tube removed from the socket under test is connected properly to the circuit in some way externally. In other words, if a socket is placed in our resistance-type analyzer, just as in the voltage-current type analyzers, and the ohmmeter is replaced by a *volt-ohmmeter*, the *voltage* between any two points can be measured with the set turned *on*, and the *resistance* between any two points can be measured with the set turned *off*. A circuit arrangement illustrating this idea is shown in Fig. 12-7.

A 9-wire cable is shown connected to the seven prongs of a socket and a grid clip for cap-type tubes. The tube whose circuit is to be tested is removed from the socket in the set and placed in the socket of the analyzer (a 7-prong socket is shown).

The cable plug is inserted in the socket in the set vacated by the tube, and the measurements made. The power to the set is shut *off* when resistance measurements are made and turned *on* when voltages are measured. For safety, the tube in the analyzer should be removed when making resistance measurements. It may be left in the socket, if it is certain that none of the elements are short-circuited to each other internally.

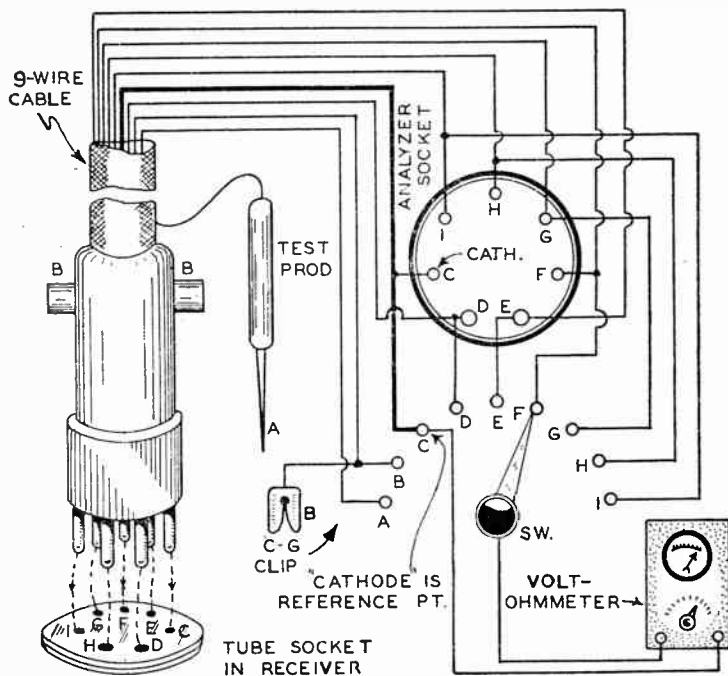

FIG. 12-7.—Circuit arrangement of a point-to-point analyzer capable of checking both resistance and voltage. Here the analyzer is provided with a tube socket in which the tube removed from the receiver socket under test is inserted. The switch enables the volt-ohmmeter to be connected between the "cathode" (which is the reference point) and any other terminal of the tube socket.

12-9. Providing for Current Measurements in the Point-to-Point Analyzer.—If a volt-ohm-milliammeter is available, the system may be made to measure voltage and current with the set turned "on", and resistance with it turned "off." The schematic circuit of a typical instrument of this type is shown in Fig. 12-8.

The wires from the plug connect to the socket through tip-jacks which are connected together by means of jumpers. When current is to be measured, the volt-ohm-milliammeter is set for the proper current range and inserted between the tip jacks in the circuit whose current is to be measured. Thus, if wire No. 3 happens to be connected to the screen-grid contact of the tube socket under analysis, the milliammeter could be connected between the

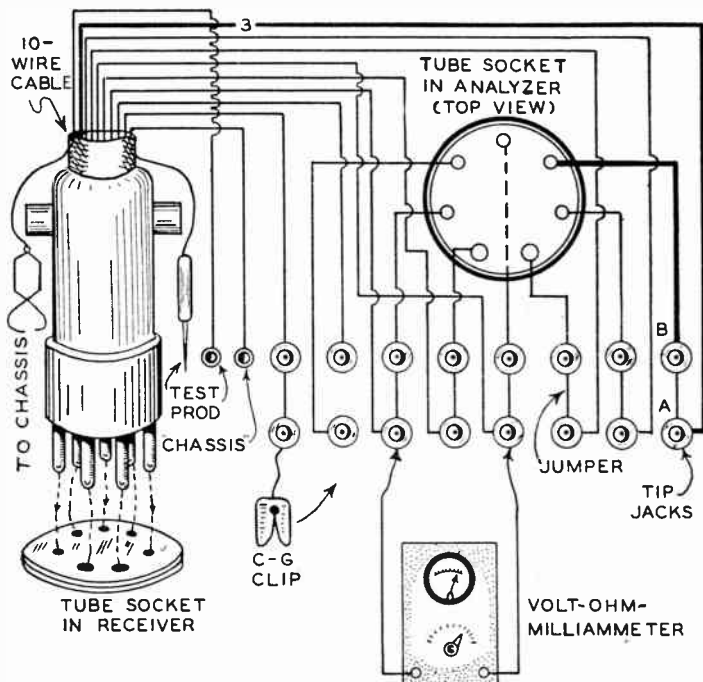

FIG. 12-8.—Circuit arrangement of a typical modern complete ("free reference point" type) point-to-point "tester" or "analyzer" which enables point-to-point voltage, current and resistance measurements to be made. Pin-jacks are used instead of switches.

jacks A and B, with the jumper removed. The meter is then in series with the particular wire through which the current to be measured (screen current in this case) is flowing. In analyzers of this kind, the tip-jacks are constructed so that the jumper is automatically disconnected when the milliammeter test prods are inserted.

Since the meter is equipped with voltage and resistance ranges,

the voltage or resistance between any two points can be measured by simply resting the test prods on any two tip jacks. Thus, this same circuit is suitable for point-to-point voltage and resistance measurements.

12-10. Point-to-Point Voltage Analysis.—An important consideration to be remembered is the fact that "voltage" analysis may be point-to-point if facilities are available for connecting the voltmeter between any two points in the circuit. This term, however, has generally been reserved for the "resistance" method of analysis. In this book, an "analyzer" is considered as a device that is capable of measuring current, voltage and resistance, and the term "point-to-point" will be reserved for that method of voltage or resistance analysis which has complete freedom with regard to the reference point.

12-11. Commercial Point-to-Point Testers.—A study of the commercial analyzers described in Chapter XIV will show that nearly all of them provide for making point-to-point tests of resistance and voltage. Few, if any, modern analyzers are limited only to resistance analysis. The differences between the tester of Fig. 12-8 and those described in Chapter XIV lie solely in the methods of switching, and the meter ranges of the instrument.

The drawing of Fig. 12-8 shows but a single socket and a 10-wire cable. Of course, when 4-, 5-, and 6-prong tubes are to be tested, adapters must be used, or else four sockets must be wired into the analyzer.* Then, only a single adapter for the testing of the few large 7-prong tubes is required. The cable may have nine or ten wires, depending upon whether or not a test prod for general use is included in the device. These are merely mechanical considerations in the design of the analyzer, and of course rest solely with the manufacturer. A study of the selected list of analyzers described in Chapter XIV, however, will furnish a great deal of valuable information concerning the tester circuit arrangements which have been developed.

It is of interest to note that the analyzer suitable for construction, described in Chapter XIII, is a point-to-point device.

12-12. Resistance Analysis Should Supplement Voltage Analysis.—It must not be assumed from this discussion that resistance analysis can replace the "voltage" method of testing. For one thing, a resistance test is what is termed a "cold" test—the

*Note: This analyzer (or any other analyzer shown in this book) may be adapted for analyzing the circuits of receivers using "octal base" all-metal tubes if the "standard" plug- and socket-adapters available for this purpose are used.

set is cold while it is being tested. In many cases, a defective part (such as a resistor) will not show up unless it is warm; the resistance analysis will fail to reveal trouble in such a unit. Then, again, many carbon resistors undergo large changes in resistance between the time they are "cold" with the set turned off, and the time they are "warm" with the set in operation. A "cold" resistance test will fail to reveal trouble in such a unit (unless the receiver is heated artificially [see Fig. 23-16]).

It must also be remembered that a resistance test cannot check low line voltage, poor tubes, and other, more incidental, troubles. The resistance test should follow a voltage test for a thorough analysis of any receiver. The practical methods of making voltage, current and resistance analyses on receivers will be discussed in detail in Chapters XX and XXI.

REVIEW QUESTIONS.

1. State four reasons why voltage-current analysis alone is of little value in the analysis of modern receivers. Explain!
2. Name five advantages of point-to-point resistance analysis of a radio receiver.
3. What is meant by point-to-point analysis?
4. What is the general principle of operation of the point-to-point tester? Draw the circuit diagram for a simple point-to-point resistance tester and explain how it works.
5. Can voltage analysis be point-to-point? Why?
6. Discuss the advantages and disadvantages of the two types of point-to-point analyzers used in practice.
7. Can resistance analysis replace voltage-current analysis entirely? Why?
8. Draw the complete circuit diagram to illustrate the circuit conditions, position of the switches, etc., and explain in your own words how you would use the analyzer of Fig. 12-6 to check the resistance between the "screen grid" of one tube and the "plate" of another tube in a receiver.
9. Referring to Fig. 12-3, suppose you were testing the plate circuit for grounds (with set shut off) and your ohmmeter indicated a resistance of 10,500 ohms between "chassis" and point *E*, and 10,500 ohms between "chassis" and point *D*. What would this indicate?
10. Suppose you are using the analyzer of Fig. 12-7 (with a suitable 5-prong adapter) to make a point-to-point voltage and resistance analysis on the circuit of Fig. 12-3. Using the cathode as the reference point, the voltage of point *F* (Fig. 12-3) is found to be 200 volts positive, that of point *G* is found to be zero.
 - (a) Which unit would you suspect to be the cause of trouble?
 - (b) What is the suspected nature of the trouble?
 - (c) What steps would you take next, to confirm or disprove your suspicion?

CHAPTER XIII

HOW TO CONSTRUCT A COMPLETE MODERN SET ANALYZER

13-1. Features which are Desirable in a Practical Analyzer.—In order to be of maximum usefulness, a set analyzer or set tester must possess certain desirable features. It must be capable of measuring all a-c and d-c voltages and currents normally encountered in radio receivers—both old and new. It must be compact and simple to operate, and its cost should be comparatively low. In order to meet the requirements of compactness and low cost, only a single sensitive meter with the necessary multiplier and shunt resistors is usually employed. To measure any voltage or current value, it should not be necessary to manipulate more than two or three controls or to consult complicated numbering or data charts upon which intelligent operation of the instrument may depend. The design of the analyzer should be flexible and of such nature as to prevent any possibility of immediate obsolescence. It should be kept up-to-date easily by simple additions or changes in wiring. It should permit all tests to be made rapidly, and should possess all necessary safety or foolproof features. A further requirement is the ability to perform all essential tests without the need for any complex adapters. The circuit diagram of an analyzer which meets these requirements is shown in Fig. 13-1, with all electrical values marked.* The panel layout is shown in Fig. 13-3. It may be constructed readily, at comparatively little expense, since *no special switches or equipment are necessary*. A detailed study of this analyzer will now be made. The reader is urged to follow every point explained by referring continually to Fig. 13-1

*Note: This analyzer may be adapted for analyzing receivers using "octal base" all-metal tubes if the "standard" plug- and socket-adapters available for this purpose are used.

and tracing through all the circuits which are explained here. This will prove exceedingly instructive.

13-2. The Meter Section of the Analyzer.—A 0-1 ma. d-c milliammeter, in conjunction with a copper-oxide type rectifier (see Art. 2-30) is used as the indicating instrument for the checking of a-c and d-c voltages. As shown in Fig. 13-1, switching from d-c to a-c measurements is accomplished by means of a triple-pole double-throw switch *S*₄. If it is desired, a commercial rectifier type a-c—d-c meter may be employed in place of the individual meter-rectifier combination shown. Through the use of the 12-position bi-polar switch, *S*₁, the various multiplier and shunt resistors are properly connected to the meter for the external measurement of voltage, current and resistance. The following ranges are available: 5, 10, 100, 250, 500 and 1,000 a-c or d-c volts at 1,000 ohms-per-volt; 1, 10, 100 and 500 d-c milliamperes; and 0-1,000, 0-100,000 ohms. By the addition of an external 45-volt battery, the 100,000-ohm range may be increased to 1 megohm.

The resistors used to make a high resistance voltmeter from the 0-1 d-c milliammeter must be accurate to at least 2 per cent if any degree of precision is to be obtained. The values are: *R*₁, 5,000 ohms; *R*₂, 10,000 ohms; *R*₃, 100,000 ohms; *R*₄, 250,000 ohms; *R*₅, and *R*₆, 500,000 ohms. If desired, any other combination of voltage ranges may be secured by employing the proper multipliers. The shunt resistors are best purchased, as they are quite inexpensive. However, they may be made up if the internal resistance of the milliammeter is definitely known (see Art. 2-14). When this internal resistance is correctly determined, the exact resistance value required for the 10-, 100- and 500-ma. shunts may be calculated by using the formula presented in Art. 2-13. The values of the shunt resistors in this analyzer are approximately 3, 0.275 and 0.05 ohms to secure the 10-, 100- and 500-ma. ranges. If great accuracy is not desired, a commercial wire-wound filament resistor may be secured and the required amount of wire removed from its resistance element in order to make the shunts (see Arts. 2-15 and 2-16). The 100- and 500-ma. shunts can be made in similar manner.

The original 0-1 ma. scale of the 0-1 milliammeter may re-

main without further markings, and a multiplying factor such as $\times 10$, $\times 100$ and $\times 1,000$ etc. may be marked directly on the panel of the analyzer and applied to the d-c readings taken. A very important point arises here for all a-c readings taken with the meter. As was explained in Art. 2-32, a copper-oxide rectifier type instrument does not really measure the *effective* value of the a-c current or voltage (which is the value we are interested in knowing), but actually measures the "average" value. For this reason, the a-c scales must be corrected in some way in order to have the meter indicate the "effective" values directly. In the event that a commercial scale with the proper correction already made is not employed, the meter will indicate only the "average" a-c values. These should be multiplied by 1.11 to obtain the *effective* values. Of course, if a commercial universal copper-oxide rectifier type instrument of the proper ranges is employed (see Fig. 2-45) in the analyzer, no trouble will be experienced with the meter scales. The scale of such an instrument is illustrated in Fig. 2-46.

13-3. Provision for Resistance Measurements.—A small 4.5 volt "C" battery is incorporated in the tester in such a manner that it is used to convert the milliammeter into an ohmmeter with two ranges, from 0 to 1,000 ohms (with which it is possible to read accurately resistance values as low as $\frac{1}{2}$ ohm), and from 0 to 100,000 ohms. This feature is useful when resistance analyses are necessary, and for checking the resistance of the various components in an offending circuit. Provisions have been made for increasing the ohmmeter range to 1 megohm by connecting a 45-volt battery as shown and multiplying the reading on the 100,000-ohm scale by 10. When this is done, additional current-limiting resistor *R10* is automatically connected into the circuit. Low resistance values are measured by the shunt method.

13-4. Provision for External E, I and R Measurements.
—All voltage, current and resistance measurement ranges of the meter are instantly made available for external test purposes at only two binding posts or pin-jacks by simply rotating the "range" bi-polar switch to the desired range setting. This feature makes it unnecessary to connect the test leads to different

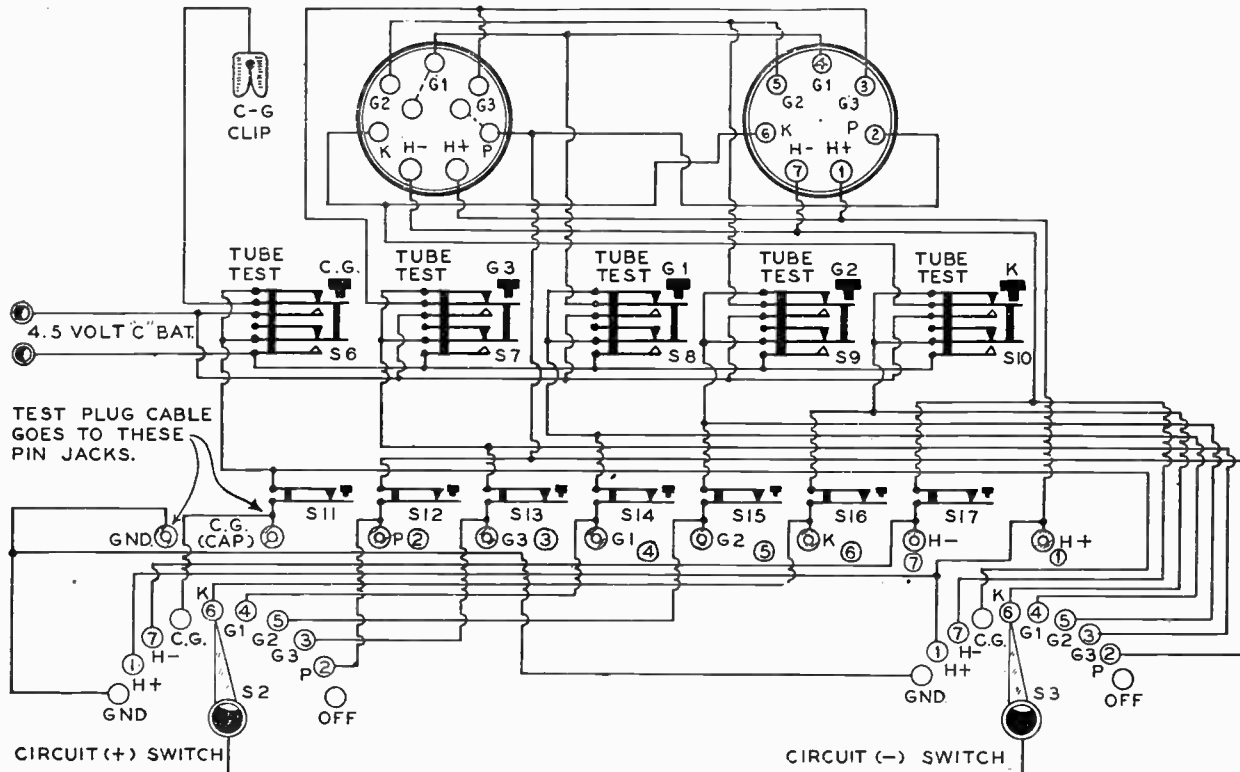

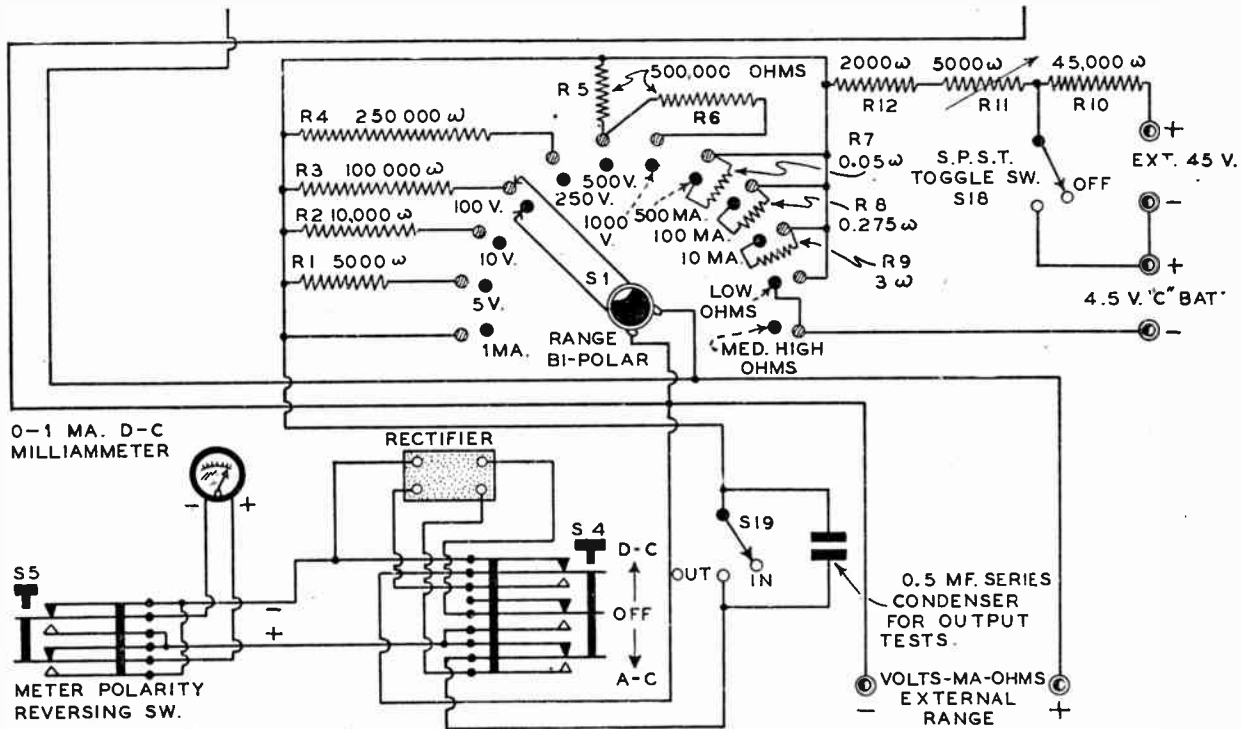

FIG. 13-1.—Schematic circuit diagram (in two parts) of the complete set analyzer described in this chapter.

sets of binding posts for external voltage, current, or resistance tests.

13-5. Flexibility of Stage Analysis Tests Possible.—This analyzer has been designed so that an analysis of every circuit of every type of tube in use at this writing can be made by means of the two "Circuit" switches, *S2* and *S3*, which connect any range of the voltmeter, milliammeter, or ohmmeter selected by the "Range" switch *S1* between *any* two circuits or between *any* circuit and chassis, *without the use of jumper or connecting leads*. In other words, either the voltage or the resistance existing between any two points may be measured with *any* circuit (not only the cathode) as the reference point. This makes the analyzer useful for *resistance* analysis (see Chapters XII and XXI) also. Current measurements in all circuits except the heater circuit are also made without using jumper leads. Special attention has been given to provide for every degree of safety to the meter through the use of momentary switches and by careful circuit design.

13-6. Provision for Tube Testing.—Any and all types of tubes may be tested with this analyzer, regardless of the base pin arrangement, by the "grid change" method, thus enabling relative mutual conductance measurements to be made. This is accomplished by the insertion of a 4.5 volt "C" battery in the control, or normal, grid circuit of the tube under test. Because of the fact that the battery may be introduced into any one of five possible circuits, both sections of double purpose tubes, such as the '19, '53, '79, '2A7, and 6F7 etc., may be checked for mutual conductance. To provide for future changes and new developments in tube design, the two "Circuit" switches *S2* and *S3* have additional blank positions.

13-7. Output Meter Facilities.—Any voltage range of the instrument may be employed for output measurements. Where the "output meter" is to be connected across the plates of power output tubes, or from the plate of one tube to chassis, a series condenser is incorporated into the analyzer to prevent a flow of direct current from injuring the rectifier. By means of the analyzer test plug, these output measurements may be made without the need for any adapters.

13-8. Numbering System For Tube Socket Terminals.—For the purpose of convenience and to aid in speedy manipulation of the analyzer, all socket terminals and circuits have been marked with letters and a numbering system. It must be remembered that these letters are symbols referring to certain socket terminals or circuits and do not refer to the elements within the tube itself. The socket terminal numbering system employed is that formulated and adopted as standard by the Radio Manufacturers' Association (see Appendix).

The analyzer is designed with a 7-prong plug to enable each circuit to be analyzed individually. The use of this plug requires a 7-to-4, a 7-to-5, a 7-to-6, and a 7-to-7 prong adapter when the test plug is inserted into 4-, 5-, 6- or large 7-prong sockets. Two test sockets are employed on the analyzer, a combination 4-, 5-, and 6-prong socket, and a combination 7-prong socket for standard and large-base 7-prong tubes. The test-plug cable is composed of 9 wires. The 9th wire is utilized for making connection to the chassis by any means desired, and terminates at the test plug in a miniature spring clip or a small tip jack so that an additional lead may be connected to the chassis from the clip to make point-to-point measurements between any circuit and chassis possible (see Chapter XII). This terminal must of necessity be very small so that it will not hinder the free use of the test plug.

13-9. Using the Analyzer.—The operation of this analyzer is extremely simple, requiring only the amount of care ordinarily exercised with any sensitive testing instrument. Placing the bi-polar "Range" switch S_1 so that a high range is connected when making voltage or current measurements, and checking the position of the a-c—d-c switch are precautions which will avoid damaging the meter and rectifier. Before changing the position of the two "Circuit" switches, S_2 and S_3 it is safest to set the a-c—d-c switch, S_4 , in the "Off" position—a position provided for safety purposes, so that the meter will not be damaged by connecting it across the wrong circuits accidentally.

13-10. Voltage, Current and Resistance Analyses.—Voltage, current, and resistance analysis with this analyzer or with any modern point-to-point instrument requires a knowledge of

tube-base or terminal-pin arrangements so that the various switches may be properly set for intelligent circuit analysis. For voltage measurements, the two "Circuit" switches are set to the taps between which a reading is desired. These switches are marked "minus" (—) and "plus" (+), so that the polarity of the meter will be correct without resorting to the use of the polarity-reversing switch, *S5*.

13-11. How Voltage Measurements are Made.—Only one "Circuit" switch is employed for voltage readings—the "plus" switch. The "minus" switch is placed on the *K* or *H*- terminal, depending upon the type of tube and which element is being used as the reference terminal. The "plus" switch is then rotated to the *P*, *G3*, *G2*, etc. terminals to check plate, screen grid, suppressor grid, etc., voltages, respectively. For control-grid voltage, the "plus" switch may be placed on the terminals *G1* or *C.G.*, but the polarity-reversing switch must be employed since a negative voltage is usually present in this circuit. If desired, the plus switch may be placed upon *K* or *H*-, and the *minus* "Circuit" switch rotated to *G1* or *C.G.* for control-grid voltage; this method makes the use of the reversing switch unnecessary.

Cathode-to-ground voltage in most receivers is "positive" when the conventional bias resistor is used. On the other hand, some sets have the cathode connected either directly to the heater, or grounded; when this is found, no reading will be obtained. For cathode voltage, the *plus* "Circuit" switch is placed on *K* and the *minus* "Circuit" switch upon *H*-. If the reading obtained is reversed, the meter-reversing switch must be pressed. The filament voltage of battery-operated tubes, or those in electrically operated d-c receivers, is read with the "minus" switch on *H*- terminal and the "plus" switch placed on *H*+. The reversing switch may have to be used in some instances, such as in the case of series-filament d-c receivers, when the meter may read reversed. When testing a-c receivers, the a-c—d-c switch, *S4*, must be placed in the a-c position so that the alternating heater or filament voltages of the tubes may be read correctly.

13-12. How Current Measurements are Made.—Current measurements in any circuit but the positive heater circuit are made by placing the "Circuit" switches on *both terminals of that*

circuit, and pressing the current button for that circuit. For example, if plate current is to be read, both "Circuit" switches are placed on *P* terminals and the "P" current-switch button *S12*, is pressed. Current in any circuit is measured in a like manner by placing the "Circuit" switches on the desired terminals and pressing the current-switch button for that circuit. The "Range" switch must be set for a range suitable for the readings. The meter reversing switch must be used for control-grid current readings.

13-13. How Rectifier Tubes are Tested.—With this system of voltage and current measurement, it is a simple matter to test both plates of rectifier tubes, such as the '80, '82, '83, 5Z3, 6Z5, etc., (see Art. 8-26). By placing one of the "Circuit" switches on the correct terminals (on the *G1* and *P* terminals in turn, in the case of an '80 rectifier) and setting the a-c—d-c switch in the a-c position, and the other "Circuit" switch on *H—* or *H+*, the high secondary voltage of the power transformer may be checked. The a-c voltage impressed on one plate is read with one "Circuit" switch upon *P* or *G1*, and the other upon *H—* or *H+*. The "Range" bi-polar switch should be placed in the 1,000 volt position for these readings.

13-14. How Tubes are Tested.—Tubes are tested by the "Grid-Shift" method (see Chapter VIII). With the test plug inserted in the receiver socket and the tube in the analyzer socket, both "Circuit" switches are placed on the *P* terminals for that type tube to be tested and the current-switch button for that circuit is pressed. The plate current reading obtained is compared with the reading when the proper "Tube Test" push-button switch is pressed. The difference between the two readings is a measure of the mutual conductance, or transconductance, of the tube.

Which of the five "tube Test" switches are pressed depends upon the location of the control-grid element with respect to the tube-base terminal arrangement. Each section of double-purpose tubes, such as the '53, '79, 6F7, etc., may be tested separately. This is accomplished by reading the plate current of one section, then pressing the correct grid "Tube Test" switch, and reading again. The process may be repeated with the other tube section. Since the voltages which operate the tubes vary with

different receivers, it is difficult to compute an exact chart of mutual conductance values. However, a chart may be made up on the basis of rated voltages by noting the changes in reading of the plate milliammeter when the grid-shift test is made with rated voltages applied to the tubes.

By means of the switches *S2* and *S3*, and the "External Range" meter terminals on the panel of the analyzer, any circuit may be opened to permit the insertion of headphones in it for aural analysis. In that case, the switch *S1* should always be in the "1000 volt" position, since this is the point at which the highest resistance is placed across the phones, thereby causing them to reproduce the signal with maximum loudness. In a like manner, phonograph pickups and microphones may also be connected to any receiver, either in series with any circuit or across any two points of a circuit, for test purposes.

13-15. How Resistance Measurements are Made. — Point-to-point resistance measurements between any two circuits or between any circuit and chassis (see Chapters XII and XXI) can be made by setting the "Circuit" switches, without regard for polarity in this case, on the terminals between which the resistance measurements are desired. The "Range" switch is placed on any one of the "Ohms" positions, as required. When measurements are made between any circuit and chassis, the small connecting lead fastened to the ninth wire terminal on the test plug is connected to chassis. One "Circuit" switch is then placed in the *Gnd.* (chassis) position. For resistance measurements from 100,000 ohms to one megohm, an external battery of 45 volts must be connected across the two binding posts provided; the ohmmeter switch, *S18*, must be turned to the "Off" position as it is used only for the purpose of opening the ohmmeter circuit so that the external voltage source may be easily disconnected, and to prevent undue battery consumption when the low-range ohmmeter circuit is employed. The additional current-limiting resistor necessary for the additional ohmmeter voltage is automatically placed into the circuit when the switch is thrown and the voltage source is connected. Proper battery polarity must be observed.

A zero-ohms adjustment for the "high ohmmeter range" is

secured by short-circuiting the test prods, or the "External Range" binding posts on the instrument, and varying the 5,000 ohm "Ohmmeter Adjuster" for full scale deflection. All that is necessary for the proper use of the low ohmmeter range is the adjustment of the 5,000-ohm rheostat so that the meter reads full scale *without* short-circuiting the test prods or instrument binding posts. When the self-contained 4.5-volt battery depreciates to such a low value that full scale deflection of the meter cannot be obtained with the "Ohmmeter Adjuster," it should be discarded.

13-16. How Output Measurements are Made.—For output measurements (see Chapter VII), any a-c voltage range of the instrument may be utilized by setting the a-c—d-c switch on the a-c position, and placing the "Range" switch on the required voltage setting. Test leads are then connected from the "External Range" binding posts to the voice coil of the speaker or output transformer secondary of the receiver. When output readings are taken from plate-to-plate of the output tubes or from the plate of one tube to chassis, the series condenser incorporated in the analyzer must be thrown into the circuit to prevent the direct current from flowing through the meter rectifier.

With this instrument, output measurements from the plate of one power tube to chassis may be made without the use of adapters, jumpers, or connecting leads. This is especially valuable in the many receivers in which space is at a premium. The power tube is placed into one of the analyzer sockets and the test plug into the receiver socket left vacant by this tube. One "Circuit" switch is then set upon the "P" terminal and the other upon the "Gnd" terminal. The small ninth wire lead on the test plug is fastened to chassis and the series condenser toggle switch is thrown to the "In" position. This latter switch shunts the series condenser which is inserted into one leg of the meter circuit, as shown in the schematic circuit diagram.

13-17. How Capacity Measurements are Made. — The capacity or impedance of solid-dielectric condensers may be measured by placing the unit under test in series with the 250-volt a-c range of the analyzer and a 115 volt, 60-cycle line source (see Chapter VI). If the reading obtained is less than

100 volts, the "Range" switch should be placed in the 100-volt position. In this manner, capacity or impedance may be read by means of a capacity-impedance curve, which can be easily drawn with the aid of readings obtained on a number of condensers of various *known* values. When making these measurements, the 250 volts a-c range of the meter should always be used *first* to prevent possible injury to the instrument in the event of short-circuited or leaky condensers. It must be remembered that, in making any capacity or impedance measurement, the unit under test must be disconnected from any component across

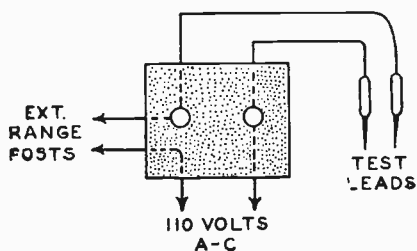

FIG. 13-2.—Simple adapter for making capacity measurements with the analyzer of Fig. 13-1.

which it may be shunted, or else erroneous readings will result. *These tests, of course, do not apply to electrolytic condensers.*

For convenience and speed in making capacity-impedance measurements, the simple adapter shown in Fig. 13-2 will prove satisfactory. The line cord marked *110-volts a-c* is plugged into any 110-volt, 60-cycle outlet or socket, and the remaining two wires are connected to the "External Range" binding posts on the analyzer. The condenser under test is placed across the "Test Leads" of the adapter by means of the test prods, which are connected to the terminals.

The use of this type of analyzer, and the correct interpretation of its readings will be discussed in Chapters XX and XXI. A suggested panel layout illustrating the position of the meter, switches, sockets and binding posts is shown in Fig. 13-3.

13-18. List of Parts Required for the Analyzer. — The point to be borne in mind when selecting parts to be used for the construction of the analyzer is that the accuracy and efficiency of the instrument are dependent upon the quality of these parts. There should be no need to state that the use of high-

grade switches, resistors, etc., will be amply repaid by long and uninterrupted service free from annoying and time-consuming

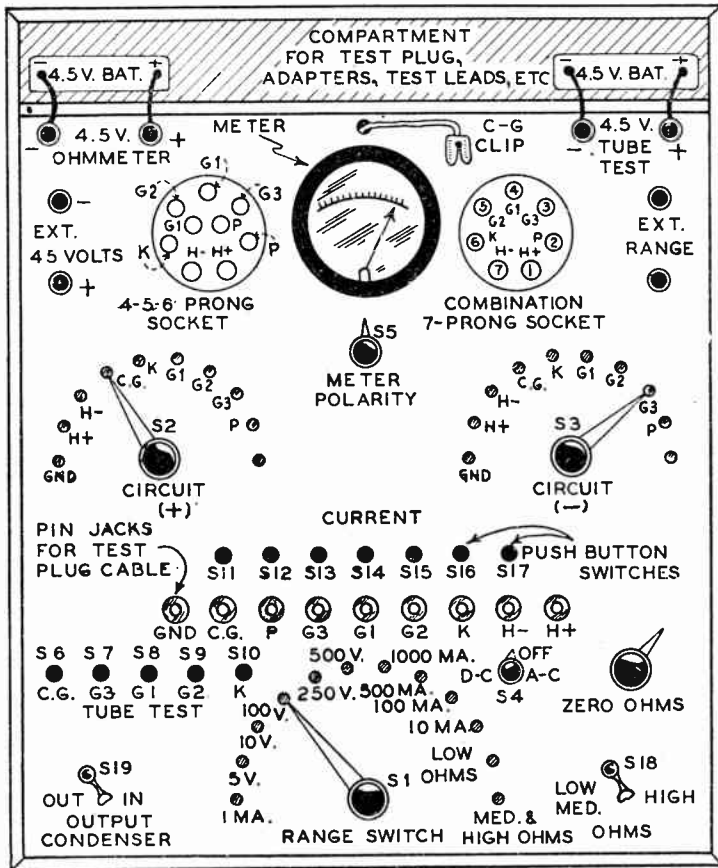

FIG. 13-3.—A suggested panel layout for the analyzer of Fig. 13-1. The labeling of the various parts shown here corresponds to that in Fig. 13-1. The compartment at the top contains the two 4½-volt dry cell batteries and also serves as storage space for the test plug and cable, adapters, etc.

troubles. Likewise, care should be observed in the assembling to insure permanent contact. Care should be taken to avoid making "rosin" joints, for such joints are extremely troublesome

and they are often very difficult to locate. A list of the parts necessary for the construction of the analyzer follows:

- One panel 9 x 12 inches, of either bakelite or hard rubber.
- One 0-1 ma. milliammeter and one copper-oxide type meter rectifier, or, one Universal a-c—d-c rectifier type meter.
- One bi-polar switch (*S1*) with 12 positions.
- Two tap-switches (*S2* and *S3*) with 10 positions each.
- One T.P.D.T. jack-switch (*S4*) for a-c or d-c volts, with "Off" position.
- Six D.P.D.T. push-button switches (*S5*, *S6*, *S7*, *S8*, *S9*, *S10*.)
- Seven S.P.S.T. push-button switches (*S11*, *S12*, *S13*, *S14*, *S15*, *S16*, *S17*). Normal position, "closed-circuit".
- Two S.P.S.T. toggle-switches (*S18* and *S19*).
- Six wire-wound resistors with a tolerance of 2% plus or minus: 5,000 ohms (*R1*); 10,000 ohms (*R2*); 100,000 ohms (*R3*); 250,000 ohms (*R4*); and two 500,000-ohm resistors (*R5*, *R6*).
- Three shunt resistors (*R7*, *R8*, *R9*), for 10-ma., 100-ma., 500-ma. ranges. (Values shown on diagram are for a 27-ohm meter.)
- One 40,000 ohm carbon resistor, filed down until its resistance is 45,000 ohms (*R10*).
- One 0-5,000 ohm zero-adjusting variable resistor (*R11*).
- One 2,000-ohm carbon resistor (*R12*).
- One composite 4-, 5-, 6-prong socket.
- One combination 7-prong socket for large and small 7-prong tubes.
- One 7-prong small size test plug and adapters (7-to-4, 7-to-5, 7-to-6, and 7-to-7) for large-base tubes.
- One 0.5 mfd. by-pass condenser (400 v.).
- One 9-wire cable and small clip for ground connection.
- One control-grid cap.
- Two 4.5-volt "C" batteries.
- Nine tip-jacks.
- Eight binding posts.
- Necessary wire, screws, etc.

Note: Simple "standard" plug- and socket-adapters for analyzing the circuits of all "octal base" all-metal tubes with this analyzer may be obtained from any manufacturer of adapters.

CHAPTER XIV

TYPICAL COMMERCIAL SET ANALYZERS

14-1. Study of Commercial Set Analyzers or Testers.—
In our fundamental study of the set analyzer in Chapters XI, XII and XIII, we studied its development from a simple arrangement for making two or three measurements to a versatile instrument capable of performing every requisite test in analyzing the circuits of the most complex receivers. To enable the reader to more thoroughly acquaint himself with the more important circuit and test arrangements employed in analyzer construction, this chapter has been devoted to descriptions of several typical commercial set analyzers.

A close study of the illustrations, schematic circuit diagrams and brief descriptions of the representative commercial set analyzers to be reviewed will reveal the fact that, in general, they are all designed to accomplish essentially the same results i.e., quickly analyze the circuits of a radio receiver in which trouble of some kind exists, and then determining the exact nature of the trouble after the circuit in which it is located has been isolated. The increasing complexity of receiver circuits and the necessity for being able to make special tests in the field has caused one or two manufacturers to incorporate oscillators, output meters, and tube testers into their analyzers, which other set analyzer manufacturers have seen fit to market as separate test instruments.

The incorporation of suitable arrangements for making the meters in the set analyzer available also for use as ohmmeters, capacity testers, and for any separate external tests or measurements has become general practice in the interests of compact-

ness and economy. Of course, the exact switching arrangements and layouts vary in the different testers.

There are a number of important advantages to be gained by a study of the circuits and constructional features of commercial set analyzers. First, the fundamental principles discussed in the previous two chapters take on a real practical significance when they are shown to be applied in commercial equipment; second, the technical descriptions serve as a foundation upon which future advancements in the field may be com-

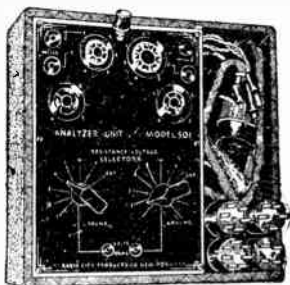

FIG. 14-1. — An analyzer-adaptor unit designed to operate in conjunction with an external volt - ohm - milliammeter for point-to-point set analysis. Its circuit diagram is shown in Fig. 14-2. (Dependable Model 501.)

Courtesy, Radio City Products Co.

pared; third, a knowledge of the equipment used at present for the analysis of radio circuits may be had; and fourth, the descriptions may serve as a guide in the selection or construction of an analyzer.

It is evident that great pains have been taken in the design of these analyzers to make them compact and readily portable, rugged, almost obsolescence-proof, reliable and complete in the sense that they will make practically any receiver analyses required in radio service work. A considerable amount of clever planning has gone into the development of the circuit-switching arrangements and the various parts, the main object being always to promote speedy manipulation in all test operations, for time means money to a radio service man and to the customer who must pay the bill for his services.

It must not be supposed that the descriptions of the commercial analyzers presented here cover all the commercially available analyzers. They are rather, in the opinion of the author,

most typical of the types most generally employed by service men and they involve most of the fundamental ideas discussed in the previous chapters. The descriptions are presented in al-

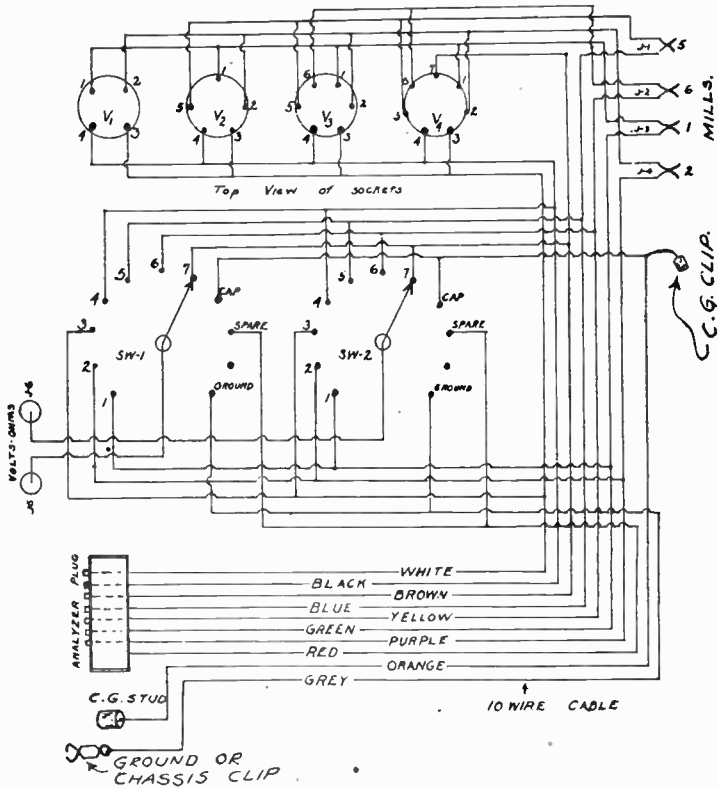

FIG. 14-2.—Schematic circuit diagram of the analyzer-adapter unit illustrated in Fig. 14-1.

phabetical sequence according to the name of the manufacturer.*

14-2. "Dependable" Model 501 Analyzer Unit.—This instrument, shown in Fig. 14-1, is, in reality, an adapter unit designed to work in conjunction with an external volt-ohm-milli-

*Note: Any of the analyzers described in this chapter may be used for analyzing the circuits of all "octal base" all-metal tubes if the "standard" adapters available for this purpose are employed with them.

ammeter with proper ranges. The service man may use an instrument which he already possesses, for this purpose. The mode of operation of the device is very simple. Referring to the schematic circuit of Fig. 14-2, all the terminals of a 4-prong, a 5-prong, a 6-prong and a 7-prong socket are connected directly to the contact points of two rotary switches, *SW-1* and *SW-2*, having eleven contacts each. All the *No. 1* terminals of the sockets connect together and to the *No. 1* contact on the switches, all the *No. 2* terminals connect together and to the *No. 2* contact on the switches, etc. This accounts for seven of the eleven contacts. The eleventh connects to the cable lead that clips to the chassis of the receiver, the ninth connects to the central-grid clip, and the remaining two contacts are spare, one of which is blank and the other going to a spare wire in the cable.

The two arms of the switches connect to tip jacks *J₅* and *J₆*,

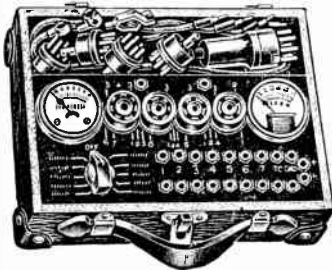

FIG. 14-3.—A complete radio set analyzer. The cable, test plug and adapters are clearly visible in the top compartment. The meters, tube sockets, pin jacks, and meter range switch may be seen on the main panel. The schematic circuit diagram is shown in Fig. 14-4. (Readrite Model 720.)

Courtesy Readrite Meter Works

into which the terminals of the voltmeter-ohmmeter-milliammeter plug. Jacks *J₁* to *J₄*, inclusive, open the connection to socket terminals 1, 2, 5 and 6 for current readings by the external instrument.

Voltage measurements are made by setting the two switches to the numbers of the socket terminals between which the voltage is to be measured, and setting the voltage range of the external meter; the same process is repeated for resistance and current measurements, except that in the latter case the proper jack, *J₁* to *J₄*, inclusive, must be used.

This instrument is versatile in the sense that measurements may be made between any two terminals on the sockets pro-

vided, and hence between any two elements in any tube, as long as the tube can fit in the socket. The analyzer cable is equipped with ten wires, one of which is a spare—it does not connect to any of the terminals of the plug. Adapters for 4-, 5- and 6-prong tubes are provided. Adapters for “octal base” all-metal tubes can also be used.

It is interesting to note that the design of this instrument

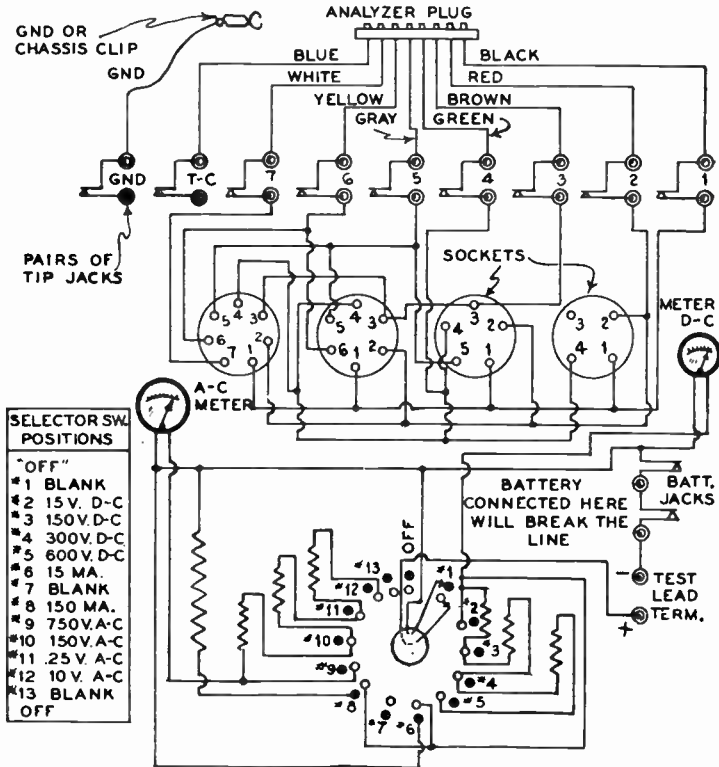

FIG. 14-4.—Schematic circuit diagram of the set analyzer illustrated in Fig. 14-3.

follows precisely the fundamental ideas presented in Chapter XII regarding point-to-point socket analysis.

14-3. “Readrite” Model 720 Tester. — This instrument, shown in Fig. 14-3, really consists of two sections both mounted in a single case, as may be seen by reference to the schematic

circuit diagram of Fig. 14-4. One section consists of the analyzer cable, tip jacks, and the required four sockets, while the second section is a volt-ohm-milliammeter.

Section *No. 1* is a point-to-point type analyzer of conventional design, which requires no further comment. An 8-wire cable and a ground connection complete the test facilities to the receiver. The socket terminals are numbered according to the RMA standard, and thus may be used for measurement purposes without having a detailed knowledge of the construction of the tube being tested. The tops of the tip jacks are of metal, so that the terminals of the volt-ohm-milliammeter may be touched quickly to any two for contact and a voltage reading. Current measurements are made by inserting the test prods into the jacks in the circuit whose current is to be measured; the closed circuit is automatically opened by the test prod.

Section *No. 2* consists of a suitable a-c and d-c meter with the proper multipliers, shunts and a switching arrangement for the use of the meters. Four d-c voltmeter ranges to 600 volts, two milliammeter ranges to 150 ma., and four a-c voltmeter ranges to 750 volts complete the facilities of this section. Two terminals enable the batteries to be connected for resistance



FIG. 14-5.—A typical single-meter point-to-point set analyzer. A unique switching arrangement makes jumper leads unnecessary. "Breakdown" schematic circuit diagrams of unique portions of this analyzer are shown in the next four illustrations. (Supreme Model 91.)

Courtesy Supreme Elect. Instr. Corp.

measurement, and an additional two jacks enable all of the facilities of the volt-ohm-milliammeter to be used for measurements at the socket in which the tube under test is placed. The plug is provided with the usual assortment of adapters so that any desired tests can be made on all types of tubes.

14-4. "Supreme" Model 91 Analyzer.—This instrument, shown in Fig. 14-5, makes use of the point-to-point method of testing described in Chapters XII and XIII. In common with all such testers, the terminals of the radio socket under test are brought to the analyzer, and connected to corresponding term-

FIG. 14-6.—Meter-rectifier system employed in the analyzer of Fig. 14-5. A compensating resistance network is employed to make the deflections for a-c the same as those for d-c, so that one set of meter scales suffices for both a-c and d-c measurements. The compensating arrangement may be studied by tracing the circuit which exists when the switch is in the d-c position, and again when it is thrown to the a-c side. Notice that for d-c measurements the meter is shunted by the 1600 ohm resistor.

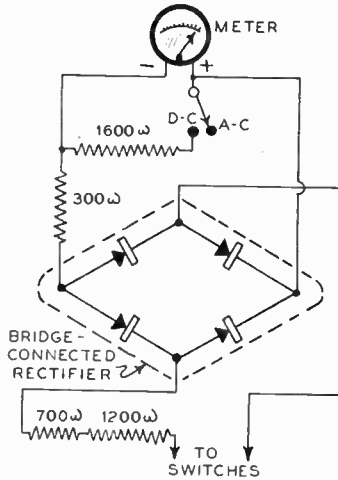

inals of two rotary selector switches. Thus, tests may be made between any two contacts on the socket by the proper manipulation of these switches. It is unfortunate that the complete circuit diagram of this tester cannot be reproduced here. It is so large that, after being reduced to a size sufficiently small to fit the page size of this book, it would be impossible to read it. However, we will study the important features of this analyzer by means of individual break-down diagrams of the various important parts.

The instrument is designed for a-c and d-c voltage measurements in six ranges to 1,000 volts; a-c and d-c milliamperere measurements in five ranges to 500 ma.; resistance measurements in four ranges to 5 megohms; and capacity measurements to 10 mfd. in three ranges. Tube tests may be made by means of the grid-shift method using the same batteries as employed in the ohmmeter, and provisions are made for the use of the

measuring facilities of the instrument for any external uses.

A single d-c meter with a bridge-connected copper-oxide rectifier (see Art. 2-31) is employed in the circuit shown in Fig. 14-6. Two arms of the bridge connect to the switching facilities through a 700-ohm and a 1,200-ohm resistor, and the remaining

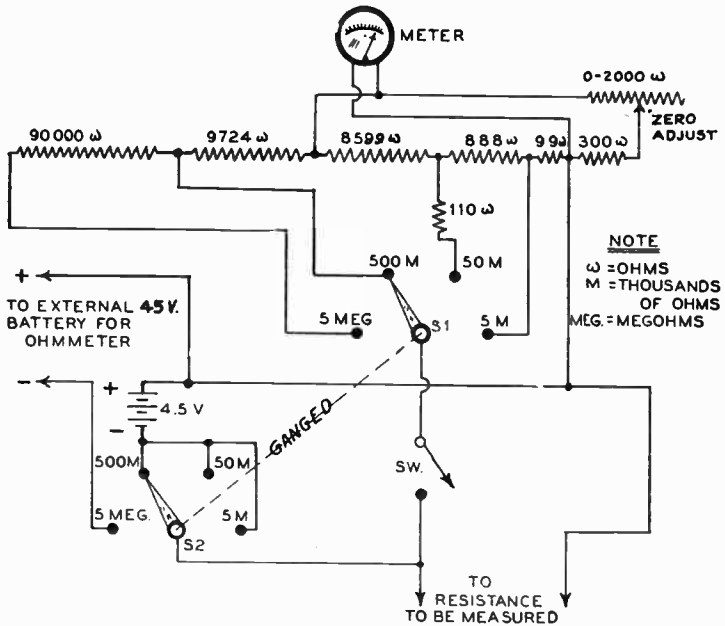

FIG. 14-7.—One portion of the ohmmeter section of the set analyzer illustrated in Fig. 14-5.

two arms connect to the meter through a compensating resistance network. The purpose of this network is to make the deflections of the meter the same for a-c as for d-c, so that separate scales for a-c and d-c measurements are not necessary. This is an unusual feature. Additional corrections for temperature are also provided.

The ohmmeter connections of the instrument are somewhat difficult to trace from the main diagram, so that a breakdown of this part of the circuit is shown in Fig. 14-7. With the switch SW closed, the 4.5-volt ohmmeter battery is connected in the

circuit and the position of the selector switch determines the range of the instrument for all but the 5-megohm range. For this latter range, an external battery of 45 volts must be connected in the circuit to supply the required potential. The two ohmmeter rotary switches, $S1$ and $S2$, shown are ganged to a single shaft, and, as seen, the latter is really connected in series with whatever battery is used for the ohmmeter.

It is interesting to note that the "zero-adjust" arrangement consists of the 2,000-ohm variable resistor in series with the

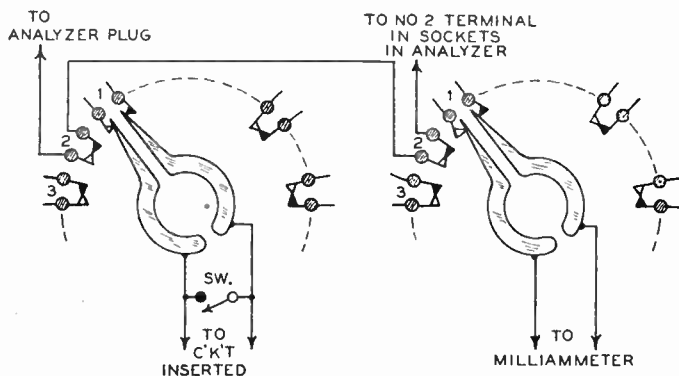

Fig. 14-8.—Unusual selector switches in the set analyzer of Fig. 14-5. Each contact point on the switches is in reality two contact points which are normally shorted together when the arm is not touching them, but "open", as shown here, when the arm makes contact with them.

300-ohm fixed resistor across the meter terminals; the 5,000- and 50,000- and 5-megohm ranges all use the series-shunt system discussed in Art. 3-18.

The main rotary, point-to-point, switches are rather unique. The usual arrangement is to employ switches of conventional design as illustrated in Chapter XIII. The arrangement of the switches in the Model 91 analyzer is shown in Fig. 14-8. Each arm of each rotary switch is divided into two sections, each insulated from the other, as shown. Each contact stud on each switch is really two contacts, which are *closed* when the arm is not on it and *open* when contact by the rotor arm is made. In this position, each section of each switch point stud makes

contact with each section of the rotor arm. The connections for a particular pair of contacts are drawn in the diagram.

The right-hand section connects to the milliammeter section of the analyzer; and when the milliammeter button is pressed after the proper range has been selected, the milliammeter is automatically connected in series with the lead connected to the particular contact opened by the switch arm.

The similarly constructed left-hand switch connects to a pair of terminals called "Insert Terminals." This enables headphones or a loudspeaker to be connected into any of the circuits selected, in a manner similar to the right-hand switch. This fea-

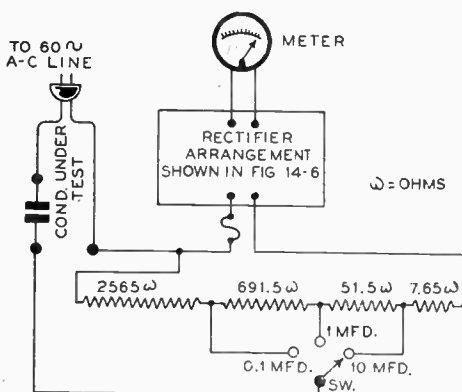

FIG. 14-9. — Circuit arrangement employed for capacity measurements in the set analyzer of Fig. 14-5. The meter rectifier enables the d-c meter to be used to measure the a-c flowing through the condenser under test. The meter shunts are selected by the switch.

ture is an excellent one for making "aural" noise tests of all the circuits in a noisy receiver. For no external connections, the switch *SW* must be closed, of course. Another significant feature common to point-to-point switching and available in this instrument is that all of the potentials of the radio receiver are available at pin jacks located on the panel of the tester.

Capacity-measuring facilities are available through the circuit illustrated in Fig. 14-9. The condenser whose capacity is to be measured is connected to the terminals as shown. The instrument is calibrated for use with a 60-cycle line, and will not be valid for frequencies other than 60-cycles unless specifically stated when ordering the instrument. Capacity measurements are read on the "100" scale of the instrument; the actual

scale readings are divided by 10 for the 10 mfd. range, by 100 for the 1 mfd. range, and by 1,000 for the 0.1 mfd. range.

These are but a few of the many measurements that may be made with this instrument. The usual output-meter facilities, leakage tests, grid-cathode resistance tests and other miscellaneous measurements are also provided for.

14-5. "Supreme" Standard Diagnometer.—The Supreme Standard Diagnometer shown in Fig. 14-10 is intended as a complete service laboratory for either portable or shop use. In a single case it contains a tube tester, a service oscillator, a

Fig. 14-10.—Supreme Standard Diagnometer. Within the single carrying case is contained what amounts to a complete service testing outfit comprising a tube checker, a service test oscillator, a volt-ohm-milliammeter providing numerous ranges, a capacity meter, a point-to-point tester, etc.

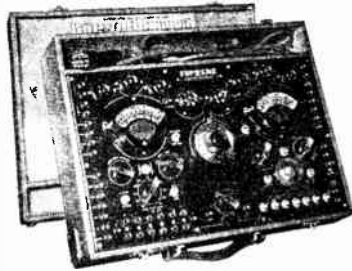

Courtesy Supreme Elect. Instr. Corp.

6-range milliammeter to 1,250 ma., a 6-range a-c and d-c voltmeter to 1,250 V., 3-range capacity-measuring facilities to 12.5 mfd., a 3-range ohmmeter to 200,000 ohms (which may be extended to 2 megohms by the addition of an external 45-volt *B* battery), a complete point-to-point analyzer, and several miscellaneous refinements which are possible because of the flexible circuit arrangement of the instrument.

Tube Tester:

The tube tester is of the emission type discussed in detail in Chapter VIII, Arts. 8-9 to 8-14. A 0-1 ma. meter is connected in the plate circuit of the tube under test, and the terminals of the sockets are connected to a row of seven switches for special circuits. There is nothing radically new about this method of testing, and the reader is urged to refer to the manufacturer if the operating procedure is desired. The scale of the tube-testing meter is calibrated simply in "good" and "bad" sections, which is typical of the "direct", or so-called "English-reading" type.

Test Oscillator:

The service test oscillator is equipped with two ranges, the first from 95 to 220 kc and from 1,500 to 3,300 kc. Higher frequencies for use with all-wave receivers may be obtained by the use of harmonics, as will be explained in detail in Arts. 15-18 to 15-22. A significant fact is that this oscillator is not equipped with an attenuator for control of output. The manu-

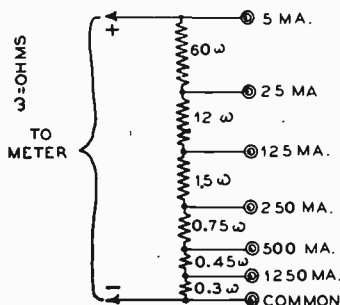

FIG. 14-11.—Circuit arrangement of the shunts in the milliammeter section of the Supreme Diagonometer of Fig. 14-10.

facturer believes that the elimination of this control also eliminates frequency-shift errors, which sometimes occur when attenuators are used. When a very weak signal is desired, the manufacturer recommends that a high harmonic of the oscillator be used. The circuit of the oscillator is of the conventional electron-coupled type, which will be discussed in complete detail in Chapter XV, Art. 15-31; the reader is referred to this section of the book for a discussion of electron-coupled oscillators.

Since the plate voltage of this oscillator is supplied by the a-c voltage obtained from the same transformer used in the tube tester, the output is modulated 100% at 60 cycles (see Art. 15-25), and hence its output is more stable than if the more usual "grid" modulation were used. Furthermore, the audio output in the receiver under test is dependent upon the per cent modulation of the carrier of the oscillator, as discussed in Art. 15-24. Therefore, if the output signal of the test oscillator is well modulated, as is the case with this oscillator, the r-f tubes of the receiver under test need not be overloaded in order to produce sufficient audio output required for the usual test purposes.

Current Measurements:

A 0-1 ma. d-c meter is used for current measurements. The connection of the various shunts is shown in Fig. 14-11. Note that, with any but the lowest range in use, there are resistors in series with the meter as well as in parallel with the terminals in use. Thus, when the 125-ma. range is in use, there is $60 + 12 = 72$ ohms in series with the "positive" lead of the meter, and the remainder is in shunt with the terminals.

Voltage Measurements:

The a-c, d-c voltmeter multiplier connections are shown in Fig. 14-12. The series connection of the multipliers is standard, but the inclusion of the condensers is a bit unconventional. The size of the condensers as marked on the diagram is for a 60-cycle supply; if the supply is of any other frequency, these values of capacity must be changed. Thus, if the supply line frequency is 30 cycles, then each condenser marked should be doubled in size so as to present the same reactance to the 30-cycle current that the size indicated here presents to 60-cycle current. Thus, if the supply frequency happens to be 50 cycles, the size of the

FIG. 14-12.—Circuit arrangement of the multipliers for the a-c—d-c voltmeter employed in the analyzer of Fig. 14-10. The shunting condensers act as compensators when alternating voltages are being measured, and make the deflections for a-c the same as those for d-c. Therefore, a single set of meter scales suffices for both a-c and d-c measurements.

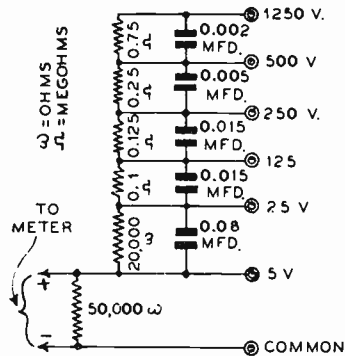

condenser across the 20,000-ohm resistor should be $0.08 \times 60/50$, or 0.096 mfd, and the condensers across all the other resistors must be similarly changed. In this manner, the size of condenser required for any line frequency may be determined. These condensers have no effect on the circuit when d-c is being measured, but act as convenient shunts when the terminals of the instrument are connected to a source of alternating current.

Capacity Meter:

The circuit of the capacity-measuring section of the analyzer is shown in Fig. 14-13. The condenser to be tested is connected between the proper terminal on the panel, and one side of the 110-volt a-c line. In the diagram, a condenser X to be measured is shown connected to the 1.25 mfd.-range terminal.

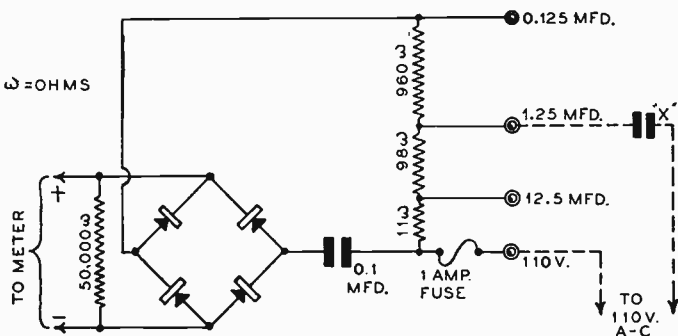

FIG. 14-13.—Circuit arrangement of the capacity-measuring section of the Diagnometer illustrated in Fig. 14-10. The three resistors act as shunts across the meter circuit. The rectifier rectifies the a-c so that it can be measured by the d-c meter.

The resistors shown act as multipliers for each of the ranges. The values of the resistors are shown only for a 60-cycle supply; when the supply is different than 60 cycles, the resistors must be *increased* in proportion to the *decrease* in frequency, similar to the case of the condenser changes just described. The 50,000-ohm resistor shown connected across the meter side of the rectifier remains fixed regardless of frequency. It will be noted that this mode of measuring capacity is similar to that shown in Fig. 14-9, and described previously in Art. 6-6.

The circuit arrangement for the ohmmeter is not unusual. The reader is referred to Chapter III for ohmmeter details.

Set Analyzer:

The "analyzer" section of the instrument employs the point-to-point system discussed previously in chapter XII. The cable is of the 9-wire type which terminates in a 7-wire plug; adapters are provided for use with 4-, 5-, or 6-prong sockets (proper adapters can also be used for the "octal base" tubes). The remaining two leads are for the top cap, abbreviated TC, and a

long lead terminates in a clip for connection to the chassis of the receiver.

The various terminals shown in the illustration of the instrument (Fig. 14-10) are used in conjunction with a suitable rotary switch for analyzing a receiver. When the voltage existing between any two elements of a tube is to be measured, the selector switch is rotated to the "d-c volts" or "a-c volts" position, which connects the meter to the voltage pin jacks on the panel. The proper voltage range is then selected by inserting one end of the test prods into the proper pin jacks; the other ends of the prods are then inserted into the jack terminals of the analyzer section between which the voltage is to be measured. For current measurements, the rotary switch is set to the "d-c ma." position and the test leads are inserted in the twin pin jacks associated with the circuit in question. The proper milliammeter jacks on the panel must be chosen with care, as the cur-

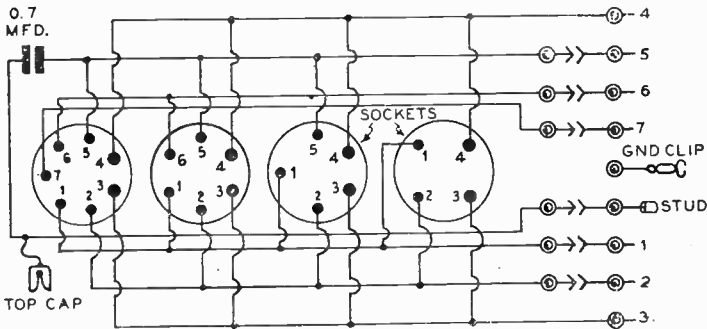

FIG. 14-14.—Point-to-point tester portion of the Diagnometer of Fig. 14-10. The pin-jacks are shown at the extreme right.

rent may be higher than that expected, which may damage the meter. The schematic circuit of the test portion of the analyzer is shown in Fig. 14-14.

Miscellaneous Tests:

There are numerous miscellaneous uses to which the facilities of this instrument can be adapted. Thus, the a-c voltage scales of the instrument are entirely suitable for output measurement work in conjunction with, or without, the test oscillator. The

ohmmeter may be used for the measurement of condenser leakage, aside from the fact that the capacity of condensers may be measured. The alternating voltage applied to rectifier tubes and the output voltage of the oscillator may be measured. Apparently similar inductances may be connected in series and compared. Both the previous and the remaining chapters of this book will suggest numerous uses of the facilities provided by instruments of this type.

14-6. "Triplett" Model 1220 Tester.—Figures 14-15 and 14-16 show, respectively, the appearance and circuit of another simple analyzer suitable for determining the condition of radio

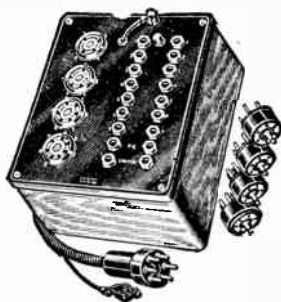

FIG. 14-15.—Another simple analyzer-adapter unit designed to be used in conjunction with an external volt-ohm-milliammeter for point-to-point set analysis. The four adapters provided are shown at the right. Additional "standard" adapters may be used for "octal base" all-metal tubes. (Triplett Model 1220)

Courtesy Triplett Elect. Instr. Co.

receivers when used in conjunction with a suitable external volt-ohm-milliammeter. The simplicity of the circuit is apparent. A 4-, 5-, 6- and 7-prong socket are connected in parallel and to the cable plug through pin jacks, as shown. Two additional wires for a ground clip and control-grid stud are provided to enable all connections to be made to the tube circuit in the receiver.

The jacks shown have metal tops, so that the test prods of the external voltmeter or ohmmeter may be touched quickly to the tops of any two jacks for voltage or resistance measurements. Current measurements with an external milliammeter are facilitated by inserting the test prods into the jacks, which automatically opens the circuit. Suitable adapters are also provided to enable the circuits of all types of tubes to be tested. These are visible in Fig. 14-15. This simple circuit employed in

this tester carries out the fundamental ideas involved in point-to-point testing of radio receivers, as presented in Chapter XII.

14-7. "Weston" Model 665 Selective Analyzer and Model 666 Socket Selector Units.—The form of this unique instrument was designed especially to reduce the possibility of obsolescence. It consists of two separate main parts; a volt-ohm-

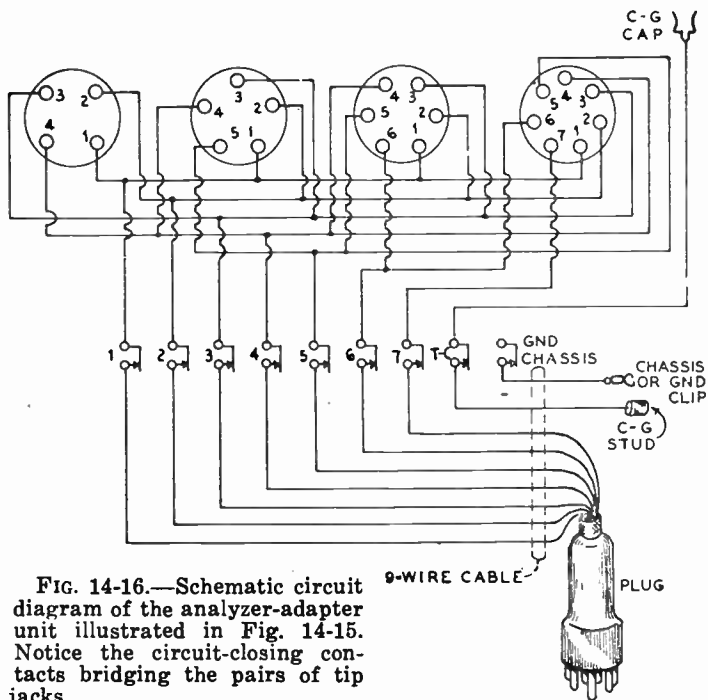

FIG. 14-16.—Schematic circuit diagram of the analyzer-adaptor unit illustrated in Fig. 14-15. Notice the circuit-closing contacts bridging the pairs of tip jacks.

milliammeter and circuit selector arrangement, known as the "selective analyzer"; and a socket with pin-jack terminals, known as a "Socket Selector Unit". The volt-ohm-milliammeter and circuit-selector section may be equipped with a rotary selector switch, in which case it is known as Type 1, or it may have all pin jacks, in which case it is known as Type 2.

Instead of bringing the receiver socket terminals through the cable direct to the inside of the tester proper, as is the case in most types of analyzers, they are brought to the small rectangular

unit carrying a tube socket and a group of pin jacks. This small unit, known as the Model 666 socket selector, has two fixed pins on its under side which fit into corresponding blank pin jacks above the volt-ohm-milliammeter on the Model 665 Selective

FIG. 14-17.—Assembly of a Weston Model 666 Socket Selector Unit plugged into the 665 Selective Analyzer Unit containing the meter and switching circuits. A detailed view of the socket selector unit is shown in Fig. 14-18.

Courtesy Weston Elect. Instr. Corp.



Analyzer so that it may be plugged into it, as shown in Fig. 14-17.

The present Model 666 Socket Selector consists of a tester plug with a 4-ft. cable wired to a small 7-prong tube socket block.

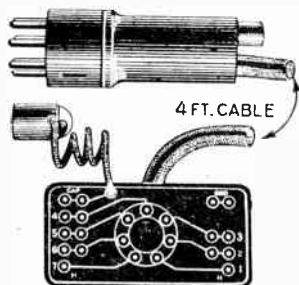

FIG. 14-18.—A detailed view of the model 666 Socket Selector Unit which plugs into the 665 Selective Analyzer Unit (as shown above). This Socket Selector Unit consists of a tester plug with a 4-ft. cable wired to a small 7-prong tube socket block. The socket terminals are connected, as shown by white tracer lines, to pin jacks on either end of the block; jacks are also provided for the cap and ground lead connection. Differently colored adapters are provided for 4, 5, 6, large 7, and also the 8 prong "octal base" tubes.

Courtesy Weston Elect. Instr. Corp.

The socket terminals are connected as shown, by white tracer lines (see Fig. 14-18) to pin jacks on either end of the block; jacks are also provided for the cap and ground lead connection. Differently colored adapters are provided for 4, 5, 6, and large-7 prong "glass tubes" and also for the 8-prong "octal base" all-metal tubes.

The operation of the selective analyzer (the schematic circuit diagram is shown in Fig. 14-19) is as follows: To analyze the circuits leading to the tubes of a radio receiver, the Socket

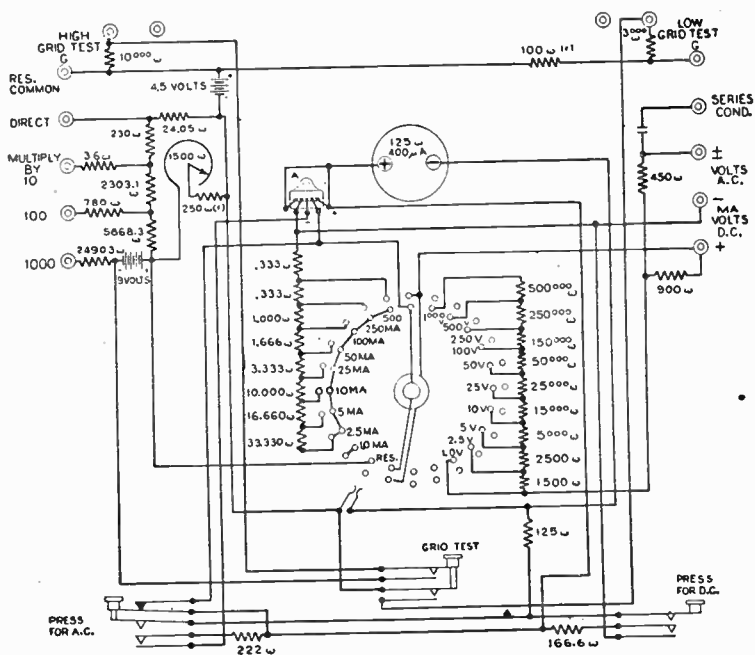

FIG. 14-19.—Schematic circuit diagram of the Selective Set Analyzer Unit illustrated in Fig. 14-17. The circuit shown here is for the Type 1 instrument, which is provided with a selector switch for switching the various circuits.

Selector Unit is plugged into the pin jacks provided for that purpose at the top of the panel of the Selective Analyzer Unit. Then the proper tube adapter is inserted into the Socket Selector Unit and the tube taken from the receiver is in turn inserted into this adapter. The analyzer plug is inserted into the vacated tube socket in the receiver. The socket selector has a group of pin jacks moulded in the bakelite, which are wired to the socket terminals as shown by the white lines engraved on the top of the unit. Pin jacks are also provided for the cap and for a ground lead to make measurements to the chassis itself. The pin jacks

are marked with a numbering system which corresponds to a similar numbering system on the socket.

Voltage readings may be made from any terminal to any other terminal by plugging two small jumper wires into the respective pin jacks and inserting the other ends of these wires in either the a-c or the d-c pin jacks on the instrument panel. The desired instrument range is obtained by turning the range-selector switch in the Type 1 instrument (visible in Fig. 14-17), or by using the proper jack terminals in the Type 2 instrument. If the current flowing in any tube circuit is to be checked, the jumper wires are plugged into the twin pin jacks corresponding to that particular circuit (see Fig. 14-18), the break-in switch between them opens automatically when this is done. The other ends of the jumper wires are then inserted into the *d-c ma.* jacks on the instrument panel, and the range-selector switch set to the desired *ma.* range (Type 1 instrument).

From this explanation, it can be seen that this instrument, whose schematic diagram is shown in Fig. 14-19, will also serve for point-to-point resistance measurements by plugging the jumper wires into the respective pin jacks on the socket selector unit with the other ends inserted in the proper resistance jacks on the instrument panel. The instrument may be employed for measuring the resistance between each tube circuit and ground by setting the range selector switch to read resistance.

A mutual conductance tube test can be made by using the internal batteries employed for resistance measurements. Two jumper wires are connected from the grid-test pin jacks on the instrument panel to the control-grid pin jacks, just as for current measurements, on the selector unit. Then, two additional jumper wires are inserted in the "Plate Current" pin jacks on the socket selector unit and the other ends inserted in the *d-c ma.* jacks on the instrument panel. The meter will then read the "plate current," and the ohmmeter battery will change this plate-current reading when the "Grid Test" button is depressed. The change in plate current is then a measure of the worth of the tube. The panel is equipped with jacks for a small grid-shift test and a high grid-shift test, of 4.5 and 13.5 volts respectively,

to check audio amplifier tubes as well as tubes with a low mutual conductance.

The volt-ohm-milliammeter section has the following ranges: 1, 2.5, 5, 10, 25, 50, 100, 250, 500, and 1,000 a-c and d-c volts at 1,000 ohms-per-volt; 1, 2.5, 5, 10, 25, 50, 100, 250 and 500 d-c milliamperes for the Type 1 and an additional 1,000-ma. range for the Type 2. Four resistance ranges are available; 1,000 ohms, 10,000 ohms, 100,000 ohms and 1,000,000 ohms, with the lowest range indicating 1-ohm per division. The a-c ranges are obtained through the use of a copper-oxide, full-wave rectifier.

All voltage and current ranges are available at the pin jacks by placing the selector switch for the desired range. A reading

FIG. 14-20. — The complete Selective Set Servicer in its carrying case. Notice the test plug and cable at the left, the Socket Selector Unit at the top with the Selective Analyzer Unit under it, four of the tube adapters, and the miscellaneous connection leads at the bottom. Additional adapters are now supplied to make tests on all types of tubes possible.

(Weston Model 698)

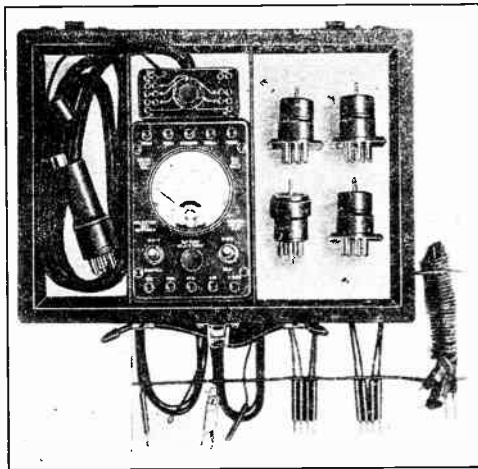

Courtesy Weston Elect. Instr. Corp.

cannot be obtained until either the d-c or a-c push-button at the bottom of the panel is pressed. These buttons are of the locking type and must be returned to their original position after each test is completed.

Although the Model 666 socket selectors were designed for use with the Model 665 selective analyzers (Type 1 and Type 2), and the Model 698 Selective Set Servicer, they may be used directly with Weston Model 660 Analyzer, 663 Volt-ohmmeter and 664 Capacity Meter by plugging the socket selectors into the top jacks on these units. The working jacks which

are occupied by the selector pins are made available for use through a special fixed attachment. These socket selector units can also be used as means of modernizing any analyzer by drilling a pair of holes to take the selector mounting pins. When these socket selectors are used in any of the older type radio analyzers, the degree of modernization depends, of course, upon the limits of the voltage, current and resistance ranges available at the binding posts or pin jacks of the particular analyzer in question.

This analyzer combination is able to make all voltage, current and resistance tests required in any set analysis. Its free-

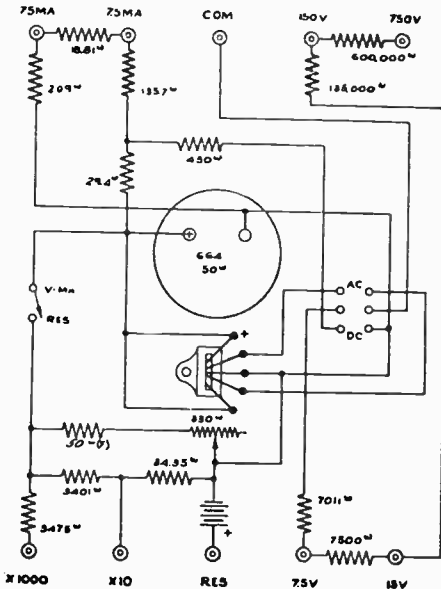

FIG. 14-21.—Rear-view schematic circuit diagram of the Selective Set Servicer illustrated in Fig. 14-20, showing all of the parts, wiring, and terminals.

dom from obsolescence lies in the fact that future developments in tube base design can be taken care of by the purchase of relatively inexpensive additional selector blocks or adapters to accommodate the new type tube bases to the analyzer.

14-8. "Weston" Model 698 Selective Set Servicer.—This instrument is substantially a simplified, less costly design of the Model 665 instrument described in Art. 14-7. It utilizes the Model 666 socket selectors in combination with a pin-jack type Universal volt-ohm-milliammeter unit. The complete unit,

together with the four adapters, test-plug and cable, test leads, etc., provided, is shown in its carrying case in Fig. 14-20. The schematic circuit of the tester is shown in Fig. 14-21.

Measurements of voltage, current and resistance are made in a manner similar to that described for the Model 665 tester,

FIG. 14-22. — Arrangement of the external resistance and battery connections which must be employed to extend the ohmmeter range of the Weston Model 698 instrument to 10,000 times scale reading.

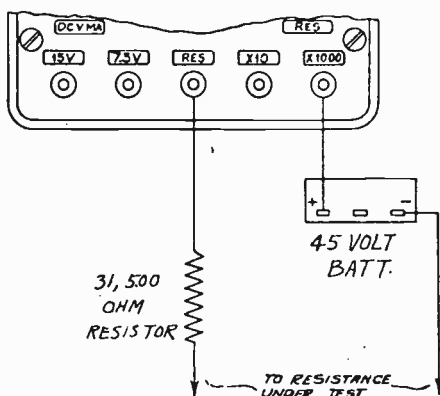

and the reader is referred to that description for the procedure to be followed here. The most significant changes between the two types are the meter ranges provided and the method of testing tubes by the grid-shift method.

The meter ranges for the Model 698 set tester are shown in the diagram; as will be seen, they are adequate for all ordinary service use. The voltmeter ranges indicated are available for both a-c and d-c measurements. The ohmmeter provides ranges of 500,000 and 5,000 ohms full scale; 3,500 and 35 ohms center scale. The ohmmeter range may be extended to 10,000 times scale reading by using an external 45-volt *B* battery in series with a 31,500-ohm resistor, as shown in the sketch of Fig. 14-22.

Testing of tubes by the grid-shift method must be effected by means of an external battery of 4.5 volts for ordinary r-f and detector tubes and of 13.5 volts for power tubes (see Fig. 14-23). The milliammeter leads of the instrument are inserted in the normal fashion to read plate current, and the control-grid circuit is opened with another pair of leads, just as if control-grid current were to be read, as described for the Model 665 tester.

The other ends of these leads connect to a 1,000-ohm resistor across the battery as shown in Fig. 14-23. The difference in plate current when the external battery circuit is opened and closed is an indication of the mutual conductance of the tube.

This analyzer can make voltage, current, resistance and continuity measurements on any receiver. Future developments

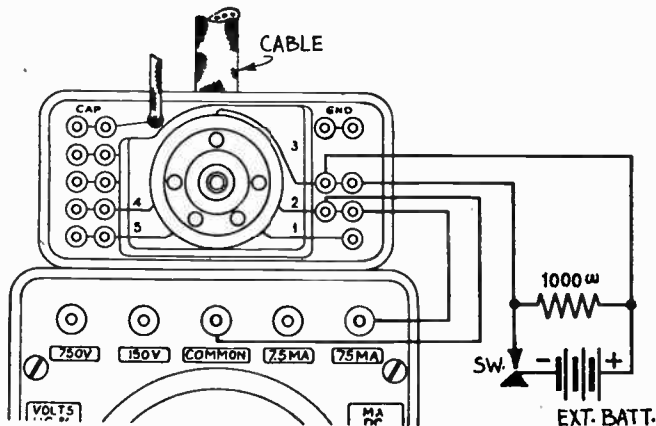

Courtesy Weston Elect. Instr. Corp.

FIG. 14-23.—External connections which enable tubes to be tested by the grid-shift method with the Weston Model 698 Selective Set Servicer. The external battery supplies the grid bias voltage for the tests.

on tube base design can be taken care of by the purchase of relatively inexpensive additional selector blocks or adapters to accommodate the new type tube bases to the servicer.

REVIEW QUESTIONS

1. Explain how current and voltage measurements are made in the Dependable Model 501 set analyzer (refer to the circuit diagram).
2. What do the two separate sections of the Readrite Model 720 consist of? What is the purpose of each section? What is the purpose of this arrangement?
3. Draw the schematic circuit diagram of the compensating network used with the meter in the Supreme Model 91 analyzer. What is its purpose?
4. What is the switching arrangement used in the Supreme Model 91 analyzer? Illustrate by means of a diagram.

5. In the analyzer of Question 4, what means is used to measure current?
6. Condensers are connected across the voltage jacks of the Supreme Standard Diagnometer. If one of these condensers has a value of 0.005 mfd. for use on 60 cycles, what should its value be when the instrument is to be used to measure 40-cycle voltages.
7. One of the resistors used in the capacity measuring section of the Supreme Standard Diagnometer has a value of 22 ohms when used on 30 cycles. What should be its value when used on a 60-cycle line?
8. Explain the unusual fundamental idea involved in the design of the Weston Model 665 and 698 set analyzers. State two advantages of this arrangement. How is danger of obsolescence minimized?
9. Draw the schematic circuit of the socket selector unit used with the Weston model 665 and 698 analyzers for 7-prong tubes.
10. What external connections are required when the Model 698 Weston tester is to be used for tube testing? Explain them!
11. What external connections are required when it is to be used for resistance measurements in the "10,000 times scale reading" range of the ohmmeter? Explain!

CHAPTER XV

THE SERVICE TEST OSCILLATOR

15-1. Why Test Oscillators are Needed.—The service man is consulted when a radio receiver operates either unsatisfactorily or not at all. He usually proceeds to test the tubes and then the individual circuits, in an attempt to localize the trouble to a particular stage. When a particular component is at fault, the trouble may usually be located by first making a voltage-current, (or resistance) analysis of the receiver, and then checking the individual components in the faulty circuit until the faulty unit is found. However, in many cases the receiver operates poorly (or not at all) but there is not one faulty unit present in its circuit. In that case the receiver may be out of alignment—its sensitivity may be too low for satisfactory reception in the particular location it is operated in (especially in rural districts), the receiver may be inoperative only over certain portions of the tuning scale, etc. In such cases, the test procedure to be followed often requires a source of signal *whose frequency and intensity may be adjusted at will* to suit any test that may be made. It is the purpose of the *test oscillator* to furnish this signal.

There are several reasons why the signals from broadcasting stations cannot be used for this purpose: first, their strength varies from instant to instant, depending upon the type of program and selection being broadcasted; second, the frequency of the signal required for a test may be different than that of the stations that could be tuned in if the receiver were operating to some extent; third, the intensity of the signal depends upon the power of the station, the distance between transmitter and receiver, the amount of absorption of the wave in the intervening

space, and the sensitivity of the receiver (all of which means that the service man must accept the signal strength as received rather than as his tests demand); fourth, broadcasting stations are unreliable in the sense that the stations which might be desired for tests purposes may not be transmitting at the particular time that they are needed; fifth, it may not be possible to receive them with the set operating in its poor condition.

The test oscillator is really a miniature broadcast station under complete control of the service man. He can vary the frequency or the intensity of its signal in a few seconds without disturbing the adjustment of the receiver with which it is used. He can modulate it or not, as he sees fit. It is ready for operation any time it is needed, and is one of the most important pieces of test equipment in the service kit.

15-2. What Test Oscillators Can be Used For.—The test oscillator can be used for any purpose for which a broadcast signal can be used, for the fundamental purpose of the test oscillator is to replace the broadcast signal for tests and adjustments. A few of the specific uses of special importance to the service man are as follows:

1. For the alignment of r-f and i-f circuits of any type and description.
2. For aligning oscillator padding circuits in superheterodynes.
3. For neutralizing receivers using any type of neutralizing circuit.
4. For checking the condition of tubes.
5. For determining the gain of any, or all, amplifier stages in a radio receiver.
6. For testing AVC circuits and their operation.
7. For checking operation and selectivity of tuned circuits.
8. For testing individual components.

We will now review these briefly.

(1) If the tuned circuits of a receiver are badly out of alignment, it may be necessary to use an oscillator whose output voltage is variable from a fraction of a microvolt to several volts and whose frequency is variable from about 100 kc to 30,000 kc. Such a source of signal is properly fed to the receiver or amplifier

under test in place of the usual broadcast station signal, and the alignment made. The use of the test oscillator for this purpose is considered in detail in Chapters XXIV and XXV.

(2) The padding circuits of the oscillators used in superheterodyne receivers must be adjusted carefully at several *specific* frequencies during the course of aligning a receiver. Broadcast signals are hopelessly inadequate for this purpose, especially when the receiver is of the all-wave type. Details on the alignment of padding circuits are given in Chapters XXV and XXVIII.

(3) The neutralization of a receiver requires a source of constant signal voltage, which can only be obtained from a test oscillator. The output of the oscillator is fed to the input of the stage to be neutralized and balanced out. Details for this procedure are given in Chapter XXIV.

(4) Tubes may be compared by connecting the output of the oscillator to the aerial and ground posts of a receiver in good working condition and noting the reading of an output meter connected to the receiver (see Art. 7-5). Now, by replacing any tube in the set with another which is of the same type and is known to be good, and reading the output meter again when the replacement tube is in the set, an indication of the condition of the tube replaced is obtained. A greater reading means that the replacement tube is better than the original; an unchanged reading means that the original tube is as good as the replacement tube. This tube test is known as the *replacement test* and was discussed in Chapter VIII.

(5) The service test oscillator is also of particular value in determining the *gain* of a radio receiver or amplifier. Its output is connected to the input of the receiver or amplifier and the oscillator voltage is measured by a suitable multi-range output meter or vacuum-tube voltmeter. Keeping this voltage constant, the output meter or vacuum-tube voltmeter is then connected across the *primary* of the output transformer of the receiver and the voltage existing here is measured. The ratio of the second to the first reading is the *gain* of the receiver. It is not necessary that the output meter or vacuum-tube voltmeter be calibrated; the ratio of the two readings obtained is quite sufficient for a rough check in most of the ordinary cases encountered.

(6) The oscillator may be used to check the avc tube and circuit action in a receiver. Merely connect the output of the oscillator to the input of the receiver and adjust the voltage so that an output meter connected to the receiver reads about half scale. Then change the avc tube and note the reading of the output meter. A reduction in the reading means that the first tube was defective; an increase in the reading means that the second tube is faulty. See Chapter XIX for further details.

(7) The selectivity of tuned circuits may be checked by varying the frequency, with constant voltage, of the oscillator connected to the tuned circuit or receiver under test. The voltage output of the tuned circuit or receiver is then noted for every setting of the oscillator from a few kc below to a few kc above the resonant frequency. For ordinary good fidelity, the curve plotted should have substantially the same height 5 kc below (and above) resonance as it has at resonance (for high-fidelity this should be 7.5 kc). Details concerning resonant radio circuits are presented in Chapters XXV and XXXI.

(8) Individual components may be tested with the oscillator if a vacuum-tube voltmeter is available. The oscillator serves as a source of high-frequency voltage which can be applied to the coils, resistors, or condensers under test to determine their condition at or near the frequency at which they will work in practice. Many occasions arise when a d-c or low-frequency test will not reveal the source of trouble and only a high-frequency test will show it up.

These are but a few of the many applications of the service test oscillator. Many incidental uses which are of inestimable value to the service man will be pointed out at various places.

15-3. What the Test Oscillator Is.—To use a service test oscillator intelligently, and to understand the actions taking place in the oscillators used in superheterodynes, it is essential that a clear understanding be had of the arrangements and characteristics of the different forms of oscillator circuits. First of all, the oscillator as we know it is a device used to generate alternating current (and hence alternating power) by means of the vacuum tube. The service test oscillator depends for its operation upon the principle that a vacuum tube can be made to pro-

duce oscillations of almost any frequency, by connecting it in a circuit arranged to continuously feed a proper amount of the energy of the plate circuit back to the grid circuit *in the proper phase*.

In an oscillating circuit, part of the energy of the operating plate current is being fed back to the grid circuit continuously. This is being amplified by the tube, and the extra energy produced by the amplification (at the expense of the energy from the batteries or other power supply) may be used outside of the oscillator circuits for any useful purpose. Now it is not essential to use a vacuum tube; any device capable of converting direct current to alternating current is a generator of electrical oscillations. But the point is that the vacuum tube is probably the most efficient and convenient converter for producing a-c of high frequencies known at this time, and it is for this reason that it enjoys such widespread use for this purpose. Furthermore, it is relatively small physically, and almost any amount of alternating power can be generated at will by properly selecting the circuits and using large enough tubes.

Oscillators are variously known as *test oscillators*, *converters*, *generators*, *signal generators* and *signal sources*, depending upon their use and the point of view of the theory of operation. The oscillator itself does not "oscillate" mechanically—it is the current through the oscillating circuit that circulates in an *oscillating* fashion (back and forth), hence the name "oscillator." If the tube is considered as a converter of d-c to a-c, the name *converter* is obvious. If it is considered as a generator of alternating current, the name *generator* is clear. But if the device is to be used as a source of signal power for some test, then it may be called a *signal source*, a *test oscillator*, or a *signal generator*. Insofar as service work is concerned, the oscillator is a convenient source of signal voltage whose frequency and intensity may be varied at will over the necessary range.

In this chapter we will make a detailed study of the operation of various oscillator circuit arrangements and their characteristics. Practical details concerning the actual use of test oscillators in service work will be presented in Chapters XXIV and XXV when the alignment of tuned receiver circuits is studied.

15-4. **The Vacuum Tube as an Amplifier.**—Consider an ordinary triode connected as an amplifier as shown in Fig. 15-1. A signal from some convenient source, such as a broadcast station, is fed into the coil L_p . The circulation of the alternating current through this coil generates an a-c voltage in coil L_s , which is tuned to the resonant frequency of the signal source by the condenser C . The a-c voltage across C is applied to the grid of the tube, as shown, and an amplified version of this voltage appears

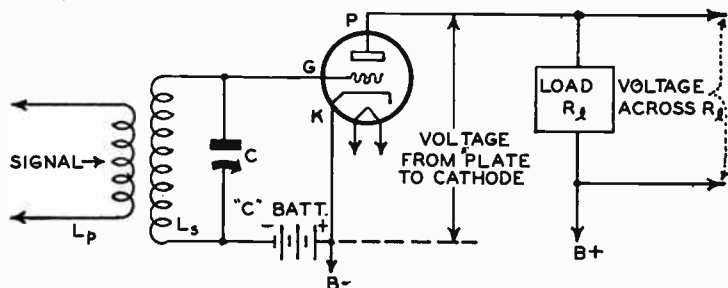

FIG. 15-1.—Fundamental circuit of a vacuum tube amplifier stage.

across the load resistor, R_l , in the plate circuit. If another stage of amplification followed, this load voltage would be fed to it.

Now the important thing is that with the proper value of load resistance, R_l , the voltage across R_l is greater than that across C because of the amplifying properties of the tube. It is the voltage that appears across R_l that is the most useful voltage in the whole circuit. As mentioned, it is this voltage that is fed to succeeding amplifiers in a radio receiver for further amplification before being fed to the loud speaker for reproduction. It is also this same voltage that is applied across the antenna and ground in a broadcast transmitter in order to produce radiations that will travel off into space to be picked up by receiving aerials. This self-same voltage is the amplified signal.

15-5. **How the Power Supplied by the Plate Battery Divides.**—When no signal is applied to the input circuit of the amplifier tube, the plate current is steady and the voltage across the load resistance is steady. The voltage of the B -battery (or other B -power supply source) multiplied by the plate current,

in amperes, gives the power in watts that is taken from the *B*-battery and dissipated as heat both in the plate-to-cathode path of the tube and in the resistance of the plate-load of the

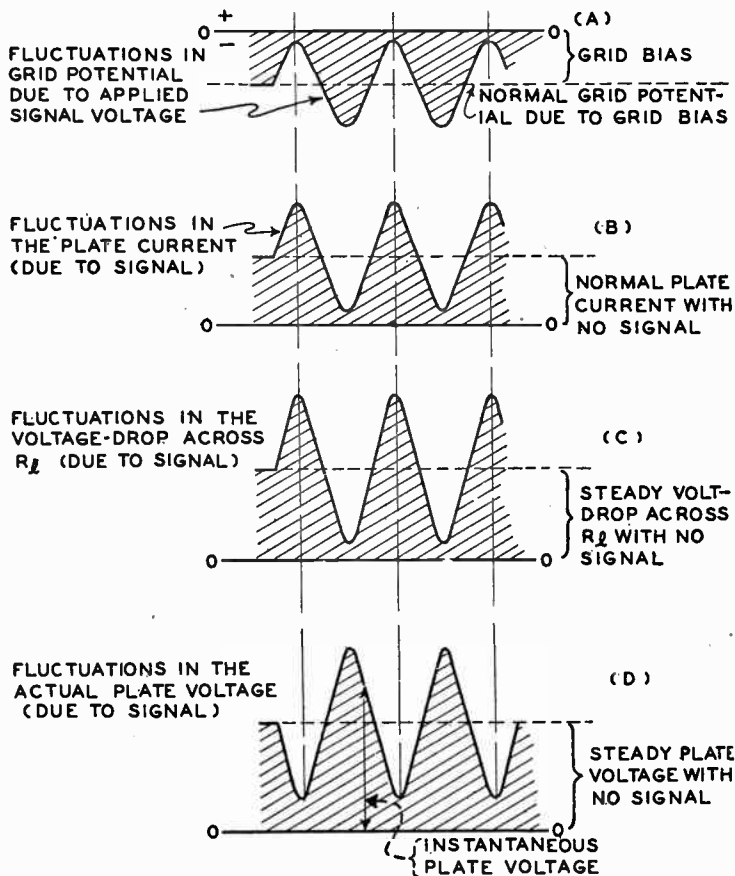

FIG. 15-2.—Graphs showing the simultaneous effects on the grid potential, plate current, voltage drop across the plate load and actual plate voltage, when a sine-wave signal voltage is applied to the grid input circuit of a vacuum tube amplifier or oscillator.

tube. The former is known as the *plate loss* because it serves to heat the plate of the tube, and the latter is known as the *external power output* because it is this power that is used up in the

actual resistance of the load; in fact, the load resistance times the square of the plate current gives the external power output. This same value may also be obtained by multiplying the plate current by the voltage across the load resistance R_l . In a test oscillator, both of these powers are a total loss, since they can be put to no useful purpose.

When a signal is applied to the grid of the tube, the potential of the grid alternately increases and decreases from its bias-voltage value, as shown at (A) of Fig. 15-2, and the plate current likewise alternately increases and decreases above and below the value when no signal was impressed, as shown at (B). When the plate current *increases*, the voltage drop across R_l *increases*, as shown at (C), and the voltage between plate and cathode *decreases* by an equal amount as shown at (D), since the sum of the two must always equal the steady B-battery voltage. When the grid potential *decreases* (becomes more negative) because of the signal, the plate current also *decreases*; this means that the voltage across R_l *decreases*, and the voltage between plate and cathode *increases* by an equal amount. Here again the sum of the two voltages is always equal to the steady B-battery voltage at any instant. The action of these two voltages is somewhat similar to that of a see-saw; when one goes *down*, the other goes *up* an equal amount, and vice versa. These conditions are all illustrated in the sketch of Fig. 15-2.

Of particular interest is the fact that the plate voltage (voltage actually existing between plate and cathode, not the B-battery voltage) always varies in a sense *opposite* to that of the voltage across R_l , because the sum of both voltages at *any instant* must equal the B-battery voltage. This is brought out clearly by the positions of the peaks in graphs (C) and (D).

The power heating the plate of the tube at any instant is the plate voltage times the plate current, and the power dissipated in the load, R_l , at any instant is the product of the voltage across R_l and the plate current. The power heating the plate of the tube (the plate loss) is the power that would be measured by a wattmeter connected in the plate circuit, and is equal to the *average* of the instantaneous powers obtained by individual multiplication. In a similar manner, the power dissipated

in the load is also the *average* of the instantaneous powers obtained by individual multiplication.

However, the power delivered to the entire circuit (plate and load) is the power delivered by the *B*-battery, which is equal to the *B*-battery voltage times the d-c plate current. Since the *B*-battery voltage is constant, and since the average plate current remains the same during each cycle, as shown at (*B*), *the average power supplied to the entire circuit remains the same regardless of whether or not a signal is applied.* This point is very important, for it means that, *with no signal, the entire power supplied by the B-battery is wasted in heating the plate of the tube; but that when a signal is applied to the grid of the tube, some of that same power is fed into the load, so that the power supplied to the plate, and the consequent plate heating, is less with a signal than without a signal!*

Further, if the grid bias and plate voltage are adjusted so that the plate current is half the maximum value, and if the load resistance is equal to the plate resistance of the tube (which is the same as saying that the varying voltage drop across R_l is equal to that from plate to cathode of the tube), then the power dissipated in the internal plate circuit is only half of what it would be if there were no signal.

For example, suppose that with no signal, the *B*-battery is supplying 10 watts of power to a certain tube, all of which is heating the plate and supplying a small loss to the grid circuit. Now, when the signal is applied, the average heating of the plate may be caused by only 8 watts; the difference of 2 watts is that power which is absorbed by the load.

15-6. Effect of the Nature of the Plate Load.—If the load of the tube we just considered is a resistance, then all of the output power developed will go toward heating this resistance. If the load is a coil coupled to an aerial, then most of the 2 watts will be radiated into space as radio waves. It makes little difference to the tube where the 2 watts goes to, and for this reason the plate load is often referred to as a resistance, even though it actually does not consist of a piece of resistance material. The circuit acts as though a resistance *were* there.

Suppose the load is simply a coil of wire, L_l , as shown in

Fig. 15-3. Then, if the coil has very low resistance, an alternating voltage will be built up across it, but there will be very little power dissipated in it because there is no place for the power to go. In other words, in this case the plate will be heated by practically 10 watts of power, referring to our previous example. The interesting condition exists, then, that the stronger the signal voltage applied to a tube, *the less is the heating of*

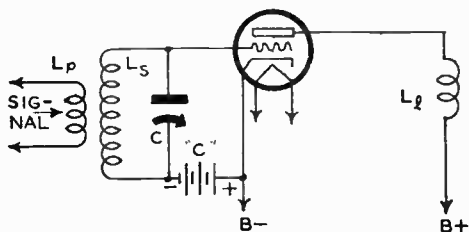

FIG. 15-3.—An amplifier tube with an inductive load in its plate circuit.

the plate of that tube if the load in its plate circuit can absorb power.

15-7. Action of the Vacuum Tube as an Oscillator.—

Suppose a signal is applied to the tube shown in Fig. 15-3; an alternating voltage will then be generated across the plate coil L_p . Now if this coil is placed near the grid coil L_g , as shown in

Fig. 15-4.—Producing a regenerative feedback action in the circuit of Fig. 15-3 by inductively coupling energy from the plate circuit back into the grid circuit.

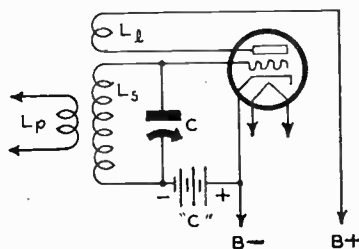

Fig. 15-4, so that L_p acts like the primary of a transformer, a voltage will be induced in the grid coil L_g because of the usual transformer action. And if the direction of the winding and the connections of coil L_p are correct, so that its magnetic *polarity* is correct, the voltage it induces into L_g will *aid* (be *in phase* with) that induced in L_g by the signal across coil L_p . Then the fluctuating potential applied to the grid will be *greater* than be-

fore, and the output will be still stronger, *i.e.*, the signal has been amplified still more. This is the principle of *regeneration*. If the original signal were removed from the circuit after this regenerative action started, and if the voltage induced in L_2 by L_1 were great enough, then the same signal would be impressed on the grid circuit of the tube again and again, being amplified more each time. If this occurred, the tube would be said to be *oscillating*, and the oscillations would be termed *self-sustaining*, because no outside influence (other than the power supplied to the filament, plate, etc.) would be required to maintain them.

The reader may well wonder if there is any definite limit to this process of continuous amplification. If a small signal is applied to the grid of a tube, it will be amplified, and part of the amplified energy will be returned to the grid circuit by the plate coil L_2 for additional amplification. The part returned to the grid circuit automatically adjusts itself to that required to supply only the losses in the grid circuit. This means that, with a somewhat constant low loss in the grid circuit, the strength of the impulse should increase steadily. It does continue to increase until the grid potential excursions become so large that twice during each cycle the tube reaches the saturation points at the upper and lower bends of its characteristic curve, *i.e.* the points at which any further change in grid voltage produces no change in plate current. Obviously, these are the limits for plate current change and of course vary for different types of tubes. Under these conditions, during oscillation the plate current fluctuates, theoretically, between zero and the saturation value of the tube for the particular steady voltages applied. This is merely another way of saying that the amplification factor drops to a fraction of its initial value, which reduces the amount of amplification secured. This drop acts as an automatic valve, and tends to maintain the amplitude of oscillation at a constant level. This means that the amplitude of the oscillations builds up gradually from a small value to a final, steady state.

15-8. Requirements for Oscillation.—In order to have oscillation in the type of vacuum tube circuit described above: (1) the tube must be an amplifier; (2) the voltage induced in the

grid coil by the plate coil must be of the proper polarity; and (3) the voltage induced in the grid coil by the plate coil must be large enough to excite the grid sufficiently.

The third requirement needs further explanation. The secondary of the transformer L_s is like the secondary of any other transformer—it must supply the losses of the circuit connected to it. In this case, the losses are due to the resistance of the coil, the condenser, the wiring, and the grid-cathode resistance of the tube. True, the grid-cathode resistance may be very high because the tube is biased negatively, but it may become positive during certain parts of the cycle, and, during these times, it draws current and dissipates power which must be supplied by the secondary. Hence, the voltage in the secondary must be great enough to supply this power. This voltage comes from the plate circuit, which means that *at least enough signal power must be transferred by the plate circuit to the grid circuit to overcome the losses in the grid circuit.* This extra plate circuit signal power will only be available if the tube is an amplifier. It is seen, then, that the tube must not only be an amplifier, but it must amplify sufficiently to supply the losses in the grid circuit.

15-9. Oscillator Grid Bias.—Without regard to *how* the plate energy is fed to the grid circuit, the question of the proper bias to apply to the grid must be considered, as it is a very important factor in the design of any service test oscillator. Bias may be obtained in three ways: by means of a grid-leak and grid-condenser; by a grid-bias resistor; or by a separate battery.

If a bias resistor or battery is used, the voltage should be such that the tube operates as an amplifier, exactly like it would be used in a radio receiving set. Sometimes the bias voltage is made greater than that required for amplifier action. In these cases, the tube operates over the lower bend of its grid-voltage—plate-current characteristic, and therefore operates as a grid-bias detector. Under such conditions, plate current flows only during one-half of each cycle. This results in increased efficiency of the tube as an oscillator. Since the plate current flows during only about one-half of each cycle, the heating of the

tube is less, but current is supplied in the tuned circuit during the other half of each cycle by the *flywheel* action of the circuit. Thus, if the half-cycle acts to charge the tuning condenser, and is then removed, the condenser will discharge of its own accord and supply the other half-cycle. In a tuned circuit of low resistance, therefore, it is not necessary to supply it with a full wave. In fact, in a Class C oscillator only a small fraction of a half-cycle is supplied to the tuned circuit, the circuit itself supplying the remainder by flywheel action. However, as we shall see in Art. 15-18, biased tubes produce a large number of strong harmonics. Whether or not this is desirable depends on the design of the particular oscillator.

When a grid leak and condenser is used, the grid leak, R_g , is connected as shown in (A) or (B) of Fig. 15-5. These connections are similar to those used in receiving sets—the only difference lies in the values employed. In either connection (A) or (B), the potential of the grid is zero with no oscillation. Any slight disturbance in the plate current (such as the turning on of the filament or plate voltages) will cause a voltage im-

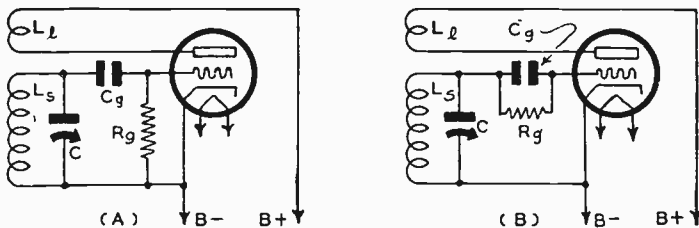

FIG. 15-5.—Two possible ways to connect the grid leak R_g and grid condenser C_g in the grid circuit of an oscillator tube.

pulse to be generated in L_s by the plate coil L_1 . During the first positive half-cycle, the grid is positive and a grid current flows. The direction of the grid current for these two circuit arrangements is as shown in (A) and (B) respectively of Fig. 15-6. Since the grid current flows through the grid-leak resistance in either case, a voltage-drop is produced across the grid leak, the "grid" end being *negative* with respect to the "cathode" end. This means that the grid receives a *negative* bias due to the

presence of the grid leak and the grid current flowing through it. It makes no difference in which of the two ways the leak and condenser are connected, the bias is generated just the same. In the first mode of connection (A), the grid current flows through

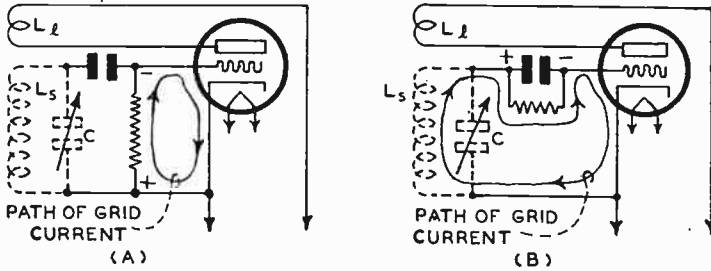

FIG. 15-6.—Direction of the grid current flow in the grid-leak and condenser circuits of Fig. 15-5.

the grid-cathode resistance of the tube and the grid leak. In (B) it flows through the coil L_s , as well.

The grid condenser in an oscillator is used solely for the purpose of by-passing the high-frequency oscillations around the leak. If the grid condenser were omitted in system (A), the tuning coil would short-circuit the leak; in system (B) the high resistance leak would be in series with the grid tuning circuit and the grid of the tube, which would cut down the voltage applied to the grid. During operation, the bias voltage developed is equal to the average grid current multiplied by the leak resistance in ohms; the grid condenser by-passes the r-f signal around this leak; hence the bias is constant. If the strength of the oscillations is increased by, say, increasing the plate voltage, then the bias applied to the grid is greater because the a-c grid voltage is greater. But this is as it should be, since an increase in plate voltage makes an increase in grid bias necessary, if the same relative operating conditions are to be maintained.

15-10. Fundamental Oscillator Circuits.—We have not yet mentioned the different types of circuits that may be used to generate oscillations, for the reason that the considerations given the problem thus far merely concerned themselves with the general action of the vacuum tube as an oscillator and not

with details of the particular circuit used. As long as energy is fed from the plate to the grid circuit in sufficient quantities and of the correct instantaneous polarity (*phase*), the tube will oscillate.

The grid and plate circuits of an amplifier tube can be arranged in several ways to produce oscillations, each arrangement having certain desirable characteristics which make it more suitable for particular applications—but they all operate on the principle of feeding energy back from the plate circuit to the grid circuit. The frequency of the oscillations produced is governed mainly by the values of inductance and capacitance of the tuned circuits in either the plate or grid circuit. If a suitable fixed inductance and variable tuning condenser of proper value are employed, the frequency of the oscillator signals may be varied over any desired frequency range. Thus it becomes a miniature radio broadcast station of variable frequency.

There are several fundamental oscillator circuits in common use, and the service man will do well to thoroughly acquaint himself with their fundamental connections so that he will be able to recognize them in other oscillator circuit diagrams which he may see.

Fortunately, the more simple oscillator circuits are perfectly satisfactory for use in test oscillators for radio service work.

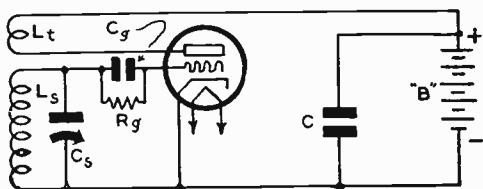

FIG. 15-7.—A self-modulated oscillator circuit of the tickler feedback type. Condenser C by-passes the plate voltage supply.

They may be easily constructed and calibrated by the average service man with the aid of a few tools and without the necessity for employing complicated calibrating instruments. Some of these will now be described. The actual procedure to be followed in using them is discussed in detail in following chapters.

15-11. Tickler Feedback Oscillator Circuit.—Probably the best-known oscillator circuit is the tickler feedback circuit

shown in simplified form in Fig. 15-7. The outstanding characteristic of this arrangement is the fact that the plate of the tube connects to B plus through a coil L_t . R-f energy in this plate coil induces additional grid voltage in L_g by induction (transformer action), and it is in this manner that the tube continues to oscillate. The closer the coupling between the tickler L_t and the grid coil L_g , the stronger the oscillation. With the connections to L_g fixed, the polarity of the wiring to tickler L_t must be in correct phase in order for the tube to oscillate.

15-12. Reversed Feedback

Oscillator Circuit. — A slightly different arrangement of the conventional feedback circuit is shown in Fig. 15-8. Note here that the tuned circuit is in the plate circuit instead of in the grid circuit, and that the proper grid voltage is obtained by inducing a voltage in L_t . This circuit is the reverse of the one shown in Fig. 15-7, and hence is called the *reversed feedback* circuit. This circuit is not used

in service test oscillators to any great extent, but is described here because of the somewhat unusual location of the tuned circuit L_p - C_p .

In discussing the theory of the oscillator from the standpoint of the amplifier, it was pointed out that the grid circuit was tuned to resonance with the applied signal. When the tube is generating self-sustained oscillations, there is no applied signal, but the frequency of oscillation is determined by that same resonant circuit. In our explanation of the action of the vacuum tube as an oscillator in Art. 15-7, we merely removed the applied signal and substituted for it a portion of the energy in the plate circuit. Now if the plate circuit is made the resonant circuit, then all that is necessary is a few turns of wire in the grid circuit coupled to the plate coil in order to obtain the requisite grid voltage to keep the tube oscillating. This is exactly what

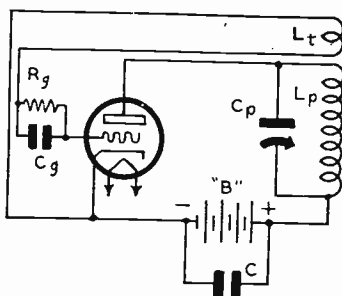

FIG. 15-8.—Reversed feedback oscillator circuit.

the reversed feedback circuit contains, as shown in Fig. 15-8.

15-13. Tuned-Plate—Tuned-Grid Oscillator Circuit.—

If the inductance of L_t in Fig. 15-8 were made as large as L_g , and if it were shunted by a condenser of the same size as C_g , the voltage built up in the grid circuit would be very large, simply because it is tuned to the same resonant frequency as the frequency of oscillation. But if both coils were coupled magnetically as shown in that figure, the grid voltage would be excessive. However, it may be reduced to almost any desired value by reducing the coupling—spacing the coils farther apart.

Suppose the plate and grid coils are not magnetically coupled at all. Then the circuit should not oscillate, because there is no induced grid voltage to keep, or even start, it oscillating. But, fortunately, every tube used for service test oscillators has a grid and a plate close to each other, and they are both of metal. This means that a capacity exists between the grid and the plate of the tube. Now r-f current will flow in the circuit associated with a condenser, because of the charge and discharge

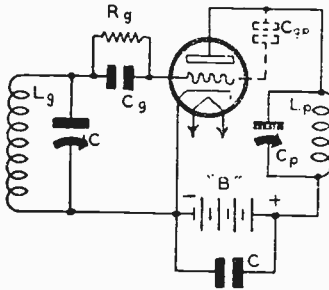

FIG. 15-9.—Tuned grid—tuned plate oscillator circuit.

of the condenser plates, which means that part of the energy in the plate circuit (obtained from some random initial disturbance) may be transferred to the grid circuit by means of this internal grid-plate capacity of the tube itself. If we take our tuned grid and tuned plate circuit, then, and connect it as shown in Fig. 15-9, the circuit will oscillate because the grid receives its exciting voltage via the internal grid-plate capacity

of the tube. If the tube has a small amount of capacity, the tube may not oscillate, and an additional condenser must be placed from grid to plate outside the tube, as shown by the dotted condenser C_{gp} .

Only a small amount of grid excitation is needed with this circuit because both the grid *and* the plate circuits are tuned

to the frequency of oscillation. Hence the name of this circuit, *tuned-grid—tuned-plate*. Because of the two tuning condensers required, this circuit is not in general use in service test oscillators, since in these instruments they would both have to be variable, thereby complicating the frequency control system.

15-14. **Meissner Oscillator Circuit.**—Another well-known variation of the conventional oscillator circuit is shown in Fig. 15-10. Here, neither the plate nor the grid circuit is tuned, the resonant frequency being determined by a separate circuit com-

FIG. 15-10. — The Meissner oscillator circuit. A separate tuned circuit composed of L and C is employed.

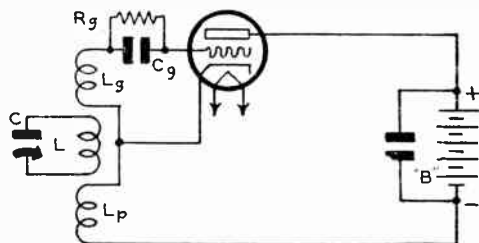

posed of L and C . The important thing about this arrangement is that any random initial disturbance will cause a change in the plate current through the plate coil L_p . This change will induce a voltage in the oscillatory, or *tank*, coil L , and set up oscillations in the L - C tuned circuit. The magnitude of these oscillations depends mainly upon the induced voltage and the resistance of the coil L . But the grid coil L_g is also magnetically coupled to this same coil L ; hence the oscillatory current in the L - C circuit induces a voltage in the grid coil, and it is this induced voltage that keeps the tube oscillating.

Another variation from what might be termed conventional circuits is the fact that the cathode, or filament, of the tube is not at B minus potential. The cathode may be grounded, and if it is, then B minus must not be grounded, otherwise the plate coil will be short-circuited.

A distinct advantage of this circuit lies in the fact that the frequency of oscillation is really controlled by the resonant frequency of the L - C circuit, and is not influenced by tube and stray capacities. This circuit has been used extensively in small transmitters, but has not been used in service test oscilla-

tors, mainly because of the fact that three separate coils are required. This is a disadvantage in all-wave oscillators which employ rather complicated coil-tap and switch arrangements, as we shall see in Chapter XVII.

15-15. Hartley Series and Parallel Feed Oscillator Circuits.—Figure 15-11 shows the schematic circuit of what is probably the most widely used oscillator circuit employed for test oscillators. The resonant frequency of the circuit LC_1 determines the frequency of oscillation. The plate of the tube

FIG. 15-11.—Series feed Hartley oscillator circuit. The feedback coil L_p is in series with the plate circuit.

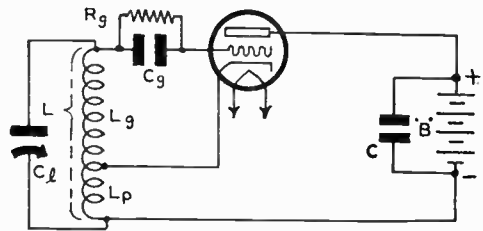

connects through the by-pass condenser C to one end of this coil, and the grid connects to the other end. The filament or cathode is tapped somewhere in between, usually about $\frac{1}{3}$ the total number of turns from the bottom. Thus the coil L is divided into two sections, L_g and L_p .

Any initial disturbance sets up a voltage in the plate coil

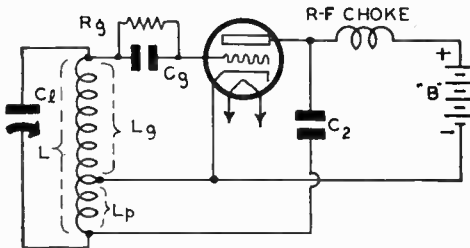

FIG. 15-12.—Parallel feed Hartley oscillator circuit. The feedback coil L_p and condenser C_2 form a parallel circuit with that of the plate.

L_g , which sets up an oscillating current in the whole coil and condenser circuit LC_1 ; part of the voltage across L is applied between grid and filament of the tube to keep the circuit oscillating. The position of the cathode tap is therefore important

in determining the value of the grid voltage and the amount of inductance in the plate circuit.

This circuit is called a *series feed Hartley* circuit because the plate battery is connected in series with the coil L_p and the plate-cathode resistance of the tube. If it is connected in parallel with the cathode and plate, as shown in Fig. 15-12, it is a *shunt*, or *parallel feed* Hartley circuit. The mode of operation is the same for both.

In the series feed circuit, the plate current of the tube, whether or not it is oscillating, flows through the coil L_p , because it is in series with the plate circuit. However, in the shunt feed circuit, the d-c plate current does not flow through L_p , because of the by-pass condenser C_b , but the r-f current is forced through it by the r-f choke.

The construction details for both a practical battery-operated

FIG. 15-13.—Circuit arrangement of the Colpitts oscillator. The tuning capacity consists of two parts, one for the grid and the other for the plate circuit.

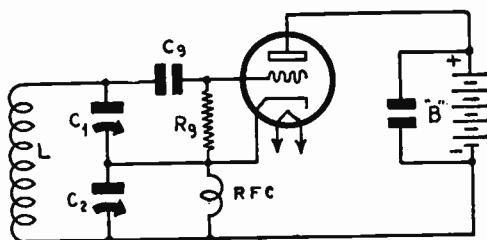

and a line-operated test oscillator employing the Hartley parallel-feed circuit are presented in Chapter XVI.

15-16. Colpitts Oscillator Circuit.—Instead of using part of the inductance of the tuned circuit for the plate and grid coils, it is entirely possible to break up the tuning capacity into two sections, using one for the grid and the other for the plate circuit. This idea is the principle of the familiar Colpitts circuit shown in Fig. 15-13. The tank condenser is now composed of C_1 and C_3 in series, the combination being in parallel with the coil L . The grid leak is connected from grid to cathode in this circuit, because the cathode is not directly connected to the coil to complete the grid-return circuit. The r-f choke is connected as shown, in order to complete the B battery circuit

to cathode. If the choke is a good one, it will not affect the operation of the tube as an oscillator.

Any disturbance will change the current through the choke, because the choke is in series with the plate circuit. A change in current means a change in voltage, and this change in voltage is applied across C_2 , because C_2 is in parallel with the choke. Now a voltage across C_2 will cause condenser C_1 to be charged and discharged according to the charge and discharge of C_2 , and in this manner an oscillating current is set up in the LC_1C_2 circuit. The alternating voltage across C_1 is that which actuates the grid; and the one across C_2 is that which excites the oscillating circuit.

In other words, the voltage across C_2 corresponds to that across L_p in the Hartley circuit, and that across C_1 corresponds to the voltage across L_g . The method of grid circuit excitation is *inductive* in the Hartley and *capacitive* in the Colpitts circuit.

15-17. The Dynatron Oscillator.—It will be recalled that the vacuum tube can be made to generate high-frequency currents because of variations in plate current caused by changes in some other element, usually the control grid. Furthermore,

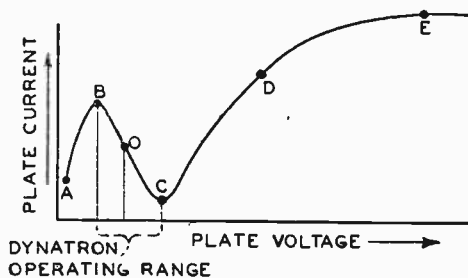

FIG. 15-14.—Fundamental dynatron characteristic of a screen grid tube. Over region $B-C$ an increase in plate voltage results in a decrease in plate current i.e., the tube exhibits a *negative resistance* characteristic.

the usual form of oscillator is equipped with two sets of coils, a grid and a plate coil.

Because of the peculiar characteristic of a screen-grid tube (not a pentode), it may be caused to generate alternating currents by virtue of the unique shape of the plate-voltage—plate-current curve. Consider such a curve as shown in Fig. 15-14. Imagine the potential of the plate of a screen-grid tube (not a pentode) to be gradually increased from zero, and the screen

voltage maintained constant. At first, the plate current increases, as shown, in the region between point *A* and *B*, and then *decreases* with increasing plate voltage (from *B* to *C*). This decrease in plate current is due to the *secondary* emission of electrons from the plate toward the screen grid. The screen grid attracts these *secondary electrons* because the fixed screen potential is greater than the plate potential in this region. Therefore, the screen

FIG. 15-15. — Fundamental circuit arrangement of the dynatron oscillator. *LC* forms the tuned circuit.

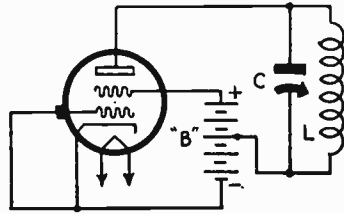

attracts all the secondary electrons until the plate has a potential equal to that represented by point *C*. Any further increase in potential beyond that point, causes an increase of plate current, because now the plate has a higher potential than any other element in the tube has, and it can therefore attract back any "secondary" electrons that it may emit. The rise from *C* to *D* to *E* is "normal".

It is the region from *B* to *C* that is the interesting one from our standpoint. An *increase* in plate voltage produces a *decrease* in plate current, and if the tube is connected as shown in Fig. 15-15, oscillations will be generated. We will now see the reason for this.

Any initial disturbance in the circuit at all (such as the application of plate or screen voltage) will cause a change in the current through the coil *L* and a change in charge in the condenser *C*, the tank circuit. This means a change in voltage across *L* (and, of course, across *C*). If this small generated voltage is such as to *increase* the total applied plate voltage, the plate current will *decrease* because of the peculiar characteristic, and this decrease in plate current will generate a voltage across *L* which will be in such a direction as to tend to maintain this current constant. In other words, the plate voltage will increase again, causing a further reduction in plate current. This process continues until point *C* on the characteristic is

reached, after which time, increasing voltage causes an increase in current. Hence the direction of the generated voltage will be reversed—in such a direction as to reduce the plate voltage—and the current will rise to point *B* on the curve. In other words, if the normal plate voltage without oscillation is represented by point *O*, the reversed slope of the curve will maintain oscillations.

Another explanation for this action is usually given in terms of the *negative resistance* of the tube in the dynatron region. Resistance is equal to *voltage* divided by *current*. A positive resistance is one in which an *increase* in applied voltage is accompanied by an *increase* in current; a negative resistance is one in which an *increase* in voltage is accompanied by a *decrease* in current. Therefore, since in the region between *B* and *C* (Fig. 15-14), an *increase* in plate voltage results in a *decrease* in plate current, the tube may be looked upon as a *negative* resistance. A glance at the schematic diagram of the dynatron circuit will show that this negative resistance of the dynatron is shunted across the oscillatory circuit composed of *L* and *C*. Now a negative resistance across a positive resistance means that the *net* is the difference between the two (one tends to increase the current while the other tends to decrease it), and, if they are both equal, the resistance of the circuit is zero.

Any circuit with zero resistance will maintain a circulating current for an indefinite length of time; hence, the oscillating current will be maintained. Any tendency to absorb energy (and hence increase the *positive* resistance of the circuit) will be compensated for by the negative resistance of the tube.

(There is no doubt about the fact that a clear conception of negative resistance is beyond the scope of the average radio man without a knowledge of at least the calculus. But so many writers have referred to the negative slope and characteristic of the dynatron, that the author has included this brief note in the hope that it may make these explanations a bit clearer.)

The dynatron oscillator cannot be considered a stable oscillator. The characteristics of a group of tubes of the same type are not likely to be the same in the dynatron region (especially since the plates of tubes are now carbonized to reduce

secondary emission). However, the use of but a single coil, and the elimination of numerous adjustments have made this form of oscillator somewhat popular for some classes of work. It is not a very stable oscillator, even with a given tube, because of the change in secondary emission with changes in temperature. Under thermostatic control, however, it should prove very suitable, but a thermostatically controlled arrangement is hardly practical for use in test oscillators.

15-18. How Harmonics are Generated in an Oscillator.—

From the previous discussion of oscillators, it is clear that the frequency of oscillation is determined by the tuned circuit, called

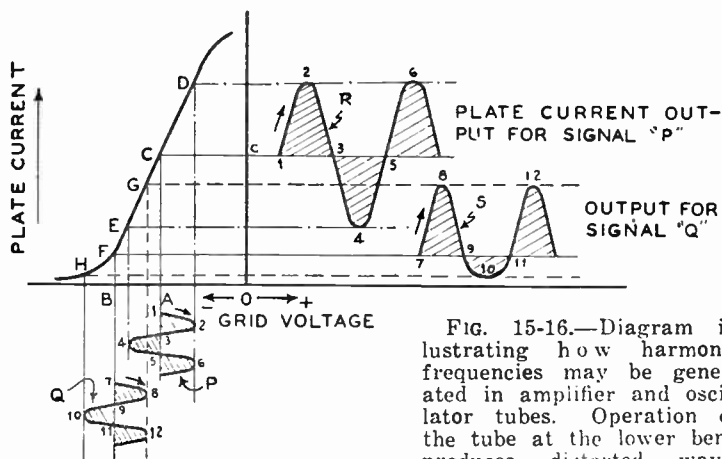

FIG. 15-16.—Diagram illustrating how harmonic frequencies may be generated in amplifier and oscillator tubes. Operation of the tube at the lower bend produces distorted waveform S which represents a condition where harmonic frequencies are present.

the tank circuit, and it appears from this discussion that but one frequency can be generated at a time—that corresponding to the resonant frequency of the tank circuit. But an important consideration arises here—almost all oscillators generate frequencies which are integral multiples of the main, or *fundamental*, frequency, and these frequencies are called *harmonics* of the fundamental. Let us revert to the theory of the vacuum tube operating as an amplifier, for a plausible explanation of this.

Figure 15-16 shows the grid-voltage—plate-current characteristic curve H-G-D of a typical triode. Assume that a grid

bias, designated by the distance $O-A$, of such value that the tube operates normally over the straight portion $E-D$ of its characteristic, has been applied. The no-signal plate current is then represented by distance $A-C$. If a signal P , represented by sine-wave 1-2-3-4-5-6, is now impressed on the grid of the tube, the plate current will vary in accordance with the corresponding plate-current curve R , marked 1-2-3-4-5-6. Since the tube is operating over the straight portion of its characteristic, the increases in plate current are equal to the decreases, and the form of the plate current variations is exactly (for our purpose) the same as the form of the applied signal voltage variations. Under these conditions, the plate current has but one frequency—that determined by the signal.

Suppose, however, that the bias is made more negative, so that the no-signal operating point is represented by F . The same signal, now labeled Q , is impressed on the tube. The resulting plate current variations, curve S , do not resemble the input voltage variations at all: the increases, 7-8-9, in plate current are much greater than the decreases, 9-10-11.

Under this condition of tube operation, the output is *distorted*, for its wave-form does not resemble that of the applied signal. There are several ways by which this distortion can be depicted: first, the distorted wave form can be plotted (as we did) and the picture studied; second, the ratio of the plate current *decreases* to the plate current *increases* can be measured and this ratio considered as a measure of the distortion; or third, the distorted wave *may be considered as being composed of a number of pure waves, of the same form as the original (sine waves) but differing either in frequency and/or in amplitude*. For practical purposes, the third method is the preferable one, the first two being used when the amplitude and number of waves or frequencies required are to be calculated. These extra frequencies are called *harmonics* of the main, or fundamental frequency.

15-19. Harmonic Frequencies.—Let us consider our distorted wave-form further. If the wave is considered as being composed of the fundamental and a number of integral frequencies, then, at any instant, the sum of all of them should equal the original distorted form. This is exactly the state of affairs.

The distorted wave may be considered as composed of waves of a number of different "harmonic" frequencies, *each bearing a definite relation to the lowest frequency generated, called the "fundamental," which is determined by the resonant frequency of the tank circuit.*

This means that if another tuned circuit were coupled to the tank circuit, and the resonant frequency of this other circuit were adjusted (in turn) to two, three, four, five, etc., times that of the fundamental frequency, currents having a frequency of two, three, four, five, etc., times respectively that of the "fundamental" frequency of the oscillator would be induced in this circuit. Each of these individual currents would be pure sine waves, and entirely suitable for service work.

To illustrate this point, let us assume that a tuned circuit is made to oscillate at a fundamental frequency of 500 kc. If a radio receiver is coupled to the tank coil of the oscillator by means of a coil having a few turns placed in inductive relation with the tank coil so as to absorb energy from it, and the receiver is tuned to 1,000 kc, the modulated oscillator signal will be heard. This frequency is the "second harmonic". Another signal will also be heard when the receiver is tuned to 1,500 kc, etc. This signal is the "third harmonic", having a frequency three times that of the fundamental.

This question of harmonics may be summed up as follows:

If a vacuum tube has a sufficiently large grid-bias voltage applied to it, any sine-wave voltage impressed across its grid circuit does not cause equal changes of plate current during each half cycle, due to the fact that the tube will be operating over the curved portion of its grid-voltage—plate-current characteristic. This causes the wave-form of the plate current to differ somewhat from that of the sine-wave grid impulses and become distorted, resulting in a generation of multiple frequencies (harmonics) in addition to that frequency (fundamental) to which the oscillating circuit is tuned.

15-20. Computation of Harmonics.—The fundamental frequency is the lowest frequency generated by an oscillator for a given inductance and capacity in its tuned circuit. This frequency, regardless of its amplitude, is determined by the resonant

frequency of the tank circuit. The next higher frequency is twice the fundamental; the next, three times the fundamental; etc. In other words, the *order* of the harmonic is the number of times it is greater than the fundamental. For instance, if the fundamental is 100 kc, the second harmonic would be 200 kc, the third 300 kc, etc. The 2nd, 4th, 6th, 8th, etc., are *even* harmonics. The 3rd, 5th, 7th, etc., are the *odd* harmonics. It should be remembered that the strength or intensity of the harmonics of the fundamental frequency generated by an oscillating circuit diminishes as the order of the harmonic signals increase. Thus, the fifth harmonic is very much weaker than the second, etc.

FUNDAMENTAL AND HARMONIC FREQUENCIES (KILOCYCLES)

| <i>Fundamental Frequency</i> | <i>Second Harmonic</i> | <i>Third Harmonic</i> | <i>Fourth Harmonic</i> | <i>Fifth Harmonic</i> |
|----------------------------------|----------------------------|---------------------------|----------------------------|---------------------------|
| 100 | 200 | 300 | 400 | 500 |
| 125 | 250 | 375 | 500 | 625 |
| 150 | 300 | 450 | 600 | 750 |
| 200 | 400 | 600 | 800 | 1,000 |
| 250 | 500 | 750 | 1,000 | 1,250 |
| 300 | 600 | 900 | 1,200 | 1,500 |
| 350 | 700 | 1,050 | 1,400 | 1,750 |
| 400 | 800 | 1,200 | 1,600 | 2,000 |
| 500 | 1,000 | 1,500 | 2,000 | 2,500 |
| 700 | 1,400 | 2,100 | 2,800 | 3,500 |
| 1,000 | 2,000 | 3,000 | 4,000 | 5,000 |
| 1,500 | 3,000 | 4,500 | 6,000 | 7,500 |
| 2,000 | 4,000 | 6,000 | 8,000 | 10,000 |
| 2,500 | 5,000 | 7,500 | 10,000 | 12,500 |
| 3,000 | 6,000 | 9,000 | 12,000 | 15,000 |
| 4,000 | 8,000 | 12,000 | 16,000 | 20,000 |
| 5,000 | 10,000 | 15,000 | 20,000 | 25,000 |

The importance of this chart lies in the fact that it shows the wide range of frequencies that may be covered with a single oscillator.

Suppose that any of the oscillator circuits shown in this chapter are tuned by a variable condenser. Further suppose that the minimum frequency is 100 kc (determined by the tuning in-

ductance and the maximum setting of the tuning condenser), and that the capacity variation range of the condenser is 16:1; that is, suppose the ratio of the maximum to the minimum capacity of the condenser is 16:1. Then, since the frequency (in *cycles per sec.*) of a resonant circuit is

$$f = \frac{159,000}{\sqrt{L \text{ (in microhenries)} \times C \text{ (in microfarads)}}$$

the frequency coverage ratio is 4:1. This means that the maximum fundamental frequency would be 400 kc (obtained at the minimum-capacity setting of the tuning condenser). The fifth harmonic of this maximum frequency is 2,000 kc. If all the harmonics to the fifth were strong enough for use, then the effective range of this oscillator would be from 100 to 2,000 kc.

Another coil could be switched in the circuit to make the lowest fundamental frequency 400 cycles, and, for this coil, the range would be from 400 to 1,600 kc without harmonics, and from 400 to 8,000 kc with harmonics.

This action of an oscillator tube to produce, in addition to the fundamental frequencies, "harmonic" frequencies which are multiples of the fundamental frequencies to which its oscillating circuits are tuned, is utilized in some test oscillators, for it makes possible the construction of cheap and simple oscillators, which cover the very wide frequency band required for adjustment and test work on both broadcast r-f, and intermediate frequencies. It is seen from the above, that, if the "harmonics" produced by the oscillators are employed, only a few coils are required in them in order to have them produce signals over the complete i-f and r-f bands used in radio receivers today. Hence their construction is greatly simplified. However, test oscillators which produce *fundamental* frequencies covering a range from about 100 to at least 25,000 kc (or, better still, up to 30,000 kc) are preferable, because the higher-frequency signals are usually stronger and the manipulation of the instrument is simplified.

15-21. **Amplitude of the Harmonics Produced.**—The amplitudes or "strengths" of the harmonics depend upon the amount of distortion in the wave form—the greater the distortion the stronger are the harmonics. In general, severe distortion of

the wave form is secured by biasing the grid of the tube to the point where it actually begins to rectify its own grid signal, as shown by waves Q and S in Fig 15-16. Under proper conditions, the amplitude of the second harmonic may be as much as 25 % of the fundamental. Also, the strength of each succeeding higher harmonic is much less than the lower ones. The strength of all harmonics may be increased by using a larger plate voltage and a greater bias voltage (within certain limits). In this case, plate current will flow only during a short portion of each cycle of the grid signal. The distortion is then very severe, and the amplitude of the harmonics is therefore large. More will be said about harmonics in Chapter XVI in connection with the calibration of test oscillators.

15-22. Calibration of Test Oscillators by Means of Harmonics.—The harmonics generated by an oscillator may be used conveniently to determine the frequency of oscillation. However, we will defer the explanation of this until the latter part of Chapter XVI, after the construction of a typical modern test oscillator has been explained.

15-23. Modulating the Oscillator Output.—The test oscillator in its simplest form will generate a signal of the frequency determined by the resonant circuit; and, if the bias is correct, harmonics of this fundamental circuit will appear in the plate circuit. If the output of such an oscillator is fed into a radio receiver, no musical note will be heard because the output of the oscillator is an unmodulated r-f current. It will sound exactly like a broadcast station when no announcer or artist is speaking into the microphone—the carrier noise can just barely be heard in most cases. For certain test purposes, it is desirable to hear some sort of note from the loud speaker of the set under test. It may often be necessary to test the audio amplifier along with the r-f end of the set; it may be that the tone, as well as the readings of an output meter or vacuum-tube voltmeter are to be observed; or, as is often the case, the psychology of listening to a note while testing makes for more efficient work.

The process of impressing a low-frequency signal (usually an *audio* signal) on a signal of much higher frequency is known as *modulation*. There are various ways in which this may be done.

The simplest method for explanatory purposes is shown in Fig. 15-17 and is known as *grid modulation*, because the audio modulation is impressed in the *grid* circuit. The oscillator shown is the tickler type, and the only change is the insertion of the secondary of an audio transformer in the grid-return lead. An audio signal from a carbon microphone or an additional audio oscillator (similar to any of the oscillators described in this chapter, for

FIG. 15-17.—Circuit arrangement of a simple grid-modulated oscillator with tickler feedback. Modulation is secured here by the use of an audio signal and transformer *T*. Condenser C_1 is merely an r-f by-pass.

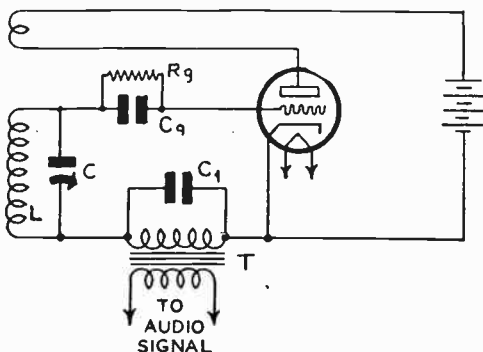

example) is impressed on the primary of this transformer; the resulting secondary voltage varies the grid bias of the tube at a rate determined by the frequency of the audio signal.

Thus, suppose the r-f grid voltage is represented by (A) in the diagram of Fig. 15-18, and the audio voltage is represented by (B); the resulting modulated r-f wave is as shown at (C). The frequency of the r-f oscillations remains about the same, but their amplitudes vary at the rate determined by the amplitude of the audio signal. If the *peaks* of all the r-f cycles are connected together, the line connecting them is called the *envelope* of the wave, because it envelopes the entire r-f wave.

15-24. **Per Cent Modulation.**—In the example shown in Fig. 15-18, the amplitude of the unmodulated wave (A) is represented by the distance A, and the audio signal is assumed to have the same amplitude, that is, the voltage impressed on the grid of the tube due to the oscillations (the voltage across the tuning condenser) is equal to that across the secondary of the audio transformer. Hence, since currents in the same phase add

and those in opposite phase oppose each other, at some instants the net voltage on the grid will be $2A$ and at other instants the net voltage will be zero. Hence the amplitude of the resulting radio wave varies from zero to $2A$, as shown in (C) of the figure.

On the other hand, suppose the amplitude of the audio volt-

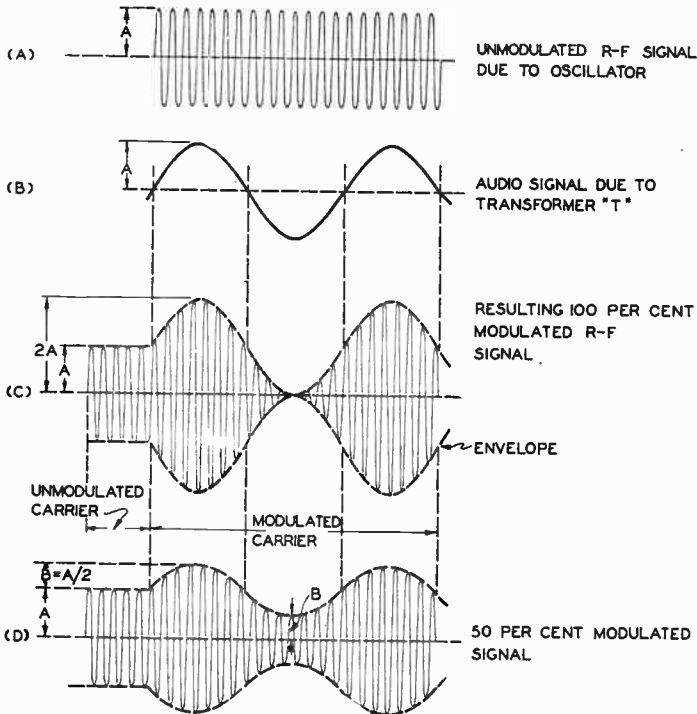

FIG. 15-18.—What happens during the modulation of r-f oscillations. Modulation consists in causing the amplitude of the high-frequency current, (A), to vary in strength in accordance with an a-f variation, (B), to produce an r-f current, (C), of correspondingly varying strength.

age (B) were but one-half that of the unmodulated r-f voltage (A); then the resulting radio wave would be as shown at (D). The amplitude now does not rise to twice its unmodulated value, but only to 50% more; and in a similar manner it does not go down to zero, but only to half its unmodulated value. In other

words, the amplitude varies at an audio rate, but only 50% above and below its unmodulated amplitude, because the strength of the audio signal is but 50% of that of the unmodulated r-f signal due to oscillation.

The *percentage of modulation* is the ratio (expressed in percentage) of the increase or decrease in amplitude due to modulation, to the amplitude of the unmodulated signal. In the case shown at (C), the per cent modulation is 100, and in the case shown at (D) the wave is modulated 50% because B/A is $0.5 = 50\%$, since the amplitude of the audio signal is half that of the r-f signal.

15-25. Plate Modulation.—The grid modulation arrangement shown in Fig. 15-17 is generally unsuitable when stability is desired, because the changes which the audio signal produces in the grid potential shift the bias too much for high percentage of modulation and introduce undesired forms of audio distortion. Then, too, the frequency of oscillation varies with the audio signal, with the result that the frequency is modulated (shifted) as well as the amplitude. Furthermore, when the audio is removed to obtain only the carrier, the frequency of the steady oscillation is different from the modulated carrier. These considerations led Heising to develop a system of modulation in which the modulating source varies the *plate* voltage of the oscillator tube, instead of the *grid* voltage. It is therefore called plate modulation.

The circuit diagram of one of the various arrangements for producing "plate" modulation is shown in Fig. 15-19. The oscillator shown is a shunt-feed Hartley. Normally, with no modulation, the B power source would be connected across terminals 1 and 2; but when plate modulation is used, an audio choke, L , is connected as shown. This choke is also in the plate circuit of an audio amplifier tube V_2 to which the audio modulator signal is fed. Variations in the grid potential of V_2 (called the *modulator tube*) vary the voltage across the choke L . This variable voltage is applied to the plate of the oscillator in series with the B voltage which is now common to both tubes. In this manner, the oscillator plate voltage is varied in accordance with the audio signal impressed on the tube V_2 . Since the

output of an oscillator is directly proportional (within limits) to its plate voltage, the *amplitude* of the generated high-frequency oscillations varies in accordance with the impressed audio signal.

The resistor R is merely a voltage-dropping resistor to make the oscillator plate voltage lower than that of the modulator in order to secure a high percentage of modulation. The choke L

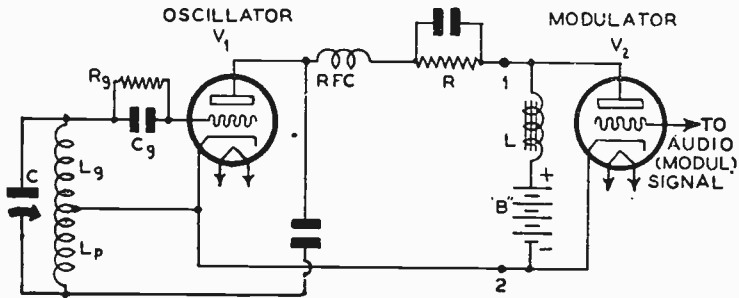

FIG. 15-19.—Heising or "plate" system of modulation. Here the modulating source modulates the *plate* voltage of the oscillator tube through choke L .

may be replaced by the secondary of an audio transformer if so desired, with exactly the same principle of operation. Since L has a very high inductance, the current through it changes but little, and for this reason this system is sometimes known as the *constant-current* system of modulation. It is without doubt one of the most commonly used methods of modulating the carrier in modulated oscillators requiring stability and faithful reproduction, as we shall see in Chapter XVII. Commercial test oscillators employing this method are described in Arts. 17-2, 17-3, and 17-4.

15-26. Electron Modulators.—The two systems of modulation already described depend for their operation upon the variation of either the control-grid or the plate potential by the modulating signal. It is possible to modulate a carrier without recourse to this method, (which almost always results in frequency modulation and instability). By applying the modulating signal to another grid placed in the electron stream between the cathode and the plate of the r-f oscillator tube, it is possible to *vary this electron stream* in accordance with the modulating

signal, and thus modulate the plate current without changing the potentials applied to the oscillator electrodes of the tube directly. A circuit diagram for such a system is shown in Fig. 15-20.

The tube shown here, the familiar 2A7 which is equipped with five grids, labeled as shown. Grid 1 is connected to the cathode because it is not required for our purpose. Grid 2 connects to one side of the modulating circuit, as does one side of the tank coil. Grids 3 and 5, tied together inside the tube, shield the control-grid, No. 4, from capacitive coupling effects and are placed at a potential slightly lower than the plate voltage, a normal connection. Now, when the audio modulating signal varies the potential of grid 2, the number of electrons reaching the plate (as a result of the r-f potential placed on the control-grid by the oscillating circuit) varies, in direct proportion to the voltage of this No. 2 grid. In this manner, the r-f plate current has an envelope similar to the audio wave, and none of the oscillation-generating elements have their potential varied. In other words, grid 2 acts on the r-f electron stream directly and

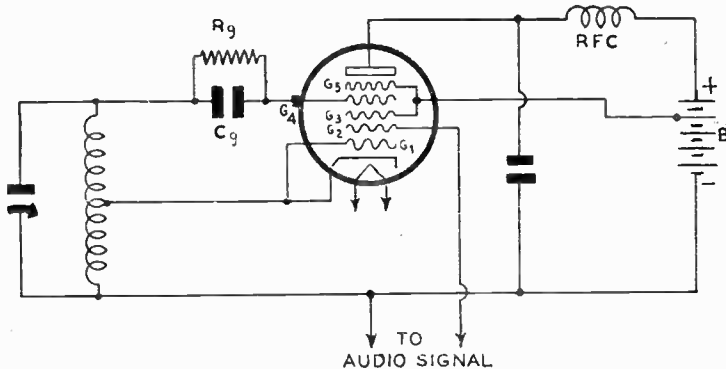

FIG. 15-20.—An electron modulator system. Modulating grid G_2 controls the flow of the stream of electrons between the cathode and plate and modulates it in accordance with the modulating signal impressed upon it.

“modulates” the flow of electrons between the cathode and the plate.

It is not essential for grid 2 to be the modulating grid. Any of the grids in the tube are suitable: the r-f oscillator grid may be No. 2 and the modulating grid No. 4, etc. As long as the tube

oscillates and the modulating grid varies the electron stream, the tube current is modulated. Also, a separate oscillator and modulator tube may be employed, so long as modulation takes place by control and variation of the electron stream within the modulator tube. A commercial test oscillator employing this arrangement is described in Art. 17-11. This system is gaining much favor in low-powered oscillators, and its stability has much to recommend it. The important point about it is that there is no mutual inductance or capacitance coupling between the oscillator and modulator sections of the system—the coupling or control is obtained purely by the electron stream. Despite the fact that these somewhat ideal conditions are not realized in practice, practical electron modulators are sufficiently good to warrant their favor.

15-27. Self-Modulated Oscillators.—The oscillator systems already described are suitable for tests where stability and accuracy are of importance. For the radio service work ordinarily encountered, extreme stability and accuracy are not necessary nor desirable from the standpoint of cost, portability, upkeep, fragility, and test requirements. A simple one-tube oscillator, capable of modulating itself, or of being modulated from an external source such as a phonograph pickup, an a-f oscillator, etc., is really what is desired. The modulating system must be simple and fairly reliable. There are many oscillators available that use separate modulators and that are very stable for service work. These oscillators are better than any self-modulated system. The *leak-modulator* system is used in many of the less expensive self-modulated radio test oscillators because of its simplicity.

If the grid leak and condenser, R_g and C_g , respectively, in any of the oscillator diagrams shown previously, are made large enough, then the condenser will accumulate a negative charge on the side nearest the grid. This charge cannot leak off fast enough to keep the grid from becoming more and more negative because of the large size of the condenser and leak, with the result that, eventually, the negative charge becomes great enough to stop the flow of plate current. This means that the tube stops oscillating.

When the tube stops oscillating, there is no varying potential on the grid, so the grid condenser starts to discharge slowly through the leak (the power stored in the condenser is dissipated as heat in the leak resistance) until the plate current rises sufficiently to start oscillation again. Just as soon as the oscillations start, the grid condenser begins to accumulate a charge again, and the process repeats itself. In this manner the tube starts and stops oscillating at a rate depending upon how fast the condenser can charge and discharge. This rate, in turn, depends upon the size of the condenser and leak. The higher the capacity and the higher the resistance of the leak, the more time it takes to build up a charge and the longer it takes to discharge. This means that the oscillations are stopped and started again at a slower rate than with a smaller condenser and leak. It is this starting and stopping action that modulates the normal plate current—hence the name *self-modulation*, or, *grid leak and condenser modulation*. Of course, the advantage of this circuit lies in the fact that the oscillator is simple since it does not require any external modulator. Commercial test oscillators employing this method of modulation are described in Arts. 17-5 and 17-7.

It should be pointed out that with a small condenser and a small leak resistance the charging and discharging takes place just the same. But the point is, that it charges and discharges fast enough so that the amount of charge (and hence the highest negative potential) is never great enough actually to stop oscillation. It is only when the capacity is large and the leak resistance is large that self-modulation can take place.

It will be recalled that the purpose of the leak is to provide an automatic grid bias for the tube. But if the leak resistance is too great, the bias becomes too great, and the tube stops oscillating. The condenser, whose function is solely to by-pass the leak during the “no-modulation” condition, assumes an important role when self-modulation takes place. Instead of merely by-passing, its charge becomes greater and greater during each r-f cycle, until finally it becomes great enough to stop oscillation. As mentioned previously, small condensers take a correspondingly smaller charge, and under normal conditions

this charge is never great enough to seriously affect the operating conditions.

Another method which may be employed to produce self-modulation in test oscillators is to operate the oscillator from the 60-cycle a-c power line, supplying this 60-cycle alternating current to both the filament and the plate circuit of the oscillator tube. Naturally, the plate current will be a d-c current pulsating 60 times per second. This causes a 60-cycle modulation in the r-f output. A commercial test oscillator employing this principle is described in Art. 17-8 of Chapter XVII.

15-28. "Frequency" Stability of Oscillators.—An oscillator is said to be *stable* when its frequency and voltage output do not vary with time. In other words, the frequency and voltage output of an oscillator should remain constant both during a test and from one test to another. When output readings are taken on a radio set which is being fed by an oscillator, it is quite essential that the oscillator output remain constant, else the readings can have little significance.

The stability of the usual oscillator of the vacuum-tube type is very good, unless the dynatron is used. As pointed out in Art. 15-17, the dynatron is inherently an unstable form of oscillator, and its use should be limited to tests where accurate calibration is not essential. There are two classes of instability of the frequency—"drift" and "flick". When the frequency of an oscillator changes very slowly, the change is called a *drift*, and when the change is rapid, it is called a *flick*.

Slow changes or "drifts" in frequency are due to the changing characteristics of the tube or batteries used, to any gradual absorption of moisture in the insulating forms of the coil and the insulation of the tuning condenser, to any gradual deterioration of the grid leak and condenser, and to any change in tuning coil characteristics due to temperature changes. "Flicks" are due to poor or loose connections, and more generally to poor grid leaks. It must be remembered that the grid current of certain types of oscillators may be greater than the plate current, and a small leak, unable to handle this current safely, will show erratic changes in resistance value from instant to instant because of overheating.

15-29. "Amplitude" Stability of Oscillators.—Oscillators tend to function more strongly at the higher than at the lower *fundamental* frequencies because of the existence of the internal capacity of the tube. However, a given oscillator may give more output as the tuning-condenser capacity is reduced (higher frequency), and then, quite suddenly, the output drops. This rapid drop is due to the very small value of tuning condenser in the tank circuit, which is unable to keep the circuit oscillating. This point may be explained as follows:

An oscillator is a power generating device, and, as such, must store power in the tuning coil and condenser. The coil and condenser do not absorb power, they just store it up for use by the external circuit. The energy stored in a condenser of capacity C is $\frac{1}{2}CE^2$, where E is the voltage across the condenser. Now, with the alternating grid voltage fixed by the tube, bias, plate voltage, etc., sufficient energy cannot be stored when the capacity C is too small; hence the power output must drop. This accounts for the rather sudden drop in output at the very low capacity settings.

The rise in output due to inter-electrode feedback is compensated for to some extent by the grid leak and grid condenser. It may be further improved by the use of a large plate (tickler) winding closely coupled to the grid circuit. The large plate coil acts to some extent like a choke (see the tickler oscillator circuit), which tends to reduce the high-frequency output by increased choking action. Too big a tickler, however, will stop oscillation. Therefore, the tickler should be adjusted so that best oscillation is obtained at the highest fundamental frequency.

15-30. Effect of Coupling to the Oscillator.—An oscillator in itself is of little use; it is useful only when part of the energy of the tank circuit can be removed for "test" or other useful purposes. But when a coil is coupled to the tank coil and energy is removed in this fashion, the inductance of the tank coil changes. This causes a change in the frequency of the output of the oscillator. All the types of oscillators already described in this chapter, therefore, are subject to changes in frequency with changes in the load. This frequency shift may be small or it may be very large, depending upon many factors, such as

the amount of coupling, the amount of energy removed, the size of the inductance, the frequency, etc. Any means which provides for the removal of energy without shifting the frequency of the tank circuit will result in increased stability and constancy of frequency. The *electron-coupled* type oscillator accomplishes this.

15-31. The Electron-Coupled Oscillator.—There is nothing radically different about the “oscillator portion” of an elec-

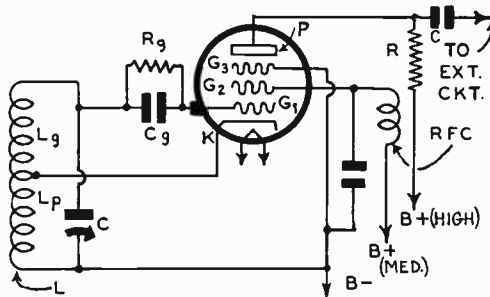

FIG. 15-21.—A typical electron-coupled oscillator circuit. A Hartley oscillator arrangement is used. The oscillator is electron-coupled to the plate, *P*, and the external circuit via the electron stream in the tube.

tron-coupled oscillator. The main deviation from the conventional oscillator circuit lies in the method of coupling the main oscillator plate circuit to the *external* or *output*, circuit of the oscillator. A typical electron-coupled oscillator arrangement is shown in Fig. 15-21.

First of all, only the cathode *K*, control-grid *G*₁, and grid *G*₂ act in the oscillation-producing circuit. Grid *G*₂ is ordinarily the *screen grid*, but in this oscillator circuit a *positive* potential is applied to it and it acts as the “plate” of the triode which comprises the oscillator portion of the tube. A higher positive potential is also applied through load resistor, *R* (which may be a choke instead), to the electrode *P* of the tube. The electron stream between the cathode and *G*₂ (which is really acting as a plate here) varies in accordance with the r-f oscillations set up in the oscillatory circuit. Since this grid is not solid like an ordinary plate—it is really composed of a mesh (or coarse coil) of fine wires; therefore, since the electrons which are moving rapidly toward it from the cathode are also attracted by the strong positive charge on electrode *P* beyond it, many of them shoot through the open spaces in this grid, continuing on their way past it to electrode *P*, then around through *R* and the plate circuit. For a given fixed voltage applied to electrode *P*, the number of these electrons reaching it at any instant will be proportional to the number which reach the “plate” electrode *G*₂ at that instant. Therefore, the current in the *P*-electrode circuit varies exactly in accordance with the cyclic changes of the oscillator current, that is, the frequency of the current in the *P*-electrode circuit is exactly the same

as that of the current in the main oscillator circuit. Since this current flows through R , a corresponding cyclic voltage drop is developed across R , and the output circuit may be connected across R (either directly, through a coupling transformer, or through a coupling condenser, C , as shown).

It is evident that in the electron-coupled oscillator, the main oscillator circuit is really extended (or coupled) to electrode P (and the output circuit) through the medium of the electron stream which shoots through the meshes of electrode G_2 ; i.e., the *output* circuit is *electron-coupled* to the *oscillator* circuit. Hence, the name *electron-coupled oscillator*. It is important to note that any changes in the voltage applied to electrode P (or in the plate load R) cannot affect the *frequency* of the oscillations, since electrode P is not directly a part of the oscillating circuit. The increased stability and constancy of frequency which this results in, is the main reason for the use of this type of circuit in many of the commercial test oscillators used in radio service work. (The oscillators described in Arts. 17-3, 17-4 and 17-9 employ this type of oscillator; a study of their circuit diagrams at this point in order to see how the electron-coupled oscillator arrangement is obtained, will prove beneficial.)

There are but two places in the circuit of Fig. 15-21 where coupling other than *electron* coupling can exist: (1) from electrode P to grid G_2 inside the tube, because of the capacity between them; or (2) because of part or all of the load current flowing through part of the oscillatory circuit. The first possibility is taken care of by placing grid G_2 at the same potential as the cathode; since it is interposed between P and G_2 , it effectively shields one from the other, reducing the actual capacity to nearly zero.

The second condition is not so easy to minimize with the Hartley circuit. An examination of Fig. 15-21 will show that the cathode con-

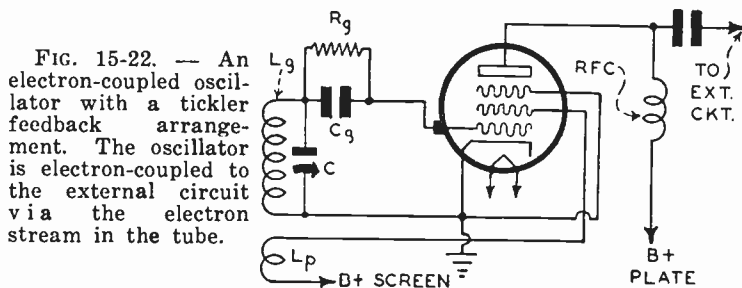

nnects to ground (B minus in this case) through part of the oscillatory circuit, L_p . This makes L_p part of the output load circuit, since all references in a tube are with respect to cathode, which in this case is not at ground potential. Hence, changes in load current will change, to a small extent, the frequency of the oscillatory circuit. By changing the form of the oscillator to a tickler feedback circuit, this latter objection is removed. The new circuit is shown in Fig. 15-22. For the sake of variation, a choke is shown in the plate circuit instead of a resistor; both work equally well. Notice that the third grid and the cathode are both grounded in this circuit. Inductance L_g and condenser C comprise the entire tuned circuit.

The frequency of oscillation of this type of oscillator can be affected by coupling effects caused by poor shielding of the third grid, no shielding near the tube socket, capacity between connecting leads, etc. But aside from these extraneous effects, this form of oscillator is probably the most stable one known that is not crystal or otherwise controlled.

Tetrodes may be used in electron-coupled oscillator circuits, but the stability will not be as good as might be desired, because of the capacity-coupling between plate and screen grid. Filament-type tubes may be used in electron-coupled oscillators, but that leg of the filament not connected to L_0 must have a choke in series with it in order to keep its potential above ground when the Hartley arrangement is used. No choke is required if the circuit with the tickler arrangement is employed.

A little thought will make it apparent that the r-f output of this type of oscillator can be modulated easily either by applying the modulating voltage to an additional suitable grid placed in the electron stream of the tube (employing the principle of "electron modulation" explained in Art. 15-26), or by applying the modulating voltage to the plate electrode P of the tube (as explained in Art. 15-25). An example of the use of the former system is presented by the oscillator described in Art. 17-11, the latter system is used in the oscillators described in Arts. 17-4 and 17-9.

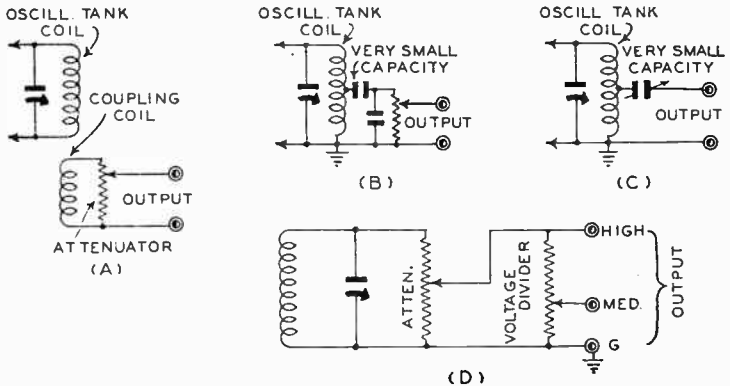
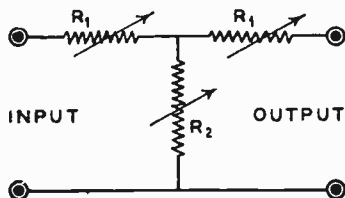

FIG. 15-23.—Several simple output-level (attenuator) control arrangements for test oscillators.

15-32. Attenuators for Test Oscillators.—If the oscillator is to be used to feed a signal to some sort of radio equipment, such as a radio receiver, it is desirable to have some means of varying the output voltage of the oscillator. The most desirable range of the output indicating device may then be employed, and the output of the oscillator may be adjusted to the value best suited for the desired test conditions. This detail is especially important in cases where the test oscillator is used in

testing or aligning receivers employing automatic volume control. To really line up a/c circuits closely, it is necessary to be able to attenuate the signal of the test oscillator to a very low value at all test frequencies. This requirement calls for a good output voltage control on the oscillator. Any of the simple potentiometer control methods shown in Fig. 15-23 can be used

FIG. 15-24.—A constant-impedance attenuator circuit. All three resistors are varied simultaneously by a single knob. A constant impedance is presented to both the input and output sides.



for this purpose, but they all have the disadvantage of presenting a varying impedance to the terminals to which the test oscillator is connected. However, they are employed in many test oscillators, as we shall see in Chapter XVII.

A discussion of the design of an attenuator (device that varies the output signal strength) that presents a *constant impedance* to the external circuit is beyond the scope of this book, although the general arrangement of such an attenuator is pictured in Fig. 15-24. Three variable resistors are used, two of which, both labeled R_1 , are equal at all times. This condition is secured by "ganging" the shafts of all three resistors. When the voltage at the "output" terminals is to be increased, R_1 is decreased and R_2 increased at the same time. Furthermore, the decrease in R_1 is compensated for by the increase in R_2 , so that the impedance looking into the *input* terminals always remains the same. Since both series resistors are the same and R_2 is common to both the input and output circuits, the impedance looking into the *output* terminals is also always the same. All three resistors are controlled by the same shaft and knob.

A further advantage in the use of the constant-impedance type of attenuator is that it maintains the amount of load on the tuned circuit constant with changes in its frequency setting, thus minimizing the amount of "frequency" shift of the oscillator (see Art. 15-28).

15-33. General Conclusions.—The oscillator theory and circuit development presented in this chapter are intended to act as a guide to the clear understanding of the function, operation and characteristics of test oscillator equipment. For further details concerning oscillator theory, the reader is referred to the *Radio Physics Course*, by Ghirardi. Many service men prefer to build their own oscillators and still others prefer to purchase them. For this reason information on the construction of several practical test oscillators is presented in the following chapter. In Chapter XVII will be found descriptions of several typical modern commercial test oscillators suitable especially for service test work and embodying many of the oscillator, modulator and attenuator features described in the present chapter. A study of the circuit arrangements employed in them is very instructive.

REVIEW QUESTIONS

1. (a) Are the signals from broadcasting stations suitable for aligning all the tuned circuits of a modern all-wave superheterodyne receiver employing an i-f of 456 kc? (b) State 3 reasons for your answer.
2. (a) Of what value is a modulated test oscillator in service work? (b) What frequency range should it cover in order to be of maximum usefulness? (c) Why?
3. (a) Why is the signal delivered by a test oscillator purposely modulated? (b) What determines the frequency of modulation in the grid leak and condenser arrangement for self-modulation? Explain.
4. With no signal, a power unit supplies 17 watts of power to the plate circuit of an output tube used as an amplifier. When a certain signal is received, the plate absorbs but 11.5 watts. What is the signal output in watts? Explain fully.
5. (a) What three requirements must be satisfied in order that oscillation may take place in a vacuum-tube oscillator circuit. (b) Explain each requirement.
6. Explain the two common methods of obtaining the bias voltage in an oscillator.
7. (a) Name the seven fundamental types of oscillator circuits. (b) Draw the circuit diagram for each one and explain the outstanding features of each.
8. (a) Under what conditions are harmonics generated by an oscillator tube. (b) Explain fully.
9. How can a distorted wave-form be depicted graphically?
10. Explain what is meant by the "order" of a harmonic.
11. (a) Compile a table showing the 2nd, 3rd, 4th, 5th and 6th harmonics of the following fundamental frequencies; 175 kc,

- 275 kc, 425 kc, and 600 kc. (b) Which are the "even" harmonics; which are the "odd" harmonics.
12. What is meant by (a) "modulation"; (b) per cent modulation?
 13. Draw an illustration showing (a) a completely modulated high-frequency current; (b) a similar partly modulated current.
 14. Explain several common methods of modulation.
 15. Draw the circuit diagram for a typical plate-modulated oscillator and state the functions of each part.
 16. What is meant by the stability of an oscillator?
 17. (a) What is meant by "amplitude stability" of an oscillator? (b) What factors may affect it in a practical oscillator?
 18. (a) What is meant by "frequency stability"? (b) What may cause a practical oscillator to be unstable in this respect?
 19. What is an electron-coupled oscillator?
 20. What is meant by "electron coupling"?
 21. What are the advantages of electron-coupled oscillators over those employing ordinary methods of coupling?
 22. To obtain stability in an electron-coupled oscillator, what requirements must be satisfied?
 23. (a) How may the strength of the output signal of a modulated test oscillator be controlled? (b) What is the best form of control?
 24. (a) Draw a circuit diagram of a constant-impedance attenuator. (b) Describe its construction, and state its advantages.
 25. When testing tubes by the "replacement method", using a modulated test oscillator and an output meter, you find that the meter needle shows a steady rise and fall at regular intervals when the original tubes are in the receiver, but shows a steady reading when one of the i-f amplifier tubes is replaced with a similar new one. What would be your conclusion regarding the fault in this tube?
 26. Suppose you are making a stage-by-stage test on a super-heterodyne receiver by means of a test oscillator, in order to localize trouble. When the oscillator test lead is connected to the plate of the first i-f tube, the signal is heard in the loud speaker; but, when it is connected to the plate of the mixer tube, the signal is not heard. What does this indicate regarding the location of the trouble?

CHAPTER XVI

HOW TO CONSTRUCT AND CALIBRATE A TEST OSCILLATOR

16-1. Requirements for a Service Test Oscillator.—There are five fundamental requirements that a test oscillator must satisfy in order to be suitable for radio service work. It must be simple, versatile, stable, rugged, and portable.

The simplicity of an oscillator depends upon its construction. Oscillators having four or five tubes are usually very complex. Shielding between tubes, the necessity for large power units, the possibility of failure, all place too much uncertainty of performance upon a device intended for work in which simplicity and freedom from trouble are paramount. One or two-tube oscillators are adequate for the usual routine testing requirements of the service man.

Versatility, at the present time, cannot be under-estimated. With tube testers, analyzers, ohmmeters, adapters, hand tools, etc., all necessary units of standard service equipment, it is essential that every device be made to perform as many functions as possible so that the service man will not be obliged to carry too much equipment around with him on service calls. The oscillator is no exception to this. It should be designed to cover the complete frequency range needed for service work—from the lowest intermediate frequency used in superheterodynes to the highest radio frequency used in short-wave broadcast transmission. This means that the oscillator should cover the range from *at least* 100 to about 25,000 kc without any gaps—preferably on its “fundamental” frequencies. If it covers a range from about 100 to 30,000 kc, so much the better.

Oscillator stability is just as essential in service work as it is in the laboratory. Stable equipment in an experimental laboratory

is necessary for precision and convenience; it is also necessary in service work for speed, accuracy, and convenience. True, the accuracy required is by no means as great in the service field as it is in the laboratory; but a certain degree of accuracy, say, 1%, is necessary. Furthermore, the customer usually pays for the time spent on a particular job, and it is only fair to the customer to do a certain amount of work in the least possible time. Stability of test equipment contributes largely to speedy service. Convenience, of course, lends interest, and personal interest always leads to greater accuracy.

The last two requirements, ruggedness and portability, must be satisfied when the oscillator is to be carried from place to place. When the equipment is to remain in one place it may be less rugged, and even bulky, as long as the first three requirements are met. Service men, however, usually carry their equipment with them, and it is for this reason that these two features are mentioned. The construction of two test oscillators will now be described. The first one is for battery operation. The second one (Art. 16-7) is for a-c or d-c line operation.

16-2. Constructing A Battery-Operated Test Oscillator.—

Figure 16-1 shows the schematic circuit of a simple one-tube oscillator suitable for radio service work. It is designed to cover the band from 100 to 24,000 kc without the use of harmonics and without any gaps. This is accomplished by using five separate coils and a single tuning condenser. Any one of the five coils may be switched into the circuit at will by means of the double-pole, five-point rotary switch composed of S_1 and S_2 , which are ganged to a single shaft. Tuning is accomplished by means of the condenser C_t , and the output voltage is varied by means of the potentiometer R_p .

16-3. The Circuit.—By imagining the switches to be set at any position and tracing the circuit, it will be found that it is of the electron-coupled type using the Hartley parallel-feed connection (see Art. 15-15). Although the tickler arrangement would place the rotary plates of C_t at ground potential and give slightly more stability, the circuit used here has several advantages from a construction standpoint.

First, only a single coil is necessary for each band; second,

one of the filament terminals may be placed at ground potential, which will prevent radiation from the filament leads if they are outside the oscillator proper; third, the shield can may be grounded to the filament lead, which prevents coupling from these leads to the shield—an important consideration when the

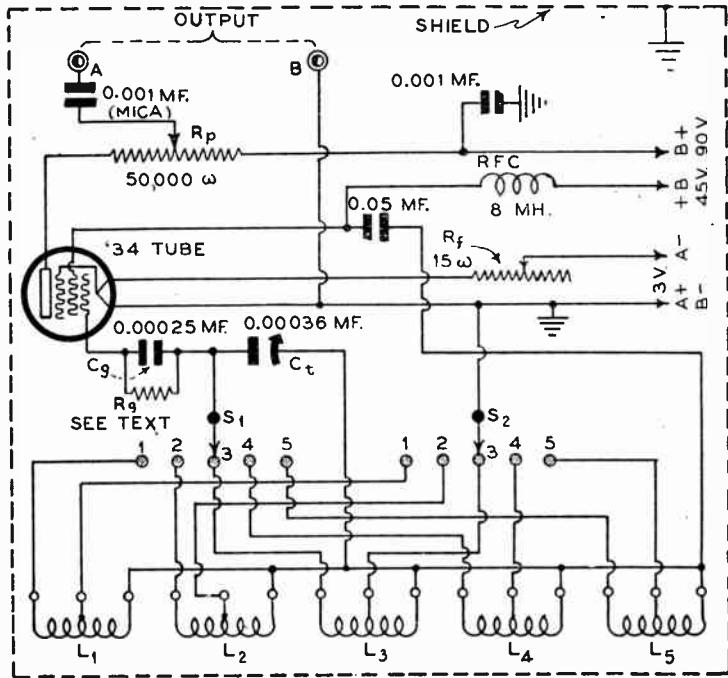

FIG. 16-1.—Schematic circuit diagram of an all-wave, battery-operated electron-coupled test oscillator. Instructions for constructing and operating it will be found in the accompanying text. The same oscillator, arranged for line operation, is shown in Fig. 16-3.

filament batteries are outside the oscillator proper or are placed close to the shield can inside the shield; fourth, since the filament is tapped to the coil, there is little possibility of varying calibration because of varying coupling between the plate and grid coils, which might result if the tickler arrangement were used, since two coils per band would then be required.

The tube selected is a type '34 because it may be operated

from a small 3-volt battery, and since it is a pentode it makes electron-coupling possible (see Art. 15-31). If the *B* batteries are placed within the shield can—as they should be—the choke *RFC* may not be required. However, if one is used, it should be placed close to the screen-grid terminal of the tube socket. The 15-ohm rheostat *R_f* is used to shut the oscillator off and turn it on, and to adjust the filament voltage to the proper value before using. As mentioned previously, the output voltage is varied by means of the potentiometer *R_p* in the plate circuit of the tube. Of course, a more costly constant-impedance type attenuator may be used here instead, if desired.

16-4. **Coil Data.**—Five coils are required to cover all the i-f and r-f bands used in commercial receivers today. They should be wound on a form $1\frac{1}{4}$ -inches in diameter, and placed as far from one another as possible. When wiring them to the grid terminals of the switch contacts, be certain to place the coils so that the leads from the grid terminals of the coils to the switch contacts are as short as possible—preferably no more than an inch or two in length. The table below gives the winding data for all the coils:

WINDING DATA FOR THE OSCILLATOR COILS

| Coil No. | Band (in kc) | Number of Turns | Wire size and insul. | Tap from Bottom |
|----------------|-----------------|--------------------|--------------------------------|--------------------|
| L ₁ | 100-300 | 500* | No. 32 enam. (112 T.P.I.)** | 170 |
| L ₂ | 300-900 | 226 | No. 32 enam. | 75 |
| L ₃ | 900-2,700 | 46 | No. 32 enam. | 15 |
| L ₄ | 2,700-8,100 | 17 | No. 20 enam. (29 T.P.I.)** | 5 |
| L ₅ | 8,100-24,000 | 5.2 | No. 14 enam. (15 T.P.I.)** | 1.4 |

*Coil form 2.5 inches in diameter. **T.P.I.—Turns Per Inch.

After the coils are wound and tapped properly, they should be coated with a thin layer of collodion or similar substance to hold the wire in place. After they have dried, it is wise to connect the mounting brackets (if used) to them. Test all coils for

continuity after the brackets are mounted, as frequently short-circuits to the brackets occur, which prevents oscillation. Mount all the parts required, make the wiring short and direct, solder each joint so that it is both mechanically and electrically secure.

16-5. Some Precautions in Construction.—When wiring to the switch contacts, care must be taken to wipe *every* joint clean of soldering flux or rosin. While these substances are insulators of direct current and low-frequency alternating current,

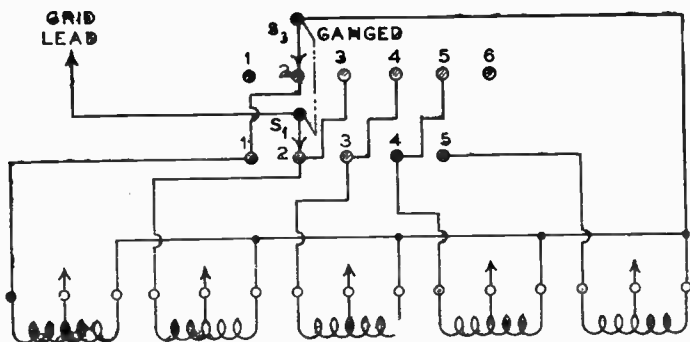

FIG. 16-2.—Switching system for short-circuiting one unused oscillator coil for each band, to prevent absorption and possible in-operation of the oscillator. This should be substituted in the circuit arrangement of Fig. 16-2 if "dead spots" are encountered. The five coils here correspond to those shown in Fig. 16-1. The connections to switch S_2 (not shown here) are the same as in Fig. 16-1.

they leak quite a bit at i-f and r-f. Electrical leakage between the coils will almost certainly make oscillation impossible.

It may be found after operating the oscillator that, at a single spot on the dial, oscillations cease. If the oscillator stops functioning at only *one* point in a given band, it is an indication that one or more of the unused coils are resonating at the frequency at which oscillations stop. Means must then be taken to prevent the absorption of energy by the unused coils. This may be done in two ways: (1) revise the electrical connections so that one or more of the unused coils are short-circuited automatically with the same switch used to change wave bands; or (2) thoroughly shield one coil from another, so that there can be no transfer of energy from one to the other.

If the first remedy is to be employed, the circuit change shown

in Fig. 16-2 is recommended. It consists of an additional switch S_3 ganged to S_1 and S_2 and connected as shown. At any position of the switches, the *next larger* coil is short circuited. It is not necessary to short-circuit all the coils not used, because it is usually only a single coil that is causing the trouble. However, if desired, still another deck may be added to the switch to short-circuit two unused coils. It is best first to construct the oscillator without the short-circuiting arrangement and try it. If absorption is encountered, simply add another deck to the switch and change the switch wiring to that shown in Fig. 16-2. Deck switches are usually constructed so that they may be easily enlarged by the addition of more decks.

If shielding is to be resorted to for the solution, then each coil should be separated from the adjacent one by a *complete* shield. Under these conditions, it is usually necessary to change the entire layout of the oscillator in order to fit the shields. Incidentally, the diameter of each shield can (if cans are used) should be at least *twice* the diameter of the form on which the coils are wound. If shielding is obtained merely by placing metal barriers between the coils, then the barriers should be spaced a distance equal to at least *twice* the coil-form diameter.

The tuning condenser C_t is above ground potential. Therefore, it cannot be grounded directly to the shield can which houses the oscillator. This may give rise to what is known as *hand-capacity effect*. If the hand or any other part of the human body is placed in the vicinity of any part of a tuned circuit, the natural frequency of that circuit is changed. The change in frequency is greater when the part of the oscillator near the hand is further above (or below) ground potential. Ground potential is the potential of the earth or any other very large mass. Practically, this means that if the hand is placed near the tuning condenser in order to tune it, the frequency of the oscillator will change, especially in our case when the condenser is above ground potential. To minimize this effect, it is necessary that the condenser be mounted near the center of the oscillator shield box, and as far away as possible from all sides of the box. The shaft may then be extended to the dial by means of a bakelite, or similar composition, rod. Hand-capacity

effects will then be very small, because the front panel, which is grounded, is between the hand and the condenser.

16-6. Testing the Oscillator.—After the oscillator is finished, it should be turned on and tested by listening to it on a good all-wave receiver. The low-frequency coils may be tested by bringing a lead from terminal A of the oscillator to the grid cap of an i-f amplifier tube in a superheterodyne receiver. Rotating the condenser will change the frequency until a point is reached where the oscillator will operate at the i-f used in the receiver, at which time it will be heard. The object of testing the oscillator over its entire operating range is to make certain that there are no breaks, *dead spots*, etc., over the entire range of the instrument.

As mentioned in Art. 15-23, no audible note can be heard with an unmodulated oscillator. For this reason, it is desirable to provide some means for modulation. The simplest method is to make the grid leak variable from 0.5 to 5 megohms, which will provide a variety of audible tones. For the alignment of tuned circuits, the leak should be adjusted for no modulation, else the radiated wave will be too broad for any accurate use. Merely turn on the modulation for picking up the signal; once obtained, turn the modulation off. Another thing to be careful of is the change in calibration with the use of self-modulation. The scale as calibrated for modulation is different from that obtained for no modulation.

When the oscillator is first turned on and tuned in on a receiver, it will be found that, for the same setting of the oscillator, it can be tuned in at different points on the receiver, these points being very close to one another. This is due to the fact that the oscillator tube—and perhaps the tubes in the receiver—has not heated up properly. Always allow the oscillator to warm up for a few minutes before attempting to use it.

If, after a half hour or so of operating the oscillator, you are certain that it is functioning properly on all bands, you are ready for calibration. This will be explained in Arts. 16-12, 16-13, etc.

16-7. Operating the Oscillator from a D-C or A-C Line.—The oscillator we have just described may be operated from a d-c or an a-c line by the addition of a rectifier tube. Of course,

it is possible to use a-c on the plate, grid and filament of the oscillator as it stands, but then the output is modulated at the frequency of the supply line (usually 60 cycles) and is very

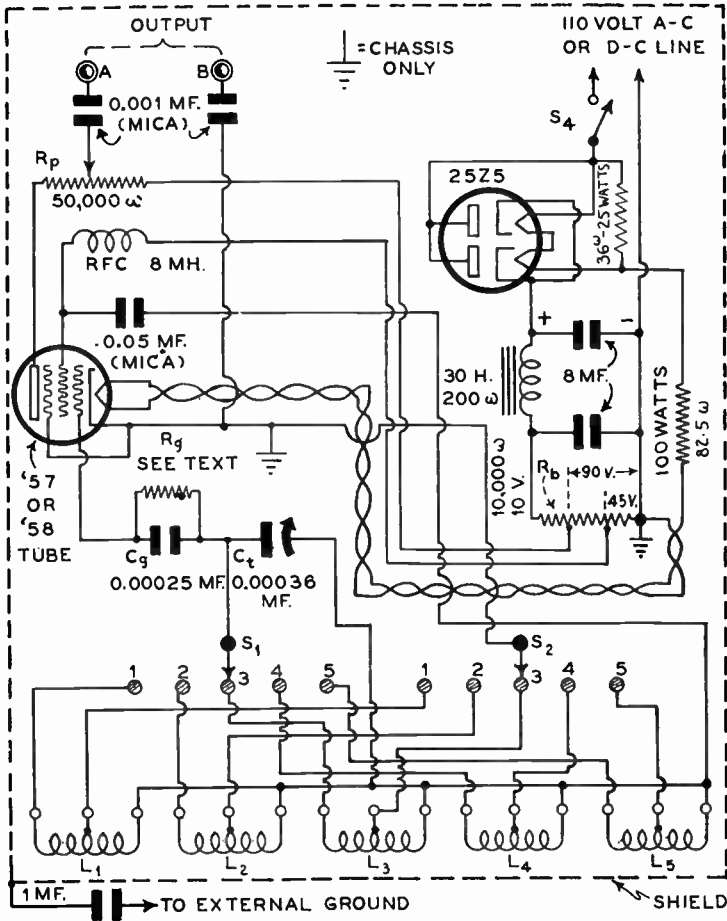

FIG. 16-3.—Schematic circuit diagram of the test oscillator of Fig. 16-1 arranged for operation from the a-c or d-c electric light line.

broad—certainly too broad for accurate alignment purposes. Consequently, several minor changes are necessary. The oscillator tube should be replaced by a type '57 or '58 tube, other-

wise the a-c through the filament will modulate the output. The schematic circuit with all electrical values for the power system, and the connections for the type '57 or '58 tube, is shown in Fig. 16-3.

The circuit is essentially the same as the battery-operated version shown in Fig. 16-1, with the exception that a cathode-type tube is used instead of a filament type. The oscillator should be thoroughly shielded, and the power unit placed to one side of the shield can. The only additional precaution to be taken is to ground the shield can through a 1-mfd. condenser. *Do not apply the ground connection directly, as there is a possibility of blowing the line fuse if it is inserted into the line socket in the wrong way.*

Many experienced service men will recognize the power circuit as being of the "universal" a-c—d-c type. That is, the oscillator will function regardless of the type of power line used. If it is a-c, the 25Z5 rectifier will rectify it to d-c; if it is d-c, the plug should be inserted so that the plate lead (of the rectifier) connects to the *positive* side of the line. It is not necessary to test for correct polarity on d-c lines, as the oscillator will function only with the plug in one direction. If it does not work one way, reverse the plug.

The bleeder resistor R_b is a 10,000-ohm, 10-watt fixed resistor of the uninsulated type with two variable clamps on it. One of these clamps connects to the r-f choke in the screen grid circuit, and the other connects to R_p for the plate voltage adjustment. With the tube oscillating, adjust these taps so that the screen voltage is 45 volts and the plate voltage is about 90 volts.

The coil data and construction details given for the battery-operated type hold also for this oscillator, and the oscillator should be checked for dead spots in the same manner as previously described in Art. 16-5. When everything is working normally, the oscillator should be calibrated.

16-8. What "Calibration" Means.—The term "to calibrate" has two different meanings, depending upon the nature of the work. If a scale is divided into any given number of arbitrary parts, and the *absolute* value of each part is to be determined,

then the scale is to be *calibrated*. The Fahrenheit thermometer is divided into 180 even parts, starting at 32 and ending at 212 (this range of the thermometer reads from the melting point of ice to the boiling point of water). Now each division on the scale has no meaning in itself; it is only when each division is marked according to temperature that it takes on significance. Thus, the fifth division is nothing but a fifth division until it is calibrated and given an absolute number of *37 degrees Fahrenheit*. In this sense, calibrating a scale means giving each, or a selected, part of the scale an *absolute* value. It is in connection with this meaning that we shall use the term *calibrate* when referring to oscillators.

However, the term "calibration" is used in still another sense. A scale may be calibrated, but the calibration may be suspected of being in error. The procedure, then, is to check the calibration of the scale by some means or other in order to rectify any error in the existing calibration. The process of rectifying the errors is also commonly called "calibration". A voltmeter, for instance, has a direct-reading scale from 0 to 150 volts. The 150-volt mark must be checked, for, as pointed out in Art. 2-41, the accuracy of a meter is a given percentage of the *full-scale* reading. The process of comparing the full-scale reading with a standard voltmeter reading is often called "calibration," even though the voltmeter has been calibrated before. In order to differentiate between the two meanings, we will refer to the first as *calibration*, and to the second as *checking*.

Finally, there are two types of calibrations, direct and indirect. A *directly calibrated* instrument is one in which the absolute values are read directly on the scale of the instrument; and an *indirectly calibrated* instrument is one in which arbitrary graduations of a scale are referred to some other chart or scale to obtain the absolute value of the quantity desired. Both direct and indirect calibrations are used in radio equipment.

16-9. Calibration is Really a Comparison.—For our purpose, a calibration is nothing more than a comparison. When an oscillator is to be calibrated, we mean that it is to be compared with some other instrument which will give us absolute frequency values. If a wavemeter is available, the readings of the

oscillator are compared with the corresponding frequency readings of the wavemeter. If a standard radio signal is available, the reading of the oscillator is compared with the frequency of the signal. And, if a calibrated radio receiver is on hand, the readings of the oscillator may be compared with the calibration of the radio receiver.

This idea of comparison emphasizes a very important point in connection with all forms of empirical calibrations. If a calibration is a comparison, then the accuracy of the final calibration cannot be greater than the accuracy of the device against which the comparison is made. If the accuracy of calibration of a wavemeter is 2%, and if an oscillator is compared with this wavemeter, the oscillator readings cannot be more accurate than 2%. Many people are under the impression that if a standard (that which the unknown is compared against) is accurate to, say, 5%, then it is possible for some inaccuracy in the oscillator to be calibrated to compensate for all or some of this 5%, and thus secure a calibration more accurate than the standard.

But the point is that one never knows how much of the 5% applies at any given setting and whether the 5%—or part of it—adds to the reading or subtracts from it. The net error would be known if we knew how much and in which sense the wavemeter error is. But if we knew which way and how much the wavemeter error was, *then it would really have no error at all*, because we could immediately apply it as a correction to every reading of the wavemeter!

These points have been emphasized before going into the actual calibration of the oscillator in order to point out the necessity for care in performing the calibration.

16-10. Methods of Calibrating Test Oscillators. — A simple and accurate method of calibrating an oscillator is to connect it up for operation and place the coil of a calibrated wavemeter close to a coil connected to the oscillator output terminals. The reading of the wavemeter for the setting which gives maximum indication, is the frequency of the oscillator. A wavemeter is nothing but a coil, condenser, and indicating device, so constructed that its coil may be placed close to the circuit which is

to be calibrated; the remaining part of the wavemeter is shielded. A diagram of such a device is shown in Fig. 16-4. To be suitable for use, the wavemeter must have been already calibrated. Since a wavemeter is not generally considered a service instrument, no further discussion of its use will be presented here.

The second method of calibration involves the tuning in of the signal on a radio receiver which has been calibrated previously. The reading of the dial of the radio set where the oscillator is tuned in is noted and compared with the calibration of the re-

FIG. 16-4.—Schematic circuit arrangement of a simple wavemeter. The resonance point is indicated by maximum current indication on the galvanometer.

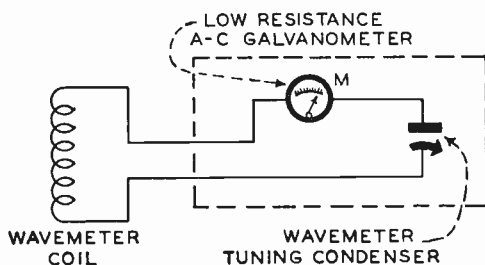

ceiver. The use of this method necessitates several precautions. First, the range of the receiver must be within the range of the oscillator, otherwise it is impossible to tune in the oscillator signal. Second, the operator must be sure that he is not tuning in a harmonic of the oscillator; the amount of error involved here is considerable.

The third method of calibration, and the one most suitable for the service man, involves the use of the harmonics of the oscillator and is the method to be given detailed study in the following sections of this chapter.

16-11. Some Characteristics of Harmonics.—As discussed in Arts. 15-18 and 15-20, any oscillator with distorted plate current will generate harmonics. A "harmonic" of a fundamental frequency is a multiple of this frequency, having a value of two, three, four, etc. times the fundamental, depending upon its *order*. This is another way of saying that the difference between any two successive harmonics (or the fundamental and the second harmonic) is equal to the fundamental frequency. Thus, suppose the fundamental frequency of an oscillator is

125 kc; the harmonics would be 250, 375, 500, 675, etc. kc; and the difference between any two successive harmonics is 125 kc. This is shown in the following table.

| | | <i>Difference</i> |
|---------------------|--------|--|
| <i>Fundamental</i> | 125 kc | } ----- 125 kc ----- 125 kc ----- 125 kc ----- 125 kc |
| <i>2nd Harmonic</i> | 250 kc | |
| <i>3rd Harmonic</i> | 375 kc | |
| <i>4th Harmonic</i> | 500 kc | |
| <i>5th Harmonic</i> | 675 kc | |

The fact that *the difference between a given harmonic and the following harmonic is equal to the fundamental frequency of the oscillator*, is the basis of the method of calibration about to be described.

As the order of the harmonic in use increases, the accuracy of the harmonic remains the same, although the absolute error in kilocycles increases. For instance, suppose that an oscillator has a fundamental frequency of 100 kc and has strong harmonics up to the fourth; further, suppose that the 100 kc is accurate to 1%; this means that the actual frequency is between 99 and 101 kc, a maximum deviation of 1 kc either way from the stated value. The second harmonic would have a stated frequency of 200 kc, and it, too, would be accurate to 1%; the actual frequency in this case would lie between 198 and 202 kc. The maximum possible deviation is 2 kc either way. In a similar manner, the third harmonic would be 300 kc, and its maximum deviation would be 3 kc. either way. The fourth harmonic would have a maximum deviation of 4 kc, either way, from the stated value.

The point to be emphasized is that the *per cent* accuracy is still 1% for *any* harmonic, but the error *in kilocycles* increases. In fact, the accuracy of the *fundamental* (expressed in kc) multiplied by the *order* of the harmonic (second, third, etc.), is equal to the error of that harmonic in kc. Thus, if the 28th harmonic of an oscillator is to be used (not uncommon in certain forms of radio work), the possible error of the harmonic frequency in kc is twenty-eight times that of the error of the fundamental. When high-order harmonics are used therefore, more exact calibration is required than is the case when only low-order harmonics are employed.

If the fundamental tone of a harmonic is modulated by a 400-cycle audio note, then any of the harmonics will be modulated by that same 400 cycles. In other words, even though the frequency corresponding to the harmonic in use is greater than that of the fundamental, the frequency of its modulations is the same as the frequency of the modulations of the fundamental. Therefore, the fourth harmonic of a 100 kc signal modulated at 200 cycles is a 400 kc signal modulated at 200 cycles, etc.

16-12. **Calibrating the Receiver.**—Since a calibration is a comparison, then the oscillator to be calibrated must be compared against something that is already calibrated. The most convenient piece of apparatus that can be accurately calibrated is a radio receiver, and we will base our measurements on the use of such a device. The receiver should preferably be of the t-r-f type, as a superheterodyne gives rise to image response and undesired beats between the set oscillator and its harmonics, and the harmonics of the oscillator to be calibrated. If a superheterodyne must be used, then it should be thoroughly shielded and have one, or preferably two, stages of tuned radio frequency ahead of the detector.

Now, the usual type of broadcast receiver can tune easily from about 500 to 1,500 kc, and the first thing to be done is to calibrate the receiver. If the dial is divided into 100 divisions, it is desirable to get a calibration point on at least every 10 divisions. Some dials have more than 100 arbitrary divisions. It makes little difference, as about ten stations, evenly distributed, must be obtained. The more modern sets are already calibrated in kilocycles, but the calibration should be checked in exactly the same manner used to calibrate a receiver with an arbitrary scale, for the receiver dial calibrations are often inaccurate.

Tune the receiver to about 95 on the dial (or tune it to 95% of the top mark) and tune in a station carefully. Note its call letters and look up its frequency in your local newspaper since broadcast stations in this country must keep within 50 *cycles* of their assigned frequency, they are sources of extremely accurate standard signals. A station in the middle of the band may have a frequency of 1,000 kc, and, if it must keep within

50 *cycles* of this, it has an accuracy of 50 parts in 1,000,000, or 1 part in 20,000 (0.005 per cent). It is best to tune in the station between selections, when there is no one on the air, because an unmodulated carrier is much sharper than a modulated carrier. Once it is tuned in, jot down the frequency of the station and the exact reading of the broadcast receiver dial.

Then tune the receiver to about 90 on the dial and try to tune in another station in that vicinity. It is not at all necessary to get a station at exactly 90; it may be between about 87 and 93 just as well. Tune it in carefully and listen for the station announcement. Look up the frequency and again jot down the receiver-dial reading and the frequency of the station. Repeat this procedure for about every ten degrees of the dial. Of course, if more than 10 stations can be received, so much the better, but the object is to get at least 10 stations evenly distributed over the dial.

When you have finished, go over them again to check over your work. It must be remembered that the accuracy of the final result cannot be any more accurate than the calibration of the receiver. The broadcast stations are accurate enough; it will be, in all probability, the exactness of your work that will determine the final accuracy.

16-13. Drawing the Calibration Curve.—Upon the completion of the listing of the stations, the next step is to draw a calibration curve. If you have but ten stations, the listing is good for those ten only, and some means must be available for determining the frequency corresponding to points on the receiver dial other than those ten. It is for this reason that a calibration curve is drawn.

Procure a sheet of cross-section paper having about ten divisions to the inch; the size of such a sheet is, say, about 5 x 10 inches. Keep the 5-inch side horizontal. On the 10-inch side, label the top horizontal line 500 (or else the lowest frequency to which the receiver tunes) and mark off every ten divisions. Thus, the horizontal lines will be divided into 10 equal parts, the first being labeled 500, the second, 600; the third, 700, etc. In a similar manner the vertical lines should be divided into 10 equal spaces, labeled evenly from 0 to 100.

The final sheet will then be marked in accordance with the ruled lines and scales on the typical graph of Fig. 16-5.

For every point calibrated, there is a location on the curve such that a horizontal line through the point meets the fre-

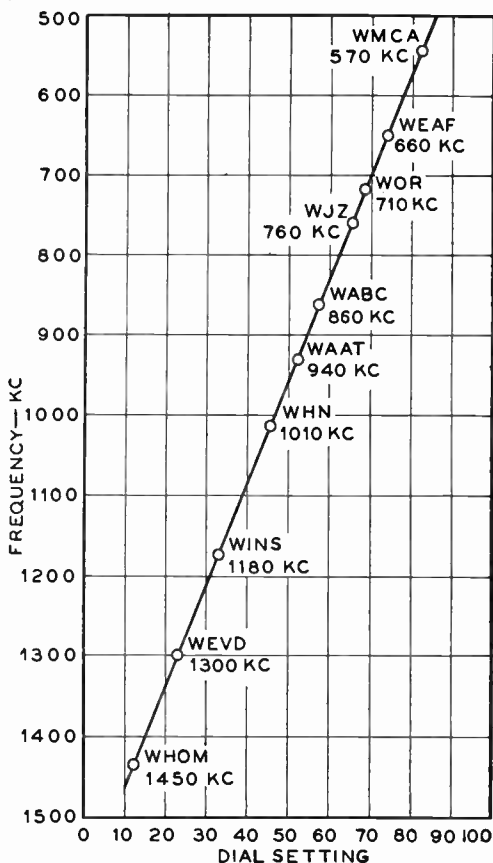

FIG. 16-5.—Calibration curve for a broadcast receiver. It shows the frequencies in kc corresponding to the various settings of the tuning dial—and the dial settings at which various stations are received.

quency of that station and the vertical line through the point corresponds to the dial setting of the receiver. Locate the points and draw a *smooth* curve through all the points. If the conden-

sers used in the receiver are of the straight-line-frequency type, the curve will be a straight line; if they are of the straight-line-wavelength or straight-line-capacity type, the curve will not be straight. In all cases, though, a smooth line should be drawn through all the points. The particular receiver corresponding to the curve shown in Fig. 16-5 employed straight-line-frequency tuning condensers and tuned to below 500 kc and above 1,500 kc.

16-14. **Calibrating the Oscillator.**—When the receiver has been calibrated as described, you are ready to calibrate the oscillator. Turn it on (with modulation on) and allow it to warm

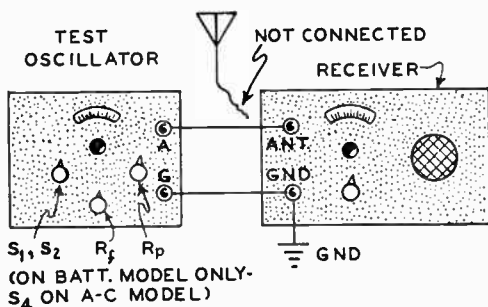

FIG. 16-6.—Connection of the test oscillator to the broadcast receiver for calibration.

up for about ten minutes so as to reach a constant temperature. As shown in Fig. 16-6, connect post *A* of the test oscillator output terminals to the aerial post of the receiver, and post *G* to the ground post. Of course, the receiver aerial should be disconnected, but the external ground may be left attached. Set S_1 - S_2 (of the oscillator described in this chapter) to position 1, which connects coil L_1 for operation to cover the band from 100 to 300 kc. Set the oscillator dial at about 90, and tune in its signal on the receiver.

The signal now tuned in is not the fundamental, but a harmonic of the oscillator. At 90 on the oscillator dial, the capacity of the oscillator condenser is nearly maximum (unless the dial reads reversed), which means that the fundamental frequency of the oscillator is about 100 kc. Since the lowest frequency tuned in by the receiver is 500 kc, and the highest 1,500 kc, you may tune in any harmonic from the fifth to the fif-

teenth. If you *know* that the oscillator fundamental is about 100 kc and that the signal is tuned in near the top end of the receiver scale (lowest frequency), then, by referring to the receiver calibration chart, the frequency corresponding to the point where the signal is tuned in may be read. Dividing this frequency by 5 gives the fundamental frequency of the oscillator. For example, suppose that at 82 on the receiver dial, some harmonic of the oscillator is being heard. The calibration chart of the receiver tells us that 82 corresponds to a signal of 540 kc. And if we know that the fundamental of the oscillator is about 100 kc, then we must be hearing the fifth harmonic, in which case the fundamental of the oscillator is $540/5 = 108$ kc. On a sheet of paper, the dial setting of the oscillator and the frequency corresponding to it as determined are jotted down.

If the same oscillator fundamental is tuned in at any other part of the dial, say at about 26, the fundamental may be determined in exactly the same manner. On the receiver dial 26 corresponds to a frequency of 1,272 kc. If we know that the oscillator is working at about 100 kc, then we must be hearing the twelfth harmonic, and the fundamental must be $1,272/12 = 106$ kc. In other words, because of the low frequency of the fundamental and because of the wide frequency range of the receiver, about ten different harmonics may be tuned in.

This method of calibration is based on the knowledge of the approximate fundamental of the oscillator and a knowledge of the harmonic heard. But to the inexperienced service man, this knowledge is not always available. However, another system may be used which pre-supposes no approximate knowledge at all. This will now be described!

16-15. Calibrating the Test Oscillator by the "Difference" Method.—It was pointed out in Art. 16-11 that the difference between any two harmonics is equal to the fundamental frequency. Thus, if any harmonic of the oscillator is tuned in on the receiver, and then the *next* highest or lowest harmonic is tuned in, the fundamental frequency of the oscillator is the difference in frequency corresponding to the two settings of the receiver.

For example, suppose that the oscillator is connected to the

receiver as described, and a harmonic is tuned in at 50 on the dial. On the receiver dial 50 corresponds to 972 kc. The oscillator is left alone, and the receiver dial is rotated slowly to the next point at which the oscillator harmonic can be heard. Suppose one can be heard at 57.5 on the dial, corresponding to a frequency of 864 kc. The difference between 972 and 864 is 108 kc, the fundamental frequency of the oscillator at the point at which it is set.

This method of calibration is known as the *difference* method, because the difference between two readings is obtained. It is to be preferred over the method of division because less information is pre-supposed and because the fundamental may be checked again and again by tuning in different harmonics over the scale of the receiver.

During this time, but one point on the oscillator has been calibrated. In order to obtain sufficient points for a given coil, it is necessary to repeat the operations for at least ten evenly spaced points on the oscillator dial. When finished, a tuning curve similar to that of the receiver (Fig. 16-5) should be drawn from the readings obtained.

This point will be valid for position 1 of the switch, and must be repeated for position 2. But in position 2 only the fundamental of the oscillator can be tuned in, using one part of the oscillator scale, and harmonics on the other.

The fundamental of the oscillator on position 2 is from 300 to 900 kc, approximately. The 300 kc fundamental produces harmonics of 600, 900, 1,200, and 1,500 kc, which can be tuned in on the broadcast receiver because they lie within the tuning range of the receiver. When the oscillator is set to, say, 800 kc, the fundamental will be tuned in, but it is not possible to tune in any of the harmonics of the oscillator because the lowest-order harmonic, the second, is 1,600 kc, which is outside the tuning range of the receiver. You will know when you reach this point because the oscillator will be tuned in at only *one point* in the receiver. And these "one-spots" are the fundamental frequencies of the oscillator. Theoretically, if the receiver tunes *only* from 500 to 1,500 kc inclusive, a 499 kc fundamental from the oscillator can be tuned in at only

two points—at 998 kc (corresponding to the *second* harmonic) and at 1,497 kc (corresponding to the *third* harmonic).

At 500 kc, just about three points are available—500, 1,000, and 1,500 kc; at 510 kc fundamental, two points are available, 510 and 1,020 kc; at 750 kc fundamental, two points are available, 750 and 1,500 kc. But only one point can be tuned in when the fundamental oscillator frequency is between 751 and 1,500 kc.

The rule to remember is that when two spots are available, the “difference” method should always be used; when only one spot is available, that frequency corresponding to the single spot is the fundamental of the oscillator.

In this manner oscillator frequencies up to 1,500 kc may be tuned in on the receiver, and points of the oscillator scale can be given absolute values. But part of band 3 of our oscillator is above 1,500 kc, and thus cannot be tuned in on the receiver. Oscillators do not generate frequencies lower than the fundamental—the fundamental is the lowest frequency.

16-16. *Calibrating the Higher Frequencies.*—Up to this point, all of the positions 1 and 2 of the switch have been calibrated. A separate curve should be drawn for each of these positions in a manner similar to that described for the broadcast receiver. Only part of the third position has been calibrated because of the limitations of the broadcast set. In order to calibrate the third and remaining oscillator bands, a short-wave (or all-wave) receiver must be available.

It is not necessary to calibrate the short-wave receiver carefully. Such a calibration may be made, but the number of accurate stations available are not nearly as great as on the broadcast band, and for this reason some other means must be resorted to. If two of the oscillator sections have calibration curves, they may be used to obtain the curves for the remaining three bands.

Most all-wave and short wave receivers have some sort of calibration. As long as it is sufficiently accurate to give one an idea of *approximately* what frequency the receiver is being tuned to, it is suitable. The procedure for calibration is now as follows:

Set the oscillator switch on position 2 and generate a fundamental frequency of, say, 850 kc. The harmonics will then be 1,700, 2,550 etc., kc. Tune the receiver to approximately 1,700 kc and then tune more carefully until the oscillator can be heard. If the fundamental of the oscillator is 850 kc, the signal heard *will be* 1,700 kc. *Leaving the receiver alone*, turn the tap switch on the oscillator to position 3, and turn the dial until the signal is heard again. The oscillator will now be generating a frequency of 1,700 kc. It cannot be any other frequency because there is no other fundamental on this position that will give a harmonic of 1,700 kc. That setting of the oscillator on position 3 corresponds to 1,700 kc.

Suppose that the next calibration point is 2,000 kc. Set the oscillator again to position 2 and tune to a fundamental of 500 kc, the highest frequency in this band generating a frequency whose harmonic is 2,000 kc. The fourth harmonic will be 2,000 kc, and may be heard by tuning it in on the receiver. The fundamental of 2,000 may be found by again setting the switch in position 3 and tuning until it is heard. Since the third position covers the range from 900 to 2,700 kc, there is but one frequency in this band that can produce a *harmonic* of 2,000 kc, and that is 1,000 kc. But the dial reading of the oscillator for the 1,000 kc fundamental will be near one end, while we know that the setting for the 2,000 kc fundamental should be near the center; in this manner the proper setting may be selected. This procedure is continued, always using the calibrated readings of the previous switch positions, until all five bands are covered. When completed, five sets of curves will be had, one for each band. These curves will correspond to the fundamentals of the frequencies generated.

16-17. Use of Harmonics vs. Fundamentals.—The question may be raised that, if the oscillator produces harmonics strong enough for use in calibration work, why cannot they be used in regular service work? If they are used, only one, or possibly two coils will be required. The answer is that it is perfectly possible to use the harmonics of the fundamental, but the point is that, unless considerable experience is had, it is difficult to differentiate between one harmonic and the other.

It is true, of course, that the fundamental is far stronger than any of the harmonics, and that the strength of the harmonics *decreases* as the order of the harmonic *increases*, which may serve as a guide in some tests. But the fact remains that the use of fundamentals obviates the necessity for computation; and, when the dial of the oscillator is set for 18,700 kc, it is the fundamental that is being used, not some harmonic of some other fundamental. However, to an experienced service man, the use of harmonics have the advantage of simplifying the construction of the oscillator. In any event, the use of fundamental frequencies alone gives a more constant output. Opinion on this point seems to be well divided.

The use of the test oscillator in radio service work will be treated in Chapters XXIV and XXV.

REVIEW QUESTIONS

1. What are the requirements of a service test oscillator?
2. Discuss each of these requirements in detail.
3. Draw a circuit diagram of an electron-coupled test oscillator and explain the function of each part.
4. What precautions must be observed in building a service test oscillator?
5. (a) What is meant by "dead spots"? (b) How may they be eliminated?
6. (a) What is meant by hand-capacity effect? (b) Explain two methods of eliminating it.
7. May an oscillator be operated with a-c applied to the plate and filament? Explain!
8. Is a-c applied to the plate and filament of an oscillator desirable for alignment purposes? Why?
9. What is meant by calibration?
10. How many types of calibrations are there, and when is each used?
11. What limits the accuracy of calibration? Explain!
12. What are the three methods of calibrating a test oscillator?
13. What is the basis of the method of calibration described in detail in this chapter?
14. Does the accuracy (expressed in kc) of a harmonic decrease with the order of the harmonic? Explain!
15. How would you go about calibrating the tuning dial of a broadcast receiver?
16. What is the advantage of drawing a calibration curve of a receiver for test purposes?
17. Explain in detail how you would go about calibrating a test oscillator by the harmonic method, using a calibrated receiver.
18. What is the "difference" method of calibration? Explain!

CHAPTER XVII

TYPICAL COMMERCIAL TEST OSCILLATORS

17-1. Introduction.—It is the purpose of this chapter to present descriptions of several representative commercial service test oscillators of different types which have been developed especially for radio service work. We will see how manufacturers have met the requirements for test oscillators able to perform satisfactorily under modern servicing conditions. This study will also add to our academic knowledge of oscillators obtained in Chapter XV, a wealth of practical information which can only be obtained by a thorough study of representative commercial instruments. The use of test oscillators in alignment work will be studied in Chapters XXIV and XXV.

Service oscillators have undergone radical changes in design during the past few years because of the large number of short-wave and all-wave receivers in use. The popularization of all-wave receivers for the home has naturally resulted in the necessity for a great deal of alignment work on them. This work requires the use of test oscillators capable of producing sufficiently strong signals of a wider range of frequency (as high as 30 megacycles) than has ever been necessary in radio service work before, since it is necessary to produce every common short wave, intermediate and broadcast frequency employed.

The almost universal use of automatic volume control on modern receivers has made necessary a special refinement in the service test oscillator. Previous to the use of avc, the "attenuator" was simply a handy device that was used to lower the output of the oscillator; with present receivers, it has become an important control—important because the threshold at which avc action starts varies with different receivers; and for some test purposes, as we shall see, it is essential that the output of

the oscillator be kept very low, and within very close limits.

The use of harmonics for obtaining the very high frequencies required for the aligning of all-wave receivers is used to some extent, although the trend is toward the use of a complete range of fundamentals, from the lowest to the highest frequencies required. Harmonics, of course, are also available from these same units, although the strength of any harmonic is always less than that of the fundamental (see Arts. 15-21, 16-11 and 16-17).

Modulation of the test oscillator signal is now being more generally accomplished by the Heising circuit (see Art. 15-25) using a separate modulator tube. This represents a decided change from test oscillators of a few years ago. As was shown in Chapter XV, Arts. 15-27 and 15-28, self-modulation of an oscillator is usually accompanied by a change in the fundamental frequency of the oscillator when the modulation is turned on and off. This effect is entirely eliminated when a separate modulator tube is used. All these points will be apparent as the following descriptions of representative commercial test oscillators are studied.

17-2. "Burton-Webber" Model 10 Oscillator.—Figure 17-1 shows an external view of the Burton-Webber Model 10 all-wave oscillator which incorporates many of the features mentioned in the introduction to this chapter. Its schematic circuit is shown in Fig. 17-2. This diagram shows that two type '30 tubes are employed, one as an oscillator and the other as a separate modulator. The oscillator is battery-operated, employing one $4\frac{1}{2}$ -volt *C* battery for filament supply and one $22\frac{1}{2}$ -volt *B* battery for plate supply. These batteries fit into the oscillator cabinet.

The oscillator section uses the tickler feedback circuit discussed in Art. 15-11. Proper bias is obtained through the use of grid leak *R*, and grid condenser *C*₄. The frequency range of the instrument is from 90 kc to 25 mc (megacycles), in eight different bands, the range of each band being as follows: *A*, 90-140 kc; *B*, 140-300 kc; *C*, 300-650 kc; *D*, 650-1550 kc; *E*, 1.55-3.5 mc; *F*, 3.5-6.5 mc; *G*, 6.5-13 mc; *H*, 13-25 mc. Eight separate grid circuit tuning coils and eight tickler coils

are employed in connection with a 3-section range switch to provide these eight frequency bands. The connections of the grid and tickler coils used for each of these bands are shown in the schematic diagram. The row of C_7 condensers shown in the upper right-hand part of the diagram are used for individual calibration of each band, and a fixed series padder, C_8 , is used in conjunction with the main tuning condenser to facilitate tracking over the dial. The plate of the oscillator tube connects to the attenuator, R_4 , through a fixed condenser C_5 .

A Hartley a-f oscillator circuit (see Art. 15-15) is employed with the modulator tube to generate a 400-cycle note, which mod-

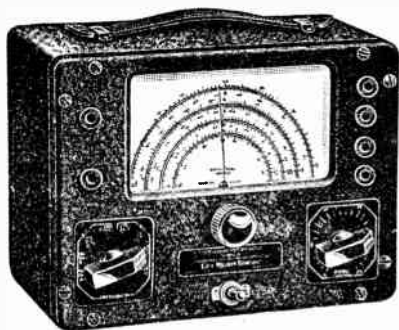

FIG. 17-1. — Exterior view of the all-wave battery-operated test oscillator whose schematic circuit diagram is illustrated in Fig. 17-2. The large dial face with the scales for the various frequency ranges can be seen plainly. The frequency range switch is at the lower left and the attenuator control is at the right. (Model 10.)

Courtesy Earl Webber Co.

ulates the carrier of the oscillator tube about 35%. The modulation choke has a tapped winding which enables it to be used also as the oscillator coils of the modulator tube, and the B plus is fed through the center tap of the choke. This means that the modulator grid portion of the choke is in series with the oscillator plate circuit, and it is in this fashion that modulation occurs. Since the modulation choke is center-tapped, there is no d-c potential difference between its outside terminals, although, of course, they are at different 400-cycle potentials. This condition makes it possible to take the voltage drop across the choke and lead it out for possible external use. Two pin jacks T_1 and T_2 which connect to the outside terminals of the choke are provided for external use of the 400-cycle impulses generated by the modulator tube. When these pin jacks are

short-circuited by a short length of wire, the modulator tube does not generate oscillations, and the output of the oscillator is unmodulated. Thus, either a modulated or unmodulated output can be secured.

The “attenuator” (output control) is of the so-called “ladder” type, consisting of a tapped voltage-divider resistor R_3 ,

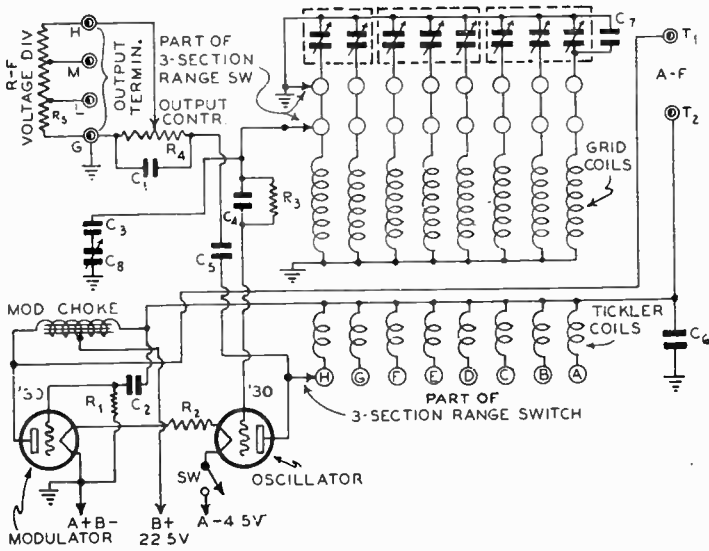

FIG. 17-2.—Schematic circuit diagram of the all-wave test oscillator illustrated in Fig. 17-1. A separate oscillator and modulator tube are used, and a 3-section range switch is employed with 8 grid and tickler coils to cover the entire frequency range from 90 kc to 25 mc. Only fundamental frequencies of the oscillator are employed.

and a continuously-variable resistor R_4 , both across the output. This provides both “step” and “continuously-variable” control. There are three steps: low, medium and high, represented by the designations L , M and H , respectively, available at pin jacks on the panel. The output is obtained between each of these jacks and ground, designated by G . The variable output control may be employed with any output level. The location of these output terminal pin jacks, as well as the location of the modulator output jacks and range-switch knob, is shown in Fig.

17-1. A shielded wire lead (not shown) is furnished with this instrument for connecting its output terminals to the receiver, being aligned. The shielding prevents radiation of the oscillator signal through the air to the wiring of the receiver under test.

17-3. "Clough-Brengle" Model OC Oscillator.—Figure 17-3 shows an external view of the Clough-Brengle Model OC all-wave test oscillator. The arrangement of its main parts is



Courtesy Clough-Brengle Co.

FIG. 17-3.—Exterior view of the all-wave oscillator whose rear view and schematic circuit diagram are shown in Figs. 17-4 and 17-5 respectively. It operates from either a 110-volt a-c or d-c line. (Model OC.)

shown in the interior view of Fig. 17-4. This service oscillator has several interesting features. It uses three tubes (a rectifier, an oscillator and a modulator tube), operates from either a-c or d-c power lines, and makes use of fundamental frequencies only, to cover its entire range from 50 kc to 30 mc (6,000 to 10 meters).

As shown in the schematic circuit diagram in Fig. 17-5, the 110-volt a-c or d-c line enters a line filter network to a type '37 tube, with grid and plate connected together as a rectifier for the plate and screen grid *B* supply, using the conventional a-c—d-c circuit. This enables the instrument to be operated on either a-c or d-c current. The line filter prevents feedback through the power supply circuit. The output of the rectifier is filtered by an iron-core choke and condensers *C*₇ and *C*₈; the positive *B* lead connects to one end terminal of the modulation choke *L*₈. The center tap of this choke supplies plate voltage to the type '36 oscillator tube and the other end terminal supplies plate voltage to the modulator tube; thus, constant-current "plate" modulation (see Art. 15-25) is secured.

The oscillator circuit is of the electron-coupled type, whose frequency is not affected by wide fluctuation in tube voltages (see Art. 15-31). Modulation may be applied to the plate circuit. The grid, cathode and ground leads terminate in three

wiping contacts which make connection with the corresponding terminals of whichever oscillator coil happens to be in the circuit. The six tuning coils are all mounted on one rotatable form, and are turned into position as used so that their terminals make contact with the leads, rather than the leads being switched to make contact with the coils, as is usually the case. This results in very short leads throughout the tank circuit, which reduces undesired interaction at the high frequencies. Six tapped, shielded, rotatable coils are used in all (see Figs. 17-4 and 17-5), and the frequency range of each band is as follows: (1) 50-175 kc; (2), 155-530 kc; (3), 500-1,750 kc; (4), 1,750-6,000 kc; (5), 6,000-21,000 kc; (6), 21,000 kc-30 mc.

The high B voltage is dropped through resistor R_3 to the value required by the screen grid of the '36 oscillator tube. The plate circuit also contains a choke L_7 through which the high-frequency plate current flows. Coupled to this coil is another, L_9 , which leads to the output attenuator. The oscillator tube

FIG. 17-4. — Rear view of the interior of the oscillator shown in Figs. 17-3 and 17-5. The three tubes, tuning condenser and six shielded coil units may be seen.

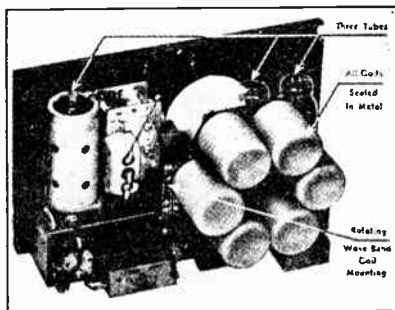

Courtesy Clough-Brengle Co.

obtains its proper bias through the use of grid leak R_2 and grid condenser C_2 .

The separate a-f modulator stage employed assures freedom from "frequency drift" (see Art. 15-28) and also a pure 400-cycle note that does not shift with line voltage variation or tube replacement. The grid coil of the separate modulator tube is coupled to its plate circuit, since it really is the secondary of a transformer of which L_8 is the other coil; in this manner, a 400-cycle modulating current is generated. A third coil (lower)

picks up part of this 400-cycle oscillation for external use through the tip jack J_1 . The modulation switch SW_1 across the entire modulation choke is used to stop the generation of the 400-cycle oscillation when an unmodulated carrier is desired. The grid coil of the modulator tube is also equipped with a jack which allows the insertion of an external modulating source whenever desired. In other words, this jack allows a phonograph or microphone circuit to be connected to the input of the

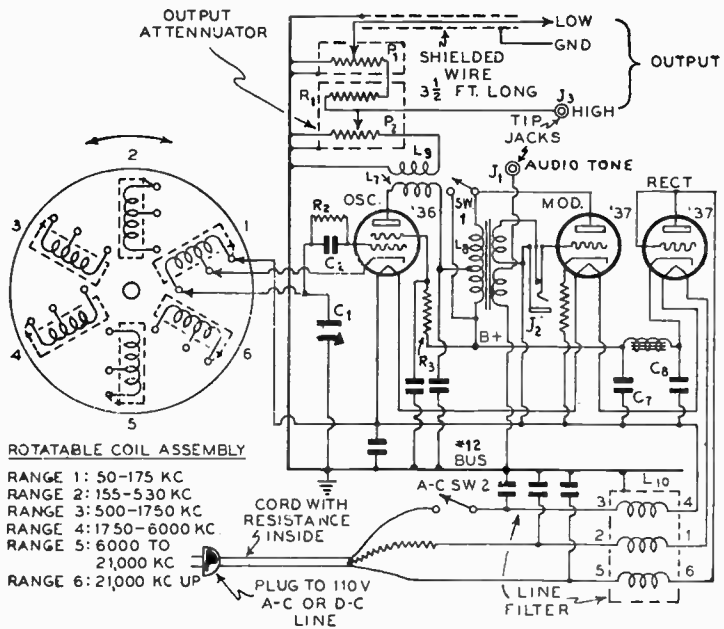

FIG. 17-5.—Schematic circuit diagram of the all-wave line-operated test oscillator illustrated in Figs. 17-3 and 17-4. Three tubes are employed, and a fundamental-frequency range from 50 kc to 30 mc is provided. The oscillator is of the "electron-coupled" type.

modulator tube for modulation of the oscillator; the 400-cycle oscillation is not generated when this is done because the normal grid circuit is broken by the jack.

Two separate attenuators are used: one for high output and the other for low output. When the *Gnd.* and *Low* terminals are used, potentiometer P_1 is used for variation of signal out-

put strength; when *Gnd.* and *High* output terminals are used, potentiometer P_2 is used. By means of these two attenuators, the output of the oscillator may be varied continuously from less than 0.5 microvolt to 2 volts, low enough for sensitive receivers and high enough for receivers badly out of alignment and for all general work. The shielded output lead connects the test oscillator to the receiver being aligned, the inside wire and the shield serving as the two conductors. The purpose of the shielding is to prevent radiation of the oscillator signal.

A unique feature is the gear-driven tuning condenser, C_1 , with a 100-division dial extending over 360 degrees and a separate four-position marker dial. The effect of this dial is to spread the 100 divisions to 400 divisions, which are, in turn,

FIG. 17-6. — Exterior view of the all-wave line-operated test oscillator whose circuit diagram is shown in Fig. 17-7. The large scale of this instrument is reproduced in Fig. 17-8. Notice the compactness and provisions for ease of manipulation of this instrument. (Model 440)



Courtesy Jackson Elect. Instr. Co.

spread over nearly 28 inches of scale length. The manufacturers claim that this dial may be read to an accuracy of 1/10 of 1 per cent, as compared with an accuracy of 1/2 of 1 per cent to which the oscillator is calibrated.

17-4. "Jackson" Model 440 Oscillator.—The Jackson Model 440 service test oscillator is a three-tube all-wave instrument designed for operation from either an a-c or d-c power line. An illustration of the instrument is reproduced in Fig. 17-6, and its schematic circuit diagram is shown in Fig. 17-7.

Since the instrument is to operate from either an a-c or a d-c line, a '37 tube with its grid and plate connected together is employed as a half-wave rectifier for the plate and screen currents, in the usual way. The full line voltage is applied to the plate of this tube. All the heaters of the tubes are connected in series with each other and with a voltage-dropping resistor which

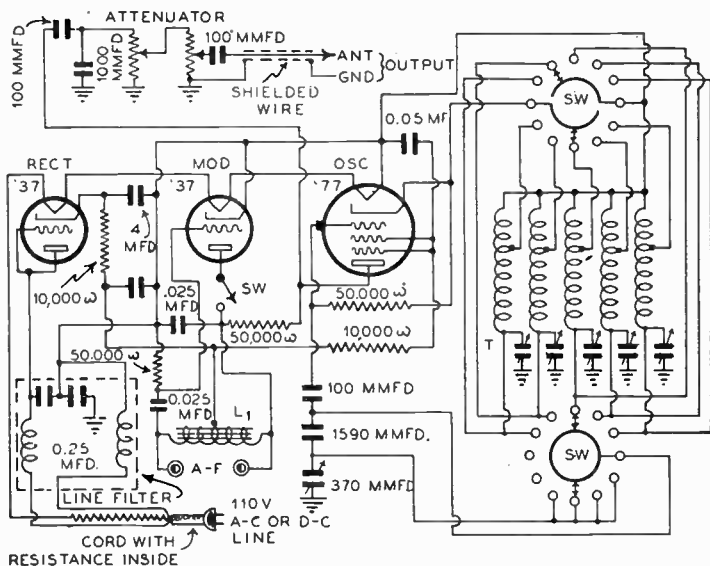

FIG. 17-7.—The schematic circuit diagram of the all-wave test oscillator illustrated in Fig. 17-6. Three tubes are employed—one as a rectifier. A fundamental-frequency range of 100 kc to 10 mc is provided. This oscillator is of the "electron-coupled" type.

is built into the line-plug cord. A line filter consisting of two chokes and two 0.25 mfd. condensers is provided to prevent oscillator voltage from feeding back into the line and disturbing the measurements or adjustments being made on the receiver connected to the same line. The rectified output voltage from the rectifier tube is filtered by a 10,000-ohm resistor and two 4 mfd. condensers.

The second type '37 tube is used as the modulator. This audio oscillator employs a single center-tapped modulator choke,

L_1 , connected in a Hartley circuit (see Art. 15-15). It produces a pure 400-cycle output, and its plate circuit is provided with a switch so that the r-f output of the signal generator may be modulated or unmodulated, as desired. Two leads from the terminals of the modulator choke connect to binding posts A-F, on the panel of the instrument, so that the 400-cycle a-f note may be used for other external a-f tests or measurements.

An electron-coupled type r-f oscillator employing a '77 type screen-grid tube is used. It will be recalled (Art. 15-31) that high-frequency stability is obtained by using this type of circuit.

The screen and suppressor grids of the r-f oscillator tube connect to the plate voltage source through a 10,000-ohm resistor, thus acting as the "plate" of the oscillator portion of the tube. The "real"

FIG. 17-8.—Reduced facsimile reproduction of the scale of the oscillator illustrated in Figs. 17-6 and 17-7. Five fundamental-frequency ranges and scales are provided to cover the range from 100 kc to 10 mc. In addition, a second harmonic range from 8 to 20 mc is provided.

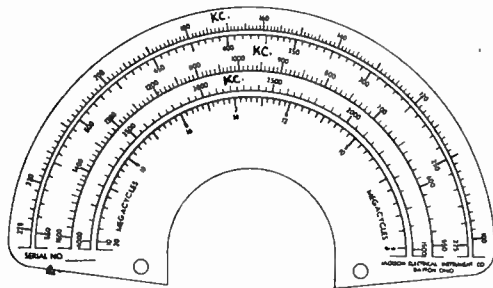

Courtesy Jackson Electr. Instr. Co.

plate and the external "output circuit" are coupled to them by the electron stream within the tube, so that we have here, an electron-coupled oscillator (see Art. 15-31). Since one end of the modulation choke L_1 connects (through the 50,000-ohm resistor) to this real plate, modulation of the generated r-f oscillations is effected through the plate circuit without altering the frequency of the r-f oscillations.

This test oscillator covers the complete frequency ranges used in all-wave receivers in five bands: 100-225 kc, 225-550 kc, 550-1,500 kc, 1,500-4,000 kc, 4-10 mc. The frequency indications are calibrated directly on the scale. As shown by a facsimile of its scale in Fig. 17-8, another range from 8 to 20 mc is also available. This latter range makes use of the harmonics of the fundamental frequencies of the fifth range; hence, the frequency of every division of this scale is just *double* that of the

corresponding division of the fifth (4 to 10 mc) scale. This may be seen by inspecting Fig. 17-8 closely.

The coil-switching system is apparent from the diagram. Five tapped oscillator coils are used—one for each of the fundamental ranges (see Fig. 17-7). Each one has a separate trimmer condenser, *T*, for calibration. The coil-switching system consists of two sets of switches, as shown. One set controls

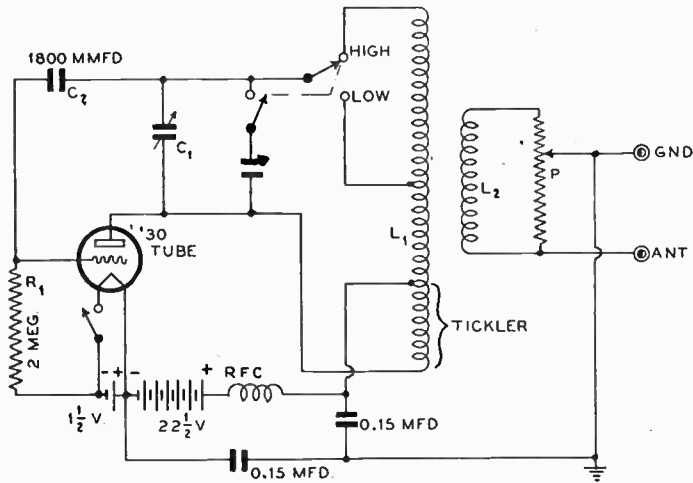

FIG. 17-9.—Simple battery-operated test oscillator employing the Hartley circuit. This is a portion of the Philco Model 048 all-purpose set tester shown in Fig. 5-19. (Courtesy Philco.)

the screen grid and tap terminals of the five coils and another switch controls the control-grid terminals. A 370 mmfd. variable condenser is used for the main tuning.

The plate of the r-f oscillator tube connects to the attenuator network through a 100 mmfd. fixed condenser. The attenuator is composed of a dual potentiometer connected as shown, which permits variation of volume from the minimum required for sensitive receivers, to the maximum output of the device for receivers badly out of alignment, etc. The entire oscillator is well shielded to prevent the direct radiation of signals. A shielded wire is furnished for connection between

the test oscillator and the receiver being aligned, the inside wire and the outside shield serving as the two conductors. The shield prevents radiation of the oscillator signal.

17-5. "Philco" Model 024 Test Oscillator.—Figure 17-9 shows the circuit diagram of the Philco Model 024 test oscillator. This is also the test-oscillator portion of the Philco Model 048 all-purpose set tester which was described in Art. 5-10 and illustrated in Fig. 5-19. This oscillator differs from the others previously described in that it is simple, self-modulated and has but two fundamental-frequency ranges. Higher frequencies are obtained by utilizing the harmonics of the fundamentals.

By means of the tapped grid coil arrangement shown, the range of fundamental frequencies available is from 105 to 2,000 kc. Higher frequencies can be obtained through the use of harmonics. The main tuning condenser is C_1 . This oscillator uses the series-feed Hartley oscillator circuit (see Art. 15-15), and is self-modulated by the grid lead R_1 and grid condenser C_2 . The grid coil, L_1 , is coupled to the attenuator magnetically by means of the pickup coil L_2 . The attenuator is simply a potentiometer, P , connected across the output of the pickup coil. The oscillator is battery-operated, the batteries for which are contained in the instrument case itself. The A battery is a single flashlight cell, and the B battery is a small $22\frac{1}{2}$ -volt unit.

17-6. "RCA Victor" Model 97B Oscillator.—The RCA Victor Model 97-B service oscillator is a 2-tube battery-operated unit designed for radio service work. It has a frequency range from 90 kc to 25 mc. a separate modulator tube is used. The illustration of Figure 17-10 shows the external appearance of the instrument. Its internal construction and arrangement of parts is shown in Fig. 17-11. The complete schematic circuit diagram is shown in Fig. 17-12.

The oscillator circuit is the familiar tickler type, with eight grid and tickler coils to cover the complete range in fundamental frequencies only. A three-gang coil switch is used to select the various coils in order to obtain the following bands of frequency ranges: (1), 90-200 kc; (2) 200-400 kc; (3), 400-800 kc; (4) 800-1,500 kc; (5), 1.5-3.1 mc; (6), 3.1-6.8 mc; (7), 6.8-14 mc; (8), 14-25 mc. Section $S-2$ of the gang switch is used to

select the grid coils, which have the *even* numbers from *L-2* to *L-16* inclusive; section *S-3* of the switch selects the *tickler* coils, which have the *odd* numbers from *L-1* to *L-15* inclusive; and section *S-1* is used to short-circuit two of the grid coils not in use,

FIG. 17-10.—Exterior view of the battery-operated all-wave test oscillator shown in Figs. 17-11 and 17-12. The range switch is at the left, and the frequency-calibrated dial is at the center. The output (attenuator) control is at the right. (Model 97B)



Courtesy RCA Victor Co.

for these might otherwise absorb excessive oscillator power. The illustration of Fig. 17-11 shows the arrangement of these coils in the oscillator.

A tap is taken from the coil side of the grid circuit to the



FIG. 17-11.—Interior view showing the construction of the test oscillator above. The two tubes, tuning condenser, coils, and filament and plate batteries are plainly visible.

Courtesy RCA Victor Co.

attenuator potentiometer *R-1* through a 4.5 mmfd. condenser, *C-1*. Control of oscillator voltage is secured through the use of the simple potentiometer circuit.

The second type '30 tube is the modulator. The *B* plus con-

nects to one side of the primary of the audio transformer *T-1*, the other side of which connects to the plate of the modulator tube and to the *B* plus side of the tickler coils in the high-frequency oscillator circuit. Thus, the same coil that feeds the modulator tube also feeds the oscillator, and hence modulation

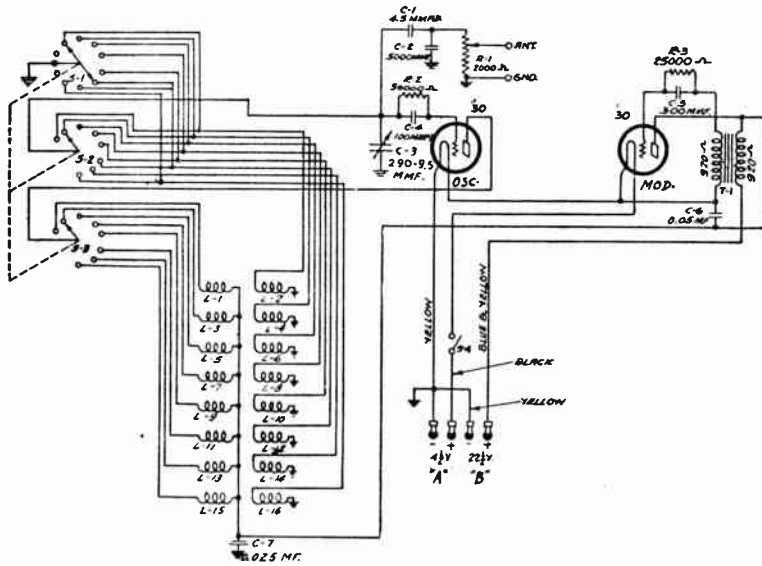

FIG. 17-12.—Schematic circuit diagram of the battery-operated all-wave test oscillator illustrated in Figs. 17-10 and 17-11. One tube acts as an oscillator, and the other as the modulator.

of the oscillator is secured by the usual constant-current system. The grid circuit of the modulator connects to the secondary of the modulation transformer, and, since the two coils of *T₁* are coupled magnetically, the modulator tube generates oscillations. The modulator frequency is 400 cycles, and the output of the oscillator is modulated about 50% by this.

Tuning is accomplished by means of a single knob of varying ratio. In other words, the knob of this oscillator has provisions for varying its tuning ratio from 6:1 to 20:1 by adjustment of the position of another small knob situated above the tuning knob. This variable ratio enables the operator to obtain a fine

variation of frequency at the high frequencies and a more rapid rate of control at the lower frequencies.

As already mentioned, the attenuator is of the potentiometer type. In some instances it may not be possible to lower the oscillator output sufficiently for sensitive receivers. The manufacturer recommends the following to be used to alleviate this condition. Two carbon resistors, one having a value of 100 ohms and the other a value of 100,000 ohms should be connected in series and placed across the *Ant.* and *Gnd.* terminals of the oscillator with the 100-ohm resistor connected to the *Gnd.* terminal. The "antenna" terminal of the receiver is then connected to the junction of the two resistors and the ground to the *Gnd.* terminal of the oscillator. Control of volume is then effected by the usual knob on the oscillator.

The oscillator is calibrated to within 3% of the scale reading and a special correction chart is supplied so that the user may correct the calibration for more accurate results. A special adapter may be obtained which, when plugged into the modulator socket, provides an unmodulated output.

17-7. "Readrite" Models 553, 554 and 556 Oscillators.— These test oscillators are similar except for the fact that the Models 553 and 556 have output meters incorporated in them

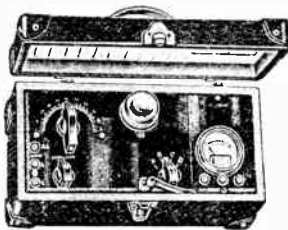

FIG. 17-13.—Exterior view of the battery operated test oscillator whose circuit diagram is shown in Fig. 17-14. The oscillator is shown here in its carrying case, with an output meter at the right. (Model 553)

Courtesy Readrite Meter Works

and the Model 554 has no output meter; the meters in the Models 553 and 556 are of different quality. A reproduction of the Model 553 instrument is shown on Fig. 17-13, and its schematic circuit diagram, except for the output meter, is shown in Fig. 17-14.

These oscillators are typical of the commercially available single-tube self-modulated units. A 2-turn pickup coil con-

needed to the potentiometer-type attenuator is coupled to the three grid coils, as shown. A 32-turn tickler coil in the plate circuit of the tube also couples to the grid coils for feedback

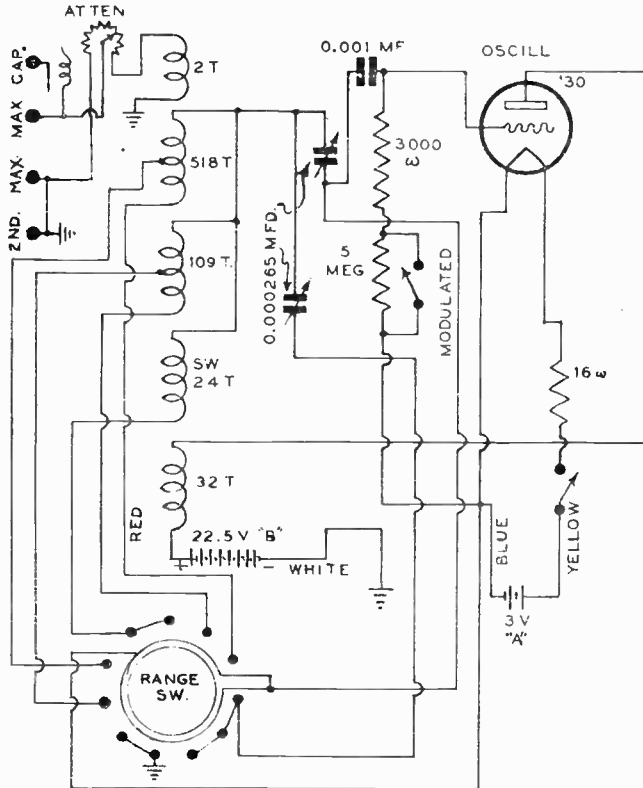

FIG. 17-14.—Schematic circuit diagram of the test oscillator illustrated in Fig. 17-13. Notice that the oscillator tube is self-modulated by the leak-condenser method.

purposes. A type '30 tube with self-contained batteries is used.

Self-modulation is accomplished by the leak-condenser method discussed in Art. 15-27, and a switch is utilized to facilitate short-circuiting part of the 2-section grid leak when no modulation is desired. The oscillator has four bands and can tune from 110 to 14,000 kc. Although there are only three tuning

coils, there are two variable condensers, which enable (by means of the switching system) the four ranges to be obtained.

Four output terminals are used. For weak signals, the *CAP.*, and *2nd* terminals are used, and the two center terminals marked *MAX.* are used for large outputs. It is to be noted that the lower *MAX.* terminal connects through the full attenuator resistance. The *CAP.* terminal is capacitively coupled to the small coil which connects to the upper *MAX.* terminal. A shielded wire is supplied for leading the oscillator signal to the receiver without radiation of the r-f signal.

17-8. "Supreme" Model 61 Test Oscillator.—The Supreme Model 61 all-wave test oscillator is a typical example of a single-tube unit of the a-c operated type that is automatically 100% modulated by the a-c power supply line. The oscillator is shown in Fig. 17-15 and its schematic circuit diagram in Fig. 17-16.

Two bands of fundamental frequencies are available: the first from 95 to 220 kc, and the second from 1.5 to 3.3 megacycles. Frequencies up to 21 megacycles are readily obtainable by the use of harmonics. As can be seen, the a-c line connects

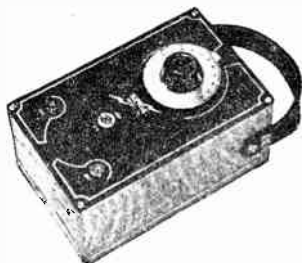

FIG. 17-15.—The line-operated, single-tube, all-wave test oscillator whose schematic circuit diagram is shown in Fig. 17-16. The compactness, and simplicity of control, of the instrument is apparent. (Model 61)

Courtesy Supreme Elect. Instr. Corp.

to the primary of a power transformer, *T*, the secondary of which develops 41 volts. This voltage heats the filament of the type '30 tube through a 200-ohm resistor and supplies plate voltage through the 2,000-ohm resistor. The secondary of this transformer is filtered by means of the elaborate choke-condenser filter system shown, to prevent the oscillator from feeding back into the line.

Two coils labeled *L* and *H* are, respectively, the coils for

the low- and high-frequency bands. The tuning condenser is shown above coil *H*. The plate and grid, through the grid leak and condenser, connect to the terminals of the two coils, in turn, through the double-pole double-throw tumbler switch, *S*. The

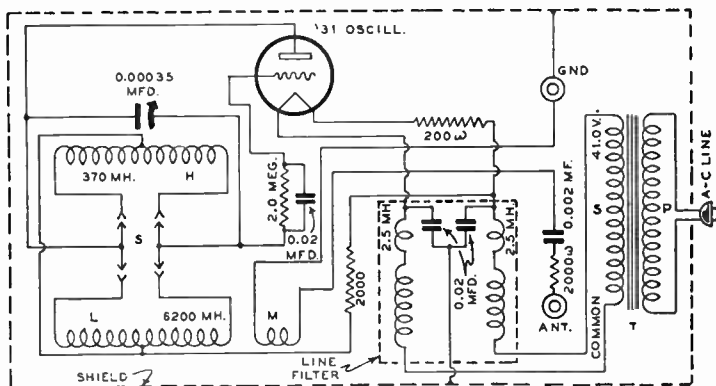

FIG. 17-16.—Schematic circuit diagram of the test oscillator illustrated in Fig. 17-15. A single tube is employed, and its output is modulated by the a-c line. A fundamental frequency range of 95 kc to 220 kc, and from 1.5 to 3.3 mc is provided.

center tap of each of the coils connects to the high-voltage line (which serves as both the filament and plate voltage supply), hence, the circuit is of the Hartley type. The small coil, *M*, near coil *L*, is a pickup coil and connects to the output terminals (*Ant.*, *Gnd.*) of the oscillator. No attenuator circuit is provided.

The values of the grid leak and grid condenser are such that practically no grid modulation takes place. It is the purpose of the grid resistor and capacitor combination (1) to provide the proper grid bias for the oscillator tube so as to maintain the proper impedance relations between the grid and plate circuits, and (2) to provide protection to the oscillator circuits against possible short circuits between the grid and plate elements of the oscillator tube.

The fact that a-c is supplied to both the filament and the plate automatically modulates the r-f of the oscillator 100% (see Arts. 15-25 and 15-27). This 100% modulation is a desirable feature when aligning the tuned circuits of modern radio

receivers in which the blasting effect of strong signals is minimized by volume level circuits which are most efficient when operating with signals from a 100% modulated broadcast station. If strong r-f signals are applied to a sensitive receiver of this type by a weakly modulated oscillator, it is possible to overload the detector with energy without having any appreciable loudspeaker output (or output meter reading). In some receivers, an overloading of the above-mentioned circuits with r-f energy may result in two maxima or "peaks" of the radio output, and in broad tuning when the modulation is considerably less than 100%. It is, therefore, obvious that the loudspeaker output (or output meter reading) is greatly dependent upon the percentage of the modulation of the input r-f signals. Since a-c is the only form of line voltage which will operate this instrument, it is not possible to secure an unmodulated output. However, 60-cycle modulation (the modulating frequency is

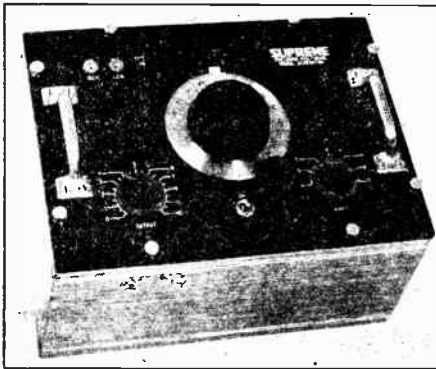

FIG. 17-17. — The battery-operated, two-tube, all-wave test oscillator whose schematic circuit diagram is shown in Fig. 17-18. (Model 180)

Courtesy Supreme Elect. Instr. Corp.

equal to the line supply frequency) is quite suitable for ordinary set aligning purposes.

The instrument is completely shielded in a cast aluminum case, which is grounded; it is hand calibrated with the tube supplied with the instrument. A calibration chart showing the frequencies supplied by the oscillator at any dial setting is furnished with the instrument. A shielded lead is provided for leading the oscillator signal to the receiver without radiation.

17-9. "Supreme" Model 180 Test Oscillator.—This is a 2-tube separately-modulated, battery-operated, all-wave oscillator of the electron-coupled type. A type '30 tube is the modulator, and a type '32 tube is used in the high-frequency oscil-

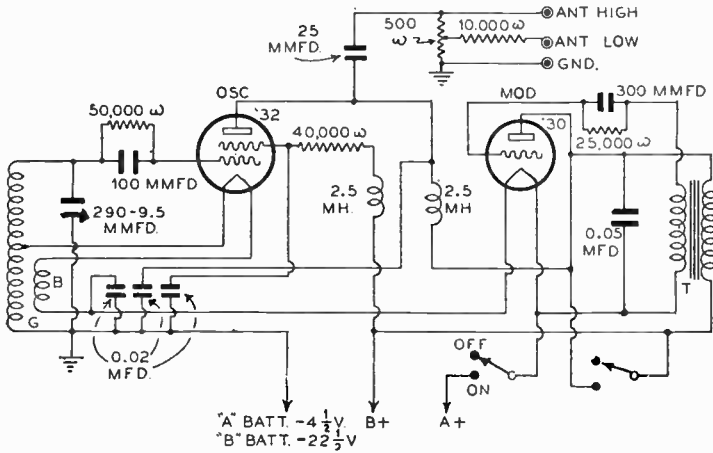

FIG. 17-18.—Schematic circuit diagram of the test oscillator illustrated in Fig. 17-7. This is a 2-tube, separately modulated, oscillator of the electron-coupled type.

lator circuit. The instrument itself is shown in Fig. 17-17, and the schematic circuit diagram is presented in Fig. 17-18.

The modulator circuit uses the transformer *T* in the conventional connection: one winding in the plate circuit couples to the other winding in the grid circuit. The constants are adjusted for the generation of a 400-cycle modulator signal. The grid leak and condenser in the modulator grid circuit are used to obtain proper automatic bias in the usual manner.

The oscillator circuit is of the electron-coupled type (see Art. 15-31). While only one set of oscillator coils is shown in Fig. 17-18 for simplicity, there are actually seven such sets whose connections are switched by means of a five-gang seven-position rotary switch. Three of the switch gangs switch the grid, tap, and ground connections of the main coils, labeled *G*; the other two are used to switch the additional small windings labeled *B*. It

will be recalled that one fundamental requirement of an electron-coupled oscillator circuit is that the filament tap be at a high-frequency potential; this means that the other leg of the filament must be at the same r-f potential, otherwise part of the coil will be short-circuited through the filament of the tube. It is the function of the "bucking" winding *B* to place one leg of the filament at r-f potential; the other leg of the filament is already at this potential because it connects to the tap on the main coil *G*. This idea has already been explained in Art. 15-31.

It will be noted that the plate of the oscillator tube is connected to the plate of the modulator tube through the 2.5 mh. r-f choke; hence the oscillator is modulated in the plate circuit. It is known that the frequency of a triode oscillator depends to some extent upon the plate voltage of the oscillator, which in the case of an electron-coupled oscillator means the screen-grid circuit. Therefore, if the screen-grid circuit of the oscillator were modulated, some *frequency* modulation might result at the same time that it is being *amplitude* modulated. It is also known that, in an electron-coupled oscillator, the plate (actual) is coupled to the oscillator elements by the electrons in the tube, and hence the *frequency* of oscillation is independent of the plate voltage. Since the r-f current in the plate circuit depends upon the plate voltage, it is convenient to modulate the plate current of the oscillator, thereby maintaining frequency stability, but varying the r-f output voltage at the rate of 400 cycles per second, which is exactly what modulation really is. Stated in another manner, the amplitude of oscillation in the oscillatory circuits remains constant, and the amount transferred to the plate circuit varies with the frequency of the modulation voltage.

The output of the oscillator is coupled to the attenuator through a 25 mmfd. fixed condenser, and the resulting voltage across the terminals of the attenuator is r-f modulated about 50% at 400 cycles. The manufacturer has found that a 20% decrease in the potentials of the self-contained operating batteries results in no appreciable change in oscillator frequency. The audio output is available from two jacks on the panel of the instrument (not shown), and the modulation may be shut off by means of the short-circuiting switch provided across

the plate circuit winding of the modulation transformer *T*.

Seven tuning bands are available, covering the complete range from 90 kc to 20 mc. This arrangement provides complete coverage, using fundamental frequency signals, of all super-heterodyne intermediate frequencies, standard American broadcast frequencies, police tuning bands, and all short wave bands down to approximately 15 meters. The guaranteed accuracy of the calibration is $\frac{1}{2}\%$.

Three attenuator pin jacks are on the panel. The "Ground" and "High" terminals provide maximum signal output, with no variable control, for circuits which require "feeling" with an oscillator until it is heard. This connection is also useful when neutralizing old types of insensitive neutrodyne receivers, and for preliminary adjustment of receivers which are badly out of alignment. The terminals "Ground" and "Low" are used for all other test work which requires variable attenuation.

17-10. "Weston" Model 694 Oscillator.—This oscillator is representative of the type using a single multi-element tube. One section generates the audio oscillations and the other generates

FIG. 17-19.—The test oscillator whose schematic circuit diagram is shown in Fig. 17-20. This oscillator is battery-operated and employs a single multi-element tube. (Model 694)

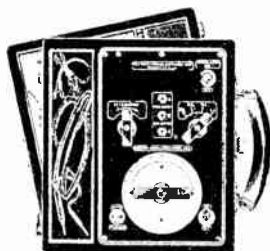

Courtesy Weston Elect. Instr. Corp.

the r-f oscillations, modulation being accomplished by the electronic coupling between the two sections (an application of the electron modulation principle discussed in Art. 15-26). Figure 17-19 shows an illustration of the oscillator, and Fig. 17-20 is its schematic circuit diagram.

The tube used is the 1A6 (or 1C6), which has a filament, a plate and five grids. Reading in the direction from filament to plate, we will refer to the grids as G_1 to G_5 inclusive. A breakdown of this circuit would show that the plate, filament, and

grids G_3 to G_6 , inclusive generate audio oscillations of sufficient intensity to modulate the r-f by about 30%. This generation is accomplished by the transformer, T , shown, one winding of which connects between plate and B plus while the other connects between G_4 (control grid) and filament. Grids G_3 and G_6 , connected internally, are shields to decrease cap-

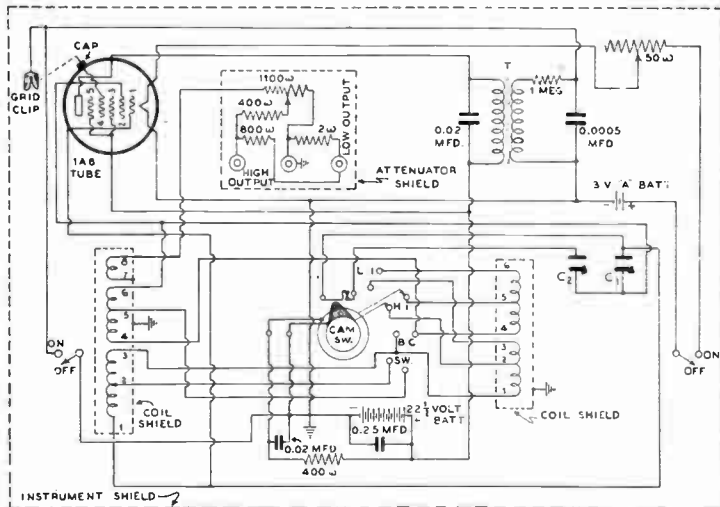

FIG. 17-20.—Schematic circuit diagram of the battery-operated test oscillator illustrated in Fig. 17-19. A multi-element tube is used, one section of which generates the r-f oscillations, and the other section of which generates the a-f oscillations for modulation. An "electron-modulation" arrangement is used.

acity-coupling to grids G_1 and G_2 , the oscillator section of the tube. In this discussion we will refer to grid G_2 as the oscillator plate and G_1 as the oscillator grid, because G_2 , G_1 and the filament constitute a separate triode for the generation of r-f.

There are four frequency bands in all: band LI covers the range from 100-300 kc, HI covers the range from 200-600 kc, BC from 500-1,600 kc, and SW from 1,500-3,000 kc. The letters are abbreviations for "low intermediate," "high intermediate," "broadcast," and "short-wave."

Although not apparent from the switching arrangement as drawn, the four ranges are obtained by two plate coils, and two

grid coils, each tapped as shown. The top coil on the left, designated by terminals 7 and 8, is a pickup coil which connects to the attenuator network for variation of the output from maximum to a minimum of 1 microvolt.

On the *SW* position coil 6-5 (left) and coil 2-1 (left) are in the circuit, with the *B* plus connected to terminal 5. On the *BC* position, coil 6-4 (left) and coil 3-2 (left) are in the circuit with the *B* plus connected to terminal 4. On the *HI* position, the plate coil consists of the coils 6-4 on the left and 5-4 on the right connected in series, and the grid coil consists of coils 3-1 on the left and 2-1 on the right connected in series; the lowest band, *LI*, contains 6-4 on the left in series with 6-4 on the right, while the grid coil consists of the series connection of 3-1 on the left and 3-1 on the right. The right- and left-hand sections are shielded from each other to avoid interaction.

The attenuator system provides for two outputs, "low" and "high". The "low" output voltage is that across a 2-ohm resistor connected in series with 1,100 ohms, the total being in parallel with the arm of the potentiometer and one end. "High" output is obtained across the potentiometer, with 400 ohms in series.

One of the two tuning condensers, C_1 , is always in the circuit, and the other, C_2 , is thrown in by the cam-switch to secure the desired frequency range on the *HI*. and *LI*. bands. Normally, it is connected across the grid and plate coils.

17-11. "Wireless Egert" Model 99 Test Oscillator.— This battery-operated test oscillator is typical of the type which uses a separate modulator tube electron-coupled to an oscillator (this is electron-modulation; see Art. 15-26) which covers the range in fundamental frequencies from 100 to 21,000 kc. The instrument itself is shown in Fig. 17-21, and its schematic circuit diagram is shown in Fig. 17-22.

The main tuning control is varied by a knob under the air-plane-type dial shown. This dial has a pointer which is equipped with a true vernier, which allows the dial to be read accurately to within 1/10 division; it has a ratio of 14 to 1.

As shown in Fig. 17-22, coils L_1 to L_7 are the oscillator coils, which connect to the type '30 oscillator tube in a standard tickler circuit. A 7-point two-gang switch *SW* changes the

plate and grid coils for each of the seven bands, the frequency range of each being as follows: (1), 12-21 mc; (2), 6.75-13.5 mc; (3), 3-7 mc; (4), 1.4-3.4 mc; (5), 550-1,500 kc; (6), 250-570 kc; (7), 100-255 kc. These are fundamental frequencies; hence it is not necessary to resort to the use of harmonics. Condenser C_1 is the main tuning condenser.

The r-f signal generated by the type '30 tube is fed to the fourth grid of the 1A6. This fourth grid is shielded by grids



FIG. 17-21. — The battery-operated all-wave test oscillator whose schematic circuit diagram is shown in Fig. 17-22. The circuit diagram reveals several very interesting circuit features of this oscillator. (Model 99)

Courtesy Wireless Egert Eng., Inc.

3 and 5, which also connect to the plate and to one side of the modulation transformer L_3 ; the other side of the modulation transformer connects to B plus. The other coils of this transformer, together with condenser C_2 , connects to grid No. 1 of the tube. Hence, the 1,000-cycle audio signal is generated by grids 1, 2, 3 and 5, and the plate. Modulation is accomplished inside the 1A6 tube by the modulating action of the audio grids on the electron stream (electron modulation).

It will be noted that the r-f attenuator connects to the plate of the modulating tube through a 0.006 mfd. fixed condenser. The audio-frequency signal is available externally as the voltage drop across one winding of L_3 . The connections are such that the audio signal may also be obtained from the r-f tip jacks, in which case the voltage output is approximately 1/20 volt at the full setting of the r-f attenuator.

The output impedance of the attenuator is low, about 100 ohms, which prevents ordinary loads from disturbing the calibration of the instrument. An unmodulated signal may be ob-

tained by short-circuiting the a-f pin jacks. An interesting feature of the instrument for service work is that the attenuator is of the logarithmic output type, and is calibrated directly in

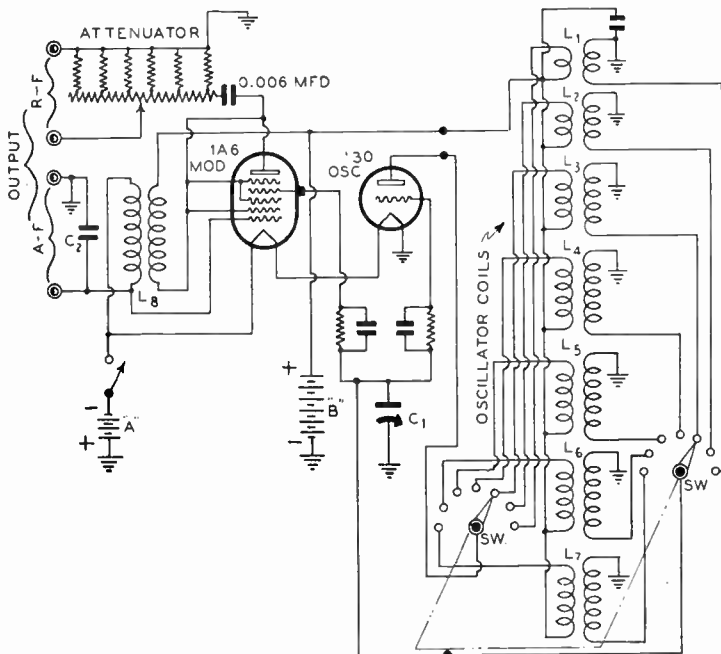

FIG. 17-22.—Schematic circuit diagram of the battery-operated test oscillator illustrated in Fig. 17-21. A separate combination “a-f oscillator” and “modulator” tube, electron-coupled to the oscillator tube, is employed for “electron modulation”. Seven coil units are employed to cover the frequency range of 100 kc to 21 mc.

“microvolts”, although the calibration is only approximate. However, it permits the operator to obtain some idea of the value of voltage he is feeding to the apparatus under test.

REVIEW QUESTIONS

1. Draw the circuit diagram of the modulating system used in the service test oscillator of Fig. 17-2, and show the means used to shut off the audio modulation.
2. What is the principle of the attenuator used in the test oscillator whose schematic circuit diagram is shown in Fig. 17-5?

3. What type of modulation is used in the oscillator of Question 2? Explain how you arrive at your answer.
4. What type of oscillator circuit is used in the signal generator of Fig. 17-7?
5. What type of oscillator circuit is used in the test oscillator of Fig. 17-12? How is the oscillator modulated?
6. What modulating system is used in the service test oscillator of Fig. 17-14?
7. The test oscillator of Fig. 17-16 uses but two tuning coils. How are the higher frequency signals necessary for the alignment of short-wave and all-wave receiver circuits obtained? Explain!
8. The signal generator of Fig. 17-18 uses filament-type tubes in an electron-coupled circuit. What means is taken to keep the entire filament at r-f potential? Illustrate by diagram.
9. How are both audio and radio-frequency voltages generated by the single tube used in the oscillator of Fig. 17-20? Explain!
10. Why can audio-frequency energy be obtained from both the audio tip jacks and the r-f attenuator tip jacks in the test oscillator of Fig. 17-22? Explain!
11. Why is the r-f signal output of test oscillators purposely modulated?
12. Explain why a high degree of modulation is desirable.
13. Under what servicing conditions must battery-operated test oscillators be used exclusively?
14. What is meant by "frequency-drift" of a test oscillator? What is the objection to it?
15. (a) Explain why test oscillators are usually completely shielded.
(b) Explain why the connecting lead between the test oscillator and the receiver under test is shielded.

PART 2

**THE PRACTICAL SERVICING
OF RADIO RECEIVERS**

CHAPTER XVIII

PRELIMINARY TESTS FOR TROUBLE

18-1. Introduction.—The process of testing a radio receiver to determine the location and cause of trouble is commonly called *trouble shooting*, and it is the goal of every radio service man to become expert in locating trouble quickly and directly. The ease and rapidity with which a receiver may be analyzed or diagnosed depends largely upon the technical knowledge and practical experience possessed by the individual, as well as upon the test equipment he has available. It is impossible for one to become an expert trouble shooter unless he has a thorough knowledge of the fundamental principles and circuits upon which the operation of different parts of radio receivers depends. This knowledge can be gained only by thorough training in electrical and radio principles, and by the constant application of these principles.

Service men usually work out their own methods or procedures for revealing the location and nature of troubles that may cause a receiver to operate unsatisfactorily or not at all. The set analyzer is a valuable aid in this work, but, as we shall see, intelligent radio servicing consists of far more than merely operating a set analyzer mechanically. It is of utmost importance that the service man learn to observe and recognize the symptoms which the analyzer, or other meter equipment, reveals, as well as those which it cannot disclose. This chapter is intended to serve as an outline and a guide for the development of a rapid system for making preliminary tests on receivers. Undoubtedly, each man will continue to add additional tests or "short cuts" to those presented here as his experience in radio service work increases, but the tests described in this chapter will

serve as a solid, practical foundation. The more detailed tests will be described in later chapters.

18-2. Preliminary Questions to Ask the Owner.—Before any effort is made to analyze a receiver, the service man should question the set owner briefly in order to acquaint himself with all the information about the receiver that the owner can give. In many instances, the information obtained by these questions will furnish some indication of the probable source of trouble before any testing is done. Upon arriving at the owner's home, questions such as the following ones should be asked:

1. What is your complaint regarding the receiver?
2. Did the trouble develop recently?
3. Has the set ever experienced the same trouble before?
4. Did the set stop suddenly?

If the trouble is "gradual fading" or "intermittent reception", the following questions should be asked:

5. Does reception die out or fade gradually, or does it cut off sharply?
6. How long does it take before reception is again obtained?
7. Can you make reception normal by operating any switches, striking the cabinet, or by any other unusual method?
8. How often does the fading occur?
9. When reception fades out and comes back either gradually or suddenly, can you hear a click?

If the trouble is "noisy reception", ask these questions:

10. How long has this noise existed?
11. Is the noise of an intermittent nature?
12. During what time of the day or evening have you noticed the presence of the noise?

The purpose of the first set of questions is to get the owner talking about the set. The fact that the owner of the set can definitely state his complaint is an indication that something is actually wrong with the receiver. Very often, service men are called on jobs, only to find that the owner *thinks* something might be wrong, not because he *knows* definitely that something

is wrong. If the owner's reply to the second question is that the trouble only developed a short time ago, then the service man is more sure of the fact that the trouble is not inherent in the particular design of the receiver. If the owner experienced the same trouble before, then try to determine who repaired the receiver, if at all, and if the set worked satisfactorily after it was repaired. This is a very important point to settle definitely. The fact that the receiver stopped operating suddenly is an indication that the trouble is something definite, and not one of those elusive symptoms that never seem to occur when the service man is present!

The remaining questions will enable the service man to get the owner's opinion regarding the trouble. It often happens that the trouble, if it is of an intermittent nature, may not develop as soon as the set is turned on. Questioning the owner will establish this fact, and the service man should not leave until the trouble has appeared. If the owner is not questioned, the service man may leave without noticing any trouble at all, pronounce the set *O. K.*, and have his reputation as a service man suffer when the set exhibits the same troubles again at some later time.

The few questions suggested here will undoubtedly lead to others, and an idea of where to begin trouble shooting may often be obtained from them. Under no circumstances should the owner be asked the question, "What is the trouble?" for, if this were known, the probability is that a service man would not have been called in the first place! The asking of too many questions should also be avoided, for the customer may feel that he is hiring and paying *you* to *find* the trouble, not to cross-examine *him*. The manner and willingness with which the owner volunteers information regarding the set should be the service man's guide regarding the number of questions to ask.

18-3. Receiver Symptoms which are Common.—The receiver switch should now be placed in the "on" position and, after allowing sufficient time for the tubes to heat up, tuned to the signal of a broadcasting station. The next step depends upon what happens when this is done. It is very likely that a clue to the trouble will be obtained quickly by carefully noting the

symptoms exhibited by the receiver, and making a few preliminary tests which take only a few minutes to perform. Some of these symptoms are as follows:

1. The receiver may not operate at all.
2. The output may be weak.
3. Reception may be noisy or intermittent.
4. The tone quality may be poor.
5. The loud speaker may blast or rattle on certain notes.
6. One or more tubes may not light up.
7. The set may oscillate, or hum.
8. The set may be noisy only while tuning.

18-4. Preliminary Tests to be Made.—After the trouble symptom is noted, the service man should reason carefully, and attempt to think of the various troubles which might lead to such a symptom. Preliminary tests to check on these assumptions should then be made. Of course an experienced service man will often be assisted greatly at this point by any previous experiences with troubles of a similar nature in similar receivers. We will now consider some of the simple preliminary tests which should be part of every service man's routine, since they will disclose troubles that the usual receiver analysis with a set analyzer will not reveal. In many cases, they can be made without removing the chassis from the cabinet. The sequence in which these preliminary tests are made really depends upon the trouble symptom noted, experience and personal preference. No importance should be attached to the order in which they are presented here. The time required to make these tests is actually very short, even though it requires several pages to explain them here.

18-5. Checking the Entire Antenna Circuit.—When the volume is low, or no signals at all are heard when the receiver is set in operation with the volume control adjusted to its "maximum-volume" position, the *B* battery voltages should be checked at once, if it is a battery-operated receiver. If it is an a-c operated set, the voltages applied to the tubes (and the tubes themselves) should not be tested first. It is preferable to check

over the antenna* system first in either of the two ways which will now be explained.

A rough, comparative test of the signal pick-up of which the aerial is capable may be made by tuning the receiver to a broadcast signal, with the volume control at "maximum", and then disconnecting the lead-in wire from the receiver. The signal strength should fall off very noticeably when this is done, regardless of what its original strength was. In a well-shielded set, very little or no signal at all should be heard when the lead-in wire is removed from its binding post. If a broadcast signal is not available, the lead-in wire should be disconnected and tapped repeatedly on the "Ant" binding post of the receiver. A series of *loud* clicks should be heard when this is done. The *absence* of these reactions usually indicates an *inefficient antenna circuit*, assuming that there are no tube or internal receiver troubles.

A high-resistance ground also is often the cause of weak signals. The efficiency of the ground circuit may be checked in a manner similar to that employed for the aerial circuit. However, there may be little or no drop in volume when the ground lead of an a-c operated receiver, which employs "grounding condensers" for minimizing hum effects, is removed. These condensers offer a low-impedance path for the r-f signals from the power-supply-circuit ground to chassis. Also, the capacity between the primary and secondary of the power transformer may effectively ground the receiver. Transformers with electrostatic shields are usually no exception to this.

A more detailed test of the antenna system is to inspect carefully as much of the aerial and ground wires as are conveniently accessible. The lead-in and aerial portions of the antenna should not touch any grounded metal objects at any point. All aerial, lead-in, and ground joints should be properly soldered or carefully spliced and taped to prevent corroded connections. The insulation on the lead-in strip should also be examined. The common practice of nailing this strip to the win-

*NOTE: The horizontal, or elevated wire is the *aerial*; the wire from the aerial to the set is the *lead-in*, and the aerial, lead-in and ground wires together constitute the complete *antenna circuit*.

dow sill should be avoided, especially where the sill is of metal, and, if possible, other means should be employed to hold this device in place. The ground clamp should be *clean* and fastened *tightly* to a *clean* portion of the object used for grounding (usually a cold water pipe). The locations of possible and common defects in an outdoor antenna system are pointed out in Fig. 18-1.

A quick test to determine if the aerial or lead-in is grounded at any point may be made by connecting an ohmmeter be-

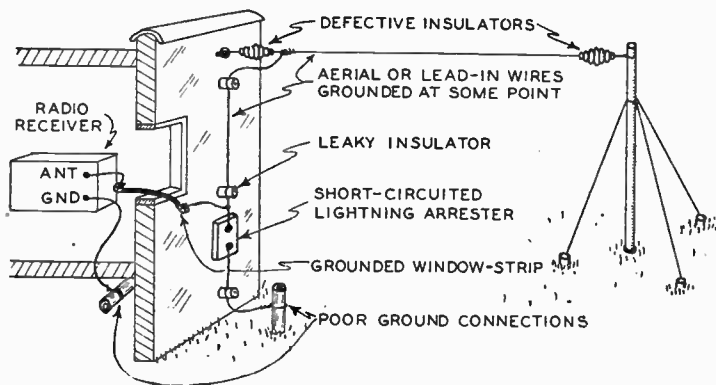

FIG. 18-1.—Places in a typical outdoor antenna system where trouble is likely to occur.

tween the lead-in and ground leads (when they are disconnected from the receiver), and measuring the insulation resistance between them as shown at (A) of Fig 18-2. Any other method of measuring resistance (see Chapter III) may be employed if an ohmmeter is not available. High-resistance type grounds, however, will not be disclosed readily with these simple set-ups. The lightning arrester also should be tested with an ohmmeter for leakage and short-circuits, as shown in (B) of Fig. 18-2. All wires should be disconnected from one terminal of the arrester when this test is made; the wires should be replaced properly after the test. A complete open circuit ("infinite resistance" reading on the ohmmeter) indicates a good arrester.

The condition of the receiver ground may be checked by first

measuring the line voltage directly with a low resistance a-c or d-c voltmeter, depending upon the type of line supply. This is shown at (A) of Fig. 18-3. The voltage should now be measured by connecting one side of the voltmeter to the ground connection to be tested, and inserting the other voltmeter lead into

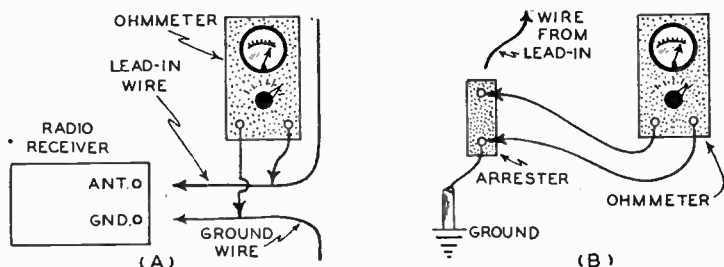

FIG. 18-2.—(A): Testing the aerial and lead-in circuit for grounds or high-resistance leaks, using an ohmmeter.

(B): Checking the lightning arrester for leakage and short circuit, using an ohmmeter.

each terminal of the line outlet in turn until a reading is obtained on the voltmeter as shown at (B). The circuit is being completed through the "ground" circuit of the electric light line,

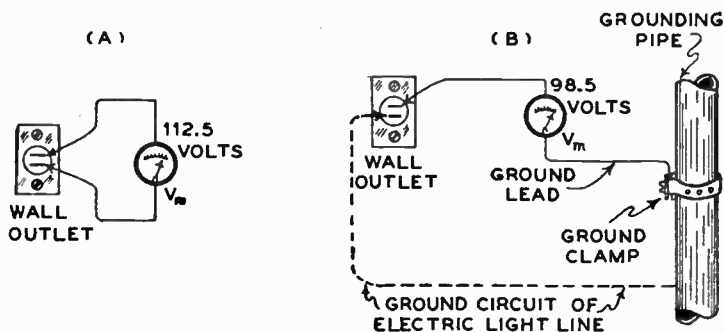

FIG. 18-3.—Measuring the resistance of the "ground" employed on a radio receiver.

as shown by the dotted-line circuit in (B). The second reading should be substantially the same as the first reading. If they differ noticeably, it shows that there is some resistance in the

ground circuit. Its value may be determined by considering the difference in voltage between the two readings and the ohms-per-volt value of the meter employed in making the measurements.

Thus, suppose the first reading gives a true line voltage of 112.5 volts, and the second reading of the meter, through the ground to be tested, is 98.5 volts. The voltage drop across the resistance of the ground circuit is then $112.5 - 98.5 = 14$ volts, as shown by the sketch of Fig. 18-3, (A) and (B). It is clear from (B) that the current flowing through the ground resistance in the second test is the same as that through the meter. If the sensitivity of the meter is 1,000-ohms-per-volt, and if the *full-scale* deflection of the meter is 150 volts, its resistance is 150,000 ohms. The voltage across the meter in the second test is the reading of the meter, that is 98.5 volts. The meter current is, therefore, $98.5/150,000 = 0.00065$ ampere; this is also the current flowing through the ground resistance. The resistance of the ground is found by dividing the voltage across it by the current through it, or $14/0.00065 = 21,500$ ohms (nearly).

18-6. Noisy Reception.—If the complaint is noisy reception, it is possible that it may be caused by a defective tube, a loose connection, some broken wires, one or more arcing components within the receiver, or by a faulty antenna system. It is also possible that it may be due to unfiltered or faulty electrical appliances or machinery operated in the vicinity of the radio receiver or antenna (these causes are discussed in detail in Chapter XXX).

While the noise is being received strongly, disconnect both the lead-in and ground wires from the receiver terminals. (Of course, the broadcast program may not be heard when this is done.) Usually, it is also best to short-circuit the "Ant" and "Gnd" terminals of the set by a *very short* piece of wire. If the noise *does not disappear or decrease in strength* when this is done, the trouble is most likely in the radio apparatus itself. On the other hand, *if the noise does disappear or diminishes* in strength, it may safely be assumed that the source of the noise is located outside the receiver. In this case the problem is more difficult, for the disturbance may be set up by an electrical device which may be located in some inaccessible place, per-

haps hundreds of feet away from the receiver or the aerial.

The complaint of *noisy reception* is such a common one with modern receivers of high sensitivity, especially with the use of many electrical appliances in the modern home, that the different tests and apparatus required to track down and eliminate sources of noise will be considered in detail in Chapter XXX. This phase of radio servicing is a special field in itself, and often taxes both the skill and patience of those engaged in it.

18-7. **The Main Units of the Receiver.**—If the foregoing tests do not disclose the cause of the trouble, or if the receiver does not operate at all, attention must be directed to the receiver itself. There are several preliminary tests which should be made for they will often enable the service man to quickly localize the trouble in the receiver without removing the chassis from the cabinet or using any meter equipment. Before suggesting any preliminary tests, let us review the general types of receivers that may be encountered in service work.

There are two main types of broadcast receivers in common use in the United States at the present time: the tuned radio-frequency type of receiver and the superheterodyne, the latter having attained great popularity during the past few years. Of course, receivers of different manufacturers and of different dates of manufacture differ greatly as to individual circuit and tube arrangements, parts design and layouts, etc., but they all may be resolved into these two main types. Every radio receiver consists of several separate electrical units, each of which performs a distinct function. These units are all assembled and wired together on a single chassis, but, for purposes of receiver analysis, it is more convenient to consider them separately.

The usual tuned-radio-frequency type of broadcast receiver consists of the *tuner and radio-frequency amplifier* for amplification of the carrier; the *detector*, to remove the audio component; the *audio-frequency amplifier* for the amplification of this audio; the *loud speaker*, and the *power supply*. A simple block diagram showing these units in their proper sequence, from left to right, as the radio signal progresses through them is shown in Fig. 18-4. The block diagram showing the units of the superheterodyne receiver is presented in Fig. 18-5. A study of this

diagram shows that the signal impulses progress from the antenna to the *r-f amplifier*, which amplifies the signal; thence to the *first detector* or "*mixer*" tube (the *local oscillator* also feeds into this tube) where the carrier frequency of the signal is reduced to that of the *i-f amplifier*; through the *intermediate-frequency amplifier* for further amplification; through the

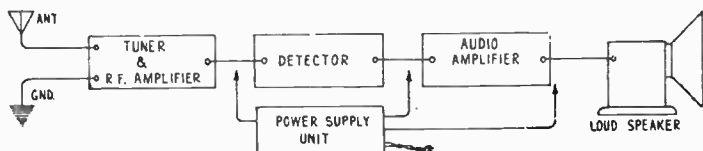

FIG. 18-4.—The main units of a t-r-f receiver shown in proper sequence, from left to right, as the radio signal passes through them.

second detector for the removal of the audio component; through the audio amplifier for the amplification of the audio component; and finally into the *loud speaker*. The *power supply unit* furnishes the necessary voltages to operate the tubes in each of these systems. In many superheterodynes, particularly of the

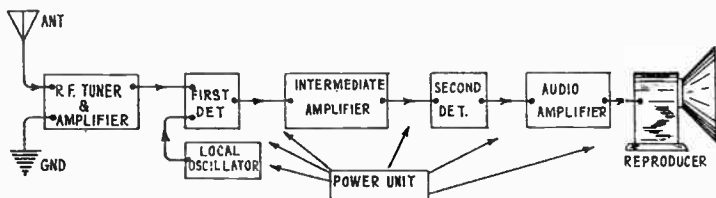

FIG. 18-5.—The main units of a typical superheterodyne receiver shown in their proper sequence, from left to right, as the radio signal passes through them.

midget type, the *r-f amplifier* ahead of the first detector is not employed, the signal being fed directly to the first-detector or "*mixer*" tube. Also, in many receivers the functions of "*oscillator*" and "*mixer*" are performed simultaneously by a single pentagrid converter tube.

18-8. Preliminary Tests on the Receiver Proper.—There are several simple tests which usually enable the service man to tell in just which of the main portions of a receiver trouble may exist. These tests are as follows:

If the detector tube is tapped sharply with the finger and a

ringing sound, or "bong", is heard, it indicates that the audio-frequency amplifier, the reproducer, and the power-supply unit are at least operating.* If this is the case, pass on to the next test. If no ringing sound is produced, attention should be directed to individual analysis and tests of each of these parts. These tests will be considered in Chapters XX, XXI and XXII. Another detector test consists of placing either a finger or the aerial lead-in on the *grid* terminal of the detector tube while it is in its socket. A loud hum should be heard if the detector, audio amplifier, reproducer and power-supply systems are functioning. If the detector is a screen-grid tube, the tube test should be applied to the control-grid cap of the tube—with the connecting clip removed. If this test fails to indicate trouble, then the radio- or intermediate-frequency sections of the receiver are at fault or the detector is of the "diode" type, in which case the "hum-response" test cannot be used. At any rate, the detector, audio amplifier, reproducer and power supply have been eliminated from our consideration for the time being if the "finger response" test give a "positive" result.

Suppose the receiver is of the t-r-f type and these tests show the detector and parts following it to be operating; then the next step is to locate the portion of the radio-frequency amplifier in which the trouble lies. Localization in the r-f amplifier can be effected by first removing the *last* r-f amplifier tube from its socket and inserting the end of the lead-in wire into the *plate* hole of the socket of this tube, so that it makes contact with the plate-prong contact spring. The receiver should then be tuned to a local station (one which is normally received very loudly) to see whether any reception can be obtained (weak, of course). If this stage proves satisfactory, the tube should be replaced; the tube from the stage immediately preceding should be withdrawn and the lead-in wire placed on the "plate" contact spring of that tube socket. This procedure should be continued until the inoperative stage is found.

This method cannot be used in superheterodyne receivers because the tube usually preceding the second detector is an

*NOTE: In receivers employing all-metal tubes, tube-tapping, etc., may not produce any such sounds, since in these tubes the elements are supported more rigidly.

intermediate-frequency amplifier, which is tuned, in most instances, to a frequency lower than that of the broadcast band. When this is the case, a quick test can be performed by tapping or touching the control grids of the i-f amplifier or amplifiers, first detector, oscillator and r-f tubes, in turn, with the end of the lead-in wire. A loud "click" should be heard when this test is applied, and the strength of the click should increase as the amplification of each stage is added to the circuit. This test, however, will not disclose inoperation due to mis-alignment of the tuned circuits.

Still another method which many service men use to isolate receiver failures quickly, is to quickly remove and re-insert each tube in its socket, noting the intensity of the clicks produced in the loud speaker. This test should start with the last audio tube. If no click is heard upon removing a tube, it is almost certain that the faulty stage or circuit has been located, and that particular part of the receiver should be tested thoroughly, at once. This method however, should be employed as little as possible, especially in the audio amplifier portion of the receiver, since the surge caused by the rapid removal and insertion of an audio tube may cause the primary or secondary winding of an audio transformer to break down. Removal of power tubes while the set is operating may also damage or puncture electrolytic filter condensers because of the increased voltage stress placed upon them due to the surge caused by the almost instantaneous reduction in the load current.

As each tube is being tapped to determine the condition of the audio amplifier, it is well to listen for a peculiar type of musical "bong" that indicates loose elements. When a tube is good and when the stage to which it connects is in working condition, the musical note heard upon tapping the detector or first-audio tube is clear and sharp. But if the tube has one or more loose elements, the note will be raspy, erratic, and sometimes will increase and decrease in strength several times before dying out. Such a tube should be replaced and the test continued.

18-9. Value of the Preliminary Tests.—The reader may well inquire at this point why, if the radio set analyzers studied

in Chapters XI to XIV are so helpful and important in radio service work have they not been mentioned thus far in the tests described for locating trouble in the receiver? The answer to this logical question is that, while the service man could start trouble shooting by immediately bringing his analyzer into use and checking all readings at the various tube sockets in the receiver in order to locate trouble, it has been found by experience that many radio receiver troubles are of such nature that they may be determined more quickly if the preliminary tests mentioned thus far in this chapter are made first, provided that the trouble symptoms are common ones. After these tests are understood and practiced for a short time, they take but a few minutes to perform, and are carried out almost automatically by experienced service men. If they show the trouble to exist in the antenna system, no time need be wasted in testing the entire receiver. Localization of the cause of inoperation (or poor operation) of the antenna system should then be attended to. Likewise, if these tests show definitely that the trouble exists in the detector circuit, or in the i-f or r-f amplifier, the set analyzer may then be used to test the circuits of the tube in the particular stage suspected—without spending the time necessary to test the circuits of all the other tubes.

If the receiver will not operate at all and these primary tests do not provide any clue to the possible source of the trouble, the set analyzer must be resorted to, and the circuits of each tube must be analyzed completely with it. At most, only a few minutes will have been lost by having made the preliminary tests first.

18-10. **Limitations of the Preliminary Tests.**—These preliminary tests are of value only when some sort of sound can be heard from the loud speaker. If the speaker, for example, is inoperative, no finger or tapping tests can reveal the trouble—the set will act in exactly the same manner as if the tubes had no plate voltage. Even after tapping the detector tube and hearing the desired “bong”, it is by no means certain that all tubes and circuits following the detector are in good condition. The only thing that is certain is that any signal that *does* reach the detector will be amplified to some extent by the audio system—possibly not enough. If the complaint of the customer

is that the receiver has normal volume but distortion, no amount of finger-tap testing will reveal the trouble. The main virtue of these tests is, then, that they enable the service man to get a general idea of the operation of the receiver in a very short time, and *may* indicate where the trouble lies—quickly.

REVIEW QUESTIONS

1. Formulate a set of questions which the service man should ask the set owner upon arrival at his home. Explain just how the answer to each question will assist the service man to diagnose the trouble quickly in many instances.
2. Explain briefly the procedure followed in checking the efficiency of an antenna system.
3. If a loud "click" is heard when the ground wire is touched to the "ground" terminal of the receiver, what does this indicate?
4. Explain how to make a rapid test of a receiver to determine whether or not a complaint of noisy reception is caused by the receiver itself.
5. Why is the practice of removing the aerial and ground wires from a receiver to determine the cause for noisy reception insufficient in most cases?
6. Will a ringing sound be produced in the loud speaker if the detector or audio tubes in a receiver are tapped sharply with the finger? What does this indicate? Why cannot this same test be applied to the tubes in the radio-frequency amplifier?
7. How may the r-f amplifier stages be tested quickly if a receiver is inoperative and the test mentioned in the previous question shows the detector, audio amplifier, and reproducer to be operating properly?
8. Explain why it is usually best to make preliminary routine tests on a receiver before using the set analyzer.
9. Why is the practice of removing a power tube to determine the condition of that stage by listening for a "click" inadvisable?
10. Make a list of the different preliminary tests which should be made on an inoperative electric receiver before employing the set analyzer.
11. Explain how each of the tests in Question 10 are made.
12. Explain the value of each of these tests.
13. Select any two of the foregoing tests and explain in detail just what troubles might be revealed by their use.
14. (a) If an ohmmeter were used to check the insulation between the aerial circuit and the ground, what would it read if the insulation were very good?
(b) What would the meter read if the ohmmeter test were made on a "shorted" lightning arrester?
15. Describe briefly the manner in which the service man may isolate the cause for the inoperation of a superheterodyne receiver by means of preliminary tests before using the set analyzer.

CHAPTER XIX

PECULIARITIES OF AVC AND QAVC CIRCUITS

(Tuning Indicators)

19-1. Automatic Control of Volume.—Many troubles associated with modern radio receivers are caused by some failure in the automatic-volume-control (abbreviated *avc*) system. In most instances, these failures cannot be checked and located by ordinary voltage-current analyzers, since very high resistances are employed in *avc* circuits, and the connection of an ordinary voltmeter to these circuits will often alter the existing voltages considerably (see Art. 2-19) even if high-resistance type voltmeters are employed. Of course, the use of a vacuum tube voltmeter overcomes this difficulty, but V.T. voltmeters can hardly be classed as common instruments possessed by most service men. In any event, the presence of extremely high resistances in *avc* circuits may prevent accurate voltage measurements with the instruments which most service men possess. For this reason, the determination of receiver failures caused by trouble in the *avc* circuit requires an intimate knowledge of the “whys and wherefores” of automatic-volume-control systems. Of course, it is true that these troubles may be located through the use of point-to-point tests, but, by knowing the purpose of the various common circuit arrangements and methods for securing *avc* action, a much better understanding of the problems which may be encountered will be had.

Automatic-volume-control systems have been designed in order to reduce the necessity for repeated manipulation of the volume-control knob of radio receivers, and to prevent overloading of the amplifier tubes on strong signals. In the average receiver of a few years ago, when the signal of a powerful broadcast station was tuned in (with the volume control setting

unchanged) after the tuning controls had previously been set for a weaker station, the strong signal from the powerful station would roar in very loudly and uncomfortably. The volume control would have to be manipulated to reduce the sound to a comfortable level. Similarly, it was necessary to remember to increase the setting of the volume control when the receiver was tuned from a powerful station to a weaker station. The use of automatic volume control has remedied this condition by providing a means whereby setting the volume control for a weak station will not produce sudden, loud blasting when passing the carrier wave of a strong signal. In other words,

the automatic volume control continuously and automatically adjusts the sensitivity of the receiver, so that the signal input to the audio amplifier remains fairly constant, within certain limits, over a wide range of received signal strengths.

The loudness level desired is set by the manual volume-control setting. If the signal from a distant station is much weaker than that from a local station, when the weak signal is being received the avc increases the amplification of the receiver by a sufficient amount so that the weak signal is amplified to the point where it will be heard at the desired volume level. When a very strong signal is being received, the reverse action takes place. In other words, the avc system may be considered as an automatic electric valve that raises the sensitivity of a receiver when weak signals are being received, and automatically lowers it when strong signals are received.

The signal from a loud local station requires but a fraction of the amplifying possibilities of the receiver in order to be heard at comfortable volume; the signal from a very weak or distant station may require more than the amplifying ability of a certain receiver in order to be heard with the same volume as the stronger signal. This means that a very weak signal, in spite of the avc system, may not be amplified sufficiently to produce the desired volume. The avc system is not a cure-all for insensitive sets; it is merely a device to adjust whatever amplifying ability a set has, to suit particular signal strengths. When a receiver with a good avc system is tuned from

one end of the scale to the other, most of the stations will be heard with the same volume. The only stations that will be heard very weakly are those which require more amplification than the receiver is able to produce.

The possibility of distortion is also less with receivers equipped with good avc systems. Since the avc system keeps the input to the audio system at a nearly constant level for a fixed setting of the manual volume control, it is clear that designers of radio sets may adjust this level so that the audio tubes are never overloaded under normal operating conditions. This is probably the most important feature of the avc system from the standpoint of the service man.

From the discussion thus far, it is clear that for the tuning-dial settings between stations, the signal strength is *zero* and therefore the sensitivity of the set is *maximum*. This means that any bit of background noise is amplified with the receiver operating at its *maximum* amplification condition, so the noise is heard loudly. But when a station is tuned in, the sensitivity of the receiver drops, and the amplification of the noise drops. In fact, when a fairly loud signal is tuned in, the background noise may drop out completely, only the desired signal being heard. This fact may be used to good advantage by the service man to determine if a receiver is provided with avc, without tracing the circuit or examining the circuit diagram. But this check is not always valid either. If the noise level is greater than a weak signal, then it will be the noise that will drop the sensitivity of the set, and the weak signal will disappear altogether. The rule is, then, that the noise will drop out only if it is weaker—much weaker—than the signal being tuned in.

Another advantage of the avc system is its ability to maintain the level of fading signals constant. The manner in which this is done is simple. As a station fades out, either slowly or rather rapidly, the sensitivity of the set is automatically increased, and the signal is amplified more; the reverse is true when the signal strength builds up to more than its average value. This ability is not so important in receivers designed for home use as it is for those sets intended as automobile receivers. As will be discussed in Chapter XXVII, the field strength of a

signal varies greatly as the automobile in which the set is placed passes under or over bridges, through tunnels, close to steel buildings, etc., and it is the purpose of the avc system to maintain the output level fairly constant with widely fluctuating signal strengths. It is evident that auto-radio receivers must be extremely sensitive in order to amplify the very weak signals encountered at certain times, and must be provided with very effective avc systems.

There are many other peculiarities of avc systems that can be appreciated only after a study of the systems themselves has been made. They will be discussed at various places in the following part of this chapter.

19-2. Action of Several Typical AVC Circuits.—The fundamental purpose of the avc system is to vary the amplification produced by the r-f and/or i-f amplifier of a radio receiver *in inverse proportion* to the strength of signals received—loud signals are amplified proportionately less than weak signals. There are several ways in which this may be accomplished. In one, the signal is fed to a tube and the plate resistance of this tube is shunted across the primary of an r-f or i-f coupling transformer. A loud signal will lower the plate resistance of the tube and thereby increase the shunting effect on the transformer—decreasing the amplification of the stage connected to the amplifier. This method was used in some receivers, but was later discarded because sufficient control could not be obtained with it, and because the decrease in amplification was not *proportional* to the loudness of the signal.

Another method is to feed the signal to a tube, and by means of certain circuit arrangements automatically vary the screen-grid voltage of one or more amplifier tubes in the receiver in proportion to the strength of the incoming signals. On loud signals the screen-grid voltage is lowered; on weak signals it is raised. In this manner the amplification of any particular tube can be automatically controlled. This idea is shown in the circuit diagram of Fig. 19-1. Part of the signal from the last i-f stage of a superheterodyne (the form of home and auto receiver now in general use) is applied to the control-grid of a triode (the avc tube) biased so it acts as a linear, or grid-bias detector

—via the coupling condenser C_c . With no signal, the avc tube is biased so that its plate current is very nearly zero. This means that the voltage drop across R_1 is nearly zero; hence, practically the full $B+$ screen voltage is applied to the r-f and i-f tubes under avc control. But when a signal is applied, plate current starts to flow in the plate circuit of the avc tube. This increases the flow of current through resistor R_1 and therefore *increases* the voltage drop across it. Consequently,

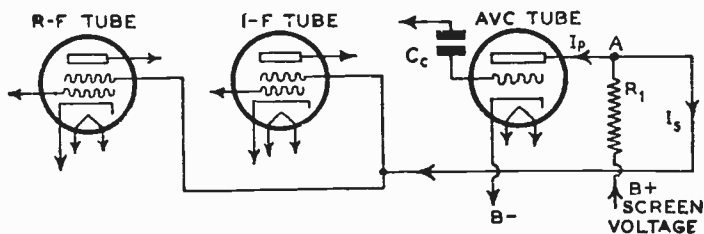

FIG. 19-1.—The circuit arrangement of a simple avc system in which the avc tube controls the screen voltage of the r-f and i-f tubes in the receiver so as to vary the amplification they produce.

the potential of point A decreases, which means that the screens of the amplifier tubes now have less voltage applied to them. This reduces the amplification produced by these tubes. Since the avc tube is operated as a grid-bias, or *linear*, detector, the d-c plate current is proportional to the signal strength, and hence the drop in screen voltage is proportional to the signal. By using this circuit arrangement, good avc was secured in many receivers.

The disadvantage of this system is that the amplifier tubes operate as detectors when the screen voltage is too low. Consequently any interfering signal is rectified in the first tube under avc control and passed on to the audio stage. Interference will be obtained no matter how many tuned circuits follow this first controlled tube. This unfortunate state of affairs means that designers cannot control the first few tubes in a receiver when this system is used, because the selectivity is needed. If only a few tubes are under avc control, there will not be enough avc action for constant output.

It was with exactly these difficulties in mind that the *remote cut-off* (variously called *extended cut-off*, *exponential*, or *vari-*

able-mu tubes) such as the type '58 were designed. The control grids of these tubes are so constructed that, regardless of the bias applied, rectification of the signal cannot take place. These tubes, then, are ideally suited for use in avc circuits. By merely varying the control-grid bias, the amplification factor of the tube may be varied, and it can never detect sufficiently to give an interfering action.

Just about the time when this type of tube (the '58, '78, tetrode section of the 2A7 and 6A7, etc.) was developed, there arose a demand for a diode rectifier, similar to the type '80 but smaller, which could be built into the same glass envelope with a triode or pentode. The diode (two element) is essential because it is one of the few simple tube structures which produces a d-c current proportional to the carrier wave of a signal. This tube is now widely used as a detector (rectifier) in conjunction with variable-mu amplifier tubes. An extra tube is sometimes used to provide avc, but most receivers employ a single duodiode triode tube for performing the function of diode detector and avc tube.

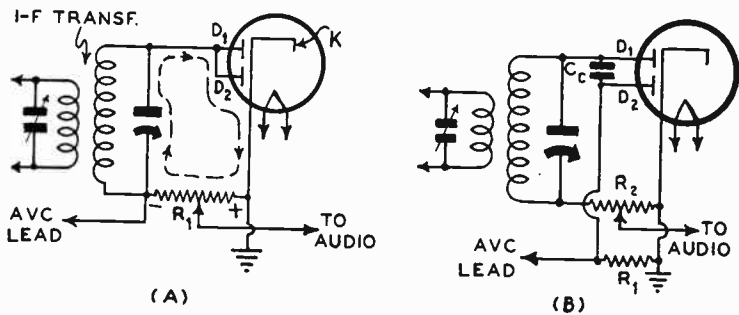

FIG. 19-2.—Two diode detector and avc circuits. In that at (A) the detection and avc action occur in the same circuit. At (B), the detection and avc action take place in two separate circuits.

Fig. 19-2 (A) shows the typical circuit arrangement employed with one form of such a combination tube. The two diode plates D_1 and D_2 are connected together and to one side of the last i-f transformer secondary. The signal voltage is rectified (because no current can flow when the diode plates are

negative) and flows through resistor R_1 . This resistor will be "positive" (as far as the signal is concerned) at its grounded end. A wire from the negative end then connects to the control-grid return leads of the tubes under avc control, as will be shown later. Since rectification takes place in this diode

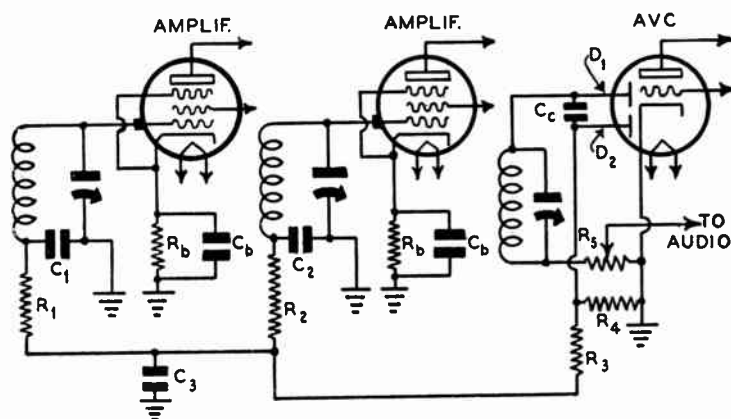

FIG. 19-3.—Controlling the grid bias of amplifier tubes by avc action obtained from the triode section of a duo-diode triode tube in the receiver. This circuit is shown in simplified form in Fig. 19-4.

circuit, the audio portion of the signal also appears across it, so the arm of this potentiometer connects to the audio circuit.

Some engineers prefer to keep the rectification (same as detection) separate and distinct from the avc action. This may be accomplished very simply by connecting D_2 to D_1 through a small condenser C_c as shown in (B) of Fig. 19-2. C_c serves the same purpose here as C_c in Fig. 19-1. The rectified current due to D_1 goes to the audio amplifier, and that due to D_2 to the avc lead. Each diode plate has its own resistor across which the rectified voltage appears, as shown.

Figure 19-3 shows the circuit of a typical avc system. Diode D_2 rectifies the signal, a small portion of which is taken from D_1 through condenser C_c . This rectified current produces a voltage across resistor R_4 . Now the voltage across R_4 is of a pulsating nature, and it therefore contains an average d-c value and an alternating value; the alternating value is composed of

the r-f carrier and the audio. The audio is there for exactly the same reason that it appears across R_s , or in the plate circuit of any detector tube. For purposes of avc, all of the alternating components must be eliminated; only the d-c is wanted. It is

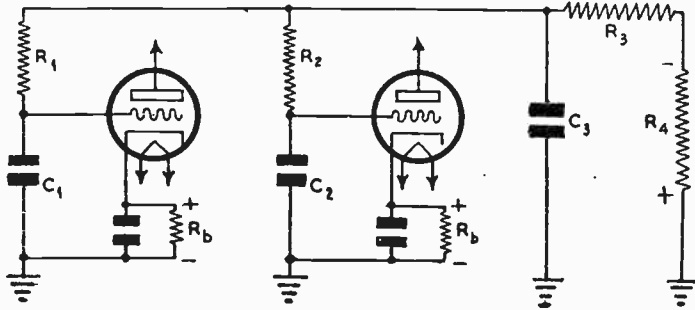

FIG. 19-4.—The main parts of the circuit of Fig. 19-3 are arranged here in simplified form for purposes of study.

the purpose of condensers C_1 , C_2 , C_3 and resistors R_1 , R_2 and R_3 , to filter out this alternating component and leave only the d-c.

C_3 and R_3 are made large enough so that once C_3 charges to the value determined by the strength of the signal, any variations due to audio or r-f are so fast that this condenser cannot take on more charge or give off some of its existing charge in synchronism with the signal; hence, the voltage across C_3 is constant, and equal to the d-c value of the voltage across R_4 . A further examination of this circuit, re-drawn in more simplified manner in Fig. 19-4, shows that it is the voltage across C_3 , that varies the bias on the controlled tubes. This is explained in the following manner.

The voltage across R_4 is applied to C_3 through R_3 . These latter two have such large values that, with a given strength of carrier, the voltage across C_3 is constant, regardless of the audio variations (of course, if the audio variations are too fast, the r-f variations will certainly be too fast). Now the grid bias of any tube is the bias from grid to cathode. This means that the biases of the amplifier tubes shown are the sum of the voltage across R_b , determined by the plate current of the par-

ticular amplifier tube, and that across R_1 . The resistors R_1 , R_2 , and R_3 do not drop this voltage because the grids of the tubes never draw current, and there can be no voltage drop in a resistor unless there is current through it.

If a stronger signal is tuned in, the d-c value of the voltage across R_1 , and hence across C_3 , rises, increasing the total bias applied to the tubes, which reduces the amplification of the tube; the reverse takes place when the signal strength decreases. If the signal should suddenly change in intensity for any reason, the voltage across C_3 changes, and the bias on the tubes shifts to accommodate the new signal level. It is interesting to note at this time that if the signal strength changes fast enough, due to very rapid fading for example, the voltage across C_3 may not be able to follow it, and automatic compensation will not occur. The design of the receiver should be such that the voltage across C_3 can respond to changes that occur not faster than about one every 0.05 second.

19-3. AVC System Using a Triode as a Diode.—One avc system employs a three-element tube as a diode detector, as shown in Fig. 19-5. The incoming signal is converted, or rec-

FIG. 19-5.—An avc system in which a 3-element tube is used as a diode detector. The avc voltage controls the grid bias of the r-f and i-f tubes.

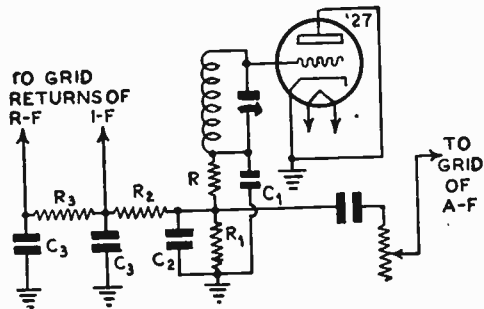

tified, by the diode detector into a d-c and a-f signal. The rectified signals appear across R and R_1 , and are proportional to the strength of the carrier voltage. Since the d-c component flows through R and R_1 , increases or changes in carrier signal strength vary the voltage drop across resistors R and R_1 . The d-c voltages thus developed are applied to the control grids of the i-f (or r-f) tubes, varying the amplification produced by

these tubes. The greater the signal strength, the greater the voltage impressed on the grids, and, consequently, the lower the amplification.

19-4. Purpose of Condensers in AVC Circuits.—The condensers utilized in avc circuits serve definite purposes. In Fig. 19-5, condenser C_1 is used to by-pass the high-frequency signal around R and R_1 so as to obtain maximum signal voltage at the tube. Its capacity is usually some value between 0.0001 mfd. and 0.0005 mfd. Condenser C_2 , on the other hand, charges up like a tank condenser, so that the voltage developed for avc purposes does not vary with signal modulation. The capacity of this condenser is usually from 0.01 mfd. to 0.1 mfd., although a condenser of the same value as C_1 has been used in many instances. It is interesting to note here that the voltage available for audio and avc purposes is not the total voltage across R and R_1 , but only that across R_1 . The fraction of the total voltage is thus $R_1/R+R_1$.

19-5. Additional AVC Systems.—In one avc system, a single triode is employed as both detector and avc tube. The avc action is similar to that in the diode-detector avc circuit. In the circuit shown at Fig. 19-6, an avc potential is built up

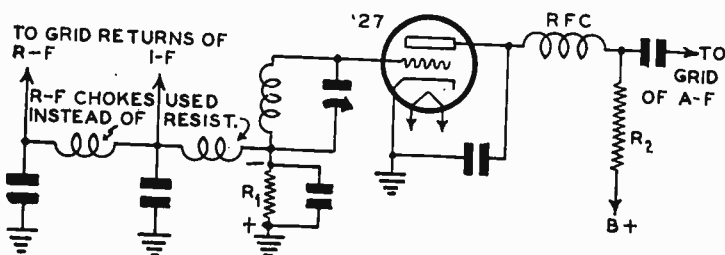

FIG. 19-6.—An avc system in which a single triode is used as both a detector and avc tube. The avc voltage developed across resistor R_1 controls the grid bias on the r-f and i-f tubes.

across R_1 in the following manner. As the signal strength increases, more grid current flows through the grid circuit of the detector avc tube. The greater this current, the greater its d-c component, and, since R_1 is really part of the grid circuit, the

d-c component of the voltage across it *increases*. The audio voltage is that across resistor R_2 .

The voltage drop thus developed is impressed on the control grids of the r-f or i-f tubes under avc control. It is interesting to note that in this circuit the grid is not biased in the usual fashion. The grid current produces the avc voltage across R_1 ,

FIG. 19-7.—An avc system in which a screen grid tetrode is used as a detector and avc tube. The avc control voltage is obtained across grid circuit resistor R_1 .

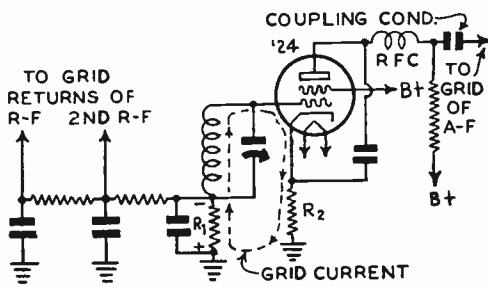

the polarity being as shown. This negative bias, generated by the signal itself, is what gives the tube its bias to rectify the plate current to produce the audio. Hence, rectification takes place in the grid as well as in the plate circuit at the same time. The grid circuit rectifies because no grid current can flow while the grid is negative, and rectification takes place in the plate circuit because of the steady bias applied to the grid with a steady carrier voltage.

A type '24 screen grid tetrode tube has been used in a manner similar to the type '27 triode, as shown in Fig. 19-7. Here again, the avc voltage is obtained across R_1 . When a signal of sufficient intensity or strength is received, grid current will flow in the grid circuit as shown by the arrows. This current produces a voltage drop across R_1 , which is fed to the control grids of the r-f (or i-f tubes) thus decreasing their amplification and maintaining the volume to the level to which the manual volume control has been set. R_2 merely supplies a small, steady bias to the tube.

Some very popular commercial receivers use a type '27 triode tube as a "double diode", combining the functions of detector and avc in one tube. The cathode and grid form one two-

element rectifier, and the cathode and plate form the other, as shown in Fig. 19-8. From the diagram, it can be seen that the cathode-grid diode is used to rectify the signal voltage to secure the audio component; the cathode-plate diode is used to provide direct current in its output circuit to generate the voltage for the avc circuit. The avc voltage is built up across resistor R_1 , connected from the plate of the tube to ground. Since the volt-

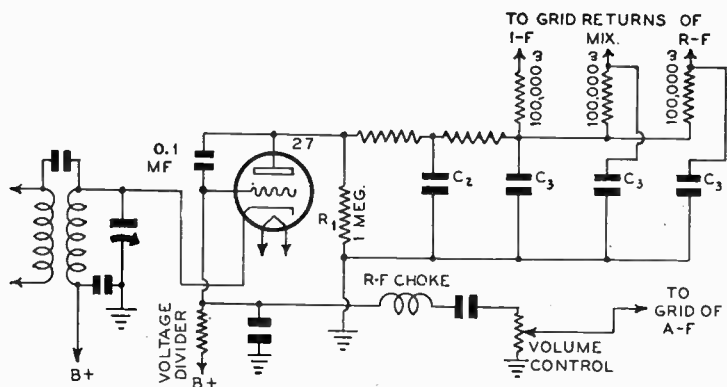

FIG. 19-8.—An avc system in which a triode tube is used as a double diode, combining the functions of detection and avc in one tube. The avc control voltage is built up across resistor R_1 . (Used in Stromberg Carlson 22 receiver.)

age-drop across R_1 varies as the strength of the input signal varies, a suitable variable voltage is secured which is fed to the control-grids of the controlled tubes.

19-6. AVC with Combination Diode-Type Tubes.—No amplification is derived from any sort of diode detector. For this reason, dual-purpose tubes were developed in which two diodes and a triode, or two diodes and a pentode, are combined in a single glass envelope. Since the diodes and the triode (or pentode) are independent of each other, such a tube can be made to perform as detector, avc tube, and audio amplifier. The types '55, '75, '85, 2A6, 2B7 and 6B7 are typical examples of such tubes. The triode or pentode portion of the tube is generally employed as a triode or pentode audio amplifier, although in some cases the tube has been worked "backwards"—the tri-

ode or pentode portion being made to serve as an i-f amplifier. In most instances, however, the two diodes of the tube are tied together and connected as shown in Fig. 19-9; they then act as a half-wave rectifier. The avc voltage is secured by the voltage drop across resistor R_1 , in the same manner as with the ordinary two-element diode detector. A lead from the ungrounded side of R_1 connects to the control grid through a coupling condenser C_c . Hence, the audio component of the voltage across R_1 is fed to the grid for amplification in the usual manner. R_2 is sufficiently large to supply the necessary bias for the triode to act as an amplifier.

It is clear that if R_2 places a negative bias on the grid of the tube, the diodes cannot begin to function until the *peak* value

FIG. 19-9.—An avc system in which a combination duo-diode triode tube is employed. The avc voltage is the voltage drop across resistor R_1 , through which the diode current flows. (Used in Majestic receivers.)

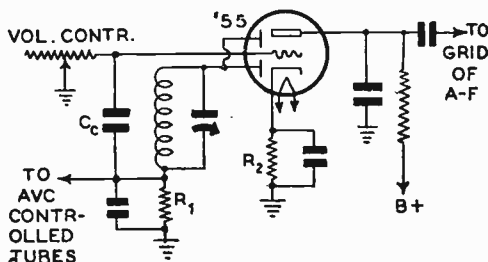

of the signal is greater than this negative bias. In other words, the avc action will not commence until a certain signal voltage is applied to the diodes of the tube. This point will be discussed further in Art. 19-9.

19-7. Additional Interesting AVC Systems. — Another greatly used form of avc system is that shown in Fig. 19-10. The avc functions in the usual manner in that the signal voltage is supplied to the grid of the '27 tube through condenser C_1 , and the voltage-drop across resistor R_1 in the plate circuit is the grid voltage applied to the r-f or i-f stages. Since the value of the plate current is proportional to the signal voltage applied to the grid, increasing signal voltages cause greater voltage drop across R_1 . This results in a higher bias on the r-f and i-f stages, which means less sensitivity.

In some receivers, instead of coupling the grid of the avc

tube to the detector or i-f amplifier through a condenser, the output of the i-f amplifier is coupled directly to the grid of the avc tube through the secondary winding of the second i-f transformer (two i-f stages are used), as shown in Fig. 19-11. The action of this avc tube is identical to that described for Fig. 19-10. Another secondary, S_s , on this same transformer couples the signal to the second i-f tube. The main advantage

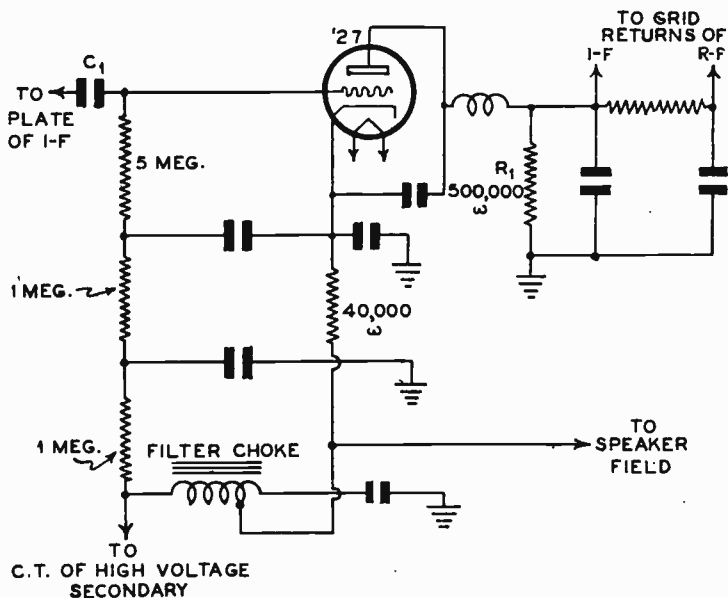

FIG. 19-10.—Another avc circuit arrangement. The avc voltage is taken from across the plate circuit resistor R_1 . The grid of the avc tube is coupled to the i-f plate circuit by a condenser. (Used in RCA Victor 11 receiver.)

of this system is that noise or other signals cannot exceed the level for which the volume control has been set.

Another frequently used avc system is that shown in Fig. 19-12. Here, a type '24 screen-grid tube is employed. This tube has its control grid coupled to the grid of the second detector through a 0.0001 mfd. fixed condenser. When a signal is impressed upon the grid of the avc tube, an increase in plate current results. This change in plate current, in turn, varies the

voltage drop across plate resistor R_1 , which changes the control-grid voltage of the controlled tubes. Any increase in signal strength raises the grid bias automatically, thereby reducing volume on a loud signal to a value previously set by the manual control. The resistor R_2 develops a small voltage equal to that across R_1 with no signal. In this manner, the no-signal R_1 voltage is bucked by the R_2 voltage, and the avc potential on the controlled tubes is zero. The application of a signal raises the R_1 voltage and lowers the voltage across R_2 , thus increasing the avc potential. The voltage across R_2 decreases because in-

FIG. 19-11.—In this avc circuit the output of the i-f amplifier is coupled directly to the grid of the avc tube through the secondary winding of the last i-f transformer. Another secondary, S_2 , couples the signal on to the second i-f tube, shown at the right. (Used in RCA Victor 50 receiver.)

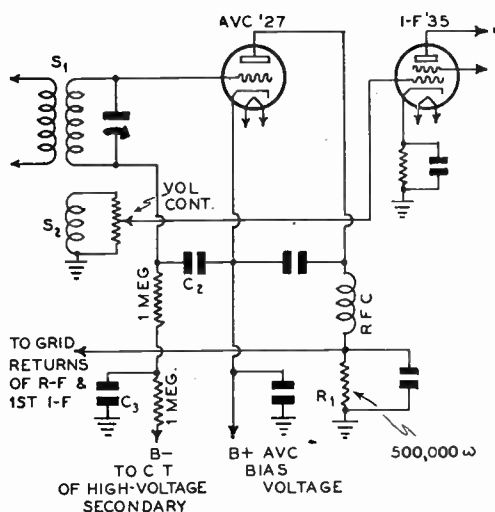

creased plate current means increased voltage drop in R_2 and R_4 . Since the sum of the voltages across R_2 , R_3 and R_4 must equal the total B-supply voltage (which is maintained constant), that across R_2 must decrease when a signal is applied.

An avc system similar to that shown in Fig. 19-12 is illustrated in Fig. 19-13. A type '56 tube is employed as a diode. The signal voltage is fed to the grid of the control tube through a 0.00025 mfd. fixed condenser connected to the plate of the i-f tube. This signal develops a voltage across the plate resistor R_1 . Because variations in the carrier signal will vary the voltage drop across this load resistor, a means is provided for ob-

taining a variable voltage to be applied to the control grids of the controlled tubes through suitably designed filters to suppress any a-c component that may be present.

19-8. Necessity for Delayed AVC Systems.—One marked disadvantage of the avc systems thus far described is that they start to act as soon as the signal reaches the avc tube. Weak

FIG. 19-12.—A frequently used avc system which employs a screen grid avc tube whose control grid is coupled to the grid of the second detector. The variations in plate current of the avc tube vary the avc voltage-drop across R_1 . This is the avc control voltage. (Used in Zenith 91, 92, type 1.)

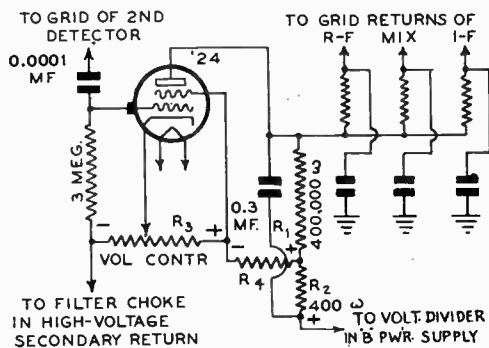

signals, therefore, cannot receive the full amplification which the receiver is capable of supplying. This is so because the avc system prevents the receiver from exerting its full amplifying properties due to the fact that any input signal impressed upon the receiver immediately causes its sensitivity to decrease.

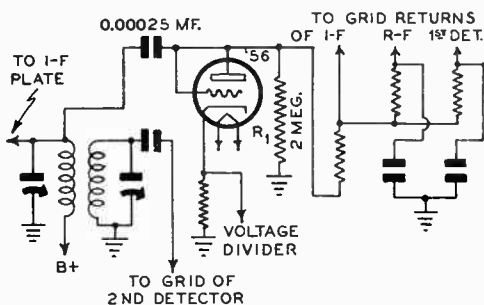

FIG. 19-13.—Here, a triode, connected as a diode, acts as the avc tube. Signal voltage from the i-f plate circuit feeds the avc diode. The variations in diode plate current vary the avc voltage-drop across R_1 . (Used in Atwater Kent 310 receiver.)

To overcome this serious limitation, a method of automatic volume control has been devised whereby the automatic volume control action does not begin unless the incoming signal is at, or exceeds, a certain strength. This is termed *delayed avc*, because *the avc action is delayed, i.e., it does not come into play*

unless a signal exceeding a certain strength is tuned in. In this way, much greater power output for weak signals can be obtained, since no avc is hampering their amplification to the fullest extent.

19-9. Delayed AVC Systems.—One method of securing delayed action is shown in Fig. 19-14. A type '55 tube is employed, although a type '75, '85, 2A6, or 2B7 can be used. The diode detector action is separate from the avc, and the secondary of the i-f (or r-f) transformer is in two sections, one for the diode circuit and the other for the avc circuit. The triode portion of the tube secures its fixed bias by means of R_2 , and the return

FIG. 19-14.—A delayed avc circuit in which delayed action is secured by arranging the circuit so that no avc voltage is produced across R_1 until the signal is strong enough to overbalance the bias voltage across R_2 and make avc diode plate D_2 "positive" with respect to the cathode so that current can flow through R_1 .

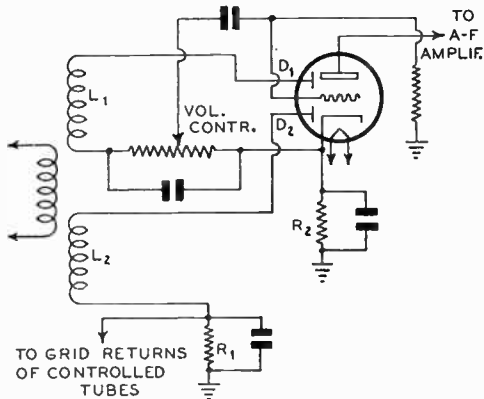

of the second diode plate is grounded through R_1 . Hence D_2 is at a *negative* potential with respect to the cathode of the tube, by an amount equal to the voltage across the bias resistor R_2 . Because of the fact that the two secondary windings are equally coupled to the primary of the transformer, the signal voltages induced in each half will be equal. The input signal induced in L_1 is rectified by diode D_1 , and the audio component is applied to the triode grid. The negative second diode plate prevents the voltage across the lower section of the secondary winding, L_2 , from being rectified until its peak value is greater than the bias voltage across R_2 because of the fact that a tube cannot function while its plate is negative. Therefore, the second diode plate will produce no avc action until signals of suffi-

cient strength are received to make it *positive*, so as to enable it to draw current.

Another version of this method of obtaining delayed avc is shown in Fig. 19-15. Coupling to the diode plates by condensers obviates the necessity for having two secondary windings. It will be seen that the cathode of the '55 tube has a fixed bias of 10 volts above ground potential. This is secured from the voltage divider system and the plate current of the tube. The avc diode, D_1 , is connected to ground through resistor R_1 , making this diode "negative" with respect to cathode. Since the detector diode, D_2 ,

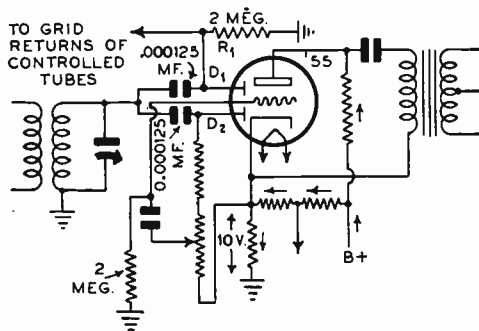

FIG. 19-15. — Another version of the delayed avc circuit of Fig. 19-14. Here the diode plates are coupled to the i-f transformer by condensers. (This circuit is employed in the Atwater Kent 711 receiver.)

is *not biased* (it is connected, through resistors, to the cathode), delayed avc action is obtained. The detector diode rectifies the signal voltage for any signal applied (even if the signal is weak). However, the avc diode, because it is *negative* with respect to the cathode (and the detector diode) on weak signals, does not function for weak signals. It only begins to operate when the signal is sufficiently strong to cause a voltage drop in R_1 at least equal to the steady 10-volt potential applied between the cathode and ground. When these two voltages are equal, the potential of the avc diode is equal to that of the cathode. It then begins to function, rectifying the signal, and avc action starts. For stronger signals, the potential of the avc diode rises higher than that of the detector diode, and stronger avc control is exerted. Thus, delayed avc action is secured because the avc diode does not operate unless the incoming signals exceed a certain strength.

There are numerous other types of avc and delayed avc

systems, and those described here are but representative of the methods used in the numerous types of commercial receivers. It is immaterial whether the avc action is obtained by means of a separate tube or by means of a single tube serving a dual purpose—the principle is the same.

19-10. Troubles in Diode-Detector AVC Systems.—Perhaps the most suitable course to pursue in discussing the troubles associated with and due to avc systems is to analyze each system described. This can be done more easily by “breaking down” each avc circuit and determining the symptom associated with the failure of any constituent part.

The troubles usually encountered with any of the diode-detector avc systems are few compared to those found in separate avc tube systems, because of the independence of the combination detector-avc action on the receiver power supply. Let us suppose, however, that no avc action is being obtained from a system similar to that shown in Fig. 19-5. It may be thought from this symptom that the diode-connected detector tube is at fault, with its plate short-circuited to the grid. Were this the case, however, no reception would be obtained at all, since the grid would be connected to the plate which is tied directly to the cathode. If condenser C_2 were short-circuited, there would be no avc voltage and no audio signal, since resistor R_1 would be short-circuited, grounding the avc and audio leads. Because of the fact that R_1 is usually a high resistance unit (approximately 100,000 ohms or more) leakage in C_2 due to defective insulation will result in diminished avc and audio output, as any voltage variations across the resistor R_1 would be smaller because of the smaller value of R_1 . No avc action could be obtained if R_1 were open-circuited, and the receiver would operate weakly, if at all. This resistor is almost invariably a carbon type unit, and, although it will seldom, if ever, be found open-circuited because of the small current through it, it is more or less subjected to the common failures of carbon resistors, so far as the method of fastening the pigtailed to the carbon element is concerned. A poor contact here will result in a high resistance, and, should the value of R_1 be much larger than it should be, the voltage across R_1 compared to $R + R_1$ will be much larger than neces-

sary, resulting in overloading of the audio stage and too much avc action.

Should one of the by-pass condensers, C_s , become leaky, the avc voltage developed across R_1 will not be applied to the control-grid of the tube in whose stage the leaky condenser C_s is connected, since this voltage is short-circuited. The resistors R_2 and R_3 and their associated by-pass condenser C_s are employed to prevent interstage coupling; therefore, instability and oscillation will result if the avc voltage is fed directly to the control-grid circuits of these stages because of short-circuited resistors R_2 and R_3 .

Another complaint frequently encountered with diode-detector avc systems is that of too strong an avc action. It may be that the receiver does not possess sufficient sensitivity for the weak signals received. But if it is found that the control-grid bias on the controlled tubes is too high when the receiver is tuned to a station, in all probability the resistor R_1 has too high a value, producing too much avc voltage for the signal strength of the station. It should be noted that if R_1 is just a little higher than it should be, the audio output increases and the avc voltage increases. However, upon increasing R_1 , a point is soon reached where the avc voltage becomes so great that the sensitivity of the receiver drops to a fraction of what is required for normal audio output; then, of course, the volume will be low. There is no fixed rule as to what value R_1 should have in order for the audio volume to drop appreciably. If the correct value of R_1 is unknown, the best procedure is to remove it and substitute others, one at a time, until best results are obtained. If, on the other hand, the avc action is insufficient to successfully reduce the sensitivity of the receiver on powerful signals, it will be necessary to substitute a higher value of R_1 in order to obtain a greater voltage drop.

In the event that condensers C_s , by-passing the isolating resistors R_2 and R_3 , should become short-circuited or leaky, a severe motorboating may be experienced as the receiver is tuned from one station to another, and it will be difficult to properly set the station selector at the resonant point. This condition is due largely to the fact that as the avc voltage is diminished,

the circuits of the tube or tubes in which condensers C_s are connected will operate at full sensitivity because of the lack of this control voltage, and too much sensitivity will always result in motor-boating unless special precautions are taken to prevent it. Open-circuited condensers, however, will result in oscillation, low sensitivity, fading and intermittent reception because of interstage coupling due to insufficient filtering. Usually, the resistance of a leaky condenser varies, and for that reason the avc control voltage fed to that stage will vary, thus causing fading and intermittent reception.

In the circuit shown in Fig. 19-7, in which a type 24 tube is used in the same manner as the type 27—as both detector and avc tube—the same symptoms described here will also apply.

19-11. Troubles in Double-Diode AVC Systems. — In the “double diode” detector and avc system shown in Fig. 19-8 a cause for complaint may be traced to resistor R_1 . When this unit is open-circuited, the avc system will be inoperative and the total grid bias will be “zero”. Also, there will be no avc action if any or all of the by-pass condensers C_s should short-circuit or become leaky. In this case, however, the defect will be manifested by the fact that the receiver will operate “wide open”—at full sensitivity—since the control bias on these stages will be short-circuited, leaving only the fixed bias in the individual stages. If R_1 is open, however, the grid bias on each controlled tube will be zero, since the avc voltage is in series with the fixed tube bias (see Fig. 19-4).

In the avc system shown in Fig. 19-9, which employs a type '55 tube, the diode portion of the tube is, in most instances, used for both detection and avc. For this reason it is subject to the same failures common to any other diode-detector avc system. The triode or pentode portion of the tube usually serves as either an audio, r-f, or i-f amplifier. Should either, or both, of the diodes short-circuit to the common cathode sleeve of the tube, the receiver will become inoperative. There may be instances, however, where some reception will be obtained when the short circuit does not have zero resistance. Since the two diode plates in most systems are tied together (usually not in delayed avc systems), and are connected to the high side of the

secondary winding, the short-circuiting of one of the diodes to the cathode due to loose elements or other causes will result in total inoperation. As with the diode avc-detector, insufficient avc action may be overcome by substituting a higher value of resistance for R_1 .

An unusual condition characterised by the tuning-in of signals with a "plop", and difficulty in setting the station selector at resonance, may be experienced. This condition may be remedied by reducing the value of the resistor employed as the voltage-dropping resistor, R_1 .

19-12. Troubles in "Separate AVC Tube" Systems.—The most common trouble encountered with separate avc tube systems is "weak" or "no" reception, generally caused by a poor avc tube. This tube is invariably biased near its plate-current cut-off point, that is, biased until no plate current flows when no signal is impressed. The first step to be taken in diagnosing a complaint of this kind is to check the tube used in the avc stage. A gassy or a too high-emission tube will pass plate current before a signal is applied, thus generating an avc voltage, and reducing the amplification of the r-f or i-f tubes. A method of testing for this trouble is to tune the receiver to some weak station and then withdraw the avc tube from its socket. If the volume increases considerably, the tube should be replaced. In some cases it may be necessary to try several tubes before a satisfactory one is found. If it is established that the trouble could not possibly be a poor tube, the grid voltage impressed on the avc tube should be checked. If this voltage is too low, the tube will pass plate current with no signals, and so reduce the sensitivity of the receiver because of the excessive voltage applied to the control grids of the r-f or i-f tubes.

Very often, totally inoperative receivers are found that cannot be made to deliver signals until the avc tube is withdrawn from its socket. A socket analysis of the receiver almost always discloses an abnormally high control-grid voltage on the avc controlled tubes with the avc tube in its socket. This high bias definitely points to the fact that excessive avc voltage is being developed by the control tube. As a general rule, the carbon resistors which are almost universally used in avc cir-

uits do not change in value unless the unit open-circuits entirely. If the voltage-dropping resistor in the plate circuit of the avc tube were open-circuited, no avc action could be obtained, and a complaint of this kind could not be produced. The only remaining possibility is that of insufficient (or lack of) bias voltage on the avc tube. This may be due to the open-circuiting of some resistor in the grid circuit or to the presence of leaky by-pass condensers.

If it is found that normally powerful signals are received weakly and normally weak signals not at all, and a socket analysis of the receiver discloses an excessive control-grid voltage on the tubes in the avc circuit, the trouble can be traced to leaky by-pass condensers C_4 and C_5 , Fig. 19-11, for instance. This failure may also be disclosed by the fact that the level of the received signals can be increased considerably by removing the avc tube from its socket. Since the resistors in the grid circuit of a separate avc tube are of high values, usually of the order of one megohm or more, leakage of a few thousand ohms in these by-pass condensers will be sufficient to neutralize part of the grid bias of the avc tube and cause it to pass excessive plate current. For this reason, it is necessary to employ a high-range ohmmeter or a good condenser leakage tester to successfully locate the leaky condenser. Of course, it is simple enough to disconnect these condensers while the receiver is in operation and note the effect of the removal. When operation is normal for a minute or two after the receiver is first switched on, and the volume level gradually decreases until reception of even powerful broadcast stations is weak, the avc grid by-pass condensers should be checked immediately for leakage.

On many occasions, the complaint of gradual fading after the receiver has been operating for some time, perhaps for an hour or two, may be received. Leaky avc grid by-pass condensers have been found to cause this condition in receivers employing separate avc tubes.

Quite often, separate avc-tube receivers tune-in stations with a "plop", and it is difficult to set the station selector accurately at the resonant point. These symptoms are usually caused by

excessive avc action. In this case, the avc grid voltage is not at fault. Excessive avc action may be traced to too much heater voltage on the avc tube, and may be corrected by inserting a small $\frac{1}{2}$ -ohm strip resistor in series with one of the avc heater legs. On some few occasions, reduction of the avc heater voltage is necessary in order to eliminate this condition, despite the fact that the heater voltage is within the rated value. Another cause for excessive avc action is the use of a plate resistor whose value is too high. All that is necessary in this case is to reduce its value so that a lower voltage drop will be obtained across it.

In many receivers, a separate avc tube is coupled either to the plate of the last r-f, i-f or the detector stage by means of a small fixed condenser having a value of approximately 0.0001 mfd. If this condenser open-circuits, no avc action will be obtained.

A frequent cause for distortion caused by overloading of the r-f or i-f stages, poor avc control, and in some instances oscillation and motor-boating, is "leaky" or "short-circuited" r-f, first detector, or i-f grid-return by-pass condensers in the avc circuit. If the leakage in these condensers varies, fading will result. Open-circuited condensers, however, will cause weak and unstable operation, often accompanied by station hiss, oscillation and motor-boating. If the open-circuit is of an intermittent nature, intermittent reception will be obtained.

19-13. General AVC Troubles.—A complaint not infrequently encountered in receivers employing avc is no control of volume. By this is meant the inability to reduce the volume level by adjustment of the manual volume control. This condition will not be experienced where the manual volume control is located in the audio portion of the receiver, but only when it is in some part of the avc circuit. A very weak avc tube will produce this symptom in receivers using separate avc tubes. In almost every instance, the plate circuit of a separate avc tube is at least 100,000 ohms above ground. Leakage or short-circuiting, therefore, of any portion of the avc circuit to ground will diminish the automatic volume control voltage, and the receiver will operate at maximum sensitivity. If

this occurs, the full volume of the receiver will be obtained.

In some receivers, this condition has been traced to leaky by-pass condensers in the control-grid return circuits of the avc controlled tubes; and in others, to a resistor or choke-coil terminal lug short-circuiting to the chassis at some point. In one particular model, the condition was found to be due to leakage of the "fish-paper" insulation used between the can of an electrolytic condenser (which was below chassis potential) and the chassis. A point-to-point resistance test with a high range ohmmeter is generally sufficient to isolate this form of leakage. Each part of the circuit may be disconnected and checked, and by the process of elimination, the offending member found. On some occasions, however, the leaky condition will clear up as soon as the receiver is switched off for the purpose of making a resistance test. Under these conditions, it will be necessary to disconnect by-pass condensers while the receiver is operating, or actually move leads and resistors in their relation to the chassis.

Some manufacturers have produced a few models of receivers in which the avc system has an appreciable time lag. In other words, the avc tube takes a large fraction of a second to operate, introducing a time lag. This design was incorporated for the purpose of reducing interstation noise. In most avc receivers not employing silent tuning or noise suppressor circuits, the sensitivity of the receiver increases to maximum when the set is tuned between stations, because the avc system increases the sensitivity until the receiver is tuned to a station. The time lag, however, is supposed to be great enough to keep the sensitivity low until the dial, turned at a normal speed, reaches the next station. This is supposed to keep inter-station noise at a low level. Because of the time lag, it is difficult to tune a station accurately to the point of resonance, and stations will be received with a "plop." The time lag may be reduced by reducing the rate of charge and discharge of the avc system; the value of the various by-pass condensers may be lowered, or the value of the isolating or voltage-dropping resistors may be decreased.

19-14. Amplified AVC.—The designs of certain receivers are such that it is necessary to have the voltage actuating the avc tube larger than could be obtained with the systems described

thus far. Such design necessitates amplifying that portion of the signal that would ordinarily go to the avc section of the set; hence the name for such systems is *amplified avc* systems.

There is nothing fundamentally different about an amplified

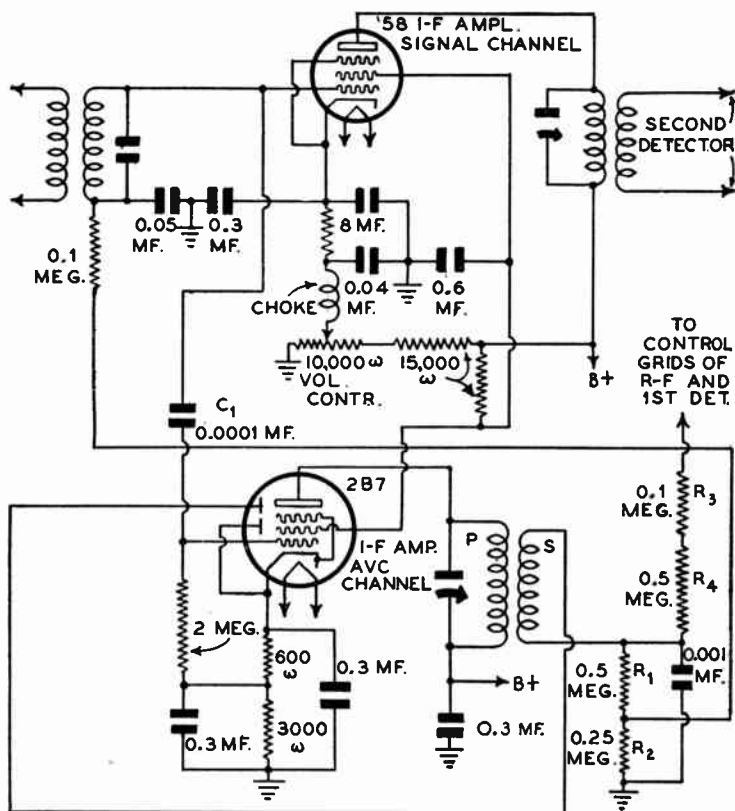

FIG. 19-16.—An amplified avc circuit arrangement employing two i-f amplifiers. The top one amplifies the signal and feeds it to the second detector. The lower one obtains part of the signal through coupling condenser C_1 . (This arrangement has been used in many RCA Victor receivers).

avc system. In all cases, part of the signal is removed from the i-f amplifier, is amplified, and then fed to the avc tube in the normal manner. That part of the signal which is not removed for avc action may be still further amplified, rectified

by the second detector, and passed on to the audio amplifier in the normal manner. The term *amplified avc* applies only to that function of the receiver which amplifies part of the signal specifically for avc purposes, so that a higher controlling voltage is produced.

The amplifying part of the avc section may not necessarily be a separate tube; in fact, recent receivers make use of the combination tubes for this purpose. One modern receiver incorporates two i-f amplifiers: in one, a '58 type tube amplifies the signal and feeds it to the second detector, as shown in the upper part of Fig. 19-16; the other amplifier obtains part of the signal through a 0.0001 mfd. condenser and feeds it to the control grid of a 2B7, a combination tube consisting of a pentode and a double diode. An i-f transformer in the plate circuit of the diode is tuned to the i-f, and the amplified signal appears across the secondary S of this transformer, as shown in the lower half of Fig. 19-16.

The top of S connects to one diode plate, the other diode plate is connected to cathode because it is not required. The lower part of S connects to the cathode through a resistance network. The amplified voltage is rectified by the single diode and appears across resistors R_1 and R_2 . The 600-ohm resistor in the cathode leg supplies bias for the control-grid of the pentode section, and both the 3,000- and 600-ohm resistors place the active diode at a negative potential for delayed avc, as previously explained. R_1 and R_2 are divided into two separate units so that only part of the rectified avc voltage may be removed for the signal channel i-f stage. The full rectified output is obtained for the r-f amplifier and first detector. Of course, part of the avc voltage is built up across the 3,600 ohms in the cathode leg, but 3,600 ohms is very small compared with the 750,000 ohms of R_1 and R_2 , and may be neglected. The d-c voltage across resistors R_1 and R_2 is applied to the controlled tubes through the two filter resistors R_3 and R_4 , as shown.

Substantially the same idea is used in another popular, modern receiver. Two i-f stages are employed: one for the signal channel feeding the second detector, and the other for the avc tube. In this case, however, the amplifier feeding the avc tube

is a type '58 tube, and the avc tube is a '56; thus the functions of avc amplification and avc control is vested in two tubes instead of one. The circuit of this arrangement is shown in Fig. 19-17.

The plate circuit of V_1 feeds the second detector for signal rectification and amplification for the audio amplifier. At the same time, a portion of the signal from the grid of this tube is taken through a 0.0003 mfd. condenser and fed to the grid of a type '58 tube. The signal is amplified and passed to the '56, which operates as a half-wave rectifier. The d-c avc voltage

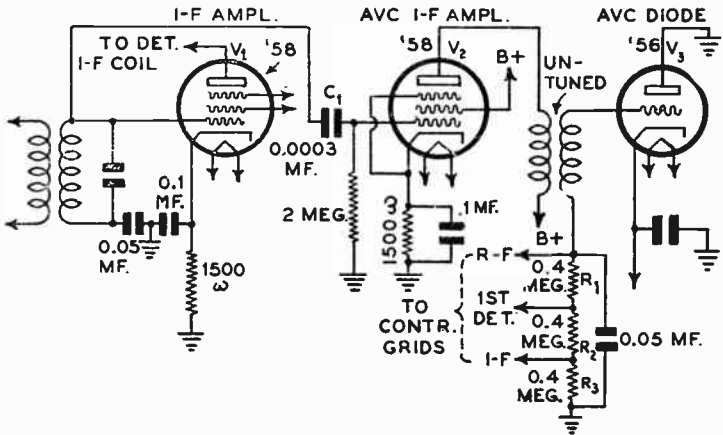

FIG. 19-17.—Amplified avc circuit arrangement in which energy taken from the i-f stage is amplified by the '58 tube and impressed upon the separate '56 avc tube connected as a diode. The avc control voltages appear across resistors R_1 , R_2 , and R_3 connected in the diode circuit.

is obtained in the usual manner across the resistors R_1 , R_2 , and R_3 . Portions of this voltage are removed to control different circuits, as shown in the diagram.

Another interesting example of amplified avc is shown in Fig. 19-18. This circuit is different than the others inasmuch as a single 2B7 tube is made to function as second detector, avc amplifier, and avc tube. As seen, the two diodes are connected together to form a half-wave detector circuit, and the a-f and d-c components appear across R_1 in exactly the same manner

as described previously. The total voltage across R_1 is fed to the audio amplifier through the coupling condenser C_1 , which only passes the audio part of the voltage. The by-pass condensers C_2 and C_3 serve to keep the r-f out of the audio amplifier, thus preventing "fringe howls." The d-c component of the voltage across R_1 is applied to the control grid of the pentode portion through resistor R_2 , which acts, at the same time, to prevent any of the audio from actuating the grid of the tube. Since the cathode is above ground potential by an amount equal to the voltage drop in the cathode resistor R_3 , any changes in the

FIG. 19-18.—Amplified avc circuit in which a single 2B7 tube is made to function as the second detector, avc amplifier and avc tube.

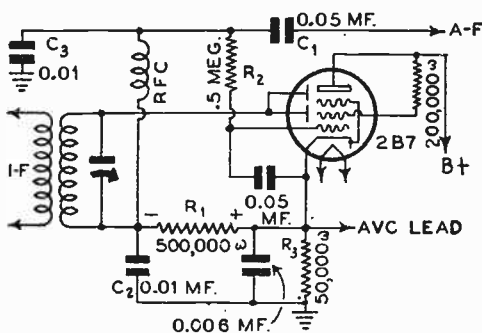

d-c grid potential of the control grid will vary the current through R_3 and thus change the voltage drop across it. Increasing signal carrier strengths will increase the voltage drop across R_2 , which, in turn, will apply a greater negative d-c voltage to the control grid, thus lowering the plate current through R_3 . Hence, the voltage across R_3 will decrease. This voltage is applied to the grid-return leads of the tubes under avc control in the usual manner. This is an amplified avc system because the d-c voltage across R_3 is amplified by the mutual conductance of the 2B7 tube.

19-15. Silent Tuning Systems.—Since the normal action of an avc system is to *decrease* the sensitivity of the receiver on strong signals, and since the sensitivity of such a receiver is *maximum* when the station selector is tuned off resonance, reception is usually very noisy when the receiver is tuned off resonance, due to the fact that any natural and man-made elec-

trical disturbances which are picked up by the antenna system at this time are amplified by the full amplifying power of the receiver. If a very sensitive set equipped with *avc* is operated in a "noisy" location, the background noise will be troublesome when passing from one station to another unless specific precautions are taken in the design. This does not mean that a set equipped with *avc* gives more noise than one not so equipped, but that when tuning it exactly the same effect is obtained as is obtained with an ordinary set having its volume-control fully advanced.

A number of methods have been devised to reduce this *inter-channel-noise*, since it is very disturbing to have no noise come in when a station is tuned in, and to suddenly have irritating noises come in at full volume when shifting the station selector to receive another station. One early device used to make this inter-station noise inaudible, was a "mute" switch which was connected across the secondary of the output transformer. The switch was manually operated, and short-circuited this secondary while the receiver was being tuned; hence the noise could not be heard. The point of station resonance was indicated by some form of resonance indicator, such as a tuning meter, shadowgraph or tone beam arrangement (these resonance tuning indicators will be discussed in later sections of this chapter), so that the operator could tell just when the station was tuned in exactly, before opening the "mute" switch.

Another means employed to eliminate inter-station noise was to remove the volume control from the grid or cathode circuit of the *avc* tube and place it in some other portion of the receiver, as shown in Fig. 19-11. In this circuit, the primary and secondary of the second i-f transformer are widely separated so as to prevent the transfer of signal energy except by means of the small pick-up coil, S_2 . The volume control is a potentiometer shunted across this coil. This determines the amount of signal energy which will be passed to the secondary. Setting this control at zero reduces the i-f input to the second detector to zero, and the noise cannot be heard. However, a tuning indicator connected in the plate circuit of a previous i-f amplifier tube will show when a station carrier has been tuned in. When this is known, the volume control can be raised.

A variation of this method of reducing inter-station noise is shown in Fig. 19-19. Here, the volume control is in the grid circuit of the second detector. The primary and secondary of the second i-f transformer are isolated from each other by a small copper shield, so that there can be no transfer of energy except via the small pick-up coil inductively coupled to the primary. The volume control is connected across this coil. In this man-

FIG. 19-19.—A circuit arrangement for reducing the noise heard between the points at which stations may be tuned in on the dial. (Used in RCA Victor 11 receiver.)

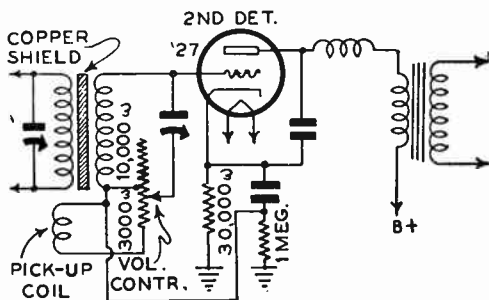

ner, the signal voltage applied to the second detector is manually controlled, and under no conditions can the noise level exceed that set by the volume control.

Many receivers employ a variable resistor in the cathode circuit of the i-f stage for the control of volume. When this variable resistance is set at maximum, the i-f tube under control receives a high negative bias, which lowers the plate current and hence reduces the amplification of that stage. Although this type of control tends to reduce inter-stage noise to some extent, it decreases the sensitivity of the receiver so that only strong signals can be heard. This variable resistance is generally termed the *sensitivity* or *noise suppressor* control.

19-16. Silent Tuning (QAVC) Circuits.—The early receivers which appeared with an *automatic* silent tuning control employed a separate tube to silence inter-station noise. A typical arrangement of this kind is shown in Fig. 19-20. The plate of this tube is connected in series with the plate circuit of the first a-f tube. The plate current of the a-f tube flows through R_1 , as does the plate current of the noise silencing tube. Hence the plate volt-

age of the audio tube is the "B" voltage minus the voltage drop in R_1 . The action of the silencing tube is as follows: Since its control-grid is connected to the avc circuit, its grid bias is equal to that generated by the avc tube. When the receiver is tuned off resonance, or between two stations, the avc voltage is low, which means that the grid voltage of the silent-tuning tube is also low. A small bias means a high plate current, which results in a large voltage drop across the resistor R_1 . This voltage

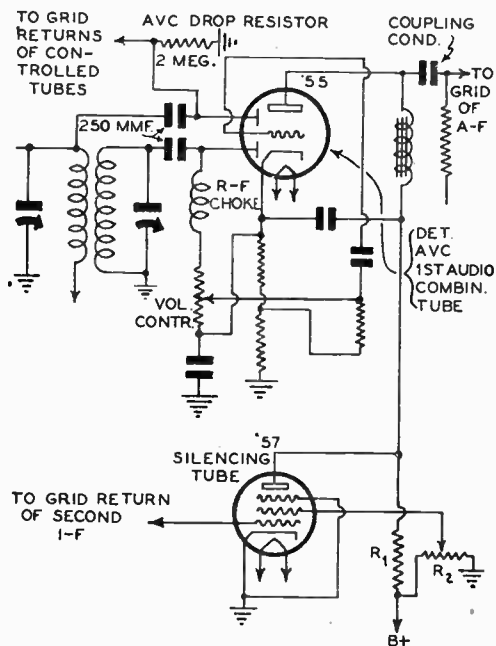

FIG. 19-20.—A typical circuit arrangement employed to silence inter-station noise in some of the early receivers. A separate silencing tube is connected in series with the plate circuit of the first a-f tube. The plate current of this silencing tube (which is controlled by the avc tube) controls the plate voltage applied to the first audio tube and hence controls its amplification, reducing it when the receiver is tuned off resonance. (Used in Atwater Kent 812 receiver.)

drop reduces the plate voltage on the first a-f tube (which is a type '55 functioning as second detector, avc, and first audio tube in this particular circuit). The reduced plate current "silences" any noise that might be heard between stations. When a signal is tuned in, the avc voltage is increased, and the control-grid bias on the silencing tube is increased. This high bias decreases the plate current, and the voltage drop across R_1 is thereby less. The full "B" voltage on the first a-f tube is restored, and the audio sensitivity rises. Since the amount of

inter-station noise varies with the location, a variable adjustment is provided for obtaining almost any desired amount of silencing between stations by having potentiometer R_s regulate the screen voltage of the silencing tube. This type of silent tuning control, although satisfactory in the majority of instances, is limited in its action, especially in extremely noisy locations.

Another type of inter-channel noise suppressor arrangement

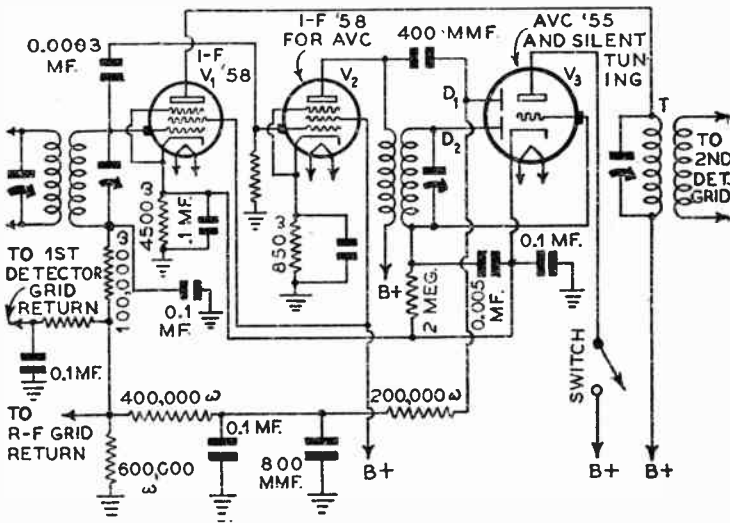

FIG. 19-21.—A circuit arrangement in which the avc tube V_3 also functions as the silent tuning (qavc) control. (Used in RCA Victor 78A receiver.)

(variously called *silent tuning* and *quiet automatic volume control*, abbreviated *qavc*) is shown in Fig. 19-21. In this circuit, the avc tube V_3 also functions as the silent tuning control. Two independent last i-f stages are employed. One supplies signal voltage to the second detector. The other feeds signal voltage to the avc and noise-suppressor circuit. When the receiver is tuned between stations, no signal voltage is present across the secondary, which feeds diode D_2 of V_3 . No current, therefore, is rectified by the diode, and the control grid of the '55 operates at zero bias. The plate current of the '55 tube will then be

maximum because of the zero grid bias and the voltage drop across the 4,500-ohm cathode resistor, which is common to the cathodes of V_1 and V_2 . Hence, the i-f tube is biased to cut-off, which prevents any noise voltage from reaching the second detector. When the receiver is tuned to a signal, it is amplified in the i-f—avc amplifier V_2 (since it is removed from the control grid of V_1) and appears across the secondary coil. The signal is rectified by diode D_2 of V_2 and a negative potential is impressed on the grid of V_3 . The plate current is then reduced

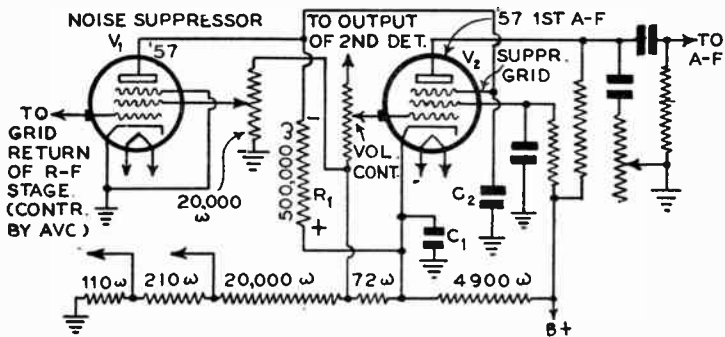

FIG. 19-22.—A qavc circuit arrangement in which the suppressor voltage of the '57 tube used in the first audio stage is controlled by the (qavc) noise suppressor tube so that its plate current is reduced to the cut-off point (preventing reception) when the receiver is tuned off resonance. (Used in Majestic 300 receiver.)

to approximately zero. This removes the high bias from the grid of V_1 , and signal voltage will then be impressed on the second detector via transformer T . A small portion of the signal is obtained from the plate of V_2 , and rectified by diode D_1 for avc in the usual manner.

The tuned circuit for D_2 is designed to tune sharply so that the noise suppressor acts as near the center of the carrier as possible. A variable resistance is placed in the cathode circuit of the r-f and first detector stages to reduce the sensitivity of the receiver by increasing the normal bias on these tubes. A switch, S_4 , is provided on this sensitivity control so that the noise-suppressor circuit may be cut out of the circuit if it is desired. In this case, the manual control is used instead.

Another qavc circuit is shown in Fig. 19-22. A type '57 tube, V_s , is used in the first-audio stage of the receiver because of its sharp grid-voltage cut-off characteristic. (The plate current cuts off sharply at a certain value of suppressor-grid voltage.) When a high negative bias is impressed on the suppressor-grid of V_s , the tube is biased at the cut-off point and the plate current is zero. Another '57 tube, V_i , is employed for qavc action. This tube receives its plate voltage through a resistor, R_1 , which is also in the suppressor grid circuit of V_s . Since the control-grid bias of V_i is determined by the avc voltage, it will have zero bias when the receiver is tuned between stations, as the avc voltage is then zero. The relatively heavy plate current will then flow through R_1 . This plate current produces a voltage drop across R_1 which biases the suppressor grid of V_s so highly negative that its plate current is reduced to the cut-off point, preventing reception. When the receiver is tuned to a station, avc voltage is developed, and since it controls the control-grid bias of V_i , a high negative bias is impressed on it. This bias causes V_i to draw little or no plate current, thus reducing the voltage drop across R_1 . When this voltage drop is removed, the high negative bias on the suppressor grid of V_s is also removed, and the receiver will operate. In order to compensate for noise conditions in different localities, a variable resistance is provided which regulates the screen voltage of V_i , and governs the point at which the tube "takes hold."

Another version of the qavc system just described is shown in Fig. 19-23. Instead of operating on the suppressor grid of the first audio tube, inter-station noise suppression in this circuit is accomplished by controlling the screen voltage of first audio amplifier tube— V_s . When the receiver is tuned between stations, the plate current of V_s is high, since the control-grid voltage is governed by the d-c voltage developed in the detector load resistance. The plate current drawn by this tube causes a voltage drop across the 1-megohm resistor, R_1 , in its plate circuit. This voltage drop reduces the screen voltage of V_s to such low value that the tube is operating almost at cut-off, hence no noise will be received. When the receiver is tuned to a station, the control-grid of V_s becomes more negative, its

plate current is reduced, and consequently the voltage drop across R_1 is reduced. Therefore, the screen voltage on the first audio tube is increased and the receiver functions normally. As with the previously described qavc circuit, a variable resistance is provided to control the screen voltage on V_1 , so that its action may be adjusted for existing local noise con-

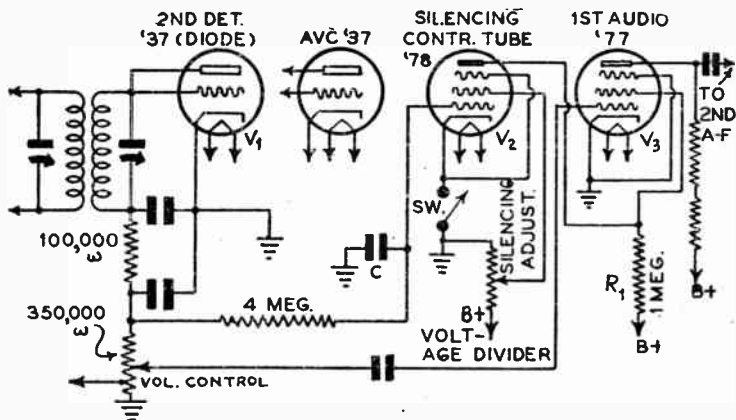

FIG. 19-23.—A qavc circuit arrangement somewhat similar to that of Fig. 19-22 excepting that the screen voltage of the first audio tube is reduced to the cut-off point by the silencing control tube when the receiver is tuned off resonance. (Used in Philco 16 and 17 receivers.)

ditions. By means of a switch in the cathode circuit, the noise suppressor circuit may be cut in and out at will.

19-17. "Noise Gate" QAVC Systems.—There are many variations of the qavc systems just described, especially in the more recent commercial receivers in which noise suppression is effected in the audio circuit. One particular receiver which incorporates silent tuning employs a four-element neon tube as both a resonance tuning indicator (which indicates when the set is tuned to resonance) and noise suppressor, being more popularly known as a *noise gate*. No vacuum tube is required for obtaining the silent tuning feature with this system.

The circuit is shown in Fig. 19-24. Three of the four elements in the neon tube are used to indicate station resonance.

The voltage required for the operation of the tuning indicator is obtained from the drop across a resistor located in the plate circuit of the r-f and i-f tubes. Since an avc system is used in the receiver, the voltage drop across this plate resistor (which depends upon the plate current of the controlled tubes) will vary as the receiver is tuned to, or off, resonance. When the receiver is tuned to resonance, the voltage drop across the plate resistor will decrease because of the decrease in the r-f and i-f

FIG. 19-24.—A circuit arrangement in which a special four-element neon tube acts as both a resonance indicator and a noise suppressor or noise gate. Its noise gate action depends upon the fact that it causes a high bias to be placed on the first audio tube (making it inoperative) when the receiver is tuned off resonance.

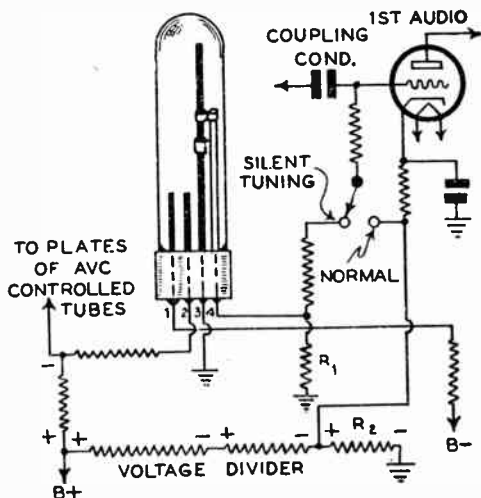

plate current, caused by the increase in control-grid bias. As the voltage drop across the plate resistor decreases, the voltage between two of the neon elements increases, increasing the neon glow, which travels up the long electrode. (A detailed description of the action of this tube as a tuning indicator is given in Art. 19-23.) Electrode No. 4 has only the top portion of its length exposed to the discharge, the lower section being insulated by a glass sleeve. When the gaseous discharge rises up the long electrode, No. 3, and reaches the level of the exposed portion of the fourth electrode, a discharge takes place between the long electrode and the fourth electrode. This discharge develops a voltage across resistor R_1 . Since the first audio tube is biased to the cut-off point by the drop across R_2 , the voltage developed

across R_1 reduces the high bias on the a-f tube and permits plate current to flow. Reception will then be normal. If the receiver is tuned off resonance, the light column developed in the long electrode of the neon bulb will fall below the exposed portion of the fourth element, and the voltage developed across resistor R_1 will be removed. This will return the first audio tube to the high-bias condition and the tube will not amplify. A switch is provided so that the "noise gate" action may be cut out if desired.

19-18. Servicing Silent Tuning Systems.—In the silent tuning control circuit shown in Fig. 19-20, no inter-station noise suppression will be obtained if trouble develops in the screen circuit of the silencing tube. If the movable contact arm of the silencing adjustment potentiometer, R_s , which is insulated from the chassis, should short-circuit to the chassis, the silencing tube will be inoperative because the plate current will be very nearly zero. Likewise, an open-circuited screen resistor in the silencing tube circuit will produce the same condition. These causes of inoperation, however, will be easily disclosed by the usual voltage or resistance analysis to be described in Chapters XX and XXI. Should the reproduction be distorted and choked, the adjustment of the variable silencing control may be at fault. This same symptom also may be caused by a grounded silencing tube control-grid lead or by a short-circuited or leaky by-pass condenser in the avc circuit to which the control-grid lead is connected. These defects will remove the negative bias from the silencing-tube grid, and increased plate current will flow. This plate current will produce a large voltage drop across the plate resistor in the first-audio plate circuit and consequently reduce the plate voltage to a small value. In most instances, however, it is best to check the condition of the silencing tube first.

Should the 0.1 mfd. condenser by-passing the cathode of V_s in Fig. 19-21 become short-circuited or leaky, the high initial cut-off bias of the control grid will be reduced or removed, and no silent tuning will be obtained. The same condition might result if leakage should develop between the cathode and heater of the tube itself. Of course, in this case the leakage will manifest itself by a hum when the receiver is tuned to resonance. No avc action will take place under this condition.

The service problems most likely to develop in a receiver employing the qavc system of Fig. 19-22 would be those resulting from lack of plate voltage on V_1 and lack of suppressor-grid voltage on V_2 . If the plate by-pass condenser C_2 should become short-circuited, the short-circuit current would flow through R_1 , changing the voltage distribution sufficiently so that the plate of V_1 does not receive its proper voltage. This would make noise-suppressor tube V_1 inoperative. If C_1 should "short", neither the plate of V_1 , the suppressor grid of V_2 , nor the cathode of V_2 would receive any voltage, and the receiver would become inoperative. If the 500,000-ohm resistor R_1 should open-circuit, there would be no suppressor-grid voltage and inoperation would result.

In a similar manner, if the 1-megohm resistor, R_1 , in the plate circuit of V_2 of Fig. 19-23 should open-circuit, the receiver would be inoperative due to lack of plate voltage. Should this resistor increase in value, the receiver would operate only with very strong signals with the noise suppressor in the circuit. Should the 4-megohm resistance in the grid circuit of V_2 open-circuit, unstable operation of the receiver would result, since condenser C would charge and discharge periodically. Of course, a weak (low emission) tube in the noise-suppressor stage will reduce the effectiveness of the silent tuning to an extent depending upon the weakness of the tube.

In the silent-tuning control circuit employing a four-electrode neon tube, shown at Fig. 19-24, any trouble which might develop to prevent the neon glow from extending up the long electrode above the exposed portion of the fourth electrode would result in an inoperative receiver when the switch is placed in the silencing position. This may be caused by a faulty neon tube (one in which the gas content has decreased), or by any failure in the avc circuit, since this affects the neon tube action.

19-19. Tuning Indicators.—Many receivers employing avc use some form of indicating device to show when the receiver is tuned to the exact frequency of broadcast signals. Exact tuning is necessary for proper reproduction with all radio receivers, and it is the purpose of the tuning indicator to indicate when exact tuning is established. Incidentally, since many of these devices

operate independently of the manual volume control, it is possible to obtain silent tuning manually by first turning the manual volume control to its minimum position so that no reception is heard. The desired station may then be tuned in the usual way, the tuning being guided visually by watching the tuning indicator.

Any device that indicates when a station has been tuned in properly is called a *resonance indicator* or *tuning indicator*. Different manufacturers use rather ingenious devices to indicate resonance, and they give these devices trade names that identify the device itself rather than its principle of operation or function. For instance, the neon tube resonance indicator is usually called a *Flashograph*; a device which operates on the same principle as a d-c meter is called a *Shadowgraph* or *Shadowmeter*; one employing cathode rays is called a *Magic Eye*, etc. The several distinct types of tuning indicators which are employed may be classified as follows:

1. Visual—A small milliammeter with a special scale and inverted needle position. The receiver is exactly in tune when the maximum deflection of the meter needle is reached.
2. Visual—A shadow appearing in an illuminated space above the tuning dial. The receiver is exactly in tune when the minimum width of shadow is obtained.
3. Visual—A column of red light in a special neon tube. The height of the light column is maximum when exact tuning is accomplished.
4. Visual—A change in brilliancy of the dial-light itself. Minimum brilliancy occurs at exact tuning.
5. Visual—A wedge-shaped shadow appears in a circular illuminated space. Minimum shadow results when the receiver is exactly in tune.
6. Audible—A means of providing silence except when the stations are actually tuned in. This function is a refinement of the interstation tuning silencer (see Art. 19-17) which permits hearing the station over only an extremely small dial motion with a marked increase in

volume or clarity as the approximate center of this range is reached. This method must require that not over about 1 kc of dial motion either way from the exact tuning point can take place before there is a noticeable reduction in volume or change in tone quality.

Before explaining how these commonly-used forms of tuning indicators operate, it will be well to show how they are connected in the circuit and why they indicate the resonance condition at all.

From the theory of avc action explained in this chapter, it is seen that on strong signals the grid bias of certain of the r-f

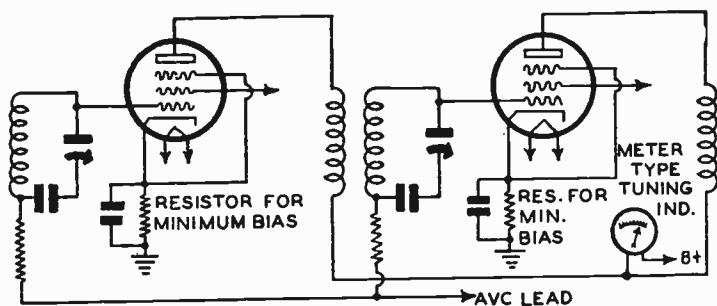

FIG. 19-25.—How a "meter" type tuning indicator is connected in the plate circuits of the avc-controlled tubes in a receiver.

and i-f amplifier tubes is increased by the avc action in proportion to the bias, and the amplification factor of the tubes decreases as a consequence. Now, when the grid bias of any tube is made more *negative*, the plate current of that tube *decreases*, and the decrease in plate current is nearly proportional to the increase in negative bias. Let us illustrate this with a numerical example.

Suppose the plate current of a certain tube controlled by avc is 10 ma. with no signal received. Under these conditions, the grid bias is a minimum and is, say, 3 volts negative. When a sufficiently strong signal is tuned in, the grid bias increases automatically because of the avc to, say, 25 volts negative. Then the plate current drops to some lower value, 2.5 ma., for example, and the r-f or i-f signal on the grid of this tube varies the plate current above and below this 2.5 ma. value, in accordance with the usual amplifier theory.

This means that if an ordinary moving-coil meter movement is connected in the plate circuit of one or more tubes under a-c control, the current through the coil of this movement will be small on loud signals and large on weak signals; and if the meter is placed on the panel of the set with the pointer face down instead of up, it will swing to the extreme left on the loudest signals and to the extreme right when no signal is received. The connection for such a meter is shown in Fig. 19-25. It is not necessary that a d'Arsonval movement be used as long as the meter is of a type that will respond to changes in d-c, it is suitable for use as a tuning indicator. The meter scale is usually divided into arbitrary divisions for ease in determining maximum swing.

19-20. The Shadowgraph.—The shadowgraph is a unique tuning indicator device used to facilitate the precise tuning-in of a station. Resonance is indicated by a shadow on a luminous screen. When a station is properly tuned-in, the shadow is narrowest; when the receiver is tuned between stations, the shadow is widest. Sketches showing the details of construction are presented in Fig. 19-26.

The unit is housed in a small wedge-shaped metal box. Its small end consists essentially of a screen upon which light from a pilot lamp falls. The bottom of the box, as shown in the sketch, holds a coil of wire *E*, a deflecting vane *B*, and a thin circular permanent magnet, *D*. The vane, *B*, is rigidly attached to a small soft-iron disc, *C*, which is pivoted inside the coil and whose horizontal position is in the same plane as the magnet *D*, as shown in the detail sketch at the left. Notice the two small projections on its periphery! With no current through the coil, the disc assumes a horizontal position because of the magnetic field of the permanent magnet. The vane (there is really one vane *below* and another *above* the disc) is not affected by this field, because it is of non-magnetic material.

It is well known that a magnetic ring has no external magnetic field, and hence it may seem paradoxical that its field can keep the disc in a horizontal position. But this magnet has a small air-gap in it. The magnetic field crossing this air gap spreads out to some extent and threads through the plane iron

disc (*C*), tending to hold it in place in a horizontal position.

If the pilot lamp is now lit, light will pass through a hole in the bottom of the box, through the center of the coil form, up through the rectangular slit on either side of the vane in the disc, and come to rest on the screen on the opposite side of the box. Hence, the entire screen will be illuminated except for a thin shadow of the vane, as shown by *A* in the sketch. If the vane—and, of course, the disc—is tilted slightly to the right or left by any force, the light from the pilot lamp will be cut off

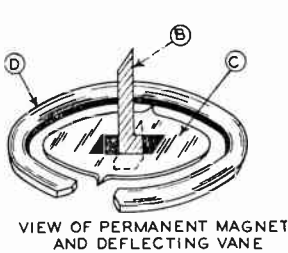

VIEW OF PERMANENT MAGNET AND DEFLECTING VANE

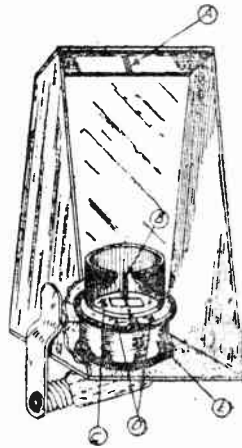

FIG. 19-26.—Construction of the Shadowgraph tuning indicator. A detailed view of the permanent magnet *D*, iron disc *C* and deflecting “shadow”-vane *B*, is shown at the left. The entire unit assembled in its box, is shown at the right. The pilot lamp is at the bottom.

to the right and left of the small initial shadow by the upper and lower vanes, and the width of the shadow of the vane on the screen will therefore be increased. The more the vane is tilted, the wider is the shadow, and the vanes are cut to such shapes that the shadow to the right is equal to that to the left of the initial position, regardless of the angle of the disc.

If current now is sent through the coil *E*, another magnetic field will be produced. This is at right angles to that created by the permanent magnet *D* in the gap. The soft-iron disc *C* will tend to line itself up in the direction of the resultant of these two fields, i.e., it will move on its pivots and assume a tilted position, the angle of tilt depending upon the relative strengths of the two fields. With no coil current, that due to *D* alone remains, and the disc is horizontal; with a field due

to E as strong as that due to D , the disc assumes an angle of 45° , etc. Therefore, as the coil current is increased or decreased, the disc tilts more or less, and the width of the shadow of the vanes on the screen increases or decreases, respectively.

The coil of the shadowgraph is connected in series with the plate circuit of the tubes under avc control. When a station is being tuned-in, the avc voltage increases as resonance is ap-

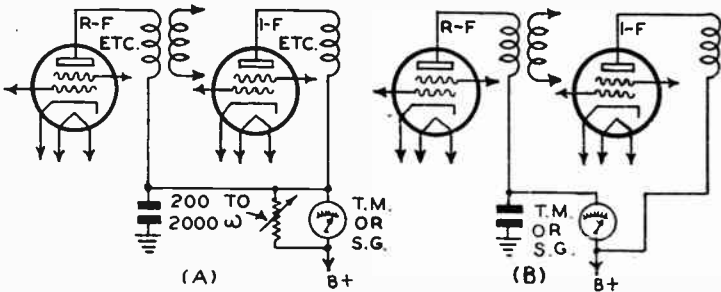

FIG. 19-27.—(A) How a variable resistor may be connected across a Shadowgraph coil, or a tuning meter, to correct the condition of insufficient variation of the shadow or meter indication. The resistor may also be used to permit emergency operation of the receiver if the Shadowgraph or tuning meter coils should open-circuit. (B) How the condition of insufficient indication may often be remedied by connecting the tuning indicator into the plate circuit of one tube only.

proached because the signal strength increases. At resonance, the avc voltage is greatest, and the plate current of each controlled tube is least. This low plate current, flowing through the coil, reduces the coil field, and makes the field due to D relatively greater. Hence the disc assumes a more horizontal position. The result is that the shadow on the screen is narrowest. If a stronger signal is tuned-in, the minimum shadow will be still narrower at resonance, i.e., for any signal strength there is a minimum shadow length which indicates exact resonance.

19-21. Possible Troubles in the shadowgraph.—If the shadowgraph coil should open-circuit, the receiver will become inoperative unless the shadowgraph coil has been shunted by a resistor. In many cases, insufficient variation of the shadow makes tuning difficult, and must be remedied. Repair may be effected by shunting the indicating device with an adjustable.

wire-wound resistor, as shown in Fig. 19-27 at (A). The value of the resistor may be varied to obtain the desired meter swing or shadow width. Either a 500-ohm or a 2,000-ohm adjustable wire-wound resistor is sufficient for this purpose. On some occasions, the condition is best corrected by removing the indicating instrument from the plate circuit of one of the controlled tubes. For example, should the shadowgraph be connected in the combined plate circuit of an r-f and an i-f stage as shown at (A), it should be re-connected so that it is in the plate circuit of the r-f tube alone, as shown at (B) of the Figure.

Another complaint not infrequently encountered with shadowgraphs is that the width of the shadow may not be the same for the same station at different times, or that the shadow is too wide and operates intermittently. These troubles are often due to an incorrectly balanced vane within the shadowgraph, excessive vibration, or the binding of the pivot supports, which prevent the vane from operating freely. Although the shadowgraph may be disassembled and a repair effected, extreme care should be exercised when doing it, as the mechanism is delicate. Any mis-step may damage the pivots and supports beyond repair.

Of course, the pilot lamp which furnishes the necessary light for the shadowgraph has a definite useful life and must be replaced when it burns out.

19-22. Dial-Light Resonance Indicator.—Some receivers (among which are several models of the Majestic receivers) utilize the ordinary dial light of the receiver (or another tuning light) in a rather novel fashion for indicating when the receiver has been tuned exactly to resonance with the incoming station. A *saturable-core reactor* having three legs and three windings (one on each leg) as shown in Fig. 19-28, is employed to make this possible. The basic idea employed is to make the changes in the d-c plate current of the avc-controlled tubes in the receiver control the flow of a-c current through the dial light through the action of this saturable-core reactor.

As shown in Fig. 19-28, two a-c coils, A-A, having an equal number of turns are mounted on the outer legs of the reactor core. They are connected in series with the dial light which obtains its operating voltage from a secondary winding on the

power transformer. These two coils are properly connected together so they produce a-c magnetic flux around the outside legs of the core, in the *assisting* directions shown in the illustration. The center winding, *D*, is connected in series with the *plate* circuits of all the tubes which are controlled by the *avc*, so it carries the total d-c plate current of these tubes.

When the receiver is *not* tuned to resonance with the signal

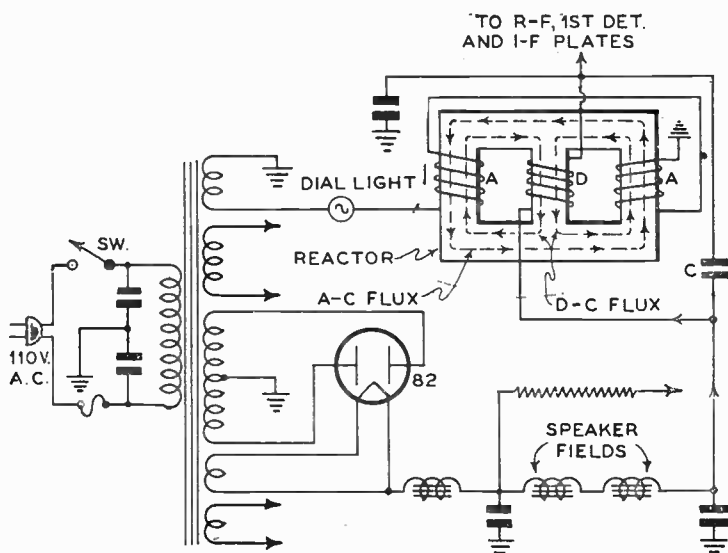

Fig. 19-28.—Connection of the saturable-core reactor and tuning dial light circuit in a receiver which employs the dial-light form of tuning indicator. Only a portion of the power supply circuit of the receiver is shown here.

of any station, a relatively high d-c plate current flows through winding *D*, since the *avc*-controlled tubes draw maximum plate current when no signal is being received. This current flowing through coil *D* sets up a magnetic flux in one direction, in the two paths which are indicated by the d-c flux lines in the illustration. The reactor is so designed that this d-c flux magnetizes the iron core past its saturation point. Hence, the a-c dial-light current flowing through coils *A* and *C* does not produce any appreciable change in magnetization of the iron (since it is being worked past its saturation point). Consequently, the reactance

and a-c impedance of these coils is low and full current flows through the circuit, lighting the dial light up to full brilliance.

When the receiver is tuned to a station, the negative bias placed on the avc-controlled tubes by virtue of the avc action *reduces* the plate currents of these tubes. The more nearly the receiver is tuned to the incoming signal, the lower the plate current of these tubes gets. Since this current flows through the center coil *D*, it means that the d-c magnetic flux in the core diminishes greatly in strength when the station is tuned to resonance. This allows the core to operate below its magnetic saturation point, and now the a-c dial current flowing through coils *A-A* is able to produce cyclic variations in the magnetism in the core. This greatly increases the reactance and impedance of these coils, thereby limiting the dial-light current flowing through them, causing the light to grow dim. The closer the receiver is tuned to resonance with the incoming signal the dimmer the dial light gets. Therefore, the dial light serves as a visual resonance indicator.

It is evident that any stray a-c flux from the dial light coils *A-A* that may thread through the center coil, *D*, will induce an a-c voltage in it. Since this center winding is in series with the plate circuits of the r-f and i-f tubes in the receiver, any 60-cycle voltage induced into this circuit will cause hum. An electrolytic condenser, *C*, having a capacity of 1 mfd. or more may be connected across this center winding to by-pass any small a-c voltage that may be generated in it. Or, a single short-circuited turn of thick copper wire placed around (or inside of) this coil will absorb the energy of this stray a-c flux, thus preventing it from inducing any a-c voltage in coil *D*.

Troubles may develop in this type of dial-light resonance indicator system. It should be remembered that since the center coil is in series with the plate circuits of the avc-controlled tubes, if an open-circuit occurs in it, these tubes will not operate, and the receiver will go dead. Should it be found that the receiver is inoperative and the dial light operates but does not dim when the receiver is tuned slowly over the range of its dial, check the continuity of the center winding of the reactor.

Since this resonance indicator depends upon the avc action

for its operation, it will be affected by anything which goes wrong with the avc. If the receiver does operate normally, but the dial light does not grow dim as the receiver is tuned to a station, check for a "short" between one side of the dial light

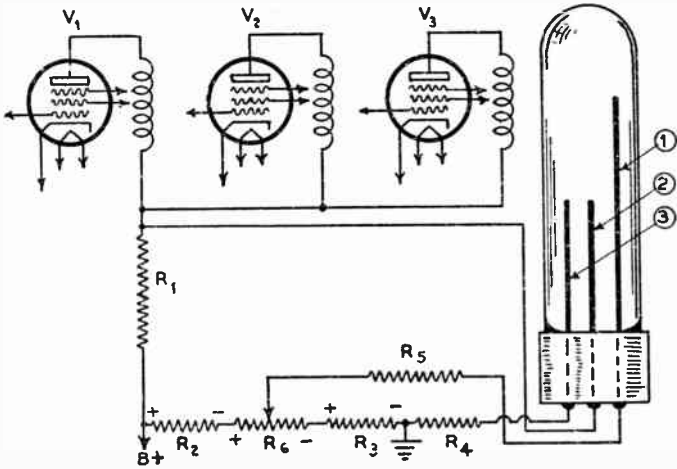

FIG. 19-29.—Connection of the 3-element Flashograph to the r-f or i-f amplifier tube circuits.

and ground, and between the outer windings and ground (remember that one side of these outer windings connects to ground); for a "short" across one of the outer windings, or a ground in one of them; for a "short" in the middle winding; and for a "short" in the electrolytic condenser connected across it. This condenser has a low working voltage, and sometimes short-circuits, especially if the center winding should become open-circuited. An open-circuit in this condenser will cause excessive hum in the receiver.

If the dial-light does not light up at all, check the continuity of the entire dial-light circuit, check also for a short-circuit or a ground in the power transformer winding which feeds this circuit.

19-23. The Flashograph.—An interesting application of the neon tube as an indicator of proper tuning is the *Flashograph*, or *Tune-A-Lite*. This device makes use of the fact that the greater the voltage applied to the terminals of such a tube,

the *higher* is the column of light in that tube. In other words, the action is analogous to the action of a thermometer: the more heat applied to the bulb of a thermometer, the higher the column of mercury or alcohol in it rises.

As shown in Fig. 19-29, the Flashograph consists of three (the older models had two) electrodes, one longer than the others, mounted in a thin cylindrical glass tube filled with neon gas. The neon gas is first ionized by the small potential between electrodes 1 and 2, the exact value of this bias being made variable between about 90 and 185 volts by means of the potentiometer R_6 . Resistor R_5 is connected in series with this electrode to insure stable operation. The third electrode is used to maintain the tube in a state of ionization when the signal strength fluctuates over wide limits.

With no signal tuned in, the plate currents of V_1 , V_2 and V_3 , (which may be r-f or i-f amplifier tubes under avc control) are high, and the voltage drop across R_1 is high. This voltage "bucks" the voltage across R_2 , R_6 and R_3 , so that the net voltage across electrodes 1 and 2 is small. The height of the ionized column in the tube is small as a consequence. But when the signal strength is above the avc threshold, the plate currents of the tubes decrease, the bucking voltage across R_1 decreases, and the net voltage applied to electrodes 1 and 2 increases. Note that electrode 1 is taller than electrode 2; this means that the height of the ionized portion of the gas in the tube increases, depending upon the amount of voltage applied to electrodes 1 and 2. The tuning knob of the receiver should therefore be adjusted until the height of the neon glow is greatest.

If a receiver should be serviced in which the variation in height of the glow is small (or zero) as the set is tuned from station to station, resistors R_2 and R_3 should be checked for open circuit. An open circuit in either one will not affect the operation of the receiver to any marked extent, although the tuning indicating device will not work. Of course, the neon tube may have to be replaced at times.

19-24. "Magic Eye" Resonance Indicator.—This resonance indicator employs the 6E5 cathode-ray tuning tube, which is really two tubes in one.

It has a common hot-cathode K (see (A) of Fig. 19-30), the lower part of which supplies a stream of electrons for the triode section of the tube (composed of one cathode section, triode-grid TG , and the triode-plate TP), the upper part of the cathode supplies electrons which bombard the fluorescent screen coating on a cone-shaped target, T , (located in the dome of the bulb), in order to illuminate it with a greenish light. A small ray-control electrode, CE , (connected to the plate inside the tube) placed in this electron stream exercises a control over this area of target which is struck and illuminated by these electrons—a fan-shaped shadow appearing where electrons do not strike it.

The detected signal voltage is applied to the triode control-grid,

as shown. As a station is being tuned in (by turning the receiver tuning knob slowly) this grid becomes more *negative* with respect to the cathode. Since this decreases the plate current, there is a smaller voltage drop through the 1-meg plate-resistor R , and the positive voltage applied to both the triode-plate and the ray-control electrode *increases*. The effect of this increased positive potential of the ray-control electrode on the displacement of the negative electron stream is to cause the shadow on the target to *narrow down to a thin line* (as shown at (B)) when the station is tuned in exactly. As one tunes off resonance, the shadow widens as shown at (C). In the 6E5, the impression of a human "eye" is created, the pupil being simulated by a small circular light-shield cap placed over the tip of the cathode. This indicator greatly enhances "silent tuning", inasmuch as the volume-control knob can remain "down" until the station is precisely tuned by visibility alone.

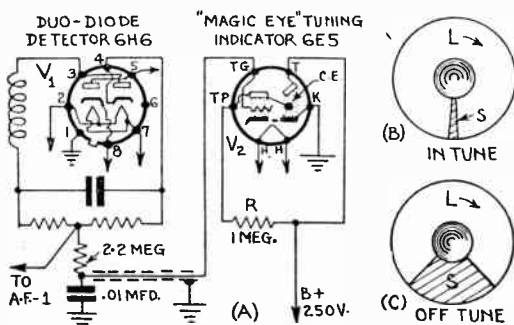

FIG. 19-30.—Connection of the 6E5 "Magic Eye" cathode-ray type tuning indicator to a 6H6 duo-diode detector in a modern receiver. The narrowing of the shadow, S , when the receiver is brought in tune is shown at the right, in (B) and (C).

19-25. Conclusion.—It is obviously beyond the scope of this book to analyze all the avc and qavc circuits in use. However, an attempt has been made to analyze the principle of operation of the more fundamental and important types so that the reader will develop a system of analysis that can be used for other systems that may be developed in the future. It is one thing to *know* the principle of operation of a system and another to memorize the troubles as they are solved by yourself and others. The memorization method is hopelessly inadequate in the case of avc and qavc systems as they exist today, for there are too many of them. Moreover, the development of additional new systems presents such a fertile field for the creative instincts of the circuit designer that it is safe to say that many more of them will be brought out from year to year—with added complexities. A fundamental knowledge of the operation of the general circuits and methods used in these systems is obviously more useful to

the service man than attempts to memorize the exact connections or troubles. In the final analysis, most troubles in avc and qavc systems simmer down to troubles in the tubes, resistors or condensers associated with them, or in the indicating device employed.

REVIEW QUESTIONS

1. Explain the advantage gained by incorporating automatic volume control in a receiver. State briefly, exactly the manner in which this feature is obtained.
2. Draw a diagram of a simple automatic volume control system employing a 3-element tube as a diode detector and avc. How is the avc action secured in this particular circuit?
3. Draw a diagram of an avc system employing a separate tube, showing the manner in which the tube is connected and only those portions of the receiver which it controls.
4. What is meant by delayed avc? In what respect has this system an advantage over the conventional avc system?
5. Draw a diagram of a type 55 tube employed in a delayed avc circuit and explain how the delayed action is obtained.
6. How would you remedy a condition where the avc action in a receiver is excessive?
7. What will happen if the resistor in the plate circuit of a separate avc tube open-circuits? Why?
8. What is the purpose of the resistance and by-pass condensers in the secondary return circuits of the tubes controlled by the avc tube?
9. State briefly the symptoms to be expected when one or more of these by-pass condensers open-circuit. If they short-circuit? -
10. What might cause broadcast stations to come in "abruptly" when a receiver is tuned?
11. You are servicing a receiver with the complaint of "no control of volume." You find that the volume control is in the grid circuit of the avc tube and is perfect. What would you say could cause this condition?
12. What is meant by silent tuning? Describe briefly, three common methods employed in commercial receivers to obtain silent tuning.
13. What is a tuning meter? What would you do if you were called upon to service a receiver in which the tuning meter did not operate? The meter itself is in good condition.
14. A receiver using a three-element Flashograph as a tuning indicator works normally but the Flashograph does not function. What would cause this trouble?
15. Draw the circuit diagram for, and explain the operation of, the "Magic Eye" tuning indicator.

CHAPTER XX

RECEIVER ANALYSIS BY VOLTAGE-CURRENT TESTS

20-1. Importance of Correct Interpretation of Set Analyzer Readings.— All commercial set analyzers are supplied with instruction books which explain, in detail, the proper use of the various push-buttons, selector switches, adapters, meters, etc., for performing the various tests. Since the arrangements of these switching devices are different in each analyzer, it is impossible to discuss the exact button to press, or switch to turn, in order to make a certain test, unless a specific analyzer is considered. We are not interested in this detail here anyway, since the manufacturer's instruction book supplies this information adequately. We are interested here in the general procedure to follow in analyzing a receiver, and in the correct interpretation of the meter readings obtained during this analysis. It is not sufficient merely to manipulate a set analyzer according to the accompanying instruction book. The readings obtained must be interpreted intelligently in order to determine the location and nature of the trouble.

The interpretation of the readings of a set analyzer depends a good deal upon the design of the receiver, and it is often essential that the circuit of the receiver under test be known in order to determine the trouble quickly. This is especially true of modern receivers of complicated design, many of which incorporate push-pull resistance coupled circuits, automatic volume control, silent tuning circuits, etc. This important point will be brought out at several places in this chapter—especially in Art. 20-15. Circuit diagrams of most of the radio receivers manufactured in the United States can be obtained from radio service manuals compiled for this purpose, or from the service departments of the receiver manufacturers themselves.

20-2. Sources of Correct Receiver Data.—Of course, no service man can tell whether the voltage and current readings he obtains with a set analyzer are correct or not unless he knows just what these readings *should be* for that particular model

RADIOTRON SOCKET VOLTAGES
115-Volt A. C. Line—No Signal—Volume Control "Maximum"

| RADIOTRON NUMBER | | CATHODE TO GROUND, VOLTS, D. C. | SCREEN GRID TO GROUND, VOLTS, D. C. | PLATE TO GROUND, VOLTS, D. C. | PLATE CURRENT, M. A. | HEATER VOLTS, A. C. |
|----------------------|------|---------------------------------|-------------------------------------|-------------------------------|----------------------|---------------------|
| RCA 4D6—R. F. | | 6.0 | 105 | 265 | 9.0 | 6.3 |
| RCA-6A7 | Det. | 6.0 | 105 | 265 | 3.5 | 6.3 |
| | On. | — | — | 220 | 4.5 | |
| RCA-6D6—I. F. | | 6.0 | 105 | 265 | 9.0 | 6.3 |
| RCA 6B7—2nd Detector | | 3.0 | 50 | 90* | 0.7 | 6.3 |
| RCA-41—Power | | 16.5 | 265 | 245 | 30.0 | 6.3 |
| RCA-80—Rectifier | | — | — | 600 (RMS) | 70.0 | 5.0 |

* Voltage calculated from $265 \text{ V} \div 4$.

FIG. 20-1.—A typical voltage-current socket analysis chart provided by the manufacturer for the RCA Victor Model 128-E receiver. This specifies the normal voltages and currents which should exist at certain socket terminals of each tube when the receiver is operated from a 115-volt line with volume control set at "maximum" and no signal tuned in.

receiver he is testing. This information can be obtained from the following sources:

1. From tests on new receivers. The service man should make it a practice to test all new models of receivers whenever the opportunities present themselves. The readings obtained should be recorded systematically, see Fig. 20-2, and filed away for future reference. The line voltage existing during the test should also be recorded.
2. From reliable service manuals.
3. From the service bulletins of receiver manufacturers. Almost all receiver manufacturers supply the necessary voltage and current data (and often the resistance data also) in their service bulletins. A typical voltage-current socket analysis chart taken from a service bulletin is shown in Fig. 20-1.

Notice that on the chart of Fig 20-1 the normal voltage and current readings at the various important prongs of each tube are specified for some particular value of line voltage—115 volts in this case. If the various tube voltages and currents are checked when the receiver is operating from a line having a voltage other than that specified, suitable allowance must be made when comparing the readings obtained by the analysis with those specified in the chart. Allowances must also be made for manufacturing tolerances in the receiver itself. In general, allowances up to $\pm 15\%$ may be made. However, since some voltage, current or resistance values which vary as much as 15% from normal may indicate trouble in the receiver, caution should be observed in this respect. This has been found to be true especially where control-grid voltages are concerned.

20-3. Purpose of the Set Analyzer.—The general arrangements of the circuits, meters and the ideas involved in the design of modern set analyzers have been presented in Chapters XI to XIV, and the reader is urged to familiarize himself with the contents of these chapters if he has not already done so. It should be remembered that the main purpose of the set analyzer is to extend the various circuits terminating at any tube socket in the receiver to a point outside the receiver for convenience in testing.

20-4. Preliminary Tests for Trouble.—Before starting the receiver analysis, the preliminary tests outlined in Chapter XVIII should be made, since they may reveal that the cause of the trouble lies *outside* of the receiver proper, or at least may reveal the trouble at once, and so save the time which would be spent on an unnecessary and futile receiver analysis. If these tests do not give a clue to the trouble, the receiver should be analyzed by either a voltage-current test, a resistance test, or a combination of the two. The voltage-current method will be discussed now—the resistance method will be presented in Chapter XXI.

20-5. Starting the Analysis with the Set Analyzer.—The first step in analyzing a receiver by voltage-current tests is to see that the source of operating power is connected to it properly. If it is battery operated, all batteries should be connected

properly. If it is power operated from the light socket, connect it to this circuit. Then turn on the receiver and make such adjustments as are normally required to tune it for proper reception of broadcast signals. In general, all tests should be made with the volume control set at the "maximum volume" position, since maximum voltages are generally supplied to the various circuits at this setting. A second set of readings with the volume control in the "minimum volume" position is also helpful in locating trouble in some particular receivers. During the tests, all tubes should be left in their respective sockets in the receiver, with the exception of the tube from the socket under test. The analyzer plug is placed in this socket and the tube is placed in the proper socket in the analyzer, as explained in Chapter XI.

20-6. Checking the Power Supply Unit.—The first check should usually be made on the power supply unit to determine whether or not it is supplying normal voltages to the various circuits of the set. If the receiver is battery-operated, the voltages of the various batteries should be checked by making use of the analyzer voltmeter terminals provided for "external tests". If the battery voltages are low, the batteries should be re-charged or replaced (a 45-volt *B* battery unit should be discarded when its voltage drops to about 30-35 volts. This voltage should be checked when the battery is connected to the receiver, and the receiver is turned "on").

If the receiver is powered by the light-line circuit, the rectifier tube or tubes (if it is a-c operated) and circuits should be checked by placing each tube in the analyzer, in turn (if two are used), and placing the analyzer plug into the vacant tube socket. The a-c filament voltage, and the current flowing through each plate of the tube, should be checked by manipulating the proper switches. The total plate current in a full-wave rectifier tube (type '80, 5Z3, '82, etc.) is equal to the sum of the currents through the two plate circuits. (An analysis of the conditions indicated by these and all following readings will be considered in detail later.) The d-c voltage output of the rectifier tube should then be measured. In the average set analyzer the meter-reversing switch must be pressed when this reading is taken, since each

plate of the rectifier is negative with respect to the filament, so far as the d-c voltage is concerned.

There may be some who question the advisability of checking the power unit first. It is desirable for the reason that a very frequent cause for an inoperative, or a poorly operating receiver, is some breakdown in the power unit, as, for instance, a ruptured filter condenser. If this is the case, it is unnecessary to proceed further; the chassis may be removed at once to effect the repair or replacement. On the other hand, if the amplifier stages are checked first, lack of voltage in one or more circuits may be due to two causes: either a particular part of that circuit is at fault, or the power unit is not delivering proper voltages. In any event, the power supply must be checked anyway before further analysis is made in the amplifier circuit. From this explanation, it can be seen that the first logical step in making a receiver analysis is that of first checking the power supply unit in the manner described.

20-7. Checking the Currents and Voltages at the Tube Sockets.—After the source of power to the radio set has been checked the next step is to check the voltage existing at each tube circuit and the current in some of the circuits. The usual practice is to check the tubes in the order in which the signal passes through them, that is, starting with the antenna stage and ending with the power amplifier, or "output" stage.

Each tube should be removed from its socket, in turn, in the above-mentioned order, placed into the socket of the analyzer, and the plug of the analyzer placed into that receiver tube socket from which the tube was removed. By pressing the proper buttons and manipulating the proper switches, all the important voltages and currents existing at each tube socket may be checked. The number of readings taken depends upon the type of tube used. For a complete analysis of the circuits for a three element tube, it is necessary to measure the following: (1) plate voltage, (2) plate current, (3) grid voltage, (4) grid current, (5) filament voltage. When indirect-heater type screen grid, or pentode tube circuits are being analyzed, the following additional measurements should be made: (6) cathode voltage,

(7) screen-grid voltage, (8) screen-grid current, (9) suppressor-grid voltage. It may also be necessary to measure the voltage impressed on diode plates, anode grids, etc.

The insertion of the plug of the analyzer into the tube socket of the radio-frequency or detector stages of a receiver will detune that stage during the test because of the added capacity, inductance and resistance of the analyzer circuits, so that whatever signals are heard before plugging into the socket may be weakened or eliminated during the test. Instead of broadcast signals, hum, oscillation or other circuit noises may be heard while the set analyzer is plugged into one of the tube sockets. This lack of signals does not, however, affect the continuity of the circuit nor indicate any defect in either the receiver or the set analyzer. Some of the recent set analyzers incorporate bypass condensers so that the disturbing effect which the capacity, inductance, and resistance of the analyzer cable adds to the circuits of the tube may be lessened.

20-8. Testing the Tubes With the Set Analyzer. — In many instances, weak, short-circuited or burned-out tubes are causes for an inoperative receiver. Therefore, every tube in the receiver should be tested and a good one of the same type substituted for each one found to be bad. Radio receiver servicing, to be profitable, necessitates the speediest form of work consistent with accuracy and good results. Tube checkers suitable for this work have been described in Chapters VIII, IX and X. However, for the convenience of service men who do not care to carry a tube checker along on their service calls in addition to the set analyzer and other equipment, most voltage-current type analyzers are provided with facilities for checking the tubes of the set—although, as was explained in Chapter VIII, testing tubes with the set analyzer is not as dependable a method as testing them with a good tube checker is, because of the non-uniformity of the test voltages and conditions under which the tubes must necessarily be tested when this method is employed.

For the testing of three-electrode tubes, the set analyzer is usually provided with a switch or push-button which connects a 4.5-volt flashlight battery into the grid circuit of the tube,

thereby changing the grid potential by 4.5 volts. The change in plate current that this bias shift produces is read on the plate milliammeter and recorded. The value of this plate current *change* is a measure of the mutual conductance (worth) of the tube for use as an amplifier (see Arts. 8-15 to 8-18).

For the testing of tetrode and pentode tubes, the 4.5-volt flashlight battery is connected in the *control grid* circuit when the proper button or switch is operated. In some analyzers, the dry-cell battery is connected so as to make the grid voltage

SUPREME

Radio Diagnostic

FOR John Brown PHONE Main 351
 APT. 4 B AT 325 Walnut ST.
 MODEL 44 Radiola RADIO
 PURCHASED July 15 1931 LAST SERVICED Dec 15 1931

AA-1 TUBE AND SOCKET ANALYSIS

| TUBE POSITION | TUBE TYPE | PLATE VOLTS | A. S. VOLTS | CATHODE VOLTS | SP. CHG. VOLTS | C. GRID VOLTS | PL. VOLTS | A. S. BILD. | SP. CHG. BILD. | PLATE BILD. | BIAS CHANGE PER PHASE | TUBE TEST CHANGE |
|---|-----------|-------------|-------------|---------------|----------------|---------------|-----------|-------------|----------------|-------------|-----------------------|------------------|
| RF-1 | 224 | 164 | 4.5 | 1.5 | — | 1.5 | 2.35 | — | — | 1.5 | 3.8 | 2.3 |
| RF-2 | 224 | 164 | 4.5 | 1.5 | — | 1.5 | 2.35 | — | — | 1.5 | 3.8 | 2.3 |
| DET. 3 | 224 | 100 | 5.0 | 7.0 | — | 6.0 | 2.35 | — | — | 0.1 | 0.8 | 0.7 |
| AF-1 | 245 | 230 | — | — | — | 6.0 | 2.5 | — | — | 32.0 | 39.0 | 2.0 |
| RECT 5 | 280 | 260 | — | — | — | — | 5.0 | — | — | 50.0 | — | — |
| RECEPTION WEAK | | | | | | | | | | | | |
| Tested by Walter Blank | | | | | | | | | | | | |
| RADIO SERIAL NO. <u>131510</u> TUNED AT <u>50</u> VOLUME SETTING <u>MAX.</u> LINE VOLTAGE <u>118 V.</u> | | | | | | | | | | | | |

FIG. 20-2.—A typical radio set analysis chart form on which the readings obtained on a particular receiver with the set analyzer have been recorded by the service man. Charts of this kind enable him to keep a permanent record of the current and voltage readings which he obtains at each tube socket of a receiver.

more negative, thus causing the plate current to *decrease*. There are a few analyzers, however, in which the battery is connected so as to make the grid voltage *more positive*, causing the plate current to *increase*. It is evident, therefore, that a chart giving the expected plate-current changes for various types of tubes can be valid only for a particular type of analyzer, and therefore a chart for one model analyzer cannot be used to determine the worth of a tube tested in some other analyzer.

By making this grid-shift test at the time that the circuits of a tube are being analyzed, the condition of the tube itself may be ascertained. Definite allowable variations from the "plate-current—bias-change" values shown in these charts cannot be specified, since a relatively large change in mutual con-

ductance causes only a small change in tube performance as judged by a listening test under receiving conditions. It may be stated generally that an amplifier tube which shows *no* change in plate current when manipulating the proper "bias change" switch will not amplify signals at all well, and that readings that are within 25% of the values stated on these charts indicate that the tube will operate satisfactorily. When the plate-current changes are less than one-half than those specified on the chart, however, the tubes should generally be replaced.

20-9. Recording the Set Analyzer Readings.—It may be noticed that quite a few instrument readings are obtained during the complete analysis of the tube circuits of a receiver. It is difficult to attempt to remember all these readings for comparison and study after they are taken, particularly in the case of receivers employing many tubes. For this reason, it is advisable to record all readings on a suitably prepared analysis chart when they are taken. Such charts may be prepared by the service man himself, or may be purchased from the manufacturer of the analyzer. A typical chart of this kind, in which the readings taken with a set analyzer have been recorded, is shown in Fig. 20-2.

20-10. Interpreting the Analyzer Readings.—After each reading has been obtained with the analyzer, it must be compared with the reading which should be obtained under normal operating conditions. As explained in Art. 20-2, and shown in Fig. 20-1, charts specifying the normal voltages and currents which *should* exist at the various tube terminals are available for many popular receivers. In some instances, these charts are supplied by the receiver manufacturer, but they are usually obtained from service manuals. Of course, if a tube tests satisfactorily and the proper voltages and currents exist at its terminals, both the tube and its circuits may be dismissed from suspicion for the time being. If the tests indicate that one or more of the currents or voltages are not normal, *the service man must interpret the readings actually obtained*, in terms of "what possible trouble existing in the circuits connected to that particular tube could cause the voltages or currents to be as they are".

In order fully to comprehend the meaning of readings ob-

tained from the analysis of a receiver, it is important to consider the characteristics of certain parts of complete receiver systems. Each receiver has its own circuit peculiarities, and therefore the interpretation which must be given to an analyzer reading that reveals the existence of some abnormal voltage or

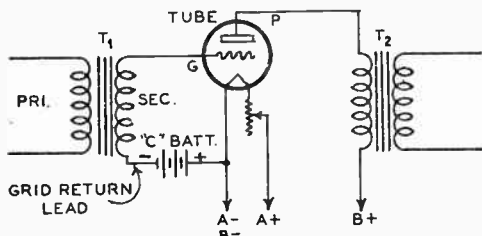

FIG. 20-3.—In most battery-operated receivers, the *C* bias voltages for the amplifier tubes are supplied by one or more dry-cell *C* batteries connected in the grid-return circuit as shown here.

current condition depends upon the receiver circuit design to a great extent. We will now consider, therefore, the most common fundamental circuit arrangements employed in radio receivers, from the point of view of how they affect the correct

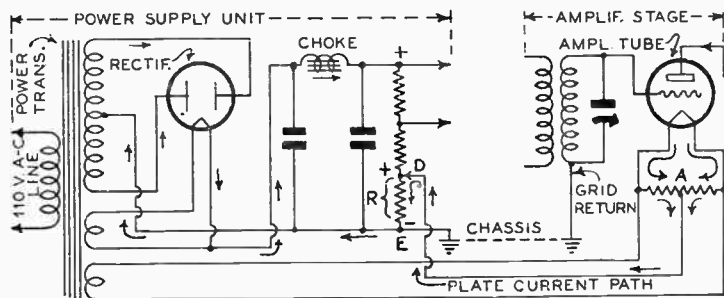

FIG. 20-4.—One of the two circuit arrangements used for obtaining the required *C* bias voltages in many old electric receivers which employed direct-heater type tubes. Resistor *R*, which forms part of the voltage-divider resistor, is the grid-bias resistor. The arrows show the complete path of the plate current of the amplifier tube.

interpretation of abnormal tube socket voltage and current readings taken on them by set analyzers.

20-11. Circuit Arrangements for Securing Grid Bias in Receivers.—In most small battery-operated receivers, only the audio amplifiers have any grid bias, and this usually is supplied

by a small C battery connected in series with the grid-return circuit of that stage, as shown in Fig. 20-3.

In all modern socket-power operated radio receivers (with the exception, perhaps, of a few d-c models), the grid bias voltages applied to the tubes are obtained from the voltage drops produced across resistors by the flow of the cathode current through them.

When direct-heater type tubes, such as the '26, '71A, '45 and 2A3, are employed in an a-c receiver, two general methods

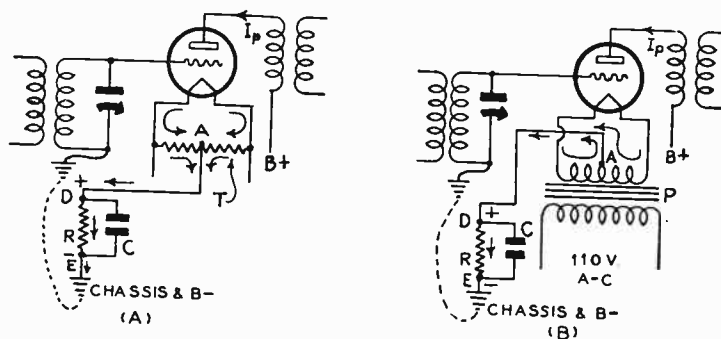

FIG. 20-5.—(A) A circuit arrangement used for obtaining C bias voltage in many old electric receivers. The plate current of the tube is made to flow through a C bias resistor R . The voltage drop produced in this resistor is utilized as the negative C bias voltage.

(B) A C bias voltage arrangement similar to that of (A) excepting that the filament winding of the power transformer P is center-tapped instead of using a center-tapped resistor, T , across the filament circuit.

of securing proper grid bias are commonly employed. The first method is shown in Fig. 20-4 which shows the complete circuit of the power-supply unit in the receiver properly connected to one of the amplifier stages, so that the complete paths of the plate current for the stage can be traced. The path of the plate current of the tube is shown by the arrows: the plate current flows through resistor R (which is a portion of the voltage-divider resistor) and produces a voltage drop across it so that point E is *negative* with respect to point D . The grid-return circuit of the tube is connected to point E through the common return circuit through the chassis, thereby placing it at a nega-

tive potential with respect to points *D*, *A*, and the filament of the tube. Several manufacturers have used this method of biasing all the tubes in the receiver. The Kolster models 6J and K20, and the Stromberg Carlson model 635 are examples of this.

The second, and more popular, *C* bias arrangement used with direct-heater type tubes is shown at (A) of Fig. 20-5. The *B*-power supply unit is not shown in this diagram. Here center point *A* of a center-tapped resistor *T* is connected to the bias resistor *R* in the plate-return circuit of the tube. The plate current of the tube flowing through resistor *R*, produces a voltage drop across it. This makes the *B*-minus end, *E*, *negative* with respect to end *D* and center-tap *A*. Since the grid-return lead is connected directly to *B*-minus, the grid becomes *negative* with respect to center-tap *A* and the filament, by an amount equal to the voltage drop across *R*. The value of *R* in all such cases may be calculated by dividing the bias voltage desired, by the plate current (in *amperes*) of the tube. Thus, if 50 volts bias

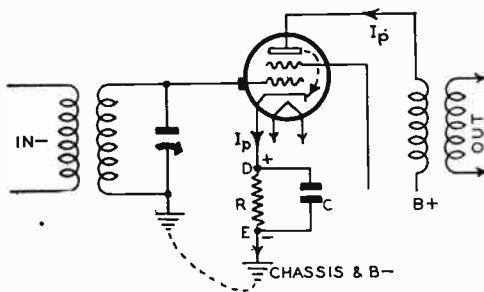

FIG. 20-6. — The most common method for obtaining the negative grid bias for an indirect-heater type tube by making its plate current flow through resistor *R*. This makes point *E* (and the control grid) *negative* with respect to point *D* (and the cathode).

is desired, and the plate current will be 30 ma (0.03 ampere)

when the bias is applied, then $R = \frac{E}{I} = \frac{50}{0.03} = 1,667$ ohms.

If the tube has other grids passing current, then those grid currents must be added to the plate current in determining *R*. If, in this example the tube had a screen grid passing 20 ma

(0.02 ampere), then $R = \frac{50}{0.03 + 0.02} = \frac{50}{0.05} = 1,000$ ohms

would be the proper resistance value to use for the bias resistor.

In some cases, the center-tapped resistor is omitted, and the filament-supply winding of the power transformer, P , is center-tapped instead, as shown at (B). The bias resistor, R , is again connected in the plate-return lead, as shown. The operation of the grid-bias circuit is the same in either case.

When indirect-heater type tubes, such as the '27, '56, and '24, are employed, grid bias is secured in the manner shown in Fig.

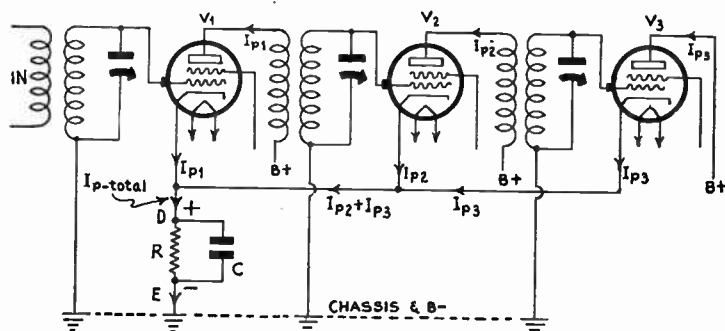

FIG. 20-7.—A common method of using a single grid-bias resistor R for obtaining the proper negative grid bias voltage for several *similar* indirect-heater type tubes in an amplifier.

20-6. The resistor R is connected in the plate-return circuit of the tube. The plate current flows from plate to cathode inside the tube, and through resistor R to B -minus outside the tube. The resulting voltage drop across R is applied to the control-grid of the tube. For the sake of economy, many radio receivers employing several tubes of the same type operating at the same voltages utilize a single resistance to obtain the proper grid bias for all these tubes. This arrangement, shown in Fig. 20-7, has the disadvantage that it tends to increase the possibility of interstage coupling caused by the common bias resistor. The value of R in this case is equal to the required bias voltage divided by the sum of the plate and screen currents of all the tubes served by resistor R . Thus, if a 5-volt bias is required and the *sum* of all the plate and screen currents of the three tubes to be served by R is 20 ma. (0.020 amperes), then

$$R = \frac{E}{I} = \frac{5}{0.02} = 250 \text{ ohms.}$$

In some receivers, the bias resistor may consist of both a fixed and a variable section, as shown in Fig. 20-8. Here, the variable resistor R_2 is usually employed as the volume control. When the resistance setting of R_2 is *decreased*, the grid bias *decreases*. This increases the plate current and the amplifica-

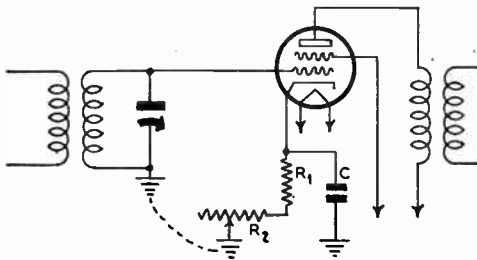

FIG. 20-8. — Grid bias voltage is obtained here by the combination of a fixed and a variable resistor in the cathode circuit. The variable resistor is used for the purpose of varying the bias voltage in order to control the volume.

tion of the tube. When the resistance setting of R_2 is *increased*, the bias is increased and the amplification is *decreased*. Thus R_2 controls the amplification of the tube (or tubes) and the output volume of the receiver. The purpose of R_1 is to prevent

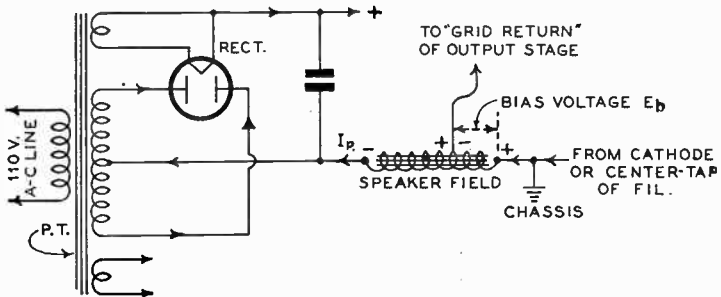

FIG. 20-9.—A circuit arrangement employed for obtaining the grid bias for the power amplifier tube in the receiver by utilizing the voltage drop in a portion of the speaker field winding which is connected in the plate-return circuit.

the bias from reaching zero when R_2 is set at its zero-resistance position for "maximum" volume.

Grid bias for power amplifier tubes is sometimes obtained by means of a tap on the dynamic speaker field (or filter choke) which has been connected in the high-voltage secondary return line to act as a choke in the filter system, as shown in Fig. 20-9.

Usually, the total voltage drop across the speaker field (or filter choke) is 100 to 120 volts. Therefore, the tap is taken from the winding at a point *A* which will deliver the required grid bias.

Still another method of securing the power-amplifier tube grid bias from the dynamic speaker field (or filter choke), is to shunt two series resistors across the dynamic speaker field (or filter choke) which is in the negative side of the filter circuit, as shown in Fig. 20-10. The values of these resistances depend upon the grid bias required, the voltage drop across the field, and the

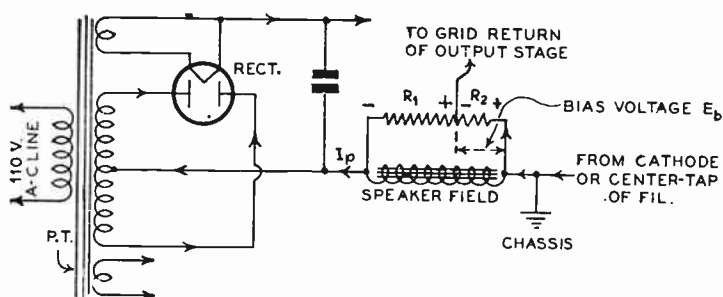

FIG. 20-10.—This output stage grid-bias arrangement is the same as that shown in Fig. 20-9, with the exception that resistors R_1 , R_2 serve to proportion the voltage drop across the speaker field winding so that the output tubes get the proper *C* bias voltage. No tap is required on the speaker field.

resistance of the field. The required resistance values of R_1 and R_2 may be calculated by means of the formulas

$$R_1 = \frac{E - E_b}{I} \quad \text{and} \quad R_2 = \frac{E_b}{I}$$

where, E = the voltage drop across the speaker field (or choke), as measured by the set analyzer voltmeter.

E_b = the required bias voltage.

I = the current flowing through the bias resistors (in amperes).

Example: Suppose, for example, that the speaker field has a resistance of 1,000 ohms, the total "plate + screen" current drain, I_p , of the set is 100 ma. (0.1 ampere), and the speaker field current must be 90 ma. (0.09 amp.). The voltage drop across the speaker will be $E = R \times I = 1,000 \times 0.09 = 90$ volts. (This can

be checked by the analyzer voltmeter). 10 ma. (0.01 amp.) will flow through resistors R_1 and R_2 . Suppose now, that the bias voltage required for the proper operation of the power amplifier tubes is 30 volts. Calculate the values of the bias resistors R_1 and R_2 required.

Solution:

$$R_1 = \frac{E - E_b}{I} = \frac{90 - 30}{0.01} = \frac{60}{0.01} = 6,000 \text{ ohms, Ans.}$$

$$R_2 = \frac{E_b}{I} = \frac{30}{0.01} = 3,000 \text{ ohms, Ans.}$$

Note that $R_1 + R_2$ is equal to 9,000 ohms, which is 9 times the resistance of the speaker field (or the filter choke) used.

If resistor R_2 should open-circuit, an excessive grid bias equal to the total voltage drop across the choke would be obtained, and the plate current would be abnormally low. The ordinary trouble symptoms of the receiver in this case would be "*weak and highly distorted reproduction,*" because of the excessive grid bias on the power amplifier tubes.

If resistor R_1 should open-circuit, no current would flow through either R_1 or R_2 , hence there would be no voltage drop in them. Since the grid-return circuit would really connect to "chassis" in this case, the grid-bias voltage would be zero. The plate current would be abnormally high (likely to damage the power tubes). The receiver reproduction would be loud, but badly distorted.

In order to check these bias resistors properly with the ohmmeter, it is usually necessary to disconnect them first from the speaker field coil (or filter choke) which shunts them.

Grid-bias resistors are usually shunted by a by-pass condenser. The size of the by-pass condenser is determined by the circuit in which it is used. It has become common practice to employ by-pass condensers of 0.1 to 0.5 mfd. capacity for shunting the grid-bias resistors of r-f amplifier tubes; in audio-frequency circuits, by-pass condensers of from 0.5 to 50 mfd. are used, depending upon the lowest frequency response desired and the value of the resistors across which they are connected. In general, the reactance of the by-pass condenser (measured at the lowest frequency it will be subjected to) should be about 1/10 the resistance of the unit across which it is connected, in

order to act as an effective by-pass. When audio amplifier tubes are connected in a push-pull arrangement, a common bias resistor is employed. The by-pass condenser is unnecessary and is commonly omitted, since the push-pull arrangement balances out all fluctuating currents in this resistor circuit.

20-12. Interpreting Grid-Bias Readings Obtained with the Set Analyzer.—As an illustration of the importance of understanding the circuit arrangement of the receiver when interpreting set analyzer readings taken on it, let us assume that a particular receiver is to be diagnosed. The analyzer plug is inserted into, say, the last audic tube socket, and the tube placed into

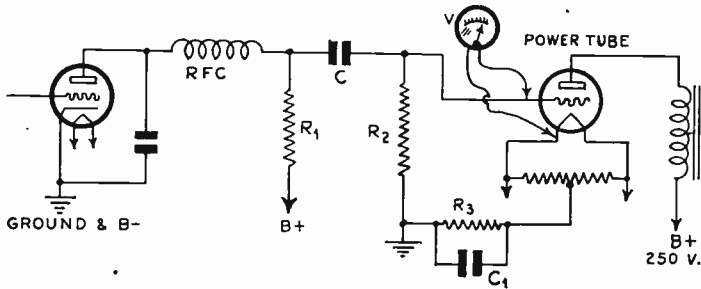

FIG. 20-11.—How the voltmeter of the set analyzer may be connected across the grid and filament terminals of the power tube socket in the receiver in order to check the grid voltage of the tube. In this case, the output stage is resistance-capacity coupled to the preceding stage.

a socket of the analyzer. According to the manufacturer's specifications for this receiver, we should obtain a plate voltage of say 250 volts, a plate current of 32 ma., and a negative grid bias of 50 volts for the power tube. Suppose we find the plate voltage and current normal, but when the grid bias is checked by the voltmeter in the analyzer (see Fig. 20-11), it is found to be only 8 volts. This would naturally lead to the conclusion that there is trouble in the grid circuit. However, upon examination of the circuit diagram, we find that this stage is resistance-capacity coupled to the preceding tube, as shown in Fig. 20-11. Since the grid leak resistor R_2 has a value of 500,000 ohms, allowance must be made for the drop in voltage caused by the flow of the voltmeter current through it whenever the grid voltage is to be checked with the voltmeter of the set analyzer.

If the 100-volt scale of a 1,000-ohms-per-volt meter is used, the total resistance *around* the grid circuit is 600,000 ohms, neglecting R_2 . The voltmeter has but 100,000 of the 600,000 ohms, so it reads $1/6$ of the true voltage. Now $1/6 \times 50 = 8.33$ volts, which is approximately our reading. (Note: 600,000 ohms equals the 500,000 ohms of R_2 plus the 100,000 ohms of the voltmeter.) This accounts for the grid-voltage reading of only about 8 volts when the grid-bias potential of 50 volts actually exists.

The true voltage in this circuit could only be measured with an indicating instrument that required little or no current for its operation, such as a vacuum tube voltmeter (see Arts. 7-9 to 7-13) or a voltmeter of 20,000 ohms or more per volt. If the tube were transformer-coupled to the preceding stage, the resistance of the audio transformer secondary would be too low to have any appreciable affect on the bias voltage indicated on the meter, and the true value would be read.

As another example, let us assume that the *plate voltage and plate current readings are excessive and no grid-bias* voltage reading is obtained. It is evident from Fig. 20-11, that this condition may be caused by either an open-circuited transformer secondary winding or an open-circuited grid leak resistor R_2 , (depending upon the type of inter-stage coupling employed), a short-circuited bias resistor R_3 , or short-circuited by-pass condenser C_1 . It may then be necessary to test some of these components independently by the most suitable method (see Chapter XXII) in order to determine just which unit is at fault.

However, if we remember that both plate voltage and plate current exist and are *higher* than normal, then a little reasoning will enable us to eliminate several of the components from suspicion. If the grid-bias resistor R_2 were open-circuited, no plate voltage or current indications could be obtained, since this resistor completes the plate circuit. The only possible defects that remain, then, are an open-circuited grid leak, R_2 , or a short-circuited by-pass condenser C_1 . In both cases, the symptoms of choked and choppy reproduction will be present. An open grid leak may result in a lower than normal plate current because of the accumulation of electrons on the grid. This, however, is not a general rule, as it depends upon the amount of gas in the

tube, the voltages applied, etc. If the set analyzer incorporates a grid-to-plate test, an open-circuited grid leak R_g will be disclosed by the fact that no voltage reading is obtained. If a reading is obtained, then the by-pass condenser C_1 is short-circuited.

At times, the by-pass condenser C in Figs. 20-6, 20-7 and 20-8 and C_1 in Fig. 20-11, will open-circuit. If the condenser is in an r-f stage, the attendant symptoms are, usually, oscillation and general instability of the receiver. When the by-pass condenser is employed in an audio stage, an open-circuited unit will result in oscillation, distortion and poor low-frequency response. The same symptoms will be manifested in the case of indirect-heater type tubes.

When indirect-heater type tubes, such as the '27, '56, '36 or '24, are employed in a grid-leak and condenser detector circuit, such as is shown in Fig. 20-12, no grid bias will be obtained, since

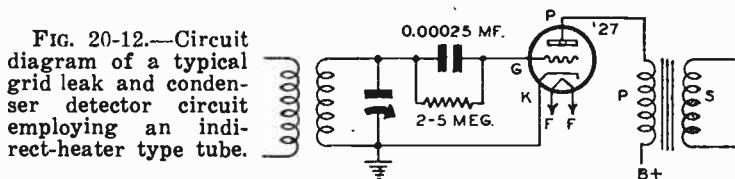

FIG. 20-12.—Circuit diagram of a typical grid leak and condenser detector circuit employing an indirect-heater type tube.

the cathode is connected directly to the grid return. If the tube is used as a power or grid-bias detector, the arrangement of Fig. 20-6 is used, and the grid bias can be measured. Should no grid bias—or less than normal grid bias—be indicated, it is possible that the cathode by-pass condenser C is short-circuited or leaky. If the secondary winding of the r-f or i-f transformer is open-circuited, no *grid bias* reading could be noted, but *cathode voltage* would be obtained. In this instance, an open-circuited secondary winding would result, most likely, in an inoperative receiver.

It is interesting to note here that “cathode voltage” is not always the same as “grid voltage.” *Cathode voltage* is the voltage from *cathode* to chassis. *Grid voltage* is the voltage from *grid* to cathode. In most cases, they are the same numerically, but a circuit design may be such that a difference of potential of as much as 50 volts may exist between cathode and chassis, but

a potential difference of only 10 volts may exist between the cathode and the grid because of a tap on the cathode-to-chassis resistor to which the grid return connects.

In many superheterodyne receivers, the oscillator tube is connected as shown at Fig. 20-13. A low grid-bias reading should be expected when the grid bias is checked in this type of circuit, because the grid-return path is completed through R_2 ,

Fig. 20-18.—A typical oscillator circuit arrangement employed in superheterodyne receivers. R_1 is the grid-bias resistor.

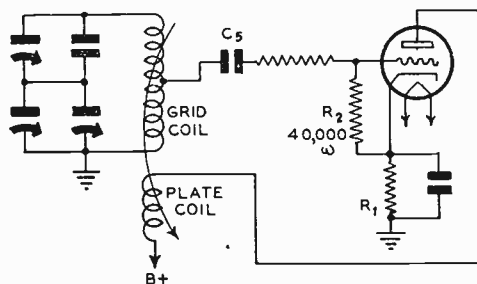

a 40,000-ohm resistor, since the path through the grid coil is blocked by the grid condenser C_5 . Allowance must be made, therefore, for the drop in voltage caused by the flow of meter current through R_2 , which accounts for the low grid-bias reading obtained with the voltmeter.

A *positive* grid-bias voltage reading is an infrequent, though by no means impossible, occurrence. This may occur when the coupling condenser in a resistance-coupled r-f or a-f stage short-circuits or becomes leaky, or when the primary winding of a transformer-coupled stage short-circuits to the secondary, impressing a positive voltage on the grid. This trouble will be accompanied by an abnormally high plate current in the tube in that stage.

20-13. Interpreting Plate Voltage Readings Obtained with the Set Analyzer.—In cases where an abnormally low r-f plate voltage is revealed by the set analyzer, the exact manner in which the tube is being used should be determined before any diagnosis is made. In the older receivers using three-electrode tubes in the a-f amplifier stages, manufacturers often employed a variable resistance in the cathode circuit to control volume or

oscillation. When it is found that the receiver employs a variable resistor as in Fig. 20-8 to vary the cathode voltage of the tube, this control should be turned to its "minimum" resistance position before any plate voltage tests are made, since it is in the plate circuit as well as in the grid circuit.

If the analyzer indicates that some one tube is not receiving grid bias voltage, the trouble may be caused by either a faulty volume control, a faulty series plate resistance, or an open-circuited plate-coupling device (such as the choke in parallel-feed circuits, the primary of an a-f transformer, or the plate resistor in a resistance-coupled stage). Very often, it will be found that instead of having a resistance in the plate circuit of an r-f tube to cut down oscillation, this resistance is connected in series with the grid. It is then called a grid suppressor, and is connected as shown in Fig. 20-14. An open-circuit in this resistor, of course, will prevent grid bias from being present at the grid of the tube.

Suppose no plate voltage reading is obtained at the sockets of any of the r-f or i-f amplifier tubes employed in a receiver. This may be caused either by failure of the bias resistor (should this be common to all these stages as in Fig. 20-7) or to an open

FIG. 20-14. — The grid-suppressor resistor arrangement used in the grid circuits of the 3-electrode r-f amplifier tubes of many early t-r-f receivers.

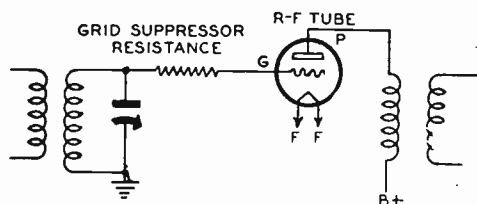

section of the voltage divider in the power pack, assuming that all circuit connections and joints are well made and in perfect condition. If it is noted that the plate voltage on the output tube (which usually receives the highest voltage of any tube in the receiver) is lower than normal, and all other corresponding voltages are also lower, there is a strong likelihood that an r-f by-pass condenser has become leaky or partially short-circuited. This failure may be disclosed by an ohmmeter test of each condenser. In some instances, however, an r-f by-pass condenser may break down only under load, and it cannot be located by

means of the ohmmeter. Because of this fact, it may be necessary to unsolder or disconnect each r-f by-pass condenser, in turn, with the receiver switch "on". An increase in plate voltage when any one of the condensers is disconnected will indicate the faulty unit.

Any high-voltage by-pass (filter) condenser can cause the same symptoms as those described in the previous paragraph. Usually, however, power-unit condensers are of the types designed to

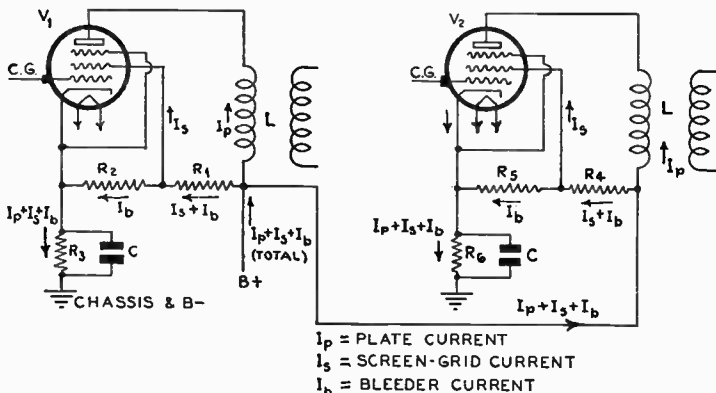

FIG. 20-15.—Typical plate, screen and grid bias circuits of two screen-grid amplifier stages employing a bleeder resistance system. Correct interpretation of analyzer readings taken on a receiver employing circuits of this kind are discussed in the text.

withstand high voltage safely, and do not break down as easily as the much smaller units used in r-f circuits.

In some receivers a low plate voltage reading is caused by a defective voltage divider system which employs moulded carbon resistors. Excessive current causes these units to lower in resistance value. This defect will result in the variation of other voltages from normal, as well as in oscillation and distortion. Methods of testing carbon resistors are presented in Chapter XXII.

20-14. Interpreting Analyzer Readings on Bleeder-Type Screen Circuits.—The screen-grid tube circuits of modern receivers require, perhaps, the most analysis. The screen voltage measurements are made during the routine checking of the socket terminal voltages and currents. If they are normal the

analysis may be continued; if not, the interpretation of the trouble depends entirely upon the type of screen-grid circuit employed in the particular receiver under test. For this reason, the following paragraphs will be devoted to a discussion of the most common screen-grid tube circuits used in modern receivers.

Figure 20-15 is a common type of circuit. The screen-grid voltage for tube V_1 is obtained through resistor R_1 , which is really a tap on a bleeder resistor composed of R_1 , R_2 and R_3 . Note, also, that R_3 is the grid bias resistor for V_1 . The direction of the current is shown by the arrows. That through L is the plate current (I_p); that through R_1 is the screen and bleeder current ($I_s + I_b$); that through R_2 is the bleeder current alone (I_b); and that through R_3 is the sum of the plate, screen and bleeder currents.

If L should *open-circuit*, the current through R_3 would decrease, which would reduce the bias applied to the control grid of the tube. This low bias would *increase* the screen current (which acts now as the plate of a triode), which means that the current through R_1 also *increases*. Increased current through R_1 causes an increased voltage drop across R_1 , which means lower screen voltage. Hence, if when a particular stage is analyzed it is found to have abnormally low bias, no plate voltage, no plate current, abnormally high screen current, and normal or less than normal screen voltage, then the plate load, L in this case, is open—provided the circuit network is similar to that shown in Fig. 20-15.

If R_1 were open circuited, the tube would become totally inoperative on account of the great increase in its plate resistance. Therefore, the screen voltage and current would be zero, and although the plate voltage would be normal, no plate current can flow on account of the high plate resistance. As a result, the grid bias will also be zero since no current is flowing through R_3 to cause a voltage drop through it.

If R_1 were *short-circuited*, the screen and plate voltages would be equal, the screen current would be *higher* than the plate current, the grid bias would be abnormally high (because of the high screen current), and the plate current would be low because of the high bias.

If R_s were *open-circuited*, the screen voltage would be high because of the decreased drop across R_1 , the plate voltage would be about normal, the screen and plate currents would be high and the grid bias low.

If R_s were *short-circuited*, the plate voltage and plate current would be slightly lower than normal (depending upon how good the voltage-regulation of the power unit is), the screen voltage would be equal to the grid-bias voltage, the screen current would be low, and the grid bias would probably be low.

If R_s were *open-circuited*, the screen and plate voltages would be zero, the screen and plate currents zero, and the grid bias would be zero.

If either R_s or the by-pass condenser C across it were *short-circuited*, the plate voltage would be about normal, the plate current would be high because of the zero bias, the screen current would be about normal (it should also be high, but the high screen current flows through R_1 , which tends to drop the screen voltage, lowering the screen current), and the screen voltage would be low.

It is of greatest importance here to note that the analyzer voltmeter will read zero, indicating *zero* grid-bias voltage, if R_s is either *open-* or *short-circuited*. This serves as a good illustration of the fact that when a voltmeter reads *zero* it is not always an indication of an open circuit; it merely means that there is no difference of potential between the two points between which the meter is connected. If R_s in Fig. 20-15 is either open- or short-circuited, there is no difference of potential between the grid terminal and cathode, and the voltmeter will indicate *zero* grid bias. Hence, in a case of this kind, it is necessary to determine which condition exists. This may be done by checking the plate and screen voltages and currents, for they are affected differently by an "open" or a "shorted" grid-bias resistor R_s .

The screen circuits for two or more tubes are exactly the same as that for V_1 . For instance, the screen circuits for tube V_2 in Fig. 20-15 may be analyzed by checking the circuits of R_4 , R_5 and R_6 which correspond to R_1 , R_2 and R_3 respectively.

20-15. Interpreting Analyzer Readings on Series-Connected Screen Circuits.—Figure 20-16 illustrates a simple series type screen circuit. The B plus connects to a resistor R_2 , which feeds the screen grids of all the tubes. This is perhaps the most common screen voltage-reducing system in use. If R_2 open-circuits, the screen voltage and current will be zero in both tubes, and since no plate current will flow on account of the great increase in plate resistance, the grid bias will therefore be zero. The plate voltage, as in the case described previously will be about normal. The only current through R_2 is the screen

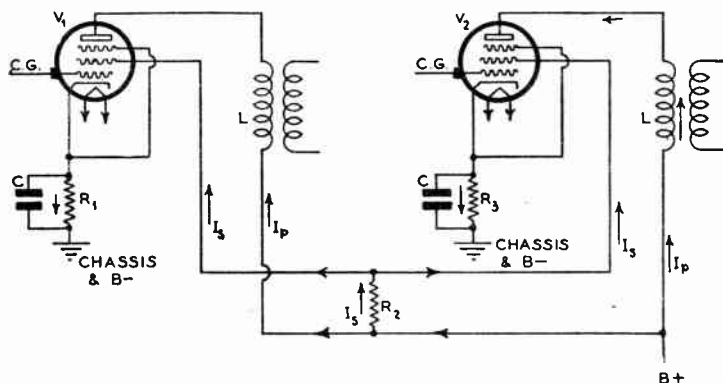

FIG. 20-16.—Typical amplifier stages having a common series-connected voltage-dropping resistor R_2 in the common screen circuit. The total screen current I_s flows through this resistor, producing a voltage drop in it.

currents of all the tubes. Compare these symptoms with those indicated for Fig. 20-15 with R_1 open-circuited. They will be found to be the same.

If R_2 short-circuits, the screen voltage will be equal to the plate voltage, the screen current will be slightly greater than the plate current, the grid bias will be larger than normal, and the plate current will be below normal because of the high bias. Note that in this case the analyzer readings would be exactly the same as if R_1 of Fig. 20-15 were short-circuited. The necessity for having a schematic circuit diagram of the receiver on hand when the analysis of the set is being made, so that the type of cir-

circuit employed for each tube in the receiver can be learned, is very forcefully brought out by the analysis considerations in both this and the preceding paragraphs. It is easy to see that an incorrect interpretation of the analyzer readings can be made easily if the circuit arrangement in the receiver is not known.

If bias resistor R_3 (in Fig. 20-16) should *open-circuit*, the grid-bias voltage and plate and screen currents of V_2 will be zero, the plate voltage of V_1 will be about normal, the screen voltage and current of V_1 will be high because of the low voltage-drop in R_3 , the grid bias will be high, and plate current low. It is possible that the screen current will be about normal because of the high bias. Whether it is high, low, or normal depends upon the values of the individual resistors used.

It is important to note that the symptoms described here for an *open-circuited* grid-bias resistor in the cathode circuit of V_2 will be the same, though for the opposite tubes, as if R_1 were open-circuited. The plate and screen currents would be zero, the plate voltage of V_2 about normal, etc. It is also im-

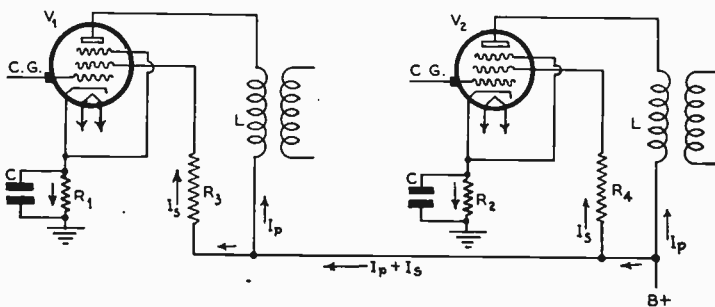

FIG. 20-17.—Typical amplifier stages of the type having individual series-connected voltage-dropping resistors in the screen circuits.

portant to note that any variation in R_3 affects the voltages and currents in both tubes, because it is common to both tubes. If R_3 supplied the screen grids in three or more tubes, then any variation in it would affect the voltages and currents in these three or more tubes. Knowledge of this fact enables the alert service man to tell quickly if the defective component is com-

mon to two or more tubes, by simply noting if abnormal voltages or currents exist at only one tube or if the *same* abnormalities exist at several tubes. The circuit of Fig. 20-15 is such that each tube has an individual circuit, and variations in the resistors of one tube circuit will not affect the voltages and currents in another tube circuit to any marked extent.

A second type of series screen circuit is shown in Fig. 20-17. This is substantially the same as that of Fig. 20-16, except that each tube has a separate screen voltage-dropping resistor, so that *variations* in the screen circuit of one tube will not affect the screen voltage of any other tube. It is a relatively simple

Fig. 20-18.—A common circuit arrangement in which the bleeder resistor R_2 is part of the voltage-divider resistor in the power supply unit. The bleeder current I_b flows through it.

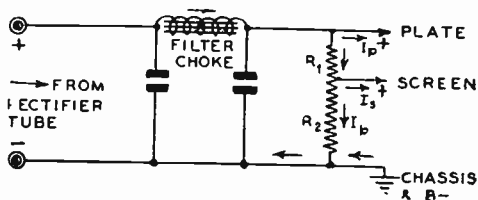

matter to interpret analyzer readings taken on a circuit of this type, if the directions of the currents shown in this diagram are studied and understood.

20-16. Interpreting Analyzer Readings on Shunt-Connected Screen Circuits.—The shunt system of feeding screen grids and plates is shown in Fig. 20-18. It is to be noted that this connection is similar to that described for Fig. 20-15, except for the fact that the bleeder current I_b does not flow through the grid bias resistor of any tube. It is *shunted* directly back to the rectifier tube circuit in the power supply unit, as shown. The bleeder resistors in this type of circuit are usually considered as part of the power supply unit, and will be treated under that heading. Various troubles may be predicted from their symptoms by the analysis method given for Fig. 20-15, (Art. 20-14).

20-17. Interpreting Analyzer Readings on Double-Series Screen and Plate Circuits.—Some receivers are designed so that the full B plus voltage is applied to the plate circuit of the power output tube or tubes, some lower voltage is applied to

the plates of the amplifier and detector tubes, and a still lower voltage is applied to the screen grids of the amplifier tubes. The arrangement commonly employed for such a circuit is shown in Fig. 20-19. Resistor R_1 drops the full B voltage to that required for the plates of amplifiers and detectors, and resistors R_3 , R_4 , etc., drop the voltage from that point to the value required for the screen grids. If two or more screen grids are to be fed from a single resistor, as in the circuit of Fig. 20-16, then only resistor R_3 is required. On the other hand, if a separate

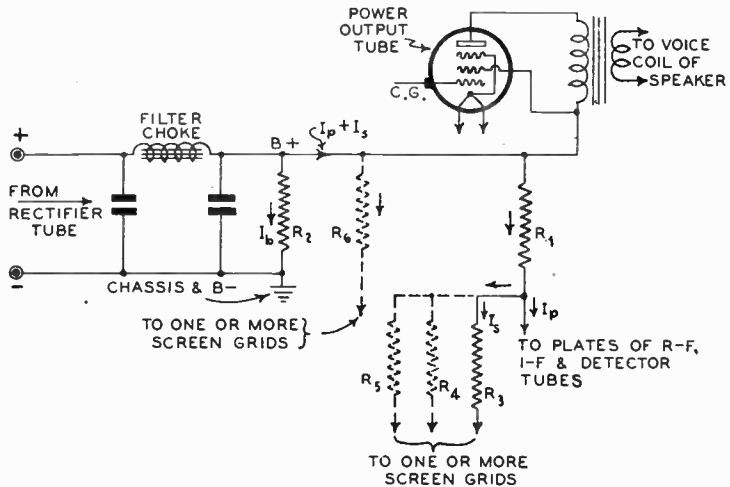

FIG. 20-19.—A circuit arrangement in which double-series resistors are employed for dropping the voltage for the plate and screen circuits. R_2 is the bleeder resistor connected directly across the output terminals of the power supply unit.

resistor is to be used for each screen, as shown in Fig. 20-17, then R_4 , R_5 , etc. are required. It is also possible to drop the full B voltage directly to that required for the screens, independently of the dropping of this voltage for the plates. In such instances resistor R_1 is used for the plate-voltage line and resistor R_6 is utilized for dropping the screen voltage when all the screens are to be fed from a single resistor. Of course, separate resistors may be used—one for the screen of each tube.

The analysis of such a circuit, and the correct interpretation of the analyzer readings, are no more complicated than has

been described for the other circuit arrangements, except for the effect of the additional resistor R_1 . It is evident, however, that when R_1 *open-circuits*, the voltage on the plates of all the tubes fed by R_1 becomes zero, while the plate voltage on the output tube or tubes (shown at the right) remains substantially constant. If the screen voltages are also supplied by R_1 , then they too will be zero. If they are fed by separate resistors from the original B plus line, like R_s , then the screen voltages will be normal. The bias voltage will change according to whether R_s is *open* or *shorted*, and the effect of too much or too little bias can be predicted in a manner similar to that previously explained.

For those service men with little experience, it is recommended that the currents through each voltage divider circuit illustrated here be traced, and the analyzer readings for various trouble symptoms predicted. The symptoms as indicated by the analyzer should be memorized for each type of circuit, so that little time will be wasted in attempting to determine their significance. Then, too, the symptoms as revealed by analyzer readings are characteristic of the type of voltage divider circuit employed, and with a little practice, it is possible to make a good guess regarding the type of circuit in use by merely interpreting the readings of the analyzer.

Regardless of the voltage divider system in use, however, most power supply units are shunted by a "bleeder" resistor, R_b , shown in Fig. 20-19, to maintain the voltage applied to the filter condensers fairly constant as the load current changes. Also, if all the tubes were to be removed from their sockets and R_b were open-circuited (or were not present), the decreased voltage-drop in both the rectifier tube and the filter choke would allow the voltage across the filter condensers to increase to such a high value that it might rupture the dielectric in these condensers.

20-18. The Power-Supply Unit of the Receiver.—If no plate voltages, or abnormally low plate voltages are found at the sockets of all the tubes in the receiver, it is possible that the trouble lies in the power supply unit. The power supply unit (see Fig. 20-20) is composed essentially of a power transformer,

a rectifier-filter system, comprising one or more filter chokes and several filter condensers, and a voltage-divider system composed of a suitable resistance bank. The power transformer consists of a primary winding, P , and several secondaries, wound over a laminated steel core. One secondary winding, S_1 , the "high-voltage secondary," contains more turns than the primary. Other low-voltage windings, S_2 , S_3 , and S_4 , supply current for the filament of the rectifier tube, and for the filaments or heaters of the other tubes used in the receiver.

The alternating current that is rectified by the rectifier tube R_B becomes a pulsating direct current. This is delivered to the filter system composed of the iron-core chokes L_1 and L_2 and the filter condensers C_1 , C_2 , C_3 , which smooth out the pulsating component and deliver a smooth d-c voltage to the voltage divider.

The circuit shown in Fig. 20-20 is that of a typical power supply unit. Of course, variations in this circuit arrangement will be found (two are shown in Figs. 20-10 and 20-11). The speaker field may be employed as a filter choke or voltage divider, or the

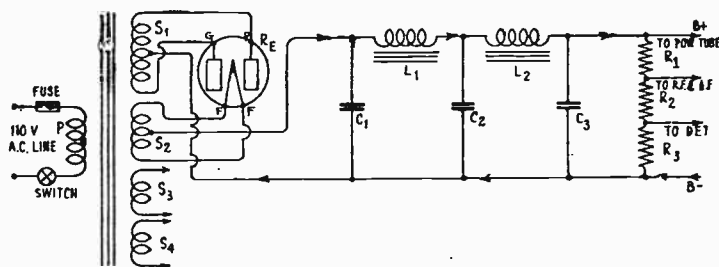

FIG. 20-20.—The fundamental circuit arrangement employed in most typical power supply units in a-c electric receivers. In many, only a single filter section is used instead of the two sections shown here.

entire filter arrangement may consist of only one filter choke and two filter condensers, etc.

20-19. Action of the Filter Circuits in Power Supply Units.—Of the enormous variety of filter circuits that may be used to smooth out the pulsating d-c variations from rectifiers, but two types are employed in radio receivers. These two are

known respectively as “choke-”, and “condenser-input” type filters. A choke-input type filter is shown in (A) of Fig. 20-21, and the condenser-input type filter is shown in (B) of the same illustration.

The input voltage to a filter of the choke-input type is shown in Fig. 20-22. Because L_1 is a large iron-core inductance, the current variations through it cannot be very rapid, since the inductance tends to prevent any change (either an *increase* or a

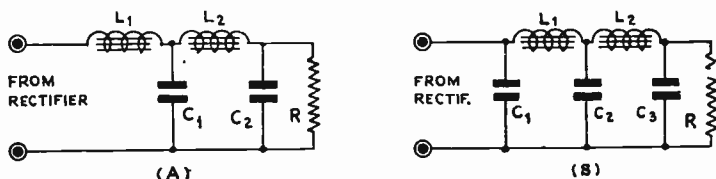

FIG. 20-21.—Typical filter systems employed in the power supply units of radio receivers.

(A) This is the choke-input type filter.

(B) This filter is of the condenser-input type.

decrease) in current through it. The voltage output of the first inductance, L_1 , is applied to the first condenser C_1 , which charges up to the “average” value of the fluctuations. When the voltage input to this charged condenser tends to *decrease*, it discharges into L_2 , and when its voltage input tends to *increase*, it charges up again. Therefore, the current entering the second inductance, L_2 , is fairly constant with but slight variations. This second inductance tends to prevent what small variations are left from taking place, so that the voltage across C_2 is the average of whatever variations remain. This action is illustrated in the series of diagrams of Fig. 20-22.

The analysis of the second section, L_2, C_2 , of this filter may be made in exactly the same manner, considering the voltage across C_1 as the input voltage of the system.

The condenser-input type filter of (B) in Fig. 20-21 has a somewhat different action. As soon as the rectifier starts to function, the input condenser C_1 starts to charge to the peak value of the input. And, as the input voltage drops, the condenser discharges into the first inductance L_1 , which tends to maintain the current constant. The shape of the voltage across

C_1 is shown by the heavy curve of Fig. 20-23. Now, the larger the value of C_1 , the more charge it can take, and the more it must discharge in order to have its voltage drop to a certain point. If C_1 is very large, it discharges slowly and steadily into L_2 , and its voltage drops but little before the input voltage starts to charge it again. Hence, in a condenser-input filter, the voltage output rises as the size of the input condenser is made larger. In fact, it acts exactly like a tank with a hole in its side. As the water is forced out of the hole steadily, the level of the water in the tank falls. However, just as the water reaches the level of the hole, the tank is filled again, and the process continues. If the tank is made larger in diameter, then more water can leak out before the level decreases to that of the hole.

The action in the foregoing analogy corresponds to that of the filter. The load draws current from the filter continuously. When the rectifier voltage falls below the voltage to which C_1 is initially charged, then C_1 begins to discharge into the load

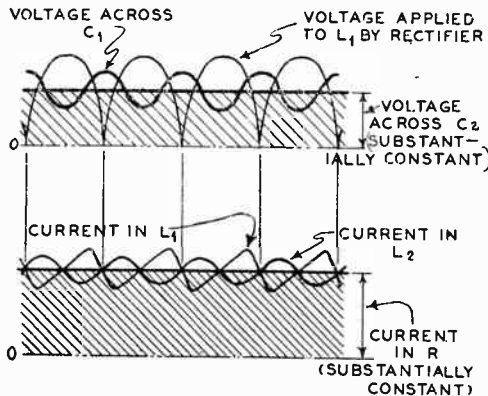

FIG. 20-22.—Graphs showing the waveforms of the currents and voltages in a choke-input type filter (see (A) of Fig. 20-21).

to supply it with current until its voltage falls below the value of the applied voltage, when it again begins to charge up. The larger C_1 is made, the more current can be drained from it without having its voltage fall below a certain level.

From a practical standpoint, the difference between these two filter systems is that the condenser-input system delivers more voltage output because of the fact that the *tank* condenser, C_1 ,

charges up to the *peak* value of the input voltage; in the choke-input system the first condenser charges up to only the average of the input voltage minus the voltage drop in the first choke. A filter system designed for choke input can have its output voltage *raised* by installing an input tank condenser, and a condenser-input type filter can have its voltage *lowered* by removing the tank condenser.

Care should be taken when installing tank condensers, or appreciably increasing the size of tank condensers. If the rise in



FIG. 20-23.—The wave-form of the voltage across the tank condenser C_1 in a condenser-input type filter such as is shown at (B) of Fig. 20-21.

output voltage is great enough, it may rupture the existing filter condensers which were installed for a lower voltage system.

20-20. Analyzing Troubles in the Filter Circuit.—Should any one of the chokes in the filter of Fig. 20-20 open-circuit, no voltage will exist at the tubes in the receiver. This is not true in those receivers in which the plate voltage supply for the power output stage is taken out after the *first* filter choke. In these receivers, an open-circuited *second* filter choke will affect the plate voltage of the power output tube, or tubes, only insofar as *increased* voltage is concerned. If any one of the condensers, C_1 , C_2 , or C_3 becomes short-circuited, no voltage at all, or a very low voltage (if leaky filter condensers or high-resistance chokes are present) will exist at the plates of the tubes in the receiver.

The most common trouble occurring in power units is that of shorted filter condensers. When the plates of a rectifier tube become red, it is usually a good indication of a short-circuited filter tank condenser, C_1 . Should C_2 short-circuit, the choke L_1 will heat up considerably, and sometimes the rectifier tube plates will become red. Shorted filter condensers of the tinfoil-paper type must be replaced by new units of similar capacity and voltage

rating. Faulty electrolytic condensers must be replaced if they do not renew their insulating film when removed from the source of voltage. (See Chapter XXII on the testing of electrolytic condensers.) The dry type of electrolytic condenser does not possess the self-healing characteristic to the same degree as the wet type, and generally must be replaced when found short-circuited. Open-circuited filter condensers almost always manifest themselves by increased hum and decreased voltage output.

Testing the voltage-divider resistor does not present any special difficulties if the resistance of each section may be measured. Should section R_1 , Fig. 20-20, open-circuit, no voltage will be obtained on any of the tubes except the power output tubes; if R_2 is open-circuited, the detector plate will receive no voltage and the r-f and i-f tubes will have more than normal voltage. Regardless of whether resistance R_3 is open-circuited or not, voltage readings will be obtained at each section of the voltage divider. The effect of an open-circuited resistor R_3 will be to slightly increase the voltage at the other taps and cause unstable operation, perhaps oscillation. If a dynamic-speaker field coil is employed as the second filter choke (see Figs. 20-9 and 20-10), the voltage drop across the field will be substantially reduced if R_3 open-circuits, and low volume and poor tone may result because of insufficient energizing current for the speaker field.

If R_1 (Fig. 20-20) *short circuits*, the r-f and a-f tubes will have the same plate voltage as the power tube; the overall voltage will be less because the increased current causes an increased voltage drop across the two filter chokes. The decrease in voltage, however, will be small in most cases.

If R_2 *short-circuits*, the r-f, a-f and detector tubes will receive the same plate voltage, though less than normal because the additional current will increase the voltage drop through R_1 and the filter chokes.

If R_3 should short circuit, the detector tube will have no plate voltage, and the other tubes will have slightly less than normal plate voltage because of the increased voltage drop across the two chokes and the resistor R_1 .

A partially *short-circuited* high-voltage secondary of the

power transformer will result in overheating of the transformer and decreased voltage output on all plates, since a short-circuited secondary reduces the primary inductance, causing an increase in the flow of primary current. This increased current increases the voltage drop in the resistance of the primary, and decreases the secondary voltage. Short-circuited filament windings will also increase the primary current and lower the secondary voltages. If the primary current should increase above a certain value for any reason whatsoever, the line fuse may burn out, or the primary winding itself may become so hot that the insulation on the wire will soon become heated and break down. This causes a general "shorted" condition in the primary, which eventually results in the burning out of the primary winding. As far as the rectifier tube or its output circuits are concerned a shorted power transformer primary or secondary will not affect them in any way.

When making an analysis of a receiver for a new customer, always determine how long the receiver has been in use in the existing location. Many people move from one town to another and plug the radio set into the nearest outlet indiscriminately, without inquiring as to whether the frequency of the power line is 25 or 60 cycles. (Of course, a d-c set will hum terrifically if it is operated on a-c, and an a-c set will blow a fuse if it is connected to a d-c line.) The usual a-c receiver will operate on lines of from 50 to 60 cycles, and is called a 60-cycle receiver. If the electric light line has a frequency *lower* than 50 cycles, it should not be connected to an ordinary 60-cycle receiver. A receiver designed especially to operate from a power line of the lower frequency should be employed instead. For instance, a 25-cycle receiver is one in which a power transformer and filter designed especially to operate satisfactorily at this low frequency, is used.

A 25-cycle set will operate on 60 cycles without any noticeable change in voltage, but a 60-cycle receiver cannot operate from a 25-cycle line successfully.

If an attempt is made to operate a 60-cycle receiver from a 25-cycle line, the power transformer will overheat, and the output voltages will be low because of the excessive primary cur-

rent. In most cases, the primary winding of the transformer will eventually burn out if the line fuse does not blow first.

REVIEW QUESTIONS

1. Make a list of the different tests which should be made on an inoperative a-c electric receiver with the set analyzer if the "preliminary tests" fail to reveal the trouble. State the order of these tests.
2. Explain how each of the tests in the preceding question are made.
3. Explain the value of each of these tests. Select any two of them and explain in detail just what troubles might be revealed by their use.
4. What does the failure to obtain voltage readings at the following points of the tube socket of an i-f amplifier indicate in each case: (a) filament; (b) plate; (c) control grid?
5. Why is it more practical to first check the power unit when an inoperative receiver is serviced? If the plates of a rectifier tube become red hot, what does this indicate? How may it be remedied?
6. What indications would be obtained on a set analyzer in each case if the following troubles occurred in an i-f stage of a receiver in which an indirect-heater screen-grid type tube is employed with the circuit arrangement of Fig. 20-17? (a) an "open" grid-bias resistor; (b) a "shorted" grid-bias by-pass condenser; (c) an "open" secondary winding in the stage tuning coil; (d) an open-circuit in the primary of the following tuning coil; (e) a short-circuited tuning condenser in the stage.
7. What reason would you give for obtaining a low grid-voltage reading on a triode power tube which is resistance-coupled to the preceding stage. Assume values and calculate a typical case.
8. What effect would a leaky plate-grid audio coupling condenser in a resistance-capacity coupled a-f amplifier have upon the grid voltage of the tube to which it is connected? What effect would this have on the operation of the entire receiver?
9. Draw a simple sketch of a typical r-f stage employing a screen-grid tube, and point out the possible causes for the lack of screen voltage on the tube in that stage.
10. How many different ways are there of obtaining screen voltage? Name them!
11. Draw a diagram of each type, and predict what the analyzer readings would be if the various resistors were: (a) "shorted" in turn; (b) "open" in turn.
12. What two types of filter systems are used in power supply units? Draw a circuit diagram of each type.
13. What is the advantage of the condenser-input type? Why?
14. What is the effect of a shorted filter condenser in the center position of a three-condenser-two-choke filter system? Explain!
15. Can a 25-cycle receiver operate from a 60-cycle line successfully without changes? State reason!
16. Can a 60-cycle receiver operate from a 25-cycle line successfully without changes? State reason!

CHAPTER XXI

RECEIVER ANALYSIS BY RESISTANCE TESTS

21-1. Introduction.—In Chapter XII we discussed the advantages and disadvantages of receiver analysis by means of resistance tests and concluded that a *voltage-current* test is as essential as a *resistance* analysis for accurate localization of trouble. We also pointed out the fundamental principle upon which a resistance analysis is based, and showed how the individual resistors may have their values checked—usually without removing the set from the cabinet. It is not the purpose of this chapter to discuss these questions again, but rather to show by means of an actual analysis just how a point-to-point tester should be used on a modern receiver.

We will consider, for our purpose, the typical all-wave receiver whose schematic circuit diagram is shown in Fig. 21-12, and analyze every circuit in it. An important consideration must be emphasized here: a resistance test is usually a “cold” test. A resistor may be normal when “cold” and have a much different value of resistance, or even be “open” or “shorted”, when “warm”. For this reason, it is well to heat the chassis artificially during a resistance test whenever possible and whenever a defective unit is difficult to locate. This is especially important when the symptom of trouble is “intermittent reception”. Artificial heating may be effected by means of a small electric heater, directed on the chassis as shown in Fig. 23-16.

In order to correctly interpret the readings taken during the complete resistance analysis of modern radio receivers, most of which employ rather complicated resistance networks, it is essential that a thorough knowledge of series, parallel and series-parallel circuits be had. Although it is assumed in this book

that the reader is sufficiently well versed in fundamental electrical and radio theory to know the laws of series and parallel circuits, the following few sections will be devoted to a brief resume of these laws for the benefit of those who require "brushing up" at this point, and to show the reader just how these circuits enter into modern radio receivers. (For a more detailed and complete discussion of the theory of series and parallel circuits, the reader is referred to the *Radio Physics Course*, by Ghirardi.)

21-2. Series Circuits.—For current to flow in any conductor or circuit, a difference of potential must exist between the terminals of that conductor or circuit. Current flows from the *positive* terminal to the *negative* terminal (using the conven-

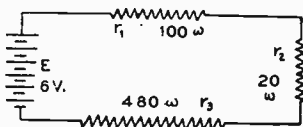

FIG. 21-1.—Three resistances connected in series with each other across a source of voltage, E . All of the current flows through each resistor. Each resistor has a different voltage drop across it.

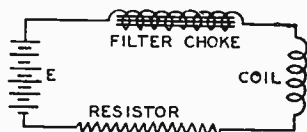

FIG. 21-2.—A choke, a coil and a resistor are shown here connected in series with each other. The respective *resistances* of these devices might be represented as shown in Fig. 21-1.

tional notation). When electrical devices are connected one after the other in such a way that *all* of the current flows through each of them they are said to be in *series*. In other words, a series circuit is one in which the current has but one path. Thus, in Fig. 21-1, three resistances of unequal value are connected in series with each other across the voltage source E (*all* the current flows through each resistor). The *total* resistance, R , of the circuit is equal to the sum of the individual resistances, that is:

$$R = r_1 + r_2 + r_3 + \dots etc.$$

If the values of the individual resistances are as marked, the total resistance of the circuit is:

$$R = 100 + 20 + 480 = 600 \text{ ohms.}$$

While all of the units indicated in the circuit of Fig. 21-1 are shown as resistors, it is not necessary that they actually be

simple resistors. Since we are simply considering *resistance* here, it might be the *resistance* of a commercial resistor, the *resistance* of a transformer winding, the *resistance* of a choke coil, etc. Whatever the *form* of the resistance is, does not matter, as long as it is *electrical* resistance that we are considering. For instance, the resistances of Fig. 21-1 might represent the respective resistances of a filter choke winding, the primary winding of an r-f transformer, and a commercial resistor, all connected in series as shown in Fig. 21-2. Figure 21-2 shows the circuit with the symbols for the units themselves. Each of these units offers some definite resistance to the flow of current through it. Fig. 21-1 shows the circuit with merely the *resistances* of these units indicated.

There is a voltage drop across each resistance in a series circuit, due to the passage of the current through it. It is perhaps clearer to look on "voltage drop," or "fall of potential," simply as *the amount of voltage which is required to force the current through the resistance, against its opposing action*. Naturally, the voltage drop is equal to $E = I \times R$, in accordance with Ohm's Law. It is seen that the amount of this drop depends upon both the resistance and the current, and increases as either of these units is increased.

If a voltmeter were connected across resistor r_1 in Fig. 21-1, it would indicate the "voltage drop" or "fall of potential" across this resistance, i.e., it would indicate how many "volts" of electrical pressure are required to send the current (that is flowing) *through* this resistance, against its opposing action. In the case of r_1 , connected in the circuit shown, this is 1 volt. Similarly, the voltmeter would read 0.2 volt when connected across r_2 . If it were connected across resistance r_3 , it would indicate 4.8 volts. The sum of all these voltage drops around the circuit is equal to $1 + 0.2 + 4.8 = 6$ volts, which is equal to the voltage E of the source. This illustrates another fundamental law of the series circuit:

The sum of all the voltage drops across the individual resistances which are connected to form a series circuit is equal to the total voltage applied to the complete circuit.

If any unit in a series circuit becomes *short-circuited*, the current will *increase*, because the total resistance of the circuit is thereby decreased. However, if the resistance of the unit which "shorts" is only a small proportion of the total resistance of the circuit, the increase in the current may be so small as to be hardly noticeable. This should be kept in mind.

For instance, consider the primary winding, of an r-f or i-f transformer, which forms a series circuit with the plate-cathode resistance of the vacuum tube, possibly a voltage-dropping resistor, one or two choke coils in the *B*-filter, the plate-filament resistance of the rectifier tube, and half the high-voltage secondary winding of the power transformer (trace out the complete plate current circuit for tube No. 4 in Fig. 21-12). In a circuit of this kind, the resistance of the primary winding of the r-f or i-f transformer is only a very small proportion of the *total* resistance of the circuit, hence the current flowing in the circuit would hardly be disturbed if this coil were to short-circuit. Therefore, such a trouble could not be detected by measuring the plate current of the tube. However, if its resistance were, say, $\frac{1}{2}$ that of the entire circuit, shorting it would cause an appreciable increase in the current (50%).

If any unit in a series circuit becomes *open-circuited*, the current path is broken, and no current will flow through the circuit.

21-3. Parallel Circuits.—When parts of a circuit are connected in such a way that they present separate paths through which the current can divide, they are said to be connected in *parallel*, *multiple*, or *shunt*. The total voltage is applied to each part of the circuit, but only a portion of the total current flowing from the source of e.m.f. flows through *each* path.

A parallel circuit consisting of three resistances connected in parallel to a source of voltage, E , is shown in Fig. 21-3. Only a portion of the total current, I , flowing through the battery passes through each of the three parallel paths, but the sum of the three parallel-path currents is equal to the total current supplied by the battery. Each current has a value determined by Ohm's law, $I = E/R$, and the total current equals the sum of the individual currents.

Electrical devices connected in parallel need not necessarily be resistors. The parallel circuit may be composed of any electrical devices, such as resistors, coils, chokes, etc., as shown in Fig. 21-4.

The electrical devices connected in parallel may all have the

same resistance or they may all have unequal resistances. In special cases where all the resistances are *equal*, the total current divides equally among the various units, and the combined resistance of all the paths considered together is equal to *the value of one of the resistances divided by the number of resistances*. Thus, if the three units in Fig. 21-4 have a resistance of 300 ohms each, the total resistance of the circuit is $300/3 = 100$ ohms, since three equal paths or branches are being presented to the flow of current instead of only one.

When the resistances of electrical devices connected in parallel are *not equal*, the combined resistance must be found by

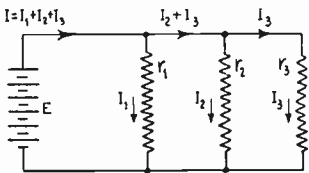

FIG. 21-3. — Three resistances connected in parallel with each other and across a source of voltage, E . The total current, I , divides, part of it flowing through the path presented by each resistor.

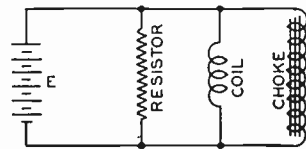

FIG. 21-4.—A choke, a coil and a resistor are shown here connected in parallel. The respective *resistances* of these devices might be represented as shown in Fig. 21-3.

considering the *conductances* of the various paths. Conductance is the opposite of resistance. The resistance of a circuit is the *opposition* it offers to the flow of current; conductance is a measure of the ability of a circuit to *conduct* current, and is therefore the reciprocal of resistance. Conductance is measured in the unit called the *mho*, which is *ohm* spelled backward. The *total conductance of a parallel circuit is the sum of the conductances of its individual branches*. Thus, if R is the combined resistance of the parallel circuit, and r_1, r_2, r_3 , etc., are the individual resistance of the parts of the parallel circuit, then, since the conductance of a circuit is equal to

$\frac{1}{R}$, we have:

$$\frac{1}{R} = \frac{1}{r_1} + \frac{1}{r_2} + \frac{1}{r_3} + \dots \text{etc.}$$

from which the combined resistance R may be calculated if the resistance of the individual branches are known. Accordingly, if the resistor, coil and filter choke shown in Fig. 21-4 have values of 480, 20 and 100 ohms, respectively (same as considered in Figs. 21-1 and 21-2), then the combined resistance of these units in parallel is,

$$\frac{1}{R} = \frac{1}{480} + \frac{1}{20} + \frac{1}{100} = 0.002 + 0.05 + 0.01 = 0.062 \text{ mhos.}$$

$$\text{and } R = \frac{1}{0.062} = 16.1 \text{ ohms.}$$

Notice that in Art. 21-2 we found the total resistance of these same three units to be equal to 600 ohms when they were connected in *series* with each other. Here we find their combined resistance to be 16.1 ohms, when they are connected in parallel.

When there are only two branches in a parallel circuit, the *combined* resistance may be obtained by dividing the *product* of the two branches by their *sum*. This is expressed as

$$R = \frac{r_1 \times r_2}{r_1 + r_2}$$

It can be seen that the *combined resistance* in a parallel circuit is *less than the resistance of any of the paths*. In a parallel circuit, the voltage across each branch is the same as that across every other branch, and is equal to that supplied by the source of e.m.f. The current which flows in each branch is simply equal to this voltage divided by the resistance of the branch (Ohm's law). If any one of the branches in a parallel circuit is "open," current will continue to flow through the others. However, the total current from the source will be less, since the combined resistance of the parallel circuit has increased because one path less is now presented for the conduction of the current.

21-4. Series-Parallel Circuits. — Electrical circuits may consist of several devices so connected that some are in parallel with each other, and others are in series with each other and are in turn connected in series with the parallel combination. Circuits of this kind are called *series-parallel* circuits, since they

are a combination of both series and parallel circuits. Series-parallel circuits may be simple or they may be exceedingly complex, since many combinations and arrangements are possible. A simple circuit of this kind is shown in Fig. 21-5. Here, a total of seven resistors are connected in series-parallel across the source of voltage E . Resistors r_1 , r_2 , and r_3 , are in *parallel* with each other. This group is in series with resistors r_4 and r_5 , which are in *parallel* with each other. Resistor r_6 is in *series* with both

FIG. 21-5.—A series-parallel combination of resistors connected across a source of voltage, E .

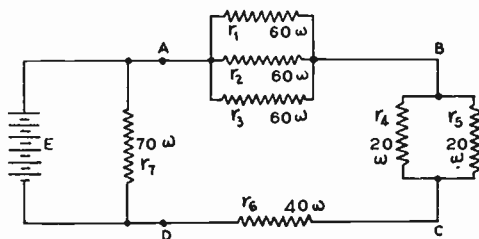

groups, and resistor r_7 is in *parallel* with the combination of all the aforementioned resistors.

The "total resistance" of the entire circuit can be found by solving each section separately and gradually reducing the circuit into an *equivalent* series, and then parallel, circuit. For example, resistors r_1 , r_2 and r_3 are in *parallel* with each other. Since the value of each resistor is 60 ohms, their combined resistance is $60/3 = 20$ ohms. Resistors r_4 and r_5 are each 20 ohms, so that their combined resistance is $20/2 = 10$ ohms. These two parallel combinations are in *series* with resistor r_6 , whose value is 40 ohms. Thus, if the combined value of the first combination is 20 ohms and that of the second is 10 ohms, the effective resistance of the circuit $A-B-C-D$ is $20 + 10 + 40 = 70$ ohms. The total circuit resistance across the voltage source E , however, will be $70/2 = 35$ ohms, since resistor r_7 , whose value is 70 ohms, is connected across (in *parallel* with) this entire circuit.

21-5. Combining Resistances.—Resistances are often purposely connected in series, parallel, or series-parallel in order to obtain odd resistance values or current-carrying capacities that are not easily obtainable in standard single commercial units.

For instance, suppose a resistor of 125,000 ohms rated at 2 watts is required for the voltage-divider system of a radio receiver. If such units are not readily available, two 250,000-ohm units of 1-watt rating may be connected in parallel—the 250,000-ohm units are standard items. Since each unit carries only half the total current here, it dissipates only half the total power dissipated by the resistors, so 1-watt units are satisfactory.

As another illustration of the connection of standard size resistors to obtain some desired odd value, let us suppose that we require a resistance of 1,620 ohms for some special purpose. Standard resistors of this value are not easily available, but standard resistors of 1,000, 600 and 20 ohms are readily available. By connecting one of each of these in series, a total resistance of 1,620 ohms can be obtained.

21-6. Checking Resistance Networks in Radio Receivers.

—The relation between series and parallel circuits, and those in a radio receiver can be more clearly understood by examining and breaking down several circuits of a receiver so that each one may be isolated and studied without the complexities caused

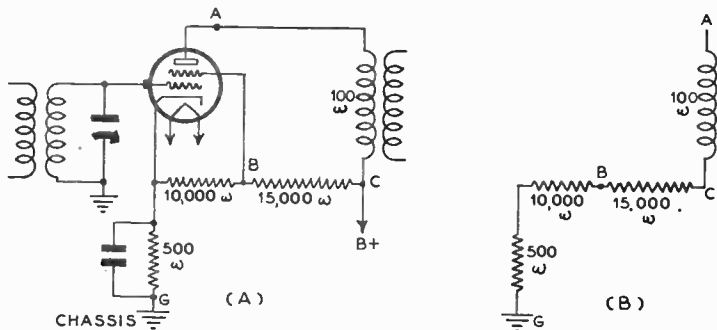

FIG. 21-6.—(A) Circuit of a typical i-f amplifier stage.

(B) The actual series circuit formed by the plate circuit coil and the three resistors in the path between points A and G of circuit (A).

by the presence of the others. This study will also reveal some of the precautions which must be observed when checking resistors which are part of resistor networks. Let (A) of Fig. 21-6, represent the i-f stage of a superheterodyne receiver under test. If no power supply unit were connected to this stage, and

an ohmmeter were connected from the plate of the tube, (point A), to the chassis, (point G), a reading of 25,600 ohms would be obtained, since the plate coil winding (100 ohms), the screen voltage-drop resistor (15,000 ohms), the screen bleeder resistor

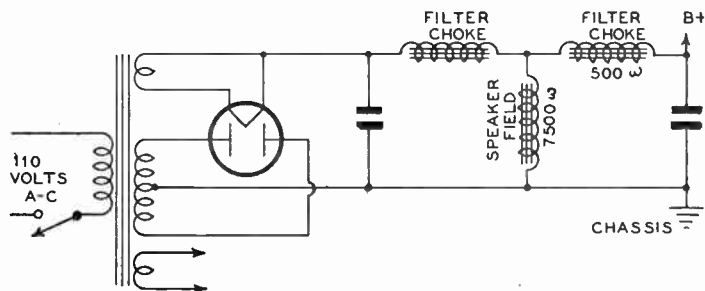
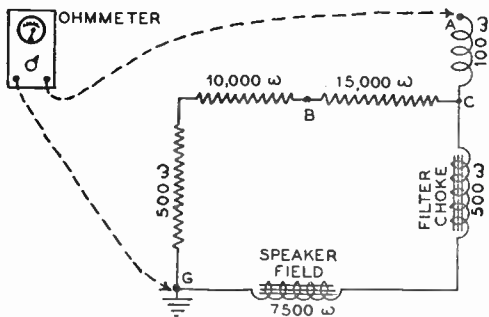

FIG. 21-7.—Schematic circuit diagram of a typical simple power supply unit having the 7,500-ohm speaker field connected directly across the circuit, as shown.

connected between the screen and cathode (10,000 ohms), and the cathode bias resistor (500 ohms), are all connected in series. This entire series circuit may be drawn in simplified form as shown at (B). A resistance check between points B and G by

FIG. 21-8.—The actual series-parallel circuit resistance network which would exist across points A and G of Fig. 21-6 if points C and G were connected across the power supply unit of Fig. 21-7.



means of an ohmmeter should give a reading of 10,500 ohms, since only the screen bleeder resistor and the cathode bias resistor are in series between these two points.

Suppose, however, that this tube circuit is connected across a power supply unit similar to that illustrated in Fig. 21-7. It

will be noted that the power supply consists of the usual power transformer, rectifier tube and filter system. Instead of using the speaker field as one of the filter chokes, the field is shunted across the junction between the two chokes and ground (B—). If the same check is now made with the ohmmeter by connecting it again from A to G, the reading will not be 25,600 ohms again, because now another circuit, consisting of the second filter choke in the power unit and the speaker field in series, is in parallel with the series circuit from point C to point G of (B) in Fig. 21-6. The series-parallel circuit which now exists is shown in

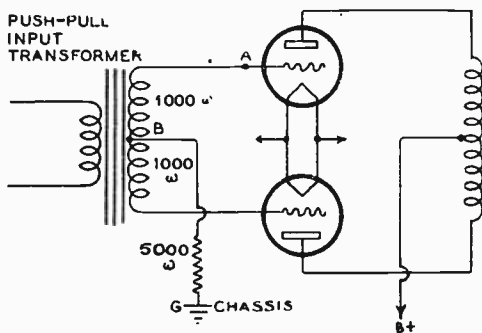

FIG. 21-9.—A typical push-pull output stage of a receiver. The resistance of each half of the input transformer secondary is considered to be 1,000 ohms.

Fig. 21-8. The ohmmeter will now indicate approximately 6,190 ohms if it is connected between points A and G.

One point must be kept in mind when making resistance measurements of this nature—the accuracy of the resistors and the probable error in the ohmmeter. If the resistors in the voltage-divider circuit shown in Fig. 21-5 are of the carbon variety, a possible plus or minus 10% deviation from their rated resistance value must be expected. In other words, any ohmmeter reading between 5,571 and 6,809 ohms could be obtained from point A to point G in the circuit of Fig 21-8, without there necessarily being any trouble in the circuit. By-pass condensers have been omitted purposely from the diagram, since we are considering only the relation of parallel and series circuits to radio receivers insofar as their d-c electrical resistance is concerned. How much the variation in the value of a re-

sistor affects the operation of the radio receiver depends of course upon its function in the circuit.

As another illustration of the caution to be observed when checking resistances, consider that the circuit diagram of the push-pull output stage of a receiver under test is as shown in

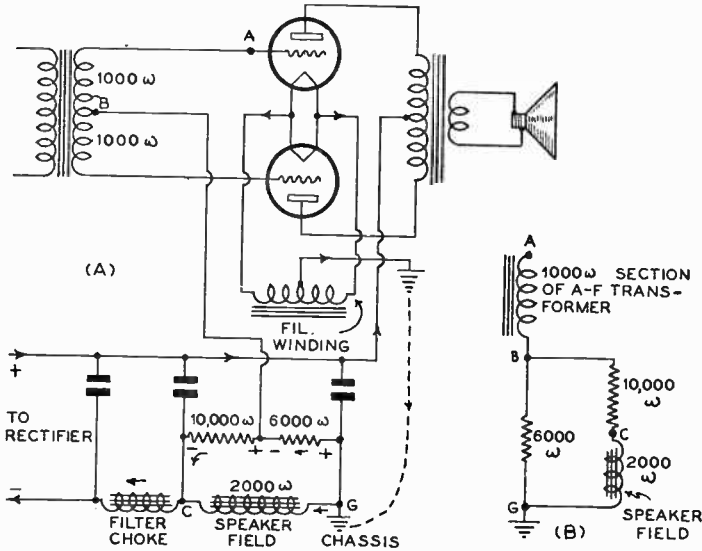

Fig. 21-10.—(A) A push-pull output stage connected to the power supply unit. The grid bias for this stage is obtained from the voltage drop across the 6,000-ohm resistor connected across the speaker field.

(B) The actual circuit network which exists between points A and G in circuit (A) is shown here in simplified form.

Fig. 21-9. The grid bias for the tubes is obtained in the conventional way by a resistor in the cathode circuit of the tubes. If it is desired to check the resistance of the grid circuit connected to each tube, an ohmmeter connected between points A and G (which is the chassis) should read 6,000 ohms. Making this test in this particular receiver is simple and straightforward, since the grid circuit is isolated.

Let us suppose, now, that the receiver circuit is such that the grid bias for the push-pull tubes is not obtained from the con-

ventional cathode resistor, but from resistors connected across the field coil of the dynamic speaker which is in the *B*-return circuit (see Art. 20-11), as shown at (A) of Fig. 21-10. Now, when the ohmmeter is connected between point *A* and ground, *G*, the reading will be about 5,000 ohms. There is a series-parallel combination involved in this circuit. The actual arrangement of the circuit network across which the ohmmeter is now being connected is shown at (B). The combined resistance of the 6,000-ohm bias resistor, shunted by another resistor of 10,000

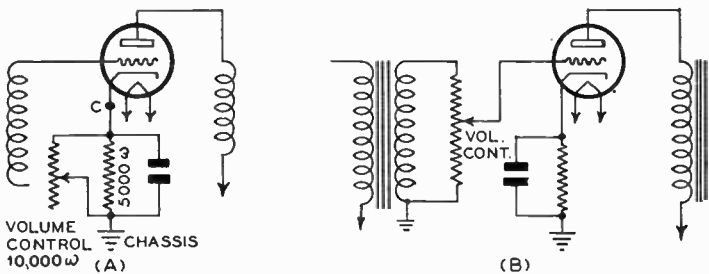

FIG. 21-11.—(A) A grid-bias resistor which is shunted by a variable volume-control resistor.

(B) An a-f transformer secondary shunted by a variable volume-control resistor.

ohms in series with the 2,000-ohm field coil, is about 4,000 ohms. This resistance value, added to that of the input transformer secondary winding, results in a total resistance of about 5,000 ohms between *A* and *G*.

As another example of the precautions which must be observed when checking resistance values between various points in a receiver, consider the fixed grid-bias resistor and variable volume-control resistor arrangement shown at (A) of Fig. 21-11. Suppose trouble is suspected in this part of the receiver and it is desired to check the resistance from the cathode, *C*, to chassis. The reading of an ohmmeter connected between these two points will depend upon the setting of the variable volume-control resistor. If the control happens to be set at the "minimum resistance" position, a "zero" ohm reading will be obtained. If the control is set at the half-way position (assuming the resistance

element is not tapered), a 2,500-ohm reading will be obtained, etc. Evidently, the resistance reading obtained depends on the setting of the volume control. The same condition exists for the circuit shown at (B). The audio transformer secondary should be checked with the volume control resistor in the maximum-resistance position, so that the value of this high resistance will have but little effect upon the reading.

21-7. Point-to-Point Resistance Analysis of a Complete All-Wave Receiver.—Now that we have studied the principles of point-to-point testing, the testing instruments employed in making the tests (Chapter XII), the principles of series, parallel and series-parallel circuits and the precautions to be observed when checking resistance values in these circuits, we are prepared to consider the method of making a complete point-to-point resistance analysis of a typical modern all-wave receiver. This will be presented step-by-step for clarity.

When checking receivers by the point-to-point resistance method, the receiver must first be disconnected from the power supply line and all tubes removed from their sockets. The tubes should be checked separately, and the line voltage measured to ascertain its value. Then, the receiver is ready to be given a "cold" resistance analysis. It is essential that the ohmmeter used in the point-to-point tester be capable of indicating resistance values from *at least* $\frac{1}{2}$ ohm to 5 megohms in several ranges, (*preferably* from about $\frac{1}{2}$ to 15 or 20 megohms) so the total resistance of any series circuit that may be encountered may be read.

The receiver selected for our purpose is the RCA Victor Model 140, since it is a typical all-wave modern receiver having waveband switches, avc circuits, etc. Its schematic circuit diagram is shown in Fig. 21-12. An examination of this diagram will show that the receiver is a representative type. In this analysis attention is to be devoted to the resistance values between any two points, the causes for incorrect readings, and their effect upon the operation of the receiver.

21-8. Analysis of the Second R-F Plate Circuit.—The first group of readings is taken at the second r-f stage, since the first is utilized only for reception of short-wave signals from 8,000 to 18,000 kc. The test plug of the point-to-point tester is inserted

PLEASE
TURN OVER FOR
PAGE 540 AND
FIG. 21-12.

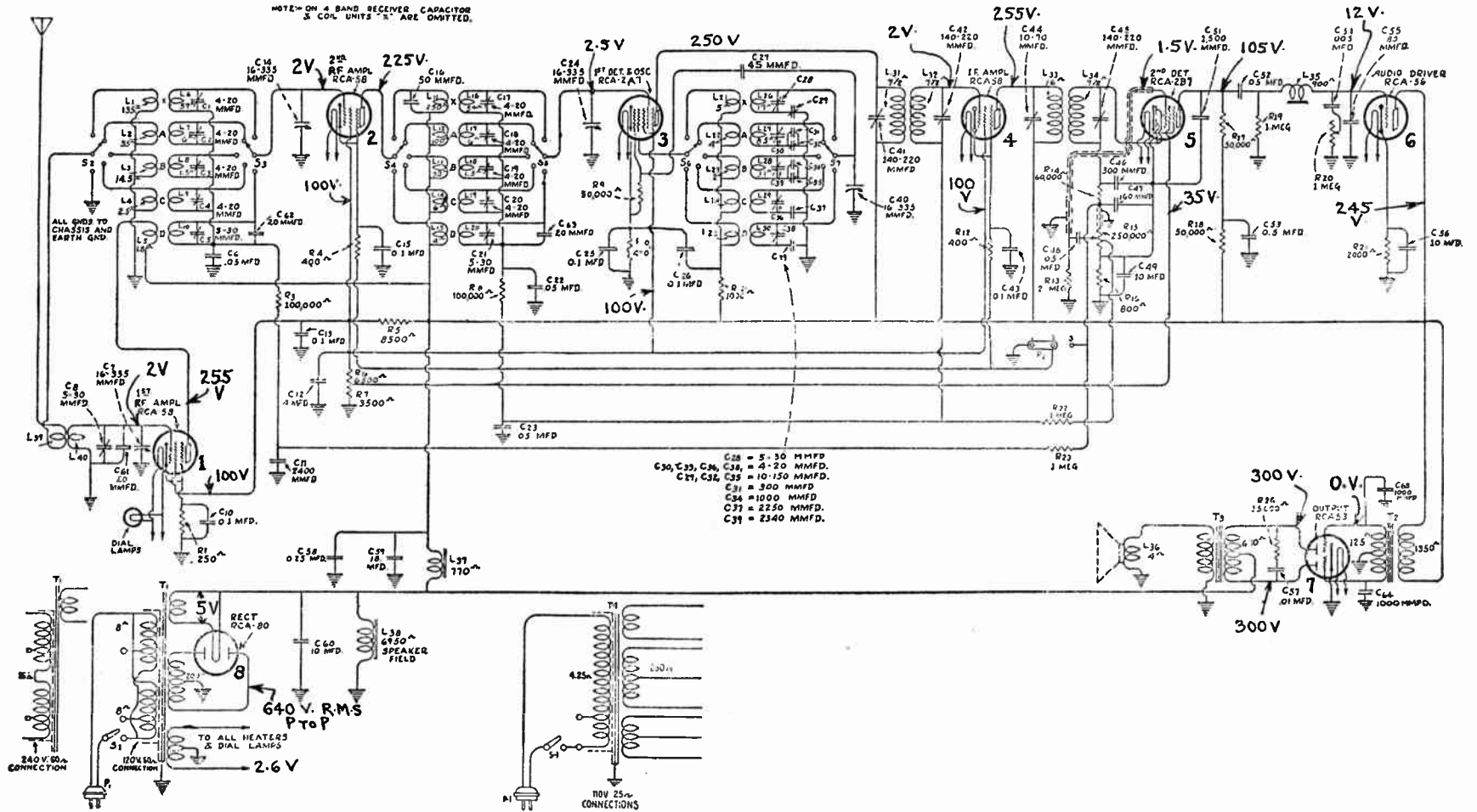

Courtesy RCA Victor Co.

FIG. 21-12.—The schematic circuit diagram of a typical modern all-wave receiver. Complete resistance data and other electrical constants are marked directly on the various parts. The way in which a complete point-to-point resistance analysis would be made on it is described in the accompanying text in connection with several break-down diagrams showing specific portions of this circuit in detail. (RCA Victor Model 140).

in the second r-f socket and the 6-section wave-band switch of the receiver is placed in the "A" position for standard broadcast reception (switches S_2 - S_3 - S_4 - S_5 - S_6 - S_7 are shown in this position in the diagram). With the point-to-point tester connected between "plate" and "ground" a reading of approximately 5,500 ohms should be obtained. In this circuit, the primary of the r-f coil, L_{12} , which has a d-c resistance of 100 ohms, resistors R_5 , R_6 and R_7 , of 8,500, 6,500 and 3,500 ohms, respectively, are connected in series. However, there

is a parallel circuit also to consider. It consists of the iron-core choke L_{37} , of 770 ohms, and L_{38} , the speaker field, of 6,950 ohms, connected across the $B+$ output of the receiver and shunting R_5 , R_6 and R_7 . The equivalent circuit is shown in Fig. 21-13. Because of the speaker field connection, it is somewhat difficult to analyze the results of this measurement, or of subsequent

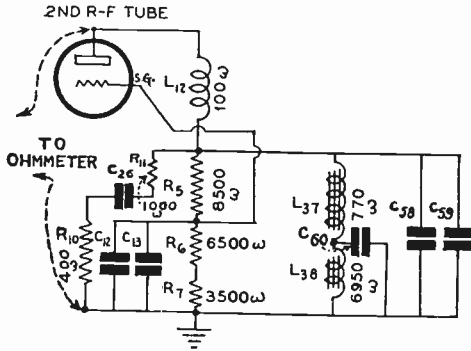

FIG. 21-13.—Equivalent simplified circuit diagram of the plate-to-ground and the screen-grid-to-ground circuits in the second r-f stage of the all-wave receiver whose circuit diagram is shown in Fig. 21-12.

tubes in the receiver, unless full consideration is given to this series-parallel path. For this particular receiver, it would be best to disconnect one side of the speaker field to simplify the interpretation of the measurements. Thus, with the speaker field disconnected, a plate circuit resistance analysis of this second r-f stage should give a reading of about 18,600 ohms, the combined resistance of the series circuit composed of R_5 , R_6 , R_7 and the primary coil L_{12} .

Let us suppose that a reading of, say, 100 ohms is obtained instead. The most logical cause for this low reading is either a short-circuited filter condenser C_{59} or a short-circuited by-pass condenser C_{58} . To check this conclusion, the test plug is re-

moved from the r-f stage and inserted into the rectifier tube socket. A reading of 770 ohms (choke L_{37}) from the rectifier-tube filament to chassis will bear out the conclusion. However, it is necessary to remove the chassis from the cabinet to determine which one of the two condensers is at fault. Should a reading of 846 ohms be obtained from r-f plate to ground, then filter condenser C_{60} is shorted.

The test plug is now placed in the second r-f tube socket again. Should a reading of 8,600 ohms be obtained from plate to chassis, then either—or both—by-pass condensers C_{12} or C_{13} are short-circuited. This can be definitely ascertained by connecting the ohmmeter from screen-grid to ground, as can be seen from Fig. 21-14. A zero-ohm reading will be obtained at this point if either C_{12} or C_{13} is short-circuited. Suppose that a plate-ground reading of approximately 1,250 ohms is indicated. This would be the result if condenser C_{88} were short-circuited. In this case, a resistance path of 1,400 ohms, that of R_{10} and R_{11} in series, is connected across the resistance of R_5 , R_6 and R_7 .

There is one additional likely cause of trouble to consider insofar as the plate circuit of this stage is concerned. The possible incorrect readings noted thus far, involve only short-circuited filter or by-pass condensers (although it is possible that one or more of these condensers may be "leaky"). If resistors R_5 , R_6 and R_7 are of carbon, as is the case in many modern commercial receivers, it may be that R_5 , R_6 or R_7 has carbonized and lowered in resistance value. The condition of these resistors may be checked by measuring the resistance between the screen-grid terminal and chassis (see Fig. 21-13). This measurement will give the value of $R_6 + R_7$, which should be 10,000 ohms. The value of R_6 (which should be 6,500 ohms), can be determined by subtracting from this $R_6 + R_7$ (10,000 ohms) value, the resistance value obtained by measuring between the screen grid of the second detector tube and chassis (see Fig. 21-12), since this latter measurement gives the resistance of resistor R_7 (which should be 3,500 ohms).

21-9. Analysis of the Second R-F Screen-Grid Circuit.— Resistance measurements of the screen-grid circuit are made in a manner similar to that employed in the plate circuit. With the

ohmmeter connected from screen grid to chassis, a reading of 10,000 ohms should be obtained, as shown in Fig. 21-14, since the speaker field is disconnected. A "zero"-ohm reading will be caused by the short-circuiting of either condenser, C_{12} or C_{13} . Should a reading of approximately 4,600 ohms be obtained, then filter condenser C_{59} or by-pass condenser C_{58} is short-circuited, placing the screen drop-resistor R_5 directly in parallel with R_6

FIG. 21-14.—Equivalent simplified diagram of the screen-grid circuit of the second r-f tube in the all-wave receiver whose circuit diagram is shown in Fig. 21-12.

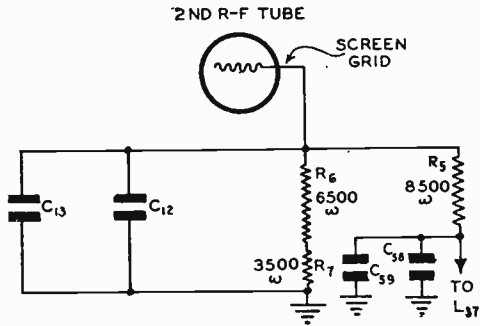

and R_7 . If these condensers were short-circuited, however, the fact would already have been ascertained by the analysis of the plate circuit.

21-10. Analysis of the Second R-F Suppressor-Grid-Cathode Circuit.—Because the suppressor grid is tied to the cathode and only one resistor and one by-pass condenser is in the cathode circuit of this receiver, a check of the suppressor grid and cathode circuits is comparatively simple. With the ohmmeter connected from cathode to ground, a reading of 400 ohms, the resistance of R_4 , should be obtained. A zero-ohm reading will invariably be caused by a short-circuited by-pass condenser C_{15} . (Note: If the tester is equipped with a socket and is able to make point-to-point voltage tests, the tube should be inserted in the tester socket. A "zero"-ohm reading obtained from cathode to chassis could be caused by an internal cathode-heater short-circuit in the tube.)

21-11. Analysis of the Second R-F Control-Grid Circuit.—The only remaining circuit to be analyzed in this stage is the control-grid circuit. The normal resistance which should be indicated when the point-to-point tester is connected from control-

grid to chassis (or ground) is approximately 1,350,806 ohms. In this circuit (see Fig. 21-15) we have 6-ohm secondary winding L_7 , R_3 (100,000 ohms), R_{23} (1 megohm), the volume control R_{15} (250,000 ohms), and the second-detector cathode bias-resistor R_{16} (800 ohms). If a zero-ohm reading should be obtained, it would indicate a short-circuited tuning condenser section, C_{14} , for this stage. This is not likely, however, and may be checked

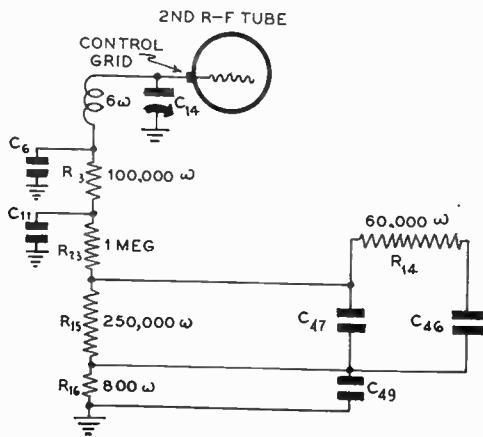

FIG. 21-15.—Equivalent simplified circuit diagram of the control grid-to-chassis path of the second r-f stage of the all-wave receiver whose circuit diagram is shown in Fig. 21-12.

by turning the condenser gang so that the plates are un-meshed. It is also possible that a "zero" ohm reading may be due to the "high" side of the secondary coil shorting to the chassis or shield. Turning the wave-band switch to band "B" will settle this point. A reading of only 6 ohms indicates a short-circuited secondary return by-pass condenser C_6 . The effect of a short-circuit at this point on the operation of the receiver will be poor AVC action, distortion, oscillation and motor-boating. If condenser C_6 is leaky, it will result in almost the same symptoms, and will be disclosed by a reading of between 6 ohms and several hundred thousand ohms, depending upon the degree of leakage. If a reading of 100,000 ohms is obtained, the by-pass condenser C_{11} may be short-circuited. A reading of approximately 1,160,000 ohms may result if condenser C_{14} is short-circuited. This fact may be checked immediately by inserting the test plug into the socket of the second detector stage and measuring the resistance be-

tween either one of the diode plates to chassis. If a reading of 800 ohms is obtained, the condenser C_{46} is short-circuited; if a reading of 60,800 ohms is obtained, condenser C_{47} is short-circuited; and if a reading of 310,000 ohms is obtained, condenser C_{49} is short-circuited, etc. The analysis of the second r-f stage may now be considered complete for our purposes, and attention must now be turned to the first-detector—oscillator stage.

21-12. Analysis of the First-Detector—Oscillator Stage.

—A resistance measurement between the plate of the combination first-detector—oscillator tube and chassis should result in a reading of approximately 18,500 ohms, since the speaker field is disconnected. (The $7\frac{1}{2}$ ohms of coil L_{s1} could not be read on the high-range ohmmeter scale.) This circuit contains L_{s1} , the primary of the first i-f transformer, and resistors R_1 , R_2 and R_7 in series. A $7\frac{1}{2}$ -ohm reading will indicate short-circuited filter condensers C_{s8} or C_{s9} . Should a reading of approximately 1,300 ohms be obtained, however, condenser C_{s8} should be checked for short-circuit. This low value may be due to the series circuit of R_{11} and R_{10} , 1,000 and 400 ohms respectively, in parallel with resistors R_5 , R_6 and R_7 . The resistance of the primary winding L_{s1} may be checked by connecting the point-to-point tester from the plate of this stage to the plate of the second r-f stage with the wave-band switch in the "D" position. A reading of approximately 11.5 ohms should be obtained. A value of 4 ohms would signify that L_{s1} is short-circuited. This may be due to a short-circuited trimmer condenser C_{41} , or to grounded pig-tails or connecting lugs of this winding.

21-13. Analysis of the First-Detector—Oscillator Screen-Grid Circuit.

—The screen circuit of the first-detector-oscillator tube (third and fifth grids), should have the same resistance to chassis as the second r-f stage screen circuit, since these two circuits are connected together. Failure to obtain the correct normal resistance will be caused by the same conditions discussed for the second r-f screen-grid circuit.

21-14. General Notes on Resistance-Check Receiver Analysis.

—The above data present the idea and methods involved in the analysis of receivers by point-to-point resistance measurements. It is not necessary to discuss here the analysis of the

rest of the receiver, since the procedure is the same for the circuits leading to all tubes. There is no doubt that the resistance-check method of receiver analysis enables many problems encountered in the servicing of modern radio receivers to be solved, but whatever advantages may be gained are *entirely dependent upon the intelligent interpretation of the meter indications obtained.*

It should be remembered that many parts of a receiver cannot be checked by a point-to-point resistance measurement at the sockets of the receiver. In many instances, a coil winding cannot be checked because it is isolated by a condenser; this is especially true of the oscillator circuits in many superheterodyne receivers. In other cases only a portion of a coil winding is connected in the circuit under test, the remainder being isolated by a series, tracking, or neutralizing condenser. In cases of this kind, it is necessary to remove the chassis of the receiver from the cabinet in order to get at the proper points in the wiring to complete the analysis. This is not objectionable, however, because the chassis must usually be removed from the cabinet in order to make the final repairs anyway.

21-15. Making Point-to-Point Resistance Analysis When Receiver Diagram is not Available.—On many occasions, the circuit diagram of the receiver under test is not available. Unless the service man is familiar with that particular receiver, it is difficult to make accurate tests, since the careful study and examination of the receiver circuit diagram is essential in interpreting the results of a point-to-point resistance analysis. However, if certain general features concerning basic circuit arrangements of *most* radio receivers are understood, useful point-to-point testing may be carried out in such cases. The more important of these will now be considered.

Ordinarily, a "zero" resistance reading will never be obtained between the plate and control-grid of a tube unless the tube is a rectifier with the grid tied directly to the plate. In like manner, a "zero" resistance reading will not be obtained between the plate and cathode of the same tube, unless the tube is a rectifier or diode detector. Zero resistance will seldom be found between the control grid to chassis, or *B—*, of a receiver. In very few instances, except in certain oscillator circuits, will

there be "zero" resistance between the screen grid and the cathode of the same tube. Likewise, "zero" resistance will seldom exist between the plate and screen grid of the same tube, unless that tube is a power amplifier having its screen connected directly to the plate. Many power tubes are operated this way.

A lower resistance will be obtained from the screen grid of a power amplifier tube to ground than from the plate of the same tube to ground, although a higher voltage may be obtained at the screen than at the plate. This statement is also true of the dynatron oscillator, in which the screen operates at a higher voltage than the plate; therefore, an ohmmeter test will disclose a lower resistance between the screen of the tube and chassis than from plate to chassis.

Zero resistance should never be obtained between the plate of one tube and the control grid of a subsequent tube in a receiver—the direct-coupled amplifier is one exception to this statement. Zero resistance should never exist from the filament to the plates of a filament-type rectifying tube. In like manner, there should never be zero resistance between the cathode (or filament terminals) of a rectifier tube and its plate terminals.

As mentioned, these statements are general and are true in most instances, but exceptions will be found. They are meant to serve only as a guide in interpreting the results of a point-to-point resistance analysis on receivers for which no schematic circuit diagrams are available.

21-16. Effect of Electrolytic Condensers on Resistance Measurements.—Many radio receivers employ electrolytic condensers for filter and by-passing purposes. These units possess a certain amount of leakage, that is, the insulation-resistance between the terminals is not of infinite value. The effect of this leakage, which depends upon the condition of the condenser, is to cause the condenser to act just as though a continuous high-resistance path exists between its terminals. When testing any circuits in which an electrolytic condenser is used, make certain that the polarity of the ohmmeter corresponds to the polarity of the electrolytic condenser, otherwise a very low and misleading resistance reading will be obtained.

Generally, electrolytic condensers are employed as filter con-

condensers in the power-supply unit of a receiver, or as by-pass condensers in grid-bias and bleeder circuits. In the first case, the *negative* side of the condenser is connected to the "low" side of the filter supply. This may be the chassis, or it may be some other point which is *negative* with respect to the chassis. If the electrolytic condenser is a by-pass unit connected across the cathode bias resistor of a tube, the *positive* terminal of the condenser will be connected to the cathode, since the cathode is invariably positive with respect to *B*-minus or the chassis. When an electrolytic condenser is used to by-pass a bias resistor connected from the center-tap of a tube's filament supply to *B*-minus or ground, the positive side will be connected to the filament side of the bias resistor, since this point is *positive* with respect to ground. Thus, when making resistance measurements with the ground as the reference point, always connect the *positive* side of the ohmmeter to the cathode or filament circuit.

It is not entirely necessary to remember this, for if an incorrect resistance indication is obtained in any circuit using electrolytic condensers, all that need be done is to reverse the ohmmeter test leads. If the circuit is really faulty, an incorrect indication will again be obtained, which may not be the same as the first incorrect reading.

When the correct polarity of the ohmmeter is maintained in making resistance measurements, the presence of an electrolytic condenser in shunt with any resistor of ordinary resistance value will have a negligible effect on the resistance reading, provided, of course, that the condenser is good. It is only when these condensers are connected in parallel with very high resistances that a variation of any consequence may be noted. Tests show that an 8-mfd. high-voltage electrolytic condenser connected in the average filter system, or across the voltage-divider system of a radio receiver, changes the effective resistance of the circuit by less than 5%. The effect of a low-voltage, high-capacity electrolytic condenser when making point-to-point tests is not more than one or two per cent, at most. Since most resistors employed in modern radio receivers are only kept within a tolerance of about 10%, the negligible shunting effect of electrolytic condensers across such resistors may be disregarded during point-to-

point resistance measurements when the polarity of the ohm-meter is correct.

21-17. Using Manufacturers Resistance Data.—The point-to-point resistance analysis method outlined in this chapter depends upon the fact that a circuit diagram (or chart) having the resistances of all coils and resistors in the receiver marked on it, is available. When a measurement is made, the resistance reading is compared to that specified on the circuit diagram, and any deviation is interpreted in terms of "what trouble in the receiver might have caused it." The method is analytical in the sense that many equivalent circuits must be pictured (mentally) for intelligent interpretation of the ohmmeter readings.

MODEL 45 SOCKET VOLTAGES

Make voltage tests with 1000 ohm per volt meter. Voltages given in table are only comparative due to variance in battery voltage. Plus or minus 20% on all voltages acceptable.

| Tube | Heater | Plate | Screen | Cathode | Suppressor | Control |
|------|--------|----------|--------|---------|------------|------------|
| 75 | 6.3 | 250 | 60 | 2.2 | 2.2 | *2.0 |
| 77 | 6.3 | 250 | 60 | 2.2 | 2.2 | *2.2 |
| 78 | 6.3 | 250 | 60 | 1.6 | 1.6 | *1.4 |
| 37 | 6.3 | 60 | — | 0 | — | *6-1500 KC |
| 75 | 6.3 | 135 | — | 1.3 | — | *1.3 |
| 75 | 6.3 | 135 | — | 1.3 | — | *1.3 |
| 41 | 6.3 | 245 | 250 | 18 | — | *18 |
| 41 | 6.3 | 245 | 250 | 18 | — | *18 |
| 84 | 6.3 | 275 (AC) | — | 255 | — | — |

* Measured with vacuum tube voltmeter only.

MODEL 45 POINT-TO-POINT RESISTANCE CHECK

All readings to ground unless otherwise specified. Readings taken with all tubes removed from set and R. F. chassis disconnected from power pack unit.

| 1a78 | 1a77 | 1a75 | 1a74 | 1a73 | 1a72 | 1a71 | 1a70 |
|-------------------|-------------------|-------------------|-------------------|-------------------|-------------------|-------------------|-------------------|
| + Heater | + Heater | + Heater | + Heater | + Heater | + Heater | + Heater | + Heater |
| - Heater | - Heater | - Heater | - Heater | - Heater | - Heater | - Heater | - Heater |
| Plate to B+ | Plate to B+ | Plate to B+ | Plate to B+ | Plate to B+ | Plate to B+ | Plate to B+ | Plate to B+ |
| Screen Grid to B+ | Screen Grid to B+ | Screen Grid to B+ | Screen Grid to B+ | Screen Grid to B+ | Screen Grid to B+ | Screen Grid to B+ | Screen Grid to B+ |
| Suppressor Grid | Suppressor Grid | Control Grid | Control Grid | Control Grid | Control Grid | Control Grid | Control Grid |
| Cathode | Cathode | Cathode | Cathode | Cathode | Cathode | Cathode | Cathode |
| Control Grid | Control Grid | Control Grid | Control Grid | Control Grid | Control Grid | Control Grid | Control Grid |
| 1a68 | 1a67 | 1a65 | 1a64 | 1a63 | 1a62 | 1a61 | 1a60 |
| + Heater | + Heater | + Heater | + Heater | + Heater | + Heater | + Heater | + Heater |
| - Heater | - Heater | - Heater | - Heater | - Heater | - Heater | - Heater | - Heater |
| Plate to B+ | Plate to B+ | Plate to B+ | Plate to B+ | Plate to B+ | Plate to B+ | Plate to B+ | Plate to B+ |
| Diode | Diode | Diode | Diode | Diode | Diode | Diode | Diode |
| Cathode | Cathode | Cathode | Cathode | Cathode | Cathode | Cathode | Cathode |
| Control Grid | Control Grid | Control Grid | Control Grid | Control Grid | Control Grid | Control Grid | Control Grid |
| 1a58 | 1a57 | 1a55 | 1a54 | 1a53 | 1a52 | 1a51 | 1a50 |
| + Heater | + Heater | + Heater | + Heater | + Heater | + Heater | + Heater | + Heater |
| - Heater | - Heater | - Heater | - Heater | - Heater | - Heater | - Heater | - Heater |
| Plate to B+ | Plate to B+ | Plate to B+ | Plate to B+ | Plate to B+ | Plate to B+ | Plate to B+ | Plate to B+ |
| Diode | Diode | Diode | Diode | Diode | Diode | Diode | Diode |
| Cathode | Cathode | Cathode | Cathode | Cathode | Cathode | Cathode | Cathode |
| Control Grid | Control Grid | Control Grid | Control Grid | Control Grid | Control Grid | Control Grid | Control Grid |
| 1a48 | 1a47 | 1a45 | 1a44 | 1a43 | 1a42 | 1a41 | 1a40 |
| + Heater | + Heater | + Heater | + Heater | + Heater | + Heater | + Heater | + Heater |
| - Heater | - Heater | - Heater | - Heater | - Heater | - Heater | - Heater | - Heater |
| Plate to B+ | Plate to B+ | Plate to B+ | Plate to B+ | Plate to B+ | Plate to B+ | Plate to B+ | Plate to B+ |
| Diode | Diode | Diode | Diode | Diode | Diode | Diode | Diode |
| Cathode | Cathode | Cathode | Cathode | Cathode | Cathode | Cathode | Cathode |
| Control Grid | Control Grid | Control Grid | Control Grid | Control Grid | Control Grid | Control Grid | Control Grid |

† Reads leakage of electrolytic condenser.

Courtesy Noblitt-Sparks Industries Inc.

FIG. 21-16.—Voltage-current-resistance analysis data chart for a typical automobile radio receiver.

Manufacturers realize that resistance analysis is helpful but requires, at times, considerable calculation to determine if the readings obtained are correct or not. They have compiled service data sheets which are intended to make these calculations unnecessary for point-to-point resistance measurement reference. These data sheets not only have the resistances of all components marked on them but also have in tabulated form the correct ohmmeter readings for every test on each socket of the particular receiver.

Figure 21-16 shows a typical tabulation of voltage-current-resistance data furnished by the manufacturer of an automobile radio receiver, for reference purposes when making point-to-

point analyses on it. Chassis to socket-prong resistance measurements are made and referred to the chart for comparison. It is thus not absolutely necessary to have the schematic circuit diagram available for reference if the manufacturer's chart is on hand. Of course, when a reading is different from that specified by the chart, it is desirable to have the schematic circuit diagram available to determine the exact component at fault. Charts such as that of Fig. 21-16 are available from many manufacturers or from service manuals. Many service men are also in the habit of compiling their own data from the routine tests they make on receivers for which no charts are available.

REVIEW QUESTIONS AND PROBLEMS

1. Two resistors are connected in series. The total resistance is 475 ohms. One of them has a value of 312 ohms. What is the resistance of the other?
2. Three resistors are connected in parallel. Each has a value of 10 ohms. What is the total resistance?
3. The resistance of a parallel circuit is measured and found to be 700 ohms. The parallel circuit has four resistors of the same value. What is the value of each?
4. Three resistors of 200, 500 and 1,000 ohms, respectively, are connected in parallel. What is the total resistance as read by an ohmmeter? Draw the circuit diagram.
5. A source of e.m.f. has a 1,000-ohm resistor connected across its terminals. Connected to one terminal is a 500-ohm resistor, the other end of which connects to two 1,000-ohm resistors in parallel. The other end of this parallel branch connects to the second terminal of the source of e.m.f. What current flows out of the battery if the e.m.f. source supplies a potential of 750 volts? Draw the complete circuit diagram.
6. In the circuit of Fig. 21-12, what resistance should normally be read from the plate of the second r-f stage to ground, with the speaker field connected? With it disconnected?
7. Draw an equivalent circuit showing all by-pass condensers connected properly, for the networks involved in Question 6.
8. The oscillator tube in the circuit of Fig. 21-12 refuses to function. What resistance measurements should be made to determine which component is faulty?
9. The power unit of the circuit of Fig. 21-12 delivers insufficient voltage. What resistance measurements would you make to locate the trouble, and what should the readings be?
10. The receiver of Fig. 21-12 is very noisy on the "C" band. The slightest touch of the wave-changing switch alters the volume. What measurements would you make and what readings should you obtain? (Hint: The low-resistance range of the ohmmeter should be used.)
11. What precautions must be exercised when making a resistance-analysis of a set using electrolytic condensers? Explain fully!

CHAPTER XXII

TESTING INDIVIDUAL RADIO COMPONENTS

22-1. Need for Testing Individual Components. — The voltage-current and resistance methods of analysis described in Chapters XX and XXI serve to localize trouble to a particular circuit or to a particular portion of a circuit. However, the jobs of the service man and the set analyzer do not end after localization of the trouble. The service man must use other functions of the analyzer to locate the exact troublesome component; he must determine what is wrong with that component, and, he usually must also try to ascertain the reason for the failure, before repairing or replacing the component.

These determinations necessitate the testing of individual components after the voltage-current and resistance analyses have been completed. While it is true that in many instances, a resistance analysis enables the service man to complete the trouble localization directly to the faulty component, such is not always the case; and even when such complete localization is possible, it is always, without exception, desirable to test that component individually to substantiate previous tests. Let us illustrate this by means of a typical example.

Suppose a receiver analysis localizes r-f circuit trouble to some component in the plate circuit of the r-f tube. Further, suppose that this plate circuit consists of several resistors in series with the primary of the following r-f transformer. If the plate circuit is open, then either the r-f transformer primary or one of the plate circuit resistors must be open. By checking the plate current and screen voltage, it may be possible to conclude that the primary of the r-f transformer is open-circuited. But the

point is that we cannot actually be sure of this fact until the coil itself is tested alone, after being disconnected from the circuit. It may be that a wire to the coil is broken or has never been properly soldered to the lug connection to the coil. It may be that the lug itself is broken. There may be a "rosin joint" between the wire and the lug on the coil. No method of circuit analysis can point to the actual location of the open circuit in the component itself in every case.

The procedure, then, is to remove the set from the chassis and disconnect the wires from the coil under consideration. The coil must then be tested individually, regardless of how it is connected in the circuit; for it is only after such an individual test that the service man can be sure of the nature of the failure. And when the nature of the failure has been ascertained, the cause should be determined and rectified if possible.

All the components employed in radio receivers can be reduced to three fundamental types: resistances, inductances, and capacitances. All radio circuits contain all of these parts, though they are sometimes found in somewhat disguised forms. It is the purpose of this chapter to describe in detail the general characteristics of, and the methods of testing, resistors, inductors and capacitors used in radio receivers. In Chapter XXVI the methods of repairing these components (when repair is advisable) will be explained in detail.

22-2. Required Tests of Components.—After the analysis of a circuit is completed and one or possibly more components are definitely suspected of causing the trouble, the chassis must be removed from the cabinet and each of the suspected components tested in turn. For a complete test of a component, there should be facilities for determining the following:

1. Open-circuits.
2. Short-circuits.
3. Partial short-circuits.
4. Grounds.
5. High-resistance grounds.

Any one or more of these five possible defects may exist in a resistor, condenser, or coil, and the condition may be either permanent or intermittent. Moreover, it may be necessary to

conduct tests when the suspected unit or units are *hot* and also when they are *cold*, for often the abnormal condition exists only when the unit is hot. Further details on this point will be deferred until the actual tests are described.

22-3. Instruments Used for Testing Components.—The instruments required for testing individual components should be part of the regular service man's equipment, and should consist, in general, of the following:

1. Ohmmeter.
2. Capacity meter.
3. Capacity tester.

All of these instruments have been described in previous chapters of this book, and the reader is referred to them for complete details of their theory of operation and manner of use. In this chapter it will be assumed that the reader is thoroughly familiar with them. The ohmmeter and capacity tester are integral parts of most set analyzers nowadays.

We will first discuss the necessary tests using the proper instruments, and then discuss the same or similar tests using simplified equipment in the event that the proper instruments are not available at the time the tests are to be made, or are temporarily out of order. It is important in this respect to note that the limitations of any test depend to a large extent upon the nature and accuracy of the instruments used, and that thoroughly reliable results cannot be obtained unless the test instruments themselves are in good working order and are suitable for the test to be made. This important point will become more and more evident as we proceed.

The tests will be divided into three general groups; those for testing *resistors*, those for testing *coils*, and those for testing *condensers*. Under each group the possible troubles will be discussed and the proper method of testing described.

22-4. Construction of Resistors.—Resistors find extensive and extremely important applications in radio receivers. One glance at the underside of a radio receiver chassis will convince anyone of this fact. They are employed as current limiters, for obtaining bias voltages, for "bleeding" currents, for securing desired potentials, for voltage-dropping, for volume control, etc. They are made in resistance values which cover a very

wide range from a few ohms to several million ohms.

There are two main types of resistors used in radio circuits: *fixed* and *variable*, the latter being commonly known as rheostats or potentiometers, depending upon their mode of connection. Fixed resistors may be of wire-wound, of either carbon or metal-coated film, or carbon-composition moulded construction. Variable resistors of low resistance values are usually wire wound, and those of high values usually consist of some high-resistance material to which a movable contact arm makes contact either directly or indirectly.

Wire-wound resistors are employed in fixed-resistance types when a fair degree of precision is required or when the power dissipated is more than about 1 or 2 watts. In variable-resistance form, they offer numerous important constructional advantages over other types. Wire-wound resistors of the fixed-resistance type are made by winding predetermined lengths of resistance wire on suitable porcelain or other ceramic insulating forms. Usually in the large sizes, the entire assembly, with the exception of the extreme ends of the tab terminals or pig-tails (see (A) and (B) of Fig. 22-1) is coated with a vitreous enamel or refractory cement which serves to protect the fine wire from mechanical injury, and keeps out moisture. The resistors of lower wattage rating are wound with enamel-covered or oxidized resistance wire. These resistors are usually wound with wire of nickel-chromium alloys (such as "nichrome"), but nickel-iron and nickel-copper alloys are also used. Since the values of wire-wound resistors can be controlled accurately during production, they consequently are suitable when accurate resistance values are required.

In some applications, where inexpensive wire-wound resistors which are not required to dissipate much power are required, the bare resistance wire is wound on flat fibre strips, and terminal connections are made by fastening terminal lugs to the strip and resistance wire with eyelets. A unit of this kind, provided with a center-tap, is illustrated at (C) of Fig. 22-1. Such units will be found employed as filament center-tap resistors and filament current-reducing resistors in many of the older receivers. Most variable wire-wound resistors also have the resistance wire

wound on a flat strip of fibre bent into a circular shape.

The second class of fixed resistors, the carbon- or metal-coated type, are made by depositing a thin film of carbon or tungsten on a thin glass or porcelain rod which is in turn sealed in another enclosing glass or ceramic tube for protection. Metal caps forced on the ends of the outer glass tube make contact with the resistance material. A unit of this type is illustrated at (D)

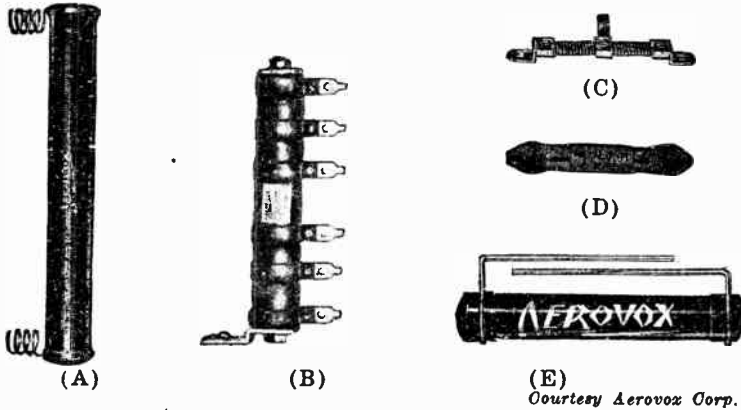

(E)
Courtesy Aerovox Corp.

FIG. 22-1.—A few of the typical forms of fixed resistors employed in radio equipment.

(A) A vitreous-enamel covered wire-wound resistor having pig-tail-lead terminals.

(B) The same type of resistor with metal-tab terminals. Several taps are provided on this resistor.

(C) A center-tapped wire-wound resistor. The resistance wire is wound on a fibre strip and metal clamp terminals connect to it. The wire is left exposed.

(D) A metal-coated film type of high resistance. This resistor has a very small current-carrying capacity.

(E) Solid moulded-carbon resistor with wire pigtail terminals. This makes a non-inductive resistor of medium resistance value and current-carrying capacity.

of Fig. 22-1. Such resistors are made in high resistance values (from about 10,000 ohms to 10 megohms) and cannot carry much current without overheating, and resultant damage to the resistance coating. Their use is restricted principally to applications where a high resistance is desired in very compact form, and where very little current is to be carried.

The third class of fixed resistors, the moulded-carbon stick or composition type, are used most extensively in radio receivers

today because of their low cost. They consist of a mixture of a very small percentage of conducting material (carbon or graphite) and a binder of insulating material (in the proper proportion to produce resistors of the desired resistance value) moulded into shape under pressure. Clay, rubber, and various chemical plastics are used for the binder. A more recent form consists of carbon and another material which itself is a material of higher resistance (not an insulating material). This is mixed in the proper proportions to make the desired resistance value, is then subjected to intense temperature and pressure, and is finally extruded at yellow heat into the form of rods.

Electrical connection is usually made to the resistance rod by means of metal end-caps forced-fitted to it, or by pigtail leads wound around (and soldered to) the ends. Uniform, positive area of contact is often obtained by first coating the ends of the rod with a metallic coating. A typical moulded carbon resistor is illustrated at (*E*) of Fig. 22-1.

Moulded carbon or graphite resistors are subject to change in resistance value due to moisture absorption, deterioration of the binder due to operation at elevated temperature, etc., when in use. Due to their changing nature, they are seldom manufactured in large quantities with actual values that are close to their rated value. The difference between the actual and rated values, expressed in per cent, is called the *tolerance*, and is a direct indication of the deviation of the actual values from the rated values. These resistors are usually manufactured with a tolerance of plus or minus 10%. The subject of tolerance in resistor values will be considered in detail in Art. 22-12.

22-5. Open-Circuited Resistors.—Resistors may open-circuit, that is, it is possible for the resistance between the resistor terminals to become infinite, for various reasons. In moulded carbon resistors, the metal caps or pigtail leads may come loose (or break) and make poor contact with the resistance element, or the resistance element itself may change in chemical composition or disappear altogether because of excessive heat. Not all fixed carbon resistors are composed of a solid rod of carbon. In some instances there is only a thin deposit of carbon on a glass or ceramic form, and it is perfectly possible for

excessive heat to deteriorate this thin carbon deposit to such an extent that the resistance becomes open-circuited. The same thing is true of metallized resistors—excessive heat may vaporize the metallic resistance deposit to such an extent that the unit open-circuits.

A wire-wound resistor, on the other hand, may become open-circuited because of a break developing in the resistance wire, an imperfect contact may develop between the resistance wire and one of the end terminals, or it may burn out (the “burning out” of a resistor is really the melting of the resistance material at some point, thereby breaking the continuity). Imperfect contacts at the terminals are common, for pressure contacts are employed by many manufacturers.

Variable resistors are subject to the same troubles as the fixed units, in addition to special ones such as dirty arm contact, insufficient arm pressure, etc., which develop as a result of the mechanical systems involved. For this reason, the following discussion of resistors will pertain to fixed resistors in particular, and it is to be understood that the same defects can occur in variable units.

22-6. Power Rating of Resistors.—The power rating of a resistor in watts depends mainly on the area of the resistance element exposed to ventilation, the heat radiating qualities of the surface of the resistance element, the heat conducting properties of the insulating form on which the resistance wire is wound, and the temperature difference between the resistor and its surroundings. When a resistor has a certain power rating, it means that that electrical power (in *watts*) can be dissipated in it by being converted into *heat*. This heat is subsequently radiated and conducted from the resistor when it is in open space at room temperature. If that same resistor were placed in a refrigerator which is held at a low temperature, then that self-same resistor could be made to dissipate much more electrical power and heat than its rating indicates, without anything happening to it. In other words, the *power rating* of a resistor is *the amount of electrical power (in watts) that it can dissipate in the form of heat without producing more than a certain specified temperature rise, when it is located in surroundings*

of a certain specified temperature. If there were some external, artificial means present to cool the resistor (a refrigerator, a fan, etc.), then it could handle more power and radiate much more heat without reaching a high temperature. At a certain high temperature, a chemical change takes place in the resistor element, and it usually burns out as a result. If the temperature at which this would occur is always much higher than the normal operating temperature of the resistor, then it can operate at the normal value (without deterioration) for relatively long periods of time.

The importance of this point must not be underestimated. The final temperature which a resistor assumes depends not only upon the heat generated in it, but, also, upon the temperature of the surroundings. A certain resistor may be generating about 0.1 watt of heat, and it may be tucked in some corner of a radio set chassis which is at a temperature much higher than that of the resistor alone. The result is that heat enters the resistor *from* the surroundings instead of the resistor radiating heat *to* the surroundings. When equilibrium is established, the temperature of the resistor is much higher than normal and is probably equal to that of the surroundings. And if this temperature is high enough, the resistor may burn out, *even though the current through it is well within the value recommended by the manufacturer.* This condition is very apt to occur in those extremely compact midget receivers in which sufficient ventilation is not provided. It is interesting to note here that the standard RMA definition of the *maximum wattage rating* of wire-wound resistors of the vitreous enamel type is:

“the input in watts required to produce a temperature rise of 250 degrees Centigrade (482 degrees Fahrenheit) at the hottest point of the resistor, *when the resistor is surrounded by at least one foot of free air, the surrounding air being at a temperature not exceeding 40 degrees Cent. (104 degrees Fah.)*.”

This is the basis upon which manufacturers of wire-wound resistors for radio work rate their resistors. Any radio service man knows that when these resistors are mounted in the usual posi-

tions inside of radio sets, where ventilation is extremely restricted, and where heat from adjacent parts such as power transformers, other resistors, tubes, etc., makes the surrounding temperature much higher than 40° C., the condition existing is very far from the 40° C. *open-air* condition for which the power rating of the resistor is really specified. Because of these conditions, wire-wound resistors should be operated at no more than a fraction (usually $\frac{1}{2}$) of their nominal power rating when mounted inside of a radio receiver chassis.

Since the resistance of moulded-carbon type resistors depends so much upon the temperature and applied voltage, they may change their resistance so much because of these two factors that their resistance value may be incorrect for the purpose intended. Therefore, greater difficulties are encountered when attempting to rate resistors of this type. In fact, no standard rating has yet been worked out, but in practice, as a maximum, one square inch of radiating surface of these resistors is considered capable of dissipating safely the heat generated by one watt of electrical energy.

When selecting resistors for replacement purposes, great care should be taken to obtain units which are large enough for the applications for which they are to be used, and also to get high-quality units which will stand not only the heat generated but also the alternate heating and cooling to which the unit may be subjected in service. This will obviate future difficulties. The difference in cost between satisfactory resistors and inferior (or insufficiently large) ones is usually so small that it does not pay to run the risk of repeated trouble by using the latter.

22-7. Short-Circuited Resistors.—A resistor rarely short-circuits within itself. Short-circuits practically never occur in solid and metallized types of resistors, although they may occur in the wire-wound type. Short-circuits may occur between turns of wire or between layers of multi-layer resistance windings, and thereby decrease the value of the resistance between the main terminals. It is possible, though, for any type of resistor to have its terminals short-circuited by some other piece of metal, such as the chassis; but this condition does not constitute a short-circuit within the resistor itself. Moreover, in this case the resistor

will test normal when removed from the circuit in which it is connected.

The possibility of a resistor becoming partially short-circuited internally is even less than its becoming completely short-circuited. When a resistor becomes partially short-circuited, one part of the resistance element must touch some other part, and this can occur only in wire-wound units.

22-8. Grounded Resistors.—Vibration may cause a resistor to become grounded to some other component or circuit through physical contact, resulting in the altering of its position. However as a general rule a resistor does not ground within itself. There is an exception to this, though, in the case of resistors which are insulated and encased in a metal shield, as shown in Fig. 22-3. Since the unit is mounted upon the chassis, breakdown of this insulation at some point may cause the unit to ground. Also, in some cases, the heat may cause the form, on which a wire-wound resistor is wound, to warp so that the wire touches some part of the chassis.

22-9. Noisy Resistors.—Noisy resistors are one of the most frequent causes of noisy reception. A resistor is said to be "noisy" when it changes in value from instant to instant. If the rate of change is fast enough, the varying current caused by the varying resistance generates a varying voltage in the r-f or a-f circuits which is amplified and reproduced in the usual manner as continuous "scratchy" noise. If the rate of change is slow the noise may appear simply as a series of intermittent clicks.

A fixed resistor may become noisy if it is operated with much more current flowing through it than it is designed to carry, or when its operating temperature is higher than it would be if normal, rated current flowed through it in surroundings of normal temperature. However, fixed wire-wound resistors are not usually noisy. Moulded-carbon resistors are the most frequent offenders in this respect. When they are raised to a high temperature during operation, the particles of the carbon in the mass become so hot that tiny arcs occur between them. Furthermore, the carbon particles fuse together, and their resistivity consequently changes. The net current flowing through the unit will then have minute variations, which may be called the *noise*

current. The only manner in which this noise current may be reduced, is by reducing the operating temperature of the resistance element either by reducing the temperature of the surrounding air or decreasing the current through it. Of course, substituting a resistor of the same resistance value but adequate power-rating is the more practical remedy.

Variable resistors are especially apt to become noisy. Poor contact between the arm and the resistance element, poor tension in the spring that keeps the arm on the resistance element, wearing away of the element due to pressure of the arm, bumpy spots in the element, oxidation of the surface of the element and the wiping surface of the arm, and oxidation of the contact surface between the rotating arm and the terminal, all result in noisy reception. The only manner in which these units can be repaired is by taking them apart and cleaning the oxidized elements whenever it is practical to do so. For details concerning the repair of components used in radio receivers, the reader is referred to Chapter XXVI.

22-10. **Temperature Coefficient of Resistance.**—It is generally well known that temperature has an effect on resistance. In instances when the resistor is of the wire-wound type, the resistance will *increase* with an increase in temperature, and, when the unit is of the composition type, such as carbon or graphite, the resistance will *decrease* with an increase in temperature. (The change in resistance per ohm per degree *C* change in temperature is called the *temperature coefficient* of resistance.) Since many of the resistors in radio receivers are connected in circuits in which appreciable current is flowing, a certain amount of heat is generated in them. This heat will change their resistance. Therefore, the unit will possess “cold” and “hot” resistance values, which may differ considerably.

For most resistance measurements, it is necessary to make a “cold” resistance test, in order to obtain uniform indications; that is, the resistor must be permitted to cool before making the test. On the other hand, there are some instances when a “hot” resistance test is valuable. This is true in the case of carbon resistors employed as part of the voltage-dividing systems of radio receivers. Excessive current passing through such units will mater-

ially change their value, often affecting the normal operation of the receiver. This condition may not be disclosed if the test is made after the resistor has been given an opportunity to cool. (See *Resistance Data for Common Elements and Alloys*, in the author's *Radio Trouble-Shooter's Handbook* for further technical details concerning the effect of temperature on the electrical resistance of common elements and alloys.)

22-11. Voltage Coefficient of Resistance.—Closely allied with temperature coefficient is *voltage coefficient*. This is defined as *the difference between the resistance value obtained when the measurement is made with a high voltage, and that obtained when a low voltage is used*. In other words, a resistor may have one resistance value when measured with a high voltage applied across it for the measurement, and quite another value when measured by this same method when the applied test voltage is small. The reason for the change in resistance with changes in applied voltage is the same as for changes in temperature, for the increased applied voltage causes an increased current to flow through the resistor, and increased current generates increased heat, which increases the operating temperature and changes the resistance.

Both voltage and temperature coefficients really mean the same thing, but resistance manufacturers use the term *voltage coefficient* because its interpretation is in terms of more practical units. The measurement of temperature coefficient of resistance requires rather an elaborate laboratory set-up, which is not required for voltage coefficient measurements. Of course, composition carbon type resistors are the worst offenders in this respect. Increases in applied voltages to circuits in which they are connected cause their resistance to *decrease*. This drop, in poor resistors, may be as high as 25 per cent of the total resistance—enough to cause serious electrical unbalance of the circuits they are connected in. Wire-wound resistors are affected very much less by this condition. Their resistance tends to increase slightly with increase in applied voltage.

22-12. Tolerance of Resistors.—When checking the resistance values of resistors, or when purchasing new ones, the man-

ufacturing tolerances should be considered. The average tolerance of resistors employed in radio receivers is usually about plus or minus 10 per cent. As an example of just what this means, if such a resistor is marked 1,000 ohms, its actual resistance may be anywhere between 900 and 1,100 ohms. This tolerance will vary in different cases, the *function* of the unit in the circuit being the determining factor. If the resistor carries current, thereby producing a voltage drop, the average tolerance is from 5 to 10 per cent. Wire-wound resistors are commonly held to tolerances of plus or minus 5%. In the case of high resistances, such as are used for grid leaks in resistance-coupled amplifiers and in AVC circuits, a tolerance as high as 20 per cent is permitted, since these units carry very little, if any, current, and their resistance value is not critical. Closer tolerances are employed, and should be expected, when measuring the value of resistors employed in filament circuits. Usually the tolerance here is approximately 5 per cent.

22-13. Testing Resistors for Open-Circuits with the Ohmmeter.—Testing a resistor is usually synonymous with measuring its value, and the ohmmeter is without doubt the most convenient and most accurate device at the disposal of the service man for making this test. Readers who wish to refresh their knowledge of ohmmeters should review Chapters III to V.

If a resistor is suspected of being open-circuited, it should first be disconnected from the circuit in which it is connected, and then tested. If it is not disconnected, there is a possibility of some other unit connected to it acting as a shunt path, causing a false resistance reading to be obtained on the ohmmeter. For example, a leaky condenser may be in parallel with the resistor under test, as shown at (A) of Fig. 3-16 (Chapter III). If the ohmmeter is placed across the terminals of the resistor, and if the resistor itself is open-circuited, the ohmmeter will read the resistance of the leakage path in the condenser. On the other hand, if the resistor is normal, the ohmmeter will read the combined leakage and resistor resistances. To avoid any such discrepancies, one end of the unit under test should always be disconnected from all other components in the circuit, as shown at (B) of Fig. 3-16 (in Chapter III).

Set the ohmmeter range so that the normal value of the resistor is read on a convenient part of the scale, and place the test prods across the terminals of the resistor (observing the precautions illustrated in Fig. 3-16). If it is open-circuited, the ohmmeter will read *infinite* ohms. It must be recalled that zero ohms on an ohmmeter may be indicated by either full-scale or zero deflection, depending upon the type of ohmmeter. It will be remembered from our study of ohmmeters in Chapter III that *zero deflection* of the pointer is *zero* ohms on shunt-type ohmmeters, and *full-scale deflection* is *zero* ohms on series type ohmmeters. Throughout this chapter the diagrams will illustrate the readings of series type ohmmeters; the text will refer to the reading of the ohmmeter in ohms, not in deflection of the pointer, unless otherwise stated.

If the ohmmeter indicates a very high value of resistance, it may not mean that the resistor is *closed*, since a shunt path that is not apparent may exist. For example, if the fingers touch the metal parts of the test prods while making a reading, a very appreciable error will result (see Fig. 3-15), especially if the fingers are moist and the high-resistance ranges of the instrument are employed. The table or bench on which the resistor is rested should be a fair insulator, and should not be painted with paint having an excessive amount of lamp black, (which contains carbon), otherwise the ohmmeter will indicate the resistance of the paint in parallel with that of the resistor.

In connection with the ohmmeter test, the important thing to realize is that the ohmmeter will read the actual value of resistance between the test-prod terminals, not only open- and closed-circuits.

22-14. Emergency Open-Circuit Tests for Resistors.—Although the ohmmeter is undoubtedly the most convenient device for continuity testing, there are times when it is not available or it has been damaged accidentally. In such cases, the service man should know other emergency methods for performing the simple fundamental tests already outlined—even if only temporarily.

Perhaps the best known and most widely used emergency continuity testing device when no electrical measuring instru-

ments are available, is that of a battery and pair of earphones connected as shown at (A) of Fig. 22-2. Two adaptations of this method which are also very handy are the combination of an incandescent lamp bulb in series with the light line circuit, as shown at (B), and a $4\frac{1}{2}$ -volt C battery and flashlight bulb, pictured at (C).

When the test arrangement of (A) is used and the test prods are connected across the resistor, a click will be heard in the phones; likewise when the test prods are removed. Obviously,

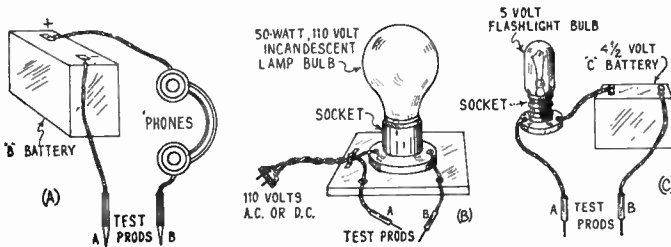

FIG. 22-2.—Three simple continuity testers which may be used when an ohmmeter is not available.

(A) Tester consisting of a B battery and a pair of earphones.

(B) Tester consisting of a 110-volt incandescent lamp and voltage supply. A neon bulb used here instead of the incandescent lamp is more reliable, as it requires much less current to operate it.

(C) Tester employing a small $4\frac{1}{2}$ -volt C battery, or flashlight batteries, and a 5-volt flashlight bulb.

this test depends upon the change in current occasioned by the opening and closing of the circuit actuating the phones. It is also clear that this test only indicates whether or not the circuit is open or closed, and does not give any quantitative indication of the value of the resistance.

The systems shown in (B) and (C) are suitable only when the resistance under test is of the same order of magnitude as the resistance of the lamps. If the value of the resistor under test is very small compared to the resistance of the lamp, then the lamp will light brightly—under these conditions, the resistor is definitely shown to have a closed (continuous) circuit. On the other hand, if the value of the resistor is very high compared to the resistance of the lamp, then, even if the resistor cir-

circuit is continuous, the current flowing through the lamp will be so small that it will be insufficient to light it at all. Consequently, when this is the case the lamp test is not a reliable indicator of whether the circuit of the resistor under test is continuous or open.

It is not always desirable to increase the battery voltage used in the test circuit in order to try to light the lamp, since the current flowing through the resistor may be made so high that it will burn out; hence, this type of test has definite limitations. It is suitable for determining open-circuits only when the resistance under test is not greater than about five times the resistance of the lamp. The system at (A), however, is suitable for testing resistances hundreds of times greater than the d-c resistance of the windings of the phones, since a good pair of ear-phones will "click" on very minute currents.

The system shown at (B) can be improved considerably so that it will give a reliable continuity indication, if a small 110-volt 2-watt neon lamp (an ordinary neon "nite-lite" will do) is used instead of the incandescent lamp. On d-c circuits, one electrode will glow if the circuit is continuous; on a-c circuits, both electrodes will glow. Neon lamps require such small currents to make them glow, that they give satisfactory continuity indications even if the circuit contains a high resistance. For this same reason, when the circuit of any resistor is tested for continuity with a neon tube tester, first make sure that the resistor is not shunted by any condenser, no matter how small, for the condenser itself will cause the neon tube to light, especially if the condenser is leaky (see Arts. 22-27 and 22-30).

A voltmeter alone (see Art. 3-7), or a voltmeter and milliammeter (see Art. 3-4), may also be used for emergency checking of the continuity of resistors, if they are available. Of course, a suitable source of voltage must also be at hand if these instruments are used.

22-15. Testing Resistors for Short-Circuits. — The method of testing resistors for short-circuits is similar to the open-circuit test described in the preceding section. The terminals of the ohmmeter are placed across the terminals of the

resistor under test and the reading noted. If the ohmmeter reads zero ohms (*full-scale* on a series ohmmeter, or *zero* on a shunt instrument), then the resistance is short-circuited.

One precaution must be taken in this test: the ohmmeter must be capable of reading low values of resistance—values considerably lower than the rated value of the resistor. Thus, if the rated value of a resistor is 100,000 ohms, and the ohmmeter reads about zero on the 0-2,000-ohm scale, the resistor is definitely short-circuited. On the other hand, if the rated value of the resistor is but 5 ohms and the ohmmeter reads about zero ohms, the accuracy of the ohmmeter at very low resistance values on this range should be considered before definitely judging the resistor to be either perfect or faulty. It would be more satisfactory to use a lower range, say 0-10 ohms to measure this resistance.

Emergency test circuits using earphones, a lamp and a battery, or a voltmeter and milliammeter, are valuable for testing for short-circuits. If no click is heard in the phones when the test prods are connected across the terminals of the resistor, it is open-circuited; if a click is heard, and the intensity of the click is less than that heard with the test prods touched directly together, the resistor is not short-circuited, although it is difficult to tell if it is partially short-circuited. However, partially short-circuited resistors are so rare that if the click is less intense than that heard with the test prods touched together, the resistor may be assumed to be good.

The earphone test has one serious limitation: it is necessary that the resistance of the unit to be tested be appreciable compared to the d-c resistance of the windings if a click of lowered intensity is to be heard. In other words, if the resistor has a value that is small compared to the resistance of the windings of the phones (2,000 ohms or more), the intensity of the click may be just as loud as when the test prods are touched directly together; under these conditions, one cannot tell the difference between a short-circuited resistor and a normal one.

The incandescent lamp test in Fig. 22-2 can be used for short-circuit tests only when the resistor to be tested has a value that is appreciable compared to the resistance of the lamp. If it is small compared to the lamp resistance, the lamp will appear

fully lit, and the short-circuited condition, if it exists, cannot be identified with certainty.

22-16. Testing Resistors for Partial Short-Circuits.—Although partially short-circuited resistors are rare, tests may be made for this condition. The ohmmeter is the most reliable instrument that can be used; the emergency tests described in Arts. 22-14 and 22-15 (with the exception of the milliammeter-voltmeters test) are entirely unreliable for this test. The limitations imposed by the emergency tests have been discussed in the two preceding sections, and the reader is referred to them for a discussion as to why partially short-circuited resistors cannot usually be distinguished from short-circuited resistors by means of these tests with any degree of success.

22-17. Testing Resistors for Grounds.—The metal caps at the ends of the resistor, or the lead wires at the terminals of a resistor may touch the metal chassis of the receiver and so become grounded. This condition can usually be ascertained by visual inspection of the resistor while it is in the receiver. There are certain other resistors which may become grounded within

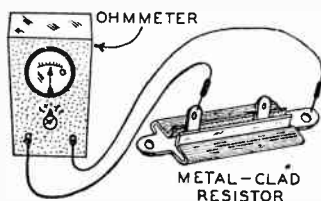

FIG. 22-3.—How a metal-clad resistor should be tested for possible grounds between the resistor element and the metal shield. The test is made between the shield mounting lug and one terminal of the resistor.

themselves. These units are usually encased in a metal shield which is grounded to the chassis. Any short-circuit between the resistance element and the shield will, of course, ground the resistor.

This condition may be determined by removing the unit from the chassis and testing between shield and each terminal, in turn, with an ohmmeter. A continuity indication on the ohmmeter indicates a grounded resistor. If it reads "zero ohms" when the test prods are connected between the shield and one terminal, then that terminal or the resistance wire near that terminal is touching the shield; if the ohmmeter reads some

definite resistance, then the resistance element is touching the shield somewhere along its length. The ohmmeter connections and reading for this condition should be as shown in Fig. 22-3. An "infinite resistance" reading (open-circuit) indicates that no ground exists between the resistance element and the metal shield.

For emergency purposes, either the earphone, lamp test, or voltmeter test may be used for determining whether a ground

FIG. 22-4.—A calibrated "resistor indicator" which may be used for determining resistance values, and for miscellaneous other uses.



Courtesy International Resistance Co.

exists in a resistor, as described in Art. 22-15 for short-circuits and in Art. 22-16 for partial short circuits. These sections should be read carefully, so that the limitations of tests made with these emergency set-ups will be understood clearly.

22-18. Resistor Indicator.—A rather novel little device which finds many uses in the daily work of the radio service man is illustrated in Fig. 22-4. Essentially, it consists of a wire-wound resistor. A slider moving over the resistance element enables any part of the total resistance to be selected. In other words, it is a large potentiometer—and it is calibrated directly in ohms by the manufacturer. The "ohms" scale may be seen in the illustration, along the top of the enclosing case. Two ranges of resistance are available, 100 to 10,000 ohms and 10,000 to 100,000 ohms. The resistance element is protected from accidental overloads and consequent burn-outs by a small fuse which may be seen mounted at the right end.

Although this "resistor indicator" has many useful applications where a calibrated adjustable resistor is necessary, there is one that is particularly important. The service man is called upon to service many receivers in which the resistors are not color coded at all, or are color coded according to some individual manufacturer's system instead of to the standard-RMA code (see *RMA Color Codes* in the author's *Radio Trouble-*

Shooter's Handbook). Furthermore, a circuit diagram of such a receiver, with all resistor values marked on it, may not be available. If a resistor in such a receiver becomes open, or shorted, etc., the service man has no simple way of finding out what size replacement resistor should be substituted for the faulty one, for he is unable to measure its correct resistance. The correct value of replacement resistor can be determined quickly, however, by disconnecting the faulty resistor from the circuit and inserting this "resistor indicator" in its place. The receiver is then turned on, and the value of the resistor indicator is varied until the voltage drop across the indicator is the same as that which should exist across a good resistor of proper value normally connected in the circuit. From the position of the arm, the value of resistance that should be used may be read directly. If a replacement resistor of the correct value is not at hand, this resistor indicator may even be used to permit temporary use of the receiver until the proper resistor can be obtained.

22-19. Common Troubles in Air-Core Coils.—Two main types of coils are used in radio receivers: those wound on iron cores (such as the windings of power and audio transformers, filter and audio chokes, dynamic speaker fields, iron-core i-f transformers, etc.), and those coils which have an air core (such as r-f and most i-f coils, and r-f chokes). It is possible for the windings of any of these units to become open-circuited, short-circuited, partially shorted, or grounded.

Any of the continuity-testing devices already described may be used to test coils, as the fault (if any) is most often caused by either short-circuited or open-circuited windings. However, in the case of partial shorts, it is necessary to use a good ohmmeter or other test instrument capable of measuring resistance values accurately to at least $\frac{1}{2}$ ohm.

The reader may wonder how it is possible to tell whether a coil is partially shorted unless the full, normal resistance is known. In most receivers there is usually another coil which is similar to the one suspected, and the d-c resistance of one of these may be compared with the resistance of the suspected one. For example, a receiver may have two to four r-f stages, neces-

sitating, in most cases, the use of from three to five r-f coils. In superheterodynes, there are usually one to three i-f stages, necessitating the use of from two to four i-f transformers. Generally, these coils are wound alike and therefore have equivalent characteristics, so their d-c resistance values are comparable.

A partial short-circuit is most often encountered in coils which have more than one layer of turns. The partial short-circuit occurs when one or more turns of one layer short-circuit to one

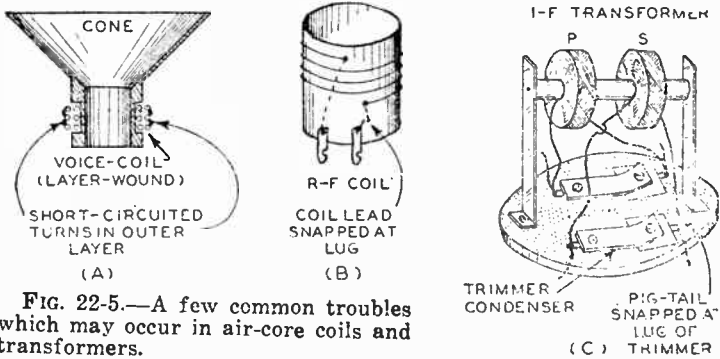

FIG. 22-5.—A few common troubles which may occur in air-core coils and transformers.

or more turns of an adjoining layer due to breakdown of the insulation between them. In the case of a dynamic speaker voice coil, the constant, rapid movement of the cone often loosens the coil winding. If the loosened wire rubs against the pole pieces, the enamel or cotton insulation on the top layer of wire will be worn away. This results in the short-circuiting of almost the entire layer, as shown at (A) of Fig. 22-5.

The short-circuiting of a single layer is usually of major consequence in dynamic speaker voice coils, since the entire winding consists only of two, three, or possibly four, layers. The short-circuiting of a single layer is usually of little consequence in a multi-layer coil winding (such as one winding of an a-f transformer), since the one layer is only a small part of the entire coil. This is also partly true of r-f and some i-f transformers, for when the coils are tuned the partial short-circuit may usually be compensated for, by an adjustment of the tuning condenser, unless, of course, the tuning condenser associated with the partially shorted coil is part of a "gang" unit. In this case, "in-

dividual" compensation is secured by adjusting the trimmers.

Any of several conditions may cause open-circuits in air-core coils. In r-f coils and chokes, an open-circuit is most frequently caused by a break in a connecting lead directly at the terminal lug, as shown at (B) of Fig. 22-5. Since the coils are wound tightly and are of thin wire, vibration or contraction of the wire due to temperature changes may snap one of the leads.

The most common cause for an open-circuited i-f coil winding can be traced to the pigtail connections used. Here, the fine wire comprising the winding is usually brought out to the lug terminal by means of flexible lengths of insulated stranded wire (pigtails). The break usually occurs at the point of connection, as shown at (C), due to a poorly soldered or corroded joint or excessive trimmer condenser vibration caused by the speaker.

Grounding of the terminals of an air-core coil or transformer is also possible when the coil or transformer is enclosed in a shield. In this instance, however, the ground is generally due to one or more of the terminal lugs or leads shifting its position because of vibration, as shown at (A) of Fig. 22-6, resulting in a short-circuit to the metal shield which is usually at ground

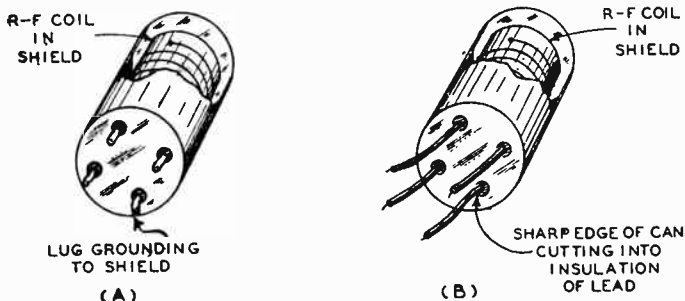

FIG. 22-6.—Two possible ways in which the terminals of a coil or transformer may ground to the metal shield which encloses it. At (A) the coil has metal terminal lugs; at (B) the coil has flexible-lead terminals.

potential. In other cases, the defect may be caused by a sharp edge on the shield piercing the insulation of one of the connecting wires to the coil where the wire passes through the shield, as shown at (B). The presence of such a grounded circuit will usually result in an inoperative receiver, unless the grounded cir-

cuit was also previously at ground potential or slightly above it.

Short-circuits in the coils of radio receivers are not infrequent. This trouble in the case of air-core coils is usually due

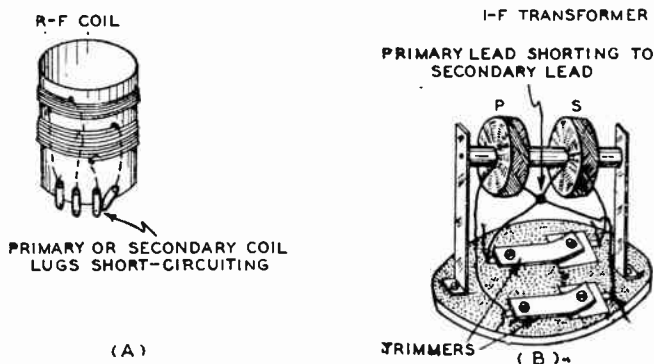

FIG. 22-7.—How short-circuits may occur between the terminals of the same winding, or between separate windings, of air-core coils.

to two or more terminal lugs or leads short-circuiting to one another as shown at (A) of Fig. 22-7, or to a lead of one coil winding short-circuiting to another lead from the same coil, or to one from another coil, as shown at (B). This latter trouble is found most often in i-f transformers. If it is the primary winding of the coil that is short-circuited to itself, it is possible that the receiver will operate weakly, or not at all, but a short-circuited secondary winding will generally result in an inoperative receiver. Should a lead from the primary winding short-circuit to one from the secondary winding, as pictured at (B), the receiver will be inoperative; and if the secondary return is above ground potential, an abnormally high "positive" voltage (the plate voltage of the preceding tube) will be applied to the grid of the tube.

Leakage between coil terminals (caused by absorption of moisture by the coil form) necessitates the baking out and subsequent moisture-proofing of the entire coil.

22-20. Common Troubles in Iron-Core Coils and Transformers.—Coils having iron cores are subject to the same general troubles as are air-core coils: they can open-circuit, short-circuit, become partially short-circuited, and grounded.

The troubles occurring in filter chokes and dynamic speaker field coils may be considered together, since they are quite similar. The most common troubles in these units are open-circuits and grounds. When a ground occurs, it is usually possible to locate the point where the winding is touching the core by inspecting the unit closely—removing the coil from the core if necessary. Additional insulation should be introduced at this point. If this is not possible or to do this is impractical, a new choke or field coil should be used.

In the case of open-circuits, the location of the open point should first be determined by test and inspection. If the open-circuit is due to a broken coil lead, or a faulty terminal joint, the remedy is apparent. If the break lies inside the coil winding, it is usually best to replace the unit. If the coil has actually burned out (as evidenced by a charred condition of the winding) the entire receiver circuit should be checked carefully for a "grounded" or "shorted" positive potential circuit, for a trouble of this kind causes excessive current to flow through the filter choke windings, causing excessive heating, progressive deterioration of the insulation on the windings, and eventual layer-to-layer shorts with consequent breakdown. Naturally, any such trouble must be remedied before a new choke or speaker field winding is installed, for otherwise the new unit will shortly meet with the same fate as the previous one.

In the case of filter chokes, loose laminations often cause excessive hum. This may be remedied by tightening the screws in the core-clamping frame or by first loosening these screws, inserting thin fibre wedges between the loose laminations, and then tightening the screws. It is well to place lock washers under the nuts of these screws to prevent them from being loosened by vibration. It is often necessary to drive (very carefully so as not to damage the windings) small wooden wedges between the coil and the core in order to prevent a winding which is loose, from vibrating on the core. In extreme cases of hum due to vibration, it may be necessary to enclose the complete unit in a metal can and fill up the entire space around the unit with hot pitch or some other impregnating compound.

Audio transformers (including input, intermediate and out-

put types) are usually wound with thin enamel-covered wire (No. 40 or smaller). Heavier flexible pigtail leads are soldered to this small wire at the ends of the windings, and connect them to the transformer terminals. The use of this thin wire and these soldered joints makes these units subject to the following trouble: (a) mechanical fracture of the wire due to expansion and contraction caused by excessive temperature changes; (b) chemical corrosion due to unsuitable enamel coating on the wires, acid soldering flux, human acid from the hands of workers, chemicals exuded from the transformer bobbin or the interleaving paper, acid in the impregnating compound; ;(c) burned-out primary due to the flow of excessive plate current because of some other trouble in the receiver; (d) breakdown of internal insulation due to surge voltages. Let us now analyze these troubles in detail.

When the temperature of the wire of a coil is raised by the flow of current through it (and possibly by heat from other components near it) the coil expands. If the wire is wound tightly and the expansion is too great, the wire will experience increased tension and it will snap. In reality, it is the combination of the expansion and another contributing factor which causes it to go. When the tension on a wire increases, it becomes thinner; and when the diameter of a wire decreases, the safe current-carrying capacity decreases. The result is therefore cumulative, so that a poorly ventilated coil may burn out when carrying much less than rated current because of the cumulative action of the high-temperature, expansion, and decreased current-carrying capacity.

The troubles due to chemical corrosion in the windings are of course entirely at the control of the manufacturers. Improved manufacturing methods have reduced these troubles in the more recent receivers, but they are still common in the older sets. Corroded internal joints are prevalent especially where receivers are located along sea coasts or other places of high humidity. In many cases, intermittent contact occurs at the joints before final failure results, making the receiver extremely noisy. Of course, the transformer should be replaced if any of these troubles occur

In the case of a burned-out primary winding in an audio

transformer, a thorough check should be made of the circuits of the tube preceding the transformer before a new one is installed, for some trouble in these circuits may result in the flow of excessive current through the primary winding of the a-f transformer, leading to its eventual burn-out. Among such possibilities may be mentioned, shorting of the plate to some other element in the tube preceding the transformer, grounding of the "plate end" of the plate circuit, shorting of the grid-bias resistor by-pass condenser, an open circuit in the control-grid circuit, etc. All of these troubles will result in excessive current flow through the primary winding of the a-f transformer which follows, and possibly cause it to burn out eventually.

Breakdown of the internal insulation in an a-f transformer can occur in several ways. An a-f transformer coil with many turns of fine wire usually has a high resistance, and, when the current through the coil is comparatively high, a high difference of potential exists between the terminals of the coil, between layers, and between layers and the core (which is usually grounded). This means that if the insulation between layers of a coil is poor at one spot, the potential difference between that point and a corresponding point on an adjacent layer may become high enough to cause a spark or arc to jump between layers. This raises the temperature of the points between which the sparking or arcing takes place, and the intensity of the spark or arc increases. This, in turn, raises the temperature still further, until eventually the temperature becomes so high that the thin wire burns out.

The insulating paper used between layers must be perfectly dry throughout, and the insulation on the wire must be uniform throughout. One weak spot is usually sufficient to cause the cumulative action just described to take place.

Sudden surges of current may also cause a-f transformer and other iron-cored coils to burn out. When the current flowing through a coil varies in any way, a voltage is generated in that coil (by self-induction); and, if the current changes are rapid, the voltage generated becomes high. Thus, if a tube which has the primary of an audio transformer connected in its plate circuit is pulled out and pushed into its socket frequently, the sudden

interruptions of the plate current may generate an excessively high voltage in the primary winding and so cause a breakdown of the insulation between layers. The primary, of course, then open-circuits. This is especially important in the case of power tubes which draw rather large plate currents. They should never be removed from their sockets unless the receiver is turned off.

The breaking down of the insulation between the winding

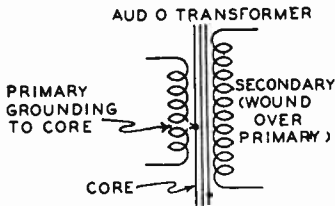
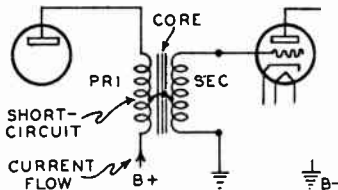

FIG. 22-8.—How breakdown may occur between the inner winding and the core of an a-f transformer. The fine wire usually burns away at the point of breakdown, resulting in an open-circuit in the winding.

and the core of an audio transformer is illustrated in Fig. 22-8, but it should be remembered that the breakdown may occur through several layers to the core, not necessarily between the core and the layer adjacent to it.

Parts of a-f transformer windings may short-circuit together.

FIG. 22-9.—How the *B*-voltage sends an excessive current through part of the primary and secondary coils of an a-f transformer whose primary has grounded to the secondary.



The short-circuit is almost invariably caused by excessive current or operating temperature, for the reasons discussed in the preceding few paragraphs.

Short-circuits between the primary and secondary of audio transformers are rarely detected by tests, inasmuch as such short-circuits usually place the *B* voltage across part of the primary and secondary in series, as shown in Fig. 22-9. This high voltage is usually great enough to send sufficient current through the wires to burn them out at the point of contact before the actual primary-secondary short-circuit is detected.

Power transformers are subject to three main troubles: open, shorted, and grounded windings.† These transformers usually contain a primary winding which may or may not have taps, a high-voltage secondary winding with a center tap, and a number of low-voltage filament windings. Due to the multiplicity of windings these transformers should be tested preferably when entirely disconnected from the receiver—if this is feasible. The primary winding often grounds to the core or the static shield* (if one is used). The usual power transformer is constructed with the primary wound directly over the core, the static shield (if one is employed) surrounds the primary winding, the high-voltage secondary is wound over the static shield, and the low-voltage filament windings are wound over the high-voltage winding. The various windings are insulated from each other and from the core and static shield. However, some fault may develop, and cause a “ground” between the primary and either the core or static shield, between the high-voltage secondary and the static shield, or the filament winding next to it, etc.

One point to remember here is that in some power transformers the center-tap of the high-voltage winding is connected to the core or the static shield, so that the midpoint of this winding is always at ground potential. Naturally, in this case, an ohmmeter test between each end (or the center-tap) of this winding and the static shield (or core) will reveal a closed circuit. In such cases it is best to make a check by measuring the a-c voltage existing across each half of the winding when the transformer is loaded normally. If normal voltage readings are obtained across both halves, it indicates that the center tap is purposely grounded to the core or to the static shield.

22-21. Testing Coils and Transformers for Open-Circuits.—Any continuity-testing instrument or arrangement may be used for testing coils for open-circuits (see Art. 22-14) regard-

*Note: See pages 1100 and 1101 and Fig. 30-22.

†Note: A disturbing hum caused by excessive vibration of the laminations of power transformers may be eliminated by the same remedies explained for filter chokes (Art. 22-20).

When a power transformer has failed, the filter condensers should be checked. Wet electrolytic condensers will often test O.K. when cold, but when voltage is applied, the defective one will heat up and place an abnormal load on the transformer. Observe a set carefully for the first 15 minutes after installing a new power transformer, to see whether or not the filter condensers are heating. This precaution will prevent a possible second transformer failure.

less of whether the coil is of the air- or iron-core type, provided that the instrument is such that it would indicate properly if the coil were not open. For instance, either of the incandescent lamp arrangements of (B) or (C) of Fig. 22-2 would not be satisfactory for testing the windings of audio transformers for open-circuits, for, even if the windings were in perfect condition, the lamp would not light because the resistance of the windings is so high that the current flowing through the circuit would not

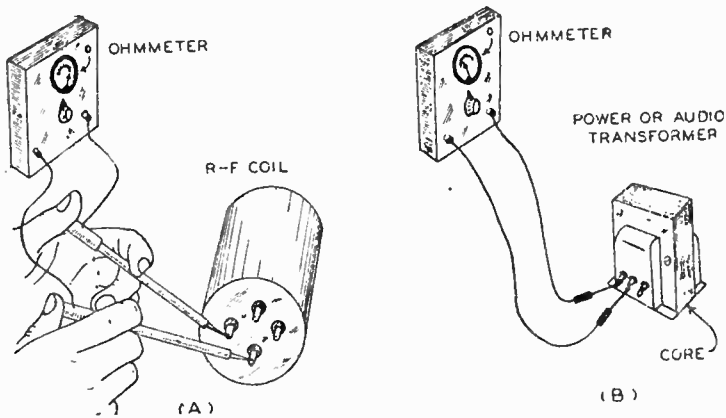

FIG. 22-10.—How an ohmmeter is used to test coil windings for continuity.

(A) The ohmmeter is here shown connected to the two terminals of one winding of an r-f transformer to test its continuity.

(B) Here the ohmmeter is connected to the two terminals of a winding on a power or audio transformer to test its continuity.

be sufficient to light up the lamp. If a neon tube is used instead of an incandescent lamp, this trouble does not occur, since the neon tube will light up and indicate continuity even though only a small current flows through it. A voltmeter can also be used satisfactorily for this test. However, the ohmmeter is undoubtedly the best instrument for this test for the service man. The procedure is simply to disconnect both ends of the transformer coil from the receiver circuit, and connect the test prods of the ohmmeter to these coil terminals. If the ohmmeter reads *infinite* resistance, the coil is *open-circuited*; if the ohmmeter reads some

other value, then that value must be compared to the normal resistance which that winding should have. Figure 22-10 shows how the test prods of the ohmmeter should be applied to the lug terminals of one coil of an r-f or a-f transformer to check the continuity of the winding.

An emergency check of the continuity by means of a pair of earphones and a battery (see (A) of Fig. 22-2), requires special consideration when it is applied to iron-cored coils. If the winding of such a coil happens to be broken near its center, there may be considerable capacity between the two parts of the winding, and the earphones will reproduce a click every time the circuit is made and broken, as the capacity between the two sections charges and discharges. For this reason, the earphone emergency test is not to be relied upon for making open-circuit tests of large coils. On the other hand, it is thoroughly reliable for r-f or i-f transformers because the coils are relatively small and the capacity existing in the circuit is negligible.

22-22. Testing Coils and Transformers for Complete and Partial Short-Circuits.—The test for complete short-circuits involves disconnection of the coil or transformer from the receiver circuit and the application of the ohmmeter test prods to the terminals of the winding to be tested. If the ohmmeter reads zero resistance, then the coil is short-circuited; if it reads some other value, then the reading must be compared to the normal resistance value of the winding. The procedure here, it is seen, is the same as that for testing resistors for complete short circuits, and the reader is referred to Art. 22-15 for further details.

If the coil is not completely short-circuited, then the ohmmeter will indicate some definite coil resistance. It is essential that this resistance be compared with the known resistance of the winding measured. Receiver service notes which have been published recently (within the past several years) have marked on them the resistance of every winding of every coil in the receiver (see Fig. 21-12). Such a diagram must be on hand if the service man is to determine whether or not the ohmmeter reading is correct for the coil under test.

If the reading is normal, then the coil may be assumed to be

normal; if the ohmmeter reading is lower than normal, then the coil is partially short-circuited, and should be investigated further; if the reading is much higher than normal, then there is a poor connection somewhere in the coil circuit. An examination of the terminal lugs and the wires connected to the lugs should then be made.

It should be noted here that the low-voltage filament windings of power transformers contain comparatively few turns of wire of fairly large cross-section, so their resistance is very low compared to the resistance of the primary winding or the high-voltage secondary.

R-f coils are wound, at the present time, to within an accuracy of a fraction of 1 per cent, so that the ohmmeter reading in ohms should check very closely with the rated resistance of the coil if the ohmmeter calibration is correct. The resistance of the windings of audio transformers, filter chokes and power transformers, on the other hand, may vary within 10 and sometimes 20%, so that a maximum deviation of 20% from the rated value should be expected in low-cost products. If the measured resistance deviates from the rated value by more than 20%, then the coil should be examined carefully for defects.

A check may be made in instances where there is more than one choke or transformer of a given type in the receiver. For example, there may be two r-f coil secondaries and primaries alike, two or three i-f transformers alike, and two filter chokes alike. The resistance of one may be compared to the other (or others) and again compared to that of the coil under suspicion.

A very important point concerning audio transformer windings should be mentioned here. Even the readings of an ohmmeter cannot be relied upon when making tests for partial short-circuits in these units. This is true because these windings contain thousands of turns of wire, so that as many as 10 to 25 or more turns can short together without noticeably changing the resistance of the winding, i.e., the change would really be less than is allowable for manufacturing tolerance. The best procedure to follow where a partial short is suspected in an a-f transformer winding is to substitute a similar new transformer for it and then to compare the results obtained with it.

The emergency tests described in Art. 22-14 cannot be relied upon for the determination of partial short-circuits; they are only suitable for determining whether or not a circuit is completely open or closed, and then the measurements are limited, as already explained.

22-23. Testing Coils and Transformers for Grounds.—The test for grounds is similar to the tests for open- and short-circuits described previously. The only change in the procedure is that one test prod must be placed on the shield or case of the coil or transformer, and the other test prod on one terminal of the winding under suspicion; it is wise to test from ground to the other terminal as well.

If the ohmmeter reads *zero* ohms when the test is made, then the winding is grounded to the core; if the ohmmeter indicates *infinite* resistance, then the winding is not grounded to the core; if it reads some definite value between zero and infinity, then the winding is grounded to the core somewhere between the terminals of the coil, or there is a high-resistance leakage path between the winding and the core. In connection with the testing of power transformer windings to the core or the static shield the reader should refer to the last portion of Art. 22-20.

The emergency tests described in Art. 22-14 may be used for the determination of grounded windings, but they are subject to the same limitations as explained in Arts. 22-14 and 22-15.

In all of these tests it must be remembered that it is because of the resistance of the windings that the tests are possible. In this connection the coil or circuit between coil and ground, or the leakage circuit between one winding and another may be considered as a simple resistance, with the ohmmeter, earphones or lamp indicating either visually or aurally the resistance of the path. To fully appreciate the limitations of the tests discussed in this chapter and the precautions to be observed when making them, the reader should understand thoroughly the material in Chapters II and III, that describes in detail the various methods of measuring resistance.

22-24. Miscellaneous Coil and Transformer Troubles.—Aside from open-circuits, short-circuits and grounds, coils are subject to other troubles. The forms on which r-f coils

are wound may absorb moisture, causing leakage and decreased inductance, even though the d-c resistance of the coil remains about the same.* The turns of wire may slip along the form, causing a change in inductance while the d-c resistance remains the same. Short-wave tuning coils are composed of relatively few turns, as low as three in some cases, and these turns are spaced a distance of two or three wire diameters. A slight change in the location of one (or part of) one turn may change the inductance appreciably.

The short-wave tuning coils in an all-wave receiver cannot be checked for partial short-circuits because their d-c resistance is so low that few, if any, ohmmeters generally used by service men can check their resistance with any degree of accuracy. It is necessary, therefore, to make a careful visual examination for possible partial short-circuits in such coils, rather than rely upon an ohmmeter or similar test.

Iron-core coils are often enclosed in metal containers with the space between the coil (or transformer) and the container filled with some tar-like substance for protection. It is important that this compound be free of moisture if the coil is to be free from grounds and short-circuits. This means that if the compound is removed for any reason, it should be kept in a dry place until it is returned to the unit.

22-25. Types of Condensers in Radio Receivers.—There are two main types of filter and by-pass condensers generally employed in radio receivers; the solid dielectric paper or mica type and the electrolytic type. Both types are subject to the same failures; they may become open-circuited, short-circuited or leaky. In general, any method which will indicate an open-circuit or a short-circuit may be used in testing either type condenser if the proper precautions are observed, but, because of the differences in dielectric, the same test for leakage cannot be employed.

In Chapter VI the different instruments which may be employed for testing and measuring the capacities and leakage of condensers were discussed in detail. In this section of the

*NOTE: The coil form must be dried out by baking, and then moisture-proofed.

present chapter some practical aspects of the various tests which can be made with these instruments will be discussed.

Before the capacity of a condenser is measured by any device, it is advisable to test it to determine if it is leaky, short-circuited, or open-circuited. A leaky condenser is equivalent to a perfect one having a resistance shunted across it, a short-circuited condenser is equivalent to a condenser of infinite capacity as far as a-c currents are concerned, and is valueless as far as blocking d-c currents is concerned, and an open-circuited condenser is equivalent to having no condenser in the circuit at all. Before discussing the details of condenser testing, we will discuss the common troubles in condensers.

22-26. Common Troubles in Solid-Dielectric Condensers.—Solid dielectric condensers may be either normal, open-circuited, short-circuited, or grounded to the case which encloses

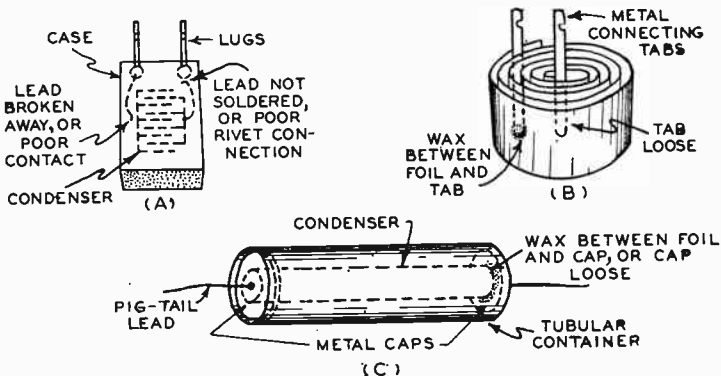

FIG. 22-11.—Various ways in which open-circuits may occur in filter and by-pass condensers of three different types of construction.

them. When such a condenser is open-circuited, it is usually caused by one or both of the leads from the condenser plates not touching, or being insecurely connected to, the terminal lug, as shown in Fig. 22-11 at (A).

Heat applied to a terminal lug may melt the solder holding the lead to the condenser, as at (A), and thus cause an open-circuit. For this reason, never keep a soldering iron on a condenser terminal for too long a time. Have the soldering iron sufficiently hot to make it possible to make the joint quickly.

Some condensers have their connecting leads riveted or soldered to lug terminals which loosen or corrode in time, thereby resulting in an open-circuit, as illustrated at (A). In many condensers poor contact is caused by the connecting tabs which depend solely upon pressure for their contact. Some have metal tabs inserted into the condensers, as shown at (B), while others, usually (those of the tubular non-inductive type) have metal caps pressed against the tin-foil ends of the condensers, as shown at (C). The vibration and temperature normally encountered in a radio receiver may shift the metal contacts or cause the impregnating compound or wax from the paper dielectric to be forced between the metal contacts and the condenser plates, thus producing an open-circuit.

When a condenser short-circuits, it is because the dielectric breaks down or the plates or electrodes actually make contact with one another. A sudden surge of current or the application of an excessive voltage beyond that for which the condenser is rated, may puncture the dielectric at some point, causing the plates to short-circuit.

High temperature may also cause the dielectric of a condenser to puncture. For every material used as a dielectric there is a certain temperature at which the dielectric breaks down and becomes conductive. When the dielectric becomes conductive, the condenser becomes leaky or short-circuited, depending upon the conductance of the dielectric. Breakdown may be caused by the application of excessive voltage to the plates. Every insulating material has a *puncture voltage*, a voltage at which the material breaks down and conducts; this puncture voltage is not constant, but depends to an appreciable extent upon the temperature, becoming less as the temperature increases.

Suppose, for example, a paper dielectric condenser is rated at 200 volts, and 400 volts is applied. At the temperature of the dielectric, it may puncture i.e., a hole may be burned through it and a small spark may jump between the plates. This spark raises the temperature of the dielectric at the point of puncture, with the result that the puncture voltage becomes less, so that the 400 volts, which is still applied, causes a hotter spark to jump through the dielectric, which raises the local temperature

still further. This action is cumulative, and continues until the condenser is fully short-circuited.

The insulating properties of solid dielectrics depend upon the nature of the substance and the care with which it is treated. Mica is perhaps the best insulator for all-around condenser work, while suitably paraffined paper is next best, at appreciably lower cost. The paper in paper dielectric condensers must be free of all moisture if the condenser is to withstand rated voltage for a long time, as the presence of moisture or air alters the type of dielectric in use. A bit of moisture may break down before the paper dielectric does; this raises the temperature at that point, causing the main dielectric to puncture.

Air-dielectric condensers are self-healing, for once the air has ionized and broken down, its insulating properties may be restored by merely allowing the plates to cool off.

22-27. Testing Solid-Dielectric Condensers.—Solid dielectric condensers should be checked by means of condenser testers of the types described in Chapter VI, if they are available. If such instruments are not at hand, an ohmmeter may be used, but ohmmeter tests on condensers are not always reliable, especially when testing condensers of small capacity, or those having high-resistance leakage.

A condenser may be defined technically as a device that is capable of storing energy in the form of an electrostatic field; more popularly, a condenser may be defined as a device that can hold an electric charge. This means that, when a d-c voltage is applied to a condenser, the condenser charges, and, when the voltage is removed, the charge remains in the condenser if the leakage is zero. If a charged condenser be short-circuited, its voltage will send a "discharge current" through the external circuit, until the potential of both sets of plates reaches a common level.

This fundamental property of a condenser may be used to test it for open-circuit, short-circuit or leakage by means of an ohmmeter. If the terminals of an ohmmeter are placed across those of an uncharged condenser (which is disconnected from all receiver circuits), a charging current will flow into the condenser from the battery in the ohmmeter. This charging cur-

rent (or a part of it) will flow through the coil of the meter used in the ohmmeter, and, if the charging current is large enough, the meter pointer will deflect until the condenser is fully charged, at which time the voltage across the condenser will equal that of the battery in the ohmmeter and the charging current will become zero. At this time, the meter pointer will return to its initial position.

If the ohmmeter pointer kicks over the scale and then down to zero again when the test prods are connected across the terminals of a condenser, the condenser is *good*, and will maintain

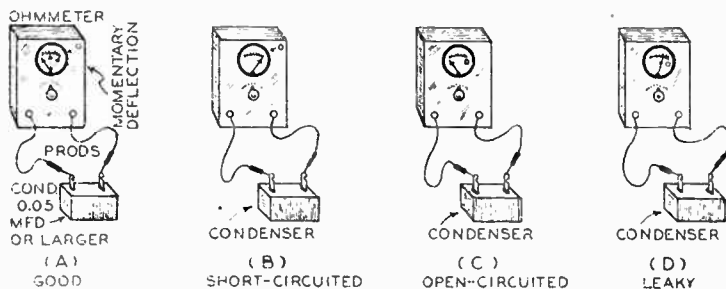

FIG. 22-12.—Sketches showing the four possible pointer indications of an ohmmeter when it is used for testing a condenser having a capacity larger than about 0.05 mfd.

its charge for an appreciable period of time; if the meter pointer kicks over and remains somewhere on the scale, even though the reading of the ohmmeter is less than the full reading of the initial kick, the condenser is *leaky*, and the reading is the leakage resistance of the condenser; if the pointer does not kick at all, and the charging current is large enough, then the condenser is *open-circuited* (see Fig. 22-12).

The value of the charging current that will make the pointer of the average ohmmeter “kick” appreciably depends upon the voltage of the ohmmeter battery, the resistance of the ohmmeter to some extent, the mechanical inertia of the meter pointer and the size of the condenser. Under ordinary conditions, though, the condenser must have a value of at least 0.05 mfd. in order to be tested by this method. Assuming that the condenser is of

this size or larger, the indications on a series type ohmmeter for a good, short-circuited, open-circuited, and leaky condenser are shown in the series of sketches of Fig. 22-12.

The ohmmeter may be used to make an interesting test on large solid-dielectric condensers. When the terminals of the ohm-

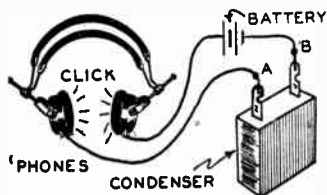

FIG. 22-13.—Earphone test which may be used to test a condenser for open-circuits or short-circuits when no better method is available.

meter are applied to the condenser terminals in the usual manner, the pointer of the ohmmeter will kick and return to its initial position if the condenser is good. Now, if the ohmmeter test prods are again applied to the condenser, the ohmmeter pointer will not kick because the condenser is fully charged; but, if the test prods are reversed and applied to the charged condenser terminals, the pointer of the ohmmeter will kick twice as far as it did on the

initial test. This double kick is caused by the fact that the voltage across the condenser and that across the ohmmeter battery are now connected in series, and the total voltage causing current to flow through the ohmmeter is twice as great as before.

22-28. Emergency Tests on Solid Dielectric Condensers.

—The earphone test may be used to test solid-dielectric condensers for open-circuits and short-circuits, although it is not a very good test for leakage. A pair of phones and a battery of 4.5 volts or more are connected in series with each other, and across the terminals of the condenser to be tested, as shown in Fig. 22-13.

The *first time* the condenser terminals are touched, a click should be heard in the phones if the condenser is not open-circuited; if it is open-circuited, then no click, or a very weak one, will be heard. If the condenser is either normal, or open-circuited, no click will be heard if the wires are touched to the condenser terminals a few times after this. If the condenser is short-circuited, a loud click will be heard *every* time, especially if a battery having a voltage of 45 volts or over is employed. In

this test, the clicks are due to the charge and discharge currents flowing in and out of the condenser under test.

22-29. **A Limitation of the Ohmmeter and Earphone Tests for Condensers.**—It was mentioned in Art. 22-26 that the applied voltage determines whether or not a condenser will puncture. A corollary of this statement is that a condenser should be tested at rated voltage to determine its breakdown possibilities. When the 4.5 volts or so from an ohmmeter or earphone test is applied to a punctured condenser, it may test normal; but, when rated voltage is applied, the condenser may puncture. The ohmmeter test, therefore, must be considered as valid only for the voltage of the ohmmeter battery, not for any higher voltage.

When the size of the condenser is about 0.1 mfd. or greater, and rated voltage is available, then a conclusive test of the condenser may be made. One or more *B*-batteries or a *B* power unit may be connected to the condenser to be tested, as shown in Fig. 22-14 (A) and (B). The voltage should be applied for a few moments and then removed. The terminals of the conden-

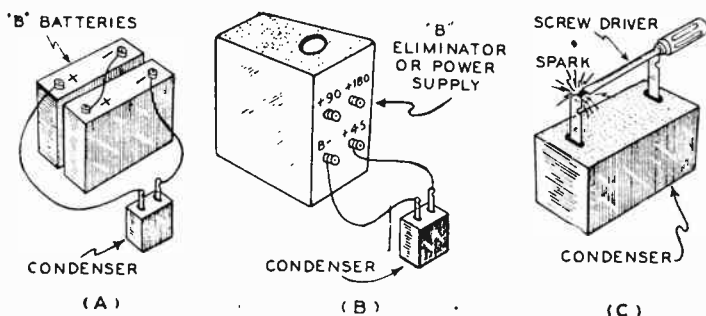

FIG. 22-14.—Testing a large solid-dielectric condenser by means of the charge and discharge method. If the condenser is normal, a spark will be produced on discharge.

ser should then be short-circuited with some handy metallic object, such as a screw driver with an *insulated* handle, as shown at (C), and the intensity of the spark noted. A good condenser will produce a fat spark when being short-circuited; a poor condenser will produce no spark at all.

The length of time between charge and discharge is a measure of the leakage in the condenser. The longer the time be-

tween charge and discharge, the more time there is available for the leakage resistance to absorb the energy in the condenser. A condenser with high leakage (low leakage resistance) will not be able to hold its charge more than a few moments, while a condenser with good dielectric will be able to hold the charge for 10 minutes and up, depending upon the leakage resistance.

A condenser with a very good dielectric may not discharge entirely after the first short-circuit. It may be necessary to short-circuit a condenser two or three times before all the energy stored up has been dissipated in the form of heat in the discharge.

22-30. Testing Solid-Dielectric Condensers With a Neon Lamp.—It is possible to determine if a solid-dielectric condenser is normal, short-circuited, or leaky by connecting it in series with a 2-watt neon lamp and a 110-volt d-c power source, as shown in Fig. 22-15 (or two 45-volt *B* batteries connected in series). Condenser testing with a neon lamp was discussed at length in Art. 6-4, but the simple tester of Fig. 22-15 is effective. The condenser to be tested should first be entirely disconnected from its circuit, for if any resistance or other condenser shunts it, the neon tube will glow even if the condenser under test happens to be open-circuited. If the condenser is not open-circuited, there should be an instantaneous flash in the neon tube at the

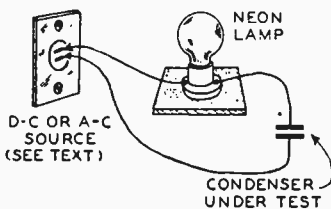

FIG. 22-15.—A simple method for testing solid-dielectric condensers for open-circuits, short-circuits, or leakage, by means of a neon lamp and a 110-volt a-c or d-c voltage source.

instant the wires of the test circuit are touched to the terminals of the condenser. For condensers of low capacity, this flash will be fairly feeble and short. No flash indicates an open condenser.

For condensers having paper or mica dielectric, there should be no glow in the neon lamp after the initial flash. If the neon tube glows steadily or flutters, it indicates that the condenser is leaky and should be replaced. The value of the neon lamp test

lies in its simplicity and sensitivity. A small 2-watt neon lamp of the type sold as "night lites" will glow visibly when a current as small as a fraction of a milliampere flows through it. If it is connected to a d-c circuit, only one of its electrodes glows; when connected to an a-c circuit, both electrodes glow. Hence it also serves as a handy tester to find out whether the current supply in a house is d-c or a-c.

22-31. Checking the Capacity of Solid-Dielectric Condensers.—Chapter VI explained the theory of capacity testers in detail. It will be recalled that the method consisted of applying

FIG. 22-16.—A simple circuit arrangement for checking the capacity of condensers having a mica or paper dielectric.

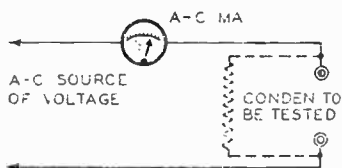

a known voltage of known frequency to the condenser to be tested and measuring the amount of current flow by means of an a-c current-indicating device, as shown in Fig. 22-16.

The current as read by this meter depends upon the value of the applied voltage and the reactance of the condenser at the frequency of the applied voltage. Usually, the resistance of the meter is small compared to the reactance of the condenser and may be neglected in the computation.

The meter current also depends on the amount of leakage current which flows through the condenser. The leakage path is represented by the dotted resistance in Fig. 22-16. This means that the capacity tester will indicate the correct capacity only if the leakage current is small compared to the displacement current through the condenser. The meter readings may then be calibrated in terms of mfd. as explained in Arts. 6-6 to 6-8.

It should be noted that if the condenser is short-circuited, the meter will, in all probability, burn out, so that it is essential that the condenser be tested for short-circuit and leakage *before* connecting it to the capacity tester.

22-32. Testing Solid-Dielectric Condensers for Grounds.

—Many of the fixed condensers employed in radio receivers are enclosed in metal containers which are usually mounted on the chassis. In the event that one of the condenser plates or connecting leads short-circuits to the can internally, a “grounded” condenser results. In order to check for this condition with an ohmmeter, the ohmmeter should be connected from either one of the condenser terminals to the can, as shown at (A) of Fig. 22-17.

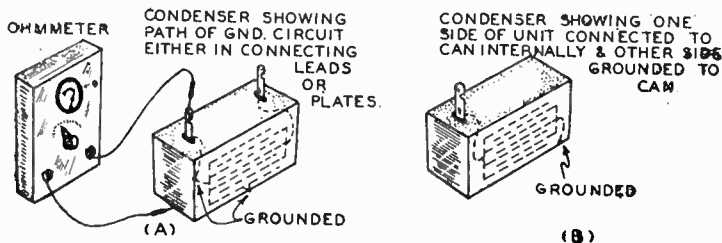

FIG. 22-17.—Testing condensers of the solid-dielectric type for possible grounds to the metal container. Two common causes of internal grounds are illustrated at (A). A condenser designed with one terminal already grounded to the metal container as shown at (B).

In some instances, a condenser may have one terminal already connected to the can internally, as pictured, at (B). Here, if the insulated lead of the condenser should short-circuit to the can, or should the condenser plate connected to this lead short-circuit to the can, not only would a second “ground” exist, but the condenser would be short-circuited as well.

22-33. The Electrolytic Condenser.—The electrolytic condenser is a form of condenser designed for obtaining a high capacity in a small amount of space. The so-called “dry” type, which is now used extensively, consists essentially of two metal electrodes separated by gauze that has been saturated with an electrolyte. Upon connecting such a combination to a source of direct voltage, one plate becomes positive and the other negative. An oxide film only about one atom deep forms on the positive plate, and it is this thin film that forms the dielectric. Since the plates are of aluminum, the oxide is aluminum oxide.

It is because the oxide film is so thin that the capacity of this type of condenser is large per unit area, and any desired capacity may be obtained by rolling up a suitable length of alum-

inum foil into a compact form, as shown in Fig. 22-18. The electrolyte is really the negative side of the condenser; the negative aluminum foil is used merely to make contact with the electrolyte.

This construction has the property of allowing current to pass from the electrolyte (negative plate) through the oxide film to the positive plate, but not from the positive plate through the oxide film to the electrolyte. This means that if the condenser is connected across a d-c source of voltage in the wrong direction, the current flow will be heavy; but when connected correctly, the current flow through the dielectric will be small. The application of an alternating voltage will cause heavy current to flow during one-half of each cycle and no current during the other half cycles. However, the heavy passage of current during the wrong polarity half cycles will ruin the condenser quickly, due to the heat developed, etc. For a more comprehensive discussion of the theory and construction of electrolytic condensers, see the *Radio Physics Course*, by Ghirardi.

These characteristics of electrolytic condensers make it necessary to test them in special ways. While the testing of these condensers by means of condenser testers was explained in Chapter

FIG. 22-18. — Cross-section view showing the internal construction of a "dry" electrolytic condenser. Two sheets of aluminum foil are rolled up with a strip of electrolyte-saturated gauze in between.

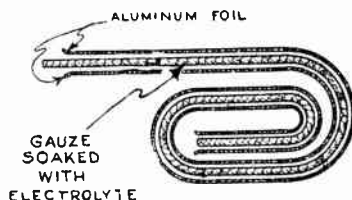

VI, the use of the ohmmeter for testing them will be explained here. The correct interpretation of leakage tests made on them will also be considered.

22-34. Checking Electrolytic Condensers with the Ohmmeter.—Unlike solid dielectric condensers, electrolytic condensers have a certain amount of direct-current leakage, and for this reason will produce some indication upon an ohmmeter, even if the condenser is good. Since electrolytic condensers are

polarized, it is possible to secure an erroneous result when testing for a leaky condition with the ohmmeter, unless the polarity of the ohmmeter is correct. The polarity of the ohmmeter is determined by the polarity of the battery in its circuit. In other words, that side of the ohmmeter circuit which is connected to the negative terminal of the battery is *negative*, and that side which is connected to the positive side of the battery is *positive*. If the terminals of both the ohmmeter and the electrolytic condenser are poled incorrectly, a very low resistance indication will be obtained which is not the normal d-c resistance of the unit, but the resistance of the electrolyte only. To be certain of having the correct polarity, always reverse the ohmmeter leads when testing an electrolytic condenser, and use that reading of the ohmmeter which indicates the *highest* resistance.

22-35. Leakage Tests on Electrolytic Condensers.—The usual method of specifying the “goodness” of an electrolytic condenser is to state the leakage current per microfarad of capacity which flows through the condenser when d-c voltage of approximately the rated value is applied. These leakage currents should not be taken too seriously, as the actual allowable leakage current for a normal condenser depends upon a number of factors, including the age of the condenser, the manufacturer, the rectifier tube used, the design of the power unit, the design of the filter and the load on the power unit. An electrolytic condenser that may have leakage which is considered excessive for one receiver may be perfectly good for a receiver of another design. However, in general, an 8 mfd. electrolytic filter condenser rated at 450 volts should have a maximum leakage current of about 3 to 5 ma. If the leakage current is greater than this value, the filtering usually will be incomplete.

Common manufacturers' acceptance tests for electrolytic condensers will be mentioned here to present some idea of the tolerances involved. A standard 8 mfd., 450-volt working voltage electrolytic condenser is connected in series with a source of d-c voltage equal to the voltage rating of the condenser, a milliammeter of suitable range, and a resistance R of 2,500 to 5,000 ohms shunted by a switch, as shown in Fig. 22-19. The condenser is allowed to charge steadily for five minutes and then

switch S is closed. The milliammeter is then read. An 8 mfd. condenser should have a leakage current of about 1.8 ma. when new. As the condenser ages, the leakage current increases. The figure of 3 to 5 ma. mentioned previously should be considered the maximum allowable value for this leakage.

Leakage tests of small electrolytic by-pass condensers having capacities of less than 1 mfd. are unimportant. Capacity tests are more informative for revealing the effectiveness of these condensers for their job of by-passing. For the service man, any of the capacity testers described in Chapter VI may be used for

FIG. 22-19.—Circuit employed for measuring the leakage current of an electrolytic condenser at normal voltage.

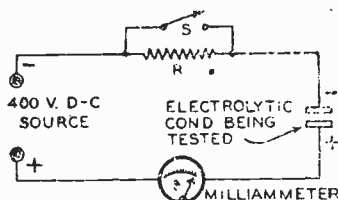

this purpose. It will be recalled that these capacity testers also considered the effect of leakage in the condenser, so that the single test is complete in itself.

Small electrolytic by-pass condensers are usually rated at 25 or 50 volts working voltage. The manufacturer's acceptance test of these condensers requires a set-up similar to that shown in Fig. 22-19, except that the resistance R has a value of about 300 to 400 ohms. The rated voltage (or slightly higher) is applied to the condenser through R for five minutes, then switch S is closed, and the milliammeter is read. For a new condenser to be acceptable, the leakage current flowing through the condenser must be no greater than approximately 0.1 ma. per mfd.

Of course, it is possible to check the condition of an electrolytic condenser quickly without employing the foregoing method. Merely substitute another similar condenser known to be good for the doubtful one, and note the two milliammeter readings. If the current is appreciably higher when the doubtful one is in the circuit, discard it. Another good condenser may also be connected across the one under test, and the increased current reading noted. If both condensers are identical and good, the reading should

about double. Because of the fact that, in most instances, electrolytic condensers are used to filter the hum from a rectified circuit, a 2 or 4 mfd. paper condenser can be substituted for the electrolytic condenser to determine its condition and efficiency by noting its filtering qualities as evidenced by the amount of hum produced by the loud speaker.

22-36. Causes of Breakdown of Electrolytic Condensers.

—Since the dielectric in an electrolytic condenser is very thin—about an atom deep in some cases—more than rated voltage cannot be applied without endangering the life of the condenser. Electrolytic condensers undergo a process known as *forming*, during which the condenser is connected to a source of direct voltage for a period of time: the longer the time of forming, the lower the capacity per unit area and the higher the voltage rating. Thus, for every size and rating of condenser there is an optimum forming time.

If the voltage applied to the condenser in service exceeds its safe working voltage rating, the dielectric breaks down, the film of aluminum oxide disappears, and the condenser conducts current in both directions with equal facility. This means a high leakage current—so high in fact that the condenser is valueless. It is possible in some instances to re-form the condenser, starting with a low voltage, until the film is replaced, although this expedient cannot be relied upon for satisfactory service. It is for this reason that the leakage test previously described is used; leakage affects the ability of the condenser to hold a charge, and high leakage currents mean low charge-holding ability.

These characteristics of electrolytic condensers indicate the reasons why the simple charge and discharge method cannot be used for testing them. The leakage in even a normal electrolytic condenser is so great that the condenser is unable to hold a charge long enough for the test to be completed. Moreover, it is not possible to apply high a-c voltages to this type of condenser, as the reverse current is sure to de-form the anode plate (connected to the positive terminal) and increase the leakage considerably. Any test of an electrolytic condenser must involve the use of unidirectional (d-c) voltage of the rated value for the condenser.

Deterioration, or "drying up," of the electrolyte is another cause for failure of electrolytic condensers. If the unit is subjected continuously to too high a temperature, the leakage increases, thereby causing the leakage current to increase greatly. This increased flow of current through the internal resistance of the condenser produces still more heat, etc. If the unit is operated in this condition very long, this cumulative action causes it to deteriorate and dry out. For this reason, electrolytic condensers should be located at the coolest place on the chassis. Wet electrolytic condensers will very often check O.K. when cold, but when voltage is applied, defective ones will heat up, and place a heavy load on the power transformer.

22-37. Testing Variable Condensers With the Ohmmeter.

—A variable air condenser used for tuning radio circuits may be tested for short-circuits by connecting an ohmmeter to its

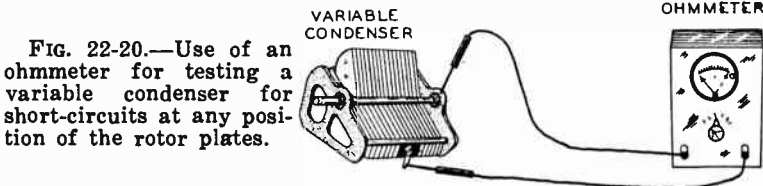

FIG. 22-20.—Use of an ohmmeter for testing a variable condenser for short-circuits at any position of the rotor plates.

terminals, as shown in Fig. 22-20 (after all tuning coils, etc., have been disconnected from it). If the ohmmeter reads zero resistance at any time while the condenser is rotated from zero to maximum, then it is short-circuited at that point; if the ohmmeter indicates infinite resistance throughout the rotation of the rotor of the condenser, then it is good. The "leakage" of an air-dielectric condenser is usually so small that it cannot be measured with the ohmmeter or any of the other tests that have been described here; delicate laboratory apparatus is required.

Short-circuits in variable air condensers are usually due to bent or warped plates or to the accumulation of foreign matter between the plates and to the peeling of their surfaces. The remedy for this condition will be discussed in Art. 26-13. In many instances, small burs which appear on the plates close to the shaft of the condenser cause peeling of the surface of the plates near them if the temperature varies appreciably.

22-38. Testing Grid Bias Cells.—Bias cells are electrochemical units used only for supplying bias potential of approximately 1 volt. Since their current-supplying capacity is less than one *micro-ampere*, their voltage and condition should be checked with a V.T. voltmeter which draws no current—never with an ordinary voltmeter! Another simple method is to connect a milliammeter in the plate circuit of tubes biased by these cells ('6A7 or '6D6, 2 cells; '75, 1 cell; etc.). Measure the plate current with the cells in the circuit; then carefully remove the cells and substitute in their place, a voltage equivalent to the *total* rated cell voltage. If the reading obtained *with* the bias cells is more than about 40% different from that with the other bias voltage source, the bias cells should be replaced.

The commonly used form of "C" bias cell is filled with a thick liquid. When the receiver is in its normal position, the bias cell will be mounted on its side (which is the correct position), so that the liquid comes in contact with the carbon block and the inside of the metal container. However, a receiver is sometimes stood up on its end when a service man is working on it on the service bench. In this position, the bias cell may be in an upright position and the liquid may *not* touch the carbon block. If this happens, it will cause severe distortion if the receiver is being operated. If the foregoing test is being conducted on the cell with the receiver in this position, misleading readings will be obtained of course. Accordingly, the necessary precaution should be observed when working on "C"-bias cell receivers on the service bench.

REVIEW QUESTIONS

1. Describe the construction of typical wire-wound resistors used in radio receivers. State their advantages! Disadvantages!
2. At what points in wire-wound resistors are open-circuits likely to occur? Explain the reasons for your answer.
3. In what way may a wire-wound resistor become grounded within itself? Draw a sketch to illustrate your answer.
4. Describe the construction of typical moulded-carbon type resistors. What are their advantages? Disadvantages?
5. At what points in moulded-carbon type resistors are troubles likely to occur, and what are the causes of these troubles?
6. What type of resistor should you employ in a particular case if it is to dissipate a power of 3 watts? Why?
7. How would you test a resistor for: (a) continuity; (b) short-circuits; (c) grounds, if you had a multi-range ohmmeter at hand?
8. Describe how you would make the tests in Question 7, if your ohmmeter was out of order and you had no other instruments of any kind available.
9. The value of a moulded-carbon type resistor in the voltage-dividing system of a radio receiver is specified as 15,000 ohms. An ohmmeter test shows it to be actually 13,500 ohms when the set is operating. Is the unit defective and should it be replaced? Explain!
10. What is meant by measuring the "cold" resistance of a resistor?
11. When should "cold" or "hot" resistance measurements be made?

12. What is meant by "temperature coefficient of resistance"? Explain! Of what importance is it to the radio service man?
13. What is meant by "voltage coefficient of resistance"? Explain! Of what importance is it to the radio service man? What is its relation to temperature coefficient of resistance?
14. How would you test a 2,000-ohm resistor for continuity, by means of a 150-volt d-c voltmeter and a 110-volt source of d-c voltage?
15. How would you test a resistor for continuity by means of a neon lamp? Explain!
16. What, in your opinion, is a satisfactory way of testing a resistance which you suspect of having an intermittent contact which causes intermittent reception in the receiver?
17. How would you test a 5-megohm resistor for a possible defect? What defect would this most likely be?
18. A resistor is marked *2,000 ohms*. If the tolerance is plus or minus 10 per cent, what might be the actual resistance of this unit if it is normal?
19. The resistor of Question 18 is of moulded-carbon construction. How would increase of temperature affect its resistance?
20. Upon checking a certain resistor in a receiver, you find it to be "open". No resistance value is marked on it, and you have no circuit diagram or service data sheet for the receiver. How would you determine the resistance value and power rating of the replacement resistor which you would use to replace this faulty unit?
21. Draw simple sketches showing the two most frequent causes for open-circuited r-f coils. How would you test for this condition?
22. Would it be satisfactory to test the primary winding of an audio-frequency transformer for continuity by means of an incandescent lamp in series with the electric light circuit? Give reasons for your answer.
23. A radio receiver exhibits all the symptoms usually caused by a partially shorted transformer primary. There is another similar transformer in the receiver. Explain how you would determine whether the first transformer primary is partially shorted.
24. Describe the type of instrument you would use to test a transformer for: (a) opens; (b) shorts; (c) grounds. State your reasons for the choice in each case.
25. If you examined an inoperative receiver and found the top windings on the power transformer charred, explain the steps you would take to ascertain the trouble.
26. How would you eliminate vibration of the laminations of a power transformer?
27. Explain why it is bad practice to remove the power tubes in a radio receiver while it is operating, in order to find out if this produces a "click" in the loudspeaker.
28. A power transformer winding checks O.K. between the two coil leads, but when the ohmmeter is connected across the soldering lugs which connect to them, it indicates that the circuit is open. What would you suspect, as the most likely cause of this trouble? How would you verify your suspicion? How would you eliminate the trouble?
29. A 4-mfd. 450-volt paper type condenser is suspected of breaking

- down under load. Describe a simple method for testing this condenser by the "spark discharge" method. An ohmmeter or capacity tester is available. Suppose a spark is obtained when the condenser is discharged immediately after charging, but no spark is obtained if the condenser is discharged 3 minutes after charging. What would you conclude?
30. Can an electrolytic condenser be tested by the spark discharge method? Explain!
 31. A 2-section 450-volt electrolytic filter condenser having a capacity of 8 mfd. per section and having a common negative terminal is to be tested for leakage. Explain how you would proceed to do this. What total leakage per section would you consider allowable?
 32. What precautions must be observed when testing an electrolytic condenser for leakage with an ohmmeter? Why?
 33. How would you check the condition of an electrolytic filter condenser if no meters or other test instruments were available?
 34. What would happen if a large alternating voltage was applied for testing electrolytic condensers? Explain!
 35. Is it possible to employ an ohmmeter to check the condition of a solid-dielectric type fixed condenser with absolute certainty? Give reasons for your answer.
 36. When a solid-dielectric type condenser is being tested with an ohmmeter and the meter needle kicks up and then down once, what does this indicate? Why does the needle deflect?
 37. A reading of 20,000 ohms is obtained upon an ohmmeter when testing a 2-mfd. paper-type filter condenser. Explain two possible causes for this indication and what effect this condenser might have if it were used in the *B*-filter of a receiver.
 38. Explain how you would test a 1-mfd. paper-type filter condenser with a pair of earphones. How would you test a 0.001-mfd. mica condenser by this method? How would an open circuit be indicated? How would a short-circuit be indicated? How much battery voltage would you use?
 39. A 1-mfd. paper-type filter condenser is tested by means of a neon bulb connected in series with it and the 110-volt electric light circuit. If the condenser is perfect what indication should the neon tube give; (a) at the instant that the circuit is closed; (b) after the circuit is closed—if direct current is used. What indications would be obtained if a-c is used?
 40. What would be the neon tube indications for Question 39 if direct current was used, if: (a) the condenser is "open"; (b) the condenser is "shorted"; (c) the condenser is slightly "leaky"; (d) the condenser is very leaky?

CHAPTER XXIII

OBSCURE RECEIVER TROUBLES NOT REVEALED BY SET ANALYZERS

23-1. **Obscure Troubles in Receivers.**—Possibly the most perplexing troubles encountered in radio service work are those which do not manifest themselves by abnormal currents, voltages, or resistances and hence are not located by the usual current-voltage or resistance-analysis of the receiver. The analyzer readings may all be normal, all the tubes may test within acceptable tolerances—and yet the receiver may operate poorly, intermittently, or not at all. Cases of this kind are most common in superheterodyne receivers, because many troubles and misadjustments may exist even though the tubes, voltages and parts are in normal condition. The hunting down of these obscure troubles often taxes the resourcefulness and ingenuity of the service man and calls forth from him every bit of radio knowledge and experience he possesses. It is the purpose of this chapter to point out some of the causes, and, what is even more important, remedies for common receiver troubles that are not usually revealed by the ordinary voltage, current, or resistance analysis of the receiver.

In Chapter XVIII, some preliminary tests were explained, which may be made to localize the trouble to a particular portion of the receiver. These preliminary tests should be made in all cases. However, for the purposes of radio servicing, the receiver should not be considered as a complete unit, but rather as being composed of a number of main correlated parts. Since each main part of a radio receiver may develop certain individual troubles that are characteristic of that part, it is logical that we should treat and discuss each one of these troubles separately.

One important point should be kept clearly in mind throughout this chapter. For instance, an open-circuited primary wind-

ing or plate impedance, such as the resistance or choke coil of an r-f or i-f transformer, can be revealed by lack of plate voltage in that stage. An open-circuited secondary coil will often manifest itself by zero grid bias and an increase in the plate current of that stage, etc. These causes of trouble will undoubtedly be revealed quickly by the set analyzer and a point-to-point test, so we are not interested in them here. However, other more obscure troubles, which the set analyzer would not reveal, might cause the same symptoms. These are the types of troubles in which we are interested in this chapter. This point will not be mentioned again, but it should be kept clearly in mind throughout the entire chapter. We shall call these "obscure" troubles, since their causes are not readily apparent and they are not easily located.

23-2. Obscure Troubles in R-F and I-F Amplifiers.—The main trouble symptoms which may result from "obscure" troubles in radio-frequency and intermediate-frequency amplifiers are:

1. Lack of sensitivity.
2. Oscillation or regeneration.
3. Station interference.
4. Double-spot tuning.
5. Code interference.
6. Hum.
7. Fading.
8. Intermittent reception.
9. Distortion.
10. Noisy reception.

These will now be considered in detail in the above order.

23-3. Lack of Sensitivity Caused by Coupling Coil or Condenser.—Lack of receiver sensitivity, resulting in weak signals, is often due to some failure in the coupling arrangement employed to transfer energy from one r-f stage to the next. To illustrate this point, let us consider the r-f amplifier stage circuit at (A) of Fig. 23-1. In this case L_1 is a high-impedance plate choke constructed so that its resonance point occurs at some frequency near the low-frequency end of the broadcast band. It may be located some distance from tuning coil L_2 , as the transference of energy does not depend entirely upon inductive

coupling between L_1 and L_2 . The coupling between the plate circuit of one tube and grid circuit of the next is mainly *capacitive*, and is obtained by the capacity action between the grid coil L_2 and the "coupling winding" (which consists of a few turns of wire placed near L_2), or by means of a low-capacity coupling condenser, C_c , as shown at (B) of Fig. 23-1. An open-circuit in the lead connecting the "coupling coil" to the plate of the tube, or an open-circuited coupling condenser C_c , causes the set to be

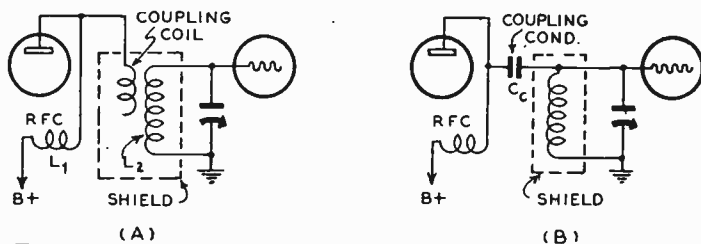

FIG. 23-1.—An open circuit in either the coupling-coil circuit shown in (A), or in the coupling-condenser circuit shown in (B) will cause lack of sensitivity in an r-f or i-f amplifier which employ them. These obscure troubles would not be revealed by the usual voltage-current analysis of the receiver.

insensitive, and weak reception results—or the set fails to operate altogether. If the insulation between the coupling coil and L_2 becomes faulty, leakage (or a short-circuit) will take place between them, resulting in "noise", or even complete inoperation. The faulty insulation should be replaced.

An open circuit in either the coupling coil or coupling condenser cannot be disclosed by a voltage-current test with a set analyzer. A point-to-point resistance check may reveal the open coupling coil. However, these parts may be placed under suspicion by the action of the receiver. A study of their function in the receiver will show why they may cause lack of sensitivity. The primary L_1 is usually a universal-wound coil placed inside and close to one end of the secondary, L_2 . Transfer of energy takes place from L_1 to L_2 inductively, mostly at the low-frequency end of the tuning band only. Near the high-frequency end, the current actually flowing through the coil is small compared to that through the distributed capacity of the coil (it is usually tuned by means of its distributed capacity to about 600 meters in a broadcast receiver), so that the amount of energy transfer is

small. The additional coupling coil is placed as shown at (A) or a small amount of capacity is added, as shown at (B), in order to bring up the high-frequency response. Therefore, if a receiver operates well over the low-frequency end of the scale, but the response falls off *gradually* as it is tuned to a higher and higher frequency, any coupling arrangements such as these should be suspected if they are employed. The receiver response may be tested by feeding a signal of constant strength to it by means of a test oscillator, and measuring the receiver output by means of an output meter while the tuning of both the test oscillator and receiver are varied, in step, over the entire broadcast range.

23-4. Lack of Sensitivity Caused by Mis-alignment.—Lack of normal sensitivity in a t-r-f receiver may also be due to mis-alignment of its tuning circuits. Although the methods

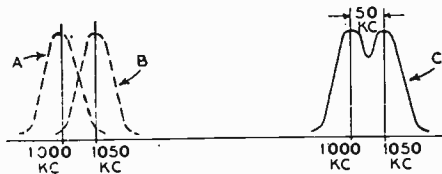

FIG. 23-2. — Resonance curves illustrating how “double-hump” response, C, will occur due to mis-alignment of the tuning circuits whose individual resonance curves are A and B respectively.

used to align tuned circuits of t-r-f receivers will be discussed in detail in Chapter XXIV, it is well to point out here how mis-aligned tuning circuits may be recognized by certain symptoms of the receiver. If the tuned circuits of a t-r-f receiver are not aligned properly, the receiver will be insensitive because all the individual tuned circuits will not be tuned to the same common frequency at all settings of the tuning dial. This results in weak signals and “double-hump” tuning.

The form of double-hump tuning to be described here is not the same as that encountered with superheterodyne receivers, though it may occur in both types. If one tuned circuit is tuned to 1,000 kc and another to, say, 1,050 kc, the combination of the two resonant frequencies will give rise to a type of response not characteristic of t-r-f receivers. Thus, suppose response curve A of Fig. 23-2 is that of circuit No. 1, and curve B that of circuit No. 2. The overall response of the tuning system will be that shown by curve C. If the two peaks are 50 kc apart, then the

tuning system will respond to a range of frequencies at least 50 kc wide. When tuning a t-r-f receiver with mis-aligned circuits, the response will be weak and the tuning broad; furthermore, there will be two distinct points, close together, at which definite resonant peaks can be noted. These points correspond to the individual peaks shown in the figure. If the misalignment of the tuning circuits is caused by the gang tuning condensers, the receiver should be realigned in accordance with the information presented in Chapter XXIV.

A change in coil inductance, caused by the absorption of moisture or the shifting of the turns of wire of which the coils are composed, can also cause misalignment of the tuning circuits, with the resulting broad tuning and insensitiveness. Modern receiver manufacturers take precautions to prevent the absorption of moisture or the slipping of turns, but they often occur nevertheless. In some instances, when the shift in inductance is slight, it may be compensated for by a readjustment of the trimmer condenser, but, when the shift is fairly large, a new coil must be used. Attempts to compensate for appreciable inductance shift by capacity readjustment almost always results in misalignment at frequencies other than the one at which the realignment was made.

23-5. Use of Tuning Wand for Checking Alignment.—

If a gang-tuned receiver has symptoms of broad tuning and abnormally low sensitivity, it is natural to suspect that one or more of its r-f tuning stages are mis-aligned (of course it is assumed that a tube check and analyzer test has revealed no other troubles). Before making any r-f, oscillator, or first-detector adjustments, the accuracy of the existing adjustments should be checked. This can be done quickly without disturbing the adjustment of the trimmer condensers, by means of a simple little tool called a *tuning wand*, provided the receiver construction is such that it is possible to insert a tuning wand through an opening in the shield of the tuning coil (if shields are employed) so that it may be inserted into the coil-form proper. The receiver should be tuned either to the signal from a broadcasting station, or a signal should be fed to it by a test oscillator and its output measured by a suitable output indicator when this is done.

The tuning wand, Fig. 23-3, consists of a bakelite rod having a *brass* cylinder at one end and a special finely-divided *iron* core insert at the other end. Inserting the *brass* cylinder into the center of a tuning coil *lowers* its inductance because of the reaction of the eddy currents induced in the brass. Inserting the *iron* end *increases* its inductance because of the high permeability of the iron. From this it is evident that before adjusting the trimmer condensers on the main gang tuning condenser, the adjustment may be checked by inserting each end of the wand into the coil. If insertion of the brass end *increases* the receiver output, the tuning capacity must be *reduced*. If insertion of the

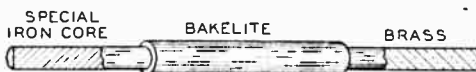

FIG. 23-3.—A “tuning wand” which may be used to determine whether a tuned stage is properly aligned with others in the same amplifier.

iron end *increases* the output, the tuning capacity must be *increased*. From this it is evident that unless the trimmer adjustment for a particular coil is perfect at alignment frequencies, inserting one end of the wand may increase the output of a particular signal. A perfect adjustment is evidenced by a *lowering* of the output when *either end* of the wand is inserted into the coil. In this way each of the tuned stages may be checked for alignment. If the receiver is found to be out of alignment, adjustments should be made, as explained in Chapters XXIV and XXV, to make the receiver output maximum. If it is badly out of alignment, the coils should be examined for short-circuited turns, slipped turns, or discoloration due to the absorption of moisture.

23-6. Lack of Sensitivity in Superheterodyne Receivers.— Insensitivity of superheterodyne receivers may be divided into two general types: that originating in the r-f and oscillator portions of the receiver, and that confined to the i-f amplifier section. Insensitivity is characterized in superheterodynes by weak signals and excessive tube noise, not by broad tuning. As is well known, the i-f amplifier in a superheterodyne is tuned to some fixed frequency, which is always the difference between

the signal frequency and that of the oscillator. If the alignment of the oscillator stage becomes shifted in some way, the oscillator frequency changes, which changes the "difference frequency," or i-f produced. This "difference frequency" will not be the same as the frequency to which the i-f stages are fixed-tuned. Therefore, the amplification produced by the i-f amplifier is greatly reduced. A change in coil inductance caused by the absorption of moisture or shifting of the turns of wire (see Page 605) is often responsible for this mis-alignment of the oscillator stage. Regardless of the degree of selectivity of the r-f amplifier preceding the first detector, the *sharpness of tuning* remains, although other forms of interference may be experienced.

The alignment of the oscillator stage may be checked easily through the use of a calibrated r-f test oscillator producing an unmodulated signal. A small pickup coil (of 5 or 10 turns), which fits over the first-detector tube is employed to couple the test oscillator to the receiver. Before switching on the test oscillator, tune the receiver to the correct, or known, frequency of some broadcast station operating on about 1,100 or 1,200 kilocycles. If the receiver uses a separate oscillator tube, it should be removed. Now adjust the test oscillator to produce a signal frequency which is *higher* than the frequency to which the receiver is tuned by an amount equal to the frequency of the i-f amplifier. In other words, if the receiver is tuned to a 1,200 kc broadcast station, and a 260 kc i-f amplifier is employed in the receiver, then the test oscillator should be adjusted to 1,460 kc. The broadcast station should now be heard if the receiver is in operating condition, since the test oscillator signal will beat with the station carrier to produce the intermediate frequency. It is assumed that the dial calibration of the receiver is correct. Should satisfactory operation be obtained in this manner, and the receiver fail to operate satisfactorily when connected in the normal way, then the oscillator circuit in the receiver is at fault.

Once the oscillator has been adjusted, the r-f circuits may be checked by means of the tuning wand described in Art. 23-5. The alignment of the i-f amplifier, however, cannot be checked unless a test oscillator and an output indicator are available, as will be explained in Art. 25-13 of Chapter XXV.

Poor sensitivity in superheterodyne receivers may also be found to be caused by poor, or "flat," oscillator tubes which

operate at certain frequencies and not at others, although they test satisfactorily in a tube checker. The type '36 tube employed in superheterodyne receivers as a combination first detector and oscillator is a frequent offender of this type and is a source of much annoyance. It may oscillate only over certain frequencies, sometimes at both ends of the broadcast band and sometimes at either the low or high-frequency end. This condition may be remedied by reducing the value of the cathode bias resistor so as to increase the plate current. Usually, however, merely changing the oscillator tube is sufficient.

An excellent manner by which obscure troubles in the r-f stages of superheterodyne receivers may be localized is as follows. Disconnect the oscillator voltage by removing the oscillator tube or short-circuiting the oscillator tuning condenser. Place a pair of headphones in place of the primary of the first i-f transformer and tune the receiver for signals.* The signals should have fair strength because the mixer tube is usually a good detector (except in the pentagrid converter tubes, which are only fair detectors); the r-f-circuits should now be lined up. The oscillator tube should then be placed in operation and the phones connected in the plate circuit of the second detector; the oscillator and r-f circuits may then be adjusted. In this manner, troubles in the r-f end of the receiver may be discovered and corrected, without the complications usually added by the oscillator and i-f amplifier.

23-7. Lack of Sensitivity Caused by Faulty Connections.

—There are several causes of insensitivity common among t-r-f and superheterodyne receivers which are not usually revealed by an ordinary receiver analysis. These causes are usually most difficult to find, and therefore require the most time to locate.

A high-resistance joint in the primary or secondary of tuned circuits will result in low sensitivity. A high-resistance joint is usually caused by faulty soldering, and, though it may have little effect on the voltage readings, may offer considerable resistance to the radio *signals*. The best method of determining whether such a condition exists, is by means of an ohmmeter used

*NOTE: If a crystal detector is connected in series with the ear-phones, the oscillator tube need not be removed. This unit may then be used for checking the signal at any stage of either the r-f or i-f amplifier.

as a point-to-point tester. Difficulties of this nature are also often associated with the fact that reception is obtained over only a part of the tuning range, usually the low-frequency section. To illustrate how obscure a trouble of this kind may be, mention may be made of a case in which a superheterodyne receiver was serviced. The set received stations below 860 kc at low volume, but no reception was obtained at all above 860 kc. The usual set analysis disclosed all operating voltages to be normal and beyond suspicion. However, a careful resistance check brought to light a high-resistance connection between the choke in an r-f plate circuit and the lead connected to the small, double-turn coupling coil placed at one end of the secondary. The resistance of this connection was about 1,000 ohms—enough to impair the sensitivity of the receiver.

High resistance joints cannot always be located by mere visual inspection or ohmmeter tests. The degree of contact, and

FIG. 23-4.—How degenerative effects occur when the by-pass condenser across a grid bias resistor has an open-circuit "X" either externally or internally.

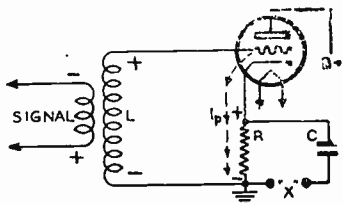

resistance of the joint, may depend upon the temperature of the receiver—the joint may have a high resistance only when the receiver is either "hot" or "cold". More will be said about this later, when discussing intermittent reception. Sometimes, it is necessary to test or resolder almost every connection in the receiver in order to locate the faulty one.

An external or internal open-circuit in a grid-bias by-pass condenser can reduce the sensitivity of a receiver considerably. For example, consider the simple commonly-used "automatic bias" arrangement shown in Fig. 23-4. When a signal is applied to the tuning coil primary, an alternating voltage is induced in the secondary, L . The amplitude of this voltage is less than that of the grid bias. However, this alternating signal voltage causes the potential of the grid of the tube to become alternately more and less negative once every cycle. When the grid becomes *less*

negative due to the signal, the plate current increases, and, since this plate current flows through the resistor R , furnishing the bias, the voltage drop across R would increase if C were not present (or if C had an internal open-circuit) thus tending to cause the grid bias and potential of the grid to become *more negative*. The reverse action takes place when the signal polarity is such as to tend to make the grid *more negative*. It is evident that the polarities of these changes in the bias voltage are such as to buck the signal voltage variations across L . This results in decreased signal voltage variations at the grid of the tube, with consequent loss of sensitivity. *It is the purpose of by-pass condenser C to maintain sufficient electrical charge so that the voltage across R remains constant during the individual cycles of signal voltage.* If C becomes open-circuited, then the voltage across R fluctuates a half cycle out of phase with the signal and results in what is sometimes called *degeneration*.

It is interesting to note at this time that a push-pull amplifier requires no by-pass condenser across its bias resistor, because the plate currents of both tubes are always a half cycle out of phase with each other—one decreases by the same amount and at the same time that the other increases, hence the net fluctuating current through their bias resistor is always zero. Consequently no by-pass condenser is necessary to steady the voltage across it—it is already steady.

23-8. Oscillation in Receivers.—In Chapter XV we described oscillation as the transference of energy from one electrode to another, such as from a plate to a grid. If the transfer of energy is not sufficient to maintain the circulation of energy without external aid, then the tube is said to be *regenerating*. A regenerating receiver is evidenced by extreme sensitivity and instability. High sensitivity is desirable in many cases, but, when it is beyond the point originally set by the designer, tube noises become large, the quality is impaired because of the cutting off of side bands, and the receiver becomes unstable. Instability means that the receiver will not have uniform response over the entire tuning range. Signals nearest the frequency where regeneration is greatest will have more strength than others; the signal strength of stations, especially weak ones, will vary from

time to time; the dial setting for a given station will not be the same at all times; the tuning circuits will not stay aligned, because regeneration changes the effective inductance of the tuned circuits, and the change in inductance is dependent upon the amount of regeneration.

For our purpose, oscillation may be considered as an advanced degree of regeneration, and the causes of both are, in practically all instances, the same. For this reason, we will discuss the causes of oscillation and regeneration as if they were both one and the same thing. For further simplification, the discussion will be divided into two sections, one for r-f and the other for i-f circuits.

23-9. Obscure Causes of Oscillation in R-F Circuits.—

Oscillation in a t-r-f receiver may be recognized instantly by the audio-frequency beat notes set up between the signals tuned in and the oscillations in the receiver. Thus, if a 1,000 kc station is tuned-in, and the receiver is oscillating at a frequency of 1,001 kc, a 1,000-cycle note will be heard in the loud speaker. This 1,000-cycle note will usually overlap the modulation of the original signal so that intelligent interpretation of the original audio modulation is impossible. Oscillation of this form may be verified by turning the tuning dial slowly. As a station is approached, the beat note will decrease in pitch to nearly zero, and then, as the tuning dial is turned further, the note will gradually rise in pitch until it is beyond audibility or the station is tuned out completely.

This test is an important one, for the mere presence of an audible note is not always an indication of an oscillating receiver. If the carrier waves of two powerful transmitters are but 5 kc apart, and each is modulating up to 5,000 cycles, then there will be interference between the two modulations. It is true that the carrier frequencies of local stations are separated by at least 10 kc, but a low-powered local and a high-powered distant station may be separated by only 5 kc, in which case both will be received with audible strength and interference will result. Turning the tuning dial will not produce a changing-pitch beat note here, for now the beat-note frequency is determined by the frequency separation of the two stations, not by the receiver adjustment.

Oscillation originating in a t-r-f receiver may also be detected by placing a finger *lightly* on the control-grid terminal of each of the r-f amplifier tubes. At one of them the beat note will stop, and the audio will come through clearly. This is almost always a certain indication of oscillation in the receiver, and in the stage corresponding to the tube on which the finger was placed.

The removal of the antenna lead will often make a receiver oscillate. The antenna places a certain load on the first r-f stage of a receiver, just as a resistor across the secondary of a transformer places a certain load on that transformer. If the load is too small, the tube will break into oscillation for the following reason: every stage in every receiver has a certain amount of regeneration, regardless of how small it may be. In most instances, the amount of regeneration is not great enough to cause the receiver to oscillate or become unstable. However, we know from our study of oscillator action (Art. 15-7) that when the energy fed back from the plate to the grid circuit is great enough to supply the losses in the grid circuit, oscillations will be sustained. This means that if the antenna system is removed from the input terminals of the receiver, the losses attributed to that stage are reduced, and the tube may generate self-sustained oscillations.

A receiver may oscillate if the aerial to which it is connected is too small. The remedy here, of course, is to make it longer. An excellent test for oscillation due to insufficient aerial length is to tune in a strong local station that can still be received if the aerial is disconnected. This station must also be such that a beat note is produced when it is being received with the aerial connected normally. Now, short-circuit the aerial and ground posts of the receiver and note if the beat note is still produced. If it has disappeared, then the aerial length must be increased.

Another test is to lightly tap the control-grid of the first r-f tube. If oscillations exist, a *distinct* "click" will be heard every time the finger is touched to and is removed from the cap. With the aerial-ground posts short-circuited, the clicking should disappear if the aerial needs lengthening.

23-10. Oscillation Due to Inter-Stage Coupling in Plate Circuits.—Open-circuited by-pass condensers in the plate or

screen-grid circuits are one of the most frequent causes of oscillation in receivers. A typical example of such plate-circuit by-passing is illustrated in Fig. 23-5. By-pass condensers C_1 , C_2 and C_3 by-pass the plate circuits; and chokes L_1 , L_2 and L_3 are in the plate circuits. Suppose C_2 were to open-circuit. The $B+$ Line, carrying all the currents for the plates of the other r-f or i-f tubes, would be at a different r-f or i-f potential than the bottom of the primary P_2 . Now current flows whenever there is a difference of potential, so, if the choke L_2 is not large enough

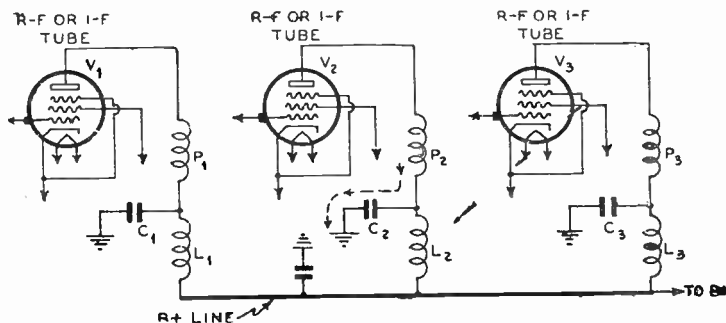

FIG. 23-5.—A typical arrangement for by-passing the plate circuits of a receiver. Chokes are shown inserted in the plate circuits to assist the by-passing action of the by-pass condensers.

to prevent the flow of r-f current, some of the weak r-f current in the $B+$ Line will flow through P_2 . Hence, the plate circuit of V_2 will have r-f or i-f that belongs to some other stage. This circulation of energy between one stage and another gives rise to what is called *inter-stage coupling* (another name for oscillations generated because of the transfer of energy from one stage to another instead of from one electrode of one tube to another electrode of the same tube).

The purpose of the condenser C_2 is to by-pass any r-f in the plate circuit to ground. In other words, the reactance of C_2 must be small enough to pass all the r-f currents through the circuit shown by the arrow. By so by-passing, the potential of the bottom of P_2 is made the same as that of $B+$ Line; hence removing the difference of r-f or i-f potential, which was causing the transfer of energy from this stage to another.

Another way of looking at the problem is to think of C_2 as

having a small enough reactance to by-pass any r-f in the plate circuit of V_2 directly to ground before it gets to the $B+$ Line, and the purpose of the chokes is to assist the by-pass condenser by making the reactance of the path to this $B+$ Line great enough so that the current will flow through the easier path through C_2 to ground instead. In this manner, the $B+$ Line will have little or no r-f or i-f current flowing in it.

If any of the plate circuit chokes become open-circuited, then there will be no plate voltage on that tube in which the open-circuited choke is connected. On the other hand, if the choke becomes short-circuited, there will be plate voltage, but the receiver may oscillate because the reactance of the choke is not present to prevent high-frequency current from staying in the circuit in which it belongs—the reactance of the by-pass condensers may not be low enough to by-pass all the high-frequency currents to ground.

To sum the whole thing up in a general statement, it is good practice to employ proper by-passing and choking in order to keep all high-frequency current within the stage in which it belongs. Anything that prevents this localization of current will tend to cause oscillation. The chokes and by-pass condensers are used for this purpose—they prevent inter-stage coupling, and hence are called de-coupling filters. The chokes may be replaced by resistors with no change in action, with perhaps the added advantage that the impedance from P_2 to the $B+$ Line is independent of frequency; a disadvantage, however, is that the plate voltage is reduced by the voltage drop in the resistor.

23-11. Oscillation Due to Inter-Stage Coupling in Screen-Grid Circuits.—The problems arising in screen-grid circuits are somewhat different. Consider the circuit of Fig. 23-6. The $B+$ voltage is fed to all the screen grids through the voltage-dropping resistor R . Each screen circuit is equipped with a separate by-pass condenser used to pass to ground any r-f or i-f in the screen circuit. It is generally conceded that choking is not needed in screen circuits. If the screen by-pass condensers are of insufficient size or are open-circuited, then it is possible for inter-stage coupling to take place because of the presence of the common voltage-dropping resistor R .

The high-frequency screen currents in the successive tubes of the amplifier are 180 electrical degrees (a half cycle) out of phase with each other, i.e., when the screen current of V_1 is *rising*, that of V_2 is *falling* and that of V_3 is *rising*. This phase shift is due to the reversal of phase in the coupling devices between the tubes. Now suppose that there were no screen by-pass condensers at all, or that they were too small or open-circuited.

An increase in screen current due to V_1 would cause an increase in the voltage drop across R . This would reduce the

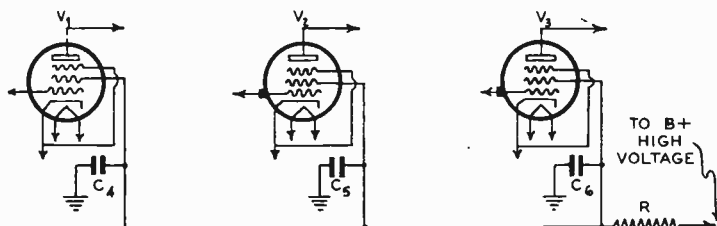

FIG. 23-6.—How several screen-grid circuits which are fed through a common voltage-dropping resistor R must be by-passed by condensers to prevent oscillation due to inter-stage coupling.

screen voltage on V_2 , causing a drop in the screen current of V_2 . But the drop in screen current in V_2 is greater than the increase in screen current in V_1 because the signal voltage on V_2 is greater than that on V_1 by the amplification of the preceding stage. Without considering V_3 , then, the net result is a *decrease* in the current through R , which means increased voltage applied to the screen of V_1 . Increased voltage on the screen of V_1 means more screen current, and more screen current means more voltage drop in R . More voltage drop in R means less voltage on the screen of V_2 , etc.

This process continues to build up, with the result that the fluctuating screen currents reach proportions entirely unwarranted by circuit conditions, and, if these fluctuating currents are not by-passed to ground, oscillation due to inter-stage coupling is sure to result. On the other hand, the phase of the screen current in V_3 is the same as that in V_1 , so that any increase in screen current in V_1 will lower the screen voltage on V_3 . And since the screen current in V_3 is in the process of increasing, in phase with V_1 , the net result is a smaller variation in current

than is warranted by circuit conditions, and inter-stage coupling is minimized.

Of course, the same thing happens if the plate circuits are fed by a common resistor which drops the higher B voltage to the proper value required for the plates of the tubes. In this case, a large condenser, about 4 mfd., must be connected to the plate side of the common resistor. This condenser, having a large capacity, will maintain the voltage applied to the plates constant during high-frequency changes, preventing the cumu-

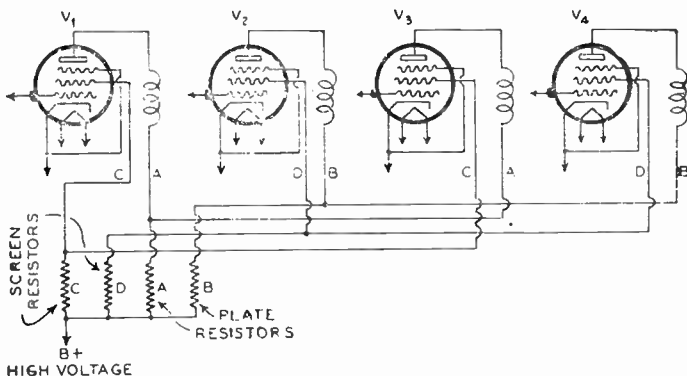

FIG. 23-7.—An amplifier circuit arrangement in which the connecting together of the screen grids and plates of the alternate tubes prevents inter-stage screen- or plate-circuit coupling without the need for by-pass condensers or chokes.

lative action described. The action of each of the by-pass condensers shown in Fig. 23-6 serves the same purpose, so that if one of them becomes open-circuited, there is a possibility of oscillation, or at least regeneration, taking place.

This discussion leads to the interesting fact that since the r-f or i-f current variations in the screen and plate circuits of successive amplifier tubes are a half cycle out of phase, the plate circuits of *alternate tubes* may be connected through a common resistor without by-passing of the resistor or use of plate circuit chokes (as shown in Fig. 23-7) without danger of oscillation. The same is true for the screen-grid circuits, as shown. This circuit arrangement, which is shown here for the "plate" as well as for the "screen" circuits is used in many commercial receivers.

23-12. **Miscellaneous Causes of Oscillation.**—All of the foregoing causes for oscillation in receivers are troubles which may develop in receivers which were once in good operating condition. It was pointed out in detail that open-circuited or leaky by-pass condensers are a common source of this trouble. But there are causes of oscillation other than those originating in the de-coupling filter circuits. Excessive plate or screen voltages will cause oscillation, but they can be detected by the usual voltage analysis of the receiver. Some of the very old t-r-f receivers use fixed resistors of about 1,000 ohms (called *suppressors*) in series with the grid leads of the r-f tubes. A short-circuited resistor of this type will cause oscillation, and cannot be detected by a voltage analysis.

A very frequent cause of oscillation is the formation of high-resistance contacts in the grounding of shield cans and shielded leads. Inter-stage coupling is prevented in practically all modern receivers by shielding each transformer, tube and some of the high-potential leads.* After the receiver is used for awhile, the pressure of the shield cans against the chassis, or some sliding contact ground connection may become poor, thus reducing the shielding effect. This causes oscillation!

When a service man wires in a new r-f or i-f transformer to replace a faulty one, he may alter the positions of some wires sufficiently to cause coupling to take place between the wiring of the receiver. A good rule to remember here is to place all leads differing in high-frequency potential as far apart as possible. Leads differing in d-c potential do not matter, so long as they are properly by-passed to ground.

23-13. **"Image Interference" in Superheterodynes.**—Any of the r-f amplifier troubles outlined in Art. 23-9 may occur in the pre-selector circuits of superheterodynes. However, there are instances where *station interference* troubles in superheterodynes cause them to act exactly as if they were oscillating. The service man must learn to differentiate between this "interference" condition and the condition of "oscillation".

First of all, any signal which is able to "beat" with the re-

*NOTE: In metal-tube receivers, the metal envelopes of the tubes themselves act as the shields.

ceiver oscillator frequency to produce a resultant signal equal to the i-f of the set will be amplified by the i-f amplifier, detected, and amplified further by the a-f amplifier. Let us suppose that the tuning dial of a superheterodyne receiver employing a 450-kc intermediate amplifier is adjusted so the receiver is tuned to an incoming signal having a frequency of 550 kc. Now it must be remembered that most modern superheterodyne receivers are designed so that the oscillator frequency is always

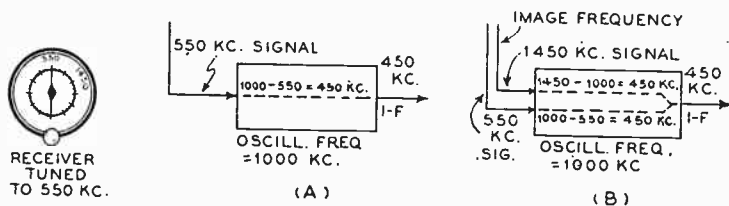

FIG. 23-8.—The receiver is tuned to 550 kc for the reception of a 550-kc station. At (A) the signal of this 550-kc station beats with the 1,000-kc set-oscillator frequency to produce an i-f of 450 kc. At (B) is shown how an “image-frequency” signal of 1,450 kc can also beat with the 1,000-kc oscillator frequency to produce an i-f of 450 kc which will interfere with the first (desired) signal. This is a typical example of “image-frequency” interference.

greater than the signal frequency by an amount equal to the i-f used. Therefore if the receiver is tuned to the 550-kc incoming signal, the oscillator must be operating at 1,000 kc (since $1,000 - 550 = 450$ kc, the i-f). This is illustrated in a simple way at (A) of Fig. 23-8. However, for this setting of the receiver tuning dial there is another signal (shown at (B)) which will also produce an i-f of 450 kc, if it is powerful enough, or able, to get through to the mixer tube. If a signal having a frequency of 1,450 kc (which also lies within the broadcast band) is received by the antenna and gets through to the mixer tube of the receiver, it will also produce an i-f of $1,450 - 1,000 = 450$ kc. Therefore both signals will be heard together, creating a condition of interference.

It is important to notice that the difference between the frequency of the desired signal (550 kc) and that of the oscillator (1,000 kc) is 450 kc, and the difference between the frequency of the interfering signal (1,450 kc) and that of the oscillator (1,000 kc) is also 450 kc, as shown pictorially at (B). Therefore

the *interfering* signal is always one whose frequency is equal to *that of the desired signal plus twice the numerical value of the i-f of the receiver*—for this type of interference, and for receivers in which the oscillator frequency is *higher* than that of the desired station. This is a distinguishing characteristic of this type of interference. In receivers employing an oscillator frequency which is always *lower* than that of the desired signal, the same kind of interference may occur, but in this case the frequency of the interfering signal is equal to the frequency of the desired station *minus* twice the numerical value of the i-f. Of course t-r-f receivers employing short-wave converters are also subject to this form of interference.

The frequency of the interfering signal, which can be received when the receiver dial is set for reception of the desired signal, is called the *image frequency* of the desired signal. This type of interference is called *image interference*.

Further details concerning "image interference" in connection with all-wave receivers will be discussed in Chapter XXVIII.

The reader has probably wondered by this time why no mention has been made of the sharply-tuned circuits or r-f (pre-selector) stages which are incorporated *ahead* of the mixer tube of most superheterodynes so that the interfering image-frequency signals might be prevented from getting through to the mixer tube where they beat with the oscillator signal. Such pre-selector circuits are employed, but, before considering them in detail, we shall point out another trouble which arises in superheterodynes—a trouble which is also minimized by the use of a pre-selector stage ahead of the mixer tube. (The tests and remedies for image-frequency interference will be discussed in Arts. 23-16, 25-9 and 25-21 to 25-23).

23-14. "Double-Spot" Reception in Superheterodynes.—Another trouble peculiar to superheterodyne receivers, one whose fundamental cause lies in image interference, is that of *double-spot reception*, i.e., reception in which the signal of a station can be tuned in at *two points* on the tuning dial.

This trouble has always been a nuisance in old superheterodyne receivers which employ a separate oscillator control, for, in these receivers, several adjustments of the oscillator dial setting will provide heterodyning frequencies which, when mixed with the desired

carrier, will produce the correct i-f beat for the receiver. Since nothing can be done about this condition in these receivers, they will not be considered here. We are interested here simply in modern single-control superheterodynes in which double-spot reception appears.

It is apparent from the discussion regarding image frequency interference (Art. 23-13) that in the particular case considered the 1,450 kc signal will be heard in this particular receiver for *two* settings of the tuning dial—first, at the 550 kc setting (where it appears as an interfering “image frequency”) and again when the receiver is tuned to 1,450 kc (where it appears as the desired signal). This is illustrated in Fig. 23-9. Consequently,

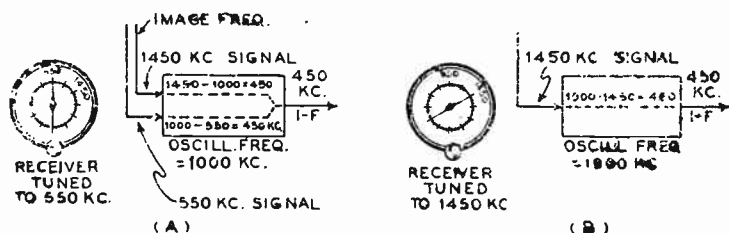

FIG. 23-9.—Double-spot tuning caused by image interference. The 1,450 kc station will be heard both when the receiver dial is set for 550 kc reception (A), and also when it is set for 1,450 kc reception (B), since it beats with the oscillator frequency to produce an i-f of 450 kc in both cases.

due to the image frequency trouble in this receiver, we also have double-spot reception. Of course there are two conditions in which the 1,450 kc signal may appear. If there happened to be a 550 kc station broadcasting at the time, and it was receivable by the receiver, it would appear together with the 1,450 kc signal when the receiver dial was at the 550 kc setting. The result in this case might be squealing, whistling, or the modulation of both stations appearing as “hash” at the loudspeaker. If it so happened that no 550 kc signal were being received, the program of the 1,450 kc station would be heard clearly at both the 550 and 1,450 kc settings of the tuning dial.

It is important to notice here that the double-spot reception points on the tuning dial are always separated by *twice* the numerical value of the i-f employed in the receiver. Obviously, anything that will cure the image-interference condition, will also eliminate the double-spot reception due to this cause. Rem-

edies will be discussed in Arts. 23-16, 25-21 and 25-23.

Beside the foregoing cause for double-spot reception, there are other causes which should be kept in mind. Most oscillators generate harmonic frequencies (see Arts. 15-18 to 15-21), and the oscillators used in superheterodyne receivers are not immune to this condition. Thus, suppose we consider the case of the same superheterodyne receiver discussed in Art. 23-13. It employs a 450 kc i-f amplifier, the tuning dial is set for the reception of a 550 kc station signal, and the local oscillator is of course operating at 1,000 kc. In addition to the 1,000-cycle fundamental frequency, the oscillator may be generating harmonics of 2,000, 3,000, etc., kc. Now it is possible for a strong broadcast signal of the proper frequency to beat with a sufficiently strong harmonic of the oscillator and produce a beat equal to the i-f used. In our case, signals from a 550 kc and a 1,450 kc station might both beat with the 1,000 kc signal of the oscillator, and the signals from a 2,450 kc station and a 1,550 kc station might both beat with the 2,000-kc second harmonic of our 1,000-kc oscillator—all to produce a 450-kc beat. The signal circuit, however, is tuned to 550 kc. Therefore under this condition, four stations might be received simultaneously when the receiver dial is set for 550 kc reception, and repeat-tuning could also occur. It is again obvious that it is important to have efficient tuned (pre-selector) circuits ahead of the mixer tube to discriminate against such stations. Good shielding, and sharp r-f tuning aid in preventing the signals of these unwanted stations from getting through to the mixer tube.

In the same way, harmonics of broadcast stations may beat with the fundamental or harmonics of the set oscillator to produce the necessary i-f beat for reception. While this is somewhat uncommon in the broadcast band, it is a very common occurrence on the short-wave bands.

23-15. Band-Pass and Rejector Pre-Selector Circuits for Image Interference and Double-Spot Tuning Elimination.—It is evident that both the image interference and double-spot tuning troubles could be eliminated if *only* the incoming signal which it is desired to receive were allowed to get through to the mixer stage, and the signals of all other stations were blocked

out before they reached this stage. This calls for one or more selective tuning circuits ahead of the mixer stage—*pre-selector* circuits. Some receiver designers provide this selectivity by using one or more t-r-f stages ahead of the mixer; others include some form of band-pass circuit, somewhat as shown in Fig. 23-10. This type of circuit consists, of the antenna coil, L_1 , coupled to a secondary L_2 , which is tuned by a condenser C_2 through a large fixed capacity C_4 . L_2 is then coupled to a second secondary L_3 , which is tuned by condenser C_3 through a fixed

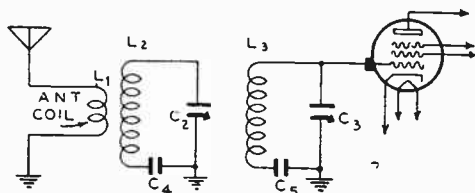

FIG. 23-10. — Band-pass input circuit for increasing the selectivity of the r-f pre-selector of a superheterodyne in order to reduce image-frequency interference and double-spot tuning.

capacity C_5 . The coupling between L_2 and L_3 is such as to pass a band width of approximately 10 kc, the sides of the selectivity curve being very sharp so that interference from stations removed from the resonant frequency of the tuned circuits is small. The disadvantage of this system is that as much as 50% (depending upon the degree of selectivity provided) of the antenna signal voltage is lost—sacrificed for selectivity.

Instead of using a band-pass circuit, which, although it insures against severe interference of any form, results in loss of signal strength, many receivers employ specially tuned “rejector” circuits which are ganged to the main tuning control and are always tuned to the second repeat point. In other words, if this arrangement were used in the receiver discussed in Art. 23-13, the 1,450 kc signal could be received with the normal receiver tuning dial setting, but, when the receiver was tuned to 550 kc, (the marking on the dial at which this 1,450 kc station might be tuned in again) (see Fig. 23-9), the special rejector circuit would cut it out. Several of these circuits are discussed in Arts. 25-21, 25-22 and 25-23.

The action of the rejector circuit may be checked by adjusting rejector circuit trimmer so that “minimum” response

is produced when the receiver is tuned to a "double-spot" point, the receiver being supplied with the proper double-spot frequency signal by a test oscillator. For example, if the i-f of the receiver is 450 kc, a test oscillator is first set to supply a 1,450 kc signal to the receiver, and the rejector circuit trimmer is adjusted for minimum response with the receiver tuned to 550 kc, the double-spot point of the 1,450 kc signal (see Arts. 25-22 and 25-23).

23-16. Eliminating Image Interference and Double-Spot Tuning.—In all service work connected with these troubles in superheterodyne receivers, the following must be kept clearly in mind:

Any signal which beats with the receiver oscillator output to produce a resultant signal whose frequency is equal to that of the i-f amplifier, will be amplified by the receiver, and will be heard if it is strong enough.

The problem lies in keeping the interfering signals from reaching the mixer tube. It is the purpose of the tuned pre-selector circuits ahead of the mixer tube to reject all signals except the one corresponding to the frequency for which the receiver tuning control is set. The possible reasons for failure to block out these interfering signals in modern receivers are:

1. Excessively strong interfering signal.
2. Incorrect adjustment of "image frequency" band-pass or rejector circuit trimmers—or defective circuits.
3. Insufficient selectivity in the pre-selector stages.
4. Incorrect trimmer adjustments on i-f transformers.
5. Incorrect tracking of r-f, oscillator and mixer circuit tuning condensers.
6. Possible coupling between the antenna or ground lead and the mixer or oscillator circuits.
7. Imperfect shielding of the r-f, mixer and oscillator circuits.
8. Excessive control-grid bias on r-f and mixer tubes.

If the interfering signal is excessively strong, it may get through the pre-selector stages with sufficient strength to cause image interference and double-spot tuning even though all adjustments in the receiver are set correctly. In the case where

some one strong interfering local station is troublesome, a fixed or semi-adjustable trap circuit tuned to its frequency may be added to the receiver (see Art. 23-17).

If the selectivity of the pre-selector stages is insufficient due to their design, or because their trimmers are not adjusted properly, the interfering signals will not be blocked out and hence will reach the mixer tube. Interference will result! Likewise, if the i-f transformers are not all "peaked" at the same frequency, interference will result. If the two peaks of poorly adjusted i-f stages differ by, say, 20 kc, it is entirely possible to receive two stations at once, since each transformer responds strongly to a different i-f. Naturally, either of these troubles must be corrected by re-aligning the tuned stages (see Art. 25-18).

Double-spot reception may also occur when the oscillator stage in the receiver is not tracking correctly with the r-f and mixer circuits. The repeat points, in this case, will usually be separated by not more than 50 kc or so, and all that is necessary is to re-align these circuits to secure proper tracking (see Arts. 25-13, 25-14 and 25-16).

If any stray coupling exists between the antenna or ground lead and the mixer or oscillator circuit, interfering signals will get through. Of course, all shielding between the various stages should be well grounded and in perfect condition. High-resistance contacts in the shielding reduces its effectiveness. If a pre-selector circuit is not incorporated in the receiver, it may be possible to reduce or eliminate repeat points by *completely* shielding the receiver so that none other than the desired carrier can pass into the receiver, and that only through the "input" of the receiver. If the bottom of the chassis is not shielded, a grounded metal plate should be installed. Shielding the top of the chassis with another grounded metal plate, so as to shield the variable condenser sections and the control-grid caps of the screen grid tubes, is also of much assistance.

At times, it is an extremely difficult matter to tell whether a superheterodyne receiver is being troubled by "image interference" or by oscillation. The cause of whistles or squeals should be determined first, before attempting a remedy, since the audible effects for the various causes may be very similar. Oscillation

in the r-f or i-f stages gives rise to "birdies," or "squeals," that sound exactly like the beating of two carriers. This results when "image" interference is present. The service man must learn to differentiate between this "interference" condition and the condition of "oscillation," for the causes and the remedies for both are different. One practical test to find out whether a whistling, squealing condition is caused by image interference, or by oscillation, is to disconnect the antenna wire from the receiver while this action is observed, and listen to the program. If it now comes through clearly, the program heard is undoubtedly that of the strong interfering station, and the squeal or whistle heard with the antenna connected to the receiver is due to "interference" and not to "oscillation". A further check can be made by setting the tuning dial quickly to the frequency setting of the interfering station (whose frequency will be equal to the frequency of the desired station plus twice the numerical value of the i-f employed in the receiver). The program heard now should be the same one heard before when the antenna was disconnected from the receiver.

Another test consists of tuning the receiver to different points within its tuning range and listening. If squeals are heard over a certain portion of the tuning range—or over all of it—the receiver is very likely oscillating. If squeals are heard only at one or two points, they may be attributed to some form of interference.

Many commercial receivers employ some form of special double-spot suppression circuit in the pre-selector. This type of circuit and the correct method of adjusting it are explained in Arts. 25-21, 25-22 and 25-23 of Chapter XXV.

23-17. "Code" Interference in Superheterodynes.—A complaint frequently encountered with superheterodyne receivers is that of "code" interference. This type of interference originates principally from Airway and Coast Guard Beacon stations, which operate on frequencies between 260 and 320 kc, and commercial transmitters in the vicinity, all operating in the i-f band of certain receivers. The trouble may appear only at the low-frequency end of the broadcast scale or it may be heard over the entire band, regardless of the tuning-dial setting. In the first

instance, the interference may be reduced or entirely eliminated through the use of a wave trap, tuned to the frequency of the interfering signal, as shown at (A) of Fig. 23-11, inserted in the antenna circuit. Of course, it is imperative that the lead from the wave trap to the receiver be shielded, and the shield grounded. In place of a trap circuit, some receivers already incorporate an *acceptor* circuit composed of an inductance and a semi-fixed condenser connected in series across the antenna and ground circuits, as shown at (B). The acceptor circuit pre-

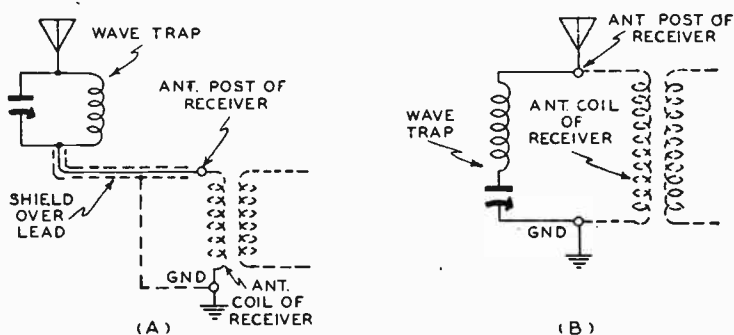

FIG. 23-11.—(A) A wave trap connected in the antenna circuit of a superheterodyne which is troubled by code interference at the low-frequency end of the broadcast scale.

(B) An acceptor circuit which may already be incorporated in a receiver for by-passing the interfering signal (to which it tunes) to ground.

sents a high impedance to all signals except that to which the circuit is tuned, thus by-passing the interference signal to ground. Of course a circuit of this kind may also be added to an existing receiver. Since trouble of this nature is more or less produced by high-powered commercial code stations, operating between ship and shore in the region of 600 meters, shortening and changing the direction of the antenna often aids matters considerably also.

When interference is received over the entire dial, as a background to any and all stations, the shielding of the receiver, especially the i-f amplifier, is probably inadequate. This conclusion is based on the fact that the interference cannot be tuned.

in other words, it is not prominent at any *one* portion of the band, denoting that the interference is being picked up by the i-f amplifier. The interference may be entering the receiver directly through the i-f amplifier, due to inadequate or faulty shielding of the i-f coils and tubes, or through the power line, some of the wires of which are in close proximity to the i-f amplifier wiring in the receiver. In other cases, the trouble may be traced to the lead between the antenna binding post and antenna coil, the wave-band switch, or the volume control, which runs adjacent or parallel to some i-f amplifier wiring. Altering the position of the lead, or replacing it with a length of shielded cable is usually sufficient to eliminate the trouble. On several occasions, though, thorough shielding of some of the i-f amplifier leads is absolutely necessary.

Pickup by the power lines, and consequently by the i-f amplifier leads, is remedied in like manner. Isolate the power line, line switch, and power transformer primary leads from the i-f amplifier by altering their position. The usual line-filter device has been found to be of no help in eliminating code interference.

Direct pickup by the i-f amplifier presents a more difficult situation. It is most important that the coils and tubes as well as the control-grid leads be completely shielded. When it is found that a shielding plate for the bottom of the chassis is lacking, one should be supplied. In many cases, it is necessary to shield the entire top of the chassis with a grounded metal plate, cut to size and shape, to eliminate direct pickup by the i-f amplifier. Most of the more recent superheterodyne receivers employ intermediate frequencies between 450 and 485 kc. This range lies within the transmitting frequencies of commercial code stations. For this reason a wave trap is employed in the antenna circuit, tuned to the frequency of the i-f amplifier, to prevent interfering signals of this frequency from entering the receiver through the antenna circuit. When this provision does not suffice, after it has been definitely ascertained that the wave trap is correctly tuned, an acceptor circuit, (*B*) of Fig. 23-11, should be tried across the antenna and ground, as previously explained. This should be tuned to the specified i-f of the particular receiver, which of course must be known.

In order to determine just which part of the receiver is responsible for code interference reception, the antenna lead may be disconnected from the receiver and the antenna post short-circuited to chassis with a short jumper. This procedure will immediately rule out pickup of code signals by the antenna lead as a possible source of trouble. If it still persists, all shielding in the receiver should be checked. In general, code interference over the entire band is due to direct pickup by the i-f amplifier because of inadequate or faulty shielding. Faulty shielding may be caused by shield cans or housings which have become loose from the chassis or have become corroded at their contact surfaces, etc.

23-18. Causes of Modulation Hum.—Surprising as it may seem, hum currents can be generated in r-f or i-f circuits. The word "hum" as used here does not include low-frequency oscillations or the residual hum left by inadequate power supply unit filters; it means only a hum which is really *the low-frequency modulation*, at the supply-line frequency, of a received signal. This form of hum is present only when a carrier wave is tuned in, and is known as *modulated hum*, *modulation hum*, or *tunable hum*. Modulation hum may be due to several causes:

(1) The a-c leads supplying filament voltage may be too close to amplifier grid wires. This proximity induces a voltage in the grid leads (at the supply frequency). This modulates any carrier wave that is being received. The output may be rectified in the tube itself in many cases and passed on to the following stage—but only when a station is tuned in. With no station, of course, the r-f or i-f transformers cannot efficiently transfer energy of a frequency of 60 cycles when they are designed to transfer high-frequency energy having a frequency of hundreds or thousands of kilocycles.

(2) The varying fields surrounding the filaments or cathodes of tubes may sometimes cause modulation hum due to their control effect on the plate current. The field inside the tube, varying at a rate determined by the supply frequency, is electron-coupled to the signal, and modulates the carrier for exactly the same reason that a superheterodyne oscillator beats against a signal in a pentagrid converter tube. This form of hum must

be eliminated by the designer, not by the service man, but it is mentioned here to acquaint the service man with something that may exist and not be his fault at all.

(3) Inadequate by-passing is another item that can cause modulation hum. If the by-pass condensers are too small, the potential of the terminals to which they connect may fluctuate at the supply-line frequency because of induction, and modulate the carrier of a station being received.

(4) Modulation hum may also be caused by open-circuited line-buffer condensers, leakage between the cathode and heater of indirect-heater type tubes, and an open-circuited power detector cathode by-pass condenser.

(5) Modulation hum may frequently be caused in small Universal a-c—d-c receivers by power lines which carry the signal voltage into the rectifier tube. Here, the signal voltage is modulated with the rectified a-c hum-voltage, and then either re-radiated to the antenna or to other circuits in the receiver. This trouble can usually be remedied by either connecting a 0.05 to 0.25 mfd. condenser *across the power line*, or connecting a 0.001 mfd. to 0.25 mfd. condenser *from one side of the line to ground*. Another remedy is to connect a 0.001 to 0.1 mfd. *mica* condenser *from each rectifier tube plate to the rectifier filament*. When tunable hum is present in receivers which already contain line by-pass condensers, it may be cured by increasing the size of these condensers.

Causes (1), (3), (4) and (5) can be minimized, or eliminated, by the service man. Removal of the a-c leads from the vicinity of the grid leads will reduce modulation hum due to cause (1). Often, nothing but the use of a power transformer having a static shield (see Fig. 30-22 in Chapter XXX) between the primary and secondary windings will cure modulation hum.

In the case of cause (2), present tubes are designed to reduce this trouble greatly. However, in receivers where the heaters or filaments are operated in series, a rearrangement of the heater sequence may reduce the hum. The heaters of the more critical tubes should be nearest the side of the line to which the negative plate supply is connected. Usually the second detector is the most critical, then the mixer (first detector), then the out-

put tube. Their heaters should be arranged in that order with respect to the negative side of the line. The heater of the rectifier should be next to the ballast resistor which is connected to the high side of the line.

In sets employing a voltage-doubler arrangement, the heaters of the most critical tubes should be connected to the side of the line terminating between the condensers of the doubler. Also, if the speaker is used as a filter choke it should be placed in the negative side at the *B* supply to reduce the potential difference between the cathodes and heaters.

In many instances, it is good practice to reduce the antenna length to the minimum size required by the receiver and its location. Too long an antenna system results in too much signal pickup, and too much signal strength in a sensitive receiver may cause certain tubes of the i-f amplifier to detect, resulting in "birdies". A small series condenser in the antenna lead, or shortening of the aerial wire itself, is sufficient to eliminate this in most cases. Modern receivers use variable- μ tubes in the r-f and i-f amplifiers. One of the features of these tubes is that they do not detect (normally). Now, if such a tube is used in an r-f or i-f amplifier, any voltage applied to its grid will not be detected, and hence will not appear rectified in the plate circuit. However, tubes of the same type number may differ as to characteristics, so that, if a modern receiver suffers from modulation hum, it is a good idea to try several new tubes before attempting to look further. Even though each tube tests normal in a tester, because of manufacturing tolerances the shape of the characteristic may be favorable for detection.

23-19. Common Causes and Remedies for Excessive Steady Hum in Receivers.—One common receiver complaint which the radio service man is called upon to rectify, and which is almost always due to obscure troubles, is excessive, steady hum. The cause of this hum is often difficult to trace and locate.

We are interested here only in the presence of excessive, *steady* hum which has developed in a receiver an appreciable time after its purchase and, which is not affected by tuning the receiver. Of course it is assumed that all the tubes in the receiver have been tested and found satisfactory, and that all op-

erating voltages have been checked and found to be correct. The common obscure causes of such hum will now be considered:

(1) Every experienced service man knows that in the majority of cases, excessive hum originates in the power pack and is caused by an open-circuited filter condenser, by one that has lost its effective capacity, by a short-circuited filter choke, or by a combination of these troubles.

Because of their design, filter condensers of the electrolytic type are more susceptible to these troubles than are those of the paper-dielectric type. Drying out of the electrolyte, excessive heat, and momentary voltage overloads caused by the removal of one or both of the power tubes while the receiver is oper-

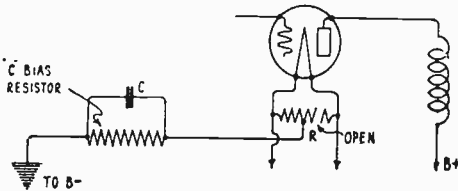

FIG. 23-12.—How a center-tapped filament resistor may become "open" thus upsetting the electrically-neutral condition of the center-tap and causing hum.

ating are some of the reasons why electrolytic condensers lose their effective capacity and produce hum. Of course, the remedy for this is to locate and replace the faulty unit (see Arts. 22-33 to 22-36, and Art. 26-12).

(2) In other cases, a loud hum will result if one side of a center-tapped filament resistor, R , in the circuit (Fig. 23-12) becomes open-circuited. The existence of this open section will not be revealed by the usual voltage-current analysis of the set, for every circuit is still complete and every voltage and current reading will be correct. When such a defect is suspected, it is necessary to test the center-tapped resistor in question with an ohmmeter. The remedy, of course, is to replace the unit with a similar one. Since some receivers use a potentiometer instead of a fixed center-tapped resistor in order to obtain the exact electrical center of the filament secondary, the position of this potentiometer arm may have been disturbed, thus causing the filament secondary to become unbalanced, resulting in hum. These

units are called *hum controls*, and are easily accessible for purposes of adjustment without disturbing the receiver chassis. Of course, they should be adjusted with the receiver turned on but with no station tuned in.

(3) Hum is frequently caused by a faulty tube that may test perfectly in any type of tube checker. Generally these defective tubes are of the indirect-heater type, and the hum is due to poor insulation between the heater and the cathode of the tube, resulting in leakage from the heater to the cathode. The insulation may not be poor enough to show up definitely in the usual cathode-heater leakage test of the tube checker (see Art. 8-20). Insufficient heater-cathode insulation may also cause serious cases of modulation hum which does not respond to the usual remedies. This is more likely to occur in a-c—d-c receivers because of the higher potential between the heater and cathode in most of these receivers. When tubes with this defect are used in audio-frequency or detector stages, the hum will be more pronounced, for it is amplified by the a-f amplifier of the receiver. When a screen-grid tube is employed as a detector, care should be exercised in choosing one, since in many receivers this stage is very critical regarding the generation of hum.

(4) A low-emission or "gassy" rectifier tube is often the cause of excessive hum. This may easily be detected, however, since all plate and grid voltages will be lower than normal. Very often, a hum that develops and increases in intensity after the receiver is operating for ten minutes or more may be caused by a poor '47 type pentode tube. In some instances, the same condition will again develop even after several tubes of this type have been replaced. This condition may be remedied by reducing the value of the grid resistor in the grid circuit of the pentode tube.

(5) A not infrequent cause of steady hum is that due to a decrease of inductance of the filter chokes in the power supply. This condition may be due to a short-circuited or partially short-circuited choke coil, or to some change in the size of the air-gap in the choke core, which is employed to maintain a high inductance even though d-c current flows through the choke. If the d-c resistance of a filter choke is measured with an ohm-

meter and found to be correct, its filtering ability may be determined by short-circuiting its terminals with a short length of wire while the receiver is in operation but not tuned to a broadcast station. It is likely that a closed air gap exists if very little increase in the hum is noted when this simple test is made.

(6) In many cases, hum may be traced to a short-circuited or open-circuited "tuning" condenser, C , connected across the filter choke, as shown at (A) of Fig. 23-13. This condenser is used to *resonate* the choke to a certain frequency. A great many Philco, Bosch, Majestic, General Motors, RCA Victor, etc. receivers employ this method of filtering. When the condenser

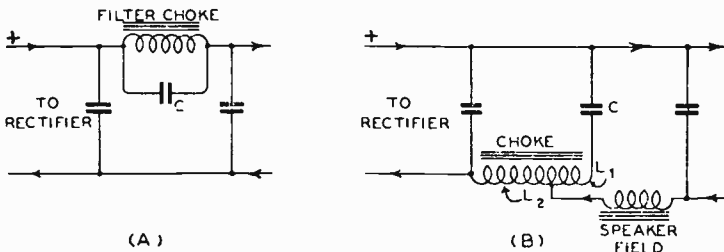

FIG. 23-13.—Two filter choke arrangements employed in the B supply portions of a-c electric receivers. That at (A) uses a condenser C to tune the choke. That at (B) uses a tapped choke. Causes of hum in these circuits are discussed in the text.

short-circuits, the choke coil is rendered entirely ineffective, and a loud hum will result. An open-circuited condenser, however, will raise the "pitch" of the hum and make it more apparent.

A few other receivers utilize a *tapped* filter choke, usually in conjunction with another choke which may be the speaker field, as shown at (B). The increased filtering which this provides, is due to the neutralizing effect of the alternating current through the condenser C and part L_1 of the choke, on that through L_2 . A strong hum encountered in receivers using this type of filter system is frequently caused by the open-circuiting or burning-out of L_1 . This, in effect, not only renders the system inoperative, but also disconnects the filter condenser C .

(7) Objectionable hum may also be caused by loose laminations in the core of a power transformer or filter choke. Any

excessive vibration of these loose laminations can be detected by feeling the core with the hand, or touching it with a screw-driver. It may be eliminated usually by tightening the core clamping screws. In severe cases, the unit should be removed from the receiver, and allowed to stand for a sufficient time in a pot of impregnating compound which is molten but not too hot. The molten compound will run in and fill up the spaces between the laminations, thus preventing their vibration. Very often, the insertion of thin strips of cardboard or stiff paper between the loose laminations is sufficient to stop their vibration and the hum.

(8) Another cause of steady hum which is not common in commercial receivers, but which is very troublesome when it is encountered, due to the fact that the usual hum remedies do not have any effect on it, is that of magnetic coupling or interaction between the power transformer (or a filter choke) and an audio transformer in the receiver—especially a first-stage audio transformer. The stray varying magnetic field of the power transformer or choke induces an alternating voltage in the windings of the audio transformer. This voltage is amplified greatly by the audio amplifier and appears as a low-pitched hum in the loud speaker.

To test for this type of hum, disconnect the leads which are normally connected to the primary of the audio transformer. Connect, temporarily, a resistance of about 10,000 ohms across these primary terminals. Join together the two leads originally connected to the primary of the transformer so that the plate current may still flow through the tube, and thus avoid any appreciable disturbance of the normal voltage and current distribution throughout the set. If the hum still persists but disappears when the audio transformer secondary is short-circuited, it is quite certain that magnetic interaction is responsible for the hum.

In order to cure this condition, disconnect the filter choke from the receiver and place it a few feet from the set temporarily to remove its effect; then wire it into the circuit normally but with long leads. With the 10,000-ohm resistance still across the primary and the secondary connected normally (but with

long flexible leads), rotate the audio transformer slowly until the position for minimum hum is found. Remount it permanently in this position. Replace the filter choke in its original position. If the hum appears again, rotate the choke slightly until the hum is minimum.

23-20. Systematically Tracing Sources of Steady Hum.—

The first step in the elimination of steady hum is naturally that of tracing its source. Perhaps the most direct and effective way of locating the source of hum in a radio receiver is through the process of eliminating stage by stage from suspicion by conducting a stage-by-stage test. It is advisable to start this elimination process at the output end of the set rather than at

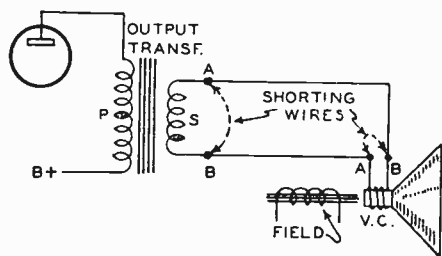

FIG. 23-14. — How the output transformer secondary, or voice coil, should be shorted across points A-B to test for hum in the loud speaker.

the input, as is usual when carrying out systematic tests for other faults. By "shorting" first the *input* and then the *output* of each stage successively, hum originating in any one stage can be isolated. Of course, before proceeding from one stage test to the next, all temporary short-circuits or other test alterations must be removed and all connections restored to normal.

(1) If a dynamic type loud speaker is employed, its voice coil (or the secondary winding of its output transformer) should be short-circuited with a screw-driver or a *short* piece of wire as shown in Fig. 23-14, so that no signal can reach it. Any hum which may still be heard is due to ripple voltages in the speaker field, causing pulsating field magnetism. This may be caused by insufficient filtering of the current supplied to the field coil. If the speaker field is energized with filtered current from the B-supply of the receiver, the filter condensers, filter "tuning" condenser (see Fig. 23-13) and filter chokes should be checked (see Art. 26-31). If the speaker field is operated direct from the a-c

line in conjunction with a transformer, a rectifier, and a filter condenser, the rectifier or filter condenser may be the source of the trouble (see Arts. 26-29 and 26-30). Of course, replacement of the faulty unit will cure this. Other causes for hum in dynamic speakers are discussed in Art. 26-34. On the other hand, if the hum is materially reduced or eliminated when the foregoing short-circuit test is applied, it must be due to some fault in the receiver circuits proper and the trouble must be looked for in the balance of the receiver by making a stage-by-stage check in such a manner that *none of the operating voltages are disturbed*.

(2) The short should be removed from the speaker voice coil and the last audio (output) stage should now be isolated and

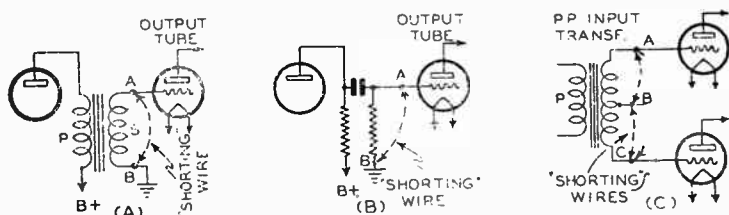

FIG. 23-15.—Testing the last audio stage of a receiver to determine whether the hum is originating in the output stage or in the part of the receiver ahead of this stage. The method of applying the “short” test in: (A) a transformer-coupled, (B) a resistance-coupled, and (C) a push-pull output stage, is shown here.

checked by short-circuiting the secondary of its input transformer, see (A) of Fig. 23-15. This makes it possible to determine whether the hum is originating in the output stage or in the part of the receiver prior to the output stage, since any hum originating in the latter part is cut off from the last audio stage and the loud-speaker by short-circuiting the transformer winding. If the hum persists when this is done, the trouble is due to a faulty output tube, to insufficiently smooth output from the *B* power supply system (which should be checked at once), or to any one of the hum causes outlined in Art. 23-19. Larger filter condensers and or substitution of a better filter choke should remedy the trouble in the second case. If the output stage is resistance-coupled to the preceding stage, the grid leak resistor should be short-circuited in this test, as shown at (B) of Fig. 23-15.

If the output stage is of the push-pull type, hum may be due

to an incorrectly located center-tap in the secondary of the push-pull input transformer. The grids of both tubes should be shorted to the center tap of the secondary winding, as shown at (C) of Fig. 23-15. If this causes a noticeable reduction in hum, the trouble is in a preceding stage. However, if the hum is still present, one or more of the parts or tubes in the output stage are at fault.

(3) If the hum source has not yet been located, and the receiver employs another a-f stage, the "shorting" wire from the output stage should be removed and the grid circuit of the first audio tube should be short-circuited. If this "short" results in a marked decrease in hum, the hum is originating in one of the preceding stages. If not, the source of hum lies in this stage, and may be due to one of the causes outlined in Art. 23-19. All parts in it should then be tested. There is a possibility that the hum is caused by magnetic interaction between the a-f transformer and the power transformer or one of the filter chokes in the receiver. To test for, and correct this condition, proceed in accordance with the instructions given in Section (8) of Art. 23-19.

(4) If the hum source has not yet been located, continue "shorting" the control-grids of all the preceding stages, in turn, until you come to a stage where no reduction of hum is noticed when the grid of the tube in that stage is shorted. The trouble causing the excessive hum then lies in this stage, and the hum causes listed in Art. 23-19 should be checked.

If upon removing the detector grid short-circuit, when testing the detector stage, a relatively high-pitched hum is heard, it is probably due to electrostatic pickup by the parts in the detector stage. If a high-pitched hum is obtained, try changing the location of the grid leak and condenser (if used) so that the leads are made shorter. It may even be necessary to shield these components in some cases. If a low-pitched hum is obtained, it indicates that additional smoothing for the *B* current supply to the r-f or i-f tubes is required. This may be supplied by the addition of extra filter condensers across these circuits.

By these tests, each stage is successively short-circuited to isolate the source of the hum. Once the faulty stage is deter-

mined, each component comprising that stage should be individually tested, and the sources of hum outlined in Art. 23-19 should be suspected and checked for. By-pass condensers may be shunted with similar-sized capacities or disconnected so that other units may be tried in their place.

After carrying out these tests and applying the proper remedies, a normally silent background should be obtained.

23-21. "Fading" in Radio Receivers.—Of all the complaints encountered in radio servicing, one of the most difficult to solve is that of fading of signals. By *fading* is meant the gradual falling off of volume to a low level, with equally slow recovery following. This phenomenon repeats itself periodically at short or long intervals. While fading is really a form of intermittent reception, it will be considered separately from the type of intermittent reception which cuts on and off rather abruptly (Art. 23-22). It should also be understood that we are not concerned here with fading due to the falling off of the strength of the signal from the broadcasting station. That is not the fault of the receiver—except in cases where the automatic volume control is not operating properly (see Chapter XIX).

Usually, the repair of a receiver that has developed a condition of intermittent reception of any form is very difficult, for the trouble may be caused by an obscure defect or failure in practically any part of the entire receiver and the antenna system. Such repairs often tax the ingenuity of the service man and call forth from him every trick and resource that he has learned from experience. In addition they probably are the most time-consuming tests that he is called upon to make. However, experience with the failure of the same parts in certain models of receivers often helps to ease the task*.

In some cases, fading may be due to a faulty condenser that open-circuits intermittently, to a break in a wire-wound resistor (the break usually not being visible to the naked eye), or to a

*NOTE: In this connection, the compilation of the common causes and remedies for troubles in over 3,300 models of various makes of radio receivers, which forms a Section of the author's *Radio Troubleshooter's Hand-book* (Radio & Technical Pub. Co.) is extremely helpful, for it contains the common causes, and remedies for fading and intermittent reception for most of the receivers listed.

poorly soldered connection in some circuit. Almost every case of fading requires its own plan of attack and solution, and that which may be said about one receiver may not be true about another.

The best course of procedure is to place the receiver in operating condition. A broadcast station whose signal is known to be steady should then be tuned in. After this is done only one thing remains—wait for the fading to occur.

Before any testing or trouble-shooting is done, every bit of available information that may assist matters should be “extracted” from the owner of the receiver. A few of the preliminary questions have already been mentioned in Art. 18-2. It may be found that the fading occurs when a light in the room is switched on or off, when someone walks across the room or closes a door, when a trolley car or a heavy automobile truck goes by, or when the receiver is turned off and on, etc.

Reception that has faded out and that can be brought back by snapping the receiver switch off and on is usually caused by a leaky or intermittently open-circuited by-pass condenser which breaks down under load, vibration, or after the receiver has been operating for a short period of time. A faulty resistance element in a volume control may produce the same symptoms. The difficulty with locating trouble of this nature is that it may disappear as soon as the chassis is disturbed for the purpose of making a voltage or resistance check.

One particular case is brought to mind in which a certain receiver would fade continually only when in its normal position, but as soon as any attempt was made to insert an analyzer plug into one of the sockets or to connect a voltmeter across any two terminals, the signal would come in with normal volume, and no fading would occur again until the analyzer plug or voltmeter terminals were removed and the chassis turned upright. In some instances, fading can be accentuated by pulling at the connecting wires of by-pass condensers or resistors. In these cases, locating the cause of trouble is comparatively simple. When fading does not occur until after the receiver has been in operation for some time or until after the chassis has been heated, the only logical procedure is to test each and every component in the

receiver while it is warm. One simple method which may be employed, is to focus an ordinary electric heater on the underside of the chassis, as shown in Fig. 23-16, to heat the components while they are being tested with the receiver turned off. Another very effective method for accelerating the heating of all the parts mounted on the chassis, is to place the receiver in operation and then cover the entire chassis with a wooden box or corrugated paper carton to prevent circulation of air. This will cause the entire chassis to heat up quickly.

An idea of how many different failures may cause fading may be obtained from an analysis of the results of observations

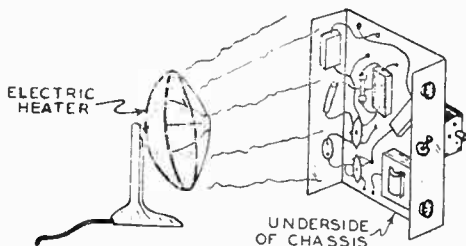

FIG. 23-16. — Heating the underside of the receiver chassis with an electric heater (carefully) prior to making tests on individual components in cases where fading and intermittent reception are experienced.

made on a particular model of receiver often afflicted with fading. In this particular model, different components were found to cause fading on many different occasions. The 0.1 mfd. audio coupling condenser was found to be the most frequent cause, as it open-circuited. The variable condenser stator plates were mounted on porcelain brackets. A sudden jolt would snap the porcelain, permitting the stator to shift with the least vibration, causing fading. The r-f coil secondaries were wound very tightly, and extreme changes in temperature or excessive vibration of the dynamic speaker would cause the coil terminals to snap at the lug. This would result in a make and break contact, causing fading. Numerous condensers in the r-f portion of the receiver would open-circuit or become leaky, producing the same symptom. It is evident that troubles of this kind can only be found by keen observation and attention to the smallest details which might pass unnoticed by the novice. Often, the observation of any unusual effects accompanying the fading gives a clue to the source or type of trouble.

Perhaps fading is caused most frequently by defective screen-

grid tubes. When these tubes are tested with the ordinary set analyzer, the difficulty is seldom disclosed; but if they are checked with a good a-c tube tester, poor ones will be revealed immediately (see Chapter VIII).

Some receivers employ a type of r-f coupling system in which a choke in the plate circuit of the tube is coupled to the tuned secondary by a small coil consisting of a few turns mounted at one end of the secondary (Fig. 23-1). Should these coupling coils become loose and "float" from side to side because of vibration, the coupling will vary and fading will result. In some few cases this winding is held in place by strips of friction tape which dry up and permit the coil to "stray."

The various methods of testing individual components have been described in detail in Chapter XXII. The methods of repairing them will be considered in Chapter XXVI.

23-22. Locating Causes of Intermittent Reception.—By *intermittent reception* we mean reception in which the receiver cuts "on and off" abruptly and periodically. This may occur regularly or only occasionally, and at either long or short intervals. This type of trouble is closely related to that of fading, (Art. 23-21). As with fading, intermittent reception may be due to a number of causes which are usually difficult to trace. The more common ones are; broken and poorly soldered connections, momentary short-circuits and open-circuits (particularly in the by-pass and audio-coupling condensers). Because of the nature of the trouble, the receiver may not exhibit its symptoms when the service man is present, or it may take a comparatively long time for it to start. It is desirable in such cases, to hasten the start of the trouble in some way. This may be accomplished by setting the receiver up for operation, and striking each component and each tube sharply though carefully. Leads and connections should also be prodded with a blunt, insulated tool. A loose connection or loose element in a tube will very often be disclosed in this way. Heating the entire chassis quickly by either of the two methods described in Art. 23-21 may also prove effective.

Faulty tubes, which may test satisfactorily in most tube checkers, are often the cause of intermittent reception. One

tube trouble which may cause this symptom is a broken heater in an indirect-heater type tube. With a broken heater, it often happens that the two ends remain in contact so that no defect is revealed if the heater is tested for continuity. When the receiver is switched on, the heater warms up and the set functions temporarily. However, when the heater has reached its full operating temperature, it has expanded to such a degree that the broken ends no longer make contact. This interrupts the heater current, the heater cools, the electron emission of the cathode decreases, and reception gradually ceases. As soon as the heater has cooled sufficiently, the ends again make contact, and current again flows, so that reception is again obtained. This cycle repeats itself indefinitely with the attendant intermittent interruption of the program.

Heater-cathode insulation which has broken down is another defect which can be very troublesome, puzzling, and will lead to intermittent reception if the trouble is intermittent itself. A test of the heater-cathode insulation by means of an ohmmeter with the heater cold is of no value. It should be checked by means of the usual heater-cathode leakage test in a tube checker.

The coil connections to each lug on r-f and i-f coils should be examined carefully (see Arts. 22-19 to 22-24). It is possible that the coil winding has contracted slightly, and, since r-f and oscillator coils are usually wound tightly, the coil leads may be snapped at the connecting lugs, making contact intermittently. The fact that the winding or lead is impregnated with wax does not imply that trouble does not exist there. It may be necessary to dig down into the moisture-proofing compound. Nothing should be taken for granted in looking for the trouble—the most insignificant detail may be the cause for intermittent operation.

A number of receivers do not employ terminal strips for the many carbon resistors in them. In these receivers, the resistors are connected from one point to the other directly. If the pigtail of the resistor is too short to reach the connecting point, an additional lead is soldered to the pigtail and the junction is insulated with a length of spaghetti or cambric tubing. This connection or junction may often be the cause of intermittent reception, so it is always best to push back the insulation and inspect

all connections. Vibration may also shift these resistors, and they may short-circuit to one another, to another component, or to the chassis. The various methods of testing individual resistors have been described in detail in Arts. 22-13 to 22-18. The methods of repairing them will be considered in Arts. 26-2 and 26-3.

A defect in the antenna system often results in intermittent reception. This is frequently due to some loose or corroded connection in the lead-in, either at the aerial or at the window lead-in strip. In some cases, an intermittently shorted lightning arrester may produce the same symptoms.

In receivers employing avc, the action of the avc will tend to level out increases or decreases in signal strength to some degree if fading or intermittent reception is caused by some defect in the antenna or r-f part of the receiver.

When fading or intermittent reception is encountered in a receiver employing a tuning meter, shadowgraph, or other resonance indicator, these devices may also serve to determine whether the condition is caused by a trouble in the r-f or the a-f portion of the receiver. If the audio amplifier is at fault, *the tuning meter or shadowgraph will show no variation in reading.* Should the trouble lie in the r-f circuits, it will almost invariably be disclosed by a varying reading of the indicator which will change in unison with the fading or intermittent reception.

23-23. Locating Causes of "Distortion".—Despite the development of extremely sensitive superheterodynes of the broadcast and all-wave type which are capable of picking up signals from great distances, the average set owner, on the whole, demands little more than good quality from local stations. To meet this requirement many set manufacturers design their receivers with anti-overload and "non-oscillating" circuits, and furnish them with tubes capable of handling large amounts of power without distortion. The problem of localizing the cause of distortion in such a receiver is indeed a difficult one.

In most cases, distortion is due to weak tubes, especially in the output stage, and the presence of a "gassy" tube helps to aggravate the condition. Should the bias-resistor by-pass condenser or any of the coupling units become leaky, the same trouble will result, especially if the leakage is appreciable.

At other times, when the voice coil of the dynamic reproducer is out of alignment, when the paper parchment cone loses its "stiffness" or "body," or when the cone spider snaps (see Arts. 26-36 to 26-42), the receiver cannot deliver as much sound energy in undistorted form. Loose or rattling components in the receiver proper will also cause disturbances which interfere with good quality of reproduction.

In other instances, voltage divider systems of the carbon resistor type may change in value, thus upsetting the electrical balance of the receiver and producing distortion. This condition, however, is evidenced by variation of the normal voltages applied to the tubes, which may be readily determined by the use of a set analyzer or a point to point tester. When the receiver is incorrectly aligned, especially in the case of superheterodynes, a certain amount of distortion that is due to the cutting of side bands may be introduced. Distortion may also be due to an output stage grid resistor which is faulty, or whose value is too high. Similarly, if the output power stage is operating with less-than-normal grid bias, or with none at all, distorted reproduction will result.

Modern multiple-unit tubes present a special problem with reference to distortion. It is not uncommon for one-half of a multi-unit tube to fail before the other. The result is that the receiver may, or may not, continue to function. If it does, distortion may appear. It is well, therefore, to test each unit of such a tube separately. The diode sections of duo-diode-triodes do not usually cause much trouble, but it is well to keep in mind that the portion of the cathode which feeds the diodes may lose its emission if a severe overload occurs. This results in a decrease in efficiency, distortion, and possibly incorrect functioning of the avc.

"Microphonic *howls*" should also be included under this heading since they are a form of distortion. Tubes with loose elements, especially in the detector stage, will produce microphonics. Manufacturers have mounted receiver chassis on rubber cushions in an attempt to overcome the condition. The development of the more recent types of tubes having the dome-shaped glass bulb has decreased the number of microphonic

tubes considerably because of the increased support given the elements by the mica disc set in the dome of the bulb. The all-metal type tubes are even superior to these tubes in this respect.

In certain commercial receivers, microphonics have been traced to vibrating condenser-gang plates. This condition may be eliminated by inserting small felt wedges between the vibrating plates to prevent this, but in such a way that the condenser action is not disturbed. Due to their excessive sensitivity, microphonic howls will result in many receivers if they are operated too close to the point of oscillation. This may be remedied by reducing the amplification of the r-f stages, or by locating and remedying the cause of oscillation (see Arts. 23-8 to 23-12).

23-24. Locating Causes of Noisy Reception.—During the past few years, this complaint has become of increasing importance because of the widespread use of sensitive receivers and electrical appliances. For this reason, Chapter XXX has been devoted to a discussion of the causes and reduction of noises which may originate within, or outside of the receiver itself.

23-25. Obscure Troubles in Transformer-Coupled A-F Amplifiers.—Transformer-coupled a-f amplifiers are relatively stable. The primary or the secondary windings of the transformers may open-circuit or short-circuit, but these faults will invariably disclose themselves by causing abnormal plate or grid

FIG. 23-17.—A typical transformer-coupled audio amplifier stage.

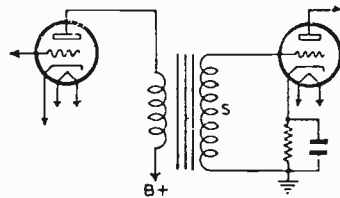

voltages on the tubes to which the windings connect, and so will be discovered by the ordinary voltage or resistance analysis of the receiver.

There are cases, however, when only a few layers of the a-f transformer winding short-circuit, or a winding may ground to the core; then, too, the primary may short-circuit to the secondary, or vice versa (see Art. 22-20). These troubles will result in certain definite symptoms which may be recognized easily (see

Fig. 23-17). When a primary winding grounds to the core of the transformer, the plate voltage of the tube connected to this primary drops below normal. Of course, this condition also affects the voltages on the other tubes as well. This trouble is peculiar inasmuch as it is usually present only when the receiver is operating. Therefore, it is difficult to locate it with an ohmmeter since the ohmmeter may be employed only when the receiver is switched off. The best way to proceed in this case is to disconnect each component, in turn, with the receiver operating and with the set analyzer connected either to the particular stage in question or to any other stage. If the plate voltage returns to normal upon disconnecting any component, that component should be

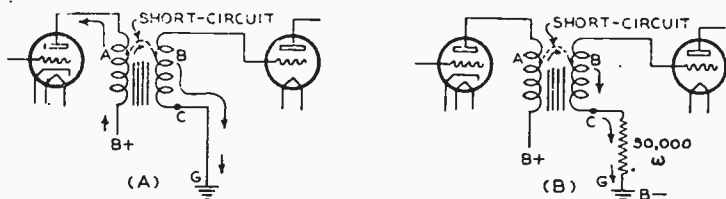

FIG. 23-18.—(A) Plate current flowing in the grid circuit as a result of a short-circuit between the primary and secondary windings of an audio transformer.

(B) An a-f amplifier stage in which the secondary-return of the transformer is connected to ground through an oscillation-suppression resistor. A short-circuit has also occurred here between the primary and secondary resulting in a flow of plate current from the preceding tube into the secondary circuit.

tested thoroughly. A completely or partially short-circuited primary of an audio transformer will evidence itself by slightly-higher-than-normal plate voltage and weak and "tinny" reproduction, if at all. Such cases, however, are comparatively few.

When the primary of an audio transformer short-circuits to the secondary, *B* current flows through the portion of the secondary between the "short" and ground or *B* minus, as shown at (A) of Fig. 23-18. The most common indication of this is high *positive* bias caused by the voltage drop produced by the flow of this portion of the plate current through the winding from *B* to *C*, and high plate current in the tube connected to the secondary of the transformer. If the secondary return of the winding is connected directly to *B* minus or chassis, the

plate voltages of all the tubes may also be low due to the heavy *B* current drain through the path. When the secondary return of the transformer is connected to the *B* minus through a high resistance, as shown at (B) of Fig. 23-18 (in order to minimize audio oscillation) low plate voltage is not likely to result, because the presence of this high resistance reduces the "short-current" drain. Usually, this resistance is of only about $\frac{1}{2}$ -watt rating, so it may open-circuit because of the relatively high current which flows through it under these conditions. A completely, or partially, short-circuited secondary will only manifest itself by extremely weak and distorted reproduction. An open-circuited secondary will result in zero grid bias and a blocking of the audio tube. The receiver will function for only a few moments and then stop completely. This symptom—the alternate blocking and operating of the tube—is one of the most positive indications of an open-grid circuit in an audio amplifier, and is due to the periodic charge and discharge, through the tube, of the distributed-capacity current of the secondary.

23-26. Obscure Troubles in Resistance-Coupled A-F Amplifiers.—Because of the existence of various resistors and condensers in resistance-coupled audio amplifiers (see Fig. 23-19), many difficult service problems may arise in receivers employing this form of coupling. The coupling condenser in resistance-coupled audio amplifiers usually has a capacity between 0.01 mfd. and 0.1 mfd. In some instances, it may be as low as 0.001 mfd. The capacity of these units determines the frequency response of the amplifier, reproduction of the lower frequencies increasing as the size of the condenser is increased. Impedance-coupled amplifiers develop nearly the same troubles as those encountered in resistance-coupled systems so far as the coupling or isolating condenser is concerned.

Should the coupling condenser become short-circuited, no reception will usually be obtained. The tube whose grid is connected to the shorted coupling condenser will have a positive grid bias and a correspondingly high plate current. If the grid bias voltage is, say, 50 volts, and the voltage *actually* impressed on the plate of the preceding tube is almost the same, the net, or measured grid bias will be zero if the coupling condenser is

shorted, since these voltages will "balance out." However, when the plate voltage of the preceding tube is higher than the grid bias of the coupled stage then the bias voltage indicated by the set analyzer meter will be *positive* by an amount roughly equal to the difference between the plate and grid-bias voltages measured. Aside from these unusual voltage indications, a short-cir-

FIG. 23-19.—A typical resistance-coupled audio amplifier stage. Either one, or both resistors may be replaced by a-f choke coils to obtain an impedance-coupled amplifier. Usually the plate resistor is the one which is replaced, or is used in combination as shown in Fig. 23-22.

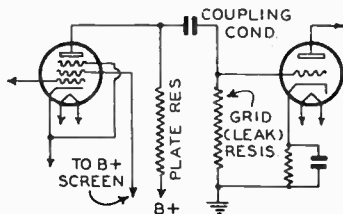

cuit coupling condenser makes itself apparent by the very weak and greatly distorted reproduction obtained.

When the coupling condenser open-circuits, the symptoms are weak (and distorted) reception or no response at all. Muffled reproduction from a resistance-coupled audio amplifier may often be caused by leakage in the coupling condenser. This defect may also be indicated by a positive bias on the grid of the tube in the coupled stage, not unlike that described for a short-circuited coup-

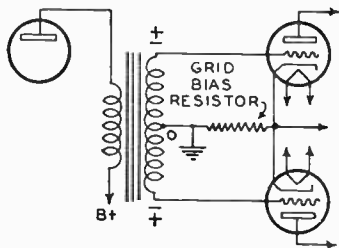

FIG. 23-20.—Input circuit of a transformer-coupled push-pull amplifier.

ling condenser. The value of the grid-bias reading depends upon the amount of leakage in the condenser. Because of the difficulty and the time consumed in testing for an open-circuit in a low-capacity coupling condenser, the best method for determining its condition is to bridge another condenser of similar capacity across the suspected unit. Should reception improve, then the coupling condenser in the receiver is open. Care should be taken

to keep the fingers free from the terminals of the condenser while doing this, as they may cause audio oscillation. Note that this bridging test is unsuitable if the condenser in the receiver is leaky, as the leakage will still be present even when the new bridging condenser is used. A quick check for leaky coupling condensers is to disconnect them; then test them for leakage, or substitute others known to be perfect.

23-27. Obscure Troubles in Resistance-Coupled Push-Pull A-F Amplifiers.—Some receivers employ a resistance-coupled push-pull circuit. The primary requisite of push-pull amplification is that the grids of the push-pull tubes must be

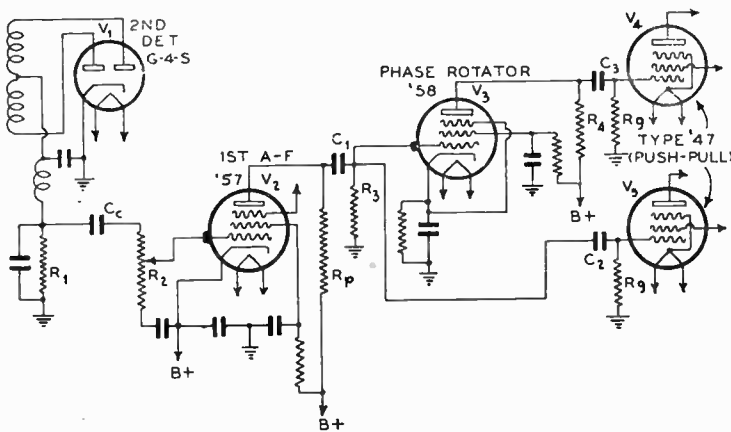

FIG. 23-21.—The audio amplifier employed in the Majestic Model 300 receiver. A push-pull output stage is resistance-coupled to the first audio stage, with a phase rotator tube in between.

fed with voltages that are equal in magnitude but opposite in phase, or polarity. (See *Radio Physics Course*, by Ghirardi, for detailed information on the theory of the push-pull amplifier.) This is accomplished easily enough with a transformer by connecting the two ends of the secondary winding to the push-pull grids; the center tap of the transformer secondary connects to *B—* as shown in Fig. 23-20. In a push-pull resistance-coupled circuit, phase "rotation," or reversal, of polarity is accomplished by making use of the fact that a signal is rotated in phase exactly 180 degrees in passing through a vacuum tube.

Since a circuit of this kind may develop troubles not common to the usual type of resistance-coupled amplifier, a knowledge of its operation is essential. Figure 23-21' shows the schematic circuit diagram of the audio amplifier portion of the Majestic Model 300 receiver. Notice that a resistance-coupled push-pull output stage is employed. The audio voltage built up across resistor R_1 is fed to the '57 first audio tube through C_0 and the potentiometer R_2 . The output of this audio amplifier (the voltage drop across R_p) follows two channels; the direct, and conventional, channel is through condensers C_1 and C_2 to tube V_5 , the lower of the two '47 push-pull output pentodes; the remaining channel is through the phase-rotating tube V_3 . The signal output of this tube, reversed in phase, is built up across R_4 , and is fed through condenser C_3 to V_4 . *No change in the magnitude of the signal takes place*, since V_3 is adjusted to have a gain of 1—no amplification. In this manner two voltages are fed to the two '47 push-pull output tubes (V_4 and V_5). These voltages are equal in magnitude and opposite in instantaneous polarity, or phase.

Distorted and weak signals in audio amplifiers of this kind are often due to a poor phase-rotating tube. Otherwise the troubles that develop are strictly analogous to those described for resistance-coupled amplifiers (Art. 23-26). The failure of part of the circuit of the phase rotator or even of the tube itself will not prevent the receiver from operating to some extent, as only the push-pull features are destroyed, unless, of course, the failure seriously disturbs the normal voltages applied to the other tubes.

23-28. Faulty Resistance Units in Resistance-Coupled Amplifiers.—There are but two main resistors in a resistance-coupled stage. They may open-circuit, short-circuit, become partially open, or partially short-circuited. An open-circuited plate resistor will remove the plate voltage from the tube. The signal strength will be reduced to zero, or be extremely low. A short-circuited plate resistor will manifest itself by increased voltage at the plate of the tube, high plate current, and no signal strength. A partially open-circuited plate resistor (resistor with too high a value) will be indicated by erratic, though

low, plate voltage and intermittent reception. If the value of this resistor should change to a high value and remain high, reception will be weak because of the low plate voltage, although the quality will be good. A partially short-circuited plate resistor will be revealed by high plate voltage and low volume, though the quality will be good.

Grid resistors rarely become defective, because they carry (theoretically) no current. However, aging, heat from the rest of the receiver and mechanical vibration may change their values. If the grid resistor open-circuits, the receiver will work for a few moments after it is turned on, then it will suddenly choke up and stop operating. The signal may be brought in again by turning the receiver off for a little while and turning it on again, or by placing one finger on the grid terminal of the tube to which the resistor connects and another on the chassis. Reproduction will then sound very much like normal.

The reason for this action is apparent when the grid-coupling condenser is considered. When the receiver is first turned on, the coupling condenser charges up, and because the grid leak (it actually acts like a grid leak) is open, the accumulated charge has no path through which to leak off, so the grid becomes highly negative and the plate current decreases to zero. Turning the receiver off for a few moments allows the charge to dissipate itself in the small leakage path in the condenser, for no condenser is perfect. Placing two fingers between grid and chassis really is substituting the resistance of part of the human body for the faulty one in the set. An open-circuited grid resistor may also be indicated by a rapid decrease in the plate current of the tube connected to this resistor. Exactly the same symptoms are evident in impedance-coupled audio circuits.

A partially open-circuited grid resistor will exhibit somewhat the same symptoms as an open-circuited one, except that the charge and discharge of the coupling condenser will take place very slowly and may not even cause any noticeable trouble. A short-circuited grid resistor may be determined quickly by simply checking the grid bias voltage. If the full value of the bias can be measured from grid to filament, then the grid resistor must be short-circuited. In this case, of course, reception will be very

weak, and none but the loudest stations can be heard. The symptoms produced by a partially short-circuited grid resistor are difficult to describe unless the correct and measured values are known. In general, however, the grid resistor may change in value by as much as 50 or 75%, and the only noticeable symptom will be reduced volume. However, if the value changes rapidly, from instant to instant, then the rapidly varying volume can be detected without knowing what the value *should* be.

23-29. Obscure Troubles in Impedance-Coupled Audio Amplifiers.—The impedance-coupled audio amplifier is very similar to the resistance-coupled unit, except that either one, or both, of the resistors are replaced by impedances. If the plate load is an impedance (an audio choke of about 30 henries for triodes and about 100 to 200 henries for multi-grid tubes), the tube will have more nearly full plate voltage, just as if an audio transformer were used. This higher plate voltage results in greater amplification, and hence is preferred by many engineers.

But the resistance-coupled amplifier has one feature not characteristic of any other method of coupling—it will pass all frequencies within the audio range without any discrimination when properly designed. Since this feature is desirable in many cases, a combination resistance-impedance system, shown in Fig. 23-22, is used in many receivers. The resistor R is shunted across the impedance L so that the plate voltage on the tube is high because of the low resistance of L . However, when audio voltage is developed across the combination, the effect of the resistance is to straighten out the response curve so that amplification is practically independent of frequency. The effect of an open- or short-circuited resistor R in this circuit may not be noticeable at all. But if L open-circuits, the plate voltage will drop considerably because the plate current must now flow through R instead of L ; the volume will therefore be low. The effects of other changes in R or L may easily be predicted after an examination of the figure. Many of them are similar to those previously described.

23-30. Obscure Troubles in Transformer-Impedance Coupled Audio Amplifiers.—A coupling device known as an *Impedafomer* has been available for some time and has been

used in a number of receivers. Essentially, it consists of an audio transformer and a coupling condenser arranged as shown in Fig. 23-23. Transfer of energy here takes place both by magnetic coupling (as in the audio transformer) and by impedance coupling through the coupling condenser C_c . On the very high audio frequencies, the response of the transformer drops off. Then,

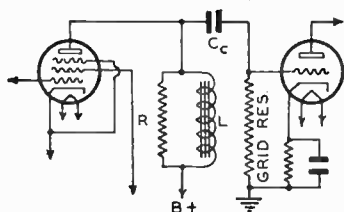
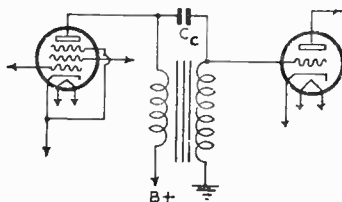

FIG. 23-22. — Resistance-impedance audio-frequency coupling system.

each winding acts as a choke and the system is impedance coupled. The symptoms caused by faulty parts are the same as those described previously for the transformer and resistance-coupled systems.

23-31. Servicing Direct-Coupled Audio Amplifiers.—Although the direct-coupled audio amplifier has found its greatest application in public-address work in conjunction with micro-

FIG. 23-23.—The "Impedaformer" coupling unit. This is a combination of an a-f transformer and a condenser connected between its windings, as shown.



phones, phonograph pickups or talking motion picture equipment, a number of commercial radio receivers also employ this system of amplification because of its high gain and wide audio-frequency response.

In the conventional resistance-capacity-coupled amplifier, there is a strong tendency for the grid circuit of the last audio tube to block on strong signals because of the accumulation of electrons on the grid, resulting in the cutting off of the plate

current. In addition, the input capacity between the grid and cathode (or filament) acts as a shunt condenser across the grid leak, and the plate-cathode (or filament) capacity acts as a shunt across the plate load resistor, at high audio frequencies. Therefore, the response drops off. Furthermore, the reactance of the coupling condenser is so large at the low audio frequencies as to severely limit the gain below a few hundred cycles. In the direct-coupled audio amplifier, the plate of one tube and the grid of the next are coupled *directly* (hence the name) through a common resistor—no coupling condenser or leak resistor being employed. By eliminating these, grid blocking due to strong signals is avoided and the frequency response is improved.

A typical direct-coupled audio amplifier circuit is shown in Fig. 23-24. It can be seen that the B current flows through the plate circuit of V_2 to point A . At this point, the plate current of this tube divides: part flowing through the voltage divider and screen-grid to B —, and part through the coupling resistor R_c , through the plate-cathode circuit of the tube, V_1 , through resistor R to B —. The current through R is the sum of the plate and screen currents of the tube. The voltage drop across the voltage divider, represented by R_1 , R_2 , R_3 , and R_4 , is, of course, the same as the total voltage drop through R_c plus that across the plate-cathode path in V_1 , plus the voltage drop across R , since these are two *parallel* circuits. It is evident, therefore, that the *total voltage which must be supplied by the power unit is equal to the sum of the plate voltages impressed across V_1 and V_2 , plus the voltage drop across R_c and R* . This means that the power unit in a direct-coupled amplifier must be capable of supplying a higher voltage than when the more conventional forms of coupling are used.

It is also evident that *the grid of V_2 is connected to the same positive voltage as the plate of V_1* . This appears theoretically unsound until we realize that *the filament of V_2 is at a higher positive voltage than the grid* because of the voltage drop across the coupling resistor R_c . This voltage drop across R_c is equal to the plate current of V_1 multiplied by R_c . It follows, therefore, that *the grid of V_2 is negative with respect to the filament* by the amount of this voltage drop. The resistor values are so cal-

culated, that the voltage drop across R_c enables V_2 to operate at standard voltages. The important point to remember is that grid voltage is always measured from grid to filament, and plate voltage from plate to filament (or cathode), any other existing voltages notwithstanding.

Some means, however, must be employed to maintain the stability of the amplifier. An amplifier tube has a tendency to in-

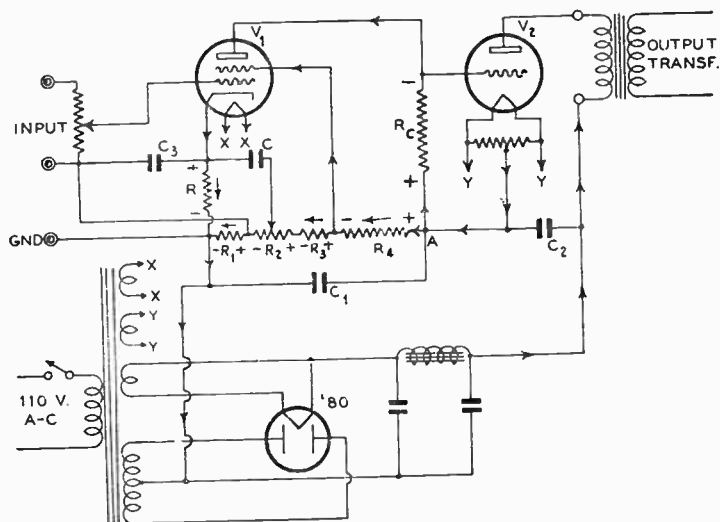

FIG. 23-24.—A typical direct-coupled a-f amplifier. Resistor R_c couples the two tubes together.

crease its plate current when a signal is applied to its grid. From the diagram, it is seen that when an increase in the plate current of V_1 occurs for any reason, the bias voltage on V_2 increases automatically because of the greater voltage drop in R_c . This produces a decrease in the plate current of V_2 . Since this latter plate current constitutes the major portion of the current through the voltage divider, when it decreases, the voltage drop in R_1 decreases. Since the normal grid bias on V_1 is equal to the difference between the voltage drop in R_c and that in R_1 , if the voltage drop across R_1 decreases, the grid of V_1 becomes more negative and the plate current of V_1 decreases. This automatically maintains the plate current of tube V_1 constant.

The condenser C is connected between the cathode of V_1 and the arm of the potentiometer R_2 (part of the voltage divider). Its object is to introduce a small hum voltage into the grid circuit of the tube (of equal value but of opposite phase to the hum introduced by the voltage drop across R caused by any ripple or hum from the B supply). The potentiometer R_2 is varied until the hum is neutralized, or balanced out. Condensers C_1 , C_2 , and C_3 are used to prevent possible undesirable coupling due to the use of a common impedance.

Direct-coupled audio amplifiers may best be serviced by checking all resistance and voltage values, *provided such values are known*, but the problem becomes exceedingly difficult unless the principle involved is clearly understood, especially when the circuit diagram or constants are not available.

The service problems encountered with direct-coupled amplifiers are comparatively few, the most common one being distorted reproduction. Almost invariably, this is due to a low emission tube used in the V_1 position. Since the grid bias of the succeeding, or output tube depends upon the plate current drawn by V_1 , it is important that the plate current of V_1 be normal, or else the bias on the output tube will be abnormal, and distortion will result.

In some amplifiers, a series screen resistor is employed. An open-circuited screen resistor will cause V_1 to draw less plate current, thereby lowering the grid bias on V_2 . This failure may be recognized by weak and distorted reproduction. Frequently, the cause of lowered grid bias on V_2 is the coupling resistor R_6 , which is usually a carbon unit, and which often changes in value. It is best that this component be of the highest quality.

Should distorted reproduction be accompanied by hum which cannot be reduced to a minimum with the hum-bucking potentiometer, check the hum-bucking condenser C for leakage. Distortion which is found to be caused by an abnormally high grid bias on V_2 will often be traced to a tube having cathode-heater leakage, or to a short-circuited or leaky cathode by-pass condenser C_3 .

Motor-boating and distortion can be caused by a grounded hum-bucking potentiometer R_2 , whose shaft is usually insulated

from the chassis by an insulating bushing or washer. In this case, it is only necessary to loosen the mounting nut to re-locate the unit. Of course, total inoperation may be due to the open-circuiting of a resistor or short-circuiting of one of the filter condensers, C_1 , or C_2 . This may be ascertained simply enough by a continuity or resistance test. The latter is much to be preferred in this circuit.

There are many other versions of direct-coupled circuits, but they all operate on the same principle and are subject to the same limitations. The arrangement shown in Fig. 23-24 has been used extensively in this type of amplifier.

23-32. Classes of Audio Amplifiers.—There are several conditions of tube operation which may be employed for audio amplification. The operating point on the grid-plate characteristic, determined by the grid bias and the amplitude of the exciting grid (signal) voltage, varies over a wide range in amplifiers designed for different fields of application. The plate efficiency of the amplifying tube, and the degree to which the alternating component of the plate current is a true reproduction of the varying applied grid voltage, depends upon the operating point on the grid-plate characteristic as determined by the grid bias and upon the magnitude of the exciting grid voltage.

Amplifiers are grouped into three general classes (A, B and C), according to the region of the grid-plate characteristic in which the operating point, as determined by the grid bias, is located, and the magnitude of the exciting grid (signal) voltage. In other words, this classification depends primarily upon the fraction of input cycle during which plate current is expected to flow under rated full load conditions. This classification is merely a recognition of current practice in amplifier tube operation, and offers a convenient terminology for the description of amplifiers. It is understood that this classification refers only to single-stage amplifiers; a multi-stage amplifier may consist of two or more of these classes. Definitions describing these classes have been standardized by the Institute of Radio Engineers. These will now be considered.

23-33. Class A Amplification.—A Class A amplifier is one in which the grid bias and the exciting grid voltage are such

that the plate current through the tube flows at all times. The *ideal* Class A amplifier is one which operates in such a manner that the plate output wave-form is essentially the same as that of the exciting grid (signal) voltage at all times.

This condition is obtained by operating the tube with a negative grid bias such that some plate current flows through the tube at all times, and by seeing to it that the alternating signal voltage applied to the grid is such that the dynamic operating characteristics are essentially linear. The grid must not be driven "positive" by the signal on peaks, and the plate current must not fall low enough at its minimum to cause distortion due to operation over the lower bend of the characteristic. The amount of second harmonic present in the output wave, which was not present in the input wave, is generally taken as a measure of distortion, the usual limit being 5 per cent. This is the usual condition of audio amplifier operation which we have already discussed in this chapter. This type of amplification results in low distortion, relatively low efficiency and power output, and a large ratio of power amplification.

The main difference between a power output tube and one designed for r-f or i-f amplification is the fact that, in the output tube, voltage amplification is sacrificed for power-handling ability; hence the necessity for securing as much *undistorted power output* per volt applied to the grid as possible. The ratio of the power output in watts to the square of the input grid (signal) volts (*r-m-s* values) is a measure of the *power sensitivity* of the tube. Thus, a power tube delivering 8 watts output with an applied signal of 10 volts r-m-s has a power sensitivity of $8/10^2 = 8/100 = 0.08$ watt per volt² = 80 milliwatts per volt²

23-34. **Class B Amplification.**—To secure a further increase in power output, a power tube may be operated with a negative grid bias such that the plate current is reduced to approximately zero when no signal voltage is applied, and plate current flows only during the *positive* half cycles of the signal, exactly as in the bias type of detector. This is called a *Class B* amplifier.

The plate current of a single tube operated as a *Class B* amplifier is severely distorted since it has no "negative loops"; this is another way of saying that the output of a single tube

operated as Class B amplifier contains a number of strong *even* harmonics (the second, fourth, sixth, etc.) which are undesirable. The grid may usually go "positive" on peaks of the signal, the harmonics produced by this being removed from the output by suitable means. The characteristics of a Class B amplifier are medium efficiency and output, with a relatively low ratio of power amplification.

The high distortion resulting from the use of a tube as a Class B amplifier must be balanced out if the wave-form of the

FIG. 23-25. — Circuit of a typical Class B amplifier stage. The push-pull arrangement balances out the distortion generated by each tube.

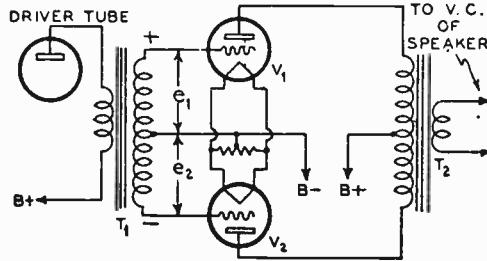

output signal is to resemble that of the input signal. This balancing out is accomplished by using two such tubes connected in a push-pull arrangement, as shown in Fig. 23-25. The wave-form of the plate current and the mode of operation are illustrated in Fig. 23-26. Graph, 1, is the grid voltage—plate current characteristic of tube V_1 , and graph, 2, is that of tube V_2 . When the signal voltage e is applied, the plate current, I_{p1} , of tube V_1 varies as shown in the upper right-hand quadrant. The plate current, I_{p2} , of the second tube is shown in the lower left-hand quadrant. The result of the push-pull arrangement is that both combine in the output choke or transformer to put together the complete wave. The wave-form of the output is a comparatively faithful reproduction of that of the input signal, so that but little distortion is present.

On weak signals, the regions OA and OB (Fig. 23-26) become increasingly important, and contribute to the distortion, so that the Class B system is of special advantage when the signal strength is large. The *ideal* Class B amplifier is one in which the alternating component of plate current is an exact replica of the

alternating grid voltage for the particular half cycle when the grid is positive with respect to the bias voltage, and the plate current flows during $\frac{1}{2}$ of this cycle.

23-35. The Driver Tube.—It is not necessary that the grid of a single Class B tube be biased highly negative in order to operate at the cut-off point. By designing the tubes for this service with a high amplification factor, cut-off (or nearly cut-off) may be obtained with zero bias. The grid will then draw current;

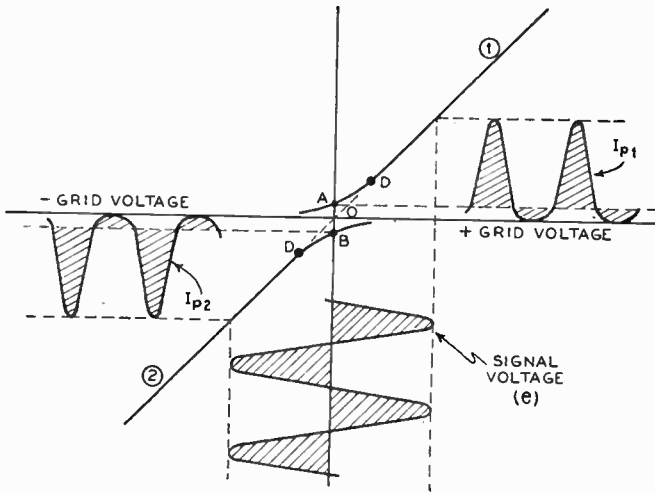

FIG. 23-26.—Graphs illustrating the wave form of the plate current existing in each tube of a push-pull Class B amplifier stage when a signal voltage e having the wave form shown is applied to the stage. The graphs are plotted with plate current as ordinates (vertical scale) and grid voltage as abscissae (horizontal scale).

but if the tube feeding the Class B stage is designed to supply a reasonable amount of *power*, then the losses in the grid circuit if the Class B stage are supplied. The tube feeding the Class B stage, then, must be something of a power amplifier of the Class A type, and for this reason it is called a *driver tube*.

23-36. Special Class B Amplifier Service Considerations.

—It was mentioned that the driver stage must supply enough power to the input of the Class B stage to supply the grid losses. This means that the losses in the input transformer must be as low as possible, and that this transformer must be designed with

the same considerations in mind as for a power transformer. It is usually constructed with a step-down ratio (from primary to $\frac{1}{2}$ of the secondary) of about 1.5 to 1. Its normal resistance and leakage reactance must be low, otherwise the high notes will be attenuated. For these reasons, *an ordinary audio transformer cannot be used as the input transformer in a Class B amplifier circuit.*

The *output transformer* is special, too. The plate current of each tube is very high during the "positive" swings of the signal, so that the core of the transformer must be large enough to handle the high flux density without saturating. Furthermore, the flux in the core does not balance out as it does in a Class A push-pull circuit—each tube works for half a cycle *in turn*, (not at the same time) so the flux density may be very high at the peaks of the plate current. Finally, the ratio of an output transformer intended for Class B work is different than that required for the same tubes in Class A push-pull. In a Class A transformer the entire primary works at once; in a Class B transformer each half works by itself, in turn.

Thus, if a 10-ohm voice coil is to be fed from two tubes working in Class A push-pull having a total plate-to-plate impedance of 9,000 ohms (4,500 ohms per tube), the ratio of the output transformer must be:

$$\sqrt{\frac{9,000}{10}} = \sqrt{900} = 30 \text{ to } 1.$$

But in Class B, the ratio must be computed for one-half of the primary, and then doubled. Thus, the plate-impedance of one tube is 4,500 ohms. Then half the ratio would be:

$$\sqrt{\frac{4,500}{10}} = \sqrt{450} = 21.2 \text{ to } 1$$

and the entire ratio would be 42.4 to 1. These considerations lead to the conclusion that an output transformer *intended for push-pull Class A operation cannot be used satisfactorily for Class B systems.*

The power transformer and filter systems used in Class B systems are different from those used in Class A systems. Since the plate current in a Class B system fluctuates between wide limits

and depends upon the signal voltage on the grid of the Class B stage, it is imperative that the voltage output of the power unit be as unaffected by these current fluctuations as possible. This condition limits the permissible resistance of the chokes, rectifier tube, and power transformer to a very few ohms. Chokes suitable for Class B work should have a resistance of about 20 ohms; power transformers should have large cores and low-resistance windings, especially the plate winding; and the rectifier tube should be of the mercury-vapor type because of its low internal

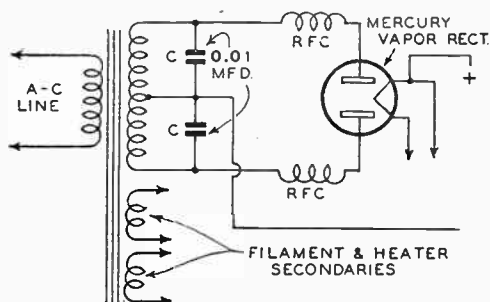

FIG. 23-27. — Connection of the power transformer in a Class B system showing the location of the r-f filter system between the high-voltage winding and the rectifier tube.

plate-cathode resistance. These considerations again lead to the conclusion that power systems intended for Class B work *can* be used for Class A systems, but a *power pack originally designed for Class A cannot be used in a Class B system.*

The power transformer of a Class B system usually has small fixed condensers connected from each side of the high-voltage secondary to ground, and one or more r-f chokes in the high-voltage leads, as shown in Fig. 23-27, to filter out any high-frequencies that may be generated in the mercury-vapor rectifier during ionization.

These condensers should have a sufficiently high voltage rating to stand the high peak surges developed across the high-voltage secondary winding. They should be of the mica-dielectric type to insure a small amount of leakage during the high surges of voltage; the r-f chokes must be heavy enough to carry the rectifier-tube current without burning out. The effects of open- or short-circuited chokes and open- and short-circuited by-pass condensers are apparent. If any of the high-

frequency currents generated by the rectifier tube should get into the receiver because of some failure in the r-f power filter system, the receiver will become very noisy, especially on the short-wave bands (if the receiver is of the all-wave type). Examination of these r-f chokes and by-pass condensers should be made first, if a symptom of this kind appears.

A comparison of Class A and Class B amplifiers is instructive. The Class B (push-pull) combination is operated so that a greater power output per tube (with comparable fidelity) can be obtained than is possible from the formerly popular and time-tried Class A type using similar tubes. Class A design is relatively simple, and tubes such as the '71A, '10, '45 or '50 types have been employed in them for years. The Class A amplifier in push-pull requires 2 tubes which need not be "matched" very closely to give satisfactory reproduction. The Class B amplifier, on the other hand, involves the use of more accurately matched tubes and greater care in design, both of the circuit and the associated equipment. The older type tubes can be used in it, but not as advantageously as the newer ones designed especially for Class B use. A "power" tube is required to feed the Class B amplifier. The major advantage of Class B amplification is the availability of large sound volumes at reasonable cost with fair fidelity. It is usually considered worth while only when dance-floor volume is required. A usual fault is its tendency to give poor reproduction for low volume (about that required for a small room) even though the fidelity at large volume may be satisfactory, this effect being very pronounced if the tubes are mismatched to an extent that would have negligible effect on a Class A amplifier.

23-37. Class C Amplification.—A Class C amplifier is an amplifier operated with a negative grid bias more than sufficient to reduce the plate current to zero when no exciting grid (signal) voltage is present. Plate current pulses of large amplitude flow in each tube during only a fraction of each "positive" half cycle of the grid excitation (signal) voltage variation. The grid voltage usually swings sufficiently positive to allow saturation plate current to flow through the tube. Thus the plate output waves are not free from harmonics, and suitable

means are usually provided to remove the harmonics from the output.

Class C amplifiers find application where high plate circuit efficiency is a paramount requirement, and where departures from linearity between input and output are permissible. The characteristics of a Class C amplifier are high plate circuit efficiency, high power output and relatively low ratio of power amplification.

23-38. Class A-Prime (AB) Amplification.—When the type of amplifier service is intermediate to the foregoing main classes, it is convenient to designate the service by other terms. The most important of these is the Class A-Prime (also called Class AB) service.

The advantage of large power output with tubes operated as Class B amplifiers disappears, as pointed out in Art. 23-36, when the signal strength is small. To retain the high power sensitivity with large signals, and at the same time reduce the distortion with small input voltages, the Class AB system is used. The Class AB amplifier is one which is overbiased, operating as a Class A system for weak signals, and as a Class B amplifier when the signals are large. Essentially, it is the same as an amplifier bias between the Class A and Class B conditions of operation. The result is that plate current flows during appreciably more than half of each signal voltage cycle, yet for less than the complete cycle, since the fixed-bias non-adjustable system is used. As shown in Fig. 23-26, plate current flows during more than half a cycle, for the fixed bias is adjusted to about point *D*. For small signals, the plate current varies above and below point *D* uniformly with the signal voltage, and the system is Class A; when the signal strength becomes large, the plate-current swing on one half-cycle alternately becomes greater than that on the other, and the system is Class B. The service problems connected with Class AB systems are essentially similar to those of the Class B system (see Art. 23-36).

The driver tube need not supply much power, nor must the input, output, and power transformers be as large in a Class AB as in a Class B amplifier. However, they should correspond

more to Class B than to Class A apparatus. Several models of household receivers employ a Class AB amplifier in the output stage.

23-39. Fixed- and Self-Bias in Class B Amplifiers.—The usual resistor in series with the cathode or filament of a tube supplies bias because of the flow of cathode current through this resistance. A by-pass condenser of large capacity must be connected across it, however, to prevent degeneration, as explained in Art. 23-7. With Class AB and Class B systems, the fluctuating plate current is sometimes so great that it is difficult to keep the bias constant unless a by-pass condenser of prohibitively large capacity is used. It is for this reason that many of the present-day Class B tubes have been designed for use with zero bias to obtain Class B operation.

But when the output tubes are not so designed, it is necessary to maintain the bias fixed, otherwise the degeneration will appreciably reduce the power output. In such cases, the bias is usually kept constant by incorporating a separate rectifier-filter system for the sole purpose of supplying bias to the Class B stage. In some cases, this rectifier-filter system also supplies plate voltage to the r-f and i-f amplifier tubes, since they draw but little current and therefore cannot appreciably affect the bias voltage developed. A receiver utilizing such a system will then have two power systems, and, when servicing them, each must be considered as if the other did not exist.

23-40. Miscellaneous Amplifier Systems.—Aside from the usual types of amplifier systems described here, there are several other types that are in common use in some radio equipment. The service man should become familiar with them. The service problems to be encountered with these systems are not unlike those already mentioned, and will not be repeated here. Only the general theory of operation will be pointed out. From this, service problems may be anticipated and the solutions predicted.

23-41. The Direct-Coupled Amplifier Tube.—The direct-coupled amplifier tube, shown at (A) of Fig. 23-28, is employed in a number of receivers now in use. It consists of two triodes in a single envelope. P_1 , G_1 , and K_1 are the plate, grid and cathode, respectively, of the first, or *input*, section; and P_2 , G_2 , K_2 are

the plate, grid and cathode, respectively of the second, or *output*, section. The distinguishing characteristic is that the input cathode is connected to the output grid directly, *inside the tube*, as shown. The circuit arrangement employed is shown at (B) of the figure. The cathode of the input section connects to the grid of the output section, so that the grid-cathode resistance of

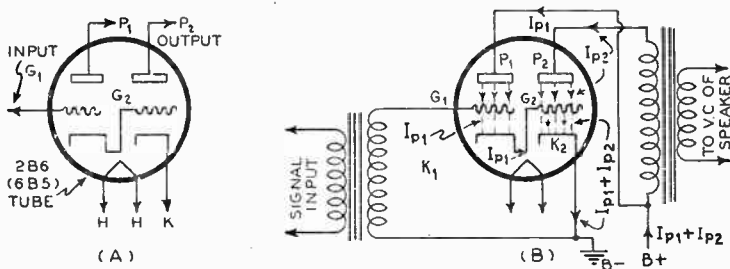

FIG. 23-28.—(A) Arrangement of the electrodes and internal connections in a direct-coupled amplifier tube.

(B) The circuit arrangement employed with the tube connected as a direct-coupled audio amplifier.

the output section is the load of the input; it is in the “cathode” instead of in the “grid” circuit. The plate and grid return of the first section, therefore, is made through the input resistance of the second section. Furthermore, the bias on the *No. 1* grid is the grid-cathode voltage drop in the second section. The path of the plate current for each section of the tube is indicated by dotted lines and arrows.

A signal applied to the first grid varies the plate current of the first section. This plate current flows from the cathode of the first section to the grid of the second section. This varying current changes the voltage drop across G_2-K_2 , which actuates the plate current of the output plate circuit in the normal fashion. The system is strictly Class A, and the one tube shown could be replaced by two separate tubes with equal results.

23-42. Meshed Duo-Grid Tube Operation.—A rather unique detector-amplifier circuit is shown in Fig. 23-29. The tube structure consists of a heater, a cathode, two inter-meshed grids equally spaced from the cathode and from the plate, and a single plate. The two grids connect to both ends of the r-f

transformer secondary and the center tap of that winding connects to cathode through the conventional grid leak and condenser, R and C . The primary of the audio transformer is connected between the single plate and $B+$.

When a signal is tuned in, one grid becomes positive while the other one becomes equally negative, and vice versa. Therefore, the plate current does not vary, so far as the r-f signal is concerned, since both grids are always at exactly the same potential but of opposite polarity; i.e., one grid tends to increase the plate current while the other tends to decrease it an equal amount, so the net r-f plate current change is "zero". However, each of the grids becomes "positive" once during each cycle. Each time that happens, the positive grid draws *grid current* which flows through the leak and condenser; on the other half cycle the other grid draws grid current, which also flows through the leak. In this manner the potential of both grids decreases according to the audio variations of the modulated signal, and the plate current changes accordingly. In other words, the r-f plate current changes are zero, but the audio voltage built up across the grid-leak and condenser is applied to both grids in parallel, since they are in the common leg, and vary the plate current at an audio

FIG. 23-29. — Circuit arrangement for a meshed duo-grid tube (Wunderlich tube) operated as a detector.

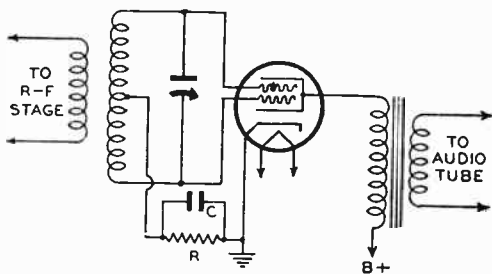

rate in accordance with the modulation of the incoming r-f signal.

This is the distinct advantage of the meshed duo-grid tube—the plate current varies only at an audio rate, thus preventing r-f from entering the audio system and generating what is known as "fringe howl."

23-43. Tone Controls.—Many people do not desire the full audio range of reproduction possible with a given receiver. They

demand more of the low notes than the high—they are willing to sacrifice purity of sound for “mellowness.” To accomplish this, and to enable the same receiver design to satisfy the different tastes of a number of people, it is customary to provide some means of reducing the high note reproduction at will. The device which does this is called a *tone* or *color* control.

Figure 23-30 shows several common tone-control circuit arrangements. They all contain a condenser in one form or another. The system at (A) consists of a resistor R in series with a condenser C connected from the plate of the output tube to

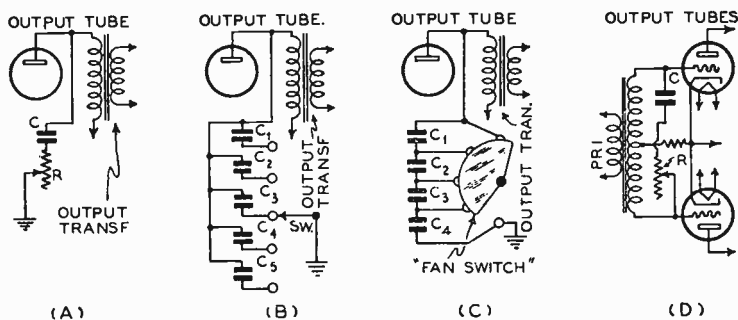

FIG. 23-30.—Several common tone-control circuit arrangements.

ground. C may have a value of about 0.003 mfd. and R a value of 50,000 ohms, the exact sizes depending upon the type of tube in use, the frequency response of the audio system, etc. When R is set at its minimum value, C is most effective in by-passing the high audio frequencies to ground; when R is set at maximum, C does the least amount of by-passing.

System (B) does not use a resistor, but consists of a number of small condensers arranged to be individually selected by means of a tap switch. The condensers are of various capacities, arranged so that each one by-passes a little more than an adjacent one.

A third method in common use, shown at (C), is similar to that at (B), except that the condensers are connected in series, and as many as three may be short-circuited at once by a fan-switch, leaving the fourth to by-pass. As the switch is turned back, more and more condensers are connected in series, thereby

lowering the resultant capacity and thus decreasing the by-passing effect.

Not all tone controls are connected in plate circuits; some are in grid circuits, as shown in (*D*). This circuit shows the most common location of the tone control in push-pull circuits. It consists of the usual capacity-resistor series arrangement. But regardless of whether the tone control is in the circuit of the plate or the grid, the fact remains that it is connected somewhere in the audio circuit so that it by-passes the higher audio frequencies.

It should be noted that the usual type of tone control does not increase the low-frequency response at all; it merely reduces the high-frequency response. Due to a peculiar physiological action of the ear, the result sounds as though the intensity of the low notes were increased instead. In this connection, it will be well to mention here another point about steady low-frequency hum in receivers employing a tone control. In such receivers, the hum which is present will become much more noticeable when the tone control is adjusted to reduce the high-frequency note reproduction. This action really makes it appear as though the cause of the hum is of such a nature that it increases when the tone control is set in this position—which of course is not the case.

Troubles in tone-control circuits are usually confined to poor tone control operation due to open circuits, loose or imperfect switch or resistor arm contact, or open-circuited tone control resistor elements (when they are employed). Of course, the usual routine tests (see Chapter XXII) made on the components employed in the tone control circuit will quickly reveal such troubles.

23-44. Volume Controls.—Almost every receiver manufactured during the past few years uses some form of diode detection. This detection arrangement is almost always accompanied by automatic volume control, which requires that the manual volume control be placed in the audio amplifier. Some receivers use a three-winding i-f transformer, one for the avc tube and one for further amplification. In such cases, the volume control may be connected in the i-f circuit. The reader is

referred to the many circuits presented in Chapter XIX for the location of the volume control in modern receivers.

In older receivers, the screen-grid voltage of the r-f and/or i-f tubes is varied for control of volume. This type of control is connected somewhat as shown in the sketch of Fig. 23-31. The plate voltage is reduced to the maximum value suitable for the screen grids by R_1 ; R_2 varies the screen-grid voltage for control of volume; and R_3 is a small bleeder resistor to prevent the screen voltage from reaching zero when R_2 is set at the "minimum voltage" position.

Another favorite form of volume control which has been used in many of the older receivers was one which varied the control-

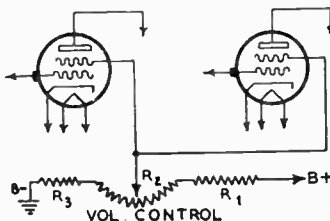

FIG. 23-31.—A typical circuit arrangement for the control of volume by the variation of the screen grid voltage in the r-f or i-f circuits.

grid bias and effective length of the antenna coil at the same time, as shown in Fig. 23-32. When the arm of potentiometer R is set so that the ground and $B-$ wires are connected to point A , the bias on the tube is a minimum (which makes its amplification maximum) and the full antenna coil is used. Therefore, this is the "full volume" position. When it is at B , the antenna is grounded and the bias is maximum (making the tube amplification minimum). Of course, only the bias may be varied in some systems of this kind, and only the antenna-coil length (effective) in others, but the combination of both is more effective, since it helps to give better control for low volume due to the fact that not only the amplification of the first tube is reduced, but the coupling of the antenna coil is reduced as well.

There are numerous other methods used to control volume, but the ones described here are the most important and the ones most encountered in the service field. Practically all volume control arrangements employ variable resistors, and it is in these that trouble may occur. The usual troubles are, dirty

contact, or insufficient pressure, between the resistor element and the movable arm. Very often, sharp burrs or nicks are present on the surface of the resistance element or the contact arm. These troubles may result in very noisy operation of the volume control, or even intermittent operation. Dirty contacts can be cleaned with a cloth soaked with gasolene, alcohol, or ordinary clothes-cleaning fluids. Insufficient contact-arm pressure may be remedied by bending the arm. Nicks or burrs may be carefully filed, scraped or sanded down if it is worth while. An open-circuit, caused by a break in the thin resistance wire used in these resistors, usually necessitates replacement of the volume control resistor (see Arts. 22-9 and 26-3).

23-45. Obscure Troubles in Receiver Output Circuits.—

In many of the early receivers which employ magnetic type loudspeakers (service men are still called upon to service them), no provision is made to safeguard the fine-wire coils of the speaker against possible burnout by the plate current of the output tube. They were simply connected in series with the plate circuit of the last audio tube as shown at (A) of Fig. 23-33. Later receiver designs incorporated a choke-condenser combination as shown at (B), to keep the high direct plate current of the tube from injuring the fine wire of the speaker windings.

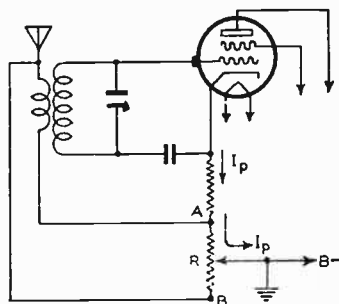

FIG. 23-32.—A typical volume control arrangement in which the grid bias of the first tube, and the effective length of the antenna coil are varied simultaneously.

If the blocking condenser, *C*, in (B) becomes short-circuited, it will be evidenced by choked and distorted reproduction, sounding very much as though the grid bias of one of the audio tubes is low. This trouble will not be revealed by the usual tube socket voltage analysis of the receiver. Sometimes, no signals at all will be heard. If the choke *L* open-circuits, the plate of the

power tube will receive no voltage and operation will cease. Of course, this trouble would be revealed by a voltage analysis of the receiver.

Many of the older magnetic speakers were equipped with a filter to prevent the generation of fringe howl. A typical diagram of such a filter is shown in Fig. 23-34. It consists of a single choke coil, L , and two condensers, C , connected between the speaker winding and the speaker terminals. If severe distortion is experienced when this type of speaker is employed, the individual parts of this filter should be tested thoroughly, for a partially short-circuited condenser may be the cause. If the choke becomes open-circuited, or one of the condensers become completely short-circuited, the speaker windings will receive little or no current and reception will be weak or absent alto-

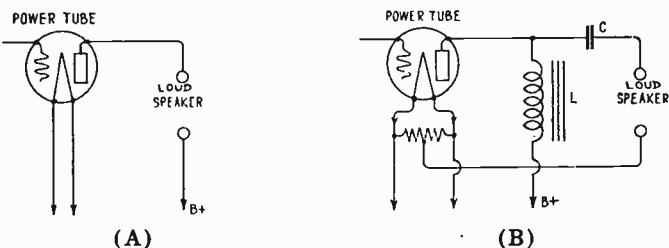

FIG. 23-33.—(A) Connecting the loud speaker winding directly into the plate circuit of the power tube.

(B) Use of the choke and condenser coupling arrangement for magnetic speakers. This keeps the heavy plate current of the power tube out of the delicate windings of the speaker.

gether. Magnetic speaker repairs are considered in Arts. 26-17 to 26-25.

Dynamic speakers usually have a very low-resistance *voice coil* of comparatively few turns. Therefore, the voice coil has a low impedance and acts practically like a pure resistance. The impedance of voice coils in dynamic speakers commonly employed in radio receivers is usually between 1 and 15 ohms. Two exceptions to this are found in some early Colonial and Peerless types which employed a voice coil consisting of a single turn of thin copper strip having an impedance of approximately 0.006 ohm. Roughly speaking, the impedance (at 1,000 cycles) of a

dynamic speaker voice coil is about 33% greater than its d-c resistance. Since the output impedance of power amplifier tubes is so much greater than that of dynamic speaker voice coils, an impedance-matching transformer of proper design must be used between them. The primary, *P*, of this transformer is connected in series with the plate circuit of the power amplifier

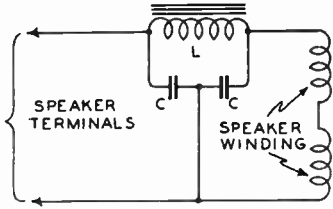

FIG. 23-34.—A typical filter for a magnetic speaker. This prevents fringe howl.

tube, as shown in Fig. 23-35; the low-impedance secondary, *S*, is connected directly to the voice coil of the speaker.

When a push-pull power amplifier stage is used, the primary of the output transformer is center-tapped, as shown in Fig. 23-36. It is advisable, when one of the tubes is found without plate voltage, to test for an open-circuit in that section of the output transformer primary which connects to this tube.

A partially short-circuited secondary winding will result in

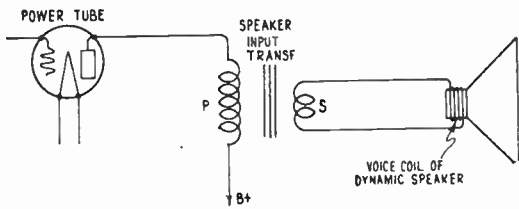

FIG. 23-35.—The connection of a speaker input transformer between the plate circuit of a single power output tube and the voice-coil of a dynamic speaker.

weak and distorted reproduction. The same symptom results if the voice coil of the speaker becomes partially short-circuited (this trouble and its remedy will be discussed at length in Art. 26-35 of Chapter XXVI). To check for this condition, it is not necessary to disconnect the secondary winding from the voice

coil before checking its resistance with an ohmmeter. A more rapid test may be made by short-circuiting these windings with a very short length of wire, provided some reception is obtained. If the response is materially weakened when the voice coil or output transformer secondary is short-circuited, then these windings are not likely to be at fault. If little or no variation of signal strength results, it indicates a short-circuited or partially

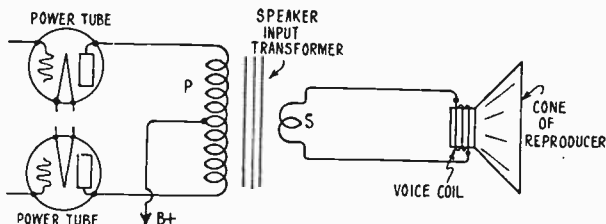

FIG. 23-36.—The same speaker circuit arrangement as that of Fig. 23-35—for two power tubes in push-pull.

short-circuited output transformer secondary or voice coil. Of course, each should then be disconnected and tested *separately* with an ohmmeter to find out which one is at fault.

23-46. Obscure Troubles in Loud Speakers. — Many troubles which are not revealed by the usual receiver analysis may develop in the loud speaker. Fortunately most of these loud speaker troubles result in symptoms which are easily recognized, and they are not extremely difficult to repair. Magnetic type speakers (which employ a permanent magnet for the field) are subject to such troubles as weak reproduction, no reproduction, distortion, noisy operation, rattling and rasping. In addition to these, dynamic speakers are subject to hum and chattering. Since all of these troubles and the methods of eliminating them are discussed at length in Arts. 26-14 to 26-45 of Chapter XXVI, it is sufficient for our purpose merely to mention them here.

23-47. Distortion Due to Improper Speaker Phasing. — Many receivers and public-address systems employ two or three dynamic speakers, all operating from the same output transformer. When repairs are made on such speakers, it is essential that their voice coils be connected back properly so that they

operate in the proper phase relation. When the voice coil leads, or terminals, are not color-coded for identification, it is easy for them to become interchanged accidentally. If this should happen, a simple test must be made in order to re-connect them properly, so that the voice coils and cones of all the speakers operate in unison, i.e., so that they are properly *phased*. Let us see why "phasing" is so necessary.

The illustration of Fig. 23-37 shows the results produced when the voice coils and cones of dynamic speakers are, and are not, phased properly.

There are three speakers, 1, 2 and 3, each inclined so as to direct sound to a region designated as "listener." It is not necessary that the speakers be inclined as shown; the result will be the same if they are all facing in one direction; the inclined arrangement is shown for easier visualization of the action which takes place. Let us suppose that the voice coils of speakers 1 and 2 are connected properly, but that of speaker 3 is not phased properly with them.

At a given instant, the cone of speaker 1 is moving forward and pushing air away from the front of the cone; speaker 2 is doing exactly the same thing in unison with 1, and is therefore in phase with 1; but the cone of speaker 3 is moving back, creating a partial vacuum directly in front of it. The movement of the cone of speaker 3 is therefore out of phase with that of speakers 1 and 2.

When a cone or any other form of diaphragm vibrates, it pushes air away from it in front when it moves out, and "sucks in" air when it moves backward. For our purpose, this action may be considered as being similar to that of a piston moving in a cylinder. On the forward motion it *increases* the air pressure in front of it, and on the backward motion it *decreases* the normal air pressure, which is normally about 14 pounds per sq. in. The regions of greatest pressure (compressions) are indicated in the illustration by closely-spaced lines, and the points of least pressure (rarefactions) are indicated by widely-spaced lines.

Let us now see what happens at the region of the listener as a result of this improper phasing. We will consider, first, the

instants when compressions from speakers 1 and 2 reach this point. At these instants, the *compressions*, indicated by C_1 and C_2 , of speakers 1 and 2 meet *in phase* with each other and therefore *reinforce* each other. At such instants, the cone of speaker No. 3 is moving in the opposite direction, since it is out

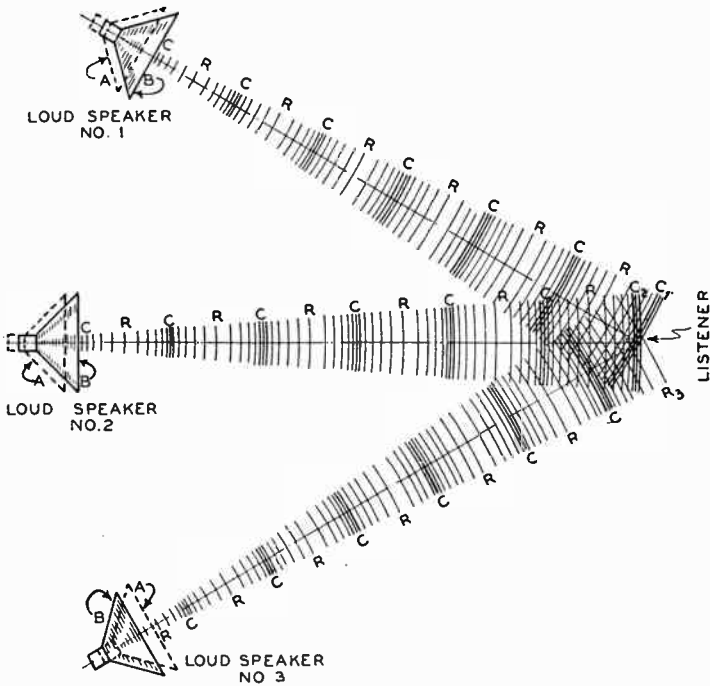

FIG. 23-37.—What happens when a number of loud speakers operating from the same radio receiver (or public-address amplifier) are not properly “phased”. At the location of the listener, the sound waves from speakers No. 1 and No. 2 arrive “in phase” and reinforce each other. Since speaker No. 3 is out of phase with these two, its sound waves arrive at the listener out of phase with those of the other speakers and tends to neutralize the sound. For all three speakers, A is the “at rest” position of the cone and B is the position of the cones considered simultaneously at some other instant.

of phase with the other two cones. Therefore, a condition of *rarefaction* from this speaker (indicated by R), also reaches the listener. The result is that the rarefactions produced by speaker 3 partially neutralize the compressions produced by speakers

1 and 2, thus decreasing the intensity of the sound heard. Of course, at the instants when *rarefactions* from speakers 1 and 2 reach the listener, *compressions* from speaker 3 get there and partially neutralize them. It is unnecessary to go into further detail here concerning the effect of improper speaker phasing on the tone quality (remember that when two or three loudspeakers are employed in receivers, each one is designed to reproduce only a certain portion of the audio-frequency range).

The plunger action of the speaker cone as described here is true only for the lower audio frequencies; at the higher frequencies the mode of vibration of the cone does not exactly follow plunger action, so severe distortion of the resulting sound may take place if the speaker cones are not properly phased; i.e., connected so that they all move in the same direction at the same time.

In cases where only two loud speakers are operated in the same room from the same receiver or public-address system, it is quite conceivable that objectionable cases of neutralization of the sound waves may result if the voice coils are not properly phased. Neutralization of the sound waves gives rise to *dead spots*. These are locations in a room where little or no sound from the loud speakers is heard. This action may also produce regions in the room where the little sound that is heard is so distorted that the intelligent interpretation of speech is impossible.

23-48. Phasing Dynamic Speakers.—To ascertain whether or not the voice coils of multiple loud speakers are properly phased, the speakers may be removed from the cabinet but left connected to the receiver so that the movement of the cones may be observed. The receiver should be turned off. A small 4½-volt *C* battery (or an ordinary 1½-volt dry cell) should then be connected either in parallel with, or in series with, the main secondary winding of the output transformer which feeds all the voice coils of the speakers (see Fig. 31-16). At the moment electrical contact is made, all the cones should move in, or out, *together*. The direction of motion when this is done may be determined by placing the fingers lightly against each speaker cone, in turn, and feeling the movement of the cone. If the cone of one speaker moves *in* while the others move *out*, the voice

coil of the former one is out of phase. The remedy for a two-speaker installation is to reverse the connecting leads to the voice coil of *either* of the speakers. When three speakers are employed, the leads to the voice coil of that *one* which is out of phase should be reversed.

23-49. Radio-Phonograph and Phono Pickup Troubles.—The rubber-damped magnetic phonograph pickup is very widely employed in commercial combination "radio-phono" receivers. This type of pickup operates on much the same principle (reversed) as the magnetic speaker. The unit here is somewhat similar, except for the addition of rubber damping pieces and a device (called the *stylus*) to hold the phonograph needle to the armature. The magnetic pickup is essentially a miniature alternating current generator, having a vibrating armature in place of a rotating member. The vibrations of the armature are produced by the movement of the needle (fastened to the armature) caused by the irregular grooves of a rotating phonograph record. Since the armature vibrates between the pole pieces of a strong permanent magnet, the variation of the magnetic field in the gap cuts the many turns of wire of the small coil which is also mounted in the field of the magnet and through which the armature passes. The alternating voltage generated in the pickup coil by this action is fed into the audio amplifier of the receiver and amplified. (A description of the construction and arrangement of the various parts in a typical rubber-damped magnetic phono pickup is presented in Art. 26-47 of Chapter XXVI.)

Low volume, distortion and "rattling" observed *only* when the phonograph section of a radio-phonograph receiver is operated, may usually be traced to some fault in the pickup. The repair of common pickups used in radio-phono combinations will be discussed in Arts. 26-48 to 26-52 of Chapter XXVI. Improper turntable speed and alignment are also causes of distorted phonograph reproduction. The method of ascertaining the speed of phonograph motors and the procedure to follow in aligning them will be presented in Arts. 26-53 to 26-54.

REVIEW QUESTIONS

1. State 5 possible causes for lack of sensitivity in a receiver, if all the tubes test perfect and the voltages are normal.

2. Suppose you are testing a t-r-f broadcast band receiver and obtain good reception only at the high-frequency end of the dial. What would you attribute the insensitive condition of the receiver at the low-frequency end of the dial to? How would you check this?
3. Describe the construction of a tuning wand. Explain how it is used.
4. You find that a broadcast superheterodyne receiver is insensitive on the higher frequencies. To what could this condition be due, and how would you determine the cause definitely?
5. What is meant by "degeneration" in an amplifier? Explain its possible causes.
6. Mention 5 possible causes for oscillation in a radio receiver, in which the audio amplifier is known to be normal.
7. What recognizable symptoms accompany oscillation in t-r-f receivers? Describe a simple test for detecting the oscillating condition definitely.
8. How would you locate and eliminate the cause of whistles which are heard over the entire tuning range as a t-r-f receiver is tuned from station to station?
9. State the various types of interference it is possible to encounter in superheterodyne receivers.
10. State 5 conditions that may cause a station to be received at more than one point on a superheterodyne receiver? What is this trouble called? State briefly how you would go about eliminating it.
11. What is the main purpose of the usual tuned r-f amplifier stage, ahead of the mixer stage? Explain how it accomplishes the desired result.
12. What is the relation between image-interference and double-spot tuning?
13. What steps would you take to remedy a condition of code interference in a superheterodyne?
14. What is a band-pass antenna circuit? What is an "acceptor" circuit?
15. What is meant by modulation hum?
16. How would you determine definitely whether a certain r-f stage was producing modulation hum?
17. State 4 possible causes for such hum.
18. How would you proceed to minimize, or eliminate it for each of the causes you mentioned?
19. Discuss the complete procedure for locating the cause of steady hum in a radio receiver. Mention 10 possible causes for this condition.
20. Why should all a-c leads be kept away from the detector tube? Why is the detector tube particularly critical in this respect?
21. A receiver is reported to be troubled by "fading". How would you determine definitely whether the fading is due to some condition in the receiver, or to natural fading of the transmitted signal due to transmission peculiarities?
22. How would you proceed to determine the cause of "fading" in

- the receiver, when the foregoing test shows definitely that it is not due to transmission fading of the signal?
23. What tests would you make on an antenna system in order to reveal possible causes for intermittent reception?
 24. Suppose you are testing a superheterodyne receiver, and find that intermittent reception occurs between 550 and 650 kc but not above 1,000 kc? What would you suspect to be the cause for this? State your reasons.
 25. Why is it more desirable to check a receiver for intermittent reception in the shop instead of in the home of its owner?
 26. If the resistors and condensers in a receiver, tested normal with the set turned off, and you were certain that one of them was defective, what expedient would you use to simulate operating conditions with the set turned off?
 27. Explain just how you would examine the wiring and joints in a receiver for poor contacts.
 28. Explain your method of re-soldering a poorly made joint, or a "rosin" joint that is suspected of causing intermittent reception.
 29. What would be the best conditions under which to visually examine all the parts of a receiver to locate any possible arcing or sparking which might be causing noisy or intermittent reception?
 30. How would you check a variable-resistor volume control for possible causes of intermittent reception?
 31. Explain how adding a pig-tail lead on the rotor of the main tuning condenser in a receiver might remedy intermittent operation caused by the r-f circuit oscillating.
 32. Explain how noisy or intermittent reception may be caused by peeling of the plating employed on the plates of the variable tuning condensers used in the r-f tuning sections of some receivers. What operation peculiarity would lead you to suspect this as a cause of the trouble?
 33. Explain how you would use a test oscillator to find out definitely whether intermittent reception in a particular superheterodyne receiver was due to trouble in the stages ahead of the second detector, or in those following the second detector.
 34. Explain how you would proceed to check each a-f stage, and the loud speaker separately in the foregoing receiver, if the oscillator test shows definitely that the cause of the intermittent reception lies in this portion of the receiver.
 35. What are the most frequent causes for "microphonics" in a radio receiver? Describe 3 simple remedies to overcome this trouble.
 36. Discuss, briefly, 5 causes for weak and distorted reception caused by some fault in an audio amplifier.
 37. You find a "positive" grid bias on a tube in a transformer-coupled audio stage. In your opinion, what is the most probable cause for such a condition? The same symptom is observed in a resistance-coupled stage. What would be the most probable cause in this case?
 38. What trouble symptom would a leaky coupling condenser in a

- resistance-coupled a-f amplifier cause in a receiver? Explain why?
39. What is meant by a direct-coupled amplifier? Draw a schematic circuit diagram of one and explain its operation.
 40. Explain the difference between Class A, Class B, and Class AB amplification.
 41. What is a "driver tube"?
 42. What is meant by the "power sensitivity" of a power output tube?
 43. What is the purpose of operating two Class B amplifier tubes in push-pull? Explain how the push-pull arrangement accomplishes this purpose.
 44. Can the same input, output, and power transformers be used in a Class A and Class B amplifier? Why?
 45. What is the advantage of the Class AB type of amplifier when used in the output stage of a household receiver?
 46. Explain the reason for using a separate rectifier-filter system for supplying bias voltage to the Class B amplifier output stage in some receivers.
 47. By carefully tracing out the paths of the plate currents in (B) of Fig. 23-28, explain exactly how the input tube section obtains its negative grid bias in the direct-coupled amplifier tube shown.
 48. How would the operation of the input tube section in this direct-coupled amplifier tube be affected if the cathode emission of the second section only was to decrease greatly due to some cause? Explain!
 49. Explain the operation of the meshed duo-grid tube (shown in Fig. 23-29) as a detector.
 50. What trouble symptom would result in a receiver employing the detector arrangement of Fig. 23-29 if (a) the grid leak resistor was to become open-circuited; (b) the grid condenser was to become open-circuited; (c) the grid condenser was to become short-circuited? Explain fully in each case.
 51. Draw the circuit diagrams, and explain the operation of, three different arrangements for tone control. Tell what possible troubles can occur in each type, and what the receiver symptoms would be in each case.
 52. What trouble symptom would be apparent in a receiver employing the volume control arrangement of Fig. 23-31, if resistor R_1 became open-circuited? Explain!
 53. What abnormal condition, noticed when the screen-grid voltage was checked, would make this trouble apparent?
 54. Explain how you would proceed to determine quickly, without the use of testing equipment, whether weak and distorted reproduction in a receiver employing a dynamic loud speaker is due to a partially short-circuited output transformer secondary or speaker voice coil. What result would be obtained in this test, if the winding and coil are in perfect condition?
 55. Why would the test employed in question 54 not be reliable in the case of loud speakers employing a single-turn low-resistance voice coil?

CHAPTER XXIV

ALIGNING AND NEUTRALIZING T-R-F RECEIVERS

24-1. *Necessity for Realignment.*—Many of the millions of t-r-f receivers which have been manufactured are still being used, and servicemen are constantly being called upon to service them. It is evident that maximum sensitivity and selectivity cannot be obtained from any t-r-f receiver having single-dial tuning control unless the tuned circuits are properly lined up—each tuned circuit is tuned to exactly the same frequency at any setting of the tuning dial. If one or more of the stages tunes to a higher, or lower, frequency than the rest, that stage will not be tuned to exact resonance with the signal the others may be tuned to, and consequently lower amplification and loss of selectivity will result. Of course, the tuning circuits of t-r-f receivers are aligned properly at the factory when manufactured, but there are many reasons why the adjustments do not hold indefinitely.

The coils of the tuned circuits may absorb moisture, they may expand and contract, and perhaps shift their position in the shield can slightly if the receiver is jarred. Any of these changes will tend to change the inductance of the coils slightly, thereby unbalancing the tuned circuit. However, this may be compensated for to some extent by adjusting the tuning condenser capacity. The small trimmer condensers used across the tuning sections of t-r-f receivers certainly do not maintain their capacity setting for long periods of time and are subject to variation with changes in weather. These trimmers, called *semi-variable* condensers, hold their setting in most instances because of the tension in one plate. The strain set up in this plate during the initial adjustment at the factory often changes later due to periodic changes in temperature and humidity, vibration and

aging, just as a strained spring will lose its tension if left exposed to the elements for a long time. This will also tend to unbalance the tuned circuit.

Changing a tube will often necessitate realigning a tuned circuit in some t-r-f receivers. The reason for this is apparent when it is known that the effective tuning capacity in a tuned circuit is the sum of the tuning-condenser capacity, the distributed capacity of the coils, the stray capacity of the wiring, the capacity of the socket of the stage under consideration, and the input capacity of the tube. Tubes of the same type but of different manufacture often have different internal capacities, and, while the differences are small, their effect (especially upon short-wave circuits) may be such as to appreciably decrease the sensitivity of a receiver.

It is not well appreciated by the average serviceman that the input capacity of a tube is not just merely the capacity from grid to filament. The *effective* input capacity of a tube depends upon the grid-filament capacity, the amplification factor of the tube, the grid-plate capacity, and the load impedance. This is an important consideration in triodes, for any change in load impedance will be reflected through the tube to the input circuit, and manifest itself by a change in effective tube capacity. In tetrodes and pentodes, the grid-plate capacity is so small that the effective input capacity is about equal to the grid-filament capacity.

The gang tuning condenser itself is not immune from causing variations in capacity with time. In these condensers the shaft carries the rotor plates, and the shaft rests in bearings, which may or may not be of the ball-bearing type. Usually, only the front bearing is of the ball type. In any event, friction in the bearing will gradually cause it to wear down, changing the position of the rotor plates with respect to the stator, and changing the capacities of the individual sections. If this change in position is permanent, the tuned circuits must be realigned, especially if the receiver is very selective.

24-2. Realignment of Tuning Circuits.—Because the distributed and stray capacities in the tuned circuits are invariably somewhat different for every stage in the receiver, some means

must be used to make them all equal and to keep the *total* capacity of each stage exactly equal to that of every other stage throughout the entire tuning range of the receiver. The process of making them equal is commonly called *balancing*, *lining up*, *aligning*, or *synchronizing*.

The alignment of some of the older receivers must be accomplished by adjusting a number of small, variable, built-in com-

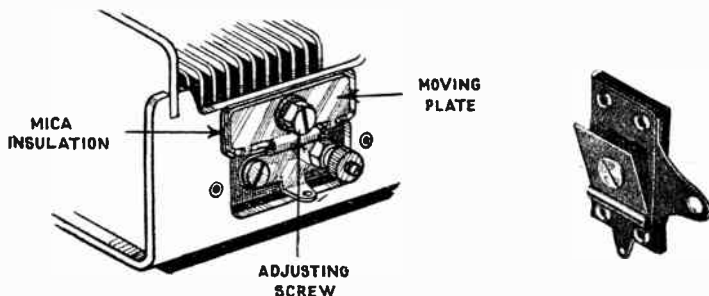

Courtesy The Wireless World

Courtesy Hammarlund Mfg. Co.

FIG. 24-1.—The usual form of trimmer condenser construction is illustrated here. At the left, a trimmer condenser is shown built on to the side of a gang tuning condenser in the usual way. The metal frame of the gang condenser forms one plate of the trimmer. A small plate of springy metal, insulated from it, forms the other plate. At the right, a typical individual trimmer condenser is shown. Its adjusting screw and other construction features are clearly shown.

pensating condensers or “trimmers”, one being connected in parallel with each of the main tuning sections of the condenser gang, as shown in Fig. 24-1. In the later receivers, these trimmer condensers are supplemented by supplying each section of the main tuning condenser with one or two rotor end plates, which are slotted, allowing the fan-shaped segments of the plate to be bent one way or another, to allow capacity adjustment. When a segment is bent *in* toward the stator plate next to it, the capacity *increases*. When it is bent *out* away from the stator plate, the capacity *decreases*. The fan-slotted plate in the rotor unit of each section of a modern gang condenser is clearly illustrated in Fig. 24-2. The fan-shaped segments can be seen.

The trimmer condensers, and the split end-rotor plates mounted on the condenser shafts of the more recent t-r-f receivers constitute the only two devices employed to line up their tuning

circuits. It is important to note here that practically all of the gang-tuning condensers used in *standard-broadcast band* receivers are provided with trimmer condensers. Those in *all-wave* receivers usually do not have trimmers built into them because all-wave receivers use separate tuning coils for each band, hence a different trimmer capacity is required for each coil that is used. Consequently, each tuning coil of these receivers is usually provided with its own trimmer condenser mounted near it. (See Chapter XXVIII for further details regarding all-wave receiver tuning circuits.)

24-3. Uses of the Trimmer Condensers and the Split End-Rotor Plates.—The trimmer condensers connected in parallel with each section of the main tuning condenser are used to equalize the capacities of the different tuned circuits that are being lined up. The shunt trimmers are most effective at the low-capacity settings of the tuning condenser; they are least effective on the high-capacity settings. The reason for this may be seen by studying the electrical constants of a tuning condenser section and its trimmer in a modern receiver. The tuning condenser has a *maximum* capacity of 450 mmfd., and a *minimum*

FIG. 24-2. — A 5-gang tuning condenser. Five sets of rotor plates are rotated simultaneously by a single common shaft. The groups of stator plates are insulated from each other. Notice the slotted rotor plate at the end of each section.

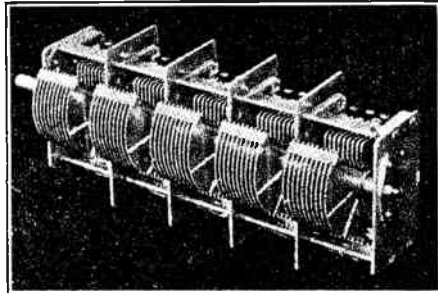

capacity of about 11 mmfd. Its trimmer has a *maximum* capacity of 20 mmfd. and a *minimum* capacity of 3 mmfd. Assume the trimmer to be set at its minimum capacity setting, and further assume that the tube and stray capacities, and the distributed capacity of the tuning coil, all add up to about 20 mmfd. The *maximum* capacity in the tuned circuit is then $450 + 3 + 20 = 473$ mmfd.; and the *minimum* is $11 + 3 + 20 = 34$ mmfd.

(Notice that the trimmer has a maximum capacity equal to about *half* the total capacity in the circuit at the *lowest-capacity* setting of the main tuning condenser.) At the *highest-frequency* (*minimum-capacity*) setting of this particular tuning condenser, the trimmer condenser is able to change the circuit capacity by $\frac{20-3}{34} \times 100 = 50\%$ (which corresponds to about an 18.5% shift in *frequency*). At the *lowest-frequency* (*maximum-capacity*) setting of the tuning condenser, the trimmer condenser is able to change the circuit capacity by only $\frac{20-3}{473} \times 100 = 3.6\%$. From this example it is evident that the trimmer is most effective in changing the natural frequency of the tuned circuit at the *low-capacity* settings of the main tuning condenser.

Since the tuning condensers of the older broadcast band t-r-f receivers are not provided with slotted end plates, these receivers can be balanced *at but one point* on the dial. This is generally

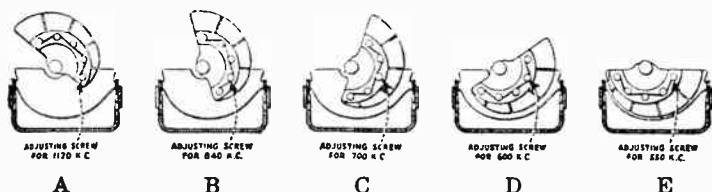

FIG. 24-3.—The slotted end-plate on each section of a gang tuning condenser. Set-screw adjustments are provided on this particular type for accurately adjusting the position of each segment. The rotor plates are shown in the 5 different positions at which the adjustments should be made, and the test signal frequency for each adjustment is also shown.
Courtesy ROA Victor Co.

done with the receiver tuned to a test oscillator signal at about 900 or 1,000 kc. (approximately 50 on the tuning dial). If the alignment is "off" at each end of the dial, nothing much can be done about it. If some particularly desired station that comes in at some other point of the dial is received poorly, the receiver may be balanced at the frequency of this station instead, so that this station is received well. Of course, if this is done, it is very likely that stations at other points on the dial will then be received with less sensitivity and volume than before.

When a fan-cut (split) rotor plate is provided on each section of the gang tuning condenser, the circuits may be aligned exactly over the entire tuning range. In some of these condensers, adjustment is accomplished by simple bending of the fan-plate sections in or out with a short, insulated rod. Since it is rather difficult to bend the segments delicately and accurately by hand, some t-r-f receivers employed a gang condenser with a set-screw arrangement as shown in Fig. 24-3. The set screws pass through a solid plate fastened to the rotor shaft, and are mounted so that the end of one screw presses against one segment of the split end-rotor plate. By turning the screw, the segment it rests against can be pushed in or out from the adjacent stator plate by a very small amount, thus altering the capacity. The screw is then locked in place to prevent it from turning due to vibration from the loud speaker. Adjustment is usually made with the receiver tuned to frequencies corresponding to the number of slits in the rotor plate. The five positions of the rotor (and the frequencies) at which these adjustments are made, are shown in the illustration.

The purpose of the split rotor plates is not to line up the tuning circuits at the minimum setting of the tuning condenser, but to compensate for small capacity variations throughout the range of the tuning condenser. The fact that the tuned circuits of selective receivers must be lined up *exactly* over the entire scale may be appreciated if it is realized that many radio manufacturers make provisions for adjusting the tuning capacities so that the frequency difference between the various tuned circuits tuned by the sections of the gang condenser may be kept as low as a fraction of one per cent at any setting.

24-4. Location of Trimmer Condensers.—In most commercial receivers, the compensating or “trimmer” condensers for the tuned r-f circuits are located at the top, side, or bottom of the tuning gang. In a few receivers, however, these aligning condensers are mounted above or under the chassis. In the latter instance the adjusting screws or nuts are accessible through an opening in the chassis. Each trimmer condenser usually consists of a fixed plate (which may be the grounded metal frame of the condenser gang) and an adjustable plate of springy metal sep-

arated from the fixed plate by a thin piece of mica, as shown in Fig. 24-1.

24-5. Preliminary Considerations before Alignment. — Incorrect alignment in t-r-f receivers is usually evidenced by *loss of sensitivity* and *poor selectivity* at least over part of the tuning range. Since many other troubles can produce these same operating symptoms in this type of receiver, the logical thing to do first when such symptoms are noted is to check the tubes and check the entire receiver with a suitable analyzer. This does not take long in t-r-f receivers. Any tubes which test weak should be replaced, and the set should otherwise be restored to best operating condition electrically. If the same symptoms still persist after this is done, the tuned circuits may be suspected of being mis-aligned.

Before making any adjustments on them, it is wise to determine the accuracy of the existing alignment. This may be done by supplying a signal to the receiver (preferably from a test oscillator) and inserting the "tuning wand" of Fig. 23-3 into the various tuning coils, as explained in Art. 23-5. If the receiver alignment is correct, the insertion of *either end* of the wand will cause a *reduction* of the receiver output; whereas, if the individual circuits are not exactly in tune or resonance with the incoming signal, one end will bring about an *increase* of the signal and the other end will cause a *decrease*. When an *increase* in signal is obtained with the *iron-filled* end of the wand, it indicates that there is insufficient inductance or capacitance in the circuit. The reverse is true if a gain in signal is obtained when using the *brass* cylinder end of the wand. In either case, if the signal strength changes appreciably, the receiver should be realigned.

24-6. Use and Connection of the Test Oscillator. — The aligning process consists merely of supplying steady r-f signals to the input terminals of the receiver, tuning the receiver to this frequency, and varying the setting of whatever alignment adjustments are provided until maximum output is obtained from the receiver. This process is usually repeated for several input frequencies, covering the full tunin range of the receiver. The use of a calibrated test oscillator for supplying the input signal during the aligning process is essential for accurate alignment. Since

the reasons for this were explained in detail in Arts. 15-1 and 15-2 (Chapter XV), they will not be repeated again here. If the reader is not familiar with them, he should refer to them at this time. The test oscillator should be considered as a convenient calibrated source of steady signals whose strength and frequency can be varied to the desired values at will.

The aerial wire is first disconnected from the *Ant.* post of the receiver, so that broadcast signals will not interfere with the signal of the oscillator. The shielded cable supplied with most test oscillators (see Chapter XVII) should now be used to connect the output of the oscillator to the input terminals of the receiver. The *Ant.* terminal of the oscillator (the inside wire in the shielded cable) should be connected to the *Ant.* post of the receiver (or to any other point specified by the receiver manufacturer. The outer shield of the shielded cable, which usually

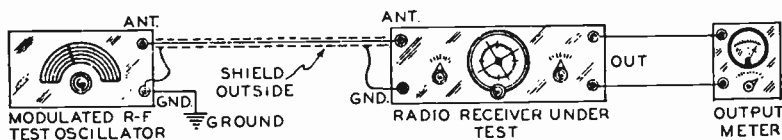

FIG. 24-4.—Arrangement of the test oscillator, radio receiver and output indicator for aligning the tuned circuits in a single-dial t-r-f receiver. The oscillator feeds signals of the desired frequencies to the receiver. The output meter indicates the relative output of the receiver when the capacity adjustments provided in the receiver are varied. When these adjustments are set properly so that the output of the receiver is maximum, at each of the aligning frequencies, the tuning circuits have been aligned properly.

serves as the *Gnd* lead from the oscillator, should be connected to the *Gnd* terminal of the receiver. These connections are shown in Fig. 24-4.

24-7. Use and Connection of the Output Indicator.—The use of some form of output meter or indicator is well established as the proper way of accurately judging the output of a receiver during alignment. The reasons were explained in detail in Art 7-1 of Chapter VII. The reason is simply that the human ear cannot detect as small a change in volume as can readily be seen on an output meter. As a matter of fact, a deflection of 5 or more full divisions on the scale of a meter-type output meter is re-

quired before a change in volume is noticed by the average ear. Since the gain in volume may amount to an increase of only a few divisions on the output meter for each stage adjusted, it is obvious that an output indicator must be used if each stage is to be brought up to its best operating point; the sum total of several stages which are improved a few divisions each, can, however, be noticed readily by the ear, since this total may amount to 30 or 40 divisions on the output meter. This is especially so in the case of very selective receivers. Of course, any of the various types of output indicators described in Chapter VII are suitable for this purpose.

The output indicator may be connected to the receiver in any one of several ways, depending upon the type of output stage and loud speaker arrangement. These methods have been fully discussed and illustrated in Chapter VII for each type of output

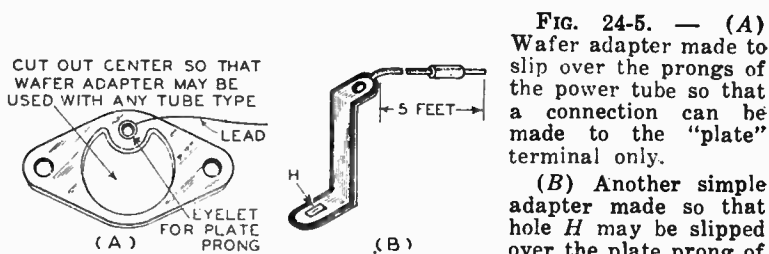

FIG. 24-5. — (A) Wafer adapter made to slip over the prongs of the power tube so that a connection can be made to the "plate" terminal only.

(B) Another simple adapter made so that hole *H* may be slipped over the plate prong of the power tube.

indicator and will not be repeated here. If the output indicator is connected from the plate of the output tube to ground, a wafer type "plate lead output adapter" such as is illustrated at (A) of Fig. 24-5 should be used. These adapters may be purchased ready made, or may be made from a wafer socket with its center cut so that it slips over all of the prongs of the tube except the "plate" prong. A lead is brought out from the plate terminal of the socket, as shown, for connection to the output meter. A simple adapter designed to be slipped over the plate prong of the power tube is shown at (B).

24-8. Aligning Procedure for Ordinary T-R-F receivers.—After the test oscillator and the output meter are connected properly, both the receiver and the test oscillator should be turned on and allowed to warm up for at least 5 minutes.

The usual types of t-r-f receivers have two stages of tuned r-f amplification, a detector, and two stages of audio amplification. They are not complicated with AVC or QAVC systems, and are therefore easy to line up properly. If the receiver is a very old one and contains trimmer condensers but no slotted end plates, the best that can be done with it is to align it by adjusting the trimmers at a single frequency which is tuned in at about 50 on the dial, unless the customer especially desires to hear some particular station toward either end of the dial—in which case the alignment is performed at a frequency near this dial setting. If the receiver is of modern construction and is provided with both trimmer condensers and slotted end plates for alignment, the following procedure should be employed:

Adjust the oscillator frequency-control so that the oscillator produces a signal having a frequency equal to the highest that the receiver is able to receive. Now, with the volume control of the receiver set at its "maximum volume" position, tune the receiver carefully to the signal and frequency of the oscillator, meanwhile adjusting the attenuator control of the oscillator so that when the receiver is tuned exactly (as evidenced by a "maximum" reading on the output indicator), a reading equal to about $\frac{1}{3}$ of full-scale deflection is obtained on the output meter. The output indicator deflections or indications are arbitrary, and are watched during the alignment process merely to find out when "maximum" output is obtained in each case. It is important to use the lowest practical power from the oscillator which will permit the alignment procedure to be started.

Now, starting at the section of the gang condenser which tunes the *detector* stage, adjust its trimmer until the output meter indicates the *maximum* output that can be obtained, then retune the main receiver tuning dial slowly, rocking it back and forth a few divisions, until maximum response is obtained. Now adjust the detector trimmer condenser again for final maximum response.

Attention must now be directed to the next r-f tuning condenser and trimmer, ahead of the detector stage. Leaving both the oscillator and receiver dials set exactly where they were left after the final adjustment of the detector trimmer (this is important), adjust the second r-f trimmer for maximum response

on the output indicator. If the indicator reads too high, turn down the attenuator on the oscillator, *not the volume control on the receiver*. Now rock the tuning dial slowly until maximum response is obtained and carefully make the final adjustment on the trimmer. Repeat this for the remaining r-f trimmers. The adjustments for the high-frequency setting of the receiver are now completed. At this frequency the first segments of the slotted rotor plates are usually just about in mesh with the stator plates, these first segments should not be touched.

Now turn the tuning condenser of the receiver until the *second* (second from the meshed ones) segments of the tuning condenser sections are fully in mesh. Adjust the oscillator frequency until maximum output from the set is indicated. Now vary (slightly) the position of the second meshed segment of the detector-tuning section of the gang condenser, and notice the effect on the reading of the output meter. Adjust the position of these segments carefully with an insulated tool (or merely a wedge-shaped stick of wood), until the output meter reading is greatest. Do not use a metal tool for bending the segments, since the capacity to a metal tool may vary the results. *Do not touch the trimmer condensers*. After shifting the segments, one by one, for greatest reading, "rock" the receiver dial carefully, and readjust again. When you have finished with a segment, be certain that, for the frequency tuned in, the greatest output meter reading is obtained.

Now turn the tuning condenser of the receiver until the *third* segments of the tuning condenser sections are fully in mesh, and proceed to align the receiver in this position, employing the same procedure as was just employed for the second segments. Then proceed to align with the remaining segments meshed in turn, until the job is completed, being careful not to disturb the settings of the trimmer condensers.

Usually, the fan-shaped end-rotor plates are made with five or six segments. If reliable information from the receiver manufacturer is at hand, specifying the exact frequency at which each segment is to be adjusted, then the alignment should be carried out at these exact frequencies instead of at the segment positions just specified. One prominent t-r-f receiver manufacturer has employed condenser gangs which had each end-rotor plate cut

into five segments, and recommends the following frequencies at which adjustment of the segments are to be made: 1,120, 840, 700, 600 and 550 kc. The positions of the segments for these frequencies are illustrated in Fig. 24-3.

24-9. Checking the Alignment.—After the alignment has been completed in accordance with the foregoing instructions, it should be checked. To do this, turn off both the receiver and the oscillator. Disconnect the oscillator and the output indicator from the receiver. Reconnect the aerial wire to the receiver, and turn the receiver on again. Test its ability to bring in stations over the entire dial, judging its performance by the loudness of the stations brought in and the sharpness with which it is able to tune them in and out.

An excellent test to determine if a t-r-f receiver has been properly lined up is to tune in a loud local station carefully and notice if it comes in at only one point on the dial. If the circuits are out of line, a loud station may be tuned in at, say, 47 and 50 with about equal volume; the response midway, at $48\frac{1}{2}$, will be low. If such is the case, then the circuits are out of line. This phenomenon was explained in Chapter XXIII, Art. 23-4. The alignment may also be checked by means of the "tuning wand", as described in Art. 23-5.

24-10. Aligning T-R-F Receivers Having Cam-Operated Tuning Condensers.—It should be noted at this point that although the alignment of most t-r-f receivers employing gang condensers of the common type may be carried out as described here, there are some receivers which, due to their peculiar construction, may present individual problems which modify the alignment procedure somewhat. The manufacturers of these receivers recognize this fact and their servicing instructions quite generally carry complete information as to how the tuning units are to be aligned. After a certain amount of experience has been obtained in this work, the particular alignment method which is most suitable for any radio set will usually be obvious on inspection, and experience is perhaps the best teacher. Special details concerning the alignment of receivers employing two of the most common special arrangements will now be explained.

Several t-r-f models of the Victor Micro-Synchronous receiv-

ers (among which are the R-35, R-39 and RE-57) employ a condenser gang whose stator sections are attached to a cam roller so arranged as to engage a large cam wheel which is actuated by the tuning drive. Inside of the cam wheel are five groups of five screws each. The end of each screw presses against a copper band held around the cam wheel by a coiled spring. By adjusting these screws, the copper band may be forced out or in, thus varying the action of the cam roller at different points. Since the *stator* sections of the condenser gang are semi-variable, the condenser gang may be aligned accurately over the entire tuning range. The first screw of each group is adjusted for maximum output at 550 kc, the second screw of each group at 710 kc, the third at 1,000 kc, the fourth at 1,300 kc, and the fifth screw of each group at 1,500 kc, by means of a test oscillator and output

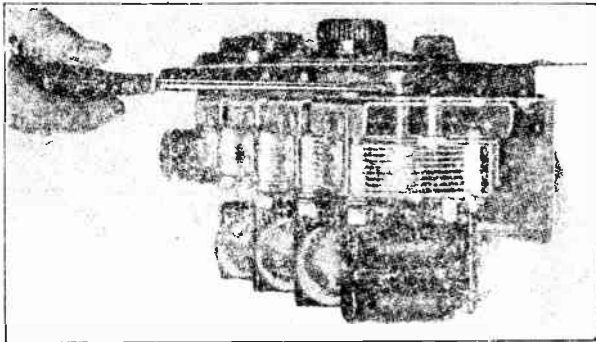

Courtesy Atwater Kent

FIG. 24-6.—Top-end view of a typical single-dial t-r-f receiver employing individual tuning condensers belted together by means of pulleys and flexible metal belts. The method of tightening the pulley set-screws after the condensers have been synchronized is shown here.

indicator so that the receiver will be aligned properly over the entire tuning range.

24-11. Aligning T-R-F Receivers Having Belted Individual Tuning Condensers.—A number of models of single-dial t-r-f receivers which enjoyed a wide sale during the period in which they were popular, did not employ a gang condenser. Instead, they were tuned by individual tuning condensers coupled together by a pulley-belt arrangement, as illustrated in Fig. 24-6, so that they could all be operated simultaneously by a single

tuning dial. Thousands of these receivers are still in operation and radio service men are still called upon to service them. The old Atwater Kent receivers are typical of this type.

In order to re-synchronize the variable condensers on these belted-type receivers as well as can be done at one point on the dial (around the middle), it is necessary to loosen the set-screws or binding nuts holding each pulley to its condenser shaft and adjust the position of the rotor of each tuning condenser separately to produce maximum output when a 1,000 kc modulated signal is fed to the receiver by means of a test oscillator. The pulley screws are then tightened, and, if the condensers and the r-f transformers are properly matched, the synchronism should be good at all points on the dial. If the synchronism is not good at other points on the dial, as evidenced by weak reception, either the condensers or the r-f coil group are not properly matched. In this case a new condenser group or a new r-f transformer group (as necessary) should be installed and the condensers should be re-synchronized.

24-12. Necessity for Neutralization in T-R-F Receivers.

—It is not infrequent for a t-r-f receiver to be completely free from oscillation when its tuning circuits are out of alignment, and to oscillate more or less violently as soon as the tuned circuits are nearly aligned. When this occurs, the alignment procedure must be stopped and the receiver neutralized (see Art. 24-17); then the entire alignment must be performed again. If the receiver breaks into oscillation a second time, the neutralization must be repeated. It is seldom, however, that the alignment and neutralizing procedures need be repeated more than twice.

24-13. General Methods of Suppressing Oscillation.—It was pointed out in Art. 15-7 in Chapter XV that oscillation takes place because of the transfer of energy from the plate to the grid circuit of a tube, either inductively or capacitatively. It was further emphasized that a primary requisite for oscillation is that the energy induced in the grid circuit must be sufficiently large to overcome the losses in the grid circuit.

This latter requisite has served as a basis for a very simple method of preventing oscillation in a number of models of old t-r-f receivers—a resistance of about 1,000 ohms was connected in

series with the tuned circuit and the grid of the tube. Normally the energy fed back is never great enough to supply the losses in this resistor, so oscillation never takes place. For obvious reasons, this method is commonly called the *losser* method. However, oscillation in triode is more prevalent at the higher frequencies than at the lower, for the reason that energy is fed back via the grid-plate capacity ordinarily, and the reactance of this "capacity" becomes smaller as the frequency is increased. Since the oscillation tendencies are stronger at the higher frequencies, the *losser* resistance was designed to suppress all oscillation at the high-frequency end of the tuning range of the receiver. Consequently, at the low-frequency end, more *losser* resistance than was necessary to prevent oscillation was in the circuit and the signal strength was low.

This limitation gave rise to several circuits which attempted to balance out, or cancel, the energy in the grid circuit that was fed back from the plate circuit; such circuits are commonly called *balancing* or *neutralizing* circuits. Several such circuits are shown in Figs. 24-7, 24-8, and 24-9, and will now be described.

24-14. The Bridge Circuit for Suppressing Oscillation.—
Figure 24-7 shows the essential circuit arrangement of what was

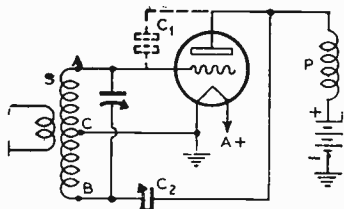

FIG. 24-7. — The "grid" or "bridge" type of neutralizing applied to an r-f stage of a t-r-f receiver. C_1 is the grid-plate capacity of the tube. C_2 is the neutralizing condenser.

a very popular balancing circuit, employed in early t-r-f receivers. The secondary of the tuned circuit of the stage to be balanced is S , and point C is a tap on the coil, usually the center of the coil. Condenser C_1 is the inherent grid-plate capacity of the tube, shown dotted, and C_2 is another condenser (the *neutralizing condenser*) connected as shown.

A study of this diagram reveals that any alternating voltage in the plate circuit cannot be communicated to the grid circuit, for the following reason: If C is the center of the coil and C_2 is equal to C_1 , then any disturbance in the plate circuit will make

end A of the coil of the same potential and of the same polarity as end B . This means that the plate circuit disturbance does not cause any *difference of potential* across the terminals of the coil. Therefore, since no energy is fed back to the grid circuit, the circuit cannot oscillate. Similarly, any disturbance in the grid circuit cannot affect the plate circuit through the capacities because whatever potential the plate receives through C_1 from this disturbance is balanced out by an equal and opposite potential through C_2 . If C is not the center of the coil, then C_2 must be

FIG. 24-8.—The “plate” type of neutralization. Its action is fundamentally the same as the “grid” type of Fig. 24-7. This is also called the *neutrodyne* circuit.

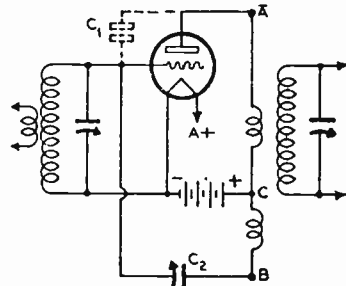

increased proportionally. In other words, the stage is balanced when the ratio of C_1 to C_2 is equal to the ratio of the number of turns from BC to CA .

The distinct advantages of this system, theoretically, is the fact that, once balanced, the system will not oscillate over a wide range of frequencies. This system is also known as the *bridge method* of balancing because condensers C_1 and C_2 and the two sections of the coil BC and CA form the four arms of a Wheatstone bridge arrangement. It is to this circuit that the term balancing is applied. Since oscillation is balanced in the grid circuit, it is also referred to as the *grid* form of neutralizing.

24-15. The Neutrodyne or Plate-Neutralized Circuits for Suppressing Oscillation.—Neutralization may be effected in the plate as well as in the grid circuit. Coil AC of Fig. 24-8 is the normal primary of an r-f transformer. If more turns (as CB) are added to the primary, point B will be opposite in polarity to point A at all times; and if AC equals CB , then point B will be of the same potential as point A , as well as of opposite polarity. The neutralizing condenser C_2 is connected from point B to the grid, as shown. Hence, any alternating plate voltage cannot alter the

grid potential through C_1 , because it is immediately balanced by the equal and opposite potential through C_2 . In other words, C_2 is adjusted so that the variation in potential of the grid is always balanced out. If AC equals CB , then C_2 is adjusted to equal C_1 . The greater the ratio of AC to CB , the greater the ratio of C_2 to C_1 must be to preserve this balance.

The only reason the circuit of Fig. 24-8 works is that point B is 180° out of phase with point A . It is necessary to wind additional turns on the primary after point C in order to secure this condition. But if the condenser C_2 is connected to a tap on the

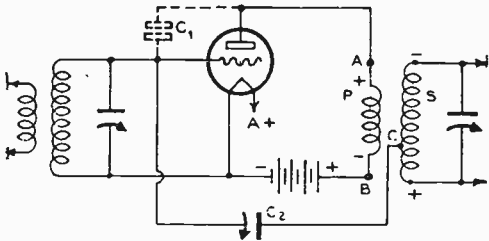

FIG. 24-9.—Another neutralizing circuit similar to that of Fig. 24-8 excepting that here the neutralizing condenser C_2 is excited from the induced e.m.f. in the secondary coil S . This coil is tapped at C . This is also a form of *neutrodyne* circuit.

secondary coil, as shown in Fig. 24-9, the system is identical with that of the previous figure. The primary P induces a voltage of reversed phase in secondary S . Hence, point C on the secondary is of opposite polarity to point A . As before, C_2 is adjusted so that the fluctuating voltage on the grid due to the grid-plate capacity of the tube is neutralized by an equal and opposite potential through C_2 . The circuits of Figs. 24-8 and 24-9 are called *neutrodyne* circuits.

24-16. Neutralization to Prevent Oscillation in T-R-F Receivers.—From the discussions of the foregoing circuits, it is clear that when they are employed, any signal in the grid circuit cannot be transferred to the plate circuit through the grid-plate capacity of the tube because of the neutralizing circuit. That is, alternating plate voltages cannot be transferred to the grid circuit through the tube capacity, and alternating grid voltages cannot be transferred to the plate circuit through the grid-plate capacity of the tube, because of the neutralizing circuit. The path presented for signals in the grid circuit is through the usual amplifying action of the tube. This arrangement is made use of to neutralize r-f circuits to prevent oscillation.

If the filament prong of a tube is isolated from its socket contact (the rest of the prongs still making proper contact), it will not light, and hence the tube will not amplify. However, if there is no balancing or neutralizing circuit present, signals will still be heard because they will get to the plate circuit through the grid-plate capacity of the tube. With a balancing circuit, however, the signal divides through the grid-plate and neutralizing capacities, and balances at the plate. This means that a stage is properly balanced *when no signal can be heard through the grid-plate capacity of the tube.*

Few of the receivers being manufactured today make use of the neutralizing systems which are employed in the older neutrodyne and other t-r-f receivers—simply because the use of modern, shielded tuning coils and screen-grid tubes have decreased the main cause of feed-back—the grid-plate capacity of the amplifier tubes. However, there are still many of these old receivers in use, and it is important that the service man know how to balance or re-neutralize such receivers so that they do not oscillate.

24-17. Neutralizing Procedure for T-R-F Receivers.—

The equipment required for the neutralizing of t-r-f receivers is a test oscillator, an insulated neutralizing tool and a “dummy” tube. Although the test oscillator is not absolutely essential (the signal from a broadcasting station may be used instead, if necessary), far better results can be obtained through its use, since a strong, constant signal is necessary for accurate and rapid neutralizing. Furthermore, it is quite likely that a suitable powerful broadcast station of the frequency desired may not be “on the air” at the time desired. An insulated neutralizing tool must be used, as the neutralizing adjustment screws or nuts are not usually at ground potential, and a metal instrument will introduce added capacity, making accurate neutralization very difficult. Instead of a “dummy tube (which is a good tube of the same type as used in the stage to be neutralized, but having one of its filament or heater prongs cut off) an adapter such as shown in Fig. 24-10 which has one filament leg “open” may be used. These “neutralizing” adapters are preferable, because they enable each r-f stage in the receiver to be neutralized *with the tube*

that is normally employed in that stage, thus minimizing the possibility of incomplete neutralization due to the use of a "dummy" tube whose inter-electrode capacity does not match that of the tube used in that stage.

In order to neutralize the receiver, the aerial lead-in is first disconnected from the set. The *Ant.* and *Gnd.* terminals of the receiver are then connected to the "high" output terminals of the test oscillator just as for the alignment of the tuned circuits, (see Art. 24-6 and Fig. 24-4.) No output meter need be used as the ear will suffice in this work. The loud speaker should be con-

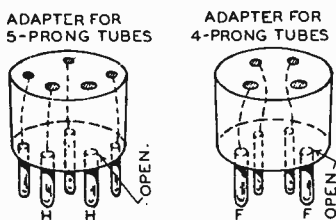

FIG. 24-10.—A neutralizing adapter for 5-prong tubes (*left*) and one for 4-prong tubes (*right*). In each, one leg of the filament circuit is left *open*.

nected. Then put the receiver in good operating condition, set the test oscillator operating at about 1,000 kc. (modulated signal) and tune its signal in on the receiver as strongly as possible with the volume control of the receiver in the full "loud" position.

The last r-f tube should be removed and placed into the neutralizing adapter, which in turn is inserted into the socket from which the tube was removed. If a "dummy" tube is to be employed instead, it should be inserted directly into the socket from which the receiver tube has been removed. If the signal of the test oscillator is still heard in the loud speaker, however weak it may be, the neutralizing condenser associated with this stage should be adjusted with the balancing tool (which may be an insulated socket wrench, an insulated screw driver, or a wooden dowel stick whittled to a wedge-shape at one end) until the signal is no longer audible, or is weakest.

The *receiver dial* must now be retuned again, until the signal is heard as loud as possible, as a change in the neutralizing capacity changes the effective input capacity of the tube. This causes the receiver to be detuned slightly from the signal of the test oscillator, and it is necessary to retune the receiver to bring it into exact resonance with this signal. The same procedure is

followed for the successive preceding r-f stages in the receiver. Any oscillation that may still be present after this neutralizing procedure is carried out carefully, is undoubtedly caused by interstage feedback due to magnetic coupling between wiring or between the tuning coils, and cannot be eliminated by neutralizing circuits. Proper shielding of these coils or wiring is a possible remedy. If an output meter is used, the neutralizing condensers should be adjusted until *minimum* reading is obtained on it.

After neutralizing, it is advisable to check over the alignment of the tuned stages (see Art. 24-5). If they are properly aligned, the work is finished, if not, the receiver should be aligned, after which, it may again have to be re-neutralized. The final check is good alignment with no oscillation at any setting of the tuning dial.

REVIEW QUESTIONS

1. What is meant by "aligning" the tuned circuits of a t-r-f receiver? What is its purpose? When is it necessary?
2. Explain, step by step, the procedure for aligning the tuned stages of a single-dial receiver having two stages of tuned r-f and a gang tuning condenser provided with only trimmer condensers for capacity adjustment.
3. A receiver employs a 3-gang condenser with trimmers and slotted end-rotor plates. Explain how you would go about aligning the tuned stages of this receiver.
4. How would you align a t-r-f receiver tuned with three individual variable condensers that are coupled by means of a pulley-belt arrangement?
5. Explain why some form of output indicating device must be used when aligning t-r-f receivers.
6. Explain why the signal from a test oscillator must be used during the aligning procedure instead of that from a broadcast station.
7. What symptom will be noticed when a neutrodyne receiver needs to be re-neutralized?
8. State two reasons why a neutrodyne receiver may have to be re-neutralized.
9. Explain in detail the procedure to be followed in re-neutralizing a neutrodyne receiver having two r-f stages.
10. Draw the schematic circuit diagrams of three types of commonly used balancing or neutralizing circuits, and explain how each works.
11. A "dummy tube" is used for neutralizing a receiver. How does this make neutralizing possible?
12. How would you proceed to determine whether a t-r-f receiver needed to be realigned? What instrument would you use to determine this? Explain fully!

CHAPTER XXV

ALIGNING AND NEUTRALIZING SUPERHETERODYNE RECEIVERS

(INCLUDING THE USE OF THE CATHODE-RAY OSCILLOSCOPE)

25-1. Introduction. — The superheterodyne is, without doubt, the most popular radio receiver circuit employed today, mainly because, through its use, more amplification can be obtained with a given number of tubes, and it provides greater selectivity. Although its fundamental principle of operation was first suggested and used by Armstrong in 1918, it was not until a few years ago that the problem of providing single-control tuning for it was solved successfully, removing the main objectionable feature which had existed up to that time. This and other features of its design have been strengthened sufficiently by succeeding developments in the radio industry so that it is now the most widely used receiver circuit. In some respects, the modern superheterodyne is the simplest of circuits; in others it is the most complex. It is the simplest in the sense that no other known circuit, however simple or complex, has the selectivity and sensitivity which the modern, well-designed superheterodyne has. It is the most complex in the sense that it has more semi-variable adjustments which must be set properly before best performance is obtained, than any other circuit in common use. The procedure which is followed in setting all of these adjustments correctly is usually called "aligning", "ganging", "tracking", etc., (see Arts. 24-1 and 24-2).

It is the purpose of this chapter to discuss the essentials of superheterodyne alignment. Details will be given of the procedure to be followed in most cases, but, since some receivers may

have certain design features which make special alignment operations necessary, the service man is urged to consult a reliable service manual for these special details regarding the particular receiver under consideration whenever possible.† The i-f used in one model of receiver may be different than the i-f used in other models produced by the same manufacturer.* There is no real standardization in this respect. The only reliable sources of information for specific details are the service sheets of the manufacturer of the receiver, or a reliable list of receiver i-f's."

At the present stage of the art there are two main groups of superheterodyne receivers: the *broadcast* receivers intended for 540 to 1,600 kc reception, and the *all-wave* receivers intended for reception of frequencies from approximately 540 to 18,000 kc. It should be pointed out here that the general alignment procedure is the same in both types, although each has peculiarities of its own. In this chapter we will deal mainly with the alignment of standard broadcast-band receivers; in Chapter XXVIII special details concerning the alignment of all-wave receivers will be presented.

25-2. Reasons for the Development of the Superheterodyne.—The superheterodyne receiver is the outgrowth of an attempt to surmount difficulties that were experienced with the t-r-f type of receiver in the early days of radio. In the t-r-f system, the signal is amplified *at its own carrier frequency*—which is a *high* frequency. It was difficult to design a receiver of this type which would employ only a few amplifier stages and yet provide high enough amplification which would be uniform over the entire range of broadcast frequencies to be received. Remember that the three-electrode tube was the only type available at the time, screen-grid types of tubes which have low inter-electrode capacitance and produce high amplification had not yet been developed. From our knowledge of vacuum tube amplifier theory, we know that the larger the impedance connected

*NOTE: The service man is referred to the author's *Radio Trouble-Shooter's Handbook* for a comprehensive list presenting the intermediate frequencies employed in nearly all superheterodyne receivers of American manufacture produced up to the date of its last printing.

†*Rider's Perpetual Trouble Shooters Manuals* (published by John F. Rider, 404 Fourth Avenue, N. Y. C.) contain this information.

in the plate circuit, the greater is the amplification produced by the stage. However, the larger this impedance is, the greater is the tendency for oscillation to occur. (Neutralizing circuits had not yet been developed.) Hence if attempts were made to secure high amplification per stage in t-r-f receivers by using high plate circuit impedances, severe oscillation would result. To complicate the situation still more, the feedback energy fed back from the plate circuit to the grid (through the plate-grid capacity of the tube) increases with the frequency, so that oscillation tendencies are greater at the high-frequency end of the received signal band. Therefore, a compromise had to be made in the design of these receivers; the amplification was kept down so that oscillation would not occur at the high frequencies—this made their sensitivity drop at the middle and low-frequency end of the broadcast range, and required the use of a large number of amplifier stages if high sensitivity was to be obtained.

25-3. The Superheterodyne System.—This situation led Armstrong to seek some method whereby the frequency of the incoming signal could be reduced sufficiently so that the amplification could be made to take place at this frequency and could be made large without causing any oscillation. It was also considered desirable to have this reduced frequency fixed for all settings of the tuning dial, so that the circuits of the reduced-frequency amplifier could be designed and adjusted to produce maximum response at one frequency. Such a state of affairs would mean that more amplification could be obtained with a given number of stages (without oscillation), and that the amplification would be more uniform over the entire tuning range. This, in general, is the idea behind the superheterodyne.

25-4. How the Frequency is Reduced in the Superheterodyne.—The signal to be amplified must be received first by a tuned circuit, similar to those used in a t-r-f receiver, after which it may or may not be amplified before its frequency is reduced. Once received, it is ready for the frequency-reduction.

The reduction of the frequency is really the most ingenious part of Armstrong's invention. It was known that if currents of two different frequencies are combined and rectified, the output consists of a number of frequencies, two of which are the sum

and the *difference* frequencies, respectively, of the original signals. Thus, if the signal received from a broadcast station has a carrier frequency of, say, 1,000 kc and another local signal having a frequency of 1,450 kc is mixed with it *and the combination is rectified*, the output of the rectifier will contain, among other irrelevant frequencies, a current whose amplitude varies at a frequency equal to the sum of the two original frequencies (2,450 kc), and one whose amplitude varies at a frequency equal to their *difference* (450 kc).

Two things are therefore unique in this type of circuit: (1) the incoming broadcast signal must be mixed with that generated by a local oscillator; (2) the combination *must be rectified* in order for the sum and difference frequencies to appear, just as a t-r-f receiver must rectify a modulated carrier in order for the audio note to be heard. A superheterodyne receiver, therefore, is equipped with, (as most every service man is aware), a local oscillator and a detector (called the *first detector, modulator, or mixer*). (In many superheterodynes, the function of "local oscillator" and "mixer" is performed simultaneously, but independently, by a single "pentagrid converter" type tube.) Another detector, called the *second detector*, is also necessary to obtain the audio modulations.

Now if the output circuit of the first detector is tuned to the *difference* frequency of the broadcast signal and local oscillator, then the "reduced frequency" current is selected and may be subsequently amplified. It is clear that the lower the difference frequency, the more nearly alike must be the signal and local oscillator frequencies. It is also clear that if provision is made to have the oscillator frequency change simultaneously with changes in the resonant frequency of the input tuned circuits *so that it is always a fixed amount* above or below the incoming desired signal frequency, the signal current in the succeeding amplifier, called the *intermediate-frequency amplifier*, will always be of this one (difference) frequency. Therefore, its tuned circuits can be adjusted once to tune exactly to this frequency and can be left alone thereafter.

25-5. Review of the Entire Superheterodyne System.—
A block diagram showing the main parts of a superheterodyne

receiver of modern design is illustrated in Fig. 25-1. The antenna system connects to a t-r-f amplifier (often called a pre-selector) which is designed to tune over the entire frequency range it is desired to receive. It is the purpose of this amplifier to make a fairly rough preliminary selection of the signal of the station it is desired to receive (in order to prevent image-frequency interference: see Art. 23-13) and amplify it somewhat for additional sensitivity. This stage is not absolutely necessary, and many midget receivers do not use one; but the majority of the larger sets have at least one of these t-r-f (*pre-selector*) stages.

The pre-selector amplifier output feeds into the first detector (or "mixer") stage, where it mixes with the oscillator

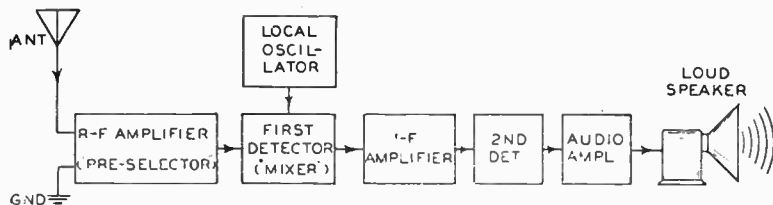

FIG. 25-1.—Block diagram showing the main parts and their sequence in a typical superheterodyne receiver.

voltage and is rectified. In the many modern receivers which employ a single multi-electrode pentagrid converter tube (such as the types 2A7 and 6A8) designed to perform simultaneously the function of both a "mixer" and an "oscillator" tube, the independent control of each function is made possible within a single tube.

The output of the mixer tube contains a number of frequencies, among which is one equal to the *difference* between the signal and oscillator frequency. It is to this *difference* frequency that the i-f amplifier is tuned. The i-f amplifier may consist of at least one, and usually not more than three, stages. Of course, more than three may be used, but this makes the sensitivity so great that the set is apt to be unstable.

The output of the i-f amplifier is fed to the second detector where it is demodulated. The audio output of this detector is amplified further by a one- or two-stage audio amplifier.*

*NOTE: For a more detailed and comprehensive discussion of the theory of operation, and the construction, of superheterodyne receivers the reader is referred to the *Radio Physics Course* text by Ghirardi.

25-6. Frequency of the Oscillator.—In most superheterodyne receivers, the intermediate frequency is equal to the *difference* between the oscillator and signal frequencies. This means that the oscillator frequency may be greater or less than the signal frequency by the amount of the i-f. For instance, suppose a signal of 1,000 kc is tuned in by the r-f amplifier and mixer stages; further assume that the i-f is 200 kc. Then the oscillator frequency may be either 1,200 or 800 kc, the difference frequency in either case will be 200 kc. Either one may be used, but in practice the oscillator frequency is always *higher* than the signal frequency by an amount equal to the i-f. The signal strength would be the same if the oscillator were lower than the signal frequency by the amount of the i-f, but image interference (see Arts. 23-13, 23-15 and 23-17) would be excessive and commercial code interference would be troublesome in certain localities. Furthermore, the design and adjustments of the r-f and oscillator circuits must be such that the oscillator frequency will stay as nearly as possible at the same number of kilocycles *above* the resonant frequency of the r-f circuits *for every setting of the tuning dial*. That is, the oscillator frequency must “track” with the frequency of the r-f circuits (always remaining higher by a constant amount equal to the i-f of the receiver). This is illustrated graphically in Fig. 25-12 by the tuning curves of the oscillator and that of the dial (r-f) for a receiver employing a 130-kc i-f. Notice that the oscillator frequency tracks along *exactly* with the dial (r-f) frequency, always being 130 kc above it, regardless of the dial setting. This will be considered further in Arts. 25-10, 25-17 and 25-18.

25-7. Adjustments Necessary in Superheterodynes.—It is evident that certain adjustments must be made in superheterodyne receivers to enable them to function normally if their original adjustments have become disturbed. The various tuned circuits in the i-f amplifier must be lined up, or *peaked*, at the specific frequency (or several frequencies close to it); for which it is designed. The r-f and mixer stages must be aligned with each other as in a t-r-f amplifier, and the oscillator tuning condenser must be “tracked” with them so that the oscillator frequency is *always* greater than the signal frequency by an amount equal

to the i-f used in the particular receiver, regardless of the position of the receiver tuning dial. If these adjustments become disturbed, it will lead to certain difficulties which cannot be remedied by any means other than proper readjustment. These will now be considered.

25-8. Effects of Misalignment in the I-F Amplifier.—If the individual tuned circuits of the i-f amplifier of a superheterodyne are not peaked at the proper frequency for which it is designed, four distinct operating symptoms may result: (1) lowered or zero signal strength, depending upon the amount of misalignment; (2) high noise level; (3) poor selectivity and possible interference from undesired "adjacent channel" stations, and (4) possible improper tone quality due to possible cutting of sidebands in the i-f amplifier—especially in high-fidelity receivers. Each of these symptoms will be discussed in turn.

(1) Lowered signal strength will be obtained from a receiver with a misaligned i-f amplifier because the difference frequency between the oscillator and signal will not be equal to that to which the i-f amplifier is tuned. For instance, if a receiver is designed so that the i-f *should* be 450 kc, but because of misalignment the i-f tuned circuits are actually tuned to 500 kc, then maximum amplification cannot be obtained since the 450-kc signal output of the mixer goes through the i-f amplifier which is tuned to a different frequency, 500 kc in this case. The results are equivalent to deliberately mistuning a t-r-f receiver. But not all the stages of an i-f amplifier may be mistuned—perhaps but one or two are out of alignment. In this case the desired signal may be heard if it is strong enough, and interference may be encountered if the r-f amplifier is not sufficiently selective. See (3) for further details on this point.

(2) Increased noise level is a very definite indication of a misaligned i-f amplifier if the r-f and oscillator circuits are normal. The mixer tube is the source of most of the noise in a superheterodyne. The noise is generated in the tube itself, and its magnitude is a function of the signal strength and plate current of the tube. But with a given plate current, and with a given signal applied to the tube, any noise that may be generated is amplified by the i-f amplifier. If the i-f amplifier is misaligned, the

strength of the signal output is reduced, and may be comparable with the noise voltage. With high signal strength, of course, the noise is small compared to the signal. The noise voltage is then actually reduced in intensity in the second detector. Furthermore, if the receiver is equipped with avc, the sensitivity of the i-f amplifier is reduced on strong signals, so that the noise is reduced also. When the i-f amplifier is misaligned, the avc may not work at all if the signal voltage is below the avc threshold, and the sensitivity of the i-f amplifier is high for the noise.

The sensitivity for the noise is high because the type of noise generated in the mixer stage of a superheterodyne is not of one, but of many frequencies. The i-f amplifier merely selects the one particular frequency to which it is tuned. But if it is misaligned, then it selects a noise voltage whose frequency is equal to that to which it is tuned rather than that to which it *should* be tuned. The result is low signal strength of the desired stations and a high noise level because the sensitivity of the i-f amplifier is high for the noise frequency.

(3) Interference from undesired stations differing slightly in frequency from that of the desired station is a natural consequence if the i-f amplifier is not properly aligned and the r-f amplifier is not selective. A very selective r-f amplifier preceding the first detector will be sensitive to only the one frequency to which it is tuned and will therefore so greatly reduce the strength of all adjacent channel station signals, that no interference will result from them even if the i-f amplifier is mistuned somewhat. But if the r-f amplifier is not selective, then signals of more than one frequency may enter the mixer stage, and if the frequency of some interfering station is such that it mixes with the oscillator frequency to produce an i-f equal to that to which the i-f amplifier happens to be tuned, it will be heard. This is known as "adjacent channel" interference.

This phenomenon may be illustrated by means of an example. Let us assume that a certain superheterodyne employs an i-f of 450 kc. Suppose the r-f amplifier of this superheterodyne is tuned to 1,000 kc, but because it is not sufficiently selective, it does not greatly reduce the strength of an incoming signal from a strong 1,050 kc station. Now the adjustment of the oscillator

is assumed to be accurate, so that it is set for 1,450 kc because the signal circuit is adjusted for 1,000 kc and the i-f is 450 kc. Then the incoming 1,050 kc interference signal will become a 400 kc signal in the i-f amplifier. But, if one or two stages of the i-f amplifier happen to be misaligned to, say, nearly 400 kc instead of 450 kc, then the undesired signal will be amplified by the i-f amplifier and heard along with, perhaps, the desired signal (which is reduced in strength by the misalignment). These conditions are illustrated in Fig. 25-2.

It is important to realize that it makes no difference which i-f transformer is misaligned. The same amount of interference

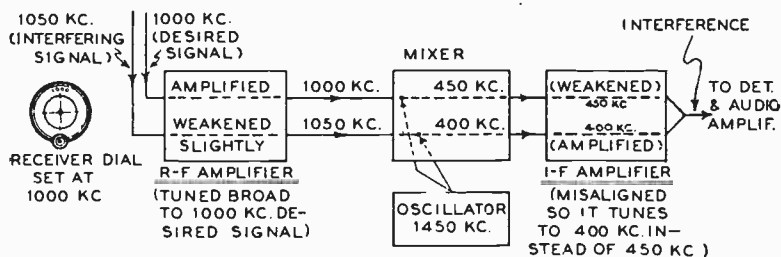

Fig. 25-2.—What happens in a superheterodyne receiver whose r-f amplifier is not sufficiently selective and whose i-f amplifier is misaligned, when a 1,000-kc desired signal and a 1,050-kc (adjacent channel) interfering signal are received by the antenna. Both signals are heard, resulting in interference.

will be obtained if the first or the third tuned i-f circuit is out of adjustment. The reason becomes clear when it is realized that the amplification of each transformer and tube *multiply* at any point to secure the overall gain. This is shown in Fig. 25-3.

Curve *A* represents the overall gain of the first i-f stage at various frequencies above and below the resonant frequency f_r , curve *B* is for the second, and curve *C* is for the third stage. They are shown with different shapes for purposes of visualization only; usually they are all the same, with the exception of the last tuned stage feeding a diode detector. This latter curve is broader than the rest because the relatively small resistance of the diode circuit shunts the tuned circuit. Note the steepness of the sides of the overall selectivity curve *D*. Note, also, that its value at any point is equal to the *product* of the three curves at that point. Thus, if *any one* of the curves reached zero at a

certain frequency, the overall response would also be zero at that same frequency.

(4) The ideal i-f or r-f selectivity curves for truly faithful audio performance are almost straight sided and vertical, enclosing a total band width of approximately 10 kc for ordinary good receivers and 15 kc (see (B) of Fig. 31-5) for high-fidelity receivers. In many receivers, especially those of the high-fidelity type, the design is such that in order to obtain the desired broad i-f amplifier selectivity curves (see Fig. 25-9) for good audio reproduction, the primary-to-secondary coupling is close or the "peaking" of the i-f transformers is staggered. Staggered peaking may be obtained by tuning the second transformer to the exact i-f resonance frequency, the first transformer slightly to the high-capacity side of this resonance frequency, and the third slightly to the low-capacity side. Another method is explained in Art. 25-14. The final result is a broad-

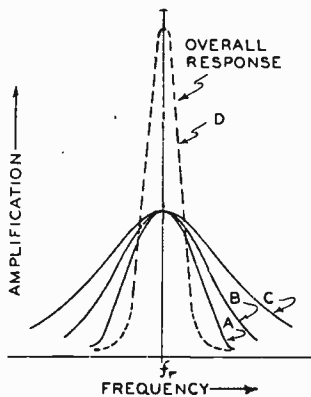

FIG. 25-3. — Amplification curves of the individual i-f amplifier stages A, B and C of a superheterodyne. D is the overall response curve. The resonant frequency is f_r .

er, more vertical-sided resonance curve than could conveniently be secured if all the i-f tuned circuits had been peaked to exactly the same frequency—with resulting better fidelity. This will be discussed in greater detail in Chapter XXXI. At any rate, it is evident that in these receivers, if the adjustment of one or more of these i-f tuning circuits is disturbed, the width of the frequency band passed may be either increased or decreased, with resulting change in the quality of the audio output of the receiver.

25-9. Effects of Misalignment in the R-F Amplifier or Pre-Selector.—The effects of misalignment in the r-f amplifier of a superheterodyne are, weakened signals, interference, possible image-frequency interference and a high noise level. The weak signals are obtained because maximum voltage cannot be built

up across all the tuned circuits in the receiver unless they are in resonance with the signal passing through them; this fact is evident from the very fundamental theory of resonant circuits. What happens, may be understood from the cases presented pictorially in Figs. 25-4 and 25-5.

Let us suppose that a receiver employing an i-f of 450 kc has its r-f amplifier misaligned so that it tunes to a frequency

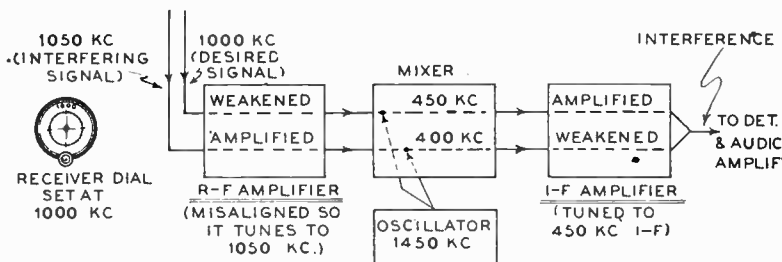

FIG. 25-4.—Effect of misalignment (by 50 kc) in the r-f amplifier of a superheterodyne. If the receiver dial is set at the frequency (1,000 kc) of the desired signal, this signal may not be heard (or heard weakly) and a sufficiently strong interfering signal (1,050 kc) may be heard.

50 kc higher than it should. Let us further suppose that the receiver dial is adjusted to what would normally be the setting for the reception of a 1,000 kc station. This is illustrated in Fig. 25-4. Since the r-f amplifier is misaligned, if it tunes sharply it will greatly reduce the strength of the 1,000-kc signal before it reaches the mixer. If this signal is very weak, the tuning is sharp enough and the misalignment is sufficient, it might cut out the desired signal altogether so that it would not reach the mixer and would therefore not be heard (or, it might be heard weakly). Meanwhile, if a strong, 1,050 kc signal from an interfering station were also received, it would be amplified greatly by the r-f amplifier, and even though it would produce a "difference frequency" of 400 kc, if the i-f amplifier were not very sharply tuned, it might not reduce its strength sufficiently to prevent it from being heard either alone (if the 1,000 kc weak desired signal has been completely shut out) or as an interfering signal with the weakened desired signal.

Even if the receiver dial were set at 950 kc in the foregoing

case in order to bring the r-f tuned circuits into resonance with the desired 1,000 kc signal (remember that the r-f tuned circuits in the receiver are considered to be misaligned so their resonance frequency is 50 kc *above* the tuning dial indication), interference would very likely result. These conditions are shown in Fig. 25-5. For this setting of the tuning dial the oscillator frequency would be $950 + 450 = 1,400$ kc. Even though the desired 1,000 kc signal would be amplified satisfactorily by the r-f amplifier, it would produce a "difference frequency" of 400 kc in the output of the mixer. This 400 kc output would be weakened by the 450-kc i-f amplifier. Whether it would be heard or not would depend on its initial strength and the overall sharpness of tuning of the i-f amplifier. Meanwhile, any received strong interfering signal having a frequency of 950 kc would undoubtedly get through the r-f amplifier even though it were tuned to 1,000 kc, and would produce a "difference frequency" of 450 kc when acted upon by the 1,400 kc oscillator signal and rectified. This would be greatly amplified by the i-f amplifier and

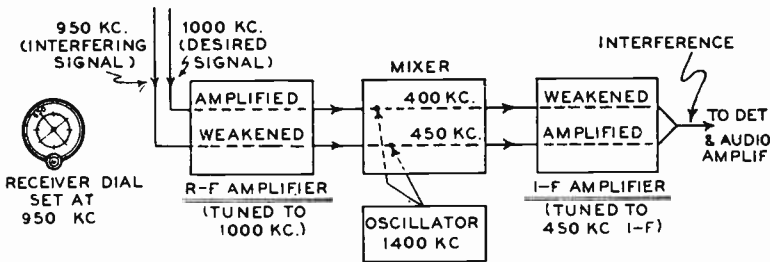

FIG. 25-5.—Effect of misalignment in the r-f amplifier. Even if the receiver dial is adjusted so the r-f amplifier is tuned exactly to the desired 1,000-kc signal, the oscillator frequency will be "off" and interference will very likely result. Thus, the misalignment in the r-f amplifier really causes the "tracking" between the oscillator and r-f amplifier circuits to be upset.

would be heard as an interfering signal. So no matter where the tuning dial were set, an interfering station would very likely be heard, and the desired signal would be weakened—all because of the misalignment of the tuned circuits of the r-f amplifier. It is evident that serious misalignment in the r-f amplifier really has the final effect of disturbing the correct "tracking" between

the oscillator frequency and the overall resonant frequency of the r-f amplifier.

It is quite possible for "image-frequency" interference and double-spot tuning (see Arts. 23-13 to 23-16) to occur in certain receivers having misaligned r-f amplifiers if their design is such that the r-f circuits do not tune sharply. This is especially true if the image-frequency interfering signal is a powerful one, for then it is able to get through the misaligned, broadly-tuned r-f amplifier and mix with the oscillator signal, producing (after rectification) a "difference frequency" equal to the i-f employed. Naturally the i-f amplifier will amplify such a signal. The ways in which an image-frequency signal (a signal whose frequency is *higher* than that of the local oscillator by an amount equal to the i-f of the receiver) is able to get through a receiver and cause interference is illustrated at (A) of Fig. 23-9 in Chapter XXIII.

The reason for the increased noise level which results when the r-f tuning circuits are misaligned is the same as that outlined in part (2) of Art. 25-8.

25-10. Effects of Incorrect Oscillator Tracking. — The symptoms which result when the oscillator frequency does not "track" properly (it should always be higher than the frequency to which the r-f circuits are tuned by an amount equal to the i-f employed in the receiver) depends upon whether or not the r-f and i-f amplifiers are selective. If they are selective, then *no signals*, and *increased noise level*, will be obtained. The lack of signals is due to the "difference frequency" being different than the frequency to which the i-f tuned circuits are tuned, and the high noise level is due to the same causes discussed in part (2) of Art. 25-8. If the r-f amplifier is not selective, then interference will be obtained. For instance, if instead of producing a signal always 450 kc above the resonant frequency of the t-r-f amplifier, the oscillator does not "track" properly and its frequency is always 500 kc above it, any interfering signal whose frequency is 50 kc above that to which the unselective r-f circuit is tuned, may get through it (even though somewhat reduced in strength.) If it does get through, it will beat with the oscillator signal to produce (after rectification) the designated

i-f of 450 kc (for which the i-f amplifier is designed). Therefore, it will be heard.

25-11. Superheterodyne Alignment Sequence.—The foregoing discussions should serve to make clear how important it is for all the tuned circuits of a modern superheterodyne receiver to be accurately adjusted. Regarding the alignment sequence, many service men are under the impression that it makes little difference which of the tuned circuits are aligned first. At first thought, it might seem as though the r-f stages should be aligned first, then the oscillator, and, finally, the i-f amplifier. But a little reflection will show that such is not the case. Perhaps the best sequence for the service man to follow when making these adjustments *on standard broadcast-band receivers* (unless the manufacturer of the receiver instructs otherwise) is:

1. The various tuned circuits of the i-f amplifier are first aligned properly with each other at the i-f for which the i-f amplifier is designed.
2. The oscillator circuit should then be adjusted at about 1,400 kc so it "tracks" properly with the r-f circuits at the high-frequency end of the dial; this should be repeated at about 600 kc so it "tracks" properly with these circuits at the low-frequency end of the dial.
3. At the same time that the "tracking" of the oscillator is being adjusted, it is preferable (in most cases) to properly align the tuned circuits of the r-f (pre-selector) stages with each other. (If a "double-spot" image-suppression circuit is employed in the receiver, its adjustment should be carried out as directed in Arts. 25-21 to 25-23.)

As we shall now see, if the work is done in any other sequence, inaccurate alignment or "tracking" may result, or the operation may take a longer time to accomplish.

Maximum output of a superheterodyne is obtained when every tuned section of it is properly aligned. Maximum output from the i-f amplifier is obtained when it is adjusted to the frequency for which it is designed *and when exactly that frequency is applied to the i-f amplifier* by the output of the mixer. In

practice, the service man never knows offhand whether the i-f amplifier of a receiver he is called upon to service is properly adjusted as he finds it. This means that if he blindly aligns the oscillator or r-f circuits first, he does not know whether or not the "difference-frequency" produced will match the frequency of the i-f amplifier; furthermore, since the condition of the i-f amplifier is unknown, it cannot be used as a basis for the alignment of the r-f or oscillator circuits. The alignment could be carried on without the i-f amplifier, but it is more advisable to use it. It is wise, therefore, to first align the tuned circuits of the i-f amplifier properly, in the manner dictated by its design.

Once the i-f circuits are properly adjusted, the i-f amplifier may be used to determine whether the "difference frequency" between a signal tuned in and that of the oscillator is equal exactly to the i-f. To do this, a signal of known frequency is fed into the mixer stage. Maximum output will be obtained from the i-f amplifier when the difference between the oscillator frequency and that of this signal is equal to the frequency to which the i-f has been peaked, i.e., when the oscillator "tracks" correctly with the r-f and mixer stages. But since the i-f amplifier has already been adjusted; all that remains to be done, then, is to adjust the oscillator circuits until maximum response is obtained (see part (1) of Art. 25-18.) This is usually done at a high-frequency (1,400 kc) point on the dial and again at a low-frequency (600 kc) point. There are now two circuits known to be accurately adjusted.

Once the oscillator circuit has been properly adjusted (or, usually at the same time that it is being adjusted) it is a simple matter to align the tuning of the r-f circuits with each other to give maximum output from the i-f amplifier (see part (2) of Art. 25-18). The exact procedure to follow will be given in detail in the following sections of this chapter. If the receiver employs automatic volume control, the precautions explained in Art. 25-19 must first be taken before starting any aligning.

25-12. The I-F Amplifier.—The schematic circuit diagram of a typical 2-stage i-f amplifier used in superheterodynes is shown in Fig. 25-6. The three transformers T are the i-f transformers, and are tuned by the small condensers C_1 to C_6 in-

clusive; resistors R are de-coupling resistors; and condensers C are by-pass condensers. Our immediate concern is with the i-f transformers.

These units usually consist of universal-wound coils properly spaced and mounted on wooden dowels. The use of special magnetic cores in these coils is becoming more widespread. Each coil is tuned by its condenser which is mounted inside the shield can in which the coils are located. Leads are brought out from the coil terminals for connection to the other related components in

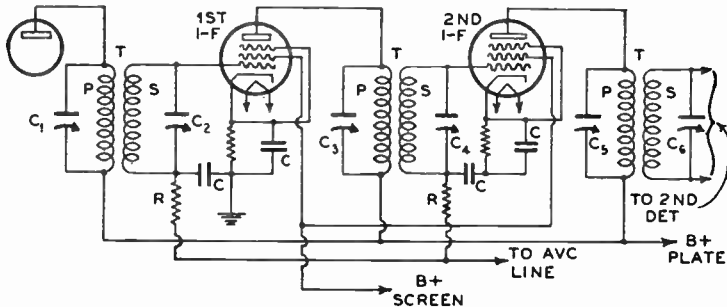

FIG. 25-6.—A typical i-f amplifier for a very sensitive superheterodyne receiver. Two stages of i-f amplification are used. Each i-f transformer winding is tuned by an adjustable tuning condenser C_1 , C_3 , etc. Most "midget" superheterodyne receivers employ only one such stage.

the circuit. A typical i-f transformer of this type employing variable tuning condensers of the *air dielectric type* is illustrated at the left of Fig. 25-7 which shows a cut-open view revealing the interior. The two small tuning condensers which tune the coils may be seen at the top and bottom. They are small, variable air-dielectric condensers similar to those which tune the r-f circuits. These transformers are therefore said to be "air tuned." Other i-f transformers use almost the same coil construction, except that the tuning condensers resemble the small padding condensers ("postage stamp" type) used on gang condensers. They are of the compression type with a mica dielectric. An i-f unit of this type is shown at the right of Fig. 25-7, and in (C) of Fig. 22-5. Aside from these mechanical details, all i-f transformers are essentially the same. One exception to this is the case of

those i-f transformers which employ special magnetic cores. In the air-tuned transformers, the tuning of one coil is adjusted from the top of the can and the other from the bottom.

25-13. Aligning Procedure for Peaked I-F Amplifiers.— The operating symptoms which will usually be noted if the i-f amplifier is out of alignment, were outlined in Art. 25-8. A suitably calibrated modulated test oscillator is essential for supplying the proper signals for the correct alignment of the various

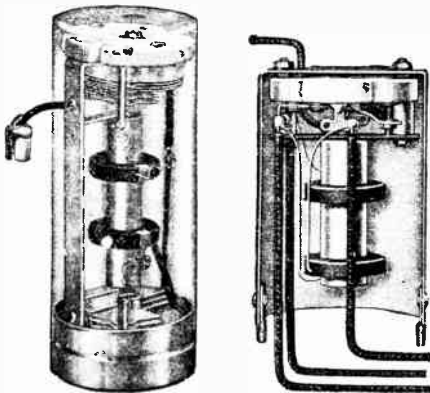

FIG. 25-7. — (Left) An i-f tuning unit which employs an air-dielectric tuning condenser for each coil. One condenser is at the top and one is at the bottom.

(Right) An i-f coil which employs two compression-type mica tuning condensers built into the base. The coil shields are cut open to reveal the interiors.

Courtesy Hammarlund Mfg. Co.

circuits in superheterodyne receivers, for the same reasons which were explained in Arts. 15-1 and 24-2. An output indicator of some kind (see Chapter VII) should be employed to indicate when the receiver output is maximum, as explained in Arts. 7-1 and 24-7. The i-f which the receiver is designed to employ, and to which its i-f amplifier must be tuned, should be known before starting the work.* If it is not known, the method outlined in Art. 25-20 should be followed. If the i-f is known, the alignment of the i-f tuning stages should be carried out as follows if the i-f amplifier is of the "peaked" type:

(1) First make sure that all the tubes of the receiver are in their proper sockets, that all control-grid leads are properly con-

*NOTE: For a complete table in which the intermediate frequencies of practically all American superheterodyne receivers which have been manufactured up to the date of the last printing of this book are listed, refer to the author's *Radio Trouble-Shooter's Handbook*.

nected, and that all shields are properly in place. The aerial wire should be disconnected from the receiver, but the ground wire left in place. The shielded output cable of the test oscillator is then connected to the receiver, the outer shield being connected to the "Gnd" post of the receiver (or to the chassis if the chassis is grounded), and the inner wire being connected to the control-grid of the *first* detector or "mixer" tube. This is the best connection for the i-f amplifier alignment of most receivers. It is usually best to make this connection to the control grid and then put the control-grid clip and tube shield back in place. The oscillator should then be turned on (so that it will have an opportunity to warm up and reach a steady state) and set to deliver the correct i-f for the receiver under adjustment. The output indicator (whatever type is employed) should then be connected to the receiver in the proper way. The best ways to connect the various types of output indicators were discussed in detail in Chapter VII. Let us assume that a meter-type output meter is connected as shown in Fig. 7-8 if the receiver employs a single output tube and a dynamic speaker; or as shown in Fig. 7-10 if it employs a push-pull output stage. (If a cathode-ray oscilloscope is to be used as the output indicator, the directions outlined in Art. 25-38 should be followed.) The complete aligning set-up for a typical midget receiver is illustrated pictorially in Fig. 25-8.

(2) The oscillator tuning condenser in the receiver should now be short-circuited, or the control grid of the oscillator tube should be grounded to the chassis to prevent the oscillator in the receiver from functioning during the alignment. The receiver should now be turned on. If it has a "normal-maximum" switch, the switch should be placed in the "normal" position and the volume control should be set at the full "on" position. The test oscillator should now be readjusted carefully to the correct i-f setting, and its attenuator control should be adjusted until the output meter reads about one-half the full scale deflection. The test oscillator should be operated with its output signal modulated.

(3) Locate the i-f transformer unit which is connected between the last i-f tube and the second detector tube. Its tuning

condensers are to be adjusted first, starting with the condenser nearest the second detector in the circuit (condenser C_2 in Fig. 25-6). An insulated screw driver or socket wrench (whichever is required) should be used for making the adjustments, inserting the proper tool in the holes provided for this purpose in the shield can, as shown in Fig. 25-3. Special fibre or bakelite tools are available for this work. Turn the adjustment of the secondary tuning condenser of this i-f transformer slowly, until the

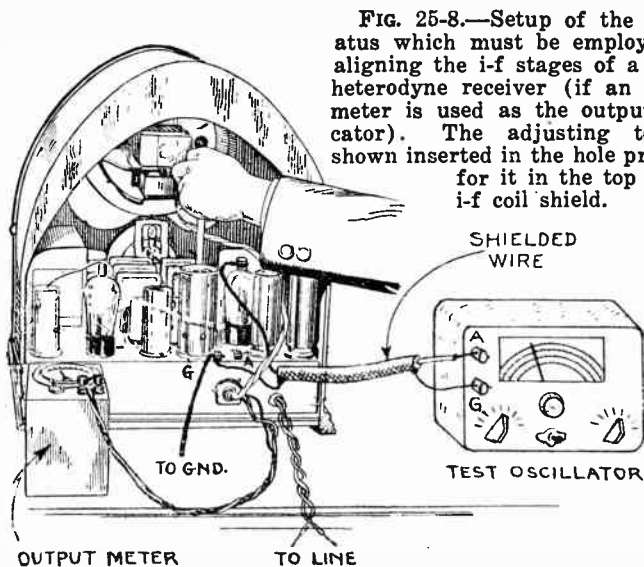

FIG. 25-8.—Setup of the apparatus which must be employed for aligning the i-f stages of a superheterodyne receiver (if an output meter is used as the output indicator). The adjusting tool is shown inserted in the hole provided for it in the top of the i-f coil shield.

reading of the output meter is greatest.* If this unit is very much out of adjustment, it may be necessary (while the adjustments are being made) to reduce the test oscillator output by lowering the setting of its attenuator control from time to time so as to keep the output meter reading within the scale range. Continue to turn the screw or nut until the meter reads highest. Then adjust the primary tuning condenser (condenser C_2 in Fig. 25-6) on this same transformer until the meter reads highest

*NOTE: Inability to "peak" an i-f transformer may be due to absence of "trimmer" capacity variation, even though the trimmer screw turns. This occurs when the trimmer has been turned down too tight, causing the plate to become permanently sprung. In such cases, it is best to replace the trimmer, or the entire i-f unit, with a new one.

again. When this is finished, check the adjustment of the secondary condenser, as frequently the adjustment of the primary will change the adjustment of the secondary slightly. Repeat this for the primary condenser to make sure.

(4) If the receiver employs more than one i-f transformer unit (see Fig. 25-6), similar adjustments must be made on the tuning condensers of each one, progressing step by step back toward the first detector. In each case, first the secondary, and then the primary, tuning condenser is adjusted for highest reading on the output meter. Usually, the attenuator control on the test oscillator will have to be lowered after each adjustment is completed, in order to keep the output meter reading within the scale range.

(5) When aligning the i-f stages of some receivers, it may be found difficult to obtain a fine adjustment for the line-up of a particular stage when the test oscillator is coupled to the input of the entire i-f amplifier by connecting it as directed in part (1). In such cases, closer adjustment may be made by coupling the oscillator direct to the particular stage being aligned. For instance, if the grid circuit tuning condenser of an i-f stage is being adjusted, the inside lead of the test oscillator shielded cable should be connected to the *plate* of the preceding tube. If the plate circuit condenser is being adjusted, the test oscillator lead should be connected to the control grid of this preceding tube. In all cases, the outside shield of the test oscillator cable should be connected to the "Gnd" post of the receiver and the tube shield should be tightly in place. The foregoing i-f alignment procedure is satisfactory only for receivers which employ i-f transformers designed to be "peaked" at one frequency. The individual-stage resonance curves, and the overall amplifier resonance curve of a typical i-f amplifier of this type is shown in Fig. 25-3.

25-14. Procedure for Aligning Flat-Top or Band-Pass I-F Amplifiers.—There are some receivers, especially those of the high-fidelity type, which employ i-f transformers designed to have resonance curves which are wide at the top (as shown in Fig. 25-9) instead of sharp, so that the side-bands will not be suppressed in the i-f amplifier to such a degree that the receiver

will lack "highs". In most cases, the primary and secondary windings of these i-f transformers are closely coupled by being mounted close to each other, as distinguished from the more loosely coupled arrangements employed in the sharply-peaked transformers where the primary and secondary windings are spaced far apart or have a copper shield placed between them. The alignment of such i-f stages must be carried out carefully so that there will not be any serious cutting of side bands. These "flat-top" transformers are not supposed to be peaked at any

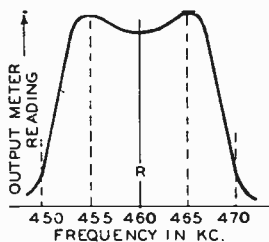

FIG. 25-9.—Response curve of a 460 kc "flat-topped" i-f transformer (or amplifier). Here the transformer (or amplifier) response is flat-topped from about 455 to 465 kc—5-kc each side of the main 460-kc i-f.

single frequency, but rather to a band of frequencies about 4 or 5 kc on each side of the main i-f frequency in ordinary receivers having high selectivity, and about 7.5 kc on each side in high-fidelity receivers. For instance, with a 10 kc *total* flat-top, if the main i-f is 460 kc, the flat-top band width of the resonance curve might extend from $460 - 5$ to $460 + 5$, i.e. from 455 to 465 kc as shown in Fig. 25-9. When receivers employing these i-f amplifiers are to be aligned, it is always best to carefully consult the manufacturer's instructions for the particular receiver under consideration, for, special adjustments must often be made. If these instructions are not available, the following information may be found useful:

The receiver, test oscillator and output meter* should first be connected exactly as explained in parts (1) and (2) of Art. 25-13. There are two methods in use for aligning these flat-top transformers. In the first, the secondary is tuned to one of the

*NOTE: If a cathode-ray oscilloscope is to be used (instead of the output meter) for the purpose of making "visual" alignment possible, it should be connected to the receiver as directed in Art. 25-38. The alignment of the i-f amplifier of the receiver should then be carried out as explained in detail in Art. 25-40.

flat-top frequency limits, and the primary is tuned to the other. For instance, suppose the i-f amplifier is to be flat-topped from 455 to 465 kc. Starting, at the i-f transformer nearest to the second detector (in the usual way), the secondary would be adjusted to produce highest output when the test oscillator was feeding a 465 kc signal into the i-f amplifier. Then the primary would be adjusted to produce highest output when the test oscillator was set to feed a 455 kc signal into the i-f amplifier. It would be best to check these adjustments at least *three* times to insure accurate setting. As a final check, the test oscillator dial would be rotated slowly to vary its frequency from 455 to 465 kc and the output meter reading noted at the same time. The change in reading of the output meter should be just about as represented by the flat-top portion of the resonance curve in Fig. 25-9, dropping slightly at the center region

Another method of aligning these flat-top transformers is to first adjust the secondary and primary to the peak i-f, and then slightly detune each (detuning one *above* and one *below*) until the variation of the output meter readings as the test oscillator frequency is varied over the desired flat-top range is very slight. The important thing is that the change in reading of the output meter should be the same on either side of the center or main i-f frequency.

25-15. Neutralizing I-F Circuits.—It is interesting to note that several of the older type superheterodynes employed a neutralizing system in the i-f amplifier to balance out the oscillation effects caused by the inter-electrode capacities of the i-f tubes. At the time these receivers were designed and manufactured, modern screen-grid tubes were not available. In addition to aligning the i-f stages of these receivers at a specified frequency, they must also be “balanced” or “neutralized”. Balancing, or neutralizing these stages is accomplished in precisely the same manner as described in Art. 24-17. A dummy tube or neutralizing adapter is employed while the neutralizing condensers are adjusted for *minimum* response of the receiver as read on the output meter.

25-16. Aligning the I-F Amplifiers of All-Wave Receivers. The general procedure for aligning the i-f stages of all-wave re-

ceivers is exactly the same as described here for the standard broadcast-band type receivers, except for the fact that the intermediate-frequencies used in all-wave receivers usually range from about 450 to 460 kc instead of 175 or 260 kc as is commonly used in standard broadcast-band receivers. Of course the alignment of the r-f circuits differs. Further details concerning the servicing of all-wave receivers will be presented in Chapter XXVIII. Their alignment will also be considered there.

25-17. Arrangements Employed in Superheterodynes for Making the Oscillator "Track".—While it is essential that the r-f tuning stages be selective and that they be "aligned" well, this is not sufficient for the elimination of image interference (Art. 25-10) nor for the making of a sensitive superheterodyne. It is necessary that the oscillator "track" with the radio-frequency tuner because the oscillator frequency determines when a given signal comes in, that is, when the "difference" frequency between the given signal and the oscillator frequency is equal to the fixed intermediate frequency. In order for the circuit as a whole to be sensitive and selective, it is necessary that the radio-frequency tuner be exactly in tune with the desired carrier when the "difference" frequency is exactly equal to the fixed intermediate frequency. *This condition must be fulfilled at every setting of the tuning dial*, hence it follows that there must be close tracking between the oscillator and the radio-frequency tuners. The preciseness of this tracking determines (to a large degree), the excellence of a given receiver as regards its sensitivity and selectivity.

The tracking problem is complicated by the fact that the "difference" frequency is constant whereas the signal and oscillator frequencies which "beat" to produce this are both variable. Theoretically, a simple solution of the problem would be to have tuners (both for the oscillator and the radio-frequency circuits) in which the frequency of resonance would be strictly proportional to the angular displacement of the tuning condensers. But such condensers are extremely difficult to produce. Therefore, the tracking must be accomplished in some other manner.

One way in which the problem has been solved is by special design of the condensers. The condensers used in the radio-fre-

quency tuners are alike and are of no special design. The oscillator condenser, however, is designed to have a different rate of change of capacity. This means that the rotor plates, and sometimes also the stators, are *shaped differently* from the corresponding plates of the radio-frequency condensers so that the proper frequency variation is produced in the oscillator circuit. If the design is right, close tracking is attained.

This method of tracking seems to be the ideal arrangement, yet it has its drawbacks. For example, a condenser that has been designed for use in a receiver using an intermediate frequency of 175 kc is not good for use in a set using any other i-f, for the relative difference between the condenser plates is a function of the intermediate frequency. Also, it is necessary to hold the inductances in the circuits within close limits. When the receiver is designed to permit of both short wave and standard-broadcast band reception, shaped oscillator condenser plates are not feasible because a given shaping is suitable only for a given set of coils and for a given i-f. Any change in the ratio of r-f signal-circuit inductance to oscillator inductance necessitates a change in the shaping of the oscillator condenser plates even though the i-f remains the same. This means that in multi-band receivers—and even in many single-band receivers—the condenser plates cannot be “shaped” and the oscillator tuning capacity must be altered in some other manner to provide the constant “difference frequency”.

There is another method of making the oscillator track with the radio-frequency circuits, and that is by “padding” the oscillator circuit. This means that the oscillation circuit is treated to make the rate of change of frequency such that the difference between the oscillator frequency and the frequency of the r-f circuits is always constant. This requires a special choice of inductance, a semi-variable condenser in series with the oscillator tuning condenser, and a small semi-variable condenser in shunt with either this condenser alone or with it and the series condenser. This arrangement is applicable to the case when the oscillator frequency is *greater* by a constant amount than the signal frequency (the usual practice).

There are three different electrical “padding” circuits which

may be used to obtain correct oscillator tracking. They are shown in Fig. 25-10. The simplest, but most ineffective, type of circuit is shown at (A). The main "ganged" oscillator tuning condenser is C , and the small adjustable padder mounted on its side is C_1 ; condenser C_1 has a low capacity value (about 25 mmfd). It is clear that the capacity of C_1 is most effective in the circuit at the minimum settings of C (at the highest frequencies), since then the capacity of C_1 is an appreciable part of the total capacity in the circuit. Therefore it can be used effectively for

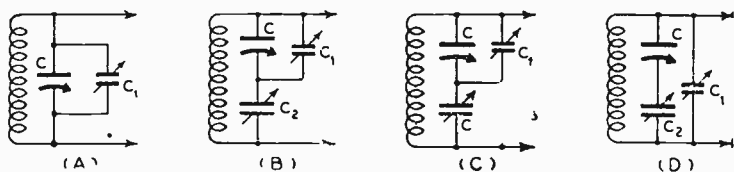

FIG. 25-10.—Several oscillator "padding" circuits which are employed for maintaining the difference between the oscillator frequency and the r-f signal circuit frequency constant over the complete tuning range of the receiver. In each case, C is the main ganged tuning condenser of the oscillator, C_1 is the adjustable high-frequency "tracking" trimmer, and C_2 (also C_3) is the adjustable low-frequency "padding" trimmer.

making the oscillator and r-f signal tuning circuits track properly over the high-frequency end of the tuning range. However, if these circuits should not track at the low frequencies, nothing can be done about it.

The arrangement of circuit (B) is a considerable improvement over that of (A) and is used in the majority of padding circuits. Condenser C is the main tuning unit as before, C_1 is the small adjustable padder mounted on its side, and C_2 is a much larger adjustable condenser. The value of this latter condenser must be so large, and the amount of its variation need be so small, that it is often split into a large fixed condenser in parallel with a much smaller adjustable one (see circuit (C)). Since C_2 is very large and is in series with tuning condenser C , it has little effect on the circuit at the high frequencies (when C is very small). On the other hand, padder C_1 , being in parallel with tuning condenser C , is able to control the total circuit tuning greatly at the high-frequency end of the dial. Hence, C_1

is usually called the *high-frequency padder* and C_2 the *low-frequency padder*.

The circuit arrangement shown at (C) of Fig. 25-10, is essentially the same as that at (B) with the exception that a large fixed condenser C_1 and a small adjustable condenser C_2 are connected in parallel. It is these two condensers that constitute condenser C_1 at (B). This arrangement is shown in a separate diagram here because one very prominent manufacturer has shown this padding arrangement in this way on all his schematic diagrams for a number of years, and service men may have occasion to refer to these diagrams.

The circuit at arrangement (D) is essentially the same as that at (B) except that the high-frequency trimmer C_1 is across both the tuning condenser and low-frequency padder. It is little different from (B) as far as operation is concerned, because C_1 is very large compared to C_2 . However, its effect on the tuning of the circuit at the high frequencies is still more pronounced than when it is employed across the tuning condenser alone.

In all four circuits shown in Fig. 25-10, C is the main "ganged" oscillator tuning condenser, C_1 is the adjustable high-frequency trimmer, and C_2 (or C_3 in circuit (C)) is the adjustable low-frequency padder.

25-18. Aligning the Oscillator and R-F Circuits. — The alignment of the oscillator and r-f circuits in standard-broadcast band receivers will now be considered. The short-circuit which was put across the receiver oscillator tuning condenser, or the grounding wire which was put on the control grid of the oscillator tube in order to prevent the oscillator from operating while the i-f amplifier was being aligned (see part (2) of Art. 25-13) should now be removed. The operating symptoms which should be observed if the oscillator does not track properly with the r-f tuning circuits, were outlined in Art. 25-10. The effects of misaligned r-f stages were discussed in Art. 25-9.

If the tracking between the receiver oscillator frequency and that of the r-f circuits, and also the alignment of the r-f amplifier and mixer circuit tuning condensers (which are ganged together), are to be checked and adjusted, the shielded output

cable of the test oscillator should be connected to the *Ant.* and *Gnd.* posts of the receiver, exactly as specified in Art. 24-6 for aligning t-r-f receivers. The output indicator should also be connected properly to the receiver (see part (1) of Art. 25-13). The oscillator tube, as well as all other tubes, shields, control-grid leads, etc., should be in their proper places.

Directions for the alignment of superheterodyne receivers often specify that the r-f circuits, consisting of the r-f amplifier (pre-selector) and the mixer tuning condensers must be aligned last—after the oscillator tracking has been checked. However, for speed and directness in this work, it is best to align them with each other at the same time that the oscillator circuit is being adjusted. The trimmers on the r-f condensers may be adjusted for the high-frequency end of the dial at the same time that the oscillator high-frequency tracking trimmer (padder condenser) is being adjusted. In this way, both operations are performed at almost the same time.

(1) **Adjusting the Oscillator for correct "tracking" at the high-frequency end:** First, set the test oscillator operating at 1,400 kc. This is the signal frequency at which the adjustable high-frequency tracking trimmer of the oscillator (condenser C_1 in Fig. 25-10) is commonly adjusted so that the ganged oscillator-tuning condenser will track properly with the r-f circuit tuning condensers at the high frequencies. The test oscillator signal should be tuned in by setting the dial of the receiver exactly to the 1,400 kc division. If the signal is not heard at this receiver dial setting, but is heard at an "off" point, say 1,300 kc, the receiver should be retuned by adjusting the other (pre-selector and "mixer") tuning condensers to produce maximum output at this "off" point setting of the receiver dial; then retuning the set nearer the 1,400 kc division and readjusting these r-f tuning circuit condensers there. This alternate process must be repeated, approaching closer to the 1,400 kc dial division each time, until the signal comes in at maximum strength when the receiver dial is set at the 1,400 kc division.

When the 1,400 kc signal from the test oscillator is finally brought in with maximum strength when the receiver dial is also set exactly at the 1,400 kc division, the high-frequency

tracking trimmer of the receiver oscillator should be adjusted until the highest output meter deflection is obtained.

(2) **Aligning the r-f and mixer tuned circuits at the high-frequency end:** The tuned circuits of the r-f (pre-selector) stages (if any are employed), and of the first detector or "mixer" stage may now be aligned with each other conveniently at the high-frequency end. With the test oscillator still connected and set at 1,400 kc, the trimmers on those sections of the gang tuning condensers which tune these r-f circuits should be adjusted for maximum output, exactly as was explained in Art. 24-8 for the high-frequency-end adjustment of t-r-f receivers. The tuning dial should be "rocked" back and forth slightly about the 1,400 kc point while the adjustments are being made. If the plates of these condenser sections have been bent, they should be readjusted over the entire range of the broadcast band. This completes all the high-frequency adjustments to be made on the receiver.

(3) **Adjusting the oscillator for correct "tracking" at the low-frequency end:** The low-frequency tracking padder of the receiver oscillator (if one is provided) should now be adjusted with both the test oscillator and the receiver tuned exactly to 600 kc. This condenser (condenser C_2 in (B) and (D), or condenser C_3 in (C) of Fig. 25-10) should be adjusted until the highest output meter deflection is obtained. This adjustment should be made while the receiver dial is "rocked" slightly about its 600-kc position. The r-f circuit tuning condensers are not provided with low-frequency padders, but their split rotor plates can be manipulated as directed in Art. 24-8 so as to make the output meter deflection maximum. It is wise to re-check the high-frequency oscillator tracking adjustment at this point, for accurate results.

(4) **Receivers without a padder for low-frequency tracking of the oscillator:** In a few commercial receivers, particularly of the midget type, a low-frequency oscillator-tracking padder is not provided (as shown at (A) of Fig. 25-10). In such cases, the tuning dial of the receiver must be turned about the shaft (after loosening the set-screws) so that broadcast signals at the low-frequency end of the tuning range are received at the

correct receiver dial settings. The high-frequency oscillator tracking trimmer is then adjusted so that when a 1,400 kc signal from the test oscillator is received, it produces maximum output, when the receiver tuning dial is set very close to the 1,400 kc point.

(5) **Oscillator tracking over middle of dial:** Although no adjustment for correct tracking between the r-f and the oscillator circuits is made between 1,400 and 600 kc, some modern circuits automatically track exactly at 1,000 kc because of the design of the padding circuits, if the tracking is correct at 600 kc and 1,400 kc. In such cases, the test oscillator should be adjusted to feed a 1,000 kc signal to the receiver, and the oscillator tracking should be checked at this point. If it is off at this frequency, it may be necessary to realign at 1,400 and 600 kc to make the 1,000 kc point check closely. Otherwise, it may be assumed that the oscillator frequency tracks above the signal frequency by an amount equal to the i-f of the receiver (or at least within a few kc of it), over the entire dial. Only in rare cases need the plates of the oscillator tuning condenser be bent.

The arrangement of the oscillator padding circuits and the procedure for aligning the oscillator circuits of all-wave receivers will be discussed in detail in Chapter XXVIII. It will be seen that the general method employed, is similar to that used for single-band receivers.

25-19. Aligning Receivers having Automatic Volume Control.—An important precaution must be observed when using an output meter during the alignment of receivers which employ avc (most modern sets). With the avc functioning properly, wide changes in the alignment of the receiver might produce no noticeable changes in the receiver output, i.e., the output meter will not indicate any changes in output when adjustments are made in the r-f, oscillator, or i-f circuits, since it is the function of the avc system to keep the output constant. Hence the action of the avc must be prevented while the alignment adjustments are being made. The best method to employ for preventing the avc from functioning depends a great deal on the particular avc arrangement employed in the receiver.

In some receivers, the avc action is obtained by the use of a separate avc tube. This tube should *not* be removed from the

receiver when making adjustments of any kind, for it will disturb the normal characteristics of the receiver. To use an output meter with receivers of this kind, the lead which couples the signal to the control grid of the avc tube should be opened. This will allow practically the normal tube currents to flow, but at the same time prevent the avc action from taking place.

Another expedient which may be resorted to is to use such a weak signal from the test oscillator that the avc action does not take place, (see Art. 19-2). This latter method is especially recommended when aligning receivers which employ delayed avc circuits (see Art. 19-9).

Still another method to prevent the avc action is to break the lead which picks off the avc voltage from the avc circuit and distributes this voltage to the avc-controlled tubes. The part of the lead which goes to the grid circuits of these controlled tubes should then be grounded directly to the chassis. This will place only the small residual bias on the tubes, which will raise the sensitivity of the receiver to maximum, necessitating a reduction in the test oscillator output. This latter method is of special value in receivers using a "combination tube" in which the second detector, avc and first-audio functions all take place. The 55, 75, 85, 2B7, 6B7 etc., types are typical examples of such tubes. Naturally it is not possible to disconnect the avc portion of such tube circuits without appreciably affecting the detector and first audio sections.

In some receivers of the foregoing type which use a combination second detector, avc and first-audio tube, it may be inadvisable to operate the tubes which are normally under avc control, without proper grid bias voltage. In such cases, the normal fixed grid bias voltage may easily be supplied to these tubes by connecting a potentiometer of about 100,000 ohms directly across a 45-volt *B* battery. The *positive* terminal of the battery should be connected to the chassis of the receiver. No connection other than that of the potentiometer is made to the *negative* terminal of the battery. After the lead which picks off the avc voltage from the avc circuit and distributes it to the control-grid circuits of the avc-controlled tubes has been broken, the part of this lead which goes to the grid circuits of these con-

trolled tubes should be connected directly to the movable arm of the foregoing potentiometer. The setting of this arm may be adjusted to provide the correct negative grid-bias voltage for the normal operation of these tubes during the alignment of the receiver.

After the avc has been made ineffective by one of these means, the alignment of the receiver may be carried out exactly as described in this chapter for receivers without avc.

Receivers employing a tuning meter, shadowgraph, "magic eye", or other device for indicating station resonance, do not require the use of an output meter for indicating the receiver output when aligning the tuned circuits. The foregoing precautions regarding the avc action are also unnecessary in these receivers, since the resonance indicator of the receiver can be used instead of the output meter, for indicating the output.

25-20. Aligning a Receiver Whose I-F is Unknown.—

When a superheterodyne receiver exhibits definite symptoms which point to incorrect alignment of the i-f stages (see Art. 25-8), the condition may be remedied easily enough with the aid of a calibrated modulated test oscillator and an output indicator, (as previously explained in Arts. 25-13 and 25-14), provided the correct intermediate frequency of the receiver is known. However, the occasion may arise where alignment is found necessary, but the intermediate frequency is unknown. If a test oscillator is available, the determination of the correct i-f is not difficult, since the majority of commercial superheterodyne receivers employ, more or less, one of several standard intermediate frequencies.

The test oscillator must be capable of supplying fundamental signals over an i-f range from about 100 kc to around 550 kc at least, so that the range of intermediate frequencies which have been commonly employed in receivers may be covered. (Very few commercial receivers use a lower i-f than 130 kc.) (See the author's *Radio Trouble-Shooter's Handbook* for a complete tabulation of the i-f's of American superheterodyne receivers.)

The receiver to be aligned should first be placed in the best operating condition possible. Then the output indicator, if one is used, should be connected properly to the output circuit of the

receiver. A modulated signal from the test oscillator should now be fed into the grid of either the first or the last i-f tube and the *oscillator* section of the receiver tuning condenser should be "shorted out" to prevent harmonics from the test oscillator from feeding back into the r-f circuits of the receiver. The frequency of the test oscillator should then be varied *slowly and carefully* between about 550 kc and 100 kc, *starting at 550 kc* and slowly *reducing* the frequency until a signal is heard in the receiver loudspeaker, or is shown by the output indicator. The frequency setting of the test oscillator at which the signal is heard (or indicated) is *probably* the i-f peak of the receiver (although it *may* be a *harmonic* of the i-f peak).

A check should now be made to find out whether it is really the i-f peak or whether it is a *harmonic* of it. To do this, first set the test oscillator at *twice* the frequency found by the foregoing procedure. If no signal is heard (or indicated), then the original frequency setting of the test oscillator is the i-f peak of the receiver. (Now, by setting the frequency of the test oscillator at *half* the determined peak, its *second harmonic* signal should be heard—or indicated—but not quite as strongly as before, which is further confirmation of the i-f peak.)

It is quite possible that the intermediate frequency determined by the foregoing procedure results in some *odd* frequency, such as 459 kc or 461 kc, etc. By consulting a compilation of intermediate frequencies, the nearest *commonly used* i-f to this can be determined—in this case it is 460 kc. This latter frequency can therefore be taken as the correct i-f of the receiver, since the i-f alignment of the receiver as it was brought into the shop may have been "out" by just one or two kc. However, the resonance points of i-f transformers seldom vary by more than one or two kilocycles from the specified correct i-f peak frequency unless they have been disturbed or the receiver has undergone unusually rough handling.

Another important matter is that of *adjacent* i-f peaks—that is, cases where definite peaks are obtained at adjacent frequencies (such as 175 kc and 177.5 kc, 260 kc and 262 kc, etc.) In such cases, is one to determine which of the two adjacent intermediate frequencies is the correct receiver i-f? In almost

every instance of this kind it will be found that the i-f transformers will peak more readily at one of these frequencies—the one which is the correct receiver i-f—without the necessity of tightening down or entirely loosening the trimmer condenser adjustments. For example, should the foregoing i-f peak check-up reveal definite peaks, say, at both 260 kc and 262 kc and should it then be found that the “trimmers” must be tightened down considerably to align the i-f amplifier correctly at 261 kc, then by this reasoning 262 kc would most likely be the correct receiver i-f.

25-21. Operation of the Double-Spot (Image-Suppression) Circuit.—The difficulties which may be caused in superheterodyne receivers by image frequency interference were discussed in Arts. 23-13 to 23-16 inclusive. It was explained there that image-frequency interference results in double-spot reception, unless it is prevented. As the frequency of the interfering signal that may cause the double-spot reception is always *higher* (by an amount equal to *twice the i-f*) than the frequency to which the r-f circuits are tuned at the particular dial-setting

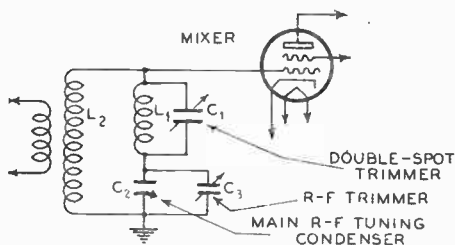
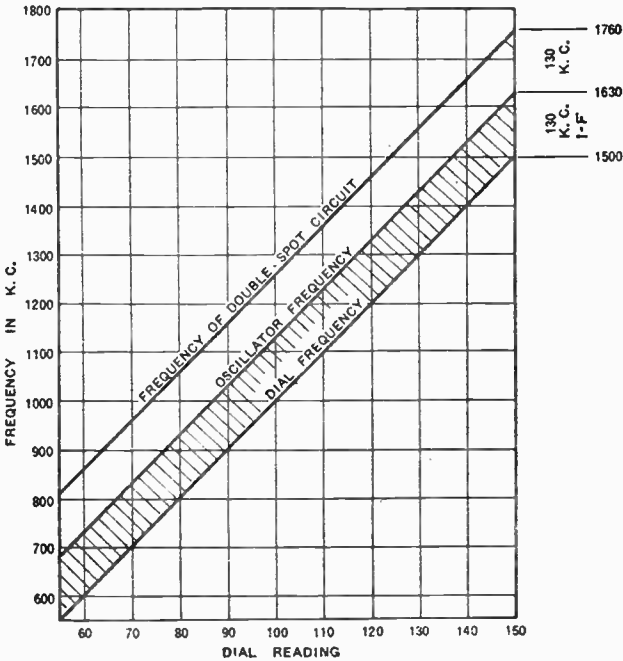

FIG. 25-11.—Double-spot tuning circuit which has been used in Atwater Kent receivers for the prevention of image-frequency interference and double-spot tuning. The main tuning circuit and the double-spot circuit are tuned simultaneously to two different frequencies.

being considered, it is necessary to prevent any energy at this frequency from entering the first detector or “mixer”. Most receivers accomplish this by using one or two ordinary stages (pre-selector stages) of sharply-tuned r-f amplification ahead

of the first detector. These stages are tuned to the frequency of the desired station, and their natural selectivity is depended upon to prevent interfering signals of all other frequencies (in-



Courtesy Atwater Kent

FIG. 25-12.—Graphs showing how the oscillator frequency is varied automatically over the entire dial range so it “tracks” above the frequency of the r-f signal circuits by an amount equal to the i-f of the receiver (130 kc in this case). The double-spot circuit is also varied in step with these two, it being tuned always to the double-spot frequency. For any given setting of the dial, the oscillator frequency is 130 kc higher than the dial-frequency setting, and the double-spot circuit is 260 kc higher than the dial-frequency setting.

cluding the image-interference signal) from getting to the first detector.

In some other commercial superheterodynes this problem has been attacked in a more direct way by incorporating in the input circuit of the receiver, a “double-spot” circuit which is always tuned automatically to the image frequency (by means

of one section of the main gang tuning condenser) no matter what the position of the main tuning dial is. Its effect is to effectively present what amounts to a short-circuit to the image frequency, across the complete tuning circuit from the control-grid to the ground or cathode, so that the image-frequency signal for any receiver dial setting never gets to the mixer circuit. The circuit arrangement of this kind which has been employed in Atwater Kent receivers is shown in Fig. 25-11.

In this arrangement, the complete pre-selector circuit, consisting of L_2 , L_1 and C_1 , and C_2 plus C_3 , (all in series) tunes to the desired broadcast frequency. A part of this circuit, consisting of L_1 , the double-spot trimmer C_1 and variable tuning condenser C_2 (with its trimmer C_3) tunes simultaneously with the pre-selector, but its frequency is always higher than that of the pre-selector or dial frequency by an amount equal to twice the i-f. This is shown pictorially in Fig. 25-12 for a broadcast-band receiver which employs a 130-kc i-f. As the receiver dial is turned from about 60 to 150, the frequency to which the r-f (pre-selector) circuits tune varies from about 600 to 1,500 kc. At the same time, the oscillator frequency varies simultaneously, so that it "tracks" exactly 130 kc above this pre-selector (r-f) frequency for every setting of the tuning dial. At the same time, the frequency to which the double-spot (or other image-suppression) circuit tunes is always exactly 260 kc (twice the i-f) above the pre-selector frequency. Therefore, it always tunes to the *image* frequency. Since this latter circuit is an "acceptor" circuit and is connected from the control grid to the cathode of the mixer, it acts as a short-circuit to the frequency of the image signal that might otherwise cause double-spot reception and practically eliminates any such energy from reaching the mixer.

25-22. Adjusting a Double-Spot (Image-Suppression) Circuit.—Because of the fact that the double-spot trimmer C_1 and the trimmer C_3 of the variable condenser C_2 are in the same circuit, adjustment of one affects the other. The proper adjustment is secured when further adjustment of either trimmer does not increase the 1,500 kc signal strength, and does not

further decrease the double-spot volume at a frequency equal to 1,500 kc minus twice the i-f. In practice, in receivers which use the double-spot circuit, the double-spot trimmer need never be adjusted unless the trimmer C_3 (Fig. 25-11) has been adjusted, or unless image interference occurs.

The adjustment of the double-spot circuit is not difficult. In order to make it on the Atwater Kent receivers which employ this circuit (these receivers employ an i-f of 130 kc), a 1,500 kc test oscillator that may be switched from a normal strength to an extra-strong signal is necessary. The extra-strong 1,500 kc signal must be of such strength that the double-spot volume of this signal (which is tuned in at 1,240 kc) can not be entirely eliminated even with the double-spot circuit correctly adjusted. This is necessary in order to make an accurate adjustment of the double-spot trimmer. If there was no response at the double-spot point over a wide adjustment of the double-spot trimmer it would be impossible to set this trimmer to the correct point. The adjustment procedure is as follows:

- (1) The output indicator should first be connected in the usual way to indicate the output of the receiver. Then the shielded cable of the test oscillator should be connected properly to the *Ant.* and *Gnd.* posts of the receiver. With the test oscillator supplying a 1,500-kc signal of normal strength, and with the dial pointer of the receiver set to 1,500 kc, the pre-selector trimmers, the antenna trimmer, and the oscillator trimmer should be adjusted for maximum reading on the output meter.

- (2) Now the test oscillator output control should be turned up to full "on" position to supply an extra-strong signal (still at 1,500 kc), and the receiver should be set with its dial pointer at 1,240 kc. When the dial pointer is in this position, the double-spot circuit is tuned exactly to 1,500 kc (see Art. 25-21). Now the double-spot trimmer (C_1) should be adjusted to give as close to *minimum* response on the output indicator as is possible. This sets the double-spot circuit so it is most effective in *eliminating* any incoming double-spot (image) interfering signal.

- (3) Now the test oscillator should be switched back to normal strength (still at 1,500 kc), the set should be tuned to the 1,500 kc signal, and trimmer C_3 should be readjusted for *maximum* output.

- (4) The receiver should now be tuned back to 1,240 kc, the extra-strong 1,500 kc test-oscillator signal should be switched on, and final adjustment of the double-spot trimmer C_1 should be made for *minimum* output.

These adjustments may be considered to be correctly made and final when further adjustment of trimmer C_3 (with the oscillator operating at normal strength at 1,500 kc and the receiver tuned to 1,500 kc) does not produce an *increase* in output, and, second, when further adjustment of the double-spot trimmer, C_1 , does not produce a further *decrease* in the output (with the test oscillator set at 1,500 kc and the receiver tuned to 1,240 kc).

25-23. Adjusting Other Types of Image Suppression Circuits.—As explained in Art. 23-15, many receivers employ a continuously-tuned trap circuit (see Fig. 23-11) designed to prevent interfering image signals from getting through to the mixer tube. This circuit is tracked with the other tuned circuits in the receiver and simultaneously tunes to a frequency which is always higher than that of the pre-selector by a figure equal to twice the i-f. Therefore, when such image-suppressor trap circuits are to be adjusted at any dial setting of the receiver, the test oscillator which feeds its signal into the *Ant* and *Gnd* terminals (see part (1) of Art. 25-22 for the proper connection of the test instruments) should be set at a frequency higher than the receiver dial setting, by a frequency equal to twice the i-f.

Let us suppose that a trap circuit of this kind is to be adjusted in a receiver whose i-f is 180 kc. The receiver dial should be set at about 1,200 kc. The test oscillator should be connected to the receiver and set for maximum signal output at 1,200 plus 2×180 , or 1560 kc. This would be the frequency of an image-interference signal for this receiver dial setting. Since it is being fed into the receiver, the image suppressor circuit must now be aligned so that it shuts out this signal, thus preventing it from reaching the mixer tube. Of course, when this signal is completely shut out, the fact will be indicated by a *minimum* deflection of the output meter.

Of course, if, as in the case of the double-spot circuit described in Arts. 25-21 and 25-22, the suppressor trap circuit forms a part of (or affects in any way) another tuned circuit, perfect alignment will have to exist at the pre-selector frequency

as well as at the image frequency. This may be secured by the method outlined in Art. 25-22.

25-24. Use of Insulated Tools During Alignment.—Since the adjusting nuts, screws or plates of the condenser gang, and the i-f transformer trimmer condensers in superheterodyne receivers are not at ground potential in all receivers, the use of a metal socket-wrench or screw-driver for making the adjustments may cause very disturbing hand-capacity effects which

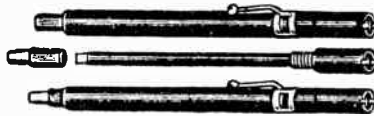

FIG. 25-13.—Three views of a combination fountain-pen size neutralizing tool made of fibre. By screwing the various sections together in different combinations 1/4- and 5/16-inch nut wrenches, a miniature blade screw driver for neutralizing and aligning, and a full-size general-purpose screw driver with insulated handle are provided.

may prevent accurate adjustment of the circuits. A bakelite or similar composition socket-wrench or screw-driver about 1/4-inch in diameter, or an insulated "neutralizing" tool should be employed for making these adjustments. Many effective tools designed especially for this work are available. The parts of a typical fountain-pen size combination tool of this kind which can be clipped to the vest pocket like a fountain pen, are illustrated in Fig. 25-13. Such tools are also useful for adjusting neutralizing condensers (see Arts. 24-17 and 25-15), etc. If hand-capacity effects are noticed at any time when such adjustments are made, it is usually necessary to make the adjustment so that *the peak output reading is obtained when the aligning tool is removed from the adjusting screw or nut.*

25-25. Need for the Cathode-Ray Tube in Receiver Alignment.—All of the methods for aligning the tuned stages of receivers which have been described thus far in this chapter and in Chapter XXIV, make use of a test oscillator to supply sig-

nal voltages of the desired frequency and strength to the receiver, and some device to indicate the output voltage or current of the receiver during the alignment. These are connected to the receiver as already described. It is a fairly simple matter to align the r-f tuning circuits of ordinary t-r-f receivers and the i-f circuits of superheterodynes which employ *peaked* i-f amplifiers, when this equipment is used, for the circuits are simply adjusted or "peaked" until maximum indication is obtained on the output indicator. Any of the simple forms of output indicators already described in Chapter VII are satisfactory for this purpose.

When superheterodyne receivers which employ i-f amplifiers having flat-top or band-pass characteristics (see Art. 25-14) are to be aligned, the problem is much more difficult. Most high-fidelity receivers employ this type of i-f amplifier so that a band width approximately 15 kc wide may be passed by the i-f amplifier without appreciable attenuation of any of the upper audio frequencies. This will be discussed in detail in Chapter XXXI. Most of these receivers have an i-f amplifier characteristic with a pronounced double peak, as shown in Fig. 25-9. In some, this double peak is obtained by a slight staggering or de-tuning of the successive i-f tuned circuits, in others it is obtained by tight coupling which produces the characteristic double-hump tuning curve. Since the performance of such receivers depends to a large measure upon the correct adjustment of these tuned circuits, they require more precise adjustment than it is usually possible to make when the ordinary meter type or neon-tube type output indicator is employed; otherwise, distortion and other troubles will result. It is difficult to *double-peak* an i-f amplifier properly and quickly with this equipment since the depth of the "valley" between the peaks is difficult to determine unless a plot of the curve can be examined. Most of the difficulties which arise in this work can be eliminated however, if it is made possible to look in on the tuned circuits and actually *see* their tuning characteristics during the alignment. In other words, if, instead of relying on the usual output indicators to tell merely when the circuits are "peaked", some other device is available which automatically and instantan-

eously plots the response curve of the receiver, so that the service man can see it while making the adjustments, he will then be in a position to see exactly what effect each adjustment is producing and know *exactly* when the circuits are properly adjusted. This may easily be accomplished by using a suitable cathode-ray tube in conjunction with several important associated circuits which will be described in the following sections. "Visuals", or resonance-curve tracing devices for showing the resonance curves of the intermediate- or radio-frequency stages of broadcast receivers have been used for some time by many receiver manufacturers who have installed cathode-ray outfits to align their regular production sets. So, when radio service men employ these devices in their service work, they are merely following in the footsteps of these alert manufacturers.

25-26. Cathode-Ray Tubes.—The cathode-ray tube has been used for quite a number of years as a tool for laboratory research. Professor F. Braun is credited with having first applied the tube for measurement purposes, about 1897. However, its extensive practical application did not occur until about eight years ago when it was employed for surge measurements in the study of natural lightning phenomena, for surge investigations in the laboratory, etc. Considerable improvements have been made in it since then in the many attempts to utilize it in television systems. Now, the development of a series of new improved types of cathode-ray tubes designed for specific purposes, and the reduction in cost of complete cathode-ray oscilloscope outfits and accessories has opened up extensive new applications for this versatile instrument—especially in the radio servicing field. Possibly the two main reasons why the cathode-ray oscilloscope is so valuable are: (a) the negligible inertia of the electron beam eliminates all damping effects and enables it to follow variations of almost any frequency in the voltages applied to the deflecting plates, (b) the electron beam traces a picture of the circuit conditions on a screen, which can be conveniently observed visually.

It is unnecessary, and beyond the scope of this book, to enter into an extended discussion of the theory of operation and construction of all types of cathode ray tubes, for they are

Braun's
tube

made in several forms—each designed to perform a certain desired task best. If he desires these details, the reader is referred to the *Radio Physics Course* by Ghirardi. Only the construction and operation of the type of cathode-ray tube which is being used most in oscilloscopes which are designed especially for radio service work will be described here.

25-27. Structure of the Cathode-Ray Tube.—The modern form of cathode-ray tube consists essentially of six main parts. These are:

1. A filament which serves to heat the cathode.
2. The cathode from which the electron stream is emitted.
3. A device for concentrating, controlling and focusing this electron stream into the form of a fine beam.
4. An arrangement for deflecting the beam (either *electrostatically* or *electromagnetically*).
5. The fluorescent screen or target which emits light when struck by the electron beam.
6. The glass envelope into which all the foregoing parts are sealed for the maintenance of a vacuum.

The arrangement of these various parts is shown diagrammatically in Fig. 25-14. The deflecting plates, screen and glass

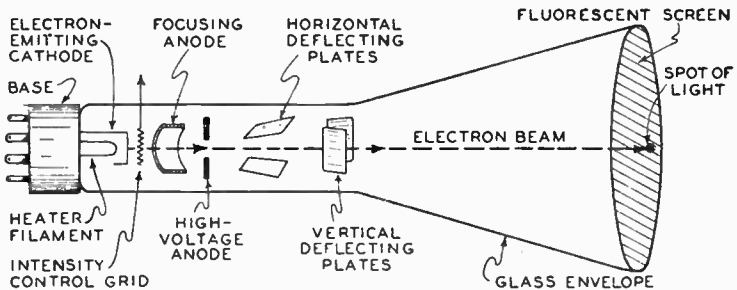
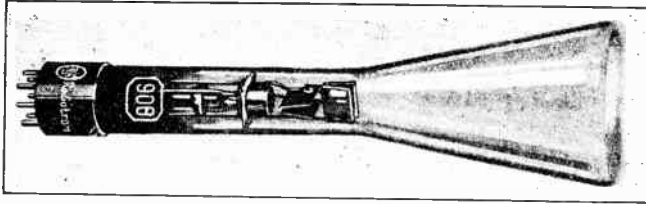

FIG. 25-14.—Arrangement of the various main parts in a typical cathode-ray tube designed for radio service work. An actual tube of this type is illustrated in Fig. 25-15.

envelope are visible in the illustration of Fig. 25-15, which shows a modern cathode-ray tube provided with a 7-prong tube base to which all the internal connections are brought out.

25-28. The Electron Emitter of the Cathode-Ray Tube.

—Referring to Fig. 25-16, the tube contains a coiled tungsten heater filament *F* similar to that used in a radio vacuum tube. This is connected to a source of low alternating voltage and heats the tubular metal cathode, *K*, which surrounds it. The emitting surface, which is usually flat, is coated with an oxide preparation which emits a copious stream of electrons when heated,



Courtesy RCA Radiotron Co., Inc.

FIG. 25-15.—A typical cathode-ray tube of the type shown diagrammatically in both the foregoing and following illustrations. The two sets of deflecting plates, glass envelope, fluorescent screen and base with connection prongs are clearly visible.

just as does the cathode in an ordinary vacuum tube. These liberated electrons are attracted strongly by the positively-charged high-voltage anode, *A_s*, and move toward it at high velocity under the influence of the “positive” potential which is

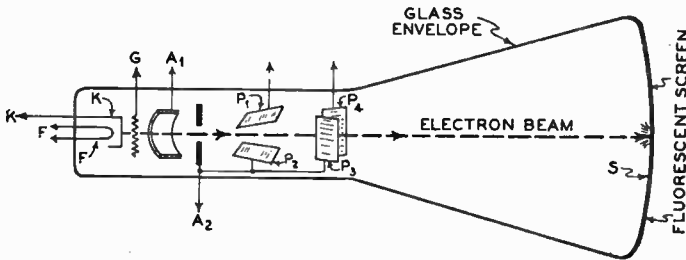

FIG. 25-16.—Internal construction of a typical cathode-ray tube. The electron beam is projected along the length of the tube to the fluorescent screen upon which it impinges and produces a spot of visible light.

applied to it. The speed of the electrons is proportional to this voltage. This stream of electrons moving at high-speed constitutes the *cathode-ray*, hence the name cathode-ray tube. Although this electrode has a *positive* potential applied to it, the

term *anode* is applied to it in preference to the term *plate*, because of the confusion that would arise due to the fact that there are other (deflecting) plates in the tube. The term *plate* is reserved solely for the *deflecting* plates P_1 , P_2 , P_3 and P_4 .

25-29. Action of the Intensity-Control and Focusing Electrodes.—On their way from the cathode to the anode the electrons are acted upon by the *intensity* control grid, G . The bias voltage applied to this control grid is made variable to provide a means of controlling the *intensity* of the electron stream.

As the electrons leave the cathode there is a tendency for the beam to spread out, fan-shaped, as it travels toward the screen. This spreading out is caused by the mutual repulsion of the individual electrons of which the beam is composed, since they are really all *negative* electrical charges and "like" charges repel each other. It is necessary to prevent this spreading out of the electron stream; in fact in order to get only a tiny spot of light on the fluorescent screen, S , it is necessary to actually focus the electron stream to a fine, sharp point at the screen, much the same as the light rays from an incandescent lamp, L , may be focused to a point, P , on a screen, S , by means of the two lenses L_1 and L_2 as shown at (A) of Fig. 25-17. The amount of light may be controlled by the shutter T , which, if closed will shut off the light completely. The size or definition of the image on the screen S is controlled by adjusting the position of the lenses to the correct distance. This is called "focusing"!

The arrangement employed for controlling the intensity and focusing of the electron stream in the cathode-ray tube is shown in detail at (B). The cathode, focusing electrode (A_1) and anode (A_2) considered together are often referred to as the *electron gun* because their function is to "shoot" the electrons along through the length of the tube. The various parts in this illustration are labeled to correspond with those in Fig. 25-16.

The bias voltage of grid G controls the number of electrons allowed to pass through it. After passing through this grid the electrons enter the hollow anode A_1 at one end. By the time they reach the opposite end of A_2 , the action on the electrons due to the electrostatic field created by the charges on these electrodes

causes them to tend to converge into a thin pencil or beam; these two electrodes therefore, act very much like an *electron lens*. The distance from the "gun" to the point at which the electrons converge to a point, or "focus", is determined by the ratio of the voltages on the two anodes A_2 and A_1 . Obviously, there is a particular ratio of these two voltages which will cause the beam to focus exactly at the screen. This ratio is in the neighborhood of

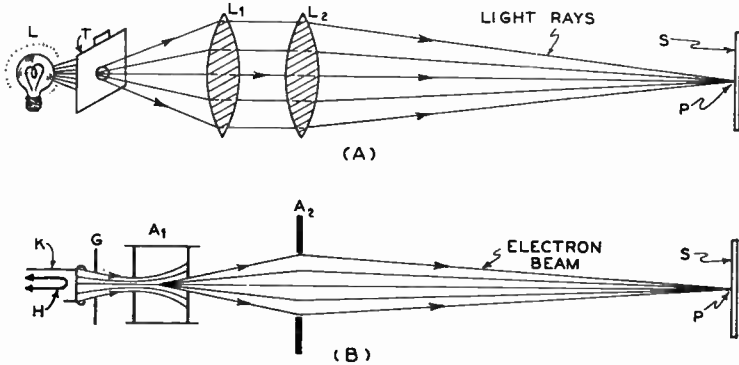

FIG. 25-17.—(A) How light rays may be focussed to a small point by means of glass lenses.

(B) An electron stream may also be focussed to a small point by means of electrically charged electrodes surrounding it.

5 to 1 for the tube of Fig. 25-15. In practice, the voltage of anode A_2 is generally held constant and that of A_1 is made variable through a sufficient range to assure the focusing of the beam at the screen, since it is the smaller voltage to control. If a minute quantity of a suitable inert gas is introduced in the tube, it is possible to produce an ionization effect along the bulb. The negative ions produced will repel the electrons in the cathode-ray stream and thus tend to keep them crowded together in the form of a fine beam.

Some of the older models of cathode-ray tubes were not equipped with a focusing anode, and variation of the spot size and intensity could only be controlled by the heater current and anode potential. This control method was generally unsatisfactory.

25-30. The Fluorescent Screen.—When the electrons reach the anode they will have attained such high velocity due to its

attraction that those which are in line with the tiny hole in its center will shoot right through it and continue on their way until they strike the inner surface of the flat, far end of the tube.

The inner surface, *S*, of the flattened end of the tube is coated with a material that glows or "fluoresces" when electrons impinge upon it, thereby producing a bright spot of light. The material is usually bound on with pure water glass. Several different materials, and combinations of them, are in current use for different colors of fluorescence. The most active one for producing visual light is zinc silicate (in the form of the powdered mineral known as *Willemite*). This glows a bright yellow-green, to which the human eye is most responsive. If the trace of the cathode-ray beam is to be photographed, calcium tungstate, which glows a bright blue color is better, since its light is about thirty times as active on a photographic plate as is that from zinc silicate. Cadmium tungstate may also be employed. Mixtures of these substances are often used to produce a fluorescence fairly well suited for both visual and photographic requirements.

When the rapidly moving electrons strike the screen of fluorescent material, they are stopped suddenly and their impact energy produces light which appears as a spot of fluorescent glow. Since the impact energy of the electrons varies as the square of their speed (which depends upon the square of the voltage on the anode A_2), the fluorescent-spot brilliancy increases rapidly as this voltage is increased. If the electron stream is focussed carefully by adjusting the voltage on anode A_1 , the spot of light produced will be very small, but intense.

Because the size and intensity of the fluorescent spot of light produced on the screen are very important in the use of the cathode-ray tube, the intensity-control grid and the focussing anode are very important parts of the tube. A spot that is too *large* will not give a sharp image; one that is too *small* may be difficult to see. A spot that is too *dim* may not photograph well or may not be seen with ease in a lighted room; a spot that is too *intense* will cause deterioration of the active material with which the screen is coated. This is caused by the intense bombardment resulting at the point of impact of the electron stream on the coating of the screen. Just how intense this bombard-

ment and impact is may be realized when it is known that the electron stream bombards the screen very much like rapidly-fired machine-gun bullets would bombard a target, excepting that the machine-gun bullets would have a muzzle velocity of only about 2,000 miles per hour whereas the electrons in an ordinary cathode-ray tube operated with 1,000 volts on the anode have a velocity of approximately 42 million miles per hour! Because of this intense bombardment of the screen, the beam should never be allowed to remain motionless, for if this occurs, the full impact energy of the electrons will be liberated and concentrated at the focussed spot on the screen, causing the fluorescent material to disintegrate. A black spot will be observed in the screen after this occurs.

Cathode-ray tubes are rated according to the diameter of the screen: a 3-inch tube is one with a screen 3-inches in diameter; a 5-inch tube is one with a 5-inch screen, etc.

25-31. Action of One Pair of Deflecting Plates.—The beam of electrons which is projected along the tube from the cathode to the screen, is nothing more than an ordinary unidirectional electric current since it consists merely of a beam of rapidly moving electrons. Therefore, since it is the equivalent of a current-carrying wire without inertia, it can be deflected or bent by the application of a magnetic field produced by either a magnet or a current-carrying coil, or by an electrostatic field such as is set up between metal plates to which a potential is applied. The latter method is the one employed in the cathode-ray tubes employed in radio service work. These *deflecting plates* constitute the important elements as far as the actual use of the tube is concerned. The tubes shown in Figs. 25-14, 25-15 and 25-16 have two pairs of deflecting plates each. In Fig. 25-16, one set of plates, P_1 and P_2 , are arranged almost parallel to each other in one plane along the axis of the tube, and are equidistant from the electron beam. They actually diverge outward slightly in the direction of the screen, so that even though they are mounted close to the electron beam for strong deflection control, they will not be in its way whenever the beam is deflected near the extreme edge of the screen. The second pair of plates, P_3 and P_4 , are mounted at right angles to the first pair, and are also equi-

distant from the electron beam. The mutual positions of these plates can be seen clearly in the cathode-ray tube illustrated in Fig. 25-15. In some tubes, one of the plates of each pair are connected together and to the high-voltage anode *inside the tube* (see Fig. 25-16), in others, separate leads are brought out from each of the plates, there being no *internal* connections between

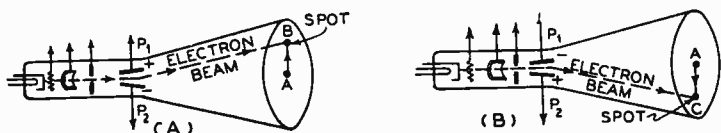

FIG. 25-18.—How the electron beam is “bent” or “deflected” by the electric charges applied to the deflecting plates. Only one pair of deflecting plates is shown here for simplicity.

them. The latter arrangement permits greater freedom in the use of the tube for measurement purposes.

The action of these deflecting plates upon the electron beam will now be studied. Suppose the cathode-ray tube is connected for operation and a spot of light is seen in the center of the fluorescent screen. Now suppose that a voltage is applied to the two deflecting plates P_1 and P_2 as shown in (A) of Fig. 25-18 (the other two plates are not shown here) so that plate P_1 is made *positive* and plate P_2 is made *negative*. The positive plate will attract the negative electrons flying past it, and cause the beam to bend or deflect toward it as shown. The negative plate will repel the negative electron stream, aiding the action of the other plate in deflecting the beam to the position shown. Upon the application of this deflecting voltage, the spot of light moves from point A to point B on the screen. Naturally, the amount of deflection depends upon the intensity of the beam, the anode voltage, and the voltage applied to the deflecting plates. If, now, the polarity of the deflecting plates is reversed, as shown at (B), the electron beam will be deflected in the opposite direction, and the spot of light will move back through point A to point C on the screen.

Now suppose that a potentiometer connected across a B-battery serves as a source of adjustable voltage to be applied to these two deflecting plates P_1 and P_2 , as shown in Fig. 25-19

When arm K is above center-tap T on the potentiometer, plate P_1 is made *positive* with respect to plate P_2 , and the normal electron beam (which takes the path OA when no potential is applied to the plates) will be deflected toward plate P_1 , and strike the screen at point B . When the arm K is below the point T , the spot of light will appear at point C , because P_2 is now *positive* with respect to P_1 , and the electron beam. These plates attract the electron beam just as the plate of any radio tube attracts electrons. However, in this case, the entire beam is bent by the attractive (or repulsive) force. If the contact K is now moved back and forth rapidly, the spot of light will move up and down the screen in a straight line $B-A-C$, and will trace this straight line on the screen.

Although each section of the line is generated at a slightly different time, the entire line will appear continuous because of the "persistence of vision" property of the eye and because the spot on the screen actually remains bright ("persists") for a short time after the spot itself moves away. (Persistence of vision is a property of the eye which enables it to retain the image of an object

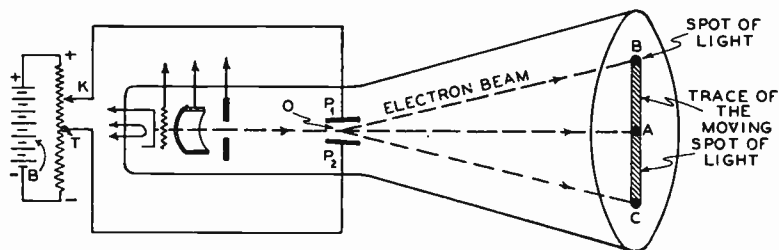

FIG. 25-19.—How a *vertical* image is traced on the screen by the moving spot of light in a cathode-ray tube when varying potentials are applied to the pair of *horizontal* deflecting-plates only.

after the object itself has been removed. It is upon this principle that the motion picture projector works.) Furthermore, the movement of the beam follows the variation in potential instantaneously, since an electron beam has no inertia. For this reason, the movement of the cathode-ray beam will respond faithfully to rapid changes of the deflection potentials, even though these changes may take place in a small fraction of a

millionth of a second. Therefore, this device may be used even on high radio frequencies.

In a similar manner, if the deflecting voltage is applied to plates P_3 and P_4 , as shown in Fig. 25-20, and varied in the same

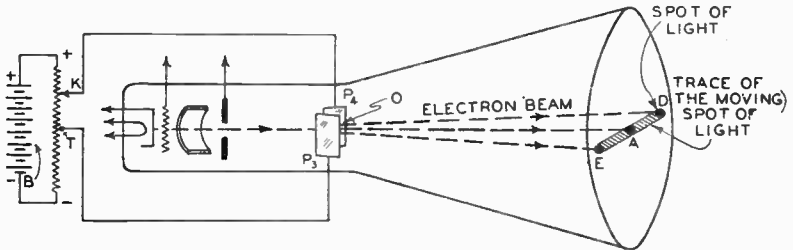

FIG. 25-20.—How a *horizontal* image is traced on the screen by the moving spot of light in a cathode-ray tube when varying potentials are applied to the pair of *vertical* deflecting-plates only.

way, the line which the spot of light traces will appear in the horizontal direction shown. The amount of deflection of the beam is proportional to the voltage applied to the deflection plates, and the amount of voltage required to deflect the spot of light a distance of one inch over the screen is a measure of

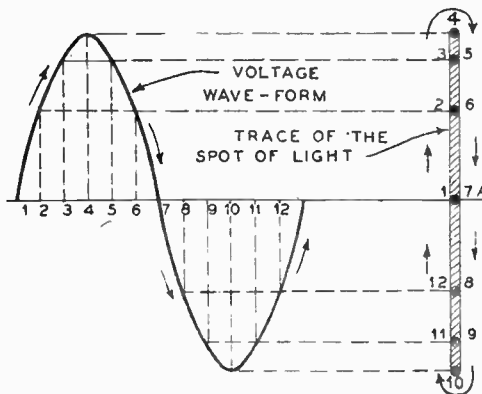

FIG. 25-21.—The location of the instantaneous positions of the spot of light at various corresponding instants during one cycle of a sine-wave voltage which is applied to only one set of the deflecting plates, is shown at the right.

the sensitivity of the cathode-ray tube. For instance, this value for the tube shown in Fig. 25-15 is approximately 75 volts per inch.

Now, let us suppose that an alternating voltage from a transformer is applied to one set of deflecting plates, and the second

set is left open; the resulting path traced over by the spot of light will be a straight line, as shown at the right of Fig. 25-21. The voltage wave-form which causes this line to be traced is shown at the left. At any instant, the deflection of the spot of light from its zero position, *A*, will correspond to the value of the voltage at that instant. For instance, at instant 1 on the voltage wave the spot of light is at point 1 on its path, at instant 2 on the voltage wave it is at corresponding point 2 on its path, etc.

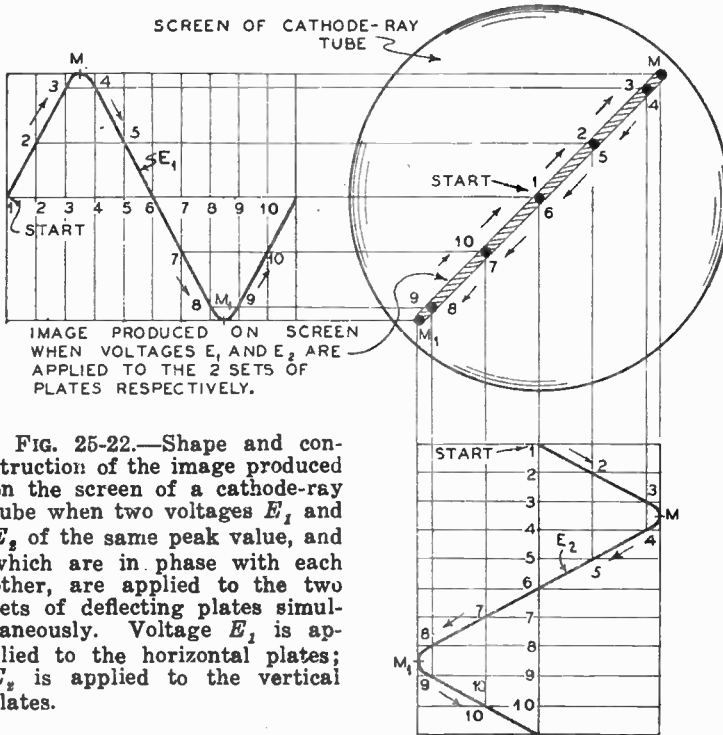
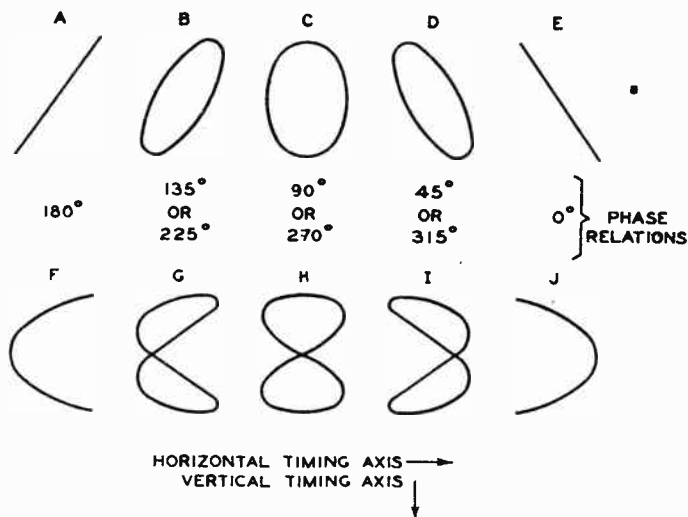

FIG. 25-22.—Shape and construction of the image produced on the screen of a cathode-ray tube when two voltages E_1 and E_2 of the same peak value, and which are in phase with each other, are applied to the two sets of deflecting plates simultaneously. Voltage E_1 is applied to the horizontal plates; E_2 is applied to the vertical plates.

During the interval that the voltage wave goes through the complete cycle shown, the spot of light moves over the straight-line path 1-2-3-4-5-6-7-8-9-10-11-12-1.

25-32. Simultaneous Combined Action of Both Pairs of Deflecting Plates.—Now, with this same voltage applied to one set of plates, suppose another identical voltage is applied to

the second pair of deflecting plates in the tube, and let these two voltages be in the same phase, i.e., reach zero and maximum at the same instants. The wave forms of these voltages are drawn on their respective horizontal and vertical axes of the cathode-ray tube in Fig. 25-22. There are now *two* forces acting on the electron beam simultaneously at every instant, one tending to move



Courtesy R.C.A. Mfg. Co.

FIG. 25-23.—The patterns which are traced by the spot of light in a cathode-ray tube when the two voltages acting on the two sets of deflecting plates have the various phase relations indicated. The patterns *A* to *E* are traced if the voltages have a frequency-ratio of 1 to 1. Those from *F* to *J* are traced if the voltages have a frequency-ratio of 2 to 1. These are commonly known as *Lissajous' Figures*.

it in one direction, and the second trying to move it at right angles to the first. The resulting location of the spot on the screen at any instant depends upon the *algebraic* sum of both these forces at the instant. The resulting pattern traced out by the spot of light is a straight line inclined at an angle of 45 degrees with respect to each of the lines that would be obtained if either voltage was removed. This is shown as line *M-M₁*, on the screen in Fig. 25-22, and again at *A* of Fig. 25-23.

If the wave-forms, frequencies or phase relationships of

these applied voltages are changed, the resulting image may take any one of a number of shapes or patterns. Thus, if one of the voltages is of greater amplitude than the other and differs in phase with it by 90 degrees or 270 degrees, the resulting pattern traced out will be an ellipse, as shown by *C* of Fig. 25-23. If the phase relation is such that one voltage leads the other by 45 degrees, or 315 degrees, the resulting pattern traced will be that of *D*; if leading by 135 degrees, or 225 degrees, the resulting pattern will be that of *B*. By means of the cathode-ray tube, the resultant pattern is traced on the fluorescent screen by the moving spot of light. Conversely, from the pattern observed, the frequency and the phase relations of the two deflecting voltages can be determined. Where, in addition, the wave form is known for one of the deflecting voltages, the wave form of the other can be readily obtained by graphical analysis. Figs. *A* to *E* in Fig. 25-23 represent the patterns traced by the spot of light if the voltages applied to the two sets of deflecting plates have a 1-to-1 frequency ratio. When the frequency ratio is 2-to-1, the patterns of *A* to *E* change respectively to those of *F* to *J*. As the ratio of the frequencies of the two deflecting voltages increases, the patterns change from these shapes and become increasingly complex.

25-33. Need for the Sweep Voltage When Observing Wave Forms.—The various patterns (called *Lissajous'* figures after Jules Antoine Lissajous who first demonstrated them for showing the exact relation between the vibratory motions of two sounding bodies) which may be observed with the cathode-ray tube when two independent voltages are applied to its deflecting plates are of value in some applications of the cathode-ray tube, but the operator must be entirely familiar with the significance of most of the different complex images that can be formed so that he can identify the pattern and tell at once what it indicates regarding the phase relation, frequency relation and wave form of the two applied voltages.

Very often it is desired to observe the wave form of a single current or voltage. This is the case when i-f amplifier circuits are being aligned or adjusted. This requires that the voltage which is to be observed, be connected to one set of the de-

deflecting plates—usually the horizontal plates (see Fig. 25-19).

Let us assume that the voltage to be observed is that shown at (A) of Fig. 25-24 and that it is applied to the horizontal deflecting plates. If this is done, the varying voltage on the horizontal plates will cause the beam to oscillate up and down vertically in synchronism with its variations in intensity, and the spot of light will trace a *straight vertical line* on the screen,

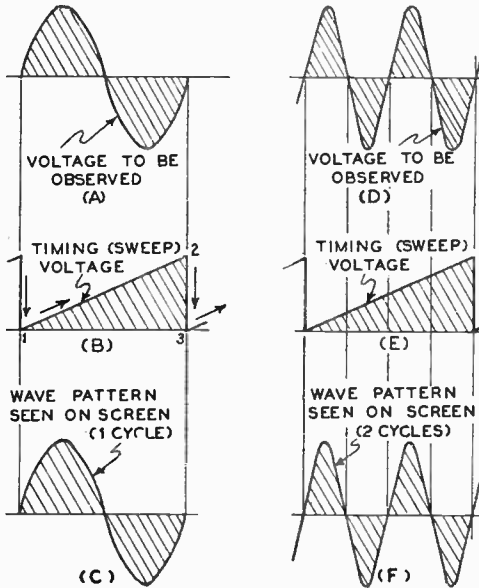

FIG. 25-24. — Diagrams showing the relation between the frequency of the voltage whose wave form is to be observed, and that of the timing or "sweep" voltage when various numbers of cycles are to be viewed on the screen at one time. If only 1 cycle is to be viewed, the frequency of the voltage to be observed must equal that of the saw-tooth voltage (see (A) and (B).) If two cycles are to be viewed, the saw-tooth voltage frequency must be only $\frac{1}{2}$ that of the voltage to be viewed, etc.

as was shown in Figs. 25-21 and 25-19. It is evident that if the exact *curved* wave form of this voltage is to be traced, some means must be provided for shifting the beam *simultaneously* in a horizontal direction while it is being moved up and down *vertically* by the voltage to be observed, so that the trace will be *spread out*. Furthermore, the beam must be shifted at a *uniform* speed, say to the right, such that it travels from its neutral position to the extreme right of the screen in exactly the time (or a multiple of it) which it requires for a complete cycle of the vertical movement to take place, then it must be shifted back almost *instantaneously* to its neutral position, so that the cycle can be repeated all over again.

Since it is extremely important to understand and visualize this action, perhaps the illustration in Fig. 25-25 will make it clear. Let us imagine that a suitable linear *sweep* voltage is applied to the vertical plates, $V-V$, and that the action of the tube is slowed down sufficiently so that we can actually watch the spot of light trace out the wave form of the deflecting voltage on the screen. At the moment shown, the spot of light has already traced out the portion of the wave form shown, and is at point A . At this moment, the force exerted by the horizontal deflecting plates $H-H$ is tending to pull the beam straight up in the direction H_1 ; at the same instant the force exerted by the vertical de-

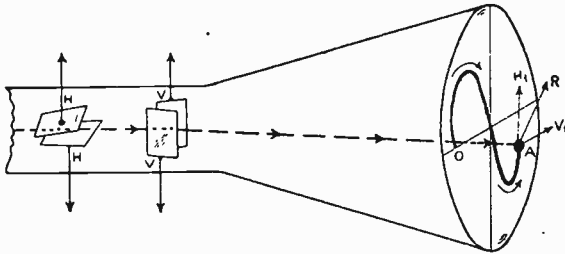

FIG. 25-25.—How the cathode-ray beam traces a wave-form pattern when acted upon by a sinusoidal voltage applied to the horizontal pair of plates, $H-H$, and a saw-tooth sweep voltage applied to the vertical pair of plates, $V-V$. At the instant pictured here, the beam is acted upon by force H_1 tending to move it vertically in direction H_1 , and by force V_1 tending to move it horizontally in direction V_1 . It actually moves along the direction of the resultant force R .

flecting plates $V-V$ is tending to pull the beam straight across to the right in the direction V_1 . Naturally, since the beam is being acted upon *simultaneously* by both forces at right angles to each other, it actually moves along the line of the resultant force R . The exact direction of R at any instant of course depends upon the relative magnitude of the two forces H_1 and V_1 at that instant, so the direction of movement of the spot of light obeys the variations in the deflecting voltages from instant to instant.

This action may be likened to that of a man attempting to row a boat directly across a stream whose current is swift. If the man steers his rowboat straight across, the swiftly moving stream at right angles carries his boat downstream at the same time that he is rowing directly ahead, so that the actual path of

his boat is not a straight line directly ahead, but rather a curved path pointing downstream. He will strike the opposite shore at a point below the one toward which he rowed.

When a complete cycle of the wave being observed has been completed, the electron beam and light spot must be shifted back *abruptly* to the normal position at point *O* so that the curve will be traced again for the next cycle. If this occurs say 60 times a second (if the voltage to be observed is a 60-cycle voltage), although 60 individual pictures will be traced each second, persistence of vision will make the result on the fluorescent screen appear as a steady picture of the wave form, as shown at (*C*) of Fig. 25-24.

25-34. Operation of the "Sweep" or "Timing" Voltage.— Let us now consider the type of voltage that must be applied to the vertical deflecting plates for "sweeping" the beam horizontally, or "timing" it. This is commonly known as the *sweep* or *timing* voltage. From what has already been said, it will be realized that the voltage used should be a repeating or "recurrent" one. Furthermore, for most purposes it is preferable that it be one, which, when applied to the vertical plates will deflect the beam so that the spot of light is shifted *uniformly*, say, from left to right with an *abrupt* return from right to left, the return occurring in only a small fraction of the time taken to travel from left to right (so that the return may be considered as being practically instantaneous). If a voltage which varies in this way is plotted against time, the wave form is of the type shown at (*B*) of Fig. 25-24. Because its shape resembles the tooth of a saw, it is commonly referred to as a *saw-tooth* voltage. Notice that this voltage increases uniformly (linearly) from instant *1* to instant *2*, then it drops *abruptly* to zero at instant *3*, then begins to increase uniformly again etc., this variation repeating itself over and over.

The frequency of the saw tooth voltage applied must have a definite relationship to the frequency of the voltage which is to be observed. For example, to examine one cycle of it, the saw-tooth voltage must be of exactly the same frequency as that of the voltage to be observed, since the timing voltage must be ready to shift the spot of light back just at the instant that each

cycle of the voltage being observed is completed. This condition is shown in (A) and (B) of Fig. 25-24. If two cycles of the voltage being observed are to appear on the screen at one time, then it must go through two cycles before the timing voltage shifts the spot back to the starting position, i.e., before the timing voltage has completed one cycle. This is shown at (D) and (E) of Fig. 25-24. The wave pattern (2 cycles) which will appear is shown at (F). For this condition, the frequency of the saw-tooth voltage must be equal to *one-half* that of the voltage being observed. If three cycles are to be observed at one time, the frequency of the saw-tooth voltage must be *one-third* that of the voltage being observed, etc.

It should be noted that it is the *uniform* rise of the "sweep" or "timing" voltage that spreads out the trace of the spot of light, and it is its sudden drop to zero that shifts the spot back to the starting position so that the spreading may start all over again for the next one or more cycles of the observed voltage. The circuit which is employed to generate the sweep voltage is called the *sweep circuit*.

25-35. Generating the Sweep Voltage.—There are several ways of generating a saw-tooth sweep voltage of the wave form shown in Fig. 25-24. Whatever develops it must be designed to generate a voltage which will increase uniformly to a certain value, then drop *abruptly* to zero, and repeat itself. It is preferable that the frequency with which this variation takes place be made easily adjustable over a wide range.

There are a number of electrical "sweep circuits" which may be employed for this purpose. A typical, simple circuit of this kind, which employs a type '885 thyatron type tube is shown in Fig. 25-26. This particular circuit is employed in the commercial cathode-ray oscilloscope described in Art. 25-44 (the complete schematic circuit diagram of which is presented in Fig. 25-34).

The thyatron tube employed contains the cathode, grid and plate, as shown. Since it also contains gas, it is a tube capable of exerting a "trigger" action in the circuit. When normal grid-bias voltage is supplied to it, no current will flow through the tube unless the voltage applied to its plate is made high enough

to ionize the gas in the tube (300 volts in this case). If this happens, the ionization of the gas causes the tube to break down immediately, the resistance of the path between the plate and cathode suddenly becomes very low, and the grid loses all control of the plate current. Once the gas ionizes in this

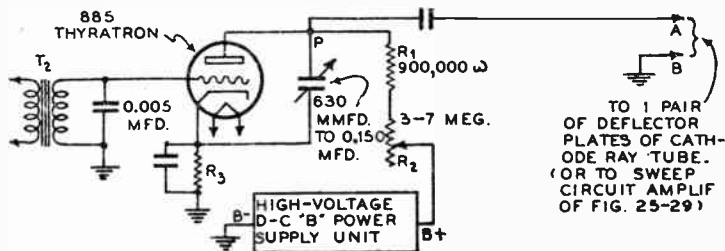

FIG. 25-26.—Schematic circuit arrangement of a typical sweep circuit which generates a saw-tooth sweep voltage by means of the “trigger” action of a thyratron tube.

tube, the plate-cathode voltage-drop across the tube remains very steady at about 15 volts. Thus, we have a sort of “trigger” action here, for as soon as the gas ionizes, the resistance of the plate-cathode path drops immediately to a very low value.

Now let us see how this tube operates in the sweep-voltage circuit of Fig. 25-26. The 630-mmfd. plate-cathode condenser is charged by the plate supply voltage through resistors R_1 and R_2 . The grid-bias voltage of the tube (resistor R_3 supplies it) prevents plate current flow through the tube until the voltage across this condenser builds up to the breakdown value of the tube (300 volts in this case). The flow of the current into the condenser during this interval is shown in the simplified diagram at (A) of Fig. 25-27. The potential of point P rises practically uniformly from value 1 to value 2 (as shown at (B)) during this charging period. When the potential of point P has reached a value of 300 volts, the gas in the tube ionizes, and the condenser discharges almost instantaneously through the plate-cathode circuit of the tube, thereby losing its potential rapidly so that the potential of point P drops from point 2 to 3 (at B). The path of the condenser current flow is shown at (C). As soon as the plate potential drops low enough,

the discharge ceases and current flows from the supply voltage source into the condenser to charge it up again. This process repeats itself. The saw-tooth voltage which appears across the condenser is applied to one pair of deflector plates in the cathode-ray tube. Resistors R_1 and R_2 are used mainly for the purpose of limiting the charging current of the condenser and preventing the plate supply source from sending a heavy current through the thyatron tube when it breaks down. Since this circuit generates the sweep voltage by the charging of a condenser, this charging must be at a constant current rate if it is to be linear. Since the exponential charging characteristic of a condenser is essentially linear over a small portion of its initial charging curve, if only a small portion of the charging curve is used and a high resistance is put in series with the condenser so that a high charging voltage may be used, the charging of this

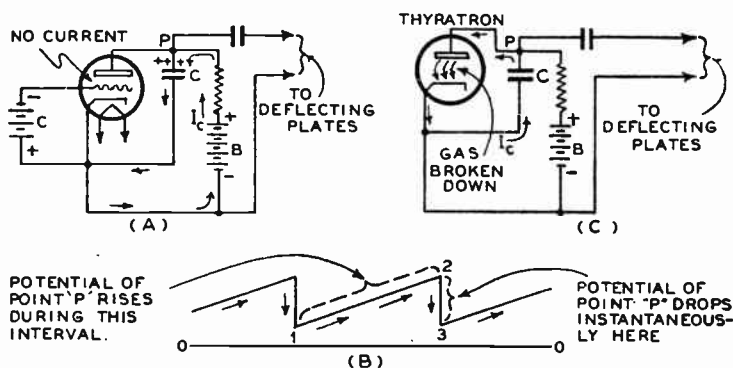

FIG. 25-27.—A simplified analysis of the “trigger” action which takes place in the sweep circuit of Fig. 25-26 is shown at (A) and (C). The saw-tooth voltage shown at (B) exists across condenser C and is applied to one pair of plates of the cathode-ray tube (not shown here).

condenser will be essentially linear and a linear sweep voltage will be produced.

The frequency of the charge and discharge is governed by the size of the condenser C and the total resistance of the charging circuit. With a suitable choice of C (often obtained by a number of “fixed”, and one “adjustable” condenser) and with the proper bias on the '885 tube, the frequency of the sweep circuit

may be adjusted to the value required for the particular wave form to be viewed. This type of sweep circuit can be made to perform satisfactorily only over the audio-frequency range from about 20 to 15,000 cycles.

To synchronize the sweep circuit with the voltage to be observed, the coupling transformer T_1 connected in series with the grid circuit is used. This couples the grid circuit of the thyatron tube to the circuit of the voltage to be viewed or to a circuit

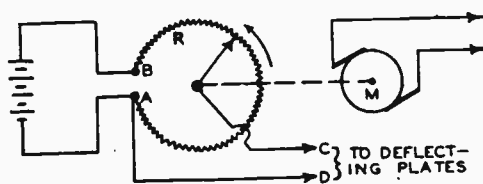

FIG. 25-28.—A saw-tooth sweep voltage may be generated by arranging a motor M to drive a potentiometer R connected across a source of potential.

whose voltage is in synchronism with it (see Fig. 25-36), so that when the proper value of C is chosen to make the frequency of the sweep circuit correct, the sweep circuit will lock in step with the voltage being observed. It is interesting to note that the arrangement of Fig. 25-26 is really a form of oscillator which generates a current having the peculiar wave form described.

Another form of sweep circuit which may be used, is shown in Fig. 25-28. This is a motor-driven type. A motor whose speed may be controlled very accurately is ganged to the arm of a potentiometer, R , connected across a battery. As the arm of the potentiometer (which we will assume is rotating counter-clockwise) turns from A to B the voltage tapped off increases *uniformly* from zero to the full value of the battery. At point B the contact is broken, so the current drops quickly to zero and remains at zero until the arm reaches point A where contact is re-established and the cycle is repeated over again. A saw-tooth voltage, having the wave form shown at (B) of Fig. 25-24 will appear across terminals C and D which lead to one pair of deflector plates of the cathode-ray tube. The sweep frequency may be varied by varying the speed of the motor. Of course the usual objections to a mechanical rotating-contact device hold against this system, and the sweep frequencies that can be generated are confined to rather low limits.

When a cathode-ray tube is to be used to view the resonance curves of a superheterodyne which is being aligned, this motor may also be arranged to drive a "frequency-wobbler" condenser connected in parallel with the condenser of the test oscillator. This will be discussed in greater detail in Art. 25-37.

25-36. The Sweep Circuit Amplifier.—The sensitivity of the ordinary cathode-ray tube is such that an appreciable voltage is required to deflect the beam over a 3 or 4 inch screen. For instance, the sensitivity of the cathode-ray tube illustrated in

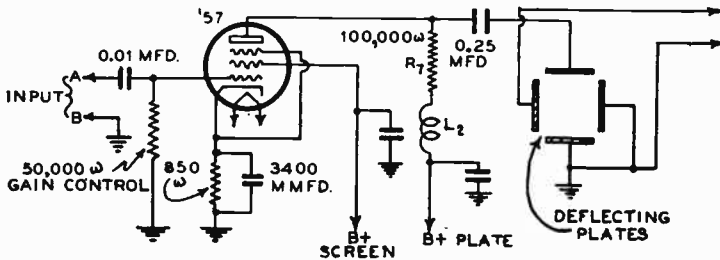

Courtesy R.O.A. Mfg. Co.

FIG. 25-29.—A high-gain linear amplifier that may be used to amplify the low-voltage output of the sweep-voltage generator of Fig. 25-26, or the voltage which is to be applied to the deflecting plates of the cathode-ray tube for observation.

Fig. 25-15 is such that a voltage of 75 volts is required to deflect the beam either horizontally or vertically a distance of 1 inch. Because the output voltage of the ordinary electrical sweep circuit such as is shown in Fig. 25-26 is very small, an amplifier is usually used to step it up. A high-gain linear amplifier suitable for this purpose is shown in Fig. 25-29. The terminals *A-B* connect to the corresponding output terminals *A'-B'* of the sweep circuit of Fig. 25-26. The output terminals of the amplifier connect to the proper pair of deflecting plates of the cathode-ray tube. This amplifier stage will produce a gain of approximately 40 and the amplification is *linear* from 20 cycles to 90,000 cycles $\pm 10\%$. Its frequency response is excellent mainly because of the use of the combination resistive and inductive load R_7-L_2 in the plate circuit of the tube. This same amplifier may be used to amplify the voltage which is to be observed in the cathode-ray tube, if this voltage is small. Two such ampli-

fiers V_1 and V_2 are incorporated for these very purposes in the commercial oscilloscope shown in Fig. 25-34. When they are employed, a change of only 2 volts in the voltage to be observed (or the sweep voltage) is amplified by 40 and is made to produce over 1-inch of deflection of the spot of light in the cathode-ray tube illustrated in Fig. 25-15 (the sensitivity of this tube being about 75 volts per inch).

25-37. Wobbling the Test Oscillator Signal Frequency for Visual I-F Stage Alignment.—Now that we are acquainted with the construction and operation of the cathode-ray tube, the sweep circuit and the amplifier, we are prepared to consider the use of the cathode-ray tube as a visual resonance curve tracer in the alignment of the tuned circuits of i-f amplifiers. The advantages and reasons for the use of the cathode-ray tube in this work have already been stated in Art. 25-25. We are interested here merely in how it is accomplished.

Let us suppose that the response characteristic of a flat-topped i-f amplifier in a superheterodyne receiver is to be observed either when checking over the receiver or when actually aligning the i-f stages. Ordinarily, a service test oscillator would be connected to this i-f amplifier as explained in Art. 25-13. As explained in Art. 25-14, its frequency would be varied over the flat-top frequency range of the i-f amplifier and the reading of the output meter connected to the receiver would be watched to find out whether the flat-top characteristic extended over the proper band of frequencies. If it did not, adjustments would be made to align it as nearly as possible so that it would conform to the desired characteristic. However, with the cathode-ray tube method, the cathode-ray tube is connected to the receiver output instead of the output meter, and the voltage output of the i-f amplifier is *viewed* on its fluorescent screen instead.

When the cathode-ray tube is employed to view the resonance curve of the i-f amplifier the object is:

to produce a visual plot of the exact voltage output of the tuned stage (or stages) under consideration, when an input signal voltage of constant amplitude but varying in frequency over the frequency band at which the

resonance curve is to be observed, is applied to the particular stage (or stages).

To obtain this resonance curve, it is first necessary to have a signal source of variable frequency covering a range which extends sufficiently above and below the resonant frequency of the i-f amplifier so that the complete i-f resonance curve may be traced. The input signal must be varied over this frequency range repeatedly, at a speed sufficiently high so that the individual output curve traces which appear on the screen of the cath-

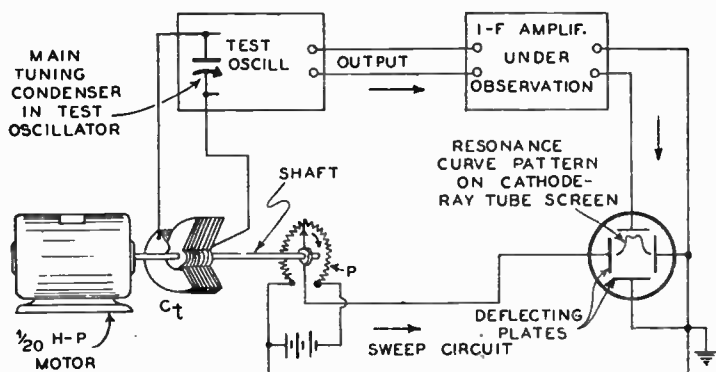

FIG. 25-30.—Arrangement of a motor-driven sweep circuit and frequency-wobbler system for taking visual resonance curves on an i-f amplifier. An electric motor drives the frequency-wobbler condenser C_t and the sweep-circuit potentiometer P .

ode-ray tube occur fast enough to appear continuous (say about 20 times per second). There are several ways of obtaining this cyclic variable-frequency signal.

One of the methods that may be used is to gang the rotor shaft of a small tuning condenser, C_t , (in Fig. 25-30) to the shaft of the same motor that drives the sweep-frequency generating arrangement of Fig. 25-28. This condenser is then connected in parallel with the main tuning condenser of the ordinary test oscillator which is to be used as the source of i-f signal voltage to be fed to the i-f amplifier. This condenser C_t may be considered merely as a trimmer condenser in parallel with the main tuning condenser, so that rotating it continuously merely varies the frequency of the test oscillator from several kc below to

several kc above the resonant frequency of the i-f amplifier, i.e., it causes the frequency of the test oscillator to "wobble". The *average* frequency of the test oscillator signal may be adjusted to any intermediate or radio frequency within the range of the equipment. By rotating this "wobble condenser" continuously, the test oscillator is made to feed a signal whose frequency varies over the intermediate frequency band at which the i-f amplifier resonance curve is to be observed. A portable motor-driven frequency-wobbler unit which contains a motor *M* driving a 2-section wobble condenser *W* is illustrated in Figs. 25-35 and 25-36. It will be described later. In this unit, two values of wobble condenser are available, a *low-range* value from 15 to 37 mmfd., and a *high-range* value from 20 to 70 mmfd.

Mounted on the same shaft with this condenser is the sweep circuit potentiometer, *P*, (see Fig. 25-28) the voltage of which controls the horizontal sweep of the cathode-ray beam. For a single rotation of this condenser, the sweep circuit potentiometer makes one complete rotation, so that by properly synchronizing the two units, the saw-tooth sweep voltage is *zero* at the *lowest* frequency of the oscillator and is *maximum* at the *highest* frequency of the oscillator.

The output of the second detector of the i-f amplifier is connected to one pair of deflecting plates of the cathode-ray tube. The saw-tooth timing (sweep) voltage is connected to the other pair. Now, as the output of the i-f amplifier changes from instant to instant because of the varying frequency of the steady signal applied to it during one rotation of *C*, the sweep circuit is spreading this response out on a horizontal axis, of the cathode-ray tube so that the response curve is traced on the screen, and since the image is repeated twenty times a second (the speed of the motor), it will appear stationary. Hence, the screen of the tube will show a resonance curve of the entire i-f amplifier. If the output signal of the test oscillator is connected to the input of the final i-f stage, then the response curve of *only* this stage can be observed. Extreme flexibility is thus available with this system.

Another arrangement which makes use of a saturable-core reactor, operated from the source of the horizontal sweep volt-

age, to frequency-modulate the test oscillator signal without employing any motor-driven devices, will be described in Art. 25-45. Its schematic circuit arrangement is shown in Fig. 25-40.

25-38. Connecting the Cathode Ray Tube to the Receiver Being Aligned.—There are no fixed rules regarding the connection of the cathode-ray oscilloscope to the receiver which is being aligned. Every oscilloscope manufacturer supplies detailed instructions for its use, which should be followed. The following points should be kept in mind however whenever such instructions are not available. The best way to connect the cathode-ray oscilloscope to the receiver output depends on whether the receiver uses (1) diode, (2) biased, or (3) grid-leak detection.

If a diode second detector is employed, the output should be taken off across the volume control alone, or across both the volume control and the avc resistor, if this connection is convenient. Otherwise, it is satisfactory to take the output voltage off between the grid of the tube following the diode circuit, and ground. This output is fed to the internal amplifier in the cathode-ray oscilloscope and the amplifier, in turn, feeds the proper pair of deflecting plates in the cathode-ray tube.

When the second detector is a biased triode, tetrode or pentode, *resistance-coupled* to the first audio stage, the output signal may be taken off between the plate of the tube and ground. If it is impossible to take off one connection from ground, a 60-cycle gradient may be built up between the oscilloscope and the receiver itself. This will deform the image on the cathode-ray screen. It can be eliminated by connecting the cathode of the second detector to the "ground" side of the oscilloscope amplifier, or to the grounded plate of the pair of deflector plates.

In the case of a triode, tetrode, or pentode, *transformer or impedance-coupled* to the first audio stage, connect a resistor of approximately 20,000 ohms in series with the plate of the tube and by-pass the inductance in the plate circuit with a 1.0 mfd. or larger capacitor. This changes the impedance of the plate circuit to a *resistance* rather than an *inductive reactance*. The audio output voltage should then be taken off between the plate of the tube and ground, in order to take it off across this resistor.

When the detector is of the grid-leak type, it is usually best

to take the output out from between the plate of the detector tube and the negative side of the *B* circuit.

25-39. Connecting the Test Oscillator to the Receiver Being Aligned.—The test oscillator output (it is assumed that some frequency-wobbling arrangement has been added to it) should be coupled to the control-grid of the tube preceding the i-f stage under alignment. It is essential that this connection be made without altering any of the operating characteristics of this stage. If the grid of the tube to which connection is to be made is at zero d-c potential with respect to ground, the oscillator should be connected to the grid of the tube and the lead which normally goes to this grid should be disconnected, and connected to the low side of the test oscillator output returning to the "chassis" or ground. If the grid is not at zero d-c potential with respect to ground, connect the high side of the oscillator to the grid (disconnecting the lead on the grid) and the low side to the *C*-minus lead for this grid.

The output of the second detector may be connected to the cathode-ray tube as explained in Art. 25-38. With this connection, the image on the screen of the tube will represent the *overall response of the receiver*. Of course, the oscillator must be of the high-frequency type and the "wobble" condenser rotated by the motor must be small enough so that the frequency is varied only by about 20 kc on either side of resonance. This connection is used when the r-f stages of a receiver are to be aligned.

25-40. Aligning I-F Amplifier Stages with the Cathode-Ray Oscilloscope.—The cathode ray oscilloscope should be connected to the receiver as outlined in Art. 25-38 and the test oscillator should be connected to the receiver as explained in Art. 25-39. The various beam-focusing, intensity, amplifier, synchronizing, etc., adjustments on the oscilloscope should now be set properly in accordance with the instructions furnished by the manufacturer. The test oscillator should first be set at the i-f alignment frequency with the modulation "on", but with the "wobbler" circuit disconnected. It then feeds a signal of a single frequency to the i-f amplifier.

The i-f transformer trimmers should now be adjusted for maximum output, i.e., peaked as much as possible (see Art.

25-13). The resonance curve will be seen on the screen. Now the modulation on the test oscillator should be removed, and the "wobbler" circuit should be connected to the test oscillator and put into operation. The frequency of the test oscillator should now be readjusted until the forward and reverse waves show on the screen of the tube. The frequency of the test oscillator should now be raised carefully until the highest points of the two waves coincide. (This readjustment is necessary to compensate for the added capacity of the cable and one-half of the sweep condenser capacity.) The dial setting of the oscillator should be recorded for future reference. The trimmer condensers of the primary and secondary of the i-f transformer should be adjusted to produce whatever tuning characteristic is desired (see Fig. 25-31). The final curve should be symmetrical with respect to the intermediate frequency. During i-f alignment, the receiver tuning dial should be set at a point where variation of its position has no effect on the resultant curve. If this point cannot be found, the grid or plate coil of the r-f oscillator in the receiver should be short-circuited. The i-f stages should be aligned in order, starting at the last stage and working toward the first detector. If the receiver employs avc, the precautions explained in Art. 25-19 should be taken before alignment is started.

In general, the procedure is somewhat the same as when the more conventional output meter arrangement is employed, except that the service man *sees* what he is doing. The effect of every change made in the i-f circuit adjustment is instantly revealed by a change in the shape of the resonance curve on the screen. The actual shape and symmetry of the resonance curve is seen; overcoupling, insufficient coupling—everything is visible. The cathode-ray tube is really a unique form of output meter, and the sweep circuit and frequency-wobbler enable the tube to draw, automatically, the response curve of the receiver.

25-41. Interpreting the Resonance Curves Seen in the Cathode-Ray Tube.—It is possible, by carefully studying the resonance curve which appears on the screen of the cathode-ray tube, to tell just what the tuned circuit will do to a signal. If, for example, the tuning system cuts off too sharply or its reson-

ance curve is not symmetrical, severe distortion may be introduced in the sound output of the receiver. Once the resonance curve is obtained on the screen, the problem resolves itself into knowing whether or not it is good or bad, and what is wrong with the tuned circuits if the curve is not as it should be.

A number of typical oscilloscope curves depicting several different receiver conditions are shown in Fig. 25-31 in the hope that they will act as a helpful guide in this work. The width of each small vertical space represents 1-kc.

Pattern No. 1 shows that the side bands, 3 kc on either side of resonance are cut off. Hence, the tuned circuits represented

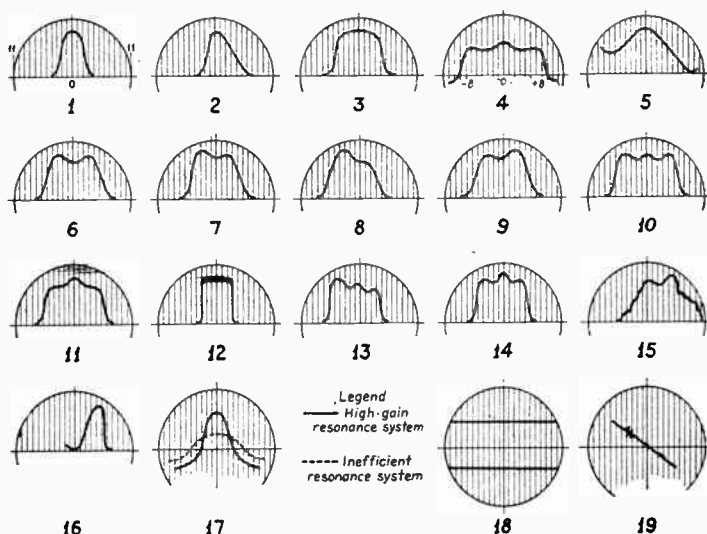

Courtesy Service Magazine

FIG. 25-31.—Various types of resonance curves as seen on the screen of a cathode-ray oscilloscope equipped with the proper frequency-wobbler and sweep circuit. The width of each small vertical space represents 1 kc.

by this overall curve are unsuitable for high-fidelity reception since the high-frequency response will be poor, although interference will be small.

Pattern No. 2 shows one side cutting off at 3 kc and the other extending over 6 kc. The result is that the receiver may be expected to have severe distortion because of the 3 kc cut-off

and interference because of the 6 kc extension. If the receiver has a diode detector (or any other type of linear detector), distortion will be generated in this circuit because of the asymmetry of the response curve.

Pattern No. 3 is a nearly perfect response curve of a good receiver (not high-fidelity), since a frequency band over 8 kc is passed almost uniformly. Selectivity will be good because of the steep sides of the curve.

Pattern No. 4 illustrates a good resonance curve for high-fidelity reception. It is substantially flat-topped and passes a total band of frequencies 16 kc wide.

Pattern No. 5 is not an unusual response curve for an improperly aligned receiver. There is definite overlap into the adjacent channels, which will almost certainly give rise to excessive interference.

Pattern No. 6 is an excellent response curve of a properly aligned receiver having "flat top" i-f transformers. Note particularly that the two humps are equal in height and equally spaced from the central resonant-frequency line. In any form of ordinary flat-top i-f amplifier, the circuits should be adjusted until a resonance curve approaching this pattern is obtained.

Pattern No. 7 is similar to No. 6 except that one of the i-f stages is slightly out of line. A slight shift in the tuning capacity in this transformer will make the curve symmetrical.

Pattern Nos. 8 and 9 are similar to No. 7 but with different proportions of misalignment. The same method of adjustment is valid here as for curve No. 7.

Pattern No. 10 shows the final overall effect of staggering three i-f stages. This consists of tuning the second i-f transformer to exact resonance, the first i-f transformer slightly to the high-capacity side of resonance and the third to the low-capacity side. During such adjustments numerous unwanted humps appear when certain adjustments are carried too far, but each is seen immediately on the screen of the oscilloscope and the condition can be corrected at once. Each peak is definitely noticeable here and symmetrically arranged. Almost perfect amplification of all the side bands which are passed is possible

with an i-f amplifier having a response curve such as this.

Pattern No. 11 shows the response curve of an i-f amplifier having somewhat different staggering than that corresponding to No. 10. The response with No. 11 is such that the low audio frequencies receive slightly more amplification than the high notes. This serves to make the amplitude of both the "lows" and the "highs" more nearly uniform, since the "lows" naturally have a somewhat lower amplitude.

Pattern No. 12 is unusual in the sense that it shows the extreme selectivity that may be obtained from some receivers having a straight-sided narrow-band tuning characteristic. If the set is tuned to a distant signal which is located adjacent to a channel occupied by a powerful local station, no interference should result. This pattern may also represent severe overloading of the tubes. In order to check this, the input signal should be reduced to a small value, and the change in slope produced should be noted.

Patterns Nos. 13 and 14 show several types of response curves that may be obtained when attempting to stagger three i-f stages. The circuits need realignment to obtain the curves of either Nos. 10 or 11.

Pattern No. 15 indicates that oscillation is present in the receiver. Note the wave formations, or ripples, in the response curve. These ripples arise from the fact that the oscillation alters the sensitivity of the receiver considerably at these points.

Pattern No. 16 shows the response of a single circuit which is tuned definitely to a frequency 4 kc *above* the correct resonance frequency. It cuts off one sideband entirely. Such a circuit certainly needs realignment.

Pattern No. 17 shows the different response curves that may be obtained from high- and low-gain circuits.

Pattern No. 18 shows the response from an automobile vibrator *B* unit when the sweep frequency is different than the vibrator frequency.

Pattern No. 19 is interesting in that it shows the pattern produced when one plate of each pair of deflector plates is connected across the primary and the other two plates are connected across

the secondary, respectively, of the power transformer; the secondary voltage being reduced so that it equals the primary voltage. The conditions, then, are exactly the same as for the construction shown in Fig. 25-22. (The line may be made to slant in the opposite direction by merely interchanging the deflector plates used for the primary and secondary voltages.) The small areas that appear like smudges really represent *transient* voltages (voltages that are built up instantaneously due to various causes). The primary and secondary voltages from a power transformer that feeds a mercury-vapor rectifier tube may well simulate Pattern No. 19 because of the transients caused by ionization of the mercury in the rectifier. It is to eliminate these transient voltages that by-pass condensers and r-f filters are inserted in the circuits of these tubes.

25-42. Aligning R-F and Oscillator Stages with the Cathode-Ray Oscilloscope.—The equipment used for the alignment of the r-f and oscillator stages of superheterodynes is identical with that used for the i-f stage alignment, except that the test oscillator output is connected to the antenna and ground posts of the receiver (see Art. 25-18).

The test oscillator should be set at the r-f alignment frequency of the receiver and the tuning dial of the receiver should be set at this frequency. The cathode-ray oscilloscope should be connected to the output of the second detector (see Art. 25-38) and the test oscillator should be turned "on" with modulation "on". The various controls of the oscilloscope should now be adjusted properly with the frequency "wobbler" circuit disconnected from the test oscillator. The oscillator and r-f trimmers of the receiver should now be adjusted (see Art. 25-37) until maximum possible output is obtained. The modulation of the test oscillator should now be turned "off", the frequency wobbler circuit (adjusted for the correct amount of r-f frequency wobbling) should be connected to the test oscillator, and the sweep circuit should be properly synchronized with it. The test oscillator tuning should be adjusted until two curves show on the screen and the oscillator tuning should be readjusted until the two curves coincide at their highest points. The dial setting of the test oscillator

should be recorded for future reference. The receiver oscillator trimmer should now be adjusted until the forward and reverse curves coincide as well as possible and then the r-f trimmers should be adjusted until the curves coincide throughout.

25-43. Additional Uses for the Cathode-Ray Oscilloscope.

—It is impossible here to do any more than merely hint at some of the possible additional applications of the cathode-ray oscilloscope in radio service work. In general, the cathode-ray tube and its associated circuit may be likened to a vacuum-tube voltmeter. Since the deflecting plates have a very small capacity between them, its input impedance is almost infinite.

(1) **Measurement of voltage:** One of the simplest uses of the cathode-ray tube is for the measurement of voltage. Since the deflection of the spot on the screen is directly proportional to the deflecting voltage, the screen may be calibrated and the instrument used as a voltmeter for either direct, low-frequency or high-frequency voltages.

When a d-c voltage is applied, the polarity as well as the magnitude is indicated by the displacement of the spot. When an alternating voltage is applied, the spot oscillates back and forth with an amplitude proportional to the peak-to-peak value of the applied voltage. For example, a 10-volt root-mean-square sine wave produces a sweep with an amplitude equal to 28 volts. At frequencies above about 8 cycles per second, the sweep of the spot appears as a line, due to the persistence of vision. There is no error due to frequency until extremely high radio frequencies are reached. Overvoltage on the deflecting plates (if it is not excessive) merely sweeps the spot off the screen. Thus, the cathode ray tube, being rugged, having a high impedance, and being independent of frequency, is useful as a peak voltmeter. A transparent celluloid scale can be made up with the voltage calibrations marked directly on it, so that when it is placed over the screen any deflection of the spot can be read off immediately in terms of the voltage applied to the deflecting circuit.

(2) **Measurement of current:** If the cathode-ray tube is connected across a resistor of known value which is inserted in series with a circuit, and the voltage drop across this resistor is

measured with the cathode-ray tube (calibrated as a voltmeter) the current flowing through that resistor, and hence through the circuit may be calculated by ohm's law. Hence the tube may be used (indirectly) to measure current.

(3) Measurement of capacity and inductance: By using a cathode-ray tube to determine the shape of the resonance curve, the resistance of coils and of condensers may be ascertained. A high and narrow curve signifies a low-resistance circuit. Condensers may be compared as to capacity and coils as to inductance by the simple process of tuning a circuit consisting of a standard coil and condenser and noting the wave shape on the screen of the cathode-ray tube. Then the coil or condenser to be compared to the one already in the circuit is substituted and the wave shape noted. From the change in oscillator frequency required to again establish resonance, as indicated on the screen, the capacity of the condenser or the inductance of the coil may be ascertained. Also, from the wave shape observed, the resistance of the new coil and condenser may be determined.

(4) Test of overall receiver sensitivity: A rough check on the overall sensitivity of a receiver may be made by connecting the test oscillator to its input terminals, and the direct input terminals of the oscilloscope to the output of the power stage. Using an arbitrary value of sweep frequency (within the audio range of the receiver) the output wave form should be observed when the intensity of the test oscillator signal is raised to full strength and also when it is reduced to minimum value. If the receiver amplification is low, a limited change in height of the wave form will result, if it is high, a large noticeable change will result.

(5) Test of overall audio fidelity of a receiver: If it is desired to measure the overall audio fidelity of a receiver, the audio voltage which modulates the test oscillator should be connected to one set of deflecting plates of the oscilloscope (many test oscillators have convenient terminals from which the modulating voltage may be picked off). The frequency control of the saw-tooth oscillator should now be adjusted to be near that of this audio input signal, so that one cycle of it is observed on

the screen. Its wave form should be observed carefully!

Now the modulated r-f test oscillator signal should be connected to the *Ant.* and *Gnd.* terminals of the receiver, and the input terminals of the oscilloscope connected to the loudspeaker voice coil. The wave form now observed should be compared with that which was seen when the test oscillator audio output was connected directly to the oscilloscope. If it is sensibly the same, no audio distortion has taken place in the receiver; if it is not the same, the distortion is caused by the receiver. If distortion is present, it may be localized to a particular audio stage in the following way.

(6) **Localizing audio distortion in a receiver:** In order to localize the source of the distortion, the r-f output of the modulated test oscillator should be connected to the *Ant.* and *Gnd.* terminals of the receiver, and the oscillator set at a frequency at which the distortion is experienced. The proper "input" terminals of the oscilloscope should now be connected between *B-*minus and the "plate" terminal of any audio stage. The "sweep" frequency of the oscilloscope should be reduced so that several cycles of the audio modulation of the test oscillator signal show on the screen.

The input terminals of the oscilloscope should now be connected successively to the output of the detector, first audio and output stage of the receiver, in turn, and the exact wave form produced on the screen in each case should be noticed carefully. If the wave form is entirely symmetrical at one stage and distortion occurs in the next one, the wave form will lose its symmetry when the oscilloscope terminals are connected to the plate circuit of the offending stage.

A test to determine if the distortion is due to overloading may be made by simply reducing the output intensity of the test oscillator signal while watching the wave form on the screen. If this reduction causes the wave form to assume a symmetrical shape, it is likely that distortion was caused by overloading. If the wave form still remains unsymmetrical, the circuits of the distorting stage should be analyzed to determine if any component in it is faulty.

Not only the stage in which distortion occurs, but at what

volume level it takes place, and in which stage it occurs first may be ascertained quickly by means of the cathode-ray oscilloscope, and the proper remedies applied to eliminate the distortion.

(7) **Test of overall audio fidelity of an a-f amplifier:** If the overall fidelity of an audio amplifier alone (such as a public-address amplifier) is to be checked, an r-f test oscillator cannot be used as a signal source. An a-f signal source must be used instead. The signal output of an audio oscillator or a good phono-pickup unit played from a constant-frequency test record is suitable for this purpose. The procedure is sensibly the same as has already been described. This method has an advantage in that the audio fidelity may be checked at a number of audio frequencies over any desired band by setting the a-f oscillator (or using proper test records) to cover these frequencies. An "audio wobbler" may also be used for this purpose.

(8) **Localizing distortion in an a-f amplifier:** If the foregoing test reveals that distortion is present, the particular stage in which it occurs may be localized by feeding the audio signal (or "audio wobbler") to the amplifier input. The oscilloscope input terminals should now be connected successively to the input and output terminals of each stage (starting with the first one) and the wave form produced on the screen in each case noticed carefully. The stage *ahead* of the point at which distortion of the wave form is observed is the offending one.

(9) **Checking a receiver for intermittent operation:** If a receiver operates intermittently, it may be checked by applying the modulated signal from a test oscillator to its input terminals in the usual way, and then examining its wave form in its passage through each successive stage. The proper pair of deflecting plates of the oscilloscope should be connected to the "plate" of each successive stage and "ground". The saw-tooth oscillator voltage of the oscilloscope should be set at a maximum value in the case of the r-f stages and at a lower value (less than the a-f examined) in the case of the a-f stages. The signal pattern on the screen should be observed long enough to determine whether the first r-f stage is functioning. Then proceed to the next, etc. The faulty stage will show up visually!

These are but a few of the many uses of the cathode-ray

oscilloscope in which the service man is interested. Present indications point to its becoming one of the most useful pieces of test equipment in his daily work.

Precautions When using cathode-ray tubes, it should be remembered that a cathode-ray beam producing a light spot of high brilliancy will burn the fluorescent screen if it is allowed to remain stationary even for a short interval. Such operation may cause excessive heating of the glass, with resultant puncture. To prevent this possibility, the beam should be kept in motion. It is well to apply controlling voltage to the deflecting system before permitting the electron stream to flow. Stopping of the electron beam may be accomplished by removing the voltage

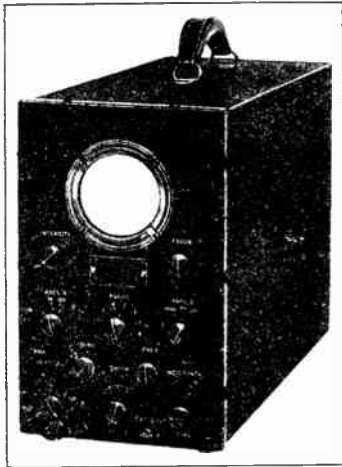

FIG. 25-32.—Exterior view of a typical commercial cathode-ray oscilloscope designed for use in radio service work. The circular screen of the cathode-ray tube and the control panel with its various control knobs are plainly visible. The interior of this instrument is shown in Fig. 25-33. Its schematic circuit diagram will be found in Fig. 25-34. (Type TMV-122-B)

Courtesy R.C.A. Mfg. Co.

on the high-voltage anode or by increasing the bias voltage on the control electrode to the cut-off point.

At this point, two commercial cathode-ray oscilloscopes designed especially for radio service work will be described. These instruments possess many unique circuit features which are interesting and should prove instructive.

25-44. RCA Type TMV-122-B Cathode-Ray Oscilloscope.

—This commercial instrument, designed especially for radio service work, provides cathode-ray measuring facilities by incor-

porating most of the essential equipment in a single case, shown in the illustration of Fig. 25-32. The screen and various control knobs are plainly visible. An interior view of the instrument, showing the cathode-ray tube and the various rectifier and amplifier tubes, is shown in Fig. 25-33. The complete schematic diagram of the circuit arrangement employed is shown in Fig. 25-34.

The device uses six tubes in the following manner: a type '57 tube, V_1 , as an amplifier for the voltage to be observed (which is applied here to the vertical deflecting plates): another type '57 tube, V_2 , as an ampli-

FIG. 25-33.—Interior view of the RCA Cathode-Ray Oscilloscope showing the rectifier tubes at the rear, the amplifier tubes directly in front of them, the cathode-ray tube vertically along the center and the saw-tooth oscillator tube near the front of the panel. The power transformer which supplies power for all the tubes and rectifier circuits is in the case at the rear. (Model TMV-122-B)

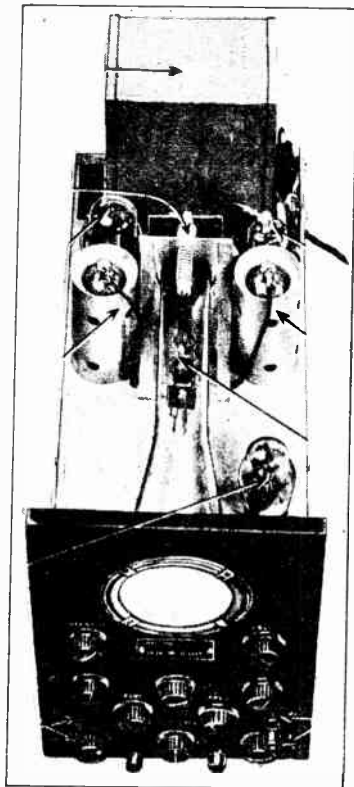

Courtesy R.C.A. Mfg. Co.

fier for the saw-tooth sweep or timing voltage generated in the instrument (which is applied to the horizontal deflecting plates); a gas-filled tube, V_3 , for generating the saw-tooth timing voltage; a half-wave rectifier, V_4 , for supplying the 1,200-volt d-c polarizing voltage for the cathode-ray tube; a full-wave rectifier, V_5 , for supplying voltage to the plates of the two amplifier tubes and the gas-filled tube; and V_6 , the 3-inch cathode-ray tube which requires about 1,000 volts on its high-voltage anode. A single power transformer T_1 is used for V_4 and V_5 , but their outputs are filtered individually.

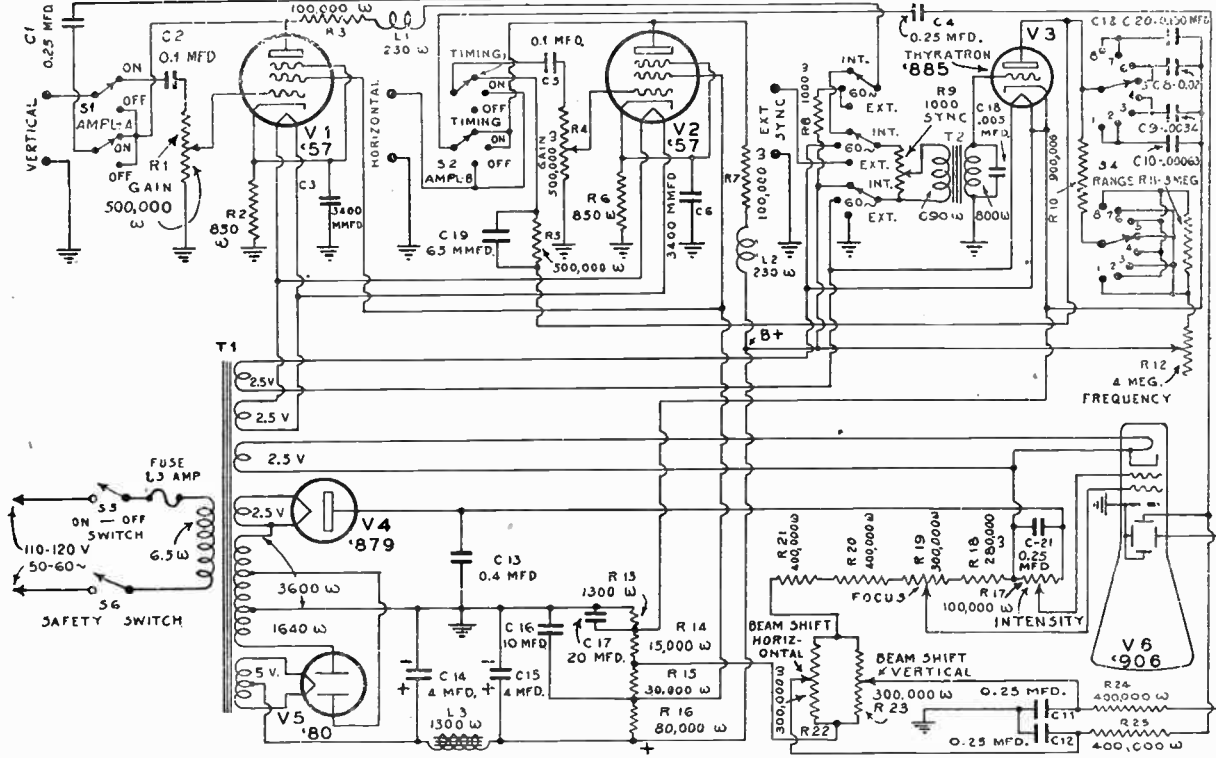

FIG. 25-34.—Schematic circuit diagram of the complete oscilloscope illustrated in Figs. 25-32 and 25-33. (Courtesy R.C.A. Mfg. Co.)

The two binding posts marked "Vertical" are to be connected to the voltage under observation or to the second detector tube of the receiver to be aligned. With the "Ampl-A" switch turned on, these posts connect to the input of $V1$. The output of $V1$ connects through $C1$ to the vertically deflecting plates of the cathode-ray tube. Potentiometer $R1$ varies the amplitude of the input signal to this tube.

$V3$ is a type '885 gas tube connected as shown in Fig. 25-26. Its action in generating the sweep or timing voltage was explained in Art. 25-34. The voltage across any one of the bank of condensers is fed to the input of $V2$ for amplification and the output of $V2$ connects to the horizontally deflecting plates of the cathode-ray tube. The connections are made with the "Amp. B" switch, S_2 , in the "Timing" position. This saw-tooth timing voltage is not available externally, but suitable switching is provided so that either this internal timing oscillator or an external source of timing voltage may be connected to the cathode-ray deflection plates through the amplifier tube $V2$. The frequency response of the two stages of amplification is substantially uniform from 20 to 90,000 cycles per second because of the use of the combination resistive and inductive load in the plate circuit of each tube, represented by $R3$ and $L1$ in the plate circuit of $V1$ and $R7$ and $L2$ in the plate circuit of $V2$. These amplifier stages were described in Art. 25-36, and shown in Fig. 25-29. The two binding posts marked "Horizontal" facilitate the connection of some other external voltage to the horizontally deflecting plates.

R-F or I-F Circuit Alignment with the Oscilloscope:

In order to visually align the r-f and i-f stages of a receiver with the oscilloscope, it is necessary to employ a test oscillator to feed a signal into the r-f or i-f stage to be aligned, and to also arrange to apply the output voltage of the receiver to one pair of deflecting plates (usually the horizontal pair) of the cathode-ray oscilloscope, so that it will cause vertical deflection of the cathode-ray beam in accordance with the instant-to-instant output of the receiver. In addition, this constant-intensity r-f or i-f signal supplied by the test oscillator must have its frequency varied ("wobbled") up and down (at an audio rate) over the

small frequency band for which the resonance curve is to be observed, so that the variation which occurs in the receiver output when the *frequency* of the input signal is varied over this band will be obtained and recorded on the screen of the cathode-ray tube. For instance, if the resonance curve of a 460 kc i-f stage which is flat-topped from about 455 to 465 kc is to be checked, the test oscillator *frequency* must be varied up and down (at an audio rate) from at least 455 to 465 kc in order to obtain the output at each frequency within this band so that the flat-top portion of the resonance curve (similar to that shown in Fig. 25-9) will be obtained. It would be preferable to vary the oscillator fre-



FIG. 25-35.—A portable motor-driven "frequency-wobbler" and saw-tooth voltage synchronizing unit for use with a cathode-ray oscilloscope when aligning tuned circuits. (Model TMV-128-A)

Courtesy R.C.A. Mfg. Co.

quency over a larger range from about 450 to 470 kc so that the entire resonance curve could be checked.

This recurrent frequency variation must be obtained by using some sort of "frequency-modulating" or "frequency-wobbler" arrangement which will continuously vary or "wobble" the frequency of the test oscillator above and below the frequency for which its main tuning condenser is set. As explained in Art. 25-37, this frequency "wobbling" may be accomplished by means of a special "trimmer" condenser of small capacity connected across the main tuning condenser of the test oscillator and arranged to be motor-driven at the correct speed.

Simultaneously with such frequency variation, it is necessary that an a-c voltage be generated to properly *synchronize* the saw-tooth sweep voltage generator (in the oscilloscope), so that the saw-tooth sweep voltage impulses will be in exact synchronism with this frequency variation—that is, so that one complete saw-tooth voltage impulse occurs exactly during the same time, *and at the same instant*, that the band of frequencies is swept over. Then, the output of the receiver over this entire band of frequencies will be traced on the screen of the cathode-ray tube in the form of a resonance curve (see Fig. 25-31).

A complete motor-driven frequency-“modulator” (or “wob-
bler”) and synchronizing impulse-generating unit designed es-

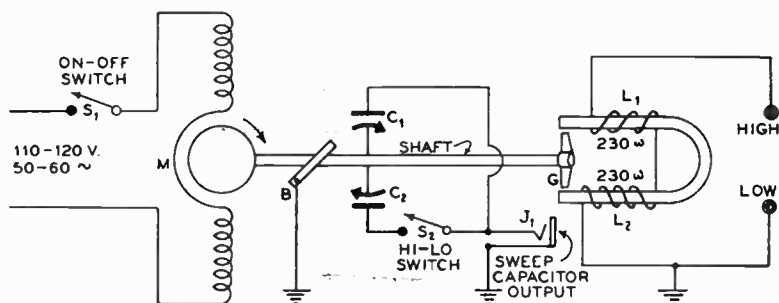

FIG. 25-36.—Schematic circuit arrangement of the motor-driven “frequency-wobbler” and saw-tooth voltage synchronizing unit illustrated in Fig. 25-35.

pecially for this purpose, and arranged in a portable mounting case is illustrated in Fig. 25-35. Its circuit arrangement is shown in Fig. 25-36. Referring to the former illustration, the electric motor M drives both the “wobble” condenser W and the rotor R of the a-c synchronizing impulse generator by a common shaft. As may be seen from Fig. 25-36, the “wobble” condenser is composed of two sections C_1 and C_2 , consisting of conventional type rotary condensers, each having a single rotor plate attached to the common motor-driven shaft and each arranged to rotate between two stationary plates. Contact is made to the rotor shaft by means of brush B . The stators are connected so that one remains connected at all times. This provides a capacity variable from 15 to 37 mmfd. When switch S_2 is closed,

the section C_2 is connected in parallel with the first, providing a capacity variable from 25 to 70 mmfd. These condensers are driven at a normal speed of 1,550 r.p.m., providing a complete "up" and "down" frequency variation of the test oscillator signal $1,550 \div 60$ or about 16 times per second.

The small synchronizing impulse generator consists of a horse-shoe permanent magnet having a coil wound on each leg (coils L_1 and L_2). In the magnetic field existing between the poles of this magnet is rotated the iron rotor G having a special shape to produce the desired impulse-voltage wave form due to its effect of increasing and decreasing the strength of the field across the gap and through the coils. The result is that suitable a-c voltage impulses are generated in coils L_1 and L_2 , and since the rotor G is rotated in synchronism with the rotor plates of condensers C_1 and C_2 , these generated voltage impulses will be in exact synchronism with the changes in *capacity* of these condensers and the *changes in frequency* which they produce in the test oscillator to which they are connected. This synchronizing voltage is connected to the "synchronizing transformer" T_2 (through the "EXT. SYNC." terminals) in the oscilloscope (see Fig. 25-34) so that it acts on the grid of the saw-tooth sweep voltage generator tube and thereby accurately synchronizes the saw-tooth impulses produced by this tube circuit with the frequency variations produced in the test oscillator output by the frequency-wobbler condenser. This results in synchronizing the horizontal deflection of the cathode-ray beam with the r-f or i-f frequency variation.

If an i-f amplifier is to be aligned, the external signal generator is connected to its input in the usual fashion and the output of the second detector is connected to the vertically deflecting plates of the oscilloscope. The synchronized saw-tooth oscillator voltage is applied to the horizontally deflecting plates at the same time, and its frequency is adjusted so that a single pattern is obtained on the screen. Under these conditions, the overall resonance curve of the tuned circuits between the point to which the variable-frequency constant-intensity signal of the test oscillator is applied and the point to which the oscilloscope is connected will be shown on the screen. The effects which any

trimmer adjustments produce on this resonance curve are immediately seen on the screen (see Fig. 25-31), so the necessary alignment adjustments may be performed properly and quickly.

The following are the essential control adjustments of this oscilloscope. They can be followed by referring to the schematic circuit diagram of Fig. 25-34.

1. "Intensity" control, *R-17*, is a 100,000-ohm potentiometer in the low side of the 1,200-volt bleeder. Its position controls the bias on the grid of the cathode-ray tube, which, in turn, determines the quantity of electrons emanating from the "gun," thus controlling the spot size. The power switch *S5* is located on this potentiometer.

2. "Focus" control, *R-19*, is a 300,000-ohm potentiometer in the 1,200-volt bleeder. Its position controls the anode No. 1 voltage, which (with constant anode No. 2 voltage) determines the distance at which the electron beam focuses. In general, for a given "Intensity" setting, the "Focus" control should be set for maximum distinctness of spot or image.

3. "Ampl. A" switch, *S1*, connects the "Vertical" binding posts either straight through to the vertical deflecting plates on the cathode-ray tube or through amplifier tube; *V1*, to these deflecting plates. In either case there is a condenser in the input circuit.

4. "Ampl. B" switch, *S2*, has 3 positions: "Timing," "On" and "Off." In the "Timing" position the "saw-tooth," or timing axis, oscillator feeds through amplifier, *V2*, to the horizontal deflecting plates on the cathode-ray tube. When in the "On" position the "Horizontal" binding posts are connected through amplifier, *V1*, to these deflecting plates. When in the "Off" position, the binding posts are connected straight through to the deflecting plates. In either of the latter two cases there is a condenser in the input circuit.

5. "Ampl. A Gain" control (vertical), *R1*, is a 500,000-ohm potentiometer on the input circuit of the vertical amplifier. With "Amplifier A" switch "On," this potentiometer controls the vertical deflection.

6. "Ampl. B Gain" control (horizontal), *R4*, is a 500,000-ohm potentiometer on the input circuit of the horizontal amplifier. With "Amplifier B" switch in the "Timing" or "On" position, this potentiometer controls the horizontal deflection.

7. "Range" switch, *S4*, selects one of four timing capacitors and on alternate positions it places a 3-meg. resistor, *R11*, in and out of the circuit. It thus changes the timing axis oscillator-frequency in steps, giving 8 ranges, as follows: No. 1, 20-37; No. 2, 37-120; No. 3, 120-205; No. 4, 205-700; No. 5, 700-1,100; No. 6, 1,100-3,700; No. 7, 3,700-5,700, and No. 8, 5,700-15,000 cycles per second.

8. "Freq." control, *R12*, is a 4-meg. rheostat in a series with the timing condenser. It changes the timing axis oscillator frequency gradually as it is rotated, and, in conjunction, with "Range" switch *S4* above, gives continuous range between the extremes of frequency (20-15,000 cycles).

9. "Sync." control, *R9*, is a 1000-ohm potentiometer controlling the amount of synchronizing voltage fed to the grid of the 885 tube. In general it should be set as far counter-clockwise as is consistent with a locked image, as over-synchronization causes poor wave-form from the timing axis oscillator.

10. "Synchronizing" switch, *S3*, has three positions, "Int.," "60 Cycle," and "Ext." In the "Int." position the voltage drop across resistor *R9* in the plate circuit of the vertical amplifier is fed through the input transformer to the grid of the 885 tube. Thus, the timing axis oscillator can be synchronized with the signal on the vertical axis at fundamental frequency or any small sub-multiple, such as $\frac{1}{2}$, $\frac{1}{3}$. . etc. Synchronization is not effective if it is attempted to operate the timing axis oscillator at a higher frequency than that of the synchronizing voltage. In the "60 Cycle" position a 2.5 V. 60 cycle source is impressed across the "Sync." control, and can be used for locking the timing axis oscillator at 60, 30, or 20 cycles. In the "EXT." position the "EXT. SYNC." binding posts are connected across the "Sync." control. This allows the use of an external source for synchronizing.

11. On the right-hand side of the cabinet, toward the rear, are two potentiometers slotted for screw-driver control. These potentiometers control the amount of d-c potential between the two deflecting plates of each pair, and thereby allow adjustment of the position of the spot or image. The rear potentiometer, *R22*, (300,000 ohms), controls the horizontal deflection and the front one, *R23* (300,000 ohms), controls the vertical deflection.

12. There are three pairs of binding posts on the unit. Voltage impressed on the "Vertical" posts will produce *vertical* deflection. Voltage impressed on the "Horizontal" posts will produce *horizontal* deflection. The "Ext. Sync." posts are used when it is desired to

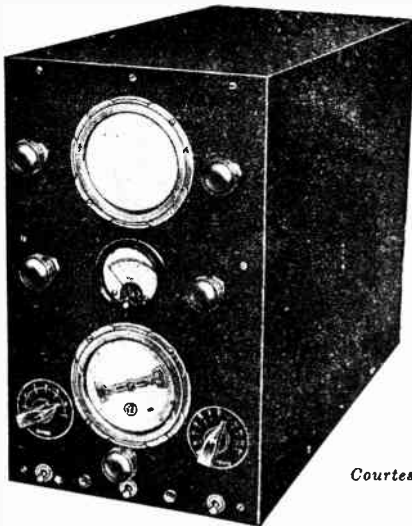

FIG. 25-37.—A combination cathode-ray oscilloscope and test oscillator built into a single portable case. The cathode-ray tube screen is at the top. The frequency-selector dial of the test oscillator is at the bottom. (Model CR500)

Courtesy Wireless Egert Eng., Inc.

synchronize the timing axis oscillator with some external source. The binding posts marked "O" are all common ground and the ones marked "High" are insulated from ground, which is the chassis.

25-45. **Wireless Egert Model CR500 Visual Resonance Oscilloscope.**—This device is a complete cathode-ray instrument designed especially for radio service work. It is of con-

siderable technical interest since it contains in compact, self-contained form an all-wave test oscillator capable of covering a range of 100 to 22,000 kc, a cathode-ray tube with associated power supply equipment, and an electrical sweep circuit. The complete unit is illustrated in Fig. 25-37. The screen of the cathode-ray tube is near the top, and the tuning dial for the test oscillator is near the bottom. A block diagram showing the

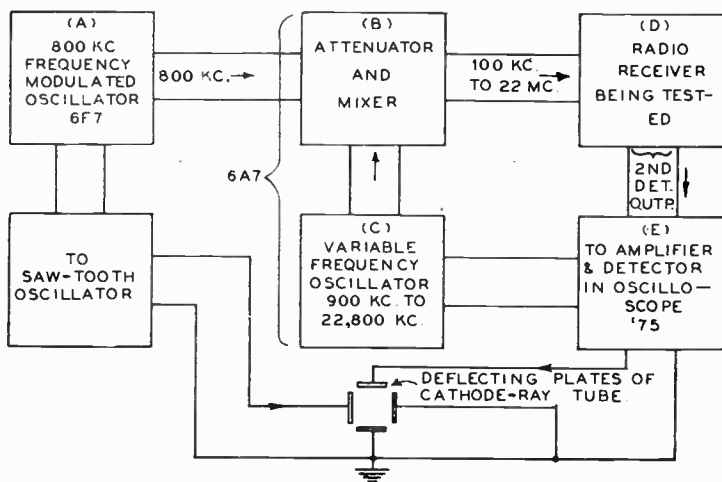

FIG. 25-38.—Block diagram showing the main parts of the visual resonance oscilloscope illustrated in Fig. 25-37. Their relation to each other is indicated by the circuit lines. The frequency of oscillator (A) is indicated as 800 kc. here. This is actually the *average* frequency between 789 and 811 kc., as is explained on Page 787.

relation of the various main parts of the instrument is shown in Fig. 25-38.

This device provides direct-reading resonance indications for all types of intermediate, broadcast and short-wave frequency alignment tests, and may also be used for visual indications of selectivity curves, adjacent channel selectivity, avc action, r-f signal distortion, presence of regeneration or oscillation in circuits, hum measurements, vibrator-transformer operation, a-f harmonic distortion, noisy circuits, etc.

The operation of the instrument *without the sweep circuit* is as follows. Referring to Fig. 25-38, tube (A) oscillates at

about 811 kc in a conventional oscillating circuit. Tube (C), which is one section of a 6A7 tube, constitutes a variable-frequency oscillator having a range from about 900 to 22,800 kc. The output of oscillator (A) modulates the output of oscillator (C) in the 6A7 tube, and the output consists of the sum and difference frequencies, exactly as in the mixer stage of a superheterodyne. The *difference* frequency is the one that is utilized. This difference frequency is therefore variable from 89 to 21,989 kc by varying the tuned circuit in oscillator (C). Thus, the action so far is exactly the same as in any superheterodyne receiver. The 811 kc oscillator output is equivalent to an incoming signal and the 900 to 22,800 kc oscillator is equivalent to the local oscillator in the receiver.

The output of this combination is then fed to the receiver

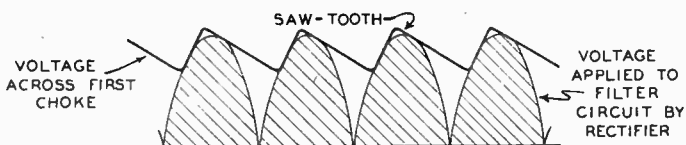

FIG. 25-39.—How a saw-tooth voltage may be obtained from the output of a full-wave rectifier-filter system.

whose circuits are to be aligned. The output of the detector of the radio receiver under test is then fed to a type '75 tube in the oscilloscope. The '75 is a triode-diode, so that the receiver output connects to the triode section and its output is rectified by the diode section. It is the diode section that is applied to the vertical deflecting plates of the cathode-ray tube. With no sweep circuit, therefore, the image on the screen of the cathode-ray is merely a vertical line (see Fig. 25-21), and is of little significance to the service man.

The sweep circuit is especially unique, as it does not make use of thyratron tubes or motors; it uses the output of a rectifier tube for the saw-tooth timing voltage. It was shown in Art. 20-19 and in Fig. 20-23 that the output of a rectifier tube fed into a filter has ripples, and that the shape of these ripples is saw-toothed, as shown in Fig. 25-39. This saw-toothed voltage is coupled to the 811 kc oscillator circuit as shown in Fig. 25-40

This oscillator, like the usual Hartley circuit connection, consists of tank coils L_1 and L_2 and tuning condenser C . Since the frequency is not variable, condenser C is fixed. The coils of this oscillator are wound on an iron core, and on this same core is another winding L_3 , which connects to the saw-toothed voltage generated by the rectifier tube. The form of this voltage is substantially that shown to the lower right of L_3 .

When the voltage across L_3 rises, from a to c , the core becomes saturated, and the inductance of L_1 and L_2 decreases, lowering the frequency of the 811 kc oscillator. Thus, the fre-

FIG. 25-40.—Circuit arrangement employed in the oscilloscope of Fig. 25-38 for obtaining frequency-modulation of the 800-cycle oscillator. A saturable-core reactor arrangement is used.

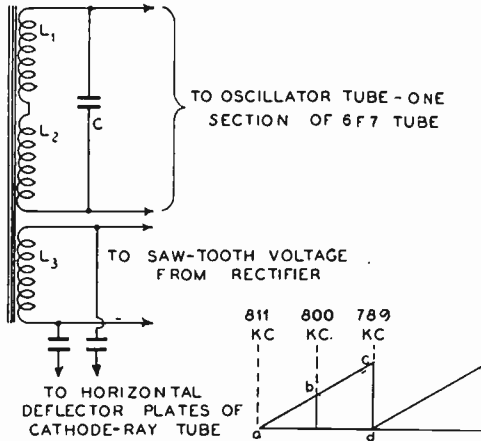

quency lowers *uniformly* as the saw-tooth voltage rises through values a , b and c . With the saw-tooth voltage at a , the frequency of the oscillator is about 811 kc, at b it is about 800 kc, and at c is about 789 kc. The average frequency, corresponding to point b of the saw-tooth voltage, is 800 kc, and is so labeled at (A) of Fig. 25-38.

Thus, the output of oscillator (A) is frequency-modulated by the induction effect of the saw-tooth voltage, and its variable-frequency voltage is mixed with the output of oscillator (C) in the mixer circuit (B). The output of (B) therefore varies about 11 kc on either side of the setting determined by oscillator (C). Thus, if the fundamental frequency of oscillator (C) is 1,250 kc,

then the output after mixing would be varying between 439 and 461 kc, and it is this variable frequency that is applied to the receiver under test. By varying the magnitude of the saw-tooth oscillator voltage, the degree of saturation of the core of oscillator (A) may be varied, which in turn, will vary the amount of change in inductance, which results in a variation in the amount of frequency modulation. By reducing the saw-tooth voltage to zero, oscillator (A) will function at 811 kc. In normal use, however, the 22-kc (11 kc on either side) variation in frequency is necessary.

The saw-tooth oscillator is also connected to the horizontal deflecting plates of the cathode-ray tube for timing purposes, and since the timing and amount of frequency modulation (or "wobbling") are determined by the same saw-tooth oscillator, a synchronized image of the response curve of the receiver under test is obtained.

For example, consider oscillator (C) tuned to 1,250 kc; also consider oscillator (A) varying between 789 and 811 kc as in the previous example. The voltage fed to the receiver under test then will vary between 439 and 461 kc. The receiver is tuned to the *average* of the two, or to 450 kc, so that its output will vary according to the selectivity of the receiver. The output of the detector is then fed to the '75 tube in the oscilloscope and rectified. This rectified voltage is then applied to the vertically-deflecting plates of the cathode-ray tube. A straight vertical line would be seen were it not for the sweep voltage. The saw-tooth oscillator is also connected to the horizontally-deflecting plates of the cathode-ray tube, so that the wave is spread out. Thus, in Fig. 25-40, when the saw-tooth oscillator voltage is at point *a*, the frequency fed to the receiver is 439 kc; the spot on the screen will therefore be at the extreme left since the saw-tooth voltage is zero. As the frequency of oscillator (A) decreases to 789 kc, the frequency applied to the radio receiver increases to 461 kc, and *at the same time* the saw-tooth oscillator voltage, connected to the horizontal deflecting plates, moves the spot to the right, and the response curve is taken. At point *c*, the saw-tooth voltage is maximum, and at *d* it is zero, so the spot moves almost *instantaneously* to the left and

the frequency of oscillator (A) is raised to 811 kc and the operation begins all over again. This is repeated as many times per second as the saw-tooth voltage repeats, which, in the case of a 60-cycle supply, is about 1/60 second per sweep, or about 60 sweeps per second. This is more than enough to furnish a constant image.

The instrument may also be used for any other type of measurement for which cathode-ray tubes can be used. Connections to the deflecting plates and the oscillator terminals are brought out for external use, a microammeter is used for setting the frequency of both oscillators, and the entire instrument is self contained with all power units intact. The usual controls are available for changing the intensity and size of the spot. The "frequency wobble" obtainable in this instrument is limited to 11 kc. on either side.

Because of its wide radio-frequency range, the instrument is suitable for aligning and testing all i-f broadcast and high-frequency (short wave) amplifiers and filters.

25-46. Oscillograph and Oscilloscope.—At the present writing there seems to be some confusion concerning the use of the terms cathode-ray *oscillograph* and cathode-ray *oscilloscope* for the type of apparatus which has been described in the latter part of this chapter, especially in Arts. 25-44 and 25-45. Manufacturers of these instruments are using both terms for these devices. Although the distinction between these terms is rather a fine one, it is the opinion of the author that if one must be made, the term cathode-ray *oscilloscope* should be applied to the device in which the wave form produced on the screen is viewed or observed *visually* with the naked eye; the term cathode-ray *oscillograph* should be applied to that type of apparatus in which the image on the screen is *recorded*, usually on a photographic plate or film. If the origin of the two suffixes are investigated, we find that "scope" and "graph" are both derived from the Greek. The former means "to view" with the eye; the latter means "to write". Since the average cathode-ray instrument of the general type described in this chapter, designed for radio service work, simply permits the service man to view the image on the screen *visually*, the name *oscilloscope* would

seem to be the more appropriate one. This term has been used in this book. As soon as a camera or other recording device is added to the oscilloscope, so that the image may be recorded, the entire unit becomes an *oscillograph*.

REVIEW QUESTIONS

1. What is the main advantage of the superheterodyne circuit?
2. How is the advantage of Question 1, obtained in practice?
3. How is the frequency of the incoming signal reduced to that to which the i-f amplifier is tuned?
4. Is the oscillator frequency in a superheterodyne receiver usually made higher, or lower, than the signal frequency? Why?
5. What is meant by the "difference frequency" in a superheterodyne? What is another name for it?
6. What adjustments are necessary to completely align a superheterodyne receiver?
7. What operating symptoms will be noticed in a broadcast-band superheterodyne receiver whose i-f circuits are misaligned; (a) if the i-f transformers are of the sharply-peaked type; (b) if they are of the flat-top type designed to flat-top over a 10 kc band?
8. What operating symptoms will be noticed in a broadcast-band superheterodyne receiver in which the r-f tuning circuits are not aligned properly with each other?
9. What operating symptoms will be noticed in a broadcast-band superheterodyne receiver in which the oscillator frequency tracks properly above the signal frequency over the high-frequency end of the dial, but does not track properly over the low-frequency end?
10. If the receiver of Question 9 employs an oscillator padding circuit, what is the most likely cause for this trouble?
11. What alignment sequence should be followed if a broadcast-band superheterodyne is to be completely realigned? Why is this sequence best?
12. Draw the schematic circuit of a typical 2-stage i-f amplifier. Point out the i-f tuning condensers. Describe the construction of the i-f transformer units.
13. Explain how you would connect all the apparatus required for the complete alignment of a broadcast-band superheterodyne, starting with the alignment of the i-f stages. The receiver employs one stage of t-r-f amplification ahead of the first detector, and two stages of 485.5-kc i-f amplification. A push-pull output stage, feeding into an output transformer mounted on a dynamic speaker, is employed. The voice coil terminals of the speaker are not accessible.
14. Where would you couple the test oscillator output for aligning the i-f stages when the receiver employs a '36 type tube as a combination first detector-oscillator?
15. Explain in detail how you would proceed to align the i-f ampli-

- fier in the receiver of Question 13, if it is to be sharply peaked at 485.5 kc.
16. How would you align the i-f amplifier if its main i-f was 485.5 kc, and it was designed to be aligned so as to produce a flat-top characteristic having a *total* flat-top band with 8 kc?
 17. What two methods are employed in the design of superheterodynes for obtaining proper tracking between the r-f tuning circuits and the local oscillator? Describe each one. Why is this correct tracking necessary over the entire dial range?
 18. What is meant by: (a) the low-frequency padder; (b) the high-frequency padder (or trimmer), in the oscillator stage? What is the purpose of each?
 19. What procedure would you use in aligning the oscillator and r-f circuits of the receiver of Question 13?
 20. What special steps would you take if you found it necessary to realign a superheterodyne using automatic volume control obtained by a separate avc tube?
 21. What special steps would you take if you found it necessary to realign a superheterodyne, using automatic volume control, if it employed a combination tube performing the functions of second detector, avc, and first audio tube?
 22. A receiver whose i-f is unknown is to be aligned. A test is made on it for the purpose of determining its i-f experimentally. A test oscillator is connected to it. When the frequency dial of the test oscillator is slowly varied, its signal can be heard in the receiver at settings of 93 kc, 155 kc, and 232.5 kc. What i-f is the receiver designed to employ?
 23. Suppose that after you have adjusted the high-frequency trimmer in the oscillator stage of a broadcast-band superheterodyne, you find that stations can be received only over part of the dial. What is the trouble, and what would you do to correct it.
 24. Explain how you would proceed to adjust an image-suppression trap circuit in the r-f amplifier of the receiver of Question 13, stating the frequencies you would employ, etc.
 25. Why should the tools employed for turning the aligning adjustment screws and nuts in receivers be made for a good insulating material? What is apt to happen if they are made entirely of metal? Explain!
 26. What is the principle of operation of the cathode-ray tube?
 27. Draw a sketch of a typical cathode-ray tube, and label all parts. Name the six main parts of the tube.
 28. State the function and explain the operation of each part of the tube which you have drawn.
 29. What material is most suitable for the screen of a cathode ray tube which is to be employed for visual work only?
 30. What is the electron gun in a cathode-ray tube?
 31. Draw a sketch showing the shape of the pattern traced out on the screen of a cathode-ray tube if a sine-wave voltage is applied to one pair of deflecting plates—the other pair remaining idle. Explain!
 32. Explain what must be done in order to have this pattern appear as a sine-wave.

33. Explain in as few words and as clearly as you can what the purpose of the "sweep" or "timing" voltage is?
34. What is the preferred wave form for the sweep voltage? Draw a few cycles of this voltage. Why is this wave form preferred?
35. Draw, and explain the operation of, an electrical sweep circuit which will generate a saw-tooth sweep voltage.
36. Draw, and explain the operation of, a simple mechanically-driven sweep circuit. What are the advantages and disadvantages of this arrangement over that in question 35?
37. What must be done to the frequency of the signal output of the test oscillator when it is used to feed the i-f amplifier of a receiver whose i-f stages are to be aligned by "visual" means with a cathode-ray oscilloscope? Why is this necessary?
38. Describe a mechanical means for performing the function described in question 37 together with generating a saw-tooth sweep voltage in synchronism with it.
39. Explain how you would proceed to align the i-f stages of a high-fidelity receiver having a 2-stage flat-top 460-kc i-f amplifier designed to pass a total band of frequencies 15 kc wide. The receiver employs a diode second detector and avc. A cathode-ray oscilloscope is to be used, in conjunction with a motor-driven frequency-wobbler and potentiometer-type sweep circuit.
40. Draw five different sketches of typical resonance curves which might be obtained on misadjusted i-f amplifiers by means of a cathode-ray oscilloscope. Explain what trouble each one reveals.
41. Explain how a cathode-ray tube may be used to measure d-c voltage.
42. If it is used to measure a-c voltage will it indicate the "peak," or the "effective," voltage? Why?

CHAPTER XXVI

REPAIRING INDIVIDUAL RADIO COMPONENTS

26-1. When Repairing of Components is Justified.—The preceding chapters in this book have outlined in detail the causes of the majority of troubles that may be encountered in radio receivers and the methods of locating them. It is the purpose of this chapter to show tried and tested ways in which many of the components which these tests reveal to be faulty may be repaired.

It is a relatively simple matter to replace every piece of equipment that is found to be faulty, however slight the trouble may be. Such a procedure, obviously, is not the best nor the most economical course to follow in every case, and it certainly is not justified in the eyes of the customer. There are certain components whose construction is so simple and rugged that a repair may be effected quickly and without much trouble. Such units should usually be repaired in the field! On the other hand, there are components whose construction is simple, but whose assembly is such that, it is quite difficult to effect a repair. Then, too, there are components whose cost is so low that it is much cheaper to replace them than to devote the time required to repair them. In this chapter we will confine our attention to those components which can usually be repaired in the field with the limited facilities which are ordinarily available, and at a time cost below what it would cost to replace the component. We will also consider those components which can be repaired economically in the shop—possibly during spare time.

There is another important consideration in this question of whether it is better to repair, or to replace, a faulty unit. Many customers want repairs effected in a hurry, and since no service

man has on his shelves a complete stock of parts for all models of radio receivers which he may be called upon to service, a temporary repair must often be made so that the receiver can be operated during the period required to secure the replacement component if it is advisable to obtain a new component finally. It should be remembered that service men in isolated communities are often forced to wait an appreciable time for the delivery of certain components. There are also many cases where the manufacturer of the receiver being serviced has long since gone out of business, and proper replacement units are not obtainable even from the ordinary concerns who deal in replacement parts. In such cases, the service man is virtually forced to effect a repair himself if it is possible.

These are but two illustrations of conditions which can modify the advisability of replacement. Many more could be cited, but the main point is that certain receiver components can and should be repaired rather than replaced. The practical service man should know how, and be properly equipped, to make these repairs economically, and satisfactorily. If such work is properly done so that it saves the customer money, it cannot fail to promote worthwhile good will between the service man and the set owner, thereby creating for the service man a reputation for his ability to solve such problems which other less versatile service men are unable to cope with. In this chapter only repair methods which have been tested in practice and found to be satisfactory in every respect will be presented.

26-2. Repair of Fixed Resistors.—The various types of resistors employed in radio receivers, the common troubles they are subject to, and the methods of testing them, were considered in detail in Arts. 22-4 to 22-18 inclusive, so this phase of the subject will not be repeated here. In general, it may be said that resistors of the metallized-film and moulded-carbon types are so inexpensive that they are not worth repairing—excepting for emergency purposes. If the end terminals of these resistors become loose it is best to replace them, for repairs made on them seldom are permanently satisfactory.

If a carbon resistor becomes carbonized due to continuous overheating, it indicates that a unit of similar resistance but

higher wattage rating should be substituted for it. When such units become carbonized, their resistance decreases in value. If the decrease is not appreciable, but enough to affect operation of the receiver, the resistance may be raised and the unit used temporarily by simply scraping part of the carbon from the body of the unit until the correct value is obtained. The smaller the diameter, the *greater* the resistance; the shorter the resistor, the *less* the resistance. This latter property immediately suggests the possibility of breaking a resistor into smaller sections to obtain one of lower resistance value. It may be done provided the end clamps are of such construction that

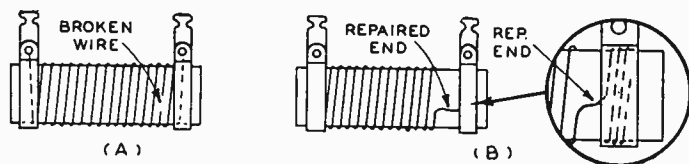

FIG. 26-1.—Method of repairing a wire-wound fixed resistor in which the resistance wire has broken near one of the end terminal clamps.

good connections can be made to the ends of the broken pieces. These repairs are useful merely for emergency purposes. In general, it is not advisable to make them for permanent repairs.

Wire-wound resistors may often be repaired satisfactorily and quickly, depending upon the nature of the trouble. If the resistance wire breaks near the center it is not worth while to attempt a repair, for most resistance wires cannot be soldered by ordinary methods. If the break occurs near the metal terminal clamps, as shown at (A) of Fig. 26-1, the main end of the broken winding can usually be brought over to the end clamp and connected to it in the proper way. First the terminal clamp at the broken end should be removed. Then at least five turns should be unwound at the broken end of the resistance wire, the wire should be cleaned carefully with No. 00 (fine) sandpaper, and then carried over and rewound on the resistor form at the place where the terminal clamp will be put back, as shown at (B). The terminal clamp should then be placed over it and tightened securely so that it makes good contact with the several turns

of wire. The fact that the resistor now has a few turns less than it originally had only makes a negligible reduction in the resistance, if it is wound with numerous turns of fine wire. Incidentally, this method may be used (by removing the proper number of turns of resistance wire) to make wire-wound resistors of lower resistance value from units on hand.

Very often the terminal clamps of wire-wound resistors loosen up, resulting either in a complete open circuit, or intermittent contact. In most cases of this kind, it is possible to make a temporary repair by carefully squeezing together the ends of the clamp, thus tightening it so it makes better contact with the resistance wire. Such repairs are usually makeshifts, however. Especially in cases where intermittent reception occurs, it is best to replace the resistor.

In cases where internal grounds occur in resistors, repairs can sometimes be made by properly inserting insulation to prevent the contact which is causing the ground. These grounds usually occur when one of the end terminal clamps touches the mounting bracket nearest to it. A fibre washer properly inserted will usually remedy this trouble.

26-3. Repair of Variable Resistors and Potentiometers.—Many forms of variable resistors and potentiometers are used in radio receivers, usually as volume and tone controls. Some of these are constructed in such a way that they cannot be opened for repair. Since volume and tone control resistors are usually located in the circuit in such a position that only a very small current flows through them, they seldom burn out unless some other related component becomes faulty and causes excessive current to flow through the resistance element, causing it to overheat or actually burn out.

Noisy operation which is traced to a volume or tone control usually accompanies excessive wear or dirt at the rubbing contact surfaces. In such cases (in wire-wound resistors), the contact arm and the contact surface of the entire resistance element should be cleaned thoroughly with a clean rag dipped in ordinary cleaning fluid or alcohol to remove all dust, grit, etc., and the surfaces may be polished with an ordinary eraser which is not too gritty. Then a light film of Nujol or other min-

eral oil should be spread on these parts. It is absolutely essential not to use any type of oil other than pure colorless mineral oil. Other household oils may give satisfactory results for a few days or a few weeks, but, owing to their acid content, they will eventually cause more harm than good. The purpose of the oil is not to lubricate the parts, but to prevent the contact surface of the resistance unit from becoming coated with gummy dirt or oxide. Use only a slight amount of the oil! The tension of the arm should be adjusted so it makes firm contact with the resistance element without exerting too much pressure. If the contact surface of the resistance element is uneven or has dents in it, the entire resistor had better be replaced, for it will always produce noisy and erratic operation. Slight noises in the volume control may frequently be cleared up by turning the knob back and forth a few times to clean the contact surfaces.

In cases of intermittent or noisy reception caused by a variable resistor, if a similar replacement resistor is not at hand, a fixed resistor having a resistance equal to the highest resistance value of the suspected variable unit should be substituted for it (provided reception can be obtained when this value of resistance is employed, otherwise a lower value may be used). If the trouble stops when this is done, the variable resistor should be replaced. Substitution of a fixed resistor is also helpful for temporary repair in cases where a variable resistor is completely inoperative and no satisfactory replacement variable resistor is at hand.

26-4. Repair of R-F Coils.—Major troubles in the r-f coils of modern selective receivers generally do not lend themselves to economical and wholly satisfactory repair by the average service man.

This statement will undoubtedly be challenged by some, but it is made here in the light of experience with such troubles and a consideration of the time it takes to complete major r-f coil repairs. By a "major trouble" is meant one which necessitates the re-winding of the coil. Experience has shown that, while a faulty coil may be re-wound easily, it is a time-consuming matter to wind one that will enable accurate realignment of the tuned

stages to be made quickly after it is connected into the receiver. Probably one of the most important problems in the manufacture of commercial r-f coils is the work of matching them to one another, or to a predetermined standard, within the close limits which are necessary in modern selective receivers. This has been a troublesome production problem which receiver and coil manufacturers have solved only by the development of ingenious coil-winding machinery, delicate test equipment, and close attention to minute details. Not only must the coils be matched carefully, but their electrical constants must remain unchanged after they are wound, matched and subjected to temperature changes in the receiver.

Of course, if the receiver is of the old three-dial type, or is a t-r-f set of early vintage in which the selectivity is so poor anyway that close alignment of the r-f stages is not necessary, a faulty winding may be replaced in a few minutes by merely counting the turns on the coil (or on a similar one in the receiver) and duplicating it with wire of the same size and insulation, but winding on a few more turns than is considered necessary. After the proper number of turns have been wound tightly, it may be necessary to make an adjustment in the inductance of the coil by removing turns until it has been brought down so near to the correct value that the removal of another turn would overshoot the mark. The second step, that of fine adjustment (when necessary) is usually carried out by spreading the end turns a little. By this means, a close adjustment of the inductance can be made. The coil should be impregnated, if the other similar coils in the receiver are so treated. A slight adjustment in the number of turns may be necessary after impregnation.

Another important point to consider is the effect of the shield can when it is put over the coil. Since the shield causes the inductance of the coil to decrease somewhat, the final adjustment of the coil winding must be made with the coil shield in its normal position over the coil, and properly grounded to the chassis.

Loose windings on r-f coils may be repaired easily by unwinding the loose portion of the wire, without breaking it, and, re-winding it back on the form, the proper tension being applied during the winding. The number of turns should be checked

carefully, for it is usually found that the wire has stretched sufficiently to make a few more turns than the coil contained before.

Broken coil lugs or mounting brackets may usually be repaired without much difficulty. There are so many different methods of coil mounting and types of connecting lugs that a general statement cannot be made concerning these. Fortunately, however, their repair is usually so simple that the requirements may be understood after a few moments of inspection. Poorly soldered joints, open circuits, snapped coil leads, etc., can easily be repaired, (see Art. 22-19 for additional details on this point). When coil ends are to be soldered to the connecting lugs, the wires should not be pulled too tightly, for subsequent temperature changes may cause the thin wires to snap at the lugs. Leakage between coil terminals (caused by absorption of moisture by the coil form) necessitates the baking out and subsequent moisture-proofing of the coil.

26-5. Repair of I-F Coils.—Intermediate-frequency transformer windings may or may not require accurate adjustment; it depends upon the range covered by the trimmer condensers which tune them. Of course, loose connections, open connections, etc., in these coils can be easily repaired. Major repairs which might necessitate re-winding the coils are usually beyond the scope of the service man, for these coils are universal-wound. In such cases, immediate replacement of the faulty unit is advisable.

26-6. Repair of Audio Chokes and Transformers.—Audio choke coils and audio transformers employed in the a-f circuits of receivers contain thousands of turns of extremely thin wire wound over iron cores. The common troubles which may occur in these units were discussed in Arts. 22-20 to 22-24. Since they are usually completely sealed into their containers by means of insulating compounds, the making of internal repairs in them is usually not practical. However, if the trouble happens to be a poorly-made internal connection at the lug terminals, the connection can be re-soldered if the terminal is accessible. Internal open circuits, shorts, grounds, etc., in the coils are not easily repaired. In such cases, a new unit should replace the faulty one.

26-7. Repair of Filter Chokes.—The choke coils employed in the filter systems of the *B* power supply sections of radio re-

ceivers usually consist of a large number of turns of thin wire wound over an iron core. The construction of a typical a-f choke is illustrated in Fig. 26-2. The winding is separated from the core proper by several layers of fibre, fish paper, etc., although some chokes usually have a more rigid independent bobbin on which the winding is wound. The important point is that the coil is electrically insulated from the core (see Art. 26-9). It is this electrical insulation that determines the maximum potential difference that may safely exist between the core and the layer of the winding nearest to it.

Very often, the insulation between the core and the coil weakens because of the absorption of moisture or because of

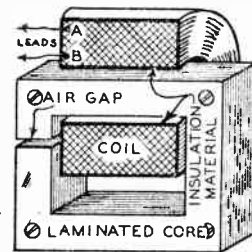

Fig. 26-2.—Typical internal construction of a core-type filter choke.

excessive heat. If such a condition should exist, and end B (Fig. 26-2) of the coil is at a very high potential with respect to ground (the core), then the insulation will break down, a heavy current will flow between coil and core, and the winding will burn out. If it burns out near the inside end B, the entire coil must be taken apart and rewound if a repair is to be effected. This is usually not to be recommended. On the other hand, if the open-circuit occurs near the top layer, a few layers of the wire may be removed and a new terminal brought out. The removal of one or two layers of the wire will not materially change the coil's inductance, and a repair may be made easily.

When removing the coil from the core, care must be taken to maintain the length of the air-gap in the core the same after repair as before. The inductance varies greatly with changes in air gap length, especially when the flux density is very high or very low. It is wise to measure the air-gap length by inserting a number of metal or fibre shims in the gap before dismantling, and then use the same shims for making sure that the air-gap length is the same after repair. This is shown in Fig. 26-3.

In many cases, the choke is contained in a metallic can filled

with a tar-like impregnating compound. The purpose of this compound is to keep the windings intact and to protect them from severe changes in humidity, salt air, and temperature fluctuations. To effect a repair on a *sealed choke* (a transformer, or a condenser), it is necessary to melt the "compound" before the unit can be removed from the can. One way to do this is to place the can (open end at the top) on a small tripod with a bunsen burner or other gas flame under it, and a metal plate of some kind between the flame and the choke case, as shown at (A) of Fig. 26-4. If this equipment is not available, the container may be heated in the same manner by the gas flame of an ordinary cooking stove or by an electric stove as shown at (B).

impregnating compound removal.

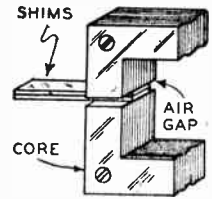

FIG. 26-3.—Simple method of determining the size of the air gap in cores by inserting thin metal shims in the gap.

The important thing is to use a small flame and *melt* the compound *slowly*. If the compound should become too hot, the enamel insulation on the wire of the choke may peel or blister

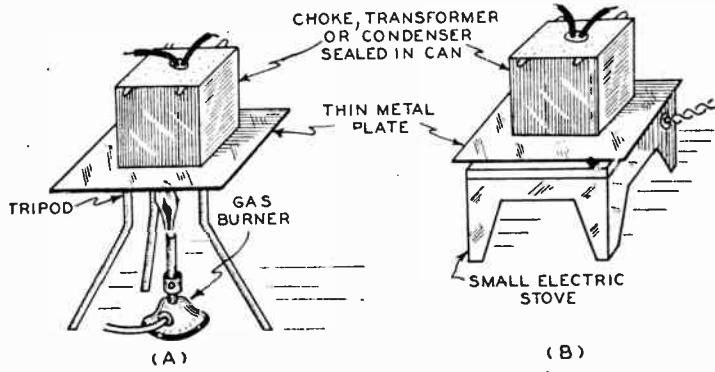

FIG. 26-4.—Two convenient methods of heating the compound in a sealed choke, transformer, or condenser unit so that it may be melted out. At (A) a gas burner is used; at (B) an electric "hot plate" or stove is employed.

and the entire choke will be rendered useless. If you are inexperienced in this sort of work, melt the compound slowly until the top surface begins to flow. Remove the can from the burner

with a large pair of pliers and pour out into another receptacle what little compound is melted. Then re-heat and pour out a little more. Continue this until the entire can is emptied of the compound. This same procedure may be employed to remove power transformers and condensers which are sealed in cans. In the case of condensers, even more caution must be observed when applying the heat, so as not to raise the temperature to too high a point, or the condenser itself will be damaged.

If the coil of the choke is open-circuited and *must* be repaired, unwind the wire until the break is found. If the break is near the outside layer, merely remove the turns of wire between the break and the terminal lead. Then make a new connection to the outgoing lead.

If the break is near the inside, or start, of the coil, then unwind all the wire *carefully and wind it* on another spool until the break is found. Then wind back the same wire that was removed. Each layer should be insulated from the next by fish paper or some other suitable insulating paper (see Art. 26-9). This will enable you to have about the same inductance when finished as at the start.

If the break is near the center of the coil, new wire should be used. The best procedure in this case is to remove all the wire, weigh it accurately, and purchase the same weight of the same size wire with the same kind of insulation as was used in the original coil.* Wind the choke full with this wire, insulating each layer from the next one as described, and the job is finished.

After rewinding, the coil should be tested for resistance, and possible grounds between itself and the core (see Art. 22-23). Complete rewinding of filter chokes is usually not worth while from a practical standpoint, unless it is for emergency purposes and the service man possesses equipment for winding such coils. It is a laborious and time-consuming job to unwind all the wire on a filter choke and rewind the coil properly with insulating paper between each layer.

26-8. Repair of Power Transformers.—The construction

*Note: For complete data on all sizes of wire employed for windings of filter chokes, transformers, etc., consult the Copper Wire Table (for Bare and Magnet wire) in the author's *Radio Troubleshooting Handbook*.

features of power transformers, as far as repair is concerned, are not very different from those of filter chokes (Arts. 22-20 and 26-7). The same general methods and considerations regarding insulation and rewinding may be applied to them. They are also removed from their containers by melting the sealing compound in the same way as explained in Art. 26-7 for filter chokes. However, there are two major types of trouble that can develop in a power transformer which cannot occur in a choke; for instance, one of the secondary windings may burn out or become shorted. If this happens, it is advisable to replace the entire transformer. However, if temporary or emergency repair must be made, the damaged winding may be repaired if the service man possesses sufficient skill to surmount the many mechanical difficulties which will present themselves in most cases. These difficulties depend upon the construction of the transformer and the location of the faulty winding. If the open- or short-circuited winding is near the top, where it is easily accessible, the rewinding may be easy; but, if it is located between several other windings, all the good windings over it may have to be removed to determine the number of turns, size wire, etc., on the faulty one. After this one is removed and rewound with the same number of turns of wire of exactly the same size and type as the faulty one was composed of, the other windings must be put back over it, observing all necessary precautions as to insulation (see Art. 26-9), etc. It is evident that this is no simple task, nor is it a job for an inexperienced service man. Usually in power transformers the primary is wound nearest to the core, then comes the static shield (if one is employed), over this is the high-voltage secondary, and over this are the low-voltage filament windings.

In some transformers the construction is such that there is some vacant space around one or more of the core legs, usually the ones facing the leg on which the main windings are placed. If such space is available, it is not necessary to remove any of the original windings of the transformer in order to replace a faulty low-voltage secondary winding with a new one. The procedure now to be described may be employed instead, after the transformer is removed from the receiver.

The first step is to ascertain how many turns of wire the

faulty winding contains. This may be determined without even inspecting the winding. Wind about 10 to 20 turns of thin enamel- or cotton-covered wire around whichever core leg has sufficient space around it to accommodate the replacement winding, carefully counting the turns as they are put on. The number of turns wound is not important, as long as the exact number is counted and recorded. However, enough turns should be wound so that when the primary winding is connected to the a-c electric light line, a voltage large enough to be read easily and accurately on a voltmeter will be developed in this temporary secondary coil.

Connect the terminals of the temporary winding to an a-c voltmeter and connect the primary winding of the transformer

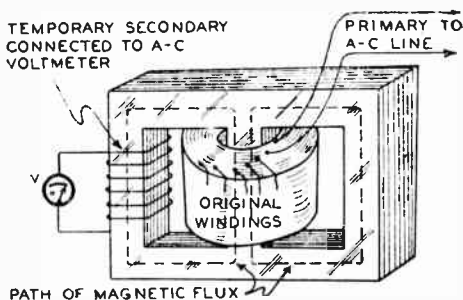

FIG. 26-5.—Method of determining the number of turns to wind on a power transformer for an extra winding to develop a definite specified voltage — without disturbing any of the original windings of the transformer.

to the a-c power supply line. Now carefully measure the voltage developed in the temporary winding. The connections are shown in Fig. 26-5. Let us assume (as shown) that the temporary winding has been wound on any one of the core legs other than the one on which the main windings are located. Let us suppose also that 20 turns of wire have been wound on, and that the total voltage induced in them has been found to be, say, 10 volts. Then $20/10 = 0.5$ volt-per-turn is induced in this winding, and 0.5 volts-per-turn will be induced in any other winding wound in the same place. Now, if the faulty low-voltage secondary winding to be replaced is, say, a 5-volt winding, the replacement winding should be wound with wire of the same diameter and type of insulation as the faulty one is composed of (this may be determined by an inspection of the end leads of the faulty winding) and should contain $5/0.5 = 10$ turns. The temporary

winding should be removed, and the new 10-turn winding should be wound in its place, being careful to insulate it thoroughly from the core (see Art. 26-9). This new winding may then be used in place of the faulty one. It is best to wind on a few turns more than the above consideration indicates (about 15 per cent more) for the voltage available at the terminals of the new winding when the receiver is in operation will be somewhat less than that obtained during this test, due to the effect of the load on the transformer. A turn or two can always be removed easily if the voltage is too high.

The elimination of hum caused by the vibration of loose laminations in the cores of filter chokes and power transformers has already been considered in Art. 22-24 in Chapter XXII. The reader is referred to this section for information on this subject.

26-9. Insulating Filter Choke and Transformer Windings.

—Whenever filter chokes or power transformers are repaired every precaution should be taken to provide proper insulation for the windings. The insulating materials generally used in these components are pressboard, paper, varnished cambric, cotton, etc., made especially for insulating purposes. The places at which each type of insulation is used depend upon the existing voltage differences, etc. For example, the insulation between the core and the innermost winding usually consists of layers of heavy paper, varnished cambric, pressboard, etc. After proper varnish impregnation, these materials are capable of withstanding the voltage stresses and the operating temperatures which exist, at this region, without deterioration. Care should be taken to insure that the wire insulation is not damaged in any way while winding the coils; the wires should not rest against any unprotected sharp edges of the laminations, etc.

Sufficient insulation must be inserted between the adjacent layers of each winding. This insulation can be a thin paper (such as the ordinary thin "glassine" paper employed for wrapping picnic lunches) because the voltage-per-layer which exists is much under 100 volts. Sufficient insulation must also be provided between the various windings. Since these places must have higher insulation strength, varnished paper, cotton tape, pressboard, etc., is employed.

For most satisfactory service, power transformer and filter choke coils should be impregnated. While the service man does not possess the equipment required for vacuum-impregnation, he can do a fairly good simple impregnating job by first driving off as much moisture as possible by baking the coils in an oven for several hours (left slightly open so the moisture can escape) at a temperature which will not damage the insulation. Then they should be impregnated with a good insulating varnish which should be allowed to soak into the insulation so that the coils will be completely protected.

26-10. Repair of Vacuum Tubes.—In general, it may be said that it is not possible to make any internal mechanical or electrical repairs to vacuum tubes as they are constructed at present. Rejuvenation of the cathodes of tubes can only be accomplished successfully with thoriated-filament type tubes, and, even then, under rather exacting conditions. Rejuvenation consists of applying excessive filament voltage for small periods of time until the active material in the filament comes to the surface. If this is done in oxide-coated tubes of either the "indirect-heater" or "filament" type, the electron-emitting coating will be ruined in a short time.

26-11. Repair of Paper-Wound and Mica Type Condensers.—Modern construction of mica type fixed condensers is such that the entire assembly is sealed into a bakelite case that is airtight and moisture-proof. This prevents any possibility of repair if an open- or short-circuit develops—which very seldom happens anyway. These units are also in the low-cost class, and any repair that may be effected is not warranted when considered from a standpoint of the time required for repair.

Single-unit paper-wound condensers present much the same problem. They are inexpensive, and their repair is hardly worth considering, especially since the most common trouble which develops in them is that of short-circuiting due to breakdown of the paper dielectric by the applied voltage. Since this causes holes to be punctured in the paper, repair is not practical. However, condenser blocks which contain several 1- or 2-mfd. condensers, or single 2- or 4-mfd. condenser units composed of several 1- or 2-mfd. condensers connected in parallel, may often

be repaired successfully and economically when only one of the condensers in the group has become damaged. Such repairs are made by first heating the entire assembly (see Fig. 26-4) slowly until the impregnating compound (pitch or paraffin) melts and can be poured out. Then the internal connections are located and both terminals of each condenser are disconnected. Each condenser is then given an open-circuit, short-circuit, leakage and ground test (see Art. 22-26 to Art. 22-32 for details). When the faulty condenser has been located, it should be removed, and a new one of the same capacity, physical size and voltage-rating should be substituted for it and connected permanently in place. All of the condensers should be insulated from the metal container by a lining of thin pressboard. The impregnating compound (preferably new compound) is then poured in around the condenser assembly until the can or other container is filled. To avoid internal cracks and voids caused by shrinkage, it is best to pour the compound back a bit at a time so as to make layers about 1 inch thick, allowing each layer to harden before the next is poured over it.

26-12. Repair of Electrolytic Condensers.—Electrolytic condensers cannot generally be repaired successfully. Certain types (especially the wet type) have the property of healing themselves after being punctured; but, unless the plates of the condensers are properly formed when healed, the heal will not be a permanent one. Electrolytic condensers make use of a film of oxide on the surface of the metal used for the anode. This film is exceedingly thin, and punctures easily when the rated voltage of the condenser is exceeded.

When such a condenser breaks down, the best procedure for attempting to repair it is to apply the smoothest d-c (of *less* than rated voltage) available, to the condenser for a few moments. The film will be re-formed at the point of puncture. The applied d-c voltage should then be raised slowly until rated voltage is reached. It is best to start re-forming with the highest voltage that the punctured condenser can stand without leaking through. Also, be certain that the final application of voltage is made with *rated* voltage; if the re-forming process is stopped before rated voltage is applied, the *capacity* of the condenser

will be *greater* than the rated value but the *voltage rating* will be *lower* than rated. It will then repuncture when placed in its normal circuit. This is so because in an electrolytic condenser *the capacity varies inversely as the forming voltage*. As the forming voltage is increased, the thickness of the dielectric increases, thereby reducing the capacity per unit area. However, the thicker dielectric is able to withstand higher operating voltage without breaking down. If this attempt to re-form the condenser is unsuccessful, it had better be discarded and replaced with a new one of similar capacity and voltage rating.

26-13. Repair of Variable Condensers.—So much improvement has been made in the design of variable condensers that the modern gang condenser is truly an instrument of precision and is likely to remain in good order. If a variable tuning condenser is not abused physically, the only troubles that are likely to occur are:

1. Wobbling or scraping of the rotor plates due to loose or worn bearings.
2. Noise due to a poor wiping contact to the rotor.
3. Noise due to "peeled" or dirty plates.

If one of the bearings of a variable air condenser becomes loose, it may be tightened properly. A special wrench is usually required for this purpose. When the bearing has been tightened, be sure that the rotor does not bind and can be moved freely. Also make certain that the rotor plates are centered between the stator plates and do not touch them.

If a bearing becomes worn greatly, the rotor will wobble, and the best procedure is to replace the condenser immediately. It may be possible to make a temporary repair, but the rotor will not turn smoothly for very long and will usually give trouble again after a short time. Modern condensers may be rotated many thousands of times before bearing trouble exists, so that this form of difficulty is usually encountered only occasionally.

A noisy condenser is one which generates noise in the receiver while it is being rotated. This noise is usually caused by dirty wiping contacts, and can be usually repaired by simply cleaning the contact with sand paper, cigarette lighter fluid, or alcohol, and bending them so as to make firm contact. As a matter of fact,

many cases of intermittent receiver operation due to oscillation of the r-f amplifier are caused directly by poor wiping contact at the rotor of the tuning condenser. The wiping contact may be located in the bearing itself, in which case it is often advisable to dismantle the condenser and clean the bearing to eliminate the noise if this does not take too long. On the other hand, the wiping contact may be made by means of a small end finger strip pressing against the far end of the condenser shaft. Cleaning the end of the shaft and the contact strip itself will usually eliminate the noise.

Instead of attempting to eliminate "tuning condenser noise" by cleaning the wiping contacts, the most effective expedient of all is to make a positive contact to the rotor by installing a pigtail connection between the rotor shaft and the frame of the

FIG. 26-6.—A variable tuning condenser showing the location of the spring pigtail to eliminate the possibility of bearing- or wiping-contact noise caused by poor rotor-shaft contact.

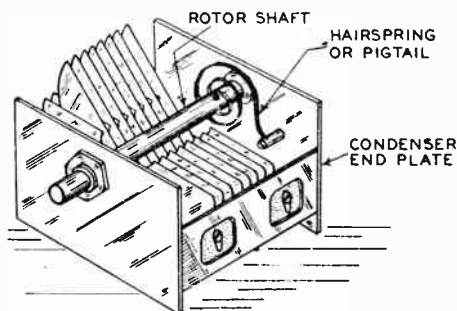

condenser. A short length of thin copper braiding or wire composed of a large number of small, annealed copper wires may be used for this purpose. This is installed by attaching one end of the pigtail to the rotor shaft while the condenser plates are unmeshed, and then winding up the pigtail by meshing the condenser plates, after which the other end is secured to the condenser frame or to the chassis. In some receivers employing gang condensers, oscillation can be stopped only by soldering such a separate pigtail lead to the condenser shaft at each section of the rotor.

Several makes of condensers are manufactured with these pigtails already installed. A small spiral spring, similar to the mainspring of a watch, encircles the rotor shaft and connects to it. The other end of the spring connects to the rear end plate

of the condenser frame. Under normal conditions, the spring is wound slightly so that it winds up full when the plates are fully meshed. This type of condenser cannot be rotated more than 180°. A sketch showing a spring arrangement of this kind is shown in Fig. 26-6.

The plates of many variable condensers "blister" or peel, after some use. Blisters often occur on the surface of the plates of die-cast condensers. Peeling occurs on condenser plates which have been plated. In other types, peeling occurs at the joints between the rotor plates and the shaft. The small peelings do not fall out, but cling to the sides of the plates and collect dust and dirt. The result is that the condenser becomes partially or totally short-circuited in many spots over the tuning range. This trouble usually manifests itself by loud crackling in the loud speaker at one or more definite condenser settings. A continuity test applied with a sensitive ohmmeter will also reveal this condition (see Art. 22-37).

The remedy is to clean every plate and the rotor shaft with a small brush or pipe-stem cleaner until as many particles as possible have been removed. Sections of the plates that look as if they will peel in a short time should be stripped of the loose surface immediately and smoothed off with the brush. Then the tuning coils should be disconnected from the stator terminals and a high voltage (500-700 volts), obtained from the full high-voltage secondary winding of an ordinary power transformer should be connected between the rotor and each stator section, in turn, while the condenser is rotated slowly to each extreme position. The circuit arrangement for this is illustrated in Fig. 26-7. The application of this high voltage burns away all projecting slivers of metal which might cause short-circuits. The test prods should be handled carefully, because of the high voltage. If the work is done with the condenser removed from the receiver, the condenser shaft may be turned by means of a knob placed on it, as shown. The knob will insulate the hand from the shaft.

26-14. Repair of Loud Speakers.—Loud speakers are among the few audio components that can be repaired successfully. In this respect, there are two types of speakers that must be considered; the *magnetic* and the *electro-dynamic* (commonly re-

ferred to as "dynamic"). The former is characterized by the use of a stationary permanent magnet, and a movable iron diaphragm, reed, or armature. The latter is identified by the use of a stationary electromagnet and a movable coil. Even this distinction is not complete, since dynamic loud speakers are also made with a stationary permanent magnet and a movable voice coil. Such speakers are aptly called *permanent-magnet dynamic speakers*, and will be considered as *dynamic speakers* in this book.*

Before discussing the various troubles which may occur in loud speakers, it is well to point out that in many cases where

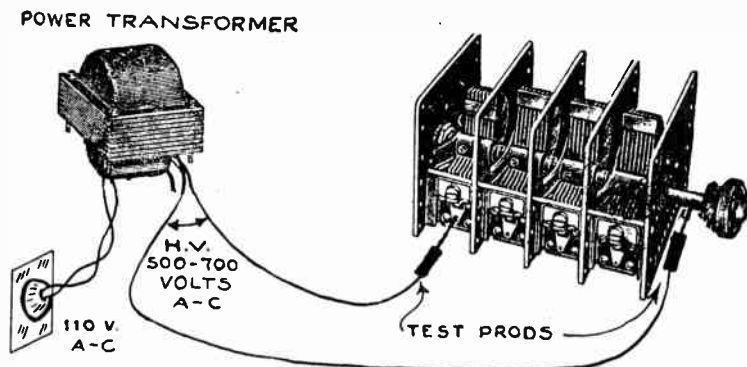

FIG. 26-7.—Circuit arrangement for burning out dust, or metal peelings, from the plates of a tuning condenser by using the high voltage from an ordinary radio receiver power transformer.

the loud speaker is suspected as a cause of trouble in a receiver, the trouble is really due to something in the receiver proper itself. For this reason, unless the trouble is one that can be traced definitely to the loud speaker at once, no tests or repairs should be made on it until it has been ascertained beyond a doubt that the receiver proper is in perfect operating condition.

A quick way to determine whether it is the loud speaker or the receiver proper that is faulty is to connect a "substitute" speaker in place of the regular speaker and then listen to the reproduction. If it is still unsatisfactory, the trouble undoubtedly

*Note: For a comprehensive discussion of the construction and theory of operation of all types of loud speakers in common use, the reader is referred to the *Radio Physics Course*, by Ghirardi.

lies in the receiver proper, if good reproduction is obtained with the substitute speaker, the regular speaker should be checked for the trouble. An excellent portable "multi-test" speaker designed especially for such substitution purposes is illustrated in Fig. 26-7A.

This speaker is provided with a universal output transformer so that it can be properly matched to all output tubes to give the minimum possible distortion. It also contains a universal voice-coil transformer which has taps that coincide with the values of all the common voice-coil impedances of dynamic speakers. This permits the easy checking of those radio receivers and amplifiers that have the output transformer built into the chassis, and enables checks to be made on output transformers under *actual* operating conditions.

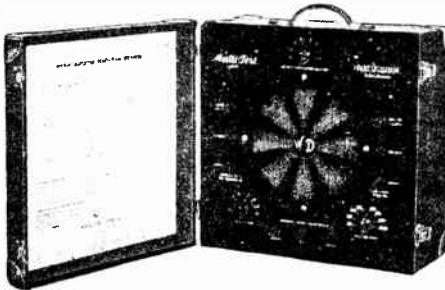

FIG. 26-7A.—A portable "universal test speaker" designed for substitution purposes. It will match all output tubes, all output transformers, and all field coil resistance values. (Model 3000.)

Courtesy Wright-De Coster Inc.

The field coil is also of the "universal type" with taps at resistance values agreeing with all the field resistances used in standard practice—even including a tap for use as a bias resistor in sets which have this feature. No "dummy" field resistance is used—all field resistance taps are taken off directly from the field coil so that the speaker can also be used to check the operation of the filter circuit. It is evident therefore, that this versatile speaker will match all tubes, all output transformers, and all field coil values.

Many of the troubles in loud speakers are of the "obscure" type (see Arts. 23-46, 23-47 and 23-48), that is, they are not revealed by the usual voltage, current, or resistance analysis of the receiver, but an experienced service man can spot them instantly by listening to the reproduction. Such troubles as a loose cone apex, improperly centered armature, scraping voice coil, broken spider, etc., cannot be detected by any electrical measuring instruments but they can be detected quickly by the ear.

26-15. Electrical Tests on Horn-Type Magnetic Speakers.
—Although the popularity of magnetic speakers has dwindled

greatly and they have not been employed in recent receivers to any extent, many thousands of them are still in use in old receivers. Service men are often called upon to service them. There are two general types of magnetic speakers used with radio receivers. The first is the type which employs a diaphragm and a horn; the second is the type which employs an iron

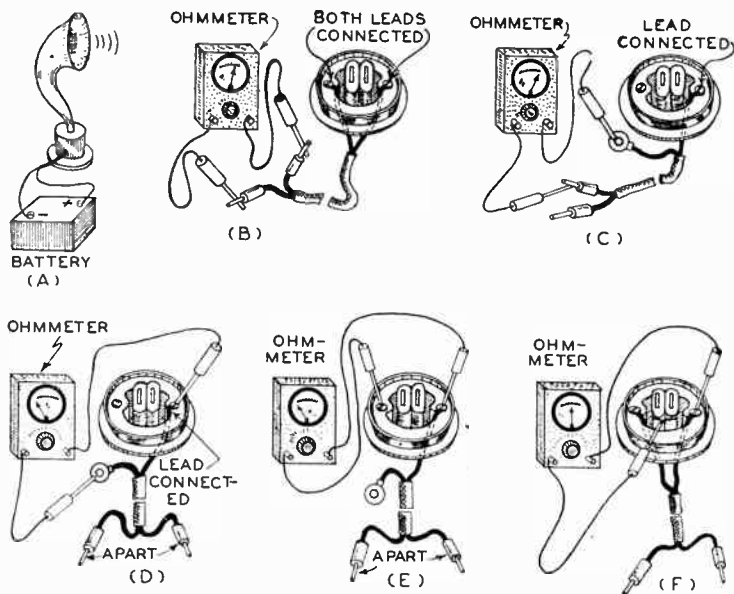

FIG. 26-8.—Various electrical tests which should be made on a magnetic loud speaker of either the *iron-diaphragm* or *balanced armature* type in order to locate electrical trouble in either the speaker cord or the coils. These tests are described in detail in the accompanying text.

reed or armature actuating a cone. Both types will be considered, separately, here.

Horn-type magnetic speakers are no longer in general use in radio receivers, and, where they are encountered with major troubles, it is usually best to replace them with one of the magnetic cone speakers which can now be obtained at low cost. However, the service man often encounters large horn-type speakers employing iron-diaphragm type units in public-address

systems of small size. At any rate, it is well to know how to test and repair this type of speaker if the occasion arises.

A quick test to determine if the speaker operates at all may be made by simply touching the cord tips of the speaker across some source of low voltage as shown at (A) of Fig. 26-8. A sharp "click" should be heard each time this is done, if the speaker operates. If only a slight click is heard, the winding may be open, for a small current can flow due to the capacity between the two parts of the winding (which consists of many turns of fine wire).

If the speaker does not operate at all, the trouble is most likely an electrical one in either the speaker cord or the coils.

The cord should be tested first. Test for continuity across the tips of the speaker cord, as shown at (B). A constant deflection of the ohmmeter needle should result if the speaker winding is good. Bend the loud speaker cord back and forth at the tips; if the meter reader varies, it indicates a faulty connection at the tips. The connection should either be resoldered or, better still, the entire cord should be replaced with a new one. If no reading is obtained on the first test, open the case of the unit and remove the diaphragm and washers. Then remove one lead of the cord from the speaker unit. The ohmmeter should indicate a complete circuit from one of the cord tips to one of the lugs at the speaker end of the cord, as shown at (C). Repeat this test from the second tip to the second lug.

With one lug still disconnected from the unit, test for continuity across both lugs at the speaker end of the cord as at (D), making sure that the tips on the other end of the speaker cord are not touching each other. No complete circuit should be indicated; if a complete circuit is indicated, it shows that the two cord leads are shorted inside the covering. With one speaker cord lug still disconnected from the unit, test both unit terminals for continuity, as

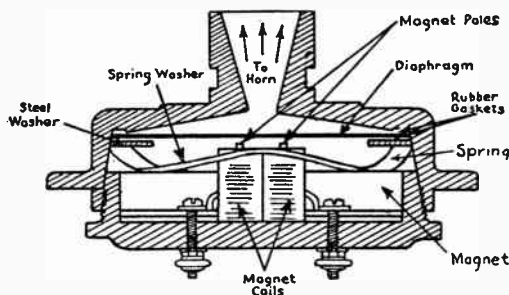
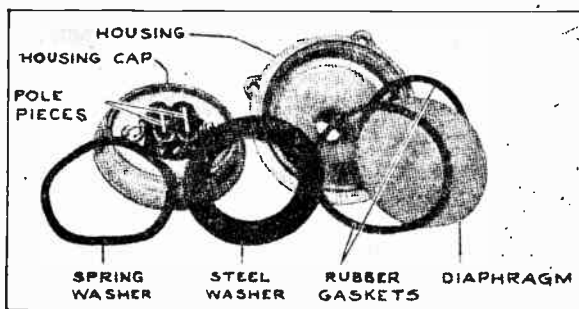

FIG. 26-9. — Cross-section view of a typical horn-type iron-diaphragm loud speaker unit, showing the relative arrangement of its parts. A disassembled unit of this kind is illustrated in Fig. 26-10.

shown at (E). An "open" indication obtained here points to an open circuit somewhere in one of the magnet coils, or possibly in the leads to the terminals on the unit. These leads should be inspected carefully, for the thin wire often breaks, or corrodes away at the soldered joint. A break here can easily be resoldered. If resoldering is necessary, be careful to scrape away the enamel insulation and use rosin-core solder *only*. Never use "acid" or soldering paste fluxes as they will corrode the fine wire. If the ohmmeter shows a continuous circuit when the coil test is made, but shows that the coil re-

sistance is extremely low, there is a "short" or "ground" within either or both of the coils. The next test will indicate which one is faulty.

As shown at (F), each winding should now be tested separately between its terminals, and between each terminal and the case of the unit. If a winding is found to have an internal short, open, or



Courtesy Atwater Kent Radio Co.

FIG. 26-10.—A typical iron-diaphragm type loud speaker unit disassembled to show its various parts.

ground, it should be replaced. Each winding should have approximately the same resistance.

This completes all the electrical tests that may be made on magnetic units. As we shall see in Art. 26-17, precisely the same electrical tests may be made on magnetic speakers of the balanced armature type. Any other troubles will be of a mechanical nature.

26-16. Repair of Horn-Type Magnetic Speakers.—As has already been explained, horn-type magnetic speakers should be repaired only when the troubles are of a minor nature or when the owner insists on such repairs being made. Major repairs involving the removal of one or both of the coil bobbins, etc., usually take considerable time and require skill and patience. The parts of such speakers are delicate and crowded close together.

Replacement with one of the balanced-armature cone type speakers which are now available at extremely low cost will usually be much less costly and give more satisfactory performance. However, if the faulty speaker must be repaired, the service man will have to do the work. A brief description of some of the mechanical service problems which may be encountered now follows.

A cross-section view of a typical horn speaker unit of the balanced-armature type is shown in Fig. 26-9. A speaker unit of this type with the parts disassembled is illustrated in Fig. 26-10. It consists, essentially, of a case, two magnet coils mounted over the pole pieces of a permanent magnet, and a diaphragm suspended

between rubber gaskets and a steel washer. The diaphragm is held in the upward position by a wavy spring washer, which is shown at the extreme left in Fig. 26-10. Of course, not all units are constructed exactly as shown here, but the illustration is typical of the majority of them, and the following service notes will, in general, hold for all types.

Iron filings or other foreign matter may collect on the pole pieces and cause rattling and low volume. The filings around the sides may be removed with a pocket knife by working outward and upward from between the pole pieces. Those filings on top of the pole pieces may be removed by simply wiping them off with a clean cloth. The thin varnish-like coating on the pole pieces is used to prevent the formation of rust. This coating often peels, so that it is necessary from time to time to remove the small flakes of it that collect on and about the pole pieces. Rubbing some light mineral oil on the pole pieces will assist in preventing the future formation of rust.

The spring which may loosen its tension and produce insufficient pressure against the diaphragm, causing rattling on high volume, may be replaced, or all of the bends may be heightened by hand to supply the desired pressure. It is important here to be certain that all bends have exactly the same height. A simple test is to place the spring on a flat table and place the diaphragm on top of it. A small level may then be placed on top of the diaphragm. The bends may then be adjusted for equal heights. It is wise to test the level of the table before bending the spring.

The rubber gaskets are used to damp the vibration of the diaphragm at its natural frequency. They may dry out and lose their elasticity after some use. This condition will manifest itself by rattling at some particular frequency, and by poor tone quality. The remedy, of course, is to replace the gaskets with new ones of live rubber, as they cannot be repaired.

The diaphragm may be bent, buckled or dented. If this occurs, it should be replaced. In many cases, the underside of the diaphragm has rusted, the rust clogging the small air gap between the diaphragm and the pole pieces. Unless the diaphragm is replaced in such cases, the rust spots should be cleaned thoroughly, and a coat of thin lacquer or varnish applied to protect the metal.

Weak magnets give rise to weak and "tinny" reproduction. While more elaborate tests may be made, service men usually test permanent magnets for strength by touching the magnet face or the pole pieces with a screw driver. A tenacious "pull" should be felt. Of course, experience teaches how much pull to expect for strong magnets and for weak magnets, since the size of the magnet should also be considered. If there is only a weak pull, or none at all, the permanent magnet is demagnetized and should be either replaced, or removed from the unit and re-magnetized by the method described in Art. 26-18.

26-17. Electrical Tests on Balanced-Armature Magnetic

Speakers.—The electrical tests to be made on balanced-armature type magnetic speaker units of either the cone or horn type are precisely the same as those outlined in Art. 26-15, and illustrated in Fig. 26-8, for iron-diaphragm type speakers. First the cords, and then the coils are tested for continuity, shorts, and grounds by means of an ohmmeter. Any electrical troubles revealed by these tests should be eliminated either by repair or replacement of the part in question. The service man should keep in mind what has already been said in Art. 26-15 about the advisability of making major repairs on these speakers.

26-18. Remagnetizing Permanent Magnets. — If the magnet test described in the last paragraph of Art. 26-16 reveals the

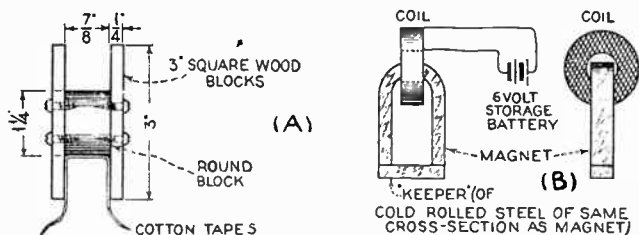

Courtesy Radio News Magazine

FIG. 26-11.—Construction details of a coil which may be used to remagnetize the permanent magnets of loud-speakers and phonograph pickups. The winding form for the coil is shown at (A). The method of magnetizing is shown at (B).

permanent magnet of a magnetic-type loudspeaker, or a phonograph pickup unit, to be weak, it should be remagnetized. Mag- neto and automobile ignition service stations are equipped to remagnetize permanent magnets quickly and at small cost. How- ever, if the service man desires to do this work himself, the simple arrangement of Fig. 26-11 may be employed.

The magnetizing coil should be constructed first. A form on which the coil is to be wound must be made. The details of this form are shown in (A) of the figure. Note that the sides of the form are attached to the core of round wood by means of wood screws; this is quite essential, as the form is to be taken apart after the coil is wound. After the form is made, two layers of wrapping paper are wound over the core; then

several strips of cotton tape are placed in the trough of the form, at intervals around it, as shown at (A), and spot-glued to the sides with a little mucilage to keep them in place while winding the coil. Now wind 196 turns of No. 16 d.c.c. wire in 14 layers of 14 turns per layer; this requires one pound of wire. After winding, the cotton tape is bent over the top of the coil to hold the turns in place. The end pieces of the form are then removed and the core slipped from the center of the coil. If desired, additional tape may be wound over the coil to hold the turns of wire in place, although impregnating the coil with paraffin or pitch will help it to withstand rough usage.

The magnet to be remagnetized is then slipped through the opening in the coil and a "keeper" of cold-rolled steel is placed across the terminals, as shown at (B). The coil terminals are then connected to a 6-volt storage battery for a few moments (the magnetizing process is *almost instantaneous*). The drain on the battery is about 12 amperes, which is well within the limits of an ordinary battery used for automobile starting. The battery should be well charged! The magnet should be struck a few sharp blows with a small hammer while the current is turned on. This will aid the molecules to rearrange themselves to produce the magnetized condition. The coil is then disconnected, removed from the magnet, and the job is finished. This magnetizing coil is adequate to saturate all types of small permanent magnets including those of earphones, magnetic speakers, phonograph pickups, etc. The coil may be placed at any position on either leg of the magnet if necessary; it is not essential that it be placed at the bend as shown at (B). Permanent magnets should never be allowed to lie around unless a soft iron keeper (which may be an ordinary large iron nail) is placed across the poles.

26-19. Repair of Balanced-Armature Type Magnetic Speakers.—Figure 26-12 shows a cut-away view revealing the construction details of the typical form of motor unit employed in magnetic speakers of the *balanced-armature* type. The permanent magnet and its pole pieces have been omitted purposely as they would make it impossible to see the coils and the armature. These parts may be seen in the illustration at the right of

Fig. 26-13. Two magnet coils containing many turns of fine enamel-covered wire are wound over an armature which is pivoted between the pole pieces of a horseshoe-shaped permanent magnet, as shown in Figs. 26-12 and 26-13. The armature connects to the thrust lever (Fig. 26-12) through a drive pin, and the thrust lever actuates the cone of the speaker through the driving rod.

The trouble symptoms that may arise in balanced-armature type magnetic cone speakers are weak reproduction, no reproduction, distortion, noise and rattle. There are a number of causes for these symptoms, and each cause may give rise to more than one symptom. For this reason, the troubles will be listed and considered according to their causes and remedies. A summary of the common symptoms of trouble which develop in balanced-armature type cone speakers, and their causes follows:

1. No operation:
 - (a) open cord
 - (b) faulty tip terminal joints
 - (c) open coil
 - (d) open coil leads to terminals
2. Weak operation:
 - (a) weak magnet
 - (b) shorted coil (partial or complete)
 - (c) grounded coil
3. Noisy operation:
 - (a) frayed cord
 - (b) internal defect in cord
 - (c) poor joints at cord tips
4. Distortion or rattle:
 - (a) armature striking pole pieces
 - (b) sticking armature
 - (c) foreign matter interfering with armature action
 - (d) torn or otherwise damaged cone
 - (e) improperly seated cone
 - (f) loose thrust lever
 - (g) bent drive pin
 - (h) loose or bent drive rod

The first three trouble symptoms have already been considered in Arts. 26-15, 26-16 and 26-18. The troubles which may cause the last one, and the remedies for them will now be considered.

26-20. Recentring the Armature of a Balanced-Armature Speaker Unit.—If the armature is not centered correctly between the pole pieces, a very disagreeable rattle and distortion may result on loud notes. The space between the armature and

each pole piece is different in different makes of speakers, but the average is about 0.1-inch. If the armature is misaligned, it may be realigned by the following method. Two similar spacer tools are required, and may be made up by the service man. They are simply pieces of non-magnetic sheet metal cut to the proper size and shape and of the proper thickness to be inserted between the armature and the pole pieces. A sketch of a typical spacer tool is shown at the left of Fig. 26-13. It consists, essen-

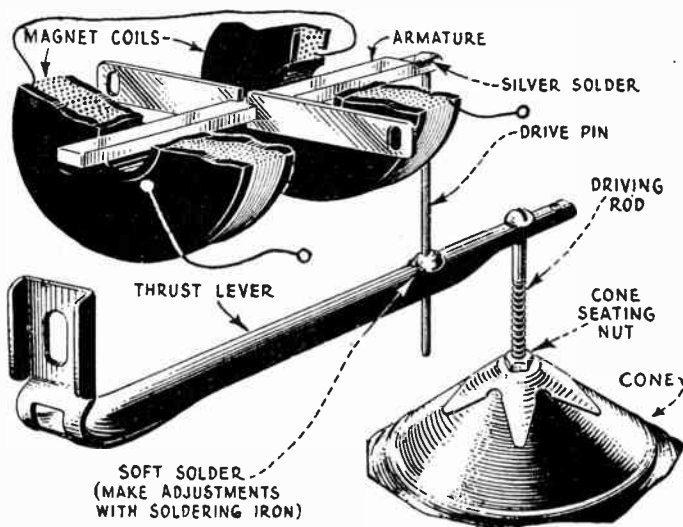

FIG. 26-12.—Cut-away view showing the essential components in the motor of a typical balanced-armature type loud speaker unit. The permanent magnet and pole pieces have been omitted for clarity.

tially, of a strip of phosphor bronze or brass having a thickness equal to the spacing between the armature and pole pieces and about $\frac{1}{4}$ -inch wide and 6 inches long, bent into the form shown. The ends should be tapered to a width of $\frac{1}{8}$ -inch.

Two of these tools are necessary when adjusting the armature. Insert the prongs of one tool in the spaces between the armature and pole pieces at one end of the unit, as shown at the right of Fig. 26-13. The other tool should be placed in similar position at the other end of the armature—a little to one side in the case in order to clear the drive pin which is located at this end. By loosening screws (A) and (B), any tension in either direction that may have been on the armature is released, and the spacer tools will provide the correct clear-

ance or spacing. Now while the spacer tools are in place, a hot soldering iron is applied to the drive pin—thrust lever connection point (see Fig. 26-12), and the solder is heated sufficiently to allow the drive pin to find its normal position with regard to the thrust lever. (Since the solder used at this joint has a low-melting point very little heat is necessary.) The iron is now removed. Screws (A) and (B) are now tightened and the spacer tools are removed.

The armature is now correctly aligned and balanced so that no abnormal strain is being imposed upon it in any direction, and it is correctly centered between the pole pieces so rattling should not occur on normal signal volume.

26-21. Freeing a Sticking Armature.—Very often the armature of a balanced armature speaker is found to be sticking

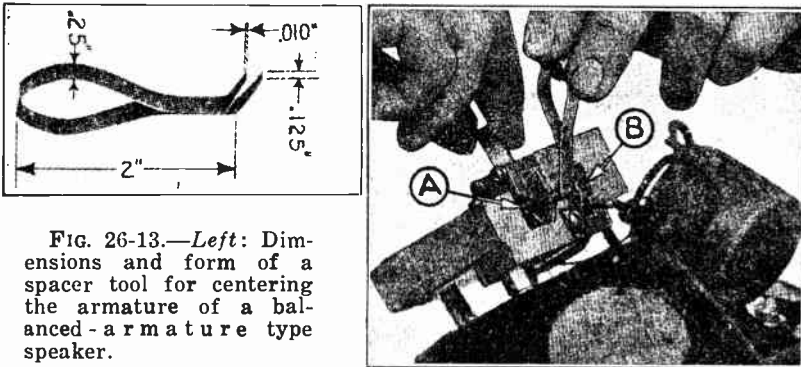

FIG. 26-13.—Left: Dimensions and form of a spacer tool for centering the armature of a balanced-armature type speaker.

Right: How the tips of the spacer tools are inserted (one at each end of the armature) so that the armature is held in a centered position between the pole pieces.

Courtesy R.C.A. Victor

(by magnetic attraction) to the face of one of the pole pieces at either end. The repair in such instances is the same as for the incorrectly centered condition of Art. 26-20. The assembly must be loosened and the armature spaced properly with spacers. Be certain that all screws are tight, as a sticking armature may be caused by one or more of the tension screws working loose because of vibration and allowing the armature to sag to one side.

26-22. Removing Foreign Material from the Air Gap. — Foreign matter lodged between the armature and pole pieces is a frequent cause of trouble. This interferes with the movement of the armature, resulting in poor reproduction. A visual in-

spection will reveal this condition. This foreign matter may consist of dirt and dust, small pieces of iron filings and peelings from the coating on the armature. The armatures of loud speakers are usually given a protective coating to prevent the formation of rust. In time, especially if the motor temperature becomes high, this coating has a tendency to peel, and the small flakes lodge between the armature and the pole pieces. This is the equivalent of reducing the armature spacing, with the result that the armature motion is reduced and the output is weakened and distorted. This foreign matter is best removed by working small strips of heavy paper or strips of thin copper or brass back and forth between the armature and pole pieces. Every time the paper or metal is removed, clean it off before reinserting. The spacer tools already described may also be used for this purpose. In many instances, recentering of the armature is necessary after cleaning. It is also a good idea to rub some light mineral oil over the armature to prevent the formation of rust after peeling has occurred.

26-23. Repairing the Cones of Magnetic Speakers.—Very often, the paper cone is damaged sufficiently to cause distortion or paper rattle, but not enough to make its replacement necessary. Small holes or tears in the paper may be repaired by cementing a small piece of paper over them, using Du Pont Household Cement, rubber cement, etc. Opened seams may be repaired by coating both surfaces with cement and holding them tightly together until the cement sets.

If a cone has lost its "body" or stiffness at the apex, Dupont Household Cement, or a collodion solution (which may be purchased at any drug store) should be soaked into it and allowed to harden. This will stiffen the paper and make it as good as new.

26-24. Replacing and Seating Cones.—An improperly seated cone will cause a strain to be put on the driving rod, resulting in poor reproduction. This is very likely to occur when replacing a cone. If a cone is to be replaced, extreme care should be exercised in its removal and in the installation of the new one. The screw or nut in the apex of the cone should be removed carefully, after first removing any sealing wax which

may have been used to prevent it from loosening. The screws fastening the edge of the cone should be removed next.

If the speaker has a nut on the side of the cone near the thrust lever, it should be loosened (the nut screwed back) and the new cone seated. The nut or screw and washer on the outside of the driving rod should then be attached loosely. The holes at the edge of the cone should now be lined up with those of the metal frame, the outside ring put in place with the screws, and tightened one at a time (and a little at a time) to be sure that the entire periphery of the cone has the same tension. The back nut on the driving rod (if there is one) should then be screwed up until it just meets the apex of the cone. The front nut or screw is then tightened and a bit of sealing wax is placed over it to prevent the vibration from loosening it, for, if it loosens, considerable buzzing and rattling will result.

26-25. Tightening the Thrust Lever and Driving Rod.—

Rattling and noisy reception are often caused by a loose thrust lever, see Fig. 26-12. The remedy for this is simply to tighten the screw that holds it to the motor assembly. Any loose screw or nut will cause an audible rattle when the speaker operates. Be certain that all parts are thoroughly secure, that all screws and nuts are tight, and that the cone is properly seated. A cone that is not properly seated may cause the drive pin to bend and displace the armature. It is best, therefore, to inspect the entire assembly before actually beginning to center the armature, if it appears to be displaced from its center position.

The drive pin is soldered to the iron armature with (hard) silver solder (see Fig. 26-12). Do not use the ordinary tin-lead alloy (soft) solder when this connection must be resoldered, as it is too weak mechanically. Silver solder may be procured in any jewelry store, and must be applied with a flame of high temperature. A special small blow torch is usually used for this work.

26-26. Dynamic Loud Speakers.—By far the most commonly used type of loud speaker, and the type which the service man is called upon to service most frequently, is the *dynamic* or moving coil speaker. In this type, the magnetic excitation of the field is secured usually by the use of an *electromagnet*

instead of a permanent magnet, and motion is secured by the interaction of this magnetic field and that of the *voice coil* through which the audio signal currents flow. The internal arrangement of the various parts of a typical dynamic speaker are shown in Fig. 26-13. Common trouble symptoms which develop in this type of speaker are:

1. Weak, or no reproduction
2. Rattling
3. Chattering
4. Harshness
5. Fuzzy reproduction
6. Hum

These troubles and their remedies will now be considered in detail. The first thing to do in any case is to make electrical tests on all the electrical parts of the speaker, especially if *weak* or *no reproduction* is obtained.

26-27. Electrical Tests on Dynamic Speaker Cable.—If it is definitely established that the loud speaker is faulty, the wires of the speaker cable should be tested first, for continuity and short circuits (see Art. 26-15). (For an explanation of the standard RMA Color Codes for dynamic loudspeaker cables, see the RMA Standard Color Code section in the author's *Radio Trouble-Shooter's Handbook*). The cable will contain two wires leading to the field coil (three wires if the field is tapped) and two or three wire leading to the primary of the output transformer (depending upon whether single, or push-pull output tubes are employed). Continuity and resistance tests must be made across paired leads, i.e., across the two or three leads going to the field coil, across the leads going to the output transformer primary, etc. If the cable leads are found to be in good condition, it is fairly certain that the trouble lies somewhere in the speaker itself.

26-28. Trouble in the Dynamic Speaker Field Coil.—If the speaker cable tests O.K. and it has been definitely decided that the trouble lies in the speaker, the field winding should be tested for continuity and grounds at once. If it is found to be open, it should be replaced or rewound. When a replacement cannot be made, the amount of wire to be rewound may be

determined as follows: Remove the faulty coil intact from the core of the unit and strip all tape and other binders from it, only the actual wire coil should be left. The size of wire employed may now be determined with a wire gauge and the type of insulation noted. The field coil is then weighed. Purchase the same weight and size of wire with the same type of insulation, and rewind the coil. A winding form should be made for this purpose, and removed after the coil is completed. The details of the winding form are somewhat the same as for the magnetizing coil form illustrated at (A) of Fig. 26-11.

If the continuity test indicates that the field has a definite value of resistance, this value should be checked with information (usually available in Service Manuals) for the particular receiver and speaker in question. If the resistance is over 10 per cent less than the rated value, it is possible that a partial short-circuit exists in it. In this case, the coil should also be rewound or replaced. A resistance reading much higher than the rated resistance indicates a high-resistance contact at a soldered connection.

If the field coil tests satisfactory, turn the set on and hold a screw driver as near to the pole piece as possible (how near the screw driver can be placed depends upon the design of the speaker). The screw driver should be attracted strongly to it. If it is not, the current flowing through the field coil is less than normal. The next step depends upon the arrangement employed for obtaining the field current. If the speaker field is employed

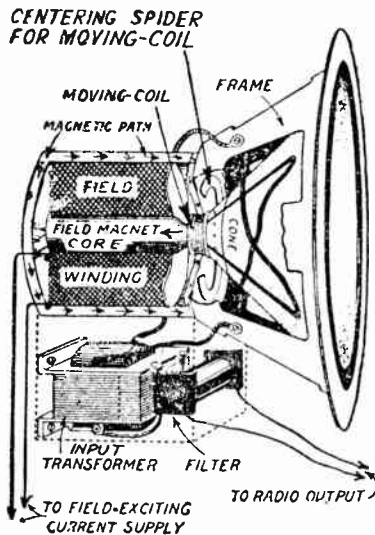

FIG. 26-13.—A cross-section view of a typical dynamic speaker with the field shown cut open to illustrate the arrangement of the field coil, field core, moving coil, cone and frame. The input transformer and high note filter (if one is used) are shown at the bottom.

as a choke in the *B* filter system of the receiver, it is possible that one or more of the filter condensers are leaky, placing an additional load on the rectifier, and robbing the speaker field of some of its energizing current. Of course, such condensers should be replaced. If the speaker contains its own rectifier of the dry-disc or vacuum-tube type, it is possible that this rectifier needs replacement, or the filter condenser (if one is used) across it is leaky and should be replaced.

26-29. Troubles in Dry-Disc Rectifier Type Field Supply Arrangements.—In order to trace trouble in the field coil circuits of dynamic speakers, it is important to be familiar with the various common field supply arrangements which are employed,

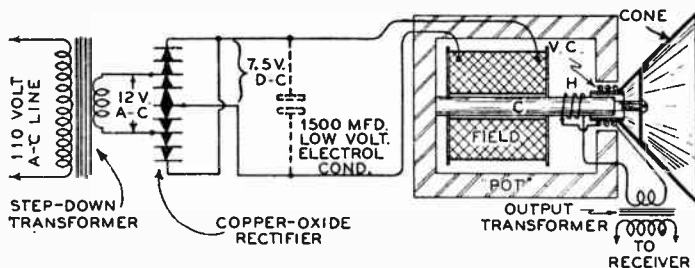

FIG. 26-14.—One arrangement for supplying low-voltage rectified current from the 110-volt a-c line for energizing the field of a dynamic speaker. A step-down transformer and low-voltage type copper-oxide rectifier are used. A "hum-bucking" coil *H* reduces the line hum.

for some troubles are traceable directly to this portion of the speaker or receiver.

In the earlier types of a-c dynamic speakers employed in radio receivers, the d-c field current is obtained from the 110-volt a-c line by feeding the a-c to a step-down transformer whose low-voltage secondary is connected to a copper-oxide full-wave rectifier which changes the a-c to full-wave rectified d-c. This d-c is fed to the speaker field, which in this case is a low-voltage type field composed of fairly thick wire. This arrangement is shown in Fig. 26-14. In some cases, the current is smoothed by a low-voltage type dry electrolytic condenser of about 1,500 mfd. capacity connected directly across the rectifier output as shown by the dotted lines. The hum-bucking coil

which is shown in place on this speaker will be explained later.

In some a-c dynamic speakers the circuit arrangement shown in Fig. 26-15 is employed for obtaining field current. A field coil requiring slightly less than 110 volts d-c for its operation is employed. This energizing voltage is supplied by a pair of 110-volt dry-disc rectifiers suitably connected to form a full-wave rectifier arrangement, as shown.

When these dry-disc rectifiers have completed their useful life, the current through them diminishes and the units must be replaced in order to secure the proper and original speaker field current and magnetic strength. A certain amount of hum is always present in these speakers, but faulty rectifier "stacks" will cause an abnormal amount of hum to be heard. Breaking

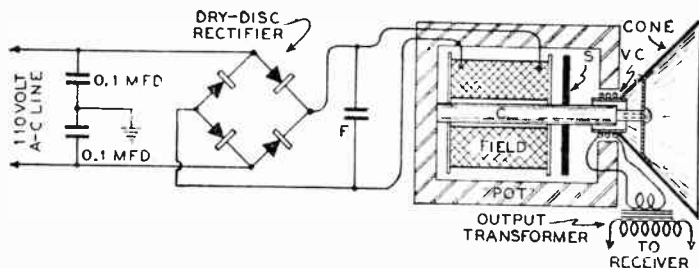

FIG. 26-15.—A high-voltage type dry-disc rectifier arrangement for rectifying the a-c voltage from the line so that d-c may be supplied to the speaker field. A "shading" ring *S* is used to prevent line hum.

down of the rectifier in the speaker of Fig. 26-14 will overload the step-down transformer—which may eventually cause either the primary or secondary winding to burn out. In the speakers employing 110-volt dry-disc rectifiers (Fig. 26-15) partial short-circuiting of the rectifier discs will often cause the line fuse to blow. In this type of speaker, the condition of the rectifier stacks may be checked by measuring the d-c resistance of each section with an ohmmeter (with the line and field disconnected), or by measuring the d-c voltage output of the rectifiers with the field coil disconnected. The latter test should give a reading of approximately 105 to 120 volts; this reading dropping to some value between 90 and 100 volts as soon as the field is reconnected (since it puts a load on the rectifier).

26-30. Troubles in V.T. Rectifier Type Field Supply Arrangements.—In some dynamic speakers, a self-contained vacuum tube rectifier arrangement is employed to change the 110-volt a-c line current to d-c current for the field coil supply. This arrangement, shown in Fig. 26-16, consists of a power transformer feeding into a full wave rectifier tube in the usual manner. The output current of the rectifier is filtered by the filter condenser, *F*, and the inductance of the speaker field winding through which it flows. Of course, when the rectifier tube has served its useful life, its output will diminish. This will cause the speaker field strength to diminish, with resulting weak and distorted reproduction. Obviously, the remedy lies in replacing the rectifier tube.

26-31. Troubles when Speaker Field is Employed as Filter Choke.—The most commonly found dynamic speaker field arrangement is that in which the power required for energizing the speaker field is taken from the *B* supply system of the receiver. Economy is secured by this arrangement, for the speaker field also acts as a very effective choke in the *B*-filter

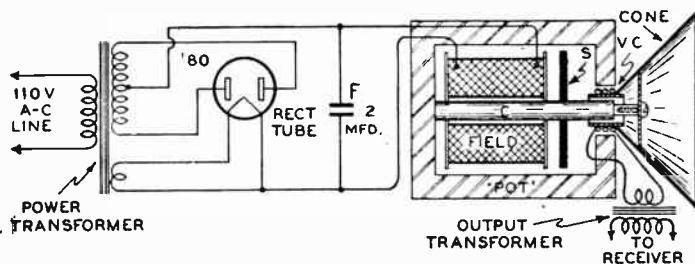

FIG. 26-16.—Here a power transformer and full-wave vacuum tube rectifier operating from the 110-volt a-c line are used to change the a-c to d-c for the field coil of the dynamic speaker. A shading ring *S* prevents line hum.

system. Two arrangements of this kind are illustrated in Fig. 26-17. At (*A*), the speaker field is connected in one leg of the *B* supply circuit, so that the total *B* current flows through it. At (*B*), a tapped field is employed, and it is connected in the *B*-return side of the filter system (see also, Figs. 20-9 and 20-10 in Chapter XX) so that it serves both as a choke and as a source

of grid-bias voltage for the output tubes in the receiver. The strength of magnetization of the speaker field in both cases depends upon the load current flowing through it. It is evident that in these two arrangements, the speaker field current will be affected by almost any abnormal receiver circuit condition which tends to affect the total *B* current. Among these may be men-

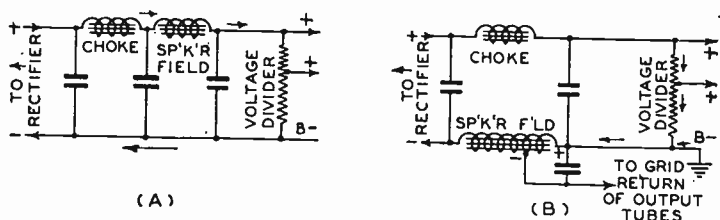

FIG. 26-17.—Two circuit arrangements which are employed in radio receivers for energizing the dynamic speaker field with current from the *B* power supply unit. At (A) the speaker field acts simply as a choke; at (B) the speaker field is tapped so that it not only acts as a choke but also supplies the negative grid bias for the output stage of the receiver.

tioned, leaky or broken-down filter condensers, a weak rectifier tube, weak amplifier tubes in the receiver, leaky plate or screen by-pass condensers in the receiver, etc.

In receivers designed for 110-volt d-c operation, the field of the dynamic speaker usually obtains its current direct from the line.

26-32. How Hum Originates in Dynamic Speakers.—

Whenever objectionable hum which has definitely been traced to the dynamic speaker is observed, it is caused either by a poorly filtered field current or by a faulty hum-bucking coil.

Whether the fault lies in the speaker, or in the receiver circuit proper, can be determined easily by removing the output tube (or tubes) from the receiver while the receiver is turned on, so that no signal is fed to the voice coil. If the hum disappears, or greatly diminishes, it is caused by some trouble in the receiver (see Arts. 23-18, 23-19 and 23-20). If the hum persists when this is done, it must be originating from the field portion of the speaker.

The field coil is excited by a supposedly-smooth d-c current which is obtained from a filter system. The various common

field-supply arrangements employed in receivers were discussed in Arts. 26-28 to 26-31 inclusive, and are illustrated in Figs. 26-14, 26-15, 26-16 and 26-17. As absolutely perfect filtering is not provided (for reasons of filter economy), the field current is never exactly smooth but contains ripples or variations of either half or the same frequency as that of the power supply, depending upon the type of rectifier system employed. Unless the speaker is provided with special features to greatly reduce the effect of these slight variations in the field current and field magnetism, the resulting variations in the magnetic field react on the voice coil, inducing voltages and currents of the same frequency in its circuit. This causes motion of the coil, at this same frequency, and hence causes a low-frequency (either 60 or 120-cycle) hum to be produced by the speaker. This hum may be drowned out when a musical program is being received, but it may be extremely annoying when receiving weak stations, speech, or in the lull between station announcements.

26-33. Hum-Elimination Provisions in Dynamic Speakers.

—In many dynamic speakers, a hum-reducing arrangement is already built into the speaker. These hum reducers are of two types, one is an arrangement which *bucks out* the hum voltage induced in the voice coil, the other *prevents it* from being induced there. The hum-bucking arrangement is illustrated in the speaker of Fig. 26-14. A flat *hum-bucking* coil, *H*, consisting of several turns of wire is placed in a space provided for it, usually at the end of the field coil. Naturally, a hum voltage, similar to that induced in the voice coil, will be induced in this hum-bucking coil. The design of the coil and its position in the speaker are carefully arranged to make the hum voltage induced in it exactly equal to that induced in the voice coil. Therefore, by connecting it in series with the voice coil circuit, as shown, so that the instantaneous hum voltage polarities of the two coils buck each other, the two hum voltages will cancel each other, and no hum current will flow in the voice coil circuit. Hence no hum is produced. However, there is no effect on the signal audio-frequency currents. This arrangement effectively minimizes the hum.

The other hum-prevention arrangement consists of a thick-

copper disc, S, placed between the voice coil and the field coil as shown in the speakers of Figs. 26-15 and 26-16. This acts as a single-turn coil of extremely low resistance in which strong "eddy currents" are induced by any fluctuations of the field magnetism. These eddy currents react on the main field, tending to oppose and suppress any such fluctuations, thereby preventing them from existing and preventing them from inducing any hum voltage in the voice coil. This disc is often called the *shading ring*. This very simple arrangement is widely used, and is very effective.

26-34. Eliminating Excessive Hum in Dynamic Speakers.

—Speakers in which the shading ring is used are not subject to as much hum trouble as those in which the hum-bucking coil arrangement is employed. The hum-bucking coil, or the connecting leads to it, may open, short-circuit, or ground. If the hum-bucking coil circuit opens, the entire voice coil circuit becomes open (since they are in series with each other) and the receiver becomes inoperative. If it short-circuits, its bucking effect ceases, and a very noticeable hum results, especially when the receiver is turned on but no program is being received. When a program is being received, the output will also be somewhat distorted because of the resulting mismatching between the impedance of the output transformer secondary and that of the voice coil plus the hum-bucking coil.

If the hum-bucking coil grounds to the speaker core or frame in any way, it may or may not cause trouble, depending upon whether the voice coil circuit of the speaker is already grounded to the speaker frame. In some receivers (as in the Atwater Kent sets) the voice coil is purposely grounded to the speaker housing. Naturally, if the hum-bucking coil in such speakers grounds, it may result in objectionable hum (if part or all of this coil is thereby shorted and made ineffective), or it may result in shorting the voice coil circuit, thereby making the set inoperative. What happens in any particular case depends upon which end of the hum-bucking coil grounds and which end of the voice coil is already grounded.

Tests for grounds, open-circuits, or short-circuits in the hum-bucking coil can be made very easily by means of an ohmmeter.

Occasionally, hum is caused in a dynamic speaker by the induction of hum currents into the windings of the output transformer which is mounted directly on the speaker frame. This trouble is rare, for speaker manufacturers are careful to mount the output transformers where stray fields from the speaker will not affect them. However, it is mentioned here because it is usually overlooked as a possible source of speaker hum.

Although most dynamic speakers in recent models of receivers have some effective hum-reducing arrangement incorporated in them, the service man is often called upon to service some of the

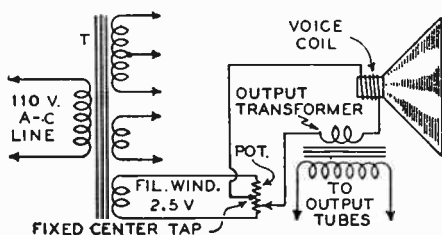

FIG. 26-18. — How a "hum-bucking" potentiometer can be installed to introduce a hum-bucking voltage into the voice coil circuit of an old dynamic speaker not equipped with any hum reducing arrangement. *T* is the power transformer already in the receiver.

early electric receivers in which no such provisions for hum reduction were incorporated. These receivers are notorious for their objectionable hum. While it is not practical to install hum-bucking windings or shading rings in them, because of lack of space, etc., a simple external arrangement can be applied for accomplishing this result. This is illustrated in Fig. 26-18. A potentiometer having a resistance of approximately 20 ohms is connected across one of the low-voltage filament windings of the power transformer, *T*, in the receiver; a $2\frac{1}{2}$ -volt winding is satisfactory. Either one of the leads which connect the voice coil to the secondary of the output transformer is now disconnected at the voice coil terminal. This lead is then connected to a fixed tap made to the center of the resistance element of the potentiometer. This tap should be made in a way which does not interfere with the movement of the contact arm past it. The contact arm terminal of the potentiometer is then connected to the open terminal of the voice coil. By means of this arrangement, a small a-c voltage from the filament winding is fed in series with the voice coil circuit in a phase opposite to the

hum voltage being induced in it by the speaker field. By moving the arm of the potentiometer to either side of the center tap, the proper phase relation for bucking may be secured; by adjusting its setting on the side at which proper bucking is obtained, the exact amount of bucking voltage necessary to balance out the hum voltage in the voice coil can be secured.

Incidentally, this same arrangement can often be employed for bucking out hum voltages induced in other parts of radio receivers. In such cases, it is usually necessary to employ a filament winding which is not being used in the receiver, so that the circuit conditions will not be disturbed. If a spare winding is not available, a small filament-heating transformer, or even a small bell-ringing transformer, may be employed to supply the hum-bucking voltage.

26-35. Electrical Troubles in Voice Coils and Output Transformers.—If the electrical tests already described indicate that the field coil and the hum-bucking coil (if one is used) are not faulty, the voice coil and output transformer should be tested next. In most dynamic speakers, the output transformer is mounted directly on the speaker frame. The voice coil should be disconnected from the output transformer secondary before testing. Then the voice coil and the output transformer secondary winding should be tested separately with an ohmmeter for continuity. The voice coil may be open internally, or at the flexible leads. Remember that if a hum-bucking coil is employed, its continuity must also be checked, since it is in series with the voice coil.

If the continuity of the voice coil checks satisfactorily, it should be tested for possible short-circuits between its turns, or between its ends (especially if they cross over each other), by measuring its resistance with the low-resistance range of an ohmmeter. The resistance reading obtained will be very low, and it should be compared with the normal resistance specified on the manufacturer's data sheet for the receiver. In the case of a speaker employing a single-turn voice coil, the resistance is so low that it cannot be measured reliably with an ohmmeter. Careful visual inspection must be resorted to in order to locate "shorts" which may occur between the ends of such windings.

Both the voice coil and the output transformer secondary should now be tested for grounds to the frame. Keep in mind that some voice coil circuits are purposely grounded (as in Atwater Kent receivers, etc.). It is well to carefully move the speaker cone in and out with the fingers while the voice coil is being tested for grounds, since a ground may occur only at certain positions of the cone due to rubbing of the voice coil against the pole piece. The repair of faulty voice coils will be considered in Art. 26-39. This completes all of the electrical tests which may be made on dynamic speakers. Any other troubles will be of a mechanical nature. In fact, the majority of troubles which arise in dynamic speakers really are mechanical troubles occurring in the cone, voice coil, or spider.

26-36. Cone, Voice Coil and Spider Troubles.—The cone, *C*, is fastened at its outside edge to a flexible leather or cloth

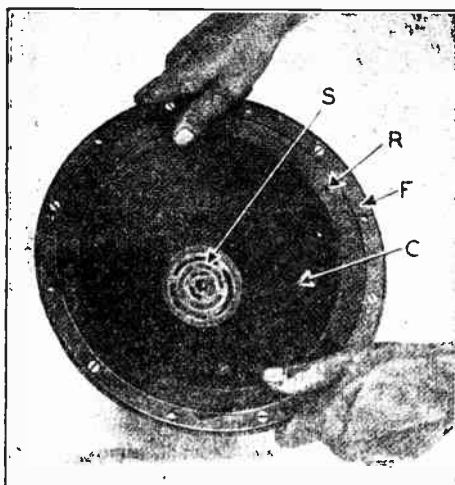

Courtesy Atwater Kent

FIG. 26-19.—Correct method of holding the speaker frame and cone to determine if the voice coil scrapes against the pole pieces. The cone is gently moved straight in and out with the thumbs of both hands. If a dull scraping sound is heard when this is done, it indicates that the voice coil is not properly centered and is rubbing against the metal pole piece. The main parts of the cone assembly are labeled.

ring, *R*, which in turn is clamped to the speaker frame, *F*, as shown in Fig. 26-19. At its apex, the cone is cemented to the circular voice-coil form. This form and the voice coil wound on it, travel back and forth in the small annular air gap surrounding the round pole-piece of the field. In most cases, the cone is kept aligned to the exact center position by a flexible

spider support which is fastened to it either at the inside of its small end (later speakers) or around the outside of the outer end of the voice coil form (older speakers). The spider permits more or less unrestricted straight-line movement of the voice coil along the axis of the main pole-piece.

The common causes which are responsible for most dynamic speaker mechanical troubles are:

1. The voice coil may be off center and rubbing against the sides of the pole pieces.
2. The voice coil form may be warped out of round, resulting in its rubbing against the pole pieces.
3. The voice coil wires may be loose from the coil form and scraping against the outer pole piece.
4. The cone or spider may become warped, causing the voice coil to be off-center and scraping.
5. A seam on the cone may loosen, the spider may loosen from the cone where it is cemented, the voice coil wire leads may come loose from the side of the cone to which they are cemented. These troubles all cause "rattling".
6. Chattering may result from broken spiders or spiders which are not stiff enough, and from cones which come loose at the outer edge where they are clamped by the metal ring.
7. Rattling may occur due to a loose spider screw, or other loose screws in the speaker.

These troubles and the remedies for them will now be considered in detail.

26-37. Recentering Voice Coils.—The circular form on which the voice coil is wound fits into the circular air gap with a very small clearance, and should be centered in it perfectly so that it does not touch the metal poles at any point. If the coil is not properly centered, the wire of which it is wound rubs against the pole pieces. If the friction is sufficient, the insulation of the wire wears away and short-circuits occur between the various turns, at the scraped surface. Then too, the output may be distorted because of the enforced limited movement of the coil caused by the excessive friction. There are two types

of voice coil centering arrangements: those in which either an internal or external spider is employed (see Fig. 26-19 for internal type), and those in which waxed string suspensions are used. The former is the most common, and the centering of voice coils in speakers employing it will be considered first.

To find out whether the voice coil needs recentering or not, the cone and frame assembly should be grasped in both hands exactly as illustrated in Fig. 26-19. The cone should be moved straight in and out by pushing gently with both thumbs. If a dull scraping or scratching sound is heard, it indicates that the coil is off center and is rubbing against the pole piece; consequently, recentering is necessary. Care should be taken not to push the cone assembly to one side when doing this, for it is possible to throw the entire assembly off center so that the voice coil scrapes if the cone is pushed on one side only.

Another method for determining whether the voice coil needs recentering is to connect the loud speaker to the receiver and tune in a steady signal of low pitch. An excellent low-pitched sound may also be obtained by disconnecting one or more of the filter condensers in the receiver, and allowing the speaker to reproduce the resulting hum. If the receiver is inoperative, the primary of the speaker output transformer may be disconnected from the receiver and connected to a 110-volt a-c line, in order to produce the hum. With the hum as loud as possible, run the thumb around the edge of the *spider*; press firmly and listen carefully. The *quality* of the hum should be the same for all positions of the thumb. If it is not, the cone must be recentered.

In order to recenter the voice coil, it is necessary to make the spacing between the voice coil and the pole pieces the same at every point. To do this, loosen the screw which passes through the center of the spider and screws into the center core-leg of the field. Now insert three narrow, thin cardboard or paper shims, *H*, of proper thickness in the cut-outs in the spider (see Fig. 26-20), so that they fit in between the voice coil and the center core-leg. This forces the voice coil to take a centered position in the air gap. Now tighten the center screw, so as to clamp the spider in this correct position. At

this point, it is well to make sure that the screws in the core-clamping ring at the top are tight. Then remove the shims.

The method of recentering just described is what might be called the *static* method, since no signal is applied and the cone is at rest while it is being recentered. Some service men prefer the dynamic method. The *dynamic* method of recentering is to reproduce the low-frequency hum of the unfiltered power supply, loosen the spider centering screw, insert the shims, and, with the hum coming in strongly, tighten the centering screw and remove the shims.

Some speakers have their spiders at the rear of the cone instead of in front. These spiders have no centering screw, as the spider arms are fastened to the frame of the speaker by screws. In other words, the center of the spider is fastened to the cone, and to the voice coil, while its individual arms

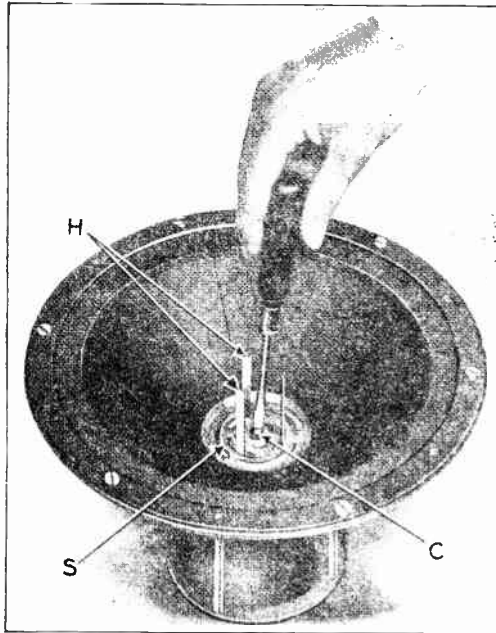

Courtesy Atwater Kent

FIG. 26-20.—Here the voice-coil centering shims, *H*, are shown in place in the air gap while the spider set-screw *C* is being loosened to allow the voice coil, spider, *S*, and cone to assume a "centered" position.

are fastened to the frame of the speaker by screws. The process of centering such cones is the same as for the center-screw spider type, except that three or four screws or nuts must be loosened and tightened instead of one. Since these screws are behind the cone, it is usually difficult to get at

them and an off-set screwdriver or wrench must usually be employed. The centering shims should be placed at three equally-spaced points 120 degrees apart.

Instead of using a spider to center the voice coil, a few speakers use three thin, waxed strings stretched radially from the voice coil and separated evenly—by 120° arcs. The far ends of these strings fasten to thumb screws which may be tightened or loosened at will. The recentering of these cones is accomplished by using shims in the customary manner and then tightening or loosening the thumb screws to secure the proper position of the voice coil.

The shims used for recentering voice coils should be about $\frac{1}{8}$ -inch wide and 2 inches long. Suitable shims may be made by cutting strips from an ordinary calling card or other thin cardboard, or from stiff paper. Since the air gaps employed in dynamic speakers vary to some extent, the serviceman will find that three or four shims each of the following thicknesses 0.125, 0.01, 0.0075 and 0.005 inches will take care of all speakers. All the shims of each thickness should be marked so they can be identified easily.

After a voice coil has been recentered carefully by one of the foregoing methods, it should be checked by the method of Fig. 26-19 to find out if it is properly centered. By listening carefully, and by the "feel" of the thumbs, it will be possible to determine if the coil still scrapes.

26-38. Recentering Voice Coil When Cone or Spider is Slightly Warped.—If the voice coil still continues to scrape after it has been recentered by one of the methods explained in Art. 26-37, it is possible that the cone is slightly warped, or that the leather supporting ring is placing an uneven tension on the cone edges because it is unevenly stretched. It is sometimes possible to correct this trouble by first loosening the spider screw (or screws) and placing the centering shims in place. Then loosen all screws around the cone-clamping ring. Now tighten them until they just begin to clamp. Then turn any one screw a full turn. Now turn the screw diametrically opposite to it, a full turn, and then turn one of the screws half way between these two, a full turn. Next turn the one dia-

metrically opposite to this one, a full turn. Continue this until all the screws have been turned one full turn. Then repeat the operation, in this same order, until all of the screws are tight. In this way the outer edge of the cone will be clamped down evenly all around, and an even tension will be placed around the entire cone edge. Now tighten the spider screw (or screws) and remove the shims.

The cone and voice coil should now be tested for centering (see last paragraph of Art. 26-37). If the voice coil still scrapes, it is likely that the spider is warped (inspect it carefully; normally it should be perfectly flat), the cone is warped out of shape, or the form on which the voice coil is wound is warped so that it is no longer round. If this is the case, it is usually advisable to replace the entire cone, spider, and voice coil assembly with a new one, for repair of these parts is usually a tedious, time-consuming job which calls for considerable mechanical skill. However, if these parts must be repaired, either because of emergency or because the owner insists upon repair, the work may be done by the service man.

26-39. Repairing the Voice Coil.—The first step when making almost any repair on the cone, voice coil, or spider is to remove the entire cone and voice coil assembly. Every step should be performed carefully so as not to damage either the cone or the voice coil form or winding. The speaker should be laid on its back with the cone pointing straight up. First the screws should be removed from the ring which clamps the outer rim of the cone to the frame. In many of the recent loud speakers, the cone is cemented to the rim. In order to remove this cement (it cannot be removed with water or ordinary solvents), the cemented portion should be saturated with "lacquer thinner" which can be purchased at any paint store. When the cement dissolves (it usually requires 5 to 10 minutes), the edge of the cone may be freed. Then the voice coil leads should be disconnected, and the spider set-screw (or screws) removed. The cone should now be lifted from the speaker frame carefully so as not to damage either the voice coil or the cone.

The voice coil should now be examined carefully. If the

form is out of round, it may be repaired by inserting a round, tapered cork of the proper size into its open end—exactly as you would in the neck of a bottle. Do not stretch the coil form—just push the cork in snugly enough to fill the coil-form diameter. Now test for perfect roundness by means of a pair of calipers. Alter the position of the cork a little here and there, as requirements dictate, in order to make the coil form round. Now coat the coil with a very thin solution of a good grade of collodion or cement that will not warp the coil when it dries. No lumps or thick spots of cement should be left on the coil, for they will prevent its insertion into the small air gap later. While you are at it, it is a good plan to re-cement all the seams in the cone, and the cemented parts of the spider. This will strengthen them and repair any seam which contains cracked cement that is not visible. After at least 1 hour (when all the cement is thoroughly dry), remove the cork from the voice coil form, test again for roundness, and install the cone. It should be recentered with shims (Art. 26-37), and the spider set-screws tightened. The outer rim should then be re-cemented, the ring put back in place, and the shims removed after the job is complete. The voice coil leads should now be connected properly, and the speaker tested (see Fig. 26-19).

Very often, an inspection of the voice coil (after the cone has been removed from the speaker) will reveal that the voice coil winding has become loose. This will cause a peculiar buzz or a rapid rattle. It may have rubbed against the pole piece and scraped some of the enamel insulation off its outside surface. If the damage is slight it may be repaired by scraping the burrs off the copper wire with a sharp penknife, and then coating the surface of the scraped wire with a thin varnish or household cement. However, if the damage is serious, the cone and voice coil should be replaced with a new one.

26-40. Repairing the Spider.—It is possible for the spider to warp and become out of true. If this happens, it is practically impossible to properly center a voice coil. In other cases, the spider causes chattering, rasping, or high-pitched reproduction. Spiders that are not stiff enough will also cause chattering. A new spider (or a spider, voice coil, and cone assembly)

should be installed, but if one is not available, another may be cut from thin sheet bakelite or fibre having the proper degree of flexibility. In order to do this, remove the cone-spider assembly (see Art. 26-39) and place it cone-up, on a table. With a good grade of solvent (lacquer thinner will do), remove the cement that holds the spider to the cone. In some speakers the spider is cemented to the cone at the back of the speaker, in which case the cone should be placed with the large-diameter end on the table. When the solvent has loosened the cement, carefully remove the spider from the cone with the aid of a safety-razor blade.

Remove the voice coil from the spider in a similar manner. Now, using the old spider as a template, cut out a new spider from the thin bakelite or fibre. A simple expedient is to cut out the old spider with a razor blade, leaving a $\frac{1}{8}$ -inch flange of this spider remaining stuck to the cone. Then, using this spider as a template, cut out a new spider from a discarded cone whose diameter is about $\frac{1}{4}$ -inch larger than the opening it is to cover. Cement the new spider to the $\frac{1}{8}$ -inch flange, and allow it to dry. The voice coil is then recentered in the usual manner.

An annoying rattle very often develops due to excessive vibration of one of the legs of the spider. The guilty member may be located by placing the finger lightly on each leg in turn until the rattle stops when one is touched. A thin piece of leather or felt is then glued over this leg to dampen its vibration.

26-41. Eliminating Paper Rattle.—Although the voice coil and spider may be in good condition, a high-pitched rattle may be heard—a rattle that sounds more like the rustle of leaves than a metallic noise. This is due to some section of the cone proper vibrating in an abnormal manner. The most frequent cause of this *paper rattle* is a faulty seam in the cone. The edges of this seam must be stuck together tightly from end to end; any opening will cause paper rattle. It is usually best to open the entire seam with a good grade of solvent and re-cement the entire length. The stiffness of the entire seam will then be uniform throughout its length.

Paper rattle can also be caused by a tear in the cone itself. The best procedure here is to cement the seam only, if the tear is slight and the edges overlap. Under any other conditions, the cone must be replaced, as the paper rattle will be particularly bothersome because of the vibration of the edges. Thin strips of paper cemented on both sides of the cone to cover the seam can be resorted to in some cases, though it is not particularly recommended if the tear is very large, because the stiffness of the cone is then changed and the quality of the reproduction impaired.

26-42. Repair of Leather Suspension Ring.—In most dynamic speakers, the outside edge of the cone is cemented to a flexible chamois, leather, or cloth suspension ring for support. This is in turn clamped to the frame of the speaker. If leather is used, it has a tendency to dry out and harden in time. This results either in a “fuzzy” sort of sound similar to paper rattle, or, poor low-frequency reproduction results. Often, it dries out and hardens unevenly at certain spots, resulting in poor reproduction. It is often possible to soften a stiff leather cone-edge by carefully applying and rubbing in a small quantity of mineral oil or a good leather dressing such as Neatsfoot oil. When this does not soften it sufficiently, or when the leather or cloth ring is worn or cracked, the entire cone and voice-coil assembly should be replaced.

In the event that the leather or cloth ring loses its “body” and becomes flabby, insufficient support is given to the cone and it may work out of alignment, and cause rattling. In this case, the entire assembly should be replaced.

The ring which clamps the leather cone edge to the frame of the speaker should always be screwed down tightly, for, if it loosens, rattling will result. It is often necessary to insert paper or cardboard ring washers between here in order to prevent rattling.

26-43. Removing Iron and Dust Particles from Air Gap.—The presence of small iron and dust particles in the gap between the voice-coil form and the central pole-piece frequently causes “raspy” and “rattly” reproduction. In some cases, this may be eliminated by placing the speaker in an inverted position and gently moving the cone backward and forward, so that these

particles may fall out. Usually, however, it will be necessary to dismantle the speaker and wipe the voice coil and pole piece clean with a wad of soft cloth. Speakers of recent manufacture are constructed with the air gap entirely enclosed so that iron particles and other foreign matter cannot enter it.

26-44. Repair of Permanent-Magnet Type Dynamic Speakers.—While most dynamic speakers employ an electromagnet for supplying the field magnetism, this type of speaker is also constructed with a permanent magnet field—the usual movable voice coil, spider and cone construction being retained. All of the troubles, and their remedies, which have already been described for the voice coils, spiders and cones of electromagnet type dynamic speakers hold for these units also. The only trouble experienced with the permanent magnets is that of loss of magnetic strength. These may be remagnetized (see Art. 26-18) by the service man, but it is preferable to have them remagnetized strongly by an automobile ignition repair shop which possesses a large electromagnet for remagnetizing the magnets of magnetos.

26-45. Repair of Condenser-Type Loud Speakers.—Another form of loud speaker which was employed in at least one make of receiver in the United States several years ago (the Peerless receivers which were made by the United Reproducers Corp.) is the *electrostatic* or *condenser* type speaker (for details of its construction and operation see Ghirardi's *Radio Physics Course*). The construction of this type of speaker is extremely simple. Each section consists of a stationary plate of perforated metal and a movable plate consisting of a thin tinfoil sheet approximately 0.0001 inch thick. Between these, and stuck to the movable tinfoil sheet, is a thin insulating sheet of rubber compound which acts as the dielectric. The movable plate acts as the diaphragm, vibrating in accordance with the signal and imparting its motion directly to the air, resulting in sound waves. A high d-c polarizing voltage (about 500 volts) is used. The complete speaker is made up of several 8 x 12-inch units of this type.

The main trouble which occurs in this type of speaker is that of deterioration of the rubber dielectric, followed by its break-

down due to the high polarizing voltage which must be applied across it. When the dielectric becomes punctured, it should be replaced, but replacement of this dielectric is extremely difficult and not lasting. In fact, so far as the author is aware, it is no longer possible to secure this material. Perhaps the most practical thing to do if called upon to service a speaker of this type in a Peerless receiver is to replace it with a dynamic speaker. A speaker having a push-pull output transformer designed to work out of push-pull '45 tubes should be employed. Its field resistance should be approximately 500 ohms. The connections in the receiver should be changed so that the plates of the '45 output tubes go direct to the two outside ends of the speaker output transformer primary. Connect its center-tap to the *B* plus lead. Remove the choke in the output of the filter circuit and connect the 500-ohm field coil of the dynamic speaker in its place. Remove all the apparatus which was employed for securing the d-c polarizing voltage for the condenser speaker. The receiver is now ready for operation with its new dynamic speaker.

26-46. Phonograph Pickups. — A magnetic type phonograph pickup (sometimes called a *reproducer*) is a carefully assembled device that must be handled delicately and with patience. Though similar in construction to the motor unit of a balanced-armature magnetic speaker, its parts are much smaller, and often times proper spacing and adjustment must be carried out with the aid of a small pocket-size magnifying glass. There are many types of phonograph reproducers in use, but the *magnetic* type is very widely used for home radio-phono combinations and can be easily repaired. The copper-oxide, oil damped, crystal, and other types are subject to misalignment and wear, but their construction is such that the average service man does not have the necessary facilities for making satisfactory repairs on them. One of the most common troubles encountered in the "crystal" type of pickup is that due to the snapping of the leads to the crystal unit. It is not always possible to repair such a fracture.

26-47. Construction of the Magnetic Phono Pickup. — Figure 26-21 shows three interior views of a typical magnetic pickup. Essentially, it consists of chromium steel magnet, two

thin pole pieces, a mechanism support and bracket, a coil and an armature that is damped by means of an anchored rubber damping block. The needle holder is pivoted in rubber pivots. Movement of the needle in the grooves of the record changes the magnetic flux in the center of the coil, and a voltage is generated which is proportional to the rate of change of flux. The damping block is used to prevent excessive vibration at the resonant frequency of the mechanical system.

26-48. Centering the Phono Pickup Armature.—The complaint of weak and distorted phonograph reproduction, such as would be obtained if the grid bias were removed from an audio-amplifier tube, is frequently due to the armature of the pickup being off-center. In most pickups, the armature is centered by means of a small clamp which fits tightly over the rubber damping blocks. The two screws, *A* & *B* (Fig. 26-21), that hold this clamp in place should be loosened and the plate so ad-

justed that the armature is centered between the pole pieces of the magnet. To determine whether or not the armature is correctly adjusted, the pick-up should be re-assembled and the phonograph set up for operation. With the phonograph volume con-

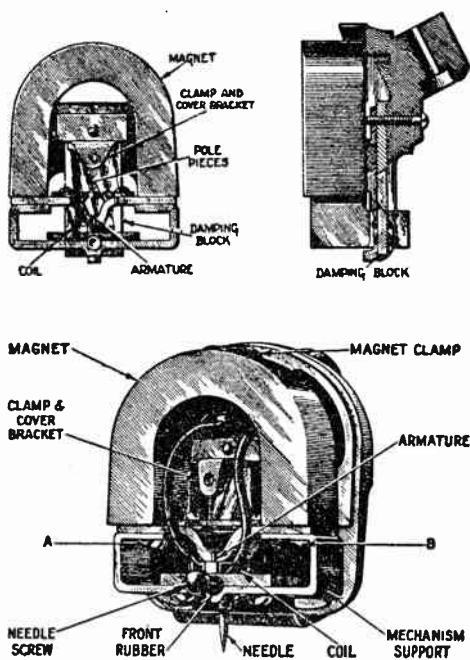

Courtesy RCA Victor

FIG. 26-21.—Details of the assembly of a typical phonograph pickup unit of the magnetic type.

trol turned up full, the needle in the armature should be moved back and forth with the finger. Unless the same response is heard in the speaker when the needle is pushed to the right and to the left, the armature is not properly centered. The armature should then be centered by moving the damping block plate, after loosening the mounting screws, in the direction opposite to the side at which the weak response was heard.

26-49. Replacing Rubber Damping Block and Pivots in the Pickup.—The symptoms of weak reproduction accompanied by blasting on low-frequency notes, and rattles on the high frequencies, are generally caused by the hardening or deterioration of the rubber damping blocks and rubber pivot supports. The test for this failure may be made by moving the needle in the pickup first to the right and then to the left. It should take as much force to move the needle in either direction. If it is found that the armature is more easily moved in one direction than the other, it will be necessary to replace the rubber damping block and pivot supports. This usually necessitates dismantling of the entire mechanism.

26-50. Remagnetizing the Magnet in the Pickup. — In certain types of pickups it is often necessary to remove the permanent magnet in order to make any adjustments or replacements. If this is necessary, a steel or iron "keeper" (such as a large nail) must be placed across the poles of the magnet before it is removed from the pole pieces. Failure to do this will result in a weakened magnet. *This keeper should not be taken off until after the magnet is placed back on the pole pieces in the pickup.* If the magnet is found to be weak (this may be determined by testing its magnetic attraction with a screwdriver), it will be necessary to remagnetize it in accordance with the remagnetizing procedure explained in Art. 26-18. It is preferable to check the magnetic polarity of the pickup magnet and to re-magnetize it so that the same polarity is maintained.

26-51. Removing Foreign Material from the Pickup Air-gap.—A fuzzy, crackling noise which is heard during the playing of a record is often caused by the presence of small iron particles which are attracted by the magnet to the base of the pickup near the stylus. These particles may be removed

easily with the aid of a small stiff brush, such as a toothbrush, or may be blown away, or picked off with small tweezers.

26-52. Repair of Open Phono Pickup Coil.—Total inoperation of a magnetic pickup is often caused by an open-circuited coil which must be replaced or rewound. In some instances, weak response may be due to a coil winding that has become short-circuited, partially short-circuited, or grounded to one of the pole pieces or to the armature. This condition may be checked readily by the use of an ohmmeter. Should the pickup coil be found to be short-circuited to the pole piece or armature, thin strips of empire cloth may be used to insulate it. A practical, quick test for determining the condition of a pickup may be made by connecting a pair of headphones directly across its terminals. When the needle in the pickup is moved back and forth with the finger, a clicking sound should be heard. If the needle is played in the groove of the phonograph record, the recording should be heard clearly in the earphones.

26-53. Repair of Phonograph Turntables.—One of the most common troubles with phonograph reproduction is that of distortion. Although this condition may be caused by trouble in the pickup, it is more frequently due to incorrect speed of the turntable. A "wow" sound caused by variations in the speed of the turntable, is evidenced by distortion on long, sustained notes, especially on long playing records. As the first step toward eliminating complaints of this nature, the speed of the turntable should be checked. The correct speed for standard records is 78 revolutions per minute *while the record is being played with the needle of the pickup in position on it*. Although the speed may be determined by counting the number of revolutions made in a minute by a small strip of ordinary white paper inserted between the record and the turntable, it is preferable to regulate the speed with the aid of a *stroboscope disc*. A stroboscope is a circular cardboard disc with lines so drawn and spaced that when the disc is placed on a record which is being played, and the disc is illuminated by an ordinary incandescent (or preferably a neon) lamp bulb lighted by an a-c supply of specified frequency (60 cycle will do), *the lines appear to stand still* when the speed of the record is correct. If the lines appear to be

traveling forward, the speed of the turntable is too fast, and, when the lines appear to travel backward, the turntable is regulated at too slow a speed, and it should be adjusted.

The speed of most turntables is regulated easily by a screw or lever adjustment which controls the action of the governor operating in conjunction with the phonograph motor. Many of the new phonograph motors are equipped for two-speed operation of the turntable, one for the playing of 78-r.p.m. records, and the other for the 33 $\frac{1}{3}$ -r.p.m. records.

Fluctuation in the speed of the turntable, or "wow," is usually caused by the hardening of the leather, soft rubber, or felt washer, upon which the turntable rests. Replacement of the washer or washers is often all that is necessary to correct this condition. In some instances, the entire motor must be overhauled, oiled, greased, and each electrical connection checked and resoldered. When the motor is of the commutator-brush type, the commutator and brushes must be carefully cleaned with fine *sandpaper* (not emery cloth) and fitted properly.

Speed variation may be noticed only on certain types of records, especially those of the long-playing kind. This will be found to be due to excess pressure of the pickup in many cases. It may be counteracted by the adjustment of the counter balance fastened to the far end of the pickup arm or by the installation of a light spring between the motor board and the pickup arm to reduce the pressure of the pickup upon the record.

26-54. Repair of Phonograph Motors.—The phonograph motors employed in combination radio-phonograph receivers are usually sturdily constructed and seldom require attention, except for periodic oiling and greasing. However, when induction motors are encountered which cannot be made to operate at correct speed or are sluggish in operation, the trouble may be due to the turntable shaft which has become slightly "frozen" at the point where it passes through the motor assembly. This condition may be rectified by working the shaft loose with the aid of some light mineral oil. In cases where the motor is sluggish, or has a tendency to stall or lose power, a drop or two of machine oil should be applied to the bearings. In the commutator type of phonograph motor, this latter condition may be overcome by

cleaning the commutator with a strip of fine *sandpaper* and resurfacing and fitting the carbon brushes (see Art. 27-40).

A large number of radio-phonograph combinations employ an induction disc-type motor. These motors have two sets of field coils, or *inductors*, each of which consists of three coils and five *poles*. The magnetic field produced between the poles by the passage of alternating current through the inductors causes the non-magnetic rotor disc, which fits in the narrow gap between the poles of each inductor, to rotate. Because of the high current passing through these coils, one or more of them may burn out or become partially short-circuited if the motor is operated continuously for any length of time. When it becomes necessary to replace these coils, care should be exercised to connect them in *exactly* the same manner as previously found, otherwise the disc and turntable will be found to be "running backward".

26-55. Eliminating Hum Caused by Phonograph Motor.

—Very often, phonograph reproduction is accompanied by annoying hum. In such cases, the pickup arm and motor frame should first be grounded. The pickup leads should also be shielded with grounded shield covering. If these remedies do not eliminate the hum, a plate of soft iron approximately 0.1 inch thick and 10 inches in diameter should be screwed to the top of the motor board, under the turntable. This will act as a magnetic shield preventing the stray magnetic field of the phonograph motor from inducing hum current in the coil of the pickup.

In one make of magnetic pickup, a "hum-bucking" or "hum-neutralizing" coil (see Art. 26-33) has been incorporated in the pickup (connected in *series* with the regular coil) to buck out the hum current which may be induced in the regular pickup coil by the motor field or any other stray magnetic fields. Of course this makes the iron plate shield unnecessary.

26-56. Automatic Record Changers.—Because of the fact that the design and construction of automatic record-changing mechanisms are so varied and more or less complicated, no attempt will be made here to discuss their troubles and the remedies which apply to them. Some of the trouble symptoms which occur in a few of these devices, and the remedies which will correct them, have been listed in the compilation of Symptoms and

Remedies for Troubles in Home Receivers, which will be found in the *Radio Field Service Data and Answer Book Supplement to Modern Radio Servicing*. The reader would do well to consult also the instruction and service literature of the manufacturer of the particular record-changer in cases where trouble is experienced.

26-57. Adding Phonograph Pickups to Radio Receivers.

—There are instances when it is desired to add to an existing radio receiver, facilities for making phonograph reproduction possible. In such cases, the installation must be made in as simple and direct a way as possible, and at low expense. This means that, aside from the mechanical problems of locating the turntable and reproducer, the electrical connections to the receiver must be considered. Of course, they must be kept as simple as possible, consistent with satisfactory performance. Methods of adding phonograph pickups of the "crystal" and "magnetic" types to receivers by making simple circuit connections to the receivers will be considered first. Then, an entirely different method which makes use of a modulated oscillator arrangement will be described in Art. 26-65. Although this work cannot really be classed as repair work, it is presented here for lack of a more appropriate place to put it in this book. It does however, entail reconnection of a few circuits in the receiver.

The service man must decide first to which part of the radio receiver it will be best to connect the pickup. This, of course, depends on the circuit arrangement of the particular receiver. In receivers which employ but one audio stage following the second detector, the volume will usually be insufficient for satisfactory phonograph reproduction if an average pickup is connected to the input of the a-f amplifier (after the detector). It is better to connect it to the input side of the second detector and make the necessary circuit changes to decrease the control-grid bias on this tube so that it operates as an amplifier when the pickup is connected for phonograph reproduction. If this is done, two stages of amplification are available for amplifying the output of the pickup—which is ample for good volume.

In receivers which employ at least two stages of a-f amplification, the phono pickup may be connected to the input circuit of the first audio stage, although in this case too, it is often

connected into the input side of the detector stage when it is to be used. Since several different detector circuit and tube arrangements have been used widely in receivers during the past few years, it is essential that the service man who attempts to install magnetic type phonograph pickups in existing receivers be familiar with the proper method of connection for each common detector circuit arrangement.

Also, suitable switching arrangements must be provided for connecting the phono pickup to the circuit at will, and preventing the radio signals from feeding through along with the phonograph reproduction. For convenience, it should only be necessary to flip one switch for changing from radio to phono reproduction.

Pickup circuit arrangements to meet the various circuit conditions usually encountered will now be considered.

26-57A. Adding "Astatic" Crystal Phono Pickups to Radio

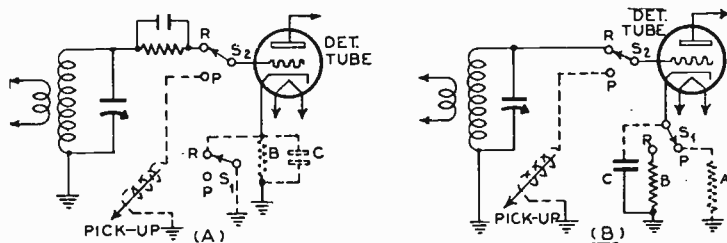

FIG. 26-22.—(A) Method of connecting a phonograph pickup to the detector input circuit of a receiver employing grid-leak detection.

(B) Method of connection when the receiver employs grid-bias detection. In each case, the additional pickup and other wiring is shown dotted.

Receivers.—Because of their high impedance, "astatic" crystal type phono-pickups may be connected *directly* between any of the points in the receiver to which a magnetic type pickup may be connected (see Figs. 26-22, 26-23, 26-24 and 26-28)—but preferably between the control-grid and *B-minus* of the first audio amplifier input tube.

The average voltage output of this type of pickup is over 2 volts when shunted by the usual 0.5 meg. potentiometer-type volume control used with it (see (A) of Fig. 26-25), so the tube grid should be operated at from 4 to 6 volts *negative* to prevent distortion at this point.

26-58. Connecting Phono Pickup to Input of Grid Leak and Condenser Detector.—If the receiver the pickup is to be

operated with contains a detector of the grid leak and condenser type, it may be connected to the input circuit of the detector tube when used, as shown at (A) of Fig. 26-22. In order to connect a bias voltage into the circuit automatically when the pickup is used, so that the tube will operate as a linear amplifier, bias resistor, *B*, (of the proper value) and its by-pass condenser, *C*, are connected in the cathode circuit as shown. When switch *S*₁ (which consists of one side of a d.p.d.t. switch) is thrown to position, *R*, for radio reception, the bias resistor is short-circuited through the chassis ground circuit so the tube operates as a detector. At the same time, switch *S*₂, which forms the other side of a single double-pole—double-throw toggle switch which is employed for both switching purposes, switches the grid of the tube to the grid leak and condenser to complete the circuit. When the switch is thrown to the *P* position for phonograph reproduction, switch *S*₂ connects one end of the phono pickup to the grid of the tube. In doing this, it automatically disconnects the grid from the tuning coil circuit in order to prevent any radio signal from feeding through the audio amplifier along with the phonograph pickup impulses. At the same time, switch *S*₁ opens its circuit, thereby putting bias resistor *B* and condenser *C* into the cathode-return circuit. The pickup is now connected directly across the input circuit of the tube, which is being operated as an amplifier.

Several other circuit connections and arrangements for connecting a phono pickup to a detector circuit of this kind can be employed, but this one has the distinct advantages of completely eliminating the radio signal when the pickup is used, operating the detector tube as an amplifier along with the a-f amplifier for phonograph reproduction so that additional amplification is obtained, and eliminating the necessity for having any long leads from the grid of the tube to the phonograph pickup in the circuit when radio reception is desired. Such leads often cause annoying feedback and resulting oscillation in the receiver.

26-59. Connecting Phono Pickups to the Input of a Biased Detector.—If a simple grid-bias triode or screen-grid detector is employed in the receiver, the phonograph pickup can be connected to its input by employing the arrangement shown at (B) of Fig. 26-22. Resistor *B* and by-pass condenser *C* are the units which were originally in the receiver (reconnected as shown of course). Resistor *A* is an additional new bias resistor of the

proper value which will cause the tube to operate as a linear amplifier. The operation of switches S_1 and S_2 , which form the two sides of a d.p.d.t. toggle switch may be understood from a study of the diagram. For radio reception, high-bias resistor B is put into the circuit; for phono reproduction, lower-bias resistor A is switched in. In either case, by-pass condenser C connects across the bias resistor being employed. With this arrangement only a simple toggle switch and a single-bias resistor of proper value need be added to the receiver. The proper value of bias resistor, A , to use, is that which makes the tube operate as a linear amplifier (see Chart of Grid-Bias Resistors in *Radio Field Service Data and Answer Book* supplement to Modern Radio Servicing).

26-60. Connection of Phono Pickup in Detector Circuits vs. Connection in A-F Amplifier.—In many cases (aside from those where diode detectors are used) it is desirable to connect the phono pickup into the input circuit of the audio amplifier instead of into that of the detector. This is usually the case when a diode detector is employed (since the diode produces no amplification), or when the circuit of the receiver is not known or available. It is also the case when the receiver contains plenty of a-f amplification. In such receivers, too much volume is obtained when the phono pickup is connected ahead of the detector tube. It makes little difference as regards "quality" whether the phono pickup is connected into the detector, or the audio input circuit (so long as the detector tube is operated as a linear amplifier when the pickup is used); the main difference lies in the volume obtained. When plenty of volume is required, or, when the receiver contains only one audio stage, it is usually best to connect the phono pickup into the detector input circuit. When the receiver circuit is complicated and is not known, or when it contains two good audio stages, it is usually simpler to connect it into the a-f amplifier circuit. Whenever possible, this arrangement is to be preferred.

26-61. Connecting Phono Pickups to Duplex-Diode Detectors.—Many broadcast receivers employ a duplex-diode triode tube which combines the functions of automatic volume control, detection and audio amplification. A typical circuit ar-

arrangement for a composite circuit of this type is shown at (A) of Fig. 26-23. The heater, cathode, two diode plates and triode (or pentode) grid and plate are in the same tube. The signal input to the tube connects between the diode and cathode, as shown, through volume-control potentiometer R . The arm of R may connect to the control grid of the audio triode (or pentode) section directly, or through some sort of resistance-coupled arrangement.

The tube connections other than those shown here are not important for our consideration. The phono pickup is simply connected across the volume-control resistor of the receiver, this volume control then serving for both radio and phonograph operation. This connects it to the input circuit of the triode

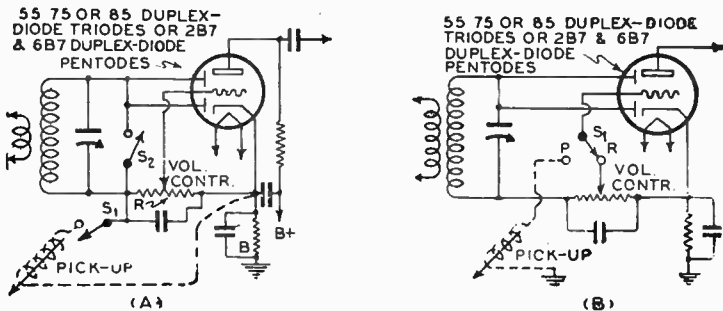

FIG. 26-23.—Two methods of connecting a phonograph pickup to receivers employing a duplex-diode triode (or duplex-diode pentode) tube. The pickup is connected to the input of the audio triode (or pentode) amplifier section of the tube.

portion of the tube (there is no point in connecting phono pickups to the diode sections of diode detectors since these detectors do not amplify). Switch S_1 cuts the phono pickup in or out. Another switch, S_2 , may be connected across the input tuning coil for short-circuiting the input to the detector so that no radio programs will be reproduced while the phonograph is operating. Switch S_1 and this switch can both form part of a single d.p.s.t. toggle switch.

Another arrangement which may be used in receivers which employ a duplex-diode triode (or duplex-diode pentode) tube is shown at (B) of Fig. 26-23. This arrangement is also useful if

the receiver does not contain two a-f amplifier stages—the detector feeds directly into an output stage—and if the circuits already described are not applicable for one reason or another. A conventional detector circuit employing a duplex-diode triode tube is shown. The same arrangement to be described is also satisfactory if a duplex-diode pentode tube is employed. The s.p.d.t. toggle switch S_1 is connected so that when thrown to the R side the grid of the audio section of the tube is connected for normal radio reception; when connected to the P side, this grid is connected to the phonograph pickup and the radio circuit is disconnected. When making this type of phonograph pickup connection, care should be exercised to make the lead from the grid of the triode section of the tube to switch S_1 , and that from

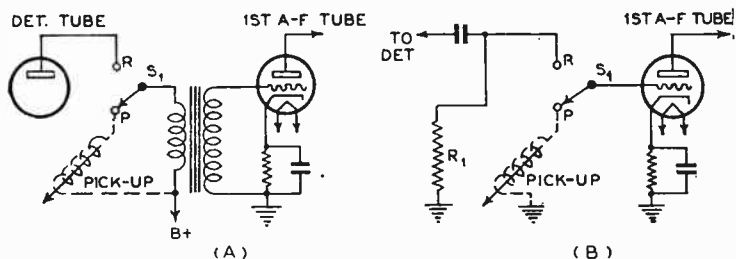

FIG. 26-24.—Two methods of connecting a phonograph pickup to the input of the receiver audio amplifier when independent a-f amplifier tubes are employed in the receiver.

(A) The pickup is connected to the primary of the first a-f transformer when the a-f amplifier is transformer-coupled.

(B) The pickup is connected to the grid circuit of the first a-f tube when the a-f amplifier is resistance coupled.

S_1 to the arm of the volume control, as short and direct as possible to prevent possible coupling between these leads and the input side of the diode. In some cases, it may be necessary to shield these leads with a grounded shield. In the circuit arrangements of (A) and (B), the volume control resistor of the receiver must have a large resistance compared to the impedance of the phonograph pickup.

26-62. Connecting Phono Pickups to Simple Audio Circuits.—In receivers in which simple audio circuits having independent audio tubes are employed, the phono pickup may be connected to the input of the first audio tube. If the first audio

tube is transformer-coupled to the detector, the pickup may be connected across the primary winding of the audio input transformer, as shown at (A) of Fig. 26-24. A simple s.p.d.t. toggle switch is employed for connecting the primary of the a-f transformer to either the phono-pickup or the detector tube. In this way, either the phonograph or the radio can be used without interfering with each other.

If the first audio tube is resistance-coupled to the detector,

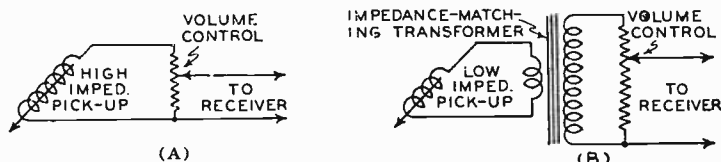

FIG. 26-25.—(A) Connection of a volume control potentiometer to a high-impedance magnetic type pickup, or an “astatic” crystal type pickup.

(B) Connection of a low-impedance magnetic type pickup to its impedance-matching transformer and volume control potentiometer.

the phono pickup may be switched into the circuit (as shown in (B) of Fig. 26-24) by means of s.p.d.t. toggle switch S_1 employing the circuit arrangement shown. When the switch is in the *R* position, the radio is in use and the phono pickup is disconnected. When it is in the *P* position, the radio is disconnected and the phonograph pickup is connected directly to the input terminals of the audio tube. Resistor R_1 is the grid-leak resistor in the receiver (usually a 2-megohm resistor).

26-63. Volume Controls for Phonograph Pickups.—In the circuit arrangements of (A) and (B) of Fig. 26-23, the volume control resistor of the receiver acts also as the volume control when the phono pickup is in operation. However, in the circuit arrangements of Figs. 26-22 and 26-24, it is very likely that the volume control of the receiver would be in either the r-f or detector circuits where it could not serve for control of the phono pickup volume. If the phono pickup employed is not already provided with a built-in volume control of its own, an external volume control must be added to it in these cases. This volume control (which may consist of a 50,000-ohm potentiometer in the case of a magnetic pickup, or a 0.5 meg. potentiometer in the case of an “astatic” crystal type pickup), should be

connected with its full resistance across the output of the pickup. The arm and one end of the potentiometer should be connected to the receiver, as shown at (A) of Fig. 26-25. Fig. 26-26 illustrates two typical magnetic type phonograph pickups. That at the left does not contain a volume control. The one at the right has a volume control built into the base. Its control knob is visible!

26-64. High-Impedance and Low-Impedance Pickups.—

If the pickup to be employed is of the *high-impedance* type (impedance is several thousand ohms), it may be connected directly into the most suitable point in the receiver circuit (see Fig. 26-22) without additional accessories. However, if a *low-impedance* type pickup is used (impedance is only several hundred ohms), for proper energy transfer, its impedance must be matched approximately to that of the circuit it is connected to. An impedance-matching transformer must be connected between the pickup and receiver for this purpose. The proper *turns ratio* of such a transformer is equal to the *square root* of the *impedance ratio* required. Proper impedance-matching transformers to operate with low-impedance pickups are available in a number of standard impedance ratios. The connection of an impedance-matching transformer of this kind (together with an external

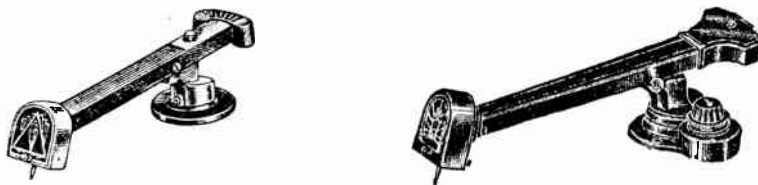

FIG. 26-26.—(Left) A typical magnetic type phonograph pickup unit complete with its tone arm and base.

(Right) A similar pickup which has a volume control built into its base. The volume control knob can be seen at the lower right.

volume control) to a low-impedance magnetic pickup is shown at (B) of Fig. 26-25. "Astatic" crystal type pickups are of the high-impedance type.

26-65. Adapting a Phono Pickup to a Receiver by means of a Phonograph Oscillator.—In all of the phonograph pickup arrangements considered up to this point, the pickup is connected *directly* into the circuits of the radio receiver. From what has al-

ready been said, it must be apparent that the job of connecting phonograph pickups into the circuits of all sorts of existing radio receivers is not a very simple one for the service man, if satisfactory results are to be obtained. The connection arrangement employed depends upon the number of audio stages employed by the receiver, the types of audio tubes, the type of detector tube, the type of detector circuit, etc. Another method, which feeds the output of the pickup to the receiver in an indirect way, but which is simple to adapt to practically any type of a-c electric receiver manufactured during the past five years, will now be described. The installation work can be completed in about five minutes, for, since no changes whatsoever are made

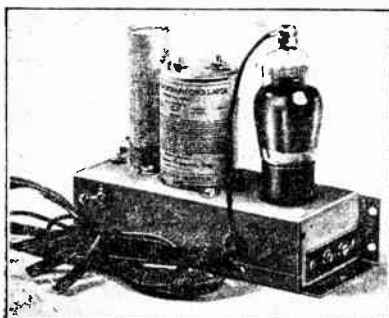

FIG. 26-27. — A modulated oscillator unit for connecting a phonograph pickup unit to any existing radio receiver without need for making any wiring changes in the receiver circuits proper. Its circuit diagram is shown in Fig. 26-28. (Model RK-24)

Courtesy RCA Victor

in the wiring of the receiver, the receiver chassis does not need to be removed from the cabinet.

The entire adapter unit, which may be mounted anywhere inside (or in back of) the receiver cabinet, is illustrated in Fig. 26-27. Its complete schematic circuit diagram is shown in Fig. 26-28. The unit is really a miniature broadcast transmitter which is energized from the power supply of the receiver and modulated by the phonograph pickup. It consists of either a 6A7 or a 2A7 tube—the type of tube used depending upon whether the receiver to which the unit is connected employs 2.5-volt tubes (in which case the 2A7 is used) or 6.3-volt tubes (in which case the 6A7 is used). The tube, which is a pentagrid converter designed to perform simultaneously the function of an oscillator tube and a mixer tube, is connected with its triode portion acting in an r-f oscillator circuit of the Hartley type, having an ad-

justable frequency from 1,400 kc to 1,700 kc. The phonograph pickup is permanently connected across the control-grid and cathode of the pentode section of the tube, the pentode section functioning as the modulator. Suppressor grid modulation is employed. The phonograph pickup modulates the r-f signal of the oscillator, in other words, the tube is used in much the same manner as the combination mixer-oscillator in a superhetero-

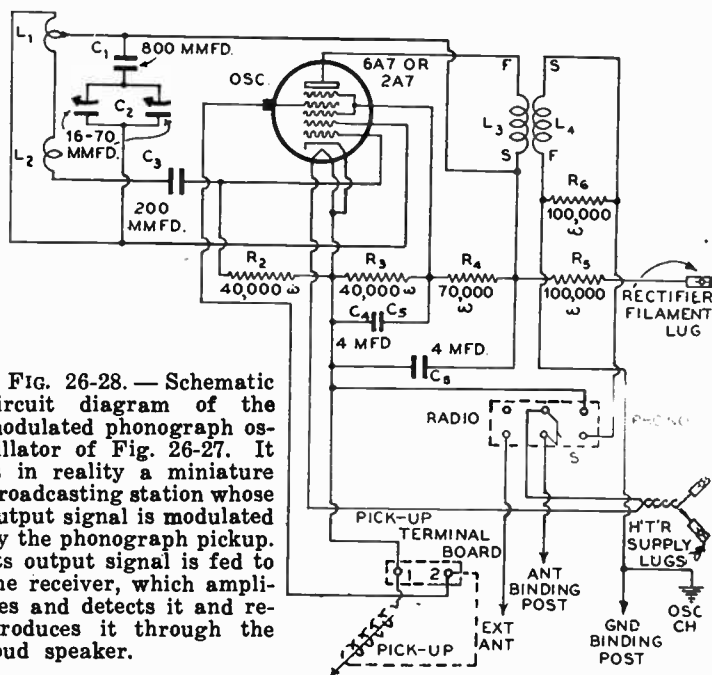

FIG. 26-28. — Schematic circuit diagram of the modulated phonograph oscillator of Fig. 26-27. It is in reality a miniature broadcasting station whose output signal is modulated by the phonograph pickup. Its output signal is fed to the receiver, which amplifies and detects it and reproduces it through the loud speaker.

dyne receiver. The modulated output signal from pickup coil L_4 is fed directly to the antenna and ground terminals of the receiver. When the receiver is tuned exactly to the carrier frequency of the output signal of the oscillator, the receiver amplifies and demodulates this signal just as it does any signal received from a broadcasting station. The result is that the phonograph recording is reproduced by the loudspeaker of the receiver. The volume control of the receiver acts as the volume control for the phonograph reproduction also.

In order that no internal connections need be made to the

receiver, three adapter lugs are provided for direct connection to tube prongs of two of the tubes in the receiver. These are labeled in Fig. 26-28. One lug is slipped over one of the filament prongs of the rectifier in the receiver for providing the necessary plate and screen voltages for the tube in the oscillation unit. The other two lugs which are slipped over the heater prongs of one of the tubes in the receiver, supply heater current for the tube in the oscillator unit.

A double-pole double-throw toggle switch is employed for changing from radio to phonograph. This is so connected that, when thrown to the "Phono" position, the antenna is discon-

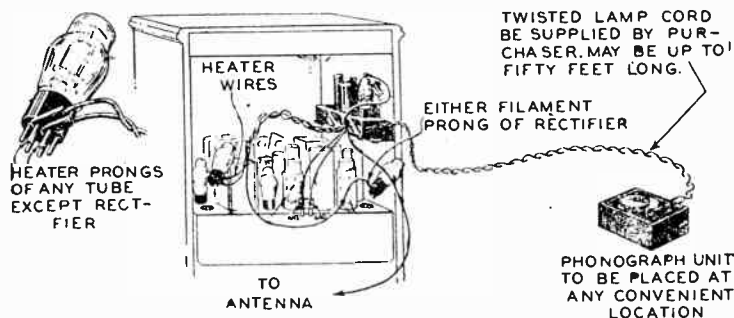

Courtesy ROA Victor

FIG. 26-29.—Typical installation of the phonograph oscillator unit of Figs. 26-27 and 26-28. The method of slipping the lugs over the heater prongs of a tube in the receiver for filament current supply is shown at the left.

nected from the receiver, the heater supply to the 'A7 tube is closed, and the output coil L_4 of the phonograph oscillator is connected to the antenna post of the receiver. When it is thrown to the "Radio" position, the antenna is connected to the receiver and the supply to the heater of the 'A7 is opened. A pictorial view showing the phonograph oscillator unit mounted inside of a receiver cabinet, and the various connections which must be made, is shown in Fig. 26-29. The detailed view at the left shows how the two adapter lugs for the heater circuit are placed on the heater prongs of one of the receiver tubes. If a low-impedance type magnetic pickup is used, an impedance matching transformer must be connected between it and the input term-

inals of the oscillator unit. If a high-impedance magnetic type (or an "astatic" crystal type) pickup is used, no impedance-matching transformer is necessary.

26-66. Repairing and Refinishing Damaged Receiver Cabinets.—The refinishing, and repair of minor damages, to receiver cabinets is a very important part of radio repair work, for the service man who is able to do this work himself can save the cost of complaints, returning scratched or damaged cabinets to the factory, and having marred cabinets spoil the chances of making a sale. In addition, he can refinish and repair the receiver cabinets of his customers at regular service rates.

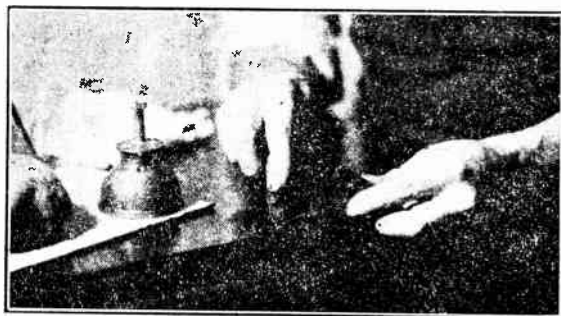

Courtesy Radio Retailing Magazine

FIG. 26-30.—How burning-in shellac is filled into a deep scratch or minor dent in a radio receiver cabinet with a small penknife to bring the surface up to the level of the rest of the wood.

There are five common types of damages which occur in radio receiver cabinets. These can be repaired easily after a bit of experience has been obtained. They are: *press marks* (bruises due to improper packing); *scratches* (deep and surface); *dents*; *rubbed edges* and *fractures*. The tools and materials required for their repair are: $\frac{2}{3}$ quart of crude oil thinned with $\frac{1}{3}$ quart of benzine; 1 small can of furniture glue; very fine steel wool, No. 0000 pumice stone powder; walnut stain; No. 0000 sand paper; an alcohol lamp; a stick of transparent, burning-in shellac; a small pen knife or scapel. All of these supplies may be obtained at any paint supply store for approximately one dollar. The alcohol lamp can be made by cutting off the small end of

a machine oil can spout and inserting a wick into it so that it dips into the alcohol contained inside. A lamp of this kind may be seen in Fig. 26-30.

If the cabinet has a "press mark" or surface scratches, first rub it down well with the crude oil and benzine mixture. Then follow with pumice stone over the entire surface and finish with a soft dry rag. The pumice is applied by dipping a rag or small piece of felt soaked in the crude oil, into the pumice powder.

If the cabinet has deep scratches, minor dents, or other marks, they must first be filled in with the burning-in shellac. To do this, light the alcohol lamp, soften the shellac stick in the flame and get a piece of this transparent shellac on the side of the rubbing-in knife. Fill the indentation by carefully pressing the softened shellac in with the knife, as shown in Fig. 26-30. Build it up until the surface comes slightly above that of the cabinet. After the indentation is completely filled, sandpaper the projecting rough surface flush with the wood. Then finish the job with pumice and oil in the same manner as already explained for "press marks".

Deep dents may sometimes be swollen flush by the application of hot water or steam. However, this process requires considerable care, or the glue under the top layer of veneer will become moist and the veneer will peel.

Rubbed edges are very common, and give the cabinet a shabby, shopworn look. Generally, alcohol (colored with walnut, oak or mahogany stain according to the finish of the set) applied along these edges with a piece of felt will suffice. Bottles of these various stains should be kept at hand.

Fractures in radio receiver cabinets may be caused by extremely rough handling during shipment. Splitting and checking may sometimes be caused by the use of improperly seasoned wood in cheap cabinets or by subjecting the cabinet to extreme temperature changes during shipment. Very often, these may be repaired by smearing the surfaces of the split portions with a good grade of furniture glue and clamping them together properly until the glue has set. After the clamps have been put in place, any excess glue should be wiped off carefully with a cloth moistened with hot water. Be careful to insert blocks of

soft wood between the clamps and the polished surfaces of the receiver cabinet to prevent denting by the jaws of the clamps when they are tightened. Two or three five-foot adjustable iron rack-type "C" clamps supplemented by a few of the smaller wooden "C" clamps are excellent for this purpose.

REVIEW QUESTIONS

1. Explain in detail how you would proceed to repair a 2,000-ohm wire-wound resistor in which the resistance wire has broken near one of the end terminals.
2. You require a moulded carbon type resistor of 2,500 ohms, but you have only one of 2,000 ohms on hand. Explain what you would do to increase the 2,000-ohm unit to 2,500 ohms. How would you know when you had the correct resistance?
3. Suppose you needed a 1,500-ohm resistor and you had a 2,000-ohm wire-wound unit on hand; what would you do to it to make it serve the purpose satisfactorily?
4. Explain how you would proceed to repair a variable wire-wound volume control resistor which is responsible for noisy operation of a radio receiver.
5. How would you proceed to re-wind an r-f coil in a t-r-f receiver employing a 3-gang tuning condenser?
6. How would you match the coil with the others in the receiver, so that the tuning would track satisfactorily over the entire dial?
7. Explain with the aid of sketches, how you would test an i-f transformer unit to determine and locate the following troubles: (a) short between the primary and secondary windings; (b) open primary; (c) shorted primary tuning condenser; (d) ground between the shield can and one of the coils.
8. A filter choke is burned out near its center so that its resistance cannot be measured. How would you determine the amount of wire that must be purchased to rewind the choke? The size of the wire?
9. How would you make sure to have the same air-gap length in the core of the choke of Question 8, after it is rewound, as was present before?
10. Explain how you would remove a choke coil from its housing, if it is sealed in with pitch.
11. Ohmmeter tests show that one of the low-voltage filament windings of a power transformer is burned out because of overloading. Explain in detail, how you would proceed to repair this transformer if the winding is the 3rd winding from the outside one, and it is not desired to disturb any of the outside windings. How would you determine the size wire and number of turns to use for the replacement coil?
12. Name the various insulating materials that are employed to insulate the windings of filter chokes and power transformers from themselves and the core, stating the particular applications for which each material is best suited and your reasons for same.

13. A condenser block containing three filter and four by-pass condensers of the paper-type, with a common grounded terminal throughout, is to be tested for opens, shorts, leakage and grounds. Explain how you would make each test, and what instruments you would use in each case.
14. One of the 2-mfd. filter condensers in the condenser block of Question 13 is found to be leaky. All of the condensers are sealed in pitch in a metal container. Explain how you would proceed to remove this condenser from the block and connect and seal another similar one in its place.
15. How could the receiver which employs the condenser block of Question 13 be put back into normal operating condition if it is not desired to bother sealing a new condenser into the block?
16. An electrolytic condenser of the wet type breaks down because it is accidentally connected across a voltage greater than its maximum rated value. How would you go about re-forming the plates?
17. A variable condenser is noisy. After cleaning the wiping contact, it is still noisy. What expedients would you resort to, in order to eliminate the noise?
18. Explain how you would make complete electrical tests on the speaker cord of a balanced-armature cone speaker. Illustrate your explanation with a sketch for each test.
19. Assuming that the tests of Question 18 indicate that the speaker cord is perfect, how would you proceed to locate possible electrical troubles existing in the coils of the speaker?
20. Explain how you would test the permanent magnet of the speaker in Question 19 for strength. How would you remagnetize it?
21. Can a-c be used for remagnetizing a permanent magnet? Why?
22. A balanced armature magnetic speaker is noisy. Upon investigation, it is found that foreign matter is clogging up the air gap and the armature is not centered. How would you go about repairing it?
23. The cone of the speaker of Question 22 is not properly seated. How would you reseal it?
24. (a) How would you repair a tear in the paper cone of a loud speaker?
(b) How would you repair a seam which has opened up?
25. What kind of current should be supplied to the field coil of a dynamic speaker? What will be the effect on the reproduction of the speaker in each case if the following types of currents are supplied: (a) a-c; (b) pulsating d-c; (c) smooth d-c?
26. Describe 4 different ways in which the dynamic speaker field current can be obtained in practice in a common a-c line-operated radio receiver. Illustrate your description with circuit sketches.
27. Explain how excessive leakage in the dry electrolytic filter condenser employed in the speaker field circuit of Fig. 26-14 would affect the operation of the speaker. Would the hum be increased by this condenser condition? Why?
28. The field coil of a dynamic speaker obtains its current from a full-wave rectifier system operating from the 60-cycle line. The speaker does not contain any provisions for reducing hum. Ex-

CH. XXVI REPAIRING INDIVIDUAL RADIO COMPONENTS 865

- plain how hum that will be heard in the speaker output will be produced. What will be the frequency of this hum? Explain!
29. A dynamic speaker is equipped with a hum-bucking coil to reduce hum. Explain how this coil operates to reduce the hum.
 30. What effects will be noted if the hum-bucking coil should open-circuit? If it should short-circuit?
 31. Explain the purpose of the copper shading ring in some dynamic speakers. How does it accomplish this purpose? Why is it made of copper?
 32. The voice coil of a dynamic speaker is not properly centered. The spider and cone are in good condition, but the voice coil is "out of round." How would you attempt to repair and recenter the coil?
 33. What effect, on the operation of a dynamic speaker, would several loose turns on the voice coil have? How would you proceed to repair this trouble?
 34. The internal spider of a dynamic speaker is broken, although it is cemented rigidly to the cone. What two methods may be used for repairing the spider?
 35. State 5 causes for raspy and distorted reproduction in a dynamic speaker. The receiver is perfect and the voice coil of the speaker is properly centered.
 36. The output of a loud speaker sounds "fuzzy." The spider and voice coil look normal and properly aligned. What would you look for in the speaker, as the possible cause of trouble?
 37. What would be the audible result, in each case, if the following trouble were present in a dynamic speaker: (a) loose soldered joint on input cord tip terminal; (b) output transformer primary or secondary open; (c) output transformer primary or secondary shorted; (d) open voice coil; (e) shorted voice coil; (f) open hum-bucking coil; (g) shorted hum-bucking coil; (h) open field winding or connecting leads; (i) voice coil off center; (j) loose cone edge?
 38. What is the most common trouble which occurs in condenser type speakers? What causes this trouble?
 39. How does a magnetic phonograph pick-up operate? Explain!
 40. What will cause the complaint of weak and distorted reproduction from a magnetic pick-up? What will cause "blasting"?
 41. How would you go about recentering the armature of a magnetic phonograph pickup of conventional construction?
 42. What precaution would you observe when removing and replacing the permanent magnet of a magnetic pickup? Why?
 43. Reproduction from a phonograph is distorted. The pickup is tested and found to be normal, but the turntable is turning too slowly. What means would you use to adjust the turntable speed?
 44. What is the effect on the entire "pitch" of the reproduction from a phonograph record if: (a) the turntable rotates at higher than normal speed; (b) rotates at lower than normal speed?
 45. Discuss 5 causes for the complaint of "wow" during record reproduction.
 46. How would you proceed to eliminate excessive hum in a phono-

radio installation, the hum being present only when the pick-up is operated. Grounding the components, and shielding the pick-up leads do not help matters. Explain!

47. A high-impedance phono pickup is to be installed in the input side of the detector circuit of a receiver. The receiver uses a grid leak-condenser detector with no bias. Draw a circuit sketch showing how you would connect the pickup into the receiver circuit so that either radio or phono reproduction may be obtained at will by flipping a single toggle switch.
48. If the pickup of Question 47 is of the low-impedance type, what other piece of equipment will be needed for satisfactory operation? Why? Draw it in its proper position in the circuit sketch you drew for Question 47.
49. You are called upon to install a low-impedance magnetic phonograph pickup in the receiver whose circuit diagram is shown in Fig. 21-12 (Chapter XXI). Decide where you would connect it for good volume, and draw a simple circuit sketch showing the connections as you would make them.
50. Explain the idea involved in, and the operation of, the phonograph oscillator shown in Figs. 26-27 and 26-28. What are the advantages of this method of phonograph pickup connection?
51. Explain how you would proceed to repair a deep scratch which was made in an expensive walnut radio cabinet.

PART 3

SPECIALIZED
SERVICING PROBLEMS

CHAPTER XXVII

INSTALLING AND SERVICING AUTO-RADIO RECEIVERS

27-1. Introduction.—The auto-radio receiver has become such a widely accepted offspring of the home radio set that little need be said regarding its increasing popularity as a convenient source of entertainment and information in automobiles. From the standpoint of the radio service man, it is sufficient to know that the sale of auto-radio receivers has increased at a very rapid pace and that the season at which most auto-radio work is done occurs just at the time when the servicing of home receivers is usually at a low ebb, so that auto-radio work helps to fill in the otherwise dull months of the year. Millions of these receivers will be sold and installed every year, and millions of them will require some servicing.

As every service man knows, the satisfactory installation of auto-radio receivers involves a great deal more work than the mere drilling of a few mounting holes for the receiver, and its connection to the car battery. If this were not the case, there would be no need for a special chapter on the subject in this book. There are many auto-radio installation and servicing problems which are unknown in home-receiver installations. For example, the receiver must be mounted in a location which is almost always very cramped and hardly accessible. Unless the car is already equipped with a built-in antenna system, an aerial must be installed in (or on) the roof, under the running boards or chassis of the car, or in some other location. Portions of the upholstery may have to be removed and put back later in order to do this. Considerable attention must also be given to the ignition and other electrical wiring of the car in order to eliminate all electrical interference which it produces in the receiver. Suppressor resistances must usually be installed in the high-tension

wiring; by-pass condensers (and often chokes) must be put in at various places in the low-tension wiring; brake rods and other control rods may have to be bonded to the chassis; and it is often necessary to shield, re-route, or make other changes in the car wiring itself before satisfactory noise-free operation is obtained. The increased sensitivity engineered into modern auto-radios and the growing tendency to eliminate individual spark-plug suppressors have thrown the burden of noise elimination where it should be—on expert installation work.

An itemized list of the operations involved is presented here, so that a general idea of what the installation of auto-radio receivers really involves may be had before the various problems are considered in detail.

1. The receiver must be mounted in the most suitable place.
2. The tuning-control unit (if one separate from the receiver is provided) must be mounted on the steering column or the instrument panel.
3. The loud speaker (if one separate from the receiver is employed) must be mounted.
4. The receiver must be connected to the car storage battery. The battery terminals may first have to be cleaned thoroughly.
5. If an aerial is not already provided in the car, a suitable one must be installed.
6. The charging rate of the generator must usually be increased to compensate for the increased battery drain caused by the radio set (unless the car is already provided with automatic charging-rate regulation).
7. By-pass condensers must be connected at the generator terminals and very likely at other places in the car to reduce electrical interference.
8. The spark plug gaps and breaker points may have to be cleaned and adjusted, or the distributor rotor-arm peened, in order to clear up electrical interference.
9. In many installations, suppressor resistors must be installed at the spark plugs and the distributor.

10. Miscellaneous shielding of wires, bonding of control-rods and wire-shields to ground, and by-passing may have to be done in order to eliminate troublesome electrical interference.
11. In some cases, certain wires in the ignition system of the car may have to be re-routed, and the ignition coil may have to be re-located in order to minimize interference.

In the face of all these installation problems, it is no wonder that auto-radio installation and service work has often been found unprofitable by the uninitiated or poorly-equipped service man who does not have sufficient knowledge of the electrical systems of automobiles, or the many possible causes for electrical disturbances which may be set up by them, to locate and remedy such troubles rapidly and directly.

It is unfortunate that automobile owners do not realize that when an auto-radio installed in their car gives noisy reception, it is usually the fault of the car and not the radio receiver. They do not realize that the noise problem depends not only upon the make and model of car but also upon its age and the condition of its ignition system. The radio service man is often forced to recondition the entire ignition system of the car before he can make the radio installation (which may be perfect in every respect) operate to the entire satisfaction of the owner. Usually, the owner is not willing to pay extra for this service. He is often quick to point out that an auto-radio set installed in a friend's car of the same make and model gives perfect reception, while his does not—being unaware of the fact that the electrical and ignition systems of his particular car may be in extremely poor condition, and further that it is usually easier to make a high-grade receiver give excellent performance than it is to do so with a cheap one whose "engineering" has been skimped to meet price competition. High-grade auto-radio receivers are usually double-shielded to prevent direct pickup by the internal wiring of the receiver and are provided with an array of chokes and by-pass condensers which filter out all noise currents from the battery and control wiring. These features are often omitted in the cheaper receivers, with the result that more elaborate measures have to be taken with the wiring of the car

itself to eliminate all noise. Naturally, this takes more time, and it is on just such jobs as these, where a very inexpensive set is being installed, that the owner is not willing to pay much for the installation work. These are but a few of the conditions which the service man must contend with and overcome successfully if he is to do this branch of radio work satisfactorily.

It is to thoroughly acquaint the reader with modern auto-radio service problems and their solution that this chapter is included. The information contained herein represents the practical findings resulting from the experience of the author and many others engaged in this work. Its purpose is to make clear most of the problems that confront the service man in this branch of work, and to specify direct, rapid solutions to most of them.*

27-2. Qualifications and Equipment for Auto-Radio Service Work.—No special training is required to install and service the average auto-radio receiver. The usual thorough knowledge of radio circuits and theory—which is essential for any sort of radio service work—some knowledge of the electrical wiring systems of automobiles†, and the ability to follow directions carefully, are all the essentials required. Once installed, the receiver must be freed from the various types of noise interference, and it is here that the specialized knowledge contained in this chapter is of importance.

The equipment required for the installation and servicing of auto-radio receivers is not greatly different from that required for home receivers. In addition to the usual set analyzer, tube tester, hand tools, etc., a vibrator tester, a hack saw, an electric drill, socket, monkey and off-set wrenches, and a heavy-duty soldering iron are quite sufficient for all ordinary purposes. In addition, accurate thickness or “feeler” gauges for adjusting the breaker points, the spark-gap points, and the distributor; sand paper for cleaning the commutator of the charging generator and other incidental motors that may be used, plus a few additional small

*NOTE: Definite remedies for stubborn cases of noisy auto-radio operation in the various makes and models of American cars are presented in the author's *Radio Trouble-Shooter's Handbook*.

†NOTE: The wiring diagrams for the electrical systems of recent model American automobiles will also be found in the *Radio Trouble-Shooter's Handbook*.

items completes the tools of the auto-radio installation and service man. A supply of shielded loom, wire-shielding, flexible copper bonding braid, etc., will also be required. These will be considered at the proper places later.

A word or two about the size and location of the shop. If possible the shop should be large enough, and so located that the customer can drive the car into it. Experience has shown that best

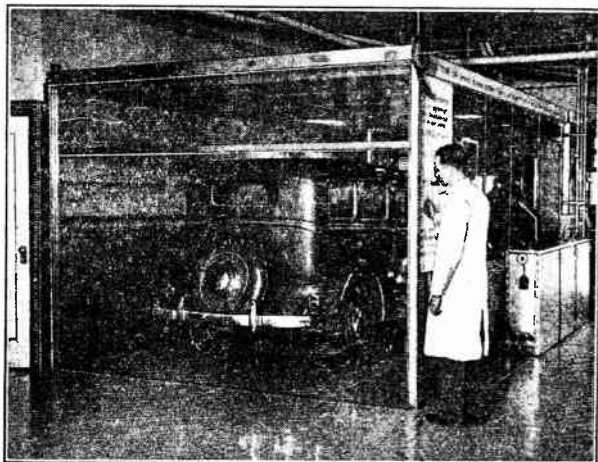

Courtesy Radio Craft Magazine

FIG. 27-1.—An auto-radio test room arrangement whereby the car and auto-radio receiver under test (as well as all test equipment) is completely shielded from all outside sources of electrical interference. The operator is shown here about to complete the shielding of the car by pulling cables which lower the screen door at the front.

service can be rendered, and the customer more easily and completely satisfied, when the work is done inside the shop than when conditions are such that the car must be left in the open, over night perhaps, while the installation is being made or the repair effected. More important than this, however, is the fact that external interference from other passing vehicles and all electrical devices in the vicinity is minimized when the car with the receiver under test is brought into a closed, and preferably shielded test space whenever it is necessary.

Figure 27-1 is an interesting photograph of a modern auto-radio installation and service station showing a car driven into

the special screened cage, having its radio receiver tested. The test enclosure consists of a massive copper screen cage which completely surrounds the car being tested and keeps out man-made static and other extraneous disturbances. The entire cage, including the floor immediately under it is thoroughly grounded, and the repair shop is in the cage as well. An installation of

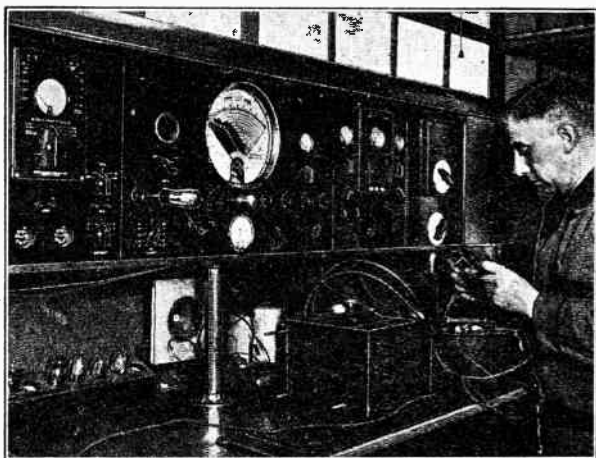

Courtesy Radio Craft Magazine

FIG. 27-2.—A modern test bench for auto-radio service work. A direct-reading tube checker is at the center. The test panel also contains a test oscillator, set analyzer, volt-ohm-milliammeter, condenser tester, etc. Notice the neat straightforward arrangement of all the equipment, and the free bench space for working. This test bench is located within the test cage shown in Fig. 27-1.

this kind makes it possible to provide proper test conditions at all times. Of course, it is rather elaborate, but in congested areas troubled with excessive noise interference, such an arrangement may be absolutely necessary.

Figure 27-2 is an illustration of a modern auto-radio test bench showing the neat layout of the test oscillator, analyzer, tube checker and other test instruments arranged on a vertical panel in back out of the way so as not to interfere with the service work proper. This test bench is actually located within the shielded test cage shown in Fig. 27-1. It should be emphasized, however, that even more important than a good, suitably-

equipped shop is a thorough understanding of auto-radio receivers. Their construction, installation, relation to the electrical system of the car, the methods to be employed in tracking down and eliminating all sources of electrical interference which make them noisy, and their repair are vital points that the auto-radio service man must know all about, if he is to be successful.

27-3. Mechanical Requirements and Construction Features of Auto-Radio Receivers.—The auto-radio receiver differs from the home receiver in some important mechanical and electrical details which are necessarily caused by its different environment. The home receiver is intended for operation in a location relatively free from wide atmospheric and temperature changes, dust and mechanical vibration. It is also assumed that it is fairly well removed from sources of disturbing electrical interference so as to be reasonably free from such disturbances, and that most of any noise that is heard must come either from the power line or from the antenna system. Of course, all coils and most of the critical wiring are shielded to prevent as much of the direct pickup as possible. If the natural environment of the receiver is not conducive to such noise-free operation, suitable measures can be taken to make it quiet (see Chapter XXX).

The auto-radio receiver, however, must contend with much worse conditions. It must withstand the almost constant vibration and jarring of the car—even if it travels over the roughest country roads—it must be compact enough to enable convenient location out of the way, of both driver and passengers; the tuning control system must be so arranged that it can be manipulated from a point remote from the receiver in most cases; the design of the housing should be such that the receiver may be mounted and dismounted with ease whenever servicing becomes necessary.

Mechanical rigidity is secured by mounting all components firmly and permanently. Metal chassis are used, and the tube socket contacts are made to grip the tube prongs firmly to provide good contact in spite of severe mechanical vibration. The outer casing of heavy metal protects the components against dust and the elements, provides a means for mounting the receiver securely in the car, and also acts as a shield to reduce direct pickup of radiations by the wiring or other parts of the receiver.

Compactness is very essential in an auto-radio receiver. As will be shown in a later section of this chapter, difficulty is sometimes experienced in finding sufficient clear space where it may be mounted near the driver. The steering-wheel post, brake and clutch pedals, the emergency brake and additional equipment such as a car heater, etc. (all on the passenger side of the bulkhead) reduce the available room left in the car for the receiver. One trouble with the older auto-radio receivers was that they were so large that they could not fit into the available spaces in those locations which were best suited for them. The development of the new combination high-gain tubes has been the largest contributing factor toward making the auto-radio receiver more compact, and therefore easier to install.

Ease of installation depends upon the type of receiver and car; no specific rules can be given. But regardless of the method of mounting, the important thing is that an auto-radio receiver should be designed so that it can be installed easily and with the least amount of mechanical labor. It is important to distinguish between ease of installation and the amount of mechanical work involved. Certain receivers may be easily installed, themselves, but only after a considerable amount of drilling of holes and moving of other parts in the car proper has been accomplished. Other receivers may be installed with little mechanical work, but what there is of it is tedious and difficult.

Most auto-radio receivers have a built-in *B*-power supply unit which operates from the car storage battery. However, some of the older receivers employ a separate power unit which is mounted at some convenient place away from the receiver proper—often in the floor of the car. The same applies to the loud speaker. Some auto-radio receivers have built-in speakers, while others use separate speaker units. Each type has its own advantages and disadvantages, a discussion of which does not come within the scope of this book. Suffice it to say, however, that both types are in general use, and the radio man should know how to install and service both types.

Ease of service means that the receiver must be so designed that the set can be removed from its moorings in a few minutes without detaching any of the equipment not associated with it.

Several means by which this can be accomplished will be described in Art. 27-8. The ease with which a receiver can be serviced depends, among other things, upon its mechanical design. The tests of the circuits of the receiver and the servicing procedure are practically identical with those described for home receivers, in previous chapters of this book. The main exception lies in the power supply unit. Since this is somewhat different from the usual type encountered in home receivers, it will be discussed at length in Arts. 27-53, 27-54, etc.

27-4. Tuning Control Arrangements Employed.—There

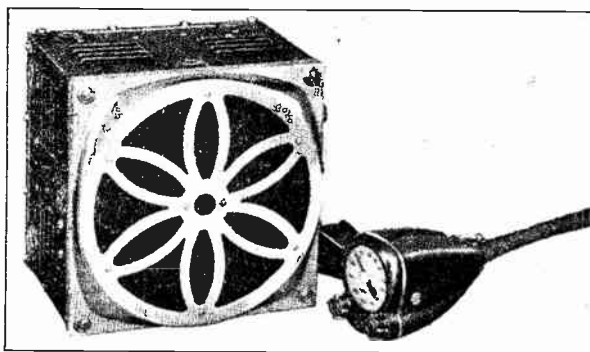

Courtesy Noblitt-Sparks Industries Inc.

FIG. 27-3.—A typical modern auto-radio receiver with self-contained loud speaker at the front. The remote-control tuning head and cable are shown at the right. The speaker grille is plainly visible at the front of the set.

are several general types of auto-radio receivers in use. These are distinguished from each other mainly by the tuning control and mounting arrangement used, rather than by the electrical circuits employed (all employ the usual superheterodyne circuit).

Several tuning arrangements are employed in these receivers—all bringing this control within convenient reach of the driver. In the earliest, and still the most popular one, the on-off switch, volume and tuning controls are placed in a housing called the *control-head*, which is mounted at a convenient location a short distance away from the receiver proper. A typical modern auto-radio receiver with built-in loud speaker is shown in Fig. 27-3. The remote-tuning control head and cable are shown at the

right. These controls are connected to the receiver proper by flexible drive shafts between the control head and the receiver. These drive shafts consist of special "dental cables" composed of as many as 45 fine steel wires twisted in a special way to form a flexible shaft about $\frac{1}{4}$ -inch in diameter (see Fig. 27-10)—one that can transmit twisting effort in either direction with very little torsional deflection. These shafts run in flexible metallic

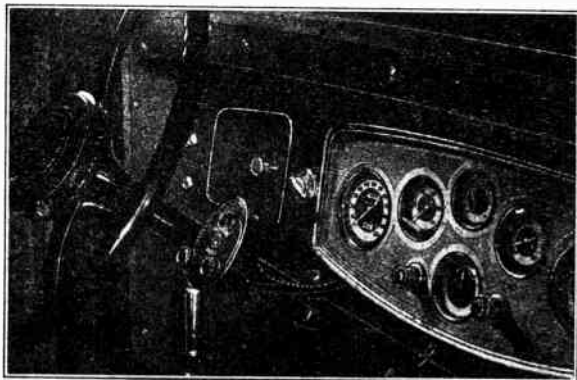

Courtesy Radio Craft Magazine

FIG. 27-4.—How the remote tuning control head of an auto-radio receiver is mounted on the steering column within convenient reach of the driver. The flexible cables run down from the control head, down along the steering column to the radio receiver mounted under the dashboard out of the way.

casings similar to speedometer cable housing. Their ends are swaged into square or hexagonal shape to facilitate their mechanical connection to the driving controls at one end, and driven units at the other.

Figures 27-4 and 27-5 show two different methods of mounting these remote tuning-control heads. In the former, the control head is mounted on the steering-wheel column (see Fig. 27-9 also), and in the latter the control head is built into the center of the dashboard or instrument panel of the automobile. In either case, tuning and other control is accomplished by this flexible "mechanical" drive between the control knobs and the receiver.

Dashboard control such as shown in Fig. 27-5 is easily installed in most recent models of cars, because the instrument

panels of the cars are designed to receive the "control heads". Special tuning-head escutcheon plates which "match" the finish, color, and design of the instrument panels of all popular cars are available. Notice how well, the radio tuning control escutcheon plate at the center of the instrument panel in Fig. 27-5 harmonizes with everything else.

A second method of obtaining dashboard control is provided

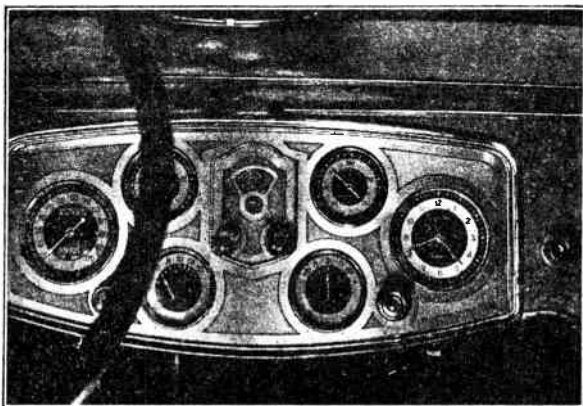

Courtesy Radio Craft Magazine

FIG. 27-5.—An auto-radio installation in which the tuning and volume control unit is built into the center of the instrument panel of the car. The tuning and volume control knobs, as well as the tuning dial window, may be seen here. The flexible control cables run from this unit down behind the instrument panel to the receiver mounted on the bulkhead behind.

by the type of receiver illustrated in Fig. 27-6. This has the tuning and volume controls built directly into one end of the receiver case. Note that this receiver is completely self-contained—the loud speaker, tuning control, power unit and radio receiver proper are housed in a single compact case. The receiver is designed to be mounted directly under the cowl, between the bulkhead and the dashboard, and to have the control units protrude conveniently from under the front of the dash, as shown. In one variation of this method, the extremely compact receiver is placed in one of the glove compartments of the dashboard. Operation is effected by merely opening the door of the compartment and manipulating the controls.

A third control scheme which was used in the past, but which has now lost favor, is to place the r-f and oscillator tubes in a small box mounted on the steering-wheel column and connecting the i-f output (a superheterodyne circuit is used) to the rest of the receiver placed in some convenient part of the car. This method has the advantage that the i-f amplifier, second detector, and audio amplifier unit is very small, and may be tucked in almost any convenient corner of the car, since flexible shafts are not required. However, it has many other practical disadvantages.

In many limousines which are driven by chauffers, it is desirable to have the tuning control in the rear of the car where the passengers may have convenient access to it. A special installa-

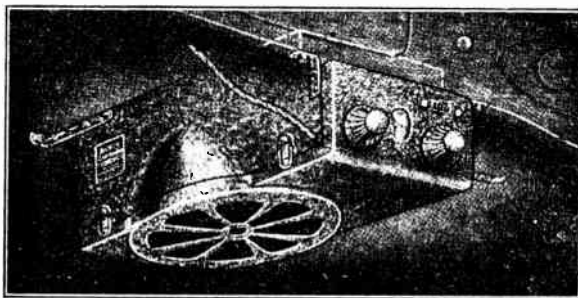

Courtesy Noblitt Sparks Industries Inc.

FIG. 27-6.—A single-unit auto-radio receiver designed for dashboard mounting and dashboard control. The tuning and volume controls are built directly into the receiver proper as shown.

tion of this type, in which the tuning control is built into the arm rest of the rear seat of the car, is illustrated in Fig. 27-7.

27-5. Electrical Features of Auto-Radio Receivers. — Thorough shielding is one of the primary electrical considerations in the design of an auto-radio receiver. Although the necessity for mechanical rigidity and electrical shielding are closely allied, nevertheless the receiver could be designed for less efficient shielding with the same mechanical rigidity. Good electrical shielding demands that all seams be tightly closed, all covers make good electrical as well as mechanical contact, all bushings be tight and snug, and all wires leading to the receiver be thoroughly shielded, and the shielding grounded.

Although the avc systems used in auto-radio receivers accomplish the same general function that they do in home receivers, they are employed here for a somewhat different purpose. As pointed out in Chapter XIX, the main purpose of the avc system in home receivers is to prevent overloading of the audio stages on loud signals and to maintain the output at some substantially constant level (depending upon the setting of the manual volume control) for different stations that may be tuned in. The fundamental purpose of the avc system in the auto-radio in-

FIG. 27-7.—An unusual auto-radio installation in which the tuning control head is built into the arm rest of the rear seat of the car. A close-up view of the tuning unit installation is shown in the insert. The loud speaker is placed in one of the rear doors and concealed with upholstery material. Wires to the speaker are carried through the door-check strap. The radio chassis is in a waterproof box beneath the floor boards.

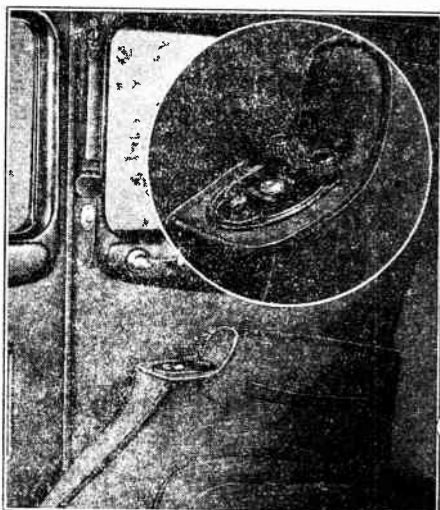

Courtesy Radio Craft Magazine

stallation is to prevent noticeable decrease in audio output as the car passes through signal fields of various strengths during its travels.

Since the auto-radio receiver is used while the car is in motion, it is therefore natural to expect that the signal strength will vary as the car passes through good and poor locations. The change in signal strength may be very rapid—and very extreme. The proximity of bridges, surface cars, trucks, steel buildings, trees, and other large electrical conductors often lowers (and sometimes raises) the signal strength. It is the purpose of the avc system in the auto-radio receiver to automatically increase or decrease the sensitivity of the receiver sufficiently to maintain

the output level substantially constant. Those who have operated auto-radio receivers which were not provided with sufficient AVC are aware of the widely fluctuating output levels which can result, and can appreciate the necessary wide range over which the AVC system must work. In practice, this range should be about 40 db, which corresponds to signal level changes of 100; in other words, the signal received can vary between 10 and 1,000 microvolts per meter and the AVC system should maintain the audio output level substantially constant (provided the receiver sensitivity is sufficient to provide sufficient output with the low-level input).

In order for the audio output level to be sufficiently strong with an input of 10 microvolts per meter, the sensitivity of the receiver must be high enough to amplify this small input sufficiently. The modern auto-radio receiver can do this easily, and is substantially as sensitive as the majority of home-installed receivers. This is contrary to a somewhat general impression that auto-radio receivers are insensitive; those built several years ago were relatively insensitive, but those manufactured at present are not. They must be extremely sensitive because of the extremely poor antenna systems they are forced to operate from and the fact that the signal field strength is comparatively weak in the city streets in which they may be operated.

Practically all auto-radio receivers employ the superheterodyne circuit, because of its many important advantages. The only great difference between these receivers and those employed in the home lies in the power units which are employed in them for converting the 6-volt d-c potential of the car storage battery into smooth high-voltage potentials for the plate and screen circuits of the tubes. In some receivers, vibrator arrangements (see Art. 27-53) are employed; in others a rotating power supply unit is used. These will be considered later. The tubes employed are those of the 6.3-volt indirect heater type—their filaments being connected in parallel with each other and operated directly from the car storage battery. The incoming filament-supply line from the battery is filtered through several chokes and by-passed to ground by a number of condensers so as to reduce the amount of interference ("hash") which would otherwise be conducted

into the radio-frequency circuits by the current supply wiring.

Due to their extremely compact construction, it is often difficult to get to the tube sockets of these receivers for test and analysis purposes unless the receiver chassis is first removed from the case. The same holds true for the power unit and speaker, if they are built as integral units in the main receiver case.

27-6. Specialization in Auto-Radio Work.—Most service men who do auto-radio work specialize in the installation of one or two types of receivers. These receivers, in their opinion, yield the most profit for the amount of installation and service work required. It is for this reason that the preceding details are given. Before a service man selects a particular make of receiver for his special attention, these details should be investigated thoroughly.

It may seem strange that mechanical details are usually of greater importance than electrical characteristics. The reason is that the circuits employed in most auto-radio receivers are about the same, and about the same types of troubles occur in them. The important problems confronting the service man are more of a mechanical nature—especially those concerning the ease of installation of the receiver and the ability of its electrical components such as filter and bypass condensers, resistors, vibrators, etc., to stand up under the vibration and temperature conditions existing in the car; the electrical problems such as ignition noise are perhaps more a function of the type and construction of the car than the circuit used in the receiver.

27-7. Locating the Receiver in the Car.—Perhaps the first thing to be done when a new receiver is to be installed is to study the layout of the portion of the car where the receiver is to be mounted. There is no standard location for the receiver proper if it is of the remote-control type. Of course, if it is of the direct tuned type, the only suitable location is under the cowl on the driver's side of the bulkhead; it can only be placed where it can be tuned by either the driver or a front-seat passenger. The presence of other wires or rods, especially the speedometer cable and the instruments on the dashboard may require that the receiver be moved to the right or left of the "ideal" location, but the general location of the receiver will be more or less

determined or "fixed" by its size and construction.

Clearance must be allowed for cowl-ventilator levers, terminal strips, fuse blocks, or hot-water heaters, and special care must be taken not to kink the speedometer cable. It will be found that a car possessing a hot-water heater usually has little room left for the receiver proper, and a great deal of patient figuring may be required before a suitable "spot" for the set can be found. Under no circumstances should an auto-radio receiver ever be mounted where any metal parts of the car will make intermittent or imperfect contact with the receiver case. This is certain to cause noise when the car is in motion. Bare choke rods, speedometer cables, copper tubing, etc., should never touch the case. If this cannot be avoided, they should be well taped where they are apt to touch the case, so that they will be insulated from it. This condition is especially important when a directly-tuned receiver that must be tuned from the dash is installed. In many cases it may be necessary to move the heater a few inches to secure sufficient room.

Indirectly (remote) tuned sets have more leeway in installation, although there is a definite practical limit to the maximum distance the control head can be placed away from the receiver. There are several possible locations for the receiver, once the control head position has been decided upon.

Most modern auto-radio receivers are designed so that the speaker, power unit and receiver proper are encased in a single housing; in the alternative construction, the speaker is a separate unit. In either case, the same rules for locating the proper position of the receiver hold. Care must be taken that the receiver (and the separate speaker) do not obstruct any apparatus on either the engine or driver side of the bulkhead. In some instances it may be necessary to shift the position of heaters, ignition coils, and certain wiring to fit the receiver in place.

It is an excellent idea to hold the receiver against the bulkhead in what seems to be a good position and mark off its location with a piece of chalk. Then, on the engine side, locate the same area and note carefully if it is obstructed by apparatus. Once a good location for the receiver has been determined, the set should be taken into the shop for a thorough test before

actual installation begins. It is best to test the receiver just before the actual installation, as it excludes the possibility of anything going wrong while locating the proper place for it.

The placement of parts on the bulkhead on older model cars are such that difficulty may be had in finding a location for the receiver. This condition existed because car manufacturers did not have radio in mind when the cars were designed. However, most recent cars are constructed so that sufficient space is left somewhere on the dashboard or bulkhead for the radio receiver. It is wise to attempt to determine where the manufacturer intended a receiver to be placed, before proceeding with the installation, as it will be found that, in most cases, that location will result in less noise after the installation is finished.

It is unfortunate that no additional specific data can be given regarding the selection of the proper location of the receiver, since the design of the car and set must be considered for specific data to be of value.

27-8. Mounting the Receiver and Loud Speaker.—Once the location has been determined, the next step is to mount the set in accordance with the instructions of the manufacturer. Here again, very little specific information can be given, since because of the numerous mounting arrangements employed, the exact procedure is different for almost every set. However, there are several general rules that may be followed in all cases.

Modern auto-radio receivers are constructed so that they mount on the vertical part of the dashboard (on the bulkhead) with hook-bolts, studs, or some similar fastening. First, one or more holes are drilled in the bulkhead, the location and spacing of these holes being specified by the set manufacturer. A drilling template is usually furnished with the receiver. Then the receiver may be fastened directly to the bulkhead, or, a plate is fastened to the bulkhead and the receiver proper is "hung" on this plate. This mounting arrangement is not the same for every receiver—it is mentioned here merely to supply some idea of the general arrangement. Those who have attempted to install early auto-radio receivers are well aware of the large number of mechanical problems that had to be solved before a good installation could be made. This is in direct contrast to the recent receivers,

many of which may be mounted with a single bolt, as shown in Fig. 27-8. This simplifies and speeds up the installation work.

Some idea of a typical 1-bolt mounting arrangement can be gained from a study of Fig. 27-8. To mount such a receiver, the location is first determined and the area of the rear of the receiver case is marked off on the bulkhead with a piece of chalk or pencil. Then the center of the area is determined by drawing diagonals (lines between opposite corners) and marking their intersection. A $\frac{1}{2}$ -inch hole is drilled here. The small "dash-support" plate is loosely mounted with the carriage bolt through this hole, and the nut and lock-nut are screwed on loosely

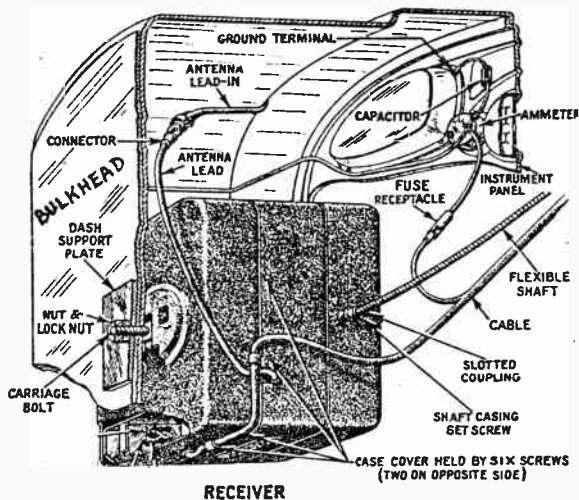

FIG. 27-8.—Detail showing how a typical single-bolt mounting auto-radio receiver is fastened to the driver's side of the bulkhead between the engine compartment and the passenger portion of the car. This view is drawn looking from the engine side of the bulkhead back toward the driver's compartment.

Courtesy RCA Victor

on the engine side of the bulkhead. The set is hooked on over the head of the carriage bolt, is straightened, and then the two nuts on the engine side of the carriage bolt are tightened, holding the dash support plate and the receiver case tightly to the bulkhead. If the receiver is to be removed at any time for test or repair, the single nut and lock nut are simply loosened, and the entire receiver case is slid up off the head of the carriage bolt.

In other receivers the method of mounting is slightly different, but most all of them make use of a template of one sort or another. In the receiver just described, the "template" is easily drawn on the bulkhead by the service man himself.

If the receiver contains a separate loud speaker, this should be mounted next. These speakers are usually designed for single-bolt mounting and are very simple to fasten to the bulkhead. In most instances, the best location for the speaker is on the bulkhead, to the left of, or above, the steering column. Enough room should be left for unobstructed foot action on the brake and clutch pedals. The loud speaker cable should then be connected

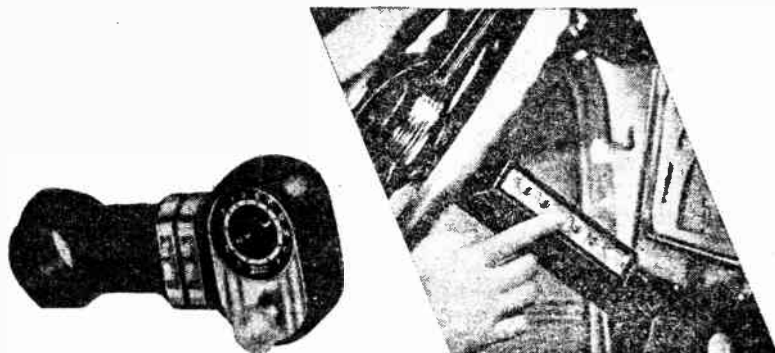

FIG. 27-9.—A modern auto-radio control head designed for easy steering-column mounting is shown at the *left*. At the *right*, a special type of push-button tuning control box is shown mounted in place on the steering column.

properly to the receiver in accordance with the manufacturer's instructions.

27-9. Mounting the Tuning Control Unit.—After the receiver and loud speaker have been mounted securely, the tuning control unit should be fastened in place (if a separate one is employed). If it is designed to be mounted directly on the instrument panel (see Fig. 27-5), a suitable hole may have to be cut for it. If it is to be mounted on the steering column it should be located a short distance under the steering wheel (see Fig. 27-4) so as to be easily accessible, and it should not obstruct the driver's view of the instrument panel. A detailed view of a modern control-head designed for easy steering-column mounting is shown at the *left* of Fig. 27-9. At the *right*, a special type of push-button tuning control box is shown mounted in place on the steering column.

In many of the older steering-column type control heads, a

clamp bracket and circular strap are fitted to the steering column, and the necessary bolts are put in place and tightened. Steering columns vary in diameter, the usual sizes being $1\frac{1}{2}$, $1\frac{5}{8}$, $1\frac{3}{4}$, $1\frac{7}{8}$ and 2 inches in diameter. In some units, an additional hole must be drilled in the strap to permit clamping it to a 2-inch column. The proper location of this hole may be determined after one or two trials by clamping the strap tightly with the hand and estimating the correct location of the new hole.

The flexible drive-shaft (or shafts) between the tuning control unit and the receiver are installed next. The shaft must be so run to the receiver that there are no sharp kinks or bends

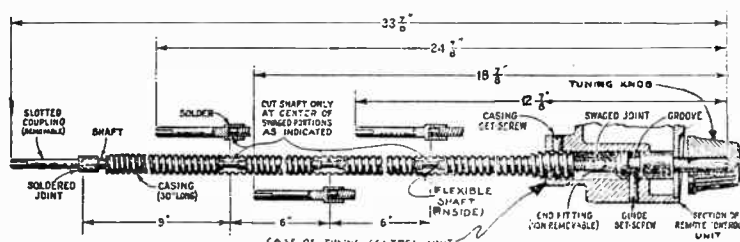

FIG. 27-10.—Detailed cross-section view of a typical flexible drive shaft used between the receiver and its remote tuning control unit in auto-radio installations. This shaft may be cut at any of the swaged joints to facilitate installation when a shaft of shorter length than that provided is required. In this way, four different cable lengths are made available.

in it, and so that it does not obstruct the action of the feet in manipulating the foot pedals of the car. It is usually run down the steering column and fastened to it with small clamp straps provided for the purpose. It is then bent *gradually* until it reaches the receiver. One or two such flexible shafts may be used, depending upon whether the volume control resistor and battery switch are built into the tuning control unit, or whether they are built into the receiver and operated by a flexible cable from the tuning unit. The procedure for mounting a unit having one drive shaft is usually the same as for units having two, and the manufacturer's data sheet should be examined for specific details on the shafts used in the particular receiver.

One widely used form of flexible drive shaft contains a slotted end, as shown in Fig. 27-10, which is inserted into the corres-

ponding slot in the receiver and rotated until it engages with a pin in the tuning mechanism in the receiver. When it engages, the shaft is slid forward the maximum amount. Then the opposite end of the shaft is pushed through a bushing in the remote control unit and the set-screw tightened. After the proper adjustment is secured, the remaining set-screws are tightened firmly, making for good electrical as well as mechanical contact.

In many installations, it is not possible to utilize the full length of the shaft. Of course, a shorter shaft may be procured; but when this is not feasible, the existing shaft may be cut to the correct length. As shown in Fig. 27-10, the flexible shaft usually contains several sections, the end of each section being a suitable place for cutting. In order to be cut, the shaft proper must be removed from its outer casing by removing the slotted coupling shown to the extreme left of the sketch. The shaft is then cut *only* at the center of the swaged joint, selecting that joint which allows at least the required shaft length. Then the outer casing of the shaft is cut to the same length as the cable, and the shaft is replaced in the casing. The slotted coupling is resoldered to the end of the shaft for insertion in the receiver bushing. Thus, it may be seen that this form of shaft can easily be cut to a length of $12\frac{7}{8}$, $18\frac{7}{8}$, or $24\frac{7}{8}$ inches, or may be used at its full length of $33\frac{7}{8}$ inches.

After the receiver is properly installed and the shaft connected, the tuning knob should be turned and the position of the dial when the tuning condenser of the set is turned to either end of its travel should be noted. Readjustment of the flexible shaft may be necessary if the tuning dial position does not correspond properly with the end position of the tuning condenser.

A pictorial view of a complete single-unit auto-radio receiver with its tuning-control head, A-battery lead and mounting bolts, is shown in Fig. 27-1. The receiver is of the single-unit type having two flexible drive shafts and a control head for mounting on the instrument panel of the car. An A-battery lead is provided for direct connection to the car ammeter post. The receiver "bolts" on to the car bulkhead by means of the mounting bolts shown.

Many receivers have a fuse in the battery cable to provide

proper "overload" and "trouble" protection in the battery line. In the receiver of Fig. 27-11, a fuse is provided as shown (inside the removable rubber sleeve) in the battery cable between the receiver and control head. This may be renewed easily whenever necessary.

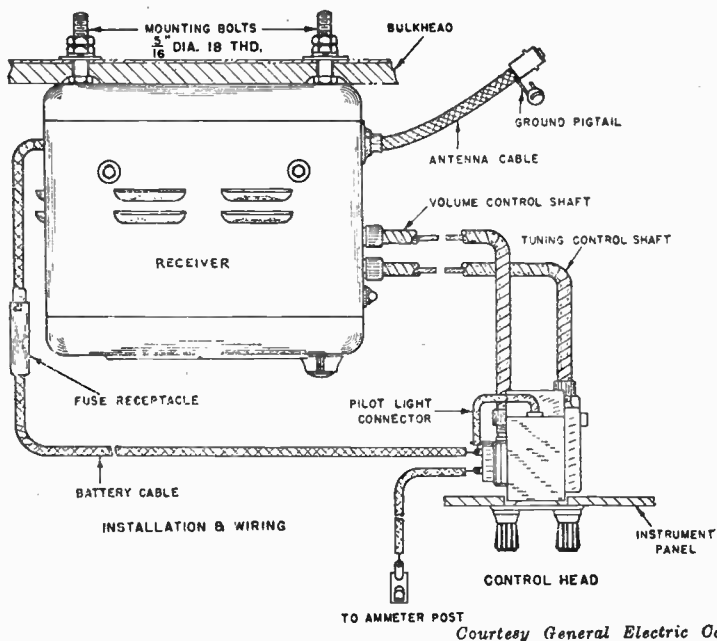

FIG. 27-11.—Looking down on a typical auto-radio installation, showing the location of the various main units. Note especially the method of mounting the receiver by bolting it to the car bulkhead. The tuning-control head and two flexible shafts running to it are also shown. The "fused" battery cable and the "hot" A-lead which goes to the car ammeter post are at the lower left.

27-10. Connecting to the Car Storage Battery.—After the receiver (with the loud speaker) and tuning control head have been mounted, and connected together properly, the electrical connections to the car storage battery should be made. Several important precautions must be observed when making them.

The electrical systems of all cars are such that one terminal of the storage battery is "grounded" to the chassis and the other

side connects to the ignition and lighting systems. One side of these systems is also "grounded" to the car chassis to complete the electrical circuits (see Fig. 27-57). The "grounded" terminal of the battery is connected to the chassis by a short, thick flexible copper braid or strap. One end of this strap is provided with a large lug which clamps over the terminal post of the battery; the other end is bolted to the channel-iron frame of the chassis. It is essential that *clean, tight* connections be maintained both at the battery terminals and the chassis if the full battery voltage is to be available and interference noise is to be kept at minimum value. If these terminals are found to be dirty, they should be dismantled and cleaned thoroughly with emery cloth. The battery terminal posts and the insides of the lug holes should then be coated with a thin film of white vaseline (do not use ordinary car grease) before assembling. Then they should be put back in place securely, connecting the battery leads from the receiver properly in place with them, with due consideration being given to the following important points.

Either the *positive* or the *negative* terminal of the battery may be the one grounded to the frame of the car—depending entirely upon the make of the car.* It is usually important to know which system is used, for in auto-radio receivers which employ a "synchronous" type vibrator (see Art. 27-55), either the receiver will not operate at all or trouble may be experienced if the battery polarity is wrong. In most receivers of this type, a simple means is provided in the receiver itself for correcting the polarity of the input to the receiver *B*-voltage vibrator (such as by having the vibrator *reversible* so that it may be inserted in two possible positions, etc.). On a car having "negative ground" it is necessary to withdraw the vibrator unit, rotate it 180 degrees, and re-insert it in the new position. If the car-battery polarity data is not at hand,* the service man may check the battery polarity with the low-reading scale of the d-c voltmeter in his set analyzer. This is recommended as a check in

*NOTE: A complete tabulation showing just which side of the car battery is grounded in all models of the popular makes of American cars manufactured from 1933 to date, will be found in Section 8 of the author's *Radio Trouble-Shooter's Handbook* (Radio & Technical Publishing Co.).

all cases anyway when installing those auto-radio receivers which require a definite battery polarity for successful operation.

In some receivers, two battery leads are provided; one is to be connected directly to the chassis of the car, the other one is to be connected to the "hot" side of the battery. *The "hot" side of the storage battery is always understood to be the side that is NOT grounded, regardless of the polarity of that side.* In other cases, one lead connects to the "hot" terminal of the battery, the other is fastened under the head of the same bolt which fastens the lug of the battery-grounding strap to the chassis.

In still other cases, one of the battery leads of the set is to be connected directly to the car frame, and the other connects to one terminal of the ammeter on the instrument panel of the car. The procedure in any case is simple. If the set manufacturer's instructions are followed, correct operation will result. The effects that a storage battery which is in poor condition will have on the operation of the receiver will be discussed in Art. 27-34. The adjustment of the charging rate of the car generator to compensate for the increased current drain caused by the auto-radio set will be discussed in Art. 27-36.

After the receiver has been connected properly to the car battery, it should be turned on to see if the dial lights up properly and if the set functions. A slight vibration should be felt when the hand is held on the receiver case, and a slight hum should be heard in the speaker.

27-11. Installation in Cars Provided with Built-In Antenna System.—After the receiver has been installed and connected to the car battery, attention may be directed to the installation of the antenna system, if one has not already been provided as standard equipment by the car manufacturer. If the car already contains an antenna, no further antenna installation is necessary, *provided the one already on the car has a sufficiently high signal to-noise ratio to give satisfactory reception with the particular receiver being installed.*

The lead-in wire should be located (since it is usually run down through one of the hollow corner posts of the car, it will usually be found on the right or left hand side behind the in-

strument panel).* In order to make certain that the antenna is not grounded to the chassis at any point, it is well to test for a "direct" or "high-resistance" ground between the wire of the lead-in and a "clean" spot on the car body. If a "ground" does exist, it must be cleared up before the antenna is used. Otherwise, the lead-in may be connected to the antenna terminal of the receiver with a piece of shielded wire, as will be explained later in Art. 27-16. Any surplus wire should be clipped off. In this case the next step will be to clear up all ignition noises, as explained in Arts. 27-40 to 27-51.

27-12. Installation in Cars Not Provided with a Built-In Antenna.—Recent cars having all-steel (so-called "turret-top") type roofs, open touring cars, roadsters, and most cars manufactured previous to 1932 are not provided with a built-in antenna. If a radio set is to be installed in these cars, a suitable antenna system must be installed by the radio service man, at the time the set is put in. He should therefore know all about this phase of the work.

Although there is no question but that a suitably-installed roof-type aerial is the ideal type from the point of view of electrical efficiency (except in those cars which have all-steel roofs), its installation is not always possible nor desirable. For this reason, several other types of car aerials have been developed, but the type used in any case depends almost entirely upon several construction features of the car itself. Since the success of the auto-radio installation depends in a large measure upon the antenna system, we will digress somewhat from our discussion of the actual installation procedure for auto-radio receivers in order to consider the various auto-radio antenna systems and their installation in some detail.

27-13. Requirements of a good Auto-Radio Antenna System.—Regardless of how or where the antenna system is placed in the car, there are several important facts which should be

*NOTE: Most of the sedan models made since 1934 (excepting those having all-steel roofs) are provided with a roof-type antenna built in at the factory. A chart which lists the various makes and models of American cars manufactured during the past few years, and tells whether or not they are equipped with roof antennas, will be found in Section 8 of the author's *Radio Trouble-Shooter's Handbook* (Radio & Technical Publishing Co.).

known about the factors which influence its operation. The main requirements for a good auto-radio antenna system are:

1. Large signal pickup.
2. Ease of Installation.
3. Small noise pickup.
4. Ease of servicing.
5. Durability.

(1) There are a limited number of suitable places in which the *aerial* portion of the car antenna may be located. This limitation is necessarily imposed by the construction features of the car and the location of the engine with its interfering ignition system wiring. Regardless of the type of antenna used, one important factor is its height. In general, all other things being equal, the higher the aerial, the stronger is the signal, for the signal voltage across the primary of the antenna coil is equal to the product of the field strength in microvolts per meter times the *effective* height of the aerial in meters.* Perhaps the ideal car aerial would consist of one or more wires strung between two upright masts mounted on the front and rear bumpers, but, for rather obvious reasons, this arrangement is not suitable for ordinary use. The next best compromise is the installation of the antenna in the car roof. When this is not feasible or desirable for one reason or another, one or two metal plates, rods, or tubes mounted under the running boards (see Fig. 27-24), an "undercar" wire aerial mounted under the chassis of the car (see Fig. 27-27), or metal rods of various sizes and shapes mounted in various positions around the outside of the car (see Fig. 27-23A for a wide assortment of "under-car" and "outside-of-car" aeri-als which are now in use) may be used. Of course, the "under-car" types of aeri-als have weaker signal pickup than do most of the "roof" and "outside" types.

(2) Ease of installation is important when an aerial system

*NOTE: It is interesting to note that the effective height of the average roof-type car aerial is about $\frac{1}{4}$ meter, as contrasted with 4 meters for the average home aerial; thus $\frac{1}{16}$ the signal voltage would be obtained with the car aerial if the signal field strengths were the same. However, since the radio field strength in city streets is much lower than on the tops of the roofs of the buildings, it is evident that the signal pickup of the car aerial (which is in the street) suffers even more in comparison with the pickup of the home roof-top aerial.

has to be installed in a car after the car itself is finished. Some older types of aerials require removal of the roof upholstery and placement of a screen netting between the roof and the upholstery; others require drilling holes in the corner posts and other parts of the car to obtain a neat job. Then, too, the cost of an installation rises as the difficulty of installation rises, since more time is required. Therefore, the service man must consider the cost of antenna installation as an important factor in determining the total cost of installing a receiver. This item should be listed separately in the estimate and called to the attention of the car owner.

(3) The question of small noise pickup by the antenna system is an important consideration that is too often overlooked by the service man. Interference pickup by the *lead-in* wire can be almost entirely prevented by proper location and shielding. However, if the *aerial* portion of the antenna picks up considerable interference from the ignition system, it cannot be shielded, for this would also eliminate the *signal*. Hence, the interference must be tolerated unless elaborate measures are to be taken to completely suppress all interference at its source in the car. In many cases, the service man can save himself a great deal of time and annoyance if he uses an under-car aerial instead of a roof-type aerial when installing auto-radio receivers in makes of cars which he knows from past experience are notoriously difficult to "quiet down". Even though the signal pickup will not be quite as great, the noise pickup may be greatly reduced, so that better overall performance will be obtained because of a higher "signal-noise" ratio.

(4) Ease of servicing usually goes hand in hand with ease of installation. An aerial that is easily installed is usually the easiest to service. After the wires of an aerial have been exposed to the elements for some time, connections may become poor unless they have been well soldered, and reception weakens. This is especially true in under-car types of aerials. A poor antenna system causes proportionately greater reduction in signal strength in an auto-radio installation than it does in home installations, for the signal strength is so low to begin with that any decrease is immediately apparent. In many instances (es-

pecially in the case of under-car aerials) it is desirable to replace the entire aerial rather than attempt to repair it.

(5) Durability is another important consideration. The insulation between the wire proper and the shielding braid on the lead-in is sometimes exposed to the elements, especially in under-car antennas which are splashed with water, mud and slush from the wheels of the car. This deteriorates it! The moisture and grime cling to the shielding and lodge between the fine wires of which the shielding is composed. As a result, the electrical contact between these individual wires of the shield becomes poor, the shielding action decreases, and reception may become noisy after a time. When copper mesh is used for a roof-type aerial, the individual fine copper wires may corrode after a time, the contact resistance between them gradually increases. Finally, the aerial resistance becomes so high that reception is weakened.

Running-board aerials are particularly subject to physical damage caused by driving the car close over corner curbstones, the concrete "islands" around the gasoline pumps at filling stations, through snow and ice-choked streets, and over rocky country roads. The chassis of modern automobiles are slung so low to the ground that under-car aerials of both the running board type and the wire type strung under the chassis are impractical in rural sections where the car must often be driven over rocky country roads, or roads having deep wheel ruts and a high "crown". They are too often ripped off the car by some such projecting obstruction to be practical under these conditions. For city driving there is no particular objection to them from this point of view.

27-14. Types of Car-Top Construction.—Since the type of aerial to be installed in a car depends to a degree upon the construction of its "top", the service man should be familiar with the various forms of "top" construction employed in cars—especially from the point of view of possible aerial installation in them. Typical arrangements which have been used in American cars will be considered here first. Then, details concerning the methods of installing the different forms of roof-type aerials in them will be present. The *top* of a car is gen-

erally understood to mean that part of the "head" construction upon which the roof rests and to which the interior upholstery of the car is attached. It corresponds, in general, to the roof beams and preliminary roof sheathing of a house.

There are six general types of top construction used in automobiles today. These may be classified as follows:

1. Slat tops.
2. Poultry-wire tops.
3. Fabric tops.
4. Metal bow and cross-braced tops.
5. Folding tops.
6. "Turret" or all-metal tops.

These will now be described in the order in which they appear above. While the folding tops do not fall strictly within the definition of car "top" stated above, they have been included here for the sake of completeness.

(1) *Slat Type Tops*: These car tops are constructed of wood bows running transversely (as shown in Figs. 27-13 and 27-14), with wooden slats running longitudinally (parallel to the length of the car) and fastened to the bows. The top padding and waterproof roof material, as well as the interior upholstery, are supported by the slats.

(2) *Poultry-Wire Tops*: In these tops, the slats are replaced by ordinary poultry (chicken) wire which is stretched tightly over the bows and fastened to the roof rails (the wooden rails around the edge of the roof). The waterproof roof material and roof padding in this case are laid over the poultry wire, and the upholstery (headlining) is fastened to its under side.

(3) *Fabric Tops*: These tops are similar to the slat-type tops except that strips of muslin or similar cloth are stretched over the wooden bows to support the waterproof material, padding and upholstery. No wooden slats are used. In some cases, these lengthwise cloth strips are tacked to the top bows at the front and rear of the car only—in others, they are tacked to each bow.

(4) *Metal Bow and Cross-Braced Tops*: These tops are strengthened by two diagonal cross-braces running from corner to corner, and fastened together at the middle. These metal

braces are almost always "grounded", being attached to the wooden frame of the body at the back, and to the metal frame at the front.

(5) *Folding Tops*: Roadsters, touring cars, convertible coupes and convertible sport sedans employ a folding top construction in which canvass or some other suitable waterproof material is stretched and supported on wooden or metal cross braces which may be folded down. No interior upholstery is used in the tops of these cars.

(6) *"Turret" or all-metal Tops*: Beginning with the 1935 models, many makes of cars have been made with "all-steel" tops. In bodies built by Fisher, the entire front end, from the instrument panel forward, including the corner posts at either side of the windshield, is a single steel assembly without any back panel. The one piece steel roof is brought down to form the top of the steel frame around an enclosed luggage compartment. Quarter panels are curved to form the sides. The steel floor with the necessary moulding is the bottom. This is referred to as a "turret" top. All sections are electrically welded together. Another method of all-steel construction flanges the sides of the top, and laps the flanges so that the welded connection forms a box trough around the entire roof. It will be noted that both these methods of steel construction effectively *shield* any radio aerial that may be placed *inside* of the top itself. This makes it necessary to locate the aerial at some other more favorable place on the car, such as under the running boards, under the chassis, on the side, or rear, or top of the body, etc. Further discussion of these aerials will be deferred to Art. 27-24. We will now consider the methods of installing aerials in cars having various types of non-metal tops, assuming that the car does not come already equipped with an aerial.

27-15. *Installing an Aerial in a Slat-Type Top*.—Perhaps the best type of aerial to be installed in closed cars having slat-type tops is the *wire-mesh* aerial. This consists of a piece of copper screen, or galvanized iron screen that has been tinned or galvanized after weaving. It is tacked to the bows in the top, a space being left between it and the metal apron of the car, as shown in Figs. 27-13 and 27-14. The lead-in wire is soldered

to the edge nearest the side at which the set is to be mounted.

To install an aerial of this type, it is first necessary to remove the headliner (top upholstery cloth). This is usually done by first removing the front moulding over the windshield, which is usually held in place by a few screws. The side moldings, which are tacked, or sometimes glued, to the side of the top, are then removed carefully, starting from the front and working toward the rear. They usually run to the back of the rear door.

Finally, the headlining must be removed. This is held to the

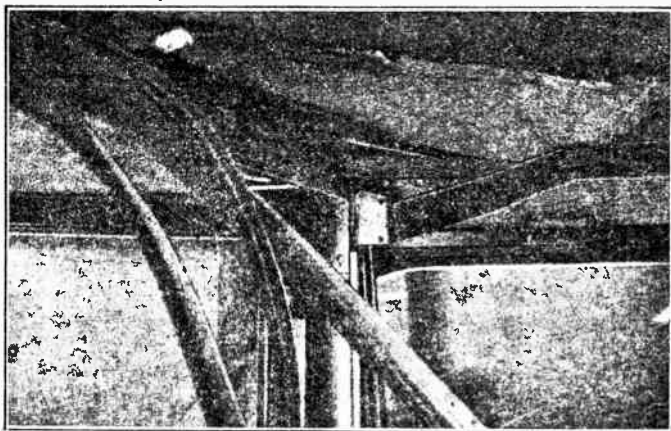

Courtesy "Motor"

FIG. 27-12.—How the front moulding and side mouldings may be stripped back in a car in order to allow the headlining (at the top) to be removed for the installation of the aerial screen in the space above it. In this illustration, the stripping of the mouldings has been started at the front left post of the car.

top by tacks on alternate bows and on all four sides of the car. These tacks must be removed carefully if the headlining is to be preserved. Again, work from the front to the rear of the car. These various parts are shown pulled out at the left front corner of a car in Fig. 27-12 in order to illustrate just how they are arranged.

The antenna screen which should consist of a piece of copper screen (or galvanized iron screen) that has been tinned or galvanized after weaving, should have from 8 to 16 meshes per inch and should be about 36 inches wide. Some service men attempt to

use ordinary screening which has not been tinned or galvanized. The result is that oxidization occurs, high-resistance contacts between the individual strands develop, and the aerial resistance increases rapidly with age. Measure the length of screening

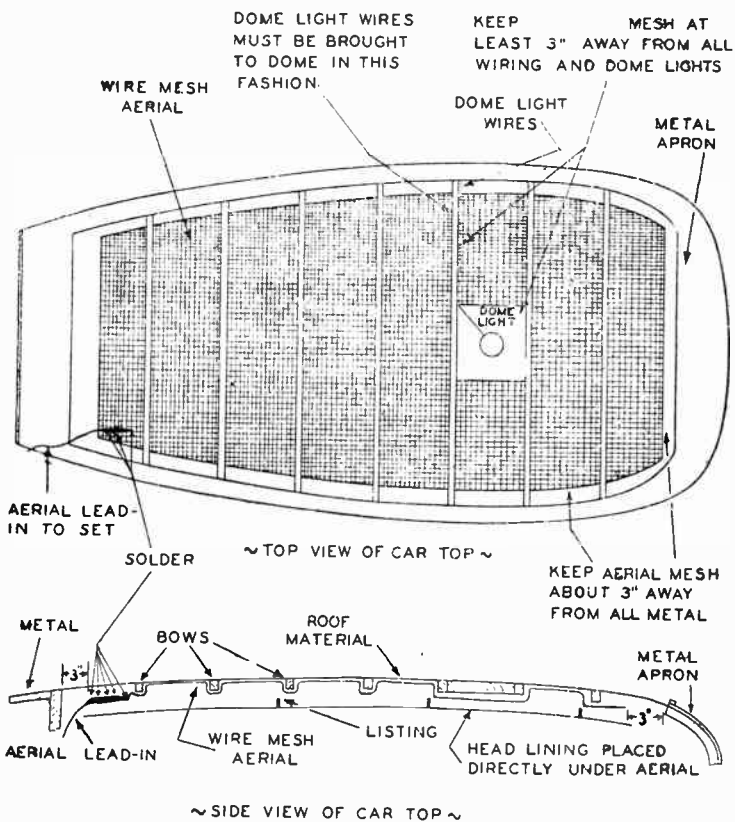
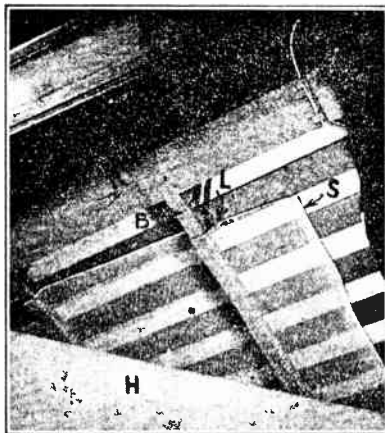

FIG. 27-13.—Method of installing a screen mesh aerial in a slat-type car top. Top and side views of the car top with the screen aerial installed in place are shown here.

needed and cut it to that length, plus an additional eighteen inches for bending up to the sides of the bows. If the car has a dome light, a hole about 8 or 10 inches in diameter must be cut in the screen so that the dome-light fixture comes at the center of the hole with plenty of clearance all around it, as shown in

Fig. 27-13. The screen around the edges of this hole should be bent *up* and *over* to prevent the ragged edges from projecting through the headliner later. If a better job is desired, the edges of the screen should be trimmed with shears and all the edges soldered with a large hot iron. This bonds them together electrically. The dome-light wires should be separated from the aerial screen by several inches. This means that the dome-light wires should be tacked along the upper part of the nearest bow, (near the roof) or the screen may be cut away, parallel to the

FIG. 27-14.—How the screen aerial is tacked around the under side of the wood bows, *B*, and then folded up tight against the roof fabric to keep it as high and as far away from the metal of the car as possible. The longitudinal slats, resting on top of the bows are clearly visible here. The lead-in wire is soldered to the screen at *L*. The screen aerial is *S*. The headlining, (interior upholstery), *H*, has been pulled back to reveal the screen aerial.



Courtesy Radio Retailing Magazine

bows, and the wiring run to the dome light in this cut-away. The former method is simpler, and is shown in Fig. 27-13. It may be necessary to lengthen and re-route this dome-light wiring before the screen is installed. The main object is to have as little magnetic or capacitive coupling between the dome-light wires and the antenna screen as possible.

Start tacking the screen from the rear of the car toward the front. Tack the screen to the bow furthest back that will allow *at least* a 3 inch clearance between its rear edge and the metal apron. Tack the screen to the underside of each bow (excepting those bows to which the headlining strips are fastened) and fold it up tight against the roof fabric in the spaces between bows, as shown in the lower part of Fig. 27-13, and in the illus-

tration of Fig. 27-14. This gives the screen almost an extra inch of height. Work toward the front of the car, tacking the screen to the undersides of the bows, and folding it up between the bows, until the front bow is reached.

After the aerial screen has been tacked in place securely, the lead-in should be soldered to its front edge nearest the side of the car at which the receiver is mounted. It should be soldered



Courtesy Lenz Elect. Mfg. Co.

FIG. 27-15.—(A) Shielded low-capacity weatherproof tubing (loom). The insulated wire to be shielded is pulled through the hole in the center.

(B) Shielded low-capacity cable. This cable is already supplied with an insulated, stranded conductor through its center. The shielding is on the outside.

Both make excellent shielded lead-ins because of the low capacity which exists between the inside conductor (the lead-in) and the outside shielding braid. This capacity is only approximately 16.5 mmfd. per foot for this particular make of cable

to a large area of the screening, as shown in Figs. 27-13, and 27-14. If ordinary single-conductor stranded, insulated wire is used for the lead-in, it should be inserted into a piece of a good grade of shielded low-capacity weatherproof tubing (loom) such as is illustrated at (A) of Fig. 27-15. Otherwise, shielded low-capacity cable (which comes with the wire already inside of it), as illustrated at (B) should be employed. Low-capacity shielded loom or cable has a very closely-woven shielding which surrounds a rather thick-walled insulating tubing. Since this thick-walled tubing introduces quite a separation between the inside wire and the shielding, the capacity between them is much smaller than it would be if the shielding fitted closely over the thin insulation of the wire itself.

The shielding on the lead-in should now be stripped for a distance of about 1 inch from the soldered end and securely taped in place to prevent any possibility of its grounding to the lead-in wire or screen aerial in the future. A point on this shield (near the screen aerial end) should be grounded to the body of

the car, and the shielded lead-in should then be run down to the receiver.

27-16. Installing the Lead-In for a Roof-Type Aerial.—

The shielded lead-in may be run down to the receiver in several ways. The front corner posts of many cars are hollow. These present a convenient and efficient duct for the shielded lead-in. If they are to be utilized, the lead-in is pushed down into the top of the corner post near the point where it is soldered to the screen aerial, and is pulled out at the bottom, near the point where it connects to the receiver. If the corner post is not hollow, and is of wood, then the wire may be run down the side of the post (as shown in Fig. 27-16) and tacked to it with large, insulated staples. If the corner post is of metal, then the shield of the lead-in may be stretched tightly down the length of the post and supported at two points—near the top where the shield grounds to the frame of the car, and near the bottom, where the shield should be grounded again to the frame of the car or to the instrument panel. If the instrument panel is not already grounded (this can be checked quickly with an ohmmeter),

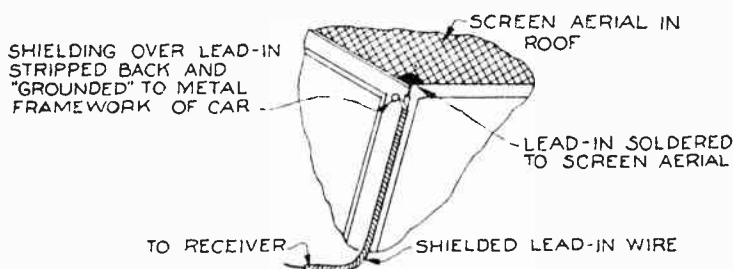

FIG. 27-16.—How the shielded lead-in may be connected to the aerial and run down the side of a front post of the car.

grounding the lead-in shield to it may introduce motor noises. In this event, either the instrument panel should be grounded to the chassis by means of flexible copper bonding braid, or else the shield should be insulated with tape at the place where it will pass the instrument panel, and it should be grounded directly to the chassis of the car.

The lead-in should be clipped off near the *Ant.* terminal of

the receiver, and the shielding should be stripped back for a distance of about 1 inch and securely taped to prevent future unravelling. The lead-in wire should then be connected to the receiver. In all cases, the lead-in wire should be made as short as possible.

In those cars which are already equipped with a built-in aerial and a short lead-in inside one front corner post, the lead-in must be extended to the radio set by adding on a piece of properly-soldered shielded lead-in cable. The shield of both the original

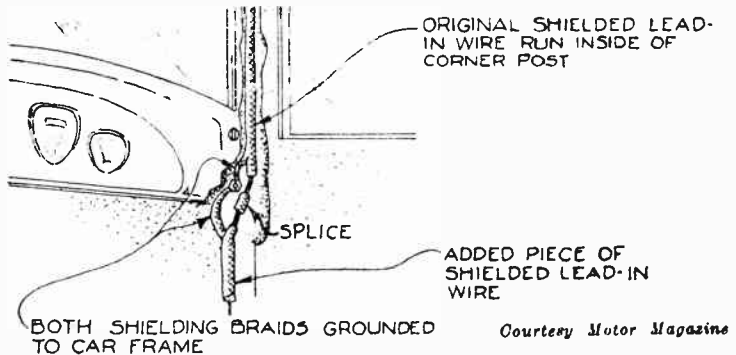

FIG. 27-17.—Splicing a short piece of shielded wire to an existing lead-in already installed in the front right post of the car. The shielding braid is grounded to the car frame at the instrument panel. If the original lead-in wire has a shielding braid, this braid must be “bonded” to that of the new piece.

cable (if it has a shield) and that of the new piece must be bonded together by means of well-soldered copper-braid bond, and grounded. This is illustrated in Fig. 27-17.

Some interesting statistics regarding the effect of the location of the lead-in wire in auto-radio installations upon the noise voltage picked up from the engine wiring have been compiled by Browning and Haskins. The results of their work are shown graphically in Fig. 27-18. These graphs show the relation between the “noise voltage” (in microvolts) induced in the lead-in and its distance in feet from the spark plugs of the engine. Note how the noise level *decreases* as the distance between the lead-in and the spark plugs is *increased*. These curves emphasize the advisability of keeping the aerial lead-in as far back from the

engine as possible. Moving it back from the front to the rear of the car will greatly reduce any interference picked up by it, but of course it is not always feasible to keep it at the rear of the car. Incidentally, the graphs also show the noise level at three different broadcast-band frequencies. The fact that the level is about the same throughout the tuning range of the receiver,

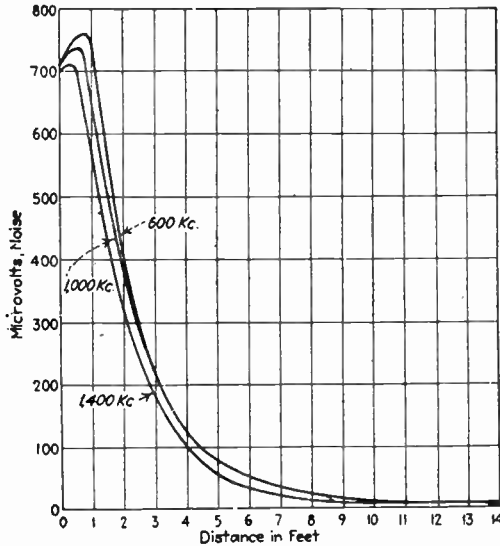

FIG. 27-18.—Graphs showing how the interference radiated from the high-tension system diminishes as the distance from the spark plugs increases. The radiation at three different frequencies is shown. Notice that the relation is practically the same for each frequency — showing that the noise is of the “shock-excitation” type.

Courtesy Electronics

shows that the radiation from the high-tension system of the car is of the “shock excitation” type, and, therefore, cannot easily be “tuned out” completely in any simple way from the signal input to the receiver (see Art. 27-41).

27-17. Finishing the Aerial Installation in the Slat-Type Top.—After the lead-in has been installed properly and the screen aerial is securely in place, the edges should be inspected. Any projections should be bent up out of the way. The final installation should be such that about 3 inches of clearance exists between the screen aerial and all of the inside metal framework of the car; at least a few inches clearance should exist between the dome-light wiring and the aerial and between the dome-light fixture and the aerial, and at least $\frac{1}{2}$ inch between the roof top and the aerial. A test for possible “grounds”

should be made between the free end of the lead-in wire (before it is connected to the receiver) and a clean spot on the car chassis. This checks both the lead-in wire and the aerial at once. A *high-resistance* ohmmeter should be used for this test, so that any possible high-resistance leakage that may exist will be discovered. The headlining should then be replaced in a manner opposite to the way in which it was removed (see Art. 27-15) and the job is finished so far as the aerial installation is concerned.

Since the advent of the auto-radio receiver, several "roof-type" aerials have been developed in attempts to provide ease of



Courtesy Fishwick Radio Co.

FIG. 27-18A.—A typical flat type auto-top aerial which may be inserted above the headlining in the top of a sedan. Here it is shown flat-coiled to a dimension of 9 x 36 inches. When it is uncoiled and spread out flat, it has an area of 3 x 5 feet.

installation and good signal pickup. Most of these aerials are constructed in ways which simplify their installation in the roof of the car without the necessity for removing the entire headliner, tacking wire screens in place, insulating metal braces, etc. They are usually made flat and consist of either fine-mesh screening or many turns of wire wound on a form—the entire assembly being insulated by an enclosure of some sort. They may be inserted above the headlining of a car after the front moulding has been removed and the headlining has been loosened sufficiently at the front to permit the aerial to be slipped in above it. A typical aerial of this type is illustrated in Fig. 27-18A.

27-18. Installing an Aerial in a Poultry-Wire Top.—The poultry wire used in the construction of this type of automobile top is not unlike the wire which is used for screen aerials; as a matter of fact, this same poultry wire may actually be utilized as the *aerial* for the auto-radio receiver. Since it is usually

grounded to the metal apron of the car, and often to the dome-light wiring, a test for grounds should first be made between the poultry wire and a clean spot on the chassis of the car, by means of an ohmmeter. If the poultry wire is not grounded, it is only necessary to solder the lead-in wire to it (as already described for the case of the slat-type roof) to use it as the aerial.

If it is found to be grounded, it must first be freed from all grounds. This is done by removing the headliner (see Art. 27-15) and cutting a 3-inch strip of the poultry wire away around the four sides. The section around the dome light should also be cut away so that a clearance of at least 3 inches exists between the dome light and the poultry wire all around (see Fig. 27-13). The 3-inch strips cut away should be removed, but the remaining rim of poultry wire should be allowed to remain fastened. Now the part to be used should be checked again with the ohmmeter to be sure it is free of grounds. It should then be laced to the narrow portions remaining attached to the car with strong waxed cord or fish line in two or three places on each of the four sides, so as to support it. The cord should be pulled tight to hold the center portion of the screen up so as to prevent the top from sagging.

The lead-in is installed in the same manner as described for the wire-mesh aerial (Art 27-16) and run to the receiver as described. A high-resistance ohmmeter should be used to test the entire system for grounds. The test should be made between the aerial and frame of the car and between the "set" end of the lead-in and the frame of the car. After the test is completed, the headlining should be replaced, in a manner opposite to the way in which it was removed (see Art. 27-15).

27-19. Installing an Aerial in a Fabric Top.—The fabric-tops in cars are similar in construction to the slat tops, the only difference being in the use of strips of muslin instead of wooden slats running longitudinally, parallel to the length of the car. In some cases, the muslin strips are tacked to the bows at the front and back of the car only. In such cases, the wire screen which is to be used as the aerial is slipped between the muslin strips and the bows, after it has been cut to the proper length and width and its edges properly soldered. Of course, the dome-

light cut-out should be made. If the muslin strips are tacked to the top of each bow, then the wire mesh is installed under these strips and the bows in exactly the same way as was described for slat tops in Art. 27-15 (see Figs. 27-13 and 27-14).

The lead-in installation and the tests for grounds should be made exactly as explained in Art. 27-16. It will be found, however, that relatively few cars are equipped with fabric tops.

27-20. Installing an Aerial in a Metal Bow Top.—If the bows of the top are entirely of metal and bonded securely to the frame of the car, it is not desirable to attempt to insulate them from the car frame because the structure of the roof will be weakened materially. In such cases, it is also not advisable to attempt to install an individual wire-mesh aerial between each two bows, because the amount of bonding which would be required for connecting all the sections together, and the close proximity to the many grounded bows, would impair the signal pick-up efficiency of the aerial.

It is preferable to use a "strung" wire aerial in tops of this kind. The headlining is removed as previously described (Art. 27-15) and the top cleared of all other padding that may be used. Then, screw eyes should be securely fastened to the inside sides of the wooden top frame of the car, as shown in Fig. 27-19. These screw eyes should be kept at least 3 inches away from the metal bows, and spaced about 2 inches apart. Now, starting at that corner from which the lead-in is to be taken (see Fig. 27-19), thread the end of a coil of No. 18 rubber-covered wire through the first screw eye and make a small knot to hold the end fixed. The other end of the coil is then laced through the other screw eyes in turn, as shown in the sketch, until the far end is reached. The wire is pulled taut and another knot made at the far end. The shielded lead-in is then soldered to the beginning of the aerial in the usual manner. Insulated staples may be used instead of screw eyes. In this case the wire is simply tacked to the wooden top frame as shown. The use of staples saves time since they are put in more quickly.

The screw eyes or staples must be tight, or else the entire aerial will become loose in a short time. After the lead-in is soldered and in place, the system should be tested for grounds, and, if

it is found to be ungrounded, the headlining should be replaced as previously directed.

27-21. Installing an Aerial in a Metal-Braced Top.—

There are a few cars whose tops are strengthened by metal diagonal cross-braces running from corner to corner. They are fastened together at the point of intersection. These braces are usually grounded, being attached to the wooden frame of the car at the rear and to the metal frame of the car at the front.

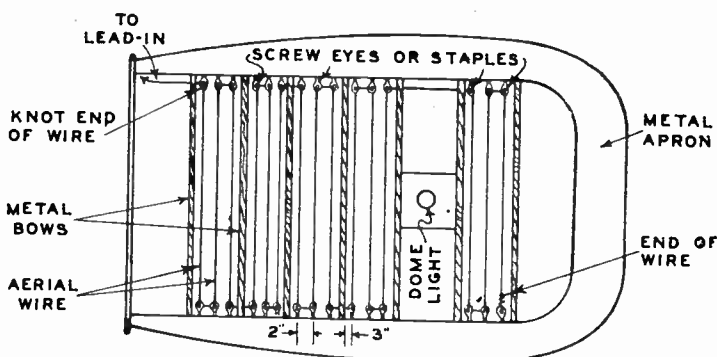

FIG. 27-19.—A "strung" wire aerial suitable for use in closed cars having all-metal bows in their tops. The insulated wire is strung back and forth across the top of the car through screw eyes or insulated staples fastened to the wooden top frame.

To obtain even reasonably good reception, the grounds must be removed from the fronts of the braces before installing an aerial in such tops. This can be accomplished by first removing the headlining as previously directed (Art. 27-15) and releasing the braces from the front of the car. The holes in the front brackets which hold the diagonal cross-braces to the metal frame of the car should be reamed out to enable the insertion of fibre washers and insulating sleeves. With the bolt removed, the insulating sleeve is slipped over it and the fibre washers are used to insulate the bolt head and the nut.

The metal braces should be tested for grounds after insulating them. If they are found to be ungrounded, a wire mesh aerial may be slipped between the bows and the metal diagonals; the wire mesh aerial should be soldered to the metal braces at several

places to insure positive contact so that intermittent contact, and resulting noise, will not occur due to vibration when the car is in motion on the road.

In some cars the metal brace consists of a single transverse brace replacing one of the wooden bows. In this case it is not possible to insulate the metal bow, as this would weaken the structure materially. In such cases, the wire mesh must be cut in two, and one half installed on either side of the metal brace, just as if the other did not exist. The two parts of the aerial should not come closer than 3 inches from either the side of the car or the metal brace, otherwise the capacity of the aerial to ground will be excessive and this will cause the signal strength to drop appreciably. The two aerials are then connected together with well-insulated jumpers in several places, the lead-in is installed, and the headlining is replaced as previously described.

27-22. Installing Tape Aerials.—A special type of aerial tape has been developed for certain types of installations in cars

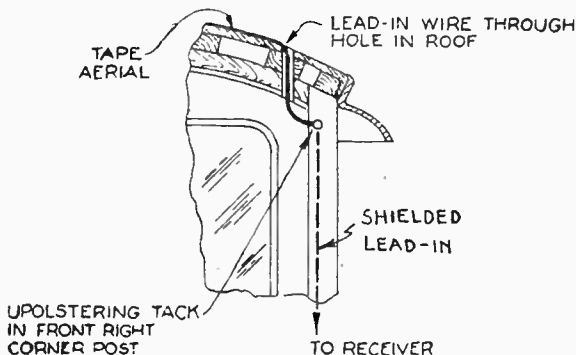

FIG. 27-20.—Location of the lead-in hole drilled in the roof of a car when a tape aerial is installed as shown in Fig. 27-21. The lead-in wire is brought into the car through this hole.

which have slat-type or insulated poultry-wire type tops and where it is not desired to remove the headlining from the roof for some reason. The tape is $\frac{1}{4}$ -inch wide and is rolled with a solder lug at the start end. Essentially, it consists of a thin strip of copper or aluminum foil with an adhesive backing. Contrary to the other types of roof aerials thus far described,

this type aerial is designed to be installed outside of the car, on the *outside* surface of the roof fabric. It is installed as follows:

The outside surface of the roof material of the car is first thoroughly cleaned of all moisture and dirt (using gasoline) and is left to dry (this aerial should not be installed on all-steel roofs). A hole large enough for the shielded lead-in wire is

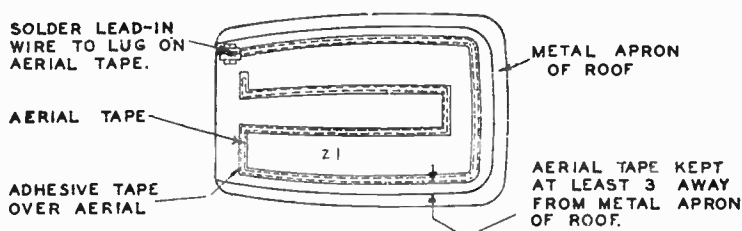

FIG. 27-21.—Method of laying the tape aerial on the roof of the car. The lead-in is brought up through a small hole in the roof, as shown in Fig. 27-20. The hole should be filled and sealed with ordinary plastic roofing cement to prevent water leakage.

then drilled in the roof of the car. This hole is drilled in the roof on that side of the car at which the receiver has been mounted, (see Figs. 27-20 and 27-21). Now, starting with the hole in the roof, the tape is unrolled and layed on the roof of the car to form the pattern illustrated in Fig. 27-21. The tape should be kept at least 3 inches away from the metal apron of the car (the standard distance for separation in auto-radio installations). After the tape is layed in the pattern shown, the lead-in is brought up through the hole in the roof and soldered to the lug provided at the start of the roll. The soldered connection should be made as flat as possible to avoid the formation of a large lump at the point of connection.

After the aerial is layed in this manner, it is covered with long strips of adhesive tape, 1-inch wide, and flattened against the tape. Ordinary friction tape should not be used here as it will quickly dry out and strip off. Adhesive tape is much more satisfactory. It is necessary that all seams be tight, or else moisture and dirt will enter, the aerial will deteriorate with age and the resistance of the antenna system will increase appreciably. It may even loosen from the roof. The hole where the lead-in is

brought through the roof should be filled up with plastic roofing cement to prevent any leakage of rain through it later. After this cement has set, the connection near the corner post where the lead-in wire is soldered to the aerial should be covered with adhesive tape. Finally, the sections of the roof covered by the tape should be given two coats of weatherproof top dressing to prevent deterioration of the adhesive tape.

This type of aerial system is not quite as good as the wire mesh aerial, but is easier to install and costs less. It has the disadvantage that it cannot be used in those tops which have grounded poultry wire, metal bows or braces, as the close proximity of these braces reduces the "effective height" of the aerial considerably, which reduces signal strength. If the tape aerial is desired in cars with such grounded structures, it is necessary to insulate the grounded parts in them for good results. However, in order to insulate these parts it is usually necessary to remove the headlining from the interior of the roof in order to reach them. If this must be done, the service man might just as well install a screen or wire aerial as directed in Arts. 27-15 to 27-18, for either of these aerials will give better results.

27-23. Installing an Aerial in a Folding Top.—The tops of roadsters, touring cars, convertible coupes and convertible sedans are designed to fold back. Therefore any aerial which is installed in them must be sufficiently flexible so as not to interfere with this folding. For this reason, wire screen aerials are not commonly used in these tops. Either a wire aerial consisting of a long length of flexible insulated wire tucked away under the "pads" of the canvas top, an under-car aerial, or a "buggy-whip" or "fishpole" aerial may be employed instead (see Fig. 27-23A).

A roof aerial is not satisfactory in those cars whose tops fold into a metal compartment when "down", because the aerial is effectively shielded by this metal compartment when the top is folded down with the result that the reception is greatly weakened. In these cars the other aerials are more satisfactory.

The installation of a roof-type aerial in a folding top does not involve as much mechanical labor as is necessary in closed

cars, because there is no headlining and trimming to be taken out and put back. The tacks that fasten the top material to the front bow over the windshield should be removed first. The top material should then be laid back, leaving the bows exposed.

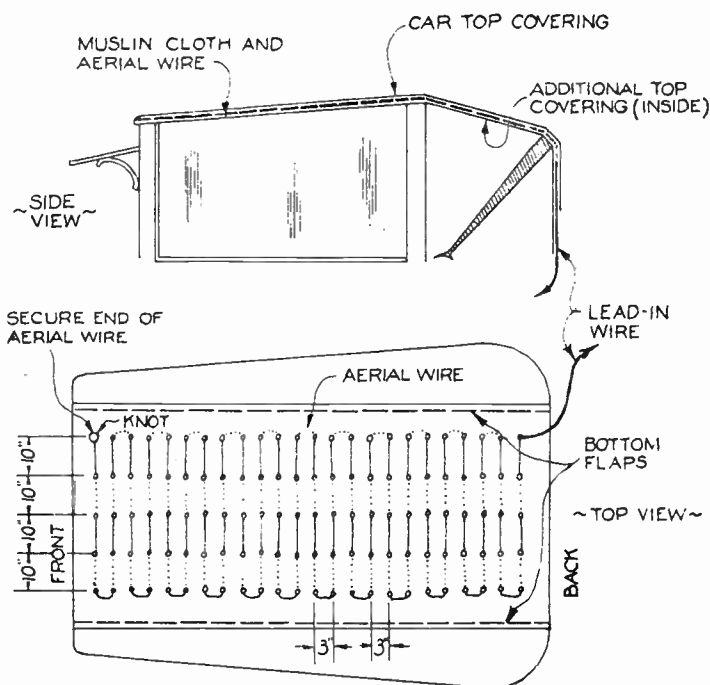

FIG. 27-22.—Method of installing a wire-type roof aerial in a car having a folding type top. Side and top views of the method of installation are shown here.

The cloth pads (quarter-deck pads) on each side of the top will also be exposed. Another piece of top material which matches that just removed should be obtained. It should be fastened in place over the bows and over the flaps. Next, a piece of drill cloth (or muslin) about 3 inches narrower than the width of the top, and just about as long, is obtained. Holes should be punched in the drill cloth in rows which are 3 inches apart, as shown in the lower part of Fig. 27-22. The holes should be spaced about 10

inches apart in each row. Now a coil of No. 18 rubber-covered stranded wire is woven in and out through the holes, back and forth, until all the holes have been utilized, as shown. The muslin (or drill cloth) is then fastened *only* to the front and rear bows, otherwise difficulty will be had in lowering the top.

The side view in the illustration of Fig. 27-22 shows the successive layers of cloth used in this type of aerial. The covering resting against the bows from underneath, is the new material

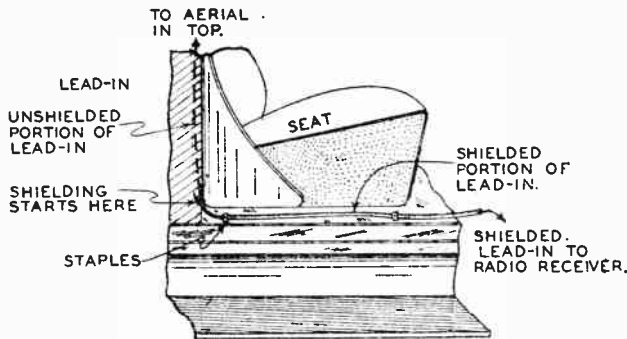

Fig. 27-23.—How the partly-shielded lead-in is run down along the side of the seat and along the floor of the car when a wire aerial is installed in a car having a folding top.

which matches that already on the car so as to hide the aerial; the center material is the drill cloth or muslin into which the aerial wire is woven; the top material is the original top material of the car. Thus, the aerial is protected on top and bottom by this additional material. The drill cloth is used merely as a convenient form on which the wire is supported.

The aerial should finish up at the rear of the top, on the same side of the car as that at which the radio receiver has been installed. The rear end of the aerial wire should be carried down along that rear corner of the top (inside of the car) and stuck in along the side of the seat as shown in Fig. 27-23. At the point where it reaches the floor, the shielding should start; the wire may be inserted in shielded low-capacity tubing or loom (see (A) of Fig. 27-15). The lead-in is to be shielded from the point where it reaches the floor right up to the receiver, two or three

places on the shield being grounded to the chassis to reduce noise pickup. The shielded wire may be run along the edge of the door opening and fastened with staples as shown in Fig. 27-23, from there it is run under the edge of the floor mat to the receiver. The top material and any disturbed trim should then be put back in place carefully.

Of course, this type of aerial is more efficient when the top is up than when it is folded down, for in the latter case its "effective" height is reduced since it folds down close to the metal car body (which is the "ground" for the receiver).

27-24. Aerials for Cars with "Turret" or Other All-Metal Tops.—In the "Turret" or other all-steel top construction (see Art. 27-14) a single sheet steel stamping replaces the wood slat



FIG. 27-23A. — Twelve different types of auto-radio aerials which are in popular use. All but the "screen" and "open" types are used on cars having "all-steel" tops, since they are mounted on the outside of the car proper. This makes a wide variety of aerials to choose from.

(Courtesy Radio Retailing Magazine)

and bow, poultry-wire, fabric, and felt combinations which have been used for car tops, making the top of the body literally a complete steel enclosure. Naturally, any form of aerial installed *inside* of a top of this kind will be effectively shielded from all surrounding radio signal fields and will have extremely poor pickup. Therefore, some form of aerial which is mounted *outside* of the

body—or *under* the running boards or the chassis—must be employed for these cars. A variety of aerials of this type will be found illustrated in Fig. 27-23A. They will now be studied.

27-25. Under-Car Aerials.—The installation of a roof aerial is not always possible or desirable. From the descriptions of the roof aerials given in the preceding sections, it is clear that the cost of installation and the time consumed may not be warranted in view of the current market price of the car. Then, too, the car owner might not want an expensive permanent installation as far as the aerial is concerned because he may contemplate purchasing a new car in a few months or a year; in the meantime, however, he wants radio reception in it.*

In those cases where an aerial must be installed, but it is not desirable for one reason or another to install a roof-type aerial, one may be installed somewhere *under*, or on the *outside* of the car. Although all types of aerials which are installed under the car can properly be called “under-car” aerials, it has become common to reserve this name for a special wire-type aerial which

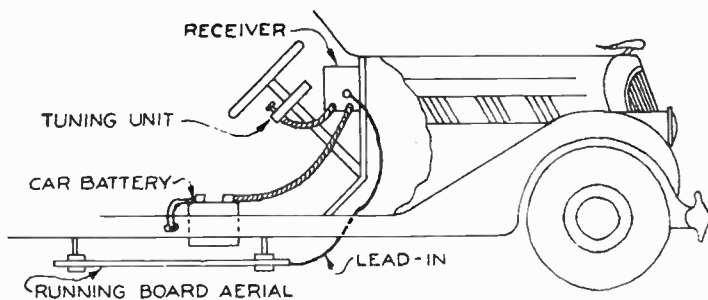

FIG. 27-24.—The location of the running board type aerial with respect to the running board, radio receiver and the rest of the car.

is suspended under the chassis in some way. The type of aerial which consists of a metal plate, rod, or tube mounted under the

*NOTE: These problems do not confront most owners of those 1933 to 1935 cars which do not have all-metal tops, because most closed cars manufactured in those years were equipped with a roof aerial at the factory. Of course, in these cases, all that the auto-radio service man needs to do is to install the receiver proper and run a short length of shielded wire to the already shielded lead-in (see Fig. 27-17).

running board is usually called a "running board" aerial. We will discuss these types separately.

27-26. Installing a Running Board Aerial.—A running board aerial usually consists of either a sheet of flat metal (preferably copper measuring about 8 by 40 inches), a metal rod, or metal tubing, fastened to insulating supports which are in

FIG. 27-25.—A modern under-the-running-board aerial mounted in position. One of these sections is mounted under each running board, the two are connected together. Each section consists of galvanized heavy-steel tubular rods bonded together at one end.

(Courtesy Philco Radio & Telev. Corp.)

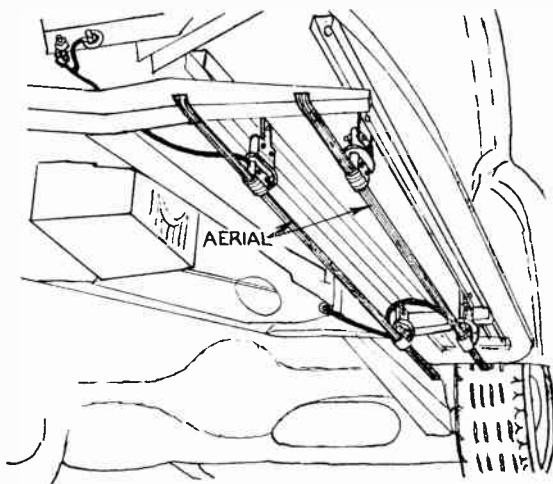

turn clamped or otherwise fastened to the underside of the running board, or to the channel iron, of the car. The location of this type of aerial with respect to the running board is shown in Fig. 27-24. A shielded lead-in wire is run from the radio receiver to this aerial, the shield being grounded near each end to the chassis of the car. In view of its relatively high "aerial to ground" capacity, it is often called a *capacitor-plate* aerial. For greater pickup, one such aerial may be used under each running board, both being connected together with a heavily insulated weatherproof wire at the rear. Several good forms of these running-board type aeri-als are now available (see Figs. 27-23A, 27-25 and 27-26). They come already equipped with a shielded lead-in wire, and some are encased in rubber, or water-proof fabric for protection.

There are a number of wire-wound versions of the metal-plate running board aerial available. Some consist of flat forms of

insulating material upon which as much as 300 to 900 feet of insulated wire is wound. All these variations have the same fundamental idea—they tend to expose as large a conductive surface as possible to the signal wave.

The relative signal-pickup efficiency and the desirability of running board aerial systems as compared to the other types will be discussed in some detail in Art. 27-28.

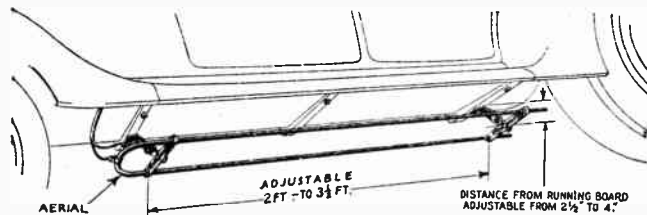

Courtesy RCA Manufacturing Co.

FIG. 27-26.—A popular type of “Di-Pole” aerial shown installed in position under the running board of the car. Notice its “adjustable construction”. The lead-in connection is taken off from the “U”-bend end of the tubing (as shown here).

27-27. Installing a Wire-Type Under-Car Aerial.—As has already been mentioned in Art. 27-25, wires strung under the chassis of the car may be used as aeri­als. These are especially advantageous in cars having all-steel tops. The wire in the under-car aerial is usually strung in the form of an “open-end” triangle, and is suspended by special brackets and insulators from the flywheel housing and each end of the rear axle of the car, as shown in Fig. 27-27. A spring tension adjuster keeps the entire assembly taut. About 20 feet of wire is employed for the aerial.* Of course specially designed brackets and insulators must be used with a system of this kind if the service man is to be able to install it quickly.

*NOTE: The performance of this type of antenna is greatly improved if a correctly-designed shielded transmission line with proper impedance-matching transformers is used between the aerial and the receiver. One manufacturer furnishes this equipment as a complete kit of parts for the aerial installation. One transformer is installed at the aerial end of the lead-in to match the impedance of the aerial to that of the transmission line. The other is installed at the receiver and to match the impedance of the receiver to that of the line. In this way, the losses usually associated with long shielded lead-ins are greatly reduced. The noise pickup of the lead-in is also reduced.

27-28. Comparison of Auto-Radio Aerial Systems.—There is always some question about which type of aerial works best in a car. In the average sedan which does not have an all-metal top, a good roof type aerial installed properly with a satisfactory lead-in gives greatest signal pickup and is to be preferred. However, in cars having “all-metal” tops, one of the other types, which are less efficient and desirable (but which must be used nevertheless), must be resorted to (see Fig. 27-23A). Best estimates place the efficiency of the average under-car aerial at about 75 per cent of that achieved by the average top-type under similar conditions; however, this value varies.

Some disadvantages of under-car and running board types of aerials, from the point of view of durability, have already been outlined in section (5) of Art. 27-13. The efficiency of the under-chassis types is almost directly proportional to their “effective” area, effective distance from the chassis, and closeness to the road. The underside contour of the car strongly affects the signal potential difference which may be developed

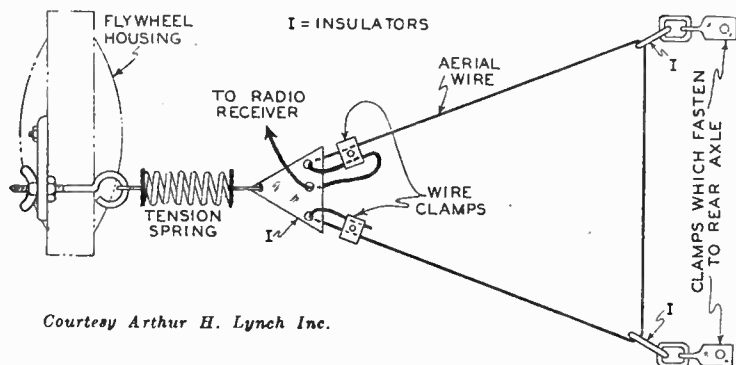

Courtesy Arthur H. Lynch Inc.

FIG. 27-27.—An under-car aerial system which employs a single copper wire arranged in triangular form and suspended by insulators and special brackets from the flywheel housing and the ends of the rear axle of the car.

between the under-car or running-board types of antenna and the chassis of the car. These antennas usually have poor signal pickup when installed on cars which have “transmission” or “body” projections that extend down quite close to the street surface. Since cars are now being designed with fenders, running

boards, and chassis closer and closer to the ground, the signal pickup of under-car aerials installed on them is often unsatisfactory, due to the shielding effect which these large "grounded" masses of metal have on them.

The general trend to all-steel tops in automobiles, and the use of large, low fenders and running boards has resulted in widespread use of a variety of aerial systems external to the car body* (see Fig. 27-23A). Among these, first choice may be given to aerials of the type installed on top of the car and running back from the windshield. The signal pickup of these aerials, especially if they are mounted 4 to 6 inches above the surface of the car top, is approximately the same as with a "fish-pole" type aerial, but their signal-to-noise ratio is better. The signal-to-noise ratio of the "whip" type aerial is usually about the same as that of the "fish-pole" type, though its signal pickup is slightly less. However, its simple installation, and the short transmission line necessary with it, make it preferable.

27-29. Interference Noise.—After a satisfactory aerial and lead-in wire have been made available, the lead-in should be connected to the "Ant." terminal of the receiver. The set is automatically "grounded" to the chassis of the car through the battery lead which connects to the grounded terminal of the storage battery. In some auto-radio receivers (but not all of them) the case is also grounded. The receiver is now ready for its first "air test". When it is turned on with the engine of the car at rest, it may be tested for signal pickup, selectivity, etc. In most receivers, an antenna-compensating condenser in the receiver must be adjusted in accordance with the manufacturer's instructions at this point, in order to match the input circuit of

*NOTE: Several novel methods of picking up radio signals in an automobile without installing any of the common forms of aerials have been used. The front and rear bumpers (after being properly insulated from the chassis proper) may be used as an aerial; the trunk rack and the metal trunk itself may be used as an aerial if it is insulated from the chassis; and even metal tire covers have been insulated, bonded, and used as aerials. Some of these expedients detract from the mechanical rigidity of the car only slightly. However, these aerials are directional in their receiving characteristics because they are usually low and on one side of the car only. The metal body of the car (being close to them) shields them from radio signals in at least one or two directions. This is annoying!

the receiver to the constants of the antenna system installed.

If the receiver is turned on with the engine in operation, reception will most likely be extremely noisy due to interference set up by the electrical ignition system of the car. In order to obtain quiet reception, certain steps must now be taken to minimize this interference at its source. The complete elimination of interference from an auto-radio installation is by no means a simple matter in every case, for, due to the differences in the wiring and physical layout of the ignition system parts, the expedients that work satisfactorily in one make of car are not always satisfactory in another. As a matter of fact, so many conditions in the individual car itself may cause interference, that very often remedies which work perfectly satisfactorily in one car are insufficient in another of the same make and model.

Fortunately, there are certain standard methods of interference suppression which do all that is necessary to eliminate the ignition system interference in most cars, but some cars (especially the older ones manufactured a few years ago) require, at times, numerous extra special treatments which must be resorted to in order to clear up all noise. Bonding of certain parts may have to be resorted to, certain ignition wires may have to be re-routed, others may have to be shielded, etc. For this reason, a complete study of the problem will be presented here step by step. Each possible cause of interference will be analyzed in detail, and the most effective suppression method for it will be given. The causes which are most common will be treated first, then consideration will be given to the more "difficult" ones which are found only in certain models of cars, or "occasionally" in particular individual cars which prove to be exceptions.

The elimination of interference is probably the most difficult problem which the service man encounters in the installation of auto-radio receivers. So many of the problems which arise are intimately tied up with the entire electrical system of the car, that it is extremely important for him to be on intimate terms with the entire system both as regards its general theory of operation, its actual construction, and the effects which changes he may have to make on it (in order to eliminate all interference in the radio receiver) will have on its performance.* It is

*NOTE: In Section 10 of the author's *Radio Trouble-Shooter's Handbook*, the complete electric wiring diagrams for many models of various American cars are presented for reference purposes. An analysis of these diagrams will prove to be a very instructive and helpful supplementary study to the data which will now be presented here, since they show not only the wiring of the ignition system, but all other electrical wiring on the various cars.

for this reason, that considerable space will be devoted here to a presentation of the elements of common automobile ignition system arrangements, their operation, and care.

27-30. **External Interference.**—Interference may be caused both by sources within the car and others external to it. The former may be termed “internal interference” and will be discussed in detail in the following sections; the latter requires little comment, as nothing much can be done about it by the service man. Assuming that a receiver is working normally in a given installation, it may be noisy at intervals because of interference picked up by the antenna system from the ignition systems of other passing vehicles (especially trucks and busses), electric signs, electric surface cars, electric subway systems under the street, leaky insulators in various types of power lines in the vicinity, etc. In fact, any device that can cause interference in a home-installed receiver will create interference in an auto-radio installation if its interference radiations reach the antenna system of the auto-radio receiver with sufficient strength.

As mentioned previously, nothing much can be done about this condition by the service man. In most cases, this external interference picked up is of a temporary nature, since it is assumed that the car is in motion and will move away from the source of interference in a short time. All that the service man may be interested in, is testing to find out definitely whether interference which is present in an auto-radio installation is due to *external* sources such as these or to some source *within the car itself*. Two tests for determining this will be discussed in Art. 27-49. For the present, we will assume that the radio receiver with its tuning control, and the aerial and lead-in have been properly installed, and that the set is found to be very noisy when the car engine is running. The next step is to suppress the interference created by all the usual electrical disturbances within the car itself. We will now consider the sources of these disturbances, starting with the ignition system of the automobile.

27-31. **Operation of the Gasoline Engine.**—The operation of gasoline engines such as are used in all modern automobiles is based upon the fact that when a mixture of gasoline vapor and air is compressed and ignited, the burning gases become highly

heated, and tend to expand suddenly (an *explosion* really takes place). If they are confined within a suitable container while doing so, they exert a considerable pressure which can be utilized to do work. Since the heating or combustion takes place inside the engine, it is called an *internal combustion engine*. If the gases are compressed into a small space before being ignited, much more power is produced due to their expansion when ignition occurs.

In the automobile engine, there are a number of specially constructed cylinders (4-, 6-, 8-, 12-, 16-, etc.) in which this compression, ignition and consequent expansion of the gases is made to take place in a definite sequence so that the power produced may be directed to do the greatest amount of useful work. A simplified cross-section view of one of these is shown in Fig. 27-28. It consists of a strong metal cylinder *C* (a water jacket surrounds it for cooling) which is open at its lower end. Inside of this is a close-fitting metal piston, *P*, which is free to slide up and down while remaining tight against any leakage of gas past it (through the use of expanding piston rings, *R*). The cylinder is mounted on a base or crankcase, *K*, in which is a crankshaft, *S*, which is arranged to rotate in bearings. A crank, *F*, forms a part of this shaft. To the crank is attached a connecting rod, *H*, the lower end of which is free to turn on the crank. The upper end of the connecting rod is pivoted to the piston by the wrist-pin *W*. A spark plug, *P*, screwed into the upper closed end of the cylinder contains two electrodes separated from each other by a short gap, and insulated from each other (see Fig. 27-50). One of these electrodes grounds to the metal of the cylinder. An inlet valve, *I*, is provided for allowing the fresh mixture of air and gasoline vapor to enter the cylinder; an exhaust valve, *E*, allows the burned gases to escape after they have expanded sufficiently.

Let us assume that the engine is to be started. The self-starter motor causes the crankshaft to turn. Assume that the piston is on its way down to start its "intake" stroke. Inlet valve *I* opens automatically and allows the suction created by the receding piston to draw in a mixture of gasoline vapor and air which has been mixed in the proper proportions by the car-

buretor to form a highly-explosive mixture. This is the *intake* or *suction* stroke.

When the piston reaches its lowest position in the cylinder, the inlet valve closes. The piston then travels up to a point close to, but not quite touching, the "head" of the cylinder, thereby greatly compressing the gas mixture so that only a flame or spark of some kind is required to explode it. This is the *compression* stroke. At the instant that the piston reaches its top position (or a fraction of a second before this position is reached),

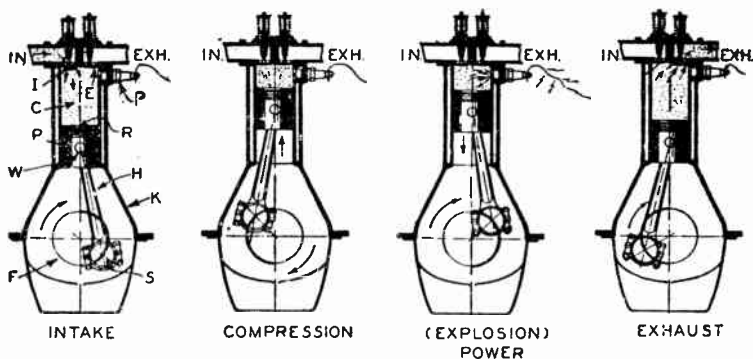

FIG. 27-28.—Cross-section view of a cylinder of an automobile engine showing the main parts. The positions of the valves and piston are shown for the four main strokes of the piston which are necessary to complete one full cycle of events. An electric spark, properly timed, is necessary to ignite the compressed gas. It is the electrical apparatus used on the car to generate and time this spark that causes most of the electrical interference in the auto-radio set.

a high-voltage electric current is sent to the spark plug by the electrical ignition system of the car, causing an electric spark to jump the short gap between the two electrodes of the spark plug.

This spark ignites the highly compressed gas mixture, causing it to explode and expand with terrific force. Since the walls of the cylinder are built to stand this explosive force, the only thing that can move is the piston. This does move down, forcibly, driving the crankshaft around while doing so.

When the piston has reached the end of this *power* stroke it is "driven" up again by the influence of the inertia which has been stored in the fly-wheel of the engine on the "downstroke".

The exhaust valve, *E*, opens automatically, allowing the piston to push the burned gases out through it. At the end of the *exhaust* stroke, the exhaust valve closes, the inlet valve opens, and the process or "cycle" repeats itself over and over again. It is evident that four individual strokes of the piston (two down, and two up) go to make up the full cycle of events. Hence it is called a *four-stroke cycle engine*. This piston makes *four* strokes (the crankshaft makes *two* revolutions) for one discharge of the spark plug in any cylinder. The entire series of events, *admission—compression—explosion* (expansion)—and *exhaust* take place in a very short time in an automobile engine running at normal speed. For instance, in an engine running at 3,600 revolutions per minute, each spark plug fires 1,800 times a minute, or 30 times every second!

The automobile engine actually has a number of these cylinders, all similar and all operating together continuously. However, in order to get a smoothly distributed power output, all of the cylinders do not go through the same parts of their cycles simultaneously. Thus, while cylinder No. 1 is firing, cylinder No. 2 may be completing its compression stroke, cylinder No. 5 may be exhausting, etc. The order in which the cylinders fire is called the "firing order". The common "firing orders" employed in modern automobile engines are as follows: *4-cylinder engines* 1-3-4-2; *6-cylinder engines* 1-5-3-6-2-4; *8-cylinder engines* 1-6-2-5-8-3-7-4, or 1-5-4-8-6-3-7-2, or 1-4-7-3-8-5-2-6, or 1L-4R-4L-2L-3R-3L-2R-1R; *12-cylinder engines* 1L-2R-5L-4R-3L-1R-6L-5R-2L-3R-4L-6R, or 1R-6L-5R-2L-3R-4L-6R-1L-2R-5L-4R-3L; *16-cylinder engines* 1L-2R-5L-6R-2L-8R-6L-4R-8L-7R-4L-3R-7L-1R-3L-5R.

From this simple discussion, it is evident that the electrical ignition system performs a very vital function in the operation of the engine. Its duty is to supply a high-voltage current to the various spark plugs in the engine (in turn), in the proper firing order, and at the exact instant that the piston in the cylinder in which the explosion is to occur has reached the top of its *compression* stroke. If the spark occurs in a cylinder appreciably *before* the piston reaches the end of this stroke, the force of the explosion will tend to drive the piston back against its natural motion; if the spark occurs *after* the piston has reached the end of the compression stroke and has already started moving downward, the gas in the cylinder will have

already expanded somewhat by the time the spark occurs, with the result that less power will be derived from the explosion. Hence, the necessity for correct split-second *timing* of the spark, and for proper *distribution* of the high-tension spark current to the various plugs in the proper firing order. The exact "timing" is accomplished by the combined action of the *timing gears*, *breaker points* and *breaker-point cam*; the "distribution" of the high-tension spark current to the spark plugs in the proper firing sequence is performed by the *distributor*. These names should be remembered, as they will be referred to repeatedly.

27-32. Operation of the Automobile Ignition System.— A high voltage is required for "jumping" across the gap between the electrodes in the spark plugs in order to "fire" the compressed charges of gas in the cylinders. The only source of current supply on the car is the 6- or 12-volt storage battery. Consequently, this low-voltage d-c must be stepped up to the high voltage necessary. This is accomplished by a mechanical circuit interrupter mechanism (called the "breaker") connected in series with the storage battery, ignition switch and the primary winding of a step-up transformer called the "ignition coil". The fundamental circuit arrangement is shown in Fig. 27-29. The car chassis acts as the "ground return" circuit for the current to return to one terminal of the battery.

The interrupter or *breaker* mechanism is important. One contact point is mounted on a metal arm, and is held normally closed against another adjustable contact point by a tension spring on the arm. At the center is a cam which is rotated by the engine in synchronism with the crankshaft. When the cam rotates, its lobes (corners) press against a rubbing block of insulating material fastened to one side of the breaker arm, pushing it out and causing the two contacts to separate quickly, thus rapidly *interrupting* the primary circuit of the ignition coil. When the flat faces of the cam rest against the rubbing-block, the arm is not pushed out, and the breaker contacts touch each other, thus *closing* the circuit. This rapid interruption of the low-voltage battery current which flows through the primary winding, *P*, of the ignition coil, causes a very high voltage to be induced in the secondary winding, *S*, by "transformer action". Since the secondary winding contains thousands of times as many turns of wire as does the primary, there is a great step-up in voltage. In this

way, a current of sufficient voltage to jump the gap in the spark plug is obtained from the 6- or 12-volt battery in the car. A small condenser, *C*, able to withstand high voltage is connected directly across the breaker points. It serves to greatly intensify the voltage induced in the secondary winding, and also reduces

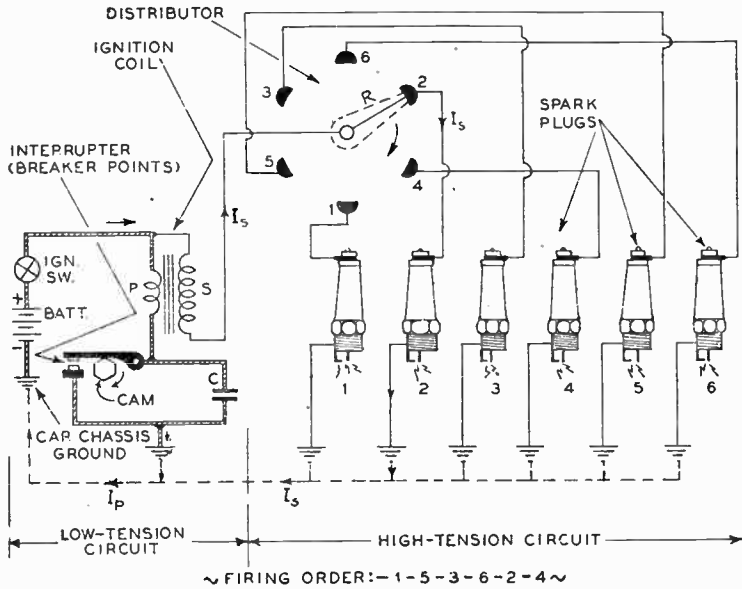

FIG. 27-29.—Fundamental circuit arrangement of an ignition system for a 6-cylinder car. The breaker points and distributor are actually built into the same housing—one above the other. The breaker cam and distributor arm are rotated by the same shaft.

the sparking which occurs at the breaker points due to the opening and closing of the primary circuit.

The secondary or "high-tension" circuit of the ignition coil contains a rotor arm, *R*, and distributor cap which is made of bakelite. The cap has moulded into it a number of contact points (similar to switch points used in radio)—one for every cylinder in the engine. The rotor arm connects to the high-tension end of the secondary winding, *S*, of the ignition coil, and each distributor point connects to the top terminal of a spark plug in the engine. The other end of the spark plug is grounded through the frame, and the other end of the secondary winding

is grounded through the battery circuit. Thus, the rotor arm and each distributor contact, in turn, are in series with the high voltage and a spark plug, in turn. Stated in another way, the rotor makes contact with one point at a time while it is being rotated by the engine, and the spark plug which is connected to a particular point is the one that receives the high voltage at that instant. The function of the rotor arm, therefore, is *to distribute the high voltage necessary for the firing of the plugs to them at the proper instants and in the proper firing order*. The spark plugs and distributor terminals are marked with numerals in Fig. 27-29 to correspond with each other.

The motion and position of the breaker arm and the distributor rotor arm are so related that, at the instant when the breaker arm and breaker points open the primary circuit and so induce a voltage in the secondary, the distributor rotor arm is making contact with the particular contact point which leads to the spark plug that is to be fired at that instant. The induced current then flows into that particular spark-plug and the gas is ignited in that cylinder.

The general theory of operation, then, may be summarized as

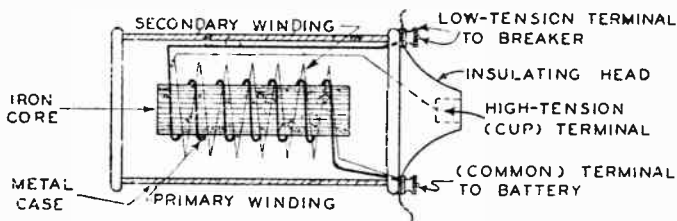

FIG. 27-30.—Interior of a typical automobile ignition coil. Several external connection arrangements which are employed are shown in Fig. 27-31 to 27-35 inclusive.

follows. The ignition switch is closed and the motor is turning over. This means that the breaker arm is opening and closing the breaker contacts at a certain, predetermined rate. When the breaker points open the primary circuit, the primary current in the ignition coil drops; this induces a high voltage in the secondary. At this same instant, the rotor arm is in position to touch a certain contact point connected to a spark plug; this

spark plug therefore receives the high voltage generated by the secondary, and it fires the compressed gas in that cylinder.

The interior arrangement of a typical ignition coil is illustrated schematically in Fig. 27-30. It consists, essentially, of a laminated iron core on which is wound a primary coil of rela-

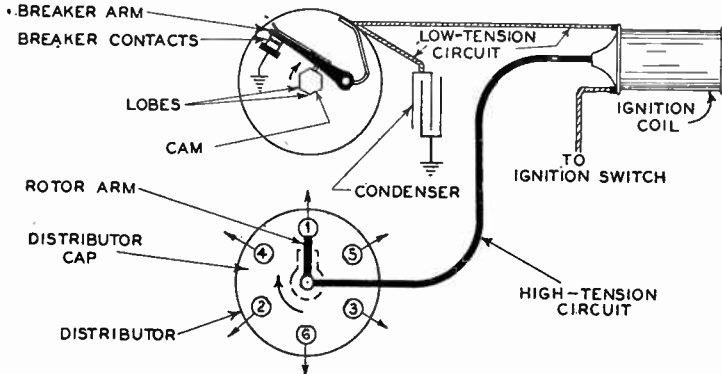

FIG. 27-31.—The simplest type of automobile ignition system is shown here. A single ignition coil and a breaker cam having as many lobes as there are cylinders (six in this case) are employed.

tively few turns of thick insulated wire (to have low resistance) whose ends are brought out to two terminals. Over this, is a secondary winding consisting of thousands of turns of very fine wire wound in layers insulated from each other by waxed paper. One end is brought out to a "cup" terminal on the head of insulating material at one end of the coil. The other end goes to the common low-tension terminal which leads to the battery and eventually to the chassis. The entire coil assembly is impregnated and sealed into a waterproof metal case, as shown.

27-33. Typical Ignition System Arrangements.—Several breaker and distributor arrangements are employed in American cars. Of course, the order of the connections between the distributor cap and the spark plugs depends on the firing order employed—this, in turn, depends upon the number of cylinders in the car. Several typical breaker, coil and distributor circuit arrangements which the auto-radio service man will encounter are illustrated in Figs. 27-31 to 27-35 inclusive. These will now be analyzed in detail.

The system shown in Fig. 27-31 is the simplest type. The breaker cam has six lobes, one for each cylinder, and one breaker arm. For a 4-cylinder car there would be four lobes, for an 8-cylinder car there would be eight, etc. This is the simple straightforward arrangement shown schematically in Fig. 27-29.

In the arrangement shown in Fig. 27-32, the breaker cam has as many lobes as there are cylinders, but there are two breaker arms. They are connected in parallel but are set so that one opens slightly later than the other. Therefore one breaker *opens* the circuit each time and the other one does the *closing*. This system is advantageous in cars having high engine speeds. It allows the ignition coil a little more time to build up the high voltage, and gives better performance at the high engine

FIG. 27-32. — The ignition system shown here uses a breaker cam having as many lobes as there are cylinders (eight in this case) and two breaker arms in parallel. One set of breaker points opens slightly later and closes an instant later than the other.

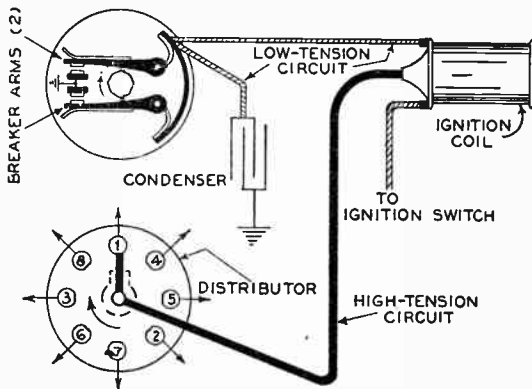

speeds where the breaker points are opening and closing very rapidly.

The arrangement shown in Fig. 27-33 is similar to the one just described, in that two breaker arms are used, but it differs in that there are only half as many lobes on the breaker cam as there are cylinders in the engine. In this system, the breaker arms operate alternately, one arm opens and closes the coil circuit for firing one cylinder, the other arm does likewise for the next cylinder. Thus one arm opens and closes its breaker points for half the cylinders and the other arm does likewise for the other half. With this arrangement, each arm only makes half as many movements, and each set of breaker contacts oper-

ate only half as frequently as in the other two systems already described.

In the system shown in Fig. 27-34, the breaker cam has half as many lobes as there are cylinders, and there are two breaker

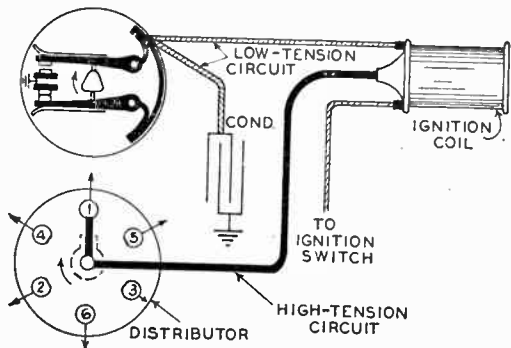
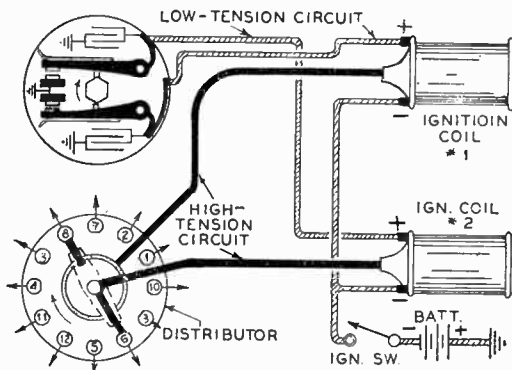

FIG. 27-33.—Two breaker arms are used in this ignition system. There are half as many lobes on the breaker cam as there are cylinders. One breaker arm fires half the cylinders; the other arm fires the other half.

arms. Two ignition coils are also used, one for each set of breaker contacts. This system is really similar to the one just described, excepting that the two coils are used instead of one. Here, each coil and each set of breaker points serves for half the

FIG. 27-34. — An ignition system in which two ignition coils are employed—one for each set of breaker points. There are half as many lobes on the cam as there are cylinders. Each of the two high-tension circuits serves half the cylinders in the engine.



cylinders in the engine. The arrangement shown here is that for a 12-cylinder engine.

The arrangement shown in Fig. 27-35 is used for dual-ignition systems, i.e., systems in which each cylinder contains two spark plugs which fire simultaneously. The breaker cam has as many lobes as there are cylinders, and the two sets of breaker

points are set to operate simultaneously. However, they are connected to separate ignition coils. The high-voltage secondaries of the coils lead out to two rotor arms in the distributor head. These rotate together but are insulated from each other, so that the current from each coil is led into a separate contact in the distributor cap. The contacts are so arranged (16 contacts for an 8-cylinder engine are shown here) that the two

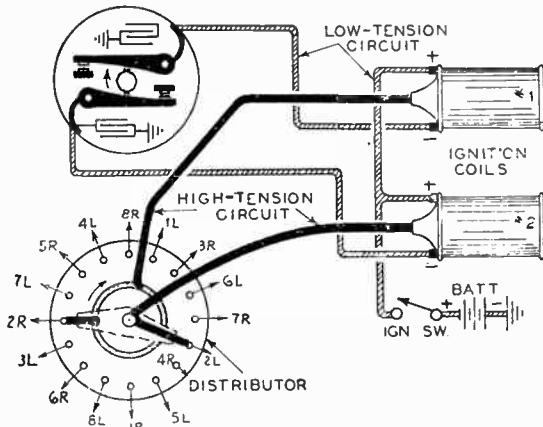

FIG. 27-35.—An ignition system similar to that shown in Fig. 27-34, excepting that the breaker cam has as many lobes as there are cylinders, and the breaker points open simultaneously. A double-arm distributor rotor is used. Two plugs in each cylinder fire simultaneously. This arrangement is used in "dual" ignition systems.

spark plugs in each cylinder are fired simultaneously, each being supplied with current from a separate ignition coil.

27-34. The Car Storage Battery.—The storage battery in the car has many duties to perform. Its primary functions are to operate the self-starter motor and to operate the ignition system of the car when the engine is running at low speed (at high speed the generator supplies this current). During recent years, however, a number of secondary functions such as the operation of the various lights, horns, cigar lighters, electric windshield wipers, electric defrosters, electric gas and oil indicators, heaters, etc., have been forced upon it. In addition to these, it performs the important function of supplying both *A* and *B* power for the operation of the auto-radio receiver.

All of these functions impose a severe drain on the battery, especially during the winter months when the lights, heaters, etc., are used more, and less opportunity is afforded the battery for re-charging because the car is driven less. It is unfortunate

that modern automobiles are not provided with larger generators and batteries—units of sufficient capacity to meet the increased current drain now imposed on them. When it is considered that the average car battery has a capacity of about 100 ampere-hours and that the radio receiver alone draws about six or seven amperes (six or seven ampere-hours per hour), it will be readily appreciated that precautions must be taken to keep the battery fully charged at all times. A storage battery is generally considered as requiring charging when about 50% of its capacity has been used up; this leaves about 50 ampere hours available for all purposes. Furthermore, in cold weather, when the engine is cold and stiff and must be turned over a number of times before it starts, the battery must be at least 80% fully charged to deliver the necessary 100 to 200 amperes required to operate the self-starter motor. If the battery is allowed to become fairly well discharged, especially if it is an old battery, its internal resistance will increase greatly. This often causes coupling effects which result in noisy operation of an auto-radio receiver that may be normally quiet in operation when the battery is well charged. The battery terminals should always be kept clean, and its cells should be kept filled with distilled water to a level $\frac{1}{2}$ -inch above the tops of the plates.

27-35. **The Generator and the Cut-Out.**—Naturally, the storage battery must be maintained as consistently near the fully-charged condition as possible, despite the many current drains on it. The source of charging current is the generator, which is driven by the engine. This usually produces a potential of 6 to 8 volts d-c, and a current as high as about 20 amperes. This generator is of the *shunt* type and contains a fixed field electromagnet and a revolving armature having 3 brushes resting against its commutator (the reader is referred to the *Radio Physics Course* by Ghirardi, or to any electrical textbook for a discussion of the theory of operation and construction of d-c generators). Two of the brushes are used for the d-c voltage for charging the battery; the third is used for altering the charging rate (voltage output) of the machine. The schematic circuit diagram of a generator of this type is shown in Fig. 27-36.

When the car travels very slowly, the engine and generator

rotate slowly and the voltage of the generator falls below that of the battery. When the engine is stopped altogether, the voltage of the generator is zero. Under these conditions, the battery would *discharge* back into both the armature and field coils of the generator (thereby discharging itself and possibly ruining the

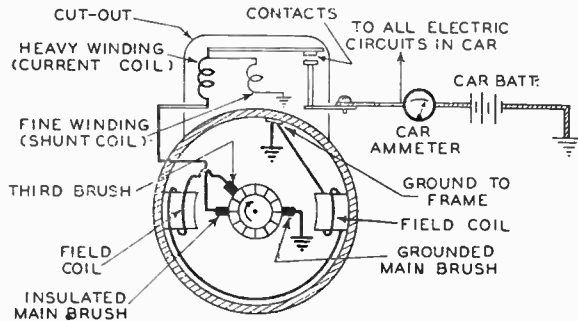

FIG. 27-36.—The low-tension battery and generator circuit of an automobile. The location of the main brushes and the third brush of the generator is shown. The cut-out relay is mounted on top of the generator.

generator) if it were not for an automatic switch, called the *cut-out* which is connected in the circuit between the generator and the battery to *close* the circuit when the generator voltage is *higher* than that of the battery, and to *open* the circuit when the generator voltage *falls below* that of the battery. This protects both the battery and the generator. As shown in Fig. 27-36, the cut-out consists of a heavy *current-coil* and a pair of contacts connected in series with the circuit between the ungrounded main brush of the generator and the ungrounded terminal of the storage battery. There is another *shunt coil* composed of a larger number of turns of fine wire shunted across the generator output circuit. The magnetism of both of these coils acts on the magnetic arm which carries one of the contacts. As long as current flows from the generator to the battery the magnetism of both coils is of such polarity that they aid one another and the contact arm is held down, thereby keeping the circuit between the battery and generator closed. As soon as the battery attempts to *discharge* back into the generator, the current through the current-coil reverses and the polarity of its magnetism is now

such that it *bucks* that of the shunt coil (whose current is still in the same direction) thereby releasing the contact arm which is pulled away by a spring—opening the contacts. As soon as the generator voltage gets high enough, the shunt coil pulls the arm down again and the generator current flows through the contacts into the battery. Thus, the cutout acts as an automatic switch. When its contacts are open, the battery operates the ignition system, auto-radio receiver, etc., and the ammeter on the dashboard indicates “discharge”. When its contacts are closed, part of the current from the generator operates these devices, and the rest charges the battery. The ammeter then indicates “charge”.

27-36. Increasing the Generator Charging Rate.—After the auto-radio receiver has been mounted in the car and connected, the generator charging rate must be *increased* by the radio service man to compensate as nearly as possible for the increased current drain imposed on the storage battery by the receiver. The ideal charging rate is the *lowest* rate which will maintain the battery fully charged on an average. Overcharging the battery is undesirable, as it will greatly shorten its life and at the same time tend to overheat the generator. Of course the correct charging rate which will maintain the battery in fully-charged condition depends upon how much the radio set is used, the mileage driven, the speed (fast, or in traffic), the time (day or night) when most driving is usually done, and the season (summer or winter). The charging rate must also be changed to suit the summer and winter operating conditions of the car (higher charging rate in the winter).

The radio service man must make an approximate guess as to the correct value required (after questioning the owner regarding the foregoing driving habits) and re-adjust it later if it proves to be too high or too low. A 10-ampere charging rate is the normal value for average driving conditions *before* an auto-radio set is installed. After its installation, the rate should be increased to about 15 amperes. Since most cars employ the “third brush method” of voltage regulation to keep the generator voltage sensibly constant over quite a wide range of speed, this type of generator will now be considered—especially since the charging rate of the battery has to be adjusted by

adjusting the position of this third brush with the commutator.

The third brush method of regulation is universally used because of its simplicity and because of the lack of any moving parts. The theory of operation is not difficult. The third brush, located between the two main brushes, as shown in Fig. 27-36, picks off part of the generated d-c voltage by virtue of its contact with the commutator. As the engine speed increases, the voltage generated by the armature increases, and, consequently, the voltage between the third brush and ground also increases. The increased current flowing through the third brush circuit in the armature creates a magnetic field in the armature which bucks the field caused by the main field coils, thus decreasing the generated voltage. Thus, at some definite speed, the generated voltage stops increasing, and keeps practically constant over a considerable range of speed. At much higher speeds, it starts to decrease. Continued increase of the voltage is thus prevented.

The holder for the third brush is mounted on a movable plate located inside the commutator-end portion of the generator housing. This plate is usually held in place by a clamp which is tightened by a small locking screw located either *inside* or *outside* of the generator housing. To *increase* the rate of charge of the battery, this locking screw should be loosened and the movable plate, on which the third brush is mounted, should be moved *in the direction of rotation* of the commutator. To *decrease* the charging rate, the plate should be moved in the direction *opposite* to that of rotation. The locking screw should then be tightened to prevent the third brush from "creeping" around the commutator when the car is in operation.

It is best to make adjustments with a good ammeter connected in the circuit between the cut-out and the battery (see Fig. 27-36). Although the car ammeter may be used, better results will be obtained with an accurate external meter, as those found on cars are not made to be extremely accurate since their purpose is more to indicate *approximate* charging and discharging rates than the *correct* amount of current that is flowing. A good rule to remember regarding this adjustment is that, with the car going at approximately 40 miles per hour, there should be no charge or discharge indicated on the ammeter with

the dim headlights and radio set turned on. This rule, however, is not valid for all cases. The best course to pursue is to check the condition of the battery with a hydrometer; then advance the charging rate as per the instructions given and allow the owner to use the car and auto-radio set normally for about two weeks. After that period, the condition of the battery should be checked again with a battery-testing hydrometer and the rate of charge increased or decreased as conditions dictate. One other precaution should be kept in mind—the charging rate should never be set to exceed that specified for the particular generator used. On the other hand, if it is not possible to bring the charging rate up to that required to keep the battery charged, even though the full output of the generator has not been exceeded, then the small series resistor (usually about one ohm) which will usually be found connected in series with the field coil should be removed. If, upon removing this resistor, the charging rate is too high, then it should be replaced by another of about one-half ohm and having sufficient current-carrying capacity.

Suppression of interference that is created by the generator, the cleaning of the commutator, and re-fitting of its brushes will be considered in Arts. 27-39 and 27-40.

27-37. Automatic Generator Voltage Regulation.—With the increased use of heaters, electric fans, cigar lighters, auto-radios, etc., the load imposed on the car battery has increased considerably in the last few years. As a result, the simple third-brush system of control of the charging rate used on most inexpensive cars has been found to be inadequate. The charging rate which is often set by a repairman who does not know the requirements, will probably be either too high or too low, and the battery will either be overcharged or allowed to run down. Thus, an increase in the charging rate when the battery is low and a decrease when the battery is high has become important. This should be performed automatically by a device in the generator.

There is a method of accomplishing this end (by "voltage regulation") which was used in some of the first generators. A contact cuts a resistance in and out of the field circuit rapidly enough to maintain a constant voltage. If the voltage of the

generator is kept constant, the rate of charge of the battery will automatically increase when the battery is low, because the battery voltage (which bucks the generator voltage) is lower; and the rate of charge decreases when the battery charge is high, because the voltage of the battery is higher. Therefore, if the current drawn from the battery is not greater than the capacity of the generator, the generator will keep the battery up. Some models of *Hudson, Chrysler, De Soto, Dodge, Plymouth De Luxe, Hupmobile, 8,* and *Terraplane* have employed this system.

Another system which has been used employs the third brush principle supplemented by a bi-metal thermostat. When a predetermined temperature of 165° F or 200° F is reached in the generator, the thermostat opens, cutting a resistance into the shunt-field circuit, thus decreasing the current output and thereby protecting the generator from overheating. Resistances of $\frac{1}{2}$, $\frac{3}{4}$, 1 or $1\frac{1}{2}$ ohms are used for this purpose, the size depending upon the type of operation to which the generator is to be adapted. As soon as the temperature drops to normal, the contacts of the thermostat close, thus shorting out the resistance. This system allows a high charging rate when the car is driven over short distances, especially in cold weather. The thermostatic cutout has been used on *Auburn 12, Buick, Cadillac, Duesenberg, Franklin, Marmon, Packard, Pierce-Arrow, Reo, Studebaker Commander 8, Studebaker President,* and *Stutz* cars.

In a third system, called the "lamp-load control," a resistance unit in series with the shunt-field is cut out of the circuit by the headlight switch, so as to increase the current from the generator when the headlights are turned on. This system has been used on *Oldsmobile* and *Chevrolet Master 6* cars.

There are several types of automatic devices available which, when connected to the car generator, increase the charging rate automatically when the radio set is in operation and which reduce this rate to normal when the receiver is shut off. These devices usually consist essentially of a resistor and relay switch. When the receiver is off, the resistor is connected in the circuit and the charging rate is reduced to about 12 amperes. With the receiver on, the resistor is automatically short-circuited and the charging rate is increased to about 18 amperes. The 6-ampere

increase is equal to the current drawn by the average receiver. This device, then, automatically adjusts the charging rate so that the power for the radio set is obtained from the generator rather than from the battery. Of course, this holds true only while the car is in operation at normal driving speed. If the radio set is operated while the car is at rest, all the current for its operation is drained from the battery. The switch may be either a current- or voltage-operated device, current-operated by the *A*-battery drain of the set or voltage-operated by connecting it across the *A*-battery leads of the set.

27-38. Interference Created by the Electrical System of the Car.—We are now ready to consider the interference which the various parts of the electrical system of the car may cause in the auto-radio receiver. After the nature of this interference and the various ways in which it may be caused are understood, we will be better prepared to understand the various remedies which must be employed for suppressing it to a level which will make it inaudible in the loud speaker.

The main sources where interference may originate in the average car are:

1. At the generator brushes.
2. At the breaker points.
3. In the low-tension wiring.
4. In the high-tension lead between the ignition coil and the distributor.
5. At the high-tension distributor contacts.
6. In the wiring leading from the distributor cap to the spark plugs.
7. In electrical appliances on the car (heater, fan motors, horn vibrators, etc.).
8. In loose contacts in the electrical system on the car.

A study of these interference sources reveals that the first six cause interference only when the engine is running. The seventh group of sources cause trouble only when the particular appliance in question is turned on. The eighth is usually noticed only when the car is in motion—especially if it is travelling over

bumpy roads. The interference need not be conducted from these sources to the auto-radio receiver directly—it may reach it by any of the many indirect means or paths which exist in the car. The three main ways in which interference may get to the set are:

1. By *direct radiation* from the source of interference to the antenna system employed with the radio set.
2. By *conduction* along some metallic path to the receiver proper, similar to the ordinary flow of current through a conducting circuit.
3. By *re-radiation* from a metallic path which has had noise currents induced in it by the direct radiation of the noise source.

We will now consider these important points in detail, starting with the low-tension circuits, and finishing with the high-tension circuits.

27-39. How the Generator Causes Interference.—The generator may cause interference for two reasons: (a) its voltage output is pulsating; (b) sparking occurs at its brushes. Since

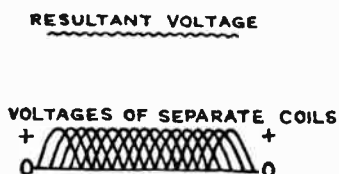

FIG. 27-37. — The “resultant voltage” graph shows the “ripply” nature of the output current of a d-c generator due to the fact that this current is really the sum of the various rectified sine-wave currents of the individual coils on the armature as shown below.

the armature of the generator is composed of a number of individual coils, each one of which has a varying voltage generated in it due to its rotation in the magnetic field, the output voltage of the generator (which is the algebraic sum of the various coil voltages at each instant) is a pulsating d-c voltage as shown in Fig. 27-37. This causes the charging current which flows in the circuit between the generator and battery, and the current fed to the ignition circuit, lights, etc., to be pulsating in nature. When this current flows in the network of wires comprising these circuits, see Fig. 27-38, pulsating induction magnetic fields are created around them, spreading out in all directions. These induction fields (which are distinct from the

radiated fields from the high-tension ignition circuits) are almost certain to reach the antenna system of the car radio, and will induce noise voltages in it. Although these voltages may be very feeble, the extremely high amplification of the receiver amplifies them sufficiently to make them heard as interference in the received radio program. Generator interference is easily distinguished from that caused by the high-tension circuits because it results in a *whirring* or *whining* sound in the loud speaker instead of the *staccato* noises caused by the latter. Moreover, the whining sound increases in pitch as the engine is speeded up, because the generator armature rotates faster, and

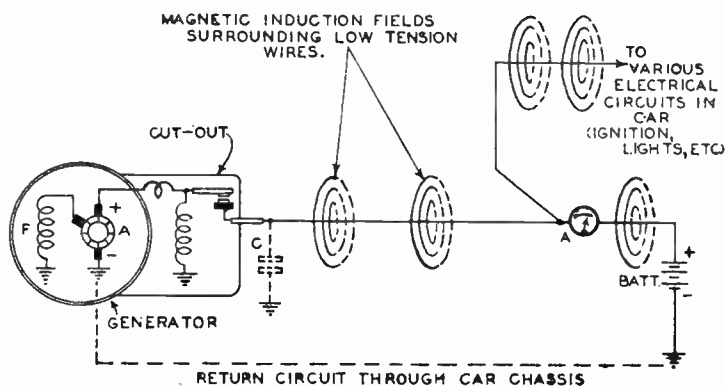

FIG. 27-38.—How electromagnetic "induction" fields are set up around the low-tension wiring of the ignition and battery-charging circuits, spreading out in all directions.

the current pulsations are produced more rapidly (see Fig. 27-37), i.e., more are produced per second.

Interference may also be produced by sparking which occurs between the brushes and the commutator of the generator. Although this sparking is small in a machine which is in good operating condition and is adjusted properly, the impulses created by this sparking are of high frequency and if they are allowed to be conducted into the live lead from the generator cut-out and from there into the low-tension circuits which the generator feeds, they will create *radiation* fields which will be induced in the antenna circuit and cause interference. If the auto-radio receiver is not provided with an effective r-f filter system in its battery-

supply circuit, these disturbances will also be conducted directly into these circuits of the receiver by the battery wires. As most auto-radio receivers are now provided with such filters built into the receiver chassis, no trouble is usually experienced from this source.

27-40. How Generator Interference is Eliminated.—Regardless of what means are to be used to suppress generator interference, any excessive sparking at the brushes should first be reduced to a minimum. Minimum sparking will only exist when the commutator surface is clean and true, when the contact surfaces of the brushes are clean and fit the commutator

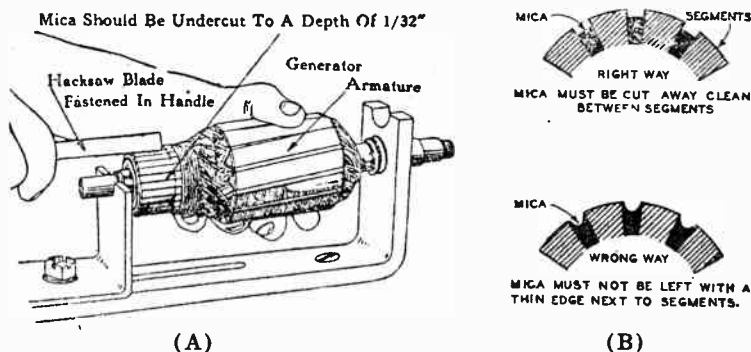

Courtesy Delco Products Corp.

FIG. 27-39.—(A) Method of holding the generator armature in a stand while the mica between the commutator segments is undercut with a ground-down hacksaw blade.

(B) Right (top) and wrong (bottom) ways of undercutting the mica between the commutator segments.

contour exactly, and when the brushes press against the commutator with sufficient force to make good contact.

The commutator surface may be cleaned by first removing the cover band which covers the opening at the commutator end of the generator housing. Then a narrow strip of No. 00 sandpaper (never use emery cloth) is held against the commutator surface while the engine is running and the generator armature is in motion. If the commutator is eccentric, or has grooves worn into it by the brushes, it should be turned down carefully in a lathe to true it up. The truing up should be done at fairly high speed and a light cut should be taken with a sharp tool.

The mica between the bars should then be undercut to a depth of $1/32$ inch below the surface of the commutator bars by means of a piece of a hacksaw blade insert into a file handle. (Fig. 27-39 shows how this is done.) The blade should have the sides of its teeth ground down until it is of proper thickness. After undercutting, the burrs on the copper commutator segments should be removed with sandpaper and all particles of copper should be cleaned out thoroughly with an air blast if possible.

The brushes and brush holders should be cleaned free of all grease, etc., with gasoline. In order to clean the contact surfaces of the brushes and seat them properly against the commu-

FIG. 27-40.—This illustration shows the method of inserting a strip of fine sandpaper around the periphery of the generator commutator for wearing down the contact surface of the brushes until they fit the commutator contour perfectly. This is often necessary to prevent excessive sparking and interference.

(Courtesy Delco Products Corp.)

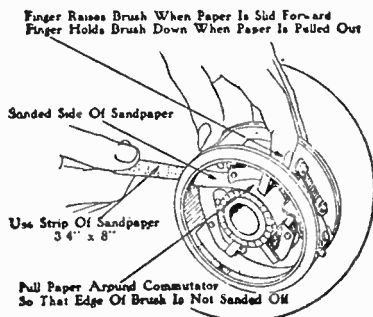

tator surface, the engine should be shut off and a strip of No. 00 sandpaper (never use emery cloth) $3/4$ inch wide and about 8 inches long should be wrapped around the commutator (under the brushes) as shown in Fig. 27-40, with the sanded side against the brushes. It should then be drawn out by pulling it around the commutator. This causes it to wear away the contact surface of the brushes, thus cleaning them. *while the brushes are pressing against the commutator.* Hence the curve of the brush is bound to be the same as the contour of the commutator surface, so it will fit it perfectly when the sandpaper is removed. The sandpaper should be re-inserted and pulled around several times until the brushes fit properly.

If the brush spring tension is weak, sparking and burning at the commutator occurs, and decreased and irregular charging will result. In this case, the tension must be increased—but not to the point where excessive brush friction will result, for this will

cause the commutator and brushes to wear faster. If the brushes squeak, it most likely is caused by a hard or glazed spot on at least one of the brushes, although a poorly seated brush or improper spring tension will also cause this trouble. The remedies are obvious.

The interference created by both the brush sparking and the

FIG. 27-41.—Two by-pass condensers designed to be connected across the generator output to suppress all interference from it. The one at the left is a $\frac{1}{2}$ -mfd. unit; that at the right is 1 mfd. They are impregnated with a special compound able to withstand temperatures up to 160 degrees Fahrenheit.

Courtesy Aerovox Corp.



current ripple of the generator may be effectively suppressed by by-passing the live lead which comes from the cut-out, directly to the generator housing by means of a $\frac{1}{2}$ -mfd. or 1-mfd. condenser. (This is condenser C in Fig. 27-38.) Condensers sealed in metal cans, with one terminal grounded to the can and the other terminal brought out by a flexible lead terminating in a

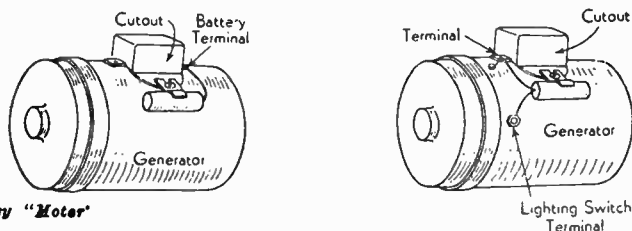

Courtesy "Motor"

FIG. 27-42.—Two typical generator by-pass condenser installations. The illustration at the left shows the usual installation in which a single condenser is connected between the battery terminal of the cut-out and the frame of the generator. The one at the right illustrates the use of a 2-section by-pass condenser which is necessary on some cars which have a "light-switch" terminal on the generator. One by-passes the "lighting switch" terminal, and the other by-passes the "battery" terminal of the generator.

lug, are made especially for this purpose, as illustrated in Fig. 27-41. The mounting lug of the by-pass condenser should be fastened under the head of the fastening screw which holds the cut-out to the generator housing, (as shown at the left of Fig. 27-42) after all paint has been scraped from both this lug and

the metal it is to make contact with. The flexible lead of the condenser should be made as short as possible (so that it does not radiate interference energy) and should be connected to the "battery" terminal of the cut-out in all cars excepting the Chevrolet models which have a "light-switch" terminal on the generator. In these cars, since both the battery line and the light-switch line must be filtered, a dual condenser with a common terminal grounded to its case is employed. One condenser terminal is connected to the light-switch terminal of the generator, and the other is connected to its battery terminal, as shown at the right of Fig. 27-42.

Condensers used for by-passing generators or ignition coils must have certain characteristics. They must be able to withstand the voltages to which they are subjected; they must be able to maintain low leakage even under high temperature fluctuations; they must be non-inductive; and they must be able to withstand the high temperatures which exist under the engine hood (especially during the summer time).

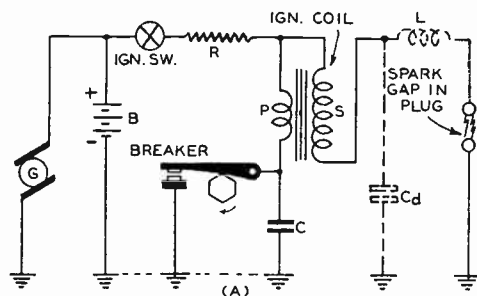

FIG. 27-43.—A typical automobile ignition system is drawn here in simplified schematic form for the purpose of analysis. Only one of the spark-plug gaps is shown.

tuations; they must be non-inductive; and they must be able to withstand the high temperatures which exist under the engine hood (especially during the summer time).

27-41. How the Ignition Circuits Cause Interference. —

The essential parts comprising a typical automobile ignition system are shown in the simplified schematic circuit diagram of Fig. 27-43. The generator and battery are G and B respectively; R is the resistance of the connecting leads, primary coil, etc.; P is the primary winding of the ignition coil, S is the secondary. The spark gap of only one plug is shown. When the breaker contacts close, the primary current cannot build up instantaneously to the value determined by the applied voltage E and the resistance R of the circuit. Due to the fact that the primary

winding of the ordinary ignition coil has an inductance of from 5 to 10 millihenries, the current takes a definite time to build up, (as shown in Fig. 27-44) increasing from zero value to a to its definite E/R value at b in about the way shown by the graph. The condenser C also charges during this time. At a certain point b , the breaker opens, thereby breaking the circuit. When this happens, the voltage across the primary of the coil goes up considerably above the 6-volts of the battery (due to self-induction). The peak value of this voltage may reach as high as 200 volts for an instant! This self-inductive effect tends to keep the current flowing across the gap in the form of a spark, even though the breaker points have separated. Therefore, the current does not drop instantaneously at b , but falls somewhat as shown by the curve $b-c$. Condenser C now discharges through the primary coil in a direction opposite to the normal flow of battery current and quickly reduces the magnetism to zero. Due to the step-up ratio of the windings in the ignition coil, this induces a high voltage (3,000 volts or more) in the secondary S .

At the instant that the breaker gap opens and the high-voltage is induced in the secondary, the distributor rotor closes the circuit to a spark plug. The spark plug gap breaks down, its resistance dropping practically to zero, while the high-voltage

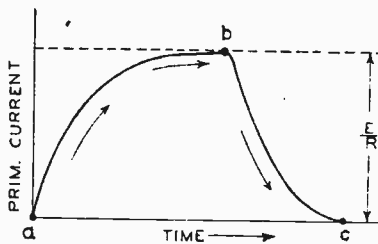

FIG. 27-44. — How the primary current of the ignition coil increases (a to b) when the breaker points close (at a), and falls (b to c) when they open (at c).

spark jumps across it. The distributed capacity C_d of the secondary coil also discharges and its current leaks through the spark plug gap to ground and into the condenser C which is across the breaker points (these are in the return path of the secondary circuit). The discharge of the condenser C sets up comparatively heavy currents in both the primary and secondary circuits.

The important point is that when the spark plug gap breaks

down and the spark jumps across it, the gas between the electrodes becomes ionized and its resistance drops almost to zero for this small interval of time. If L represents the inductance of the secondary circuit, then we have here a case of a condenser discharging through an inductance and a spark gap. This forms an oscillatory circuit (as shown at (A) of Fig. 27-45) similar to that employed in the old spark transmitters used in the early

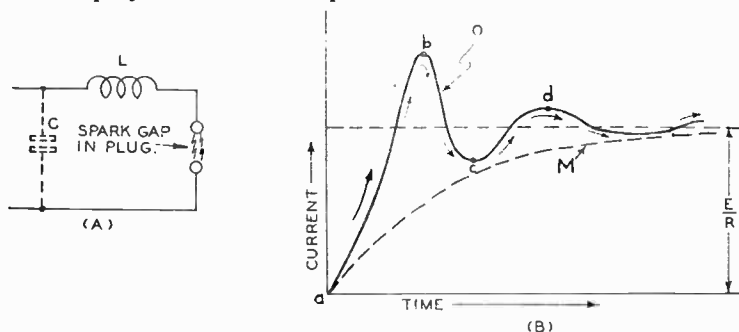

Fig. 27-45.—(A) The oscillatory circuit which is formed by the spark plug circuit.

(B) Character of the oscillating currents, O , which are set up in the spark plug circuit when a plug fires. The current not only varies in strength but also in frequency.

days of radio. The discharge is logarithmic in nature, the current increasing as shown by curve M in (B) of Fig. 27-45, so long as the resistance of the circuit is greater than $2\sqrt{LC}$, but if R is less than $2\sqrt{LC}$, the discharge of the condenser is oscillatory in nature, as shown by curve O , the frequency of the oscillations depending upon L , R and C . In the usual automobile ignition system the latter is the case, so that an oscillatory current flows back and forth in the high-tension leads and across the spark plug gap every time a spark plug fires. Since the resistance of the spark-plug gap changes progressively with the amount of current across the gap (as the degree of ionization changes) the resistance of the entire oscillatory circuit is changing up and down. This causes the frequency of the oscillations, as well as their strength, to vary. The frequency then changes from its high (open gap) value progressively all the way down to practically zero each time a spark plug fires. The oscillations produced might be pictured as shown

by curve *O* at (*B*) of Fig. 27-45. The spark gap breaks down at instant *a*. The current through it increases from *a* to *b*, then decreases from *b* to *c*, increases from *c* to *d*, etc. These oscillatory currents flowing in the ignition wiring will induce currents of this same wave-form in any nearby conductors (including the antenna conductors of the radio receiver) as long as the spark plugs are firing. Naturally, this will cause interference in the radio set—this interference being characterized by its “staccato” nature. In effect, each spark plug circuit acts as a small but troublesome radio transmitter whose frequency from instant to instant is determined by the electrical constants of the circuit.

Since the spark plugs fire in rapid succession, and the circuits of each one radiate these disturbances, many of these oscillatory discharges occur each second. Since the intensity and duration of the oscillations generated depend upon the resistance of the individual circuits, the radiations will cover a very broad range of frequencies and can be picked up by the aerial and exposed wiring of the car, regardless of the frequency to which the receiver is tuned. Furthermore, each individual spark plug circuit radiates energy, and if the periods of the various circuits are different, more than one noise voltage will be received. As a matter of fact, very complex interfering currents ranging all the way from audio to high radio frequencies, and of wave form equal to the summation of the many wave forms radiated, will be induced in the aerial and lead-in. This means that it may not be possible to obtain a peak of noise on the receiver at all. It is interesting to note that one amateur radio operator was able to find a definite noise peak in the ignition-system interference created by a Ford Model A car at the frequency of 60 *megacycles*, even though this same interference was distinctly audible on the 500-1500 *kc* broadcast band. This illustrates how wide a band of frequencies such disturbances may cover. Consequently, the noise cannot be filtered out of the auto-radio antenna system because it is not of any particular frequency. It is really caused by “shock excitation”.

27-42. Possible Methods of Eliminating Ignition System Interference.—It is evident that one method of eliminating the interference generated by ignition and accessory systems is to

shield every wire and part comprising the entire ignition system. This is actually what is done in airplane radio installations. However, with present automobile engine designs it is not a practical remedy for auto-radio installations. In order for such shielding to be effective, it is necessary that the tubular shielding be large so that the capacity between it and the conductors is kept small. Also, all wires, except those which it is absolutely necessary to keep free, must be enclosed in the shielding and all shielding must be thoroughly grounded. With automobile engines designed as they are at present, servicing of the engine would be extremely difficult if such total shielding were used, and the shielding would soon become grease-soaked, making it less effective. Such shielding would be extremely costly—more so than the simple suppression methods now in use, and it would also be difficult to keep it from shorting live wires. Then too, unless the shielding were thorough and effective, it would serve only to change the frequency of the radiated energy (because of the added capacity)—not *eliminate* it entirely.

Another noise elimination method which has been used, but which has not attained any great degree of popularity, is the use of an anti-resonant circuit in the high-frequency leads to reduce the efficiency of the radiating system over a given band at which the impedance of the anti-resonant circuit is high. This method is inexpensive, because only a small coil is required so that it is anti-resonant with its own distributed capacity. The field is thus small and the spark intensity is not reduced. These coils are normally of a 20-millihenry value resonated at about 700 kilocycles. However, radiations above and below the band are not prevented. They are merely reduced.

The only other logical method of minimizing the interference is to suppress the disturbing radiations at their source. Then, assuming that the receiver is equipped with shielded and filtered battery cables and other external leads, little, if any, energy can be picked up by the set, provided that the exposed aerial wire is placed in a location where it is not affected by whatever weak radiations may still exist. This is the practice resorted to in most auto-radio installations. Since oscillations will only be set up in the spark plug circuit (see curve *O* in (*B*) of Fig

27-45) if the total resistance of the circuit is *less than* $2\sqrt{LC}$, (otherwise the discharge currents will be logarithmic in nature, as shown by curve *M* in (B) of Fig. 27-45), the oscillations can be prevented by the simple but effective expedient of connecting sufficient resistance into each spark-plug circuit to damp the oscillations by making the resistance of the circuit *greater than* $2\sqrt{LC}$ when the spark plug gap breaks down and its own resistance is zero. Special resistor units designed to be attached directly to the center terminal of the spark plugs (see Figs. 27-48 and 27-49) are made for this purpose. A resistor is used for each spark plug, and is mounted as close to the plug as possible (usually directly on it) so that radiation will not occur from any length of wire between the gap in the spark plug and the resistor, for such leads have distributed capacity and inductance. Since these resistors suppress the interference, they are called *suppressor resistors*.

27-43. Use of Spark Plug Suppressor Resistors. — The spark plug suppressor resistors should have high enough resistance to suppress the oscillations, but on the other hand should not be so high as to impair the operation of the ignition system. In cars which are a few years old, the interference is so great that suppressors having a value of as high as 25,000 ohms each must usually be used. During the past few years automotive engineers have recognized the auto-radio problem and have taken some pains to alter the position of the car wiring and ignition apparatus so that the interference radiations which reach the antenna system have been reduced greatly. In one car, the ignition coil was moved off the bulkhead, and mounted close to the distributor to minimize the length of the high-tension lead. In another, the high and low-tension ignition leads have been run so that they are well separated, in others, the spark-plug leads have been shortened. At this writing, at least one laboratory is experimenting with distributor rotors having built-in suppressors. At any rate, these improvements, and those made in the shielding in auto radio receivers have been so effective that in at least half of the newer cars no spark plug suppressors are required at all; a single suppressor in the short high-tension lead between the ignition coil and the center of the distributor cap is all that is

necessary. In those recent cars which do require spark plug suppressors, a value of from 8,000 to 12,000 ohms is sufficient.

Suppressor resistors are commonly made with a carbon composition resistor element encased in a bakelite or isolantite housing and provided with proper terminals for rapid connection into the circuit. The internal construction of a typical suppressor resistor unit is illustrated in Fig. 27-46. A suppressor resistor should have certain characteristics. It must be able to withstand the high temperatures existing under the engine hood without appreciable change in resistance or breakdown of its insulation; the resistor ele-

FIG. 27-46.—Internal construction of a typical elbow-type suppressor resistor. The complete resistor is shown at the top. The moulded carbon resistor element is under it. Next is the contact spring and screw-type ignition cable terminal. A cross-section view of the completely assembled suppressor is shown at the bottom.

Courtesy Erie Resistor Corp.



ment should be long and narrow to reduce the capacity between the terminals; it should be constructed so that firm and unvarying contact is established between the resistor element and the terminals; its surfaces must not tend to accumulate excessive grease and dust which will cause high surface-leakage between the terminals; its voltage coefficient (see Art. 22-11) should be low so that its resistance remains practically unchanged at the peak of the discharge of the spark plug (the current is maximum at this instant).

Suppressor resistors are made in two general shapes, the *elbow* and the *straight* types. Typical examples of each type are illustrated in Fig. 27-47. Elbow types are used when the spark plug wires emerge from the cable duct almost at the level of the spark plug terminals. The use of elbow-type suppressors in such cases makes it possible to keep the spark plug leads short. Typical installations of these suppressors on the spark plugs are shown at (A) of Fig. 27-48 and in Fig. 27-49. The straight type

is more suitable for some installations. The vertical method of mounting the suppressor is illustrated at (B) of Fig. 27-48.

Several types of terminals are employed on these suppressors. In any installation, it is essential that the end terminal of the spark-plug suppressor be of a type suitable for the spark plug arrangement and the types of spark-plug cable terminals in use on the car, so that time will be saved in the installation work. In the elbow suppressor (shown in Fig. 27-46 and again at (A) of Fig. 27-47) a screw type terminal is employed for connecting to the spark-plug lead. The screw is simply screwed into the

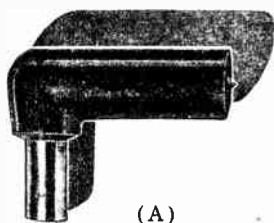

(A)

FIG. 27-47.—(A) A typical "elbow" type spark plug suppressor.

(B) A typical "straight" type suppressor with a U terminal which enables it to be mounted either vertically, or horizontally, on the spark plug terminal.

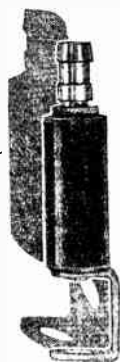

(B)



(C)

Courtesy Continental Carbon Co.

(C) A "straight" suppressor with a brass threaded insert at its lower end. This may be screwed directly on to the spark plug terminal screw.

wires of the cable, after the end of the cable has been squared off. In the suppressors illustrated at (B) and (C) of Fig. 27-47, a ferrule terminal is used. The spark plug lead must be equipped with a spade terminal which clips on to the ferrule terminal of the suppressor. In dual-ignition systems where two spark plugs are employed for each cylinder, a suppressor must be installed on *each* plug.

27-44. Spark Plugs Having Built-In Suppressors.—The closer the suppressor resistor is to the spark plug, the more effective is the oscillation-suppressing action. This has led to the development of specially constructed spark plugs having the suppressor resistor built directly into the center of the porcelain

insulation as an integral part of the plug. An external (left) and cross-section view (right) of a spark plug of this type is illustrated in Fig. 27-50. The position of the suppressor resistor R is shown. While this arrangement is very effective, it has not

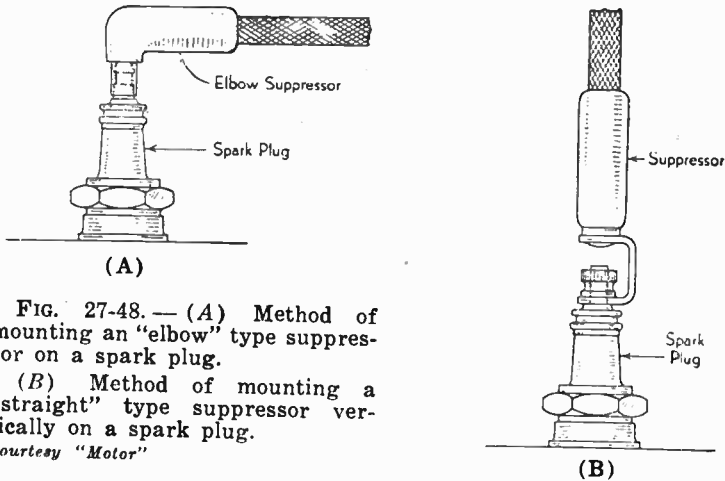

FIG. 27-48.— (A) Method of mounting an "elbow" type suppressor on a spark plug.

(B) Method of mounting a "straight" type suppressor vertically on a spark plug.

Courtesy "Motor"

attained great popularity mainly because of the fact that the car owner must discard his entire set of spark plugs (which may still

FIG. 27-49.— A typical installation of "elbow" type spark plug suppressors on an 8-cylinder automobile engine. The spark plug leads emerge from the wire duct almost on a level with the tops of the plugs.

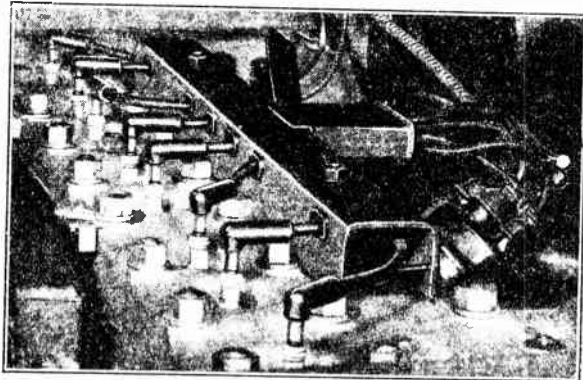

Courtesy Erie Resistor Corp.

be in good working condition) when these plugs are installed.

27-45. Use of a Suppressor Resistor at the Distributor.— The distributor rotor arm (or arms) does not actually touch the

electrodes which are moulded into the distributor cover, and which lead to the various spark plug circuits. Since the arm is rotating very rapidly, a gap of a few thousandths of an inch is provided between its end and these electrodes for mechanical clearance. Therefore, a tiny spark occurs across this clearance gap

FIG. 27-50.—External and cross-section views of a special type of spark plug having a suppressor resistor *R* built into the center of the insulating core as an integral part of the plug.

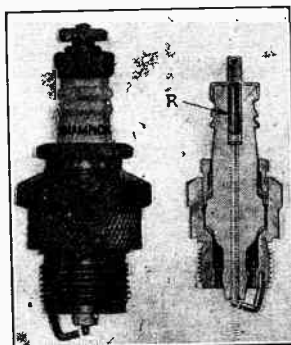

Courtesy Champion Spark Plug Co.

when the rotor arm comes around to each electrode, in turn. This spark tends to set up oscillations in the wire between the ignition coil and the distributor cover. These oscillations, in turn, radiate interference energy to the rest of the wiring of the car and to the antenna system of the auto-radio receiver. This interference from the distributor may be eliminated, or at least minimized to a large extent, by the insertion of a suppressor resistor in series with the high-tension lead to the rotor arm. The resistor introduces

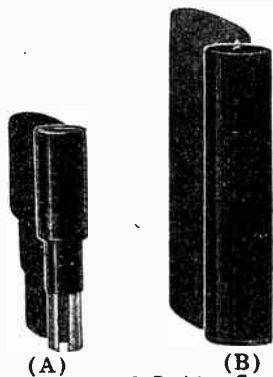

Courtesy Continental Resistor Corp.

FIG. 27-51.—(A) A distributor suppressor having a split tubular end for insertion into the center terminal of the distributor cover, as shown at (A) of Fig. 27-52.

(B) A "screw" type of distributor suppressor designed to be cut into the high-tension lead between the ignition coil and the distributor, as shown at (B) of Fig. 27-52.

sufficient resistance in the circuit so that forced oscillations cannot occur and radiation of the oscillating energy is thus prevented. The value of the resistance required is less than that used at the spark plugs. A resistance of 3,000 to 5,000 ohms is usually sufficient for this purpose.

Two typical forms of suppressors designed especially for the distributor lead are illustrated in Fig. 27-51. The one at (A) is provided with a tubular split prong at one end, which fits snugly into the cup terminal at the top of the distributor cover. The other end has a screw type terminal which screws into the

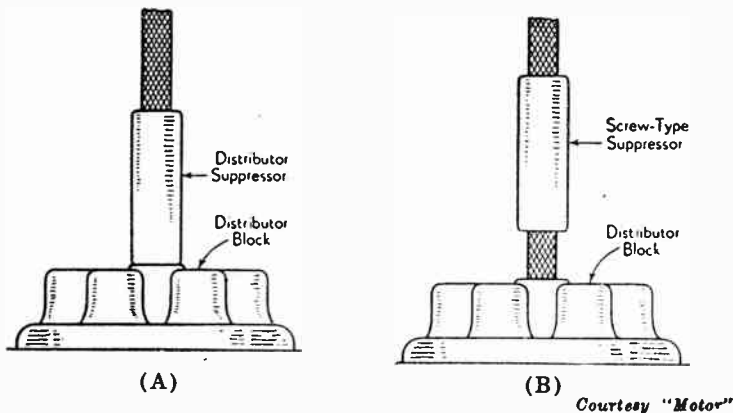
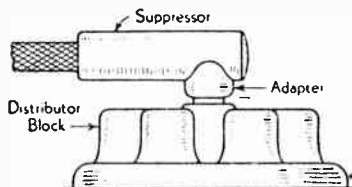

FIG. 27-52.—Typical distributor suppressor installation arrangements. The "plug" type is shown at (A); the "screw" or "splice-in" type is shown at (B).

wires of the high-tension lead between the ignition coil and the distributor cover. The method of installing this type of suppressor is illustrated at (A) of Fig. 27-52. The suppressor at (B) is designed to be used where the suppressor must be inserted in the lead itself. It is provided with a screw-type terminal at

FIG. 27-53.—"Elbow" type distributor suppressor mounted in place on the cover or "block" of the distributor. This type must be used in installations on some cars.

(Courtesy "Motor")



each end. The high tension lead is cut near the distributor cover and the suppressor is screwed firmly into the wires of the two cut ends as shown. There are several cars which require an "elbow" type suppressor in the distributor lead. The method of installing a suppressor of this type is illustrated in Fig. 27-53. In those cars which employ two ignition coils (see Figs. 27-34

and 27-35), a separate suppressor must be installed in the high-tension lead of each coil, as near to the distributor cover as possible. In all cases, even though a suppressor is installed, the high-tension lead between the ignition coil and the distributor should be made as short as possible. If this lead happens to be run through the same conduit as the spark-plug wires, it should be removed and re-routed. If the distributor housing is manually retractable for timing, connect the two parts together with flexible copper braiding to assure good electrical connection between them.

27-46. Effect of Suppressors on Engine Performance.—

A great many conflicting statements have been published regarding the effect which the spark-plug and distributor suppressor resistors have on the performance of the engine. Some have maintained that the addition of suppressors causes undesirable effects on the performance; others claim that they do not affect it at all. Exhaustive tests made by responsible ignition and automotive experts have revealed that the engine operation is *not* affected by the addition of the suppressors, provided that: (1) *the engine is in good operating condition to start with*, (2) *the spark plug suppressors are of less than 20,000 ohms resistance each*, and (3) *that the distributor suppressor is of 5,000 ohms resistance or less*.

One explanation offered for this experimentally proved fact is as follows: When the spark gap (in the plug) breaks down, the gas in the cylinder ignites and the piston is forced down. Now the compressed gas really ignites before the full voltage has been built up across the spark gap. Therefore, even if suppressors are used, and even though they undoubtedly decrease the intensity of the spark somewhat because of their resistance, the full spark intensity is not required.

On the other hand, if the motor is not properly timed, if the plugs are fouled, or if the carburetor is improperly adjusted, the suppressors may decrease the engine efficiency (resulting in somewhat increased gasoline consumption), affect the operation at both low idling speeds and full top speeds, and cause hard starting in cold weather if they are of very high resistance. When the motor is idling and not properly adjusted, the effect of the sup-

pressors is to cause misfiring. The main point, however, is that with a properly adjusted motor, correct suppressors do not make any detectable difference in motor action or efficiency.

27-47. **By-passing the Low-Tension Circuits at the Ammeter and Ignition Switch.**—Ignition-system disturbances are apt to come into the battery circuit through the wire leading from the ignition switch to the ignition coil (this is common to both the primary and secondary circuits). In order to show clearly how this may occur, a portion of the electrical circuit of a typical automobile has been reproduced schematically in Fig. 27-54. This common wire has been labeled *A*. Any radiated disturbances

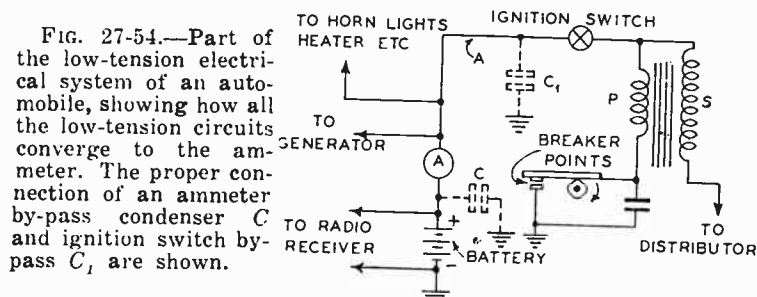

may also be picked up by other wiring in the car, such as the wiring to lights, horns, etc. Since all of these lines feed into the battery, disturbances in them may find their way into the battery leads of the receiver, or they may re-radiate to the antenna system. Since all of these lines join at the ammeter, it is a convenient place at which to by-pass them to the car chassis by means of a $\frac{1}{2}$ - or 1-mfd. by-pass condenser *C*. This should be connected to the "battery" terminal of the ammeter as shown, in order to minimize these disturbances. The by-pass condenser may be mounted back of the dashboard near the ammeter so its case and its "ground" terminal ground to the dash. The flexible lead of the condenser should be connected to the *battery* terminal of the ammeter, as shown at (*A*) of Fig. 27-55.

The circuit leading from the battery to the ignition coil may also be by-passed conveniently at the ignition switch by means of a $\frac{1}{2}$ - or 1-mfd. by-pass condenser *C₁*. This condenser is also mounted on the rear of the dash so it grounds to it, and its

flexible lead is connected to the battery terminal of the ignition switch as shown at (B) of Fig. 27-55. In some installations, it will be found that this condenser is more effective if connected

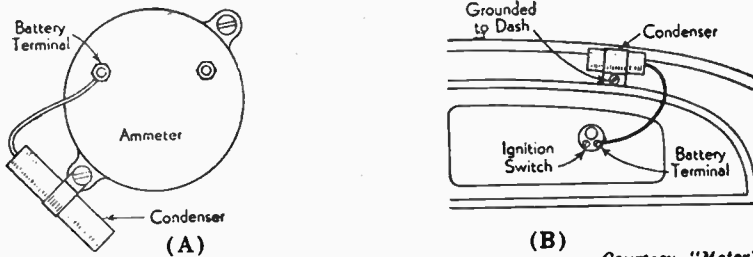

FIG. 27-55.—(A) How the "ammeter by-pass" condenser is mounted back of the dashboard and connected to the "battery terminal" of the ammeter.

(B) How the "ignition switch by-pass" condenser is mounted back of the dashboard and connected to the "battery terminal" of the ignition switch.

directly between the battery terminal of the ignition coil and the grounded coil-mounting bracket instead, as shown in Fig. 27-56.

27-48. Cases where Additional Interference Prevention Measures are Necessary.—In general, the foregoing measures will reduce ignition interference to a negligible level and they

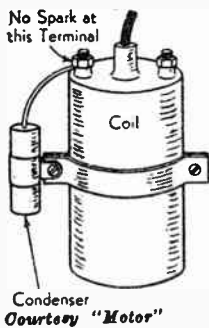

FIG. 27-56.—How the "coil by-pass" condenser is mounted on the ignition coil bracket and connected to the "battery terminal" of the primary.

may be regarded as the "standard" measures to take when installing a modern auto-radio receiver in a modern car. Not all cars require the extensive filtering and suppression described—some require more. Some cars require but a single distributor suppressor and no spark plug suppressor—others require suppressors on all spark plugs. Some require a by-pass condenser only across the generator output, others require additional by-passing at the ammeter, ignition switch, battery terminal of the ignition coil and other places. The auto-radio service man will often come across many

cars in which the foregoing measures do not suffice, that is, after they have all been applied, annoying interference still persists.

No specific directions can be given for the procedure to follow from this point on, for the simple reason that the cause of the trouble may be rather an obscure one which will require a considerable amount of hunting down. However, a number of additional preventative measures which are commonly necessary

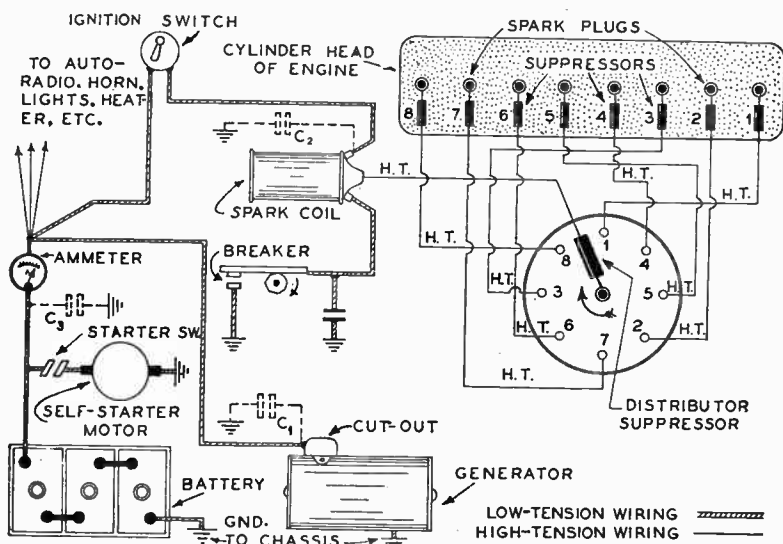

FIG. 27-57.—Complete schematic wiring diagram of the ignition wiring on a typical 8-cylinder automobile. C_1 , C_2 and C_3 are the added generator, coil and ammeter by-pass condensers respectively. The distributor and spark plug suppressors are shown installed in place. This represents the "standard" suppression measures which are sufficient for interference suppression on about half of the cars encountered. Additional measures must be taken in the others.

in some cars will now be presented. They will be considered in the order of the frequency in which they are necessary.

27-49. Tests to Determine by what Path Interference is Reaching the Receiver.—It is assumed at this point that the receiver is in proper working order and is properly installed. It is also assumed that the "standard" interference-suppression measures which have already been described have been applied, as shown in Fig. 27-57, but do not succeed in eliminating the interference completely. If such is the case, the first thing to do is to determine definitely whether the interference comes from a

source *outside* of the car or from a source *within* the car. If it comes from within the car, it is important to find out how it is reaching the receiver. It may either get to the receiver via the antenna, or it may also find its way in through direct pickup by the receiver battery wires or through the shielding of the set itself. When this is known definitely, it will furnish some clue to the most effective steps to be taken next. Of course, if the interference appears only intermittently and disappears as soon as the car has travelled to another location, it is most likely of external origin. However, there are many cases where the radio receiver is steadily noisy due to external interference when operated anywhere in a location of very wide area—possibly an entire town. This is very often the condition in rural communities having electric light transmission lines with leaky insulators, or having lines which pick up excessive atmospheric radiations and re-radiate the impulses (see Chapter XXX). In such cases, the auto-radio set may be noisy when operated anywhere in the town, yet the entire installation may be entirely blameless of itself. In such cases, and others, the service man probably knows of the fact but he must have some method of determining definitely whether interference which is heard in a new auto-radio installation (or an old one which is to be serviced) is of external or internal origin. There are two conditions under which a test to determine this may be made. They are:

1. Test the set in the noisy location, to determine whether the operation of the car and all electrical appliances on it makes any difference in the noise intensity.
2. Test in a spot free from all external electrical disturbances, to see if the operation of the engine and all electrical appliances on the car cause any noise in the receiver.

We will now consider these tests in the foregoing order.

(1) Test in Noisy Location: If the service man is not equipped with a shielded cage into which he can run the entire car (see Fig. 27-1), and the vicinity of his shop is not entirely free from electrical disturbances, he must make the test under noisy conditions. The receiver should be turned on (without the

car engine running), and with the volume control turned, all the way up. If any noise which is heard is "tunable," the receiver should be tuned to bring in with greatest volume whatever noise is present. However, this should be a point where no broadcasting signal is heard. The noise should be observed carefully so that its intensity may be remembered fairly accurately for comparison later.

(a) The lead-in wire should now be disconnected from the receiver. If this makes the noise disappear, or greatly reduces its intensity, it is undoubtedly due to interference originating outside of the car being picked up by the aerial wire and fed to the receiver. In this case, nothing much can be done about it. On the other hand, if the noise still persists undiminished in intensity when this is done, it indicates that the receiver itself is probably noisy. In this case loose connections, a faulty rectifier or vibrator, etc., should be looked for in the set.

(b) The engine should now be started (with the lead-in still disconnected from the receiver). If the receiver is more noisy than it was with the engine shut off it indicates that interference from the ignition system of the car is reaching the set by way of its battery wires or through the chassis. Receiver designers have done much of late to eliminate this form of noise pickup, by thoroughly filtering the battery leads and thoroughly shielding the receiver chassis.

(c) With the engine still running, the various electrical appliances on the car (heater motor, electric windshield wiper, lights, etc.) should be turned on, one at a time, and the effect of each one on the noise should be noted. Any appliance that increases the noise requires a by-pass condenser and possible shielding of its leads. The engine should now be shut off.

(d) The lead-in wire should now be re-connected to the receiver and the noise noted. Then the engine should be started. If the noise increases greatly, it indicates that high-frequency interference from the ignition system is reaching the aerial (assuming that the lead-in is well shielded).

(e) Now, to complete the test, the car should be run for several blocks with the set turned on. Notice whether the noise

increases when the car is in motion. If it does, it indicates that static discharges are being generated by the front wheel, the tires or the brake linings. It is well to run the car over bumpy cobblestone streets or a bumpy road during part of the test, so that any noises which may be caused by loose connections either in the set or in the car will also be revealed.

(2) Test in Location Free From External Disturbances: If a shielded test cage into which the car can be run (see Fig. 27-1) is available, a test may be made to find out directly whether the operation of the engine and any of the electrical appliances on the car are causing interference. To do this, the car is run into the cage, and the cage is closed so as to completely shield the entire car from any *external* electrical disturbances.

(a) Now the set is turned on with the volume control full "on" and the engine shut off. If noise is heard, since neither the engine nor any external source is producing it, the set should be checked for noises.

(b) If all is quiet (except for the slight hum due to the *B* power vibrator unit in the receiver) the engine should be started. Any noise which is now heard, is due to the ignition system of the car.

(c) The lead-in wire should now be disconnected from the receiver. If this *eliminates* the noise, the high-frequency interference radiations from the ignition system were being picked up by the aerial. If this only *reduces* the noise somewhat, then the pickup is partly through the aerial and partly through the battery leads of the receiver on the chassis. If it has *no* effect on the noise, the pickup is entirely through the battery leads or the chassis of the receiver.

(d) With the lead-in connected to the receiver, the various electrical appliances on the car should be turned on, one at a time, and their effect on the noise level noted.

(e) If the noise level increases greatly as the car is run out of the shielded test cage, it is safe to assume that the increase is due to external interference reaching the aerial.

27-50. Procedure for Eliminating Receiver Wiring or

Chassis Pickup.—A step-by-step procedure which will be found useful when attempting to eliminate all remaining interference which may still be present after the "standard" suppression methods have been applied and the tests outlined in Art. 27-49 have been made will now be presented. Pickup by the receiver wiring, or the chassis, will be considered first.

1. If the tests of Art. 27-49 indicate that the interference is finding its way into the receiver by way of the receiver battery leads or shielding, go over all ground connections and make sure that they are clean and tight. Remember that painted or rusted surfaces, "parkerized" lock washers, etc., do not permit good electrical contacts to be made. All metal contact surfaces should be scraped clean and bright with emery cloth or a suitable file. If the receiver does not contain an effective battery line filter, a small choke coil consisting of 10 to 20 turns of No. 18 bell wire wound on a $\frac{1}{2}$ or $\frac{3}{4}$ inch form and connected in series with the hot "A" lead between the set and the battery is often effective.

2. Excessive noise is very often caused by an imperfect grounding contact between the receiver chassis and the car frame. When the receiver is bolted to the bulkhead or fire-wall between the engine and driver's compartments (or to the instrument panel) it is important that all paint be scraped off at the area of contact and that all bolts be tightened firmly to assure good electrical contact between the receiver case and the metal of the car.

3. Interference may be picked up by the battery leads of the receiver if they are run through the engine compartment. They should be re-routed through the driver's compartment instead. In some receivers, a single flexible lead runs from the receiver to the remote tuning control unit to supply current for the tuning dial light. This dial light lead may be picking up interference and leading it into the receiver. If this is the case, it may cause the noise heard when the receiver antenna lead is disconnected. If the interference is reduced when this wire is disconnected at the set chassis, it should be shielded with copper shielding braid slipped over it to prevent this pick-up; the shield, of course, being grounded both at the receiver and at the remote control end. Also try grounding the tuning and

volume control cable sheaths to the receiver case by means of a screw driver. If this reduces the interference, these sheaths should be bonded to the receiver case with copper shielding braid.

4. If a separate speaker is used, the shield of the cable between it and the chassis should be well grounded at both ends. If an unshielded cable between radio chassis and speaker is used, proper filters should have been built into the radio set to eliminate motor interference. It is well to check the efficiency of these filters by connecting a 0.01 mfd. condenser between each lead in succession and the ground. If the condenser reduces the interference it should be permanently installed.

27-51. Procedure for Suppressing Remaining Interference Reaching the Antenna.—The case where persistent interference gets to the antenna will now be considered.

1. First be sure that the aerial lead-in wire is properly shielded right from the receiver case to within 1-inch of the aerial itself (see Art. 27-16) and that this shield is properly grounded at both ends.

2. If the interference still continues, the next step is to determine whether it is caused by the high-tension or the low-tension circuits. Remove the high tension lead between the ignition coil and the distributor (remove both leads if two coils are used), turn on the ignition switch, and turn the motor over by hand (with the radio set turned on). Do not use the self-starter for this purpose, as both the sound it makes and the electrical disturbances it will set up may prevent you from hearing the "clicks" which are to be heard. If "clicking" from the breaker point interruptions is heard in the loud speaker, the indication is that part of the interference at least is from the low-tension circuits or breaker points. If no "clicking" is heard, the low-tension circuit may be removed from suspicion. In this case, pass on to test No. 3.

If "clicking" is heard, remove the primary lead running from the ignition coil to the breaker points on the distributor (see Fig. 27-57) and either shield it with shielding braid or replace it with a piece of No. 14 shielded low-tension cable. The shield of this cable should be grounded in two places with connections as short as possible. If necessary, either shield or replace the lead from the ignition switch to the ignition coil with No. 14 shielded low-tension cable, making good soldered ground connections to the shielding. Care must be taken with the shielded leads so that the connections to the coil switch or distributor are not grounded by them. Never use a by-pass condenser on the "breaker side" of the primary of the coil, as the operation of the engine will be affected. If one must be used, connect it to the battery terminal of the coil (condenser C_2 in Fig. 27-57).

The breaker points should be inspected. If they are badly burned and pitted, or dirty, they should be filed flat with a special thin file or stone made for this purpose, and should be adjusted for the proper gap (in accordance with the car manufacturer's instructions) so

that a clean "break" is obtained.* The test for "clicking" should now be made again to make certain that all of the interference originating in the low-tension circuit has been completely eliminated.

3. If interference is still present after the low-tension circuits have been attended to and the "clicking" test gives a negative indication, the high-tension circuits must be considered next. The ignition circuit should first be put in good order. The spark plugs should be removed from the cylinder head and inspected. If they are fouled, they should be cleaned—new ones should be substituted if necessary. Otherwise, the gap should be checked with a thickness gauge and adjusted if necessary. The gap separation should be about 0.025 inch for low-compression engines and about 0.020 inch for high-compression engine.† The spacing of the spark plug electrodes is important, since the greater the gap resistance is, the greater is the tendency to reduce the high-frequency oscillations (see Art. 27-42). However, if larger gaps than these are used the interference will increase.

All high-tension ignition cables should be inspected next. Grease and dirt should be cleaned off. If their rubber insulation is brittle and badly cracked, it will be "leaky" at radio frequencies, and new wires should be installed. All connections to the suppressors and plugs should be tight and secure. The distributor cap should also be inspected and cleaned. If it is cracked at any spot it should be replaced, for leakage will occur between the contact studs.

4. If interference is still present, the location of all high-tension wires should be studied. All low-tension wires which run parallel to, or in the field of, the high-tension circuits act as carriers and they should either be moved whenever possible, or the high-tension wires re-routed. In cases where the high-tension duct is used to house low-tension wires, the removal of the low-tension wires from the duct will usually be found sufficient.

In cars where the ignition coil is mounted behind the instrument panel or elsewhere under the cowl, one of two procedures should be followed. First, shield the high-tension lead from the coil to the distributor. This may be done by covering the lead with shielded flexible loom (see (B) of Fig. 27-15). The shield should be grounded to the frame of the coil at one end and to the motor block or high-tension cable duct at the other. This lead should be run as directly as possible from the coil to the motor compartment, even if it necessitates drilling a new hole in the dash.

If the interference still persists, it may be necessary to move the ignition coil (or coils) into the motor compartment on account of coupling of the electromagnetic field of the coil with the receiver apparatus. Mount the coil on the motor block as near as possible to the distributor, making sure that a good grounding contact is obtained. If it is necessary to mount the coil above the motor, make sure that a location is selected where the coil will stay sufficiently cool. The new primary wires required should be of No. 14 shielded

*NOTE: A chart giving the correct breaker-gaps for all models of American cars will be found in Section 8 of the author's *Radio Trouble-Shooter's Handbook*.

†NOTE: A chart giving the correct spark plug gaps for all models of American cars will be found in Section 8 of the author's *Radio Trouble-Shooter's Handbook*.

low-tension cable. These wires should not be run too close to the high-tension leads, and the shields should be well grounded.

In some automobiles the ignition switch is built in as an integral part of the ignition coil. If this is the case, a separate ignition switch may be installed on the instrument panel. The new switch should be connected to the coil with heavy-duty, well insulated wire in a properly grounded shield. The original key should be placed into the ignition coil and soldered to keep it in place. Another method is to "short" the primary of the original ignition coil, and connect its circuit to the primary of the new coil placed in the engine compartment. The original ignition switch and key can then be used.

Moving the ignition coil is impractical in many instances and undesirable in others. If it has been definitely established that interference is caused by the magnetic field around the ignition coil, the coil may be thoroughly shielded instead of moving it. This may be accomplished by covering the entire upper end of the coil with a metal can which has had a hole drilled in its end to admit the shielded loom-covered high-tension lead. The shield over this loom should be soldered to the can. Slots must also be cut into the can to admit the low-tension wires to the coil. The can should fit snugly over the coil and should be taped into place securely so it will not shift. The can must be well grounded either to the instrument board or to the body of the car. This type of trouble is usually encountered when the ignition coil is encased in a bakelite container instead of the more common metal case.

5. As mentioned previously (Art. 27-45), the rotor arm of the distributor does not make actual contact with the distributor points—except in a very few cases—for a very good reason. The small air gap of a few thousandths of an inch provides mechanical clearance and prevents the flow of current to the spark plug for a very short time in order to allow the secondary voltage to build up to the proper value. If the gap is more than between 0.001 to 0.004 inches, the amount of interference that may be generated is large, and the gap must be reduced, but care must be taken that the rotor does not brush any of the contacts.

This may be done by removing the rotor arm from the distributor and placing one side on a flat steel plate. Then lightly pound (with a small machinist's ball-peen hammer) the end of the rotor arm that approaches the points, until it is elongated slightly. Dress the end of the rotor with a file, to its original shape. The judging of the correct amount of lengthening of the rotor arm may be done by putting a heavy chalk mark on each of the contacts. After the arm is lengthened, the distributor is assembled and the motor turned over *by hand* so that the arm makes a complete revolution. The cap is then removed and the end of the arm examined for traces of chalk. If a mark is found, the contacts are examined to determine which one has close spacing and the arm filed to clear it (or them). If the distributor head is considerably "off center", it may be necessary to replace it. If there is evidence of the rotor touching the contacts, file off about .001 inch and recheck. If the rotor is double ended, both ends should be treated in the same manner. The operation should be completed on one end before doing the other. The spacing should be reduced to about 0.002 inch. Do not space it closer, as the rotor elongates slightly at high speeds because of centrifugal force, and there is a possibility of its hitting the contact points and either snapping itself or ripping the entire distributor

cap apart. Elongating the rotor arm by pounding is known as *peening* the rotor. Building up the rotor arm with solder (instead of peening it), is not recommended, for the heat of the spark soon burns the solder away. Peening of the rotor must be done with extreme caution, to prevent damaging the distributor, and should best be left to one who is experienced in doing it correctly.

6. Interference may be conveyed to an auto-radio receiver system by three distinct paths:

1. By *direct radiation* from the source of interference and associated wiring, similar to the radiation which occurs from radio transmitting to receiving antennas.
2. By *conduction* along some metallic path to the receiver proper (similar to the ordinary flow of current through a conductor).
3. By *re-radiation*.

The first two methods are self-explanatory. The third means that radiation from the interference source is picked up by some other wire (such as the tail-light wire for instance) or other metallic current path (such as a copper oil-pipe line coming through the engine bulkhead) which acts just like a radio receiving aerial. An inter-

FIG. 27-58. — Flexible copper bonding braid. This is made in stock sizes from 1/8 to 11/16 inches wide. Since it is really tubular, it may also be slipped over insulated wires to shield them.



Courtesy Lenz Electric Mfg. Co.

ference or "noise" voltage is thereby generated in this conducting circuit, and a noise current may flow in it. This current flowing through the conductor causes a radiation of energy from it (*re-radiation*) of the same, or some other, frequency. This re-radiated energy may reach the aerial or other wiring of the auto-radio installation, causing interference to be set up in it. The process is cumulative, so that in many cases a number of parts and wires in the car seem to be the source of noise, when they are actually re-radiating electrical disturbances received from some other source in the car. This makes it difficult to locate the actual source of the interference.

Conveyance of interference by the second and third methods may be effectively minimized by electrically *bonding* the conducting or re-radiating conductor to the chassis of the car. Low-resistance flexible copper braid of the general type illustrated in Fig. 27-58 is employed extensively for this purpose. This braid is really a tubular copper braid which may be used either for shielding wires or as a bonding braid.

7. In order to test quickly whether bonding certain members reduces the interference, it is convenient to make up a few test bonding leads composed of 18-inch pieces of shielded bonding braid terminating at each end in a large size battery clip for quickly clipping one end of the braid to the member in question and the other end to the car chassis. These temporary bonds may be clipped in place, one at a time, where experience has shown that trouble exists, and then removed, one at a time, until one is found whose removal increases the motor interference. This should then be replaced with a permanent bond of copper braid soldered or otherwise securely fas-

tened in place. Several by-pass condensers of 0.5- or 1-mfd. capacity may also be provided with leads and battery clips of smaller size to assist in locating points in the various car wiring circuits that require by-pass condensers. Places where these condensers should be tried and where they frequently result in reduction of motor interference, are: on the battery side of the ignition coil, on one electric clock lead, on the cigar lighter lead, on the electric windshield wiper lead, on the dome light lead and, if an under car antenna is employed, on the rear light leads and on the other wires running under the car, such as electric gasoline gauge leads, etc.

8. The dome light wire running from the ammeter over to the door post often picks up considerable interference, and because it re-radiates it, it is a frequent source of noise when a roof type antenna is being used. Usually, the interference caused by this wire may cease when the dome light is turned on. In order to find out whether it is causing interference, disconnect the dome light feed wire from the point of connection (usually behind the instrument panel). If this lessens the interference heard in the loud speaker, replace the lead and try a $\frac{1}{2}$ - or 1-mfd. by-pass condenser from this point to the car ground. If the by-pass condenser does not reduce the interference, insert a 20-turn choke coil wound with No. 18 bell wire on a $\frac{1}{2}$ - or $\frac{3}{4}$ -inch wooden form, in series with this dome light lead, and close to the hot battery lead feeding the dome light circuit. Leave the by-pass condenser connected on the *battery* side of the choke coil. It is often necessary to move the dome light switch to a point on the instrument panel, close to the ammeter.

9. The establishment of good electrical contact between the motor block, motor bulkhead, instrument panel, chassis and body of the car where such contact does not already exist, is essential in eliminating interference. In many cases a good electrical contact between the motor block, dash, and frame of the car will eliminate much of the interference. These electrical connections may be made by connecting together the parts with short pieces of copper braid. Such bonding is particularly necessary on those cars incorporating "floating power," in which the engine is mounted on rubber blocks. These metal parts of the car must be maintained at a common ground potential by bonding them together. In such cars the bonds from the motor block must be long enough to allow for vibration. A good connection between the instrument panel and the body and frame of the car may aid materially in reducing noises. Special attention should be paid to the thorough grounding of the bodies of cars which employ a wooden body sill, for very often these bodies are not well grounded to the chassis.

10. A good deal of the noise encountered in automotive receiver installations is due to ignition circuit interference being conducted into the driver's compartment from the engine compartment by way of choke and spark control rods, copper-tubing oil lines, cowl ventilator levers, and other controls. From the driver's compartment it may be re-radiated to the antenna system. Every wire, control-rod, or pipe that runs from the motor compartment through the dash may re-radiate interference and it should be grounded to the dash, (wires should be shielded and the shields grounded). Use heavy flexible copper conductor or braid to ground them to the dash, allowing for any necessary movement of the rods. The method of bonding all pipe lines together and to the dash is illustrated in Fig. 27-59. If the iron rods are rusty, scrape them clean so that the copper bonding

conductor may be securely soldered or clamped to them. The wire conduit that runs to the base of the distributor in some cars should also be grounded in the same manner. Sufficient slack should be left in the bonding of all control rods so that the greatest normal movement of the rods will not tear the bonding loose.

11. On some of the recent cars, the steering column is not well grounded, since it is mounted on rubber to absorb road shocks. Such steering columns may be veritable "racetracks" for interference currents unless they are well bonded to the bulkhead or chassis with copper braid of low resistance (preferably soldered for perfect connection).

12. Some interference may also be caused by changes in the resistance between the receiver case and ground, when another grounded conductor, such as the choke rod, free-wheeling control, speedometer cable, or steering column, touches or rubs against the receiver. These controls and cables should not be allowed to touch or rub against the receiver case. In some receivers, the remote tuning-control cables are grounded to the receiver chassis, an inch or so beyond the point where they actually enter the chassis. This may cause interference, and it is best to bond all remote tuning cables to the outside of the chassis to be sure that they are at the same potential.

13. In some cases, the interference being heard is intermittent and is caused by loose electrical contacts in the electrical wiring of the car. Connections to all lights, horn button and horn, cigar lighters, etc., should be checked to see that the contacts are clean and the wire connections are tight. It is a good plan to install lock-washers on all loose connections. Loose connections will usually cause excessive "scratchy" noises in the loud speaker when the car is jolting over a rough road.

14. In a few cases it may be noticed that interference is present only when a passenger is in the front seat of the car. This type of interference is caused by the fact that some automobiles have wooden toe boards, or floor boards, and if some high-tension wiring runs near the bottom of the engine compartment, the body of the driver or passenger transmits the interference from it to the antenna system. This condition may be checked by getting in and out of the front seat and noticing whether the interference varies in strength. It may be eliminated by placing a piece of copper screening under the floor mat (it may be tacked to the floor board) and grounding the screening securely to the body or chassis of the car. When a wooden bulkhead is encountered, this must also be shielded with copper screening and grounded, or the same interference will be experienced.

15. In those installations where a running-board antenna is

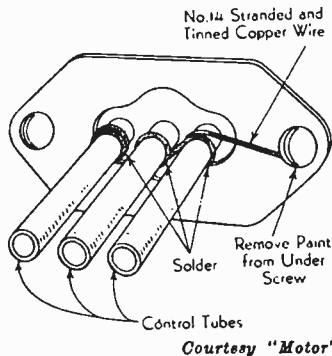

FIG. 27-59.—How the various metal tubes which are brought through the dash may be bonded together and to the metal framework of the car by means of copper wire or "bonding braid" soldered to them.

employed, a rather unusual form of interference may be experienced. It may be found that a peculiar "clicking" sound that is not caused by the electrical system of the car is heard in the receiver while the car is in motion. This may be checked easily by tuning the receiver between two stations *with the car in motion, but with the ignition turned off (coasting down hill)*. The noise will usually cease as soon as the brakes are applied. In some cases, the interference is due to friction between the brake drum and the brake lining at some point, creating a charge of static electricity. The application of "brake-juice" will usually remedy this condition since it makes the lining a better conductor. However, its use depends on the brake adjustment and the kind of brake lining used and may not always be desirable. The noise may be eliminated by bonding the brake rods and brake assembly to the body of the car with heavy flexible braid with sufficient slack provided so that their movements will not be inter-



(A)

FIG. 27-60.—(A) commercial phosphor-bronze helical coil spring for "grounding" the hub of the front wheel to the front "axle" in order to eliminate front tire "static".

(B) The method of mounting the spring in the front wheel hub cap.

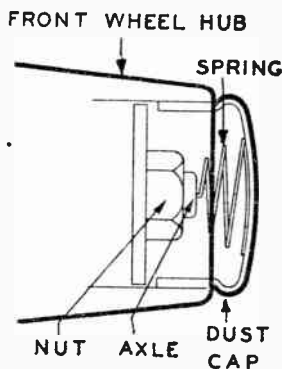

(B)

Courtesy Philco

ferred with. Should this prove ineffective or impractical, the only remaining solution is to install an aerial in the roof of the car—away from the source of noise.

16. "Tire static" is another cause of interference. Noise is obtained which is not due to the electrical system of the car or to the brakes. It is evident only when the car is in motion on a hard surface road, and ceases when the car is stationary.

Tire static is due to the generation of static electricity by the friction between the rubber tires and the road surface. The electrical charges produced cause intermittent discharges to take place. These produce radiations which are heard in the radio receiver as noise. If the wheels have wooden spokes, especially if large air-cushion tires are used, the static charges generated on the tire cannot get to the metal wheel hub and axle since the wood acts as an effective insulator. In such cases, it may be necessary to bond the metal tire rims to the metal wheel hubs with flexible copper bonding braid. However if wire or metal-disc wheels are used, this trouble is not usually experienced in the rear wheels, since these conduct the static charges directly to the chassis of the car via the hub, the rear axle to which it is rigidly fastened, and the springs.

In the case of the *front* wheels, static charges may accumulate even if the wheels are of metal, because the grease used to lubricate the front wheel bearings may form effective insulating or high-resistance films between the front-wheel bearings and the axle, thus presenting a high-resistance path for the static charges to leak through intermittently to the axle and car chassis. One remedy for this condition is to mix some graphite (an electrical conductor) with the front-wheel grease so as to make it a better electrical conductor. A more permanent remedy though, is to use two coiled springs, as shown at (A) of Fig. 27-60, and insert each one between the axle and the hub cap of each front wheel, as shown at (B) of the figure. The spring should be about $1\frac{1}{2}$ inches in diameter. Its starting end is inserted in the centering hole which will be found in the end of the axle. It will make positive electrical contact between the rotating metal hub cap and the stationary front axle. If the wheel is of metal, the static charges will be conducted from the tire rim through it to the hub and axle and so will be discharged. If the wheels are of wood, the tire rim may have to be bonded to the metal hub. When an under-car aerial is used, tire static may become particularly annoying.

17. When an under-car or running board type aerial is employed, the treatment of all wires and unbonded parts of the car near the aerial and the lead-in become very important. Stop-light and tail-light leads may have to be shielded and by-passed to ground with $\frac{1}{2}$ -mfd. condensers. Since the gasoline feed lines, brake rods, etc., may conduct high-frequency interference currents back from the engine compartment and re-radiate this interference to the aerial, they should be properly bonded to the metal frame of the car.

A study of the foregoing instructions for minimizing ignition interference shows that a considerable number of factors must be considered in this work. While it is rarely necessary to go through every one of the steps presented here and to apply every one of these remedies when installing modern sets in recent cars, it is a fact that the suppression of ignition noise to an allowable level is a very difficult task in some cars—especially old ones. Experience provides very tangible and definite assistance in this work.*

27-52. Auto-Radio Receiver Troubles.—The superheterodyne circuit is employed exclusively in auto-radio receivers at the present time, since its extreme sensitivity is a very valuable feature in automobile work. Automatic volume control is a very necessary requisite to good auto-radio reception, so it is incor-

*NOTE: For this reason, there has been presented in Sections 8 and 9 of the author's *Radio Trouble-Shooter's Handbook*, a compilation of numerous definite special measures which have been found to be effective in suppressing the ignition interference encountered in particular models of popular American cars. It is hoped that this information will prove helpful to those who may have occasion to install auto-radio in these cars.

porated in these receivers. Aside from the extreme compactness and the use of remote tuning controls, the power unit which supplies the plate and grid voltages for the tubes is perhaps the only part of the auto-radio receiver which is radically different from the ordinary home receiver. Since these sets are occasionally afflicted with exactly the same troubles that we have already studied for home receivers, they will not be considered again here. Suffice it to say that the same methods of analyzing them for trouble, and the same repair and aligning methods are used with them. However, since the power-supply unit is different and presents special service problems, it will now be considered.

27-53. Plate Power Supply for Auto-Radio Receivers.—The power units employed to convert the 6-volt d-c current of the car storage battery to the higher d-c potentials (180 volts or more) required for the plate circuits of auto-radio receivers are of two general types: *rotating* and *vibratory*. In the rotary type, two forms must be distinguished. In the first one, a permanent magnet is used for supplying the magnetic field; in the second, the field is furnished by electromagnets energized by current from the car storage battery. These will be considered in Art. 27-57. The vibrator type will be studied first.

The vibrator type *B*-power supply unit is the most widely used type employed in auto-radio receivers, mainly because it

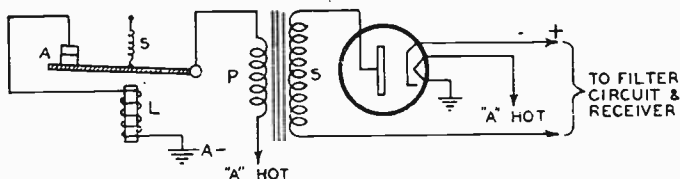

FIG. 27-61.—A simple auto-radio vibrator and half-wave tube rectifier circuit.

is less costly than the other types. In this type, a rapidly-vibrating reed interrupter rapidly interrupts the battery current to produce a pulsating direct current. When this is fed through the primary of a suitable power transformer, it produces a high-voltage a-c in its secondary. This may be rectified either by some type of half-wave or full-wave tube rectifier, or by a mechanical synchronous-rectifier arrangement on the vibrator, the

rectified output being filtered and finally applied to the plates of the tubes of the auto-radio receiver. It is in the arrangement used for rectification of the high-voltage a-c output of the transformer that various makes of vibrator-type power supply units differ. Several common arrangements employed for this purpose will now be considered.

27-54. The Vibrator Type B—Power Unit with Tube Rectifier.—A very simple vibrator and rectifier arrangement is shown in Fig. 27-61. Its operation is as follows:

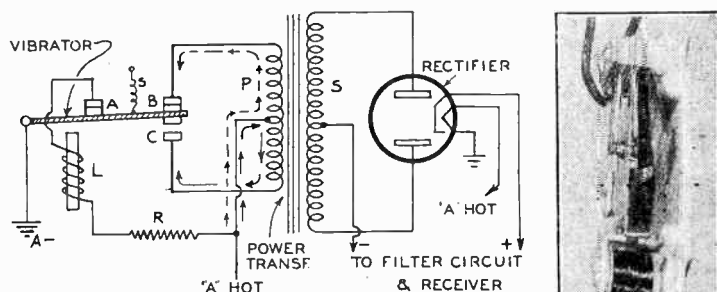

FIG. 27-62.—*Left*: Circuit arrangement of an auto-radio vibrator employing a full-wave rectifier tube.

Courtesy P. E. Mallory & Co.

Right: A typical auto-radio vibrator unit of this type.

Contact *A* is normally held closed by the spring action of the vibrator reed. A small coiled spring *S* is shown here to represent the "springiness" of the reed. When the receiver is turned on, current from the car battery flows through the primary *P* of the transformer, through contact *A*, and through magnet coil *L*. This induces a voltage pulse in the secondary winding *S*. Since the secondary has a much greater number of turns than the primary, it steps up the voltage, so that between 200 and 250 volts are induced in it. Meanwhile, coil *L* magnetizes its iron core. Its magnetism attracts the magnetic reed, thus quickly opening contact *A* and interrupting the primary current. This induces another high-voltage pulse in the secondary, but of opposite polarity from the previous one. As soon as the primary current is interrupted, *L* loses its magnetism and releases the reed. This closes contact *A*, and the primary current flows again. The complete cycle of events is established and is repeated over and over, the reed vibrating back and forth rapidly. Meanwhile, a high-voltage a-c is induced in the secondary winding *S*. This may be applied to a conventional half-wave rectifier tube as shown, and the output filtered to obtain a smooth d-c voltage for the plate and screen circuits of the receiver.

Of course, this arrangement has all of the undesirable features associated with half-wave rectifier systems.

A typical full-wave system employing a full-wave rectifier tube is shown in Fig. 27-62. The vibrating reed in this case employs three contacts *A*, *B* and *C*, arranged as shown. Contact *A*, actuating magnet coil *L* and resistor *R* serve merely to cause the reed to vibrate rapidly, the action being the same as already explained. Resistor *R* acts merely as a current-limiting resistor for the primary circuit. The operation is as follows:

When the reed is up so that contact *A* is closed, contact *B* is also closed. The battery current then flows *through the upper half* of the primary winding, through contact *B*, through the reed to the end, and finally to the grounded *A minus* terminal and through the battery completing its circuit. Its path is shown by the dotted arrows. When the reed is down, contact *B* is open and contact *C* is

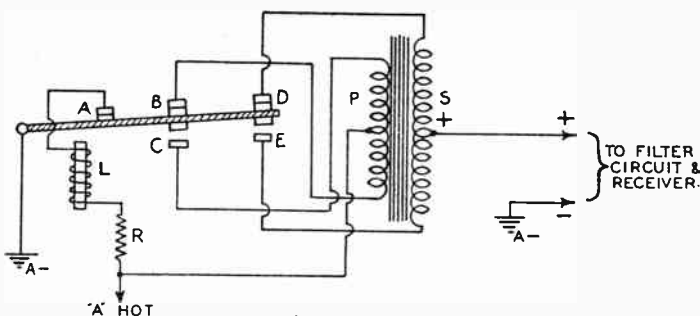

FIG. 27-63.—A “synchronous” auto-radio vibrator circuit arrangement in which full-wave rectification is accomplished by the use of synchronous contacts *D* and *E*. No rectifier tube is necessary in this system.

closed. The current then flows *through the lower half* of the primary winding (in a direction opposite to its flow before), through contact *C*, through the reed, and down to *A minus*, as shown by the solid arrows. In this manner, the current flows through half of the primary in one direction for a length of time equal to the time contact *A* and *B* are closed, and through the other half of the primary in the opposite direction for a time equal to that for which contact *A* is open and *C* is closed. This rapid reversal of the current through part of the primary induces a higher alternating voltage in the secondary by transformer action. The secondary is center-tapped and connected to a full-wave rectifier tube and filter in the usual manner.

This, in general, is the operation of this form of vibrator arrangement. Notice that a separate rectifier tube must be used with each of the two types described.

27-55. The Synchronous Vibrator-Rectifier B-Power Unit.

—It is possible to combine the vibrator and the rectifier actions

in a single vibrating reed, making the rectifier action mechanical instead of electrical, and synchronized with the action of the contacts in the primary circuit. In order to do this, another set of contacts, *D-E* (shown in Fig. 27-63) which are added to the reed, are connected to the secondary winding, as shown. The purpose of these contacts is to automatically switch the connections between the secondary winding and the filter circuit each

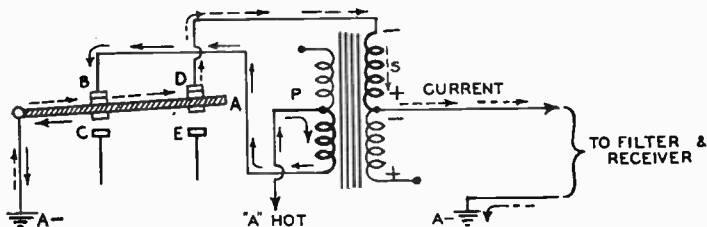

FIG. 27-64.—Simplified diagram showing the direction of flow of the primary and secondary current, and the circuit connections which exist when the vibrator reed in Fig. 27-63 is "up".

time the induced secondary voltage reverses. The voltage applied to the filter circuit and the receiver will then be *unidirectional*. The operation is as follows:

The coil *L*, current-limiting resistor *R* and contact *A* serve the same purpose described previously—to cause rapid vibration of the reed. When the reed is "up" so that contacts *A, B* and *D* are "closed", the circuit conditions are as drawn in Fig. 27-64. Current flows

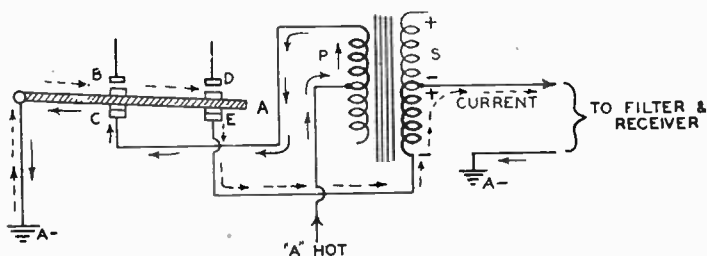

FIG. 27-65.—Simplified diagram showing the circuit conditions when the vibrator reed is "down".

through the *lower* half of the primary winding (drawn dark) and through contact *B* to ground, as shown by the *solid* arrows. This induces voltage in the upper half of the secondary winding; let us say the polarity is such as to make the *top* end *negative* and the *center tap* *positive*, as indicated. Then since the connection to the bottom end is open at contact *E*, no current flows through the lower half of the

winding so it is shown open for simplicity. The center-tap is then positive with respect to the upper end, so current flows out of it to the filter circuit and receiver, returns through the *A-minus* terminal, through contact *D* and down through the upper half of the winding (which is drawn dark because it is in operation), as shown by the dotted arrows.

The conditions at the next instant when the reed is "down", and contacts *C* and *E* are "closed" (*B* and *D* are "open") are shown in Fig. 27-65. The upper half of the primary, and the lower half of the secondary, are now in action. The path of the primary current is shown by the solid arrows; that of the secondary current is shown by the dotted arrows. It is evident that although the polarity of the induced secondary voltage has now reversed (the center tap or top terminal of the secondary is now positive and the bottom end is negative), contacts *D* and *E* have switched the connections so that the current still flows into the filter and receiver in the same direction as before—i.e., rectification has been accomplished. Notice that the center tap of the secondary is positive with respect to either end, in turn, and is solidly connected to the filter circuit and receiver. Therefore, all that contacts *D* and *E* do is to select the proper secondary terminal which happens to be negative at each half cycle, and switch it to the filter circuit.

Since the contacts operate in synchronism with the voltage reversals, this is called a *synchronous* vibrator arrangement. The advantage of this system over that of Fig. 27-62 is that no rectifier tube is required.

The vibrator circuits shown thus far contain only the elements necessary to explain their operation. In actual practice, additional components are employed in them. The secondary is often shunted by a resistor and condensers, the primary lead is by-passed with condensers, and the battery leads have r-f chokes inserted in them—all to prevent the transmission of any interference (caused by the interrupted currents, and the sparking at the contacts) to the radio receiver. Fig. 27-66 shows a typical circuit arrangement used in a power unit of this kind when installed in an auto-radio receiver. The various chokes, by-pass condensers, etc., are drawn in their proper places. The connection of the speaker field, pilot light, and heater circuit of the receiver are also shown. Notice the liberal use of r-f chokes and by-pass condensers to prevent interference disturbances from entering the heater, screen grid, or plate circuits of the receiver.

27-56. Servicing Vibrator Units.—It is usually not advisable to attempt to service, adjust or repair a vibrator after it has given its normal period of service. Experience shows that repaired or adjusted vibrators seldom give satisfactory, depend-

able service for any length of time, unless the repair or adjustment is a minor one. Replacement with a new vibrator unit is usually the least expensive and most satisfactory course to follow when a vibrator gives serious trouble. Proper adjustment of many designs of these vibrators can only be made with special equipment which the service man does not possess—in fact many manufacturers try to insure freedom from tampering etc., by sealing the vibrator in such a manner that adjustment cannot

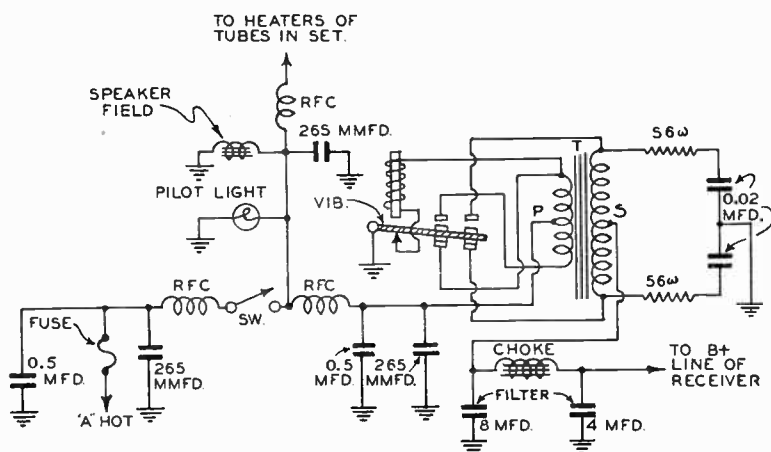

FIG. 27-66.—A typical complete synchronous vibrator and filter circuit in a commercial auto-radio receiver. Note that several r-f filter chokes and by-pass condensers are included in the battery circuit to prevent the transmission of interference from the vibrator unit to the radio receiver by way of the common battery circuit.

be made without breaking the seal (which automatically voids the guarantee). For those service men desiring to attempt to repair vibrator units, the following may prove helpful:*

One simple way to check an auto-radio receiver to determine if the vibrator is operating satisfactorily, is to measure the total plate and screen current (in the main positive lead of the B-filter) when the receiver is turned on. The current indication on the milliammeter should be steady and no appreciable flutter of the pointer should be noticed. If the vibrator contacts are

*NOTE: Auto-radio vibrator testers are available to service men either as independent units or built-into certain makes of tube checkers.

out of adjustment or sticking, the current output will be "jumpy".

The contact points of the vibrator give more trouble than any other part. They become oxidized, and pitted due to the current passing through them and the spark which occurs at their surfaces. When they are in this condition, their operation is noisy and erratic and they often stick together. If they are not too badly pitted, they may be dressed down with a thin automobile breaker-point file, being careful to keep the surfaces square and parallel. Never file one surface at a time, for it will surely be rounded. Insert the file between the two surfaces, and pressing them together lightly, clean both at once. This will insure their being parallel and meeting each other squarely when making contact. Since the air gap varies in different makes of vibrators, no definite figure can be given for it, but about 0.005 of an inch is a fair average. It should be checked with accurate "feeler" gauges. The stationary points should be adjusted to be spaced equally distant from the reed contacts. Alignment of the points is generally controlled by the position of one or more springs. These may be adjusted either by bending carefully at the base of the spring with a pair of long nose pliers, or by adjusting special screws which are provided for the purpose. A set of feeler gauges and a thin breaker-point file for this work may be purchased at any automobile supply store.

If the vibrator fails to start when the receiver is switched on, faulty vibrator contacts should be suspected. Quite frequently two contacts become "oxidized", "stuck", or "welded" together at their contact surfaces, this failure being caused by excessive sparking. They should be filed flat and the springs adjusted.

Low battery voltage may also prevent the vibrator from functioning properly, despite the fact that the receiver tubes may light up visibly. This low voltage may be due either to a weak battery or high-resistance connections. The set connection should be made to the battery side of the ammeter, otherwise the resistance of the ammeter may be sufficient to reduce the voltage at the vibrator to such a degree that it will fail to start. If any doubt exists, measure the voltage between the "A" hot connection of the ammeter and ground with the set turned "on".

Vibrator-type *B*-units sometimes cause interference noise

in the auto-radio receiver. This sounds exactly like that from the ignition system of the car; the difference is that the vibrator noise can still be heard when the car engine is shut off, whereas ignition system interference cannot. Interference of this sort, called "vibrator hash," may be due to imperfect bonding between the battery-cable shield and the receiver; this shield must be grounded in several places (see Art. 27-51). It may also be caused by coupling to the set output transformer, in which case a large capacity (about 4 mfd.) must be connected between positive *B* lead and ground.

When checking for trouble in vibrator unit filter circuits, it is well to remember to "open" the closed contacts of the vibrator by inserting a small strip of insulating material between the contacts (a piece of paper will do), to avoid a great deal of "clipping" or unsoldering of wires to isolate an "apparent short" of the filter supply. Unless this is done, an ohmmeter test across the output of the vibrator will disclose a reading of only several hundred ohms (the d-c resistance of one-half the power transformer secondary) leading one to suspect short-circuited or leaky filter condensers. When the vibrator unit is sealed, as many are, the insulating strip cannot be inserted between the closed contacts, and it will be necessary to unsolder the vibrator leads. In some instances, the vibrator is of the plug-in type (similar to a tube socket) in which case, it may be removed to permit further tests to be made.

Occasionally, low d-c output from a full-wave vibrator unit may be traced to the failure of the secondary vibrator contacts to open, making the unit operate as a half-wave rectifier. When a "shorted output" is encountered with the tube-rectifier vibrator unit, test the rectifier tube before checking for short-circuited or leaky filter condensers. Leakage between cathode and heater will result in decreased output voltage, or "shorted output" in the case of a direct short-circuit between cathode and heater of the rectifier tube. "Leaky" or "shorted" buffer condensers will also cause trouble.*

27-57. Generator Type B-Power Supply Units.—Generator type *B*-power units which employ a permanent magnet field

*NOTE: Vibrators are not all designed to operate at the same vibration frequency. Therefore, they require buffer condensers of different capacities. Consequently, when replacing a faulty buffer condenser, install a new one of the proper capacity — exactly the same capacity as the one originally used. Unless this is done, the vibrator contacts will arc badly. (Arcing with the new condenser in place may be worse than with the old one.) Don't substitute a new 1.0 mfd. condenser for a 0.1 mfd. faulty one, etc.

(called a "magmotor") usually require very little servicing or attention. The magnets must be kept fully magnetized, the bearings oiled at long intervals and all wiping contacts cleaned.

Motor-generator or converter units which employ electromagnets for the field magnetism are also particularly free from annoying troubles as a rule. A typical compact unit of this kind is illustrated in Fig. 27-67. The entire unit is so compact that it is housed in a metal case that may be held in the palm of a hand. Its schematic circuit arrangement is shown in Fig. 27-68.

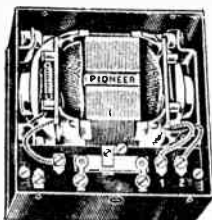

FIG. 27-67.—A typical "generator" type B power supply unit for auto-radio receivers. The unit is shown here with the cover removed so that the field core, field coil, and terminal arrangement may be seen. These units are so compact that they may be held in the palm of the hand.

Courtesy Pioneer Gen-E-Motor Corp.

The field coils $F-F$, as well as the motor portion, M , of the rotating armature operate from the car battery. The single armature shaft is equipped with two separate windings and two separate commutators. Into the motor armature M is fed 6-volt current

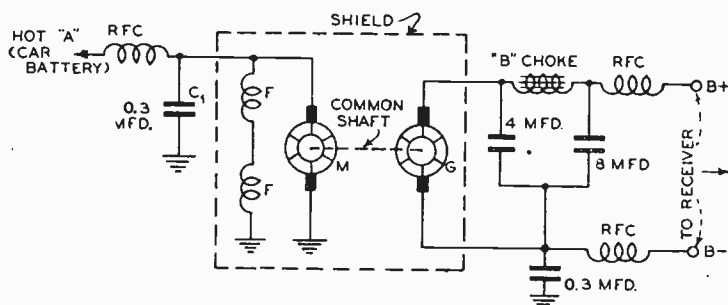

FIG. 27-68.—The circuit arrangement of the "generator" type auto-radio B power unit illustrated above. Both the r-f choke and B-filter systems are built into the unit.

from the car battery. The other armature (containing a larger number of turns of fine wire) is connected to commutator, G . This delivers generated d-c at a voltage suitable for operating the plate and screen grid circuits of the auto-radio receiver. The current is taken from the generator commutator by the two

brushes shown. Since the generator output is somewhat "ripply", it is filtered by the "B" choke and filter condensers shown. *R-F* chokes and by-pass condensers are connected in both the input and output leads to the unit to prevent any interference from leaving it and entering the receiver by either the *A* or the *B* circuits.

Perhaps the only servicing which units of this type require after very long periods of operation (unless burnouts of any of the windings occur) is that of attention to the two commutators and four brushes. The commutators and brushes should be kept clean, and the brushes should fit the contour of the commutator surface perfectly. The same procedure for cleaning the commutators and fitting the brushes that was explained in Art. 27-40. for car generators applies for these units also, so it will not be repeated here.

REVIEW QUESTIONS

1. List in consecutive order, at least 8 steps which must be taken to install a single-unit automobile-radio receiver having remote tuning control, in a car with a "turret" top. The car is not already provided with an aerial.
2. What tools is it desirable for the automobile service man to have, in addition to his regular testing equipment, for the rapid installation of auto-radio receivers? State some uses for each of these tools.
3. State and explain some of the mechanical requirements which should be met in the design of a modern automobile radio receiver.
4. State and explain some of the electrical requirements for the above.
5. What two main functions does the automatic volume control in auto-radio receivers accomplish?
6. How many types of tuning controls are employed in auto-radio receivers? Describe each type, and state the car or installation condition under which it possesses advantages.
7. How is remote tuning and volume control accomplished between the radio receiver, and the remote-control unit on the steering column? Explain!
8. How would you proceed to reduce the length of a remote-control flexible shaft?
9. What precautions must be observed when seeking a location for an auto-radio receiver? State the reason for each, and tell what might happen if these precautions are not observed.
10. When a satisfactory location for the receiver has been found, what is the general procedure for its installation in the car?
11. Which is the "hot terminal" of a car storage battery?
12. What would you do if you found the battery terminals corroded

- when making the battery connection for an auto-radio receiver? Explain! What would be the effect of this corroded condition?
13. Discuss at least five main requirements for a good auto-radio antenna system.
 14. What are the six different types of car top construction?
 15. Describe each type named in Question 14.
 16. Describe in detail the method of installing a wire-mesh aerial in a car of slat-top construction.
 17. Explain how the lead-in should be installed for the aerial in Question 16.
 18. What precautions should be taken, when using the poultry wire which is already in the top of the car for an aerial?
 19. What kind of an aerial would you install in a car having an all-steel roof? Why?
 20. Explain how you would install the aerial of Question 19.
 21. What are some of the disadvantages of the under-car wire-type aerial? What are its advantages?
 22. What are some of the disadvantages of the running board type aerial? What are its advantages?
 23. Why is it desirable for an automobile-radio service man to be familiar with the circuit arrangement, operation, and care of all common automobile ignition systems?
 24. Explain the four parts of the complete cycle of an internal combustion engine. At what point in the cycle does the spark plug fire?
 25. What is the purpose of the spark plug in the cylinder? How is it constructed?
 26. What does "firing order" mean?
 27. Why are the cylinders in an automobile engine not made to fire in consecutive order according to their positions in the engine block?
 28. What is the chief purpose of the ignition system on an automobile?
 29. An 8-cylinder engine has the following firing order; 1-3-6-8-7-5-4-2. Draw the 8 spark plugs, and number them consecutively, 1-2-3-4-5-6-7-8. Now draw the proper connections from the distributor cap terminals to the spark plugs of this engine, and number them.
 30. How is a voltage of several thousand volts obtained for the firing of the spark plugs in an automobile engine, when the only source of current on the car is the 6- or 12-volt storage battery (or car generator)? Explain fully!
 31. What is the purpose of the circuit breaker? How is it constructed?
 32. What is the purpose of the circuit-breaker-cam? What are the "lobes" on the cam? Illustrate your answer with a sketch.
 33. Why must the breaker points be kept clean, and their surfaces kept flat and parallel?
 34. Why must the gap between them be kept adjusted to the proper value? What will happen if the gap is too small; if it is too large?

35. What is the purpose of the distributor? How is it constructed? What does it distribute?
36. Why must the spark plugs be kept clean? Why must the gap be adjusted to the proper value? What will happen if the gap is too small; if it is too large?
37. Describe the construction of a typical ignition coil. What feature of its construction is responsible for its ability to greatly step up the voltage supplied to its primary coil?
38. What will happen to the ignition system of an automobile, if the condenser across the breaker points: (a) open-circuits; (b) short-circuits. What effect will it have on the operation of the car in each case?
39. Draw the circuit diagram of the ignition coil, circuit breaker arm and points, cam, and distributor rotor and points, for a 6-cylinder engine in which a single breaker arm, and single ignition coil are used.
40. Draw the same if a double breaker arm and single coil are used. (The cam has as many lobes as there are cylinders.)
41. Draw the same if a double breaker arm, and two ignition coils are used.
42. Draw the same for a 6-cylinder engine having a "dual ignition" system.
43. What is the purpose of the car storage battery? Why must it be kept in a charged condition?
44. What precautions would you take to keep the car storage battery fully charged, if you have installed an auto-radio set in the car?
45. How would the electrical system of a car be affected, if the car were not equipped with a generator?
46. What type of generator is used in modern cars?
47. Explain in detail how the third brush maintains the generator voltage fairly constant even though its speed varies over a wide range when the car is driven at various speeds.
48. How would you proceed to: (a) *increase* the charging rate of the generator; (b) *decrease* it. How would you find out *exactly* what the charging rate was at any time?
49. What is the purpose of the cut-out on the generator? How would the electrical system of a car be affected if: (a) the cut-out failed to *close* at the proper time; (b) if it failed to *open* at the proper time?
50. When does the generator supply the electrical system of the car with current? When does the battery supply it? Explain!
51. Name six possible sources of electrical interference set up by the ignition and electrical system of a modern automobile.
52. State (and explain) the ways in which the interference from these sources may be eliminated after the radio receiver installation.
53. (a) Explain how the car generator may cause interference in the auto-radio receiver. (b) Explain how this interference may be eliminated.
54. Explain how you would clean the commutator of a car generator.
55. Explain how you would re-seat the brushes of a car generator.
56. Explain how interference is set up by the high-tension circuits of the ignition system.

57. Explain how this interference may be suppressed effectively, and simply. What is the theory of suppression by this method?
58. Describe the construction of a typical "suppressor" resistor.
59. How would you determine the type of suppressors to use for a certain type of car?
60. Describe the construction of a typical spark plug provided with a built-in suppressor. What are its advantages; disadvantages?
61. Explain why the suppressor is needed in the high-tension lead, between the ignition coil, and the distributor.
62. What is the purpose of the by-pass condenser which must be connected at the ammeter of the car?
63. If the auto-radio receiver is still noisy after the "standard" suppression methods have been applied to the car, how would you determine whether the interference is coming from the electrical system of the car, or from some source entirely external to the car?
64. If your test shows that the interference is coming from the electrical system of the car, how would you determine definitely whether it is being picked up by the antenna circuit, or whether it is entering through the battery supply circuit through the receiver?
65. In the former case, (Question 64) how would you proceed to eliminate the interference?
66. In the latter case (Question 64) what would you do
67. What is meant by "electrical bonding?" What is its purpose, and how does it accomplish this purpose?
68. How would you determine whether or not a particular electrical accessory on a car was causing interference in the auto-radio receiver?
69. Why is it that we connect *resistors* in the high-tension circuits to suppress ignition interference, but connect *condensers* in the low tension circuits to suppress interference? Explain!
70. Explain how the dome light wiring is apt to cause interference in the auto-radio receiver, if a roof type aerial is used.
71. How would you proceed to find out definitely whether the dome light wiring is causing the interference?
72. Why is it often necessary to move an ignition coil from its position under the instrument panel to a point close to the distributor in the engine compartment when an auto-radio receiver is installed? When is mere shielding of the high tension lead to the distributor sufficient to eliminate interference from this cause?
73. List as many miscellaneous causes of noise in auto-radio installations, as you can think of.
74. Describe two different forms of vibrator *B* units used in auto-radio installations (one using a tube rectifier and one employing a mechanical rectifier). Explain the operation of each.
75. Explain how you would test a vibrator unit in an auto-radio receiver in order to determine if it is in good operating condition.
76. Explain how you would proceed to clean and adjust the contact points in a unit of this kind.
77. What attention does a rotary type auto-radio *B* power unit require?

CHAPTER XXVIII

SERVICING ALL-WAVE RECEIVERS

28-1. **Introduction.**—The all-wave receiver has dominated the receiving field to such an extent that it may now be considered the most popular type of home receiver. It must not be supposed from this statement, however, that it is the *most used* type of set, for all-wave reception has been popularized for only a relatively short time, while the single-band set has been in use for many years and millions of them are still in use. Nevertheless, these older receivers are being replaced rapidly, and before many years have passed, all-wave receivers will undoubtedly form a large majority of the receivers in use. The servicing of these sets is already calling for a large proportion of radio service men's time and skill.

Practically all all-wave home type receivers are superheterodynes. They may or may not have a tuned r-f stage preceding the mixer, but they all contain the usual oscillator, mixer, i-f amplifier, second detector and audio amplifier. The fundamental circuit and principle of operation of the all-wave receiver is therefore identically the same as for the standard broadcast band receivers which we have already discussed, and the service man should expect radical differences in their design. However, because of the switching systems and the relatively high frequencies involved, the requirements for successful operation—and hence for successful servicing—are much more rigid than they are for standard broadcast band receivers. However, the procedure to be followed when testing and servicing an all-wave receiver is sensibly the same as for a standard broadcast band receiver, and no great deviations from standard practice should be ex-

pected. The same analyzers, tube checkers, measuring instruments, etc., are employed; the only important point in this respect being that the test oscillator must be of the all-wave type capable of operating over the complete range of all-wave band frequencies (see Art. 16-1).

All-wave receivers, however, do have several important special features in their construction and have several peculiar characteristics which are not found in standard broadcast band receivers. Since the service man must be familiar with them, this chapter will be devoted to discuss them and present the special troubles (and their remedies) that arise because of them. It is fortunate, however, that it is not necessary to resort to special test methods for their localization, the usual testing routine will reveal them.

28-2. RMA Receiver Designations.—With the increased popularity of receivers affording short-wave reception facilities, a great deal of misconception and misunderstanding has arisen concerning the proper designations of the various types of radio receivers, particularly with respect to the particular wave band which they cover.

Numerous cases of misleading advertising by manufacturers who provided limited short-wave tuning facilities (down to about 175 meters) in their receivers (by incorporating in them a simple switching arrangement which decreases the inductance of the tuned circuit for short-wave reception by tapping it at the proper point so that police station signals could be brought in) has also added to this confused condition. These manufacturers advertised their sets as "all-wave" receivers, and in many instances the owners of these sets really believe they have purchased all-wave receivers and cannot understand why they are unable to tune in important short wave broadcasts which friends who own real all-wave receivers are able to get. Service men are often called in to service such receivers because the owners think something has gone wrong with them—when in reality the sets are working perfectly (but of course only on the bands they were designed for).

In order to clarify this situation the RMA (on Nov. 12, 1934)

defined the following radio receiver designations as standard in the United States.

1. A *Standard Broadcast Receiver* is one which will respond to the entire broadcast frequency range of 540 kc (555.2 meters) to 1,600 kc (187 meters).
2. An *All-Wave Receiver* is one whose tuning ranges will respond to all frequencies between 540 kc (555.2 meters) and 18,000 kc (16.6 meters).

The term "dual-wave" receiver which was used for some time to designate receivers covering the "standard" range between 540 and 1,600 kc, and also the continuous "short-wave" band between 4,000 and 20,000 kc, has been officially discontinued by the RMA.

28-3. Use of Terms "Kilocycle", "Megacycle" and "Meters".—When speaking of the "short wave" channels, it is sometimes convenient to use the term *megacycles* (abbreviated *mc*) instead of kilocycles or wave length. The frequencies involved are so high that it is much easier to conceive of frequency in terms of megacycles than in terms of kilocycles. (It is well to remember that 300 divided by the wavelength in *meters* is equal to the frequency in *megacycles*.)

There are one or two exceptions to this general rule: when a much used short-wave broadcast band involves a wavelength which is an odd figure that does not divide evenly or conveniently into 300 (the frequency of which is therefore an odd number which is inconvenient to remember) the *wavelength* is generally specified instead of the frequency. For example, the 49-meter band is a "standard" short-wave broadcast band; it could be expressed in terms of frequency (6.123 megacycles), but this is such an inconvenient number to remember, that in common practice it is always referred to it in terms of *wavelength*. Throughout this chapter we will use that designation which is most convenient for a quick comprehension of the quantity involved.

28-4. The Radio Spectrum.—In view of the wide frequency range covered by the all-wave receiver, it is important to have a fairly accurate idea of what can be heard on the various bands so that receiver reception tests can be carried on intelligently. The Standard American Broadcast (540 to 1,600 kc) and the

Police Call (1,600 to 1,720 kc and 2,300 to 2,500 kc) bands are well-standardized, and most service men are aware of what is and what is not available for either entertainment or test purposes on them. But, below the so-called Police Band there are short-wave bands of somewhat confused assignments, both national and international.

The service man should become well acquainted with the general divisions of the short-wave region and the times of the day when programs are most likely to be heard from the various short-wave broadcast stations operating on the various bands in it (due allowance being made for time differences, the geographical location of the transmitting station, etc.).

28-5. Short-Wave Transmission Peculiarities.—The service man should also acquaint himself with some of the more important transmission characteristics and peculiarities of short-wave signals. Among these are "fading", "skip", etc. (see Ghirardi's *Radio Physics Course*). The following information concerning the transmission characteristics of the various common short-wave bands on which short-wave broadcasts of an entertaining type will be found will prove helpful when making actual receiver reception tests on these bands.

13-Meter band (21,450 to 21,850 kc): Stations operating in this band are best heard when the area traversed by the signal lies within the daylight period.

16-Meter band (17,750 to 17,850 kc): Stations operating in this band are best heard when the area traversed by the signal lies within the daylight period.

19-Meter band (15,100 to 15,350 kc): Stations operating on this band are heard best when the distance between the transmitter and receiver is greater than 1,500 miles, and when the area traversed by the signal lies within the daylight period. Reception on this band is unreliable when a considerable portion of the traversed area is in darkness.

25-Meter band (11,700 to 11,900 kc): Broadcast transmission on these wavelengths is usually well received at distances exceeding 1,000 miles. At distances less than 2,000 miles best reception will be obtained during the daylight hours. With favorable conditions the more distant stations can be received during the early hours of darkness.

31-Meter band (9,500 to 9,700 kc): Stations included in this wave band area offer reliable service during both the day and the night in localities situated more than 800 miles from the transmitter.

49-Meter band (6,000 to 6,200 kc): Transmission on wavelengths in this part of the short-wave spectrum is best received when the distance between the transmitter and the receiver is 300 miles or more.

For reliable reception at locations 1,500 miles or more from the station, it is usually necessary that a considerable portion of the area traversed by the signal be in darkness (nightfall).

28-6. The Audio and Power System in All-Wave Receivers.—The all-wave receiver of today is of the superheterodyne type (with rare exceptions). It consists, therefore, of one or two tuned r-f stages, a mixer, an i-f amplifier, a second detector, an audio amplifier, and a power unit. Since the audio amplifier and power unit are similar in every respect to those used in standard-band receivers, no further comment regarding them is necessary here. They are tested, serviced and repaired in the manner described in previous chapters in this book. The reader is referred to them for further details.

28-7. The I-F Amplifier.—The i-f amplifier in the all-wave receiver differs somewhat from that in a standard-band set. The circuit arrangement is usually the same, but the electrical characteristics are different. First of all, the i-f used is high—much higher than in a standard-band receiver. 472.5, 465, 460, 456 and 450 kc are commonly used intermediate frequencies in all-wave receivers.*

It is necessary that the i-f be high in order to minimize "image frequency" interference (see Art. 23-13). (The frequency of the "image" signal is *higher* than that of the "desired" signal by an amount numerically equal to *twice* the i-f employed in the receiver.) The reason why a high i-f reduces the image frequency interference in an all-wave receiver may be understood from the following consideration. Let us consider the effect for a "standard" broadcast band signal of 1,000 kc first. At a receiver dial setting of 1,000 kc and with an i-f of 175 kc, the frequency of the "image" signal is $(1,000 + [2 \times 175]) = 1,350$ kc. Now a 1,350 kc signal differs from the desired signal (1,000 kc) by $350/1,000 \times 100$, or 35% of the desired signal frequency. If the i-f were higher (say 450 kc), the new image signal (1,900 kc) would differ from the desired signal (1,000 kc) by $900/1,000 \times 100$, or by 90% of the desired signal frequency. The advantage

*NOTE: The reader is referred to Section 2 of the author's *Radio Trouble-Shooter's Handbook* for a complete list of the intermediate frequencies used in both all-wave and standard-band receivers.

of using the higher i-f is apparent, for it is much easier for the tuned circuits of the receiver to eliminate the image interfering signal if its frequency differs from that of the wanted signal by 90% than it is if the frequency difference is only 35%. This illustrates the advantage of using a high i-f in order to reduce "image frequency" interference insofar as reception of signals in the standard broadcast band is concerned.

Now let us consider the effect of a high i-f when short-wave signals are being received. Consider the case for the reception of a 15,000 kc signal. If the same low i-f (175 kc) were used, and the receiver were tuned to this 15,000 kc signal, the frequency of the image signal would differ from that of the desired signal by $350/15,000 \times 100$, or by only 2.33% of the desired signal frequency. If a higher i-f of 450 kc is employed instead, the frequency of the "image interfering signal" differs from that of the desired signal by $900/15,000 \times 100$ or by 6% of the desired signal frequency. Hence the amplifier tuned circuits are better able to discriminate against the unwanted "image signal", although with only 6% frequency separation the pre-selector r-f stages ahead of the mixer must be relied upon for *most* of this signal separation. This is the condition which exists in all-wave receivers.

These simple calculations are sufficient to show that image interference will occur in all-wave receivers unless special precautions are taken to increase the selectivity of the r-f stages ahead of the mixer, or some other effective precaution is taken. It is evident that if a single i-f is used for both short-wave and broadcast band reception some compromise must be effected. The image interference problem dictates that a very high i-f be used for its solution. However, it is not advisable to employ a very high i-f for standard broadcast band reception because the i-f will then fall within the standard broadcast band range. The compromise i-f frequencies which are therefore being used in all-wave receivers lie in the region between about 450 and 472.5 kc.

28-8. The AVC System.—The avc system is used for a slightly different purpose in the all-wave receiver than in the standard-band set. Signal fading is very common on the high frequencies, and it is one of the functions of the avc system to vary the sensitivity of the receiver in inverse proportion to the

signal strength (which varies because of fading). The prevention of overloading of the audio amplifier, the main requisite of the AVC system in the standard-band set, is of secondary importance in the all-wave receiver. To the service man, therefore, this state of affairs means that the values of the components used in the AVC system must be exactly as specified by the receiver manufacturer.

The service problems involved in the i-f amplifier are not different from those encountered in standard-band receivers, and the reader is referred to Chapters XIX and XXV for complete details on AVC systems and superheterodynes, respectively.

28-9. The Mixer Stage.—The mixer tube (first detector) circuit of the all-wave receiver is often different from that used in a standard broadcast band set because of the higher frequencies involved on the majority of its bands. Mixer stages may be classified according to the tube used: those having a combination oscillator first detector, and those using separate tubes for these purposes.

As shown in Chapter XXV, receivers using separate oscillator and first-detector tubes must provide for some coupling arrangement between the first detector and oscillator. This coupling may be magnetic, electrostatic, resistive or electronic. The details of the first three systems have already been covered and will not be repeated here; the electron-coupled system used between oscillator and first-detector when a separate oscillator tube is employed will be explained shortly. Combination oscillator and first-detector tubes also have been referred to in Chapter XXV, and the details will not be repeated again. However, there are several characteristics of this system that are of small importance on the standard band but which assume appreciable significance as the frequency is increased.

Figure 28-1 is the schematic circuit diagram of a typical oscillator first-detector circuit. L_o and L_p are the grid-plate coils of the oscillator section, and they connect to G_1 and G_2 of the tube, respectively. G_3 is the signal grid, which is shielded from the oscillator section and the plate by G_4 and G_5 . Now, the oscillator section is distinct from the signal section, so that the triode portion of the tube, composed of the cathode, G_1 , and

G_2 , generates oscillations in the usual manner. Mixing of the signal and the oscillator is accomplished because the oscillator plate, G_3 , (as well as the grid) is in the path between cathode and output plate. Therefore, it varies the electron stream and in addition the signal grid, G_4 , varies the electron stream; thereby "mixing" the two signals. This is known as *electron coupling*.

Now it is evident that at the very high frequencies encountered in short-wave work, a certain amount of capacity does exist between G_4 and G_3 , in spite of the shield G_3 , with the result that the signal, if strong enough, can induce a voltage on the oscil-

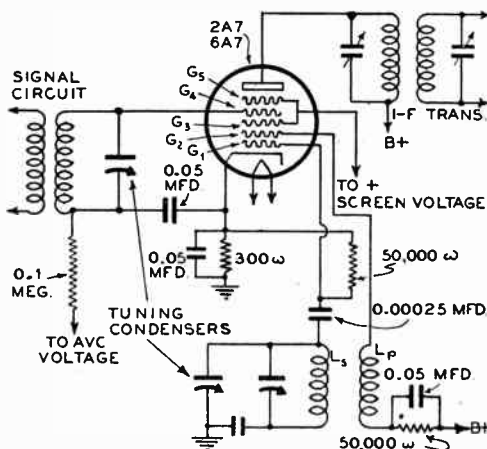

FIG. 28-1.—Schematic diagram showing the circuit arrangement of a typical oscillator—first-detector circuit employed in superheterodyne receivers. A single 2A7 or 6A7 combination tube performs both functions.

lator plate, G_3 , and so cause the oscillator frequency to shift. This frequency shift becomes greater as the signal and oscillator frequencies approach equal magnitudes. Of course, under these conditions perfect alignment of the circuits is not possible regardless of the care used in the alignment, because the frequency of the oscillator is a function of the signal voltage. Although the amount of frequency shift is not large; however, in some cases it may become large enough to be important.

Still another possibility exists! Since the plate voltage of the oscillator is varying (see Chapter XV), the oscillator can induce a voltage on the signal grid, because the capacity between the two grids becomes appreciable at high frequencies. This means that the signal grid now has a voltage on it of the same

frequency as the oscillator. This voltage can react on the oscillator plate and cause shifting of the frequency. The induced voltage on the signal grid depends upon the impedance in the signal-grid circuit: if it is large, the induced voltage is large; and if it is small, the induced voltage is small. This means that, if the signal and oscillator frequencies are close (low *i-f*), oscillator instability will occur.

A practical method of minimizing this undesirable condition is to use a separate oscillator tube and couple its output to one of the grids in the converter tube, as shown in Fig. 28-2. G_2 is now grounded to the cathode, and, therefore, acts like a pentode grid in an ordinary output tube. The capacity between G_1 ,

FIG. 28-2.—Electron coupling between the oscillator and mixer sections of the tube to minimize shifting of the oscillator frequency.

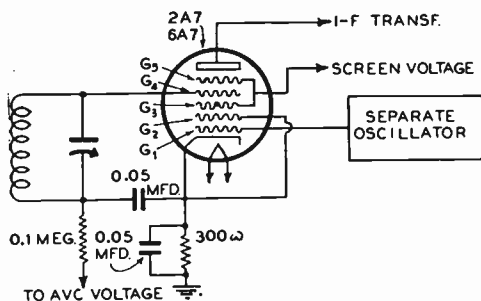

and G_2 is reduced to a small value, and the frequency of oscillation cannot change materially because it is determined by a separate tube in which the grid G_1 of the converter tube plays a small part. G_1 , therefore, is nothing but a means of coupling the oscillator voltage to the mixer tube (first detector).

This system has the further advantage that increased output voltage is obtained on the high frequencies, as it has been found that the triode portion of converter tubes are not strong oscillators on the high frequencies. It will sometimes be found that another tube is connected in parallel with the triode section of the converter tube to increase the oscillator output if an external oscillator is not employed.

The method of coupling the oscillator to the first-detector shown by Fig. 28-2 is not used in single-band sets because on these receivers the oscillator frequency always differs from the signal frequency by a relatively high per cent. Furthermore, the

capacity between the signal and oscillator grids (or plate) is comparatively ineffective at the relatively low frequencies which are encountered in standard-band receivers.

28-10. The Oscillator.—Any of the oscillator circuits shown in Chapter XV are suitable for use in superheterodynes, although some are better high-frequency oscillators than others. In general, those oscillators which depend upon plate-to-grid capacity for feedback are not desirable because of the possibility of frequency shift caused by varying loads. Modernized variations of the standard electron-coupled tickler circuit shown in Fig. 15-22 are now the most widely used. One of them is shown in Fig. 28-1. Coil L_p may be regarded as the tickler coil and L_g as the grid coil. Adaptations of the electron-coupled Hartley circuit shown in Fig. 15-21 will also be found in many receivers.

Stability and intense oscillation are important in a high-frequency oscillator. If the i-f of a receiver is 450 kc, then only a 1% shift in the i-f is sufficient to detune it by 4.5 kc. The signal will be reduced greatly if this occurs, for response of a sharply-tuned i-f transformer is small if it is 4.5 kc off resonance. The necessity, therefore, for maintaining extreme stability cannot be overemphasized. Intensity is important because the i-f output is dependent upon the magnitude of the oscillator voltage: the greater the oscillator voltage, the greater the i-f output. High-frequency signals are usually weak, so that the oscillator should have a large output to maintain a reasonable i-f voltage—a voltage sufficiently high to override tube and circuit noises.

The service man will find that trouble occurs occasionally in all-wave superheterodynes due to difficulty in getting the oscillator to function either at all or over a part of the tuning range. In such cases, it is necessary to determine first whether the oscillator is functioning or not—on all parts of each band. One simple way to check this is to first connect a milliammeter into the plate circuit and observe the steady plate current. Now steps should be taken to insure that the oscillator cannot possibly function. This may be done by short-circuiting the tuned circuit of the oscillator coil with a short piece of wire. If the oscillator has been functioning, a change in the plate current will

occur when this is done; otherwise no change will be noticed. Whether the current *increases* or *decreases* depends upon the type of oscillator. Almost invariably, one which functions with a grid leak will show a *rise* in current when it stops oscillating, whereas one which has a low resistance grid-cathode path and is biased by a battery or by a cathode resistance will show a *decrease* in current. A normal oscillating condition is also indicated by a steady small variation of the plate current as the tuning condenser is rotated.

If the foregoing test shows that satisfactory oscillation is not being obtained, the tube should be checked and another similar one tried. If this fails to reveal the trouble, the connections to all grid and plate coils in the oscillator circuit should be checked for open-circuits and short-circuits. All by-pass and grid condensers should also be tested for leakage, opens, and shorts. Resistors which may possibly be the cause of trouble should also be tested. In some cases, a few turns must be added to the feedback coil, but this is not usually the case since it is assumed that the set was properly designed and operated satisfactorily when new.

28-11. The Oscillator Padding Circuit.—The most radical difference between the oscillator design in standard broadcast receivers and that used in all-wave receivers lies in the padding circuit. As pointed out in Art. 25-17 of Chapter XXV, proper "tracking" of the oscillator frequency with that of the signal circuits in standard broadcast receivers is often accomplished by designing the oscillator tuning condenser plates so they have a different shape than those used for tuning the r-f circuits. It was also pointed out that this arrangement is not satisfactory when different coils are used for tuning to the different bands, as one plate shape is suitable only for one set of coils. Therefore, in all-wave receivers, it is necessary to resort only to the use of padding condensers to maintain proper "tracking" between the oscillator frequency and that to which the signal circuits are tuned.

Figure 28-3 shows three types of padding circuits in common use; together with a common signal tuning circuit at (A) for comparison. The oscillator tuning and padding circuits are

shown at (B), (C) and (D). In all of these circuits C is the main tuning condenser, which is used on all the bands for all the tuning; C_2 is used to adjust the distributed and stray capacities of the oscillator and signal circuits to equal values; the remaining condensers are used for correct "tracking" adjustment. Since the theory of operation of these circuits was presented in Art. 25-17, and the method of adjusting them for correct "tracking" was given in detail in Art. 25-18; it will not be repeated here. The main point to bear in mind is that in all-wave receivers there is a separate signal circuit coil and trimmer condenser as-

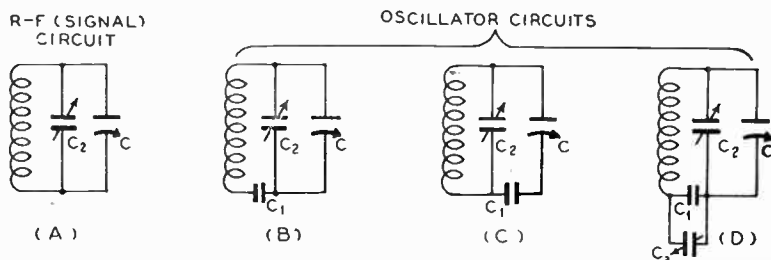

FIG. 28-3.—Comparison of the signal circuit and three types of oscillator tuning circuits used in all-wave receivers.

sembly and a separate oscillator coil and padder circuit condenser assembly for each waveband the receiver is designed for. Therefore, when aligning the oscillator and signal circuits of the receiver, adjustment of the proper trimmer and padding condensers for the particular coils used for the band must be performed—and this must be done for each separate band. Some idea of the number of coils which are employed in a 3-band all-wave receiver employing a stage of t-r-f amplification ahead of the mixer may be gained from an inspection of the illustration of Fig. 28-8, which shows the tuner section of the chassis of a typical all-wave receiver with the coil shields removed. There is an r-f, mixer and oscillator circuit coil for each band—9 coils in all. The condensers which must be adjusted are built into the bases of the individual coils.

As far as the service man is concerned, this means that one wave band requires 2 or more adjustments for the mixer and oscillator, and if there are four bands, 8 or more adjustments

will be required. If there is a stage of tuned r-f ahead of the mixer, then four more adjustments are required, making a total of twelve or more. Two stages of i-f use three transformers, and since each usually has two adjustments (one for the primary and the other for the secondary), six more are added, making a grand total of 18 or more adjustments for the alignment of this particular all-wave receiver. Some receivers having this many stages and wave bands require even more adjustments.

The same type of oscillator padding circuit is not used on all bands in every case. In some receivers, the standard band may use circuit (C) of Fig. 28-3, the first short-wave band circuit (D) and the remaining high-frequency bands circuit (C). This arrangement is not universally used; many sets employ others.

28-12. Line-Up Frequencies and Procedure for All-Wave Receivers.—There are definite frequencies at which the various circuits of an all-wave receiver are aligned. Common frequencies at which alignment is performed are, 600 kc, 1,400 kc, 4,800 kc and 15,000 kc, and the i-f employed in the receiver. The 600- and 1,400-kc points are for the standard band, the 4,800-kc point is for the first short-wave band, the 15,000-kc point is for the second short-wave band, and there may or may not be a line-up point for the final band. The exact line-up frequencies for a given set must be obtained from manufacturer's data, as few receivers cover precisely the same band for each position of the wave changing switch; hence each make of set must be lined up at different frequencies.

In general, it will be found that the highest frequency band requires no adjustment at all because, for this band, large changes in the padding condensers make small differences in the resulting i-f, so that once a fixed unit has been installed, and adjusted at the factory, no further adjustment is usually required.

As has been mentioned, the procedure to follow for alignment is sensibly the same as for the standard-band receiver described in Chapter XXV (with the exception that the r-f, mixer and oscillator stages are adjusted on each band), and the reader is referred to it for further details. Of course, the test oscillator used for aligning the set must cover the desired frequency range with sufficient output; in some cases it is desirable to also measure the

image response on the higher frequencies (see Art. 28-14); the test oscillator described in Chapter XVI, and most of those described in Chapter XVII, are suitable for this purpose. For any alignment procedure that is different than that described in the general data already given in this book, the service notes of the receiver manufacturer should be consulted.

In order to give the reader some idea of the number of adjustments, what they are, and the order in which they must be made in order to completely align a modern all-wave receiver, the manufacturer's alignment instructions for a typical 3-band all-wave receiver of popular make are reproduced here (by courtesy of the RCA Mfg. Co., Inc.). Of course these instructions do not apply exactly for other receivers.

(1) Checking with the tuning wand:

Before making any r-f oscillator, or first detector adjustments, the accuracy of the existing adjustments may be checked with a tuning wand (see Arts. 23-5 and 25-18). This wand consists of a bakelite rod having a brass cylinder at one end and a special finely divided iron insert at the other end. Inserting the cylinder into the center of a coil lowers its inductance, while inserting the iron end increases its inductance. From this, it is seen that unless the trimmer for a particular coil is properly aligned, the wand may increase the output of the receiver. A perfect adjustment is evidenced by a lowered output when either end of the wand is inserted into a coil.

The shield over each r-f coil assembly has a hole at its top for entrance of the tuning wand. An example of the proper manner of using the tuning wand would be to assume the test oscillator were set at 1,720, the signal tuned in, and the output indicator connected across the voice coil of the loudspeaker. (Note: A cathode-ray oscilloscope properly connected may be used as a visual output indicator, as explained in Arts. 25-38 to 25-42.) Then the tuning wand should be inserted, first one end and then the other end, into the top of the three transformers at the left of the r-f assembly, facing the front of the chassis. A perfect adjustment of the trimmer would be evidenced by a reduction in output when each end of the wand is inserted into each of the three transformers. If one end—for example, the iron end—when inserted in one coil caused an increase in output, then that circuit is high. An increase in the trimmer capacitance would be the proper remedy.

(2) I-F Tuning Capacitor adjustments:

Since this receiver has one i-f stage, there are two i-f transformers, each having two adjustable capacitors requiring adjustment. The transformers are all peaked, being tuned to 460 kc.

The detailed procedure for making the i-f stage adjustments follows:

- (a) Connect the output of the test oscillator operating at 460 kc between the first detector grid and ground. Connect the output indicator across the voice coil of the loudspeaker.
- (b) Place the receiver in operation and adjust the station selector

until a point is reached where no signals are heard. Then turn the volume control to its maximum position. Reduce the test oscillator output until a slight indication is obtained in the receiver output indicator.

- (c) Adjust the trimmers of the i-f transformers until a maximum output is obtained. Go over the adjustments a second time!

This completes the i-f adjustments. It is good practice to follow the i-f adjustments with the r-f and oscillator adjustments due to interlocking which often occurs between the two.

(3) R-F, oscillator and first detector adjustments:

Four r-f oscillator and first detector adjustments are required in band "A". Three are required in bands "B" and "C".

To properly align the various bands, each must be aligned individually in the order given. This is, "A," "B" and "C". The preliminary set-up requires that the test oscillator be connected between the antenna and ground terminals of the receiver and the output indicator be connected across the voice coil of the loudspeaker. The volume control must be at its maximum position and the output of the test oscillator must be at the minimum value possible to get an output indication under these conditions. In the high frequency bands, it may be necessary to disconnect the test oscillator from the receiver and place it at a distance in order to get a sufficiently low input to the receiver.

The dial pointer must be properly set before starting actual adjustments. This is done by turning the variable capacitor until it is at its "maximum capacity" position. One end of the pointer should point exactly at the horizontal line at the lowest frequency end of band "A", while the other end should point to within 1/64 inch of the horizontal line at the highest frequency end of band "A".

Band "A"

Care must be exercised to adjust only those trimmers in the band under adjustment in each case.

- (a) Set the band switch at "A".
- (b) The oscillator series capacitor, located on the rear apron of the chassis, should be set at about the center of its range.
- (c) Tune the test oscillator to 1,720 kc, set the pointer at 1,720 kc and adjust the oscillator, detector and r-f trimmers for maximum output.
- (d) Shift the test oscillator frequency to 600 kc. Tune in the 600 kc signal, irrespective of scale calibration, and adjust the series trimmers, located on the rear apron of the chassis, for maximum output, at the same time rocking the variable tuning capacitor. Then readjust at 1,720 kc as described in (c).

Band "B"

- (a) Set the band switch at "B".
- (b) The detector and antenna trimmers should first be tightened to approximately $\frac{3}{4}$ maximum capacity (turned $\frac{3}{4}$ inch).
- (c) Tune the test oscillator to 5,160 kc, set the pointer at 5,160 kc. Adjust the set oscillator trimmer for maximum output. The trimmer should be set at the first peak obtained when increasing the trimmer capacitor from minimum to maximum.
- (d) Check for the image signal, which will be received at approximately 4,240 kc on the dial, if the trimmer is set prop-

erly in accordance with (c). It may be necessary to increase the test oscillator output for this check.

- (e) Reduce the capacity of the detector trimmer, while rocking the tuning capacitor, until the signal disappears. *The first detector circuit is then aligned with the oscillator circuit and the 6A7 mixer tube is blocked.* Then increase the capacity of the detector trimmer, while rocking the tuning condenser, until the signal is "peaked" for maximum output.
- (f) The antenna trimmer should now be peaked for maximum output. It is not necessary to rock the main tuning capacitor while making this adjustment.

Band "C"

- (a) Set the band switch at "C".
- (b) The detector and antenna trimmers should first be tightened to approximately $\frac{3}{4}$ maximum capacity (turned $\frac{3}{4}$ in.)
- (c) Tune the test oscillator to 18,000 kc, set the pointer at 18 Mc. Adjust the set oscillator trimmer for maximum output. The trimmer should be set at the first peak obtained when increasing the trimmer capacitor from minimum to maximum.
- (d) Check for the image signal, which will be received at approximately 17,080 on the dial, if (c) has been properly done. It may be necessary to increase the test oscillator output for this check.
- (e) Reduce the capacity of the detector trimmer, while rocking the tuning capacitor, until the signal disappears. *The first detector circuit is then aligned with the oscillator circuit and the 6A7 mixer tube is blocked.* Then increase the capacity of the detector trimmer, while rocking the tuning capacitor, until the signal is peaked for maximum output.
- (f) The antenna trimmer should now be peaked for maximum output. It is not necessary to rock the main tuning capacitor while making this adjustment.

A comparison of these alignment instructions with those presented in Arts. 25-13 to 25-19 for standard broadcast band receiver alignment, will show the reader that the essential difference between the alignment procedures for these two general types of receivers is simply one of detail—since the r-f, mixer and oscillator circuits of all-wave receivers must be adjusted on each band, a larger *total* number of adjustments must be made.

28-13. Use of Low Test-Oscillator Signal Level During Alignment.—A word of caution regarding the test oscillator signal employed for the alignment of all-wave receivers is important. It is advisable to use the *lowest* possible power from the test oscillator, which will permit the alignment procedure to be started. This is especially important when aligning the "short-wave" bands of most all-wave receivers. If the test oscillator is set to deliver a powerful output signal, its harmonics will be comparatively strong and will be fed into the receiver

along with the desired frequency. For example, if the test oscillator were set at a frequency of 800 kc and adjusted to deliver a powerful output signal, its 1,600-kc second harmonic, 2,400-kc third harmonic, and 3,200-kc fourth harmonic would have appreciable strength and be fed to the receiver. Since a large number of all-wave receivers (especially the "midget" types) do not use r-f or "pre-selector" circuits in their short wave bands, the selectivity on these bands is not adequate to prevent image-frequency response if the image-frequency signal is fairly strong. In such cases, the receiver will respond to a number of these test oscillator "harmonic" frequencies at points above the fundamental frequency to which the oscillator dial has been set. These harmonic frequencies will be received at receiver dial settings corresponding to "even" multiples of the test oscillator fundamental frequency. There is, of course, no particular harm in a test oscillator signal level which produces audible harmonics, except the possibility of setting the receiver dial in error to the frequency of a harmonic instead of to the fundamental frequency at which the test oscillator dial has been set. Of course the image-frequency responses are usually much less audible than the true frequency responses, but they should be avoided.

Reducing the test oscillator output control to a satisfactory minimum will result in a signal level sufficiently low to prevent receiver response to a great number of the test oscillator harmonics and the true signal will be received at the correct point on the receiver dial. If the test oscillator level cannot be brought down low enough, it may be necessary to disconnect the test oscillator from the receiver entirely and place it at a distance in order to get a sufficiently low input to the receiver. From the foregoing comments, it can be seen that attention must be given to using the lowest possible (minimum) test oscillator signal at which alignment of the receiver can be started. Also, if the alignment work has progressed with an improvement in receiver response, the signal should again be retarded to a lower value before proceeding with the alignment in order to secure greater receiver sensitivity.

28-14. Checking the Image Response of the Receiver.—After lining up the r-f, oscillator and first detector circuits of

a particular band of an all-wave receiver, it is desirable to check the image response of the receiver on that particular band. The procedure for doing this will be described for a single band; it may be repeated for any other desired band.

Suppose the circuits have been lined-up at 15,000 kc. The test oscillator is set to this frequency and its output control is then set so that the output indicator used on the receiver indicates as near "maximum" as possible. This reading should be taken. The frequency of the test oscillator is then increased by a value numerically equal to twice the i-f of the receiver; and the reading of the output meter is noted again. If the test oscillator output signal has the same strength for the two settings, and if the output meter is calibrated in volts, the ratio of the two readings is the "image ratio" of the receiver.

For example, if the reading of the output meter is 10 volts for the 15,000 kc setting and is 0.25 volt for the second setting of the test oscillator (15,900 kc for a receiver having an i-f of 450 kc), the "image ratio" is $10/.25$ or 40. An image-frequency interfering signal will then be received with an intensity of $1/40$ that of the desired signal (if they both have equal strength to start with).

The test must be made in a different manner [see (d) in the instructions for lining up Band "B" in Art. 28-12] if the test oscillator is such that its output varies with the frequency it is adjusted to produce. In this case, tune both the receiver and the test oscillator to a line-up point, say 15,000 kc. Leave the test oscillator alone and tune the receiver to 14,100 kc (15,000 minus 2×450) and read the output meter. The ratio of the first to the second reading is the image ratio of the receiver at that point. Note that with the receiver tuned to 14,100 kc the oscillator in the set is working at 14,550 kc (assuming a 450 kc i-f); the test oscillator frequency is then 450 kc higher than that of the receiver oscillator and 900 kc higher than the frequency to which the receiver is tuned, which is the requirement for the reception of an image signal. It is wise to check the image response on all but the standard band. A poor (low) image ratio is a good indication that the tuned circuits are not lined up properly, and they should be rechecked.

If the test oscillator output must be increased to obtain a reading on the meter, then the range of the output meter must be lowered or else the test oscillator must have its attenuator calibrated in volts. For the general run of service work, though, an actual figure representing the image ratio is not required as long as it is certain that the image interference is negligible.

28-15. How to Determine the Frequency to which the I-F Amplifier is "Actually" Tuned.—An excellent test that may be made to determine the actual frequency at which the i-f transformers are lined-up in any receiver brought in for test or repair involves the reception of the image frequency. Tune the receiver to some convenient point near the low-frequency end of a short-wave band and tune the test oscillator to resonance with it. Note the test oscillator frequency setting. Now increase the frequency of the test oscillator *slowly* (with its intensity control full on) until the signal is heard again. Note its frequency setting again. This is the image-frequency signal. Continue to turn the test oscillator slowly and note whether or not the reading of the output meter connected to the receiver decreases and continues to decrease. If it does, then the i-f to which the i-f amplifier of the receiver happens to be *actually* tuned (not the value stated by the manufacturer) is the *difference* between the frequencies corresponding to the two oscillator settings that gave the audible signals, divided by 2. Thus, if the initial reading of the test oscillator at which the signal is heard is 15,000 kc and it is next heard at 15,930 kc, the i-f of the receiver is

$$\frac{15,930 - 15,000}{2} = \frac{930}{2}, \text{ or } 465 \text{ kc.}$$

If it is possible to obtain more than one image point, the others will be very close to the first. This may be due to misalignment of the i-f transformers, that is, one may be peaked at 465 kc, the second at 470 kc and the third at, perhaps, 460 kc. It is clear that a different image frequency will be obtained for each i-f peak frequency.

Then, too, if the i-f transformers have a flat-top response curve, as in high-fidelity receivers, the test oscillator may be rotated over twice the frequency width of the i-f transformers at the image point without any change in output. Thus, suppose

the response of the i-f transformers is flat from 450 to 465 kc and that the signal circuits are tuned to 15,000 kc. The image signal will begin to be heard at 15,900 kc and will remain until 15,930 kc. The width of the image band is then 30 kc, twice the width of the i-f transformers. If this small difference can be read on the test oscillator dial, the width of the response of the i-f transformers can be measured conveniently.

28-16. The Signal Circuits.—The signal circuits of the typical all-wave receiver are conventional in every respect, with the exception that distinct tuning circuits are employed for each band. Each coil in the band has its own trimmer condenser which is adjusted for that band alone. The connections of the tuning coils for a particular band are no different than ordinarily used.

28-17. Coil-Switching Systems Used.—Means must be provided for the selection of any of the bands used in the receiver. Band selection may be accomplished by changing the coils themselves, in which case the system is referred to as a plug-in coil arrangement, or a switch may be provided to automatically cut in and out a desired group of coils: These comprise the tuning coils in the r-f, oscillator and first detector circuits of the receiver. The former arrangement is used to some extent in specialized receivers intended for use by amateurs, while the latter is employed almost exclusively in receivers intended for general short-wave reception in the home. Since the plug-in coil arrangement is not used in all-wave receivers for the home, we will confine our attention solely to the switching systems which are employed. (For a detailed description of plug-in coil systems, the reader is referred to the *Radio Physics Course* by Ghirardi,* and the *Short Wave Handbook* by Denton.*)

To understand the common switching systems used, it must be remembered that the same tuning condenser must be used on all bands, and that the shift toward the high signal frequencies is therefore obtainable by lowering the coil inductance. For a given tuning inductance, the frequency ratio covered between the "maximum" and "minimum" positions of the tuning con-

*NOTE: Published by the Radio & Technical Publishing Co., 45 Astor Place., New York, N. Y.

denser is equal to the square root of the ratio of the maximum and minimum capacities of the *entire tuned circuit*. Thus, a certain tuning condenser may have a minimum capacity of 11 mmfd., and the total stray and distributed capacities of the circuit may be about 20 mmfd. The total minimum capacity is then 31 mmfd. The maximum capacity of the condenser may be 450 mmfd., and when this is added to the 20-mmfd. stray and distributed capacities, the total maximum capacity in the circuit is then 470 mmfd. The *capacity ratio* is then $470/31$, or

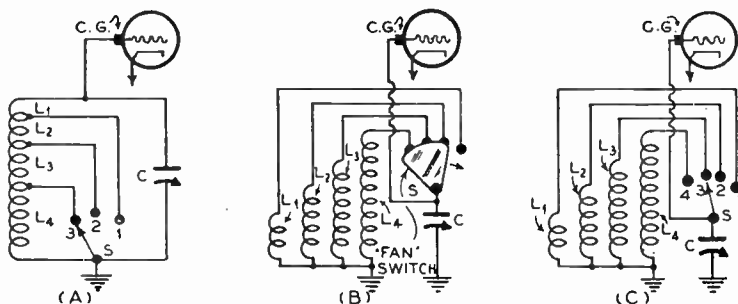

FIG. 28-4.—Three methods for reducing the tuning inductance for changing wave bands in the signal circuits of all-wave receivers. (A) and (B) are most suitable for “extended-band” receivers.

about 15 to 1. The *frequency ratio* is the square root of 15, or only about 3.9 to 1. With these tuning circuit constants, the *minimum* frequency of each band is then multiplied by about 3.9 to obtain the *maximum* frequency in that band.

There are several ways by which the inductance of a circuit may be lowered. All of them have been employed in all-wave receivers. A single coil may be tapped; two or more coils may be connected in parallel (coupled or uncoupled); or a separate and distinct coil may be used in each circuit for each band. Figure 28-4 shows the switching arrangement used in each case.

The system at (A) utilizes a single coil tapped as shown, for each tuning circuit. The switch shorts out part of the tuning coil for each higher frequency band so that only the small section is used for the highest-frequency band. Thus, coil section L_1 is for the highest frequency band, $L_1 + L_2$ is for the next band, $L_1 + L_2 + L_3$ are for the next band, and the entire coil is for the *lowest-frequency* band.

In the arrangement shown here, the switch S short-circuits the preceding (unused) portions of the coil in addition to selecting the desired coil tap. This is to prevent "dead" spots due to the absorption effects caused by the unused portion of the coil, the natural period of which (if the tuning condenser were disconnected from it entirely) would fall in the next higher frequency band. In some receivers, the portion of the oscillator coil which is unused when the switch is in the "highest-frequency" position is *not* shorted, because of the possible difficulty in making the tube oscillate. Since separate padding condensers are used for each band this can be compensated for by the padding condenser used for this band. Also, in some cases the switch arm is in the "grid" end instead of in the "ground" end of the coil circuit, but the principle remains the same.

Good contact is essential in this mode of switching, because if an appreciable resistance should develop between the switch arm and a contact, the unused portion of the coil will not be well short-circuited, and absorption, with consequent drop in signal strength, will take place. Also, this resistance will be directly in series with the tuned circuit, resulting in reduction of the signal current at resonance, and broadness of tuning. Be certain that the contacts are clean and that the tension of the spring is sufficient to maintain good contact. In the average all-wave receiver which has been in use for some time, probably more noise is caused by dirty coil-switch contacts than by any other part.

The system shown at (A) is in general use only in extended band receivers which have a limited short-wave tuning range (see Art. 28-2). Then, only one coil tap is used, though the principle which has just been described remains the same.

In the arrangement shown at (B) of Fig. 28-4, small coils L_1 , L_2 , etc., are switched in *parallel* with the regular standard broadcast band coil L_3 by means of a "fan" switch S (see Fig. 28-7) which "shorts" the upper coil terminals together. Inductances in parallel with each other (if they are not coupled together magnetically) act to reduce the overall inductance, just as resistors in parallel act to reduce the overall resistance (the same formula may be used to calculate the net inductance in

the circuit). In the diagram, the coils are shown permanently connected to ground with the switch in the grid side. In some receivers this is reversed, the switch being put in the ground side instead.

This arrangement is a simple one to use, since it is only necessary to connect simple, small coils of about 25 turns wound on a $\frac{7}{8}$ or 1-inch forms, in parallel with each of the signal circuit secondaries, a somewhat smaller coil of about 20 turns in shunt with the oscillator secondary, and a switch. The primary is usually coupled to the large secondary coil (L_4). This coupling will be sufficient for the short-wave band since this large secondary is still part of the grid coil when the short-wave bands are used. In some receivers, the shunting coils are wound at one end of the same form on which the standard broadcast band coil is wound. In this case, the inductance of the small coil is adjusted to take care of the mutual inductance between it and the regular standard broadcast band secondary. Incidentally, the first arrangement [(A) of Fig. 28-4] may be employed very conveniently by radio service men for extending the high-frequency tuning range of existing standard broadcast band receivers to incorporate "police" band reception.

As in the case of arrangement (A), the parallel-coil arrangement of (B) is used extensively only on extended-band receivers (those which have a limited short-wave tuning range), since the necessity for the use of a number of coils when several short-wave bands are to be provided, makes the use of the separate-coil system of (C) instead more desirable.

The coil-switching arrangement shown at (C) of Fig. 28-4 is the one most commonly used in present day all-wave receivers. Here, entirely separate coils (each one of the proper inductance for the frequency of the band over which it is to be used) are switched into the circuit by switch S. One coil is used for each tuned circuit for each band. It is common to provide each secondary coil with its own primary winding, the separate primaries also being switched in and out with their respective secondaries by means of a multiple tap switch "ganged" with the grid circuit switch. A typical circuit arrangement of this kind between the r-f tube and the combination first detector and oscillator tube is

shown in Fig. 28-5 (for a 3-band receiver). The broadcast band coil is *A*, the first short-wave coil is *B* and the highest frequency coil is *C*. Rotary switch S_1 selects the primary windings of the coils. Switch S_2 selects the corresponding secondary windings simultaneously.

In addition to selecting the proper coil system for the band desired, another switch S_3 is provided for short-circuiting the preceding lower frequency secondary coil. This is to prevent

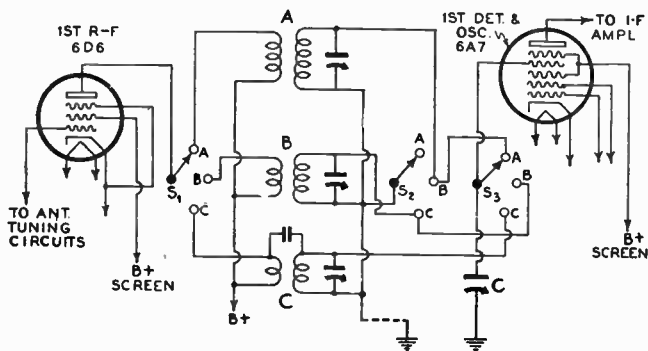

FIG. 28 5.—One signal-circuit stage of a modern all-wave receiver showing the tuning coil switching system in which separate primary and secondary coils are used for each wave-band. They are selected simultaneously by the switches shown. Switch S_2 short-circuits the preceding lower-frequency secondary coil to prevent absorption and "dead-spots". All of the switches are ganged together.

"dead" spots (spots where the receiver is weak or totally inoperative) due to absorption effects caused by the resonating of the unused coils, the natural period of which, with the tuning condenser disconnected, falls in the next higher frequency band. For instance, when the switches are set on contacts *B* for band *B*, the main tuning condenser *C* is connected across the secondary winding of coil *B* and tunes it. Meanwhile, the arm of switch S_2 in touching its contact *B* short-circuits the secondary of the "next lower frequency" coil *A* in order to prevent absorption by it. The secondary of the "next higher frequency" coil *C* is left open for this position of the switches.

The use of separate coils for each band in each variably-tuned circuit is, without doubt, the most suitable arrangement (although it is the most costly), and will be found in most re-

ceivers which provide complete all-wave tuning coverage. The arrangement of a bank of tuning coils of this kind in a 3-band receiver is illustrated in Fig. 28-8. Each coil may be removed, tested, repaired if necessary and replaced without altering any of the circuits of the other coils—an advantage in service work. All of the coils usually have individual shields, *S*, as shown here.

The respective oscillator coil-switching arrangements for the three signal-circuit coil-switching schemes of Fig. 28-4 are shown in Fig. 28-6. The tapped coil arrangement is shown at (A). Each tap has its own series padding condenser *C*₁ (see also Fig. 28-3) which is switched into the circuit automatically.

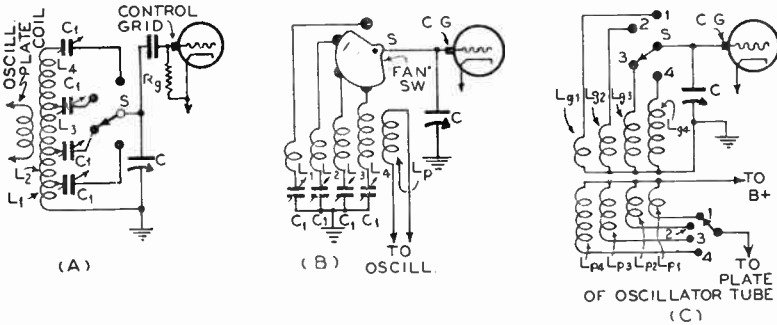

FIG. 28-6.—Three coil-switching arrangements for reducing the tank inductance when changing wave bands in the oscillator circuit. (A) and (B) are suitable for “extended-band” receivers. (C) is commonly used in all-wave receivers. These oscillator coil-switching arrangements correspond respectively with the three signal circuit coil-switching arrangements shown in Fig. 28-4.

Shunt padding condensers may or may not be used. In general, a single plate coil is employed with this system; this is coupled magnetically to the grid end of the tuned grid coils when the switch is connected as shown. This arrangement is not universal, however, so variations from it will be encountered.

It will be noticed that the unused portion of the coil is *not* short-circuited in this case. It is not shorted for the simple reason that, if it were, the appreciable mass of copper comprising the shorted unused portion of the coil would absorb considerable energy from the coil section in use, thus robbing the oscillator of this energy. This might stop the oscillator from functioning at all frequencies whose harmonics would be resonant with the

shorted unused portion of the coil—making the receiver inoperative at these points. By not shorting the unused portion, this is avoided, since its resonant frequency is shifted so as to be be-

FIG. 28-7.—A typical "fan" type switch which may be used for "paralleling" coils (as shown at (B) of Figs. 28-4 and 28-6) in extended band receivers.

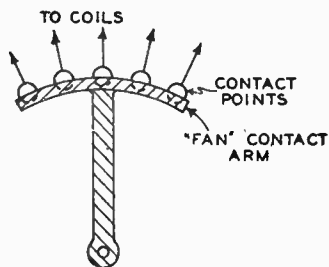

yond the range of the low order harmonics (these are the only ones of any appreciable strength). No difficulty is then experienced in making the oscillator function over the entire fre-

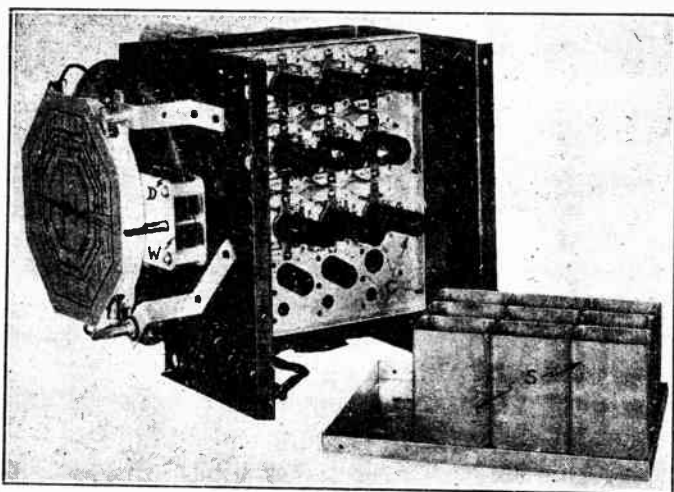

Courtesy Stromberg Carlson Tel. Mfg. Co.

FIG. 28-8.—An under-chassis view of a modern all-wave receiver showing the arrangement of the many tuning coils (9 in all). The coil shield assembly, S, has been removed to reveal the coil assembly. The coils, (C), friction dial disc (D) and spindle (W) which drives it may be seen.

quency range demanded by the receiver. However, in view of the fact that this arrangement is not used for any but extended-band sets, no difficulty is usually experienced in maintaining oscillator stability because but two coil sections are used.

The oscillator coil switching system shown at (B) of Fig. 28-6 corresponds to the signal circuit coil switching system at (B) of Fig. 28-4. The single plate coil L_p couples to the largest (standard broadcast band) inductance L_1 , and series padding is accomplished with the condensers C_1 . As mentioned, the switch parallels one or more coils for short-wave reception. Note that a four-contact fan switch is shown. The actual switch may not be of the fan type, but the electrical connections are such that

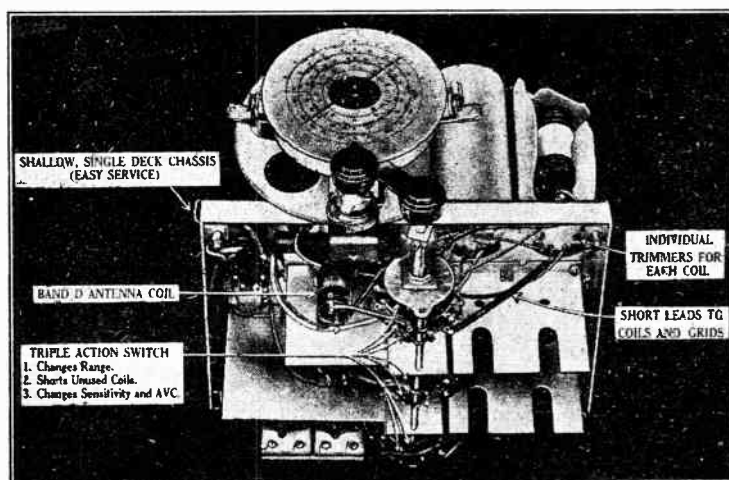

Courtesy RCA Victor

FIG. 28-9.—Under-chassis view of another modern all-wave receiver showing the 3-section wave-band changing switch. Each section of the switch is in the particular shield compartment occupied by the coils it switches. The full-vision tuning dial and pointer are also visible.

it acts as a fan switch. A common arrangement is the use of a single arm with a semi-circular ring at the tip which slides over the contacts, as shown in Fig. 28-7. A spring arrangement usually supplies pressure to the contact points.

Separate individual plate coils are used in the arrangement at (C). The coils should be shielded from one another and a short-circuiting switch provided to prevent absorption. The system is electrically simple, and little additional comment is necessary.

The illustration of Fig. 28-8 shows the coil arrangement and

coil shielding precautions employed in a modern 3-band all-wave receiver. The complete shield can assembly, which fits over the coils, so that each coil is shielded from the next one by a double thickness of shielding metal, may be seen at the lower right of the illustration. Note particularly that each individual shield can is appreciably larger than the coil it shields so that an appreciable "clearance" space exists between the coil winding and the shield. This greatly reduces the losses due to shielding. In spite of these elaborate shielding measures, switches are also used to short-circuit the unused coils in order to prevent the absorption effects already explained.

The illustration of Fig. 28-9 shows the under-side of another modern all-wave receiver and the arrangement of the 3-gang coil selector (wave-changing) switch operated by the knob at the center. Each section of the switch is placed in the particular shielded compartment occupied by the coils it switches, so that short coil-to-switch leads and low stray capacity will result.

28-18. Switches Used in All-Wave Receivers.—The coil-selector switches employed in extended-band and in all-wave receivers are usually one of three types: compounded snap switches, gangs containing arms and taps, and rotary snap switches. The most popular one is the rotary gang or "deck" switch containing one or more wafers of insulating material on which the contact points are mounted. A contact arm sweeps over these contact points to establish individual connections. The switch may have more than one arm which will contact several points in one position and, perhaps, none at all in another. These switches are sometimes very complicated in appearance, and their mode of operation is not at all obvious unless careful inspection is made. It is best, therefore, to trace out the circuit with a continuity meter whenever in doubt as to operation of the switch.

The requirements for a good wave-band switch are, extremely low *non-variable* contact resistance, very low capacity between contacts, and negligible insulation losses. The first requirement is met by employing for the contact points, a metal which has low surface-to-surface contact resistance. Silver meets this requirement, and it is used extensively in these switches. A

typical switch in which silver contacts are employed has an average contact resistance of about 0.0022 ohm and a maximum of 0.0026 ohm. Low capacity is obtained by keeping the distance between adjacent contacts as large as possible; one switch in use has a capacity of only 0.04 mmfd. between contacts. It must be remembered that the total capacity introduced by the switch—the capacity between adjacent wires and ground—is greater than this value. High insulation resistance, of course, is obtained by employing high-grade insulating material; in a typical switch, the insulation resistance between contacts is in the neighborhood of 1.2×10^9 ohms (1,200,000,000 ohms).

Good contact between the switch arm and the contact points is extremely important in wave-band switches. A high-resistance switch contact will increase the resistance of the tuned circuits considerably. This may cause broad tuning, image interference, and low signal strength. Furthermore, noise will be heard as the switch is thrown from one band position to another.

Noisy contacts are generally due to the fact that the owner of the receiver seldom listens-in on the short waves. The surfaces of the contacts then become oxidized, and, when the user decides to give the short-waves "a try", he finds the set much noisier and weaker than expected. The contacts may be cleaned easily with an ordinary pencil eraser that is not gritty enough to scratch the contact surfaces.

The wiring to the switch should be rigid and exactly the same as it was when the receiver came from the factory. The replacement of a coil or a small condenser may necessitate re-wiring a small section of the circuit. If this section connects to the switch, the placement of the individual wires must be *exactly* as they were originally. Any switch introduces a certain amount of capacity between the arm and wires, wires and ground, between wires going to the same section of the switch, etc. The value of this capacity is known by the designer who takes it into consideration when calculating the ranges and line-up points of the set. Any radical changes in the wiring, especially in the oscillator circuit, may increase or decrease the capacity existing between circuits and cause dead spots.

28-19. The Tuning Coil Shields.—Exact placement of the

tuning coil shields is very important. The presence of a shield *reduces* the inductance of a coil and *increases* its distributed capacity at the same time. If these two effects were equal, the coil would act somewhat as if the shield were removed. But they seldom neutralize one another fully, with the result that coil shields must be properly centered if the receiver is to be aligned exactly over the entire band. A misplaced coil shield may be compensated for at any *one* point by adjustment of the trimmer and padding condensers. At most other points the alignment will be off considerably.

Grounding of the shields has more significance as the frequency increases. An imperfect grounding contact between the coil shield and chassis will change the apparent coil inductance and make proper alignment impossible.

A misaligned or poorly grounded coil shield may increase or decrease the natural frequency of a coil. This may cause excessive absorption and "dead" spots at some much-used portion of the dial, especially in receivers which do not short-circuit the unused coils.

28-20. **Dead Spots in the Tuning.**—One of the most frequent causes of trouble in some extended-band and all-wave receivers is *dead spots*—spots on the tuning dial at which the receiver does not function. Dead spots may be caused by failure of the oscillator to function at certain frequencies or by absorption of energy from the signal circuit by adjacent coils. Lack of sensitivity, provided everything else is correct, is usually due to misalignment of the oscillator and signal circuits.

Failure of the oscillator may be caused by dirty or imperfect switch contacts. If the contacts are merely dirty, they can be cleaned easily; but if the switch loses its spring tension, repair may be difficult. It is unfortunate that many of the earlier extended-band and all-wave receivers were not equipped with good switches. Frequent adjustment of the spring tension and periodic cleaning of the contacts must be made in these sets if reception is to remain normal. If a switch is replaced for some reason, the service man should attempt to replace it with one of the wiping contact type—a contact that wipes over the surface it touches, thus cleaning it whenever the arm is rotated.

Although it is assumed that the receiver leaves the factory free from dead spots, there are certain extended-band and all-wave receivers which have dead spots that are inherent in the design of the set, and the service man can do nothing about it unless he wishes to undertake to practically redesign the receiver. It will be found that these dead-spots exist in the earlier models, and not in those of recent design. In many cases, the manufacturer will suggest the recommended changes to make in the receiver.

28-21. Number of Tuning Bands.—The standard broadcast band range of an all-wave receiver has a tuning range covering from 540 to 1,600 kc. This means a *frequency ratio* of $1,600/540$, or about *3 to 1*. Apparently, if the same tuning condensers are used for all the bands, the same frequency ratio is obtained on all bands. On this basis, the next higher-frequency band will cover the range from 1,600 to 4,800 kc ($1,600 \times 3$ equals 4,800). The third band will have the range from 4,800 to 14,400 kc ($4,800 \times 3$ equals 14,400). The fourth band will usually tune to about 23,500 kc. Of course, these rough calculations do not take into consideration the necessary overlap, between bands; when they are taken into account, the spectrum is divided nicely into four parts: one for broadcast reception and three for short-wave reception.

Consider the 4,800 to 14,400 kc band! The range of frequencies covered in it is considerably greater than in the standard band—about 9 times as great, since the standard band tunes from 540 to 1,600 kc (a range of only 1,060 kc) and the foregoing short-wave band covers a range of 14,400—4,800, or about 9,600 kc.

It is clear that the frequency band which will be covered by a single sweep of the tuning condenser depends upon the coil inductance, the ratio of the maximum and minimum tuning condenser capacity, and the value of the stray and distributed capacities. In general, the frequency ratio is about 3 to 1 with sufficient overlap between bands so that the tuning range is continuous. This means that certain stations may be received on the high end of one band and also on the low end of the next one. It is best to use that band in which the station is

received with the *minimum* value of tuning capacity.

One sweep of the tuning condenser covers the broadcast band from 540 to about 1,600 kc. At least three additional bands are required to cover the remaining frequencies without crowding the tuning too much. Some receivers cover the short-wave range with but two bands, but short-wave tuning is extremely critical in these sets. The service man should instruct the set owner regarding the sharpness of tuning and the proper manner of tuning slowly and carefully—especially on the short-wave bands.

Many receivers intended for amateur use employ tuning condensers having a maximum capacity of 140 mmfd. so that four bands are required to cover the short-wave spectrum and two additional bands are needed for the standard band. In a similar manner, there are receivers having tuning condensers with a maximum capacity of 100 mmfd. Five short-wave and three standard bands are required for all-wave reception with these condensers.

Many receivers are manufactured for export purposes and are used for the reception of the "ultra-long wave" broadcast stations employed in Europe. This long-wave band covers the range from about 140 to 410 kc, and it may be built into a receiver purchased in this country. Of course, the range of such a set is wider than the more usual receiver, but the reception of long-wave European stations in this country is extremely difficult, and service men should caution the users of such sets against the possibility of receiving such stations. For this reason, it is the policy of many manufacturers of export receivers to leave out the coils for the "export band" when the receiver is to be sold and used in the United States.

28-22. All-Wave Receiver Dials.—The dials used in all-wave receivers are somewhat complicated, and should not be tampered with unless it is absolutely necessary. The tuning is so sharp on the short-wave ranges of the average all-wave receiver that dials having a high drive-ratio are used very extensively. Some dials are equipped with double ratios; the smaller one enables the scale to be spanned rapidly, and the larger one permits fine adjustments. In one commercial receiver the large

ratio is approximately 60 to 1. The tuning dial drive of the all-wave receiver illustrated in Fig. 28-8 is clearly visible. Notice that it depends upon a friction drive between the small grooved spindle *W* on the dial knob shaft and the large disc *D* which is fastened to the dial pointer and tuning condenser shaft. Since the drive spindle is much smaller in diameter than is the disc, a large drive ratio is obtained for close tuning. This is an important advantage!

The speed-reduction mechanism is not the only complicated part of the dial. In some receivers, as the wave bands are changed, the part of the scale exposed to view is also changed by some means. The proper section of the dial may be exposed in either of several ways: by keeping the dial-light fixed and raising or lowering the scale by the wave-band switch; by keeping the dial fixed and varying the height of the dial light assembly, or by turning on different dial lights placed at various positions behind the dial scale. There is no standardized method of accomplishing these changes.

Noise generated while the tuning dial is rotated may often be traced to friction between fibre and metal gears or between friction wheels and discs which are not properly greased or which do not track smoothly. A good lubricant may be made by mixing powdered graphite with white vaseline. Be certain that the action of the dial mechanism is understood perfectly before any attempt is made to take it apart for repair, as some of these dials are rather intricate in construction and are difficult to reassemble.

28-33. Noise in Short-Wave Receivers. — The first effect often noticed when an all-wave receiver is set to receive one of the short-wave bands is that excessive noise is present—noise that would be considered intolerable on the Standard Broadcast Band. Noise and interference caused by *electrical storms* and *atmospheric conditions* are usually less noticeable on short waves than on the standard broadcast band. On the other hand, *man-made "static"*—noise caused by household electrical appliances, automobile ignition systems, power lines, and telephone circuits—is more noticeable on the short wave bands. However, man-made interference can usually be greatly reduced by the use of

a good noise-reducing antenna system and suitable electrical filters (see Chapter XXX).

Of course, noise can also be caused by components in the receiver itself. Aside from noise resulting from loose connections in the wiring, leaky condensers and the like, there are two other causes of internal receiver noise: "*shot effect*" and "*thermal agitation*". *Shot effect* noise is caused by the fact that the stream of electrons in a vacuum tube is not an infinitely fine fluid, but consists of discrete particles — electrons. Thus, the average plate current has certain irregularities in it, and these irregularities constitute the noise current. This noise current flows through the plate load and develops a noise voltage across the load. Since the noise current is really a series of impulses, it has no definite frequency, and the voltage developed, therefore, depends, among other things, upon the width of the band to which the plate load can respond.

Thermal agitation noise is that caused by the random motion of electrons in a wire or circuit. Its value depends upon the temperature of the wire or circuit, the resistance of the wire or circuit (the resistance of the plate load in our case), and the band width to which the wire or circuit responds. The noise voltage increases with an increase in any of these factors.

Now, for distant short-wave station reception the noise is more apparent because the signal strengths are small; the noise voltage is therefore comparable to the signal. This often leads owners of all-wave receivers to call in the service man since they imagine that the excessive noise is caused by some trouble in the receivers. Attempts to increase the sensitivity of the r-f or i-f amplifier result in increased noise and signal, but the ratio remains about the same. When the signal input is large, the noise is masked; and if a linear second detector is used, the noise will not be amplified above a certain level when a strong station is tuned in.

It must be remembered at this point that the actual noise level is not important; the important thing is the level of the noise with respect to the signal to be heard. For this reason, the terms *signal-to-noise* or *noise-to-signal* ratios are used. For best results, the former should be as high as possible; stated in another way, the latter should be as small as possible.

Receivers using AVC seem less noisy in some cases, especially when the signal strength is high. The reason is that a strong desirable signal reduces the sensitivity of the receiver through the AVC system and so reduces the noise. However, on weak

signals—signals that are below the threshold of the *avc*—the noise is just as loud as if the *avc* system were not used.

28-24. Antenna Requirements.—The antenna requirements for short-wave reception are simple. The aerial must be fairly short and as high as possible; it must also be directed properly (depending upon its type) toward the countries whose short-wave programs it is most desired to receive. The all-wave antenna must be such that the all-wave receiver it is used with will be sensitive not only on the standard broadcast range, but on all the short-wave ranges as well. This is the ideal condition to be sought for. Three types of receiving aerials are in general use at present: the inverted-*L*, the *T* type, and the *doublet*. These are all described in detail in Chapter XXX.

If the directional effects of an inverted-*L* aerial are to be utilized to bring distant station signals in with somewhat increased intensity, it should be erected so that it is directed toward, and the lead-in taken from, the end nearest that pointing to the country from which good reception is desired. In other words, if best reception is desired from the northeast, the aerial should be erected so it points in a north-east and south-west direction. The lead-in should be taken from the north-east end.

The *T* aerial receives best from a direction at right angles to its length, as shown in Fig. 30 56. Thus, for a given direction in which the aerial must point, the lead-in may be taken from either the center or one end, as demanded by receiving conditions. Other popular types of antenna systems are described at length in Chapter XXX.

For best results at a given frequency, the length of the aerial can be calculated to deliver the highest voltage at the desired frequency. For details on this point, the reader is referred to Chapter XXX.

Noise-reducing antenna systems have been designed and are used to a great extent with all-wave receivers. These systems make use of twisted or transposed lead-in wires that cancel, (in the primary of the receiver antenna coil or in the primary of a special transformer provided with the system), any noise voltages induced in them. The horizontal part of the system should be as high and as free from noise as possible in order for the system to be as effective as possible. Further details on noise-reducing antenna systems will be given in Chapter XXX.

A good antenna system is most essential if reliable distant reception is to be expected. Place the aerial as high above the ground or grounded objects as possible. If a flat-top antenna system is used, the flat top (aerial) portion should be from 50 to 75 feet in length. (Copper wire No. 14 gauge or heavier should be used). It is well to use 2 or 3 insulators in series at each end of the aerial instead of the single insulator commonly used at each end. The lead-in wire should be properly soldered to the

antenna. Keep the lead-in wire as far from sources of man-made static as possible, so that a minimum of interference will be picked up. Some chief offenders of this nature are trolley wires, electric oil burner installations, automobiles in motion, flashing signs, neon signs, motors and power lines. Methods of minimizing interference from these will be considered in Chapter XXX.

REVIEW QUESTIONS

1. Define the following: standard-band receiver; extended-band receiver; all-wave receiver.
2. What are the i-f's commonly used in all-wave receivers?
3. What are the advantages of a high intermediate frequency in all-wave receivers?
4. A certain receiver has an intermediate-frequency of 456 kc and is tuned to a 12,000-kc signal. What is the image frequency of this signal?
5. Upon testing for image response in an all-wave receiver, it is found that the output remains substantially constant only while the test oscillator dial setting is changed from 12,910 to 12,930 kc. What is the width of the peak of the i-f transformers.
6. Assuming that the receiver is properly designed and adjusted, what is the main i-f used in the receiver of Question 5?
7. Draw a diagram of a commonly used mixer stage using electron-coupling and a separate oscillator tube.
8. What is the most common type of oscillator circuit now used in all-wave receivers? What are its advantages?
9. What operating symptom would result in an all-wave receiver if: (a) the oscillator failed to function at all; (b) the oscillator failed to function only on some bands?
10. How would you determine quickly whether the oscillator was functioning over the entire range of the receiver?
11. If the foregoing test indicated that the oscillator was not functioning properly, what steps would you take to locate the cause of the trouble?
12. Why are "shaped" oscillator tuning condenser plates not employed in all-wave receivers?
13. Which circuit is padded in an all-wave receiver, the signal or oscillator circuit?
14. What determines the number of different padding circuits that an all-wave receiver contains?
15. Explain the essential difference in the amount of work involved in the complete alignment of a standard broadcast band receiver and that necessary when completely aligning a 3 or 4-band all-wave receiver having a similar number of stages.
16. Why is it advisable to use a low output test oscillator signal level when aligning all-wave receivers? Explain!
17. Explain how you would check the image response of an all-wave receiver on a certain short-wave band after that band has been

- lined up at 4,800 kc. The i-f of the receiver is 450 kc. You are not certain whether the signal output intensity of the test oscillator you must use varies as its frequency is changed, or not.
18. Explain how you could quickly determine the exact frequency (or band of frequencies) to which the i-f amplifier of a receiver under observation is "actually" tuned.
 19. How would you calculate, roughly, the frequency ratio of the following circuit: Minimum capacity of tuning condenser, 12 mmf.; stray capacity of circuit, 14 mmf.; tube capacity, 3 mmf.; distributed capacity of coil, 3 mmf.; maximum capacity of tuning condenser, 365 mmf.
 20. Assuming the lowest frequency of the standard band of an all-wave receiver is to be 540 kc, how many bands would be required if the tuning condenser and circuit of Question 19 are to be used? Do not consider overlap between bands.
 21. Describe the three common arrangements which are employed in all-wave receivers for reducing the inductance in the tuning circuits in order to receive the high-frequency band signals.
 22. Draw simple sketches showing each of the arrangements you described for Question 21 (three in all). Show all the necessary switches, taps, etc., if a total of 3 bands are to be covered by the receiver.
 23. Explain what effect poor switch contacts will have on the operation of the all-wave receiver, for each of the coil-switching arrangements of Question 22. In which two arrangements would a break in the continuity of the coil winding used for one band affect the operation on another band?
 24. What steps are usually taken in the signal circuits of all-wave receivers to prevent "absorption" by "adjacent-band" coils?
 25. What is the effect of such absorption occurring in the signal circuits?
 26. What is the effect of such absorption occurring in the oscillator circuit?
 27. What is the objection to shorting unused coils in the oscillator tuning circuit?
 28. What would you suspect as the cause of the trouble and how would you proceed to check your suspicions and correct the trouble if you find that a 3-band all-wave receiver operates satisfactorily only on the standard broadcast band? The set analyzer shows that its i-f amplifier, second detector and a-f amplifier are operating satisfactorily. Explain!
 29. What simple test could you apply to determine quickly if the oscillator is operating satisfactorily over the bands on which no reception is obtained in the receiver of Question 28?
 30. What general types of switches are used in the tuning coil circuits of all-wave receivers? What are the characteristics of a good short-wave switch.
 31. Why is it extremely important not to alter the exact positions of the wires connecting to the coils and wave-band switches when making repairs on all-wave receivers? What may happen if some of these wires are shifted? Explain!
 32. What is meant by the term "dead spots"? How may dead spots in the tuning be eliminated in all-wave receivers?

CHAPTER XXIX

INSTALLING AND SERVICING MARINE-RADIO RECEIVERS

29-1. Introduction.—Now that highly efficient and satisfactory auto-radio receivers have been developed and are in popular use, it is natural that owners of marine craft should seek the same radio news and entertainment aboard their boats while travelling. The installation of radio receivers in many types of boats is governed by somewhat the same conditions which control auto-radio installations. It was pointed out in Chapter XXVII that the main requirements that had to be met in the design of auto-radio receivers were those of small size, mechanical rigidity, electrical stability, sensitivity, resistance to atmospheric conditions, low noise and ease of control. The installation of radio receivers in marine craft of small size presents almost identical problems, in addition to those of deterioration because of exposure to salt air, and the need for low battery-power drain. The power available aboard small craft is almost a direct function of their size, so that the type of receiver and power supply arrangement employed depends to some extent upon this factor. The height and length of the aerial which may be used is also determined directly by the size of the craft.

29-2. Classification of Marine Craft.—To discuss the important problems of marine-radio installation intelligently and directly, it is necessary to divide boats into six different classes and discuss each class separately. They are:

- Class 1. All small row-boats, canoes and outboard motor boats
2. Inboard runabouts and speedsters

3. Motor cruisers
4. Auxiliaries
5. Straight sailing craft
6. Yachts

These general classes may also be subdivided into groups according to design—as, open or cabin type, etc. However, it will be found that the available power supply determines the type of marine-radio installation that must be employed to a greater extent than does the construction, so the classification as listed here will suffice. In discussing these craft, it is feasible to start with Class 6 (which presents the simplest installation) and work to the smaller size boat, in which the most difficulties are encountered.

29-3. Radio Installation on Class 6 Craft.—Boats of the Class 6 type, or large cruisers of more than about 50 feet in length, are usually equipped with lighting units operated separately from the main engines. On such boats, therefore, it is possible to use power without the necessity of turning over the main engines. This lighting power in some installations is supplied by special gasoline-electric units, which may be either one of two types: one generating 110 volts d-c, the other generating 110 volts a-c.

Instead of having a gasoline engine driving a generator which supplies its power *directly* to the circuit, some craft are equipped with banks of storage batteries which are charged by a generator driven by the main engines when the boat is in motion, and which deliver their stored energy to the lighting circuit when the main engines are not operating. Others employ an auxiliary generator and battery system, but the generator here is driven by a separate gasoline engine. In either case, the batteries deliver 110 volts d-c. Many large cruisers are equipped with a simple switching arrangement which permits the lighting power to be derived from either the batteries when the engines are not running or from a generator coupled to the main engines when they are running. In any event, on craft of this class, the power available in addition to its many other duties, is more than adequate for the operation of a radio receiver.

Obviously, in such craft, any type of home receiver may be

used provided it can operate from the 110-volts a-c or d-c power supply available. The popular universal type midget receiver is ideal for this purpose. If a d-c system is employed, it may be necessary to shunt an 8-mfd. filter condenser directly across the line at the radio receiver to help smooth out the current, since the d-c lighting circuits of marine craft are very "ripply" and often noisy. This is especially necessary if cheap midget receivers whose filter circuits have been "skimped" in design are employed. If noise is encountered, a good line filter properly connected will usually clear it up (see Chapter XXX). It may also be necessary to install suppressor resistors in the ignition system if a gasoline engine is employed for the lighting system.

The receiver should be fastened down securely, whether it is of the midget type or a large console model, so that when the craft pitches or rolls, it will remain in place. This is very important. There is usually enough space available in the cabins or in the lounge to enable the receiver installation to be made without cramping. In fact, such installations are comparable to those usually made in homes. However, if more than one receiver is to be installed, the service man should consult with the chief engineer, as he can be of valuable aid in advising of any possible limitations which may exist regarding the amount of excess power that can safely be drawn from the batteries or generator, etc.

Separate power lines should be run from the source of power to the outlet. If more than one receiver is to be installed, a main power line should be run to the deck on which the receivers are to be installed, and branch lines run from a fused outlet box at the end of the main line to the individual receivers. Do not fail to fuse the circuits adequately, as fire is much more dangerous aboard ship than it is on land.

Many installations have one or more portable receivers, electrically operated, which plug into outlets installed on open decks. Only *marine type* outlets should be used here. They may be obtained from any marine hardware dealer. These are large, brass-housed cases with the plugs inside. A cap screws to the top of the case and protects the plugs from possible short-

circuit due to entry of water in rainy weather. Heavy rubber-covered wire must be used throughout, as the ordinary, thin rubber insulation commonly used on ordinary wire will deteriorate in a short time on board ship, and result in repeated short-circuits every few weeks.

Yachts or large cruisers usually have two masts between which it is convenient to string the aerial. The usual marine aerial on large craft consists of two, three or four wires suspended by spreaders and strung between the masts. A single-wire aerial however, will serve the purpose in most cases. The usual rules for good antenna installation are especially important here: insulation must be good, the lightning arrester must function, and the ground must connect to a *good* ground.

There are several locations on board a large cruiser where good grounds may be obtained. The keel is usually of metal, and a connection can be made to it. In many cases, a main ground connection is made during the construction of the craft. This is accessible by the service man while the craft is afloat. If such a ground is not available, a sheet of copper may be attached to one side of the hull below the water line, and a ground lead brought from it. Do not depend upon some nearby ground connection for the lightning arrester; make a direct connection to the lowest possible ground terminal in the boat.

29-4. Radio Installation on Class 5 Craft.—Straight sailing craft in this class are usually equipped with 110-volt or 32-volt lighting systems. Those with power systems of the former voltage may have the same type of radio installation as described for the Class 6 craft, and the same precautions apply also. However, there are few receivers designed for operation from 32-volt lines; it is often necessary, therefore, to use a 32-volt d-c to 110-volt a-c converter or motor-generator set to deliver sufficient voltage for the ordinary receiver.

If the 32 volts is obtained from a bank of storage batteries, then the receiver may be of the automobile type connected so that it operates from one of the six-volt batteries in the storage battery bank. A simple switching arrangement may be provided to shift the receiver connections from one battery to another to prevent uneven drain on the complete bank of batteries.

Under some conditions, it may be possible to set aside one particular battery for the exclusive use of the radio set, and it may be charged by the same gasoline engine which charges the main bank. It may be necessary to install the usual suppressor resistors, etc., on the gasoline engine to suppress interference from it.

Battery receivers are also to be recommended for this type of craft. Such receivers usually utilize the 2-volt series of tubes and may be operated either from No. 6 dry cells or from one of the many "built-up" special *A* batteries designed for such receivers. *B* potential, of course, must be obtained from *B*-batteries. It should be noted that *B* batteries deteriorate rapidly when exposed to moisture, so that they should be housed in a rust-proof metal box with a tight fitting cover and leads should be brought out through tight-fitting bushings. The *B* batteries should be of the heavy-duty type, as one set of these will usually last throughout the entire yachting season. The batteries should be tested frequently under normal load, and when the potential of a 45-volt unit under that load drops below about 35 volts, it should be replaced. Obviously, the *A* battery should also be tested periodically to insure rated voltage at the filament terminals. These batteries must be fastened securely to prevent shifting due to the motion of the ship.

When these types of craft are too small to allow the use of a second mast, the aerial wire may consist of a copper strip, running up the side of the mast and insulated from it, as shown in Fig. 29-1. On some types of straight sailing craft, the aerial wire must be run flush with the mast, and not separated from it. The exact type of installation may be ascertained easily after an inspection of the craft has been made and the proposed location of the receiver has been decided upon.

29-5. Radio Installation on Class 4 Craft.—An "auxiliary" is a type of sailing craft equipped with an engine which may be used instead of the sail when there is no wind or when the wind is adverse. The general rules for antenna installation here are the same as for the straight sailing craft. The auto-radio receiver is well suited for this type of craft, as it usually is equipped with a 6-volt lighting system. However, if the storage battery which

operates the lighting system has no facilities for being charged by the engine, the auto-radio receiver should not be used, as the drain on the battery is apt to be excessive. If such is the case, the receiver should be of the battery-operated type, as discussed for the Class 5 craft. The same precautions regarding battery care and protection should also be adhered to here.

The ground connection on this type of craft may consist of a copper plate attached to the outer side of the hull and connected to the radio receiver by a copper strip. This type of ground has been used for many years and has been found to render excellent service. A further advantage is that the potential of the radio receiver chassis will not be different from that of the engine, so that ignition interference will not be so severe. Suppressors may have to be installed in the ignition system of the engine (see Chapter XXVII).

29-6. Radio Installation in Class 3 Craft.—This type of craft is often supplied with a 32-volt lighting system, the details of which have been covered in Art. 29-4. However, there may be available a 6-volt battery which can be charged by a generator driven by the engine, or there may be two sets of 6-volt batteries that are charged alternately.

Obviously, the auto-radio receiver is of special value in these cases. As discussed in detail in Chapter XXVII, the modern auto-radio receiver is well shielded and designed to withstand

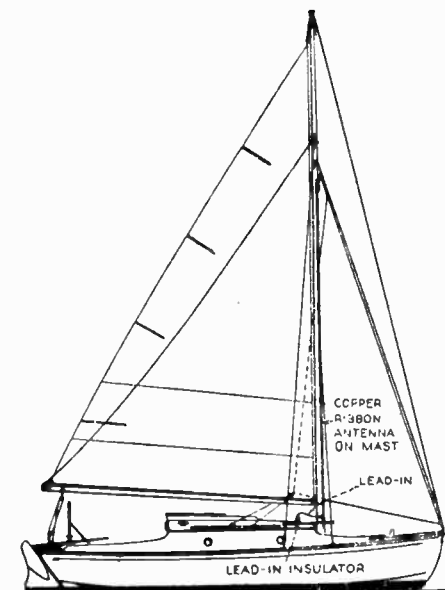

Courtesy Radio News

FIG. 29-1.—A simple but effective antenna system for small sail boats. The aerial is of the vertical type run up the side of the mast so that it does not interfere with the manipulation of the sails.

the mechanical vibration and adverse weather conditions encountered in all parts of the country. These design features make it valuable in small cruisers because of the close proximity of the radio receiver and engine in these compact boats.

Figure 29-2 shows an illustration of a typical cruiser with a single jury mast and a closed cabin. This type of construction lends itself to easy antenna installation. Either a roof wire-mesh aerial may be installed (see Art. 27-15 and Fig. 27-16), as shown in Fig. 29-4, or a single- or two-wire antenna may be



Courtesy Radio News

FIG. 29-2.—A typical cabin-type cruiser ideally adapted for easy radio aerial installation. Two simple types of aerials which may be installed in craft of this type are illustrated on the next page.

run from the mast to the far end of the cabin roof, as shown in Fig. 29-3. The construction of such aerials is perfectly standard and straightforward, and no additional data are required. Good insulators should be employed throughout.

29-7. Radio Installation in Class 2 Craft.—Inboard runabouts and speedsters are practically similar in construction (as far as controls, engine and other facilities are concerned) to the automobile, so that the auto-radio receiver is well suited for this type of boat. The receiver itself may be installed on the dashboard with the control unit on the steering-wheel shaft, exactly as in the case of automobile installations (see Figs. 27-8 and 27-9). Standard ignition interference suppression must be em-

ployed on the engine (see Arts. 27-40 and Arts. 27-43 to 27-47)—including a generator by-pass condenser.

The mesh-type roof antenna may be used if there is a roof; or, if not, it may be installed under the front cowl (if the engine is in the rear), or stretched on both sides of the bow, on the ribs, exactly as shown in Fig. 29-5, for an outboard boat. It

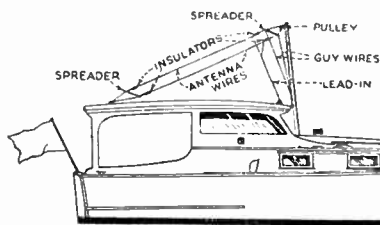

FIG. 29-3.—Method of installing a single or two-wire antenna supported by the mast on a small cabin cruiser.

(Courtesy Radio News)

should be remembered that the ignition system of the engine is not enclosed by a metal bulkhead, metal hood, etc., in this type of craft as it is in an automobile. Therefore, more intense *direct radiation* of interference from the ignition system to the aerial and lead-in wires will occur, so it is particularly important to locate the aerial as far from the engine as possible. Consider-

FIG. 29-4.—Method of installing a simple wire-mesh aerial in the cabin roof of a small cruiser.

(Courtesy Radio News)

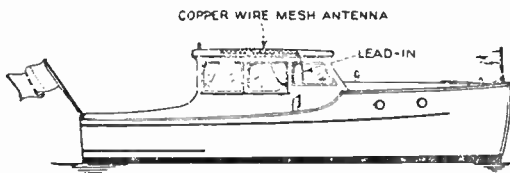

able shielding of wires is necessary in some boats, especially in short ones. In some cases, the entire engine compartment must be completely shielded internally with grounded *sheet* copper or brass in order to reduce the interference to a permissible level. All connections should be well soldered, and all wires should be fastened securely, for considerable vibration and "weaving" exists in these craft.

29-8. Radio Installation in Class 1 Craft.—This class of craft is well represented by row-boats or canoes powered by outboard motors, and other similar types of craft. Although they

are simple in construction, the radio installation difficulties are often numerous. First of all, the direct noise from the exhaust is great, although it has been reduced to some extent by the development of underwater exhaust systems. Second, space is usually at a premium, and it may be difficult to properly locate a receiver. A suppressor resistor must be placed in each spark-lead to reduce interference.

A suggested arrangement for a canoe is shown in Fig. 29-6. It will be seen that the aerial system consists of an insulated

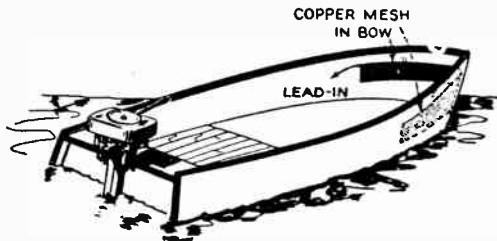

FIG. 29-5.—How a copper mesh (or sheet copper) type aerial may be installed in the bow of a boat. This may be employed in row-boats, out-board motor boats, and speedsters.

(Courtesy Radio News)

wire tacked along the gunwales; and the ground is nothing more than a connection to one of the brass "bang-plate" strips which are already on the canoe. It acts, in reality, as a counterpoise.

Battery receivers of the compact, portable type are recommended for this type of craft. These receivers have the advantage that they may be removed easily or shifted from place to place, as the number of passengers vary. All batteries should be thoroughly enclosed in metal boxes to prevent short-circuits when they become wet because of spray, etc.—especially if the boat is to be used in salt water.

29-9. **Selecting the Receiver.**—As mentioned in the previous sections, the type of receiver to be employed depends, primarily, upon the type of craft; it also depends upon whether the craft is to be operated in salt or fresh water. Salt water will cause rapid deterioration of the insulation of the wire, especially on the coils, which shortens the efficient life of the receiver. Corrosion of metal contacts—especially where dissimilar metals join—is also a very troublesome factor. In fact, because of these troubles many makes and models of receivers which give perfect satisfaction in home or automobile installations are ab-

solutely worthless for marine use. All coils in the receiver should be thoroughly impregnated against moisture. In this connection, it may be worth while to investigate, before installing a number of receivers of a certain design, to find a suitable line of receivers which are made by a manufacturer who has had considerable experience in manufacturing receivers for use in tropical regions, and whose sets have established a reputation for standing up well under the extreme heat and moisture conditions which exist there. Because of their special construction features, such receivers generally have a better chance for successful marine radio service than others do. It is wise to use, whenever possible, a receiver that is completely enclosed by a metal case and is as airtight as possible if it is to be used in salt-water locations.

The third factor governing the selection of the receiver is the available power supply. As we have already seen, this may be 110-volt a-c or d-c, 32-volt d-c, 6-volt d-c, or nothing at all! Naturally, the type of receiver to be used in any case, depends upon the operating current supply available.

Space is another factor which is often very important. Crafts, even up to yacht size, are designed for conservation of space, and in some cases the amount of space available is more limited than in an automobile. It is wise, therefore, to decide

FIG. 29-6. — Suggested radio installation for a canoe. The aerial and ground leads are tacked under the gunwales.

(Courtesy Radio News)

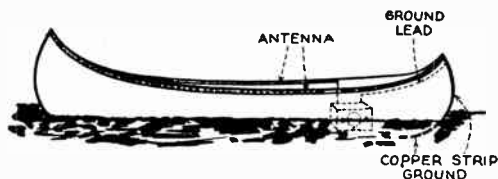

definitely upon the location of the receiver before selecting one.

Chapter XXVII gave specific details regarding the construction and method of installing auto-radio receivers. The same rules apply to the installations in marine craft which employ internal combustion gasoline engines for motive or lighting power. Of course, exceptions will be found, but the general rules must be adhered to at all times, especially those with regard to the drain on the batteries, and the necessity for keeping all battery terminals thoroughly clean. The chief engineer of

the craft should be advised of the power consumption of the receiver, so that he can make periodic checks on the condition of the power supply. Remember, a service man cannot be called in when the boat is miles out at sea!

29-10. Ignition Interference.—Obviously, marine radio receivers are not immune from interference generated by the ignition system of the engines if they are of the internal-combustion type. Suppressors and shielding must be resorted to in almost all cases, exactly as in an auto-radio installation. One additional good rule to remember is that both the receiver and the aerial should be located as far from the engine room or compartment as possible, to minimize interference. Shielded lead-ins and good grounds which are always an advantage in eliminating inductive interference, are especially important in boat installations, where the receiver must be located close to the engine.

Medium and large sized cruisers are designed so that people may live in them for days or weeks. This means that many household appliances will be found on board that are not used in automobiles. The service man must determine the number and types of equipment that can cause interference, and provide for proper filtering (see Chapter XXX) and perhaps shielding of these units in his estimate to the customer, for this will have to be done before noise-free radio reception is made possible.

29-11. Servicing Marine-Radio Installations.—The servicing of ordinary marine-radio installations does not present any special problems which are not common in the servicing of home and auto-radio receivers, and which have not already been covered in this book. The same methods of testing and analyzing the receiver circuits, etc., are employed, and, of course, the same repair methods are used. Perhaps the one special case of trouble which is intimately associated with marine-radio is that of corrosion. Unprotected dissimilar metals in contact with each other are especially subjected to this bugaboo, since any collection of moisture on their surfaces immediately sets up tiny electrolytic cells, and local electric currents are generated. These eat away the metal at the point of contact. This trouble is especially prevalent in salt water locations. Unprotected copper and iron combinations are especially bad in this respect. For this reason,

open-circuits and short-circuits in the wiring and receiver components (especially those which employ very thin copper wire) are very common. All wiping contacts such as those at the tube prongs, at volume controls, etc., must be kept clean and free from corrosion. Loud speaker voice coils should not be allowed to scrape against the pole pieces, for if this happens, the bared copper wire of the coil will soon corrode and stick fast to the iron pole piece. The iron armatures and pole pieces of balanced-armature type speakers are also apt to corrode together.

All connections to batteries must be cleaned and coated with white vaseline periodically to prevent trouble at this source. The water in the batteries must be kept up to proper level—and never yield to the temptation to fill them with the salt water (or even lake water) which you will find everywhere around you!

29-12. General Notes.—It is important that all electric wiring on board ship be installed in an approved manner by a competent licensed electrician. Insurance rates are high on gasoline-powered craft, and insurance companies will not tolerate the haphazard, sloppy wiring that may be found in some home or auto-radio installations. It is essential that the service man provide himself with the rules and regulations governing marine installations, and have the electric wiring installed in the approved fashion. A certificate of approval should be obtained after the wiring is finished.

When installing radio receivers in small boats, the radio service man should explain to the owner the necessity for removing the receiver when the boat is laid up for the winter months. If this is not done, the receiver will usually be found to be inoperative the following season because of a corroded voice coil and pole pieces in the dynamic speaker, ruined tuning coils and speaker field coil, open a-f transformer coils, corroded tuning condenser plates, corroded tube socket contacts, faulty by-pass and filter condensers, etc. If the receiver is removed from the stored craft this trouble will be avoided.

It is difficult for one who has never done this type of work, to appreciate the problems that arise in connection with the installation of radio receivers aboard small boats. But what most service men do not realize is that the majority of the problems

are almost identical with those of auto-radio installations, so that a service man who is experienced in auto-radio work is already well advanced toward mastering the technique of marine radio installation.

REVIEW QUESTIONS

1. What are the general power facilities usually available on Class 1 craft?
2. Repeat Question 1 for Class 2 craft.
3. Repeat Question 1 for Class 3 craft.
4. Repeat Question 1 for Class 4 craft.
5. Repeat Question 1 for Class 5 craft.
6. Repeat Question 1 for Class 6 craft.
7. What precautions are necessary when installing outlets on open decks?
8. What determines the maximum number of receivers that may be installed in a small cruiser?
9. What are the general requirements regarding the selection of a radio receiver suitable for marine purposes?
10. What can you say regarding the receiver requirements with regards to the source of power supply from which the receiver is to operate?
11. How would you obtain a good "ground" on a boat?
12. What kind of an aerial would you install on a cruiser having a single mast?
13. What kind of aerial would you install in a small inboard runabout?
14. Why must ignition interference suppression be used on the type of craft specified in Question 13?
15. What precautions should be observed with regard to the installation of electric wiring carrying relatively high voltages?
16. If the braided shielding used in a marine radio installation corrodes due to the action of the salt air and moisture, what effect will this have on its shielding properties? Explain!

CHAPTER XXX

REDUCING ELECTRICAL INTERFERENCE

(Including Noise-Reducing Antenna Systems)

30-1. **The Interference Problem, Noisy Reception.**—The problem of minimizing or entirely eliminating man-made electrical interference which appears as disturbing crackles, clicks, buzzes, crashes, etc., along with the programs heard from radio receivers is one with which radio service men are now being faced squarely, and with greater frequency, than ever before. The term “interference” is commonly applied to include under one heading, all of the various classes of disturbing noises of this kind. Noisy reception occurring in radio receivers is one of the most serious and troublesome problems which the radio technician is called upon to solve. The problem of eliminating *man-made* interference to radio broadcast reception has become so serious, that several European countries have already taken definite steps to relieve the situation by law if possible. For instance, in France, under date of April 1, 1934, a ministerial decree (a law) which defines radio interference, lists all the common sources of interference and makes it obligatory for *the owner of the interfering equipment* to eliminate the interference (under penalty of the law) was put into effect. Should an interfering electrical device used in an apartment tend to create disturbances in radio receivers in the surrounding vicinity, for instance, the owners of the receivers in which the interference is being received have the right to complain to the Ministry of Posts, Telegraphs, and Telephones. The owner is notified immediately by the latter and given a period of one week in which to eliminate all electrical disturbances caused by his device—at *his own expense*. In fact, since

the early part of 1935, the installer of a new device, as well as the manufacturer who provides it, is held responsible for the elimination of any interference which it creates. In Germany, England and Canada, official government recognition and assistance has also been given in this problem. In the United States, no such general laws exist (except in a few local communities, particularly in the middle west and on the Pacific coast) and the government has not interested itself in the problem. The RMA has formed a Committee on Interference which will work in cooperation with others interested in electrical and radio organizations to study and classify the various general sources of this interference, investigate the efficacy of the various methods of eliminating it and endeavor to enlist the help of all concerned in eliminating such sources of interference. Just how much success the last mentioned step will meet with in the absence of any compelling laws remains to be seen, for anyone who has had considerable experience in attempting to persuade owners of interfering devices to equip them with effective interference-suppression devices (which cost money) knows that a good majority of such attempts are met with the proverbial "cold shoulder". People are not generally willing to comply with such requests when it is going to cost them money, in fact, it is often exceedingly difficult to convince them at all that some common electrical appliances in their homes are causing interference in the radio sets of strangers living in the same apartment house—much less a few blocks away.

30-2. Position of the Radio Service Man.—In the United States at least, when a dealer sells a radio set and installs it, it is up to him to provide noise-free reception. The customer usually expects it, and the sale of the receiver often depends on it. When a service man is called in on a complaint of noisy reception due to interference, it is up to him to hunt down the cause of the interference and apply the proper remedy to eliminate it. The remedy must be as effective and inexpensive as possible, for his customer must pay the bill—even though an electrical device belonging to a neighbor is causing the trouble.

In order that service men may eliminate man-made interference as effectively, directly and inexpensively as possible, they

must be thoroughly acquainted with the various causes of interference, the common devices which produce it, the various ways in which it may reach the receiver, the methods of testing to find out definitely how it is reaching the receiver and the most effective remedies to apply to minimize or eliminate it under any installation conditions which may be encountered. It must be realized at the start that interference elimination often is a very difficult task. It is a problem that cannot be solved by the wave of a magician's wand, the rubbing of an Aladdin's lamp, or the indiscriminate purchase and installation of all sorts of "gadgets" which are advertised as cure-alls for interference and which are applied to filter "this and that." In other words, as is the case with so many other problems in radio servicing, the service man must possess a thorough knowledge of the entire subject, use good sense in applying it, and be level headed throughout the job when tackling interference problems.

The set analyzer is almost useless for this sort of work, excepting in some cases where the interference is caused by one of the parts in the receiver itself, in which case, the set analyzer may help to locate the offending part. As a result of considerable experimental work on this problem, it is now possible to follow definite plans of attack in order to minimize interference, and in most cases, to actually identify the type of device which is producing the interference simply by listening to the character of the interference noise as evidenced in the loud speaker of the radio receiver. The service man should be thoroughly acquainted with the various methods which have been developed to accomplish this quickly and effectively.

30-3. Increasing Interference Troubles a Result of Receiver Improvement.—One very interesting fact concerning the entire noise problem, though it may seem ambiguous at first thought, is that the increasing importance and seriousness of the noise problem is due fundamentally to the many improvements which have been made in receivers during the past few years. Even simple sets of today are many times more sensitive than the most pretentious "super-blooperdynes" of a few years ago. They are so sensitive, that thousands of them will be found installed without benefit of any honest-to-goodness aerial. The owners, us-

ually at the short-sighted advice of the dealers who sold them the sets and stressed the fact that they were so "good" and so sensitive that they would work "without an aerial" (thus making the sales easier for themselves and eliminating the need for installing aerials free with the set installations) simply took the sets home and installed them by plugging into the power line and throwing a short piece of wire out of the window, placing it behind the picture moulding, under a rug, or in some other easily accessible location. Since such locations are low and usually within the strong field of man-made electrical interferences, these installations are often found to be extremely noisy. Also, since the signal pickup with such aerials is small, the receiver must be operated at almost full sensitivity most of the time, thereby greatly amplifying the interference impulses as well as the signal.

The widespread popularization of short wave and all-wave receivers has also had its effect. Since short-wave programs usually originate at distant points and the short-wave signals reach the listener in greatly weakened condition, short-wave and all-wave receivers are built more sensitive than the standard broadcast band sets. The greater sensitivity at which they must be operated in order to pick up these weak signals is the main reason why more interference is experienced on the short wave bands than on the standard broadcast band. Also, the interference created by most electrical appliances and automobile ignition systems is stronger in the short-wave region and therefore is more troublesome in short-wave receivers. Since the sale of short-wave receivers is often impeded by noisy receiving conditions, the problem of interference elimination becomes a matter of dollars and cents to both the radio set manufacturer and the dealer.

Finally, the improvement in the high-frequency audio response of receivers has had its effect. It is generally well known that a great deal of the noise (both "static" and man-made electrical interference) produces audio disturbances in the neighborhood of 4,000 cycles and higher in the loud speaker. Consequently, receivers with good high-frequency response reproduce these noises with greater intensity than do those having poorer

high-frequency response. Of course, the usual "tone control" may be used to suppress the high-frequency response of the receiver and thus reduce the noise, but the quality of reproduction also suffers if this is done.

30-4. How "Interference" Radiations are Produced.—The fundamental principles of radio transmission involve the setting up of electric waves at the antenna of the broadcast station. These are radiated through space to the antenna of the receiving sets in which they induce modulated high-frequency currents which are amplified and rectified (detected) by the radio receiver so that a more or less faithful reproduction of the original voice-frequency sound waves are delivered from the loud speaker. Now any electrical circuit which involves a spark or arc also sets up radio-frequency waves or radiations which are propagated into space; in fact, this is the principle upon which the operation of the now outmoded spark transmitters operated. How far they travel, and how strong they are depends upon the energy involved in the sparking circuit and to a large extent, upon the circuit itself. Most of these disturbances which cause noise in radio receivers are of relatively small power at their source, compared to the power radiated from a broadcast station. However, since their sources are very much nearer to the receiver than the broadcast station is, they often reach the receiving equipment with an intensity comparable to that of the broadcast signals and cause annoying interference. The one main exception to this lies in the case of disturbances due to lightning flashes. A single lightning flash puts out far more radiated power than all the broadcast stations in the world combined, so even though it takes place a great many miles away from the radio receiver, its disturbance may reach the receiver with sufficient intensity to cause interference—especially in sensitive receivers.

Disturbing radiations, then, may be set up by practically any electrical circuit which involves a make and break of contact. Lightning discharges, atmospheric discharges not quite of lightning intensity, all switches, thermostat controls, motor commutators, automobile and oil burner ignition systems, X-ray, violet-ray and diathermy apparatus, and any other devices which involve the making or breaking of an electric circuit (even if

the making and breaking is regular and continuous) are potential sources of radio interference, *provided the amplification of the radio receiver is sufficient to make these disturbances heard at an annoying noise level along with the desired program.* Also, any disturbances may be carried along wires or other conductors and re-radiated by them for some distance. Finally, if the radiating circuit is untuned (as it usually is), the radiations will cover a wide frequency range as contrasted to a broadcasting station, which radiates its signal energy on practically a single frequency (or at least a very narrow band of frequencies).

We will now study these various sources of interference systematically and in detail so that we may be thoroughly acquainted with the exact types of interference they set up and how it is likely to be propagated to the radio receiving equipment. When this is known, the problem of eliminating their interference can be attacked more directly and intelligently.

30-5. General Types of Interference.—Generally speaking, *interference* (so far as it relates to broadcast reception) includes any sound emitted from the loud speaker, that does not originate at the transmitter but detracts from the full enjoyment of the broadcast program. Interference may be classified broadly into 4 types, according to the origin of the electrical disturbances which cause it. They are:

- (1) Interference caused by natural "static" (atmospheric disturbances).
- (2) Inter-station interference.
- (3) Interference caused by some part in the receiving equipment.
- (4) Interference caused by external electrical devices controlled by man (commonly termed *man-made* interference).

The nature of these types of interference will now be considered in the foregoing order.

30-6. Natural Static.—Clouds become electrically charged by the friction set up between the droplets of their water vapor and the surrounding air. Considerable electric potentials may thus be built up. When the potential difference between two such

banks of charged clouds or between one cloud bank and the earth becomes sufficiently high, it breaks down the insulating qualities of the intervening air and an electric discharge takes place in the form of the familiar zig-zag "lightning" flash or spark. This action is illustrated in Fig. 30-1. Since the two cloud banks, or the one cloud bank and the earth, really form two plates of a large condenser with the intervening air as the dielectric, the dis-

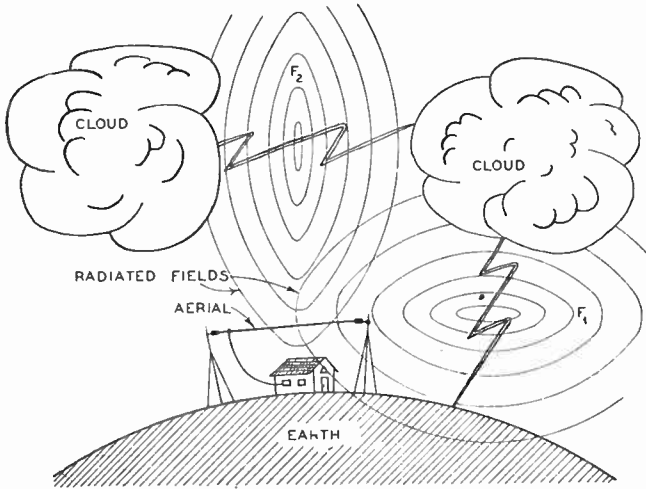

FIG. 30-1.—How the electromagnetic fields produced by lightning discharges (or other atmospheric discharges) between charged clouds (and between charged clouds and the earth) are radiated out into space, where they may induce interference potentials in the antenna systems of radio receivers located even many miles away. If these radiations reach the antennas with sufficient strength, interference known as natural "static" results.

charge is really that of a condenser and is of the usual oscillating form associated with discharges of this nature. Since these lightning discharges really constitute the flow of powerful electric currents, they produce electromagnetic radiations, F_1 and F_2 , which are exactly of the same nature as those of radio signals from broadcast stations and spread out in practically all directions. It is not necessary that an actual lightning flash or discharge take place. Intermittent leakage currents which flow between charged clouds or between clouds and the earth also cause "static" disturbances. In general, lightning storms, "north-

ern lights," heat-lightning, dust storms, rain storms, etc., may be the cause of particularly annoying electrical interference, even at considerable distances.

A receiving aerial located in the path of these radiations will have corresponding voltages induced in it, and the discharges will be heard as a series of crashes and individual impulses. The intensity of the disturbance which reaches the receiving antennas on any particular locality depends on whether the nearest flash of lightning is taking place near the aerial, a few hundred miles away, or a few thousand miles away. It is reasonable to suppose that thunderstorms and atmospheric electrical discharges are occurring somewhere in the world at all times, and even though a single flash radiates far more power than all the broadcasting stations in the world combined, the extreme distance reduces their intensity so that they are not all disturbing in the average radio receiver. It is only when the disturbances are particularly severe, or within a reasonable distance from the receiving equipment, that they are annoying.

The important point about natural static is, that since it is caused by disturbances which cover a broad frequency range and are of exactly the same nature as the broadcast radio signals, it cannot be tuned out or suppressed without reducing the strength of the desired signals also. Regardless of the fact that many so-called "static eliminators" or "suppressors" are offered for sale for the elimination or reduction of atmospheric static, the truth is that all of them reduce the static effects simply by reducing the sensitivity of the receiver, so that both the desired *signals* and *static* are heard more weakly. Practically the same result could be obtained at no cost by simply turning down the volume control of the receiver. It is the opinion of responsible investigators that natural atmospheric disturbances cannot be *eliminated* successfully, although under some circumstances they can be *reduced* somewhat in intensity. A few static eliminators which do *reduce* the effect of atmospheric static have been designed, but these devices are so intricate, elaborate and costly as to prohibit their general use in home receivers.

Although the intensity of static is much less on the shorter waves (higher frequencies) than it is on the longer waves, it is

often a source of very annoying noises on the standard broadcast bands. Since this class of interference may be said to be beyond man's immediate control there is little that the radio service man can do about it. Fortunately it is not really troublesome everywhere, or at all times. In locations where it is very strong, it is best to educate the owners of radio receivers to reduce the sensitivity of their receivers by operating them with the volume control down as much as is consistent with audible reception; to place the tone control in the "bass" position when static is severe, so as to reduce the high-note response of the receiver; to have all interference other than natural static cleared up if possible, so that the total noise level will be reduced, and to maintain all antenna and receiver connections electrically and mechanically secure to prevent them from causing additional noises.

30-7. **Interstation Interference.**—Interstation interference is usually evidenced by high-pitched "peanut-stand" heterodyne whistles which may be either steady or slightly varying in pitch. It is caused by heterodyning of the carrier waves of stations occupying adjacent frequency channels, and sometimes by the *harmonics* of stations which broadcast at fundamental carrier frequencies which are quite widely separated. In superheterodynes, "image interference" caused by the simultaneous reception of two stations whose carrier frequencies differ by approximately twice the i-f of the receiver (see Arts. 23-13 to 23-16) may be heard if the pre-selector is not able to eliminate the image-frequency signal, and if the resultant beat note between the two signals falls within the range of the audio amplifying and reproducing equipment in the receiver. By suitable pre-selector design, this trouble has been largely eliminated in modern receivers, though it is often encountered in many of the older sets. In such receivers, the service man can eliminate the whistle effectively by following the image-interference elimination suggestions outlined in Art. 23-16, or by connecting to the receiver a suitable low-pass filter adjusted to have a cut-off point just below the heterodyne (whistle) frequency. An ordinary "tone-control" arrangement connected in the audio amplifier and adjusted to the proper point is satisfactory. This, of course im-

pairs the reproduction of all the frequencies above this cut-off point of the receiver, but, since half a loaf is better than none, the owner of the receiver will undoubtedly be satisfied to forego the pleasure of hearing a few high notes if the annoying heterodyne whistle can be eliminated simply and inexpensively.

30-8. Interference Originating in the Receiver.—Interference may be due to causes within the receiver itself. Loose connections, leaky condensers, noisy resistors, noisy a-f transformer windings, high-voltage "sparkover" in condensers or transformer windings, dirty or peeling tuning condenser plates, dirty or corroded gang tuning condenser rotor wiping contacts, scraping speaker voice coil, broken speaker spider, loose cone apex, faulty or loose line fuses, a defective *B* battery, run-down batteries, etc., may produce scratches, rattles, buzzes, etc., in the receiver. Naturally, interference due to any of these causes can be eliminated by the service man—even though it is often a very tedious job to track the trouble to its source. The methods of locating and repairing a large proportion of these faults have already been explained fully in Chapters XXIII, XXVI and other parts of this text. However, several additional common troubles which may cause objectionable noises will be discussed here.

If the preliminary tests which will be outlined in Art. 30-14 indicate definitely that the noise is originating in some part of the receiver itself, the following possibilities (as well as those mentioned in the previous paragraph) should be checked, and the proper steps taken to eliminate any of the troubles which may be found. Generally, tubes are the most frequent offenders! Each one should be tapped lightly on the top with the finger while the receiver is operating. If the tube contains loose elements, a loud noise will be heard in the loud speaker at once, and the tube should be replaced. A quick visual inspection and jarring the set may reveal a loose connection and will not be amiss. Should this procedure fail to disclose the cause, the following systematic mechanical tests should be made.

The first r-f tube should be removed after the set has been placed in operating condition. Should the noise cease, then the trouble is caused by some defect in that stage and an inspection

of all parts, circuits, and connections of the first stage should be made immediately. If the noise is heard with the tube removed, the second r-f or the "mixer" tube should be withdrawn and the same tests carried out in that stage. In this way, employing the same procedure, the faulty stage may often be localized and the cause of the trouble ascertained and eliminated.

The detector plate by-pass condenser is a frequent cause of noise. This may be checked easily by disconnecting the unit

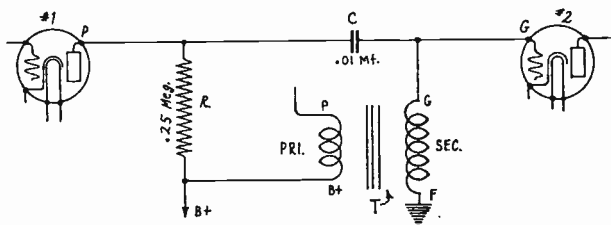

FIG. 30-1A.—Testing an audio transformer primary for noise by substituting resistance plate coupling for its primary winding.

from the circuit *while the set is operating*. Although these condensers may check satisfactorily when a continuity or ohm-meter test is applied, they may break down and become leaky when the high voltage is applied to them in the circuit. In receivers employing power or grid-bias detection, the cathode by-pass condenser may often be found to be at fault. A leaky condition of this unit will produce a puzzling and annoying irregular frying or sizzling noise. In some of the older receivers, where glass tubular grid leaks are used in grid leak-condenser detection, this unit has been found to be a frequent source of noisy reception.

The most common cause for noisy reception in an audio amplifier lies in the primary of one of the audio transformers. The best test for a noisy primary winding is that of substituting another transformer for the one in use, or to disconnect the "plate" terminal of the *primary* of the suspected one from the circuit entirely and substitute a plate resistance, *R*, and a blocking condenser, *C*, in its place, connected as shown in Fig. 30-1A. This condition will sometimes evidence itself even when the de-

ductor or first audio tube is removed from its socket. Noisy plate circuit resistors (where resistance-capacity coupling is used) are also common, and may be found by the substitution test.

In cases where the noisy condition continues after all tubes but the last audio have been withdrawn, it is probable that the power pack or the reproducer is at fault. In the power pack there are several units which may be responsible for noisy reception. Most common is a voltage-divider resistor which "sparks" across. These resistors are usually covered with an enamel coating to make them moisture proof. Imperfections in the enamel, or impurities of a metallic nature, will produce sparking at that point. This condition may be noted by a visual examination (preferably in a darkened room), and the remedy is replacement. At times, a power transformer will be the source of interference. Many good power transformers employ an electrostatic shield between the primary and the secondary windings to prevent the transfer of any electrical disturbances that might be carried in by the line. It has been found that arcing takes place in some cases between the primary and the shield due to breakdown of the insulation. This will produce an annoying interference that is exceedingly difficult to trace. When this condition is found to exist, a new transformer must be installed.

A number of dynamic speakers used on some of the older broadcast receivers employed copper tinsel cord to make connection to the voice coil. This wire or cord, similar to that on earphones and magnetic reproducers, has great flexibility, but after some time becomes worn and frayed, resulting in noise. The complaint of intermittent reception may often accompany noise of this nature. A repair may be effected easily only by replacing the tinsel cord.

The "Off-On" switch and fuse mounting block in radio receivers are frequent offenders. Contacts become worn or corroded and will upon vibration set up a disturbing "crackle". If the switch or fuse block is at fault, a flickering or lowering of the pilot lights will often be noticed.

The presence of dust, peelings of the plating, burrs, or small foreign particles between the plates of the variable tuning con-

condensers will also set up noise (especially when the station selector is rotated through its range), since they produce high-resistance intermittent contacts between the rotor and stator plates. An ordinary pipe cleaner may be used to advantage for removing the foreign matter in such cases, or it may be burned out by the arrangement illustrated in Fig. 26-7. The rotor contacts of the variable condensers also become corroded and cause a scraping sound in the reproducer as the receiver is tuned. Although this condition may be corrected by cleaning the rotor friction contacts, the best repair is effected by "pigtailling" the condenser gang rotor shaft to the chassis of the receiver.

Any corroded or poorly soldered joints will cause unnecessary and undesirable noise. One source of this trouble, usually overlooked by many service men, is in corroded or dirty tube socket contacts. When engaged in the task of locating noise originating within the receiver itself, it is the best policy to clean all contacts thoroughly and to resolder every suspicious soldered connection to eliminate any possibility of "rosin joints" or any other trouble on this score. Many receivers come out of the factory with one or two joints poorly soldered—or not even soldered at all!

This type of noise is often due to poor set design or faulty components, but even the best receiver is apt to be noisy if it is sufficiently sensitive. Tube "hiss" is often a limiting factor to the amount of receiver sensitivity which can be employed satisfactorily. Tube hiss in superheterodynes can be reduced considerably by the proper mixing or modulating of the oscillator voltage with the signal voltage in the first detector stage. If the ratio between these two voltages is not correct, noise current will be generated in the mixing tube. This may be amplified to considerable intensity after it has passed through the many i-f stages of the receiver. Tube noise can also be reduced further by careful consideration of the voltages and biases on the r-f and i-f amplifier stages so that the tubes will always be operating under the most favorable conditions.

The method of testing a receiver installation to determine whether the interference is originating in the set itself or is coming from some external source will be discussed in Art. 30-14.

30-9. **Man-Made Interference.**—We now come to the interference which is set up by the many man-made electrical devices. Almost every piece of electrical machinery and every electrical device is a potential producer of electrical disturbances—especially if it is faulty or in need of attention. The majority include a high-frequency component which is often modulated by low-frequency disturbances falling within the audible range covered by the audio amplifier and loud speaker of the radio receiver. These electrical radiations may be picked up by some part of the antenna system, or conveyed directly to the set by the power supply line—most often by a combination of both.

Man-made interference is especially common and serious in congested city districts where many electrical appliances and devices are operated from the same power supply lines as are the electric radio receivers, and often within comparatively short distances of both the receivers and the receiving antennas. Even in outlying rural communities, this sort of interference is not absent, for it is not only produced by any electric appliances employed in the immediate vicinity, but it may be brought in along the electric light and telephone lines which are usually strung overhead on poles. It is not uncommon for both man-made and atmospheric disturbances to be conducted by such lines for many miles and then be either conducted directly into the power supply circuits of radio receivers fed from them, or re-radiated to their antenna systems.

Although interference estimates depend entirely upon the local conditions which exist, i.e., whether it is a congested city, a rural town, a district subject to severe atmospheric disturbances, etc., it has been estimated that on the average about 15 per cent of all cases of interference can be traced to natural static and other untraceable sources, about 20 per cent to faults in the receiving installation, and the remaining 65 per cent to man-made interference caused by household electrical appliances, industrial electrical apparatus, and generating, transmission and distribution equipment. This shows that man-made interference is the most common, and incidentally presents the most serious and largest problem of all, as its origin is often difficult to trace and, even after it is finally located it may not be possible or

desirable to eliminate it at the source. In such cases, attempts must be made to minimize it at the receiving equipment. It should be realized at the start that there are so many ramifications to the problem of man-made interference suppression that no study of it, or actual attempts to minimize it, will make much progress unless it is *systematic* and proceeds with a clear understanding of the nature and causes of the interference and the many ways in which it can be propagated. Erratic "try-this" and "try-that" methods will only consume valuable time and often fail to cure the trouble at all.

30-10. How Man-Made Interference is Generated and Transmitted.—Man-made interference is generated by the sudden interruptions or variations in the operating current of many electrical devices. These generate radio-frequency disturbances. Some devices produce (in the radio receiver) noise of a uniform character, such as humming, buzzing, whining, whirring, etc. Some produce *impulse-type* noises such as rattles, clicks, crashes, etc., (see Art. 30-16). In the former cases, the periodic changes of operating current have a fundamental frequency, usually well within the audio-frequency range. The high-frequency disturbances give rise, in general, to a complex variation of potential in the space surrounding the devices, and may be either radiated or conducted to the radio receiving equipment.

Investigation has shown that the disturbances which they set up in the receiving equipment may usually be regarded as consisting of an infinite series of component radio-frequency disturbing e.m.f.'s distributed over the whole range of radio frequencies. These components combine with the broadcast signal carrier either in the antenna circuit of the radio receiver (if the disturbance is picked up by the antenna) or in the plate and screen circuits of the receiver tubes (if the interference is borne by the powerline), and when passed through the detector give rise to an infinite series of beat notes. Of these beat notes, those which are audible and within the reproduction band of the audio apparatus in the receiver appear as noise in the loud speaker. When the broadcast carrier is modulated by a program, the modulations due to noise exercise an interfering effect upon the program.

Let us see what happens in the case of a d-c motor. Consider a simple d-c motor connected to a d-c line as shown in Fig. 30-2. The motor is equipped with a commutator and one pair of brushes, which are connected to the line. The shaft of the motor may drive any number of devices, but these have no relation to our problem. Now it is clear that all the electrical power absorbed by the motor is used up in overcoming the various losses in the motor and in the device that the motor turns over; and it is just as evident that all this electrical power must

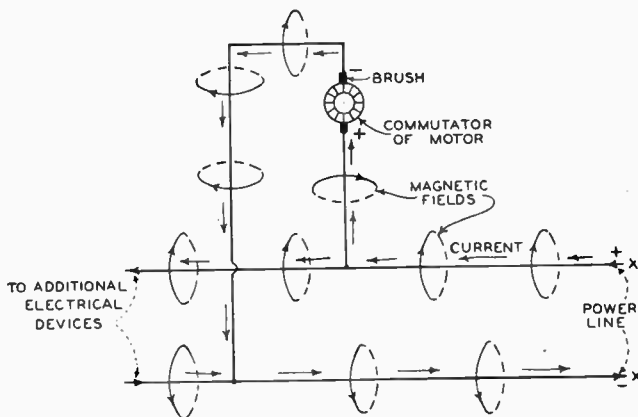

FIG. 30-2.—The magnetic field surrounding all of the wires comprising the circuit to which a d-c (or a-c “universal”) type of motor is connected. Since the current flowing is not steady and smooth, these magnetic fields also vary from instant to instant.

come from the line. The electrical power absorbed by the motor is to equal $E \times I$, where E is the steady voltage of the line and I is the current. It is the current I which flows through the lower brush into one or two segments of the commutator of the armature, then through the armature coils, and out of the other end of the armature windings via the commutator segment and top brush. Since the armature is revolving, there are ripples in the wave form of this current, precisely as was shown in the upper part of Fig. 27-37 for a d-c generator. (A cathode-ray oscilloscope can be used to show this condition visually.) The rapid variations in the current are caused by the action of the revolving commutator segments making and breaking their contact with the brushes. They act like a series of rapidly operating switches!

If, for any reason at all, there should be sparking between the brushes and the commutator (every d-c motor has some sparking), the current I , drawn by the motor, will vary even more rapidly and erratically from instant to instant, depending upon the number of segments, the number of brushes, the speed of the armature, the amount of sparking, the cleanliness of the commutator segments and the brushes, and the power consumed by the motor. It is important to visualize this state of affairs, for it is upon this foundation that the entire understanding of interference production by electrical devices rests.

The current which flows through the power line to the motor (even if it is d-c) has variations in it. The nature of these variations is not simple, by any means. The sparking at the brushes

FIG. 30-4. — Equivalent circuit showing the analogy of a sparking motor (or any other device) and its circuit to a "spark" type radio transmitter.

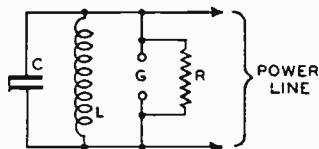

gives rise to high-frequency variations of the line current. These are in the form of rapid impulses having no one particular frequency. The equivalent electrical circuit of the sparking d-c or "universal" motor is shown in Fig. 30-3. Coil L represents the inductance of the armature and the field winding of the motor; C , the distributed capacity of the armature and field windings (which may be quite large); G , the spark gap represented by the sparking at the brushes; and R , the resistance of the gap.

This circuit is an oscillatory circuit if the power line has low leakage (which is usually the case). Oscillations are set up in the line and in the inductance and capacity. These oscillations are radiated into space by the coil if it is not thoroughly shielded by the frame of the motor, and by the line if it is not enclosed in a grounded conduit. If the shield and grounding is good, then the noise is conducted directly along the power line and terminates at the various outlets connected to that same line. Any radio receiver, then, that is plugged into this same line will have this interference conducted into it—resulting in "noise"

In many instances the line terminates at a junction box into which a number of other circuits also run. The close proximity

of these circuits to the line carrying the noise results in an inductive transfer of noise from the original to these other lines, so that these lines now convey the noise to various outlets. A radio receiver plugged into an outlet connected to any one of these lines will receive and amplify these interference impulses.

An important consideration is the fact that the varying exciting current is an impulse; consequently, the noise current has no definite frequency. This means that the circuits connected to the original line and those coupled to the line are excited by impulses, and oscillations are built up, the frequency of these oscillations depending upon the natural frequency of the coupled lines or circuits.

The sweeping conclusion, then, is that a sparking motor will cause the line to which it is connected, to become a source of interference. It may act as a direct *conductor* of interference to any radio receiver plugged into it (or any of its branches), or it may act as a *radiating system* radiating interference fields close to the ground where radio-frequency noise voltages that are noise-modulated abound. In this latter role, it becomes (with all its branches) a transmitting antenna network capable of radiating the interference impulses (sometimes at considerable distance from the original source of interference) either to other adjacent power circuits, or to antenna system of the receiver directly. The "adjacent" power circuits may in turn re-radiate the interference to the antenna systems of radio receivers. In the usual noisy condition, all three methods of interference transmission often occur. Noise voltages induced in neighboring lines cause noise currents to flow in them. These are conducted along the line to the various outlets. Noise will be heard in radio receivers connected to any of these outlets. These lines may in turn re-radiate noises of some definite frequency, (depending upon the natural frequency of the lines) to the nearby antenna system of a radio receiver.

This means that some noises are "tunable" and some are not. Those that are tunable are generally the result of radiation; those that are not are the result of direct conduction. It can be seen, therefore, that the paths taken by the noise impulses are very complex, and it is possible for very annoying in-

terference to manifest itself at points far removed from the original source.

An attempt to show this condition has been made in Fig. 30-4. The various branch circuits of the power line feeding the various lighting and other outlets in a building have been drawn heavy. An electric fan motor which is setting up interference, is being fed from this line at the upper left. A radio receiver is installed in a room at the lower right, and is fed from the aerial on the

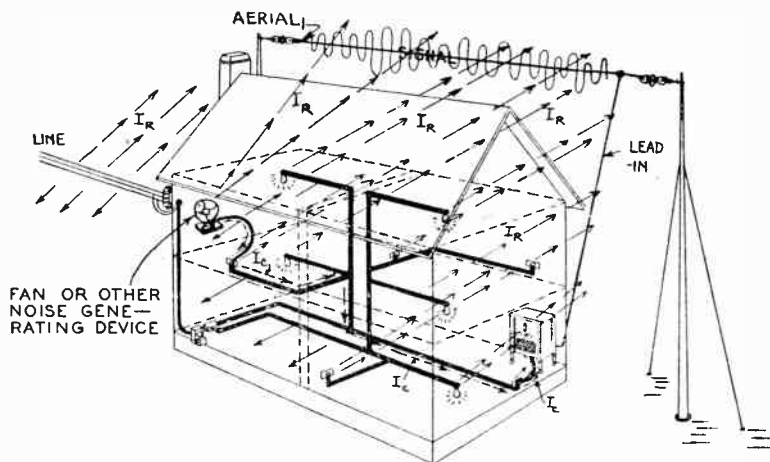

FIG. 30-4.—How an electrical device located in one part of a building can produce electrical interference part of which (I_c) is conducted directly through the electric light wiring to radio receivers operating from the same lighting line; the other part (I_R) may be radiated either directly from the device or from the electric light circuit wiring in the building to the aerial, lead-in and ground wires of the receiver, inducing interference voltages in them. These are heard in the radio receiver as disturbing noises of a certain character depending upon the nature of the interfering device (see Art. 30-16). The path by which the interference may be conducted to the radio receiver by the power line wiring is shown by the dotted-line arrows labeled I_c . The interference radiated from the incoming overhead line, and the various branch circuits to the aerial and lead-in wires, (and the line cord of the receiver) is represented by the solid-line arrows labeled I_R . A “skeleton view” of this kind makes one realize how very many circuits, ordinarily hidden from view and therefore unthought of, may participate in conducting, radiating and re-radiating interfer-

ence within a building, or even from one building to another.

30-11. Interference from Devices Employing Vibrators.

—Current interruptions caused by electrical devices which employ vibrators or interrupters generate interference in a fashion similar to that already considered for sparking motors. The circuit of a simple interrupter is shown in Fig. 30-5. It will be seen that the interrupter contacts interrupt the current from the line at a definite frequency depending upon the frequency of vibration of the interrupter. The interrupted current generates a varying magnetic field which can induce a voltage in any coupled circuit by simple electromagnetic induction, (transformer action). Since sparking also occurs at the contacts, oscillatory currents

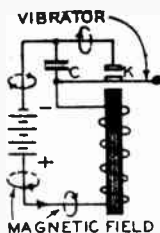

FIG. 30-5.—Schematic circuit diagram of a simple vibrator. Condenser *C* is used to reduce sparking at the make-and-break contacts *K*. The magnetic field surrounding the wires is shown by the loops.

will be generated if the resistance of the circuits is low enough, and interference impulses will be conducted and radiated as previously described.

In general, it may be stated that any electrical device (such as a motor or a vibrator device) that draws a varying or interrupted current from a line, or supplies a rapidly changing current to a line (such as a generator), is a potential cause of interference. Alternating-current motors and generators usually do

not have commutator segments, and for that reason do not radiate much noise. Some small a-c motors of the repulsion-starting—induction-running type (these are used a great deal on washing machines, electric refrigerators, etc.) have a commutator for starting purposes only, and they generate interference only until they build up to normal running speed (if they are operating properly and are not in need of repair).

30-12. Power Line Interference.—A study of the table of possible sources of interference presented in Art. 30-16 will show that leaky power insulators, pole transformers, trolley switches, etc. cause interference. Now it is beyond the jurisdic-

tion of service men to attempt to eliminate the noise from these sources. In fact, the service man is not allowed to apply noise-reduction devices to any interference-creating unit unless the consent of the owner of the device is obtained. In instances where noise is traced to equipment of public utility companies or to railroads, the service man should report his findings to the proper official of the company who may take the necessary steps to eliminate the trouble. He should not attempt to eliminate such cases of interference himself, for in doing so he may cause severe trouble on the power line and may also expose himself to dangerous voltages. No matter how expert a radio service man is in his own line, he should refrain from tampering with power lines.

During the past few years public utility companies have spent considerable time and money in eliminating faulty equipment that cause interference in radio receivers in the vicinity. In many cases, these companies maintain a staff of engineers for the express purpose of tracking down noise and eliminating the cause. Leaky insulators and power transformers are costly to the company, and it is usually more than willing to cooperate with the community it serves by eliminating all such faulty units.

30-13. The Signal-to-Noise Ratio.—It is important at this time to clearly bring out the significance of the term *signal-to-noise ratio*. The *absolute* value of the noise voltage means very little unless the intensity of the signal heard through the noise is specified at the same time. The reason for this is that the limit of the gain which can actually be employed in a receiver under actual installation conditions, is a function of the permissible noise level. Stated in another manner, the weakest signal that can be fed into an amplifier and intelligibly reproduced depends upon the fixed noise level. The greater the noise, the greater must be the signal, and vice versa, for the same degree of intelligibility.

The ratio of the signal voltage to the noise voltage is a convenient measure of the "clearness of reception." A high signal-to-noise ratio means that the signal voltage is much higher than the noise voltage; a low signal-to-noise ratio means that the signal is weak compared to the noise. Suppose, for example, that the signal-to-noise ratio is 10 and that the noise voltage

is 80 millivolts. The signal voltage is, then, 80×10 , or 800 millivolts. The object of most of the practical expedients used to minimize interference is to raise the signal-to-noise ratio by *decreasing the noise voltage*, although it is practical to *increase the signal voltage* in many cases by employing a *longer aerial*, or one located in a more favorable zone of greater signal strength. This will be discussed in greater detail in Art. 30-38.

30-14. Determining the Path by which Interference is Reaching the Receiver.—Now that we have some idea of what causes interference and how it may reach the receiving equipment, we are prepared to proceed to study the methods to follow in locating and suppressing or eliminating interference in actual practice. When the radio service man is called in on a complaint of “noisy reception”, the fact that there *is* interference is all he knows about the situation. The rest is entirely up to him. The customer is interested merely in having the interference eliminated—at low cost.

There are four possible ways for interference to enter a receiver; by the receiver wiring itself picking up either the direct radiated (or re-radiated) interference, via the power supply line, through the antenna system, or by some combination of these. Since the steps which are finally taken to minimize the interference depend, among other things, upon the manner in which it enters the receiver, the first step the service man should take is to ascertain definitely through which path (or paths) it is reaching the receiver circuits.

(1) The first test is simple: Tune the receiver to a point between the programs of two stations, and increase the volume control setting to maximum. Usually, the noise will be very loud when this is done. Now remove the lead-in wire from the *Ant* post of the receiver, and keep it several feet away from the set. This prevents any noise from reaching the receiver by way of the *aerial* and *lead-in* circuit. Listen to the noise. If it has *not* decreased materially, the aerial and lead-in wires may be removed from suspicion. If it *has* decreased noticeably, the aerial and lead-in are partly to blame for the noise. If it is hardly heard at all, they are entirely to blame.

If there was no decrease, or a noticeable decrease, short-cir-

cuit the *Ant.* and *Gnd.* posts of the set with a *very short* piece of wire and listen again. The reduction of noise should be still more appreciable. The short-circuiting of these posts is necessary to prevent the leads from the posts to the coils and condensers in the set from acting as a short aerial. The short-circuit reduces this antenna-circuit impedance to such a small value that the voltage developed across the antenna coil is small.

Now the noise may or may not drop to zero. If it does, then the aerial or lead-in is picking it up, and means (to be described later) must be taken to minimize this pickup; if the noise does not drop to zero, so that a residual noise remains, then the test must be continued to determine the other point or points through which it is entering the receiver.

Before continuing the test, it is necessary to listen carefully to the noise with the aerial and lead-in disconnected and the *Ant.-Gnd.* posts short-circuited, and compare the *character* of the noise heard when the aerial is connected, to the character heard when it is disconnected. By the term "character" is meant the *characteristic sound* of the noise, i.e., whether it is a "whine" or a "crackle", whether it is low-pitched or high-pitched, etc. This is necessary in order to ascertain definitely whether or not the residual noise heard after the aerial and lead-in are disconnected and the *Ant.-Gnd.* posts are short-circuited is the same as that with the aerial and lead-in connected and the short-circuit removed. If it is the same, then the noise is entering the receiver through the power line or the chassis itself. (A list of the characteristic sounds originating from different types of interference-generating devices will be presented in Art. 30-16).

(2) Let us assume, now, that the residual noise is still loud enough to be objectionable after the tests of the previous paragraphs have been made, or that disconnection of the lead-in wire from the set does not decrease the noise appreciably. The second step of the test, then, is to disconnect the ground lead from the receiver; the aerial and lead-in may or may not be attached, (preferably not). Removal of the ground lead will eliminate the possibility that the "ground" (which is part of the antenna system) is conveying noise to the receiver. If, after removing the ground wire, the noise is still objectionable, short-cir-

cuit the *Ant.* and *Gnd.* posts of the receiver with a *very short* length of wire and note the noise level. A material reduction of the noise means that the ground is "noisy," and means must be taken to find a good ground—a ground that is free from noise.

These two tests (tests for a noisy aerial and ground) will localize the entrance of the noise to some extent. In many cases, a large part of the noise will be eliminated by removing the aerial and ground leads, while in others the reduction of noise will be only slight. In either case, further tests must be made, as the only other two possible entrances are the power line and the receiver chassis.

Modern receiver design is such that it is difficult to isolate the chassis from the power line and at the same time have the receiver operate from the line to which it normally connects. The idea in all of these tests is to make the test conditions such that the receiver is operating under normal conditions—with its normal aerial, lead-in and power supply line. For this reason, the tests become useless when an attempt is made to try the receiver elsewhere in the same vicinity. Noise conditions are often such that one power line may be noisy and another in the same building may be quiet; one receiver installation will pick up noise and another will not. Therefore, the set must be tested in the exact room in which it is to be used and under the identical conditions under which it will work normally.

Two methods of attack then present themselves. The first method is to get a definite idea of the noise level of the receiver by comparing it with another thoroughly shielded receiver under identical conditions; that is, in the same room, with the same antenna system and using the same line plug as the customer's receiver. It is important that the receivers be adjusted for the *same* degree of sensitivity, not merely set at the *maximum* degree of sensitivity on each set. Naturally if the noise levels of various receivers are measured at their maximum sensitivity, the least sensitive receiver will appear to be the quietest, when it is possible that if both receivers were measured at the same sensitivity, the most sensitive receiver might actually have the lowest noise level.

The thing to do is to tune in a distant station on the two

receivers which are to be compared for noise level. When both sets are adjusted to provide the same volume, on the same station, it is apparent that they are adjusted to the same approximate sensitivity. Now without disturbing the sensitivity adjustments, disconnect the aerial and ground from both receivers. Now turn them on, in turn, and note the noise level of each. If the original set is noisier than the thoroughly shielded test set, then the original set is not shielded sufficiently. This is true regardless of whether or not the actual noise level is zero. There is but one remedy in this case—the original set must be completely enclosed in a copper shield and the shield grounded to the chassis.

This is usually not an easy job, even with simple sets. The author has had occasion to shield many receivers, and the results have not always been completely satisfactory. The placement of the wires in the set, the disposition of the coils and condensers, the location and type of tubes used, all have a bearing on the noise heard. However, the addition of the shield may tend to reduce the noise materially, so that the signal-to-noise ratio is acceptable to the customer. If the ratio is not acceptable, then the noise may be traced to its source and eliminated there, or else another thoroughly shielded receiver must be used.

Very often all of the previous tests may indicate that the noise is coming in through the power line. That is, the removal of the aerial and ground and the use of a thoroughly shielded receiver may not result in any appreciable reduction in the noise level. In such cases, the final test must involve the power supply line. It is unfortunate that the power line cannot be disconnected from the receiver (the use of a line-operated receiver is assumed here) and it is just as unfortunate that the power line is a frequent carrier of noise. The only good test for the supply line is to insert one of the special line filters (see Art. 30-34) between the line and the receiver and note whether this reduces the noise level.

In work of this kind, where several possibilities exist, and the method of trial and error must be used, every step should be carried out carefully and checked before proceeding to the next one. Unless one is very familiar with a particular neighborhood

and is thus aware of the general characteristics of various locations as regards noise, the power supply line to the receiver should be checked by the use of a filter. It is only after all four possible sources have been investigated that the service man can point definitely to the means of entrance of noise and take the necessary steps (to be described later) to eliminate it.

It must not be supposed from this discussion that all interference will be found to be entering the receiver through one path at all times. In fact, the more usual cases are those where the noise enters the receiver through the aerial, the ground, the chassis and the power line. Of course, the noise is not evenly distributed among all four, and one will generally predominate, but the noisy location may require treatment in several places before the noise level drops sufficiently to give an acceptable signal-to-noise ratio. In some cases, interference radiated from the power supply line to the lead-in and aerial wires constitutes the strongest and most annoying noise heard.

30-15. Suppression of Interference at Source vs. at Receiver.—After it has been determined definitely by the foregoing tests that the interference is reaching the receiver by way of the aerial and lead-in, the ground, the power supply line, or a combination of these, the question is "what is to be done about it?" Shall no attempt be made to track the interference down to its fundamental source and apply proper interference suppression measures there so as to eliminate it, or shall the problem be attacked by attempting to apply interference prevention measures at the receiver instead. The best course to follow in any case depends entirely upon the conditions encountered. It is at this point that experience and good judgment on the part of the service man are a very important asset in pointing out the best procedure, for, if the wrong course is taken, a great deal of time and effort may be consumed without producing any worthwhile results.

Records of organizations which have done a great deal of interference elimination work show that in nearly half of the cases the trouble is caused by appliances and circuits right on the customer's own premises. Motors in household appliances, thermostats, loose lamps in sockets, faulty switch contacts, ar-

mored cable rubbing against pipes, etc.—these are common causes of noises in the set owner's own premises. Since this is so, it is advisable to proceed first with the idea of finding the source of interference right on the premises and eliminating it there. The owner should be asked at once if there are any electrical devices in his home. Mention such common ones as an electrical refrigerator, a sewing machine, a mixing machine, an oil burner, a vacuum cleaner, etc. Also ask him to tell as nearly as possible whether the noise is heard steadily or only at intervals. If it is the latter case, is it heard in the morning, afternoon, or evening; for how long, and how frequently. This may lead to a clue! The various electrical appliances on the premises should be turned on, in turn, while the radio receiver is operated at full sensitivity with no station tuned in. Any disturbing unit will reveal itself immediately by the noise it causes. It will usually take only a few minutes to check all of the appliances on the premises in this way. If a noisy one is found, a suitable filter connected to it (as will be described later) will generally eliminate the trouble due to it. If no interfering appliance is found on the premises, or if the application of proper suppression methods to those that are found does not clear up the interference completely, another decision must be made.

If the tests outlined in Art. 30-14 showed definitely that the interference enters by way of the power line *only*, then a suitable filter applied at the outlet to which the set is plugged (see Art. 30-34) will usually clear up the trouble. If it enters by way of the antenna system, the service man may either decide to give up the idea of locating the source of interference and adopt interference prevention measures at the receiver installation instead, or he may decide to continue in his hunt for the source. The choice made in any case depends on the particular conditions encountered, and should be one which will make for overall economy consistent with effective noise prevention.

It is often a very difficult matter to trace interference down to its source—for it may originate at some distance and be carried in on the power distribution system. Also, the source may be of such a nature that the cost of effectively eliminating its interference may be prohibitive, as in the case of a large indus-

trial motor, an elevator motor, or a congested business district full of flashing electric light signs, trolley car lines, motors, etc. On the other hand, it may be impractical for the service man to even attempt to carry out the job because he may have absolutely no jurisdiction over the interfering apparatus. It will also be found at times that the owner of the offending appliance not only refuses to pay for any interference-prevention device the service man may recommend, but even refuses to permit any such device to be put on his apparatus at no cost to himself. Of course in such cases, it is futile to spend time in locating the interfering device, for after it is located nothing can be done about it unless there is a specific local ordinance covering such cases. Preventative measures must be applied at the receiver installation instead.

However, since there are many cases where it is desirable or absolutely necessary to track down the cause of the interference, the service man should know exactly how to do it. For this reason, we will proceed to discuss first, the method of identifying (if possible) the type of device causing the noise; then practical methods of tracking down the source; next, effective methods of filtering the interference at the source; and, finally, the latest methods employed to reduce noise at the receiver when this is the desirable course to follow.

30-16. Identifying Interfering Devices by the Character of the Noise Produced.—In searching for an unknown source of interference, it is very helpful if one first has an idea of the type of device he is looking for. It will be realized that a search for perhaps a single motor may lead one into numerous nooks and corners, and if the service man has no idea as to the nature of the device causing the interference, a great deal of valuable time may be spent tracking down the guilty device before it is located and the actual filtering is done. For this reason, it is wise to note carefully the nature of the noise and classify it according to its characteristic sound. The following table has been prepared as a guide to give the service man an idea as to the type of device which may be causing interference according to the characteristic sound which it produces in the radio receiver.

- (1) **CRACKLING, SCRAPING, SHORT BUZZES, SPUTTERING**
May be caused by: door bells and buzzers, door openers, loose bulbs in electric light sockets, loose or corroded connections in electric light sockets, floor lamps, electrical appliances and cords, broken heating elements, wet power insulators, leaky power transformer insulators, power line grounded on tree branches, elevator control contacts, high tension lines, leaky cables.
- (2) **CLICKS**
May be caused by: telephone dialing systems, switches of any kind, as in sign flashers, elevator controls, heaters with thermostats, heating pads, electric irons with thermostats, telegraph relays, etc.
- (3) **STEADY HUM**
May be caused by: poor ground on set, antenna or ground wires running close to and parallel to power line. (This should not be confused with "tunable" or "modulation hum" which is present only when the carrier wave of a station is tuned in (see Art. 23-18 in Chapter XXIII), nor does it include those cases of steady hum where the hum is due to some trouble existing in the receiver itself (see Arts. 23-19 and 23-20).
- (4) **BUZZING OR RUSHING**
May be caused by: automobile ignition, moving picture machine, arc lights, street car switches, oil burner ignition, battery chargers, diathermy machines, high frequency apparatus, X-ray or violet-ray machines.
- (5) **RATTLES, MACHINE-GUN FIRE**
May be caused by: telephone dial systems, automobile ignition systems, buzzers, vibrating rectifiers, sewing machine motors, dental laboratory motors, annunciators, doorbells.
- (6) **WHISTLES, SQUEALS**
May be caused by: defect in the receiver, heterodyning broadcast station signals, picking up radiations of an oscillating radio receiver nearby.
- (7) **BUZZING, HUMMING, WHINING, DRONING, WHIRRING**
May be caused by: electric motor noise. May be on vacuum cleaner, electric fan, electric dryer, massage machine, hair dryer, motor generator set, small blower, farm lighting plant, electric refrigerator, oil burner, dental apparatus, cash register, dishwasher, sewing machine, etc.

It must not be thought that this list is complete. It is merely intended to serve as a guide to the *type* of electrical equipment that can generate a characteristic sound in the receiver. Nor must the characteristic sound be interpreted as absolutely conclusive evidence that a certain type of device is causing the trouble. For instance, the interference caused by an electric motor may be either a staccato machine-gun sound, indicated by (5), or a buzzing sound more in the nature of a whine or drone, as indicated by (7). However, it will be found in most cases that the characteristic sound is caused by any one of the devices listed in the group.

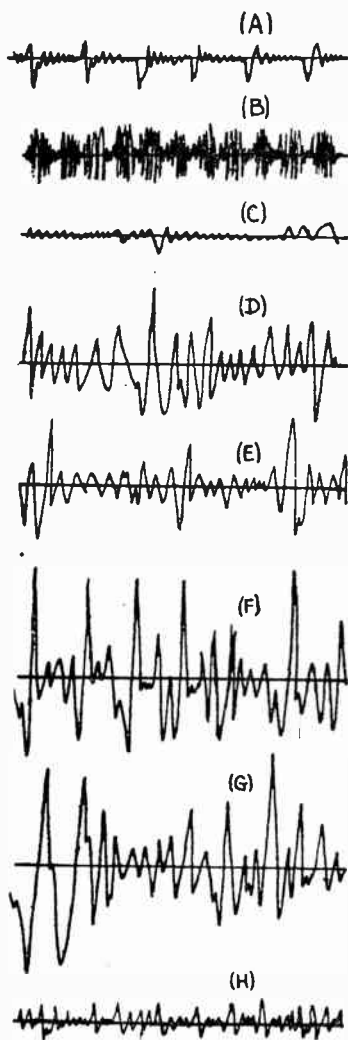

The probability that some particular device listed in the group may be in the vicinity of the receiver may be used as a clue to narrow down the choice in any case.

The reason why most disturbing electrical devices can be recognized by the sounds they cause in the radio receiver output is that almost every one of these electrical devices produces in its supply line, disturbances having a particular wave-form. When these are received by the receiver, and are amplified and detected, they produce particular sounds. In order to make this clear, a number of oscillograms of the characteristic disturbances produced by several common electrical devices were taken. They are reproduced in Fig. 30-6 and labeled. An oscillograph was connected to the output circuit of a receiver whose antenna circuit was subjected to the interference in each case. These oscillograms show some very interesting things about such interference. Note the general similarity of inter-

FIG. 30-6.—Oscillograms of typical disturbances produced by the following electrical apparatus: (A) A short steady arc between carbon electrodes. (B) Leakage of 5,500-volt lighting circuit through a high-resistance ground. (C) Small single-phase a-c motor running. (D) A loaded d-c—a-c motor generator set. (E) A mechanical interrupter. (F) Violet-ray apparatus. (G) Small universal motor with badly sparking brushes. (H) The same motor after the commutator was cleaned and the brushes were cleaned and fitted properly.

ference produced by sparking devices (A), (D), (E), (F), (G). Also notice the great reduction brought about in the interference (G) which was produced by a badly sparking universal motor when the brushes were fitted properly and the commutator was cleaned (H). The use of cathode-ray oscilloscopes in noise-reduction work by service men in order to reveal the *character* of the interference, is very helpful. (See Art. 25-43 of Chap. XXV.)

30-17. Types of Electrical Devices Commonly Used in Various Establishments.—As a further aid toward identifying the source of interference, the following table (which is reproduced here by courtesy of *Tobe Deutschmann, Inc.*) may be of value. As shown, it lists the various devices according to the types of establishments in which they are commonly employed and found. When interference is encountered, the service man should endeavor to find out if any of these establishments are in the immediate vicinity. If one is found, investigation should be made to find out if one of the devices listed here under the heading of that type of establishment as being a potential cause of interference is being used. If so, tests should be made to find out if it is the cause of the interference complained of, and the proper filter should be applied to it if it is. This list, in conjunction with the one presented in Art. 30-16, will be of material assistance in tracking down sources of interference.

Code: A indicates a-c operated equipment
 D indicates d-c operated equipment
 AD indicates a-c or d-c operated equipment
 * indicates a-c operated equipment which may or may not create interference.

A. GENERAL BUILDING EQUIPMENT

- 1.—A*D—Fans of all description
- 2.—A*D—Blowers (ventilating systems)
- 3.—D —Elevator motors
- 4.—A*D—Motors on heating plants
- 5.—A*D—Pump motors
- 6.—A*D—Air compressors
- 7.—A*D—Vacuum cleaner installations
- 8.—A*D—Refrigerator motors

B. BUSINESS OFFICE EQUIPMENT

- 1.—AD —Dictating machines
- 2.—A*D—Calculating machines
- 3.—A*D—Mailing machines
- 4.—A*D—Multigraphing machines
- 5.—AD —Stock tickers
- 6.—D —Telegraph equipment

C. DOCTORS' OFFICES

- 1.—A —X-ray
- 2.—A —Diathermy apparatus
- 3.—A*D—Static machines
- 4.—AD —Massage equipment
- 5.—AD —Violet ray

D. DENTISTS' OFFICES

- 1.—A —X-ray
- 2.—AD —Dental motors
- 3.—AD —Laboratory motors
- 4.—AD —Chair elevating motors

E. BEAUTY PARLORS AND BARBER SHOPS

- 1.—AD —Hair dryers
- 2.—AD —Motor driven clippers
- 3.—AD —Massage equipment
- 4.—AD —Violet ray
- 5.—AD —Motor driven cash register
- 6.—D —Neon sign converter

F. SODA FOUNTAINS

- 1.—A*D—Refrigerating equipment
- 2.—AD —Drink mixers
- 3.—AD —Fruit juice extractors
- 4.—AD —Cash registers
- 5.—AD —Electrically operated advertising display

G. DEPARTMENT STORES

- 1.—AD —Cash registers
- 2.—A*D—Carrier systems
- 3.—AD —Telautograph systems
- 4.—AD —Call systems
- 5.—AD —Animated displays
- 6.—AD —Display studio equipment
- 7.—AD —Flashing signs
- 8.—D —Neon sign converters

H. RESTAURANTS, BAKERIES AND CONFECTIONERS' STORES

- 1.—A*D—Rotary ovens
- 2.—A*D—Doughnut machines
- 3.—A*D—Electric hoists
- 4.—A*D—Dish washers
- 5.—A*D—Mixing machines
- 6.—A*D—Refrigerators
- 7.—A*D—Slicing machines
- 8.—A*D—Food choppers
- 9.—A*D—Ice cubing machines
- 10.—A*D—Candy pullers
- 11.—A*D—Corn poppers
- 12.—AD —Cash registers
- 13.—A*D—Coffee grinders
- 14.—AD —Flashing signs
- 15.—D —Neon sign converters

I GROCERY AND BUTCHERS' SHOPS

- 1.—AD —Cash registers
- 2.—A*D—Slicing machines
- 3.—A*D—Coffee grinders

4.—A*D—Refrigerators

J. CLEANING ESTABLISHMENTS

- 1.—A*D—Vacuum cleaners
- 2.—A*D—Hat cleaners
- 3.—AD —Cash registers
- 4.—A*D—Shoe buffers
- 5.—A*D—Rotary dryers
- 6.—AD —Sewing machines
- 7.—AD —Flashing signs
- 8.—D —Neon sign converters

K. SHOE REPAIR SHOPS

- 1.—AD —Sewing machines
- 2.—A*D—Buffers
- 3.—A*D—Grinders

L. PRINTING SHOPS AND NEWSPAPER OFFICES

- 1.—AD —Press motors
- 2.—A*D—Cutters
- 3.—A*D—Linotype and monotype machines
- 4.—A —Electric neutralizers
- 5.—AD —Flashing signs
- 6.—D —Telegraph equipment

M. JEWELERS' AND OPTICIANS' STORES

- 1.—AD —Cash registers
- 2.—AD —Lathe motors
- 3.—AD —Grinders and buffers
- 4.—A*D—Compressors
- 5.—AD —Drills
- 6.—AD —Flashing signs
- 7.—D —Neon sign converters

N. GARAGES, BATTERY SHOPS and FILLING STATIONS

- 1.—AD —Portable motors
- 2.—A*D—Air compressors
- 3.—A*D—Shop motors
- 4.—AD —Charging equipment
- 5.—A* —Gasoline pumps
- 6.—A*D—Spray equipment
- 7.—A*D—Pressure lubrication systems
- 8.—AD —Flashing signs
- 9.—D —Neon sign converters

O. DRESSMAKING, TAILORING, AND GARMENT SHOPS

- 1.—A*D—Sewing machines
- 2.—AD —Vacuum cleaners
- 3.—A*D—Electric cutters

P. LAUNDRIES

- 1.—A*D—Washing machines
- 2.—A*D—Mangles
- 3.—A*D—Dryers
- 4.—AD —Sewing machines

Q. MACHINE SHOPS

- 1.—A*D—Motors, driving
- 2.—AD —Portable tools
- 3.—A*D—Air compressor, electric driven

R. THEATRES

- 1.—A*D—Ventilating systems
- 2.—A*D—Cooling systems
- 3.—AD —Hand dryers
- 4.—A*D—Projectors
- 5.—A*D—Motor generator sets
- 6.—A* —Synchronizing motors
- 7.—AD —Flashing signs
- 8.—D —Neon sign converters

S. HOTELS, HOSPITALS, AND INSTITUTIONS

- 1.— Restaurant
- 2.— Laundry
- 3.— Valet
- 4.— Soda fountain
- 5.— Barber shop
- 6.— Shoe cleaning equipment
- 7.— Hand dryers
- 8.— Vacuum cleaner installations
- 9.— Ventilating and heating systems
- 10.— Telegraph equipment
- 11.— Call systems
- 12.— Telautograph
- 13.— Clocks
- 14.— Medical and dental equipment

T. TELEGRAPH AND TELEPHONE OFFICES

- 1.—D —Keys
- 2.—AD —Battery chargers
- 3.—D —Relays
- 4.—AD —Clocks
- 5.—AD —Motor generators
- 6.—AD —Ringing equipment
- 7.—D —Switchboard

U. STREET RAILWAY SYSTEMS

- 1.— Arcing at trolley wheels
- 2.— Air compressors
- 3.— Driving motors
- 4.— Buzzers
- 5.— Semaphore signals
- 6.— Trolley crossovers
- 7.— Trolley disconnect relays. (To signal when trolley pole is off)

V. STREET RAILWAY STATION EQUIPMENT

- 1.— Motor-generator sets
- 2.— Water-pump motors (run from trolley current)
- 3.— Air compressor motors (run from trolley current)

W. POWER AND LIGHT COMPANIES

Transmission Circuits

- 1.— Scale on insulators
- 2.— Loose bonds
- 3.— Static discharge from unbonded hardware to adjacent hardware
- 4.— Loose tie wires
- 5.— Cracked insulators
- 6.— Pole top switches

X. POLICE AND FIRE ALARM SYSTEMS

- 1.—AD —Battery charging equipment
- 2.—D —Relays
- 3.—D —Telegraph equipment
- 4.— Tree grounds

Y. TRAFFIC SIGNALS

- 1.—AD —Blinkers
- 2.—AD —Control mechanisms

In general, it may be stated that all universal (a-c—d-c) motors and all d-c motors produce interference. Alternating current motors of the repulsion-starting—induction-running type often produce interference (especially when starting), while large a-c motors of the three-phase type seldom, if ever, cause interference.

30-18. Classification of Interference by Method of Pickup by Receiving Equipment.—Before proceeding with a study of the methods of tracking down interference to its source, it will be well to differentiate between the various ways in which interference may reach the receiving equipment. The following classification may prove helpful:

- (1) *Conducted* interference is that part (if any) which enters the receiver proper *via* the power supply line by simple conduction.
- (2) *Direct radiated* interference is that radiated part which is picked up *direct* from the source of disturbance by the antenna system.
- (3) *Re-radiated* interference is that part which is conducted from the source by the power supply line (or some other conductor) and is then re-radiated from the live wiring and picked up by the antenna system.

It is fortunate that the majority of interference that is heard as noise arrives through the antenna system. The first conclusion to be drawn, then, is that the interference is radiated into space for a short distance directly from the source, and for much longer distances from the power line to which it is connected. Not all of the interference is *radiated*, however, some is *conducted* along the power line and into the power circuit of the receiver as previously described. But in the majority of cases of ordinary interference, most of the interference is radiated from the

power circuit wiring, like a radio signal, and is picked up by the aerial and lead-in and sometimes by the chassis. Chassis pickup is somewhat rare in well-shielded receivers, so that whatever does come in through the chassis is caused by the same sources as those picked up by the aerial and lead-in.

30-19. **Tracking Down the Source of Interference.**—Once the type of interference has been classified according to its characteristic sound, and the nature of the interfering device or the establishment it is used in has been ascertained in a general way if possible, the difficult problem of locating the actual guilty device or devices must begin *if it has been decided to track the interference down to its source and apply the proper remedies to suppress it there*. While this procedure is usually a laborious one, there are many cases where it is absolutely necessary. For instance, although much of the noise produced by man-made interference may be greatly reduced by the use of special noise-reducing antenna systems (since the greater part of it is radiated by the line to the antenna system), the installation conditions may be such that it may be impractical to erect the aerial portion of the noise-reducing antenna system high enough to be beyond the zone of the disturbing radiations. Under conditions of this kind, the use of such systems is only partially effective, and the disturbance must be eliminated directly at its source if quiet reception is to be obtained. Placing a filter in the power line at the receiver will not eliminate the trouble, for since the interfering device is located some distance from the receiver, a considerable amount of energy may still be radiated by the line between the noise source and the filter. Of course, this noise will be picked up by the aerial and heard regardless of the filter. In those cases where the interference is reaching the receiver solely by way of the power line, it may also be advisable to track down the source if it does not take too much time—otherwise, a line filter may be installed at the receiver line plug.

At this stage of the proceedings, it is known whether or not the aerial, the ground, the receiver chassis or the power line is feeding most of the noise (see Art. 30-14). This knowledge is useful in locating the source. It is much easier to *describe* how

the sources of interference should be tracked down than it is to *do* the actual tracking, for many conditions which alter the procedure are usually met with in the field. Methods which are found to be effective in rural communities are worthless in congested city districts; others which are effective in private dwellings are not practical in apartment houses and hotels. So much impractical information has been published concerning this part of interference elimination work, that the inexperienced service man had better start reading the following pages by first forgetting most of what he has read about the subject in magazine articles, house organs, etc., lest he be clapped into a lunatic asylum for wandering in and out of buildings where he has no business to be, and around town in circles with an interference locator strapped on his back, a loop antenna sticking out in front of his nose and a far-away look in his eye hunting for the all-elusive source of interference. He should realize that the tracking down of interference sources is no simple job (on the average) even for men experienced in this work. He should also realize that there is hardly another branch of service work where practical experience, attention to small details, keen observation, perseverance, tact in questioning people, and systematic methods are more necessary for success. This is probably the main reason why the trend (at least in large cities) has been toward the erection of specially designed noise-reducing antenna systems and the elaborate use of line filters to eliminate interference, rather than attempt to track down the interference to its source. However, the service man should know how to "track" interference if it is ever necessary for him to do so. Since the procedure depends to a great extent upon whether the receiver is installed in a hotel or apartment house, a private dwelling in a city, or a private dwelling in a rural community, we will divide our study in accordance with these conditions.

(1) "Tracking" interference in hotels and apartment houses:

When called upon to track *man-made* interference in a receiver installation in a hotel or apartment house, the service man should first realize that there may be fifty or a hundred different small motors or other electrical devices generating interference in the many rooms or apartments in the building. There will usually be elevator motors and contactors (usually in the elevator pent house on the roof) which will add their share to the general melee of interference. Some idea of what an X-ray eye might see in a modern

apartment house is illustrated in Fig. 30-7. Electric fans, refrigerators, vacuum cleaners, mixers, telephones, clothes washers, violet-ray apparatus, heating pads, etc., go to make up only a small part of the list that might be found. Evidently, even if every single interfering device were located (admittedly a laborious task), it would be a very costly job to clean commutators, fit brushes, apply line filters, repair worn and frayed cords, etc., in order to eliminate all

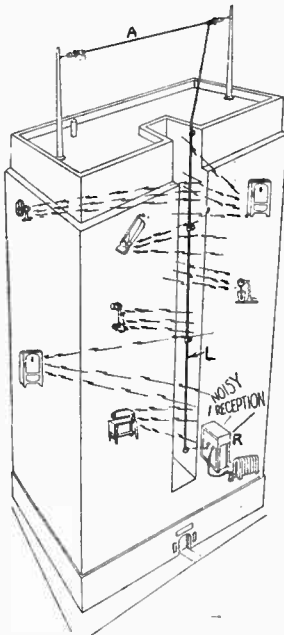

FIG. 30-7. — How various electrical appliances in an apartment house or hotel will cause disturbances not only through the power supply line (see Fig. 30-4) but also by direct radiation and re-radiation to the lead-in (and possibly the aerial) due to their close proximity to it.

producing it (see Art. 30-16). Experience is valuable in this connection. If this noise lasts long enough he should attempt to find out how it is reaching the receiving equipment (see Arts. 30-14 and 30-18).

From this point on, the problem resolves itself into hunting for the guilty device. If the service man has formed some opinion regarding the nature of the device he has something to start on. In some cases, questioning the building superintendant regarding the possible location of such devices in the building may lead to a clue. In others, an interference-locating receiver with a loop may be help-

ful. The interference (and don't forget that many of the residents would object very forcibly to any suggestion by a service man that he be allowed to do such and such a thing to the "mixing machine" because it is causing interference in Mr. Blank's radio set across the hall). Such "wholesale" tracking down and interference prevention measures in a building of this type are usually out of the question. Usually, the most practical thing to do in such cases is to install a line filter (see Art. 30-34) at the outlet to which the set is plugged (or at the fuse box in the apartment), and erect an effective noise-reducing antenna system with the aerial portion in a zone as free from interference as possible (see Arts. 30-36 to 30-58).

If only a particular device in the building is causing serious trouble, that is another matter. The service man may find this out by carefully questioning the set owner as to whether the interference appears at all times, or only at certain times of the afternoon or evening; whether it always starts at *exactly* the same time (or on some exact part of the hour)—also, whether it lasts a short time or a long time, etc. He may be able to furnish considerable valuable information in this connection. If the particularly annoying noise occurs only at certain times, the service man should arrange to be present at the time the noise is starting. He should note the character of the sound and attempt to form some opinion regarding the nature of the device which is

ful, but this is not usually the case in a building of this kind where so many false indications may be received. When a suspected device is found, it should be turned on and off by one person, while another listens at the radio set (some communication arrangement between the two persons is desirable here) to find out if it is causing the interference complained of. If it is, proper interference suppression measures should be applied to it (as will be explained later). If not, the search must continue—mainly by inquiry among the various occupants of the building (when this is practical) about the ownership of motors, electrical household appliances, etc. (name them for the person, as most people forget about at least one third of the electrical appliances they have). Courtesy and tact are essential in this phase of the work. In a large building, this may be a considerable task.

In many cases, it will be found that some source outside the building is causing the disturbance. Of course, if electric surface car lines, elevated railroads, flashing electric signs, etc., are operating in the vicinity, these should be suspected at once, and in order to check the suspicion, careful observations should be made at the noisy receiver while the vehicle or device in question starts and stops. In connection with trolley lines, etc., remember that the powerful disturbance caused by a car which is out of sight may be *conducted* along the third rail or overhead trolley wire for a long distance and be re-radiated to the antenna lead-in wire or even the power supply lines in the building and cause interference in the radio receiver. Of course the service man can do nothing directly regarding such sources of interference. A well-erected noise-reducing antenna system with the aerial wire located in a zone as free from the disturbance as possible (not necessarily the highest point possible) will usually be the best remedy for this trouble. Often, a line filter must also be used. The directional effects of the particular type of aerial employed should also be taken advantage of in the installation. It should be erected so that its best receiving direction (whatever that may be) is *not* the direction toward the trolley line or other seat of disturbance. The directional properties of various types of aeri-als will be discussed later. Even if a noise-reducing type lead-in is used, it should be run down from the aerial to the set in a location *as far* from the disturbance *as is practical*. For instance, the lead-in *L* shown in the installation of Fig. 30-7 is in a poor place since it is subject to interference radiations in 3 directions in the building and from external street disturbances from the fourth direction. It would be much better to carry it down at the rear far corner of the building and then around the far side wall to the receiver—provided no other strong source of interference would be encountered on that side of the building!

As an example of how a source of interference external to a building in a congested section of a large city may be tracked down step by step by simple, level-headed reasoning, even though the problem seems quite hopeless at the start, the following actual case may be of interest:

One of the branch stores of a large radio retail organization located in a congested section of a large city which is noted for its severe electrical interference reported that demonstration of any radio receiver, after four o'clock in the afternoon, was impossible because of loud clicking noises. A service-man experienced in interference work was put on the job. After first going over the entire installation,

he noticed that the clicks followed one another closely and resembled the type of interference created by an electric sign "flasher". Since the aerial portion of the antenna system was erected far above the street level and the lead in wires were completely shielded through metal conduit to the receivers in the demonstration booth, it was hardly possible that the interference was picked up through the aerial-ground system. A test proved this conclusively! The only remaining assumption was that the interference reached the receivers only through the power supply lines. However, the insertion of a filter into the line at the meter where it entered the building failed to accomplish any results.

An investigation was then made to determine the location of all flashing signs which were placed into operation at the observed time. As the store was located in a congested business section of the city and a great number of nearby flashing signs were switched on at or about four P. M., it was difficult to determine just which sign was the cause of the disturbance. However, the fact that the steady clicking interference started at *exactly* four P. M. every day, indicated that some timing device was being employed to operate the flasher. Further inquiry finally revealed a large 3-section flashing neon sign which was operated by a four-gang—four-circuit sign flasher unit to obtain certain running-border and other motion effects.

Through the cooperation of the manager of the store operating the neon sign, a man was stationed at the switch of the sign so that the effect produced by switching the sign on and off could be noticed by another stationed at the radio receivers. Telephone communication was established between the two. Starting the sign flasher produced the clicking interference complained of, which ceased as soon as the device was turned off. Now that the source of the interference was located, the elimination was simple. Each circuit of the four-gang—four-circuit breaker mechanism was filtered separately by the insertion of a suitable filter and by-pass condenser. (Fig. 30-19) This case is related here for the purpose of demonstrating the value of employing a systematic method for locating a source of interference, and for observing all details regarding the interference itself.

(2) "Tracking" interference in private dwellings in cities:

When *man-made* interference exists in radio installations in private dwellings in cities, the service man is able to concentrate more on the building itself, since he is usually given a free hand in the job. The usual questions should be asked of the set owner in an attempt to secure as much information as possible from him regarding the noise [see (1)]. In addition to questions regarding the location of all electrical appliances in the building, inquire about the possible proximity of power houses, sub-stations, trolley lines, elevated railroads, elevators in adjoining buildings, doctors' or dentists' offices in the immediate neighborhood, flashing electric light signs, etc. Any clue he gives should be checked at once.

The usual preliminary tests should be made in order to get some idea of the character of the noise, the "probable" type of device which is causing it and how it is reaching the receiver equipment. All electrical devices in the building should be checked to find out if they are causing interference. Proper filters should be applied to any that do. If the trouble still persists (perhaps it is weaker now), find out from the owner where the meter and fuse box for the electric light circuits in the building are located. With the set turned on so the noise comes in as loudly as possible and either

the owner (or an assistant) listening, go down to the fuse box and unscrew one fuse at a time until you find out which one makes the set stop playing. Screw it back. That one is not to be touched again. Now unscrew *both* fuses in each branch circuit (actually remove them from the fuse block, in one branch circuit at a time) and after each pair is removed, get a report regarding the noise in the receiver. Unscrewing the fuses cuts out the branch circuit so that any loose lamp socket terminals, loose lamp plugs or cords, noisy switches, etc., that may be in the line are prevented from affecting the receiver. If the noise stops when some branch circuit is "killed" check the connections etc., at every outlet, switch,

FIG. 30-8. — A n "interference locating" portable receiver with its extremely directional loop antenna. In some cases it may be advisable to mount the loop on top of a small pole which may be carried around.

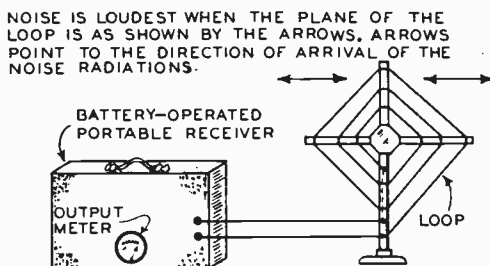

and plugged-in device in that circuit for a possible internal loose connection, intermittently "grounding" contact, etc. Of course, the main power supply switch should *not* be opened (as so many interference-suppression articles advise) for if this is done, the electrically-operated receiver will not operate and of course the noise will not be heard. If the branch circuit to which the receiver is connected is to be tested, the receiver may be plugged into a nearby outlet on one of the other branch circuits and its aerial and ground leads extended to it while the test is being made.

If disconnection of the branch circuits makes a difference in the noise, but no loose connection, etc., can be found in them, it is possible that the circuits are re-radiating line-conducted interference to the antenna system. In this case, by-passing should be tried across the line at the "meter" side of the fuse block. If the power supply line is not the cause of the noise, the hunt should be directed to the immediate vicinity outside the building [see part (1)]. (It is assumed of course that all power, telephone and other circuits are installed in underground ducts under the streets). It is well to investigate the possibility of electrical devices such as oil burners, x-ray, ultra-violet ray, or diathermy apparatus installed in adjacent buildings. The offices of physicians, dentists, etc., should also be checked.

(3) "Tracking" interference in rural dwellings:

The interference "tracking" procedure for rural dwellings is the same as that just outlined for city dwellings. However, if the tests show that the disturbance is being carried in on the power supply line (which is assumed to be of the elevated type supported on poles), or if it is definitely shown to originate at some other source external to the building, a portable interference-hunting receiver (shown in Fig. 30-8) will prove useful in tracking it down. It is in rural communities that such receivers find their most important use, but even here they have limitations which are not generally recognized but which are important.

Portable, sensitive, noise "hunting" receivers with directional "loop antennas" have been developed especially for tracking down the exact source of such disturbances. By simply carrying them in the direction in which the interference comes in louder and louder, the source is usually located. These "interference locators" usually comprise a two or three stage tuned r-f amplifier, detector, and one or two stages of audio frequency—the entire receiver being constructed in compact, battery-operated portable form. Instead of using a loud speaker, a pair of headphones and output meter are connected to the receiver so that the intensity or strength, and the nature of the interference may be accurately gauged by both a visual and aural indication. A receiver and loop antenna of this kind are illustrated in Fig. 30-8. In some cases, a 50-100 turn coil wound on a 6-inch form is mounted on a rod which is carried in the hand to serve as the aerial. The advantage of this method lies in the fact that the aerial may be pointed in any direction more conveniently, than is possible with the "loop aerial". Of course, it is essential that the "noise locator", as well as the lead connecting the "coil antenna" to the receiver, be completely shielded. A receiver utilized in locating causes of interference is necessarily battery-operated for portability. Incidentally, the old Radiola 26 portable loop-operated receiver makes an excellent interference locator when an output meter is built into it (see Chapter VII for details concerning various forms of output meters).

If the incoming power supply line is suspected of carrying the disturbance, and either conducting it into the receiver directly, re-radiating it to the receiver antenna, (or both), set up the portable interference locating receiver a short distance back of the building—away from the power line. Now tune the noise in on this portable receiver (cruise around and come closer to the power line if it cannot be heard) and observe the output meter indication. Slowly turn the loop antenna until the noise is loudest. Walk in that direction *parallel to the plane* of the loop (see Fig. 30-8) which leads toward the power line. If the noise intensity *increases* as you walk toward the incoming power line with the loop pointing toward it, and *decreases* when you walk back away from it, it is safe to conclude that it is responsible for the noise. Now follow the branch line from the building to the street and, follow the street line for a short distance in the direction in which the noise gets more intense (if it does).

This is about as much as any radio service man needs to do. He should not attempt to tamper with any circuits, poles, transformers, etc., belonging to the electric light company. Instead, he should communicate at once with the maintenance office and explain the situation to the person in charge, respectfully requesting that the line be checked over and any defective apparatus on it be remedied in order to stop the interference. *He should not tell the person how to do the job.* Most public utility companies are anxious to maintain their equipment in such condition that radio interference is reduced to a minimum. They therefore maintain trained test crews who are properly equipped and experienced in tracing down such troubles to their sources. Very often the trouble will be found to originate a long distance from the place where the radio service man observed it, and will be due to a cause which the radio service man would never have located or even guessed about in a hundred years!

From these discussions, it is apparent that tracking the in-

terference to its source may consume considerable time—in most cases an amount of time which is considerably more than it takes to actually suppress the noise at the source after it is found. For this reason, it is necessary for those service men who make interference elimination a specialty, to equip themselves with good test instruments and a thorough knowledge of the types of electrical installations, interference, etc., which are apt to be encountered in the community in which they work. Their experience and knowledge of local interference conditions also aids them to decide quickly, without waste of time, just what the best course to pursue in any case is.

30-20. **Filters for Eliminating the Interference at its Source.**—There is little question about the desirability of getting at the source of interference in order to eliminate it, *provided it is practical, possible and economical to do so*. If this is the case, after the interference has been traced to some particular device, and it has been definitely established that that device is causing the noise, the next step is to *eliminate* the noise.

From the theory of noise interference presented in Art. 30-10, it is evident that interference is due fundamentally to variations or interruptions which the device causes in the line current, and to sparking which may occur. This is especially so if the construction of the device is such that sparking occurs, a very rapid oscillation of current lasting for the duration of each spark (see Fig. 30-6) results. This causes similar oscillations through the power lines which feed the device, with the result that electromagnetic fields (similar to the electromagnetic field around a radio transmitting antenna) are created around the lines. Thus, the *entire* line feeding the device becomes a veritable broadcasting antenna, radiating interference impulses to any radio receiving equipment which happens to be within its range, (see Fig. 30-4).

It is evident that if the interference is to be minimized, the interruptions or variations in the current must be *minimized*, i.e., they must be *smoothed out*. This is accomplished by the use of appropriate *filters* connected between the interfering device and the line which supplies power to it, *as close to the device as possible*.

The simplest type of filter is a single condenser, connected

between one side of the line and the frame of the device, as shown at (A) of Fig. 30-9. If the device were a motor, for instance, the condenser *C* would be connected to it as shown in Fig. 30-10. The condenser used should be of sufficient capacity to smooth

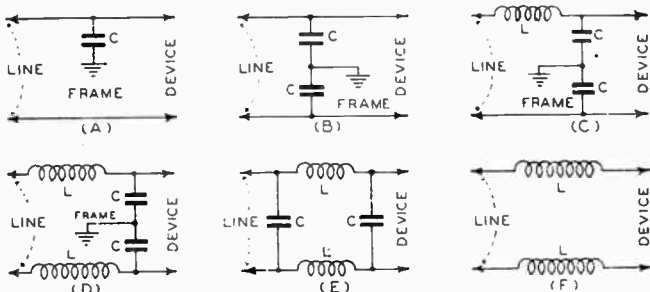
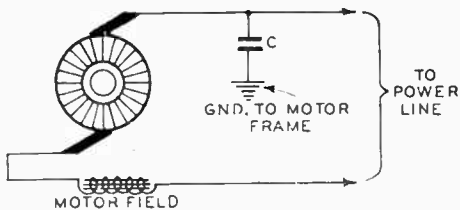

FIG. 30-9.—Six filter arrangements which may be used for minimizing the feeding of interference from an interference-producing device into the power supply line. Arrangements (A), (B), (C) and (D) are the most common ones. The condensers may be of 0.1 to 1.0 mfd. or larger. (NOTE: Any of these filters may also be applied to the power supply line of a radio receiver [see Art. 30-34] to prevent interference from entering the receiver via the power supply line. For such applications, the chokes *L* in arrangements [C] and [D] should be connected between the by-pass condensers and the radio receiver. When this is done, the end of the filter marked *DEVICE* in the above sketches becomes the “line” end, and that marked *LINE* becomes the “radio receiver” end.

out the current variations—the size required depends upon the size and type of device it is used on. About 0.1 to 1-mfd. is the aver-

FIG. 30-10.—Schematic diagram of a series wound (Universal) motor commonly used in household appliances. An interference-suppressing filter condenser is shown connected to it.



age size for household appliances, (1-mfd. being most common).

The single-condenser filter is effective only on devices which draw small currents and whose interference is not of a very disturbing nature. It is usually necessary to use a pair of condensers across the device, as shown at (B) of Fig. 30-9. This arrangement is shown in Fig. 30-11 for a series (universal)

motor. The junction of the two condensers is connected to the frame of the device and in some cases, also to a good "ground" (see Art. 30-22 on the effect of "noisy" grounds). As a safety measure, a fuse (not shown) may be connected in the line lead of each condenser. This type of filter is quite effective in most cases, and is convenient to apply if the condensers can be mount-

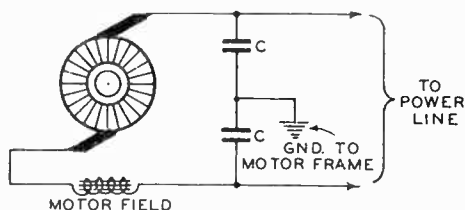
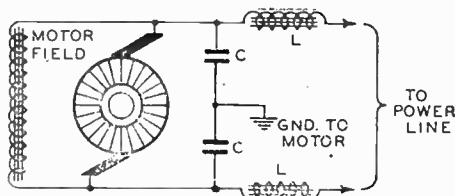

FIG. 30-11. — Schematic diagram of a series wound (Universal) motor showing the use of two filter condensers (one for each brush). The common terminal is grounded to the motor frame.

ed within the housing of the interfering device or fastened to it on the outside.

In instances where the interference is very severe and is not minimized sufficiently by the use of condensers alone, choke coils must also be inserted in series with the line, *on the "line" side of the condensers*, as shown at (C) and (D) of Fig. 30-9 (and also in Fig. 30-12) in order to aid the action of the condensers. These choke coils may be of the radio- or audio-frequency type, depending upon the type of noise, and must be

FIG. 30-12. — Schematic diagram of a shunt type motor with an inductance-capacity filter connected to its input circuit.



wound with wire of sufficiently large size to safely carry the full load current of the device continuously without overheating. Choke coils having an inductance of about 2 millihenries are commonly used in the filters for those small and medium sized electrical devices which require them.

In most instances a single radio-frequency choke connected

on one side of the line as shown at (C) is sufficient; one may be made as follows:

Wind 75 turns of enameled or cotton-covered wire (of proper size, depending upon the current it must carry) on a form 2 inches in diameter, wrap a piece of Empire cloth around it and continue the winding in the same direction. Wind another 75 turns over the first, making a total of 150 turns. The coil should be taped to hold the wire in place, and sealed in a metal can about 4 inches in diameter. A lead should be brought out from each end of the coil before it is sealed.

If no appreciable decrease in noise is noted after the coil is connected in the line, an iron core from any old power transformer (or ordinary stove-pipe iron) should be inserted in the form and made to form a closed ring, leaving a small air gap of about $\frac{1}{8}$ inch. This makes it an a-f choke. It may be necessary to use two such chokes—one in each leg of the line, as shown at (D) and (E).

The length of the coil form and the size of the wire to be used are dependent upon the current which the choke must carry, i.e. the current which the interfering device draws for its operation. The table below lists the safe current-carrying capacity of the various sizes of ordinary magnet wire (having silk, cotton, or enamel insulation) that may be used for those devices ordinarily encountered.* The resistance of the chokes should be kept as low as is practical, so too much power will not be wasted in them.

| | | | | | | | | |
|--|-----|-----|-----|-----|-----|------|------|------|
| Wire Gauge (B & S) | 18 | .16 | 14 | 12 | 10 | 8 | 6 | 4 |
| Safe Current-Carrying Capacity (Amps.) | 1.1 | 1.7 | 2.7 | 4.4 | 6.9 | 11.0 | 17.5 | 27.7 |

The condensers employed in interference-suppression filters should be preferably of the *non-inductive* type and have a voltage rating *double* the working voltage of the line to which they are attached. This will take care of the "peak" voltage of the line. Several typical compact condensers suitable for use in the filter circuits of Fig. 30-9, are illustrated in Fig. 30-13. The type at the right, having the pig-tail leads, is very convenient for this work.

The problem of interference elimination has been studied so thoroughly that various commercial filter units have been developed for effectively eliminating the interference from practically every type of interfering electrical device. These are made with combinations of condensers (or condensers with chokes having the proper size wire) of the proper size for the purpose. All the service man needs to do is to order the correct filter unit for the particular job

*NOTE: A more complete and comprehensive Magnet Wire Table giving the turns-per-inch, etc., for all sizes of wire will be found in Section 21 of the author's *Radio Trouble-Shooter's Handbook*.

at hand. These units are applicable to both a-c and d-c circuits and are particularly advantageous when inductive-capacitive filter units are required, for it is often rather difficult for the service man to build these chokes—especially if they are to carry heavy currents. In some cases, the construction is so specialized that a certain type of filter unit is specified for eliminating interference only from a certain type of device (see Fig. 30-20).

30-21. Best Physical Location for the Filter.—Interference prevention filters are frequently found to be ineffective. One of the main reasons for this is that the filter is not connected close enough to the source of the disturbances in the interfering device. This point is not generally accorded the importance which it deserves. It is essential that the filter be

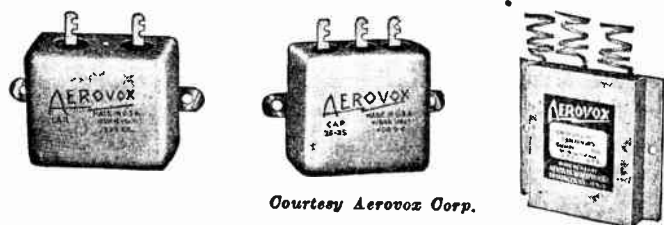

Courtesy Aerovox Corp.

Fig. 30-13.—Left: A single 1-mfd. by-pass condenser with metal-tab terminals.

Center: Two 1-mfd. condensers in a single case, with the common terminal at the center.

Right: A 2-condenser unit having flexible pig-tail lead terminals.

Condensers such as these are useful for use in the filter arrangements of Fig. 30-9.

placed as close to the unit to be filtered as possible. This means that the filter should actually be mounted inside the frame of the device if it can fit there, or, if not, it should be not more than a few inches away at the most.

The reason for this close proximity is apparent when the circuit of Fig. 30-14 is considered. If the filter unit be placed at some distance from the interfering device, for example, then the leads from the filter to the device will be of appreciable length and will radiate interference because the noise current flows in the portion of the line between the device and the filter as shown. This interference may be picked up by the part of the line beyond the filter and be conducted to the receiver or re-radiated to the receiver antenna by it, or, it may be radiated directly to the receiver antenna system if the interfering device is close enough to it. Remember that the filter does not eliminate the noise, it

merely prevents it from flowing through the entire length of the power line to the receiver. It is evident therefore that under such conditions interference will persist even after the interference source has been hunted down and a filter has been connected to it (but improperly). This is why many filters do not produce the results expected of them. The remedy is obvious!

Keep the leads from the filter to the seat of the interference as short as possible. Every superfluous inch of wire is a potential source of radiation and interference!

If the leads cannot be kept short, they should be shielded with a

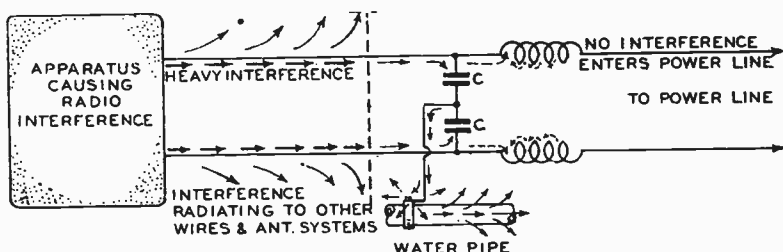

FIG. 30-14.—Schematic circuit showing how the ground pipe may radiate interference, and how the leads which connect the filter to the interfering device may also radiate interference impulses to the part of the line beyond the filter unit, and possibly to the antenna system of the receiver, if it is near enough. The filter should therefore be mounted close to the interfering device and the leads to it should be kept as short as is possible in order to prevent this.

good shielding braid, and the shield grounded to the frame of the device.

The manufacturers of various electrical appliances such as drink mixers, irons, washing machines, vacuum cleaners, neon signs and beauty shop equipment are now, to a large extent, equipping their products with *built-in* filters to eliminate possible radio frequency disturbances at the source.

30-22. Noisy "Ground".—It is interesting to note (see Figs. 30-9 to 30-12) that the by-pass condensers used in interference filters are "returned" to the frame of the device causing the noise rather than to an actual "ground". The reason for this is evident when it is realized that few easily accessible grounds have a low resistance. If the resistance of an available ground connection is high and if the by-pass condensers of a filter are

connected to this ground, the noise current will flow through this ground wire and cause a "noise voltage" drop across it. This means that a radio receiver, connected to some other section of this ground (it might be in the same building), will have its potential *above* actual ground by an amount equal to the noise voltage drop in the ground wire, and noise will be heard, especially when one side of the power line to which the chassis also connects is grounded. It is usually best, therefore, *not* to ground the frame of the motor. This, however, is only a general rule, and is not valid for all cases. It takes but a few moments to experiment in each case and determine whether more or less noise is obtained by actually grounding the by-pass condenser terminal and the frame of the interfering device.

A second reason for not using a real "ground" is the fact that if one is used, the "noise currents" flow through the wire to this "ground", and through this ground conductor (water pipe), as shown in Fig. 30-14. In doing so, they radiate interference impulses, just like an aerial. The lower the ground resistance is, the greater is the noise current in this ground lead and the ground pipe, and the more noise radiated. If radiation from the pipe is strong enough, it may affect other wires, which, in turn, will radiate energy. On the other hand, if the distance to actual "earth" is short, the *resistance* of the ground is low, and if radiation from the ground wire does not affect reception, then the use of an actual "ground" may be preferable. The best procedure is to try an "earth" ground in every installation and observe its effect on the interference—do not rely upon general rules in this work as there are too many special factors which may affect the results.

30-23. **Eliminating Interference from Motors.**—The most frequent sources of interference produced by household electrical appliances are: sparking at the brushes of motors, and arcing at the contacts of thermostats and vibrators. Sparking commutators or contacts radiate a considerable amount of interference because of the oscillations set up, (see (*G*) of Fig. 30-6). It is for this reason that the spark should be reduced to a minimum even though a line filter is to be installed.

The series motor (commonly called a "universal motor" because it will work on either a-c or d-c) is employed very widely

in small appliances such as vacuum cleaners, sewing machines, washing machines, clippers, grinders, fans, mixers, etc. It may be recognized easily by its commutator and pair of brushes. The interference it produces in the radio receiver is distinguished by the "singing" or rotary sound which increases in pitch as the motor gets up to normal speed, and by the fact that it may be tuned in at almost all parts of the broadcast band with approximately equal intensity.

Extremely annoying interference may be caused by these motors if excessive sparking occurs at the brushes due to poor commutation (which is inherent in the design of the motor and cannot be corrected by the radio service man), a dirty or worn commutator, open or shorted coils or commutator segments, dirty or poorly fitting brushes, etc. In such cases, cleaning and smoothing the commutator with fine sandpaper, refitting or replacing worn brushes (see Art. 27-40 and Fig. 27-40) are the first steps which must be taken to reduce interference—otherwise the use of a filter will not suffice. The actual effect of these steps on the interference created by the motor is shown very strikingly by the oscillograms at (G) and (H) of Fig. 30-6. That at (G) shows the wave form of the interference produced by a universal (series) motor whose commutator was dirty and worn and whose brushes sparked badly. The result of putting both the commutator and the brushes in first class operating condition so that very little sparking occurred is shown by the greatly subdued interference illustrated at (H).

It is often necessary to move the position of the brushes in d-c motors and generators to minimize sparking. In a motor, the brushes should be moved in a direction *opposite* to that of rotation; and in a generator, in *the same* direction as that of rotation. The brushes should be moved only if the sparking is still excessive after the commutator has been cleaned and the brushes reseated. There will always be some sparking present normally, especially when the load on the motor or generator is very close to or greater than rated load. Any adjustment of the brush positions should be made while the motor or generator is running with its normal load.

All motors used in home appliances such as vacuum cleaners,

sewing machines, washing machines, hair clippers, grinders, fans, juice extractors, mixers, d-c electric refrigerators, oil burners, etc., and in such devices as cash registers, dental motors, motor generator sets and rotary converters, farm lighting units (generators) may be effectively suppressed by means of a suitable filter installed as close to the seat of disturbance as possible and so connected that the leads from the filter unit to the device are just as short as they can possibly be made so that no interference will be radiated from them. The filters shown at (A)

FIG. 30-15. — Filter arrangement for eliminating the interference created by thermostat controls.

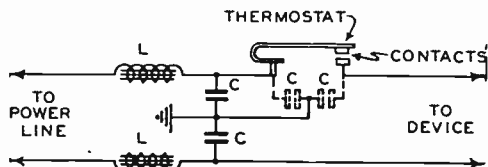

and (B) of Fig. 30-9 are suitable for small motors up to $\frac{1}{4}$ h.p., condensers of 0.1- to 1.0-mfd. being commonly used. Larger motors require larger capacities from 1 to 5 mfd., and often make the use of an inductive-capacitive type filter such as shown at (C), (D) and (E) necessary (see Art. 30-20 for details regarding the construction of these filters). The brushes and commutator should be attended to first so that minimum sparking occurs before the filter is connected. In motor-generator sets and rotary converters, a filter may only be necessary at one end (usually the d-c end), or quite often at both the a-c and d-c ends.

30-24. Eliminating Interference from Thermostats and Contacts.—Thermostatically controlled apparatus in homes usually consists of heating pads, room temperature controls, electric irons, some types of refrigerators, oven controls and electric water heater-controls. As in the case of the series motors, thermostats may cause interference inherently due to their design or because their contacts require cleaning or adjustment. It is usually impracticable to attempt to repair the thermostats in heating pads, but the interference can usually be prevented from being radiated by connecting a small capacitor-type filter (condensers C-C) across the power line supplying the heating pad, as shown in Fig. 30-15.

In other thermostat applications, the contacts should first be put in good mechanical condition and adjusted so that they do not open so slowly that an arc is drawn out, for this will produce interference. If interference persists after adjustment has been made, two 0.1- to 1-mfd. condensers *C-C* should be connected across the line as shown in Fig. 30-15. In special cases where the contacts break circuits carrying appreciable currents, two additional condensers (shown dotted) may be required across the contacts. Finally, in very severe cases, the line choke coils *L-L* may be necessary. The leads from the filter to the thermostat should always be kept as short as possible to prevent radiation of interference from them.

Elevator controls, motor starter and control contactors, street cars, large power applications to ventilating systems, refrigeration, etc., all may cause interference, especially when operated from direct current. Since a great deal of such apparatus is present in dense business areas, suppression of all interference from it is usually impracticable and economically unsound. In these districts it is simpler to use a special noise-reducing antenna system. If interference caused by switch contacts in lighting circuits is to be eliminated, a 200-ohm resistor in series with a 0.1 mfd. condenser should be connected permanently across the switch contacts.

30-25. Shielding the Source of Interference.—Shielding of the device causing the noise interference is not unusual, though somewhat undesirable from some standpoints. First of all, *complete* shielding is necessary; the entire unit must be enclosed in copper mesh and the mesh grounded to the frame of the device in several places. Second, servicing the device is difficult; the mesh must be removed and replaced, (usually by men not aware of the problems of noise reduction)—which is somewhat undesirable. Third, the proper kind of shield may hamper the operation of the device to some extent. It must be remembered that a shield *may* be built, but whether or not its presence is detrimental to the appearance of the device, or makes its operation inconvenient, depends upon the nature of the shield and the device. These considerations are usually the deciding factors in any question involving the complete shielding of the

device causing the interference. Also, it must be remembered that a line filter (located *inside* of the shield) must be used even though complete shielding is resorted to, for the shielding will not keep the disturbances out of the line. It merely kills off all direct radiation of the disturbance from the interfering device.

30-26. Eliminating Interference from Buzzers, Door Bells, etc.—Interference caused by vibrating contacts, such as are used in call buzzers, door bells, dial telephones, etc., is of such an intermittent nature that filtering is usually not justified. However, if

FIG. 30-16.—Filter arrangement for eliminating the interference created by electric bells, buzzers, etc. The condensers and chokes across the battery line are only required in cases where the interference is particularly severe.

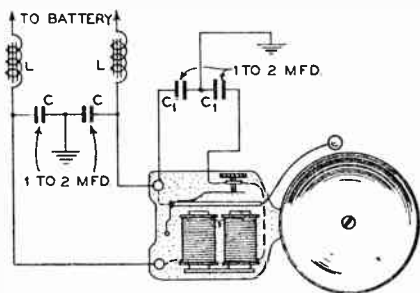

this interference must be eliminated, two 1 mfd. condensers may be connected in series across the contacts with the junction of the two condensers grounded to the device and/or to a separate ground. In some instances, however, it is also necessary to install two condensers across, (and often two choke coils in series with) the line circuit of the interfering device as shown in Fig. 30-16. When it is found, however, that the addition of the choke coils has changed the frequency of the interference so that it may be heard at another dial setting of the receiver, it is then necessary to change the inductance of the choke coils (either by increasing or decreasing the number of turns on them) in order to shift the interference from the broadcast band.

30-27. Eliminating Interference from Oil Burners.—Interference caused by oil burners is due mainly to the ignition system, although a certain amount of interference may be caused by the motor that operates the blower and by the motor that operates the temperature-control system if one is used. Ordinarily, an a-c motor operating the blower of an oil burner creates

interference only for a few seconds, at the instant of starting. These motors are usually of the repulsion-starting—induction-running type and create interference only for a few seconds during the starting period. *Provided the motor is in good electrical condition*, no interference should be created by this type of motor while running; if interference is present, the motor should be carefully inspected for defects or necessary cleaning. If the motor is of the single-phase type in which the brushes remain in contact with the armature, and the brush circuit is opened by means of a centrifugal switch, a slight continuous interference may result. This may be filtered out easily by a common capacitive line filter.

If the oil burner is operated from a d-c line, the d-c motor which is employed may produce interference at a steady intensity during the periods that the oil burner is in operation. This interference may be eliminated in the usual way with a proper capacitive-inductive filter unit (see Art. 30-23), such as is shown in (D) of Fig. 30-9. It is necessary that the units comprising the filter be encased in a metal cut-out box and provided with fuses so as to conform with Fire Underwriter regulations. The choke coils used in the filter unit must be wound with wire large enough to handle safely the current requirements of the motor (see Art. 30-20). The ground lead must be connected to some part of the motor frame.

The same type of filter unit (in some cases a simple capacitive type will suffice) must be employed in cases where the small series-wound motor driving the temperature-regulating control (used in some oil burner systems) causes interference which sounds as a loud roaring noise lasting from 20 to 100 seconds. In such instances, the filter unit must be installed *directly* at the power input to this motor and its "ground" lead should be connected to a carefully cleaned part of the motor frame.

Interference caused by the ignition system and high-tension wiring of an oil burner is generally the chief cause of interference, and is heard as a loud roaring noise which may last from 15 to 60 seconds, or during the entire period during which the oil burner is in operation. To prevent disturbances from this

source from feeding back into the line it is necessary that a suitable capacitive-inductive filter unit be installed in series with the input leads to the ignition transformer and as close as possible to that unit. All wiring must be enclosed by conduit or "BX" cable. The ground connection of the filter unit should be made to a cleaned spot on the metal case of the ignition transformer and to the BX cable or conduit. In some oil burners, most of the high-tension leads are contained within the fuel tube and are shielded by it to some extent. In order that no

FIG. 30-17.—Filter arrangement for eliminating the interference created by vibrator-type storage battery chargers. In some cases it is also necessary to completely shield the charger in addition to connecting the filter to it.

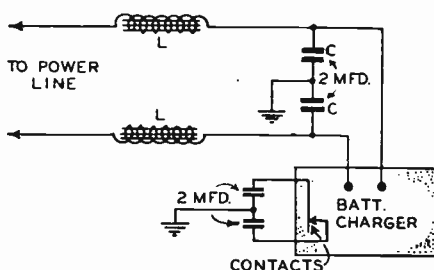

possible radiation by the high-tension wiring shall exist, every part of it must be completely shielded by conduits or shielded braid, these shields being well grounded to both the case of the ignition transformer and to the fuel tube of the oil burner. As a final measure of interference prevention, a good electrical connection should be made between the boiler (which may act as a radiator of noise interference) and the oil burner frame.

30-28. Eliminating Interference from Battery Chargers.—Battery chargers of the vibrator type used in the home and in auto-service shops are very frequent offenders and are somewhat difficult to filter. After considerable experimenting, the author has found the arrangement of Fig. 30-17 to be effective. A choke-condenser arrangement is connected to the power line as shown, and two additional condensers are connected to the vibrator contacts. All leads from the filters to the units should be kept as short as possible. It may also be necessary to shield the unit, as many of these battery chargers are of the "open" type, with coils and vibrator contacts exposed.

30-29. Eliminating Interference from Electric Refriger-

ators.—When a-c operated electric refrigerators are new and in perfect electrical and mechanical condition, they may cause radio interference only during the few seconds when the motor is starting up. However, in refrigerators which have been operated for a long time, the motor starting contacts, etc., may become dirty and worn and interference may result during the entire periods when the motor is running. A suitable inductive-capacitive type filter (see (D) of Fig. 30-9) mounted as close as possible to the motor and connected across the supply line *at the* motor with short leads will generally eliminate interference from this source.

If interference still persists after the filter has been connected, other causes may be responsible for it.

The most common cause is due to the accumulation of static charge on belt driven compressors in dry weather. On many refrigerator units the compressor and motor are mounted on spring supports or vibration absorbers in such a manner that the frames are not permanently grounded to the larger metal parts of the refrigerators. A simple remedy for this type of trouble is to bond the frame of the motor and compressor to the frame of the refrigerator or other large metal body in the immediate vicinity, with a flexible jumper. The jumper should be sufficiently flexible so as not to interfere in any way with the operation of the refrigerating unit.

In other cases, weakening of one or more of the spring supports causes a periodic contact between the motor frame and the refrigerator frame, resulting in fairly steady interference while the motor is running. Mechanical adjustment of the spring, or bonding the same units mentioned above will eliminate this noise. In general, interference from these troubles is very similar to natural static and usually does not affect receivers which are very remote from the refrigerator.

Thermostats and their associated relays are a source of trouble when not in good operating condition. When the contacts of the thermostat or the relays are in need of cleaning or adjustment, a small arc is apt to be drawn while the unit is in operation. Troubles of this type sometimes become very severe from the standpoint of radio interference, particularly when the

thermostat is so mounted as to permit changing of the contact pressure by the vibration of the unit. When difficulties of this type are experienced, it is advisable to communicate with an established electrical refrigerator service organization since the performance of the refrigerator depends to a great extent on the proper setting and operation of the thermostat.

If the refrigerator is operated from a d-c source, a d-c motor is employed. If the brushes and commutator require attention

FIG. 30-18.—Filter arrangement for eliminating the interference created by violet-ray apparatus. The condensers *C* are of 2 mfd. capacity each.

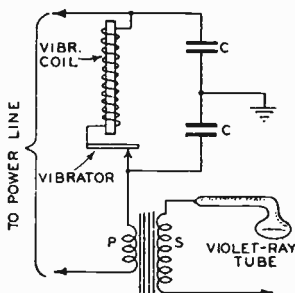

(see Art. 30-23) interference is likely to result during the full time that the motor is in operation. No filter should be connected to the motor until the commutator has first been cleaned and the brushes have been cleaned and re-fitted.

30-30. Eliminating Interference from Electro-Medical Apparatus.—Electro-medical equipment, particularly violet-ray, X-ray and diathermy apparatus, is probably the most prolific producer of interference. This is all high-frequency apparatus, and the interference generated by it is not only radiated directly into space in all directions for a short distance, but the greater part of it is fed back into the power line where it may be *conducted directly* to receivers located considerable distances away, or may be *re-radiated* to other power wiring, telephone circuits, etc., which may carry it along and *re-radiate* it to radio receiving equipment located as far as a few *miles* away. Thus, it may not only create interference in the immediate locality, but over a large area as well. Service men should remember this, and not be too quick to hold such apparatus blameless because it happens to be located at what appears to be a considerable distance from the location where the interference is received.

Interference from the usual violet-ray apparatus is in the form of a roaring sound varying somewhat in intensity from time to time and having no definite frequency. An oscillogram of the wave-form of this kind of interference is shown at (F) of Fig. 30-6. Notice its oscillatory character and the presence of strong harmonics evidenced by the many "kinks" in the wave form. A very effective filter for preventing the interference from a violet-ray tube from feeding back into the line is shown in Fig. 30-18. This may also be applied to other similar electro-medical devices—always keeping the leads from the condensers to the seat of the disturbance just as short as possible. Of course the *direct radiation* from the device will still be present. If this is particularly severe and annoying, the entire device (including the patient) will have to be enclosed in a large shield cage such as will now be described for diathermy machines.

A diathermy machine is a device for the production of high-frequency currents to be used in the treatment of certain diseases such as rheumatism, etc. Such machines will be found in hospitals, in the offices of some physicians, etc.

The circuit used for obtaining these frequencies is essentially the same as that used in early spark transmitters whose operation is now forbidden by federal law. In the diathermy machine a transformer, condenser, and adjustable spark gaps are used to produce high-frequency currents. These currents are carried along flexible leads to metal electrodes applied to the body of the patient. The similarity to a spark transmitter is obvious. The "antenna" consists of the electrode leads and the body of the patient. In the case of some types of treatment the body of the operator is also a part of the antenna system. The "counterpoise" is the power line. Fortunately, the "antenna system" of the diathermy apparatus is not designed for maximum radiation at the frequencies used, and consequently, the area affected by the *direct radiation* from the electrode leads and the body of the patient is relatively small. This *directly radiated* interference seldom affects receivers more than 200 feet from the apparatus. The greater part of the interference (which often affects receivers located several miles from the apparatus) is fed back into the power line and is radiated by it.

Early models of these machines employed frequencies from 900 to 1,400 kc (ranging over practically the whole of the standard radio broadcast band) but in the newer models, an attempt has been made to keep the frequencies used outside of the broadcast band. However, since the circuits of the apparatus are so broadly tuned, this is difficult. The operation of a diathermy machine produces interference of the "shock excitation" type. It appears in the radio receiver as a fairly high-pitched roaring sound which may vary both in frequency and in intensity as adjustments on the machine are varied.

From the foregoing discussion, it is evident that complete elimination of the interference from these machines involves:

- (a) elimination of the feeding of the high-frequency energy back into the power line.
- (b) elimination of the direct radiation of interference from the machine.

The first problem is solved by connecting a filter between the machine and the power line. Due to the intensity of the interference from this type of apparatus and the fact that it is of the "shock excitation" type, this filter must be unusually effective and should be designed preferably to suppress the particular band of high frequencies which these machines produce. Special commercial filter units designed especially for these machines are available. The current which these machines draw from the a-c line varies from 6 amperes (small size) to 25 amperes (the very large size).

It is not practical to install filters in the output (high-frequency) circuit of the diathermy machine in order to solve the second problem by suppressing the high-frequency interference at its source and thus preventing its radiation since, if such filters were effective in suppressing radiation of the interference they would also prevent the passage of high-frequency currents to the body of the patient, and would thus render the apparatus ineffective in the treatment of disease. It is, therefore, evident that this problem can only be solved by complete shielding, i.e., completely enclosing the entire machine, the line filter unit, the operator and the patient taking the treatment in a large screening cage, (since the application of the electrodes to the body of the patient causes the patient to act as a broadcasting antenna which will radiate the interference). It has been found that an enclosing cage measuring about 7 x 5 feet and 6½ feet high constructed with a *wooden* framework and completely covered with ordinary galvanized iron screening (exact size of mesh not important) on all four sides as well as on the top and bottom (a hinged screen door is used for entrance and exit) serves the purpose. The complete continuity of the screening must be maintained at all joints in it by providing firm metallic contact between the various sections of which it is composed. Several

parts of the cage should be well grounded to earth.

It is important to note that any wiring which enters the screen booth must pass through the filter, otherwise, interference will be picked up on this wiring and carried out of the cage, thus reducing the value of the shielding. In other words, any lighting fixtures used for illuminating the interior of the cage must be mounted above the top of the booth so that the light shows through the screen, or if they are installed within the booth must

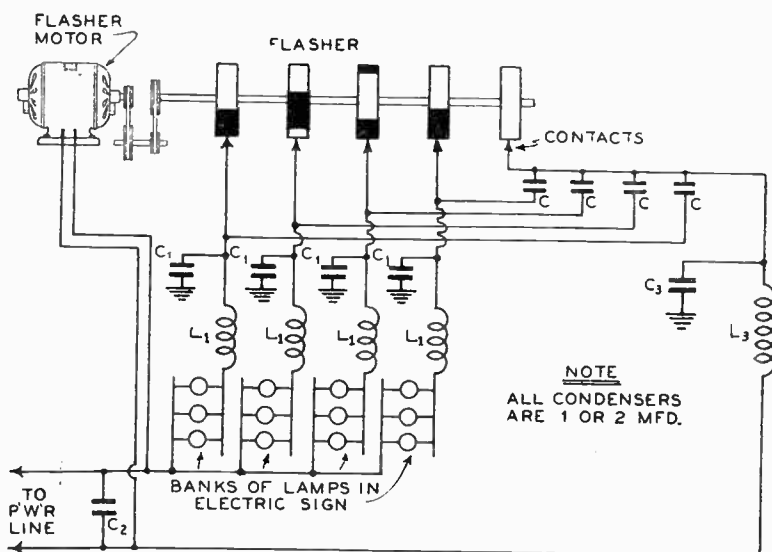

FIG. 30-19.—Filter arrangement for eliminating the electrical interference created by electric sign flashers.

be connected to the load side of the filter. Doorbell, annunciator, or telephone wiring must also be kept outside the screen, otherwise, the interference will be picked up on this wiring and carried out into the building, thus nullifying the value of the filter and screening.

30-31. Eliminating Interference from Sign Flashers. — Electric sign flashers are often a source of interference (see Sec. (1) of Art. 30-19) which can be prevented by the use of suitable filters of the capacitive and inductive type. The interference heard from signs of the type in which various sections flash on and off is a steady series of "clicking" noises noticeable

whenever a section of the sign is flashed on or off. Although interference from this type of sign is extremely annoying, it is not so objectionable as that created by those signs which have a running border or "bursts". This type of sign produces interference which sounds like the steady rattling of machine-gun fire in the radio receiver which picks it up. These running borders or "bursts" are controlled by high-speed rotary switches mounted on a long drum which is revolved by an electric motor operated from the line. These clicks are caused by the make and break of the circuits as different parts of the sign are switched on and off. The switching action sets up oscillations in both the supply lines to the flasher mechanism, and in the connecting lines between the flasher mechanism and the lamps in the sign.

The complete schematic circuit arrangement of a typical electric sign flasher installation with all the chokes and by-pass condensers necessary for the complete elimination of interference from it is shown in Fig. 30-19. The interference created by the motor (if any) and that created by the flashing circuits is blocked from being conducted back into the power supply line by the filter system composed of line condenser C_1 , plus condenser C_2 and choke L_2 which are in the common load lead at the right.

Interference may also be caused by direct radiation caused by the oscillation set up in the leads between the flasher contacts and the lamps in the sign. This radiation may be picked up by the supply line and re-radiated to radio receiving antennas at points further along it, or it may be picked up directly by the antenna system of any receiver within several hundred feet of the sign. If the leads between the flasher contacts and the sign are very short and run in metallic conduit, no suppression need ordinarily be applied to them. However, if they are long, it is necessary to apply a proper capacitive-inductive filter to *each* of the leads. This may consist of an inductance L_1 in series with each lead, and a by-pass condenser C_1 from the lead to the frame of the flasher. In addition, a by-pass condenser C is connected directly across each flasher contact, as shown. Of course, all condenser leads should be kept as short as possible.

It is important to keep in mind that a filter must be connected in *each* of the flasher leads—if a single one is left unfiltered, that lead will radiate interference, and the effect of the filters in the other leads will be reduced materially. Also, each filter section should be shielded from the rest. Also, in most cases all grounds should be made to the frame of the flasher, and any actual “earth ground” to the flasher frame should be removed.

Flashing signs drawing a total of as much as 10,000 watts and having from 25 to 50 contacts on the flasher are not uncommon. Naturally, the filter inductances which must be applied to large signs must be constructed of heavy wire able to carry the current in each flasher circuit. Such inductances are rather difficult for the individual radio service man to construct himself. Commercial filter units containing all the necessary units in a single case are available for suppressing interference from flashing signs of all sizes, and are designed especially for this purpose. A typical unit of this kind, one of which is to be used for each 4-circuit section in a multiple-section flasher installation is illustrated in Fig. 30-20.

30-32. **Eliminating Interference from Neon Signs.**—Neon signs which operate steadily (are not flashed) will seldom cause

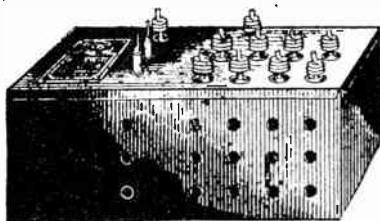

Courtesy Tobe Deutschmann Corp.

FIG. 30-20.—A commercial electric sign flasher filter unit containing both the line and flasher circuit filters complete in one compact case. One of these units is used for each 4-circuit section on a multiple-section flasher installation.

any radio interference if they are in good electrical and mechanical condition—even though they are operated from high-tension transformers. If interference is traced to such a sign, the sign itself should be inspected and repaired before any filtering arrangements are tried. It may need cleaning, the electrodes may require rebushing, loose connections between the transformer and the neon tubes (or between separate sections of the tubing) may

have to be tightened, a larger transformer may have to be substituted because of overloading, the transformer case and the metal sheaths of any connecting wires may have to be thoroughly grounded, etc. All of these possibilities should be checked carefully.

If the interference still persists after all of these details have been attended to, an inductive-capacitive type filter (see Fig. 30-9) should be connected at the primary side of the transformer used for supplying the high-tension current for operation of the sign.

If the sign is of the "on-off" variety or is of the type which consists of a number of sections operated by a rotary sign flasher, both the line circuit and *each* flasher circuit will have to be filtered in exactly the same manner as explained in Art. 30-31 for sign flashers, and shown in Fig. 30-19.

30-33. Minimizing the Interference at the Receiving Equipment.—The question as to whether it is better to attempt to suppress the interference directly at its source so that it does not reach the receiving equipment at all, or whether it is best to concentrate attention on the receiving equipment instead and take steps to prevent the interference from affecting it, has already been discussed in detail in Art. 30-15 and to some extent in Art. 30-19. The answer to it, and the decision regarding the course which the service man is to follow in any case, must be arrived at only after a careful level-headed consideration of the installation conditions which each case presents has been made. There is no single "sure-cure" formula for interference elimination. Before making any decision, the following points should be considered carefully:

- (1) Is the interference reaching the set by way of; (a) the power line; (b) the ground lead; (c) the lead-in and aerial; (d) a combination of these?
- (2) Is the nature of the immediate vicinity surrounding the place where the receiver is installed such that you would expect to find that the interference was caused by only one (or a few) electrical devices which can be located fairly easily, or is it likely that a large number of elu-

sive devices are contributing to the interference (see Fig. 30-7)?

- (3) Is the interference likely to be caused by a device that can be suppressed effectively by a filter or other means which the owner of the device is willing to allow the service man to install and which either the owner of the interfering device or the owner of the receiver is willing to pay for?
- (4) If it has been determined that at least a good part of the interference is reaching the receiver by way of the aerial and lead-in, is it likely that the *aerial* can be erected in a location which is reasonably free from the disturbance so that this portion of the antenna will not pick up noise even after a noise-reducing lead-in arrangement has been installed?

The answers to these important questions (and to any others which the service man's experience on noise-elimination jobs in the particular locality has shown him are very important), are the factors which should determine his course of action. They should tell him whether it is advisable to attempt to track down the source of interference and suppress it right at its source, whether to employ a line filter at the power line outlet to which the receiver is plugged, or whether to erect a special noise-reducing antenna arrangement instead, etc. The economics of the situation, and the degree of freedom from the interference which each remedy will finally provide are the key considerations in each case.

There is little question but what it is usually very convenient to minimize the interference at the receiving equipment rather than at the source whenever this is the best course to follow. Such a procedure often results in decreased cost of filtering apparatus, decreased cost in terms of time consumed in locating the source, and probably better results when the interference originates from several sources as is common in congested city districts. A consideration of what has been said here must show that there are many cases where it is not economical to devote the large amount of time required to hunt down

the source of interference in the veritable maze of electrical disturbances which may exist in the locality. In others, it is just plainly impossible to locate it, and the sooner the service man realizes it the better. This condition is very common in cities (especially where apartment houses are crowded together). With these facts in mind, let us see how interference may be prevented from affecting the receiver by taking proper steps *at the point of location of the receiving equipment*.

30-34. Suppressing Interference from the Power Line.—

Let us assume that the tests outlined in Art. 30-14 show conclusively that the interference (or at least a good part of it) is being *conducted* directly to the receiver from an outside source of disturbance by way of the power supply line, and that it has been decided for one reason or another that it would not be wise to attempt to hunt down the source of this interference. What should be done?

Noise entering the receiver by direct conduction via the power line can be minimized in two ways: first, by the insertion of a filter between the line and the receiver; and second, by the use of a shielded power transformer in the receiver. The first expedient makes use of a suitable filter (one of the types designed especially for use at the noise-generating device may be used). This filter may consist of condensers alone (as the ones at (A) and (B) of Fig. 30-9), or combinations of condensers and chokes, as previously described and shown at (C) and (D), placed in a shielded container. When used at the receiver, it should be placed *as close to the electrical outlet as possible in order to prevent the receiver supply cord from radiating noise over its length from the outlet to the receiver wiring or to the lead-in wire*.

Whenever it is at all practical to do so (especially in private homes) it is best to connect the filter at the incoming "service" switch near the house meter. By connecting the filter right at this main switch, the disturbances are prevented from circulating through the electric wiring of the building. This prevents them from reaching the receiver via the power line and also prevents them from setting up fields which might also affect the receiving antenna system. The filter ar-

rangement shown at (B) of Fig. 30-9 is a good one for this purpose if 1-mfd. condensers are used. Keep the leads to the condensers as short as possible, and connect their junction point to a good ground. This ground should be preferably a separate ground from the one used for the receiver—generally made quite

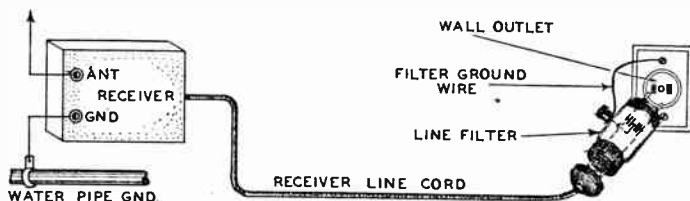

FIG. 30-21.—Correct method of connecting a line filter unit directly at the power line outlet so that no interference will enter the receiver line cord and be radiated to the receiver wiring or antenna system from it. The “ground” terminal of the filter unit should be grounded to the conduit of the line—not to the receiver ground. It is preferable to locate the filter unit at the main service switch of the building if it is possible (see text).

conveniently to the metal conduit in which the supply wires are run. In fact, even if the filter is connected at the outlet to which the receiver is plugged, its “ground” terminal should not be connected to the ground terminal of the receiver—it is usually much

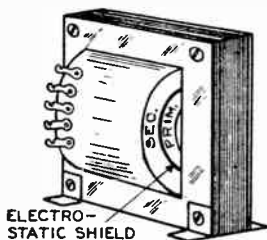
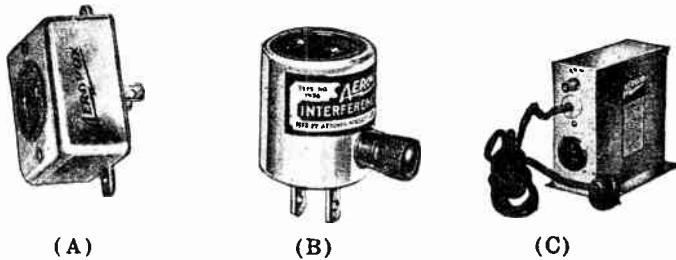

FIG. 30-22.—How the electrostatic shield is placed between the primary and secondary windings of a power transformer.

more effective to ground it to the metal conduit of the line by connecting it to the outlet plate as shown in Fig. 30-21. In fact, in many cases this “ground” may be found to have more effect on eliminating the interference than the filter itself has. And don't use a line filter the size of a thimble. Remember that it is the capacity (or inductance) of the filter that does the trick. Therefore, if the filter is one of those tiny things that are often seen, it does not have much capacity in it, and consequently will not do much filtering.

The use of a shielded power transformer is common prac-

tice in many medium-priced (and in all well-designed) modern receivers. An electrostatic shield is built in between the primary and the secondary windings of the power transformer in the receiver as shown in Fig. 30-22. The presence of this shield prevents line interference from getting across from the primary winding to the high-voltage secondary winding. Two by-pass condensers of about 0.1 mfd. each are also often connected across the supply line in the receiver. Of course, it is not generally necessary to replace an unshielded type power transformer with one having an electrostatic shield when noise is entering the set via the power line, but it is well to know why some receivers



Courtesy Aerovox Corp.

FIG. 30-23.—Three typical commercial line filters which contain filter condensers. They are made in the various forms shown here in order to facilitate their installation under various conditions.

(with unshielded power transformers) are noisier than others (with shielded transformers) even though chassis shielding is about the same in both.

There are many commercial compact, inexpensive line filter units designed with a male plug at one end (which plugs into the wall outlet) and a female socket at the other end into which the plug on the line cord of the receiver is inserted. When properly installed, as shown in Fig. 30-21, they automatically connect into the line between the wall outlet and the receiver line cord. Three typical units of this kind are illustrated in Fig. 30-23. The unit at (A) contains a single 1 mfd. condenser which automatically connects across the line. The female socket at the left and male plug at the right are visible. It can be mounted directly on any wall outlet, the screw which mounts it on the

wall plate serving to ground it. The filter shown at (B) contains two 1 mfd. condensers which form the circuit arrangement of (B) of Fig. 30-9. The binding post at the right is for the connection to ground. The filter illustrated at (C) employs the same circuit arrangement but contains condensers of larger capacity. It is designed for use in cases where the interference is quite strong. Its line cord (which plugs into the wall outlet) should be made as short as possible when the unit is installed, so that it will not radiate interference directly to the receiver chassis wiring or the antenna system. All of these units can also be used at the source of interference (between the device which is causing the interference, and the power supply line), but when they are so used, the wiring from the filter to the seat of the disturbance in the interfering device should be made very short to prevent direct radiation to the line and to other wires and antenna systems which may happen to be close by (see Fig. 30-14).

30-35. Interference Pickup by the Antenna Circuit.—Let us now consider the case where the tests outlined in Art. 30-14 show definitely that the interference (or at least a major part of it) is being picked up by the antenna system of the receiver. The interference may get to it in either (or both) of the following ways:

- (1) By *direct radiation* from the disturbing device.
- (2) By *indirect radiation* from the power supply line or some other circuit which has picked up the disturbance.

The first condition, that of "direct radiation pickup," is apt to occur if the disturbing device is located in the same building that the antenna installation is in. As shown in Figs. 30-4 and Fig. 30-7, even small electrical appliances can radiate disturbances to the lead-in wire if they are near enough to it. In apartment houses, the elevator motors and contactors which are usually in the elevator pent house on the roof radiate very strong disturbances which may be picked up directly by both the aerial and the upper part of the lead-in if they are near enough to it. Such prolific sources as diathermy machines (see Art. 30-30), large electric sign flashers, etc., cause the radiation of consider-

able interference energy which may be picked up directly by radio antennas over an appreciable area.

The second condition, that of "indirect radiation pickup", is perhaps the most common one. The branch circuits of the power supply lines in a building may pick up disturbances, conduct them, and re-radiate them to a radio antenna system at some point a considerable distance away either in the same building or in some other building (see Fig. 30-4). In rural districts, the elevated power supply line may conduct such disturbances for a considerable distance and re-radiate them to receiving antennas. The same is true for electric surface car lines, etc. Even double re-radiation may occur! A power supply line may conduct disturbances and radiate them to another conductor such as a metal gutter or drain-pipe, a metallic roof, a stand-pipe, pipe lines and shafts, etc. The latter conductor in turn may re-radiate the energy to a receiving aerial or lead-in in the vicinity. The possibilities and ramifications of such re-radiation are so complex that they are often responsible for very perplexing interference situations which are encountered. Nevertheless, its importance and prevalence should be understood, for it is often the mysterious reason why an aerial located in a high position ostensibly free from all electrical devices and circuits is very noisy because it happens to be within a zone of disturbance re-radiated by a roof gutter, a metal roof, a metal flagpole, etc., in the vicinity. More will be said about this in Art. 30-58.

Whenever an aerial is installed, it is good practice to use two or three insulators in series at each end. They should be separated about 12 inches from each other. This brings the end of the aerial wire no closer than 3 feet from its support. This is extremely important when the aerial is suspended from metal supports, such as iron pipe supports, vent pipes, etc., which are either driven into the ground or fastened to the metal framework or cornice of the building. These metallic structures may be re-radiating interference from some other source and the receiving aerial should be kept as far from them as possible, even though they may be necessary to support it.

30-36. Interference Pickup by Component Parts of the Antenna Circuit.—It should be remembered that the ordinary

inverted-*L* or *T* type antenna system consists of three parts. The horizontal portion is the *aerial*; the portion which leads from the aerial to the receiver is the *lead-in*; the portion leading from the set to the ground is the *ground lead*, or more simply, the *ground*. In "doublet" antenna systems there are only the aerial and the lead-in, no "ground" (as such) is used. In the "vertical" antenna there are only the aerial wire and the ground, although strictly speaking, if the aerial is erected very high above the roof, a lead-in will be used to connect it to the receiver.

In the majority of cases where interference is experienced, most of the electrical disturbance exists in the immediate vicinity

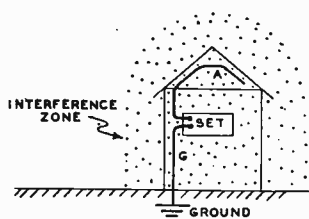

FIG. 30-24.—A typical example of an indoor aerial installed in a location full of interference. Both the indoor aerial, the lead-in and the ground wires run right through the strong interference zone and all of them pick up the disturbances. Noisy reception is bound to result.

of the building due to electrical devices located therein, or to the electric light and power wiring in the building which radiates interference that has been conducted in from the outside. It is picked up by the lead-in and ground leads, and very often by the aerial as well.

30-37. Interference Pickup by the "Ground".—The ground lead, and the ground itself, should come in for a great deal more attention by service men than they usually do. It should be remembered that in all antenna systems (except the loop and the doublet types) the ground lead alone may make quite a fair aerial—especially when the set is installed in an upper story of an apartment house so that the ground lead is high up from the actual earth. (How effective an aerial the usual ground lead makes, may be checked in a minute by disconnecting the aerial lead-in and ground leads from the receiver, connecting only the ground lead to the *Ant.* post of the set instead and tuning for a signal with the volume control full up). As soon as this is realized, the fact that the ground lead will also be affected by all interfer-

ence radiations from nearby electrical devices, the electric light wiring in the building, (and even water and gas pipes if they are acting as re-radiators of disturbance due to their being located close to interference-carrying lighting circuits at some point), follows naturally. The practice of running the ground lead to the plate of an electrical outlet for convenience should

FIG. 30-25.—A typical example of an outdoor aerial installation in which part of the aerial and the entire lead-in and ground leads are in the strong interference zone localized about the building. Since only a small proportion of the antenna system lies in a noise-free zone the signal-to-noise ratio will be low and noisy reception will result.

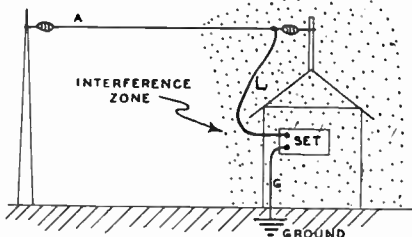

certainly be discontinued, for this connects the ground lead of the set directly to the conduit in which the electric light circuit, alive with interference, runs. The set is really then using the main source of the interference as a ground lead—which is certainly not a pleasant condition to picture!

Because of the foregoing conditions which may occur, the

FIG. 30-26. — Lengthening the aerial wire as shown here, often improves the signal - to - noise ratio, for it adds more 'wire' which picks up signal impulses but no noise impulses, since it lies outside of the interference zone.

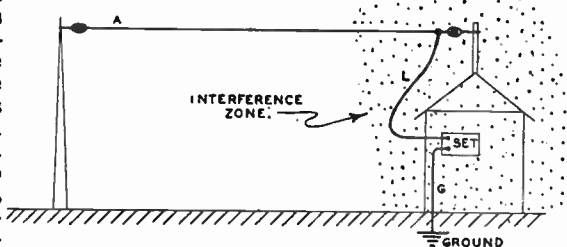

“ground” should be given some attention when noisy reception is experienced. In rural districts, perhaps the best ground is one that is buried outside the house where it is definitely away from all electric light wiring. Obviously, nothing will be gained by sinking a ground close to the point of exit of the electric light circuit, or even the water and gas pipes. A position at least 6

to 10 feet from the building and clear of the foregoing pipes and cables should be selected if possible. Six to ten feet of rod or ordinary iron pipe driven down into the earth, or about fifty feet of bare wire (at least No. 14 gauge or larger) buried in a shallow trench will make a good ground. Of course it is not possible to install such grounds in cities. The only thing that can be done in such locations when interference is experienced is to make a good ground connection (with a ground clamp) to the cold water pipe, or the steam pipe. The higher the connection is made in the building, the noisier the ground will be, for all piping between this connection and the earth will be picking up interference. For this reason, the use of a doublet antenna (Art. 30-48) is very advantageous when conditions of this kind are encountered, for no ground is necessary when it is employed. Therefore, all noise from this source is eliminated by its use.

30-38. Interference Pickup by the Aerial.—If the location is “noisy”, an indoor aerial is the worst possible type to install, for, as shown in Fig. 30-24, the entire antenna system in such cases is located right in the interference zone. Naturally, extremely noisy reception is bound to occur under such conditions.

If an outdoor aerial is employed (an inverted-*L* type is shown here although the same holds true for a *T* type or a doublet) and is installed so that it is *all within the interference zone*, even more noise will result because of its greater pickup of both the signal and the noise due to its greater length. If only part of it is in the interference zone, as shown in Fig. 30-25, the signal-to-noise ratio will be improved, for there is now a portion of the aerial which picks up signals but does not pick up interference because it is out of the interference zone.

When noise is experienced in an installation of this kind, it is very often possible to reduce it somewhat by simply lengthening the aerial portion of the existing antenna (if it is possible to do so) provided the added section is *certain* to be out of the interference zone, as shown in Fig. 30-26. Now, since a greater portion of the aerial picks up signals, but comparatively little or no noise, the signal-to-noise ratio is improved. This should really be the first thing to try in cases where the noise is only *moderately*

bad. In many cases, this simple expedient will convert noisy reception to satisfactory quiet reception on both the standard broadcast band and short waves. And, although 35 to 60 ft. aerials are commonly recommended, do not be afraid to try an aerial as much as 100 to 120 ft. long! Of course, lengthening the aerial will increase the capacity between it and the ground. This capacity acts as a small condenser across the primary coil of the antenna stage in the receiver, and may increase its natural wavelength to an undesired figure. In such cases, a small condenser (which may be an ordinary midget tuning condenser having a maximum capacity of 30 to 90 mmfd.) may be connected in series with the aerial lead-in wire close to the set. Putting this in series with the circuit reduces the effective antenna-ground capacity. Moderate background noise may also be reduced greatly in some cases by the simple expedient of shifting the aerial to a different location, out of the interference zone, when this is possible. A method of actually locating the zone of minimum or no interference for this purpose will be explained in Art. 30-58. This zone may occur above, to one side of, or even below the location of the existing aerial in some cases. The lead-in should be kept free of metal gutters. The service man should not overlook these two simple expedients (lengthening the existing aerial so as to extend it out of the noise zone, and shifting it to a location out of the noise zone) in cases where only a moderate amount of interference is experienced. He should always keep in mind the important fact that the *aerial* portion of the antenna must be erected in a zone which is at least comparatively free of electrical disturbances. Unless it is, no elaborate noise-reducing lead-ins of any kind are going to completely eliminate the noise, for the aerial will still be picking it up.

30-39. Interference Pickup by the Lead-In.—Assuming that noise pickup by the "ground" has been reduced to a low value and that the aerial has been erected in a noise-free zone (see Art. 30-58), the problem of the lead-in remains. The lead-in can be (and usually is) responsible for a great deal of the noise pickup—especially in apartment house installations where it must run right down for a considerable distance through the

thick of the strong interference zone created by electrical appliances and by the network of electric light wiring circuits in the building. A glance at the conditions represented in Fig. 30-7 (which are by no means exaggerated) should certainly enable the reader to visualize this condition. Even in a private dwelling, the lead-in may pick up a considerable amount of interference from these sources (see Fig. 30-4) not to mention interference from elevated power lines, surface car lines, etc., which may pass close by. This problem of interference pickup by the lead-in is solved in practice by:

arranging the lead-in so that it is impossible for it to transfer to the receiver any interference which it may pick up.

In other words, if the aerial can be located in a zone which is reasonably free from man-made electrical disturbances, and if the lead-in can be so arranged that even though it runs through the noise-infested area it does not transfer to the receiver any of the disturbances which it may pick up, then, assuming that the ground is also reasonably free from noise (if it is not possible to get an interference-free ground, a doublet aerial may be used, for it needs no ground at all), satisfactory noise-free reception (so far as the entire antenna system is concerned) should be obtained. Several practical lead-in arrangements which are designed to accomplish this result will now be described.

30-40. The Shielded Lead-In for Noise Reduction.—

When we speak of preventing electrical disturbances from af-

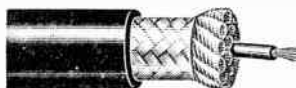

Courtesy Lenz Elect. Mfg. Co.

FIG. 30-27. — Rubber-jacketed shielded low-capacity single-conductor cable for use as a shielded lead-in wire.

fecting a conductor, the first thought which naturally comes to mind is that of electrically *shielding* the conductor from the disturbance by surrounding it with a shield or screen of conducting material. This idea has considerable value when applied to the lead-in of a standard broadcast-band receiver (but it is not satisfactory for short wave or all-wave receivers, as we shall see presently), and has been used to some extent in receiver installations of this kind where annoying interference has been experienced.

The entire lead-in right from the aerial to the *Ant.* post of the receiver is made of single-stranded copper wire which is surrounded by (though insulated from) a low-resistance closely-woven braid of tinned copper which shields it effectively. In the better grades of shielded lead-in the entire conductor and shield is jacketed by a waterproof outer covering of rubber which

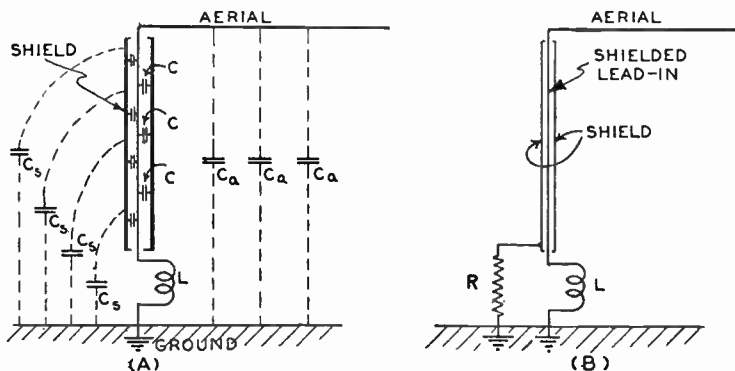

FIG. 30-28.—(A) The various capacities which exist between the aerial, ground, lead-in and shield in a shielded lead-in antenna system. (B) How the lower end of the shield may be connected to ground through a resistance (or choke) to reduce local oscillations of noise current in the shield circuit.

protects the shield from moisture and corrosion. A wire of this kind is illustrated in Fig. 30-27.

It is evident that the 20 or more feet of metal shielding (depending upon the length of the lead-in) surrounding the central lead-in wire may act as an independent receiving aerial which will pick up both signals and electrical disturbances (mostly the latter). Furthermore, this 20 or more feet of metal shielding surrounding the central lead-in wire and separated therefrom by rubber insulation (which is a good dielectric having a dielectric constant of about 3) forms a "condenser" of appreciable capacity, C , distributed along the entire length as shown at (A) of Fig. 30-28. This shielding also has a capacity, C_s , to ground, and the aerial wire has a capacity, C_a , to ground. These are all shown in the illustration. The equivalent electrical circuit which results is shown at (A) of Fig. 30-29 where A represents the lead-

in S represents the shield and L is the primary of the antenna coil in the receiver. Keeping in mind the fact that signal voltage is induced in the aerial wire and both noise and signal voltage is induced in S , it is evident that we have here two possible oscillating circuits, each one having its own natural resonant frequency determined by its inductance and capacity. One of these circuits consists of the aerial (in which the signal voltage is induced), C_a , the "ground", and L , as shown at (C) of Fig. 30-29. Notice that the signal current flows through the receiver coil when it oscillates in this circuit. The other oscillating circuit consists of S (in which the noise voltage is induced), C , A ,

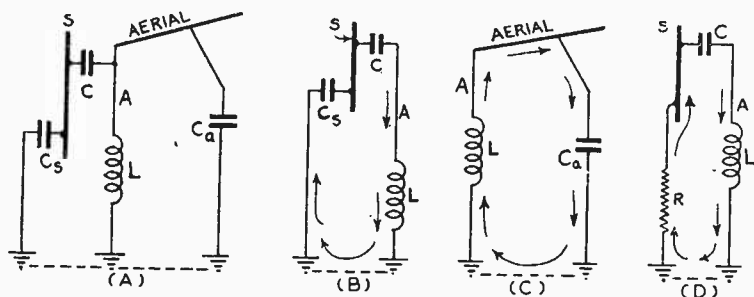

FIG. 30-29.—Equivalent electrical circuits which exist in the circuit arrangements shown in Fig. 30-28.

L , the "ground", and C_a , as shown at (B). Notice that since receiver coil L is also in the path of the noise current which will flow through this latter circuit, the effectiveness of the shield in eliminating noise pickup is greatly reduced. These interfering oscillating currents can be suppressed by grounding the shield at both ends as shown in Fig. 30-31 (and at intermediate points along it if possible) so that its entire length will be maintained at as nearly ground potential as possible. Since it is usually very inconvenient to make such a "ground" connection to the top end of the shield in actual installations, most manufacturers of shielded antenna kits resort to a different method of accomplishing the same result. The shield is grounded at the receiver end only, and a high resistance is connected in series with this ground lead (as shown at (B) of Fig. 30-28). Connecting this resistance in this way has the effect of introducing it directly in series with the oscillating circuit formed by the shield, antenna coil and

ground, as shown at (D) of Fig. 30-29, and it therefore suppresses the noise currents in this circuit. In some cases, a suitable r-f choke is used instead of a resistor for this purpose (see Fig. 30-30). Unfortunately, this resistance also reduces the effectiveness of this ground connection to the shield in bypassing the inductive interference currents to ground, but in actual commercial shielded antenna kits some sort of compromise is attempted between these two conflicting conditions by using a compromise value of resistance or choke.

Now if the simple shielded lead-in which we have considered thus far is installed in this way (so that it connects the aerial directly to the input circuit of the receiver) reception will be found to be quite poor. First, since the capacity between the lead-in wire and shield (capacity C in (A) of Fig. 30-29) is appreciably large for a long

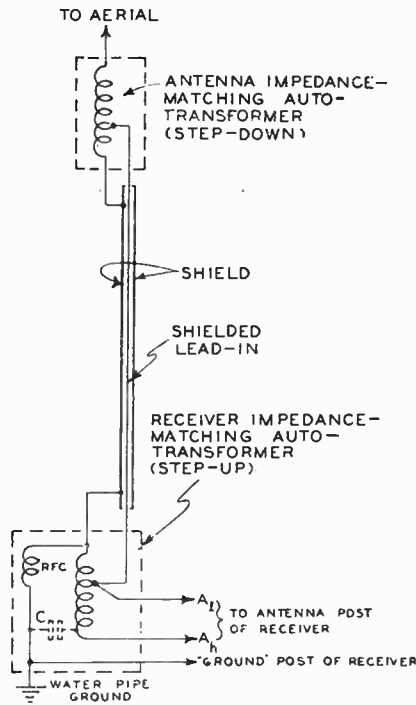

FIG. 30-30.—How impedance-matching transformers are connected at both the aerial and the receiver end of the shielded lead-in.

length of lead-in, and since both the aerial and the receiver end the shield is grounded, a considerable amount of by-passing of the high-frequency signal to ground will result. A study of (B) in Fig. 30-29 reveals that the capacities C and C_s in series really shunt the primary of the antenna coil in the receiver. Since C_s is appreciably large, its shunting effect is appreciable—especially for high-frequency signals. Viewed from another angle, the impedance of a line of large capacity is small, and when it is connected to the relatively large impedance of the aerial at one end and receiver at the other end, the transfer of energy to the receiver will be small.

It will be recalled that, in any system, maximum power is transferred when the impedance of the source is equal to the impedance of the circuit it feeds into (whatever it may be). In our case, the impedance of the aerial is very high compared to the impedance of the shielded lead-in, so that an impedance-matching transformer must be inserted between the aerial and the lead-in line. This transformer may be of the auto-transformer type as shown in Fig. 30-30, or it may be of the two-winding (separate primary and secondary) type. In either case, the primary winding of the transformer is designed to match the impedance of the aerial circuit to which it connects, and its secondary is designed to match the *lower* impedance of the line (the shielded lead-in to which it connects). Thus it really steps *down* the signal voltage of the aerial and increases the current in proportion (less the losses) so that the signal power may be transmitted through the lead-in at low voltage and higher current (the total signal power would remain unchanged if it were not for the losses which occur in the trans-

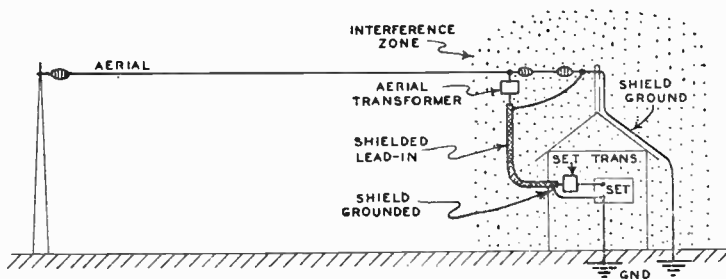

FIG. 30-31.—Method of installing a shielded lead-in for broadcast-band reception only. Impedance-matching transformers are connected at both the aerial and receiver ends of the shielded lead-in wire. The shield is grounded at each end. The ground to the upper end may be conveniently made to a metal roof gutter or leader in many cases.

former). Transmitting the signal power at this lower voltage results in less loss in the inefficient condenser formed by the lead-in, the shielding and the rubber insulation between them (since the power lost in any condenser increases greatly as the voltage is increased). At the receiver end of the shielded lead-in, the impedance of the line must be matched to the higher impedance

of the input circuit of the receiver so that the signal power may be transferred to it efficiently. Therefore another transformer (a step-up type) whose primary matches the impedance of the shielded lead-in and whose secondary matches that of the receiver input circuit as closely as possible, is used at this end, as

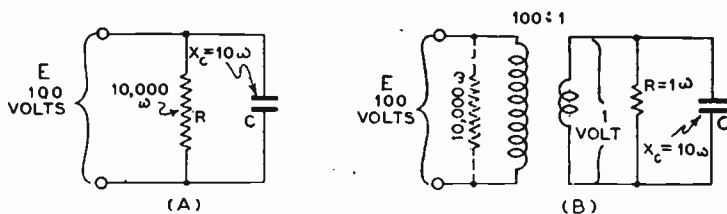

FIG. 30-32.—Equivalent electrical diagrams showing the effect of the impedance-matching transformer on the by-passing action of the lead-in-to-shield capacity of the shielded lead-in.

shown in Fig. 30-30. Under these conditions, the entire system is *matched* so far as impedance is concerned.

In terms of voltage and current, the antenna transformer reduces the voltage developed in the aerial to a low value and increases the current in proportion. The receiver transformer steps up this voltage again by transformer action and reduces the current. The effect of the ideal shielded lead-in system, then, is to virtually place the radio set up on the roof where the aerial is located, and if the aerial is in a substantially noise-free area, no noise should be heard. In practice, this will be true only if any signal or noise which the shielded lead-in picks up is effectively prevented from affecting the receiver input circuit, and if the transformers are designed correctly to keep the impedances matched. The arrangement of the aerial, shielded lead-in and the aerial and receiver impedance-matching transformers in a receiving installation of this kind is shown in Fig. 30-31. These transformers are really radio-frequency transformers and are ordinarily made of coils wound in either "scramble" or "universal" manner. When purchasing kits of parts for shielded lead-in antennas, the service man should be careful to avoid those types which have excessive losses at certain signal frequencies, and also those whose antenna impedance-matching transformer

is improperly weatherproofed to stand exposure to rain, extreme changes in temperature, humidity, etc., without deterioration.

Since impedance-matching transformers are so commonly used in noise-reducing lead-in systems, it will be well at this point to show why the capacity between the lead-in wire and its shield does not have so much by-pass action when it is terminated by a *low* impedance.

Consider the circuit shown at (A) of Fig. 30-32. A high-frequency voltage, E , of 100 volts is impressed across a resistance, R , of 10,000 ohms and a capacity, C , whose reactance at the impressed frequency is 10 ohms. The current through R is simply $100/10,000 = 0.01$ ampere, and that through the condenser is $100/10$ equals 10 amperes. It is clear, then; that under these conditions the impedance of the condenser is so *low* compared to that of the resistance (this could also be an inductance) it is connected across, that it takes nearly all of the current that flows from the source of voltage.

Now suppose that the source voltage be stepped down by a transformer so that the voltage applied to the circuit is now only 1 volt (as shown at (B) of Fig. 30-32); the transformer ratio required to reduce this voltage is 100-to-1 (step down). But the impedance is now reduced according to the inverse square of the transformer ratio, so that the 10,000 ohms now looks like 1 ohm, but the capacity remains the same, because it is connected *after* the transformer. The current through R is now 1 ampere, and that through the condenser is 0.1 ampere. Hence; the *capacity current* is now but a fraction of the *total current*, whereas previously it represented nearly all of the total current.

The same circuit and reasoning applies to the antenna system just described (see Fig. 30-30). The applied voltage, E , is that generated in the aerial by the signal, R may be considered as the impedance of the aerial, and C is the capacity of the shielded cable. The impedance-matching transformer reduces the voltage applied to C , so that a smaller proportion of the *total* current flows through it. At the receiver end of the line, the reverse takes place, and the voltage is stepped up to the required value. In an actual line, of course, inductance, resistance and capacity are present, so that the conditions are somewhat more complicated than presented here. However, it shows definitely why it is necessary to match the impedance of the aerial to the lower impedance of the shielded lead-in and to match the latter to the higher impedance of the receiver input.

The example presented here did not *match* the impedances, but made them unequal in the opposite sense. This was done to emphasize the effect of varying the impedance connected across a fixed capacity. In fact, though maximum *power* would not be transferred by the system shown here, reflections would occur from one end of the line to the other creating standing waves, and the system would be unbalanced unless the receiver were connected to very definite points along the line. In actual practice, it is essential that the impedances be really matched.

The main difficulty with the shielded lead-in type of noise-reducing system is that the non-adjustable impedance-matching

transformers can effectively match the impedances over only a comparatively narrow band of signal frequencies (unless variable controls are to be added at the two impedance-matching transformers, which of course is impractical). These transformers can be designed to work fairly efficiently over the limited standard broadcast band of frequencies from 540 to 1,600 kc, and a number of satisfactory units of this kind are on the market. In most of these, the winding which connects to the input circuit of the receiver is tapped (see Fig. 30-30) so that the full winding (tap A_h) may be used if the set is of the type having a high-impedance input and only part of the winding (tap A_l) is used if the set has a low-impedance input circuit. This makes better impedance matching to both types of receivers possible.

Unfortunately, the difficulties involved have prevented the development of suitable impedance-matching transformers which will work efficiently over the large range of frequencies covered by the short wave as well as the standard broadcast ranges. Severe line losses drastically cut down the signal intensity if this is attempted. It is for this reason that *the shielded lead-in type of noise-reducing antenna system is suitable when only the standard broadcast band is to be received. It should not be employed if man-made interference picked up by the lead-in is to be minimized when either a short-wave or all-wave receiver is to be used.* In such cases, one of the other systems which will be described shortly, should be used instead. Even in the case of standard broadcast band reception there is some loss between the receiver and the aerial. For the average case, about 30 to 50 per cent of the induced antenna voltage is lost in the transformers and lead-in. Of course, this loss can be tolerated if the interference is lowered to a far greater extent than the signal is, for then the reserve sensitivity of the receiver (most modern sets have an appreciable reserve) will make up for the increased antenna loss and give adequate volume with a lower background of interference.

The lead-in wire of any inverted- L or T type antenna system (if it is unshielded) picks up signal voltage, especially from nearby broadcasting stations. However, after it is shielded, it becomes merely a power-transmission line serving to connect the

aerial to the receiver. If it is a well-shielded lead-in, it no longer picks up any signal. Therefore, in cases where the unshielded lead-in has been picking up an appreciable portion of the total signal received, a decrease in signal voltage will result when a shielded lead-in is substituted for it. To compensate for this elimination of the lead-in pickup, the horizontal portion (aerial

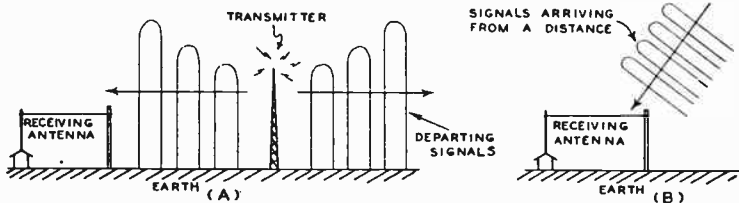

FIG. 30-33.—Near the transmitting antenna, the radiated waves are almost vertical, as shown at (A). At some distance from the transmitting antenna the signals arrive at an angle, as shown at (B), due to the fact that they have been reflected by the Kennelly-Heaviside layer.

part) of the antenna should be made longer than it was when the unshielded lead-in was used.

30-41. The Twisted-Pair Wire Lead-In for Noise Reduction.—Another very simple type of noise-reducing lead-in which does not transfer to the receiver any of the interference (or signal) which it picks up, consists essentially of a pair of twisted wires which connect the aerial to the receiver. A lead-in arrangement of this type is shown (without the aerial and receiver) in Fig. 30-34. Note that it is merely a pair of vertical twisted wires in free space.

Now let us see how the waves arrive at the receiving antenna. Near the transmitting station the waves are departing from the transmitting aerial in the manner shown at (A) of Fig. 30-33. They are mainly vertical ("vertically polarized"). The fronts of the waves are energized from top to bottom and hence are best received by a vertical (or partly vertical) wire. Now interference radiations come from nearby sources also, and a good part of these are also vertically polarized. Hence, we may say that both the radiations from interference-producing devices and those from loud local stations are both *vertically polarized* and hence can induce voltages in a vertical wire. Signals from

distant stations are reflected from the Kennelly-Heaviside layer, and approach the receiving aerial at an angle, as pictured at (B) of Fig. 30-33. Since this angle is usually very flat, horizontal aerial wires are usually best for the reception of distant stations.

A study of (A) of Fig. 30-34 shows that the vertically-polarized signal and noise waves induce voltage in the two wires of the twisted-pair lead-in. Since these wires are close together, the voltages E_1 and E_2 induced in them are equal and in phase with each other, so that their polarities are always similar. At one instant their polarities will be as indicated here, at the next both will be reversed, etc. It is important to remember that this is only true if the wires are very close together (close compared to the wavelength of the signal), so that both wires are being acted upon by the same part of the field (same phase) at the same time. Therefore, since the two lower terminals (that connect to the receiver) are both positive, and then both negative, simultaneously, there is never any *difference* of potential between

FIG. 30-34.—How a vertical twisted-pair wire lead-in cancels any voltage induced in it by any kind of a signal (including noise) provided it is terminated in a transformer winding in which the induced voltages E_1 and E_2 can balance each other out.

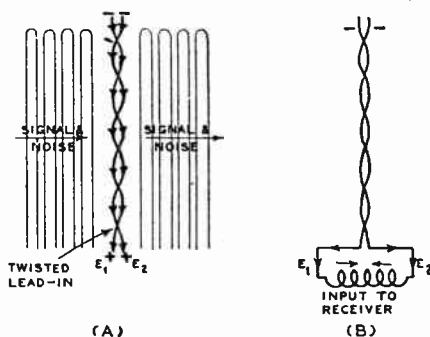

them. Consequently, if they are connected to a coil, as shown at (B), no current due to these voltages will flow in it, since current only flows between points which differ in potential. Another way of looking at it is to consider that the two induced voltages E_1 and E_2 being equal and acting in opposite directions *in the coil* at all times, cancel each other's effects.

This coil may be the antenna coil in the receiver or the primary of a transformer connected between the lead-in and the receiver. It makes little difference to the lead-in what kind of a

coil it is; the fact that no potential difference due to signal or noise pickup by the lead-in exists between the terminals of the coil prevents the flow of the noise current in the coil; hence, no noise voltage will be induced in another coil coupled to the first. Therefore, no matter what vertical wave induces a voltage in the lead-in, it cannot be transferred to the receiver or actuate the grid of the first tube in it because of the lack of potential difference. Since this type of noise-reducing lead-in depends for its action upon the *balancing* of the two induced voltages in it, and since it also acts as a *transmission line* to conduct the desired signal from



Courtesy Lenz Elect. Mfg. Co.

FIG. 30-35.—*Left*: A twisted-wire pair in which the wires are enameled and covered with a waterproof braiding.

Right: A twisted-wire pair in which the conductors are encased in a rubber jacket to protect them from moisture, etc. This is more suitable than the former one for use as a twisted-wire lead-in.

the aerial to the receiver, it is commonly called a *balanced transmission line*.

A consideration of the action of the twisted-pair lead-in and the vertical polarization of both the interference impulses and the signals from nearby transmitting stations would lead us to conclude that a twisted-pair lead-in should be as vertical as possible if the interference induced in it is to be cancelled out. It may seem that if the lead-in is placed horizontally, no noise can be induced in it and hence none will be received. This statement is true under ideal conditions; but in practice, it is found that while noise radiations are mainly vertically polarized, at least a part of them may be horizontally polarized, i.e., there may be a *horizontal* component. Furthermore, it is quite difficult to erect a lead-in that is not horizontal for at least some part of its length.

The twisted-pair lead-in must be constructed of a high grade of twisted wire which has low losses and can stand the weathering action of sun, rain, wind, etc. Ordinary twisted-pair telephone wire or lamp cord does not meet this requirement. One prominent manufacturer of noise-reducing antenna kits employing this type of lead-in uses stranded, tinned copper wire for each

conductor. Each wire is insulated with high-quality submarine cable rubber and an outer covering of weatherproof braid. The wires are twisted closely. Another uses two conductors of "litz" wire, each wrapped with a very thin specially prepared cambric cover, impregnated with an insulating varnish. These twisted conductors are protected by a heavy moisture-proof casing of high-grade rubber. Two representative types of wire for twisted-pair lead-ins are illustrated in Fig. 30-35.

30-42. The Twisted-Pair Lead-In With An Inverted-L (or T) Aerial.—If an inverted-L type aerial is to be used with a twisted-pair lead-in for minimum lead-in pickup of interference, the upper end of the lead-in may connect to the aerial wire in the way shown in Fig. 30-36. One wire of the lead-in connects to the aerial wire at point *D*, and the other wire, *A*, is either connected to a short length of the aerial support wire (between insulators) merely to support it as shown, or it may be left entirely unconnected in space. The same type of connection may be employed if a T aerial is used. Thus, only one lead-in wire is effective in carrying down the signal from the noise-free horizontal aerial section, and the other is merely used to cancel noise picked up by the lead-in, as previously described. With the free wire removed from the system, the aerial is simply the

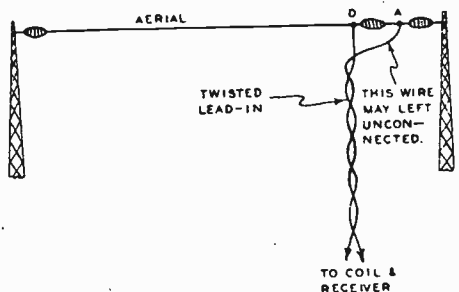

FIG. 30-36.—Method of connecting a twisted-wire lead-in to an inverted-L (or T) type aerial. One end, *A*, of the lead-in is either left entirely unconnected, or it is connected to a short section of the aerial guy-wire for support.

ordinary inverted-L (or T) type used by so many millions of radio owners. With the second section of the lead-in present, any noise voltage picked up by the lead-in is cancelled in the coil connected to the bottom end, and if the horizontal aerial section of the antenna is in a noise-free zone, reception will be comparatively free from noise disturbances (provided the cir-

cuit is exactly balanced, and no disturbances reach the receiver by any other path).

The question of "best aerial length" always arises in the installation of an inverted-*L* antenna. How long should the horizontal "aerial" portion be made for best results? The answer to this question depends to a large degree on whether the antenna is to be used for general all-wave reception with a com-

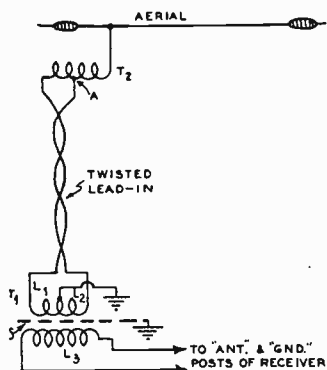

FIG. 30-37. — Circuit arrangement of an antenna system having a twisted-wire lead-in. The method of connecting the two impedance-matching transformers T_1 and T_2 , and the electrostatic shield S is shown.

mon all-wave receiver, or whether it is desired to construct the antenna so that it will receive some particular frequency best (perhaps it is desired to arrange the antenna to be most efficient at the frequency of a certain distant station it is particularly desired to receive, or it is to be used by an amateur to receive desired signals on a certain band best, etc.). If the antenna is to receive best on a particular frequency (such as for communication purposes on 20, 40, 80 or 160 meters as used by amateurs), the choice of the length of the aerial portion is rather important. In such instances the most suitable length (in meters) is *one half* of the actual wavelength on which the amateur desires to transmit and receive.

For use in connection with all-wave receivers, a compromise must be made since the frequency band to be covered is very large. One compromise is to make the length of the aerial portion of the antenna equal (in meters) to *one-half* the length of the *shortest* wavelength it is desired to receive, if the antenna is an inverted-*L* type. If it is a doublet type, it is well to make a double-doublet out of it, as explained in Art. 30-55, in order to cover the large frequency range efficiently. A doublet antenna receives best those signals which have a wavelength equal numerically to *twice* the *total* length (in meters) of the two wires which form the horizontal portion of the doublet. The inverted-*L*

type antenna receives best those signals whose wavelength is *equal* numerically to *twice* the length (in *meters*) of the horizontal aerial portion.

As an example of how a typical calculation for the length of aerial wire to use in these special cases is carried out, let us consider the inverted-L antenna shown in Fig. 30-36. The overall length of the aerial wire should be equal to $\frac{1}{2}$ the wavelength of the particular frequency it is desired to receive best. Thus, to receive a 49-meter station with best results, the length of wire used should be $49/2$ or 24.5 meters. And since there are about 3.3 feet in a meter, the wire length should be 24.5×3.3 , or about 80 feet. But when the length is made 80 feet, the impedance of the line may not match that of the aerial, so that another impedance-matching transformer T_2 must be connected between the aerial and the transmission line, as shown in Fig. 30-37.

Whether one or two transformers are used depends upon the design of the individual system. The general principles, though, are common to all, especially regarding the placement of the aerial portion of the antenna in a zone as free from interference as possible, etc.

One of the main troubles with these simple antenna systems is that unless a switching arrangement is used (see Art. 30-47) good impedance matching can only be effected over a fairly narrow band on either side of the frequency for which good matching occurs, so that the response of many of these noise-reducing systems falls off considerably at some signal frequencies. Obviously, *maximum* response can only be secured on certain frequencies but *good* response will be obtained on many of the harmonics of these frequencies. The response at a harmonic frequency is less than that at the fundamental frequency of the aerial, but despite this it may still be fairly strong at the harmonic frequency.

For example, suppose a half-wave antenna is constructed and let the length of the aerial be 58 feet. Converted into meters and then into frequency, the response of the system will be best at about 8 megacycles. For signals of higher frequency, the response of the system falls off gradually and then starts to rise again, and another peak will occur at 24 megacycles (the third

harmonic of 8 megacycles); another peak will also occur at 40 megacycles, (the fifth harmonic), and so forth.

Under normal conditions, a *T* or inverted-*L* type antenna is desirable for use mainly on the broadcast band and also the next lowest band, commonly referred to as the "police band". Below this, a grounded antenna system is not efficient unless separate antennas cut to proper length for optimum reception are used for

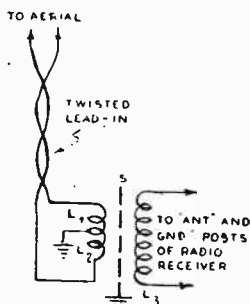

FIG. 30-37A.—How the impedance-matching transformer is connected between the twisted-wire transmission line and the receiver. *S* is the electrostatic shield.

each short-wave band. This, of course is not practical for an average all-wave home receiver. "Doublet", or "double-doublet", antennas possess advantages for this class of receiver operation, as we shall see in Art. 30-55.

30-43. The Impedance-Matching Transformers.—The use of a twisted-wire lead-in from the aerial to the receiver for noise reduction is simple, but is not without some practical difficulties. The lead-in has a certain impedance. The further apart twisted wires are, the smaller is the capacity between them, and the higher is the impedance of the line. The size of the

wires and the length of the lead-in also affect its impedance. If the lead-in (more technically called the *transmission line*) is long, then the impedance of the line must be taken into consideration. For best results, the impedance of the aerial must match that of the line at the aerial end, and the impedance of the line must match the impedance of whatever it is connected to at the receiver end. If the impedances are not properly matched, maximum signal power cannot be transferred from the aerial to the receiver, and the transmission of the signal from the aerial to the receiver will not be uniform at all frequencies.

The usual method of matching the impedances for a twisted lead-in (or a transposed lead-in) is by the use of a properly designed transformer, at the receiver, as shown in Fig. 30-37A. A transformer at the aerial end of the twisted-wire lead-in is not generally required if a commercial kit of antenna parts is em-

ployed, for these are designed so that the piece of twisted wire lead-in furnished in the kit has an impedance which effectively matches that of the aerial sufficiently closely. It is for this reason that the lead-in wire which is furnished with these kits *should not be cut to the exact length actually needed for the installation*; the total length of lead-in which is supplied in the kit *must* be used. If any of this is excess, it must be coiled up and tucked away at the receiver. In such cases, since the impedance of the lead-in already matches that of the aerial, it is only necessary to use an impedance-matching transformer at the receiver end to match the lead-in impedance to that of the input circuit of the receiver. If more wire than the supplied length is required, only definite *multiples* of the original length supplied can be used, as we have seen in Art. 30-42.

30-44. Static Shield in Impedance-Matching Transformers.—The mere presence of a transformer at the receiver end of the twisted (or transposed), lead-in does not necessarily eliminate the noise voltages by cancellation because if the system is not balanced and there is capacity coupling between the primary and secondary of the transformer the disturbances will be transmitted to the receiver through that capacity. Let us see why this is so:

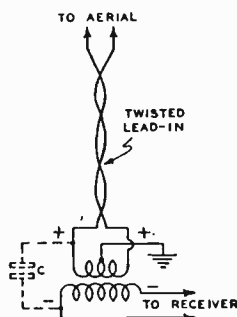

FIG. 30-38.—How noise voltage appearing across the primary of the receiver impedance-matching transformer may induce noise voltage in the secondary winding if appreciable capacity, C , exists between them.

Referring to Fig. 30-38, if appreciable capacity, C , exists between the primary and secondary windings of the impedance-matching transformer, then the noise voltage appearing across the primary will induce an equal and opposite voltage across the secondary by *electrostatic* induction. No noise would be heard if the entire antenna system were perfectly symmetrical from the aerial right down to the input coil in the receiver. If the system is not exactly symmetrical (and it hardly ever is in practice),

some slight interference noises will be heard, but they will usually not be very strong.

If a grounded electrostatic shield, *S*, is interposed between the primary and secondary windings, it serves to reduce the capacity between these two coils to a low value—almost zero if possible. This prevents the capacity coupling from transmitting the noise to the secondary. The shield must be so constructed, however, that it permits *magnetic* coupling between the two coils so that the signal current flowing through the primary can induce signal voltage in the secondary by *electromagnetic* induction. Hence its name—*electrostatic shield*. This shield usually consists of a piece of thin sheet copper or copper-foil making slightly less than a complete turn around the primary winding.

30-45. Constructing an Impedance-Matching Transformer for a Twisted-Wire Lead-In.—It is possible for the service man to construct his own impedance-matching transformers to be used between a twisted-wire lead-in and the receiver when

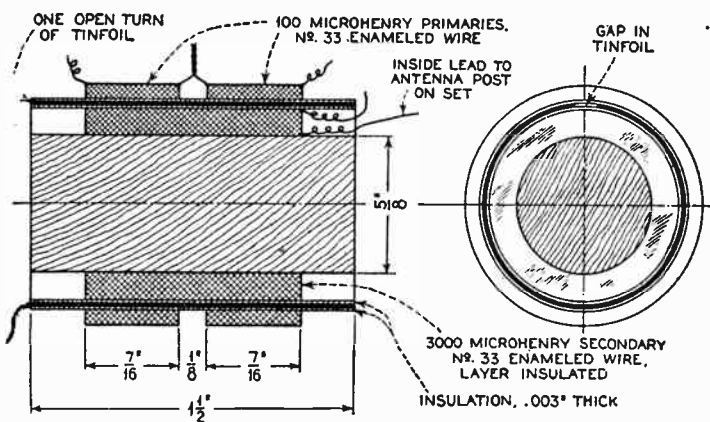

Courtesy Radio News

FIG. 30-39.—Construction details of an efficient impedance-matching transformer to be connected between the twisted-wire lead-in and the receiver.

an ordinary inverted-*L* type antenna is employed, and operation over the *standard broadcast band only* is desired. The unit about to be described is suitable for use with a twisted-wire

lead-in about 50 feet long. Its construction is illustrated in Fig. 30-39 and its circuit diagram is shown in Fig. 30-40. Intensive tests by one of the large receiver manufacturers have shown that when it is used with an ordinary twisted-wire lead-in, the noise picked up in the lead-in is reduced by 55 decibels, while signals picked up by the aerial are attenuated a maximum of only 9.5 db. at 1,500 kc and 5.0 db. at 550 kc (a receiver having an overall gain of 114.0 db. was used in the tests). Thus, the reduction of noise picked up by the lead-in is very great, while the attenuation of the signals is small—over the standard broadcast band. The construction data for this unit is presented here by courtesy of H. J. Adler its designer, and Radio News Magazine, in which it was first described.

It consists of a $\frac{5}{8}$ -inch diameter wooden or cardboard form $1\frac{1}{2}$ -inches long on which the primary and secondary are wound. The secondary is wound on it first, and consists of 450 turns of No. 33 enameled wire. The winding length of this coil is 1-inch, so that several layers are required; each layer should be insulated from the adjacent one by waxed or "glassine" paper about 0.001-inch thick. Both secondary leads should then be taken from one end, as shown in the sketch of Fig. 30-39. When the secondary is finished, wind an insulating layer of paper over it; the thickness of the paper being about 0.003-inch. The electrostatic shield is placed on next! It consists of a strip of tin or copper foil, $1\frac{1}{2}$ -inches wide and just long enough so that the two ends will just *miss meeting* by $1/16$ -inch; in other words, wrap the foil around $1/16$ -inch less than one turn. If the two edges of this shield should touch, a low-resistance short-circuiting turn of copper will be formed. This will absorb most of the energy and the transformer will be useless. Solder a lead to the shield as shown. Over this shield is placed another layer of insulating paper 0.003-inch thick, and the two primaries are then wound. Each primary winding consists of 75 turns of No. 33 enameled wire. The two windings must be identical and equidistant from the center of the form, as shown in the sketch. Wind each primary coil, starting from the center and working toward the end; each primary will take slightly over one layer. The primary leads should be brought out as shown. When finished, each primary coil will have an inductance of 100 microhenries and the secondary an inductance of 3,000 microhenries; the coupling between primary and secondary will be approximately 65%. The method of connecting the coil in the antenna circuit is shown in Fig. 30-40. It is important to keep the primary leads well shielded from the secondary leads to prevent capacity coupling between them.

Primary L_1 , when tuned by the antenna capacity, resonates within the broadcast band, making it necessary to place C_1 , a 100 mmfd. condenser, in series with it. C_2 , which is semi-variable is put in the other lead to make both circuits symmetrical. With the above values and on an average antenna, L_1 and L_2 will resonate at about 1,800 kc. The adjustment of condenser C_2 is neither dependent upon

the length of the lead-in, nor upon the capacity of the antenna.

In adjusting the system, connect the twisted-wire lead-in and the receiver to the transformer in the usual manner as shown in Fig. 30-40, but do not connect the far end of the transmission line to the aerial. Turn on the receiver and tune in a weak station, if possible. Then adjust C_2 for minimum signal! Con-

nect the aerial end of that wire of the transmission line which connects to C_1 to the aerial, and the adjustment is finished. No further adjustments of C_2 are required.

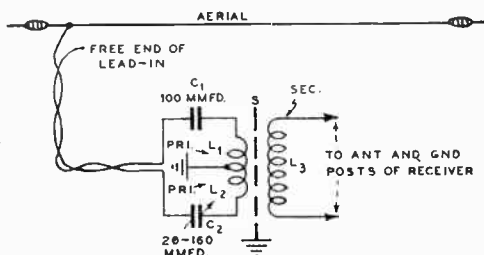

nect the aerial end of that wire of the transmission line which connects to C_1 to the aerial, and the adjustment is finished. No further adjustments of C_2 are required.

30-46. Connecting Twisted-Pair Wire (and Transposed) Lead-Ins to Receivers.—After a noise-reducing lead-in is in-

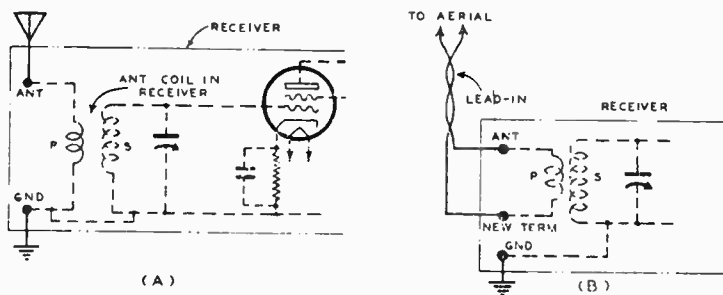

FIG. 30-41.—(A) How the antenna coil circuit of most ordinary receivers is arranged.

(B) How the primary must be isolated from the "ground" if a twisted-wire (or transposed) lead-in is to be connected directly to the receiver without any intervening impedance-matching transformer.

stalled, it must be connected to the receiver in the proper manner if it is to work satisfactorily. The exact method of connecting either a twisted-pair wire or a transposed type noise-reducing lead-in to a receiver depends mainly on the type of input circuit

which the receiver has. Several possible arrangements will now be considered.

Most of the older standard broadcast-band receivers have one Ant. and one Gnd. post, connected as shown at (A) of Fig. 30-41. The *Gnd.* post not only connects to one side of the primary winding of the antenna coil in the receiver but also connects to the receiver chassis and grid-return circuits, as shown. Although this is not common practice, if a transmission line lead-in of either the twisted-pair wire or the transposed type is to be connected *directly* to a receiver of this type without the use of any intervening impedance-matching transformer, the primary winding of the receiver's antenna coil must be isolated from the

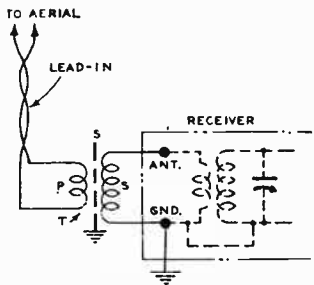

FIG. 30-42.—How the twisted-wire (or transposed-wire) lead-in is connected to the type of receiver input shown at (A) of Fig. 30-41 when an impedance-matching transformer, *T*, is to be used between the lead-in and the radio receiver.

ground, and the lead-in connected directly across it as shown at (B). The ground must remain connected to the rest of the receiver circuit (chassis, etc.). To do this, locate the primary winding of the antenna coil in the receiver by tracing back from the *Ant.* and *Gnd.* posts. Locate the end of this primary which is grounded, and break its ground connection. Bring this lead out to another terminal which is to connect to one side of the lead-in. The regular *Gnd.* post can then be used for the ground connection in the regular way. If an impedance-matching transformer is used between the lead-in and the receiver, the connections are simply as shown in Fig. 30-42. No changes need be made in the receiver wiring in this case.

Some of the older receivers are provided with one *Gnd.* post and two *Ant.* posts. One is for use when a long antenna is used; the other is to be employed when a short antenna is used. The

Long Ant. post connects to a tap on the primary of the antenna coil in the receiver, as shown at (A) of Fig. 30-43. If the lead-in is to be connected directly to the receiver with no intervening impedance matching transformer (this is not the common practice), the primary winding should be isolated from the "ground" and the *Long Ant.* post should be connected directly to the lower end of the winding instead of to the top. The lead-in is then connected directly to the primary coil, as shown at (B). If an impedance-matching transformer is to be used between the lead-in and the receiver, it should be connected to the receiver and the lead-in as shown at (C). In this case, no changes in the wiring of the receiver are necessary.

Many of the recent all-wave receivers are equipped with a *Gnd.* post and two *Ant.* posts, but the latter are connected

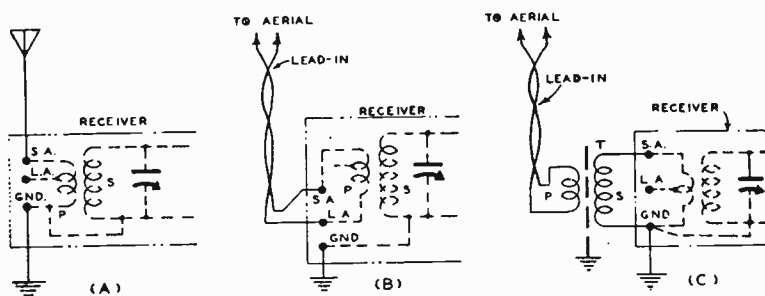

FIG. 30-43.—(A) Arrangement of the antenna coil in a receiver provided with L.A. and S.A. antenna posts.

(B) How a twisted-wire or transposed-wire lead-in is connected to it if no impedance-matching transformer is to be used. The primary of the antenna coil is isolated from the ground.

(C) How the connections are arranged if an impedance-matching transformer is used between the lead-in and the receiver.

directly to the primary winding of the antenna coil which is isolated from the "ground". The circuit arrangement is already as shown at (B) of Fig. 30-41. Therefore, either a twisted-wire or transposed type noise-reducing lead-in with its proper impedance-matching transformer may be connected directly to these two *Ant.* terminals of the receiver without any necessity for changes in its wiring.

The primary of the impedance-matching transformer may

(or may not) have a center-tap which is to be grounded. In the circuit arrangement shown in Figs. 30-42 and 30-43 no center tap is provided. In the ones shown in Figs. 30-37 and 30-40, the primary has a center tap which is grounded. This merely places the center of the coil at the fixed potential of the ground and has no bearing on the operation of the twisted or transposed lead-in. In any case, the leads from the secondary of the impedance-matching transformer to the receiver should be made *absolutely as short and direct as possible*. The transformer should be mounted right close to the *Ant.* and *Gnd.* posts of the receiver.

30-47. Antenna Circuit Switching Systems for All-Wave Receivers.—When noise-reducing antenna systems are to be used with all-wave receivers, some means must usually be pro-

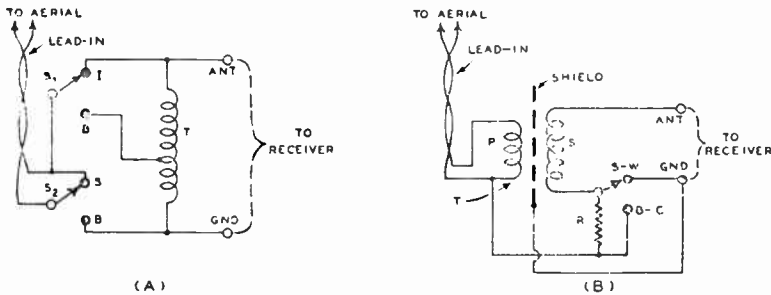

FIG. 30-44.—Two typical switching systems for use with transmission-line aerial systems when they are applied to all-wave receivers. In each case, *T* is the impedance-matching transformer connected between the lead-in and the receiver.

vided to switch from one frequency band to another (unless a special circuit arrangement such of the general type described in Art. 30-55 is used), since the efficiency of the impedance-matching transformers used depends upon the frequency band covered. In other words, the usual system designed to cover the 540 to 1,600 kc standard broadcast band will be hopelessly inefficient when used on, for instance, the 31-meter short wave band; therefore, some means must be provided to change the characteristics of the system, especially the impedance-matching transformers, to give as nearly equal efficiency as possible over the

most important tuning ranges over which the receiver is designed to operate.

The circuit at (A) of Fig. 30-44 is one type of switching system commonly used. Two s.p.d.t. switches S_1 and S_2 are employed: with S_1 on tap B and S_2 on B , the transmission line is connected across the lower part of the coil for good impedance match over the broadcast-band from 500 to 1,500 kc; on position I and B , the entire coil is used for good impedance match when the 1,500 to 6,000 kc short-wave band is employed; on position I and S , the transmission line is short-circuited and connected to the top

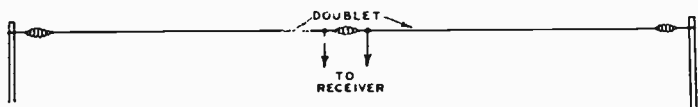

FIG. 30-45.—A simple "doublet" aerial. It is really a split aerial with an insulator at the exact center and a lead-in taken off from the inside end of each of the two sections.

of the coil, giving best reception in the short wave band from 6,000 to 15,000 kc. A total aerial length of approximately half a wave length is recommended with this system. The method of calculating the length of the aerial in feet was given in Art. 30-42.

The system shown at (B) of the figure is simpler to operate inasmuch as but two switch positions are available. The antenna used with this arrangement is of the double-doublet type (see Art. 30-55) and resonates in the important short-wave broadcast bands. With reference to this diagram, it is seen that with the switch thrown to the "short-wave" position ($S-W$), the connections, of the impedance-matching transformer, T , are standard, except for the presence of resistor R . This resistor is connected from one side of the primary to ground, and serves to ground any static charges that may accumulate on the antenna system so that they do not spark to ground and cause disturbing periodic "clicks" in the receiver. This resistor is not essential to the operation of the antenna as a collector of "noise-free" signals, however. With the switch in the $B-C$ position, the primary and secondary connect together directly for standard-broadcast band reception, and the antenna system functions practically as if the impedance-matching transformer, T , were not in use.

This system, therefore, only uses the noise-reducing lead-in arrangement on the short waves where interference from man-made electrical devices is much more severe than on the standard broadcast band. On the standard-broadcast band, it uses the aerial as either an inverted-L or T type for good pickup, and the lead-in is not noise-reducing since it is no longer balanced.

30-48. **The Doublet Antenna.**—Up to this point we have talked about antennas which employ a ground connection. Since Marconi first used such antennas they are commonly called *Marconi* antennas. These include the “inverted-L,” “T,” and “vertical” types. There is another type of antenna which requires no ground connection whatever. Since it was first used by Hertz over half a century ago, it is sometimes called the *Hertz* antenna, although it is more commonly known as the *doublet* antenna. A “doublet” is merely a split aerial with an insulator at its exact center and a separate lead-in taken off from the “inside” end of each of the two halves, as shown in Fig. 30-45. Since it is most efficient in picking up those signals whose wavelength is equal to *double* the overall length of the aerial in meters (see Art. 30-42) it has been named the “doublet”.

If the two wires are erected horizontally we have a “horizontal” doublet. This is most suitable for receiving short-wave signals from distant stations since the waves from these stations usually arrive in a horizontally-polarized state (see Fig. 30-33). This is the most common type of doublet. It also has an advantage insofar as noise is concerned. Since *noise* comes from nearby sources and a good part of it is vertically polarized, it is not picked up as strongly by the horizontal doublet antenna as it would be by a vertical antenna. If the two wires are erected vertically, we have a “vertical” doublet. This is best suited for the reception of signals from nearby stations (due to the vertical polarization of the waves from these stations), although it is not as practical a form of antenna to erect as is the horizontal type. In any case, the two halves of a doublet should be of *exactly the same length*.

As an instrument of signal pickup, the doublet does not differ much from the inverted-L type antenna. As a matter of fact, it may be looked upon as a tandem arrangement in which two

inverted-L types are used back-to-back instead of one, and the signal energy is collected from both. The service man should keep one point firmly in mind. The term "doublet" refers to a specific type of aerial. This form of aerial in itself is in no way to be considered as a "noise-reducing" aerial any more than an inverted-L or T type aerial can be so considered. Unless it is erected in a noise-free zone it will pick up noise disturbances just as well as it will pick up signals. The signal induced in each half of the aerial portion of the "doublet" antenna must be conducted to the receiver by a lead-in wire. If these lead-in

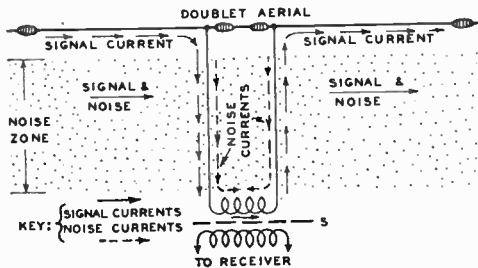

FIG. 30-46. — How the noise voltages induced in a parallel-feeder lead-in are cancelled out in the primary impedance-matching transformer. The signal voltages induced in the two halves of the doublet are additive.

wires pass through a zone of man-made interference, they will pick up these disturbances, and noisy reception will result. Consequently, in such cases, some noise-reducing lead-in arrangement must be used with the doublet if quiet reception is to be obtained. Three types of lead-ins may be employed for this purpose. They are, the "twisted pair" lead-in, the "parallel feeder" lead-in and the "transposed" lead-in. In either case, the lead-in forms a balanced "transmission line". The construction and operation of the twisted-pair lead-in, as well as the necessity for correct balancing and impedance matching when it is used, has already been presented in detail in Arts. 30-41 to 30-46 inclusive. All that was said about it in these sections in connection with inverted-L or T type antennas also holds true when it is used with doublets. The other two types of lead-ins for use with the doublet will now be considered.

30-49. The Doublet with a Parallel Feeder Lead-In.—If the two lead-in wires are connected to the doublet and run par-

allel and close to each other down through the noise area, the conditions are as pictured in Fig. 30-46. We shall assume that at a given instant a *signal* current is induced in the two aerial wires of the doublet in the direction shown by the solid-line arrows. Notice that this current is in the *same* direction in both aerial wires. It flows *down* through the left hand lead-in wire through the primary winding of either the impedance-matching transformer at the receiver, or the antenna coil in the receiver, and *up* through the other lead-in, following along its original direction through the right-hand half of the aerial. The path and direction of this current flow is shown by the solid-line arrows. Naturally, any noise pickup by the *aerial* wires will flow through this same path and be heard in the receiver along with the signal. If the aerial is well located, the noise impulses will be very weak compared with those of the signal i.e., the signal-to-noise ratio (see Art. 30-13) is high.

Since the noise radiations sweep across both parallel lead-in wires, if they are separated the proper distance apart from each other so that the noise voltage induced in them is sensibly of the same phase, this noise voltage will be in the *same direction* in each wire (as shown by the dotted-line arrows); furthermore the *same amount* of noise voltage will be induced in each wire. These noise voltages meet in the primary of the impedance-matching transformer and neutralize each other. Therefore they produce no sound in the receiver if the primary winding is properly shielded electrostatically from the secondary (see Art. 30-44). Of course, any signals picked up by these lead-in wires are also cancelled out and are not heard in the receiver. Under these conditions the parallel lead-ins form a balanced transmission line or "noise-reducing lead-in".

In practice the lead-in wires must be separated by numerous insulators (one about every 15 inches) to keep them the proper distance apart. Notice that the system operates as a "balanced" transmission line *only* as long as the two wires are so spaced apart that the noise voltages induced in them are *exactly in phase* with each other. If one wire were to have induced in it, a stronger noise voltage impulse than the other, it would force a noise current to flow through the primary winding against the

bucking action of the weaker impulse induced in the other wire, and noise would be heard. To avoid this, the leads should be run very close together so that the noise voltages induced in them are sensibly in the same phase and of the same strength. However, there is a limit to how close they may be run, for if they are too close together, the capacity between them will be increased so much that losses will occur. As a compromise, the leads are generally spaced about 3-inches apart. These conflict-

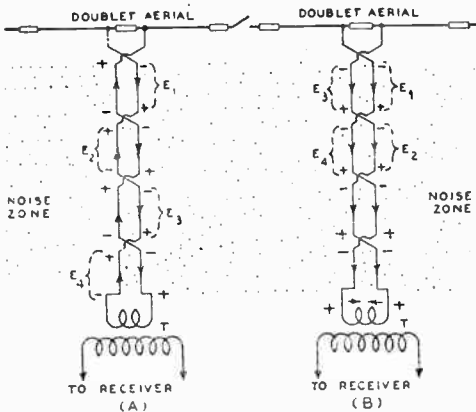

FIG. 30-47.—Action of a transposed lead-in. The illustration at (A) shows how out-of-phase noise potentials are cancelled within the lead-in wires themselves. That at (B) shows how in-phase noise potentials are cancelled in the primary of the impedance-matching transformer T at the receiver.

ing conditions, and the necessity for a variable spacing of the wires if reduction of the noise over the whole standard broadcast and short wave band is to be achieved, make this type of lead-in impractical for use with all-wave receivers. It finds its greatest use in the transmitting aerials of amateurs, where the correct spacing for the single frequency on which the station is to be operated is easily calculated and obtained.

30-50. The Doublet with a Transposed Lead-In.—The *transposed* lead-in eliminates some of the practical difficulties that are encountered with the parallel-feeder lead-in. Instead of running the two wires parallel throughout their entire length, they are *transposed* or *crossed* every two or three feet, as shown in Fig. 30-47. By arranging them in this way, the directions of whatever voltages are induced in them (*signal* or *noise* voltages) are such that they cancel either in the lead-in or the transformer.

There are two possible conditions of operation of a transposed lead-in. In the first case the frequency of the radiations and the spacing of the wires may be such that the two sides of the line lie in fields of opposite phase and will therefore have noise voltages of opposite phase induced in them. Thus, if all the voltages induced on the right-hand transpositions are in a downward direction as shown at (A) of Fig. 30-47, all the voltages induced on the left are upward at that instant, as shown. If we consider either of the wires alone, we can see that since E_1 is equal and opposite in direction to E_2 , E_2 is equal and opposite to E_3 , etc., the voltage induced in each transposition of each wire cancels that induced in the next transposition since it is equal and opposite to it. Consequently, all the induced voltages in each wire cancel each other and the potential at the ends of the two wires (so far as any induced voltage in them is concerned) is zero.

Under the second condition of operation, the spacing of the wires may be very small compared to the wavelength of the radiations. In this case, the induced voltages in both sides of the line are in the same direction and equal each other, as shown at (B) of Fig. 30-47. Thus $E_1 = E_2 = E_3 = E_4$, etc. In this case, the total voltage induced in each wire bucks and neutralizes that induced in the other wire. This neutralization takes place in the primary winding of the impedance-matching transformer, at the lower end, as shown. Consequently, in this case also, no induced current flows, but now it is because the potential difference between the corresponding ends of the transposed wires is zero. Consequently, the transposed lead-in provides a form of lead-in which picks up neither signal nor noise (so long as it remains balanced), even though it passes through a strong noise zone. It serves merely as a noise-free conducting path to lead the signal currents from the aerial wire down to the receiver.

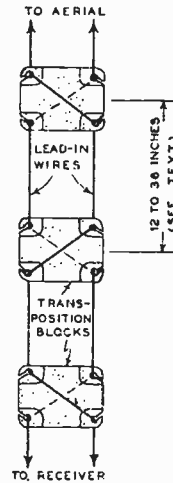

FIG. 30-48.—Detail of a typical transposed lead-in with transposition blocks in position.

30-51. Use of Transposition Blocks.—Separation of the wires and transposition is conveniently accomplished by means of special blocks of insulating material such as pyrex glass, isolantite, etc., as shown in Fig. 30-48. These are called *transposition blocks*. They are usually rectangular (or round) with four slots 90 degrees apart. The two wires therefore cross at right angles to each other and on opposite sides of the block. Hence, the capacity and leakage between them is kept small.

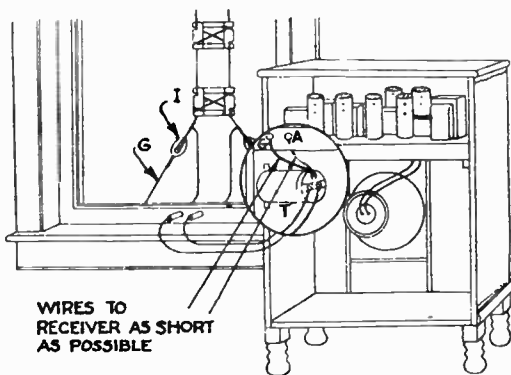

FIG. 30-49.—How the leads of a transposed lead in may be brought in through the window to the impedance-matching transformer *T* at the receiver, when the receiver is near the window. The wires to the receiver may be twisted if the distance is short.

Courtesy E. F. Johnson Co.

The allowable distance between the transposition blocks depends entirely upon the intensity of the local interference in relation to the signal.

In some locations, where the local interference is comparatively light, it is possible to place the blocks as much as three feet apart. There are some locations where they should be placed as close together as 12 inches. When a transmission line is used to connect a doublet aerial, which is located some 200 or 300 feet from a main highway in order to avoid automobile ignition interference, the blocks should be placed 15 inches apart for the first 100 feet, 24 inches apart for the next 100 feet, and 36 inches apart for the remainder of the transmission line. This, of course, presupposes that the aerial itself is located in a noise-free area.

30-52. Erecting the Transposed Lead-In.—It is good practice to keep a transposed transmission line at least 2 feet from the side of any kind of a building. This is particularly important

where the transmission line runs parallel to a portion of the building. If the line crosses at right angles to the edge of a roof it can come within one foot of the building without any noticeable disadvantage. The transmission line can be erected either in a straight line or it can be run at various angles if necessary. The transposed lead-in should be carried to a point as close to the receiver as possible. Where it enters the building, it is guyed to the building by means of insulators *I* and guy wires *G* as shown in Fig. 30-49. Lightning arresters may be installed—one in each lead if desired. If it is inconvenient to continue the transposition where the lead-in runs within the house to the receiver, the leads may be twisted together (to form a twisted-pair) for a short distance—the shorter the better. Mr. Arthur H. Lynch suggests that the easiest way to run a transmission line

from the point where the transposed line enters the house, to the radio receiver itself, is by using ordinary No. 14 two-wire BX cable. This is the same type of wire that is used for electric house wiring. Many experts consider wire of this nature to be entirely unsuitable for transmission-line work. However, extensions of this character have been run several hundred feet into buildings without any noticeable loss in signal strength.

Lines of this nature are very desirable for running the leads from an antenna to the receiver when the receiver is located in an apartment house, where the use of a regular transposed transmission line would be difficult. The ideal arrangement in apartment houses is to run the transposed transmission line to the level of the roof, and BX from the roof level to the receiver. In suburban locations, it is desirable to run the transposed trans-



Courtesy RCA Mfg. Co.

FIG. 30-50.—A typical kit of parts for an all-wave double-doublet antenna which uses a twisted-pair lead-in.

mission line to the window nearest the location of the receiver, and a short length of BX from there to the receiver itself.

30-53. Connecting the Transposed Lead-In to the Receiver.—If the receiver is of the all-wave type provided with input terminals for direct connection to a doublet antenna, the transposed lead-in wires should be connected directly to these terminals. No impedance-matching transformer is usually required at the receiver in this case. On the other hand, if the receiver has the conventional *Ant.* and *Gnd.* posts, an impedance-match-

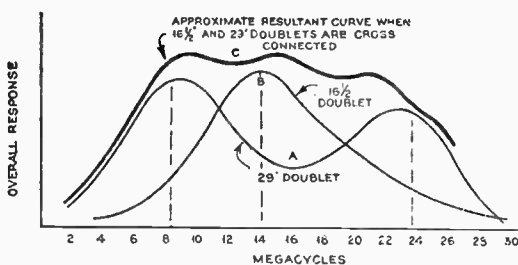

FIG. 30-51. — Individual response curves (A and B) of each doublet, and the overall response, C, of both doublets together in the double-doublet system of Fig. 30-52. The lengths of the doublets as marked here are the lengths for each section— $\frac{1}{2}$ the overall length.

ing or “coupling” transformer of proper design must be used between the lead-in and the receiver. This has already been discussed in Art. 30-46 (see Figs. 30-41 to 30-43). The impedance-matching transformer (*T* in Fig. 30-49) should be mounted directly in the receiver cabinet so that the leads between it and the receiver will be as short as possible.

30-54. The Doublet with a Twisted-Pair Lead-In.—The doublet is also commonly used with a twisted-pair lead-in terminating in a suitable impedance-matching transformer (see Arts. 30-41 to 30-46). Of course the twisted-pair wire used for the lead-in must be able to resist even extreme weathering conditions without increase in its losses. All that has already been said about the twisted-pair lead-in in the foregoing pages in connection with the inverted-L antenna applies equally well when it is used with a doublet. A typical antenna kit which contains all parts for a doublet antenna with twisted lead-in is illustrated in Fig. 30-50. The two equal rolls of bare copper wire for the doublet aerial portion are at the top. Directly under these is the roll of twisted-pair lead-in wire. The various

insulators, etc., are shown at the bottom. The receiver impedance-matching transformer is at the center.

30-55. **The Double-Doublet for All-Wave Reception.**— It is well known that the signal pickup efficiency of the half-wave doublet antenna for a given signal frequency or wavelength bears a direct relationship to its length. As was explained in Art. 30-42, the response of a doublet is greatest at a wavelength (in meters) which is numerically equal to *twice* the *total* length (in meters) of the horizontal portion, or, stated in the reverse way, the pickup will be greatest at a certain wavelength if the length of the doublet is numerically equal to $\frac{1}{2}$ that wavelength. Good (peaked) response will also be obtained at many of the harmonics of this "fundamental" or "resonance" frequency. Of course, the response at the harmonic frequencies will be less than that at the "fundamental" frequency of the aerial, but nevertheless it will be better than at the frequencies between these values. For instance, let us consider the actual response curve, *A*, in Fig. 30-51, for a doublet aerial having a wire 29 feet long for each half section (a total length of 58 feet). Converted into meters the best response of this aerial will be at about $(58 \div 3.3) \times 2 = 35.2$ meters. Converting this into frequency in megacycles, we have $300 \div 35.2 = 8.5$ megacycles approximately (see Art. 28-3) for the "fundamental" response peak. This doublet will also give "peaked" (but somewhat weaker) response at about 25.5 megacycles; its *third* harmonic. The response curve of this doublet will then look like that labeled, *A*. Notice that the response falls off considerably for the frequencies *below* the fundamental resonant frequency of the aerial, for those lying between its fundamental and third harmonic frequencies, and for those above its third harmonic. This is characteristic of the doublet form of antenna.

It is evident that this particular doublet, if used alone with an all-wave receiver having the usual frequency range from 540 to 18,000 kc (0.540 to 18 mc) would not supply very strong signals to it in the frequency band below about 4 mc (which includes the standard-broadcast band), and in the frequency band between about 13 and 19 mc (short-wave region). It is obvious that this latter deficiency could be fairly well made up for, if it

were possible to connect to the same transmission line (lead-in) without either harming the performance of the other, another doublet of such a length that its fundamental resonance point occurs at about 14 mc. This corresponds to a "fundamental" resonance wavelength of $300 \div 14 = 21.4$ meters. The total overall length of this doublet would have to be $21.4 \div 2 = 10.7$ meters, or $10.7 \times 3.3 = 35$ feet long (approximately). Let us say we will use a doublet about 33 feet long (total) consisting of two $16\frac{1}{2}$ -ft. sections. The response curve of this doublet would be as shown by curve, *B*, in Fig. 30-51. Notice that it peaks sharply at about 14 mc, just where our other doublet provides rather poor response. We are not interested in the third-harmonic response of the short doublet, for that lies way beyond the range of present all-wave receivers.

If some satisfactory arrangement can be devised for operating these two doublets satisfactorily with the same transmission line, the overall response of the two combined will be as shown by curve *C*. Notice that it is fairly uniform over the important part of the short-wave spectrum. This uniformity extends over a wider range of frequencies than would be possible with a single doublet.

The foregoing arrangement will provide good antenna response over the short wave band, but not over the broadcast band. The first thought would logically be to employ a third doublet of suitable length to favor the broadcast band. However, a little thought will show that this is ordinarily impracticable simply because such an aerial would have to be so long that it could be erected only under the most unusual circumstances. For instance, if it were to be made resonant at the standard-broadcast band frequency of say 1,000 kc, it would have to have a total overall span of about *495 feet* from end to end! Naturally, an aerial this long is out of the question for home use. A practical solution to the problem is to use some arrangement for converting the double-doublet antenna into another type for reception over the standard broadcast band. It is usually convenient to convert it into a T-type antenna for this band, since a T-type antenna of a medium length which is convenient to erect will give fairly good

response over the standard-broadcast band of frequencies.

From the foregoing discussion, it is clear that if two properly designed dissimilar doublets be installed and connected by a single transmission line to the receiver in such a way that their outputs are additive, the double-doublet system which results can be made to give an overall response which is high and fairly uniform over the entire short wave range. Furthermore, the

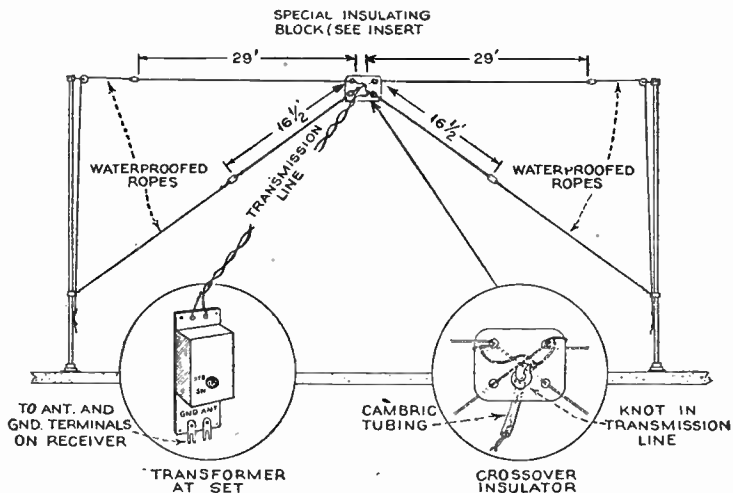

Courtesy RCA Mfg. Co.

FIG. 30-52.—How a double-doublet receiving antenna system may be erected. The response characteristics of a double-doublet of the dimensions shown here are presented in Fig. 30-51. The special crossover arrangement shown here in the circle at the lower right is important. The antenna impedance-matching transformer (see Fig. 30-53) is not shown here.

double-doublet can be re-connected to form a T antenna for good response over the standard-broadcast range. That much is fairly simple. Now let us see how one manufacturer (the RCA Mfg. Co.) has attempted to solve the important and difficult problem of providing a transmission line which will not pick up any interference disturbances itself, but which will transmit this very wide range of signal frequencies from the aerial to the receiver with sufficiently high and uniform efficiency—without need for any elaborate switching arrangements.

A long doublet consisting of two 29-foot horizontal sections

is used with a shorter doublet consisting of two $16\frac{1}{2}$ -foot sections. The shorter one is erected under the larger one, as shown in Fig. 30-52, with sufficient space left between them to prevent one from affecting the other. The individual and overall response characteristics of these aerials are as shown in Fig. 30-51 (in our previous discussion of the double-doublet antenna we

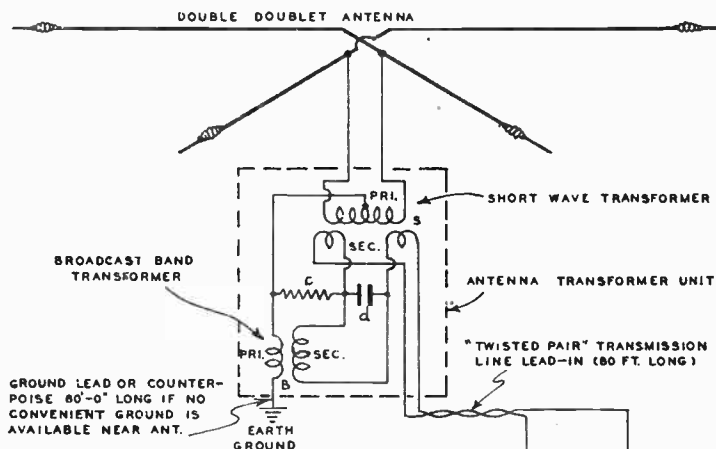
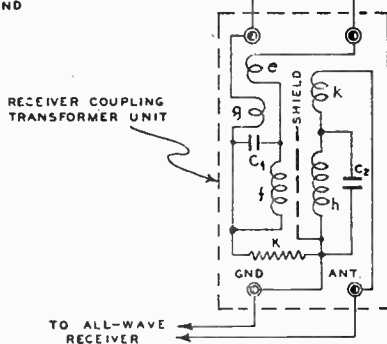

FIG. 30-53.—The circuit arrangement of the double-doublet aerial, the antenna impedance-matching transformers, the twisted-wire transmission line, and the receiver coupling transformer for the system shown in Fig. 30-52. (RCA DeLuxe Double-Doublet Antenna System.)



Courtesy RCA Mfg. Co.

purposely considered doublets of the particular lengths and characteristics which are employed in this system).

(1) The cross-connection at the aerial: The first important point is the special cross-connection between the doublets. In order to make the output of the short (lower) doublet *additive* to the output of the longer (upper) doublet at a frequency midway between their resonance points, the *left* arm of the

longer doublet is connected to the same side of the transmission line as the *right* arm of the short doublet.

Likewise the *right* arm of the longer doublet and the *left* arm of the shorter doublet are connected to the other side of the transmission line. This cross-connection is shown in the enlarged detail *E* in the lower right-hand part of Fig. 30-52. In order to understand this, it is helpful to consider the fact that the long and short doublet arms which are connected to a single side of the transmission line form a single and nearly straight wire which is resonant in the half-wave mode at the frequency midway between the resonance peaks of the two individual doublets.

If the two sides of the line were connected near the center of these two straight wires, the antenna would form a low-impedance termination for the line. If the two-line connections were then moved out from the center in opposite directions, the impedance of the antenna would rise progressively, reaching a very high value when the ends of the wires were reached.

At the point actually used, the impedance of the antenna at this frequency is slightly *higher* than the line impedance.

At the frequency of resonance of either the long or the short doublet, the impedance of the antenna system is somewhat *lower* than the line impedance. Thus it can be seen that the line impedance chosen is a good compromise value. The overall performance of the double-doublet is shown by curve, *C*, in Fig. 30-51. The response of the combination is relatively flat over the important part of the short-wave spectrum.

(2) The aerial coupling transformer: The double-doublet must be coupled to the transmission line by an impedance-matching transformer arrangement which will provide efficient transfer of energy from the aerials to the line over the entire all-wave frequency range of 540 to 18,000 kc! The fundamental antenna impedance-matching transformer arrangement which is used in the RCA Victor De Luxe Double Doublet System is shown in Fig. 30-53. (The receiver coupling transformer, which is also shown, will be considered later.) The operation of the entire coupling system will now be explained in detail.

By referring to this diagram, it will be seen that the antenna

transformer unit consists of two special transformers. Transformer *S* transfers the short-wave signal energy from the double-doublet to the transmission line lead-in and matches the impedance of the doublets to that of the lead-in at these frequencies. The center-tap of its primary connects to ground through the primary winding of the broadcast band transformer *B*, but since the impedance of the primary of *B* is so high for short-wave frequencies that it has relatively little effect on the short-wave reception. The secondary of the short-wave transformer is split into two parts connected in series with each other,

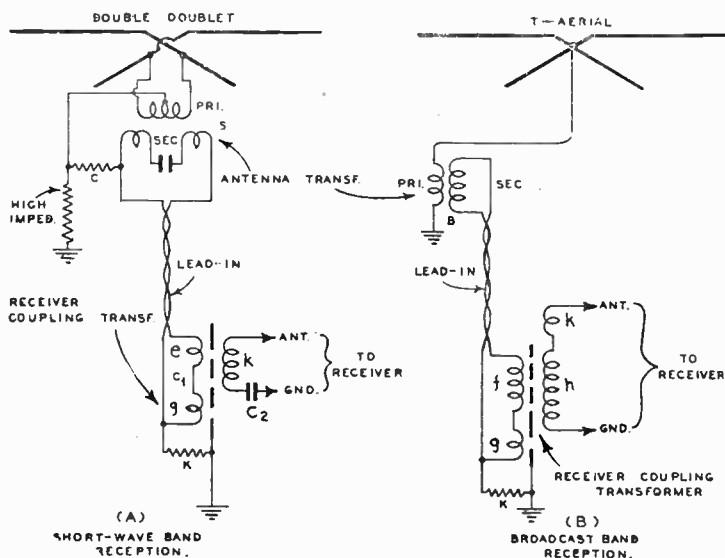

FIG. 30-54.—(A) The essential circuit arrangement which exists when short-wave signals are being received by the double-doublet antenna circuit of Fig. 30-53.

(B) The arrangement which exists when standard-broadcast band signals are being received. Notice that the circuit automatically connects the two parts of the double-doublet together at the center to form a T-type antenna for more effective pickup over the standard-broadcast range.

with the secondary of transformer *B* and with the transmission line. The by-pass condenser *d* is of such value that it by-passes the short-wave (high-frequency) signals past the secondary winding of the broadcast transformer. Therefore, when short wave signals are being received, transformer *B* is ineffective and transformer *S* is in operation. The effective circuit connections are then essentially as shown at (A) of Fig. 30-54. Notice that the aerial functions as a double-doublet for these frequencies. Resistors *C* and *K* are used to prevent the system from collecting a high static potential and sparking to ground intermittently. If this were to happen, it would most likely cause disturbing periodic clicks to be heard in the receiver.

When broadcast-band frequency signals are received, transformer S (having relatively few turns) ceases to transfer the signal energy efficiently, and is ineffective. The signal energy is now transferred to the lead-in through transformer B (which is designed especially to transfer energy of these frequencies efficiently) instead. When this happens, the effective circuit connections are essentially as shown at (B) of Fig. 30-54. The doublets are really connected to each other (through the few turns of the primary of short-wave transformer S) to form a T type aerial. The signal flows through the primary of transformer B to ground, and is transferred through the secondary of B to the lead-in. Thus, transformer B serves to match the impedance of the aerial (now a T type) to the transmission line lead-in over the broadcast band of frequencies.

(3) The receiver coupling transformer: It is important to realize that the noise-eliminating feature of the complete antenna system depends entirely upon the design of the receiver coupling transformer. Since a twisted-pair lead-in is used, a balanced condition must be maintained at all times if the noise voltages induced in the lead-in are to cancel out (see Art. 30-41). One of its functions is to effectively match the impedance of the lead-in to that of the input circuit of the receiver at all frequencies over the entire all-wave range. Another task which it must perform is that of allowing the out-of-phase signal impulses from the double-doublet aerial to be transferred along to the receiving set, while effectively cancelling the in-phase noise impulses picked up by the twisted-pair lead-in. (Remember that the twisting of the lead-in wires causes the induced noise voltages to be *in phase* with each other at the transformer, while the regular signal is unaffected by the line (see Fig. 30-34). A static shield is incorporated between the primary and secondary windings to prevent the noise impulses from getting through by capacity effects (see Art. 30-44).

The fundamental feature of the receiver coupling transformer is that it uses different transformers for different frequency bands, and places these transformers in series to obtain good transmission over their combined frequency ranges. The circuit arrangement for doing this is shown at the lower part of Fig. 30-53. Referring to this diagram, the transformer winding e having the smaller inductance, transmits the highest-frequency signal currents to its secondary winding k . The high-frequency primary currents are by-passed around the other transformer f by condenser C_1 . The effective circuit which exists for this condition is shown at the lower part of (A) in Fig. 30-54.

Lower-frequency signals are transmitted, by the transformer winding f to its secondary h . This condition is shown in the diagram at (B) of Fig. 30-54. There is a certain intervening frequency at which the transformers e and f are equally effective in passing on

the energy. At this frequency, the outputs of the two transformers e and f are additive, provided the polarities of the mutual inductances of the transformers are the same. In this manner, any desired number of transformers may be connected in series and the frequency range extended almost without limit in either direction. The efficiency of transformation is high and practically constant over the extended frequency band.

In designing this transformer system the component transformers are designed separately for adjacent bands, providing a slight overlap. These transformers are then connected together as shown.

(4) **General:** The matched twisted-pair transmission line lead-in supplied with this double-doublet antenna kit is 80 feet long and *must not be cut for any reason whatsoever*. If the double-doublet aerial must be erected at a greater distance from the receiver than this in order to remove it sufficiently from the local interference zone so that it does not pick up any appreciable amount of noise, additional 80-foot unit lead-in sections can be used. The double-doublet should be erected *at least 30 feet above the ground*. Through the use of this type of antenna system, the following features are obtained.

- (1) Efficient all-wave reception with only one antenna of medium length.
- (2) Effective elimination of noise pickup *by the lead-in* on all frequency bands.
- (3) Elimination of all need for "switching" arrangements in the impedance-matching transformers when shifting from one band of frequencies to the other during reception.
- (4) Ease of installation due to simple twisted-pair lead-in without necessity for transposition blocks, etc.

By means of the unique circuit arrangement in the antenna-matching transformer, the advantages of the double-doublet for wide-band short-wave reception are obtained, and those of the T-type antenna for standard-broadcast band reception are also secured.

(5) **Erecting Double-Doublet in Limited Space:** Very often, the space available for the double-doublet antenna is such that it is not possible or practical to erect the full horizontal span of approximately 60 feet (including support wires at ends, etc.). In such cases, loading coils may be employed. These permit the span length to be reduced with but a slight decrease in efficiency.

However, by erecting the short length doublet at the top and the long doublet at the bottom, considerable reduction in span length may be obtained without any reduction, in efficiency. By increasing the angle of the spans (bringing the long span farther down each pole) the total length may be adjusted from 33 feet

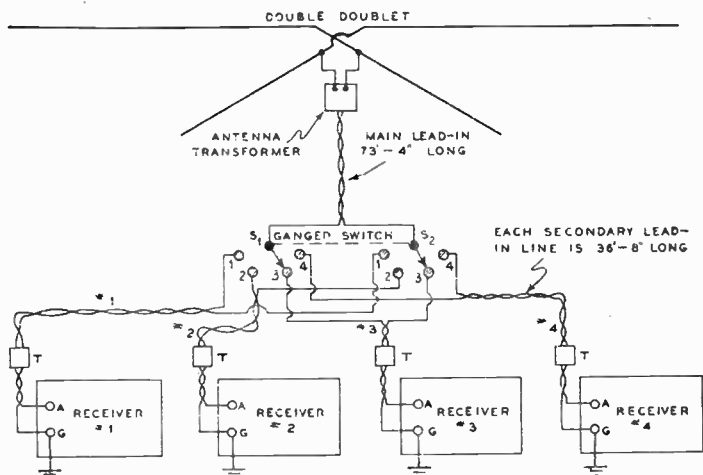

FIG. 30-55.—A “dealer demonstration antenna” system which permits the demonstration of four all-wave receivers (one at a time). The receivers may be switched to the antenna by the simple 2-gang switch shown. A double-doublet antenna system (similar to the one shown in Fig. 30-53) is used. An individual impedance-matching transformer *T* is used at each receiver. (Courtesy RCA Mfg. Co.)

to 52 feet. The shortest span loses the most efficiency by this change, while the longest span is equally as effective whether it is on top or on the bottom.

30-56. Radio Dealer Demonstration Antenna System.—Many radio dealers who complain of their inability to make good noise-free demonstrations of short-wave and all-wave receivers can lay the blame almost entirely on the poor antenna installations which they use in these demonstrations. This condition is especially prevalent in radio stores located in crowded city districts where it is often difficult to erect a good antenna system that is free from the influence of man-made electrical disturbances. In many cases, dealers attempt to demonstrate all-wave receivers with the same antennas which they have been employ-

ing for demonstrating standard broadcast receivers—and often, these antennas have not been inspected for years. Invariably, the antenna system which enabled fairly noise-free reception to be obtained with the standard broadcast band sets is very noisy when used with all-wave receivers, simply because a great deal of the man-made electrical disturbance which it picks up lies in the short-wave region and therefore affects the latter type of set only. Tuning in of distant European short-wave stations for a demonstration is usually impossible with the noisy background which results under such conditions.

A special all-wave antenna system which embodies all of the features of the double-doublet all-wave system described in Art. 30-55, and in addition contains several features which make it particularly useful for receiver demonstration purposes in radio stores, is shown in Fig. 30-55. This antenna employs the same double-doublet aerial arrangement which has already been described (see Art. 30-55 and Figs. 30-51 to 30-54). The transmission line from the antenna impedance-matching transformer, however, is broken by a four-way two-gang switch S_1-S_2 from which four secondary transmission lines (each exactly 36 feet 8 inches long) are run to four receivers which can be demonstrated with it. This switch enables the aerial and transmission line to be switched instantly to any one of the four receivers at will; the receivers being placed at any desired demonstration points in the store within the length of the secondary transmission lines.

The main transmission line, 73 feet 4 inches long, leading from the switch to the aerial, makes the correct total of 110 feet of transmission line, including the secondary line, in use at any one time when a receiver is being demonstrated. A second 110-foot length of transmission line may be added if it is needed in order to place the antenna in the most noise-free location available. Beyond 220 feet, the length of transmission line is not critical. Additional line may be added up to a total of 500 feet for the main and secondary line if necessary.

A transformer to match the impedance of the complete transmission line to the input impedance of the receiver is installed at each receiver, as shown. The impedance-matching transformer arrangement is essentially the same as that shown in Fig.

30-53. This puts the proper impedance-matching transformers in the circuit to efficiently couple the double-doublet aerial to the twisted-pair lead-in, and the lead-in to the receiver, over the short-wave bands. It automatically changes the aerial connections so that it becomes a T type aerial for reception over the standard broadcast band range of frequencies, and efficiently couples the aerial to the lead-in, and the lead-in to the receiver, over this range.

A good antenna system of this type (or any other which provides similar features) is a worthwhile asset to any radio store in which all-wave receivers are demonstrated, for the following reasons:

- (1) By bringing in more short-wave stations with greater volume and greatly reduced noise, it is a big help in making all-wave set demonstrations satisfactorily so that the sets will be sold.
- (2) It makes possible convincing demonstrations in the dealer's store where the prospect's undivided attention may be obtained, and where the salesman is in a position to quickly concentrate his attentions on any receiver which the prospect shows an interest in.
- (3) By making satisfactory demonstrations in the dealer's store possible, it makes costly and generally unsatisfactory (unsatisfactory because of noisy reception conditions) demonstrations on a temporary set-up in the customer's home unnecessary.
- (4) By making instant switching from one set to another easy, it simplifies the process of building up the unit of sale from a cheap set to a better one by actually allowing the prospect to make a direct comparison between any two sets for himself (whenever this is advisable).
- (5) It enables the dealer to forcefully demonstrate the effectiveness of a well-erected modern noise-reducing antenna system for minimizing man-made electrical interference, and thereby promotes the sale of such systems along with the receivers.

30-57. Directional Characteristics of Various Types of

Antennas.—*Theoretically*, all types of antenna systems (excepting the vertical antenna) have directional characteristics, though the degree of directivity is affected greatly by the proportions of the aerial and lead-in sections and some types are more directional than others. An antenna system is said to be *non-directional* when it receives (or transmits) energy in all directions with equal facility; an antenna system is *directional* when it receives or transmits best in one or more well-defined

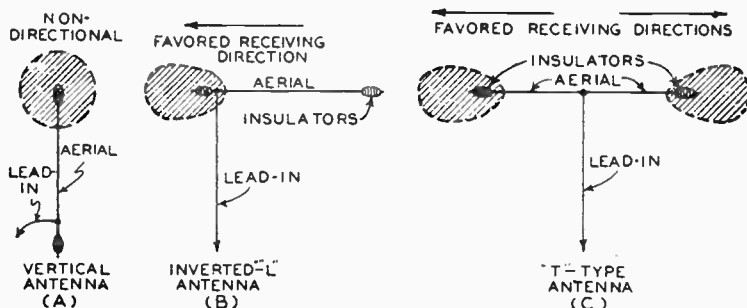

FIG. 30-56.—Directional characteristics of three types of commonly-used receiving antennas. All other things being equal, signals coming from the direction of the largest part of each shaded lobe are favored the most if the antenna construction is such that any directional characteristics are present at all.

directions. Before entering upon any discussion of the directive properties of antennas, it will be well to point out that while the directional property of closed "loop" antennas, see Fig. 30-8, is very marked (that is why they are used in direction-finding and radio-beacon systems), the directional properties of ordinary "open" types of antennas are generally greatly over-estimated. Very often, they do not exist at all, because of the proportions which exist in the various antenna parts as they are actually erected.

Regardless of these factors, it is well for the service man to be familiar with the *theoretical* directional characteristic of the common types of receiving aerials. This knowledge will enable him to take advantage of these properties in both a "positive" and "negative" way. If reception of signals from distant stations located in a certain direction from the receiver is to be improved, the directional characteristics (if any) of the par-

ticular type of receiving antenna which is employed may be taken advantage of by erecting the aerial portion in such a direction that it receives *best* in the direction of these stations. On the other hand, if the *aerial* portion of an antenna is picking up man-made interference from a nearby source, its directional properties (if any) may be taken advantage of for reducing the interference pickup by erecting it in such a direction that it receives *most poorly* in the direction from which the interference is arriving.

(1) The "loop" Antenna:

The directional characteristics of the ordinary closed loop antenna (see Fig. 30-8) are well known. The loop receives *best* in either direction *along the plane of the loop*; and most weakly in the directions at right angles to this plane.

(2) The "vertical" Antenna:

The antenna system shown at (A) of Fig. 50-56 is perhaps the simplest of all systems, and is particularly effective in receiving the signals of *nearby* stations since the waves from them are vertically polarized (see (A) of Fig. 30-33) when they arrive. It consists of a single conductor rising vertically from the ground; the lead-in is taken from the bottom. Such an antenna is non-directional if the surrounding space is free from obstructions (we shall assume that all our aerials are free from obstructions). The circular shaded portion at the top represents the relative receiving ability of the aerial in all horizontal directions from its vertical axis. Since this pattern is circular, it indicates that the aerial receives from all of these directions equally well.

(3) The "inverted-L" Antenna:

The inverted-L antenna system, shown at (B), derives its name from its physical shape—that of an inverted-L. This type of aerial is somewhat directional but the amount of directivity which it possesses in any case depends upon the relative lengths of the horizontal aerial portion and the vertical lead-in. The lead-in is a very important part of this antenna system, since it collects energy just as the horizontal aerial portion does. In fact, for local stations, it collects more energy than does the horizontal portion, because the so-called "ground wave" of a local sta-

tion is usually vertically polarized. Also, since the lead-in acts essentially as a vertical antenna, it is non-directional.

The horizontal portion of the antenna is directional, and favors the reception of those signals which come to it from the direction of the end at which the lead-in is connected. If the aerial runs north and south and the lead-in is taken from the south end, then it will favor the reception of stations located to the south of the aerial (all other things being equal). Since the lead-in is non-directional and the horizontal section is slightly directional, the overall directivity depends upon the relative

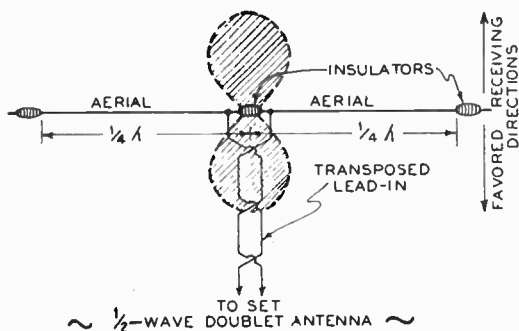

FIG. 30-57.—Directional characteristics of the doublet (and double-doublet) antenna. This type of antenna favors the reception of those signals which approach it from directions at right angles to its length, as indicated by the two shaded lobes.

lengths of the two. The antenna is not directional to any extent unless the aerial portion is at least 4 or 5 times as long as the lead-in. If the lead-in is of the shielded, transposed, or twisted-pair type, all of the energy, which it collects is effectively prevented from entering the receiver—only the energy collected by the flat-top aerial portion gets to it. Under these conditions, the directional characteristic of the aerial is slightly emphasized. The condition which exists when the aerial is directional is shown by (B) of Fig. 30-56. All other things being equal, the signals arriving from the direction of the largest shaded lobe (the lead-in end) are favored the most.

(4) The "T-type" Antenna:

Suppose the single-wire lead-in of an inverted-L antenna is slid along until it is at the center of the aerial, as shown at (C) of Fig. 30-56. We now have two inverted-L antennas, or a T-type antenna. One of these component antennas will favor the reception of signals arriving from the direction of its lead-in,

and the other will do likewise. Therefore, *the entire T-type antenna will favor (equally) the reception of those signals which arrive from the direction of either of its free ends*, as shown. Like the inverted-L antenna, though, the horizontal aerial portion must be long compared to the length of the lead-in before any directional characteristics become apparent. The overall length of a T-type antenna must be twice as long as the inverted-L

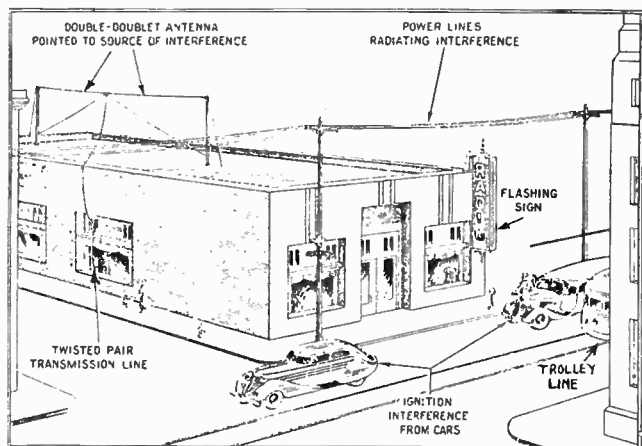

Courtesy ROA Mfg. Co.

Fig. 30-58.—How the “directional” characteristics of a double-doublet antenna may be taken advantage of to reduce pickup of interference by the aerial portions. Here the double-doublet is shown erected so that it points as nearly as possible *directly toward* the various sources of man-made interference which are illustrated. By erecting it in this direction, it does not favor them, and therefore picks them up more weakly than it would if it were erected in any other direction.

aerial, for the same signal pickup, since the complete system can be thought of as consisting of two separate inverted-L systems with a common lead-in.

(5) The “doublet” Antenna:

It might seem at first thought that the familiar doublet antenna has the same directional characteristics as the T-type has, but such is not the case, as evidenced by the directivity patterns drawn on the antenna diagram of Fig. 30-57. Why this is so will become evident from the following consideration. Suppose a radio wave approaches this doublet from left to right in the direction of its axis. The end of the aerial which the wave first

intercepts will receive a charge, and as the wave progresses along to the right, it induces charges in each section. Now if the total doublet wire from tip to tip is half a wavelength long, then the polarities of the two outside ends will be similar at each instant. Therefore, the two points to which the lead-ins connect will have similar polarities at each instant. Hence, no reception will result since the two signal currents will balance each other out in the transformer winding which terminates the lower end of the lead-in. But, if the wave approaches from a direction at right angles to the axis of the aerial, each half of the doublet will receive equal charges. Therefore, at the instants that the lead-in end of the *left-hand* section is positive, the lead-in end of the right-hand section will also be positive and vice versa. Hence the voltages of the two sections add together in the terminating transformer winding and signal current flows through the lead-in. Therefore, *the doublet favors the reception of those signals which arrive from directions at right angles to its length.* The directional properties of the doublet are more marked than those of either the inverted-L or T type antennas.

(6) The "double-doublet" Antenna:

The directional characteristics of the double-doublet antenna are similar to those of the simple doublet, i.e., *the double-doublet favors the reception of those signals which arrive from directions broadside to its length.*

By taking advantage of these directional characteristics of the various types of antennas (whenever they actually exist) the service man may often erect the aerial portion of the antenna system in a way that will assist in reducing the electrical disturbances which may be reaching it from some source of interference. For instance, since a doublet or double-doublet has *minimum* pickup ability in the direction of its length, erecting it so that it points toward the source of interference will reduce the noise pickup. A typical case of this kind is illustrated in Fig. 30-58. Here, a double-doublet is shown erected on the roof of a building which is close to several strong sources of man-made interference (a flashing electric sign, elevated power lines, an electric trolley line, and ignition systems of passing automobiles). Since the double-doublet itself is erected so that it points to the sources of

interference, it picks up less interference than it would if it were pointed in any other direction. All interference which is picked up by the twisted-pair lead-in is cancelled out in the winding of the terminating transformer (see Fig. 30-47), so it is not transferred to the receiver.

30-58. Method of Testing for a Noise-free Zone for the Aerial.—In closing our study of noise-reducing antenna systems, several important points which are too often lost sight of when they are erected should be emphasized. First of all, it is not the *aerial* portion of the antenna that reduces the noise, but the special noise-reducing lead-in of one form or another. The object of all noise-reducing antenna systems is to place the aerial itself in a zone as free from interference disturbances as possible; the special noise-reducing lead-in (of one type or another) serves simply as a transmission line to lead the signals from the aerial down through the noise zone to the receiver (see Fig. 30-31). The lead-in is to act merely as a conductor for the desired signals, and is not to add to them any interference which it may pick up because of the fact that it must be run through the noise zone. Therefore, the mere fact that a much-advertised noise-reducing lead-in is installed does not necessarily mean that all interference will disappear as though by magic. Unless the aerial portion of the antenna is located in a zone which is entirely free from the interference—or in a relatively weak field of interference as compared with that in which the lead-in is located—noisy reception will result, regardless of what type of special lead-in is employed. Hence, the problem of erecting the aerial in a relatively noise-free zone is of just as much importance as is that of providing an effective noise-reducing lead-in to the receiver—but it is not usually given as much consideration!

It is obvious that in cases of interference pickup by the aerial the first consideration should be to erect it in such a direction that its directional characteristics are utilized to reduce the pickup of the interference if this is at all possible. But, even though this is thought of, and it is planned to erect the aerial as high as possible and away from all obvious interference sources such as elevator pent houses, etc., the service man has no way of knowing that the antenna is going to be noise-free after he has installed

marked directly on the diagram. The coil consists of a 2-inch length of $1\frac{1}{8}$ -inch diameter tubing with the various windings placed on it as indicated. The primary is a separate little 12-turn coil wound on a 1-inch length of $\frac{3}{4}$ -inch tubing which is slipped into the tickler end of the larger piece of tubing. The taps on the tickler are connected to the double-pole double throw switch S_1-S_2 as shown. This provides two tuning bands. Fixed regeneration is provided by a tiny 30-mmfd. trimmer condenser. Since the set is to be used only for general noise and signal receiving purposes, it is not necessary to adjust this frequently. It is merely adjusted once for greatest sensitivity without oscillation, and is left undisturbed thereafter. Tuning is accomplished with a 50-mmfd midget condenser. The entire receiver with batteries may be placed in a metal cabinet measuring about $7 \times 7 \times 7$ inches, and it may be slung from the shoulders by a strap in camera fashion.

The "probing aerial" for the receiver consists of an "Airod" antenna, mounted on a 1 by 2 inch wooden pole about 8 or 10 feet long. This should be light enough to make it possible to carry it around and manipulate it easily on the roof top. If the pole is made of sections hinged together, it can be folded up for easy transportation. The aerial is a telescoping duraluminum tube intended for 5-meter reception and transmission and lends itself nicely for the purpose of interference field testing and even noise source location (see Art. 30-19) because of its marked directional properties and the fact that it can be adjusted for a spread of from four to ten feet. It consists of two sections held by an insulating bushing at the center, and therefore forms a simple "doublet" aerial. The aerial is connected to the primary coil in the receiver by an 8 or 10 foot length of good twisted-pair lead-in wire.

The noise locator unit is used in the following way. It is set up on the site at which it is planned to erect the receiving aerial. With the locator receiver hung from the prober's shoulder, the probing aerial rod is carried through the entire space where the receiving aerial is actually to be erected. The probing aerial itself should be swung around in different directions, and the signal-to-noise ratio as heard in the earphones should be observed carefully for each position. The general area or direction that seems to be quietest should be selected for the ultimate permanent receiving aerial. Very often, this place will not be accessible, for it may lie over the side of a building, over an obstruction, etc. However, if carrying the probing aerial slowly in the direction of this inaccessible place results in lower and lower noise, it is safe to conclude that the area will be a zone of weakened interference. Incidentally, it should be remembered that since the probing aerial is a doublet, if it is rotated through a horizontal angle of 90 degrees from the position where *minimum* noise is heard in the earphones, it will then be pointing straight to

the arrival of the interfering radiations, (see Fig. 30-57).

If no reasonably quiet spot is found, it is safe to conclude that the contemplated erection of the receiving aerial in that particular location would not be particularly satisfactory from the interference standpoint—even if an efficient noise-reducing lead-in were used with it. If a quiet zone is located, that will usually be the best place to locate the aerial. Because of the peculiar ways in which large metal surfaces such as metal roofs, gutters, etc., can reflect and distort the noise fields, and the ways in which isolated vertical pipes or shafts can conduct noise disturbances, the noisy and the quiet zones will often be found in most unexpected places. In suburban districts where the buildings are made mostly of wood, the field patterns will be found to be quite uniform, and a noise-free zone will usually be found a short distance above the building, and in the space behind it even if interfering devices are located within the building. In congested city districts, however, the influence of steel building frameworks, large metal surfaces, etc., may cause the interference field patterns to assume the most erratic shapes. Although the advice to “erect the aerial as high as possible” has been almost worn out through use, many cases will be found where the interference gets stronger the higher up the aerial is located, simply because buildings on either side of the one on which the aerial is erected may act as partial shields for interference coming from the side. In such cases, erecting the aerial high above the building puts it above this shielded zone and into the noise zone. While such cases are exceptions rather than the rule, they serve to illustrate forcefully the usefulness for some sort of portable interference locator or tester, such as has been described here, for actually finding out what the interference conditions are, before any attempt is made to erect the aerial.

REVIEW QUESTIONS

1. What is meant by “natural” static? What is it due to?
2. Why is it impossible to completely eliminate interference caused by atmospheric “static”?
3. What is meant by man-made interference? Name some common household electrical devices which produce it.
4. Why is man-made electrical interference more troublesome when

the short wave bands of an all-wave receiver are used, than when the standard broadcast bands are employed?

5. Why is a set analyzer of very little value in trouble-shooting for the cause of noisy reception?
6. Why have the great improvements made in radio receiver design during the past few years made the interference problem more troublesome and serious?
7. Explain how a d-c motor, having brushes which spark, produces interference in radio receivers located in an adjacent building.
8. Name the four general types of electrical interference. Explain what each may be caused by.
9. How would you proceed to cure a case of interstation interference resulting in high-pitched whistling in a moderately old superheterodyne receiver?
10. State 7 possible causes for interference originating within a receiver. How would you proceed to locate the exact source of the noise in the receiver?
11. Describe (with the aid of sketches), two ways in which interference originating outside the receiver, may travel to the receiving equipment and affect it so as to cause noisy reception. How could you prove this?
12. The signal-to-noise ratio of a certain receiver is 25 in a certain location. Another receiver in that same location has a ratio of 10. How much less objectionable is the noise from the first than from the second receiver?
13. The noise voltage at 20 feet from a source is approximately 0.5 volt. If the antenna of a receiving set is at that point and the signal strength of a certain broadcasting station is 1 volt, what is the signal-to-noise ratio?
14. If the antenna of Question 13 is moved 20 feet further away from the source, and if the field strength of the station remains the same, what is the signal to noise ratio (assuming that all the noise impulses are being *radiated* directly to the antenna and that the intensity of radiated energy varies inversely as the distance from the source of radiation)?
15. What simple tests can be made to determine if man-made interference is entering via the antenna system, the chassis or the power supply line? Describe them!
16. What two methods may be used to determine whether noise is entering a receiver through the chassis directly or through the power supply line? Explain them!
17. It has been ascertained that noise is entering the receiver through the power supply line. How would you proceed to locate the source of interference if you desired to eliminate it at the source?
18. What are the seven different characteristic sounds caused in radio receivers by interference from different electrical sources?
19. Describe the characteristic noises which would be produced in a radio receiver in each case, by interference from the following electrical devices (a) a d-c electric motor; (b) a spark coil; (c) elevator control relay contacts; (d) a nearby high tension a-c transmission line with a leaky insulator; (e) an oil burner; (f) a door bell; (g) a 6-contact motor-driven electric sign flasher.
20. Classify interference into three main divisions according to the

- method by which it gets to the radio receiving equipment. Explain each fully! Which is usually the strongest?
21. Explain in a general way how you would proceed to track down the cause of a strong buzzing interference which is heard for a minute or so at a time at intervals of about 2 hours in a receiver located on one of the upper floors of an apartment house in a congested section of a city.
 22. If trolley cars also caused excessive interference in the foregoing installation, what would you do to overcome the trouble?
 23. You are called in to eliminate a peculiar "clicking" interference in a receiver located in a private dwelling in a fairly busy section of the city. There are a number of stores within a radius of one block. The interference is steady and occurs only between the hours of about 5 P. M. and 11 P. M. Explain exactly how you would proceed to diagnose the case, how you would track down the trouble, and how you would eliminate the interference.
 24. Of what value is an interference-locating receiver? Under what conditions is it; (a) particularly useful; (b) not helpful. What is the purpose of the loop antenna used with it. What general type of receiver should it be?
 25. How would you find out definitely whether defective house wiring in a private dwelling was causing intermittent interference? If your test indicated that it was, how would you localize the trouble?
 26. In a general way, explain under what conditions it is usually desirable to track down interference to its source. Under what conditions is it more advisable to suppress the interference at the receiver?
 27. Draw circuit diagrams of 3 different line-filter arrangements which may be used to prevent interference from an interfering device from being conducted *back* into the power line. For what particular applications does each one have advantages?
 28. Draw three circuit diagrams showing the foregoing filters connected to a d-c fan motor.
 29. What important precaution must be observed when such filters are connected to an offending device? Just how will interference get out if this precaution is not observed? Explain!
 30. What expedient besides line filtering may be used to prevent *direct* radiation from the source of interference? Why is this method not used more? State one cause of interference in which it *must* be applied if all the interference is to be eliminated.
 31. Explain in detail why it is usually better to connect the "ground" lead of the filter to a clean spot on the metal case or base of the offending device rather than to an actual "earth" ground. Why does the interference usually persist if the latter connection is made?
 32. What is meant by a "noisy" ground?
 33. What mechanical or electrical troubles in d-c motors will cause excessive electrical interference? What does this type of interference sound like? Explain how you would remedy each of these.
 34. What would be the character of the noise heard if a thermostat

- in the heating system of a home caused interference? What circumstances would lead you to suspect the thermostat? How would you eliminate the interference (give circuit diagram)?
35. What parts of an oil burner installation may cause interference? Which part is likely to cause the most interference? Explain in detail what must be done (step-by-step) to eliminate it completely, telling why the particular remedy you use for each part is the best one to use.
 36. You are called into a store in which a radio receiver is installed. Every time the cash register is operated, annoying interference is heard in the receiver. When the electric fan is operated, the same thing happens. Explain exactly what kind of filter you would use to suppress the interference from each device.
 37. Draw the complete circuit diagram for a d-c motor-driven 6-circuit electric sign flasher connected to an electric sign having six banks of lamps connected to the flasher. The installation is such that the flasher must be installed at a point about 50 feet from the sign. (a) Explain just which main parts of this installation are apt to produce interference in radio receivers within a radius of 1 block. (b) Explain just how interference is caused by these parts. (c) Explain by what paths and methods the interference from each main part can get to the radio receiver installation. (d) Explain how you would effectively prevent the interference from each of these parts from leaving the flasher and sign installation. (e) Draw all the necessary interference eliminating equipment in the proper places in your circuit diagram.
 38. Cite 2 cases in which it would be better to attempt to eliminate interference at the location of the receiver installation rather than at the source.
 39. How would you effectively eliminate (at the receiver) interference which was entering the receiver by way of the power supply line? What precautions would have to be observed when installing the interference-eliminating device? Why?
 40. What is the function of the electrostatic shield used in some receiver power transformers?
 41. What questions would you ask yourself regarding the various conditions existing in a noisy receiver installation before you would decide definitely regarding the course of action you would take in order to minimize the interference?
 42. In what two ways may interference reach an antenna system. Which one is the most common?
 43. What component parts of the following types of antenna systems may pick up interference: (a) an inverted-L type; (b) a T type; (c) a doublet type?
 44. How can the interference in each part of each type of antenna in the foregoing question be minimized? Explain!
 45. What is the fundamental idea upon which all noise-reducing antenna systems are based?
 46. How is the use of shielded wire for the lead-in of an antenna supposed to eliminate noise that the antenna system may be picking up?
 47. What effect will the increased lead-in-to-ground capacitance caused by the grounded shield have on the antenna-stage tuning

- condenser adjustment in a single dial receiver? State briefly 3 ways in which this effect may be reduced.
48. Why should the shield on the lead-in be grounded? At what points should it be grounded? Why?
 49. Why are impedance-matching transformers required between the aerial and shielded lead-in, and between the lead-in and the receiver, if the shielded lead-in is long? What does the antenna coupling transformer do? What does the receiver coupling transformer do?
 50. Why are shielded lead-ins unsatisfactory for use with all-wave receivers?
 51. What is the theory of operation of the twisted-pair lead-in insofar as its ability to prevent noise pickup by the lead-in is concerned? Where does the cancellation of the noise voltages take place?
 52. What two types of aerial systems can be used with twisted-pair lead-ins? Illustrate with drawings!
 53. Why are impedance-matching transformers used with twisted-pair lead-in systems?
 54. State whether the radiations arriving at the receiving aerial wire from the following sources is vertically or horizontally polarized: (a) interference from electrical devices below; (b) signals from a nearby broadcast-band station; (c) signals from a nearby short-wave station; (d) signals from a distant short-wave station. Of what significance is this if we desire to greatly minimize noise from the electrical devices so that we can hear the weak signals from the distant short-wave station without appreciable noise background?
 55. Describe two examples of balanced transmission lines—with sketches?
 56. What construction features should high-grade twisted-pair lead-in wire possess?
 57. Draw a sketch showing how a twisted-pair lead-in wire may be connected in an inverted-L antenna system so that it minimizes noise pickup in the lead-in. You are also to show the proper way to connect this lead-in to a common standard-broadcast band receiver having one *Ant.* post and one *Gnd.* post.
 58. State one important installation advantage which the twisted-pair lead-in has over the transposed-wire lead-in.
 59. It is desired to erect an inverted-L receiving antenna which will receive the signal from a distant 300-meter station as strongly as possible without regard to how it will receive other stations. What should be the length of its horizontal portion in feet?
 60. It is desired to erect a doublet antenna system to receive best on about 90 meters. What should the length of each section of the aerial be (in feet)?
 61. Why must the entire length of twisted-pair lead-in wire which is furnished with a noise-reducing antenna kit be used—whether it is required or not? What effect will cutting off a long piece have on the reception?
 62. What is the purpose of the “static shields” employed in the impedance-matching transformers used between noise-reducing lead-ins and the receivers?

63. You must connect a transposed lead-in to a fairly old receiver which has the antenna and ground posts marked as follows: *S.Ant.*, *L.Ant.*, *Grd*. Explain (including a sketch) how you would connect the lead-in to this receiver for best reception.
64. What is a "doublet" antenna? Draw a diagram showing how one should be installed.
65. State one advantage which the doublet type of antenna possesses. State one disadvantage.
66. What is the difference between an ordinary doublet antenna and a double-doublet?
67. What main advantage does the double-doublet possess over the ordinary doublet? Explain fully!
68. Is there anything about the *aerial* portion of a doublet antenna that makes it noise-reducing?
69. Explain how a parallel-feeder lead-in eliminates lead-in pickup of interference under favorable conditions. Under what conditions would its use not entirely eliminate this type of interference pickup? Explain fully with sketches.
70. (a) What is the theory of operation of the transposed lead-in? (b) Explain in detail, with sketches just why it makes a good noise-reducing lead-in. (c) What is the purpose of the transpositions? (d) Do the noise voltages cancel each other in the lead-in wires themselves, or in the receiver coupling transformer? Explain! (e) What are transposition blocks, and why are they used?
71. A transposed lead-in is led down to the outside of a window. The radio receiver is several rooms away inside the house. Explain how you would connect this lead-in to the impedance-matching transformer at the receiver.
72. What is the greatest allowable spacing between transposition blocks? Under what conditions may this spacing be employed? Under what conditions must closer spacing be used? Why?
73. How far from the side of the building should a transposed lead-in be kept?
74. Does the transmission line have to be run in a straight line direct from the aerial to the window where it is to enter the building, or may it be run around obstructions which may be in the way?
75. It is important to have both aerial wires of a doublet antenna of exactly the same length? If installation conditions do not permit the erection of a uniform doublet, what should be done?
76. Why does an all-wave receiver seem more noisy when operated on the short-wave band than when it is switched to the standard broadcast band, unless a noise-reducing antenna system is used with it?
77. Is the input impedance of an all-wave receiver higher or lower when it is adjusted for the reception of the broadcast band than when its range switch is set for a short-wave band? Explain!
78. Why is a simple doublet antenna not suitable for use with an all-wave receiver?
79. (a) What advantage does a double-doublet have in this respect? (b) What important considerations regarding its length must be kept in mind if these advantages are to be realized in practice?

80. Explain one practical way of making a double-doublet antenna system operate efficiently over the standard broadcast band of signal frequencies as well as over the short-wave bands, without using an excessively long aerial.
81. It is desired to erect a double-doublet for all-wave reception. The longer doublet is to have a fundamental response peak at 6 megacycles, and also a third-harmonic peak. The shorter doublet is to have its fundamental response peak at 15 megacycles. What must the overall length (in feet) of each doublet be for these conditions?
82. Draw a diagram of this doublet, with the dimensions of the doublet wires marked on it, showing how you would erect it.
83. Add to the diagram just drawn, the complete internal and external circuit connections of an antenna transformer unit and a receiver-coupling transformer unit which will efficiently match the impedance of a twisted-pair lead-in to both the double-doublet aerial and the all-wave receiver over the entire short-wave spectrum. These units are also to change the connections automatically (without need for any switches) so that the double-doublet is connected as a T aerial whose impedance is effectively matched to the lead-in when standard-broadcast band signals are being received.
84. Explain the operation of the entire system shown in the diagram drawn in Question 83 for; (a) the lower short-wave band; (b) the intermediate short-wave band; (c) the standard broadcast band.
85. State at least five reasons why a good noise-reducing all-wave antenna system is a valuable asset to the service man or dealer who demonstrates receivers in his store.
86. Draw a circuit diagram showing the complete layout for a double-doublet noise-reducing all-wave system for use in demonstrating any one of five receivers (one at a time) in a radio store. A twisted-pair lead-in is to be used. How many aerial impedance-matching transformers are required? How many receiver impedance-matching transformers are necessary. What type of switch must be used?
87. An inverted-L antenna whose aerial portion is 8 times as long as its lead-in is located in New York City. It is desired to erect it so that it will favor the reception of European short-wave stations. In what general direction should the aerial point? At what end should the lead-in be connected?
88. Repeat Question 87 for the case of a double-doublet antenna.
89. In what direction should the aerial of Question 87 point if it is to be erected so that it picks up as little interference as possible from a trolley line which runs in front of the building? At what end should the lead-in be connected? What type of lead-in should be employed if the receiver is to be used for standard broadcast band reception only?
90. Draw a sketch showing the antenna installation conditions outlined in Question 89.
91. Repeat Question 89 for the case of a double-doublet antenna.
92. Repeat Question 90 for the double-doublet antenna case.

CHAPTER XXXI

HIGH-FIDELITY RECEIVER PROBLEMS

31-1: Introduction. — The commercial development and marketing of "high-fidelity" receivers of both the standard-broadcast band and all-wave types has brought about new problems in radio service work—special problems which are not encountered in the servicing of the ordinary types of receivers. These have resulted from the new circuit and construction features which these sets incorporate in order to make satisfactory high-fidelity reproduction possible. In order to solve these problems successfully, it is important that the service man be thoroughly acquainted with those circuit and construction features of high-fidelity receivers which differ from those encountered in the ordinary average radio receiver. He should also know their functions and the reasons for their use, so that he will understand them thoroughly. Finally, he should know all about the special troubles (and their symptoms) which occur in these receivers. This information, together with his fundamental background knowledge of ordinary service work should enable him to solve any high-fidelity receiver service problems successfully. It is the purpose of this chapter to present the special information which is required for this purpose. It should be understood that the majority of the troubles occurring in these receivers are exactly similar to those with which the service man is already familiar, and require no special treatment. Such troubles as short-circuits, open-circuits, "grounds", broken down condensers, poor or defective tubes, burned-out windings, etc., fall in this class. Also, the test instruments which are used for servicing ordinary receivers are adequate for service work on high-fidelity receivers—no special equipment is required. The cathode-ray oscilloscope, however, is especially useful for per-

forming visual alignment of the i-f stages (see Art. 25-40) and also for checking audio distortion (see Art. 25-43).

31-2. Frequency Range Required for High-Fidelity Reproduction.—For the full realistic enjoyment of broadcast musical programs there is no doubt that a high standard of quality of reproduction is necessary—a standard considerably higher than ordinary types of receivers provide. Broadcast programs consist essentially of the transmission of human speech (both male and female) of all sorts of musical compositions rendered in many forms ranging from the solo performance and single instrument to the full rendition of a composer's masterpiece by a complete symphony orchestra, and of incidental "sound effects" which are broadcast as parts of programs, or as "air signatures" for purposes of "aural" station identification, etc.

If realistic reproduction of these sounds is to be accomplished by the radio receiver, at least one requirement is that the entire receiver taken as a unit (including the loud speaker) shall leave unchanged (within permissible limits) the envelope forms of the received waves. Another way of saying this is that the receiver shall pass, amplify and reproduce without discrimination (within permissible limits) the entire band of audio frequencies involved in these programs. Let us see what these frequency limits are. Average male speech involves necessary frequencies from about 120 cycles up to some 8,000 cycles per second. The average female voice is capable of producing sound frequencies from about 200 cycles to 10,000 cycles. Orchestral music involves important components as low as 20 cycles and as high as 12,000 cycles or more, but there is no appreciable impairment of the tone quality if all frequencies above 10,000 cycles are not reproduced. However, a considerable impairment results in the reproduction of music and many of our common sounds if *cut-off* occurs at 5,000 cycles. Noises such as the rattling of keys, the tearing of paper, etc., contain appreciable components as high as 15,000 cycles, but while a cut-off at 10,000 cycles does affect the naturalness of their reproduction, it does not make it impossible to recognize the noise.

In view of these figures, it would seem that "realistic" high-fidelity reproduction of all these types of sounds and programs

could only be obtained if an audio-frequency range extending from about 20 to 10,000 cycles were transmitted and reproduced. This is an audio-frequency range almost 3 times as large as the reproduction range of the average ordinary "good" console receiver which was available up to the time of the advent of high-fidelity receivers. This is illustrated graphically in Fig. 31-1.

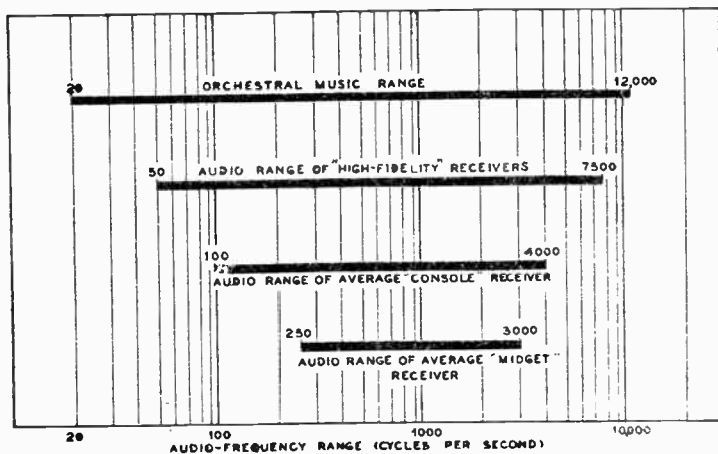

FIG. 31-1.—The average audio reproduction ranges of various classes of radio receivers are shown here. They are arranged so they may be compared to the full frequency range of orchestral music.

For practical reasons, the manufacturers of radio receivers have not seen fit to extend the reproduced audio range to these extreme limits. Instead, the RMA (up to the time of this writing) has defined a *high-fidelity* receiver as:

"one which has an audio reproduction range from 50 to 7,500 cycles, with a harmonic distortion content not to exceed 5 per cent, and a volume range of reproduction of at least 70 db."

It is held that a wider frequency reproduction range than this is not necessary, since only a musically-trained listener can recognize the difference between reproduction which includes only those sounds between about 40 to 7,500 cycles and that which includes the larger range from 20 to 10,000 cycles. Since only a very small percentage of the listeners to radio broadcast programs are so trained, it is felt that the reproduction range from 50 to 7,500 cycles provides an acceptable standard.

The comparative average frequency ranges of orchestral music, high-fidelity receivers, good "ordinary" console receivers and midget receivers are shown graphically in Fig. 31-1 for comparison. Notice what a small part of the orchestral range the midget receiver is able to reproduce (only about $\frac{1}{4}$ of it). Due to the small loud-speaker baffle area of a midget cabinet (and also the poor overall electrical characteristics), the low frequencies are sadly missing. To compensate for this and effect a balanced tone, the highs are badly cut off (purposely) by the set manufacturer. While this type of set has a mellow tone, the brilliant highs and rumbling lows which give life to music are lacking.

31-3. Volume Range Required for High-Fidelity Reproduction.—The foregoing facts show that a high-fidelity receiver should be constructed so as to be able to amplify and reproduce the entire range of audio frequencies from 50 to 7,500 cycles with no more than 5 per cent of harmonic distortion. However, in contrast to a somewhat popular notion, true high-fidelity reproduction requires more than mere wide-frequency response and freedom from distortion. It must also have a large *volume range* (at least 70 db.), that is, it must be able to handle and reproduce (without more than the allowable amount of distortion) the full range of volume from the softest passages to the loudest crescendo of a philharmonic orchestra.

Amplifiers and loud speakers are limited in the amount of power that they can deliver in undistorted form. Harmonic content is primarily a function of the tubes used and their operation. When properly used, an amplifier tube is practically a linear device (at the point of departure from linearity, harmonics are produced). Therefore, in order to meet high-fidelity requirements, proper vacuum tubes correctly operated so that not over 5 per cent harmonic distortion results *at the highest power output normally required*, must be employed. If an attempt is made to force an amplifier to deliver more than its maximum undistorted power rating allows (this might occur in an ordinary receiver when the orchestra suddenly bursts into a loud passage), overloading occurs. This results in a flattening of both the tops and the valleys of the wave, i.e., above the overload point, the

power output does not increase in proportion to the power input. In cases of very bad overloading, a distinct *rattle* is heard in the *resultant* sound, very much as if the diaphragm of the loud speaker were loose. This flattening of the wave tops results in an addition of harmonics to the pure tone, and actually causes the introduction of frequencies which were not present in the original sound, when two or more tones are being reproduced simultaneously.* This form of overload distortion, called *non-linear*, is extremely disagreeable and of course cannot be tolerated in high-fidelity receivers. From a standpoint of the resulting sound, a similar effect results from overloading a loud speaker.

It is evident, therefore, that both the amplifier and loud speaker are limited in the maximum power that they can handle satisfactorily without producing too much distortion. This limitation in their maximum undistorted power output capabilities may limit the quality of the reproduction in two respects. First it may limit the loudness range obtainable without distortion. Second, it may prevent the loudest tone of the reproduction from being as loud as the sound reaching the ears of a member of the audience sitting in an average audience position, i.e., it may cause the louder parts of the reproduced program to be insufficiently loud thereby robbing it of its full naturalness. Consequently, the entire audio system including the loud speaker must be designed and maintained so that it is capable of handling the volume range required for true high-fidelity reproduction. Let us see what this volume range is.

The volume range of properly reproduced speech is about 40 db; that of a symphony orchestra, or of a vocal concert is of the order of 55 to 65 db. This represents a sound intensity range of from 700,000:1 to 7,000,000:1! It is readily seen that this is a considerable range and calls for almost unbelievable versatility in the audio equipment. The loud speaker, for instance, which must be so delicate that it is able to operate and produce the sound of a faint whisper must also be rugged enough to produce a sound seven million times as intense! The volume range (from

*NOTE: For a more detailed discussion of the various types of distortion which occur in audio amplifiers, see the *Radio Physics Course* by Ghirardi.

the noise level to the overload level) of the majority of ordinary console type radio receivers is of the order of 30 to 40 db. Evidently, this is not sufficient for the true rendition of orchestral music. The volume range of high-fidelity receivers is 70 db. This is adequate to handle all orchestral programs without overloading.

31-4. Noise Level in High-Fidelity Receivers.—In order

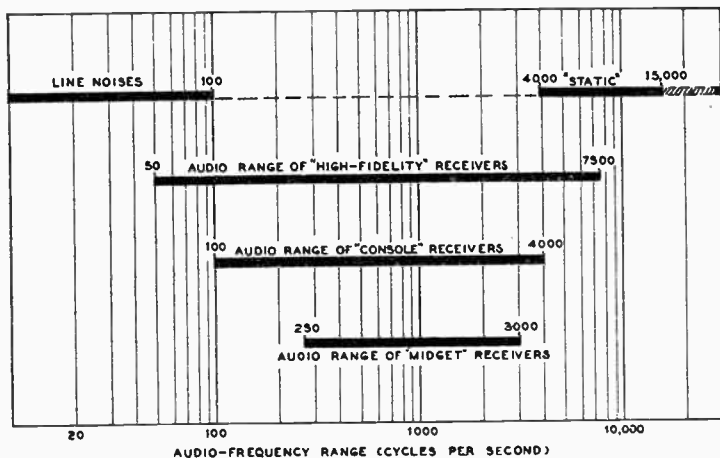

FIG. 31-2.—The effective audio-frequency ranges of line noises and “static” are shown here in comparison with the reproduction frequency ranges of the three common classes of radio receivers. Notice that since the reproduction range of high-fidelity receivers falls within the range of line noises and static (both man-made and natural), they are affected more by these disturbances than are the other two classes of receivers which have a more limited audio range.

to fully enjoy the reproduction produced by high-fidelity receivers, natural and man-made disturbances should be absent. The greater the fidelity of the receiver, the more vigorously must this requirement be fulfilled. The reason for this is clear. Line noises and hum produced by incomplete filtering in the power pack occur in the lower audio-frequency region up to about 100 or 120 cycles. A consideration of the frequency ranges of the various classes of receivers (see Fig. 31-1) shows that since high-fidelity receivers reproduce well down to 50 cycles they are likely to reproduce any such noises very strongly—noises that would not be heard on ordinary console or midget receivers whose low-fre-

quency cut-offs are around 100 cycles and 250 cycles respectively. The same condition exists at the upper end of the frequency range. It is well known that man-made electrical interference and natural "static" disturbances have most of their energy in the upper regions of the audio spectrum between around 3,000 or 4,000 cycles and 15,000 cycles. While the reproduction of most ordinary console and midget receivers cuts off below this range, high-fidelity receivers reproduce *well* everything right up to 7,500 cycles—including of course, all such noises. This condition is illustrated in Fig. 31-2 which shows not only the audio-frequency ranges of the various classes of receivers but also the usual audio-frequency ranges of both line noises, static and electrical interference.

It is true that high-fidelity receivers are provided with means for restricting the frequency response at will, in order to cut out the high-frequency noises when they are objectionable, but of course this also reduces the fidelity of the reproduction. There is not much use in purchasing a high-fidelity receiver for the purpose of securing high-fidelity reproduction if the receiver must actually be operated with its reproduction range restricted because of disturbing interference! It is evident then, that in high-fidelity receiver installations every attempt must be made to keep the noise inherent in the receiver equipment itself, as well as that which enters it from external sources, as low as possible. The many practical causes which result in internal receiver noise were discussed thoroughly in Art. 30-8 of Chapter 30 and should be reviewed at this time. If annoying hum is experienced, particular attention should be paid to the rectifier tube and the filter condensers, for any trouble with them will cause far more hum in high-fidelity receivers than in ordinary receivers. Man-made electrical interference reaching the receiver, either by way of the power-supply line or the antenna circuit, must be effectively reduced to a very low level if high-fidelity reproduction is to be enjoyed. This phase of the subject has already been treated exhaustively in Chapter 30, so it will not be repeated here. The use of effective noise-reducing antenna systems in noisy locations is very important.

31-5. The Tuned R-F Circuits of High-Fidelity Receivers.

The tuned r-f circuits of a high-fidelity receiver do not differ materially from those employed in ordinary receivers. The only important additional requirement demanded of them is that they have a sufficiently broad acceptance band to admit all the sidebands ($7\frac{1}{2}$ kc on each side of the carrier) necessary for high-fidelity reception. The antenna circuit of any receiver is usually sufficiently broad to admit more than the highest side bands desired for high-fidelity reproduction, but the first r-f stage is usually sharper. This condition, however, is compensated for by the decreased drop in the i-f transformer at the peaking frequency. Referring to (A) of Fig. 31-3, it is seen that the response curve of an over-coupled i-f transformer has a dip in the center. This means that the low-frequency amplification is less than the high-frequency response, and so compensates for the selectivity of the r-f circuit as far as high fidelity is concerned. In any event, there are but two or three tuned circuits in the r-f amplifier, which generally are sufficiently broad to admit the higher side bands desirable for high-fidelity reception.

If the receiver is a standard-broadcast band type, simple r-f coils are employed. If it is of the all-wave type, the usual coil-switching arrangements which are employed with such receivers will be found (see Art. 28-17).

31-6. The Oscillator in High-Fidelity Receivers. — The most important requirement which the oscillator in a high-fidelity receiver must meet, is that it be stable, i.e., that its frequency does not drift. The stability of oscillators was discussed in detail in Art. 15-28. Oscillator stability is even more important in high-fidelity receivers than it is in ordinary receivers if real high-fidelity performance is desired. If the oscillator frequency drifts after a station is tuned in, poor audio quality will result. The illustration in Fig. 31-3 will aid in understanding this. Suppose a high-fidelity receiver which employs an i-f of 260 kc is tuned exactly to a station so that the frequency of the signal in the i-f amplifier is equal *exactly* to 260 kc, the frequency to which the i-f stages are tuned. The condition is then as shown at (A), where the signal is shown by the shaded portion. The response curve *R* of the i-f amplifier is broad enough to allow the necessary 15 kc band of signal frequencies ($7\frac{1}{2}$ kc

above 260 and $7\frac{1}{2}$ kc below 260) to pass through without appreciable attenuation, and good reproduction results. Now suppose that as the set warms up, the oscillator frequency drifts (upsetting the tracking between it and the r-f signal circuits) to such an extent that the frequency of the signal which exists in the i-f amplifier is say 267.5 kc (in general, oscillator drift due to warming up causes the i-f to become *higher* than normal). The condition is now as represented at (B) where the sig-

FIG. 31-3.—The effect of frequency drift of the oscillator (in a high-fidelity superheterodyne receiver) on the fidelity with which the signal is reproduced.

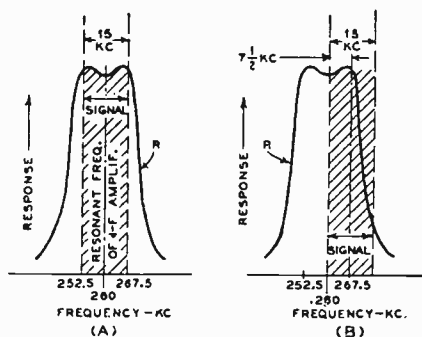

nal side bands are again shown by the shaded portion. Since the i-f signal frequency has been shifted over $7\frac{1}{2}$ kc to the right, one of the $7\frac{1}{2}$ -kc side bands falls outside of the i-f resonance curve a good deal and is therefore greatly suppressed. Only the lower $7\frac{1}{2}$ -kc side band gets through with full strength! However, the low frequencies of the suppressed side band might still be of sufficient amplitude so that when they are added to the passed side band the balance is upset and the set sounds "boomy". If the drift were even greater than this, the low frequencies would be suppressed altogether, and high-pitched "screechy" reproduction would result.

It is apparent from this typical example that it is essential that the oscillator frequency remain stable. The oscillator must therefore be of such design that warming up (especially of the converter tube), change of line voltage, change of load, etc., will not cause any change in its frequency. One manufacturer has taken a step back to former superheterodyne design in order to minimize this trouble. Instead of performing the oscillator and mixer functions in a single tube, a separate oscillator tube coupled

to a pentagrid converter tube, as shown in Fig. 31-4, is used in the Stromberg Carlson 70 Series all-wave high-fidelity receivers for stability. This novel circuit arrangement is likely to become popular for this purpose. A '76 tube is used as a tuned-grid oscillator, and a 6A7 is used as the modulator. The plate of the '76 tube is coupled to the inner grid of the 6A7 through a small condenser C_1 . The No. 2, 3 and 5 grids are by-passed by condenser C_2 . The arrangement really amounts to an electron-coupled oscillator!

This circuit will not be very strongly affected by temperature changes in the 6A7, or by extremely strong incoming signals. Because the 6A7 tube serves only as a modulator in this circuit (the triode portion does not serve as the oscillator and the pentode portion as the modulator as is the case when it is used for the dual purpose), maximum freedom is

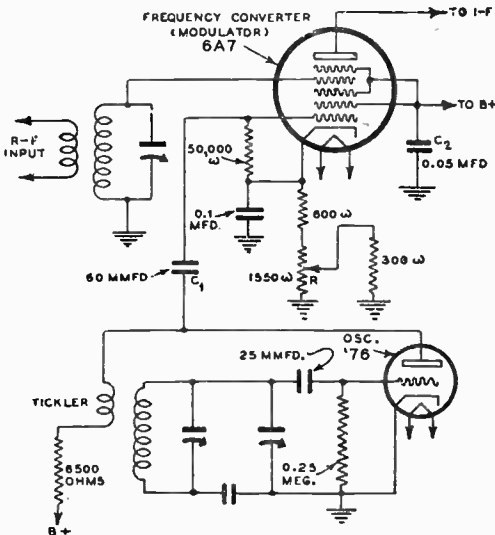

FIG. 31-4.—Oscillator and modulator circuit arrangement employed in a commercial high-fidelity receiver for stability and freedom from frequency drift. (Stromberg Carlson 70 Series.)

secured from detrimental coupling which would otherwise occur between the elements. Since in this arrangement, the inner grid of the 6A7 is shielded from possible capacity feedback due to capacity coupling between the modulator grid and inner grid, strong signals are prevented from feeding back to the oscillator.

Of course, from what has already been said it is clear that proper tracking of the oscillator is very important in high-fidelity receivers so that the signal in the i-f amplifier will always be of such a frequency that it will fall exactly in the center of its re-

sponse curve (see (A) of Fig. 31-3) when properly tuned in. If the tracking is off, the condition similar to that shown at (B) will result, and the reproduction will be anything but high-fidelity. In addition, the troubles due to image-frequency interference, etc., which were discussed in Art. 25-10 may also follow.

31-7. The Station Interference Problem in High-Fidelity Receivers.—The intermediate-frequency amplifier of a high-fidelity receiver is the first unit whose design is essentially different from that of the corresponding unit in an ordinary receiver. This difference is brought about by selectivity problems which must be met with in these receivers. The usual high-fidelity receiver as it is being built at this writing, allows a maximum passage of frequencies of $7\frac{1}{2}$ kc on both sides of the carrier—so that the total band is 15 kc. Now in the United States, all stations with an air-line range of over 100 miles have a frequency separation of 10 kc. The so-called *local* stations, however, (those within a radius of 100 miles) have a frequency separation of 50 kc in order to make possible the broadcasting of 7,500 kc wide high-fidelity programs with limited power during the daytime if desired.

When the receiver is operated with its full 15-kc broad tuning in order to obtain high-fidelity performance, no selectivity difficulties usually appear when local stations are being received, because the 50 kc separation between them is sufficient to prevent overlap. However, a powerful distant station whose carrier frequency differs from that of the local station by less than 15 kc may appear in an adjacent channel with a loudness which is appreciable by comparison. In this case, the high-fidelity receiver with its wide open input channel will accept the full program of the station to which it is tuned, as well as parts of the sidebands of the interfering station, resulting in a condition such that the signal from the unwanted station is inverted thereby making the low notes sound like high notes and vice versa. This cross-talk is commonly known as *monkey chatter* since it usually appears as a series of high-pitched twitterings. In addition, there may be a steady high-pitched whistle due to the beating together of the carriers of the two stations. The frequency of this *beat* is equal to the difference between the carrier frequencies of the

two stations. This is really station interference of a "heterodyning" nature! Another annoying type of station interference is that of the reception of the signals of foreign stations, some of which broadcast on frequencies midway between the regularly assigned U. S. station channels. These foreign signals beat with those of the local station and cause a 5-kc beat note.

Whether interference from these causes is audible or not, depends upon the relative strengths of the carriers of the desired and the interfering signals when they reach the second detector. If the carrier of the wanted station is sufficiently stronger than that of the interfering station, the interference, although still present, will be below audibility and so will not be heard—otherwise it will be heard. The extent to which the interference must be weaker than the wanted signal for it to be inaudible depends upon the volume level at which the receiver is operated, and may be as much as 50 db.

31-8. Why the Station-Interference Problem is Usually Solved in the I-F Amplifier.—It is evident that the selectivity problem is one of supplying adequate selectivity somewhere in the receiver to prevent the station signal interferences just described. First of all, it should be understood that the selectivity of a superheterodyne receiver lies largely in the i-f amplifier. Therefore, it is natural that designers should turn to the i-f amplifier for a solution to the problem. For high-fidelity reproduction, the i-f amplifier response should be such that it passes (uniformly) a 15 kc band of frequencies ($7\frac{1}{2}$ -kc above and $7\frac{1}{2}$ -kc below the i-f). However, for sufficient selectivity to prevent interference when receiving distant stations, much sharper tuning is required. This is obtained in ordinary receivers by constructing the i-f transformers so that the primary and secondary of each one is loosely coupled for high selectivity, permitting a band of frequencies only about 2-kc above and 2-kc below the i-f to pass through it. If this kind of an amplifier is used in a high-fidelity receiver, the selectivity will be good but the fidelity will be extremely poor due to the cutting of side bands. The receiver will then have an audio-frequency range of only 3,000 or 4,000 cycles instead of the 7,500 cycles required.

It is clear that the conflicting nature of the selectivity and

the fidelity requirements permit no satisfactory compromise to be made at the receiver. *No high-fidelity receiver with fixed selectivity characteristics will give the best results under all reception conditions*, for high-fidelity reception and extreme selectivity simply do not "mix". In order that high-fidelity receivers shall be able to provide both distant-station reception (not high-fidelity) without interference, and high-fidelity reception of local stations when desired, the selectivity (and hence the frequency response) must be made variable. A control must be provided so that the set owner can *contract* the frequency response or "admitted band" at will to provide maximum selectivity for distant station reception (or reception under interference or noisy conditions), and open or *expand* the band for high-fidelity local station reception. When "expanded", the full audio response of the broadcast station is permitted to pass through.

Of course, the fidelity of the reproduction on distant stations will suffer, but nothing can be done about that under our present broadcasting conditions. It is much more desirable to listen to uninterfered-with but fair reproduction than it is to listen to high-quality reproduction that is broken up by adjacent-channel interference and *monkey chatter*.

31-8A. Several of the Methods which are being Employed to Solve the Station-Interference Problem.—Various receiver manufacturers have attacked this selectivity problem in different ways.

At the time of the present writing, Philco, Stromberg-Carlson and Zenith high-fidelity receivers use an arrangement which enables the frequency response of the i-f amplifier to be varied (continuously without jumps) at will, so that just enough selectivity may be had at any time. Atwater Kent receivers employ a system controlled by a two-position switch, providing two degrees of selectivity (*maximum* and *minimum*). In at least one General Electric receiver, the entire i-f amplifier is cut out of the circuit and the r-f amplifier feeds directly into the second detector when high-fidelity local-station reception is desired. In at least one Howard receiver, separate i-f amplifiers are used for high-fidelity and distant reception, and the tone response is further enhanced through the use of separate audio amplifiers for high and low frequencies.

31-9. How the Selectivity of the I-F Amplifier may be Varied.—There are two general ways of accomplishing the desired variation in selectivity of the i-f amplifier. One is mechanical, the others are electrical.

Up to the time of this writing, the electrical arrangements

have been used exclusively on commercial receivers manufactured in the United States. However, since it is likely that the mechanical arrangement will also be used in some receivers in the near future, this will also be described here.

The arrangement that is mechanical in nature utilizes the fact that the selectivity of a tuning transformer may be increased or decreased merely by loosening or tightening the magnetic coupling between the primary and secondary coil. This may be accomplished by simply moving the primary and secondary further apart or closer together. Thus, if we consider the typical tuned i-f transformer shown at (A) of Fig. 31-5, we may first adjust the tuning trimmer condenser across each coil, (separately), with very small coupling between the coils, until each coil is tuned *exactly* to the i-f desired, let us say 175 kc. The tuning or response curve will then be very narrow, as shown by curve *S*, at (B). This would be the desirable response if station interference were present. If the coils are now brought closer together so as to *increase* the magnetic coupling between them, the

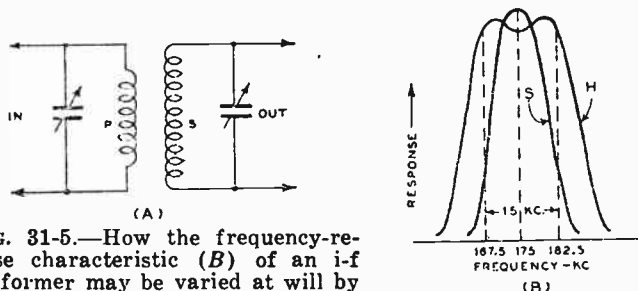
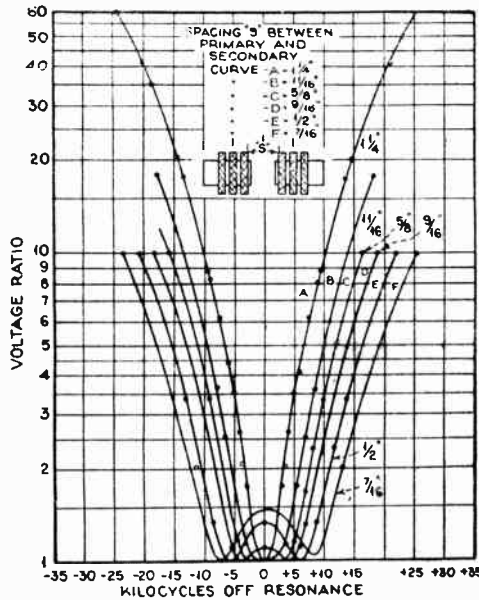

FIG. 31-5.—How the frequency-response characteristic (B) of an i-f transformer may be varied at will by varying the distance between the primary and secondary windings shown at (A). Two extremes of coupling desirable in an i-f transformer suitable for use in a high-fidelity receiver are shown at (B). The tuning characteristic labeled *S* provides high selectivity but poor high-note reproduction; that labeled *H* provides less adjacent channel selectivity but better audio fidelity.

characteristic broad double-humped response curve represented by *H* results. This would be the desirable condition for high fidelity response! Of course, any response condition between the two can be easily obtained by moving one coil closer to, or further away from the other. The exact manner in which the response curves actually vary in a commercial unit of this type (the one illustrated in Fig. 31-7) is illustrated by the family of response curves plotted in Fig. 31-6. The spacing *S* which existed between the primary and secondary coil when each response curve was taken is indicated. Notice that when the spacing was $1\frac{1}{4}$ inches, response curve *A* (which is so sharp that a total band of frequencies only about 5 kc wide is passed) was obtained. At a closer spacing of $\frac{5}{8}$ -inches (curve *C*) the characteristic double-hump response begins. At the close spacing of $9/16$ -inches (curve *F*) the double-hump is very pronounced, and the frequency response is very broad.

The actual commercial intermediate transformer unit upon which these response curves were taken is illustrated in Fig. 31-7. In it, one of the two coils of the regulation intermediate-frequency transformer is rendered movable so that the coupling between the two coils can be varied at will. This is accomplished by means of a threaded rod which engages with a suitable threaded sleeve on the movable coil support. By rotating this rod, the movable coil is caused to move nearer or further away from the stationary coil so that variable coupling is available to decrease or increase the width of the frequency band allowed to enter the receiver. It is possible to mechanically connect this rod to a control on the panel so that this function may be adjusted as the occasion requires from the front panel where all the other controls are placed. The air-dielectric type condensers which tune the primary and secondary coils to the proper i-f are visible at the top and bottom of the unit.



Courtesy Hammarlund Mfg. Co.

FIG. 31-6.—Family of frequency-response curves which show the selectivity characteristics obtained when the primary and secondary windings of an actual i-f transformer are separated by the different distances indicated. These curves were taken on the commercial variable i-f transformer unit illustrated in Fig. 31-7.

When aligning the i-f stages of a receiver which employs transformers of this type, it is important that the coupling be as loose as possible during the lining-up process, otherwise difficulty will be encountered in securing a symmetrical resonance curve. With loose coupling, a single peak will be obtained, and

the i-f may be adjusted to the desired frequency. Alignment is greatly facilitated and can be done much more accurately if a cathode-ray oscilloscope is employed to give a visual picture of the i-f response. It is interesting to note that a mechanical device for panel control of coupling may be employed. All the i-f transformers in the receiver are adjusted to the same frequency, and the coupling controls are ganged to a single shaft for variable control of fidelity from the receiver panel.

A second method of varying the frequency response of the i-f transformers is essentially electrical and is shown in Fig.

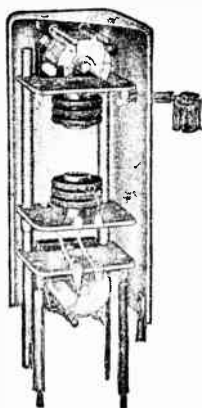

Courtesy Hammarlund Mfg. Co.

FIG. 31-7.—An i-f transformer unit which provides variable coupling and response by mechanical means. The distance between the primary and secondary windings may be varied by means of a threaded rod to change the coupling.

adjust the setting of the 8,775-ohm variable resistor in the circuit of coil *C*, this resistor being ganged to a similar unit in the second i-f transformer circuit and also to a bias control resistor in the first detector and the first i-f cathode circuits.

When maximum resistance is in the circuit, coil *C* has a relatively small effect on the normal circuit operation, and the response of the unit is narrow for maximum selectivity, (approxim-

31-8. This method has been employed successfully in Philco and Stromberg Carlson high-fidelity receivers. The intermediate transformers have three coils each, instead of the conventional two. Coil *A* is the usual tuned primary; coil *B* is the usual tuned secondary, the coil *C* is a special winding which when tuned by its condenser *C*, forms an absorption circuit, which is tuned to the exact center of the i-f band. Since this circuit is tuned to the same frequency as the secondary *B* and the primary *A*, and is closely coupled to them (in fact this winding serves as a link circuit to transfer the i-f energy from primary *A* to secondary *B* to which it is inductively coupled), it will absorb energy from these circuits and thus introduce i-f resistance. However, it is possible to

ately 4,000 cycles wide). As the resistance is lowered, circuit C absorbs more and more energy from the adjacent windings. This reduces the gain and increases the width of the response of the transformer to admit the high frequencies for high-fidelity reproduction. But, since the gain also decreases as the response of the transformers is widened, the bias control for the first detector and i-f stages is ganged to the "fidelity control" shaft and operates simultaneously with it. When the receiver is operated so as to have a wide frequency response for good fidelity, the bias

FIG. 31-8.—An electrical circuit arrangement which is employed for varying the width of the frequency response characteristics of the i-f transformers in high-fidelity receivers.

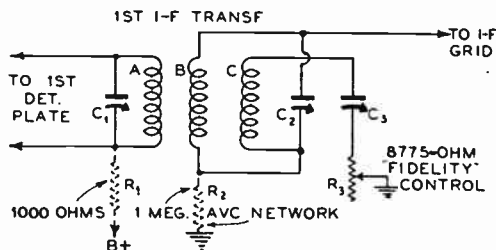

on the first detector (by means of resistor R in Fig. 31-4) and first i-f stages is reduced to raise the gain to that obtainable, when the receiver is adjusted to provide sharp tuning (a total band width of about 4,000 cycles).

Tuning is necessarily critical when operating the set at the maximum selectivity setting. A tuning meter driven by a special grid-leak detector, T_s , used just for this purpose and driven from a separate winding, L_s , on the second detector input coil as shown in Fig. 31-9, is therefore used, indicating resonance irrespective of the fidelity control setting.

A third method of varying the band width of the i-f transformers is to shield the primary from the secondary (using them simply as *inductances*) and couple the two by means of a variable condenser, C , somewhat as shown in Fig. 31-10. When C is set at its minimum coupling-capacity setting, the constants of the circuit should be such that the band width is about 4,000 cycles for sharp tuning; with the maximum capacity of C in the circuit, the frequency response band width should be about 15 kc. wide, so as to be suitable for high-fidelity reception and reproduction.

The foregoing descriptions represent the three fundamental methods of varying the band width of the i-f transformers used in high-fidelity receivers to suit the reception conditions at any time. No doubt, improvements in design and modifications of these will appear from time to time, but the general ideas upon which these operate will undoubtedly be utilized. For instance, in the Stromberg Carlson 70 series high-fidelity receivers which

FIG. 31-9. — Circuit arrangement for driving the tuning meter by a special grid-leak detector tube T_2 operated by winding L_3 , so that the correct response will be indicated regardless of the setting of the "fidelity" control.

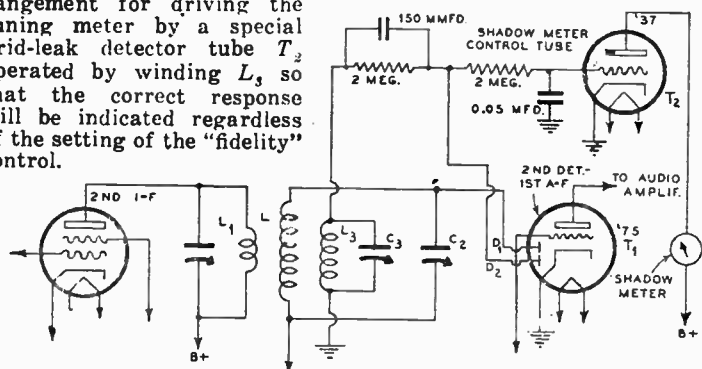

employ the second arrangement, a switch is also provided in series with each of these "fidelity control" resistors. These switches (incorporated in the variable resistors) automatically open the absorption circuits entirely when the fidelity control is turned counterclockwise as far as possible to make the variable resistor *maximum*.

31-10. Iron-Core i-f Coils.—There has recently been made available a specially treated ferrous metal suitable for use for the cores of high-frequency coils. This core material consists, essentially, of specially prepared finely-divided ferrous metal particles held together by a suitable binder. The material is poured into molds and pressed into the desired shape.

These special cores have comparatively low losses at radio frequencies, and when used as the core for a coil, result in a material reduction in the overall coil resistance because of the small amount of copper wire required for the coil. It will be recalled that the inductance of a coil is directly proportional to the permeability of its core material. Since the inductance

of a coil is also nearly proportional to the square of the number of turns, it is possible to reduce the number of turns according to the square root of the permeability of the core, and hence make the coil much smaller in physical dimensions for a given inductance.

The use of coils having these special magnetic cores possesses a unique advantage in high-fidelity receivers. If the core be maintained in a fixed position with respect to one coil, say the primary, and if the secondary first be placed with respect to the primary so that zero magnetic coupling exists, then only a slight motion of the secondary is required to widen the frequency response of the transformer as a whole. The effect of this small change in position of the secondary is due to the fact that the iron core concentrates the flux of the coil to the immediate space surrounding the coil, and but a small motion of the secondary is required to bring it within the field of the primary. Thus, a control of the i-f band width may be obtained by moving the secondary coil slightly.

It is interesting to note that some years ago iron cores were used to *increase* the resistance of tuned circuits so that they could respond over the entire broadcast band (500 to 1,500 kc)

FIG. 31-10.—Capacitively-coupled circuit arrangement which may be employed for controlling the fidelity of a high-fidelity receiver. The primary and secondary windings are here used merely as inductances capacitively coupled together.

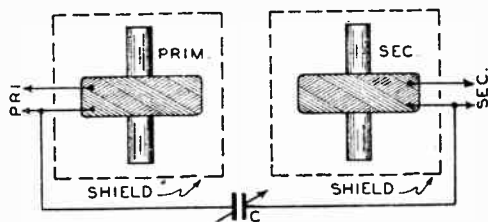

without any tuning whatsoever. This effect was due mainly to the eddy current loss in the iron (which varies approximately as the square of the frequency). But by using the special finely-divided iron particles mentioned here, the eddy-current losses have been reduced to a very small value. This, together with the fact that the resistance of the wire of the coil is also less because less wire is necessary for a given inductance when the iron core is employed, has made it possible to produce iron-core i-f trans-

formers which actually have less r-f resistance than similar ones of the air-core type—with a great saving in the space occupied.

31-11. **The Second Detector.**—There are several reasons why the second detector of a high-fidelity receiver should be a linear detector. Since many of the advantages of linear detection for these receivers are not generally known, they will be discussed here. To begin with, all detectors, regardless of type are really *square law* in action (like a grid-leak condenser detector) for weak signals, and *linear* in action when the applied signal voltage exceeds a certain value. The value of this voltage varies with the type of detector, and with the values of the components used in the individual circuit.

A *square law* detector has the following characteristics, which will be compared with those of the linear detector:

(1) The audio output of the fundamental is proportional to the product of the carrier and the side band amplitudes.

(2) The d-c component of the plate current is proportional to the *square* of the carrier voltage and for large percentages of modulation it is affected by the audio modulations.

(3) The per cent second harmonic distortion is equal to 25% of the per cent modulation.

The following are the corresponding characteristics of the *linear* detector:

(1) The audio output at the fundamental is proportional to the side-band amplitudes *only*, and is independent of the carrier amplitude.

(2) The direct-current output is proportional *only* to the carrier, and is independent of the audio modulations.

(3) No harmonics of the audio signal appear.

We will now discuss the significance of these characteristics as they apply to receiver design, especially high-fidelity receivers.

Suppose a receiver has a certain amount of residual noise generated either internally in the set itself or by some external man-made device. This noise will be amplified by the tubes and associated circuits and heard in the loudspeaker. This

residual noise is usually of a high frequency. Whether it increases or remains constant when a louder signal is tuned in, depends upon whether the second detector is of the square law, or the linear type.

It is easy to conceive of this noise as being part of the audio modulations of the signal; in other words, consider noise just as if it were one of the audio signals modulating the carrier. What happens to it, therefore, depends upon the type of second detector. If it is a *square-law* detector, then, as mentioned in (1), the audio output is proportional to the product of the amplitude of the carrier and of the side bands, which means the product of the signal carrier and the noise. The stronger the carrier is (the louder the signal) the louder will be the noise, because the noise output is proportional to the product of carrier and noise (we are considering the noise as part of the side band of the signal). On the other hand, if a *linear* detector is used, the audio output is proportional only to the side-band amplitudes; hence the noise will not increase as the signal strength is increased, because its value is constant.

This same condition may be viewed from another angle. Suppose the signal and noise voltages remain constant and the sensitivity of the receiver is gradually increased from a low value by, say, decreasing the bias on the r-f and i-f tubes (a common form of volume control, especially in avc circuits). If a *square-law* detector were used, the noise would naturally increase with the sensitivity, and the signal strength would likewise increase with the *square* of the sensitivity. However, if a *linear* detector were used, the noise output would remain constant. The second characteristic mentioned here is important when the plate current of the detector is used for avc control.

The d-c plate current of the square-law detector is proportional to the *square* of the carrier voltage and to the per cent modulation of the signal (see Art. 15-24, Chapter XV, for the significance of per cent modulation). At high percentages of modulation, the plate current varies with the modulation. Thus, for a 100% modulated signal, the plate current will be twice that for no modulation, and the grids of the avc-controlled tubes will be twice that for no modulation. This corresponds to a 6 db

drop in audio output if variable-mu tubes are used, which is quite appreciable in a high-fidelity receiver. On the other hand, in a linear detector the d-c plate current is *independent* of the side bands, and hence is not affected by the per cent modulation or any noise voltages.

The third and final important characteristic is the second harmonic distortion in the plate circuit of the detector. We said that in a square law detector this distortion is 25% of the per cent modulation. Thus, a 100% modulated signal will have present in its output second harmonics equal to 25% of the fundamental. If the per cent modulation is 75, a common value, then the second harmonic distortion would be $75/4$, or 19% (nearly). The truly linear detector has no distortion of this form when the modulation does not exceed 100%—the highest value obtainable with no transmitter distortion.

This latter characteristic is important when the characteristics of high-grade transmitters are considered. The "coverage" of a transmitter is almost a direct function of its per cent modulation, so that it is the object of nearly all good stations to have as high a per cent modulation as possible. Thus, for a given signal strength at the receiver, a square-law detector will give more distortion on the better stations than on the poorer ones! With linear detection, the distortion will be independent of the per cent modulation, and thus will truly reproduce whatever is fed into it.

Now it was pointed out previously that it is desirable to have powerful transmitters for high-fidelity receivers. This advantage is evident in the light of the detector characteristics presented herewith. With a fixed noise level, the point at which any detector becomes linear depends upon the signal strength. With sufficiently weak signals, the detector, regardless of type, is *square law* in action; and, as pointed out in (1), the noise voltage in the plate circuit will increase with carrier voltage. At a certain carrier voltage, the detector becomes linear, and the noise ceases to be amplified as the carrier is increased, though the actual modulations of the signal increase simply because the signal strength is greater. Therefore, with a strong carrier actuating the detector, the point of linearity is arrived at with

comparatively small amplification of the noise. Of course, this results in a greater signal-to-noise ratio. This is commonly referred to as "demodulation of noise at the detector".

This same reasoning applies to the case of a weak and a strong signal reaching the detector. In a linear detector, the weak carrier is demodulated by the strong one, so that only the

FIG. 31-11.—Graphs showing the relative amplification of noise and signal voltage in a receiver which employs a linear detector. For weak signals, the detector operates in square-law fashion, and the signal output of the receiver (see curve *S*) increases as the square of the input. The noise output (see curve *N*) is directly proportional to the input signal strength. For signal inputs stronger than the value *O-O*, the detector operates in linear fashion, i.e., the signal output is proportional to the input. However, as shown by curve *N*, the noise output no longer increases proportionally to the signal input.

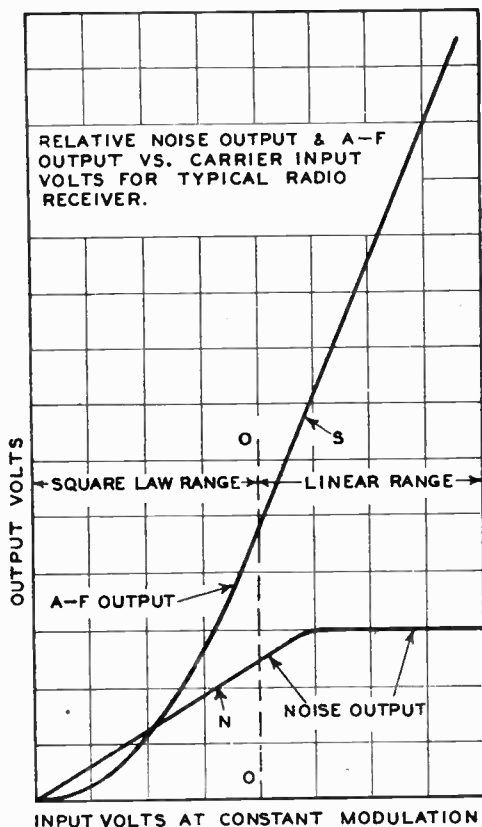

carrier of the strong one remains, and since an r-f carrier cannot be amplified in an audio amplifier, the weak station cannot be heard. The curves of Fig. 31-11 illustrate the idea of demodulation of noise by a strong carrier in a linear detector. Notice that the noise output curve *N* flattens out soon after a signal input which makes the detector operate linearly is applied.

These excellent advantages of the linear detector have led to the almost universal adoption of diodes (or triodes connected as diodes) in the detector circuits of both ordinary and high-fidelity receivers to provide linear detection.

31-12. The Audio Amplifier in High-Fidelity Receivers.—At the present stage of the radio art, there is little difficulty in designing an audio amplifier for use in high-fidelity receivers that will give exactly the desired response over the entire range of audio frequencies which are to be reproduced. In other words, there is little difficulty in designing an audio amplifier to have the desired amplification characteristics from 50 to 7,000 or 8,000 cycles. The second detector is usually resistance-capacity coupled to the driver stage. The latter is then transformer-coupled to the push-pull output stage in the customary manner.

Class A amplification is to be preferred in a high-fidelity receiver. Though the power output of a tube is smaller when it is used as a Class A amplifier than when it is used in any of the other arrangements (see Arts. 23-32 to 23-39) the acknowledged low distortion and the low cost of the audio and output transformers required for Class A operation, together with economical design of the power unit, has made this form of amplification highly desirable. However, when the required audio signal is quite high, economic considerations favor the use of class B or class A-Prime (AB) amplification, and it is being used in many high-fidelity receivers. Incidentally, the use of '45 tubes operated as push-pull class AB amplifiers has some merit in high-fidelity receivers. It has been shown that some 12 watts of power may be obtained from push-pull tubes operated in this way. Furthermore, since Class AB amplifiers operate as Class A amplifiers at low signal inputs and as Class B amplifiers at medium and high inputs (see Art. 23-38), their distortion varies between the Class A and Class B values depending upon the input signal strength. However, the performance of '45 tubes operating as Class AB amplifiers approaches quite closely to that of Class A operation insofar as harmonic distortion is concerned. As little as 3% total harmonic distortion can be obtained with them. Eight of them are being used in at least one current high-priced receiver!

31-13. The 10-kc Filter.—If the high-fidelity receiver is

designed to cover an audio range up to say 7,500 cycles, a *total* band of frequencies 15,000 cycles wide must be passed by the i-f amplifier. Under these conditions, the tuning is so broad that it is almost a certainty that a filter will be required to eliminate the 10-kc beat note caused by interference by carriers on adjacent channels (see Art. 31-7), since the i-f amplifier will not discriminate against these carriers enough to suppress them sufficiently when the full high-fidelity i-f band width is employed. Therefore, this 10 kc beat note must be prevented from reaching the loud speaker. It is common to accomplish this by means of a

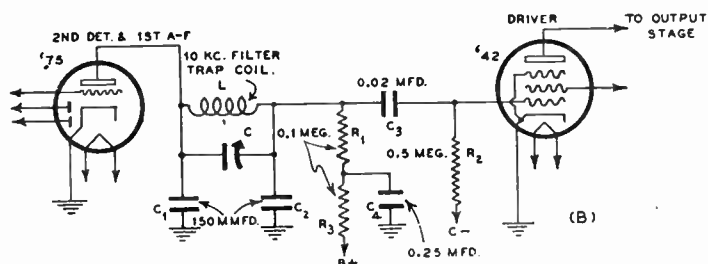
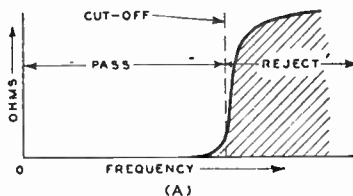

FIG. 31-12. — A 10-kc filter employed in the audio amplifiers of high-fidelity receivers is shown at (B). Its frequency response characteristic is shown at (A). Notice that it is a low-pass filter, passing all frequencies up to the cut-off point and offering a high impedance to all higher frequencies.



suitable low-pass filter which cuts off sharply at around 7,500 or 8,000 cycles. This filter is located in the audio amplifier.

The details of this filter arrangement as used in the Philco 200-Series high-fidelity receivers are shown at (B) of Fig. 31-12. The filter consists of an anti-resonant circuit made up of L and C (resonant at 10 kc) connected in series with the circuit between the second detector and the driver tube. Two equal condensers C_1 and C_2 act as shunt arms. Since the filter works out of the plate circuit of the '75 second-detector tube, it is terminated in a resistor R_1 of similar resistance value (by-passed to ground by C_1). The frequency characteristic of a filter of this type is essentially as shown at (A). It presents a very low impedance to the pass-

age of all currents up to the cut-off frequency of about 7,500 cycles. At this frequency the response cuts off sharply so that all currents of higher frequency than this meet with a high opposition and are greatly attenuated. Thus, the 10-kc beat note from interfering adjacent channel stations is effectively prevented from getting through the audio amplifier and reaching the loud speaker. This particular filter has a discrimination of about 25 db. at 10 kc. The condenser *C* is made adjustable to allow for the various conditions of interference that might arise from adjacent channel stations in different localities.

31-14. Power Output and Tone Control in High-Fidelity Receivers.—The undistorted power output capacity of a high-fidelity receiver should be 15 or 20 watts. Now 15 watts of acoustic power is much more than sufficient for ordinary reproduction in the average home, but reserve power is often required for the faithful reproduction of low-frequency passages in orchestral music since considerable power is involved in the rendition of these notes. Then too, the high-fidelity receiver must supply sufficient power on fortissimo passages to be heard clearly throughout an entire apartment without any overloading. An output of 15 watts is about sufficient for this purpose.

Theoretically, a receiver should be operated with an output such that the listener hears the musical program with the same volume that he would hear it if he were actually seated in the average location in the music hall where it is originating. Of course, it is not practical to operate the radio set at anywhere near this volume in the home. For practical reasons, it must be operated at a much lower level. Unless some compensation is provided when this is done, true fidelity will not be obtained, because of a well-known characteristic of the human ear. As the volume of the radio receiver is reduced so it is less than that of the original performance, the *low-frequency* tones seem to disappear i.e., they seem *less* prominent. The reason for this is that the sensitivity of the human ear varies automatically with the *volume* of the sound as well as with the frequency, and is lower at the two extreme ranges of the sound-frequency spectrum than it is at the middle range. When the volume is decreased, however, its sensitivity to the high-frequency notes

does not decrease as much as its sensitivity to the low-frequency notes does, so the net result is that the low-frequency notes seem to disappear when the radio receiver is played at low volume.

It is evident from the foregoing considerations that in order to preserve the fidelity of the reproduction even though it is desired to have the volume low, it is necessary to equip the receiver with an automatic tone control that will boost the low-frequency reproduction as the manual volume control is varied toward the low-volume end. An interesting low-frequency tone control arrangement which has been employed (in the Philco

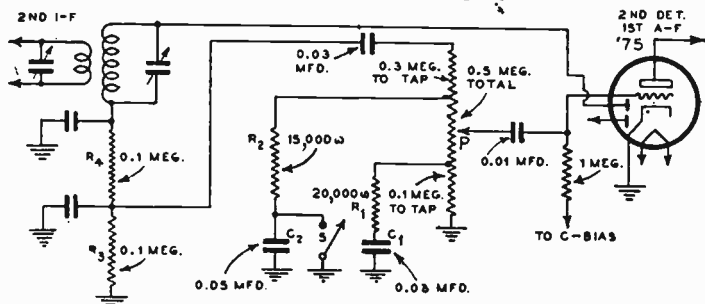

FIG. 31-13.—An interesting low-frequency tone control arrangement used in the Philco 201 high-fidelity receiver to automatically boost the low-frequency response when the volume is turned down low, in order to compensate for the characteristics of the human ear and preserve good fidelity of reproduction at the low volume.

Model 201 high-fidelity receiver) is shown in Fig. 31-13. The volume level control potentiometer P is tapped at two points. To the lower tap (corresponding to the low-volume region) a 20,000 ohm resistor R_1 in series with a 0.03 mfd. by-pass condenser C_1 is connected to ground. This provides a fixed filter which tends to by-pass the high-frequencies (thus increasing the apparent bass to compensate for the ear's deficiency in this region) when the volume control is set near the low-volume end. The tap near the high-volume end of the volume control is connected to a 15,000-ohm resistor R_2 in series with a 0.05 mfd. by-pass condenser C_2 to ground. A switch S , which shorts this condenser when minimum low-frequency response is desired, is also provided. This reduces the low-frequency response because it shunts the 15,000-ohm resistor R_2 directly across nearly half of the potentiometer resistance.

The amount of hum heard in high-fidelity receivers is often somewhat above the maximum permissible level. If the receiver employs 2A3 tubes in the output stage, the hum may be due to them. In such cases, several of these should be tried in the output stage sockets until minimum hum is obtained.

31-15. Loud Speaker Arrangements for High-Fidelity Receivers.—The loud speaker is the last link in the chain of important components which the high-fidelity receiver contains. Unless it meets all the requirements imposed upon it by high-

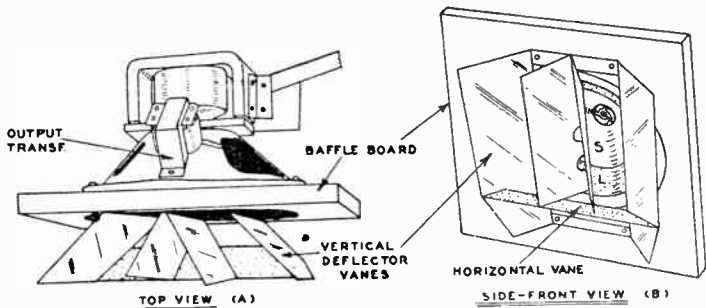

FIG. 31-14.—Top and front-side views of a single-unit high-fidelity loud speaker employed in a commercial high-fidelity receiver (Philco). Notice the four vertical and one horizontal deflecting vanes mounted in front of the cone. These “spread” the high-frequency sound waves (see Fig. 31-15) which would otherwise be projected forward in the form of a narrow sound beam.

fidelity service, it will utterly ruin (so far as any musical program heard is concerned) the most perfect fidelity signal that the receiver feeds to it. The operating conditions imposed upon the loud speakers in a high-fidelity receiver are severe, and the requirements for a good speaker for this service are much easier to specify than they are to fulfill in practice. The speaker must respond to (within a few db) from about 40 to 8,000 cycles. The usual dynamic speaker which is employed in ordinary receivers, has a frequency range (within a few db) of about 80 to 3,500 cycles, beyond which the response falls off rather rapidly. Because of this rather limited frequency range of ordinary dynamic speakers, either one of two alternatives must be employed in high-fidelity receivers. Either a *single* special dynamic speaker designed entirely with a view toward

meeting high-fidelity reproduction requirements must be employed, or, *two* speakers (one to reproduce the low- and middle-frequency sounds, and the other to reproduce the high-frequency sounds) may be used. Since both arrangements are employed in commercial high-fidelity receivers, they will both be discussed here.

31-16. The Single-Unit Loud Speaker Arrangement. —

Several interesting construction details of a typical *single* high-fidelity speaker are illustrated in Fig. 31-14. The speaker itself

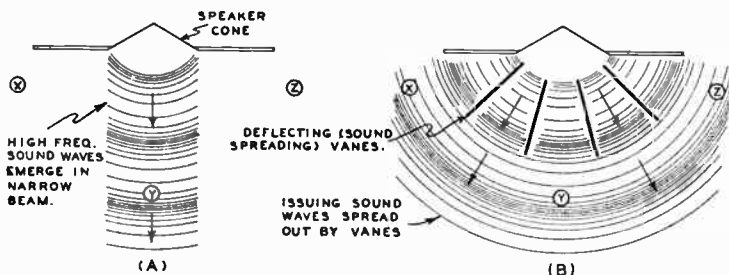

FIG. 31-15.—Sounds having frequencies up around 5,000 cycles or over do not radiate very well, but issue from the loud speaker in the form of a rather narrow beam, as shown at (A). Such sounds cannot be heard very well at any positions more than about 20 degrees off the axis of the cone. By placing deflecting vanes in front of the cone, these high-frequency sound waves can be deflected and "spread out" so they radiate in all directions as shown at (B). For details regarding the mounting of such vanes, see Fig. 31-14.

is of unusually large diameter, and has an unusually powerful field. To maintain unattenuated response at the high frequencies requires a voice coil and cone having a small effective mass. In order to attain this end, the voice-coil is wound with aluminum wire. In addition the cone itself is constructed to increase its radiation of sound at the high frequencies. This is accomplished by making it of two different grades of paper, as shown at (B). The apex, close to the voice-coil is made of stiff material, *S*, while the outer portion is constructed of lighter, more flexible paper, *L*. This construction makes the inner portion effective in producing the low-frequency sounds effectively, while the entire assembly operates for the "lows".

A very important action takes place when high-frequency sounds are being produced. The lower frequency sounds are

radiated by the loud speaker with sensibly uniform strength in all directions; the very high frequencies above about 5,000 cycles, on the other hand, are thrown principally straight forward in a narrow beam as shown at (A) of Fig. 31-15, much as a beam of light is directed from a flashlight. Only those listeners who are in a fairly direct line (position Y) with the loud speaker emitting the high notes will hear them with full strength and obtain the full benefit of the high-fidelity reproduction. Listeners who are on the side (positions X and Z), away from this high-frequency sound beam, do not hear the majority of these notes, even if they are actually present in the output from the receiver.

In order to prevent this action in high-fidelity receivers which reproduce these high frequencies, deflecting vanes are mounted in front of the speaker cone to deflect the high-frequency sound waves as they issue from the speaker, so that they are evenly distributed throughout the room, as shown at (B). These vanes are commonly arranged in front of the loud speaker as shown in Fig. 31-14. They are made of metal or wood, and consist of several vertical vanes arranged obliquely directly in front of the cone to give wide-angle lateral diffusion, and a single horizontal vane to give vertical diffusion. The latter, aided by a slight upward tilt of the cone itself, keeps the tone approximately equal in fidelity to both a person seated directly in front of the receiver and one seated on the side of it.

31-17. The Multiple-Unit Loud Speaker Arrangement. — The other solution to the problem of producing unattenuated sound radiation over the full high-fidelity frequency range is to use two loud speakers, one to produce all sounds up to about 2,500 or 3,000 cycles per second, and the other, having moving parts of much smaller mass, to produce all sounds above this range. When this arrangement is used, either both speakers are of the dynamic cone type, or else the low-frequency unit is of the dynamic cone type while the high-frequency unit is of the crystal type. The former arrangement will be described first.

The low-frequency speaker is usually of large size and constructed so it has a large power-handling capacity. A powerful magnetic field is required (as high as 40 watts is required for the

field alone in one commercial loud speaker of this kind).

The high-frequency speaker (usually called a "tweeter" or a "treble" speaker) is small (about $\frac{1}{3}$ the size of the larger one) and its voice coil is often wound with aluminum wire to reduce the mass so that the speaker will operate well on the high frequencies. In one commercial speaker of this kind, the mass of the entire moving system is only 0.8 gram. The high-frequency speaker is equipped with a set of deflector vanes (see (B) of Fig. 31-15) to spread the sound radiation over a wide angle.

Because of their delicate construction, care should be exercised in handling speakers of this type. In some types, the voice-coil leads are made of fine aluminum wire in order to keep the mass small. Avoid touching them, as they are easily broken! Do not use compressed air to blow dust or chips from these speakers, as breakage of these leads may result. The movement of the cone in actual service is only a few thousandths of an inch and is adequately taken care of by the thin aluminum center suspension. Do not force the cone back and forth with the fingers as you would an ordinary dynamic speaker, for this may damage the center suspension.

Once the voice coils on these speakers are correctly centered at the factory, they rarely need readjustment. However, in case the center screw should be inadvertently loosened and the adjustment lost, the following general method of re-centering should be followed:

Obtain three strips of clean, smooth paper, 0.006" to 0.008" thick, about $\frac{1}{4}$ " wide, and about 3" long, for use as "gauges". With the cone center clamping screw loosened, insert one end of each of the paper strips in the gap between the outside of the voice coil and the hole in the front plate, spacing the strips equidistantly around the coil. This may easily be done if the ends of the paper are cut to a point and tweezers are used for inserting them.

Now, tighten the center clamping screw and "feel" the paper strips by pulling them with the tweezers to determine if any are pinched tightly in the gap. If this is found to be the case, the center screw should be loosened, and the cone moved slightly sidewise in a direction to relieve the pinched strip. Then, the screw should be retightened.

The coil is considered centered when the three strips are equally free in the gap. Remove the strips by grasping them with the tweezers close to the front plate, rather than by pulling on the end of the strip, otherwise the paper may tear off against the edge of the hole, and thus a piece may be left in the gap. In performing the centering operation, use great care not to damage the driving coil leads.

When two loud speakers are used, the output power of the set must be divided between them correctly according to the frequency. This is usually accomplished in the output circuit of the amplifier by means of a filter network designed especially for the purpose. The simple filter arrangement for the two dynamic cone speakers employed in the Stromberg Carlson 70 Series high-fidelity receiver is shown in Fig. 31-16. The push-pull output tubes feed into the output transformer T . The low-impedance secondary winding of this transformer feeds into the filter and

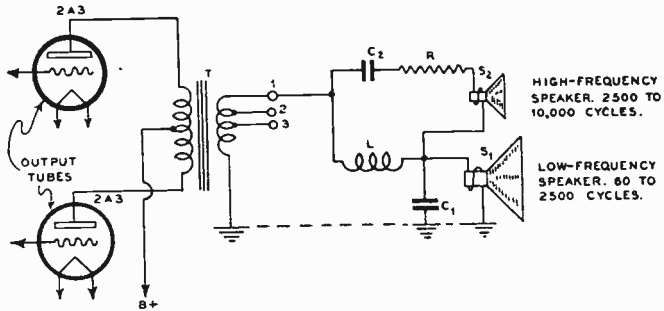

FIG. 31-16.—The speaker filter arrangement which is used in the Stromberg Carlson 70 Series high-fidelity receivers for feeding all audio currents up to 2,500 cycles to the low-frequency dynamic speaker and all those above 2,500 cycles to the dynamic "tweeter".

the voice-coils of the two speakers. The voice coil S_1 , of the low-frequency speaker is fed through the series air-core inductance L , and is shunted by by-pass condenser C_1 . The voice-coil, S_2 , of the high-frequency speaker is fed through series condenser C_2 and resistor R . Now the low-frequency output currents (from 50 to 2,500 cycles) of the receiver cannot flow through S_2 , because the condenser C_2 presents a high impedance to their flow. However, air-core inductance L presents a low impedance to them, so they flow through L and coil S_1 , thereby causing the low-frequency speaker to operate over this frequency range. At 2,500 cycles and higher, the impedance of L is so high, and that of condenser C plus resistor R is so low (the impedance of a coil *increases* as the frequency is increased, whereas, the impedance of a condenser *decreases*), that the high-frequency output power of the receiver is fed through condenser C_2 and resistor R to the high-frequency speaker S_2 . Since the impedance

of condenser C_1 is low at these frequencies, it shunts the signal current of S_2 around the voice coil of S_1 so that it does not serve to actuate it. Resistor R acts as a protective device to limit the current which would flow into S_2 and very likely damage it if C_2 were to short circuit. The purpose of this simple filter arrangement, then, is to effectively lead all low-frequency audio currents below 2,500 cycles into the low-frequency speaker and

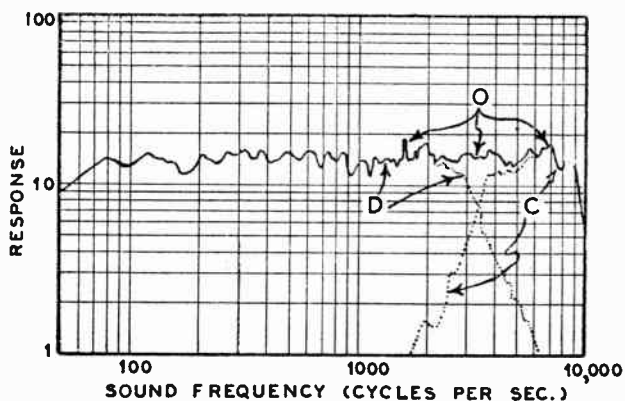

FIG. 31-17.—The axial sound-pressure—frequency characteristics of an ordinary dynamic speaker (D), a crystal “tweeter” (C), and the overall performance of both operating together (O).

all those above 2,500 cycles into the “tweeter”. Thus, each speaker is fed only with those parts of the program which it is able to reproduce effectively.

Another speaker arrangement employs a dynamic cone speaker for the low-frequency reproduction and a piezo-electric (crystal) type “tweeter” for the high frequencies. This crystal type speaker is designed especially to flatten out the overall response curve where the dynamic speaker begins to fall off, and to carry on the high-frequency end of the high-fidelity reproduction up to around 8,000 cycles. The individual frequency-response curves of a typical low-frequency type dynamic speaker, D , and a crystal type tweeter, C , together with the overall response, O , which results when they are operated together is shown in Fig. 31-17. Notice how the tweeter response starts just at the frequency region where the dynamic speaker response begins to

fall off and how the tweeter keeps the high-frequency response up fairly level to almost 8,000 cycles, although the dynamic speaker response has fallen off rapidly after 3,000 cycles.

A front and rear view of a typical crystal tweeter is illustrated in Fig. 31-18. This type of speaker requires no additional transformer or filter network since it can be connected directly across the primary winding of the output transformer. These tweeters may be installed in existing radio receivers to increase the high-frequency response so as to make better fidelity

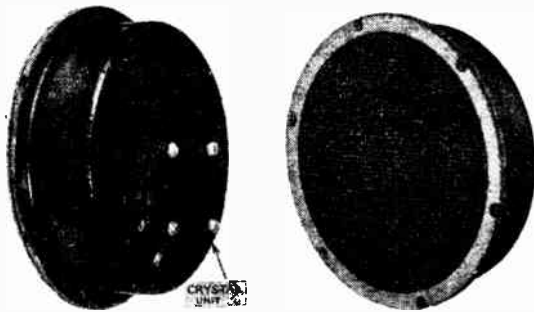

Courtesy Brush Development Co.

FIG. 31-18.—Two views of a commercial piezo-electric crystal type high-frequency "tweeter" speaker.

(not essentially high-fidelity) possible. A number of possible connection arrangements for this purpose are shown in Fig. 31-19. Each one shows the best arrangement when the receiver uses the particular output tubes indicated. Resistor R is the volume control for the "tweeter" in each case. A small impedance-matching transformer which effectively matches the impedance of the crystal speaker unit to that of the output circuit of the receiver is built inside of the speaker case so no additional impedance-matching transformer is necessary.

31-18. The Baffle for Good Low-Frequency Response.—

It is well known that a large speaker baffle is required if the low-frequency notes are to be reproduced. The baffle acts merely as a barrier between the front and rear of the cone so that compressions and rarefactions produced simultaneously by the front

and rear of the cone will not cause air to rush around the cone edge and neutralize each other. The baffle makes the air path from the front of the cone to the rear long enough so that the air cannot travel the distance around the baffle in the short space of time it takes for $\frac{1}{4}$ of a cycle of the sound wave to

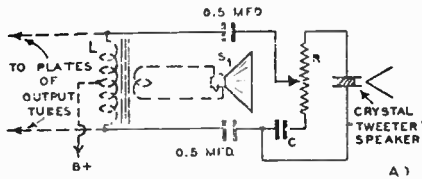

| OUTPUT TUBE TYPES | R (OHMS) | C (MFD.) |
|-------------------|----------|----------|
| 45-50 | 25,000 | 0.1 |
| 47-42 | 20,000 | 0.03 |

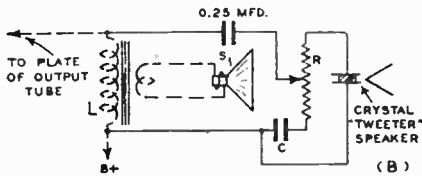

| OUTPUT TUBE TYPES | R (OHMS) | C (MFD.) |
|-------------------|----------|----------|
| 45-50 | 25,000 | 0.05 |
| 47-42 | 25,000 | 0.015 |
| 2A5 | 20,000 | 0.015 |

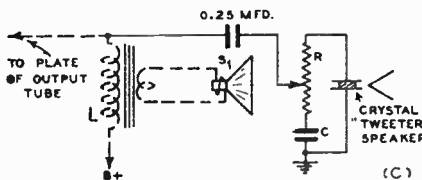

| OUTPUT TUBE TYPES | R (OHMS) | C (MFD.) |
|-------------------|----------|----------|
| 45-50 | 25,000 | 0.05 |
| 47-42 | 25,000 | 0.015 |
| 2A5 | 20,000 | 0.015 |

FIG. 31-19.—Various ways of connecting a crystal-type “tweeter” speaker to the ordinary dynamic speaker which is already in a radio receiver. The “tweeter” extends the high-frequency reproduction range of the receiver. A high-frequency volume control, R , is incorporated in the circuit in each case. Its value, together with that of condenser C is specified at the right for the various output tube combinations that may be encountered. Resistor R and condenser C also form a filter which serves to block out all but the high-frequency audio currents from the speaker.

occur*—even on the lowest frequency to be reproduced. The cabinet of the console receiver has been used as an effective baffle in most receivers. However, the use of the cabinet as a baffle often results in “cavity” resonance which causes a “boomy”

*NOTE: For a thorough explanation of loud speaker baffles see the Chapter on Loud Speakers in the *Radio Physics Course* by A. Ghirardi.

effect in the reproduction. This makes the reproduction far from realistic.

An unusual type of space-saving baffle which has been termed an *acoustical labyrinth* has been developed for the low-frequency speaker of one commercial high-fidelity receiver (Stromberg Carlson), and will be described here because of its unusual construction features and general technical interest. The back of the low-frequency cone is not permitted to radiate sound directly

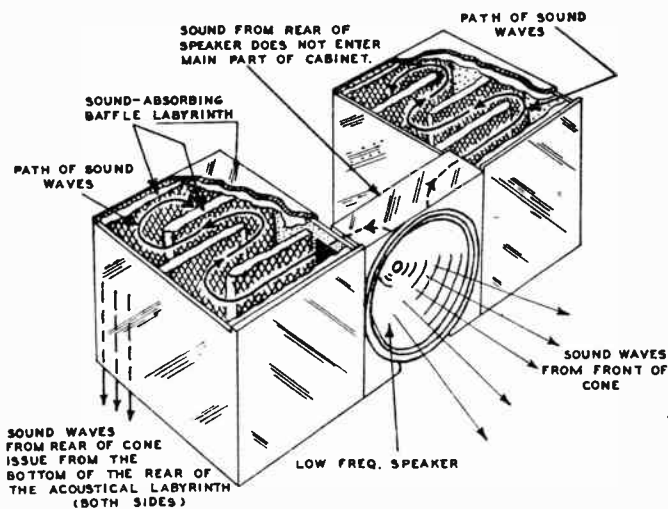

FIG. 31-20.—An acoustical labyrinth type of low-frequency baffle which makes the sound waves from the rear of the speaker cone take a long winding path through the labyrinth before they emerge from the bottom of the receiver cabinet.

into the space inside the cabinet. Instead, its sound waves are led into a 2-section acoustical conduit which is built in the form illustrated in Fig. 31-20, to save space. This conduit is folded in the form of a labyrinth of many sections, each one having walls which are highly sound-absorbent. Notice the *long*, tortuous path which the sound waves are forced to take from the rear of the cone to the discharge opening in the bottom of the cabinet. This presents the same essential length of acoustical path from the front of the cone to the rear regardless of whether the receiver is placed close to a wall, in a corner, etc. The acous-

tical passage is of such length that the fundamental resonance occurs in the frequency range where the efficiency of the cabinet as a baffle begins to fall off. The conduit serves, therefore, to extend the low-frequency range of the system beyond the limit made possible by the cabinet itself. Thus the response characteristic of the system over the entire frequency range is much better than it would be if the same speaker were mounted in a flat baffle of equivalent size. Resonances of the conduit at its harmonic frequencies are made negligible by the increasing absorption of the conduit walls at the higher frequencies. Since no sound is allowed to radiate through the back of the receiver cabinet, the position of the set from the wall that it is placed in front of does not affect the tone qualities.

31-19. Installation Pointers for High-Fidelity Receivers.

—The high-fidelity receiver requires careful placing in the room in which it is to be used, if the full capabilities of the set for high-fidelity reproduction are to be realized under the actual installation conditions. If the receiver discharges a part or all of its sound from the bottom of the cabinet (see Fig. 31-20) it may be placed either near the wall or in a corner without affecting the low-frequency response. However, if it discharges sound from the rear, the cabinet should be kept at least a few inches from the wall, or better still, "catty-corner". If the room is long and narrow it is usually best to place the receiver at one end of the room and as near the center of the wall as possible. In a square room, the "catty-corner" position is usually good. The receiver should always be placed so that the listeners in the room will receive as much of the directly-radiated sound from the receiver, and as little reflected sound, as possible. The sound should not be directed toward such sound-absorbing materials as tapestries, curtains, heavy drapes, etc., for the rooms with such furnishings may already be acoustically "dead" due to their presence. On the other hand, if the room is acoustically "live", the receiver should not be placed so that its sound will be directed against hard wall surfaces and be reflected back to the listener.

The service man may make several simple tests to determine if the fidelity of a given high-fidelity receiver is normal, by sim-

ply listening carefully to the reproduction which results when a program of orchestral music is being received *from a station which is known definitely to broadcast high-fidelity programs*. Faithful reproduction of the low register will be indicated if, *with moderately loud* volume setting, the very low-pitched or bass instruments of an orchestra or the lowest tones of a piano or organ can be definitely heard without emphasis on any tones. A "boom" reminding one of the sound noted when the head is placed in a barrel while speaking, or a "mumbly" and indistinct quality of speech indicate either a too-pronounced low-register response or an equally undesirable deficiency of an important part (or all) of the higher frequencies.

In general, a receiver satisfactory as to fidelity will provide speech which is thoroughly intelligible without conscious effort or sense of listening strain, and music which free from pronounced effects (such as "boom") of any kind. A persistent impression of mellowness or "richness," for example, is likely to be actually due to an absence of upper-register response, the undesirability of which would be readily noted in a direct comparison with a properly designed set. Rattles, or noticeable "hum", are annoying to say the least, and become increasingly so as one uses the set. The former is usually the result of loose, or flimsy equipment, and the latter is often due to poor design but may be caused by defective tubes or equipment. Listen to other sets of the same model to see if the trouble is inherent or not.

REVIEW QUESTIONS

1. What is a high-fidelity receiver?
2. What are the three main requirements for high-fidelity reception?
3. What audio range is generally conceded to be the most practicable for high-fidelity reception?
4. How does this compare with the audio range in: (a) a midget receiver; (b) an ordinary "good" console type receiver?
5. What can be said regarding uniformity of response in a high-fidelity receiver?
6. What volume range should a high-fidelity receiver be able to handle without overloading.
7. (a) What actually happens to the signal if overloading does occur? (b) How does the program sound under these conditions?
8. Why are precautions to prevent man-made electrical interference

from entering the receiver circuit by either the aerial, the lead-in, the ground wire, and the power-supply line even more important with high-fidelity receivers than with ordinary receivers? Explain!

9. (a) What can be said regarding the importance of securing as nearly perfect oscillator stability in high-fidelity receivers as possible? (b) Why is the problem even more important in high-fidelity receivers than it is in ordinary receivers?
10. What would be the effect, as heard, if the frequency of the oscillator in a high-fidelity receiver were subject to "drifting"; (a) during the warm-up period; (b) when strong signals come in?
11. What steps have been taken to reduce oscillator drift in commercial high-fidelity receivers? Explain!
12. What is meant by the term "monkey chatter" when applied to high-fidelity receivers? Explain in detail why and how it is produced.
13. What effect will be noticed in a high-fidelity receiver if the tuning of the oscillator stage does not "track" properly with the tuning of the t-r-f stages? What is the remedy?
14. Explain in detail the special station interference problems which are encountered in the operation of high-fidelity receivers.
15. What practical step has been taken in the design of high-fidelity receivers to get around this station interference problem?
16. What sacrifice in operating characteristics must be made in high-fidelity receivers under present broadcasting conditions in order to get around the station interference problem?
17. Why is the station interference problem usually attacked in the i-f amplifier?
18. State the three fundamental means which may be employed to vary the response-band width of the i-f transformers in a high-fidelity receiver.
19. Describe a *mechanical* means for accomplishing the above. Explain how it operates!
20. (a) Describe a special *electrical* circuit arrangement for accomplishing the above. Explain how it works! (b) What are its advantages over the mechanical method?
21. Describe and explain a third method for accomplishing the above.
22. State two advantages of iron-core i-f transformers over the air-core type. How have the eddy-current losses in the iron at the high frequencies been reduced in the recent types of iron-core i-f transformers?
23. State two important advantages which are obtained by using a linear detector instead of a square-law detector in a high-fidelity receiver.
24. A radio signal is modulated 30 per cent. What is the per cent distortion in the plate circuit of a square-law detector which demodulates this signal?
25. What is the purpose of the 10-kc filter in the audio circuit of high-fidelity receivers?
26. (a) Draw the circuit diagram of a filter suitable for the above

- purpose. What type of filter is it? (b) Draw its frequency-response characteristic curve and explain it.
27. What effect does turning the volume control *down* have on the tone reproduction from an ordinary receiver? What is the reason for this effect?
 28. How is the effect mentioned in Question 27 compensated for in high-fidelity receivers so that the "naturalness" of the reproduction will be just as good at low volume as it is at high volume?
 29. Why must a loud speaker capable of reproducing the higher sound frequencies necessary for high-fidelity reproduction be equipped with deflecting vanes? How do they accomplish their purpose (illustrate your answer by means of sketches)?
 30. What is the purpose of the speaker cut-off filter in a high-fidelity receiver which employs two dynamic speakers?
 31. In a high-fidelity receiver which employs the speaker filter arrangement shown in Fig. 31-16, what operating symptoms would result if: (a) condenser C_2 were to short-circuit; (b) condenser C_2 or resistor R were to open-circuit; (c) condenser C_1 were to open-circuit; (d) condenser C_1 were to short-circuit; (e) inductor L were to open-circuit; (f) voice-coil S_2 were to open-circuit?
 32. (a) What is the purpose of the speaker baffle? Describe the construction of the acoustical-labyrinth type of baffle. (b) What are two of its main advantages over the flat type of baffle?
 33. (a) How would you make a practical field "listening test" to tell if a high-fidelity receiver was producing normal fidelity on the low and high-frequency registers? (b) How will good low-register reproduction be indicated? (c) How will good upper-register response be indicated? (d) What might "rattling" on the high frequencies be due to?
 34. What general types of loud speakers are used in high-fidelity receivers?
 35. A high-fidelity receiver which is constructed so that parts of its sound output discharge from the rear of the cabinet *must* be placed in front of a hard-surfaced wall in a room which is particularly "live" acoustically. How would you prevent reflection of sound (especially the high-frequencies) from the wall directly back into the speaker?

CHAPTER XXXII

HOW TO SELL YOUR SERVICE

32-1. How to Get Business.—A radio service man may be the best technician in his town, but if he cannot sell his services, at a profit all his training and experience will be of little value to him. With radio service men, as with many other kinds of professional men, there exists far too often a certain lack of business ability that seems to be quite natural with that type of personality.

Yet, there is no need for this state of affairs. Every service man can easily be a good business man as well, if he will apply himself seriously to the problem. First of all, it must be realized that there is a definite technique involved in getting business, just as there is a definite technique in servicing radio equipment or doing almost any other worthwhile thing.

There are also many different methods to be employed in getting business. Most service men fall down when trying to use only one or two of them—if any at all! For example—there is “personal” selling (and that includes both *counter* selling and house-to-house selling), *telephone* selling, *direct mail* advertising (postcards, blotters, sales letters, etc.), *newspaper* advertising, *radio* advertising, *displays*, and many other types of selling which will be described further on in this chapter. Best results are usually obtained when the service man uses a combination of these sales methods such that one follows up the efforts of the other—for example, direct mail followed by telephone or personal selling, etc.

32-2. Salesmanship.—First, it must be thoroughly understood that *salesmanship is basic in a successful service business.*

Your business is a *personal* service business! Your customers

are not buying merchandise as much as they are buying your own *personal* services. The thing you've really got to sell is—*yourself*. Therefore isn't it obvious that the most logical way to sell yourself is through *personal contact*?

Many service men shy away at the idea of personal contact, feeling that they aren't salesmen. But a good radio technician doesn't have to be a "natural-born salesman" in order to build up a good service business. In fact, it is really comparatively easy to sell the type of service he has to offer the public, for, fundamentally, it is a service that they really need. The specific suggestions that follow, and the general principles outlined at the end of this chapter have been included here with the hope that they will assist alert service men to conduct their shops on a really modern, business-like basis. These suggestions will be presented in a personal way, for after all, the matter of a serviceman's business is a very personal one.

32-3. Counter Selling.—Every time a prospect comes into your shop you have to be two men in one. An expert technician—and an expert salesman. One without the other is a serious handicap in these days of exceedingly keen competition. But selling at the counter is the easiest of all kinds of selling. If you "play your cards right", the prospect will sell himself. And here's how—

In the first place, your shop should be so laid out as to properly "merchandise" your service. It should be impressive. It should be instructive. It should demonstrate what you have to sell. But more of that later.

Of great importance are your test panel and testing equipment. Get as much of it as you can out front where the prospect can actually "see the wheels go round". There is nothing like a good cathode-ray oscilloscope to catch the prospect's interest, for its never tiring beam of light is fascinating to most people. You can even arrange it to reproduce the voice waves of the prospect by means of a simple microphone and audio amplifier. To most people it will be a novelty and something quite mysterious. The more it is, the more it puts you in a superior position and develops the prospect's friendly attitude and confidence in you. And that friendly feeling and confidence will generally develop to the

"buying point", if you take pains to explain what you are going to do (or have done) to his radio, what all the different "gadgets" on your test panel are, and what they are for—in a general way of course, for he won't understand the details.

In your own shop, the most important sales technique you can use is to develop the prospect's confidence. You can do that—(1) by the good appearance of your shop; (2) by the impressiveness of your equipment; (3) by the information you pass on; and (4) by your personality. The last is very important. If you are friendly with your prospect and put him at ease, so that he won't feel you are going to try to sell him something he doesn't really need, you have already made more than half the sale of your services or your merchandise.

Here's a tip on "closing". Suppose your prospect develops a little hesitancy about putting a lot of money into a repair job—he may feel that it is perhaps not quite necessary, or that if he went to some other service man he could get the job done more cheaply. When you sense a prospect in this situation, say to him—"Just a moment, Mr. Blank! The troubles with your radio is a very special and unusual one. It so happens we have a man in our shop who is an authority on this particular sort of thing. I'd just like to get his opinion on it." Everybody likes to feel he is getting expert attention, and while you yourself may be just as expert as the "authority" you call over, it is not so easy to give your prospect that impression as it is to point out someone else as an expert.

32-4. **Outside Selling.**—The first job in outside selling is to know to whom you are going to sell. Lay out your campaign in advance. *Plan your work—then work your plan.* A systematized program is essential in this work. It is queer, but nevertheless a well known fact that the most methodical and systematic of service men will carry on their selling and advertising campaigns in a hit-and-miss fashion that does nothing for them but waste time and money. They would not think of expecting results if they went at their actual radio service work that way, yet they expect all sorts of wonderful things from outside selling campaigns that are carried on in sporadic fashion whenever the spirit moves them. Outside selling campaigns are serious under-

takings that require considerable planning and plugging to put over, for many phases of them depend entirely upon the correct follow-ups to break down the sales resistance and human inertia of the prospect. Without these follow-ups, the initial efforts are doomed to failure at the very start. Large organizations spend millions of dollars annually to test out new ideas for outside selling campaigns and to follow them through. One method is found to work best in one type of community for one product—another is worthless for that type of community but is a world beater among a different class of people, etc. The service man should realize this before he starts any advertising ideas. Plan them carefully, then test them and make plenty of changes until you get the right ones for your particular conditions. Then—and not until then—go ahead!

If you have several men you can send out, then you will probably find it profitable to make a thorough house-to-house canvass within a certain radius of your shop, providing canvassing is not prohibited by any local ordinance. If you do this, get a map and lay out carefully each man's territory, assigning a certain area to be covered each day during the campaign. You will make a better impression on the prospect if you are able to address her by name; so get a city directory and have 3" x 5" cards made out for all residents in your area, giving each man a quota of cards to work on every day.

If you cannot make an intensive coverage of this kind, there are several ways of building a selective list. In many cities the telephone company makes up a "Telephone Address Directory" which it will rent for a reasonable fee. This Directory lists all telephone subscribers according to street and number. It is usually very useful for selling radio service, since almost everyone who can afford a telephone is very likely to own a radio set. In using it, you can pick out just those streets that are of interest to you, and get the name and telephone number of your best prospects on each street. Then of course there are city directories and voting lists that are useful too. Many dealers and service men hire boys to go around their neighborhoods and copy the names off the mail boxes, or to try and spot antennas and take down the names of those who own them. Of course

this applies only to suburban districts. If you can possibly make an arrangement with some radio dealer to furnish you with the names of those people to whom he has sold new sets, it will certainly be to your advantage to do so. If most of your business comes from apartment houses, go to the superintendent and ask him for the names of all the families in his building who own radios. If you offer to give him free tubes and service for his own radio receiver, he will usually give you this list, which should be very valuable to you.

Before you go out to canvass your prospects, make out a 3" x 5" card for every name, with the address and phone number, and space to record the type and condition of her radio and electrical appliances (if you can find this out) and to make a note as to her reaction to your canvass and the date when a "call back" should be made. Have a general idea of what you are going to say to your prospect before she opens the door. Some salesmen work best when they go through a regular routine with a memorized sales talk. Others sell better when they vary their talk to fit the prospect and the circumstances. Which method is better depends entirely on the individual salesman. In any case it is preferable to have an outline or a rough plan of how you are going to make your sale.

In personal selling, the most important thing you can do is to make friends with your prospect, especially on your first call. Don't try to be smart or "flip". Don't annoy and antagonize your prospect with tactless bullying. Some salesmen have been very successful using "high-pressure" methods, but the average man is more successful when he avoids these methods entirely, and tries merely to tell a straightforward story in a natural, friendly way, expressing (without boasting) the self-confidence which every service man should have in his work. That is the easiest way to sell—and for most people is the most profitable. Needless to say, you should take pains to make your personal appearance as pleasing as possible—without unnecessary "flash".

On all your calls carry a good kit with you, containing not only tubes, tools and some testing equipment, but also a few small electrical appliances (if you sell them). Whenever you get inside the house to examine a radio, open up your kit conspicuously so the prospect will see its contents—it will impress her with the fact that you must know your business to have all those things there.

In outside selling you cannot of course expect everyone you call on to be a prospect—only a small percentage of your calls

will be real prospects. But you must remember that sooner or later almost every one who owns a radio set will need service. The important thing on your first call is to make a contact—to get in and get known. Whether your first call is profitable or not, it may lead to business in the future, or it may provide you with an opening for some appliance which you carry as a side line.

Give some real thought to the "approach" which you use. As you know, housewives are continually besieged by canvassers, so much so that they automatically put themselves in a negative frame of mind when they open the door—just for self-protection. In order to get her interest at all, you must "pack a wallop" in your first few words—otherwise you will find yourself facing a closed door again. Avoid generalities and commonplace expressions. The best possible kind of approach is to make the prospect some tangible, specific offer or proposition that appears to be a little different from what she usually hears. Here are a few opening phrases and ideas along this line that have been used with success:

Open your conversation with, "Good morning! Is this Mrs. Blank? I am Jones the neighborhood radio man, and am making a":

- (1) "*Check-up on radio sets.*" (You can generally get a lot of useful information on a check-up of this kind. After you get talking a bit with the housewife you will find it easy to swing the conversation into the subject of a tube test, a receiver check-up, or service.)
- (2) "*Service survey.*"
- (3) "*Noise survey in connection with all-wave sets.*"
- (4) "*Free inspection.*" (If you use this plan, have some impressive-looking forms printed. You can call them "Report of Condition", and fill out and sign. Even if you don't get an authorization to proceed with the repairs, your prospect will have this written report to show her husband and to act as a constant reminder. It will also be useful to refer to when you make a personal or telephone follow-up. Keep a carbon copy of the Report for future reference).
- (5) "*Courtesy call to all new residents in the neighborhood.*" Offer to help them install their radios and make necessary

adjustments at a special price—as a neighborly courtesy. Most people will greatly appreciate an act of genuine helpfulness such as this. You can count on them as regular customers in the future.

- (6) "*Check on short-wave radio sets.*" (Your explanation can be that you have heard so many complaints from this neighborhood on noise and lack of good reception, that you are making an investigation as a service to your customers, and at the same time will be glad to check over her set without obligation and make recommendations for the elimination of noise. Of course *you* will want to do the job.)
- (7) "*Free tube test as a special introduction to my service.*" (There are few sets in use that couldn't be improved with one or more tube replacements, but most people don't realize it until they actually hear the difference when new tubes are inserted. Prove this difference by inserting the new tubes, and if your prospect doesn't want to buy them then, offer to leave them overnight so her husband can judge the difference. Be sure to leave the old tubes too so he can make a comparison—but mark your new ones properly for undisputed identification later.)
- (8) "*Special offer on a 'tune-up' of your radio set for only \$1.50.*" (Many large service shops make a feature of this special offer. The following "12 Services" are the ones usually featured: 1. Check *aerial installation*. 2. Inspect and clean *lead-in* and *ground* connections. 3. Inspect *lightning arrester*. 4. Test all *tubes* and attach labels (bearing your shop name and address) on them to show their condition. 5. Check *tube sockets* for poor prong-contacts, and tighten *tube shields*. 6. Inspect and clean the *chassis*. 7. Check all *power connections*. 8. Check *speaker* connections and test it for "rattling". 9. Check *volume control* for noisy operation and "dead spots". 10. Tighten *dial knobs*. 11. Clean interior of *cabinet*. 12. Check operation of *set* over entire frequency range and submit free *estimate* for any additional repairs.)

This "special" in itself is not very profitable of course, but

almost invariably, the service man uncovers a need for parts or repairs, and makes a real "pay call" out of his visit.

- (9) "*Call to see how your new set is working.*" (This follow-up of a new sale—to see how the set is working—or after the service guarantee expires (in cooperation with a new-set dealer with whom you have a servicing arrangement) is an excellent way to keep up a friendly contact with your customer.)
- (10) "*Announcement of a new short-wave adapter (converter, antenna, or an attachable record-player).*" (Carry the equipment with you and offer to leave it twenty-four hours on trial.)
- (11) "*Offer of a complete 'kit of tubes' with each repair job.*" (By quoting a lump price for the repair job together with all new tubes, you can often break down the resistance you meet on making single tube sales. While a few tubes may still be good in the receiver, you can point out that it is only a question of time before they will go too, necessitating another service call and another charge, so the prospect will probably save money by getting a complete replacement now.)
- (12) "*Distribution of free radio logs.*" (Unless overdone in your neighborhood, this is always a good method of sales promotion, whether it is done purely as advertising (the logs being distributed by boys) or for the purpose of giving you an entree.)

One large tube manufacturer laid out for his dealers an elaborate plan along this line and achieved unusual success through it. This plan called for postcards to be mailed out two days in advance of the salesman's call. The card stated that a representative would call in a few days to deliver a new radio log free, providing the postcard was retained and given to the salesman when he called. His name and photograph were on the card for identification. When the salesman called, he asked for the card, requesting permission to wait inside while it was being fetched. When the prospect returned with the card, the salesman opened up his kit (where he purposely kept the logs) gave her one and explained the kilocycle index by making a practical demonstration on her radio. This gave him the opportunity to check the set and take out his tube tester, explaining its purpose, and make a free tube check-up. As we shall see later (page 1248), attractive logs may be obtained at fairly low cost from a number of manufacturers.

32-5. Selling by Telephone.—Some service men are able to make very effective use of the telephone in selling. The advantages of this method are that it is personal; that it assures you of a direct contact with the prospect; and that it takes less time than personal canvassing. On the other hand, there are disadvantages—your call may reach your prospect at an inconvenient time, causing him or her to resent the interruption; unless your prospect is sufficiently interested or gracious to give you plenty of time, you are not likely to be able to tell your whole story; and finally, every call costs a nickel, which is small compared with a personal call but large as against direct-mail solicitation. Even so, if you are able to develop a real telephone sales-technique, you may find your sales cost lower in this medium than in any other.

Where will you secure the names and phone numbers of prospects for phone-selling? Use your own lists of past customers, and any prospect lists you may have. The local telephone directory will also furnish names. Get names from social items published in the local newspaper, and look them up in the phone book.

In all telephone selling take care to develop the right approach. Know exactly what you are going to say, and practice condensing your story until you get it down to the minimum number of words. Talk pleasantly and clearly, without hesitation, and without rushing. Be natural and friendly, but make your voice carry conviction and genuineness. Don't do all the talking—ask some questions—make it a conversation, not a monologue. Don't try to do too much selling on the telephone—if you can get the prospect into your store or arrange an appointment for an inspection, that is enough. Avoid calling at inconvenient times.

Have some specific offer or proposition to make—a free premium, a “special”, a free test. If you haven't any really attractive offer to make, it is usually better to avoid telephone selling except in conjunction with other sales methods—for example, to follow up a direct-mail campaign, or to “break the ice” for a personal call. Used in this connection, telephone selling can be very useful, especially in suburban communities.

The telephone is good for following up old customers. With

them the major selling has already been done and a reminder is usually enough to keep their business coming your way. If you adopt this plan, do it consistently—call up first just a few days after you have made a repair or sold him tubes, and merely inquire how the set is working. Five or six months later call again to inquire about the set's performance, reminding your customer how long it has been since you did the job. Then keep calling up every few weeks, if necessary, to suggest another set inspection or tube test. Keep a "tickler file" of all your customers, which will automatically show you when these various phone calls are due.

Whenever an outstanding "national" or "special" program is scheduled to be broadcast, there is always a good opportunity for a telephone solicitation. Call up your prospects and customers and say something like this: "Tomorrow night is the big Such-and-Such Broadcast, Mrs. Jones. I just thought I'd remind you—it's on Station XXX at 9 P. M. I hope you're planning to listen in." Then after her reply, add, "And by the way, how's your set working these days?" If this lead doesn't produce a sales opening for you, you might continue in this manner—"You know, I'm so anxious to have the Such-and-Such program come in well on your radio that I'm going to do something very special for you, Mrs. Jones. I'm going to loan you a complete new set of tubes. No, there won't be any charge or obligation of any kind. I just want you to try these at my expense on this broadcast.—Do this, and then just notice how much better it comes in than the reception you're getting now. I'll bring them right over now." When you or your assistant goes over to Mrs. Jones' to install the new set of tubes, don't try to do any selling at that time, but merely test and label the old tubes (leaving them there) and mark your new ones (positively) for identification. The time for the selling is the next day when you come back to pick up the tubes. At that time, try to sell the tubes to her, along with what repairs you can see are necessary.

32-6. Making your Advertising Effective.—After a few misguided splurges with the inevitable disappointing results, some service men are apt to come to the conclusion that advertising is just a means for throwing away money. Yet you will find few

large successful service organizations that do not consistently make use of some form of advertising. They have learned that well-directed advertising campaigns and merchandising plans not only made selling a lot easier and quicker, but in many cases did the whole selling job. There was a time when a service man could pick up a clientele if he merely put up a sign outside his shop and printed some common business cards. Competition has changed that condition radically. Today a service man must know something about advertising and be able to use it intelligently, if he expects to build up his business. True, if his advertising runs into any volume he will undoubtedly profit by hiring the services of professional advertising counsel, but even so, he should familiarize himself with the fundamental principles of advertising for his own information.

There is no simple formula for advertising success that can be glibly handed out. There are no circuit diagrams that will enable one to construct a sure-fire promotional campaign. Advertising is a technique of trial and error, but many of the errors can be avoided by following a few general principles and benefitting by the tested experience of others.

First of all, *plan* your advertising. Study the different advertising mediums available to you. Select those you want to test. Then work out a consistent, logical plan, coordinating with your sales policy your direct mail, newspaper advertising, displays and whatever other advertising or merchandising you do. Don't jump from one thing to another in hit-or-miss fashion. You will accomplish nothing that way. Before advertising begins to show any effects at all, it has to be used sufficiently long to make an impression. Any good advertising program must allow for *repetition, continuity, persistency*, and plenty of it.

Your advertising must have "attention-value" if you expect it to register in the minds of people who may be perfectly indifferent to what you have to say. Without being offensive, it must make a striking impression in a flash. That impression may come from the message (idea-content), or from the physical appearance of the advertising, or preferably from both at once. To inject this quality into your message, your approach or appeal becomes, therefore, of utmost importance. Psychology shows

us that there are many ways of appealing to the average man or woman. You can appeal to his ego, to his comfort, to his sense of humor, to his love for new sensations, but most of all and strongest of all, to his pocket-book. If you can definitely show a man just how you can save or make money for him, you will always be sure to receive a sympathetic audience.

The same psychology can be used in the "hook"—the definite idea you must plant at the end of your advertising message that will give your prospect the stimulus to act—to buy what you want him to buy. There above all you must prove to him what he will gain by using your service, offering whatever inducements you are in a position to make. Show your prospect that a transaction with you is not just a one-way proposition—make him feel that you are willing to give even more than you want him to give. A tangible demonstration of this practical type of "giving" is the free premium. Being in the radio business you know to what extent the big national advertisers make use of the free gift or premium in order to get response from their audiences. You can use the same strategy in your own business. Radio logs are used as premiums by a great many service men. They are still good, especially in new and different formats, but by using a little ingenuity you will be able to devise other inexpensive "give-aways" to bait the hook in your message.

Try to avoid the commonplace in all the advertising you do. Ideas wear out like tubes. You'll get much better reception if you replace worn-out expressions with fresh, original, naturally-expressed ideas. You ought to be able to think of plenty of them after a little thought.

There are many different mediums of advertising. All of them are good, but not all are good to the same degree for all service men. You will have to do a little experimenting to find out which ones work best for you. Since direct-mail and display advertising have generally proved to be the most effective in this business, we will place most emphasis upon these two mediums in this chapter, but the other mediums will not be neglected.

32-7. Display Advertising.—The best type of display is that which demonstrates, as well as calls attention to, *your ser-*

vice. Demonstration of the product is essential in any kind of selling. Radio servicing may not be quite as easy to demonstrate as some products, but those service men with imagination have found many interesting and effective means of doing this. The cathode-ray oscilloscope is proving to be an excellent medium for this purpose, for at last the many interesting things which go on inside a radio set can be made visible—and in an extremely fascinating way that never fails to attract attention



(Courtesy Radio Retailing and Butler & McCall Co.)

FIG. 32-1.—An attractive and unusual window display dramatizing the idea of “First Aid to Sick Radio Tubes,” and a free tube-testing service.

(see Section 6 of Art. 32-8). Sets can be aligned, sound wave-forms can be shown, etc.

Naturally you will have a store-front and sign that are attractive in appearance. But it's what you put in your window that is responsible for pulling the passer-by inside. Always remember—the public likes to be entertained. So put on a radio show in your window—avoid the usual show cards and display pieces—try to dramatize your story—use showmanship. For example, a Pennsylvania tube dealer made up the fairly inexpensive window display illustrated in Fig. 32-1, dramatizing the idea of “First Aid to Sick Radio Tubes”. From 3 to 6 o'clock from

Monday to Friday, and from 3 to 9 P.M. on Saturday, an attractive girl dressed as a Red Cross nurse tested tubes in the window. The rest of the window was filled with various piles of old tubes, labelled, "We have howled our last tune," "We made a lot of noise," "Free Burial for Dead Tubes," etc. Under a sign "Radio Tube Cemetery" there was a "coffin" filled with worn-out tubes. The public was invited to guess the number of tubes in the coffin and win a valuable prize. This window more than doubled that dealer's tube business during the two weeks it was used and, in addition collected a number of good prospects for

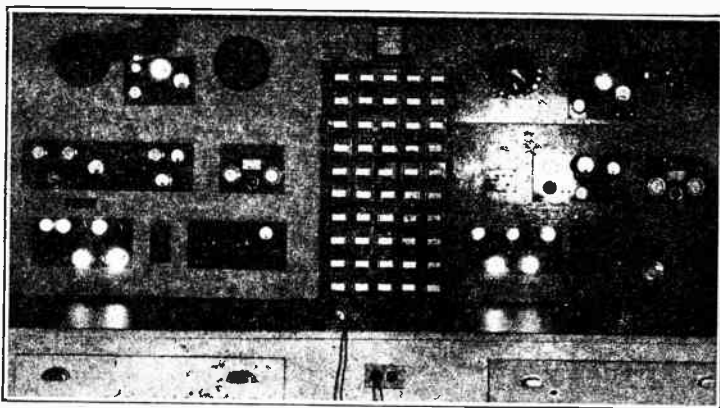

(Courtesy Radio News and Colony Radio Co.)

FIG. 32-2.—A service bench and test panel that have a professional touch. Notice the file cabinet for 3 x 5 inch index cards. This contains service records, customer lists, service data, etc., in a convenient place where they can be reached easily.

sets and electric appliances. A good, unusual idea like this can be used more than once—at sufficiently long intervals.

Another enterprising dealer has three elaborate tube testing panels in use, not because he needs that many, but to impress his prospects. One of the panels is placed in the window (along with appropriate display signs) so that it is visible from the street. A man is at work testing tubes with it! It brings in a lot of business for him.

From time to time you can always make a display of your servicing equipment, within the limitations of your window space. Better still, keep a repairman at work in the window if

you can—especially with a cathode-ray oscilloscope. Put up a sign describing what the different pieces of equipment are and what they do.

Don't leave one display up too long in your window. After it reaches the point of "diminishing returns", its effectiveness decreases very rapidly. If you find one display that pulls exceptionally well, keep repeating it, but alternate it with others. The



(Courtesy Radio Retailing and Int'l Radio Shop)

FIG. 32-3.—An unusual display of defective and worn out radio parts which is used in one radio shop to arouse the interest of the customer. It serves to drive home the fact that the parts of radio receivers may become worn out or inoperative and require replacement or repair just as the parts of any device that is used day after day do.

posters and displays furnished by manufacturers are usually worth using for short periods, even though they impart no individuality to your service.

Inside your shop be sure that everything makes a good impression—that it looks clean, business-like and modern. Display your equipment as prominently as possible. Don't be afraid to show off your business. It pays to build an impressive, modern test panel—it will do as much to sell your service as anything else. The illustration in Fig. 32-2 shows a typical impressive

test panel and service bench. A California service man goes further than that. In his shop he keeps a permanent display of defective parts—condensers, transformers, etc. He has broken them down and mounted them on a board as shown in Fig. 32-3 so he can demonstrate to his customers how the main parts in a radio set are built, and how they can go bad. Most people do not realize that radio parts can actually *wear* out. They think that because the set has no visible moving parts in it, it should last forever. This display is convincing salesmanship. Another dealer, just for effect, has his walls literally lined with tube cartons. He sells 1,000 tubes a month!

By setting a stage for your work, you can use the same principles of display when you are working in the customer's home. Lay out your equipment conspicuously and get good light on it—if necessary move a floor lamp. Explain your work as you go along if you find your customer is interested. This will enable you to create a friendly atmosphere.

You can probably find additional opportunities for promotional displays among stores in your neighborhood. Simple show-cards announcing your service, if placed in a few electrical stores, garages, hardware stores, vacant stores, etc., may pull in quite a little business. If necessary, offer the store owners a small fee or commission for displaying your sign and referring business to you.

32-8. Direct-Mail Advertising.—The advantage of direct-mail advertising is that it allows you to send your message to a selected group of prospects and customers at a relatively low cost. Although a tremendous amount of advertising is sent through the mails, most of it is seen by the recipients and, if interesting enough, is read. Direct-mail also has the advantage of being a medium which is comparatively easy to check up on for returns. Of course it is much more effective in some localities than it is in others, but it is worth a real test.

The same material that you prepare for direct-mail can sometimes be distributed by hand. In this case, no addressing or list of prospects are necessary. However, distribution material lacks the personal touch of a letter or post-card and is not given the attention that direct mail receives. In your town

there may be one or more organizations which specialize in distribution of advertising material, who will be glad to quote you rates. You may also find it satisfactory to direct the distribution yourself, using Boy Scouts or school boys.

Coming back to direct-mail, the matter of *cost* is important. Since the percentage of sales from direct-mail or any type of advertising is bound to be small, the cost must be kept down to a minimum in order to make your advertising pay. The cost depends on many factors—the format (that is, the postcard, folder, letter, etc.), postage, cost of list, addressing, etc.

As for formats, unquestionably the most economical is the postcard. And while the postcard isn't as impressive as some of the other formats, it often "pulls" just as well and even better. The postcard is also the best "buy" in postage, for it goes first-class for one cent. If you are in a position to make large mailings fairly frequently, it might be well to consider the purchase of a post-card printing and addressing machine, such as the Cardvertiser put out by the Elliott Addressing Machine Company of Cambridge, Mass.

One disadvantage of the postcard which should be mentioned, is that it does not allow you much space for your message, but as we shall see, very effective postcards have been devised by careful thought. If you have a longer story to tell, probably your best format will be a form letter, but if you use letters be careful of their appearance. A multigraphed or "processed" letter is more expensive than a mimeographed letter, but in appearance is far superior. Again, if you fill in the name and address of the prospect on the letter, be sure to do it well or not at all. As a matter of fact, tests will probably prove to you that you can get just as good results if you start your letters with, "Dear Friend", as you will if you go to the expense of a personal fill-in for each one. You will find letter shops (or multigraphing and addressing organizations) listed in your telephone directory, who will quote you rates on multigraphing and also on addressing envelopes or post-cards.

Folders are generally too expensive for the average service man to prepare himself. Blotters are so common today that they do not get the attention of the prospect that they did years

ago. The advertising value of novelties is highly questionable, as too often they fail to sell what they are intended to sell—the prospect's attention is diverted by interest in the novelty itself.

Postage costs in the United States are as follows: (a) First-class sealed envelopes—2c local, 3c outside local zone; (b) First-class postcards, standard government size—1c; (c) Third-class postcards, larger than government size—1½c, under Section 562, PL&R (a permit may be obtained from your Postmaster); (d) Third-class unsealed envelopes—1½c, under Section 562, PL&R (e) Third-class unsealed envelopes, mailed in bulk—12c per pound (1c each, if mailing unit weighs less than one and one-third ounces—see your Postmaster about bulk mailings).

As you will remember from the discussion earlier in this chapter in connection with outside selling, you have a wide choice of mailing lists which you may use. For example—city directories, telephone directories, lists of club or lodge members, etc. Perhaps you can get your present customers to cooperate by giving you the names of their friends. A guessing contest in your window, requiring all contestants to fill in their names and addresses, will give you a good list. Likewise, a "noise" survey. Your mailing list plays a very important part in the success of your advertising. Take pains to build up a good one, and when you get it, keep it on cards or on stencil plates—and *keep it up to date!* Incidentally, the card-file idea illustrated in Fig. 32-2 is a good one.

The question is often asked whether it is better to use literature furnished by tube manufacturers or for the service man to prepare his own advertising material. The tube manufacturers are interested primarily in selling tubes. You on the other hand are interested in selling service as well as tubes. Therefore, while some manufacturers' literature is very skillfully prepared and is well worth your utilizing, it cannot entirely take the place of your own individualized advertising about your service. If you do use manufacturers' folders or postcards, be sure that your personal imprint is well done—a rubber stamp is false economy, have it printed! In many large cities there are printing concerns that specialize in doing work of this kind. They

may be located by referring to a telephone directory under the heading of "Imprinting".

When you decide to do some direct-mail advertising, make up your mind to plan a real campaign and actually go through with it. Don't get out a mailing piece one month and then wait another month or two until you get another bright idea or find yourself with a little surplus money for promotion. Don't start, unless you are prepared to carry on to a finish. Try to get out a mailing a month if you can; or one every two or three weeks during the good radio season. Plan your mailings in advance, so that your campaign will be logical in its development and continuity. Try to get out a mailing before each large national broadcast, whether it be a prize fight or a speech by the President. Some special cards for such purposes will be shown later.

If you mail out letters you will be able to enclose "Business Reply Cards" which the prospect can fill out, naming the date when he wants a service man to call, and mail back to you without postage. The postman collects the postage due from you when he delivers the filled-in business reply card to you. For this service the Post Office Department charges you one cent more than the regular first-class rate, but it is more than worth it, for you do not pay anything for the cards which are not returned to you. Thus, if it is a return card (not an envelope), you pay the postman two cents. You are pretty sure of getting better returns if you use Business Reply Cards than if you merely ask the prospect to phone, for in the latter case he is likely to forget about it. One test made by a Kansas City service organization showed a 30% return from Business Reply Cards against 10% from requests to telephone. You can get a free permit from your postmaster for using Business Reply Cards in the United States under Section 510, P.L.&R.

As suggested previously, it is advisable to follow up your direct mail from time to time, either by telephone or personal call. This will at least give you the opportunity to check on your direct-mail and see if it is registering with the prospect.

Below you will find tabulated and described a number of different ideas that you can use in planning your direct-mail advertising. In adapting these to your purposes, it is assumed that you will "personalize" them as much as possible, injecting all the elements you can to individualize your service.

- (1) Premiums. A logical use for direct mail is to offer a free gift or premium. There is, for example the postcard offering the free log (described in Section 32-9 of this chap-

ter). This may also contain the name and photograph of the salesman who will call to deliver the log. Personalization of this kind is always good, but quite expensive. Several of the large tube companies supply their dealers with a stock postcard offering a free radio log with every service call. While this premium is given the most prominent display on the card, the copy of a postcard put out by the National Union Radio Corp. takes advantage of the reader's interest and does a straight selling job on service, as follows:

"FREE RADIO LOG WITH EVERY SERVICE CALL. Call us to inspect or repair your radio. Expert service, all makes. Written guarantee. Standard parts, Professional work. We are equipped with up-to-the-minute data and modern precision testing instruments for most efficient radio service work. See Special Offer Other Side of Card."

RCA puts out a stock card (see Fig. 32-4) with a blind

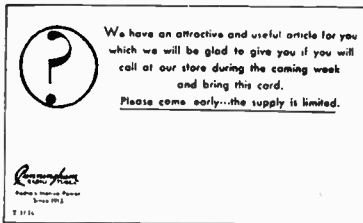

(Courtesy RCA Radiotron Co.)

FIG. 32-4.—A direct-mail card which makes a "blind" premium offer counting on the reader's curiosity to attract him into the store. Naturally, he should be greeted in a friendly manner rather than by high-pressure sales methods.

premium offer, counting on the reader's curiosity to get him into the store. The card reads:

"We have an attractive and useful article for you which we will be glad to give you if you will call at our store during the coming week and bring this card. Please come early—the supply is limited."

(2) Free inspection. If you really believe it is good business to

offer free tube tests or free set inspection (the general consensus of opinion among the radio servicing fraternity seems to be against this practice) it is most advisable to state specifically just what is free, in order to forestall complaints from your customers (see page 1211). For example, a Brooklyn service company gets out a card offering a free check-up, which includes examination of the antenna and power pack, testing of tubes, speaker, voltages and noises. There is a place for the prospect to sign name and address.

Another free inspection offer that purposely makes everything clear to avoid any possible misunderstanding is used by Marconi Brothers, Inc., of New York City. This is a double post-card, one half being a Business Reply Card for the prospect to fill out and mail back. The copy reads:

"Is your Radio out of whack? FREE INSPECTION. Has that rich tone gone sour? Does it roar one minute and whisper the next? Or howl...? It's been a real friend . . . perhaps just a simple adjustment or just a single tube or perhaps a more costly transformer replacement is needed . . . but what of it! Don't wait another minute! It's worth it, it's your real friend. Telephone—or mail the card! We have a real laboratory and our men are Radio Engineers. You can depend upon an absolutely accurate examination, you can know the complete cost in advance and above all know that the work will be done well. FREE INSPECTION ENTAILS NO OBLIGATION."

The natural, easy style of this copy cannot help but induce confidence and a feeling of friendliness.

- (3) In announcing a fixed charge for an examination or "tune-up" it is always advisable to state specifically what you will do for the money. Invariably this will be more impressive than mere generalities, and will avoid unfortunate misunderstandings and disputes later. An example of this is furnished by the double post-card put out by a large New York servicing organization, offering the "12 Services for

\$1." This particular card is illustrated in Fig. 32-5.

- (4) If you don't believe in *free* examinations, etc., why not tell your customers so and give them your good reasons for doing so. The card shown in Fig. 32-6 puts this message across in friendly but convincing style and is likely to inspire admiration and confidence in your prospective customer as well.

- (5) One of the most effective subjects for a direct mail piece is that of "self-servicing". Almost anyone will read something which looks as though it will tell him how to service

EVERY Radio set should have a "Tune-up" at least once a year. Most radio troubles are caused by lack of just ordinary care. Here is what we will do to your radio for \$1.00: (outside N. Y. C. \$1.50)

1. Remove corrosion from aerial and ground connections
2. Tighten aerial and ground connections.
3. Inspect for all loose connections.
4. Test tubes and attach labels showing condition.
5. Check tube sockets for poor connections.
6. Tighten tube shields.
7. Inspect loud speaker for rattles
8. Clean exposed volume control.
9. Check volume control for noisy operation or dead spots.
10. Tighten dial knobs.
11. Check operation of set over entire frequency range.
12. Clean chassis.

I want my radio "Tuned-up." Have your serviceman call on:

NAME _____

ADDRESS _____ Apt. No. _____

CITY _____ Phone _____

Mail This Card -- No Postage Necessary. Or Telephone:
 Lackawanna 4-5811 . . . 9 A. M. to 5 P. M.
 Elmhurst 6-7200 . . . 5 P. M. to 10 P. M.

(Courtesy Davega-City Radio Co.)

FIG. 32-5.—A direct-mail card which lists 12 simple services for \$1 and makes clear just what these will be so that there will be no misunderstanding regarding them.

"FREE" RADIO SERVICE ??

Surely, you must know that no business can give you something for nothing. Our service is not free.

But we do offer you something you need—professional radio service at an honest price. We have the knowledge, equipment and integrity to put your set in perfect condition.

If your radio is not working at its best—if reception is noisy and poor, won't you phone us now. We know that you will be more than satisfied with the results.

RELIABLE
Tube Testing
IN YOUR OWN HOME

AVINS RADIO SERVICE
303 Richmond Road .. New Dorp

Phone DONGAN HILLS 6-0565

Integrity — Reliability — Quality



(Courtesy RCA Service News and Avins Radio Service)

FIG. 32-6.—A direct-mail well-planned card that clearly states definite objections to free radio services and at the same time tends to command prestige and confidence for the sender.

his own radio. While you may actually give away a few tips in such a piece, you can very easily make it apparent

to the reader that if he wants a real job of servicing done, it's necessary after all to get a trained technician. This is the theme of two good direct-mail pieces. One is a stock folder supplied by National Union and is illustrated in Fig. 32-7. The other card is used by Hulbert of Los An-

BUT IF YOUR SET PLAYS

BUT

Plays intermittently . . . Stops for a few seconds . . . Then continues to play —

This may be caused by a tube with shorting elements, or a noisy tube. Look at all your tubes. If one burns brightly, and then dims or flickers, and then brightens again, this tube is probably defective.

Take it to your Dealer for test

Plays with a very bad crackling noise at times —

With your finger tip, tap the tubes gently on the glass, one at a time. If this crackling noise results from tapping any one tube, take this tube out.

Have it tested at your Dealer's

Acts weak on nearby or semi-distant stations —

This may be caused particularly by tubes which have been in a set for more than one year.

Have all your tubes tested at your Dealer's

OR IF —

Your rectifying type 280 tube is more than one year old —

If this tube burns out while the set is operating, it may cause considerable damage to your set, such as burnt out power pack, condensers, resistances or well as tubes. This tube should be tested and if found to be at all doubtful,

Replace it at once

WARNINGS: When removing or replacing tubes, set should always be turned off. Many tubes are destroyed by placing them in the wrong socket. If tubes are removed be sure they are put back in the correct sockets.

BUT IF YOUR SET IS SILENT

BUT

When your set is turned on, do your tubes light? If all but one light, this is probably a defective tube.

Take it to your Dealer's for test

If more than one tube fails to light, they may all be defective, but more than likely, something else is wrong with your set, so more than one tube seldom burns out at the same time under normal operation. Before putting in new tubes, it is best to

Call your Service Man

If none of your tubes light,

something is wrong with your set —

Look to see if your set is on, or has plug in, or if the terminal wires are in good order and properly connected. If you see nothing wrong, it is best to

Call your Service Man

If all tubes light, but the set does not play —

Look to see if your antenna or ground has become disconnected. YOUR SERVICE MAN can probably locate this trouble very quickly.

Call your Service Man

OR IF —

There is Noise —

If not due to defective tubes can be easily identified by tracing your set to different points on the dial. If the disturbance becomes louder or weaker from point to point, it is in most cases an external condition or is not trouble, set due to the tubes.

Call your Service Man

There is Hum —

This can be caused by improper A. C. filter, or unbalanced line adjuster. Bad tubes can also cause a hum.

Call your Service Man

WE RECOMMEND NATIONAL RADIO TUBES FOR BEST RECEPTION

(Courtesy National Union Radio Corp.)

Fig. 32-7.—A "self-servicing" folder which looks as though it might tell the recipient how to service his own radio set. It actually gives him a few tips and thereby commands his attention.

geles and is shown in Fig. 32-8. The latter has other good points, for it also illustrates Hulbert's test panel, and on the reverse side of the card has a station log and lists "News of the Hour" programs.

The use of test panels and other test equipment for advertising purposes has not received the amount of consideration that it merits from radio service men. If time and money are spent in an effort to equip the service shop with an elaborate test bench, then this equipment should be featured for advertising purposes for it is a worthwhile asset to the shop. Some service men gain a great deal of worthwhile advertising from their test equipment by having it located right out in the shop where everyone can see it. Others do not approve of this arrangement, but mention the equipment and even show illustrations of it (see Fig. 32-8) in their direct-mail literature, using this method to bring it to the attention of their prospects and customers.

Another sales letter on the self-servicing theme is shown below:

Dear Mr. Jones:

Do you know how to give First Aid to a noisy radio?

I'll tell you—but first of all, let me say that it all depends on what make and model radio you have. No two are exactly alike you know—each has its own little quirks and peculiarities; each calls for individual treatment. So let's assume an imaginary radio—say a "Blank—Model Z".

Now when a Blank—Model Z develops a case of "noisitis", it might be due to any one of 11 different causes. Let me just list them for you—(1) loose connections; (2) loose connection to oscillator series condenser; (3) loose elements in the tubes; (4) corroded rotor contact or tuning condenser; (5) "peeling" tuning condenser plates; (6) leaky detector plate by-pass condenser; (7) poorly soldered audio transformer leads; (8) dirty volume control contact; (9) dirty or poorly-adjusted switch contacts; (10) noisy plate circuit resistor; (11) external electrical apparatus in vicinity.

Well now, of course you might try to fix up your radio yourself by examining carefully each of those 11 trouble sources with the proper type of equipment, and using the proper remedy. Or you might call in some electrical tinkerer who is handy with a screwdriver and a jack-knife, but short on radio knowledge.

But—if you really value your radio and if you really want to get that noise eliminated—call on trained technicians, skilled in servicing all types of radios. Have them make a complete examination with the latest methods and scientific instruments, and let them make your radio as sweet and healthy as the day you bought it.

We will be glad to make an expert examination of your radio absolutely free of charge and before proceeding with any repairs we will be glad to give you our written "Diagnosis" showing you just what needs to be done and just how much it will cost. Return the post-free card today—or telephone Main 0000—and our radio ambulance will be on its way!

Sincerely yours,

THE RADIO DOCTORS

(signed).....

Surgeon-in-Charge

A variation on the radio doctor theme is the "radio dentist". A postcard may be prepared with a humorous cartoon showing a "humanized" radio set being operated on in a dentist's chair. Next to this cartoon, suitable copy may

be imprinted to tie in with the illustration. Copy appropriate for this purpose might read as follows:

**HOW LONG SINCE YOUR RADIO'S BEEN TO
THE DENTIST?**

You can't neglect your radio and get away with it any more than you can your teeth. Play safe and let the Radio Dentists look it over today.

Maybe it's only a filling or two. Or just a good cleaning. But if it's so far gone that we have to make an extraction, you can be sure we'll make it as painless to your pocket-book as we possibly can.

Call Main 1000 now and we'll come right over. It's only a dollar for the examination and "tune-up".

THE RADIO DENTISTS

(signed).....

- (6) Your servicing equipment is always a feature you can capitalize on. Here is a card (Fig. 32-9) with a simple illustration of a test panel, that reads:

"EVER SEEN OUR TEST PANEL? It's the most up-to-date scientific instrument there is for spotting trouble in your radio. It tests your tubes, resistors and condensers. It tests for short-circuits, open-circuits, defective parts, alignment of fixed tuned stages, etc., etc. Bring your radio in and watch us put it through a complete set of tests—or phone Main 1000—and we'll come and get it.

As mentioned in Art. 32-7, the Cathode-Ray-Oscilloscope makes an excellent attention getter. Fig. 32-10 shows a specially prepared card which uses the oscilloscope as bait to get the customer to visit the service shop. The Oscilloscope can also be featured in a window display.

- (7) You can use a certain coming broadcast program as an attention-getter in direct mail as well as in telephone sell-in. This method is especially effective if the program is to be a national or international event that has been widely publicized in the newspapers beforehand. Many people will consent to have a check-up of their radio receivers

How to Service Your Own Radio

One of the commonest radio troubles is "so called" noise or static. This is caused usually from one of two sources:

(1) MAN MADE STATIC OR ATMOSPHERIC STATIC.
(2) NOISE WITHIN THE RADIO ITSELF.

One of the easiest ways to determine whether it is caused *outside* or *inside* your radio, is to tune in a station at normal volume and then disconnect the aerial wire at the radio. If the noise stops or diminishes materially, you can be quite sure the noise is outside the radio. IF THE NOISE CONTINUES WITH THE AERIAL DISCONNECTED, CALL OUR RADIO TECHNICIAN FOR A COMPLETE CHECK OF YOUR RADIO, No charge.

If your radio plays intermittently, the trouble may be caused by a bad tube. Look at all tubes. If one burns brightly and then dims or goes out, bring it to Hulberts for a test. No charge.

If your radio is weak on local or semi-distant stations, this may be caused by weak tubes—have Hulberts test them for you.

If your set is turned on and no tubes light—possibly a bad fuse. Have a thorough check made for the cause of fuse blowing out—saving expensive repair later to power pack and condensers. No charge for testing.

If all your tubes light and radio does not play—check your aerial and ground connections or you may have a bad tube or defective parts in your radio. Hulberts can locate such trouble quickly for you.

When removing or replacing tubes, be sure your radio is turned off. Tubes are often damaged or destroyed by plugging in wrong sockets. Be sure they are always put back in the correct socket.

Have Hulberts test your tubes twice a year—replace them once a year and hear the difference. We test tubes free.

Remember your radio is an *iron* item in *steel* and ground insulation. Do not expect to get distant reception with a poorly constructed metal. If in doubt, call Hulberts for service or advice. Free service if brought to our store.

POSITIVE
ACCURATE
TESTS BY
PRECISION
INSTRUMENTS



THE MOST
UP-TO-DATE
RADIO
LABORATORY
IN LOS
ANGELES

NEW HULBERT RADIO TEST PANEL
DEFECTIVE SOURCE OF TROUBLE INSTANTLY

FREE If you are having trouble with your radio, we will call at your home, make a thorough test of the set and give you an estimate of the needed repairs **WITH-OUT COST OR OBLIGATION.** We have one of the most complete and up-to-date radio laboratories in Los Angeles. Nothing but the finest materials used! All work guaranteed at new reduced prices! We service **every** brand.

JUST CALL ALBANY 4506

HULBERT RADIO ELECTRIC COMPANY
3046 BAGLER ROCK BOULEVARD • LOS ANGELES, CALIFORNIA
PHILCO RADIOS AND KEELVINATOR REFRIGERATORS

FIG. 32-8. — Another "self-servicing" card which not only gives the set owner hints on determining the cause of trouble in his set, but also illustrates the test panel of the service man and tends to convince him that the service man is well prepared and equipped to make any tests and repairs that may be necessary in order to restore satisfactory operation of the set. Direct-mail literature that illustrates the test panel or other servicing equipment which the service man owns (especially if it contains any exclusive or unusual features) always helps to build up prestige for the shop.

(Courtesy Radio Retailing and Hulbert Radio Elect. Co.)

made at such times. RCA has an attractive stock post-card (shown in Fig. 32-11) for this purpose. It reads:

"DON'T MISS HEARING..... On
..... At..... M., over Station.....
This program is of special interest to everyone. We know you will want to hear it. If your set is not working perfectly, call our service department. We will restore your set to first class condition."

Another effective card of this type is shown at the left of Fig. 32-11. The illustration and caption attract attention.

(8) Some alert service men not only build up an excellent mail-

ing list but also do some fine business by conducting Noise Surveys. Jackson's Radio Service in Lexington, Ky., dis-

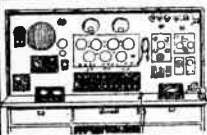

Ever seen our TEST PANEL ?

IT'S the most up-to-date scientific instrument there is for spotting trouble in your radio. It tests your tubes, resistors and condensers. It tests for short-circuits, open-circuits, defective parts, alignment of fixed tuned stages, etc., etc.

Bring your set in and watch us put it through a complete set of tests with our test panel -- or phone Main 1000 and we'll come and get it.

BLANK RADIO SERVICE
100 Main Street
NEW YORK
Phone - Main - 1000

FIG. 32-9. — A direct-mail card that capitalizes on the test panel of the service man and creates the feeling that he is well equipped to solve any service problem that may arise.

tributes a postcard (Fig. 32-12) which reads as follows:

“RADIO OWNERS! IS LEXINGTON THE NOISIEST CITY FOR RADIO RECEPTION? Every residential district is to be checked with special equipment for power leaks, sign flashers, etc., by JACKSON'S RADIO SERVICE as an extra service at no cost to you. Better radio reception will be the outcome of this radio noise survey. Please answer the following questions and mail at once so your district will be checked immediately.

KIND OF NOISE..... TIME OF MOST INTERFERENCE..... YOUR NAME AND ADDRESS..... MAKE OF RADIO..... AGE.....”

Of course the cards that come back give this dealer a made-to-order set of data to use in soliciting business. In the

FIG. 32-10.—A direct-mail card that capitalizes on the interest which the visual pictures of the Cathode-Ray Oscilloscope will arouse in the prospect.

(Courtesy RCA Radiotron Co.)



RADIO WEAK ?

We can see as well as hear exactly what is wrong with your radio on our RCA Cathode Ray Oscillograph. Drop into our Service Department and see this remarkable instrument.

We recommend and install the RCA World-Wide Antenna System. A necessity for noise-free short-wave reception.

YOUR IMPRINT HERE

Street Address _____ Phone Number _____
City and State or Zip Here _____

store Jackson had a large map of Lexington on the wall with the trouble areas marked. This gave his customers proof that he really was “shooting interference” for them.

- (9) You will make a hit with new residents in your community if you send them a friendly letter welcoming them and offering to install or adjust their radios at a special rate as a neighborly courtesy. Such an "introductory" offer is well justified as "sales promotion", for it is almost sure to result in future "pay business" from those people. Lists of new residents are often available from merchants associations, boards of trade, chambers of commerce, real estate

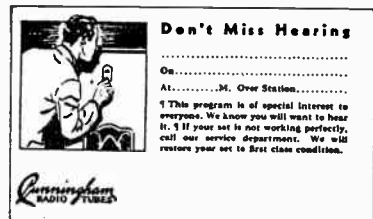
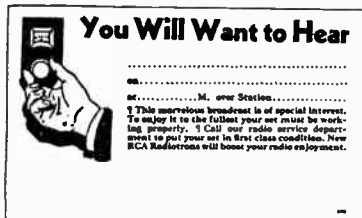

(Courtesy RCA Radiotron Co.)

FIG. 32-11.—Two direct-mail cards that use a particular future broadcast program as an attention getter and as a reminder to have the radio set checked over beforehand so that the program will be received satisfactorily on the prospect's receiver.

- boards and community organizations—or they can be compiled from the "personal" columns of the daily "local" newspapers.
- (10) If you handle radio accessories, and get hold of some good equipment at a very low price, you can offer this "special" to advantage in a postcard or letter. It is risky to depend entirely on manufacturers' specials for your business, but when used in the right-way they often have their value.
- (11) In times when people haven't the money to buy new sets, there is a good business opportunity in rebuilding sets. To get this type of business Mr. F. C. Rockhill of St. Regis Falls, N. Y. sent out this sales letter with good results:

Dear Sir:

Would you pay \$20 for a new set? A new SUPERHET-ERODYNE with all the latest trimmings—automatic volume control, tone control, selectivity that allows you to cut through interfering stations and bring in the one you wish to hear clearly. Power enough to pull in far distant stations with ease.

With the advent of pentode and duplex-triode tubes, radio sets have been greatly improved. All the new sets have these tubes and we are prepared to rebuild your set so it will use them.

We are proud that we can bring these improvements to you at such a low cost. We can safely guarantee that your set's power and selectivity will be doubled and the tone greatly improved.

Very truly yours,
F. C. ROCKHILL

The National Union Radio Corp. supplies a series of post-cards primarily for securing new-chassis business. Many

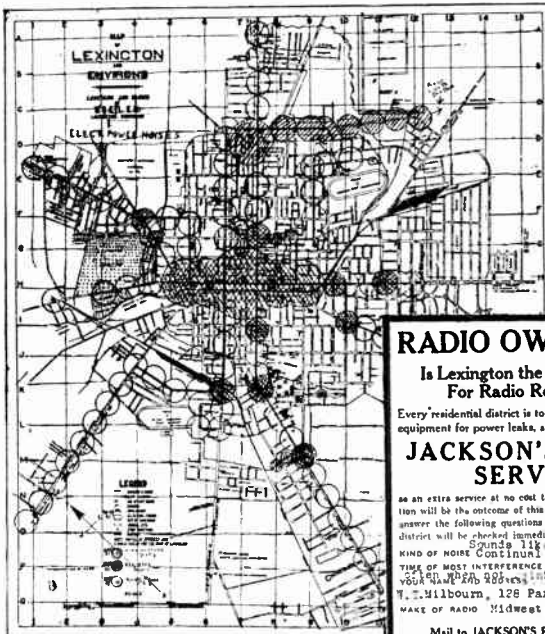

(Courtesy Radio Retailing and Jackson's Radio Service)

RADIO OWNERS!!!

Is Lexington the Noisiest City
For Radio Reception?

Every residential district is to be checked with special equipment for power leaks, sign flashers, etc., by

JACKSON'S RADIO SERVICE

as an extra service at no cost to you. Better radio reception will be the outcome of this radio noise survey. Please answer the following questions and mail at once so your district will be checked immediately.

Spounds like power leak.
KIND OF NOISE CONTINUAL or BUTTER.
TIME OF MOST INTERFERENCE When raining; very
your name and address please.
T. T. Wilbourn, 128 Paris Av.
MADE OF RADIO Midwest 406 1934

Mail to JACKSON'S RADIO SERVICE

132 Indiana Avenue, Phone Agh. 4776
DAY AND NIGHT SERVICE
Member Official Radio Service Men's Association

FIG. 32-12.—A direct-mail card that features a noise survey made in the locality. A card of this kind cannot help but create the impression that the service man in question knows all about the noise problem in the vicinity and is well qualified to eliminate interference in any radio installation. At the same time, it serves to give him leads to prospects who are really in need of his services.

service men have done a considerable amount of this type of business on a very profitable basis. The improved re-

ception resulting from fairly inexpensive installation of the modernized chassis never fails to win over a satisfied customer that can be counted on for future servicing business. One of the cards prepared especially for this purpose reads:

"KEEP YOUR BEAUTIFUL RADIO CABINET, BUT . . . Let us bring it up-to-date with a complete new radio chassis, including dynamic loudspeaker and all the latest improvements . . . all-wave foreign reception, automatic volume control, improved tone, noise suppression, superheterodyne circuit, etc. The cost is so low that it is comparable with the average "Midget" radio set. Call on us for any radio service or repair problem. Estimates gladly given. All work guaranteed."

- (12) The National Union Radio Corp. presents another good merchandising feature in one of its postcard offering to

FIG. 32-13. — A direct-mail card that presents another good merchandising feature — that of loaning a radio set free during the time the repair job is being done, so that no programs will be missed.

(Courtesy National Union Tube Corp.)

RADIO SET LOANED FREE

While we are repairing yours

WE don't want you to miss a single moment of radio enjoyment. When we take your receiver to our shop for overhauling and repair work, we leave a set operating in your home. There is no charge or obligation for this special service. We are Qualified Radio Experts, fully equipped with modern instruments for radio testing and repairing. Lowest prices. Every job guaranteed. Call us with confidence.

NATIONAL UNION RADIO CORP.
EST. 1911

WE RECOMMEND
NATIONAL
RADIO TUBES
for PERFECTION

loan a set free during the repair job. This card is illustrated in Fig. 32-13 and reads as follows:

"RADIO SET LOANED FREE—WHILE WE ARE REPAIRING YOURS. We don't want you to miss a single moment of radio enjoyment. When we take your receiver to our shop for overhauling and repair work, we leave a set operating in your home. There is no charge or obligation for this special service. We are Qualified Radio Experts, fully equipped with modern instruments for radio testing and repairing. Lowest prices. Every job guaranteed. Call on us with confidence."

Every job guaranteed. Call on us with confidence." This offer is a good example of the "hook" which here not only stimulates action but acts as the main feature of the mailing.

- (13) Human-interest is a safe subject for any kind of advertising. Here is an illustrated post-card (Fig. 32-14) which was simply and inexpensively reproduced on a stencil and

"WE GOT A SWELL RADIO. --
 ..GEE!.. WE CAN GET ANY STATION--
 ANYWHERE. SO CLEAR IT'S LIKE
 HAVIN' THE ORCHESTRAS RIGHT IN
 THE SAME ROOM. THE FIRE CHIEF
 AN' WILL ROGERS WALK RIGHT
 THROUGH THE DOOR.
 WASN'T ALWAYS THAT GOOD, THO'..
 JUST SINCE PUBLIC RADIO SERVICE
 PUT IT IN SHAPE, DAD SAID IT COST
 NEXT TO NOTHING."
 REPAIRS AS LOW AS 75¢
 ONE-YEAR WRITTEN GUARANTEE WHEN WE TAKE
 UP A SET. WE TEST YOUR RADIO FREE--IN YOUR
 OWE HOME. DAY AND NIGHT SERVICE

PUBLIC RADIO SERVICE CORP.
 1110 BROAD STREET NEWARK, N.J.



PHONE
 BICKLOW
 3-2277

FIG. 32-14.—A human-interest type of direct-mail piece which is simple and inexpensive to produce.

(Courtesy Elliott Addressing Machine Co.)

run off on an Elliott "Cardvertiser". This is a fairly inexpensive hand-operated machine which will automatically address from stencils and print the complete message on 125 cards in less than 6 minutes. The copy for the card shown in Fig. 32-14 reads:

"We got a swell radio— . . . Gee' . . . We can get ANY station—anywhere. So clear it's like havin' the orchestras right in the same room. The Fire Chief an' Will Rogers walk right through the door . . . Wasn't always that good, tho' . . . just since Public Radio Service put it in shape. Dad said it cost next to nothing."

You can use your own personality as a human-interest

FIG. 32-15. — A direct-mail card that uses the personality of the radio service man as a human-interest subject and tells about his progressiveness and radio education at the same time.



JOHN JONES
 Radio Service
 Technician
 100 Main St.
 NEW YORK
 Main-2000
 ESTABLISHED 1926

I went to school—
 I wasn't satisfied with being a good radio "handyman". I wanted to become an expert technician. So I went to school — learned all about oscillators, set analyzers, audio amplifiers, intermediate frequencies, vacuum tubes, electrical interference, cathode-ray — well, in short, I studied all the latest scientific methods for doing a better job of servicing more economically.
 Perhaps that's why so many of my customers today recommend me to their friends. Perhaps they have to you — but in any case won't you come in or call up — and let me look over your set without obligation! — I may be able to save you some money.

subject, too, and by using a similar card, with a stencil reproduction of your snapshot, you can get out a highly personalized mailing at low cost. For example, the card shown in Fig. 32-15, which reads:

"I WENT TO SCHOOL—I wasn't satisfied with being a radio 'handy-man'. I wanted to become an expert technician. So I went to school—learned all about oscillators, set analyzers, audio amplifiers, intermediate frequencies, vacuum tubes, electrical interference, cathode-ray—well, in short, I studied all the latest scientific methods for doing a better job of servicing more economically. Perhaps that is why so many of my customers today recommend me to their friends. Perhaps they have to you—but in any case won't you come in, or call up—and let me look over your set without obligation? I may be able to save you some money."

- (14) If you service electrical household appliances as well as radios, you will be interested in two mailing pieces that have been used with great success. One of them, issued by the Colony Radio Company of Washington, D. C., is a 7" x 9" card (shown in Fig. 32-16) which was distributed from door to door on a systematic schedule that kept a steady flow of business coming in all summer. The card features "REPAIR SERVICE ON ALL ELECTRICAL HOUSEHOLD APPLIANCES AS NEAR TO YOU AS YOUR PHONE" and has "thumb-nail" illustrations of waffle irons, house wiring, radios, washing machines, vacuum cleaners, fans, irons, and miscellaneous appliances.

Fischer & Smith of West Englewood, N. J. went a step further by offering specific types of repair service for definite "flat-rate" prices. On radios, for example, they offered a general "tune-up" for \$1.50 and a complete shop overhaul for \$6. Likewise for washing machines. On this card (Fig. 32-17) the prospect had places to check the types of service desired and fill in his name, address and time when he wanted the service man to call. The back of the card was originally used for a Business Reply Card form, but

since it was found that most of the service requests came by phone, it was changed to a station log. A quantity of these were printed and distributed for a total cost of \$20 and resulted in approximately \$200 worth of extra business.

- (15) Radio accessories, like electrical appliances and manufacturers' specials, are often worth promoting by direct mail.

REPAIR SERVICE

ON ALL
ELECTRICAL HOUSEHOLD APPLIANCES
AS NEAR TO YOU AS YOUR PHONE



HAROLD STULL
OWNER and MANAGER
Who is an Electrical
Engineer and Personally
Supervisor of Repairs

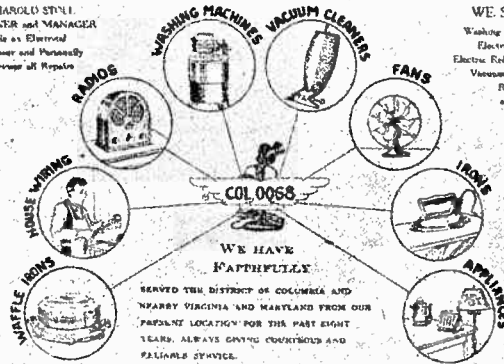

WE HAVE
FAITHFULLY
SERVED THE DISTRICT OF COLUMBIA AND
NEARBY VIRGINIA AND MARYLAND FROM OUR
PERMANENT LOCATION FOR THE PAST EIGHT
YEARS. ALWAYS GIVING COURTEOUS AND
PROMPT SERVICE.

WE SELL
Washing Machines
Electric Irons
Electric Refrigerators
Vacuum Cleaners
Radio Sets
and Parts

FREE
INSPECTION
ON ALL REPAIRS



FREE
ESTIMATES
ON ALL REPAIRS

RETAIN THIS CARD FOR READY REFERENCE

(Courtesy Radio Retailing and Colony Radio Co.)

FIG. 32-16.—A direct-mail piece that tells about a general repair service for all household electrical devices as well as for radio sets. It also introduces the personality of the owner and manager.

RCA has put out a number of post-cards for its dealers on Phonograph Record Players and Antenna Systems. One of these special phonograph Record Player postcards is illustrated at the left of Fig. 32-18. It reads as follows:

"HAVE YOU OLD RECORDS . . . AN OLD PHONOGRAPH? When you can't get what you want on the radio why not listen to your old favorites on your phonograph—played through your radio? It costs very little to install an electric motor and pickup in your old phonograph and connect it to your radio . . . Then you can have the music you want when you want it, without even bothering to wind a spring. Phone us; we'll be glad to tell you more about it."

FISCHER & SMITH
RADIO SERVICE
 Automobile Dept.

1401 Station St.
 24 Hour Service

| Station | Address |
|---------|---------|
| WPGH | 170 |
| WPCA | |
| WEAF | |
| WOR | |
| WJZ | |
| WNYC | |
| WAB | |
| WAA | |
| WR | |

Do You Need One Of These?
 Just check desired service and mail card, or phone TELEPHONE 7-4113.

RADIO—A.
 Voltage on all sockets tested. Tubes all checked. Aerial and ground inspected. Radio tested up \$1.50
 (No extra charge for minor repairs.)

RADIO—B.
 Complete overhaul at factory. Condensers all cleaned. All parts brush dusted. All connections resoldered. Tuning condenser re-calibrated. Bearings adjusted \$4.00
 Includes all of item A.

WASHING MACHINE—C.
 Seasonal Service.
 Clean motor brushes. Oil and grease all gears and bearings. Inspect electric cord, switch and plug. Make minor adjustments \$1.50

WASHING MACHINE—D.
 Five Year Service Period.
 Complete overhaul at factory. Replace worn or leaking bearings. Change oil. Tighten all couplings and pulleys \$1.50
 Includes all of item C.

REFRIGERATOR.
 Serviced \$1.50

VACUUM CLEANERS.
 Overhauled \$2.50

Please call at my home for items checked on

Day
A. M. **P. M.**

NAME
ADDRESS

(Courtesy Radio Retailing and Fischer & Smith)

FIG. 32-17.—A direct-mail piece which offers not only specific types of service on all electrical household appliances for flat-rate prices but features a useful station log as well.

Many service men have capitalized on the phono-radio angle of the radio business, not only to sell phonograph pickups, electric turntables, etc., but also to sell tubes and minor repairs in the radio receiver.

Here is the copy which appears on the Noise-Reducing Antenna System post-card shown at the right of Fig. 32-18:

"YOUR RADIO CAN TAKE IT. It takes all the noise and interference and passes them on to you unless it is equipped with a scientific antenna system. For short-wave reception especially, you must have an efficient antenna. We specialize in antenna installations and recommend the noise-reducing RCA World-Wide Antenna System . . . a remarkable "double-doublet" system that reduces noise and brings in stations you never got before. Let us make a *Certified Installation* . . . Phone us today."

- (16) If your location is not well known to all your prospects (especially if you are new in the neighborhood) it may be



**HAVE YOU OLD RECORDS . . .
AN OLD PHONOGRAPH ?**

When you can't get what you want on the radio, why not listen to your old favorites on your phonograph—played through your radio?

It costs very little to install an electric motor and pickup in your old phonograph and connect it to your radio . . . Then you can have the music you want when you want it, without even bothering to wind a spring. Phone us, we'll be glad to tell you more about it.

YOUR IMPRINT HERE
Street Address Phone Number
City and State or Slogan here



Your Radio Can Take It

It takes all the noise and interference and passes them on to you unless it is equipped with a scientific antenna system. For short-wave reception especially, you must have an efficient antenna. We specialize in antenna installations and recommend the noise-reducing RCA World-Wide Antenna System . . . a remarkable "double-doublet" system that reduces noise and brings in stations you never got before. Let us make a *Certified Installation* . . . Phone us today.

YOUR IMPRINT HERE
Street Address Phone Number
City and State or Slogan here

(Courtesy RCA Radiotron Co.)

FIG. 32-18.—(Left): A direct-mail card that promotes the sale of electric phonograph motors and pickups.

(Right): A direct-mail piece that promotes the sale of noise-reducing antenna installations—especially for short-wave reception.

a good idea some time to get out a simple post-card with a rough map drawn on the stencil to show the exact location of your shop, such as the specimen illustrated in Fig. 32-19. This one even shows the sign that the customer will find hanging outside of the door of the shop when he reaches it.

- (17) Illustrated in Figs. 32-20 and 32-21 you will find two direct-mail pieces advertising tubes and service. Another good piece (one side of which is shown in Fig. 32-22) is a folder



Courtesy Elliott Addressing

Fig. 32-19. — A direct-mail card that is especially appropriate for a new service shop. It tells the prospect exactly where the shop is, and even illustrates the sign which will be found outside the door.

supplied by the Hygrade Sylvania Corp. to its dealers. It has particular merit in that it explains and illustrates servicing procedure in a way that is pretty sure to interest the average prospect. The copy reads as follows:

"NOISE — FADING — TONE — DISTANCE — BLARE — INTERFERENCE — CRACKLING — WE CAN SPOT WHAT'S WRONG WITH YOUR RADIO AND FIX IT — PROMPTLY — REASONABLY! . . . IT MIGHT BE ONLY WIRING. Radio receivers—well made as they are—develop loose wires, corrosion, are subject to maladjustments due to long use, abuse and natural deterioration of parts. When your reception is off-color our expert service men will make repairs thoroughly, promptly, reasonably. SOMETIMES THE SPEAKER CRACKLES AND BUZZES. Room temperatures, vibration and wear all can affect the accuracy and quality of the modern speaker. Adjustment is usually a simple job for us—because we know how. MOST LIKELY ITS TUBES. Most radio noises are blamed on the receiver or local interference and static, when in reality it is worn out tubes giving you a warning you failed to understand. Don't let a few weak or worn out tubes spoil your radio enjoyment. We will gladly test your tubes at any time and demonstrate why Sylvania tubes—tested for a set like yours—will give your radio new life. And they cost so little. WHATEVER YOUR TROUBLE. Whether your radio needs circuit checking, speaker adjustment or one or more new tubes—whatever your trouble, you will find our service prompt and reasonable. Your inquiry puts you under no obligation. 'Change your Spark Plugs every 10,000 Miles,' 'See your Dentist Twice a Year,'—and let us CHECK YOUR RADIO IF ONLY ON SUSPICION. MAKE OUR SERVICE DEPARTMENT YOUR RADIO HEADQUARTERS. We lay special emphasis on our personnel of trained radiotricians, complete testing equipment, stocks of tubes and small parts for prompt service in the home. Although our service call may

be short and the charge correspondingly small, we know you will not forget us when complete overhauling or perhaps a new radio is needed. And you will appreciate the businesslike and courteous manner with which our experts go about their work—and do the job well. BRING YOUR RADIO TUBES IN FOR FREE TEST—or call us for house service any time you need anything in radio."

32-9. Other Forms of Advertising and Merchandising.—

The value of newspaper advertising for the radio service business is always a matter of dispute. In some cases it pays out very well; in others it is a total loss so far as tangible results are concerned. The only way you will know its value in your own business is to test it out; nor can you expect to make a fair test with less than six insertions. Check the response as



"LIT"
—And That's About All!

Just because a tube still lights is no sign that it is operating satisfactorily. It may be all but "out" on its feet and yet continue to give off that deceptive glimmer. Don't take chances with worn-out tubes. Have them tested. We test them FREE.

We Recommend
RCA Radiotrons



Too Old to Fight?

Radio tubes more than a year old should be placed on the retired list. They've done all that's expected of them. If you can't remember their age, bring them in and we'll test them free. Our modern tester tells the truth about tube condition—in terms anyone can understand.

We Recommend
RCA Radiotrons

(Courtesy RCA Radiotron Co.)

FIG. 32-20.—Two interesting direct-mail pieces which dramatize the fact that tubes wear out and should be tested periodically.

well as you can—ask the people who come into your store whether they have been noticing your advertising.

The advantages of newspaper advertising are that it reaches a large audience at a relatively low cost per reader and gives you a good tie-up with your other advertising mediums. The disadvantages are that it is a non-selective audience (you have no way of picking your prospects), that you need constant repetition of your message in order to make any impression—and, in the case of large metropolitan newspapers, you also need large space.

For the average service shop, large-space display advertising is generally inadvisable, except when there is some outstanding special item to offer. You can get the assistance of the newspaper in laying out your advertisement and in obtaining the art

work necessary to give it the right appeal. Or you may prefer to use "mats" supplied free by manufacturers or purchased from

SURE - RADIO TUBES Get Sick!
ALMOST EVERY TIME IN THE REASON YOUR RADIO GIVES POOR RESULTS IS BECAUSE OF CRACKS OR WORN-OUT TUBES. TRY YOU MIGHT NOT BE AWARE OF THE FACT AT ALL, THE TUBES ARE THE VERY HEART OF ANY SET. WE TEST TUBES, FREE, AND JUST NOW YOU CAN GET ALL OF THE FAMOUS WIDELY ADVERTISED TUBES, AT APPRECIABLY REDUCED PRICES. TELEPHONE OR CALL

RUSSELL'S RADIO SERVICE
671 LEXINGTON AVE. AT 51st ST. NEW YORK CITY
PHONE-BROOKLYN 5-2197

FIG. 32-21.— Another direct-mail piece which dramatizes tube weakness and advertises free tube tests. Literature of this kind awakens the radio set owner to the realization that his tubes may need testing and replacement.

(Courtesy Elliott Addressing Machine Co.)

a commercial "mat service". Some of the manufacturers' mats do a real job of promoting the interest of the service man. The one

and Fix it—PROMPTLY·REASONABLY!

It might be only WIRING

Radio receivers—well made as they are—develop loose wires, corrosion, are subject to maladjustments due to jarring use, abuse and natural deterioration of parts. When your reception is off-color our expert service men will make repairs thoroughly, promptly, reasonably.

Sometimes the SPEAKER Cracks and Buzzes

Room temperatures, vibration and wear all can affect the accuracy and quality of the modern speaker. Adjustment is usually a simple job for us—because we know how.

Most likely it's TUBES

Most radio noises are blamed on the receiver or local interference and static, when in reality it is worn out radio tubes giving you a warning you fail to understand. Don't let the few weak or worn out tubes spoil your radio enjoyment. We will gladly test your tubes at any time and demonstrate why Sylvania tubes—tested for a set like yours—will give your radio new life. And they cost so little.

Whatever your TROUBLE

Whether your radio needs circuit checking, speaker adjustment or one or more new tubes—whatever your trouble you will find our service prompt and reasonable. Your inquiry puts you under no obligation.

"Change your Spark Plugs every 10,000 Miles"
"See your Dentist Twice a Year"
—and let us
CHECK YOUR RADIO
IF ONLY ON SUSPICION

(Courtesy Hygrad, Sylvania Corp.)

FIG. 32-22.—A folder that dramatizes radio servicing procedure in a way that is very likely to interest the average non-technical prospect.

which is illustrated in Fig. 32-23 is an example. (A *mat*, or *matrice*, is a piece of special composition cardboard in which an

impression from type has been made. The newspapers make an electrotype direct from this mat, inserting your name and address at the proper place in it.

Small-space display advertisements are more practical, provided they are used frequently enough. Star Radio Company of Washington, D. C., insert a simple one-inch single-column advertisement (see Fig. 32-24) every day in the year and get good results from it. On the \$1. call advertised they furnish minor repairs, testing of antenna, ground, speaker, chassis, connections, tubes, general analysis and free dial lights. This is not very profitable in itself but it leads to good future business. An even better "card" to use regularly in the newspapers would be one which advertised some house specialty, stating specifically the service rendered, and used purely as a "come-on".

A similar card, consistently used, often produces good results in the classified section of the newspaper, listed under "Radio Service". The same principle applies to card advertising in your local classified telephone directory.

Advertising on the programs of local radio stations is an opportunity that far too few service men take advantage of. There could be no better time to approach your prospects for business than when they are actually listening to a broadcast on their own radio set which may be giving them poor performance, and, furthermore, you can be sure that everyone who is listening is a real prospect either for the present or the future. The most practical way to use radio advertising is through "spot announcements", that is, commercial announcements one or two minutes



You want expert Radio Service!

SET ANALYZER
A scientific mechanism used in modern radio service.

Your radio is a delicate, complex instrument. Only fully equipped professional service experts can fix it right. We're equipped. We have complete data on all make sets. We give a written guarantee on our work, use standard parts and charge fair prices. Call us for the expert radio service . . . quick and efficient.

DEALER'S NAME AND ADDRESS

NOTE: We are cooperating with National Union Radio Corporation, manufacturers of professional, guaranteed radio tubes to improve radio service under the Sign of Efficiency

INTELLIGENT RADIO SERVICE IS CHEAPEST!

(Courtesy National Union Radio Corp.)

FIG. 32-23.—A typical part-column ad for insertion in the local newspaper. Mats for such ads are available from manufacturers.

in length. The cost depends on the listening area and power of the station, and may run somewhere between \$5. and \$25. per minute. Consult your local station for rates. "Continuity" for this announcement can be obtained free from your station or from tube manufacturers. There is no reason, however, why you cannot write up your own continuity. If your station will per-



FIG. 32-24.—This simple 1-inch single-column advertisement which has been inserted in the local newspaper every day in the year by one radio service shop has proved to be a worth while business getter.

(Courtesy Radio News and Star Radio Co.)

mit you to do it, a "blind" tagged on to the end of a good broadcast announcement may pull the best results—something like this, for example:

"We wish especially to request all our listeners to let us know if they had good reception during this past program. Please write, addressing —, care of the station."

In small towns, advertising slides in the moving picture theatres have some value. One must always remember, however, that many movie patrons are annoyed and antagonized by this form of advertising which is more or less boring because it is usually overdone. Arrangements for slide showings can often be made on an exchange basis for P-A service work on the theatre's sound equipment, and the slides themselves can be procured free from some tube manufacturers.

If you have a delivery truck, take every advantage of it as an advertising medium. Dress it up to give it the maximum display. By using a little ingenuity you can make it distinctive. Anderson Radio Hospital of Seattle, for example, use a truck (shown in the upper right-hand corner of Fig. 32-25) that very cleverly suggests an ambulance. If you want to try something really sensational, set up a "Service Shop on Wheels", doing all your service work out in the field and carrying all your equip-

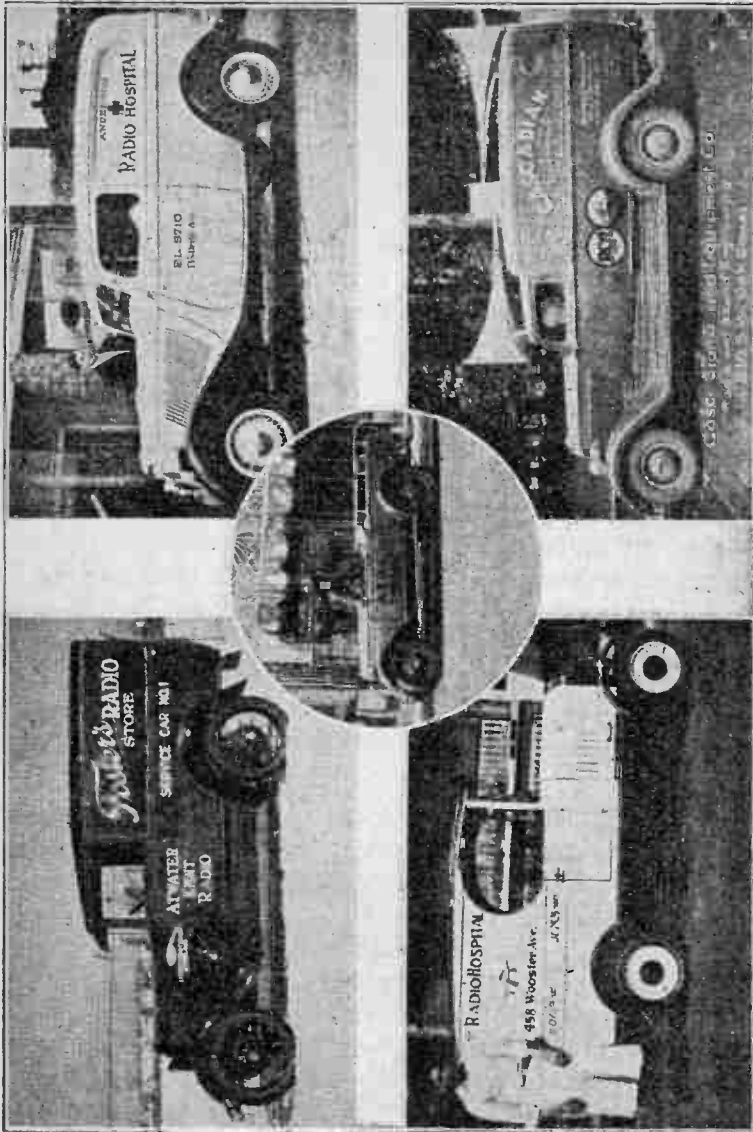

(Courtesy RCA Radio Service News; Foster's Radio Store; Anderson Radio Hospital; Radio Hospital of Akron, Ohio; A-1 Radio Co.; and Cascadian Sound Service).

FIG. 32-25.—Five examples of impressive radio service trucks that give their owners a great deal of worthwhile advertising every day, besides providing transportation for receivers, supplies, etc.

ment in the truck. We have never seen it done, but there ought to be great advertising possibilities in it if it is handled right. By making arrangements with one or more local amateurs you could possibly have phone calls for service made direct to them, relayed on to you by short-wave which you can pick up in your truck. This will give you an exceptionally good opportunity to feature short-wave installations and adjustments.

If you specialize on P-A work, you will of course want to use a sound truck, such as the one shown at the lower right of Fig. 32-25 which is used by Cascadian Sound Equipment Company of Hood River, Oregon, and keep it circulating freely wherever crowds gather, at fairs, airports, parades, municipal events, etc. Of course the lettering on the panels of the truck should be done by an experienced sign painter so that it will look well.

Even your business cards and letterheads should be designed from an advertising standpoint. If possible, illustrate them, and in any case, make them distinctive, but do not make the mistake of trying to say too much on them. This applies especially to card (if you distribute them from door to door), for unless the cards really get attention, they are hardly worth the effort to distribute them. A typical example of a card which can be obtained at small cost is shown in Fig. 32-26. A neat letterhead which carries the same monogram as the card is shown in Fig. 32-27.

Make use of every opportunity you can get to obtain free publicity. Newspapers are often glad to take a story on some unusual prize contest or merchandising stunt. If you do P-A work there are many chances to publicize your installations. Perhaps you can write a Question and Answer column on radio problems in your local newspaper. That would not only give you good publicity, but would give you a little extra income besides.

Keep your eyes open for every opportunity to promote a new merchandising stunt that will appeal to the public. A new twist to a special offer or deal might bring you a lot of business. Or try a prize contest to bolster up a slack season. For example, offer a free radio for the best list of stations received two hundred miles or more distant. Furnish the contestants with free logs and verification cards. You will find that this will not only

create a lot of public interest, but will also stimulate some sales of antenna installations. Or make a feature of premiums and "give-aways". If nothing better is available, use logs. As you

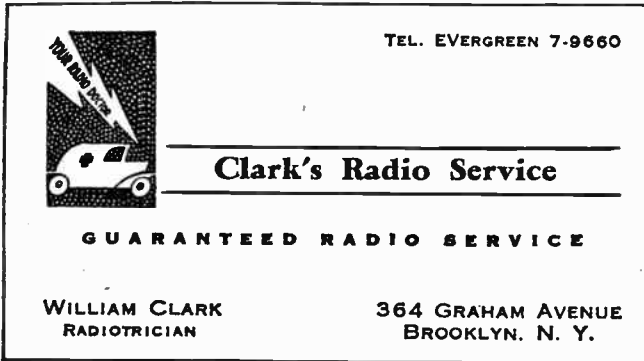

(Courtesy Arcturus Radio Tube Co.)

FIG. 32-26.—A typical example of a small business card which effectively advertises the service business. A card of this kind would tie in well with the Radio Hospital service trucks illustrated in Fig. 32-25.

know, there are elaborate logs in the form of booklets available at small cost from manufacturers. But even a simple station log has some merchandising value. There are many varia-

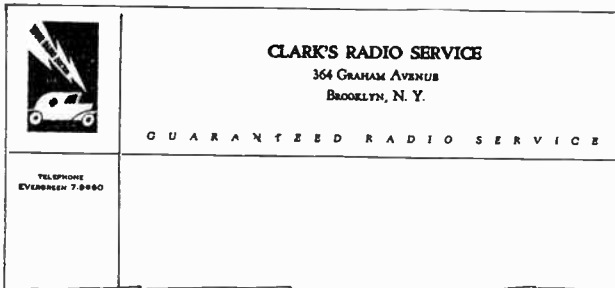

(Courtesy Arcturus Radio Tube Co.)

FIG. 32-27.—An example of a neat letterhead designed to tie in with the business card shown above. It carries the same monogram.

tions in form you can use in making up a log, and of course the more novel, the more interesting to the user. Green Radio of Kalamazoo, Michigan have gotten out and copyrighted an im-

pressive dial log in celluloid (see Fig. 32-28), which is the sort of thing most any radio set owner would like to keep and use. Watch *Radio Retailing*, *Radio News*, and other trade publications for news about novel merchandising ideas—in most cases you can apply them to your own business.

The matter of making the right "contacts" is a very important part of success in business. If you do not sell new sets, by all means make an arrangement with a good non-servicing new-set dealer to do servicing for his customers, and perhaps also to make his deliveries. You can work out your deal on some commission basis or perhaps exchange leads, turning over to him prospects for new sets and electrical equipment. Through clubs,

Fig. 32-28.—A novel dial "log" printed on celluloid—with the name of the service shop at the top. It features both *alphabetic* and *kc* listings of "within range" stations; *N* denotes *NBC* chain stations, *C* denotes *Columbia* network stations. If a program "fades" or comes in noisily on one station, the listener can find out immediately what other stations of the same broadcasting chain he can receive it on.

(Courtesy Mr. A. O. Green)



schools, business groups, etc. you may be able to make many helpful contacts. And don't overlook your own local trade associations.

32-10. Selling Auto-Radio Servicing.—The auto-radio field is still growing and is one of the most lucrative side-lines for service men. It calls for special advertising and merchandising plans. It is well to contact all the garages and auto repair shops in your vicinity and endeavor to secure their cooperation in recommending all prospects for sales of new sets and servicing of old ones to you. Offer them a fair commission for every customer they turn over to you. If they will agree to this, fur-

nish a conspicuous sign for them to display. This might read somewhat as follows:

R A D I O S
Installed and Serviced
in All Makes of Cars
by Auto-Radio Experts

When they get a call for this kind of work, you can either drive right down to the garage yourself, or have the motorist come to your shop. The extra advantages of specializing in auto-radio are that the greatest volume comes in the slack summer season and that it gives you an additional means for making contacts that will lead to home-radio work. Used-car dealers are also good prospects for you, since the resale value of a car is often increased when it has a radio installation. This type of business is profitably handled on a contract basis. The same holds true for taxi fleets.

If you sell new auto-radio sets, you will find it helpful to arrange your different sets on display stands around the store and connect them up for convenient comparison.

Your auto-radio business may justify the expense of getting a special demonstrating truck which you can keep circulating wherever motorists are apt to gather. In any case you can fit up your delivery truck for demonstration purposes on special occasions. If you are located in a suburban town, you can pick up some extra business by parking your demonstration truck at the railroad station late in the afternoon. If you do this, print up some inexpensive "hand-outs" on colored paper and slip them under the windshield-wipers of all cars parked there, offering to make a check-up or free demonstration on the spot.

The best place to reach the motorist with an advertising message is on the highway, so if you can put up some attractive signs in good locations which your *local* motorists pass by frequently, you find that they will serve to impress your name in their memories and bring in new customers.

32-11. Customer Follow-up.—People who have bought

radio service from you are your A-Number 1 prospects for future business. If they fail you, there are two very serious weaknesses in your business—(1) either your service is unsatisfactory; or (2) your follow-up system is inadequate. Assuming that you know how to do a good service job, let us see what follow-up methods are advisable.

First of all, you should not consider your servicing job completed until you have made some kind of check on the set to see if it is working properly and if it is giving good reception. This should be made at the home of the customer within a week after the work is done, and it can be done by phone call, postcard or letter. The purpose of this contact is not only to demonstrate your personal interest to the customer, which is sure to please and flatter him, but also to eliminate any possibility of kick-backs. Here are the contents of a postcard which the Clark Radio Service Company of Granville, Ohio mail out one week after every service call:

Dear Customer:

Since our reputation depends upon the radio satisfaction of our customers, we take this method to check up on the services rendered during the past few days.

Was everything satisfactory and are you pleased with the service?

Any constructive criticism is welcome. We strive to do everything possible to give you the best radio service, and helpful ideas will be appreciated.

CLARK RADIO SERVICE

QRV Radio Service, Inc. of New York send out a letter right after completing a service job. It concludes with this thought:

“May we also mention that, from years of experience with many thousands of radios, we have found *every* radio to require thorough testing and minor adjustments at least every four months, in order to insure continuous satisfactory operation and to avoid expensive repairs which often result from neglect of such regular service.”

This letter opens the way for the regular series of follow-ups which every service man should use, and which unfortunately are so often neglected. The first step in such a system is a "tickler" file. That is, a card file of all your servicing jobs arranged according to the date when the follow-up should be made. Suppose you do a repair job on January 1st. You will at that time decide that July 1st will be the proper date to check on the customer for another inspection. So you will tabulate that customer's card in such a manner that on next July 1st his card will show up automatically. Some system of this kind should be used by every service man, just as it is used by aggressive dentists and optometrists. You should have a series of postcards, letters or phone calls all prepared to use on these customers upon the expiration of the period you have set.

QRV Radio Service have a very fine series of postcards which they send out monthly to their customers four months after a job. They employ humor in these cards by personalizing the radio set. The first one reads as follows:

"Hello, Doc QRY—It has been four months since you were here to see me, and you know it is time to look me over again. My volume control and tube sockets feel dusty, and some of my tubes are a little weak. When are you coming?"

Ten months after the service work has been completed, this card (see Fig. 32-29) goes out:

"Hello, Doc QRV.—Do you suppose my owner doesn't know that I could give much clearer programs if you came and made me well again? I'm pretty sick, and I'm getting worse, but I can't seem to make my owner understand that I need a good doctor."

Both of these cards are designed to catch the attention of the set owner through humor, and to make him conscious of the fact that his radio receiver *may* actually need checking over even though it is apparently operating satisfactorily. Any trouble it may have is likely to develop into a more serious one if neglected.

And the final card in the campaign reads:

"Doc (weakly) it's a whole year since you were here, and now you'd better bring a vacuum cleaner and your entire set of operating tools. I have a high fever and my tubes have pneumonia or something. Perhaps you better bring me an ambulance. I'm very sick. I hope I don't die!"

You can be sure that with a series of cards like these, QRV Radio Service won't lose many customers.

A variation on the straight follow-up method is to adopt a

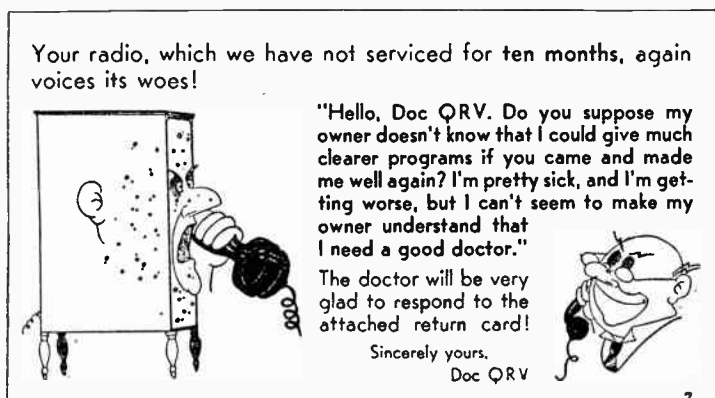

(Courtesy Printer's Ink and QRV Radio Service)

FIG. 32-29.—A good business-getting follow-up card which carries out the idea of "personalizing" the radio set by means of cartoons.

policy of regular "inspections" on all jobs you have done. The first card in a series of this kind might read:

"Dear Mr. Blank:

It is a policy of our firm to give all our customers a periodical inspection of radio sets which we have serviced. According to our records it is time for your set to be examined. Will you please note on the attached card what day and hour will be most convenient for our inspector to call. There is no charge for this service."

32-12. Meeting Specific Objections.—After making a certain number of calls you will invariably find that the sales resistances you meet, or objections offered by the prospect, fall into a few definite classifications. If you analyze these carefully, and have good answers already prepared for a dozen or so general objections, you will be able to batter down the most serious obstacles to the sale of your service.

For example, suppose your prospect says, "All the tubes light." A very good answer to that is contained in the postcard illustrated at the left of Fig. 32-20, which reads:

• "LIT"—"And That's About All! Just because a tube lights is no sign it is operating satisfactorily. It may be all but 'out' on its feet and yet continue to give off that deceptive glimmer. Don't take chances with worn-out tubes. Have them tested. We test them FREE."

Or she may say—"The radio works O.K." You might answer that in some such fashion as this:—"It's just the same with a radio as it is with your teeth. Everyone knows it's wiser to go to a dentist periodically for an examination rather than wait for a toothache and the expensive work that may be involved later. So with a radio—it may seem to be all right, but there may be some trouble developing, not apparent to you, which if not checked by an examination may lead to an expensive repair job or replacement very soon.

There are many answers to the sales resistance offered by cut-price tubes. You can counter by asking: "Do you care what you put into your stomach? Then don't put cheap tubes into a good radio if you want it to stay good." You can point out that cut-price tubes are often factory seconds or thirds. A Mount Vernon, N. Y. dealer has a very good method for cutting short any objections to the price of standard brand tubes. He takes a "second" off his shelf and offers to sell it to the customer for *twelve cents*. In answer to the customer's query as to the low price, he explains it is a "second", that it will work. but how well or for how long no one knows. If it's cheap mail-order tubes you're up against, often a comparison of readings of the plate current changes of the mail-order tubes against those of a stand-

ard brand will show enough difference to convince the customer.

If you have a fixed charge for an examination and run into a lot of competition from *free* examinations, you can meet it by pointing out frankly and fairly what the difference is between the two examinations. The card illustrated in Fig. 32-6 is an excellent example of how this may be done in a way that will really add to your own prestige. The man who makes a free check-up can do only a certain amount of work and still stay in business. You generally have a pretty good idea of what that is and you can point it out to your prospect, at the same time telling him specifically what you do in your examinations and tests and how much more comprehensive they are.

There are of course many more general objections you will meet, and many more answers you can make, but by studying the problem systematically you will soon find there is some way you can overcome practically every sales resistance in your path. Make a conscious effort to learn those ways and you will never be "stumped" for an answer that will be convincing.

32-13. Opportunities for Extra Profits.—Sometimes it's the "extras" that make the difference between *profit* and *loss* in a business. There is such a thing as having too many sidelines, but a few can always be handled without too much trouble. Below is a check-list of some that have been utilized profitably in connection with radio servicing:

- (1) A hook-up with a new-set dealer on an exchange basis, as mentioned previously. On all your servicing calls you will have a good opportunity to secure leads for new-set business by recording the age and condition of the set on your customers' file card.
- (2) Auto-radio installations and servicing. Also testing and servicing auto batteries.
- (3) Installation of antenna systems for better reception and noise reduction. Converters for short-wave sets.
- (4) Additional loud speakers in the home. Remote-control business.
- (5) Remounting the receiver chassis in a new cabinet or in the wall to improve the decorative scheme of the house.
- (6) Modernizing old receivers or installing a new chassis.

- (7) *P-A* business, not only for commercial purposes, but also in the home, as for nurseries, kitchens and maids' rooms.
- (8) Electrical household appliances—selling, servicing, or both. (Refrigerators, washers, ironers, vacuum cleaners, ranges, wiring, etc.) When you are making radio service calls or set inspections, you have an excellent chance to find out (through observation or questioning) what electrical equipment is in the house and what condition it is in. You can either make direct use of this information or sell the tips to someone in the business. Here is a sales letter used by the Radio Service Company of Hammond, La., in soliciting refrigerator servicing:

My dear Mr.—:

Do you realize that your refrigerator has been working away for you day and night for a longer period of time than you would expect of almost any other modern convenience—from your radio to your auto? And with warm weather definitely upon us an even greater burden will be placed on the machine for months to come. Would it not be worth while to have your refrigerator checked over NOW—for a few cents—and prevent a failure when you need it most—and which might very well run into considerable money?

Perhaps you have noticed that, of late, it requires more frequent defrosting? Or is noisy? Or runs much more constantly than it did when first purchased? Has your cream soured, by any chance, for the first time since you have had the refrigerator? Are your electric light bills unusually high?

All these things are symptomatic of troubles which can be quickly and easily eliminated, without interruption of service, and the savings actually effected in lowered electrical consumption will probably more than cover the cost of service.

Our charges for inspection and adjustment are nominal; and where actual repairs are required the cost will be the lowest consistent with reliable work by refrigeration experts.

Yours Sincerely—

See also the advertising pieces illustrated in Figures 32-16 and 32-17.

- (9) Installation of phonograph pickups, adapters and automatic record changers in existing receivers.
- (10) In connection with the above—phonograph records, etc.
- (11) Servicing of sound equipment for local motion picture theatres. This may be carried out on a contract basis.

(12) "Electric Eye" installations. There are, of course, innumerable commercial and industrial applications of the photoelectric cell that call for expert knowledge, but among the simpler installations that many radio service men can handle are those for burglar alarms, garage-door opening, and advertising novelties in store windows.

(13) Marine radio.

Much of this servicing business can be done on a contract basis, which, even if it amounts to only \$5. to \$10. a year per job will, in volume, serve as a mighty good backlog to stabilize your business.

32-14. Business Methods.—While you need to be a good business man in order to run a service business successfully, plain common sense will tell you most all you need to know about the routine of things. It is important to standardize your charges and make them fair in order to gain the respect and confidence of your customers. Of course before you can do that properly you must know what your actual costs are—and those include not only parts and labor, but overhead and selling expense as well.

It is also important to determine upon a fixed policy that you will follow religiously. There is no one policy that will apply equally well to all service men. You will have to choose your own. Here are two good declarations of policy, even though they express different points of view. Robertson's Radio Service, of Long Beach, California, print this on their cards:

"1. Free Inspection. 2. No Labor Charge over \$1.00. 3. Work and Parts Guaranteed 6 Months. 4. Your Credit is Good."

Mr. Ralph E. Loomis, of Tillamook, Oregon, states his policy as follows:

"A 75-cent service call; sets checked and repairs estimated free if the set is brought to the shop; a charge of one dollar per hour for labor; all parts and tubes at list prices; a liberal guarantee; repair or merchandise, cash or thirty days. 10 per cent discount to amateurs and dealers for whom I make repairs. Shop hours from 8 a.m. till 6 p.m. Calls made at any time, any place. Mileage charged for on special out-of-town calls."

You will notice that in both cases a guarantee has place in the

policy—and that is something that all service men should be able to adopt.

32-15. How to Keep Service Records.—In conducting a successful radio service business, a most important consideration is that of keeping service records. This is important not only from a standpoint of regularity of business (which is self-evident) but that of efficiency, as well as establishing a means of com-

| S. N. _____ | | | | | | | | | | | | |
|--|----------------------------------|----------------------------|--|-------------|-------|-------|-------|-------|-------|--|------------------------------|-------------------------|
| Installation - Duplicate of Send Order No. _____ | | | | | | | | | | | | |
| Manager's O. K. | DAVEGA - CITY RADIO, Inc. | No. _____ | | | | | | | | | | |
| <input type="text"/> | STORE | Date _____ 19__ | | | | | | | | | | |
| Name _____ | <input type="text"/> | When No. _____ | | | | | | | | | | |
| Address _____ | | | | | | | | | | | | |
| Avt. No. _____ Phone _____ City _____ | | | | | | | | | | | | |
| Deliver _____ | | Install _____ | | | | | | | | | | |
| CHAR. # No. _____ | Salesman _____ | T-C _____ | | | | | | | | | | |
| S-t (Inc. Cabinet) | Serial No. | Total Time Price | | | | | | | | | | |
| Tubes (State Make) | | T. A. | | | | | | | | | | |
| Radio Accessories | | Balance | | | | | | | | | | |
| Refrigerator | | Payment on | | | | | | | | | | |
| Refrigerator | | Signing Contract | | | | | | | | | | |
| Accessories | | Amount Payable | | | | | | | | | | |
| Miscellaneous | | on Delivery | | | | | | | | | | |
| Credit No. | | Balance at Time | | | | | | | | | | |
| | | Instal. | | | | | | | | | | |
| | | Fin. Chge. | | | | | | | | | | |
| | | Total on | | | | | | | | | | |
| | | Installments | | | | | | | | | | |
| <table border="1"> <tr> <th colspan="2">FIGURE-UP</th> </tr> <tr> <td>Description</td> <td>_____</td> </tr> <tr> <td>_____</td> <td>_____</td> </tr> <tr> <td>_____</td> <td>_____</td> </tr> </table> | | FIGURE-UP | | Description | _____ | _____ | _____ | _____ | _____ | <table border="1"> <tr> <td>Payable on Delivery \$ _____</td> </tr> <tr> <td>Date _____ Driver _____</td> </tr> </table> | Payable on Delivery \$ _____ | Date _____ Driver _____ |
| FIGURE-UP | | | | | | | | | | | | |
| Description | _____ | | | | | | | | | | | |
| _____ | _____ | | | | | | | | | | | |
| _____ | _____ | | | | | | | | | | | |
| Payable on Delivery \$ _____ | | | | | | | | | | | | |
| Date _____ Driver _____ | | | | | | | | | | | | |
| RECEIPT | | | | | | | | | | | | |
| The above was received and installed to my satisfaction. | | | | | | | | | | | | |
| Date _____ | Signed _____ | Customer's Signature _____ | | | | | | | | | | |
| Installed by _____ | | | | | | | | | | | | |

(Courtesy Davega-City Radio Co.)

FIG. 32-30.—Facsimile reproduction of the front of the "Send Order" sheet which is made out upon the sale of every radio receiver by one large radio sales-service organization. The rear of this sheet is shown in Fig. 32-31.

putting "past" and possibly "future" service costs and following up customers. There can be no doubt that the *continued* success of a service organization is largely dependent upon the method and type of service records it maintains. This statement may be illustrated by describing the working structure of an exceptionally progressive and successful sales and service organization which has developed a system for keeping accurate service records.

This department is maintained by a leading radio retail company which operates a chain of retail stores. Upon the sale of a radio receiver, a "send order" is made out in triplicate and dispatched to the warehouse. One copy of the "send order" is kept for warehouse records after the receiver is delivered. The second is left with the customer. The third copy is given to the service department. The front and rear of this "send order"

| INSTALLER'S REPORT | |
|---|-------|
| Date | 198 |
| TO INSTALLER: | |
| In what condition did you find the following merchandise? | |
| Cabinet | |
| Chassis | |
| Speaker | |
| Tubes | |
| How was set packed? | |
| Did you record the Serial Number? | |
| Did you instruct the customer how to operate the set? | |
| Time of arrival | |
| Time of departure | |
| Was aerial kit used? | |
| Type of aerial installed | |
| Serviceman | |

FIG. 32-31.—Facsimile reproduction of the rear of the "Send Order" sheet illustrated in Fig. 32-30. Notice the installation data which the service man who installs the set is required to fill in. This provides a permanent record of the installation, and it is filed away so that it may be referred to in the shop at any time in the future.

(Courtesy Davega-City Radio Co.)

are shown in Figs. 32-30 and 32-31 respectively. Each installation sheet is stamped with a service number, and a folder is prepared with the same number immediately. Installations are usually made the day after delivery. This is done so that the customer may have ample opportunity to decide upon a definite location for the receiver and to avoid the possible appearance of the installer on the site before actual delivery is made. Of course, in the case of a small radio establishment, the latter is highly improbable, since installation is generally made upon delivery.

The installer furnishes the customer with the standard guarantee of the company (unless some special guarantee has been given) and a service card containing the telephone number of

the service department, the customer's service number, and certain definite instructions as to the proper manner of securing the speediest possible service. The installation sheet or "ticket", after being returned to the service department by the installer, is then placed into the folder bearing the customer's service number, and filed numerically after the date of installation has been stamped upon the outside of the folder. The name and address of the customer, as well as the date of purchase, store purchased from, and the mode of purchase, whether for cash or on account, is also noted upon the folder. At the same time, an index card is filled out with the customer's name and address, etc., with the address on top, and filed according to the address, so that the service number of any customer may readily be found.

When service becomes necessary, or is desired, the customer calls the given telephone number, and the "call" is received by one of a group operating a telephone switchboard. The service number, name, address, telephone number if any, apartment number, type of receiver, date and store of purchase, and the complaint of the customer is requested by the operator. An appointment is made (usually for the following day) for the service man to call, unless a later date is requested. All

| | | | | |
|--|-------------|---|----------|-------------------|
| Davega-City Radio, Inc. | | | | Service No. |
| SERVICE DEPT. | | | | STORE |
| CHECK <input type="checkbox"/> T <input type="checkbox"/> C | | Appointment 90° To Salesmen—Do Not Specify Time of Day | | 183 |
| NAME | | | | |
| ADDRESS | | | | |
| Apt. | | Tel. | | City |
| Set | | Serial No. | | |
| Date of Sale | | Call Rec'd By | | From |
| Previous Address | | | | |
| COMPLAINT | | | | |
| Do Not Write in Space Below | | | | |
| Insp. O. K. | Entry Stamp | Amount Collected | Analysis | Line No. |
| Disposition of This Call Depends Upon Where Checked | | | | |
| SERVICE CHARGE if Antenna or tube trouble | | | | |
| No free tube replacements if over 6 months | | | | |
| SERVICE CHARGE if unwaranteed | | | | |
| SERVICE CHARGE | | | | |
| All defective parts must be returned to Stock Room if you call new tubes, leave the old ones with the customer | | | | |
| RECEIPT No. | | BROUGHT TO SHOP | | RETURNED TO CUST. |
| C.O.D. | | Serviceman | | Serviceman |
| | | Clerk | | Clerk |

(Courtesy Davega-City Radio Co.)

FIG. 32-32.—Facsimile reproduction of the front of the "Service Report" form sheet which the service man fills out for every service job. The rear of this sheet is shown in Fig. 32-33.

this information is filled in on a "Service Report" form sheet, a sample of which is shown in Fig. 32-32.

All service requests are checked back against the filed records to determine whether the receiver is still within the service guarantee period. The folders are withdrawn from the files and

| SERVICE REPORT | |
|---|--|
| Date | FILL OUT COMPLETELY |
| CUSTOMER'S 1. | |
| COMPLAINT: 2. | |
| 3. | |
| 4. | |
| What I found and did: | |
| REMARKS: | |
| IF NOISE COMPLAINT Fill out the following: | |
| Internal? | External Source |
| Is Ant. O. K.? Length? | Did you lengthen it? |
| Did rest. go to a neighbor with you? | |
| How did the following stations come in? (O.K., Fair, Noisy) | |
| WMCA WIP WEAF WOR WJZ | |
| WABC WENY WOY WINS WEVD | |
| REMARKS: | |
| IF FADING COMPLAINT Fill out the following: | |
| Did you hear set fade? | Gradual or abrupt |
| Tube O.K.? | Ant. and wiring O.K.? |
| What was the cause and remedy | |
| REMARKS: | |
| If not at home — what is neighbor's or | |
| Sup't's name | FOR THE CUSTOMER |
| Time of Arrival | Demand a receipt for any money paid to |
| Departure | Serviceman |
| Serviceman | Signature for Satisfactory Service |
| | X |

(Courtesy Davega-City Radio Co.)

FIG. 32-33.—Rear of the "Service Report" sheet shown in Fig. 32-32. The complete service record is filled in on this side by the service man.

of those customers whose receivers are being serviced, without the necessity of handling large cumbersome folders.

After the "service calls" have been routed, those calls assigned to each service man are listed on separate Daily Work Sheets (see Fig. 32-34) small checks being made regarding the disposition of the call (whether an *installation*, *service call* or *delivery*) and a duplicate furnished to the service man so that

placed into a separate compartment, after the date of service (the following day) has been stamped upon the outside of the folder. All service requests for the following day are routed at night and assigned to the different service men on the service staff, who report to the service department each morning. At the same time, small cards bearing the customer's name and address, and the name of the service man assigned to make this call are placed in a file box, so that the name of the service man assigned to the job may be quickly and readily determined, as well as having in convenient form, the names and addresses

the time of arrival and departure, C.O.D.'s if any, and a concise report of the job may be entered. This *duplicate* work sheet is turned in with the service calls of the preceding day when the service man reports each morning.

Upon arrival at the customer's home, although the service request form may contain a specific complaint, the service man makes the proper inquiries, (these have been discussed in Chapter XVIII, Article 18-2), concerning the faulty operation or inoperation of the receiver in an effort to correctly diagnose or trace the cause for such operation or inoperation. Experience

| SERVICEMAN'S DAILY WORK RECORD | | | | | | |
|---|---------|---------|----------------------|----------|--------------------|------|
| DATE _____ | | | SERVICE MAN _____ | | | |
| CUSTOMER'S NAME | ADDRESS | TIME OF | | C. O. D. | REPORT | E.P. |
| | | ARRIVAL | DEPARTURE | | | |
| | | | | | | |
| | | | | | | |
| | | | | | | |
| | | | | | | |
| | | | | | | |
| | | | | | | |
| | | | | | | |
| | | | | | | |
| TIME LAST JOB FINISHED _____ DATE _____ | | | TOTAL C.O.D.'S _____ | | TOTAL E.P.'S _____ | |

(Courtesy Davega-City Radio Co.)

FIG. 32-34.—“Serviceman's Daily Work Record” sheet on which the daily service calls assigned to each service man are listed for his guidance and for future record.

has proved that these preliminary questions are of prime importance, and in a great many cases they not only aid in locating trouble but cut the actual time required for the service work.

A complete detailed report of the trouble found, and work done, must be made for each service call by the service man. Space is provided for this report on the back of the service form sheet (as shown in Fig. 32-33), in addition to the customer's definite complaint. In the event that some replacement component part not at hand, is needed, or additional work is to be performed, it is so stated. No promises to return at a definite time are made by the service man unless sanctioned by the ser-

vice department and after it has first been determined that the required part is in stock. The reasons for this rule are obvious.

Where the receiver cannot be conveniently repaired at the home of the customer for some reason, the entire chassis, tubes *and* reproducer, are returned to the service department the following morning and checked in with the receiving clerk. The receiving ticket is attached to the service call, the service man turning in a duplicate receiving ticket in place of his original service call. Here, the "inside" service men who are directed by a shop foreman, make all necessary repairs upon the receiver. A complete detailed report and the time expended must also be made for each job by the individual shop men. This report is placed upon the receiving ticket for file record purposes and upon his own Daily Work Sheet. When receivers are returned or "repeat" calls are made with required material, a card is mailed to the customer, stating the date for such return.

When the service reports are turned in each morning, a "Checker" reads each report carefully and makes the proper disposition in each case. If the call is completed, it is filed away in the customer's folder. Should material be needed, a requisition for such material is forwarded to the stock room so that the required merchandise may be "laid out", or placed on order. If the material is at hand, the requisition is then attached to the service call, which is re-routed for the date promised. The service man obtains the necessary part by presenting the requisition at the stock room.

At the close of the guarantee period, the customer's folder is removed from the "guarantee" files and placed in the O.O.S. (Out Of Service) file. Should customers request service after this period, a service charge is made, plus the cost of material furnished. A separate department and group of service men, who are called "paycall men", are maintained for all O.O.S. service calls. This special department also renders service to owners of radio receivers which were not originally purchased from the company. The records of completed "pay calls" are suitably filed for future reference.

The advantages derived from accurate, well-kept service records are manifold. As an example, let us take the case of

Mr. Smith who requested service on a Stromberg Carlson model 64 receiver which had become inoperative. A service call was filled out, checked, and the customer's folder stamped with the date of service by the checker. About a week later, the Checker found another service request on file. The complaint again was "inoperative". From the customer's folder, it was seen that service had been rendered a few days previously, by reason of the date on the outside of the folder. Since it was possible that some different trouble had arisen, the call was checked through. However, a third request for service was made within a few days. The Checker examined the two previous service reports and discovered that, in both instances, the line fuse had been replaced and nothing more. Acting upon the plausible theory that two fuses would not burn out "of their own accord", and that some receiver failure was the cause, the checker made a notation on the service call to this effect. The next service man who covered the call, having this information to "work on", found the temporary breakdown of the first filter condenser (a 1.3 mfd. unit within the second audio transformer block) to be the reason for fuse failures. This example is cited solely to show the value of maintaining service records in view of furnishing more efficient service. Again, by counting the number of calls and adding the time spent on each call, a good idea of the cost of service may be determined in the least possible time, without external references.

32-16. Conclusion.—Here is a little formula you can use with sure success on any problem you meet in your business. It has three parts: 1. The *Objective*; 2. The *Resistances*; 3. The *Plan of Action*. Your Objective is undoubtedly to make a success in the radio servicing business. The Resistances in the way of attaining this Objective are the various obstacles that stand in the way of your making sales. The Plan of Action is what you formulate to overcome those Resistances and attain your Objective. Sounds simple—and it really is, when you attack every problem in this systematic way. Try it out and you'll see that it actually works.

But you can't stop with just a *plan of action*. Just "thinking" about action isn't action after all. You've got to *follow the*

plan into action—and that means *activity*. In a recent editorial in the *RCA Radio Service News* there was a piece of excellent advice which is good food for any service man's thought. Here it is:

"He also serves who only sits and waits—but in most cases he doesn't serve enough customers to spend his waiting time figuring out how to invest his surplus income. It is time for radio service men to stop sitting and waiting. In justice to ourselves and to the public, we must tell the public what it needs—what we have to offer."

And of course there's a right way and a wrong way to tell and sell the public. Bull-headed, unscrupulous, high-pressure aggressiveness may make a few sales, but it will lose more than it makes. If you can succeed in making your prospects like you—through sheer friendliness, self-confidence and a spirit of giving—then you won't find much difficulty in turning them into steady customers whose satisfaction in you will pyramid your business through repeat calls and recommendations to their friends.

This attitude, plus a desire to make the best of every opportunity, to learn new methods, to use the most up-to-date equipment, can bring about only one result—a balance for you in the bank.

There is just one thing more. Don't ever lose sight of the fact that you are one element in a big industry. Whatever you sell and whenever you sell—*sell radio*—"the cheapest form of entertainment in the world". And be a credit to your profession!

PART 4

APPENDICES A & B

**(RECEIVING TUBE CHARACTERISTICS
& BASING DIAGRAMS)**

RECEIVING TUBE OPERATING CHARACTERISTICS AND BASING CHART*

| Type Number | Similar To | Description | Base Connection | Fila-ment Volts | Fila-ment Amps. | Fila-ment Type | Plate Volts | Screen Volts | Control Grid Volts | Plate Current (MA) | Screen Current (MA) | Amplifi-cation Factor | Mutual Conduc-tance in Micromhos | Power Output in Milliwatts | Lead Resistance in Ohms |
|-------------|------------|-------------------------------|-----------------|-----------------|-----------------|----------------|-------------------------|--------------|--------------------|--------------------|--|-----------------------|----------------------------------|----------------------------|-------------------------|
| | | | 4V Anode | Volts | RMS | 105-130 | Maximum Cathode Current | | Peak D.C. | 100 M. A. 25 M. A. | A. C. & R. F. Starter Aeade Volts 110 Min. | | | | |
| 0A4B | | Cold Cathode Rectifier | | | | | | | | | | | | | NU |
| 023 | — | Full Wave Gaseous Rectifier | 5N | — | — | Cold | 350 | — | — | 75 | — | — | — | — | — |
| 024 | 023 | Full Wave Gaseous Rectifier * | 4R | — | — | Cold | 330 | — | — | 75 | — | — | — | — | NU |
| 024G | | Full Wave Gaseous Rectifier | 4R | — | — | Cold | 350 | — | — | 75 | — | — | — | — | NU |
| 00 | 01A | Triode Detector-Gas | 4D | 5.0 | 0.250 | F(T) | 45 max. | — | 0 | — | — | — | — | — | Replace with NU01A |
| 00A | 40 | Triode Detector-Gas | 4D | 5.0 | 0.250 | F(T) | 45 max. | — | 0 | 1.5 | — | 20 | 656 | — | Replace with NU01A |
| 01 | 01A | Triode Detector-Amplifier | 4D | 5.0 | 0.250 | F(T) | 90 | — | —4.5 | 2.5 | — | 8 | — | — | Replace with NU01A |
| 01A | — | Triode Detector-Amplifier | 4D | 5.0 | 0.250 | F(T) | 135 | — | —4.5 | 2.5 | — | 8 | 725 | — | — |
| 01AA | 01A | Triode Detector-Amplifier | 4D | 5.0 | 0.250 | F(O) | 90 | — | —9.0 | 3.0 | — | 8 | 800 | — | NU |
| 01B | 01A | Triode Detector-Amplifier | 4D | 5.0 | 0.1250 | F(T) | 90 | — | —4.5 | 3.2 | — | 8 | 650 | — | NU |
| 1 | 6Z3-IV | Half Wave Rectifier | 4G | 6.3 | 0.300 | C | 350 max. | — | — | 50 | — | — | — | — | Replace with NU01A |
| KR1 | 6Z3-IV | Half Wave Rectifier | 4G | 6.3 | 0.300 | C | 350 max. | — | — | 50 | — | — | — | — | Replace with NU1V |
| RA: | — | Amplifier | 4Q | 15.0 | 0.350 | C | 90 | — | —4.5 | 4.5 | — | 11 | 1185 | — | Obsolete |
| RE1 | 80 | Full Wave Rectifier | 4C | 5.0 | 2.000 | F(O) | 350 max. | — | — | 125 | — | — | — | — | Replace with NU80 |
| RE2 | 81 | Half Wave Rectifier | 4B | 7.5 | 1.250 | F(O) | 700 max. | — | — | 85 | — | — | — | — | Replace with NU81 |
| 801 | — | Amplifier | 4Q | 15.0 | 0.400 | C | 180 | — | —40.5 | 21 | — | 3 | 1500 | — | Obsolete |
| S02 | 80 | Amplifier | 4D | 7.5 | 1.250 | F(O) | 450 | — | —34 | 5 | — | 3.8 | 2100 | 4600 | 4350 |
| IA1 | — | Current Regulator | 4A | 0.7 | 0.500 | F | — | — | — | — | — | — | — | — | — |
| IA4 | 34-1D5G | Super Control R.F. Amplifier | 4K | 2.0 | 0.060 | F(O) | 180 | 67.5 | —3.0 | 2.3 | 0.70 | 720 | 750 | — | NU |
| IA4P | — | Super Control R.F. Pentode | 4M | 2.0 | 0.060 | F(O) | 180 | 67.5 | —3.0 | 2.3 | 0.8 | 750 | 750 | — | Replace with NU1A4 |
| IA4T | IA4 | Super Control R.F. Tetrode | 4K | 2.0 | 0.060 | F(O) | 130 | 57.5 | —3.0 | 2.3 | 0.7 | 720 | 750 | — | Replace with NU1A4 |
| IA5G | — | Power Output Pentode | 6X | 1.40 | 0.050 | F(O) | 85 | 85 | —4.5 | 3.5 | .70 | — | 800 | 100 | 25,000 |
| IA5GT | IA5G | Power Output Pentode | 6X | 1.4 | 0.050 | F(O) | 85 | 85 | —4.5 | 3.5 | 0.7 | — | 800 | 100 | 25000 |
| IA5GT/G | IA5G | Power Output Pentode | 6X | 1.4 | 0.050 | F(O) | 85 | 85 | —4.5 | 3.5 | 0.70 | — | 800 | 100 | 25000 |
| IA6 | IC6-1D7B | Pentagrid Converter | 8L | 2.0 | 0.060 | F(O) | 180 | 67.5 | —3.0 | 1.2 | 2.6 | — | 275 | — | — |
| IA7G | — | Pentagrid Converter | 7Z | 1.40 | 0.050 | F(O) | 90 | 90 | — | 0 | .60 | .65 | — | 125 | — |
| IA7GT | IA7G | Pentagrid Converter | 7Z | 1.4 | 0.050 | F(O) | 99 | 45 | — | 0 | 0.55 | 0.60 | — | 250 | — |
| IB1 | — | Current Regulator | 4A | 0.7 | 0.360 | F | — | — | — | — | — | — | — | — | NU |
| IB4 | 32-1E5G | Screen Grid R. F. Amplifier | 4K | 2.0 | 0.060 | F(O) | 180 | 67.5 | —3.0 | 1.7 | 0.4 | 780 | 650 | — | NU |

*Reprinted by courtesy the Engineering Dept. National Union Radio Corp.

| | | | | | | | | | | | | | | | | | |
|---------|----------|--------------------------------------|-----|------|-------|------|-----|------|---|-----|------|-----|------|------|-----|-------|-------------------------|
| 1B4P | — | Screen Grid R.F. Pentode | 4M | 2.0 | 0.060 | F(0) | 180 | 67.5 | — | 3.0 | 1.7 | 0.6 | 1000 | 650 | — | — | Replace with NU1B4 |
| 1B4T | 1B4 | Screen Grid R.F. Tetrode† | 4K | 2.0 | 0.060 | F(0) | 180 | 67.5 | — | 3.0 | 1.7 | 0.4 | 780 | 650 | — | — | Replace with NU1B4 |
| 1B5-25B | 1B6G | Duplex Diode Triode | 8M | 2.0 | 0.060 | F(0) | 135 | — | — | 8.0 | 0.8 | — | 20 | 575 | — | — | NU |
| 1B7G | 1A7G | Pentagrid Converter | 7Z | 1.4 | 0.100 | F(0) | 90 | 45 | 0 | 1.3 | 1.3 | — | — | 350 | — | — | NU |
| 1B7GT | 1B7G | Pentagrid Converter | 7Z | 1.4 | 0.100 | F(0) | 90 | 45 | 0 | 1.5 | 1.3 | — | — | 550 | — | — | Replace with NU1B7G |
| 1B63T | — | Diode-Triode-Beam Power Amplifier | 8AW | 1.4 | 0.100 | F(0) | P90 | 90 | — | 0 | 0.15 | — | — | 275 | — | — | 0 |
| 1C1 | — | Current Regulator | 4A | 0.7 | 0.740 | F | — | — | — | — | — | — | — | — | — | — | — |
| 1C5G | — | Power Output Pentode | 6X | 1.40 | .100 | F(0) | 90 | 90 | — | 9.0 | 6.0 | 1.4 | 180 | 1550 | 240 | 8000 | Replace with NU 1C5GT/G |
| 1C5GT | 1C5G | Power Output Pentode | 6X | 1.4 | 0.100 | F(0) | 90 | 90 | — | 9.0 | 6.0 | 1.4 | 180 | 1550 | 240 | 8000 | Replace with NU 1C5GT/G |
| 1C5GT/G | 1C5G | Power Output Pentode | 6X | 1.4 | 0.100 | F(0) | 90 | 90 | — | 9.0 | 6.0 | 1.4 | 180 | 1550 | 240 | 8000 | NU |
| 1C6 | 1A6-1C7G | Pentagrid Converter | 6L | 2.0 | 0.120 | F(0) | 180 | 67.5 | — | 3.0 | 1.3 | 2.0 | — | 300 | — | — | NU |
| 1C7G | 1C6 | Pentagrid Converter* | 7Z | 2.0 | 0.120 | F(0) | 180 | 67.5 | — | 3.0 | 1.5 | 2.0 | — | 325 | — | — | NU |
| 1D2 | — | Current Regulator | 4U | 0.7 | 0.420 | F | — | — | — | — | — | — | — | — | — | — | — |
| 1D8G | 1A4 | Super Control R.F. Amplifier* | 5R | 2.0 | 0.060 | F(0) | 180 | 67.5 | — | 3.0 | 2.3 | 0.7 | 720 | 750 | — | — | Replace with NU1D8GT |
| 1D5GP | — | Super Control R.F. Pentode* | 5Y | 2.0 | 0.060 | F(0) | 180 | 67.5 | — | 3.0 | 2.3 | 0.8 | 750 | 750 | — | — | NU |
| 1D5GT | 1A4 | Super Control R.F. Tetrode* | 5R | 2.0 | 0.060 | F(0) | 180 | 67.5 | — | 3.0 | 2.3 | 0.7 | 720 | 750 | — | — | NU |
| 1D7G | 1A8 | Pentagrid Converter* | 7Z | 2.0 | 0.060 | F(0) | 180 | 67.5 | — | 3.0 | 1.2 | 2.5 | — | 275 | — | — | NU |
| 1D8GT | — | Diode Triode Power Amplifier Pentode | 8AJ | 1.4 | 0.100 | F(0) | 90 | 90 | — | 9.0 | 5.0 | 1.0 | — | 925 | 200 | 12000 | NU |
| 1E1 | — | Current Regulator | 4A | 0.7 | 0.488 | F | — | — | — | — | — | — | — | — | — | — | — |
| 1E2 | — | Current Regulator | 4U | 0.9 | 0.680 | F | — | — | — | — | — | — | — | — | — | — | — |
| 1E4G | — | Triode Voltage Amplifier | 5S | 1.4 | 0.050 | F(0) | 90 | — | — | 3.0 | 1.5 | — | 14 | 825 | — | — | NU |
| 1E5G | 1B4 | Screen Grid R.F. Amplifier* | 5R | 2.0 | 0.060 | F(0) | 180 | 67.5 | — | 8.0 | 1.7 | 0.4 | 780 | 650 | — | — | NU |
| 1E5GP | — | Screen Grid R.F. Pentode* | 5Y | 2.0 | 0.060 | F(0) | 180 | 67.5 | — | 3.0 | 1.7 | 0.6 | 1000 | 650 | — | — | Replace with NU1E5G |
| 1E5GT | 1B4 | Screen Grid R.F. Tetrode* | 5R | 2.0 | 0.060 | F(0) | 180 | 67.5 | — | 8.0 | 1.7 | 0.4 | 780 | 650 | — | — | Replace with NU1E5G |
| 1E7G | 2-1F4 | Double Pentode Power Amplifier * | 8C | 2.0 | 0.240 | F(0) | 135 | 135 | — | 4.5 | 7.5 | 2.1 | 350 | 1600 | — | — | NU |
| 1F1 | — | Current Regulator | 4A | 0.7 | 0.720 | F | — | — | — | — | — | — | — | — | — | — | — |
| 1F4 | 850-1F5G | Output Pentode | 5K | 2.0 | 0.120 | F(0) | 135 | 135 | — | 4.5 | 8.0 | 2.6 | 360 | 1700 | 340 | 16000 | NU |
| 1F5G | 850-1F4 | Output Pentode * | 6X | 2.0 | 0.120 | F(0) | 135 | 135 | — | 4.5 | 8.0 | 2.6 | 360 | 1700 | 340 | 16000 | NU |
| 1F6 | — | Duplex Diode Pentode | 8W | 2.0 | 0.080 | F(0) | 180 | 67.5 | — | 1.5 | 2.0 | 0.8 | 650 | 650 | — | — | NU |
| 1F7B | 1F6 | Duplex Diode Pentode * | 7AD | 2.0 | 0.060 | F(0) | 180 | 67.5 | — | 1.5 | 2.0 | 0.8 | 650 | 650 | — | — | Replace with NU1F7GV |
| 1F7GH | 1F6 | Duplex Diode Pentode | 7AD | 2.0 | 0.060 | F(0) | 180 | 67.5 | — | 1.5 | 2.0 | 0.8 | 650 | 650 | — | — | NU |
| 1F7GV | 1F6 | Duplex Diode Pentode | 7AF | 2.0 | 0.060 | F(0) | 180 | 67.5 | — | 1.5 | 2.0 | 0.6 | 650 | 650 | — | — | NU |
| 1G1 | — | Current Regulator | 4A | 0.7 | 0.420 | F | — | — | — | — | — | — | — | — | — | — | — |
| 1G4G | — | Triode Voltage Amplifier | 5S | 1.4 | 0.050 | F(0) | 90 | — | — | 6.0 | 2.3 | — | 8.8 | 825 | — | — | Replace with NU 1G4GT/G |
| 1G4GT | 1G4G | Triode Voltage Amplifier | 5S | 1.4 | 0.050 | F(0) | 90 | — | — | 6.0 | 2.3 | — | 8.8 | 825 | — | — | Replace with NU 1G4GT/G |
| 1G4GT/G | 1G4G | Triode Voltage Amplifier | 5S | 1.4 | 0.050 | F(0) | 90 | — | — | 6.0 | 2.3 | — | 8.8 | 825 | — | — | NU |

(Cont'd over)

Receiving Tube Operating Characteristics and Basing Diagram Charts

(Cont'd)

| Type Number | Similar To | Description | Base Connection | Fila-ment Volts | Fila-ment Amps. | Fila-ment Type | Plate Volts | Screen Volts | Control Grid Volts | Plate Current (mA) | Screen Current (mA) | Ampli-fication Factor | Mutual Conduc-tance in Micromhos | Power Output in Milliwatts | Load Resistance in Ohms |
|-------------|------------|-----------------------------|-----------------|-----------------|-----------------|----------------|-------------|--------------|--------------------|--------------------|---------------------|-----------------------|----------------------------------|----------------------------|----------------------------------|
| 1G5G | 1F4 | Output Pentode* | 6X | 2.0 | 0.120 | F(O) | 90 | 90 | - 6.0 | 8.5 | 2.7 | 200 | 1500 | 300 | 8500 NU |
| 1G6G | — | Class B Twin Triode | 7AB | 1.4 | 0.100 | F(O) | 90 | — | 0 | 14.0 | — | — | — | — | — Replace with NU 1G6GT/G |
| 1G6GT | 1G6G | Class B Twin Amplifier | 7AB | 1.4 | 0.100 | F(O) | 90 | — | 0 | 14.0 | — | — | — | 675(2) | 12000(2) Replace with NU 1G6GT/G |
| 1G6GT/G | 1G6G | Class B Twin Amplifier | 7AB | 1.4 | 0.100 | F(O) | 90 | — | 0 | 14.0 | — | — | — | 675(2) | 12000(2) NU |
| 1H4G | 30 | Triode Detector-Amplifier | 5S | 2.0 | 0.060 | F(O) | 180 | — | -13.6 | 3.1 | — | 9.3 | 900 | — | — NU |
| 1H5G | — | Diode-Triode | 5Z | 1.40 | .050 | F(O) | 90 | — | 0 | .15 | — | 65 | 275 | — | — NU |
| 1H5GT | 1H5G | Diode Triode | 5Z | 1.4 | 0.050 | F(O) | 90 | — | 0 | 0.15 | — | 65 | 275 | — | — NU |
| 1H6G | 1B3 | Duplex Diode Triode * | 7AA | 2.0 | 0.060 | F(O) | 135 | — | - 3.0 | 0.8 | — | 20 | 575 | — | — NU |
| 1J1 | — | Current Regulator | 4A | 0.7 | 0.620 | — | — | — | — | — | — | — | — | — | — |
| 1J5G | 850 | Power Amplifier Pentode | 6X | 2.0 | 0.120 | F(O) | 135 | 133 | -16.3 | 7.0 | 2 | 100 | 850 | — | — NU |
| 1J6G | 10 | Class B Twin Amplifier | 7AB | 2.0 | 0.240 | F(O) | 135 | — | 0 | 10.0 | — | — | — | 2100(2) | 10000(2) NU |
| 1K1 | — | Current Regulator | 4A | 0.7 | 0.550 | F | — | — | — | — | — | — | — | — | — |
| 1L1 | 1B1 | Current Regulator * | 4T | 0.7 | 0.360 | — | — | — | — | — | — | — | — | — | — |
| 1LA4 | — | Power Output Pentode | 5AD | 1.4 | 0.050 | F(O) | 90 | 90 | - 4.5 | 4.0 | 0.8 | — | 850 | 115 | 25000 NU |
| 1LA6 | — | Frequency Converter | 7AK | 1.4 | 0.050 | F(O) | 90 | 45 | 0 | 0.55 | 0.60 | — | 250 | — | — NU |
| 1LB4 | — | Power Output Pentode | 5AD | 1.4 | 0.050 | F(O) | 90 | 90 | - 8.0 | 5.0 | 1.0 | — | 925 | 200 | 12000 NU |
| 1LB6 | — | Pentagrid Mixer | 8AX | 1.4 | 0.050 | F(O) | 90 | 67.5 | 0 | 0.4 | 2.2 | — | 100 | — | — |
| 1LC5 | — | R. F. Pentode | 7AO | 1.4 | 0.050 | F(O) | 90 | 45 | 0 | 1.15 | 0.20 | — | 775 | — | — NU |
| 1LC6 | — | Pentagrid Converter | 7AK | 1.4 | 0.050 | F(O) | 90 | 35 | 0 | 0.75 | 0.70 | — | 275 | — | — NU |
| 1LD5 | — | Diode-Audio Pentode | 6AX | 1.4 | 0.050 | F(O) | 90 | 45 | 0 | 0.60 | 0.10 | — | 575 | — | — NU |
| 1LE3 | — | General Purpose Triode | 4AA | 1.4 | 0.050 | F(O) | 90 | — | - 3.0 | 1.40 | — | 14.5 | 760 | — | — NU |
| 1LH4 | — | Diode Triode | 5AG | 1.4 | 0.050 | F(O) | 90 | — | 0 | 0.15 | — | 65 | 275 | — | — NU |
| 1LN5 | — | Pentode Voltage Amplifier | 7AU | 1.4 | 0.050 | F(O) | 90 | 90 | 0 | 1.8 | 0.35 | 880 | 800 | — | — NU |
| 1NI | 1E1 | Current Regulator * | 4T | 0.7 | 0.480 | — | — | — | — | — | — | — | — | — | — |
| 1N5G | — | Radio Frequency Pentode | 5Y | 1.40 | 0.050 | F(O) | 90 | 90 | 0 | 1.2 | .3 | 1125 | 750 | — | — NU |
| 1N5GT | 1N5G | R.F. Pentode Amplifier | 5Y | 1.4 | 0.050 | F(O) | 90 | 90 | 0 | 1.2 | 0.3 | — | 750 | — | — NU |
| 1N6G | — | Diode-Power Output Pentode | 7AM | 1.4 | 0.050 | F(O) | 90 | 80 | - 4.5 | 3.1 | 0.6 | — | 800 | 100 | 25000 NU |
| 1N6GT | 1N6G | Diode Power Output Pentode | 7AM | 1.4 | 0.050 | F(O) | 90 | 90 | - 4.5 | 3.1 | 0.6 | — | 800 | 100 | 25000 Replace with NU 1N6G |
| 1P1 | 1G1 | Current Regulator * | 4T | 0.7 | 0.420 | — | — | — | — | — | — | — | — | — | — |
| 1P5U | 1D5GP | R.F. Pentode Amplifier | 5Y | 1.4 | 0.050 | F(O) | 90 | 90 | 0 | 2.3 | 0.7 | 640 | 800 | — | — Replace with NU 1P5GT |
| 1P5GT | 1P5G | H.F. Pentode Amplifier | 5Y | 1.4 | 0.050 | F(O) | 90 | 90 | 0 | 2.3 | 0.7 | 640 | 800 | — | — NU |
| 1Q1 | 1F1 | Current Regulator * | 4T | 0.7 | 0.720 | — | — | — | — | — | — | — | — | — | — |
| 1Q5G | — | Beam Power Output Amplifier | 6AF | 1.4 | 6.100 | F(O) | 90 | 90 | - 4.5 | 9.5 | 1.6 | — | 2100 | 270 | 8000 Replace with NU 1Q5GT/G |
| 1Q5GT | 1Q5G | Beam Power Output Amplifier | 6AF | 1.4 | 0.100 | F(O) | 90 | 90 | - 4.5 | 9.5 | 1.6 | — | 2100 | 270 | 8000 Replace with NU 1Q5GT/G |
| 1Q5GT/G | 1Q5G | Beam Power Output Amplifier | 6AF | 1.4 | 0.100 | F(O) | 90 | 90 | - 4.5 | 9.5 | 1.6 | — | 2100 | 270 | 8000 NU |

| | | | | | | | | | | | | | | | | | | |
|---------|-------|----------------------------------|-----|------|-------|------|-------|---------|--------------|----------|------|-----|-----|-------|------|---------|---------------------|----|
| 1K1G | -- | Current Regulator * | 4T | 0.7 | 0.540 | F | -- | -- | -- | -- | -- | -- | -- | -- | -- | -- | -- | -- |
| 1R5 | -- | Pentagrid Converter | 7AT | 1.4 | 0.050 | F(D) | 90 | 45 | 0 | 0.8 | 1.8 | -- | 250 | -- | -- | NU | | |
| 1B1G | -- | Current Regulator * | 4T | 0.7 | 0.580 | F | -- | -- | -- | -- | -- | -- | -- | -- | -- | -- | -- | -- |
| 1B4 | -- | Power Amplifier Pentode | 7AV | 1.4 | 8.100 | F(O) | 40 | 45 | -- | 4.5 | 8.8 | 0.8 | -- | 1250 | 65 | 8000 | NU | |
| 1B5 | -- | Diode-Pentode | 8AU | 1.4 | 0.050 | F(D) | 45 | 45 | 0 | 1.2 | 0.3 | -- | -- | 825 | -- | -- | NU | |
| 1BA6GT | -- | R. F. Pentode | 8BD | 1.4 | 0.050 | F(O) | 90 | 67.5 | 0 | 2.45 | 0.68 | -- | -- | 970 | -- | -- | NU | |
| 1B86GT | -- | Diode-Pentode | 6BE | 1.4 | 0.050 | F(O) | 90 | 67.5 | 0 | 1.45 | 0.38 | -- | -- | 665 | -- | -- | NU | |
| 1T1G | -- | Current Regulator * | 4T | 0.7 | 0.560 | F | -- | -- | -- | -- | -- | -- | -- | -- | -- | -- | -- | -- |
| 1T4 | -- | Super Control R.F. Amplifier | 6AR | 1.4 | 0.050 | F(O) | 90 | 45 | 0 | 2.0 | 0.85 | -- | -- | 750 | -- | -- | NU | |
| 1T5GT | -- | Beam Power Output Amplifier | 6X | 1.4 | 0.060 | F(O) | 90 | 90 | -- | 6.0 | 6.5 | 1.4 | -- | 1150 | 170 | 14000 | NU | |
| 1U1 | -- | Current Regulator * | 4T | 0.7 | 0.740 | F | -- | -- | -- | -- | -- | -- | -- | -- | -- | -- | -- | -- |
| 1V | 025 | Half Wave Rectifier | 4Q | 0.3 | 0.300 | C | 360 | -- | -- | 50 | -- | -- | -- | -- | -- | -- | NU | |
| 1V1 | -- | Current Regulator | 4A | 0.7 | 0.580 | F | -- | -- | -- | -- | -- | -- | -- | -- | -- | -- | -- | -- |
| 1W1 | -- | Current Regulator | -- | 1.0 | 0.600 | -- | -- | -- | -- | -- | -- | -- | -- | -- | -- | -- | -- | -- |
| 1Y1 | -- | Current Regulator | 4A | 0.7 | 0.540 | F | -- | -- | -- | -- | -- | -- | -- | -- | -- | -- | -- | -- |
| 1Z1 | -- | Current Regulator | 4A | 0.7 | 0.900 | F | -- | -- | -- | -- | -- | -- | -- | -- | -- | -- | -- | -- |
| 2 | -- | Ballast Tube | 4A | 0.8 | 0.300 | F | -- | -- | -- | -- | -- | -- | -- | -- | -- | -- | -- | -- |
| 2A3 | -- | Power Amplifier Triode | 4D | 2.8 | 2.800 | F(O) | 250 | 300 | Push-Pull | -45 | 60 | -- | 4.2 | 5250 | 3500 | 2500 | | |
| | | | | | | | | | | -62 | 40 | -- | -- | 15000 | 3000 | 3000 | NU | |
| 2A3H | 2A3 | Power Amplifier Triode | 4Q | 2.8 | 2.800 | C | 250 | 300 | Push-Pull | -45 | 60 | -- | 4.2 | 8250 | 3500 | 2500 | | |
| | | | | | | | | | | -62 | 40 | -- | -- | 15000 | 3000 | 3000 | Replace with NU2A3 | |
| 2A4G | -- | Thyratron Tube | 8S | 2.60 | 2.500 | F(O) | 200 | -- | -- | -- | 100 | -- | -- | -- | -- | -- | NU | |
| 2A5 | -- | Power Amplifier Pentode | 6B | 2.8 | 1.750 | C | 250 | 250 | -- | -16.8 | 34 | 0.8 | 220 | 2200 | 3000 | 7000 | NU | |
| 2A6 | -- | Duplex Diode Triode | 6G | 2.5 | 0.800 | C | 250 | -- | -- | -2.0 | 0.8 | -- | 100 | 1100 | -- | 100,000 | NU | |
| 2A7 | -- | Pentagrid Converter | 7C | 2.5 | 0.800 | C | 100 | 100 | -- | -5.0 | 3.8 | 2.2 | -- | 820 | -- | -- | | |
| | | | | | | | | | | -1.5 | 1.3 | 2.5 | -- | 350 | -- | -- | NU | |
| 2A7B | 2A7 | Pentagrid Converter with Shield | 7C | 2.5 | 0.800 | C | 100 | 80 | -- | -3.0 | 0.5 | 2.5 | -- | 820 | -- | -- | | |
| | | | | | | | | | | -1.5 | 1.8 | 2.5 | -- | 350 | -- | -- | NU | |
| 2B6 | -- | Power Amplifier Direct Coupled | 7J | 2.5 | 2.250 | C | 250 | 250 | Input Output | -24.8 | 4 | -- | 7.2 | 600 | -- | 8000 | | |
| | | | | | | | | | | + 2.5 | 40 | -- | 18 | 3500 | 4000 | 5000 | | |
| 2B7 | -- | Duplex Diode Pentode | 7D | 2.5 | 0.800 | C | 100 | 100 | -- | -8.0 | 9.0 | 2.3 | 750 | 1125 | -- | -- | | |
| | | | | | | | | | | -8.0 | 5.8 | 1.7 | 285 | 950 | -- | -- | NU | |
| 2B7B | 2B7 | Duplex Diode Pentode with Shield | 7D | 2.5 | 0.800 | C | 100 | 100 | -- | -8.0 | 9.0 | 2.3 | 750 | 1125 | -- | -- | | |
| | | | | | | | | | | -8.0 | 5.8 | 1.7 | 285 | 950 | -- | -- | | |
| 2E5 | -- | Electron Ray Tuning Indicator | 6R | 2.5 | 0.800 | C | 250 | -- | -- | 0 to -8 | -- | -- | -- | -- | -- | -- | NU | |
| 2E8 | -- | Electron Ray Tuning Indicator | 6R | 2.5 | 0.800 | C | 250 | -- | -- | 0 to -22 | -- | -- | -- | -- | -- | -- | NU | |
| 02-026 | 06-27 | Duplex Diode | 5D | 2.5 | 1.750 | C | -- | -- | -- | -- | -- | -- | -- | -- | -- | -- | -- | -- |
| 2V3G | -- | Half Wave Rectifier | 4Y | 2.5 | 8.000 | F(T) | 16500 | Inverse | -- | -- | 2.0 | -- | -- | -- | -- | -- | NU | |
| 2W3 | -- | Half Wave Rectifier | 4X | 2.5 | 1.500 | F(O) | 350 | -- | -- | -- | 55 | -- | -- | -- | -- | -- | NU | |
| 2W3GT | 2W3 | Half Wave Rectifier | 4X | 2.5 | 1.500 | F(D) | 350 | -- | -- | -- | 55 | -- | -- | -- | -- | -- | Replace with NU 2W3 | |
| 2X2/879 | -- | High Voltage Half Wave Rectifier | 4AB | 2.5 | 1.750 | C | 4500 | -- | -- | -- | 7.5 | -- | -- | -- | -- | -- | NU | |

(Cont'd over)

Receiving Tube Operating Characteristics and Basing Diagram Charts

(Cont'd)

| Type Number | Similar To | Description | Base Connection | Fila-ment Volts | Fila-ment Amps. | Fila-ment Type | Plate Volts | Screen Volts | Control Grid Volts | Plate Current (mA) | Screen Current (mA) | Ampli-fication Factor | Mutual Conduc-tance in Micromhos | Power Output in Milliwatts | Load Resistance in Ohms | | |
|-------------|------------|-----------------------------|-----------------|-----------------|-----------------|----------------|--------------|--------------|--------------------|--------------------|---------------------|-----------------------|----------------------------------|----------------------------|-------------------------|-------------------------|-------------------------|
| 2Y2 | — | Half Wave Rectifier | 4B | 2.5 | 1.750 | C | 4400 | — | — | 5.0 | — | — | — | — | — | Replace with NU 2X2/879 | |
| 22Z-G84 | — | Half Wave Rectifier | 4B | 2.5 | 1.500 | F | 350 | — | — | 80 | — | — | — | — | — | | |
| 8 | — | Balast Tube | 4A | 128.0 | 0.308 | F | — | — | — | — | — | — | — | — | — | | |
| 3A8GT | — | Diode-Triode-Pentode | 8AB | 2.8 1.4 | 0.050 0.100 | T90 F(O) | 190 P90 | 90 | — | 6 6 | 0.15 1.2 | — 0.3 | 85 750 | 275 | — | — | NU |
| 3B5GT | — | Beam Power Output Amplifier | 7AP | 2.8 | 0.050 | F(O) | 87.5 | 67.5 | — | 7.0 | 6.7 | 0.5 | — | 1500 | 180 | 5000 | NU |
| 3C5GT | 1C5G | Power Output Pentode | 7AQ | 1.4 2.8 | 0.100 0.050 | F(O) | 90 90 | 90 | — | 9.0 8.0 | 6.0 1.4 | — | 1550 1450 | 240 250 | 8000 10000 | | |
| 3LE4 | 1E4G | Power Amplifier Pentode | 6BA | 2.8 1.4 | 0.050 0.100 | F(O) | 90 | 90 | — | 9.0 | 10.0 | 2.0 | — | 1750 | 325 | 6000 | |
| 3LF4 | — | Beam Power Amplifier | 6BB | 2.8 1.4 | .05 .10 | F | 90 90 | 90 | — | 4.5 4.5 | 8.0 9.5 | 1.0 1.3 | — | 2000 2200 | 0.230 0.270 | 8000 8000 | |
| 3Q4 | — | Power Amplifier Pentode | 7BA | 2.8 | 0.050 | F(O) | 90 | 90 | — | 4.5 | 7.7 | 1.7 | — | 2000 | 240 | 10000 | |
| 3Q5G | 1Q5G | Beam Power Output Amplifier | 7AP | 2.8 1.4 | 0.050 0.100 | F(O) | 90 90 | 90 | — | 4.5 4.5 | 7.5 9.5 | 1.0 1.6 | — | 1800 2100 | 250 270 | 8000 8000 | Replace with NU 3Q5GT/G |
| 3Q5GT | 1Q5G | Beam Power Output Amplifier | 7AP | 1.4 2.8 | 0.100 0.050 | F(O) | 90 90 | 90 | — | 4.5 4.5 | 9.5 7.5 | 1.6 1.0 | — | 2100 1800 | 270 250 | 8000 8000 | Replace with NU 3Q5GT/G |
| 3Q5GT/G | 1Q5G | Beam Power Output Amplifier | 7AP | 1.4 2.8 | 0.100 0.050 | F(O) | 90 90 | 90 | — | 4.5 4.5 | 9.5 7.5 | 1.6 1.0 | — | 2100 1800 | 270 250 | 8000 8000 | NU |
| 3S4 | — | Power Amplifier Pentode | — | 2.8 1.4 | 0.050 0.100 | F(O) | 67.5 67.5 | 67.5 | — | 7.0 7.0 | 6.0 7.2 | 1.2 1.5 | — | 1400 1550 | 160 180 | 5000 5000 | NU |
| 4A6G | — | Class B Twin Amplifier | 8L | 4.0 2.0 | .060 .120 | F(O) | 90 | — | — | 2.0 | 21 | — | — | 1000 | 8000(P-P) | NU | |
| 4 | — | Balast Tube | 4A | 115.0 | 0.300 | F | — | — | — | — | — | — | — | — | — | — | |
| 64-G4S | 88-27 | Duplex Diode | 5D | 2.6 | 1.000 | C | — | — | — | — | — | — | — | — | — | — | |
| 8 | — | Balast Tube | 4A | 115.0 | 0.460 | F | — | — | — | — | — | — | — | — | — | — | |
| KR5 | 6A4 | Power Amplifier Pentode | 5B | 6.3 | 0.300 | F | 135 | 135 | — | 9.0 | 14 | 2.5 | 100 | 1900 | 700 | 9500 | Replace with NU 6A4 |
| 5T4 | 5Z3 | Full Wave Rectifier* | 5T | 5.0 | 2.000 | F(O) | 450 | — | — | 250 | — | — | — | — | — | — | NU |
| 5U4G | 5Z3 | Full Wave Rectifier* | 5T | 5.0 | 2.000 | F(O) | 500 | — | — | 250 | — | — | — | — | — | — | NU |
| 5Y4G | 83V | Full Wave Rectifier * | 5L | 5.0 | 2.000 | C | 400 | — | — | 200 | — | — | — | — | — | — | NU |
| 5W4 | 80 | Full Wave Rectifier * | 5T | 5.0 | 1.500 | F(O) | 350 | — | — | 110 | — | — | — | — | — | — | Replace with NU 5W4GT/G |
| 5W4G | 80 | Full Wave Rectifier | 5T | 5.0 | 1.500 | F(O) | 330 | — | — | 110 | — | — | — | — | — | — | Replace with NU 5W4GT/G |
| 5W4GT | 80 | Full Wave Rectifier | 5T | 5.0 | 1.5 | F(O) | 400 | — | — | 50 | — | — | — | — | — | — | Replace with NU 5W4GT/G |
| 5W4GT/G | 80 | Full Wave Rectifier* | 5T | 5.0 | 1.500 | F(O) | 400 | — | — | 90 | — | — | — | — | — | — | NU |
| 5X3 | — | Full Wave Rectifier | 4C | 5.9 | 2.0 | F(O) | 1275 | — | — | 30 | — | — | — | — | — | — | |
| 5X4G | 5Z3 | Full Wave Rectifier * | 5Q | 5.0 | 3.800 | F(O) | 500 | — | — | 250 | — | — | — | — | — | — | NU |
| 5Y3G | 80 | Full Wave Rectifier * | 5T | 5.0 | 2.000 | F(O) | 400 | — | — | 110 | — | — | — | — | — | — | NU |

| | | | | | | | | | | | | | | | | | | | | |
|-----------|-----------|---------------------------------|-----|-----|-------|------|------------|--------------------|----------------|-------------|------------|-----|------|------|------|-------|------------------------|----------|---------------------------|-------------------------|
| 5Y3GT/G | 80 | Full Wave Rectifier* | ST | 5.0 | 2.000 | F(O) | 350 | — | — | 125 | — | — | — | — | — | — | — | | | |
| 5Y4G | 80 | Full Wave Rectifier * | 5Q | 5.0 | 2.000 | F(O) | 400 | — | — | 110 | — | — | — | — | — | — | NU | | | |
| 5Z3 | — | Full Wave Rectifier | 4C | 5.0 | 3.000 | F(O) | 500 | — | — | 250 | — | — | — | — | — | — | NU | | | |
| 5Z4 | — | Full Wave Rectifier o | 5L | 5.0 | 2.000 | C | 400 | — | — | 125 | — | — | — | — | — | — | Replace with NU5Z4GT/G | | | |
| 5Z4G | 5Z4 | Full Wave Rectifier * | 5L | 5.0 | 2.000 | C | 400 | — | — | 125 | — | — | — | — | — | — | Replace with NU5Z4GT/G | | | |
| 5Z4GT/G | 5Z4 | Full Wave Rectifier* | 5L | 5.0 | 2.000 | C | 350 | — | — | 125 | — | — | — | — | — | — | NU | | | |
| 5Z4MG | 5Z4 | Full Wave Rectifier o | 5L | 5.0 | 2.000 | C | 400 | — | — | 125 | — | — | — | — | — | — | Replace with NU5Z4GT/G | | | |
| 8 | — | Ballast Tube | 4A | 1.0 | 0.005 | F | — | — | — | — | — | — | — | — | — | — | — | | | |
| 8A3 | — | Power Amplifier Triode | 4D | 8.3 | 1.000 | F(O) | 300 | Push-Pull | —45 —82 | 80 40 | — | — | 4.2 | 5250 | 3500 | 2600 | 3000 | NU | | |
| 8A4 | — | Power Amplifier Pentode | 5B | 6.3 | 0.300 | F(O) | 100 | 100 | —12.0 —8.5 | 22 9 | 3.8 1.8 | 100 | 2200 | 1400 | 8000 | 11000 | — | NU | | |
| 8A5G | 8A3 | Power Amplifier Triode* | 6T | 6.3 | 1.000 | C | 250 | — | —45 | 80 | — | — | 4.2 | 5250 | 3750 | 2500 | — | NU | | |
| 8A6 | — | Class B Twin Amplifier | 7B | 6.3 | 0.800 | C | 294 300 | Class A Class B | —6.0 0 | 7 17.5 | — | — | 35 | 3200 | — | — | — | 10000(2) | NU | |
| 8A7 | — | Pentagrid Converter | 7C | 6.3 | 0.300 | C | 260 100 | 100 50 | —3.0 —1.5 | 3.6 1.3 | 2.1 2.5 | — | — | 520 | — | — | — | — | NU | |
| 8A7S | 8A7 | Pentagrid Converter | 7C | 6.3 | 0.300 | C | 250 100 | 100 50 | —3.0 —1.5 | 3.5 1.3 | 2.2 2.5 | — | — | 520 | — | — | — | — | NU | |
| 8A8 | 8A7 | Pentagrid Converter o | 8A | 6.3 | 0.300 | C | 250 100 | 100 50 | —3.0 —1.5 | 3.3 1.2 | 3.2 1.5 | — | — | 500 | — | — | — | — | Replace with NU 8A8GT | |
| 8A8G | 8A7 | Pentagrid Converter * | 8A | 6.3 | 0.300 | C | 250 100 | 100 50 | —3.0 —1.5 | 3.3 1.2 | 3.2 1.5 | — | — | 500 | — | — | — | — | NU | |
| 8A8GT | 8A8G | Pentagrid Converter | 8A | 6.3 | 0.300 | C | 250 | 100 | —3 | 3.3 | 3.2 | — | — | 500 | — | — | — | — | NU | |
| 8A8MG | 8A7 | Pentagrid Converter o | 8A | 6.3 | 0.300 | C | 250 100 | 100 50 | —3.0 —1.5 | 3.3 1.2 | 3.2 1.5 | — | — | 500 | — | — | — | — | Replace with NU 8A8GT | |
| 8A8S | 8A5 | Electron Ray Tuning Indicator | 6R | 6.3 | 0.150 | C | 135 | — | 0 to | —7.5 | — | — | — | — | — | — | — | — | Replace with NU 8A8S/8A5S | |
| 8A8S/8A5S | 8A8S-8A5S | Electron Ray Tuning Indicator | 6R | 6.3 | 0.150 | C | 135 | — | 0 to | —10 | 0.5 | — | — | — | — | — | — | — | NU | |
| 8A8SG | — | Power Amplifier Direct Coupled* | 7W | 6.3 | 0.500 | C | 250 | Input Output | 0 0 | 6 34 | — | — | 72 | 1800 | 3500 | 8000 | — | — | NU | |
| 8A8S/1853 | — | Television Amplifier Pentode | 8N | 6.3 | 0.450 | C | 300 | 200 | —3.0 | 12.5 | 3.2 | — | — | 3500 | 5000 | — | — | — | NU | |
| 8AC5G | — | Dynamic Coupled Amplifier | 6Q | 6.3 | 0.400 | C | 250 | — | +15 | 32 | — | — | 125 | 3400 | 3700 | 7000 | — | — | Replace with NU6AC5GT/G | |
| 8AC5GT | 8AC5G | Dynamic Coupled Amplifier | 6Q | 6.3 | 0.400 | C | 250 | — | +15 | 32 | — | — | 125 | 3400 | 3700 | 7000 | — | — | Replace with NU6AC5GT/G | |
| 8AC5GT/G | 8AC5G | Dynamic Coupled Amplifier | 6Q | 6.3 | 0.400 | C | 250 | — | +15 | 32 | — | — | 125 | 3400 | 3700 | 7000 | — | — | NU | |
| 8AC6G | — | Power Amplifier Direct Coupled* | 7W | 6.3 | 1.100 | C | 180 | Input Output | 0 0 | 7 45 | — | — | 54 | 3000 | 3800 | 4000 | — | — | — | |
| 8AC6GT | — | Power Amplifier Direct Coupled | 7W | 6.3 | 1.100 | C | 180 | Input Output | 0 0 | 7.0 45.0 | — | — | 54 | 3000 | 3600 | 3500 | — | — | — | |
| 8AC7/1852 | — | Television Amplifier Pentode | 8N | 6.3 | 0.450 | C | 300 | 150 | —2.0 | 10.0 | 2.5 | — | — | 8750 | 9000 | — | — | — | NU | |
| 8AD5G | — | High Mu Triode | 6Q | 6.3 | 0.300 | C | 250 | — | —2.0 | 0.8 | — | — | — | 100 | 1500 | — | — | — | — | |
| 8AD8G | — | Tuning Indicator | 7AG | 6.3 | .150 | C | 150 | — | — | 3.0 | — | — | — | — | — | — | — | — | — | NU |
| 8AD7G | — | Triode-Power Amplifier Pentode | 8AY | 6.3 | 0.850 | C(P) | 250 | 250 | —25.0 —16.5 | 4.8 36.0 | — | — | 6 | 825 | — | — | — | — | — | |
| 8AE5G | — | Triode Voltage Amplifier | 6Q | 6.3 | 0.300 | C | 85 | — | —15 | 7.0 | — | — | — | 4.2 | 1200 | — | — | — | — | Replace with NU6AE5GT/G |

(Cont'd over)

Receiving Tube Operating Characteristics and Basing Diagram Charts

(Cont'd)

| Type Number | Similar To | Description | Base Connection | Fila-ment Volts | Fila-ment Amps. | Fila-ment Type | Plate Volts | Screen Volts | Control Grid Volts | Plate Current (MA) | Screen Current (MA) | Amplification Factor | Mutual Conduc-tance in Micromhos | Power Output in Milliwatts | Lead Resistance in Ohms | | |
|-------------|------------|-------------------------------------|-----------------|-----------------|-----------------|----------------|-------------|--------------|--------------------|--------------------|---------------------|----------------------|----------------------------------|----------------------------|-------------------------|-------------------------|---|
| 6AE3QT | 6AE5G | Low Mu Triode | 6Q | 6.3 | 0.300 | C | 85 | — | —15.0 | 7.0 | — | 4.2 | 1200 | — | — | Replace with NU6AE5GT/G | |
| 6AE5GT/G | 6AE5G | Low Mu Triode | 6Q | 6.3 | 0.300 | C | 95 | — | —15 | 7.0 | — | 4.2 | 1200 | — | — | NU | |
| 6AE6G | — | Single Grid-Twin Plate Control Tube | 7AH | 6.3 | .150 | C | 250 | Remote Share | —1.5 | 6.5 | — | 25 | 1000 | — | — | NU | |
| 6AE7GT | — | Combination Driver Triode | 7AX | 6.3 | 0.500 | C | 250 | — | —15.3 | 5.0 | — | 14 | 1500 | — | — | NU | |
| 6AF5G | — | Triode Voltage Amplifier | 6Q | 6.3 | 0.300 | C | 180 | — | —10 | 7.0 | — | 7.4 | 1500 | — | — | NU | |
| 6AF6G | 6AD6G | Tuning Indicator | 7AG | 6.3 | .150 | C | 135 | — | — | 1.5 | — | — | — | — | — | NU | |
| 6AG7 | — | Video Beam Power Amplifier | 8Y | 6.3 | 0.650 | C | 300 | 300 | —10.5 | 25.0 | 6.5 | 770 | 7700 | — | — | — | |
| 6AH5G | 6L6G | Beam Power Amplifier | 6AP | 6.3 | .9 | C | 350 | 250 | —18 | 54 | 2.5 | — | 5200 | 10.8 | 4200 | — | |
| 6AH7GT | — | Double Triode | 8BE | 6.3 | 0.300 | C | 250 | — | —9.0 | 12.0 | — | 16 | 2400 | — | — | — | |
| 6AL6G | 6L6G | Tetrode Power Amplifier | 6AM | 6.3 | 0.900 | C | 250 | 250 | —14.0 | 72.0 | 5.0 | — | 6000 | 6500 | 2500 | — | |
| 6B4G | 6A3 | Power Amplifier Triode ° | 5S | 6.3 | 1.000 | F (D) | 250 | — | —45.0 | 60 | — | 4.2 | 5250 | 3500 | 2500 | NU | |
| 6B5 | — | Power Amplifier Direct Coupled | 6AS | 6.3 | 0.800 | C | 300 | 300 | Input Output | 0 | 8 | — | 8 | — | — | — | — |
| 6B6G | 75 | Duplex Diode Triode° | 7V | 6.3 | 0.300 | C | 250 | — | —2.0 | 0.8 | — | 100 | 1100 | — | — | NU | |
| 6B7 | — | Duplex Diode Pentode | 7D | 6.3 | 0.300 | C | 250 | 125 | —3.0 | 9.0 | 2.3 | 730 | 1125 | — | — | — | |
| 6B7S | 6B7 | Duplex Diode Pentode | 7D | 6.3 | 0.300 | C | 100 | 100 | —3.0 | 5.8 | 1.7 | 285 | 950 | — | — | NU | |
| 6B7S | 6B7 | Duplex Diode Pentode | 7D | 6.3 | 0.300 | C | 100 | 100 | —3.0 | 9.0 | 2.3 | 730 | 1125 | — | — | NU | |
| 6B8 | 6B7 | Duplex Diode Pentode ° | 8E | 6.3 | 0.300 | C | 250 | 125 | —3.0 | 10.0 | 2.3 | 800 | 1325 | — | — | Replace with NU 6B8G | |
| 6B8G | 6B7 | Duplex Diode Pentode | 8E | 6.3 | 0.300 | C | 250 | 100 | —3.0 | 6.0 | 1.5 | 800 | 1000 | — | — | NU | |
| 6B8GT | 6B7 | Duplex Diode Pentode | 8E | 6.3 | 0.300 | C | 250 | 125 | —3.0 | 10.0 | 2.3 | — | 1325 | — | — | Replace with NU 6B8G | |
| 6C5 | 78 | Triode Detector-Amplifier° | 6Q | 6.3 | 0.300 | C | 250 | — | —8.0 | 8 | — | 20 | 2000 | — | — | Replace with NU6C5GT/G | |
| 6C5G | 78 | Triode Detector-Amplifier° | 6Q | 6.3 | 0.300 | C | 250 | — | —8.0 | 8 | — | 20 | 2000 | — | — | Replace with NU6C5GT/G | |
| 6C5GT | 6C5G | Triode Detector Amplifier | 6Q | 6.3 | 0.300 | C | 250 | — | —8.0 | 8.0 | — | 20 | 2000 | — | — | Replace with NU6C5GT/G | |
| 6C5GT/G | 6C5G | Triode Detector Amplifier | 6Q | 6.3 | 0.300 | C | 250 | — | —8.0 | 8.0 | — | 20 | 2000 | — | — | NU | |
| 6C5MG | 78 | Triode Detector-Amplifier° | 6Q | 6.3 | 0.300 | C | 250 | — | —8.0 | 8 | — | 20 | 2000 | — | — | Replace with NU6C5GT/G | |
| 6C6 | 77 | Triode Grid Detector-Amplifier | 6F | 6.3 | 0.300 | C | 100 | 100 | —3.0 | 2 | 0.5 | 1500+ | 1225 | — | — | — | |
| 6C7 | 85AS | Duplex Diode Triode | 7G | 6.3 | 0.300 | C | 250 | — | —9.0 | 4.5 | — | 20 | 1250 | — | — | NU | |
| 6C8G | — | Double Triode° | 8G | 6.3 | 0.300 | C | 250 | — | —4.5 | 3.1 | — | 38 | 1450 | — | — | NU | |
| 6D5 | 45 | Power Amplifier Triode ° | 6Q | 6.3 | 0.700 | C | 275 | — | —40.0 | 31 | — | 4.7 | 2100 | 1400 | 7200 | Discontinued | |
| 6D5G | 45 | Power Amplifier Triode ° | 6Q | 6.3 | 0.700 | C | 275 | — | —40.0 | 31 | — | 4.7 | 2100 | 1400 | 7200 | Discontinued | |
| 6D5MG | 45 | Power Amplifier Triode ° | 6Q | 6.3 | 0.700 | C | 275 | — | —40.0 | 31 | — | 4.7 | 2100 | 1400 | 7200 | Discontinued | |
| 6D6 | 78 | Super Control R.F. Amplifier | 6F | 6.3 | 0.300 | C | 250 | 100 | —3.0 | 8.2 | 2.0 | 1280 | 1600 | — | — | NU | |
| 6D7 | 77 | Triode Grid Detector-Amplifier | 7H | 6.3 | 0.300 | C | 250 | 100 | —3.0 | 2 | 0.5 | 1500+ | 1275 | — | — | NU | |

Receiving Tube Operating Characteristics and Basing Diagram Charts

(Cont'd)

| Type Number | Similar To | Description | Base Connection | Fila-ment Volts | Fila-ment Amps. | Fila-ment Type | Plate Volts | Screen Volts | Control Grid Volts | Plate Current (mA) | Screen Current (mA) | Amplification Factor | Mutual Conduc-tance in Micromhos | Power Output in Milliwatts | Lead Resistance in Ohms | |
|-------------|------------|----------------------------------|-----------------|-----------------|-----------------|------------------------|-------------|--------------|--------------------|--------------------|---------------------|----------------------|--|----------------------------|-----------------------------|-------------------------|
| 6K5GT | 6K5G | Triode High Mu | 5U | 6.3 | 0.300 | C | 250 | — | — 3 | 1.1 | — | 70 | 1400* | — | — NU | |
| 6K6G | 41 | Power Amplifier Pentode * | 7S | 6.3 | 0.400 | C | 250 | 250 | —18.0 | 32.0 | 5.5 | 150 | 2200 | 3400 | 7600 Replace with NU6K6GT/G | |
| 6K6GT | 6K6G | Power Amplifier Pentode | 7S | 6.3 | 0.400 | C | 250 | 250 | —18 | 32 | 5.5 | 150 | 2200 | 3400 | 7600 Replace with NU6K6GT/G | |
| 6K6GT/G | 6K6G | Power Amplifier Pentode | 7S | 6.3 | 0.400 | C | 250 | 250 | —18 | 32 | 5.5 | 150 | 2200 | 3400 | 7600 NU | |
| 6K7 | 6D6-78 | Super Control R.F. Amplifier * | 7R | 6.3 | 0.300 | C | 250 | 100 | — 3.0 | 7.0 | 1.7 | 1160 | 1450 | — | — | |
| | | | | | | | 90 | 90 | — 3.0 | 8.4 | 1.3 | 400 | 1275 | — | — | Replace with NU 6K7GT |
| 6K7G | 6D6-78 | Super Control R.F. Amplifier * | 7R | 6.3 | 0.300 | C | 250 | 100 | — 3.0 | 7.0 | 1.7 | 1160 | 1450 | — | — | |
| | | | | | | | 90 | 86 | — 3.0 | 5.4 | 1.3 | 400 | 1275 | — | — | NU |
| 6K7GT | 6K7G | Super Control R.F. Amplifier | 7R | 6.3 | 0.300 | C | 250 | 125 | — 3 | 10.3 | 2.6 | 990 | 1850 | — | — NU | |
| 6K7MG | 6D6-78 | Super Control R.F. Amplifier * | 7R | 6.3 | 0.300 | C | 250 | 100 | — 3.0 | 7.0 | 1.7 | 1160 | 1450 | — | — | |
| | | | | | | | 90 | 90 | — 3.0 | 8.4 | 1.3 | 400 | 1275 | — | — | Replace with NU 6K7GT |
| 6K8 | | Triode-Hexode Converter | 8K | 6.3 | 0.300 | Tri. 100 C Hex. 250 | — | — | — 3.8 | — | — | — | — (Triode Grid 300 Resistor 50000 Ohms) | — | — | |
| | | | | | | | 100 | — | — 3.0 | 2.5 | 8.0 | — | — (Triode Grid 300 Resistor 50000 Ohms) | — | — | Replace with NU 6K8GT |
| 6K8G | 6K8 | Triode-Hexode Converter | 8K | 6.3 | 0.300 | C Hex. 250 | — | — | — 3.8 | — | — | — | — (Triode Grid 300 Resistor 50000 Ohms) | — | — | |
| | | | | | | | 100 | — | — 3.0 | 2.5 | 6.0 | — | — (Triode Grid 300 Resistor 50000 Ohms) | — | — | NU |
| 6K8GT | 6K8G | Triode-Hexode Converter | 8K | 6.3 | 0.300 | C Hex. 250 | — | — | — 3 | 2.3 | 6.0 | — | 350 | — | — NU | |
| | | | | | | | 100 | — | — 3.0 | 2.3 | 6.0 | — | — | — | — | — |
| 6L5B | 78 | Triode Detector-Amplifier * | 8Q | 6.3 | 0.150 | C | 250 | — | — 5.0 | 3.5 | — | 17 | 1500 | — | — | |
| 6L6 | — | Beam Power Amplifier * | 7AC | 6.3 | 0.900 | C | 250 | 250 | — 9.0 | 8.0 | — | 17 | 1900 | — | — NU | |
| 6L6B | 6L6 | Beam Power Amplifier * | 7AC | 6.3 | 0.900 | C | 250 | 250 | —14.0 | 72 | 5.0 | 135 | 6000 | 6500 | 2500 | Replace with NU 6L6G |
| 6L7 | — | Pentagrid Mixer Amplifier * | 7T | 6.3 | 0.300 | C | 250 | 100 | — 3.0 | 5.3 | 5.5 | 880 | 1100 | — | — | Replace with NU 6L7G |
| 6L7G | 6L7 | Pentagrid Mixer Amplifier * | 7T | 6.3 | 0.300 | C | 250 | 100 | — 3.0 | 5.3 | 5.5 | 880 | 1100 | — | — | NU |
| 6L7MG | 6L7 | Pentagrid Mixer Amplifier * | 7T | 6.3 | 0.300 | C | 250 | 100 | — 3.0 | 5.3 | 5.5 | 880 | 1100 | — | — | Replace with NU 6L7G |
| 6N5 | 806 | Electron Ray Tuning Indicator | 6R | 6.3 | 0.150 | C | 135 | — | 0 to 12 | 0.5 | — | — | — | — | — | Replace with NU6A9S/8N5 |
| 6N6G | 6B5 | Power Amplifier Direct Coupled * | 7W | 6.3 | 0.800 | C | 250 | — | — | — | 6.6 | — | — | 2500 | 7000 | NU |
| | | | | | | | 250 | — | — | — | — | — | — | — | — | — |
| 6N6GB | 6B5 | Power Amplifier Direct Coupled * | 7W | 6.3 | 0.800 | C | 250 | — | — | 33.0 | — | — | 2500 | 7000 | Replace with NU6N6G | |
| 6N7 | 6A6 | Class B Twin Amplifier * | 8B | 6.3 | 0.800 | C | 300 | — | — | 17.5 | — | — | 10000 | 10000 | — | Replace with NU6N7GT/G |
| 6N7G | 6A6 | Class B Twin Amplifier * | 8B | 6.3 | 0.800 | C | 300 | — | — | 17.5 | — | — | 10000 | 10000 | — | Replace with NU6N7GT/G |
| 6N7GT/G | 6A6 | Class B Twin Amplifier * | 8B | 6.3 | 0.800 | C | 300 | — | 0 | 17.5 | — | — | 10000 | 10000 | — | NU |
| 6N7MG | 6A6 | Class B Twin Amplifier * | 8B | 6.3 | 0.800 | C | 300 | — | — | 17.5 | — | — | 10000 | 10000 | — | Replace with NU6N7GT/G |
| 6P5G | 78 | General Purpose Triode | 6Q | 6.3 | 0.300 | C | 250 | — | —18.5 | 5.0 | — | 13.8 | 1450 | — | — | Replace with NU6P5GT/G |
| 6P5GT | 78 | General Purpose Triode | 6Q | 6.3 | 0.300 | C | 250 | — | —13.5 | 5.0 | — | 13.8 | 1450 | — | — | Replace with NU6P5GT/G |
| 6P5GT/G | 78 | General Purpose Triode * | 6Q | 6.3 | 0.300 | C | 250 | — | —13.5 | 5.0 | — | 13.8 | 1450 | — | — | NU |

Receiving Tube Operating Characteristics and Basing Diagram Charts

(Cont'd)

| Type Number | Similar To | Description | Base Connection | Fila. Volt | Fila. Amps. | Fila. ment Type | Plate Volts | Screen Volts | Control Grid Volts | Plate Current (mA) | Screen Current (mA) | Amplification Factor | Mutual Conductance in Micromhos | Power Output in Milliwatts | Load Resistance in Ohms |
|-------------|------------|--------------------------------|-----------------|------------|-------------|-----------------|-------------|--------------|--------------------|--------------------|---------------------|----------------------|---------------------------------|----------------------------|------------------------------|
| 6G7GT/G | 6G7G | Duplex Diode Triode | 8Q | 6.3 | 0.300 | C | 250 | — | — 2.0 | 0.8 | — | 100 | 1100 | — | — NU |
| 6SR7 | 6R7 | Duplex Diode Triode | 8Q | 6.3 | 0.300 | C | 250 | — | — 9.0 | 9.5 | — | 18 | 1900 | — | — NU |
| 6SS7 | — | Super Control R. F. Amplifier | 8N | 6.3 | 0.150 | C | 250 | 100 | — 3.0 | 9.0 | 2.0 | — | 1850 | — | — NU |
| 6ST7 | — | Duplex-Diode Triode | 8Q | 6.3 | .15 | C | 250 | — | — 9 | 9.5 | — | 16 | 1900 | — | — |
| 6T5 | — | Electron Ray Tuning Indicator | 6R | 6.3 | 0.300 | C | 250 | — | 0 to —22 | — | — | — | — | — | — Replace with NU 6U5, 6G5 |
| 6T7G | 7S | Duplex Diode-Triode | 7V | 6.3 | 0.150 | C | 250 | — | — 3 | 1.2 | — | 65 | 1050 | — | — NU |
| 6U5 | 6G5 | Electron Ray Tuning Indicator | 6R | 6.3 | 0.300 | C | 250 | — | 0 to —22 | — | — | — | — | — | — Replace with NU 6U5/6G5 |
| 6U5/6G5 | 6U5 | Tuning Indicator | 6R | 6.3 | 0.300 | C | 250 | — | 0 to —22 | — | — | — | — | — | — NU |
| 6U6GT | — | Beam Power Amplifier | 7AC | 6.3 | 0.750 | C | 135 | 135 | —13.5 | 60.0 | 15.0 | — | 6200 | 3300 | 2000 NU |
| 6U7G | 6D6 | Super Control R.F. Amplifier | 7R | 6.3 | 0.500 | C | 250 | 100 | — 3 | 8.2 | 2.0 | 1250 | 1800 | — | — NU |
| 6V6 | — | Beam Power Amplifier | 7AC | 6.3 | 0.450 | C | 250 | 250 | —12.5 | 45 | 4.5 | 218 | 4100 | 4250 | 5000 Replace with NU 6V6GT/G |
| 6V6B | — | Beam Power Amplifier | 7AC | 6.3 | 0.450 | C | 250 | 250 | —12.5 | 45 | 4.5 | 218 | 4100 | 4250 | 5000 Replace with NU 6V6GT/G |
| 6V6GT | 6V6G | Beam Power Amplifier | 7AC | 6.3 | 0.450 | C | 250 | 250 | —12.6 | 47 | 8.5 | — | — | 4250 | 5000 Replace with NU 6V6GT/G |
| 6V6GT/G | 6V6G | Beam Power Amplifier | 7AC | 6.3 | 0.450 | C | 250 | 250 | —12.5 | 47 | 6.5 | — | — | 4250 | 5000 NU |
| 6V7G | 6S | Duplex Diode-Triode | 7V | 6.3 | 0.300 | C | 250 | — | —20 | 8.0 | — | 8.3 | 1100 | 550 | 20000 NU |
| 6X5G | 6X6B | Full Wave Rectifier* | 6B | 6.3 | 0.600 | C | 350 | — | — | 100 | — | — | — | — | — NU |
| 6W6GT | 6L6G | Beam Power Amplifier | 7AC | 6.3 | 1.250 | C | 135 | 135 | — 9.5 | 61 | 12.0 | 215 | 9000 | 3300 | 2000 |
| 6W7G | 6J7G | Triple Grid Detector-Amplifier | 7R | 6.3 | 0.150 | C | 250 | 100 | — 8 | 2.0 | 0.5 | 1850 | 1225 | — | — NU |
| 6X5 | 64 | Full Wave Rectifier | 6B | 6.3 | 0.600 | C | 350 | — | — | 75 | — | — | — | — | — Replace with NU 6X5GT/G |
| 6X5G | 64 | Full Wave Rectifier | 6B | 6.3 | 0.600 | C | 350 | — | — | 75 | — | — | — | — | — Replace with NU 6X5GT/G |
| 6X5GT | 64 | Full Wave Rectifier | 6S | 6.3 | 0.600 | C | 350 | — | — | 75 | — | — | — | — | — Replace with NU 6X5GT/G |
| 6X5GT/G | 64 | Full Wave Rectifier | 6S | 6.3 | 0.600 | C | 350 | — | — | 75 | — | — | — | — | — NU |
| 6X5MG | 64 | Full Wave Rectifier | 6S | 6.3 | 0.600 | C | 350 | — | — | 75 | — | — | — | — | — Replace with NU 6X5GT/G |
| 6Y3G | — | Half Wave Rectifier | 4AC | 6.3 | .7 | C | 5000a.c. | — | — | 7.5 | — | — | — | — | — NU |
| 6Y6 | 64 | Full Wave Rectifier* | 6J | 6.3 | 0.800 | C | 350 | — | — | 50 | — | — | — | — | — Replace with NU 6Y5V |
| 6Y3V | 64 | Full Wave Rectifier | 6J | 6.3 | 0.800 | C | 350 | — | — | 60 | — | — | — | — | — NU |
| 6Y6B | — | Power Amplifier Tetrode | 7AC | 6.3 | 1.250 | C | 135 | 135 | —13.5 | 56 | 3 | — | 7000 | 3600 | 2000 NU |
| 6Y6GT | 6Y6G | Power Amplifier Tetrode | 7AC | 6.3 | 1.250 | C | 135 | 135 | —13.6 | 60 | 3.0 | — | 7000 | 3600 | 2000 Replace with NU 6Y6G |
| 6Y7G | 79 | Class B Twin Amplifier | 8B | 6.3 | 0.600 | C | 250 | — | 0 | 10.5 | — | — | — | 8000 | 14000 NU |
| 6Z3 | 1V | Half Wave Rectifier | 4G | 6.3 | 0.300 | C | 350 | — | — | 50 | — | — | — | — | — Replace with NU 1V |
| 6Z4-84 | 64 | Full Wave Rectifier | 5D | 6.3 | 0.600 | C | 350 | — | — | 80 | — | — | — | — | — |
| 6Z5 | — | Full Wave Rectifier | 6K | 6.3 | 0.600 | C | 250 | — | — | 60 | — | — | — | — | — NU |
| 6Z6B | 64 | Full Wave Rectifier | 7Q | 6.3 | 0.500 | C | 350 | — | — | 60 | — | — | — | — | — |
| 6Z7G | — | Class B Twin Amplifier | 6B | 6.3 | 0.300 | C | 180 | — | 0 | — | — | — | — | 4200 | 12000(P.P.) NU |
| 6ZY5B | — | Full Wave Rectifier | 6S | 6.3 | 0.300 | C | 350 | — | — | 35 | — | — | — | — | — NU |
| 7A4 | 6J5G | General Purpose Triode | 5AC | 7.0 | 0.320 | C | 250 | — | — 8 | 9.0 | — | 20 | 2600 | — | — NU |

| | | | | | | | | | | | | | | | | | | |
|---|----------|------|--------------------------------|-----|-------|-------|--------|-----|------------|---|---------|------|-----|------|------|------|-------|---------------------|
| † | 7A3 | — | Power Output Pentode | 8AA | 7.0 | 0.750 | C | 125 | 125 | — | 9.0 | 37.5 | 3.2 | — | 8100 | 1900 | 2700 | NU |
| † | 7A6 | — | Duplex Diode | 7AJ | 7.0 | .160 | C | 150 | R.M.S. Max | — | 10 Max. | — | — | — | — | — | — | NU |
| † | 7A7 | — | Super Control R. F. Amplifier | 8V | 7.0 | 0.320 | C | 250 | 100 | — | 3.0 | 8.6 | 2.0 | 1600 | 2000 | — | — | NU |
| † | 7A7LM | 7A7 | Super Control R.F. Amplifier | 8V | 6.3 | 0.300 | C | 250 | 100 | — | 3.0 | 8.6 | 2.0 | — | 2000 | — | — | Replace with NU 7A7 |
| † | 7A8 | — | Octode Converter | 8U | 7.0 | 0.160 | C | 250 | 100 | — | 3.0 | 3.0 | 2.8 | — | 800 | — | — | NU |
| † | 7B4 | — | High Mu Triode | 5AC | 7.0 | 0.320 | C | 250 | — | — | 2.0 | 0.9 | — | 100 | 1500 | — | — | NU |
| † | 7B5 | — | Pentode Power Amplifier | 8AE | 7.0 | 0.430 | C | 250 | 250 | — | 18.0 | 32 | 5.5 | 150 | 2200 | 3400 | 7600 | NU |
| † | 7B5LT | 7B5 | Power Amplifier Pentode | 6AE | 7.0 | 0.430 | C | 250 | 250 | — | 18.0 | 32.0 | 5.5 | 150 | 2300 | 3400 | 7600 | Replace with NU 7B5 |
| † | 7B6 | — | Duo Diode Triode | 8W | 7.0 | 0.320 | C | 250 | — | — | 2.0 | 1.0 | — | 100 | 1100 | — | — | NU |
| † | 7B6LM | 7B6 | Duplex Diode-Triode | 8W | 7.0 | 0.320 | C | 250 | — | — | 2.0 | 0.9 | — | 100 | 1100 | — | — | Replace with NU 7B6 |
| † | 7B7 | — | Super Control R. F. Amplifier | 8V | 7.0 | 0.160 | C | 250 | 100 | — | 3.0 | 8.5 | 2.0 | 1200 | 1700 | — | — | NU |
| † | 7B8 | — | Pentagrid Converter | 8X | 7.0 | 0.320 | C | 250 | 100 | — | 3.0 | 3.5 | 2.7 | — | 550 | — | — | NU |
| † | 7B8LM | 7B8 | Pentagrid Converter | 8X | 7.0 | 0.320 | C | 250 | 100 | — | 3.0 | 3.5 | 2.7 | — | 550 | — | — | Replace with NU 7B8 |
| † | 7C5 | — | Tetrcde Power Amplifier | 6AA | 7.0 | 0.480 | C | 250 | 250 | — | 12.5 | 45 | 4.5 | — | 4100 | 4250 | 5000 | NU |
| † | 7C5LT | 7C5 | Tetrcde Power Amplifier | 6AA | 7.0 | 0.480 | C | 250 | 250 | — | 12.5 | 47.0 | 7.0 | — | 4100 | 4500 | 5000 | Replace with NU 7C5 |
| † | 7C6 | — | Duo Diode High Mu Triode | 8W | 7.0 | 0.160 | C | 250 | — | — | 1.3 | — | — | 100 | 1000 | — | — | NU |
| † | 7C7 | 6W7G | Triple Grid Detector-Amplifier | 8V | 7.0 | 0.160 | C | 250 | 100 | — | 3 | 2.0 | 0.5 | — | 1300 | — | — | NU |
| † | 7E6 | 6R7G | Duplex Diode-Medium Mu Triode | 8W | 7.0 | 0.320 | C | 250 | — | — | 9 | 9.5 | — | 16 | 1900 | — | — | NU |
| † | 7E7 | — | Duplex Diode Pentode | 8AE | 7.0 | 0.320 | C | 250 | 100 | — | 3.0 | 7.5 | 1.8 | — | 1300 | — | — | NU |
| † | 7F7 | — | Double Triode Amplifier | 8AC | 7.0 | 0.320 | C | 250 | — | — | 2.0 | 2.3 | — | 70 | 1600 | — | — | NU |
| † | 7B7/1232 | — | Triple Grid Amplifier | 8V | 7.0 | 0.480 | C | 250 | 100 | — | 2.0 | 8.0 | 2.0 | — | 4500 | — | — | NU |
| † | 7H7 | — | Semi-Remote Control Amplifier | 8V | 7.0 | 0.320 | C | 250 | 150 | — | 2.5 | 9.0 | 2.5 | — | 3500 | — | — | NU |
| † | 7I7 | — | Triode-Hexode Converter | 8AR | 7.0 | 0.320 | C | 250 | 100 | — | 3.0 | 1.4 | 2.8 | — | 310 | — | — | NU |
| | | | | | | | Tri. | 150 | — | — | 3.0 | 7.5 | — | 14 | 1350 | — | — | NU |
| † | 7K7 | — | Duplex-Diode High-Mu Triode | 8BF | 6.3 | .3 | C | 250 | — | — | 2 | 2.3 | — | 70 | 1600 | — | — | NU |
| † | 7L7 | — | R.F. Pentode | 8V | 7.0 | 0.320 | C | 250 | 100 | — | 1.5 | 4.5 | 1.5 | — | 3100 | — | — | NU |
| † | 7M7 | 6F8G | Double Triode Amplifier | 8AC | 7.0 | 0.640 | C | 250 | — | — | 8.0 | 9.0 | — | 20 | 2600 | — | — | NU |
| † | 7Q7 | — | Pentagrid Converter | 8AL | 7.0 | 0.320 | C | 250 | 100 | — | 6 | 3.4 | 4.0 | — | 450 | — | — | NU |
| † | 7R7 | — | Duplex Diode Pentode | 8AE | 7.0 | 0.320 | C | 250 | 100 | — | 1.0 | 5.7 | 2.1 | — | 3200 | — | — | NU |
| † | 7S7 | — | Triode-Hexode Converter | 8AR | 7.0 | 0.320 | C | 250 | 100 | — | 2.0 | 1.7 | 0.4 | — | 600 | — | — | NU |
| | | | | | | | Tri. | 100 | — | — | 0 | 7.0 | — | 18 | 1700 | — | — | NU |
| † | 7V7 | — | R. F. Pentode | 8V | 7.0 | 0.480 | C | 300 | 150 | — | (— 2.0) | 9.6 | 3.9 | — | 5800 | — | — | NU |
| † | 7W7 | 7V7 | Amplifier Pentode | 8BJ | 6.3 | .45 | C | 300 | 150 | — | 2 | 10.0 | 3.9 | — | 5800 | — | — | NU |
| † | 7Y4 | — | Full Wave Rectifier | 5AB | 7.0 | 0.530 | C | 350 | — | — | 60 | — | — | — | — | — | — | NU |
| † | 7Z4 | — | Full Wave Rectifier | 5AB | 7.0 | 0.960 | C | 325 | — | — | 100 | — | — | — | — | — | — | NU |
| † | 7 | — | Ballast Tube | 4A | 176.0 | 0.300 | F | — | — | — | — | — | — | — | — | — | — | — |
| † | 8 | — | Ballast Tube | 4A | 152.0 | 0.300 | F | — | — | — | — | — | — | — | — | — | — | — |
| † | 9 | — | Ballast Tube | 4A | 50.0 | 0.300 | F | — | — | — | — | — | — | — | — | — | — | — |
| † | 18 | — | Power Amplifier Triode | 4D | 7.5 | 1.250 | F (OT) | 425 | — | — | 39.0 | 18 | — | 8 | 1600 | 1600 | 10200 | NU |
| † | WD11 | WX12 | Triode Detector-Amplifier | 4F | 1.1 | 0.250 | F (O) | 135 | — | — | 18.5 | 3 | — | 6.6 | 440 | — | — | Obsolete |
| † | WX12 | WD11 | Triode Detector-Amplifier | 4D | 1.1 | 0.250 | F (O) | 135 | — | — | 18.5 | 3 | — | 6.6 | 440 | — | — | Obsolete |

(Cont'd over).

(Cont'd)

Receiving Tube Operating Characteristics and Basing Diagram Charts

| Type Number | Similar To | Description | Base Connection | Fila-ment Volts | Fila-ment Amps. | Fila-ment Type | Plate Volts | Screen Volts | Control Grid Volts | Plate Current (mA) | Screen Current (mA) | Ampli-fication Factor | Mutual Conduc-tance in Micromhos | Power Output in Milliwatts | Load Resistance in Ohms |
|-------------|---------------|--|-----------------|-----------------|-----------------|----------------|--------------|--------------|--------------------|--------------------|---------------------|-----------------------|----------------------------------|----------------------------|-------------------------|
| 12A | — | Triode Detector-Amplifier | 4D | 5.0 | 0.250 | F(O) | 180 | — | —13.5 | 7.7 | — | 8.5 | 1800 | 1285 | 10850 |
| | | | | | | | 90 | — | —4.6 | 8.0 | — | 8.5 | 1575 | 95 | 8000 NU |
| 12A5 | — | Power Amplifier Pentode | 7F | 12.0 | 0.300 | C | 180 | 180 | —27.0 | 38 | 8 | 90 | 2500 | 2600 | 8800 NU |
| 12A6 | — | Beam Power Amplifier Pentode and Half Wave Rectifier | 7AC | 12.0 | 0.190 | C | 250 | 250 | —12.5 | 30.0 | 3.5 | — | 3000 | 2500 | 7500 |
| 12A7 | — | Pentagrid Converter | 7K | 12.5 | 0.300 | C | 125 | — | —13.5 | 9 | 2.8 | 100 | 975 | — | — |
| 12ABG | 6ABG | Pentagrid Converter | 8A | 12.5 | 0.150 | C | 250 | 100 | —8.0 | 8.5 | 2.7 | — | 550 | — | — |
| 12ABGT | 6ABG | Pentagrid Converter | 8A | 12.5 | 0.150 | C | 250 | 100 | —3 | 3.3 | 3.2 | — | 500 | — | — |
| 12AH7GT | — | Double Triode | 8BE | 12.0 | 0.150 | C | 250 | — | —9.0 | 12.0 | — | 16 | 2400 | — | — |
| 12B7 | — | Super Control R.F. Amplifier | 8V | 12.0 | 0.150 | C | 250 | 100 | —3.0 | 9.2 | 2.4 | — | 2000 | — | — |
| 12B7ML | — | Super Control R.F. Amplifier | 8V | 12.0 | 0.150 | C | 250 | 100 | —3.0 | 9.2 | 2.4 | — | 2000 | — | — |
| 12B8GT | — | Triode Pentode | 8T | 12.0 | 0.300 | C | P90 T90 | 90 | —3.0 | 7.0 | 2.0 | 360 | 1800 | — | — |
| 12C8 | — | Diode Pentode | 8E | 12.0 | 0.150 | C | 250 | 125 | —3.0 | 10.0 | 2.3 | 800 | 1325 | — | — |
| 12E5GT | 6P5G | General Purpose Triode | 6Q | 12.0 | 0.150 | C | 250 | — | —15.5 | 5.0 | — | 13.8 | 1450 | — | — |
| 12E5GT/G | 6P5G | General Purpose Triode | 6Q | 12.0 | 0.150 | C | 250 | — | —13.5 | 5.0 | — | 13.8 | 1450 | — | — |
| 12F5GT | 6F5G | High Mu Triode | 5M | 12.5 | 0.150 | C | 250 | — | —2.0 | 0.9 | — | 100 | 1500 | — | — |
| 12H8 | 6H8 | Duplex Diode | 7Q | 12.0 | 0.150 | C | 150 | — | — | 8.0 | — | — | — | — | — |
| 12J5GT | 6J5G | General Purpose Triode | 6Q | 12.0 | 0.150 | C | 250 | — | —8 | 9.0 | — | 20 | 2600 | — | — |
| 12J7G | 12J7GT | Triode Grid Detector Amplifier | 7R | 12.0 | 0.150 | C | 250 | 100 | —5.0 | 2.0 | 0.5 | 1500 | 1225 | — | — |
| 12J7GT | 6J7G | Triode Grid Detector Amplifier | 7R | 12.5 | 0.150 | C | 250 | 100 | —5.0 | 2.0 | 0.5 | 1500 | 1225 | — | — |
| 12K7E | 6K7G | Super Control R.F. Amplifier | 7R | 12.5 | 0.150 | C | 250 | 125 | —5.0 | 10.5 | 2.6 | 990 | 1650 | — | — |
| 12K7GT | 6K7G | Super Control R.F. Amplifier | 7R | 12.5 | 0.150 | C | 250 | 100 | —5.0 | 7.0 | 1.7 | 1160 | 1450 | — | — |
| 12K8 | 6K8 | Triode Hexode Converter | 8K | 12.0 | 0.150 | C(H) | T100 M250 | 100 | —8.0 | 2.5 | 6.0 | — | 350 | — | — |
| 12K8GT | — | Triode Hexode Converter | 8K | 12.0 | 0.150 | C | T100 M250 | 100 | —8.0 | 2.5 | 6.0 | — | 350 | — | — |
| 12Q7G | 6Q7G | Duplex Diode High Mu Triode | 7V | 12.5 | 0.150 | C | 250 | — | —3.0 | 1.1 | — | 70 | 1200 | — | — |
| 12Q7GT | 6Q7G | Duplex Diode High Mu Triode | 7V | 12.5 | 0.150 | C | 250 | — | —3.0 | 1.1 | — | 70 | 1200 | — | — |
| 12SA7 | — | Pentagrid Converter | 8R | 12.0 | 0.150 | C | 250 | 100 | —2.0 | 3.4 | 8.0 | — | 450 | — | — |
| 12SA7B | 12SA7-12SA7GT | Pentagrid Converter | 8AD | 12.0 | 0.150 | C | 250 | 100 | —2.0 | 3.4 | 8.0 | — | 450 | — | — |
| 12SA7GT | 6SA7 | Pentagrid Converter | 8AD | 12.0 | 0.150 | C | 250 | 100 | —2 | 3.4 | 8.0 | — | 450 | — | — |
| 12SA7GT/G | 6SA7 | Pentagrid Converter | 8AD | 12.0 | 0.150 | C | 250 | 100 | —2 | 3.4 | 8.0 | — | 450 | — | — |
| 12SC7 | — | Twin Triode Amplifier | 8S | 12.0 | 0.150 | C | 250 | — | —2.0 | 2.0 | — | 70 | 1325 | — | — |
| 12SF5 | 12SF5GT | High Mu Triode | 6AB | 12.0 | 0.160 | C | 250 | — | —2.0 | 0.9 | — | 100 | 1590 | — | — |
| 12SF5GT | 6F5G | High Mu Triode | 6AB | 12.0 | 0.150 | C | 250 | — | —2.0 | 0.9 | — | 100 | 1500 | — | — |
| 12SF5GT/G | 6F5G | High Mu Triode | 6AB | 12.0 | 0.150 | C | 250 | — | —2.0 | 0.9 | — | 100 | 1500 | — | — |

| | | | | | | | | | | | | | | | | | |
|-------------|--------|--------------------------------|-----|------|-------|---|-----|----------|---|------|------|-----|------|------|------|------|------------------------|
| †125F7 | 6SF7 | Diode Pentode | 7A2 | 12.6 | 0.150 | C | 250 | 100 | — | 1.0 | 12.4 | 3.3 | — | 2080 | — | — | NU |
| †125G7 | 6SG7 | Super Control R. F. Pentode | 8BC | 12.6 | 0.150 | C | 250 | 150 | — | 2.5 | 9.2 | 3.4 | — | — | — | 4000 | NU |
| †125H7 | 6SH7 | H.F. Amplifier Pentode | 8BK | 12.6 | 0.150 | C | 250 | 150 | — | 1 | 10.8 | 4.1 | — | 4900 | — | — | |
| †125J7 | — | Triple Grid Detector-Amplifier | 8N | 12.6 | 0.150 | C | 250 | 100 | — | 3.0 | 3.0 | 0.8 | 2500 | 1650 | — | — | Replace w. NU125J7GT/G |
| †125J7G1 | 6J7G | Triple Grid Detector Amplifier | 8N | 12.6 | 0.150 | C | 250 | 100 | — | 3.0 | 3.0 | 0.8 | 2500 | 1650 | — | — | Replace w. NU125J7GT/G |
| †125J7GT/G | 6J7G | Triple Grid Detector Amplifier | 8N | 12.6 | 0.150 | C | 250 | 100 | — | 3.0 | 3.0 | 0.8 | 2500 | 1650 | — | — | NU |
| †125K7 | — | Super Control R. F. Amplifier | 8N | 12.6 | 0.150 | C | 250 | 100 | — | 3.0 | 9.2 | 2.4 | 1600 | 2000 | — | — | Replace w. NU125K7GT/G |
| †125K7G1 | 6K7G | Super Control R. F. Amplifier | 8N | 12.6 | 0.150 | C | 250 | 100 | — | 3.0 | 9.2 | 2.4 | 1600 | 2000 | — | — | Replace w. NU125K7GT/G |
| †125K7GT/G | 6K7G | Super Control R. F. Amplifier | 8N | 12.6 | 0.150 | C | 250 | 100 | — | 3.0 | 9.2 | 2.4 | 1600 | 2000 | — | — | NU |
| †125L7GT | 6SL7GT | Twin Triode Amplifier | 8BD | 12.6 | 0.150 | C | 250 | — | — | 2.0 | 2.3 | — | 70 | 1600 | 1000 | — | NU |
| †125N7GT | 6SN7GT | Twin Triode Amplifier | 8BD | 12.6 | 0.300 | C | 300 | — | — | 8.0 | 9.0 | — | 20 | 2600 | 2500 | — | |
| †125Q7 | — | Diode Diode High Mu Triode | 8Q | 12.6 | 0.150 | C | 250 | — | — | 2.0 | 0.8 | — | 100 | 1100 | — | — | Replace w. NU125Q7GT/G |
| †125Q7G1 | 6Q7G | Duplex Diode High Mu Triode | 8Q | 12.6 | 0.150 | C | 250 | — | — | 2.0 | 0.8 | — | 100 | 1100 | — | — | Replace w. NU125Q7GT/G |
| †125Q7GT/G | 6Q7G | Duplex Diode High Mu Triode | 8Q | 12.6 | 0.150 | C | 250 | — | — | 2.0 | 0.8 | — | 100 | 1100 | — | — | NU |
| †125R7 | 6R7 | Duplex Diode Triode | 8R | 12.6 | 0.150 | C | 250 | — | — | 8.0 | 8.5 | — | 18 | 1800 | — | — | NU |
| †1223 | — | Half Wave Rectifier | 4B | 12.6 | 0.300 | C | 250 | — | — | — | — | — | — | — | — | — | NU |
| †1223 | — | Voltage Doubling Rectifier | 7L | 12.6 | 0.300 | C | 225 | — | — | — | — | — | — | — | — | — | |
| †1223-625 | — | Full Wave Rectifier | 6K | 12.6 | 0.300 | C | 225 | — | — | — | — | — | — | — | — | — | |
| †19 | — | Screen Grid R.F. Amplifier | 6E | 14.0 | 0.300 | C | 250 | 90 | — | 3.0 | 4 | 1.5 | 525 | 1050 | — | — | |
| †14A4 | 7A4 | Detector Amplifier Triode | 5AC | 12.6 | 0.150 | C | 250 | — | — | 8.0 | 9.0 | — | 20 | 2800 | — | — | NU |
| †14A5 | 7A5 | Beam Power Amplifier | 6AA | 12.6 | 0.150 | C | 250 | 250 | — | 12.5 | 32.0 | 5.0 | — | 3000 | 2500 | 7500 | |
| †14A7/†12B7 | 7A7 | Super Control R. F. Amplifier | 8V | 12.6 | 0.150 | C | 250 | 100 | — | 3.0 | 9.2 | 2.6 | — | 2000 | — | — | NU |
| †14AF7 | — | Twin Triode Amplifier | 8AC | 12.6 | 0.150 | C | 250 | — | — | 10.0 | 9.0 | — | 16 | 2100 | — | — | |
| †14B6 | 7B6 | Duplex Diode Triode | 8W | 14.0 | 0.160 | C | 250 | — | — | 2.0 | 0.9 | — | 100 | 1100 | — | — | |
| †14B8 | 7B8 | Pentagrid Converter | 8X | 12.6 | 0.150 | C | 250 | 100 | — | 3.0 | 3.5 | 2.7 | — | 550 | — | — | |
| †14C5 | 7C5 | Beam Power Amplifier | 6AA | 12.6 | 0.225 | C | 250 | 250 | — | 12.5 | 47.0 | 7.0 | — | 4100 | 4500 | 5000 | |
| †14C7 | 7C7 | Triple Grid Detector Amplifier | 8V | 12.6 | 0.150 | C | 250 | 100 | — | 3.0 | 2.2 | 0.7 | — | 1575 | — | — | NU |
| †14E6 | 7E6 | Duplex Diode Medium Mu Triode | 8W | 12.6 | 0.150 | C | 250 | — | — | 9.0 | 9.5 | — | 18 | 1900 | — | — | |
| †14E7 | 7E7 | Duplex Diode Pentode | 8AE | 12.6 | 0.150 | C | 250 | 100 | — | 3.0 | 7.5 | 1.6 | — | 1300 | — | — | |
| †14F7 | 7F7 | Double Triode Amplifier | 8AC | 12.6 | 0.150 | C | 250 | — | — | 2.0 | 2.3 | — | 70 | 1600 | — | — | |
| †14H7 | 7H7 | Semi-remote Cutoff Amplifier | 8V | 12.6 | 0.150 | C | 250 | 150 | — | 2.5 | 9.5 | 3.5 | — | 3800 | — | — | NU |
| †14J7 | 7J7 | Triode Hexode Converter | 8AR | 12.6 | 0.150 | C | 250 | 100 | — | 3.0 | 1.4 | 2.8 | — | 310 | — | — | |
| †14N7 | 7N7 | Double Triode Amplifier | 8AC | 12.6 | 0.300 | C | 250 | — | — | 5.5 | 2.4 | — | 20 | 2800 | — | — | |
| †14Q7 | 7Q7 | Pentagrid Converter | 8AL | 12.6 | 0.150 | C | 250 | 100 | — | 2.0 | 3.5 | 8.5 | — | 850 | — | — | NU |
| †14R7 | 7R7 | Duplex Diode Pentode | 8AE | 12.6 | 0.150 | C | 250 | 100 | — | 1.0 | 5.7 | 2.1 | — | 3200 | — | — | NU |
| †14S7 | 7S7 | Triode Heptode Converter | 8BL | 12.6 | 0.15 | C | 250 | 100 | — | 2 | 1.6 | 3.0 | — | 525 | — | — | |
| | | | | | | | | TRI. 100 | — | 0 | 6.5 | — | 18 | 1650 | — | — | |
| †14W7 | 7W7 | Amplifier Pentode | 8BJ | 12.6 | 0.225 | C | 300 | 150 | — | 2 | 10.0 | 3.9 | — | 5800 | — | — | |
| †14Y7 | 7Y4 | Full Wave Rectifier | 5AB | 12.6 | 0.300 | C | 325 | — | — | 70.0 | — | — | — | — | — | — | NU |
| †14Z3 | 12Z3 | Half Wave Rectifier | 4B | 14.0 | 0.300 | C | 250 | — | — | 80 | — | — | — | — | — | — | Replace with NU1223 |

Receiving Tube Operating Characteristics and Basing Diagram Charts

(Cont'd)

| Type Number | Similar To | Description | Base Connection | Filament Volts | Filament Amps. | Filament Type | Plate Volts | Screen Volts | Control Grid Volts | Plate Current (MA) | Screen Current (MA) | Amplification Factor | Mutual Conductance in Micromhos | Power Output in Milliwatts | Load Resistance in Ohms | |
|-------------|------------|----------------------------------|-----------------|----------------|----------------|---------------------|-------------|--------------|--------------------|--------------------|---------------------|----------------------|---------------------------------|----------------------------|--------------------------|--------------------------|
| 15 | 52 | Screen Grid R.F. Amplifier | 5F | 2.0 | 0.220 | C | 87.5 | 67.5 | -1.5 | 1.8 | 0.5 | 450 | 710 | — | — NU | |
| 17 | — | Triode General Purpose | 6A | 14.0 | 0.300 | C | 180 | — | -15.8 | 6 | — | 9 | 1000 | — | — | |
| 18 | — | Power Amplifier Pentode | 6B | 14.0 | 0.300 | C | 250 | 250 | -16.5 | 34 | 7.5 | 185 | 2350 | 3400 | 7000 NU | |
| 19 | 1J80 | Class B Twin Amplifier | 6C | 2.0 | 0.280 | F(D) | 135 | — | 6 | 10 | — | — | 2100(2) | 10000(2) | NU | |
| 20 | — | Power Amplifier Triode | 4D | 8.5 | 0.152 | F(D) | 135 | — | -22.6 | 6.5 | — | 3.3 | 525 | 110 | 6500 NU | |
| KR20 | — | Special Detector | 8N | 2.5 | 1.000 | C | 250 | — | 0 | 3.5 | — | 14 | 1400 | — | — | |
| 21A7 | — | Triode Hexode Converter | 8AR | 21.0 | 0.160 | C | 250 | 100 | -3.0 | 1.3 | 2.8 | — | 275 | — | — | |
| | | | | | | Tri. | 150 | — | -3.0 | 8.5 | — | 52 | 1900 | — | — | |
| 22 | — | Screen Grid R.F. Amplifier | 4K | 3.3 | 0.152 | F(D) | 135 | 87.5 | -1.5 | 3.7 | 1.3 | 180 | 500 | — | — NU | |
| A22 | — | Screen Grid R.F. Amplifier | 4Q | 15.0 | 0.350 | C | 158 | 45 | -1.5 | 2.0 | 0.4 | 300 | 600 | — | — | |
| AC22 | 24A | Screen Grid R.F. Amplifier | 5E | 2.5 | 1.750 | C | 250 | 90 | -3.0 | 4 | 1.7 | 630 | 1050 | — | — Replace with NU24A | |
| KR22 | — | Special Detector | 6N | 6.3 | 0.400 | C | 250 | — | 0 | 3.5 | — | 14 | 1400 | — | 100,000 | |
| K24 | 24A | Screen Grid R.F. Amplifier | 5E | 2.5 | 1.750 | C | 180 | 18 | -1.5 | 2 | — | — | 800 | — | — Replace with NU24A | |
| 24A | — | Screen Grid R.F. Amplifier | 5E | 2.5 | 1.750 | C | 250 | 90 | -3.0 | 4 | 1.7 | 630 | 1050 | — | — NU | |
| 24S | 24A | Screen Grid R.F. Amplifier | 5E | 2.5 | 1.700 | C | 200 | 90 | -3.0 | 4 | 1.7 | 630 | 1050 | — | — NU | |
| 25-25B | 1B5 | Duplex Diode Triode | 6M | 2.0 | 0.060 | F | 135 | — | -3.0 | 1 | — | 20 | 475 | — | — Replace with NU1B5/25S | |
| KR25 | 2A5 | Power Amplifier Pentode | 6B | 2.5 | 1.750 | C | 250 | 250 | -16.5 | 34 | 6.5 | 220 | 2200 | 3000 | 7000 | Replace with NU2A5 |
| 25A6 | 43 | Power Amplifier Pentode ⊕ | 7S | 25.0 | 0.300 | C | 180 | 135 | -20 | 38 | 7.5 | 100 | 2500 | 2750 | 5000 | Replace w. NU25A6GT/G |
| 25A6G | 43 | Power Amplifier Pentode ⊕ | 7S | 25.0 | 0.300 | C | 180 | 135 | -20 | 38 | 7.5 | 100 | 2500 | 2750 | 5000 | Replace w. NU25A6GT/G |
| 25A6GT | 25A6G | Power Amplifier Pentode ⊕ | 7S | 25.0 | 0.300 | C | 180 | 135 | -20 | 38 | 7.5 | 100 | 2500 | 2750 | 5000 | Replace w. NU25A6GT/G |
| 25A6GT/G | 25A6G | Power Amplifier Pentode ⊕ | 7S | 25.0 | 0.300 | C | 180 | 135 | -20 | 38 | 7.5 | 100 | 2500 | 2750 | 5000 | NU |
| 25A6MB | 43 | Power Amplifier Pentode ⊕ | 7S | 25.0 | 0.300 | C | 180 | 135 | -20 | 38 | 7.5 | 100 | 2500 | 2750 | 5000 | Replace w. NU25A6GT/G |
| 25A7G | — | Pentode and Half Wave Rectifier* | 8F | 25.0 | 0.300 | C | 125 | — | — | 75 | — | — | — | — | — | Replace with NU25A7GT/G |
| 25A7GT/G | 25A7G | Pentode and Half Wave Rectifier | 8F | 25.0 | 0.300 | C | 100 | 100 | -15 | 20.5 | 4.0 | 90 | 1800 | 770 | 4500 | — |
| | | | | | | C Pen. 100 Res. 125 | 100 | — | — | 75 | — | — | — | — | — | NU |
| 25AC5G | 8AC5G | Power Amplifier-Positive Grid | 6Q | 25.0 | 0.300 | C | 110 | — | +15 | 45 | — | 58 | 3800 | 2000 | 2000 | Replace with NU25AC5GT/G |
| 25AC5GT/G | 25AC5G | Power Amplifier-Positive Grid | 6Q | 25.0 | 0.300 | C | 110 | — | +15.0 | 45.0 | — | 58 | 3800 | 2000 | 2000 | NU |
| 25B5 | — | Power Amplifier Direct Coupled | 6D | 25.0 | 0.300 | C | 110 | Input | — | 7.0 | — | — | — | — | — | — |
| 25B6G | 43 | Power Amplifier-Pentode ⊕ | 7B | 25.0 | 0.300 | C | 95 | Output | 0 | 45 | — | 25 | 2200 | 2000 | 2000 | — |
| | | | | | | | 95 | — | -15 | 45 | 4.0 | — | 4000 | 1750 | 2000 | NU |
| 25B8GT | 12B8GT | Triode-Pentode | 8T | 25.0 | 0.150 | C | P100 | 100 | -1 | 0.8 | — | 112.5 | 1500 | — | — | |
| 25C6G | — | Beam Power Amplifier | 7AC | 25.0 | 0.300 | C | 200 | 135 | -14.0 | 56 | 9.0 | — | 7100 | 6000 | 2800 | NU |
| | | | | | | | P100 | — | -1 | 0.5 | — | 100 | 1100 | — | — | |
| 25D8GT | — | Diode-Triode-Pentode | 8AF | 25.0 | 0.150 | C | P100 | 100 | -3 | 8.3 | 2.7 | — | 1900 | — | — | |
| 25L6 | — | Beam Power Amplifier | 7AC | 25.0 | 0.300 | C | 110 | 110 | -8 | 45 | 3.5 | 80 | 8000 | 2200 | 2000 | Replace w. NU25L6GT/G |
| 25L6G | — | Beam Power Amplifier ⊕ | 7AC | 25.0 | 0.300 | C | 110 | 110 | -8.0 | 45 | 3.5 | 80 | 8000 | 2200 | 2000 | Replace w. NU25L6GT/G |

| | | | | | | | | | | | | | | | | | |
|----------|--------|-----------------------------------|-----|------|-------|------|-----|-----------------|---|------|------|-----|------|------|------|------|-------------------------|
| 25L6GT | — | Beam Power Amplifier | 7AC | 25.0 | 0.300 | C | 110 | 110 | — | 7.5 | 49 | 4.0 | 82 | 8200 | 2200 | 2000 | Replace w. NU25L6GT/G |
| 25L6GT/G | — | Beam Power Amplifier | 7AC | 25.0 | 0.300 | C | 110 | 110 | — | 7.5 | 49 | 4.0 | 82 | 8200 | 2200 | 2000 | NU |
| 25N6G | — | Power Amplifier Direct Coupled * | 7W | 25.0 | 0.300 | C | 110 | Input Output | — | 7.0 | — | — | — | — | — | — | NU |
| 25X6GT | 25Z6GT | Voltage Doubling Rectifier | 7Q | 25.0 | 0.150 | C | 125 | — | — | 8.0 | — | — | — | — | — | — | NU |
| 25Y4GT | — | Half Wave Rectifier | 5AA | 25.0 | 0.150 | C | 125 | — | — | 75 | — | — | — | — | — | — | — |
| 25Y8 | 25Z5 | Voltage Doubling Rectifier | 6E | 25.0 | 0.300 | C | 250 | — | — | 85 | — | — | — | — | — | — | NU |
| 25Z3 | — | Half Wave Rectifier | 4G | 25.0 | 0.300 | C | 250 | — | — | 50 | — | — | — | — | — | — | — |
| 25Z4 | — | Half Wave Rectifier | 5AA | 25.0 | 0.300 | C | 125 | — | — | 125 | — | — | — | — | — | — | — |
| 25Z4GT | — | Half Wave Rectifier | 5AA | 25.0 | 0.300 | C | 125 | — | — | 125 | — | — | — | — | — | — | — |
| 25Z5 | 25Y5 | Voltage Doubling Rectifier | 6E | 25.0 | 0.300 | C | 125 | — | — | 100 | — | — | — | — | — | — | NU |
| 25Z5MG | 25Z5 | Voltage Doubling Rectifier | 6E | 25.0 | 0.300 | C | 125 | — | — | 100 | — | — | — | — | — | — | Replace w. NU25Z5 |
| 25Z5 | 25Z5 | Voltage Doubling Rectifier * | 7Q | 25.0 | 0.300 | C | 125 | — | — | 85 | — | — | — | — | — | — | Replace w. NU25Z6GT/G |
| 25Z6G | 25Z3 | Voltage Doubling Rectifier * | 7Q | 25.0 | 0.300 | C | 125 | — | — | 85 | — | — | — | — | — | — | Replace with NU25Z6GT/G |
| 25Z6GT | 25Z6G | Voltage Doubling Rectifier | 7Q | 25.0 | 0.300 | C | 125 | — | — | 83 | — | — | — | — | — | — | Replace w. NU25Z6GT/G |
| 25Z6GT/G | — | Voltage Doubling Rectifier | 7Q | 25.0 | 0.300 | C | 125 | — | — | 85 | — | — | — | — | — | — | NU |
| 25Z6M3 | 25Z5 | Voltage Doubling Rectifier * | 7Q | 25.0 | 0.300 | C | 125 | — | — | 85 | — | — | — | — | — | — | Replace w. NU25Z6GT/G |
| 26 | — | Triode Amplifier | 4D | 1.5 | 1.050 | F(O) | 180 | — | — | 14.5 | 6.2 | — | 8.3 | 1150 | — | — | NU |
| 27 | 88 | Triode Detector-Amplifier | 5A | 2.5 | 1.750 | C | 250 | — | — | 21.0 | 5.2 | — | 9.0 | 975 | — | — | NU |
| K27 | 27-56 | Triode Detector-Amplifier | 5A | 2.5 | 1.750 | C | 90 | — | — | 4.5 | 3.0 | — | 9.0 | 1000 | — | — | Replace with NU27 |
| 2711M | 27-56 | Triode Detector-Amplifier | 5A | 2.5 | 1.750 | C | 180 | — | — | 13.5 | 5.0 | — | 13.0 | 1350 | — | — | Replace with NU27 |
| 27S | 27-36 | Triode Detector-Amplifier | 5A | 2.5 | 1.750 | C | 250 | — | — | 21.0 | 5.2 | — | 0.0 | 975 | — | — | NU |
| A28 | — | Triode Detector-Amplifier | 4Q | 15.0 | 0.350 | C | 90 | — | — | 1.5 | 7.5 | — | 10.5 | 1165 | — | — | — |
| KR28 | 84 | Full Wave Rectifier * | 5D | 6.3 | 0.500 | C | 350 | — | — | 60 | — | — | — | — | — | — | Replace with NU84-6Z4 |
| 29 | — | Special Detector | 6N | 2.5 | 1.000 | C | 180 | — | — | 5.0 | 4.8 | — | 30 | 1450 | — | — | — |
| 30 | 1H4G | Triode Detector-Amplifier | 4D | 2.0 | 0.600 | F(O) | 180 | — | — | 13.5 | 3.1 | — | 9.3 | 900 | — | — | NU |
| A30 | — | Power Amplifier Triode | 4Q | 15.0 | 0.350 | C | 180 | — | — | 27.0 | 22.0 | — | 3.8 | 1085 | — | — | — |
| 31 | — | Power Amplifier Triode | 4D | 2.0 | 0.130 | F(O) | 180 | — | — | 10.8 | 12.3 | — | 3.8 | 650 | 375 | 5700 | NU |
| KR31 | — | Half Wave Rectifier * | 4G | 10.0 | 0.500 | C | 350 | — | — | 100 | — | — | — | — | — | — | — |
| 32 | 1B4 | Screen Grid R.F. Amplifier | 4K | 2.0 | 0.060 | F(O) | 180 | 67.5 | — | 3.0 | 1.7 | 0.4 | 780 | 650 | — | — | NU |
| 32L7GT | — | Beam Power Amplifier Rectifier | 8F | 32.5 | 0.300 | C | 125 | 90 | — | 7.0 | 27 | 2.0 | 81 | 4800 | 1000 | 2600 | — |
| A32 | — | Triode Amplifier | 4Q | 15.0 | 0.350 | C | 155 | — | — | 3.0 | 1.8 | — | 30 | 940 | — | — | — |
| 33 | — | Power Amplifier Pentode | 5K | 2.0 | 0.260 | F(O) | 180 | 180 | — | 18.0 | 22 | 8 | 90 | 1700 | 1400 | 6000 | NU |
| 34 | 1A4 | Super Control R.F. Amplifier | 4M | 2.0 | 0.060 | F(O) | 180 | 67.5 | — | 3.0 | 2.8 | 1.0 | 620 | 620 | — | — | NU |
| 35-51 | — | Super Control R.F. Amplifier | 5E | 2.5 | 1.750 | C | 250 | 90 | — | 3.0 | 6.5 | 2.5 | 420 | 1050 | — | — | NU |
| 35A5 | — | Power Amplifier Pentode | 6AA | 35.0 | 0.160 | C | 110 | 110 | — | 7.5 | 35 | 2.8 | — | 5500 | 1400 | 2500 | NU |
| 35ASLT | 35A5 | Beam Power Amplifier | 6AA | 35.0 | 0.150 | C | 110 | 110 | — | 7.5 | 40.0 | 3.0 | — | 5800 | 1500 | 2500 | Replace w. NU35A5 |
| 35L6G | — | Beam Power Amplifier | 7AC | 35.0 | 0.150 | C | 110 | 110 | — | 7.5 | 40 | 3.0 | 80 | 5800 | 1500 | 2500 | Replace w. NU35L6GT/G |
| 35L6GT | — | Beam Power Amplifier | 7AC | 35.0 | 0.150 | C | 110 | 110 | — | 7.5 | 40 | 3 | 80 | 5800 | 1500 | 2500 | Replace w. NU35L6GT/G |
| 35L6GT/G | — | Beam Power Amplifier | 7AC | 35.0 | 0.150 | C | 110 | 110 | — | 7.5 | 40 | 3 | 80 | 5800 | 1500 | 2500 | NU |

(Cont'd over)

Receiving Tube Operating Characteristics and Basing Diagram Charts

(Cont'd)

| Type Number | Similar To | Description | Base Connection | Filet-Ment Volts | Filet-Ment Amps. | Filet-Ment Type | Plate Volts | Screen Volts | Control Grid Volts | Plate Current (mA) | Screen Current (mA) | Amplification Factor | Mutual Conductance in Micromhos | Power Output in Milliwatts | Load Resistance in Ohms | |
|---------------|------------|------------------------------|-----------------|------------------|------------------|-----------------|-------------|--------------|--------------------|--------------------|---------------------|----------------------|---------------------------------|----------------------------|-------------------------|-------------------------|
| 35B-318 | 85 | Super Control R.F. Amplifier | 5E | 2.5 | 1.760 | C | 250 | 90 | -3.0 | 6.5 | 2.6 | 420 | 1050 | - | — | NU |
| 85Y4 | 35Z5GT | Half Wave Rectifier | 5AL | 35.0 | 0.150 | C | 235 | — | — | 100 | — | — | — | — | — | — |
| 85Z3 | — | Half Wave Rectifier | 4Z | 35.0 | 0.160 | C | 250 | — | — | 100 | — | — | — | — | — | NU |
| 85Z3LT | 85Z3 | Half Wave Rectifier | 4Z | 35.0 | 0.160 | C | 250 | — | — | 100 | — | — | — | — | — | Replace w. NU35Z3 |
| 35Z4BT | — | Half Wave Rectifier | 5AA | 35.0 | 0.150 | C | 250 | — | — | 100 | — | — | — | — | — | NU |
| 85Z50 | — | Half Wave Rectifier | 6AD | 35.0 | 0.150 | C | 125 | — | — | 100 | — | — | — | — | — | Replace w. NU35Z5GT/G |
| 35Z5GT | — | Half Wave Rectifier | 6AD | 35.0 | 0.150 | C | 125 | — | — | 100 | — | — | — | — | — | Replace w. NU35Z5GT/G |
| 35Z5GT/G | — | Half Wave Rectifier | 6AD | 35.0 | 0.150 | C | 125 | — | — | 100 | — | — | — | — | — | NU |
| 35Z60 | — | Full Wave Rectifier | 7Q | 35.0 | 0.300 | C | 117 | — | — | 110.0 | — | — | — | — | — | NU |
| 36 | — | Screen Grid R.F. Amplifier | 5E | 8.3 | 0.300 | C | 250 | 90 | -8.0 | 3.2 | 1.7 | 595 | 1080 | — | — | NU |
| 37 | — | Triode Detector-Amplifier | 5A | 6.3 | 0.300 | C | 250 | — | -18.0 | 7.5 | — | 9.2 | 1100 | — | — | NU |
| 38 | — | Power Amplifier Pentode | 5F | 6.3 | 0.300 | C | 250 | 250 | -25.0 | 22 | 3.8 | 120 | 1200 | 2500 | 10000 | NU |
| 39/44 | — | — | — | — | — | — | — | — | — | — | — | — | — | — | — | — |
| 39A/44A | — | Super Control R.F. Amplifier | 8F | 6.3 | 0.300 | C | 250 | 90 | -3.0 | 5.8 | 1.4 | 1050 | 1050 | — | — | NU |
| 40 | — | Triode Voltage Amplifier | 4D | 5.0 | 0.250 | F(T) | 180 | — | -5.0 | 6.2 | — | 30 | 200 | — | — | Obsolete |
| A40 | — | Power Amplifier Triode | 4Q | 15.0 | 0.400 | C | 180 | — | -40.5 | 21 | — | 3 | 1500 | — | — | — |
| 40Z5/45Z5GT | 45Z5GT | Half Wave Rectifier | 6AD | 45.0 | 0.150 | C | 125 | — | — | 100.0 | — | — | — | — | — | Rep. w. NU45Z5GT/40Z5GT |
| 41 | 42 | Power Amplifier Pentode | 6B | 6.3 | 0.400 | C | 250 | 250 | -10.0 | 32 | 5.5 | 150 | 2200 | 3400 | 7800 | NU |
| 42 | — | Power Amplifier Pentode | 6B | 6.3 | 0.700 | C | 250 | 250 | -18.8 | 34 | 6.6 | 220 | 2200 | 3000 | 7000 | NU |
| 42A1 | — | Ballast Tube | 42.3 | — | — | — | — | — | — | — | — | — | — | — | — | — |
| 42A2 | — | Ballast Tube | 42.3 | — | — | with Tap | — | — | For | One Pilot Lamp | — | — | — | — | — | — |
| 42B2 | — | Ballast Tube | 42.3 | — | — | with Tap | — | — | For | Two Pilot Lamps | — | — | — | — | — | — |
| 43 | — | Power Amplifier Pentode | 6B | 25.8 | 0.300 | C | 180 | 135 | -20.0 | 40 | 8 | 96 | 2400 | 2750 | 5000 | NU |
| 43MB | 43 | Power Amplifier Pentode | 6B | 25.0 | 0.300 | C | 180 | 135 | -20.0 | 40 | 8 | 96 | 2400 | 2750 | 5000 | Replace with NU43 |
| 44 | 39/44 | Super Control R.F. Amplifier | 8F | 6.3 | 0.300 | C | 250 | 90 | -3.0 | 5.8 | 1.4 | 1050 | 1050 | — | — | Replace with NU39/44 |
| 45 | — | Power Amplifier Triode | 4D | 2.5 | 1.500 | F(O) | 250 | — | -50 | 34 | — | 8.5 | 2175 | 1800 | 3900 | NU |
| 45A | 45 | Power Amplifier Triode | 4D | 2.5 | 1.500 | F(O) | 325 | — | -68 | 43 | — | 3.5 | 2370 | 3000 | 3200 | Replace with NU45 |
| 45Z3 | — | Half Wave Rectifier | 5AM | 45.0 | 0.050 | F(O) | 117 | — | — | 65 | — | — | — | — | — | NU |
| 45Z5GT/40Z5GT | — | Half Wave Rectifier | 6AD | 45.0 | 0.160 | C | 123 | — | — | 100 | — | — | — | — | — | NU |
| 46 | — | Power Amplifier Dual Grid | 6C | 2.5 | 1.750 | F(O);(B) | 400 | — | -40 | 22 | — | 6.6 | 2300 | 1200 | 6400 | — |
| 46A1 | — | Ballast Lamp | 46.1 | 0.400 | F | — | — | — | — | — | — | — | — | — | — | — |
| 46B1 | — | Ballast Lamp | 46.1 | 0.300 | F | — | — | — | — | — | — | — | — | — | — | — |
| 47 | — | Power Amplifier Pentode | 5B | 2.5 | 1.750 | F(O) | 250 | 250 | -16.5 | 31 | 0 | 180 | 2500 | 2700 | 7900 | NU |
| 48 | — | Power Amplifier Tetrode | 8A | 30.0 | 0.400 | C | 96 | 96 | -20.0 | 56 | 0.5 | — | 3800 | 2500 | 1500 | — |
| A48 | — | Triode Detector-Amplifier | 4G | 10.0 | 0.350 | C | 90 | — | -4.5 | 4.0 | — | 14 | 1185 | — | — | — |

| | | | | (A) 135 | | | —20.0 | 0 | — | 4.7 | 1125 | 170 | 11000 | | |
|----------|--------|--------------------------------|-----|---------|-------|------------|------------|-------|-------|--------|------|---------|-------------|------------------------|----------|
| 49 | — | Power Amplifier Dual Grid | 5C | 2.0 | 0.120 | F(O)(B)180 | 0 | 2 | — | — | — | 3500(2) | 12000(2) NU | | |
| 49A1 | — | Ballast Lamp | | 48.6 | — | — | — | — | — | — | — | — | — | | |
| 49A2 | — | Ballast Lamp | | 48.6 | — | with Tap | For | One | Pilot | Light | — | — | — | | |
| 49B2 | — | Ballast Lamp | | 48.6 | — | with Tap | For | Two | Pilot | Lights | — | — | — | | |
| 50 | — | Power Amplifier Triode | 4D | 7.5 | 1.250 | F(U) 450 | —84 | 55 | — | 3.8 | 2100 | 4600 | 4350 NU | | |
| 50A5 | 50L6GT | Beam Power Amplifier | 6AA | 50.0 | 0.150 | C 200 | 110 | — 8.0 | 55 | 6.0 | — | 8250 | 4700 | 3000 | |
| 50C6G | — | Beam Power Amplifier | 7AC | 50.0 | 0.150 | C 200 | 135 | —14.0 | 66.0 | 9.0 | — | 7100 | 6000 | 2600 | |
| 50L6GT | 6L6G | Beam Power Amplifier | 7AC | 50.0 | 0.150 | C 110 | 110 | — 7.5 | 43 | 4 | 68 | 6800 | 1750 | 2000 NU | |
| 50Y6G | — | Voltage Doubling Rectifier | 7Q | 50.0 | 0.150 | C 125 | — | — | 85 | — | — | — | — | Replace w. NU50Y6GT/G | |
| 50Y6GT | — | Full Wave Rectifier | 7Q | 50.0 | 0.150 | C 125 | — | — | 85 | — | — | — | — | Replace w. NU50Y6GT/G | |
| 50Y6GT/G | — | Full Wave Rectifier | 7Q | 50.0 | 0.150 | C 125 | — | — | 85 | — | — | — | — | NU | |
| 50Z6G | — | Voltage Doubling Rectifier | 7Q | 50.0 | 0.300 | C 125 | — | — | 100 | — | — | — | — | — | |
| 50Z7G | — | Voltage Doubling Rectifier | 8AN | 50.0 | 0.150 | C 117 | — | — | 65 | — | — | — | — | NU | |
| H250 | 1223 | Half Wave Rectifier | 4G | 12.8 | 0.300 | C 250 | — | — | 94 | — | — | — | — | Replace with NU1223 | |
| 51 | 35 | Super Control R.F. Amplifier | 5E | 2.5 | 1.750 | C 250 | 90 | — 3.0 | 6.5 | 2.8 | 420 | 1050 | — | Replace with NU35/51 | |
| 51B | 35 | Super Control R.F. Amplifier | 5E | 2.5 | 1.750 | C 250 | 90 | — 3.0 | 6.5 | 2.5 | 420 | 1050 | — | Replace with NU35S/51S | |
| 52 | — | Power Amplifier Dual Grid | 5C | 6.3 | 0.300 | F | 110(A) 110 | 0 | 43 | — | 5.2 | 3000 | 1500 | 2000 | |
| 53 | — | Class B Twin Amplifier | 7B | 2.5 | 2.000 | C | 300 | — | 0 | 17.5 | — | — | 6000 | 9000 | |
| 65 | — | Duplex Diode Triode | 6G | 2.5 | 1.000 | C 250 | — | — | 0 | 8 | — | 8.3 | 1100 | 350 | 20000 NU |
| 55S | 55 | Duplex Diode Triode | 6G | 2.5 | 1.000 | C 250 | — | — | 20 | 8 | — | 8.3 | 1100 | 350 | 20000 NU |
| 55A1 | — | Ballast Lamp | | 54.9 | — | — | — | — | — | — | — | — | — | — | |
| 55A2 | — | Ballast Lamp | | 54.9 | — | with Tap | For | One | Pilot | Light | — | — | — | — | |
| 55B2 | — | Ballast Lamp | | 54.9 | — | with Tap | For | Two | Pilot | Lights | — | — | — | — | |
| 56 | 27 | Triode Detector-Amplifier | 5A | 2.5 | 1.000 | C 250 | — | —13.5 | 5 | — | 13.8 | 1450 | — | NU | |
| 56A | 76 | Triode Detector-Amplifier | 5A | 6.3 | 0.400 | C 250 | — | —13.5 | 5 | — | 13.8 | 1450 | — | Replace with NU76 | |
| 56AS | 76 | Triode Detector-Amplifier | 5A | 6.3 | 0.400 | C 250 | — | —13.5 | 5 | — | 13.8 | 1450 | — | Replace with NU76 | |
| 56S | 56 | Triode Detector-Amplifier | 5A | 2.5 | 1.000 | C 250 | — | —13.5 | 5 | — | 13.8 | 1450 | — | NU | |
| 57 | — | Triode Grid Detector Amplifier | 6F | 2.5 | 1.000 | C 250 | 100 | — 3.0 | 2 | 6.5 | 1500 | 1225 | — | NU | |
| 57A | 77-6C6 | Triode Grid Detector Amplifier | 6F | 6.3 | 0.400 | C 250 | 100 | — 3.0 | 2 | 6.5 | 1500 | 1225 | — | Replace with NU77 | |
| 57AB | 77-6C6 | Triode Grid Detector Amplifier | 6F | 6.3 | 0.400 | C 250 | 100 | — 3.0 | 2 | 6.5 | 1500 | 1225 | — | NU | |
| 57B | 57 | Triode Grid Detector Amplifier | 6F | 2.5 | 1.000 | C 250 | 100 | — 3.0 | 2 | 6.5 | 1500 | 1225 | — | NU | |
| 58 | — | Super Control R.F. Amplifier | 6F | 2.5 | 1.000 | C 250 | 100 | — 3.0 | 6.2 | 2.0 | 1280 | 1600 | — | NU | |
| 58A | 75-6D6 | Super Control R.F. Amplifier | 6F | 6.3 | 0.400 | C 250 | 100 | — 3.0 | 6.2 | 2.0 | 1280 | 1600 | — | Replace with NU78 | |
| 58AB | 78-6D6 | Super Control R.F. Amplifier | 6F | 6.3 | 0.400 | C 250 | 100 | — 3.0 | 6.2 | 2.0 | 1280 | 1600 | — | NU | |
| 58B | 58 | Super Control R.F. Amplifier | 6F | 2.5 | 1.000 | C 250 | 100 | — 3.0 | 6.2 | 2.0 | 1280 | 1600 | — | NU | |
| 59 | — | Power Amplifier Pentode | 7A | 2.5 | 2.000 | C 250 | 250 | —18.0 | 35 | 9 | 100 | 2500 | 3000 | 6000 NU | |
| 59B | 59 | Power Amplifier Pentode | 7M | 2.5 | 2.000 | F(D) 250 | 250 | —28.0 | 26 | — | 6 | 2600 | 1250 | 5000 | |
| 64-6A | 36 | Screen Grid R.F. Amplifier | 8E | 6.3 | 0.400 | C 180 | 90 | — 3.0 | 3.1 | 1.5 | 525 | 1050 | — | Obsolete | |
| 65-65A | 39/44 | Super Control R.F. Amplifier | 5E | 6.3 | 0.400 | C 180 | 90 | — 3.0 | 4.6 | 1.5 | 750 | 1000 | — | Obsolete | |

Receiving Tube Operating Characteristics and Basing Diagram Charts

| Type Number | Similar To | Description | Base Connection | Fila-ment Volts | Fila-ment Amps. | Fila-ment Type | Plate Volts | Screen Volts | Control Grid Volts | Plate Current (MA) | Screen Current (MA) | Ampli-fication Factor | Mutual Conduc-tance in Micromhos | Power Output in Milliwatts | Lead Resistance in Ohms |
|-------------|------------|--------------------------------|-----------------|-----------------|-----------------|----------------|-----------------|--------------|----------------------|--------------------|---------------------|-----------------------|----------------------------------|----------------------------|-------------------------|
| 67-67A | 87 | Triode Detector-Amplifier | 5A | 6.3 | 0.400 | C | 100 | 4.3 | — | — | —13.5 | 8.2 | 900 | — | — Obsolete |
| 68-68A | 38 | Power Amplifier Pentode | 8E | 6.3 | 0.400 | C | 133 | 80 | —13.5 | 14 | 3 | 92 | 1400 | 850 | 7500 Obsolete |
| 69 | — | Detector-Double Grid | 8N | 6.3 | 0.300 | C | 100 | — | — 8.0 | 4.5 | — | 30 | 1400 | — | — |
| 70 | — | Detector-Double Grid | 6N | 6.3 | 0.300 | C | 100 | — | — 6.0 | 2.5 | — | 15 | 800 | — | — |
| 76A/7GT | — | Rectifier Beam Power Amplifier | 8AB | 70.0 | 0.150 | C | 110 Rec. 125 | 110 | — 7.5 | 40 | 3.0 | 80 | 5800 | 1500 | 2500 NU |
| 76L/7GT | — | Rectifier-Beam Power Amplifier | 8AA | 70.0 | 0.150 | C | R125 A110 | 110 | — | 70 | — | — | — | — | — |
| 71 | 71A | Power Amplifier Triode | 4D | 6.0 | 0.500 | F(T) | 180 | — | —40.5 | 20 | — | 3 | 1700 | 790 | 4800 Replace with NU71A |
| 71A | — | Power Amplifier Triode | 4D | 6.0 | 0.250 | F(O) | 180 | — | —40.5 | 20 | — | 3 | 1700 | 790 | 4800 NU |
| 71B | 71A | Power Amplifier Triode | 4D | 6.0 | — | — | 180 | — | —40.5 | 20 | — | 3 | 1700 | 790 | 4800 Replace with NU71A |
| 75 | — | Duplex Diode Triode | 6G | 6.3 | 0.300 | C | 250 | — | — 2.0 | 0.8 | — | 100 | 1100 | — | — NU |
| 75B | 75 | Duplex Diode Triode | 6G | 6.3 | 0.300 | C | 250 | — | — 2.0 | 0.8 | — | 100 | 1100 | — | — Replace with NU75 |
| 76 | 87 | Triode Detector-Amplifier | 5A | 6.3 | 0.300 | C | 230 | — | —13.5 | 5 | — | 13.8 | 1450 | — | — NU |
| 77 | 6C6 | Triple Grid Detector-Amplifier | 6F | 6.3 | 0.300 | C | 250 | 100 | — 8.0 | 2.8 | 0.8 | 1500 | 1250 | — | — NU |
| 78 | 6D3 | Super Control R.F. Amplifier | 6F | 6.3 | 0.300 | C | 250 | 100 | — 8.0 | 7.0 | 1.7 | 1150 | 1450 | — | — NU |
| 79 | — | Class B Twin Amplifier | 6H | 6.3 | 0.600 | C | 250 | — | — | 10.0 | — | — | — | 8000(2) | 14000(2) NU |
| 80 | — | Full Wave Rectifier | 4C | 5.0 | 2.000 | F(O) | 400 | — | — | 110 | — | — | — | — | — NU |
| 80M | 80 | Full Wave Rectifier * | 4C | 5.0 | 2.000 | F(O) | 450 | — | — | 125 | — | — | — | — | — Replace with NU80 |
| 80A1 | — | Ballast Lamp | 78.7 | — | — | — | — | — | — | — | — | — | — | — | — |
| 80A2 | — | Ballast Lamp | 79.7 | — | — | with Tap | — | — | For One Pilot Light | — | — | — | — | — | — |
| 80B2 | — | Ballast Lamp | 79.7 | — | — | with Tap | — | — | For Two Pilot Lights | — | — | — | — | — | — |
| 81 | — | Half Wave Rectifier | 4B | 7.5 | 1.250 | F(O) | 700 | — | — | 85 | — | — | — | — | — NU |
| 81M | 81 | Half Wave Rectifier | 4B | 7.5 | 1.250 | F(O) | 750 | — | — | 85 | — | — | — | — | — Replace with NU81 |
| 82 | — | Full Wave Rectifier * | 4C | 2.5 | 3.000 | F(O) | 500 | — | — | 125 | — | — | — | — | — NU |
| 83 | 523 | Full Wave Rectifier * | 4C | 6.0 | 3.000 | F(O) | 500 | — | — | 250 | — | — | — | — | — NU |
| 83V | 83-523 | Full Wave Rectifier | 4AD | 5.0 | 2.000 | C | 400 | — | — | 200 | — | — | — | — | — NU |
| 84-624 | 824 | Full Wave Rectifier | 5D | 6.3 | 0.500 | C | 500 | — | — | 75 | — | — | — | — | — NU |
| 8-84 | 222 | Half Wave Rectifier | 4B | 2.5 | 1.500 | F | 350 | — | — | 50 | — | — | — | — | — |
| 85 | — | Duplex Diode Triode | 6G | 6.3 | 0.300 | C | 250 | — | —20.0 | 8 | — | 2.3 | 1100 | 350 | 20000 NU |
| 85AS | — | Duplex Diode Triode | 6G | 6.3 | 0.300 | C | 250 | — | — 9.0 | 4.5 | — | 20 | 1250 | — | — NU |
| 85S | 85 | Duplex Diode Triode | 6G | 6.3 | 0.300 | C | 250 | — | —20.0 | 8 | — | 8.3 | 1100 | 350 | 20000 Replace with NU85 |
| 86A1 | — | Ballast Lamp | 86.0 | — | — | — | — | — | — | — | — | — | — | — | — |
| 86A2 | — | Ballast Lamp | 86.0 | — | — | with Tap | — | — | For One Pilot Light | — | — | — | — | — | — |
| 86B2 | — | Ballast Lamp | 86.0 | — | — | with Tap | — | — | For Two Pilot Lights | — | — | — | — | — | — |
| 88 | 83V | Full Wave Rectifier | 4C | 6.0 | 2.000 | F(O) | 450 | — | — | 125 | — | — | — | — | — Replace with NU83V |

| | | | | | | | | | | | | | | | | |
|---------------------|-----|--------------------------------|------|----------|---------------|----------|---------------------|--------|--------|--------------|-----|-----|------|------|---------|----------------------------------|
| 89 | -- | Power Amplifier Pentode | 8F | 6.3 | 0.400 | C | 250 | 250 | --25.0 | 32 | 5.5 | 125 | 1800 | 3400 | 6750 | NU |
| 92 | -- | Detector-Double Grid | 8N | 2.8 | 1.000 | C | -- | -- | 0 | 3.5 | -- | 14 | 1400 | -- | 100,000 | |
| 90 | -- | Detector-Double Grid | 6N | 6.3 | 0.400 | C | -- | -- | 0 | 3.5 | -- | 14 | 1400 | -- | 100,000 | |
| 92A1 | -- | Ballast Lamp | 92.3 | -- | -- | -- | -- | -- | -- | -- | -- | -- | -- | -- | -- | -- |
| 92A2 | -- | Ballast Lamp | 92.3 | -- | -- | with Tap | For One Pilot | Light | -- | -- | -- | -- | -- | -- | -- | -- |
| 92B2 | -- | Ballast Lamp | 92.3 | -- | -- | with Tap | For Two Pilot | Lights | -- | -- | -- | -- | -- | -- | -- | -- |
| 98 | 2A5 | Power Amplifier Pentode | 8B | 2.5 | 1.750 | C | 315 | 315 | --22.0 | 42 | 8 | 220 | 2500 | 8000 | 7000 | Replace with NU2A5 |
| 98 | -- | Half Wave Rectifier * | 4B | 16.0 | 0.600 | C | 359 | -- | -- | 100 | -- | -- | -- | -- | -- | -- |
| K98 | 84 | Full Wave Rectifier * | 8D | 6.8 | 0.600 | C | 350 | -- | -- | 80 | -- | -- | -- | -- | -- | Replace with NU84 |
| V99 | X99 | Triode Detector-Amplifier | 4E | 8.5 | 0.963 | F(T) | 90 | -- | --4.5 | 2.5 | -- | 6.6 | 425 | -- | -- | NU |
| X99 | -- | Triode Detector-Amplifier | 4D | 8.5 | 0.963 | F(O) | 90 | -- | --4.5 | 2.5 | -- | 6.6 | 425 | -- | -- | NU |
| 117L7GT | -- | Rectifier-Beam Power Amplifier | 8AD | 117.0 | 0.090 | C | R105 A105 | 100 | -- | 75.0 45.0 | 4.0 | -- | 4000 | 550 | 4000 | Replace w. NU117L7GT/ 117M7GT |
| 117L7GT/ 117M7GT | -- | Rectifier-Beam Power Amplifier | 8AD | 117.0 | 0.090 | C(P) | (R) 117 C(P) 105 | 105 | -- | 75 43 | 4.0 | -- | 5300 | 850 | 4000 | NU |
| 117M7GT | -- | Rectifier-Power Amplifier | 8AD | 117.0 | 0.090 | C(P) | (R) 117 C(P) 100 | 100 | -- | 75.0 56.0 | 4.5 | -- | 7000 | 1200 | 2000 | Replace w. NU117L7GT/ 117M7GT |
| 117N7GT | -- | Rectifier-Beam Power Amplifier | 8AV | 117.0 | 0.090 | C | R117 A100 | 100 | -- | 75 51 | 5.0 | -- | 7000 | 1200 | 3000 | NU |
| 117P7GT | -- | Rectifier-Beam Power Amplifier | 8AV | 117.0 | 0.090 | C(P) | (R) 117 C(P) 105 | 105 | -- | 75 43 | 4.0 | -- | 5300 | 850 | 4000 | NU |
| 117Z4GT | -- | Half Wave Rectifier | 5AA | 117.0 | 0.040 | C | 117 | -- | -- | 90 | -- | -- | -- | -- | -- | NU |
| 117Z6G | -- | Full Wave Rectifier | 7Q | 117.0 | 0.075 | C | 117 | -- | -- | 80 | -- | -- | -- | -- | -- | Replace w. NU117Z6GT/G |
| 117Z6GT | -- | Full Wave Rectifier | 7Q | 117.0 | 0.075 | C | 117 | -- | -- | 80 | -- | -- | -- | -- | -- | Replace w. NU117Z6GT/G |
| 117Z6GT/G | -- | Full Wave Rectifier | 7Q | 117.0 | 0.075 | C | 117 | -- | -- | 80 | -- | -- | -- | -- | -- | NU |
| 140R | -- | Ballast Lamp | 42.3 | -- | -- | -- | -- | -- | -- | -- | -- | -- | -- | -- | -- | -- |
| 140R4 | -- | Ballast Lamp | 42.3 | With Tap | For One Pilot | Light | -- | -- | -- | -- | -- | -- | -- | -- | -- | -- |
| 140R8 | -- | Ballast Lamp | 42.3 | With Tap | For Two Pilot | Lights | -- | -- | -- | -- | -- | -- | -- | -- | -- | -- |
| 165R | -- | Ballast Lamp | 46.6 | -- | -- | -- | -- | -- | -- | -- | -- | -- | -- | -- | -- | -- |
| 165H4 | -- | Ballast Lamp | 46.6 | With Tap | For One Pilot | Light | -- | -- | -- | -- | -- | -- | -- | -- | -- | -- |
| 165R8 | -- | Ballast Lamp | 46.6 | With Tap | For Two Pilot | Lights | -- | -- | -- | -- | -- | -- | -- | -- | -- | -- |
| 181 | -- | Power Amplifier Triode | 4D | 8.0 | 1.350 | C | 180 | -- | --33.0 | 18 | -- | 8 | 1600 | -- | 4500 | Replace with NU71A |
| 182A | 71A | Power Amplifier Triode | 4D | 5.0 | 0.800 | F(O) | 200 | -- | --25.0 | 18 | -- | 8 | 1500 | 1500 | -- | Replace with NU483 |
| 182B | 483 | Power Amplifier Triode | 4D | 5.0 | 1.250 | F(O) | 250 | -- | --35.0 | 18 | -- | 8 | 1800 | 1750 | -- | Replace with NU483 |
| 183 | 483 | Power Amplifier Triode | 4D | 8.0 | 1.250 | F(O) | 250 | -- | --40.0 | 25 | -- | 3.2 | 1800 | 2000 | -- | |
| 185R | -- | Ballast Lamp | 54.9 | -- | -- | -- | -- | -- | -- | -- | -- | -- | -- | -- | -- | -- |
| 185R4 | -- | Ballast Lamp | 54.9 | With Tap | For One Pilot | Light | -- | -- | -- | -- | -- | -- | -- | -- | -- | -- |

(Cont'd over)

(Cont'd)

Receiving Tube Operating Characteristics and Basing Diagram Charts

1285

| Type Number | Similar To | Description | Base Connection | Filament Volts | Filament Amps. | Filament Type | Plate Volts | Screen Volts | Control Grid Volts | Plate Current (mA) | Screen Current (mA) | Amplification Factor | Mutual Conductance in Micromhos | Power Output in Milliwatts | Load Resistance in Ohms |
|-------------|------------|----------------------------|-----------------|----------------|----------------|---------------|-------------|--------------|--------------------|--------------------|---------------------|----------------------|---------------------------------|----------------------------|-------------------------|
| 183R3 | — | Ballast Lamp * | — | 54.9 | — | With Tap | — | — | — | — | — | — | — | — | — |
| 213 | 80 | Full Wave Rectifier | 4C | 5.0 | 2.000 | F (T) | 220 | — | — | 65 | — | — | — | — | — |
| 216 | 81 | Half Wave Rectifier | 4B | 7.5 | 1.250 | F (T) | 350 | — | — | 65 | — | — | — | — | Replace with NU80 |
| 257 | — | Power Amplifier Pentode | 5B | 5.0 | 0.300 | F | 110 | 110 | -21.5 | 20 | 7 | 55 | 1350 | 800 | — |
| 264 | WX12 | Triode-Non Microphonic | 4D | 1.1 | 0.250 | F (O) | 135 | — | -8.0 | 3.5 | — | 8.2 | 645 | — | — |
| 291 | — | Triode Twin Amplifier | 5G | 12.3 | 0.300 | C | 173.5 | Input | -11.0 | 3 | — | — | — | — | — |
| | | | | | | F (O) | 180 | Output | +11.0 | 30 | — | — | — | 1250 | 3000 |
| 293 | — | Triode Twin Amplifier | 5G | 6.3 | 0.600 | C | 250 | Input | -6.5 | 4 | — | — | — | — | — |
| | | | | | | F (O) | 250 | Output | +6.5 | 17.0 | — | — | — | 1250 | 8000 |
| 295 | — | Triode Twin Amplifier | 5G | 2.5 | 4.000 | C | 284 | Input | -14.0 | 4 | — | — | — | — | — |
| | | | | | | F (O) | 290 | Output | -8.0 | 82 | — | — | — | 4500 | 4000 |
| 401 | — | Triode Detector-Amplifier | 4D | 3.0 | 1.350 | C | 90 | — | -3.0 | 8 | — | 9.5 | 1000 | — | — |
| 401A | — | Triode Detector-Amplifier | 4D | 5.0 | 0.250 | F | 45 | — | -9.0 | 1.0 | — | 8.0 | 800 | 55 | 20000 |
| 402-403 | — | Power Amplifier Triode | 4D | 3.0 | 1.500 | F (O) | 180 | — | -40.0 | 20 | — | 3 | 1000 | — | Replace with NU01A |
| 450 | 50 | Power Amplifier Triode | 4D | 7.5 | 1.250 | F (O) | 450 | — | -64.0 | 55 | — | 3.8 | 2100 | 4600 | 4350 |
| 482A | 71A | Power Amplifier Triode | 4D | 5.0 | 0.800 | F (O) | 200 | — | -45.0 | 18 | — | 3 | 1500 | 1500 | 4500 |
| 482B | — | Power Amplifier Triode | 4D | 5.0 | 1.250 | F (O) | 250 | — | -38.0 | 18 | — | 5 | 1500 | 1750 | 4500 |
| 483 | 182B | Power Amplifier Triode | 4D | 5.0 | 1.250 | F (O) | 250 | — | -65.0 | 20 | — | 3 | 1500 | 2000 | 4500 |
| 484 | 485 | Triode Detector-Amplifier | 5A | 2.8 | 1.600 | C | 180 | — | -9.0 | 6 | — | 12.5 | 1350 | — | — |
| 485 | 484 | Triode Detector Amplifier | 5A | 3.0 | 1.250 | C | 180 | — | -9.0 | — | 9 | 12.5 | 1350 | — | — |
| 486 | — | Triode Amplifier | 5S | 3.0 | 0.250 | F | 90 | — | -3.0 | 3 | — | 12.5 | 450 | — | — |
| 583 | 50 | Power Amplifier Triode | 4D | 7.5 | 1.250 | F (O) | 450 | — | -64.0 | 55 | — | 3.8 | 2100 | 4600 | 4350 |
| 588 | 50 | Power Amplifier Triode | 4D | 7.5 | 1.250 | F (O) | 450 | — | -64.0 | 65 | — | 3.8 | 2100 | 4800 | 4350 |
| 840 | — | R.F. Pentode | 6J | 2.0 | 0.130 | F (O) | 180 | 67.5 | -3.0 | 1.0 | 0.7 | 400 | 400 | — | — |
| P86J | 84 | Full wave Rectifier | 5D | 6.3 | 0.800 | C | 225 | — | — | 80 | — | — | — | — | — |
| 864 | WX12 | Triode Non-Microphonic | 4D | 1.1 | 0.250 | F (O) | 135 | — | -8.0 | 3.5 | — | 8.2 | 645 | — | — |
| 866 | — | Half Wave Rectifier | 4P | 2.0 | 0.0 | F (O) | 7500 | — | — | 600 | — | — | — | — | — |
| 874 | — | Voltage Regulator | 4S | — | — | — | 90 | — | -10-50 | — | — | — | — | — | — |
| 876 | — | Ballast Tube | — | 40-60 | 1.700 | F | — | — | — | — | — | — | — | — | — |
| 886 | — | Ballast Tube | — | 40-60 | 2.050 | F | — | — | — | — | — | — | — | — | — |
| 950 | 1F4 | Power Amplifier Pentode | 5K | 2.0 | 0.125 | F (U) | 130 | 135 | -16.5 | 3.5 | 2 | 100 | 800 | — | — |
| 951 | 1B4 | Screen Grid R.F. Amplifier | 4K | 2.0 | 0.050 | F (O) | 180 | 67.5 | -3.0 | 1.7 | 0.4 | 780 | 800 | — | — |
| 985 | — | Full Wave Rectifier R | 5D | 5.0 | 0.500 | F (O) | 254 | — | — | 50 | — | — | — | — | — |
| 986 | 83 | Full Wave Rectifier R | 4C | 3.0 | 1.000 | F (U) | 400 | — | — | 100 | — | — | — | — | — |

Replace with NU-85

| | | | | | | | | | | | | | | | | | |
|----------------------|-----|------------------------------|-------|------|-------|------|-----|-----|---|------|-----|-----|------|------|------|-------|---------------------|
| †120t | — | Ultra High Frequency Triode | 8XA | 6.3 | 0.150 | C | 180 | — | — | 3.0 | 5.5 | — | 36 | 3000 | — | — | — |
| †1203A | — | High Frequency Diode | 8XB | 6.3 | 0.150 | C | 10 | — | — | 9.0 | — | — | — | — | — | — | — |
| †185I | — | Television Amplifier Pentode | C | 6.3 | .450 | C | 300 | 150 | — | 2 | 10 | 2.5 | 6750 | 9000 | — | — | — |
| AD | 1V | Half Wave Rectifier | 4G | 6.3 | 0.300 | C | 300 | — | — | 80 | — | — | — | — | — | — | Replace with NU-1V |
| AF | 82 | Full Wave Rectifier * | 4C | 2.5 | 3.000 | F(O) | 500 | — | — | 125 | — | — | — | — | — | — | Replace with NU-82 |
| AG | 83 | Full Wave Rectifier * | 4C | 5.0 | 3.000 | F(O) | 300 | — | — | 250 | — | — | — | — | — | — | Replace with NU-83 |
| Ax | 91A | Triode Detector-Amplifier | 4D | 3.0 | 0.250 | F(T) | 135 | — | — | 9.0 | — | — | 8 | 800 | 55 | 20000 | Replace with NU-01A |
| B | V99 | Triode Detector-Amplifier | 4E | 6.3 | 0.063 | F(T) | 90 | — | — | 4.5 | 2.5 | — | 6.0 | 425 | — | — | Replace with NU-V99 |
| BA | — | Full Wave Gaseous Rectifier | 4J | Cold | — | — | 350 | — | — | 350 | — | — | — | — | — | — | — |
| BB | 5A | Full Wave Gaseous Rectifier | 4J | Cold | — | — | 350 | — | — | 120 | — | — | — | — | — | — | — |
| BR | — | Half Wave Gaseous Rectifier | 4H | Cold | — | — | 300 | — | — | 50 | — | — | — | — | — | — | — |
| D% | 81 | Half Wave Rectifier | 4B | 7.5 | 1.250 | F(O) | 700 | — | — | 85 | — | — | — | — | — | — | Replace with NU-81 |
| D1 | 80 | Full Wave Rectifier | 4C | 5.0 | 2.000 | F(O) | 300 | — | — | 125 | — | — | — | — | — | — | Replace with NU-80 |
| DE1 | 27 | Triode Detector | 5A | 2.5 | 1.750 | C | 250 | — | — | 21.0 | 0.2 | — | 9 | 975 | 300 | 54000 | Replace with NU-27 |
| E | 20 | Power Amplifier Triode | 4D | 3.3 | 0.132 | F(O) | 135 | — | — | 22.6 | 6.5 | — | 3.3 | 525 | 110 | 6500 | Replace with NU-20 |
| G | 40 | Triode Voltage Amplifier | 4D | 5.0 | 0.250 | F(T) | 180 | — | — | 3.0 | 0.2 | — | 30 | 200 | — | — | — |
| GA | — | Pentode | 5B | 5.0 | 0.250 | F(T) | 180 | 180 | — | 10.0 | 25 | 7.5 | 60 | 2800 | 800 | 7000 | — |
| H | 01A | Triode Detector | 4D | 5.0 | 0.250 | F(T) | 45 | — | — | 8 | 1.8 | — | 20 | 668 | — | — | Replace with NU-01A |
| LA | 6A4 | Power Amplifier Pentode | 5B | 6.3 | 0.300 | F(O) | 180 | 180 | — | 12.9 | 22 | 3.9 | 100 | 2200 | 1400 | 8000 | Replace with NU-6A4 |
| PZ | 47 | Power Amplifier Pentode | 5B | 2.5 | 1.750 | F(O) | 250 | 250 | — | 16.5 | 31 | 6 | 150 | 2500 | 2700 | 7000 | Replace with NU-47 |
| PZH | 2A5 | Power Amplifier Pentode | 6B | 2.5 | 1.750 | C | 250 | 250 | — | 16.5 | 34 | 6.6 | 220 | 2200 | 3800 | 7000 | Replace with NU-2A5 |
| †XXB | — | Double Triode | 8X3 | 1.4 | 0.100 | F(O) | 90 | — | — | 0 | 4.5 | — | 14.5 | 1300 | — | — | — |
| †XXD | — | Twin Triode Amplifier | 8AC | 12.6 | 0.150 | C | 250 | — | — | 10.0 | 9.0 | — | 16 | 2100 | — | — | NU |
| †XXFM | — | Twin Diode High MU Triode | 8XE | 6.3 | 0.300 | C | 250 | — | — | 1.0 | 1.9 | — | 100 | 1500 | — | — | — |
| †XXL | — | Triode Amplifier | 5AC | 6.3 | 0.300 | C | 250 | — | — | 8.0 | 8.0 | — | 20 | 2300 | — | — | NU |
| Wunderlich A Auto | — | Special Detector | 6N | 6.3 | 0.400 | C | 250 | — | — | 16.5 | 7 | — | 9.2 | 900 | — | — | — |
| Wunderlich A | — | Special Detector | 5H-6N | 2.5 | 1.000 | C | 250 | — | — | 16.5 | 7 | — | 9.2 | 900 | — | — | — |
| Wunderlich B | — | Special Detector | 6P | 2.5 | 1.000 | C | 250 | — | — | 17 | — | — | — | — | — | — | — |

★ NOTES

A—Provided filament circuits will accommodate change in filament current.

*—Mercury vapor rectifier.

O—Octal Base.

†Types 1A4G, 1B4G, 1D5GT, and 1E5GT are identical to previous N.U. types 1A4, 1B4, 1D5G, and 1E5G.

99-59B—Tie Suppressor grid terminal of socket to cathode terminal.

Majority Types. 57AS 58AS 6.3 volt tubes not replaceable by regular types 57 and 58 which are 2.5 volt tubes.

*—Column 2 "Similar To" lists types which are similar to purpose and general characteristics. These types however are not interchangeable except in a very few cases.

Some Servicemen have found that 56S substitutes quite satisfactorily for G4S—since the G4S and G2S are quite similar it may be possible the same substitution can be made with the G2S.

Type 76 may be used to replace 36-67A for greater sensitivity in most cases without circuit change.

Spartan Type 182B. This type replaceable by NU483 only when all 182B are removed and replaced by NU Type 483

National Union Types 64-67-68-65 are not manufactured by any other company, being replaced by National Union types as follows only when used in Automobile Sets. (64A 36), (67A 37), (68A 38), (65A 39).

Type Filament

F(O)—Oxide Coated Filament

F(T)—Thoriated Tungsten Filament

C—Oxide Coated Cathode

The Filament voltage and current ratings for Lehtels, such as 7.0 or 14.0 volts and .320 amps., are nominal values. Typical operating values are 6.3 or 12.6 volts and .300 amps.

† Indicates Metal Tubes. G or GT/G types recommended for replacement. In a few instances shielding or realignment may be necessary.

† Indicates Lock-in Tubes

(See tube basing diagrams on following pages.)

BASE-PIN & SOCKET-CONNECTION DIAGRAMS CHART FOR RMA STANDARD TUBE BASES —(Bottom Views)

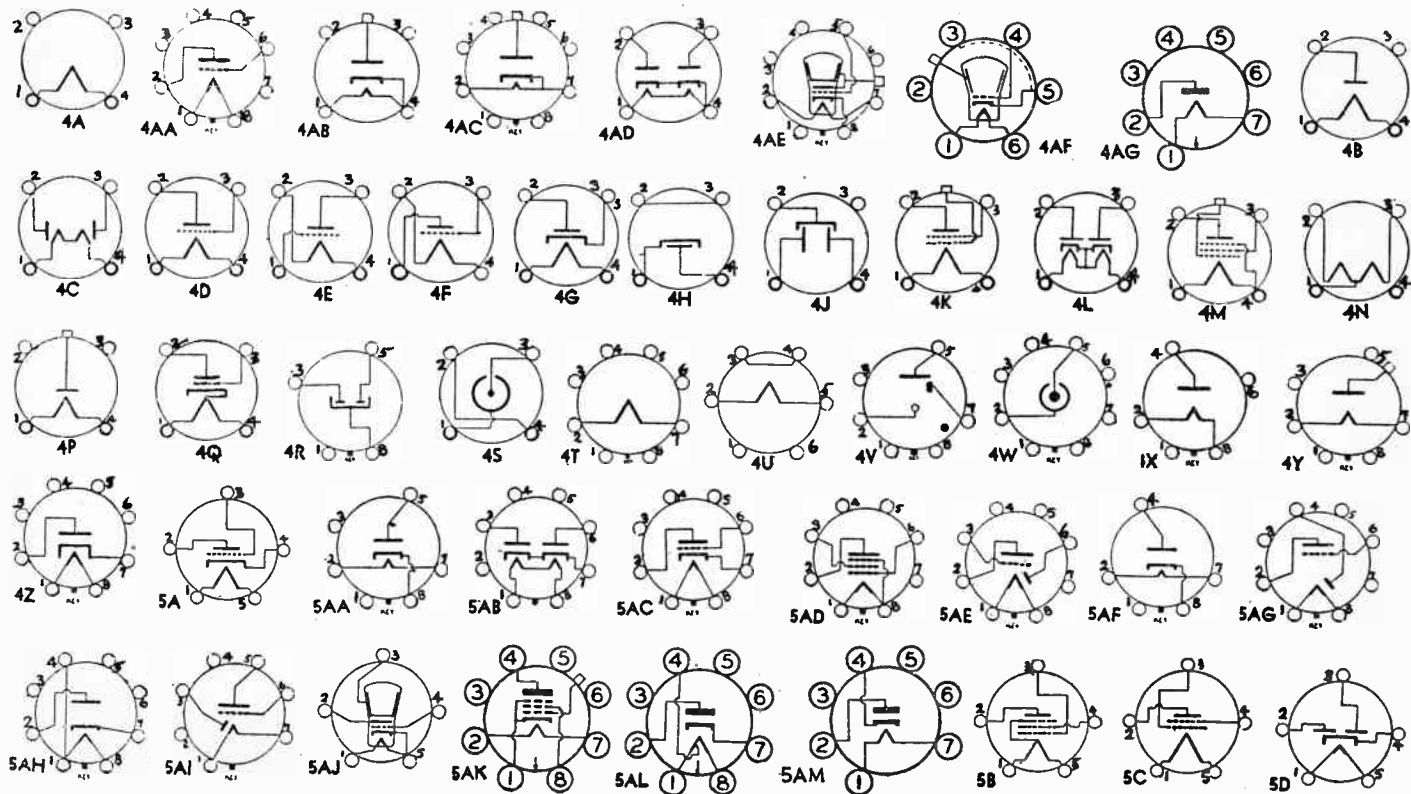

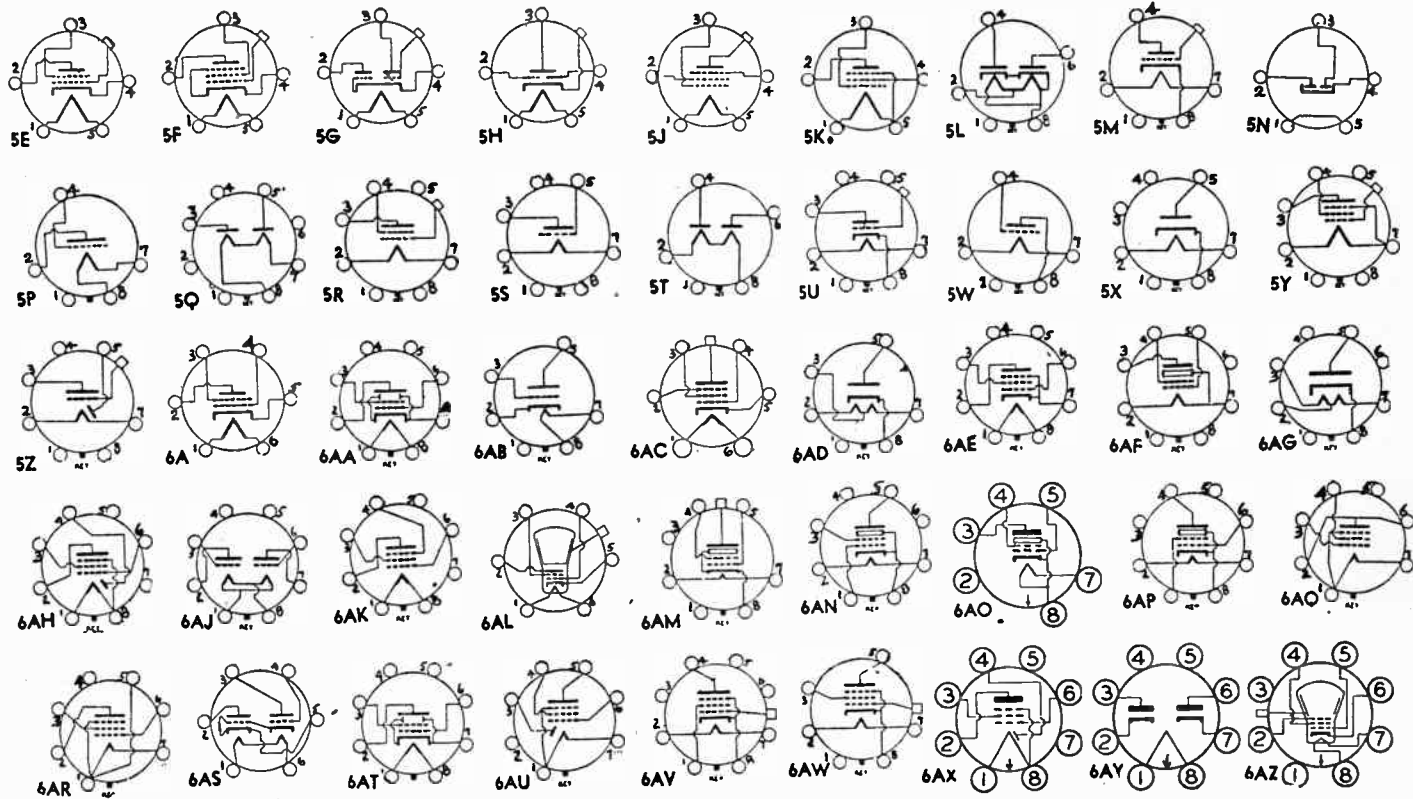

(Cont'd over)

Receiving Tube Basing Diagram Charts

(Bottom Views)

—(Cont'd)

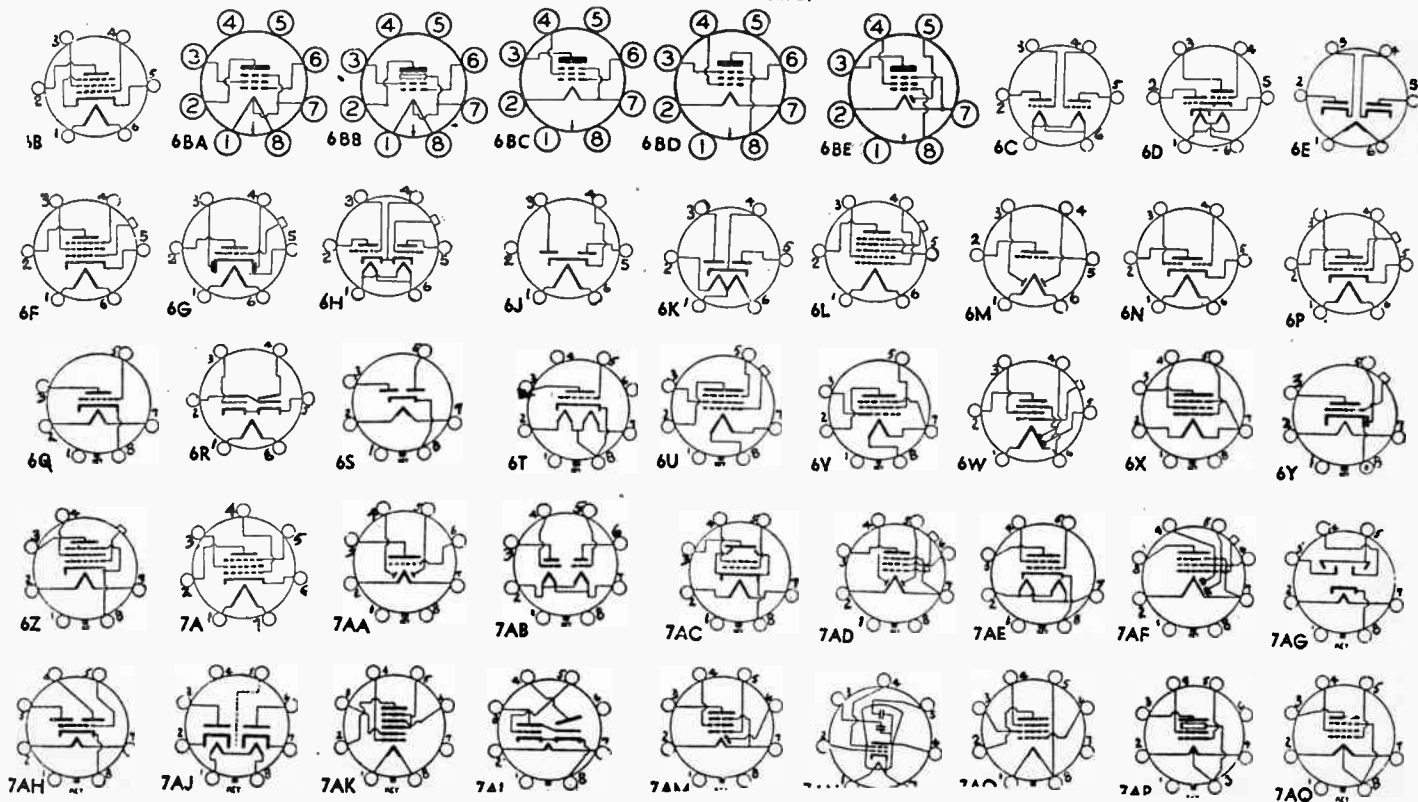

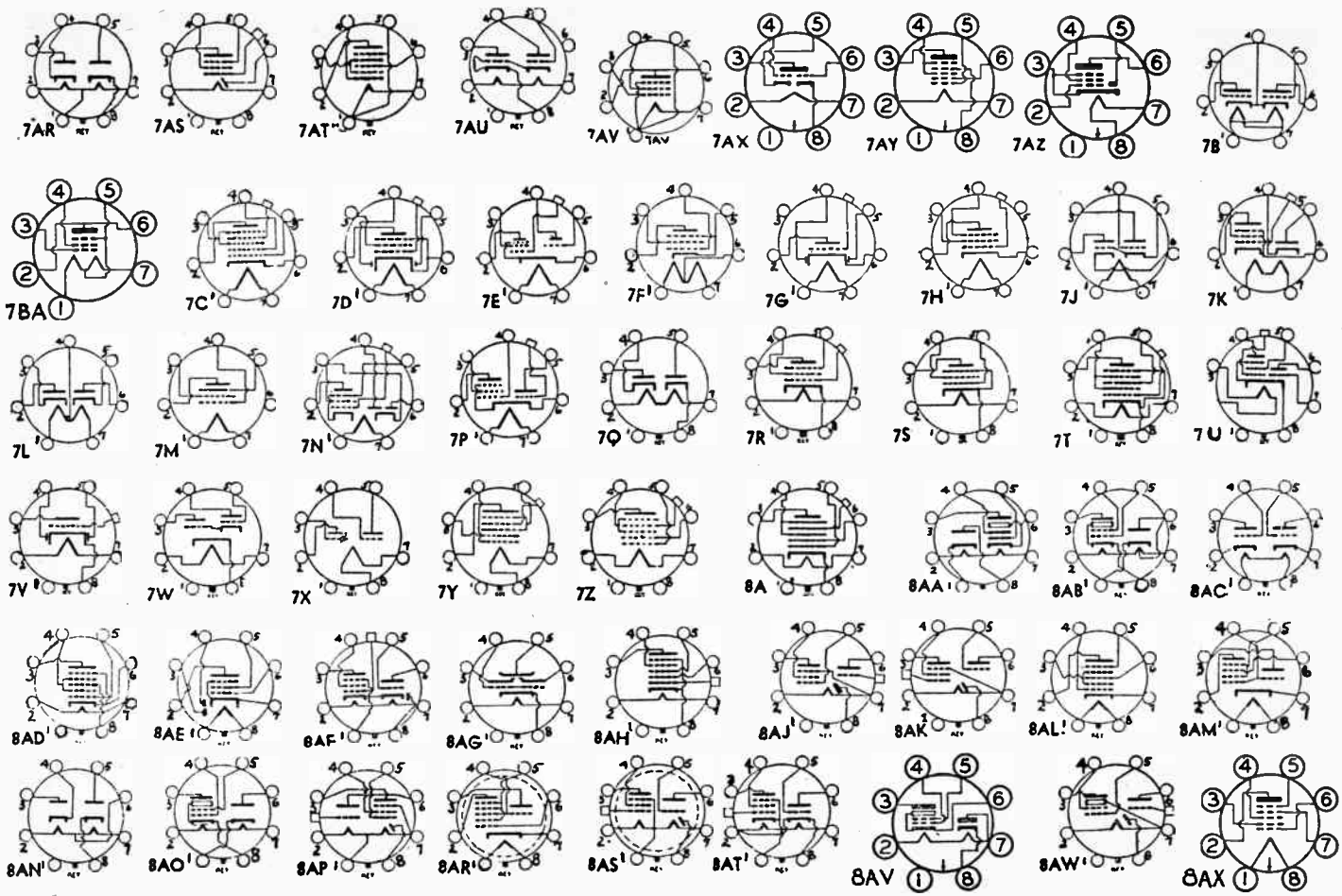

(Cont'd)

Receiving Tube Basing Diagram Charts

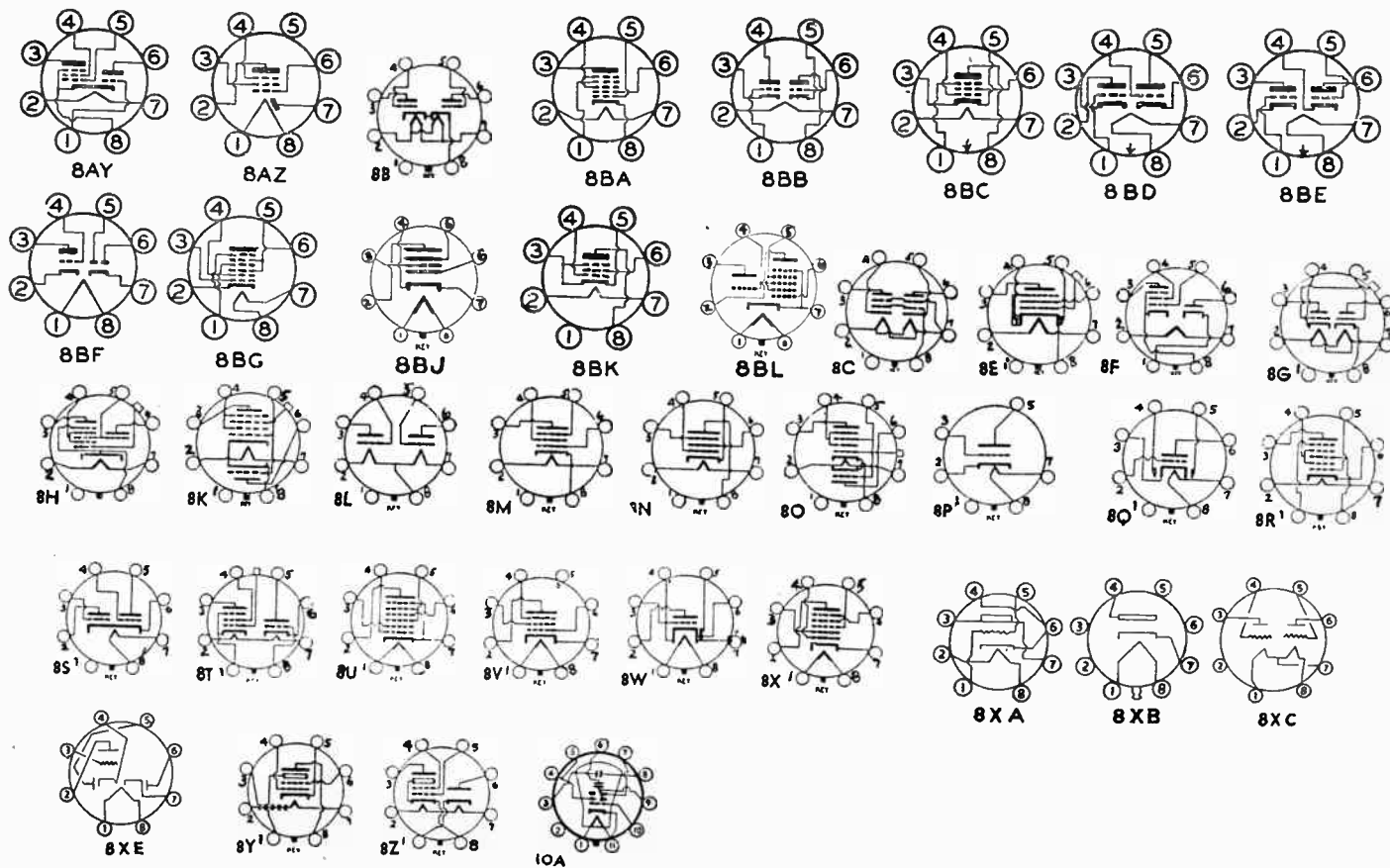

INDEX

(The figures refer to page numbers)

— A —

- Acceptor circuit, 626
- Accuracy, meter, 55-57
- A-C instruments, 36-55
 - meter rectifier for, 41, 45-48
 - movable-iron type, 36-39
 - rectifier type, 40-55
- A-C, effective value of, 43-44
 - maximum value of, 43-44
 - peak value of, 43-44
- Acoustical labyrinth, 1200-1201
- Adapters, tube, 190-201
 - for neutralizing receivers, 700
 - for output meters, 690
 - for set analyzers, 264-274
 - for testing tubes having high-voltage filaments, 197-201
 - how to make, 191
- Addressing, 1221
- Adjacent channel interference, 1175-1177
- Advertising, business cards for, 1246
 - business reply cards, use of, 1223
 - delivery truck, 1244-1246
 - direct-mail, 1220-1241
 - display, 1216-1220, 1241-1243
 - follow-ups, 1249
 - for auto-radio business, 1248-1249
 - fundamentals, 1214-1216
 - lantern-slides for, 1244
 - letter heads for, 1246
 - "logs" for, 1247-1248
 - meeting specific objections in, 1253
 - miscellaneous, 1241-1248
 - newspaper, 1241, 1246
 - plan for, 1263, 1264
 - postcards for, 1220-1241-1249
 - premiums, use of, 1223-1224
 - radio station, 1243
 - sales-resistance, overcoming, 1253
- Aerial, auto-radio, comparison of, 918 919
 - definition, 431 (footnote)
 - directional characteristics of, 1150-1155
 - double-doublet, 1120-1121, 1139-1149
 - double-doublet, directional properties of, 1154
 - double-doublet, length of, 1120-1121
 - doublet, 1131-1132, 1138
 - doublet, directional properties of, 1153
 - doublet, length of, 1120-1121
 - for metal-top cars, 915-920
 - imped. matching of, 1122-1123
 - installing in fabric car-top, 907-908
 - installing in folding car-top, 912-915

- Aerial (cont'd)**
 installing in metal-bow top, 908
 installing in metal-braced top, 909
 installing in poultry-wire tops, 906-907
 installing in slat-type car-tops, 898-906
 inverted-L, directional properties, 1151; length of, 1120-1121
 length of, 1120-1122
 loop type, directional, 1151
 pickup of interference by, 1106-1107
 running-board type, 916-917
 screen, for auto-radio, 900-903
 tape type, installing on car roof, 910-911
 testing for noise-free zone for, 1155-1158
 T-type, directional properties of, 1152
 under-car types, 915-920
 vertical type, directional properties, 1151
 wire type (under-car), 918
 (see also, *Antennas*)
- Air-core coils, troubles in, 570-573**
- Air gap, cleaning in speakers, 821, 842**
 in cores, 800-801
- Aligning,**
 all-wave receivers, 723, 997-1001
 necessity for, 682
 output indicator for, 689
 preliminary considerations for, 687
 procedure for flat-topped or band-pass i-f amplifiers, 721
 procedure for i-f amplif. of all-wave receivers, 723
 procedure for oscillator and r-f circuits, 727-730
 procedure for peaked i-f amplifiers, 718-721
 procedure for receivers having avc, 730-732
 procedure for t-r-f receivers, 690-695
 provisions for, 684-687
 receivers having avc, 730-732
 sequence for superhets, 715
 superheterodynes, 702-741, 779-784
 test oscillator for, 333, 688, (see also, *Test Oscillators*)
 tools for, 739
 use of tuning wand for checking, 605
 with cathode-ray oscilloscope, 739-741, 762-772, 779-784
 whose i-f is unknown, 732, 1003
- Alignment,**
 effects of misalignment, 604
 use of tuning wand for checking, 605
 (see also, *Aligning*)
- All-metal tubes, 1274-1276**
- All-wave oscillators, 398-423**
- All-wave receivers,**
 aligning frequencies and procedure, 997-1003
 aligning i-f amplifiers of, 723
 antennas for, 1018-1020
 ant. switching systems for, 1129-1131
 audio amplif. for, 1188-1190
 avc systems for, 990-991
 baffles for, 1193-1194, 1198-1201
 beat-note filter for, 1188-1190
 coil shields in, 1013-1014

- All-wave receivers (cont'd)**
 coil-switching systems for, 1004-1013
 dead-spots in, 1008, 1014
 determining i-f in, 1003
 dials for, 1016-1017
 double-doublet for, 1139-1149
 i-f amplifiers in, 989-990
 i-f response, variable, for, 1177-1182
 image response in, 1001
 installation of, 1201
 iron-core i-f coils for, 1182
 linear detector for, 1183-1188
 line-up frequencies, 997-1003
 line-up procedure, 997-1003
 loud speakers for, 1192-1201
 mixer stage in, 991-994
 noise in, 1017-1018
 oscill. "padding" ck'ts. in, 995
 oscillator stage in, 994-995
 "padding" circuit in, 995-997
 resist. analysis of, 539-545
 RMA designations, 986-987
 second detector for, 1183-1188
 square-law detector for, 1183-1188
 tone-control for, 1190-1192
 tuning bands in, 1015-1016
 tuning dials for, 1016-1017
 variable i-f amplifier for, 1177-1182
- Amplified avc, 465-469**
- Amplifier action of vac. tube, 337**
- Amplifiers, (see *Audio Amplifiers*)**
- Amplitude stability of oscillators, 368-369**
- Analysis, point-to-point (see *Point-to-Point Set Analysis*)**
 voltage-current methods, 234-239, 492-525
- Analyzer, commercial set, 309-330**
 current meas. with, 289
 how to construct, 293-306
 point-to-point, (see *Point-to-Point Analysis*)
 resistance '(dual-plug), 286
 resistance-voltage, 288
 selective, 323
 socket selector units, 323
 voltage, 291
 voltage-current, (see *Voltage-Current Set Analyzer*)
- Antenna, auto-radio, requirements, 894-896**
 circuit, checking over, 430-435
 circuit, switching systems for, 1129
 directional characteristics of, 1150-1155
 double-doublet, 1120-1121, 1139-1149
 doublet, 1131-1132, 1138
 doublet, length of, 1120-1121
 for all-wave receivers, 1018-1020
 for auto-radio, 892-920
 pickup of interference by, 1102-1108
 troubles, 430-435
 (see also, *Aerials*)
- Armature, loud speaker, recentering, 819-821**
 sticking, 821
- Astatic crystal pickup, 844**
 connection of, 850, 851
- Atmospheric static interference, 1040-1043**
- Attenuators, constant-impedance type, 373**
 for test oscillators, 372-374, 401, 404, 412, 422
 ladder type, 401

Audio amplifiers,

- Class A amplification, 657
- Class AB amplification, 664
- Class A-Prime amplif., 664
- Class B amplification, 658-663, 665
- Class C amplification, 664
- classes of, 657
- direct-coupled, 653-657
- distortion, localizing, 774-775
- fidelity, test of, 773
- for high-fidelity receivers, 1188-1190
- obscure troubles in, 645-653
- tone control in, 1190-1192

Audio chokes, repair of, 799
see also (*Coils, iron-core*)

Audio fidelity,

- test of in a-f amplifier, 775
- test of in a receiver, 773

Audio transformers, 574-578

- repair of, 799
- see also (*Coils, iron-core*)

Automatic record changers, 849-850**Automatic vol. control, 441-490**

- action of, 444-459
- aligning superheterodyne receivers having, 730-732
- amplified, 465-469
- condensers in, 450
- delayed, 456-459
- in auto-radio receivers, 881-882
- in all-wave receivers (use of), 990
- purpose of, 441-444
- quiet, 469-479
- systems, various, 444-459
- troubles in, 459-465
- with combination diode-type tubes, 452

Automobile, engine, operation of, 922-926

- ignition systems, operation of, 926-932
- top construction, types of, 896-898

Auto-radio, aerials, antennas (built-in), 892-893

- antennas, requirements of, 894-896
- antennas, types and installation of, 892-920
- connecting to car-battery, 890-892
- elect. features of, 880-883
- flexible shaft, 888-889
- generator type power supply units, 979-981
- installation problems, 870-871
- interference, (external), 921-922
- interference from car electrical system, 939-940
- interference from generator, 940-945
- interference from ignition circuits, 945-959
- interference in, 920-921
- interference, stubborn, 958-959, 964-971
- interference, tracing to source, 959-962
- plate-power supply for, 972-981
- receiver, location in car, 883-885
- receiver, mounting in the car, 885-887
- receiver troubles, 971-972
- receiver-wiring or chassis interference pickup elimination, 962-964
- receivers, desirable construct. features, 875-877

- Auto-radio (Cont'd)
- receivers, mechanical requirements, 875
 - service work equipment for, 872-875
 - service work, qualification for, 872
 - servicing, selling, 1248-1249
 - test bench, 874
 - test cage, 873
 - tire static, interference, 970
 - tuning control arrangements, 877-880
 - tuning control, mounting of, 887-890
 - vibrator-type power-supply units, 979-981
 - vibrator units, servicing, 976-979
- AVC action, check of, 335
(see also, *Automatic Volume Control*)
- "Average" value of a-c, 43
— B —
- Baffles, high-frequency speaker, 1193-1194
- low-freq. speaker, 1198-1201
- Balanced armature speaker. (see *Loud Speaker*)
- Balanced transmission line, 1118
- Band-pass i-f amp., aligning, 721, 739-741, 779-784
- for high-fidelity receivers, 1177-1182
- Bands, tuning, 1015
- Basing diagrams, tubes, 1288-1292
- Battery, car, 932-933
- charger interference, 1089
- Bias cell, testing, 598
- Bias, grid, circuits for 500-507
- "Birdies", 630
- Bleeder screen circuits, 512-515
- Blotters, use of in adv't., 1221
- Bonding braid, 967
- B-power supply units, vibrator type, 973-979
- generator type, 979-981
- Braun, Prof. F., 741
- Breakdown, of volt-ohm-milliammeter circuits, 102-106
- of volt-ohmmeter circuit, 110
- Breaker points, 925-926
- Bridge circuit for oscillation suppression, 696
- Bridge, commercial, 70-71
- slide wire, 69-70
 - Wheatstone, 66-69
- Broadcast band receiver, definition, 987
- Browning & Hoskins, 904
- Burton-Webber No. 10 Test Oscillator, 399
- Business cards, 1246
- Business, reply cards, use of, 1223
- extra, household appliances, 1255
 - methods, 1256, 1257
- Buzzer interference, 1087
- By-pass condensers, (see *Condensers, Electrolytic*)
(see also, *Condensers, Solid-Dielectric*)
— C —
- Cabinets, receiver, refinishing, 860-862
- Calibrating a test oscill., 384-396
- C-bias, cells, testing, 598
- circuits, 500-507
- Canvassing for sales, 1208-1209
- Capacity, meas. of, 120-125
- of solid-dielectric cond., 591
 - ratio, 1005
 - reactance, 126
 - with cathode-ray oscill., 773
- Capacity meter (tester), how to construct, 127-131
- Capacity meters, 121, 122, 125
- calibrating, 127
 - commercial, 131-138, 320
 - constructing, 128-131

- Capacity testers, 121-125
commercial, 131-135
- Car tops, construct. of, 896-898
- Cardvertiser, 1235
- Cathode-ray, 743
- Cathode-ray oscilloscope,
aligning r-f, i-f and oscill.
stages with, 771, 779-784
as business getter, 1229
audio fidelity test with, 773,
775
capacity meas. with, 773
connecting to receiver for
aligning, 765
current meas. with, 772
inductance meas. with, 773
interpreting resonance curves
seen in, 767-771
intermittent receiver oper-
ation, testing for, 775
localizing audio distortion
with, 774-775
need for in superhet. align-
ment, 739-741
precautions to observe when
using, 776
sensitivity of, 761
uses for, 772-776
voltage meas. with, 772
(see also, *Cathode-ray tube*)
- Cathode-ray tube, 741-753
action of, 747-753
deflecting plates, action of,
747-753
electron gun of, 744
fluorescent screen of, 745-747
focusing electrodes of, 744
interpreting resonance curves
seen in, 767-771
Lissajous' figures of, 752-754
precaution to observe when
using, 776
sensitivity of, 761
structure of, 742-747
sweep circuit amplif. for, 761
- "sweep" voltage for, 753-762,
780, 786-787
"sweep" voltage, synchroni-
zer for, 781
"timing" voltage for, 753-762
(see also, *Cathode-ray Oscil-
loscope*)
- Cathode-ray tun'g indicator, 490
- Characteristics, tube, 1266-1292
- Charging rate of car generator,
935-937
- Checker, tube, see *Tube Checker*
- Chokes, (see *Filter Chokes*)
- Circuit breakdown,
volt-ohm-milliam., 102-106
volt-ohmmeter, 110
- Circuits, oscillator, 345-355
- Class A amplification, 657
- Class AB amplification, 664
- Class A-Prime amplification, 664
- Class B amplif., 658-663-665
- Class C amplification, 663-664
- Clough-Brengle Model OC oscil-
lator, 402
- Code interference, 625-628
- Coil, magnetic field around, 8
- Coils, air core, repair of, 797-799
air core, troubles in, 570-573,
580-583
cause of dead-spots, 1014
change in the induct. of, 583
i-f, 717, 799, 1182
i-f, iron-core, 1182
i-f, repair of, 799
iron-core, i-f, 1182
iron-core, troubles in, 573-
578, 582-583, 799
leakage in coil-form, 573, 583,
605, 799
moisture in, 573, 583, 605,
607, 799
shields for, 1013-1014
switches for, 1012-1013
switching systems, 1004-1013
- Colpitts oscillator, 351

- Combination-tubes, failure of,
644
in a-c circuits, 452
structure, 167
tests, 188
- Combining resistors, 533
- Commercial, a-c—d-c instru-
ments, 51-54
capacity meters (testers),
131-138
ohmmeters, 100-119
oscilloscopes, 776-789
output meters, 142-146, 154
set analyzers, 309-330
set testers, 291, 307-330
test oscillators, 398-423
tube checkers, 213-231
- Components, receiver, instru-
ments for testing, 553
need for testing, 551-552
repair of, (see *Repair Of*)
repair, when justified, 793
tests for, 552, 559-597
tests of with test oscill. 335
- Compound, removing impregna-
ting, 800-801
- Condenser, (electrolytic) effect
on receiver analysis, 547
repair of, 806-807
leakage, (see *Condensers*)
loud speaker, repair, 843-844
- Condensers (electrolytic type)
breakdown, causes of, 596-597
checking with ohmmeter, 593
construction of, 592-593
leakage of, 126
leakage tests, 594-596
repair, 807
types of, 583
(see also *Condenser tests*)
- Condensers (solid-dielectric
type), breakdown, 585
capacity check of, 591
charging current of, 587
- earphone tests for, 588-589
emergency tests for, 588
grounds in, 592, 597
leakage in, 126, 588
neon lamp test for, 590
ohmmeter tests for, 587-590
puncture of, 585
repair, 806
testing, 586-592 (see also,
Capacity measurement,
Capacity meters, Conden-
ser tests)
troubles in, 584-586
- Condensers (variable), repair-
ing, 808-810
"shorts" in, 808-810
testing, 597
- Condenser tests, 120
electrolytic, tester, 129
high-resistance, 126
leakage, 126
testers, 121-125
(see also, *Condensers*)
- Conductor, magnetic field
around, 6-7
- Cones, loud speaker, repairing,
822-823, 834-835, 841
- Confidence, Model C tube check-
er, 213
"Special" tube seller, 215
- Constant-current modulation,
364
- Constant-imped. attenuator, 373
- Constructing,
battery-operated test oscilla-
tor, 377-382, 386-396
capac. meter (tester), 127-131
line-operated test oscillator,
382-384, 386-396
ohmmeters, 86-98
output meters, 150-154, 157-
160
set analyzer, 293-306
test oscill., 377-384, 386-396

- Constructing, (Con'd)
 tube checker, 202-212
 universal meter, 51-53
 v-t voltmeter, 157-160
- Contacts, interference caused by, 1085-1086
- Continuity, testing for, (see *Ohmmeter*)
- Controls, tone (see *Tone Controls*)
 volume (see *Volume Controls*)
- Copper-oxide rectifier, (see *Meter Rectifier*)
- Copper-oxide rectifier type instruments, (see *A-C instruments*)
- Corrosion of transformer windings, 575
- Counter selling, 1206-1207
- Craft, marine, (see *Marine Craft*)
- Crystal, phono pickup, 844, 850, 851
 type loud speaker, 1197
- Current measurement with, meters, 14
 Cathode-ray Oscilloscope, 772
- Customer follow-ups, 1249
- Cut-out on car generator, 934-936
- D —
- Data, receiver, sources of, 493
 when not available, 546
- Dead spots in oscill., 380-381
 in all-wave receivers, 1008, 1014
- Dealer demonstration antenna system, 1148-1149
- De-coupling filters, 614
- Deflecting vanes for spkrs. 1193
- Degeneration, 609
- Delayed avc, (see *Automatic Volume Control*)
- Delivery truck advertising, 1244-1246
- Demonstration antenna system, 1148-1149
- "Dependable", (see *Radio City*)
- Detector, effect of on noise, 1186-1188
 for high-fidelity, 1184-1188
 linear, 1184-1188
 square law, 1184-1188
- Diagram, receiver, not available, 546
- Diagrams, tube basing, 1288-1292
- Dial-light resonance indicator, 485
- Dials for all-wave receivers, 1016-1017
- Diathermy apparatus, elementary interference caused by, 1092-1094
- Diode tube structure, 166
- Direct-coupled amplif. tube, 665
- Direct-coupled a-f amplifiers, 653-657
- Direct mail selling, 1220-1241
- Directional characteristics of aerials, 1150-1155
- Display advertising, 1216-1220, 1241-1243
- Distortion, causes of, 643-645, 674
 localizing in a-f amplif. 775
 localizing (audio) in a receiver, 774
 test for, in a-f amplifier, 775
- Distributor, 925-926, 927
 suppressor resistor, 953-956
- Door bells, eliminating interference caused by, 1087
- Double-doublet aerial, dealer demonstration type, 1148
 directional characteristics, 1154

for all-wave reception, 1139-1149
 length of, 1120-1121
 Doublet aerial, 1131-1132
 directional characteristics, 1153
 length of, 1120-1121
 with twisted-pair lead-in, 1138
 Double-spot reception, 619-625
 elimination of, 621-625
 suppression circuits for, 734-739
 Driver tube, 660
 Dual-wave receiver, def. of., 987
 Dummy tube for neutralizing, 699
 Duo-diode triode, 168
 Duplex-diode pentode, 168
 Dynamic mutual conductance test, 200
 Dynamic loud speakers (see *Loud speaker*)
 Dynamic spk'r, field troubles, 574
 (see also, *Loud speaker*)

— E —

"Effective" value of a-c, 43-44
 Electric refrigerator, interference caused by, 1089-1091
 Electrode arrangements of tubes, 165-168
 Electrolytic condenser testers, 129-131
 commercial, 131-138
 Electrolytic condensers, effect on resistance analysis, 547
 (see *Condensers*, electrolytic)
 Electromagnets, 8
 Electron-coupled oscillator, 370-372, 402, 417-421
 Electron-coupling, 371
 Electron gun, 744
 Electron lens, 745

Electron modulators, 364-365
 Electro-medical apparatus, eliminating interference caused by, 1091-1094
 Electrostatic shield, 1101, 1123
 Emergency tests, for resistors, 564
 for solid-dielectric condensers, 588
 Emission tests for tubes, 169-172
 effect of gas on, 172
 English-reading, 179
 English-reading tube testers, 179, 214-215, 224, 229
 Equivalent tubes for tests, 231
 (chart)
 Extra business, household appliances, 1255
 Extra profits, opportunities for, 1254

— F —

Fading in receivers, 638-641
 Fan switch, 1010
 Feedback, reversed, 347
 tickler, 346
 Fidelity, test of, 773, 775
 Field supply, speaker, 826-833
 Filter chokes, air gap in, 800
 repair of, 799-802
 speaker field as, 828-829
 troubles in, 574
 Filter circuits in power supply units, 520-523
 analyzing troubles in, 523-525
 choke-input type, 521
 condenser-input type, 521
 Filter condensers,
 (see *Condensers*, electrolytic)
 (see *Condensers*, solid-dielectric)
 Filter, loud speaker, 672-673, 1196-1197
 Filters, decoupling, 614

Filters, interference, at receiver, 1099-1102.
 best physical location for, 1081-1082
 effect of "noisy ground" on, 1082-1083
 for eliminating interference at the source, 1077-1081
 loud speaker, 1196-1197
 10 kc beat note, 1188-1190

Firing order of automobile engine, 925, 928

Fixed resistors, 554-556
 repair of, 794-796

"Flashograph", 489

Flat-top i-f amplifier, aligning, 721, 739-741, 779-784

Fluorescent screen, 745-747

Folders, use of in advertising, 1221

Follow-up, customer, 1249

Forms, for installation records, 1258
 for service records, 1259-1263

Franklin Model H-33 tube checker, 219

Free service, discussion of, 1224-1226

Frequency bands, 988

Frequency-"modulator", (see Frequency wobbler)

Frequency ratio, 1005

Frequency range for high-fidelity, 1166-1168

Frequency stability of oscillators, 368

Frequency-"wobbler" for test oscillator, 762, 780-782

Fundamental frequency, 355, 357

— G —

Gain measurement, 334

Gap, air, 800-801
 cleaning, 821, 842

Gas test for tubes, 172-173

Generator (car), action, 933-935
 automatic voltage regulation, 937-939
 brushes, cleaning and fitting, 943
 brushes, sparking at, 942, 944
 by-pass condenser, 944-945
 charging rate, 935-937
 cleaning commutator of, 942-943
 commutator, turning down, 942
 commutator, undercutting mica, 942-943
 cut-out on, 934
 interference, caused by, 940-942
 interference, eliminating, 942-945

Generator type auto-radio power supply units, 979-981

Grid, modulation, 361
 suppressor, 511

Grid bias, cells, testing, 598
 circuits for securing, 500-7
 readings, interpreting, 507-510

Grid-shift, method of shifting, grid bias, 177-179
 tests for vacuum tubes, 173-177, 179

Ground, checking over, 431-434
 high-resistance, 431
 in coils, 572, 577, 582
 in condensers, 592, 597
 in resistors, 560, 568
 interference pickup by, 1104-1106

Ground, noisy, 1082-1083

— H —

Half-wave antenna, 1121

Hand-capacity effects in oscillator, 381

- Harmonics, 355-360**
 amplitude of, 359-360
 characteristics of, 387-389
 computation of, 357
 even, 358
 frequencies, 356-359
 how generated, 355
 odd, 358
 vs. fundamentals, use of, 396,
 399
- Hartley oscillator, 350, 377, 400**
- Headlining, in auto top, 901**
- Heising modulation, 364, 399**
- Heterodyning, interference,
 1043-1044**
- High-fidelity receiver, frequency
 range required, 1166-1168**
 i-f amplifier of, 1176-1183
 monkey chatter in, 1175
 noise level in, 1170-1171
 oscillator in, 1172-1175
 RMA definition, 1167
 station interference problem
 in, 1175-1182
 tuned R-F circuits of, 1171-
 1172
 volume range required for,
 1168-1170
- High-imped. phono pickup, 856**
- High-resistance, condenser, 126
 voltmeters, 24-28**
- "Hot" terminal of car battery,
 892**
- Household appliances, extra
 business, 1255
 servicing, 1236-1237**
- House-to-house canvassing, 1208-
 1209**
- Hum, bucking coil for in loud
 speaker, 830, 831**
 -bucking condenser, 656
 -bucking potentiometer, 656
 caused by phono. motor, 849
 due to loose laminations, 574,
 578
 elimination in loud speakers,
 830-833
 in loud speakers, 829
 in phono pickup, 849
 modulation, causes of, 628-
 630
 shading-ring for preventing,
 831
 steady, causes of, 630-635
 steady, tracing sources of,
 635-638
 tunable. causes of, 628-630
- I —
- Ignition systems, automobile,
 operation of, 926-932**
- Image frequency, definition of,
 619**
- Image-frequency, definit. of, 619
 causing double-spot reception,
 620
 distinguishing from "oscilla-
 tion", 624
 eliminating, 623-625
 elimin. by band-pass and re-
 jector circuits, 621-623
 in all-wave receivers, 1001-
 1003
 suppression circuit for, 734-
 739**
- Impedance-matching transf., 857
 connecting between lead-in
 and receiver, 1126-1129
 construction of, 1124-1126
 for aerials, 1122-1129**
- Impedance-ratio, 857**
- Impedance-coupled audio-fre-
 quency amplifiers, obscure
 troubles in, 652**
- Impregnating compound, remov-
 ing, 800-801**
- Indicator, resistor, 569**

- Indicators, tuning, (see *Tuning* indicators)
- Inductance measurement with cathode-ray oscillo., 773
- Installation records, forms for, 1258
keeping, 1258
- Insulation breakdown, 576-577
in chokes and transformers, 805
- Interaction, magnetic, 9-10
- Interchannel noise, 470
suppression of, 471-478
- Interference, adjacent-channel, 1175-1177
atmospheric-static type, 1040-1043
auto-radio, persistent, 958-959, 964-971
auto-radio, stubborn, 958-959
auto-radio, tracing to source, 959-962
battery charger, eliminating, 1089
buzzer, eliminating, 1087
caused by car generator, 940-942
caused by car ignition circuits, 945-959
caused by d-c motor, 1050-1052
caused by sparking, 1051
caused by vibrators, 1054
classification of by method of pickup by receiver, 1069-1070
code, 625-628
conducted, 1053, 1069
contacts, caused by, 1085-1086
devices used in various establishments, 1065-1069
diathermy machine, eliminating, 1092-1094
directly-radiated, 1069
door-bell, eliminating, 1087
effect of noisy ground on, 1082-1083
effect of receiver improvement on, 1037-1039
electric refrigerator, eliminating, 1089-1091
electro-medical apparatus, eliminating, 1091-1094
filters at receiver, 1099-1102
filters, best location for, 1081-1082
filters for eliminating at the source, 1077-1081
from power line, suppressing, 1099-1102
general types of, 1040
hunter (receiver), 1076
identifying device by character of noise produced, 1062-1065
image, (see *Image Interference*)
in high-fidelity receivers, 1175-1182
in marine-radio installations, 1032
in receivers, 1035-1036
interstation, 1043-1044
line filters, 1099-1102
locator, 1155-1158
locator (receiver), 1076
man-made, 1048-1054
minimizing at receiver equipment, 1097-1099
motor, eliminating, 1083-1085
"natural" static type, 1040-1043
neon sign, eliminating, 1096-1097
oil burner, eliminating, 1087-1089
originating in the receiver, 1044-1048

Interference (Cont'd)

path to receiver, determination of, 1056-1060
 pickup by the aerial, 1106-1107
 pickup by antenna, 1102-1108
 pickup by the ground, 1104-1106
 pickup by lead-in, 1107-1108
 power line, 1054-1055
 radiated, 1053
 ratio to signal, 1055-1056
 reduction by paralled feeder lead-in, 1132-1134
 reduction by shielded lead-in, 1108-1116
 reduc. by transp's'd lead-in, (see *Transposed Lead-in*)
 reduction by twisted-pair lead-in (see *Twisted-pair Lead-in*)
 re-radiated, 1053, 1069
 shielding, source of, 1086
 sign-flasher, eliminating, 1094-1096
 shielding the source of, 1086
 suppression at source vs. at receiver, 1060-1062
 surveys, 1231
 testing for noise-free zone, 1155-1158
 thermostat, 1085-1086
 through power line, 1053
 tire static, 970
 tracing path by which it reaches receiver, 1056-1060
 tracking down source of, 1070-1077
 tunable, 1052
 violet-ray, eliminating, 1091-1092
 X-ray, eliminating, 1091

Interference in auto-radio receivers, 920-922, 939-940
 Intermediate frequency, amplifier, 704-705, 716-718
 amplifier, aligning procedure for, 718-723
 amplifier, aligning procedure for, (all-wave), 723
 amplifier aligning with cathode-ray oscilloscope, 739-741, 762-772, 779-784
 amplifier, effects of misalignment in, 708-711
 amplifier, in all-wave receivers, 989-990
 determining, 732-734, 1003
 amplifier in high-fidelity receivers, 1176-1183
 amplifier, iron-core coils for, 1182
 amplifier, variable, for high-fidelity, 1177-1182
 transformers, (see *Coils*)
 Intermittent reception, 641-648
 tests for with cathode-ray oscilloscope, 775
 Internal combustion engine, operation of, 922-926
 Interpreting voltage-current set analyzer readings, 499-525
 Interstage coupling, 612-617
 Inverted-L antenna, 1151
 Iron-core i-f coils, 1182

— J —

Jackson, Model 440 oscillator, 405-409

— K —

Kennelly-Heaviside layer, 1116-1117

Kilocycle, definition, 987

— L —

Lag-loop, 487

- Laminations, loose, 574, 578**
Lantern slide advertising, 1244
Lead-in, connecting to receivers, 1126-1129
 installing in a car, 903-905
 interference pickup by, 1107-1108
 matching impedance of, 1122-1129
 parallel feeder, 1132-1134
 shielded, for auto radio, 902
 shielded, for interference reduction, 1108-1116
 transposed wire, (see *Transposed lead-in*)
 twisted-pair, (see *Twisted-pair lead-in*)
Leakage, coil-form, 573, 583, 605, 799
Leakage, condenser, 126
 of electrolytic cond., 594
 of solid-dielectric cond., 591
 tubes, in, 180-182
Length of aerials, 1120-1122
Letterheads, business, 1246
Line filters, 1099-1102
Lissajous' figures, 752-753
Logs, station, for advertising, 1224, 1247-1248
Loop, antenna, 1075-1076, 1151
 magnetic field around, 7
Loud speaker, acoustical labyrinth for, 1200
 air gap, cleaning, 841, 842
 armature, recentring, 819
 armature, sticking, 821
 baffles, for, 1193-1194, 1198-1201
 balanced armature, repair of, 818-823
 balanced armature, test of, 816-817
 burr in, 635
 cable, testing of, 824
 cones, repairing, 822-823
 cone troubles, 834-5, 841-2
 condenser type, 843-844
Loud speaker, (Cont'd)
 crystal type (tweeter), 1198
 deflecting vanes for, 1193
 dynamic, troubles in 823-824
 field as filter choke, 828
 field coil troubles, 824-826
 field supply circuit arrangements and troubles, 826-833
 filter, 672-673
 filter arrangement, 1196-1197
 high-fidelity, 1192-1201
 high-frequency, 1195-1198
 horn type magnetic, test and repair of, 812-816
 hum-bucking coil, 830-831
 hum elimination in, 830-833
 hum in, 829
 magnetic, repair of, 815-823
 magnetic, test of, 812-815
 multiple-unit type, 1194-1198
 obscure troubles in, 674-678
 permanent-magnet dynamic, repair of, 843
 phasing of, 674-678
 remagnetizing permanent magnets of, 817-818
 shading ring, 831
 spider repairing, 840
 spider troubles, 835
 substitution test, 812
 suspension ring, repair of, 842
 test type, 812
 voice coil, recentring of, 835-839
 voice coil, repairing of, 839
Low-impedance phono pickup, 857

 — M —
"Magic eye", 490
Magnet, electro-, 8-9
Magnet, permanent, remagnetizing, 817, 846

- Magnetic field, around a coil, 8**
 around a conductor, 6-7
 around a single-turn loop, 7
 of electromagnet, 8-9
Magnetic interaction, 9-10
Magnetic speakers, (see Loud speaker)
Mailing lists for direct-mail advertising, 1222
Man-made interfer., 1048-1049
 how generated and transmitted, 1049-1054
Marine craft, classification of, 1022-1023
 radio, notes, 1033-1034
 radio, ignition interference in, 1032
 radio installation, 1023-1030
 radio receiver, selecting the, 1030-1031
 radio servicing, 1032-1033
Matching, impedance, transformer, 857
Maximum value of a-c, 43-44
Meissner oscillator, 349
Merchandising, 1241-1248
Meshed duo-grid tube, 666
Metal tubes, 1274-1276
Meter movement, 10-12
 sensitivity of, 12, 26
Meter, accuracy, 55-57
 range, selecting, 56, 63
Meter rectifier, 41, 45-48
 characteristics of, 46-48
 construction of, 45-46
Meters, (see Ammeters, Capacity meters, Ohmmeters, Output meters, Power level meters, Voltmeters, Volt-ohmmeters, Volt-ohm-milliammeters)
Meters, resistances of, 17
Meter sensitivity, 12
Meter shunts, 12-21
Meter-switching systems of analyzers, 242
Methods, business, 1256-1257
Mho, 175
Microammeters, resist. of, 17
Micromho, 175
Microphonic howls, 644
Milliammeters, 11, 14
 commercial a-c—d-c, 51-54
 connection of, 15
 extending ranges of, 15-19
 making into voltmeters, 31-33
 multi-range, 19, 20
 rectif. type (a-c—d-c), 48-55
 resistance values of, 17
 sensitivity of, 12
 shunts for, 12-21
Modulated hum, (see Hum modulation)
Modulation, 360-368
 constant-current, 364
 electron, 364-366
 grid, 361
 grid-leak, 361
 Heising, 363, 399
 hum, (see Hum modulation)
 per cent, 361-363
 plate, 363, 415
 -self, 366-368, 413
 tube, 363
Monkey chatter, 1175
Moisture, in coils, 573, 583, 605, 607, 799
Motor interference, how caused, 1050
 elimination of, 1083-1085
Movable-iron meters, 36-39
 disadvantages of, 38
 voltmeters, extending range of, 39
Movement, Weston, 10-12
Multi-grid tube structure, 166
Multiplier resistors, 24, 29-33
Multi-range, ammeters, 19-20
 milliammeters, 19-20
 voltmeters, 28-29

- "Mute" switch, 470
- Mutual conductance, 174-175
 - changing grid-bias for, 177-180
- "dynamic" test, 200
 - tests, 173-180

— N —

- Na-ald 950 TR tube testing adapter, 197
- Negative resistance, 354
- Networks, resistance, checking, 534-539
- Neon lamp test for condensers, 590
- Neon sign, eliminating interference from, 1096-1097
- Neutralizing, a receiver, 334
 - an i-f amplifier, 723
- Neutralizing receivers, adapter for, 699-700
 - dummy tube for, 699
 - methods, 695-698
 - necessity for, 695
 - procedure for t-r-f receivers, 699-701
 - tools, 739
- Neutrodyne, 697
- Newspaper advertising, 1241, 1246
- Noise, gate, QAVC systems, 476-478
 - in all-wave receivers, 1017-1018
 - interchannel, 470-478
 - internal receiver, 1044-1048
 - surveys, 1231
 - (see *Interference*)
- Noise-free zone for aerial, test-in for, 1155-1158
- Noise level in high-fidelity receivers, 1170-1171
- Noise locator, 1155-1158
- Noise-reducing antenna systems
 - (see *Interference*)

- Noisy ground, 1082-1083
- Noisy reception, (see *Interference*)

- Noisy resistors, 560

— O —

- Objections, meeting specific, 1253
- Obscure troubles, in impedance-coupled a-f amplif., 652
 - in loud speakers, 674-678
 - in r-f and i-f amplifiers, 602-645
 - in receiver output circuits, 671-674
 - in receivers, 601-678
 - in resistance-coupled a-f amplifier, 647-652
 - in tone controls, 667-669
 - in transformer-coupled a-f amplifier, 645-647
 - in transformer-impedance coupled a-f amplif., 652
 - in volume controls, 669-671
- Ohmmeter, advantages of, 71, 83-84
 - calibrating, 88-90, 92-94
 - combination series-shunt, 81
 - commercial, 100-119
 - constructing, 87-97
 - extending ranges of 75-76, 79-80, 94-96
 - high-range, construct., 96-98
 - home made, 87-97
 - how to construct, 87-97
 - precautions for use, 81-83
 - principle of, 72-74
 - series, constructing, 87-90
 - series-shunt type, 81
 - series type, 72-77
 - shunt, constructing, 90-94
 - shunt type, 77-81
 - testing coils and transformers with, 578-583

- Ohmmeter, (Cont'd)
 testing condensers with, 586, 589, 592, 593, 597
 testing resistors with, 563
 types, 72
- Ohmmeters, constructing, 86-98
- Ohm's Law, 62
- Ohms-per-volt, 27
- Oil burner, eliminating interference caused by, 1087-1089
- Open-circuits, emergency tests for, 564
 in coils, 574-576, 578-580
 in condensers, 584-591, 597
 in resistors, 557, 563-566
- Opportunities, for extra profits, 1254
- Oscillation, causes of in r-f circuits, 611
 causes of, miscellaneous, 617
 distinguishing from image interference, 624
 due to interstage coupling, 612-617
 neutralizing of, 695-701
 suppression of, 695-701
 suppressor, 511, 617
 (see also *Oscillators*)
- Oscillator, action of, 341-345
 amplitude stability of, 368-369, 376
 calibration, 384-396
 circuits, various, 345-355
 coil data, 379
 Colpitts, 351
 coupling to the, 369-370
 electron-coupled, 370-372, 402, 417
 frequency range, 333, 356-359, 376
 freq. stability of, 368, 376
 grid bias, 343
 hand-capacity effects in, 381
 harmonics, characteristics of, 387-389
 harmonics in, 355-360
 Hartley, 350, 400
 in all-wave receivers, 994-995
 Meissner, 349
 modulation, 360-368 (see also *Modulation*)
 "padding" circuits, 724-727
 regeneration, 342, 610
 requirements for oscill., 342
 reversed feedback, 347
 self-sustaining action, 342
 test, (see *Test oscillators*)
 tickler feedback, 346
 tracking, (incorrect) in superhet., 714, 724-730
 tuned-plate—tuned-grid, 348
- Oscillator, relaxation, 122-125
- Oscillograph, use of term, 789
- Oscilloscope, R.C.A. types TMV-122-B, 776-779, 783-784
 use of term, 789
 Wireless Egert model CR-500, 784-789
 (see *Cathode-Ray oscilloscope*)
- Output circuits, obscure troubles in, 671
- Output meters, adapters for, 690
 commercial, 143-146
 connecting, meter types, 146-150
 connection for superheterodyne alignment, 718
 connection for t-r-f receiver alignment, 689
 constructing, 150-154, 157-160
 crystal detector type, 150-152
 meter type vs. vacuum-tube voltmeter type, 161
 neon-tube type, 154
 tube-rectifier type, 152-153
 type of meter used in, 142
 uses for, 146
 v-t voltmeter type, 155-161
 why needed, 140-141

Output power tube test, 201
Overcoming sales resist., 1253

— P —

"Padder" circuits, in all-wave receivers, 995-997
oscillator, 724-727
Padding circuit adjustment, 334
Paper rattle, 841
Paper type condensers, (see *Condensers, solid dielectric*)
Parallel circuits, 530
Parallel-feeder lead-in, 1132-1134
"Peak" value of a-c, 43-44
Pentagrid converter, 168
Pentode tube tests, 187
Permanent magnets, remagnetizing, 817, 846
Phasing of multiple loud speakers, 674-678
Philco, Model 024 test oscill. 409
Philco, Model 048 combination tester, 115
Phono pickup, adding to receivers, 850-856, 857-860
astatic, crystal, 844, 850-851
centering armature in, 845
cleaning air-gap in, 846
connecting to receivers, 850-856, 857-860
construction of, 844
crystal, type, 844, 850-851
high-impedance, 856
hum-bucking coil in, 849
low-impedance, 857
oscillator type adapter, 857
remagnetizing magnet of, 846
repairing coil in, 846
replacing damping blocks in, 846
sales, for business, 1237-1239

volume controls for, 856
Phonograph motors, eliminating hum of, 849
repair of, 848-849
Phonograph turntables, repair, 847-848
sales for business, 1237-1239
speed of, 848
"wow" in, 848
Pickup (see *Phono pickup*)
Piezo-electric, loud speaker, 1197
phono-pickup, 844, 850-851
Pin-jack meter-connecting system, 243
Plate modulation, 363
Plate voltage readings, interpreting, 510
Point-to-point, current meas. 289
reference point, 282
resistance analysis, 282-283;
"hot" analysis, 640
resistance analyzer, dual-plug type, 286
resistance measurement, 281
resistance tester, 284-286
resistance-volt. analyzer, 288
set analysis, 277-292
testers, commercial, 291
voltage analysis, 291
(see *Resistance Receiver analysis*)
Polarized waves, 1116, 1117
Postcards for advertising, 1220-1241, 1249
Postage rates in U.S., 1221-1222
Power level meter, 145
Power rating of resist. 557-559
Power-output tube test, 201
Power supply unit, analysis of, 519-525
checking, 495
Power transf., insulation in, 805
repair of, 802-805
rewinding, 803-804
troubles, 578

Preliminary, questions before
trouble shooting, 428
tests before trouble shooting,
430-440
tests, limitations of, 439
tests on receiver proper,
436-438
tests value of, 438
Profits, extra, opportunities for,
1254
Push-button, switches, 246
tap switches, 249
toggle switches, 249

— Q —

QAVC systems, 469-479
noise gate, 478
servicing, 476
Questions, preliminary, 428
Quiet avc systems, (see
QAVC systems)

— R —

Radio City, Model 205, Super
Multidapter, 198
Model 303A tube checker, 216
Model 304 tube tester, 217
Model 403 volt-ohm-milliam-
meter, 101
Model 501 set analyzer, 309
Radio-frequency amplifier ef-
fects of misalignment in,
711-714
Radio-frequency coils (see *Coils*,
air core)
Radio-phono., repair of, 844-850
troubles, 678
Radio spectrum, 987-989
Radio station advertising, 1243
Range, extending ammeter, 15-19
extending milliammeter, 15-19
extending movable-iron volt-
meter, 39
extending voltmeter, 29-31
meter, selecting, 56, 63
of resistance meas., 61
selectivity meter, 63, 66
RCA-Victor Model 97B Oscilla-

tor, 409
Model TMV-122-B Oscillo-
scope, 776-779, 783-784
Output Indicator, 154
Reactance, capacitive, 126
Readrite, Model 421-422 tube
Models 553, 554 and 556 os-
cillators, 412
checkers, 221
Model 720 tester, 311
No. 850 Capacity Meter-
Tester, 131
Realignment of receivers, (see
Aligning receivers)
Receiver, high-fidelity (see
High-Fidelity receiver)
Receiver analysis, voltage-cur-
rent method, 234-239, 492-
525
(see *Voltage-current* receiver
analysis)
(see *Resistance* analysis of
receivers)
Receiver cabinets, refinishing,
860-862
Receiver data, sources of, 493
Receiver designations, RMA,
986, 987
Receiver noise, 1044-1048
Receiver trouble symptoms, 429
Receiving tubes, basing dia-
grams, 1288-1292
characteristics chart, 1266-
1292
Recentring, armature in mag-
netic speakers, 819-821
armature in phono pickups,
845-846
voice coil, 835-839
Record changers, automatic,
849-50
Recording set analyzer readings,
499
Records, service, 1259-1263
installation, keeping, 1258
servicing, keeping, 1259-1263
Rectifier, characteristics of, 46
construction of (copper ox-
ide), 45-46

- Rectifier, (Cont'd)
 meter, 41, 45-48
 meters calibrated for "effective" values, 45
 meters measure "average" value, 44
- Rectifier tube tests, 170, 186
- Rectifier type instruments, 40-55
- Reference point, for set measurements, 282
- Refinishing set cabinets, 861
- Refrigerator, eliminating inter-fer. caused by, 1089-1091
- Regeneration, principle of, 342
 in a receiver, 610
- Relaxation oscillator, 122-125
- Remagnetizing permanent magnets, 817, 846
- Repair of, audio chokes and transformers, 799
 cabinets, receiver, 860-862
 condensers (electrolytic) 807
 condensers (solid dielectric) 806-807
 condensers (variable), 808-810
 filter chokes, 799-802
 fixed resistors, 794-796
 i-f coils, 799
 loud speakers (condenser type), 843-844
 loud speakers (dynamic), 823-843
 loud speakers (general), 810-812
 loud speakers (magnetic), 812-823
 phonograph pickups, 844-847
 phonograph record changers, 849-850
 phono. turntables, 847-849
 power transformers, 802-805
 r-f coils, 797-799
 receiver cabinets, 860-862
 vacuum tubes, 806
- Replacement test, tubes, 163-165
- Reports, servicing, keeping, 1259-1263
- Resistance, negative, 354
 positive, 354
- Resistance analysis, (see *Point-to-point analysis*)
- Resistance-coupled a-f amplifier, faulty resist. units in, 650
 obscure troubles in, 647-652
- Resistance meas., ammeter-voltmeter method, 62, 64
 by ohmmeter, 71-84
 point-to-point, 281, 527-550
 range of, 61
 slide-wire bridge method, 69-70
 voltmeter method, 65-66
 Wheatstone bridge method, 66-71
- Resistance method of set analysis, 279, 527-550
 (see *Point-to-Point analysis*)
 (see *Resistance receiver analysis*)
- Resistance networks, checking, 534-539
- Resistance, receiver analysis, 277-292, 527-550
 (see also *Point-to-Point analysis*)
 checking resistance networks, 534-539
 effect of electrolytic condensers on, 547
 of complete all-wave receiver, 539-545
 of r-f plate circuit, 539
 of r-f screen-grid circuit, 542
 of r-f suppressor-grid-cathode circuit, 543
 parallel circuits, 530
 series circuits, 528
 using manufacturer's resistance data, 548
 without receiver circuit diagram, 546
- Resistance, sales, overcoming, 1253
 temp. coefficient of, 561
 voltage coefficient of, 562
- Resistance tester for sets, 284-286
- Resistance-voltage analyzer, 288

- Resistor indicator, 569
- Resistors, carbon, 555
 combining, 533
 construction of, 553-556
 fixed, 554-556
 fixed, repair of, 794-796
 grid-bias, 500-507
 grounds in, 560-568
 indicator, 569
 moulded carbon, 555
 multiplier, 24, 29-33
 noisy, 560
 open-circuits in, 556, 563
 power rating of, 557-559
 repair of, 794-797
 short-circuits in, 559, 566, 568
 shunt, 12-21
 spark-plug suppressor, 950-953
 suppressor (for oscillation) 511, 617
 suppressor, (auto-radio), 950-957
 temp. coefficient of, 561
 testing, 563-569
 tolerance of, 562
 voltage coefficient of, 562
 wire-wound, 554
- Resonance indicators, (see *Tuning* indicators)
- Rewinding power transformers, 803-804
- RMA receiver designations, 986-987
- Rotary switches, 249
- Rotor arm, 927
- S —
- Salesmanship, 1205-1206
- Saturable-core reactor, 485-487
- Saw-tooth voltage, 756-761
- Scales, meter, non-uniform, 39
- Screen circuits, bleeder type 512-515
 double-series type, 517
 series type, 515-517
 shunt type, 517
- Selective analyzer, Weston, 323
- Selecting meter ranges, 63
- Selectivity, check of, 335
 variable in i-f amplifier, 1177-1182
- Self-modulated oscill., 366-368
- Self-servicing literature, 1226-1227
- Selling, counter, 1206-1207
 outside, 1207-1213
 telephone, 1212-1214
- Selling service, by direct-mail
 advertising, 1220-1241
 advertising, fundamentals for, 1214-1216
 advertisting, misc. 1241-1248
 auto-radio, 1248-1249
 business cards, for, 1246
 blotters, for, 1221
 canvassing, 1208-1209
 counter selling, 1206-1207
 customer follow-ups, for, 1249
 delivery truck advertising, for, 1244-1246
 direct-mail advertising for, 1220-1241
 display advertising, 1216-1220, 1241-1243
 extra profits, opportunities for, 1254
 folders, for, 1221
 follow-ups for, 1249
 lantern slides for, 1244
 letter heads, for, 1246
 logs, for, 1224, 1247-1248
 merchandising, 1241-1248
 newspaper advertising, for, 1241-1246
 outside selling, 1207-1213
 postcards, for, 1220-1241, 1249
 plan, 1263-1264
 premiums, for, 1223-1224
 radio station advertising, for, 1243
 sales resistance to, overcoming, 1253
 service, business methods, 1256-1257
 telephone selling, 1212-1214

- Sensitivity, lack of, due to coupling coil or cond., 602-604
 due to misalignment, 604
 in superheterodyne receivers, 606-608
 test of with cathode-ray oscilloscope, 773
- Sensitivity, meter, 12, 26
- Series circuits, 528
- Series-parallel circuits, 532
- Service records, keeping, 1259-1263
- Service test oscillator, (see *Test oscillator*)
- Service truck adv't., 1244-1246
- Servicing, marine radio equipment, 1032-1033
- QAVC systems, 478
- records, keeping, 1259-1263
- silent tuning systems, 478
- vibrator units, 976-979
- Set analyzer, how to construct, 293-306
 (see *Voltage-current set analyzer*)
 (see *Point-to-Point analysis*)
- Set analyzers, commercial, 307-330
- Shadowgraph, 482-485
- Shallcross, No. 681, volt-ohm-meter, 106-108
- No. 685, a-c Utility Meter, 52
- Shield, static, 578, 1100, 1123
- Shielded lead-in, 902, 1108-1116
- "Shock excitation", 905
- Short-circuits, in coils and transformers, 576, 577, 580
- in condensers, 585-591, 596-597
- "Shot" effect, 1017
- Shunts, making by trial, 18
- materials for, 19
- meter, 12-21
- Sign flasher, eliminating interference from, 1094-1096
- Signal generators, (see *Test oscillators*)
- Signal-to-Noise ratio, 1055-1056
- Silent tuning systems, 469-478
- servicing, 478
- Slide-wire, Wheatstone bridge, 69-70
- Socket selector units, "Weston", 323
- Solid-dielectric condensers (see *Condensers, solid-dielect.*)
- Spark-plug suppressor resistors, 950-953
- effect on engine, 956
- Spark-plugs with built-in suppressors, 952-953
- Speaker (see *Loud speakers*)
- Spectrum, the radio, 987-989
- Spider, of loud speaker, repairing, 840
- troubles, 835
- Split rotor plates, 685
- Stability of oscillators, 368-369, 376
- amplitude, 368-369
- frequency, 368
- Static, atmospheric, 1040-1043
- eliminators, 1042
- shield, 578, 1100, 1123
- Storage battery, car, 932-933
- Stroboscope, 847
- Structure of tubes, 165-168
- Substitute, spk'r, test, 812
- Superheterodyne receiver, 435-436
- adjustments necessary in, 707
- aligning procedure (all-wave), 997-1001
- alignment of flat-top or band-pass i-f amplif., 721
- alignment of i-f amplifiers of all-wave receivers, 997-1001
- alignment of peaked i-f amplifiers, 718-721
- alignment sequence, 715-716
- code interference in, 625-628
- determining i-f, 732-734, 1003
- development of, 702-704
- double-spot reception, 619-625
- effects of incorrect oscillator tracking, 714
- effects of misalignment in i-f amplifier of, 708-711
- effects of misalignment in r-f amplifier of, 711-714

Superheterodyne receiver

(Cont'd)

- frequency reduction in, 704-705
 - image interference in, (see *Image* interference)
 - image-suppression circuit for, 734-739
 - i-f amplifier alignment with cathode-ray oscilloscope, 739-741, 762-772, 779-784
 - i-f amplifier of, 704-705, 716-718
 - lack of sensitivity in, 608
 - mixer in all-wave receivers, 991-994
 - neutralizing i-f circuits in, 723
 - oscillator grid-bias, 510
 - oscillator padding circuit in all-wave receivers, 995-997
 - oscillator tracking in, 714, 724-730
 - system, explanation of, 704-706
 - with avc, alignment of, 730-732
- Supreme, Model 61, oscill., 414**
- Model 65, tube checker, 222
 - Model 85, tube checker, 224
 - Model 91, analyzer, 313
 - Model 111, volt-ohmmeter, 108
 - Model 180, oscillator, 417
- Sweep voltage, amplifier for, 761**
- generator for, 753-762, 786-787
 - synchronizer for, 781
- Switches, for all-wave receivers, 1012-1013**
- for set analyzers, 245-250
 - push-button, 246
 - tap or rotary, 249
 - toggle, 249
- Switching, of all-wave coils, 1004-1012**
- Symptoms, receiver trouble, 429-430**
- Synchronizer, sweep voltage, 781**
- Synchronous vibrator, 974-976**

— T —

- T-type antenna, 1152-1153
 - Tank circuit, oscillator, 355
 - Tank condenser, in filter, 522
 - Telephone, selling by, 1212-1214
 - Temperature coefficient of resistance, 561
- Test oscillators, 332-375**
- amplitude stability, 368
 - attenuators for, 372-374, 401, 404, 422
 - batt.-operated, 377-382, 399, 405, 409, 412, 417, 419, 421
 - calibrating a, 384-396
 - coil data, 379
 - coil-switching system, 408
 - commercial, 398-423
 - connecting for t-r-f receiver alignment, 688
 - construction of a, 376-397
 - dead spots in, 380-381
 - electron-coupled, 370-372
 - frequency range, 333, 356-359, 360, 376, 398-399, 407
 - "frequency" stability, 368
 - frequency wobbler for, 762, 780-783
 - hand-capacity effects in, 381
 - harmonics in, 355-360
 - how to construct, 377-384, 386-396
 - line operated 382-384, 402, 414
 - modulation in, 360-368 (see also *Modulation*)
 - principle of, 335-336
 - use of harmonics in, 396-399
 - uses, 333-335
 - why needed, 332 (see also *Oscillators*)
- Tester, combination, 114-119**
- condenser, 121-125
 - resistance, 284-286
 - tube, (see *Tube* checker)
- Testing for noise-free aerial location, 1155-1158**
- Tests, for individual components, 559-597**
- preliminary 430-440
 - tube (see *Tube tests*)
- Test speaker, 812**

- Tetrode tube tests, 187
- Thermal agitation, 1017
- Thermostat interference, 1085-1086
- Tickler feedback, 346
- Timing of spark, 925
- Timing voltage for cathode-ray tube, (see *Sweep* voltage)
- Tire static, 970
- Tube relaxation-oscillator condenser-tester, 122
- Tolerance of resistors, 562
- Tone controls, 667-669, 1190-1192
- Tools for aligning and neutralizing, 739
- Tops, automobile, types, 896-898
- Transformers, impedance-matching, 857
 - impedance ratio of, 857
 - turns ratio of, 857
- Transformer-cpl'd. a-f amplif.,
 - obscure troubles in, 645-647
- Transformer-imped. cpl'd. a-f amplif.,
 - obscure troubles in, 652
- Transformers, air core (see *Coils*, air core)
 - insulation in, 576-577, 805
 - iron-core, (see *Coils*, iron-core)
 - power, (see *Power transformers*)
- Transmission line, balanced, 1118
- Transposed lead-in, 1134-1138
 - connecting at receiver, 1138
 - connecting to receivers, 1126-1129
 - with doublet, 1134-1136 (see also *Interference*) (see also *Lead-ins*)
- Transposition blocks, 1136
- Trimmer condensers, 685-687
- Triplet, No. 1125 Universal a-c
 - d-c meter, 53
 - No. 1220 tester, 322
- Trouble-shooting, antenna and ground, 430-435
 - by resistance tests, 527-550
 - preliminary questions, 428
 - preliminary tests, 430-440
 - with voltage-current analyzer, 492-525
 - Trouble symptoms, receiver, 429
 - Troubles, obscure, (see *Obscure troubles*)
 - Troubles, avc systems, 459-465
 - Truck, advertising, 1244-1246
 - Tube, adapters, 190-201
 - basing diagrams, 1288-1292
 - cathode-ray (see *Cathode-ray tube*)
 - characteristics chart, 1266-1292
 - direct-coupled amplif., 665
 - meshed duo-grid, 666
 - structure, 165-168
 - Wunderlich, 666
 - Tube checker construction of a
 - 202-212
 - development of, 183-190
 - how to construct, 202-212
 - need for, 163-165
 - (see also *Tube tests*)
 - Tube checkers, commercial, 213-231
 - Tube currents and voltages,
 - checking, 496
 - Tubes, comparison with test oscillator, 334
 - equivalent for tests, 231
 - metal, 1274-1276
 - “shot effect” in, 1017
 - testing with analyzer, 497
 - thermal agitation in, 1017
 - Tube tests, cath.-h'tr. lkg., 180
 - combination tubes, 188
 - development of tester for, 183-190
 - dynamic mut. conduct., 200
 - emission, 169-172
 - English-reading tester, 179
 - gas, 172-173
 - grid-shift, 173-177
 - leakage, 180-182
 - mutual conductance, 173-177
 - pentode, 187
 - power output type, 201
 - rectifier, 170, 186

- Tube tests (Cont'd)**
 replacement, 163-165
 satisfactory, 168-169
 "short", 182
 tetrode, 187
Tun-a-lite, 489
Tunable hum, (see *Hum*, modulation)
Tuned-plate—tuned-grid oscillator, 348
Tuned radio freq. receiver, 435
 alignment of, 690-695
 neutralizing, 699-701
Tuning bands in all-wave receivers, 1015
Tuning circuits, realignment of, (see *Aligning receivers*)
Tuning condensers, repairing, 808-810
 testing, 597
Tuning control arrangements for auto-radio receivers, 877-880
Tuning indicators, 479-490
 dial-light type, 485
 Flashograph, 489
 "Magic eye", 490
 Shadowgraph, 482-485
 Tun-a-lite, 489
 types, list of, 479-482
Tuning wand, 605
Twisted-pair lead-in, 1116-1119
 connecting, 1126-1129
 — U —
Universal instruments, 40-54
Universal meter, how to construct, 51-53
Universal motor, interference caused by, 1083-1084
Universal test speaker, 812
 — V —
Vacuum tube, amplif. action, 337
 division of plate circuit power, 337
 metal types, 1274-1276
 oscillator action, 341-345
 plate load effect on, 340
 repair, 806
Vacuum tube voltmeter, 155
 calibrating, 159-160
 compared to output meter, 161
 constructing one, 157-160
 principle of, 155-157
 uses of, 160-161
Variable condensers, testing, 597
 repairing, 808-810
Variable coupling in i-f amplifiers, 1177-1182
Variable resistors, repair of, 796-797
Vertical antennas, 1151
Vibrators, auto-radio power supply, 973-979
 servicing, 976-979
Vibrators, cause of interference, 1054
Violet-ray apparatus, interference from, 1091-1092
Voice coil, recentering, 835-839
 repairing, 839-840
 troubles, 833-835
Voltage-current analysis chart, receiver, 493
Voltage-current receiver analysis, 234-239, 492-525
 chart, 493
 checking power supply unit, 495, 519-525
 checking tube voltages and currents, 496
 interpreting grid-bias readings of, 507
 interpreting readings on bleeder-type screen circuits, 512-514
 interpreting readings on double-series screen and plate circuits, 517
 interpreting readings on series-connected screen circuits, 515
 interpreting readings on shunt-connected screen circuits, 517
 recording readings of, 499
 starting, 494
 testing tubes, 497
Voltage-current set analyzer, 239
 adapters for, 264-274
 advantages of, 274
 checking currents with, 253

Voltage (Cont'd)

- checking tube circuits with, 257-260, 263
- checking voltages, 250, 256
- commercial, 309-330
- development of, 242
- interp. of readings, 492-493
- limitation of, 277
- meter-switching system, 242
- pin-jack meter, connecting system in, 243
- purpose of, 494
- satisfactory conditions for, 278
- step-by-step development of, 250-264
- testing tubes and resistances with, 262
- use of switches for, 245
- Voltage coeff. of resistors, 562
- Voltage divider, in power supply unit, 524
- Voltage measurement with cathode-ray oscilloscope, 772
- Voltage regulation of car generator, 937-939
- Volt-ammeters, 33-35
- Voltmeter, cathode-ray, 773
 - commercial a-c-d-c, 51-54
 - extending range of, 29-31
 - high-resistance, 24-28
 - making from milliammeter, 31-33
 - method of resist. meas., 65-66
 - movable-iron, extending range, 39
 - movable-iron type, 36-38
 - multiplier resistors for, 24, 29-33
 - multiplier, unusual, 319
 - multi-range, 28-29
 - ohms-per-volt value, 27
 - principle of, 22-24
 - rectifier type, 48-54
 - vacuum-tube type, 155-161
- Volt-ohmmeter, 100
 - circuit breakdown, 110
 - commercial, 106-111
 - (see "Shallcross", "Supreme", "Weston")

- Volt-ohm-milliammeters, 100-106
 - breakdown of circuit, 102-106
 - commercial, 101, 111-117
 - (see "Radio City", "Weston")
- Volume controls, 669-671
 - automatic, 441-468
 - connecting phono-pickup, 856
 - open circuited, 560-561, 671
 - repair of, 796-797
 - troubles in, 561, 670-671

— W —

- Wavelength, 987
- Wave trap, 626
- Weston, meter movement, 10-12
 - meters, resistance of, 17
 - movable-iron meter, 36-38
- Weston, Combin. tester, 118-119
 - No. 301 Univ. Meter Kit, 51
 - No. 571 Output Meter, 143-144
 - No. 654 Volt-ohmmeter, 111
 - No. 663 Volt-ohm-milliammeter, 111
 - No. 664 Capacity Meter, 135-138
 - No. 665 Analyzer, 323
 - No. 666 Socket Selector Units, 323
 - No. 681 Tube Checker, 228
 - No. 682 Tube Checker, 229
 - No. 694 Oscillator, 419
 - No. 695 Power-Level Meter, 145
 - No. 698 Selective Set Servicer, 328
- Wheatstone bridge, 66-71
 - commercial, 70-71
 - slide-wire type, 69-70
- Wireless-Egert, No. CR-500 Oscilloscope, 784-789
 - No. 99 Test Oscillator, 421
- Wire-wound resistors, 554
 - repair of, 794-797
- "Wow", phono. turntable, 848
- Wright-De Coster speaker, 812
- Wunderlich tube, 666

— X —

- X-ray apparatus, eliminating interference from, 1091