

PRINCIPLES OF
RADIO

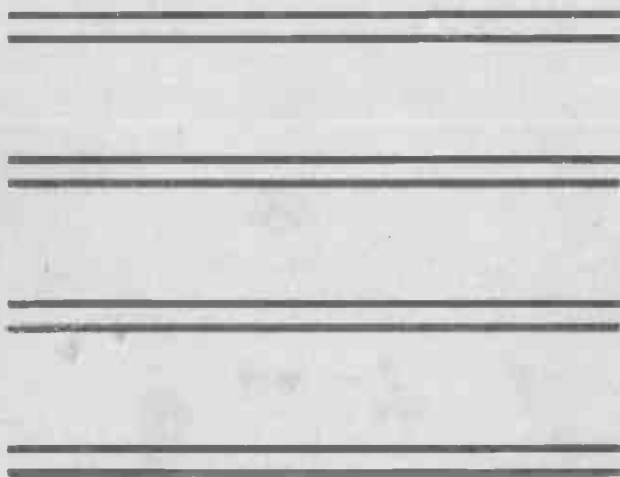

Third Edition

KEITH HENNEY

Wendall J. Louvelly Men's Dorm

**AVERAGE CHARACTERISTICS
AMPLIFIERS, DETECTORS,**

TUBE TYPE	NAME	CATHODE TYPE	FILAMENT	
			Volts	Amps.
01-A	Amp. Triode.....	Filament.....	5	0.25
112-A	Amp. Triode.....	Filament.....	5	0.25
30	Amp. Triode.....	Filament.....	2	0.06
32	R.-F. Tetrode.....	Filament.....	2	0.06
36	R.-F. Tetrode.....	Heater.....	6.3	0.3
37	Amp. Triode.....	Heater.....	6.3	0.3
38	Power Pentode.....	Heater.....	6.3	0.3
45	Power Triode.....	Filament.....	2.5	1.5
47	Power Pentode.....	Filament.....	2.5	1.75
56	Amp. Triode.....	Heater.....	2.5	1.0
58	Var. Mu Tetrode.....	Heater.....	2.5	1.0
77	3-Grid Amplifier.....	Heater.....	6.3	0.3
2A3	Power Triode.....	Filament.....	2.5	2.5
2A5	Power Pentode.....	Heater.....	2.5	1.75

RECTIFYING

TUBE TYPE	NAME	CATHODE TYPE	FILAMENT	
			Volts	Amps.
5Z3	Full-Wave Rectifier.....	Filament.....	5.0	3.0
12Z3	Half-Wave Rectifier.....	Heater.....	12.6	0.3
25Z5	Rectifier-Doubler.....	Heater.....	25.0	0.3
1-v	Half-Wave Rectifier.....	Heater.....	6.3	0.3
80	Full-Wave Rectifier.....	Filament.....	5.0	2.0
81	Half-Wave Rectifier.....	Filament.....	7.5	1.25
82	*Full-Wave Rectifier.....	Filament.....	2.5	3.0
83	*Full-Wave Rectifier.....	Filament.....	5.0	3.0
84 also 6Z4	Full-Wave Rectifier.....	Heater.....	6.3	0.5

* Mercury Vapor Type.

**-RECEIVING TUBES
OSCILLATORS, ETC.**

PLATE		SCREEN VOLTS	GRID VOLTS	PLATE RESISTANCE OHMS	MU	MUTUAL CONDUCTANCE	LOAD, OHMS	POWER OUTPUT, WATTS
Volts	Ma.							
135	3.0	- 9	10,000	8.0	800		
180	7.7	-13.5	4,700	8.5	1800		
180	3.1	-13.5	10,300	9.3	900		
180	1.7	67.5	- 3.0	1.2 megs	780	650		
250	3.2	90	- 3.0	550,000	595	1080		
250	7.5	-18.0	8,400	9.2	1100		
250	22.0	250	-25	100,000	120	1200	10,000	2.5
275	36.0	-56	1,700	3.5	2050	4,600	2.0
250	31.0	250	-16.5	60,000	150	2500	7,000	2.7
250	5	-13.5	9,500	13.8	1450		
250	8.2	100	- 3	0.8 meg	1280	1600		
250	2.3	100	- 3	1.5 megs	1500	1250		
250	60.0	-45	800	4.2	5250	2,500	3.5
250	34.0	250	-16.5	100,000	220	2200	7,000	3

TUBES

Maximum A.C. Voltage per Plate.....	500 Volts, R.M.S.
Maximum D.C. Output Current.....	250 Milliamperes
Maximum A.C. Plate Voltage.....	250 Volts, R.M.S.
Maximum D.C. Output Current.....	60 Milliamperes
Maximum A.C. Voltage per Plate.....	125 Volts, R.M.S.
Maximum D.C. Output Current.....	100 Milliamperes
Maximum A.C. Plate Voltage.....	350 Volts, R.M.S.
Maximum D.C. Output Current.....	50 Milliamperes
A.C. Voltage per Plate (Volts R.M.S.) 350 400 550	The 550-volt rating applies to filter circuits having
D.C. Output Current (Maximum MA.) 125 110 135	an input choke of at least 20 henries.
Maximum A.C. Plate Voltage.....	700 Volts, R.M.S.
Maximum D.C. Output Current.....	85 Milliamperes
Maximum A.C. Voltage per Plate 500 Volts, R.M.S.	Maximum Peak Inverse Voltage. 1400 Volts
Maximum D.C. Output Current.. 125 Milliamperes	Maximum Peak Plate Current.. 400 Milliamperes
Maximum A.C. Voltage per Plate 500 Volts, R.M.S.	Maximum Peak Inverse Voltage. 1400 Volts
Maximum D.C. Output Current.. 250 Milliamperes	Maximum Peak Plate Current.. 800 Milliamperes
Maximum A.C. Voltage per Plate.....	350 Volts, R.M.S.
Maximum D.C. Output Current.....	50 Milliamperes

PRINCIPLES OF RADIO

PRINCIPLES OF RADIO

BY

KEITH HENNEY

Editor, Electronics
Author, Electron Tubes in Industry
Editor, Radio Engineering Handbook
Member, Institute of Radio Engineers

THIRD EDITION

NEW YORK
JOHN WILEY & SONS, INC.
LONDON: CHAPMAN & HALL, LIMITED

COPYRIGHT, 1929, 1934, 1938

BY

KEITH HENNEY

All Rights Reserved

*This book or any part thereof must not
be reproduced in any form without
the written permission of the publisher.*

PREFACE TO THIRD EDITION

It has been eight years since the first edition of this book was published. In this period several printings have been necessary, and in each printing numerous changes and additions were made to keep the text up to date. In the second and third editions, these revisions became so great that the book was almost completely rewritten and a great quantity of new material added.

In the beginning the book was written for those who must study without a teacher as well as for those who attend schools where radio is taught. This attitude has been preserved. The new problems, like the older ones, are practical in nature; they deal with circuits and constants which a radio engineer encounters. The experiments, new and old, are designed to give the "feel" of the apparatus the research engineer or the experimenter uses.

The radio art still moves forward rapidly and unexpectedly. Those new devices which promise to remain in the art are described as are other elements of modern receiver design which were but dimly visioned when the last printing was made but which are now in full glory. Television, seemingly nearer technical solution, has been described briefly; so has facsimile transmission. It is possible that both these methods of communication may come into wide application soon. In the present printing many minor changes have been made to bring the book up to date. Circuits which seemed important in 1934 when the second edition was prepared but which are not used have been dropped; new ones take their places.

Radio engineering is still a great adventure. The technical and social possibilities are still very great. The student with vision and knowledge of the art still has tremendous opportunity.

KEITH HENNEY

November, 1937

CONTENTS

CHAPTER	PAGE
I. FUNDAMENTALS	1
The electron—Charged bodies—The laws of electrical charges—The atom—The ether—The electric current—Insulators and conductors—Conductivity—Resistance—The ohm—The effect of molecular motion on resistance—The effect of temperature on resistance—Temperature coefficient of resistance—The ampere—The volt—Engineer's shorthand—Mathematics in the study of radio—Curve plotting—Symbols.	
II. OHM'S LAW	20
Ohm's law—Ways of stating Ohm's law—Voltage drops—Graphs of Ohm's law—Series and parallel circuits—Characteristics of parallel circuits—More complicated circuits—Detection and measurement of current—Ammeters—Voltmeters—Sensitivity of meters—Ammeter-voltmeter method of measuring resistance—Voltmeter method of measuring resistance—Use of low resistance voltmeter and milliammeter in high resistance circuits—Resistance measurement.	
III. PRODUCTION OF CURRENT	38
Batteries—Electrolysis—Common dry cell—Storage cell—Internal resistance—Polarization—Cells in series—Cells in parallel—Magnetism—Oersted's experiment—Faraday's discovery—The electric generator—Work done by alternating current—D.-c. generator—Internal resistance—Electrical power—Power lost in resistance—Efficiency.	
IV. INDUCTANCE	57
Coupled circuits—Lenz's law—Inertia—Inductance—Self-inductance—Magnitude of inductance and induced voltage—The unit of inductance—Typical inductances—Coupling—Magnitude of mutual inductance—Measurement of inductance—The transformer—Power in transformer circuits—Transformer losses—The auto-transformer—Transformer with open-circuited	

CHAPTER	PAGE
secondary—Variable inductances—Effect of current, frequency, etc., on inductance.	
V. CAPACITY.....	74
Capacity—Capacity as a reservoir—Capacity in a power supply device—The charge in a condenser—The quantity of electricity in a condenser—Energy in a condenser—Electrostatic field—Condensers in a.-c. circuits—Power loss in condensers—Condenser tests—Condensers in general—The nature of the dielectric—Sizes of radio condensers—Condenser capacity formulas—Condensers in series and parallel.	
VI. PROPERTIES OF ALTERNATING-CURRENT CIRCUITS.....	89
Definitions used in a.-c. circuits—Instantaneous value of alternating current—Triangle functions—Means of expressing instantaneous values—Effective value of alternating voltage or current—Phase relation between current and voltage—Current and voltage in phase—Lagging current—Inductive reactance—Leading current—Capacity reactance—Comparison of inductive and capacitive reactance—Impedance—General expression for impedance—Series a.-c. circuits—Phase in series circuit—Characteristics of a series circuit—Resonance—Parallel circuits—Phase in parallel circuits—Impedance of a parallel circuit—Series and parallel circuits compared—Power in a.-c. circuits.	
VII. RESONANCE.....	120
Series resonant circuit—Characteristic of series resonant circuit—Effect of resistance on series resonant circuit—Power into resonant circuit—The resonant frequency of the circuit—Wavelength—Parallel resonance—Effective resistance—Resonant frequency—Uses of series and parallel resonant circuits—Sharpness of resonance—Selectivity—Width of resonance curve—Effect of inductance and capacity on sharpness of resonance—The resistance of coils—High-frequency resistance—Distributed capacity of coils.	
VIII. PROPERTIES OF COILS AND CONDENSERS.....	149
Tuning a receiver—The wavemeter—Heterodyne wavemeter—Calibrating a wavemeter—Standard frequencies—Calibrating by "clicks"—Coil and condenser properties—Measurement of coil resistance—Determining capacity of a condenser—To	

CHAPTER	PAGE
measure wavelength of an antenna—To measure capacity of an antenna—Measure antenna inductance—Typical receiving circuits.	
IX. THE VACUUM TUBE	165
The construction of the vacuum tube—The purpose of the filament—The purpose of the plate—Effect of filament voltage—Saturation current—The purpose of the grid—Characteristic curves—Grid voltage-plate current curves—Plate voltage—Amplification factor—The meaning of the amplification factor—Equivalent tube circuit—D.-c. resistance of the tube—Internal resistance of tube—The mutual conductance of a tube—Importance of mutual conductance—Slopes as tube constants—The “lumped” voltage on a tube—Measurements of vacuum tube constants—Bridge methods of determining tube factors—To measure the plate resistance—An a.-c. tube tester—Types of tube filaments—Alternating-current tubes—Heater types of tubes—Operation of a.-c. tubes—Operating filaments in series—Modern series-filament receivers—Universal a.-c., d.-c. circuit—Means of obtaining C bias in amplifier tubes—Screen-grid tube—Variable- μ tubes—Multi-element tubes.	
X. THE TUBE AS AN AMPLIFIER	202
The tube as an amplifier—Resistance output load—Dynamic characteristic curves—Phase of E_g , E_p , I_p —Magnitude of the amplified voltage—Equivalent tube circuit—Power output—Power amplification—Power output proportional to input grid voltage squared—Amplifier overloading—Distortion due to curved characteristic—Permissible grid swing—Distortion due to positive grid—Amount of distortion caused by overloading—Power output calculation—Harmonic distortion calculation—Power diagrams—The pentode—The beam power tube.	
XI. AUDIO AMPLIFIERS	228
Need of an audio amplifier—The requirements of an audio amplifier—Cascade amplifiers—Frequency characteristic of resistance amplifier—Overall amplification—Plate battery requirements—Inductance load amplifier—Effect of stray capacities at high frequencies—Quantitative effect of capacities on high frequencies—Tuned inductance amplifier—The transformer-coupled amplifier—Transformer with no secondary load—The advantage of the transformer—Transformer-coupled amplifiers	

CHAPTER	PAGE
—Measurements on transformer-coupled amplifiers—Calculation of overall voltage amplification—Reflex amplifiers—Modern reflex circuits—“Equalizing”—The push-pull amplifier—Class B amplification—Networks—Filters.	
XII. DESIGN OF AUDIO FREQUENCY AMPLIFIERS	266
<p>The transmission unit—Voltage and current ratios—The use of the DB—Design of audio amplifiers—Comparisons between amplifiers—Volume control—Proper C bias for tubes—Compensation at low and high frequencies—Sound frequency characteristics—Power levels—Regeneration in audio amplifiers—Filtering in audio amplifiers—Individual transformer characteristics—Comparison of push-pull and single tube—Degenerative feedback amplifiers—Direct-coupled amplifiers.</p>	
XIII. HIGH-FREQUENCY AMPLIFIERS	295
<p>Purpose of <i>r-f</i> and <i>i-f</i> amplification—Field strength—Advantage of high power at transmitting station—The task of the radio-frequency amplifier—The ideal response curve of a receiver—Types of radio-frequency receiving systems—Effect of tube input capacity—Tuned radio-frequency amplifiers—Effect of negative input-resistance—Engineering the tuned radio-frequency amplifier—Gain due the tube and gain due the coil—Effect on secondary resistance of close coupling—Selectivity—Over-coupled amplifiers—Regeneration and oscillation in radio-frequency amplifiers—Bridge systems—The neutrodyne—Neutralizing bridge circuits—Filtering radio-frequency circuits—Use of screen-grid tubes—Class B and C radio-frequency amplifiers—Ultra-high-frequency amplifiers.</p>	
XIV. DETECTION	335
<p>Distorting tubes—Modulation—Percentage modulation—Demodulation—The plate circuit detector—Conditions for best detection—The vacuum tube voltmeter—Adjusting a voltmeter—D.-c. plate current as a function of a.-c. grid voltage—Detection in a radio-frequency amplifier—Grid leak and condenser detector—Effect of grid leak and condenser values—Detector action—Power detection—Automatic volume control.</p>	

CHAPTER	PAGE
XV. RECEIVING SYSTEMS.....	356
<p>The tuned radio-frequency set—The superheterodyne—The phenomenon of beats—Superheterodyne design—Repeat points—Choice of the intermediate frequency—Selectivity of superheterodyne—Frequency changers—The autodyne—Electron-coupled oscillator—Translation gain—"Short-wave" receivers—All-wave receivers—Detuning loss in autodynes—Poor quality on long waves—"Band pass" receivers—Tone control—Automatic tone control—Acoustically compensated volume control—Measurements on radio receivers—Signal generator—Receiver performance—Automatic volume control—Noise-suppressor systems—Automatic frequency control—Shielding—Loud speakers—The horn type—The moving coil speaker—Baffles for dynamic speakers—The telephone receiver—Loud-speaker measurements.</p>	
XVI. RECTIFIERS AND POWER APPARATUS.....	391
<p>The fundamental rectifier circuit—Kinds of rectifiers—Typical filament rectifiers—Requirements for rectifier tubes—Single-wave rectifier—Gaseous rectifiers—The Tungsar rectifier—The copper oxide rectifier—Filter circuits for tube rectifiers of the filament type—Regulation—A typical rectifier—Filter system—Automotive receiver power supply—The voltage divider—Engineering the voltage divider—Controlled rectifiers.</p>	
XVII. OSCILLATORS, TRANSMITTERS, ETC.....	417
<p>Oscillating circuits—Undamped or continuous oscillations—The amplifier as an oscillator—Conditions for oscillation—Maximum oscillatory plate current—Effect of coupling—Dynamic characteristics—Conditions for oscillation—Efficiency of an oscillator—Harmonies—Power output of an oscillator tube—Maximum power output of oscillator—Obtaining grid bias by means of resistance leak—Practical circuits—Hartley oscillator—Shunt-feeding oscillators—Other oscillating circuits—Adjusting the oscillator—Frequency stability—Master oscillator systems—Crystal control apparatus—Frequency doublers—Self-rectified transmitters—Adjusting the plate load to the tube—Plate current when oscillator is connected to antenna—Keying a transmitter—Methods of connecting oscillator to antenna—Feeding power through transmission line—Modulation—Amount of power required for modulation—Antenna current increase with modulation—Frequency modulation.</p>	

CHAPTER	PAGE
XVIII. ANTENNAS, TRANSMISSION, ETC.....	455
Radiation resistance—The radiation field—Calculation of the received current—Types of antennas—Directional antennas—Inductance and capacity of antennas—Natural wavelength of antenna—Loading an antenna—Decreasing the wavelength of an antenna—Short-wave transmission—Fading—Comparison of night and day reception—Static—Anti-static antenna systems—Automobile antennas.	
XIX. FACSIMILE AND TELEVISION TRANSMISSION.....	469
The problem of picture transmission—Picture elements—Frequency band required—Method of taking the picture apart—Scanning—Flying spot—Cathode-ray television—The iconoscope—Use of ultra-high frequencies.	
INDEX.....	483

PRINCIPLES OF RADIO

CHAPTER I

FUNDAMENTALS

No one can learn a great deal about the theory and practice of radio who does not also know a few fundamental facts about electricity, for radio is but one aspect of a much broader field, electrical engineering. And since electricity is but a movement of the smallest known bit of matter and energy, the electron, it is necessary that a study of electricity must be preceded by a slight knowledge of the electron.

1. The electron.—The entire universe is made up of various combinations of about ninety substances known as **elements**. These elements are composed of but two things, negative electrical charges known as **electrons**, and positive charges known as **protons**. The electrons are all alike. The only difference between copper and aluminum lies in the difference in the number and position of their electrical charges.

2. Charged bodies.—The term charge is used in various ways. A body on which there is an equal amount of negative and positive electricity is said to be in equilibrium; but if the body has an excess of either negative or positive electricity it is said to be **charged**. Sometimes the body itself is called a **charge** and of course may be referred to as a positive or a negative charge. If it has a great excess of either of the two kinds of electricity, it is said to be highly charged. In this condition it is in a state of very unstable equilibrium, and at the least chance some change will occur to bring the body into a state of greater equilibrium.

3. The laws of electrical charges.—These electrical charges obey simple laws: like charges, whether positive or negative, repel each other; unlike charges, that is, a positive and a negative charge, attract each other. The more highly charged the bodies are the greater will be the repulsion or attraction. The closer together the charges are the greater will be the attraction or repulsion. Doubling the distance between two unlike charges divides their attraction by four. The greater the magnitude of the individual charges the greater is the attraction or repulsion; the greater the distance between the charges the less the attraction or repulsion.

Experiment 1-1. This experiment demonstrates the production of charged bodies by friction and the laws that control such charged bodies. Whenever

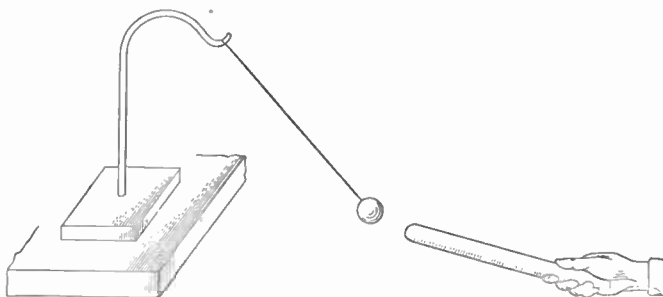

FIG. 1.—A familiar experiment in static electricity.

one body is rubbed by another, some frictional electricity is said to be generated. This amounts to stating that one of the bodies becomes charged. To get an appreciable charge, one needs a glass rod, a stick of sealing wax, a piece of silk and a piece of flannel, and a small bit of pith from a dry cornstalk or alder branch or sunflower stalk suspended as shown in Fig. 1 by means of a fine silk thread. Rub the piece of glass with the silk and bring near the pith ball; the pith ball should be attracted and then repelled. Then rub the wax stick with the flannel and bring it near the pith ball. It should be strongly attracted, proving that another kind of static or frictional electricity—or electrically charged body—has been generated. Now suspend two similar pith balls, touch one of them with the glass rod after rubbing it, and touch the other ball with the wax rod. Bring them near each other. Touch both balls with either the glass or the wax rod and bring them near each other. Now they are

repelled. The latter part of the experiment is almost the starting point of the world's history of electricity.

4. The atom.—The simplest form in which an element can exist by itself is called the atom. A combination of two or more atoms is called a molecule. Ordinarily the atom or molecule is in electrical equilibrium with its surroundings. If, however, through some severe mechanical shock for example, it should lose an electron it would be charged and then would follow the laws cited above. It would then attract or get rid of an electron at the first opportunity and become neutral again.

It is the motion of electrons that we know as the **electric current**. When there is a sufficient number of electrons, a billion billion per second, for instance, there is current enough to light an incandescent lamp or heat an electric iron.

The atoms and molecules in matter are in constant motion, carrying with them in their movements the electrons that constitute them; in the bumping of one atom against another, electrons are lost, gained, and interchanged.

Atoms of matter are inconceivably small. Everyone has seen many-colored oil films on the street. It is possible to obtain oil films less than half a ten-millionth of an inch thick. The atoms composing these films cannot be thicker than this figure; the electrons are much smaller yet. We think the distances in the solar system of which the earth is part are beyond comprehension, the sun for example being about 90 million miles from the earth; but the dimensions of the electrons in their smallness are even more difficult to picture. The diameter of the electron is estimated to be about 1 foot divided by a hundred million million. Each of these electrons resembles its brother exactly, so that when an electron is knocked out of an atom by a collision it is free to combine with any other body near by which may have a deficit of negative electricity, no matter what the body may be made of. The electron is the unit out of which everything is made.

5. The ether.—The fact that one charge can exert a force, either of attraction or repulsion, upon another implies that something connects the two. For instance, a comb which has been rubbed on the coat sleeve will pick up bits of paper even though

it does not actually touch them, the paper jumping to the comb while the latter is still some distance from it. Evidently something exists in the space between the comb and the paper. That it is not air may be demonstrated by performing a similar experiment under a jar from which all the air has been pumped.

This leads us to a conception of what is commonly known as the **ether**. It is simply the place or the substance, or whatever one may choose to call it, wherein the attraction or repulsion of electrical charges exists. The ether is an invention made necessary by our difficulty in conceiving how one body can exert an effect upon another except through some intervening medium. Between two charged bodies are said to exist **lines of force** which tend to decrease the distance between the bodies if they are oppositely charged or to increase it if the bodies are charged alike. The sum of these lines of force is called an **electrical field** and every charged body is surrounded by such a field. Since a wireless aerial is but a charged system of wires it too has a field about it. This field extends in all directions through what we call the ether.

6. The electric current.—In an ordinary piece of copper wire the electrons are moving about in a haphazard fashion at the rate of about 35 miles per second. If this wire is in an electrical circuit, in addition to this to and fro motion there is a comparatively slow drift of electrons from one end of the wire to the other. It is this slow drift of electrons in a given direction that we ordinarily call the electric current. Because each electron can carry an extremely small quantity of electricity, it is only movements of large numbers of them that we are interested in. It has been estimated that it would take all the inhabitants of the earth, counting night and day at the highest rate of speed possible, 2 years to count the number of electrons which pass through an ordinary electric light in a second. This is about the same number that is necessary to light the tubes in a modern a.-c.-d.-c. receiver.

The flow of electrons from one end of the wire circuit to another can be explained by the two fundamental laws of electrical charges (Section 3). When a wire is attached to the positive terminal of a battery there is a momentary movement of the electrons nearest the end of the wire toward the battery. This movement soon

ceases because the flow of electrons into the battery leaves a dearth of them at the other end of the wire which must be supplied. If both ends are attached to the battery a steady drift of electrons takes place out of the negative pole or terminal of the battery, through the wire, and to the battery again at the positive terminal.

Thus the actual motion of the electrons is from the negative toward the positive end of a circuit. This is in the opposite direction from the rule established many years before the electron had been discovered, namely, that current flows from positive to negative. In problems the student can assume either direction so long as he is consistent. We know that the electrons flow from negative to positive; electrical workers assume the current flows from positive to negative. In this book we shall follow the latter rule, but the student should remember that the actual carriers of electricity move in the opposite direction.

7. Insulators and conductors.—It is a matter of common knowledge that the current does not flow through the non-metallic parts of a radio set, or through the insulating material around a broken conductor. How does it happen that some materials are such good “conductors,” copper and silver for example, whereas others, such as glass or bakelite, appear not to conduct at all? Here again we are dealing with the building stones of all matter, the atom and the electron. Atoms of the so-called non-conductors maintain their hold on their individual electrons very tightly; few electrons escape. In the conductors, the electrons of the various atoms are freer to move about, and so to be interchanged among atoms. A **conductor** is a substance that quickly loses its charge when rubbed. A **non-conductor** retains its charge longer.

A good conductor is a material whose electrons are freer to move about than those of a poor conductor. Strictly speaking, there are no non-conductors. All materials will carry current to some degree. Glass, for example, which is generally considered a very good insulator, conducts electricity fairly well when it is in a molten state.

The best insulators—that is, the poorest conductors—are amber, rubber, sulphur, shellac, porcelain, quartz, silk, air. Dry

wood, paper, cotton and linen thread are semi-conductors. The best conductors are the metals, acids, moist earth, etc.

8. Conductivity.—All materials have a certain characteristic which we may call **conductivity**, which describes their ability to conduct an electric current. Among pure metals silver has a very high conductivity, copper is next, and near the bottom lies iron with about one-ninth the conductivity of copper. The **conductance** of a circuit is a term expressing its ability to pass an electric current. The greater the conductance, the greater the current. The unit of conductance is the mho.

9. Resistance.—Those metals which have a high conductivity may be said to offer little **resistance** to the flow of electrons through

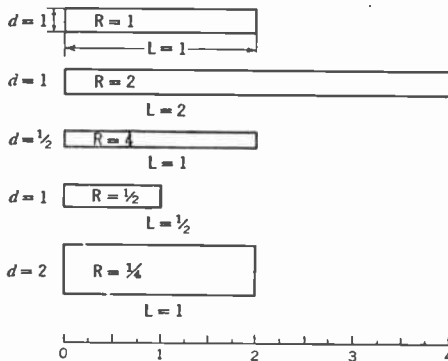

FIG. 2.—Resistance depends upon the length and size of a conductor.

them. Thus, copper has a low resistance, while some combinations of copper, nickel, and iron-manganese, for example, have resistances many times that of copper. A device added to a circuit to increase its resistance is called a "resistor." The words resistance and resistor are used synonymously in this text.

The resistance of two wires of the same material and at the same temperature depends upon two things, the length of the wires and the area of their cross-section. Naturally, the longer the wire the fewer electrons can pass through it in a given time; similarly the smaller the diameter of a wire the greater the resistance, just as you can get more gallons of water per second from a 3-inch fire hose than from a 1-inch garden hose, although they may be attached to the same hydrant.

Similarly, a wire 2 feet long has twice the resistance of a wire 1 foot long but of the same diameter. Of two wires the same length the one having the smaller diameter will have the greater resistance. (See Fig. 2.) $\text{Area} = 3.1416 \times (\text{radius})^2$.

The resistances of several metals compared to silver are as follows:

Silver.....	1.00	Platinum.....	6.15
Copper.....	1.06	German silver.....	20
Aluminum.....	1.74	Constantan.....	27
Nickel.....	4.25	Mercury.....	59
Soft iron.....	6.00	Carbon.....	215

Problem 1-1. How many times higher in resistance is mercury than silver? Than copper?

Problem 2-1. Two wires of the same length and diameter have resistances in the ratio of 5.65 to 1. If the lower resistance wire is copper, could you identify the other wire material from the above table?

Problem 3-1. Two wires, one of soft iron and the other of platinum, are to have the same resistance. They have the same diameter. The platinum wire is one foot long. What is the length of the soft iron wire?

10. The ohm.—The unit of resistance is the **ohm**. It is the resistance of a column of mercury weighing 14.4521 grams, having a uniform cross-section and a height of 106.3 cm. at 0° Centigrade. A 9.35-foot length of No. 30 copper wire has a resistance of about one ohm. The table on page 17 gives sizes and resistance per thousand feet of copper wire. The resistance per foot may be obtained from such a table by dividing the resistance per thousand feet by one thousand.

Note that increasing the size of wire by three numbers, that is, from No. 20 to No. 23, doubles the resistance of the wire from 10.15 to 20.36 ohms; going from No. 30 to No. 27 lowers the resistance from 103.2 to 51.5 ohms per thousand feet.

Copper is used in electrical and radio circuits because of its high conductivity compared to other metals and its low cost compared to metals of higher conductivity. It is readily obtainable and easily worked.

Problem 4-1. What size of soft iron wire will have the same resistance as No. 32 copper?

Problem 5-1. What is the resistance of 1 foot of No. 20 copper? Of No. 24 aluminum?

Problem 6-1. What is the resistance of a column of mercury of the following dimensions, weight 0.032 lb. (1 pound = 453.6 grams), length 41.7 inches (1 inch = 2.54 centimeters) at 0° C., the column having uniform cross-section?

11. The effect of molecular motion on resistance.—Why do some substances have greater resistance than others? Let us again consider the electrons, atoms, and molecules which make up the wires carrying the currents. Not only are the electrons in motion, but the atoms and molecules themselves are in a sluggish motion, the violence of this motion depending upon the temperature of the wire and the material of which the wire is made.

And although molecules cannot traverse the electric circuit as the electrons can, in their to and fro motion they impede the progress of the electricity bearers by countless collisions with them. The greater this molecular motion, the greater the resistance to a progressive flow of electrons, and the greater the wire's electrical resistance.

12. The effect of temperature on resistance.—The resistance of all pure metals rises with increase in temperature. This is because of the greater molecular agitation at higher temperatures, making it more difficult for the electrons to drift in their progressive motion around the circuit.

At absolute zero, 273 degrees below zero Centigrade, all molecular motion is supposed to stop, making the resistances of metals practically zero. At the lowest temperature reached it has been found that the resistance of a coil of wire is so low that current will flow for some time after the driving force is removed. Scientists have approached to within a fraction of a degree of absolute zero.

13. Temperature coefficient of resistance.—Conductors in which radio engineers are interested increase or decrease in resistance at a regular rate with respect to temperature. The change in resistance of a given wire may be computed from the following facts. The "temperature coefficient of resistance" is a term which gives the amount a resistance increases for each degree rise in temperature for each ohm at the original temperature. For example, if a copper wire with a temperature coefficient of 0.0042 has a resistance of 80 ohms at 0° C., this resistance will be increased by 80×0.0042 for each degree rise in temperature. At 50° C. the resistance increase would be $80 \times 0.0042 \times 50$ or 16.8 ohms, and the resistance would now be $80 + 16.8$ or 96.8 ohms. Manganin wire, composed of 84 per cent copper, 12 per cent manganese,

4 per cent nickel, has a very low temperature resistance. It is 0.000006. The change in resistance of two metals with temperature is shown in Fig. 3.

14. The ampere.—The ampere is the term used to express the rate at which electrons move past a given point in an electrical circuit. It is equal to 6.28×10^{18} (see Section 16) electrons per second. Since each electron carries a definite quantity of electricity, the total amount carried by 6.28×10^{18} electrons is a

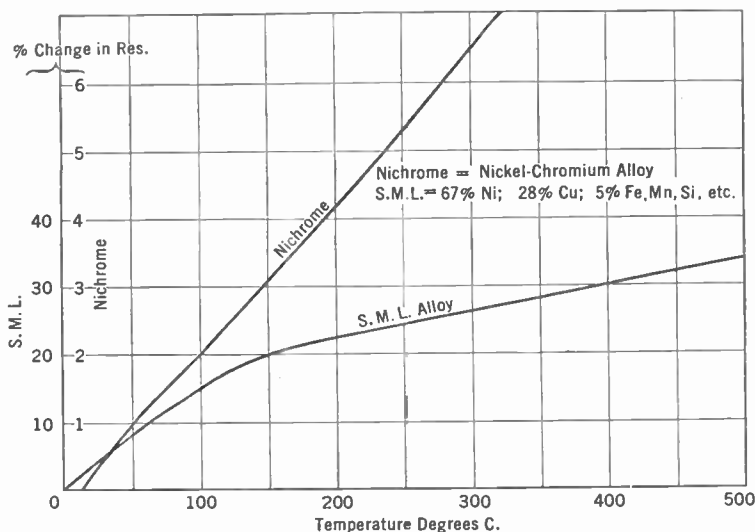

FIG. 3.—Effect of temperature on resistance.

definite quantity and is known as the **coulomb**. The ampere, however, is the term used in electrical practice. It corresponds to the term gallons per second used in speaking of the amount of water transported through a pipe or hose. The term gallons alone conveys little meaning, since the same number of gallons will flow out of a small hose as out of a large one provided we do not consider the time involved, or the pressure. But "gallons per second" involves both time and pressure and is a term easily visioned. A current of one ampere will convey through a circuit one coulomb of electricity per second.

The ampere as a quantity of electricity transported per second is a large unit if we compare it with the current flowing from the B batteries of a radio set. It is small compared with the currents encountered in power houses. The B batteries supply only thousandths of amperes or milliamperes, whereas in a small power house supplying power to a village one may have thousands of amperes flowing. A meter to measure the flow of current is called an ammeter, or milliammeter, or microammeter, depending upon the strength of current it can measure. Approximate currents flowing through commonly used devices are shown below.

Apparatus	Approximate Current in Amperes
50-watt lamp	0.5
250-watt lamp	2.5
2-horsepower motor	10
Electric iron	5
Filament of vacuum tube	0.25
Plate circuit of vacuum tube	0.001

15. The volt.—The electrons are driven through the wires and apparatus composing the circuit by a force called an **electromotive force**, abbreviated to e.m.f. The unit of force is known as the **volt**. It is the electrical force that will cause one ampere of electricity to flow through a wire which has one ohm of resistance. The common dry cell used to ring door bells has a voltage of about 1.5; storage batteries when charged have a voltage of about 2.0 and thus a three-cell battery has a voltage of 6.0. The ordinary B battery has a voltage of about 45, and if torn apart will be found to consist of 30 small cells, the voltage of which is 1.5 volts each. When the total voltage of such a battery is as low as 37 the battery should be thrown away. An instrument used to measure voltages is known as a voltmeter. A table of voltages is given below.

Apparatus	Voltage (Approximate)
Dry cell	1.5
Storage battery	6
B battery	45
House lighting circuit	115
“ Third rail ”	500

16. Engineers' shorthand.—Engineers have a simple shorthand method of working with large numbers well illustrated by the figures 6.28×10^{18} . This means 6.28 multiplied by a million million million. This many electrons flowing past a given point per second constitute the electric current known as an ampere. We shall have occasion to use this system many times in the course of the book and students are encouraged to master it as soon as possible. The table below will be helpful.

1	=	10^0	=	one
10	=	10^1	=	ten
100	=	10^2	=	hundred
1000	=	10^3	=	thousand, etc.
1	=	10^0	=	one
.1	=	10^{-1}	=	$\frac{1}{10}$ = one-tenth
.01	=	10^{-2}	=	$\frac{1}{100}$ = one-hundredth
.001	=	10^{-3}	=	$\frac{1}{1000}$ = one-thousandth, etc.

The small number above the figure 10 is called the **exponent**. Numbers less than 1 have negative exponents. Thus three-thousandths may be expressed in these several ways:

$$.003 = 3 \times 10^{-3} = \frac{3}{1000} = \frac{3}{10^3}$$

When numbers are multiplied, their exponents are added; when the numbers are divided, the exponents are subtracted. Thus 100 multiplied by four-tenths may be done in shorthand as follows:

$$\begin{aligned} 100 \times .4 &= 10^2 \times 4 \times 10^{-1} \\ &= 4 \times 10^1 \\ &= 4 \times 10 \\ &= 40 \end{aligned}$$

Similarly, let us divide 3000 by 150.

$$\begin{aligned} 3000 \div 150 &= (3 \times 10^3) \div (1.5 \times 10^2) \\ &= \frac{3}{1.5} \times 10^3 \times 10^{-2} \\ &= 2 \times 10 \\ &= 20 \end{aligned}$$

The rules are few and those are simple:

1. To multiply, add exponents.
2. To divide, subtract exponents.
3. When any number crosses the line, change the sign of the exponent.

Example 1-1. Multiply 20,000 by 1200 and divide the result by 6000.

$$\begin{aligned}
 20,000 &= 2 \times 10^4 \\
 1200 &= 12 \times 10^2 \\
 6000 &= 6 \times 10^3 \\
 \frac{20,000 \times 1200}{6000} &= \frac{2 \times 10^4 \times 12 \times 10^2}{6 \times 10^3} \\
 &= \frac{2 \times 12 \times 10^4 \times 10^2 \times 10^{-3}}{6} \\
 &= \frac{2^4}{8} \times 10^3 \\
 &= 4000
 \end{aligned}$$

Problem 7-1. How many electrons flow past a given point per second when the number of amperes is 6? 60? 600? 0.1? 0.003?

Problem 8-1. The sun is roughly 90 million miles from the earth. Express this in "shorthand."

Problem 9-1. At 100 miles per hour, how many months would it take to reach the sun?

Problem 10-1. If light travels at 300 million meters per second and if a meter equals 3.3 feet, how long does it take the sun's rays to reach the earth?

Problem 11-1. How many amperes of current flow when 31.4×10^{18} electrons per second flow past a point?

In connection with such shorthand methods the following table of prefixes commonly used will be important.

Prefix	Abbreviation	Meaning
micro	μ	one millionth
milli	m	one thousandth
centi	c	one hundredth
deci	d	one tenth
deka	dk	ten
hekto	h	one hundred
kilo	k	one thousand
mega	M	one million

Thus a thousandth of an ampere is known as a milliampere, a million ohms is called a megohm, etc.; or, expressed in numbers, 1 milliampere = 10^{-3} or .001 ampere; 1 megohm = 1,000,000 ohms.

17. Mathematics in the study of radio.—The amount of mathematics one needs varies with the intensity with which one intends to study radio. As in all other branches of science in which mathematics plays a part the easier it is to think mathematically

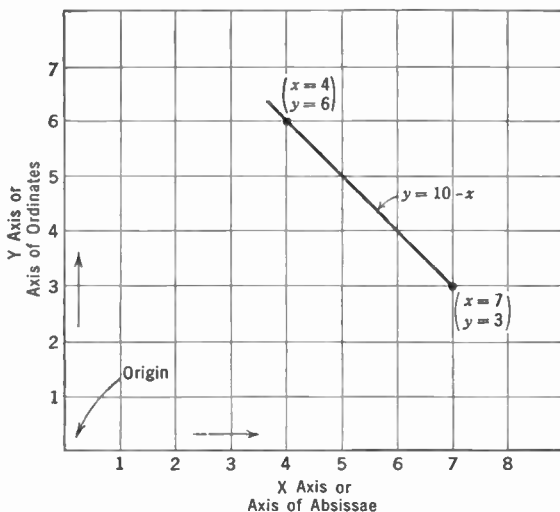

FIG. 4.—Curves are usually drawn with the origin as shown.

the greater are the possibilities ahead of the student. In this book it is necessary to have only a rudimentary knowledge of algebra to work most of the problems. The student with no mathematics beyond arithmetic and common sense will be able to work his way through most of the examples.

18. Curve plotting.—Many of the answers to radio problems can be seen visually if the problem is plotted in the form of a graph. Such graphs or curves are used frequently in this text, and it is essential that the student and experimenter not only shall be

familiar with how to plot curves but how to interpret curves that other experimenters have drawn.

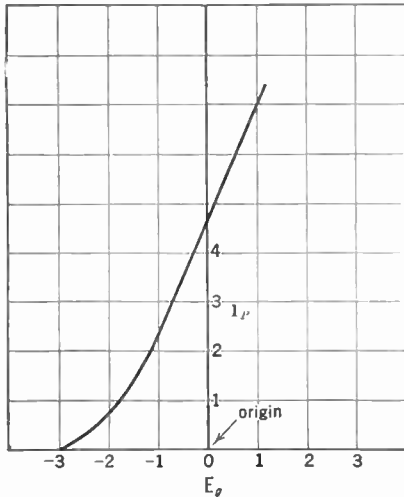

FIG. 5.—The origin in the center.

which it passes, or by giving one point through which it passes and its direction. By a point and a direction we have plotted the next simple mathematical equation, a straight line.

In radio plots the axes may be called X for the horizontal and Y for the vertical, or current for one and voltage for the other, etc. A graph is a visual expression of the relation existing between two factors, X and Y , or current and voltage, etc. When one increases the other increases or decreases. Knowing the

law connecting them (the equation or formula, we call it) we can

The simplest form of curve is a map. The map has two co-ordinates or axes, north-south and east-west. We say that a town is situated at so many miles east and so many miles south of some point that we take as the origin. We have now plotted the simplest mathematical equation, a point. A railroad runs straight north past a point, that is, so many miles east of this town. We can locate this railroad by giving two points through

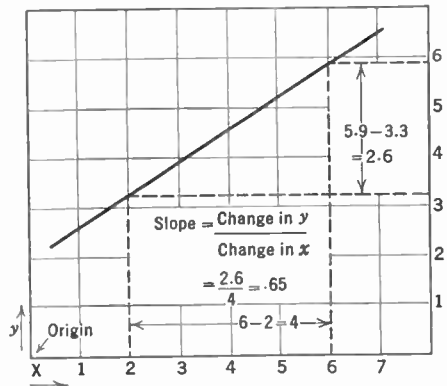

FIG. 6.—How to calculate the slope of a curve.

tell what the current is at any given voltage. If the law expressed visually in the form of a graph is a straight line, we say the two factors, current and voltage, are proportional. If one increases and the other decreases, we say they are inversely proportional.

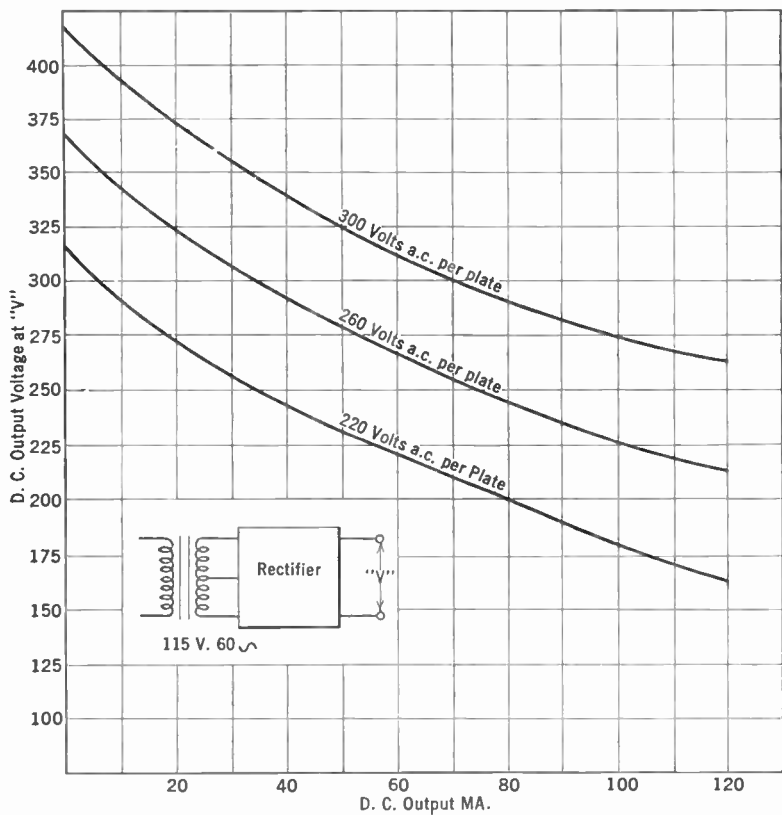

FIG. 7.—A power supply device regulation curve.

Curves are useful not only in giving us a visual picture of what is happening in a circuit, but in telling us if the figures secured in an experiment are correct. Thus we may calibrate a wavemeter in condenser dial degrees against wavelength in meters. We plot this curve and one or more points do not seem to fall on the smooth

curve that goes through the other points. Something in our laboratory experiment caused these points to be off the curve. They were incorrectly taken, and the measurement that gave us these points must be repeated.

The origin, sometimes, is at the lower left-hand corner of the curve, as in Fig. 4, although it may be in the center or somewhere else, as in Fig. 5, which shows the relation between the current in the plate circuit of a vacuum tube as it is controlled by the amount of voltage on the grid of that tube.

Points which lie to the left of the vertical axis are negative;

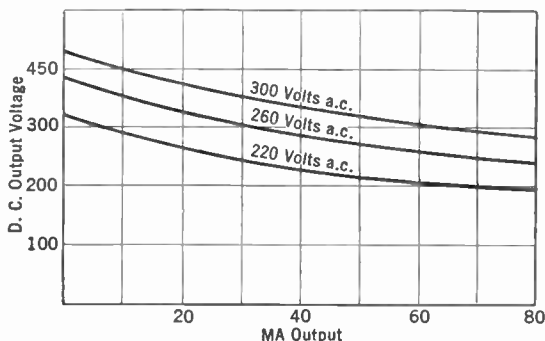

FIG. 8.—The same data as in Fig. 7 but to a different scale.—Note how much flatter the curves appear.

points which lie below the horizontal axis are negative. All others are positive.

The change in the vertical units with a given change in horizontal units is called the slope of the curve. If the curve goes through the origin this slope amounts to the ratio between the vertical and the horizontal values at any point. In Fig. 6 is shown the method of calculating the slope.

The units in which a curve is plotted change its appearance. Thus in Fig. 7 is plotted the relation between the output voltage of a "B eliminator" as the current taken by the receiver is changed. Figure 8 shows the same data but plotted to a different vertical scale. The slope of these lines looks different but really is the same. If the slope is the factor in which we are interested, the





more open scale should be used so that small changes will be visible.





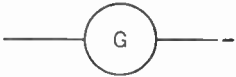

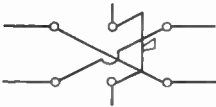
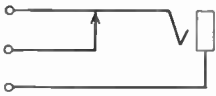
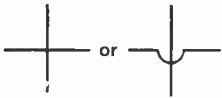

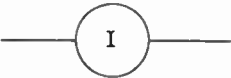
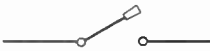
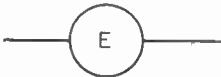
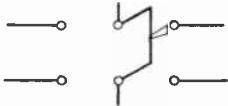

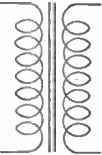

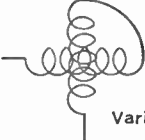

19. Symbols.—In all technical literature a number of abbreviations are used to express parts of circuits. For example, in very popular articles a "picture diagram" may be used, but picture diagrams are only for the boy and the experimenter who are too lazy or disinterested to learn radio language. The symbols used in this book are shown on the next two pages. A circuit is built up simply by connecting several of these symbols together.

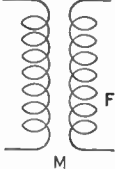
COPPER WIRE TABLES
Resistance at 68° F. (20° C.)

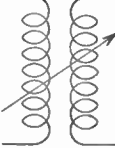
Mils. .001 inch

Size of Wire B. & S. Gauge	Diameter of Wire Mils.	Ohms per 1000 Ft.	Pounds per 1000 Ft.	Turns per Linear Inch			
				S.c.c.	D.c.c.	S.s.c.	D.s.c.
0000	460	.049	641	2.14	2.10		
000	410	.0618	508	2.39			
00	365	.0779	403	2.68	2.62		
0	325	.0983	319	3.00			
1	289	.1239	253	3.33	3.25		
2	258	.1563	201	3.75			
3	229	.1970	159	4.18	4.03		
4	204	.2485	126	4.67			
5	182	.3133	100	5.21	5.00		
6	162	.3951	79.5	5.88			
7	144	.4982	63	6.54	6.25		
8	128	.6282	50.0	7.35			
9	114	.7921	39.6	8.26	7.87		
10	102	.9989	31.4	9.25			
11	91	1.260	24.9	10.3	9.80		
12	81	1.588	19.8	11.5			
13	72	2.003	15.7	12.8	12.2		
14	64	2.525	12.4	14.3			
15	57	3.184	9.86	15.9	14.9		
16	51	4.016	7.82	17.9	16.7	18.9	18.3
17	45	5.064	6.20	20.0			
18	40	6.385	4.92	22.2	20.4	23.6	22.7
19	36	8.051	3.90	24.4			
20	32	10.15	3.09	27.0	24.4	29.4	28.0
21	28.5	12.80	2.45	29.9			
22	25.2	16.14	1.94	33.9	30.0	36.6	34.4
23	22.6	20.36	1.54	37.6			
24	20.1	25.67	1.22	41.5	35.6	45.3	41.8
25	17.9	32.37	.97	45.7			
26	15.9	40.81	.769	50.2	41.8	55.9	50.8
27	14.2	51.47	.610	55.0			
28	12.6	64.90	.484	60.2	48.6	68.5	61.0
29	11.3	81.83	.384	65.4			
30	10.0	103.2	.304	71.4	55.6	83.3	72.5
31	8.9	130.1	.241	77.5			
32	8.0	164.1	.191	83.4	62.9	101	84.8
33	7.1	206.9	.152	90.0			
34	6.3	260.9	.120	97.1	70.0	121	99.0
35	5.6	329.0	.0954	104			
36	5.0	414.8	.0757	111	77.0	143	114
37	4.5	523.1	.0600	118			
38	4.0	659.6	.0476	125	83.3	167	128
39	3.5	831.8	.0377	135			
40	3.1	1049	.0299	141	90.9	196	145

 <p>Headphones</p>	 <p>Galvanometer</p>	 <p>Key</p>
 <p>Wires Connected</p>	 <p>Reversing Switch</p>	 <p>Closed Circuit Jack</p>
 <p>Wires crossed but not Connected</p>	 <p>Single Pole Double Throw Switch "S.P.D.T."</p>	<p>L = Inductance C = Capacity R = Resistance ω = Ohms Ω = Megohms mH = Millihenries Mfd. = Microfarads Mmfd. = Micro Microfarads μH = Microhenries</p>
 <p>Ammeter or Milliammeter</p>	 <p>"S.P.S.T." Switch</p>	
 <p>Voltmeter</p>	 <p>Double Pole Double Throw Switch "D.P.D.T."</p>	

 <p>Fixed Inductance</p>	 <p>Iron Core Transformer</p>	 <p>Variable Resistance</p>
 <p>Variable Inductance</p>	 <p>Fixed Capacity or Condenser</p>	 <p>Three Element Tube</p>
 <p>Variometer</p>	 <p>Variable Capacity or Condenser</p>	 <p>Heater Type A.C. Tube</p>
 <p>Transformer with Fixed Coupling</p>	 <p>Antenna</p>	 <p>Four Element Tube (Screen Grid Type)</p>
 <p>Transformer with Variable Coupling</p>	 <p>Ground</p>	 <p>Two Element or Rectifier Tube</p>
 <p>Iron Core "Choke"</p>	 <p>Resistance or Impedance Fixed</p>	 <p>Microphone</p>

CHAPTER II

OHM'S LAW

IN the previous chapter we stated that an electric current was a motion of electrons; that the force which caused the motion of the electrons was called an electromotive force (e.m.f.) or a potential difference (p.d.), that the resistance of a circuit opposes the flow of current, and that the unit of the current which actually flows per second is called the ampere. We have then a very simple law which enables the engineer to calculate

1. The current that will flow when the voltage and resistance are known.
2. The voltage necessary to force a certain amount of current through a known resistance.
3. The resistance that will restrict the current to a certain value under pressure of a certain e.m.f. expressed in volts.

20. Ohm's law.—The law which governs all simple and many complex electrical phenomena is known as **Ohm's law**. This law states that: Current in amperes equals e.m.f. in volts divided by resistance in ohms, or, as expressed in electrical abbreviations,

$$I \text{ (current)} = \frac{E \text{ (voltage)}}{R \text{ (resistance)}}$$

21. Ways of Stating Ohm's law.—There are three ways of stating this fundamental law. They are:

$$(1) I = E/R \quad (2) E = I \times R \quad (3) R = E/I$$

These three ways of stating the same law are determined from the first statement of Ohm's law by simple mathematical transformation, and make less difficult the solving of problems.

22. Voltage drop.—The second way of stating Ohm's law is that whenever a current flows through a resistance, there is a difference of potential at the two ends of that resistance. For every ampere of current that flows through an ohm of resistance, there is a volt lost. In other words it requires a volt to force an ampere through an ohm of resistance, and once that task is over, the volt is gone.

Consider Fig. 9, which shows the voltage-divider between a radio receiver and a voltage supply system for feeding power to the receiver. The power tube may require 180 volts. Other tubes require only 90 volts or perhaps

small negative voltages. If 20 milliamperes of current flow through this voltage-divider, whose resistance may be 5000 ohms, and if there are 180 volts across the entire resistance, there will be other voltages along the resistance as indicated in the illustration. If the negative terminal of a voltmeter were attached to the negative end of the voltage-

divider and the positive terminal of the meter touched to various points along the resistance on the way toward the positive end, greater and greater voltages would be measured. What is being measured at each point is the drop in voltage between that point and the negative terminal of the voltage-divider.

Often in laboratories a voltage is needed so small that it cannot be measured with available instruments. A larger voltage can be measured easily, however; and if it is impressed across a voltage-divider, any desired part of the total voltage may be utilized by tapping into this divider. (See Problem 4-2.)

These voltages appearing across a resistance because of current flowing through that resistance are known as IR drops. They may be calculated by multiplying the resistance in ohms by the current in amperes.

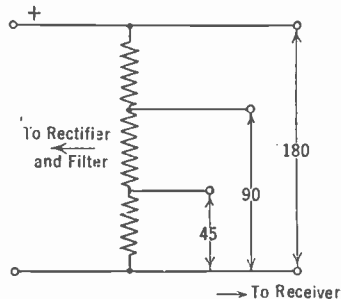

FIG. 9.—The voltage divider of a receiver's power apparatus.

Example 1-2. In Fig. 10 is an "output choke" coupling a loud speaker to a power tube. The tube requires that 180 volts shall be impressed between its plate terminal and its negative filament terminal. The question is, how many volts must the B battery have in order to impress this voltage on the tube?

The plate current is 18 milliamperes. The d.-c. resistance of the choke coil is 1700 ohms. The voltage used up in forcing 18 milliamperes through the 1700 ohms is 30.6. This voltage never gets to the tube. The voltage measured between plate and negative filament will be the B battery voltage minus the IR drop across the choke. Hence the total voltage required is 180 for the tube and 30.6 for the choke, or 210.6 volts. One of the requirements of a good choke for such purposes is that it have a low d.-c. resistance. Otherwise too much voltage is lost there.

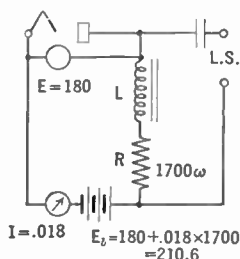

FIG. 10.—A choke-condenser coupling circuit.

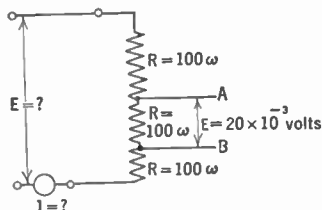

FIG. 11.—Use of an IR drop as a source of voltage.

Problem 1-2. What current flows through a vacuum tube filament connected to a 5-volt battery if its resistance is 20 ohms?

Problem 2-2. Suppose we desire to limit to 1 milliampere the flow of current in a circuit attached to a 45-volt B battery. What must be the total resistance of the circuit?

Problem 3-2. What is the resistance of a 32-tube filament designed for two-volt batteries? (0.06 ampere.)

Problem 4-2. Consider Fig. 11. How many milliamperes of current must be forced through the circuit in order to get 20 millivolts across the resistor A-B? How many volts in all will be needed?

23. Graphs of Ohm's law.—An interesting study of Ohm's law may be made by means of the circuit shown in Fig. 12 and several sheets of plotting or graph paper. The result of plotting current against voltage with constant resistance (Fig. 13); or

resistance against current with constant voltage (Fig. 14); or

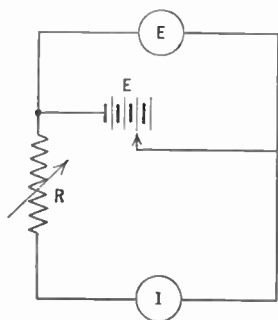

FIG. 12.—A circuit for testing Ohm's law.

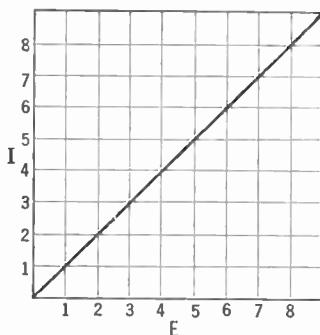

FIG. 13.—In an Ohm's law circuit plotting current against voltage results in a straight line.

voltage against resistance with constant current—all give an accurate graphical picture of what Ohm's law means.

In Chapter I the term conductance, K , was explained as equal to $1/R$. When conductance against current is plotted, a straight line results, as shown in Fig. 15. When voltage and current are plotted with a fixed resistance in the circuit, the curve is a straight line if the circuit follows Ohm's law.

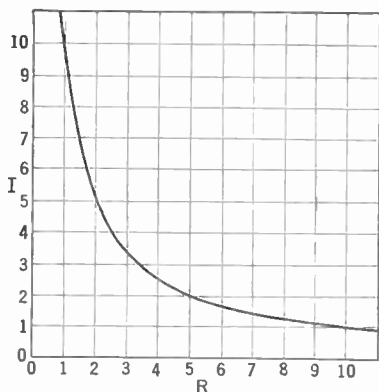

FIG. 14.—The result of plotting current against resistance.

Experiment 1-2. If the apparatus is at hand, connect it up as in Fig. 12, using a 6-volt battery, a 40-ohm rheostat, and an ammeter

reading a maximum of about 0.5 ampere. Connect the maximum resistance in the circuit and note the current as the voltage is changed from 2 to 4 and then 6 volts by tapping onto each of the three cells of the storage battery. Plot the data. Then use a smaller value of resistance and repeat.

Then use 2 volts and adjust the rheostat until several current readings have been obtained. Calculate from Ohm's law what the resistance is and plot resistance against current.

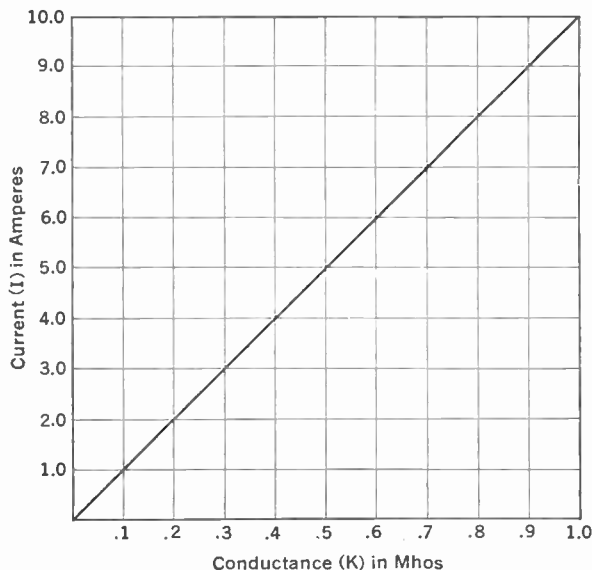

FIG. 15.—Conductance $\left(\frac{1}{R}\right)$ plotted against current.

Convert the resistances into conductances and plot against current. Calculate similar data, using 4 volts and then 6 volts, and plot the data.

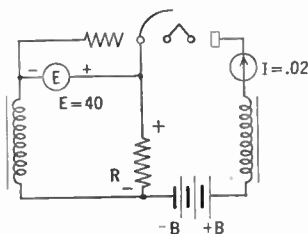

FIG. 16.—A problem in Ohm's law—to determine the value of R to provide bias for grid of tube.

Note in each case the shape of the curve has not changed, although the slopes of the straight lines vary with the resistance and the curved lines are displaced from each other.

Problem 5-2. Plate current (20 ma.) flows through R in Fig. 16. What must be the resistance in order to make the grid of the tube 40 volts more negative than the cathode? There is no loss in voltage in the coil.

24. Series and parallel circuits.—

There are two ways in which electrical apparatus may be connected together.

When two or more pieces of equipment are connected as in Fig. 17 they are said to be in series. The same current flows through each unit. The voltage drop across each unit is controlled by its resistance, and if one of these units has twice the resistance of the other, the voltage drop across it will be twice as great. The sum of the voltage drops across the three resistances must be equal to the voltage of the battery, for there is no other place in the circuit for the voltage to be used up.

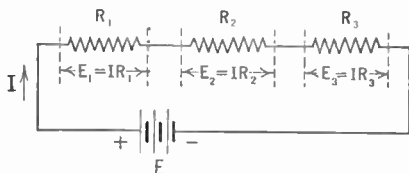

FIG. 17.—A simple series circuit.

In a series circuit the total resistance is the sum of the individual resistances. The current in each unit is the same as in all other units. The current is obtained from Ohm's law (1).

If any of the units becomes "open" the current ceases to flow. If, however, any unit becomes "shorted" the current will increase because the total resistance of the circuit has decreased.

Example 2-2. In Fig. 18 is a typical series circuit composed of a vacuum tube of the 201-A type which has a filament resistance of 20 ohms, a 6-volt

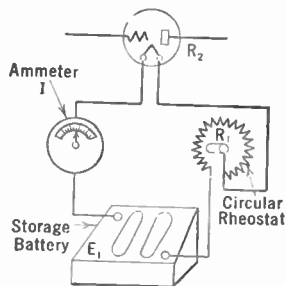

FIG. 18.—A series circuit used in radio apparatus.

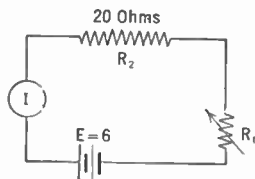

FIG 19.—The equivalent of Fig. 18.

battery, a current meter, and a rheostat or variable resistor whose purpose is to limit the flow of current through the filament of the tube. Note also Fig. 19 in which the same circuit is represented using electrical symbols. The arrow through R_1 indicates that it can be adjusted in value. R_2 indicates the resistance of the filament.

The question is, what current will flow through the circuit as the resistance of R_1 is varied? Suppose it is 4 ohms. We know the same current will flow through both the filament and the rheostat. The resistance, then, in the circuit is equal to 20 plus 4 or 24 ohms, and by Ohm's law we know that the current will be the voltage divided by the total resistance, or

$$I = \frac{E}{R_1 + R_2} = \frac{6}{4 + 20} = \frac{6}{24} = 0.25 \text{ ampere.}$$

There are two resistances in this circuit. Current flows through them. There must then be two voltage drops. Let us calculate what they are. By equation 2 we multiply the resistance by the current.

$$\text{voltage drop} = IR_1 = .25 \text{ ampere} \times 4 \text{ ohms} = 1 \text{ volt}$$

$$\text{voltage drop} = IR_2 = .25 \text{ ampere} \times 20 \text{ ohms} = 5 \text{ volts}$$

In other words, of the six volts available at the terminals of the battery, five have been used up across the 20-ohm resistance and one volt has been used to drive 0.25 ampere through the 4-ohm resistance.

Problem 6-2. In a "universal" a.-c.-d.-c. set there are 4 tubes of the 6.3-volt type connected in series. What resistance must be put in series with them if they are to be put directly across a 115-volt line?

Problem 7-2. Suppose you were going to use five 6.3-volt tubes in a series filament circuit. How many volts will be necessary?

Problem 8-2. What would be the resistance of the above tubes in series?

Problem 9-2. On a 32-volt farm system how many tubes of the automotive type (36, etc.) can be run in series? Six of the Air-cell series (30, etc.) are to be run from this system. What series resistance is necessary?

Problem 10-2. How much resistance would be necessary if one 30-type tube is to be run from a 2-volt storage battery?

Problem 11-2. An incandescent lamp has a resistance, when hot, of about 55 ohms, and requires one ampere to light at full brilliancy. How many could be run in series on a 110-volt circuit?

Problem 12-2. How many volts are required to force one milliampere through a circuit composed of a vacuum tube and a resistance, if the latter has 100,000 ohms and 90 volts are required at the tube? (See Fig. 20.)

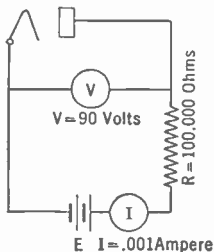

FIG. 20.—A problem in a resistance-coupled amplifier. What is the value of E ?

25. Characteristics of parallel circuits.—A parallel circuit is represented in Fig. 21. It consists of several branches. The voltage across each branch is the same as that across every other branch and is equal to the voltage of the battery. The total current supplied by the battery is the sum of the currents taken by the branches. The resistance of the group may be found by

$$\frac{1}{R} = \frac{1}{R_1} + \frac{1}{R_2} + \frac{1}{R_3}$$

where R is the resultant or total resistance, and R_1 , R_2 , etc., are the individual resistances.

The resultant resistance of several units in parallel is less than the individual resistance of any of the components. If two equal resistances are in parallel, the resultant is one-half the resistance of one. Thus if two 10-ohm resistances are connected in parallel, the resultant resistance is 5 ohms. What would it be if they were connected in series?

If any number of equal resistances are in parallel, the resultant resistance is the individual resistance divided by the number of units.

If only two resistances are in parallel the resultant may be calculated by dividing their product by their sum:

$$R = \frac{R_1 \times R_2}{R_1 + R_2}$$

Example 3-2. What is the parallel resistance of two units which have resistances of 4 and 5 ohms?

This can be solved by either of the formulas given above.

$$\begin{aligned} \frac{1}{R} &= \frac{1}{4} + \frac{1}{5} \\ &= .25 + .20 \\ &= .45 \\ R &= 1/.45 = 2.22 \text{ ohms.} \end{aligned}$$

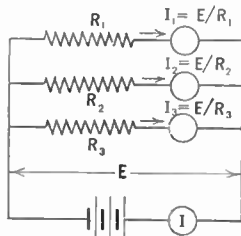

FIG. 21.—A parallel circuit.

Or,

$$\begin{aligned}
 R &= \frac{R_1 \times R_2}{R_1 + R_2} \\
 &= \frac{4 \times 5}{4 + 5} \\
 &= \frac{20}{9} = 2.22 \text{ ohms.}
 \end{aligned}$$

Example 4-2. Suppose, as in Fig. 22, these two resistances in parallel are placed in series with a resistance of 1 ohm and across a battery of 6 volts. What current would flow out of the battery and through each resistance?

The total resistance is $2.22 + 1 = 3.22$ ohms. The current flowing, then, is $6 \div 3.22 = 1.86$ amperes. This current through the combined resistance of

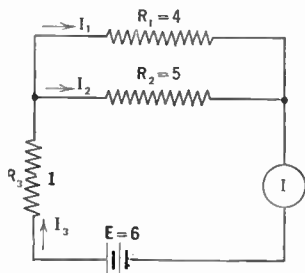

FIG. 22.—Solve for the various currents.

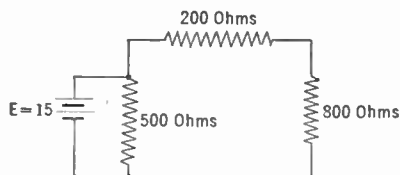

FIG. 23.—What is the voltage drop across the 800 ohms?

the 4- and 5-ohm units produces a voltage drop of $I \times R$ or 1.86×2.22 or 4.14 volts. This voltage across 4 ohms produces a current of $4.14 \div 4$ or 1.035 amperes, and across 5 ohms produces a current of 0.827 ampere. These two currents added together are 1.862 amperes, which checks our calculation above.

Problem 13-2. A radio receiver has five tubes of the a.-c. heater type, each taking 1.75 amperes. What is their combined resistance, and how much current do they take from a 2.5-volt transformer secondary? If another load of the same voltage but half the current is added, what current is required?

Problem 14-2. A circuit has three branches of 4, 6, and 8 ohms. A current of 4 amperes flows through the 6-ohm branch. What current flows through the other branches?

Problem 15-2. Consider the circuit of Fig. 23. What is the voltage drop across the 800-ohm resistor?

Experiment 2-2. Connect as in Fig. 22 several shunt resistances such as tubes, rheostats, fixed filament resistors, etc., in series with a battery and a rheostat. Measure the parallel resistance and individual resistances by reading the current through them separately and in parallel and the voltage of the battery. Test the relation $\frac{1}{R} = \frac{1}{R_1} + \frac{1}{R_2} + \frac{1}{R_3}$.

26. More complicated circuits.—Some radio circuits are combinations of series and parallel circuits. A common form and its equivalent are shown in Fig. 24. Other more complicated circuits

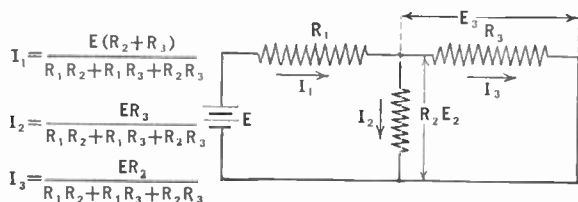

FIG. 24.—A complex circuit and its solution.

may arise in practice and may be solved by more complex algebra than is needed for simple Ohm's law cases. All such circuits can be reduced to more simple circuits by the application of certain rules which may be found in books on complicated networks of resistances, voltages, and current. In "Transmission Circuits for Telephone Communication," by K. S. Johnson, may be found the equivalent circuits of many very complex arrangements of apparatus.

Problem 16-2. In Fig. 24, $R_1 = 20$, $R_2 = 30$, $R_3 = 60$ ohms, $E = 10$ volts. Solve for the three currents. Using the laws of series and parallel circuits prove the equations in this figure by solving for currents and voltages indicated.

27. Detection and measurement of current.—We cannot see or hear or smell the passage of an electric current through a circuit. It must be made evident to us by its effect upon the circuit. There are three kinds, a magnetic effect, a chemical effect, and a heating effect. Wire gets hot if too much current flows through it; two dissimilar metals (copper and zinc, for example) placed in a solution of one of them (copper sulphate) give off gas bubbles when a wire connects them together externally; a wire carrying an

electric current if brought near a compass needle will cause the needle to change from its habitual north-south position.

These are the three fundamental effects of electricity. Any of them can be used to detect the presence of a current or even to measure the rate at which the current flows. A hot wire ammeter (Fig. 25) for example is merely a wire which sags when it gets hot by passing a current through it. A needle is attached to the wire and moves across a scale as the wire gets hot. We might measure the quantity of gas given off per unit of time and thereby deduce the amount of current flowing through an electric "cell."

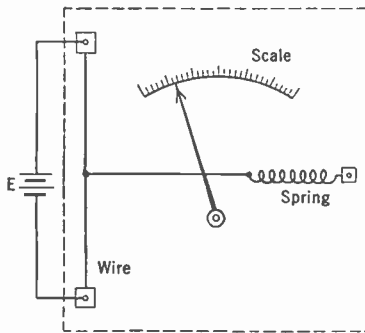

Fig. 25.—Hot wire ammeter.

Most measuring instruments use the magnetic principle. They consist of a permanent magnet near which is a coil of fine wire wound on a movable pointer. Current flowing through this coil makes a magnet of it. It changes its position with respect to the permanent magnet just as a compass needle does when brought near a current carrying wire.

Such instruments can be made sensitive enough to measure currents as low as one-millionth of an ampere or to detect the flow of even smaller currents than this.

28. Ammeters.—Meters to measure current are called ammeters. They are connected in series with the source of current and the device into which the current flows. They are made less sensitive—so they will measure large currents—by shunting them by copper wires so that only a small part of the total current flowing actually goes through the meter.

A very simple current-indicating device consists of a coil of wire through which the current flows and a compass placed in the center. A modern highly sensitive meter is a delicate instrument in which the compass needle is replaced by a carefully pivoted coil of wire carrying a pointer. Such an instrument is shown in Fig. 26.

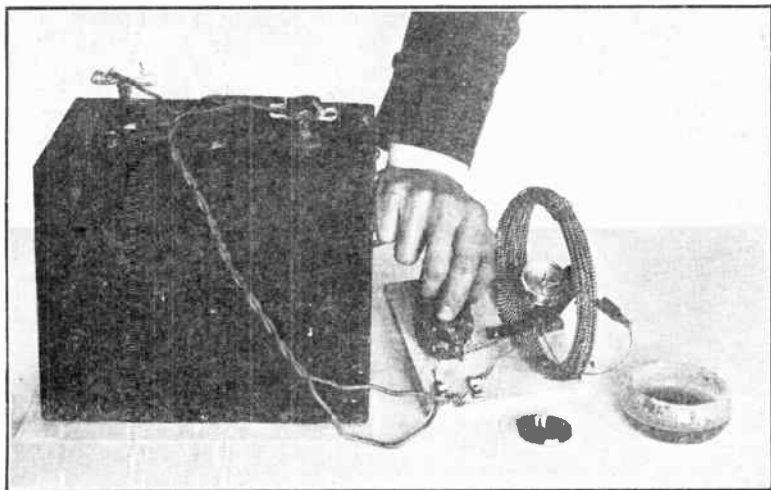

FIG. 26(a).—A simple form of galvanometer. When a current flows through the coil of about 25 turns, a magnetic field is created which affects the position of the needle.

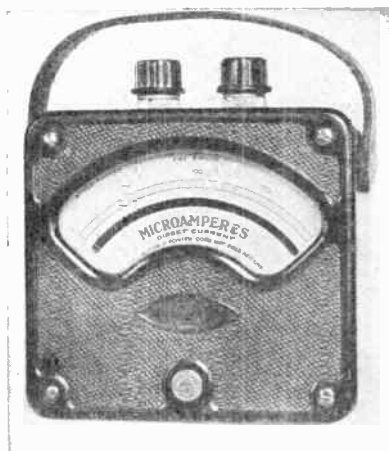

FIG. 26(b).—A modern meter (Westinghouse type PX) which reads full scale 200 microamperes and which will indicate a current of less than 2 microamperes.

29. Voltmeters.—Ammeters have low resistance. They are in series with the apparatus taking current from the source, as shown in Fig. 27.



FIG. 27.—Ammeters are connected in series with the resistance into which the current flows

Voltmeters, on the other hand, must read the voltage across some part of the circuit. They must not permit much current to flow because this current would be taken away

from the circuit. They have a high resistance. They are really high resistance ammeters. Thus an ammeter, the Weston 0-1 milliamperemeter for example, can be made to read volts by putting it in series with a high resistance and across the circuit to be measured.

For example, 1 volt is required to give 1 milliamperemeter of current through 1000 ohms. Thus if we have a 1.0 milliamperemeter and we wish to measure a voltage of the order of 1 volt, we need only a resistance of 1000 ohms. Then the figures on the meter scale will read volts instead of milliamperes. Such a series resistance is called a **multiplier**.

A Weston Model 301 meter reading 1.0 milliamperemeter full scale will measure a maximum current of 50 ma. if a resistance of 0.57 ohm is placed across it. If the resistance is reduced to 0.27 ohm, the meter will read 100 milliamperes when its needle points to 1.0 milliamperemeter. Weston Models 280 and 301 voltmeters have a resistance of about 62 ohms per volt. Thus a meter reading a maximum of 100 volts has a resistance of 6200 ohms.

Problem 17-2. How much current is required for full scale deflection on a Weston Model 301, 50-volt voltmeter?

30. Sensitivity of meters.—A sensitive current-measuring meter is one which will measure very small currents but which has a low resistance. A sensitive voltmeter is one which will give a large needle deflection through a very high resistance. Voltmeters which are used to measure the voltage of high resistance devices such as plate supply units have high resistance in order that the

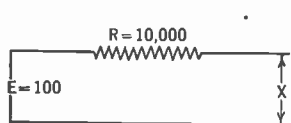

FIG. 28.—A low resistance voltmeter placed at X will not read the open circuit voltage.

current taken from the device shall not be great enough to lower appreciably the voltage of the device.

Example 5-2. Suppose we are to measure the voltage across the circuit at the point X in Fig. 28. The voltage at X depends upon the current taken by the meter. What is desired is the "open-circuit" or "no-load" voltage across X , that is, the voltage existing there if no current is taken by the meter. If no current flows, there is no voltage drop in the resistance R and hence the voltage at X is the voltage of the battery, or 100 volts. Suppose, however, the

meter has a resistance of 1000 ohms. The current flowing is given by Ohm's law

$$\begin{aligned}
 I &= E/R \\
 &= 100 \div (10,000 + 1000) \\
 &= \frac{100}{11,000} = .0091 \text{ ampere or } 9.1 \text{ milliamperes.}
 \end{aligned}$$

This current through the 10,000-ohm resistance R (which may be the internal resistance of the battery E (Section 49) causes a voltage drop across this resistance of $I \times R = .0091 \times 10,000 = 91$ volts.

The voltage actually recorded on the meter, then, is the difference between the battery voltage and the drop across the resistance R , or

$$\text{voltage at } X = E - (I \times R) = 100 - 91 = 9.0 \text{ volts.}$$

If, however, the meter is a high-resistance meter, say 1000 ohms per volt, that is, 100,000 ohms for a meter designed to read 100 volts, the current taken from the battery would be

$$I = E/R = 0.00091 \text{ ampere}$$

and the IR drop across the resistance R would be only

$$\begin{aligned}
 E &= IR = (0.00091 \times 10,000) \\
 &= 9.1 \text{ volts}
 \end{aligned}$$

and the voltage read at X would be $100 - 9.1$ volts or 91.9 volts.

In other words the high-resistance voltmeter gives a reading much nearer the open-circuit or no-load voltage desired.

31. Ammeter-voltmeter method of measuring resistance.—

The example in the above section gives a clue to a good method of measuring the resistance of a device. The method consists in measuring the voltage across the device when a measured current flows through it. If the resistance of the voltmeter is high compared to that of the device, its own resistance need not be considered, and the inclusion of the ammeter into the circuit need not be taken into account aside from exceptional cases.

Example 6-2. Consider the circuit in Fig. 29. A voltmeter across the device whose resistance is unknown reads 75 volts, and the current meter (I) indicates a current of 0.05 ampere. What is the unknown resistance?

$$R = E/I = 75 \div 0.05 = 1500 \text{ ohms.}$$

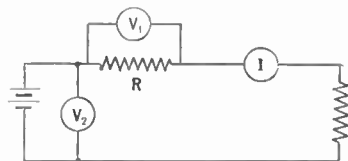

FIG. 29.—Ammeter-voltmeter method of measuring resistance.

32. Voltmeter method of measuring resistance.—If the resistance of a voltmeter is known, a resistance can be measured by its use and a battery. Weston Models 301 and 280 each have resistance of 62 ohms per volt, so that a 50-volt meter would have a resistance of 3100 ohms. Take two readings, one of the battery alone and one of the battery in series with the unknown resistance. Then the desired resistance may be found from

$$R = \left(\frac{E_b}{E} - 1 \right) R_m$$

where E_b = Voltage of battery alone;
 E = Voltage across battery and resistance;
 R_m = Resistance of meter.

33. Use of low-resistance voltmeter and milliammeter in high-resistance circuits.—A high-resistance voltmeter is expensive but is necessary when the voltage output of a socket power device for supplying plate voltages to a radio set, or any other device which has a high resistance, is to be measured. The current taken by the meter is so low that the resistance drop, caused by this current flowing through the internal resistance of the device, is small compared with the voltage being measured.

A method of using a low-resistance voltmeter and a milliammeter is shown in Fig. 30. Suppose the milliammeter is placed in series with the output resistance of the device across which the voltage is to be measured. Suppose the current without the voltmeter attached is I and the current with the voltmeter attached is I' . Let E' be the voltage indicated by the voltmeter when the key is pressed. The resistance in both cases is the ratio of the voltage and current. Thus,

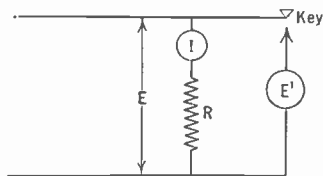

FIG. 30.—A means of avoiding the use of an expensive high resistance voltmeter.

I = current without voltmeter;
 E = voltage without voltmeter;
 I' = current with voltmeter;
 E' = voltage with voltmeter;

$$R = \frac{E}{I} = \frac{E'}{I'}$$

whence $E = \text{desired voltage}$

$$= E' \times \frac{I}{I'}$$

and $R = \frac{E'}{I'}$.

34. Resistance measurement.—Resistances are usually measured by what is known as the “comparison” method, that is, by comparing them with resistance units whose values are known. For example, we might measure the current through an unknown resistance, R_1 , as in Fig. 31, and then adjust a variable resistance,

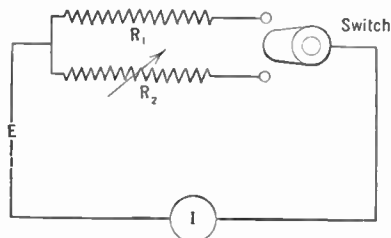

FIG. 31.—Measuring resistance by comparison.

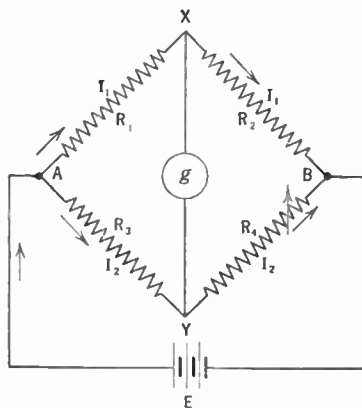

FIG. 32.—Wheatstone bridge for measuring resistance.

R_2 , whose values may be read directly until the same current flows under the same e.m.f. The two resistances are then equal in value.

The usual laboratory method employs a Wheatstone bridge. In diagrammatic form it is represented in Fig. 32, in which R_1 and R_2 are fixed resistances whose values are known, R_3 is the unknown resistance whose value is desired, and R_4 is a variable resistance to which the unknown is compared and the values of which are known. The method is as follows. A current is led into the “bridge” arrangement of resistances at the points A and B and

a sensitive current indicating meter placed at the points X and Y . The values of R_1 , R_2 , and R_4 are adjusted until the meter, g , shows that no current flows through it, that is, there is no difference in voltage between the two points X and Y which would force current through the meter. In other words X and Y are at the same voltage.

The total current I divides at A and flows into the "arms" of the bridge forming the currents I_1 through R_1 and R_2 and I_2 through R_3 and R_4 . If there is no potential difference between X and Y , the voltage drop along R_1 is equal to the voltage drop along R_3 .

$$\text{Thus} \quad I_1 R_1 = I_2 R_3 \quad (1)$$

$$\text{Similarly} \quad I_1 R_2 = I_2 R_4 \quad (2)$$

$$\text{Dividing (1) by (2)} \quad \frac{R_1}{R_2} = \frac{R_3}{R_4} \quad (3)$$

Suppose R_1 and R_2 are equal in value. Then equation (3) becomes

$$1 = R_3/R_4$$

or

$$R_3 = R_4,$$

and to find the value of the unknown resistance R_3 we need only adjust R_4 (whose values are known) until no current flows through the meter. Then the two resistances are equal. Suppose, however, that the unknown resistance is much larger than any value we can obtain by adjusting R_4 . For example, let it be ten times as large. Then it is only necessary to make R_1 ten times as large as R_2 when (3) becomes

$$\begin{aligned} R_1/R_2 &= R_3/R_4 = 10 \\ R_3 &= 10 R_4, \end{aligned}$$

and it is only necessary to adjust R_4 until no current flows through the meter and to multiply the resistance of this standard R_4 by 10 to get the value of the unknown resistor R_3 .

The resistances R_1 and R_2 are called the **ratio arms**; R_4 , the standard resistance, is usually a **resistance "box,"** that is, a box in which are a series of resistance units accurately measured and equipped with switch arms so that any value of resistance may be

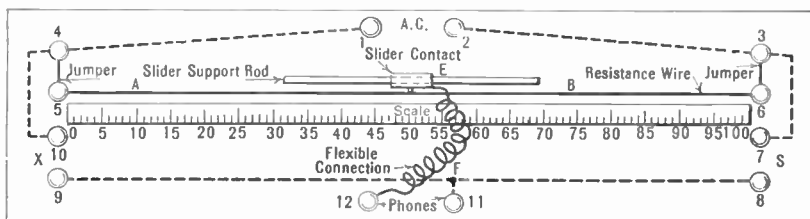

FIG. 33.—A single slide wire bridge.

obtained. A simple "slide wire" bridge is shown in Fig. 33. The unknown and known resistances are compared by means of a slider on a piece of resistance wire. The relative lengths of the wire provide the ratio arms R_1 and R_2 .

Problem 18-2. Using the method in Section 32, a 10-volt full-scale Model 301 meter and a fully charged automobile battery (6.3 volts), the voltage across battery and resistor measures 5.42 volts. What is the unknown resistance? What is the current flowing through the battery, resistor and voltmeter?

CHAPTER III

PRODUCTION OF CURRENT

ELECTRICAL energy does not exist in nature in a form useful to man. It must be transformed from some other form of energy. For example, the mechanical energy of a motor, or steam engine, may be transformed into electrical energy by means of a generator.

The commonest sources of current useful to radio workers are the **battery** and the **generator**. The battery is a device which converts chemical energy into electrical energy; the generator uses up mechanical energy with the same result.

35. Batteries.—A **battery** is made up of one or more units called **cells**. The essentials of the cell are three: two conductors called **electrodes**, usually of different materials, and a chemical solution known as the **electrolyte** which acts upon one of the electrodes more than it does upon the other. In this action, one of the electrodes is usually “eaten up,” and when this conductor, usually a metal, is gone, the battery is exhausted; it must be thrown away or the metal replaced. If the metal can be replaced by sending a current through the cell from some outside source, that is, by reversing the process through which the cell was exhausted, the cell is known as a **secondary** or **storage** cell. If the cell must be thrown away when one of the electrodes is “eaten up,” it is called a **primary** cell. The dry cell is a well-known example.

Experiment 1-3. If a plate of copper and a plate of zinc are placed in dilute sulphuric acid and a sensitive meter is placed across the terminals as shown in Fig. 34, a voltage of definite polarity will be indicated. The positive terminal of the voltmeter must be placed on the copper plate in order that the meter needle shall move in the proper direction. The copper plate is therefore positive; the zinc is negative. If a heavy external wire is attached to the plates, a current flows; the zinc is slowly dissolved, hydrogen bubbles appear

at the copper plate, and finally the voltage of the cell falls off. Other combinations of metals should be tried.

The number of combinations of conductors and solutions that will make up a primary cell is very large; only a few of them are useful. Some deliver but small currents and low voltages, others give off noxious fumes, others do not last long enough to be practical.

The e.m.f. of such a cell depends upon the nature of the electrolyte and the materials from which the plates or electrodes are

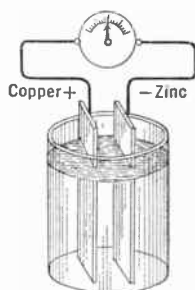

FIG. 34.—A simple primary cell.

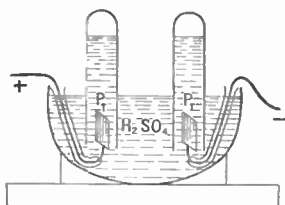

FIG. 35.—An experiment in electrolysis.

made. Copper and zinc plates immersed in a solution of dilute sulphuric acid will give an e.m.f. of about 1 volt regardless of the size of plates or their distance apart. Zinc and carbon plates in chromic acid give an e.m.f. of about 2 volts.

Until the plates are connected externally by a conductor there is a difference of electrical potential existing between the two electrodes but no flow of current. This voltage is known as the e.m.f. of the cell. When the plates are connected and the cell is put to work the destruction of the zinc begins. When the zinc is all destroyed the cell is dead.

36. Electrolysis.—The appearance of hydrogen bubbles at the copper electrode forms the basis of an interesting experiment which is illustrated in Fig. 35.

Experiment 2-3. Dip platinum electrodes into a solution of sulphuric acid and pass a current through them from a battery of about 10 or 12 volts.

Hydrogen will be evolved at the electrode attached to the negative battery terminal and oxygen at the other. These gases will exert sufficient pressure to force the solution out of the inverted test-tubes. If the volumes of the two gases are measured it will be found that the hydrogen always occupies just twice the volume required by the oxygen—which is one of the best proofs we have that water is made of two atoms of hydrogen combined with one of oxygen, whence arises the familiar chemical formula for water, H_2O .

This phenomenon in which a substance is broken down by dissociation and then under the action of an electric current is known as **electrolysis**. In this case if the solution had been copper sulphate, copper would have been deposited on the negative electrode. In the practice of electroplating, metal from one electrode is deposited on another,

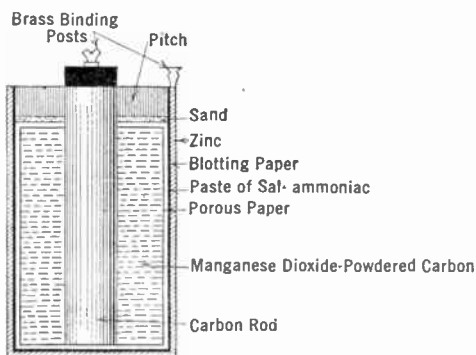

FIG. 36.—Construction of dry cell.

the strength of the solution, which is a solution of the metal to be deposited, remaining unchanged.

37. Common dry cell.—The common dry cell is illustrated in Fig. 36. The zinc container is the negative electrode, the carbon rod in the center is the positive electrode. The electrolyte is a mixture of powdered carbon and manganese dioxide moistened with a solution of salammoniac. The voltage of the cell as measured by a voltmeter is about 1.5 volts. The ordinary B batteries used in radio are made up of many small 1.5-volt cells connected in series

38. The storage cell.—When the zinc container of the dry cell is eaten up, the cell must be thrown away. In the storage battery neither of the electrodes is eaten away, but the nature of one plate is changed and when a current is sent through the battery from some external source this material is changed back to its original

form, so that the cell is said to be "charged" and can be used again.

The storage cell has two electrodes, one of lead and one of lead peroxide immersed in a dilute solution of sulphuric acid. The usual storage battery is made up of three cells in series, producing a voltage of about 6 at the terminals. The positive terminal is usually marked, either with a red terminal, or a large cross, or in some other way. It is important to know the polarity of the battery when charging it. The positive post of the battery should be connected to the positive post of the charging line.

Experiment 3-3. If two lead plates about 6 inches square are immersed in a dilute solution of sulphuric acid—say one part of acid to ten of water—and connected in series with a battery of 6 or 8 volts and an ammeter, a current will be seen to flow, and the color of the plate attached to the positive terminal of the battery begins to change and the evolution of hydrogen bubbles at the other plate will be observed. The current soon decreases. Now replace the external battery with an incandescent lamp or an electric bell and note that current flows out of the lead cell and through the light or the bell.

39. Internal resistance.—One might think that an unlimited current could be secured from a battery if it were short-circuited. Such is not the case. A very low-resistance ammeter placed across a dry cell gives a definite reading—it is not unlimited. Something must be in the circuit which has a resistance greater than that of the ammeter or the connections. For example a new dry cell will deliver about 30 amperes through wires of very low resistance.

This something which restricts the current to a limited value is the **internal resistance** of the cell. This resistance depends upon the construction of the cell, its electrode and electrolyte material, the distance apart of the electrodes, the condition of the cell—whether new or old. The older the cell the smaller the area of electrode in contact with the electrolyte and the greater the resistance. The current delivered by a cell is

$$I = \frac{E}{r + R}$$

when r = internal resistance of cell;

R = external resistance of circuit.

When a dry cell shows but a few amperes on short-circuit, the chances are that its zinc case is badly eaten up. A voltmeter which requires very little current for a deflection will still read normal voltage, 1.5, because the small current through the cell does not cause appreciable voltage drop. The ammeter, however, draws all the current the cell can deliver. This current must flow through the cell as well as through the external circuit and hence there is a large voltage drop within the cell, leaving little voltage to force current through the meter.

Cells which have a large internal resistance deliver but small currents; low-resistance cells deliver large currents.

When one tests a dry cell with an ammeter, he is actually ascertaining the condition of the cell by measuring the internal resistance. When the cell gets old or has been exhausted due to too heavy currents, its internal resistance becomes high and an ammeter reads but small current when placed across it.

The storage cell is a very low-resistance device. Its terminal voltage when fully charged is about 2.1 volts and it has a resistance of about 0.005 ohm. Placing an ammeter across such a cell is dangerous. The meter will probably be ruined.

Example 1-3. A dry cell on short-circuit delivers 30 amperes. Its terminal voltage is 1.5 volts. What is its internal resistance?

By Ohm's law,

$$I = E/r$$

$$30 = 1.5/r$$

$$r = \frac{1.5}{30} = 0.05 \text{ ohm.}$$

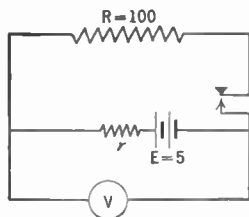

FIG. 37.—A problem in internal resistance.

Example 2-3. The e.m.f. of a battery is 5 volts. When 100 ohms are placed across it the voltage V falls to 4 volts. What is the internal resistance of the battery?

In Fig. 37, $R = 100$ ohms, $r =$ the internal resistance of the battery, the voltage drop across the 100 ohms is 4 volts, which leaves one volt drop in the internal resistance of the cell. The current through the external 100-ohm resistance is, by Ohm's law,

$$I = 4/100 = .04 \text{ ampere.}$$

This current must also flow through the internal resistance of the battery and there it causes a voltage drop of one volt.

$$\begin{aligned} E &= I \times r \\ 1 &= 0.04 \times r \\ r &= 1/.04 = 25 \text{ ohms.} \end{aligned}$$

Note that the internal resistance of the cell is represented as being in series with the voltage and the external resistance. This is because the current must actually flow through the internal resistance of all such voltage generators, and hence the resistance of the device is represented in series with the remainder of the circuit. Care must be taken in such representations not to place the voltmeter in the wrong place. In Fig. 37 the voltmeter is actually placed across the battery and its internal resistance, which is connected directly to the 100-ohm resistance.

The voltage of the cell on open circuit is its **e.m.f.** Under load the voltage falls, and is now labeled as the **p.d.** (potential difference). The e.m.f. of high-resistance cells can only be measured by high-resistance meters, those that take but little current from the cell. When the voltage of a cell or battery is mentioned its e.m.f. is assumed unless otherwise labeled.

40. Polarization.—In common with all other cells the zinc-copper sulphuric acid cell (Fig. 34) suffers from **polarization**. The hydrogen bubbles which surround the copper plate decrease its surface in contact with the active liquid. This increases the cell's resistance. In addition, a minute voltage is set up between the hydrogen and the copper. This voltage is opposite to the useful voltage and has the same effect upon the usefulness of the battery as an addition to the cell's internal resistance.

Various means are taken to overcome the bad effects of polarization. Chemicals may be placed in the cell to supply oxygen, which will combine with the hydrogen to form water; shaking the cell may remove the hydrogen bubbles and decrease the resistance of the cell. The manganese dioxide used in dry cell construction is a depolarizer. But these are only temporary remedies. Sooner or later the internal resistance of the cell becomes so high that the cell is no longer useful. A dry cell which has had large currents taken from it becomes polarized. If it is allowed to

stand for a time, the chemicals put into the cell to do away with the polarization products have the chance to "catch up" and the cell is said to have "recuperated." For this reason dry cells and others which tend to polarize are used only on intermittent service. Where a constant current is required a different type of cell is used.

41. Cells in series.—Cells and batteries may be connected together in several ways. When the positive terminal of one cell is connected to the negative terminal of the next cell, as in Fig. 38, they are said to be connected in **series**. Under these conditions, the voltage appearing at the two ends of the series of cells is the

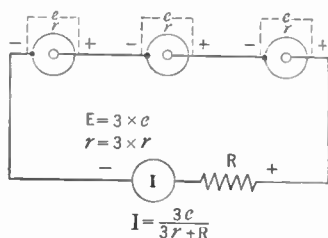

FIG. 38.—Cells in series.

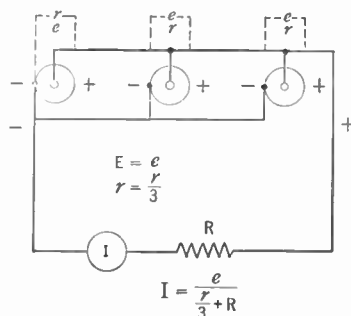

FIG. 39.—Cells in parallel.

sum of the individual cell voltages. For example, if we connect four dry cells in series, each cell having a voltage of 1.5, a voltmeter across the two ends will register 6 volts. At the same time the total internal resistance is the sum of the individual resistances and whatever current flows must flow through this resistance.

If the ends of the battery are connected together with a wire of resistance R the current that will flow may be obtained by Ohm's law as

$$I = \frac{Nc}{Nr + R}$$

42. Cells in parallel.—When the positive terminal of one cell connects to the positive terminal of the next cell, and the negative terminals are connected together, as in Fig. 39, the cells are said

to be connected in **parallel**. Under these conditions the terminal voltage of the combination is the same as the terminal voltage of each cell, but the internal resistance has been divided by the number of cells, N , and has become r/N .

If the ends of the battery are connected together with a wire whose resistance is R , the current that will flow is

$$I = \frac{e}{\frac{r}{N} + R}$$

Cells may also be connected in what is called a **series-parallel** arrangement. In Fig. 40 are P sets of S cells in series, and the sets themselves are connected in parallel.

If the battery of cells shown in Fig. 40 is connected to a wire whose resistance is R , the current that will flow is

$$I = \frac{Ne}{RP + Sr'}$$

where $N = P \times S$.

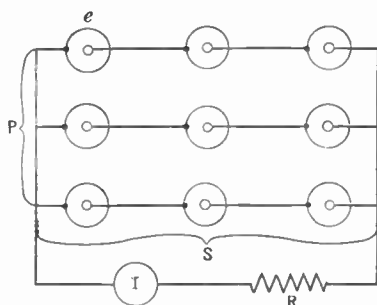

FIG. 40.—Cells in series-parallel.

43. Magnetism.—The second common source of electric currents is the generator. The magnet is the heart of the generator.

Magnets obey the same laws as the fundamental electrical charges mentioned in Section 3 in Chapter I. *Like magnetic poles repel each other, unlike poles attract.* Two magnets will repel each other if their North poles are turned toward each other, but will attract each other with considerable force when a North and a South pole are brought near.

44. Oersted's experiment.—A Danish experimenter, Oersted, in 1819 made the first of a series of discoveries concerning the relation between electricity and magnetism which resulted in many modern applications of electricity. His experiment can be repeated by anyone who has a compass, a battery, and a wire.

Oersted's experiment demonstrated that a conductor carrying a current of electricity affects a compass needle just as a bar magnet does. Another experiment will teach us more about this important phenomenon known as *electromagnetism*.

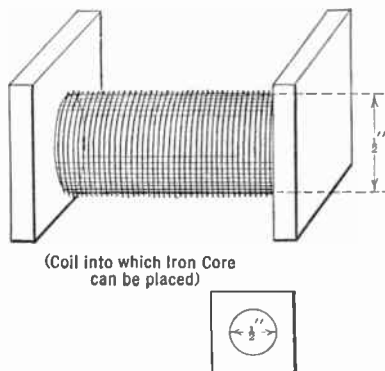

(Coil into which Iron Core can be placed)

FIG. 41.—A solenoid.

in direction of the compass needle motion. Note that the two ends of the coil act toward the compass needle just as a bar magnet would. Determine which of the coil ends is North and which is South by comparing their action on the compass with the action produced by the bar magnet whose poles are marked or by the position the needle takes with respect to the earth's poles.

Experiment 5-3. Scatter a quantity of fine iron filings on a piece of cardboard about a foot square. Place one end of a bar magnet under the cardboard, and tap the board until the filings assume a fixed position. Repeat using the other end of the bar

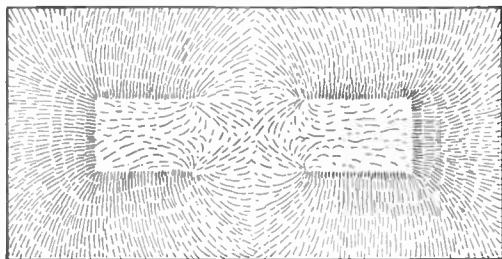

FIG. 42.—How the lines of force about a bar magnet are located.

magnet, and then with a horseshoe magnet, and finally with the coil of wire through which a current is flowing. Place the bar magnet parallel to the cardboard and again scatter iron filings. Repeat with the coil magnet. Place the bar magnet inside the coil and remove from the cardboard to such a distance that, with no current flowing in the coil, the iron filings are affected but little. Connect the battery to the coil and note the increase in action among the iron filings. Repeat with battery connected and

cardboard removed to such a distance that the filings are not affected. Then put the bar magnet inside the coil and note increased effect.

Such experiments demonstrate that coils carrying electric currents have much the same properties as iron bars which have been magnetized. The fact that such a coil or a magnet affects iron filings or compass needles even though some distance separates them, shows that in the space between them exists some force. The iron filings show the general distribution of this force. They tend to arrange themselves along lines which concentrate in strength at the two ends. These lines are called **magnetic lines of force**. The concentration points are called the **poles**. The space through which the lines pass is called the **magnetic field**.

The number of lines per unit of area, as in Fig. 43, is called the **field intensity** or **flux density**; and when one line goes through 1 sq. cm. the field strength is one **Gauss**. The total number of lines through any given area is called the **flux**, and to find the flux it is only necessary to multiply the field strength, H , by the area. Thus

$$\text{flux } \theta = A \times H.$$

Magnetic lines of force may be set up in iron much more easily than in air. The ratio of the number of lines, under the action of a given magnetizing force, that exist in iron to those that would exist in air is called the **permeability** of the iron. If one line flows through 1 sq. cm. of air and one thousand through the same area of iron the permeability of the iron is 1000.

The field strength varies inversely as the square of the distance away from the pole as shown in Fig. 43. The nearer the unit area gets to the pole piece the greater the number of lines. As a matter of fact, halving the distance multiplies the number of lines by four.

The same magnetizing effect can be produced by a strong cur-

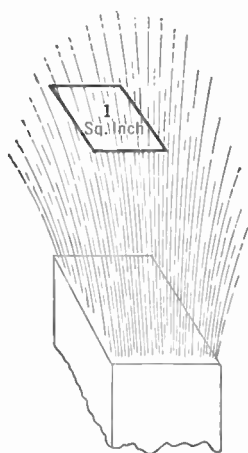

FIG. 43.—The number of lines of force going through one square inch or other unit of area is known as the flux density.

rent acting through a few turns of wire as by a weak current through many turns of wire. If the product of turns and amperes, called the **ampere turns**, is the same in two cases the magnetizing effect will be the same.

It is because of the increased permeability, and of the consequent increase in flux density, that adding the iron core to the solenoid, or coil of wire in Experiment 5-3, is so effective. Soft iron is most easily magnetized, but loses its magnetism with the same rapidity. Permanent magnets are made from steel.

45. Faraday's discovery.—The second important discovery on the way toward present-day electrical machinery was that of the celebrated English experimenter, Faraday. The experiment may be repeated by anyone who has a coil of wire, a bar magnet, and a sensitive current indicator such as the galvanometer used in Experiment 6-3.

Experiment 6-3. Construct a galvanometer like that in Fig. 26a and connect to the coil used in Experiment 4-3. Thrust a bar magnet into the coil quickly, and then remove it. Note the motions of the compass needle. Wind up another coil with about the same number of turns but of such a diameter that it can be placed around the first coil easily. Connect the second coil to a battery in series with a 30-ohm rheostat and place over the first coil and then remove with a quick motion. Note the compass needle variations.

In all of the above procedure, note the relation between the compass needle movements and the rapidity with which the various changes are carried out.

Such was Faraday's experiment. When the bar magnet, or the coil carrying a current, was motionless, there was no motion of the needle. When a bar was thrust into the coil the needle moved in one direction, and when the motion of the bar was reversed the needle reversed its motion too. There was no metallic connection between the two coils, or between the coil and the bar magnet—and yet changing the position of one with respect to the other, or changing the direction of magnitude or current through one coil produced some electrical effect in the other circuit.

The facts underlying Faraday's experiment are these: An electric voltage was generated or **induced** in the coil when the bar magnet was thrust into it. A voltage of opposite polarity was generated when the magnet was removed. This voltage sent a

current through the coil and the galvanometer so that the needle moved. The same explanation holds when two coils are used, one of them carrying a current, taking the place of the iron bar. Whenever lines of force are cut by a conductor, a voltage is generated in that conductor. So long as the conductor moves so that it *cuts* the lines, that is, does not move parallel with them, a voltage is set up. The more lines per second and the more nearly it cuts the lines at right angles, the greater the voltage. In Fig. 44, so long as the conductor AB moves in the direction of the arrow, no voltage is generated because its motion is parallel to the lines of force. But if AB moves up or down or in a direction through the paper, a voltage will be measured across its terminals.

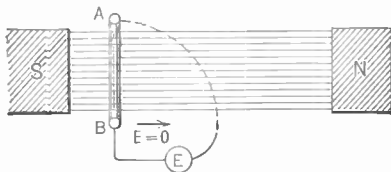

FIG. 44.—So long as the conductor AB moves across the page, no voltage is generated. If it moves perpendicular to the paper, or up and down, a voltage is generated.

This phenomenon is known as **electromagnetic induction**, and voltages and current in the conductor are called **induced**, and the electrical circuit in which they flow is usually called the **secondary**, the inducing circuit is known as the **primary**.

There is no discovery in electrical science which has been so important. Almost every application of electricity to modern life depends upon this discovery of Michael Faraday.

46. The electric generator.—The essentials of a **generator** of electricity are first, a conductor, secondly an electric field, and third a motion of one relative to the other.

A generator converts mechanical energy into electrical energy. Figure 45 is a simple generator. It consists of a turn of wire which is mechanically rotated between two magnets. Remembering that no current due to the induced voltage flows when the conductor moves parallel with the lines of force, and that the maximum voltage is induced when the conductor moves perpendicular to the lines of force, because at this point the maximum rate of cutting takes place, let us see what happens as we rotate the coil.

In position (a), Fig. 45, the conductor is moving parallel with

the field. No voltage is being generated. As the coil moves, however, it begins to cut the lines at a greater and greater angle until finally at (b) it is moving perpendicular to the lines and the voltage is a maximum. Now as the coil continues to move, the part *A-B* instead of moving upward across the lines of force moves downward across them. The induced voltage then has reversed its polarity and is increasing toward another maximum position, after which it returns to its original position, where the induced voltage is again zero.

In one complete revolution of the conductor there are two positions at which there is no induced voltage and hence no current in

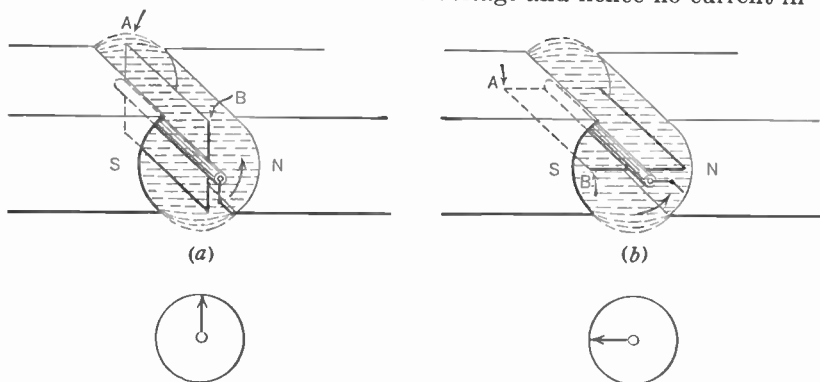

FIG. 45.—In (a) the conductor *AB* is moving parallel or along the lines of force. In (b) the conductor is moving across or at right angles to the lines.

At (a) the generated voltage is zero; at (b) it is a maximum.

the external circuit, and two in which the voltage is at maximum, although in opposite directions. At intermediate positions, the voltage has an intermediate value.

A complete circle, like a compass, may be divided into 360 degrees. Since the rotating coil moves in a circle, we can label the positions of the conductor in degrees of rotation instead of positions (a), (b), etc. At the beginning, (a), it is at 0 degrees—it has not started to move. Then at (b) it is at right angles to its original position (a), or it has gone through one-fourth of a complete revolution. It has therefore passed through one-fourth of 360

degrees or 90 degrees. When it is again parallel with the lines of force, it has passed through 180, and when it has gone through three-fourths of 360, or 270 degrees, the voltage is a maximum but in an opposite direction, and finally when it reaches its original position it has passed through a complete circle or 360 degrees.

Let us plot the current induced in the circuit against the degrees through which the coil has passed. Such a plot is shown in Fig. 46. When the current is flowing in one direction we call it positive, when it reverses we call it negative. If the conductor moves at a uniform rate, say one revolution in 360 seconds, we can plot the current induced against time in seconds.

One complete revolution is called a **cycle**. The number of cycles per second is known as the **frequency** of the induced voltage. The time required for one complete revolution is called the **period**. One-half cycle, or the part of the cycle during which the voltage is in the same direction, is called an **alternation**.

Such is the current produced by an **alternating-current**, or a.-c., generator. It flows first in one direction, then in another. The generator, of course, is a much more complex machine than we have illustrated here. The magnet is replaced by a heavy iron core covered with wire in which a direct current flows. This produces a strong unidirectional magnetic field. The moving coil is also wound on an iron form and consists of many turns of wire wound in slots.

47. Work done by alternating current.—Some may wonder whether or not a current that is continually reversing its direction—never getting anywhere, so to speak—is useful. It is.

Consider a paddle wheel in a stream of water. To the paddle

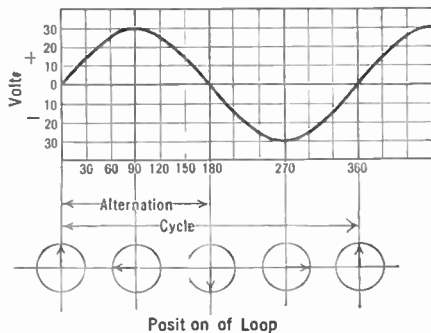

FIG. 46.—Each position of the conductor as indicated by the arrows corresponds to some voltage as shown on the graph—called a “sine wave” of voltage.

wheel are attached mill stones. Grain is to be ground between the stones. It matters little whether the water flows continuously turning the millstones in a certain direction, or whether the water flows first one way and then another. So long as the millstones turn against each other, grain will be ground. Work will be done.

The alternating current used to light our homes is usually of 60 cycles, or 120 alternations per second. In some communities 25-cycle current is supplied. In radio installations for use on ship-board, generators usually produce 500-cycle currents. At the high-power radio stations of the Radio Corporation of America at Radio Central, Long Island, are huge alternators which turn out radio frequencies of 20,000 cycles a second. Smaller generators which produce frequencies as high as 100,000 per second have been built but are not in common use.

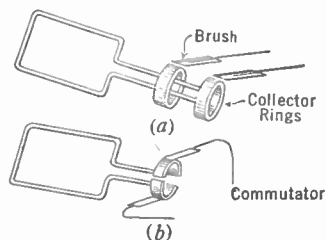

FIG. 47.—Current is taken from an alternating current generator by collector rings; a commutator serves the same purpose on a direct current machine.

48. D.-c. generator.—Current is taken out of a generator by **collector rings**. They are illustrated in Fig. 47. If current flowing in a continuous direction is desired, the collector rings are not used, but instead is used a device called a **commutator**. It is a switch, or valve, which keeps the output current flowing in the same direction by reversing at the proper time the position of the

wire with respect to the rotating wire. In this manner the current flows through the external circuit in a single direction, although the current in the conductor which cuts the lines of force must reverse each time the conductor passes through 90 degrees and reverses its direction with respect to the field.

The commutator serves the same purpose as a valve in a pump which keeps water flowing upward whether the pump handle is worked down or up. A machine which sends out current which flows in a given direction is called a **direct-current generator**, and naturally, the current is known as direct current, or d.c.

49. Internal resistance.—The generator too has an internal resistance so that the voltage measured at its terminals differs when different currents are taken from it. The voltage measured across the terminals on a meter requiring little current is called the **open-circuit voltage**. As the current taken from the generator increases, this voltage drops.

50. Electrical power.—Throughout the previous discussion we have spoken of electrical energy in a rather loose way. What do we mean by energy? What is power? What is their relation to work?

Energy is the *ability to do work*. A body may have one of two kinds of mechanical energy, either **potential energy** or **kinetic energy**. The former is due to the position of the body, the latter is due to its motion. A heavy ball on top a flag pole has potential energy because if it falls it can do work, useful or not. It may heat the ground where it falls, or it may be used to drive a post into the ground. A cannon ball speeding through the air has energy because it can do work, useful or otherwise, if it is stopped suddenly. The target may be heated thereby, converting the kinetic energy possessed by the ball into heat energy. The amount of damage done gives the eye a certain measure by which to judge the energy originally possessed by the cannon ball. This energy was originally possessed by the powder and was imparted to the ball when it exploded.

The **power** required to force a certain current of electricity through a wire at a voltage of E volts is the product of the voltage and the current. Thus

Power in watts equals current in amperes times volts,

$$\text{or} \quad P = I \times E.$$

A horsepower is 33,000 foot-pounds per minute. It is equal to 746 watts.

All expressions for power involve the factor of time. In other words, power is the *rate of doing work*. It requires more power to accomplish a certain amount of work in a short time than in a longer time. For example a ton of material raised a foot in the air represents 2000 foot-pounds of work. If it is accomplished by a

crane in 1 second of time it represents an expenditure of 2000×60 or 120,000 foot-pounds per minute of power. Since one horsepower is equal to 33,000 foot-pounds per minute, the crane has a power of $120,000 \div 33,000$ or about 3.65 horsepower.

Now if a man raises the ton of material one foot in the air in an hour's time by going up a very long and gradual incline, his power is $2000 \div 60$ or 33.2 foot-pounds per minute, or roughly one-thousandth horsepower (0.001 hp.). The amount of work done in the two cases is the same—the ton of material has been raised one foot in the air. The *rate of doing work* has changed.

Example 3-3. A generator is rated at 5 kilowatts (5000 watts) output. How many amperes can it supply if its voltage is 110 and it has no appreciable resistance? How many horsepower is this?

Power equals $E \times I$

$$5000 = 110 \times I$$

$$I = 5000/110 = 45.6 \text{ amperes.}$$

Horsepower equals 746 watts.

$$5000/746 = 6.7 \text{ horsepower.}$$

51. Power lost in resistance.—According to the law called the Conservation of Energy, energy can neither be created nor destroyed. It comes from somewhere and goes somewhere. Similarly, all *power*, which is the rate at which energy is used, must be accounted for. The energy required to force current through a resistance must do some work. It cannot disappear. This work results in heating the resistance. Whenever current flows through a resistance, heat is generated and the greater the current the greater the heat. As a matter of fact the heat is proportional to the square of the current. If the wire is heated faster than the heat can be dissipated in heating the surrounding air, the wire melts. Energy has been supplied to the unit at too great a rate.

A resistor used in a power supply device is rated at so-many ohms and as capable of dissipating so-many watts. Thus a 1000-ohm, 20-watt resistor, means that the resistance of the unit is 1000 ohms, and that 20 watts of electrical power can be put into it without danger of burn-out.

Problem 1-3. Electric power is bought at the rate of so-much per kilowatt-hour. Suppose your rate is 10 cents per kilowatt-hour. How much does it cost to run a flat-iron on a 110-volt circuit if it consumes 6 amperes?

Problem 2-3. Assuming that 20 milliamperes direct current flow through the winding of a loud speaker which has a d.-c. resistance of 1000 ohms, what amount of heat in watts (I^2R) must be dissipated? What supplies this power? Suppose an output transformer is used which has a resistance of only 200 ohms. How much power is saved?

52. Expressions for power.—Just as there are three ways of stating Ohm's law, so there are three ways of stating the relation between power, volts, amperes, ohms. Thus:

$$(1) P = I \times E \quad (2) P = I^2 \times R \quad (3) P = E^2 \div R$$

Example 4-3. A power supply device supplies 180 volts to a power tube of the 171 type which consumes 20 milliamperes. How much power is taken from the device? What is the resistance of the tube?

The power supplied is $E \times I = 180 \times 0.02 = 3.6$ watts. The resistance into which this power is fed is equal to $P \div I^2 = 3.6 \div .0004 = 9000$ ohms or $E^2 \div P = 180^2 \div 3.6 = 32,400 \div 3.6 = 9000$ ohms.

The maximum current that can pass through one's body without serious results is 0.01 ampere. The resistance varies with one's health and the surface in contact, etc. If the finger tips of the two hands are dry, the resistance from one hand to the other is about 50,000 ohms, and thus by Ohm's law the maximum voltage that can be safely touched is 500.

Problem 3-3. Assuming that a man can touch with his dry finger tips a 500-volt street car conductor, and that the resistance of his body is 50,000 ohms, how much power is used up in heating the body?

Problem 4-3. A voltage of 110 is to be placed across a circuit whose resistance must be such that 220 watts can be delivered. What is the resistance of the circuit?

Problem 5-3. How much power is taken from a storage battery which supplies five automotive radio receiver tubes?

Problem 6-3. One milliampere of plate current flows through a 100,000-ohm resistor. How much power in heat must the resistor be capable of dissipating?

Problem 7-3. How much current can be sent through a 1000-ohm 20-watt resistor without danger of burning it up? What voltage is required?

Problem 8-3. In a plate voltage supply device the voltage-divider has a total resistance of 5000 ohms. The receiver requires a maximum current of 30 milliamperes. What must be the wattage rating of the resistor?

Problem 9-3. An automobile receiver of five 6.3-volt tubes consumes a plate current of 50 milliamperes at 180 volts. Assume that the car battery supplies this load; what power is required?

53. Efficiency.—Efficiency is a term that is loosely employed by nearly everybody. Anything which works is said to be efficient, and one's efficiency is often confused with his energy—his ability to do work whether the work is actually carried out or not. The term, however, has a very exact meaning when one uses it in speaking of mechanical or electrical systems of any kind. Efficiency is a relative term. It is a ratio showing how much *useful* work one gets out of a *total* amount of work done.

Let us consider a steam engine connected to a dynamo, a combination of machines for transforming mechanical energy into electrical energy. If the steam engine consumes one horsepower (746 watts) and delivers 500 watts of electrical energy, it is said to be more efficient than if it delivered only 250 watts. Let us consider two men, one of whom gets a lot of work done in a small amount of time and with an expenditure of little effort. The other gets the same amount of work done but with great effort, perhaps flurrying about from one thing to another instead of tackling his problem in a straightforward manner. The first man is more efficient. He *wastes* less time and energy.

Efficiency, then, is the ratio between useful work or energy or effect got out of a machine to the total energy or power or effort put into it. It is expressed in percentage. A machine that is 100 per cent efficient has no losses; there is no friction in its bearings, or, if it is an electrical device, no resistance in its wires. There are no such machines in use to-day. Efficiency is the ratio of useful power one gets out of a device to the power put into it.

$$\text{Efficiency} = \frac{\text{useful output}}{\text{input}} = \frac{\text{useful output}}{\text{output plus losses}}$$

Problem 10-3. In the above problem a motor generator or vibrator system supplies the plate voltage. If its efficiency is 40 per cent what power and current are taken from the battery?

Problem 11-3. Seventy-five per cent of the ampere-hours put into a battery are returned by it on discharge. How many hours must a 100-ampere-hour battery be charged at a one-ampere rate?

CHAPTER IV

INDUCTANCE

THE experiments of Ohm, Oersted, and Faraday laid the foundation of modern electrical science. The experiments of the last chapter gave us some idea of what these investigators discovered, and gave us a background for the following fundamental facts.

54. Coupled circuits.—Consider the two coils *P* and *S* in Fig. 48. They are said to be “coupled” when lines of force from one go through the other.

When *P* is attached to a battery and the switch closed there is a momentary indication of the needle across *S*. When the switch is opened the needle moves again but in the opposite direction. So long as the current in the primary *P* is steady in value and direction, there is no movement of the needle across the secondary or coils. If a galvanometer is put across the secondary of an ordinary high-ratio

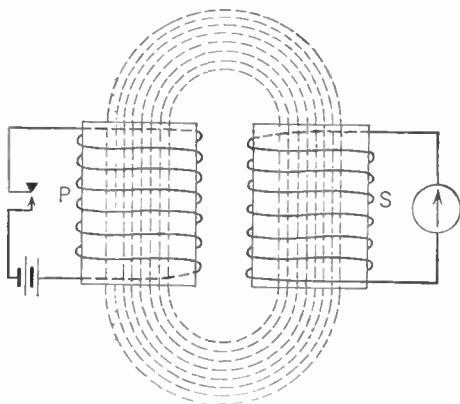

FIG. 48.—If the coils *P* and *S* are coupled so that lines of force from *P* go through *S*, a current indicator will show a flow of current in *S* when the key in *P* is closed or opened.

audio transformer, and a battery is connected across the primary, the needle of the galvanometer will kick one way when the connection is made, and in the opposite direction when the battery connection is broken. This deflection of the needle indicates a

momentary flow of current in the secondary coil; this current flows only when the primary current is changing, i.e., starting or stopping, not when the primary current is fixed in value or direction.

55. Lenz's law.—There are two fundamental facts about this phenomenon of coupled circuits. The first is that when lines of force couple two coils together, and some change in these lines takes place, perhaps due to a change in the relative positions of the two circuits, a voltage is "induced" in the second circuit. The second fundamental fact is known as **Lenz's law**: the induced current is in such a direction that it opposes the change in position that produced it.

Thus when the battery is attached to *P*, lines of force thread their way across the turns of wire in *S*. This movement of the lines of force through *S* induces a voltage across this coil and a current flows in the coil and the apparatus connected to it. This current in the second coil is in such a direction that its field, that is, its lines of force threading through the primary, induces a counter voltage in the primary opposite in direction to the battery voltage across it.

When the battery voltage is broken, the lines of force from the primary current collapse back on the coil, and, in crossing the secondary turns in an opposite direction to that taken when the current in the primary is increasing, induce a voltage in the secondary in such a direction that it tends to keep the primary current flowing.

The result is that it takes a longer time to build up the primary current to its final value at "make" and a longer time for the current to fall to zero at "break."

This phenomenon of induced current is of most fundamental importance. It is the basis of all our modern electrical machinery. Our motors, our dynamos, our radio signals all are the result of our ability to produce changes in one circuit by doing something to another although the two circuits have no metallic connection whatever.

The fact that current takes longer to reach its final value in a circuit in which there is a coil of wire indicates that something

about this coil tends to prevent any change in the current. If the current is zero, this property of the coil tends to prevent any current from flowing. If the current already exists, this coil property tends to prevent either an increase or decrease in this value of current.

56. Inertia—inductance.—The property of an electrical circuit which tends to prevent any change in the current flowing is called its **inductance**. It has a mechanical analogue in **inertia**. A flywheel requires considerable force to get up to speed; and after it is started it will continue to run for some time after the driving force is removed. It does not stop suddenly. As a matter of fact it requires considerable force to stop it, and the more suddenly one wants to stop it, the more force he must apply.

Inertia is evident in a mechanical system only when some change in motion is attempted. It is not the same as friction, which is always present.

Inductance is a property of an electrical system in which changing currents are present. It is not to be confused with resistance, which is always present. Current flowing in a resistance circuit stops when the driving force (voltage) is removed. If inductance is added to the circuit, the resistance remaining the same, a longer time will be required for the current to reach its final value, zero, when the voltage is removed.

57. Self-inductance.—Inductance is added to a circuit by winding up a wire into a compact coil. If, for example, 1000 feet of No. 20 copper wire is strung up on poles, it will have a resistance of about 10 ohms and the current into it would reach a final value very soon after a battery were applied. If, however, the wire were wound up on a spool with an iron core, the time required for the current to reach its final value would look like the curve in Fig. 49. Its resistance has not changed; we have merely added inductance.

When the switch is opened a fat spark occurs; this is not true when the wire is strung up on poles. The current seems to try to bridge the gap; to keep on flowing. It does not "want" to stop. This is because of the inductance of the coil.

A single coil can have inductance and can have a voltage

induced across it just as though it were the secondary coil shown at *S* in Fig. 48.

When the current starts to go through the coil, lines of force begin to thread their way out through the coil, thereby cutting adjacent turns of wire, and according to Lenz's law inducing in each turn a voltage in such a direction that it tends to oppose the building up of the current from the battery. When the battery connection is broken, these lines of force fall back upon the coil and

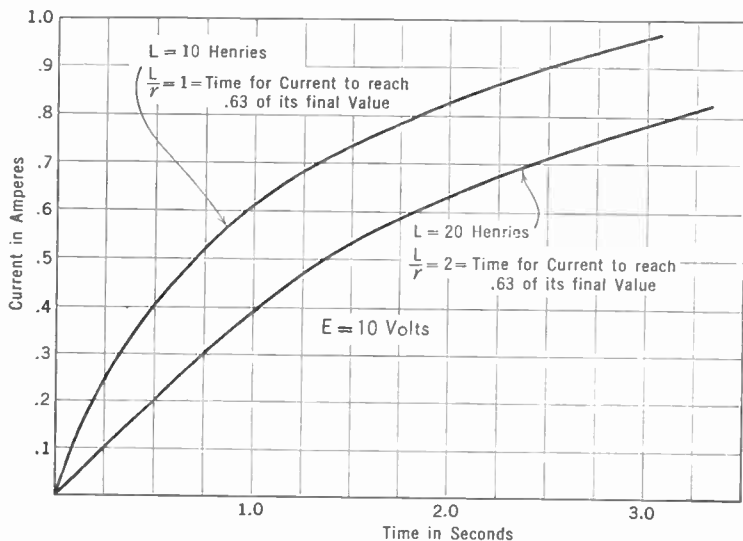

FIG. 49.—Current in an inductive circuit does not rise instantaneously to its maximum value as these curves show.

when cutting the individual turns of wire in the opposite direction they induce voltages in them which tend to keep the battery current flowing.

58. Magnitude of inductance and induced voltage.—The greater the number of turns of wire in a small space, or the better the permeability of the core on which the wire is wound, the greater will be the inductance of the coil and the longer time required for the current to reach its final value. The permeability of air is 1.0; that of iron may be as high as 25,000. This means

that the inductance of a given coil may be increased 25,000 times by winding it on a core of high permeability iron or alloy such as permalloy in which the permeability may get as high as 100,000. It is composed of nickel and iron.

The induced voltage across such a coil depends upon the rate at which the current is changing and the inductance of the coil. Since the current tends to keep on flowing when an inductive circuit is broken the voltage across the coil must be in the same direction as the battery voltage. Thus if a coil has 100 volts from a battery across it, and the current is suddenly broken, the voltage at the instant of break across the coil will be 100 plus the additional induced voltage. Breaking the current into a highly inductive circuit may set up a tremendous voltage across the coil and a severe shock can be felt by holding the ends of the wire at the moment of break. This is a practical demonstration of Lenz's law.

Example 1-4. In Fig. 50 is an inductance across which is placed a flash lamp and a battery. The current is regulated so that insufficient current goes through the lamp to light it up. Now when the switch is opened the lamp will suddenly light (and may burn out) because of the added voltage across it.

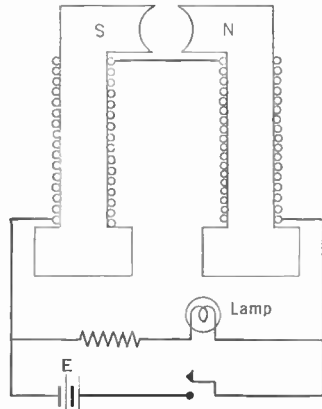

FIG. 50.—An example of Lenz's law. The lamp will light when the key is opened even though insufficient current flows through it when the key is closed.

The inductance of a coil depends upon the number of turns, the manner in which the wire is wound, and the material on which it is wound. If the coil is wound on iron, the inductance will be greater because the lines of force will be concentrated into a smaller space; more lines per unit area will go through a given area of coil.

In radio circuits the coils are usually wound on non-magnetic cores. In audio circuits iron is utilized to build up large inductances in small spaces and with a minimum of copper wire.

If an a.-c. voltage is placed across a coil, the current through the coil is much less than if a d.-c. voltage were placed across it. This is because of the counter- or back-voltage induced across the coil by the effects just described. The result is that a seeming decrease in voltage across the coil has taken place, although a voltmeter would indicate that the line voltage was across the coil.

59. The unit of inductance.—When a current change of one ampere per second produces an induced voltage of one volt, the inductance is said to be one **henry**, named from Joseph Henry, an American experimenter who discovered the phenomenon of electromagnetism at the same time as Michael Faraday. Coils added to circuits for the purpose of increasing the inductance of the circuit are properly called “inductors.” In this text the words inductance and inductor are used synonymously—incorrectly, probably.

60. Typical inductances.—The coils used in radio apparatus vary from inductances of the order of microhenries to very large

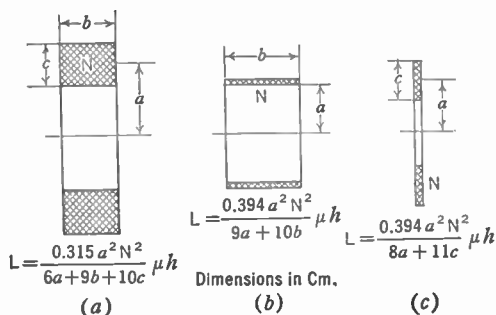

FIG. 51.—Some typical inductances.

ones having over 100 henries in inductance. Broadcast frequency tuning coils are of the order of 300 microhenries, and may be from 1 to 3 inches in diameter wound with from No. 30 to No. 20 wire of from 50 to 100 turns or so. There

are a number of complicated formulas by which one can calculate the inductance of coils of various forms and sizes. The ones in Fig. 51 are accurate enough for practical purposes.

These formulas show that the inductance increases as the square of the number of turns. Thus if a coil of 3 units inductance has its number of turns doubled, the inductance will have increased four times or to 12 units. This is true provided there is good “coupling” between turns; that is, if the coil is on an iron core this rule is strictly true, but if the coil is wound on a core of air the rule is

only approximately true. It becomes more nearly a fact the closer together the turns of wire.

Problem 1-4. A coil like that in Fig. 51*a* is called a **multilayer coil**. Such a coil is wound to have 1000 turns, in a slot 1 inch square. The distance from the center of the coil to the center of the winding (a in Fig. 51) is 2 inches. What is the inductance of the coil in microhenries? Remember that the dimensions given in Fig. 51 are in centimeters and that one inch equals 2.54 cm.

Problem 2-4. A coil like that in Fig. 51*b* is called a **solenoid**. It is the type of coil most often used in radio circuits. Calculate the inductance of such a coil composed of 60 turns of wire in a space of 3 inches, the diameter of the coil form being 3 inches. Coils used in modern broadcast receivers are wound on cores about one inch or less in diameter.

61. Coupling.—The closer together the two coils, P and S , Fig. 48, the greater the number of the lines of force due to the primary current that links with the turns of the secondary, and the better the “coupling” is said to be. The better the permeability of the medium in which the lines go, the better the coupling.

The voltage across the secondary of such a two-coil circuit as that shown in Fig. 48 depends upon the sizes of both coils, their proximity, the permeability of the medium, and the rate at which the primary current changes. All of the factors except the rate of change of the primary current are grouped together and called the **mutual inductance** of the circuit.

The secondary voltage, then, is equal to

$$M \times \text{rate of change of primary current,}$$

where M is the mutual inductance and is rated in **henries**.

62. Magnitude of mutual inductance.—Formulas in Fig. 51 show that the inductance of a coil depends upon the square of the number of turns. Doubling the turns increases the inductance four times. Consider two coils built alike and having the same inductance. If they are connected together the total inductance will be equal to that of a single coil of double the turns. In other words the total inductance of two coils connected “series aiding” will be four times the inductance of a single coil. If the connections to one coil are reversed, the total inductance will be zero because

the lines of force from one coil will encounter the lines of force from the other coil which are in the opposite direction. The coils are now connected "series opposing."

Consider the series-aiding case, Fig. 52*a*. The total inductance is made up of the inductance of coil 1, that of coil 2, the mutual inductance due to the lines of force from coil 1 which go through coil 2 and the mutual inductance associated with the lines from coil 2 which go through coil 1; these two inductances are equal because the coils are identical.

$$\begin{aligned} \text{Thus,} \quad L_a &= L_1 + L_2 + 2M \\ &= 2L_1 + 2M \quad (\text{because } L_1 = L_2) \\ &= 4L_1 \quad (\text{by experiment or measurement}) \end{aligned}$$

whence $M = L_1$.

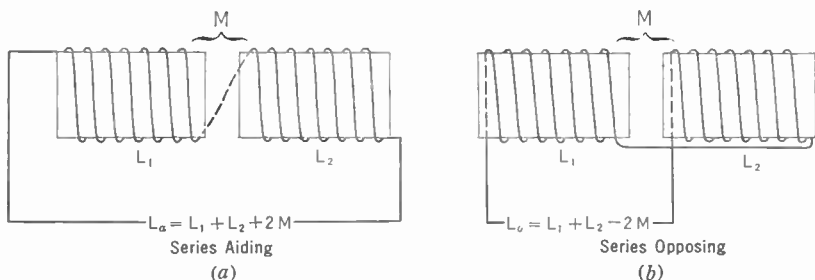

FIG. 52.—Coils may be connected so that their fields aid or "buck" and hence so that the total inductance is increased or decreased.

Now if the coupling in both these cases is less than perfect, if some of the lines from one coil do not link the other—and such is always the case—the total inductance, L_a , in the series-aiding case is less than four times the inductance of one coil and in the series-opposing case is greater than zero. But in any case the total inductance of two coils of any inductance connected in series-aiding will be given by $L_1 + L_2 + 2M = L_a$ and if they are connected series opposing the resultant inductance will be $L_1 + L_2 - 2M = L_o$. The following expression involving a new term, the **coefficient of coupling**, enables us to predict just what the total

inductance in the circuit will be once we know how well the two coils are coupled.

The coefficient of coupling $\tau = M/\sqrt{L_1 L_2}$.

The coefficient of coupling depends upon the total inductance in the primary and secondary circuits as well as upon the mutual inductance between inductances L_1 and L_2 , Fig. 53.

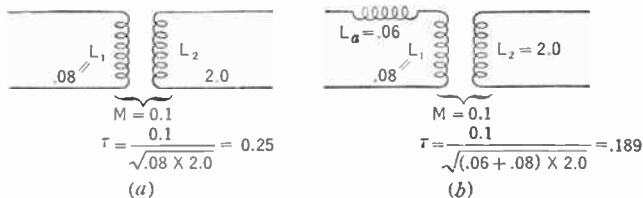

FIG. 53.—Examples showing dependence of coefficient of coupling on series inductance.

The mutual inductance depends upon only the two coils, L_1 and L_2 , and the coupling between them, or $M = \tau \sqrt{L_1 L_2}$; the coefficient of coupling between two circuits depends upon the total inductance in the circuits. The maximum possible value of τ is 1.0. This is called unity coupling, and approaches this value in iron-core transformers. In air-core coils and transformers the coupling may be very "weak," that is, of the order of 0.1, and seldom gets as high as 0.7. In an iron core transformer 98 per cent coupling ($\tau = .98$) is usual.

63. Measurement of inductance.—Inductance is usually measured by means of a Wheatstone bridge (Section 34) just as resistance is measured. This is essentially a method of comparing the unknown inductance to a known inductance. Resistances are used as the ratio arms, as in Fig. 54. When there is no sound in the telephones the inductances are equal if the ratio arms are

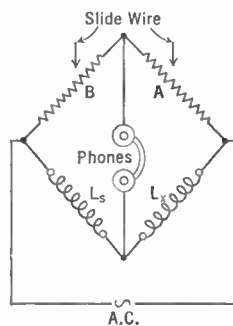

FIG. 54.—If A and B are so adjusted that there is no sound in the phones,

$$L_x = L_s \frac{A}{B}$$

equal, or if the ratio arms are not equal the unknown inductance is given by the equation, $L_x = L_s \frac{A}{B}$.

Mutual inductance is measured on a bridge, or by the following method: The inductance of the individual coils may be measured first. Then they are connected series aiding and the total inductance measured. This gives us the formula $L_1 + L_2 + 2M$, from which M can be calculated at once. Of course the same result will be obtained by connecting the coils series opposing. It is not even necessary to measure the individual inductances first, provided we can measure the inductance both series aiding (L_a) and then series opposing (L_o). Then

$$4M = L_a - L_o$$

$$M = \frac{L_a - L_o}{4}$$

Problem 3-4. In Fig. 55, when the coils are connected series aiding the inductance is measured to be 400 microhenries. What is the mutual inductance?

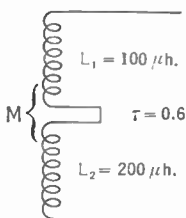

FIG. 55.—A problem in coupled circuits.

Problem 4-4. In Fig. 53 (b) calculate the coefficient of coupling if L_a is short-circuited, or removed from the circuit.

Problem 5-4. In a screen grid tube radio-frequency amplifier circuit the primary inductance is 350 microhenries, the secondary is 230 microhenries, the mutual inductance is 160 microhenries. Calculate the coefficient of coupling.

Problem 6-4. In Fig. 55, $L_1 = 100$ microhenries; $L_2 = 200$ microhenries, and $\tau = 0.6$. What is the mutual inductance? What is the total inductance ($L_o = L_1 + L_2 + 2M$)? What is it if L_2 is reversed (M is negative)?

64. The transformer.—A transformer is a device for raising or lowering the voltage of an a.-c. circuit. It “transforms” one voltage into another. It consists of two windings on an iron core, as in Fig. 56. The purpose of the iron core is to insure that the magnetic field set up about the primary will flow through the secondary coil without loss. What few lines of force do not link

primary and secondary are called **leakage** lines and the inductance associated with them is called **leakage inductance**.

The primary is attached to an a.-c. line, the secondary to the load, whether this is a house lighting circuit, a motor, or any other device which requires electricity.

The lines of force from the continually changing primary alternating current flow through the secondary and induce voltages in it. The relation between the primary and secondary voltages is simple and definite—it depends upon the relative number of turns. If there are twice as many secondary turns as there are primary turns, the voltage developed across the secondary terminals will be double that across the primary. The following formula gives the relation between primary and secondary turns and the respective voltages:

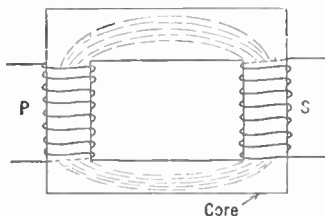

FIG. 56.—A simple transformer.

$$\frac{e_p}{e_s} = \frac{n_p}{n_s} = N \text{ (turns ratio).}$$

By using the proper ratio of turns, voltages either greater or less than the primary voltages may be secured at the secondary terminals.

Example 2-4. A transformer is to connect a 110-volt motor to a 22,000-volt transmission line. What is the ratio of turns between secondary and primary?

$$\frac{e_p}{e_s} = \frac{n_p}{n_s}$$

$$\frac{22,000}{110} = \frac{n_p}{n_s} = 200.$$

NOTE. This does not give the number of turns in either primary or secondary windings. The absolute number of turns depends on several factors; the ratio of turns depends on the voltages to be encountered.

Problem 7-4. In electric welding a very low voltage is used. What would be the turns ratio of a transformer to supply a welding plant with 5 volts if it takes power from the standard 110-volt circuit?

Problem 8-4. In Problem 13-2 what are the turns ratio and minimum primary current? If the transformer is 90 per cent efficient what power does it take from the line?

Problem 9-4. A primary consists of 200 turns of wire and is connected to a 110-volt circuit. The secondary feeds a rectifier circuit requiring 550 volts. How many turns will be on the secondary winding?

65. Power in transformer circuits.—Since the transformer does not add any electricity to the circuit but merely changes or transforms from one voltage to another the electricity that already exists, the total amount of energy in the circuit must remain the same. If it were possible to construct a perfect transformer there would be no loss in power when it is transformed from one voltage to another. Since power is the product of volts times amperes, an increase in voltage by means of a transformer must result in a decrease in current, and vice versa. On the secondary side of a transformer there cannot be more power than in the primary and if the transformer is one of high efficiency, the power will be only slightly less than on the primary side. The product of amperes times volts remains the same.

Thus the primary power is

$$E_p I_p \quad (1)$$

and the secondary power is

$$E_s I_s \quad (2)$$

and since there is no loss or gain in power

$$E_p I_p = E_s I_s \quad (3)$$

whence
$$\frac{I_p}{I_s} = \frac{E_s}{E_p} = N \text{ (turns ratio),}$$

which shows that the secondary voltage increases as N increases; the secondary current decreases when N increases.

66. Transformer losses.—Transformers are not perfect. There is some resistance in both primary and secondary coils. The current going through these resistances produces heat, which represents a certain amount of power lost. All of the lines of force coming out of the primary coil do not go through the secondary

(the transformer does not have "unity coupling"). Some of the magnetic field of the primary, therefore, is not used in inducing currents in the secondary. The iron core—which is a metallic conductor in the magnetic field of the primary, just as the secondary wire is—has currents induced in it and since the iron is a high-resistance conductor it heats up. All of these losses must be supplied by the primary source of power, the generator. Large transformers, however, are very efficient, over 90 per cent of the input power being transferred to the secondary circuit.

67. The auto-transformer.—It is not necessary for proper transformation of voltage that the primary and secondary windings shall be distinct. In Fig. 57 is a representation of what is known as an auto-transformer, in which the secondary is part of the primary. The voltage across the secondary turns, however, bears the same relation to that across the primary part as though there were two separate windings. The ratio of voltages is the ratio of the number of turns possessed by the secondary and primary.

A transformer is often used when both alternating and direct currents flow through a circuit and it is desired to keep the direct current out of the circuit to which the secondary is attached. No d.-c. current can go across the transformer when the two windings are distinct, although the a.-c. voltage variations occurring in the primary are transferred to the secondary by the effects already described. If no increase or decrease in voltage is desired the turns ratio is made unity; that is, the same number of turns will be on the secondary as on the primary.

Such a case is an output transformer which couples a loud speaker to a power tube in a power amplifier. The power tube has considerable direct current flowing in its plate circuit in which the useful alternating currents also flow. The d.c. is undesirable in the loud-speaker windings, so a transformer is used to isolate the speaker from the d.c. of the tube. A good transformer of this type

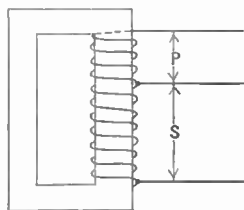

FIG. 57.—An auto-transformer. The secondary can be the entire winding or part as shown.

will transmit all frequencies in the audible range with an efficiency of about 80 per cent.

Problem 10-4. The line voltage in a certain locality is only 95 volts but a radio set is designed to operate from a 115-volt circuit. A transformer is to be used like that in Fig. 57. What will be the ratio of turns?

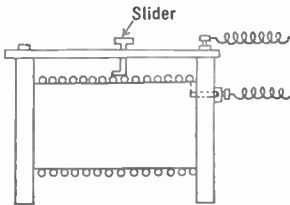

FIG. 58.—An early form of variable inductance for radio purposes called a "single slide tuning coil."

68. Transformer with open-circuited secondary.—When no current is taken from the secondary, the primary acts merely as a large inductance across the line. The current will be rather small. The energy associated with this current is used in two ways, one of which is in heating the transformer and its core. The other part maintains the magnetic field of the primary. This consumes

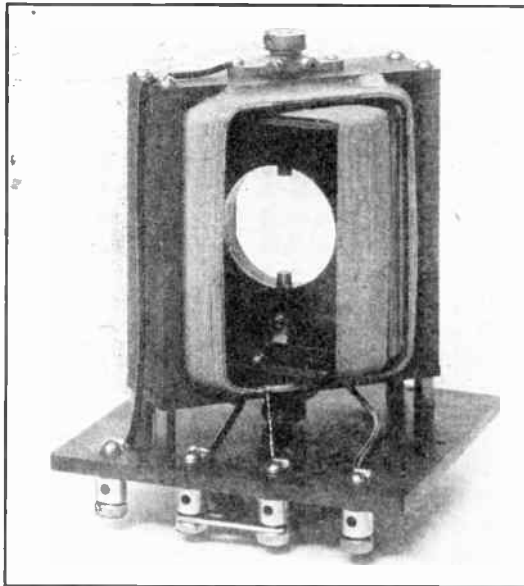

FIG. 59.—General Radio Company variable inductance.

no energy from the line because at each reversal of the current the energy of this field is given back to the circuit.

When the secondary load is put on, however, it begins to draw current from the secondary and more power is taken from the line leading to the generator. This additional power is that required by the load and the loss in primary and secondary resistance.

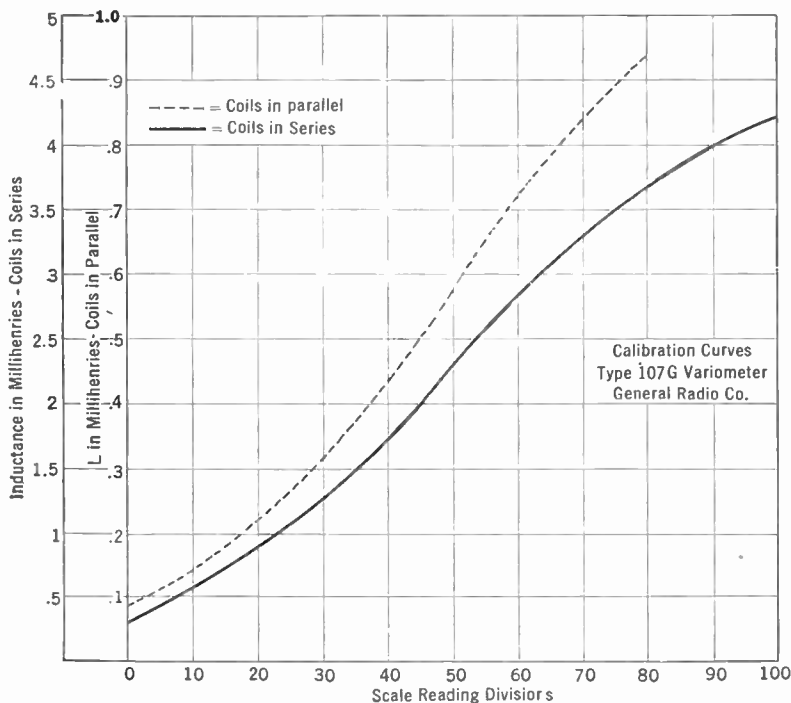

FIG. 60.—Calibration of a standard variable inductance.

69. Variable inductors.—A variable inductance may be used to regulate the current in an a.-c. circuit. This variation in inductance can be secured by means of a slider, as in Fig. 58, or by a fixed number of turns and a movable iron core. Variations in the position of the iron rod change the permeability of the core on which the wire is wound and thereby vary the inductance.

For radio-frequency work the variable inductance can take the form of a variometer, shown in Fig. 59, in which the inductance is continuously variable from a low value when the two coils are "bucking" each other, or are connected series opposing, to the maximum value where they are connected series aiding. The coils are always connected in the same manner, but by having one coil rotate within the other the variations in inductance result. The calibration of such a variometer is shown in Fig. 60.

70. Effect of current, frequency, etc., on inductance.—A good

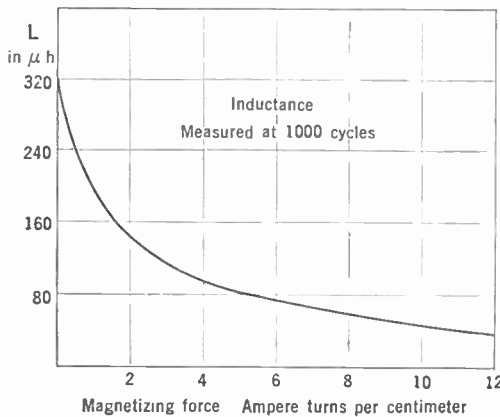

FIG. 61.—Inductance of iron core coils varies with d.-c. current because of variation in permeability.

air core coil has constant inductance at all frequencies far from its natural frequency and at all currents through it. It can be measured at 1000 cycles on a bridge with the assurance that its inductance will not be different at radio frequencies.

When d.-c. current through an iron core coil changes, the inductance changes because of the change in permeability of the core. In order to keep the inductance more or less constant a small air gap is placed in the core. The inductance of a coil to be used where both d.-c. and a.-c. currents are to flow through it should always be rated by considering the number of d.-c. amperes that are to flow through it. Thus a coil may be said to have 30 henries inductance at a d.-c. current of 30 milliamperes. This is the current at which it is supposed to be used. At other currents it may have more or less inductance. In Fig. 61, note how the inductance steadily decreases as the direct current through it increases.

The effect of leaving a small air gap in the iron core is shown in

Fig. 62. The air gap decreases the inductance at low values of d.-c. current but brings it up at high currents and thereby flattens the curve of inductance vs. d.-c. current.

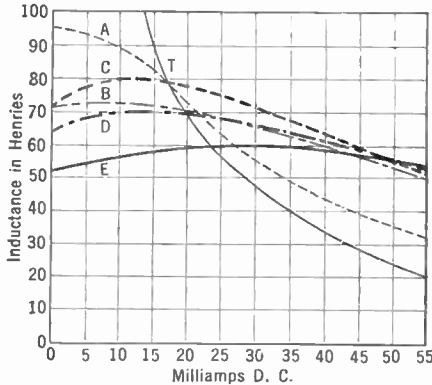

FIG. 62.—Variation of inductance with air gap.

- T*—no air gap.
A—average air gap.
B—air gap at one end, 0.01 inch.
C—air gap at both ends, 0.005 inch each.
D—air gap at both ends, 0.0075 inch each.
E—air gap at both ends, 0.01 inch each.

The effective inductance of coils changes greatly at some frequencies and in some circuits. At very high frequencies a coil may act more like a capacity because of the great number of turns between each of which exists some capacity. In high frequency transmitters or receivers, the choke coils to be used may arrive in the circuit by a cut-and-try method, calculations beforehand proving worthless.

CHAPTER V

CAPACITY

THERE are two essential electrical quantities in every radio circuit. These are **inductance** and **capacity**. They are represented in the circuit by the coils and the condensers. Upon their relative sizes depends the wavelength or frequency to which the receiver or transmitter is tuned. Resistance is always present too, but the effort of all radio engineers is to reduce the resistance and to overcome the losses in power due to its presence, just as mechanical engineers deplore the share of power wasted in mechanical friction.

71. Capacity.—Inductance has been likened to inertia. In an alternating-current circuit, it tends to prevent changes in the current flowing. Inductance is a property of a circuit; so is capacity. It is not something one can see, or feel, or hear; one cannot see, or feel, or hear electricity. We are only aware of it by the work it does. Inductance in concentrated form is possessed by coils. Whenever a coil has an alternating current flowing through it, the inductance is one of its important qualities. Capacity in concentrated form exists in condensers formed by conductors which are insulated from each other. Electricity can be stored in a condenser. This capacity tends to prevent any change in the electrical pressure or voltage which exists between these objects.

72. Capacity as a reservoir.—In an electrical circuit, a condenser serves the same purpose that the familiar standpipe or water tower serves in the water supply system of a city. The water tower maintains a constant water pressure regardless of the number of small drains from it, and regardless of the fact that the pumps filling the tower put water into it in spurts, not in a steady stream as comes from one's garden hose.

73. Capacity in a power supply device.—Alternating current taken from the house lighting wires may be put into a “rectifier” which cuts off half of the waves, as shown in Fig. 63. These spurts of current are forced through inductances which delay the rise of current to its final value on the half cycle in which current flows from the rectifier. On the other half cycle, in which no current flows from the rectifier the inductance tends to delay the decay of the current. The condensers which have been charged on the current half cycle discharge during the no-current half cycle. Current flowing into these condensers charges them to the voltage of the rectifier system. Then when the rectifier no longer passes current, the condensers begin to discharge and their voltage falls.

A proper combination of inductance and capacity, called a **filter**, will keep a perfectly steady current flowing out regardless of the fact that only spurts of current go into the system.

An inductance, then, opposes a change in current; it is like inertia in a mechanical system. Capacity opposes a change in voltage; it is like a reservoir. In an **inductive circuit**

the current does not reach its maximum value until some time after the voltage has been applied. In a **capacitive circuit** the voltage does not rise to its maximum value until some time after the current has been flowing in it. A good condenser may keep charged with electricity for many hours after the charging voltage has been disconnected.

74. The charge in a condenser.—A condenser is made up of two or more conducting plates separated by a non-conductor. The

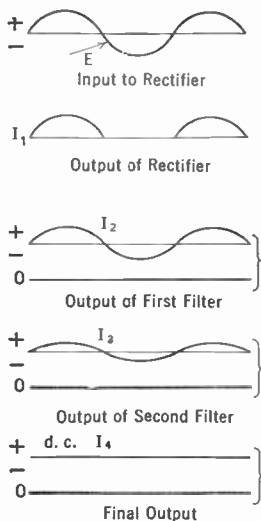

FIG. 63.—How the current in a “B eliminator” varies. The half waves from the rectifier are smoothed out by series inductances and parallel condensers until at I_4 it is pure direct current.

Leyden jar (Fig. 64) is a good illustration. Filter condensers used in radio circuits are made up of metal foil separated by waxed paper. The questions that everyone who looks at a condenser asks are these: Can a condenser pass an electric current? What is this capacity possessed by a condenser in concentrated form? How much capacity is in a condenser? What is the spark that jumps when a condenser is discharged?

When a condenser is connected to the terminals of a battery, a 45-volt B battery for example, there is a momentary rush of electrons on to one metallic condenser plate and an exit of electrons from the other.

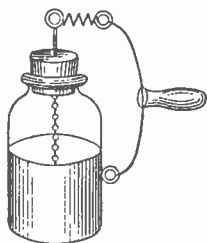

FIG. 64.—A Leyden jar—an early form of condenser.

This constitutes a current flowing into the condenser, and if a voltmeter could be placed across it the voltage would be seen to rise in much the same manner in which the current builds up in an inductive circuit. As soon as the voltage of the condenser is the same as that of the battery, current no longer flows into it. It is now charged, and if the battery is disconnected the electrons remain on the one plate and there is a dearth of electrons

on the other. Now if a wire is connected from one terminal to the other, these electrons jump across the gap in their effort to equalize the charge on the two plates.

Once this spark has taken place the condenser is discharged.

So long as the condenser is charged it possesses energy, which is like the energy possessed by a ball on top a flag pole. The kind of energy possessed by the ball is potential energy; it is due to the position of the ball. The energy possessed by the condenser when charged is also potential energy, due to the strain existing in the non-conductor. Nothing happens until the condenser discharges, then it may set fire to a piece of paper, may puncture a hole in a sheet of glass, or may give some person a severe shock. Thus the condenser, just as the ball on top the pole, has the ability to do work—which is our definition of energy. .

This is called **static** electricity, and is the same kind that produces sparks when we stroke the cat's back, or rub a comb

on a coat sleeve, or the kind of electricity that jumps from one cloud to another on a hot summer day.

75. The quantity of electricity in a condenser.—The quantity of electricity that rushes into a condenser when it is connected to a battery is a perfectly definite quantity and can be calculated or measured. This quantity, Q , rated in **coulombs**, depends upon two factors only, the capacity of the condenser and the charging voltage. The **capacity** of the condenser depends only upon the physical make-up of the condenser, that is, (1) the size of the conducting plates, (2) the nature of the non-conductor called the **dielectric**, and (3) the distance apart of the plates. The quantity Q is proportional to both these factors, and may be expressed as

$$Q \text{ (coulombs)} = C \text{ (capacity)} \times E \text{ (voltage)}.$$

The unit of capacity is the **farad**, named from Michael Faraday, and is the capacity of the condenser whose voltage is raised 1 volt when 1 coulomb of electricity is added to it; or vice versa, the capacity of the condenser to which 1 coulomb of electricity can be added by an externally applied voltage of 1 volt. This is a very large unit and in practice engineers have to deal with millionths of farads, or microfarads. A smaller unit yet, micro-microfarad, is used in some radio circuits. This is equal to 10^{-12} farads. Another unit is the **centimeter of capacity**. It is equal to 1.1124 micro-microfarads.

We write the above expression as

$$C \text{ (farads)} = \frac{Q \text{ (coulombs)}}{E \text{ (volts)}}$$

This expression shows that the capacity of a condenser is the ratio between the quantity of electricity in it and the voltage across it.

The third way of stating the relation between capacity, quantity, and voltage, defines the voltage:

$$E \text{ (voltage)} = \frac{Q \text{ (quantity)}}{C \text{ (capacity)}}$$

A discharged condenser, of course, has no electricity, Q , in it and hence no voltage across it. When it is connected to a battery, a voltage is built up across the two plates, the value of this voltage being given at any instant by the ratio between the quantity, Q , and the capacity, C , of the condenser. The greater the quantity of electricity stored on the conducting plates, the greater the voltage. When the battery is removed the quantity of electricity remains and, of course, a voltage, E , exists between the two plates.

76. Time of charge.—Since an ampere is a rate of flow of current, that is, 1 coulomb per second, one can calculate the rate at which current flows into a condenser provided the quantity, Q , and the time, t , are known. The amperes before the condenser is attached to the battery are zero, at the completion of the charging process the amperes are zero. The average rate, then, is what one secures from the equation,

$$I = \frac{Q}{t}.$$

Example 1-5. A condenser of 15 microfarads is attached to a 220-volt circuit. What quantity of electricity flows into it? If it requires 1/200 second to charge it, what is the average current?

$$\begin{aligned} Q &= C \times E \\ &= 15 \times 10^{-6} \times 220 \\ &= 3300 \times 10^{-6} \\ &= .0033 \text{ coulomb.} \end{aligned}$$

$$\begin{aligned} I &= \frac{Q}{t} \\ &= \frac{.0033}{.005} \\ &= .66 \text{ ampere.} \end{aligned}$$

This is also the average rate of discharge if the time of complete discharge is 1/200 second.

Problem 1-5. What is the capacity of a condenser that holds .0024 coulombs when attached to 220 volts?

Problem 2-5. In a radio circuit is a .0005-mfd. (500 mmfd.) condenser across a 500-volt source. What quantity of electricity will flow into it?

Problem 3-5. What voltage will be necessary to put 0.012 coulomb into the condenser of Problem 1?

Problem 4-5. The average charging current in Problem 1 is 2 amperes. How long will it take to charge the condenser?

Problem 5-5. Suppose the average voltage across a condenser when it is being discharged is one-half the voltage when fully charged. Connect a 10-ohm resistance across the condenser of Problem 1. What average current flows? What is the average power used to heat the wire?

Problem 6-5. How long would it take to discharge the condenser in Problem 5? If the resistance is doubled, what power is used up in heat and how long will it take to discharge the condenser?

77. Energy in a condenser.—The amount of energy that can be stored in a condenser in the form of static electricity can be computed from the formula:

$$\text{energy} = \frac{1}{2} C E^2.$$

This represents the work done in charging the condenser, and naturally represents the energy released if the condenser is discharged.

Similarly, the energy in the lines of force about a coil through which an a.-c. current flows is equal to $\frac{1}{2} L I^2$.

The unit of energy or work is the **joule**. It is the amount of work required to force one coulomb of electricity through a one ohm resistance. Thus if a 1-mfd. condenser is charged to a voltage of 500, the energy is

$$\frac{1}{2} \times 1 \times 10^{-6} \times 500^2 = .125 \text{ joule.}$$

Since power is the rate of doing work, we can find the power required to charge such a condenser in one second of time by dividing the above expression by one second. Thus

$$\text{Power in watts} = \frac{1 C E^2}{2 t}$$

and if we attach the condenser to a secondary of a 500-volt transformer which charges the condenser 120 times a second (60-cycle current) the power will be $= \frac{1}{2} C E^2 \times 120$ provided the condenser is permitted to discharge each time it is charged. Thus the smaller the time, the greater the power required to charge the condenser.

A general expression for such a problem is

$$\text{Power} = \frac{1}{2} CE^2N,$$

if N is the times per second the condenser is charged and discharged.

Example 2-5. A condenser in a transmitting station has a capacity of .001 mfd. and is charged with a 20,000-volt source. What energy goes into the condenser and what power is required to charge it 120 times a second (60-cycle source)?

$$\begin{aligned} \text{Energy or work,} \quad W &= \frac{1}{2} CE^2 \\ &= \frac{1}{2} \times .001 \times 10^{-6} \times 20,000^2 \\ &= 0.2 \text{ joule.} \\ \text{Power,} \quad P &= W \times N \\ &= \frac{1}{2} CE^2N \\ &= 0.2 \times 120 \\ &= 24 \text{ watts.} \end{aligned}$$

Problem 7-5. If the generator in the example above were a 500-cycle generator, what would be the power taken from it?

Problem 8-5. How much power is required to charge a 1-mfd condenser to a voltage of 220, 120 times a second?

Problem 9-5. A transmitting antenna has a capacity of .0005 mfd. It is desired to transmit 1 kw. of power. To what voltage must the antenna be charged from a 500-cycle source?

Problem 10-5. Suppose an antenna is to be supplied with 500 watts of power and that between the charging mechanism and the antenna exists an efficiency of 30 per cent. The condenser, which discharges into the antenna, has a capacity of 0.012 mfd., and the generator which charges the condenser is a 500-cycle machine. A transformer is used to step up the voltage 110 from the generator to the value required by the condenser. What is the secondary voltage of the transformer and what is the turns ratio between secondary and primary? NOTE: Remember that a 500-cycle generator charges a condenser 1000 times a second.

78. Electrostatic and electromagnetic fields.—The energy existing in an inductive circuit is said to exist in the electromagnetic field surrounding the inductance. This field is made up of lines of force and can be explored with a compass, or by sprinkling iron filings on paper as in Fig. 42.

The energy in a condenser is said to exist in the electrostatic field. This is the locality in which the electrical strain exists, that

is, in the non-conductors in the vicinity of the conducting surfaces which are charged. This field cannot be explored with any magnetic substance, but can be discovered by any form of charged bodies or any container of static electricity.

Some circuits, an antenna system for example, have both capacity and inductance and, if properly charged, have both a magnetic and a static field. Since the wire can be charged to a very high voltage with respect to earth, considerably energy can be fed into it.

Frictional electricity, such as that produced by rubbing the cat's back, is a form of static electricity. It is this kind of electricity that is produced in the tank of a truck carrying gasoline along the road. The gasoline sloshing about in the metallic tank may raise the voltage of the tank to a considerable degree above the ground from which it is insulated by the rubber tires. Finally a spark may pass, and neutralize the charge—but in the process the tank and driver may be blown to bits. To prevent such accidents, all gasoline trucks trail an iron chain which connects the tank electrically with the ground and discharges it as fast as such static charges are produced.

79. Condensers in a.-c. circuits.—A perfect condenser is one which is an absolute non-conductor to d.-c. currents—that is, it is an infinite d.-c. resistance—and one which has no a.-c. resistance. All the power that is put into it is used in setting up an electrostatic field. Unfortunately all condensers have some a.-c. resistance, and few have infinite d.-c. resistance. Otherwise a condenser once charged would keep its charge forever. The time it takes a condenser to discharge is proportional to the product of its capacity and its resistance. This is known as its **time constant**, and is also the time required to charge the condenser. The resistance to d.c. is known as its **leakage resistance**. In a good condenser this may be as high as several hundred megohms.

Experiment 1-5. Charge a filter condenser of about 2- to 10-mfd. capacity by connecting to a 110-volt d.-c. circuit. Then discharge by a heavy wire; then charge again and allow to stand for a half-hour and discharge. Charge again and permit to stand for an hour and discharge. The relative sizes of spark give an idea of how poor a condenser it may be from the standpoint of

leakage. Then charge and place a 10-megohm resistance across it for a second or so. Then see if it can be further discharged by means of a wire.

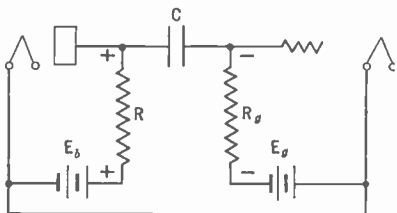

FIG. 65.—Leakage of current through the condenser C causes a voltage drop across the input of the following tube.

A good condenser may retain its charge for many hours after being removed from the source of charging current. The leakage of condensers not only takes place across the insulating material through which its terminals are brought out but through the wax filling, the container, and through the dielectric itself.

Example 3-5. In Fig. 65 is a typical coupling device used between tubes in a resistance-capacity coupled amplifier. A high-voltage battery is used. The purpose of condenser C is to keep these high d.-c. voltages from getting to the grid of the following tube. If this condenser has any leakage resistance, a d.-c. current flows through it and impresses a voltage on the grid of the succeeding tube which is highly detrimental.

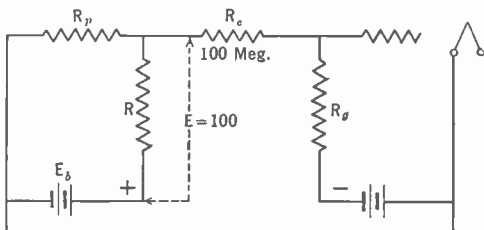

FIG. 66.—The circuit equivalent of Fig. 65.

Suppose the condenser has a resistance of 100 megohms. What voltage will be impressed on the grid if the battery has a voltage, E_b , of 200?

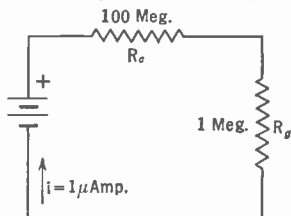

FIG. 67.—The battery in this figure represents the voltage across R_c and R_g in Fig. 65.

One hundred volts across 100 megohms (the coupling resistance R and the grid leak resistance are negligible in comparison to the condenser leakage resistance) produces one microampere of

Figure 66 represents the circuit. It has the battery in series with two resistances, the plate resistance of the tube R_p and the coupling resistor R . Across E_b and R is shunted the condenser resistance and the grid leak in series. The problem is to find what current flows through this shunt circuit and what voltage drop this causes across the grid leak. Suppose 100 volts appear across the series circuit composed of R_c and R_g . This may be as represented in Fig. 67.

One hundred volts across 100 megohms (the

current. This one microampere flowing through the grid leak of one megohm produces a voltage of 1 volt. This voltage is of a polarity that is opposite to the *C* bias and therefore decreases its value. In addition a certain amount of noise may be developed by the d.-c. current flowing through this condenser and grid leak. This noise is directly impressed on the input to the amplifier tube and may assume large values when amplified by succeeding stages. Condensers used in resistance amplifiers must have a high resistance.

80. Power loss in condensers.—A pure inductance takes no power from an a.-c. line once the magnetic field is established. If, however, the coil has resistance, power is wasted in heating it. Similarly, a perfect condenser, that is, one having no resistance, wastes no power. If the condenser has resistance—and all have—power is wasted in heat when it is connected to a source of current, whether a d.-c. or an a.-c. source. This power in watts is the current squared times the resistance.

81. Condenser tests.—If a voltmeter, a battery, and a condenser are connected in series a momentary deflection will be noted if the condenser is good. If the condenser is leaky, a constant deflection will be noted. If the condenser is fairly large, one or two microfarads, and no deflection is noted, the condenser is probably open. If the full battery voltage is read by the meter, the condenser is shorted.

If a condenser that has been determined to be not shorted is placed across a battery and then a pair of phones is placed across the condenser, a click will indicate that the condenser is good. The click is the discharge of the condenser through the phones.

82. Condensers in general.—A condenser, then, is any object with two or more conducting plates separated by a non-conductor called the dielectric. A cloud filled with moisture is a good conductor. So is the earth. The cloud may be a mile or so above the earth and subjected to all sorts of electrical differences of potential. It may become charged with respect to the earth. When this charge becomes great enough to jump the gap, a spark passes, and the condenser is discharged. This is known to us as lightning. Small discharges between parts of a cloud or between two clouds may cause only small sparks and are made known to us by "static."

The earth is considered as being at **zero potential**. All objects not connected to earth have a higher voltage than the earth.

These objects have a capacity with respect to earth. This capacity will conduct electricity just as a one microfarad by-pass condenser in a radio receiver will, and may cause considerable embarrassment to the radio engineer or the experimenter who does not take it into consideration in his calculations.

In radio circuits the conducting plates of a condenser may be aluminum or brass or tin foil, depending upon the service which the condenser is to fill. The insulating plates, called the dielectric, may be air, oil, mica, coated paper coated with beeswax or other insulating compound. The actual capacity of the condenser may be fixed, or it may be variable.

83. The nature of the dielectric.—If two square metal plates 10 cm. on a side are suspended in air and about 1 mm. from each other, the capacity will be about 88.5 mmfd. If a sheet of mica is between the plates the capacity will be increased about eight times. Other substances will give different values of the capacity. Each substance, in fact, will give a certain value of capacity depending upon what is called the **dielectric constant** of the substance. The table below gives the value of K , the dielectric constant, of several substances.

This factor K has nothing to do with the ability of a substance to withstand high voltages without puncturing. Such ability differs not only with the substance but also with the condition of the substance at the time the voltage is applied, that is, the percentage moisture present, the pressure to which it is subjected, etc. Mica for example will withstand much greater voltages than paraffined paper.

Material	Dielectric Constant K	Material	Dielectric Constant K
Air	1	Paraffin	2
Bakelite	4 to 8	Porcelain	5 to 6
Celluloid	4 to 16	Rubber	2 to 3½
Glass	4 to 10	Pyrex	5.4
Mica	3 to 7	Shellac	3.5
Oil, castor	4.7	Varnished cambric	4
Oil, transformer	2.2	Wood	2 to 8
Paper	2 to 4		

83a. Electrolytic condensers.—Of late years the majority of condensers in radio receiver power supply systems for filtering purposes have been of the electrolytic type. They provide high capacity in small space, but compared to air or mica dielectric units they have a high resistance power loss. They must, usually, be connected to the circuit correctly; that is, they have a polarity and are used on circuits which have some direct current in them.

The electrolytic condenser is made up of an anode, almost always of aluminum, a cathode, of aluminum or copper, and a chemical substance between. On the surface of the anode is an extremely thin layer of a non-conducting chemical, say aluminum oxide. Thus in a small space may be the two conducting electrodes separated by this thin oxide layer. As will be seen in Section 85, the capacity of a condenser is increased when the area of the plates is increased and when the separation between the plates is decreased. Thus, if the intervening non-conducting layer is very thin, the capacity per square inch of conducting surface may be high.

These condensers are not adapted for high-voltage work, 600 volts being about the highest practicable voltage that may be applied. Furthermore, they consume energy because of the losses in the materials. If operated on low-voltage circuits, say 6 volts, as much as 4000 mfd. may be placed in a container of reasonable dimensions. At voltages of the order of 100 to 200, capacities may range up to 100 mfd. Small leakage currents flow through these condensers in normal operation. This leakage current (which represents a wastage or energy loss) is about 0.2 milli-ampere per microfarad at 400 to 500 volts.

By etching the aluminum foil of which the condenser is made, the area of the surface may be increased, thus still further decreasing the cubic contents of the container into which a given number of microfarads is placed. An 8-microfarad, 500-volt condenser (not etched) will be placed in a can $1\frac{3}{8}$ inches by $4\frac{1}{2}$ inches.

In general there are two types of electrolytics—wet and dry. The wet type is more economical, will withstand high voltage surges (self-healing), has greater internal losses, and can be built only in a limited range of capacities and voltages. The dry type does not suffer from these faults, and can be used on a.c.

84. Sizes of radio condensers.—The farad is a very large unit. In radio work the capacities used vary from a few million millionths of a farad to several millionths of farads. A millionth of a farad is known as a **microfarad**, and a millionth of this value is called a **micro-microfarad**. These are related as shown below.

One farad equals one million mfd. and one million million mmfd.

One mfd. equals one millionth farad, and one million mmfd.

One mmfd. equals one million millionth farad, and one millionth mfd.

Sometimes the centimeter is used as a unit of capacity. It is equal to 1.1124 micro-microfarads.

85. Condenser capacity formulas.—Formulas have been worked out by which it is possible to compute the capacity of condensers of various forms. For example the capacity of two flat conducting plates separated by a non-conductor may be computed from the formula:

$$C = \frac{885 \times A \times K}{10^{10} \times d},$$

where C = capacity in microfarads;

A = area of the metallic plate in square centimeters;

K = dielectric constant of the non-conductor;

d = thickness of dielectric in centimeters.

Or

$$C = 0.0885 \frac{KA}{d}$$

where C = capacity in micro-microfarads;

d = thickness in centimeters;

A = area in square centimeters;

K = dielectric constant.

Formulas for other types of condensers may be found in the Bureau of Standards Bulletin 74, Radio Instruments and Measurements, page 235.

In receiving sets the tuning condensers are variable. The important function of separating one station from another is performed by changing the capacity of the condenser, which is called tuning the circuit. The tuning condensers have air as the dielectric and plates of various metals, usually brass or aluminum. The capacities range from 25 mmfd. to 100 mmfd. in a short-wave (high-frequency) receiver to 500 mmfd. for broadcast frequency receivers. Receivers for the long waves used in transoceanic communications are much larger. The above values of capacity may be written as .0001 and .0005 mfd. It is probably easier to express small capacities in micro-microfarads rather than in one of the larger units. Whenever an easy path for an alternating current is needed a fixed condenser is used. It is called a **by-pass** condenser.

Example 4-5. How many plates 16×20 cm. in area and separated by paraffined paper ($K = 2.1$) .005 cm. thick are required for a condenser of 24 mfd.?

$$\begin{aligned} C &= \frac{885 AK}{10^{10} d} \\ &= \frac{885 \times 16 \times 20 \times 2.1}{10^{10} \times .005} \\ &= 0.0119 \text{ mfd. capacity per plate.} \end{aligned}$$

$$\text{Number of plates} = \frac{24}{.0119} = 2200.$$

Problem 11-5. Express in micro-microfarads: $\frac{1}{10000}$ farad, 1 mfd., 0.00025 mfd. Express in farads: 500 mmfd., 0.01 mfd., $\frac{1}{10}$ mfd. Express in microfarads: 1 farad, 500 mmfd., 0.01 mmfd.

Problem 12-5. What is the capacity of two square plates suspended in air 0.1 mm. apart, if the plates are 10 cm. on a side?

Problem 13-5. A variable tuning condenser has a capacity of 0.001 when air is used as dielectric. Suppose the container is filled with castor oil. What is the capacity now?

Problem 14-5. Lead foil plates are separated by mica 0.1 mm. thick having a dielectric constant of 6. What is the capacity of a condenser made up of 200 pairs of such plates?

Problem 15-5. How many joules of energy can be stored in such a condenser as in Problem 14 when 100 volts are impressed across it? How much power will it take to charge it to this voltage 120 times a second?

86. Condensers in series and parallel.—When condensers are connected in parallel (Fig. 68) the resultant capacity is the sum of

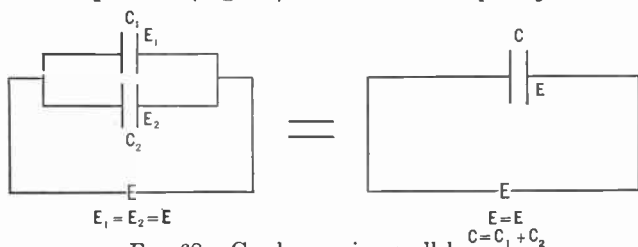

FIG. 68.—Condensers in parallel.

the individual capacities. When they are in series or parallel the resultant may be found as below:

$$C_{\text{parallel}} = C_1 + C_2 + C_3 \dots$$

$$C_{\text{series}} = \frac{1}{\frac{1}{C_1} + \frac{1}{C_2} + \frac{1}{C_3} \dots}$$

The resultant of two capacities in series is

$$C_{\text{series}} = \frac{C_1 \times C_2}{C_1 + C_2}$$

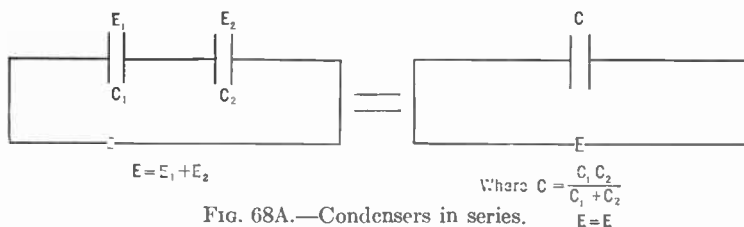

FIG. 68A.—Condensers in series.

In the parallel case the same voltage is across each capacity. In the series case the voltage varies inversely as the capacity. If two equal capacities are in series half the total a.c. voltage is impressed across each condenser. If one condenser has half the capacity of the other, that one will have two-thirds the total voltage whereas the other will have one-third the total voltage across it.

The resultant capacity of several condensers in parallel is always greater than any single capacity; in series the resultant is

less than the capacity of the smallest of the group. In series the voltage across each condenser varies inversely as its capacity and is always less than the total voltage across the combination. When a condenser is placed in an a.-c. circuit whose voltage is more than the condenser can tolerate, it is only necessary to use two or more condensers in series so that the voltage across individual members of the group is below the danger limit, and so that the total capacity in the circuit is the value desired.

When condensers are used across d.-c. circuits, as in filter circuits, the d.-c. resistance of the condenser becomes of importance. If two condensers in series across a certain d.-c. voltage have equal capacities but different d.-c. resistances, the voltage drop across the two condensers will differ. The voltage across one of them may be sufficient to destroy it.

Example 5-5. In a radio circuit a .0005-mfd. variable condenser is available but the circuit calls for a .00035-mfd. condenser. What fixed condenser may be used to reduce the maximum capacity in the circuit to the proper value? How shall it be connected?

Solution. Since the total capacity is to be reduced, the fixed condenser must be connected in series with the variable condenser. The total capacity is given as 0.00035 mfd. This is equal, from the above equation, to

$$\begin{aligned} .00035 &= \frac{C_1 \times C_2}{C_1 + C_2} \\ &= \frac{.0005 \times C_2}{.0005 + C_2} \end{aligned}$$

whence

$$C_2 = .001166 \text{ or } 1166 \text{ mmfd.}$$

Problem 16-5. Whenever the capacity of a tuning circuit is quadrupled, the inductance remaining constant, the wavelength is doubled and the frequency is halved. A broadcast receiver tunes to 600 meters (500 kc.) with a 500-mmfd. condenser. What maximum capacity must be put in parallel with this condenser in order to receive 800-meter (375-kc.) radio compass signals and ship-to-shore traffic on 2,200 meters? Ans. 390 mmfd., 6250 mmfd.

86a. Padding condensers.—In modern superheterodynes the tuning condenser has at least two sections, one of which tunes the oscillator and the other tunes the r.-f. amplifier. These sections are identical, although there must be a constant frequency difference between the frequency of oscillator and amplifier.

This constant difference of frequency (say 456 kc.) is maintained by a combination of series and shunt capacities in the oscillator circuit. Since the oscillator is generally tuned higher than the r.-f. circuits, a smaller change in oscillator capacity is required to produce the desired variation in frequency than is required to tune the r.-f. circuit over the desired bands. The oscillator inductance

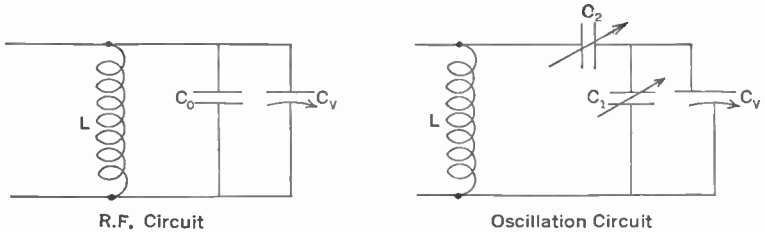

FIG. 69.

R.-F. Circuit.

 C_0 = distributed capacity. C_v = tuning capacity.

Oscillator Circuit.

 C_1 = trimmer condenser. C_2 = padding condenser.

tance is smaller than the r.-f. inductance, and the exact value is such that the two circuits tune properly (with 456 kc. difference) at the middle of the tuning range. Then at the two ends of the tuning range the proper 456 kc. intermediate frequency is attained by adjusting the series and shunt capacities—known as “padders.”

A typical circuit of the input to a superheterodyne is shown in Fig. 69. Here are the r.-f. and oscillator tuning circuits with the padding condenser in series with the oscillator tuning condenser across which is a “trimmer” which is part of the aligning system to make certain that the two identical portions of the gang tuning condenser produce the required difference or intermediate frequency (say 456 kc.) at each portion of the tuning range. Actually this exact correspondence does not take place, except at two or three portions of the range.

CHAPTER VI

PROPERTIES OF ALTERNATING-CURRENT CIRCUITS

THE two kinds of current in common use are: **direct currents** (d.c.) which have a more or less constant value and which flow in the same direction all the time; and **alternating currents** (a.c.) in which not only is the magnitude constantly changing but the direction also.

87. Definitions used in a.-c. circuits.—When the voltage (or current) has started from zero, risen to its maximum value in one direction, decreased to zero and risen to maximum value in the opposite direction and finally come back to its starting value and point, zero, it is said to have completed a **cycle**. Ordinary house-lighting current which has a frequency of 60 cycles per second goes through this cyclic change in magnitude and direction 60 times a second. The **frequency** is the number of times a second a cycle is completed. An **alternation** is half a cycle; that is, when the voltage has gone from zero to zero through one maximum it is said to have completed one alternation. In 60-cycle circuits there are 120 alternations per second. In a.-c. circuits we must consider the element of time; in d.-c. circuits time does not enter; the magnitude of the current is constant.

Alternating currents exist of nearly all ranges of frequencies. Sixty cycles is the common power frequency; tones generated by audio-frequency oscillators for testing purposes may go from almost zero frequency to as high as the human ear can hear, that is, about 13,000 cycles per second depending upon the person. Electric waves of frequencies as low as 15,000 cycles exist. They are generated in the long wave high-power radio stations carrying on transoceanic communication. From that value radio frequencies

exist up to about 300,000,000 cycles per second. This corresponds to a wavelength range of from 20,000 meters to 1 meter.

88. Instantaneous value of alternating current.—Since the voltage (or current) is continually changing in value it becomes expedient to provide a means of knowing what this value is at any time.

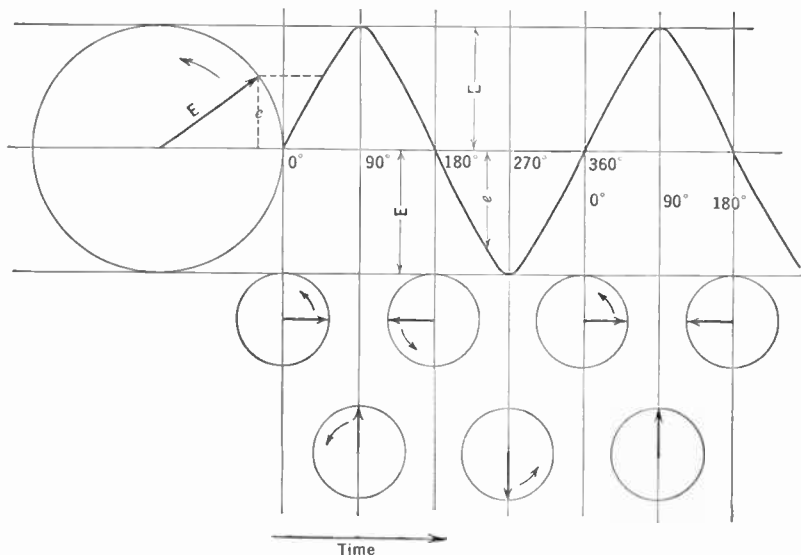

FIG. 70.—As the vector E rotates, the circle moves to the right. A piece of crayon attached to the end of the vector would trace out a curve similar to the wavy line. When the vector has the position as shown in the first small circle, the instantaneous value e is zero. At other times the instantaneous voltage has some other value.

Let us consider the circle of Fig. 70 which is moved to the right at a constant rate. Within the circle is a rotating arm, representing the motion of the rotating part of an a.-c. generator, as well as the voltage, E , it produces. It rotates at a constant speed such that one full rotation—one cycle—is completed in the time it takes the circle to move to the right a distance equal to the diameter. Now, when the arm is perpendicular to its starting position, the circle

has completed one-quarter of its movement; when the arm is pointing in a direction opposite to its starting position the circle has moved through one-half of its motion, and so on. Now let us picture what the end point of the arm would trace out if we attached a crayon to it and let it go through its motion as the circle is moved to the right. Such a tracing will be an accurate representation of an alternating current or voltage.

In Fig. 70 the height of the arm above the horizontal axis, its starting position, represents the value of the voltage at the instant the generator winding is at the position in its cycle corresponding to the position of the rotating arm whose length is E . The position of the arm at any point is known as its **phase**. Since a cycle is represented by a complete circle of 360 degrees (360°), when the arm is vertical we speak of its position at the 90° phase. Now the height of this arm from the horizontal starting position is the value of the a.-c. voltage at that position or phase or instant of time. At 90 degrees this height is equal to the length of the arm itself, or the a.-c. voltage is at its maximum value; at any other point in that half-cycle or alternation the voltage is less than this value.

Now it is handy to have something to which to compare the value of the voltage at any phase, known as the **instantaneous value**—because this value is only temporary due to rotation of the alternator armature. This basis of reference is the **maximum** or **peak** value. The instantaneous value is always rated by stating its magnitude with respect to the maximum value. Fortunately there is a factor which relates the height of the arm representing the instantaneous value and its length, or maximum value. This factor is known as the **sine** of the angle between the arm and the horizontal line. Knowing the maximum value of a.-c. voltage—the length of the rotating arm in Fig. 70—and the phase, or the angle through which the arm has rotated, to determine the instantaneous value of the voltage we need only multiply the maximum value by the sine of this angle which we may look up in a table made out for such a purpose. For example, the functions of several angles are given below. The angle itself (which is a means of expressing the time that has elapsed since the alternator arm started rotating) is called the **phase angle**.

Angle Degrees	Sin	Cos	Tan
15	.259	.966	.268
30	.500	.866	.577
45	.707	.707	1.000
60	.866	.500	1.732
90	1.000	.000	∞
110	.940	-.342	-2.747
135	.707	-.707	1.000
175	.087	-.996	0.087
180	.000	-1.000	.000
220	-.643	-.766	+ .839
270	-1.000	-.000	∞
300	-.866	+.500	-1.732
360	.000	+1.000	.000

88a. Triangle functions.—Considering the angle between CB and AB in Fig. 71 labeled as θ (the Greek letter theta), the side AC is called the **opposite** side, CB is called the **adjacent** side. Then these relations hold:

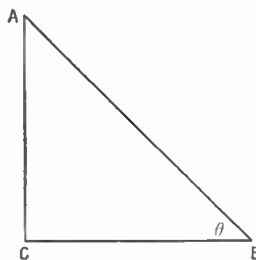

$$\frac{AC}{CB} = \tan \theta \quad (1) \quad \text{or } AC = CB \tan \theta$$

$$\frac{AC}{AB} = \sin \theta \quad (2) \quad \text{or } AC = AB \sin \theta$$

$$\frac{AC}{CB} = \tan \theta$$

$$\frac{AC}{AB} = \sin \theta$$

$$\frac{CB}{AB} = \cos \theta$$

$$\frac{CB}{AB} = \cos \theta \quad (3) \quad \text{or } CB = AB \cos \theta$$

FIG. 71.—Trigonometric
“functions.”

Knowing any two of the three functions of the right-angled triangle and the angle involved, the other function may be found by means of the table in Section 88.

NOTE. The terms “sine,” “cosine,” etc., are called the **functions of the angles**.

The function of angles greater than 90° may be found from function $(N \times 90^\circ + A) = \text{function } A$, if N is even, e.g., $\sin 210^\circ = \sin (2 \times 90^\circ + 30^\circ) = \sin 30^\circ$. Function $(N \times 90^\circ + A) = \text{cofunction } A$ if N is odd, e.g., $\sin 120^\circ = \sin (1 \times 90^\circ + 30^\circ) = \cos 30^\circ$.

89. Means of expressing instantaneous values.—We may express the instantaneous value of an a.-c. voltage or current as follows:

$$e = E \sin \theta \quad \text{or} \quad i = I \sin \theta,$$

where e or i = the instantaneous value;

E or I = the maximum value;

θ = the phase angle in degrees.

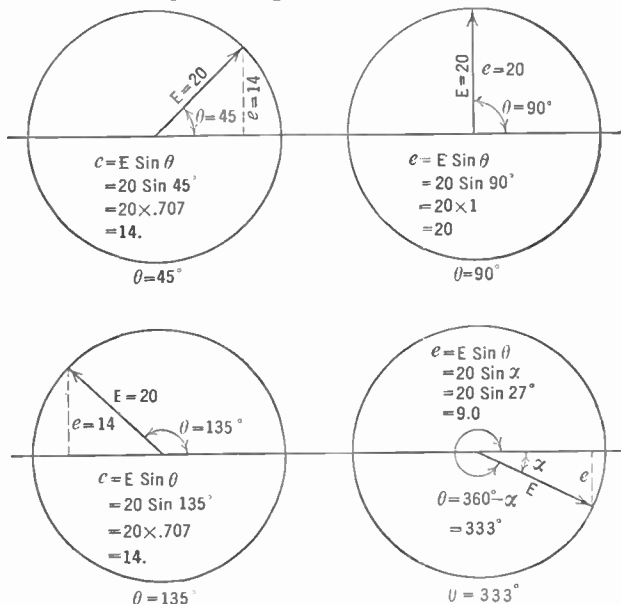

FIG. 72.—At various times in the cycle the instantaneous value of the vector E is as shown in these vector diagrams.

Small letters denote instantaneous values, capital letters denote maximum values.

Let us look at Fig. 72 which represents the rotating arm E and

the vertical height e in four typical cases, 45° , 90° , 135° , and 333° . The actual height compared to the maximum length of the arm E may be calculated by means of the above table and formulas.

Since the sine of an angle of 0 degrees is zero, the instantaneous value of the voltage at 0 phase is zero; since the sine of an angle of 90° is 1, the instantaneous value of the voltage at this point in the cycle is equal to the maximum value; and so on.

The three methods of representing an a.-c. voltage or current are:

1. By a graphical illustration such as Fig. 70, called a sine wave.

2. By an equation, such as

$$e = E \sin \theta \quad \text{or} \quad i = I \sin \theta.$$

3. By the pictures shown in Fig. 72, known as **vector diagrams**.

Such a line as E in Fig. 73 which moves about a circle is called a **vector**; the vertical distances of its end point from the horizontal axis is called its **vertical component**. The angle θ between the horizontal and the vector is called the **phase angle**; the value of the vertical component may be found by multiplying the maximum value E by the sine of the phase angle.

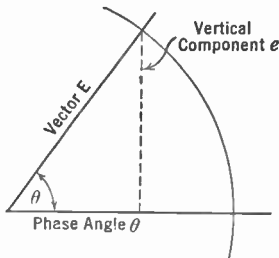

FIG. 73. — The maximum value of the vector is E ; the instantaneous value is e .

Example 1-6. Represent a voltage whose maximum value is 20 volts. Using graph or cross-section paper twelve divisions to the right equals one alternation and ten divisions vertically up and down from our horizontal line represents the maximum values of the voltage. The voltage starts at zero, increases to a maximum at 90° or six divisions, then decreases to zero at twelve divisions, etc. What is its value at other times? We can tell by using our table of sines in Section 88. At the 30° phase the instantaneous value, or the height of rotating arm above the time axis, is $e = E \sin 30^\circ = 20 \times .5 = 10$ volts. Other instantaneous values can be found similarly and the entire sine wave plotted similar to Fig. 70.

Lay off on cross-section paper a length say 20 divisions equal to the maximum value of the voltage. Then using this value as a radius draw a circle.

Then the instantaneous value at any time in the cycle can be found by measuring the vertical distance of this point on the circle to the horizontal axis. Thus at the 30° phase the vertical distance is 10 because $\sin 30^\circ = .5$. This illustrated the vector diagram.

A voltage of maximum value 20 may be represented mathematically as

$$e = 20 \sin \theta$$

Problem 1-6. The maximum value of an alternating voltage is 110. What is its value at the following phases: 30° ? 60° ? 110° ? 180° ? 270° ? 300° ? 360° ?

Problem 2-6. The instantaneous value of an alternating voltage is 250 volts at 35° . What is its maximum value? What is its value at 135° ?

Problem 3-6. The instantaneous value of an alternating voltage is 400 volts at 75° . Plot to some convenient scale its sine wave.

Note. In all this discussion voltages or currents can be spoken of with the same laws in mind. Thus the form of a sine wave of current looks exactly like the sine wave of voltage with the same maximum value. The vector diagram looks the same because it is only necessary to label the rotating arm I instead of E and the mathematical formula reads $i = I \sin \theta$ instead of $e = E \sin \theta$. The answers to the above problems will be the same numerically whether we speak of voltage or current.

A word should be said, too, about the terminology frequently used in speaking of the voltages and currents in an a.-c. circuit. Engineers use the expression "a.-c. voltage" or "a.-c. current" for simplicity, not stopping to think that such an expression really is an abbreviation for "an alternating-current voltage" or for "alternating-current current." Although one would not say the latter, one often uses the abbreviation. In many radio circuits there are both a.-c. and d.-c. branches and in some or all of them both direct and alternating currents and voltages exist. It is simpler to speak of an "a.-c. voltage" than of an alternating e.m.f. and in the interest of simplicity this terminology has been employed here whenever it is useful.

90. Effective value of alternating voltage or current.—Since the voltage (or current) in an a.-c. system is rapidly changing direction, and since the needle and mechanism of an ordinary d.-c. measuring instrument require appreciable time for a deflection, they cannot follow the rapid changes of voltage or current and would only wobble about the zero point of the meter even if they could fol-

low the fluctuations. We can, however, compare direct and alternating currents by noting their respective heating effects. An alternating current is said to be equal in value to a direct current of so-many amperes when it produces the same heating effect. This is known as the **effective value** of the alternating current and is equal to the maximum values multiplied by .707 or divided by $\sqrt{2}$.

$$\text{Thus } I_{\text{eff.}} = .707 I = I/\sqrt{2} \quad \text{or} \quad I_{\text{eff.}} = \frac{I}{1.41}$$

where $I_{\text{eff.}}$ = effective value of an alternating current;
 I = maximum value.

The effective value is also known as the **root mean square** or **r.m.s.** value for the following reasons. The heating effect of a direct current is proportional to the square of the current. Then if we take the instantaneous values of the current over a cycle of alternating current, square them, get an average of these values, extract the square root of this value, it will be equal to the direct-current value that will produce an identical heating effect. The value of current secured in this manner is .707 times the maximum value. Since it is the "square root of the average or mean squares" of several current values, it is abbreviated to the "root mean square" or r.m.s. An r.m.s. voltage is one that will produce a current whose heating effect is the same as a given direct current as discussed above.

$$E_{\text{r.m.s.}} = E_{\text{eff.}} = .707 E_{\text{max.}} = \frac{E_{\text{max.}}}{\sqrt{2}}$$

and

$$E_{\text{max.}} = \frac{E_{\text{eff.}}}{.707} = E_{\text{eff.}} \times \sqrt{2}.$$

Voltage or current is considered as effective unless otherwise indicated or stated.

Example 2-6. What is the effective value of an alternating voltage whose maximum value is 100 volts?

$$E_{\text{eff.}} = .707 \times 100 = 70.7 \text{ volts}$$

Problem 4-6. The effective value of an alternating current is 12 amperes. What is the maximum value?

Problem 5-6. The maximum value of an alternating voltage is 110 volts. What is the effective value?

Problem 6-6. At the 45° phase the instantaneous value of an a.-c. alternating current is 10 amperes. What is its effective value?

Problem 7-6. The effective value of an alternating current is 100 milliamperes. What is the instantaneous value at the 60° phase?

91. Phase relations between current and voltage.—Whenever an a.-c. voltage forces a current through a resistance, the wave forms of the voltage and the current look alike; so do their mathematical formulas, and their vector diagrams look alike. This is explained by the fact that the current and voltage start at the same instant, rise to a maximum value at the same instant and carry on throughout their respective cycles in perfect step, or **in phase**.

When an inductance or a capacity or any combination of these quantities with each other or with resistance is in the circuit, other phenomena take place differing entirely from what happens in a d.-c. circuit. For example, when an a.-c. voltage forces a current through an inductance, the current does not attain its maximum value at the same instant as the voltage, but at a later time; when the inductance is replaced by a capacity, the opposite is true, the maximum value of the current takes place before the maximum voltage is reached.

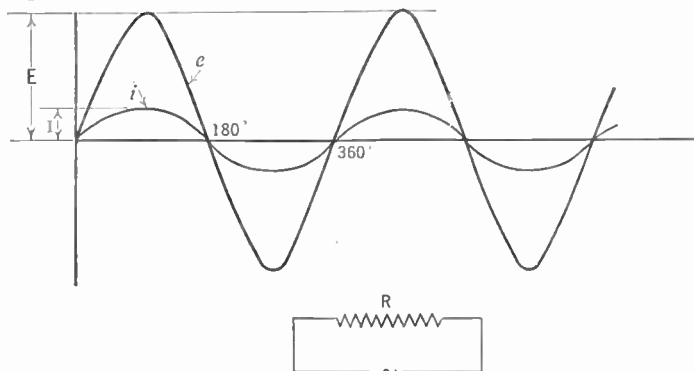

FIG. 74.—Current and voltage in phase.

92. CASE I. Current and voltage in phase.—Figure 74 represents the current and voltage in phase, i.e., in a resistive circuit. Since

the form of the voltage and current waves is exactly similar they can be drawn on the same horizontal axis, or in the vector diagram

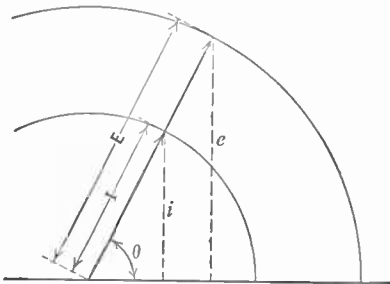

Fig. 75.—Current and voltage in phase. The maximum value of voltage greater (or drawn to different scale) than the maximum value of the current.

can be represented as in Fig. 75. They can be thought of as two vectors, which may or may not have the same length, rotating at the same speed in two different circles which move forward in the same direction at the same speed. Under these conditions, the end point of the vectors will trace out identical curves.

In such cases Ohm's law $I = E/R$ tells us the relations between current, voltage, and resistance, just as it does in a d.-c. circuit.

Example 3-6. Suppose a lamp of 55 ohms is placed across a 110-volt 60-cycle a.-c. line. What current will flow through it at the 30° phase?

We must first find the maximum value of the voltage.

$$\begin{aligned} E &= E_{\text{eff.}} \times \sqrt{2} \\ &= 110 \times 1.41 = 155 \text{ volts.} \end{aligned}$$

Since there is no phase effect in the circuit due to the resistance, the current is given by Ohm's law

$$\begin{aligned} I &= E/R \\ &= \frac{155}{55} = 2.82 \text{ amperes.} \end{aligned}$$

This is the maximum current. The current at any phase may be found by

$$\begin{aligned} i &= I \sin \theta \\ &= 2.82 \sin 30^\circ \\ &= 2.82 \times .5 = 1.41 \text{ amperes.} \end{aligned}$$

Problem 8-6. A resistance of 10 ohms is in a circuit with an alternating voltage of 20 volts maximum. At what phases will the current through the resistance be 1 ampere?

Problem 9-6. A certain alternating current has the same heating effect as a direct current of 8 amperes. It flows through a resistance of 25 ohms. What is the effective and maximum voltage? At what phases will the instantaneous value of the voltage be equal to one-half the maximum value?

93. CASE II. Current lagging behind the voltage.—Let us consider the case where the current does not attain its maximum value at the same instant that the maximum voltage is reached, as is illustrated in Fig. 76. It will be noted that the current curve does not start until 67.5° of the voltage curve has been completed, and therefore that the maximum value of the current is said to lag behind the voltage maximum 67.5° . The current and voltage in

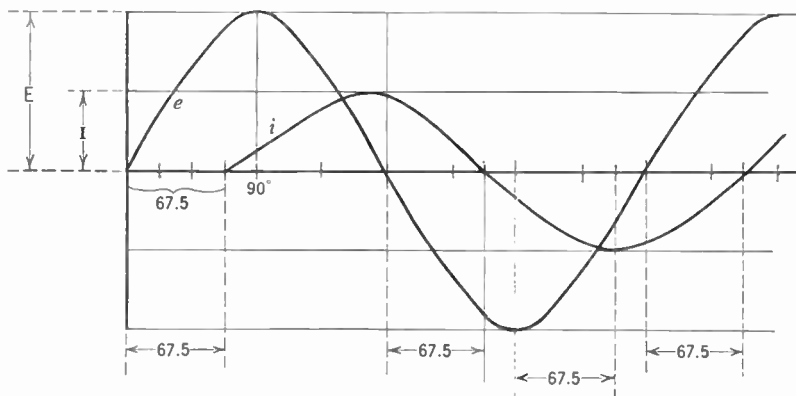

Fig. 76.—Current and voltage in an inductive circuit where the current lags behind the voltage.

such a case may be thought of as two vectors, or arms, moving in two circles one of which, the current circle, does not start until the other or voltage circle has completed 67.5° of its total movement of 360° .

The formulas for Case II where the current is lagging are

$$e = E \sin \theta,$$

$$i = I \sin (\theta - \phi),$$

where θ = phase of the voltage in degrees;

ϕ = difference in phase between E and I or the angle of lag.

(The angle ϕ is called "Phi.")

100 PROPERTIES OF ALTERNATING-CURRENT CIRCUITS

Example 4-6. The current lags behind the voltage by 60° . The maximum value of the current is 40 amperes. What is the instantaneous value of the current at the 75° phase?

Solution. Lay off on graph paper the voltage at the 75° phase and 60° behind it the current which has a maximum value of 40 amperes. The vertical component then is equal to the instantaneous value of the current at this phase.

The problem may also be solved by the mathematical formula

$$\begin{aligned} i &= I \sin (75^\circ - 60^\circ) \\ &= 40 \sin (75^\circ - 60^\circ) \\ &= 40 \sin 15^\circ = 40 \times .26 = 10.4. \end{aligned}$$

Problem 10-6. If the maximum voltage is 110 what is the instantaneous voltage at the 110° phase? At the 90° phase? At 45° ?

Problem 11-6. In an inductive circuit there is a phase difference of 25° . When the voltage is a maximum, the instantaneous value of the current is 10 amperes. What is the maximum value of the current?

The cause of lagging current is inductance, which tends to make the maximum of current take place later than the maximum of voltage. If a circuit is purely inductive (the resistance is negligible) the difference between these maxima is 90° . If there is appreciable resistance the difference is less than 90° .

94. Inductive reactance.—The opposition to the flow of current which inductance imposes on a circuit is called the **inductive reactance** and is measured in ohms just as resistance is. Its abbreviation is X_L . In any circuit in which there is only resistance, the expression which connects voltage and current is the familiar Ohm's law,

$$\text{current} = \frac{\text{voltage}}{\text{resistance}} \quad \text{or} \quad I = \frac{E}{R}$$

Similarly, the expression when inductance is in an a.-c. circuit is

$$\text{current} = \frac{\text{voltage}}{\text{reactance}} \quad \text{or} \quad I = \frac{E}{X_L}$$

and if the voltage is the maximum value the current will be the maximum value; if the voltage is the effective or r.m.s. value, the

current will be the effective value; if the voltage is the instantaneous value the current will be the instantaneous value.

Inductive reactance is numerically equal to

$$X_L \text{ (ohms)} = 6.28 \times f \times L = \omega L$$

where f = frequency in cycles per second;

L = inductance in henries;

ω = Greek letter omega = $6.28 \times f$.

Example 5-6. In an a.-c. circuit the following data are given: $E_{\text{eff}} = 110$ volts; inductive reactance, $X_L = 20$ ohms. Find the maximum and effective current and the instantaneous current at the 150° phase.

Solution. The effective current is found from

$$\begin{aligned} I_{\text{eff}} &= \frac{E_{\text{eff}}}{X_L} \\ &= \frac{110}{20} = 5.5 \text{ amperes.} \end{aligned}$$

$$I_{\text{max}} = I_{\text{eff}} \times 1.41 = 7.8 \text{ amperes.}$$

The vector diagram in Fig. 77 shows the instantaneous current to be

$$\begin{aligned} i &= I \sin (\theta - 90^\circ) \\ &= 7.8 \sin (150^\circ - 90^\circ) \\ &= 7.8 \sin 60^\circ \\ &= 7.8 \times 0.866 \\ &= 6.75 \text{ amperes.} \end{aligned}$$

Problem 12-6. In the above example find the instantaneous voltage when the instantaneous current is 6 amperes. At what phase is this?

Problem 13-6. What inductive reactance is needed to keep the maximum current down to 75 amperes in a 110-volt circuit?

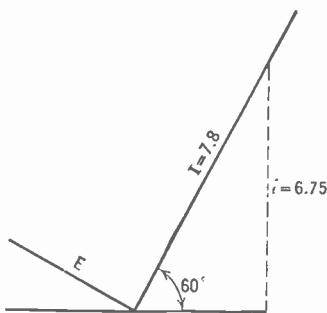

FIG. 77.—Current lagging behind the voltage by 90° .

95. CASE III. Current leads the voltage.—In this case the maximum value of the current is reached before the corresponding maximum voltage is reached. The voltage lags behind the cur-

rent, or as it is usually stated, the current **leads** the voltage. A vector diagram for such a case is shown in Fig. 78.

In this case the instantaneous values of voltage and current are:

$$e = E \sin 60^\circ$$

$$i = I \sin 80^\circ \quad \text{or} \quad i = I \sin (60^\circ + 20^\circ)$$

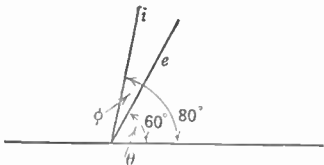

FIG. 78.—Current leading the voltage by the angle ϕ at the 60° phase. The angle of lead is 20° .

The formulas for Case III when the current leads the voltage are

$$c = E \sin \theta,$$

$$i = I \sin (\theta + \phi),$$

where ϕ is phase difference between E and I or the angle of lead.

The current in such an equation will be the maximum current if the voltage is maximum, effective if the voltage is effective, etc.

Example 6-6. The effective current in an a.-c. circuit is 70 amperes. The angle of lead is 30° . What is the instantaneous current when the voltage is at the 10° phase?

The maximum value of the current is found from

$$\begin{aligned} I_{\max} &= I_{\text{eff}} \times 1.41 \\ &= 70 \times 1.41 \\ &= 98.7 \text{ amperes.} \end{aligned}$$

By the equation

$$\begin{aligned} i &= I \sin (\theta + \phi) \\ &= 98.7 \sin (10^\circ + 30^\circ) \\ &= 98.7 \times .643 \\ &= 64.5 \text{ amperes.} \end{aligned}$$

Problem 14-6. The instantaneous value of current in a certain capacitive circuit is 8 amperes. The instantaneous value of the voltage is 25. The maximum values of the current and voltage are 15 amperes and 80 volts respectively. What is the angle of lead between them?

96. Capacity reactance.—The opposition which a condenser offers to the flow of current in an a.-c. circuit is called its **capacitive**

reactance and is measured in ohms just as resistance and inductive reactance are. The equation

$$\text{current} = \frac{\text{voltage}}{\text{capacitive reactance}} \quad \text{or} \quad I = \frac{E}{X_c}$$

is similar in form to Ohm's law and the equation for current in an inductive circuit.

Capacitive reactance is equal numerically to

$$X_c(\text{ohms}) = \frac{1}{6.28 \times f \times C} = \frac{1}{\omega C}$$

where f = frequency in cycles per second;
 C = capacity in farads;
 ω = Greek letter omega = $6.28 \times f$.

Current leads the voltage in a capacitive circuit because capacity tends to prevent any changes in voltage and so the maximum of current in a purely capacity circuit takes place 90° ahead of the maximum of voltage. If there is a appreciable resistance in the circuit the difference is less than 90° ; thus resistance tends to bring the current and voltage in phase.

Example 7-6.—If a condenser which has a capacity reactance of 5 ohms, is in an a.-c. circuit the instantaneous value of the voltage at the 20° phase is 48 volts. What is the maximum current through the condenser? What is the instantaneous current through it at the 20° phase?

Solution.

$$e = E \sin 20^\circ$$

$$48 = E \times .342$$

$$E = 140 \text{ volts}$$

$$I = \frac{E}{X_c}$$

$$= \frac{140}{5} = 28 \text{ amperes}$$

$$i = I \sin (20^\circ + 90^\circ)$$

$$i = 28 \sin 110^\circ$$

$$= 28 \cos 20^\circ$$

$$= 28 \times .940$$

$$= 26.32 \text{ amperes.}$$

Problem 15-6.—If a condenser in an a.-c. circuit whose voltage is 110 passes a current of 3 amperes what is the reactance of the condenser in ohms?

Problem 16-6.—Condensers are usually rated at the maximum voltage at which they can be operated with safety. What should be the rating of a condenser to be used in a 220-volt a.-c. circuit?

Problem 17-6.—An a.-c. circuit has a voltage of 115, and a current of 4.5 amperes is flowing. It has a condenser in it. What is the reactance of this condenser? What is the instantaneous value of the current when the voltage is 80 volts? At what phase is this?

97. Comparison of inductive and capacitive reactances.—Coils and condensers have opposite effects upon an alternating current. The reactance of an inductance increases with increase of frequency; a condenser has less reactance as the frequency increases.

A coil which will pass considerable current at 60 cycles may pass practically none at one million cycles. Where it is desired to pass a low-frequency current and to prevent the passage of a high-frequency current, an inductance in series with the circuit may be used. Note that the coil—called a **choke coil**—is in series with the circuit, where a by-pass condenser would be across the circuit. If even greater discrimination against a high-frequency current is desired, a combination of condenser and choke is used. The choke is in series, the condenser is shunted across the circuit.

Example 8-6.—Assume an a.-c. circuit composed of an inductance of one millihenry. What current will flow if E is 100 volts and the frequency is 600 cycles?

$$\begin{aligned} X_L &= 6.28 \times f \times L \\ &= 6.28 \times 1 \times 10^{-3} \times 600 \\ &= 3.8 \text{ ohms} \end{aligned}$$

$$I = \frac{E}{X_L} = \frac{100}{3.8} = 26.3 \text{ amperes.}$$

When it is desired to exclude current of a given frequency from a circuit, a shunt capacity is placed across the circuit. High frequencies will go through this by-pass condenser whereas the lower frequencies will not be so shunted and will go on through the rest of the circuit. A frequent use is where an R.F. choke passes direct current but prevents the flow of alternating current whereas a condenser passes a.c. but stops d.c. A large condenser is placed across batteries so that a.-c. currents will have an easy path around them.

Example.—What is the reactance of a 500-mmfd. condenser to radio waves of a frequency of 600 kilocycles?

$$\begin{aligned} X_c &= \frac{1}{6.28 \times 600 \times 10^3 \times 500 \times 10^{-12}} \\ &= \frac{10^9}{6.28 \times 600 \times 500} \\ &= \frac{10^5}{6.28 \times 30} = \frac{10^5}{188.4} = 530 \text{ ohms.} \end{aligned}$$

Problem 18-6.—What would the current be if the frequency were 6000 cycles? 60 cycles? If the inductance were one henry? One microhenry? Assume $E = 100$.

Problem 19-6.—Calculate the reactance of one henry, one millihenry, one microhenry at the following frequencies: 100 cycles, 1000 cycles, 1,000,000 cycles.

Problem 20-6.—What reactance is needed to keep the current into an electric iron down to 5 amperes when it is placed across a 110-volt circuit (assuming the iron has no resistance)?

Problem 21-6. The inductance in an a.-c. circuit is 0.04 henry. At what frequency will the current be 3 amperes if the voltage is 110?

Problem 22-6.—Calculate the reactance of a 1-mfd. 0.001-mfd., 50-mmfd.-condenser at 60 cycles, 60,000 cycles, 600 kc., 15,000 kc.

Problem 23-6.—The capacity in an a.-c. circuit is 1.0 mfd. At what frequency will the current through it be 415 milliamperes if the voltage is 110?

98. Measurements of capacities.—Condensers may be measured for capacity by comparing them with a known capacity by means of a Wheatstone bridge. In this case the unknown capacity may be calculated from

$$C = \frac{B}{A} C_s,$$

which differs from the formula when resistances or inductance are measured because of the fact that the reactance of a condenser decreases the larger it is. The formula when inductances are compared is:

$$L = \frac{A}{B} L_s.$$

The capacity of condensers from 0.01 to 10 or more microfarads may be measured by noting the current through them with a known

voltage across them. The condenser is first tested for open or short as indicated in Section 81. Then, in series with a milliammeter, the condenser is plugged into a light socket (a.-c. of course). Then the voltmeter may be put across the condenser, in case the voltage of the line is not known. The capacity is

$$C \text{ mfd.} = \frac{I \text{ ma.} \times 1000}{6.28 \times f \times E}$$

99. Combinations of resistance with capacity or inductance.—Coils and condensers are never pure reactances. They always have some resistance in them, although in most radio apparatus the resistance is negligible compared to the reactance. Since a reactance as well as a resistance impedes the flow of current, we must combine them to determine what current will flow through a piece of apparatus under a certain voltage and at a certain frequency.

Because an inductance has a different effect upon an a.-c. current than a resistance, and different from capacity, we cannot merely add their reactances in ohms to determine the resultant effect upon the circuit. They must be added *vectorially*, not *algebraically*.

100. Impedance.—Combinations of resistance and reactance are called **impedances**. The value in ohms may be found as follows: Two factors whose effect is at right angles to each other may be combined and the resultant secured by the formula found in plane geometry which states that "the square on the hypotenuse of a right triangle is equal to the sum of the squares on the other two sides." Thus

$$Z^2 = R^2 + X^2,$$

and if $R = 3$ ohms and $X = 4$ ohms,

$$Z^2 = 9 + 16 = 25,$$

whence

$$Z = \sqrt{25} = 5.$$

This is called getting the **vectorial** sum. The **algebraic** sum, obtained by simple addition—as when two resistances are combined—would be, in this case, 7 ohms whereas the vectorial sum is 5 ohms.

The resultant of combining a resistance and a reactance can be found graphically. Lay off on a horizontal line a number of units corresponding to the number of ohms resistance. Then if the reactance is inductive, erect a perpendicular and lay off on it a number of units equal to the number of inductive reactance ohms. The length of line connecting the extremities of these two lines is the resultant impedance in ohms.

Because capacitive reactance has an opposite effect to that of inductive reactance, the line representing it should be pointed downward. Graph paper is of great aid in solving a.-c. problems in this manner.

Example 9-6.—An alternating current of 8 amperes maximum flows through a coil whose inductance is 0.043 henry and whose resistance is 5 ohms. What voltage is required if the frequency is 60 cycles?

The current in such a circuit is

$$I = E/Z$$

$$Z = \sqrt{R^2 + X^2}$$

and $X = 2\pi f \times L = 6.28 \times 60 \times .043 = 16.25$ ohms

$$Z = \sqrt{5^2 + 16.25^2} = \sqrt{289} = 17 \text{ ohms}$$

whence

$$E = IZ = 17 \times 8 = 136 \text{ volts.}$$

Example 10-6.—What is the impedance in a circuit in which there is a condenser of 1.66 mfd. and a resistance of 800 ohms? The frequency is 60 cycles.

$$Z = \sqrt{R^2 + X_c^2}$$

$$X_c = \frac{1}{2\pi fC}$$

$$= \frac{10^6}{6.28 \times 1.66 \times 60} = 1590 \text{ ohms}$$

$$Z = \sqrt{800^2 + 1590^2}$$

$$= \sqrt{(64 \times 10^4) + (256 \times 10^4)} \quad (\text{approx.})$$

$$= 10^2 \sqrt{320}$$

$$= 1790 \text{ ohms.}$$

101. General expressions for impedance.—If an a.-c. circuit is composed of resistance and both inductive and capacitive reactance the impedance is figured as follows. Since the inductive

and capacity reactances are opposite in effect, the negative sign is fixed to the capacity reactance, the positive sign to the inductive reactance. That is, a capacity reactance is a negative reactance of so-many ohms; an inductive reactance is a positive reactance of so-many ohms. Before they are combined with the resistance

vectorially, their algebraic sum is obtained. Thus the general expression for impedance is

$$Z = \sqrt{R^2 + (X_L - X_C)^2},$$

and after the capacity reactance has been combined with the inductive reactance (it is actually subtracted because the signs of the two reactances are different) the form of the impedance becomes as before,

$$Z = \sqrt{R^2 + X^2}.$$

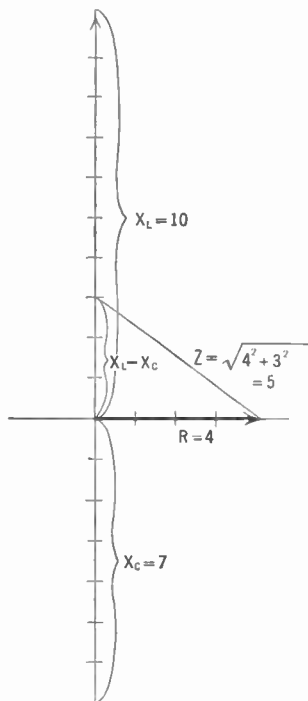

FIG. 79.—Vector diagram of a circuit containing resistance (4 ohms) capacity reactance (7 ohms) and inductive reactance (10 ohms).

It will be noted that the sign before X^2 in the above equation is positive. This is always the case since two negative quantities multiplied together (or if a negative quantity is squared) result in a positive quantity. If, for example, the actual value of the capacity reactance in ohms was greater than the inductive reactance in ohms, the effective reactance in the circuit would be negative but X^2 would be positive.

Example 11 6.—What is the impedance of a circuit consisting of a capacity reactance of 7 ohms, an inductive reactance of 10 ohms and a resistance of 4 ohms?

The vector diagram of such a case is shown in Fig. 79. Here we have X_L pointing upward at an angle of 90° from the resistance and X_C pointing downward at an angle of 90° from the resistance. The total effect of the reactances is $10 - 7$ or a positive 3 ohms which points upward.

If, however, the values of X_L and X_C are interchanged, so that the resultant of adding the reactances is a negative 3 ohms which point downward, then

In Case 1,
$$Z = \sqrt{R^2 + (X_L - X_C)^2}$$

$$= \sqrt{4^2 + (10 - 7)^2}$$

$$= \sqrt{4^2 + 3^2} = 5.$$

In Case 2,
$$Z = \sqrt{R^2 + (X_L - X_C)^2}$$

$$= \sqrt{4^2 + (7 - 10)^2}$$

$$= \sqrt{4^2 + (-3)^2}$$

$$= \sqrt{4^2 + 3^2}$$

$$= 5.$$

Problem 24-6.—An antenna (Fig. 80) may be considered as an inductance, L_a and a condenser in series.

If the voltage in Fig. 80 is 100 microvolts $f = 1000$ kc., what is the current through the coil L_s in series with L_a ? (There is no mutual inductance between L_a and L_s .)

Problem 25-6.—What is the effective reactance in a circuit which has 45 ohms inductive reactance, 70 ohms capacitive reactance and 20 ohms resistance? What is the impedance? What current would flow if the voltage were 110 effective?

Problem 26-6.—What would be the values of capacity and inductance if the frequency were 500 cycles?

Problem 27-6.—What voltage is required to force one milliampere through the following circuit: Resistance 8 ohms, inductance 300 microhenrys, capacity 500 mmfd., frequency 750 kc.?

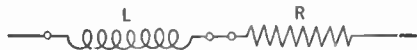

$$Z = \sqrt{R^2 + L^2 \omega^2}$$

FIG. 81.—A series circuit: $\omega = 6.28 \times f$.

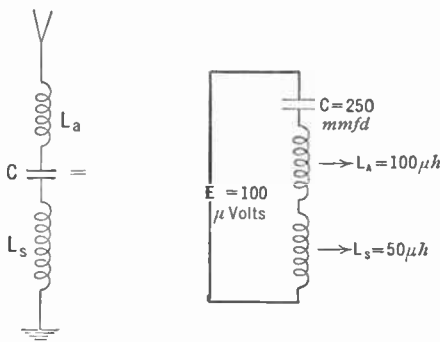

FIG. 80.—An antenna and its equivalent.

102.—Series a.-c. circuits.—In Fig. 81 is an inductance in series with

a resistance. The current flowing in the circuit may be found

by dividing the voltage across the circuit by the impedance of the circuit. That is: $I = E/Z$, in which

$$Z = \sqrt{R^2 + X^2},$$

which is quite different in numerical value from $R + X$. For example, if $R = 3$ and $X = 4$, the vector sum $Z = 5$ where as the arithmetical sum = 7.

As in a d.-c. circuit, the voltage across an impedance, a reactance, or a resistance is equal to that impedance, reactance or resistance in ohms times the current in amperes.

Voltage across a resistance	$E_R = I \times R$
Voltage across an inductance	$E_L = I \times X_L$
Voltage across a capacity	$E_C = I \times X_C$
Voltage across L and C	$E_{L+c} = I (X_L - X_C)$

The voltage across two resistances or reactances is the *algebraic* sum of the individual voltages, remembering that a capacity reactance has a negative sign and that the voltage across it is negative with respect to that across an inductance. The voltage across two impedances, however, must be determined by adding the individual voltages *vectorially*. This is because the impedance is a vector sum of a resistance and reactance.

Let us take a typical example. The current in the circuit of Fig. 81 is

$$I = \frac{E}{\sqrt{R^2 + X^2}}$$

or $E = I \sqrt{R^2 + X^2}$

$$E^2 = I^2 (R^2 + X^2)$$

or $E^2 = I^2 R^2 + I^2 X^2$
 $= E_R^2 + E_X^2$

whence $E = \sqrt{E_R^2 + E_X^2}$

Therefore the resultant voltage across a resistance and a reactance is the vector sum of the individual voltages.

Example 12-6.—If $E = 15$, $R = 3$, $X = 4$

$$I = \frac{15}{\sqrt{R^2 + X^2}} = \frac{15}{\sqrt{9 + 16}} = \frac{15}{5} = 3 \text{ amperes}$$

$$E_R = IR = 3 \times 3 = 9 \text{ volts}$$

$$E_X = IX = 3 \times 4 = 12 \text{ volts}$$

$$E = \sqrt{E_R^2 + E_X^2} = \sqrt{81 + 144} = \sqrt{225} = 15$$

Experiment 1-6.—To measure the capacity of a condenser. Place a condenser of about 10-mfd. capacity in series with an a.-c. milliammeter and measure the current through it when placed across a 110-volt, 60-cycle line.

Then

$$E = IX_c = I \times \frac{1}{6.28 \times f \times C}$$

or

$$C = \frac{I}{E \times 6.28 \times f}$$

where E = line voltage

or

$$C \text{ mfd.} = \frac{I}{41.5} = I \times .024$$

when $E = 110$;

$$f = 60;$$

$$I = \text{milliamperes.}$$

103. Phase in series circuit.—In a resistive circuit, the voltage and current are in phase, their maximum values occurring at the same instant. If the circuit is purely capacitive, or inductive, there is a 90° phase difference between current and voltage.

If, instead of a pure reactive circuit, we have some resistance, the angle of lead or lag (Sections 93, 95) is not 90° but is some value less than this. To determine the phase angle, or the difference in phase, let us draw the vector diagram of the voltages as in Fig. 82. The voltage across the resistance, IR , is the horizontal line, and at an angle of 90° with it is the voltage across the reactance, IX . The diagonal of the parallelogram represents the resultant voltage across the impedance, IZ .

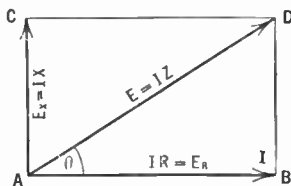

FIG. 82.—The length of the line AD represents the vector voltage across an inductance and a resistance in series.

Because a resistance in an a.-c. circuit produces no phase difference between the current and voltage the current through and the voltage across a resistance are said to be in phase. Their directions may be represented along the same line, that is, along the horizontal line representing the voltage across the resistance IR . The direction of the diagonal represents the direction of the voltage across the entire circuit. Since, then, the direction of the IR line represents the direction of the current, I , and the direction of the IZ line represents the direction of the voltage, E , the angle between these lines represents the angular difference in phase between the voltage and current. The angle θ then is equal to the angle of phase difference between the voltage across the combination and the current through it. Thus, in Fig. 82 $BD \div AB$ is the tangent of the angle θ , or

$$\frac{BD}{AB} = \tan \theta,$$

and since $BD = AC = IX$ (or the voltage across X) and $AB = IR$ (or the voltage across R),

$$\frac{E_X}{E_R} = \frac{IX}{IR} = \frac{X}{R} = \tan \theta.$$

Knowing the reactance and the resistance in ohms the tangent of the angle may be determined, and the angle itself looked up in a table. When the tangent of an angle is known but not the angle, the expression is written $\theta = \tan^{-1} \frac{X}{R}$ and is read " θ (theta) the the angle whose tangent is X over R ."

The effect of a resistance in series with a reactance is to decrease the angle of phase difference between the current and the voltage or to bring them more nearly in phase. In a pure reactance circuit, the angle is 90° ; when resistance is added this angle decreases. In a pure resistance circuit, there is no angle, the current and voltage are in phase; they reach their maximum values at the same instant.

Example 13-6.—In an a.-c. circuit there is a resistance of 10 ohms and an inductive reactance of 8 ohms. A current of 8 amperes is flowing. What voltage exists across each part of the circuit and across the entire circuit? What is the phase difference between the current and the voltage?

$$\text{Voltage across } R = IR = 8 \times 10 = 80 \text{ volts}$$

$$\text{Voltage across } X = IX = 8 \times 8 = 64 \text{ volts}$$

Draw the vector diagram to scale as in Fig. S3; then the diagonal $IZ = 102.5$ volts. (Note that the algebraic sum of the voltages across R and X is 144 volts.) The tangent of the angle of phase difference is equal to $X \div R$ or

$$\tan \theta = X/R = 8/10 \text{ or } .8$$

$$\theta = \tan^{-1} .8$$

$$\theta = 38^\circ 40'$$

or

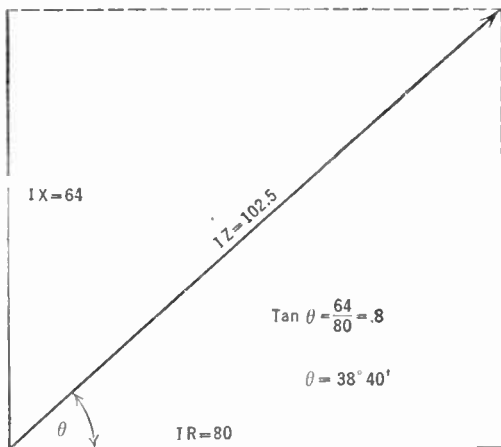

FIG. 83.—A vector diagram of problem 13.

104. Characteristics of a series circuit.—1. The voltage across a series combination of resistance and reactance is the vector sum of the voltages across the separate units.

2. The combined resistance of several resistances in series is the algebraic sum of the individual resistances.

3. The combined reactance of several reactances, whether inductive or capacitive, is the algebraic sum of the individual reactances.

4. The impedance, or combined effect of a resistance and reactance, is the vector sum of their individual values.

5. The combined impedance of several separate impedances is the vector sum of the individual impedances.

Example.—Suppose we combine two resistances, reactances, etc., of 3 and 4 ohms respectively. The table below shows the resultant values.

Combination	Sum	Resultant
1. $R = 3; X = 4$	$\sqrt{9 + 16} = Z$	5
2. $R = 3; R = 4$	$3 + 4 = R$	7
3. $X_L = 4; X_c = 3$	$4 - 3 = X$	1
3. $X_L = 3; X_c = 4$	$3 - 4 = X$	-1
3. $X_L = 3; X_L = 4$	$4 + 3 = X$	7
3. $X_c = 3; X_c = 4$	$-4 - 3 = X$	-7
4. $R = 3; X = 4$	$\sqrt{9 + 16} = Z$	5
(1) $R = 3, X_L = 4, X_c = 3$	$\sqrt{9 + (4 - 3)^2} = Z$	3.16
(2) $R = 3, X_L = 3, X_c = 4$	$\sqrt{9 + (3 - 4)^2} = Z$	3.16
(3) $R = 3, X_L = 3, X_c = 3$	$\sqrt{9 + (3 - 3)^2} = Z$	3

Note in (1) and (2) above that the resultant is the same although the conditions are different. This is due to the fact that a negative number when squared, or multiplied by itself, becomes a positive number. In other words, a negative reactance and a resistance always produce a positive impedance.

105. Resonance.—In (3) above, a very important phenomenon is illustrated. When the capacity reactance of a series circuit equals the inductive reactance, their respective effects cancel out and the resultant impedance is the resistance in ohms alone. To a circuit possessing inductive reactance one can add a certain amount of capacity and thereby reduce the impedance of the circuit (at some particular frequency) to the value of the ohmic resistance. This is the phenomenon underlying all tuning in radio circuits; it is known as **resonance**.

Problem 28-6.—Two resistances, one of 8 ohms and the other of 24 ohms, are in a 60-cycle 110-volt circuit. What current flows? What is the current if the frequency is increased to 500 cycles?

Problem 29-6.—What current exists in the above-named circuit if the second resistance is replaced by an inductive reactance of 24 ohms? If the frequency is 60 cycles what inductance will be in the circuit?

Problem 30-6.—In a circuit with 550 volts across the terminals are the following pieces of apparatus: A coil with 15 ohms reactance, a condenser with 7 ohms reactance, two resistances of 10 and 5 ohms. What current flows? What is the voltage across each part? What is the phase relation between voltage and current?

Problem 31-6.—In an a.-c. circuit appear a voltage across a resistance of 34 volts and a voltage across a capacity of 66 volts. What is the voltage across the combination?

Problem 32-6.—Two condensers are in series with two inductances and a resistance. The condensers have reactances of 8 and 10 ohms, the inductances 20 and 6 ohms, and the resistance is 4 ohms. What current flows, what voltage appears across each component and what is the phase between current and voltage? Assume $E = 110$.

Problem 33-6.—What is the phase difference in the following cases: (a) pure resistance circuit; (b) pure inductive circuit; (c) pure capacity circuit; (d) 100 ohms resistance and 100 ohms inductive reactance; (e) 100 ohms resistance and 50 ohms inductive reactance; (f) 100 ohms resistance and 100 ohms capacity reactance; (g) 100 ohms resistance and 50 ohms capacity reactance; (h) 100 ohms inductive reactance and 50 ohms resistance and 25 ohms capacity reactance; (i) 100 ohms each inductive and capacitive reactance and 100 ohms resistance?

Problem 34-6.—In a series circuit there are 45 ohms inductive reactance and 20 ohms resistance. It is desired to increase the phase angle between the current and voltage to 85° . How can this be done? How can the phase angle be decreased to 30° ?

106. Parallel circuits.—In a circuit like that of Fig. 84, in which several reactances or combinations of reactance and resistance may be connected in parallel, the following rules hold:

The *voltage* across each branch equals the voltage across the combination.

The *current* taken from the voltage source is the vector sum of the currents through each branch.

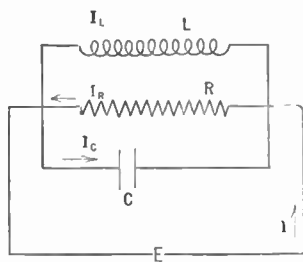

FIG. 84.—In a parallel circuit the current I may be very small compared to I_L or I_C .

The *impedance* offered to the flow of current by the combination is the voltage divided by the total current.

Thus in Fig. 84 the current through the entire combination may be found as follows, assuming $E = 120$; $X_C = 8$; $X_L = 5$; $R = 3$:

$$I_C = \frac{E}{X_C} = \frac{120}{8} = 15 \text{ amperes through the condenser}$$

$$I_R = \frac{E}{R} = \frac{120}{3} = 40 \text{ amperes through the resistance}$$

$$I_L = \frac{E}{X_L} = \frac{120}{5} = 24 \text{ amperes through the inductance}$$

$$I = \sqrt{I_R^2 + (I_L - I_C)^2} = \sqrt{1681} = 41 \text{ amperes}$$

$$Z = \frac{120}{41} = 2.92 \text{ ohms.}$$

107. Phase in parallel circuit.—The phase angle between the current and the voltage in a parallel circuit may be obtained from the expression

$$\tan \theta = \frac{I_L - I_C}{I_R}$$

or
$$\theta = \tan^{-1} \left(\frac{I_L - I_C}{I_R} \right)$$

108. Impedance of parallel circuit.—Since the impedance is the ratio between the voltage across the circuit and the current through it, in order to find the impedance of several branches in parallel we must know the voltage and the current. Often we would like to know the impedance without knowing either the voltage or the current. The procedure then is to assume a voltage, to find the currents that would flow, divide the voltage by the current and get therefrom the impedance, or

$$Z = \frac{E}{I}$$

Example 14-6.—What is the impedance of 630 ohms capacity reactance shunted by 100 ohms of resistance?

Assume a voltage of 100.

$$I_C = 100/630 = .159 \text{ ampere}$$

$$I_R = 100/100 = 1.0 \text{ ampere}$$

$$\begin{aligned} \text{Total current } I &= \sqrt{I_C^2 + I_R^2} \\ &= \sqrt{.159^2 + 1^2} = \sqrt{1.025} \\ &= 1.015 \text{ amperes} \end{aligned}$$

$$Z = \frac{E}{I} = \frac{100}{1.015} = 98.5 \text{ ohms.}$$

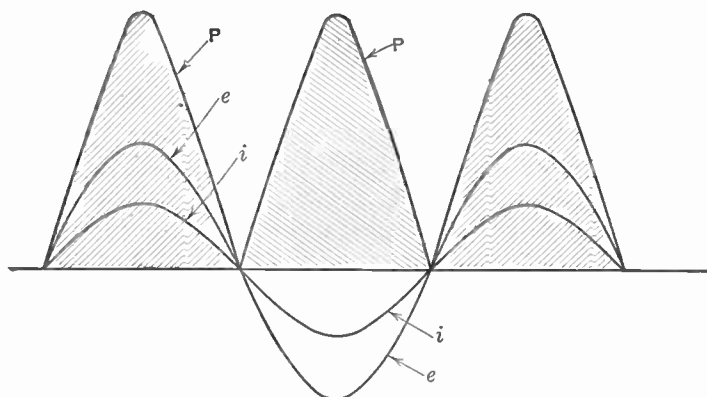

FIG. 85.—All the power in a resistive circuit is used up.

109. Power in a.-c. circuits.—In a d.-c. circuit the power is the product of the voltage across the circuit and the current through it. Thus, if one ampere is fed into a device under a pressure of 100 volts, the power used is 100 watts.

In a.-c. circuits the voltage and current are not always in phase. In fact in many circuits there is a decided difference in phase between the current and voltage. What is the power?

The power at any instant is the product of the instantaneous current and the instantaneous voltage. Thus in Fig. 85, where the

voltage and the current are in phase, as in a resistance circuit, the height of the voltage line e above the horizontal, or time, axis multiplied by the height of the current line i above this axis gives the instantaneous power.

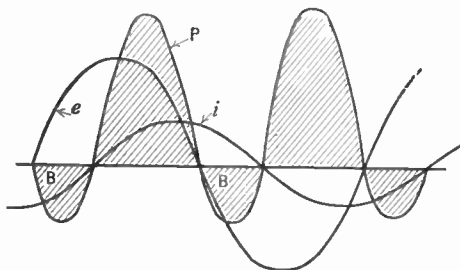

FIG. 86.—In an inductive circuit some power is consumed and some (the shaded areas below the line) is returned.

This is plotted in the curve P . When, however, the current and voltage are not in phase, as in an inductive (Fig. 86) or capacitive (Fig. 87) circuit, a different looking curve results although the instantaneous power is still the product of the instantaneous values of current and voltage. The part of the power curve marked B is interesting. It is the result of multiplying a positive current (or voltage) by a negative instantaneous value of voltage (or current). The product is negative; so the power at that instant represented by this small loop must be considered as negative power.

Power consumed in a circuit is considered as positive power. Negative power is power that is returned to the generator from the line. Power is only returned to the generator when there is reactance in the circuit.

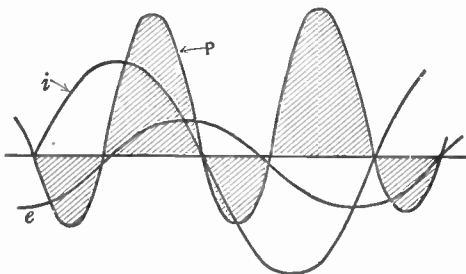

FIG. 87.—Power in a capacitive circuit.

A pure resistance circuit consumes the entire amount of the power fed it by the generator; a reactive circuit returns some of it to the generator.

The **effective power** in a resistance circuit is the product of the effective volts and the effective amperes. In a reactive circuit, however, the effective power is reduced by the power returned to

the generator, so that the product of effective volts times effective amperes does not give the true measure of the power consumed in the circuit. The true power is given by

$$P = E_F I_F \cos \theta,$$

where θ is the angle between the voltage and the current.

The product of the volts and the amperes is called the **apparent power**. Since this apparent power must be multiplied by $\cos \theta$, this factor is called the **power factor** of the circuit. When the current and voltage are in phase, that is, in a resistance or resonant circuit, the power factor, $\cos \theta$, is equal to 1.0, and the circuit is said to have unity power factor.

It often happens in radio and other circuits that the maximum transfer of power from a source to a load is desired, for example, where this power is small and must be transmitted to a considerable distance, such as from a microphone to a telephone line and thence to a loud speaker or amplifier. At other times d.-c. power is under consideration. The maximum is to be transferred.

The condition for maximum transfer under such conditions is that the load resistance be equal numerically to the generator (or other source) resistance. Thus if the generator has 1000 ohms internal resistance, the load should have approximately this resistance. If the load differs widely from this value, some adjustment must be made. In a d.-c. case little can be done; but in a.-c. circuits a transformer of the proper ratio of turns may be used to connect the source of power to the load.

This condition of "matching" the load to the source is one of matched impedances, where the latter term is used in the general sense of any impedance. If the circuit is an a.-c. circuit, strictly speaking the load and generator resistances must be equal and the reactance of the load must be equal numerically to the generator reactance but of opposite sign. Thus for maximum power transfer, the load in the above case must have 1000 ohms resistance and must be capacitive, let us say, if the generator is inductive.

Under these conditions half the power will be expended in the load and half wasted in heating the generator. The efficiency is 50 per cent.

CHAPTER VII

RESONANCE

THE most important circuits in radio are those in which either series or parallel resonance occurs. In transmitting and receiving systems resonance is used to built up large voltages and currents at certain desired frequencies and to discriminate against undesired signal frequencies by keeping their voltages and currents low. When one tunes a radio receiver, he actually adjusts the a.-c. circuits within the receiver so that a condition of resonance occurs. Everyone who has operated a receiver has, in tuning it, performed one of the most interesting experiments in all a.-c. theory and practice. It is necessary that we look into the phenomenon of resonance very closely.

110. Series resonant circuit.—Although a general idea may be obtained of what takes place in a resonant circuit when a radio receiver is tuned, a much more exact idea may be had as a result of a laboratory experiment.

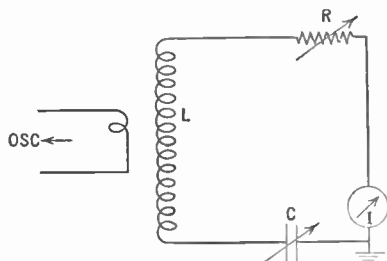

FIG. 88.—When L is coupled loosely to a generator and C is varied, the current indicated at I will go through a maximum like that in Fig. 90.

Experiment 1-7.—Connect, as in Fig. 88, a coil of about 200 microhenries inductance, a variable condenser of maximum capacity of 1000 mmfd., a resistance of about 10 ohms, and a current-indicating device such as a current squared meter or a thermocouple and meter. Couple the circuit loosely to a radio-frequency generator and (a) adjust the condenser C so that resonance is obtained and then (b) adjust the

frequency of the oscillator while the tuning condenser C of the external circuit is held constant. Plot the current in the circuit against condenser

degrees or capacity and then against frequency. Change the value of R and repeat.

In either case the voltage across the condenser and across the coil and the phase between current and voltage should be calculated and plotted.

NOTE.—If the experimenter possesses a short-wave transmitter which is equipped with an antenna meter he can carry out the same experiment by noting the antenna current as the antenna series condenser is adjusted, or as the frequency of the closed circuit is adjusted below and above resonance with the antenna. Such a curve is shown in Fig. 89.

Experiment 2-7.—Connect in series with a lamp an inductance of several henrys. Add sufficient resistance so that the lamp does not light when placed across a 110-volt 60-cycle line. Then put a condenser (of the filter type) in series with the resistance, the line, and the lamp. Add other capacity until the lamp lights up. Adding the capacity has brought the circuit to resonance so that the only hindrance to the flow of current was the lamp and the resistance. Adding something to the circuit actually made more current flow.

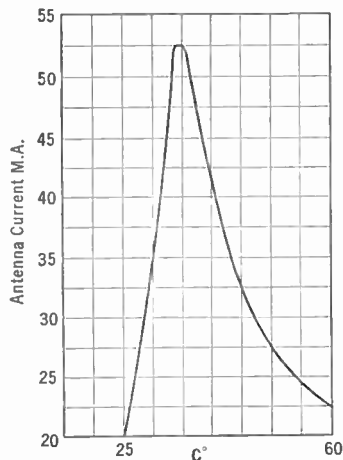

FIG. 89.—How the antenna current of a radio station varies as the series condenser is varied.

The curve in Fig. 90 shows what happens as the voltage across a series circuit is kept constant but the frequency is increased. At first the current increases slowly, then as the resonant frequency, 356 kc., is approached the current increases very abruptly and after passing through a sharp maximum at 356 kc. falls very rapidly at first and then more slowly. The voltages across coil and condenser go through similar changes. The phase between current and voltage changes also, being a negative angle (current leading voltage) below resonance, being zero at resonance (current and voltage in phase), and becoming a positive angle above resonance (current lagging behind voltage).

At zero frequency, that is at direct-current, the current in such a circuit would be zero because the condenser will not permit d.-c. current to pass. At very low frequencies, the reactance

of the condenser is very high, so that little current will flow. At very high frequencies the reactance of the coil becomes very great and therefore little current will flow. At intermediate frequencies more current flows.

When a series circuit is resonant, the current and voltage are in phase, the current is a maximum, the impedance is a minimum, the voltages across the condenser and the inductance are equal and

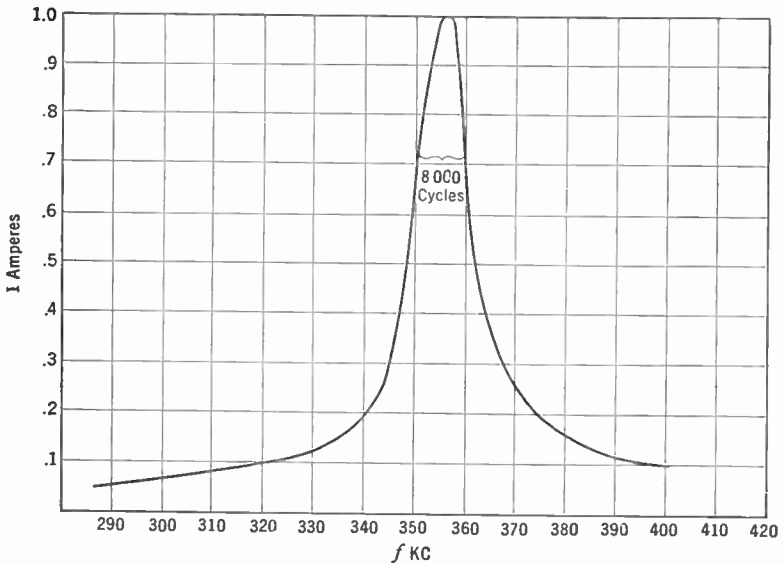

FIG. 90.—The resonance curve of a circuit like that of Fig. 88.

opposite in sign and greater in value than the voltage across the combination.

In Fig. 90 note that from 340 to 356 kc., a change of 1.047 times, the current changes from 0.19 amperes to 1.0 amperes, a change of 5.2 times. The voltages across the condenser and inductance become much greater, at resonance, than the voltage impressed upon the circuit. This voltage may become so high that the condenser will be punctured. The voltage across the coil or the condenser at resonance is equal numerically to the voltage across

the entire circuit multiplied by the factor X_L/R or X_C/R which are equal to $L\omega/R$ or $1/C\omega R$, often called the Q of the circuit.

A curve showing how the current in the circuit changes as the variable factors are changed, that is, a graph of I against the capacity, the inductance or the frequency, is called a **resonance curve** and is symmetrical about the resonant frequency if the circuit is adjusted by changing the inductance, and is dissymmetrical when the capacity or the frequency is the variable factor.

111. Characteristics of series resonant circuit.—Below the resonant frequency the reactance is mainly capacitive; above this frequency the circuit is mainly inductive. That is: the capacitive reactance is the main deterrent to the flow of current below resonance; above resonance the inductance offers the greatest opposition to the flow of current. For a narrow band of frequencies in the neighborhood of 356,000 cycles the total impedance of the circuit is less than 100 ohms. Far from the resonant frequency the reactance is much greater and very little current will flow.

Below resonance, where the capacity reactance predominates, the current leads the voltage; at resonance the current is in phase with the voltage; above resonance the current lags behind the voltage.

At all frequencies the voltage across the inductance is 90° ahead of the current and the voltage across the condenser is 90° behind the current. Between the two reactive voltages, then, is a 180° phase difference. That is, they are exactly out of phase. Their resultant may be found by looking at Fig. 91 in which E_L and E_C are plotted as 180° out of phase and of unequal magnitude. The resultant of combining them with the voltage

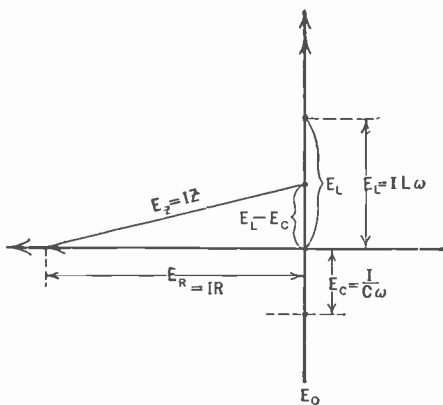

FIG. 91.—Vector diagram of a series circuit in which inductance predominates.

across the resistance must be the voltage across the entire series circuit, which is the vector sum. Thus,

$$E = \sqrt{E_R^2 + (E_L - E_C)^2}$$

At any frequency but that of resonance, one of the two reactive voltages is greater than the other. At resonance, however, the two voltages are equal in magnitude and opposite in phase so that the resultant of combining the reactive voltages is zero. When added vectorially to the IR drop in the circuit, the resultant is the voltage which is impressed by the external source.

The vector sum of the reactive and resistive voltages is equal to the impressed voltage.

Example 1-7.—What are the voltages and phase relations in the circuit of Fig. 88 at a frequency of 370 kc.?

$$I = .274 \text{ ampere}$$

$$X_C = 430 \text{ ohms}$$

$$X_L = 466 \text{ ohms}$$

$$R = 10 \text{ ohms}$$

$$E_R = I \times R = .274 \times 10 = 2.74 \text{ volts}$$

$$E_C = I \times X_C = .274 \times 430 = 118 \text{ volts}$$

$$E_L = I \times X_L = .274 \times 466 = 128 \text{ volts}$$

$$E_{R+L} = \sqrt{2.74^2 + 128^2} = 128 \text{ volts (approx.)}$$

$$\phi_{R+L} = \tan^{-1} \frac{128}{2.74} = \tan^{-1} 46.6 = 88.46^\circ$$

$$E_{R+C} = \sqrt{2.74^2 + 118^2} = 118 \text{ volts (approx.)}$$

$$\phi_{R+C} = \tan^{-1} \frac{118}{2.74} = \tan^{-1} 43 = -88.38^\circ$$

$$E_{L+C} = E_L - E_C = 9.6 \text{ volts} = E_X$$

$$E = I \sqrt{R^2 + X^2} = \sqrt{E_R^2 + E_X^2} = \sqrt{2.74^2 + 9.6^2} \\ = 10 \text{ volts}$$

$$\phi_{R+L+C} = \tan^{-1} \frac{X}{R} = \tan^{-1} \frac{X_L - X_C}{R} = \frac{466 - 430}{10} = 3.6 \\ = 74^\circ 30'$$

At resonance the reactances are equal to each other and equal to $\sqrt{\frac{L}{C}}$, i.e., $X_L = X_C = \sqrt{\frac{L}{C}}$.

For example the reactances of the condenser and inductance in the circuit of Fig. 88 may be found by

$$\begin{aligned} X_L = X_C &= \sqrt{\frac{L}{C}} \\ &= \sqrt{\frac{200 \times 10^{-6}}{1000 \times 10^{-12}}} \\ &= \sqrt{.2 \times 10^6} \\ &= \sqrt{.2} \times 10^3 \\ &= .447 \times 10^3 \\ &= 447 \text{ ohms.} \end{aligned}$$

At resonance the inductive reactance and the capacitive reactance in the equation for the impedance $Z = \sqrt{R^2 + (L\omega - 1/C\omega)^2}$ cancel out, that is, $L\omega - 1/C\omega = 0$ so that the resultant impedance is the resistance alone,

$$Z = R \text{ (at resonance)}$$

Problem 1-7.—An inductance of .3 mh., a condenser of .0001 mfd., and a resistance of 5 ohms are in series. Across the ends of this circuit is an alternator whose frequency is 900,000 cycles and whose voltage is 5. Calculate the current flowing, the phase between the current and voltage, the voltages across the coil and the condenser. What would the current be if the circuit were resonant? What is the impedance of the circuit at 900 kc.?

112. Effect of resistance on series resonant circuit.—At resonance the magnitude of the current in the circuit is controlled solely by the resistance. Its effect is most important in any radio circuits where resonance plays a prominent part. The curves in Fig. 92 show the effect of adding various resistance to the circuit of Fig. 88. The voltages across the condenser and the inductance, too, depend upon the resistance of the circuit. They are greater the smaller the resistance. This is due to the fact that the voltage across these reactances is equal to the product of the reactance

and the current. The latter, controlled entirely by the resistance at resonance, in turn produces greater voltages across the reactance when less resistance is in the circuit. If E is the voltage

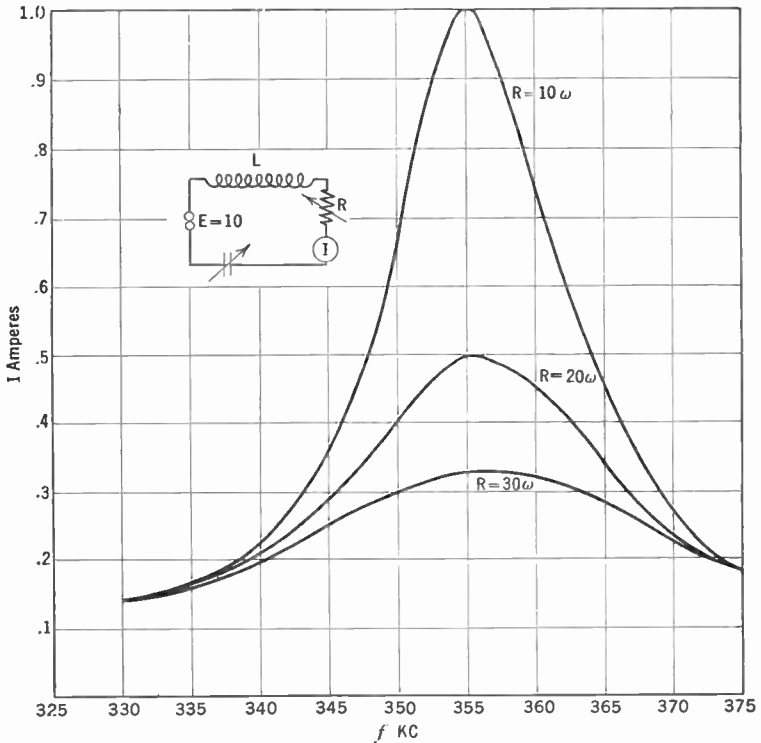

FIG. 92.—Effect of resistance on a resonance curve. Note that the current far from resonance is not changed so much as the resonant current.

impressed on the whole circuit, the voltage across the condenser is $E \div C\omega R$ and that across the inductance at resonance is $E \times \frac{L\omega}{R}$.

113. Power into resonance circuit.—No power is dissipated in heat in a pure inductance or capacity, but energy stored at one instant in a magnetic or electrostatic field is turned back into the circuit at another instant. Power is expended in the resistance of

a circuit, but since at high values of resistance the current is small, the power in the circuit will be small. This power is equal, as usual, to

$$P = I^2 \times R$$

where R is the resistance of the circuit. In case of Fig. 88, where the resistance is 10 ohms and the current at resonance 1 ampere, the power is 10 watts. Since at resonance there is no reactance effective in the circuit the power fed into it by the generator is the product of the current times the voltage, or 10×1 or 10 watts.

In other words, all the energy taken from the generator is used up in heating the resistance. None is necessary to maintain the magnetic and electrostatic fields of the coil and the condenser. The energy in these fields is transferred from one to the other, the sum at any one instant being equal to the sum at any other instant so long as the energy dissipated in the resistance is supplied from the outside. The maximum power will be absorbed by the resonant circuit when its effective resistance is equal to the resistance of the generator supplying the power.

Problem 2-7. What power is taken from the generator in Problem 1-7?

In actual circuits the resistance is not isolated as in our demonstration problems. All coils have resistance; so do all condensers, although the resistance of modern variable capacities is quite small. These resistances take power from the generator and reduce the maximum height of the resonance curve.

114. The resonant frequency of the circuit.—The condition for series resonance—that the reactances of the circuit add up to zero—is fulfilled when

$$X_L = X_C$$

or
$$X_L - X_C = 0$$

or
$$\omega L - \frac{1}{C\omega} = 0$$

or
$$\omega L = \frac{1}{\omega C} \qquad \text{or} \qquad \omega^2 = \frac{1}{LC}$$

and since $6.28 \times f = \omega$,

$$f = \frac{1}{6.28 \sqrt{LC}},$$

and since 6.28 is equal to the mathematical expression 2π we arrive at the familiar expression for the resonant frequency of a circuit as

$$f = \frac{1}{2\pi\sqrt{LC}}$$

in which f = the frequency in cycles;
 L = the inductance in henrys;
 C = the capacity in farads;
 π = the Greek letter "Pi" and is equal to 3.1416

Example 2-7. To what frequency will a circuit tune which has an inductance of 0.25 henry and capacity of 0.001 mfd.?

Let us write the above formula as

$$\begin{aligned} f^2 &= \frac{1}{4 \pi^2 LC} = \frac{1}{39.5 LC} \\ f^2 &= \frac{1}{39.5 \times .25 \times .001 \times 10^{-6}} \\ &= \frac{10^9}{39.5 \times .25} \\ &= \frac{10^9}{9.87} \\ f &= \sqrt{101} \times \sqrt{10^6} \\ &= 10.1 \times 10^3 \text{ cycles} \\ &= 10.1 \text{ kc.} \end{aligned}$$

Such an expression for the resonant frequency of a circuit shows that the frequency depends upon the product of L and C , and not upon either of them alone. If L is doubled, C can be halved and the natural frequency of the circuit will not be changed.

115. Wavelength.—The relation between the frequency of a circuit and the wavelength of transmissions to which it responds is a simple one. The **wavelength** is equal to the speed at which the electric waves travel divided by the frequency in cycles. This speed is 186,000 (approximately) miles a second and if we want the wavelength in miles we need only divide this quantity by the frequency. Ordinarily, however, we express wavelengths in meters; so it is necessary to use the velocity of transmission in meters. This is 300×10^6 meters a second, and so

$$\text{wavelength in meters} = \frac{300 \times 10^6}{f \text{ in cycles}} \quad \text{or} \quad \frac{300 \times 10^3}{f \text{ in kilocycles}}$$

$$\text{or} \quad = 300 \times 10^6 \times 2\pi \sqrt{LC}$$

The customary symbol for wavelength in meters is the Greek letter "Lambda"; so the above expression may be written:

$$\lambda = \frac{300 \times 10^3}{\text{kilocycles}} = 1.884 \sqrt{LC},$$

where $L = \text{microhenry} = 10^{-6} H$
 $C = \text{mmfd.} = 10^{-12} F.$

Example 3-7. What wavelength corresponds to 1000 kilocycles?

$$\begin{aligned} \lambda \text{ meters} &= \frac{300 \times 10^3}{1000} \\ &= \frac{3 \times 10^6}{10^3} = 300 \end{aligned}$$

Figure 93 is a graphical method of correlating L , C , and meters of wavelength. Such a curve is called in England an "abac." A table of " LC " products will be found inside of rear cover.

Problem 3-7. What inductance must be placed in series with a 2-mfd. condenser to resonate at 60 cycles? If the voltage across the combination is 110 (effective) and the resistances in the coil and condenser add up to 20 ohms, what power is consumed in the circuit at resonance, what is the resonant current, and what voltage then appears across condenser and inductance?

Problem 4-7. A coil of 0.15 henry is in series with a condenser of 28.5 mfd. and a resistance of 5.8 ohms. The voltage across the circuit is 22 volts, the frequency is the resonant frequency of 80 cycles. What would the voltage across the condenser be if the resistance were doubled? What power would be wasted in heat at resonance?

Problem 5-7. A variable condenser has a range from maximum to minimum capacity of 9 to 1, that is, from 0.0005 to 0.0000555 mfd. What wavelength range will it cover with a given coil, that is, what is the ratio between the longest and shortest wave to which it will tune the coil?

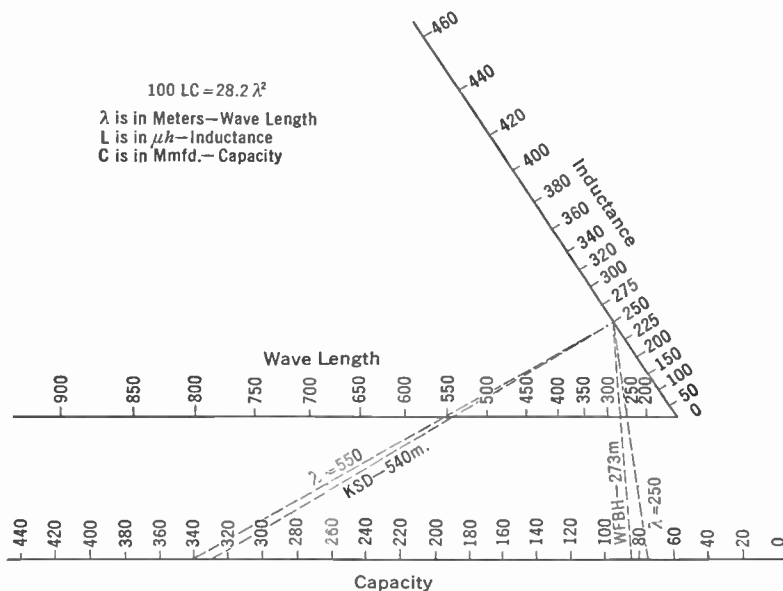

FIG. 93.—Drawing a straight line through two points (L and λ for example) and intersecting the third line gives the unknown quantity desired (C).

Problem 6-7. In Problem 1-7 what would happen to the voltage across the condenser if the capacity were reduced to half, resonance being maintained by other means which also keep the original current?

Problem 7-7. An antenna may be represented by an inductance of 50 microhenrys in series with 0.00025 mfd. capacity and 30 ohms resistance. What is its resonant frequency? If a distant station transmitting on this frequency produces a voltage of 1000 microvolts across the ends of this antenna system, what current will flow? It can be seen that even fairly high voltages at the antenna (1 millivolt) produce only small currents.

Problem 8-7. Taking typical values of L , C and wavelength, construct a chart like that in Fig. 93 for shorter wavelengths than 200 meters. As an example relabel the wavelength curve for values of L and C one-tenth those now on the chart. Since the factor of 10 is taken from each member of the product of LC , the value of LC will be decreased by a factor of 100. Therefore the wavelength line will be reduced by a factor of 10, because wavelength is a function of the square root of LC . This will leave a gap from 90 to 200 meters. Remake the chart to cover this band.

Problem 9-7. What can be done to increase the current at 150 meters in the antenna of Problem 7-7? At resonance, what voltage will appear across the 50-microhenry inductance, $R = 30$ ohms?

Problem 10-7. What power is being lost in this antenna at resonance?

Problem 11-7. The primary of an audio-frequency transformer has 100 henrys inductance. In many circuits a condenser is placed across the primary so that high radio frequencies will not have to pass through the transformer. If this condenser has a capacity of 0.001 mfd., what is the decrease in effective impedance of the circuit to a frequency of 10,000 cycles?

Problem 12-7. A loud speaker is often coupled to a power tube through a condenser as in Fig. 94. If the speaker has an inductance of one henry and the condenser is a 4-mfd. unit, to what frequency will the combination become resonant?

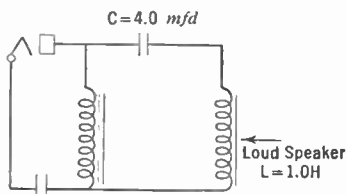

FIG. 94.—To what frequency will the loud speaker and condenser tune?

Problem 13-7. Plot a curve of the reactance of the loud speaker in Problem 12-7 from 100 to 10,000 cycles.

Problem 14-7. In an amateur's short-wave transmitting station a 100-nanmfd. condenser is in series with the antenna. What voltage has this condenser across it, if the wavelength is 30 meters and the antenna current is one ampere?

Problem 15-7. In a similar transmitting circuit an amplifier is used to boost the output of an oscillator before being fed into the antenna. The grid of this amplifier's tube requires a voltage of 80 volts at 40 meters (7500 kc.). This voltage is to be obtained across an inductance of 4.5 microhenrys. How much current must flow through the inductance? What capacity must be across it if the coil and condenser are to tune to 40 meters?

116. Parallel resonance.—Many of the circuits used in radio involve resonance in a branched or parallel circuit. Figure 95 shows a typical parallel circuit composed of an inductance shunted by a

condenser, the combination forming what is sometimes called an "anti-resonant" circuit. The effects of varying the frequency of the voltage across the circuit are widely different from the effects in a series circuit. In the latter, the currents become very large at resonance and the resultant series impedance of the circuit becomes small. In the parallel case the circuit offers a large impedance and the current from the generator becomes very small. In the series case the same current flows through the condenser and the coil. The voltages across these units differ. In the parallel case the same voltage is across each branch, but the currents through them differ.

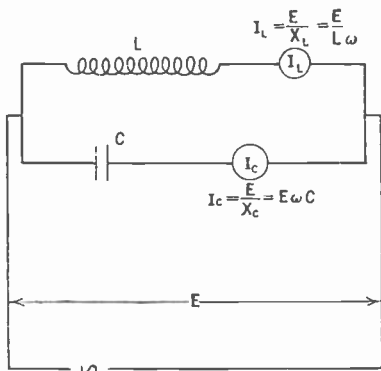

FIG. 95.—An anti-resonant circuit.

Experiment 3-7. Connect as in Fig. 95 the coil and condenser used in Experiment 1-7. If sufficient meters are available read the a.-c. current in the two branches as well as the current from the generator as the frequency of the generator is changed. Then fix the generator frequency and adjust the condenser capacity until maximum resonance occurs. Plot the currents against frequency and against condenser capacity. The generator in this experiment may be a small oscillating tube. A 5-watt output is sufficient to produce currents in the branches of the circuit of 100 milliamperes which can be read with a Weston Model 425 thermo-galvanometer.

In case laboratory apparatus is not available, the current may be calculated after L , C , and E values have been chosen.

The same voltage exists across the branches and the circuit as a whole. The current taken by each branch is the ratio between the voltage and the reactance of that branch. Thus,

$$I_L = \frac{E}{X_L} = \frac{E}{L\omega}$$

$$I_C = E/X_C = EC\omega$$

$$I = I_L - I_C = E \left(\frac{1}{L\omega} - C\omega \right) = E \left(\frac{1 - CL\omega^2}{L\omega} \right).$$

As the frequency is increased, more and more current is taken by the capacity branch, less and less by the inductance branch. In the series case the voltages across coil and condenser are out of phase; their algebraic sum at any frequency combined vectorially with the IR drop is the voltage across the combination. In the parallel case the currents are out of phase; at any frequency their algebraic sum combined vectorially with the shunt resistance current (if any) give the current taken from the generator. In the simple case where the resistance is neglected, the algebraic sum of the currents gives the generator current. Since these two currents are out of phase (the capacity current has a negative sign), adding them algebraically actually means subtracting I_C from I_L .

At resonance the currents taken by the two branches are equal and if there is no resistance in the circuit the current taken from the generator is zero, because it is the difference of the two branch currents which is read in the generator circuit ammeter.

The impedance of the circuit as a whole, that is, the impedance into which the generator must feed current, is the ratio between the voltage and current as usual:

$$Z = E/I.$$

Therefore, if no current flows, the circuit has infinite impedance. Actually there is always some resistance in the circuit. This may be in an additional shunt path, or it may exist in one or both of the other branches. Actually, then, the generator current does not fall to zero but passes through a minimum value. In most radio circuits by far the greater part of the resistance which is in the circuit resides in the coil since the resistance of the average well constructed condenser used at radio frequencies is very small. The current taken by the circuit is not exactly in phase with the generator voltage, and so minimum-current resonance differs slightly from zero-reactance resonance.

The actual resistance of a resonant circuit is usually made up of a load into which it is to feed power. Suppose that the resonant circuit is coupled to an antenna. The antenna has radiation (and other) resistance. This resistance is "reflected" into the tuned circuit by the coupling system, and it is this resistance that consumes the power from the generator.

$$I_r = \frac{ER}{R^2 + \omega^2 L^2}$$

and the impedance presented to the generator is

$$Z = \frac{E}{I_r} = \frac{R^2 + \omega^2 L^2}{R}.$$

117. Effective resistance.—If, as is usual, the resistance of the coil is small compared to its reactance, the condition for resonance is

$$\omega C = \frac{1}{\omega L}$$

and the minimum current from the generator becomes

$$I_r = \frac{ER}{\omega^2 L^2},$$

and since the impedance of the circuit is equal to the ratio between the voltage across it and the current through it, it becomes

$$Z = \frac{\omega^2 L^2}{R} = \frac{L}{CR}.$$

Since at resonance the current into the circuit from the generator is in phase with the voltage, E , across the circuit, the expression above is not a true impedance but is more nearly a resistance. It may be called the “effective resistance” of the circuit.

118. Resonant frequency.—In this manner we arrive at the frequency to which a low resistance circuit becomes resonant:

$$\omega C = \frac{1}{L\omega}$$

$$f = \frac{1}{2\pi \sqrt{LC}}.$$

The condition for resonance then is that the inductive and capacitive reactances are equal but opposite in sign—which is the same condition that holds for series resonance. Here, however, there are other conditions. The resistance must reside in the coil and must be small compared to the reactance of the coil.

For example, in the case of the circuit in Fig. 95:

$$\begin{aligned}
 L &= 200 \mu H \\
 \omega &= 2 \pi \times 356,000 \\
 R &= 10 \text{ ohms (in the coil)} \\
 X_L &= L\omega = 200 \times 10^{-6} \times 2 \pi \times 356,000 \\
 &= 447 \text{ ohms.}
 \end{aligned}$$

Here we may neglect the effect of resistance and use the simple relation for resonant current and for impedance.

If $E = 10$

$$\begin{aligned}
 I &= \frac{ER}{\omega^2 L^2} = \frac{ER}{(X_L)^2} \\
 &= \frac{10 \times 10}{447^2} \\
 &= .5 \times 10^{-3} \text{ amps.} = \frac{1}{2} \text{ milliamperes}
 \end{aligned}$$

and

$$= \frac{\omega^2 L^2}{R} = \frac{447^2}{10} = 20,000 \text{ ohms.}$$

At frequencies other than resonance the impedance is $\frac{L\omega}{1 - CL\omega^2}$ provided there is no resistance in the circuit.

At lower frequencies than resonance most current goes through the inductance because its reactance is low whereas that of the condenser is high. As the reactance of the condenser decreases, with increasing frequency, and that of the inductance increases, and since the generator current is the actual difference between these currents, the generator current decreases as resonance is

approached. At low frequencies the circuit is said to be inductive and at high frequencies is capacitive.

119. Uses of series and parallel resonant circuits.—Whenever it is desired to secure a large current and a low impedance circuit, series resonance is utilized. When it is desired to built up a high impedance or a high voltage circuit an anti-resonant circuit is used. Let us consider the antenna-ground system in Fig. 96. The

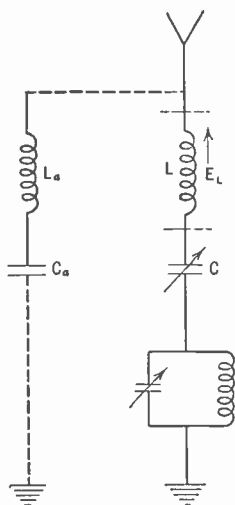

FIG. 96.—The anti-resonant circuit in series with the antenna rejects undesired signals by making the series impedance to them very high.

antenna has in series with it an inductance across which a voltage is to be developed at a desired frequency. In series with this inductance are a capacity for tuning purposes and an anti-resonant circuit. Voltages of various frequencies, among them the desired frequency, are impressed on the antenna by distant transmitting stations. The maximum voltage is desired across the inductance, L , at the desired frequency and the minimum at other frequencies. There is a specially strong signal which is setting up a voltage across the antenna. The anti-resonant circuit is tuned to this frequency.

The condenser C is adjusted until the antenna system as a whole is resonant to the desired signal. A large current flows through the series system, building up a large voltage across L . Voltages of other frequencies cause small currents to flow in the antenna system and consequently small voltages at these frequencies are built up across the coupling coil, L . The anti-resonant circuit's being tuned to the unwanted signal makes the antenna system as a whole have a very high impedance at this frequency and so very small currents will flow through it, building up small voltages of this frequency across the coupling coil.

Such an anti-resonant circuit is often called a **rejector** circuit because it rejects signals of the frequency to which it is tuned.

The series resonant circuit is called an **acceptor** because it accepts signals of the resonant frequency. The rejector used in this circuit is commonly known as a wave trap because it traps out unwanted signals.

Let us suppose signals are fed into the input of an amplifier which has an internal resistance, R , which is in series with an output circuit, as shown in Fig. 97. The voltage across this output, Z , is to be made as high as possible. The amplifier has available a certain voltage, E , which must be divided between the internal resistance of the amplifier and the output load. The proportion of the voltage that appears across this load increases as its ohmic

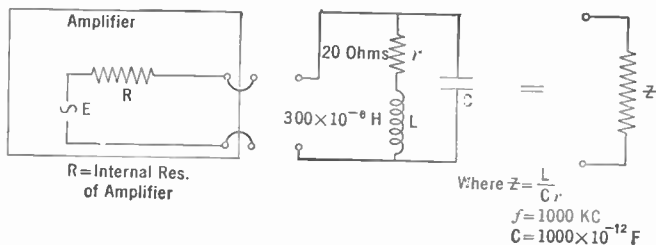

Fig. 97.—A high impedance is desired for the amplifier to work into. A tuned circuit does the trick. Numerically it is equal to Z .

impedance increases with respect to the amplifier's resistance. Thus, if the output impedance is equal to the internal resistance of the amplifier, one-half of the total voltage available will appear across it. If it is higher than this value, a greater proportion of voltage will be usefully applied across the load and less used up in the resistance.

In this case the anti-resonant circuit is used. At resonance its impedance becomes equal to $\frac{L}{CR}$ or $\frac{L^2 \omega^2}{R}$

$$\begin{aligned}
 &= \frac{(300 \times 10^{-6})^2 \times (6.28 \times 1000 \times 1000)^2}{20} \\
 &= 180,000 \text{ ohms.}
 \end{aligned}$$

If the amplifier's internal resistance is equal to 20,000 ohms, the voltage across the tuned circuit is $\frac{1800}{2000}$ or $\frac{9}{10}$ of the total available voltage.

Problem 16-7. A screen-grid tube gives the greatest voltage amplification when worked into a very high impedance. A condenser of 1500 mmfd. is available. Calculating the size of the inductance required to tune to 1000 meters and assuming it has a resistance of 30 ohms, what is the impedance $\left(\frac{L^2\omega^2}{r}\right)$ that can be presented to the tube by shunting the coil and condenser?

Problem 17-7. A wave trap is to be put into an antenna and tuned to a station whose frequency is 750 kc. What will be a convenient size of condenser and coil to use? They are to be shunted across each other and the combination put in series with the antenna. If the coil has a resistance of 10 ohms and the condenser a resistance of 1.0 ohm at this frequency, what impedance will the trap offer to the offending signal?

Problem 18-7. In Problem 17-7, neglecting phase differences between the trap and the rest of the antenna, if the total impedance of the antenna to the offending signal is double that of the trap alone so that one-half of the total antenna voltage is across the trap, what current will flow through the condenser if the total 750-kc. voltage across the system is 10 microvolts?

120. Sharpness of resonance.—The effect of resistance is to reduce the maximum current flowing in a series resonant circuit, and to make less pronounced the minimum of current flowing into a parallel resonant circuit from an external source.

Since the maximum current is desired in a series circuit, and the maximum impedance in a parallel case, the inclusion of resistance in either is deleterious.

Let us consider the antenna illustrated in Fig. 96. Suppose its inductance, L , is 200 microhenrys and C at resonance (356 kc.) is 1000 mmfd. For the moment we shall neglect the presence of the wave trap. Assume a voltage of 10 volts. What is the effect on the resonance curve of this antenna system if it has a resistance of 10 ohms or of 40 ohms? The current at resonance in the 10-ohm case is 1 ampere whereas at 370 kc. the current is .274 ampere, a ratio of 3.65. In this 40-ohm case, the resonant current would be only 0.25 ampere—one-fourth of its value with the lower resistance—and the current at 370 kc., i.e., 14 kc. off resonance, would be .188 ampere. This is a current ratio between the resonant and the off-resonant current of only 1.33.

In other words, if the antenna had impressed on it from equally distant and equally powerful radio stations two voltages, one of 356 kc.—the desired frequency,—and one of 370 kc.—the unwanted

frequency,— 3.65 times as much current flows at the desired frequency as the unwanted. In the 40-ohm antenna, however, not only is the desired current cut to one-quarter of its other value but the ratio of wanted to unwanted current has been decreased to 1.33. The low-resistance antenna is said to be more “selective” and its “selectivity” is decreased when resistance is added to it.

121. Selectivity.—The selectivity of a circuit is a measure of its ability to distinguish between wanted and unwanted signals. The steepness of the resonance curve is a direct measure of this selectivity.

Let us consider the parallel or anti-resonant circuit. At its resonant frequency it keeps currents of undesired frequency from flowing through the antenna because of its high impedance at those currents. This impedance, $L^2\omega^2/r$, increases as the resistance of the circuit decreases, so it behooves the designer to use low-resistance coils and condensers when building a trap or rejector circuit.

Since a circuit may be tuned to resonance by varying any one of three variable factors, the inductance, capacity, or frequency, we may express the sharpness of resonance in any one of three ways. It may be the fractional change in current for a given fractional change in either L or C . Naturally the sharper the resonance curve and the greater its height, the greater will be the current change for a small number of degrees of change in the tuning condenser. The circuit will tune “sharply”; it is called a sharp circuit. In practice the condenser is used as the tuning variable. If, then, the current at resonance I_r and the tuning capacity C_r are noted and then changed to give some other value of current, the sharpness of resonance may be found by substituting values in the following expression,

$$S_{res} = \frac{\sqrt{\frac{I_r^2 - I^2}{I^2}}}{\frac{C_r - C}{C}}$$

By some mathematical juggling of this cumbersome expression (see Bulletin 74, Bureau of Standards, page 36) a much simpler

expression may be obtained. This has two forms,

$$\text{Sharpness of resonance} = \frac{1}{R\omega C_r} = \frac{L\omega}{R},$$

where R = the resistance of the circuit;

C_r = the capacity at resonance;

L = the inductance of the circuit.

In other words the sharpness of resonance is the ratio between the capacitive or inductive reactance to the resistance, and thus the resonance curve rises the steeper the less resistance there is in the circuit.

Another expression for the sharpness of resonance is obtained by varying the frequency and noting how the current changes. Thus an expression is worked out which shows the width of the resonance curve where the current is equal to $.707 \times I_r$, where I_r is the resonant current.

Suppose, as in Fig. 98, we plot a resonance curve of current against capacity. Suppose the capacity is adjusted until the total reactance in the circuit ($X_L - X_C$) is equal to the resistance in the circuit. That is,

$$(X_L - X_C) = R,$$

when $I = \frac{E}{\sqrt{R^2 + X^2}}$ becomes equal to $\frac{E}{\sqrt{2} R^2}$

and $I = .707 I_r$

then $\frac{L\omega}{R} = \frac{2 C_r}{C_2 - C_1}$,

in which C_r = the capacity at resonance;

C_1 and C_2 = the two values of capacity which makes $I = .707 I_r$.

122. Width of resonance curve.—If, however, the frequency of the impressed voltage is so adjusted that two currents are reached,

above and below the resonant frequency f_r , which are equal to $.707 I_r$,

$$\frac{L\omega}{R} = \frac{fr}{f_2 - f_1}$$

whence the width of the frequency band

$$f_2 - f_1 = \frac{Rfr}{L\omega} = \frac{R}{2\pi L}$$

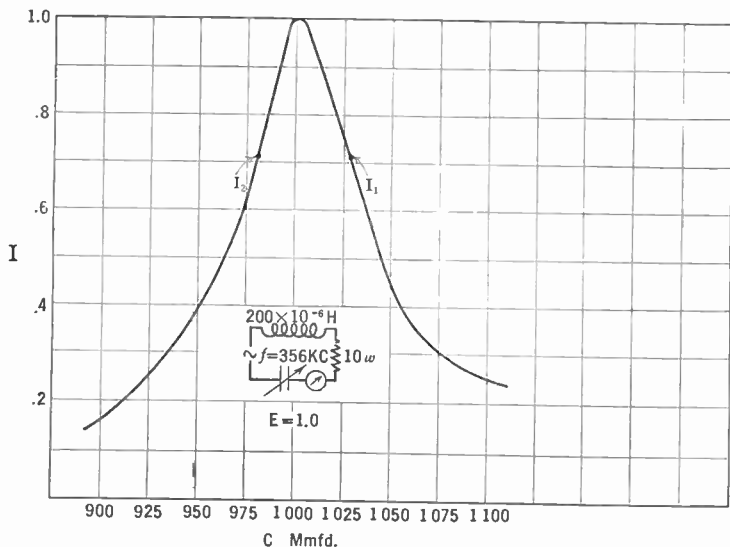

FIG. 98.—If I_1 , and I_2 are equal to 0.707 times the resonant or maximum current, the resistance of the circuit may be calculated.

Example 4-7. What will be the width in cycles of the resonance curve at a point where $I = .707 I_r$, when $L = 200\mu h$, $R = 10$ ohms, $f = 356,000$ cycles?

$$\begin{aligned} f_2 - f_1 &= \frac{10 \times 356,000}{447} = \frac{R \times fr}{L\omega} \\ &= 8000 \text{ cycles} \end{aligned}$$

and if

$$\begin{aligned}\frac{L\omega}{R} &= \frac{2C_r}{C_2 - C_1} \\ C_2 - C_1 &= \frac{2C_r \times R}{L\omega} \\ &= \frac{2000 \times 10}{447} \\ &= 44.7 \text{ mmfd.}\end{aligned}$$

= change in capacity required to change the current from $I = .707 I_r$ below resonance, to $I = .707 I_r$ above resonance, or from I_1 to I_2 in Fig. 98.

Problem 19-7. In Fig. 98, suppose the resistance is 20 ohms instead of 10. Calculate the width of the band at the point where the current is 0.7 of its maximum value, and the change in capacity required to produce this change in current.

Problem 20-7. A certain coil-condenser combination has a resistance of 16 ohms at 400 meters. The inductance is 170 microhenrys. What is the width of band passed at the point where the current is equal to 0.7 of its maximum value? What is the "sharpness of resonance" of this circuit? Note that this expression is the ratio between either reactance and the resistance.

Problem 21-7. A circuit is to pass only 0.707 of its maximum current at a point 2.0 kc. off resonance, which occurs at 500 kc. The condenser to be used has a capacity of 0.0006 mfd. Calculate the maximum resistance the circuit can have.

Problem 22-7. Suppose that increasing the size of an inductance by a factor of 2.0 increases the resistance in a circuit by a factor of 1.5. The circuit is to tune to the same wavelength. What has happened to the sharpness of resonance, or, what amounts to the same thing, to the selectivity of the circuit?

Problem 23-7. If the expression $L\omega/r$ of a coil remains constant over a fairly wide band of frequencies, does the selectivity of a tuned circuit differ at different frequencies? Does the width of band passed differ at 1500 kc. from what it is at 500 kc.?

The selectivity of a radio receiver can be illustrated by Fig. 188 which shows the relative gain of a stage of a radio frequency amplifier when the signal is so-and-so-many kilocycles away from the frequency to which the receiver is tuned. Note the sharpness of the curve at 550 kc. and the poor selectivity at high frequencies due to high coil resistance at the higher frequencies.

123. Effect of inductance and capacity on sharpness of resonance.—Since the sharpness of resonance expression, $L\omega/R$ and $1/\omega CR$ both show that the inclusion of resistance tends to cut down the selectivity of the circuit in which the resistance exists, it behooves the experimenter and engineer to keep the resistance of his circuits at a minimum—when selectivity is his goal. What effect has changing the ratio of inductance to capacity, the product of $L \times C$ remaining constant?

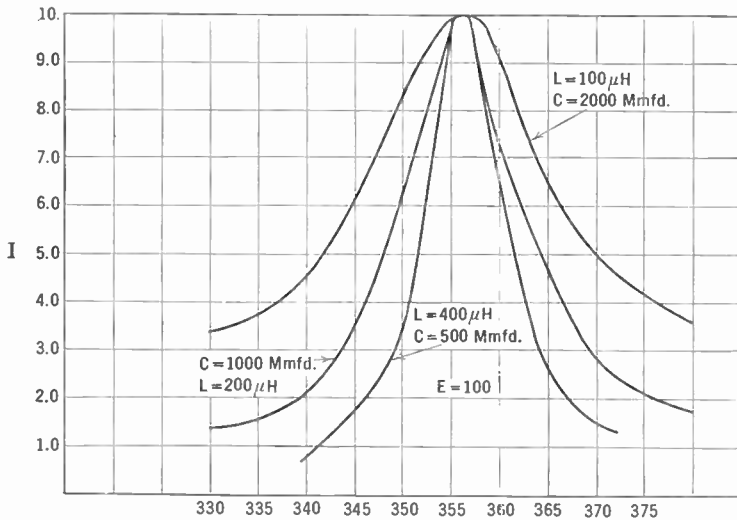

FIG. 99.—Effect on sharpness of resonance of varying ratio of L to C .

Let us consider the ratio of inductive reactance to resistance, $L\omega/R$. If we can increase L without increasing R we shall increase the sharpness of resonance. Now considering the ratio of capacitive reactance to resistance, $1/C\omega R$, increasing C has the same effect as increasing the resistance—the sharpness of resonance is decreased, the selectivity of the circuit goes down.

In a series circuit, then, the selectivity increases as the ratio L/C increases. Some theoretical curves showing this effect are plotted in Fig. 99 showing that for selective circuits a large inductance and small condenser should be used. ($R = 10$ ohms.)

The ratio of L to C occurs in many formulas dealing with the resonant circuit. For example, consider a long line with uniformly distributed capacity and inductance. The impedance of this line will be $\sqrt{L/C}$ ohms. Suppose that a tuned circuit is coupled to an antenna. The antenna resistance is a certain value; the tube resistance is a certain value. Maximum power will be transferred from the tube to the antenna via the tuned circuit when the antenna and tube resistances are equal. This may be accomplished by varying the ratio of L to C in the tuned circuit. This is why amateurs, and others, have found that the " L/C ratio" is important. There are other radio circuits in which this ratio of L to C occurs. The frequency to which the circuit tunes may be held constant (LC constant) although the ratio of L to C may be changed.

124. The resistance of coils.—The curves in Fig. 99 were plotted on the assumption that the resistance of the coil did not increase as the inductance was changed. Unfortunately this cannot be carried out in practice unless very large and unwieldy coils are made. This means, simply, that a coil has a resistance to a.c. different from that which it has to d.c. For example, a very good coil used at broadcast frequency may have a resistance as low as 10 ohms at some medium broadcast frequency. But so little wire is used in making this coil that the d.-c. resistance will be perhaps a fraction of an ohm. Even straight wires have different a.-c. and d.-c. resistances.

Straight wires, however, have the least difference in resistance between high frequency and direct current. In laboratory work where small accurately known resistances are desired to be used at high frequencies, short lengths of high-resistance wire are employed. For example, manganin or one of the other high-resistance alloys may be cut into the proper lengths, soldered to copper lead wires and used as standards of resistance where a decade box could not be utilized at all.

Even with such wires it is often difficult to separate the reactance and resistance effects; if the lead-in wires are close together and of large size appreciable capacity reactance may be added,

at high frequencies; if the lead wires are long, inductive reactance will be added. The General Radio Company has constructed fixed standards of high-frequency resistance, and special bridges have been made to measure resistance at 1,000,000 cycles and higher frequencies.

125. High-frequency resistance.—In all alternating current problems the resistance that is considered is the resistance at the frequency under consideration. Thus at broadcast frequencies 550 to 1500 kc., a coil will have a certain a.-c. resistance; at 60 cycles its resistance will be different, and to d.-c. currents its resistance may be still another figure.

A wire stretched out straight will have one resistance to d.-c. and another to a high-frequency current; therefore the fact that the wire is coiled up in an inductance is not the cause of the additional resistance. The difference arises from the fact that the current in a conductor at high frequencies is not evenly distributed throughout the cross-section of that conductor. Because of the rapid change of direction of flow and because the current within the cross-section of a conductor changes rapidly, small e.m.f.'s are generated in that cross-section, and therefore all along the wire. These voltages are in such a direction, according to Lenz's law (Section 55), that of the total current flowing more is along the surface of the wire and less along the inner parts of the wire. The result is a decrease in effective area of conductor and a consequent rise in resistance.

A table is given in Circular 74 (Bureau of Standards) showing the effect of diameter of wire, frequency, resistance, etc., upon this phenomenon known as "skin effect." For our purposes it is sufficient to know that the resistance of a coil to high-frequency current is always greater than its resistance to a direct current.

The resistance of a coil over the range of frequencies at which it is used changes somewhat, increasing with increase in frequency.

The manner in which the expression $L\omega/R$ of a coil, usually called its " Q ," varies over the frequency range is plotted in Fig. 100. Knowing this factor for the coil in a series or shunt circuit we can calculate the width of the frequency band at a point where the current is 0.707 of its resonant value, we can plot a resonance

curve, and can calculate the equivalent impedance of the circuit at resonance to a generator which must feed current into it.

Let us, however, measure the resistance of the coil at higher and higher frequencies. What happens? Figure 101 shows that at higher frequencies the coil resistance becomes very high and finally the curve rises perpendicularly, indicating that at some nearby point the resistance is infinite. What is happening?

126. Distributed capacity of coils.—Whenever two objects which conduct current are insulated from each other, they form a condenser. Electricity may be stored in it. Its capacity depends

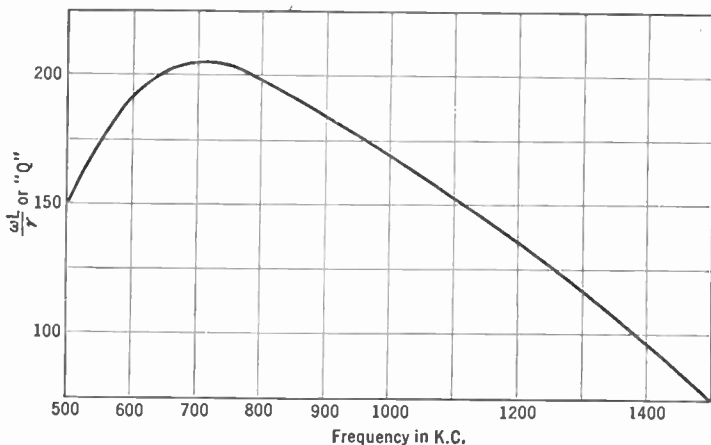

FIG. 100.—How the "Q" ($L\omega/r$) of a coil varies with frequency.

upon the proximity of the objects, the insulation between them, and their shape. In a coil of wire each turn is at a different potential from its neighbor, and is separated from it by the insulation of the wire. Thus every coil is not a pure inductance but may be thought of as a coil shunted by a capacity made up of the resultant capacity of a number of smaller capacities. At some frequency the coil shunted by its capacity becomes anti-resonant, and the circuit then becomes as shown in Fig. 102 where the tuning condenser is no longer in series with a coil but with a parallel tuned circuit which at the resonant frequency has a very high impedance. The

series impedance of the circuit, then, increases near the resonant frequency of the coil. Here its effective resistance becomes great.

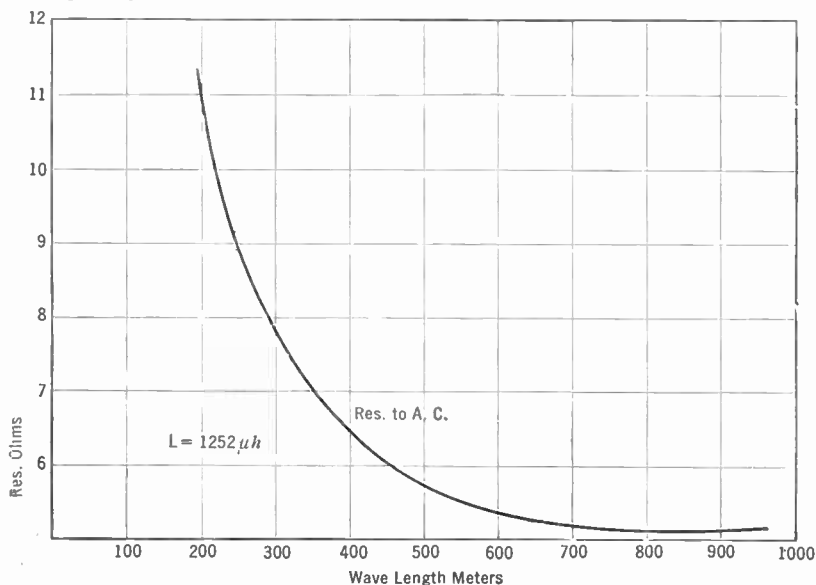

FIG. 101—High-frequency resistance of a coil.

This capacity of the inductance is known as a **distributed capacity** since it is not concentrated in any one place or form but is more or less evenly distributed along the whole length of the inductance. Its effect is to lower the effective inductance of the coil and to increase its resistance somewhat. The capacity and inductance of a coil do not change much with frequency, but the apparent inductance of this anti-resonant circuit does change with frequency. It is equal to

$$L_a = \frac{L}{1 - \omega^2 C_o L^2}$$

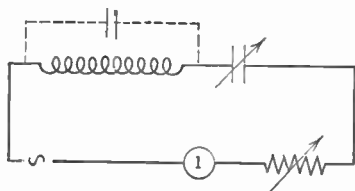

FIG. 102.—When the dotted capacity across the coil tunes it to the frequency of the generator, the series impedance of the circuit becomes very high.

in which C_o = the capacity of the coil;
 L_a = its apparent inductance;
 L = its true or low-frequency inductance;
 $\omega = 6.28 \times f$.

Various attempts have been made to calculate the capacity of coils. It has been found by experiment that the radius of the coil and its shape control the distributed capacity to a large extent. Thus a coil of average proportions, i.e., the length about equal to the diameter, has a capacity of approximately $0.6R$ mmfd. where R is the radius of the coil in centimeters. As a rough rule it has



FIG. 103. Bank Winding.

been stated that the capacity in micro-microfarads is always less than the radius in centimeters in a solenoid of

a single layer. Another experiment showed that the natural wavelength of

solenoids was about 2.54 times the total length of wire on the coil. To obtain large inductance in reasonably small space it has become customary to make multilayer coils of peculiar types of winding called "bank winding" and "universal" winding.

Air cores are wound on a core of a permeability of unity; if they could be wound on a core of higher permeability, the inductance per length of wire and per unit of space would increase. Permalloy is a kind of iron alloy dust on which coils may be wound with increased inductance at the medium frequencies. At higher frequencies one may use cores made up of finely powdered iron bound together with some sort of very fine binder. The permeability of this material may be as high as 12. With a given length of wire, therefore, of a given high-frequency resistance a greater inductance may be wound. The Q of such a coil will be higher because the ratio of inductance to resistance will be higher.

C. J. Franks has measured Q 's of the following values: 456 kc. litz wound universal coil, 80; same coil with powdered iron core, 145. Transmitter coil for 5000 kc., 650; gang condenser, ceramic insulation, 1000 kc., 3000.

CHAPTER VIII

PROPERTIES OF COILS AND CONDENSERS

COILS and condensers form the nucleus of every radio circuit. Other apparatus is needed, of course, but for each of the other units needed there are several substitutes. There are no substitutes for coils and condensers. To understand what their rôle is in the reception of radio messages, either in code or voice or musical form, we must look at a simple receiving system.

127. Tuning a receiver.—A simple receiving circuit consists of an antenna-ground system connected to a coil and a “detector” such as a crystal of carborundum or galena or silicon or other sensitive mineral which has the property of separating the audio tones from a radio wave. A pair of head phones may be put in series with the detector so that the audio tones which are filtered out of the radio wave by the detector may be made audible. A small condenser across the phones will pass the radio frequencies but not the audio frequencies which must go through the phones.

One way to get louder signals is to tune the antenna-ground system to the frequency of the desired wave. This is done by varying C in Fig. 104. When the circuit is series resonant, a large current flows through the inductance. The voltage across it ($X_L \times I$) will be large and the response from the crystal will be greater.

The voltage across the inductance can be amplified and then impressed across the detector. This amplification may take place in several stages so that very weak signals may

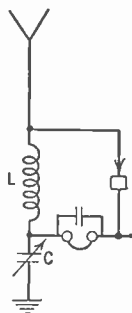

FIG. 104.—A simple radio receiver.

finally be heard with the strength of nearby strong signals which are detected directly from the antenna inductance. If desired, the signals may be amplified again after detection by means of audio-frequency amplifiers.

As we have already seen (Section 121), there is another advantage of tuning the antenna, the advantage of selectivity. Signals of low frequency find considerable impedance in the condenser of such a series-tuned antenna, signals of high frequency find impedance in the coil; signals of the desired or resonant frequency find a minimum of impedance, and so the filtering action of the tuned system is advantageous. If, in addition to the series tuned circuit, we used an anti-resonant or parallel-tuned circuit as in Fig. 105, we impose more hardships upon unwanted signals.

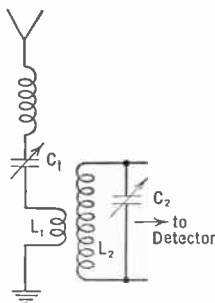

FIG. 105.—Varying C_1 until the antenna system as a whole is series resonant increases voltage across L_1 .

In this case when maximum current flows through L_1 maximum current is induced in L_2 . If, then, C_2 is tuned so that L_2C_2 form an anti-resonant circuit, the impedance to the resonant frequency will be very high and any current through it will build up a large voltage across it so that the detector gets a high voltage at the desired frequency and a low one at all other frequencies—and the selectivity of the system as a whole is improved.

If, in addition, each radio-frequency amplifier stage is tuned to the desired signal, the selectivity of the entire receiver may become very great. In the present congestion of broadcast stations, the necessity for selectivity of a high degree is evident; as we shall see later it is a disadvantage.

128. The wavemeter.—An instrument for measuring the wavelength or frequency of signals is called a **wavemeter** when calibrated in meters or a **frequency meter** when calibrated in kilocycles or cycles. It consists of a coil and a condenser and some means of indicating when this simple circuit is tuned to resonance with a radio wave. The indicator may be a current meter, a lamp which lights up at maximum current through it, or a crystal detector and

a d.-c. milliammeter. It may be connected directly into the circuit, or, preferably, coupled loosely to it.

The circuit of a simple and effective wavemeter is shown in Fig. 106. The indicating device is a crystal detector and a meter which indicates the rectified d.-c. current. If it is coupled loosely to the tuned circuit the resistance of this indicator will not broaden the response curve of the wavemeter. The inductance is usually fixed and the capacity varied to obtain resonance, but to cover a wide band of frequencies it is frequently necessary to have several coils which fit into the wavemeter by means of plugs and jacks. If the coils are arranged so that the larger coils have exactly four times the inductance of the next smaller the wavelength range will be doubled, and the frequency range halved.

A series of coils in which the same winding space is used but in which the number of turns in this space is doubled for each next larger coil will approximate very closely these conditions.

Sometimes the wavemeter is equipped with a buzzer so that it will send out a modulated wave. A receiver can be tuned to a desired frequency by starting the buzzer, tuning the wavemeter to the desired wavelength, or frequency, and adjusting the receiver until the buzzer tones are heard at maximum loudness.

129. Heterodyne wavemeter.—The most useful type of wavemeter is the **heterodyne wavemeter** which uses an oscillating vacuum tube and meter, usually in the grid circuit. The circuit diagram for such a meter is shown in Fig. 107. Tube 1 generates radio-frequency currents, which are modulated when desired by the low- or audio-frequency generator tube 2. Such a meter gives very sharp indications of resonance, and because it is a small modulated source of radio-frequency energy it can be used to tune receivers to any desired frequency. It is a much more accurate instrument than the buzzer wavemeter. The data in Table I are those of an oscillator-wavemeter. The coils are standard General

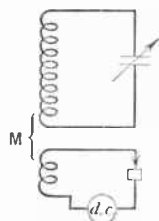

FIG. 106. — A wave meter in which the resistance of the indicator is removed from the tuned circuit and is coupled loosely to it.

Radio Company inductances (covering the wavelengths of 30 to 1000 meters).

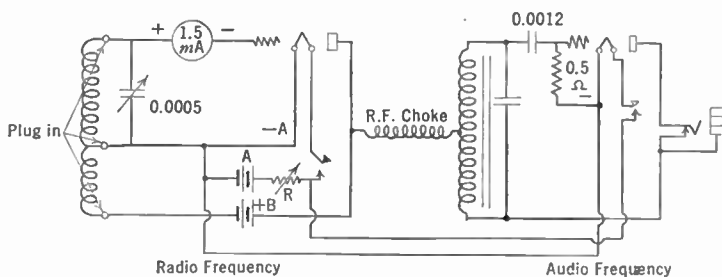

FIG. 107.—Circuit diagram of a heterodyne-wave meter or modulated oscillator.

TABLE I

Coil	λ	f	Kc. per dial degree
15	45-120	2500-6660	31.6
30	80-210	1430-3750	23.3
60	165-400	750-1820	10.7
90	265-620	485-1130	6.5

Coil	Turns	Size Wire	Diameter	Length of Winding	L
277-A	15	21	$2\frac{11}{64}$	$1\frac{5}{8}$.014 mh.
277-B	30	21	$2\frac{11}{64}$	$1\frac{1}{2}$.055 mh.
277-C	60	21	$2\frac{11}{64}$	$1\frac{5}{8}$.217 mh.
277-E	90	27	$2\frac{11}{64}$	$1\frac{3}{8}$.495 mh.

130. Calibrating a wavemeter.—A wavemeter, or frequency meter, to be most useful must be properly calibrated. This may be done in several ways. If the meter is a heterodyne meter all one needs is a source of known frequency and a receiver. The process

is simple. Tune the receiver to a station whose frequency is known. Then turn on the oscillating tube wavemeter, and when a whistle is heard from the receiver, the known station, the receiver, and the wavemeter are all tuned to the same frequency. Then tune the receiver to another frequency and repeat the performance. Then a curve can be plotted showing the calibration of the wave meter.

The following description of how to calibrate a wave meter over a wide range of frequencies by means of but a single accurately known frequency is an interesting experiment. It follows from the fact that an oscillating vacuum tube generates not only the frequency governed by the *LC* product of its circuit but also multiples (harmonics) of this frequency.

Experiment 1-8. To calibrate a wavemeter by harmonics.—The necessary apparatus consists of:

(1) An oscillating wavemeter connected as in Fig. 107.

(2) An oscillating detector tube preferably followed by a stage of audio amplification.

Tune the oscillating detector to the frequency of some known station by listening in the head phones and bringing an antenna wire near the detector inductance. The condenser of the detector should be equipped with a vernier or worm gear so that very accurate settings are possible. Tune as nearly as possible to "zero" beat with the known station. As the tuning dial is adjusted near resonance with the known station, now acting as our frequency standard, a note will be heard in the phones which represents the difference in frequency between the known station and that of the detector tube. When this difference tone (or beat note) disappears, the two oscillations are at the same frequency. Since frequencies lower than about 100 cycles cannot be heard in the phones, it will not be possible to tune closer than this to the desired frequency. By estimating the two points at which the audible beat disappears and finally setting the oscillating receiver detector at the mid-point between these two dial settings, a sufficiently accurate setting will be made.

We have now equipped ourselves with a local generator whose frequency is accurately known. For example, suppose it is 610 kc. and that we are set to within 100 cycles of this frequency. We are within 100 parts in 610,000 of being exactly correct or one part in 6100, which is sufficiently accurate. It is much more accurate than we can read the dial on the wavemeter we are to calibrate.

Now move away the antenna coupling and see if the beat note changes. If it does, again adjust for true zero beat. Then start

up the oscillating-tube wavemeter and, after giving it a few minutes to warm up, tune its dial slowly until a whistle or beat note is heard in the head phones which are still plugged into the detector-amplifier. This means that the wavemeter is being tuned to the frequency of the oscillating tube.

If we use the broadcast band coil of the wavemeter we ought to get a very loud beat note when the two circuits are in exact resonance and another loud note when the dial is tuned to the half wavelength, in this case 1220 kc. In between these points may be several other weaker beat notes.

TABLE II

Dial Degrees	Difference	Units Difference	f —approximate	f —exact
10.2*	1220	1220
34.0	23.8	2	1020	1016
47.0	13.0	1	920	915
60.0	13.0	1	820	813
85.0*	25.0	2	610	616

Now turn the dial slowly and put down on paper each time a beat note is heard. For example, the table of such points may look like Table II, in which the loudest beat notes are marked with an asterisk. Then use another wavemeter coil and repeat, always marking down the loud notes.

Now prepare data like those in the next table, in which the numbers along the top are obtained by multiplying the detector frequency by whole numbers from 1 to 10, and the vertical numbers are obtained by dividing this frequency by whole numbers. Thus our fundamental frequency is 610 kc. Twice this is 1220 kc., one half is 305, etc.

Then make a list from this table of the frequencies that may be looked for from our calibration, namely: 610, 763, 813, 915 kc., etc.

What actually happens as we tune the wavemeter dial and hear beat notes? The oscillating detector and the wavemeter tubes

are generating additional or harmonic frequencies as well as the fundamental to which they are set. These additional frequencies are much weaker than the fundamental. When we tune the wavemeter to 1220 kc. it beats with the second harmonic of the detector and gives an audible note. But how are we to recognize the 1220 point? How do we know it is not the third or the fourth harmonic instead of the second?

Consider the data in Table II. We got loud notes at 10.2° and 85° . We guess that these are the second harmonic and fundamental. We subtract the dial settings as in column 2. Then assuming that 13° is a unit, we note that there are two units between the 10.2° and the 34° beat notes. We see then that there are six units between 1220 and 610 kc. We guess again and say that each beat note represents about one-sixth of the difference between 1220 and 610 kc., or about 100 kc. per unit. Looking in our list of expected frequencies we can pick out these frequencies exactly.

TABLE III

	1	2	3	4	5	6
1	610	1220	1830	2440	3050	3660
2	305	610	915	1220	1525	1830
3	202.5	406	610	813	1016	1220
4	152.5	305	457	610	763	
5						
6						

We might guess at these frequencies from the original assumption that the two loud notes were from the 1220 and the 610 kc. frequencies and noting that between them—a difference of 610 kc.—were $85 - 10.2$ dial degrees or about 8 kc. per degree.

When the smaller coils are to be used, care must be taken to see that no harmonics are missed. Fortunately, if the coils have the dimensions given in Table I, the harmonics will fall at almost the same points on the dial. Thus on the largest coil 610 kc. is found at 85° . On the next smaller coil the 1220 kc. frequency will

be found within a degree or two of 85° . And so on until the entire set of coils is calibrated.

131. Standard Frequencies.—In this country standard frequency signals are sent out from the Bureau of Standards at stated intervals and can be heard at distances up to 1000 miles from Washington, D. C. In addition there are many long-wave and intermediate-wave stations whose frequencies are kept within very close limits and which are "on the air" 24 hours of the day. The broadcasting stations themselves form good standards of frequency—especially the better known stations—covering the band from 550 to 1500 kc., and above this are many short-wave stations whose signals may be heard the world over.

132. Calibrating by "clicks."—A method of calibration that is often used is the click method. When a tuned circuit is brought near the inductance of the heterodyne wavemeter, a sharp dip of the grid current needle will be noted as the two circuits are resonated to each other. If the same tuned circuit is brought near the inductance of an oscillating detector tube, a sharp click will be heard when the circuits are tuned to the same frequency provided one listens in the plate circuit of this tube or behind a stage of audio amplification. This click is produced by a sharp change in grid current and a corresponding change in plate current.

Experiment 2-8. Calibration by clicks.—This method requires an oscillating detector, a standard meter and the unknown meter to be calibrated.

Couple the standard meter to the inductance of the detector, and turn the dial until a sharp click is heard in the phones indicating that the circuits are tuned alike. If the two inductances are closely coupled two clicks will be heard, one when the tube stops oscillating and one when it starts again. These two points may be several degrees apart. Loosen the coupling, and note that the two clicks approach each other. Keep on loosening it until a degree of coupling is reached when only a single resonance click is noticed. Note the dial setting of the standard meter. Now remove it from the tuned circuit and bring near the latter the wavemeter to be calibrated. Turn its condenser dial until a click is heard as before. Now the meter has the same frequency, or wavelength, as the standard. Other points for a calibration curve may be noted in the same manner.

This method really constitutes setting a generator or miniature transmitter (the oscillating detector) to a given frequency by means of the standard meter and then tuning the uncalibrated meter to resonance with this generator.

133. The properties of coils and condensers.—We may investigate the properties of coils and condensers by performing the various parts of the following experiment.

Experiment 3-8. Wind up on a form about 3 inches in diameter, a coil of about 60 turns of rather large wire, preferably with silk or enameled insulation so the distributed capacity of the inductance will be rather large. Connect it across a condenser whose maximum capacity is about 500 mmfd. Starting

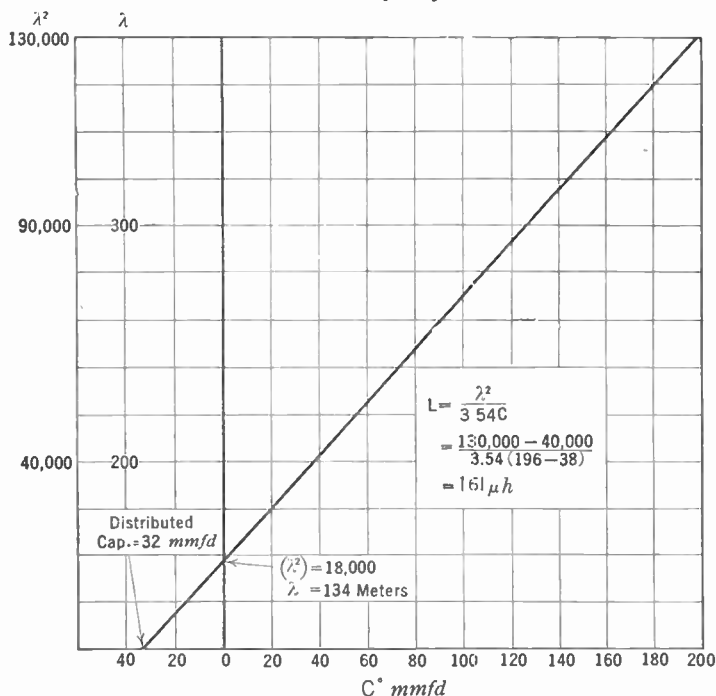

FIG. 108.—A method of determining the distributed capacity of a coil.

at the maximum capacity of the condenser, measure the resonant frequency of the coil-condenser combination by "clicking" it into an oscillating receiver, or by coupling it to an oscillator. Then decrease the capacity and repeat until several readings are taken, say at 500, 400, 300, etc., mmfd. Plot the result against C as shown in Fig. 108; that is (wavelength)² against capacity.

A straight line results because the formula

$$(\text{Wavelength})^2 = 3.54 L \times C,$$

where L is in μh and C in mmfd.,

is the equation of a straight line and states that the wavelength squared is proportional to the capacity in the circuit. The slope of the line divided by 3.54 is the inductance of the coil, that is,

$$L = \frac{1}{3.54} \times \frac{\lambda^2}{C}.$$

It will be noticed that the straight line crosses the wavelength squared axis at some distance above the zero point. This gives us the natural wavelength squared of the coil itself and therefore the resonant wavelength to which the coil with no additional capacity will tune. The point where the line crosses the capacity axis gives us the distributed capacity of the coil. This value multiplied by the inductance as obtained above gives the LC product which when fitted into the proper formula gives the natural wavelength of the coil.

Thus, in one experiment we can determine not only the frequency or wavelength to which a coil-condenser combination will tune, but we can determine the coil's inductance, its distributed capacity, and its natural wavelength.

As a check on these data: (a) calculate the inductance from the formulas given in Fig. 51. (b) If a heterodyne wavemeter is available and calibrated to short wavelengths, detach the condenser from the coil and click the latter into it, and thereby determine the natural wavelength of the coil.

134. Measurement of coil resistance.—The effect of resistance upon the sharpness of resonance and the selectivity of the circuit has been mentioned (Section 112). The **resonance curve** gives us one method of measuring the resistance in a given circuit, provided we know the inductance of the coil—which can be calculated from the formula in Fig. 51.

Experiment 4-8. To determine the resistance of a coil.—Couple a series circuit composed of a coil, condenser, and indicating meter to a generator of about 5-watts output. Adjust the frequency of the generator through resonance with the series circuit. If the generator has a constant output over this frequency range the accuracy with which the coil resistance is determined will be greater. Pick out the two frequencies above and below resonance where the current in the circuit is .707 of its value at resonance and calculate the width of frequency band at this point and the resistance of the circuit, from the equation

$$R = \frac{L\omega (f_2 - f_1)}{f_r}$$

Subtract from this value the resistance of the current meter. For example a model 425 Weston thermo-galvanometer will read currents of 115 milliamperes and has a radio-frequency resistance

of 4.5 ohms. The value of resistance remaining is the resistance of coil, leads, and condenser. Most of this resistance resides in the coil.

Experiment 5-8. To determine resistance of a circuit.—Another method of determining the resistance of a coil is as follows. It necessitates the use of a decade resistance box or series of accurately known resistances of negligible inductance and capacity and a variable condenser.

Small lengths of high-resistance wire (manganin) are to be preferred for frequencies higher than 1000 kc. Their d.-c. and high-frequency resistance is practically the same.

Connect the apparatus in series and couple to an oscillator.

With the resistance box short-circuited ($R = 0$), tune the circuit to resonance. Then add enough resistance to the circuit to halve the current, retuning to resonance, if necessary. Then since we have halved the current, Ohm's law tells us that we have doubled the resistance. In other words the added resistance is equal to the resistance already existing in the circuit. Again subtract the resistance of the current-indicating meter. What remains is the resistance of coils, condensers and leads.

Repeat at several different frequencies and calculate the "sharpness of resonance," $L\omega/R$, and plot against frequency and wavelength.

If only one or two resistance units are available, say 5 or 10 ohms and not a continuously variable standard of resistance like a decade box, the resistance of the circuit above may be determined by noting the current at resonance, and the current when some resistance has been added, retuning to resonance after adding the resistance if necessary. Then the current, according to Ohm's law, is

$$I_1 = \frac{E}{R_1}$$

$$I_2 = \frac{E}{R_1 + R_2},$$

where I_1 = current at resonance and no added resistance;

I_2 = current at resonance and R_2 added;

R_1 = resistance of circuit;

R_2 = added resistance;

whence
$$R_1 = \frac{R_2 I_2}{I_1 - I_2}.$$

If a current-indicating meter is used whose deflections are proportional to the current squared, an example is a thermogalvanometer or a hot-wire meter, it is only necessary in this experiment to add sufficient resistance to quarter the deflection of the instrument. This is equivalent to halving the current, and the added resistance is equal to the resistance already in the circuit.

The lower the resistance of the current-indicating device, the greater will be the accuracy with which such measurements may be carried out. For example, if the indicator has a resistance of 4.5 ohms and the circuit a resistance of 5 ohms, great accuracy cannot be attained, but if the circuit resistance is double or treble that of the indicator, much greater accuracy results. In any case the meter resistance must be subtracted from the measured resistance to get the resistance due the circuit alone.

135. Condenser capacity.—We will now investigate by means of an experiment the capacity of a condenser.

Experiment 6-8. To determine the capacity of a condenser.—Connect a variable condenser whose calibration is known across a coil and click into an oscillating receiver or into a heterodyne wavemeter; attach the unknown condenser across the variable condenser and retune the latter to resonance with the wavemeter. The difference in readings of the calibrated condenser is the capacity of the unknown condenser. For example, suppose resonance is obtained by the variable condenser alone when set at 400 mmfd. Connecting the second condenser across the variable forces us to reduce the capacity of the latter to 340 mmfd. The difference $400 - 340 = 60$ mmfd. is the capacity of the unknown. Such a method enables the experimenter to disregard the capacity of the coil itself or of the leads since these are connected across the variable at all times and do not change when the unknown is attached to the circuit.

136. Antenna wavelength.—We will proceed to determine the wavelength of an antenna by means of the following experiment.

Experiment 7-8. To measure the natural wavelength of an antenna.—Connect in series with the antenna an inductance which can be adjusted in even steps, say a coil of 20 turns with taps at each turn. Measure the frequency to which the antenna tunes with the entire coil in the circuit by coupling the coil to a heterodyne wavemeter. Then reduce the inductance by one turn, and repeat. Repeat until accurate readings are no longer possible. Plot wavelength, or frequency, against added turns of wire. Where the line crosses

the wavelength or frequency axis is the natural wavelength or frequency of the antenna.

137. Antenna capacity.—The capacity of an antenna may also be determined by experiment.

Experiment 8-8. To measure the capacity of an antenna.—Measure the wavelength of an antenna attached to an inductance, as in Fig. 109. Then replace the antenna-ground connections by a variable condenser (Fig. 109*b*) and tune the condenser until resonance with the wavemeter is indicated. The capacity of the condenser at this point is the capacity of the antenna.

138. Antenna inductance.—Experiment is resorted to to determine the inductance of an antenna.

Experiment 9-8. To determine the inductance of an antenna.—Connect a known inductance, L_1 , in series with the antenna and measure the wavelength λ_1 . Repeat, using a different inductance L_2 and get λ_2 . Then the two wavelengths

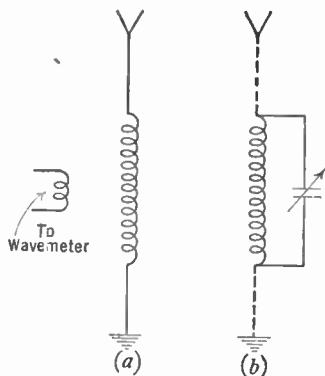

FIG. 109.—To measure capacity of an antenna.

$$\lambda_1 = 1.884 \sqrt{(L_1 + L_a)C_a}$$

$$\lambda_2 = 1.884 \sqrt{(L_2 + L_a)C_a}$$

where L_a = antenna inductance in microhenries;

C_a = antenna capacity in micro-microfarads.

Eliminating C_a between these two equations we get

$$L_a = \frac{L_1\lambda_2^2 - L_2\lambda_1^2}{\lambda_1^2 - \lambda_2^2}$$

Problem 1-8. A wavemeter is being calibrated from a standard. At resonance the capacity of the standard is 400 mmfd., the capacity of the other meter is 500 mfd. What is the ratio of their inductances? If the inductance of the standard is 300 microhenrys, what is the inductance of the other wavemeter? At what frequency are they now set? What is the wavelength?

Problem 2-8. In calibrating a wavemeter from a source of 1000 kc. which has many harmonics, the fundamental is received when the condenser

capacity is 253 mmfd. Another indication is received when the capacity is approximately 65 mmfd. What harmonic is this?

Problem 3-8. In an experiment to determine the resistance of a coil by the change of total resistance method (Experiment 5), the current without added resistance is 100 milliamperes and with 12 ohms added it is 60 milliamperes. The resistance of the meter is 5 ohms. What is the resistance of the coil and condenser in series?

Problem 4-8. A certain coil-condenser (LC_1) tunes to a frequency, f_1 . The condenser is changed by adding another to it so that the value is C_2 .

The circuit now tunes to a frequency, f_2 . Prove that $\frac{f_2}{f_1} = \frac{\sqrt{C_1}}{\sqrt{C_2}}$.

Problem 5-8. Using the formula in Problem 4, what must be done to the capacity to make a circuit tune to twice the frequency, half the frequency, double the wavelength, one-half the wavelength?

Problem 6-8. A coil-condenser combination tunes to 450 kc. when the condenser is 600 mmfd. When an unknown condenser is placed in series with the 600-mmfd. capacity the circuit tunes to 600 kc. What is the unknown capacity?

Problem 7-8. An antenna tunes to 300 meters when 100 microhenrys are in series with it, and 400 meters when 300 microhenrys are in series. What is the inductance of the antenna? Remembering that the two inductances, L_1 or L_2 , and the inductance of the antenna L_a are in series, and can be added to get the total inductance, what is the capacity of the antenna? What is its natural wavelength?

139. Typical receiving circuits.—The first essential of all receivers is an antenna to collect energy from the distant station. This can be a single wire stretched out in the open. For broadcast-frequency receivers under average conditions, it should be about 60 feet long. If everyone used the same antenna system it might be possible to tune the aerial circuit to series resonance with a high gain, but no two aeri-als are alike. Therefore engineers design the antenna input systems to modern receivers so that they are resonant to a frequency lower than any to be received. The actual antenna coil is a universal wound inductance of about 3 millihenrys. In auto radios it is possible to control the dimensions of the antenna and here it may be made resonant, say to 2000 kc. The antenna stage gain in home receivers is about 6; in auto sets it may be 20 or more. Because of the distributed capacity of the coil and the minimum capacity of the condenser as well as the capacity of apparatus attached to the coil-condenser combination

the lowest wavelength that can be attained without changing the circuit is limited. The ratio of longest to shortest wavelength received on broadcast tuners is about 3 to 1, that is, from 200 to 600 meters. Because the wavelength varies as the square root of the capacity, the capacity range of the condenser must be nine to one. If the maximum capacity of the condenser is 500 mmfd., a maximum of 50 mmfd. can be across the inductance when the condenser is turned to zero degrees and still cover the required frequency range. This capacity is made up of the coil capacity, minimum capacity of the tuning condenser, leads, etc.

The resistance of the coil has an important bearing upon selectivity and to some extent upon the sensitivity of the receiver. As we

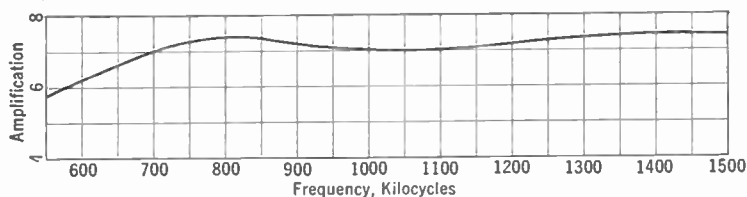

FIG. 110.—Amplification of Universal Coil (3 ml.) antenna input system.

shall see later it has an important bearing upon the fidelity, or quality, of signals as they emerge from the loud speaker. The resistance of modern, variable condensers may be neglected. The resistance introduced into coils and accessory circuits by large nearby metallic masses may be considerable, and therefore coils, if shielded, must be kept at a respectable distance from the metallic shielding material.

Modern receivers are usually of the superheterodyne type with at least one stage of tuned r.-f. amplification between the antenna and the frequency changer. Following the change in frequency, signals are amplified in one, two or sometimes three intermediate frequency stages (usually about 456 k.c.) and then the detector removes the voice and music frequency signals from the intermediate frequency. Further amplification takes place at audio frequencies.

It is desirable to enter the receiver with the highest possible signal with respect to any noise such as static, spark noise, etc. Then, since additional noises are generated in the receiver itself, it is desirable to start with a good strong signal so that there will

always be a considerable difference between signal and noise. One method of accomplishing this is to use high power in the transmitter; but an efficient antenna input circuit is effective too.

In 1936 Armstrong demonstrated a system called **frequency modulation** which makes it possible to transmit and receive signals almost free of noise. This comes from the interesting fact that

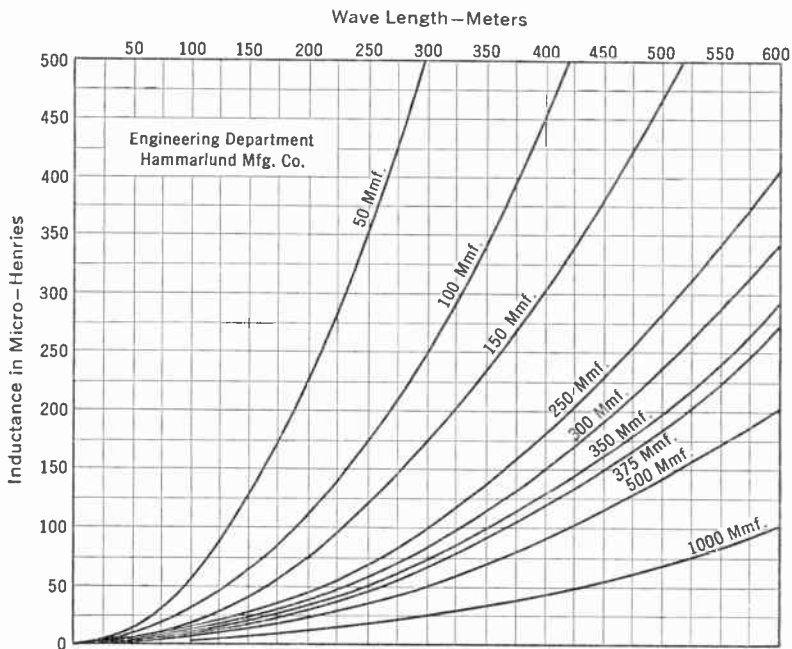

FIG. 111.—Curves showing the amount of capacity and inductance to tune to a given wavelength.

noise in the ether is almost all “amplitude modulated” just as present-day broadcast signals are modulated. Now if we modulate broadcast signals according to some other plan, say frequency modulation, and make our circuits unreceptive to amplitude modulation, then the desired signals will be admitted and the undesired noise signals will be kept out. The Armstrong system is useful only on very short waves because it requires a large band width to be effective.

CHAPTER IX

THE VACUUM TUBE

THE most important single device known to radio science is the **vacuum tube**. Although it is true that some receivers exist which use no tubes at all, and that those which are within a very short distance of broadcasting stations and which use only head phones can get along with a coil, a condenser, and a crystal detector, far the greater number of receivers in this country use tubes, some of them one, some two, many as high as twelve or more.

140. The construction of the vacuum tube.—As we know the tube today it consists of a glass wall within which are three metallic parts known as the elements. In the center is the **filament** which may be made of tungsten, carbon, tungsten covered with thorium, platinum or nickel coated with oxides of barium, strontium, caesium, and other chemical elements. Next to the filament is the **grid**, an open mesh of molybdenum (frequently) wire screen; finally is the **plate** which is a sheet or screen of metal, often of nickel. Some tubes have only two elements, the filament and the plate; many have additional grids; the mechanical construction differs according to type of tube, its use, and its manufacturer.

After the various elements are placed within the tube, the glass wall is attached to a pump and the gas is removed. During the pumping process the glass wall is heated in an electric oven to drive out the gas from it, and later the elements are heated by means of an "induction furnace" so that various gases bound up in these metals may be pumped out. The modern tube is a high vacuum tube; early types were poorly pumped and were really gaseous tubes, tubes which would be rejected by modern testing methods. When the pumping or "exhaustion" process is complete the glass wall and its contents are sealed. Then the tube

goes through several electrical tests and inspections before it can be labeled, packed, shipped and again unpacked and sold for use.

141. The purpose of the filament.—In Chapter I of this book we discussed the electron, that elementary constituent of matter which carries electricity. Little has been said about the electron in preceding chapters; now it enters again and assumes an important rôle. The filament is the heart of the vacuum tube; the electrons which rush about in this filament are the life blood. When the filament is dead—due to age or crossed wires—the electrons no longer move in the proper manner; the tube is dead and might as well be broken up. If a filament of tungsten is heated so that an individual electron gets up a speed of 1×10^8 centimeters per second (620 miles per second) it can break through the surface tension of the filament. Since it is negatively charged it will be attracted toward any positive body nearby.

142. The purpose of the plate.—When the electron is released from the filament it goes shooting out into the void in which the elements are situated. When it leaves the filament, it takes with it a negative charge, and thereby leaves the filament positively charged. If there is no body at a positive potential within the bulb other than the filament, the electron will eventually find its way back to the source whence it came. If, however, a “plate” is within the tube and is more positive than the filament, the electron will be attracted to it. Even when the plate is at the proper positive potential to attract many electrons, some go back to the filament, and others congregate somewhere between the filament and the plate and constitute what is called the “space charge.”

Every electron which hits the plate constitutes a minute electric current and when enough of them arrive per second a measurable current is attained. It is this current carried by the electrons from the filament which constitutes the tube's plate current which is used in so many ways. The symbol for plate current is I_p ; the plate current is usually measured and expressed in milliamperes.

The source of the electrons is usually called the cathode, which may be a filament or a coated cylinder heated by an internal filament. This filament is heated by a battery, called an **A battery**,

or by a step-down transformer from the a.-c. lighting circuit. A battery inserted between part of the cathode system and the plate maintains the plate positive with respect to the cathode. It is called the **B battery**.

When the cathode is heated to a proper temperature a copious stream of electrons is emitted. In a filament-type tube some electrons are attracted to the positive part of the filament, i.e., to the side of the filament attached to the positive end of the A battery. If the plate is insulated from the filament, a few electrons will get through the fog called the space charge but if it is at a higher potential than the filament it attracts many more electrons.

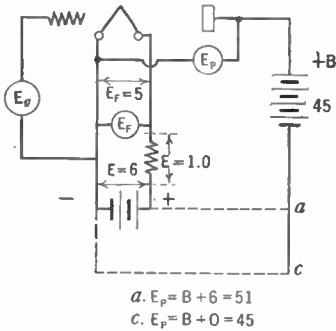

Fig. 112.—If the B battery is connected as at (a) the voltage on the plate is 51 volts; if as at (c) the voltage is 45.

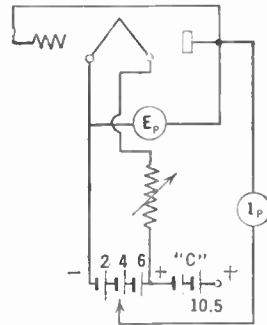

Fig. 113.—Circuit for testing effect of plate voltage on emission.

It is usually so maintained by means of the B battery which in power tubes may be as high at 10,000 volts above the potential of the filament. This B battery may be attached to the filament in several ways. Its negative end may be connected to the negative end of the A battery or to the positive end of the A battery. It is standard practice in the telephone plant to connect A plus and B minus together; in other places it is common practice to connect the two negative leads together. The most negative part of the filament in the case of d.-c. tubes, or the center of the filament or the cathode sleeve in the case of tubes run from a.c., is considered as the point to which all other voltages are referred. (See Fig 112)

Experiment 1-9. Effect of plate voltage on a two-element tube.—Connect the grid and plate of an ordinary receiving tube together and connect into a circuit as shown in Fig. 113. Use a plate-current meter reading about 5 milliamperes. Light the filament and read the plate current as the plate is connected to the negative end of the battery and then to plus 2, 4, and 6 volts by connecting it to the first, second, or third storage cell in the battery. Connect the negative terminal of a 4.5-volt C battery to the positive end of the A battery and the positive terminal of the C battery to the plate. Read the plate current. The plate is now plus 10.5 volts above the potential of the negative part of the filament. Explain why.

143. Effect of filament voltage.—The experiment above shows that the effect of increasing the positive potential of the plate is to

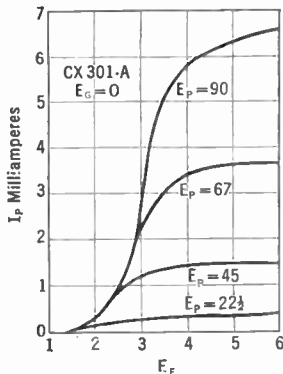

Fig. 114.—Saturation curves.

increase the flow of electrons. The filament temperature, too, has an important effect upon the flow of electrons. The hotter the filament the more electrons per second will be released into the space surrounding the heated element. If, however, the voltage on the plate is low, there will soon be reached a definite plate current which cannot be exceeded no matter how hot the filament becomes. In other words the plate is taking all the electrons it can get through the space charge. It is true that more electrons leave the filament at higher temperatures but they simply add to the space charge or return to the filament. If the plate battery voltage is increased, a greater plate current will flow, but again a point will be reached where passing more current through the filament ceases to increase the plate current. Typical saturation curves for a 201 A type of tube are shown in Fig. 114. Whenever the space charge (negative) is more effective in repelling electrons than the plate (positive) is in attracting them a flattening plate current takes place.

Experiment 2-9. Effect of filament voltage: Three-element tube.—A study of many of the tube's characteristics may be made with a set-up of apparatus like that in Fig. 115 which consists simply of a board upon which are connect'd

several Fahnestock clips to which may be attached meters and batteries of the proper potential. A good voltmeter is a two-range Weston Model 506 reading on the low scale up to 7.5 volts and on the upper to 150 volts. These will read the ordinary ranges of filament and plate voltages. A plate current meter may be any milliammeter reading from 5 milliamperes upward.

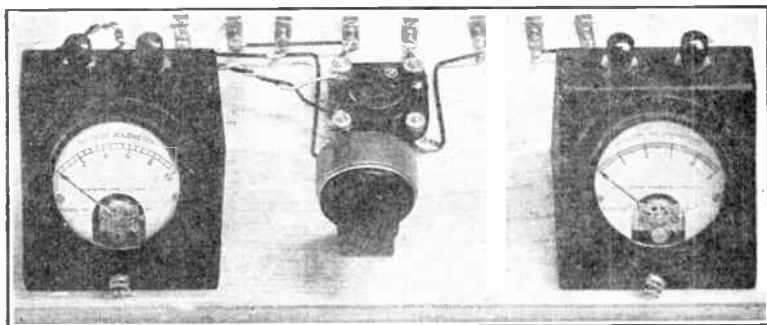

Fig. 115.—An experimental set-up for measuring tube characteristics.

Connect up a tube as shown in Fig. 116 and after reading the plate voltage, place the meter across the filament. Use at the start about 22.5 volts of B battery. Turn on the rheostat slowly and read the filament voltage and plate current. If either meter should read backwards, reverse it. Plot as in Fig. 114 the relation between E_f (filament volts) and I_p (plate current). Increase the plate voltage and repeat.

144. Saturation current.—With a given filament voltage (which produces a certain filament temperature) more and more electrons will be drawn to the plate as the voltage of the latter is increased—up to a certain point. But beyond this point additional plate voltage has little effect on plate current and the plate current curve flattens out. All of the electrons emitted by the filament are being taken by the plate and increasing the plate voltage has no effect upon the number of

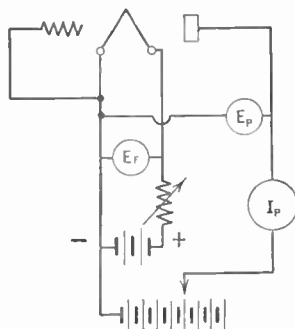

Fig. 116.—Circuit for apparatus of Fig. 115.

electrons emitted. Increasing the filament temperature produces an additional supply of electrons, and the plate current will again increase.

Experiment 3-9. Effect of plate voltage: Three-element tube.—Connect up the apparatus used in Experiment 2 as shown in Fig. 116. Set the filament voltage at some fixed value and take data showing the effect upon plate current of varying the plate voltage. Increase the filament voltage and repeat. Plot the data in a manner similar to that in Fig. 114. Remembering that 6.28×10^{18} electrons per second flowing past a certain point in a circuit constitutes an electric current of an ampere, calculate the number of electrons that arrive at the plate per second for several values of filament and plate voltage.

The experiments and curves above show

1. The relation between plate and filament voltage and plate current.
2. The saturation effect at low filament and plate voltages. Saturation due to insufficient plate voltage is known as filament saturation; that due to insufficient electron supply is called plate saturation.
3. The fact that little is to be gained by increasing the filament voltage above the rated value.
4. The curve connecting plate current (I_p) and filament voltage (E_f) is not a straight line.

This shows that Ohm's law is not being followed; the law in fact is much more complicated. The plate current is zero at zero filament voltage, and as the latter is increased the plate current begins to rise too, but not in a straight line. Soon, however, the negative space charge built up by the electrons which do not get to the plate prevents any more electrons getting to the plate. The plate current then is limited, and may be increased only by increasing the plate voltage so that it is again more positive than the space charge is negative. Various means are used to overcome this space charge which shall be discussed later.

145. The purpose of the grid.—The third element, for which DeForest is famous, is the grid, the mesh of wires between the filament and plate. It has several important uses. It may be used to neutralize the space charge so that greater plate current may flow with a given filament temperature and given plate voltage.

Suppose the grid is made positive with respect to the source of the electrons. Since it is physically nearer the filament than is the plate, a small positive potential will have the same effect as a large positive potential on the plate. A positive potential near the filament speeds up the escape of electrons, and prevents the building up of a high negative space charge and then the plate has a greater ability to attract the carriers of electric current.

Suppose, however, we make the grid negative. Owing to its relatively close position with respect to the source of electrons, a small negative voltage on it will counteract a large positive voltage on the plate. So, with a small negative voltage we can prevent any electrons from getting to the plate, or by varying this grid voltage we can regulate in any desired way the number of electrons that reach the plate, and thereby control the plate current. Since there is no time lag in the flow of electrons, the grid voltages take instantaneous effect upon the plate current. The grid, then, is a control electrode. The relation between the effects upon plate current of the grid voltage compared to the plate voltage constitutes an important tube "constant," the **amplification factor**.

146. Characteristic curves.—In the simplest receiving tube there are three electrodes. The cathode has already been mentioned, and the manner in which its temperature affects the plate current has been tested. The plate and the effect of its voltage on plate current have been qualitatively mentioned; so has the effect of grid voltage. Under ordinary conditions the cathode is operated "saturated," that is, at such voltage that there is little use in raising it further. Its voltage is then fixed; it is not varied.

If the cathode voltage is considered as fixed, we still have the plate current depending upon two variable quantities, the grid and the plate voltage (E_g and E_p). The manner in which these variables affect the plate current controls the characteristics of the tube. When plotted in graphs, they are called **characteristic curves**.

Experiment 4-9. Effect of grid bias upon plate current.—Set up the apparatus as shown in Fig. 117, using in succession several of the common types of tubes. Set the filament at the proper voltage. Fix a small voltage, say 22.5 volts, on the plate of the tube and take down data showing how the

plate current changes as the grid bias is varied from a point where the plate current is zero to a grid voltage of about positive 10 volts. The D. P. D. T. switch in the grid circuit makes possible changing the polarity of the grid without changing the meter (E_g) connection. Then raise the plate voltage and repeat. Plot these data like those in Fig. 118.

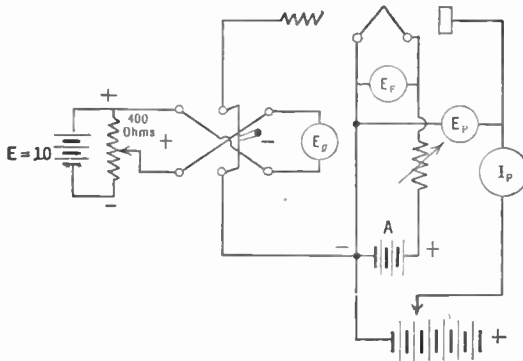

Fig. 117.—Complete apparatus for measuring characteristics. The D. P. D. T. switch reverses the grid voltage.

147. Grid voltage—plate current curves.—Several interesting and im-

portant facts may be discovered by looking at such curves which

we shall call the E_g-I_p curves. At large negative grid voltages there is little or no current in the plate circuit. As this negative voltage is decreased, some electrons get past the grid and through the space charge and to the plate. The current begins to flow, increases at a rather slow rate, then more rapidly, then in a steep and straight line, and finally, if the experiment is

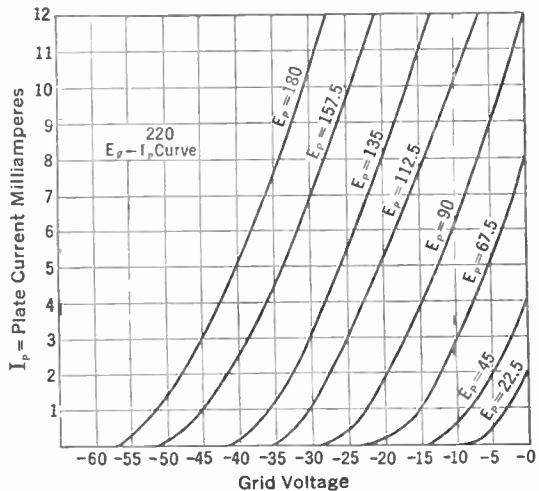

Fig. 118.—A family of E_g-I_p curves.

carried far enough, the curve flattens out. Increasing the plate potential and again varying the grid potential produces a new curve which is essentially parallel to the first, but moved to the left. Increasing the plate voltage again a like amount produces a new curve displaced an equal distance to the left of the second line. Such a graphic collection of data is known as a "family" of curves and tells all we need to know of the effect of grid voltage upon plate current. Grid voltages may be secured from a battery known

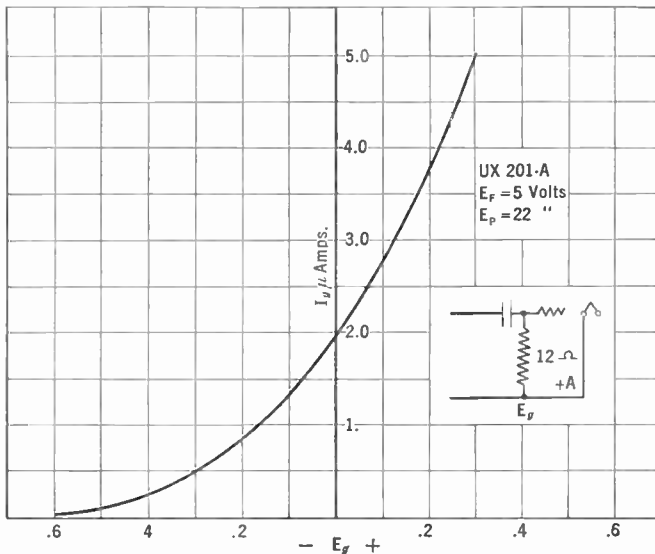

FIG. 119.—Grid current curve of a three-element tube.

as a C battery and the voltage itself is frequently called a "C" or grid "bias."

If we place a meter in the grid circuit at the same time the plate current is measured, we shall see that a very small grid current is taken at positive grid potentials. This current in ordinary practice is very small, seldom over one-tenth of the plate current, and in all amplifiers in which the minimum distortion is desired the current in the grid circuit is kept as low as possible by making the grid highly negative. The grid current curve for a typical case is shown in Fig. 119.

148. The effect of plate voltage upon plate current.—To determine this effect we will resort to experiment.

Experiment 5-9. Set up the apparatus as in Experiment 4. Set the grid voltage at some value, say minus 5 for an ordinary receiving tube, and note down the plate current as the plate voltage is changed from 0 to perhaps 100 volts in 10-volt steps. Then change the grid voltage to minus 10 and repeat; then at minus 15 and 20; 0, and plus 5 and 10, etc.

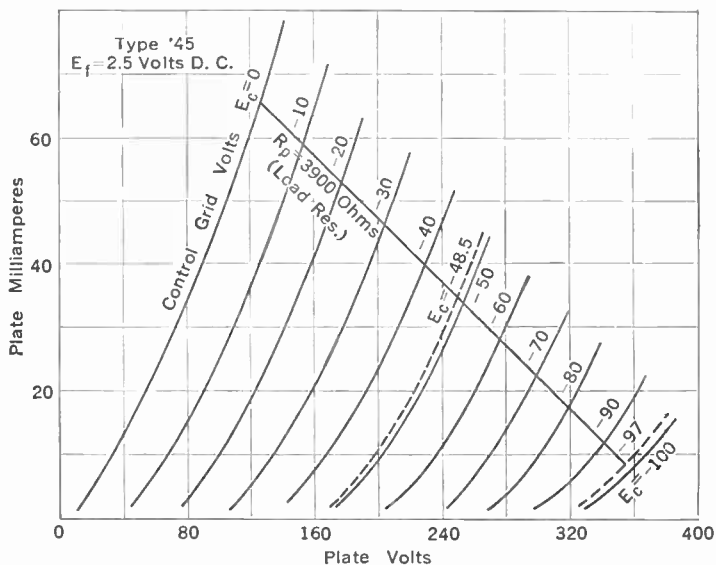

FIG. 120.—Plate current—plate voltage curves.

These data may be taken from the $E_p - I_p$ curves plotted in Experiment 4 by picking off the curves the proper values of current, and plate and grid voltages.

149. Plate voltage—plate current curves.—Here again (Fig. 120) the curves which we shall call the I_p curves are essentially parallel over the straight parts. If the grid voltages chosen are in equal steps, the plate current curves will be equal distances from each other.

From characteristic curves of this type, we may calculate all the tube constants, and foretell nearly all the properties of the tube

when connected into a circuit with other apparatus whose electrical constants we know.

150. Amplification factor.—For example we know that the grid potential is relatively more important in controlling plate current than is the plate voltage. Why? Because it is nearer the source of

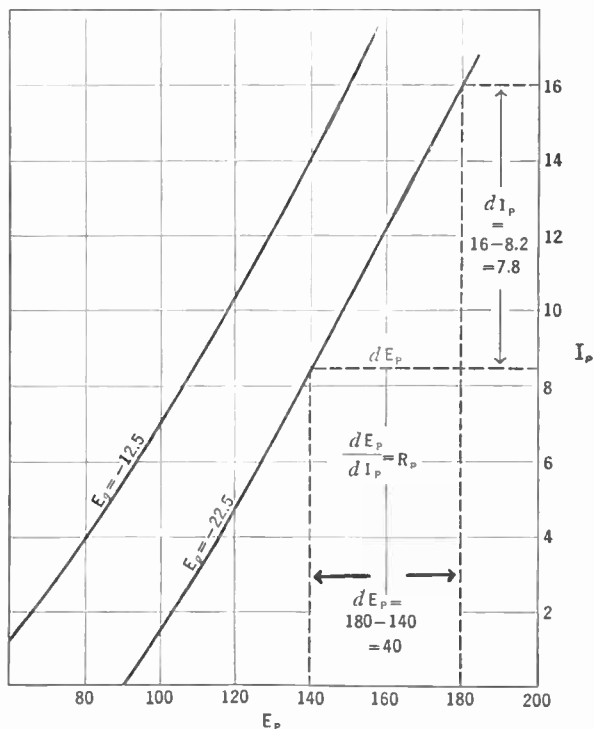

Fig. 121.—Detailed E_p - I_p curve showing how to calculate \dot{R}_p .

electrons. How much? We can tell from the E_p - I_p curves in Fig. 121. Looking at the line marked $E_g = -22.5$, we see that at a plate voltage of 180 the plate current is 16 milliamperes but that if E_p is decreased to 140 volts the plate current decreases to 8.2 milliamperes—a change of 7.8 milliamperes for 40 volts or a net change of 0.195 milliamperes per volt. This is the slope of this

particular line and, as we shall see later, it gives us another important tube constant without further calculation.

Now looking at the two curves marked $E_g = -12.5$ and $E_g = -22.5$ at the points where they cross the 140-volt E_p line, we see that at this value of plate voltage the plate current is respectively 14.0 and 8.2 milliamperes at these two values of grid voltage. This means that changing the grid voltage by 10 volts causes a change of 5.8 milliamperes in the plate current, a net change of 0.58 milliampere per volt. Dividing the change per volt caused by E_g variations, by the change per volt produced by E_p variations gives us the relative ability of the grid and plate potentials to influence the plate current. Thus,

$$\frac{\text{Ability of grid voltage to control plate current}}{\text{Ability of plate voltage to control plate current}} = \frac{0.58 \text{ ma./volt}}{0.195 \text{ ma./volt}} = 3.0.$$

This ratio is defined as the **amplification factor** of the tube. It is the ratio between the plate voltage change required to produce a certain plate current change and the grid voltage change required to produce the same change in plate current. The Greek letter mu, μ , is the symbol used in the literature for the amplification factor of a tube. Thus

$$\mu = \frac{\text{plate voltage change to produce a given plate current change}}{\text{grid voltage change to produce the same plate current change}}$$

The amplification factor for a given tube does not vary much under the conditions under which the tube is ordinarily used. It is controlled largely by its mechanical construction, and the nearness of the grid to the filament. A grid composed of many wires close to the filament produces a high amplification factor; a tube with a wide mesh and not so close to the filament produces a tube with a low amplification factor.

The student should note that the amplification factor is *not* the ratio between plate and grid voltages, but is the ratio between

changes in these voltages. It may be expressed in more mathematical language as

$$\mu = \frac{dE_p}{dE_g} \text{ to produce a given } dI_p,$$

where the prefix "d" signifies "a change in" (a differential).

The amplification factor may be obtained from the E_g - I_p curves in Fig. 121 in a manner similar to that outlined above. It is also equal to the change in I_p produced by, say 20 volts change in E_g divided by the change in I_p produced by 20 volts change in E_p . Thus in Fig. 120 changing E_g from -40 to -20 (with $E_p = 160$) produces a variation of 32 milliamperes while along the $E_g = -40$ line a change of E_p from 200 to 220 volts produces a variation of approximately 11 ma.

Then

$$\mu = \frac{32}{11} = 3 \text{ (approx.)}$$

151. The meaning of the amplification factor.—If the amplification factor of a tube is 3, for example, adding 30 volts to the plate will increase the plate current a certain amount. Adding only 10 volts (positive) to the grid will produce the same plate current change or adding 10 volts negative to the grid will bring the plate current back to its value before the plate voltage had been increased. In other words any voltage placed on the grid of such a tube has the same effect as a voltage in the plate circuit multiplied—or amplified—by the μ of the tube. A voltage E_g on the grid becomes equal to μE_g when it gets to the plate circuit.

152. Equivalent tube circuit.—Since a change in plate voltage may be replaced by a smaller change in grid voltage multiplied by the μ of the tube, we may replace the entire tube by a fictitious generator whose voltage is μE_g and whose internal resistance is equal to the resistance of the tube. In fact in all problems the tube is so considered, and is indicated symbolically as in Fig. 122.

Problem 1-9. With a 20-volt bias the plate current of a tube under a given value of E_p is 55 ma., and when the bias is increased to 30 volts the plate current is reduced to 28 ma. If, however, at this value of grid bias (-30)

the plate voltage is increased from 180 to 210 volts the plate current comes back to its original value, 55 ma. What is the amplification factor of the tube?

Problem 2-9. The amplification of a tube is 8 and when the grid is -3 volts the plate current is 3 ma. If the bias is reduced to zero the current increases to 8 ma. Both of these current values were read when the plate voltage was 90 volts. How much would the plate voltage have to be reduced (at zero grid bias) to bring back the current to its 3 ma. value?

Problem 3-9. Changing the plate voltage of a power tube from 100 to 300 volts changes the plate current from 10 to 55 ma. If the bias is zero at the latter figure what must be done to it to reduce the current to its former value if the amplification factor is 7.8?

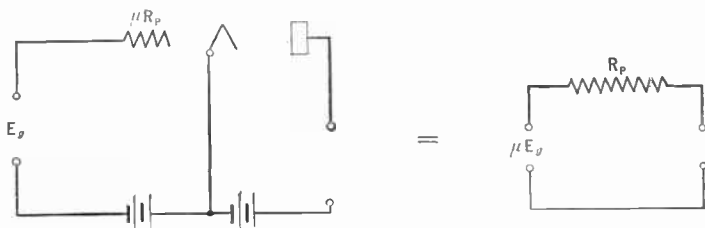

Fig. 122.—The tube and its equivalent circuit; a voltage μE_g in series with R_p and the load.

153. D.-c. resistance of a tube.—Since a certain plate current flows under the pressure of a certain plate voltage, the ratio

$$R = \frac{E_p}{I_p}$$

in which E_p = the d.-c. voltage on the plate;
 I_p = the d.-c. current in the plate circuit,

gives the d.-c. resistance of the space between the filament and the plate. The power used up by the electronic current may be found by multiplying the plate voltage by the plate current, or

$$P = I_p E_p \quad \text{or} \quad \frac{E_p^2}{R} \quad \text{or} \quad I_p^2 R.$$

This power is the rate at which the kinetic energy possessed by the moving electrons is given up to the plate. When the electron leaves the filament it is attracted toward the plate, increasing in

speed as it gets closer and closer to the positive potential which is the attracting force. When the electron hits the plate its kinetic energy due to its motion is given up. In a transmitting tube the number of electrons that arrive per second may be so high that the plate becomes red- or white-hot.

154. Internal resistance of the tube.—This d.-c. resistance is not what is popularly known as the “impedance” of the tube, or more properly called its “plate resistance” or “differential or internal resistance.” The latter is the ratio between a *change* in plate voltage and the *change* in plate current produced by this change in plate voltage. It is the resistance offered to the flow of a.-c. currents in the plate circuit and is not the same resistance as is offered to the flow of d.-c. current from the battery. Then

$$R_p = \frac{\text{change in plate voltage}}{\text{change in plate current}} \quad \text{or} \quad \frac{dE_p}{dI_p}$$

For example changing the plate voltage from 180 to 140 volts (Fig. 121) produced a plate current change of 7.8 milliamperes (0.0078 ampere)

$$R_p = \frac{dE_p}{dI_p} = \frac{180 - 140}{.016 - .0082} = \frac{40}{.0078} = 5200 \text{ ohms (approx.).}$$

Problem 4-9. Make a table showing the d.-c. resistance of various tubes in general use at the conditions they ordinarily work, that is, a 32 tube at $E_p = 135$ volts and $E_g = -3$, a 45 with $E_p = 180$ and $E_g = -33$. Use values of plate current in the tube chart. Compare the d.-c. resistance with the a.-c. resistance.

Problem 5-9. The plate current of a tube is 4.5 ma. when $E_p = 90$ volts, and is equal to 0.9 ma. when $E_p = 40$ volts. What is the plate resistance?

Problem 6-9. The plate resistance of a tube is 12,000 ohms. At $E_p = 140$, $I_p = 14.5$ ma. What is I_p when $E_p = 100$ volts?

Problem 7-9. Calculate the d.-c. resistance of the tube under the two conditions of E_p and I_p in Problem 6, and the power used in heating the plate.

The internal resistance changes with plate and grid voltages and so the conditions of both must be considered when the resistance is mentioned. Thus the 171 tube has an internal resistance of 2000 ohms when the plate voltage is 180 volts, and the grid

voltage is 40.5 volts negative. Its internal resistance differs if either E_p or E_g is varied.

The student should note that R_p is not the ratio between a plate voltage and a plate current but is a ratio between *changes* in both plate current and plate voltage. Thus a 201-A tube at a plate voltage of 90 has a plate current of 2.5 ma. The ratio $\frac{90}{.0025} = 36,000$ ohms is the d.-c. resistance; R_p is equal to about 13,000 ohms under these conditions.

155. Mutual conductance of a tube.—There is one more important tube constant, the **mutual conductance**. This is the factor which tells us how much plate current change is caused by a given grid voltage change. (This is not the plate conductance $1/R_p$.) Thus

$$G_m = \frac{\text{change in plate current}}{\text{change in grid voltage}} = \frac{dI_p}{dE_g}$$

Thus if a change of one grid volt produces a change of plate current of 1 milliamper, the mutual conductance

$$G_m = \frac{1 \times 10^{-3}}{1} = 1 \times 10^{-3} \text{ mho or } 1000 \text{ micromhos.}$$

The mutual conductance is defined, too, by the ratio between the amplification factor and the plate resistance. Thus

$$G_m = \frac{dI_p}{dE_g} = \frac{\mu}{R_p} \text{ because } \mu = \frac{dE_p}{dE_g} \text{ and } R_p = \frac{dE_p}{dI_p}.$$

$$\text{Therefore } \frac{\mu}{R_p} = \frac{\frac{dE_p}{dE_g}}{\frac{dE_p}{dI_p}} = \frac{dI_p}{dE_g}$$

Problem 8-9. A tube has a plate current of 7.75 ma. at zero grid bias and 3.8 ma. at $E_g = -4$. What is the mutual conductance?

Problem 9-9. The mutual conductance of a tube is 800 micromhos. What change in plate current is produced by a 1 volt change on the grid?

Problem 10-9. The mutual conductance of a tube is 775 micromhos. The plate current at $E_g = -6$ is 2 ma. What is the plate current at $E_g = -2$?

156. Importance of mutual conductance.—The tube is ordinarily so worked that small variations in input (grid circuit) a.-c. voltage produce variations in output (plate circuit) a.-c. currents, and it is important that the mutual conductances of a tube shall be high. Tubes are in general use which have amplification factors as low as 3 and as high as 30, the plate resistance ranging from 800 to 100,000 ohms. When still greater amplification constants are desired—we are speaking of small receiving tubes only—it is necessary to change the construction of the tube. It is here that the screen-grid, or four-element tube, arrives on the scene. It is described in Section 170.

When one is considering two tubes of the same type, say two 27 tubes, the one with the higher mutual conductance is the better, but rather large differences in mutual conductance must occur before any difference in the operation of a circuit in which the two tubes are to be used will be noted. If one is to compare a 46 with a 50 he will see that the mutual conductance of the 50 is less than of the former, and yet the 50 tube is capable of furnishing much more undistorted power to a loud speaker than the 46. In comparing tubes of the same type which are to be used for the same purpose the mutual conductance is the best single factor. Recently the term “transconductance” has come into general use instead of mutual conductance. It has the same meaning.

157. Slopes of characteristic curves as tube constants.—Since the plate resistance of the tube is defined as

$$R_p = \frac{dE_p}{dI_p}$$

and the mutual conductance as

$$G_m = \frac{dI_p}{dE_g},$$

these values may be taken directly from the curves showing the relation between plate voltage and plate current and between grid voltage and plate current; the reciprocal of the plate resistance is the slope or steepness of the E_p - I_p line, that is, $\frac{1}{R_p} = \text{slope of the}$

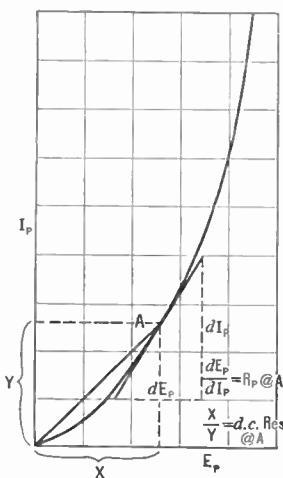

Fig. 123.—Note how R_p is obtained. It is not E_p divided by I_p , which gives the d.-c. resistance.

plate resistance, mutual conductance, and amplification factor. Plot these values against grid voltage for one curve and against plate voltage for another curve. Such data for a typical tube are shown in Fig. 124.

158. "Lumped" voltage on a tube.—An expression in England for the voltage on the plate of a tube is very useful. It involves the expression,

$$E = E_p + \mu E_g,$$

E_p-I_p curve; the mutual conductance is the slope of the E_g-I_p line. When changing the grid voltage produces no change in plate current (saturation) the mutual conductance is zero, that is, the E_g-I_p curve no longer has any slope or "steepness" and it flattens out, as for high positive values of grid bias. On the other hand, when the E_p-I_p curve flattens out the plate resistance becomes infinite—and so the steeper the E_p-I_p curve the lower the plate resistance. Care should be taken that the plate resistance is obtained properly from the E_p-I_p curve. Figure 123 shows the correct and incorrect methods.

Experiment 5-9. From the curves plotted in Experiments 4 and 5 measure the slopes at various values of E_p and E_g and calculate the

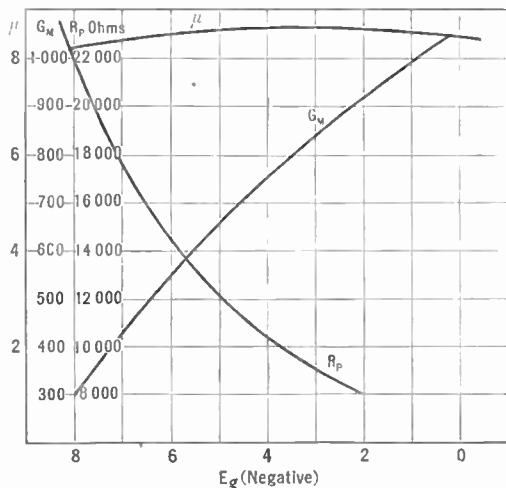

Fig. 124.—Effect of grid voltage on tube characteristics.

where E = the effective or “lumped” voltage on the plate;

E_p = the plate voltage due to the B battery;

E_g = the voltage on the grid, due a C bias;

μ = the amplification factor of the tube.

For example we know that adding a negative C bias to a tube grid reduces the plate current. The same value of plate current may be attained without the C bias by reducing the plate voltage. Then for every value of plate current there are several combinations of grid bias and plate voltage that will produce it, the actual values being given by the above expression.

If, then, we plot the single curve showing the plate current at various plate voltages but with the grid at zero bias, we can easily calculate what the plate current will be under some other condition of B and C voltage. Thus with zero bias and 90 volts on the plate, the plate current may be 10 ma. That is,

$$E = 90 + \mu \times 0 = 90$$

Now suppose $\mu = 8$ and $E_g = -3$

$$E = 90 + 8 \times (-3) = 90 - 24 = 66.$$

To get I_p , it is only necessary to look at our E_p - I_p curve for $E_g = 0$ and find what I_p is when $E_p = 66$. This is the value of current desired, and is one point on the new curve $E_g = -3$. Then assume some other value of E_p and find the new I_p and place a mark on the graph paper for this point which is the second for the $E_g = -3$ curve. Other points may be obtained for other values of E_p and E_g and thus any number of curves may be drawn which will be parallel to the first or $E_g = 0$ curve.

Problem 11-9. The μ of a tube is 3; what is the lumped or effective plate voltage when $E_p = 180$ and $E_g = -40$?

Problem 12-9. The plate voltage E_p on a tube is 120 but the plate current corresponds to a plate voltage of 40 at zero grid bias. If the value of E_g is 10, what is the μ of the tube? Do you see a simple way of measuring the amplification factor of a tube by this method?

Problem 13-9. If the plate current of a tube is 2 ma. when $E_p = 90$ and $E_g = -4.5$ and $\mu = 8$, at what value of E_p will it be equal to 2 ma. when $E_g = 0$?

159. Measurements of vacuum tube constants.—The various factors which define all of a tube's characteristics— μ , R_p , and G_m —are known as the **tube constants**. It is very important that means be handy for measuring these constants at various values of plate and grid voltage so that a full knowledge of a tube's characteristics may be had.

Such calculations may be made by means of the characteristic curves. This is slow work, however, and the experimenter or radio service man has no time for such processes. A simpler method will be described.

(a) *To measure the plate resistance of a tube.*

This is the ratio between the change in plate voltage and the change in plate current: dE_p/dI_p . Set the grid bias at the value desired, for example -6 for a 37, and choose the plate voltage at which the tube will operate in practice at this bias. Then set the voltage at values somewhat higher and then somewhat lower than this median value, measure the plate currents, set down the data below in which the currents and voltages will be values secured by testing a 37.

$$R_p = dE_p/dI_p = \frac{100 - 80}{.0033 - .0007} = \frac{20}{.0026} = 7700 \text{ ohms.}$$

This means that at a grid bias of $E_g = -6$, the average plate resistance between the values of $E_p = 80$ and 100 volts is 7700 ohms.

It will be somewhat difficult to measure tubes of high resistance, screen grid tubes, by this method because the plate current curves are almost flat over the working range of plate voltages.

(b) *To measure the mutual conductance.*

This is the ratio between plate current change dI_p and the grid voltage change dE_g that produced it. Set the plate voltage at the value at which the tube will operate, for example: 90 volts. If the bias under operating conditions is to be 6 volts (a 37) set the grid at minus 7 and then minus 5 and read the plate cur-

rents. Set down the data as follows, assuming the plate currents are respectively 6 and 4 milliamperes:

$$G_m = \frac{dI_p}{dE_g} = \frac{.006 - .004}{7 - 5} = \frac{.002}{2} = .001 \text{ mho} = 1000 \text{ micromhos.}$$

(c) *To measure the amplification constant.*

The value of the amplification constant may be calculated directly from the results obtained in (a) and (b) above. Since

$$G_m = \frac{\mu}{R_p}$$

or

$$\mu = G_m \times R_p,$$

it is only necessary to multiply the plate resistance by the mutual conductance. Thus if

$$R_p = 10,000 \text{ ohms}$$

$$G_m = 1000 \times 10^{-6} \text{ mhos}$$

$$\mu = 1000 \times 10^{-6} \times 10,000 = 10.$$

The amplification constant may be determined in the following manner, which makes it unnecessary to determine first the mutual conductance and the plate resistance.

Set the plate voltage at a certain value, say E_{p1} , read the plate current, I_{p1} ; change the plate voltage to E_{p2} , note plate current I_{p2} . Then bring the current I_{p2} back to its original value I_{p1} by varying the grid voltage. The ratio of the corresponding plate and grid voltage changes is the amplification constant, as indicated in Section 150. That is

$$\mu = \frac{E_{p1} - E_{p2}}{E_{g2} - E_{g1}}.$$

160. Bridge methods of determining the tube factors.—A number of meters have been devised to measure the three tube constants by the methods outlined above—meters which read them directly and in a very simple manner. Other methods of obtaining the tube constants are in common use in laboratories. These methods involve balancing out one voltage by another.

For example let us consider the circuit in Fig. 125. An a.-c. current flowing through R_1 and R_2 in series sets up two voltages across them. The voltage $E_1 = I \times R_1$ becomes E_g and is impressed across the grid-filament input of the tube where it is amplified by the tube to appear in the plate circuit as μ times E_g . When the bridge is balanced by varying R_1 and R_2 no voltage is across the telephones and accordingly no sound is heard. At balance

$$\mu IR_1 = IR_2$$

$$\mu R_1 = R_2$$

$$\mu = \frac{R_2}{R_1}.$$

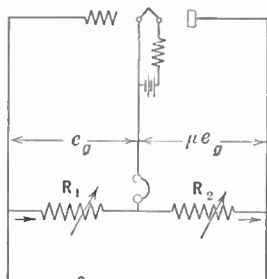

Fig. 125.—Bridge for determining amplification factor.

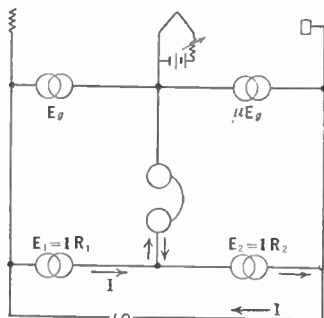

Fig. 126.—Equivalent of Fig. 125.

It is only necessary to adjust the ratio between the two resistances until the sound in the telephones is balanced out when the amplification factor is equal to the above expression. The same balance conditions may be found by substituting a battery and a key for the a.-c. voltage, and a plate current meter for the telephones. Pressing the key will change the plate current unless the ratio of R_2 to R_1 is adjusted properly. When no plate current change occurs

$$\mu = \frac{R_2}{R_1}.$$

In either of these bridges, R_1 may be fixed at 10 ohms and R_2 varied. Thus if $R_1 = 10$ ohms, and at balance $R_2 = 134$ ohms, the μ of the tube is $134 \div 10$ or 13.4.

161. To measure the plate resistance.—A bridge circuit may be set up to measure the plate resistance. There are several such bridges; one of them is shown in Fig. 127. Let us consider Fig. 128 which is equivalent to Fig. 127 (neglecting L) in which R_p represents the internal plate resistance of the tube. Current

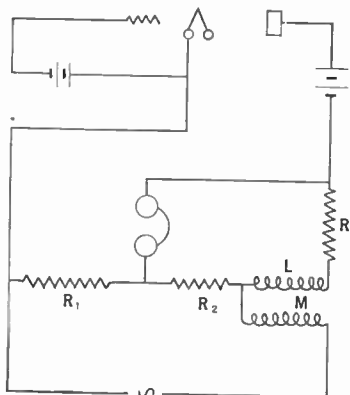

Fig. 127.—A bridge for measuring R_p .

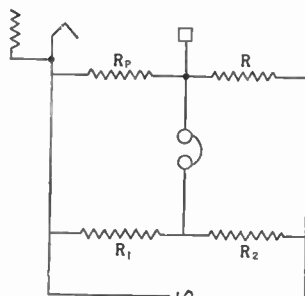

Fig. 128.—The equivalent of Fig. 127.

I from the alternator flows through R_1 and R_2 as well as through R_p and R . When no sound is heard in the telephones

$$\frac{R_p}{R_1} = \frac{R}{R_2}$$

or

$$R_p = R \times \frac{R_1}{R_2}$$

If $R = 10,000$ ohms

$R_2 = 100$ ohms

$R_p = 100 \times R_1$

The inductance L is useful in balancing out certain capacity voltages. It is not necessary and its reactance can be neglected in calculating the tube constant being measured.

It is essential that small variations of voltage be used. Since the E_p-I_p curve is not straight, its slope differs at different points and is only a "constant" over a limited part of the curve. If a large variation, dE_p , is used to measure the plate resistance, or a large grid variation, dE_g , when the mutual conductance is measured the values obtained will not be very accurate. Under normal conditions the a.-c. voltage put on the grid of an amplifier tube is seldom over 3 volts, and so it is absurd to measure the various constants by varying the grid more than this amount. Since the amplification factor of such a tube is about 8, a grid voltage of 3 corresponds to a plate voltage variation of about 24, and so changes in plate voltage, dE_p , greater than this value should not be used when obtaining tube constants.

162. An a.-c. tube tester.—A simple tester which the diagram in Fig. 129 describes pictorially will be useful for quick tests to

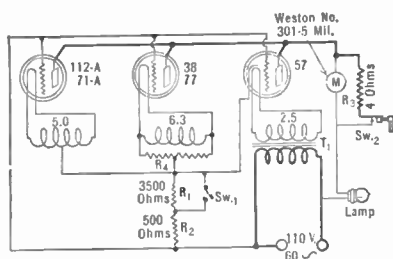

Fig. 129.—An a.-c. tube-tester.

determine whether or not a tube should be thrown away. It comprises an a.-c. transformer which provides the proper filament voltages for standard tubes, and a resistor divided into two parts through which the plate current flows. Across this resistance appears a voltage which may be used as C bias. The operation of the tester is as follows: it is plugged into a lamp socket (a.-c. of course), the tube is inserted, and the reading of plate current noted. Then part of the grid bias resistor is shorted, thereby changing the plate current and the C bias. The ratios between the corresponding plate current changes and the grid bias changes give an indication of the mutual conductance of the tube. In actual tests it would determine the mutual conductance

of several types of tubes within 80 per cent or better of the value as measured upon an accurate bridge.

Suppose for example that the plate current is 0.001 ampere when the bias resistor is 4000 ohms and 0.003 ampere (3 milli-amperes) when the bias resistance is reduced to 500 ohms. We set the data down as

$$\begin{aligned} G_m &= \frac{dI_p}{dE_g} = \frac{.003 - .001}{.001 \times 4000 - .003 \times 500} = \frac{.002}{4.0 - 1.5} = \frac{.002}{2.5} \\ &= .0008 \\ &= 800 \text{ micromhos.} \end{aligned}$$

163. Types of tube filaments.—The filament of the vacuum tube has undergone many mutations since the invention of the tube. What is desired, of course, is a copious emitter of electrons, that is, one which gives off many electrons at a low filament temperature and with expenditure of little current from the heating battery. Tubes which burn with a dull glow—Western Electric tubes, the 30, 45, 47, 71-A, 2A3, 112-A, 26, etc., and the rectifier tubes such as the 80, 83, have filaments which burn at a comparatively low temperature. They are very efficient because they are coated with rare elements which emit many electrons even though the temperature is not high.

Another type of filament is the thoriated tungsten filament. It is made of tungsten which is impregnated with atomic thorium. When the filament is heated the thorium gives off the electrons, and as the supply on the surface of the wire is exhausted a new supply comes from the interior of the filament. If, due to an accidental overload of filament voltage, the tube seems not to have the required plate current, it is probable that the balance between the rate at which the surface electrons are used up and the rate at which they come from the interior of the filament has been upset. The tube may then be reactivated, as explained in the following section.

The thoriated filament is very efficient, requiring much less power from the filament battery than any other kind of filament for a given amount of power output. The filament in the 199 type

of tube is finer than the human hair, and requires only 60 milliamperes to give sufficient emission.

164. Filament life.—Formulas have been worked out and checked experimentally which relate the emission of electrons as a function of the temperature of the filament and of the life of the filament as governed by temperature. At the higher temperatures more electrons are emitted and naturally the life decreases.

For example, a filament coated with a mixture of oxides of barium and strontium on a core made up of 95 per cent platinum and 5 per cent nickel will have an emission and life as shown below when the electron current is limited by space charge to 0.010 ampere per square centimeter and with 150 volts on the plate.

$$\text{Average life} = 0.00015e^{22000/T} \text{ hr.}$$

<i>T</i> Kelvin	Emission ma./sq. cm.	Life, hours
900	20	730,000
1,000	90	55,000
1,100	310	7,400

165. Alternating-current tubes.—Tubes which can be heated by a.c. are almost universally used (heater-type) because of the greater simplicity of operation. A transformer attached to an a.-c. circuit is much less cumbersome than a storage battery which must be periodically charged. There are several reasons why we cannot run the ordinary type of tube from a.c. When ordinary battery-operated tubes are lighted by a.c. an objectionable hum results. Suppose we lighted the filament from a.c. The voltage along the filament is continually changing, part of the time one side is positive with respect to the other, and part of the time it is negative. There is a continual heating and cooling going on which cannot help but transmit some of its variations to the plate circuit.

If a centertapped resistor is placed across the filament and the plate and grid circuits are attached to the center of the filament as in Fig. 176, the hum emanating from the plate circuit is less, but the filament is too light and has too little thermal inertia to withstand the continual heating and cooling without transferring some of its variations to the plate circuit. The hum is still too great.

Suppose, however, we have a very heavy filament with a low voltage across it. It has a high thermal inertia and it is possible to get a good balance between the electromagnetic and electrostatic fields at the value of plate current desired by introducing the grid and plate circuits to the center of the filament by means of a centertapped transformer winding, or a resistor. Such is the 226 type of tube. This uses a very rugged oxide-coated filament which consumes 1.05 amperes at a voltage of 1.5. The voltage drop across the tube is low, its thermal inertia is high, it has a very low hum output. It can be used as a radio-frequency amplifier and to some extent as an audio-frequency amplifier.

166. Heater types of tubes.—The heater cathode type of tube has a metal cylinder which surrounds a filament heated by alternating current. The cylinder is heated by conduction and convection from the filament proper from which it is electrically insulated. The thermal inertia of the cylinder and the insulating material is so great that fluctuations in a.-c. voltage of the filament do not affect the plate current.

The hum appearing in the plate circuit of such tubes, when operated from alternating current, is much less than in the 226 type. In addition to the decrease in hum there are other advantages to the heater type of tube. As a matter of fact, so great are the advantages of this type that it has practically displaced the filament type in home radio receivers.

The cathode, which is the coated cylinder and from which electrons flow, has no connection with the filament inside it which may be heated from a.c. or d.c.

Often the heater is biased either positive or negative with respect to the cathode. The idea is to still further prevent any flow of hum or noise from the a.-c. line into the cathode and thence into the amplification system.

The heater-type of tube is sturdier; therefore less subject to microphonic noises; in less danger of damage from shocks, etc. It has the disadvantage that appreciable time is required to get the cathode hot enough to emit electrons.

167. Operating filaments in series.—Under ordinary circumstances vacuum tubes are operated with their filaments in parallel,

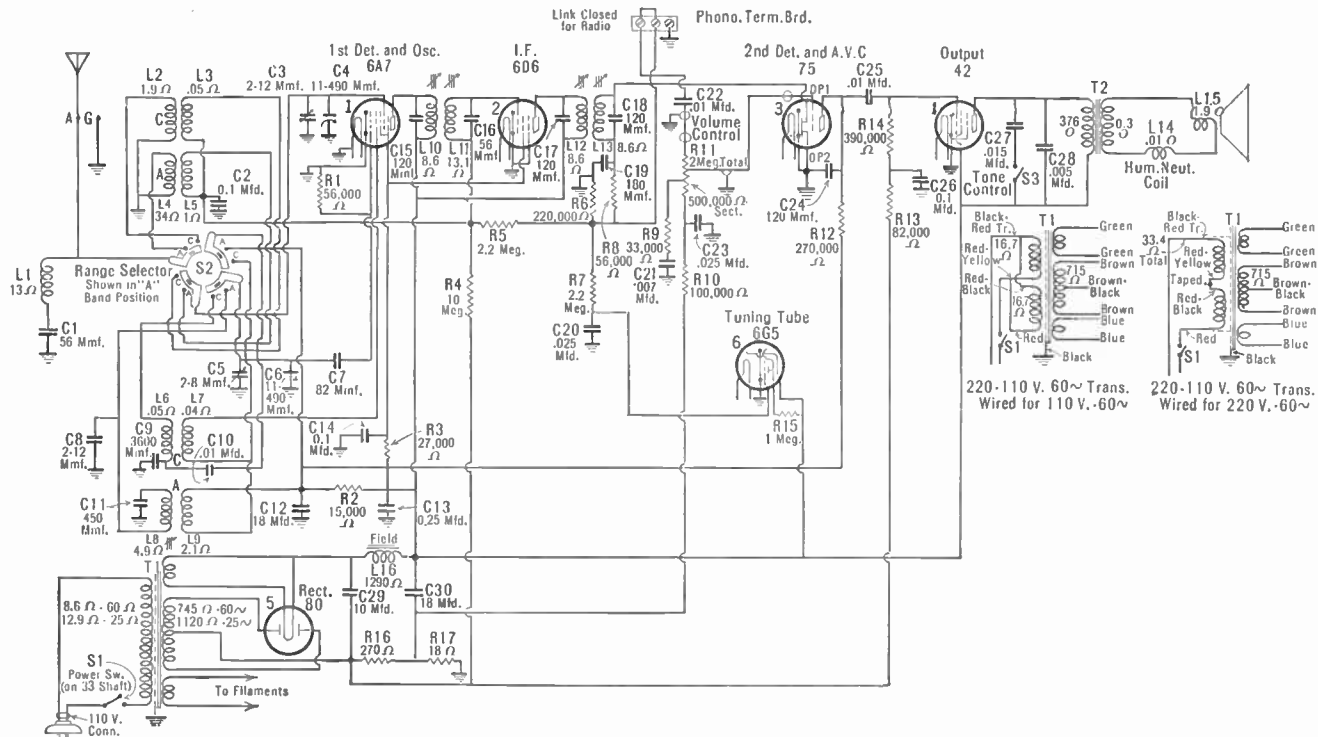

FIG. 130.—Circuit diagram of 1937 superheterodyne with coils in input and oscillator for multi-band reception.

so that the total current taken is the sum of the filament currents of the individual tubes. It is possible, however, to operate the tubes with their filaments in series, and under some circumstances this is preferable to the other arrangement.

It is more difficult to rectify and filter large currents at low voltages than small currents at high voltages. If, however, it is possible to get a well rectified and filtered source of current at say 250 ma. we can operate a radio receiver with ordinary tubes from the a.-c. circuit by connecting the filaments in series.

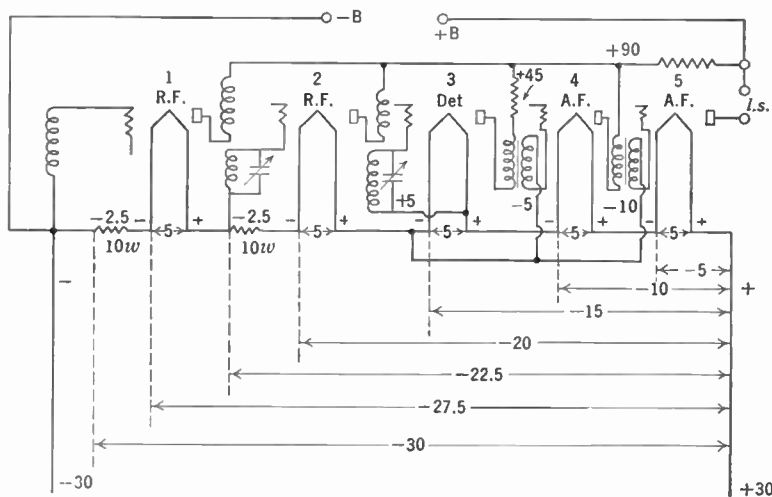

Fig. 131.—A series filament circuit in which the voltage drop across a tube filament is used as another tube's grid bias, etc.

Let us consider the circuit of Fig. 131 in which the filaments are wired in series. In this case the same current flows through each tube and the total voltage required is the sum of the voltage drops across the tubes and the 10-ohm resistor. To operate a receiver using five 5-volt tubes requires a source of current that will produce 250 ma. at a voltage of 5×5 or 25 volts plus whatever additional *C* bias voltages may be necessary. The current enters one end of the filament series and exits at the other. As we go along the receiver there is a series of voltage drops, each filament as it gets

farther and farther away from the positive terminal becoming more negative with respect to the preceding tubes. The drops in voltage along the line may be utilized as C bias voltages for other tubes.

For example suppose the final tube (No. 5) is a power tube requiring a C bias of 10 volts. We note that the negative terminal of the filament of tube 3 is 10 volts more negative than the negative terminal of tube 5 because there is a 5-volt drop across the filament of tube 4 and an additional drop of 5 volts across tube 3. We attach the grid circuit to this point in the circuit. If tube 4 requires only 5 volts C bias we can attach its grid circuit to the same point in the circuit because so far as tube 4 is concerned this point is only 5 volts negative. If the detector tube 3 requires a C bias of positive 5 volts we can attach its grid circuit to the positive leg of its own filament.

Suppose the first two tubes in the set do not require 5 volts bias but some value less than this. All that is necessary is to insert a resistor in the circuit ahead of that tube so that the negative drop in voltage in this resistance will be utilized. Thus in Fig. 130 the 250 ma. through a resistance of 10 ohms will produce a drop of 2.5 volts. The grid circuit should be attached as shown.

The 250-ma. supply may be a rectifier such as is used to charge storage batteries, or it may be a gaseous tube of the Raytheon type, or a chemical rectifier or some other means of rectification. The filtering is a big problem, and has limited the use of such a system. It is fairly simple, however, to get a 60-ma. current which may be used to light the filaments of 199-type tubes, and many series filament receivers have been built utilizing this scheme of connections.

168. Modern series-filament receivers. The "Universal" circuit.—For years the series filament style of wiring was dormant; then it blossomed forth again and became of tremendous importance. The heater-type of tube made the new circuits possible; the circuits themselves made new tubes of high efficiency necessary and stimulated the tube designers to improve their product.

The new circuits were built around the idea that a truly universal set could be made, i.e., one which would work interchange-

ably on a.c. or d.c. Although the number of homes in the United States having d.c. is few, nevertheless the idea took hold and hundreds of thousands of these receivers have been built. They are, in general, small sets selling at low prices. Early models suffered from many mechanical and electrical faults. They brought radios to many homes which could not afford the more expensive models, and thus served a very useful purpose.

The circuit of a simple universal set is shown in Fig. 132. It will be noted that all of the tubes are heater type; each has a

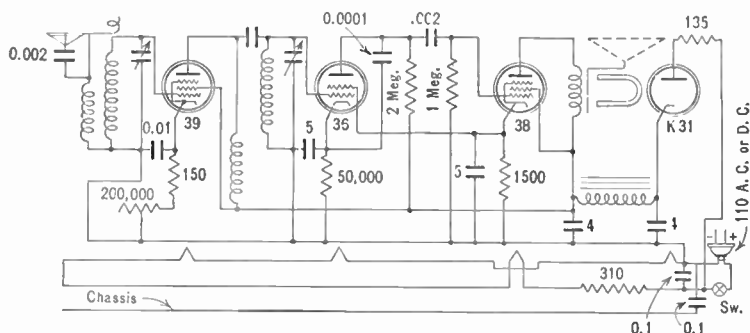

FIG. 132.—Circuit of the International Kadette Universal tuned r-f. receiver.

6.3 volt filament (these tubes were originally designed for automobile use) and that in series with this string of tubes is a 310 ohm resistance. This series of filaments and the resistor is put directly across the d.c. or a.c. line. The resistor is to reduce the line voltage to the value required by the tubes. Thus if three tubes are used they require 3×6.3 volts or 18.9 volts. They take 0.3 ampere. Therefore a drop of $115 - 18.9$ or 95 (approximately) volts must be secured through the resistor. The current (0.3 ampere) through 310 ohms produces this drop (93 volts).

In many sets of this type an amplifier with grid and plate connected together is used as rectifier. On d.c. of course there is nothing to rectify, and the tube and filter merely act as a resistance in series with the power circuits. If the plug is inserted reversed the polarity (on d.c.) will be incorrect and the plates of the tubes

will be negative with respect to the source of electrons. Therefore the set will not "play." It is only necessary to reverse the plug. On a.c. it makes no difference, except that the set may hum less if the plug has a certain polarity.

169. Means of obtaining C bias in amplifier tubes.—In all amplifiers of the present time it is desirable to maintain the grids of the tubes at a negative potential with respect to the filament. Such biasing keeps the plate current low, and if properly done will situate the operating point on such a part of the characteristic that minimum distortion due to overloading and curvature results.

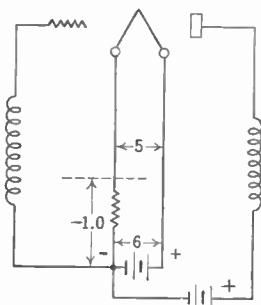

Fig. 133.—Obtaining grid bias by means of filament-current flowing through a resistance.

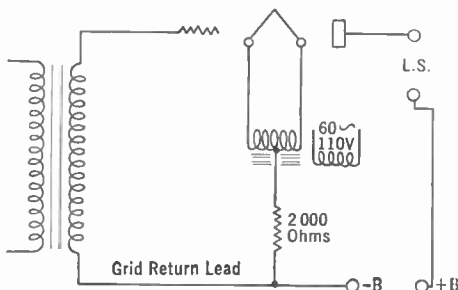

Fig. 134.—Obtaining grid bias by means of plate current flowing through a resistance.

Bias voltages may be obtained from a C battery. The voltage drop across a resistance in the filament circuit may be used as bias, as is shown in Fig. 133. Remembering that all voltages in the circuit are reckoned either from the negative side of the filament or from the center of the filament (or the cathode in the case of heater tubes) we see that the grid of this tube is negative by the amount of the voltage drop in the resistance. Attaching the grid "return" to this point gives it a 1.0-volt bias. Another method involves using a resistance through which flows the plate current of the tube (or several tubes). Thus in Fig. 134, which represents the conventional power stage for the radio receiver, the 2000-ohm resistor is connected to the center tap of the filament transformer. The plate current flows through this resistor, pro-

ducing a voltage drop there, and since the end toward the B battery is more negative than the end toward the filament, the grid return lead of that tube may be connected to the same point as the negative B lead. The grid is then biased negatively by the voltage drop in this resistor. If the plate current is 20 ma. the grid bias will be equal to $.020 \times 2000 = 40$ volts. If because of an increase in plate voltage from any cause the plate current increases to 25 ma. the grid bias increases to 50 volts—and such a biasing scheme provides some protection for the tube. When the plate voltage changes, the grid bias changes too and tends to keep the plate current within prescribed limits.

170. Screen-grid tube.—In many uses, notably as radio-frequency amplifiers, the capacities which exist within the tube are detrimental. There are three such capacities, the grid to filament, grid to plate, and filament to plate. Because of the grid-plate capacity a path exists between the input (grid circuit) and the output (plate circuit) of the tube so that variations in the output may affect the input. Because of the amplification factor of the tube these variations may be amplified and repeated back into the plate circuit and the performance repeated until the normal functioning of the tube is seriously impaired. It would be an advantage if the grid-plate capacity of tubes could be eliminated or reduced.

Because of the space charge—the cloud of negative electrons between the filament and the plate—the current that can flow in the plate circuit is limited, and if this space charge could be eliminated, or at least reduced, the grid voltage would have a much greater controlling effect on the plate current.

Both of these beneficial effects may be secured by the addition of more grids. For example in the **screen-grid** tube the grid-plate capacity has been reduced from an average value of 6.0 mmfd. to about 0.02 mmfd. and an amplification factor of several hundred is not difficult to attain.

The screen-grid tube consists of the usual elements and an additional grid. The second grid is maintained at a positive potential with respect to the heater or filament. The second or screen grid is maintained at zero potential so far as signal frequencies are concerned and thereby screens the grid from the plate circuit signal variations.

In Fig. 135 is an illustrative example of what the second grid does to the tube. A capacity exists between the plate and grid, and any a.-c. voltage attached to the system will cause an a.-c. current to flow. Now if a plate is placed between *P* and *G* and grounded, the current as read by the current meter drops to zero, because this part of the circuit has been shielded or protected from the a.-c. voltage. The capacity between *P* and *G*, then, becomes zero.

An interesting point mentioned above is that the screen is at ground potential so far as signals are concerned, but is above ground as far as d.c. is concerned. Screen leads are always well filtered.

In the tube *P* and *G* are the plate and control grid respectively and the extra grid is the screening plate. It is impossible

to screen the plate from the grid completely because some electrons must get to the plate through the grid, or the tube would be worthless. The screen grid is fixed at some positive potential lower than that of the plate. The fineness of this grid and its position controls the screening effect upon the plate. The electrons from the filament proceed toward the screen grid at considerable speed and most of them go through it and are collected by the plate provided it is at a higher potential than the screen. Because of the inter-

position of the screen grid between the plate and the control grid, the rate at which electrons go across the space is not controlled so much by the plate voltage as it is by the voltages on the two grids. In other words the plate current is more or less independent of the plate voltage, and the plate resistance is very high, 550,000 ohms for a d.-c. tube (36) and 600,000 ohms for the a.-c. tube (24-A).

The mutual conductance of the a.-c. tube is about 1000 and the amplification factor is 630. It has a 2.5-volt heater type of filament.

Because of the high voltage amplification, the control grid must be protected from all other wires and circuits. It is connected to a cap on top of the tube, and in practice is connected to its proper circuit by a wire which is covered with a grounded shield.

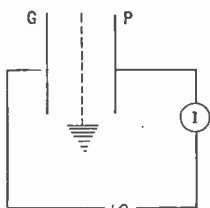

Fig. 135.—Capacity current from grid to plate is nullified by grounded shield or screen.

The entire tube is also covered and thus all stray voltages are prevented from getting to the control grid.

171. Characteristic curves of the screen-grid tube.—Some of the characteristic curves of an a.-c. screen-grid tube are shown in Fig. 136. It will be seen that changes of plate voltage have

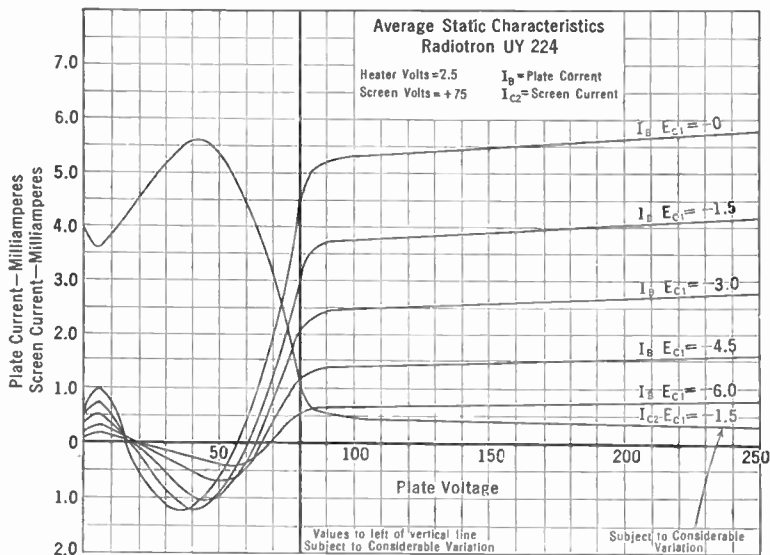

Fig. 136.—Characteristic curves of UY 224. In the region to the left of the 80-volt line there may be as much or more current flowing away from the plate as toward it, due to “secondary emission.”

little effect on plate current; that at low plate voltages the current actually decreases instead of increases. At plate voltages lower than the screen grid voltage electrons may come from the plate and go to the screen grid, thereby causing the current to the plate actually to decrease. This backward-flowing circuit is due to “secondary emission.” That is, an electron from the filament may get through the screen grid, but at the plate it dislodges an electron and then both are dragged back to the screen grid because of its greater positive potential.

When used as an amplifier, the tube is operated on some portion of the long almost-flat part of its $E_p - I_p$ curve.

172. Variable-mu tubes.—Early receivers utilizing screen-grid tubes suffered from many troubles. Among others was the production of cross-modulation or cross-talk by strong undesired signals. These tubes had such a short range of grid voltage over which they could work that a strong signal would force the grid voltage to the point where the a.-c. plate current would cut off. This resulted in severe distortion, evidenced

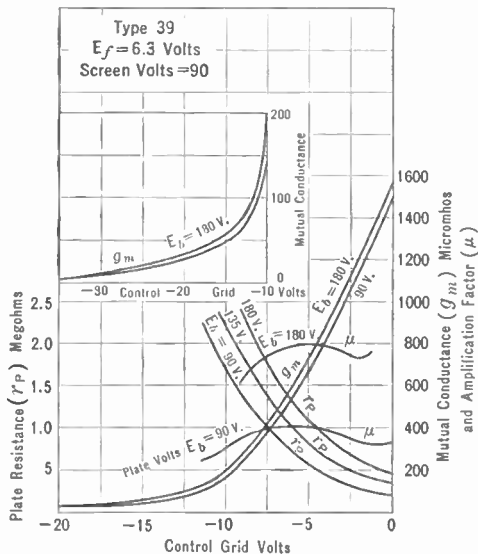

FIG. 137.—Characteristic of variable-mu tube.

by blurs or gasps of undesired modulation crashing through the desired program, or by hum entering from the power supply.

Late in 1930 a new screen-grid tube made its appearance and became of considerable importance in the following year. This was the variable-mu or exponential tube. It had a very long, fairly flat characteristic at the bottom of its E_g - I_p curve. In other words strong negative voltages on the grid did not force the plate current to zero, and cross-modulation was prevented.

Because of the very long even characteristic, the tube was

nically adapted for automatic volume control, for radio and intermediate amplifiers, and for recording signal strength, or loud speaker output or other measurements where large ranges of current or voltage, etc., were to be measured. These tubes have come to be described as super-control tubes.

The variable-mu tube gets its characteristic from the way the grid is wound, not perfectly regular with even spacing between turns as in other tubes, but with wide spacing at some portion, close spacing at another. The characteristic may be controlled by varying the winding pitch.

173. Multi-element tubes.—Another grid may be added to a screen-grid tube just as in a power pentode. Its function is to push back, to the plate, electrons which may tend to go to the screen. This eliminates the dip in the characteristic shown in Fig. 136.

It is possible to put two tubes in one envelope. Thus a 55 has a triode (3-element tube) and a pair of diodes (2-element tubes) in the same bulb and mounted on the same internal structure. Other tubes comprise triode-pentodes, diode-pentodes, etc. The triode may perform its usual function of amplifier; the diodes act as detectors.

Recent practice is to mount tubes in metal shells with a new type of base. The advantages of these tubes over glass envelope tubes seem to be slight although time may show that the new construction is superior.

CHAPTER X

THE TUBE AS AN AMPLIFIER

In the usual receiver, tubes are used to amplify the signals at radio frequencies or at intermediate frequencies in superheterodynes and at the voice or musical frequencies after another tube has demodulated the amplified wave. How does the tube amplify?

174. The tube as an amplifier.—Let us look at the curve in Fig. 138 which shows in exaggerated form the relation between plate current and grid voltage. The slope of the curve, $\frac{dI_p}{dE_g}$, is the mutual conductance of the tube and tells how many milliamperes the plate current changes when the grid potential is changed one volt. The curve shows that adjusting the *C* bias on the grid of the tube to 5 volts, that is, placing a 5-volt battery between the grid and the most negative part of the tube filament, permits a plate current of 3 milliamperes to flow. If this bias is decreased to 4 volts, the plate current increases to 3.6 ma.; if the bias is increased to 6 volts the plate current decreases to 2.4 ma. These points on the static characteristic curve are labeled as *A*, *B*, and *C*.

These points are called the **operating points**. Thus when the *C* bias is changed the operating point slides up and down on this steep E_g - I_p curve. If this *C* bias is changed in some regular fashion, say in the form of a sine wave of one peak value, the plate current must change accordingly, that is, it will increase and decrease between 3.6 ma. and 2.4 ma., as the curve shows. The average bias is 5 volts; the average current is 3.0 ma. The maximum bias is 6 volts, the minimum is 4; the maximum current is 3.6 ma., the minimum is 2.4.

The bias may be changed in this manner by setting up an a.-c. voltage across a resistor as in Fig. 139. Suppose, as an example the voltage, E , across this resistor is a sine wave of a maximum value of one volt. When this sine wave of voltage makes the grid end of the resistor negative by one volt the actual voltage on the

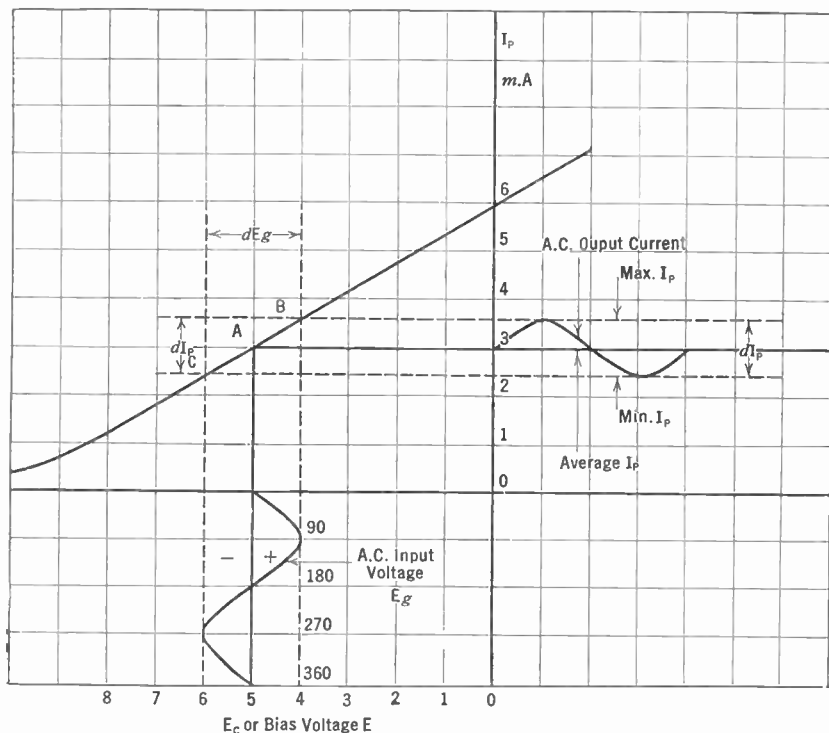

Fig. 138.—Use of straight part of characteristic. The wave form of output current will be exactly similar to the wave form of the input voltage if the characteristic is straight.

grid will be 5 volts (E_c) plus 1 volt (E) or 6 volts in all. The plate current will be, at that instant, 2.4 milliamperes. When the a.-c. voltage reverses and makes the bottom or filament side of the resistor negative, the bias on the grid is 5 volts (E_c) minus 1 volt (E) or 4 volts in all; the plate current at this instant will be 3.6

ma. At all other instants the plate current will be different depending upon the instantaneous value of the a.-c. input voltage. The plate current changes in unison with the grid voltage, and if this grid voltage varies in a sine wave there will be a sine wave of current in the plate circuit.

We can picture what happens by the sine waves in Fig. 138. With no input the grid voltage is that of the C battery, the plate current is that corresponding to this value of C bias and a plate voltage, E_p . Now let us assume that an a.-c. voltage requiring one second for a complete cycle is applied to this grid. Starting

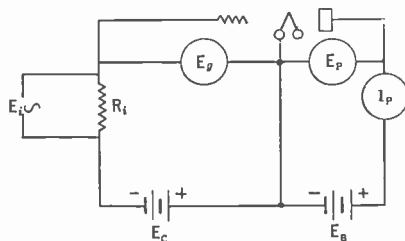

Fig. 139.—When E_i is applied, I_p consists of an a. c. current as well as steady plate current.

from zero it increases in a positive direction making the grid more positive (less negative) with respect to the filament. The plate current begins to rise accordingly. At the end of a quarter-second (90°) the voltage is a maximum in the positive direction and the plate current is correspondingly a maximum. Now the grid voltage begins to decrease (become more negative), the plate current decreases, and at the end of a half-second (180°) the voltage and current arrive at their original no-input values. Now the grid voltage ($E_g = E_c + E_i$) continues to decrease until at the three-quarter-second phase the voltage is a minimum and so is the plate current. Thereafter the voltage and current increase again and at the end of a full second are equal in value to the starting or no-signal values. Thereupon the cycle is repeated.

Notice that the two curves have the same form; that the steady bias line of 5 volts is in the exact center of the a.-c. input voltage curve; that the average plate current is the current corresponding to 5 volts negative C bias. The fact that the plate current curve seems to have less amplitude than the grid voltage variation is not important—this is a matter of the scale to which the two are drawn. One is in volts, the other is in milliamperes. This a.-c.

plate current may be thought of as a variation in the d.-c. plate current at a rate corresponding to the frequency of the input voltage, or as a true a.-c. current which flows in the plate circuit in addition to the d.-c. current.

A meter in the plate circuit of the tube would read only the average current unless its needle were capable of following the changes in current. If the input a.-c. voltage were 1000 cycles, for example, the needle would not be able to follow such rapid variations and would register only the average value of plate current, that is, the plate current corresponding to 5 volts bias or 3.0 milliamperes.

This is essentially the theory of the action of the tube as an amplifier. An input a.-c. voltage is applied to the grid. The variations in grid voltage about some average value equal to the C bias produce corresponding variations in plate current. These variations in current are caused to flow through some sort of output load impedance, and across this impedance they set up voltage variations. If the bias (E_c) and plate voltage E_p are properly chosen so that the variations in E_g (dE_g) take place on a straight part of the E_g - I_p curve the form of the a.-c. current wave in the plate circuit will be exactly similar to the a.-c. voltage wave on the grid. If the proper conditions of E_c , E_p , and load impedance are fulfilled, the voltage appearing across this impedance will be not only an exact replica of the a.-c. grid input voltages, but will be an amplified replica of them.

The question naturally arises, how much amplification can be obtained? What are the conditions for such maximum amplification?

175. Resistance output load.—If, in the plate circuit of the tube we put a resistance, R_o , as in Fig. 140, we may adjust conditions so that distortionless amplification results. These conditions, briefly, are: (a) the C bias and magnitude of the input a.-c. voltage must be such that only the straight part of the characteristic is used; and (b) the load resistance, R_o , must be large compared to the plate resistance of the tube.

Let us look at the circuit in Fig. 140 rather critically. It is the fundamental amplifier circuit. The plate voltage, E_p , as

measured by a voltmeter connected from plate to the negative filament lead is no longer the voltage across the B battery. It is less than this value by the voltage drop in the resistor R_o , i.e., the IR drop caused by the plate current. The voltage actually on the plate then is

$$E_p = E_b - I_p \times R_o \quad (1)$$

If, for example, the B battery voltage = 180 volts, $R_o = 100,000$ ohms, $I_p = 0.5$ milliampere, $I_p \times R_o = 0.0005 \times 100,000$ or 50 volts, and $E_p = 180 - 50 = 130$ volts.

Now it can be seen that any variation in I_p causes a variation in the IR drop across R_o , and hence the plate voltage E_p must change according to equation (1). For this reason any variation in the grid bias will cause a variation, not only in the plate current of the tube but a variation in the plate voltage as well. We cannot use the static characteristic to determine what the output voltage looks like, because the plate voltage is no longer constant, but changes in instantaneous

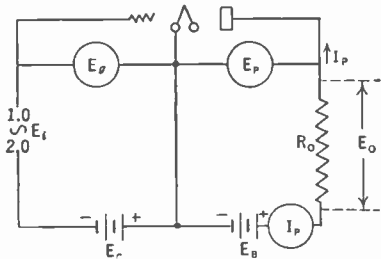

Fig. 140.—Ratio of E_o to E_i is the voltage amplification of circuit.

value with each instantaneous value of the grid voltage. The operating point, then, does not slide up and down the characteristic curve as plotted in Fig. 138 but along a new kind of curve known as a **dynamic characteristic curve**.

176. Dynamic characteristic curves.—A series of dynamic curves is shown in Fig. 141. They were taken by placing resistances in series with the plate battery and a 71-A power tube maintaining the voltage on the plate equal to 180 when the C bias was 38.5. It will be noted that they are much flatter and longer than the static curves. This means that plate current variations are much smaller in magnitude under the same grid voltage variations. The mutual conductance of the circuit is no longer as high as the value for the tube alone—but the slope of the curve tells us the

a.-c. current which will flow through the resistor when a given a.-c. voltage is applied to the grid, and these curves are therefore more useful than the static curves.

Experiment 1-10. Connect as in Fig. 140 a tube of the 37 type, a plate battery, and a resistance. Short-circuit terminals for E_i . Measure and plot the current in the plate circuit as the grid voltage is varied. Then change the resistor and repeat. Use values of 8,000, 16,000, 24,000 and 48,000 ohms.

177. Phase of E_g , E_p , and I_p .—When the grid of the tube is made negative the plate current decreases; when the grid is made

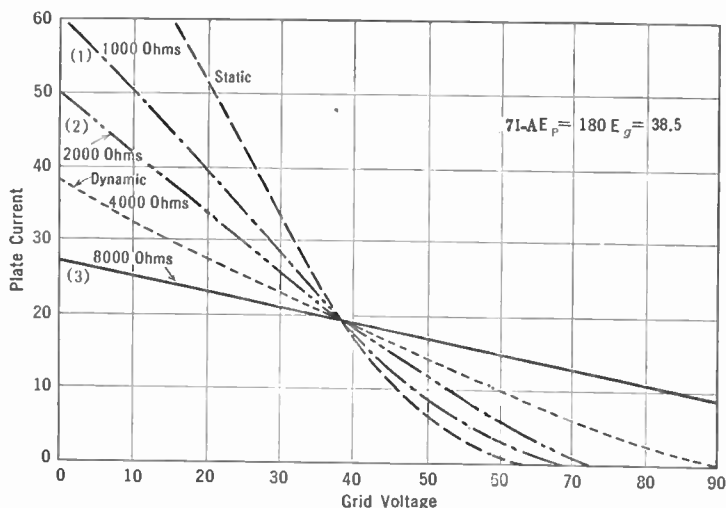

Fig. 141.—Dynamic characteristic curves.

less negative the plate current increases. When the plate current increases, however, the voltage drop, $I_p R_o$, across the resistor, R_o , increases and for this reason the voltage E_p actually on the plate decreases. That is, the plate current increases when the grid voltage increases (becomes less negative), but on the contrary the plate voltage decreases when the grid voltage increases. Thus we may say that the plate current variations are in phase with the grid voltage variations whereas the plate voltage variations are

out of phase with the grid voltage variations. These phase relations are shown in Fig. 142.

178. **Magnitude of the amplified voltage.**—There are several variable factors in a one-stage resistance-coupled amplifier, as shown in Fig. 140. The grid bias, E_c , the battery voltage, E_b , the

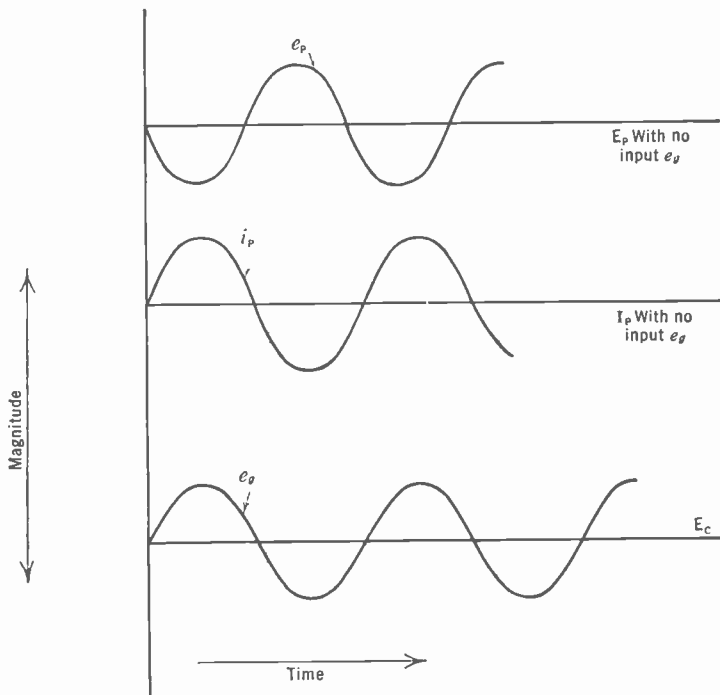

Fig. 142.—Phase relations between a.-c. grid and plate voltage and plate current.

load resistance, R_o , all may be changed as desired. With a fixed value of E_c and E_b , the plate resistance of the tube, R_p , is fixed. If we go into the laboratory and measure the voltage across a load resistance with a given value of a.-c. voltage on the grid we shall determine the voltage amplification of the stage. Then if we change the load resistance and measure the output voltage across R we shall get a curve which shows that the amplification increases

as the load resistance increases, but finally comes very near a certain fixed value—which is numerically equal to the amplification factor of the tube—and that increasing the load resistance beyond this point has little effect on the amplification.

Because each change in R_o will change the plate current, we must adjust the plate battery each time so that the voltage actually on the plate—which is E_b minus the voltage drop along the load resistance—is the same.

The amplification that will be realized in a laboratory experiment of this kind may be calculated from this formula

$$\frac{\mu R_o}{R_o + R_p} = G \text{ (voltage amplification)} \quad (2)$$

and the r.m.s. a.-c. plate current from

$$\frac{\mu e_u}{R_o + R_p} = i_p \quad (3)$$

and the r.m.s. a.-c. voltage across the load from

$$\frac{\mu e_u R_o}{R_o + R_p} = G e_u, \quad (4)$$

where e_u = r.m.s. grid voltage.

179. Equivalent tube circuit.—These same voltages and currents can be obtained from the circuit in Fig. 143 by simple Ohm's law calculations. For this reason it is standard practice to substitute for the tube its equivalent consisting of a voltage μE_g in series with two resistances, one equal to R_p , the tube resistance, and the other, R_o , equal to load resistance.

The maximum voltage amplification takes place when the external resistance, R_o , is infinite. Practically, however, 75 per cent of the maximum amplification is obtained when R_o is 3 times

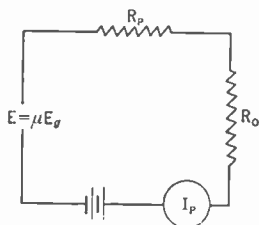

Fig. 143.—Equivalent circuit of amplifier tube.

as great as R_p . For example, if R_p is 10,000 ohms, a coupling resistance of 30,000 ohms will realize 75 per cent of the μ of the tube. The maximum possible value is the amplification factor of the tube. Thus if a tube especially made for resistance-coupled amplifiers having an amplification factor of 30 is used, the maximum possible amplification will be 30, but under actual operating conditions the voltage amplification, G , of the complete circuit is about 20.

180. Power output.—The a.-c. power in the load resistance is calculated as follows,

$$P = i_p^2 R_o$$

$$i_p = \frac{\mu e_o}{R_o + R_p}$$

$$P = \frac{(\mu e_o)^2 R_o}{(R_o + R_p)^2} \quad (5)$$

This is a maximum when the two resistances are equal, that is, when

$$R_p = R_o$$

Then the power
$$P = \frac{\mu^2 e_o^2}{4R_p} \quad (6)$$

where e_o = r.m.s. input voltage;
and

$$P = \frac{\mu^2 E_o^2}{8R_p} \quad (7)$$

where E_o = peak or maximum input voltage.

This power which is fed into the load resistance must come from the plate battery, because the tube itself generates no power—it acts merely as a transformer or valve which takes small voltages and currents on its input and turns out larger voltages and currents to its output circuit. The power in the input circuit must come from the circuit to which the tube is attached. The power in the output must come from the batteries. The tube therefore releases power from the batteries in a form which is an

exact replica of the power utilized in the input circuit to which the tube is attached.

181. Power amplification.—Ordinarily the grid of a tube is biased so highly negatively that practically no current flows in the grid circuit. The tube input circuit itself then draws little or no power. If, however, the a.-c. voltages are fed into the tube through a resistance, some power is expended in this input resistance. If the values of resistance and current are known the power may be calculated. The power amplification will be the output power divided by the input power. The fact that a tube is a power multiplier distinguishes it from a transformer which is merely a power transmitter, taking power at one current and voltage and passing it on at another current and voltage. The transmitted power is never more than or even equal to the input power. It is always less; unlike a tube, the transformer cannot amplify power or release it from local batteries. The power output is proportional to the square of the voltage on the grid. Thus doubling the input a.-c. voltage quadruples the output a.-c. power.

Example 1-10. Four milliamperes of current at 1000 cycles are fed through a 10,000-ohm resistance in series with the grid of a tube and its C battery. In the output is a 2000-ohm resistor. The amplification factor of the tube is 3, its internal plate resistance is 2000 ohms. What is the power output, what is the voltage across the output, what is the voltage and power amplification, and what power is lost on the internal resistance of the tube?

Let the input voltage $E_i = I_i R_i = .004 \times 10,000 = 40$ volts r.m.s.

$$\begin{aligned} \text{voltage amplification } G &= \frac{\mu R_o}{R_o + R_p} \\ &= \frac{3 \times 2000}{4000} = 1.5 \text{ times.} \end{aligned}$$

The output voltage $E_o = E_i \times G = 40 \times 1.5 = 60$ volts r.m.s.

$$\begin{aligned} \text{Power output } P_o &= \frac{\mu^2 E_i^2}{4 R_n} \\ &= \frac{9 \times 40^2}{4 \times 2000} = 1.80 \text{ watts} \end{aligned}$$

$$\begin{aligned} \text{Power input } P_i \quad I_i^2 R_i &= (.004)^2 \times 10,000 \\ &= 16 \times 10^{-6} \times 10,000 \\ &= .16 \text{ watt} \end{aligned}$$

$$\text{Power amplification} = P_o/P_i = 1.8/.16 = 11.25 \text{ times.}$$

Since I_p (a.c.) flows through both R_o and R_p and since $R_p = R_o$ a.-c. power lost in $R_p =$ power lost in $R_o = 1.8$ watts.

Total power taken from batteries = 3.6 watts.

$$\text{Efficiency} = \frac{\text{useful power}}{\text{total power}} = \frac{1.8}{3.6} = 50 \text{ per cent.}$$

Problem 1-10. Assume a 201-A tube with a load resistance of 12,000 ohms and an a.-c. grid voltage of 3 volts (peak). The μ of the tube is 8, its R_p is 12,000 ohms. What is the maximum value of the a.-c. plate current? (Use formula 3.) What is the r.m.s. value? What a.-c. power is developed in the load resistance? What voltage appears there?

Problem 2-10. What is the voltage amplification in the above circuit? (Use formula 2.) How much would it be increased if the load resistance were increased to 36,000 ohms? How much would this change the power output?

Problem 3-10. The plate resistance of a certain "high μ " tube is 60,000 ohms and its amplification factor is 20. What plate resistor value in ohms must be used to realize a voltage amplification of 15?

Problem 4-10. A 112-type tube has an internal plate resistance of 5000 ohms, its amplification factor is 8; it is worked into a load of 5000 ohms. Plot the output power in the load resistance as the input a.-c. voltage is increased from 1 to 8 volts (peak). (Use formula 7.)

Problem 5-10. What is the voltage amplification in Problem 4.

Problem 6-10. The power output of a tube when worked into a load whose resistance is equal to the tube resistance (when the input grid voltages are maximum volts) may be written as $\frac{\mu^2}{8 R_p} \times E_g^2$. If we divide this expression by E_g^2 we shall have a figure which gives us the power output in watts per (volt input)². Make a table of such values for all the tubes used at the present time, getting the tube data from the tube chart.

Problem 7-10. The normal C bias for a 112-type tube is 9 volts. What is the largest r.m.s. voltage that may be applied to its grid before the grid goes positive?

182. Amplifier overloading.—The conditions for undistorted amplification are: (a) the C bias and magnitude of the a.-c. input voltage must be such that only the straight part of the tube

characteristic is used, and (b) the load resistance must be large with respect to the internal resistance of the tube, R_p . Let us examine these conditions. Suppose first that the C bias is too great, as in Fig. 144, so that the operating point goes into a curved part of the characteristic. The wave of plate current is no longer similar to that of the grid voltage, and its average value is no longer equal

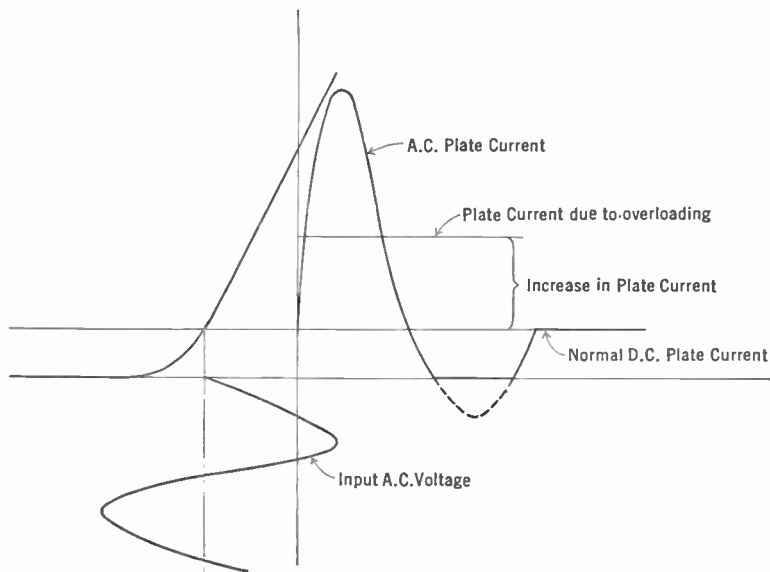

Fig. 144.—Effect of using curved part of characteristic. Note dissimilarity between output and input.

to the zero a.-c. input condition as is true when the bias is such that input voltages carry the grid operating point only over a straight part of the curve. The negative parts of the a.-c. waves are partly cut off. Distortion results because the negative and positive halves of the cycle are not amplified alike. A meter in the plate circuit would show an increase in current when signals were put on the grid—an infallible sign of overloading distortion. If the C bias is great enough and input signals are strong enough

the grid may be forced so far negative that the plate current may be reduced to zero on the negative halves of the wave. This would produce even worse distortion.

Overloading, then, is a technical name for operating a tube under a wrong C bias, or with too strong input signals.

If the C bias is too small, input signals force the grid positive at times and distortion again occurs for a reason explained in Section 185. In this case the plate current as read by a d.-c. meter would decrease when the input voltages are applied to the grid.

Suppose, however, the tube is biased properly, say at the center of the region between the lower bend of the E_g-I_p curve and the point which corresponds to zero grid voltage. Distortion does not occur unless too great a.-c. voltages are put on the grid—voltages sufficient to drive the operating point down on the curve, or up on the positive part of the curve.

There are two possible remedies for such kinds of distortion. One (*a*) is to reduce the input voltage until the operating point moves over only a straight portion of the curve; another (*b*) is to increase the B and C voltages until a longer straight portion is available. As shown in Fig. 118, increasing the plate voltage moves the E_g-I_p curve to the left and increases its straight part. The C bias would be increased accordingly.

If the tube is properly biased, the input a.-c. voltage must be such that its peak value does not exceed the value of the C bias voltage. Thus if a tube has a bias of 40.5 volts, the input value of the a.-c. voltage must not exceed this value, and thus its r.m.s. value must be not over $40.5 \div 1.4$, or about 28.5 volts. A voltage input greater than this will force the grid positive with consequent distortion. As seen in Section 186, the peak voltage input must be even less than this value to prevent the operating point going down into this curved region.

183. Distortion due to curved characteristic.—When a load is in the plate circuit of a tube its characteristic becomes flatter and its straight part longer, but at the lower part of the curve there is still a bend and throughout the E_g-I_p graph there is considerable curvature unless the load resistance is high. Large input voltages,

therefore, may cause distortion because the operating point traverses curved parts of the characteristic.

Although the maximum power output is obtained from a tube when the load resistance is equal to the internal tube resistance, the maximum *undistorted* power output is attained when the load resistance R_o is twice as great as the tube resistance, R_p . Some power is sacrificed under these conditions but, as the curve in Fig. 145 shows, the loss is not great until the output load resistance is several times the tube resistance. If the load resistance is lower

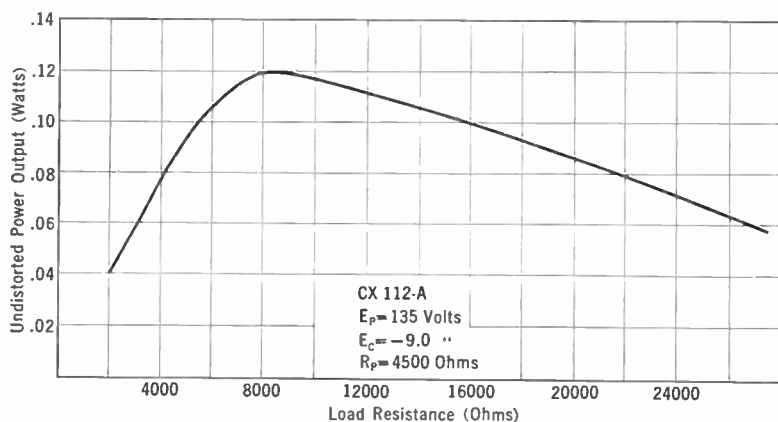

Fig. 145.—Output power as a function of load resistance.

than the tube resistance distortion due to curvature of the characteristic is bound to occur. Even with a load equal to twice the tube resistance there is considerable curvature at the bottom of the characteristic and so input voltages high enough to drive the plate current too low must not be applied. See Section 186. The power output when $R_o = 2 R_p$ is

$$P = \frac{1}{9} \times \frac{\mu^2 e_a^2}{R_p} \text{ where } e_a \text{ is r.m.s. input voltage.} \quad (8)$$

Distortion frequently occurs at low audio frequencies. There are two reasons for this. In the first place the excursions of the operating point may be somewhat greater on these frequencies

because of the greater power in them than in high tones. In the second place, the loud speaker may have an impedance which varies with frequency, becoming low at low frequencies, probably lower than the tube resistance. Thus distortion due to curvature as well as loading distortion may occur on low notes.

The solution is to use a power tube which will easily handle the greatest input grid voltages that will be encountered, and secondly, to use a power tube with a low internal resistance so that the load impedance will, at the lowest frequency, be larger than the tube resistance.

184. Permissible grid swing.—The expression “grid swing” is often used, especially in England, to indicate the extent to which the voltage of the grid varies under the incoming signals. To state that the grid swing on a certain tube is 10 volts means that the voltage of the grid varies between 5 above and 5 below some fixed value, a total swing of 10 volts. In this country we should say the maximum input voltage was 5. Under these conditions the *C* bias should be 5 volts at least, preferably more. The maximum permissible grid swing is the range of voltage on the grid which will not cause distortion either because of the grid going positive or because of the operating point traversing the lower bend. Whether one says the grid swing that may be applied to a 171 power tube is 80 volts or whether he says that the peak voltage that may be applied is 40 volts is immaterial. They mean the same thing. The grid swing cannot be determined by looking at the static characteristic curve. It can be determined from the dynamic curve or as indicated in Section 186.

185. Distortion due to positive grid.—Why does distortion occur when the grid of an amplifier tube is permitted to swing positive on loud signals? If we plot the plate current against grid voltage, as the *C* bias in Fig. 139 is changed, we find that, when the grid goes positive, the plate current curve no longer is straight; it slumps off and soon becomes almost horizontal. Distortion will occur at the instant the input voltage takes the operating point up on the upper bend.

The reason for this bend is as follows. When the grid becomes positive with respect to the negative side of the filament, it begins

to attract electrons to it and these electrons constitute a flow of current. Current flows in the grid circuit, and must go through the input resistance R_i . There is, then, an IR drop in the grid circuit, so that the voltage actually on the grid (E_g) is not the applied grid voltage E but this value minus the drop in the input resistance—just as the plate voltage is not the voltage of the B battery but this voltage minus the drop in the output load resistance. The greater the input voltage the more the grid goes positive, the greater the voltage drop in this resistance and the bias voltage that is actually on the grid because of rectification.

The grid must never be permitted to go positive in ordinary circuits. Some circuits have been developed in which the grid is not only permitted to go positive but is forced to do so with a consequent greater power output. Such circuits (Class B) are used where plate power must be small.

186. Amount of distortion caused by overloading.—What is the result of operating amplifier tubes over a curved part of the characteristic? The result is an output wave form quite different from the input wave. Distortion is taking place whenever the magnified output voltage is not exactly, in all respects, like the input voltage. When the d.-c. plate current of an amplifier tube changes under the action of an input a.-c. grid voltage, distortion is taking place; the form of the wave in the output circuit does not look like the form of the input wave. This output wave may be very complex.

When a tube distorts, it adds certain frequencies to the output circuit which were not present in the input. All of these frequencies added together at any instant produce a wave form which looks unlike the original wave form.

How can we tell the amount of distortion to be expected with given tube and circuit constants? It is not difficult to determine what percentage of distortion will occur. Here is another place where the characteristic curves come in handy; this time the E_p - I_p curves are used.

Let us look at Fig. 146 which gives the characteristic of a 71-A type of power output tube. The vertical 180-volt line is the working line for this tube. The intersection of this line

with the 40-volt grid bias line gives the plate current, 19 milliamperes. If an a.-c. voltage is placed on the grid—in addition to the 40-volt d.-c. bias voltage, of course—say of a maximum or peak value of 10 volts, the actual grid voltage will vary 10 volts up and 10 volts down from the 40-volt bias; that is, at one instant

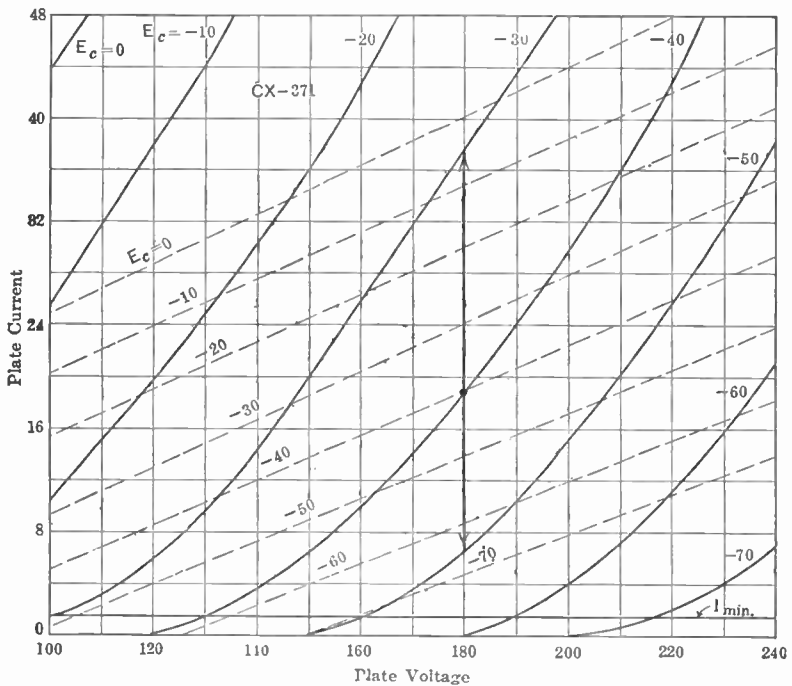

FIG. 146.—Static characteristic of power tube. Dashed lines represent characteristic with a load in the plate circuit.

it will be -30 volts and at another -50 volts. Looking at the appropriate curves in Fig. 146 we see that when the grid voltage E_c is -30 the plate current is 38 ma. and when the voltage is -50 the plate current is 6 ma. These represent changes of 19 ma. (38 - 19) and 13 ma. (19 - 6) respectively. Although the input voltage is symmetrical about the 40-volt bias voltage, the plate

current is obviously not symmetrical—there is a greater change in current (19 ma.) in one direction than there is in the other (13 ma.). The output curve would not be a magnified replica of the input curve. Harmonics would appear in the output.

Now when a load resistance is placed in the plate circuit, the straight part of the curve becomes longer and flatter as shown in Fig. 141, and as more and more resistance is added the actual

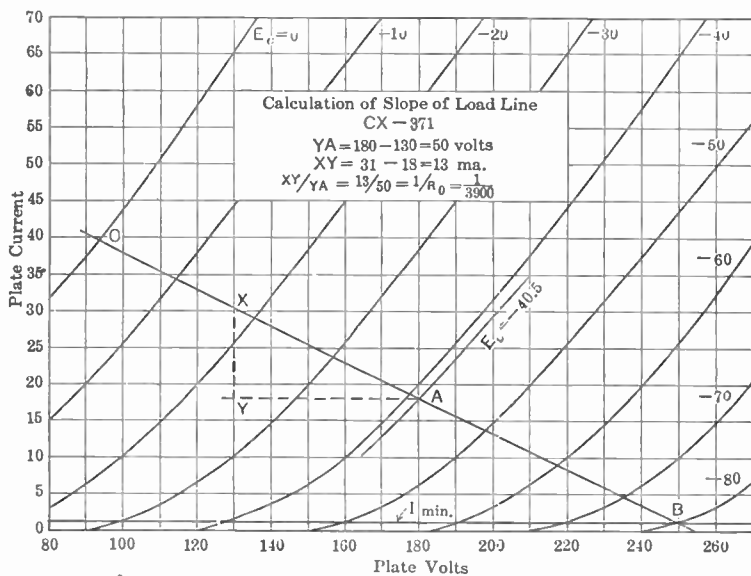

FIG. 147.—Method of plotting "load line" of a power tube. From such a curve all of an amplifier's performance can be determined.

working lines rotate about the intersection of the 180-volt plate voltage line and the grid bias line which for this curve was 38.5 volts. The plate current changes are no longer as great but they occur symmetrically about the normal plate current value which is governed by the plate voltage and the bias voltage. Thus for a given value of load resistance such that the dotted lines in Fig. 146 represent the plate current as controlled by plate and

grid voltages, the same input voltage 10 (peak) causes the plate current to increase from 19 to 24 ma. in one direction and to decrease from 19 to 14 ma. in the other—a symmetrical variation.

It is a simpler process to determine the plate current variations with a given plate load resistance by the method of plotting the "load line." To do this a family of E_p - I_p curves is necessary as in Fig. 147. The load line gives the plate current at any given set of E_c and E_p values and with a given resistance load. It is determined as follows: it must pass through the intersection of the $E_p = 180$ and $E_c = -40.5$ lines, or A in the figure, because these are the recommended values for this tube, a 71-A. Through this point A draw a line parallel with the plate voltage axis. Make it any convenient length. Then at the end of this line erect a perpendicular line of such length that $YX/AY = 1000/R_o$, where R_o is the plate load resistance, in this case 3900 ohms. Through X draw a line through A and extend to the $E_c = 0$ line and the $I_p = 0$ line as in the figure.

The reasons for this bit of apparent sleight-of-hand are as follows. The slope of this load line must be the reciprocal of the load resistance, i.e., if the load resistance, R_o , is 3900 ohms, the slope of this line must be $1/3900$ ohms. The slope of the line will be equal to the vertical side of a triangle divided by the horizontal side of this triangle which has for the third side either the load line, or a shorter line parallel to the load line.

Thus, slope of load line:

$$\frac{\text{vertical}}{\text{horizontal}} = \frac{1}{R_o} = \frac{I(\text{amps.})}{E(\text{volts})} = \frac{I \times 1000 \text{ ma.}}{E \text{ volts}}$$

The value of plate current corresponding to any set of E_p and E_c values with this particular load resistance may be found from this line. Thus with $E_c = 0$ and $E_p = 92$ volts, $I_p = 39$ ma., with $E_c = -60$ and $E_p = 218$, $I_p = 9$ ma. Thus if the bias voltage is 40.5 and the peak voltage applied to the grid is 10, the actual grid voltage varies from $40.5 - 10$ or 30.5 to $40.5 + 10$ or 50.5 and the corresponding plate currents will be 24 and 13 approximately, or approximately 5.5 ma. up and down from the 18.5 ma. value.

Now the grid must not go positive, and the plate current must not become so low on strong signals that the curved part of the characteristic is used. Thus 1.0 ma. is about the lowest the plate current should go, or the value when $E_c = -80$. From -40.5 to -80 is 39.5 volts which is the peak a.c. that should be put on the grid. This input will cause the plate current to vary between 39 ma. and 1 ma.

187. Power output calculation.—The power output may be calculated from the above data by means of the following formula:

$$\begin{aligned} P &= 1/8 (E \text{ max.} - E \text{ min.}) \times (I_p \text{ max.} - I_p \text{ min.}) \\ &= 1/8 (250 - 92) \times (.039 - .001) \\ &= .75 \text{ watt} = 750 \text{ milliwatts of output power.} \end{aligned}$$

188. Harmonic distortion calculation.—The amount of distortion present in such an amplifier working under such conditions may be found from the following equation in which $I_o = 18.5$ ma. which is equal to the plate current when 180 volts are on the plate and the C bias is 40.5 volts.

$$\begin{aligned} \text{Distortion} &= \frac{\frac{1}{2} (I_p \text{ max.} + I_p \text{ min.}) - I_o}{(I_p \text{ max.} - I_p \text{ min.})} \\ &= \frac{\frac{1}{2} (.039 + .001) - .0185}{.039 - .001} \\ &= \frac{.02 - .0185}{.038} = .039 \\ &= 3.9 \text{ per cent.} \end{aligned}$$

This distortion is the amount of second harmonic current in the output. Thus if the input a.c. grid voltage has a frequency of 1000 cycles and if the output current is 10 milliamperes (fundamental) there will be in the plate circuit 3.9 per cent of this current or about 0.4 milliampere in the form of a 2000-cycle wave.

It has been determined that a 5 per cent distortion is not objectionable to the ear—but this involves a matter of opinion and other factors. If and when better loud speakers are available it is possible that the average ear will detect less distortion than this.

189. Power diagrams.—To review the tube with a resistance load as a power amplifier, and to gather a few additional facts, let us draw the E_p - I_p curves as shown in Fig. 148, which is a purely theoretical case—the curves and values of current and voltage represent no particular tube now available; they were chosen at random. Let us assume that the voltage actually on the plate is 160 volts when the steady plate current is 20 ma. That is, $E_p = 160$, and $I_p = 20$ ma. Let us assume a load of 5000 ohms, find

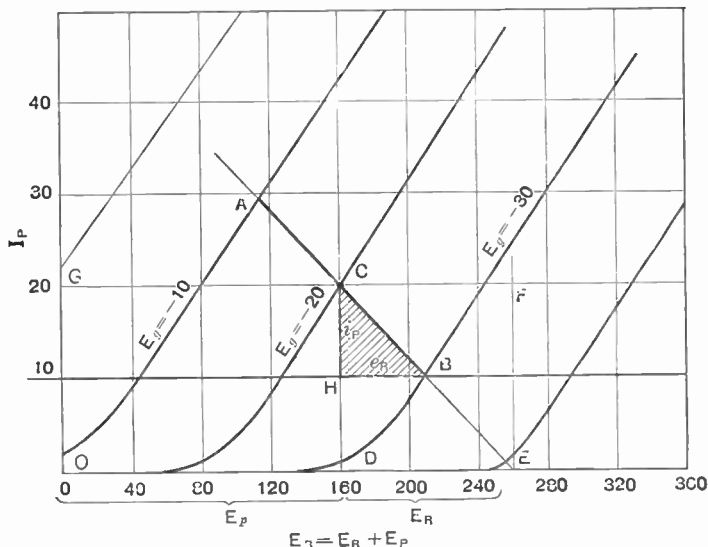

Fig. 148.—Power diagram. The area of shaded triangle represents a.-c. power used in load.

the slope, and draw the load line through the intersection of the $I_p = 20$ -ma. line with the $E_p = 160$ -volt line, and find that the bias on the grid to maintain such a plate current is 20 volts. Let us assume that a sine wave is put on the grid whose maximum value is 10 volts, so that the actual grid voltage varies between -10 and -30 volts. The corresponding I_p variations are from 30 to 10 milliamperes.

We note that the load line crosses the battery voltage line at about 260 volts. This, then, is the battery voltage necessary to

insure that the plate of the tube gets its 160 volts. In other words there is a drop of 100 volts ($5000 \times .02$) in the resistance of the load, R . Under normal conditions of no a.-c. input to the grid, the voltage across the tube is 160 volts, across the load is 100 volts, and the plate current is 20 ma.

Now the d.-c. power lost in the load is the product of the voltage across the resistance R and the current through it; and the power lost on the plate of the tube is the product of the voltage across the tube and the current flowing. Thus,

$$\text{Power lost in load} = E_R \times I_p = DE \times CD$$

$$\text{Power lost in tube} = E_p \times I_p = OD \times CD$$

and the total power supplied by the battery must be the sum of these powers, that is

$$\text{Power from battery} = E_B \times I_p = OE \times CD$$

Now the area of the rectangle $CDEF = DE \times CD =$ power in load, and the area of the rectangle $ODCG = OD \times CD =$ power lost in tube, and the area of the rectangle $OEEFG = OE \times CD =$ total power from battery.

When an a.-c. input is applied to the tube so that the grid is operated about its mean or average value of -20 volts, the maximum a.-c. current through the load is given by the line IIC and the maximum a.-c. voltage across the load is given by the line IIB . Let us call these values of current and voltage

$$e_R = \text{maximum a.-c. voltage across load} = IIB$$

$$i_p = \text{maximum a.-c. current through load} = IIC$$

Since a.-c. power in a resistance circuit is the product of the r.m.s. current and the voltage, to obtain the a.-c. power in the load we must first get the r.m.s. values of the above values and then multiply them

$$e_R \text{ r.m.s.} = e_R \text{ max.} \times \frac{1}{\sqrt{2}}$$

$$i_p \text{ r.m.s.} = i_p \text{ max.} \times \frac{1}{\sqrt{2}}$$

whence a.-c. power in load = $e_R i_p$ (r.m.s.)

$$\begin{aligned}
 &= e_R \times i_p \times \frac{1}{\sqrt{2}} \times \frac{1}{\sqrt{2}} \\
 &= \frac{e_R \times i_p}{2} \\
 &= \frac{HB \times HC}{2} = \text{area of triangle } HCB.
 \end{aligned}$$

This power is dissipated in the load resistance in addition to the d.-c. power lost there due the voltage drop across it and the current through it. Since the average current drawn from the battery has not changed, the power taken from the battery has not changed—and yet the load has an additional amount of power used up in it. Where does this power come from? Clearly it must come from the power used up on the plate of the tube. *When an a.-c. voltage is placed on the grid, then a.-c. power is developed in the load, less power is wasted on the tube plate, and the tube will actually run cooler when it is delivering power to the load than when standing idle, that is, with no a.-c. input grid voltage.*

Let us see what these values of power are. We can take them directly from the graph in Fig. 148.

$$\begin{aligned}
 &\text{d.-c. power lost in load (no a.-c. grid voltage)} \\
 &= DE \times CD = (260 - 160) \times (20 \text{ ma.}) \\
 &= 100 \times .02 = 2 \text{ watts}
 \end{aligned}$$

$$\begin{aligned}
 &\text{d.-c. power lost in tube (no a.-c. grid voltage)} \\
 &= OD \times CD = (160) \times (20 \text{ ma.}) \\
 &= 160 \times .02 = 3.2 \text{ watts}
 \end{aligned}$$

$$\begin{aligned}
 &\text{d.-c. power taken from battery} \\
 &= OE \times CD = 260 \times .02 = 5.2 \text{ watts}
 \end{aligned}$$

$$\begin{aligned}
 &\text{max. a.-c. voltage across a load (a.-c. grid voltage} = 10) \\
 &= HB = 210 - 160 = 50 \text{ volts}
 \end{aligned}$$

max. a.-c. current through load (a.-c. grid voltage = 10)
 $= IC = 10 \text{ ma.} = .01 \text{ ampere}$

a.-c. power in load (a.-c. grid voltage = 10)

$$\frac{1}{2} \times IB \times IC = .5 \times 50 \times .01 = .25 \text{ watt}$$

= 250 milliwatts, which is subtracted from d.-c. power in tube.

In Section 180 the formula for the power output of a tube was stated to be

$$\text{power output} = \frac{\mu^2 e_g^2 R}{(R_p + R)^2}$$

and in order to check the above calculations we must find the tube constants from the curves in Fig. 148. The plate resistance of the tube is simply the reciprocal of the slope of the $E_p - I_p$ line, and noting that a change of 160 - 100 volts on the $E_g = -10$ line produces a change in plate current of from 42 to 25 ma. we calculate

$$R_p = \frac{160 - 100}{.042 - .025} = \frac{60}{.017} = 3500 \text{ ohms,}$$

and from the two curves, $E_g = -10$ and $E_g = -20$ we ascertain that a change of 10 volts on the grid produces a change in plate current of from 42 to 20 ma. when the plate voltage is 160, we calculate

$$G_m = \frac{.042 - .020}{10} = 2200 \text{ micromhos}$$

whence

$$\begin{aligned} \mu &= R_p \times G_m = 3500 \times 2200 \times 10^{-6} \\ &= 7.7 \end{aligned}$$

whence power output

$$= \frac{(7.7 \times 7.07)^2 \times 5000}{(5000 + 3500)^2}$$

$$= .206 \text{ watt} = 206 \text{ milliwatts.}$$

This value agrees closely enough with our data secured from the characteristic curves in Fig. 148.

Thus from a collection of the E_p-I_p curves of any tube we may obtain all the necessary data upon which to build an amplifier and calculate its power output, the losses in the various tubes, the percentage distortion, etc.

190. The pentode.—A triple-grid tube which has come into wide use as an a.-f. amplifier is the pentode. It is a screen-grid tube with an additional grid between the plate and the screen grid and permanently connected, within the tube, to the cathode. Its purpose is explained as follows.

In the screen-grid tube, as shown in Fig. 136, at values of plate voltage less than the screen voltage the space or electron current tends to go backwards and makes a portion of the characteristic useless for amplification. The question naturally arises, why make the plate less positive than the screen grid? The reason is that when an a.-c. voltage is put on the grid of the tube, this voltage is multiplied by the μ of the tube and reappears in the plate circuit as an a.-c. voltage. This is superimposed upon the steady or d.-c. voltage, at some moments adding to this voltage and increasing the plate current and at other moments decreasing the effective voltage on the plate. If we put sufficient voltage on the grid the instantaneous plate voltage may fall to a low value, lower than the screen voltage, with the result that electrons will flow from the plate to screen and the amplifier breaks into oscillation or causes some other sign of distress.

The suppressor grid, which is at zero potential because it is connected to the cathode, acts as a wall over which the electrons emitted from the plate cannot hurdle. They are suppressed or thrown back to the plate. The bad part of the characteristic is ironed out, and greater voltages may be impressed on the grid.

The tube is a high-resistance, high- μ tube. It has much greater sensitivity than a triode designed for power output. Thus a 47 will deliver about 3 watts at a signal voltage of approximately 15 while a 45 will deliver but 1.6 watts with a signal voltage of approximately 35 volts.

The difficulty with the pentode is the fact that not only does it produce more harmonics than a triode but that it is more difficult to use. Despite these difficulties nearly every home or automobile receiver put out uses a pentode as a power output tube. It is noteworthy, however, that those few receivers made for a high-quality market selling at a high price and aimed at listeners of discrimination use triode output tubes.

A most useful tube for this purpose was the 2A3, a remarkable tube with a mutual conductance of 5000, an internal resistance of less than 1000 ohms and delivering 3.5 watts with an exciting voltage of about 32 volts.

The pentode is useful where economy of space or amplification is of importance, as in automobile or aircraft receivers, or in midgets or very cheap sets.

A new type of tube was introduced in 1936, known as a "beam" power tube. Here the electrons are made to flow in beams, like a cathode-ray tube. It has a remarkable output and in certain circuits will deliver many watts at very low orders of distortion. This is the 6L6.

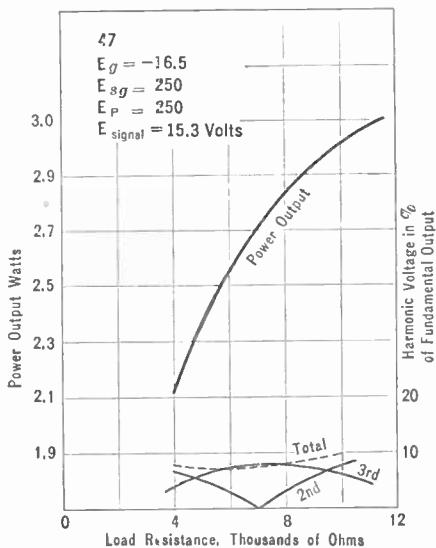

FIG. 149.—Pentode output characteristics.

Note that the second harmonic passes through a minimum.

CHAPTER XI

AUDIO AMPLIFIERS

So FAR we have not spoken of the frequency or band of frequencies at which the vacuum tube and its associated apparatus will amplify. The theory up to the present point deals with amplifiers in general. It is necessary now to consider the types of amplifiers, and their differences.

191. Need of an audio amplifier.—All radio receivers in use at the present time have an audio amplifier of more or less amplification. The principles of such amplifiers underlie the whole phenomenon of amplification.

Let us think of the broadcasting studio in which originate the signals which we must amplify. A microphone stands in front of a musician or a speaker. It has two electrodes which for the sake of our discussion may be made of carbon. Between them is a little box of carbon granules. One of the electrodes has a metal diaphragm attached to it which is so located that the air vibrations we call sound impinge on it. When sound is directed into the microphone it moves the diaphragm which in turn moves one of the electrodes which squeezes the carbon granules and thereby changes their electrical resistance. The steady battery current which normally flows through the microphone from one carbon electrode through the carbon granules to the other electrode is changed in accordance to the frequencies of the music or speech directed into it.

This steady current of the microphone is said to be "modulated" or changed in accordance with the voice frequencies; and after the steady current is filtered out, the changes are built up in strength by amplifiers which will transmit the range of frequencies

that will be encountered in practice. Here then is the first need for amplifiers. They must make up the loss resulting from transferring the energy in the moving air particles we call sound into the energy of the changing electric current. This loss in energy that must be made up is considerable.

The frequencies normally transmitted over telephone lines range from 250 to about 2500 cycles. These are complex audio-frequency a.-c. currents. Most of the energy of the voice occurs in the frequencies below 1000 cycles, most of the intelligibility above that frequency; therefore if a filter is put in the telephone line which admits only frequencies below 1000 cycles we would hear a sound but it would be unintelligible. On the other hand, if the filter cut out all the low tones and transmitted only those above 1000 cycles, we could understand what the speaker was saying, but the sound would not carry, it would be weak.

For best intelligibility and carrying power—naturalness, we say—all the frequencies from about 120 to 2500 are necessary for transmission of speech.

Music, however, is more complex and for realism and naturalness a much greater frequency range must be transmitted, not only by the microphone but also by the amplifiers, the radio broadcasting station, the ether, the receiver, the amplifier, and finally the loud speaker in one's home. Music requires the transmission of all frequencies between 100 and 5000 cycles per second, and many critics desire that a still greater range shall be transmitted. At the present time, in the United States, the best broadcasting stations and connecting circuits transmit from below 100 to above 5000 cycles per second. After a certain amount of amplification these tones are mixed with a radio-frequency wave which is emitted from the antenna of the transmitting station. Just as the microphone current is said to be modulated, so is the radio-frequency wave of the station said to be modulated by these amplified audio-frequency tones. The program then becomes inaudible and remains so until some demodulating device separates the program from the radio-frequency voltages.

In spite of the fact that considerable power is used at the broadcasting station, there is an enormous loss in signal strength as we

go away from the transmitter. These radio-frequency waves modulated at audio frequencies are greatly reduced in strength owing to absorption and dissipation in the medium through which they travel. It is now our duty to make up the transmission losses, to amplify them again, to demodulate or separate the audio- and radio-frequency currents, and then to forget all about the radio circuit from then on.

An audio amplifier, then, has nothing to do with radio at all, and can be used to amplify any voice or music frequency-modulated electric currents that are placed upon its input. Its job is to build up the strength of a minute electric current to the point where the audio modulations on this current are of equal or greater strength than they were originally.

From the moment the sound in the studio enters the microphone, it ceases to exist as sound, and becomes an electric current. The amount of voltage amplification necessary depends of course upon the ultimate strength of the desired signal and the strength of the signal which is to be raised to this level. The maximum amplification that has been attained is of the order of 10^{1200} which is used in some tests on telephone cable. No sound is emitted again until some translating device is used, a device that will have electric currents in its input and sound or air waves in its output. Then, and only then, is sound emitted. Nowhere along the line from microphone to loud speaker can the signal be heard, unless some translating device is "plugged in." After demodulation the currents of audible frequency are amplified as much as desired by an audio amplifier.

The voice-frequency currents that can be amplified by an audio amplifier may come from a phonograph "pick-up," a telephone transmitter mouthpiece, or the plate circuit of a detector tube in a radio receiver. The radio link is, then, only an incidental and extremely inefficient part of the whole system—better results could be secured by eliminating the radio link completely and using telephone or power lines between the receiver and the transmitter. The advantage of radio is the ability to "broadcast" in all directions, and to eliminate the need of a metallic circuit between the person broadcasting and the person listening.

Let us forget all about the radio part of our receiver, temporarily, and consider only the audio-frequency amplifier.

192. The requirements of an audio amplifier.—An amplifier to accept, transmit, and amplify audio-frequency tones has several requirements which have taxed the ingenuity of many engineers:

(1) The amplifier must transmit all the tones required, in their proper proportion. It must have no frequency distortion.

(2) The amplifier must amplify all frequencies properly whether the input voltage is high or low. It must have no volume distortion.

(3) It must have an overall amplification which added to the radio-frequency amplification will make up for the enormous loss of power between the input to the microphone and the output from the loud speaker.

Let us consider, for the moment, only the amount of amplification necessary. This value of overall amplification varies, of course, with the input signals possible, and the output power required. For home reception an output of one watt of electrical power into a loud speaker of average efficiency—perhaps 5 per cent—is sufficient, although many people get along with much less than this value, and some require much greater power outputs.

If the amplifier works out of a “grid leak and condenser” detector tube, the maximum voltage available without distortion due to detector overloading is about 0.3 volt. If the speaker has a resistance of 4000 ohms and if the output is 0.7 watt, and tube resistance is 2000 ohms, there must be the following amplification:

$$\begin{aligned}
 W_o &= \text{power into load} && = 700 \text{ milliwatts} \\
 R_o &= \text{resistance of load} && = 4000 \text{ ohms} \\
 E_L &= \text{voltage across load } E_o && = \sqrt{W_o \times R_o} = 53 \text{ volts r.m.s.} \\
 E &= \text{total a.-e. voltage in} \\
 &\quad \text{plate circuit of last tube} && = 53 \times 3/2 = 79 \text{ volts} \\
 E_i &= \text{input voltage to amplifier} && = 0.3 \text{ volt r.m.s.} \\
 G &= \text{voltage amplification} && = 79/0.3 = 260 \text{ times}
 \end{aligned}$$

It is better that the amplifier shall have considerably more gain than this figure so that the detector may be worked at a safe dis-

tance below its overloading point—to have a good factor of safety—and that weak signals from distant stations can “load up” the amplifier and its speaker.

In many modern receivers certain modifications have been made so that the detector output is sufficiently high that a loud speaker can be operated on but one stage of audio amplification. In others two or more stages are necessary to get the desired output of power.

Let us say, then, that the minimum gain for our amplifier is 300 times. How can we secure this amplification? There are several ways and we have already discussed the various types of amplifier arrangements. It is only necessary so to design each stage or to add a sufficient number of stages that the overall voltage amplification will be sufficient. The next problem is to see if the required frequency characteristic can be secured to prevent distortion due to over emphasis or discrimination at some frequencies.

Example 1-11. An amplifier has a voltage gain, up to the grid of the last tube, of 200. The last tube has a μ of 8 and a plate resistance of 5000 ohms. It works into an impedance of 10,000 ohms. The input to the amplifier is 0.1 volt r.m.s. Calculate the power into the resistance, the voltage across it and the ratio between this voltage and the input voltage to get the overall voltage amplification.

The a.-c. voltage on grid of last tube = $E_i \times G = 0.1 \times 200 = 20$ volts.

The a.-c. voltage in plate circuit of last tube = $20 \times 8 = 160$ volts.

The a.-c. voltage across 10,000-ohm load = $2/3 \times 160 = 106$ volts.

Power into load = $E^2/R = 106^2/10,000 = 1.2$ watts.

Voltage amplification = $E_o/E_i = 106/0.1 = 1060$ times.

Problem 1-11. What voltage gain must an amplifier have to deliver 1.5 watts to a 4000-ohm load in the plate circuit of a tube whose plate resistance is 2000 ohms if the input voltage to the amplifier is 0.3 volt r.m.s.?

Problem 2-11. The load of an amplifier is a 2000-ohm resistor. The plate resistance of the last tube is 2000 ohms and its μ is 3. The gain in voltage up to the grid of this last tube is 100. What input voltage is required to deliver 50 milliwatts of power?

Problem 3-11. Prove that if the load resistance is double the tube resistance, the voltage across the load is two-thirds of the total a.-c. voltage in the plate circuit of the tube and the voltage amplification is equal to the amplification up to the grid of the tube times the μ of the tube times $2/3$.

Problem 4-11. If the load resistance is twice the tube resistance and the a.-c. voltage across the load is 100 volts, what must be the total a.-c. voltage in the plate circuit? If the μ of the tube is 8, what must be the grid a.-c.

voltage? If this is the r.m.s. voltage, what must be the minimum C bias of the tube to keep its grid from going positive?

Problem 5-11. The voltage gain per stage is 8. How many stages will be needed to produce an overall gain of 500? Remember that voltage gains are multiplied, not added. Estimate the gain as the total a.-c. voltage in the plate circuit of the last tube divided by the input voltage.

Problem 6-11. The voltage gain per stage is 10. What is the total voltage gain (total a.-c. plate voltage divided by input voltage) in three stages?

193. Cascade amplifiers.—It is usually necessary to use more than one stage of amplification, whether this is at high (radio), intermediate or at low (audio) frequencies. That is, an a.-c. voltage is applied to the grid of one tube and amplified; this amplified a.-c. voltage is used to drive the grid of another tube where it is again amplified. This voltage may again be amplified or used to drive the grid of a power tube whose function is not voltage amplification but the delivery of power to a loud speaker. The first tube in a two-stage amplifier is designed to amplify the voltage alone, and the transfer of power either at maximum efficiency or at maximum output is not a consideration. The second tube, or the third in a three-stage amplifier, is designed solely for the purpose of delivering power to the load, whether this is a loud speaker, or group of speakers, or a telephone line where it may be again amplified and put into the loud speakers. When two or more amplifiers are connected “in series” they are said to be connected in “cascade.”

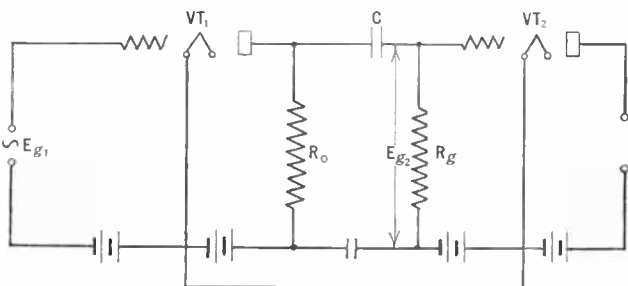

Fig. 150.—Two tubes coupled by a resistance-capacity unit.

194. Frequency characteristic of resistance amplifier.—Let us look at the circuit in Fig. 150 which gives two tubes coupled by

means of a resistance-capacity unit. Voltage is fed to the grid of the first tube VT_1 , is amplified there, and reappears across R_o . This amplified voltage is applied to the grid of the second tube and amplified, whence it reappears across whatever load is in its plate circuit. The voltage gain of such a stage is the ratio between the voltage on the second grid and the voltage on the first grid. That is,

$$G = \frac{E_{g2}}{E_{g1}} \quad (1)$$

We have already spoken about the conditions that result in maximum amplification in such a system, that is, the impedance in the plate circuit of the first tube must be large compared with the plate resistance of that tube. That is, the equivalent impedance of R_o shunted by C

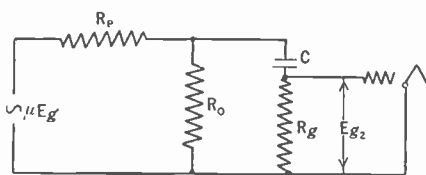

FIG. 151.—Equivalent circuit of Fig. 150.

and R_o in series must be large compared to R_p (Fig. 151).

Now the only part of this circuit which has a different impedance at different frequencies is the condenser. To get a good frequency characteristic, then, it is necessary to choose a value of C which will transmit the lowest frequency desired, because all other frequencies above this limit will find less impedance than this value. (The reactance of a condenser decreases with increase in frequency.)

The voltage that is developed in the plate circuit of VT_1 is divided between the plate resistance of that tube and the load in the plate circuit. The voltage across this impedance is the output voltage, and is divided between that lost on the condenser reactance C and the grid resistance R_g of the following tube. The only useful part is that appearing across R_g .

The purpose of the condenser is to prevent the positive plate voltage of the first tube from being impressed upon the grid of the second tube. It is an isolating condenser and must have high d.-c. resistance. Any current flowing (d.c.) through it will cause a

voltage drop in such a direction that the grid will be unfavorably biased. The purpose of the grid leak, R_g is two fold; one is to provide a means of biasing the second tube grid, as by putting a C battery between the lower terminal of this resistor and the cathode of the tube, and secondly to provide a high impedance in series with the low impedance of the capacity to be bridged across the plate coupling resistor of the first tube.

In modern resistance-coupled amplifiers the value of capacity is of the order of 0.1 mfd. The grid resistor is 0.5 to several megohms. With care in construction, seeing that stray capacities which shunt the two resistors do not become large enough to reduce the effective impedance of those resistors at the desired frequency, a resistance-coupled amplifier will provide uniform amplification over a very wide frequency range.

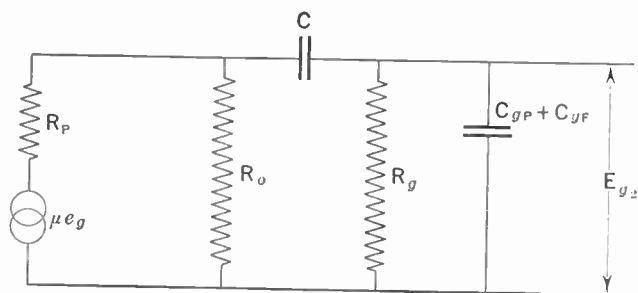

FIG. 152.—Equivalent of tube and load and shunting capacities.

At the high frequencies the stray capacities which shunt the resistances so reduce the effective impedance of the load in the tube plate circuit that little amplification, and hence little voltage, is developed. These stray capacities are made up of the plate to filament capacity of the first tube, the grid to filament (or cathode) capacity of the second tube, the capacity in the wiring, etc. These may be lumped together to form an equivalent capacity across the grid resistor as shown in Fig. 152.

At 1000 cycles or so, where the reactance of the coupling condenser will have no effect, the maximum possible amplification is obtained. It is equal as shown in Section 178 to the μ of the tube multiplied by the ratio between the effective load resistance to the

sum of this resistance and the plate resistance of the tube. Thus

$$G = \frac{\mu R_{c_7}}{R_{c_7} + R_p} \quad (2)$$

where R_{c_7} is equal to the load resistance shunted by the grid resistance of the following tube. The circuit is shown in Fig. 152. At these middle frequencies the reactance of C may be neglected. Therefore the tube has, as its load, three resistances in parallel.

Therefore to calculate the amplification it is first necessary to calculate the equivalent resistance which the tube works into, i.e., the shunt circuit composed of the coupling resistor and the grid resistor. Then calculate the amplification as in formula 2.

At low frequencies the effect of the coupling condenser cannot be neglected. Across its reactance will appear a voltage which cannot be impressed upon the following grid-cathode input circuit. It is a voltage that is supplied by the previous tube and is then lost. The load, then, of the tube is more complicated than at middle frequencies. In the low-frequency case it consists of the load resistance R_o shunted by a condenser and a resistance in series. It is not difficult to calculate the effective load resistance in this case but it is rather tedious. If the grid resistance is high, and the capacity large enough, the calculation can be simplified as follows. This is not strictly correct but will give answers which compare favorably with measured data.

The relation between these factors is shown in the table below. K is the percentage of middle frequency gain.

$K = 90$ per cent at 50 cycles		$K = 80$ per cent at 50 cycles		$K = 70$ per cent at 50 cycles	
C , mfd.	R_o , meg.	C , mfd.	R_o , meg.	C , mfd.	R_o , meg.
0.0132	0.5	0.0084	0.5	0.0062	0.5
0.0066	1.0	0.0042	1.0	0.0031	1.0
0.0033	2.0	0.0021	2.0	0.00156	2.0
0.0013	5.0	0.0008	5.0	0.0006	5.0

Let us assume that the voltage developed by the tube appears across R_o and is not affected by the shunt circuit across R_o . In other words, the grid resistor is high enough to wipe out any possible shunting effect of the capacity. How much of the total voltage developed will appear across the grid resistor where it is useful, and how much will be lost in the capacity reactance?

The a.-c. voltage across the resistor R_o will produce a current through the condenser and the grid resistor of

$$i = \frac{E_{R_o}}{\sqrt{R_o^2 + X_c^2}} \tag{3}$$

and the voltage across the grid resistor will be

$$E_{g2} = iR_g = \frac{E_{R_o}R_g}{\sqrt{R_o^2 + X_c^2}} \tag{4}$$

Now let us call N , the ratio between the useful voltage, E_{g2} , to the total voltage, E_{R_o} .

$$N = \frac{E_{g2}}{E_{R_o}} = \frac{R_g}{\sqrt{R_o^2 + X_c^2}} \tag{5}$$

from which we can get the value of C

$$C = \frac{N}{2\pi f R_g \sqrt{1 - N^2}} \tag{6}$$

which states that the value of capacity to secure a certain percentage of the total voltage depends upon the frequency and the resistance of the grid resistor. It is interesting to note that the proper value of capacity depends not only upon the frequency desired but upon the value of a unit whose value does not vary at all with frequency, i.e., a resistor.

From this equation the values for determining any one of the

variables controlling the frequency characteristic of low frequencies may be determined. It is worth noting that C increases as R_g decreases in value.

Problem 7-11. Assume the following values and calculate the efficiency: $C = 1$ mfd.; $R_g = 500,000$ ohms, $R_o = 200,000$ ohms, $R_p = 60,000$ ohms, $f = 800$ cycles, and $f = 40$ cycles.

Problem 8-11. The μ of a tube is 30 and its plate resistance is 60,000 ohms. Calculate and plot the voltage amplification as the load resistance varies from 10,000 ohms to 200,000 ohms.

Problem 9-11. A condenser and a grid leak are in series. $C = 0.006$ mfd., and $R_g = 2$ megohms. Across them is a 40 cycle-voltage of 10 volts. Calculate the current flowing, the voltage drop across C and across R_g ; and, assuming the voltage across R_g is the only useful voltage, calculate the efficiency by dividing the voltage across R_g by the total voltage and multiplying by 100 per cent.

Problem 10-11. A frequency of 100 cycles is to be transmitted across the grid leak and condenser in Fig. 150 at 90 per cent efficiency. If, then, $N = 0.9$, $R_g = 500,000$ ohms, what must C be in microfarads?

Problem 11-11. Suppose a tube with a μ of 30 and R_p of 150,000 ohms is used with a coupling resistance of 250,000 ohms. The following tube has a grid leak of 0.5 megohm. What must be the coupling capacity to get a gain of 13 at 50 cycles?

Problem 12-11. What is the amplification in Problem 11-11 if $C = 0.006$ mfd., $f = 20$ cycles, and $R_g = 1.0$ megohm?

195. Overall amplification.—Let us consider a three-stage amplifier, having resistances, tubes, etc., as shown in Fig. 153.

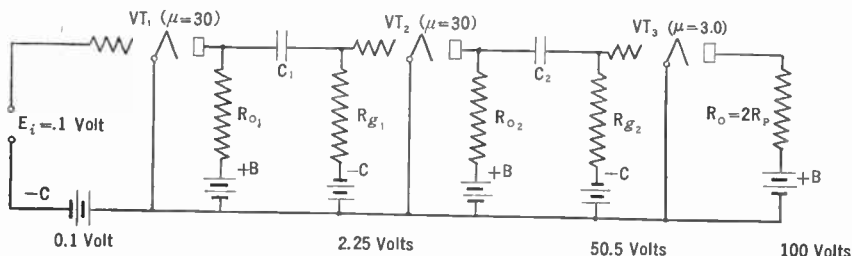

FIG. 153.—Three stage resistance coupled amplifier.

The first two tubes have an amplification factor of 30, the final or power tube has a μ of 3. What is the overall voltage amplification? If the values of R , C , and R_g are properly chosen, the amplification per stage will be 75 per cent of the μ of the tube, and

what the first tube amplifies will be amplified again by the second. That is, if an input of 0.1 volt is applied to the grid-filament input of the first tube a voltage of $0.1 \times .75 \times 30$ or 2.25 volts will be applied to the second, and a voltage of $2.25 \times 30 \times .75$ or 50.5 volts to the third input; and if the resistance into which this tube works has twice the value of the plate resistance of the tube, two-thirds of the total a.-c. plate voltage of the last tube will be applied to the load. That is, the load will have across it a voltage equal to $50 \times 3 \times \frac{2}{3}$ or 100 volts.

The overall voltage amplification in such a case will be $100 \div 0.1$ or 1000. This is equal numerically to the product of the voltage gain of the individual stages. Thus if each stage has a gain of G , two stages will have a gain of G^2 , three stages a gain of G^3 , etc. In this case it will be $(22.5)^2 \times 3 \times 2/3 = 1000$ (approximately).

196. Plate battery requirements.—One of the objections to the resistance amplifier is the excessive plate battery voltages that are necessary. The voltage on the plate of a tube in whose plate circuit is a high resistance is not the voltage of the battery but this voltage minus the voltage drop across the resistor in the plate circuit. We want the a.-c. voltage drop across this resistance to be high but the d.-c. voltage drop to be low. As an example suppose a tube has a plate resistance, R_p , of 60,000 ohms when the plate voltage (E_p) is 100 volts. To get 75 per cent of the μ of the tube as the overall amplification from grid input voltage to the voltage output across the resistor, we need a resistance in the plate circuit of 180,000 ohms. Suppose under these conditions the plate current is 1 ma. What plate battery voltage is necessary if 100 volts are required on the plate?

The plate voltage may be found from

$$\begin{aligned} E_p &= E_b - I_p R_p \\ 100 &= E_b - 0.001 \times 180,000 \\ E_b &= 280 \text{ volts.} \end{aligned}$$

Now the tube will amplify with fewer volts on the plate than this—as many manufacturers and experimenters have proved—but

the difficulty lies in the following fact. The plate resistance of a tube is a function of the plate voltage. That is, at low plate voltages the plate resistance is high, which in turn necessitates a higher value of load resistance to get the 75 per cent of the μ of the tube, which means that the voltage drop will be high across this resistor and so on. A high plate battery is always needed.

To get 100 volts on the plate of this tube requires a plate battery of 280 volts. This is inefficiency, of course. What can be done about it?

197. Inductance load amplifier.—Suppose instead of the resistor in the plate circuit we substitute a low resistance inductance with a high value of reactance

at the frequencies at which the amplifier is to work, for example a 100-henry choke coil with a d.-c. resistance of 1000 ohms. The circuit looks like Fig. 154. Now the d.-c. plate current encounters no appreciable opposition in the 1000-ohm resistance. In fact

the voltage drop is 1 volt per milliampere of plate current. The a.-c. current, however, must flow through the high inductance and the resistance in series. Across this impedance ($\sqrt{R^2 + L^2\omega^2}$) will appear the amplified a.-c. voltage which may be used to drive another amplifier stage if desired.

Such an amplifier is commonly called an **impedance amplifier**. The loss in d.-c. voltage between the plate battery and the plate itself is only 1 volt per milliampere current, and if the plate current is 2 ma. only 102 volts of B battery will be required to put 100 volts on the plate of the tube.

Problem 13-11. An amplifier is to be used at audio frequencies. What must be the impedance of the choke coil at 100 cycles to secure an amplification of 7.5 from a tube whose μ is 10 and whose plate resistance is 15,000 ohms? What will be the amplification at 1000 cycles?

Problem 14-11. If the resistance of the choke coil used in Problem 13 is 500 ohms, what is the inductance required?

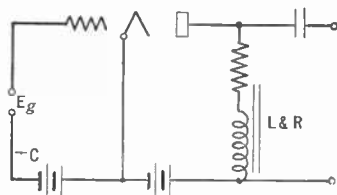

FIG. 154.—Inductance-capacity or "impedance" coupled amplifier.

Problem 15-11. A tube has a load resistance of 100,000 ohms. The plate current is 2 ma. and the plate voltage required is 90 volts. What plate battery voltage is necessary?

Problem 16-11. A tube draws 0.5 ma. from the B batteries whose voltage is 180 volts. A coupling resistance of 100,000 ohms is used. What is the voltage actually on the plate?

198. Capacity effects at high frequencies.—We have already explored the resistance coupled amplifier at middle and low frequencies. The same maximum amplification formula will apply to the impedance amplifier. The lower frequencies in this amplifier are not amplified as well as the median frequencies because of the fact that the choke used as the load of the first tube does not have a uniform reactance at all frequencies. This reactance is low at low frequencies and therefore the extent to which these tones are amplified depends upon the magnitude of this reactance.

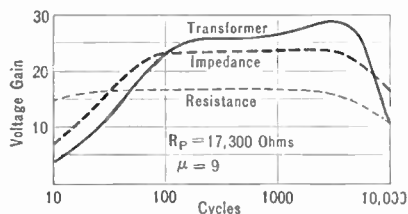

FIG. 155.—Comparison of three types of audio amplifiers showing high amplification of transformer coupling; wide range of resistance amplification. (Terman.)

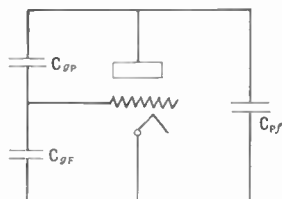

FIG. 156.—Tube capacities.

The choke consists of some resistance, a large inductance and some capacity since there are many turns of wire insulated from each other and just as in a solenoid this coil has distributed capacity. At some intermediate frequency the inductance resonates with its distributed capacity forming a high impedance anti-resonant circuit. At this frequency the amplification is a maximum. Below this frequency the inductance is not great enough to build up the maximum load impedance; at higher frequencies the shunting distributed capacity together with other capacities as explained below reduces the plate load impedance and reduces the amplification.

The impedance amplifier saves B batteries since the voltage drop is much less than in a resistance coupled amplifier. The latter, however, will have a flat characteristic over a much wider range of frequencies. In addition the choke costs much more than a resistance; for these reasons the impedance coupled amplifier is seldom used.

Both amplifiers suffer at high frequencies because of the capacities which shunt the grid resistor and the plate coupling resistor (or choke). The percentage of the maximum possible amplification that is attained at frequencies of several thousand cycles in a resistance coupled amplifier is

$$N_{hf} = \frac{1}{\sqrt{1 + \frac{R_{hf}^2}{X_c^2}}} \quad (7)$$

where R_{hf} is the equivalent parallel resistance of R_p of the first tube, R_o the coupling resistance, R_g the grid resistance of the second tube, and X_c is the reactance of the various capacities shunted across these resistances.

In the impedance coupled amplifier the percentage of the maximum possible amplification that is secured at low frequencies is given by an exactly similar expression in which X_L is substituted for X_c in this case standing for the inductive reactance of the choke.

To attain 70 per cent of the maximum possible amplification at a low frequency the reactance of the coupling condenser (or the choke) must equal the coupling resistance in ohms. At high frequencies the reduction in amplification will be about 5 per cent if the shunting capacities have a reactance equal to about three times the equivalent resistance as used in formula 2. At three times this frequency the amplification will have fallen to about 70 per cent of the maximum.

In both amplifiers the greatest voltage gain will be secured with high μ tubes; the best frequency characteristic will be secured with low μ tubes.

These effects are illustrated in the curve in Fig. 157, taken from a Radio Club of America paper by A. V. Loughren, published in *Radio Broadcast*, August, 1927, and in 155 after Terman.

Not only do the tubes and wiring capacities, which are represented in Fig. 152, play havoc with high frequencies, but the effect of the grid-plate capacity of the second tube is multiplied by the μ of the tube—a very interesting and unfortunate fact.

The capacities which cause trouble at high frequencies are:

- (1) Grid-filament capacity, C_{of} .
- (2) Plate-filament capacity C_{pf} .
- (3) Grid-plate capacity, C_{o1} .
- (4) Stray capacities in wiring, etc.

The capacity C_o across the input to the tube is equal to

$$C_o = C_{of} + C_{op} (\mu_o + 1),$$

where μ_o is the effective amplification in the circuit, and the other factors are as itemized above and shown in Fig. 156.

These values for the Radiotron UX-240, a tube adapted for resistance-coupled amplifiers, are $C_{pf} = 1.5$ mmfd., $C_{of} = 3$ to 4 mmfd., and $C_{op} = 8.8$ mmfd. In practice C_o may vary from 20 to as high as 300 mmfd. depending upon the intrinsic values of its components and the amplification of the system. That is, if the $C_{of} = 3.0$ mmfd., and $C_{op} = 8.0$ mmfd. and the effective amplification of the system is 20, C_o becomes 3 plus 8×20 or 163 mmfd.—which is an appreciable

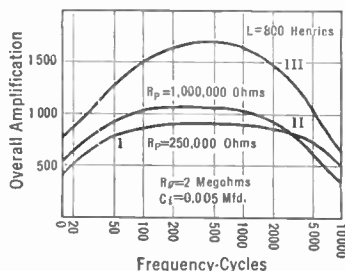

FIG. 157.—Frequency characteristic of resistance- and inductance-coupled amplifiers.

capacity and not at all what one would expect. The effective capacity across the input to the tube is a function of the μ of the tube; thus the greater the amplification factor the more trouble one gets into because of this capacity-multiplying effect. Low μ tubes are not so troubled, but their amplification is low; and so the amplifier designer and experimenter must compromise between a good frequency characteristic and a high gain. If the gain is good the high frequencies are discriminated against, and if the characteristic is very good the overall gain is likely to be low.

Problem 17-11. The μ of a tube is 8, its grid-filament capacity is 6 mmfd., its plate-grid capacity is 8.0 mmfd. The effective amplification of the circuit is 7, and stray capacities across the filament and grid circuit amount to 2 mmfd. What is the effective shunting capacity C_g ?

199. Frequency characteristic of amplifiers.—So far we have discussed only isolated points in our frequency response, either high, medium or low frequencies. What happens at other points? In the case of the resistance coupled circuit the reactance of the coupling condenser reduces the amplification at lower frequencies as indicated before; in the impedance amplifier the reactance of the choke limits the response. If the response at any frequency is calculated it will be less at lower frequencies and will rise to the maximum possible amplification, which will in general be higher in the impedance coupled stage than in the resistance stage.

At the higher frequencies in both amplifiers the shunting capacities of tube and wiring control the characteristic. For example, a resistance shunted by a capacity will have the following effective resistance

$$R_{eff} = \frac{R}{\sqrt{1 + \omega^2 R^2 C^2}}$$

and in the table below will be found some values of a quarter-megohm shunted by 60 mmfd.

Frequency	Effective resistance in ohms
2,000	246,000
4,000	234,000
6,000	218,000
8,000	200,000
10,000	182,000

If the resistor is one megohm and the capacities rise to 300 mmfd., the effective load becomes only 53,000 ohms although it is 965,000 ohms at 100 cycles. This represents a tremendous drop.

Therefore the stray capacities must be kept low. As shown above, the capacity between tube elements is effective in reducing the amplification particularly that existing between grid and plate of the second tube. This value is multiplied by the (effective gain in the circuit plus 1). Therefore the higher the gain the greater becomes the difficulty of keeping the response up at the

high frequencies. The higher the coupling resistor the greater in effect become these capacities. Therefore for flat amplification it is almost necessary to use low- μ tubes with low gain per stage.

Example 2-11. Suppose a 1-megohm resistor is in the plate circuit of a tube and that 10 volts are developed across it. If 100,000 ohms are shunted across it, the effective impedance becomes 0.91×10^5 , and if the current is the same the voltage developed has been reduced to 0.91 volt. Now, suppose 10 volts are developed across 100,000 ohms and that another 100,000-ohm resistor is shunted across it. What is the resultant reduction in voltage? Clearly it is 50 per cent—a much smaller percentage reduction.

Problem 18-11. A tube with an amplification factor of 30 and a plate resistance of 150,000 ohms is used with a half-megohm coupling resistance. Suppose that in construction a path of soldering flux is placed across the terminals of this resistor accidentally so that the half-megohm is effectively shunted by 100,000 ohms. What is the resultant amplification? What is the amplification without the shunting resistance? What is the percentage loss due to the flux?

200. Tuned inductance amplifier.—In both the resistance load and the inductance load amplifier the maximum amplification is attained when the impedance in the plate circuit is a maximum. If, then, we desire to receive only one frequency, say 1000 cycles, we can get greater amplification by tuning the inductance with a shunt condenser so that we have an anti-resonant circuit in the plate circuit of the tube, as shown in Fig. 158. If an inductance of 0.1 henry is tuned with a 0.254-mfd. condenser the resonant frequency will be about 1000

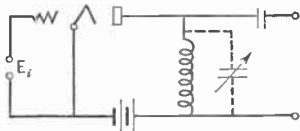

FIG. 158.—Tuned inductance output.

cycles. If the coil has a resistance of 100 ohms the impedance of the anti-resonant circuit will be roughly 3950 ohms whereas the reactance of the coil alone will be only 628 ohms. Tuning the coil therefore increases the load impedance in the plate circuit by about 6.3 times.

The voltage gain will be given by the formula of Section 178:

$$G = \mu \frac{R_o}{R_o + R_p}$$

which shows that the maximum possible amplification is the μ of the tube, and, as we have already seen, increasing the load impedance R_o to the point where it is three times the tube internal resistance results in a voltage amplification of $\mu \times .75$.

Problem 19-11. An inductance of 170 microhenries has a resistance of 6.0 ohms at 500 kc., 10 ohms at 1000 kc., and 18 ohms at 1500 kc. Assuming a fixed capacity—due to distributed capacity of winding, connections, etc.—across the coil of 60 mmfd., calculate the condenser capacity that will tune the coil over the broadcast frequency band. Calculate the reactance of the coil at the three frequencies above and the voltage gain to be expected when used with a tube whose plate resistance is 12,000 ohms and a μ of 8. Then calculate the impedance in the plate circuit if the inductance is tuned at each of the three frequencies and the voltage gain to be expected when connected as in Fig. 158. Plot the voltage amplification of this single stage against frequency. Explain why the curve is not flat.

The untuned inductance or "impedance" amplifier can be used where it is desired to transmit a fairly wide band of frequencies; tuning it makes it possible to get greater amplification over a narrow band of frequencies.

201. The transformer-coupled amplifier.—The output a.-c. voltage across the resistance or inductance—tuned or not—can never be higher than the input grid voltage multiplied by the μ of the tube, and can attain that value only when the resistance or

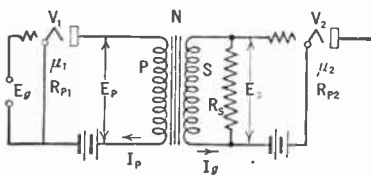

FIG. 159.—Transformer coupled amplifier

impedance is high compared to the plate resistance. Suppose, however, we use a transformer, as in Fig. 159. The voltage across the secondary will be increased by the turns ratio of the windings and so the voltage developed in the plate circuit of the tube may not only be

passed on to a following tube multiplied by the μ of this tube but multiplied by the turns ratio as well.

If the secondary circuit takes no current or power the greatest voltage will appear across the secondary when a very high turns ratio is used, but this is not the case when power is taken—and some always is.

The maximum voltage across the secondary will be obtained when the turns ratio is given by the expression

$$N^2 = \frac{R_s}{R_p},$$

where R_s and R_p are the resistances between which the transformer works. When such a turns ratio is used the voltage across the secondary is given by

$$E_s (\text{max.}) = \frac{\mu_1 E_{g1} N}{2}. \quad (7)$$

All of this assumes that a perfect transformer is used, that is, one which has no d.-c. resistance, no magnetic leakage, and infinite primary and secondary reactances. If the resistance of the load across the secondary is 1 megohm, and the plate resistance of the tube is 10,000 ohms, the proper turns ratio,

$$N = \sqrt{\frac{1,000,000}{10,000}} = 10,$$

and the voltage gain from (7) is

$$\frac{E_s}{E_{g1}} = \mu_1 \times 5 = 40 \text{ if } \mu_1 = 8.$$

The foregoing mathematics discloses several interesting points. In the first place it is possible to get much greater voltage amplification by means of a transformer than is possible with the same tube and either resistance or inductance output. In the second place, for every ratio of resistance across the secondary and primary of the transformer there is a certain turns ratio which will produce the maximum voltage step-up. This means that once the resistances on either side of the transformer are determined, the turns ratio for maximum voltage gain is fixed. This, in turn, means that

a transformer can be used as an impedance adjusting device, that is, a coupling device between two circuits of different impedance, one of which acts as a source of voltage and the other is the recipient of a voltage, amplified or not.

Whenever the impedances of the two sides of the transformer are not that indicated by the expression above, there is a loss in secondary voltage, a transmission loss, engineers say. Whenever two circuits are to be coupled together with the least loss in voltage or power the proper turns ratio transformer must be used, that is, $N^2 = Z_s/Z_p$, where Z_p and Z_s are the impedances between which the transformer works.

Problem 20-11. A tube whose plate resistance is 12,000 ohms (UX-201-A) works into a resistance, R_o , of 600,000 ohms. What is the proper turns ratio, and what is voltage gain if $\mu = 8$? If $E_{g1} = 1$ volt what voltage will appear across R_o ?

Problem 21-11. One tube whose plate resistance is 25,000 ohms is connected to another whose grid circuit has a resistance of 400,000 ohms. What is the turns ratio of the transformer for maximum voltage amplification?

Problem 22-11. An "output" transformer is to be used to connect a loud speaker to a tube. The impedance of the loud speaker at the desired frequency is 4000 ohms, the tube has a resistance of 2000 ohms. What is the proper value of N ?

Problem 23-11. A telephone line has an impedance of 600 ohms. The a.-c. voltages in the plate circuit of a 6000-ohm tube are to be transferred to this line. What must be done to effect such a transfer with least power loss?

202. Transformer with no secondary load.—If the secondary of the transformer works into a true no-load impedance, that is, an open circuit, or $R_o = \text{infinity}$, the voltage appearing across the secondary will be μE_g multiplied by the turns ratio of the transformer and not, as given in (7) $\mu E_g \times N/2$. The voltage gain is equal to

$$G = \mu \frac{2 \pi f L_1 N}{\sqrt{R_p^2 + (2 \pi f L_1)^2}} = \frac{N \mu}{\sqrt{1 + \left(\frac{R_p}{X_L}\right)^2}}$$

where $L_1 = \text{inductance of the primary, etc.}$

Example 3-11. Transformers of a few years ago had very little primary inductance. Assume an inductance of 2 henrys, $f = 800$ cycles, $\mu = 8$, and

$R_p = 10,000$ ohms, $N = 4$. Calculate the voltage amplification. Then assume $f = 80$ cycles and calculate G .

$$G = 8 \frac{2 \times 3.14 \times 800 \times 2 \times 4}{\sqrt{10^8 + (2 \times 3.14 \times 800 \times 2)^2}} = 22.7$$

If $f = 80$ cycles

$$G = 8 \frac{2 \times 3.14 \times 80 \times 2 \times 4}{\sqrt{10^8 + (2 \times 3.14 \times 80 \times 2)^2}} = 3.2.$$

Problem 24-11.—What is the maximum shunting capacity in Problem 11-11 if the gain at 10,000 cycles is down not more than 10 per cent from the value at, say, 1000 cycles?

203. The advantage of the transformer.—The transformer has the great advantage that it can contribute toward the voltage amplification, and can contribute toward the maximum power output when the load resistance or impedance differs from the tube resistance. In addition, high B battery voltages are not necessary.

A transformer can be constructed so that it has little loss in itself. This loss is due the d.-c. resistance of the windings, the fact that perfect coupling between primary and secondary is not attained, and because of iron losses, that is, currents set up in the iron core represent a loss in power which must be supplied from the source. This power therefore does not get out of the transformer and cannot appear in the output.

If a good transformer is used, its transmission loss is small. Its effect, then, upon the circuit is of two sorts; first it may contribute toward the voltage gain by having a voltage step up in it; second, it may be used to "match" the load resistance to the tube resistance. Let us suppose the tube resistance is 10,000 ohms, and that the secondary load resistance is 100,000 ohms. A resistance of this value interposed in the plate circuit of a tube will not have the maximum power developed in it. (See Section 180.) But if we use the proper transformer such that $N^2 = 10$, this 100,000 ohms will look, to the tube, like a resistance of $100,000 \times 0.1$ or 10,000 ohms—the condition for maximum voltage and maximum power.

The transformer can always be forgotten if we substitute for

it and its secondary load this load divided by N^2 . Looked at from the secondary we may replace the transformer by $N^2 \times Z_p$.

Example 4-11. A transformer with a turns ratio of 3 connects a 10,000-ohm tube with a load which has a frequency characteristic such that at 100 cycles the load has one-tenth of the impedance it has at 1000 cycles. The load impedance at 100 cycles is 90,000 ohms. The μ of the tube is 8. What are the voltage amplification and the power output at 100 and 1000 cycles?

The transformer may be dispensed with in the calculation if we transfer the secondary load directly into the plate circuit of the tube by multiplying it by $1/N^2$, that is, $1/9$.

Thus at 100 cycles the impedance in the plate circuit is

$$90,000 \times \frac{1}{9} = 10,000 \text{ ohms}$$

and the voltage amplification is

$$\frac{\mu \times R_o}{R_o + R_p} = \frac{8 \times 10,000}{20,000} = 4$$

and the power

$$P_o = \frac{\mu^2 E_g^2 R_o}{(R_o + R_p)^2} \\ = E_g^2 \times 1600 \times 10^{-6}$$

at 1000 cycles, $R_o = 900,000 \times \frac{1}{9} = 100,000$ ohms

and $G = \frac{8 \times 100,000}{110,000} = 7.3$ and $P_o = E_g^2 \times 533 \times 10^{-6}$

Problem 25-11. Assuming no loss in the transformer, what is the power transmitted to a 6000-ohm load from a 2000-ohm tube when they are coupled by a transformer whose load winding has 2.24 times as many turns as the primary? Assume $\mu = 3$, $E_g = 10$ volts r.m.s. Use formula (5) in Section 180. What would be the value of N for maximum power in the load? What would be the power then? What value of N would deliver maximum undistorted power output into the load? What is this value of power?

204. Transformer-coupled amplifiers.—The single transformer has already been discussed. It was stated in Section 201 that the maximum ratio for a transformer working between a 10,000-ohm tube and the input of another tube which might have an impedance of 1 megohm was 10 to 1. Unfortunately, this is only theoretically true, just as the calculations on resistance coupling without regard to certain factors produce erroneous results. A transformer to give a good low-frequency response when worked

out of a detector tube—which normally has a rather high plate resistance—must have a primary inductance of about 100 henrys. Now a 9 to 1 transformer would have a secondary inductance of $9 \times 9 \times 100$ or 8100 henrys, and unfortunately such a transformer cannot be wound without its secondary having considerable capacity between layers of wire and between individual turns. This secondary distributed capacity shunts out the high frequencies just as the stray capacities in a resistance- or inductance-coupled amplifier lose the high audio tones.

It has not been found possible to build a transformer which will yield a flat frequency characteristic when worked out of a high impedance tube, and when using ordinary iron for the transformer core, with a turns ratio of much greater than 3 to 1. Using higher permeability iron, a somewhat greater turns ratio can be secured because less wire need be used to get a given value of inductance but there are very few transformers on the open market with a turns ratio of more than 4 to 1 that give a flat characteristic.

This statement does not preclude the possibility of using a higher ratio and overcoming the loss of either low or high tones—or both—in some other part of the circuit, and in fact many amplifiers have been so designed.

Figure 160 is a characteristic of a single transformer obtained by putting known voltages across the primary and measuring the secondary output voltage, but without secondary load.

The hump at 5000 cycles is due the leakage inductance between primary and secondary resonating with the secondary distributed capacity. Beyond this point the whole transformer looks like a capacity to the tube and hence the effective resistance into which the tube works becomes steadily less as the frequency increases.

205. Measurements on transformer-coupled amplifiers.—The curve in Fig. 160 on a single transformer may be no indication at all of what a two-stage amplifier may do. This is due to the fact that a certain amount of “regeneration” takes place in the average amplifier unless considerable pains are taken to prevent such difficulties. This regeneration distorts the curve, and makes laboratory measurements difficult to check. One

day the curve may be one thing, and on the next it may be different.

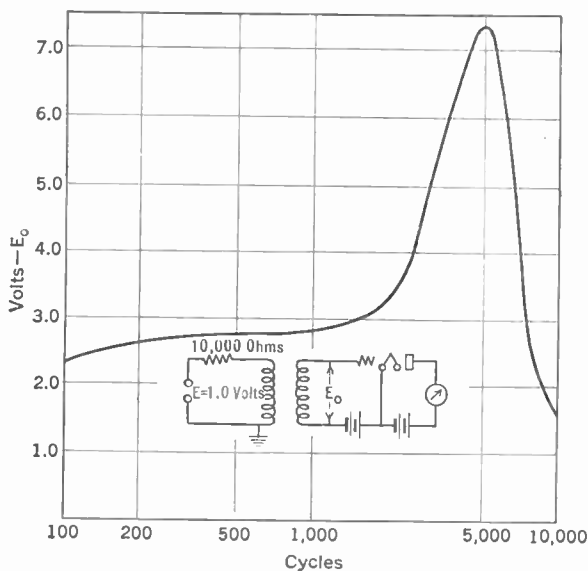

FIG. 160.—Characteristic of single audio transformer.

206. Calculation of overall voltage amplification.—Let us consider the amplifier in Fig. 161. The overall amplification is the

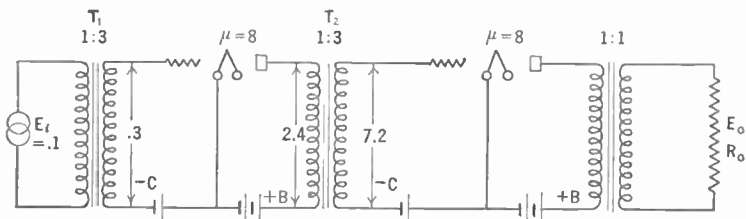

FIG. 161.—How a voltage E_i is amplified in a transformer coupled amplifier.

ratio between the voltage, E_o across the output load and that across the input, E_i .

$$G = \frac{E_o}{E_i} = \frac{3 \times 8 \times 3 \times 8}{E_i} \times \frac{R_o}{R_o + R_p}$$

$$= \frac{576 R_o}{E_i (R_o + R_p)}$$

where R_p = plate resistance of last tube.

It is actually not possible to realize all this amplification because it is never possible to realize the full μ of the tubes. The voltage gain measured and calculated will check very closely, usually.

Now suppose we apply an input voltage of, say, 0.1 volt across the primary of the first transformer. Across the secondary this will become 3×0.1 or 0.3 volt and so the value of the C bias for this first tube which is fed out of the secondary of T_1 need not be greater than 1 volt since that will take care of severe overload, and if the tube is a triode type a plate voltage of 45 will be sufficient. Somewhat better amplification and fidelity will result by using 90 volts on the plate and 4.5 volts bias on the grid, since the plate resistance will be somewhat less under these conditions. If the impedance of the following transformer as looked at from the tube is high compared to the R_p of this first tube—as it will be at frequencies of the order of 1000 cycles if the transformer is any good at all—nearly all of the μ of this tube will be realized. Across the primary of the second transformer, T_2 , then will appear a voltage of 0.3×8 or 2.4 volts and across the secondary a voltage of 7.2 volts which will require C bias of 9 volts and about 135 volts on the plate. The tube should be a 112 type. This voltage will be multiplied by 8 times in this tube and will appear across the output load as 38.4 volts provided the load is twice the resistance of the last tube. This voltage across a 10,000-ohm load will produce 147 milliwatts of power.

207. Reflex amplifiers.—When two sets of frequencies of widely different order are to be amplified it is possible to make one tube serve as both a low-frequency and as a high-frequency amplifier. Such a system in which the energy from a tube is

fed back into the input of a previous tube in a cascade amplifier is called a **reflex** system; although such systems are not in as great vogue at the present time as they were in the early days of broadcasting they may become important again.

Modern tubes may be made to perform so many functions simultaneously or chronologically that it is no wonder that wide-awake engineers have adopted old art to new problems. The following description of a reflex circuit is characteristic of such methods of saving tubes and space.

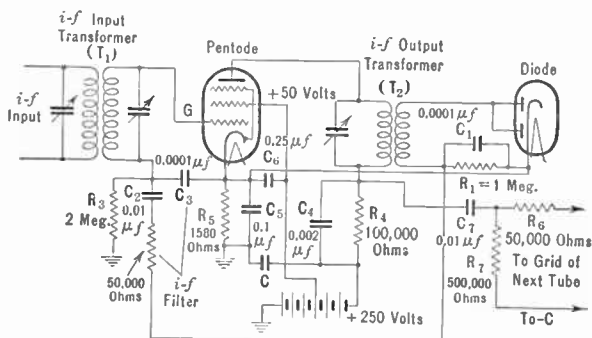

FIG. 162.—Typical reflex circuit. In this case the diode and pentode are distinct; they may be combined in a single envelope, such as the 6B7.

208. Reflex circuit operation.—The circuit employs a pentode and a diode all in the same envelope (2B7 or 6B7) although for simplicity the tubes are shown as separate in the figure. In operation the incoming i.-f. signal (or r.-f.) is passed through the transformer to the grid of the pentode, amplified there and passed to the diode detector through the transformer in the plate circuit. This circuit contains an audio load R_4 which is by-passed for intermediate frequencies and so no loss in voltage occurs there. The primary of the transformer has low impedance at audio frequencies and so no loss occurs there. Of course there is no a. f. in this circuit until after the signal has passed through the diode.

The a.f. produced in the diode is coupled to the grid of the pentode through R_1 and C_2 . Condenser C_3 permits i.f. to get

to the cathode of the pentode but is of such high impedance at audio frequencies that these voltages are impressed upon the grid of that tube.

After being amplified again in the pentode the audio frequencies build up a voltage across R_4 , and are then passed on to the following stage through C_7 and R_6 .

Although the values given in the diagram are designed for use at intermediate frequencies, the combination of pentode and diode may be employed at radio frequencies if desired. Such a combination should have the sensitivity, as a one-tube receiver, of the triode-crystal detector so popular before commercial set manufacturing took the bulk of set building away from the home builders. It is probable that such a circuit would have greater sensitivity because of the high gain possible in the pentode. Certainly it would be more stable. For example, calculation tends to show that the amplification at i.f. would be of the order of 100 and of 50 at audio frequencies. Since the transformer T_2 has a step-down ratio the overall amplification would be somewhat less than the product of these two figures.

209. "Equalizing."—It is possible by means of correcting circuits to get almost any kind of frequency response curve desired. For example, if a certain amplifier is deficient at low frequencies, one stage may be made resonant to these frequencies and so pull up the characteristic. If the amplifier tends to sing at some frequency, a loss may be put in at this frequency, and the overall curve will be flatter than without the equalizer. In the telephone plant the use of equalizing networks is very important and has come to be almost an exact science. These consist of resistances, inductances, and condensers. Equalizing usually results in an overall loss in amplification; that is, some loss is incurred which must be made up by additional stages. In other words one gains a better characteristic at the expense of amplification. In some amplifiers a better low-frequency response is secured by tuning the primary of the transformer by a capacity to a low frequency.

210. The power amplifier.—The final tube in an audio amplifier which is feeding audio frequencies into a loud speaker must be essentially a power amplifier. Its task is to deliver undistorted

power to the loud speaker, and not to develop any great amount of voltage amplification. The task of the previous amplifier stages is to build up the small output voltages of the detector so that the large voltages necessary to swing the grid of the power tube may be obtained. The a.-c. power in the plate circuits of tubes previous to the power stage is small; what is required is that each previous stage shall give a maximum of voltage amplification without distortion, and the fact that maximum power may not be developed in these plate circuits is not important. These tubes work into very high impedances in which it is not possible to generate much power although it is possible to build up considerable voltages across them.

The a.-c. plate current of the last tube, then, must be rather large and this means that the grid a.-c. voltages must be large, which in turn means that the E_g-I_p curve of this tube must have a long and straight part. The 45 tube, for example, which can deliver about 1600 milliwatts without much distortion must have an r.m.s. grid voltage applied to it of about 35 volts; there must be a portion of the E_g-I_p curve which is straight over at least twice this number of volts. Thus if the grid is biased 50 volts, the characteristic must be straight from minus 97.5 to minus 2.5 volts. The next preceding tube has much smaller voltage swings to handle and so its characteristic need not be straight over such a long part.

The final tube, then, is to deliver power. Its grid must be driven with sufficient voltage so that the plate current variations, acting through the load, produce this desired power. The final tube (or tubes) may be a fairly low- μ triode or a high- μ pentode. The triode will produce the same amount of power as a pentode but will require more grid voltage. It will produce a cleaner output, i.e., less distortion. Single tubes are rarely used in either high-class radio receivers or public address system final stages. It is better practice to use two tubes, in push-pull.

Since the triode requires greater input voltages, the gain of the system ahead of the final tube must be greater than if a pentode were used. Therefore there is more chance for hum to enter the amplifier.

The pentode, however, is a high- μ tube which will deliver

considerable power output. Class B amplifiers, as described below, utilize high- μ tubes. In fact, the tube is so designed that the plate current with no grid bias and no signal is very low and therefore no bias is needed. This permits the total voltage output of the rectifier-filter system to be applied to the plate of the tube. For example, the 46 has a no-signal plate current of 4 ma. on 300 volts and delivers 16 watts (two tubes) in a class B circuit.

Types of tube	Power output watts	Plate volts
45	1.6	250
50	4.6	450
47	2.5	250
2A3	3.5	250

211. The push-pull amplifier.—High-quality receivers, public-address systems or other places where considerable sound output is desired with maximum tone fidelity utilize two power amplifier tubes connected in a push-pull circuit shown in Fig. 163. The advantages of this circuit are several, as outlined below.

Distortion due to second harmonics is reduced to a low figure compared to a single tube; the power output is twice that obtainable with a single tube, and because of the elimination of troublesome second harmonics the input voltage can be raised somewhat with corresponding greater output; there is no d.c. in the output transformer which can therefore have less iron; there are no hum voltages in the output and therefore less filtering of the plate supply is necessary; there are no currents corresponding to the frequency of the signal in the center-tap which supplies plate voltage, and therefore these signal currents cannot get into the plate supply system to create regeneration.

Tubes may also be operated in parallel. In this case twice the power output is delivered on the same signal excitation. To deliver equivalent power the push-pull amplifier must be supplied with twice this input voltage. Distortion will be comparable in the parallel case to that encountered in the use of a single tube.

Push-pull operation is not limited to any type of tube. Either low- μ triodes of the 45 or the 2A3 type, or pentodes like the 47

may be operated in this manner. In many cases a combination of the push-pull and parallel operation of tubes is utilized. In this case two tubes in parallel are on each side of the amplifier, making four tubes in all. The two parallel tubes give twice the output of a single tube and the push-pull set-up of these two sets of parallel tubes multiplies the output by another factor of two. Therefore at least four times the power output is secured. The same result could be attained by substituting a single tube of double the rating for the parallel tubes, but such single tubes usually require high plate voltages, are large in size, and increase the expense of the power supply considerably.

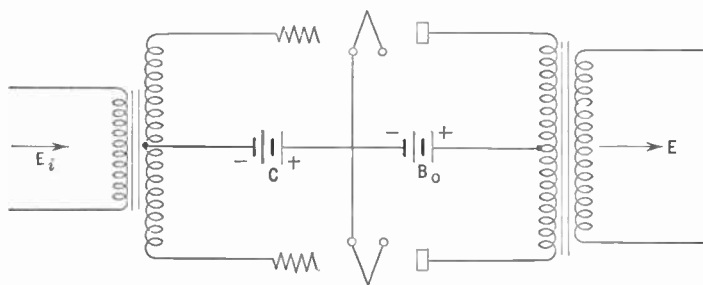

Fig. 163.—Push-pull amplifier.

In broadcast stations where great power is required it has come to be standard practice to use tubes in parallel. Thus if 25 kw. of power is desired, a bank of 10 kw. tubes in parallel will be used rather than a single tube. Then if any one tube goes bad the others carry on with only slight lowering of the total output power.

The push-pull amplifier circuit is shown in Fig. 163. It consists of a center-tapped input transformer, two tubes of identical characteristics, and a transformer, or a choke, with a center tap. When a voltage is induced into the secondary winding of the input transformer one grid becomes less negative a certain amount and the other grid becomes more negative the same amount.

If the *C* bias, which is attached to the center of the input winding, is 35 volts and if across the entire secondary winding appears

a peak a.-c. voltage of 20, one tube has its negative grid voltage increased by 10 volts, or to 45 volts, and the other decreased by 10 volts, or to minus 25 volts. Therefore one plate current increases and the other decreases. These variations in a.-c. plate current flow through the output winding and may be transferred to the load. These plate circuit current variations are out of phase by 180° , one increasing, the other decreasing a like amount. One tube "pushes" current through the output, the other "pulls" current through it. Suppose both tubes pushed at the same time. What would happen? If they both pushed the same amount and at the same time no current would flow through the output winding because the two currents would neutralize each other.

If, then, we can cause the second harmonic currents to be in phase, that is, to push or pull at the same instant, and the same amount, they will not get into the load, and distortion due to these extra currents will not appear in our loud speaker.

212. Push-pull characteristics.—Distortion is caused in an amplifier because the characteristic curve is not a straight line, but has a curve in it near the bottom. This curve is such that even harmonic currents, not only the second but all even-numbered harmonics, will either "push" or "pull" simultaneously. Whereas the fundamental and odd harmonics decrease in one tube and increase in the other as the grid is excited and so cause an effective voltage to appear across the output transformer windings, the even harmonics decrease and increase together and effectively balance each other out across the transformer. They do not appear in the load.

All of this hinges on the supposition that the two tubes are alike, that is, they have identical characteristics. If they do not have identical characteristics, some even harmonics will appear in the output.

Because the input voltage across such an amplifier is divided into two parts this amplifier requires twice the input voltage to give the same output power—unless the turns ratio of the input transformer is doubled, which is difficult to carry out in practice. Because of the push-pull arrangement, however, considerable overloading can be tolerated before the third harmonics which are not

canceled out become objectionable. And there is another advantage—the output transformer or choke need not have such a large core because of the fact that the d.-c. currents in the two halves are flowing in opposite directions; and since the two windings are closely coupled the resultant magnetization of the core is very low. Since the two windings are connected, “series aiding” so far as a.-c. currents are concerned, the total inductance is increased. Not only less iron is necessary but less copper as well. The proper match between the tubes (twice the impedance of a single tube) and the loud speaker can be obtained by the use of such a transformer.

The output resistance of such an amplifier is double that of the single tube; therefore when worked into a low impedance load an output transformer must be used to see that maximum undistorted power is fed to the load. In other words the plate load must be matched to the plate resistance of the amplifier by means of an appropriate output transformer.

The output device for the push-pull amplifier may have at least two forms. Either it is a straight transformer with two windings of the proper turns ratio, or it is a center-tapped choke. The output transformer is almost invariably used. Its turn ratio may be arranged to properly match the tubes to the load. With the choke there is no matching function; the tubes “look into” the load directly. With a choke, at first thought one would judge that the terminals of the loud speaker would be at high voltages from each other because they are attached to the plates of the tube, but this is not the fact. It is true that they are at high potential with respect to earth or to minus *A* and so one may get a severe shock if the voltage is high and if one of the terminals of the speaker is touched by anyone who is in contact with ground. But the two ends of this choke are at the same d.-c. voltage and so no d.-c. voltage exists across the speaker. This situation, of course, prevents any current from flowing through the speaker. If one desires protection against the high d.-c. voltage from one speaker terminal to ground, he may isolate the loud speaker from the plates of the tubes by means of a condenser, but even here there are large a.-c. voltages developed, particularly when a percussion instrument in the orchestra to which one is listening is hit a sharp blow.

The push-pull amplifier, then, is a device for eliminating the even harmonic distortion which occurs when tubes are worked too far down on the curved part of their characteristic. Since the distortion is inherently less, the tubes can be worked harder, having greater input voltages impressed on them, and having somewhat lower output resistance loads to work into. Therefore the lowering of efficiency caused by the division of input voltage by the two halves of the input transformer is somewhat ameliorated and the overall efficiency may not be different from a single tube.

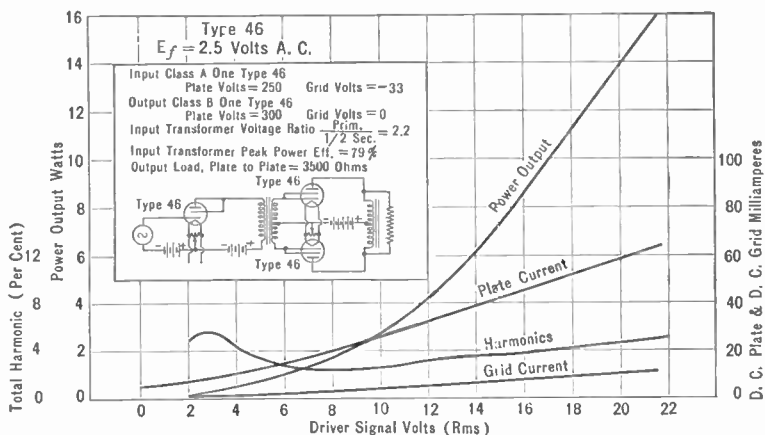

FIG. 164.—Characteristics of Class B Amplification.

213. Class B amplification.—Suppose, for example, we increase the steady *C* bias to the two push-pull tubes so that the plate current is near zero. Now there will be no plate-current flow until the input a.-c. signal overcomes this d.-c. bias. For this reason there will be an appreciable fraction of the a.-c. cycle in which no plate current flows.

It is also possible to drive the grids of these tubes positive so that they actually consume power. This power must be supplied by the circuit from which the two tubes are driven. This preliminary stage is called a “driver” and must be essentially distortion free. Ordinarily this driver stage is push-pull.

Such an amplifier is known as Class B. Very high efficiency

from small tubes with medium plate voltage can be secured. The two tubes must be well matched, and frequently are in the same envelope.

Two tubes must be used; they are connected just as any other push-pull amplifier. No *C* bias is used, the tubes being specially built with a high μ so that with no bias the plate current is small. When the excitation is applied little or no current flows in the plate circuits except on the half-cycles which make the grid positive. Since the tubes are already drawing little current, making the grid more negative cannot result in greater current flow; therefore current flows only during the positive half-cycles.

Where the ordinary push-pull circuit, connected and biased for class A operation, draws plate current in both halves at all times, one tube taking more current when the other takes less from the plate supply source, class B tubes draw current in spurts. When one tube grid is going negative the other is going positive. The latter tube draws current; the other tube does not.

The amount of current each tube draws depends upon the exciting grid voltage. The power output of such a pair of tubes may be very high; the distortion may be made quite low by careful design. Since the current taken from the plate supply system varies with the exciting voltage applied to the tube grids, the voltage regulation of this supply must be very good. That is, the terminal voltage of the filter must not drop appreciably when a sudden large current is drawn from it. For this reason the rectifier usually employed is a mercury-vapor tube which has a very low and constant voltage drop across it regardless of the current taken from it. This voltage drop amounts to about 15-20 volts.

Since the grids of the two tubes are driven positive, they will draw current. This flow of current represents power and this power must be supplied by the previous tube. The previous tube is usually called a "driver" and is connected to the class B tubes through a step-down input transformer. Distortion present in the driver stage will go through the power stage to appear in the output. Therefore this stage must be carefully designed.

The 46 is a tube specially designed for this service. With 300 volts on the plates, zero bias, load resistance of 5200 ohms and

with an average power input (grid to grid) of 950 milliwatts—nearly one watt—the two tubes will deliver 16 watts.

In 1933 the functions of several tubes were combined into one envelope. Thus the two tubes of a class B stage were put into a single bulb, for example the 79, which has a 6.3 volt heater and will produce 5.5 watts on 180 volts.

Another interesting combination of tubes especially designed for a.-f. amplification is the 2B6 in which a single heater supplies two cathodes. There are two grids and two plates. The grid of the second section is connected within the tube to the cathode of the first tube which is above ground potential by the bias of the second tube. The plate of the first tube is connected to B plus, the second plate feeds the output into a transformer. The second grid draws power which is supplied from the first section. With a signal input to the second tube of 25 volts, r.m.s., a power output of 4 watts is obtained.

214. General conditions for voltage and power amplification.—

In general, voltage amplification must always take place between a source of voltage in a low impedance circuit and a receiver of a voltage which is higher in impedance. The turns ratio of a transformer for the greatest voltage amplification is given by $N = \sqrt{Z_s/Z_p}$, where Z_s is the impedance into which the secondary looks and Z_p is the impedance of the transmitter. If these two impedances are equal the transformer must be a one-to-one ratio affair. There will be no step-up in voltage; no d.-c. currents in the output.

Where voltage amplification is the goal the greatest amplification will be attained when working from a very low impedance device into a very high impedance device, for example a tube with a low plate resistance working into a tube with a very high grid-filament resistance. This means that the grid of the following tube must never be permitted to go positive, for then the input resistance of this circuit becomes quite low and the amplification falls and amplitude distortion results.

215. Networks.—It is often desired to limit a voltage which may be applied to an amplifier, and to limit it in such a way that all frequencies are reduced alike, i.e., the limiting device must have no frequency characteristic. For example, suppose that an ampli-

fier is to be bridged across a line carrying a broadcast program. It is desirable to have the level of this signal on the line as high as convenient so that the ratio of signal to noise may be high. But the level may be too high to impress upon the amplifier.

In such cases it is customary to make use of a network of series and parallel resistances known as a "pad." Fig. 165 shows several such pads. In practice they may be variable as to loss or they may be fixed units of so much loss. Thus, if it is desired to control the output of an amplifier, or microphone, without controlling the frequency characteristic or without changing the impe-

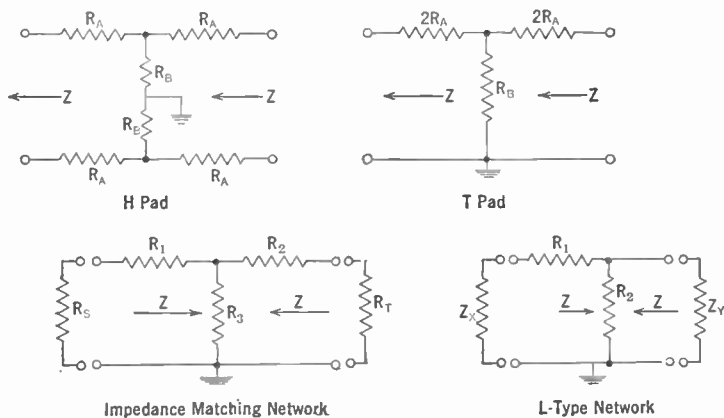

FIG. 165.—Characteristics of Class B Amplification.

dance relations in the circuit, a variable pad is used. Pads are often used when it is desired to isolate an amplifier from impedance changes on a line, for example, by providing a more or less constant load impedance for the amplifier to work into.

In many circuits it is desirable to have both sides of the system balanced with respect to ground. Thus the balanced H pad has its series resistances equal to each other, and the shunt resistance grounded at the center point. The T pad can be used where minor unbalances with respect to ground are not important. In other cases a network is desired which will insert a given loss between devices which do not have the same impedance, or conversely, to

use a network to adjust the two devices so that the impedance unbalance will not be so marked. Here the network takes the place of a transformer and will have a greater loss than a transformer but might have a better frequency characteristic.

216. Design of pads.—The formulas below are used in designing fixed pads of the T or H type. One must start with the value of the impedance into which the pad works, and the value of the loss desired. This loss can be expressed in several ways, but it is simplest to use the decibel system described in the next chapter.

$$R_A = \frac{Z(K-1)}{2(K+1)}, \quad R_B = \frac{2ZK}{K^2-1}, \quad K = \text{antilog} \frac{DB}{20}.$$

217. Filters—There are many places in the telephone system where it is desirable to cut off the response of an amplifier, or the transmission of a line, at a certain upper or lower frequency. Often it is desirable to pass a given band of frequencies, or to refuse passage to (attenuate) a certain band of frequencies. A tuned circuit is a very simple circuit of the type that will pass or attenuate a band of frequencies, and a series of tuned circuits may be thought of as a band-pass or band-rejection filter.

These filters, as they are called, are made up of inductances and capacities and are of the recurrent type; i.e., they are made up of several identical sections of fairly simple or perhaps very complex unit circuits. Thus a two-section filter has a sharper cut-off and greater attenuation than a single section and is made up of two single sections connected in tandem or series. Telephone engineers have worked out extremely complicated and useful filters or networks of these general types, and the study and use of them have become very complicated.

CHAPTER XII

THE DESIGN OF AUDIO AMPLIFIERS

THE audio amplifier is at least half of the modern radio receiver. In addition to being necessary to the reception and reproduction of radio signals, the audio amplifier may be used with phonographs, talking films, public address systems, etc. The design of audio amplifying equipment forms a large part of the work of any radio engineer. This chapter gives some of the theoretical and practical work that must be understood before one can intelligently design an amplifier.

218. The transmission unit.—When one compares the voltage amplification of the power output of any system in which the ear is likely to play a part—as in an audio amplifier—it is convenient to express the greater amount of amplification, or power, which one amplifier gives over another by means of a unit that bears some relation to the sensitivity of the ear. For example one amplifier may turn into a loud speaker a power output of 800 milliwatts and another an output of 1000 milliwatts. How much difference would this make to the ear? Offhand it seems that a considerably greater volume would result. But such is not the case. Such a ratio of one power to another as 1000 to 800 is scarcely discernible to the ear.

We can state that an amplifier has a voltage gain of 50 and that under some other condition it has a gain of 60 and imagine that the latter is easily noted by the average ear. But is it?

Several attempts have been made to express gain in units more nearly like the units in which the ear hears, logarithmic for example. Such a convenient unit of loss or gain is the **decibel**, abbreviated as **DB**. The Bel was universally adopted in 1928—it is ten decibels—

and is named in honor of Dr. Alexander Graham Bell, the inventor of the telephone. The difference in two powers differing by one DB is just discernible to the ear.

The DB is a logarithmic unit—that is, each time the amount of power of a device is doubled—or multiplied by 2—we add 3 DB. When the power is increased ten-fold—multiplied by 10—we add 10 DB. Here, then, is the second advantage in the DB. We can add them, instead of multiplying them. For example let us suppose the voltage amplification of an amplifier is 25 and that it is to be connected after another similar amplifier. What is the voltage gain? Evidently, if the second amplifies what the first gives it, the overall gain will by 25^2 or 625. Here we must multiply 25 by 25, which is awkward. But if we knew that one amplifier had a voltage gain corresponding to 25 DB and was to be used after another of similar characteristics, we would state that the overall gain was 25 plus 25 or 50 DB. The DB is defined as “ten times the common logarithm of the ratio of two powers,” or

$$N_{DB} = 10 \log_{10} (P_1/P_2) \quad (1)$$

in which N is the number of DB by which the two powers P_1 and P_2 differ. The table below gives some easily remembered values of DB and their corresponding power or voltage and current ratios:

N_{DB}	Approximate Power Ratio	Approximate Voltage or Current Ratio
3	2.0	1.41
4	2.5	1.59
6	4	2.0
7	5	2.24
9	8	2.82
10	10	3.16
20	100	10.0
23	200	14.1
30	1000	31.6

Let us consider an amplifier with an output power of 100 milliwatts. How much must we increase its power output before the

ear can just detect the difference? Suppose we double the output. The ratio is then 200/100 or 2 and the DB corresponding to this power ratio is 3. The ear can detect one DB difference and using a table of DB or a slide rule we find that 1 DB corresponds to a power ratio of 1.25 roughly. Thus the power output to which 100 milliwatts must be increased before the ear can detect the difference is such that $P = P_2/100 = 1.25$ or 125 milliwatts. Adding another DB brings the level up to 160 mw. and another unit brings it to 200 mw., as indicated above.

In this case it would have been foolish to go to great efforts to effect an output of 115 compared to an output of 100—because the ear could not tell the difference. In fact the ear can only with some difficulty tell the difference between the amplifiers differing by 3 DB—double the power—unless single tones are used and then only in a quiet room.

219. Voltage and current ratios.—Strictly speaking the DB should be used only when expressing the ratios of powers. Let us suppose two amplifiers are feeding current into equal resistances. The currents are different. How can we express in DB the advantage of the one as a current amplifier? We need only find out the ratio of the powers as before, and multiply the logarithm of this ratio by 10. Thus,

$$P_1 = I_1^2 R$$

$$P_2 = I_2^2 R$$

$$\begin{aligned} \text{DB} &= 10 \log P_1/P_2 = 10 \log \frac{I_1^2 R}{I_2^2 R} \\ &= 10 \log \frac{I_1^2}{I_2^2} \\ &= 20 \log \frac{I_1}{I_2} \end{aligned} \quad (2)$$

If the resistances are not equal (2) becomes

$$\text{DB} = 20 \log \frac{I_1 \sqrt{R_1}}{I_2 \sqrt{R_2}} = 20 \log \frac{E_1/\sqrt{R_1}}{E_2/\sqrt{R_2}} = 20 \log \frac{E_1 \sqrt{R_2}}{E_2 \sqrt{R_1}} \quad (3)$$

The factor 20 arises from the fact that when one squares a number the logarithm is doubled. For power ratios, the DB is 10 times the logarithm, for current or voltage ratios the DB is 20 times the logarithm of the ratio.

Voltage or current ratios can be translated into DB only when the impedances into which the current flows, or across which the voltage exists, are taken into account. If these impedances are equal for both currents or both voltages, they cancel out, one being in the numerator and one being in the denominator, but in general they do not cancel out and must be considered.

The DB is always an expression for a ratio. We cannot speak of an amplifier that has an output of so many DB, but if we assign some arbitrary level—say 10 milliwatts—and compare all amplifiers to this amount of power we can say that one has 20 DB or 100 DB greater output, or less output, or is “up” or “down” 20 or 100 DB. All these DB are expressions for the ratio between these powers and the “zero level” power of 10 milliwatts.

Example 1-12. An amplifier has 1 volt applied to its input resistance of 10,000 ohms. Across its output resistance of 4000 ohms appears a voltage of 40. What is the power gain in DB? The voltage gain? Would it be worth while to increase the output voltage from 40 to 50 volts?

Solution.

$$\text{Power input } P_i = \frac{E_i^2}{R_i} = \frac{1}{10,000} = 10^{-4} \text{ watts.}$$

$$\text{Power output } P_o = \frac{E_o^2}{R_o} = \frac{40^2}{4000} = \frac{1600}{4000} = 0.4 \text{ watt}$$

$$\frac{P_o}{P_i} = \frac{0.4}{10^{-4}} = 4 \times 10^3 = 4000$$

$$\text{Power gain} = 10 \log 4000 = 36 \text{ DB (because the log of 4 is 0.6 and the log of 1000 is 3 and the log of 4000 is 3.6)}$$

$$\text{Voltage gain} = 36 \text{ DB} = 20 \log \frac{E_o \sqrt{R_i}}{E_i \sqrt{R_o}}$$

$$\text{Hence} \quad \log \frac{E_o \sqrt{R_i}}{E_i \sqrt{R_o}} = 1.8$$

$$\frac{E_o \sqrt{R_i}}{E_i \sqrt{R_o}} = \text{antilog } 1.8$$

$$\text{Voltage gain} = 63$$

If E_o becomes 50 volts,

$$P_o = \frac{50^2}{R_o} = \frac{2500}{4000} = .625$$

The gain due to this increased output over P_o (above) is

$$\begin{aligned} \text{gain} &= 10 \log \frac{.625}{.400} = 10 \log 1.56 \\ &= 2.0 \text{ DB (approximately).} \end{aligned}$$

And so the gain due to increasing the output from 40 to 50 volts—or from 400 to 625 milliwatts—will be audible to the ear, but the difference is not worth a great deal of effort to attain it.

The solution of the above example is characteristic of the solutions of all such problems. Given the power ratio it is only necessary to look up the logarithm of this ratio to get the DB gain. The student must not forget that all numbers between 100 and 1000 have as the first digit of their logarithms the number 2. Hence all power ratios between 100 and 1000 lie between 20 and 30 DB. Multiplying any power by 10 represents a gain of 10 DB. Thus of two amplifiers having outputs of 50 and 500 watts, the latter is said to be 10 DB better than the former. A loss of 10 DB means that the power in any circuit has been divided by 10. If it is decreased or increased by 100 times the loss or gain in DB is 20 DB.

Example 2-12. A certain amplifier has a characteristic such that at 100 cycles its amplification in voltage is 8, at 1000 cycles it is 80, and at 6000 cycles, where the amplifier tends to "sing," the voltage amplification is 200. Are these differences appreciable to the ear?

Let us take the amplification at 1000 cycles as a zero level and find out how much above or below this level the other frequencies are. At 100 cycles

the voltage ratio is 80/8 or 10. At 6000 cycles the voltage ratio is 200/80 or 2.5. At 100 cycles there is a loss, at 6000 cycles there is a gain. Thus,

$$\text{Loss at 100 cycles} = 20 \log \frac{80}{8} = 20 \log 10 = 20 \text{ DB.}$$

$$\text{Gain at 6000 cycles} = 20 \log \frac{200}{80} = 20 \log 2.5 = 8 \text{ DB.}$$

Such a characteristic indicates a poor amplifier. The low notes would be totally lost and high ones would overload the last tube.

Example 3-12. In a certain circuit there is a loss of 25 DB. What power ratio corresponds to this loss?

Power ratios of 10 = 10 DB, 100 = 20 DB and 1000 = 30 DB. Therefore the power ratio of 25 DB lies somewhere between 100 and 1000. The figure 2 of 25 DB tells us that the loss is somewhere between 100 and 1000 times. The figure 5 of 25 DB is 10 times the logarithm of 3.1 and so 25 DB corresponds to a power ratio of 310.

The solution of such a problem is as follows:

$$25 \text{ DB} = 10 \log_{10} \frac{P_1}{P_2}$$

$$2.5 = \log \frac{P_1}{P_2} \text{ (dividing both sides by 10)}$$

$$\frac{P_1}{P_2} = \text{antilog } 2.5$$

$$= \text{antilog } 2.0 \text{ times antilog } 0.5$$

$$= 100 \times 3.1 = 310$$

If the loss were a voltage loss of 25 DB the solution would be:

$$25 \text{ DB} = 20 \log \frac{E_1}{E_2}$$

$$1.25 = \log \frac{E_1}{E_2} \text{ (dividing both sides by 20)}$$

$$\frac{E_1}{E_2} = \text{antilog } 1.25 = \text{antilog } 1.0 \text{ times antilog } 0.25$$

$$= 10 \times 1.78 = 17.8$$

220. The use of the DB.—The transmission unit may be used to express any ratio of power, voltage, current, mechanical loss or

gain, etc. Thus we may say that symphony orchestra has a range 60 DB in power. That is, when it is playing very loudly, fortissimo, it is 60 DB louder than when playing very softly, pianissimo. This corresponds to a power range of one million to one. In the wire circuits which carry the microphone currents from the symphony hall to the broadcast station, the weakest of the desired signals must be 40 DB above the noise in the line. The very weak passages of the orchestra are built up by local amplifiers until the currents are greater than the noise currents. The limit to the louder passages is the overloading of the amplifiers either at the hall or in the broadcasting station. And so the stronger passages are cut down.

Whenever a circuit suffers a loss in power or voltage or current, we may express that loss in DB. The frequency characteristic of an amplifier, or a loud speaker, or of a telephone line may be expressed in DB by plotting a curve in which zero level is the amplification or power output at some arbitrarily chosen frequency. Thus if we chose 1000 cycles as a reference frequency, all other frequencies are either up, down, or flat with respect to the level at 1000 cycles.

Problem 1-12. What in DB corresponds to a voltage ratio of 100? Power ratio of 100? What voltage ratio corresponds to 100 DB? What power ratio?

Problem 2-12. A current of 0.006 ampere flows through a resistance of 1000 ohms. A switch reduces this current to 1.0 milliamperere. How much is the current reduced in DB?

Problem 3-12. An amplifier has a normal output of 1 watt. A switch is provided that its output can be reduced in 5-DB steps. What is the output in watts when it is reduced by 5, 10, 20, and 25 DB?

Problem 4-12. An amplifier has its power output reduced by 25 per cent. Is such a reduction in power audible to the ear?

Problem 5-12. A radio receiver has a voltage gain in its radio-frequency amplifier of 50 DB. Express this in voltage gain, and in power amplification provided that the same impedance closes the input and output of the amplifier.

Problem 6-12. A radio receiver is so adjusted that a station 20 kc. off the frequency at which the receiver is tuned is reduced by 40 DB in voltage below the station that is being listened to. What is the ratio in voltage between the desired and undesired station?

Problem 7-12. A broadcasting station increases its power from 500 to 5000 watts. What is this in DB? What is the increase if the power is increased to 50,000 watts?

Problem 8-12. If an audio amplifier has two stages and each stage has a gain of 25 DB, what can the gain of the receiver be reduced to when listening to the 50,000-watt station compared to the 500-watt station provided they are equidistant? In other words, a given station increases its power from 500 to 50,000 watts. How much audio gain in DB is this worth to the listener?

Problem 9-12. The noise on a certain telephone line is 40 DB down from the broadcasting signals. What is their power ratio? If the telephone currents are of the order of milliamperes, what are the noise currents?

Problem 10-12. Phonograph records with single frequencies are made by the Victor Phonograph Company for use as frequency standards. A certain record is labeled as being "— 2.0 TU" compared to a certain arbitrary level. What is the voltage ratio of the record compared to the arbitrary zero level?

Problem 11-12. The maximum power output from a 45 type of tube is 1600 milliwatts. The 2A3 has an output of 3500 milliwatts. How much greater in DB is the 2A3 power output?

Problem 12-12. A loud speaker is 5 per cent efficient and requires 1.5 watts to give sufficient volume output. If it is made 50 per cent efficient how much can the power input be reduced to give the same output?

Problem 13-12. A tube has a plate resistance of 5000 ohms. Calculate the power into a load which varies from 1000 to 20,000 ohms and convert the ratio between the power at maximum to the power at other values of load resistance in DB. How great can the difference between the load and the tube resistance be before the ear will note the difference?

Problem 14-12. The sensitivity of a condenser transmitter (high quality microphone used in better broadcast studios) is 0.35 millivolt per dyne of force exerted by an air wave impinging on each square centimeter of the diaphragm. The carbon button microphone has a sensitivity of 5.0 millivolts per dyne per square centimeter. How much more sensitive is the latter over the condenser transmitter, expressed in DB? How many stages of transformer-coupled audio amplification using 2 : 1 transformers and tubes with a μ of 8 will be required to bring the output of the condenser transmitter up to the level of the carbon button microphone? A commercial telephone transmitter—such as is used in ordinary telephones—is tuned to the average speech frequency and therefore amplifies what corresponds to its input about 1000 times. Express in DB its sensitivity compared to the other two microphones.

Problem 15-12. A radio receiver is so adjusted that its output is 8 DB above an arbitrary level. The maximum power the receiver can put out is 10 DB above this level. If the output power is proportional to the square of the power of a broadcasting station which is producing the output of 8 DB, by how much will the output tube of the receiver have to be increased in DB if the transmitter doubles its power?

Problem 16-12. A radio receiver is tuned to a certain distant station which gives at the receiver input a voltage of 500 microvolts. A nearby station on a different frequency produces a voltage of 50,000 microvolts at the same

time. How much loss in DB must be put into the receiver at the frequency of the undesired station to reduce the signals to the same level? How much additional loss must be put into the receiver to reduce the unwanted station to 60 DB below the desired signal? The curves in Fig. 166 will be interesting in connection with this problem. They were published by Lloyd Espenschied in the Bell System Technical Journal, January, 1927. They show the relative selectivity of several types of receiver. The "double detection" receiver is a superheterodyne.

Problem 17-12. It is desired to make a gain control which will affect the output of a receiver in steps too small to be noted by the ear. An average

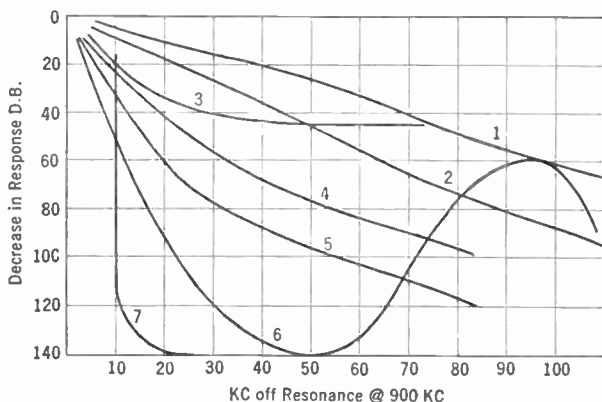

FIG. 166.—Selectivity of several circuit combinations.

- 1 = Single circuit non-regenerative
- 2 = Couple circuit non-regenerative
- 3 = Single circuit regenerative
- 4 = Tuned Radio Frequency
- 5 = Tuned Radio Frequency
- 6 = Double Detection (Super Heterodyne)
- 7 = Ideal Characteristic

person will readily note a change of volume of 3 DB in the middle of the audio-frequency band, but changes of 10 DB at the extreme upper and lower frequencies are not noticed. Suppose the loud speaker has an impedance of 4000 ohms, and that the gain control is to be placed across it. What shunting resistance will be necessary in the gain control so that the changes in volume will occur in steps too small to be noticed? The gain control has a maximum value of 20 DB.

Problem 18-12. The ratio of peak power in the voice (accented syllable) to average may be 200 to 1. Thus if the average power is 10 microwatts, the peaks may be as high as 2000 microwatts. Express the range in power of the human voice in DB?

221. Three general types of amplifiers.—Amplifiers have been divided into three general types according to which part of the grid-plate characteristic is used and according to the magnitude of the applied signal voltage. Class A amplifiers are operated so that plate current flows at all times; the grid is not usually driven positive; the plate current represents exactly the input signal. It has low efficiency and low output.

Class B amplifiers have the grid biased almost to plate current cut-off; plate current flows to any extent only when the grid is on the positive half cycle of input voltage, and during this half cycle the plate current in an ideal amplifier will represent exactly the input grid voltage. This amplifier has medium output and efficiency.

Class C amplifiers are operated so biased that no plate current flows when the grid is not excited, and as a matter of fact it flows only during a portion of the half cycle when the grid is driven positive. This type of vacuum tube amplifier has high efficiency and high power output. The distortion inherent in this type of amplification precludes its use for speech or musical amplification. It is useful at radio frequencies where harmonics generated will be filtered out of the antenna, for example, by tuned circuits resonant only to the fundamental.

Amplifiers are often spoken of as voltage, current, or power amplifiers. These are more general terms and are used to indicate that one or the other of these three fundamental electrical quantities is amplified particularly. Voltage amplification is the ratio of the output voltage to the input voltage; likewise current and power amplification are ratios of the output to the input.

Radio-frequency amplifiers for use in receivers are invariably voltage amplifiers; in transmitters they may be power amplifiers. In the latter case the tube and associated circuits may produce very little, or no, amplification, merely acting as an isolating circuit or a "buffer" stage to separate two circuits.

Transformers often have cores of iron dust such as "permalloy." They should be operated with no d.-c. through them. This is accomplished by feeding the plate current of the previous tube through a choke and the a.-f. currents through a condenser.

222. Rules for the amplifier designer.—In general the rules the amplifier designer must follow are these:

1. He must so design the amplifier that no stage can overload even on the strongest signals that are to be received. This implies that each tube has its proper C bias and plate voltage.

2. In the plate circuit of each tube must be a sufficient impedance that at low audio frequencies the characteristic is straight and not curved. This implies that the E_g-I_p curve for a circuit may be one thing for 1000 cycles and another for 100 cycles—which is correct when apparatus is used that has reactance. At 1000 cycles the tube works into one impedance—at 100 cycles into a much lower one.

3. He will get a better characteristic—although less gain—from low impedance, low μ tubes. This will require more tubes, of course, to get a predetermined amount of amplification.

4. He will get more amplification—but a poorer characteristic with high- μ , high-impedance tubes.

5. The more tubes in the amplifier, the greater will be the noise in the output due to “tube noise.” Where the amplification must be carried to a high degree, special tubes with low internal noise must be used, for example, in the microphone amplifier.

6. The more tubes and the higher the overall gain of the amplifier the greater will be troubles from instability and from unwanted pickup from nearby a.-c. magnetic fields.

These are general rules and statements, and it will not pay to be dogmatic about them. They may work in some instances, and fail in another.

The maximum voltage amplification that can be secured from a transformer-coupled stage is μ times the turns ratio of the transformer. If the impedance into which the tube works—the *reactance* of the primary if the secondary is open-circuited—is two times the plate resistance of the tube, 89 per cent of the μ of the tube will be realized. If the impedance of the transformer at the lowest frequency it is desired to amplify is two times R_p , the amplification at this frequency will be 89 per cent of the maximum possible, and nearly 100 per cent of the maximum possible will

be attained at all frequencies. Then the range in amplification will be from 89 per cent to 100 per cent at all useful audio frequencies. The difference between these values of amplification will not be audible to the ear.

223. Comparisons between amplifiers.—The only fair test between two amplifiers is made by means of a switch which alternately throws one set-up and then the other to the detector tube or phonograph pick-up being used. A test on one amplifier at one time and a test on another at some different time is no test at all. The music may be different, the mood of the listener may be different, and there are too many other variables to give any faith in such a test. A simple four-pole double-throw switch will throw the amplifiers to the input and to the loud speaker with but a second's delay.

The engineer must remember that the ear can scarcely detect volume differences in which the power ratio is 2 to 1 and that, at the two extremes of the audio-frequency range, differences in power of 10 to 1 are none too easily noted. It has become standard practice in public address systems and in amplifiers for broadcast station pick-ups to use very high quality components amplifying a wide band of frequencies, even if radio receivers go no higher than 4000–5000 cycles.

224. Volume control.—The point in a radio receiver where the volume is controlled has varied from time to time. In the early sets the volume was controlled by changing the audio amplifier gain, or by shunting the loud speaker. Then it shifted to the radio-frequency part of the circuit. With the advent of automatic volume-control circuits the volume control (manual) was shifted back to the audio amplifier. It became standard practice to take more or less of the detector output by means of a potentiometer, for example, in Fig. 167, where the detector feeds a following audio amplifier through a transformer. Where the detector feeds the amplifier through a resistance-capacity coupling the same potentiometer arrangement may be used, for example Fig. 168, in which a 200,000-ohm potentiometer acts as the volume control resistor.

If the amplifier is to be used with a phonograph pick-up, or practically any other source of tone to be amplified and controlled as to volume, the potentiometer method may be used. Since the

grid-cathode circuit bridged across the potentiometer is virtually an open circuit, so far as taking power is concerned, the load put upon the source of tone is not far from the load taken by the resistance of the potentiometer.

The virtue of controlling volume by affecting the amount of voltage to be amplified rather than by changing the gain of the amplifier lies in the fact that the best operating conditions for the tubes can be chosen, i.e., load resistance, bias voltage, and plate voltage. Changing the volume does not change these conditions.

Likewise the detector input voltage (r.f. or i.f.) can be chosen for maximum sensitivity or least distortion, and by means of the a.v.c. system this voltage will be fed to the detector regardless of the setting of the manual volume control.

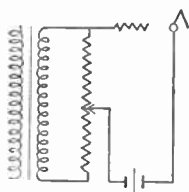

FIG. 167.—Potentiometer gain or volume control.

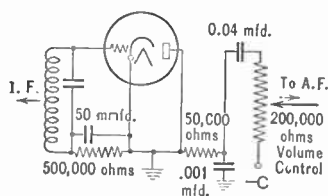

FIG. 168.—Volume control between second detector and audio amplifier.

225. Proper C bias for power tubes.—The proper value of C bias for an amplifier tube is determined partly by the input voltages to be encountered and partly by the amount of d.-c. power the plate can dissipate safely. This power is the product of the plate voltage and the plate current, and the latter is controlled to some extent by the C bias.

Problem 19-12. A power tube's plate current is as follows,

E_p	E_c	I_p , ma.
450	0	100
	20	55
	30	35
	40	18

and the maximum safe power that can be dissipated at the plate is 10 watts. What is the minimum value of grid bias (E_c)?

Several methods of connecting a tube to its load are shown in Fig. 169. For example in A, an audio amplifier feeds a second stage through a step-up transformer. This is the usual method of interstage coupling. In B is shown a shunt-fed arrangement used when the primary of the interstage transformer should not carry the d.-c. plate current of the first tube. Here a choke carries the d.-c. and the audio-frequency currents are led to the succeeding stage through a condenser.

The condenser must have low impedance to the audio currents, the choke must have high impedance and low d.-c. resistance.

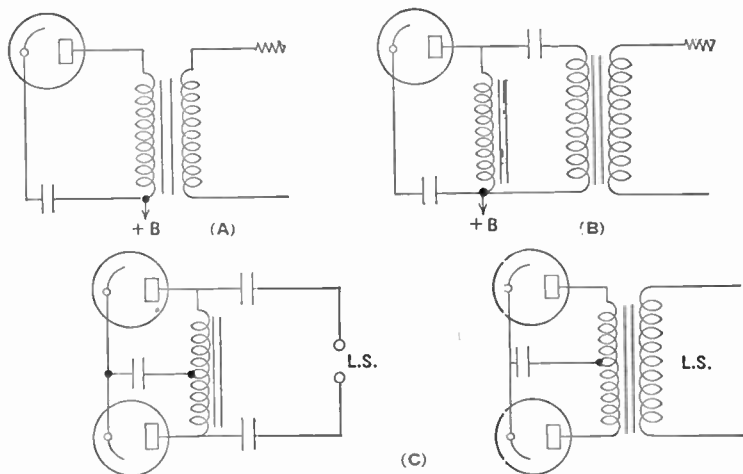

FIG. 169.—Methods of connecting a tube to its load.

In C is a simple arrangement for feeding a push-pull amplifier into a loud speaker or line. Here the impedance of the load must be correct for connecting directly to the two tubes. Since the two ends of the choke are at the same d.-c. voltage, no such voltage exists across the condensers. They are "above ground" potential, however. This connection, once fairly popular, is not used today. Instead the straight output transformer system is used since the transformer can take care of differences in impedance existing between the two tubes and the load, which might be an 8-ohm loud speaker winding, a 600-ohm line, or might even consist of another stage of audio.

226. Manner of coupling tube to load.—Output devices are used to

- (1) Keep d.-c. current from the loud speaker winding;
- (2) Prevent serious loss in plate voltage;
- (3) Prevent heating the loud speaker winding by the plate current of the last tube;
- (4) Prevent placing a mechanical bias on the loud speaker armature or moving element;
- (5) Adjust serious impedance differences between tube and speaker, and therefore to improve fidelity and increase power;

and some output devices

- (6) Keep the loud speaker terminals at low d.-c. potentials.

227. Compensating amplifiers at low frequencies.—In many

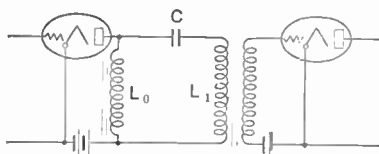

FIG. 170a.

cases the loss in low frequencies in parts of the circuit may have to be made up in the audio amplifier. For example, if the baffle in which the speaker is placed is too small to radiate properly the low tones, the amplifier may be "tilted" so that these frequencies are over-emphasized. Coupled with the loss in the baffle the overall response may be fairly flat.

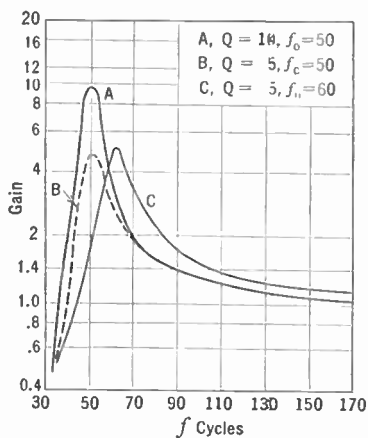

FIG. 170b.

One of the simplest methods of pulling up the low frequencies is that shown in Fig. 170a. Here the primary of the coupling transformer is resonated by the series capacity. The coupling inductance which carries the plate current must have a reactance at any frequency which is high compared to the reactance of the transformer inductance and the series capacity.

The effect of using such a system is shown in Fig. 170*b*, where various values of Q for the series tuned circuit and for the resonant frequency are used (taken from Aceves, *The Radio Engineering Handbook*). By interposing variable series resistance between the condenser and the inductance, the value of Q may be changed so that the circuit will be enabled to build up more or less resonant voltage.

228. Compensation for high-frequency loss.—In superheterodynes and in some phonograph amplifiers it is desirable to overcome the loss of high-frequency response. One method with transformer coupling is to utilize the leakage reactance of the transformer

to resonate with the secondary winding capacity to form a resonant circuit which will pull up these higher frequencies.

229. Power levels.—Engineers frequently use the decibel system in expressing the output level of a signal, mentally comparing it with some fixed and understood level.

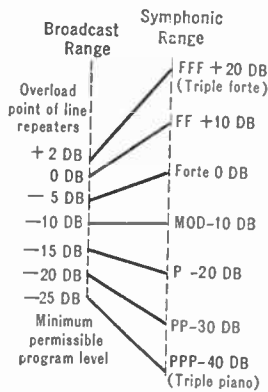

FIG. 171.—Compression of dynamic range in broadcasting system.

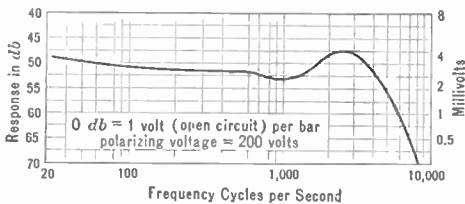
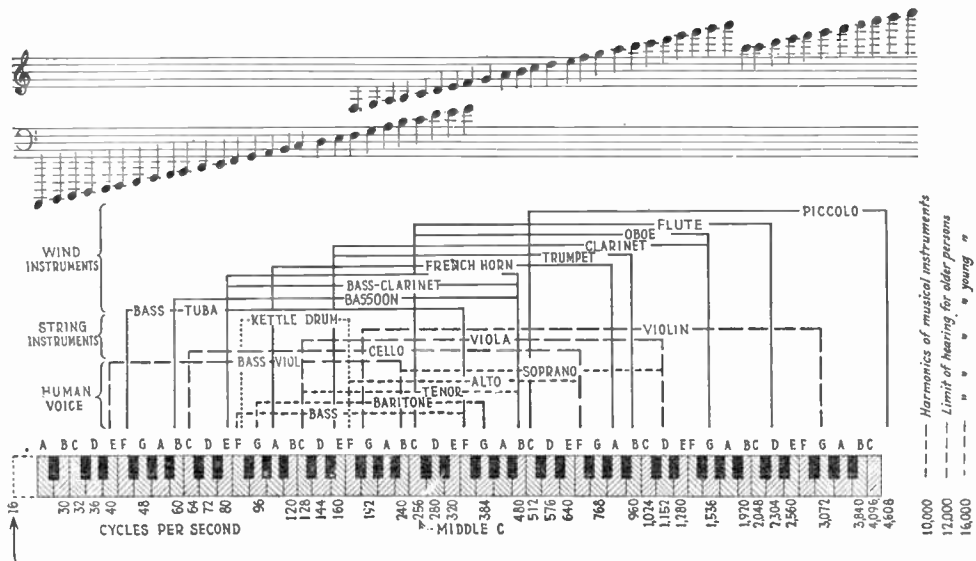

FIG. 172.—Studio characteristics of microphone.

In the telephone plant, zero level has come to be 0.006 watt (to be exact it is 0.0059 watt) because this was the output power of a tube very often used in telephone repeaters. Thus a certain set-up was said to operate at about plus 10 DB, meaning that this instrument put out ten times the power of an "L" tube.

In Fig. 171 is indicated the amount the broadcast system compresses the power range encountered in music. A symphony orchestra covering a range in power from minus 40 to plus 20, or 60 DB, must be compressed into a range of 27 DB when it is broadcast. Here the zero level is the power output of the orchestra when playing at what a musician knows as "forte."

Electronics' Chart of Sound Frequency Characteristics



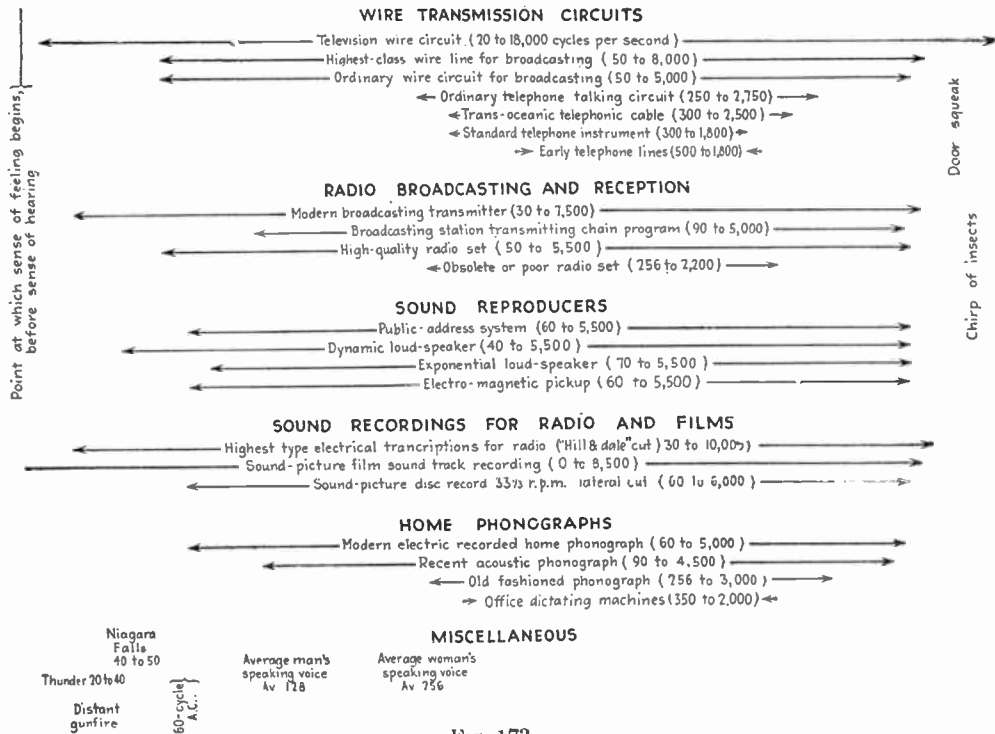

FIG. 173.

Radio engineers have debated whether to rate the sensitivity of receivers in the microvolt or the decibel system. Thus to state that a receiver is a 10-microvolt set indicates that it requires this input to produce a given output, probably 50 milliwatts. A receiver which requires 100 microvolts would be a "100-micro-volt set."

In the decibel system the sensitivity of the set would be rated in decibels below 1 volt. Thus a receiver which required 1 volt to produce a given output would have a rating of zero; one which required only 0.5 volt would have a rating of 6; one requiring only 1 microvolt would have a rating of 120. In this case zero level would be 1 volt, or one million microvolts. Thus a high sensitivity set would have a high rating number or value.

230. Regeneration in audio amplifiers.—The troubles from regeneration in audio-frequency amplifiers have been largely over-

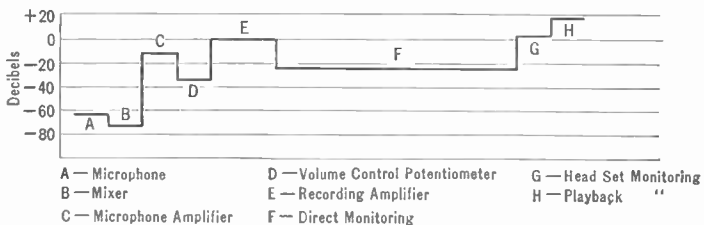

FIG. 174.—Another example of the use of power levels. A level diagram of a recording studio.

looked. A.-c. currents in an audio amplifier must be returned directly to the cathode of the tube they are generated in, and never permitted to roam around through the wiring, through the power supply, through the *C* bias resistor, etc. Otherwise, regeneration cannot help being sometimes helpful, sometimes harmful.

Regeneration occurs when any impedance is common to two amplifier circuits. Currents from one circuit set up a voltage across this impedance. If this voltage is impressed upon a previous amplifier circuit, regeneration takes place. Coupling may take

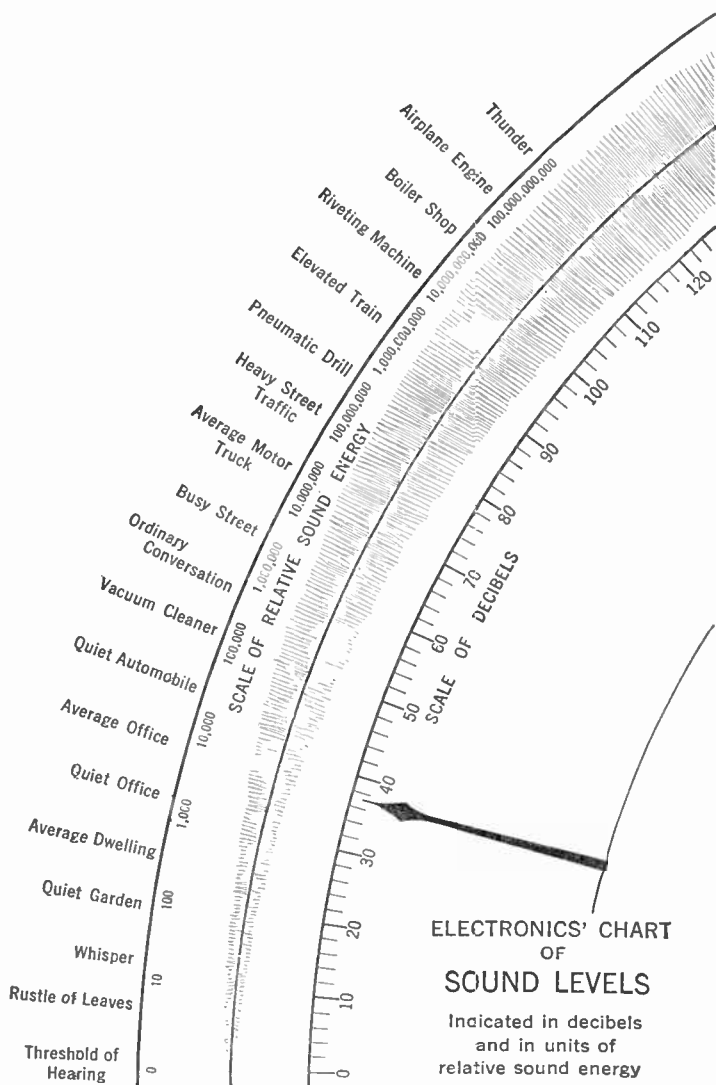

FIG. 175.—Zero level for sounds has been taken as one ten-billionth of a microwatt of sound energy per sq. cm.

place across a resistance, a condenser, a coil, or across any complex combination of these three components of impedance.

To avoid unwanted coupling between stages, it is necessary that currents carrying audio frequencies go directly to the points desired and not through some roundabout way. Thus in the plate circuit of a tube there may be a. f. currents as well as d. c. current. The a. f. currents must flow through the load and then directly back to the cathode of the tube, not through the power supply and then to the cathode.

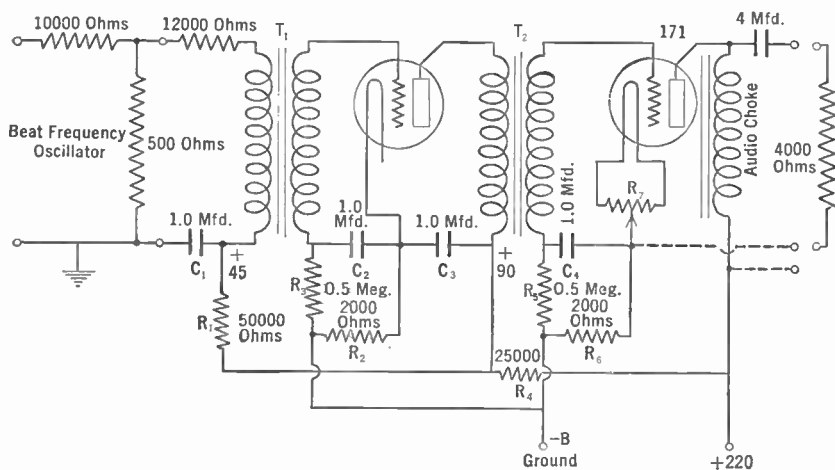

FIG. 176.—A high quality, well-filtered audio amplifier.

This is accomplished as shown above by proper uses of series and shunt by-paths which make it easy for currents to go where they are wanted and difficult to go where they are not desired. This is most important in amplifiers in which there is considerable voltage amplification.

231. Filtering in audio amplifiers.—A filter in an audio amplifier, as indicated in the last section, is designed to keep out of a certain circuit a. c. currents of a certain frequency or frequencies. Let us see the grid circuit of the first tube in Fig. 176. Plate current flowing through the resistance R_2 causes a voltage drop.

This drop is utilized as the C bias for the tube. If a.-c. currents flow through the resistance, they, too, cause a voltage drop, and since this resistance is now part of the grid circuit the voltages are impressed on the grid. Since the plate and grid a.-c. voltages are out of phase, these unwanted voltages getting into the grid circuit from the plate circuit cause a reduction in the amplification.

If the inductance in the plate circuit is 100 henrys and the frequency is 100 cycles, the current through the 2000 ohm resistance R_2 will be such that for every volt across the inductance there will be 0.032 volt across the resistor. This voltage is impressed on the grid of the tube and if multiplied by 8 will reappear in the plate circuit as though coming into the system from the outside via the transformer. Thus a 25 per cent reduction in output will occur. This is a loss of 2.0 DB in voltage.

Now this loss may be reduced by by-passing the resistor so that the impedance offered to 100-cycle currents is smaller and so the voltage there will be smaller. A 1 mfd. condenser C_2 has a reactance of 1600 ohms at 100 cycles and when placed across this resistor will reduce the voltage there by a ratio of 2000 to 1250. Much greater isolation of the grid circuit will take place, however, if a high resistance R_3 is placed in series with the grid and a by-pass condenser C_2 is placed as shown in Fig. 176. Still greater isolation and freedom from unwanted coupling will occur if the plate circuit is filtered too, either through a resistance R_4 or through a low-resistance, high-reactance choke and, of course, a condenser C_3 . Such filtering prevents a.-c. current from flowing through the C bias resistor. Grid-circuit filtering reduces the effect of such a.-c. currents as do get into C bias resistors.

In all such circuits, and indeed in radio-frequency amplifiers, too, the a.-c. currents in the plate should be returned directly to the cathode of the tube in question. They should not be permitted to go back through any part of the B supply or even through the leads to it. The condenser should be a part of the amplifier, and the choke or resistor may be a part of the B supply, although it is preferable to have it in the amplifier itself. Then the amplifier is forever independent of its source of plate voltage.

The purpose of the series impedance in such filter circuits is to

impose a high series loss on any a.-c. voltages or currents that may try to get into the grid or out of the plate circuit. The purpose of the condenser is to provide a low loss shunt path for these same voltage or currents to get to the filament. Any a.-c. current that gets through the resistance or choke must be very greatly attenuated and on arriving at the grid end of such a series impedance it finds an easy path to the filament which is at ground potential, and therefore does not affect the plate or grid as the case may be. In case of plate filtering, a.-c. currents find an easy path to the filament through the condenser and a high impedance path to the B supply.

Such a filter is helpful in keeping any hum at 60 or 120 cycles from getting into the amplifier from the B supply.

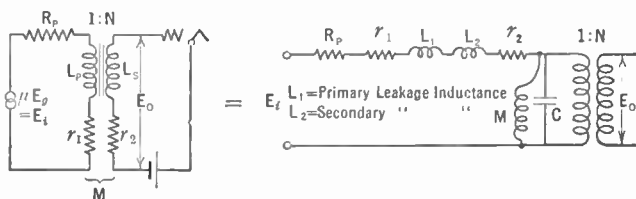

FIG. 177.—Equivalent circuit of transformer.

232. Individual transformer characteristics.—An audio-frequency transformer may be looked at as a simple series circuit which may go resonant at some one or more audio frequencies. Such a transformer is never perfect; it has some primary and secondary resistance, which consumes power and puts losses into the system, and there is always some magnetic leakage (Section 64) even though this may be reduced to a very great extent by using high permeability cores, etc. The secondary resistance and leakage inductance may be transferred to the primary circuit, theoretically, and for purposes of analysis, by simply multiplying them by $1/N^2$ where N is the turns ratio of the transformer. The transformer then looks like Fig. 177 in which are the series resistances R_p , r_2 and r_1 , and leakage inductances L_1 and L_2 and the shunt mutual inductance M —which should be very high—shunted by the capacity C of the tube and the windings, and followed by

a perfect transformer which only serves to give the proper turns ratio N . If the mutual inductance—coupling between primary and secondary—is very high, it may be neglected in the following analysis of why a transformer characteristic goes up at high frequencies.

If the series inductances, caused by magnetic leakage, and the capacity C form a series resonant circuit, a voltage input E_i of this resonant frequency will build up a high output voltage E_o . This resonant peak varies from 4000 to 9000 cycles in transformers usually used in audio amplifiers. The greater the distributed capacity plus tube capacity across the secondary of the transformer, the lower in frequency is this peak. If the series resistances, due to primary and secondary resistance and other losses, is low enough the “ Q ” (Section 125) may be high enough for the circuit to oscillate at this resonant frequency, or to sing, as amplifier engineers say. Since the plate resistance of the tube is part of the series resistance, any decrease in R_p through use of a low-resistance tube will increase the tendency to peak or to sing at the high resonant frequency. Such a rise at the high-frequency end of the audio band may be seen in Fig. 160.

So much for the high audio frequencies. What happens at low frequencies? At low frequencies the series leakage inductance is not of importance because of the low impedance to low frequencies. The ratio between the tube plate resistance and the mutual reactance of the transformer, which is large, determines how much of the low-frequency voltage generated in the plate circuit of the tube is usefully applied to the transformer. If the plate resistance is high, or the mutual reactance is low—a poor transformer—the low frequencies will be largely lost in the tube and will not be impressed upon the amplifier. If the capacity across the transformer resonates with this mutual inductance another peak may occur in the response characteristic of the tube and transformer. This peak will be at a low frequency, and in some cases may occur as low as several hundred cycles. After this resonance occurs, there is a tendency for the response to fall off, and in some poorly designed transformers a rapid rise in amplification at say 500 cycles is followed by an equally rapid drop beyond 1000 or 2000 cycles. This

tendency to drop off at high frequencies is usually overcome by the tendency to rise due to series resonance between the capacity and the leakage inductance. Making the plate resistance of the tube very high drops out all the low frequencies.

Some tricks can be played with individual transformer circuits to change the response. For example a resistance in the secondary circuit, either next to the grid or next to the filament (a *C* bias resistor for example) will drop off the high-frequency response. If next to the filament, as is customary for *C* bias requirements, the current through the capacity of the secondary of the transformer flows through the resistance and sets up an out-of-phase voltage there which may cut down the high-frequency response considerably.

233. Degenerative feedback circuits.—The advent of the 6L6 type of beam power tube introduced to public address and radio receiver amplifiers a principle which had been worked out by Black and others at the Bell Telephone Laboratories for uses at somewhat higher frequencies. This is known as the feedback amplifier. It can be used where more voltage gain is available than is necessary and where the smallest amount of distortion is desirable.

The system consists in feeding back to the input of an amplifier a certain portion of the output. Now offhand this sounds like getting into trouble, but when carefully engineered it is capable of producing amplifiers with very flat characteristics and of very low distortion.

The feedback must be in the correct phase. In this case it is in such a direction as to lower the amplification: it is a reversed feedback, or a degeneration system. Since the amplification is thereby reduced, an excess of amplification to start with is necessary. There are various methods of securing this feedback voltage from the output and of introducing it into the input.

The frequency characteristic of such amplifiers may be improved by using feedback. Amplitude distortion is reduced by the feedback and the stability of the amplifier is increased by the use of degeneration. Another characteristic is the fact that when the amount of voltage fed back is large, the effective amplification of the system depends only upon the percentage of the output that is

fed back and therefore is practically independent of the actual gain of the amplifier.

Since the feedback can be produced through resistance or other elements which are permanent in characteristic, the amplification with large feedback is practically independent of tube characteristics and electrode voltages.

Feedback reduces amplitude distortion, crosstalk, and noise introduced into the amplifier. Since all of these factors are effective at the higher audio frequencies, the use of degeneration may be thought of as one way in which to make usable, amplifiers employing wider audio frequency ranges.

Simple circuits using feedback are shown in Fig. 199 (from *Electronics*, January 1937) and the effect of using feedback in an amplifier made by Professor Terman are shown.

234. Comparison of push-pull and single tube.—Figure 178 shows the result of a laboratory test to determine the relative advantages of the push-pull compared to the one-tube amplifier. The advantages are shown clearly to be two: increased power output and decreased distortion. The latter is the more marked. That twice the power output may be obtained from two tubes may seem obvious; but that the distortion would be reduced to much less than one-half is not so apparent. It is a fact, however, and it is one of the reasons why all high-class receivers and public-address amplifiers use two tubes in push-pull.

235. Direct-coupled amplifiers.—It is possible to make a resistance-coupled amplifier respond to and amplify very low a.-c. frequencies by increasing the size of the coupling condenser. But there is a limit. In time it takes so long to charge the large coupling capacity that difficulties are encountered. For example, no matter how large the coupling condenser, direct current (zero frequency) will not go through it. And in many cases it is desirable to amplify direct currents.

If the coupling condenser is eliminated, the grid of the second tube will be at a high positive potential because it is directly connected to the plate of the previous tube—unless the cathodes of the two tubes are at different potentials with respect to ground. If, for example, the second cathode can be isolated from the first so

that the grid of the second tube is negative with respect to its own cathode, even though it may be positive with respect to the first cathode, then the circuit will amplify direct currents and voltages.

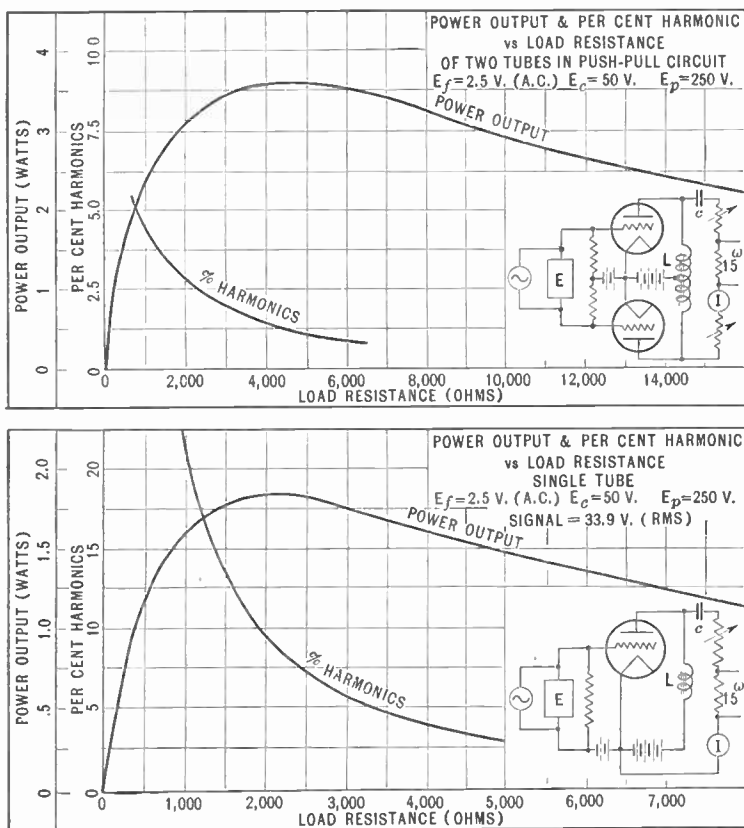

FIG. 178.—Demonstration of advantages of push-pull tubes.

With filament types of tubes this necessitates two filament batteries insulated from each other, one of which is considerably above ground potential. With heater-type tubes, however, the two cathodes may be appreciably different in potential even though the two filaments which heat the cathodes may be operated

from the same battery or transformer. In this case one cathode is higher in potential than the heater; therefore adequate insulation must exist between heater and cathode.

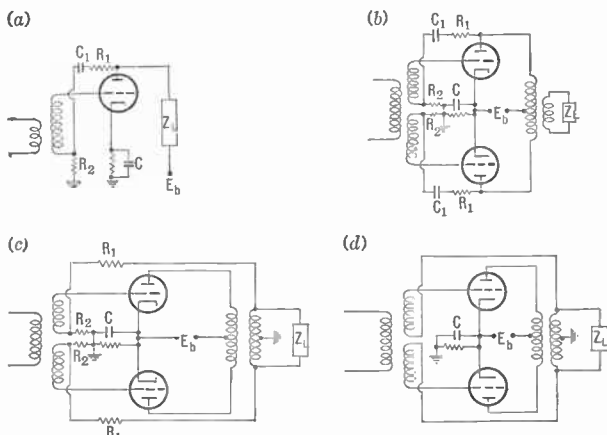

FIG. 179.—Negative feedback circuits.

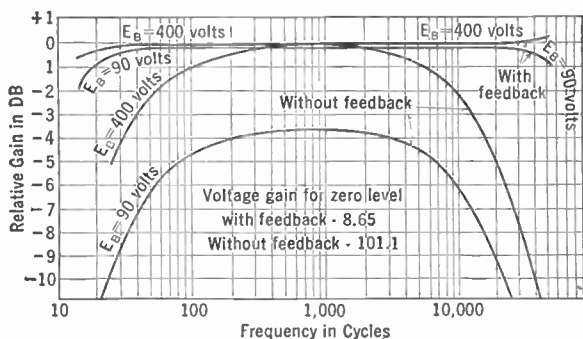

Fig. 179a.—Frequency response in feedback amplifiers.

In Fig. 180a is a simple circuit representing a “direct-coupled” amplifier, of which the Loftin-White circuit is a more or less special case. Note that both heaters are run from the same transformer but that the cathodes are at different potentials; that the grid of the second tube is connected directly to the plate of first tube, but that adequate bias exists between grid and cathode of the second tube.

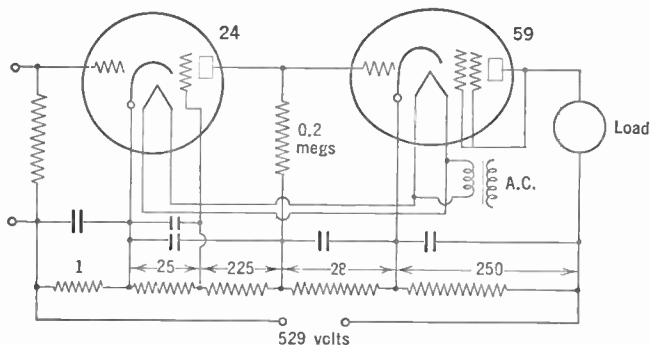

FIG. 180a.—Simple direct-coupled amplifier.

A typical amplifier with a voltage gain of 56 DB (613) is shown in Fig. 180b. It uses type 58 tubes. It will amplify alternating voltages too, and is flat from 30 cycles to about 1000 and then drops slightly until at 10,000 cycles it is down 3 DB.

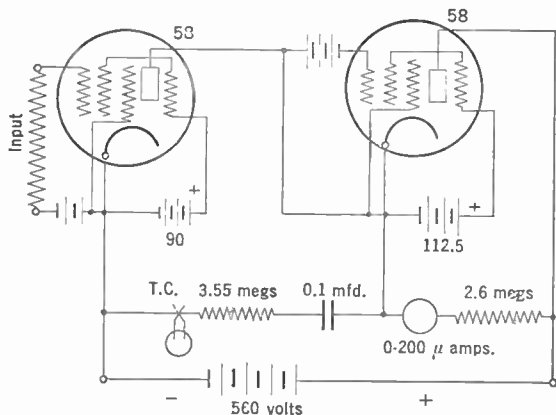

FIG. 180b.—High gain amplifier for use on direct or alternating voltages.

Loftin and White have developed very stable circuits of the direct-coupled type—circuits which do not permit positive or negative regeneration. These circuits, unless properly stabilized, have a tendency to wind up and to become inoperable because of the coupling existing in the common plate supply system.

CHAPTER XIII

RADIO-FREQUENCY AMPLIFIERS

237. THERE are three basic qualities which must be weighed not only by the designer of a radio receiver but by the purchaser and ultimate user as well. These are the **sensitivity**, the **selectivity**, and the **fidelity** of the receiver. The sensitivity of a receiver is an indication of the overall amplification from antenna-ground binding posts to loud speaker. A receiver that is very sensitive requires but a small input voltage to deliver considerable output power. The selectivity of a receiver is an indication of its ability to discriminate between wanted and unwanted signals. An infinitely selective receiver would be one that would respond only to a given station and not at all to another no matter how powerful this undesired signal was, nor how close in frequency it was to the desired signal. That there is no such receiver goes without saying. The fidelity of a receiver tells how well it reproduces what takes place in the broadcasting studio. If a certain voltage at 100 cycles is set up in the broadcasting studio, then an equal amount of 100 cycles should come out of the receiver, no more and no less. The same should be true at 1000 and at 10,000 cycles. In other words a receiver that delivers a perfectly faithful signal is one which has a perfectly flat audio-frequency response curve from antenna to loud speaker input. It has a high degree of fidelity.

A receiver that is perfectly selective, infinitely sensitive, and delivers a perfectly faithful signal is impossible to obtain. A receiver which is selective and sensitive enough for practical purposes, and the frequency curve of which is so good that the ear would not detect its infidelity is not difficult to design, to build, or to operate.

It is an unfortunate fact, however, that the human ear is so

easily deceived. Every engineer of any experience has had trained musicians congratulate him on the "perfect" tone quality of some assembly of apparatus whose frequency characteristic was anything but good and whose content of harmonics was anything but low. All broadcast and phonograph music suffers considerable distortion at the start of its journey by being greatly compressed in volume range—the reason being the inability of lines, transmitters, and receivers to handle the volume range.

238. Purpose of r.-f. and i.-f. amplification.—Although the majority of receivers are used in cities where very little r.-f. amplification is necessary, so strong are the signals from local stations, yet manufacturers have never seen fit to make receivers of low r.-f. gain. They feel that some sets will be used in the rural districts and under other adverse conditions, and since selectivity is secured at the same time as sensitivity, the vast majority of receivers have much more r.-f. and i.-f. amplification than is necessary.

239. Field strength.—The voltage that is set up across a receiving antenna is called the **field strength** of the transmitter at that particular point on the earth's surface. It is of the order of microvolts or millivolts, and because a higher antenna will pick up a greater signal—that is, the voltage across it will be greater—it is the practice to rate field strength as so many microvolts or millivolts per meter. Thus an antenna that has an effective height of one meter and has four microvolts across it is situated in a field strength of four microvolts per meter. The effective height of the antenna is somewhat less than its actual physical height above ground, and in most receiver measurements is assumed as four meters (13 feet). An antenna that has an effective height of 4 meters and a voltage of 10 microvolts across it is immersed in an electric field due to some transmitting station whose strength is 2.5 microvolts per meter.

The greater the field strength at a given point the more volume one can get out of a receiver with a fixed amount of amplification. Similarly the greater the field strength the less receiver amplification is necessary to give out a certain amount of power.

Dr. Alfred N. Goldsmith, in the Proceedings of the I.R.E.,

October, 1926, has given the following tables which are self-explanatory. They are for the 550–1600 kc. band.

TABLE I

Signal Field Strength	Nature of Service
0.1 millivolt per meter	poor service
1.0 millivolt per meter	fair service
10.0 millivolts per meter	very good service
100.0 millivolts per meter	excellent service
1000.0 millivolts per meter	extremely strong signals

TABLE II

Antenna power	Service Range
5 watts	1 mile
50 watts	3 miles
500 watts	10 miles
5,000 watts	30 miles
50,000 watts	100 miles

Now quoting Lloyd Espenschied in the Bell System Technical Journal, January, 1927, "Fields between 5 and 10 millivolts per meter represent a very desirable operating level, one which is ordinarily free from interference and which may be expected to give reliable year round reception, except for occasional interference from nearby thunder storms.

"From 0.1 to 1.0 millivolt per meter, the results may be said to run from good to fair and even poor at times. Below 0.1 millivolt per meter reception becomes distinctly unreliable and is generally poor in summer. Fields as low as 0.1 millivolt per meter appear to be practically out of the picture as far as reliable high quality entertainment is concerned."

These figures of Goldsmith and Espenschied give us a good idea of what may be expected from stations of certain power at certain distances from the receiver. From these and other data we may assume that a 5000-watt station may be expected to deliver a field of about 10 millivolts per meter at distances up to 20 miles and 1.0 millivolt per meter not over 50 miles. According to the Bureau of Standards paper, "Progress of Radio Measurements," April, 1924, "When WEA F was transmitting with 3 kw. in the

antenna its field strength at 10 miles was 32 millivolts per meter. When KDKA had a nominal power of 10 kw. its field at 10 miles was 43 millivolts per meter."

The purpose of the transmitting station is to provide a good lusty signal that will override static and other disturbances; the purpose of the radio-frequency amplifier is to provide the listener with good loud signals from the field strengths which the stations produce.

240. Advantage of high power at transmitting station.—Whatever voltage exists across the antenna, whether noise or desired signal, is amplified by the radio-frequency amplifier; there is therefore a distinct advantage, so far as the receiver is concerned, in using large amounts of power at the transmitting station. The greater the ratio of signal to noise the better will reception be. No matter how great the voltage gain of a radio-frequency amplifier, it cannot bring a weak signal out of the noise and give satisfactory reception. The signal must always be about 40 DB above the noise level in order to provide an entertainment free from a noisy background that is apparent on weak musical passages. Whenever the noise comes up, as on a warm summer day, and the transmitter station power remains constant, reception suffers, and it suffers in a very rapid manner the farther the receiver is removed from the station. The noise about a given receiver is more or less constant under a given set of conditions, whereas the field strength due to a transmitter decreases as one gets farther and farther from the transmitter.

If a receiver is situated in a quiet locality, where the noise level made up of stray voltages from street cars, elevators, arc lamps, power leakages from high tension wires to trees, sputtering flat-irons, X-ray machines, etc., is weak, the greater the amount of the overall amplification, the greater the distance away a transmitter of a given power can be and still provide an adequate loud speaker signal; and, of course, with this amount of amplification the weaker a station can be at a given distance to provide this loud speaker output. The purpose of the radio-frequency amplifier is the same as of a telescope; it is to decrease the effective distance between the transmitter and the receiver. Unlike the telescope, it

cannot be aimed at a particular station but must pick up all the r.-f. voltages not only between it and the desired station but in other directions as well. If the power of the transmitter is increased by 10 DB (ten times the power) the receiver amplifier can be made 10 DB less sensitive and thus unwanted signals are automatically reduced 10 DB compared to the desired signal.

241. The task of the radio-frequency amplifier.—The r.-f. amplifier employed in a broadcast frequency receiver may differ decidedly from that used in a receiver serving other purposes or tuned to other frequencies. For example it is possible to make a much more efficient amplifier if it is to work at one frequency instead of at any one of many. A broadcast receiver, for example, must be capable of amplifying at any frequency between 500 and 1600 kc. It must be easily changed from one frequency to another, and its amplification at all frequencies within this band should be uniform. If it selects and amplifies too, its task is much more difficult to perform, as we shall see.

The energy thrust upon the ether from a given broadcasting station is a complex bit of wave motion. If the microphone is idle, what comes from the antenna may be considered as a very narrow band, at say 600 kc., called the **carrier wave**. If a tone, say 1000 cycles (1 kc.), is put into the microphone, the antenna current has in it frequencies not only of 600 kc. but 599 and 601 as well, and when music is broadcast the frequencies in the antenna may be varying between zero and 5000 cycles above and below the carrier from instant to instant. These frequencies on either side of the carrier are called the **side bands**. The characteristics of the transmitter must be such that each of these audio frequencies is given equal power compared to the others. The resonance curve of the antenna system of the transmitter, then, must not be sharp but must be rather flat or dull as shown in Fig. 181. It must have a rather flat top from 5 kc. below to 5 kc. above its carrier frequency.

If audio frequencies up to 5000 cycles are transmitted, each station requires a channel 10 kc. wide for its transmission, and if there are 1000 kc. available there are 100 channels or places for 100 simultaneous transmissions.

At the listening station, the receiver must be able to pick out any one of these stations, and to receive it without being bothered by others on other channels. This means that a receiver with a good degree of selectivity is one which will receive, transmit, and amplify signals on the band from 595 to 605 kc. but not recognize a signal in the adjacent channels, that is, on the channel extending from 585 to 595 kc. and the channel extending from 605 to 615 kc. In other words, to cope with conditions in the broadcasting band a receiver should have "ten kilocycle selectivity."

242. The ideal response curve of a receiver.—To carry out this double purpose of the r.-f. amplifier the response curve should be a square-topped steep-side curve as in Fig. 181, like the transmitter curve. This is very difficult if not impossible to attain. In TRF sets, the response curve is either so broad that stations on the adjacent band, or even

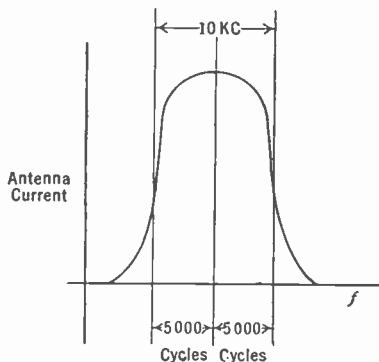

FIG. 181.—A flat-topped steep-sided response curve is the ideal. This curve approaches it.

two or three channels away, will be audible during weaker passages of the desired signals, or so selective that the high audio tones are lost, due to what is called "side band cutting." This means simply that the radio-frequency waves corresponding to 600 kc. plus or minus 5000 cycles are cut off in the r.-f. amplifier.

A receiver which has such a sharp curve that the higher audio tones are discriminated against cannot possibly deliver a high quality loud speaker output even though a flat audio amplifier is used. A receiver that has a flat-top curve usually has too gently sloping sides so it is subject to interference from unwanted signals.

243. Types of radio-frequency receiving systems.—All radio receivers for use on broadcast frequencies amplify and select at the same time. They use tuned circuits, and so the receivers are called "tuned radio-frequency sets," or simply "t.r.f." Be-

cause of the steepness of a resonance curve, the overall response of several circuits to frequencies off resonance is diminished, and is a logarithmic function. That is, if two amplifiers deliver ten times as much voltage at resonance as they do at some other frequency the total discrimination in favor of a desired signal is 100 times in a two-stage amplifier, or 10^N if there are N stages.

Another type of receiver, the super-heterodyne or double detector, changes the frequency of the incoming signal to a lower frequency and then amplifies at this frequency.

Systems have been devised and operated whereby the selectivity and sensitivity were not secured in the same circuits. Thus in one receiver all the amplification was secured in an untuned amplifier.

In another system (Polydoroff) an improvement in selectivity without sacrifice in gain is obtained by varying the inductance of the coils to tune them over the proper range rather than by varying the capacity. This is done by pushing into the inductances an iron-dust core of special construction thereby changing the permeability of the core on which the coils are wound.

Although this tuning method has not come into general use, the practice of tuning intermediate frequency transformers by permeability variation is fairly common as is the use of iron cores for auto radio antenna stages and i.-f. coils.

Problem 1-13. The response curve of a single tuned circuit in a radio-frequency amplifier is given in Fig. 182. Remembering that the amplification of two stages is the square of one stage, calculate and plot the result of using two such stages. Then calculate and plot the response curve in percentages, using the response at resonance as 100 per cent. Finally, plot this curve in DB using the response at resonance as 0 DB; and, remembering that a station 10 kc. off resonance must be about minus 40 DB in voltage if it is not to be too loud during weak passages of the resonance signal, determine if two stages of such amplification and selection are sufficient. If not, would another stage be sufficient? How many DB does a single stage "put down" a signal 20 kc. off resonance; how many DB down is it after passing through two stages; how many after going through three stages?

Problem 2-13. Suppose a station increases its power from 500 watts to 5000 watts and thereby increases its "service range" (radius) from 10 miles to 30 miles. Suppose the density of population in the area covered by the station's signals is 140 people per square mile. Calculate how many more people

can now hear the station and the saving to the community if each listener would have to pay \$1.00 each to increase the r.-f. gain of his receiver to get the station properly if it had not increased its power. If it costs the station \$35,000 to make this change in power, has it been economical from the standpoint of the community?

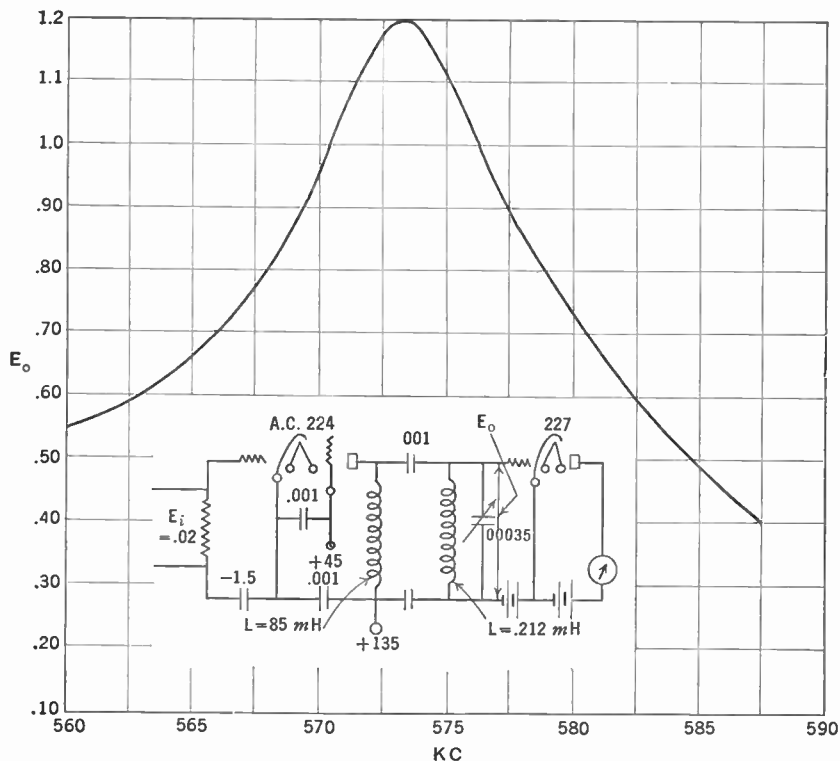

FIG. 182.—Response curve and diagram of connections of single-screen grid stage.

244. Radio-frequency amplifiers in general.—In amplifiers which are to operate at frequencies far above the audio tones with which Chapters XI and XII dealt, we have, in addition to the problems encountered there, several new ones. The difficulty in maintaining amplification with ordinary tubes and circuits at high audio frequencies was mentioned, and the reason—the stray

capacities and those due to the tube input circuit—was discussed. These stray capacities in a radio-frequency circuit become much more important, not only for their shunting effect—which is severe at frequencies of the order of one million cycles—but because of other interesting phenomena which will be discussed at this point.

245. Effect of tube input capacity.—In general a voltage amplifier must be one which works from a low impedance into a high impedance load. The problem in all tube amplifying circuits in which high-voltage amplification—at the expense of low-power amplification if necessary—is desired, is to get a high impedance for the tube to work into. Suppose this load impedance is a resistor shunted by the succeeding tube grid-filament path. The effect of the input capacity of this tube upon the load impedance was discussed in Section 198. If the frequency at which the amplifier is to work is multiplied by 100, the shunting effect of the condenser becomes 100 times as great.

Problem 3-13. A tube with a plate resistance of 12,000 ohms and a μ of 8 has a resistor in its plate circuit of 50,000 ohms. The following tube is a UX-240 with an effective μ of 20 and a grid-filament capacity of 4.0 mmfd., a plate-grid capacity of 8.8 mmfd., and a plate-filament capacity of 1.5 mmfd. Other capacities across its output circuit bring up the total plate-filament capacity to 6.0 mmfd. What will be the impedance in the plate circuit of the first tube and what will be the voltage gain at 10, 100, 1000 kc.? (Section 178.)

Now it is generally assumed that if an amplifier tube has a sufficiently high grid bias that no grid current flows, the input impedance of the tube is infinitely high and acts as a pure capacity which is given by the expression

$$C_o = C_{gf} + C_{gp} (G + 1),$$

where G = the effective amplification;

C_{gp} = the plate-grid capacity;

C_{gf} = the grid-filament capacity.

If this were true at radio frequencies, as is usually true at audio frequencies, we could find a way to get around the shunting effect of the input capacity. But at high frequencies this is not exactly true. The fact that the input impedance is not a pure capacity

becomes important. There is resistance as well as capacity in this input circuit, and this resistance may vary from a high positive resistance which absorbs power from the previous tube's output circuit, to a negative resistance which delivers power to the previous circuit.

246. Tuned radio-frequency amplifiers.—The serious shunting effects of the input capacity of the circuit into which a tube works and which make it impossible to build resistance-coupled amplifiers to work at frequencies of the order of 1000 kc. can be avoided by the simple expedient of using this capacity to tune an inductance, or, stated in another way, by balancing out the capacity reactance by means of an inductance. For example in Fig. 183 the effect of the capacity C_o is to so reduce the impedance in the

plate circuit that no amplification can result. If, however, we place an inductance across this condenser of such a value that at the desired frequency the coil and condenser form an anti-resonant circuit of very high

impedance, the load into which the tube works will be not much less than R_o and high enough to permit some amplification. Since fairly low resistance coils are easily obtainable, and since the effective resistance of such a tuned circuit is $L^2\omega^2/r$ or $L/C_o r$, a value that may be considerably beyond that of the resistor, we may as well do away with the resistor and use merely the coil and condenser. For purposes of selectivity we may place a variable condenser across L and so tune the coil over the entire broadcasting—or other—band.

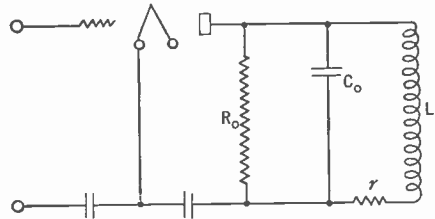

FIG. 183.—Balancing out capacity reactance by means of shunt inductance (L).

Problem 4-13. Suppose an inductance of 200 microhenrys is in the plate circuit of the tube in Problem 3. Its resistance is negligible in comparison to its reactance. Calculate the impedance in the circuit at 1000 kc. and at 1010 kc. and hence the voltage gain. Then assume that the coil has a resistance (r) of 10 ohms, and when tuned by means of a condenser to

1000 kc. calculate the impedance in the circuit at 1000 kc. and at 1010 kc. Calculate the voltage gain of tube and load, and the relative advantage of the tuned circuit in selectivity over the untuned inductance.

The advantages of such a circuit are: first, the effect of the capacity C_0 is eliminated; second, the effective resistance in the plate circuit of the tube may be made as high as we desire by making the inductance large and its resistance low (effective values of 100,000 ohms are not difficult to attain); and third, where a resistance amplifier would be absolutely non-selective, this tuned amplifier can be made very selective.

247. Effect of negative input resistance.—Now, such a tuned radio-frequency amplifier works out very nicely theoretically, and practically comes quite close to the final solution, except for one thing. This is the changing input resistance of the tube.

The input impedance of a tube is not a pure capacity. It is a capacity and a resistance. The value of this resistance may be high and positive if the load in the plate circuit of this tube is negative in sign—a capacity load, or negative if the load is inductive and of sufficient value. For example the curves in Fig. 184 (taken from Bureau of Standards Circular No. 351, Effect of Load on Input Impedance of Tubes, by J. M. Miller) show the input resistance of a typical tube at various values of inductance and resistance in the plate circuit. In other words, the minute we put an inductance in the plate circuit of a radio-frequency amplifier, we have done something to the grid circuit of that tube. If (1) the inductance is high enough, we have decreased the input resistance of the tube to a very low value; if (2) the inductance is increased still more, the input resistance becomes negative.

Up to the point when the input resistance becomes negative, it takes power from the circuit to which it is attached, because any r.-f. currents flowing through this resistance must suffer an I^2R loss. But the minute the resistance becomes negative, power is fed into the circuit to which the tube is attached. Now, feeding power into that circuit has the same effect as decreasing the resistance of that circuit by some other means, and when sufficient power is fed into the circuit that all of its resistance has been reduced to zero, radio-frequency currents flow although the input is removed from

its original driving source, and the circuit is said to oscillate. Direct-current power from the batteries is used up in producing and maintaining radio-frequency power in the coils and condensers. The circuit is useless as an amplifier.

We come then to this impasse, that, to get any amplification out of a tube at radio frequencies, we must put an inductance in its plate circuit and tune that inductance with a condenser. Putting

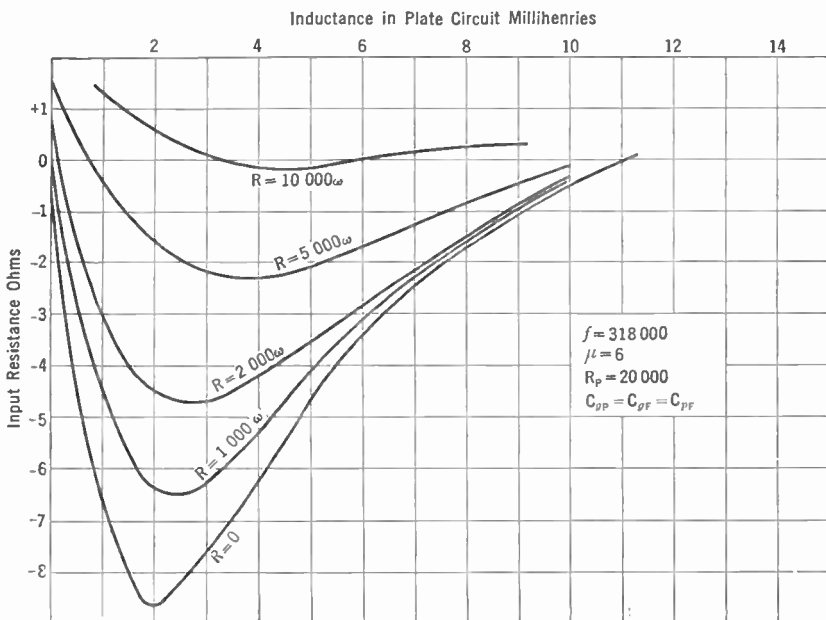

FIG. 184.—Dependence of input resistance upon inductive load.

the inductance in the plate circuit reduces the input resistance of the tube, and when the inductance is tuned to resonance, the circuit is in a highly critical condition. Any increase in inductance, or decrease in capacity—which amounts to the same thing—is liable to make the whole system oscillate. Any inductance in the plate circuit reduces the resistance in the grid circuit and results in a reduction in the effective resistance losses in the circuit out of which it works. So any resonant circuit that may be present—an

antenna for instance—becomes very sharply tuned, and the higher audio frequencies are completely lost. The circuit is said to be regenerating. Regeneration is merely a minor case of oscillation.

For the moment let us forget this trouble from regeneration and oscillation with the remark that it is caused by the inter-electrode capacity of the tube, and is of sufficient magnitude to have prevented efficient r.-f. amplifiers from becoming generally used for a long time after the need for such equipment was felt. Let us look into the tuned radio-frequency amplifier, just as though we never heard of oscillation or regeneration, and see what engineering we can bring to bear on the problem of getting the most amplification and the best fidelity with the apparatus at hand.

248. Engineering the tuned radio-frequency amplifier.—The inductance and capacity required for resonance at any point in the broadcast frequency band (550 to 1500 kc.) may be calculated easily. These values are more or less fixed by the sizes of condensers generally available. Let us suppose their values are such that with the resistance of the coil taken into consideration they produce an effective resistance at resonance L/Cr (an anti-resonant circuit) of 100,000 ohms. In the plate circuit of a 12,000-ohm tube this load should give considerable amplification except for the fact that bridging a resistance of 12,000 ohms across such a coil-condenser combination would have the same result as adding considerable resistance in series with the coil, and therefore the effective resistance into which the tube works will decrease at an alarming rate.

For example, if the effective resistance of a coil condenser combination is 100,000 ohms and is shunted by a 12,000-ohm tube, the equivalent impedance is now reduced to 10,700 ohms which represents the same change produced in the selectivity of the anti-resonant circuit as if its resistance had been increased by something over nine times. Of course this would give a very poor degree of selectivity, and the voltage amplification would not be as high as desired.

If, however, we use a transformer with a step-up ratio from the plate of one tube to the next grid circuit, the plate resistance is stepped up by the turns ratio squared and is then placed upon the

tuned circuit. If, for example, the turns ratio between secondary and primary is 4, the effective resistance placed across the tuned circuit would be $12,000 \times 4^2 = 193,000$ and so the resistance of this tuned circuit would be increased only by a ratio of 10 to 6.1. Furthermore, there is a voltage step-up in the transformer, therefore some voltage gain may be secured by its use. Of course this transformer need have only one winding, the input coil to the following tube being tapped as in Fig. 185 for the plate inductance of the previous tube, an auto-transformer, in fact.

In this case the transformer may be looked at as a kind of selectivity adjuster, since one can adjust the selectivity by its use.

Let us look at the problem in another way. A transformer with tuned secondary will give maximum power in the secondary load and maximum voltage across the secondary when the resistance across secondary and primary are related by the proper turns ratio. If, then, the load across the secondary is the effective resistance of the secondary when tuned to resonance, and the resistance across the primary is the plate resistance R_p of the preceding tube, the proper turns ratio can be found by the usual means, namely,

$$\frac{Z_s}{Z_p} = N^2 = \frac{L^2 \omega^2}{r R_p} = \frac{L}{C r R_p},$$

whence

$$N = \frac{L \omega}{\sqrt{r R_p}},$$

and when this turns ratio is used the voltage gain of tube and transformer is

$$G = \frac{\mu}{2} \times \frac{L \omega}{\sqrt{r R_p}}.$$

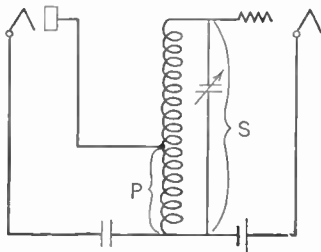

FIG. 185.—Proper selection of the tap will provide maximum voltage amplification.

This expression involving the turns ratio is not the number of turns on the secondary divided by the number of turns on the primary because in an air core transformer of this type it is not possible to obtain 100 per cent coupling, but for the moment let us not bother about this problem. We shall return to it later. The actual turns ratio is somewhat greater than N , and can be determined by experiment.

249. Gain due the tube and gain due the coil.—There are two parts to the above expression for the voltage gain of tube and transformer. Part is due the tube and part is due the transformer. That is, we may divide up this expression into two parts.,

$$G = \frac{1}{2} \frac{\mu}{\sqrt{R_p}} \times \frac{L\omega}{\sqrt{r}},$$

in which the first part shows that the gain is proportional to one-half the μ of the tube divided by the square root of its plate resistance and the second part shows that the gain is proportional to the inductive reactance of the coil divided by the square root of its high-frequency resistance. From such an expression we may learn several things.

In the first place G is the maximum possible voltage gain that can be obtained from a given tube working into a given resistance and this is obtained only when the turns ratio N of the transformer

is properly adjusted. For a certain tube, the expression $\frac{\mu}{\sqrt{R_p}}$

is a constant and is related to the mutual conductance so that once we have determined its value we can multiply it into the corresponding values for the voltage gain due the transformer and we then have the maximum voltage gain. The figure of merit for the transformer ($L\omega/\sqrt{r}$) is not constant over the broadcast frequency band as the curve in Fig. 186 shows, and from it we learn at once that the overall gain, G , of tube and transformer will not be equal at all frequencies. It is a characteristic of tuned radio-frequency receivers to have less selectivity at the higher frequencies because the coil resistance increases faster than the frequency increases. Thus the Q is less at high frequencies.

We are now in a position to perform a very interesting experiment, one that requires neither laboratory nor apparatus. We need only a pencil, some paper, a slide rule, some values of the factors that enter into the expression for the maximum voltage amplification, G .

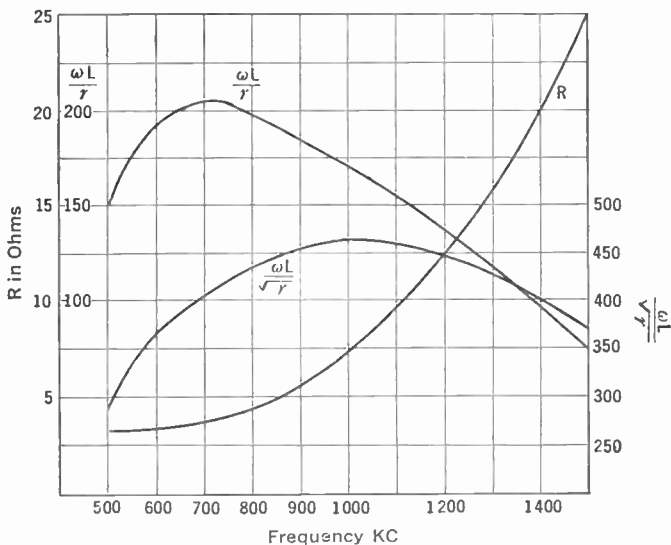

FIG. 186.—How resistance and figure of merit “ Q ” $\left(\frac{\omega L}{r}\right)$ of a coil vary with frequency.

Experiment 1-13. A coil has an inductance of 168 microhenrys, and a high-frequency resistance, r , of 4 ohms at 700 kc., 6 ohms at 1100 kc., and 9 ohms at 1500 kc. Plot this resistance against frequency. Calculate the figure of merit $\left(\frac{L\omega}{\sqrt{r}}\right)$ for the coil and plot against frequency. Assume it to be used out of a tube whose plate resistance is 12,000 ohms and whose μ is 8. Calculate the proper turns ratio for maximum voltage amplification at the above frequencies and what the amplification is, that is, calculate and plot $N = \frac{L\omega}{\sqrt{R_p r}}$ and $G = \frac{1}{2} \mu \times N$ against frequency, assuming that the proper turns ratio is used at each frequency.

Then calculate N and the voltage amplification at 1000 kc. of such a coil and a 199 tube with a plate resistance of 16,000 ohms and μ of 6.6, and then when a 240 type tube is used. It has a plate resistance of 150,000 ohms and a μ of 30.

Problem 5-13. The effective resistance of a coil-condenser combination is 100,000 ohms when the resistance of the coil is 10 ohms. That is, $L/Cr = 100,000$ ohms, where r is the series resistance. Calculate what the equivalent resistance of such a circuit is when shunted by 10,000 ohms. (Two resistances in parallel have a resistance equivalent to their product divided by their sum.) Then assuming that this value is the effective resistance of another tuned circuit having the same L and C but a different series resistance, calculate what the value of r is.

Problem 6-13. A tube of 5000 ohms (UX-112A) is to be used as an r.-f. amplifier and to be worked into a tuned circuit whose effective resistance is 120,000 ohms. What is the proper turns ratio for maximum voltage amplification and what is the amplification? Remembering that a resistance across a primary of a transformer is equivalent to another resistance across the secondary stepped up by the square of the turns ratio of this transformer, what is the equivalent resistance that is placed across the tuned circuit by this transformer? What happens to the effective resistance L/Cr of this circuit?

Problem 7-13. A voltage gain of 10 is desired. The plate resistance of the tube is 12,000 ohms, its μ is 15, the inductance of the coil is 186 microhenrys, and the capacity is 0.0001 mfd. What is the maximum resistance the coil can have?

250. Effect of coupling.—The foregoing argument on maximum possible amplification of tube and its accompanying transformer has been based on the assumption that the coupling between primary and secondary was adjusted to the proper value at each frequency. Actually, such is seldom or never the case, and even if it were it is doubtful if receiver designers would so choose the coupling that maximum amplification would result owing to the decrease in selectivity of the circuits under these conditions.

In general the voltage amplification of a tube and transformer when the secondary is tuned may be expressed as

$$G = \mu \frac{\omega^2 M L_2}{R_p R_s + \omega^2 M^2}$$

which involves not only the resistance of the apparatus (R_p and R_s) on the two sides of the transformer but the coupling M in the transformer itself. If we go into the laboratory and measure the

voltage across the secondary with a constant input voltage to the tube but with various degrees of coupling we shall find that the

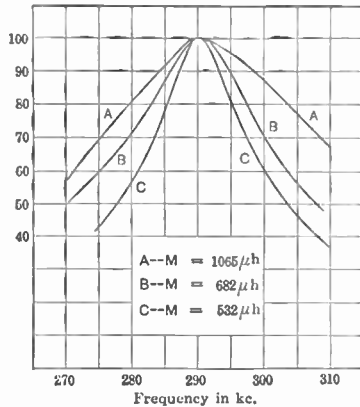

FIG. 187.—Relation between coupling and selectivity.

amplification increases with increases in mutual inductance but only up to a certain value. Then it falls off. We shall also find that a continuously variable mutual, increasing at lower frequencies, would result in uniform amplification. Mechanical systems for effecting this change of coupling as the set is tuned have been worked out but have not come into general use. Figure 187 is from Morecroft.

251. Effect on secondary resistance, of close coupling.—

The increase in resistance—and

consequent decrease of selectivity—of the secondary circuit may

be calculated from the expression

$$r = \frac{M^2 \omega^2}{R_p},$$

which states that the resistance introduced across the secondary by the transformer is equal to the square of the mutual reactance divided by the resistance in the primary, in this case the plate resistance of the tube. This resistance introduced across the secondary goes up with the frequency and the mutual inductance squared and is inversely proportional to the plate resistance of the tube out of which the transformer works. This means simply that the greater the impedance of this tube, the less will the selectivity be decreased with a given turns ratio, and the reason for such an inverse function is simply that a larger resistance shunted across

the tuned circuit will introduce less resistance in series with that circuit than will a smaller resistance across the circuit. No matter what the plate resistance, if M is adjusted for maximum possible voltage amplification the selectivity of the secondary circuit will be cut in half, because this selectivity is a function of the series resistance of the secondary which is doubled when the turns ratio is such that G is a maximum. Now the coupling between primary and secondary is controlled not only by the physical proximity of the two windings, but upon the number of turns in the primary, if the secondary turns are held constant. Therefore, decreasing the primary turns will increase the selectivity and decrease the amount of voltage amplification. Mathematical analysis of the problem will show that decreasing the turns in the primary from the number required for optimum voltage transfer to zero, only increases the selectivity by a factor of two. This means simply that when the number of turns in the primary is zero, none of the plate resistance of the tube is transferred to the secondary circuit, and, of course, then the selectivity of the secondary is its selectivity when standing alone. No voltage is transferred under this condition, and so such selectivity for a single stage is never attained.

There is another variable factor in this transformer, this is the ratio of L to C . We have already discussed the voltage gain and selectivity as controlled by the secondary resistance and the turns ratio and the plate resistance of the previous tube. Calling upon either experimental proof or mathematical analysis, we can show that the greater the inductance of the secondary, other factors being maintained, the greater will be the selectivity of the system, and that when the secondary is adjusted to give the maximum amplification, given by

$$R_p R_s = \omega^2 L^2$$

(where $\omega = 2\pi \times$ resonant frequency) the selectivity will depend upon the ratio of L to R_s (secondary resistance) only and that if the circuit is adjusted for the greatest amplification for a desired signal it will also give the smallest amplification to an unwanted signal (K. W. Jarvis, Proc. I. R. E., May, 1927). Other curves

showing the influence of coupling, etc., on selectivity and amplification are shown in Figs. 188 and 189.

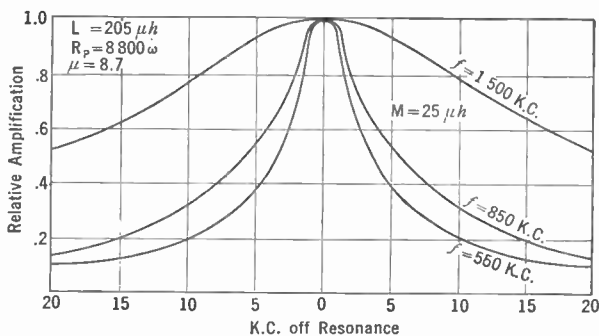

FIG. 188.—Curves showing how selectivity of tuned r.f. circuit depends upon frequency.

252. Selectivity.—So far we have treated the selectivity problem in a qualitative way only. We have not said anything about how much selectivity we needed or desired, or how much we could get. We stated that increasing the coupling between the primary and secondary circuits (decreasing N) of our tuned transformer increased the resistance in the secondary circuit and thereby decreased the selectivity of that circuit, and that at the coupling for maximum voltage gain the selectivity was halved. What does this mean? How much selectivity is needed to prevent cross-talk between stations 10 kc. apart? How much selectivity

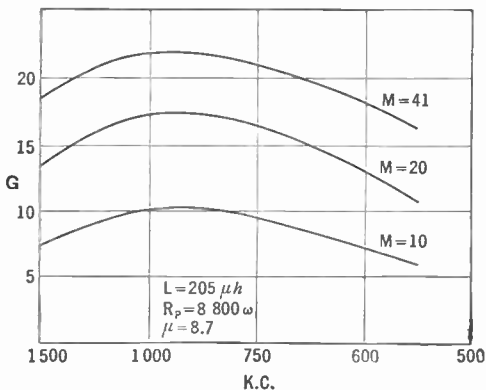

FIG. 189.—Relation between mutual inductance and gain in an r.f. amplifier.

can be secured? What are the coil characteristics to provide such selectivity? How much selectivity can be tolerated before side band cutting becomes audible to the ear? These are questions that assail every receiving set engineer.

In Chapter VII we discussed the simple series resonant circuit, and stated that the steepness of its response curve at resonance depended upon the resistance in that circuit. The greater the resistance, the duller the curve, and the less difference in voltage, or current, between the resonant frequency and frequencies off resonance by say 10 kc. In fact the width of the resonance curve is a direct measure of the resistance in the circuit. Consider such resonance curves as that in Fig. 188. If f_1 and f_2 are two frequencies on either side of the resonant frequency, f_r , such that the current, or voltage, at these frequencies is 0.707 of the value of voltage, or current, at resonance, then the following formula is true:

$$\frac{L\omega}{r} = \frac{f_r}{f_2 - f_1}$$

Here again we run into an expression involving the inductive reactance and the ohmic resistance of the coil. It states that knowing the value of $L\omega/r$ of the coil, we can tell at once how wide the resonance band is going to be at a point where the current, or voltage, is 0.707 of its maximum value. (This amounts to a 3 DB loss in voltage in a single circuit.) How is this useful in our present problem?

The tuned transformer used in t.r.f. sets, or neutrodynes, or in any system in which the secondary of a transformer is tuned, may be considered as a simple series circuit provided we choose the constants of that series circuit correctly. The resistance of that circuit will be its series resistance, r , usually consisting of the high-frequency resistance of the coil alone, plus the resistance "reflected" into that circuit by the transformer. This resistance considered as shunted across the tuned secondary is the plate resistance of the tube stepped up by the square of the effective turns ratio of the transformer, just as in any transformer case.

Now any resistance shunted across the tuned circuit is equiva-

lent to a smaller resistance in series with the circuit, and such a resistance is the controlling factor in determining the width of the resonance curve. And since selectivity is but a term describing the width of this resonance curve, we have in our hands all the necessary facts regarding the voltage amplification and the selectivity of such circuits.

For example, at the coupling between the primary and secondary for maximum voltage amplification the effective turns ratio is given by

$$N^2 = \frac{Z_s}{Z_p} = \frac{L^2 \omega^2}{r R_p},$$

which means that the secondary of the coil will be shunted by a resistance equal to the plate resistance of the previous tube multiplied by the turns ratio squared, and this numerically will be equal to the effective resistance of the tuned secondary, $L^2 \omega^2 / r$. Now the secondary effective resistance, being shunted by another resistance equal to it numerically, becomes half its former value (two equal resistances in parallel have a resultant resistance of one-half of one of them). Such a decrease in effective resistance can also be produced in one other way—by increasing the resistance of the coil to twice its normal value. And what effect has doubling the coil resistance upon selectivity? Clearly it halves it, because selectivity may be thought of as proportional to $L\omega/r$ and doubling r halves this factor.

The following example may fix the whole problem in one's mind.

Example 1-13. Consider a coil whose inductance is 200 microhenrys, and whose resistance r at 1000 kc. is 10 ohms. This coil is to be tuned and fitted with a primary to work out of a tube whose plate resistance is 12,000 ohms and whose μ is 8. What is the proper turns ratio for maximum voltage amplification? What is the voltage amplification? What is the width of the frequency band with and without the tube connected across the primary?

Effective resistance of coil-condenser alone

$$\begin{aligned} &= \frac{L^2 \omega^2}{r} = \frac{(200 \times 10^{-6})^2 (10^6 \times 6.28)^2}{10} \\ &= 158,000 \text{ ohms} \end{aligned}$$

Width of frequency band when $I = .707$ maximum value

$$\begin{aligned} &= f_2 - f_1 = \frac{f_r r}{L\omega} = \frac{r}{2\pi L} \\ &= \frac{10^6 \times 10}{200 \times 10^{-6} \times 6.28 \times 10^6} \\ &= 8000 \text{ cycles.} \end{aligned}$$

Turns ratio for maximum voltage amplification.

$$= \sqrt{\frac{Z_s}{Z_p}} = \sqrt{\frac{158,000}{12,000}} = 3.6.$$

Voltage gain

$$\begin{aligned} G &= \frac{\mu L\omega}{2\sqrt{r R_p}} = \frac{8 \times 200 \times 10^{-6} \times 6.28 \times 10^6}{2\sqrt{12,000} \sqrt{10}} \\ &= 14.5 \text{ times.} \end{aligned}$$

Resistance reflected from primary to secondary

$$\begin{aligned} &= Z_p \times N^2 \\ &= 12,000 \times 13 = 158,000. \end{aligned}$$

New effective resistance of secondary circuit

$$= \frac{158,000 \times 158,000}{158,000 + 158,000} = 79,000 \text{ ohms} = \frac{L^2\omega^2}{R_1}.$$

New effective series resistance in secondary

$$= R_1 = \frac{L^2\omega^2}{79,000} = \frac{158,000 \times 10}{79,000} = 20.$$

Width of frequency band where $I = .707$ maximum value

$$\begin{aligned} &= f_2 - f_1 = \frac{f_r R_1}{L\omega} = \frac{10^6 \times 20}{200 \times 10^{-6} \times 6.28 \times 10^6} \\ &= 16,000 \text{ cycles.} \end{aligned}$$

This indicates that a voltage gain of 14.5 would be obtained with such a coil-condenser combination and tube at a frequency of 1000 kc. and that at a frequency 8000 cycles either above or below resonance, the current in the secondary circuit, or the voltage across it, would be 0.707 of its value at exact resonance. This

voltage ratio corresponds to a loss of 3 DB, which is not very great. The selectivity of the transformer and tube, then, is not very great, certainly not great enough to provide much discrimination between a station on 1000 kc. and another at 1010 kc.

253. Overcoupled amplifiers.—It has been mentioned that the effect of coupling upon selectivity might be utilized if a system were provided so that as the receiver is tuned to the lower frequencies, the coupling between the coils could be increased automatically. In an intermediate frequency amplifier, where a single frequency (say 456 kc.) is to be handled, this variable coupling may be utilized.

In a superheterodyne with minimum coupling between primary and secondary of the i.-f. transformers the selectivity is very great. Now if the coils are pushed closer together the selectivity decreases, which means that a wider and wider band of frequencies is amplified. Such a receiver would have variable selectivity and it can be arranged that this change in coupling be accomplished mechanically or by the use of electric circuits and tubes. It is possible to have the band passed only a few thousand cycles wide, say 2500 cycles, at the most selective position and as wide as 10,000 cycles when the coupling is increased.

Now it will be shown in the next chapter that overcoupling two coils tuned to the same frequency results in a curve which has two peaks separated by a dip. Thus the frequency characteristic of such a transformer, when its coils were closely coupled, would not be ideal because the center of the response band would get much less amplification than the outer limits.

What would happen, then, is that the higher audio frequencies would get a lot of amplification and those near the carrier frequency (i.e. the low audio notes) might be decreased materially. Engineers have worked out a clever way of getting around this difficulty and of producing a response curve that has steep sides and an almost flat top.

Suppose the receiver has three i.-f. transformers, the final one feeding into the diode detector. Now let us connect the first two transformers mechanically so that the coupling can be increased or decreased. The third one, however, is undercoupled so that it

is fairly sharp. When the coupling of the first transformers is increased so that a dip occurs in the curve, the third transformer still has a sharp response exactly on the carrier frequency and on the lower audio frequencies.

If the over-all response of such an amplifier is measured it will be found that the overcoupled transformers produce amplification at the higher audio frequencies filling in the portion of the range not covered by the third transformer. Furthermore the final transformer, having good response at low frequencies, fills up the

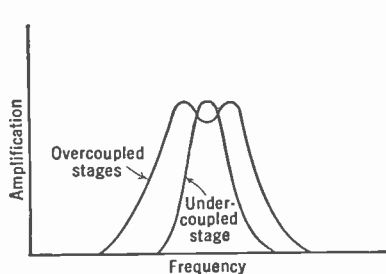

FIG. 190.—Response of variable and fixed coupling stages in an i.-f. amplifier.

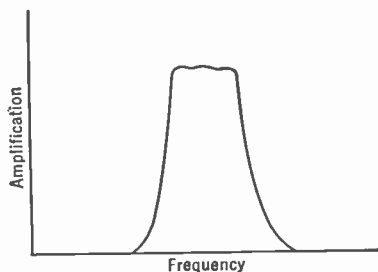

Fig. 191.—Overall response produced by amplifier of Fig. 190.

gap in the characteristic produced by overcoupling the earlier transformers. This is shown in Fig. 190.

254. Regeneration and oscillation in r.-f. amplifiers.—All of the discussion up to this point assumes that the tubes and transformers operated in a stable manner, repeating into the plate circuit what appears in the grid circuit in amplified form, and not repeating back to the grid circuit any of this amplified voltage. Practically, such conditions do not hold. Unless precautions are taken, the circuit oscillates long before the proper inductance has been added to the plate circuit to provide a reasonable amount of amplification.

There are two reasons for this unwanted oscillation. One lies in the unintentional couplings provided between output and input circuit, for instance through mutual inductance between the coils,

through capacities which connect the two circuits, and through other couplings. The other source of coupling is also unintentional

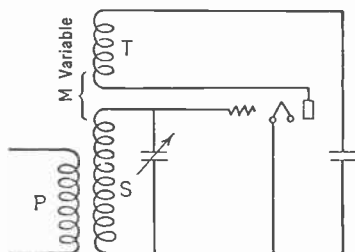

FIG. 192.—A simple regenerative circuit.

but, unlike those mentioned above, cannot be eliminated. This second coupling is that existing within the tube, and is due the capacity between the plate and the grid.

Let us look at Fig. 192 and assume that there is an amplification in voltage of 10 in the tube, that is, whatever voltage, E_i , is placed across the input appears as 10 times this value in the output.

The voltage is applied to the input through the mutual inductance between the primary, P , and secondary, S , of the transformer. Whatever a.-c. current flows in the plate circuit must also go through the coil, T , commonly called a "tickler." If this coil is coupled to S in the proper manner, it will induce a voltage in the input coil S in such a direction that it will be in phase with the voltage induced there from P . Suppose the voltage due P is 1.0 volt and that the voltage on S due to T is one-half volt. We now have not 1 volt on the grid of the tube but 1.5 volts. This is what is known as regeneration; part of the output voltage is fed back to the input and *in phase*. When the feed-back voltage is of the correct magnitude and phase, we may remove the input voltage due the primary, P , and a.-c. currents will still flow because whatever came from P originally has been amplified in the tube and fed back to the grid where it is amplified again, and again returns to the input. In other words the tube oscillates; it supplies enough energy from the B battery to wipe out all the power losses in the circuit.

Let us look at the phenomenon of regeneration in another way. Suppose the input circuit to the tube is tuned. The current in the tuned circuit is controlled by the resistance in that circuit—provided a constant voltage is impressed from P . If, now, we decrease the resistance in the circuit the current increases, and the voltage across the circuit (and hence on the grid) increases.

Now suppose the voltage across the input is increased by means of the tickler coil, T . This produces exactly the same result as if the resistance in the tuned circuit were decreased. We may express what has happened by stating that feed-back, if in proper phase and magnitude, may introduce a *negative* resistance into the tuned circuit. This negative resistance added to the already existent positive resistance decreases the total resistance there. When the tube feeds back sufficient negative resistance so that the entire resistance losses in this circuit are wiped out, the system maintains itself in a state of continuous oscillation requiring no additional a.-c. energy from without, and capable of supplying considerable a.-c. power to some external circuit coupled to it.

Such a feed-back of voltage from the plate to the grid circuit may take place through desired coupling—as in case of the tickler feed-back—or through unwanted coupling, as mentioned above. The grid-plate capacity is the most prolific source of trouble from regeneration, because the voltage fed back from this small interelement capacity may be of the proper phase and magnitude to cause not only regeneration but oscillation as well.

It is an important fact that the input impedance of a vacuum tube is not a pure capacity, but that it may be a capacity plus a resistance which may be either positive or negative depending upon the load in the plate circuit. If the load is a positive reactance, an inductance, the input resistance of the tube may be negative, and so the voltage fed back there from the plate circuit through the grid-plate capacity will be in phase with the voltage already appearing there. Regeneration takes place. If the resistance of the input circuit is sufficiently negative the circuit may oscillate.

If the load in the plate circuit is a negative reactance, a capacity, the input resistance of the tube will be positive, and will shunt the input circuit. If this circuit is a coil-condenser combination tuned to resonance with some incoming voltage, the positive resistance of the grid-filament circuit of the tube will be placed across this tuned circuit and of course will decrease its selectivity.

The input impedance of a tube, then, depends upon the plate load. Any change occurring in the plate circuit is repeated back to the input grid circuit through unwanted couplings, usually through the grid-plate capacity, and may cause either regeneration

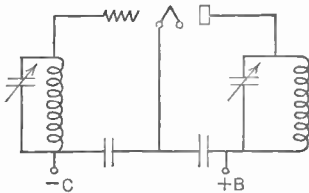

FIG. 193.—Tuned plate-tuned grid circuit.

due to an inductance load or degeneration due to a capacity load, which produces a positive input resistance.

If the load in the plate circuit is resistive or capacitive the tube and circuit cannot regenerate or oscillate. Signals may even be weaker.

255. Bridge systems.—There is a large class of circuits in which unwanted feed-back is fought in an elegant way—a way that seems more scientific to many engineers, although it may be not a great deal more effective than the simple use of resistance to damp out the oscillations. These circuits are the “bridge circuits” of Hazeltine, Rice, Hull, Ballantine, Hartley, Horle, and several others.

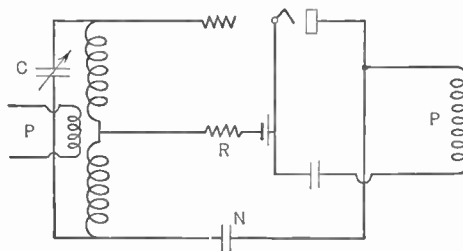

FIG. 194.—Rice neutralized circuit.

The Rice circuit is the simplest to understand. It appears in Fig. 194. It involves tapping the input coil in the exact center, and connecting a “neutralizing” condenser from the plate of the tube to the bottom of this coil. If the input coil is tapped at the exact center, and if the neutralizing condenser has the same capacity as the grid-plate capacity, for every voltage fed back through the

latter capacity, of the proper phase to cause regeneration—due to the inductive load in the plate circuit—there will be an equal and opposite voltage fed back through the neutralizing condenser.

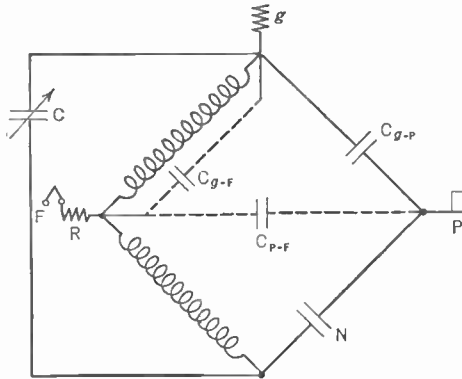

FIG. 195.—Equivalent bridge circuit of Fig. 194.

The equivalent bridge circuit is shown in Fig. 195. If the coupling between the two halves of the input circuit is perfect and if the grid-filament capacity and the filament-plate capacity (in dotted lines) are equal, the bridge will be balanced at all frequencies. Actually these conditions do not exist and so there may be some regeneration, or even degeneration in a given circuit.

256. The neutrodyne.—The neutrodyne of Hazeltine gets the neutralizing voltage from the plate voltage instead of the grid voltage as shown in Fig. 196. The Roberts system, Fig. 197, also uses plate circuit neutralization. Other systems are in use, but in general they are more complex than these illustrated here.

The Rice circuit has the advantage that the circuit is complete in itself and no wires need to go to any other circuit for neutralizing voltages. The plate circuit load may be placed at some distance from the amplifier tube itself. It has the disadvantage that half the input voltage is not usefully used, that is, it is not applied to the grid-filament path of the tube. It also has the disadvantage that both sides of the tuning condenser are above ground potential,

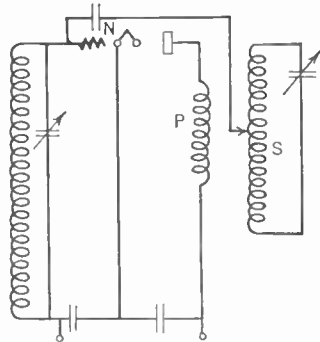

FIG. 196.—Hazeltine neutralized circuit.

one side being connected to the grid and the other to the neutralizing condenser. Some trouble with "hand capacity" will be experienced in using this circuit unless precautions are taken to use a non-metallic shaft on the condenser.

The Rice circuit is troubled with parasitic oscillations, that is, oscillations at some other frequency than those determined by the capacity and the inductance of the tuned circuit. For example, in a Rice neutralized amplifier operating on broadcast frequencies oscillations frequently take place on a wavelength of about 75 meters, corresponding to the inductance of half the input coil and the capacity across it due the grid-filament capacity of the tube, wiring, etc. The other half of the input coil may be thought of as a tickler.

A high loss put into this oscillating circuit, as R in Fig. 194, will stop all such oscillations. Such a loss may be a high resistance, 500 ohms will do, a choke coil, or an anti-resonant circuit tuned to the offending frequency.

257. Neutralizing bridge circuits.—A single neutralized amplifier is often placed ahead of a regenerative detector by experimenters. In such cases it is only necessary to make the detector oscillate and to so adjust the neutralizing condenser that tuning the input to the r.-f. amplifier does not throw the detector out of oscillation. When such a condition exists, the r.-f. amplifier is independent of its following circuit, and so the detector and the amplifier may be tuned separately to the same frequency without disturbing noises. Actually it is practically impossible to neutralize an amplifier to the point where it will not throw the detector out of oscillation at some frequency. This is because of other couplings that exist in addition to the plate-grid capacity.

If such couplings exist their presence will be indicated by the following test. Make the detector oscillate and pick up a broadcasting station carrier. This will cause a distinct beat note to appear in the head phones or the loud speaker. Now vary the r.-f.

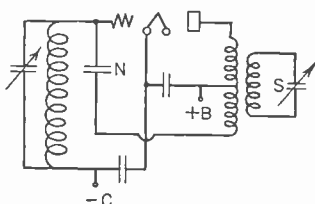

FIG. 197.—"Roberts" neutralized circuit.

amplifier tuning condenser through resonance with the detector. The beat note will now change. If there are no couplings aside from the grid-plate capacity the tone of the beat note will change to a maximum, or minimum, pitch and then return to its original value. When the tube is properly neutralized this beat note will not change in tone. But if unwanted couplings exist due to wiring, or capacities between plate and grid apparatus, the beat note will have a double hump in it.

The experimenter should not take the exact neutralizing of his amplifier too seriously. All that is really desired is a value of capacity such that oscillations will not take place in the r.-f. amplifier at any frequency within the band that will be tuned over. As a matter of fact a slight misadjustment may increase the strength of the signals.

If an oscillating detector is not used, another method may be used which leads to the same result. The filament of the tube to be neutralized is not lighted. A buzzer-modulated signal is picked up and the neutralizing condenser in this tube's circuit is adjusted until the note of the buzzer as heard in the head phones or loud speaker is a minimum. Then the tube is lighted and the next stage is neutralized in the same manner.

Such a method is faulty in that the plate-grid capacity of a tube is not the same lighted as unlighted, but practically the method leads to stable amplifiers, and this is the ultimate object of neutralization.

258. Filtering r.-f. circuits.—Oscillation is the most serious difficulty which amplifier designers run into. It is caused, as stated above, by coupling part of the plate a.-c. voltage back to the input of the tube. When occurring through wiring, or faulty layout of apparatus, or from one coil to another, it is unpardonable, because it shows evidence of poor design. Let us consider the circuit in Fig. 198. The r.-f. currents should follow the dotted lines, and should go nowhere else. If they do they are sure to get mixed up with similar r.-f. currents from other stages of the amplifier, and thereby cause unwanted coupling. This is analogous to the audio-frequency amplifier problem of keeping a.-c. currents where they belong and out of external circuits.

Filtering of all B and C leads will keep the a.-c. currents in their proper places in the circuit and will keep them from becoming sources of unwanted coupling with other parts of the amplifier. Such a filter may consist of a 50,000-ohm resistor in series with the plate battery leads and a fairly large condenser in shunt as shown in Fig. 198. A capacity of 100 mmfd. at 1500 kc. has a reactance of 10^3 ohms and is much to be preferred to a large paper condenser of perhaps 1.0 mfd. capacity which may have considerable inductance in it. Some condensers made of large sheets of paper rolled up together have such an inductance that they present a very high anti-resonant reactance at the higher radio frequencies. For this reason a small mica condenser of 0.01 or 0.001 mfd. capacity will provide good bypassing if the series impedance is fairly high.

Ballantine cites the case of two No. 18 wires two inches apart that have a reactance of 5.8 ohms per foot. A ground

wire carrying r.-f. currents and near a grid wire also carrying r.-f. currents or of the proper phase may provide sufficient coupling between circuits to cause trouble from regeneration. No a.-c. currents should be permitted to flow through the filament circuits, or the metallic shields if such are used. Shields should be grounded at only one place, to avoid circulating currents in them.

Magnetic coupling from a plate to a grid coil is a prolific source of unwanted coupling. One method of avoiding this difficulty is to use coils in large and heavy metallic containers which are grounded. Any magnetic field from the coils which would ordinarily become mixed up with similar fields from other circuits (and thereby induce unwanted voltages in them) induce voltages in the

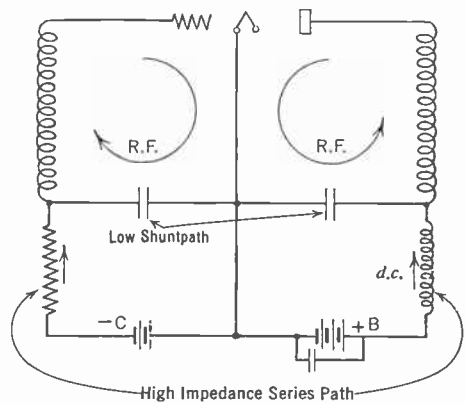

FIG. 198.—Proper use of filtering to keep r.-f. currents where they belong.

grounded shield instead. It must be remembered that the induced voltage is capable of setting up an r-f. current in this shielding and that the I^2R loss in power in the shields must be supplied from the power in the coils themselves. This results in an equivalent increase in the resistance of the coils inside the shield and a decrease in their inductance. This, of course, decreases the coil's $\frac{L^2\omega^2}{r}$ factor with consequent decrease in both amplification and selectivity. When coils are to be shielded they usually have small diameters and small fields. This construction minimizes the increase in resistance and decrease in inductance.

Modern practice is to filter every circuit with series resistance and shunt capacities to ground. Thus the r-f. currents are returned directly to the cathode of the tube whence they come. None are permitted to get into the plate voltage supply; screens of multi-grid tubes are carefully grounded and filtered. So extensive is the filtering in modern complex circuits that ten or more resistors and an equivalent number of capacitors do nothing but keep r-f. currents where they belong.

259. Use of screen-grid tube as r-f. amplifiers.—The screen-grid tube removed the necessity for neutralizing the grid-plate capacity; but it did not remove the necessity for carefully shielding "hot" leads, for shielding the coils, and for taking many precautions to prevent feed-back. In one case a manufacturer found his receiver unstable. One coil was nearly completely shielded but the end near the metal chassis was open. A hole had been cut in this chassis so that the remaining metal plate resembled a large closed loop of wire. This metal loop picked up r-f. currents from the partially shielded coil, transferred them to an adjacent grid lead, and caused regeneration. It was necessary to cut a slot in the chassis to break up the closed loop of metal; and several hours of frantic hunting for the trouble were required to discover this simple cause of feed-back.

For a time certain manufacturers coated the tube envelopes with conducting material as a sort of shield; then all tubes carrying radio or audio currents were covered with metallic shields; and finally the metal tube provides a self-shielded tube.

All modern receivers display the set makers' desire to completely shield the various circuits from any stray fields. Coils, tubes, tuning condenser, wiring are protected.

260. Gain with screen-grid tube.—The screen-grid tube has almost completely displaced the triode as an amplifier at high frequencies, not only because it is easier to control on account of the greatly decreased grid-plate capacity (about 0.007 compared to 3 mmfd.), but also because of greater stage gain, due to its higher internal resistance and to its higher amplification factor. Greater selectivity may be obtained per stage than with triodes.

Using the formulas given in Section 249 for the gain of tube and coil it may be calculated that with a secondary inductance and resistance such that a load impedance of 100,000 ohms is obtained, a gain of 200 is possible with a 58 tube having a resistance of 0.8 megohm, a mutual conductance of 1600, and an amplification factor of 1280. In practice the gain is not permitted to go so high at broadcast frequencies largely because it would tend toward making the set unstable. Gains of 30 to 60 per stage at broadcast frequencies and more may be obtained. For example, with a particular interstage coil wound with Litz wire so that the capacity is low (bank wound) a gain of 62.5 at 1500 kc. and 42.5 at 550 kc. was obtained. The coil tuned from 1700 kc. to 550 kc.

One of the difficulties of getting high gain out of screen-grid tubes at broadcast frequencies is the necessity of having a high mutual inductance between primary and secondary of the interstage transformer. This arises from the fact that the formula on page 314 giving the relation between mutual inductance and gain shows that for maximum gain the coupling between coils increases as the plate resistance of the tube increases. Thus in a typical calculation the mutual inductance between coils amounted to 325 microhenries while the secondary standing alone had an inductance of 180 microhenries. This implies a very large primary with appreciable distributed capacity.

Interstage coils have been made and widely used with high-inductance primary coils. In other receivers both primary and secondary are tuned increasing the impedance into which the screen-grid tube works. In a typical receiver the primary and

secondary of the interstage i.-f. transformers and the primary of the r.-f. interstage transformer had inductances of 5.5 millihenries; the antenna coil was 0.9 millihenry.

Modern practice is to use small coils, well shielded, usually of Litz, universally or bank wound and of as high Q as can be obtained. Considerable loss to the higher audio frequencies occurs in stages using such coils with high-resistance tubes; but this loss cuts out tube noise, static, and other undesirable noise which the public seems not to like. The Q values are of the order of 100 at i.f.

261. Selectivity with screen-grid tubes.—With low-resistance tubes, triodes for example, the maximum amplification per stage is obtained when the load the tube works into equals the tube load. Under these conditions the Q of the circuit is one-half the Q of the coil-condenser combination. This is due to the fact that the effective resistance of this anti-resonant circuit, numerically equal to the product of the reactances divided by the coil resistance, is shunted by a resistance (the internal tube resistance) equal to itself. Therefore the effective resistance has been reduced by a factor of 2, which is the same result as if the coil resistance had been doubled.

With screen-grid tubes the tube resistance is so high that it is difficult to make a tuned circuit with an effective resistance equal to the tube resistance. In other words, whatever the effective resistance of the tuned circuit, it is shunted by a resistance much larger than itself; therefore the Q of the circuit is reduced by much less than a factor of 2. Therefore the selectivity of the stage is much better than if a low-resistance tube were used.

Thus the use of screen-grid tubes has increased not only the gain per stage but also the selectivity per stage. The actual value of the selectivity may be ascertained as follows.

Suppose the tube resistance to be bridged directly across the tuned circuit. Across this circuit is impressed the input grid voltage multiplied by the mutual conductance of the tube. Thus the voltage at resonance divided by the voltage at any other frequency, which will give us an idea of the selectivity, will be expressed as

$$\frac{e_0 G_M Z_0}{e_0 G_M Z} = \frac{e_0}{e}$$

The resonant impedance, if the coil resistance is low, is

$$Z_0 = \frac{\omega^2 L^2}{R}$$

Now the tuned circuit resistance has been increased by the tube resistance across it. The resultant resistance is

$$R = r + \frac{\omega^2 L^2}{r_p},$$

where r = coil resistance;
 r_p = tube resistance.

Whence, by substitution,

$$Z_0 = \frac{\omega L}{\frac{r}{\omega L} + \frac{\omega L}{r_p}}$$

At a non-resonant frequency the impedance is equal to

$$Z = \frac{Z_0}{\sqrt{1 + \frac{\left[1 - \left(\frac{\omega_0}{\omega}\right)^2\right]^2}{\alpha^2}}}$$

where $\alpha = \frac{r}{\omega L} + \frac{\omega L}{r_p}$ and ω = off-resonant frequency.

Thus at 1000 kc. the following table gives the attenuation for signals off resonance.

Cycles Off Resonance	Attenuation (DB)
1,000
2,000	0.3
3,000	0.65
4,000	1.07
5,000	1.6
10,000	4.4

Carrying out the same calculations for an intermediate frequency of 175 kc. the attenuation at 10 kc. off resonance is 13.4 DB. Thus is demonstrated one of the virtues of the superheterodyne

system—the increased selectivity per stage possible at the lower frequency. This is because 10 kc. off resonance at 175 kc. is much further from the resonance peak than it is at 1000 kc. To secure the same selectivity at broadcast as at intermediate frequencies, more stages must be used. Thus the superheterodyne system, in which the incoming signal is lowered in frequency, is a more economical system than the tuned r.-f. system in which all the gain and selectivity are obtained at the incoming frequency.

262. Class B and C radio-frequency amplifiers.—In radio transmitters it is naturally desirable to get the maximum power output with the least expenditure of power.

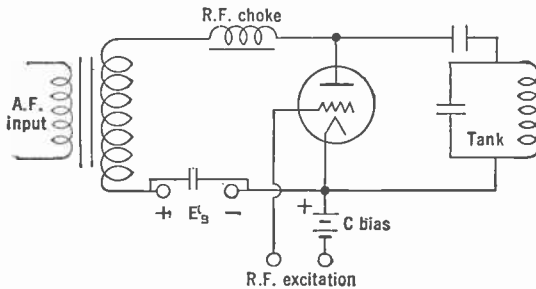

FIG. 199.—Class C modulated amplifier circuit:

If the power amplifier is biased so that current flows in the plate circuit only on the positive half cycles of grid swing, less power will be wasted in heat on the tube plates; the circuit will operate with greater efficiency. The output load is adjusted so that the tube works over a linear part of its dynamic characteristic. Therefore the Class B amplifier is often called a *linear amplifier*.

In such an amplifier the power output is proportional to the square of the excitation. The output has harmonics in it. For example, if the amplifier is working at 1000 kc. the higher harmonics will be 2000 and 3000 kc. But since the output is tuned to 1000 kc. these higher harmonics, far removed from the resonant frequency, will build up very low voltages and will not radiate.

Still greater efficiency can be obtained from a Class C amplifier where the grid is so over-biased that plate current flows for only a

fraction of the cycle which drives the grid positive. Efficiencies as high as 85 per cent (compared to 70 per cent for Class B at 100 per cent modulation) can be obtained.

263. Class B and Class C characteristics.—Because the power output from a Class A amplifier is low, and because the dissipation of heat at the plate is greatest when the grid is being excited the least, Class A amplifiers are seldom used for audio amplification at the higher powers and hardly ever for radio power amplification. Instead these radio-frequency amplifiers are operated as Class B (little current flow at zero excitation) or Class C where no current flows until the grid is excited.

In Class B the output voltage is proportional to the input voltage. Thus if a modulated radio-frequency voltage is used to drive a power tube so biased that little plate current flows, the voltage output (and the power output) should be a replica of the input signal. As much as 20 to 100 times as much power output as input can be secured from such an amplifier.

If the plate voltage of a heavily overbiased amplifier (Class C) is varied, as by modulation, while the grid is excited by a constant source of r.-f., the current in the tuned plate circuit will vary in accordance with these audio modulations. If the relation between tank current and plate voltage is linear, there will be little distortion. The relation between the plate voltage and plate current should also be linear, so that the load formed by this tube to the modulating system shall be uniform in resistance. The grid bias for Class C is about twice the cut-off value.

Considering tubes for a broadcast station, the designer must not forget that at 100 per cent modulation the peak power output is 4 times that when the modulation is zero. If 100 per cent modulation is secured for a steady period, then the steady power output is 1.5 times the output of zero modulation. Thus the designer must use tubes with sufficient filament emission and capable of plate dissipation such that 4 times the station carrier power can be handled.

264. Ultra-high-frequency amplifiers.—The history of the short waves, those below 200 meters, will undoubtedly be repeated on the very short waves, below 10 meters.

In 1932-1933 when the tubes with dome-shaped top were developed new possibilities for waves of the order of 5 meters were opened up. Prior to this time much difficulty was experienced in making stable oscillators at waves of 5 meters or somewhat above, and amplification at such wavelengths was impossible. The dome-shaped tubes, however, with smaller elements and better shielding made possible efficient operation at 5 meters.

In 1933, other very interesting developments took place. B. J. Thompson described before the Institute of Radio Engineers, in June of that year, work he had carried on for months leading toward the ultimate manufacture of tubes especially designed for ultra-short-wave work. His premise is interesting—if you reduce the physical dimensions of the tubes their interelectrode capacity will go down but the tube constants will remain the same. Thus a tube, say a triode of mutual conductance of 1000 and an amplification factor of 10, might have a grid-plate capacity of 3.3 mmfd. If all dimensions were reduced by a factor of 10, the electrical characteristics would not change but the capacity between plate and grid would be reduced by a factor of 10.

With such tubes, which are scarcely larger than a thimble, amplification at wavelengths less than 1 meter is possible. Oscillators operate without trouble at 1 meter; and a superheterodyne was made which would give a gain of 4 per stage at this wavelength prior to the frequency changing.

These oscillators use conventional circuits, i.e., Hartley or Colpitts, etc. Other types of oscillators have been developed which will generate frequencies much higher than well-known triode oscillator circuits. In conventional circuits, generation is due to feed-back of energy from the output to the input. In the other circuits to be described the phenomena of generation is produced in another way.

For example, in a circuit called the Barkhausen-Kurz arrangement after its discoverers, the grid of a triode is maintained positive with respect to the cathode and the plate is negative. Now one would not suppose that any current would flow in the anode circuit under these conditions, but it is a fact that if the voltages are correct and if the dimensions of the tube are correct, oscillatory

currents will flow in an external tuned circuit connected to the plate and grid.

Suppose an electron leaves the cathode and is attracted toward the grid because of its positive potential. If the grid is fairly open, the electron may overshoot and not hit the grid and give up its charge. Now the electron goes on and comes within the negative field of the plate. Here it is repelled and turns about, going back toward the grid and cathode. When it gets within the positive field of the grid it is again attracted and again overshoots its mark, going through the open mesh toward the anode on the other side. This cycle may become continuous. Tubes for this purpose are usually made with concentric cylindrical elements.

The frequency of oscillations is mostly independent of the inductance and capacity of the circuit elements and is controlled by the voltages and the tube dimensions. Oscillations corresponding to wavelengths of a fraction of a meter have been detected from such an arrangement. The power that may be obtained from these oscillators is small because the tubes are small and not much power may be dissipated at the plate.

There are other types of oscillators in which the time of flight of the electron within the tube is the factor determining the frequency, and still others in which other phenomena come into play. Present trends, however, are to use conventional tubes of small size, although they may be water cooled, when it is desired to generate power at wavelengths of 1 meter wavelength and upward.

CHAPTER XIV

DETECTION

SUPPOSE we have received a signal and have amplified it in a radio-frequency amplifier. How may it be detected, or demodulated so that it can be put into an audio amplifier and then a loud speaker?

Up to the present time we have considered the applications of the vacuum tube which call for its operation on a straight part of its characteristic where little distortion takes place. We have considered the tube only as an amplifier. We shall discuss now the uses for the curved part of the characteristic.

Tubes act as amplifiers either with or without distortion and as detectors and modulators in which distortion is the essential feature. The latter uses of the tube require a curved characteristic. The output no longer is an exact replica of the input.

265. Distorting tubes.—In Section 188 we were able to calculate the amount of distortion (second harmonics) that resulted when the tube was worked on a curved part of its characteristic, and found that in the distortion process a certain amount of d.-c. current was generated. In other words a pure sine wave voltage put on the grid-filament input of a tube resulted in an output current or voltage composed of not only the frequency that was put on the input but some additional frequencies and some additional d.-c. current as well.

If we desire to get d.-c. current from an a.-c. voltage, the tube acts as a rectifier. If we desire to get audio-frequency voltages from a modulated r.-f. voltage, the tube acts as a detector. If we desire to mix two frequencies, say a low audible frequency with a high or radio frequency, we put them both into a modulator. All of these uses require a non-linear characteristic. Detectors and

modulators have three elements just as amplifier tubes have. Tubes designed for rectifiers have only two elements, plate and filament.

266. Modulation.—Consider the circuit in Fig. 200. If the high-frequency generator is turned on and the low-frequency generator is shorted, high-frequency currents will flow in the antenna. Their amplitude will depend upon the amplifying ability of the tube and the amplitude of the applied grid voltage at this frequency. If the grid voltage is of constant amplitude and frequency, the plate current variations and hence

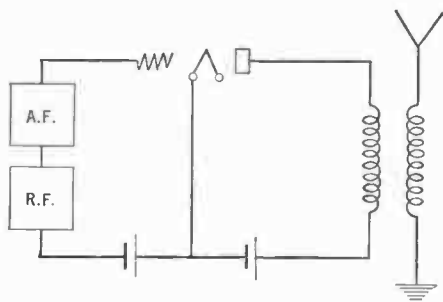

FIG. 200.—A simple modulator.

the antenna current variations will be of constant frequency and amplitude. Now let us turn on the low-frequency generator. The amplitude of the antenna current will vary and if the proper relations between the plate current and the grid voltage are satisfied the amplitude of the high-frequency antenna current will vary at the frequency of the low-frequency generator.

An idea of how the antenna currents look before and after modulation may be seen in Fig. 201. The high frequency is called the **modulated** or **carrier frequency**, and the low frequency is called the modulating or **side-band frequency**.

Let us call the maximum amplitude of the antenna current B , and its frequency f_c . Then the current at any instant will be $i = B \sin 2\pi f_c t$ in which the " $2\pi f_c t$ " takes the place of the phase angle θ but expresses the same thing exactly, namely the amount of time that has elapsed since the beginning of the cycle. Now instead of a constant maximum amplitude B let us vary this amplitude above and below B at some rate, say in the form of a sine wave. The maximum amplitude is no longer constant, but is equal to $B + A \sin 2\pi f_m t$ in which f_m stands for modulating frequency just as f_c indicates carrier frequency. The current at any

instant is a function of two factors, and may be expressed as $i = (B + A \sin 2 \pi f_m t) \sin 2 \pi f_c t$.

This process whereby a high frequency is varied in amplitude by a lower frequency is called **modulation**. The system outlined above is called **grid-circuit modulation**. Plate-circuit modulation is explained in Section 363.

The tube in such a process is called a modulator. Once the high-frequency wave is modulated, it acts as a carrier for the low frequency and wherever it goes it takes the modulating frequency with it.

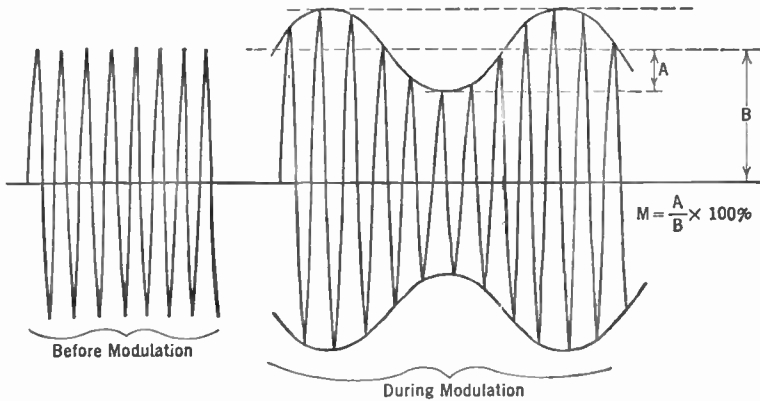

FIG. 201.—Unmodulated and modulated wave.

The depth to which the high frequency is modulated depends upon the relative maximum amplitudes of the two frequencies. If they are equal, the wave is said to be completely modulated, and the “percentage modulation” is 100.

267. Percentage modulation.—If the two peak voltages are not the same, the high-frequency wave will not be completely modulated, and the modulation will be less than 100 per cent. In broadcast transmission the modulation rarely exceeds 90 per cent. The greater the modulation percentage the further will the signals from a given station be heard and the greater will be the distortion arising from demodulators or detectors following a “square law.”

High-class receivers use diode detectors which operate on a

linear law and are supposed to cause much less distortion, especially on strong signals, than the older types of square law detectors.

In Fig. 201 is the carrier before and after modulation. The percentage modulation is defined as the ratio between A , the peak current of the modulating frequency, and B , the peak current of the non-modulated carrier. A glance at Fig. 201 will give a good idea of what is meant by the expression. When 100 per cent modulation is effected, the values of A and B are equal.

$$\text{Percentage modulation} = M = \frac{A}{B} \times 100 \text{ per cent.}$$

268. Demodulation.—If such a modulated wave is turned into a “demodulator,” the side-band frequencies can be got back. A demodulator, or detector, acts as though it were made up of two filters, of which one will not pass the high or carrier frequency and the other will not pass the low or modulating frequency. In the demodulator the two frequencies are separated.

A modulator, then, is a device for combining two frequencies. A demodulator, or detector, is a device by means of which we get back from the radio-frequency carrier the modulation or intelligence carrying frequencies.

269. A simple detector.—Let us consider the case of a device which has a response characteristic like XYZ in Fig. 202. When the voltage across it is as large as 4 volts, current begins to flow through it, and from then on the current is proportional to the voltage. Below this value, no current will flow. Now suppose we put an a.-c. voltage on this device. If the average value of the a.-c. voltage wave is at the point A , the same current flows when the voltage is positive or negative—the current wave looks exactly like the voltage wave, just as in the distortionless amplifier. But suppose the average value of the sine wave is at the point B . Then current flows only on the positive halves of the cycle. Such a device is a rectifier or detector and if the operating point is at the exact place where the current begins to flow (as at B), perfect rectification will result.

Now let us consider an unmodulated wave. When it passes into a perfect rectifier, current flows during the positive half-cycle

only. Then, if the normal steady current is zero milliamperes, when no a.-c. voltage is applied, this current will become some positive measurable value when the a.c. is applied because, though a meter cannot follow these spurts of current, it will take up some average value between the peak of the spurt and the zero value—which is the same as the normal no-signal value of the current.

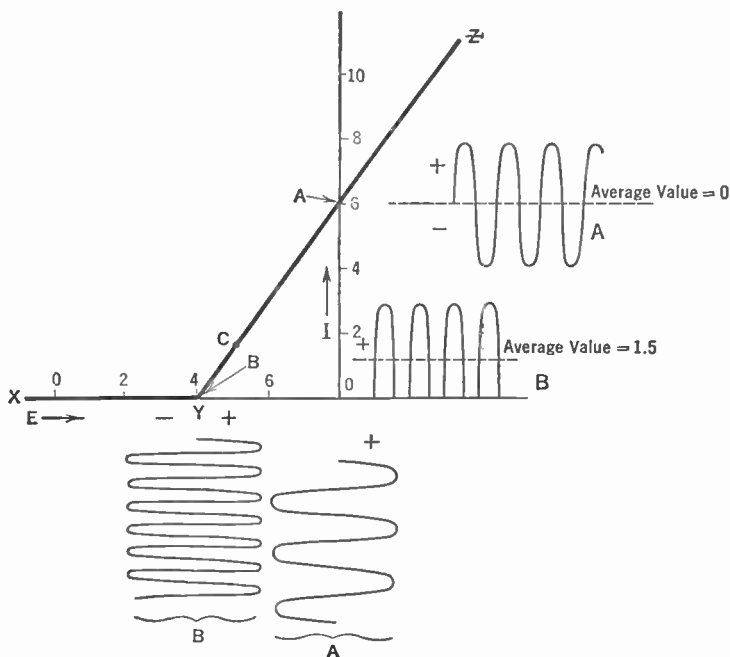

FIG. 202.—Rectification takes place when the operation is at (Y) but not at (A). Thus the plate current in (A) is similar to the input voltage while at (B) the output differs from the input.

In such a detector there is an increase in current when a.-c. voltages are applied. Now if the a.-c. voltage is modulated as in Fig. 203, the average value of detector current goes up and down in accordance with these modulations. This varying average value is the useful part of detection since it has the same form as the original modulating voltage and in a distortionless system is exactly

proportional to this voltage. This varying value occurs at an audible frequency.

270. The plate circuit detector.—The simplest tube detector is the plate circuit or *C* bias detector, that is, a rectifier which operates upon a curved part of the grid voltage plate current characteristic curve of a tube. It is not a perfect rectifier, but as greater and greater voltages are placed upon it the positive halves of the current waves are much greater than the negative waves,

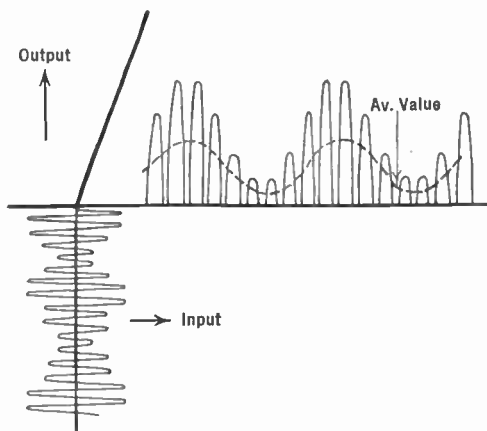

FIG. 203.—Rectification taking place about a non-linear part of a characteristic.

and so the average value of plate current due to rectification increases a corresponding amount. In this process, there are three points to note. First the very rapid radio-frequency variations in input voltage modulated at an audio rate. Each audio cycle is made up of thousands of radio-frequency cycles—only a few of them are shown in the diagrams, for simplicity. When this voltage is placed upon a curved part of the plate curve, the difference between the positive and negative current waves takes the form of the audio variations. Because these positive and negative portions differ in amplitude, the average between them is not zero and therefore the plate circuit contains a current of the frequency of the audio signals. In this process there is an increase in average d.-c. plate current when the input wave is modulated. The plate current meter cannot follow the change in audio plate current and does not indicate whether or not the carrier is being modulated.

271. Detection of modulated wave.—Suppose for example we connect antenna and ground to the grid and filament input of

a tube. A nearby station is putting into the ether an unmodulated wave. As soon as we tune to this station's frequency a voltage is developed across the input circuit to the tube; this a.-c. voltage fluctuates the grid voltage, and a change takes place in the average value of the plate current. If the station is powerful enough, and if it is modulated with a key—that is, if its antenna current is started and stopped in accordance to some code—we can use a sensitive relay in the plate circuit of our detector and either read the signals directly from the relay or operate a telegraph sounder with it, or light a lamp, or fire a gun or do anything else which it is required to control by radio. If the transmitted frequency is 1000 kc. it may be necessary to tune the input of the tube to this frequency. A pair of telephones in the plate circuit of the detector, in place of the relay, will indicate by means of clicks when the transmitter started and stopped the antenna current but would not give off any sound in the middle of dots and dashes. If, however, we operated a buzzer with the relay we could read the signals by the audible sound of the buzzer.

We can get around the difficulty of needing a receiving buzzer by having a buzzer or "chopper" at the transmitting station. Now when the key is pressed, the modulated 1000-kc. wave is sent into the ether. If the modulator tone, say 1000 cycles, has a maximum amplitude equal to the maximum value of the 1000-kc. voltage, the antenna current will be doubled 1000 times a second when these two voltages will be in phase. At 1000 other instants the two voltages will be out of phase and the antenna current will be reduced to zero. Across the receiving tube is a 1000-kc. voltage broken up into 1000-cycle sections—modulated as we say.

Now if we place a pair of telephones in the plate circuit of the detector tube, it will offer a certain amount of impedence to these 1000-cycle sections of 1000-kc. currents. A voltage will be built up across the telephones, and our ears will tell us that 1000-cycle signals are being received. The d.-c. plate current meter will still indicate an increase in average plate current when the transmitter key is pressed, but of course its needle cannot follow the 1000-cycle variations. Neither will a relay indicate that the 1000-kc. input is modulated, because it is too sluggish to follow the variations,

but it will indicate the average of each section and will close when the key is pressed. The telephones, however, will respond to frequencies as high as 10,000 cycles per second.

If, now, we use a microphone at the transmitter instead of a constant peak amplitude source of tone, like a buzzer, and talk into it the voltage variations impressed on the 1000-ke. voltage may be very complex, perhaps something like Fig. 203 for example. Telephones in the output of the detector will respond to these modulated sections of 1000 kc. while the r.-f. currents will be by-passed or will go across the capacity between the phone windings. Hence the telephones will give off a note or sound corresponding to what was put into the microphone. If, in the process of detection, other audio frequencies are generated, distortion results, because the audio components heard in the telephones are no longer exact replicas of what was put into the microphone. Fortunately these additional frequencies, the strongest of which are of double the original audio tone, are of small amplitude provided the detector is properly operated, and so the tone as heard from the telephone sounds exactly like that put into the microphone.

The process of detection by means of the bend in the plate current curve is essentially one of distortion, in which the r.-f.

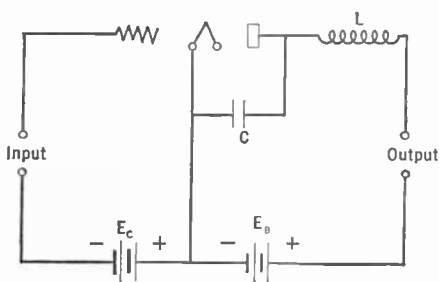

FIG. 204.—To keep radio-frequency currents from the output, a low impedance path (C) and a high series impedance (L) are used.

wave is distorted and out of which we get the audio wave by placing some audio-frequency impedance in the plate circuit of the detector. Usually the plate circuit has a low impedance to the r.-f. a.-c. plate currents, that is, they are by-passed as in Fig. 204, and sometimes an additional precaution is taken to prevent any r.-f. voltages from being built up across the audio impedance in the plate circuit. For example, in Fig. 204 a choke, L , is used.

prevent any r.-f. voltages from being built up across the audio impedance in the plate circuit. For example, in Fig. 204 a choke, L , is used.

272. Conditions for best detection.—There are several variable factors in such a detector circuit as shown in Fig. 204. One is the grid bias, E_c , and the other is the plate voltage. Some combination of these two voltages will create the greatest amount of a.-f. voltage across a given impedance when a given r.-f. voltage is put on the grid. The C bias is governed to some extent by the amplitude of the r.-f. voltages to be put on the grid of the tube.

If an r.-f. voltage of 1 volt maximum is to be impressed on the grid of the tube, a C bias of slightly over this value will take care of the signals and offer a certain margin of safety. The problem then is to find the plate voltage that will put the operating point at a place of great sensitivity. Values for an ordinary tube of the 201-A type are about minus 4.5 with a plate voltage of 45 and minus 9 with a plate voltage of 90.

In such a detector the greater the r.-f. voltage the greater the change in average plate current and the greater the audio signal in the output load. With a given r.-f. voltage the audio signal will be proportional to the amount of modulation at the transmitter. That is, as the power from the radio oscillator at the transmitter is varied by the voltage coming from the microphone, the audio notes at the receiver should vary in exact proportion to the microphone notes.

Otherwise there is distortion. The audio notes of a given modulation vary approximately as the square of the r.-f. voltage when the latter are small. That is, doubling the radio-frequency voltage across the antenna will result in multiplying by 4 the audio tones from the detector. Actually the square law holds only over the certain small part of the plate current curve, for example: for low input signal voltages. The law is less than a square function for large input voltages. The change in d.-c. current (increase) is independent of the modulation and a meter in the plate circuit will not tell whether or not the r.-f. input is being modulated.

273. The vacuum tube voltmeter.—The detector may be calibrated and used as an a.-c. voltmeter. Such vacuum tube voltmeters are useful at all audio and nearly all radio frequencies, and can be made to read d.-c. voltages. The range of voltages that can be measured is very large, the upper limit being the voltage the

tube can stand without breaking down, and the lower limit depending upon the sensitivity of the indicating instrument.

The principle of such devices is simple. The operating point is chosen, by adjusting the C bias and the plate voltage, so that it is on a point of considerable curvature. When an a.-c. voltage is put on the grid, rectification takes place in the plate circuit, and the d.-c. part of the rectification product is read on a d.-c. instrument. If the voltmeter is properly biased, its input resistance is very high and it takes so little power from the device whose voltage is being measured that it may be considered as having no effect upon the circuit.

The choice of C bias depends upon the input voltages to be measured. Let us suppose we are to measure a peak voltage of 5 volts. Clearly the C bias cannot be less than this because of the decreased input resistance when the grid draws current and the effect of such a meter upon the circuit under measurement. The C bias would be some value over 5 volts, 6 for example. The next step is to fix the plate voltage. This is determined by the range in input volts to be measured, and the kind of instrument used to read the d.-c. current. For greatest accuracy E_p should be such that the greatest deflection of the current meter will be obtained by the given input voltage. In general a voltage range of about 5 to 1 is all that can be read with an ordinary voltmeter, that is, from about 0.5 volt to 3.0 volts. The problem then is to choose a plate voltage that will enable the desired range to cover completely the scale of the meter being used.

For measurements of average voltages, say up to 10 or 15 volts and as low as 0.5 or 1.0 volt, a microammeter reading 200 microamperes and costing about \$35 is a good instrument. A small laboratory model of milliammeter reading 1.0 or 1.5 milliamperes can be used although the accuracy of measurement will not be so great as with a more sensitive instrument.

274. Adjusting a voltmeter.—What is desired is the greatest change in plate current with a given a.-c. voltage. In Fig. 205 are some curves taken with a 3-volt, 60-milliamper tube, showing the plate current at various values of a.-c. grid voltage and at various values of plate voltages. The change in plate current, that

is, the value *with* a.-c. input voltage minus the value *without* input, is plotted and shows the futility of using plate voltages greater than 35 volts when sensitivity is the criterion.

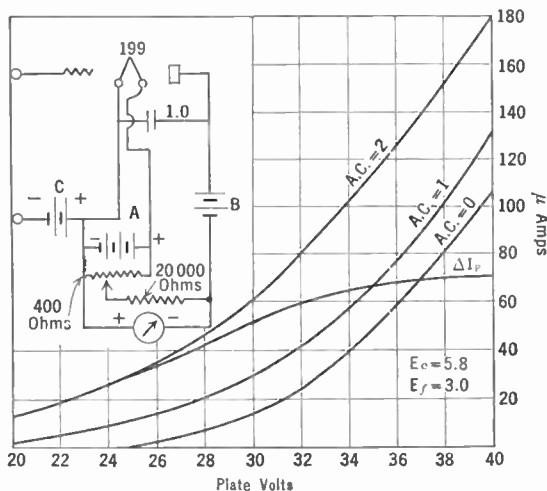

FIG. 205.—Calibration and circuit of vacuum tube voltmeter

Because the tube takes some plate current even when there is no a.-c. grid voltage, part of the scale of the d.-c. meter is taken up with this steady reading. This reading can be balanced out by means of the zero adjuster on the meter, or by using another current through the meter in such a direction that the original plate current is "bucked out." The whole meter scale is available then for plate current changes occurring under input grid voltage excitation. Such a balancing out voltage may come

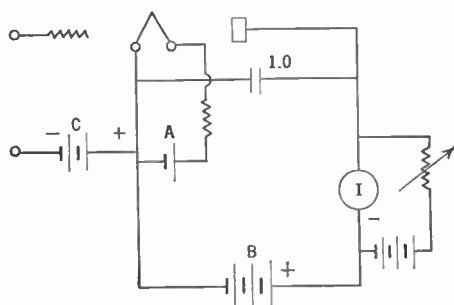

FIG. 206.—Method of balancing out the steady plate current from the indicating meter.

from an additional battery and adjustable resistance, as in Fig. 206, or from the voltage drop across the tube filament as in Fig. 205.

Experiment 1-14. Use of the Vacuum Tube Voltmeter.—There are two types of vacuum tube voltmeter: the *C* bias type and the grid leak and condenser type. The latter is more sensitive but draws current from the device whose voltage is being measured. Both types should be experimented with. They are the most versatile and useful of all radio instruments.

Connect up a *C* bias voltmeter using a 0-5 milliammeter in the plate circuit, about 45 volts on the plate, and add sufficient *C* bias to decrease the plate current to nearly zero. Then use a more sensitive plate current meter, and a bucking battery to reduce the deflection to zero. Calibrate the meter by putting known currents through known resistances at 60 cycles or at any radio frequency. With 45 volts on the plate and about 9-13 volts *C* bias with average tubes, voltages as low as 1.0 will give a good deflection and peak voltages up to about 7.0 can be read on a meter reading about 1.0 milliamperere.

Fairly accurate calibration may be performed by using the voltages available from a filament current transformer, that is, 1.5, 2.5, and 5.0, and of course combinations of these voltages depending upon how the windings are connected together.

Connect the voltmeter across the tuned circuit of a radio-frequency stage, or across the coil-condenser combination that can be coupled to an oscillator. Tune the condenser and note how the voltage across the coil increases through resonance. Insert some resistance into the tuned circuit and repeat. Note how much broader the resonance curve is and how the minimum voltage has decreased.

Connect the voltmeter across the resistor of a resistance-coupled amplifier tube—inserting a large capacity between the plate terminal of the amplifier tube and the grid of the voltmeter so that the d.-c. voltage across the resistor will not bias the grid of the voltmeter. Apply a known voltage to the input of the amplifier and measure the output voltage. Then change the plate resistor and again measure the output voltage. Plot a curve showing amplification against plate load resistance.

Place the voltmeter across the secondary of an audio transformer and apply a known voltage in series with a resistance of about 15,000 ohms and the primary. Measure the turns ratio of the transformer at 60 cycles or some other frequency by measuring the secondary voltage.

These are but a few of the many experiments that can be performed with the vacuum tube voltmeter. It can be used to measure field strength of distant transmitters, resistance of coils, amplification of amplifiers, resonance curves, frequency characteristics of amplifiers, etc.

275. D.-c. plate current as a function of a.-c. grid voltage.—The vacuum tube voltmeter is really a *C* bias or plate circuit

detector, and the change in plate current is a function of the a.-c. voltage on the grid. It is only necessary to calibrate the detector, using any source of a.c. and any standard a.-c. voltmeter as a standardizing voltage, or a known current can be passed through a known resistance and the voltage drop used for calibration.

The detector in one's radio is also a vacuum tube voltmeter although it is not so calibrated. If a sensitive meter, say reading up to 1 milliampere, is placed in the detector plate circuit of any radio receiver, changes in the reading will be noted when a strong signal is tuned in. If the detector is a grid leak and condenser type, the reading will decrease. If greatest sensitivity is desired, the steady no-signal current may be balanced out and then a sensitive microammeter may be used. The changes in this meter reading may serve as a measurement of fading, signal strength, etc. No change will occur unless the r.-f. voltage on the input to the tube changes. Modulation will not cause any change unless the transmitter is over-modulated. Generally speaking an r.-f. signal at ordinary modulation percentages causing a change in detector plate current of 100 microamperes will, with two stages of audio amplification, deliver a good loud speaker signal.

276. Detection in a radio-frequency amplifier.—Because the r.-f. stages of a receiver are biased, it often happens that some detection takes place in one or more of them, probably in the first. What happens is something like the following: the first tube is so biased, and may have such a low load impedance in its plate circuit at the frequency under consideration that the operating point is on a part of considerable curvature. Now a strong signal comes in, a large a.-c. voltage is impressed on the r.-f. grid and detection is the inevitable result. A pair of receiving telephones in the plate circuit of this tube would have an audio-frequency voltage across them, due to the rectified voltage, and would give an audible response.

For example suppose the receiver is tuned to a frequency of 600 kc. This means that the load impedance in the plate circuit of the r.-f. amplifiers will be high at 600 kc. but low to all other frequencies. The tube will have a curved characteristic to any signal of higher frequency than this. A powerful local station on

some other frequency puts a strong signal on the grid of the r.-f. tube, and the rectified voltages modulate the r.-f. voltage of the 600-kc. wave so that what gets into the second r.-f. stage is a 600-kc. signal modulated with what is going on at the studio of the other station. The modulation of the distant station may be inaudible.

A wave trap tuned to the offending local station is a good remedy for such trouble.

277. Grid leak and condenser detector.—In the plate circuit detector, we may look upon the signal as having first been amplified by the tube and then as going through the detection process when it reaches the plate circuit. There is little amplification in such a tube at r.f. because of the low plate circuit resistance at r.f.

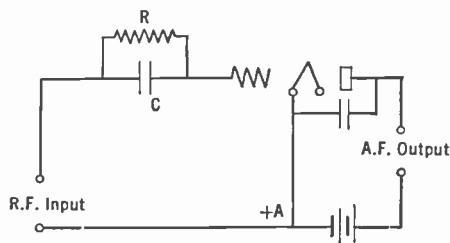

FIG. 207.—Grid leak-grid condenser detector.

The once used grid leak and condenser detector shown in Fig. 207 is more sensitive and more complex in theory but has limited power handling ability. It is seldom used in high-class receivers. In this case we may think of the r.-f. signal as going through the demodulation or detection process in the grid circuit of the tube and then having the resulting audio tones amplified in the plate circuit just as in an ordinary amplifier. Because of this amplification, this type of detector is more sensitive than the *C* bias type.

Such a tube detects on its grid-current curve, and so the grid voltage must be such that the operating point is on a curved part of the grid-voltage-grid-current curve, and because it amplifies on its plate-current curve the plate voltage must be fixed so that the operating point is on a straight part of the plate-current curve.

The grid current plotted against grid voltage of a typical tube is given in Fig. 208. It will be noted that even though the grid is negative a certain amount of grid current flows. This is due to the few electrons which leave the filament with sufficient velocity

to get to the plate even through the negative retarding force of the grid. This grid current must flow through the grid leak, usually of the order of from 1 to 10 megohms. The voltage drop across this resistance is such the the grid end is negative with respect to the filament even though the "grid return" is connected to the

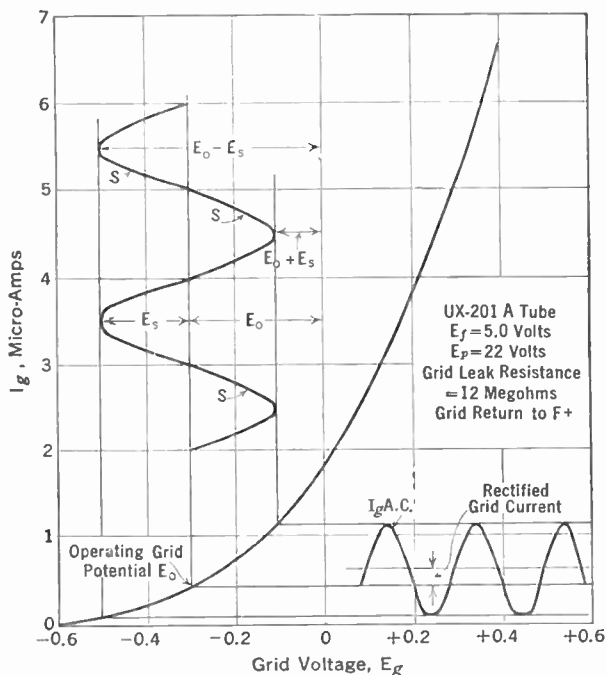

FIG. 208.—Rectification on the grid voltage-grid current curve.

positive end of the filament battery. The value of the grid leak fixes the point on the grid-current curve at which the input signals operate. In Fig. 208 the operating point is about 0.3 volt negative.

Because the grid leak is effectively across the tuned circuit feeding the detector it is important that the value in resistance be high if any selectivity and gain are to be secured in the input tuned circuit. Otherwise the shunting effect will make a very broad circuit.

278. Effect of grid leak and condenser values.—Changes in grid leak value produce no other change in the detector action than is produced by changing the operating point. This is the entire purpose of the grid leak. The purpose of the grid condenser is to by-pass the high resistance so far as r.-f. currents are concerned so that the greatest possible r.-f. voltage may be built up across the grid-filament input of the tube. If the condenser is too small, there will be an appreciable r.-f. voltage loss in it, and the tube will not get all possible of the input signal. If the grid condenser is too large, the audio-frequency voltages built up across the grid leak will be by-passed. The grid condenser with modern types of tubes should never be greater than 0.00025 mfd. and a value of 0.0001 may be used satisfactorily. Smaller condensers than this produce some loss in r.-f. voltage, and result in decreased sensitivity.

279. Detector action.—When an input signal is applied to the tube the grid voltage changes in accordance with the incoming signal just as it does in the case of an amplifier or a plate current detector. These changes in grid voltage produce a change in grid current in accordance with movements up and down on the curve of Fig. 208. Because of the curvature the grid current increases more when the grid is positive than it decreases during the negative half-cycles of input voltage. The result is a net change in grid current, in this case an increase. This increase in grid current produces an increased voltage drop across the grid leak and a greater negative voltage in the grid. This increase in bias causes a *decrease* in plate current. It will be remembered that an input signal caused an *increase* in plate current in the plate circuit detector. These audio grid current changes produce corresponding plate current changes whence they are passed on to the audio amplifier.

In practice, then, modulated r.f. voltages are put on the input to a detector; within this detector the modulations are separated from the carrier that brought them to the receiver; and finally these modulations in the form of a.f. frequencies are applied to a plate-circuit load—usually the input to an a.f. amplifier.

How this separation of carrier from modulation takes place, and how much a.f. one gets out of a given detector with a given input

modulated at a given percentage may be determined experimentally as follows. We may fix upon some grid bias voltage, e.g., in the case of a 27 tube about 18 volts with a plate voltage of 180. Then we can put on the input to this tube, operating as an overbiased amplifier, or detector, various alternating voltages which need not be at radio frequencies. These input voltages

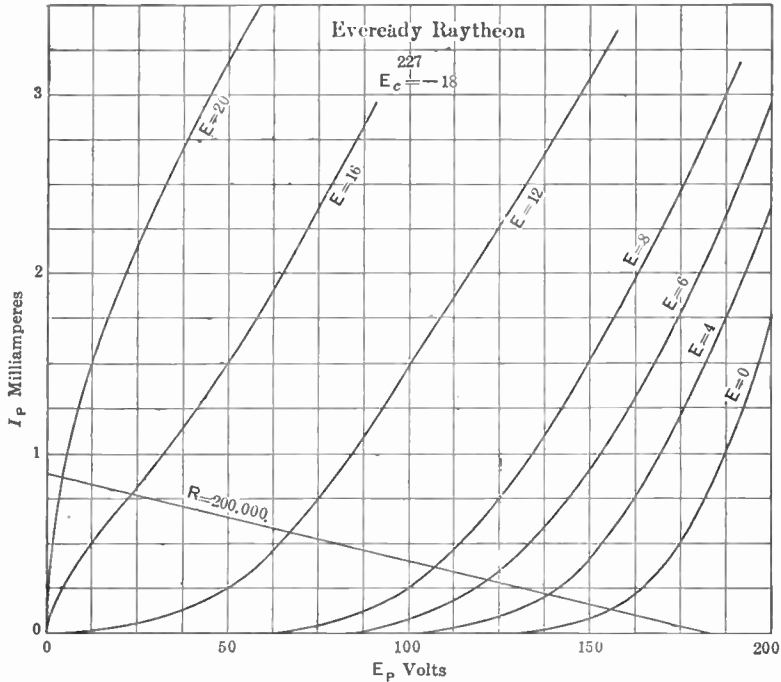

FIG. 209.—Plate current curves as controlled by plate voltage and input carrier voltage applied to grid.

cause some change in plate current which may be read with a fairly good milliammeter. All that is needed then to experimentally determine the detection characteristic of a C-bias detector is a source of known alternating voltages and a good milliammeter.

Such a series of curves are shown in Fig. 209. For example with 100 volts on the plate, an input alternating voltage of 12 produces

a plate current of 1.5 milliamperes. Across such a family of curves a load line (see Section 186) can be drawn for any load resistance, in this case 200,000 ohms. This is about the highest resistance load that can be used because of various capacities which will shunt it and reduce its impedance at the higher audio frequencies.

The rectified output voltage of the detector, e.g., the a.f. voltage applied across the 200,000 ohm resistor and hence to the input of the a.f. amplifier, can be obtained from such a curve. For example with an input of 12 volts ($E = 12$) the rectified voltage may be found by noting the intersections of the load line with the $E = 0$ line and with the $E = 12$ line. Thus the rectified voltage is the difference between $E_p = 156$ (intersection with $E = 0$) and 66 (intersection with $E = 12$) or 90 volts. Taking several of such voltages a curve like that in Fig. 210 can be plotted.

Now this curve gives not only the rectified voltage due various values of carrier voltage but by knowing how strongly this carrier is modulated, the actual a.f. voltages applied across the load resistance may be ascertained. For example, if the plate voltage is 300 and $E_c = 27$ volts, suppose a carrier voltage of 12 is modulated 33 per cent. The carrier voltage will then vary between

$12 - (12 \times 33 \text{ per cent})$ and $12 + (12 \times 33 \text{ per cent})$ or between 8 and 16 volts.

These values of carrier voltage represent rectified voltages of 47 and 124 and because the carrier swings as far up as it does down from its unmodulated value of 12, the audio voltage produced by these

variations is $\frac{124-47}{2}$ or 38.5 volts.

280. Power detection.—

Because of distortion and hum arising in the audio

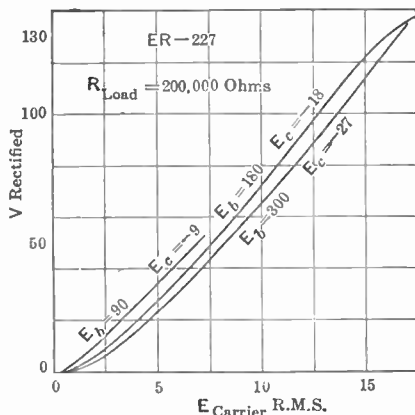

FIG. 210.—Plate rectification "power" detector characteristic.

amplifier and for other reasons it has become standard practice to use much amplification at radio and intermediate frequencies and

not so much at audio frequencies. Many receivers have been built with but a single stage of audio, the power stage, which is driven by the output of the detector, usually a heavily biased triode or screen-grid tube with high plate voltages. Such a tube will tolerate high input voltages and will turn out high audio voltages suitable for driving the final power stage.

With the realization that distortion of rather high order often occurs in older detectors and that true linear detection may be obtained from diodes, many designers used a triode with its grid and plate or plate and cathode connected together to act as a diode. Introduction of combined diodes and triodes, or pentodes, in the same envelope made simpler the method of getting diode detection.

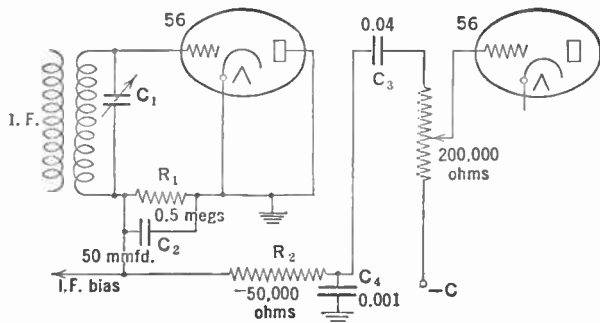

FIG. 211.—Typical diode detector circuit.

For example, Fig. 211 shows a 56 type tube acting as a diode detector. Intermediate-frequency voltage is applied to the grid and through C_2 to the plate-cathode forming the second element of the diode. When the positive half-cycles are applied to the grid, current will flow to the grid but not when the cathode is positive. Therefore complete rectification is obtained. In this process the audio voltage is built up across R_1 by the grid currents flowing through this resistor. This voltage is applied to the following tube through R_2 and C_3 . To prevent loss of i.-f. voltage in R_1 it is by-passed by C_2 , and to prevent i.-f. currents from getting into the a.-f. amplifier they are filtered by the high impedance of R_2 and the low impedance of C_4 .

In Fig. 212 is a more complicated detector circuit. Here a 55 acts as diode detector, a.v.c. tube, and at the same time suppresses all noise when the receiver is tuned to dial positions intermediate between station channels.

Both diode plates of the 55 are used, one to provide detection, the other to supply a.v.c. This second grid is driven with r.f. (or i.f.) by means of a small condenser connected to the input. The grid of the triode section of the 55 gets its bias from the detector diode; the a.-f. input comes from this circuit too. When no signal comes to the diode, as when the set is tuned between

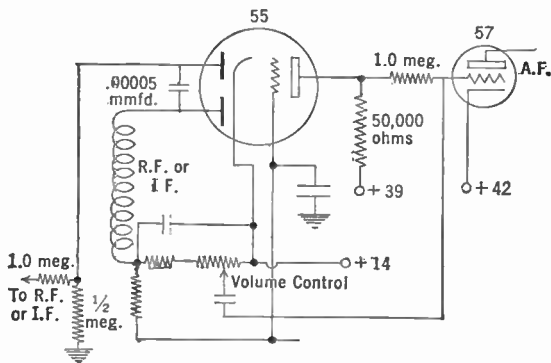

FIG. 212.—Detector, a.v.c. and intercarrier noise suppressor.

stations, there is no bias and the plate current of the triode is high. This current flows through the 50,000 ohm plate resistor, producing a high voltage across it. The grid of the a.-f. tube gets some of its bias through this resistor and therefore is biased to cut-off under these conditions.

Now when the receiver is tuned to a carrier, some bias voltage is generated, the grid of the triode is biased, less plate current flows, less bias is on the a.-f. tube and therefore it can amplify.

Note that the cathode of the 55 is not at ground potential but has a positive bias of 14 volts. The diode is negative and therefore there will be no production of rectified current until this bias is

overcome by the incoming signals. This is known as **delayed a.v.c. system**. This means that the production of a.v.c. voltages

is prevented until incoming signals are sufficiently great to overcome an initial bias on the detector. Therefore signals which are too weak to get up above the noise level will not operate the receiver because they will not free the a.-f. tube from its excessive bias.

281. Modification of a.v.c. systems.—There are more complicated a.v.c. systems than have been described here. A separate i.-f. channel may be used to provide the final voltages which are rectified to provide a.v.c. The a.v.c. signal voltages (separate rectifier) may come from a point in the circuit different from that to which the audio detector is connected. There may be less selectivity

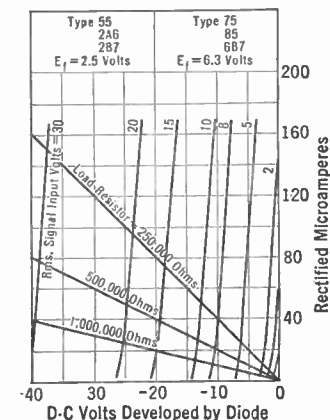

FIG. 213.—Diode characteristics. Fifteen r.m.s. volts input produces about 20 peak output volts with a load of one megohm.

ahead of the a.v.c. than preceding the detector. Thus when the receiver is not tuned to exact resonance there will be less noise than is usually encountered. This is due to the fact that the less selective circuits will deliver a larger voltage to the a.v.c. tube and therefore the amplification ahead of the audio detector will be decreased.

CHAPTER XV

RECEIVING SYSTEMS

THERE are two general types of receiving circuits in use: (1) the tuned r.-f. receiver; and (2) the superheterodyne. There are other systems such as the simple regenerative circuit of many types, and the super-regenerator in which the circuit is allowed to build up almost to the oscillation point and is then quenched. The simple regenerative set has almost passed out of existence; the super-regenerator has not as yet come into wide use.

282. The tuned radio-frequency set.—This type of circuit was once most popular. Until the owners of the superheterodyne patent permitted its wide use, the tuned r.-f. set was the only one that could be generally sold. It suffered from various faults; poor selectivity at high radio frequencies, and excessive selectivity and low gain at the lower frequencies. Until the Neutrodyne was exploited the t.r.f. set was unstable and had low sensitivity.

For a time this circuit was not so popular as the super; then the desire for very small inexpensive sets coupled with the development of better tubes and some circuit features brought the t.r.f. set back into popularity.

283. The superheterodyne.—The double detector or superheterodyne circuit operates on a very interesting principle. It has inherently more sensitivity than the t.r.f. set and is more selective.

The stage gain possible, with stability, at broadcast or higher frequencies is not sufficient to make a really sensitive receiver unless several stages are employed. For a number of reasons much greater amplification can be obtained at lower signal frequencies. If, then, we can change an incoming frequency of say 1000 kc. to 100 or even 50 kc., we can get as much amplification in

two stages as are obtained from four stages at the original frequency. This means simplification in apparatus, and because of the lower frequencies the problems of stability and shielding are also simplified. An additional advantage lies in the constant band width passed by the amplifier, regardless of the frequency of the incoming signal. How is such a frequency change performed?

284. The phenomenon of beats.—Suppose two loud speakers are attached to two oscillators, one generating a 1000-cycle tone and the other an 1800-cycle tone. When these two tones enter the ear, the listener hears not only the two individual tones but an 800-cycle tone too. If one of the two original tones is modulated at another frequency, say 50 cycles at a given per cent, this 800-cycle tone will be so modulated. By turning this modulated 800-cycle tone into a demodulator, the 50-cycle modulations can be got back.

The two frequencies above are said to **beat** with each other and the difference frequency is called the **beat note**. If the two oscillators are adjusted so that they are at **zero beat** they have the same frequency and no beat note will be heard. In addition to the two beating frequencies and the difference of the two (the difference or beat frequency) there is a third frequency generated. This is the sum of the two beating frequencies. It is called the **sum frequency**. Thus in the above case there are in the ear 1800-, 1000-, 800- and 2800-cycle tones.

Now suppose we are receiving a 1000-ke. signal and want to turn it into a 100-ke. signal. All we need is a local oscillator which turns out either 1100-ke. or 900-ke. signals. We turn these two signals into a mixing tube where the difference or beat frequency is generated, put its output through a filter which cuts off everything but the 100-ke. signal (which is now modulated at the same modulations as the incoming 1000-ke. signal), and amplify it in an **intermediate-frequency** amplifier. After sufficient amplification has been attained the 100-ke. signal is put through a demodulator and the original microphone modulations secured. These frequencies can be put through an audio-frequency amplifier of conventional design and the output finally put into a loud speaker. The system is shown in Fig. 214.

285. Superheterodyne design.—Some superheterodynes use a stage or two of radio-frequency amplification ahead of the frequency changing system; others do not. Some have sufficient amplification so that the input voltages are taken from a small loop; others require an antenna of conventional form and size. Some have one, two, or three stages of intermediate amplification. In some the function of oscillation and frequency mixing goes on in the same tube; in others these functions are separate. Some systems amplify the sum of the two beating frequencies; most of them utilize the difference frequency. Some have high and some

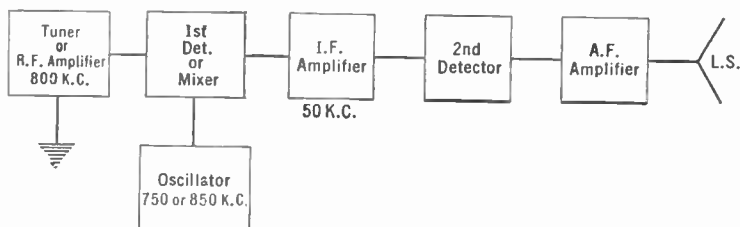

Fig. 214.—Symbolic diagram of superheterodyne.

low intermediate frequencies. Some use *C* bias detection and some use grid leak and condenser detection. Some use air core and some iron core intermediate transformers. And so on. Every designer has his own ideas of which is best, or which avoids patents held by some other designer. In one receiver of this type the beat frequency was secured from mixing a locally generated second harmonic of the incoming frequency with the signal frequency.

In all of the double detector receivers, the signals must first be received and usually tuned—whether amplified or not—at the frequency of the incoming signals. Then the mixing with the local oscillator goes on, either in a separate tube—the first detector—or in the oscillator tube, and then the unwanted products consisting of the beating frequencies, etc., are filtered out. There need be no more than two dials, one tuning the input circuit to the incoming signal, the other tuning the oscillator within the required intermediate frequency of the incoming signals. This produces

the beat frequency which is passed through the intermediate amplifier.

Modern design has eliminated one of the dials, so that both the tuning process and the adjusting of the oscillator to produce the required difference frequency are controlled by the same dial.

286. Modern superheterodyne practice.—This circuit has changed greatly since the days when it first came into popularity. For years permission to use the circuit was not granted by the owners of patents governing it; when it had once been thrown open it soon superseded other types of circuits. The reasons are simply that it is more selective and more sensitive than other circuits for the same wave bands and for the same expense in circuit apparatus. Competition among many companies, technically and economically, brought rapid development to the circuit until receivers are made of all degrees of complexity.

Supers have been made with very few tubes, for example, a frequency changer operating through an interstage transformer directly into the second detector and thence to a pentode output. The antenna circuit gain added to the voltage step-up in the i.-f. transformer, plus regeneration in both detectors, provides the only amplification. Supers have been built of many tubes, composed of elaborate preselector circuits with or without gain, several i.-f. stages, diode detection with a.v.c. on the frequency changer as well as the r.-f. and i.-f. tubes, intercarrier noise suppression and finally audio amplifiers of various sorts.

It is generally believed that a certain amount of selection at radio frequencies must take place before the frequency is changed. This lowers the noise compared to the signal by narrowing the band of frequencies that are admitted to the receiver. This preselection may take the form of tuned circuits without tubes and, therefore, with little or no voltage gain. Then comes the first detector, and parallel to it, or perhaps in the same tube, is the oscillator. This is followed by two interstage transformers with a tube between, sometimes two tubes and another transformer and then the demodulation process and a.-f. amplifier.

Considerable use has been made of antenna coils in which the primary has a high inductance tending to resonate the system to a

frequency below the lowest radio frequency to be received. This brings up the sensitivity of the receiver at the lower end of the tuning range and flattens out the reception characteristic.

Radio-frequency coils are usually made of Litz wire to sharpen these preselecting circuits. The intermediate stages are sometimes of Litz, but in general more than sufficient selectivity is obtainable at intermediate frequencies with solid wire coils. Oscillator circuits have been worked out which give uniform output over the tunable range. The i.-f. coils are often tuned both

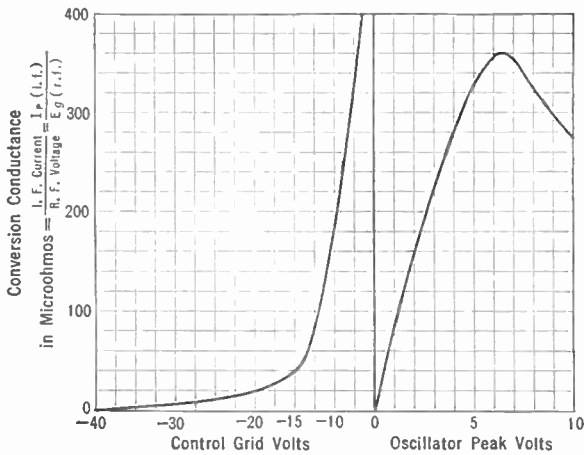

FIG. 215.—First detector characteristics—type 35 with 250 volts on plate, 90 volts on screen. Left curve with oscillator voltage of 4.6 rms.

on the primary and secondary sides in an effort to broaden out the top of the response and not cut high frequencies too much.

The curve in Fig. 215 gives a new type of measurement, the ratio of the i.-f. current in the first detector plate circuit to the r.-f. signal voltage on the grid. This gives a measure of the efficiency of the 35 variable- μ tube, as a frequency converter. The figure also shows the ability to control the sensitivity of the frequency-changing function by increasing the negative bias on the grid of the tube. This function may be automatically controlled by the strength of the incoming signals.

287. Repeat points.—Early receivers suffered from many faults. The ability, or the curse, of getting a given station at more than two points on the tuning dial was one of these faults.

Suppose that the beat or intermediate frequency is 50 kc. and that a station on 600 kc. is to be received. Now the oscillator can be set at either 600 plus or 600 minus 50 kc. to produce the required beat frequency which will carry with it the modulation into the i.-f. amplifier. Therefore, the operator can tune in the desired station at two points on his oscillator dial.

This trouble is avoided by tuning the input to the set at the same time that the oscillator is tuned and making the input circuits so sharp that when the input is tuned away from the 600-kc. station by twice the intermediate frequency such a small voltage will get into the receiver that the signal will not be heard.

It is general practice to make the oscillator generate frequencies higher than the incoming frequency. Thus if the intermediate frequency is 50 kc. the range will be from 550 plus 50 kc. to 1500 plus 50 kc. or the oscillator will tune from 600 kc. to 1550 kc. at the same time that the input circuits are tuned from 550 to 1500 kc.

As a typical example suppose that an 800-kc. station is to be received. The input will be tuned to this frequency; the oscillator to 850 kc. But if the input is tuned to 700 kc. and the oscillator to 750 kc. the required difference of 50 kc. will exist between the 800-kc. station and the local oscillator. Therefore, unless the input circuits are sharply tuned so that the station will produce little voltage when the set is tuned 100 kc. away from the station, trouble will exist with repeat points.

Furthermore, consider the set tuned to 800 kc. (oscillator to 850 kc.). Now suppose a local station to be operating on 700 kc. Between this undesired station and the oscillator will be a 50-kc. difference, and unless there is sufficient selectivity in the input both stations will be heard. This is called "image frequency" trouble, the channel differing from the desired station by twice the intermediate frequency being called the image frequency.

There is still another cause for repeat points. If the oscillator generates harmonics, they may heterodyne a higher frequency incoming signal according to the following reason. Suppose the oscillator is set at 600 kc. but generates a strong second harmonic,

1200 kc. This harmonic will provide the proper 50-kc. beat note with either a 1150- or a 1250-kc. station at the same time the fundamental heterodynes a 550 or 650 station. Such harmonics can be reduced by making the oscillations feeble, by reducing the plate voltage or by placing a large resistance in the plate circuit to make its characteristic straight, or by giving the grid the proper bias.

Let us suppose, however, that the beat frequency is 600 kc. The oscillator frequency range must be from 550 plus 600, or 1150 kc., to 1500 plus 600 or 2100 kc., and there will be no repeat points due to heterodyning two incoming signals to give the required 600-kc. beat frequency.

The use of a radio-frequency amplifier ahead of the frequency system will provide considerable discrimination against unwanted stations. It must be tuned to the required station at the same time the oscillator is tuned so that it gives the required beat frequency. Increased selectivity in the r.-f. amplifier will provide selectivity not only against image frequencies, but also against stations differing from the desired station by the intermediate frequency, and will add something to the "adjacent channel" selectivity which is largely secured from the i.-f. amplifier.

Thus it has become standard practice to use one or more stages of tuned radio frequency ahead of the frequency changer in high-class supers. There are still other sources of interference, for example harmonics of the oscillator heterodyning undesired stations or harmonics generated in the second detector, etc.

288. Choice of intermediate frequency.—When preceded by some preselection, the chance of image-frequency trouble decreases as the intermediate frequency increases. At the same time the chance of trouble from stations separated from the desired station by the intermediate frequency is decreased. For these reasons it is desirable to have a high intermediate frequency.

With a low intermediate frequency the chances of harmonic troubles due to energy from the second detector getting back to the input of the set are lessened because only the higher, and weaker, harmonics would fall in the broadcast band. At the same time, lower frequencies are amplified better in the i.-f. amplifier. And, finally, more selectivity against adjacent channels can be obtained if the intermediate frequency is low.

All manner of beat frequencies are used, going from 175 kc. to several hundred kilocycles, depending upon the manufacturer, the type of set, the input frequencies to be received, etc.

289. Selectivity of superheterodynes.—The curves in Fig. 216 show the degree of selectivity obtained in the r.-f. and the i.-f. systems of a good super. It will be noted that the selectivity gained in the i.-f. amplifier is greater than that secured at the incoming frequency. This is due to the fact that 10 kc. is a small part of the incoming frequency; but it differs by quite an amount from the intermediate frequency. The image-frequency ratio of high-class sets is about 100,000 to 1. This is the voltage required to produce the same output as the desired signal but differing from it by twice the intermediate frequency.

290. Frequency changers.—Any tuned r.-f. receiver can be converted into a superheterodyne by the addition of an oscillator and a mixing tube. In such a system the r.-f. amplifier is used as the intermediate-frequency amplifier, and is set to give maximum amplification at some fixed frequency within the broadcasting band. Then the oscillator beats with the incoming signals so that this frequency is generated and the signals are finally detected in normal manner.

291. The "autodyne."—It is possible to do away with one tube by combining the functions of oscillator and mixing tube, or first detector. It is only necessary to couple the input circuit, the antenna-ground system for example, to the oscillator which acts as detector. The latter is tuned so that its frequency differs from

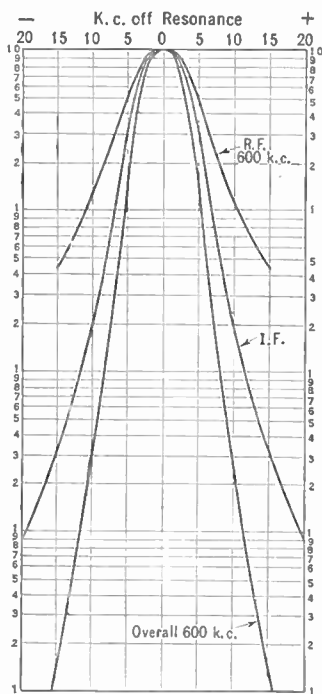

FIG. 216.—Response of modern superheterodyne.

the incoming frequency by the number of kilocycles to which the intermediate amplifier is tuned. Such a "super" is called an **autodyne** because the signal is automatically heterodyned in the local oscillator, or first detector, instead of requiring a third or mixing circuit.

292. The electron-coupled oscillator.—In the autodyne there is considerable difficulty in preventing interaction between the two circuits, one working at the incoming frequency, the other at the incoming plus the beat frequency.

A most interesting tube, developed in 1933, does away with this trouble. It is called the electron-coupled oscillator since the

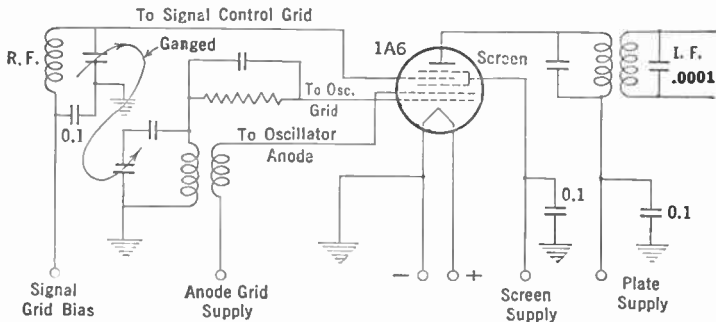

FIG. 217.—Circuit of electron-coupled oscillator combining both the functions of oscillation and mixing in the same tube and using the same electron stream.

electron stream is modulated within the tube so that it carries both the incoming and beat frequencies. Figure 217 shows the circuit and the disposition of the grids. Electrons going from cathode to anode (which has the form of an open mesh or grid) overshoot their mark and go on through the anode. They are attracted onward by the positive screen and go through it to the plate. As they move toward the final anode they are modulated by the mixer grid. Thus between the oscillator plate and the control grid of the mixer is a congregation of electrons acting as a virtual cathode.

The **translation gain** of circuits using the 1A6 and typical i.-f. transformers is of the order of 40. This is another new term

produced by the modern tubes and circuits. It is the gain in converting radio frequency to intermediate frequency. Thus a microvolt of radio frequency put into the frequency changer becomes 40 microvolts of intermediate frequency in the output.

293. "Short-wave" receivers.—The majority of the traffic carried on in the higher frequency bands, from 1500 to 15,000 kc., is in code and it is not necessary to transmit a very wide range of frequencies to convey good signals.

The usual short-wave receiver for code reception consists of an "autodyne" detector, that is, an oscillating detector which is detuned from the incoming signal by about 1000 cycles. The plate circuit has a low impedance to both the locally generated and the incoming frequency but a high impedance to the 1000-cycle note which is amplified by an ordinary audio amplifier and then passed into a pair of head phones. Frequently, one or more screen-grid tubes are used between the detector and the antenna, to provide somewhat greater amplification, to prevent interaction between antenna and detector, and to prevent oscillations in the detector circuit from getting into the antenna and being radiated from it.

Of course it is possible to make the beat frequency between the detector oscillation and the incoming signal some intermediate frequency and to pass it into an intermediate-frequency amplifier. Many of the short-wave "adapters" consist of such apparatus. The intermediate-frequency amplifier can be the usual radio-frequency amplifier from a broadcast receiver. To receive short-wave signals on a super designed for broadcast frequencies, it is only necessary to have a second input circuit, or taps on the broadcast input circuit, to reduce the wavelengths it tunes to.

Other adapters are merely oscillating detectors which are plugged into the detector socket of a broadcast receiver. The tube gets its filament and plate voltage from this socket, and passes its 1000-cycle beat note into the audio amplifier of the broadcast receiver.

294. Short-wave receiver circuits.—The short-wave receiver detector can be made to oscillate in any of the standard regenerative circuits. Since the detector is to work at very high frequencies where any stray capacities or shunt paths become of great impor-

tance, several circuits have come through the development period to be almost standard, combining ease of adjustment and stability of operation. In Fig. 218 are shown two common circuits. They differ in the manner of securing regeneration. They employ a fixed tickler and a variable capacity adjustment. The variable tickler has been abandoned in short-wave circuits because of variations in tuning when its position is varied with respect to the secondary winding. In Fig. 218 *A* the r-f. currents are prevented from going into the a.-f. amplifier and made to go through the regeneration system by means of the choke coil, *RFC*. If the choke is poor, or if good coupling between tickler and secondary

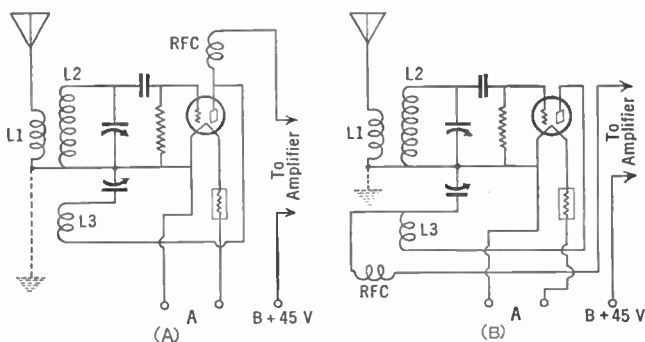

FIG. 218.—Two methods of connecting feed-back circuit in short-wave receiver. A preferred circuit is in Fig. 221.

coils cannot be obtained so that regeneration is not under good control, the series arrangement in 218 *B* may be used. Here all of the plate circuit currents, a.-f. and r.-f., go through the choke coil. Such a circuit is especially useful if the choke coil does not have a high impedance over the band to be tuned to.

Since the choke coil is directly across the tickler coil and regeneration condenser shown in Fig. 218 *A* (the *B* battery is at ground potential and so is the filament), its low impedance at some frequency may prevent oscillations. This choke coil because of its inductance and capacity will have a resonant frequency, and some harmonic of it may appear within the band to which the receiver may be tuned, or the choke may tune within the band by means of some series capacity. Under these conditions the operation of the receiver will be erratic.

Receivers designed solely for code reception are often made extremely selective by the proper use of piezo-electric crystals in part of the circuit much as transmitters use crystals to keep them on their assigned frequency. In the receiver the crystal is made part of the intermediate frequency circuit which becomes so sharply tuned, because of the mechanically resonant crystal, that only those signals appearing in a very narrow band are admitted to the second detector and headphones.

Many modern short-wave receivers are as complex as broadcast frequency sets employing a.v.c., multi-stage amplifiers, and other recent developments.

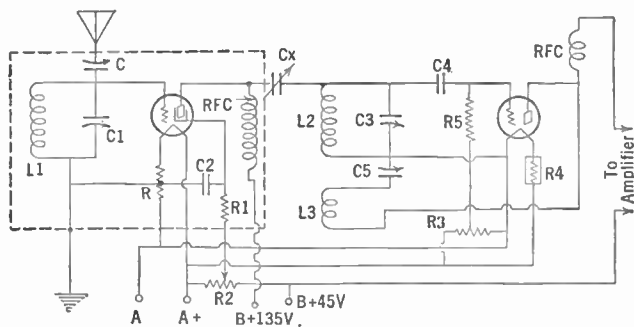

FIG. 219.—A short-wave detector circuit preceded by a tuned amplifier.

295. All-wave receivers.—Any modern home radio receiver, except the very small cheap units, covers much more than the broadcast band of 550 to 1600 kc. Many of them cover a complete spectrum, say from 60 megacycles (5 meters) up to the longer waves (approaching 1000 meters) on which aviation weather reports are transmitted. These are known as “all-wave” sets, although there are other receivers which include several bands with skipped regions between which also claim to be all-wave.

The all-wave set started modestly. A few manufacturers discovered that the public wanted to listen to the police band just below the broadcast band. The next move was to extend this

band still further into the higher frequency region. Then they put on several bands, covering especially the international short-wave broadcast bands centered about 49, 31, 25, 19 meters. On these bands it is possible to get good reception from powerful sta-

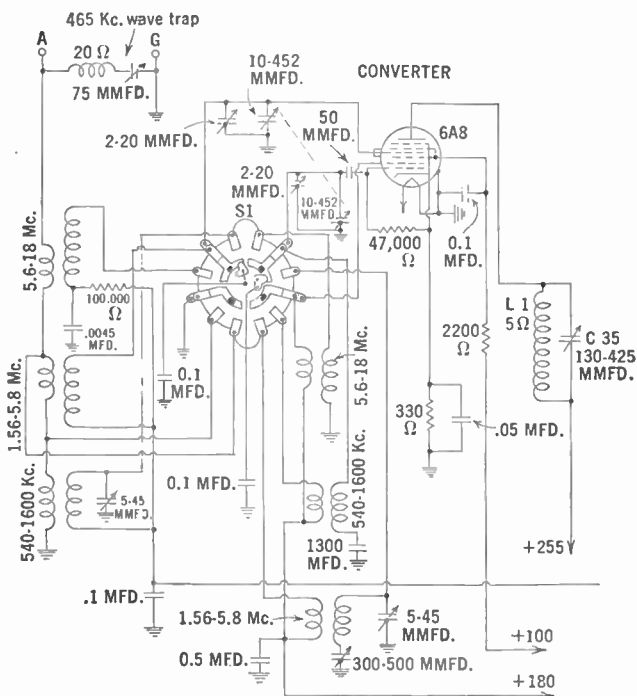

FIG. 220.—Antenna to output of converter of an all-wave superheterodyne receiver.

tions over distances of several thousand miles. Even the lower powered stations can be heard well at times. The all-wave idea introduced the home listener to a new world of adventure.

All-wave receivers introduced several new problems. It is not possible to tune a given coil over a band much wider than 3 to 1 in frequency range. Therefore it became necessary to use more than one set of coils for each r.-f. and oscillator stage. Various

arrangements were perfected for switching the tubes to these various sets of coils which were connected in series, at times, and at other times and in different sets, in parallel. The beautiful switches, with low losses and short leads, developed by component parts manufacturers, were one of the important factors making all-wave receivers possible.

Such receivers have been a gradual development. If a manufacturer had requested his engineering department to build a receiver covering the band from 60 megacycles to 550 kc. the first

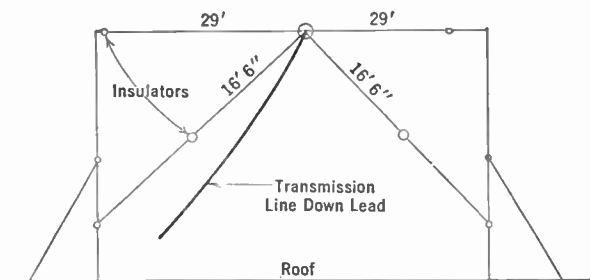

FIG. 221.—Special form of antenna for reception on the short-wave broadcast bands.

year the idea took hold, he would have requested the near impossible. The set would probably have had little amplification at the higher frequencies and still less selectivity. It would probably have oscillated or been unstable.

Choice of intermediate frequency is now related to the all-wave problem, because a low intermediate frequency would not provide selectivity at the higher incoming frequencies even if it were satisfactory at the broadcast wavelengths. The antenna to be used on an all-wave set enters into the problem, especially because the signal coming from a station 3000 miles away is weak compared to the signals nowadays expected from broadcast stations. Furthermore, the average power of these short-wave broadcast stations is low compared to the broadcast band stations.

Thus the manufacturers encouraged users to install antennas especially engineered to be receptive to the short waves and at the

same time to discriminate against local forms of man-made interference. In general these antennas are made resonant or partially resonant to the desired short-wave bands and by complicated switching systems they are changed in their resonance characteristics as the listener adjusts his receiver to cover the several bands. This switching now takes place at the same time the various sets of coils are chosen.

It has been found that much of the noise that enters into radio receivers from the outside, does so by virtue of the ground lead. Noise is brought near this down lead by electric light wires which enter the house after being exposed to all sort of interferences. Thus if the ground lead can be kept clean of noise, the signal-to-noise ratio will be better. One way to do this is to have a very short ground lead. Suppose the antenna in the back yard consists of a vertical mast insulated from ground. Now secure good ground connection at this point and bring both ground and antenna leads to the set, after going through a matching transformer, through an underground conduit.

296. Long-wave receivers.—Although a simple long-wave receiver may use an autodyne detector a better scheme is to use a separate oscillator and to beat it with the incoming signal because of the detuning effect, which may be serious at low frequencies.

When one listens to long-wave stations for the first time on such simple receivers, he is struck by the fact that many stations are heard at the same time. The reason is as follows: These stations operate on the frequency band from 10,000 to 20,000 meters or from 15 to 30 kc. When a receiver is tuned to a 20-kc. station, it is detuned only 1000 cycles—an audible amount—from a 21-kc. station, only 2000 cycles from a 22-kc. station, and so on. If the operator tunes to the 10,000-meter—30-kc.—station he is only detuned by 15 kc., an audible amount, from the station allotted the channel at the extreme other end of the band.

In commercial receiving stations the signals are tuned and filtered so that a very narrow band is passed, about 200 cycles. In this manner stations can be separated. All of the long-wave stations in the world are in this limited band, and of course any station can be heard in any other part of the world.

The coils frequently used in receiving high-power long-wave stations are the commonly known "honeycomb" coils and are highly concentrated multi-layer inductances. A table showing the wavelengths to be received with certain sizes of coils is given herewith.

TABLE I

Number of Turns	Inductance, at 800 Cycles, in Millihenrys	Natural Wavelength, Meters	Distributed Capacity in Mmfd.	Wavelength Range, Meters	
				0.0005-mfd. Condenser	0.001-mfd. Condenser
25	.039	65	30	120 to 245	120 to 355
35	.0717	92	33	160 to 335	160 to 480
50	.149	128	31	220 to 485	220 to 690
75	.325	172	26	340 to 715	340 to 1,020
100	.555	218	24	430 to 930	430 to 1,330
150	1.30	282	17	680 to 1,410	680 to 2,060
200	2.31	358	16	900 to 1,880	900 to 2,700
249	3.67	442	15	1,100 to 2,370	1,000 to 3,410
300	5.35	535	17	1,400 to 2,870	1,400 to 4,120
400	9.62	656	13	1,800 to 3,830	1,800 to 5,500
500	15.5	836	13	2,300 to 4,870	2,300 to 2,000
600	21.6	1045	14	2,800 to 5,700	2,800 to 8,200
750	34.2	1300	14	3,500 to 7,200	3,500 to 10,400
1000	61	1700	13	4,700 to 9,600	4,700 to 13,800
1250	102.5	2010	11	6,000 to 12,500	6,000 to 18,000
1500	155	2710	13	7,500 to 15,400	7,500 to 22,100

Experiment 1-15. Connect three honeycomb coils as shown in Fig. 222 making *S* a 1500-turn coil, *P* about 1000-turn, and *T* about 750-turn. The tuning condenser can be either 500 or 1000 mmfd., preferably the latter. Connect an antenna as long as possible to the 750-turn coil and listen in the plate circuit. It may be necessary to reverse the connections to the coil *T* in order to make the tube oscillate. It should be possible to hear many long-wave stations transmitting traffic to foreign countries. The phenomenon of zero beat is beautifully illustrated by such an experiment. Some of the long-wave stations that should be heard are:

Although the long-wave stations are important in transmitting part of the world's transoceanic telegraph traffic, the short-wave stations have taken over the big burden of handling the many of thousands of words per day that go across the oceans.

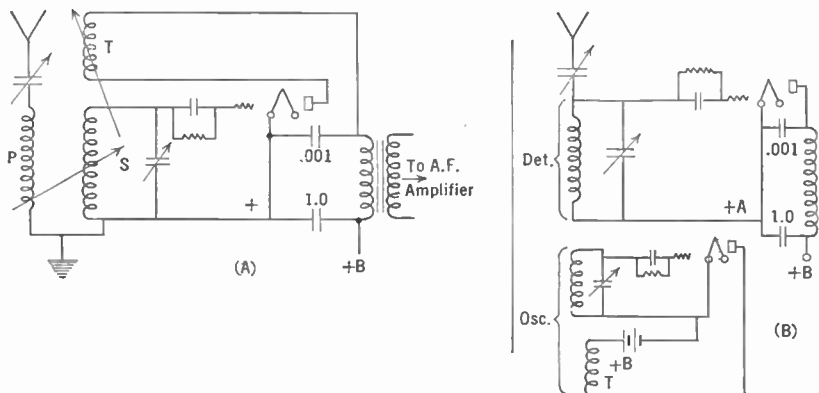

FIG. 222.—The beat note in a code receiver may be obtained in the "autodyne" manner (A) or in heterodyne (B).

297. Detuning loss in autodynes.—Some loss in signal strength is experienced in autodynes because the detector is actually detuned from the incoming signal. At high frequencies where such a system is frequently used, the detuning is not serious. Thus at 30 meters, 10,000 kc., a deviation of 100,000 cycles is only 1.0 per cent. At the longer waves, however, detuning only 1000 cycles to get an audible beat note represents an appreciable loss. Thus at 20,000 meters, 15 kc., a detuning of 1000 cycles represents a detuning of over 6 per cent. The use of a separate oscillator, as in Fig. 222B, will prevent this loss.

Problem 2-15. The following voltages were measured across a 600-turn honeycomb coil when it was tuned to 40 kc. and the input frequency was changed. How much loss in signal strength would be incurred if the coil and condenser were used in an autodyne detector and detuned from 40 kc. so that

a 1000-cycle bear note was secured? Plot the curve of voltage against frequency and note the loss from it.

TABLE II

Frequency	Voltage	Frequency	Voltage
38.0	.4	40.0	2.5
38.5	.65	40.5	1.75
39.0	1.05	41.0	.95
39.5	1.75	41.5	.55

298. Poor quality on long waves.—It is much more difficult to transmit or receive high quality music or speech on the longer waves. Suppose the transmitter is tuned to 10,000 meters, 30 kc. The band transmitted must be 10 kc. wide or 30 per cent. At broadcast frequencies, however, the band passed is only 10,000 cycles in a mean frequency of 1000 kc. or 1.0 per cent. This means that very broad circuits must be used at intermediate or low radio frequencies, which in turn means poorly selective circuits.

299. Band-pass amplifiers.—The ideal response characteristic of a receiver would be a flat top with very steep sides. The flat top should be approximately 10,000 cycles wide, or more, and the sharper the sides the more selective would be the receiver without cutting off the higher modulation frequencies. An amplifier with such a characteristic may be said to be a "band-pass" amplifier, meaning that it passes and amplifies a band of frequencies and rejects all falling either above or below that band. Numerous attempts have been made to accomplish this effect.

By the use of coupled circuits it is possible to approach the ideal. Thus in Fig. 223 if both coils are individually tuned to the same frequency, and then coupled together, the resultant response characteristics may be a single narrow-topped curve, like that of a single tuned circuit, or a flat-topped curve, or a curve of two more or less widely separated peaks with a hollow between, depending upon the degree to which the circuits are coupled.

In Fig. 223 is given the result of coupling two such circuits together with various degrees of coupling. It will be seen that too close coupling gives the widely separated peaks, proper coupling gives a comparatively flat-topped characteristic, and too loose coupling gives a sharply tuned circuit, cutting side-bands as badly as a single circuit. In a multi-stage circuit, one might use a com-

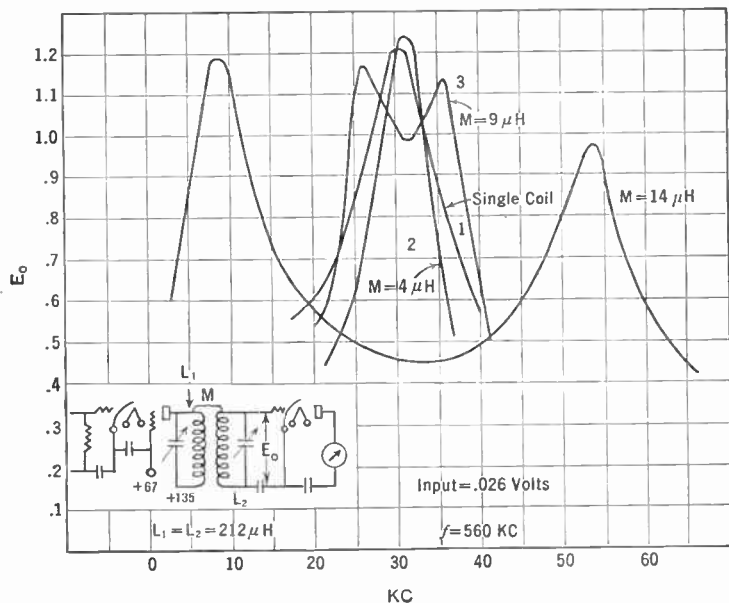

FIG. 223.—Experimental determination of effect of close coupling in band pass filter at high frequencies.

bination of two coupled circuits, one like 3 and the other like 1 or 2 in Fig. 223. The overall effect would be better than one alone.

Superheterodynes now use such a "band pass" circuit in the intermediate frequency amplifier. Here the frequency is fixed, and one adjustment will do for all signals put into it. When the band pass arrangement is used at broadcast frequencies, the width of band passed may differ at each frequency to be received. If the coupling is by inductance the band will be broad at the high fre-

quencies; if the coupling is capacitive, the curve will be broad at low frequencies. Some combination may be arranged so that a more or less uniform band is passed at all broadcast frequencies.

300. Tone control.—Manual control of the tone emitted by the loud speaker is incorporated in many receivers. This consists, usually, in a resistance in series with a capacity and the combination shunted across some part of the audio amplifier. The capacity shunts out the higher audio tones; the resistance, which is the variable feature, increases or decreases this shunting effect. In other words the usual tone control is nothing but a loss for high notes.

301. Automatic tone control.—When static is bad, as when receiving a weak station, cutting out the higher audio notes is

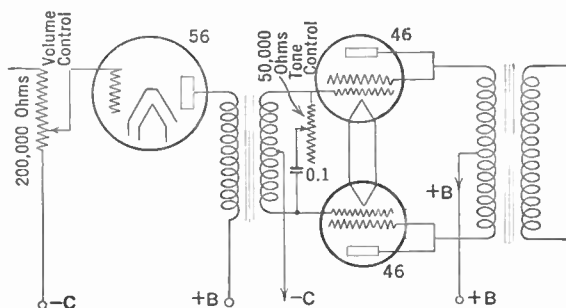

FIG. 224.—Tone control across input to power amplifier.

advantageous. Often a program that is hopelessly lost in noise can be received with a certain amount of pleasure if the tone control is advanced to the point where little beyond 2000 cycles is received.

Circuits have been devised which give some measure of automatic tone control. Thus when the receiver r.-f. gain is low, as it would be if receiving a strong station, or local, the tone-control function is not in operation. Then as weaker and weaker stations are tuned in, this tone-control function, which is connected with the a.v.c. system, cuts off more and more of the high frequencies. In certain circuits this function is inherent; in others an additional tube acting as a variable resistance or reactance is employed.

To date (1937) such circuits have not come into general use. Automatic selectivity control (a.s.c.) circuits which make the set less selective when receiving strong signals and more selective on weak signals will probably be incorporated in receivers ultimately.

302. Acoustically compensated volume control.—When the volume of a speaker system is turned down, the very low and very high notes seem to be relatively weaker. This is because they require more energy to become audible, in proportion, than the middle-frequency notes. Therefore, combined volume and tone control circuits have been devised. When the volume is turned

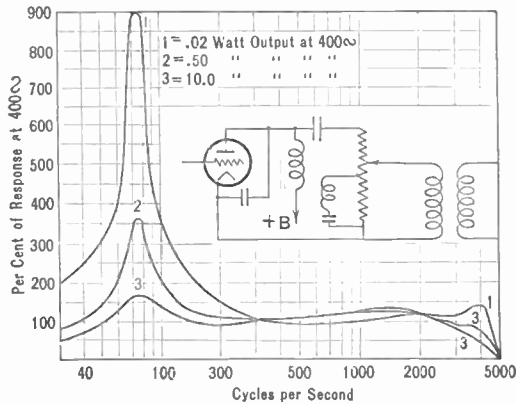

FIG. 225.—Circuit and response of acoustically compensated volume control.

down, both the low and high notes are turned up, automatically, so that the extremes in the frequency range do not seem to fall out of proper proportion.

Figure 225 shows the circuit used as well as the results of varying the control. The low notes are boosted much more than the extreme highs, although any desired characteristic can be obtained. Some trouble is encountered with such systems either with instability, because of the high gain at low frequencies, or from "flutter" caused by the low beat note between stations.

303. Measurements on radio receivers.—It is now possible to make very comprehensive and thoroughly quantitative tests on

radio receivers, either as a whole or upon the component parts. Such tests consist in measuring what comes out of a receiver when known voltages at known frequencies modulated at known percentages are placed on the antenna-ground binding posts of the receiver.

The voltage on the antenna-ground posts is secured in several ways. Some laboratories use an artificial or "dummy" antenna consisting of concentrated capacity and inductance and resistance of such values that they simulate the antenna-ground system ordinarily used. Such values used in some laboratories are: 200 microhenrys, capacity 200 mmfd., and resistance 25 ohms. Other laboratories use a coupling coil into which the desired voltage is induced, and others take the voltage drop across a known resistance which is in series with the artificial antenna. If comparative measurements and not absolute are required, the output from the receiver when it is attached to an antenna of the usual type can be employed. Of two receivers the one which gives more output from a given station on a given antenna has the greater overall amplification. A crystal rectifier and meter will measure output.

The load into which the output of the receiver is measured is usually a non-inductive resistance and the standard output is taken at 50 milliwatts. Sometimes a loud speaker is placed across the receiver output and the current into it and voltage across it are measured with given input voltages and at various frequencies. These volt-amperes plotted against input frequency or against input modulating frequency give an indication of the overall voltage amplification as well as the overall fidelity characteristics of the receiver.

For receiver measurements some means must be provided for furnishing known amounts of radio-frequency voltages. Since the modern radio receiver has a very high voltage and power amplification, these voltages must be very small when it is desired to measure the overall characteristic or performance. It is desirable to have a known voltage at least as low as 1 microvolt, and anyone who has worked intimately with radio-frequency voltages—at one million cycles for example, knows how difficult it is to know when one has an e.m.f. of this order or a current of one-millionth of an

ampere. The laboratory worker must know how much current or voltage he has, and he must be certain that his meter shows all the current or voltage, no more and no less.

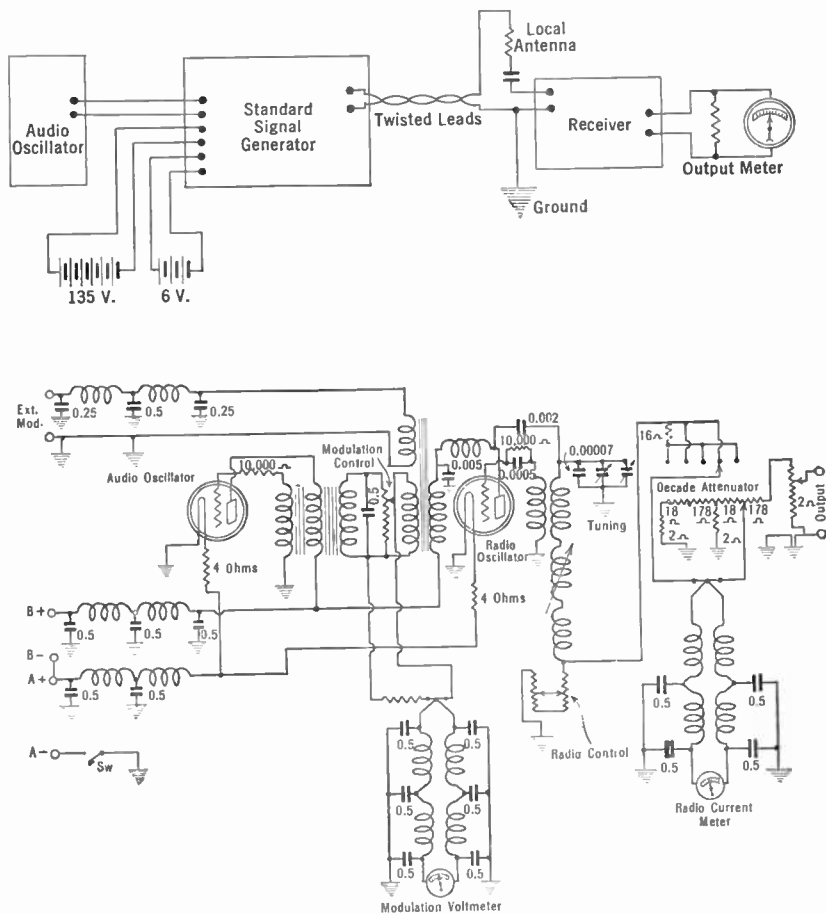

FIG. 226.—Circuit diagram and method of using signal generator.

The circuit diagram in Fig. 226 is that of a General Radio Signal Generator, a device which consists of a radio-frequency

oscillator, a means of measuring and controlling its output, and a means of using any desired part of this output for purposes of measuring receivers, either as a whole or in component parts.

304. Receiver performance.—Graphical data taken on 64 superheterodynes are summarized in Figs. 227 and 228. The

curves give the characteristic of the least and most selective and the average selectivity. These curves do not indicate such selective sets as were obtainable before the midget became so popular. Voltage gain in i.-f. amplifiers in these years was of the order of 15,000 to 30,000 for three transformers and two tubes and 5000 for one tube with two transformers.

Screen-grid tubes have made possible receivers with fewer tubes, greater sensitivity, greater selectivity, and better fidelity. The total amplification in a high-class set is tremendous. At rare intervals and in few localities is it possible to utilize any appreciable proportion of this amplification.

The enormous amplification preceding the second detector eliminates considerable distortion occurring in weak signal detectors by working them at higher levels where linear detection takes place, removes some hum and considerable audio-frequency regeneration from the output. At the same time the screen-grid tubes make possible a more selective receiver (their resistance is very high and can be shunted across tuned circuits without increasing the resistance of the latter so much as when 12,000-ohm tubes are employed). Such selectivity results in considerable loss of higher audio tones, so much loss in fact that many modern receivers transmit very little beyond 4000 cycles and some are pretty dead at 2500 cycles. This is true in spite of advertisements stating that

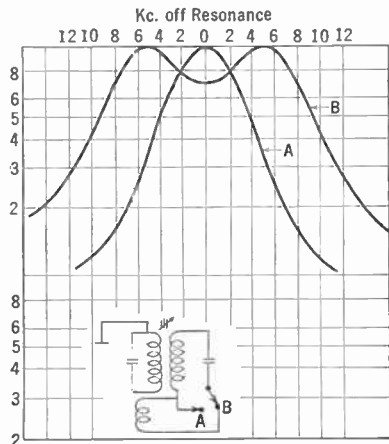

FIG. 227.—Selectivity curve for two-position i.-f. transformer (RCA).

the sets in question have "perfect fidelity." The rapid development of small sets in 1933 resulted in some decrease in average selectivity and somewhat better transmissal of high audio frequencies.

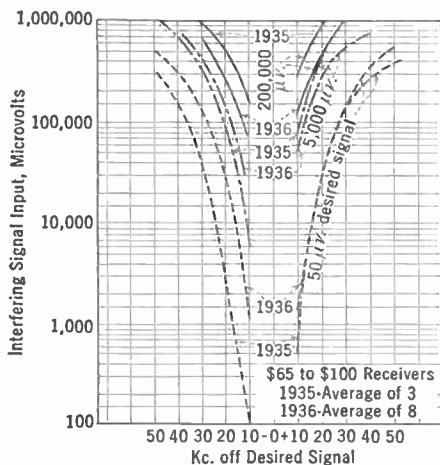

FIG. 228.—Selectivity curves of 1935 and 1936 superheterodynes.

better transmissal of high audio frequencies.

305. Automatic volume control.—Great advance has been made in controlling the volume of the receiver automatically. There are at least two virtues: fading is overcome to some extent; tuning through local stations will not produce blasts of volume which are not only annoying but often destructive to loud speakers.

There are many automatic volume-control circuits (known as "a.v.c.") but they all depend upon a rectification of the signal with resultant production of direct current which, flowing through a resistance, produces a voltage drop that varies with the signal strength. This voltage may be applied as bias to the grids of the r.-f. or i.-f. tubes (or both) varying with signal strength so that when the signal is weak the bias applied to the tubes is low, their mutual conductance and gain are high; on strong signals much bias voltage is developed, and the sensitivity goes down accordingly.

Some circuits use an additional tube; others produce the a.v.c. voltage in the second detector; in others the diodes of a 55 are utilized for this function. For example, in Fig. 229a is a simple a.v.c. circuit. The grid of the a.v.c. tube is supplied with intermediate frequency from the plate of the final i.-f. amplifier through a small condenser. With no signal this grid is heavily biased, about 60 volts, by the plate current of all the tubes flowing through the 60-ohm resistance and the oscillator plate current flowing

through the 17,500-ohm resistance. Now when sufficient intermediate frequency is developed to overcome this bias, the tube draws current which must flow through the 500,000-ohm resistor. The grid end of this resistance will be negative, and this negative voltage added to the drop across the 60-ohm resistor, acting as an initial bias, is applied to the grids of the tubes to be controlled.

The initial bias voltage is called a "delay," indicating that no a.v.c. voltage is developed and applied to the grids of the amplifiers until the incoming signal is strong enough to develop the required 60 volts steady bias on the a.v.c. tube. Thus the amplification is a maximum until this voltage is reached; all signals after this value operate the a.v.c. system and reduce the sensitivity.

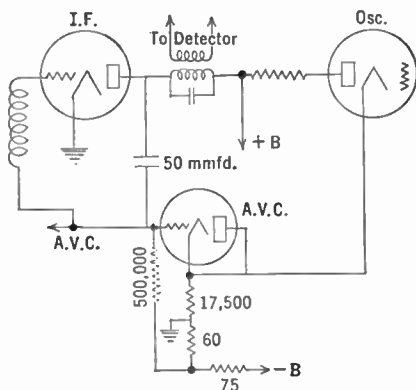

FIG. 229a.—Simple a.v.c. circuit.

Another a.v.c. system (229b) uses a 6B7 to control the mutual conductance of the electron-coupled oscillator and the pentode section in the same envelope with the a.v.c. diode plates of the 6B7.

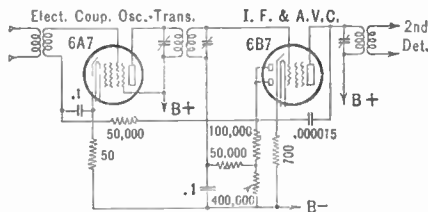

FIG. 229b.—Circuit employing duplex diode pentode tube.

306. Noise suppressor systems.—In an a.v.c. receiver the sensitivity is at maximum when no signal is being received, for example, between carrier signals. Therefore any static or other radio

noise will be amplified to the limit of the circuit and be passed to the loud speaker. Circuits have been developed which shut off this noise (see Fig. 212).

307. Automatic frequency control.—Another automatic feature which has been incorporated into modern receivers is that of maintaining the oscillator frequency accurately at the desired value. The frequency at which an oscillator functions is dependent upon several variables, one of them being the voltage on the plate, another being the capacity of the input (grid to cathode). If, after a receiver is tuned to the desired station, these values should change, due to temperature or line voltage variations, or any other cause,

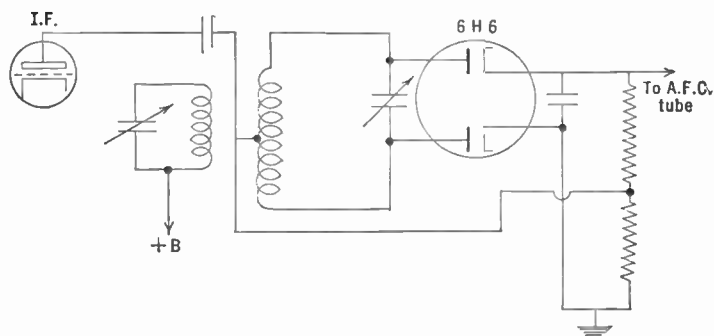

FIG. 230.—Discriminator Circuit for a.f.c.

the oscillator would not be tuned to the frequency which would provide the required intermediate frequency.

Furthermore, in a highly selective superheterodyne with several tuned stages, the difficulty of accurately tuning it is very real. When tuned off resonance with the desired signal, bad quality results.

308. How a.f.c. works.—A fundamental circuit for an a.f.c. system is shown in Fig. 230. Here is an i.-f. transformer, primary and secondary tuned to the same frequency, secondary connected to two diodes. Positive or negative voltages are obtained from the diodes, depending upon whether the receiver is tuned above or below resonance. These voltages of opposite sign are connected to a control tube as a bias and have the ability to change the capacity of a condenser up or down from some mean value through this control tube.

This variable capacity is shunted across the tuned circuit of the oscillator in the frequency-changing system of the superheterodyne. Thus when the oscillator tends to drift in frequency, the a.f.c. network begins to function and forces the oscillator to generate the correct frequency.

Furthermore, when the listener has tuned his receiver to the vicinity of resonance with the incoming signal, the a.f.c. system takes hold and forces the oscillator to generate the correct frequency to be amplified by the i.-f. amplifier.

309. Shielding.—In any high-gain amplifier it is necessary to prevent any source of high energy from being coupled in any way to a point of low energy. For example, if the plate lead of a tube near the detector feeds voltage by coupling of any sort to the grid lead of a previous tube, regeneration and instability will result.

Proper filtering by series resistance and shunt capacity of all plate, grid and screen voltages will aid in keeping r.-f. or i.-f. currents where they belong. All inductances must be shielded; often grid wires are run in shielded wire.

Now placing a coil in a metal box seems like a simple trick to keep the lines of force from that coil from getting mixed up with lines of force from another coil. But the size of the metal box, its material, the size of the coil, whether or not the metal box is grounded, and to what, and whether it carries current or not—all these things enter into the problem of shielding.

The subtraction of energy from the tuned circuit by the shield has the same effect as though the resistance of the tuned circuit were increased. In other words, if currents are induced in the shield, the effective resistance of the coil is increased, its selectivity factor goes down, the voltage gain due the coil and condenser is decreased. It is also true that the inductance of the coil decreases too, so that the value of effective resistance, or Q , $L^2\omega^2/r$, is greatly decreased. The nearer the coil is to the shield, and the greater the resistance of the shield, the greater is the power loss in it.

The shield should never carry current. It should be heavy and from the best conductor possible, and all joints in it should be

carefully soldered. It should be connected at only one point to a heavy conductor leading to the common ground of the set. Holes in it for leading-in or -out wires should be small.

From the electrical standpoint, copper is better than brass or aluminum; from the standpoint of weight and cost per pound, copper is handicapped.

It is interesting to consider the circuit as a transformer and its load. The resistance of the shield represents the load across the transformer. The power in this load is taken from the generator which is the tuned circuit. As a matter of fact any two wires which couple any two circuits together may be considered as a transformer, one acting as the primary and the other as the secondary. The power wasted in the load on the secondary wire must come from the generator or the circuit attached to the primary wire and represents an increase in the resistance of the circuit attached to this wire, and a decrease in its inductance.

310. Loud speakers.—The loud speaker is the final link in the broadcasting system, and because of its position with respect to the listener it is frequently blamed for much of the bad reproduction that really originates somewhere else.

The task of the loud speaker is to translate into sound energy the electrical energy in the power tube. It must do this as effectively and faithfully as possible. It is useless to design and operate a high-class amplifier with a poor loud speaker. The wide range of tones coming from the amplifier is lost in the loud speaker and does not get to the listener. Likewise, it is absurd to install a perfect loud speaker in the hope that the fidelity of reproduction from an antiquated or poorly engineered receiver will be bettered. The full benefit of a perfect loud speaker cannot be attained until the complete chain of apparatus is perfect—amplifier, power tube, plate voltage supply, loud speaker, etc.

Loud speakers in general are notoriously inefficient—the best in common use is not over 30 per cent. Most of them are less than 5 per cent efficient. Some of them reproduce the whole audio range of tones with almost equal fidelity. Others reproduce only a very small section of the audio spectrum—such were the short-horned loud speakers of a few years ago.

311. The horn type.—Any device which will move when a modulated electric current flows in it will make a loud speaker. Its movements are imparted to the air which in turn affect our ear drums and our auditory nerves in a sensation we call sound. The object is to effect as large a movement of air as possible with the least possible electrical input, and to effect this efficient transfer of electrical into sound energy over as wide a band of audio tones as possible.

The horn type of speaker may use a thin steel or iron diaphragm as the moving element or a non-magnetic diaphragm actuated by a mechanical coupling system as in Fig. 231. The electric currents

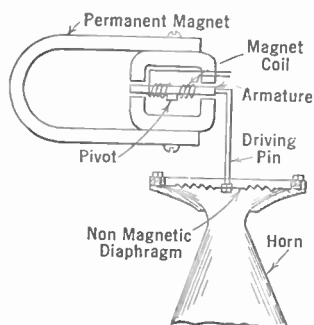

FIG. 231.—Horn type speaker mechanism.

are sent through the winding of a nearby electromagnet which has a certain amount of permanent magnetism in it. When the electric currents change the latter's magnetism, the diaphragm or the armature is moved accordingly. These movements are imparted to the air.

If the horn is large enough the resonance effect of the diaphragm may be partially eliminated. Otherwise when the frequency at which this diaphragm mechanically resonates comes through the speaker windings, a very loud output will be given out showing that the loud speaker element is more efficient at this particular frequency. The horn acts as a load upon the diaphragm much as a resistance across the secondary of a transformer acts as a load on a generator connected to the primary which supplies the power. The power in this case is sound power radiated from the horn. Very long horns which expand from a small opening near the diaphragm to a very wide mouth in an "exponential" manner give the best response characteristic, in that they are freest from resonances.

If the horn is replaced by a cone, as shown in Fig. 232, much better frequency response results because the cone has a larger

area and can give appreciable sound output at low frequencies. With a given diaphragm area, halving the frequency requires four times the relative motion of the diaphragm to produce the same sound power, while increasing the size of the cone so that much greater areas of air are displaced with a given amount of diaphragm (cone) motion, enables lower frequencies to be reproduced.

Such speakers have an impedance that increases with frequency, being about 1000 ohms at 100 cycles and running as high as 40,000 ohms at 5000 cycles. This means that the tube works into a constantly varying impedance as the frequency varies, and that most efficient transfer

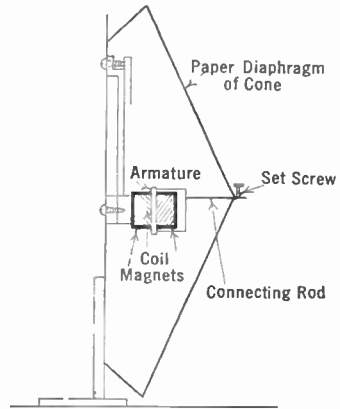

FIG. 232.—Cone type speaker.

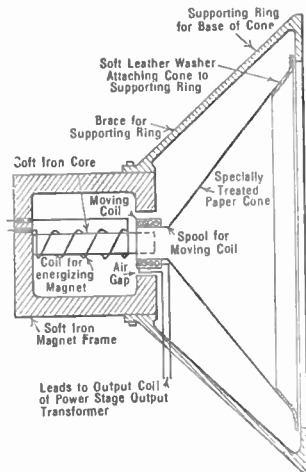

FIG. 233.—Modern "dynamic" or moving coil loud speaker.

of energy, or transfer with least distortion, can occur at only a small range of frequencies. Owing to the fact that the impedance is low at low frequencies, more distortion due to curvature of the tube characteristic takes place at this end of the audio band. It is a fact that such speakers have a very limited motion so that it is impossible to transmit very large low-frequency responses to them, and so the distortion due to curvature is not so pronounced as theory would indicate. For average home use, a good cone speaker about 2 feet in diameter will satisfy the vast majority of listeners.

312. The moving coil speaker.—

The construction of the moving coil or dynamic type of speaker is shown in Fig. 233. A strong magnet is energized by a direct current, either from a storage

battery, or from part of the plate current supply system, or from the 110-volt a.-c. line by means of a rectifier. The voice frequency currents coming from the final power tube in the amplifier are passed through a few turns around a small movable coil to which is attached the diaphragm, or cone. When a.-c. currents flow through the coil, it tends to move at right angles to the lines of force across the air gap. These motions of the coil are imparted to the cone and thence to the air.

The impedance of this movable coil is very low, of the order of 5 to 10 ohms, and is almost constant at audio frequencies. This means that the tube looks into its own impedance through a step-down transformer. For this reason a much flatter response curve is possible. Because the coil can move through a considerable distance without danger of any mechanical noises—such as caused by the diaphragm rattling against the poles of a unit of the type of Fig. 231—much better low-frequency response is possible. Considerable sound energy can be got from such a speaker. The resonant frequency of the moving part is usually lower than the lowest audio tone to be reproduced.

313. Baffles for dynamic speakers.—It is necessary to install such a speaker in the center of a rather large and heavy "baffle" if the low notes are to be properly reproduced. Otherwise the wave set up from the back of the cone can interfere with the wave set up by the front with the result that little or no sound gets to the listener. The baffle increases the air path between front and back and should be great enough so that the shortest mechanical path between front and back edges is at least one-quarter wavelength for the shortest lowest note to be received. Since the wavelength of sound, like that of radio waves, is equal to the velocity it travels divided by the frequency, it is not difficult to prove that a baffle at least 32 inches square is necessary for notes as low as 100 cycles, and 110 inches for notes as low as 30 cycles. When the unit is mounted in a box, peculiar resonances are set up which spoil the good qualities of the moving coil speaker. These resonances are sometimes smoothed out by the use of resonating chambers or diaphragms which absorb energy at the offending frequency.

314. Loud speaker improvements.—Cabinets in which loud speakers are placed have natural resonances and produce "boom" when these frequencies are to be reproduced. Several methods have been developed for eliminating this trouble. One is to use cones resembling loud speakers which have resonance at the same place as the cabinet interior. These are coupled to the loud speaker so that they absorb energy at these resonant frequencies.

The resonant pipes of RCA and the labyrinth of Stromberg Carlson are useful for this purpose. In addition they tend to bring the back radiation from the speaker into phase with the front radiation and thereby actually improve the bass response more than is possible to attain with an infinite baffle area.

315. The telephone receiver.—Long before the day of the loud speaker, the pair of head phones which could be strapped to an operator's ears was the translator of electric currents into sound waves. Such a device consisted of a permanent magnet and a coil of wire wound about one or both of the poles of the magnet. A diaphragm was placed in the permanent field of the fixed magnet, and also in the field of the coil through which the changing electric currents passed. Why is the permanent magnet necessary?

Consider only the coil through which the a.-c. currents flow, and the diaphragm. Any current flowing through the coil regardless of its direction would attract the iron diaphragm. If, then, a sine wave at 500 cycles were put through the coil 1000 times a second there would be a maximum of current through the coil, and the diaphragm would be attracted toward it this many times, each time being pulled back to its original position by a spring or by its own resilience. In other words, a 500-cycle note would sound to the listener like 1000 cycles; all frequencies put into the receiver or head phones would be doubled in pitch.

This causes no great difficulty in code reception, but in voice reception it would be strange indeed. If, however, a permanent magnet is used, the pull on the diaphragm is made up of $k(B + k_1i)^2 = kB^2 + 2kk_1Bi + kk_1^2i^2$, in which k and k_1 are constants. B is the pull due to the magnet, and i is the current

through the coil. Now the important pull is that which is proportional to the current. The first term is the fixed pull due to the permanent magnet; the second term is the desired one; the third is distortion since it is proportional to the square of the cur-

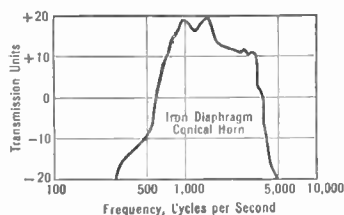

FIG. 234.—Limited response of horn speaker.

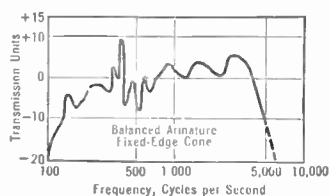

FIG. 235.—Response characteristic of good cone.

rent. If B is large, and it is, there is an actual amplification; but if, by poor design, etc., the final term is large there will be much distortion.

316. Loud speaker measurements.—The procedure in measuring the performance of a loud speaker is to hang a calibrated

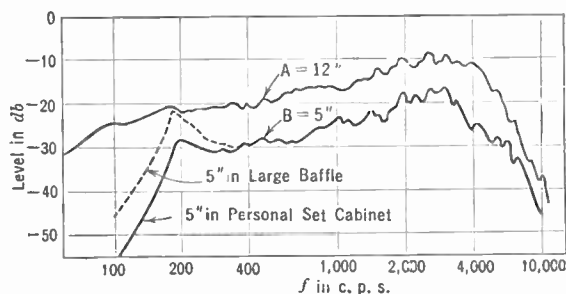

FIG. 236.—Response of 1933 dynamic speakers. A is the characteristic of a high class large speaker.

microphone in front of the speaker which is actuated by various tones of known amplitudes from an oscillator. The output of the microphone is amplified and measured, and thus a curve of output versus frequency may be obtained.

Dynamic type speakers have a tendency to deliver more output at high frequencies where the cone ceases acting as a plunger and begins to act merely as a small cone. An electric filter consisting of inductance, capacity, and resistance may be put across the speaker to absorb this greater output and keep it from bothering the listener. If, for example, the frequency is about 4000 cycles, as in Fig. 236, a condenser in series with resistance and inductance may be tuned to this frequency and placed across the loud speaker. At all other frequencies it will be merely a high shunting path and take no power. But at 4000 cycles its impedance is low, and currents of this frequency go through it instead of the speaker. The resistance is used to keep the filter from being too sharply tuned.

Similar filters are used in phonograph reproduction to eliminate the needle noise. They are called scratch filters and may tune somewhere between 3000 and 5000 cycles. Of course such filters take out their share of the desired signals and may make the records sound "boomy" which is an indication of too much bass for the amount of high notes.

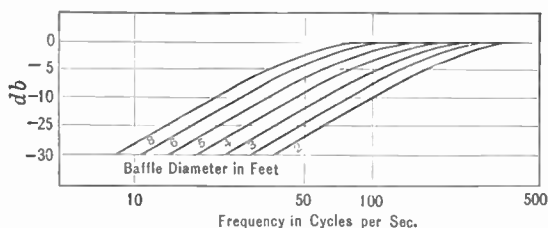

FIG. 237.—Effect of using large or small baffles on dynamic speakers.

Combination dynamic and horn speakers developed by the Western Electric Company for use in theater and public-address systems are very efficient. Often a small "tweeter" horn is used with large dynamics to produce the high audio frequencies, say up to 10,000 cycles, because dynamics usually reproduce poorly beyond 5000 cycles.

The effect of using various sizes of baffles with a particular dynamic speaker is shown in Fig. 237. It is evident that to secure good response at low frequencies large baffles must be used.

CHAPTER XVI

RECTIFIERS AND POWER SUPPLY APPARATUS

TUBES which distort may act as rectifiers to transform a.-c. currents into d.-c. currents and thereby be useful as sources of unidirectional current either for charging batteries or for supplying plate voltages to a receiver or other device. Such tubes have only two elements, the source of electrons and the plate or receiver of electrons. Tubes of this general type have been developed for high-voltage, low-current work, as for supplying transmitters with plate voltage, or for low-voltage, high-current work for battery charging. Rectifier tubes may be high vacuum and may handle several hundred thousand volts, or they may be gaseous to handle several thousand amperes, and for special purposes they may have grids in them, then being known as controlled rectifiers (grid-glow tubes and thyratrons).

317. The fundamental rectifier circuit.—When such a two-element tube filament is heated to a proper temperature electrons will flow to the plate provided it is at a higher positive potential than the filament. If an a.-c. voltage is connected between the filament and the plate (Fig. 238) an electron current will flow to the plate when the latter is positive and not when it is negative. In other words current flows on the halves of the cycle when the plate is positive; on the halves of the cycle when the plate is negative, the electrons return to the filament as fast as they escape. The a.-c. voltage may be introduced into the plate-filament path by means of a transformer, which also supplies the heating current for the filaments.

A d.-c. meter in the plate circuit would read a certain amount of current which would be a value somewhere between the maximum current that flowed during each positive half-cycle, and zero. The meter needle would not follow the rapid spurts of current and so would assume some average value. If we consider as the input

the a.-c. voltage, and the d.-c. meter as the output circuit, it is clear that distortion is taking place, because there is no d.-c. in the input and there is a readable amount of d.c. appearing in the output. In other words the output is not a perfect replica of the input.

Such a rectifier may be arranged to transform a.c. to pulsating d.c. either at low, medium, or very high voltages. Whenever one wants a source of d.c. voltage or current and an a.-c. voltage only is available, a vacuum tube operating as a rectifier may be employed.

Rectification takes place only in this one direction. It is not a reversible process. If we want a.c. from d.c. we must use a motor-generator, a converter, or a vacuum tube which can be made to oscillate and thereby convert a certain amount of d.-c. power from batteries into a.-c. power.

The amount of d.-c. current that would be read by a meter in the plate circuit of such a tube would depend upon the voltage, the form of the wave being rectified, the shape of the tube characteristic, the amount of current that flows when the plate is negative with respect to the filament, and upon other factors. If one could listen to the output of such a tube, as one may by putting a loud speaker in series with it, he would hear a buzzing or throbbing sound.

The a.-c. voltage input wave is as in *A*, Fig. 239, which shows the output without a rectifier. The pulses of d.-c. in the plate circuit of a single wave rectifier are as in *B*. This is not a direct current in the ordinary sense of the expression. It is a current which varies in amplitude over the half-cycle of the a.-c. voltage which makes the plate positive. The current throughout this half-cycle flows in the same direction, however, and so may be considered as a pulsating direct current. These pulsations may be smoothed out by filters and as a result nearly pure uni-directional constant amplitude d.-c. current may be obtained.

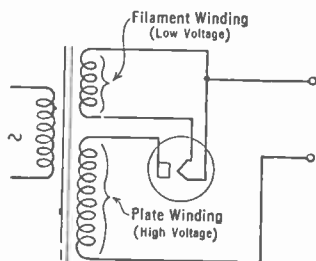

FIG. 238.—Operating rectifier filament from a. c.

318. Kinds of rectifiers.—A rectifier, then, is a device which transforms a.c. current into a pulsating current which can be smoothed out into pure d.c. current if desired. Rectification may take place (a) in a device which passes more current in one direction than it does in another, or (b) in a device which does not pass any current at all in one direction, or (c) in a device which passes

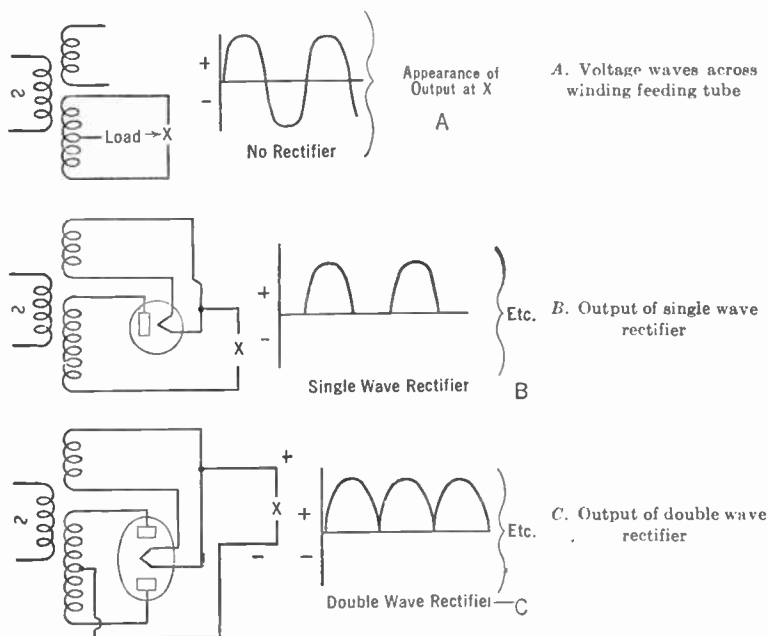

FIG. 239.

current when the voltage is increased beyond a certain limiting value, but no current below that value or in the opposite direction.

If the plate of a rectifier tube is kept cool, so that it cannot act as a source of electrons, the tube will pass no current when the plate is negative with respect to the filament and the two-element tube rectifier then is a member of class (b) above. If, however, a large amount of rectified current is permitted to flow through a fairly high resistance tube the plate may become hot, and so act as a

source of electrons on the half-cycle when the plate is negative with respect to the filament, and some "back" current will flow. The tube then falls into class (a). Such a condition in a modern plate voltage supply system is not likely to occur and will be evidenced by a high degree of hum in the output of the receiver.

Certain crystals, such as galena, silicon, or silicon carbon (trade name "carborundum"), etc., are rectifiers, passing more current in one direction than they do in another and fall into class (a). Some tubes do not use a filament, but have in them a gas, neon or helium for example, which ionizes when the voltage reaches a certain value and conducts current in a definite direction. They are members of class (c) and will be described below.

The more perfect the rectification the greater will be the d.-c. output from a given a.-c. input. If the rectifier is perfect and if

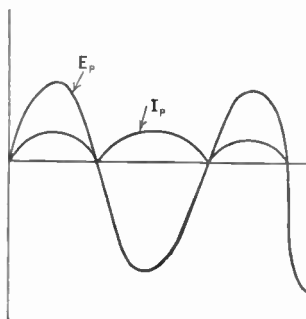

FIG. 241.—Current from a double- or full-wave rectifier to the form approximated by I_p .

the input is a sine wave, a d.-c. meter in a resistance load will read 0.901 times the a.-c. input current. If 1 ampere a.c. flows in, 0.901 ampere d.c. flows out.

319. Typical filament rectifiers.—

Tubes used primarily for rectifiers have only two elements, the plate and the filament. They are of two kinds, the single or half-wave rectifier, and the double or full-wave rectifier. The single-wave rectifier has a single filament and a single plate and rectification takes place in it according to the process described above. If desired

two such tubes may be arranged, as in Fig. 240, so that each half of the a.-c. cycle is rectified, and so the output current would look like Fig. 241.

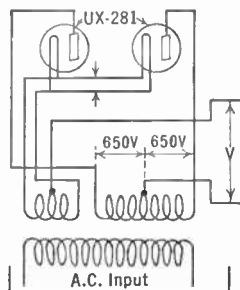

FIG. 240.—Connections of a full wave rectifier.

cycle is called a half-wave or single-wave rectifier. The two-tube

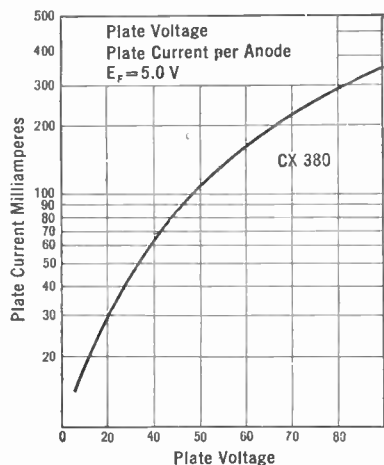

FIG. 242.—Characteristic of double wave rectifier tube.

rectifier is called a full- or double-wave rectifier. It is possible to combine both the single-wave rectifier tubes into one glass container by using two filaments in series and two plates. In such a case full-wave rectification takes place with the use of only one tube. The 80 is such a tube. It has two filaments and two plates and is connected as in Fig. 239C.

Characteristic curves of single- and full-wave rectifiers are shown in Figs. 242 and 243.

320. Requirements for rectifier tubes.—The filament of a rectifier tube must be rugged and capable of supplying many more electrons than are ever needed for the proper operation of the output circuit. Thus if a tube is to supply 125 milliamperes steadily, it is possible that in some circuits the instantaneous current through the tube may be as high as 300 milliamperes and the tube must be able to supply this current without saturating. If the tube saturates, the pulse of current when the plate is positive will be difficult to filter, and the rectifier and circuit would suffer from other faults.

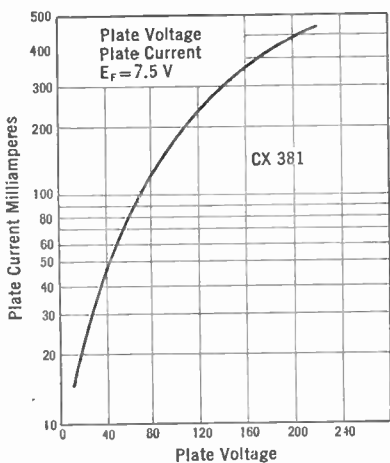

FIG. 243.—Single wave rectifier tube characteristic.

The resistance of the tube should be low so that no great amount of voltage is lost in it, and so that the "regulation" of the

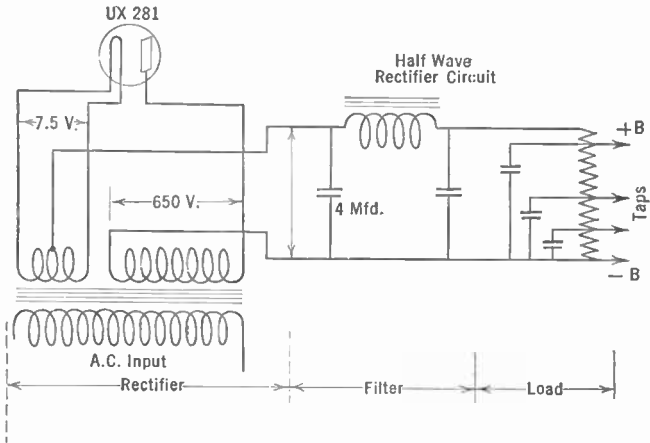

FIG. 244.—Circuit of single wave rectifier, filter and load.

rectifier and filter may be good. A low-resistance tube of course wastes less power, and so less heat must be dissipated. The insulation between filament and plate must be such that breakdown cannot occur either due to direct puncture of some part of the tube or to heating due to leakage currents.

321. Single-wave rectifier.—Typical single-wave rectifier circuits are shown in Figs. 244 and 245. The only difference between these circuits lies in the manner in which the load is connected to the circuit, that is, whether it goes next to the plate or next the filament of the rectifier tube. In Fig. 245 the plate of the tube is near ground potential but the transformer is "hot." In the other case, Fig. 244—which is more generally used—the transformer is nearest the ground potential while the tube has a

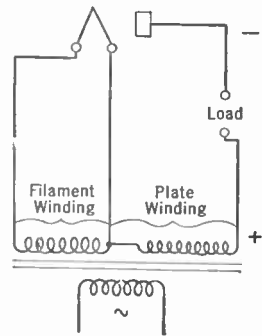

FIG. 245.—Single wave rectifier circuit employed by some Western Electric systems

high potential across it. Considering Fig. 244 when the plate end of the secondary or high-voltage winding of the transformer is positive, the other end of the secondary winding is negative with respect to the plate end and a large voltage exists across it—perhaps 400 or 500 volts. This makes the end of the load attached to this end of the transformer negative; and as we proceed in this direction, through the load and back to the filament of the tube, the circuit becomes more and more positive. The filament of a rectifier, then, is the positive end of the circuit so far as the load is concerned. The plate end is the negative or grounded end so far as the load is concerned, and a voltmeter across the load must be connected with this polarity in mind.

When the polarity reverses, on the other half-cycle, the plate end of the transformer becomes negative and the filament end positive. No current flows through the load or tube then, because the plate cannot attract electrons to it from the filament. The device is a half-wave rectifier only. It rectifies half the time. When current flows, the voltage drop across the tube is only the IR drop there—not the full transformer voltage.

Now suppose we connect another transformer secondary and another tube as in Fig. 246. When the plate terminal of S_1

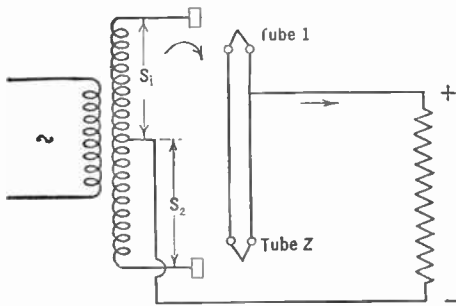

FIG. 246.—Direction of flow of current in full wave rectifier.

attached to the plate of tube 1 is positive, current flows through that tube and returns to the center of the transformer. Nothing happens in tube 2 because the plate of this tube is negative. When the direction of the a.-c. voltage reverses, the plate of tube 2 becomes positive and current flows through this

tube returning through the center of the secondary winding as before. Current flows in a given direction through the load resistance regardless of which tube is passing current.

322. Gaseous rectifiers.—Whenever a large amount of current with a low voltage drop in the rectifier is desired, gaseous rectifiers are used. The gas is usually mercury but in small tubes may be other gases such as neon or argon. The gas plays a very important role as will be seen below. There are several types of gaseous rectifiers; one of the earliest, the Raytheon tube, had no filament. Other types are the Tungar or Rectigon tube for battery charging, and the mercury-vapor rectifier such as the 82, 83 or 866.

The purpose of the gas in heated cathode types is to neutralize the space charge which prevents a large flow of electrons from cathode to plate in a high-vacuum tube. In the latter type of tube many electrons congregate near the filament and constitute a cloud of negative carriers through which a few electrons with sufficient velocity pass before they can transport their share of the electricity to the plate.

Now suppose that there is a gas in the tube. An electron leaves the filament and goes toward the plate. On its way it may collide with a gas atom with sufficient velocity to "ionize" it. In this process the gas atom loses an electron. The remaining part of the atom is charged positively and is now known as a positive ion. The second electron may join the first and go on toward the plate. The positive ions will attract the electrons in the space charge, each ion neutralizing the effect of one electron. Therefore, as soon as ionization begins, the space charge is neutralized, additional electrons are produced by the ionizing process, and more current can get through to the plate.

The high-vacuum tube is also a high-resistance tube. It gets very hot if much current is taken from it because of the resistance in the space charge. A gaseous rectifier is a low-resistance tube and a thousand times as much current, or more, can be taken from it as from a high-vacuum tube without getting too hot. Furthermore, the voltage drop in the gaseous rectifier is constant regardless of the current taken. This voltage drop corresponds to the voltage necessary to ionize the gas, which depends upon the kind of gas and the temperature of the tube.

A rectifier made with a high-vacuum tube has a bad regulation curve; that is, its terminal voltage falls off rapidly when higher

and higher currents are taken from it. Therefore, the voltage output is a function of the current output. In the gaseous rectifier the internal drop is constant, the only resistance in such a supply system being in the filter chokes which can be made as low as one desires by using large wire. Its output curve then is flat when voltage versus current is plotted.

The operation of the Raytheon tube depends upon an interesting phenomenon. In the tube, shown in Fig. 247, are two small anodes and one large cathode since it is a full-wave rectifier.

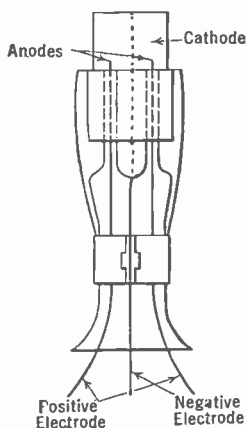

FIG. 247.—Raytheon tube construction.

Consider only one anode and the cathode. The anode has small area; the cathode has large area. Since the entire voltage drop across the tube must appear on the very small surface of the anode the drop takes place in a small distance or space. Therefore, there is a very large voltage per unit of area and any electrons in the vicinity will be attracted at high speed.

On the half cycle which makes the large electrode positive, the potential drop is distributed over a large area and the voltage at any one place is not so high. Therefore, ionization will not take place on this half cycle. On the other half cycle, however, owing to the high voltage drop near the point of the electrode, ionization takes place and a high current will pass to the anode.

Another type of rectifier of very great virtues in the control of large amounts of power is the three-element gaseous rectifier known in the trade as thyatron or grid-glow tube. In this tube the current can be prevented from starting, even though the anode is positive, by placing a certain negative bias on a third element or grid. Thus the tube can start conducting as soon as the anode is positive, or it can start at any point in the cycle by adjusting the relation between grid and plate voltages. For each positive anode voltage there is some grid voltage which will permit the tube to conduct.

Once the anode current starts to flow the grid loses control and the tube acts like an ordinary gas rectifier until the end of the half cycle when the grid will again get control.

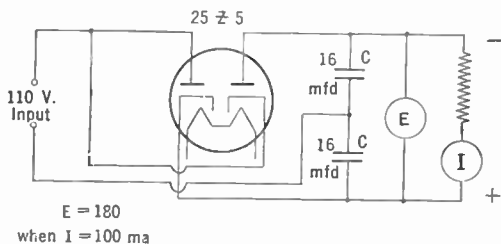

FIG. 248.—Use of a rectifier with two plates and two series cathodes to double the input voltage.

323. Characteristics of gaseous rectifiers.—The most important features of this rectifier are good regulation and low internal drop.

The output is somewhat harder to filter than the output of a high-vacuum rectifier; there is a tendency for r.-f. oscillations to occur. Therefore small chokes are connected in the plate lead when the tubes are used in sensitive radio receivers.

324. The Tungar rectifier.—The Tungar rectifier introduced in 1916 is a low-voltage, high-current tube of the combined gaseous and filament type. It is designed to rectify a.-c. current into a form suitable for charging batteries, and as a matter of fact was used to supply current for the filament circuits of some early models of a.-c.-operated radio receivers. Its starting or breakdown voltage is about 15 volts and useful life about 2000 hours. The gas is usually argon.

A diagram of the connections of a typical tungar rectifier are shown in Fig. 249. It consists of a transformer to reduce the input a.-c. voltage from 115 to from 30 to 75 volts; the tube itself, which is a simple

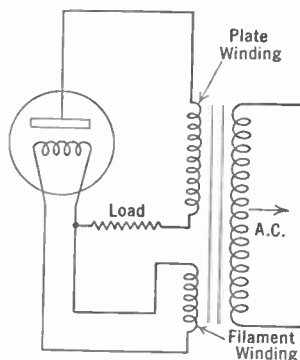

FIG. 249.—Tungar rectifier circuit.

itself, which is a simple

two-element gaseous tube, consisting of a plate and a filament.

The theory underlying the Tungar rectifier does not differ essentially from that already described for the filament and gaseous types of tubes. The filament supplies the electrons which bombard the inert gas and thereby produce more electrons and enable such a heavy current as 2, or even 5 amperes in the case of larger tubes, to be carried across the space between plate and filament.

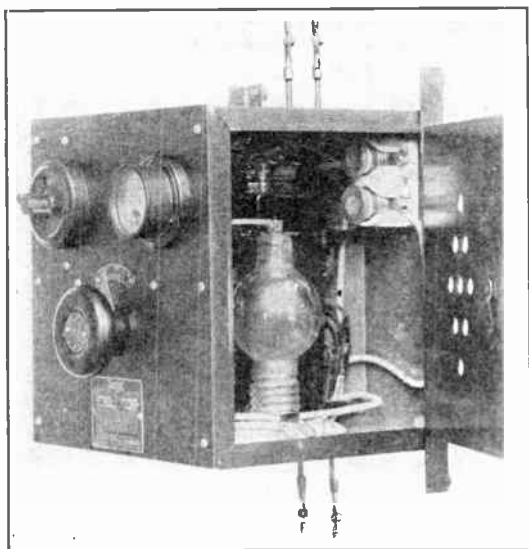

FIG. 250.—A typical Tungar rectifier.

Gaseous tubes with which radio amateurs are familiar are of a high-voltage, low-current type such as the 866. These are used for transmitters, and large ones will supply power to the amount of many kilowatts at 10,000 or higher voltages. In fact, such tubes have largely replaced high-vacuum tubes for transmitter purposes. The low voltage drop has been simulated, however, in high-vacuum tubes for certain purposes by using very small spacing between cathode and plate. Gaseous tubes create radio-frequency disturbances and must be carefully filtered.

325. The copper oxide rectifier.—The copper oxide rectifier is outstanding among rectifiers by virtue of its simplicity and reliability. The rectifier consists of a sheet of copper on one side of which has been formed a coat of cuprous oxide (Cu_2O). Properly made, this combination has relatively low resistance in the direction oxide-to-copper, with very high resistance in the reverse direction.

The units are generally made in the form of washers, of $1\frac{1}{2}$ inch outside diameter. These washers are then assembled in any desired series and parallel arrangement on mounting bolts. Soft metal washers are placed between the oxide layer and the adjacent metal surface for the purpose of improving the contact with the oxide. The surface of the oxide is graphitized for the same reason.

This rectifier operates electronically and not electrolytically. Rectification commences instantly on the application of voltage, with no forming or transient condition interposed. Current is carried not at points but uniformly over the available area. Furthermore, the rectifying elements can be paralleled to any extent. Operation in series presents no difficulties, as the discs divide the voltage with approximate uniformity.

The outstanding feature of the rectifier is its long life. Units on continuous duty life test, with battery load, show a reduction of a little over 20 per cent in charging current in $3\frac{1}{2}$ years' operation. This is remarkable performance for a rectifier, since it operates entirely without attention or maintenance.

There are no limitations to the application of the copper oxide rectifier. It may be used either half wave or full wave. The bridge connection is commonly used since it simplifies the transformer design and furthermore permits units to be operated direct from the a.-c. line without intervening transformer if so desired. The quality of the d.-c. wave obtained is excellent so that filtering is readily accomplished. Battery charging, battery elimination, magnet operation, loudspeaker excitation, etc., in fact almost any d.-c. application can be successfully handled by the copper oxide rectifier. They are often used in measuring instruments. Thus a d.-c. movement can utilize the rectified current produced by a copper oxide disc when a.c. is applied. The disc is kept as small as possible so that it will have low electrostatic capacity.

326. Filter circuits for tube rectifiers of the filament type.—

There are several kinds of rectifier tubes as described in Section 319.

The output of the rectifier circuit is not an even flow of current at all. In a loud speaker it would make considerable noise, or if used in a radio receiver without further alteration the hum would be intolerable. The next step after rectification is filtering.

A good plate voltage supply device, then, consists first of a transformer which raises the a.-c. voltage to the value required by the receiver plus the losses in voltage in rectifier, filter and voltage divider. Second, the rectifier which performs the task already described. In the third place comes the filter whose task it is to smooth out the pulsations of current in the plate circuit of the rectifier so that the final product will be d.c. of constant amplitude and a minimum amount of a.c. in it, and of a voltage high enough to supply the voltage and current required by the receiver and amplifier as well as the losses in the device itself.

A conventional filter circuit consists of series inductances which smooth out the ripples of current and keep the current flowing at the a.-c. voltage reversals, and shunt condensers which act as reservoirs of voltage as described in Section 73. A two-section filter, that is, two chokes and their accompanying condensers, is usually employed. The amount of filtering necessary depends entirely upon the amount of residual hum that is tolerable after the filtering has taken place. A very quiet power supply device is required in those receivers which have a rather high audio-frequency voltage amplification and which amplify frequencies as low as 120 to 60 cycles.

There is always a certain amount of a.-c. voltage left after the filtering has taken place. This voltage is a matter of millivolts compared to several hundred volts of d.c., but even these small a.-c. voltages may become objectionable when a loud speaker that is efficient at low frequencies is used. This voltage is a combination of the fundamental frequency, 60 cycles, and its harmonics. In double-wave power supply devices the second harmonic or 120 cycles is particularly strong.

A good loud speaker which reproduces notes as low as 120 cycles will hum badly when used with a power amplifier which gets its

voltages from a poorly filtered supply. Even with a very good filter, some a.-c. voltages are likely to be picked up by the cores of audio transformers if they are near power transformers carrying a.-c. currents. The ultimate extent to which hum may be reduced may be the amount that transformers can be shielded from stray fields, and not the extent to which a rectifier's output may be filtered. The push-pull amplifier may be operated from incompletely filtered supply. The rest of the current required from the B eliminator can be carefully filtered at reduced cost.

327. Regulation.—After passing through the filter the circuit returns to the transformer through the terminal resistance which acts as a potentiometer to reduce the full voltage to the values desired. If the full voltage is 180 volts, a tap at the proper place will give 90 volts and another will give 45 or any other desired voltage. Now it is apparent that the voltage across this resistance depends upon the current through it, and if there were no other resistances in the circuit Ohm's law would tell us at once what the voltage across the resistance would be. Unfortunately the transformer, the rectifier tube, and the filter chokes all have resistance, so that the greater the current taken from the whole device the lower is the voltage across its output. From batteries one gets 90 volts for his tubes whether he runs one or a dozen of them; the drain from the batteries is all that changes. With a voltage supply device, however, the voltage at the amplifier tap would be less than 90 if the current taken from it exceeds a certain amount. This is a distinct disadvantage from every standpoint but one.

In a high-resistance system it is difficult to blow up tubes. If a B battery is put across a tube, the filament immediately becomes very bright and probably burns up because too much current goes through it. The current that can be taken from a high-resistance device is limited and so it is doubtful if enough current could be secured to damage the tube. This, however, is a rather dubious advantage.

A series of curves showing the output voltage at various output current drains gives what is known as the **regulation** of the device, that is, the manner in which its voltage drops with increase in cur-

rent taken from it. The history of plate supply devices can be traced in a record of the regulation of such units, the older they are the worse their regulation curves, or the higher their internal resistance. The steep regulation curve of an early "B eliminator" may be seen in Fig. 251.

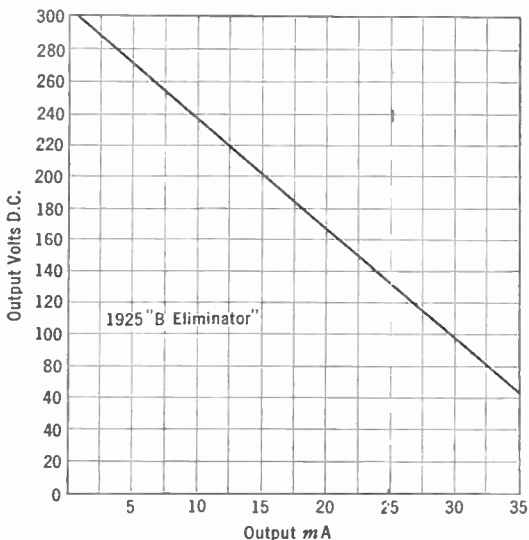

FIG. 251.—Regulation curve of early "B eliminator." Note the great voltage drop.

328. A typical rectifier-filter system.—Several curves showing the relation between the current and voltage in a modern rectifier-filter are shown in Fig. 252.

The losses in voltage are those due the IR drop in the resistance of the tube and the transformer. In Fig. 252 the voltage across the output resistance of the filter would be less than these voltages by the drop in the filter resistance. If the filter chokes have a d.-c. resistance of 1000 ohms there would be an additional drop of 1 volt per milliamperere of current from it.

A transformer which supplies 220 volts to each plate of a CX-380 tube will deliver a voltage of 220 across the input to the filter

and if the latter has a resistance of 1000 ohms about 150 volts will appear across the output at a current drain of 65 ma.

The variations in transformer voltage, current through the tube, and steady load current are shown in the oscillographs in Fig. 253. The fact that abnormally high instantaneous values of currents must be passed by the tube is clearly shown in the tube current wave. No current flows until the transformer

voltage reaches a certain minimum value and current ceases to flow as the voltage across the transformer secondary decreases. The peak current rises as high as 310 milliamperes; and on the

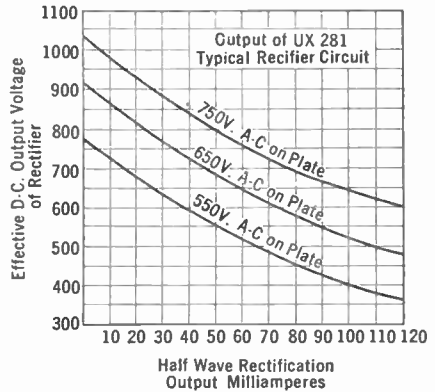

FIG. 252.—Output of modern rectifier.

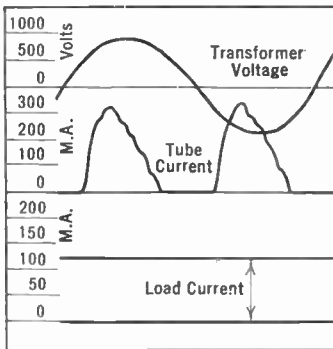

FIG. 253a.—High instantaneous current required from rectifier with capacitive input.

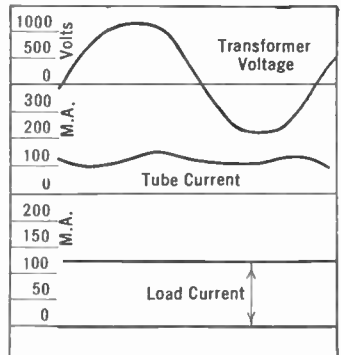

FIG. 253b.—Reduced tube current in an inductance input filter.

assumption that the resistance of the tube remains constant, the power lost in it increases as the square of the current, showing that this high current puts a severe burden on the tube. As a

matter of fact the internal resistance of the tube is almost constant, decreasing somewhat at higher current loads.

If the first filter condenser is removed and placed across the output, as shown in Fig. 254, not only does the peak current passed by the tube decrease, thereby decreasing the power lost in it, but the regulation is improved. The disadvantage of such a connection is slightly greater hum output and the fact that the output voltage is decreased by about 20 per cent. This loss in voltage may be made up by increasing the secondary voltage of the transformer, and even then the power losses in the tube will be less. The peak current passed through the tube in the second case is about 140 milliamperes when a steady current of 125 ma. is

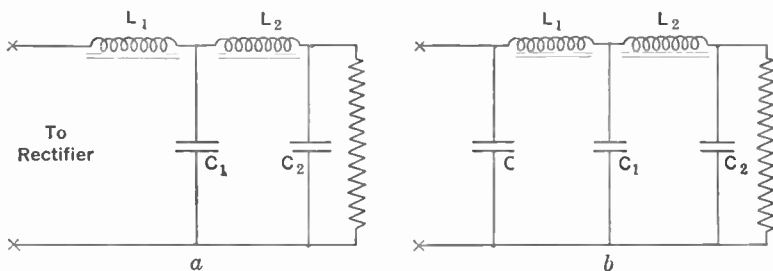

FIG. 254.—Two types of filter; *a*. inductance input, and *b*. capacity input.

required, thereby reducing the power losses in the tube by about 35 per cent.

The connection which omits the first filter condenser increases the life of the tube, permits the use of a tube whose emission has fallen below the point at which the tube would be useless in a capacity input filter, gives better regulation at current drains over 20 ma., reduces the filament emission required, and reduces the heating of the tube.

Using chokes of 11.5 and 13.5 henries for L_1 and L_2 and 4-mfd. and 8-mfd. condensers as C_1 and C_2 , a hum output of 44 millivolts was reported as typical. Although the amount of hum that can be tolerated is a matter of opinion, the following figures may be useful. With a sensitive dynamic speaker in a 3-foot baffle, a 120-cycle voltage of 540 millivolts across the primary of the trans-

former feeding the speaker was too loud for comfort. A desirable maximum was 150 millivolts. At 60 cycles these values were 5.2 and 1.3 volts. These values depend upon the loud speaker.

Small receivers with inadequate baffle and using small speakers can be fed from very poorly filtered sources of supply.

329. Automotive receiver power supply.—In 1933 a very rapid development of new methods of supplying high voltage from low-voltage direct current took place. Neglecting the motor generator or other types of rotating machinery whose use is obvious, the general method of attack was to interrupt the battery voltage

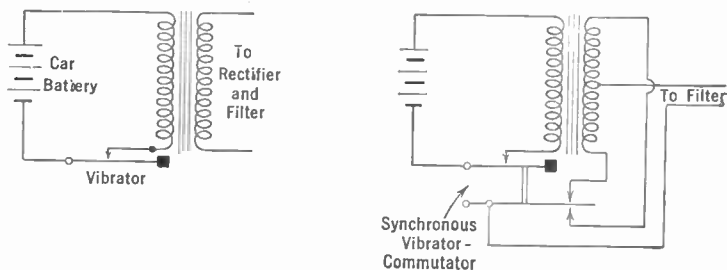

FIG. 255.—Simple vibrator to produce a.c. from d.c. and combined interrupter and rectifier.

(6 volts) producing pulses which were fed into a step-up transformer and then rectified and filtered.

In most devices the vibrator rectifies as well as interrupts by operating in synchronism with it a commutator which feeds the output of the transformer in one direction only to the filter.

330. The voltage divider.—The maximum voltage available is usually applied to the plates of the tubes. Sometimes the power tubes require higher voltages than the other tubes, but in general radio receivers are designed to use tubes which take 250 volts on the plates if a.-c. operated and 180 if battery-operated. The screens require lower voltages. Grid bias voltages must be negative.

The screen and lower positive voltages are usually supplied from the maximum voltage by means of a voltage dropping resistor properly filtered. The bias resistors may appear in the cathodes

of the individual tubes or in the negative lead to the power supply system. Sometimes a resistor known as a voltage divider may be put across the entire output of the filter and various taps brought out with the proper voltages. Thus the entire plate current of all the tubes flows through some part of this resistor. In other cases the voltage divider is a part of the bias system. The following description, although of older practice, illustrates the purpose of the voltage divider.

Let us consider the preliminary diagram in Fig. 256. Disregarding for the moment the resistance across the B voltage terminals, it may be seen that the plate of the tube gets its positive potential by being connected to the positive end of the plate supply unit.

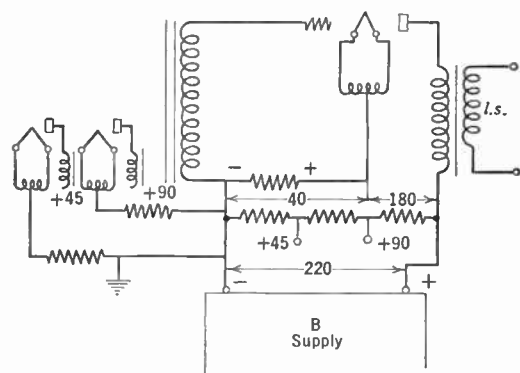

FIG. 256.—How the voltage divider originates.

The negative end of the unit is connected to the center of the filament through a resistance. The plate current must flow through this resistance and there is a voltage drop across it. The grounded end of the B plate supply unit is the most negative point in the circuit. Going through the resistance toward the filament and thence toward the plate through the tube we proceed steadily toward a more positive point in the circuit. The filament end of the C bias resistor marked (+) is at a higher or more positive potential than is the grid end. The grid end, then, is negative and the voltage drop across this resistor, due the plate current flowing through it, may be used as the C bias for the tube. The voltage actually between the center of the filament and the plate is the total voltage across the plate supply unit minus the C bias voltage; or as shown in Fig. 256, the plate supply unit must have a terminal voltage of 220 in order to place a voltage of 40 between grid and filament and a voltage of 180 between plate and filament.

It is now only necessary to place a resistance across the plate

voltage supply unit so that various voltages appear along it, each voltage being less than the voltage across the two ends. It is only necessary to fix the values of the taps so that the voltages desired are attained.

If another *C* bias is needed another resistor can be connected to the negative end of the plate voltage supply and the filament of the tube requiring the bias. The plate current of that tube flowing through the new resistor to return to the filament, the source of the electrons, will cause a voltage drop across the resistance the negative end of which is toward the grid of the tube in question.

There is another method whereby the 40-volt bias for the power tube is tapped and lower voltages are obtained for other tubes. Such a method is liable to lead to unwanted couplings between tubes. For example, in a radio-frequency amplifier such a method of obtaining bias may lead to regeneration or even oscillation because the plate current of some tubes flows through the *C* bias of other tubes.

Both these *C* bias connections are shown in Fig. 257. One set is in series, the other is a parallel set. The importance of by-passing all such resistors has been mentioned in Section 233. A better method is to make the voltage divider part of the amplifier, as in Section 233. It is only necessary then to supply one *B* plus voltage to the amplifier.

It is good practice in receiver design to supply all plates at, say, 250 volts and to drop this voltage for screens, etc., with individual resistances and with capacities to cathode to act as filters.

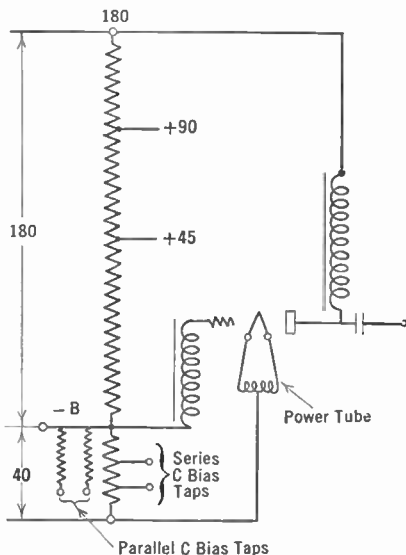

FIG. 257.—Both series and shunt *C* bias resistances are illustrated.

331. Engineering the voltage divider.—The lower the resistance of the voltage divider, the better will be the regulation of the entire device, but the

greater the load the tube must bear. In general a voltage divider is engineered as follows. In Fig. 258, suppose the current flowing through the resistance R_1 is 20 milliamperes. This is known as the "bleed" or "waste" current. It flows whether or not there are any tubes in the receiver that is supplied with voltage from the device. At the point B , a voltage of 45 is desired. The value of resistance, is, according

to Ohm's law, $E \div I$ and so is $45 \div 0.02$ or 2250 ohms. Since this tap supplies only a single plate circuit the current will be about 2.5 ma., and is added to the 20 ma. taken by the lowest resistance. Thus through R_2 flows 22.5 ma. and since 90 volts is desired at point C the resistance R_2 will be $45 \div 22.5$ or 2000 ohms. If the tubes which require 90 volts take a total of 15 ma. from the plate voltage device, the final resistance will be $180 - 90 \div 37.5$ or $90 \div 37.5$ or 2400 ohms. The entire resistance will be 6650 ohms, with taps at 2400, 2000, and 2250 ohms. The greatest amount of power must be dissipated by the 2400-ohm resistor and so if the entire resistance up to R_4 is wound with wire large enough and on a frame that can dissipate the heat corresponding to 4 watts, there will be no trouble. Voltage dividers are available which consist of a single winding of resistance wire on a heat-resisting form. There are several sliders so that the correct voltages can be obtained easily.

If any a.-c. current remains and flows through the voltage divider an a.-c. voltage will be applied to the receiver to which this

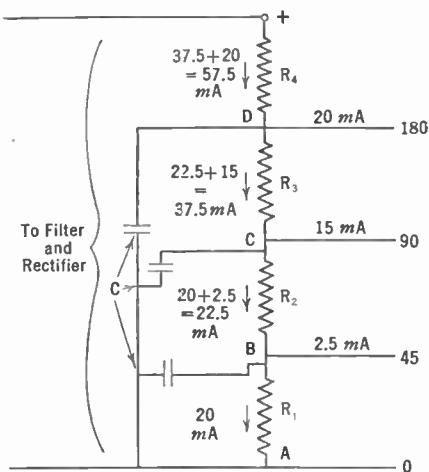

FIG. 258.—Designing the voltage divider.

part of the voltage divider connects. Hum results. If, however, a condenser is connected from the high voltage end of this resistor to the negative terminal of the divider, and if its reactance to the a.-c. voltage is small, the a.-c. currents will set up a small voltage across the low impedance of the resistor shunted by a high capacity.

Problem 1-16. The maximum voltage needed with the voltage divider of Fig. 258 is 180 volts, but the output of the filter is 200 volts under load. What is the value of resistance R_4 to reduce this voltage to 180 and what must be its power dissipation in watts?

Problem 2-16. Using a tube with a filament voltage of 7.5 volts and operated from d.c. the proper C bias is 50 volts. The plate current then is 25 ma. What is the voltage that must appear across the C bias resistor when the tube is operated from a.c. and when this resistor is connected to a center of a resistanceless transformer winding?

Problem 3-16. What power in watts is dissipated in each of the resistances in Fig. 258 under the conditions of Problem 1-16?

Problem 4-16. The resistance of the filter is 300 ohms. What must be the output of the rectifier if the output of the filter is 250 volts and if 40 ma. flow through the voltage divider resistance R_4 ?

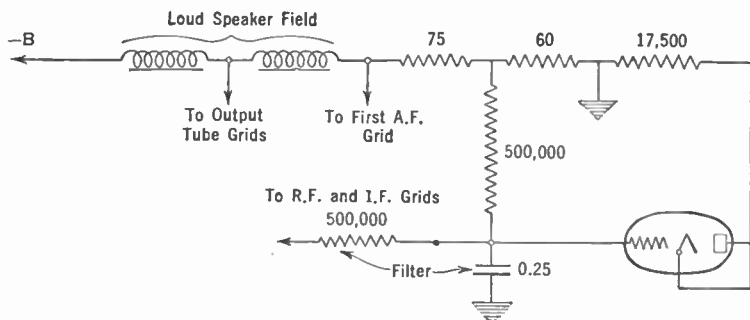

FIG. 259.—Circuit supplying bias voltages including a.v.c. bias.

A typical voltage-divider system providing C bias for several tubes in a superheterodyne will be found in Fig. 259. This bank of resistances is inserted in the minus B lead and uses the resistance of the loud speaker field winding as part of the voltage divider.

332. Voltage regulation.—In districts where the line voltages vary considerably from hour to hour or from day to day, trouble is had with the poor regulation. When the line voltage is high, the

filament or heater voltages on the tubes will be high and their life will be short. When the line voltage goes down the voltages on the tube go down and the receivers do not work properly. Several methods have been worked out to alleviate this difficulty.

One method involves the use of a line voltage regulator or ballast lamp which passes 1.7 amperes (UX-876, C-376) at any voltage between 40 and 60. The lamp is connected in series with the primary of the power transformer. If the line voltage averages 115 volts, the load is so adjusted that 65 volts appear across the primary of the transformer and 50 volts across the tube. Then when the line voltage varies the voltage drop across the tube varies and the voltage across the primary remains at 65 volts. The chief difficulty with this tube is its slow action. It requires several minutes for a steady condition to be reached. Other line ballast lamps have been used in the more expensive sets. In the cheap sets the user must take his chances with

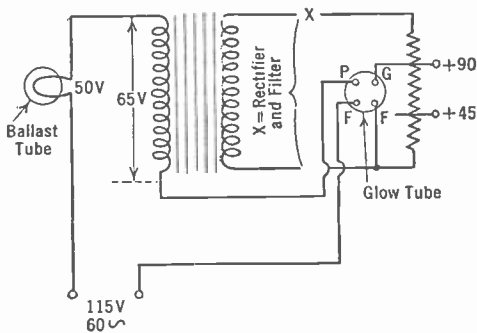

FIG. 260.— Ballast tube to maintain constant a.-c. voltage input to power transformer.

bad line conditions. In general, tubes have been so engineered that increases of filament voltage do not cause short life experienced with the old battery types of tubes.

A high voltage regulator (874) was used to some extent in receiving circuits. This is a gas lamp of two elements such that no current flows until a certain critical voltage across the tube is reached. Then the voltage drop across the tube is maintained regardless of the current taken through it. The glow tube (874) maintains 90 volts across it for current values of 10 to 50 milliamperes.

One method of connecting the glow tube is shown in Fig. 260. It will be noted that the plate and one filament prong of the

4-prong socket are connected in series with the line and the transformer primary. Since there are only two elements in the tube, these prongs are shorted within the base. Therefore the circuit in which such a tube is used will not operate until the tube is placed in its socket. The tube thereby acts as a switch preventing premature operation, or operation without the voltage regulator in position to carry out its function.

One of the most prevalent causes for tube failure in service is the varying line voltage conditions under which they must operate.

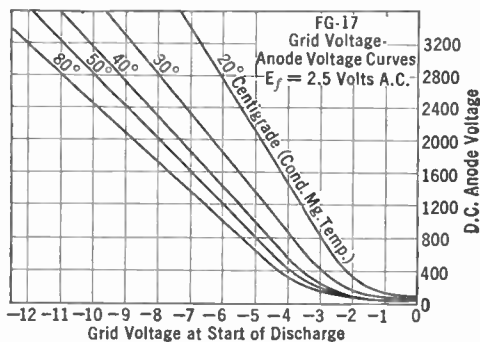

FIG. 261.—Characteristics of mercury-vapor thyratron. Note that the temperature of the tube affects the starting voltage.

In many towns the voltage at the light socket may vary as much as from 95 to 125 volts with corresponding percentage changes in the tube cathode voltage. In spite of the rough usage they get, home radio receiving tubes, on the average, last well over 1000 hours of actual operating time.

333. Controlled rectifiers.—A most important addition to the vacuum-tube family has been made in the thyratron (or grid-glow tube), which is a two-element gaseous rectifier with a control grid. The characteristics of such a tube present many interesting points. For example, if the grid is made negative by the proper amount no current whatever will flow to the plate even though it is positive with respect to the cathode. At any given plate voltage, however, there is a value of grid voltage which will permit current

to flow—and when this occurs all the current the tube can possibly create will flow, unless it is restricted in some way.

In other words, all the current flows, or none of it. There is another interesting characteristic. Once the current begins to flow, the grid has lost control over it and negative voltages on it make no difference—the current still flows. The only way to stop the flow of electrons from cathode to plate is to remove the positive voltage from the plate.

Thus the tube makes an important relay and can be used to key

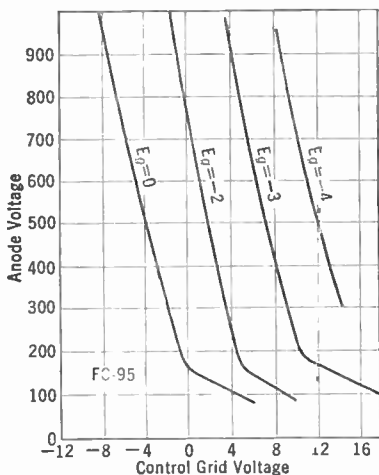

Fig. 262.—Characteristics of shield-grid thyratron. Note that various starting voltages are possible, dependent upon voltage of shield grid.

a radio transmitter or for any other purpose where the proper voltages and sequence of voltages may be applied.

Now suppose we place a.c. voltages on the plate and a fixed bias on the tube. Whenever the plate has reached the point in the positive half-cycle such that its positive voltage is high enough to overcome the inhibiting effect of the grid, current will flow. Then, at the end of the cycle, the plate becomes negative with respect to the cathode and current flow stops. By adjusting the bias on the grid the point in the cycle at which current starts may

be controlled—but it will flow throughout the rest of that half cycle.

Now if alternating current is placed on the grid as well as the plate and if the phase between grid and plate is adjusted, any amount of average current may be taken from the tube, from zero to the maximum cathode emission permissible. Thus the thyatron is a gaseous rectifier, with low internal voltage drop, which can supply many amperes of current under the control of the user by means of the variable phase between voltages on grid and anode.

The thyatron is becoming of considerable importance in non-communication applications, as in the control of power, and in broadcast stations and elsewhere in the radio system the useful characteristics of the tube are becoming recognized and put to work.

CHAPTER XVII

OSCILLATORS, TRANSMITTERS, ETC.

BECAUSE a tube acts as an amplifier, it can be made to generate a.-c. currents of constant amplitude and at frequencies covering the entire range from one or two cycles per second to well over 300 million cycles (one meter). Because the energy in the plate circuit of the tube is greater than exists in the input or grid circuit, some of this energy can be fed back by several ways into the input circuit and there amplified again. Starting with an initial oscillation in the grid or plate circuit, provided the coupling between input and output circuits is of the proper phase and magnitude, this oscillation can be repeated and amplified, until finally the tube maintains stable oscillations without the necessity of exciting the grid from any outside circuit.

Before endeavoring to learn how a tube oscillates, etc., we should get an idea of what the term "oscillation" means.

334. Oscillating circuits.—

One of the most famous experiments in all radio history is that of charging a condenser and letting it discharge through a resistance and an inductance. If the resistance takes the form of a gap (Fig. 263) in the circuit across which a spark jumps, a photograph of this

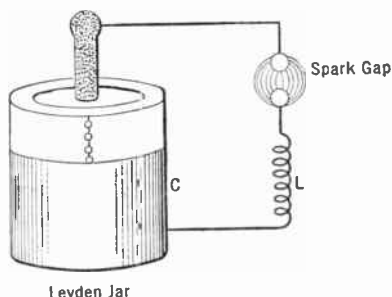

FIG. 263.—Familiar Leyden jar.

spark made on a rotating mirror oscillograph shows that during the instant of discharge the spark jumps back and forth across the gap several times, first in one direction and then in another.

In other words the current in the condenser surges back and forth across the gap instead of making one spark and thereby thoroughly discharging the condenser.

Now such a circuit will produce an oscillatory spark in the manner just explained if the resistance, inductance, and capacity have correct values. When such an oscillatory spark takes place, electric waves are set up in the ether. These waves have a frequency determined by the well-known expression:

$$f = \frac{1}{2\pi \sqrt{LC}}$$

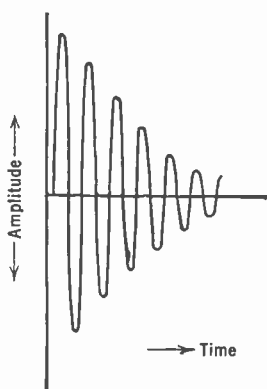

FIG. 264.—Highly damped series of waves.

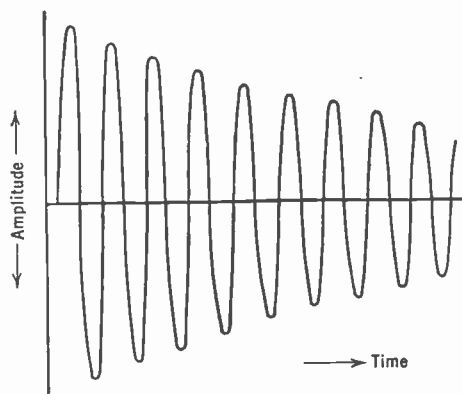

FIG. 265.—Slightly damped (low resistance circuit) waves.

If the resistance is too great, the spark will not set up such waves. The circuit is then non-oscillatory. If the resistance is decreased to a very low value, the number of oscillations that take place before the spark finally dies out becomes very great.

Thus in Fig. 264 the circuit has a high resistance; only a few oscillations take place and these at a rapid reduction in amplitude, each from the other. In Fig. 265 the resistance is very low and many oscillations take place, the amplitude falling off slowly. A circuit with much resistance is called **highly damped** because the waves decrease in amplitude—are damped out by the resistance—at a rapid rate. An **undamped** or **continuous** wave is generated

by a theoretical circuit with no resistance, or one in which there is a device which supplies the power wasted in the various resistance.

335. Undamped or continuous oscillations.—With a given circuit, if the resistance can be reduced to zero through some means—adding a negative resistance, for example, the damping factor due the resistance is wiped out and the circuit generates continuous-amplitude or undamped waves.

336. The amplifier as an oscillator.—Consider the box in Fig. 266, which is an amplifier. Any voltage put into it reappears in the output magnified by the amplification factor of the device. Suppose that the input is composed of a coil and condenser,

and that part of the output voltage can be coupled to the input coil. At the start suppose this coupling coil *T*, commonly called a tickler, is short-circuited, or removed from the input coil. Now if the condenser *C* is charged and then allowed to discharge suddenly by closing the key, *K*, oscillations will be set up which will die out at a rate depending upon the resistance of the coil and condenser.

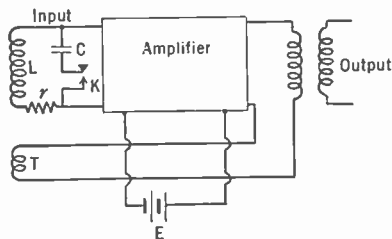

FIG. 266.—Essentials of an oscillator—an amplifier and feedback from output to input.

In the output circuit of the device will reappear an amplified version of these oscillations. They too will die out. The energy in them comes from some local battery, *E*, and the oscillations in the input circuit only serve to release some of this local energy. Now couple the tickler coil to the input in such a manner that the voltage induced into the input coil by ordinary transformer action is in phase with the oscillatory voltage. Then when the switch is closed, a voltage appears across the input, is amplified in the device, and in amplified form is impressed back on the input. This will cause an increase in the oscillatory voltage, and so the effect will be an ever-increasing series of oscillations, as in Fig. 267.

Ordinary oscillations are started in a tube circuit by thumping

the tube, or by turning on the plate battery, or by any sudden change in the electrical or mechanical constants of the circuit.

Oscillations in some circuits require appreciable time to build up to their final value. For example a loud speaker which "feeds back" mechanically into the elements of an amplifier may finally result in a steady howl. These elements may be those of a tube, or the plates of the tuning condenser (especially in short-wave sets). A tone from the loud speaker sets in motion the plates, let us say, thus changing the tuning. This change takes place at

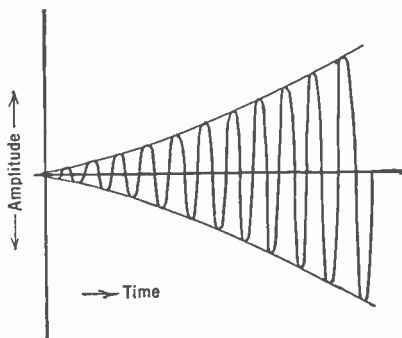

FIG. 267.—Building up of oscillations in resistanceless circuit or amplifier circuit.

an audio rate depending upon the natural mechanical frequency of the element in question. This audio tone is amplified by the following tubes and finally comes from the loud speaker. The vibrations from the loud speaker strike the plates and set them into even greater vibrations and finally the whole system howls, or oscillates at an audio rate. Microphonic tubes, particularly those with very small filaments, are prone to "bongs" which may be amplified and lead to steady howls which take a second or two to build up to final intensity.

337. Conditions for oscillation.—Oscillations depend upon the coupling between output and input, upon the fact that the device, usually a tube, can amplify, and the fact that a combination of inductance and capacity exists with resistance of such values that the oscillations have the desired frequency. It is more difficult to start and to maintain oscillations in a high-resistance circuit.

If the mutual inductance between grid coil and tickler is sufficient to start oscillations, it can be loosened with an increase in current. If the power in the oscillatory circuit is measured, it will be found to go through a maximum when the effective resistance

$\left(\frac{L^2\omega^2}{r}\right)$ becomes equal to the tube plate resistance. If the C bias on the tube is varied, it will be found that another value of mutual inductance will be necessary to make the tube oscillate. All these factors must be adjusted properly if maximum oscillatory power is to be supplied by the tube.

338. Maximum oscillatory plate current.—The oscillating tube may be thought of as an amplifier in which the exciting or input voltage which is amplified comes from the tube itself; in other words it is a self-excited amplifier. An alternating current flows in its plate circuit just as in any ordinary amplifier. What is the maximum value of this current?

Consider the tube working at the point A in Fig. 268. When oscillations start, the a.-c. plate current increases from a small value during the first few oscillations until it goes from zero to double the d.-c. value at A if a sine wave is being generated, or until the plate current curve flattens out. Then an increase in excitation does not result in an increased plate current (a.c.). The limit has been reached for the a.-c. plate current.

If the current at B is the saturation current, I_s , of the tube, the maximum a.-c. plate current will be

$$I_p = \frac{I_s}{2}, \quad (1)$$

and because the a.-c. plate current is equal to the a.-c. grid voltage

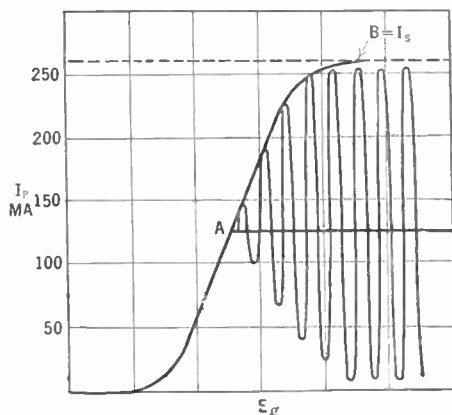

FIG. 268.—Manner in which oscillations beginning in tube circuit build up until entire characteristic of tube is utilized.

multipled by the mutual conductance of the circuit, or $I_p = G_m E_g$,

$$E_g = \frac{I_s}{2 G_m}, \quad (2)$$

which is also equal to the voltage induced in the grid coil by an a.-c. current flowing through the plate coil. This voltage is the current in the oscillatory circuit multiplied by the mutual reactance, or

$$E_g = I_L M \omega \quad (3)$$

from which we can calculate the current through this coil,

$$I_L = \frac{E_g}{M \omega} = \frac{I_s}{2 G_m M \omega} \quad (4)$$

$$= \frac{I_s}{2 \sqrt{2} G_m M \omega} \text{ (r.m.s.)} \quad (4a)$$

Example 1-17. Suppose the saturation current of a power tube is 100 milliamperes (a low figure) and the other constants in Fig. 271 are $L = 500 \mu h$, $r = 10$ ohms, $R_p = 7150$ ohms, $G_m = .76 \times 10^{-3}$, $M = 160 \mu h$, $f = 100$ kc. What is the peak and r.m.s. oscillatory current, that is, the current through the inductance, L , and what is the grid voltage due this current?

Solution.

$$\begin{aligned} I_L &= \frac{I_s}{2 G_m M \omega} \\ &= \frac{100 \times 10^{-3}}{2 \times 6.28 \times 100,000 \times .76 \times 10^{-3} \times 160 \times 10^{-6}} \\ &= 0.655 \text{ ampere} = .465 \text{ r.m.s.} \\ E_g &= I_L M \omega \\ &= .655 \times 160 \times 10^{-6} \times 6.28 \times 10^5 \\ &= 66 \text{ volts.} \end{aligned}$$

Problem 1-17. The voltage across the condenser in the tuned circuit of the above example is equal to the current through it (which differs but little from I_L) times the reactance of the condenser at the resonant frequency. Calculate the voltage across the condenser. The power used up in heating the resistance of the coil is $(I_L)^2 \times r$. Calculate this power (use the r.m.s. value of I_L). Let this be called the useful power supplied by the tube. The power from the plate battery is the product of the plate voltage and the plate

current = $I_p \times E_p$. If the steady plate current is 50 milliamperes and the efficiency of the system is 50 per cent, calculate the plate voltage necessary. The efficiency is the ratio of the power supplied to the tuned circuit to the total power supplied to the tube. Calculate this voltage.

$$\begin{aligned} \text{Thus,} \quad E_c &= I_c \times X_c \\ P_r &= I_L^2 r \\ P_T &= E_p \times I_p \\ \text{eff.} &= \frac{P_r}{P_T} \end{aligned}$$

339. Effect of coupling.—If such a circuit is set up in the laboratory, it will be found that oscillations occur over a rather wide range of coupling. Any one who has operated a regenerative receiver for short, medium, or long waves knows that the loudest signals are received just before the tube stops oscillating due to too loose coupling between the secondary or grid coil and the tickler.

Looking at formula (3) we see that the induced grid voltage, due to the oscillatory current, is proportional to the coupling between the grid and plate coils. This induced voltage must be at least equal to the original voltage there due to the condenser discharge in order that the oscillations may be built up. If the induced voltage is less than the original voltage, oscillations will last longer than if the tube were not present, but they will finally die out. The effect is as though we had reduced the resistance in this oscillatory circuit but had not completely removed it. When the induced voltage is equal to the original voltage, we have in effect reduced to zero the resistance of the circuit, and oscillations can keep up, although feebly. If, now, the induced voltage is increased all of the losses in the input circuit will be made up by the power taken from the local batteries (the plate battery) and continuous oscillations will take place, gradually increasing in amplitude until the entire characteristic of the tube is used.

If we start oscillations, and then decrease the coupling, and if E_o (induced) is to remain the same, the oscillatory current must *increase*. Thus, when the coupling is loosened, but not enough to stop oscillations completely, the oscillatory current

actually increases to make up the loss in induced voltage due to the decreased coupling. When the whole plate current characteristic is used by these oscillations, further decrease in coupling must decrease the exciting grid voltage, E_g , and oscillations cease.

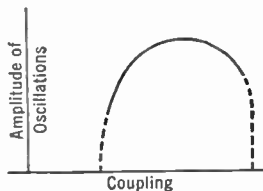

FIG. 269.—Effect of coupling between in- and output circuits.

If, on the other hand, the mutual inductance is increased, oscillations rise to a maximum and then fall off and finally cease entirely. The reason in this case for cessation of oscillations is

different from the above reason. It is due to an increase in the effective resistance of the tuned circuit, so that greater exciting voltage is necessary to overcome the increased losses.

The manner in which coupling affects amplitude of oscillatory current may be seen in Fig. 269.

340. Dynamic characteristics.—Because a change in grid voltage produces a change in plate voltage—just as in a resistance-coupled amplifier (Section 176), we can not use the static characteristic curves to predict the action in the tube. We must use the dynamic curves. In Fig. 270 are the static characteristic curves of a low- μ oscillator tube. When the grid voltage increases in a positive direction due to the exciting or induced voltage, E_g , the plate current increases but the voltage actually on the plate decreases because of the greater IR drop in voltage across the

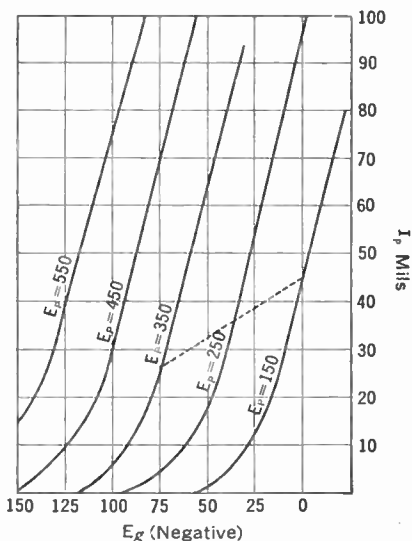

FIG. 270.—Characteristic curves of power oscillator tube. The dotted line is the dynamic curve used when the tube oscillates.

plate load. The operating point then may move along a curve like the dotted line. Because of the decreased slope of the dynamic curve compared to the static characteristic, the mutual conductance has decreased too, and it is not strictly correct to use the static value in equations (1), etc. It is approximately correct, however, unless the load in the plate circuit has a very high effective resistance, for example, a tuned circuit. In practice this load is made up of not only the resistance always in the circuit but the resistance "reflected" into it by transformer action by coupling an antenna to the plate coil by means of a mutual inductance and so has a fairly low effective resistance.

Modern tubes have such high values of saturation current that they are never operated at the point at which the d.-c. plate current is half the saturation value. Instead, they are so biased that the average value is such that the power dissipated on the plate is within the limits of safe heating. Then if sine waves are generated, the maximum value of the a.-c. plate current is twice the value read on the d.-c. meter. This value should be used in problems and examples instead of the saturation value. For example a UX-210 has a saturation current of an ampere or more, but such a tube could never be operated so that the d.-c. plate current would be of the order of 500 ma. Instead it is usually less than 100 ma.

341. Conditions for oscillation.—When the tube and circuit oscillate we can state that the resistance of the *LCR* circuit has been decreased to the point that any oscillation starting there will not be damped out. In other words, if the resistance of the circuit is R , we must supply $-R$ to it in order to get sustained oscillations.

In the circuit shown in Fig. 271 the value of resistance of the circuit when coupled to the grid coil is

$$R + \frac{L \pm \mu M}{CR_p}$$

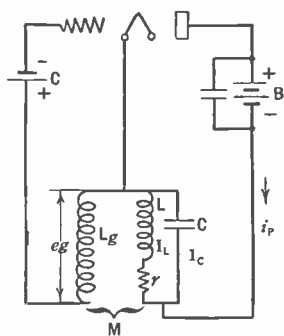

FIG. 271.—Tuned plate circuit (grid tickler) oscillator.

Now all of the factors in this equation are positive with the exception of M which may be either positive or negative depending upon how L is coupled to the grid coil. When it is connected so that oscillations occur, M is negative, and so the resistance R , in the oscillatory circuit is decreased. If the coupling coil is reversed, the total resistance in the oscillatory circuit is increased, and of course sustained oscillations cannot be built up. By making L , C , and M have the proper value, we can either add resistance to the oscillatory circuit—and then no oscillations are possible, decrease the total resistance to zero, or make it negative.

The latter case is true when $\frac{L \pm \mu M}{CR_p}$ is greater than R .

The conditions for oscillation then are:

$$\frac{L + \mu M}{CR_p} \geq R \dots\dots$$

or

$$M \geq \frac{L}{\mu} + \frac{CRR_p}{\mu}$$

or

$$M \geq \frac{CR}{G_m} + \frac{L}{\mu}$$

where the sign \geq means “is equal to or greater than,”

and \pm means “plus or minus.”

Another useful approximation is that the oscillatory current, I_L , is equal to I_p multiplied by the Q of the circuit.

A number of facts can be gathered from these formulas. The better the tube, that is, the greater its mutual conductance, G_m , the looser can be the coupling and still maintain oscillations; with a given tube whose mutual conductance is fixed, and with a given coil-condenser combination, a certain mutual inductance is required to start and maintain oscillations: the greater the resistance in

the tuned circuit the better the tube must be with a given mutual to maintain oscillations.

Problem 2-17. The mutual conductance of a power tube is 1500 micromhos, its amplification factor is 7.6 and its plate resistance is 3500 ohms. It is desired to generate oscillations of a frequency of 1000 kc. The coil to be used, in a tuned plate circuit as in Fig. 271, has an inductance of 200 microhenrys and a resistance of 30 ohms. Calculate the mutual inductance required to maintain oscillations. If the peak plate current is 100 ma.:

What is the maximum current, I_L , that can exist in the oscillatory circuit? If the power in this oscillatory circuit is $I_L^2 \times r$ and r is its resistance (30 ohms) what is the power dissipated there?

342. Efficiency of an oscillator.—As in an amplifier, when the grid is not excited, the power taken from the plate battery is equal to $I_p E_p$, and this power is dissipated in heating the plate of the tube. When oscillations take place the plate current and plate voltage vary about their average or non-oscillating values. The power taken from the battery does not change, but the power wasted in heating the plate decreases, part of it going into the load—just as in an amplifier (Section 189).

If the operating point is such that when the tube oscillates its maximum a.-c. is twice the value read in a d.-c. meter and once in each cycle is just reduced to zero plate current, the efficiency is 50 per cent. In Fig. 268 the average plate current is 0.125 ampere. The minimum value it can reach is zero and the greatest value it can reach is twice this value of 0.25 ampere. At the same time the plate voltage variations are from zero to twice the average value. In other words the variations in plate current are 0.125 ampere plus and minus 0.125 ampere, and the plate voltage is E_p volts plus and minus E_p volts. This is an a.-c. voltage whose maximum value is E_p volts, and an a.-c. plate current whose maximum is 0.125 ampere.

The power, as in a resistive a.-c. circuit, is the product of the effective current and the effective voltage, or

$$P = \frac{E_p}{\sqrt{2}} \times \frac{I_p}{\sqrt{2}} = \frac{E_p I_p}{2},$$

and since the power supplied by the plate battery is $E_p I_p$, one-half the power taken from the battery is wasted in the tube and one-

half is used in overcoming the resistance losses in the oscillatory circuit.

If we rate the efficiency of the plate circuit as the ratio between the total amount of power taken from the B battery, $I_p E_p$, to the power used in the oscillatory circuit, $\frac{E_p I_p}{2}$, we see that the above condition represents an efficiency of 50 per cent.

If the C bias of the tube is so adjusted that the operating point goes down on the lower bend, the steady plate current is small, and

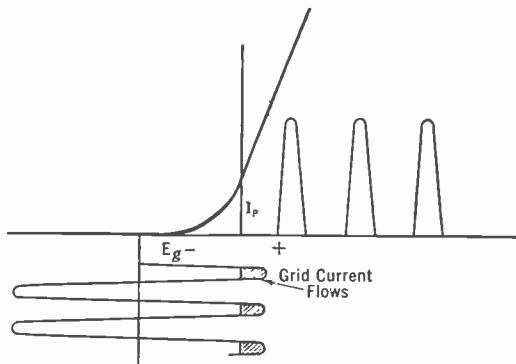

FIG. 272.—Form of plate current waves when tube is so biased that lower part of characteristic is used.

the power taken from the battery is small. As shown in Fig. 272, plate current flows only when the grid gets sufficiently positive to permit it, that is, when the operating point gets up far enough on the plate current curve for current to flow. Thus current flows during only a part

of the cycle, and because the a.-c. components decrease less rapidly than the average value of current, the efficiency may increase above 50 per cent.

343. Harmonics.—If a large C bias is used, the form of the oscillatory current is no longer a sine wave and of course many harmonics are generated. Thus an oscillator generating a wave form like that in Fig. 272 may be thought of as an oscillator producing a pure sine wave plus many harmonics. If the oscillator is used to supply power to an antenna which is tuned to the fundamental frequency, these harmonics put little power into this antenna provided it is coupled loosely enough to the tuned circuit.

On short waves this is of great importance, because of the carrying power of high frequencies. Thus if a tube oscillates at 40 meters

and puts out even a comparatively weak second harmonic on 20 meters, the latter signal can be heard over an area of many hundreds or even thousands of miles. A broadcasting station operating on 500 meters with a strong second harmonic can ruin another station's program operating on 250 meters, and so on.

There are times when it is desirable to generate a wave form that has many harmonics, or a particular harmonic of large amplitude. For example a quartz crystal is frequently used to control the frequency of a transmitter. Because the thickness of the quartz plate varies inversely as the frequency for a high-frequency circuit the crystal is very thin and there is danger of its breaking. For this reason a thicker crystal is used and a harmonic of the oscillator which it controls is used to drive a power amplifier which works into the antenna. The crystal circuit, then, is an oscillator which should generate a large second harmonic. By suitably adjusting the *C* bias such an output can be attained.

Such a highly biased tube will have strong harmonics of much higher order than the second, and if the frequency of the crystal is accurately known these higher harmonic components of the output of the tube can be used as standards of frequency over a very wide range. It is frequently possible to count up to the 50th harmonic of such a circuit. Thus if the fundamental frequency of the crystal is 500 kc., the 10th harmonic would be 5000 kc., and the 50th would be 25,000 kc.

344. Power output of an oscillator tube.—The power output from an oscillating tube depends upon the efficiency of the circuit and the amount of power that can safely be dissipated at the plate. If the circuit is 50 per cent efficient and if the tube can safely dissipate 50 watts on the plate, the output power is evidently 50 watts. If, however, a high *C* bias is used and a larger plate voltage, the steady power taken from the battery may increase appreciably but a smaller proportion of it is lost in the tube and of course more power into the load (the tuned circuit) obtained. Thus if the tube is 70 per cent efficient, and can dissipate 50 watts internally, the output power can be 117 watts and the total power supplied by the battery 167 watts.

When an amateur manages to put into his transmitting tube

twice the power for which it is rated, he may still be operating the tube as required by the manufacturer. He has increased the efficiency of his circuit by operating at a high C bias, and by making his output far from sine wave in form. The power lost on the plate may still be within the manufacturer's limit, and the power obtained from the plate voltage supply unit and usefully employed in putting signals into an antenna may be considerably increased. If, however, his tube stops oscillating suddenly, due to some maladjustment, the full plate battery power must be dissipated at the plate and it is almost certain to be melted and the tube destroyed.

Problem 3-17. An amateur desires to get 100 useful watts from a so-called 50-watt tube. This means that 50 watts can be safely dissipated at the plate. How efficient must his circuit be? If the plate voltage is 1000 volts, what will be the plate current? If his antenna has a resistance of 60 ohms at 40 meters, what antenna current must be put into it to radiate 100 watts?

Problem 4-17. The grid voltage necessary to excite a given transmitting tube is 100 volts. The frequency is 500 kc., the tuned circuit inductance, L_2 , is 200 microhenrys, the coefficient of coupling between grid coil and tuned circuit inductance is 0.3, the current in the tuned circuit is one ampere. What must be the inductance L_g of the grid coil?

$$E_g = M\omega I_L = M\omega \times 1.0$$

$$M = \tau \sqrt{L_g L_2} = .3 \sqrt{L_g L_2}$$

$$\omega = 2\pi \times 500,000.$$

Problem 5-17. The resistance of the tuned circuit when coupled to an antenna is 30 ohms. Its inductance is 300 μh , the μ of the tube is 8, its plate resistance is 5000 ohms, the frequency is 300 kc. What must be the value of M to make the circuit oscillate? On the assumption that the current in the oscillatory circuit is Q times the steady plate current (50 ma.) calculate the current through L .

Problem 6-17. The normal plate current of a UV 203-A tube is 125 milliamperes at a plate voltage of 1000. If the circuit is 65 per cent efficient, how much can the plate current be increased at this voltage without using more than 50 watts on the plate? What is the input and the output power under these conditions?

It is possible to get circuits of high efficiency by increasing the C bias so that plate current flows only during a part of the cycle when the grid is positive. At these times the plate current is high,

but at the same time the voltage actually on the plate is low—because of the fact that the grid and plate voltages are 180° out of phase and because of the high voltage lost in the load when the current is high—and so the power wasted at the plate is low. If the voltage at the plate could be reduced to zero no power would be lost there and the efficiency would be 100 per cent. Such conditions cannot happen, of course.

If the plate voltage is reduced to a value comparable to the grid voltage, the electrons from the filament would divide and more would go to the grid than ordinarily, with the result that the plate current would decrease. This would tend to increase the plate voltage, and so the limiting condition of zero plate voltage cannot be secured.

345. Maximum power output of oscillator.—As in an amplifier, the maximum power is converted from the battery to the load when the load resistance is equal to the tube plate resistance. Thus in Fig. 271 the effective resistance of the load is $L^2\omega^2/r$ which must be equal to R_p for maximum power output. This is not the condition for maximum efficiency, but is the condition for maximum power output under a given set of conditions. As a matter of fact the efficiency under these conditions is 50 per cent.

346. Obtaining grid bias by means of resistance leak.—During the part of a cycle when the grid is positive (shaded area in Fig. 272) the grid draws current. When the grid is negative it takes no current. There is in the grid circuit, then, an average grid current. This current can be made to flow through a resistance and, as in the case of a detector tube, be used to maintain the grid at a negative potential with respect to the filament. Since grid current flows it follows that some power must be wasted in the grid circuit. This power is that wasted in the grid leak, usually of the order of 5000 to 10,000 ohms, and that wasted in the grid-filament resistance. This power must be supplied by the plate battery, and lowers the overall efficiency of the tube and circuit. If the current is permitted to become very high the power dissipated in the grid may become too great for the tube to handle, and breakdown results.

In high-frequency circuits, the grid-filament capacity has low

enough reactance to conduct currents of considerable magnitude. These currents must flow through the grid-filament input resistance, and this represents another loss in power which must be kept below the value that is safe for the tube. A choke coil placed near the grid leak is one way to prevent unwanted oscillations

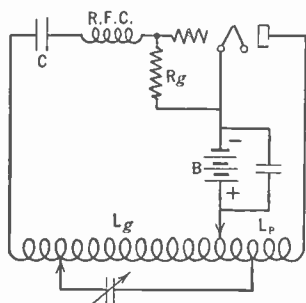

FIG. 273. — Hartley oscillator; grid current through R_g provides negative bias for the grid; choke R.F.C. prevents high-frequency oscillations.

occurring at a very high frequency partially determined by the tube capacities. (See Fig. 273.)

Problem 7-17. The grid bias required on a tube is 60 volts. If the bias resistance is 5000 ohms, what must be the grid current flowing? What power must the resistor be capable of dissipating as heat?

347. Practical circuits.—There are a number of circuits which with an amplifying tube will produce oscillations, that is, transform d.-c. power from a battery or plate supply system into a.-c. power. All that is necessary is a tube that will amplify,

coupling between input and output of proper phase and magnitude, and of course the filament, grid and plate power.

The coupling between input and output can be through inductance, mutual inductance, capacity, or resistance, or through the plate-grid capacity of the tube itself.

348. Hartley oscillator.—The simplest circuit, that is, the circuit which requires the least amount of apparatus, is the Hartley. It requires only a coil with taps on it, a tuning condenser, the tube and power supply. The coupling between plate and grid circuit is through mutual inductance between the two parts of the tuning coil, L_p and L_g . (The circuit is given in Fig. 273.) If the tuning condenser is placed across the plate circuit only, the circuit is exactly the same as Fig. 271. A.-c. currents flowing in the plate coil, L_p , induce voltages in L_g which are applied to the grid, amplified, and again applied to the plate coil. These voltages are 180° out of phase because they are at opposite ends of the coil with the center grounded to the filament. In Fig. 273 the plate

battery is placed in the center-tap so that it is at ground potential. In Fig. 271 the plate battery, which has a high capacity with respect to ground, is connected to the plate and thereby partially shorts the plate of the tube so far as radio frequencies are concerned. A better way is to use the circuit in Fig. 273. Since this circuit would make the grid and plate at the same positive potential, which is the potential of the B battery, the grid is isolated so far as d.c. is concerned by the blocking condenser. The proper bias voltage is secured through a grid leak to the filament or through a choke and *C* battery as in Fig. 274. The feed-back between grid and plate circuits is adjusted by varying the center filament tap. If more turns are in the plate coil a greater voltage will be induced into the grid coil ($L_o\omega I$) and so greater feed-back from plate to grid circuits would result.

For covering a wide range of frequencies with plug-in coils, the Hartley oscillator is useful. It is used most frequently in laboratory apparatus.

349. Shunt-feeding oscillators.—In Fig. 273 the B battery is in series with the plate coil. The terminals of the condenser, so far as d.c. is concerned, are at the same voltage as the B battery and of course this is exceedingly dangerous since the operator, who is standing on the ground to which minus B is attached, may touch the plates or shaft of the condenser, and thereby provide a short within himself for the full plate voltage.

To prevent trouble of this kind the plate voltage may be fed into the tube through a separate path by means of a choke coil and blocking condenser as shown in Fig. 274. Now the d.-c. potential of the plate is kept from the tuning coil and condenser by the condenser *C*. The reactance of the condenser must be low compared with the reactance of the choke at the desired frequency so that the plate coil is not short-circuited so far as r.f. is concerned.

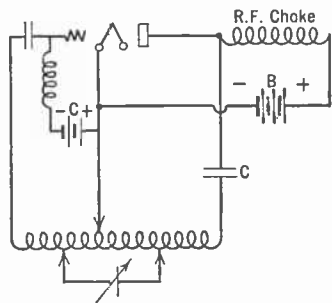

FIG. 274.—Shunt-feed Hartley oscillator keeps high d.-c. voltage from tuning condenser plates.

In a similar manner the use of a blocking condenser in the grid circuit and a choke for feeding the C bias into the grid is a shunt or parallel feed method of separating the d.-c. and a.-c. currents and voltages. In Fig. 274 there are no d.-c. currents or voltages on the tuning circuits, nor a.-c. currents in the C or B batteries.

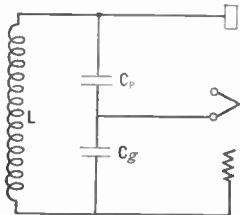

FIG. 275.—Fundamental Colpitts circuit.

350. Other oscillating circuits.—If the inductances and condensers in Fig. 273 are interchanged, as in Fig. 275, we have the Colpitts circuits, a typical arrangement of which is shown in Fig. 276. In amateur practice the tuning condensers are on the same shaft which is grounded to the filament.

The plate and grid d.-c. voltages are shunt fed under these conditions.

In Fig. 277 is the tuned-plate-tuned-grid circuit. Input-output coupling is provided by the tube's grid-plate capacity—one of the few places in radio circuits where this unwanted and obnoxious capacity is put to use. Whenever the plate circuit is tuned so that it is sufficiently positive in reactance, the system will oscillate, and it is not when the plate and grid are both tuned to the same frequency as many amateurs think. In this case the plate inductance must always be somewhat greater than that necessary to resonate the tuning condenser to the frequency at which the grid circuit is tuned. Tuning the plate circuit to a high wavelength, or lower frequency than the grid, is the same thing said in other words. This circuit has somewhat greater frequency stability because of the high-impedance plate load. In practice the C bias would not be shunt fed.

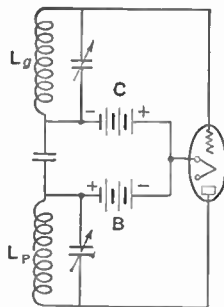

FIG. 276.—Practical Colpitts circuit.

A resistance feed-back that is employed in laboratory oscillations is shown in Fig. 278. As in all such circuits, the grid excita-

tion is greatest when the largest coupling between grid and plate coils is used. Then the plate current variations are considerable in magnitude, they use curved parts of the characteristic, and harmonics are generated. In a laboratory oscillator where harmonic production is to be kept to a minimum, the coupling between input and output circuits should be adjusted at each frequency to the least possible amount that will insure stable oscillations. The resistance feed-back method is useful in such oscillators because of the mechanical ease of adjusting the feed-back voltage.

In Fig. 278 the coils are iron core inductances and the currents generated are at audio frequencies.

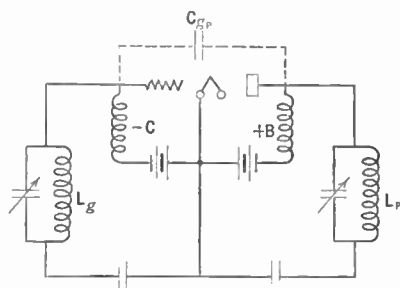

FIG. 277.—In the tuned-plate tuned-grid circuit C_{gp} acts as the feedback agency.

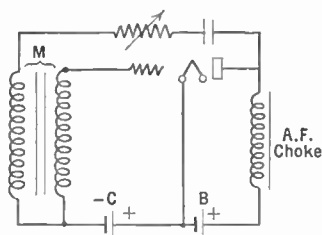

FIG. 278.—Circuit often used in low (audio) frequency oscillators.

351. Adjusting the oscillator.—When the oscillator is used to deliver power to an antenna it is desirable to attain the adjustment which will either deliver maximum output, or secure maximum efficiency so that greater inputs may be used. The tuned-plate tuned-grid circuit has no adjustments. The operator tunes either the plate or grid circuits until the tube oscillates and there is nothing else he can do. In fact, if he does not tune the circuit to an oscillating condition the plate current may be very high.

In the Hartley circuit, however, it is possible to move the center filament tap and so to get some control over the strength of oscillations, the feed-back voltage, etc. In Fig. 279 is illustrated the result of varying the filament tap on a simple 40-meter oscillator of the Hartley type. The curve gives the plate current, I_p , the

current, I_a , into an antenna coupled to the plate coil, and the ratio of antenna current to plate current as some measure of the efficiency of the circuit.

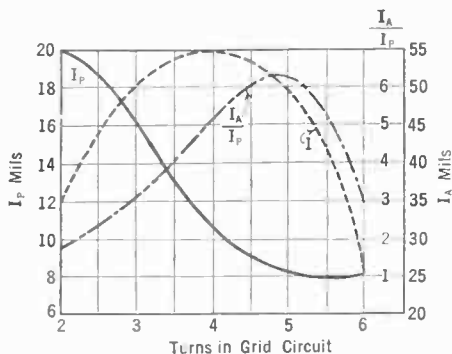

FIG. 279.—Effect of varying grid turns, thereby changing excitation.

too. The tube was a UX-210 oscillating at 1225 meters in a tuned plate circuit, Fig. 271. The effect of changing the C bias resistor of a tube in the tuned-grid-tuned-plate circuit is shown by Fig. 281.

352. Frequency stability. — When such circuits are used for transmission or for laboratory measurements where a constant frequency output is desired, complications set in. The

frequency of such circuits is determined chiefly by the inductance and the condenser across it. This condenser is also shunted by the input capacity of the tube. This input capacity

What is wanted, from an amateur's standpoint, is much antenna current and little plate current. The greater is this ratio, the greater is the efficiency of his circuit.

The connection between plate voltage and oscillating current is shown by Fig. 280 to be linear. The grid bias measured across a 5000-ohm resistor is plotted

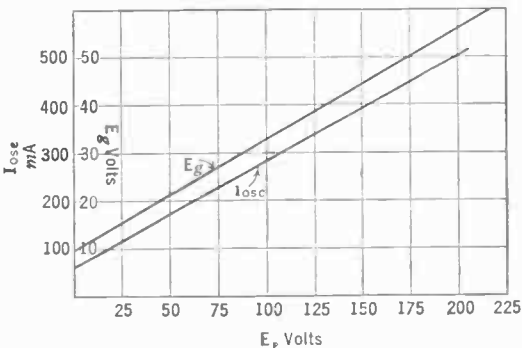

FIG. 280.—Relation between plate voltage and oscillatory current and grid bias.

is a function of the plate load and the grid-plate capacity of the tube. In fact the input capacity C_i as a function of the load and this grid-plate capacity is

$$C_i = C_{gp} + C_{op} \left(\frac{\mu R_o}{R_o + R_p} + 1 \right),$$

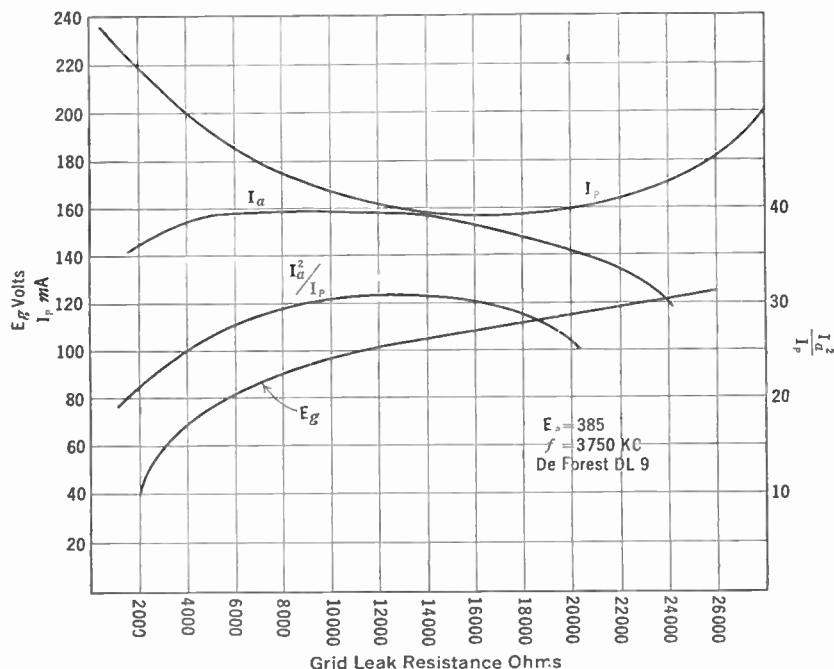

FIG. 281.—Effect of varying grid leak resistance.

which shows that any change in the plate resistance R_p of the tube or in the grid-plate capacity of the tube, or the output load R_o produces a change in the grid-filament capacity which may have a share in determining the frequency to which the system oscillates. Changes in filament temperature, in C bias, or in plate voltage will affect the plate resistance of the tube and change its relation to the load resistance. Such changes produce a change in frequency of

the oscillator's output. The smaller is the plate load, the larger the grid-plate capacity; the greater the plate resistance of the tube, the more will the generated frequency depend upon these factors.

One way to lessen this difficulty is to make the fixed input capacity of the tube which is across the tuned circuit so large compared to its normal grid-filament capacity that changes in the latter are unimportant. Thus, shunting a fairly large capacity directly across the grid and filament will increase the total effective input capacity so that small changes in the internal capacity of the tube will have little effect upon the tuning.

Another method is to make the tuning condenser very large, in other words to use a high-capacity-low-inductance circuit. Such circuits have large circulating currents in them, but small voltages, and at times are very inefficient.

353. Master oscillator systems.—Where large amounts of power are to be transferred to an antenna, or other load, the place of the single oscillating tube is taken by a smaller oscillator and a large power amplifier driven by this tube. In other words we have a self-excited oscillator and a separately excited amplifier. If the oscillator is carefully stabilized against frequency changes, the output of the amplifier will be constant too. Changes in the load (the antenna for example) into which the amplifier works will not affect the frequency at which the oscillator is generating.

Such a system is called a "master oscillator, power amplifier" system and is used in all broadcasting stations and all transmitters of appreciable power. The oscillator can be of any conventional type; the amplifier may be a single tube, may be several in parallel, or push-pull, or several in cascade, just as in audio amplifiers. The chief difference lies in the fact that considerable power is being handled and so the circuits are made up of heavy conductors and use large water-cooled tubes which may use plate voltages as high as 10,000 volts and several amperes of plate current. (See Fig. 282.)

The amplifiers may be neutralized—usually are—or they may use screen-grid power-amplifying tubes which have very low grid-plate capacities and so need no neutralization.

A simple master oscillator system is shown in Fig. 283. Here

the power amplifier is a 50-watt tube which is to be operated at 50 per cent efficiency. That is, 50 watts go into the load, and 50 into the tube. If the plate voltage is 1000 and the instantaneous voltage on the plate is to be just reduced to zero once in each cycle, the peak a.-c. voltage will be 1000. If the μ of the tube is 25, the a.-c. grid voltage must be at least 40, and if the inductance of the oscillator plate circuit is known it is a simple matter to calculate the current that must flow through it to set up a voltage of 40 with which to drive the following tube.

354. Crystal control apparatus.

—A quartz crystal cut with proper respect to its optical axis has the ability to control the frequency of an oscillator to a remarkable degree. When such a slab of quartz is compressed mechanically, an electrical difference of

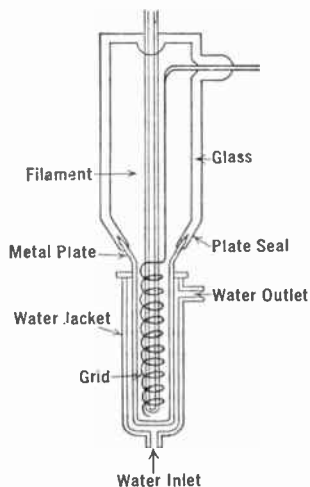

FIG. 282.—Construction of water-cooled tube.

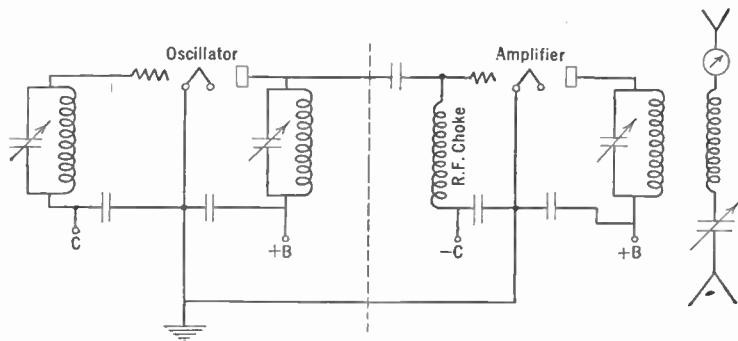

FIG. 283.—Master oscillator-power amplifier transmitting circuit.

potential is generated across its two faces. Conversely, when such a difference of potential is set up across its faces, it tends to change

its size. It may be thought of as a tuned circuit whose frequency is fixed by the dimensions of the crystal. The thicker it is the longer the wavelength to which it resonates. The manner in which

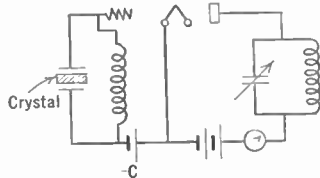

FIG. 284.—Place of crystal in oscillator circuit.

the crystal is cut is of utmost importance; if it is cut in one manner, the relation between frequency and thickness is 2.64 meters per thousandth inch, and if cut in another, the relation is 3.87 meters per thousandth inch. A crystal quartz plate 1.0 millimeter thick will resonate to 2860 kc.

If connected as in Fig. 284 it takes the place of the tuned grid coil in the tuned-plate tuned-grid circuit. For several degrees of the plate tuning condenser the output frequency is that of the crystal, and so changes in plate resistance of the tube, battery voltages, etc., will have a relatively small effect on controlling the frequency at which the circuit oscillates.

The frequency at which the crystal resonates depends to some extent upon the temperature of the crystal. In the best transmitting stations, the crystal plate is maintained at constant temperature by complicated thermostats and electrical heating coils. Then the frequency of a broadcasting station can be maintained

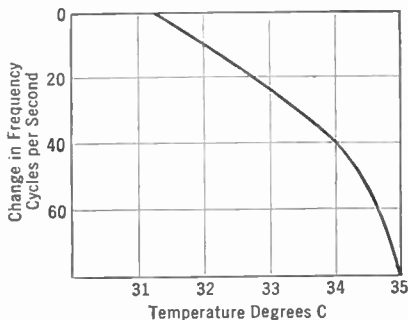

FIG. 285.—Effect of temperature on frequency.

within 5 cycles of its assigned frequency, say 1000 kc. This is an accuracy of 5 parts in one million or 0.0005 per cent. The effect of temperature on a small oscillator may be seen in Fig. 285, and the effect of changes in plate voltage on the oscillator tube in Fig. 286.

355. Frequency doublers.—The amount of power a crystal can control is limited. If the crystal is called upon to handle too much

power it is liable to crack. The power that can be controlled is about the output of a 5-watt tube on broadcast and higher frequencies where the plate becomes very thin, and certainly not over 50 watts can be controlled with safety.

The crystal oscillator is followed by amplifier stages until the required amount of power is ready for the antenna. These stages of amplification can be single tubes neutralized if necessary; they may be push-pull tubes, they may be tubes in parallel. The purpose of each succeeding tube is to provide a voltage at the required frequency and of the required magnitude which may be used to drive the grid of the next tube.

For high frequencies the problem of crystal breakage, and from oscillation in the amplifier stages, becomes serious. The method usually followed is to use a fairly large crystal which drives an oscillator. Let us suppose

the antenna is tuned to 40 meters. The crystal may oscillate at 160 meters. The tube is so biased that it generates a strong second harmonic, or 80 meters. This 80-meter output is fed into the grid of the next tube, whose output may be tuned to the second harmonic of 80 meters, or 40 meters. Neither of these amplifiers shows much tendency to oscillate because of the fact that the input and output circuits are tuned to different frequencies. By proper values of C bias a strong harmonic can be secured and the final power tube driven by a 40-meter voltage.

Such transmitters can operate from either a.c. or d.c. If they are to be used for telephone transmission, broadcasting, for example, pure d.c. is necessary. For code transmission some slight ripple in the output is probably desirable if the signals are to be copied by ear at the receiving station. If they are to operate a relay and mechanical apparatus, the character of the signal may

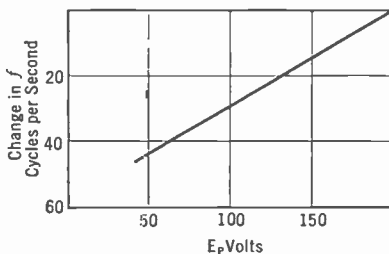

FIG. 286.—Effect on frequency of changes in plate voltage of a crystal-controlled oscillator.

be adapted to the receiving apparatus, or ignored entirely. A "frequency doubler" is shown in Fig. 287.

356. Self-rectified transmitters.—When a.c. voltages are

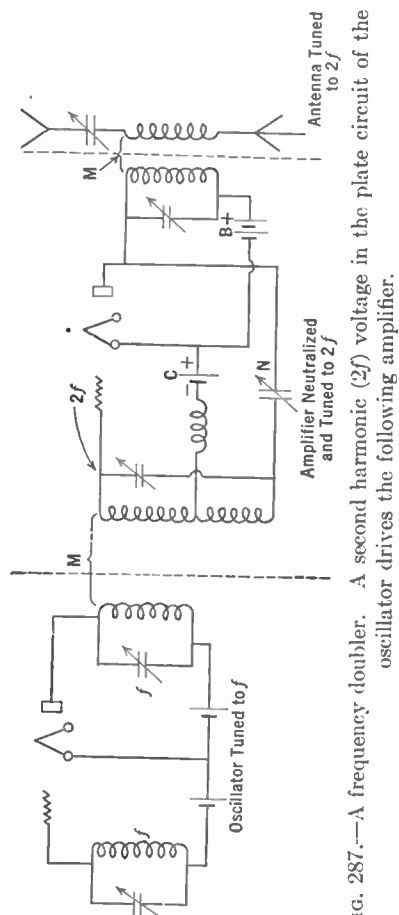

FIG. 287.—A frequency doubler. A second harmonic ($2f$) voltage in the plate circuit of the oscillator drives the following amplifier.

applied to an oscillator tube, it rectifies them and plate current flows during the time the plate is positive. In other words, the circuit oscillates half the time. On the negative half-cycles the circuit is non-operative. The signal as it is heard at the receiving station has a characteristic note depending upon the frequency of the transmitter power supply, and the adjustments at the transmitter. A transmitter of this type is called a self-rectified circuit because the tube furnishes its own plate voltage by rectifying an a.-c. wave. Two such tubes may be used in push-pull or "back to back" to rectify and oscillate on opposite halves of the a.-c. cycle. The transmitted note then will have double the frequency of a single-wave rectified transmitter. A circuit of this kind is shown in Fig. 288.

Such transmitters take up more room in the ether than is

desirable, and even though controlled by crystal seem to vary from their assigned channel because of variations in the audio-frequency modulations. A transmitter using 500-cycle source of plate voltage will require a channel width of 1000 cycles

when holding its key down. Ether space required for it depends upon adjustments of several circuit factors.

357. Adjusting the plate load to the tube.—The condition for maximum output of a tube with a given amount of power to be taken from the plate battery is that the load into which the tube works is equal to the plate resistance of the tube. The load is the resistance of the tuned circuit. Now the value of L and C are more or less fixed in this circuit, which leaves the series resistance as the only independent variable factor. Suppose, for example, we desire to generate oscillations 1000 kc. in frequency in a tuned circuit. This determines the frequency. We can choose L and then C is

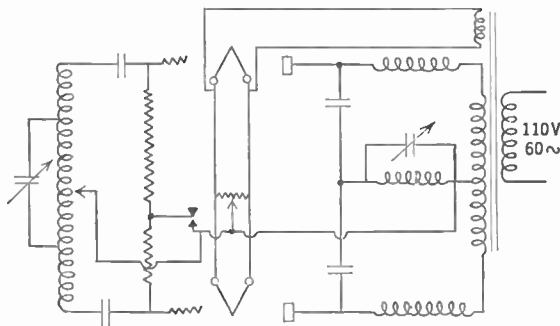

FIG. 288.—Full-wave self-rectified oscillator operated entirely from a.c.

fixed; we cannot change their ratio which determines the effective resistance, L/Cr . What can be done so that the tube generates the maximum amount of power in the tuned circuit?

If the proportion of the entire tuned circuit across which the tube is connected is varied the impedance into which the tube works will be stepped down; and by properly choosing the plate tap in Fig. 289 the proper load will be presented for the tube to work into so that the maximum power will be delivered. The inductance of the tuned circuit may be looked upon as a transformer which couples the tube to its load, usually an antenna.

358. Plate current when oscillator is connected to antenna.—An antenna-counterpoise system is usually connected to the power tube through an inductance which is a part of the tuned antenna

system. This antenna system is tuned to resonance with the tuned circuit. If the oscillator is adjusted to its proper frequency by varying the inductance or capacity of its tuned circuit, and the plate tap is then adjusted for maximum power output, the antenna coupling inductance may be brought near the tuned circuit inductance. If then, the tuning capacity of the antenna is varied through resonance with the transmitter, current will begin to flow into the antenna, and the plate current of the tube will probably increase because the battery must now furnish the power taken by the antenna as well as the power lost in the tuned circuit. Closer coupling will induce a greater voltage in the antenna, more antenna current will flow, the plate current will increase, and greater power

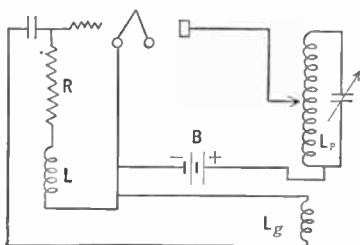

FIG. 289.—Maximum power is obtained by adjusting tap until tube works into its own impedance.

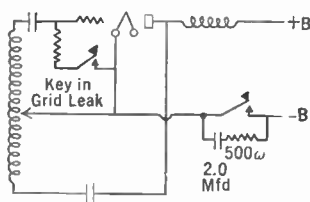

FIG. 290.—Two methods of keying transmitter. Note "thump" filter in -B lead.

will be radiated. Since the antenna is being coupled to the tuned circuit its resistance is being reflected into the plate circuit and some readjustment of the plate tap must be made. This may change the frequency slightly, and so all four variable factors—coupling, plate tap, and tuning, and tuned circuit capacity—must be adjusted until the maximum power is transferred to the antenna at the required frequency.

A rough idea of the power being radiated may be estimated in the following manner. Suppose the plate current without the antenna is 100 milliamperes and the plate voltage is 1000 volts. This represents a power input to the tube of 100 watts. Now suppose the antenna is coupled to it, and the plate current increases to 150 ma. The power is now 150 watts. The difference between 150 and 100 watts, 50 watts, may be assumed as going into the

antenna. If the antenna current is measured, a rough estimate of the antenna resistance may be had. The method is not at all accurate unless a sine wave is being radiated and then only approximately.

359. Keying a transmitter.—There are several methods of modulating the oscillations of a transmitter so that they may convey intelligence from one operator to another. The tube may be caused to cease oscillations, the antenna circuit may be broken or closed or the frequency to which the oscillator is tuned may be changed in accordance with the manipulations of the key. A key placed in the plate voltage supply (Fig. 291) will cut off the power. This method is not successful with well-filtered systems because of

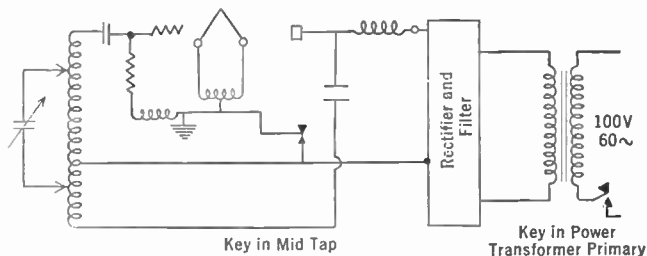

FIG. 291.—Keying in "center tap" or in transformer primary.

the time taken to completely discharge the condensers. An alternative place for the key is the grid circuit, as in Fig. 288 or 290. If the grid leak or the *C* bias lead is opened by the key, there will be no path for the electrons trapped on the grid to escape. The grid will then assume a large negative voltage which will reduce the plate current to such low value that oscillations cease.

If the key is placed in the plate lead it must break the full power to the tube, and its contacts must be able to handle the current without heating and without breakdown from the voltage drop across the key as it is opening.

The voltages and currents in the grid circuit are much lower. Both of these methods of starting and stopping the oscillations are abrupt and provide the nearby ether with profound shocks known among the amateur fraternity as "key thumps" and

cordially hated by listeners to other transmissions. Various thump filters have been devised to start and stop the oscillations in the tube less abruptly. One method is to let the tube oscillate feebly during the periods the key is up by placing a high resistance across the key contacts. Another is to place a resistance, capacity, and inductance across the key contacts. The condenser charges and discharges slowly and prevents the abrupt opening of the plate power circuit. The inductance (about 0.5 to 2 henrys) slows up the start of oscillations.

Keying can be accomplished as in Fig. 291 but generally the break is made *between* the filament and the connection to minus B, which is also attached to the grid. In other words the filament only is cut loose. This is called "keying in the common lead" and is widely used.

360. Methods of connecting oscillator to antenna.—It is possible for the inductance and capacity of the antenna-counterpoise

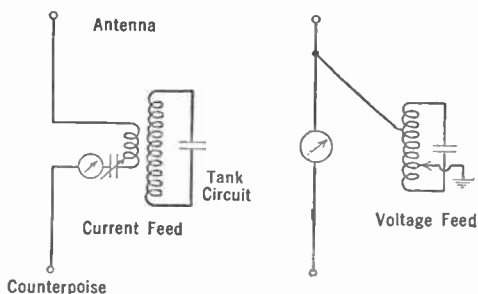

FIG. 292.—Current feed and voltage feed antenna circuits.

system to be part of the tuned circuit, and if so, the greatest amount of energy transfer will take place from tube to antenna. Modern methods, however, involve coupling the antenna to the oscillator through a "tank circuit," which the tuned circuit is usually called.

Whatever harmonics exist in this circuit find poor coupling to the antenna and are inhibited in their voyage from the transmitter to the ether.

When the antenna-counterpoise is series tuned, it is done so to attain a maximum of current in it. On short waves the antenna is somewhat larger than one whose natural wavelength is the wavelength of transmission. This wavelength is reduced by means of the series condenser.

It is possible to put power into the antenna by what is known as the "voltage feed" method which consists in attaching one

end of a wire to some high-voltage part of the tube's oscillatory circuit and the other end of the wire to some high-voltage part of the antenna. This provides sufficient coupling between transmitter and antenna to excite the latter. (See Fig. 292.)

361. Feeding power through transmission line.—Oftentimes it is impossible to put the antenna in a clear location near the transmitting apparatus. It is then possible to feed power to the antenna through a transmission line, as in Fig. 293, which is at low potential and not tuned to the frequency at which radiation is to occur. The resistance of this line is low at this frequency, little current flows in it, little power is lost in it, and the power is finally put into the antenna which may be located at some advantageous position. Transformers at the ends of this line couple it to the transmitter and to the antenna if the line is longer than $\frac{1}{8}$ wavelength.

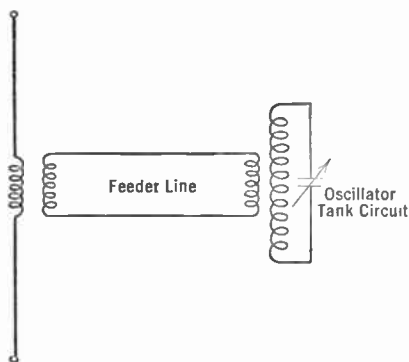

FIG. 293.—Energizing an antenna by means of a feeder line which does not radiate.

362. Modulation.—A transmitter may be designed either for code or voice transmission. More apparatus is required for the

latter means of communication. In addition to the oscillator tubes and amplifiers which may finally feed power into the antenna, there must be a modulating system. One method is to put the audio voltage variations into the grid circuit of the oscillator. These variations are, then, superimposed upon the

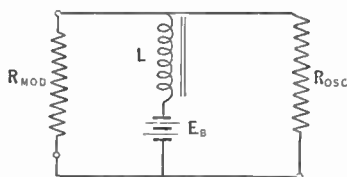

FIG. 294.—Equivalent of Heising modulation system.

a.-c. plate current and so the output into the antenna is varied at the audio-frequency rate.

The system most frequently used is known as the Heising or

constant-current system. In it, the plate voltage to an oscillator, whose frequency is the carrier or high frequency, is varied by the audio-frequency modulating voltages. Since the oscillating current and hence the antenna current is proportional to the plate voltage (Fig. 280), this current will vary with the audio variations.

Consider Fig. 294, in which the reactance of the choke L is high at all audio frequencies compared to the two resistances. The resistance R_m is the resistance of what later will be seen to be the modulator tube, which is simply a power amplifier operating at audio frequencies. The resistance R_o is the resistance of the oscillator tube. Suppose the resistance of R_m is caused to vary at some audio rate. The current taken from the B battery will not vary at this rate because of the large choking effect of the inductance L . The total current, then, from the battery is constant. If the resistance of the modulator tube, R_m , increases, less current will be taken by it and more can be taken by the oscillator tube. On the next half-cycle, the resistance of the modulator tube decreases and more current will be taken by it. The current taken by the oscillator then must decrease.

If the variations in resistance of the modulator tube are at some audio frequency, say 1000 cycles, the current taken by the oscillator will vary at this rate too—which is another way of stating that the r.-f. currents generated by the oscillator and transferred to the antenna will be modulated at the rate of the audio variations in the modulator circuit.

The actual circuit is shown in Fig. 295. When the r.-f. output of the oscillator is completely modulated, it looks as in Fig. 296 (taken from Heising, *Proc. I.R.E.*, August, 1921), and the power in the antenna is 1.5 times as great as when no modulation occurs. The antenna current meter will read the effective value of the current, or the square root of the power, and so will increase about 20 per cent when the wave is completely modulated. (The square root of 1.5 is 1.226, which is 22.6 per cent greater than 1.0.)

363. Amount of power required for modulation.—It used to be standard practice to use a modulator tube of the same rating as the oscillator tube. That is, if the oscillator was a 50-watt tube, the modulator was a 50-watt tube. Nowadays, however, the

modulator has considerably more power than the oscillator, for the following reason. When the tube circuit oscillates a considerable part of the energy from the plate battery is taken from the plate of

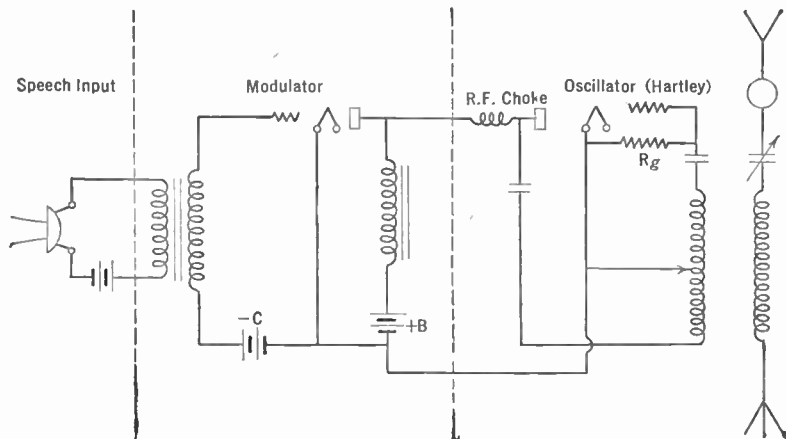

FIG. 295.—Practical modulated oscillator circuit.

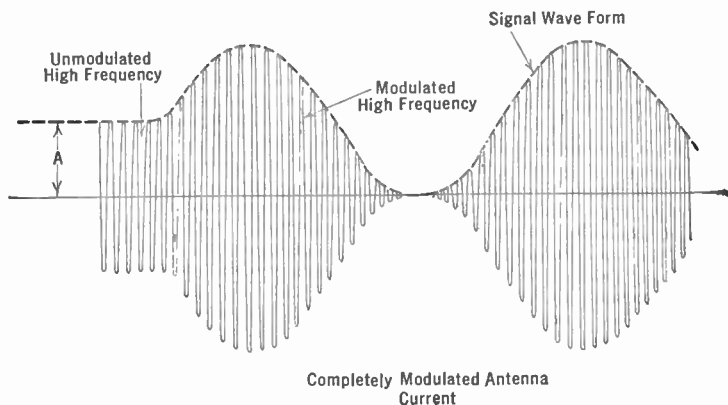

FIG. 296.—A radio-frequency wave before and after complete modulation.

the tube and used up in the tuned circuit or the antenna as the case may be. In other words a 50-watt tube may actually take 100 watts from the plate battery. Let us suppose it takes 100

watts. Now to completely modulate the oscillator means that once in each audio cycle the voltage on the plate of the oscillator will be reduced to zero, or very near it, and once in each cycle the voltage on the tube will be doubled. This means that the modulator tube must draw as much power as the oscillator, but it cannot because its plate would burn up—it is not oscillating. It must be biased so that the no-audio-signal input condition leaves the power wasted on the plate not over 50 watts. When the microphone is spoken into the steady plate current will change, showing that it was not acting as a distortionless amplifier.

The solution is to use more modulator tubes so that the combined plate current times the plate voltage is equal in power to that taken by the oscillator. Even then complete modulation of the oscillator is impossible because such a condition would imply that the plate voltage on the modulator would be reduced to zero at some instants. This is impossible without severe distortion. The result is that modern equipment operates the modulator tubes at higher voltages than the oscillator.

There is another difficulty in the modulation procedure. The antenna current under 100 per cent modulation indicates that 50 per cent more power is being supplied. This power must come from the modulator. In addition to supplying to the oscillator peak voltages equal to the steady voltage of the oscillator B battery, the modulator must supply the additional 50 per cent of power. Since the modulator, acting as an amplifier, cannot be very efficient, a large battery of tubes is required in the modulating system.

364. Modulation at low power.—Suppose, however, we modulate the output of a small tube and amplify it. We shall save on modulation equipment, because we can modulate a 5-watt tube, say with a 50-watt tube, and when small quantities of power are to be used efficiency does not matter. The succeeding power amplifiers, however, must each carry the additional 50 per cent increase in power, if the wave is to be completely modulated, and so little has been gained. It is a problem of whether to build a large modulating equipment acting at audio frequencies or large radio amplifier equipment.

365. Increase of antenna current with modulation.—The antenna current of a transmitter will increase when that station is modulated because the power into the antenna increases by the amount of the modulation. Therefore the increase in antenna current can be taken as a measure of the amount of modulation

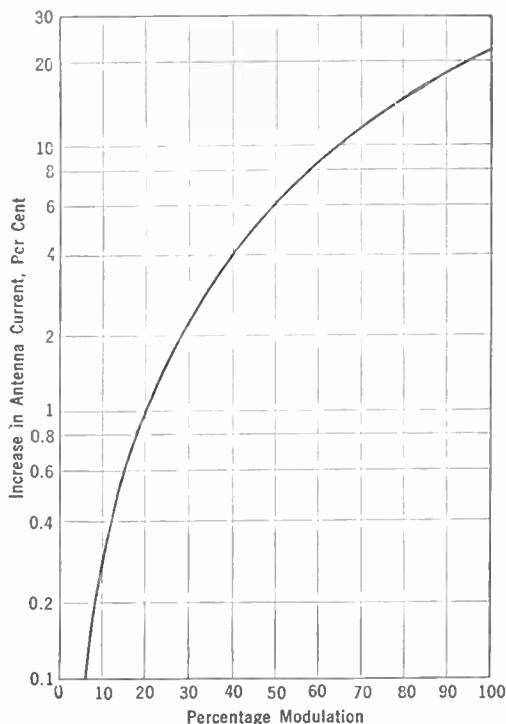

FIG. 297.—Increase in antenna current as a function of the percentage modulation.

in percentage. This additional power is represented by the side bands of modulation.

The average power in the carrier is $I^2R/2$. The amplitude of the current in each side band is the current in the carrier multiplied by $m/2$, where m is the percentage modulation. Therefore the power in each side band is $m^2I^2R/8$, and the total power for the

carrier and side bands, on the basis that each side band is a replica of the other, is

$$\text{total antenna power} = \frac{I^2 R}{2} (1 + m^2/2)$$

and since the current is proportional to the square root of the power the current at any degree of modulation is proportional to

$$\sqrt{1 + \frac{m^2}{2}}$$

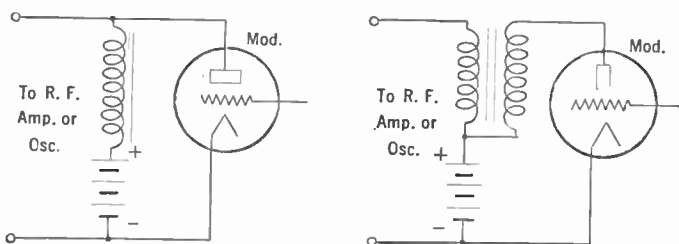

FIG. 298.—Conventional Heising modulator and on right, method of increasing percentage modulation and decreasing saturation of core.

Thus the following table can be calculated

Percentage modulation	Percentage increase in antenna current	Percentage modulation	Percentage increase in antenna current
0	0.0	50	6.0
10	0.22	60	8.7
20	1.00	70	11.7
25	1.6	80	15.0
30	2.2	90	18.7
40	3.9	100	22.5

The relation between modulator and oscillator (or r.-f. amplifier) in a Heising system may be understood from the following analysis. When the oscillator is working properly, not being modulated, its apparent resistance is the plate voltage divided by the plate current, or the plate voltage squared divided by the watts taken by the tube. Thus

$$\text{oscillator resistance } R_o = \frac{E_p}{I_{po}} = \frac{E_p^2}{W_o} \quad \dots \quad (1)$$

This must be the load into which the modulator works, since the Heising choke is assumed to be of high impedance but very low resistance and chokes and condensers are assumed to be keeping r.-f. out of the modulator. Thus

$$\text{modulator load } R_L = R_o$$

and the modulator, which may now be assumed to be merely a tube with a resistance in series with its plate battery and whose grid is excited by a.c., has a plate current of

$$\text{modulator plate current } i_{pm} = \frac{\mu e_g}{r_p + R_L} \dots \dots (2)$$

and the voltage developed across the modulator load

$$\text{modulator output voltage } e_{pm} = i_{pm} R_L = \frac{\mu e_g R_L}{r_p + R_L} \dots (3)$$

By definition the percentage modulation is the ratio between the peak a.-c. voltage to the d.-c. plate voltage applied to the oscillator. Therefore

$$m = \sqrt{2} e_p / E_p \dots \dots \dots (4)$$

Using this value for the a.-c. voltage and that in (3) above we may obtain the value of the power to the oscillator that can be modulated by the modulator to a certain percentage.

$$W_o = \frac{\sqrt{2} \mu e_g E_p}{m r_p} - \frac{E_p^2}{r_p} \dots \dots \dots (5)$$

- where μ = amplification factor of the modulator;
- r_p = plate resistance of modulator;
- m = desired percentage modulation;
- e_g = signal applied to modulator grid (r.m.s.);
- E_p = plate voltage applied to modulator-oscillator.

Modulator tubes are rated at $m = 0.6$ approximately. Thus an 842 has a rating of 8 oscillator input watts per modulator tube at $m = 0.6$. This means that an 842 will modulate 8 watts to a degree or percentage of 60 per cent.

Example. Assume the following data on an 842 which is to modulate a tube from a 350-volt source of supply.

$$\begin{aligned}
 E_c &= -88 & e_g &= 88/\sqrt{2} = 48 \\
 E_p &= 350 & I_p &= 14 \text{ ma.} \\
 r_p &= 2400 & \mu &= 3 \\
 W_0 &= \frac{\sqrt{2} \times 3 \times 48 \times 350}{0.6 \times 2400} - \frac{350^2}{2400} \\
 &= 44.4 \text{ watts}
 \end{aligned}$$

The load of the modulator, which is the apparent resistance of the oscillator, is given by

$$R_0 = \frac{E_p^2}{W_0} = \frac{350^2}{44.4} = 2260$$

From equation (4) the peak voltage produced by the modulator across the oscillator load is

$$\sqrt{2}e_{pm} = mE_p = 0.6 \times 350 = 210 \text{ volts}$$

Somewhat greater percentages of modulation may be obtained by using an auto-transformer in place of the choke as the coupling between modulator and oscillator. Furthermore, the two windings of the transformer may be properly proportioned to match the impedances on either side of the coupling unit, and by properly poling the windings the flux in the core may be decreased considerably below that required in a single winding.

366. Frequency Modulation.—We have described amplitude modulation, the method used in all radiophone transmissions at the present time. But there are other methods of modulation. Suppose, for example, that the plates of the tuning condenser in a transmitter were made to vary in their spacing as a microphone was spoken into. Now the tuning of the system would change with modulation and the more loudly the speaker talked the wider would be the frequency variations. Such is **frequency modulation**.

Now static is almost entirely amplitude modulated. If, then, we use frequency modulation and make our receivers non-receptive to amplitude modulated signals, our signal-to-noise ratio will improve. Unfortunately frequency modulation requires a very wide band in the ether, and so its application will be limited to the very short wavelengths.

Major Armstrong, of regeneration, superheterodyne, and super-regeneration fame, has worked out such a system and demonstrated it numerous times with success.

CHAPTER XVIII

ANTENNAS, TRANSMISSION

Now that we have generated oscillations and induced radio-frequency currents in an antenna, how it is that these currents convey intelligence to a receiver perhaps thousands of miles away? What is the nature of this process? What is the nature of the invisible and often unpredictable medium between transmitter and receiver?

367. Radiation resistance.—Let us suppose that two wires about 30 feet long and about a foot apart are coupled to a 40-meter transmitter through any of the familiar coupling methods, perhaps by means of a coupling coil as in Fig. 299. The current into this double-wire system will rise to a maximum when the varying tuning condenser makes the product of L and C equal to the product of L and C of the oscillator. Suppose this current is 1 ampere.

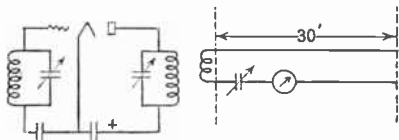

FIG. 299.—Experimental diagram to demonstrate existence of radiation resistance.

Now let us separate the ends of the two wires farther and farther until finally they are stretched out straight. More and more power will be required from the plate battery to maintain a constant value of current in the wires.

At the same time we shall note that the capacity and inductance have changed somewhat so that some minor changes must be made in the tuning condenser to keep the wires in resonance with the oscillator—but these changes cannot account for the greater power required from the battery to maintain the same current in the wires. In the first place, the changes in capacity and

inductance are balanced out each time by readjusting the tuning condenser to resonance. Then there is only resistance to impede the flow of current. Every time the reactances have been balanced against each other. Clearly the resistance of the wires has increased. At the same time if we installed a small receiver near the oscillator and kept moving away from it so that the signals picked up were of constant strength, we should find that the greater the power taken from the battery and hence the greater the power into the antenna, the farther away we could hear the signals.

It is apparent that if the current is still 1 ampere but twice as much power is taken from the battery to produce the 1 ampere, the resistance of the wires has doubled. The useful part of this resistance is called the **radiation resistance** of the wires, which may now be called the antenna. The power that goes into this resistance is the power that is effective in carrying intelligent communication from the transmitter to the receiver.

The total resistance of an antenna may be measured by the same method used to measure the high-frequency resistance of a coil. (Section 134.) If enough resistance is added to our 40-meter antenna system to halve the current, this added resistance is equal

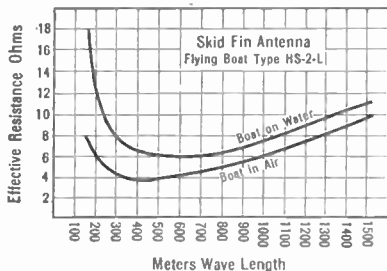

FIG. 300.—Antenna resistance.

to the resistance already there. If the resistance is measured at several wavelengths we shall get a curve similar to that in Fig. 300 (taken from the Proceedings of the I.R.E., February, 1920, by T. Johnson, Naval Aircraft Radio). This resistance is made up of the ohmic resistance of the wires, the losses in the dielectric of the antenna capacity, the loss of energy due to radiation, and other small losses. An efficient antenna is one which has a very high radiation resistance and a low resistance of all other sorts. Then most of the power put into the antenna from the oscillator will be radiated. This method of measuring antenna resistance is fairly accurate if very loose coupling and a sensitive meter are used.

The radiation resistance of most short-wave antennas used below the fundamental wavelength is of the order of 100 ohms and it requires a transmitter output of 100 watts to put 1 ampere into it. The current that goes into an antenna is a variable factor, and because one antenna has 1 ampere and another 2 amperes in it it may not mean that the second one is twice as good. The place in the antenna-ground or antenna-counterpoise system where the current is read and the physical surroundings of the antennas may be much more important in determining the effective radiation than the current into it.

368. The radiation field.—The energy which is taken by the radiation resistance is used in setting up about the antenna a **radiation field**. This radiation field moves away from the antenna with a speed equal to the velocity of light, and its strength at any distance is inversely proportional to the distance minus other losses of power in absorbing media.

When the lines of force making up this radiation field cut a conductor such as a receiving antenna a voltage is induced in this conductor and if amplified and demodulated it becomes the received part of the communication thrust upon the ether by the transmitter.

This brief and very inadequate explanation of what happens in the ether does not state how it happens. Most radio engineers, however, are interested in the result rather than the means and so we must be satisfied with the knowledge that current into an antenna produces a radiation field about the antenna, that the intensity of this field varies inversely with the square of the distance, and that when this field cuts across a conductor to which is attached a receiving apparatus a voltage is developed which is the bearer of the messages sent out at the transmitter.

369. Calculation of the received current.—If the antenna at the transmitter is the type used on shipboard, that is, a high "flat-top," and a "down lead," and if the receiving antenna is similar in construction, the received current as a function of the transmitting current, the dimensions of the antennas, and their distance apart, is

$$I_r = \frac{188 h_s h_r I_s}{R \lambda d},$$

where h_s = the transmitting antenna height;
 h_r = the receiving antenna height;
 I_s = the maximum transmitting current;
 R = the receiving antenna resistance;
 d = the distance apart in meters;
 λ = the wavelength in meters.

This formula shows that, all other conditions remaining the same, there will be more received current the shorter the wavelength, but this formula does not show the fact that short waves are absorbed more readily than long ones. The greater the height of the transmitter and receiver antenna the greater the received current. At the same time the absorption is less because of the fewer objects in the near field of the antenna and so the higher the antenna the better it is.

This formula does not include such variable factors as skip distance, sky waves, sunset effects or other vagaries of transmission on short or medium waves. It is not useful on amateur bands.

370. Types of antennas.—Antennas may take a number of shapes and sizes. Radiating systems in use in high-power long-

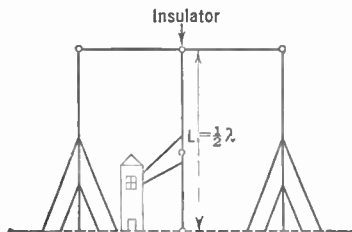

FIG. 301.—Half-wave vertical antenna.

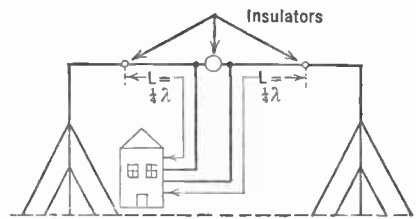

FIG. 302.—Folded half-wave antenna.

wave stations comprise a very long (one mile or more) flat-top about 400 feet high, whereas a short-wave station may have an antenna consisting of a single wire (Fig. 301), vertical or horizontal (Fig. 302), one-half wavelength long. For example, if the wave radiated is 20 meters, the total length of antenna and counter-

poise wire will be 10 meters, or about 30 feet. On shipboard the "down lead" may come from the end of the horizontal part or from the center. In portable installations an umbrella type is used, that is, an insulated mast which is held up in the air by insulated wires which act as the radiating system.

The larger the antenna the more energy it will pick up, either from desired stations or from other electrical disturbances such as static. The tendency is to use large antennas for transmitting, so that a large amount of power can be put into the radiation field, and small antennas for receiving so that the ratio of signal to static will be large.

The ordinary antenna used for broadcast reception consists of a single wire more or less horizontal or vertical as the case may be, and up to a hundred feet long. It is always an advantage to have a high and clear antenna free from electrical disturbances caused by motors, etc. Modern technique calls for antennas especially erected and connected to the receiver with transmission lines to minimize unwanted noises.

371. Directional antennas.—For broadcasting intelligence over a wide area an antenna which transmits equally well in all directions is desirable. Such is the vertical antenna. When a station is constructed to operate with one other station only, it is a waste of power to transmit its signals in all directions. Such stations use directional antennas, that is, radiating systems which transmit better in one direction, say north-south, than they do in any other. Even then energy goes out in two directions, north and south, and the receiving station is, of course, in only one direction from the transmitter.

The loop is a directional antenna. It receives better in the direction towards which the narrow dimension points. Its pick-up ability is something like Fig. 303, in which it is pointed east-west and picks up very little energy from a north-south direction. In connection with a sensitive receiver, it may be used to determine the direction whence the signals come. It is the heart of the **direction-finding** stations which are situated along the coasts of the world. When a ship wants bearings, its signals are picked up

by the coastal station which determines the position of its receiving loop which gives the least signal. A compass is attached to the base of the loop and the indicator then points out the bearing of the vessel. A receiving operator in another location also swings his loop on the vessel and thus two bearings will be obtained. From them the master of the ship can tell exactly where he is with regard to the coast line. The method is shown in Fig. 304.

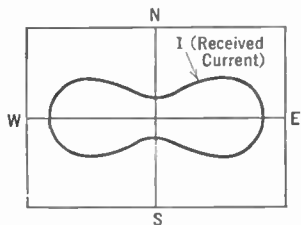

FIG. 303.—Directional effect of reception on a loop.

Other types of antenna give still greater directional effects, and those with reflectors behind them (short waves only) will transmit a narrow beam of signals in only one direction.

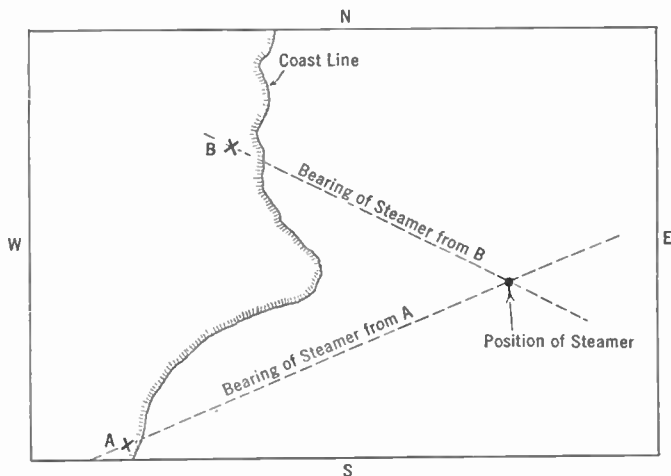

FIG. 304.—Method of plotting a ship's position by obtaining two bearings from land stations.

372. Inductance and capacity of antennas.—In Sections 136 and 137 means of measuring the capacity and inductance of an antenna were discussed. The inductance and capacity are not

concentrated as they are in a coil or condenser but are distributed throughout the structure. The capacity of the antenna wire may be with respect to ground which serves as one plate of a condenser with the antenna wires as the other and the air as the dielectric, or the capacity may be with respect to some other electrical conductor, usually of the form of a counterpoise which is merely another antenna, that is as a rule of larger dimensions and much nearer the ground. The counterpoise is used because of its lower resistance losses than the average ground.

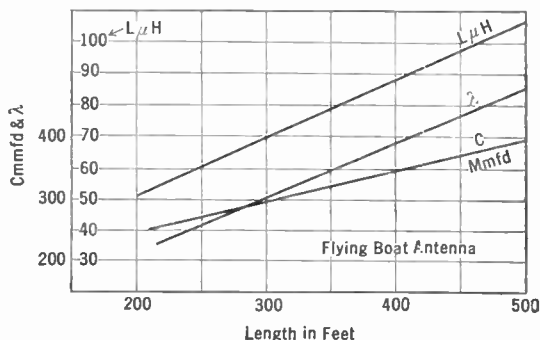

FIG. 305.—Characteristics of airplane antenna.

The inductance of most antennas is small, of the order of 50 to 100 microhenrys. The capacity of simple receiving antennas is of the order of 150–300 mmfd. (See Fig. 305.)

373. Natural wavelength of antenna.—Because an antenna has both capacity and inductance it can be made to resonate to a certain frequency or wavelength. The formula for the wavelength or frequency to which an antenna resonates is the same as in any other circuit which has a capacity and inductance, that is,

$$f = \frac{1}{2\pi\sqrt{LC}}$$

A vertical wire grounded at the lower end has a natural wavelength about 4.0 times its physical length. Thus, if the wire is 20 meters long and is grounded, its natural wavelength is about 80 meters. On the other hand, if the wire is not grounded but is

considered as being two wires, an antenna and counterpoise with maximum current in the center, the natural wavelength is roughly twice the length in meters. Thus, an antenna 20 meters long (30 feet in antenna and 30 feet in counterpoise) will radiate a wave of 40 meters if not connected to the ground. This antenna is called the Hertz because it is the type used by that investigator.

The Hertz antenna can also be made to radiate on any of its harmonics. If its natural wavelength is 40 meters it will radiate at 20 meters or if excited properly by an oscillator, at 10 meters.

374. Loading an antenna.—In case an antenna does not have the required inductance to bring its wavelength to the desired value, additional concentrated inductance can be placed in the down lead and the antenna "loaded" up to the desired wavelength. Since the coil cannot radiate to any extent and since its resistance must be added to the resistance of the antenna system, loading makes the entire system inefficient. The small antenna gets poor "hold" on the ether; the higher current causes greater power loss.

375. Decreasing the wavelength of an antenna.—If the antenna is too large to tune to the desired wavelength its natural wavelength can be reduced by placing a condenser in series with it. This reduces the effective capacity and as a result reduces its wavelength. The wavelength cannot be reduced below one-half the natural wavelength. Here again, loss in power in the condenser must be subtracted from the power that would go into the radiation resistance and so the losses in the condenser must be paid for in inefficiency. Fortunately, it is possible to build a condenser whose resistance may be very low at the frequency at which it is to be worked, and so a series capacity does not add much resistance to the antenna.

376. Short-wave transmission.—Because of the fact that short waves were highly absorbed, it was thought for many years that this portion of the radio-frequency spectrum was worthless. It was largely for this reason that amateurs were permitted to operate there. No one else wanted the short waves. Strangely enough, these short waves, once thought worthless, are now being fought for by radio communication companies the world over.

The radiation field as it goes out from the antenna is absorbed by all conductors which exist in its field. According to theory, the shorter the wavelength the greater the absorption so that for waves shorter than 100 meters very little energy arrives at a receiver any distance away. Amateurs, however, discovered that these waves did arrive at much more distant points than theory permitted and a new theory had to be developed.

Waves are radiated from the antenna at all angles to the horizontal. The **ground wave** which the old theory dealt with goes near the surface; some radiation leaves the antenna at a high angle and shoots off into space. Some distance above the earth is an ionized layer which is a fairly good conductor of electrical disturbances. It therefore reflects a certain amount of the **sky wave** which returns to earth and may be received by any antenna in its path.

The ground wave is soon absorbed. The sky wave does not come down to earth in the immediate vicinity of the transmitter. Between the area covered by the ground wave and the sky wave there is a dead spot known as the **skip distance**. Signals are not received there except with the greatest difficulty and with considerable irregularity. In the daytime this skip distance is about 200 miles at 40 meters and 800 miles at 20 meters. Beyond the skip distance the signals are audible and fall off in intensity until they are again inaudible.

By properly choosing the frequency for the time of day it is possible to maintain a continuous communication with another station at any given distance. In other words, distance, time of day, season, and frequency are related. The table at the back of this book was compiled by L. C. Young of the Naval Research Laboratory.

It is because of the sky wave that amateurs working with less than 100 watts in an antenna are frequently able to communicate over several thousand miles on waves below 80 meters. Above 300 meters the skip distance is negligible, the sky wave is not important, except as noted in Section 377.

377. Fading.—The Kennelly-Heaviside layer, as the ionized conducting layer which is about 100 miles above the earth is called, varies in height and density from moment to moment, from day

to day, and from season to season, and so the reflected wave varies in intensity. This is one cause of fading. Amateurs and other workers on short waves are the ones who have to contend most with this phenomenon since it is less effective on longer waves. It is of some importance on broadcast frequencies but at lower frequencies becomes of less and less value. When the sky wave and the ground wave arrive at a receiving station out of phase with each other, the received signal will be decreased in strength. This accounts for fading experienced on broadcast frequencies.

The automatic volume control discussed in previous sections will eliminate much of the troubles due to fading. The result of fading to the listener will be the apparent rise and fall of noise; when the signal gets weak the sensitivity of the amplifier rises bringing in more noise, and vice versa. The a.v.c. system, or the unlimited increase of power at the transmitter, will not eliminate fading in which the side bands fade less than the carrier with the effect that the carrier as it arrives at the receiver is over-modulated with resultant distortion.

Fading that varies with the frequency of modulation sometimes occurs; nothing can be done to correct it at the receiver.

378. Comparison of night and day reception.—The shorter the wavelength the greater the difference between night and day transmission and reception. On long waves there is little difference. At night signals are somewhat louder. On broadcast frequencies the difference is marked, especially in winter. Signals can be heard at night which are inaudible during the day. On short waves the skip distance becomes much greater at night. Why is this?

During the day the sun pours radiation into our atmosphere ionizing the particles which constitute it. These ionized particles absorb radiation of all kinds. Once absorbed, their energy is lost and they cannot transmit intelligence to distant receiving stations. At night this ionization ceases, the absorption of radio waves decreases and signals again reach out. The Kennelly-Heaviside layer of ionized particles which reflects the sky wave on the frequencies above 3000 kc. is very low in the daytime. The skip distance is not so great then as it is on a winter night when the reflecting layer is high, 100 miles or more above the earth.

379. Static.—Static is part of the noisy background that is

sometimes of sufficient strength to interfere with the reception of signals. It is caused by natural phenomena, such as discharges of electricity between clouds at different potential or from clouds to earth. It is not the same noise that is caused by a leaky transmission line, defective power transformers, wires rubbing in trees and sparking, or other noises which come under the heading of man-made static. All of the latter noises can be eliminated. Static cannot be eliminated but its effects can be reduced.

A receiver that operates from a very small antenna will pick up less disturbing noise than a large antenna high above the earth. The loop antenna which can be pointed at the desired signal, or any other directional antenna, will not pick up static or unwanted signals from other directions and will produce a greater signal to static ratio. It has the effect of reducing static.

A number of schemes have been devised to reduce the static to the level of the signal, but none has yet been made that will eliminate the static without also eliminating the signal. Both are produced by the same fundamental phenomenon—the charge and discharge of a condenser. One is produced in a broadcasting station by man, the other in the sky by nature.

Static is more bothersome during hot summer weather when the clouds are highly charged. The more sensitive one's receiver the further away the storms can be and still disturb reception. Man-made static is bothersome at all times of the year and at any time of the day or night. In the future all man-made static will be illegal, just as it is now illegal to operate an automobile without a muffler.

380. Elimination of man-made interference.—Considerable advance has been made towards the elimination of radio interference from all manner of sparking machines. The sparks must be eliminated or the electric waves they set up must be prevented from radiating much energy. If the sparks occur in a large system of wires the energy radiated may be considerable and may ruin radio reception over a large area. This radiated energy may be strongest at the natural frequency of the radiating wires but, because of the high resistance of the spark gap, the disturbance may cover a very wide band of frequencies.

Condensers across the place where the spark occurs reduce both spark and interference; inductances in series with the power wires leading to the electrical machine creating the disturbance prevent the radiations from getting into the power lines and hence from having much of a radiating system. Combinations of inductances and condensers may filter out the radiations by reducing or preventing sparks, by shunting them into the ground and by

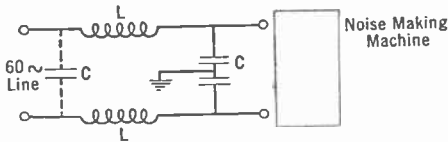

FIG. 306.—Use of noise “filter.”

preventing them from getting into power lines (Fig. 306).

To tell whether noise in a receiver comes from outside or from the receiver or power equipment itself it is only necessary to disconnect the antenna. If the noise persists, its origin is within the receiver or power supply. If it is reduced, it is being picked up by the antenna. A directional receiver may be used to determine first its general direction and finally its exact location. Noise in “a.c. operated” or electric sets may come in over the power wires and then it will be heard even though the antenna is disconnected.

The complete elimination of interference from true static and from man-made radio disturbances is one of the few big radio problems that have not yet been solved.

381. Anti-static antenna systems.—If a receiver must be operated in a noisy location so that the desired signals are immersed in man-made static, resort must be made to a rather elegant antenna system put into quite wide use in 1933. This system consists of a good antenna erected in as high and clear a location as possible and connected to the receiver by means of a transmission line of low impedance.

If the antenna is connected to the receiver by a shielded down lead most of the desired signal will be lost on the way down through the capacity between the down lead and the shielding which will be more or less at ground potential. If the down lead is not shielded it will pick up the local noise, for example elevator motor noise, and the high clear antenna will be wasted.

If, however, the shielded down lead is connected to the antenna by means of an impedance-adjusting device, a transformer for example, the down lead will be a low-impedance affair and will not lose its signal energy, and since it is shielded it will not pick up local noise.

At the lower end, another transformer steps up the signals so they go into the receiver just as they would if coming directly from the higher-impedance antenna instead of the low-impedance line. If the antenna has a capacity of 200 mmfd., an inductance of 20 microhenries, and a resistance of 25 ohms it will have an

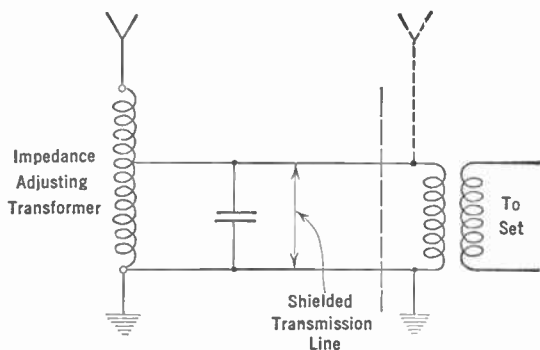

FIG. 307.—Method of connecting a good antenna to a receiver in a poor location by means of a shielded transmission line.

impedance of 1460 ohms at 550 kc. and 345 ohms at 1500 kc. The receiver will have an input impedance that is nearly pure resistance, because the input is usually tuned to resonance with the incoming signal, and if the first transformer has a primary of 2 to 3 mh. the primary resistance will be approximately 125 ohms at 1000 kc. If the primary has few turns the input of the set will look like about 1.2 ohms approximately.

The input impedance of the receiver in these cases will be approximately five times the resistance of the primary coil; hence an antenna system of this type must be connected to the receiver with knowledge at hand of the input transformer characteristics.

Such a system will make clear reception possible in a location

where little else but noise is heard with an ordinary antenna. The circuit in Fig. 307 is typical of these systems.

382. Automobile antennas.—Antennas for mobile services as in automobiles, aircraft, etc., present a difficult problem. In the first place the effective height possible is small; secondly the structure must be simple and rigid.

In aircraft the antenna is a simple pole mounted rigidly, over which the wire is strung and insulated from the ship proper. Similarly in police radio systems working on short waves, a simple rod is mounted in the rear, or the front, of the automobile chassis and is tuned to the desired wavelength. In pleasure automobiles the first aeriels were sections of chicken wire or netting imbedded in the roof. The advent of all-metal bodies, however, put a stop to this practice. Metal plates suspended under the running boards and other types of under-car antennas were successfully used. The practice of police cars putting a flexible steel rod outside the car, however, showed the way to success, and at present the tendency is toward such vertical rods or metallic devices which run up from the center of the windshield and form additional decoration for the car top. These have fair pick-up and are out of the noise field of the ignition system.

CHAPTER XIX

FACSIMILE AND TELEVISION TRANSMISSION

A NEW factor enters when pictures or television images are to be transmitted over wire or radio circuits. This is the factor of *time*. Picture transmission is much like code transmission; television is more like voice or music transmission—but both picture and television are more complex than the earlier methods of transmitting intelligence.

In code transmission the listener gets one letter after another and after recording them he may form an accurate idea of what the sender has in mind. In picture transmission the receiver puts down small pieces of the final picture in the order in which the sender transmits them, much like a cross-word puzzle, and after a certain *time* he gets an accurate idea of what the original picture is.

In voice or music transmission, time enters to a limited extent only, since the listener is not called upon to remember the exact sound that he has just heard. He is interested only in the tone or sound that is at a given instant impressing itself upon his ears. But if we wish to transmit 10 orchestras simultaneously, 10 transmitters, 10 channels and 10 receivers are required. Here is where the factor of time enters. A single channel could transmit all 10 orchestras provided they could play one after another.

383. The problem of picture transmission.—There is no known method of transmitting a picture so that the listener sees all of it simultaneously with the sender. All known methods consist in taking the picture apart, transmitting the parts, and then in putting them together again at the receiver. In facsimile transmission the time required may be fast or slow. It may take a week to transmit a single picture or it may be transmitted in a

second. But in the latter case a high premium must be paid for speed.

In television we must perforce transmit the pictures at a high speed. Not only does the problem of chronological transmission enter but the problem of simultaneity as well.

384. Picture elements.—If one looks at a newspaper photograph with a hand lens he will see that it is made up of small dots of ink, and he will realize that there is not much detail in the picture. If he looks at a photo in a high-class magazine he will discover that much greater detail is present—in other words, the dots are smaller and are placed closer together. If he looks at a photograph he will see almost infinite detail since the dots are microscopically small and almost infinitely close together.

It takes about 50 dots across and 50 dots down a picture to make a face recognizable. If there are five times this number of dots in the same space the picture will have much greater detail. If this mosaic of 50×50 or 2500 dots is placed in an area the size of a postage stamp the picture may be viewed at close range; but if it is put on a screen 10 feet across, each dot being multiplied in size accordingly, the same degree of detail will be present but the picture must be viewed at a much greater distance

Newspaper cuts have detail corresponding to about 55 dots per linear inch; high-class magazine cuts have about 100 to 200 dots per inch, a 4 by 5 inch photograph may involve as many as 100,000,000 separate dots of light and darkness.

Let us consider the 50-dot-per-inch picture. If this picture, say one inch square, is to be transmitted in one second, all the dots must be sent in this time. That is, 2500 dots or impulses per second may be transmitted and received. This will give us a picture one inch square. If the picture is to be 10 inches square and therefore include more objects the number of impulses per second will be 2500×100 or 250,000.

These figures correspond to 2500 and 250,000 cycles per second, and if transmitted by carrier frequency, the side-band width must be 5000 cycles and 500,000 cycles wide respectively. In this manner one of the most serious problems of television enters—to transmit good detail in a short space of time requires a very

wide band of frequencies, and apparatus and a medium that will handle this wide band.

The second problem is, how large shall be the field of view—not how large shall be the ultimate picture, but how much shall be included in the picture? Obviously a one-inch-square picture may be enlarged at the receiver but it will contain no more information than the original one-inch-square picture.

The third problem is the time available in which the picture is to be sent and received. If time is of no importance, as many dots as desired can be sent, and greater detail will be possible, but if the time is limited then the detail must be limited or a very wide frequency band must be used and the apparatus must be correspondingly complex. If a wide band is to be transmitted by radio, fading within that band may erase part of the picture; and of course there is always the problem of the available space in the radio-frequency spectrum.

385. Frequency band required.—The highest frequency that must be transmitted for a given picture is determined from the equation

$$\text{highest frequency} = \frac{NA}{2t}$$

where N is the number of elements per square inch;

A = side of the picture in square inches;

t = time in seconds for transmission.

Example.—The Bell system of picture transmission enables a very beautiful picture 5×7 inches with equivalent detail of 10,000 elements per square inch to be transmitted in approximately 7 minutes. What is the highest frequency necessary, and what band width is required?

The total number of elements is $10,000 \times 35$ = 350,000

The time available is 7×60 = 420 seconds

Therefore the highest frequency required is $\frac{350,000}{2 \times 420}$ = 420 cycles (approx.)

and the frequency band required = 840 cycles (approx.).

386. Method of taking the picture apart.—Since the picture is to be transmitted piecemeal, some method must be available for

taking the picture apart. In the Bell system the photograph, or a film, may be placed upon a drum which revolves in front of a small carefully focussed light source. As the drum rotates it moves along in front of this light, and the beam either goes through the film, or is reflected from the finished print into a photocell.

Since the amount of light that gets to the photocell is a function of the light or shade of the picture, each portion of the picture is translated from a visible shade into an electrical current, more

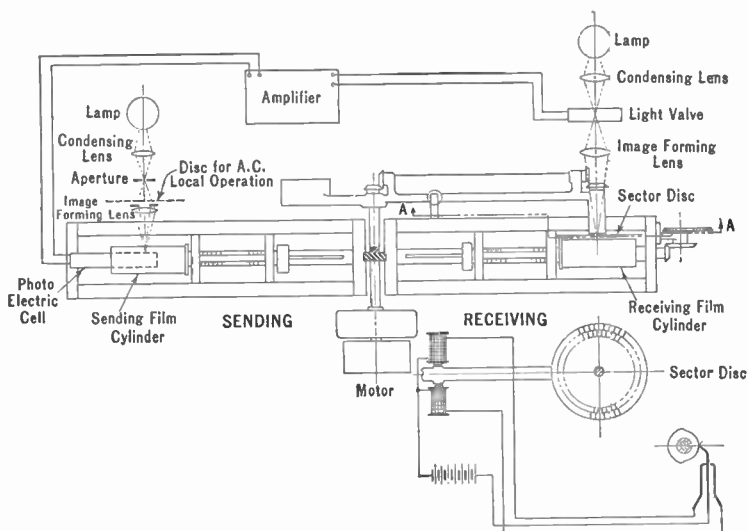

FIG. 308.—Bell system of photograph transmission.

light causing more current to flow from the photocell. These variations in the photocell current are amplified and transmitted to the receiver where a similar piece of unexposed paper, or an unexposed film, is rotated on a drum at exactly the same speed as the transmitter drum. As the variations in current come from the transmitter they are translated back into variations in intensity of light which is permitted to shine upon the photographic film and thus expose it in exact accordance with the picture at the transmitter.

This method of taking the picture apart is called *scanning*, and in all television methods some scanning scheme must be employed. In all such schemes a photocell is employed to translate the variations in light to variations in an electric current which may be transmitted after amplification to the receiver over a wire or may be used to modulate a carrier of a radio transmitter.

The frequency band calculated in the above example is the narrowest possible band; if good detail is desired, higher frequencies corresponding to the higher harmonics of the highest frequency must be transmitted. Thus when a picture is composed of alternate white and jet-black portions, the photocell gets a sudden illumination, or a steep wave front, and the electric current coming from the photocell must have a similar wave front. This means that the current must start and stop suddenly—and such circuits are extremely difficult to obtain and to maintain. Any inductance and capacity in the circuit would tend to flatten this steep wave front with the result that the received picture would not have as white a white, nor as black a black, as the original. In other words, distortion would result. Steep wave fronts imply tones with numerous harmonics; therefore the second or third harmonic of the highest fundamental tone should be transmitted for high fidelity.

387. Putting the picture together again.—Once the picture is in the form of variable electrical currents and transmitted to the receiver it becomes necessary to reconvert these impulses into a visible picture. One method is to use a sensitive galvanometer which carries a mirror whose movements, under the variations in incoming current, cause more or less light to fall upon the sensitive photographic film.

In another system (Cooley) the incoming signal caused a high-frequency, high-potential spark or corona discharge to spark through a paper, thus burning minute holes in it in accordance with the original picture. Or these sparks may be made to turn some chemical dark in color and thus leave an impression on the receiving paper.

In still other methods hot jets of air are turned on or off in accordance with the modulations of the transmitter; these jets

(which may be other liquids than air, ink for example) produce some visible change in the paper on the receiving drum.

Many systems have been suggested and employed. The Bell system has produced very beautiful pictures, difficult to tell from the original, and such pictures have been transmitted from one end of the country to the other. The Radio Corporation of America under Captain Ranger developed methods of using radio circuits for transmitting pictures and facsimiles, such as advertisements, signatures, cartoons, etc.

The great difficulties in the way of general usage of such systems lie both in technical and economic problems. Once the technical problems are solved there remains the problem of who is to pay for the pictures and how much they will pay and whether this amount will finance the development of the method, pay for the expensive circuits and terminal equipment.



FIG. 309.—Picture transmitted by very simple 1933 system (Hogan).

At present no great amount of picture transmission takes place. Rapid travel by air or train has made transmission by radio or wire less necessary than was formerly thought. It is possible, however, that simple systems that could be attached to existing broadcast stations, the receivers to be placed in the listener's home, might become successful. Such systems could transmit pictures during the night when the broadcast transmitter was off the air. The program might be news services, advertisements, weather reports, stock-market reports, entertainment features such as Crazy Kat, etc.

388. Television—rapid picture transmission.—Television does not differ fundamentally from picture transmission. In this method of communicating intelligence many pictures are transmitted per second, each slightly different from the preceding so that the observer thinks he sees a continuously changing picture much as he *thinks* he sees a continuous picture in the moving-picture theater.

Television is possible because of a peculiar characteristic of the eye. If two pictures exactly alike are transmitted at a rate exceeding 16 pictures per second, the observer thinks he has seen but a single picture. In other words, the visual system has a certain inertia in it, such that a picture snapped off suddenly persists for a fraction of a second. This is called "persistence of vision." It has become general practice to transmit at least 16 pictures (frames, as they are called, in the movies and in television) per second. Otherwise the pictures seem to flicker.

At once we begin to see why television is a difficult art. Not only must we transmit a picture of desired detail, and of desired field of view, and without distortion, but we must do it in a sixteenth of a second. Now let us see what this problem is from the standpoint of the required band width.

Example.—Suppose we are to send television pictures of the quality of the Bell System photographs. What is the highest frequency required? How many broadcast channels would be required?

Time available $\frac{1}{16}$ second =	0.06 second
Highest frequency =	$\frac{10,000 \times 35}{2 \times 0.06} = 2,915,000$ cycles
Band width =	5,830,000 cycles

And since the carrier frequency should be about 10 times the frequency of the modulation, the carrier would have to be about 60,000 kc., and to transmit 5 by 7 inch pictures with 10,000-element detail in $\frac{1}{16}$ -second intervals would require a band at least equal to 583 present-day broadcast station channels.

Such is the problem of television. The tremendous band width required was a fundamental obstacle to high definition television until the realm of the short waves began to be investigated. The calculations above show that our television channel would have to be on 60,000 kc. or 60 megacycles, and until recent years no one thought it would be possible to generate appreciable amounts of power at these frequencies.

389. Television research.—Many lines of research have converged on the television problem. Some of them were necessary to advance knowledge and practice for other purposes; some of

them were useful only to television. Many investigators have had their hand in this development and, like radio, it will be impossible to state who "invented" it when television becomes a useful service.

It was realized that the very high frequencies must be used as the television carrier. Therefore it was necessary to find methods of generating power at these frequencies, to get it into the ether and to get it out again. This called for new types of tubes; for studies of the characteristics of the transmission path between transmitter and receiver.

It was realized that some way must be provided for getting television programs from a central point, the studio, out to stations which might be miles away from the place where the show is going on—just as in sound broadcasting. This meant that new types of wire circuits must be developed. Here is where the telephone engineers' work on the co-axial cable came in handy. New types of antennas were developed, and it was realized that getting the short-wave antenna up in the air as high as possible was necessary since these waves travel only as far as the eye can see, being cut off, like a ray of light, by the earth.

Then, most difficult of all, it was realized that the early mechanical methods of television would have to be modified or discarded if high definition television were to become a practical service.

First let us see how the mechanical systems worked.

390. Scanning the image.—In general there were two methods of scanning the image. In one case the image is brightly illuminated by several sources of light. The image is focussed upon a rotating disc which is pierced with a series of holes in a spiral as shown in Fig. 310. As the spiral rotates, the holes trace across the image, which has been greatly reduced by the lens, one after another in a series of parallel lines. The light that gets through the holes falls upon a photocell and is there translated into electric currents. In one complete rotation of the disc the holes have traversed the entire picture, or frame.

In the other general method a single high-intensity source of light shines through the holes upon the image, and the reflected light is viewed by several photocells. Thus a single spot (the

flying spot) traces itself across the image from one side to another and from top to bottom.

Experiments of Dr. H. E. Ives of the Bell Laboratories show that the first method would require that the object be illuminated with a 16,000-candlepower arc at a distance of about 4 feet to secure an image bright enough that the currents from the photo-

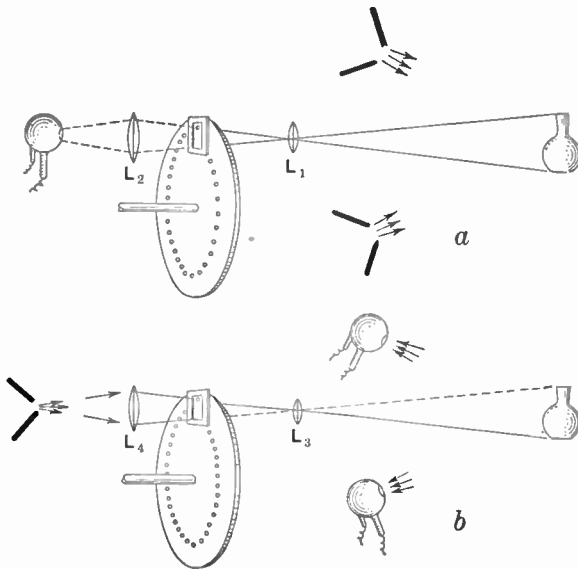

FIG. 310.—Two methods of illuminating and scanning an object. The lower is the “flying spot” system.

cell would be above the noise level. Therefore the flying-spot method was more generally used.

Lenses in place of holes in the disc improve the efficiency somewhat, but the difficulty of making, say, 48 lenses of exactly the same focus and of placing them in the periphery of a disc so that they line up their individual images properly increases the technical and mechanical problems appreciably. Deep blue light has been used to illuminate the object to prevent too intense illu-

mination on a person's eyes, for example. Photocells especially sensitive to blue were utilized in this scheme.

391. The receiving system.—Another scanning disc may be used at the receiver operated in exact synchronism with the sending scanning disc. A neon lamp, consisting of two metallic plates about 2 inches square in an evacuated envelope with neon gas admitted, is placed before the scanning disc. The voltage across this lamp is modulated by the incoming signals so that as the scanning disc rotates and holes appear across the disc the observer's eyes see momentarily each portion of the lamp which may be bright or dull according to the received signal at that instant.

Small discs, say 1 foot across, were generally used. The picture is seldom over 2 inches square unless it is projected upon a screen, when it may be 4 or more inches square or rectangular in shape. But there are never any more data in the enlarged or projected picture than exist in the 2-inch frame, and this detail has been far too meager to make commercial television possible. The picture is too small, the possible detail is too scant, and the field of view is too limited to retain the interest of the observer for long periods, even when accompanied by synchronized sound.

392. Cathode-ray television.—It has been realized that the mechanical scanning disc must be eliminated in favor of some more efficient scanning system if television is to become practicable for the home. For theaters, etc., a very large disc could be used with expensive lenses and with accurate bearings so that large, fairly well-defined pictures could be projected on a screen. But for the home, smaller apparatus is imperative, and a rapidly rotating disc seems out of the question.

The cathode-ray tube has been proposed as a substitute for the mechanical scanning system. Many methods have been suggested and tried. One of the most successful is that described by Zworykin, in 1933. The cathode-ray tube may be used at both transmitter and receiver.

The cathode-ray tube consists of a cathode which emits electrons just as the cathode of an amplifier furnishes a stream of electrons for the complicated processes of the vacuum tube. This

electron stream in the cathode-ray tube is permitted to pass through a small hole in a plate, and under the stimulus of a positive potential applied to a cylindrical element the electrons are drawn through the long expanding throat of the tube. When they hit the flare at the end they cause a chemical to emit, for a fraction of a second, a flash of light, each electron revealing where it hit the screen by this flash.

On the way to the screen the electrons may be deflected by coils through which current passes, or by plates on which either d.-c. or a.-c. voltages are placed.

Therefore if the incoming signals are modulated according to the variations in light intensity shining on the photocell at the

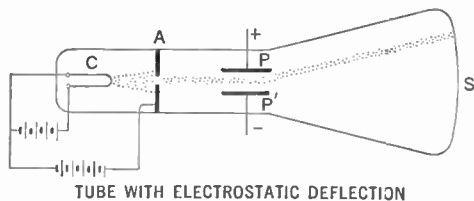

FIG. 311.—Cathode-ray tube with plates for deflecting the beam.

transmitter the intensity of the cathode-ray beam may be modulated in accordance. If, at the same time, the deflecting plates or coils are given voltages or currents corresponding to the position of the scanning disc at the transmitter the cathode-ray beam can be made to transverse the screen and reveal the original picture.

The advantage of such a device is that it has no mechanical inertia. The electrons speed at tremendous velocities, depending upon the voltages impelling them toward the screen. Each spot on the screen is very small and therefore the detail of the picture can be sufficiently great to give a good likeness. At the same time the picture may be projected from the cathode-ray tube screen, or the screen itself may be made fairly large so that the picture is at once of reasonable size. At present the largest television tubes have a screen diameter of approximately 12 inches, making possible a 7 by 9 inch picture.

393. Cathode-ray scanning—the iconoscope.—In 1933 Zworykin described for the first time his device which does away with the scanning disc at the transmitter. Several inventors have worked along similar lines, and the reason that Zworykin's device is singled out to be described here is simply that it has been most recently and most fully described.

Within the large end of the cathode-ray tube, to be used at the sender, is a square plate about 4 by 5 inches in size. This plate is covered with thousands of minute light-sensitive surfaces or photocells. The picture to be televised is focussed by a lens, external to the evacuated space, upon this plate. Between the front light-sensitive surface of these individual photocells and the rear plate exists a small capacity which may be charged by the current flowing from the individual photocell under action of the picture focussed upon it.

Suppose, therefore, we focus a still picture upon this plate. The photocells translate this picture of varying light and shade into electrical charges existing in the tiny condensers associated with the cells. Now suppose we aim at this plate a beam of electrons (a cathode ray) and sweep it across the plate, across and up and down. In other words we shall make the cathode-ray beam scan this plate of photocells. Each time it strikes the photocell it discharges the condenser associated with that photocell. The discharge current may be amplified, transmitted to the receiving station, and utilized there to modulate another cathode-ray beam which is sweeping across, or scanning, a screen which lights up momentarily when an electron hits it. If these two cathode-ray beams are operated in synchronism the picture will be recreated at the receiver.

The advantages of the cathode-ray scanner are that it is more efficient from the standpoint of using the available light—for the entire picture is illuminated all the time in this case and not just momentarily; and the cathode-ray beam can move with extreme rapidity—Zworykin states that 250 lines per inch is not difficult to attain. Further advantages are saving of space and freedom from the troubles of rotating machinery.

But not all the problems of television are solved by the cathode-

ray tube. The transmitter and receiver are complex and expensive; and the programs will be vastly more expensive than programs which are merely heard and not looked at.

Such are the problems of transmitting still pictures and moving pictures over wires and over space radio. It is probable that television of large scenes will first be made through the medium of moving-picture film. This is the only method by which sufficient light can be obtained with existing apparatus to do justice to any but a very restricted field of view.

The problem of space in the ether for high-quality transmission points to the ultra-high frequencies as the only solution. Other, and probably more important, services already tax the available frequencies above 10 meters wavelength. Between this wavelength (30,000 kilocycles) and 5 meters (60,000 kc.) there are 1000 channels three times as wide as existing broadcast bands, and there are 30 channels each 1,000,000 cycles wide, which is sufficient for good television. But already other services are making demands upon some of these channels. And so by the time television is ready for exploitation it may be that the channels at present idle may be put to full use.

All members of the radio industry—engineers, executives, broadcasters, set manufacturers, and government officials—realize the importance of preserving a space in the ether for television. Fortunately the channels reserved can be used several times within the confines of the United States. Therefore one channel can support several stations provided they are spaced widely enough apart.

Engineers of several companies have spent many hundreds of thousands of man-hours of work and many hundreds of thousands of dollars in research, all leading toward the ultimate realization of man's desire to see at a distance. Zworykin has been widely acclaimed for his work; his associates have accomplished much; and of course there are others whose contributions have been considerable.

Standards have been set up for the number of lines to be used (441 for the entire picture), the channels are available, transmitting stations are being erected and tested in New York and Phila-

delphia. RCA and NBC, Farnsworth, and Philco in this country have demonstrated high-quality television numerous times. These demonstrations have been of cathode-ray systems, both studio scenes and film programs being given.

The Bell Laboratories have developed the coaxial cable, and a first installation between Philadelphia and New York has been made. This is composed of two conductors, one in the center of the other which is grounded. The inner conductor is maintained at the center by insulating spacers. The cable has the property of conducting currents of very high frequency such as are necessary for television channels,

There are still many problems, even though in England television has been launched as a commercial system. It is highly doubtful that any appreciable proportion of the area of the United States will be covered with television signals for many years.

INDEX

- A
- "A" battery, 166
 - "Abac," 129
 - Acceptor circuit, 137
 - Adjusting a vacuum tube voltmeter, 344
 - Air gap, effect on inductance, 72
 - Alternating current, effective value of, 95
 - frequency, 51, 89
 - instantaneous value of, 90
 - maximum, or peak value of, 91
 - period, 51
 - root-mean-square value of, 96
 - tubes, 190
 - work done by, 51
 - Alternating-current circuits, 89-119
 - power in, 117
 - series, 109
 - characteristics of, 113
 - terminology used re, 95
 - tube tester, 188
 - Alternation, 51, 89
 - Ammeter voltmeter method of measuring resistance, 33
 - Ammeters, 30
 - Ampere, 9, 11
 - turns, 48
 - Amplification, 228
 - calculation of, 252
 - purpose of r-f and i-f, 296
 - Amplification factor of tube, 171, 175
 - constant, to measure, 185
 - meaning of, 177
 - Amplifier, *see* Audio, 228-295. Radio-frequency, 295-334
 - as oscillator, 419
 - Amplifier, band pass, 373
 - frequency characteristics of, 244
 - high-frequency, 295-334
 - reflex, 258
 - tube, 202-227
 - Angles, functions of, 92
 - Antenna, air-wave, 369
 - anti-static, 466
 - automobile, 468
 - capacity, 460
 - counterpoise, 461
 - current increase with modulation, 451
 - directional, 459
 - inductance, 161, 460
 - input systems, 162-164
 - loading, 462
 - types of, 458
 - wavelength of, 160
 - decreasing, 462
 - natural, 461
 - Anti-resonant circuit, 132, 136
 - Apparatus, power supply, 391-416
 - Armstrong, E. H., 164
 - Atom, 3
 - Audio amplifiers, 228-294
 - cascade, 233
 - Class A, 275
 - Class B, 261, 275
 - Class C, 275
 - compensation, 280-281
 - coupling tube to load, 280
 - degenerative, 290, 293
 - design, rules for, 276
 - direct-coupled, 291
 - equalizing, 255
 - filtering, 286

- Audio amplifiers, frequency characteristic, 233
 impedance, 240, 246
 inductance load, 240
 Loftin-White, 293
 need of, 228
 overloading, 212
 power, 255
 push-pull, 257
 reflex, 253
 regeneration in, 284
 requirements of, 231
 transformer in, advantage of, 249
 transformer-coupled, 246
 transmission unit of, 266
 tube as an, 202-227
 tuned inductance, 245
 volume control, 277
- Autodyne, 363, 364
 detuning loss in, 372
- Automobile antennas, 468
- Auto-transformer, 69
- B
- "B" battery, 167
 "B-eliminator" curve, 15
 Baffles for loud speakers, 387
 Ballast tube, 413
 Barkhausen-Kurz oscillator, 333
 Batteries, 38
 "A," 166
 "B," 167
 "C," 173
 requirement of plate, 239
- Beam power tube, 227
- Beats, phenomenon of, 357
- Bel, 266
- Bias, "C" or grid, 173, 409
 for power tubes, 278
 means of obtaining, 196
 on plate current, effect of, 171
- Bridge methods of determining tube factors, 185
 neutralizing, 322, 324
- Broadcast frequency tuning coils, 62
 by-pass condenser, 86, 104
- C
- "C" battery, 173
 bias, 171, 173, 196, 278, 409
 means of obtaining, 196
- Calibrating a wavemeter, 152
 by clicks, 156
 by harmonics, 153
- Calibration of a variable inductance, 71
- Capacities, effect of stray, 241
 in radio-frequency circuit, 304
- Capacitive circuit, 75
 reactance, 102
 comparison of, 104
- Capacity, 74-88
 as a reservoir, 74
 centimeter of, 77
 combinations of resistance with, 106
 in a power supply device, 75
 input filter, 407
 of antenna, 161, 460
 of coils, distributed, 146
 of condenser, 77
 measurement of, 105 160
 reactance, 102, 305
 tube input, effect of, 303
 unit of, 77
- Carrier frequency, 336
 wave, 299
- Cascade amplifiers, 233
- Cathode, 166, 191
- Cathode ray tube scanning, 478-479,
 480-481
- Cell, battery, 38
 common dry, 40
 internal resistance of, 41
 polarization of, 43
 primary, 38
 secondary or storage, 38, 40
 testing, 42

- Cells, in parallel, 44
 in series, 44
 in series-parallel arrangement, 45
- Centimeter of capacity, 77
- Characteristic curves, dynamic, 206
 of receiving tube, 171
 of screen-grid tubes, 199
 slopes of, as tube constants, 181
- Characteristics of a series circuit, 113
- Charged bodies, 1
- Charges, electrical, 1
 laws of, 2
- Choke coil, 104
- Circuit, acceptor, 137
 anti-resonant, 132
 capacitive, 75
 equivalent tube, 177, 209
 filter, for rectifier, 403
 regulation of, 404
 fundamental rectifier, 391
 inductive, 75
 measuring resistance of, 159
 receiving, 149
 reflex, 254
 rejector, 136
 Rice, 322
 selectivity of, 139, 314
 series resonant, 120
- Circuit diagram, of receiver, 192
 of signal generator, 378
- Circuits, alternating-current, 89-119
 automatic frequency control, 382
 automatic volume control, 354, 380, 412
 bridge, 322
 coupled, 57
 degenerative feedback, 290
 noise suppressor, 354, 381
 oscillating, 417, 432, 434
 parallel, 25, 27
 primary, 49
 secondary, 49
- Circuits, series, 24
 alternating-current, 109
 resonant, 136
 short-wave receiver, 365
 typical receiving, 162
- Coaxial cable, 482
- Coefficient of coupling, 64
- Coils, bank wound, 148
 broadcast tuning, 62
 coupling, 63
 distributed capacity, 146
 "honey comb," 371
 inductance, 62
 iron core, 148
 Litz wire, 328, 360
 multilayer, 63
 Polydoroff, 301
 properties of, 149-164
 resistance of, 144, 163
 measurement of, 158
- Comparison of reactances, 104
 night and day reception, 464
 push-pull and single tube, 291
- Comparisons between amplifiers, 277
- Condenser, 75
 by-pass, 86
 capacity of, 77
 measurement of, 160
 capacity formulas, 85
 charge in, 75
 time constant of, 78, 81
 conducting plates of, 84
 discharged, 78
 electricity in, 77
 Leyden jar, 76
 potential energy of, 76
 in electrostatic field, 80
 tests, 83
- Condensers, d.-c., resistance of, 81
 electrolytic, 84a
 in alternating-current circuits, 81
 in parallel, 87, 88
 in series, 87, 88

- Condensers, leakage resistance of, 81
 measurements of capacity, 105, 160
 padding, 88
 power loss, 83
 properties, 149-164
 sizes of radio, 85
 time constant, 81
 tuning, 86
 Conductance, 6, 23
 mutual, 180
 importance of, 181
 measurement of, 184
 Conducting plates of condenser, 84
 Conductivity, 6
 Conductors and insulators, 5
 Conservation of energy, law of, 54
 Cooley system, 473
 Coulomb, 9, 77
 Counterpoise, 461
 Coupling, 63
 coefficient of, 64
 effect of, 311
 in oscillatory circuit, 423
 on secondary resistance, 312
 Crystal control apparatus, 439
 Current, alternating, 51, 89
 and voltage in phase, 97
 definition of, 3, 4
 detection of, 29
 direct, 52, 89
 effect of, on circuit, 29
 on inductance, 72
 effective, 96
 induced, 49
 lagging, 99
 leading, 101
 measurement, 30
 meters to measure, 10
 oscillatory plate, 421
 phase relations, 97
 plate, 166, 169, 194
 curves, 172, 174
 production, 38-56
 Current, received, calculation of, 457
 saturation, 169
 Curve, "abac," 129
 as tube constant, 181
 slope of, 16
 resonance, 158
 width of, 140
 response, of receiver, 300
 Curve plotting, 13-16
 Curves, characteristic, 171, 181, 199, 206
 plate current, 172, 174
 plate voltage, 174
 Cycle, 51, 89
- D
- DB, 266
 use of, 271
 Decibel, 266
 table of values of, 267
 voltage and current ratios of, 268
 Demodulation, 338
 Design of audio amplifiers, 266-295
 rules for, 276
 Detection, 335-355
 conditions for best, 343
 in radio-frequency amplifier, 347
 of current, 29
 of modulated wave, 34C
 power, 352
 Detector action, 350
 as a-c voltmeter, 343
 diode, 201, 353
 grid leak and condenser, 348
 plate circuit, 340
 power, 352
 simple, 338
 Detuning loss in autodynes, 372
 Dielectric, 77
 constant, 84
 nature of, 84
 of tuning condensers, 86
 Differential resistance of tube, 179
 Diode detector, 201, 353

- Direct-current collector rings, 52
 commutator, 52
 generator, 52
 internal resistance of, 53
 open circuit voltage in, 53
 plate current and alternating voltage, 346
 resistance of a tube, 178
- Direction-finding stations, 459
- Distorting tubes, 335
- Distortion, calculation, harmonic, 221
 caused by overloading, 217
 curved characteristic, 214
 positive grid, 216
- Distributed capacity of coils, 146
- Dynamic characteristic curves, 206
- E
- Effective value of alternating voltage or current, 95
- Efficiency, definition of, 56
- Electric generator, 49
- Electricity, three fundamental effects of, 30
 in condenser, quantity of, 77
 frictional, 81
 static, 76, 79
- Electrodes, 38
- Electrolysis, 39
- Electrolyte, 38
- Electrolytic condenser, 84a
- Electromagnetic field, 80
 induction, 49
- Electromagnetism, 46
- Electromotive force, 10
 of cell, 39
 unit of, 10
- Electrons, 1
 diameter of, 3
 in vacuum tubes, 166
- Electrostatic field, 80
- Energy, electrical, 53
 in condenser, 79
- Energy, kinetic, 53
 potential, 53, 76, 80
 unit of, 79
- Engineering tuned radio-frequency amplifier, 307
- Engineers' shorthand, 11
- "Equalizing," 255
- Equivalent tube circuit, 177, 209
- Espenschied, Lloyd, 297
- Ether, 3
- Exponents, 11
- F
- Facsimile, *see* Television, 469-482
- Fading, 463
- Farad, 77
- Faraday's discovery, 48, 49
- Fidelity of radio receiver, 295
- Field, electrical, 4
 magnetic, 47
- Field intensity, 47
 strength, 296
 tables, 297
- Filament, in vacuum tube, 165
 life, 190
 purpose of, 166
 rectifiers, typical, 394
 types of, 189
 voltage, effect of, 168
- Filaments, operating in series, 191
- Filter, 75
 circuits for tube rectifiers, 403
 regulation of, 404
 in audio amplifiers, 286
 inductance-capacity, 407
 r.-f. circuit, 325
 telephonic, 265
- Flux, 47
- Flying spot, 476-477
- Franks, C. J., 148
- Frequencies, alternating-current, 51
 at high power stations, 52, 89
 standard, 156
 television, 471, 481

- Frequency, 51, 89
 amplifier, intermediate, 357
 carrier, 336
 changers, 363
 characteristic of resistance amplifier, 233, 242
 doublers, 440
 chart of sound characteristic, 282
 control, automatic, 382
 converter, 360
 effect of, on inductance, 72
 intermediate, 362
 meter, 150
 modulated, 336
 of series circuit, resonant, 127
 side-band, 336
 stability of oscillating circuits, 436
- Frictional electricity, 81
- Functions of angles, 92
- G
- Gain, due tube and due coil, 309
 translation, 364
 with screen-grid, 328
- Galvanometer, 31
- Gaseous rectifiers, 398
 Raytheon tube, 398
- Gauss, 47
- Generator, 38, 45
 electric, 49
 alternating-current, 51
 direct-current, 52
 internal resistance of, 53
 signal, 378
- Goldsmith, A. N., 296, 297
- Grid in vacuum tube, 165
 bias, 173, 196
 obtaining, 431
 distortion due to positive, 216
 leak and condenser detector, 348
 values, effect of, 350
 purpose of, 170
 suppressor, 226
- Grid in vacuum tube, swing, permissible, 216
 voltage, 172
- Grid-glow tube, 399
- Ground wave, 463
- H
- Harmonic distortion calculation, 221
- Harmonics of oscillator tube, 428
- Hartley oscillator, 432, 435
- Heater type of tube, 191
- Heaviside layer, 463
- Heising modulation system, 447
- Henry, 62
- Hogan, J. V. L., 474
- I
- Impedance, 106
 amplifier, 240
 general expressions for, 107
 "matching," 119
 of parallel circuit, 116
 of tube, 179
- Individual transformer characteristic, 288
- Induced current, 49
 voltages, 49
- Inductance, 57-73
 calibration of variable, 71
 combinations of, with resistance, 106
 effect of air gap on, 72
 current on, 72
 frequency on, 72
 on sharpness of resonance, 143
 input filter, 407
 iron core, 301
 leakage, 67
 load amplifier, 240
 magnitude of, 60
 measurement of, 65, 66
 mutual, 63
 of antenna, 161, 460
 of coil, 61, 74
 tuning an, 304

- Inductance, unit of, 62
 variation of, 72, 73
- Inductances, typical, 62
 variable, 71
- Inductive circuit, 75
 reactance, 100
 comparison of, 104
- Inductors, 62
 variable, 71
- Inertia-inductance, 59
- Input capacity, 303
 resistance, effect of negative, 305
 systems, antenna, 162-164
- Instantaneous value of alternating-current, 90, 91
 means of expressing, 93
- Insulators and conductors, 5
- Intermediate-frequency amplifier, 357
- Internal resistance, effect of polarization on, 43
 of cell, 41
 of direct-current generator, 53
 of tube, 179
 testing, 42
- IR drops, 21, 22
- Ives, H. E., 477
- J**
- Joule, 79
- K**
- Kennelly-Heaviside layer, 463
- Keying a transmitter, 445
- L**
- Lagging current, 99
- Leading current, 101
- Leakage inductance, 67
 lines, 67
 resistance, 81
- Lenz's law, 58
- Leyden jar, 76
- Lines of force, 4
 magnetic, 47
- Litz wire coils, 328, 360
- Loftin-White amplifier, 293
- Long-wave receivers, 370
- Long waves. poor quality on, 373
- Loud speaker, 384
 dynamic, 386
 baffles for, 387
 horn type, 385
 labyrinth, 388
 measurements, 389
 moving coil, 386
- Lumped voltage on a tube, 182
- M**
- Magnetic field, 47
 lines of force, 47
 strength, 47
- Magnetism, 45
- Magnets, 45
 laws of, 45
 permanent, 48
- Magnitude, of amplifier voltage, 208
 of induced voltage, 61
 of inductance, 60, 61
 of mutual inductance, 63
- Master oscillator systems, 438
- Mathematics in study of radio, 13
- Measurement of current, 30
- Measurements of capacities, 105
 loud speaker, 389
 on radio receivers, 376
 resistance, 35, 184, 187
- Metal tubes, 201
- Meters to measure current, 10, 29, 30
 frequency, 50
 voltages, 10
 wavelength, 150
 Weston, 32
- Mho, 6
- Microfarad, 85
- Micro-microfarad, 85
- Microphore characteristic, 281

Milliammeter in measuring resistance, 34
 Modulated wave, detection of, 340
 Modulation, 336
 at low power, 450
 frequency, 164, 454
 grid-circuit, 337
 Heising system, 447
 increase of antenna current, 451
 in transmitter, 447
 percentage, 337
 power required for, 448
 Molecular motion, effect on resistance, 8
 Moving coil speaker, 386
 Multi-element tubes, 201
 Multiplier voltage, 32

N

Negative input resistance, 305
 Networks, 263
 Neutrodyne, 323
 Noise suppressor circuit, 354, 381

O

Oersted's experiment, 45
 Ohm, 7
 Ohm's law, 20-37
 graphs of, 22-24
 ways of stating, 20
 Operating filaments in series, 191
 Operating points, 202
 Oscillating circuits, 417
 coupling in, 423, 443
 dynamic characteristics of, 424
 frequency doublers, 440
 highly damped, 418
 practical, 432
 stability of, 436
 various, 434
 Oscillation, conditions for, 420, 425
 undamped or continuous, 419

Oscillator, adjusting, 435
 Barkhausen-Kurz, 333
 connecting to antenna, 446
 crystal control in, 439
 efficiency of, 427
 electron-coupled, 364
 Hartley, 432, 433
 maximum power output, 431
 power output, 429
 shunt feeding, 433
 systems, master, 438
 transmitters, etc., 417-454
 tube, harmonics of, 423
 Output choke, 22
 Overall voltage amplification, 238
 Overloading, amplifier, 212

P

Pad design, 265
 Padding condensers, 88
 Parallel cells, 44
 Parallel circuits, 25, 115
 characteristics of, 27
 impedance of, 116
 phase in, 116
 resonance, 131, 136
 Peak value of alternating current, 91
 Pentode, 226
 Period, 51
 Permalloy, 148
 Permeability, of iron, 47
 of core, 60
 Permissible grid swing, 215
 Phase, 91
 angle, 91, 94
 sine of, 91, 92
 in parallel circuits, 116
 in series circuit, 111
 of E_p , E_g , and I_p , 207
 relations between current and voltage, 97

- Plate, battery requirements, 239
 circuit detector, 340
 curves, 172, 174
 in vacuum tube, 165, 184
 oscillator, 443
 purpose of, 166
 resistance, measurement, 187
 symbol, 166
 voltage, effect of, 168, 170, 174
- Polarization, 43
 means to overcome effects of, 43
- Poles, 47
- Polydoroff coils, 301
- Power, amplification, 211, 255, 263
 apparent, 119
 detection, 352
 diagrams, 222
 electrical, 53
 expressions for, 55
 factor, 119
 for modulation, 448, 450
 in alternating-current circuits, 117
 in transformer circuits, 68
 into resonance circuit, 126
 levels, 281
 loss in condensers, 83
 lost in resistance, 54
 output, 210
 calculation, 221
 of oscillator tube, 429
 supply apparatus, 391-416
 automotive receiver, 408
- Protons, 1
- Push-pull amplifier, 257
 tube, comparison of, 291
- Q
- Q, of circuit, 123
 of coil, 145, 148
- R
- Radiation field, 457
 resistance, 455
- Radio-frequency amplifier, Class B,
 331
 Class C, 331
 detection in, 347
 engineering tuned, 307
 intermediate-frequency, 357
 linear, 331
 negative input resistance in, 305
 overcoupled, 318
 task of, 299
 tube input capacity of, 303
- Radio-frequency amplifiers, 295-334
 in general, 302
 neutralizing bridge circuits in,
 324
 receiving systems, 300, 356
 regeneration and oscillation in,
 319
 selectivity in, 314-318
 tuned, 304, 307
 ultra-high, 332-334
- Ranger, Capt. R. H., 474
- Ratio, arms, 37
 voltage and current, 268
- Raytheon tube, 398
- Reactance, capacitive, 102
 comparison of inductive and capac-
 itive, 104
 inductive, 100
- Receiver, all-wave, 367
 automotive, 407
 "band pass," 373, 374, 375
 fidelity of, 295
 long-wave, 370
 measurements on, 376
 response curve of, 300
 selectivity of, 295
 sensitivity of, 295
 short-wave, 365
 superheterodyne, 356, 358
 telephone, 388
 tuning a, 149
 "universal" a.c.-d.c., 194
- Receiving circuits, typical, 162

- Receiving systems, 356-390
 television, 478
 types of, 300
- Reception, night and day, 464
- Recording studio diagram, 284
- Rectifier, 75
 circuit, fundamental, 391
 controlled, 414
 copper oxide, 402
 filter circuit for, 403
 -filter system, 405
 gaseous, 398
 characteristics of, 400
 Raytheon tube, 398
 kinds of, 393
 single-wave, 396
 tubes, requirements for, 395
 Tungar, 400
 typical filament, 394
- Rectifiers and power supply apparatus, 391-416
- Reflex amplifiers, 253, 254
- Regeneration, in audio amplifiers, 284
 in radio-frequency amplifiers, 319
- Regulation of filter circuit, 404
- Rejector circuit, 136
- "Repeat points," 361
- Resistance, 6
 box, 37
 coil, bearing on selectivity, 163
 measurement of, 158
 coils, 144
 combinations of, 106
 differential, 179
 effect, of molecular motion on, 8
 of temperature on, 8
 on series resonant circuit, 125
 effective, 134
 high-frequency, 45
 internal, of cell, 41
 of generator, 53
 of tube, 179
 leak, obtaining grid bias by, 431
 leakage, 81
- Resistance, measurement, 33-37, 184,
 187
 negative, 321
 negative input, 305
 output load, 205
 plate, 179, 184, 187
 radiation, 455
 ratio arms, 37
 reflected, 133
 temperature, coefficient of, 8
 unit of, 7
- Resonance, 114, 120-143
 circuit, 120
 power into, 126
 curve, width of, 140
 minimum current, 133
 parallel, 131
 sharpness of, 138, 140
 zero reactance, 133
- Resonant frequency of circuit, 127, 134
- Response of receiver, 300
- Rice circuit, 322
- Root-mean-square value, 96
- S
- Saturation current, 169
- Scanning, 473, 476, 478
- Screen-grid tube, 197, 199
 as r.-f. amplifier, 327
 gain, 328
 selectivity, 329
- Selectivity, 314
 of circuit, 139
 combinations, 274
 of radio receiver, 295, 300
 of superheterodyne, 363
 with screen-grid tubes, 329
- Self-inductance, 59
- Sensitivity, of meters, 32
 of radio receiver, 295
- Series, aiding, 63, 64
 cells in, 44
 operating filaments in, 191
 opposing, 64

- Series, alternating-current circuits, 109
 characteristics of, 113
 phase in, 111
 resonant, 120
- Series and parallel circuits, 24
 resonant, 136
 acceptor, 137
 rejector, 136
 uses of, 136
- Series resonant circuit, 120
 characteristic of, 123
 effective of resistance on, 125
 power into, 126
 resonant frequency of, 127
- Sharpness of resonance, 138
 effect of inductance and capacity on, 143
- Shielding, 383
- Short-wave receivers, 365
 transmission, 462
- Shunt-feeding oscillators, 433
- Side band, 299
 cutting, 300
 frequency, 336
- Signal generator, 378
- Sine wave of voltage, 51
- Single slide tuning coil, 70, 71
- Single-wave rectifier, 396
- Skip distance, 463
- Sky wave, 463
- Slide wire bridge, 37
- Slopes as tube constants, 181
- Solenoid, 46, 63
- Sound frequency chart, 282
- Sound level chart, 285
- Static, 83, 464-468
 man-made, 465, 466
 natural, 465
- Static electricity, 76, 79
- Supercontrol tubes, 200
- Superheterodyne, 356
 circuit, 192
 design, 358
- Superheterodyne, electron-coupled oscillator, 364
 "repeat points" in, 361
 selectivity, 363
 translation gain, 364
- Suppressor grid, 226
- Symbols, 17-19
- T
- Telephone receiver, 388
- Television and facsimile, 469-482
 Bell system of photograph transmission, 472
 cathode ray scanning, 478-479, 480-481
 Cooley system, 473
 flying spot, 476-477
 frequency band required, 471
 Hogan's facsimile system, 474
 iconoscope, 480
 Ives' picture transmission, 477
 persistence of vision, 475
 picture elements, 470
 Ranger's facsimile, 474
 scanning, 473, 476, 478
 standards, 481
 ultra-high frequencies, 481
 Zworykin's iconoscope, 480
- Temperature coefficient of resistance, 8
- Thompson, B. J., 333
- Thyratron, 399, 414
- Time of charge of condenser, 78
 constant, 81
- Tone control, automatic, 375
- Transformer 66
 advantage of, in amplifier, 249
 auto-, 69
 characteristics, individual, 288
 circuits, power in, 68
 -coupled amplifier, 246
 losses, 68
 with no secondary load, 248
- Translation gain, 364

- Transmission, 455-468
 line, feeding power through, 447
 short-wave, 462
 unit, 266
- Transmitter, field strength of, 296
 keying, 445
 modulation in, 447
- Transmitters, adjusting plate load in, 443
 self-rectified, 442
- Transmitting station, high power at, 298
- Triangle functions, 92
- Tube, *see* Vacuum tube.
- Tuned inductance amplifier, 245
 radio-frequency amplifiers, 304, 307
 receiving set, 356
- Tungar rectifier, 400
- Tuning condensers, 86
 receiver, 149
- U
- Universal a.c.-d.c., 194
- V
- Vacuum tube, 165-201
 "A" battery, 166
 alternating-current, 190
 amplification constant, 175, 177, 185
 as an amplifier, 202-227
 ballast, 413
 "B" battery, 167
 beam, 227
 characteristic curves, 171
 slopes of, as constants, 181
 constants, measurements of, 184
 slopes as, 181
 construction of, 165
 direct-current resistance of, 178
 equivalent tube circuit, 177, 209
 factors, bridge methods of determining, 185
- Vacuum tube, filament in, 165, 189
 purpose of, 166
 filaments, operating in series, 191
 grid in, 165
 bias, 171, 173, 196
 purpose of, 170
 voltage, 172
 heater types of, 191
 cathode, 191
 impedance of, 179
 input capacity, 303
 internal resistance of, 179
 "lumped" voltage on, 182
 measurement of, 184
 measurement of constants, 184-187
 metal, 201
 multi-element, 201
 mutual conductance of, 180
 importance of, 181
 plate in, 165
 current curves, 172, 174
 purpose of plate, 166
 resistance, 179, 184, 187
 voltage, 168, 170
 voltage curves, 174
 rectifier, 395
 Raytheon, 398
 resistance of, 179
 differential, 179
 direct-current, 178
 internal, 179
 plate, 179, 184, 187
 saturation current, 169
 screen-grid, 197
 characteristic curves, 199
 space charge in, 166
 supercontrol, 200
 tester, a.c., 188
 thyatron, 399, 414
 types of, 189
 variable- μ , 200
 voltage, 168

- Vacuum tube, voltmeter, 343
 use of, 346
- Variable inductances, 71
- Variable-mu tube, 200
- Variometer, 72
- Vector, 94
- Vibrator, 408
- Volt, 10
- Voltage amplification, 263
 and current ratios, 268
 divider, 21, 408, 411
 doubler, 400
 drop, 21
 effect of filament, 168
 effective, 96
 grid, 172, 346
 induced, 49, 61
 magnitude of amplified, 208
 open-circuit, 53
 phase relations of, 97
 plate battery, 239
 plate-current curves, 174
 regulation, 412
 sine wave of, 51
- Voltmeter, 10
 adjusting, 344
 vacuum tube, 343
 use of, 346
- Voltmeter method of measuring resistance, 34
 low resistance, and milliammeter, 34
- Voltmeters, 31
 multiplier, 32
 sensitive, 32
- Volume control, 277
 automatic, 354, 380, 412
 compensated, 376
- W
- Wavelength, 129
 of antenna, 160, 461, 462
- Wavelengths, table of, 371
- Wavemeter, 150
 calibrating, 152
 by clicks, 156
 by harmonics, 153
 heterodyne, 151
- Weston meters, 32, 34
- Wheatstone bridge, 35, 65
- Width of resonance curve, 140
- Z
- Zero beat, 357
- Zero potential, 83
- Zworykin, V. K., 478, 480-481

