

RADIO FOR ALL

nia

BACK



THE LIBRARY
OF
THE UNIVERSITY
OF CALIFORNIA
LOS ANGELES

RADIO FOR ALL

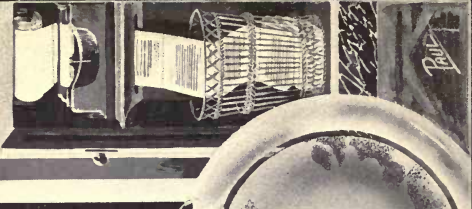
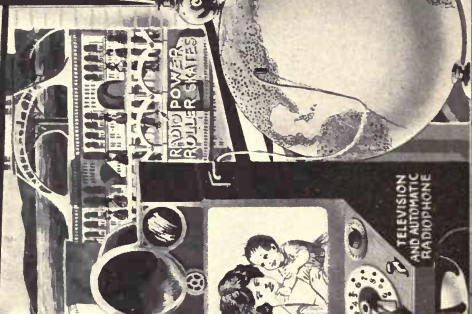
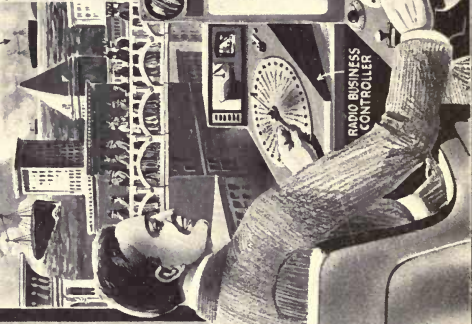
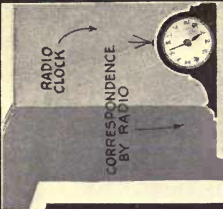

RADIO CLOCK
CORRESPONDENCE BY RADIO

RADIO POWER DISTRIBUTOR

RADIO CONTROLLED AIRPLANES

CREWLESS SHIPS CONTROLLED BY RADIO

RADIO POWER ROLLER SKATES

RADIO BUSINESS CONTROLLER

TELEVISION AND AUTOMATIC RADIOPHONE

HEARST RADIO

PAUL

THE FUTURE OF RADIO

IN this illustration are shown some of the future wonders of Radio. Several of the ideas are already in use, in an experimental way, and it should not be thought that the entire conception is fantastic.

The illustration shows a business man, let us say, fifty years hence. To the right is a television and automatic radiophone. By means of the plug shown to the right of the machine, the man can plug in any city in the United States he desires; then, by means of this automatic control board he can select any number in that city he wishes, merely by consulting his automatic telephone directory. As soon as he has obtained his number, a connection is made automatically and he not only can talk, but he can see the party whom he calls. At the top of the instrument is a loud-talker which projects the voices of the people, while on a ground-glass in front of him the distant party is made visible. This idea is already in use, experimentally.

Directly in front of the man, we see the "radio business control." By means of another television scheme, right in back of the dial, the man, if he chooses to do so, can load and unload a steamer, all by radio telemechanics, or throw a distant switch, or if a storm comes up, look into the interior of his apartment and then, merely by pressing a key, pull down the windows; all of which can be accomplished by radio telemechanics, a science already well known.

His business correspondence comes in entirely by radio. There is a tele-radio-typewriter. This electro-magnetic typewriter can be actuated by any one who chooses to do so. For instance, if we wish to write a letter to Jones & Company, Chicago, Illinois, we call up by radio, that station, and tell the operator that we wish to write a letter to the Company. Once the connection is established, the letter is written in New York, let us say, on a typewriter, and automatically sent out through space by radio; letter for letter, word for word being written by the other typewriter in Chicago. The letter when finished falls into a basket. Instead of sending our correspondence by mail we shall then do our letter-writing by radio. There is nothing difficult about this scheme, and as a matter of fact, it can be put into use today, if so desired. We have all the instrumentalities ready.

Going further, we find the Radio Power Distributor Station that sends out power over a radius of 100 miles or more. This radio power may be used for lighting, and other purposes.

In front of the bridge we see a number of people who are propelled by Radio Power Roller Skates. On their heads we see curious 3-prong metallic affairs. These collect the radio power from a nearby railing, which, however, is not in view, and which they do not touch. The power is sent through space from the rail to the 3-pronged affair and then is conveyed to the skates, which are operated by small electric motors. These roll at the rate of 15 to 20 miles an hour, and there is no visible connection between the wearer and the Radio Power Distributor.

We next see the crewless ships controlled by radio. This has been made possible today. Indeed, several U. S. battleships have already been manœuvred over

a considerable distance by radio. The time will come when we can direct a ship across the ocean without a human being on board. Future freight will be sent in this manner. The ship, every ten minutes, gives its location by radio, so that the land dispatcher will know at any time where the ship is located. Collisions are avoided by a number of instruments into details of which we need not go here, but which have already been perfected. Collision with icebergs also is avoided by thermo-couples which divert the ship away from the iceberg as soon as it enters water which has been cooled below a certain degree.

The radio-controlled airplane works similarly to the radio-controlled ship, and it will be possible to control such airships very readily in the future. As a matter of fact, John Hays Hammond, Jr., in this country, has done this very thing. Radio-controlled airplanes will play a great rôle in the next war.

It is a mistake to think that radio is only good for the distribution of intelligence. As the illustration shows, the great uses of radio have not been touched upon as yet.

THE AUTHOR.

RADIO FOR ALL

BY

H. GERNSBACK

EDITOR OF "RADIO NEWS"

WITH 13 HALFTONES AND 133 ILLUSTRATIONS



PHILADELPHIA & LONDON
J. B. LIPPINCOTT COMPANY

1922

COPYRIGHT, 1922, BY J. B. LIPPINCOTT COMPANY

PRINTED BY J. B. LIPPINCOTT COMPANY
AT THE WASHINGTON SQUARE PRESS
PHILADELPHIA, U. S. A.

TK
6550
G319r

PREFACE

IN writing the present volume the author has continually had in mind a book for the public at large, not acquainted as yet with the radio art. After having reviewed nearly all the recent books on radio that have appeared since radio took the public's fancy, the author believes that the present volume covers ground not touched upon by other writers.

The keynote of the book has been simplicity in language, and simplicity in radio. This book, therefore, is not a technical volume, and wherever possible all technicalities, all mathematics, and all abstruse subjects have been left out entirely. It will also be noted that the author has not made use of the word "ether" in this book; for the reason that modern scientists are no longer in sympathy with the ether theory. The vacuum tube, it will be noted, has been touched upon very lightly and only where it was absolutely necessary. The reason is that the vacuum tube is a highly technical subject, and therefore does not belong in this book. It is a science by itself.

The author has always been a great believer in analogies to drive a point home; and for this reason analogies have been made use of freely wherever possible in this volume.

His experience in editing the first radio journal in the United States, *Modern Electrics*, in 1908, then later, *Electrical Experimenter*, (now *Science and Invention*), and, still more recently, as editor of *Radio News*, has given him the opportunity to view the radio problem through the eyes of the "man in the street." He hopes that he has succeeded in conveying a technical message into plain English.

If the present volume is the means of converting a fair percentage of the public at large to radio, the labor expended has been well worth while.

H. GERNSBACK

New York, June, 1922

CONTENTS

CHAPTER	PAGE
I. HISTORIC.....	11
II. WAVE ANALOGIES.....	15
III. TRANSMITTING (GENERAL).....	30
IV. RECEIVING (GENERAL).....	42
V. RECEIVING INSTRUMENTS.....	51
VI. TUNING.....	101
VII. AERIALS, LOOP AERIALS, GROUNDS.....	108
VIII. RADIO DIAGRAMS AND HOW TO READ THEM.....	149
IX. RADIO TELEPHONY.....	164
X. HOW TO MAKE SIMPLE RECEIVING OUTFITS.....	180
XI. THE FUTURE OF RADIO.....	229
XII. <u>RADIO ACT OF 1912</u>	239
INDEX.....	283

LIST OF ILLUSTRATIONS

The Future of Radio.....	<i>Frontispiece</i>
Transmitting President Harding's Arlington Address.....	42
Amplifiers Used to Receive the Speech.....	42
Motorbus Equipped With Radio.....	70
Two Portraits Transmitted by Radio.....	101
The Author's Radiotrola.....	127
Mme. Olga Petrova Singing for Radio.....	149
Mme. Galski Singing Tannhäuser Aria.....	164
Broadcasting Station Power Plant.....	173
Author Delivering Lecture From Newark.....	229
Power Plant of Newark Broadcasting Station.....	239
Map U. S. Radio Broadcasting Stations.....	282

RADIO FOR ALL

CHAPTER I

HISTORIC

LET us begin at the beginning. There are so many misconceptions in radio today that it is best that the reader should know just how the art of radio came into existence. The true art of radio was unquestionably discovered by Heinrich Hertz, a German professor, living at Frankfort. His first technical papers on his epoch-making invention were published in 1887. Hertz's experiments were chiefly made in the laboratory. Years before, Maxwell had made the statement that light waves and electric waves were all of the same order. There had, however, before Hertz's time never been any experiments of electric waves in free space. Hertz was the first to send electric waves through space by means of an electric spark. His apparatus was simple; he had an electric spark coil that made intermittent sparks, and by proper arrangement of this station, he could receive sparks at a distance by the simple arrangement of cutting a single wire hoop and leaving a small gap. Between the two free ends, small sparks jumped whenever sparks were made to jump on his spark coil a few yards away. In other words, every time he pressed

the key at his sending station, a spark would jump at the small gap at his receiving station, which was composed of nothing but a wire hoop. This conclusively proved that electric or, better, electromagnetic waves had been sent through free space. His were only laboratory experiments, and while he described the phenomenon correctly in scientific papers, and while it was even in these days considered an epoch-making discovery, no one thought of using the invention for practical purposes.

However, Guglielmo Marconi, an Italian youth had read of these experiments, and being gifted along these lines, he duplicated Hertz's experiments. Soon his mind conceived the idea of using the invention for transmitting intelligence over a distance. He endeavored to send a message without wires over miles where Hertz used yards. Instead of the wire hoop, Marconi devised and used a more sensitive apparatus. He found that an instrument called the coherer was enormously sensitive to the new electric waves, and he soon was transmitting signals for many hundreds of yards on the estate of his father in Italy. By diligent labor he increased this distance, and shortly was telegraphing without wires across the English channel, and not many years later, he transmitted the letter "S" in telegraphic code across the Atlantic by means of wireless.

To Marconi, therefore, belongs the honor of having perfected the wonderful invention of radio, first discovered by Hertz. Radio telephony, con-

trary to popular opinion, is not a new invention either. It has now been known for over two decades. Radio telephony, as we know it today, was first invented by Valdemar Poulsen, the Danish Edison. Instead of using a crashing spark at his sending station, he used a silent electric arc with certain adjuncts. This was not only entirely noiseless, but it gave rise to something new, *viz.*, *Continuous Waves*. Heretofore, radio engineers had always used the electric spark which produced *interrupted waves*. With these sparks, we could not transmit the human voice because the interrupted waves would break up the words in such a way that nothing intelligible could be heard at the receiving station. It is as if you were trying to talk and somebody was vibrating the hand to and from the mouth rapidly. Naturally, no intelligible words can be heard when this is done. Since Poulsen's time, radio telephony has been well known to the radio fraternity and many messages have been sent. Thus for instance, in 1915, words spoken at the Eiffel tower station, Paris, were distinctly heard in Arlington, which is on the outskirts of Washington, D. C. At another time, the human voice flung out into space at Arlington, was heard distinctly at Honolulu, a distance of over 5000 miles. So you see, the art of radio telephony is not of recent origin, as people still believe. Not only is it possible to send the human voice from one radio transmitting station to a radio receiving station, but in

1916, an experiment was made whereby people sitting in the dining room of the *Waldorf Astoria* could hear the sound of the surf of the Pacific Ocean at San Francisco, a distance of over 3000 miles. This was accomplished by hooking up the radio station to the ordinary land station, while the radio receiving station was at Arlington, Va. Then the radio waves were conducted along an ordinary telephone wire stretched between Washington and New York, and the roar of the ocean was heard through the ordinary telephone receivers connected to the telephone switchboard in the *Waldorf Astoria*. The public for many years refused to be interested in radio telephony until very recently, when our broadcasting stations began to send out regular entertainment by radio. Then the newspapers began to take it up, and today radio is a household word in every American home, be it located in the city, the suburbs or in the country.

CHAPTER II

WAVE ANALOGIES

FIRST of all it is necessary that you implant thoroughly into your mind the fact that there is nothing mysterious about radio; it is subject to natural laws the same as other phenomena.



FIG. 1.

What is a radio wave? It is not any different physically than a sound wave or a wave in the ocean. If we throw a heavy stone in a still lake, it makes what we call a splash. This wave rapidly extends in the form of circles, as shown in Fig. 1. The heavier the stone and the higher it falls, the greater the splash, and the higher the waves. It is exactly so in

radio. If by means of certain electrical apparatus connected to an aerial, we excite this aerial electrically, waves are set up in the space exactly as water waves are set up on the lake. Radio waves, just as do the water waves, branch out in all directions. With the water waves this is not so true. A true

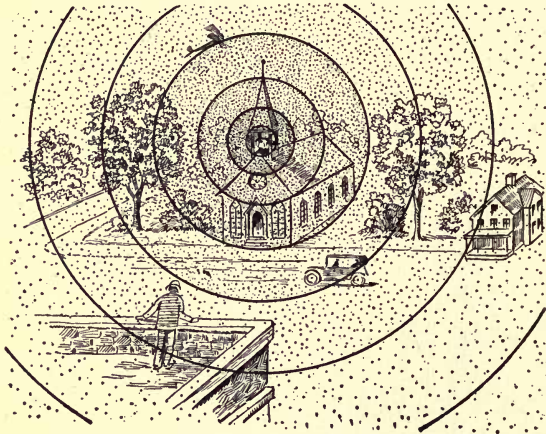

FIG. 2.

water wave, as we know, is carried along only upon the surface of the water. A few feet below the water and immediately above the water, no water waves are had. A more strict analogy would be sound waves. Take for instance, a church bell. By giving it a blow with a hammer, we excite this bell. What happens? Sound waves are set up in the air in all directions from the bell. Whether you are on the street level, 100 feet below, whether

you are 100 feet above in an airplane, whether you are in a building where it is on the same level as you are—in all these positions you will clearly hear the ringing of the bell. (Fig. 2.) What does this mean? Just this. The sound waves are propagated

in every direction in the form of waves, invisible to the eye, but “visible” to the ear. These waves are exactly of the same shape as are the ocean waves or water waves with the difference that the sound waves go out in the air in the form of spheres. In other words, the first sound wave leaving the bell

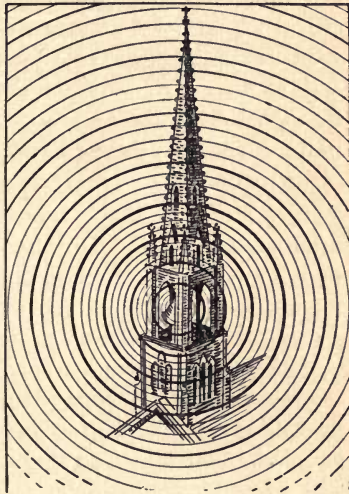

FIG. 3.

would be a sort of invisible globe all around it. The wave rapidly branches out, becoming larger and larger, always remaining, however, in the form of a sphere, as seen in Fig. 3. If the sound waves do not go out in the form of spheres, it would not be possible for us to hear them in all directions as we have seen in Fig. 2. We, therefore, come to the conclusion

that sound waves that leave a bell branch out, above, below, sideways, in fact in all directions. It is exactly so in radio. The aerial of the broadcasting station, or other radio transmitting station radiates exactly as does a bell. *Both are transmitters of waves.* The radio waves go out in the form of spheres as well, branching out in every direction of the compass, as well as below and above. Not only do the radio waves pass through the air the same as the sound waves, but radio waves pass through solid objects also, in an easier manner than sound waves.

We all know that we can hear a bell even if windows are closed. In other words, the invisible sound waves pass through the window panes although we cannot see the sound waves. Radio waves do exactly the same thing, with the exception that they pass through solids far better than do sound waves. If we are far down in a basement, and providing it is sound proof, we no longer hear the bell, but radio waves go through solid stone walls with great facility, and are, therefore, not stopped by such obstacles. Radio waves even pass through mountains, providing these mountains do not contain ores or other metallic substances. Radio waves also pass through the water just as sound waves do. We all know that if we suspend a bell below water, it may be heard if we sink a tube into the water and apply our ear to it. Thus radio waves may be received in submarines totally sub-

merged in water. Radio waves also pass through the earth with great facility. As a matter of fact, it is possible to receive radio messages readily, as we will see in a later chapter, by burying an insulated wire in the ground. Such a wire, though deeply buried, readily intercepts radio messages.

We therefore have learned here that there is nothing mysterious about the radio waves any more than sound waves. Both are subject to similar natural laws. Not only this, but as we all know the farther away we go from a ringing bell, the more difficult it is to hear it. The greater the distance the less able we are to hear the bell. The reason is of course, that the original wave, as we increase the distance between ourselves and the bell, becomes larger and larger and soon covers a tremendous distance. Finally there comes a point where we no longer can hear the bell. This may be a distance of a mile or less, that is if we have ordinary hearing. There are, however, persons and animals whose hearing is so acute that they can hear the same bell much further by reason of their being more sensitive.

If we were to take two horns and point them in the direction of the bell, as shown in Fig. 4, and apply the ear pieces to our ears, we would be able to hear the bell again, although without these appliances, we would not be able to hear it at all. Why is this so? The reason is that the vibrations that reach our ears normally are too weak to be inter-

cepted by our small ears. By enlarging our ears, as shown in Fig. 4, we intercept many more weak sound waves, and these waves, all being collected into our ears—bunched together, so to speak—are sufficient to again impress the diaphragm in the ear,

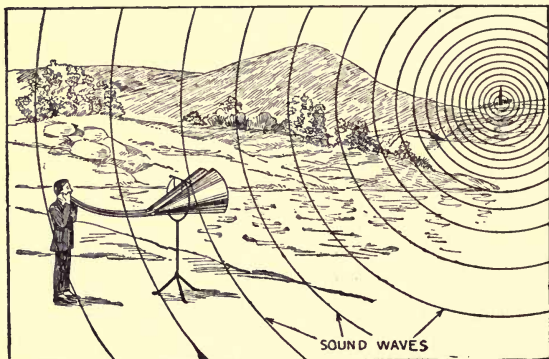

FIG. 4.

and we are thus again enabled to hear the sound. We merely cite this interesting experiment because it holds true in radio as well. If we have a transmitting station, or a broadcasting station, we can hear it only up to a certain distance with a given apparatus. If we take a small ærial, which we can liken to a normal ear, we can use it only for a given distance, let us say 25 miles. If we move this ærial 30 miles away from the radio broadcasting station, we can no longer hear it. The case here is exactly as with the sound waves. The radio waves have now to cover enormous areas, and there are not enough

waves, so to speak, to leave any impression upon our small ærial. If, however, we were to double or triple the size of the ærial, we would do physically the same thing as we were doing when we attached the two horns to our ears. By having a larger increased ærial with more wires, we would, by means of this, intercept more waves than we could with a small normal ærial; consequently with such an ærial we could hear the broadcasting station again, even though we were removed 35 miles from it. You see that the analogy between the sound wave and the radio wave holds pretty true, all the way through. Of course, in radio we have other means to bring in the signals even if we are removed still greater distances. It would not always be practical to make the ærial tremendously large in order to hear greater distances, also we would not expect to hear our bell 20 miles away by means of even large horns. We would have to devise some other more sensitive means to hear the bell, and there are such means at hand today in super-sensitive electrical microphones which magnify the very weakest sounds. So too in radio it is not necessary to build a larger and larger ærial, the more we remove ourselves from the broadcasting or transmitting station. Instead, we use more sensitive apparatus which will magnify the sounds in an electrical manner, so that we can hear the station even though we are removed thousands of miles from it.

RADIO FOR ALL

WAVE LENGTH

What do we mean by wave length? We often hear in radio that a certain station transmits at a given wave length, say 360 meters. What does this mean? First we might state that a meter is a measurement the same as the yard. A meter, roughly speaking, measures 40 inches. All European countries instead of yard, foot and inch use the

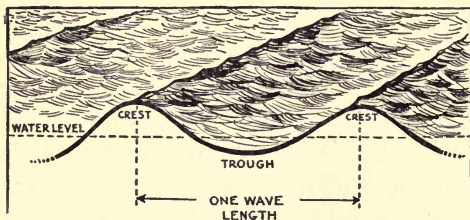

FIG. 5.

meter, centimeter and millimeter. The meter has one hundred centimeters and one thousand millimeters. Let us now return to our stone which we dropped into the water. If we were to place our eye on a level with the water, and someone was to throw a stone into a quiet surface of water, what would we see? Fig. 5 shows this. We would see a wave coming out, as shown in our illustration. Any water wave is composed of two distinct parts, the crest and the trough. In other words, the water first comes up then dips below the original surface, then up again above the original surface, etc. In our illustration, we have shown in dotted lines the orig-

inal surface of the water. The disturbance of the stone has caused the water to expand into waves. Now then, the wave length is that portion which extends from crest to crest. In Fig. 5 we see what a wave length consists of. It starts at the top of the crest, covers the trough and again up to the crest. This is exactly one wave length, because it embraces the total make-up of one complete wave.

By throwing an ordinary stone into the water, such a wave length may be anywhere from one foot upwards. Out on the ocean where we have very large waves, so called swells, such ocean waves may reach the length of about 300 yards or 100 meters or more. We might, therefore, say that an ocean wave has a wave length of 100 meters.

In radio we have the same sort of waves, and these waves go out into space in all directions, as we have learned before. In radio we can make a wave length from a few yards or a few meters up to several thousand meters and over. This all depends upon the apparatus we use. It would be the same with our bell. A very small bell, only a few inches high, would give very small sound waves, while one of the big church bells would give a much bigger sound wave. In radio too we have the same thing, and we can change from a short to a long wave length.

What are the different wave lengths used in radio? It has been found that short waves do not travel over such great distances as long waves do.

Using receiving instruments of an ordinary sensitivity, it has been found that it is better to use a wave of 2000 meters or more, if we wish to transmit messages over several thousand miles, as for instance across the ocean. A small wave length does not pass as readily over such great distances.

RADIO TELEGRAPH AND RADIO TELEPHONE WAVES

How do the waves in radio telegraphy and radio telephony differ? In radio telegraphy we simply hear the plain wave in our telephone receivers, if thus we may term it. If the operator in the transmitting station presses his key, groups of waves are sent out into space as long as the key is depressed. At the receiving side we hear the waves making a buzzing sound for the length of time that the key is depressed at the sending station. If the key is pressed down for a second, we hear a buzz for a second. If the key is depressed for two seconds we hear the buzz for two seconds, and by means of this buzzing sound the telegraphic signals are reproduced. Usually a code such as the Morse or the Continental is used. For instance, a short buzz will be the letter "E" while "SOS" would stand for the following - - - — — — - - - (a short dash being a short buzz, a long dash being a long buzz).

In radio telephony, however, we have a different and more complicated action. In the first place, we hear sounds, words, and music exactly as they are produced at the broadcasting or transmitting station. Two distinct things happen. The aerial

is made to send out a radio wave that is continuous. This wave cannot be heard by the human ear with ordinary receiving apparatus. It is what is technically called C.W. or Continuous Wave. It is also used to carry along the human speech. At this point we must resort again to our water wave. Suppose we

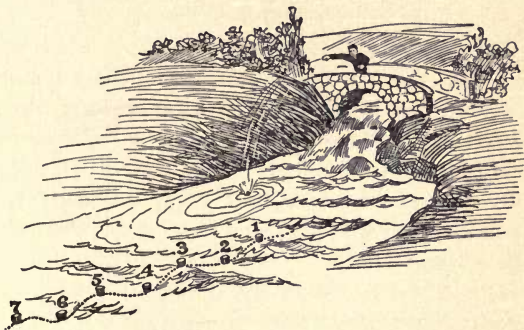

FIG. 6.

throw a stone into a river. At the same time that the stone is thrown we also throw a cork into the water, at the same spot. What happens? The cork is carried along by the current as shown in Fig. 6. First we see the cork in position 1. A little later we see it in position 2. Still later in position 4 as shown on the dotted lines. The cork, therefore, is carried along by the wave as well as by the current. As the waves progress, the cork progresses also. Exactly the same thing happens when the human speech is impressed upon the radio carrier wave. By certain means too technical to go into here, the

vibrations made by the voice are carried along upon the carrier wave, exactly as the cork is carried upon the water wave. At the receiving side we only hear the words or music, for the reason that the carrier wave is inaudible. Hence, nothing but the words or speech are heard by us in our receivers.

SPEED OF WAVES

It might not be amiss to say a few words about the speed of waves in general. If we drop a stone into the water, we all know that the speed at which the waves spread out is rather slow—a few feet per second as a rule is all. Sound waves on the other hand travel at the rate of 1,100 feet per second. The speed of sound waves we therefore see, is considerably in excess of that of water waves.

Radio waves travel with the speed of light, namely, the enormous speed of 186,000 miles per second. We, therefore, can understand that if a message is sent out anywhere on our globe, it will be received at any place almost instantaneously; the greatest distance that a radio wave or a message could travel over would be 12,000 miles, for the reason that the circumference of the earth is 24,000 miles. You will see, therefore, that a radio wave would travel around the earth at the rate of almost eight times in one second, and, although a radio message was received over a distance of 12,000 miles, it would be received in a small fraction of a second, too small to measure. For practical purposes, therefore, a radio message sent out from no matter

what distance on earth may be said to cover the distance instantaneously.

POPULAR MISCONCEPTION AS TO RADIO WAVES

Many people have an idea that radio waves broadcasted by a transmitting or broadcasting station, change their form as they are sent out into space. Many people think that, when we speak of a 360 meter wave length, that this has something to do with the distance of the sending station or of the distance that the radio waves cover. Nothing could be more erroneous. It should be thoroughly understood that if the Pittsburgh broadcasting station is sending out a message transmitted on a 360 meter wave, the length of the wave will remain 360 meters no matter how far it travels. A ship out on the ocean 3000 miles away from Pittsburgh may hear the Pittsburgh station; it will be necessary in order to hear it to tune the receiving instruments to 360 meters, otherwise Pittsburgh cannot be heard. Therefore, no matter how far a radio wave travels, it does not change its length. This is true of every wave no matter what its length, whether 100 meters or 5,000 meters. The length of the wave never changes between the transmitting and the receiving stations.

As we have seen before, the different wave lengths are purely arbitrary. For instance, the wave length of 360 meters has been chosen only because it does not interfere with the radio amateurs who transmit on a wave length of 200 meters, and

the ship stations which send out on about 600 meters. It stands to reason that if all stations were to send at exactly the same wave length, we would get nothing but a jumble.

To elucidate: Suppose you have six pianos in one room, which are all tuned alike; if we have six players sitting down at the pianos and each hits the same key, we will only hear that one note, let us say A. You could not possibly detect it if five were striking the key A, because all of the players are transmitting on the same sound wave length which transmits only the note A. Suppose, however, that one operator is striking the key A while another strikes the key E. We can immediately eliminate one or the other, and by a little concentration of our ear, we can hear either A or E. In other words the two pianos are now transmitting at different sound wave lengths, the wave length of E being different from the wave length of A, and *vice versa*. We can go still further in the analogy. Suppose one person plays a tune on the low treble, while at the same time another person in the same room plays a different tune on the high treble. With a little concentration we can listen to one tune or to the other. Of course, if we pay no strict attention we will hear both pianos play simultaneously. It is exactly as if two people talk at the table at the same time. You can listen to one and shut off your mind from the other speaker as you well know. In other words, you are "tuning out" the unwanted speaker.

It is exactly so in radio, only we have better means in radio because we can tune out entirely one station or another by means of tuning appliances so that we can hear either one at will. That is the reason why different transmitting stations send on different wave lengths. It is purely an arbitrary arrangement so as not to confuse the various receiving stations.

CHAPTER III

TRANSMITTING

(GENERAL)

We have learned something in the previous chapter about transmitting. We will now go a little further, but must be a little more technical here.

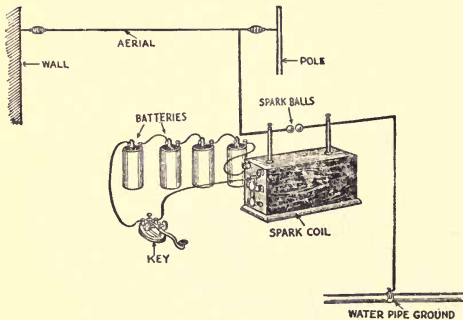

FIG. 7.

There are several ways of transmitting by radio; the oldest and historical method is shown in Fig. 7. Here we have an ordinary spark coil such as is used in automobiles, a few dry cells, a key and the so-called spark gap which may consist of wire nails or better two zinc balls. Every time we press the key a spark jumps across the open space in the spark gap. By connecting one end of an aerial to the spark gap and the other end to the ground, which

may be a water pipe, or a steam radiator, radio waves are sent out into space. This is the original arrangement that Marconi used for transmitting messages. The aerial or antenna used here may be of any size or shape. The one which we have shown is a simple single wire, which may be 50 or 100 feet long. Such a little station as this may be used to send a radio message over several miles. A station of this sort, however, is very crude because it is untuned; by this we mean, first, that it sends out

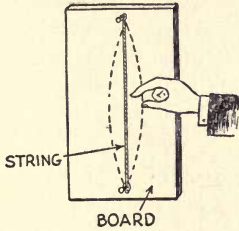

FIG. 8.

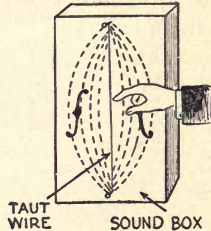

FIG. 9.

impure waves. We might compare this to a string held between two nails and plucked with the finger, when we would hear some sort of noise. In other words, it would be an impure wave. We might mention, by the way, that an impure wave is one that has several notes mixed up with the fundamental note that gives rise to a noise rather than to a note, see Fig. 8. Now turn to Fig. 9; here we have a wire stretched very taut between two nails on a sound board such as an empty box. By tightening the wire we get a pure or clear note similar to that

produced when we pluck a string on a violin or a mandolin. We all know that the violinist, before beginning to play, has to tune his violin before playing in order to get a pure note. This is his way of tuning up an instrument. Referring back to our description of simple radio transmitting, as shown in Fig. 7, this sends out what we might term a radio noise, but not a pure radio note. Furthermore, it is found that if we should take a short metal wire and stretch it taut, it would give a very high note. Thus, we know that on a harp for instance, the highest note will be the short strings and the deep bass notes will be the long strings. It is exactly so in radio. In other words, a long aerial will give a long wave length, while a short aerial will give a short wave length.

Just exactly as a manufacturer of a piano knows what the sound wave length of the longest string of his piano is, so the radio engineer will know on what wave length a given aerial will send.

Roughly speaking, an aerial 100 feet long will give a wave length of about 140 meters, while an aerial 200 feet long will give a wave length of exactly twice the length of the shorter one or 280 meters.

Suppose, with our little outfit shown in Fig. 7, we wish to send out a wave length of a thousand meters; we could do this by making an aerial 833 feet in length. That, however, would not be practicable because not in all instances could we find that much room for the aerial.

We, therefore, resort to another means, and we build an aerial indoors which we attach to the original aerial, a sort of a sending tuning coil, which we show in Fig. 10. This tuning coil is the same

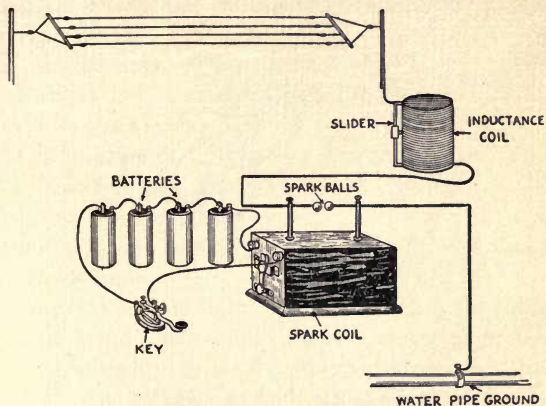

FIG. 10.

wire which we use for the aerial, wrapped around a frame or tube, as shown in Fig. 10. This coil means simply the additional wire which is necessary to lengthen our aerial in order to make it long enough to give us our thousand meters. By means of the slider, which runs up and down the wire convolutions, we now have the means of changing the wave length merely by adding more or less wire. If this is not entirely plain, take a violin as an example. When the violinist wishes to transmit a certain sound wave he plucks his string first without

touching his hand to it. As he presses down on the string, he automatically makes it shorter and shorter, and the further down his fingers slide, the higher and higher the note becomes. He does here exactly the same thing as the slider does on our

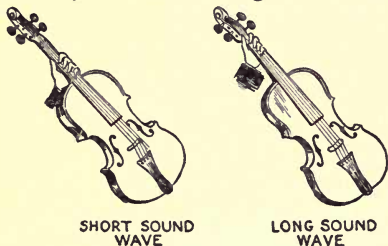

FIG. 11.

sending tuning coil, that is, he changes his sound wave length. Fig. 11.

In other words, if he wants a long sound wave he

slides his finger down the small end of the violin, and if he wants a short sound wave, he slides his finger towards his chin. This changes the sound wave length in exactly the same way as our sending coil changes the radio wave length. Both are fundamentally the same.

When Marconi first rigged up his little sending station, as shown in Fig. 7, he naturally could only send out radio telegraphic signals. Every time he pressed the key, radio waves were sent out. When he pressed the key for a second, a buzzing noise was heard for a second in the distant receiving telephone receivers. If he pressed the key for two seconds, a buzzing sound for two seconds was heard. By this means the telegraphic code is made up, as shown in Fig. 12. At the present time, the Continental code is used almost exclusively, and today,

WIRELESS CODES

LETTERS	MORSE	CONTINENTAL
A	• — • —	• — • —
B	• — • — • —	• — • — • —
C	• — • — • —	• — • — • —
D	• — • — • —	• — • — • —
E	• —	• —
F	• — • — • —	• — • — • —
G	• — • — • —	• — • — • —
H	• — • — • —	• — • — • —
I	• — • —	• — • —
J	• — • — • — • —	• — • — • — • —
K	• — • — • —	• — • — • —
L	• — • — • —	• — • — • —
M	• — • — • —	• — • — • —
N	• — • —	• — • —
O	• — • — • —	• — • — • —
P	• — • — • — • —	• — • — • — • —
Q	• — • — • — • —	• — • — • — • —
R	• — • — • —	• — • — • —
S	• — • —	• — • —
T	• —	• —
U	• — • — • —	• — • — • —
V	• — • — • —	• — • — • —
W	• — • — • —	• — • — • —
X	• — • — • — • —	• — • — • — • —
Y	• — • — • — • —	• — • — • — • —
Z	• — • — • — • —	• — • — • — • —
&	• — • — • —	• — • — • —
1	• — • — • — • —	• — • — • — • —
2	• — • — • — • —	• — • — • — • —
3	• — • — • — • —	• — • — • — • —
4	• — • — • — • —	• — • — • — • —
5	• — • — • — • —	• — • — • — • —
6	• — • — • — • —	• — • — • — • —
7	• — • — • — • —	• — • — • — • —
8	• — • — • — • —	• — • — • — • —
9	• — • — • — • —	• — • — • — • —
0	• — • — • — • —	• — • — • — • —
.	• — • — • — • —	• — • — • — • —
,	• — • — • — • —	• — • — • — • —
:	• — • — • — • —	• — • — • — • —
;	• — • — • — • —	• — • — • — • —
?	• — • — • — • —	• — • — • — • —

ABBREVIATED NUMERALS USED BY CONTINENTAL OPERATORS

1 • — • — • — 2 • — • — • — 3 • — • — • — 4 • — • — • — 5 • — • — • —
 6 • — • — • — 7 • — • — • — 8 • — • — • — 9 • — • — • — 10 • — • — • —

◀ WIRELESS ABBREVIATIONS ▶

G.E.-GOOD EVENING 4-PLEASE START ME, WHERE
 G.N. " NIGHT 30-NO MORE
 G.M. " MORNING 73-BEST REGARDS
 G.A. GO AHEAD
 D.H. FREE MESSAGE
 MSG-MESSAGE
 OPR.-OPERATOR

◀ DISTRESS SIGNALS ▶

S.O.S. OR • • • — — — • • •

FIG. 12.

as in Marconi's time, when the operator at his sending outfit presses down his key for a short duration, this is interpreted as a dot at the receiving side, and when he presses his key down for a longer period this becomes a dash on the other end. By means of dots and dashes, the telegraphic code is made up.

It is not the easiest thing to learn this code; it requires practice, the same as playing a piano or operating a typewriter. It must be learned, and it is just as important to learn to send as to receive. Of course, as soon as we have mastered sending, it is simple to receive, although, as we might suspect every operator has his individual characteristic. For instance, some of the operators, particularly the good ones, will space the dots and dashes in a certain clear manner, while others will run the signals together, making it very difficult for the operator at the receiving end to get the correct message. Some operators will go very fast, while others will go slowly. Soon it becomes possible for operators to recognize each other simply by their "hand." In radio telegraphy each sending operator has a sort of telegraphic "voice" easily recognizable by his friend.

In Fig. 7, we showed a simple sender. Of course, it goes without saying that soon after Marconi started his experiments, more complicated sending apparatus was designed. It was found, for instance, that the spark sent out by such a station was received at the other end very mushy and not at all

clear. It was nothing but a noise. Soon new apparatus was invented, such as, for instance, a quenched spark gap which clarified the sound to such an extent that instead of hearing a mushy, noisy spark at the other end, a clear whistle or flute-like sound was received. It was found that such a spark carried much further and could be worked readily through static, which is the bane of the radio

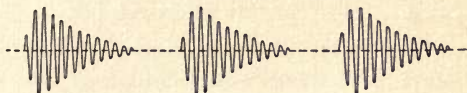
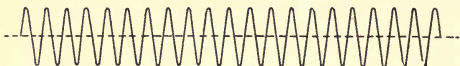

FIG. 13.

telegrapher. Static, by the way, as we will see later is an atmospheric, electrical disturbance in the air which makes receiving very difficult at times.

There are now many different transmitters in use, as for instance, the electric arc which may be used for transmitting. This has the advantage of giving rise to what is called continuous waves; this is made clear by the diagram shown in Fig. 13. When we press the key of the old Marconi outfit, we send out into space radio waves which have somewhat the form shown in Fig. 13. These waves start with a high pitch, as we might say, and die out rapidly. This happens a great many thousand times each second, but these waves are not continuous. They are small wavelets, as we might term them, which are disrupted and do not form a continuous line. Look at Fig. 14; this is what we might term a continuous wave, and is a wave which is sent out

by an arc transmitter and by a vacuum tube transmitter such as is now used universally at broadcasting stations. As long as the arc from the sending set is transmitting, a continuous wave is sent out into space which does not vary. It does not take a technical mind to know that the waves sent out, as



shown in Fig. 14, must be better and clearer than the interrupted waves sent out in Fig. 13. As a matter of fact, the interrupted wave or the wave made by the spark is coming into less and less use as time goes by. This is the day of the Continuous Wave commonly called C. W. It is the Continuous Wave that makes radio telephony possible.

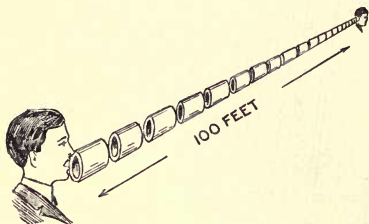

Let us make a comparison again, which can be easily understood, and which may serve to make the interrupted wave and the Continuous Wave clear in our minds. Take a number of pipes as shown in Fig. 15; one person stands at one end and another

at the other end. One talks into this interrupted pipe, which may be 100 feet long, and as will be readily seen the person at the other end will have a great disadvantage in hearing the speaker because the pipe, being interrupted so many times, breaks up the speech. This is the analogy for spark waves. Now turn to Fig. 16; here we have a long pipe, the same as we use in our speaking tubes, which is free from interruptions, and is continuous all the way through. You can readily understand why the person at the other end will have no trouble in hear-

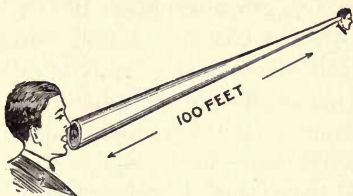

Fig. 10.

ing what the speaker says, for the reason that the pipe is continuous all the way through. This continuous long pipe stands for a continuous wave. This of course, is not a strict analogy, but may serve to implant in the reader's mind the difference between an interrupted spark wave and a continuous wave.

POWER IN SENDING

So far, we have only considered transmitting generally. The question is often asked, how much power do we need to transmit to a given distance? This is an entirely erroneous conception for a very

simple reason. The power used in sending has fundamentally nothing to do with the distance. For instance, it was demonstrated, as we stated elsewhere, that a number of American amateur sending stations were heard clearly in England, although they had a power of only 1 kilowatt, which is 1000 watts. This power is equivalent to burning twenty 50-candle power incandescent Mazda lamps on a 110 volt lighting current. Certainly a very moderate amount of power. On the other hand, the commercial companies as a rule use a power which is at least 50 times as great and often 100 to 300 times as great. Why is this so? A few words will explain. When our receiving apparatus was very crude, and not at all sensitive, a one-inch spark coil could not transmit more than one mile. In other words, it could not be heard further than one mile with ease in the time of the coherer, an instrument of which we will speak later on. A few years later, when detectors which were much more sensitive than the coherer, came into vogue, the same one-inch spark coil could be heard for 10 miles. Today, by means of our super-sensitive vacuum tubes, it is possible to hear a one-inch spark coil perhaps a hundred miles and over. So you see the power that we use at the transmitter has no bearing on the distance. As a matter of fact, it can be proved theoretically that a one-inch spark coil connected to six dry cells, and providing we have a sufficiently large aerial, may be heard as far as it is possible to

go on this globe, which is 12,000 miles. As receiving instruments are becoming more and more refined, this stage will be reached some day, because the waves of this small one-inch coil certainly reach that distance. The transmitting distance is simply a matter of the sensitivity for the receiving station. That this is not theory, is best proven by the fact that our sending stations are becoming less and less powerful. Years ago they were great thunder factories where a tremendous amount of power was used. This is a thing of the past. While we still have powerful commercial stations, their power is shrinking as the years roll on. A time will come when only an insignificant amount of power will be used to fling messages around the globe.

CHAPTER IV

RECEIVING

GENERAL

THE radio receiving station is for the sole purpose of receiving radio intelligence, be it radio telegraphy in code or radio telephony in speech, music or other entertainment.

It should be understood at once, before going further, that no matter what receiving station you have, it can receive either radio telegraphy or radio telephony. The receiving station has the exact counterpart in your ear. It receives any and all sounds and noises that are floating about in the air. So it is with the radio receiving station; with it you can hear, if properly adjusted, any and all disturbances that are flung out into space by the various transmitting stations. Of course, the radio receiving station has limitations, just the same as the human ear. To make this plain, there are many noises and sounds that the ear cannot hear, due to its physical limitations. For instance, sounds below 16 vibrations per second cannot be detected by the ear. Certain animals, however, can hear these sounds, as their hearing apparatus is tuned to low vibrations. Going up on the scale we find that the ear no longer responds when the vibrations go above 30,000 per second. Certain birds and insects, however, can hear such sounds perfectly, their

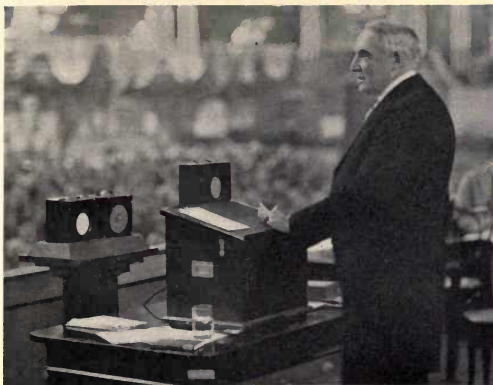

Photograph by Pacific & Atlantic Photos, Inc., New York

President Harding delivering his address at the Arlington Cemetery on Decoration Day. His voice was picked up by the microphones seen in front of the pulpit and transmitted by radio.



Photograph by Keystone View Co., Inc., New York

Here we see the huge amplifiers which were used to receive President Harding's speech. The voice issues with tremendous volume from these horns and can be heard within 500 to 1,000 feet from the tower.

ears being attuned or adjusted to these vibrations. The same is the case in radio; certain waves may be heard in a receiver while certain others may not. When we said, therefore, that a radio receiver can receive all messages that are floating about, we have said so only with certain restrictions. The radio receiver, which is just like a human ear, can only record certain radio impulses, others cannot record at all unless we take recourse to artificial means, as we will learn later on. As explained in previous chapters, receiving instruments are becoming more and more sensitive for which reason we can hear the sending station further and further away. If we have a broadcasting station which is sending out a band concert, and if we were to use Marconi's first instrument, the coherer for receiving purposes, it would not be possible for us to receive this concert at all because Marconi's coherer is totally unsuited to receive broadcasted radio music. After Marconi's coherer came the auto coherer, a somewhat more sensitive instrument. With such an instrument a broadcasting station could possibly be heard five to ten miles, but no further. Next came the crystal detectors; with a good one we may hear the broadcasting station at a distance of 25 miles or more. Still later came the audion or vacuum tube. This instrument, being enormously more sensitive than a crystal detector, at once increased the range up to a thousand miles and over. Thus, for instance, the station WJZ at Newark N. J., was

clearly heard by receiving stations 1400 miles away. Of course, the waves of the broadcasting station, as we have mentioned before, go much further, only we no longer hear them even with our present vacuum tube detectors. But the time is surely coming when, by means of a good detecting instrument, not as yet invented, we will be able to hear WJZ all over the globe. We may state right here that the range of the receiving station is mostly dependent upon the detecting instrument, all other things being equal. The range of a receiving outfit, therefore, depends entirely upon the sensitivity of the detecting means.

We often hear the remark made that Mr. John Smith has a "high power" receiving station. This is a lay expression which is totally wrong. There is no such thing as a "high power" receiving station. The statement should be that John Smith has an extraordinarily sensitive receiving station.

If you have any trouble in grasping these points, let us take recourse to another analogy. Using a candle, which will be our transmitting station, our eye will be the sensitive receiving station, a few feet away. We can see the candle perfectly, as well as the flame. Place the candle 500 feet away and we are not aware of its presence, we just see the flame rather indistinctly. At 1,000 feet, the flame plus the candle has shrunk to a fine luminous point, if we are in total darkness. Remove the candle 10 miles from our eye and we no longer see

either the candle or the flame, although we know perfectly well that the candle is still burning and is sending out its light rays.

The trouble is not, therefore, with the sending station, which is our candle in this instance, but with our eye. In other words, our eye is no longer a sensitive receiving detector for the light waves, although we know perfectly well that the light rays are still there. How can we prove this? By very simple means. We attach an amplifier to our eye, this being a telescope. If we focus this telescope correctly upon the candle, and look through our amplifier telescope, we again will not only see the distant flame of the candle, but if the telescope is a good one we will see the candle as well. Astronomers are making use of this very thing every day. Millions of stars cannot be seen by the naked eye, but the telescope brings them closer by amplifying the stars to such an extent that they become visible to our eye again. But the astronomer goes still further. He knows that the eye itself is not a very sensitive detector for light. He, therefore, substitutes a photographic plate for the eye. By exposing the photographic plate to the light of a star for many hours at a time, the star is thus photographed upon the plate, which star was previously totally invisible to the eye with the best telescope. In other words we have here to do with a super-amplifier.

We make use of just such artifices in radio as

well. For instance, a single vacuum tube is only able to detect radio signals for a given distance. By adding more vacuum tubes, more "stages" as we call them in radio parlance, we step up the faint signals until finally a radio signal that could not be heard at all with a pair of telephone receivers, and a crystal detector, will roar out of the amplifying horn with ear-splitting strength. We have done in radio exactly the same thing as the astronomer has done with his telescope. We have amplified the radio waves while the astronomer has amplified the light waves. Both phenomena are exactly alike in theory as well as in practice. The analogy holds good much further. If the astronomer has a defective telescope in which the lenses are cracked or covered by fog or moisture, we know in advance that he will not see well. His amplification of the distant star or planet will be poor or he will see nothing at all. It is exactly so with the radio receiving station. If conditions are not right, for instance, if our insulation is bad, or if the adjustments of the apparatus are not correct, we will hear the signals faintly, and often not at all. Receiving radio waves, therefore, is not any different from receiving light waves. If you go to the opera you would not think of using the opera glass unless it was properly adjusted—tuned—to your particular eye. You also would not have the lenses covered with finger marks. You know in advance that you would not see much of the opera if you were to do that. The same thing

holds true of your receiving set. We must have perfect insulation; all metal parts that carry the current must make good contact—all parts must be perfectly adjusted. Only in this case will the receiving be 100 per cent., or rather approaching it, because we have not as yet reached the stage where we can receive 100 per cent.

We have mentioned before that radio waves pass as readily through a stone wall as through the air. It, therefore, does not surprise us that we can have a modern receiving station in our library without an outdoor aerial at all and the waves will be received just as well as if the outfit was stationed on top of the roof or out in the yard. This is true only if the detecting apparatus of the receiving outfit is very sensitive, otherwise we will not be able to detect the waves, although they are there.

As a general thing, it has been found in receiving that the higher up our receiving apparatus or aerial is, the better we can receive. It also has been found that one can receive further with a given receiver over water than over land. Roughly speaking, one can hear twice as well over water as over land. To illustrate this, if we had a receiving station anywhere near the coast, we should, with a good crystal detector, hear a broadcasting station 25 miles inland. On the other hand, we would hear it about 50 miles out on the sea. Scientists are not at all certain as to the reason for this, so we will not

dwell upon it here. Furthermore, if in a mountainous country, particularly where mountains are ore-bearing, or if we are at the bottom of a valley, our receiving range will be cut down quite a good deal. Such mountains make a sort of barrier, as they do not pass the radio waves readily. Thus, if we are in the midst of a large forest, and our aerial does not extend much beyond the tree tops, we will often have difficulty in receiving. Forests cut down receiving considerably. It should be understood that these statements are only general. If we have a highly super-sensitive apparatus, we can hear in a valley or a forest, although the signals will not come in as strong as if we were out on a plain. Steel buildings also tend to cut down the receiving range. Thus, for instance, if a receiving station of moderate sensitivity is located in the heart of the New York downtown district, we will hear practically nothing from the neighboring broadcasting stations, unless of course the aerial extends far up above the buildings. All these facts should be borne in mind when erecting a good receiving station.

Another point to be remembered is that reception during the night time as a rule is better than during the day. The reason for this is that during the day time the sun's rays ionize the air, which means that the sunlight makes the air partly conductive. That cuts down the receiving range as well. It is not a rare occurrence that distant stations are heard twice

as far during the night time as during the day. Even now commercial stations handle most of their traffic between sunset and sunrise because the received signals are much more powerful during this time.

STATIC

A few words as to this greatest nuisance that the radio man has to contend with. Static disturbance is nothing but atmospheric electricity. We are not bothered much with static in the winter time, but during the months of May, June, July, August and September, there is plenty of it, particularly if we have an aerial extending up into the air. Static makes itself heard in our receivers in a sort of irregular noise that cannot be controlled today. Very often we hear sharp clicks in our receivers which vary up to a loud roar, particularly when a thunder storm is approaching. Sometimes the air, even on a perfectly clear day, is so highly charged with electricity that if we bring the lead-in from our aerial, close to the ground wire, small sparks will jump from the aerial to the ground, proving conclusively that static electricity is collecting upon the aerial. These static noises so far have not been corrected, as no way has been found to weed out or entirely tune out these disturbances. Sooner or later, however, some genius will invent a perfect static annihilator. When he does that, his future wealth will be assured. If you doubt that it is atmospheric electricity that causes the racket in your receivers on a nice warm

summer's day, you may manufacture your own static when the air is particularly quiet by means of your house cat. All you need to do is to stroke the fur of "tabby," and let the fur come in contact with the bare lead-in of your aerial while you have the receivers on your ears. You will hear exactly the same sort of static noises if you stroke the cat the right way, as her fur will generate static electricity.

CHAPTER V

RECEIVING INSTRUMENTS

THE earliest and perhaps the first instrument for detecting radio waves was the coherer. This was a rather complicated little instrument, and one that was difficult to keep adjusted. Furthermore, it was not at all sensitive, compared with the detecting instruments of today. Fig. 17 shows the in-

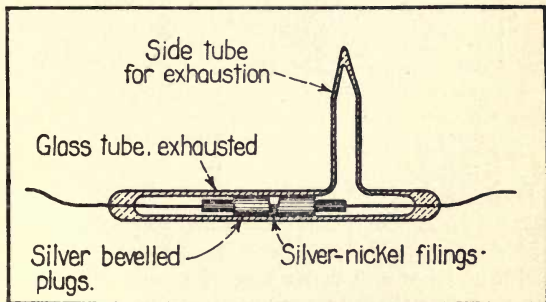

FIG. 17.

strument which was composed of nothing more than two metal plugs surrounded by a glass tube; the small space, about one-eighth of an inch, that separated the two plugs was taken up by nickel and silver filings. The proportion was roughly, 90 per cent. nickel and 10 per cent. silver. The peculiarity of this instrument was that when radio waves struck it, the filings became more conductive, and,

therefore, passed the electrical current through better. Further, it was possible to ring a bell with the coherer. The simplest connection is shown in Fig. 18. Here we see the coherer attached to the aerial and the ground, also a relay, a battery and a bell.

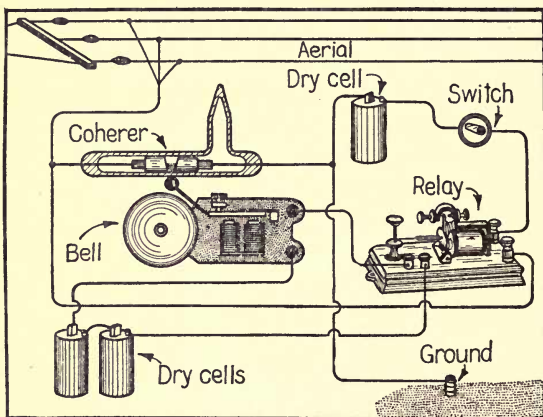

FIG. 18.

The instant that a radio wave impinged upon the aerial, the bell would ring, and would continue to ring even though the wave had passed.

In the early days, Marconi provided a sort of tapping arrangement which, hitting the coherer, disturbed the filings, destroying the conductivity, and the coherer was then ready to receive an additional signal. This instrument, however, was not very satisfactory, because it did not always respond to radio waves, and sometimes it responded to

static electricity (atmospheric disturbances) as well. This instrument, therefore, was soon discarded.

A somewhat better and simpler instrument is shown in Fig. 19. Here are two blocks of carbon filed to a sharp edge. On top of the carbon rests a sewing or darning needle; the idea is that the

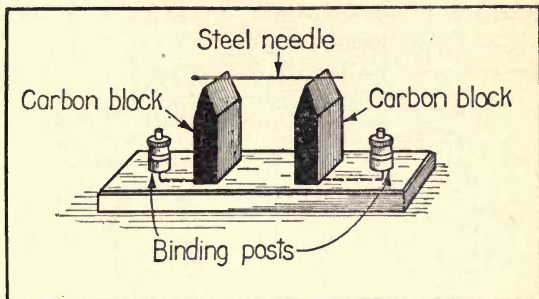

FIG. 19.

needle makes a slight contact with the carbon blocks. This was the first real detector, because unlike the Marconi coherer, it was self-restoring, that is, it needed no tapping to make it ready for the next wave. In other words, dots and dashes could be received with this detector with but little trouble. The connection is shown in the diagram, Fig. 19A, and it will be noted that a battery is required with this detector, although if adjusted exceedingly well, such an instrument works without a battery, but not so readily. Such a detector is quite unsatisfactory for the reason that the slightest vibration, such as footsteps in the room, disturbs the needle and

makes the device inoperative until it is adjusted again. This was one of its great draw-backs.

Soon afterwards there was developed the so-called electrolytic detector shown in Fig. 20. It may be considered, even today, a good detector, and while not as sensitive as the best crystal detector (this will be discussed later) it has the one great advantage in that it "stays put" and does not very easily get out of order. The electrolytic detector

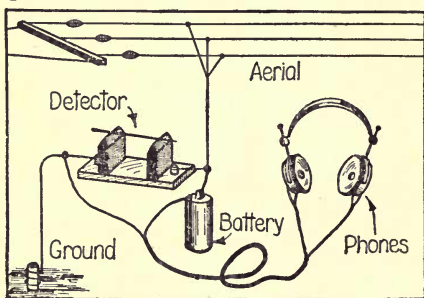

FIG. 19A.

has a fine platinum wire, as shown in the illustration that dips into a small cup containing a solution of nitric acid in the proportion of about five parts of water and one part of nitric acid. We can also use a similar proportion of water and sulphuric acid; both work very well. The wire which touches the nitric acid is exceedingly fine, for which reason it is difficult for the eye to perceive it. It is called Wollaston wire, and is a fine platinum wire covered with a heavy coating of silver.

When the wire is immersed in the acid, the silver coating is eaten away by the acid and a fine plat-

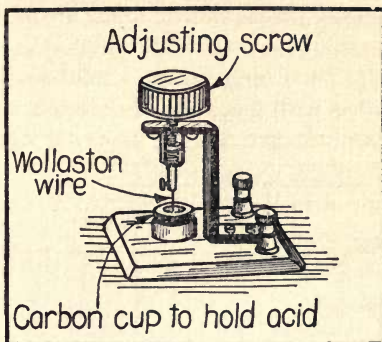

FIG. 20.

inum wire remains. This wire is less than three ten thousandths of an inch thick, so fine that it can

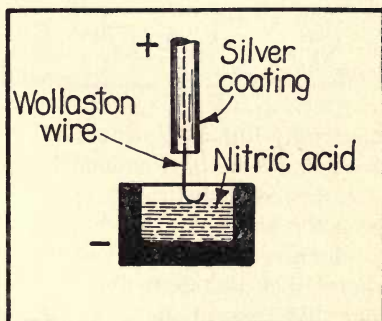

FIG. 21.

hardly be seen. Usually some sort of regulating mechanism is used to make this wire dip more or

less into the acid. As a matter of fact, the best results are had with the Wollaston wire when it barely touches the liquid, as is shown in Fig 21. The wire being so extremely thin it curls over slightly when touching the acid solution. It will be noted that with this style of detector, as shown

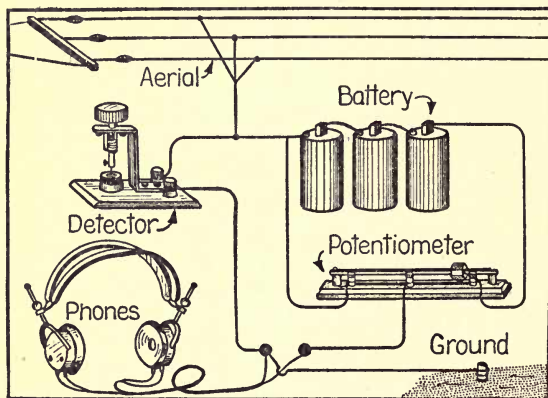

FIG. 22.

in the diagram, Fig. 22, a potentiometer is used. This potentiometer is nothing but a sort of resistance, and is employed solely to cut down the current from the batteries. High resistance telephone receivers having a resistance of 2,000 or 3,000 ohms are used with the electrolytic detector with good results. The potentiometer is adjusted until the "boiling" noise is reduced to a minimum in the telephone receivers, and the detector is now ready to receive the signals. With the electrolytic detec-

tor, signals have been received over very long distances.

The author was about the first one to introduce the use of a carbon cup in connection with the electrolytic detector, shown in Fig. 20; this carbon cup, being a conductor, made a much better instrument because metal cannot be used. Before the author's experiments, small glass vessels having a platinum wire fused into them were used, but these were rather expensive. The author also found that if a small drop of petroleum or paraffin oil was poured upon the acid, it would keep the latter from evaporating. This is quite important, as before this improvement was made, it was necessary to replenish the acid almost every day. The author who had experimented a great deal with electrolytic detectors, endeavored to develop such a detector in which no loose acids were to be used. A detector termed the "Radioson" was designed by him, and this had all the elements of the standard electrolytic detector. The fine Wollaston wire was fused in a glass tube which was immersed in the acid as shown in the illustration, Fig. 23. The Radioson was also used in connection with the potentiometer and high resistance receivers just as was the original electrolytic detector. Unfortunately the Radioson, once subjected to strong signals or even too strong static currents, would burn out the exceedingly fine Wollaston wire, after which the instrument became inoperative. Although the Radioson was perhaps

one of the best electrolytic detectors ever designed, no means could be found to keep it from burning out and the manufacture of it was given up by the makers.

Soon after the invention of the electrolytic detector, crystal detectors came into vogue. Dunwoody was perhaps the first man to use such a

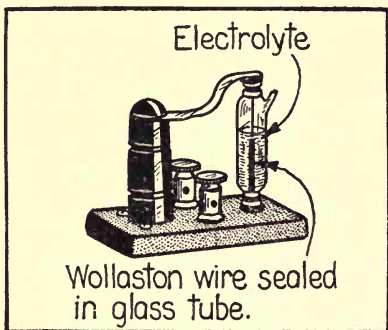

FIG. 23.

crystal, *viz.*, carborundum. The carborundum crystal is a green-bottle colored sharp crystal, which is a manufactured product. Carborundum is used mainly as an abrasive, being harder than glass, which it scratches easily. The carborundum detector is shown in Fig. 24. The connection is similar to that of the electrolytic detector and is, therefore, not shown here. As will be seen the carborundum crystal is clamped between steel needles under a certain amount of pressure, in such a way that the needles rest against the surface of the crystal. The

amount of pressure that the needles bear against the crystal is determined by experiment until the signals come in loudest. The amount of pressure varies for every crystal, and must be found by trial. Once adjusted, the carborundum detector needs no attention, and it will not get out of order readily. Jars do not affect it, and for that reason it has been

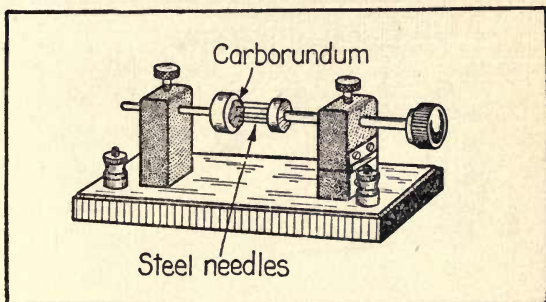

FIG. 24.

used to a great extent on board ships, in portable outfits, etc. Unfortunately, this detector is not very sensitive. As a matter of fact, it is not as sensitive as the electrolytic detector, but where stability is required this detector is excellent.

Fig. 25 shows one of the best of the early detectors, *viz.*, the silicon detector. Silicon is a manufactured substance, which is a by-product of the electric oven in the manufacture of abrasives; it is a cousin to carborundum. Silicon is a hard rock-like substance of a dark silver-gray color. The detector is shown complete in Fig. 25. A small piece

of silicon broken from a larger piece by means of a hammer or in a vice, about $\frac{1}{4}$ inch by $\frac{1}{4}$ inch, is first imbedded into a soft solder, as shown in the separate illustration of Fig. 25. The idea of this pellet is that contact is made on five sides with the metal, which is simply cast around the silicon, and the crystal part of this round pellet is after-

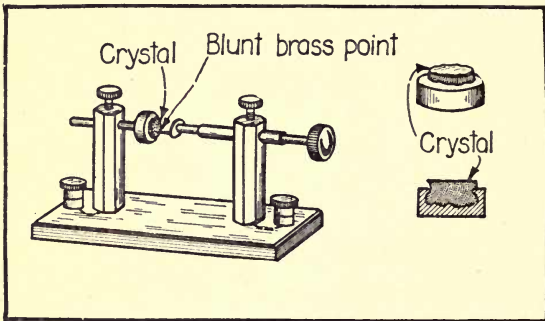

FIG. 25.

wards placed in contact with the contact member, as shown in the illustration. The contact member is nothing but a piece of brass, which is not very sharp at the end, but rather blunt. The amount of pressure upon the pellet is varied by a spring. In detectors of this kind, not every point of the silicon is equally sensitive. Some points are very sensitive while others are not. Some of the sensitive points require more pressure than others. All this is found out by experiments. The silicon detector is quite sensitive, and probably is as good a detector as the electrolytic type, with the great

advantage that it requires no battery. This was the first detector invented that required no battery whatsoever to detect radio signals, and for that reason it is a favorite instrument with the experimenter. The silicon detector has also the great advantage in that it is not easily "knocked out," as most other detectors are. It is not so sensitive to static elec-

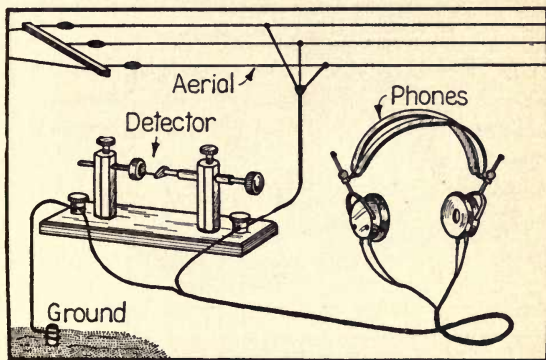

FIG. 26.

tricity and does not burn out easily. When connected, as in Fig. 26, a set of receivers of at least 1,000 ohms should be used for best results. We might state here that a 75-ohm receiver, such as is used in house phones, should never be used in connection with radio waves. The results are very poor. For short distances a 75-ohm receiver may be used, but even then it is not sensitive and not very satisfactory.

Soon after the silicon detector was invented,

Greenleaf W. Pickard, the inventor of the silicon detector, invented a host of other detectors, all of which use a native mineral crystal, such as, for instance, iron pyrite, copper pyrite, bornite, etc. All of these detectors are used similarly to the silicon detector, the crystal being cast into a soft metal in pellet form. This pellet is used in the same way as

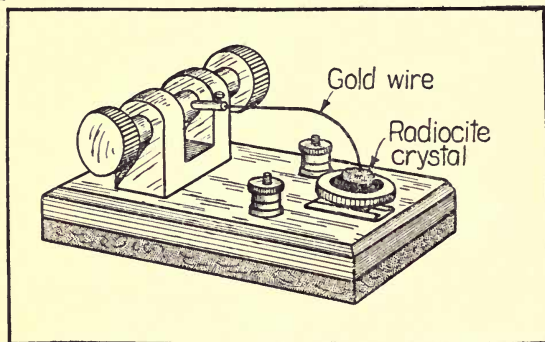

FIG. 27.

the silicon detector; sometimes a sharp brass contact point is used with some minerals and at other times a fine wire is used, which latter is termed a *Catwhisker*. Such a detector is shown in Fig. 27. This detector uses as a sensitive member the mineral or crystal known in the trade as Radiocite. Radiocite is a treated iron pyrite and is as shiny as polished gold. A good piece of radiocite is equally sensitive over its entire surface. It is probably as sensitive as any of the mineral detectors in use today. As with all other crystal detectors, no battery is used

in connection with it. In the radiocite detector no sharp point is used, but rather a fine gold wire catwhisker. A catwhisker is a piece of fine wire about No. 26 or No. 28 B & S gauge phosphor bronze. This is attached as a rule to some sort of handle or other adjusting means so that the pressure of the wire upon the surface of the mineral may be varied. If one spot burns out or becomes inoperative, a new point is found by experiment.

One of the most sensitive and most widely used detectors is made of Galena, a lead ore of which there are different grades. It is known under many trade names as well. A good piece of galena is probably as sensitive as any crystal yet discovered, but it is not stable. A catwhisker, as explained under the radiocite detector, is used with the galena crystal and the amount of pressure has to be found by experiment. Ordinary galena is not sensitive on every spot, but there are certain grades which are equally sensitive over the entire surface; this is known as Argentiferous Galena, which means that it is silver bearing. On the other hand not all argentiferous galena is equally sensitive, and there is no hard and fast rule about it. It must be found by experiment. The connection for the radiocite, as well as galena detector, Fig. 28, is the same as shown in Fig. 26. No battery is used with galena, and as a matter of fact a battery will destroy the usefulness of it by burning out the sensitive points. With galena, a fine brass wire No. 24 or No. 26 B & S

gauge is used; a stiff gold wire of the same dimension may also be used, as it is non-oxidizing. It may be stated here that most any metal wire can be used; they all work equally well with the possible exception of iron, which soon becomes coated with rust and will then no longer operate.

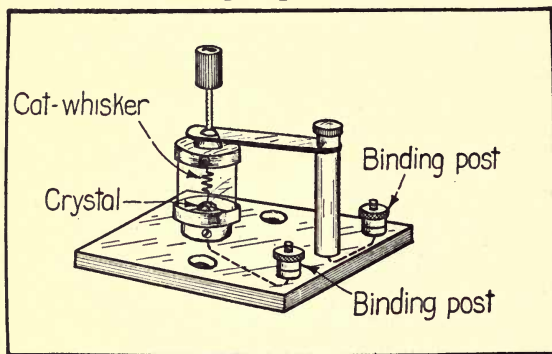

FIG. 28.

All crystals are only sensitive if absolutely clean, and their usefulness becomes destroyed immediately upon being handled with the bare fingers. The natural oil of the hands tends to destroy the sensitiveness as the crystal surface becomes coated with it. The best method to employ with all crystals is to clean them frequently with a piece of absorbent cotton moistened with carbon tetrachloride. This high-sounding name is nothing but Carbona, which may be purchased anywhere. There are some liquids advertised under high-sounding names, all of which are in reality Carbona; this does the

work 100 per cent. well, and should always be used where crystals are employed. After rubbing the crystal with the moistened cotton, it should be left

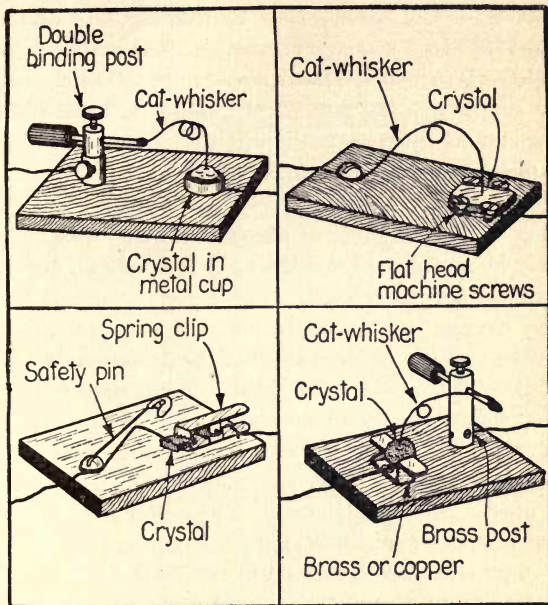

FIG. 29.

for a few minutes until the liquid has evaporated. The crystal will then be found in first class condition.

Although we have stated a little further back that most crystal detectors have the sensitive mineral embedded in a metal pellet, the amateur or experi-

menter does not always require this, and Fig. 29 shows several simple home-made detectors. The illustrations are so self-explanatory, that no further details need be given. Base boards may be of wood, hard rubber or any good insulator. As will be seen in these illustrations, the detector mineral is clamped by simple holding devices; anything that will hold the crystal down so that it will not move, and at the same time make good contact with it, may be used. The catwhisker wire is best (a No. 24 or No. 26 B & S brass gauge), or phosphor bronze wire. It may be straight, or coiled in pig-tail fashion, either will work equally well. The clever experimenter can change the design to suit his own individual tastes, and the chances are that the device will work well. The trouble with most mineral detectors is that their adjustment does not keep for any length of time. Jars, or static surges in the aerial will cause the detector to become inoperative, after which it must again be adjusted. The better the crystal and the more sensitive spots it has over the entire surface, the easier the adjustment will be.

We now come to a vastly different sort of detector, namely the Audion, or as it is commonly called, the "Vacuum Tube." This detector works upon an entirely different principle from any of the former ones described, and is in general use today for reasons which we shall learn presently. The audion makes use of a principle first discovered by Edison, and for that reason termed the "Edison

Effect." Edison found that if he placed two filaments in an ordinary electric lamp instead of one filament, and lit them both, a current would flow across the vacuum or empty space. It is this principle that is now being used in the vacuum tube. Fig. 30 shows a standard vacuum tube where we have the filament, which is the same as that used

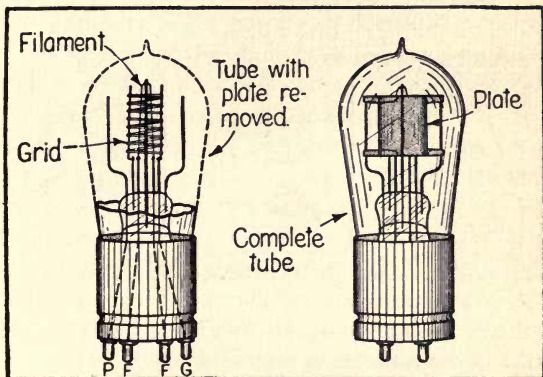

FIG. 30.

in an incandescent lamp; this is heated by means of a battery of from four to six volts. We next have the grid which may be in the form of a grid-iron or a spiral, it making little difference which. Opposite the filament and with the grid in the middle, we find the plate, usually a small piece of nickel or other metal. The connection of the simplest audion is shown in Fig. 31. If we make the plate positive with respect to the filament, we find that highly charged electrical particles called "electrons"

travel constantly from the filament to the cold plate. It was soon found that the vacuum tube acted as a sort of valve for the electrical current, allowing the high frequency currents as they came over the aerial to travel in one direction in a vacuum tube

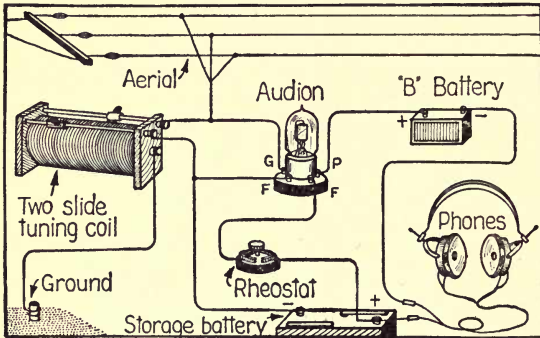

FIG. 31.

but not in the other. In this respect the vacuum tube is the same as a crystal detector, which also acts as a valve, permitting currents to pass one way only.

The vacuum tube was first invented by Dr. Fleming, to whom belongs the honor of using it first as a detector for radio. He was using only a two-element tube, *viz.*, an exhausted bulb containing a filament and a plate. Dr. De Forest conceived the idea of introducing a third electrode into the tube, as explained above. The purpose of this electrode which he called the grid, serves only to control the flow of the electrons at-

tracted by the cold plate. It is the grid that makes the vacuum tube the exceedingly sensitive apparatus that it is. Making the grid alternately positive and then negative varies the amount of current that flows from the hot filament to the plate, decreasing, and even stopping it entirely. The grid simply acts as a gate valve which controls the plate current. The curious thing about the grid is that it uses no great amount of power. A modern vacuum tube is exhausted to a very high degree, because it was found that unless the vacuum was perfect, the sensitivity of the tube was very poor. It is not necessary here to go into a very technical discussion of the vacuum tube, as we are merely interested in its functioning. The study of the vacuum tube, however, is a science in itself today, and for that reason it can only be treated generally here. We must, however, add that the vacuum tube is far more sensitive than other detectors, particularly when used in connection with other vacuum tubes. It was found, for instance, that this was the case when several tubes were coupled together; this gives us the so-called two-step or three-step amplifier, which will be discussed later on. The idea of these amplifiers is for each to step up the exceedingly weak current received from the first tube, usually called the detector tube. By means of such a stepping up process, it is possible to bring in signals over tremendous ranges, a thing impossible to do with any other detector known at this time.

RADIO FOR ALL

TUNING DEVICES

We have seen in previous chapters that each radio wave-length is dependent upon the length of wire of each aerial. If it were possible to make all aërials of exactly the same length and capacity, and if all stations were transmitting at exactly the same wave-length, we would not need any tuning devices. Unfortunately this is not the case. When we install

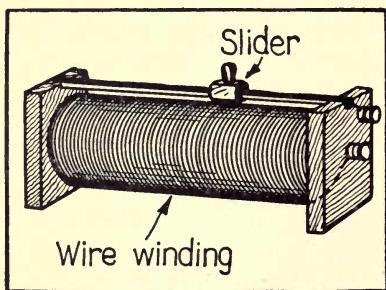
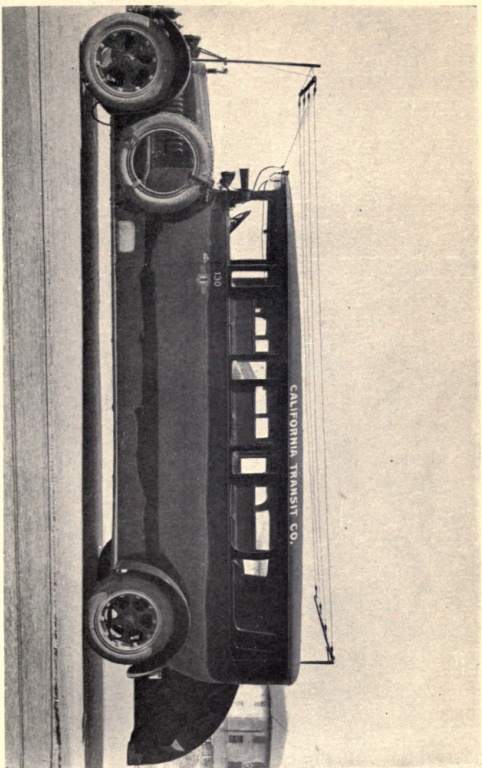

FIG. 32.

an aerial, we cannot always make it of the length or capacity which we desire, but are hampered by physical and geographical limitations. In other words, our aerial is usually a compromise. On the other hand, the various transmitting stations all send on different wave lengths, and for that reason, many different tuning devices are used. One of these, and the oldest, is the Tuning Coil, shown in Fig. 32. This is nothing but an aerial wound upon a cardboard tube or other circular or square piece of insulating material. The tuning coil is simply an extension



This motor bus has been equipped with radio to entertain the passengers while traveling. There is a large horn contained in the interior and the music can be heard quite distinctly while the auto is en route.

of the aerial. Even though we have an aerial which is only 100 feet long, by attaching more wire to it in the form of the tuning coil, we thereby lengthen the aerial. The tuning coil, as shown in the illustration, is simply an insulated wire wrapped upon a cardboard tube, its size is immaterial. Tuning coils may be made in almost any size, from the small-

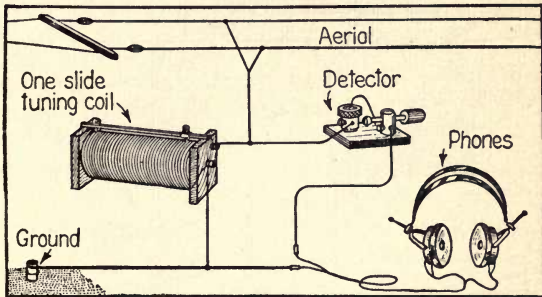

FIG. 33.

est one wound upon a pencil, to the largest, as big as a barrel. The more wire we use, the more wave-length our tuning coil will be able to absorb, so to speak. Of course, in practice tuning coils are built for a certain capacity, all depending upon what it is to be used for. If, for instance, we have but a little aerial and wish to receive from stations having a wave length of say 650 meters, a small coil about 6 inches long and 2 inches in diameter and wound with No. 24 B & S gauge wire will do nicely. The purpose of the slider is simply to add more or less wire to the aerial; it is but an adjustment the

same as, for instance, a rubber elastic that you stretch more or less to make it longer or shorter as you desired. It goes without saying that the slider of the tuning coil must touch the wire, as otherwise no connection would be made. In Fig. 33, we show the simplest connection for a tuning coil. This, as will be seen, duplicates the connection

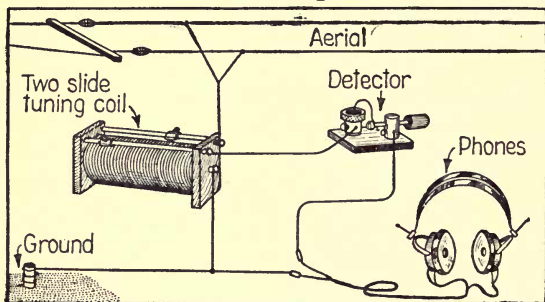

FIG. 34.

of the crystal detector. We have here merely added the tuning coil in order to tune the circuit. By means of this tuning coil, it now becomes possible to tune out unwanted stations merely by moving the slider back and forth and so connecting more or less wire to the aerial. For instance, if two stations are sending at the same time, by moving the slider backward and forward it becomes possible to tune in or out the unwanted station, and listen only to the one we desire to hear. In Fig. 34, we show the same tuning coil, but with sliders. The two sliders are somewhat of an improvement, for the reason that

better tuning is accomplished with them. This is what is technically called a more balanced circuit. It is possible to still add more sliders to one tuning coil. Years ago, three-slider tuners were in vogue, but they are now no longer the fashion.

LOOSE COUPLERS

The Loose Coupler is another form of tuning coil and this instrument, which was formerly used a great deal more than at the present time, is really one of the best tuning devices known. Instead of using just one coil, as for instance the tuning coil just described, a loose coupler uses two coils—one sliding into the other without touching. The loose coupler is an electrical transformer, as it has been found that if a radio current traversed one coil, another tuning coil standing close by would be affected, although no wire touched the first coil. This is termed an "inductive effect." In other words, the energy is radiated from one coil to another, the same as a stove radiates heat to objects that are close to it.

As we just mentioned, the loose coupler is a transformer. The current that comes in over the aerial in the form of radio waves is a high frequency current. By that we mean that waves swing back and forth very rapidly. It is the purpose of the loose coupler to change this energy into a more suitable form. We again take recourse to an analogy. In Fig. 36 we show, by means of a lever action, the principle of the transformer. We are all

familiar with the lever action whereby a man who weighs only 150 lbs. can raise a weight of 1000 lbs. by means of the lever. Is he getting something for nothing in this case? Certainly not! You cannot get free energy, but the experiment in Fig. 36 simply shows that force plus time may be transformed into something else. In this case the man who

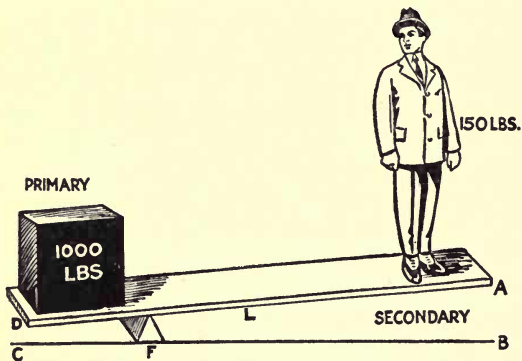

FIG. 36.

weighs 150 lbs. is the force and the time is the interval that it takes him to reach from point A to point B. The two added together are sufficient to raise the 1000 lb. weight, the distance from C to D. The longer the lever arm L, the more weight we can raise. Archimedes told us that "give him a long enough lever he could raise the earth from its hinges." Always providing that he has a sufficiently long lever and a fulcrum, or point of rest which is shown at F in Fig. 36. Summing up, we understand

now that by means of a small weight we are able to lift a much heavier one.

This analogy holds with our loose coupler, which we have shown in Fig. 35. The loose coupler has two coils; the primary, which is usually the outer tube, is always wound with a coarser wire, while the inner tube is wound with a finer wire. As in the

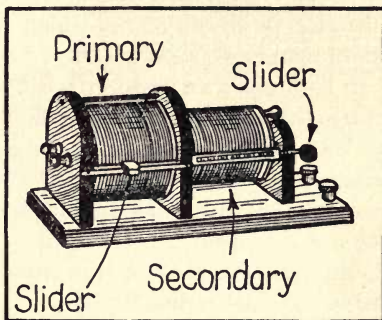

FIG. 35.

tuning coil we have a slider upon the primary, or if we do not use a slider we may have taps (connections) taken at every few turns of wire, if we so desire. On the secondary also, we may have a slider or taps brought out, both of which are the same. The inner tube is made to slide back and forth upon sliding rods so that the degree of coupling, as we call it, may be changed. If the inner tube, called the secondary, is pushed into the outer tube, which we call the primary, we have a complete electrical lever system, as shown in our analogy Fig. 36. The energy that comes into the primary is now

raised exactly as the weight is raised by means of a lever, and we get a marked effect from the secondary. The more we pull out the secondary tube, the less our lever action becomes. It is as if the man in Fig. 36 were to move down to the point F where it would become impossible for him to raise the weight at all, or even to budge it. By using the loose coupler, we do not get something for nothing any more than if we raise a stone by means of a lever. In both cases we perform work. In our loose coupler, the result as a rule is that we get louder and better signals.

Reverting back to Fig. 35, the tubes of the tuning coil may be of cardboard, hard rubber or composition, or any good insulating material. No steel or iron should be used in the construction of a good loose coupler. Its size is immaterial providing the proportions are right, this being determined by experiment. The important part is that the secondary must come as close as possible to the primary. In other words, the diameter of the two tubes must be so that the secondary tube, when moved inside the primary will take up the entire air space without, however, touching the outer tube. The closer the two windings come together, the better it is. In Fig. 37, we show the simplest connection for a loose coupler, crystal detector and phones. Very good results are had with this circuit, and the loose coupler is particularly efficient for tuning out interference to a certain degree. It gives what is called sharp tuning,

because if two stations operate at a close wave length, let us say one at 360 meters and another at 320 meters, the loose coupler will give very good results by reason of its sharp tuning. In this case, it will be possible to tune in either station, if in connection with the loose coupler we use an additional instrument, namely the condenser, which we

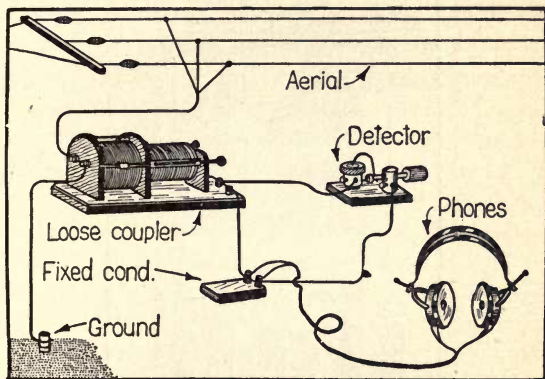

FIG. 37.

will describe presently. When the connections are made, as shown in Fig. 37, we must keep the secondary all the way in, and then adjust the slider on the primary until we hear the signals well. We now slide the secondary in and out, more or less, and in doing so, we move the slider upon the secondary also, until we reach a point where signals are loudest. This point is different for every station to which we are listening.

VARIOMETERS

Variometers, Fig. 38, are usually built by having one spherical winding rotating within another spherical winding, as shown in the illustration. Both, however, are wound with the same wire. By moving the inside, which is called the rotor, the inductive effect

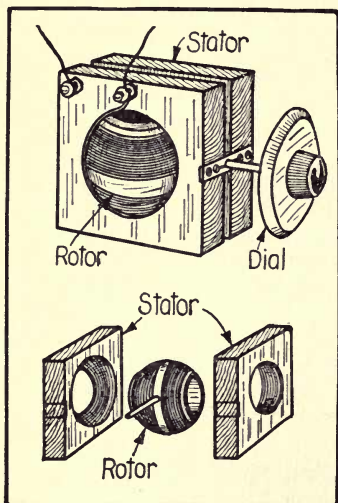

FIG. 38.

between this and the other winding, which is called the stator, is changed. It acts exactly as a loose coupler, but is somewhat less complicated. It is, however, not used much in connection with crystal detectors, but rather with vacuum tubes where a fine balance is necessary. The same is the case with the

Vario-coupler shown in Fig. 39, which is also used almost exclusively in connection with vacuum tubes. In this instrument we have an outer tube wound with a heavy wire, while the inner tube which rotates upon its axis is wound with a finer wire.

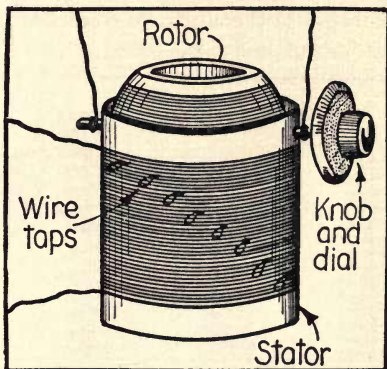

FIG. 39.

CONDENSERS

In a radio circuit, in order to do fine tuning, we must often take recourse to the condenser which instrument is used to do just what its name implies, *viz.*, condensing the electric current. This is perhaps not exactly accurate, for there is no condensing done in radio work, but rather a storing up of energy.

Consider Fig. 40. Here we have a spring which we compress by means of a weight. As soon as we take the weight away, the spring returns to its original position. What have we done? We have

simply stored energy into the spring. The electrical condenser is used in exactly the same way, *viz.*, to store electrical energy. However, that is not its only purpose. Just as the spring may be used for other purposes besides that of storing mechanical energy, so the electrical condenser may be used for other purposes also.

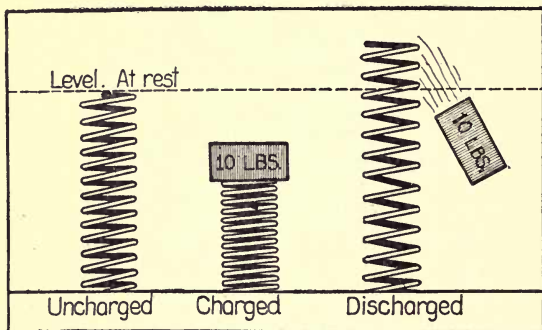

FIG. 40.

A condenser is a capacity or a vessel in which electrical energy is stored. The simplest form of electrical condenser is shown in Fig. 41, where we have a metal plate A, a glass plate B, and another metal plate C. By means of this arrangement, we may store electrical energy upon the *inside* surfaces, on plates A and C. The larger we make the metal plates, the more electrical energy may be stored.

The form shown in Fig. 41, is used in many condensers today. The metal plates A and C may be any form of metal, such as, for instance, tin or metal

foil, while the glass plate B may be replaced by a piece of paraffin paper. In other words, any good metallic conductors may be used if coupled with a good insulator. The better the insulator, the better the condenser will be and the greater its electrical capacity. In the commercial condensers, paraffin paper, varnished silk, sulphur, sealing com-

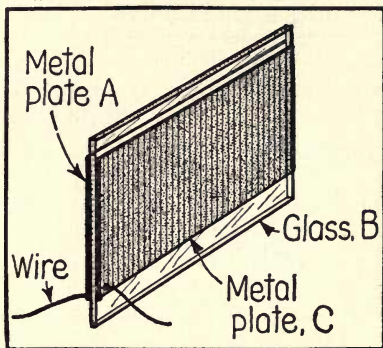

FIG. 41.

pounds, or best of all, mica, is usually used. In Fig. 42, is shown a simple condenser; this is also shown opened up in Fig. 43. It is made by rolling together two strips of tinfoil between several strips of paraffin paper. The whole, when rolled together and assembled, becomes the condenser shown in Fig. 42. By rolling it together, it takes up less room. This type of fixed condenser, as it is termed, is generally used to connect across the telephone receivers; this will be described in a later chapter. The purpose of this little condenser is to store up

the electrical current and then discharge that current into the telephone receivers when the condenser becomes full, so to speak. If you will refer to our spring analogy you will readily understand the principle, and how it operates. In radio work, where fine regulation is required, we make use of still another condenser, as shown in Fig. 44. This condenser, instead of being fixed, is variable. As

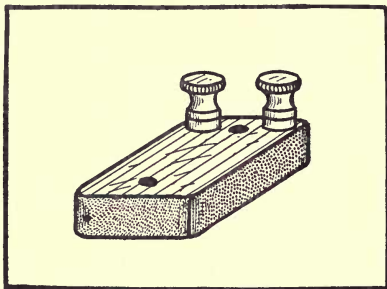

FIG. 42.

will be seen, there are a number of plates which are usually made of zinc or aluminum, which mesh into each other to a more or less degree. The more plates we have and the closer they come to each other, the higher will be the capacity of that condenser. For certain purposes we need only a small condenser of a few plates, while in others we need a larger one of a great many plates. It is just like having a small spring and still another very large one. Both have their uses, and both are very necessary, all depending upon what work they are required to do. In Fig. 45, we show the simplest elementary con-

nection, where we have a crystal detector, a tuning coil without a slider, a pair of phones and a telephone condenser. This is a peculiar connection because in it we wish to show that we can tune by means of the condenser. As will be seen in this tuning coil, we do not use any slider by which the length of the aerial may be changed, which would

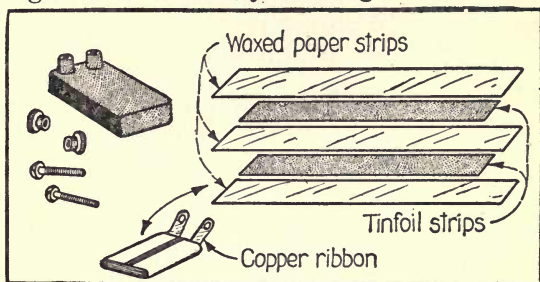

FIG. 43.

thus change the wave length. This is performed entirely by the variable condenser. When we adjust the latter, we also change the relation of the tuning coil, and in fact we are changing the wave length until a point is found where the signals come in best. This is a finely balanced circuit, and the amount of wire on the little tuning coil should be in direct relation to the condenser. In other words, if there is too much wire on the tuning coil and the capacity of the condenser is small, we cannot do much tuning. For the best results, as for instance for receiving broadcast music on a wave length of 360 meters, we could use a small coil, one inch in

diameter, wound with about 70 or 80 turns of No. 18 enamel wire, while the condenser should be of the commercial variety known as a 23-plate conden-

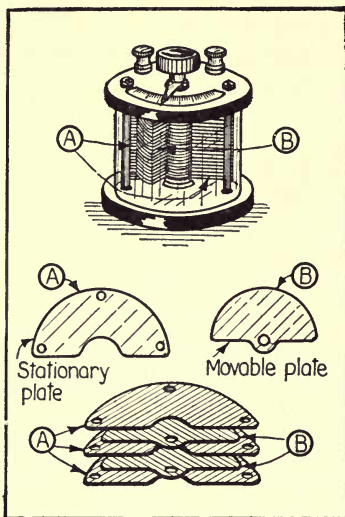

FIG. 44.

ser. Then, all we have to do is simply adjust the condenser until the signals are heard best.

In this illustration, we also see where the phone condenser is located. This phone condenser stores the energy of the circuit, and discharges it into the telephone receivers which enables us to hear the signal more loudly.

The two forms of condensers shown here are of course not the only ones, as many more types of

either fixed or variable condensers are made. However, all of them are practically the same, roughly speaking, and so it is not necessary to enlarge upon the subject which is now well understood by the reader.

VACUUM TUBE ACCESSORIES

We have learned something about the vacuum tube which was described previously in this article, and in Fig. 31 we have shown the simplest connection of an audion detector. There are, however, a number of other auxiliary instruments used in vacuum tube systems which give certain refinements.

The vacuum tube, when it is used singly, acts as a detector and detects the signals the same as a crystal detector. Also, we might state here, that the crystal detector is a better rectifier "valve" than the vacuum tube. The vacuum tube itself only becomes of great importance when used in special circuits.

With a crystal detector, or in the ordinary single vacuum tube circuit, the incoming signals act upon the phones and we hear the signals with a certain strength. Let us now consider the vacuum tube and the incoming signal. We may indeed, by certain means, boost up the very weakest of signals and amplify or magnify it a hundred or a thousand or a million times its original strength. It is just as if you take a piece of film such as is used in a moving picture theatre and examine it with your eye. The figures are so small that you can

hardly distinguish them. The regular film which is about the size of a postage stamp here stands in our analogy as a single vacuum tube. We can, how-

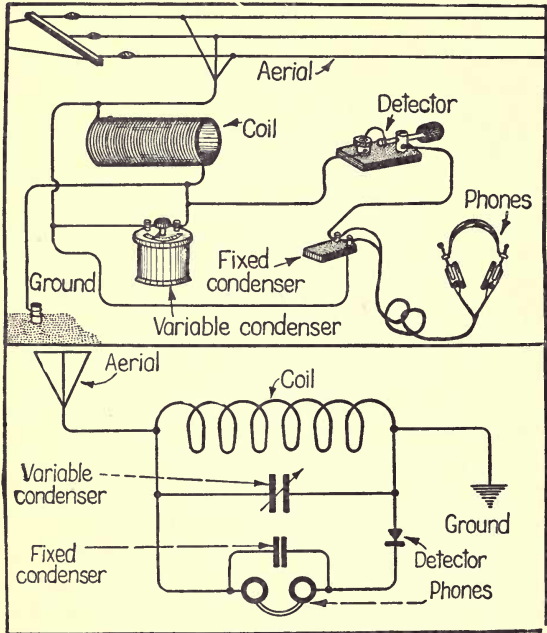

FIG. 45.

ever, take that film, and by using a powerful light enlarge the little picture (no larger than a postage stamp,) by projecting it upon the screen. We thereby amplify or magnify the original picture several thousand times. We can amplify or en-

large it a million times if necessary, all depending upon the amount of light we put behind a film and the distance from the screen. This is graphically shown in Fig. 46.

We may do precisely the same thing with a vacuum tube, but we must use additional energy, the same as in our film where we use energy (the elec-

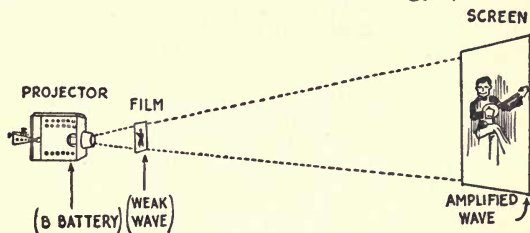

FIG. 46.

tric current which produces the light) to project the film upon the screen. In other words, we can take the detector tube and enlarge the original small and weak signal, and boost it up until the sounds come out loud from a loud speaking horn, which in our analogy stands for the moving picture screen. The electrical connections for a vacuum tube amplifier are shown in Fig. 47. This is what is called technically a two-step amplifier. We show this connection simply because without it, it is almost impossible to bring home the meaning of the vacuum tube auxiliary instruments with which the reader is as yet unfamiliar. In this circuit we have, as before, the aerial, the ground, the variable condenser, the blocking or phone condenser and several

other instruments as well. We find, for instance, that several transformers are used, *viz.*, what is technically called the Audio Frequency Transformer.

AUDIO FREQUENCY TRANSFORMER

This transformer, Fig. 48, consists of just an iron core upon which is first wound a coarse wire termed the primary, and on top of this a finer wire

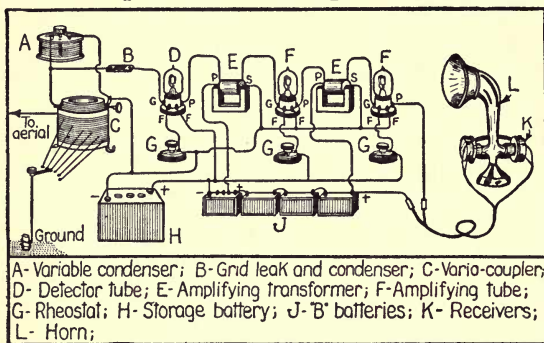

FIG. 47.

termed the secondary. The ratio of these transformers is usually such that, electrically speaking, the value of the secondary is about ten times as much as that of the primary. The audio frequency transformer is in principle the same as the loose coupler, which we studied before, and the purpose of the audio frequency transformer is to transform the energy from a low level to a high one. The purpose of this transformer, as shown in Fig. 47, is to boost up the weakest signals, trans-

forming them into stronger ones. The transformer by itself could never accomplish this, and in order to make the lever action work perfectly, we take recourse to a battery which is connected to the transformer and with the vacuum tube, as shown. By means of this additional electrical energy we are now in a position to boost up and relay the weak

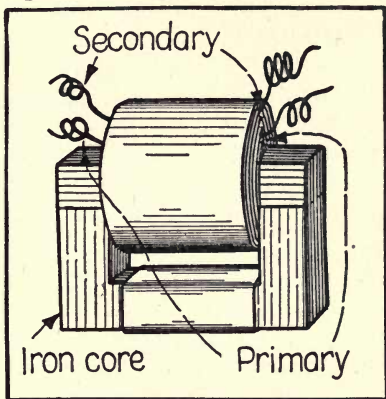

FIG. 48.

signal. In this connection, we have shown first a detector tube, while the other tubes are amplifier tubes. By this we mean that the first tube receives the signal, while the other tubes are merely used as pumps to boost up the electrical energy until the signal finally comes from the phones so loudly that if we connect the phones with an ordinary sounding horn, loud signals or music will issue from the horn. The battery used in this case is a so-called "B" bat-

tery, or high voltage battery which has been found necessary to aid in boosting up the weak signals. As a rule batteries anywhere from 24 to 300 volts are used, all depending upon the circuits and the purpose for which they are used to boost up the weak signals.

It should be understood that the audio frequency transformer is used only to boost up the weak signal as it leaves the first detector tube. It is not in the province of this transformer to do anything save amplify the signal which is detected by the detector tube. In other words, if outside interference or static comes over the aerial, the transformer amplifies these noises as well. This transformer, therefore, acts only as a sort of pump increasing the pressure, but it has no control over the flow that is pumped to the next tube. We shall see further where another sort of transformer may be used to obviate some of these difficulties.

RHEOSTATS

In Fig. 47, we also find another new instrument, the Rheostat, shown in detail in Fig. 49. This is simply an electrical resistance and is used solely to increase or decrease the glowing of the vacuum tube filament. When signals are received, it has been found that the filament must glow at a certain intensity. Some signals come in best when the filament is burning very brightly, while with other tubes the signals come in best when the filament is only of a cherry red. This depends upon the make of the

tube and the vacuum of the tube itself. The rheostat is, therefore, simply an accessory to regulate the filament's incandescence.

GRID LEAK

In Fig. 47 we have another newcomer, which is termed the Grid Leak, and its condenser. It has been found that when the grid condenser is used,

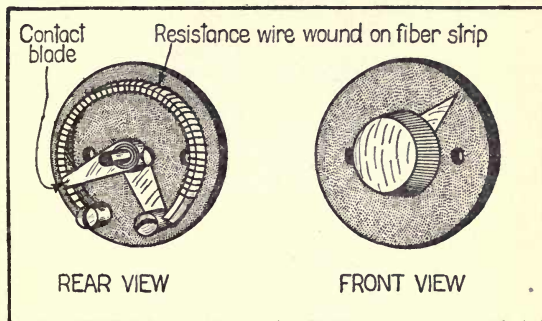

FIG. 49.

as shown in the illustration the signals will come in about twice as well as if none was used. However, this condenser alone would not be sufficient, for the reason that the accumulation of electrons, which are highly charged electrical particles on the grid of the vacuum tube, would interfere with the normal working of the tube. We must provide a means to let the surplus electrons leak out without, however, letting them out too quickly. It is as if we had a boiler under which a constant fire was maintained. In order to provide a remedy, we in-

stall a safety valve. This valve is used for the purpose of giving off the surplus steam and so keep the boiler free from harm. It is the same with the vacuum tube. While of course, the vacuum tube would not burst, even if we did not use the grid leak, electrically speaking, the tube would not function properly. Hence, the grid leak, which is a sort

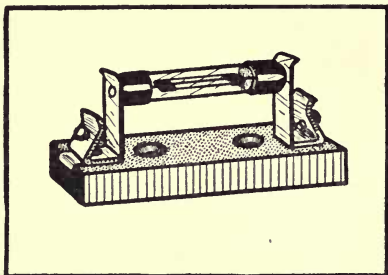

FIG. 50.

of safety valve to let the surplus accumulation of electrons run off. The grid leak is nothing but a very high resistance, sometimes millions of ohms high. It may consist of only pencil lines drawn across a piece of stiff Bristol board; These pencil lines are but slight electrical conductors, but the resistance is enormous. It suffices, however, to allow the surplus electrons to leak off. There are various ways and means to make grid leaks, and a popular form is shown in Fig. 50. Here we have a piece of cardboard or fibre upon which is traced a fine line in India ink. This line acts the same as a pencil line. The whole is enclosed in a tube to prevent

moisture or dust from settling upon the grid leak. Connections are made on the ends by metal clips. Fig. 51 shows a grid leak and condenser combined as two instruments, which are usually used in conjunction. The grid leak condenser is small and is similar to a telephone blocking condenser, and the grid leak is traced by means of China ink upon a piece of fibre; the whole is enclosed in waxed paper.

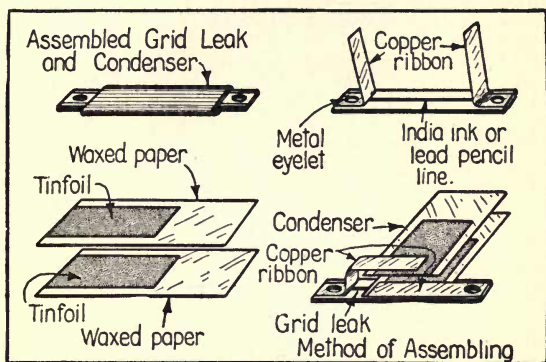

FIG. 51.

RADIO FREQUENCY TRANSFORMER

In Fig. 47 we have learned all about the audio frequency transformer. We know that this transformer amplifies static and also other disturbances, as well as the signals. For that reason it is not possible to use many such transformers, or, technically termed, many steps of audio amplification. If we use more than three such transformers and their respective vacuum tubes, additional noises are all

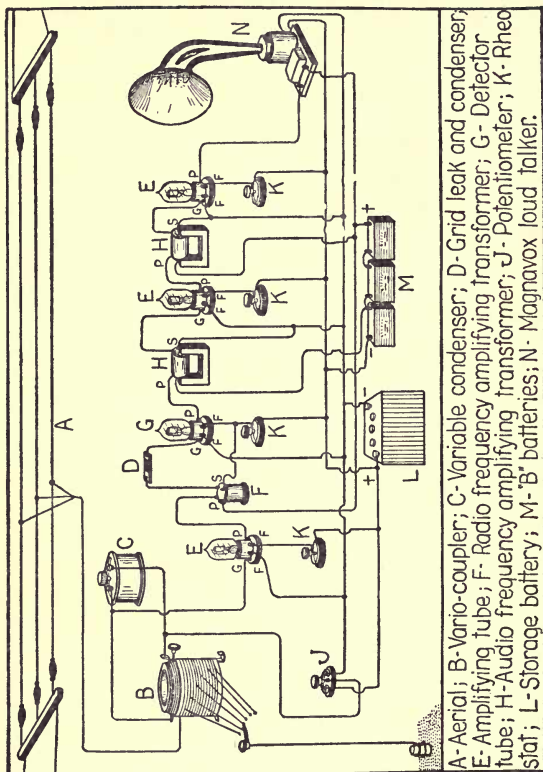

FIG. 52.

amplified, and the amount of noise which we get in the phones is tremendous. For that reason, we take recourse to what is termed a Radio Frequency Transformer, which is shown in the hook-up, Fig. 52. The radio frequency transformer may consist of only two windings, one adjacent to the other on a cardboard tube. The simplest form is shown in

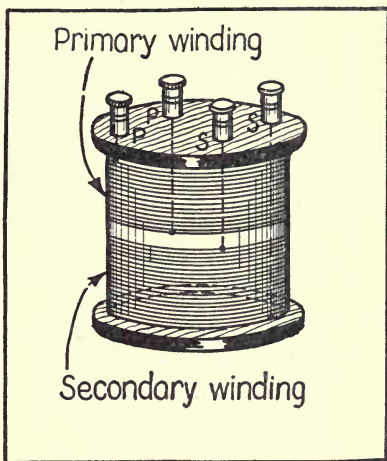

FIG. 53.

Fig. 53. The wire used on this is usually exceedingly fine, No. 40 B & S wire, or even thinner. The two windings act upon each other by induction, and do not make connections physically. In Fig. 52, the first tube is an amplifier, and this amplifies the weak signals as they are coming in over an aerial. The radio frequency transformer steps up these

weak signals, amplifying them and passing them on to the detector tube. We now get the net result, with the detector tube in a position to detect already fairly strong signals which may then be amplified in the audio frequency amplifiers, and boosted up further by a second or a third transformer, if so desired. We do not necessarily stop here because we may use more than one radio frequency transformer; we may use two or even more. As this, however, brings us into higher technicalities, we will not go further, beyond showing the principle so that the reader may grasp the difference between the two kinds of transformers.

To resume, and in a few words, we may say that the radio frequency transformer boosts up the very weak radio frequency currents so that the detector gives maximum results, whereas the audio frequency boosts up the audible signals. The radio frequency transformers, in other words, amplify signals that would be lost otherwise, while the audio frequency transformers give volume to signals which are already audible.

TELEPHONE RECEIVERS

In order to receive signals or broadcasted entertainment by ear, we use a telephone receiver, of which two simple types are shown in Fig. 54; this consists of the following: First we have a powerful magnet which attracts to it a thin iron diaphragm. This diaphragm is clamped tight like a drum head along its outer edge. Upon the magnet

are mounted two pole pieces around which are wound many thousand turns of exceedingly fine wire, almost as fine as the human hair.

Ordinarily when no current is sent into the telephone receiver, the diaphragm is pulled down somewhat to the pole pieces, although it must never touch them. If it does, no sound will be received. If, however, a weak electrical current passes through

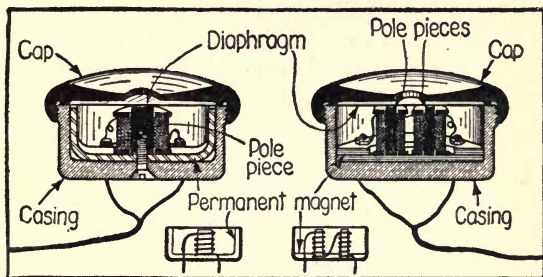

FIG. 54.

these spools, the diaphragm will either be pulled down more if the current is in the right direction, or if the current is in the wrong direction, it will weaken the magnetism on the pole pieces. In this case, the diaphragm is not attracted. These little variations make the diaphragm vibrate more or less. These vibrations are passed on to the air, and the air vibrating in unison with the diaphragm is changed into sound waves, which are sent on to our ear, where we hear them. A telephone receiver is a marvelously sensitive instrument, and it is possible with it to detect currents of less than one mil-

lionth of an ampere and less than one hundred thousandth of a volt. It is, therefore, an ideal instrument to detect the weak radio signals as they come over the aerial.

In radio we usually use two such receivers, which as a rule are provided with a head piece or head gear; this is slipped over the head, pressing the two receivers against the ears. It has been found that two receivers are better, because no outside noises reach the one ear, as would be the case if one receiver only was used.

Receivers for radio purposes should be wound at least to 1,000 ohms, or better to 2,000 ohms, and for certain other purposes to 3,000 ohms and higher. Telephones wound to 75 ohms such as the usual receiver used on our house telephones are of no value for radio. Their resistance is not high enough, not even in connection with a crystal receiver.

A good head set should give an audible click in the ears, if the two cord tips at the end of the cord are tapped upon the tongue.

LOUD SPEAKERS

In Fig. 55 is shown a Tone Amplifier or loud speaker known by its trade name as the Magnavox. This loud speaker works upon a principle where a small coil, through which the received current flows, is influenced by a powerful electro-magnet. It is another case of boosting up the sound which is received from the last amplifier tube. Such tone amplifiers can throw the voice or music over distances

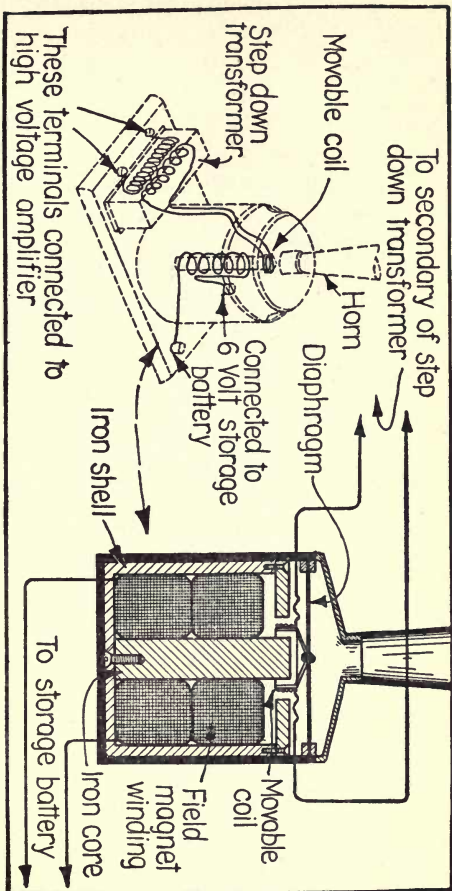
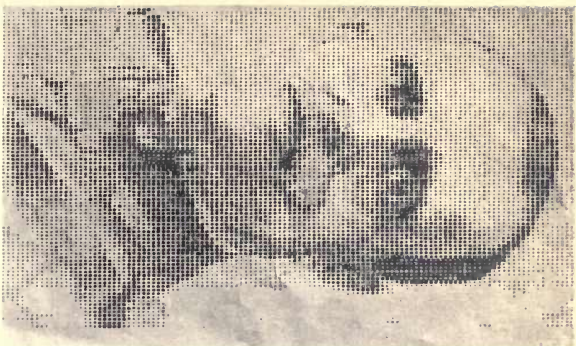
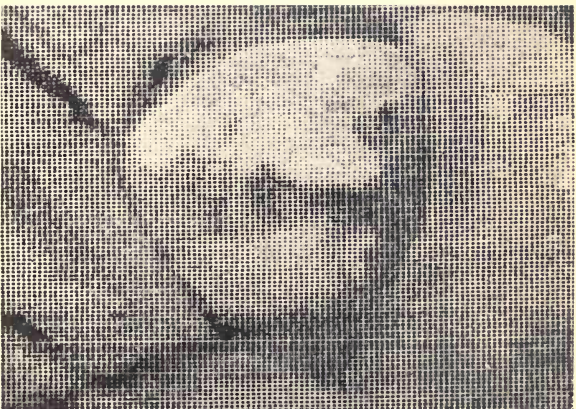

FIG. 88.

of one-half mile and more, and if a person stands in front of one of these giant horns, the amount of sound that issues from it is simply terrific. Of course, not all tone amplifiers work so loudly. Those made for home or parlor purposes do not use so much current, and therefore do not give so much power. There are a number of types of tone amplifiers, but most of them work along the same electro-magnetic lines, and if they do not use the outside battery in order to create a strong electro-magnetic field, they either use strong magnets to accomplish the same result, or necessitate the use of a very high tension battery in the amplifier. Such tone amplifiers are nothing but transformers or relays, transforming or relaying a weak sound into a loud one. As a matter of fact, most tone amplifiers rely upon acoustic means as well, all of them requiring some sort of horn, without which only mediocre results are achieved. The horn itself, is an acoustic amplifier, as anyone knows who has ever talked through a megaphone. Due to the echoes set up inside the walls of the horn, the sound is thus amplified.



Portrait of the King of Italy, transmitted by radio in the King's presence, from Rome to Massaua, Abyssinia (on the Red Sea).



Portrait of Mrs. Korn, transmitted by radio from Rome to the armored cruiser "Andrea Doria," of Spezia.

Hold at arm's length to obtain best effect.

CHAPTER VI

TUNING

IN former chapters we learned something about tuning; this is nothing but resonance. We all know the experiment of standing near the piano and singing a certain note into it; when we reach the correct or fundamental note, the piano begins to sound that particular note in sympathy. We may then say that we are in tune with that particular string which sounds in our ears. Likewise in radio, we make use of a similar system, except that we use electrical tuning instead of acoustical tuning. Tuning consists as a rule in merely attuning our aerial electrically to the same length as the aerial that is transmitting to us. In other words if a broadcasting station is transmitting on a wave of 360 meters, we must attune our aerial to the same wave, namely, 360 meters. If we have an aerial which is 260 meters long, electrically speaking, it stands to reason that we must add 100 meters to this aerial in order to receive the wave at all. We have learned in other chapters how this may be accomplished. If we have a receiving outfit, all we have to do is move the slider of our tuning coil backward and forward until the signals come in at maximum strength. When that point is reached, we know that our aerial, electrically speaking, must be

360 meters long. We have also seen in Fig. 45 that we need not have sliders on the tuning coil in order to tune. We may use a condenser for tuning purposes because its electrical equivalent is the same as a tuning coil slider. By adding more or less capacity to the condenser and therefore to the tuning coil, we change the electrical value of the tuning

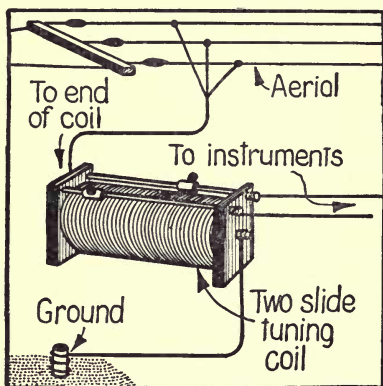

FIG. 56.

coil, and also its wave length. This is not literally true, technically speaking, but we must use this language to bring home the meaning.

We therefore learn that we may tune either by lengthening the aerial with additional wire, or by using a capacity or condenser in connection with a wire coil. Both, if correctly apportioned, give the same results. Before we can receive signals, or amplify them, it is of the greatest importance that we

tune in to the right wave length. An aerial must be in electrical sympathy with the sending station before we may hope to receive signals. In Figs. 56 and 57, we have shown the elemental methods of tuning. Of course, there are many other ways of tuning, all of which, however, are along the same principles as those just enumerated. For instance, we have seen where we tune with a loose coupler.

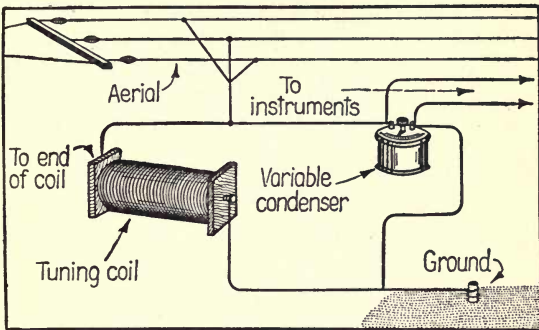

FIG. 57.

This, however, is exactly the same as if we were tuning with a tuning coil. As a matter of fact, as we mentioned in the previous chapter, referring to the loose coupler, this latter instrument is nothing but two tuning coils, one sliding into the other. In the variometer, also, we have a sort of loose coupler with which the tuning is accomplished by changing the inductive relation between the two coils. This acts similarly to the tuning coil slider because the two coils either assist or else buck each other. Elec-

trically speaking, therefore, the variometer or the variocoupler, either add wave length to the aerial or subtract wave length from the aerial. This is only figuratively speaking and mentioned here in order to drive home the point to the reader.

In a vacuum tube set, many people think that when they adjust their detector tubes, their amplifier tubes or their rheostats, they are tuning in. This is erroneous because there is no tuning done in these instruments at all. We have learned that amplifying tubes simply belong in a pumping system which does not do any tuning at all, but simply amplifies the signals already received and tuned. It should, therefore, be remembered by the reader that tuning is only done directly in the aerial system, never in the outside circuit. Of course, it goes without saying that there are circuits which are balanced in such a way that they are again influenced by the tuning, and *vice versa*. Therefore, if the two circuits are out of balance, both must be adjusted in such a way that fine tuning becomes possible.

Perhaps an analogy in tuning will not be amiss here, and we have a particular analogy that covers tuning nicely. Take the musical instrument, the trombone shown in Fig. 58. You all have seen this instrument, as nearly every orchestra boasts of one or more. It is known by all of us that while the musician blows into the mouth piece, he varies the length of the trombone by moving the sliding member back and forth. If he wants to get a deep note,

he pulls the sliding member almost all the way out, and this gives him a long sound wave. If he wishes a high note, he must have a short sound wave. This means that he must push the sliding member all the way in. It is literally, as well as scientifically, true that the lengthened trombone gives a long wave length, while the shortened trombone gives a short wave length. These are, of course, sound waves with which we have to do here. In radio we do



LONG SOUND WAVE LENGTH SHORT SOUND WAVE LENGTH

FIG. 58.

exactly the same thing in tuning. When we wish a long wave length, we must add more wire or its equivalent to the aerial. If we want a short wave length we must either have a short aerial or subtract some wire from the aerial. To lengthen an aerial in order to obtain a greater wave length, we have seen before that we make use of a tuning coil and by means of the slider which we slide up and down, we increase the wave length just as the trombone player does with his instrument. To shorten the wave length in tuning, it would not be possible to shorten the aerial, as this would be a cumbersome method; of course it can be done, but not in actual practice. We, therefore, have recourse to a condenser. The reader should remember that in order

to decrease the wave length of an aerial, all that is necessary is to put a condenser in series with the aerial which actually decreases the wave length; it does not increase it as some people seem to think. To make this clear, although it is not absolutely and literally true, just imagine that the condenser in the aerial circuit, as shown in Fig. 59, acts as a sort of

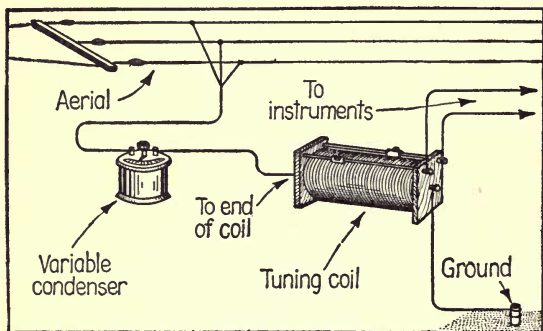

FIG. 59.

buffer which absorbs a portion of the wave length. The less condenser we add to the aerial, that is, the less capacity we interpose in the aerial circuit, the lower the wave length will be. The condenser, therefore, gives us the best practical means to decrease the wave length; this point is quite important to remember. Suppose you have a long aerial, say 200 feet, in connection with a small tuning coil, or suppose you have a short aerial and live on the tenth floor of an apartment house. The only available ground would be the water pipe. This water pipe,

however, would be so long that it would add extra meters to your wave length, and something must be done to decrease it, if you wish to receive signals sent out from a broadcasting station operating on a short wave length of 360 meters. The only way you could then tune in would be in the former case of the long aerial, to put a variable condenser

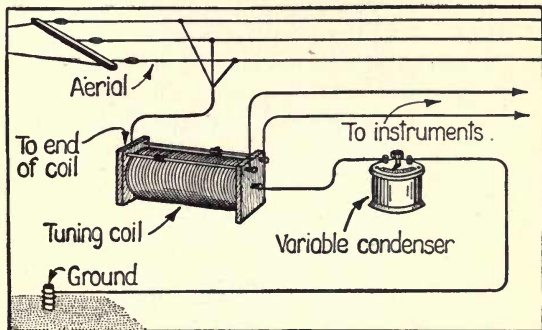

FIG. 60.

in the aerial circuit, or in the other case where you have a long ground to interpose the condenser in the ground lead as shown in Fig. 60. As a rule, in these two instances, at least what is technically called a twenty-three plate variable condenser should be used. Of course, the tuning coil must be used as well, but it should be adjusted so that it is at its lower point. In other words, it should not add more turns of wire to the aerial, which would again increase the wave length. In most cases, a few turns will do, depending upon how long your aerial or lead-in is.

CHAPTER VII

ÆRIALS, LOOP ÆRIALS, GROUNDS

WE have had occasion to speak of ærials and grounds before, and we will now go into this interesting study more thoroughly. An ærial is used to intercept radio waves; that is its sole function in the receiving set. It does not amplify or make the signals come in clearer by itself. During the past twenty-five years hundreds of different ærials have been invented, and there is hardly anything in this field that has not been tried out. An ærial, properly speaking, is an elevated wire that is well insulated, and is usually placed outside of the building or house. An ærial is one of the most important parts of a radio installation and should never be thought of in the light as an unimportant adjunct. As we said before, the ærial has the function to intercept radio waves. These waves come from afar, and are often very weak and far apart, and in order to intercept the waves at all, it is of great importance that the ærial be of good construction.

If you desired to catch butterflies, you would not use a net with large holes, because you would know in advance that with such a net you could not catch many butterflies. Likewise, if you wish to catch all the available waves that pass your house or abode, you must have an ærial that does not allow the trifling energy that you have to leak out. Using

another and a very good simile, you would not think of pouring a very precious liquid into a sieve if you wanted to preserve all that precious liquid. You would use a good container without any holes in it. Just so with the ærial. Always remember that a

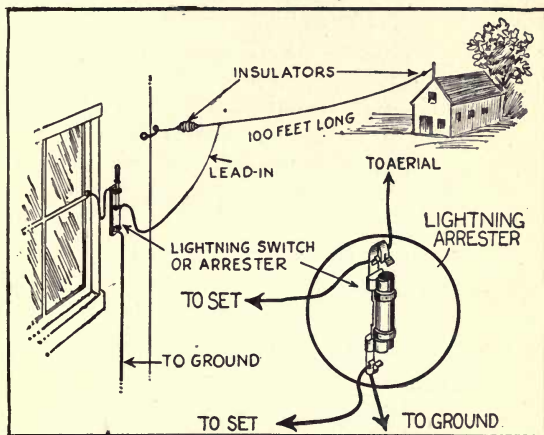

FIG. 61.

chain is no stronger than its weakest link. Conversely a radio outfit is no better than its ærial.

An ærial can be made of most any metallic wire, but the best material is either copper or copper-clad wire, which is copper wire with a thin iron core. A still better wire to use is a stranded wire, which is composed of several copper or phosphor bronze wires twisted together. As a rule, we may say that the larger the wire, the better it is for radio purposes. Very thick wires, as a rule, cost much and are very

heavy, and therefore are not very practicable. A No. 14 B & S gauge wire is a standard as used today and gives excellent results. For radio broadcasting reception it has been found that a single wire 100 feet long gives excellent results. Illustrations 61 and 62 show such a type of aerial. The single aerial is preferably used, because its construction is much simpler than that of a four-wire aerial which we will describe

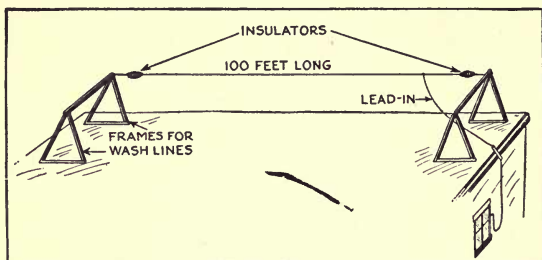

FIG. 62.

later on. If it is desired to receive from a certain station, the wire should point in the direction of that station; in other words, if, let us say you live in New York, and you wish to hear WJZ at Newark, N. J. (which is west from New York) run your aerial wire from west to east. The lead-in from the aerial (the wire connecting the aerial to the outfit) should be connected to that end of the aerial *nearest* to Newark. The free or open end of the aerial, therefore, points away from Newark; this is correct, as shown clearly in Fig. 63. This is a perspective view showing on which side the lead-in, that is the connection that

goes from the aerial to the instrument, should be placed.

Unless you wish to go to a great deal of inconvenience, make your lead-in of the same wire as the main aerial. This may be done very simply with a

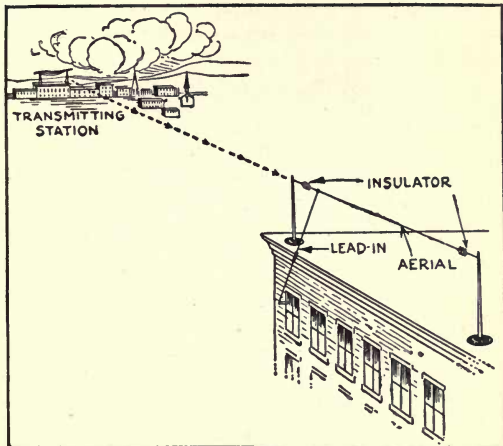

FIG. 63.

single wire aerial, for the reason that no soldered connections are necessary. This is also shown in Fig. 61 and Fig. 62. The next things to consider are the insulators, which are quite important. The insulator serves to insulate the aerial, and unless we use good ones, a great deal of energy will leak and thus weaken the reception. This is particularly the case in rainy weather where the water, or sometimes sleet, will make a

semi-conductor and unless the insulator is constructed correctly, much leakage will be the result. We show in Fig. 64 various types of insulators that may be used. One of the simplest is the ordinary porcelain cleat, but when this type is chosen, an unglazed cleat should be avoided. Insist upon get-

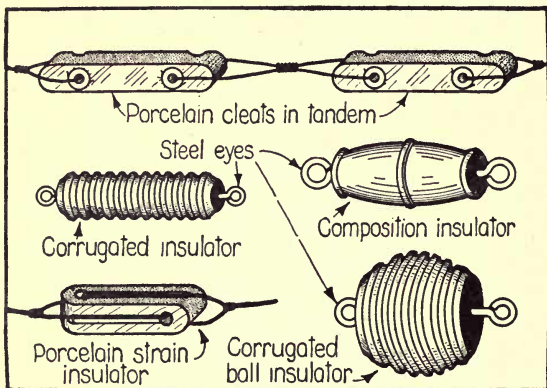

FIG. 64.

ting a glazed cleat which is a better insulator. When using cleats, put them in tandem, two or three strung in a row, as shown in Fig. 64. The more insulators we add, the better the insulation. It is however, hardly necessary to use more than three in a row. We next have the small spool insulators, which are very good and may also be strung in pairs, or sets of three. Various other types are shown in Fig. 64 and regular radio insulators provided with ribs or under cuts are preferred these days, because they

make a longer pathway for the electric current, and are, therefore, better insulators all the way through. It may be said here that the longer the ærial insulator, the better the ærial. The mode of fastening some of these insulators is shown in Fig. 64. The ærial is usually attached to the insulator, while the wire is twisted around itself after going through the hole in the insulator. Such radio insulators as a rule are quite strong, and when the ærial is put up, it can be well stretched without fear that the insulator will give way. As a matter of fact, the wire will give way long before the insulator, if the latter is perfect.

When putting up an ærial, it should be remembered always that the ærial proper must be at least a foot away from all buildings, barns, trees and the like. In other words, it should be away from all objects, whatever their names may be. In order to do so, it is often necessary to attach a wire to a cornice of the building, let us say, and extend the wire a few feet, to which we connect the insulators. The ærial proper is then connected to the other end of the insulator, which will give us a certain distance between the cornice and the actual beginning of the ærial.

The height of the ærial is often important. It should always be placed at least 20 to 30 feet above the ground. Generally speaking, the higher the ærial, the better the reception. High poles are not always necessary, although very often a good in-

vestment. Such poles, however, as a rule are expensive and most people do not wish to go to such an expense. If poles become necessary, they should be put up by someone who knows something about the erection of poles, because if not put up correctly, such a pole becomes a dangerous object when it

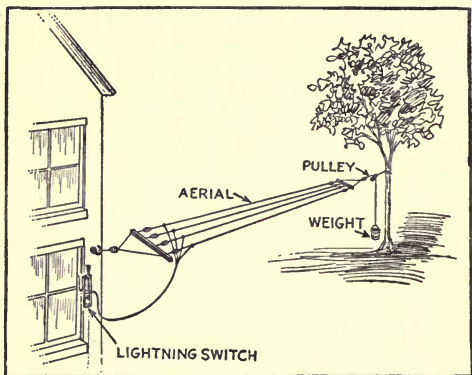

FIG. 65.

collapses from its own weight or in a storm. Good engineering in pole construction is a prime necessity.

As a rule, an aerial in the country may be stretched from the attic window to a flagpole, or if such is not at hand, a barn, garage, or even a tree could be made use of. If a tree is used, some means must be had to compensate for the swaying of the tree. Such a method is used in Fig. 65. Here we have a pulley attached to a tree by means of a rope; the end of the aerial is then run over this pulley and a fairly heavy weight secured to the open end, such

as an old pail filled with stones. As the tree sways back and forth, more or less aerial rope is paid out or taken in, and a good compensation is thus had. The weight may be 50 to 100 pounds, and an arrangement of this kind works very well. It goes without saying that the pulley must be insulated by insulators, all of which is shown in Fig. 65.

When an aerial is erected in the city, let us say on an apartment house, we usually do not have much trouble in putting up a good wire, providing the landlord does not object, and few landlords do these days, as they are becoming more and more enlightened in radio matters. The only thing that we may add is that an apartment house aerial should be at least 10 feet above the roof, particularly if the apartment has steel in its construction. If we can put up an aerial higher than 10 feet, so much the better. The aerial should always be stretched taut, as a sloppy and saggy aerial is not only unsightly, but gives rise to poor reception. See Fig. 62. The reason is that a saggy aerial will swing in the wind, and it has been found that such an aerial will not bring in sharp signals, due to this very swinging. It often gives rise to what is called "fading signals," in other words, one minute the signals may be clear and the next minute they will be faint.

For long distance work, and where we have a very good outfit that has good tuning, we often use a larger aerial, *i.e.*, an aerial that gives us more capacity; to be more explicit, an aerial that covers more

space than a single aerial. In Fig. 65 and Fig. 66, and 66A, we have shown a two and four-wire aerial

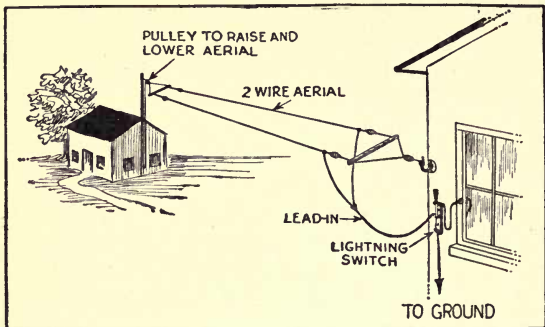

FIG. 66.

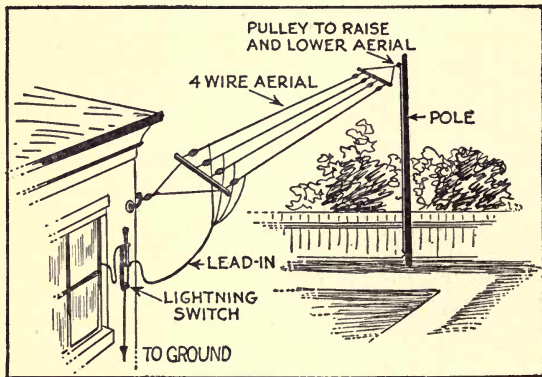

FIG. 66 A.

of the inverted L type. These aërials are simply duplications of the single wire aërial, except that more wires are used. With such aërials it is always

necessary to solder the connections or otherwise use an antenna connector as shown in Fig. 67. The types of ærial as shown in Fig. 65, 66 and 66A are commonly called the inverted L, due to their similarity to the letter L, turned upside down. Such an ærial is directive, the same as a single wire ærial, as shown in Fig. 63. As in the latter, the inverted L type

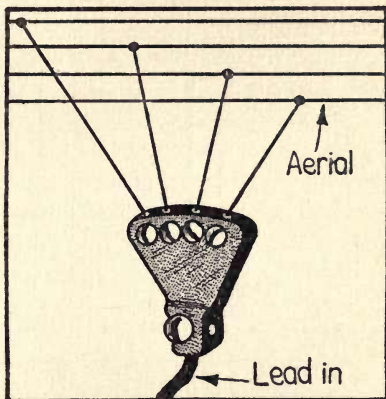

FIG. 67.

must have its lead-in taken from the nearest point to the broadcasting station. The free end, therefore, points away from the station that we wish to hear.

Fig. 68, shows a four-wire ærial. This ærial has no directive properties, and receives signals from many points of the compass almost equally well. The only difference here is that the lead-in is taken from the center of the ærial instead of from the end. An ærial of this kind may be shorter than a single

wire aerial, and the wire in this instance may be 40 or 60 feet long, and excellent results may be had with such a type. Where we have a multiple wire aerial, a new element comes into its construction, *viz.*, the Spreader. This is simply a stick of wood, well painted to keep it from decaying, upon which the

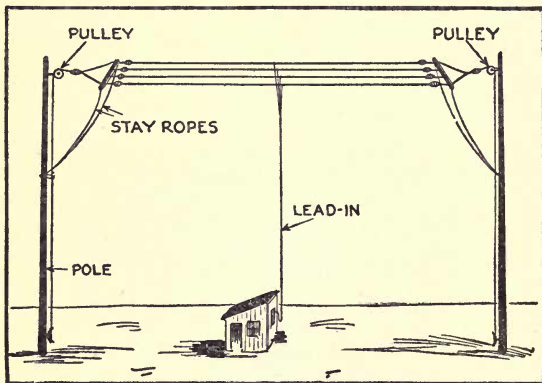

FIG. 68.

insulators are strung, as shown in the illustrations. The wires themselves, should be spaced about two feet apart. The spreader must of course, be substantial, so that it will not break under the tension. A bamboo stick about 1 inch or 1½ inches in diameter has been found to be ideal for this work. It is often necessary to take down the aerial when we have poles, and for this purpose we use pulleys, as shown in Fig. 68, by means of which the aerial may be raised and lowered when necessary. In

Fig. 68 we also see two pieces of cord or rope attached to the spreaders which are put there for the purpose of keeping the ærial from swinging sideways or turning over as would be the result if there was nothing to prevent it. Therefore, stays are used.

LEAD-IN

The lead-in is that part of the ærial that goes into the building or house to establish connection with the instruments. In a single-wire ærial, the lead-in is simply the ærial wire itself leading into the house and thence to the instruments. With a two, three and four-wire ærial, the lead-in is connected to the antenna connector described in Fig. 67, and from that point runs on to the instruments. The lead-in wire should be of the same size as the ærial. In other words, about No. 14 B & S wire. It should be insulated at the point where it nears the building, or if this is not possible in the case of a single-wire ærial, the lead-in is then strung on insulators, the wire being always at least one foot away from buildings, walls, etc., until it reaches the point where actual entrance is made into the building; at this point several things arise. We may bring the wire in through the open window, which, however, is always considered bad practice. It should only be done for temporary work. One of the simplest ways is to drill a hole in the center of the window pane at the very upper part of the window, and let the wire come in through this hole, which,

however, is not such a good practice either, for the simple reason that it becomes impossible to lower the window, as the wire will obstruct it. The best way is to drill a hole through the sash of the window at any convenient point where the window weights will not be interfered with. This hole can be about three quarters of an inch. Into this hole,

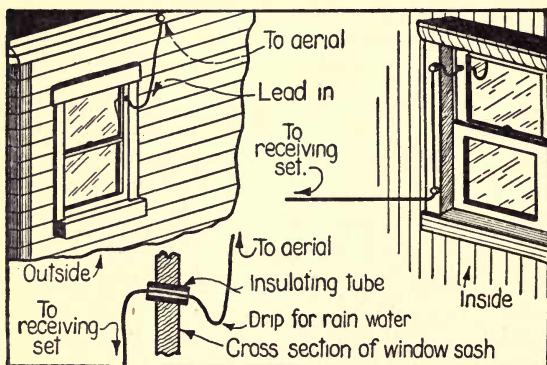

FIG. 68 A.

fit an ordinary porcelain tube which may be secured from any electrical supply house. The lead-in is then fed through this tube, and thence on insulators to the instruments; Fig. 68-A makes this clear. If we do not wish to drill such a large hole through the window sash, a small one may be made instead, in which case, we must use a piece of rubber insulated cable, such as is used on automobiles and this is fed through the small hole. The actual lead-in wire is then soldered on the outside of the window to make

connection with the automobile cable so that no part of the bare wire touches the wood work or stone work near the window. The insulated rubber cable is then carried along insulators to the instruments. It should be remembered that the ærial wire must always be well insulated, and that it cannot be insulated too well. Always bear in mind that we have but little energy coming in over the ærial, and the better we insulate the lead-in the better the results will be.

We again wish to point out here that for radio telephone reception a single-wire ærial of 100 to 150 feet long is always the best, whether used with a crystal outfit or with a vacuum tube set. The reason for this is not because the single ærial wire is inherently better, but because with it there is less interference on account of its directional properties. It has come to the author's attention that many people, when buying a small crystal set, are disappointed because they are not able to receive signals, but do receive radio telephone concerts. Many people desire to receive signals as well, as for instance the Arlington time signals, market reports that are sent out in code, etc. To all these people we say that if they desire to receive signals as well as radio telephony, they should use a two or four-wire ærial. They should, however, not complain if, when receiving radiophone entertainment, signals come in at the same time; this often happens with a two or four-wire ærial, and unless the instrument used is a very

selective one, it is not always possible to tune out the unwanted station that sends in code. This is especially true of crystal sets where it is impossible to tune quite so sharply as with vacuum tube sets.

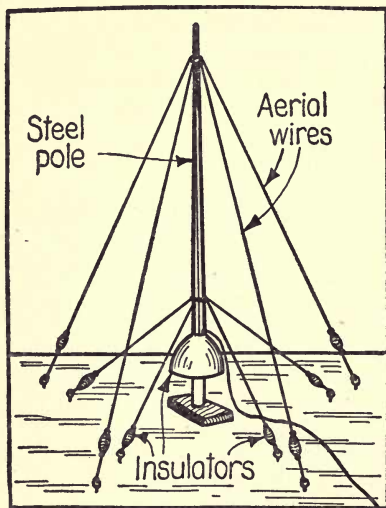

FIG. 69.

There is still another type of aerial that was used at one time extensively, and although it is not used so much today, it has a great deal of merit. We refer to the Umbrella Aerial as shown in Fig. 69. This aerial as its name implies, is in the form of an umbrella, and may be made of any size, but should never be less than 25 feet high, 50 or 75 and even 100 feet, being better. In the umbrella aerial we have

a single mast, from the top of which emerge single wires in all directions. The connections are made as shown in the illustration. This aerial has a great advantage in being able to receive from all direc-

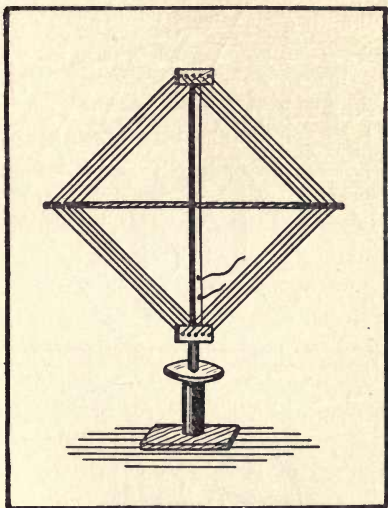

FIG. 70.

tions equally well. As we have noted before, the single-wire aerial receives with maximum intensity from one direction. The umbrella aerial, however, receives from all points of the compass with equal facility. It is also possible by a switching arrangement to connect any one of the aerial wires of the umbrella antenna in order to get rid of interference. This means, of course, an elaborate switching ar-

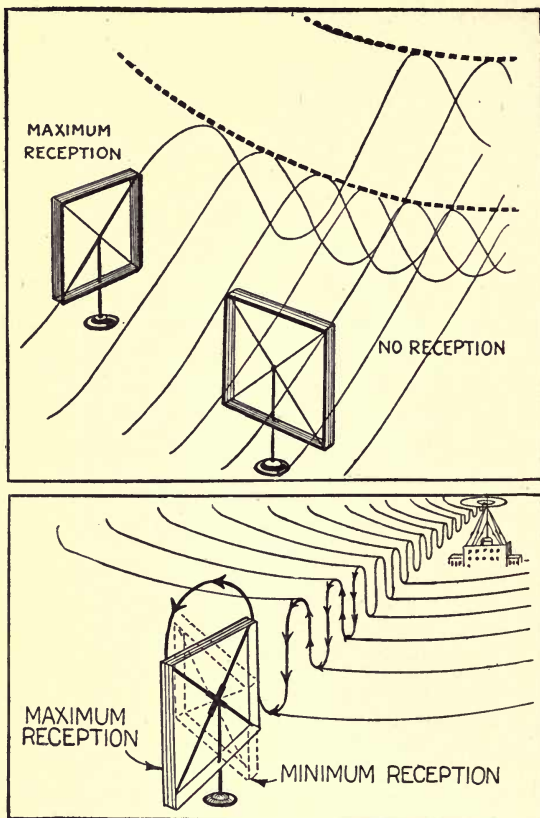

FIG. 71.

rangement, which is not very often within the reach of the layman, by whom such an aerial is rarely, if

ever used. To the man, however, who desires to go in for experimental work such an ærial has its uses, and will repay the labor spent in constructing it.

We now come to an ærial which is entirely different from those of which we have spoken before. We refer to the loop ærial, which is shown in Fig. 70. It should be understood that a loop ærial is hardly, if ever, used in connection with a crystal set. It is used almost exclusively with a vacuum tube set, as will be explained further on. The loop ærial serves several purposes. In the first place it does away with the ground connection. Secondly, the loop ærial may be made in any size from one foot square up to 20 feet square. The loop ærial is highly directive; by that we mean that it will only receive with maximum intensity if the loop is turned in the direction of the coming signals. This is shown clearly in Fig. 71. Here we see how an ordinary loop ærial is placed in a building, and we also see how the waves are propagated from a distant sending station. It will be found that the signals are strongest when the loop points exactly in the direction from which the waves are coming. The loop ærial, therefore, serves the additional purpose of telling from which direction the waves are coming, and this principle is made use of in the radio compass.

All the ships that come from points far away do not compute their own bearings any longer, but, by means of radio, call the nearest compass station.

There are usually several of these stations placed at various points along the coast, and by means of their radio direction finder, the personnel at the station turn the loop until they hear the ship with maximum intensity; the loop is then pointing directly to the ship. The station further down the coast does the same thing, while the two stations com-

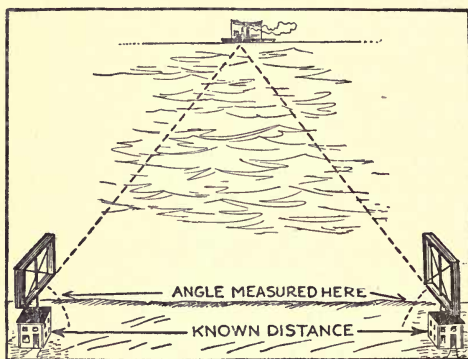
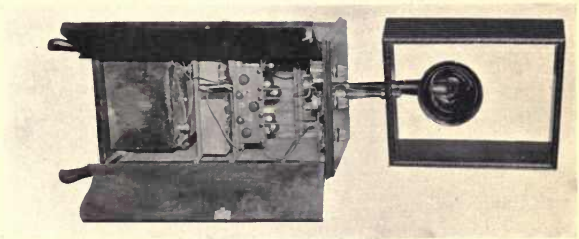
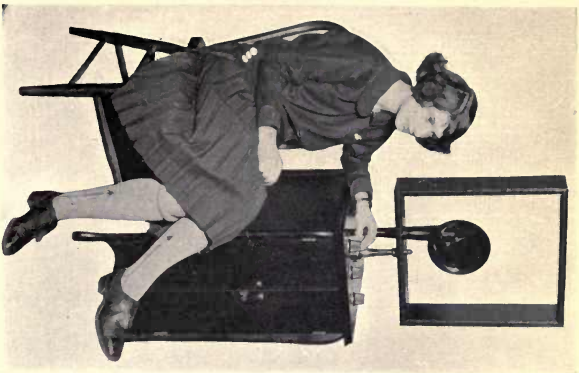

FIG. 72.

municate with each other by telephone or telegraph. By means of triangulation the operators then calculate within a few minutes just exactly where the ship is located. Within one or two minutes at the latest one of the land stations radios to the ship, telling at what latitude and longitude it is. The position can be ascertained within a few hundred feet, a thing impossible for any captain to do with his compass, or by other means. Fig. 73, shows the radio compass graphically.



The author's "Radiotrolia." This machine was built late in 1921, and is the first radio machine of its class to take on the appearance of a piece of furniture. The Radiotrolia, now used in the author's home employes neither antenna nor ground, the reception being made by the loop shown in the engraving. The music, as well as entertainment, from WJZ, Newark, N. J., although twelve miles distant, comes in so loud that the sounds can be heard all over the apartment.

As to the loop aerial itself, as we have already mentioned, its size depends upon the builder. It is usually made up of a frame as shown in Fig. 70, and this frame may be from 2 to 4 inches square. Upon the frame are usually wound about six to ten turns of insulated wire, the two ends coming out somewhere near the center and connecting with the

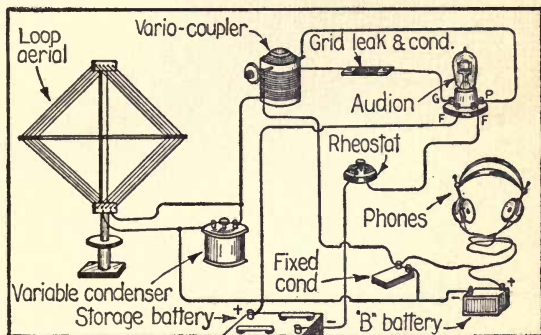

FIG. 73.

instruments. Fig. 72 shows the simplest connection of a loop aerial, with the simplest regenerative vacuum tube hook-up.

While in this diagram the loop aerial is shown, it should be distinctly understood that a loop aerial is not of much use unless we have at least two or three stages of amplification. The reason is that the loop aerial, being as a rule very small, its capacity is naturally small, and but few waves strike it. Therefore, it becomes necessary to amplify the exceedingly weak currents. The connection shown in

Fig. 72 is only good if we are located but a few miles from the broadcasting station. For longer distances, we must have several stages of amplification as already mentioned. Tuning with the loop aerial is rather difficult because, as mentioned before, the aerial must point exactly in the direction from which the signals come. Moving the loop even a few

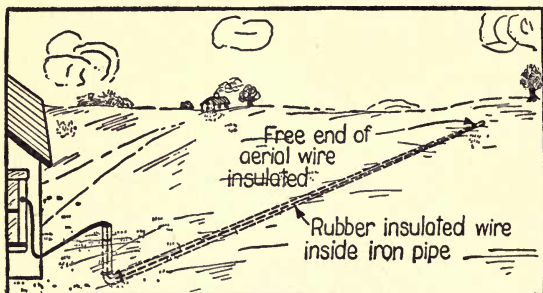

FIG. 74.

inches to the side will cut off all the signals. The best position, therefore, must always be found by experiment.

We come now to still another aerial which is the least used, but which has its advantages; we refer to the underground aerial. Fig. 74 shows the principle, which consists of a well insulated wire, usually a rubber covered automobile cable. A trench about two to three feet deep is dug in a straight line running in the same direction from which the signals are expected to be received. The wire is then carefully insulated at the open end and run through an

iron pipe. Both are then placed at the bottom of the trench. Such a wire must be at least 200 feet long to get fair results. After the trench is covered over again the other end is led into the station, and connected with the instruments, the same as the usual aerial. A ground must be used with this aerial, which will only receive signals from the direction in which it points or points away from. It can of course not be used much in the city, but is desirable in the country if a pole or overhead wires are not wanted. The underground aerial has the very great advantage of being almost entirely free from static and atmospheric disturbances. Thus, for instance, Dr. James Harris Rogers, the inventor of the underground aerial during the war, received excellent signals from Nauen, Germany, as well as other European centers while a thunderstorm was raging overhead. Of course, it goes without saying that an overhead aerial cannot be used during a thunder storm because it becomes extremely dangerous to the user. With the underground aerial such risk is entirely eliminated.

Not only that, but in the summertime the overhead aërials give quite a good deal of trouble, due to static and atmospheric electricity, even though there is a blue sky overhead. As we have already mentioned in another chapter, in the summertime the atmosphere is continually charged with electricity, and this electricity discharges through the aerial wire and gives rise to crackling sounds in the re-

ceivers which often become unbearable. So far, nothing has been invented to do away with these parasitic currents, technically called X or static.

HOW TO FIGURE WAVE LENGTHS OF ÆRIALS

Each aerial used for transmitting and receiving has a wave length of its own. It depends upon several factors beside its dimensions and it is practically impossible to calculate it accurately unless a measuring instrument is used. The wave length depends upon the length of the wire composing the aerial taken from the ground to the free end of the wire. If it is composed of several wires, the number and spacing of these wires also influence the wave length as well as the distance of the straight portion from the ground, and the shape of the aerial itself.

The wave length of a single-wire aerial is, roughly, four times the length of the wire from the ground to the free end measured in meters. For instance, if a single-wire aerial 100 feet long, is erected 50 feet above the ground with the lead-in that is vertical, the total length of the wire will be 150 feet or 45 meters. The wave length will consequently be $45 \times 4 = 180$ meters.

The wave length of an aerial depends upon the nature of the ground above which it is erected and the objects interposed between the flat portion called the flat-top and the ground. If an aerial is erected above the house, its natural wave length will be different from what it would be if erected in a field

without any obstruction in the neighborhood. For this reason, no formula can be given that will be accurate enough to tell this, and the only practical means of measuring the natural wave length of an aerial is by means of a wave meter.

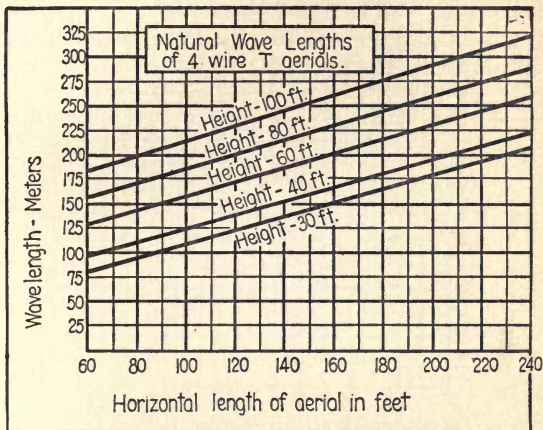

FIG. 74 A.

The accompanying charts shown in Figs. 74A and 74B have been compiled by taking the average wave length of several aërials of the same size erected at different places and give sufficient accurate measurements for the ordinary types of antennæ used by amateurs. Fig. 74A shows the natural wave length of an aërial of the "T" type, that is, those of which the lead-in is taken from the exact center. Above each curve is marked the height

from the ground to which it corresponds. Fig. 74B gives the wave length for aërials of the inverted "L" type, that is, those having the lead-in taken from one end of the wires. The free ends of the aërial wires are in both cases free. That is, without connections across on the wires.

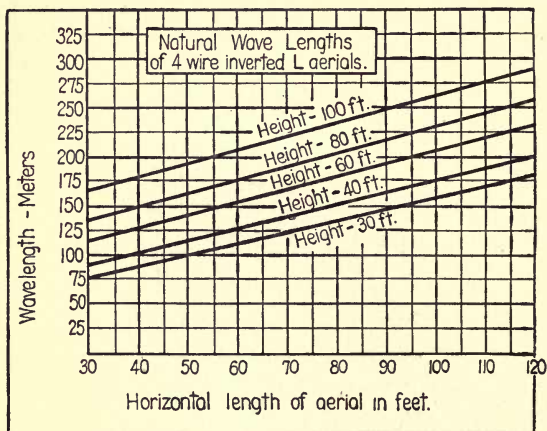

FIG. 74 B.

To find out the wave length of an inverted "L" aërial 100 feet long and 40 feet above the ground, we refer to Fig. 74B, and by means of a rule we measure on the scale indicating the wave length, how many meters correspond horizontally to the point where 100 feet in length crosses 40 feet in height. This gives us approximately 175 meters wave length.

GROUNDS

In radio, in connection with the usual aerial, it becomes necessary to use a ground, which, as its name implies, is a connection made with the earth. The earth being a good conductor, it is often used as a sort of return circuit, and it has been found, that, with the ordinary circuits, signals come in very much better if such a ground is used. It is possible

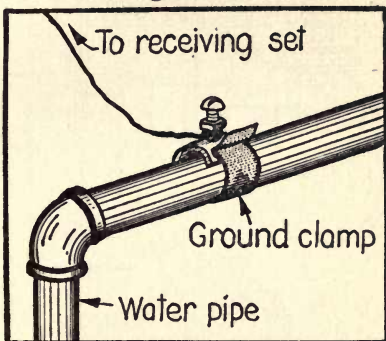

FIG. 75.

to use an aerial without a ground for short distances, in which case it becomes a sort of loop. For ordinary purposes, however, it would be impossible to use a radio outfit without a ground connection. Fig. 75 shows the simplest and perhaps the best. It is simply a wire fastened to the cold water pipe, which is found in almost every house and apartment. In order to make a good connection, we use a ground clamp, as shown in Fig. 76. This ground clamp is simply a piece of metal wrapped around

the water pipe, which should first be scraped with a file or old knife, the idea being to obtain a perfectly clean metallic connection. By means of some clamping arrangement, which differs for every ground clamp, a strong mechanical connection is made. The ground wire is then fastened to the screw or binding post attached to the ground clamp.

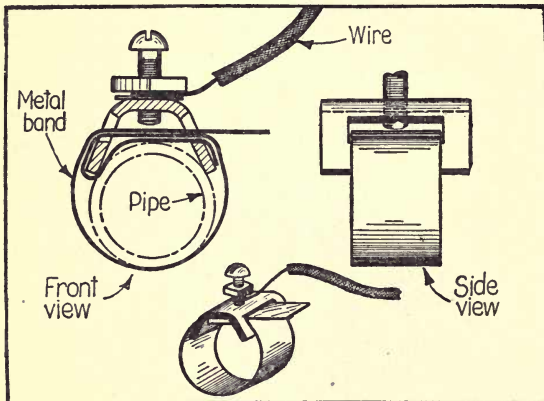

FIG. 76.

The ground wire need not be insulated. An ordinary bare No. 14 B & S wire will do nicely; in other words, the same wire which we use on an aerial may be used. It is not necessary to run the ground wire on insulators, as is done with the aerial lead-in, but it may be attached to the wall by means of nails which serve the purpose equally well. Of course, the ground wire should not be longer than is absolutely necessary. If it is not possible to find a cold

water pipe, a radiator pipe may be used, although the results may not be as good as from the cold water pipe. It is against the law to connect a ground to a gas pipe, and it should therefore never be done. In the first place you encourage fire danger, and secondly the gas ground connection is never as efficient, for the reason that the pipe does not run di-

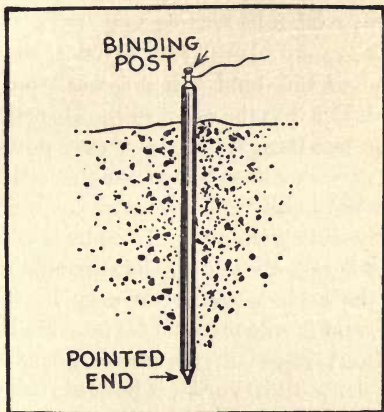

FIG. 77.

rectly into the soil. Usually such gas pipes go first to a gas meter which, due to leather washers and lead paint, often insulate the pipe from the ground, and therefore the results with a gas ground are often very poor. For these reasons it is never advisable to use such a ground except in emergency, but never for permanent use.

When we are out in the country, for instance, when camping, it is not always possible to have a

water pipe, and in that case we have to establish contact with Mother Earth direct. This is usually accomplished by driving a metal rod into moist earth, as is shown in Fig. 77. A "ground" of this sort is nothing but an iron, brass or other metallic rod sharpened at the end and driven anywhere from 18 to 36 inches into the soil. The wire to make connection may be soldered, or may have a binding post or a ground clamp just as on a water pipe. A ground of this kind will not work unless it is actually driven into the moist soil. It is thus necessary to do two things: first, we may pour a large quantity of water near the grounding rod to make sure that the earth becomes moist for quite a distance surrounding the rod. Even by applying this artifice it is not always possible to obtain results because the underlying strata may be devoid of moisture, and it will then not be possible to receive signals; this is especially the case on many hill-tops. When such conditions arise, it becomes necessary to move the ground until we actually reach a wet spot such as, for instance, in the immediate vicinity of a natural well, the shore of a creek or a small body of water such as a pond or a lake; these all make ideal grounds.

In farm houses where no water pipe exists it is usually best to drive a gas or water pipe from 1 to 1½ inches in diameter into moist soil. Connection is established by means of a ground clamp, as already explained.

The question is often asked how ships or motor boats can have a ground. The answer to this is that the ground connection is always attached to the outside metallic plating of the ship or motor boat. The connection should always be soldered. Such a ground is really a very excellent one, and will always work.

GROUNDS IN APARTMENT HOUSES

It should be understood that there are grounds and grounds. The reason is as follows. A long ground, by reason of its length, has a certain effect upon the receiving outfit on account of its own wave-length. If we have but a short ground, say ten or fifteen feet long, its wave-length is minimum. But consider Fig. 78. Here we have an aerial, say 50 feet long, on top of a ten-story apartment house. The owner of this outfit, let us say, lives on the tenth floor. If we trace the ground down to the soil, we will find a water pipe anywhere from 100 feet to 120 feet long. What is the result? Such a long ground will add about 740 meters wave-length to the outfit, and will in fact, overshadow the aerial to such an extent that the ground becomes longer than the aerial. This is very poor practice, but it cannot, of course, always be helped. It has been found that where such an occasion prevails, the usual outfits sold on the market do not work very well because they are not built to operate on such a wave length. In order to use an outfit with such a long aerial, it becomes necessary to install a var-

iable condenser in series with the ground wire in order to overcome the handicap. See Fig. 60. By adjusting the variable condenser, a point will be found where the signals come in best. The conden-

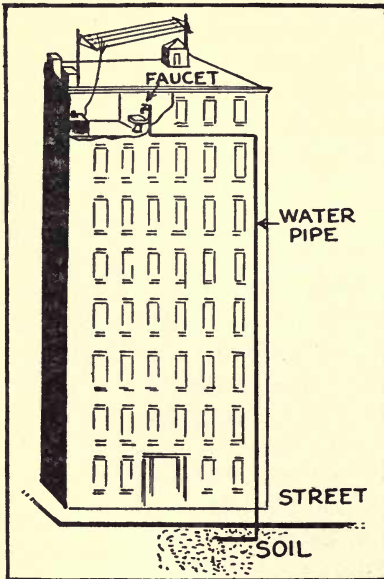

FIG. 78.

ser, in other words, cuts down the wave-length to a point where it counter-balances the excessive wave-length of the ground. Such a condenser should always be used when there is a long ground, as for instance, in apartment houses, high office buildings etc.

LIGHTNING ARRESTERS

The properly installed aerial, when used with a lightning arrester, is the best protection a building or house could have against lightning. Always remember that the aerial is nothing but a lightning conductor itself, and will actually protect the house, and will never endanger it if properly installed. An aerial will draw the atmospheric electricity *silently to the ground*, and there are very few authentic cases on record where lightning has actually struck an aerial. If it did strike it, it usually did very little damage because the lightning spent itself through the lightning arrester or lightning switch down to the ground. In former years, it was necessary to use a lightning switch by which, in a thunder storm, it became necessary to connect the aerial directly to the ground. Recent regulations, however, make it unnecessary for owners of a radio receiving outfit to have a lightning switch, although it is a good precaution and we give below the present Federal regulations for installation of lightning arresters.

The lightning arrester itself is nothing but a small spark gap either in a vacuum or in the atmosphere, which gap breaks down when a current of a few hundred volts strikes the aerial. Instead of going through the instruments which have a high resistance, the current travels direct to the ground, which has a low resistance. Secondly, the instru-

ments are not damaged. In Fig. 79 are shown the various types of lightning arrester. Fig. 61 shows the connections. The lightning regulations follow herewith:

RADIO EQUIPMENT

In setting up radio equipment all wiring pertaining thereto must conform to the general requirements of this code for the class of work installed and the following additional specifications:

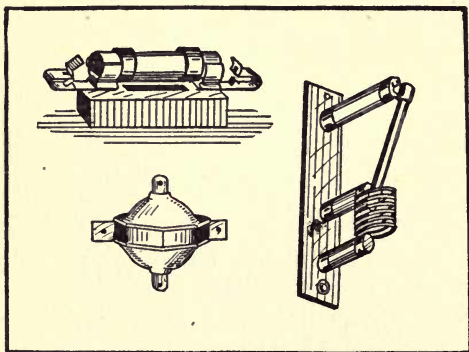

FIG. 79.

FOR RECEIVING STATIONS ONLY ANTENNA

(a) Antennæ outside of buildings shall not cross over or under electric light or power wires of any circuit of more than six hundred (600) volts or railway trolley or feeder wires, nor shall it be so located that a failure of either antenna or of the above mentioned electric light or power wires can result in a contact between the antenna and such electric light or power wires.

Antennæ shall be constructed and installed in a strong and durable manner and shall be so located as to prevent accidental contact with light and power by sagging or swinging.

Splices and joints in the antenna span, unless made with approved clamps and splicing devices, shall be soldered.

Antennæ installed inside of buildings are not covered by the above specifications.

LEAD-IN WIRES

(b) Lead-in wires shall be of copper, approved copper-clad steel or other approved metal, which will not corrode excessively and in no case shall they be smaller than No. 14 B. & S. gage except that approved copper-clad steel not less than No. 17 B. & S. gage may be used.

Lead-in wires on the outside of buildings shall not come nearer than four (4) inches to electric light and power wires unless separated therefrom by a continuous and firmly fixed non-conductor that will maintain permanent separation. The non-conductor shall be in addition to any insulation on the wire.

Lead-in wires shall enter building through a non-combustible, non-absorptive insulating bushing.

PROTECTIVE DEVICE

(c) Each lead-in wire shall be provided with an approved protective device properly connected and located (inside and outside the building) as near as practicable to the point where the wire enters the building. The protector shall not be placed in the immediate vicinity of easily ignitable stuff, or where exposed to inflammable gases or dust or flying combustible materials.

The protective device shall be an approved lightning arrester which will operate at a potential of five hundred (500) volts or less.

The use of an antenna grounding switch is desirable, but does not obviate the necessity for the approved protective device required in this section. The antenna grounding switch, if installed, shall, in its closed position, form a shunt around the protective device.

PROTECTIVE GROUND WIRE

(d) The ground wire may be bare or insulated and shall be of copper or approved copper-clad steel. If of copper the ground wire shall be not smaller than No. 14 B. & S. gage and if of approved copper clad steel it shall be not smaller than No. 17 B. & S. gage. The ground wire shall be run in as straight a line as possible to a good permanent ground. Preference shall be given to water piping. Gas piping shall not be used for grounding protective device. Other permissible grounds are grounded steel frames of buildings or other grounded metallic work in the building and artificial grounds such as driven pipes, plates, cones, etc.

The ground wire shall be protected against mechanical injury. An approved ground clamp shall be used wherever the ground wire is connected to pipes or piping.

WIRES INSIDE BUILDINGS

(e) Wires inside buildings shall be securely fastened in a workmanlike manner and shall not come nearer than two (2) inches to any electric light or power wire unless separated therefrom by some continuous and firmly fixed non-conductor making a permanent separation. This non-conductor shall be in addition to any regular insulation on the wire. Porcelain tubing or approved flexible tubing may be used for encasing wires to comply with this rule.

RECEIVING EQUIPMENT GROUND WIRE

(f) The ground conductor may be bare or insulated and shall be of copper, approved copper-clad steel or other approved metal which will not corrode excessively under existing conditions; and in no case shall the ground wire be less than No. 14 B. & S. gage except that approved copper-clad steel not less than No. 17 B. & S. gage may be used.

The ground wire may be run inside or outside of building. When receiving equipment ground wire is run in full compliance with rules for protective ground wire, in Section d, it may be used as the ground conductor for the protective device.

FOR TRANSMITTING STATIONS
ANTENNA

(g) Antennæ outside of buildings shall not cross over or under electric light or power wires of any circuit of more than six hundred (600) volts or railway trolley, or feeder wires nor shall it be so located that a failure of either the antenna or of the above mentioned electric light or power wires can result in a contact between the antenna and such electric light or power wires.

Antennæ shall be constructed and installed in a strong and durable manner and shall be so located as to prevent accidental contact with light and power wires by sagging or swinging.

Splices and joints in the antenna span shall, unless made with approved clamps or splicing devices, be soldered.

LEAD-IN WIRES

(h) Lead-in wires shall be of copper, approved copper-clad steel or other metal, which will not corrode excessively and in no case shall they be smaller than No. 14 B. & S. gage.

Antenna and counterpoise conductors and wires leading therefrom to ground switch, where attached to buildings, must be firmly mounted five (5) inches clear of the surface of the building on non-absorptive

insulating supports such as treated wood pins or brackets equipped with insulators having not less than five (5) inch creepage and air gap distance to inflammable or conducting material. Where desired, approved suspension type insulators may be used.

(i) In passing the antenna or counterpoise lead-in into the building, a tube or bushing of non-absorptive insulating material shall be used and shall be installed so as to have a creepage and air-gap distance of at least five (5) inches to any extraneous body. If porcelain or other fragile material is used, it shall be installed so as to be protected from mechanical injury. A drilled window pane may be used in place of bushing, provided five (5) inch creepage and air-gap distance is maintained.

PROTECTIVE GROUNDING SWITCH

(j) A double-throw knife switch having a break distance of four (4) inches and a blade not less than one-eighth ($\frac{1}{8}$) inch by one-half ($\frac{1}{2}$) inch shall be used to join the antenna and counterpoise lead-ins to the ground conductor. The switch may be located inside or outside the building. The base of the switch shall be of non-absorptive insulating material. Slate base switches are not recommended. This switch must be so mounted that its current-carrying parts will be at least five (5) inches clear of the building wall or other conductors and located preferably in the most direct line between the lead-in conductors and the point where ground connection is made. The conductor from grounding switch to ground connection must be securely supported.

PROTECTIVE GROUND WIRE

(k) Antenna and counterpoise conductors must be effectively and permanently grounded at all times when station is not in actual operation (unattended) by a conductor at least as large as the lead-in, and in no case shall it be smaller than No. 14 B. & S. gage copper or approved copper-clad steel. This ground wire need not be insulated or mounted on insulating supports. The ground wire shall be run in as straight a line as possible to a good permanent ground. Preference shall be given to water piping. Gas piping shall not be used for the ground connection. Other permissible grounds are the grounded steel frames of buildings and other grounded metal work in buildings and artificial grounding devices such as driven pipes, plates, cones, etc. The ground wire shall be protected against mechanical injury. An approved ground clamp shall be used wherever the ground wire is connected to pipes or piping.

RADIO FOR ALL

OPERATING GROUND WIRE

(l) The radio operating ground conductor shall be of copper strip not less than three-eighths ($\frac{3}{8}$) inch wide by one-sixty-fourth ($\frac{1}{64}$) inch thick, or of copper or approved copper-clad steel having a periphery, or girth (around the outside) of at least three-quarters ($\frac{3}{4}$) inch (for example a No. 2 B. & S. gage wire), and shall be firmly secured in place throughout its length. The radio operating ground conductor shall be protected and supported similar to the lead-in conductors.

OPERATING GROUND

(m) The operating ground conductor shall be connected to a good permanent ground. Preference shall be given to water piping. Gas piping shall not be used for ground connections. Other permissible grounds are grounded steel frames of buildings or other grounded metal work in the building and artificial grounding devices such as driven pipes, plates, cones, etc.

POWER FROM STREET MAINS

(n) When the current supply is obtained directly from street mains, the circuit shall be installed in approved metal conduit, armored cable or metal raceways.

If lead covered wire is used, it shall be protected throughout its length in approved metal conduit or metal raceways.

PROTECTION FROM SURGES, ETC.

(o) In order to protect the supply system from high-potential surges and kick-backs, there must be installed in the supply line as near as possible to each radio-transformer, rotary spark gap, motor-generator sets and other auxiliary apparatus one of the following:

1. Two condensers (each of not less than one-half ($\frac{1}{2}$) microfarad capacity and capable of withstanding six hundred (600 volt test) in series across the line and mid-point between condensers grounded; across (in parallel with) each of these condensers shall be connected a shunting fixed spark gap capable of not more than one-thirty-second ($\frac{1}{32}$) inch separation.

2. Two vacuum tube type protectors in series across the line with the mid-point grounded.

3. Non-inductively wound resistors connected across the line with mid-point grounded.

4. Electrolytic lightning arresters such as the aluminum cell type.

In no case shall the ground wire of surge and kick-back pro-

tective devices be run in parallel with the operating ground wire when within a distance of thirty (30) feet.

The ground wire of the surge and kick-back protective devices shall not be connected to the operating ground or ground wire.

SUITABLE DEVICES

(p) Transformers, voltage reducers, keys, and other devices employed shall be of types suitable for radio operation.

These rules do not apply to radio equipment installed on ship-board, but have been prepared with reference to land stations.

RECEIVING EQUIPMENT

(a) *Antenna*—Indoor receiving antennæ are not included within the requirements of this proposed rule, which provides for the protection of radio equipment against lightning. Indoor receiving antennæ and auxiliary apparatus are, however, included in the general requirements covering the wiring of signal systems, for it is obviously desirable to insure, for example, the freedom of all receiving apparatus from contact with electrical power circuits either inside or outside of buildings.

It is desirable that electrical construction companies install radio antennæ and apparatus for persons who are not familiar with electric wiring. This will tend to insure the installation of antennæ and apparatus in a strong and durable manner. It is important that antenna wire be used in such size and tensile strength as to avoid its coming in contact with any electric power wires whatsoever.

The size and material of which the antenna is made should depend, to some extent, upon the length of the span which the antenna must bridge. It is suggested that for the ordinary receiving antenna about 100 feet long No. 14 B. & S. gage soft drawn copper wire can safely be used. If other materials are used, the size which is chosen should be such as to insure tensile strength at least equal to that of the No. 14 soft copper wire suggested above.

The requirements covering splices and joints in the antenna span are for the purposes of avoiding accidental falling of such wires upon light and power wires, of less than 600 volts where it is found necessary to cross such lines. The rules, it will be noted, permit crossings with lines of 600 volts or less, if they do not happen to be trolley wires or feeders to trolley wires. In such a case, it is desirable to use wire of a larger size than 14 B. & S. gage in order to minimize the chance of accidental contact of the antenna with the power wires.

The interchangeable use of copper and of approved copper-clad conductor is suggested on account of the fact that these two kinds of

wire are practically equivalent in their conductivity for high-frequency current.

(b) *Lead-in Wires*—No mention is made of the insulation from the building of the receiving antenna or lead-in wire except that this lead-in wire should be run through a bushing. The latter provision is chiefly to protect the wiring against the possibility of short-circuiting with electric power lines which may run in the wall and whose location may be unknown to the persons installing the radio equipment. This requirement serves also to protect the antenna lead-in wire against contact with metal lath or other metal parts of the building.

From a signaling standpoint, it is desirable to use insulators for receiving antennæ in order that wet weather may not cause the antenna to become partly short-circuited to the ground.

(c) *Protective Device*—The requirement for a protective device to be connected between the antenna and ground terminals of the receiving set is for the purpose of carrying lightning discharges or less violent discharges caused by induction or by atmospheric electricity to the ground with a minimum chance of damage to the receiving apparatus, building, or operator. A fuse is not required as a part of the protective device, though lightning arresters which are provided with fuses will not necessarily fail to receive approval. If a fused lightning arrester is used, it makes it less likely that the antenna terminals of a receiving set will be put in a high voltage in case the antenna falls upon an electric light or power wire. The absence of the fuse, on the other hand, makes it possible for the antenna, if it accidentally falls across the power wires, to become fused at the point of contact and thus fall to the ground and eliminate the hazard. The antenna terminal of the receiving set should be connected to the point of junction of the fuse with the arrester.

Lightning arresters may be used inside the building, and in such a case they will receive better protection from moisture and mechanical injury than lightning arresters placed on the outside of a building wall.

Protective devices of reliable manufacture are approved by the Underwriters' Laboratories, and can be depended upon to operate at the required voltage. The use of a cheaply constructed home-made arrester is not recommended, since it may easily get out of order and fail to operate at the low voltage which is desirable. Arresters should be inclosed in such a way as to protect the breakdown gap from dust. One disadvantage of the vacuum tube type of arrester is that it may cease to function without giving warning that it is inoperative. A

list of the approved protective devices and ground clamps is contained in the "List of Inspected Electrical Appliances," published by the Underwriters' Laboratories. This list is revised semi-annually and may be consulted upon application to the principal office of the Underwriters' Laboratories, Inc., 207 East Ohio St., Chicago, Ill., and at offices and agencies throughout the United States and Canada.

While an arrester connected between the antenna and ground is regarded by many as sufficient protection, it is somewhat safer to install a switch in parallel with it as an added protection. Particularly if the arrester is inside of the building and the ground connection is made to a radiator, it is desirable to use in addition the outside ground connection.

If the antenna is properly connected to the ground, such connection prevents the antenna from becoming a hazard to the building and its contents and may act to supplement the protection given by lightning rods. The arrester should have the most direct connection to the ground which it is feasible to make, otherwise the antenna may become a hazard with respect to lightning.

(d) *Protective Ground Wire*—While it is desirable to run the protective ground wire in as direct a line to ground as possible, it is more important to provide a satisfactory contact at the ground itself than to avoid a few bends in the ground wire.

(f) *Receiving Equipment Ground Wire*—If the ground wire of a receiving set passes through a wall it should be insulated for the same reasons as the antenna lead-in wire referred to in paragraph (a) above.

If the ground wire is exposed at all to mechanical injury it should be of larger size than the minimum permitted under the rules and certainly not smaller than No. 10 B. & S. gage. It should, for mechanical protection, be enclosed in wood moulding or other insulating material. Ground wires should not be run through iron pipe or conduit because of the choking effect at radio and lightning frequencies.

TRANSMITTING EQUIPMENT

(j) *Protective Ground Switch*—On account of the larger size of the ordinary transmitting antenna, it is more likely to be subject to damage from lightning; and on account of the high voltages produced by radio transmitting equipment, it is desirable to provide for the use of a double-throw switch for connecting the antenna either to the transmitting apparatus or to the ground. The use of this switch makes it possible to entirely disconnect the antenna from the transmitting apparatus when not in use.

The objection to slate-base switches is chiefly from the radio engineering viewpoint, on account of the absorption of water by many kinds of slate and the presence of conducting streaks.

Under this rule one has the choice of the standard 100-ampere 600-volt single-pole, double throw switch or a special antenna switch using 60-ampere copper which has an air-gap distance of at least four inches.

(o) *Protection from Surges, etc.*—On account of the difficulty which has been experienced by the induction of voltages in the supply lines of a transmitting station, it is advisable to use a protective device across the terminals of each machine or transformer connected to this power line. It would also seem desirable to connect a similar protective device across the power line and near the point of its entrance to the building and on the house side of the meters.

It is desirable that research on the performance of protective devices and the means of avoiding surges and "kick-backs" in the power supply lines be promoted.

For further suggestions regarding good and bad practice in the installation and maintenance of signal wires and equipment, reference should be made to "National Electrical Safety Code, 3rd Edition, October 31, 1920, Bureau of Standards Handbook No. 3" and especially Section 39. This is obtainable from the Superintendent of Documents, Government Printing Office, Washington, D. C.

The 1920 edition of the "National Electrical Code," which contains the regulations of the National Board of Fire Underwriters, including Rule 86, which is now the rule in effect covering radio signaling apparatus, may be referred to at any local inspection department of the fire underwriters, or may be purchased from the National Board of Fire Underwriters, 76 William St., New York City.



Radio Corporation, Westinghouse Photo

Mme. Olga Petrova, famous actress, authoress of the play "White Peacock" recently entertained her largest audience through WJZ, the Westinghouse Radio Corp. Broadcasting Station at Newark, by singing several songs and telling stories about her stage and screen successes; the next day she received 968 very complimentary letters from the invisible audience.

CHAPTER VIII

RADIO DIAGRAMS AND HOW TO READ THEM

HERETOFORE in our illustrations we have shown perspective views of all the instruments and how they are wired together, etc. As the reader becomes more familiar with radio matters, he should take up the study of diagrams because a glance at one will show the connections. A radio diagram is to a perspective drawing what stenography is to long hand. Radio diagrams give us the means to tell at a glance what the connections of the various instruments are, and as a matter of fact it is much simpler to read a diagram than a perspective drawing. It is much harder to read a perspective drawing than a diagram because in the former, such as we have shown heretofore, there is nothing but a maze of wires, one crossing the other, and one really never knows where one is. The diagram on the other hand simplifies matters a great deal and it becomes a comparatively easy matter to trace a circuit by means of the diagram. Certain symbols are used to describe apparatus and in our illustrations 80 to 85, we have shown the various symbols graphically. By studying these symbols and memorizing them, it becomes a simple matter to trace the various circuits and study the diagrams.

Diagrams and circuits form a great chapter by themselves, and it is not within the range of this





















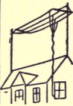





	<i>ALTERNATOR</i>	 OR 		<i>B-BATTERY</i>	
	<i>AMMETER</i>	 OR 		<i>BUZZER</i>	
	<i>AERIAL</i>			<i>FIXED CONDENSER</i>	
	<i>LOOP AERIAL</i>			<i>VARIABLE CONDENSER</i>	
	<i>ARC</i>			<i>CONNECTION</i>	
	<i>A-BATTERY</i>			<i>CONNECTION</i>	

FIG. 80-81.

book to cover all points, because a number of books could be obtained on vacuum tube diagrams alone, and for this reason we will not go deeply into the















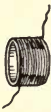





	<i>NO CONNECTION</i>			<i>SPARK GAP</i>	
	<i>COIL</i>			<i>QUENCHED GAP</i>	
	<i>TUNING COIL VARIABLE INDUCTANCE</i>			<i>GROUND</i>	
	<i>COUPLED COILS WITH VARIABLE COUPLING</i>			<i>KEY</i>	
	<i>DETECTOR (CRYSTAL)</i>			<i>RESISTANCE</i>	

FIG. 82-83.

matter. Suffice it to say that the diagrams which are shown on the following pages all have a reason for being, and all are the outcome of many thou-























	<i>VARIABLE RESISTANCE</i>			<i>CHOKE COIL</i>	
	<i>SWITCH</i>			<i>VACUUM TUBE</i>	
	<i>TELEPHONE RECEIVER</i>			<i>VOLTMETER</i>	
	<i>TRANSMITTER</i>			<i>VARIOMETER</i>	
				<i>VARIO COUPLER</i>	
	<i>TRANSFORMER</i>			<i>DYNAMO OR MOTOR</i>	

FIG. 84-85.

sands of experiments. The diagrams shown have been selected and in order that the reader may familiarize himself with them, the captions under the

diagrams show to which perspective drawing in the front of the book they refer. The diagram of

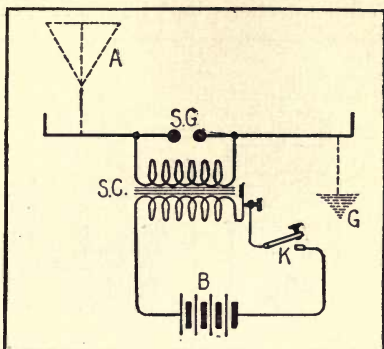

FIG. 86. REFER TO FIG. 7.

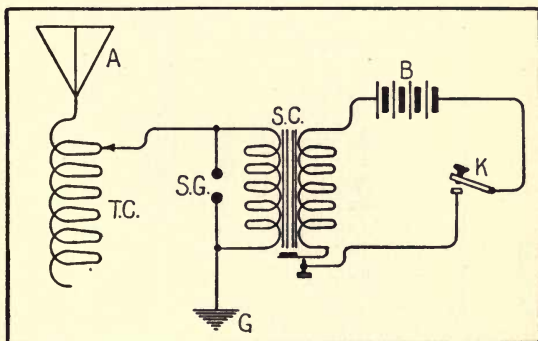

FIG. 87. REFER TO FIG. 10.

the perspective drawing, therefore, may be compared and the circuits traced. The reader should take a pad and paper and trace a few diagrams

himself in order to become acquainted with the various circuits. It should be understood, of course, that not all connections that the reader will think

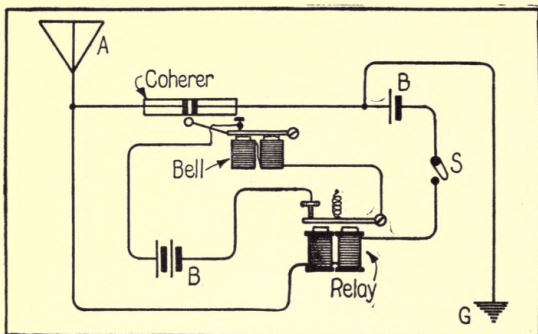

FIG. 88. REFER TO FIG. 18.

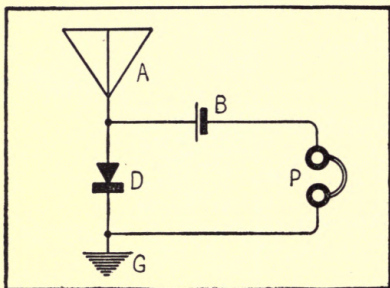

FIG. 89. REFER TO FIG. 19.

of will work. There are certain fundamentals in radio which must be observed, and there are reasons for them all. For instance, it makes a great difference in what part of the circuit the crystal detector

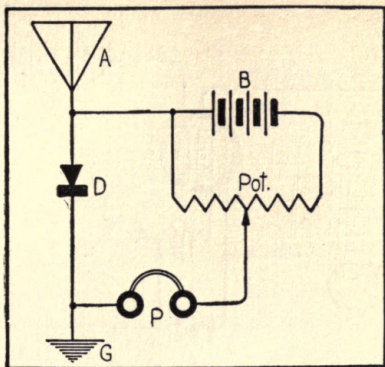

FIG. 90. REFER TO FIG. 22. 1

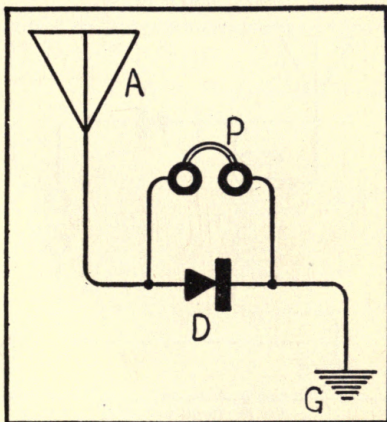

FIG. 91. REFER TO FIG. 26.

or telephone is placed. All these points have been studied in the past and certain definite results have

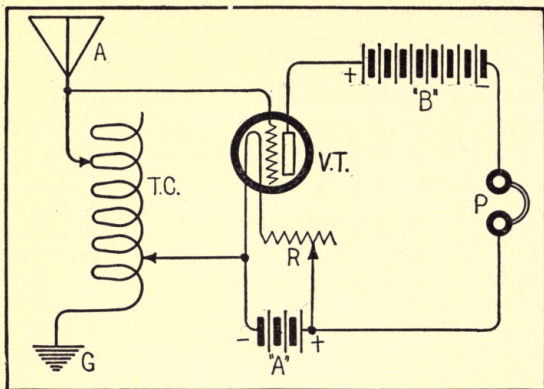

FIG. 92. REFER TO FIG. 31.

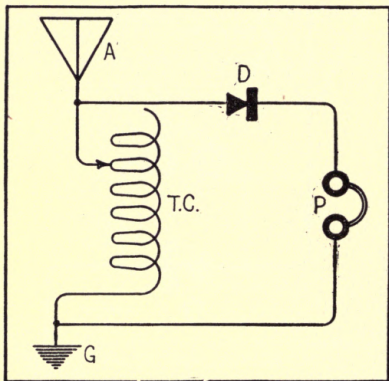

FIG. 93. REFER TO FIG. 33.

been achieved. Of course, the reader is encouraged to experiment in his own way by connecting his instruments in various combinations, which are almost

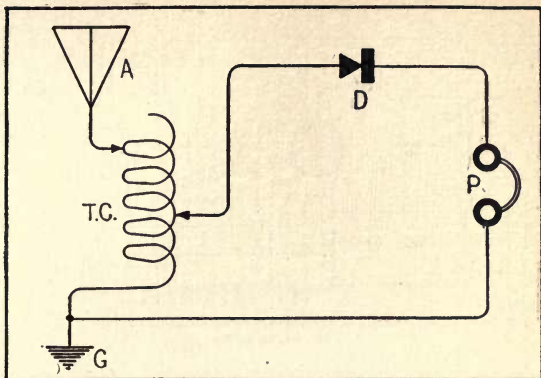

FIG. 94. REFER TO FIG. 34.

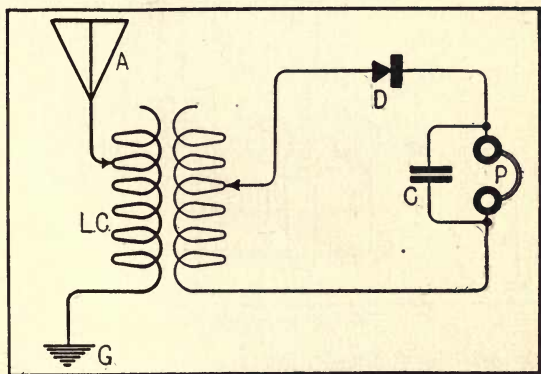

FIG. 95. REFER TO FIG. 37.

endless, but he will find that the diagrams as we show them here will work best as a general rule.

The study of radio diagrams is not difficult at

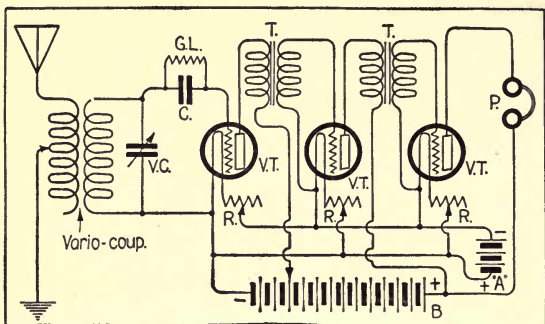

FIG. 96. REFER TO FIG. 47.

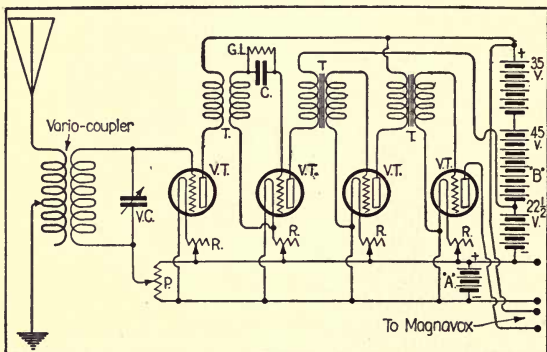

FIG. 97. REFER TO FIG. 52.

all, once the fundamentals are clearly understood, but it is necessary to first memorize symbols, otherwise not much headway will be made.

For the guidance of the reader, we would first advise memorizing the following: "ærial, ground,

detector, phones.” These are the simplest and essential ones, and for that reason, we have shown

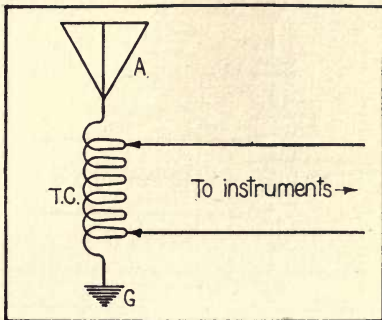

FIG. 98. REFER TO FIG. 56.

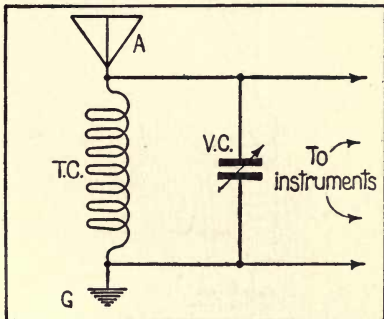

FIG. 99. REFER TO FIG. 57.

these first in our diagrams. Once the various connections have been mastered, it then becomes a simple matter to go ahead with the others.

Of course, where the reader is becoming sufficiently interested in radio to be a radio experimen-

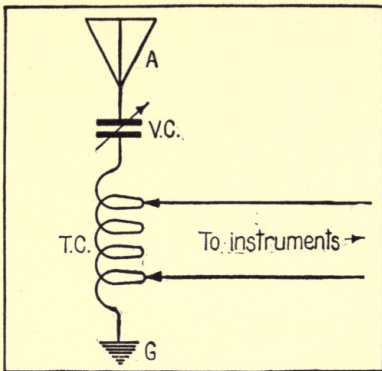

FIG. 100. REFER TO FIG. 59.

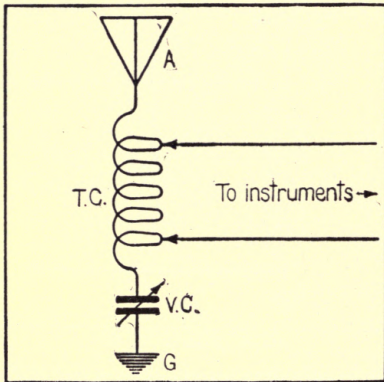

FIG. 101. REFER TO FIG. 60.

ter, the study of diagrams will not long remain fascinating. He will wish to make the actual connections on the instruments himself, and we greatly

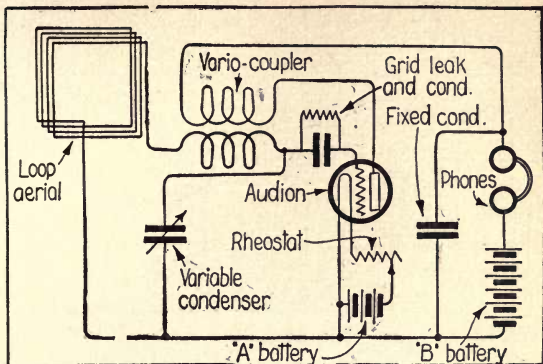

FIG. 102. REFER TO FIG. 72.

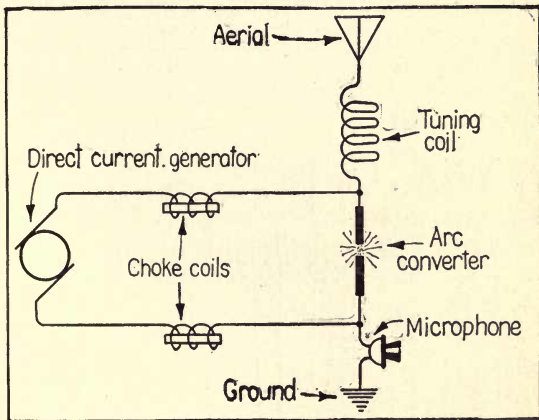

FIG. 103. REFER TO FIG. 106.

encourage this, and assure every reader that he will derive more information and satisfaction from actual connections than from anything else in radio.

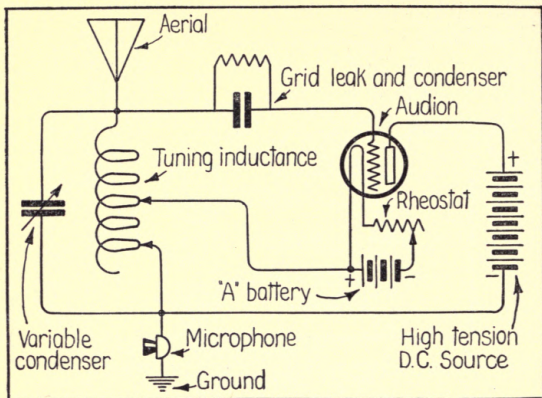

FIG. 104. REFER TO FIG. 108.

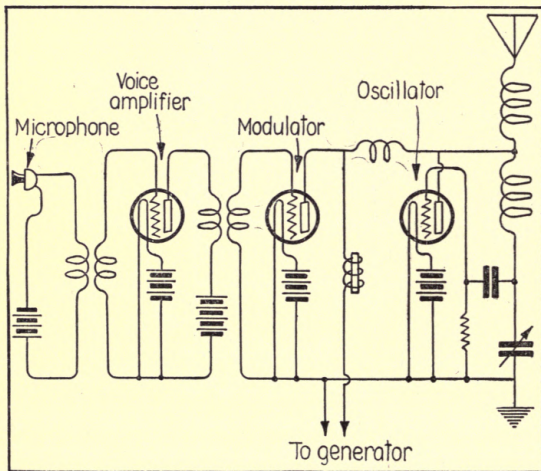

FIG. 105. REFER TO FIG. 109.

In connection with these diagrams, as mentioned before, in order that the reader may better study them, we have listed only such diagrams, the perspective drawings of which have been shown in other sections of the book.

Thus the diagram shown in Fig. 86 is shown in perspective in Fig. 7, Fig. 87 refers to Fig. 10, Fig. 88 refers to Fig. 18, Fig. 89 refers to Fig. 19, Fig. 90 refers to Fig. 22, Fig. 91 refers to Fig. 26, Fig. 92 refers to Fig. 31, Fig. 93 refers to Fig. 33, Fig. 94 refers to Fig. 34, Fig. 95 refers to Fig. 37, Fig. 96 refers to Fig. 47, Fig. 97 refers to Fig. 52, Fig. 98 refers to Fig. 56, Fig. 99 refers to Fig. 57, Fig. 100 refers to Fig. 59, Fig. 101 refers to Fig. 60, Fig. 102 refers to Fig. 72, Fig. 103 refers to Fig. 106; Fig. 104 refers to Fig. 108, Fig. 105 refers to Fig. 109.

It is not the purpose of this book to be of such a technical nature as to list several hundred diagrams, as there are other books making a specialty of this. The purpose of the few diagrams is merely to acquaint the reader with the first principles.

CHAPTER IX

RADIO TELEPHONY

We have already mentioned radio telephony in previous chapters, but not insofar as the transmitting is concerned. We have already learned that radio telephony is not a new art, but has been known for many years. The first to send radio tele-

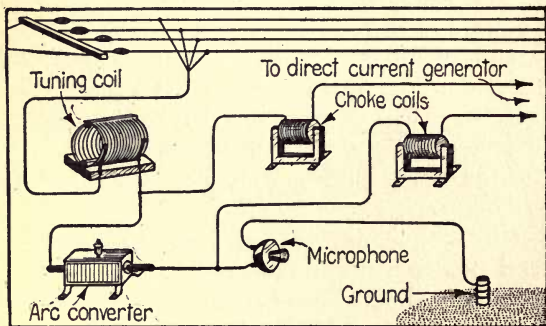

FIG. 106.

phone messages over long distances was Valdemar Poulsen. The important instrument which he used in his experiments was the electric arc. The diagram of connections is shown in Fig. 106. It was found that with a suitable arrangement the electric arc became capable of sending out undamped waves which are also known under the definition of continuous waves. In other words, the electric arc sends out a wave that is continuous without interruption.



Radio Corporation, Westinghouse Photo

Mme. Johanna Gadski, famous operatic soprano, singing Wagner's "Elizabeth's Aria from Tannhäuser" through WJZ to the radio telephone audience. Mme. Gadski began her musical education at the age of seven, had her first public appearance at ten, made her debut in opera at the age of sixteen, and later enjoyed a continuous engagement for twenty-three consecutive seasons with the Metropolitan Opera Co. of New York.

We have learned something about continuous waves in a former chapter. Such an arc transmitter, therefore, sends out waves that never stop, not even for the smallest fraction of a second. By means of the microphone into which we talk, we super-impose upon the continuous waves the voice currents which are, therefore, carried along by those waves. Hence, the continuous wave in radio telephony is

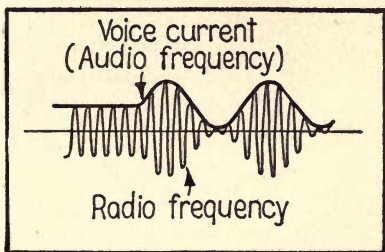

FIG. 107.

often spoken of as the carrier wave, because it carries the speech waves with it. This is shown in Fig. 107, schematically where the speech waves will be seen carried along with the continuous waves, which are emanating from the oscillating circuit.

The advent of the vacuum tube changed the entire aspect of radio telephony. In the Poulsen method as well as for radio telephone systems, it was necessary to employ a microphone, which in this case had to handle very large currents, sometimes as high as ten amperes. It was almost impossible to design a microphone or transmitter that would absorb such an excessive amount of energy,

and for that reason the modulation at the transmitting station was nearly always faulty, and the received speech, music or other entertainment was as a rule poor. Often the microphone failed to work, and then, of course nothing came through the air at all. At the present time, however, we are not dependent upon power microphones, for the

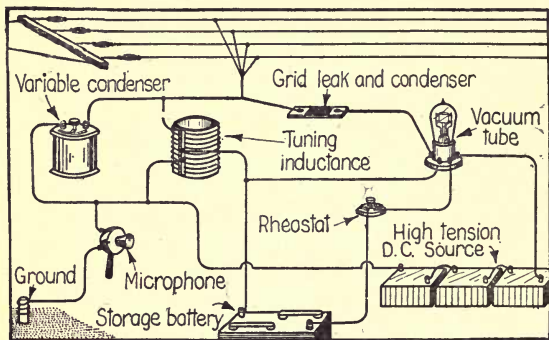

FIG. 108.

reason that we now make use of the vacuum tube. Even the simplest telephone transmitter such as used on your house telephone can be used in the modern radio telephone, and the main reason is that the vacuum tube sender acts as a valve, which amplifies many thousand times the voice current, sending it out over the aerial without having a strong current passing through the microphone.

The simplest radio telephone is shown in Fig. 108. This comprises a transmitter, a few batteries, a vacuum tube and the usual aerial and ground. The

diagram is shown fully in our illustration, Fig. 104. By means of this arrangement, when we talk into the transmitter, the oscillations generated by the vacuum tube are varied in amplitude. These high frequency radio currents are continuous as well, so that we are sending out or transmitting a continuous wave. When words are now spoken into the transmitter the voice currents are superimposed upon the continuous waves, and at the receiving station, the words will be heard. The outfit, as shown in this illustration, is of course, only good for a short range because not much power is used, and it will, therefore, not cover more than a few miles. The principle, however, is the same as that used in our large broadcasting station, as we will see further on.

The system which we have just explained is the one which is used universally today, as it has been found that by the use of the vacuum tubes almost any amount of power can be radiated from the transmitting antenna. Usually a radio telephone station is rated according to the amount of power it radiates from its transmitting aerial. This amount of power, of course, varies for the different stations. The more power we put into the aerial, the further we can transmit.

The prime reason why we can hear spark stations much further than radio telephone stations, lies in the reason that in the former many kilowatts are used, sometimes as high as a thousand kilowatts, as for instance, in the great trans-Atlantic stations.

Of course, not all this power leaves the ærial, but a fair proportion of it does. In radio telephony, however, not such a vast amount of energy is used, and most broadcasting stations do not operate on more than 500 watts, which, compared to a spark station is an insignificant amount of power. This is one of the reasons why broadcasting stations cannot be heard at such great distances as spark stations.

BROADCASTING

Radio broadcasting, contrary to public opinion, is not at all a new thing. Many claims are being made as to who was the original inventor of broadcasting, and when everything is said and done, it probably settles down to the man who sent out the first radio telephone intelligence. That man was probably Reginald Fessenden, who, as far as is known was the first and real inventor of radio telephony. Back in 1906, he operated a radio telephone transmitting station which was heard by thousands of radio professionals as well as amateurs. That advent marked the first broadcasting. Of course, this was not broadcasting as we understand the term today. By modern broadcasting is understood a radio intelligence that is sent out at a certain pre-determined schedule or program. Such broadcasting probably did not come about until 1920, when the Westinghouse Company transmitted the 1920 election returns from the East Pittsburgh station, and followed this with daily concerts and other

entertainment which has remained to this day. The country at large, however, did not become much interested until the latter part of 1921, when the Newark, N. J. Westinghouse station began to broadcast a daily program. The newspapers were not slow in taking up the new art, and one of Newark's leading newspapers was the first of the newspapers in the country to have a regular radio section in their Sunday edition. This attracted many readers, who before had not known much about radio, and to whom radio had been a sealed book.

Newark, N. J. became the first radio center of the country, and soon people were storming the electrical and radio supply stores in order to buy instruments with which to receive radio entertainments. New York soon followed suit, the *New York Globe* being the first daily newspaper to carry a daily radio department, informing the public as to the wonders of radio, and how it was possible for everyone to catch music from the air at a trifling cost. Soon other New York papers copied the idea, and in less than a month, there was hardly a city in the United States within fifty miles of a broadcasting stations that did not boast of its radio page or department. All this tremendous publicity had its effect upon the public who began to storm the stores and clamor for radio goods until in January and February, 1922, the radio boom had reached a situation that can only be compared to the oil rush of the Texas

oil fields. The country had suddenly gone wild over radio, and every one wanted to have an outfit to listen in to the fascinating entertainment.

So far for the history of broadcasting. Technically, the art of broadcasting was partially de-

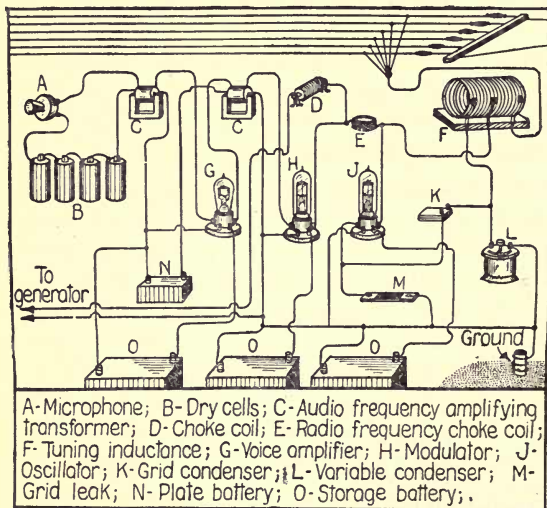

FIG. 109.

scribed in the preceding chapter. At the modern broadcasting station, the arrangement as shown in Fig. 109 is made use of. Here, we first have the microphone into which the performer sings or speaks, and a small transformer to step up voice currents. Next, we have the voice amplifier where the voice currents are stepped up and from thence

pass into a second transformer. From there the currents pass through the so-called modulator tube, and from there through several coils into the next tube called the oscillator. Then the current passes out into the antenna circuit. Of course, all this is much more complicated, and it is not within the limits of this volume to delve into all the technicalities of this circuit. Suffice it to say that by means of this arrangement, almost any amount of energy may be radiated out into space.

Of course, it goes without saying that the transmitting tubes used for transmitting broadcast entertainment are not the small vacuum tubes with which we are familiar, because these could not handle the energy. Instead, the tubes used are big fellows, a foot or so high and 6 to 10 inches in diameter. Such tubes of which an entire battery is used, are built to carry large amounts of current, and as a result become pretty hot. For that reason, they are cooled by means of fans or other circulating air methods. Even so the tubes do not last forever, and occasionally burn out. If this happens in the midst of an entertainment, which is unfortunate, a new tube must be replaced and the performer as a rule must go over the ground again, after the radio audience has been informed of the blow-out.

At the broadcasting station, it is always necessary to have a complete personnel which often comprises as many as twenty people. There are two

distinct parts in the up-to-date broadcasting station. First, the studio, and second the transmitting station proper. At the latter we have several engineers who attend to the operation of the tubes, and who are informed by telephone from the studio, whenever the artist is ready to sing or perform. The current is then switched on, the tubes begin to glow and the station now transmits continuous waves. These continuous waves cannot be heard at the receiving station, except at times, when we employ a regenerative receiver. As soon as this receiver gives its characteristic whistling note, we can tell the broadcasting station has started its power, although the performance has not begun.

Let us now enter the broadcasting station studio. We assume that an opera singer is getting ready to sing, while the accompanist is at the piano. The attendant first announces the singer, and cautions the performers not to make any noise whatsoever, because any unnecessary noises such as coughing or talking, will be heard by the radio audience. These sounds are picked up by the sensitive transmitter. In order to dim the echoes in the studio, its walls are always covered with draperies which do away with all sound reflections, echoes and the like. After the introduction by the announcer, the performer steps up to the transmitter, which is usually a form of telephone transmitter attached to a large vibrating disc and looks somewhat like a small bowl. The performer is cautioned never to stand nearer than a



Westinghouse Photo

The power plant of the broadcasting station WJZ, Newark, N. J. The power plant at the left is shown enlarged in another view. The operator is taking down the Weather Report from Arlington, Va. This Weather Report is received on the radio outfit in front of the typewriter. When time signals from Arlington are received, the phones now seen on the operator's head are held against the transmitter which the operator at the left is holding, and thus the time signals are broadcasted on a shorter wave, 360 meters. The original wave length of the time signals as they come in from Arlington is 2300 Meters.

foot or so before the transmitter when singing. Behind the piano there is usually some sort of horn which picks up the sounds and conveys them to a microphone attached to the small opening of the horn. This catches the sounds from the piano, to be sent to the transmitting station. Of course, the microphone transmitter wires coming from the piano as well as those from the performer are connected together, so that the sounds are picked up simultaneously and guided to the radio transmitter. That is why in the receiver we hear the piano and performer's voice at the same time. To be sure, there are certain refinements at every broadcasting station in order to transmit the music or other entertainment best.

Several microphones are used, for instance, when a band is playing. A totally different arrangement is used when a violinist is performing. In the latter case a very sensitive microphonic arrangement must be used, otherwise we would hear nothing of the music, which is not unduly loud anyway. On the other hand, when phonographic music is transmitted, there is a phonograph-microphone attachment, which is attached direct to the tone-arm of the phonograph, and we, therefore, hear transmitted phonograph music, the same as if we were in the room with the phonograph.

Several of our photographic illustrations shown in this book depict the various methods used

in broadcasting music from a modern broadcasting station.

We are of course only at the beginning of broadcasting. What its future will be is difficult to state, as is always the case with a new art.

At the present time there is a distinct and very important use for broadcasted entertainment. A broadcasting station now-a-days sends out news, music, which may be vocal, instrumental, or any other form. We also have stock quotations, weather forecasts, children's stories, lectures and even complete musical shows or operas have been broadcasted lately. Entire vaudeville programs that lend themselves to the purpose can thus be broadcasted. A distinct field of usefulness lies in the possibility of the radio telephone for political speeches. There is talk at Washington at the present time that Congress will install a powerful broadcasting station at the Capitol whereby the President or other politicians may broadcast their speeches so that every one in the country may hear. This is a tremendous possibility.

Then we have perhaps a more important feature of broadcasting, and that is educational programs. The day is not far off when every university will have its broadcasting station whereby special courses that lend themselves for the purpose will be broadcasted so that everyone who cares to may hear and absorb the knowledge given by our professors.

One of the surprising uses of broadcasting is that

it is possible today to make actual phonograph records from broadcasted music. There are now on the market attachments which can be placed upon your phonograph. Then by attaching a loud talking receiver to the tone-arm, it is possible to take down any form of entertainment on a wax or zinc disc, which can be put away for future use. Imagine that a great opera singer is sending out one of her arias right at the opera during a regular performance. All we have to do is to record her voice, thereby making our own phonograph records, and this today may be done without any further trouble. Then if we wish to hear the artist again, all we have to do is to place our wax or zinc record upon the turning table, and we can listen to the artist at will a month or a year later.

It is even possible today to have an entire opera broadcasted, moving pictures and radio music, all at the same time. This scheme was originated by the author in 1919 and is as follows: (See Fig. 110.)

A recent newspaper report from Chicago brought the not at all surprising news that grand opera music had been transmitted by wireless telephone for over one hundred miles. Sensitive microphones placed on the stage of the opera house caught the sound waves; the impulses then being stepped up in the usual manner by means of a transformer were led into an amplifying vacuum tube. Here the current was impressed upon the radio telephone transmitter in successive stages and then sent out over the aerial on top of the opera house. Wireless amateurs all about the surrounding country were thus able for the first time to hear grand opera. While this was only an experiment, grand opera by wireless will soon be an accomplished fact.

During the next few years it will be a common enough experience for an amateur to pick up his receivers between eight and eleven o'clock in the evening and listen not only to the voice of such stars as

Scotti, Tetrzzini, Mac Cormick and others, but also to the orchestra music as well, which is picked up by the sensitive transmitter along with the voices of the stars. The surprising thing is that it is not being done now.

This probably is due to the fact that as yet no means has been found to reimburse the opera companies for allowing everyone to listen in. While of course listening to the music is not as satisfying as witnessing the performance in person, still many music enthusiasts would rather stay home listening to the music alone than to witness the performance itself. To your true, dyed-in-the-wool opera fiend the performance is of secondary importance, the music always coming first.

But we must give a thought to the management, which cannot subsist on an empty opera house if everyone could listen in to the actual rendering of the opera without paying for the privilege. Needless to say that the producers would soon find themselves bankrupt. For this reason we cannot expect that grand opera by wireless will be an accomplished fact until some means has been found to reimburse the producers, and, as every wireless man knows, this is very difficult to do. Anyone with suitable radio apparatus can "listen in" to the music without much trouble. No matter on what wave-length the music would be rendered, every wireless man would find a way to listen to it without serious inconvenience.

Probably the only logical way out would be for the management of a grand opera company to advertise in the newspapers, stating that no grand opera via radio would be given unless a certain amount of revenue were guaranteed by radio subscribers before "radio performances" would be given. This would mean that probably ten out of one hundred radio stations, amateurs and otherwise would pay monthly or yearly dues to sustain the management, which then would not have to care how many were listening in.

This is the only practical solution. As for technical difficulties, there are of course none. All that is necessary for the producing company is to install a high-class wireless telephone outfit which can be bought on the market right now and which is immediately available. The rest is up to the wireless fraternity, which has nothing else to do but listen in.

At the receiving end, the future up-to-date radio opera enthusiast will of course, have a first-class receiving outfit, using vacuum tube amplifiers, and a loud talker. Then it will be a simple matter to listen to Scotti himself, though he be a thousand miles distant. His voice will come out loud and distinct and the amateur's family will be enabled to "listen in" to their heart's content.

There is still another novel scheme recently originated by the writer.

The underlying idea is not only to give grand opera by wireless, listen to the music and to the singers only, *but to actually see the operatic stars on the screen as well.* This is how it can be readily accomplished *by means which are available to-day,* and without the slightest technical difficulty.

Let us say, by way of example, that the opera "Aida" is filmed in its entirety. This may mean a four or five reel feature. The opera will be filmed just like any other photo-play.

Our large illustration shows what happens next. The stars, singers, players, the chorus, orchestra, conductor, etc., are then assembled in a moving picture studio and in front of them is the usual screen. The opera "Aida," which had been filmed before, *is now repeated on the screen* while the entire cast follows the screen picture closely. Each performer, every star, every member of the chorus has his or her own microphone in which he or she sings the regular score, watching closely the film-play as the action is unreeled on the screen. The moving picture opera through the film operator keeps time with the singers, and the singers themselves must keep exact time with the performance as it is unrolled on the screen before their eyes. Inasmuch as the identical cast has been filmed, it will not be difficult for them to keep time with their own performance, as may readily be imagined. *In other words, when Scotti sees his own figure appearing on the screen he will know exactly how and when to sing into the microphone in front of him.*

All of the microphones go to the wireless telephone station located in the radio room above, and there are, of course, sensitive microphones in the studio which pick up the sounds from the orchestra as well. All sounds are then stepped up through the usual amplifiers and are then fed into the high power vacuum pliotrons, *which finally amplify the original sound several million times.* These impulses are then sent out over the usual aerial located on top of the house and are shot out all over the country instantaneously.

Five hundred to 1,000 miles away—and for that matter all over the country—every moving picture house will have been supplied with the identical film at the stated performance, it having been announced days ahead that the grand opera "Aida" will be given at such and such an hour.

Of course, where the distances are large, the hour of rendering the opera will vary. Thus, for instance, if Scotti were singing in New York and a performance would start at eight o'clock in the evening,

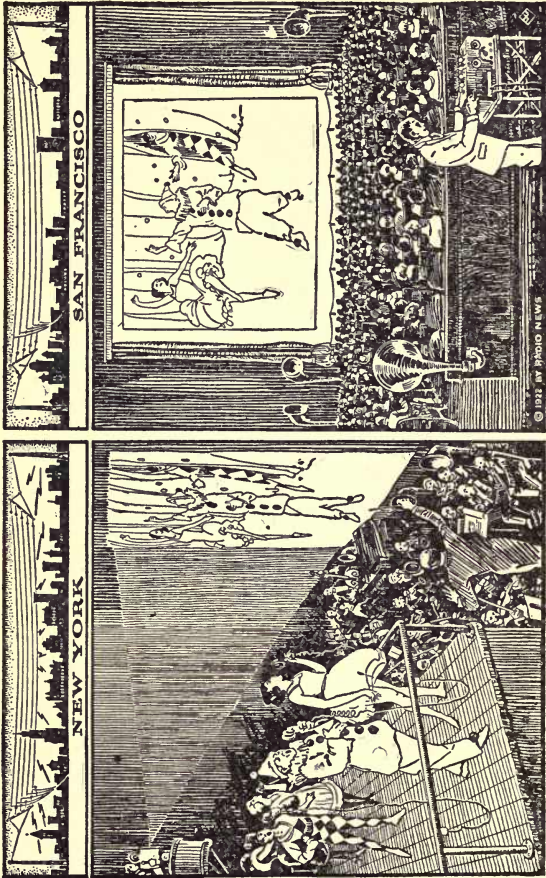

FIG. 110.

New York time, it would start in San Francisco at four o'clock in the afternoon, as a matinee, due to the difference of time. Inasmuch as such performance would probably only be held once a month, people would not mind the inconvenience due to slight difference of time.

Every moving picture house will have its receiving apparatus with its usual amplifiers and anywhere from six to one dozen loud talkers scattered through the house. Exactly at the stated time the moving picture operator will begin grinding away—the opera has begun. Simultaneously the distant orchestra will begin playing, filling the house with music.

When the actual performance begins, it will be an easy matter for the operator to keep time with the incoming music. All he needs to do is to grind faster or slower, and inasmuch as Scotti with his performers in New York is watching the identical film, the distant operator will have no trouble in having the music keep time with his film. If he finds that he runs ahead for one second, he can readily slow up the next and *vice versa*. With a little practice it will be easy for the distant operator to time himself perfectly, thus giving the patrons of his house an ideal performance.

From a financial standpoint it would be good business for the opera company, as well as for the moving picture house, *both of which would thus derive a new income running into the hundreds of thousands with hardly any expense whatsoever*. The grand opera with an outlay of from one thousand to three thousand dollars could buy its high power radio telephone outfit, while every live picture house throughout the country would be able with an expenditure of less than five hundred dollars to buy its necessary radio telephone equipment *and this cost would only be initial*, because nothing except burnt-out vacuum tubes need be replaced and there is practically no cost of upkeep.

The writer confidently expects that this scheme will be in use throughout the country very shortly.

CHAPTER X

HOW TO MAKE SIMPLE RECEIVING OUTFITS

IN the following pages the author has endeavored to show how, with little expense, very good radio telephone receiving outfits may be built by any one endowed with a little mechanical ability. The author has selected the examples with an eye towards simplicity, and while these outfits are not intended to be classed with those of a high efficiency they are excellent for the beginner, and the man who likes to "make his own."

Inasmuch as this book was written particularly for the beginner and the novice, it was thought that the more complicated vacuum tube sets and the construction thereof should best be left out until the reader has first gained his knowledge through the simple crystal outfit.

It will be noted that all of the outfits here described can be made with material usually found about the house and in a model workshop. While a number of outfits are shown here, it should be understood that, with the exception of the vacuum tube outfits, they are all of about the same value, all working about the same distance, and the reader is invited to build the outfit which he likes best, and for which he knows that he has most of the materials required on hand.

THE "SIMPLEST" RADIOPHONE RECEIVER

The important points of this set are:

- (1st) It is simple in construction and operation. (Mr. James Leo McLaughlin, a New York radio amateur has actually built and operated this outfit). A knife or razor blade and a small nail are the only tools required to make it. The complete set can easily be constructed in about one-half hour.
- (2nd) It is inexpensive, the total cost, including the 'phone and antenna is less than \$3.00, the set itself costing only 21½ cents.
- (3rd) It is as efficient as most of the crystal sets now being sold and in many cases superior to them.

The material required is as follows:

- 1 Paper container (4" in diameter).
- 13 Paper fasteners (small size).
- 2 Paper fasteners (large size).
- 3 Paper clips.
- 2 Oz. No. 26 enameled copper wire.
- 1 Small piece of silicon or galena.
- 1 Common pin.

Take the container (the kind used to carry liquids) and punch nine holes one inch down from the top with a small nail, one half inch apart. Into each hole push a paper fastener. With pen and ink number each fastener from right to left, 1 to 9.

Alongside of hole No. 1 push two fasteners with a paper clip underneath—mark GND (ground). One half inch down from GND, punch a small hole; this is the starting point of the coil. See Fig. 111.

Take the wire and push the end through the hole. Wrap the end around one of the fasteners GND

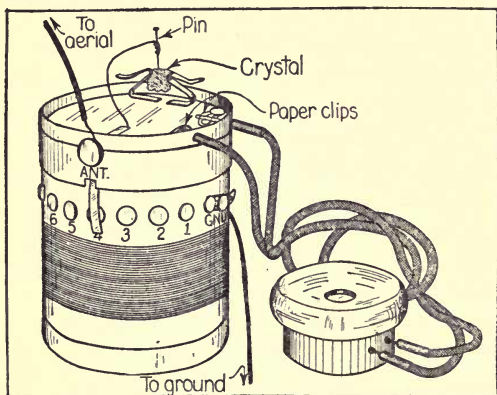

FIG. 111.

(on the inside of the container). Be sure that where the wire touches the fastener, the enamel has been scraped off, otherwise a poor connection will result.

Next pull the wire tight and commence winding the coil. The total number of turns is seventy, and a tap is taken off at each of the following turns: The 15th, 20th, 25th, 30th, 35th, 40th, 45th, 55th, and the 70th.

Fig. 112 shows how to tap the coil. The im-

portant things to look out for are that the coil is wound as tight as possible, and that the enamel is scraped off the wire, where it makes connection with the fasteners. The 15th turn is contact No. 1, the 20th No. 2, etc.

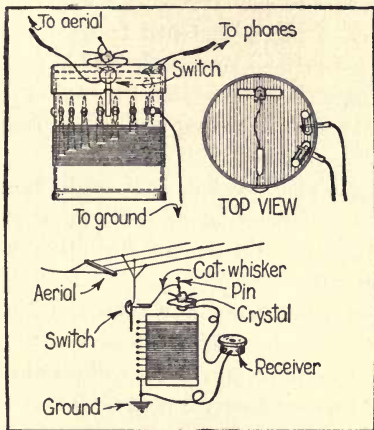

FIG. 112.

The next job is the switch that moves over the contacts. Figs. 111 and 112 show how this is made. Take one of the large fasteners, push the ends through the side of the cover, close to the lid. Bend one end down flush with the side and push the other end through the top and bend over.

Put the cover back on the container and bend the end of the fastener so that it rides over the contacts easily, when the cover is turned, but be sure

that it touches each of them. Break off the surplus end.

The other larger fastener is pushed through the lid opposite the switch and is bent, as shown in Fig. 111, so that it can hold the small crystal. A short piece of bare wire (about No. 24 will do), acts as the cat-whisker, a pin is fastened to one end and the other end is wrapped around the end of the switch—the part that is bent over (see Fig. 112).

Fig. 112 shows the diagram of connections and needs little comment.

The telephone receiver is a single Murdock or "Rico" without head band, and can be purchased for about \$2.00. Of course any other kind may be substituted.

For the antenna one-half pound of No. 18 bare copper wire will do. This will give about 100 feet of wire. Two porcelain cleats will also be required and should not cost over 5 cents. The wire can be had for about 30 cents.

String the wire the greatest length possible and attach outer end to a tree or other elevation, at least 30 feet high (see Fig. 112). The other end of the wire enters the house and is attached to the switch button marked ANT; a short piece of rubber tubing should be slipped over the wire where it passes through the wall of the building.

A good ground may be had by connecting a wire to the nearest water pipe. Scrape the pipe for a length of about two inches, so that it shines,

then wrap several turns of wire around it and twist tightly. It is, however, better to use a ground clamp.

To operate the set, bend the catwhisker wire so that the pin rests on the crystal. Move the pin over the surface until a signal is heard; at the same time move the switch over the contacts, and leave it on the one that brings the station the loudest.

With this set in New York City, using only a single No. 24 wire, 25 feet long strung up in a room, WDY's and WJZ's concerts came in fine, and on several occasions, the phone could be held about six inches from the ear, and still the music and voice could be distinguished.

A SIMPLE RADIOPHONE RECEIVER

The radio receiver shown in the accompanying drawings (Fig. 113), was designed to tune to 600 meters, using a single-wire aerial about 130 feet long. This coil has an inductance of about 537,600 cms. and with an aerial having a capacity of .0003 mfd., will tune to about 750 meters. A loading coil may be used to increase the wave length if desired.

The only tools required to make this receiver are a sharp knife, a screw driver and a pair of pliers.

A one-pound coil of No. 18 annunciator wire, obtainable at any electrical supply store, will be required for the aerial and ground. A pound of this wire will contain about 155 feet. Cut off 20 feet for the ground connection and use the rest for the aerial. The location of the station will deter-

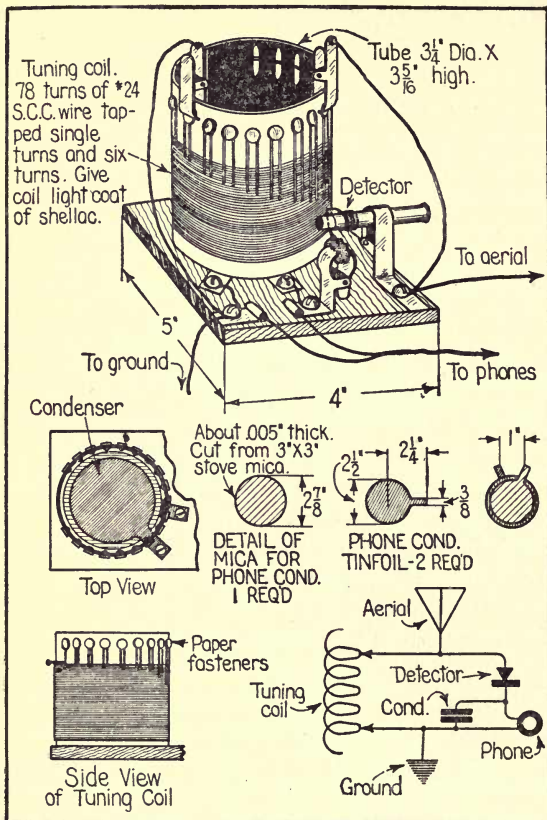

FIG. 115.

mine how the aerial is erected. Have it as high up as possible, but it will give good results if it is

only 20 feet above the earth. For insulators use porcelain cleats like those used for electric light wiring; if none of these are at hand, blocks of wood boiled in paraffin will do very well. The ground lead does not require insulation. Make ground connection to a water pipe if possible. Gas pipes or steam radiators may be used, but as a rule are not as good as water pipes. Be sure both pipe and wire are clean and bright when connection is made. For the best results all connections should be soldered.

Obtain a cardboard box or mailing tube about $3\frac{1}{4}$ inches in diameter and cut it so that it is $3\frac{5}{16}$ inches long. Civil engineers and architects get their tracing cloth in thick-walled mailing tubes that make ideal coil winding forms. If you don't happen to have a round cardboard box of this size about the house, visit your city engineer. Mark a line around the tube $\frac{5}{16}$ of an inch from one end. With the small blade of a penknife make 19 holes on this line spaced $\frac{7}{16}$ of an inch apart; these holes are for the contact points which are the common paper fasteners. Insert paper fasteners in holes but do not spread points.

The coil is wound with No. 24 single cotton covered magnet wire and $\frac{1}{8}$ lb. will be required. To wind the coil fasten one end of the wire to the first paper fastener. In doing this scrape the end of the wire, also the under part of the fastener, so that

when the points are spread and the fastener pinched with the pliers a good contact will be made. Directly under the first fastener and $15/16$ of an inch from end of tube insert a pin. Bring the wire down from the first fastener, around the pin and make one turn around the tube. Insert another pin under the second fastener, bend the wire around the second pin, up around the second fastener, back around the pin and complete another turn around the tube. Repeat this for the first six fasteners. After passing wire around the sixth fastener and pin, wind six turns and take off another tap; continue in this manner to end of coil taking off tap every sixth turn. When completed the coil should have 12 six-turn taps and 6 one-turn taps, or 78 turns in all.

It is not necessary to scrape the wire where it passes around the contact points until the coil is wound. After completing the winding, wind a cord around the top of the coil to hold taps in place, remove fasteners one at a time and scrape wire and fastener, replace and pinch with pliers. Remove cord and give winding light coat of shellac. After shellac is dry remove pins and winding is complete. It is best to keep shellac away from the contact points as it is apt to cause a poor contact between point and wire. If the maker has a soldering outfit, by all means solder wire to points, but if both are carefully scraped a good electrical connection will be obtained.

At a stationery store purchase four window hooks, (paper clips). Two of these are used to make the detector and the other two with the long end cut off are used as clips to vary the inductance as shown in the drawing; the general arrangement of the detector is also shown. One window hook holds the crystal. The other holds a short end of a pencil with a rubber eraser. The catwhisker wire is stuck through the eraser and allowed to project about an inch. The other end of the wire is looped a few times around the pencil and fastened to the window hook. By rotating the pencil the catwhisker wire can be made to touch the crystal. If galena is used, a copper wire of about No. 30 B & S gage should be used. Galena requires a very light contact. The two hooks that form the detector are fastened to the wood base with small wood screws. One end of the crystal-holding hook is bent in a loop to hold the telephone wire terminals. If ordinary insulated wire is used to connect the telephone the ends may be secured under screw heads. One of the long ends cut from the hook used to vary the inductance forms the other telephone terminal. Purchase galena at a radio store.

The telephone receiver must be of at least 1,000 ohms resistance and should be purchased from some reliable radio shop.

A condenser shunted across the telephone is not absolutely necessary, but they are easy to make and improve the working of the receiver. Purchase a

mica stove window size 3×3 and cut from it a circle $2\frac{7}{8}$ inches in diameter. From a piece of tinfoil cut two circles $2\frac{1}{2}$ inches in diameter with a tongue $\frac{3}{8}$ of an inch wide and 1 inch long. Hold the tinfoil pieces by the tongues and dip them in melted paraffin, be careful not to get any paraffin on the tongues. Lay one of the pieces of tinfoil on the mica circle as shown on the drawing. Warm a flat iron so it will just melt the paraffin and turn it face up. Lay the mica on flat iron with the tinfoil up and as the wax melts you must smooth the foil until it makes good contact with the mica. Fasten the other piece of foil on the other side of the mica in the same manner. Give the base a light coat of shellac and when it is still a bit sticky lay the condenser in place and smooth it down.

Connect up the apparatus as shown in the diagram, taking particular care that all electrical connections are clean and bright. Place the crystal in place and rotate the pencil until the catwhisker touches the crystal. You will have to move the catwhisker about until you find the most sensitive spot.

The usual method of testing the adjustment of crystal detectors is to connect up a buzzer and push button with one or two cells of dry battery. One binding post of the buzzer is grounded. When detector is adjusted properly you will hear the sound of buzzer in phones. If your house is equipped with an electric door bell, have some member of the family push the button while you adjust the de-

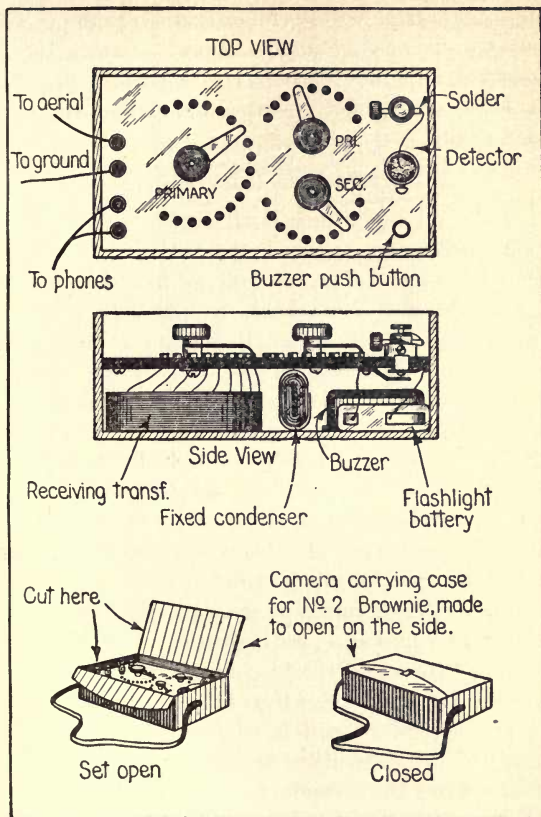

FIG. 114.

detector. Having adjusted the detector move clips about until you hear signals. It is well to avoid

handling crystal with the fingers, and if your crystal gets greasy from the fingers, it may be washed with carbon disulphide (carbona) or alcohol. Mr. H. L. Jones set up and operated this simple set with good results.

A POCKET SIZE RECEIVING SET

This is a description with drawings of a small pocket receiving set which the author constructed some time ago. He, as well as Mr. Joseph E. Aiken, obtained remarkable results with this set, considering that it is small enough to slip in a coat pocket. It measures about 4"×6"×2".

Connected to a single-wire aerial 140 feet long and 40 feet high, in southern Illinois, Arlington (NAA) came in clearly enough to be copied through considerable static. Key West (NAR) and a large number of ships and stations on the Atlantic coast have also been received. It has a maximum wave length of 3,500 meters.

The set is mounted in a small leather-covered camera carrying case, with shoulder strap (No. 2 Folding "Brownie"), which has been arranged to open on the side. (See Fig. 114).

The secondary coil is wound upon a wooden form $2\frac{3}{4}$ inches in diameter and is about an inch wide. After the secondary is removed and wound with tape, the primary is wound on top of the secondary, and then the two are wrapped together. The primary winding has 342 turns of No. 24 S.C.C. wire. Every other turn of the first 18

is brought out by leads to a nine-point switch. The remainder is tapped every 18 turns and each tap is connected to a point of an 18-point primary switch. This method allows fine tuning.

The secondary coil has 400 turns of No. 28 S.C.C. wire, divided into 10 equal sections, which are connected to the ten-point secondary switch.

A fixed condenser to connect across the phones is made from two sheets of tinfoil, 2"×6", which are separated by waxed paper and folded into a small bundle.

The detector is shown in the diagram and is of the catwhisker type, using galena.

Binding posts for aerial, ground and phones, are provided. A very small watch-case buzzer, and the smallest size two-cell flashlight battery, are included with which to adjust the detector. A small push button to control the buzzer is mounted on the panel.

The panel on which the switches and detector are mounted is made of Spanish cedar taken from a cigar box and highly finished in mahogany. The panel is mounted so that the switch knobs will not touch the lid when it is fastened.

ANOTHER LOW-PRICED RECEIVING SET

The one sure way of making a convert to the wireless art is to have him "listen in" long enough to realize that the whole world is waiting to talk to him, and then lead him to the work bench. Doubtless there are thousands of lads who look wistfully at the supply catalogs but get no further, feeling that the

cost is beyond their scant means or that their electrical and mechanical knowledge is insufficient to cope with the construction of the various condensers, coils and detectors so beautifully pictured.

The receiving set illustrated was planned for just these boys, the item of expense and the difficulties of construction having been eliminated. It was made complete in one evening with time to spare. It was designed to get the boys started in a practical way, however small, because any boy, who is a real boy, who receives a message on apparatus of his own construction will no longer be immune to the radio bacillus. He may throw the set away in a month and start after an audion, but it has served its purpose in making a convert.

In almost every community, there is one or more good amateur station operating on 200 meters or less, and to receive them is such a simple matter that the beginner would never suspect it after seeing the usual array of equipment used. One need not be deterred by the thought of putting up an elaborate aerial on poles—a single wire run from the chimney to the garage, or a large loop in the attic will answer every purpose.

The first thing to do is to get a piece of dry $\frac{3}{4}$ inch board, 4 or 5 inches wide and 6 or 7 inches long, the exact dimensions being unimportant. Boil it in paraffin, and on the underside press on a piece of paraffined paper about 4"×5". On this, build the fixed condenser, which consists in all, of three sheets

of tinfoil about two by three inches, with thin paraffined paper between and a heavy protective piece on top. Connections to the tinfoil may be readily made by means of a small screw and a washer at each end. (See Fig. 115). Fasten a small block at each corner, so that when the board is turned right

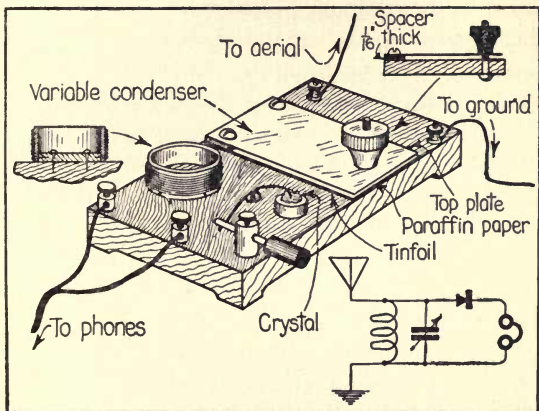

FIG. 115.

side up, the condenser will not rub on the bench. Or you can make the base in one piece as shown in illustration:

The variable condenser is arranged as follows: First press down a piece of paraffined paper and then a sheet of smooth tinfoil on top of this, working out all the wrinkles and bringing the left-hand edge around over the side of the board so that connection may be easily made therewith. The tinfoil should

contain an area of from 15 to 25 square inches, depending upon how thin the paper is between the plates. The upper plate consists of a smooth piece of heavy tin or brass, the corners and edges of which have been smoothed off. This is to be fastened down with two screws and is slightly bent down so that the free edge will stand about a quarter of an inch from the tinfoil. Cut the latter away for about a quarter of an inch from around the screw holes and coat with shellac. Cover with a piece of 1/16 inch fibre which serves as a spacer, and press flat. Screw down the tin plate, and provide a screw adjustment so that the distance between the plate and the tinfoil may be altered as desired.

The tuning coil in the usual set is here replaced with a small coil consisting of 50 feet or less of magnet wire. The capacity of the condenser being unknown, no definite data can be given for this; but it is a very simple matter to make a few tests. Take any odd length of magnet wire, say number 22 or 24, and wind it on a cardboard about an inch and a half in diameter, and the chances are that it will work. If the signals keep increasing in strength as the condenser is screwed down, it means that more turns should be added to the coil. If the signals are loudest when the condenser is wide open, it is probable that too many turns are being used. The capacity of the condenser itself may be reduced considerably by placing another sheet of paper between the plate and the tinfoil.

We have now only to construct the detector, and here more than on any other feature depends the strength of the signals. Do not use a large crystal; break it up into pieces not more than an eighth or a quarter of an inch and then test a dozen or more pieces until a sensitive face is found. To do this the crystal does not have to be mounted. Simply put it on any clean metal surface and carefully go over each with a whisker wire, which may be easily handled by sticking it in the end of a piece of wood. A test buzzer will be necessary, and, of course, connections must be made in the usual manner. When a good crystal is found, solder a brass nut or a short piece of tubing to a piece of sheet brass and fasten to the base, after which pack in the piece of galena with tinfoil.

The essential requirement in a crystal detector for a beginner is to have it so arranged that the entire surface of the crystal may be explored quickly. So many detectors have the whisker wire on the end of a screw and are almost worthless because a sensitive spot is no sooner found than lost, due to a slight wobble of the whisker caused by turning the screw further to adjust the tension. If the whisker is about $\frac{3}{4}$ of an inch long, the pressure is relatively unimportant when it has once been placed on the right point. In the design illustrated, a binding post is mounted on a block with a single head screw which is set in only fairly tightly in order that the shank

may be moved to or from the crystal. The cat-whisker wire is best soldered to the shank.

Four binding posts—two for the phones, one for the aerial and one for the ground—complete the set.

As previously mentioned, the cost is small, not exceeding 25 cents for all needed parts. The tuning is done entirely by the condenser.

It works surprisingly well.

A \$1.00 RADIO SET

The broadcasting of radiophone concerts has been given a wide publicity in the magazines, as well as in the daily press, and many people who never before had read any details about Radio and its possibilities, have become interested in it, and would like to know how these concerts may be received. Most of those who do not know anything about Radio are struck, when opening a Radio magazine, by the variety of equipment advertised, and especially by the prices quoted; some of them then become discouraged and do not push further the idea of buying a receiving set.

For these persons we shall give in this article a little practical data for making a home-made receiving apparatus, which will cost about \$1. Of course, the efficiency and sensitivity of such a set cannot be compared to the modern types of receivers which are now obtainable, and in which vacuum tube detectors and amplifiers are used, but very good results may be had with such a cheap outfit,

provided the directions given in this article are carefully followed.

To build this small receiver, the main things to secure are a good telephone receiver, which may be bought very cheaply in a second-hand shop, and a mounted crystal of galena, that is, a piece of galena inserted in a little block of lead; this may be bought at any Radio supply house for a few cents. Or else a 50 cent "Rasco" Detector will do.

The home-made detector may be built very simply, as shown in the sketch, Fig. 116 A. Two nails should be driven into a piece of wood used as a base and the mounted crystal tightly secured to one of the nails by a tight winding of copper wire fixed around both. The exploring wire, better known among amateurs as the "catwhisker" consists of a piece of the same wire wound around the other nail, as shown, and bent so that its tip lies down on the crystal with a certain pressure; this end of the wire should be sharpened with a nail file, so that the tip is about as sharp as a pin. About 2 inches of the wire from both nails should be left out to make connections with the outside circuit.

THE ANTENNA

The antenna to be used with such a receiving set may be of several types, according to the space available for the erection of the wires, which compose it. If in the open, the simplest type of antenna to erect is a single wire about 150 feet long, attached as high as possible between trees, houses or

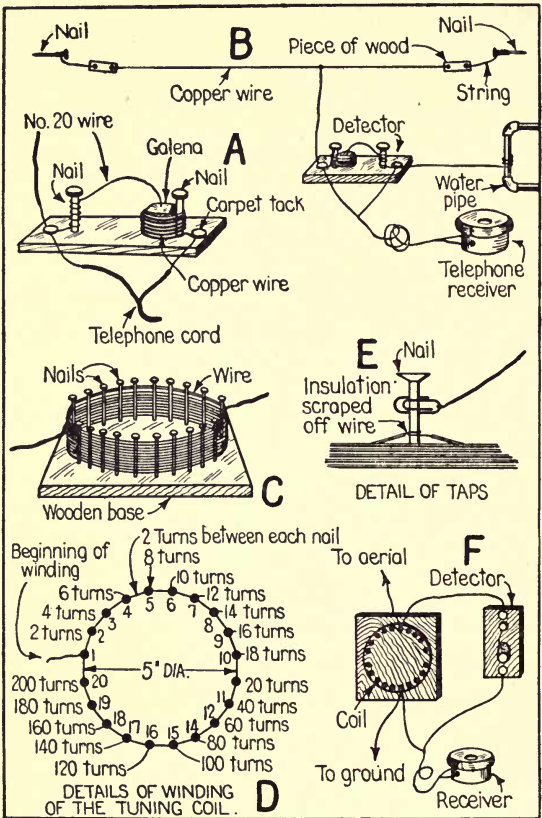

FIG. 116.

other natural supports which may be at hand; at each end of the wire, an insulator should be fixed,

and may consist of a piece of dry wood about 10 inches long, preferably, or two porcelain cleats. These insulators are then inserted between the string fixed to a nail and the wire itself, as shown in Fig. 116 B.

Almost any kind of wire may be used for an antenna and either insulated, bare, or enameled wires are quite suitable, provided they are strong enough not to break when stretched; No. 18 or 20 B.S. is quite suitable. If the set is to be installed indoors, the wire should be well insulated where it enters the house and it would be advisable to use a piece of rubber covered cable as employed in motor cars to connect the spark plugs.

If in a town or other place where it is not possible to stretch a long wire between trees or poles, a greater number of shorter wires may be used, but it should be remembered that the higher these wires are erected, the better. If only a small surface, such as a roof, is available for the installation of the antenna, four or five wires parallel to each other and about two to four feet apart will make a good antenna. They should all be connected together at one end and the connections soldered, if possible; from this end the "lead-in," that is the wire carrying the current to the instruments, comes down into the house. See Fig. 116 B.

Another case is that if it is impossible for one reason or another to install an outside antenna, an indoor one may be rigged up and may be of the same

type as the last one described. Of course, the efficiency of such an antenna is very poor with a crystal receiver, but some results may be obtained if the receiver is not more than three or four miles from some transmitting stations. With an indoor aerial composed of four wires 35 feet long and using the inductance described in this article, the author received the Radiophone transmission from WJZ eight miles away.

THE GROUND

The ideal ground connection is a large surface of zinc or copper plates buried in damp ground, about two to three feet deep. Another good ground may be made with long wires buried in the same way. These grounds are only possible for the fellow in the country, but for the city dweller, the only possible grounds are the water pipe or the radiator system. In any case, the preference should be given to the water pipe, but if it is impossible to reach it with a rather short connection, the radiator should be used. The pipe should be scraped to insure a good contact and the connections soldered if possible. The best is a ground clamp.

HOW IT WORKS

Once your detector is made and your antenna erected, with your ground wire fixed to a pipe, all that it is necessary to do, is to listen in the receiver while adjusting the detector. This adjustment merely consists in moving the sharp point touching

the crystal until some signals are heard. If in a city, or in the neighborhood of transmitting stations, some signals almost certainly will be heard with the first attempt, provided the crystal of galena is a sensitive one.

With such an outfit, there are no tuning possibilities since no means of tuning are available and a great improvement to the set would consist in a tuning inductance, which may be made as explained hereafter. This inductance is not indispensable and spark signals as well as radio telephony were heard by Mr. Robert E. Lacault with the detector alone, but in many cases the intensity of the signal will be increased many fold by the use of such a "tuning coil."

CONSTRUCTION OF A SIMPLE TUNER

Fig. 116 C shows a type of home-made inductance, which can be constructed very cheaply. It consists of a piece of wood forming the base, and 20 brass nails about $1\frac{1}{2}$ or 2 inches long, driven into the board in a circle, as shown in Fig. 116 D. To wind the inductance, about 265 feet of No. 24 or No. 26 double cotton covered wire, is necessary. The beginning of the winding should start at one of the nails, as shown in Fig. 116 C-D, the wire, which should be scraped of its insulation, should be twisted around the nail to make contact, and fastened. Then, two turns around the circle formed by the nails should be wound and the wire fixed to the next

nail, No. 2, as shown in Fig. 116 E. Twenty turns should be wound in the same manner with contacts every two turns made to the first row of 10 nails, numbered 1 to 10. From the nail No. 11, 20 turns should be wound before a contact is made on the Nail No. 12 and thereafter the same number of turns should be wound between each step.

This will form a total inductance of 200 turns and almost any number of turns may be inserted in the circuit by connecting the necessary sections of 20 and 2 turns between the antenna and ground clips. These clips making contact on the nails and shown in Fig. 116 E, are ordinary paper clips and make very good contacts on the nails. The diagram of connections of the complete set, including the tuning inductance, is shown in Fig. 116 F.

To tune the set when signals are heard in the telephone, the clip making contact with the nails connected every 20 turns of the coil, should be varied, so as to increase the intensity of the signals; then, a fine adjustment is obtained by changing the position of the other clip which varies the number of turns in the circuit only two at a time.

This little set, which is easy to build, will provide a lot of entertainment to those interested in Radio and if near enough to a Radiophone broadcasting station, the voice will be heard quite clearly.

AN EFFICIENT JUNIOR RECEIVER

Today in almost any magazine you chance to pick up it is possible to find the advertisements of

junior receivers of some kind. Most of these are nothing more than a tuning coil and detector mounted in some kind of box or cabinet. These are easily made and are quite efficient on short waves for some distances. This is the reason the author is describing the junior receiving set he constructed of material taken from old apparatus. Yours may be of old material or of material bought for the purpose.

To begin with, a cabinet is constructed to the inside dimensions of 6 by 9 inches, by 6 inches in depth, Fig. 117. The material the author used was birch one-quarter inch thick. It is put together with small screws and glue. When the glue has set it is stained a mahogany color and varnished. This coat is allowed to set for three days and is then rubbed down with pumice and water, then varnished again. If this is done carefully, you will have a cabinet closely resembling a factory product.

The front panel is of bakelite or formica one-quarter inch thick and cut six inches wide and nine inches long. Before drilling, a template of the front panel is made of heavy paper and the location of the instruments are figured out and marked on this, so as to reduce the chances of mistakes. The template is then laid over the panel and the transferring is done with some sharp pointed tool. The drilling of the holes for the panel mounting screws, the switches and switch points, variable condenser and detector is accomplished with some small sharp drill. The panel is best attached to the box as shown in Fig. 117 C.

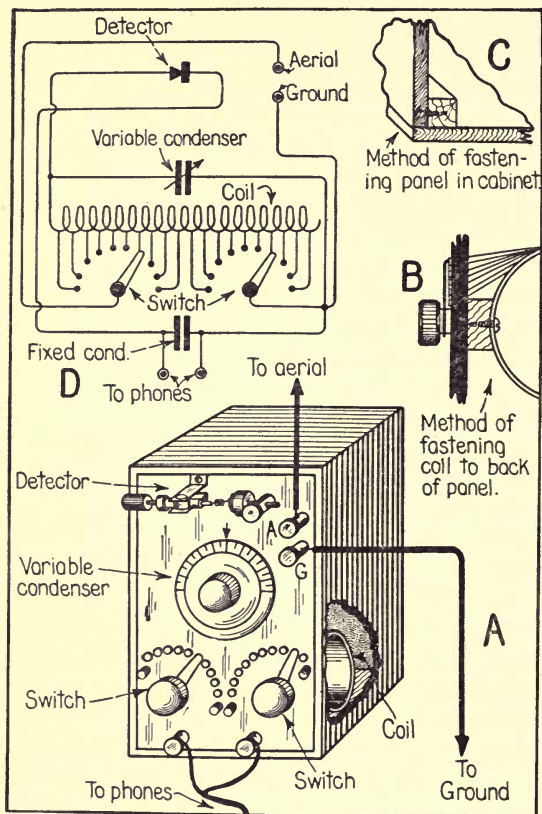

FIG. 117.

The tuning coil is of No. 24 enamel insulated magnet wire, wound on a cardboard tube

six inches long and three and one-half inches in diameter, the winding is tapped at 20 equal spaces. The switch levers, switch stops and switch points are put on the front panel and the taps are connected to the switch points and the coil is mounted behind the panel with wooden blocks as shown in Fig. 117 B. This completes the tuning coil and controlling switches.

The variable condenser is, or can be, any standard condenser having a capacity of about .0005 mf.; the author's was a Murdock panel type having that capacity. The condenser is mounted back of the panel and the indicating dial is screwed on to the shaft.

The detector can be of any good reliable type of crystal (preferably galena) detector. It may be either an old one or it may be purchased for this purpose. It is taken from its base and mounted at the top of the front panel.

A small fixed condenser having a capacity of about .0015 mf. is used for the phone or stopping condenser. This is screwed to the bottom of the cabinet and is used to shunt across the phones. This, completed, makes the set ready for work on wiring after the binding posts are put in place as shown on the drawing of the front panel.

Run a wire from the switch lever on your left to the binding post at the upper right and mark this A. The other switch is connected to the other binding post and marked G. A wire is run from the

left side of the tuning coil winding to one of the variable condenser terminals, then to one binding post on the detector. From the other detector binding post a wire is run to the phone condenser and then to the phone binding post on the left. Another wire is run from the other variable condenser binding post to the right hand end of the tuning coil winding, to the phone condenser and then the other phone binding post. The set is now completely wired and the cabinet may be closed and sealed as shown in Fig. 117 A.

For use the aerial is connected to the binding post marked A and the ground to G. The phones are connected to the binding posts on the bottom of the panel. Most of the tuning is accomplished through the switches, while the variable condenser is used mainly to tune out interference. All connections are shown in Fig. 117 D.

A PORTABLE RECEIVING SET

Herewith is described a receiving set, the construction of which is somewhat radical, as it uses no aerial of any kind. It is only in an experimental stage, but Mr. Eugene M. Riel has found it very useful for short distances. A radio club or a troop of Boy Scouts on a hike always want to keep in touch with the nearby home station, and with this set all that is necessary is to raise the lid and connect the batteries; there being no aerial to unfold and hoist in the air.

The box is 10"×10"×18" over all, constructed

of $\frac{1}{2}$ inch hardwood with one side on hinges so that it can be raised when in use, the case lying on the other side. Brass corner-pieces and angle strips make the case stronger and add much to its appearance. It is also fitted with a handle for carrying and a hinge hasp.

Two and a half inches from the top a $\frac{1}{4}$ inch Bakelite panel is mounted by means of $\frac{1}{2}$ inch cleats. On this panel are mounted the following instruments, as shown in Fig. 118: (1) The loop coil which is used for an aerial; (2) a variable condenser of .001 mf. capacity for tuning; (4) a rheostat for the filament of the audion bulb. The bulb itself (3), or, rather, the socket for the bulb, is mounted in a recess 4 inches below the top of the panel, as shown. Binding posts are provided for attachment of "A" and "B" batteries and also the telephones, for which a space is provided by the setting of the panel below the top of the case.

The coil (1) is preferably a Litz wire-wound coil of small distributed capacity, but not of the honeycomb or lattice type, because the zigzag winding of the wire will not permit a directional effect. Sixty-five turns of wire, bank-wound on a circular wooden form 2 inches in diameter as shown, will be about right for 200 to 400 meters wave-length.

The connections are self-explanatory, the condenser (5) being the grid condenser.

If desired, there is room in the case for the "B"-battery. Any amount of wire can be wound on the coil, to receive any wave-length desired.

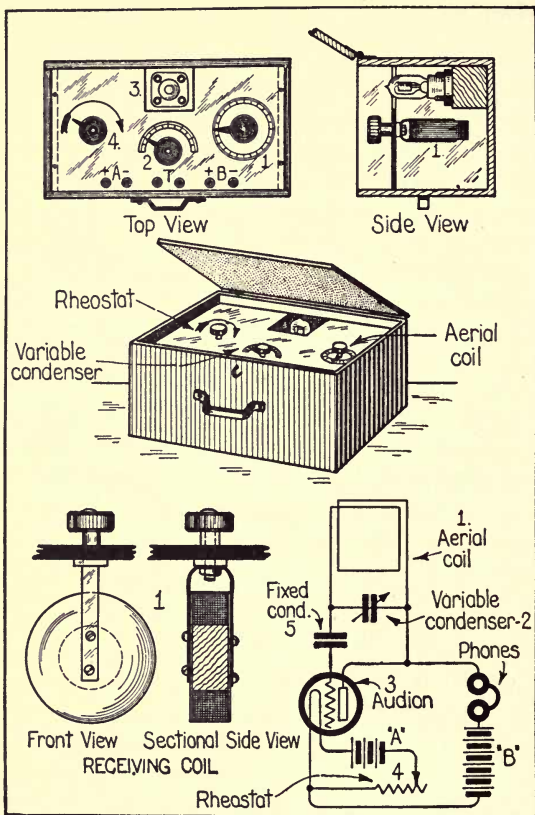

FIG. 118.

To receive, adjust the plane of the coil in the direction of the sending station and tune the signals

in with the variable condenser. It must be understood, of course, that this set will not respond to signals transmitted from great distances. Good receiving depends primarily on the power of the local transmitter as well as upon the most effective tuning of the receiver and functioning of the vacuum tube.

A SIMPLE AND EFFICIENT SHORT WAVE REGENERATIVE RECEIVER

Here is a short wave regenerative receiver which can be constructed by the amateur very economically. When the outfit described below is carefully made up, it is a credit to an operating table and is one that the most exacting of radio fans will take great delight in showing his friends and fellow bugs. It is easily made up, requires but very few parts, and is so assembled that it is easily accessible at all times for the changing of hook-ups. The builder has his choice of mounting the outfit, which is designed along the lines of the famous Paragon short wave regenerative receiver, in cabinet form or assembling it upon a pair of braces or brackets. It has not been put to any extensive test, but Mr. Frederick J. Rumford has worked on 100 to 400 meters with very good results, and the author feels sure that the builder can get still better results by further experimentation.

ARTICLES NEEDED

In making the outfit, one needs two 3-inch Bakelite dials engraved as shown and one 2-inch dial also engraved. These dials must have knobs attached to them. Eight brass or copper binding posts, such as are used with any radio receiving apparatus, are also required and one complete variable switch assembly with five contacts and their necessary nuts and washers. These would look best if they were nickel plated. The switch lever will swing within a radius of one inch. This switch is for the purpose of tapping the primary of the loose (vario-) coupler. One of the contacts on the switch is left idle. Now we will start on the panel and continue until the whole outfit is ready for instant use.

THE PANEL

Fig. 119 A shows the exterior view, or front of the panel with the necessary articles mounted in their respective places and the symbols indicating them.

Fig. 119 B represents the interior view, showing the variometers and loose coupler mounted in their places, and the method of mounting them.

Fig. 119 C shows both the internal and external hooking-up for the outfit. The builder following this hook-up should get very good results.

The panel may be bakelite, rubber, oak or box-wood and should be 12 inches long, 6 inches wide

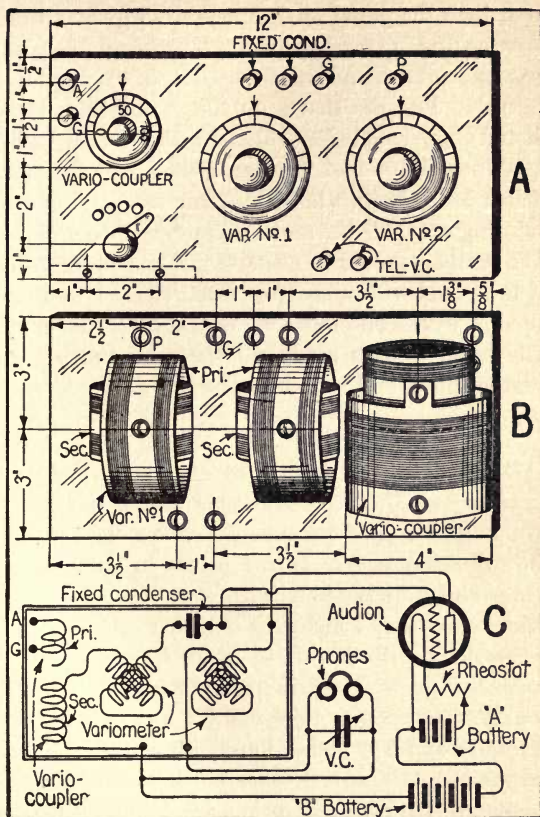

FIG. 119.

and from $\frac{1}{8}$ to $\frac{3}{8}$ inches thick. The measuring and drilling for the necessary holes should be done

first, then the panel sandpapered and given two or three coats of varnish or paint. The panel described was made of oak and had three coats of black, glossy varnish. For the shafts on the variometers there should be $\frac{1}{4}$ -inch holes drilled, for the binding posts, $\frac{3}{16}$ -inch holes and for the switch contacts and switch lever $\frac{3}{8}$ -inch holes. After the drilling and painting are done the panel is ready to be engraved. The symbols should be neatly engraved on the front of the panel with a sharp-pointed slender tool and filled in with white india ink or a similar substance. The panel is then ready for the mounting of the binding posts and switch assembly.

MAKING THE COILS

We will pass to the making of the different coils necessary for the successful operation of this outfit. The amateur must procure six cardboard tubes in the following sizes: two, 4 inches in outside diameter and 2 inches long with a wall $\frac{1}{8}$ of an inch thick; one form, 3 inches in outside diameter and 2 inches long with a wall $\frac{1}{8}$ of an inch thick; two, $2\frac{3}{4}$ inches in outside diameter and 2 inches long with a wall $\frac{1}{8}$ of an inch thick; one, 4 inches in outside diameter and $3\frac{1}{2}$ inches long with a wall $\frac{1}{8}$ of an inch thick. All forms that are 5 inches in outside diameter are the different primaries for the different variometer assemblies, and the forms smaller in outside diameter are the secondaries. Now take the two primaries that are 2 inches long and drill a hole in the

center of them to allow a loose fit of a $\frac{1}{4}$ -inch shaft. This shaft is the means by which the secondary is revolved within the primary and the hole to be drilled in the secondary forms should be small enough to allow for a snug fit on the same size shaft. After this has been done, the four coil forms should be given a couple of coats of some good insulating compound. After they have dried they are ready for the wire to be wound upon them.

In this instance, the author used No. 24 D.C.C. magnet wire, On the primary form of the variometer number one, the winding should start in $\frac{1}{8}$ of an inch and continue over for $\frac{5}{8}$ of an inch; then skip a space of $\frac{1}{2}$ inch and continue winding until $\frac{1}{8}$ of an inch from the end. The author thinks it advisable to have a little brass (never iron) machine screw on both ends of each of the coils with suitable nuts and washers to which to attach the wire upon the starting and finishing of the winding. It also provides means of hooking the primary and secondary in series. This will make about 42 turns in all on the primaries of variometers No. 1 and No. 2, making 21 turns to a section. Both primaries are wound alike. As the reader will note in Fig. 119 B, the coils are all wound in two sections; the space in the center is left to allow room for fastening the shaft securely. After being wound, the primaries should be given a coat of shellac but care taken not to get too much on them as it would cause energy losses.

THE SECONDARIES

Now comes the making of the secondaries for variometers No. 1 and No. 2. These coil forms are $2\frac{3}{4}$ inches in outside diameter and 2 inches long. The winding on the coils starts $\frac{1}{8}$ of an inch in and continues over for $\frac{3}{4}$ of an inch, leaving a $\frac{1}{4}$ -inch space. It again continues over $\frac{3}{4}$ of an inch, leaving $\frac{1}{8}$ of an inch at the end. These coils are fastened at both ends by the same means as used on the primaries. The secondaries should also be shellacked.

THE LOOSE COUPLER

The next step is making the loose coupler. The primary is 4 inches in outside diameter and $3\frac{1}{2}$ inches long with a wall $\frac{1}{8}$ of an inch thick. The primary should have a lip on it as, shown in Fig. 119 B, the purpose being a means of fastening the shaft. This coil form should be treated like the others. After it has dried, the winding will start on the lip end by attaching the wire upon the machine screw or post as was mentioned above, as was done on the other coils. It should be wound 2 inches down with No. 24 D.C.C. magnet wire. In fact, all the coils are wound with this size wire and must also be wound in the same direction. After this coil has been wound, it is ready for the shellacking. On this coil four taps will be taken off. As the two inches of winding will equal 66 turns of wire, the taps will be taken off on the 16th, 33rd,

49th and 66th turns. A good way to take them off is to scrape the insulation back on the wire on the above numbered taps or turns and solder short pieces of No. 14 bare copper wire upon the scraped section, which will in turn connect to the different contacts on the panel.

We are now ready to make the secondary coil for the loose coupler. This coil form is 3 inches in diameter and 2 inches long with a wall $\frac{1}{8}$ of an inch thick. It should have a hole drilled in the center of it to allow for the passing through of a $\frac{1}{4}$ of an inch, snug-fitting shaft. This shaft is for the purpose of revolving the secondary coil within the primary coil and should be drilled for accordingly on the primary. The winding, to be fastened the same as in the case of the other coils, will continue over for $\frac{3}{4}$ of an inch, skip a space of $\frac{1}{4}$ of an inch and continue for $\frac{3}{4}$ of an inch more. This end will be fastened upon the post fitted for it. The secondary is now ready for its coat of shellac.

As was said above, all the coils are wound with No. 24 D.C.C. magnet wire. The primaries on variometers No. 1 and No. 2 will have 42 turns upon each of them, which will be 21 turns per section, making a total of about 45 feet of wire to each primary, or 90 feet for the two. The two secondaries of variometers one and two will have 50 turns each, with 25 turns to a section. Each coil will take about 36 feet of wire or 72 feet for both. The loose coupler primary has 66 turns of wire, which would equal

about 71 feet. The loose coupler secondary has 50 turns of wire, 25 turns to a section which would equal about 40 feet. In all, it requires 273 feet or close to one-half pound of the wire.

ASSEMBLING THE PARTS

The outfit is now ready to be assembled. The binding posts and switch assembly have already been mounted. Now mount the primaries or variometers No. 1 and No. 2, by four little wood screws, two to a coil, which will screw in through the coil form into the back of the panel, so as the shaft hole on the coil form will come in line with the hole in the panel. After that, get the necessary shafts, which should be threaded their whole length. Each one of these shafts should be 5 inches long and $\frac{1}{4}$ of an inch in diameter. One end of the shafts should be screwed into the knob on the dial and soldered so that it will not work loose. It is then in turn pushed through the panel from the front through the primary coil and nuts run on it so there will be a nut on the front and back of the secondary at each end, and on the inside and outside of the primary, which, when drawn up tight to the forms, will hold them securely. The above operation should be executed on both variometer assemblies. In hooking the primaries and secondaries in series, take pieces of No. 18 flexible lamp cord of sufficient length and connect the ends of it upon the screws or posts that are provided in the coils.

In assembling the loose coupler: There is a

rest made of 8 inches long, 4 inches wide and $\frac{3}{8}$ of an inch thick, which in turn is secured to the back of the panel by two wood screws, which go through the panel from the front. This rest in turn will support the primary of the loose coupler. The primary is then mounted upon the rest and held there by four little braces, two of them angle form and the other two straight. These braces may be copper, brass or iron. The builder must bear in mind, that between the back of the panel and the front of the primary coil form, there must be just three inches of space. This is absolutely essential or otherwise, when the secondary on variometer No. 1, is rotated it will in turn rub against or strike the primary on the loose coupler. After this has been done, the secondary of the loose coupler is mounted, the same as the secondaries on the two variometers. The wiring for the back of the panel is done with No. 14 stiff bare copper wire, which can be bent into the different shapes desired by the builder. Figure 119 B, shows the true method of mounting the primary of the loose coupler. The taps on the primary are hooked to their respective contacts on the panel. Fig. 119 C, shows the method of hooking-up the outfit. Any trouble the author has encountered in the working of this receiver he has found to be due to run down "B" batteries. There should be little or no trouble for the amateur in building this receiver as the drawings are self-explanatory.

PRACTICAL V. T. DETECTOR AND TWO-STAGE AMPLIFIER

The accompanying drawing, Fig. 120, shows to good advantage a detector and two-stage amplifier, which have been in use for over a year; from this set, Mr. Frederick T. Rumford, the builder, has obtained the very best results. He designed it for the purpose of combining efficiency, simplicity and compactness. It requires but very little work to build, and its actual cost is less than \$50. This price includes the tubes, and as every amateur knows, in the average detector two-stage amplifier sets, the tubes are an extra expense.

Below is the list of necessary items, with their respective costs.

2 "Rasco" Amplifying Transformers	@ \$2.65	\$5.30
1 V. T. Detector tube	@ 7.00	7.00
2 V. T. Amplifier tubes	@ 7.00	14.00
3 Murdock V. T. sockets	@ 1.00	3.00
3 Telephone jacks	@ .85	2.55
2 Formica panels, 7" x 4½" x ¼"	@ 1.50	3.00
3 Grid leaks and condensers 0.0005 mfg., 1 megohm	@ .50	1.50
1 Telephone plug	@ .75	.75
25" of round ¼" brass stock or rod30
15" of flat brass stock ¼" wide ⅛" thick25
5" bare copper wire B. & S. No. 830
Screws and bolts50
8 Large size binding posts	@ .20	1.60
2 Rheostats for back mounting	@ 2.00	4.00
Actual cost		<u>\$44.05</u>

This outfit is so compact that the builder has often carried it from city to city in his travels.

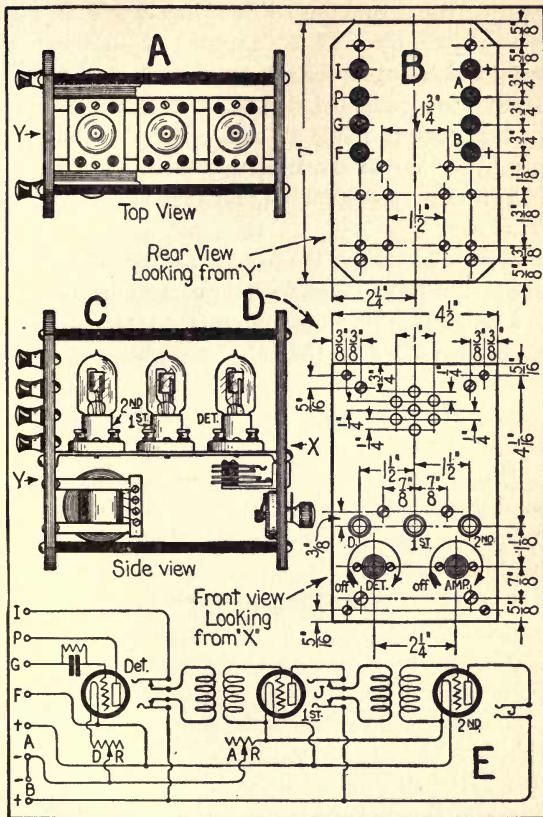

FIG. 120.

Those who build this set can mount it in a cabinet, if they so desire. It may be easily duplicated and

requires but a few tools in the making, such as a screw driver, etc. It is composed of all standard parts, which can be readily purchased in any radio supply store, but, no doubt, most amateurs have the necessary parts lying around. It will take only very little time to assemble this outfit when ready.

With the accompanying data are four drawings as follows:

Fig. 120 D shows the front panel with the different apparatus mounted, with the correct dimensions.

Fig. 120 C side view and also the interior, showing the positions of the tube, transformers, rheostats and jacks.

Fig. 120 A represents the interior looking down from the top.

Fig. 120 B represents the rear panel, showing the different dimensions for the placing of the binding posts and positions of the different attaching screws.

Fig. 120 E shows the general hook-up with proper connections.

We will now pass on to the actual making of this set. The two $7'' \times 4\frac{1}{2}'' \times \frac{1}{4}''$ panels are given a dull grain finish with No. 0 sandpaper, and then rubbed with oil. After this, the usual marking off and drilling of holes is done as shown in Figs. 120 B and 120 D. The rheostats and jacks are mounted on the front panel as shown and the binding posts are next mounted on the rear panel, which panel will be cut out at the corners, see Fig.

120 B. This gives the panel a distinctive appearance and also provides for air in case the outfit is mounted within a cabinet.

The round $\frac{1}{4}$ -inch brass rod is now cut into four 6-inch lengths, being drilled and tapped at each end to take $\frac{1}{8}$ -inch machine screws. If the outfit is not mounted in a cabinet, it would be advisable to have these rods nickel plated. For that matter, it would be a good idea to have all the metal parts that are exposed to view nickel plated, as this will set the outfit off to its best advantage.

The eight binding posts, of which four are on each side of the rear panel, are indicated by the engraving upon this panel as follows: On the right side: A is for the "A" battery, which in this particular instance is a 6-volt 60-ampere hour Eveready storage battery; B, for the "B" battery, which happens to consist of 20 No. 703 Eveready flashlight batteries, wired in series multiple. The reason for this is that with three tubes functioning, the "B" battery will not stand up very long, and it also weakens the amplifying power of the outfit. There is a jumper wire which runs from the "B" battery negative to the "A" battery negative.

Now the posts on the left-hand side are as follows: No. 1 is for the tickler connection, P, plate, G, grid, and F, filament. As will be seen, there are but very few binding posts, not at all like the old amplifier sets, which had a large number of posts, and were complicated and awkward to operate.

All the tubes are of the same filament voltage and the plates are of the same "B" battery voltage.

We will pass to the making of the strips for the socket shelf. This is cut, drilled and tapped as per Figs. 120 A and 120 C. The sockets are then placed upon the strips and held in place by means of screws and nuts; the size is left to the individual's own judgment.

The sockets are to be spaced equally apart, leaving a little margin of space at each end. The assembly in turn is mounted between the two panels as in Figs. 120 A and 120 C, and held there by means of screws, which are passed through the panel and secured on the back by nuts. The brass rods may now be screwed between the panels. The two "Rasco" amplifying transformers can then be fastened to the back of the rear panel by means of screws and nuts, which are properly spaced, as shown in Fig. 120 B. As mentioned, the holes above the jacks will give the necessary ventilation and also serve as windows so the brightness of the tube filaments may be observed.

Now that the outfit is assembled, the next step is the wiring, which is done with No. 8 B. & S. bare copper wire, which it is advisable to run as straight and direct as possible as this wire is very stiff. It would be advisable to straighten the wire out, making it firm and rigid.

The ingenious arrangement of the different parts makes most of the leads comparatively short

and direct. The wiring is extremely simple. The positive terminals of the filaments are connected together on the sockets by one wire running straight across; one wire runs from the negative terminal to the front panel and across the width, having the two rheostats connected from it onto one side of each. The other side goes to each individual tube socket, having one side of the amplifying transformer secondary connected to it. The three jacks are connected on one side to the plates of each individual tube, and on the other side, to one wire which runs direct to the positive binding post of the "B" battery; the two center strips of the jacks are connected to the two individual amplifying transformer primaries. The other side of the amplifying transformer secondaries are connected on one side of the grid leak and grid condenser which connect directly to the tube grids of each individual tube. The end jack connects on one side direct to the plate of the last amplifying tube, and the other side connects direct to the positive side of the "B" battery.

We have omitted showing the position of the grid leaks and grid condensers, which are combined, but in the outfit described, the builder has secured them to the inside of the rear panel. The maker may use his own judgement regarding this.

The grid leaks of this outfit are 1 megohm resistance and the grid condensers are of 0.0005 mfd. capacity. They were purchased from the Radio Specialty Co.; the jacks and plug were purchased

from the Federal Telephone & Telegraph Co., and the sockets from the Murdock Co. The rest of the necessary supplies were obtained from the nearest radio supply house. In this particular instance we used the Magnavox Radio Telemegaphone with one set of binding posts connected to the extra telephone plug, and the other set connected to a 6-volt 40 ampere hour storage battery, which had a rheostat connected in series, making various adjustments and continuous service possible. When the amateur wishes to use this loud speaker, he plugs into either jack he desires and, presto, the signals will be heard all over the room. With this arrangement, the necessity of having the receivers clamped on the head all the time will be eliminated and will make it also possible to entertain any number of friends, when radio music is being transmitted. No doubt, you have noticed by this time that very little adjustment is required in operating this outfit. After you have adjusted the detector and the amplifier rheostats, it is then ready for use at any time. The builder has used "Rico" phones for the headset.

By shunting a variable condenser across the posts marked No. 1 and F, you will obtain a regenerative effect, or shunting at the tickler coil which may be a honeycomb coil across No. 1 and P and a honeycomb coil across G and F will act as a secondary having the usual primary will make it possible to tune any wave-length 100 to 20,000 meters with the usual variable condenser to make sharp tuning

possible. It will be noted that all the apparatus is fastened to either the front or the rear panels and almost all the connections are made direct from the binding posts on the rear panel, making it possible to remove the different apparatus from time to time, whenever it is necessary to inspect them, or for the replacing of a new V. T. or for renewing old parts.

If traveling any distance, the outfit can be easily knocked down and the different parts stowed away in the corners of a bag or trunk. The complete diagram of the proper connections is shown in Fig. 120 E, with the proper symbols; the letters and numbers are the same as on the panels themselves. To get the proper wiring for the backs of the panels it would be advisable to reflect the drawing in a mirror, or to place it on top of a plain piece of paper, right side up and under this paper, have a sheet of carbon paper, carbon side up. This last will give the best results as the tracing of the original drawing will make the proper impression upon the under side of the plain sheet of paper. This idea would apply to any or all diagrams.

The author has covered all the necessary details pertaining to this particular outfit, but will say a few words more to the effect that its advantages are neatness, fine finish, compactness, workmanlike construction, moderate price and efficiency. To really understand and appreciate its worth, it would be advisable to compare it with some of those

sold in stores. The beginner can make this outfit without the least danger of making a "bull" of it, as all the parts are of well-known makes and widely advertised in all the radio publications and it only requires patience and time to assemble.

The author feels sure that all these outfits can be built without the least difficulty, as all the drawings are self-explanatory.



Radio Corporation, Westinghouse Photo

The author delivering his lecture, "The Future of Radio," from WJZ, Newark, N. J. An ordinary telephone transmitter was used in this case, but new models are now being used with which it is not necessary to speak close to the transmitter at all. This lecture was heard by over a hundred thousand people.

CHAPTER XI

THE FUTURE OF RADIO

As the author has mentioned often in his various editorials published in *Modern Electrics*, the *Electrical Experimenter*, *Science & Invention*, as well as *Radio News*, the radio business may be likened to the amateur photographic business. Within the next few years, we shall see every drug store selling complete radio outfits that can be put on top of the phonograph at home, and which can be worked by your six year old sister. All that is required of you is to manipulate a few knobs, and from a concealed horn, the latest jazz band music will then issue forth. To be sure, this music is broadcasted from a central station which may be a thousand miles away or farther.

Then too, the day of the radio newspaper is quickly coming. Important news of the day will be broadcasted by radio telephone daily at stated intervals, as will be weather reports and other information useful in every community. But of course, the development of radio will not stop at radio telephony alone. Great and wonderful things are coming in radio which are undreamt of today. New uses are constantly being found. New improvements are being made almost over night. We cease to wonder when we hear of some new marvel that is

being performed by radio, and simply shrug our shoulders and say "well that was predicted long ago." Thus, recently, a physician several hundred miles inland listened to the heart beats of a man lying unconscious on a ship three miles out on the ocean. Every heart beat was transmitted clearly and faithfully by radio to the physician, who was thus enabled to make a diagnosis.

We now move ships and steer airplanes by radio. Very recently in Germany, radio was used in mines underground to locate ores and coal veins accurately, surely a surprising use for the art! In this invention use is made of a receiving and sending station, both located underground, one signalling to the other. When the signals pass through a coal field, a variation is heard at the receiving end and by triangulation, the exact location of the coal veins can be found.

Recently, in Italy, radio has been used for prospecting metal ores. Here the Italian inventors use very sensitive vacuum tube outfits, and by means of a certain condenser arrangement, it becomes possible to plot accurately the exact location of the future mine. Today, every radio station has its ubiquitous aerial on top of the house. This soon will be a thing of the past. Already two American inventors have demonstrated that far better results may be had by putting the aerial underground. In their experiments, the inventors use the so-called underground loops. Of course, these are necessary

for long distance reception, but for your radio outfit on top of the victrola in the parlor, no underground loop, or ærial on the roof is necessary. The ærial will be right inside of the outfit. We are already doing this very thing today, and the outfit need not be larger than a foot square. That gives us sufficient space for the concealed ærial within the box. This is not a dream of the future, as it has already been accomplished for the reception of radio music over distances of several hundred miles.

It is even possible to do away with the loop entirely. There has appeared lately upon the market, an electrical plug which is simply screwed into any lighting fixture in your house. It makes no difference if your lighting current is 110-volt alternating current, or 110-volt direct current, or even 220-volts. This plug consists simply of a condenser arrangement, and the idea of it is as follows: We have seen in former chapters that any ærial wire will pick up radio waves. Now then, every lighting circuit forms a sort of loop ærial itself. This is particularly true in the country where the wires run for great distances out doors. By proper arrangement, as for instance, using such a plug, the radio waves are conveyed right over the lighting circuit without interfering with the electric light bulbs, and other electric appliances in your house. These condenser plugs are already a great success but they do not work under all circumstances. For instance, in apartment houses in which much steel enters into

their construction, the results are not so good as in the country where we have a stone or wood house, and where the electric lighting wires run outdoors. These condenser plugs work satisfactorily in nearly all instances, even in apartment houses, in connection with vacuum tube sets, but they do not work well as a rule with crystal receivers. Much experimental work is as yet to be done in this line, but the chances are that ten years from now, the ærial for receiving purposes will be a thing of the past.

Perhaps the greatest development will be the radio power transmission of the future. This is, of course, today, only a dream, but Nikola Tesla has demonstrated that it can be done, and it is interesting to note that this great savant's ideas are coming more and more to the front. Dr. Tesla contends that our radio conceptions are wrong from start to finish. He claims that it is not the radio waves that travel through the ether following the curvature of the earth, but rather currents that travel *through* the earth, and we seem to be coming to just this. If Tesla is right, power transmission by radio should be a simple thing. It will enable us to tap the earth at any point and receive our energy to light and heat our houses. Of course all this is in the future, but we are surely coming to it.

Another new use for radio is sending pictures, photographs, etc., through the ether, and the author believes that he cannot do better than quote part of

his editorial from the November 1921 issue of *Radio News*.

“Recently the signatures of General Foch and General Pershing were sent across the Atlantic by radio on the Belin apparatus. There is no good reason why the amateur cannot do the same thing for smaller distances at any time.

“In the very near future, the amateur in New York will buy the first copy of a New York newspaper, wrap it around his cylinder, and send out a whole sheet by radio. A thousand miles away another amateur will have a receiving machine that will reproduce the printed page, type, pictures, and all in less than a half-hour. This is a thing impossible to do by ordinary wireless telegraphy, if every word must be transmitted. The radio picture transmission solves all this. Thus, in time, a great piece of news ‘breaking’ in the city, will be sent broadcast by the enterprising amateur, who will send the entire front page of the newspaper, for instance, and the radio facsimile can then be exhibited in a distant town from 10 to 24 hours in advance of the receipt of the actual newspaper.

“All this is not a mere dream, but it already has been accomplished today. It is up to the amateur to make the thing popular.”

To go still a step further, the author in a recent article in *Science & Invention* magazine proposed a radio system, which theoretically is sound. It is nothing else than Television by

Radio. (Fig. 121). The fundamentals of this proposed scheme are correct, and there is little doubt that we will have radio television within a very few years on a scale that will be tremendous. The idea in short follows:

At the Polo Grounds of New York, let us say, we have a radio transmitting station in a box-like affair of about three or four times the size of a movie camera. We have a box with a lens in front, the back of the camera being composed of a great number of photo-electric cells. These cells have the property of passing more or less electric current, depending upon how much light falls upon the cell. A strong light will pass much current through a cell, while a weak light will pass little current. By means of these cells, we influence a modulator vacuum tube connected to the radio transmitter. This modulator sends out radio waves into space. If a strong light falls upon the electric cell, No. 1, we send out a radio wave of a certain intensity at a certain wave length, let us say $500\frac{1}{2}$ meters. At the receiving end, this wave is received and is passed through the regulation radio outfit and thence through a condenser, vacuum tube and audio-frequency transformer. This audio-frequency transformer operates a small magnet which in turn influences a pivoted diaphragm. This diaphragm has mounted upon it a strip mirror about $\frac{1}{2}$ -inch long and $\frac{1}{16}$ -inch wide. Normal and at rest, a light ray from a common source, let us say

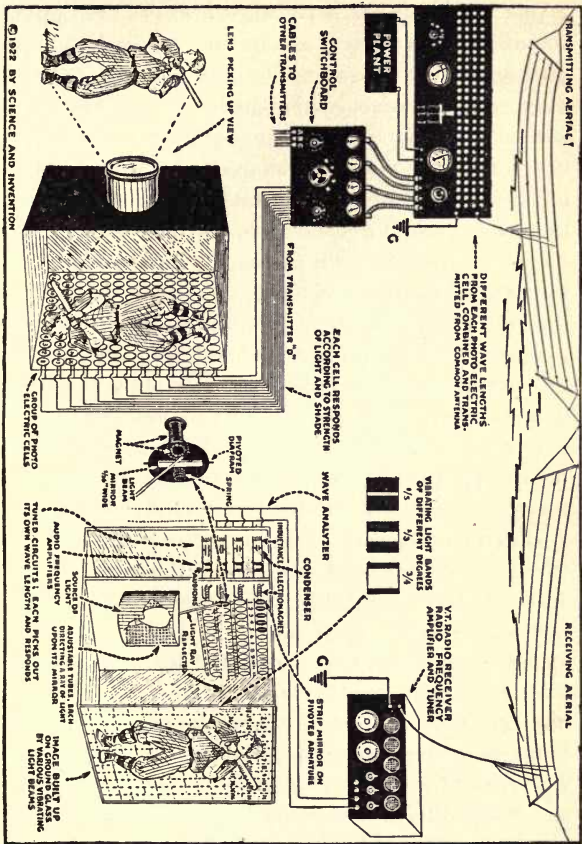

Fig. 121.

an electric lamp, directs a single beam of light upon the diaphragm in such a manner that the light ray *just misses* the mirror. The least vibration of the diaphragm, however, will intercept the light ray and will reflect it upon a ground glass plate. It is evident that the more the diaphragm vibrates, the more the light ray will vibrate back and forward upon the ground glass screen.

If we now imagine at the sending end several hundred of the photo-electric cells and at the receiving end a like number of vibrating mirrors, we can readily see how a picture sent out from the sender can be recomposed and reconstructed at the receiver. It must be understood that our photo-electric cell sends out its own wave-length. Thus, as mentioned before, photo-electric cell No. 1 sends out a wave length of $500\frac{1}{2}$ meters. Photo-electric cell No. 2 will send out a wave of $500\frac{1}{4}$ meters and so on. All these waves are sent out from the same aerial, and all the incoming waves are caught upon the same aerial, each wave operating its own electro-magnet and consequently the light beam. We can now see from this how our future audience will be able to witness a baseball game five hundred or five thousand miles distant, as if it were witnessing the game itself. It is, of course, understood that this transmission takes place instantaneously, so we will be enabled in the future to view distant games or other important events at the time they are taking place. This differs from the movies

where we are not able to view the events at the time they take place, but always at a later date. In the future there will be the possibility of our seeing the President of the United States make an important speech, and we will be enabled to not only hear every word he utters, but see him in person as well.

Of course, it goes without saying that the scheme here advanced will project the picture in black and white only. In other words, the picture will look just like a movie film with the sole difference that we are witnessing the event at the time it takes place.

Here is an interesting feature of which few people are aware. Some months ago, in one of the writer's editorials he mentioned the fact that radio waves are eternal, as are light waves; they travel according to our present conception out into space at the rate of 186,000 miles a second. We see today the light waves shot off by some far away star, which light may have originated from that star perhaps 10,000 or 100,000 years ago. And those light rays are just coming down to us now. It is the same with radio waves. Any radio message, any broadcasted radio selection that is sent out on radio waves goes out into eternity never to return, never stopping, ever traveling onward. The thought is appalling that while you are listening to a famous operatic star, who is singing from some broadcasting station, her voice may be heard 100,000 years from now on some distant planet belonging to its own little solar system.

For to believe that there is intelligence only on this earth is grotesque and foolish in the extreme. What this superior intelligence, listening to this broadcasted song will think of it 100,000 years hence, is difficult to imagine. But, there seems to be little doubt that this superior intelligence will smile at the idea of our feeble endeavors. This intelligence will probably view our attempts with the same amusement as we look upon children using a string telephone.

At the time this volume is written, radio is just about twenty-five years old. If we have accomplished such wonders in a quarter of a century, who dares say what will be accomplished in twenty-five or fifty years more. Our wildest and most impossible prophecies will seem feeble. When we, therefore, say that one of the coming things is transporting solids through space, that is, sending a carload of coal from Pittsburgh to Paris within a few minutes, all by radio, and all by the invisible self-same waves, we will probably be laughed at by our experts. The thing, however, is perfectly feasible today, as we shoot solid particles through glass walls every time an X-ray picture is taken. X-rays are composed of solid particles which are just as solid as bricks or lumps of coal. When, therefore, we are asked what the future of radio is, we may say in one word, ANYTHING! There seems to be nothing impossible that radio cannot accomplish in the future.

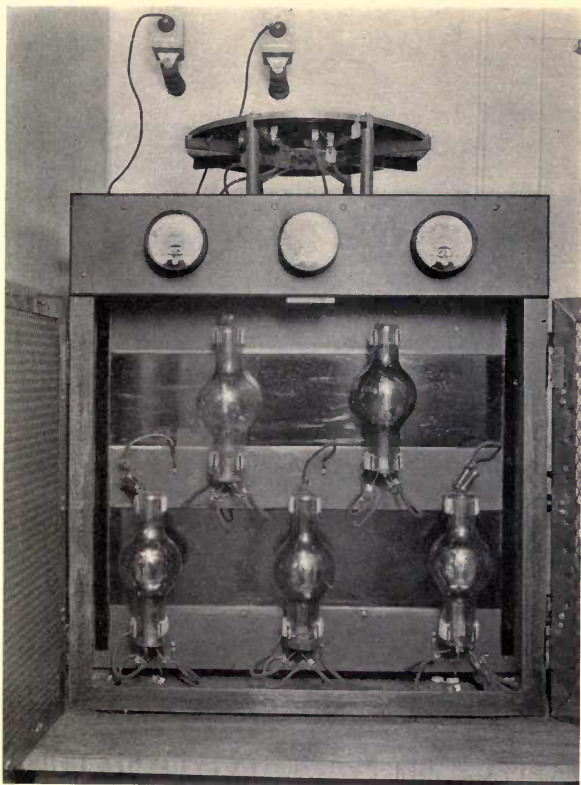

Radio Corporation, Westinghouse Photo

The power plant at the radio broadcasting station WJZ, Newark, N. J. We see here five special vacuum tubes, each generating about 50 Watts power. This gives a total power of 250 Watts, or $\frac{1}{4}$ Kilowatt. On top of the case we see the oscillation transformer which has the function of adjusting the wave length at which the broadcasting is accomplished, in this case 360 meters. The waves emitted by this station have been heard several thousand miles away.

RADIO FOR ALL

Station	Call	Wave-Length	Time
Honolulu	NPM	800 Arc	from 23,55 to 24,00 GMT.
Cavite, Philippine Isl.	NPO	952 Spark	from 02,55 to 03,00 GMT and from 13,55 to 14,00 GMT.
Cavite, Philippine Isl.	NPO	5,000 Arc	from 01,55 to 02,00 and from 14,55 to 15,00 GMT.
Pt. Arguello, Cal.*	NPK	1,512 Spark	Noon, 120th meridian, west, standard time.
North Head, Wash.*	NPE	2,800 Spark,	Noon, 120th meridian, west, standard time.
San Francisco, Cal.	NPG	2,400 Spark	Noon, 120th meridian, west, standard time.
San Francisco, Cal.	NPG	4,800 Arc	Noon, 120th meridian, west, standard time.
Great Lakes, Ill.*	NAJ	1,512 Spark	11.00 A.M., 90th me- ridian standard time.
Eureka, Cal.*	NPW	2,000 Spark	Noon, 120th meridian, west, standard time.
Balboa, Panama	NBA	7,000 Arc	5.00 A.M., 1.00 P.M., 75th meridian standard time.
Colon, Panama	NAX	1,500 Spark	5.00 A.M., 1.00 P.M., 75th meridian standard time.
San Diego, Cal.	NPL	2,400 Spark	Noon, 120th meridian, west, standard time.
San Diego, Cal.*	NPL	9,800 Arc	Noon, 120th meridian standard time.
Pearl Harbor, T. H.	NPM	11,200 Arc	180th meridian, mean noon.
Pearl Harbor, T. H.	NPM	600 Spark	180th meridian, mean noon.

SCHEDULE OF WEATHER REPORTS

UNITED STATES AND POSSESSIONS

Name of Station	Call Letter	Broadcasting Hour (75th Meridian Time)	Wave- Length
Arlington, Va.	NAA	10.30 A.M., Noon, 10 P.M.	2650
Key West, Fla.	NAR	10 P.M.	1500
Point Isabel, Tex.	NAY	12 Midnight	2850
Point Isabel, Tex.	NAY	Noon, 7 P.M.	2250

* Time signals not sent on Sundays and holidays.

RADIO ACT OF 1912

241

Name of Station	Call Letter	Broadcasting Hour (75th Meridian Time)	Wave- Length
Great Lakes, Ill.*	NAJ	Noon, 10 P.M.	1500
San Juan, P. R.**	NAU	10 A.M., 9 P.M., 600 Spark and 5250 C.W.	
San Juan, P. R.	NAU	When issued and repeated at about 4-hour intervals	2750
Portland, Me.	NAB	Noon, 8 P.M.	1620
Boston, Mass.	NAD	11 A.M., 5 P.M.	2250
New York, N. Y.	NAH	10.30 A.M., 5 P.M.	1832
Philadelphia, Pa.	NAI	10.45 A.M., 5 P.M.	1948
Baltimore, Md.	NBZ	10.30 A.M., 4 P.M.	700
Norfolk, Va.	NAM	10.45 A.M., 4 P.M., 8 P.M.	1851
Charleston, S. C.,	NAO	10.30 A.M., 6 P.M.	2250
Savannah, Ga.	NEV	11 A.M., 6 P.M.	1813
Jacksonville, Fla.	NFI	11 A.M., 6 P.M.	450
St. Augustine, Fla.	NAP	11.30 A.M., 7 P.M.	1851
Miami, Fla.	NGE	11.30 A.M., 6 P.M.	1620
St. Petersburg, Fla.	NGL	11.30 A.M., 7 P.M.	2700
Pensacola, Fla.	NAS	11.45 A.M., 6 P.M.	2250
New Orleans, La.	NAT	11 A.M., 5 P.M.	1832
Galveston, Tex.	NKB	11.30 A. M., 6 P.M.	1813
Alpena, Mich.	NSM	10.45 A.M., 11.45 A.M., 4.45 P.M., 7.45 P.M.	1200
Buffalo, N. Y.	NNZ	10.45 A.M., 4.45 P.M.	1200
Cleveland, Ohio	NRH	11 A. M., 5.30 P.M.	1080
Chicago, Ill.	NUR	11 A.M., 5.30 P.M.	1200
Duluth, Minn.	NUX	10.45 A.M., 4.45 P.M.	2200
Guantanamo, Cuba	NAW	When issued and repeated at about 4-hour intervals	2750
Port au Prince, Haiti	NSC	When issued and repeated at about 4-hour intervals	2250
St. Thomas, V. I.	NBB	When issued and repeated at about 4-hour intervals	1688
St. Croix, V. I.	NNI	When issued and repeated at about 4-hour intervals	450
San Francisco, Cal.	NPH	Noon, 10 P.M., 120th Mer.	950
North Head, Wash.	NPE	Noon, 10 P.M., 120th Mer.	950
San Diego, Cal.	NPL	Noon, 10 P.M., 120th Mer.	950

* Distribution is made from this station from April 15th to December 20th.

**Distribution is made from this station from June to November, inclusive.

NOTE: Noon transmission for Arlington and Great Lakes are storm warnings, and 10 A.M. and when "issued transmission" for San Juan are hurricane warnings.

All afternoon and evening transmission listed above, beginning with Portland, Maine, and ending with St. Croix, V. I., are storm or hurricane warnings and advices.

ABBREVIATIONS USED IN WEATHER REPORTS

ATLANTIC COAST

Sydney, N. S. S
 Nantucket, Mass. T
 Breakwater, DelawareDB
 Hatteras, N. C. H
 Charleston, S. C. C
 Key West, Fla. K
 Pensacola, Fla. P
 Bermuda B
 St. Johns, N. F. J
 New York, N. Y.NY
 Lynchburg, Va.LB
 Cape Henry, Va.CH
 Asheville, N. C.AV
 Atlanta, Ga.AT
 Jacksonville, Fla.JA
 Tampa, Fla.TA
 Mobile, Ala.MO
 Burrwood, La.BW
 Galveston, Tex.GV
 Brownsville, Tex.BV
 Fort Worth, Tex.FW
 Corpus Christi, Tex.GV
 Kingston, JamaicaKN
 Turks IslandTI
 Havana, CubaHA
 Guantanamo BayGO
 Swan IslandSI
 San Juan, P. R.SJ
 St. Thomas, Virgin Isls.ST
 Basseterre, St. KittsBT
 Roseau, Dominican Republic. .RS

Bridgetown, BarbadoesBB
 Santo Domingo, Dominican
 RepublicSD
 Puerto Plata, Dominican
 RepublicSL
 Castries, St. LuciaLU
 Willemstadt, Curacao W
 Port of Spain, TrinidadPS

GREAT LAKES

Duluth, Minn.DU
 Marquette, Mich. M
 Sault Ste. Marie, Mich. U
 Green Bay, Mich. G
 Chicago, Ill.CH
 Alpena, Mich. L
 Detroit, Mich. D
 Cleveland, Ohio V
 Buffalo, N. Y. F
 Grand Haven, Mich.GH
 Father Point, Can.FP
 Montreal, CanadaML
 St. Louis, Mo.SL
 Little Rock, Ark.LR
 Nashville, Tenn.NV
 Cincinnati, OhioCN

PACIFIC COAST

Tatoosh, Wash. T
 North Head, Wash.NH
 Eureka, Cal. E
 San Francisco, Cal.SF
 San Diego, Cal.SD

ARLINGTON WEATHER REPORT. 2,500 METERS N.A.A.

Sample Report: QSTdeNAA, USWB, So1081—To2261 DB
0251—H 00844—C 01261—K 004410—P 01243.

EXPLANATION

- QST — General call
de — From
- NAA — Arlington Station
- USWB — U. S. Weather Bureau
S — Sydney, Nova Scotia
"010" — 30.10 inches, Barometer
"8" — Wind Northwest
"1" — Light air
- T — Nantucket, R. I.
"022" — 30.22 inches, Barometer
"6" — Southwest wind
"1" — Light air
- DB — Delaware Breakwater
"020" — 30.20 inches, Barometer
"5" — South wind.
"1" — Light air
- H — Cape Hatteras
"008" — 30.08 inches, Barometer
"4" — Southeast wind
"4" — Moderate breeze
- C — Charleston, S. C.
"012" — 30.12 inches, Barometer
"6" — Southwest wind
"1" — Light air
- K — Key West, Fla.
"004" — 30.04 inches, Barometer
"4" — Southeast wind
"10" — Whole gale.
- P — Pensacola, Fla.
"012" — 30.12 inches, Barometer
"4" — Southeast wind
"3" — Gentle breezes.

RADIO FOR ALL

BEAUFORT WIND INTENSITY SCALE

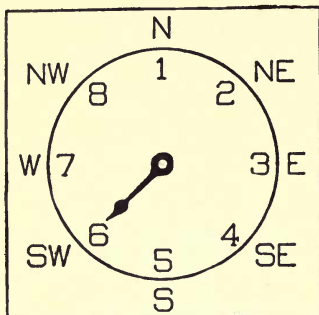

Statute Miles Per Hour

0	Calm	0—3
1	Light Air	8
2	Light Breezes	13
3	Gentle Breezes	18
4	Moderate Breezes	23
5	Fresh Breezes	28
6	Strong Breezes	34
7	Moderate Gale	40
8	Fresh Gale	48
9	Strong Gale	56
10	Whole Gale	65
11	Storm	75
12	Hurricane	90

Statute Miles per Hour:—1.15 Nautical—M.P.H.

U. S. STATIONS SENDING MARKET REPORTS

Name of Station	Call Letters	Wave-Lengths		Broadcasting Hours
		Call	Work	
Washington, D. C. ...	WWX	3800	3850	7.30 and 8.00 P.M.
Hazelhurst, N. Y. ..	WWU	3800	3400	
Bellefonte, Pa.	WWQ	3800	3450	
Cincinnati, Ohio	KDQC	3800	3600	9.00 and 11.00 A.M., 12.00 Noon, 7.30 and 8 P.M.
St. Louis, Mo.	KDEL	3800	3675	9.15, 11.30 A.M., 12.30, 3.30, 8.15 and 8.45 P.M.

Name of Station	Call Letters	Wave-Lengths		Broadcasting Hours
		Call-Work		
Omaha, Neb.	KDEF	2900	4167	9.00, 11.00 A.M., 12.00 Noon, 2.00, 3.00, 5.30, 8.00 and 8.30 P.M.
North Platte, Neb...	KDHM	2900	3400	9.30 A.M., 12.00 Noon, 6.00 and 9.00 P.M.
Rock Springs, Wyo...	KDHN	2900	3200	9.00 A.M., 12.00 Noon, 6.30, 8.00 and 8.30 P.M.
Cheyenne, Wyo.	KDEG	2900	3740	
Salt Lake City, Utah.	KDEH	2200	3600	
Elko, Nevada	KDEJ	2200	3400	8.30 A.M., 12.00 Noon, 4.00 P.M.
Reno, Nevada.	KDEK	2200	2800	9.00 A.M., and 1.00 P.M.

Stations are also now being installed at Bryan, Ohio, and Iowa City, Iowa.

The above stations are all 2-KW Federal arc transmitters and are not only used for furnishing communications to the Air Mail Service, but they are also utilized in broadcasting agricultural market reports, and weather reports. Broadcasts are now being transmitted from the stations as shown above at the hours listed.

PRESS SCHEDULES OF SPARK STATIONS

Call	Station	Wave-Length Meters	Time
NAA	Washington, D. C.	2650	10 P.M., 75th meridian
NAR	Key West, Fla.	1500	10 P.M., 75th meridian
NAX	Colon, Panama	2400	10 P.M., 75th meridian
NPG	San Francisco, Cal.	600	1.15 A.M., local time
KHK	Honolulu, Hawaii	600	11.30 P.M., local time
NAH	New York, N. Y.	1500	9.00 P.M., 5 A.M., local time
NPL	San Diego, Cal.	2400	
BZM	St. Johns, N. F.,	1500	7.30 A.M. (GMT)*
VCU	Barrington Passage, N. F..	1500	8.00 A.M. (GMT)
BZL	Demerara, British Guiana..	1300	6.00 A.M. (GMT)
BZN	Falklands	4300	3.30 A.M. (GMT)
BYZ	Malta (Rinella)	2650	9.00 A.M., 7.00 P.M. (GMT)
OAZ	San Cristobal, Peru	1500	2.00 A.M., 3.30 P.M. (GMT)

* Greenwich (England) mean time.

RADIO FOR ALL

Call	Station	Wave-Length Meters	Time
BXY	Hong Kong, China	2000	9.45 P.M. (GMT)
BXW	Singapore	2000	9.15 P.M. (GMT)
BZE	Matara, Ceylon	2000	8.45 P.M. (GMT)
BZF	Aden, British Somaliland..	2000	7.30 P.M. (GMT)
BZH	Seychelles	2000	9.45 P.M. (GMT)
BZG	Mauritius	2000	10.30 P.M. (GMT)
BZI	Durban, South Africa	2000	3.15 P.M. (GMT)
VMG	Apia, Samoa	2000	11.30 A.M. (GMT)
VLA	Awanui	2000	7.15 A.M. (GMT)
VLB	Awarua, Australia	2000	10.45 A.M. (GMT)
VID	Darwin, Australia	850	6.30 P.M. (GMT)
VKT	Naura, Australia	2200	7.00 P.M. (GMT)
VIP	Perth, Australia	1500	4.30 P.M. (GMT)
VJZ	Rabaul, Australia	2900	6.00 P.M. (GMT)
VIS	Sydney, Australia	2000	3.30 P.M. (GMT)
VIT	Tounsville, Australia	1000	4.30 P.M. (GMT)
VIF	Woodlark Isl., Australia..	1000	5.00 P.M. (GMT)
UA	Nantes, France	2400	3.30 A.M., 3.45 P.M. (GMT)
FL	Paris, France	2500	3.00 P.M. (GMT)
YN	Lyons, France	5000	8.00 A.M. (GMT)

LIST OF ABBREVIATIONS USED IN RADIO CODE

ABBREVIATION	QUESTION	ANSWER OR NOTICE
PRB	Do you wish to communicate by means of the International Signal Code?...	I wish to communicate by means of the International Signal Code.
QRA	What ship or coast station is that?	This is
QRB	What is your distance? ..	My distance is....
QRC	What is your true bearing?	My true bearing is .. degrees.
QRD	Where are you bound for?.	I am bound for
QRF	Where are you bound from?	I am bound from
QRG	What line do you belong to?	I belong to the line.
QRH	What is your wave-length in meters?	My wave-length is meters.
QRJ	How many words have you to send?	I have words to send.
QRK	How do you receive me? ..	I am receiving well.
QRL	Are you receiving badly? Shall I send 20 . . . — . for adjustment?	I am receiving badly. Please send 20 . . . — . for adjustment.
QRM	Are you being interfered with?	I am being interfered with.
QRN	Are the atmospherics strong?	Atmospherics are very strong
QRO	Shall I increase power? ..	Increase power.
QRP	Shall I decrease power?	Decrease power.
QRQ	Shall I send faster?	Send faster.
QRS	Shall I send slower?	Send slower.
QRT	Shall I stop sending?	Stop sending.
QRU	Have you anything for me?	I have nothing for you.
QRV	Are you ready?.....	I am ready. All right now.
QRW	Are you busy?	I am busy (or: I am busy with ...). Please do not interfere.
QRX	Shall I stand by?.....	Stand by. I will call you when required.

ABBREVIATION

ABBREVIATION	QUESTION	ANSWER OR NOTICE
QRY	When will be my turn?....	Your turn will be No.
QRZ	Are my signals weak?	Your signals are weak.
QSA	Are my signals strong?....	Your signals are strong.
QSB	Is my tone bad?.....	The tone is bad.
	Is my spark bad?.....	The spark is bad.
QSC	Is my spacing bad?.....	Your spacing is bad.
QSD	What is your time?.....	My time is
QSF	Is transmission to be in alternate order or in series?	Transmission will be in alternate order.
QSG	Transmission will be in series of 5 messages.
QSH	Transmission will be in series of 10 messages.
QSJ	What rate shall I collect for?.....	Collect
QSK	Is the last radiogram cancelled?	The last radiogram is cancelled.
QSL	Did you get my receipt?....	Please acknowledge.
QSM	What is your true course?	My true course is .. degrees.
QSN	Are you in communication with land?	I am not in communication with land.
QSO	Are you in communication with any ship or station; (or: with....)?	I am in communication with (through)
QSP	Shall I inform that you are calling him?	Inform that I am calling him.
QSQ	Is calling me?	You are being called by
QSR	Will you forward the radiogram?	I will forward the radiogram.
QST	Have you received the general call?	General call to all stations.
QSU	Please call me when you have finished (or: at .. o'clock)	Will call when I have finished.

ABBREVIATION	QUESTION	ANSWER OR NOTICE
QSV*	Is public correspondence being handled?	Public correspondence is being handled. Please do not interfere.
QSW	Shall I increase my spark frequency?	Increase your spark frequency.
QSX	Shall I decrease my spark frequency?	Decrease your spark frequency.
QSY	Shall I send on a wave-length of....meters? ...	Let us change to the wave-length of .. meters.
QSZ	Send each word twice. I have difficulty in receiving you.
QTA	Repeat the last radiogram.
QTB	Send initials of each word to confirm check.
QTC	Have you anything for me?	I have msgs for you (or: I have something for you.)
QTE	What is my true bearing?	Your true bearing is degrees from
QTF	What is my position?	Your position is latitude,longitude.

* Public correspondence is any radio work, official or private, handled on commercial wave-lengths.

When an abbreviation is followed by a mark of interrogation, it refers to the question indicated for that abbreviation.

CAPACITY OF CONDENSERS

To find the capacity of condensers use the following formula:

$$C = \frac{A \times K}{4 \times 3.1416 \times T \times 900,000}$$

C = Capacity in microfarads.

A = Area in square centimeters of one set of plates or surface.

K = Dielectric constant or specific inductive capacity of the dielectric used. (Given under "Dielectric Constants.")

T = Thickness of the dielectric between the plates, surfaces measured in centimeters.

RADIO FOR ALL

FORMULÆ

CAPACITY.

Capacity of two plates:

$$C = \frac{2248 \times K \times A}{T \times 10^9}$$

C is capacity in microfarads.

K is dielectric constant. See table.

A is area of plates in square inches.

T is thickness of dielectric in inches.

Capacity of condensers in parallel:

$$C = C_1 + C_2 + C_3 + C_4, \text{ etc.}$$

Capacity of condensers in series:

$$\frac{1}{C} = \frac{1}{C_1} + \frac{1}{C_2} + \frac{1}{C_3} + \frac{1}{C_4}, \text{ etc.}$$

Capacity necessary for any transformer:

$$C = \frac{KW \times 10^8}{E^2 \times f}$$

C is capacity in microfarads.

KW is kilowatts of power.

E is secondary voltage.

f is frequency of spark discharge.

INDUCTANCE.

Inductance of single layer round coil (solenoid):

$$L = \frac{0.03948 \times A^2 \times N^2}{b} \times K \text{ Value of "K"}$$

	Ratio of $\frac{\text{Length}}{\text{Diameter}}$	"K"
L = inductance in cm.	1/10	0.9588
A = radius of coil	1/4	0.9016
N = number of turns	1/2	0.8181
b = length of coil	3/4	0.7478
K = is a constant. See table.	1	0.6884
	3/2	0.5950
	2	0.5255
	3	0.4292
	4	0.3654
	5	0.3198

TABLE OF "L" AERIAL DIMENSIONS

Height Above Ground (Feet)	No. of Strands	Spacing Between Strands (Feet)	Length of Strands (Feet)	Approx. Daylight Rec. Range (Miles)	Approx. Wave-Length with Maximum Length Aerial Given (Metres)
30	4	2½	60-80	75-125	151
40	4	2½-3	80-90	100-150	165
50	4-6	3	80-90	125-175	178
75	4-6	3	80-100	150-300	240

WAVE-LENGTHS OF AERIALS

To calculate the approximate natural wave-length of an aerial, the total length of the aerial in feet should be multiplied by the factor 4.5. This gives the natural wave-length of the aerial in feet. This result may be divided by 3.28 to obtain the wave-length in meters.

Let us take, for example, a flat-top aerial with a length of 100 feet, connected to a lead-in wire at one end 100 feet long. Then 100 feet plus 100 feet gives 200 feet, and this multiplied by 4.5 gives 900 feet as the natural wave-length. Divided by 3.28, we have 274 meters wave-length.

If the above antenna happened to be connected "T" type, then the effective radiating length of same would be

$$\frac{100}{2} \text{ plus } 100 = 150 \text{ feet.}$$

This value, multiplied by 4.5 gives 675 feet wave-length, which, divided by 3.28, gives 206 meters.

LOOP ANTENNÆ

Range of ¼ Ft. Square Loop Aerial

Turns	Best Wave-Length	Meters
3	250	200-350
4	300	250-400
6	350	300-800
10	600	350-1000
20	1200	900-1800

Range of 6 Ft. Square Loop Aerial

2	220	180-400
6	500	400-900
10	700	600-1200
20	1400	1000-2000

RADIO FOR ALL

Spacing for Loops

Size of Loop in Feet	Spacing in Inches
3	1/8
4	1/4
6	7/16
8	9/16
10	3/4
12	15/16

WAVE-LENGTHS AND FREQUENCIES

W.L.—Wave-Lengths in Meters. *F.*—Number of Oscillations per Second.

W.L.	F.
50	6,000,000
100	3,000,000
150	2,000,000
200	1,500,000
250	1,200,000
300	1,000,000
350	857,100
400	750,000
450	666,700
500	600,000
550	545,400
600	500,000
700	428,600
800	375,000
900	333,300
1000	300,000
1100	272,730
1200	250,000
1300	230,760
1400	214,380
1500	200,000
1600	187,500
1700	176,460
1800	166,670
1900	157,890
2000	150,000
2100	142,850
2200	136,360
2300	130,430
2400	125,000

W.L.	F.
2500	120,000
2600	115,380
2700	111,110
2800	107,140
2900	103,450
3000	100,000
4000	75,000
5000	60,000
6000	50,000
7000	41,800
8000	37,500
9000	33,300
10000	30,000
11000	27,300
12000	25,000
13000	23,100
14000	21,400
15000	20,000
16000	18,750

Explanation: A wave of 350 meters will oscillate (vibrate back and forth) at the rate of 857,100 times in every second.

ENGLISH AND METRIC EQUIVALENTS

- 1 metre = 39.37 inches
- 1 cm. = 0.3937 inches
- 1 foot = 30.48 cms. or 0.3048 meters.
- 1 inch = 2.54 cms.
- 1 meter = 100 cms.

DIELECTRIC CONSTANTS "K"

Air	1.	Mirror Glass	6.00
Compressed Air	1.004	Common Glass	3.5
Crown Glass	6.96	Mica	8.0
Flint Glass	7.00	Paper	2.5
Plate Glass	8.45	Paraffin	2.25

Mica, therefore, is the highest (best) insulator; it is eight times better than air.

RADIO FOR ALL

ELECTRICAL UNITS

RESISTANCE.

The unit of resistance is the ohm. Very large resistances, as for instance, insulation resistances, are more conveniently reckoned in Meg-Ohms and very small resistances in Micro-ohms.

1 Meg-ohm = 10^6 ohms = 1 million ohms.

1 Micro-ohm = 10^{-6} ohms = 1 millionth of an ohm.

CURRENT.

The unit of current is the ampere, small currents being reckoned in Milli-amperes or in Micro-amperes.

1 Milli-ampere = 10^{-3} ampere = 1 thousandth of an ampere.

1 Micro-ampere = 10^{-6} ampere = 1 millionth of an ampere.

ELECTRO-MOTIVE-FORCE.

The unit of E.M.F. is the volt, small potential differences being reckoned in Milli-volts or in Micro-volts.

1 Milli-volt = 10^{-3} volts = 1 thousandth of a volt.

1 Micro-volt = 10^{-6} volts = 1 millionth of a volt.

QUANTITY.

The unit of quantity is the coulomb, which equals the quantity of electricity conveyed by a current of one ampere flowing for one second.

ENERGY.

The unit of electrical energy is the joule.

POWER.

The unit of power is the watt, large powers are best reckoned in Kilo-watts and very small powers in Micro-watts.

1 Kilo-watt = 10^3 watts = 1 thousand watts.

1 Micro-watt = 10^{-6} watt = 1 millionth of a watt.

746 watts = 1 H.P.

CAPACITY.

The unit of capacity is the Farad, smaller units being the micro-farad and the centimeter.

1 Micro-farad = 10^{-6} farads = 1 millionth of a farad.

900,000 cms = 1 micro-farad.

1 jar = 1,000 cms.

1 Billi-farad = 900 cms.

INDUCTANCE.

The unit of inductance is the henry, smaller units being the milli-henry, the micro-henry and the centimeter.

1 Milli-henry = 10^{-3} henry = 1 thousandth of a henry.

1 Micro-henry = 10^{-6} henry = 1 millionth of a henry.

1,000 cms. = 1 micro-henry.

1 Coil = 25,000 cms.

RADIO ACT OF 1912

Gauge B. & S. No.	Diameter in 1000ths	Capacity in Amp.	Ohms		Feet		Pounds		
			Per 1000 Feet	Per Mile	Per Pound	Per Ohm	Per 1000 Ft.	Per Ohm	
0000	.400	312.	.04906	.25903	.000077	1.56122	20497.7	640.51	12987.
000	.40064	262.	.06186	.32664	.00012	1.9687	16255.27	507.95	8533.
00	.3648	220.	.07801	.41187	.00019	2.4824	12891.37	410.83	5263.
1	.32486	185.	.09831	.51909	.00031	3.1303	10223.08	319.45	3925.
2	.2893	156.	.12404	.65490	.00049	3.94714	8107.49	253.34	3041.
3	.25763	131.	.1563	.8258	.00078	4.97722	6429.58	200.91	1882.
4	.22942	110.	.19723	1.0414	.00125	6.2765	5098.61	159.32	800.
5	.20431	92.3	.24869	1.313	.00198	7.9141	4043.61	126.33	505.
6	.18194	77.6	.31361	1.655	.00314	9.97983	3206.61	100.20	318.
7	.16202	65.2	.39546	2.088	.00499	12.5847	2542.89	79.462	200.
8	.14428	54.8	.49871	2.633	.00792	15.8696	2015.51	63.015	126.
9	.12849	46.1	.6529	3.3	.0125	20.0097	1599.3	49.076	80.
10	.11443	38.7	.7892	4.1	.0197	25.220	1268.44	39.636	50.
11	.10189	32.5	.8441	4.4	.0270	31.8212	1055.68	31.426	37.
12	.090742	27.3	1.254	6.1	.0501	40.1802	797.649	24.924	20.
13	.080808	23.	1.580	8.3	.079	50.5906	632.555	19.766	12.63
14	.071961	19.3	1.995	10.4	.127	63.7948	501.63	15.674	7.87
15	.064084	16.2	2.504	13.2	.200	80.4415	397.82	12.455	5.00
16	.057068	13.6	3.172	16.7	.320	101.4365	315.482	9.859	3.12
17	.05082	11.5	4.001	23.	.512	127.12	250.184	7.819	1.95
18	.045257	9.6	5.04	26.	.811	161.39	198.409	6.199	1.23
19	.040303	8.1	6.36	33.	1.29	203.374	157.35	4.916	.775
20	.03589	8.1	8.25	43.	2.11	256.468	124.777	3.899	.473
21	.031961	10.12	53.	3.27	323.389	98.3635	3.094	.305
22	.028462	12.76	68.	5.20	407.815	78.473	2.452	.192
23	.025347	16.25	85.	8.35	514.193	62.236	1.945	.119
24	.022571	20.30	108.	13.3	648.452	49.3504	1.542	.075
25	.0201	25.60	135	20.9	817.688	39.1363	1.223	.047
26	.0179	32.2	170.	33.2	1031.088	30.1681	.9699	.030
27	.01594	40.7	214.	52.9	1300.180	24.0131	.7692	.0187
28	.014195	51.3	270.	84.2	1669.49	19.5191	.6099	.0118
29	.012641	64.8	343.	124.	2067.364	15.4793	.4837	.0074
30	.011257	81.6	432.	188.	2606.959	12.2854	.3853	.0047
31	.010025	103.	538.	278.	3287.084	9.7355	.3092	.0039
32	.008928	130.	685	398.	4144.49	7.72143	.2413	.0018
33	.00795	164.	865	566.	5226.915	6.12243	.1913	.0011
34	.00708	206.	1083.	837.	6390.41	4.85375	.1517	.00076
35	.006304	260.	1389.	1166.	8312.8	3.34866	.1204	.00046
36	.005614	328.	1820.	1591.	10481.77	2.50305	.0956	.00028
37	.005	414.	2200.	2166.	13214.16	1.92107	.0757	.00018
38	.004453	523.	2765.	2969.	16659.97	1.42086	.06003	.00011
39	.003965	660.	3486.	3972.	21013.25	1.02392	.04758	.00007
40	.003531	832.	4395.	5286.	26496.237	0.72777	.03755	.00004
40	.003144	1049.	5542.	7143.	33320.63	0.52984	.02992	.00004

FEET PER POUND OF INSULATED MAGNET WIRE

Number B. & S. Gauge	Single Cotton	Double Cotton	Single Silk	Double Silk	Enameled
20	311	298	319	312	320
21	389	370	403	389	404
22	488	461	503	493	509
23	612	584	636	631	642
24	762	745	800	779	810
25	957	903	1005	966	1019
26	1192	1118	1265	1202	1286
27	1488	1422	1590	1543	1620
28	1852	1759	1972	1917	2042
29	2375	2207	2570	2485	2570
30	2860	2534	3145	2909	3240
31	3800	2768	3943	3683	4082
32	4375	3737	4950	4654	5132
33	5390	4697	6180	5639	6445
34	6500	6168	7740	7111	8093
35	8050	6737	9600	8534	10197
36	9820	7877	12000	10039	12813
37	11860	9309	15000	10666	16110
38	14300	10636	18660	14222	20274
39	17130	11907	23150	16516	25519
40	21590	14222	28700	21333	32107

TABLE OF INSULATED MAGNET WIRE

Size B. & S. Gauge	Turns per Linear Inch				
	Enameled	Single Cotton	Double Cotton	Single Silk	Double Silk
20	29	25	23	27	26
21	32	28	26	31	29
22	36	31	28	34	32
23	41	34	31	38	36
24	45	37	33	42	39
25	51	41	36	47	43
26	56	45	39	52	46
27	64	49	42	57	52
28	71	54	45	63	56
29	79	58	48	70	62
30	88	64	57	77	67
31	100	69	58	85	72
32	112	75	60	93	78
33	134	81	64	102	84

Size B. & S. Gauge	Enameled	Turns per Linear Inch			
		Single Cotton	Double Cotton	Single Silk	Double Silk
34	140	87	68	112	91
35	156	94	73	120	97
36	173	101	78	130	104
37	201	108	84	141	110
38	225	115	89	151	117
39	256	122	95	163	123
40	288	130	102	178	129

DOUBLE COTTON-COVERED MAGNET WIRE

Size B. & S. Gauge	No. Turns per Linear Inch	Size B. & S. Gauge	No. Turns per Linear Inch
0000	1.70	7	6.08
000	2.00	8	6.80
00	2.32	9	7.64
0	2.65	10	8.51
1	2.99	11	9.56
2	3.36	12	10.60
3	3.80	13	11.88
4	4.28	14	13.10
5	4.83	15	14.68
6	5.44	16	16.35

TUNING COIL DATA

No. of Wire B. & S. Gauge	Diameter of Core in Inches	Feet of Wire per Inch of Winding	Wave-Length in Meters per Inch of Winding	Turns of Wire per Inch of Winding	No. of Wire on Loose Coupler Secondary	Length of Primary and Secondary	Wave-Length in Meters of Loose Couplers
26	2 in.	30	37	58
28	2 in.	38	46	73
24	3 in.	36	44	46
*26	3 in.	46	56	58	34	4 in.	700
*24	4 in.	48	59	46	32	5 in.	800
*22	5 in.	49	60	37	30	6 in.	1000
*22	6 in.	58	70	37	30	6 in.	1200
20	7 in.	55	67	30
20	8 in.	63	77	30

NOTE—To find the wave-length in meters of any tuning coil, multiply its length in inches by length in meters per inch of winding.

* Indicates windings suitable for loose coupler primaries.

The data in this table were compiled for WINDINGS OF ENAMELED WIRE ONLY.

Wave-length in meters in above table equals length of wire on tuning coil in meters multiplied by 4 (not for couplers).

VARIOCOUPLER VALUES

With a Secondary of $2\frac{1}{4}$ inches in diameter, shunted by .0005 m. f. Condenser, the following wave-lengths are obtainable:

10 turns.....	80 to 220 meters
20 turns.....	120 to 350 meters
30 turns.....	150 to 420 meters
40 turns.....	175 to 550 meters

THE RADIO LAW OF 1912

An Act to regulate radio communication, approved August 13, 1912.

Be it enacted by the Senate and House of Representatives of the United States of America in Congress assembled, That a person, company, or corporation within the jurisdiction of the United States shall not use or operate any apparatus for radio communication as a means of commercial intercourse among the several States or with foreign nations, or upon any vessel of the United States engaged in interstate or foreign commerce, or for the transmission of radiograms or signals the effect of which extends beyond the jurisdiction of the State or Territory in which the same are made, or where interference would be caused thereby with the receipt of messages or signals from beyond the jurisdiction of the said State or Territory, except under and in accordance with a license, revocable for cause, in that behalf granted by the Secretary of Commerce upon application therefor; but nothing in this Act shall be construed to apply to the transmission and exchange of radiograms or signals between points situated in the same State: *Provided,* That the effect thereof shall not extend beyond the jurisdiction of the said State or interfere with the reception of radiograms or signals from beyond said jurisdiction; and a license shall not be required for the transmission or exchange of radiograms or signals by or on behalf of the Government of the United States, but every Government station on land or sea shall have special call letters designated and published in the list of radio stations of the United States by the Department of Commerce. Any person, company or corporation that shall use or operate any apparatus for radio communication in violation of this section, or knowingly aid or abet another person, company, or corporation in so doing, shall be deemed guilty of a misdemeanor, and on conviction thereof shall be punished by a fine not exceeding five hundred dollars, and the apparatus or

device so unlawfully used and operated may be adjudged forfeited to the United States.

SEC. 2. That every such license shall be in such form as the Secretary of Commerce shall determine and shall contain the restrictions, pursuant to this Act, on and subject to which the license is granted; that every such license shall be issued only to citizens of the United States or Porto Rico or to a company incorporated under the laws of some State or Territory or of the United States or Porto Rico, and shall specify the ownership and location of the station in which said apparatus shall be used and other particulars for its identification and to enable its range to be estimated; shall state the purpose of the station, and, in case of a station in actual operation at the date of passage of this Act, shall contain the statement that satisfactory proof has been furnished that it was actually operating on the above-mentioned date; shall state the wave-length or the wave-lengths authorized for use by the station for the prevention of interference and the hours for which the station is licensed for work; and shall not be construed to authorize the use of any apparatus for radio communication in any other station than that specified. Every such license shall be subject to the regulations contained herein, and such regulations as may be established from time to time by authority of this Act or subsequent Acts and treaties of the United States. Every license shall provide that the President of the United States in time of war or public peril or disaster may cause the closing of any station for radio communication and the removal therefrom of all radio apparatus, or may authorize the use or control of any such station or apparatus by any department of the Government, upon just compensation to the owners.

SEC. 3. That every such apparatus shall at all times while in use and operation as aforesaid be in charge or under the supervision of a person or persons licensed for that purpose by the Secretary of Commerce. Every person so licensed who in the operation of any radio apparatus shall fail to observe and obey regulations contained in or made pursuant to this Act or subsequent Acts or treaties of the United States, or any one of them, or who shall fail to enforce obedience thereto by an unlicensed person while serving under his supervision, in addition to the punishments and penalties herein prescribed, may suffer the suspension of the said license for a period to be fixed by the Secretary of Commerce not exceeding one year. It shall be unlawful to employ any unlicensed person or for any unlicensed person to serve in charge or in supervision of the use and operation of such apparatus, and any person violating this provision

shall be guilty of a misdemeanor, and on conviction thereof shall be punished by a fine of not more than one hundred dollars or imprisonment for not more than two months, or both, in the discretion of the court, for each and every such offense: *Provided*, That in case of emergency the Secretary of Commerce may authorize a collector of customs to issue a temporary permit, in lieu of a license, to the operator on a vessel subject to the radio ship Act of June twenty-fourth, nineteen hundred and ten.

SEC. 4. That for the purpose of preventing or minimizing interference with communication between stations in which such apparatus is operated, to facilitate radio communication, and to further the prompt receipt of distress signals, said private and commercial stations shall be subject to the regulations of this section. These regulations shall be enforced by the Secretary of Commerce through the collectors of customs and other officers of the Government as other regulations herein provided for.

The Secretary of Commerce may, in his discretion, waive the provisions of any or all of these regulations when no interference of the character above mentioned can ensue.

The Secretary of Commerce may grant special temporary licenses to stations actually engaged in conducting experiments for the development of the science of radio communication, or the apparatus pertaining thereto, to carry on special tests, using any amount of power or any wave-lengths, at such hours and under such conditions as will insure the least interference with the sending or receipt of commercial or Government radiograms, of distress signals and radiograms, or with the work of other stations.

In these regulations the naval and military stations shall be understood to be stations on land.

REGULATIONS

NORMAL WAVE-LENGTH

First. Every station shall be required to designate a certain definite wave-length as the normal sending and receiving wave-length of the station. This wave-length shall not exceed six hundred meters or it shall exceed one thousand six hundred meters. Every coastal station open to general public service shall at all times be ready to receive messages of such wave-lengths as are required by the Berlin convention. Every ship station, except as hereinafter provided, and every coast station open to general public service shall be prepared to use two sending wave-lengths, one of three hundred meters and one of six hundred meters, as required by the international convention in

force: *Provided*, That the Secretary of Commerce may, in his discretion, change the limit of wave-length reservation made by regulations first and second to accord with any international agreement to which the United States is a party.

OTHER WAVE-LENGTHS

Second. In addition to the normal sending wave-length all stations, except as provided hereinafter in these regulations, may use other sending wave-lengths: *Provided*, That they do not exceed six hundred meters or that they do exceed one thousand six hundred meters: *Provided further*, That the character of the waves emitted conforms to the requirements of regulations third and fourth following.

USE OF A "PURE WAVE"

Third. At all stations if the sending apparatus, to be referred to hereinafter as the "transmitter," is of such a character that the energy is radiated in two or more wave-lengths, more or less sharply defined, as indicated by a sensitive wave meter, the energy in no one of the lesser waves shall exceed ten per centum of that in the greatest.

USE OF A "SHARP WAVE"

Fourth. At all stations the logarithmic decrement per complete oscillation in the wave trains emitted by the transmitter shall not exceed two-tenths, except when sending distress signals or signals and messages relating thereto.

USE OF "STANDARD DISTRESS WAVE"

Fifth. Every station on shipboard shall be prepared to send distress calls on the normal wave-length designated by the international convention in force, except on vessels of small tonnage unable to have plants insuring that wave-length.

SIGNAL OF DISTRESS

Sixth. The distress call used shall be the international signal of distress . . . — — — . . .

USE OF "BROAD INTERFERING WAVE" FOR DISTRESS SIGNALS

Seventh. When sending distress signals, the transmitter of a station on shipboard may be tuned in such a manner as to create a maximum of interference with a maximum of radiation.

DISTANCE REQUIREMENT FOR DISTRESS SIGNALS

Eighth. Every station on shipboard, wherever practicable, shall be prepared to send distress signals of the character specified in regulations fifth and sixth with sufficient power to enable them to be

received by day over sea a distance of one hundred nautical miles by a shipboard station equipped with apparatus for both sending and receiving equal in all essential particulars to that of the station first mentioned.

"RIGHT OF WAY" FOR DISTRESS SIGNALS

Ninth. All stations are required to give absolute priority to signals and radiograms relating to ships in distress; to cease all sending on hearing a distress signal; and except when engaged in answering or aiding the ship in distress, to refrain from sending until all signals and radiograms relating thereto are completed.

REDUCED POWER FOR SHIPS NEAR A GOVERNMENT STATION

Tenth. No station on shipboard, when within fifteen nautical miles of a naval or military station, shall use a transformer input exceeding one kilowatt, nor, when within five nautical miles of such a station, a transformer input exceeding one-half kilowatt, except for sending signals of distress, or signals or radiograms relating thereto.

INTERCOMMUNICATION

Eleventh. Each shore station open to general public service between the coast and vessels at sea shall be bound to exchange radiograms with any similar shore station and with any ship station without distinction of the radio systems adopted by such stations, respectively, and each station on shipboard shall be bound to exchange radiograms with any other station on shipboard without distinction of the radio systems adopted by each station, respectively.

It shall be the duty of each shore station, during the hours it is in operation, to listen in at intervals of not less than fifteen minutes and for a period not less than two minutes, with the receiver tuned to receive messages of three hundred meter wave-lengths.

DIVISION OF TIME

Twelfth. At important seaports and at all other places where naval or military and private or commercial shore stations operate in such close proximity that interference with the work of naval and military stations can not be avoided by the enforcement of the regulations contained in the foregoing regulations concerning wave-lengths and character of signals emitted, such private or commercial shore stations as do interfere with the reception of signals by the naval and military stations concerned shall not use their transmitters during the first fifteen minutes of each hour, local standard time. The Secretary of Commerce may, on the recommendation of the department concerned, designate the station or stations which may be required to observe this division of time.

GOVERNMENT STATIONS TO OBSERVE DIVISION OF TIME

Thirteenth. The naval or military stations for which the above-mentioned division of time may be established shall transmit signals or radiograms only during the first fifteen minutes of each hour, local standard time, except in case of signals or radiograms relating to vessels in distress, as hereinbefore provided.

USE OF UNNECESSARY POWER

Fourteenth. In all circumstances, except in case of signals or radiograms relating to vessels in distress, all stations shall use the minimum amount of energy necessary to carry out any communication desired.

GENERAL RESTRICTIONS ON PRIVATE STATIONS

Fifteenth. No private or commercial station not engaged in the transaction of bona fide commercial business by radio communication or in experimentation in connection with the development and manufacture of radio apparatus for commercial purposes shall use a transmitting wave-length exceeding two hundred meters, or a transformer input exceeding one kilowatt, except by special authority of the Secretary of Commerce contained in the license of the station: *Provided*, That the owner or operator of a station of the character mentioned in this regulation shall not be liable for a violation of the requirements of the third or fourth regulations to the penalties of one hundred dollars or twenty-five dollars, respectively, provided in this section unless the person maintaining or operating such station shall have been notified in writing that the said transmitter has been found, upon tests conducted by the Government, to be so adjusted as to violate the said third and fourth regulations, and opportunity has been given to said owner or operator to adjust said transmitter in conformity with said regulations.

SPECIAL RESTRICTIONS IN VICINITIES OF GOVERNMENT STATIONS

Sixteenth. No station of the character mentioned in regulation fifteenth situated within five nautical miles of a naval or military station shall use a transmitting wave-length exceeding two hundred meters or a transformer input exceeding one-half kilowatt.

SHIP STATIONS TO COMMUNICATE WITH NEAREST SHORE STATIONS

Seventeenth. In general, the shipboard stations shall transmit their radiograms to the nearest shore station. A sender on board a vessel shall, however, have the right to designate the shore station through which he desires to have his radiograms transmitted, If this can not

be done, the wishes of the sender are to be complied with only if the transmission can be effected without interfering with the service of other stations.

LIMITATIONS FOR FUTURE INSTALLATIONS IN VICINITIES
OF GOVERNMENT STATIONS

Eighteenth. No station on shore not in actual operation at the date of the passage of this Act shall be licensed for the transaction of commercial business by radio communication within fifteen nautical miles of the following naval or military stations, to wit: Arlington, Virginia; Key West, Florida; San Juan, Porto Rico; North Head and Tatoosh Island, Washington; San Diego, California; and those established or which may be established in Alaska and in the Canal Zone; and the head of the department having control of such Government stations shall, so far as is consistent with the transaction of governmental business, arrange for the transmission and receipt of commercial radiograms under the provisions of the Berlin convention of nineteen hundred and six and future international conventions or treaties to which the United States may be a party, at each of the stations above referred to, and shall fix the rates therefor, subject to control of such rates by Congress. At such stations and wherever and whenever shore stations open for general public business between the coast and vessels at sea under the provisions of the Berlin convention of nineteen hundred and six and future international conventions and treaties to which the United States may be a party shall not be so established as to insure a constant service day and night without interruption, and in all localities wherever or whenever such service shall not be maintained by a commercial shore station within one hundred nautical miles of a naval radio station, the Secretary of the Navy shall, so far as is consistent with the transaction of governmental business, open naval radio stations to the general public business described above, and shall fix rates for such service, subject to control of such rates by Congress. The receipts from such radiograms shall be covered into the Treasury as miscellaneous receipts.

SECRECY OF MESSAGES

Nineteenth. No person or persons engaged in or having knowledge of the operation of any station or stations, shall divulge or publish the contents of any messages transmitted or received by such station, except to the person or persons to whom the same may be directed, or their authorized agent, or to another station employed to forward such message to its destination, unless legally required so to do by the court of competent jurisdiction or other competent authority. Any

person guilty of divulging or publishing any message, except as herein provided, shall, on conviction thereof, be punished by a fine of not more than two hundred and fifty dollars or imprisonment for a period of not exceeding three months, or both fine and imprisonment, in the discretion of the court.

PENALTIES

For violation of any of these regulations, subject to which a license under sections one and two of this Act may be issued, the owner of the apparatus shall be liable to a penalty of one hundred dollars, which may be reduced or remitted by the Secretary of Commerce, and for repeated violations of any of such regulations, the license may be revoked.

For violation of any of these regulations, except as provided in regulation nineteenth, subject to which a license under section three of this Act may be issued, the operator shall be subject to a penalty of twenty-five dollars, which may be reduced or remitted by the Secretary of Commerce, and for repeated violations of any such regulations, the license shall be suspended or revoked.

SEC. 5. That every license granted under the provisions of this Act for the operation or use of apparatus for radio communication shall prescribe that the operator thereof shall not willfully or maliciously interfere with any other radio communication. Such interference shall be deemed a misdemeanor, and upon conviction thereof the owner or operator, or both, shall be punishable by a fine of not to exceed five hundred dollars or imprisonment for not to exceed one year, or both.

SEC. 6. That the expression "radio communication" as used in this Act means any system of electrical communication by telegraphy or telephony without the aid of any wire connecting the points from and at which the radiograms, signals, or other communications are sent or received.

SEC. 7. That a person, company, or corporation within the jurisdiction of the United States shall not knowingly utter or transmit, or cause to be uttered or transmitted, any false or fraudulent distress signal or call or false or fraudulent signal, call, or other radiogram of any kind. The penalty for so uttering or transmitting a false or fraudulent distress signal or call shall be a fine of not more than two thousand five hundred dollars or imprisonment for not more than five years, or both, in the discretion of the court, for each and every such offense, and the penalty for so uttering or transmitting, or causing to be uttered or transmitted, any other false or fraudulent signal, call, or other radiogram shall be a fine of not more than one

thousand dollars or imprisonment for not more than two years, or both, in the discretion of the court, for each and every such offense.

SEC. 8. That a person, company, or corporation shall not use or operate any apparatus for radio communication on a foreign ship in territorial waters of the United States otherwise than in accordance with the provisions of sections four and seven of this Act and so much of section five as imposes a penalty for interference. Save as aforesaid, nothing in this Act shall apply to apparatus for radio communication on any foreign ship.

SEC. 9. That the trial of any offense under this Act shall be in the district in which it is committed, or if the offense is committed upon the high seas or out of the jurisdiction of any particular State or district the trial shall be in the district where the offender may be found or into which he shall be first brought.

SEC. 10. That this Act shall not apply to the Philippine Islands.

SEC. 11. That this Act shall take effect and be in force on and after four months from its passage.

Approved, August 13, 1912.

U. S. BROADCASTING STATIONS

(Corrected to September 1, 1922)

Call Letters	Name	City	State	Wave- Length
KDKA	Westinghouse El. & Mfg. Co.	East Pittsburgh	Pa.	360
KDN	Leo J. Meyberg Co.	San Francisco	Calif.	360-485
KDPM	Westinghouse Elec. & Mfg. Co.	Cleveland	Ohio	360
KDPT	Southern Electrical Co.	San Diego	Calif.	360
KDYL	Telegram Publishing Co.	Salt Lake City	Utah	360
KDYM	Savoy Theatre	San Diego	Calif.	360
KDYN	Great Western Radio Corp.	Redwood City	Calif.	360
KDYO	Carlson & Simpson	San Diego	Cal.	360
KDYQ	Ore. Inst. of Technology	Portland	Ore.	485
KDYR	Pasadena Star-News Pub. Co.	Pasadena	Calif.	360
KDYS	The Tribune	Great Falls	Mont.	360
KDYU	Herald Publishing Co.	Klamath Falls	Ore.	360
KDYV	Cope & Cornwell Co.	Salt Lake City	Utah	360
KDYW	Smith, Hughes & Co.	Phoenix	Ariz.	360
KDYX	Star Bulletin	Honolulu	Hawaii	360
KDYY	Rocky Mt. Radio Corp.	Denver	Colo.	360

RADIO ACT OF 1912

267

Call Letters	Name	City	State	Wave-Length
KDZA	Arizona Daily Star	Tucson	Ariz.	360
KDZB	Frank E. Siefert	Bakersfield	Calif.	360
KDZD	W. R. Mitchell	Los Angeles	Calif.	360
KDZE	The Rhodes Co.	Seattle	Wash.	360
KDZF	Auto Club of Southern Calif.	Los Angeles	Calif.	360
KDZG	Cyrus Pierce & Co.	San Francisco	Calif.	360
KDZH	Fresno Evening Herald	Fresno	Calif.	360
KDZI	Electric Supply Co.	Wenatchee	Wash.	360
KDZJ	Excelsior Radio Co.	Eugene	Ore.	360
KDZK	Nevada Mach. & Electric Co.	Reno	Nev.	360
KDZL	Rocky Mt. Radio Corp.	Ogden	Utah	360
KDZM	Hollingworth, E. H.	Centralia	Wash.	360
KDZN	Western Radio Corp.	Denver	Colo.	360
KDZP	Newbery Electric Corp.	Los Angeles	Calif.	360
KDZQ	Motor Generator	Denver	Colo.	360
KDZR	Bellingham Publishing Co.	Bellingham	Wash.	360
KDZT	Seattle Radio Assoc.	Seattle	Wash.	360
KDZW	Claude W. Gerdes	San Francisco	Calif.	360
KDZX	Glad Tidings Tabernacle	San Francisco	Calif.	360
KDZZ	Kinney Bros. & Sipprell	Everett	Wash.	360
KFAB	Pacific Radiophone Co.	Portland	Ore.	360
KFAC	Glendale Daily Press	Glendale	Calif.	360
KFAD	McArthur Bros. Mercantile Co.	Phoenix	Ariz.	360
KFAE	State College of Washington	Pullman	Wash.	360
KFAF	Western Radio Corp.	Denver	Colo.	360
KFAJ	University of Colorado	Boulder	Colo.	360
KFAN	The Electric Shop	Moscow	Idaho	360
KFAP	Standard Publishing Co.	Butte	Mont.	360
KFAQ	City of San José	San José	Calif.	360
KFAR	Studio Lighting Service Co.	Hollywood	Calif.	360
KFAS	Reno Motor Supply Co.	Reno	Nevada	360
KFAT	S. T. Donohue	Eugene	Ore.	360
KFAU	High School	Boise	Idaho	360-485
KFAV	Cooke & Chapman	Venice	Calif.	360

RADIO FOR ALL

Call Letters	Name	City	State	Wave-Length
KFAW	Register Radio Den Radiophone	Santa Ana	Calif.	360
KFAY	W. J. Virgin Milling Co.	Central Point	Ore.	360
KFBA	Ramey & Bryant Radio Co.	Lewiston	Idaho	360
KFBB	F. A. Buttrey & Co.	Havre	Mont.	360
KFBC	Normal Heights Sta., W. K. Azbill	San Diego	Calif.	360
KFBD	Clarence V. Welch	Hanford	Calif.	360
KFBE	R. H. Horn, Cline's Electric Shop	San Luis Obispo	Calif.	360
KFBF	Butte School of Telegraphy	Butte	Mont.	360
KFBG	First Presbyterian Church	Tacoma	Wash.	360
KFBH	Thomas Musical Co.	Marshfield	Ore.	360
KFBJ	Idaho Radio Supply Co.	Boise	Idaho	360
KFBK	Kimball-Upson Co.	Sacramento	Calif.	360
KFBL	Leese Bros.	Everett	Wash.	360
KFBM	Cook & Foster	Astoria	Ore.	360
KFBN	Borch Radio Corp.	(portable)	Calif.	360
KFC	Northern Radio & Elec. Co.	Seattle	Wash.	360
KFDB	John D. McKee	San Francisco	Calif.	360
KFI	Carl C. Anthony	Los Angeles	Calif.	360
KFU	The Precision Shop	Gridley	Calif.	360
KFV	Foster Bradbury Radio Store	Yakima	Wash.	360
KFZ	Doerr-Mitchell Elec. Co.	Spokane	Wash.	360
KGB	Wm. H. Mullins Elec. Co.	Tacoma	Wash.	360
KGC	Elec. Lighting & Elec. Co.	Hollywood	Calif.	360
KGF	Pomona Fixture & Wiring Co.	Pomona	Calif.	360
KGG	Hallock & Watson Radio Serv.	Portland	Ore.	360
KGN	Northwest Radio Mfg. Co.	Portland	Ore.	360
KGO	Altadena Radio Laboratory	Altadena	Calif.	360
KGU	Marion H. Mulrony	Honolulu	Hawaii	360
KGW	Oregonian Publishing Co.	Portland	Ore.	360

RADIO ACT OF 1912

269

Call Letters	Name	City	State	Wave-Length
KGY	St. Martin's College (Rev. S. Ruth)	Lacey	Wash.	360
KHD	C. F. Aldrich Marble and Granite Co.	Colorado Springs	Colo.	485
KHJ	C. R. Kierulff & Co.	Los Angeles	Calif.	360
KHQ	Louis Wasmer	Seattle	Wash.	360
KJC	Standard Radio Co.	Los Angeles	Calif.	360
KJJ	The Radio Shop	Sunnyvale	Calif.	360
KJQ	C. O. Gould	Stockton	Calif.	360
KJR	Vincent I. Kraft	Seattle	Wash.	
				360-485
KJS	Bible Inst. of Los Angeles	Los Angeles	Calif.	360
KLB	J. J. Dunn & Co.	Pasadena	Calif.	360
KLN	Hotel Del Monte	Del Monte	Calif.	360
KLP	Colin B. Kennedy	Los Altos	Calif.	360
KLS	Warner Brothers	Oakland	Calif.	360
KLX	Tribune Publishing Co.	Oakland	Calif.	360
KLZ	Reynolds Radio Co.	Denver	Colo.	360
KMC	Lindsay Weatherill & Co.	Riedley	Calif.	360
KMJ	San Joaquin Lt. & Power Co.	Fresno	Calif.	860
KMO	Love Electric Co.	Tacoma	Wash.	360
KNI	T. W. Smith	Eureka	Calif.	360
KNJ	Roswell Public Service Co.	Roswell	N.M.	360-485
KNN	Bullock's	Los Angeles	Calif.	360
KNR	Beacon Light Co.	Los Angeles	Calif.	360
KNT	North Coast Products Co.	Aberdeen	Wash.	360
KNV	Radio Supply Co.	Los Angeles	Calif.	360
KNX	Electric Ltg. Supply Co.	Los Angeles	Calif.	360
KOA	Y.M.C.A.	Denver	Colo.	485
KOB	N.M. College Agr. & Mch. Arts	State College	N.M.	360-485
KOE	Spokane Chronicle	Spokane	Wash.	360
KOG	Western Radio Electric Co.	Los Angeles	Calif.	360
KOJ	University of Nevada	Reno	Nev.	360
KON	Holzwasser, Inc.	San Diego	Calif.	360
KOP	Detroit Police Dep't	Detroit	Mich.	360
KOQ	Modesto Evening News	Modesto	Calif.	360
KPO	Hale Brothers	San Francisco	Calif.	360
KQI	Univ. of California	Berkeley	Calif.	360

RADIO FOR ALL

Call Letters	Name	City	State	Wave-Length
KQL	Arno H. Kluge	Los Angeles	Calif.	360
KQP	Blue Diamond Electric Co.	Hood River	Ore.	360-485
KQT	Elec. Power & Appliance Co.	Yakima	Wash.	360
KQV	Doubleday-Hill Elec. Co.	Pittsburgh	Pa.	360
KQW	Charles D. Herrold	San José	Calif.	360
KQY	Stubbs Electric Co.	Portland	Ore.	360
KRE	Maxwell Electric Co.	Berkeley	Calif.	360
KSC	O. A. Hale & Co.	San José	Calif.	360
KSD	Post Dispatch	St. Louis	Mo.	360
KSL	The Emporium	San Francisco	Calif.	360
KSS	Prest & Dean Radio Co.	Long Beach	Calif.	360
KTW	First Presbyterian Church	Seattle	Wash.	360
KUO	Examiner Printing Co.	San Francisco	Calif.	360-485
KUS	City Dye Works & Laundry Co.	Los Angeles	Calif.	360
KUY	Coast Radio Co.	El Monte	Calif.	360
KVQ	J. C. Hobrecht	Sacramento	Calif.	360
KWG	Portable Wireless Tele. Co.	Stockton	Calif.	360
KWH	Los Angeles Examiner	Los Angeles	Calif.	360
KXD	Herald Publishing Co.	Modesto	Calif.	360
KXS	Braun Corp.	Los Angeles	Calif.	360
KYF	Thearle Music Co.	San Diego	Calif.	360
KYG	Willard P. Hawley, Jr.	Portland	Ore.	360
KYI	Alfred Harrell	Bakersfield	Calif.	360
KYJ	Leo J. Meyberg Co.	Los Angeles	Calif.	360-485
KYW	Westinghouse Elec. & Mfg. Co.	Chicago	Ill.	360-485
KYY	Radio Telephone Shop	San Francisco	Calif.	360
KZC	Pub. Mkt. & Mkt. Stores Co.	Seattle	Wash.	360
KZI	Irving S. Cooper	Los Angeles	Calif.	360
KZM	Preston D. Allen	Oakland	Calif.	360-485
KZN	The Deseret News	Salt Lake City	Utah	360-485
KZV	Wenatchee Battery & Motor Co.	Wenatchee	Wash.	360

RADIO ACT OF 1912

271

Call Letters	Name	City	State	Wave-Length
KZY	Atl. & Pac. Radio Supply Co.	Oakland	Calif.	360
WAAB	Times Picayune	New Orleans	La.	360
WAAC	Tulane University	New Orleans	La.	360
WAAD	Ohio Mechanics Institute	Cincinnati	Ohio	360
WAAE	St. Louis Chamber of Commerce	St. Louis	Mo.	360
WAAF	Union Stock Yds. & Transit Co.	Chicago	Ill.	360-485
WAAG	Elliott Electric Co.	Shreveport	La.	360
WAAH	Commonwealth Electric Co.	St. Paul	Minn.	360
WAAJ	Eastern Radio Institute	Boston	Mass.	360
WAAK	Gimbel Brothers	Milwaukee	Wis.	360
WAAL	Minn. Tribune & A. Beamish Co.	Minneapolis	Minn.	360
WAAM	I. R. Nelson Co.	Newark	N.J.	360
WAAN	University of Missouri	Columbia	Mo.	360
WAAO	Radio Service Co.	Charlestown	W. Va.	360
WAAP	Otto W. Taylor	Wichita	Kans.	360
WAAQ	New England Motor Sales Co.	Greenwich	Conn.	360
WAAR	Groves Thornton Hdwe. Co.	Huntington	W. Va.	360
WAAS	Georgia Radio Co.	Decatur	Ga.	360
WAAV	Athens Radio Co.	Athens	Ohio	360
WAAW	Omaha Grain Exchange	Omaha	Neb.	360
WAAX	Radio Service Corp.	Crafton	Pa.	360
WAAY	Yahrling Rayner Music Co.	Youngstown	Ohio	360
WAAZ	Hollister-Miller Motor Co.	Emporia	Kans.	360
WAH	Midland Refining Co.	El Dorado	Kans.	360-485
WBAA	Purdue University	West Lafayette	Ind.	360
WBAB	Andrew J. Potter	Syracuse	N.Y.	360
WBAD	Sterling Electric Co.	Minneapolis	Minn.	360
WBAE	Bradley Polytechnic Inst.	Peoria	Ill.	360-485
WBAF	Fred M. Middleton	Moorestown	N.J.	360
WBAG	Diamond State Fibre Co.	Bridgeport	Pa.	360-485
WBAH	The Dayton Co.	Minneapolis	Minn.	360
WBAJ	Marshall-Gerken Co.	Toledo	Ohio	360

RADIO FOR ALL

Call Letters	Name	City	State	Wave-Length
WBAM	I. B. Rennyson	New Orleans	La.	360
WBAN	Wireless Phone Corp.	Paterson	N.J.	360
WBAO	James Millikin University	Decatur	Ill.	360
WBAP	Wortham-Carter Pub. Co.	Fort Worth	Tex.	360-485
WBAQ	Myron L. Harmon	South Bend	Ind.	360
WBAU	Republican Publishing Co.	Hamilton	Ohio	360
WBAV	Erner & Hopkins	Columbus	Ohio	360
WBAW	Marietta College	Marietta	Ohio	360
WBAX	John H. Stenger, Jr.	Wilkes-Barre	Pa.	360
WBAY	American Tel. & Tel. Co.	New York	N.Y.	360
WBAZ	Times Dispatch Pub. Co.	Richmond	Va.	360
WBL	T. & H. Radio Co.	Anthony	Kans.	360
WBS	D. W. May, Inc.	Newark	N.J.	360
WBT	Southern Radio Corp.	Charlotte	N.C.	360-485
WBU	City of Chicago	Chicago	Ill.	360
WBZ	Westinghouse Elec. & Mfg. Co.	Springfield	Mass.	360
WCAB	Newberg News Ptg. & Pub. Co.	Newberg	N. Y.	360
WCAC	John Fink Jewelry Co.	Fort Smith	Ark.	360
WCAD	St. Lawrence University	Canton	Ohio	360
WCAE	Kaufman & Baer Co.	Pittsburgh	Pa.	360
WCAG	Daily States Pub. Co.	New Orleans	La.	360
WCAH	Entrekin Electric Co.	Columbus	Ohio	360
WCAJ	Nebraska Wesleyan Univ.	University Place	Neb.	360-485
WCAK	Alfred P. Daniel	Houston	Texas	360
WCAL	St. Olaf College	Northfield	Minn.	360
WCAM	Villanova College	Villanova	Pa.	360
WCAN	Southeastern Radio Tel. Co.	Jacksonville	Fla.	360
WCAO	Sanders & Stayman Co.	Baltimore	Md.	360
WCAP	Central Radio Service	Decatur	Ill.	360
WCAQ	Tri-State Radio Mfg. & Sup. Co.	Defiance	Ohio	360
WCAR	Alamo Radio Electric Co.	San Antonio	Texas	360
WCAS	Wm. H. Dunwoody Indust. Inst.	Minneapolis	Minn.	360
WCAT	So. Dakota School of Music	Rapid City	S. Dak.	485

RADIO ACT OF 1912

273

Call Letters	Name	City	State	Wave-Length
WCAU	Philadelphia Radiophone Co.	Philadelphia	Pa.	360
WCAV	J. C. Dice Electric Co.	Little Rock	Ark.	360
WCAW	Q. Herald & Quincy Elec. Sup. Co.	Quincy	Ill.	360
WCAX	University of Vermont	Burlington	Vt.	360
WCAY	Kesselman O'Driscoll Co.	Milwaukee	Wis.	360
WCAZ	R. E. Compton & Q. Whig General	Quincy	Ill.	360
WCE	Findley Electric Co.	Minneapolis	Minn.	360
WCJ	A. C. Gilbert	New Haven	Conn.	360
WCK	Stix-Baer-Fuller	St. Louis	Mo.	360
WCM	University of Texas	Austin	Tex.	360-485
WCN	Clark University	Worcester	Mass.	360-485
WCX	Detroit Free Press	Detroit	Mich.	360-485
WDAA	Ward Belmont School	Nashville	Tenn.	360
WDAB	H. C. Summers & Son	Portsmouth	Ohio	360
WDAC	Illinois Watch Co.	Springfield	Ill.	485
WDAD	Wm. L. Harrison	Lindsborg	Kans.	360
WDAE	Tampa Daily Times	Tampa	Fla.	360-485
WDAF	Kansas City Star	Kansas City	Mo.	360
WDAG	J. Lawrence Martin	Amarillo	Texas	360
WDAH	Mine & Smelter Supply Co.	El Paso	Texas	360
WDAI	Hughes Electrical Corp.	Syracuse	N. Y.	360
WDAJ	Atlanta & West Point R. R. Co.	College Park	Ga.	360
WDAK	The Courant	Hartford	Conn.	360
WDAL	Florida Times Union	Jacksonville	Fla.	360-485
WDAN	Glenwood Radio Corp.	Shreveport	La.	360
WDAO	Automotive Electric Co.	Dallas	Texas	360
WDAP	Mid-West Radio Central, Inc.	Chicago	Ill.	360
WDAQ	Hartman Riker Elec. & Mch. Co.	Brownsville	Pa.	360
WDAR	Lit Bros.	Philadelphia	Pa.	360
WDAS	Samuel A. Waite	Worcester	Mass.	360
WDAT	Delta Electric Co.	Worcester	Mass.	360
WDAU	Slocum & Kilburn	New Bedford	Mass.	360
WDAV	Muskogee Daily Phoenix	Muskogee	Okla.	360

RADIO FOR ALL

Call Letters	Name	City	State	Wave-Length
WDAW	Georgia Rwy. & Power Co.	Atlanta	Ga.	360-485
WDAX	First National Bank	Centerville	Iowa	360
WDAY	Kenneth M. Hance	Fargo	N. Dak.	360-485
WDM	Church of the Covenant	Washington	D. C.	
WDT	Ship Owners' Radio Service	New York	N.Y.	360
WDV	Yeiser, John O., Jr.	Omaha	Neb.	360
WDY	Radio Corp. of America	Roselle Park	N.J.	360
WDZ	James L. Bush	Tuscola	Ill.	360
WEAA	Fallian & Lathrop	Flint	Mich.	360
WEAB	Standard Radio Equip. Co.	Fort Dodge	Iowa	360
WEAC	Baines Elec. Serv. Co.	Terre Haute	Ind.	360
WEAD	N. W. Kansas Radio Supply Co.	Atwood	Kan.	360
WEAE	Virginia Polytechnic Inst.	Blacksburg	Va.	360
WEAF	Western Electric Co.	New York	N.Y.	360
WEAG	Nichols-Hineline-Bassett Lab.	Edgewood	R.I.	360
WEAH	W. Bd. of Trd. & Lander Radio Co.	Wichita	Kan.	360-485
WEAI	Cornell University	Ithaca	N.Y.	360
WEAJ	Univ. of So. Dakota	Vermillion	S. Dak.	360
WEAK	Julius B. Abercrombie	St. Joseph	Mo.	360
WEAM	Boro of North Plainfield	No. Plainfield	N.J.	360
WEAN	Shepard Co.	Providence	R.I.	360
WEAO	Ohio State University	Columbus	Ohio	360-485
WEAP	Mobile Radio Co.	Mobile	Ala.	360
WEAQ	Y.M.C.A.	Berlin	N.H.	360
WEAR	Baltimore Amer. & News Pub. Co.	Baltimore	Md.	360
WEAS	Hecht Co.	Washington	D.C.	360
WEAT	John J. Fogarty	Tampa	Fla.	360
WEAU	Davidson Bros. Co.	Sioux City	Iowa	360
WEAV	Sheridan El. Serv. Co.	Rushville	Neb.	360
WEAW	Arrow Radio Laboratories	Anderson	Ind.	360
WEAX	T. J. M. Daly	Little Rock	Ark.	360-485
WEAY	Will Horwitz, Jr.	Houston	Texas	360

RADIO ACT OF 1912

275

Call Letters	Name	City	State	Wave Length
WEAZ	Donald Redmond	Waterloo	Iowa	360
WEB	Benwood Co.	St. Louis	Mo.	360
WEH	Midland Refining Co.	Tulsa	Okla.	360-485
WEV	Hurlburt-Still Electrical Co.	Houston	Tex.	360-485
WEW	St. Louis University	St. Louis	Mo.	360-485
WEY	Cosradio Co.	Wichita	Kan.	360-485
WFAA	A. H. Belo & Co.	Dallas	Tex.	360-485
WFAB	Carl F. Woese	Syracuse	N.Y.	360
WFAC	Superior Radio Co.	Superior	Wis.	360
WFAD	Watson Weldon Motor Sup. Co.	Salina	Kan.	360
WFAF	H. C. Spratley Co.	Poughkeepsie	N.Y.	360
W FAG	Radio Engineering Laboratory	Waterford	N.Y.	360
WFAH	Electric Supply Co.	Port Arthur	Texas	360
WFAJ	Hi Grade Wireless Instr. Co.	Asheville	N.C.	360
WFAK	Domestic Electric Co.	Brentwood	Mo.	360
WFAL	Houston Chronicle Pub. Co.	Houston	Tex.	360-485
WFAM	Times Pub. Co.	St. Cloud	Minn.	360
WFAN	Hutchinson Elec. Serv. Co.	Hutchinson	Minn.	360-485
WFAP	Brown's Business College	Peoria	Ill.	360
WFAQ	Mo. Wesleyan College & Cameron Radio Co.	Cameron	Mo.	360
WFAR	Hall & Stubs	Stamford	Me.	360
WFAS	United Radio Corp.	Ft. Wayne	Ind.	360
WFAT	Daily Argus Leader	Sioux Falls	S. Dak.	360
WFAU	Edwin C. Lewis	Boston	Mass.	360
WFAV	University of Nebraska	Lincoln	Nebr.	360-485
WFAW	Miami Daily Metropolis	Miami	Fla.	360
WFAX	Arthur L. Kent	Binghamton	N.Y.	360
WFAY	Daniels Radio Supply Co.	Independence	Kan.	360
WFAZ	South Carolina Radio Shop	Charleston	S.C.	360
WFI	Strawbridge & Clothier	Philadelphia	Pa.	360-485
WFO	Rike-Kumler Co.	Dayton	Ohio	360-485
WGAB	Q.R.V. Radio Co.	Houston	Texas	360

RADIO FOR ALL

Call Letters	Name	City	State	Wave-Length
WGAC	Orpheum Radio Stores Co.	Brooklyn	N.Y.	360
WGAD	Spanish American School of Radio-Telegraphy	Ensenada	P.R.	360
WGAF	Goller Radio Service	Tulsa	Okla.	360
WGAH	New Haven Electric Co.	New Haven	Conn.	360
WGAJ	W. H. Goss	Shenandoah	Iowa	360
WGAK	Macon Electric Co.	Macon	Ga.	360
WGAL	Lancaster Elec. Supply & Const. Co.	Lancaster	Pa.	360
WGAM	Orangeburg Radio Equipment Co.	Orangeburg	S.C.	360
WGAN	Cecil E. Lloyd	Pensacola	Fla.	360
WGAQ	Glenwood Radio Corp.	Shreveport	La.	360
WGAR	Southwest American	Fort Smith	Ark.	360
WGAS	The Ray-Di-Co Organ- ization	Chicago	Ill.	360
WGAT	American Legion, Dept. of Nebraska	Lincoln	Neb.	360
WGAU	Marcus G. Limb	Wooster	Ohio	360
WGAW	Ernest C. Albright	Altoona	Pa.	360
WGAY	North Western Radio Co.	Madison	Wis.	360
WGAZ	The South Bend Tribune	South Bend	Ind.	360
WGF	The Register & Tribune	Des Moines	Iowa	360-485
WGH	Montgomery Light & Power Co.	Montgomery	Ala.	360-485
WGI	Amer. Radio Research Corp.	Medford Hillside	Mass.	360
WGL	Thomas F. J. Howlett	Philadelphia	Pa.	360
WGR	Federal Tel. & Tel. Co.	Buffalo	N.Y.	360-485
WGU	The Fair	Chicago	Ill.	360
WGV	Interstate Electric Co.	New Orleans	La.	360
WGY	General Electric Co.	Schenectady	N.Y.	360
WHA	University of Wisconsin	Madison	Wis.	360-485
WHAA	State University of Iowa	Iowa City	Iowa	360
WHAB	Clark W. Thompson	Galveston	Texas	360-485
WHAC	Cole Bros. Electric Co.	Waterloo	Iowa	360
WHAD	Marquette University	Milwaukee	Wis.	360
WHAE	Automotive Electric Ser- vice Co.	Sioux City	Iowa	360

RADIO ACT OF 1912

277

Call Letters	Name	City	State	Wave-Length
WHAF	Radio Electric Co.	Pittsburgh	Pa.	360
WHAG	University of Cincinnati	Cincinnati	Ohio	360
WHAH	John T. Griffin	Joplin	Mo.	360
WHAJ	Radio Equipment & Mfg. Co.	Davenport	Iowa	360
WHAJ	Bluefield Daily Telegraph	Bluefield	W. Va.	360
WHAK	Roberts Hdwe. Co.	Clarksburg	W. Va.	360
WHAL	Phillips Jeffery & Derby	Lansing	Mich.	360
WHAM	University of Rochester	Rochester	N.Y.	360
WHAN	Southwestern Radio Co.	Wichita	Kansas	360
WHAO	Frederic A. Hill	Savannah	Ga.	360
WHAP	Dewey L. Otta	Decatur	Ill.	360
WHAQ	Semmes Motor Co.	Washington	D.C.	360
WHAR	Paramount Radio & Elec. Co.	Atlantic City	N.J.	360
WHAS	Courier-Journal and Louisville Times	Louisville	Ky.	360-485
WHAT	Yale Democrat - Yale Telephone Co.	Yale	Okla.	360
WHAU	Corinth Radio Supply Co.	Corinth	Miss.	360
WHAV	Wilmington Elec. Specialty Co., Inc.	Wilmington	Del.	360
WHAW	Pierce Electric Co.	Tampa	Fla.	360
WHAX	Holyoke Street Ry. Co.	Holyoke	Mass.	360
WHAY	The Huntington Press	Huntington	Ind.	360-485
WHAZ	Rensselaer Polytechnic Inst.	Troy	N.Y.	360
WHB	Sweeney School Co.	Kansas City	Mo.	360-485
WHD	West Virginia University	Morgantown	W. Va.	360
WHK	Warren R. Cox	Cleveland	Ohio	360
WHN	Ridgewood Times Ptg. & Pub. Co.	Ridgewood	N.Y.	360
WHQ	Rochester Times Union	Rochester	N.Y.	360-485
WHU	Wm. B. Duck Co.	Toledo	Ohio	360
WHW	Stuart W. Seeley	East Lansing	Mich.	485
WIAA	Waupoca Civic & Commerce Assoc.	Waupoca	Wis.	360
WIAB	Joslyn Automobile Co.	Rockford	Ill.	360
WIAC	Galveston Tribune	Galveston	Tex.	360
WIAD	Ocean City Yacht Club	Ocean City	N.J.	360

Call Letters	Name	City	State	Wave-Length
WIAE	Mrs. Robert E. Zimmerman	Vincon	Iowa	360
WIAF	Gustav A. De Cortin	New Orleans	La.	360
WIAG	Matthews Elec. Supply Co.	Birmingham	Ala.	360
WIAH	Continental Radio & Mfg. Co.	Newton	Iowa	360
WIAI	Heer Stores Co.	Springfield	Mo.	360
WIAJ	Fox River Valley Radio Co.	Nunah	Wis.	360
WIAK	Daily Journal-Stockman	Omaha	Neb.	360-485
WIAL	Standard Service Co.	Norwood	Ohio	360
WIAN	Chronicle & News	Allentown	Pa.	360
WIAO	School of Eng. of Milwaukee and Wisconsin News	Milwaukee	Wis.	360
WIAP	Radio Development Corp.	Springfield	Mass.	360
WIAQ	Chronicle Publishing Co.	Marion	Ind.	360
WIAR	J. A. Rudy & Sons	Paducah	Ky.	360
WIAS	Burlington Hawkeye & Home Electric Co.	Burlington	Iowa	360
WIAT	Leon T. Noel	Tarkio	Mo.	360
WIAU	American Trust & Savings Bank	Le Mars	Iowa	360
WIAV	New York Radio Laboratories	Binghamton	N.Y.	360
WIAW	Saginaw Radio & Electric Co.	Saginaw	Mich.	360
WIAX	Capital Radio Co. (Paul C. Rohwer)	Lincoln	Neb.	360
WIAY	Woodward & Lothrop	Washington	D.C.	360
WIAZ	Electric Supply Sales Co.	Miami	Fla.	360
WIK	K. & L. Electric Co.	McKeesport	Pa.	360
WIL	Continental Elec. Sup. Co.	Washington	D.C.	360
WIP	Gimbel Brothers	Philadelphia	Pa.	360
WIZ	Cincinnati Radio Mfg. Co.	Cincinnati	Ohio	360-485
WJAB	American Radio Co.	Lincoln	Neb.	360
WJAC	Redell Co.	Joplin	Mo.	360
WJAD	Jackson's Radio Engineering Laboratories	Waco	Texas	360

RADIO ACT OF 1912

279

Call Letters	Name	City	State	Wave-Length
WJAE	The Texas Radio Syndicate	San Antonio	Texas	360
WJAF	Muncie Press-Smith Electric	Muncie	Ind.	360
WJAG	Norfolk Daily News	Norfolk	Neb.	360
WJAH	Central Park Amusement Co.	Rockford	Ill.	360
WJAJ	Y.M.C.A.	Dayton	Ohio	360
WJAK	White Radio Laboratory	Stockdale	Ohio	360
WJAL	Victor Radio Corp.	Portland	Me.	360
WJAM	D. M. Perham	Cedar Rapids	Iowa	360
WJAN	Peoria Star-Peoria Radio Sales Co.	Peoria	Ill.	360
WJAP	Kelley-Duluth Co.	Duluth	Minn.	360
WJAQ	Capper Publications	Topeka	Kansas	360
WJAR	The Outlet Co. (J. Samuels & Bro.)	Providence	R. I.	360
WJAS	Pittsburgh Radio Supply Co.	Pittsburgh	Pa.	360
WJAT	Kelley-Vawter Jewelry Co.	Marshall	Mo.	360
WJAU	Yankton College	Yankton	S. Dak.	360
WJAX	Union Trust Co.	Cleveland	Ohio	360
WJAZ	Chicago Radio Laboratory	Chicago	Ill.	360
WJD	Richard H. Howe	Granville	Ohio	360
WJH	White & Boyer Co.	Washington	D.C.	360
WJK	Service Radio Equip. Co.	Toledo	Ohio	360
WJT	Electric Equipment Co.	Erie	Pa.	360
WJX	DeForest Radio Tel. & Tel. Co.	New York	N.Y.	360
WJZ	Westinghouse Elec. & Mfg. Co.	Newark	N.J.	360
WKAA	H. F. Paap	Cedar Rapids	Iowa	200-360-485
WKAC	Star Publishing Co.	Lincoln	Neb.	360
WKAD	Chas. Looff	East Providence	R. I.	360
WKAJ	W. S. Radio Supply Co.	Wichita Falls	Texas	360
WKAG	Edwin T. Bruce, M.D.	Louisville	Ky.	360
WKAH	Planet Radio Co.	West Palm Beach	Fla.	360

Call Letters	Name	City	State	Wave-Length
WKAJ	Fargo Plumbing and Heating Co.	Fargo	N. Dak.	360
WKAK	Okfuskee County News	Okemah	Okla.	360
WKAL	Gray & Gray	Orange	Texas	360
WKAM	Hastings Daily Tribune	Hastings	Neb.	360
WKAN	Alabama Radio Mfg. Co.	Montgomery	Ala.	360
WKAP	Dutee W. Flint	Cranston	R. I.	360
WKAQ	Radio Corp. of Porto Rico	San Juan	P. R.	360
WKR	Michigan Agricultural College	East Lansing	Mich.	360
WKAS	L. E. Lines Music Co.	Springfield	Mo.	360
WKAT	Frankfort Morning Times	Frankfort	Ind.	360-485
WKA	Laconia Radio Club	Laconia	N. H.	360
WKA	Turner Cycle Co.	Beloit	Wis.	360
WKA	Wm. A. MacFarland	Bridgeport	Conn.	360
WKA	Brenau College	Gainesville	Ga.	360
WKA	London's Music and Jewelry Co.	Wilkes Barre	Pa.	360
WKC	Joseph M. Zamoiski Co.	Baltimore	Md.	360
WKN	Riechman Crosby Co.	Memphis	Tenn.	360-485
WKY	Oklahoma Radio Shop	Oklahoma City	Okla.	360-485
WLAB	George F. Grossman	Carrollton	Mo.	360
WLAC	North Carolina State College	Raleigh	N. C.	360
WLAD	Arvanette Radio Supply Co.	Hastings	Neb.	360
WLA	Johnson Radio Co.	Lincoln	Neb.	360
WLAH	Samuel Woodworth	Syracuse	N. Y.	360
WLAJ	Waco Electrical Supply Co.	Waco	Texas	360
WLB	University of Minnesota	Minneapolis	Minn.	360-485
WLK	Hamilton Mfg. Co.	Indianapolis	Ind.	360-485
WLW	Crosley Mfg. Co.	Cincinnati	Ohio	360-485
WMAD	Atchinson County Mail	Rock Port	Mo.	360
WMAH	General Supply Co.	Lincoln	Neb.	360
WMAM	Beaumont Radio Development Co.	Beaumont	Texas	360
WMB	Auburn Electrical Co.	Auburn	Me.	360

RADIO ACT OF 1912

281

Call Letters	Name	City	State	Wave-Length
WMC	Columbia Radio Co.	Youngstown	Ohio	360
WMH	Precision Equipment Co.	Cincinnati	Ohio	360-485
WMU	Doubleday-Hill Electric Co.	Washington	D.C.	360
WNAL	R. J. Rockwell	Omaha	Neb.	360
WNJ	Shotton Radio Mfg. Co.	Albany	N.Y.	360
WNO	Wireless Tel. Co. of Hudson County	Jersey City	N.J.	360
WOC	Palmer School of Chiropractic	Davenport	Iowa	360-485
WOE	Buckeye Radio Service Co.	Akron	Ohio	360
WOH	Hatfield Electric Co.	Indianapolis	Ind.	360
WOI	Iowa State College	Hines	Iowa	360-485
WOK	Pine Bluff Co.	Pine Bluff	Ark.	360
WOO	John Wanamaker	Philadelphia	Pa.	360
WOQ	Western Radio Co.	Kansas City	Mo.	360-485
WOR	L. Bamberger & Co.	Newark	N.J.	360
WOS	Mo. State Marketing Bureau	Jefferson City	Mo.	485
WOU	Metropolitan Utilities District	Omaha	Neb.	360-485
WOZ	Palladium Printing Co.	Richmond	Ind.	360-485
WPA	Fort Worth Record	Ft. Worth	Tex.	360-485
WPE	Central Radio Co.	Kansas City	Mo.	360
WPG	Nushawg Poultry Farm	New Lebanon	Ohio	360
WPI	Electric Supply Co.	Clearfield	Pa.	360
WPJ	St. Joseph's College	Philadelphia	Pa.	360
WPL	Fergus Electric Co.	Zanesville	Ohio	360
WPM	Thomas J. Williams	Washington	D.C.	360
WPO	United Equipment Co.	Memphis	Tenn.	360
WRK	Doron Bros. Electric Co.	Hamilton	Ohio	360
WRL	Union College	Schenectady	N.Y.	360
WRM	University of Illinois	Urbana	Ill.	360
WRP	Federal Inst. of Radiotel.	Camden	N.J.	360
WRR	D. Police & Fire Signal Dept.	Dallas	Tex.	360-485
WRW	Tarrytown Radio Research Lab.	Tarrytown	N.Y.	360
WSB	Atlanta Journal	Atlanta	Ga.	360-485
WSL	J. & M. Electric Co.	Utica	N.Y.	360

RADIO FOR ALL

Call Letters	Name	City	State	Wave-Length
WSN	Ship Owners' Radio Service	Norfolk	Va.	360
WSV	L. M. Hunter & G. L. Carrington	Little Rock	Ark.	360
WSX	Erie Radio Co.	Erie	Pa.	360
WSY	Alabama Power Co.	Birmingham	Ala.	360
WTG	Kansas State Agric. College	Manhattan	Kans.	485
WTK	Paris Radio Electric Co.	Paris	Texas	360
WTP	George M. McBride	Bay City	Mich.	360
WWB	Daily News Printing Co.	Canton	Ohio	360
WWI	Ford Motor Co.	Dearborn	Mich.	360
WWJ	Detroit News	Detroit	Mich.	360-485
WWL	Loyola University	New Orleans	La.	360
WWT	McCarthy Bros. & Ford	Buffalo	N.Y.	360
WWZ	John Wanamaker	New York	N.Y.	360

CANADIAN BROADCASTING STATIONS

Call Letters	Name	City	Province	Wave-Length
CFAC	Calgary Daily Herald	Calgary	Alta.	
CFCA	Toronto Daily Star	Toronto	Ont.	420
CFCB	Daily Province	Vancouver	B.C.	440
CHCF	Marconi W. Co. of Can., Ltd.	Montreal	Que.	440
CHBC	The Morning Albertan	Calgary	Alta.	410
CHCB	Marconi Co.	Toronto	Ont.	440
CHVC	Metropolitan Motors Co.	Toronto	Ont.	420
CJCA	Edmonton Journal	Edmonton	Alta.	420
CJCB	News Publishing Co., Ltd.	Nelson	B.C.	420
CJCD	T. Eaton Co.	Toronto	Ont.	410
CJCF	Daily Record	Kitchener	Ont.	
CJGC	London Free Press	London	Ont.	
CJNC	Tribune Newspaper Co.	Winnipeg	Man.	420
CKAC	La Presse	Montreal	Quebec	430
CKCE	Can. Independent Tel. Co.	Toronto	Ont.	450
CKCK	Regina Leader	Regina	Sask.	420
3JZ	Marconi W. Tel. Co.	Toronto	Ont.	1200

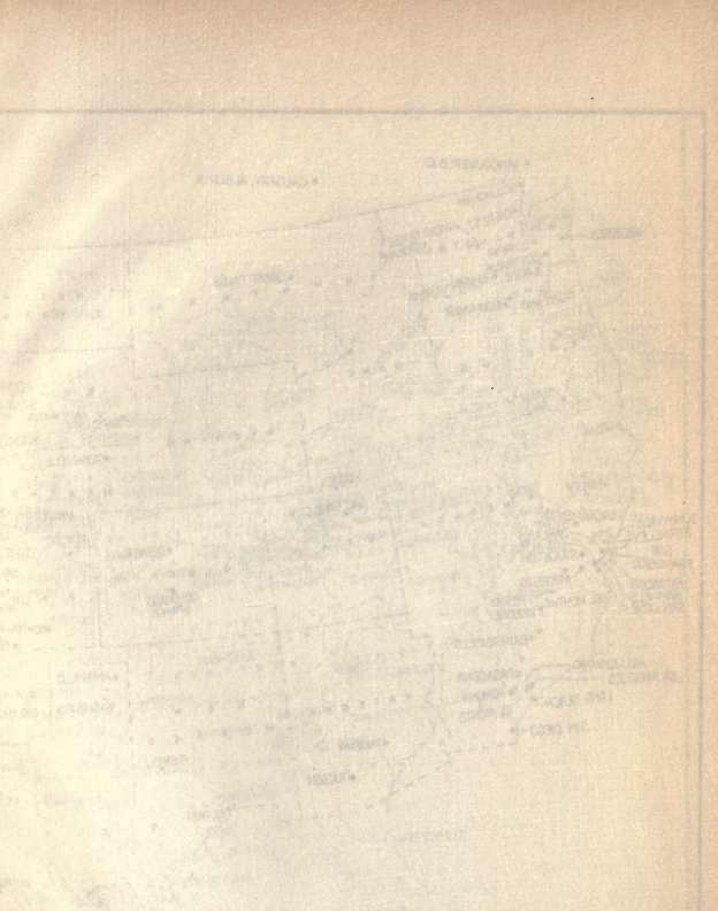

U.S. RADIOPHONE
BROADCASTING STATIONS
CORRECTED TO JUNE 30, 1933

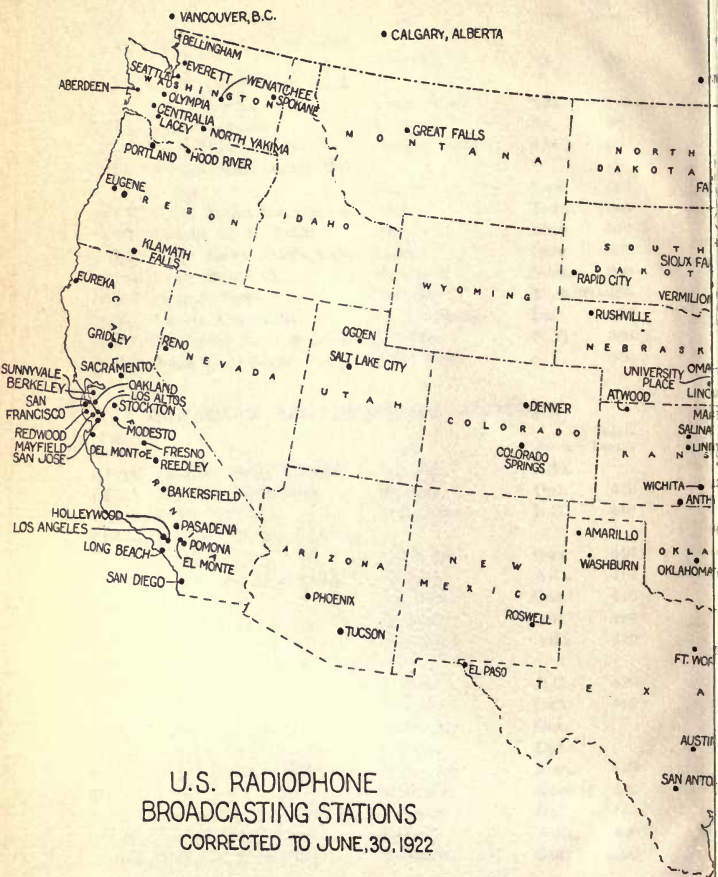

NIPEG, MAN.

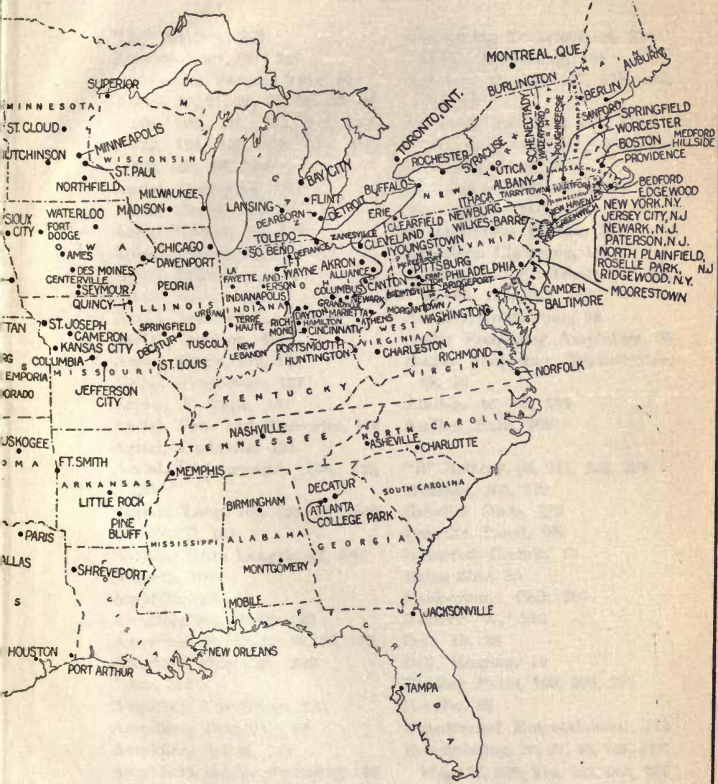

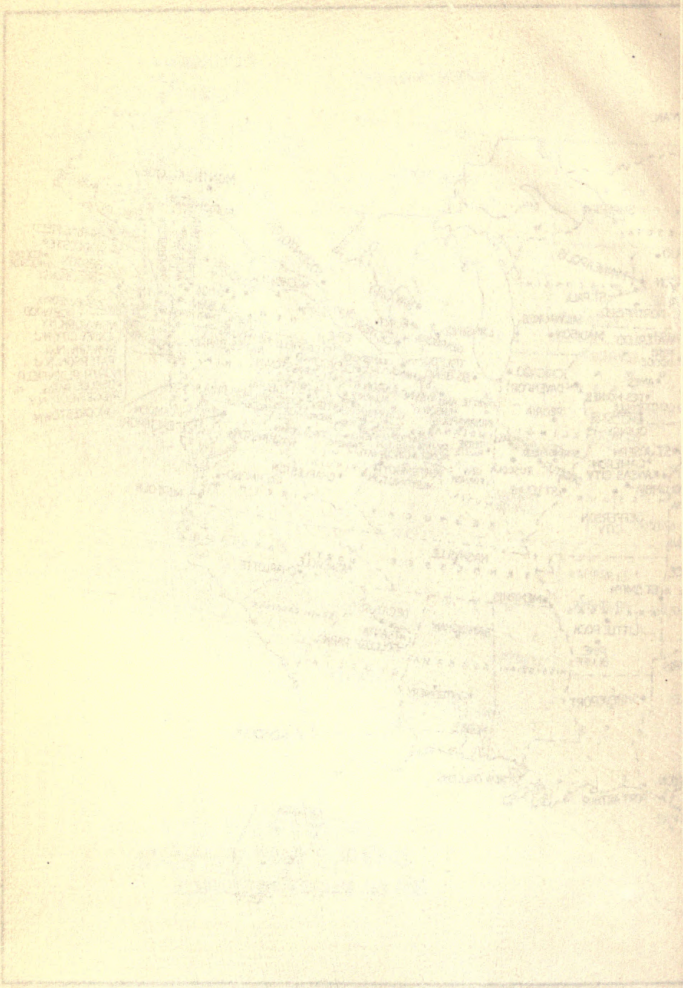

INDEX

- "A" Battery, 223
Abbreviations, 242, 247
Accessories Vacuum Tube, 85
Aerial, 20, 21, 30, 31, 32, 33, 47,
106, 108, 110, 112, 117, 121,
122, 125, 127, 128, 130, 131,
132, 137, 231, 250
Aerial, Concealed, 231
Aerial Circuit, 106
Aerial Dimensions, 250
Aerial, Four-wire, 110, 117
Aerial, Height of, 112
Aerial Indoor, 83
Aerial, Inverted L, 132
Aerial, Outdoor, 47
Aerial, Single, 110, 121
Aerial, Single-wire, 121
Aerial, T Type, 131
Aerial, Two- and Four-wire, 116
Aerial, Umbrella, 122
Aerial, Underground, 128, 129,
230
Aerials, Loop, 108, 125, 127, 250
Aerials, T, 131
Aerials, Wave Lengths of, 130
Ampere, 254
Amplification, 46
Amplification, Audio, 93
Amplifier, 45, 69, 87, 96, 98, 170,
Amplifier Rheostat, 226
220, 226
Amplifier, Two-Stage, 220
Amplifier, Two-Step, 87
Amplifier, Voice, 170
Amplifiers, Audio Frequency, 96
Amplifiers, Tone, 98
Amplify, 86
Amplifying Transformers, 224
Analogy in Tuning, 104
Antenna, 31, 142, 117, 119, 142,
199, 250
Antenna Connector, 117, 119
Antenna, Transmitting Stations,
Antennae, Loop, 250
Arc, Electric, 37, 164, 165
Arc Transmitted, 165
Argentiferous Galena, 63
Arresters, Lightning, 139
Atmospheric Electricity, 37, 49,
50, 66, 130, 139, 142
Audio Amplification, 93
Audio Frequency Amplifiers, 96
Audio Frequency Transformer,
88, 90
Audion, 43, 66, 194
Audion Bulb, 209
"B" Battery, 89, 211, 223, 225
Bakelite, 205, 212
Bakelite Dials, 212
Bakelite Panel, 209
Balanced Circuit, 73
Balls, Zinc, 80
Bank-wound Coil, 209
Battery "A," 223
Bell, 19, 23
Bell, Ringing, 19
Binding Posts, 198, 208, 222
Bornite, 62
Broadcasted Entertainment, 174
Broadcasting, 20, 27, 43, 168, 170,
174, 177, 239, 244, 263, 266, 267
Broadcasting Hour, 240, 244
Broadcasting Music, 174

- Broadcasting Station, 20, 27, 43, 168, 170, 174, 239, 263, 266, 277
- Broadcasting Stations, Canadian, 277
- Broadcasting Stations, U. S., 266
- Broad Interfering Wave, 261
- Bulb, Audion, 209
- Buzzer, 190, 193, 197
- Buzzer, Test, 197
- Call Letters, 240, 244
- Canadian Broadcasting Stations, 277
- Candle, 44
- Capacity, 196, 249, 253, 254
- Capacity, Condenser, 196, 253
- Carbena, 64
- Carbon Detector, 53
- Carbon Tetrachloride, 64
- Carborundum Crystal, 58
- Carborundum Detector, 58
- Cardboard Tubes, 214
- Carrier Wave, Radio, 25
- Catwhisker, 62, 65, 66, 184
- Cell, 234
- Cells, Photo-Electric, 234, 236
- Charts, 131
- Circuit, Aerial, 106
- Circuit, Balanced, 73
- Circuit, Oscillating, 165
- Circuits, 149
- Clamp, Ground, 133, 134, 136
- Close Wave Length, 77
- Code, 34, 35, 36, 42, 247
- Code, Continental, 34
- Code, Radio, 247
- Code, Telegraphic, 34, 36
- Codes, Wireless, 35
- Coherer, 12, 40, 43, 51, 53
- Coherer, Marconi, 43, 53
- Coil, 187, 192, 196, 209
- Coil, Bank-wound, 209
- Coil Data, Tuning, 257
- Coil, Loop, 209
- Coil, Secondary, 192, 217
- Coil, Sending Tuning, 33
- Coil, Spark, 11, 30, 40
- Coil, Tap, 182
- Coil, Tickler, 226
- Coil, Tuning, 83, 84, 70, 71, 73, 207
- Coils, 214, 217
- Cold Plate, 68
- 83, 107, 196
- Compass, Radio, 126
- Compass Station, 125
- Concealed Aerial, 231
- Condenser Capacity, 196, 253
- Condenser, Fixed, 81, 85, 195, 207
- Condenser, Grid, 210, 225
- Condenser, Grid Leak, 93
- Condenser, Phone, 84
- Condenser Plugs, 231, 232
- Condenser, Stopping, 207
- Condenser, Variable, 82, 83, 85, 107, 138, 195, 208, 209
- Condensers, 79, 80, 81, 82, 83, 84, 85, 93, 106, 107, 138, 189, 195, 196, 207, 208, 209, 210, 225, 249
- Connector, Antenna, 117, 119
- Constants, Dielectric, 249, 252
- Continental Code, 34
- Continuous Waves, 13, 25, 37, 38,
- Cooper Wire Tables, 255
- Copper Pyrite, 62
- Copper-clad Wire, 109
- Cotton, Double Wire, 256
- Cotton-covered Magnet Wire, Double, 257
- Cotton, Single Wire, 256
- Coulomb, 254
- Coupler, Vario-, 79, 212

- Couplers, Loose, 73, 75, 76, 77
 212, 216, 217, 218
 Crystal, 64, 65, 184, 189, 197, 199,
 203
 Crystal, Carborundum, 58
 Crystal Detector, 43, 58, 68, 72
 Crystal Outfit, 180
 Crystal Pressure, 59
 Current, 254
 Currents, High Frequency, 68,
 73
 Currents, Voice, 170
 Data, Tuning Coil, 257
 De Forest, 68
 Detectors, 40, 43, 44, 53, 54, 56,
 57, 58, 59, 60, 63, 68, 72, 193,
 197, 202
 Detector, Carbon, 53
 Detector, Carborundum, 58
 Detector, Crystal, 43, 58, 68, 72
 Detector, Electrolytic, 54, 56, 57
 Detector, Radiocite, 63
 Detector, "Rasco," 199
 Detector, Silicon, 59, 60, 61
 Detector, Vacuum Tube, 44
 Device, Protective, 141, 146
 Devices, Tuning, 70
 Diagnosis, Radio, 230
 Diagram, Radio, 149
 Diagrams, 149
 Dials, Bakelite, 212
 Diaphragm, 97
 Dielectric, 249
 Dielectric Constants, 249, 252
 Dimensions, Aerial, 250
 Distance, 27
 Distance, Transmitting, 40
 Distress Signals, 24, 35, 261
 Distress Wave, Standard, 261
 Division of Time, 262
 Double Cotton-covered Magnet
 Wire, 257
 Double Cotton Wire, 256
 Double Silk Wire, 256
 Doughnut Type Coil, 192
 Dunwoody, 58
 Edison, 66, 67
 Edison Effect, 67
 Effect, Inductive, 73
 Effect, Regenerative, 226
 Efficient Receiver, 205
 Electric Arc, 37, 164, 165
 Electric Cells, Photo-, 234, 236
 Electric Spark, 11
 Electric Waves, 11
 Electrical Microphones, 21, 165,
 166, 173, 174, 178
 Electrical Units, 254
 Electricity, Atmospheric, 37, 49,
 50, 66, 130, 139
 Electricity, Static, 37, 49, 50, 66,
 130, 139, 142
 Electro-Motive-Force, 254
 Electrolytic Detector, 54, 56, 57
 Electrons, 67, 68, 91
 E. M. F., 254
 Enameled Wires, 201, 256
 Entertainment, Broadcasted, 174
 Eternal Radio Waves, 237
 Fading Signals, 115
 Farad, 254
 Fessenden, Reginald, 166
 Filament, 67, 68, 69, 90, 209, 223
 Filament Voltage, 224
 Filings, 52
 Fixed Condenser, 81, 85, 195, 207
 Fleming, 68
 Force, Electro-Motive, 254
 Formica, 205
 Forms, 214
 Four-wire Aerial, 110, 117
 Frequencies, Wave Lengths and,
 251

- Frequency Amplifiers, Audio, 94
 Frequency Currents, High, 68, 73
 Frequency Transformer, Audio, 88, 90
 Frequency Transformer, Radio, 93, 94
 Fundamental Note, 31
 Future of Radio, 229
- Galena, Argentiferous, 63
 Galena, 63, 193, 197, 199, 203, 207
 Gap, Quenched Spark, 37
 Gauge, 255
 General Receiving, 42
 General Transmitting, 30, 37, 40
 Government Stations, 263
 Grand Opera by Wireless, 178
 Grid, 67, 69, 223
 Grid Condenser, 210, 225
 Grid Leak, 91, 92, 225
 Grid Leak Condenser, 93
 Ground, 202
 Ground Clamp, 133, 134, 136
 Ground, Operating, 144
 Ground Wire, 134, 141, 142, 143, 144, 147
 Ground Wire, Operating, 144
 Ground Wire, Protective, 143, 147
 Ground Wire, Receiving Equipment, 147
 Grounding Rod, 136
 Grounding Switch, Protective, 143, 147
 Grounds, 108, 133, 136
- Height of Aerial, 112
 Henry, 254
 High Frequency Currents, 68, 73
 High Power, 44
- Honeycomb, 209
 Hour, Broadcasting, 240, 244
 Impure Wave, 31
 Indoor, 33
 Inductance, 203, 204, 253, 254
 Inductive Effect, 73
 Information, Radio, 239
 Instruments, Receiving, 51
 Insulated, 256
 Insulators, 112, 118
 Intensity, 125
 Intensity Scale, Wind, 244
 Intercommunication, 262
 Interference, 76, 123
 Interfering Wave, Broad, 261
 Interrupted Spark Wave, 13, 38, 39
 Interrupted Waves, 13, 38, 39,
 Inverted L Aerial, 132
 Inverted L Type, 116
 Invisible Sound Waves, 18
 Iron Pyrite, 62
- Jacks, 225
 Joule, 254
 Jumper Wire, 223
- Key, 24, 34
 Kilowatt, 39, 254
- "L," 250
 L Aerial, Inverted, 132
 L Type, Inverted, 116
 Law of 1912, Radio, 258
 Lead-in, 110, 119, 120, 141, 142, 146, 201
 Lead-in Wires, 141, 142, 146, 201
 Leak, Grid, 91, 92, 225
 Length, Wave, 22, 23, 27, 34, 70, 77, 105, 130, 131, 244, 250, 251, 260

- Letters, Call, 240 244
 Lattice Type, 209
 Lightning Arresters, 139
 Lightning Regulations, 140
 Litz Wire, 209
 Locate Ores, Radio to, 230
 Loop, 231
 Loop Aerials, 108, 125, 127, 250
 Loop Antennae, 250
 Loop Coil, 209
 Loops, Underground, 230
 Loose Couplers, 73, 75, 76, 77, 212
 216, 217, 218
 Loud Speakers, 98
 Low Priced Receiving Set, 193

 Magnavox, 97, 226
 Magnet Wire, 256
 Magnet Wire, Double Cotton-
 256
 Marconi, Guglielmo, 12, 31, 34, 36
 37, 43, 52, 53
 Marconi Coherer, 53
 Market Reports, 244
 Meg-Ohm, 254
 covered, 257
 Messages, Secrecy of, 264
 Metal Pellet, 65
 Meter, 22
 Mica, 252
 Micro-farads, 249, 254
 Microphones, Electrical, 21
 Micro-watt, 254
 Milli-ampere, 254
 Milli-henry, 254
 Milli-Volt, 254
 Mineral, 62
 Misconception, Radio, 27
 Modulator, 234
 Modulator Tube, 171
 Motive-Force, Electro-, 254
 Music, Broadcasting, 174
 Music, Radio, 175
 Natural Wave Lengths, 131
 Night Time Reception, 48
 1912, Radio Law of, 258
 Normal Wave Length, 260
 Note, Fundamental, 31

 Ohm, 254, 255
 \$1.00 Radio Set, 198
 Opera by Wireless, Grand, 178
 Operating Ground, 144
 Operating Ground Wire, 144
 Ores, Radio to Locate, 230
 Oscillating Circuit, 165
 Oscillations, 251
 Oscillator, 171
 Outdoor Aerial, 47
 Outfit, Crystal, 180
 Outfits, Simple Receiving, 180

 Panel, 212, 223
 Panel, Bakelite, 209
 Paper, Paraffined, 195
 Paraffined Paper, 195
 Pellet, Metal, 65
 Penalties, 265
 Performances, Radio, 177
 Phone Condenser, 84
 Photo-Electric Cells, 234, 236
 Pickard, Greenleaf W., 62,
 Picture Transmission, Radio, 233
 Pictures, Radio Sending, 232
 Pipe, Water, 106
 Plate, 67, 68, 69, 223
 Plate, Cold, 68
 Plug, 231
 Plugs, Condenser, 231, 232
 Pocket Size Receiving Set, 192
 Points, Sensitive, 63
 Points, Switch, 207
 Poles, 112
 Portable Receiving Set, 208, 209
 Posts, Binding, 198, 208, 222

- Potentiometer, 56
 Poulsen, Valdemar, 13, 164
 165
 Power, 39, 40, 41, 44
 Power, High, 44
 Power Transmission, Radio, 232
 Press Schedules, 245
 Pressure, Crystal, 59
 Primaries, 215, 217, 218
 Primary, 75, 76, 192
 Principle of Transformer, 73
 Private Stations, 263
 Prospecting, Radio, 230
 Protective Device, 141, 146
 Protective Ground Wire, 143,
 147
 Protective Grounding Switch,
 143, 147
 Pure Wave, 261
 Pyrite, Copper, 62
 Pyrite, Iron, 62

 Quenched Spark Gap, 37

 Radio Carrier Wave, 25
 Radio Code, 247
 Radio Compass, 126
 Radio Diagnosis, 230
 Radio Diagrams, 149
 Radio Frequency Transformer,
 93, 94
 Radio, Future of, 229
 Radio Law of 1912, 258
 Radio Music, 175
 Radio Performances, 177
 Radio Picture Transmission, 133
 Radio Power Transmission, 232
 Radio Prospecting, 230
 Radio Sending Pictures, 232
 Radio Set, \$1.00, 198
 Radio Signals, 46
 Radio Telephone, 166, 167
 Radio Telephone Daily, 229

 Radio Telephony, 42, 164, 166,
 167
 Radio Television, 234
 Radio to Locate Ores, 230
 Radio Wave, 14, 21, 26, 27, 34,
 232, 237, 261
 Radio Waves, Eternal, 237
 Radiocite, 62
 Radiocite Detector, 63
 Radiophone Receiver, Simple,
 185
 Radiophone Receiver, Simplest,
 "Radioson" Detector, 57
 Receiver, Efficient, 205
 Receiver, Simple Radiophone,
 181
 Receiver, Simplest Radiophone,
 181
 Receiver, Short Wave Regen-
 erative, 211
 Receivers, Telephone, 56, 96
 Receiving Equipment Ground
 Wire, 147
 Receiving (General), 42
 Receiving Instruments, 51
 Receiving Outfits, Simple, 180
 Receiving Set, 47, 192, 193, 208,
 209
 Receiving Set, Low-priced, 193
 Receiving Set, Pocket Size, 192
 Receiving Set, Portable, 208, 209
 Receiving Station, 42
 Receiving Transformer, 192
 Reception, Night Time, 48
 Rectifier, 85
 Regenerative Effect, 226
 Regenerative Receiver, Short
 Wave, 211
 Regulations, Lightning, 140
 Reports, Market, 244
 Reports, Weather, 240, 242, 243
 Restrictions, 263

- Resistance, 254
 Rheostat, 90, 209, 222
 Rheostat, Amplifier, 226
 Rheostats, 90, 209, 222
 Ring Wound Coil, 192
 Ringing Bell, 19
 Rod, Grounding, 136
 Rotor, 79
- Scale, Wind Intensity, 244
 Schedule, 240
 Schedules, Press, 245
 Secondary, 75, 76, 192, 215, 216, 218
 Secondaries, 216, 218
 Secondary Coil, 192, 217
 Secrecy of Messages, 264
 Sending, 33, 39
 Sending Pictures, Radio, 232
 Sending Station, 27
 Sending Tuning Coil, 33
 Sensitive Points, 63
 Sensitivity, 44, 62
 Set, \$1.00 Radio, 198
 Set, Low-priced Receiving, 193
 Set, Pocket Size Receiving, 192
 Set, Portable Receiving, 208
 Set, Receiving, 47, 192, 193, 198, 208
 Sharp Tuning, 226
 Sharp Wave, 261
 Shellac, 188, 216
 Short Wave, 211
 Short Wave Regenerative Receiver, 211
 Signals, Distress, 24, 35, 261
 Signals, Fading, 115
 Signals, Radio, 46
 Signals, Telegraphic, 24
 Signals, Time, 240
 Silk, Double Wire, 256
 Silk, Single Wire, 256
 Silicon Detector, 59, 60, 61
 Simple Radiophone Receiver, 185
 Simple Receiving Outfits, 180
 Simplest Radiophone Receiver, 181
 Simple Tuner, 203
 Single Aerial, 110, 121
 Single Cotton Wire, 256
 Single Silk Wire, 256
 Single Vacuum Tube, 46
 Single-wire Aerial, 121
 Slider, 33, 70, 71, 72, 75, 102
 Slider, Tuning Coil, 102
 Socket, 209, 224, 225
 Solenoid, 253
 SOS, 24
 Sound, 20, 42
 Sound Waves, 16, 26
 Sound Waves, Invisible, 18
 Space, 23
 Spark Coil, 11, 30, 40
 Spark, Electric, 11, 30, 36
 Spark Gap, Quenched, 37
 Spark Stations, 245
 Spark Wave, Interrupted, 39
 Speakers, Loud, 97
 Speed of Waves, 26
 Spheres, 17
 Splices, 140
 Spreader, 118
 Standard Distress Wave, 261
 Static, 37, 49, 50, 66, 130, 139
 Static Electricity, 37, 49, 50, 66, 130, 139
 Static Surges, 66
 Station, Broadcasting, 20, 27, 43, 168, 170, 174, 239, 263, 266, 277
 Station, Compass, 125
 Station, Receiving, 42

- Station, Sending, 27
 Stations, Government, 263
 Stations, Private 263
 Stations, Spark, 245
 Stator, 79
 Step, Three-, 69
 Step, Two-, 69
 Stopping Condenser, 207
 Super-amplifier, 45
 Surges, 144, 148
 Surges, Static, 66
 Switch, 212
 Switch Points, 207
 Switch, Protective Grounding,
 143, 147
 Symbols, 158

 T Aerials, 131
 T Type Aerial, 131
 Tables, Cooper Wire, 255
 Tap Coil, 182
 Taps, 75
 Telegraphic Code, 34, 36
 Telegraphic Signals, 24
 Telemegaphone, 226
 Telephone Daily, Radio, 229
 Telephone, Radio, 42, 164, 166,
 167
 Telephone Receivers, 56, 96
 Telephone Transmitter, 166
 Telephony, Radio, 42, 164, 166,
 167
 Television, 233
 Television, Radio, 234
 Test Buzzer, 197
 Tetrachloride, Carbon, 64
 Three-Slide Tuners, 73
 Three-Step, 69
 Tickler, 223
 Tickler Coil, 226
 Time, Division of, 262
 Time Signals, 239
 Tinfoil, 195, 197
 Tone Amplifiers, 98
 Transformer, Audio Frequency,
 88, 90
 Transformer, Principle of, 73
 Transformer, Radio Frequency,
 93, 94
 Transformer, Receiving, 192
 Transformers, Amplifying, 224
 Transmission, Radio Picture, 233
 Transmission, Radio Power, 232
 Transmitter, 40, 165, 166,
 Transmitter, Arc, 165
 Transmitter, Telephone, 166
 Transmitters of Waves, 18
 Transmitting Distance, 40
 Transmitting (General), 30, 37
 40
 Transmitting Stations Antenna,
 142
 Transmitting Tubes, 171
 Trough, 23
 Tube Accessories, Vacuum, 85
 Tube, Modulator, 171
 Tube, Vacuum, 43, 46, 66, 67,
 68, 69, 85, 171
 Tubes, Cardboard, 214
 Tubes, Transmitting, 171
 Tuned, 28
 Tuner, Simple, 203
 Tuners, Three-Slide, 73
 Tuning, 32, 70, 73, 76, 77, 101,
 104
 Tuning, Analogy in, 104
 Tuning Coil, 33, 34, 70, 71, 73, 83,
 102, 103, 107, 196, 207, 257

- Tuning Coil Data, 257
 Tuning Coil, Sending, 83
 Tuning Coil Slider, 102, 103
 Tuning Devices, 70
 Tuning Out, 28
 Tuning, Sharp, 76, 77, 226
 Two- and Four-wire Aerial, 116
 Two-Stage Amplifier, 220
 Two-Step, 69
 Two-Step Amplifier, 87
 Type, Coil Doughnut, 192
 Type, Inverted L, 116
 Type, Lattice, 209

 Umbrella Aerial, 122
 Underground Aerial, 128, 129, 230
 Underground Loops, 230
 Units, Electrical, 254
 U. S. Broadcasting Stations, 266

 Vibrations, 25, 42
 Vacuum, 69
 Vacuum Tube, 43, 46, 66, 67, 68, 69, 85, 171
 Vacuum Tube Accessories, 85
 Vacuum Tube Detector, 44,
 Vacuum Tube, Single, 46
 Values, Variocoupler, 258
 Valve, 68
 Variable Condenser, 82, 83, 85, 107, 138, 195, 208, 209
 Vario-coupler, 79, 212
 Variocoupler Values, 258
 Variometers, 78, 212, 215, 216, 218
 Voice Amplifier, 170
 Voice Currents, 170
 Volt, 254
 Voltage, Filament, 224

 Water Pipe, 106
 Water Waves, 16
 Watt, 254
 Wave, Broad Interfering, 261
 Wave, Impure, 81
 Wave Interrupted Spark, 39
 Wave Length, 22, 23, 27, 34, 70, 77, 105, 130, 131, 244, 250, 251, 260
 Wave Length, Close, 77
 Wave Length, Normal, 260
 Wave Lengths of Aerials, 130
 Wave Lengths and Frequencies, 251
 Wave Lengths, Natural, 131
 Wave, Pure, 261
 Wave, Radio, 14, 21, 26, 27, 34,
 Wave, Radio Carrier, 25
 Wave, Sharp, 261
 Wave, Short, 211
 Wave, Standard Distress, 261
 Wavelets, 37
 Waves, 11, 13, 14, 16, 18, 21, 25, 26, 27, 31, 34, 37, 38, 39, 43, 47, 130, 131, 165, 211, 244, 250, 251, 260, 261
 Waves, Continuous, 13, 25, 37, 38, 165
 Waves, Electric, 11
 Waves, Eternal Radio, 237
 Waves, Interrupted, 13, 38
 Waves, Invisible Sound, 18
 Waves, Radio, 232, 237
 Waves, Sound, 16, 26
 Waves, Speed of, 26
 Waves, Transmitters of, 18
 Waves, Water, 16, 237, 261
 Weather Reports, 240, 242, 243
 Winding, 207, 216
 Wind Intensity Scale, 244

- Wire, Copper-clad, 109
Wire, Double Cotton-covered
Magnet, 257
Wire, Enameled, 256
Wire, Ground, 134, 141, 142, 143,
Wireless Codes, 35
Wireless, Grand Opera by, 178
Wire, Litz, 209
Wire, Magnet, 256
Wire, Operating Ground, 144
147
Wire, Protective Ground, 143,
Wire, Receiving Equipment
Ground, 147
Wires, Enameled, 201
Wires, Lead-in, 141, 142, 146, 201
Wire Tables, Cooper, 255
Wire, Wollaston, 54, 56, 57
144, 147
Wiring, 225
Wollaston Wire, 54, 56, 57
Wound, Ring Coil, 192
Zinc Balls, 30

THEATER ARTS LIBRARY
UNIVERSITY OF CALIFORNIA LIBRARY
Los Angeles

This book is DUE on the last date stamped below.

Sh

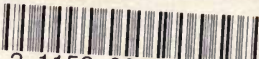

3 1158 00105 3809

TK
6550
G319r

UC SOUTHERN REGIONAL LIBRARY FACILITY



AA 000 972 755 3

Univ
So
L