

ENGINEERING EDUCATION SERIES

PRINCIPLES
OF
RADIOTELEGRAPHY

PREPARED IN THE
EXTENSION DIVISION OF
THE UNIVERSITY OF WISCONSIN

BY
CYRIL M. JANSKY, B. S., B. A.,
ASSOCIATE PROFESSOR OF ELECTRICAL ENGINEERING
THE UNIVERSITY OF WISCONSIN

FIRST EDITION

McGRAW-HILL BOOK COMPANY, Inc.
239 WEST 39TH STREET. NEW YORK

LONDON: HILL PUBLISHING CO., Ltd.
6 & 8 BOUVERIE ST., E. C.

1919

**PRINCIPLES OF
RADIOTELEGRAPHY**



McGraw-Hill Book Co. Inc.

PUBLISHERS OF BOOKS FOR

Coal Age ▽ Electric Railway Journal
Electrical World ▽ Engineering News-Record
American Machinist ▽ The Contractor
Engineering & Mining Journal ▽ Power
Metallurgical & Chemical Engineering
Electrical Merchandising

THE NEW YORK
PUBLIC LIBRARY
882699
ASTOR, LENOX AND
TILDEN FOUNDATIONS
R 1919 L

COPYRIGHT, 1919, BY THE
MCGRAW-HILL BOOK COMPANY, INC.

NEW YORK
1919

THE MAPLE PRESS YORK PA

PREFACE

The transmission of messages by radio signals is to many a mysterious process. The mystery, however, is not inherent in the transmission of intelligence by ether waves for almost every light-house is a radio transmitter which sends out signals by long and short groups of waves, and by waves of different lengths, that is, white and colored light. This is never considered mysterious for the simple reason that nature has furnished man with a sense organ by means of which these light waves are detected. If human beings were blind, like the fish of Mammoth Cave, the detection of light signals would become a very difficult and mysterious process. No light signals could be detected unless some means were devised for translating or converting light phenomena into phenomena capable of detection by some one of the other senses.

The mystery and difficulty of radio communication is primarily due to the fact that nature has not provided man with a sense organ which is capable of detecting electromagnetic waves immediately, but these waves must first be translated into other phenomena. It is undoubtedly true that space is filled with phenomena of which we are wholly unconscious, or in other words to which we are totally blind. This was true of electromagnetic waves until means of detecting these waves were devised. In reality they are no more mysterious than light.

Since radiotelegraphy is an electromagnetic phenomenon, and electric and magnetic apparatus is employed in the generation and detection of electromagnetic waves, a goodly portion of this book is devoted to a discussion of electromagnetic theory and apparatus, for without an understanding of these the student cannot understand the principles of the operation of radiotelegraphic apparatus. He may learn to operate it, but such operation will be merely a mechanical and not an intelligent process.

Although the treatment cannot be called nonmathematical, the use of mathematical expressions is limited and only the more elementary mathematics is used. In connection with the limited use of mathematics, an attempt has been made to explain the

principles involved so fully that a reader unable to follow the mathematical demonstrations may still acquire some understanding of the subject.

The author wishes to express his appreciation of the kindness of The Bureau of Standards, the Clapp-Eastham Company, The General Radio Company, and The William B. Duck Company for their kindness in lending cuts of radio-apparatus.

The author is indebted to Mr. Carl F. Kottler, graduate of the University of Wisconsin and a practical radio operator, for assistance in the preparation of the chapters on Practical Transmitting and Receiving Apparatus, and especially to Cyril Moreau Jansky, instructor in radio-physics, for the preparation of the chapter on Vacuum Tubes and Their Application to Radiotelegraphy. He is also indebted to Professor E. M. Terry who kindly criticized the manuscript and made many valuable suggestions.

C. M. J.

UNIVERSITY OF WISCONSIN,
December, 1918.

CONTENTS

	PAGE
PREFACE	v
CHAPTER I	
MAGNETIC PHENOMENA	1
Introduction—The Ether—Properties of the Ether—Magnetic Field—Like and Unlike Poles—The Magnetic Circuit—Unit Magnet Pole.	
CHAPTER II	
ELECTROSTATIC PHENOMENA	8
Electric Charge—Electric Field Between Parallel Plates—Properties of an Electric Field—Unit Charge—Electric Potential—Capacitance and Condensers.	
CHAPTER III	
ELECTROMAGNETISM	17
Introduction—Electric Current—Relation of Electric and Magnetic Fields—Strength of a Magnetic Field Around a Current-carrying Wire—Unit Magnetic Field—Absolute Electromagnetic Unit of Current—Electromagnets—Magnetic Field Inside of an Anchor-ring—Magnetic Field Inside of a Long Straight Solenoid—Magnetomotive Force and Magnetizing Force—Magnetic Properties of Iron—Hysteresis—Electromagnetic Induction.	
CHAPTER IV	
UNITS OF MEASUREMENT	37
Measurement—Derived Units—Magnetic and Electrical Units—Electrostatic Units—Electromagnetic System of Units—Electrical Units—Electromotive Force of Self-induction—Practical Electrical Units—Electric Current—Practical Unit of Quantity—Resistance—Practical Unit of Electromotive Force—Practical Unit of Inductance—Practical Unit of Capacitance—Ohm's Law—Change of Resistance with Temperature—Conductors in Series—Conductors in Parallel—Divided Circuits—Kirchoff's Laws—Work—Unit of Work—Relations Between English and Metric Units of Work—Energy—Power—Units of Power—Electricity and Electrical Energy—Electrical Work—Heating Value of Electric Current—Conversion Factors.	

CHAPTER V

ELECTROMAGNETIC WAVES	63
Cyclic Changes—Electromagnetic Pulse—Waves in General— Production of Waves—Graphical Representation of Wave Motion —Definitions—Generation of Electromagnetic Waves—Electro- magnetic Waves and Radiotelegraphy.	

CHAPTER VI

ELEMENTARY ALTERNATING CURRENTS	76
Oscillatory Motion—Displacement of a Point in Simple Harmonic Motion—Speed of a Body Having Simple Harmonic Motion— Rate of Change of Speed in Simple Harmonic Motion—Alternating Current and Electromotive Force—Phase Difference—Phase Relation Between the E.m.f. and Current in an Inductive Circuit— Mechanical Analogy—Clock and Wave Diagrams—Phase Rela- tion of E.m.f. and Current in a Circuit Containing Resistance and Inductance—Analogy for a Condenser—Action of a Condenser— Current in a Circuit Containing Capacitance—Current in a Circuit Containing Resistance and Capacitance—Relation Between Maximum Current and Pressure in a Circuit Containing Capacitance— Current in a Circuit Containing Resistance, Inductance, and Capacitance—Effective and Average Value of Alternating Current and Pressure—Influence of Frequency upon Impedance.	

CHAPTER VII

OSCILLATORY CIRCUITS	107
Condenser Discharge—Mechanical Analogy for Discharge of Condenser—Energy of a Charged Condenser—Condensers in Series and in Parallel—Energy Stored in a Magnetic Field— Closed Electric Oscillator—Analogy for Oscillatory Circuit— Period of Electric Oscillation—Undamped and Damped Oscilla- tions—Effect of Resistance in an Oscillatory Circuit—Calculation of Wave Length—Practical Oscillatory Circuit—Properties of Damped Waves—Decrement of Damped Waves.	

CHAPTER VIII

RADIO CIRCUITS	131
Definitions—Reactance Diagrams—Simple Parallel Circuits— Coupled Circuits—Properties of Coupled Circuits—Close and Loose Coupling—Coefficient of Coupling—Resonance of Simple Circuits—Analogy for Resonance of Simple Circuits—Oscillations of Coupled Circuits—Analogies for Coupled Circuits—Damping of Oscillations—Frequencies of Coupled Circuits—Damping in Coupled Circuits.	

CHAPTER IX

PRACTICAL TRANSMITTING APPLIANCES AND METHODS. 159
 Radiotelegraphic Systems—Generating Apparatus for Damped Waves—Transmitting Apparatus for Damped Waves—The Transformer—Spark Gap—Quenched Gap—The Condenser—Oscillation Transformer—Grounding—Wave Length of Antenna—Wave Length of Loaded Antenna—Constants of Antennas—Radiation Resistance or Coefficient—Undamped Wave Transmission—Alternator Method—The Inductor Alternator—Goldschmidt Alternator—The Arc Generator—Operation of the Transmitting Set.

CHAPTER X

PRACTICAL RECEIVING APPLIANCES AND METHODS. 201
 General—Cymoscopes or Detectors—Telephone Receivers—Sensitiveness and Amplitude of Vibration—Adjustments of Damped Wave Receiving Circuits—Receivers for Undamped Waves—Discontinuous or Tikker Method—Interference or Heterodyne Method—Relation Between Frequencies and Beats.

CHAPTER XI

VACUUM TUBES AND THEIR USE IN RADIOTELEGRAPHY 218
 General—Electron Theory of Electricity—Theory of Vacuum Tubes—Factors Affecting Operation—Vacuum Tubes as Amplifiers—Vacuum Tubes as Detectors—Condenser in Grid Lead—The Vacuum Tube as an Oscillator—Use of an Oscillating Vacuum Tube—Vacuum Tube as Generator.

INDEX. 237

PRINCIPLES OF RADIOTELEGRAPHY

CHAPTER I

MAGNETIC PHENOMENA

1. Introduction.—In order that a student may acquire an understanding of some of the more elementary principles of wireless transmission of intelligence he must have some conception of the entity called ether and the part this ether plays in the manifestation of electric and magnetic phenomena. Although some physicists may deny the existence and necessity of the ether and the validity of explanations of electromagnetic phenomena based on the ether theory, nevertheless, to most people the transmission of energy across and by means of a vacuum is unthinkable.

2. The Ether.—It is a matter of common experience that light passes from its source to objects, from which some of it is reflected, and if this reflected light enters the eye of an observer, he sees the object. That is, light after passing through space enters the eye and by its effect upon the optic nerve produces the sense of vision. The question naturally arises. What is light? A simple experiment will show that light will pass just as readily through a glass bulb containing the highest vacuum attainable as through a bulb filled with air or any other material medium. Hence, it follows that no material medium is instrumental in the transmission of light from one point in space to another point. Furthermore, it is known that light has the properties of waves and if that is true, it follows that because light passes through a vacuum there must be present some medium in which waves can be produced. It is impossible to think of energy being conveyed across or through a vacuum unless there is present some medium which acts as a carrier. This medium, in many respects hypothetical, is the ether.

Similarly, in order to explain many electrical and magnetic phenomena, the assumption of some nonmaterial medium is necessary. The proof of the identity of this medium, through which magnetic and electric phenomena are manifest, with the ether was one of the greatest achievements of the last century in the realm of physics.

3. Properties of the Ether.—The properties of the ether are mainly inferred from phenomena made manifest by or through it. Thus the speed of light is known to be about 3×10^{10} cms. = 30,000,000,000 centimeters, or 186,000 miles per second. Since it takes time for the waves in the ether to travel through space, it follows that it takes time to develop within the ether the condition known as light, and hence the property of inertia is inferred.

The elastic property of the ether is obvious, for if waves are transmitted by it, elastic deformations must take place. That is, there must be a yielding of the medium under the action of a suitable force, and a return of the medium to its original condition when the force vanishes.

Another obvious property is its omnipresence. This property is readily inferred from the fact that light waves are propagated through vacuum, gases, liquids, and solids to a greater or less extent, and hence, ether must permeate and be present in all. The ether can thus be regarded as a universal medium permeating all regions of space and extending beyond the remotest stars. With reference to the earth and other bodies the ether is at rest. That is, these bodies do not carry the ether with them in their motions as the earth carries an envelope of air, but they move through the vast ocean of the ether as freely as a sieve moves through the air. The properties of ether that are of interest and importance in electromagnetic phenomena, such as radiotelegraphy, are its inertia and elastic properties.

4. Magnetic Field.—If a sheet of paper be placed over a bar magnet and while in this position iron filings be sprinkled upon paper, it will be found that the filings form a pattern which is well represented by Fig. 1. This pattern shows that the iron filings are constrained or forced to arrange themselves into curved lines or rows joining two points on the magnet. It is thus evident that there is some influence permeating the space around the magnetized bar.

The space around the magnet which is permeated by a mag-

netic influence is a magnetic field. When a magnetic substance, such as the iron filings, is placed within the field, it becomes magnetized and sets itself in a definite line. The iron filings become small magnets, and when two magnets are brought near each other a force is exerted between them. This force causes the iron filings to make certain designs as shown in Fig. 1. This representation of a magnetic field is only in one plane, that is, in the plane of the paper which was laid on the bar magnet. A similar design will be obtained if the magnet is turned on edge or in any position parallel to its length. This means that the magnetic field completely surrounds the bar magnet and is carried with it when the magnet is moved.

There are explanations advanced for the development of mag-

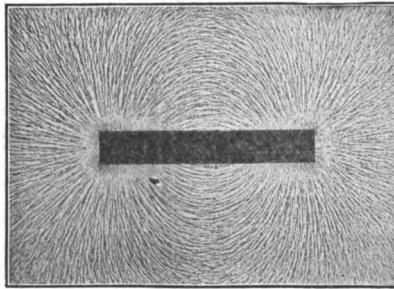

FIG. 1.—Magnetic field around a bar magnet.

netism in a steel bar, such as the bar magnet under consideration, but these theories we can at present neglect and merely recognize the existence of an influence about a bar magnet which affects iron filings when they are brought near the magnet. This influence is not conveyed from the magnet to the iron filings by the air or by any matter that may connect the two, such as the paper, for the influence will manifest itself in a vacuum. The influence is conveyed or transmitted by the ether whose properties were briefly described in the preceding article.

A brief consideration will show that when a piece of steel is magnetized it acquires some unique properties. To all appearances there is no difference between the magnetized and unmagnetized bar. They look alike; when magnetized the bar does not change in weight; nor can any change in the bar be detected by chemical analysis. Yet in the neighborhood of magnetic material or of electric currents the magnetized and unmagnetized bars

behave differently. The magnetized bar has associated with it a peculiar state of the ether which influences magnetic material in characteristic ways, the most obvious of which is the exertion of a force. The ether around the magnet is the seat of this property.

The magnetization of a bar of steel or of iron is accompanied with the development of a peculiar state in the ether which we may call a strain. The lines of strain are called magnetic lines. These magnetic lines have certain properties which are manifest under certain conditions. Thus, if another bar magnet be brought near the first and the resulting arrangement of magnetic lines be determined with the aid of iron filings, it is found that two characteristic configurations result as shown in Figs. 2 and

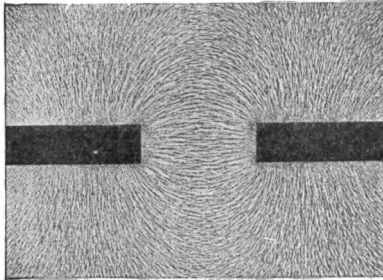

FIG. 2.—Magnetic field between like magnet poles.

3, depending upon the relative polarity of the two magnets. An examination of Fig. 1 does not show any difference in the lines radiating from the two ends of the bar magnet. If, however, a bar magnet is brought near and the resulting field is such as is shown in Fig. 2, then if one of the bar magnets is reversed the magnetic field shown in Fig. 3 results. This shows that the magnetic lines emanating from the two ends of the bar magnet behave differently in the presence of another magnet. In Fig. 2 the lines are joined and extend from one bar to the other, while it is plainly seen in Fig. 3 that the lines do not join but that those from one magnet deflect or push aside those from the other magnet. If the bar magnets were suspended so as to swing freely in a horizontal position, it would be found that the two ends near each other as shown in Fig. 2, would point in opposite directions. That is, if one pointed north the other would point south. Under the same conditions it would be found that the

two ends which are near each other in Fig. 3 would point in the same direction, either north or south as the case may be. From this and like phenomena the notion of polarity is deduced. That is, the conclusion is inevitable that the magnetic lines at the two ends of the bar magnet have different properties. A closer inspection of the figures will indicate some of these properties; for instance, as the lines in Fig. 2 extend from one of the bar magnets to the other, it is evident that the two magnets would be drawn toward each other if free to move. That this is a correct conclusion can easily be shown by suspending one of the magnets so that it can swing freely and observing its behavior when the opposite poles of the two magnets are brought near each other. When opposite poles are brought near each other, a force of

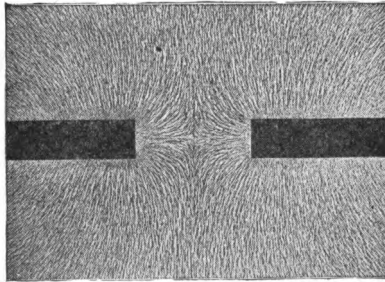

FIG. 3.—Magnetic field between unlike magnet poles.

attraction between the bar magnets results. This shows that the lines between the magnets, as shown in Fig. 2, have a tendency to contract; or, in other words, they act like rubber bands under tension.

An examination of Fig. 3 will show that when like poles are brought near each other, the lines do not join, but those from one magnet are deflected or pushed aside by those from the other magnet. Evidently, in this case a force of repulsion results. Although this force is manifested by the motion of the bar magnet, if permitted to move, nevertheless the seat of this force is in the ether between the two magnets.

5. Like and Unlike Poles.—If the bar magnet is suspended so as to swing freely in a horizontal plane, one end of it will point north while the other will point south. If the magnet be deflected from this position, it will return to it if permitted to move. The end that points north is called the *north-seeking* or *positive pole*, while the end that points south is called the *south-seeking*

or *negative* pole. For purposes of uniformity in the discussion or treatment of magnetic phenomena, the magnetic lines are always assumed to emanate from the north-seeking pole, to pass through space and return or reenter the magnetic material, in this case the iron bar, at the south or south-seeking pole. When poles of opposite polarity are brought near each other, the magnetic lines pass from the north pole into the south pole as indicated in Fig. 2, while if poles of ^{like}~~opposite~~ polarity are brought near each other, we have the results as indicated in Fig. 3.

Correction

6. The Magnetic Circuit.—The path of the magnetic line is known as the magnetic circuit. In Fig. 1 the magnetic circuit is made up of two parts—the material of the magnet and the air through which the lines pass. A magnetic circuit is said to be closed when the circuit is composed entirely of magnetic substances, such as iron or steel. A magnetic circuit is open when an air gap intervenes.

If a magnetic substance be brought into a magnetic field, the magnetic lines will be concentrated within the substance. Whenever pieces of iron or steel are brought into a magnetic field, the lines pass through them more readily than air and they become magnetized. If the material is soft iron, it will lose its magnetism when it moves from the field. Hard steel, on the other hand, when once magnetized, will retain its magnetism indefinitely.

Whenever a magnetic field is developed in any circuit the lines will pass along the path which offers the least opposition to their development. Iron offers the least resistance for the passage of the magnetic lines and so is used for a magnetic circuit whenever possible. Air offers from one to ten thousand times as much resistance to the development of magnetic lines as iron, depending upon the degree of magnetization. This property of relative magnetizability is called permeability. Copper, glass, paper, and other nonmagnetic substances offer the same resistance as air to the passage of the magnetic lines. Magnetic circuits through substances other than iron are usually made short so that the number of lines in the magnetic field will be as great as possible. The horseshoe magnet is stronger than the bar magnet of the same size because the magnetic circuit through the air is shorter. The opposition or resistance which any substance offers to a passage or development of magnetic lines is known as a *magnetic reluctance*.

7. Unit Magnet Pole.—In the measurement and calculation of magnetic forces, some unit of pole strength is needed. Since forces of attraction or repulsion are present when poles of two magnets are near each other, this fact is made use of in defining unit magnet pole.

Definition.—A unit magnet pole is a pole of such strength as will exert a force of one dyne upon a like and equal pole at a distance of one centimeter in air, or in a vacuum.

A dyne is about $\frac{1}{445,000}$ of a pound avoirdupois. A centimeter is $\frac{1}{2.54}$ inch.

CHAPTER II

ELECTROSTATIC PHENOMENA

8. Electric Charge.—The peculiar property possessed by a hard rubber comb, after it has been used in combing the hair, of first attracting and then after contact repelling any light object, has been known for a long time. As we were not concerned with the theories of the cause of magnetism, so in this case we are not concerned with the theories of the cause of this property acquired by the hard comb. What we are interested in is the fact that when a glass or vulcanite rod is rubbed with some other substance, such as silk, wool, or fur, it will acquire some properties which it did not possess at first. A substance like hard rubber or glass which when rubbed will attract light objects, is said to be electrified, or to have been given a charge of electricity. Although this does not tell us anything about the essential nature of electricity, if we study the phenomena accompanying a charged glass or rubber rod, we will acquire some knowledge of the behavior of electric charges under such condition, and the development of electric forces. For instance, if a glass rod be rubbed with fur and then suspended in a stir-

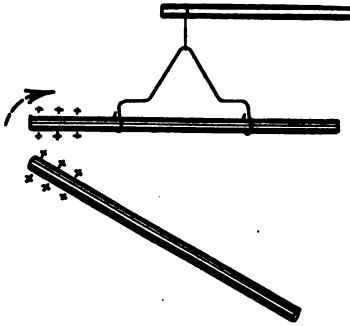

FIG. 4.—Repulsion of positively charged glass rods.

rup as indicated in Fig. 4 and another electrified glass rod be brought near, it will be found that a force of repulsion exists between the two rods. This force of repulsion is exerted through space exactly as the force of attraction or repulsion in the magnetic field was exerted through space. Likewise this force will be manifest if the experiment is performed in a vacuum; that is, if no material substance is present between the two rods. The electrification of the glass rod develops a certain property of the ether surrounding the rod

which causes the force of attraction or repulsion; in this case, repulsion upon the neighboring rod. We again have the ether as the seat of this property. Although the force exerted between the two rods would be measured in exactly the same mechanical units as the force exerted between two suspended magnets, the condition of the ether that produces the force in the one case is not the same as the condition of the ether that produces the force in the other case. Simple experiments will show this. Before pointing these out, however, it must be observed that if the glass rod in the stirrup has been rubbed with silk and a vulcanite rod which has been rubbed with a woolen cloth be brought near, the force developed will be one of attraction instead of repulsion. This, again, is analogous to the case in which unlike magnetic poles were brought near each other.

9. Electric Field.—We saw that if a sheet of paper be placed upon a magnet and iron filings be sprinkled on it, the resulting pattern is that shown in Fig. 1. If similarly a sheet of paper be placed over an electrified rod, or any electrically charged body, and instead of iron filings, powdered mica be sprinkled on it, the direction of the strains in the ether will be indicated by the arrangement of the powdered mica. But it will be observed that there is this difference in the two patterns: in the magnetic field both ends of the lines are joined to the magnet. In the case of the electric field, as is shown by Fig. 5, the lines originate at the charged body but do not reenter it. They radiate in all directions.

The reason for this difference lies in the fact that the body may be charged either positively or negatively. While it is impossible to develop a positive magnet pole without at the same time developing a negative pole on the same piece of steel, this is not the condition when a rod is rubbed with silk or fur; two kinds of electrifications are developed, but they are not confined to the rod. One kind is confined to the rod and the other to the material with which it was rubbed. If the two bodies are brought near each other, the lines extending from the rod will terminate in the material with which it was rubbed.

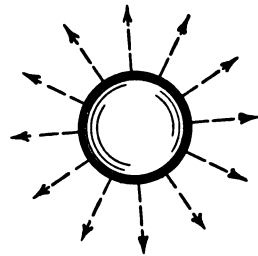

FIG. 5.—Electric lines around a uniformly charged sphere.

If two spheres be electrified with equal and like charges of

electricity, and then one sphere be brought into the vicinity of the other, the condition of the ether around the spheres will be represented by the lines of Fig. 6. The spheres repel each other, and

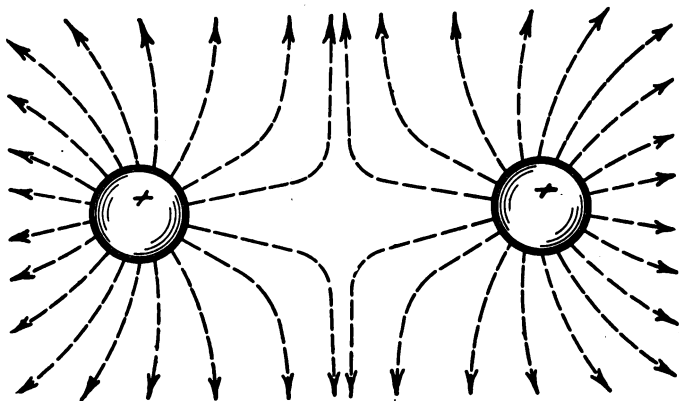

FIG. 6.—Electric field between two like charges.

this property of repulsion is indicated by the condition of the lines between the spheres. On the other hand, if two spheres charged with opposite kinds of electricity be brought near each other, the condition of the ether between the two spheres will be that

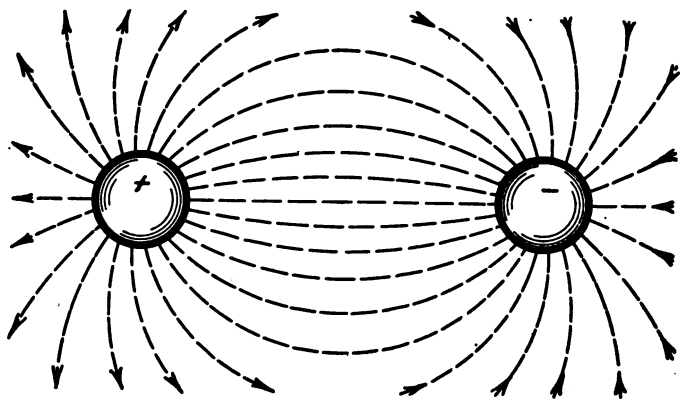

FIG. 7.—Electric field between two unlike charges.

indicated in Fig. 7. In this case the lines from one of the spheres terminate on the other. This condition of the ether will cause a force of attraction to exist between the two spheres.

10. Electric Field between Parallel Plates.—If two plates made of conducting material be placed near each other, as indicated in

Fig. 8, and if while in this position these two plates be charged with opposite kinds of electrification, the electric field between the two plates is well illustrated by the lines between them. The lines of the electric field extend from the positively charged plate and terminate in the negatively charged plate. As a consequence of this charge, there will be a force of attraction exerted between them.

From the behavior of charged bodies in the vicinity of other charged bodies, the properties of the ether, when subject to an electric influence, have been inferred. Again for purposes of uniformity in the discussion of electric fields, it is assumed that the lines of electric strain emanate from the positively charged body and terminate in the negatively charged body; or, in other words, the positively charged body is the source of the lines and the negatively charged body is the terminus of the lines. Even if no negatively charged body is in the immediate vicinity of the positively charged body, the lines emanating from it end upon the ceiling, the walls, and the floor of the room wherein the positively charged body may be placed, ultimately reaching the ground.

There are several theories concerning the physical process involved in charging a body. We are not concerned at present with these theories. The thing of importance is the condition of the ether surrounding a charged body, and the properties of this ether when the body is electrified.

We saw that when a magnetic body was placed within a magnetic field or within a space subject to a magnetic influence, the number of magnetic lines was increased, and their arrangement was modified. In an analogous manner, if a certain charge be placed upon one of two plates, Fig. 8, the space between the two plates is filled with a certain number of lines, and a definite force will be exerted between the two plates.

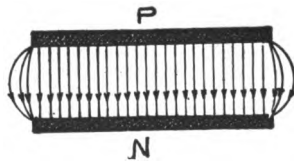

FIG. 8.—Electric field between oppositely charged plates.

If, now, instead of air we interpose between the two plates some other substance such as wax, this force will be materially reduced; that is, the medium between the two planes greatly influences the force exerted between them; or, in other words, modifies the tension of lines that extend between the two plates.

11. Properties of An Electric Field.—The electric field is

evidently a condition of the ether by means of which the influence of an electric charge is made manifest on another electric charge. As this influence usually manifests itself in the form of a force, the lines of electric strain are commonly called electric lines of force, and the electric field is called a field of force. This is hardly a correct characterization, for no force, in the usual sense of the term, exists in an electric field until a charged body is present. When, however, a charged body is brought within the sphere of influence of another charge, the reaction between them is manifest as a force. This force is found to depend upon the amount of the charges, their distance apart, and the nature of the surrounding medium, called the dielectric. In algebraic symbols this force is expressed by

$$F = \frac{q \times q'}{kd^2}$$

$$= \frac{\text{product of charges}}{\text{constant} \times \text{square of distance between the charges.}}$$

The constant k depends upon the dielectric or medium surrounding the charges. It has already been pointed out that if wax is interposed between two charged plates the force will be reduced.

12. Unit Charge.—Since two electric charges exert a force on each other when one is within the sphere of influence of the other, this force may be used to measure the quantity of the charge. A unit charge is one which will exert a unit force on a like charge when the distance between them is unity. If $q = q'$, $k = 1$, and $d = 1$ cm. then q is said to be a unit charge if the force F is one dyne. In other words, a unit electrostatic charge of electricity is one which will exert a force of one dyne upon a like charge at a distance of 1 centimeter in air. This is a small unit and not commonly used.

13. Electric Potential.—As two like charges repel each other it is evident that if one charge be kept stationary while the other is moved toward it, work must be done in transferring the movable charge from a distant point to one nearer the stationary charge. Thus, if in Fig. 9, A is a stationary charge and B a movable one, work must be done against the force of A on B when B is moved to C .

Energy must be stored in B as it is transferred to C . The condition of the point C with reference to the amount of work that

must be done in moving a unit positive charge from the earth up to that point is called its electric potential. If the unit charge be moved from C to D , more work will have to be spent. The difference of potential between C and D is measured by the difference between the work spent in moving a unit positive charge from an infinite distance to C and to D successively. If the potential at C is represented by V_C and that at D by V_D then the difference of potential between C and D is $V_D - V_C =$ work spent in moving unit charge from C to D , by definition.

Furthermore, if $V_D - V_C$ represents the work spent in moving unit charge between the two points, then if Q units are moved the work done will be Q times that required to move unit charge

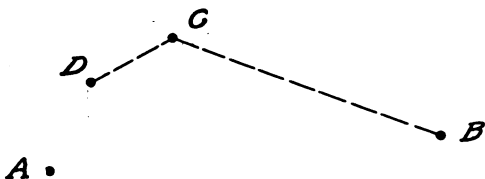

FIG. 9.—Illustrating difference of potential.

or work = $Q (V_D - V_C)$. If we represent $V_D - V_C$ by E we at once have work = QE .

Again it is evident that a positive charge at a point raises the potential of that point; for it would require more work to move a positive charge from the earth up to the point where the charge is located. If, however, some means can be employed whereby the repelling force of A can be reduced or diminished without diminishing the charge then a greater charge can be collected at the same point by the expenditure of the same amount of work.

This is accomplished in two ways; by using a medium with a high dielectric constant, and by bringing an opposite charge near the point and thus lowering its potential. This is the principle applied in electrical condensers.

14. Capacitance¹ and Condensers.—If a large and small ball be charged while in contact, they will be at the same potential but they will not contain the same quantities of electricity. The fact that it takes a greater charge to raise one conductor to the same potential as another conductor is explained by saying that one conductor has a higher capacitance than the other. By

¹ Also called electrical capacity, and permittance.

capacitance of a conductor or a system of conductors is meant, the property of holding a charge of electricity. The capacitance is measured by the ratio of the charge to the potential difference.

An electrical condenser is a system of conductors arranged so that their joint capacitance is greater than when used separately. That the electrical capacitance of a conductor is increased

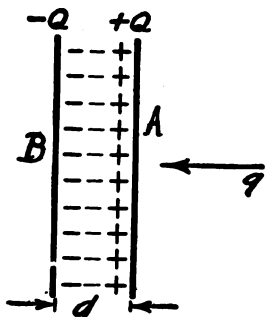

FIG. 10.—Principle of condenser.

by the presence of another conductor follows from the principles explained in the foregoing. This will be more easily understood by reference to Fig. 10 which shows two conductors *A* and *B* so near each other that the charge on one affects the charge on the other. The potential of *A* is measured by the work required to bring a unit positive charge from the earth to the conductor *A* against the repelling force of the charge $+Q$ on *A* and the attracting force of $-Q$ on *B*. The

actual repelling force is thus the difference between the repelling force of $+Q$ and the attracting force of $-Q$, and is less than the repelling force of $+Q$ only. The presence of $-Q$ on the conductor *B*, thus diminishes the potential of *A*, due to a charge Q concentrated on it. Hence, the charge to raise *A* to a given potential must be greater; that is, the capacitance of *A* is increased. It is not necessary to give a mathematical analysis to show that the capacity of *A* will increase the nearer *B* is to *A*, or the thinner the dielectric between *A* and *B*. For if we decrease the distance d , we decrease the difference between the repelling force of $+Q$ and the attracting force of $-Q$ on the unit charge q . That is, the potential of *A* is reduced by bringing *B* nearer. The capacitance thus varies inversely as the thickness of the dielectric.

Again if the two plates *A* and *B* be separated by air as shown in Fig. 11, and the plates be charged to a given difference of potential, they will hold a certain definite charge Q . If now the plates be immersed in water as indicated in Fig. 12, and if they be charged to the same difference of potential E , the charge will be about 90 times as great, or $90 Q$. Thus, when water is the dielectric, the capacitance is greatly increased. The ratio between the capacitance of the plates with some substance as the dielectric and the capacitance of the plates with air as the di-

electric is called the dielectric constant of that substance. In the example this ration is

$$C_w : C_A :: 90Q : Q$$

or

$$\frac{C_w}{C_A} = \frac{90Q}{Q} = 90 \text{ about.}$$

This shows the influence of the dielectric upon the capacitance of a system of conductors or of a condenser.

It is almost self-evident that the ability of a system of conductors to store electricity is dependent upon the surface or area

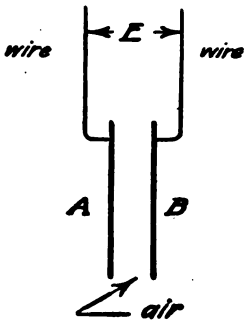

FIG. 11.—Condenser with air dielectric.

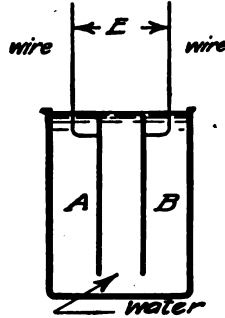

FIG. 12.—Condenser with water dielectric.

of the conductors. Grouping these facts together we learn that the capacitance of a condenser is directly proportional to the area of the conducting plates in contact with the dielectric, to the dielectric constant, and inversely to the thickness of the dielectric. In algebraic symbols

$$C = K \frac{kA}{d},$$

where K is a proportionality factor, k is the dielectric constant, A is the area of one side of the dielectric in contact with the conducting plates, and d is the thickness of the dielectric. The value of K will be determined by the units used in measuring A and d , and the unit in which the capacitance C is to be expressed. If C is to be in farads, A in sq. cm., and d in centimeters, then

$$K = 884 \times 10^{-16}.$$

Hence,
$$C = 884 \times 10^{-16} \frac{kA}{d} \text{ farads.}$$

A farad will be defined later.

Example

A condenser is made of 301 sheets of tin-foil separated by paraffined paper (Fig. 13). If the tin-foil is 25×25 cms. and the paper is 0.02 cm. thick, what is the capacity of the condenser?

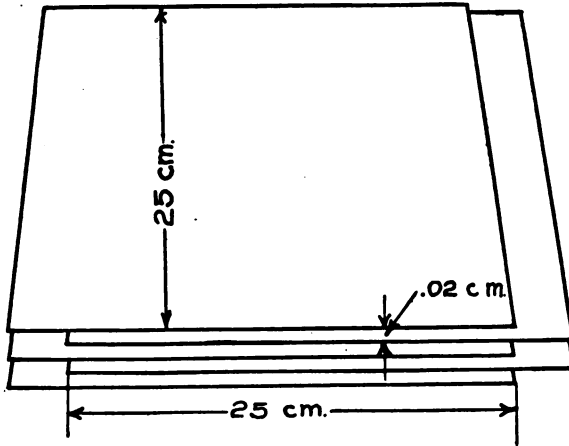

FIG. 13.—Condenser plates.

Solution

$$C = 884 \times 10^{-16} \times \frac{kA}{d}$$

Data

$$k = 2.3 \text{ about.}$$

$$A = 25 \times 25 \times 300.$$

$$d = 0.02.$$

Then

$$\begin{aligned} C &= \frac{885 \times 10^{-16} \times 2.3 \times 25 \times 25 \times 300}{0.02} \\ &= 1.9 \times 10^{-6} \text{ farads.} \\ &= 1.9 \text{ microfarads.} \end{aligned}$$

A microfarad is one-millionth of a farad.

Condensers are of great importance in wireless telegraphy. A further discussion of their operation on charge and discharge will be given later.

CHAPTER III

ELECTROMAGNETISM

15. Introduction.—In the first chapter we learned that the space surrounding a permanent magnet possesses some peculiar properties. Some of these properties become apparent when iron filings are sprinkled upon paper placed on the magnet. Other properties become apparent when a compass needle is brought near the magnet and when the magnet is suspended so as to swing freely in a horizontal plane. In the second chapter some of the properties of electric charges were pointed out. It was shown that these properties are analogous to the properties of magnets, but that essentially they are radically different. Although magnetic forces and electric forces are both made manifest or apparent through the instrumentality of the ether, the condition of the ether when subjected to a magnetic influence is not the same as when it is subjected to an electric influence. Under the conditions assumed in the two preceding chapters, electric and magnetic phenomena appear to be distinct. We shall now see whether this is always the case.

16. Electric Current.—In Chapter II the electric charges considered were stationary, or in a static condition. The influence permeating the ether is that due to a charge at rest. What phenomena would become apparent were the charge to move at a high velocity? Some of these phenomena can be studied by the aid of an experiment suggested by Fig. 14, which shows a wire connected to two dry cells and passing vertically through a sheet of paper. If iron filings be sprinkled on the paper while the current is flowing in the wire, the iron filings will arrange themselves in circles around the wire as shown. While Fig. 14 is merely a diagram, Fig. 15 is a reproduction of a photograph of the pattern made by iron filings around a current-carrying wire. Is this a new phenomenon or is the cause of the influence on the iron filings the same in nature as that around a bar magnet? One or two simple experiments will show that the phenomenon is magnetic, for if the current-carrying wire be held above and par-

allel to a compass needle, Fig. 16, it will be found that the compass needle will be deflected. The effect is just the same as when a bar magnet is held near the compass needle. This would indicate

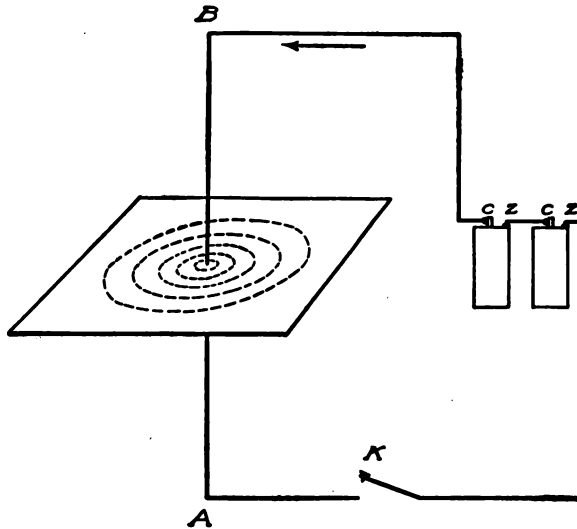

FIG. 14.—Diagram of magnetic field around a current-carrying wire.

that the field surrounding a current-carrying wire is a magnetic field. Another simple experiment to show the nature of the influence around a current-carrying wire may be performed as indicated in Fig. 17. When the wire is wrapped into a solenoid

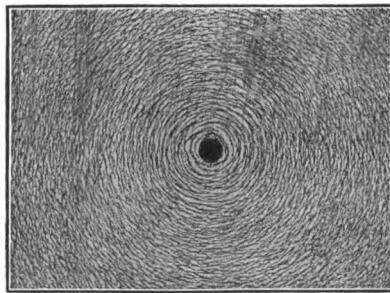

FIG. 15.—Magnetic field around a current-carrying wire.

as indicated, and the solenoid is tested, it is found that it has north and south magnetic poles, and that in every way it has the properties of a bar magnet. Thus a current-carrying wire is

surrounded by a magnetic field. This is an important fact as it is the basis of the operation of all electromagnetic machinery.

To the inquiring mind it may seem that while the foregoing phenomena are apparent, yet no relation has been shown between the charge on a glass rod and the electric current in the wire. This relation has been determined by discharging a static machine or a condenser through a coil wrapped around a sewing needle. When this is done, it is found that the needle is magnetized.

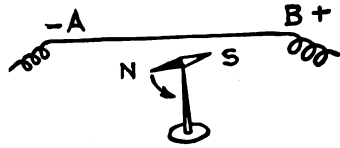

FIG. 16.—Magnetic effect of current-carrying wire.

On account of the oscillatory discharge of the condenser the experiment is not always successful. This shows that an electric charge in motion produces a magnetic effect exactly as the current in the wire, Fig. 16. Hence it is reasonable to conclude that an electric current is merely a continuous passage of electric charges, and that one of the results of this continuous passage of electric

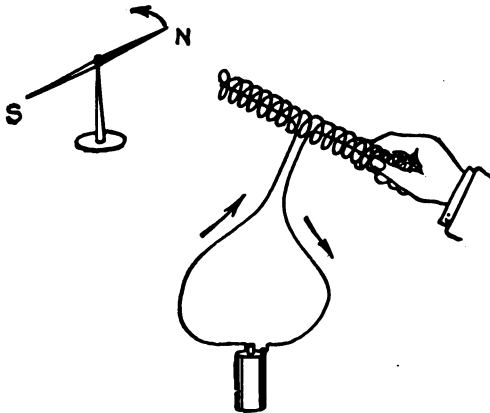

FIG. 17.—Magnetic properties of a solenoid.

charges is the production of a magnetic field in the space around the wire carrying the charges or current of electricity.

17. Relation of Magnetic and Electric Fields.—In the preceding article it was stated that a current of electricity is the continuous passage of electric charges. It is this and more, for these charges move from points of high potential to points of low or lower potential. According to the definition of potential, the work done in transferring a charge of Q units between two

points, whose difference of potential is E , is QE if the charge Q is transferred from a point of low to a point of higher potential. If the direction of transfer is reversed, and the charge is permitted to move from higher to lower potential, then according to the law of conservation of energy, the energy that was stored must be given back. That is, the transfer of electric charges from high to low potential is accompanied by the development of energy. An electric current is thus accompanied by energy manifestations. These manifestations of energy are of two kinds, (a) heating of the conductor and (b) energy stored in the space or ether surrounding the conductor. The energy converted into heat is spent in heating the air and surrounding objects and is thus

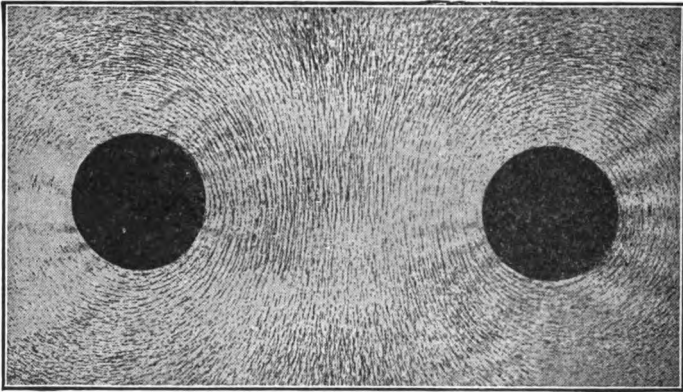

FIG. 18.—Magnetic field between conductors.

wasted. With this, we are not at present concerned. In radiotelegraphy or wireless telegraphy, the energy in the ether surrounding a conductor is of first importance. This energy is in two forms, electromagnetic and electrostatic.

If the two wires of a circuit be run vertically through a sheet of paper in a horizontal position, and if while a current is flowing in the circuit, iron filings be sprinkled on the paper, a magnetic field will result, as is shown in Fig. 18. The magnetic lines form closed curves around the conductors whose cross-sections are shown in black. The crowding of the lines between the conductors will produce a force tending to separate them. That energy is present, or is stored, in the magnetic field is manifest by the force between the two wires.

If a source of high potential be connected to two ends of two

wires while the two other ends are left separated so no current can flow, as shown in Fig. 19, and if powdered mica be sprinkled on the paper as indicated, the lines of electric strain in the ether between the two wires will likewise become visible. A pattern or map of such an electric field is shown in Fig. 20. The lines emanate from one conductor and terminate on the other. The tension of these lines, or tubes as they are sometimes called, will tend to draw the conductors together. This shows that energy is stored in the electric field and that it is manifest by a force of attraction between the two conductors.

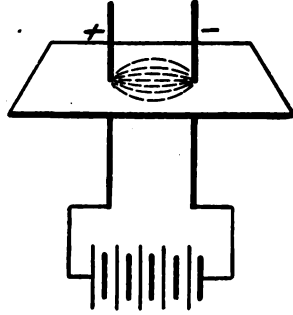

FIG. 19.—Diagram of electric field between two conductors.

By combining, or superposing, Fig. 18 on Fig. 20 a combined map of the electrostatic and electromagnetic fields results. Such a combination is shown in Fig. 21. An examination of this figure shows that the lines of magnetic strain are at right angles to the lines of electric strain. This is brought out more clearly in the graphical representation, Fig. 22. The magnetic field shown in Fig. 18 was produced when a current was flowing in the conductors in opposite directions, and the electrostatic field,

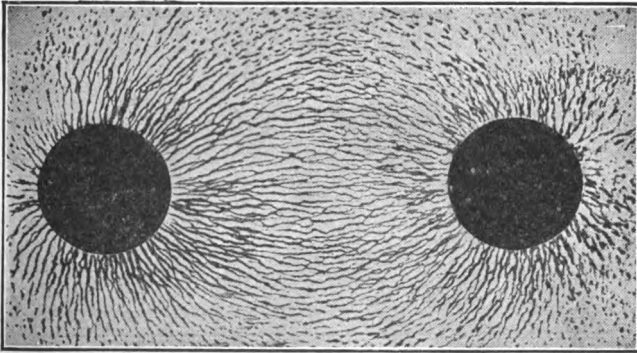

FIG. 20.—Electric field between oppositely charged conductors.

Fig. 20 was determined when the circuit was open. Under this condition no magnetic field surrounds the conductors. The geometric relation or relative position in space of the two fields is well shown by Fig. 22, but the physical relation between the two is

not apparent. This relation can be made apparent in another way. Suppose two electrically charged bodies, Fig. 23, be connected by two conductors AB and CD . So long as the ends B and D are kept separate, an electrostatic field exists between the

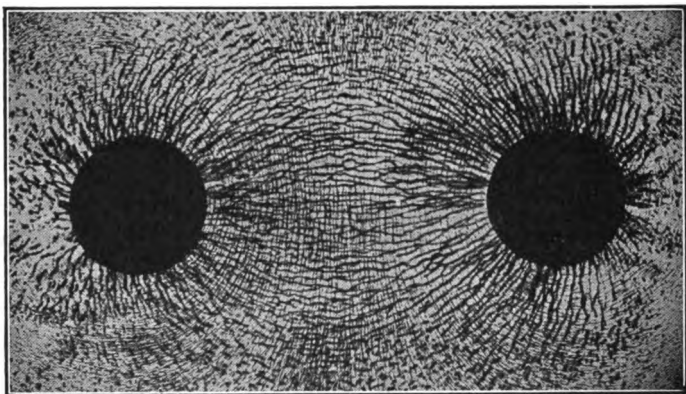

FIG. 21.—Magnetic and electric fields between two wires of a circuit.

charged bodies and between the two conductors. The lines of electric strain will tend to shorten or draw the conductors toward each other. When the two ends B and D are brought into contact, the lines are permitted to shrink or collapse, their two ends

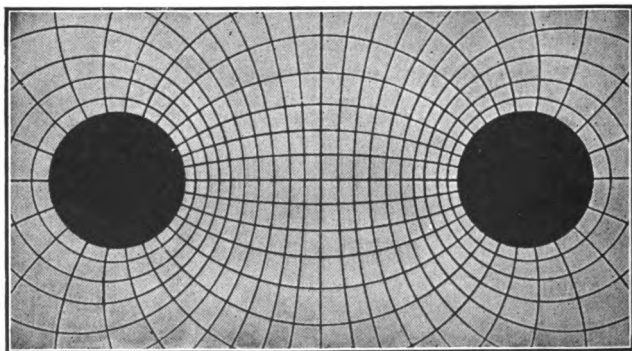

FIG. 22.—Diagram of electric and magnetic fields around two wires of a circuit.

being drawn together. The two ends of the lines slide along the conductors toward B and D and these shrink or collapse. The motion of these lines accompanies or is the current in the conductors. But we have seen that a current of electricity in a

conductor is accompanied by a magnetic field around the conductors. Hence it follows that the motion of the electric lines along the conductors produces or is accompanied by a magnetic field whose lines are at right angles to the direction of motion of the electric lines and also at right angles to their direction.

Energy does not flow from one point to another point unless

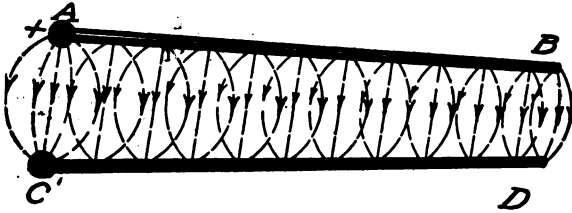

FIG. 23.—Electric field between two conducting rods.

these two fields exist together. A source of constant electromotive force or electrical potential connected to A and C will develop the lines of electric strain at a constant rate, and their motion will be accompanied by a magnetic field of constant strength.

18. Strength of a Magnetic Field Around a Current-carrying Wire.—Before discussing the application of the principles out-

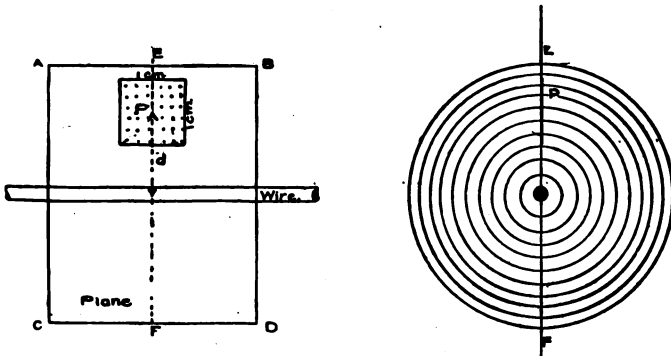

FIG. 24.—Strength of magnetic field around a wire.

lined in the preceding articles, some other properties of the electric circuit must be considered. We have just learned that a current-carrying wire is surrounded by a magnetic field, but nothing has been said with respect to the the relation between the current and the strength of the resulting magnetic field. As experiment shows the magnetic field around a straight current-carrying wire is composed of concentric circles wrapped around

the wire. The strength of the field at any point will then be represented by the number of lines per square centimeter in a plane containing the wire, Fig. 24. The density, or number of lines per square centimeter, decreases from the wire outward. Experiments, as well as theory, show that the strength at a point in space of a magnetic field due to a current depends directly upon the current strength and inversely upon the distance of the point from the wire. In algebraic symbols, if H represents the field strength at the point P , I the current in absolute units, and d the distance of the point from the current-carrying wire, then,

$$H = \frac{2I}{d}.$$

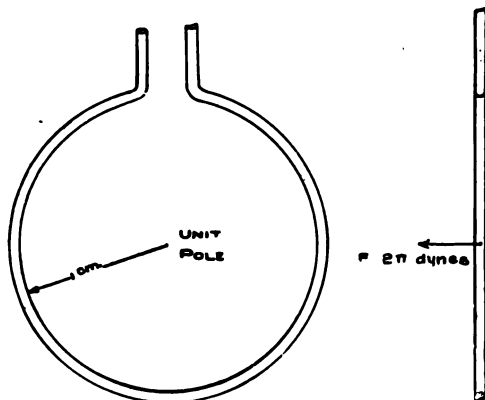

FIG. 25.—Force of current on magnet pole.

The current I is measured in certain units as yet undefined. The intensity or strength of magnetic field H , is measured by the force exerted by the magnetic field upon unit magnet pole. A unit magnet pole is defined in Art. 7.

19. Unit Magnetic Field.—A magnetic field of unit intensity is such a magnetic field as will exert a force of one dyne upon a unit magnet pole. As the magnetic field is produced by the current and as it is directly proportional to the current, the force a magnetic field, due to a current, exerts upon a unit magnet pole may be used to measure the current strength. Unit current may be defined in terms of this force.

20. Absolute Electromagnetic Unit of Current.—When a wire along which an electric current is flowing is bent into a ring, all of the magnetic lines due to the current will pass through the

ring, Fig. 25. The definition of the electromagnetic unit of current is based on this fact. The absolute ampere is defined as the current which will exert a force of 2π dynes upon a unit magnet pole placed at the center of a circular coil of 1 turn of wire, of 1 centimeter radius, of which the current-carrying wire is the circumference. The current is thus defined in terms of the force it exerts upon a unit magnet pole. This unit is commonly called the *abampere* to distinguish it from the ampere which is the practical unit of current and is equal to $\frac{1}{10}$ of the abampere, or 10 amperes = 1 abampere.

21. **Electromagnets.**—A current-bearing solenoid has the properties of a bar magnet. It would, however, require enormous

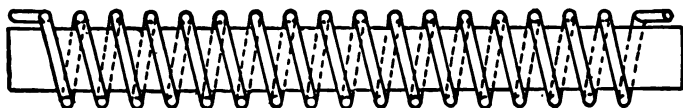

FIG. 26.—Electromagnet.

currents to make very strong magnets so long as the solenoid had only an air core. It is the combination of a solenoid and an iron core that makes possible the development of strong magnetic fields. Such a combination is called an electromagnet, Fig. 26.

When a current of a given value is sent through the convolutions of the solenoid, magnetic poles are developed at the ends of the solenoid in accordance with the principles already explained. If, while the current is flowing, an iron rod be inserted into the solenoid, it will be found that the electromagnet becomes a much stronger magnet. The iron has thus a property of greatly increasing the number of magnetic lines. Perhaps a better way

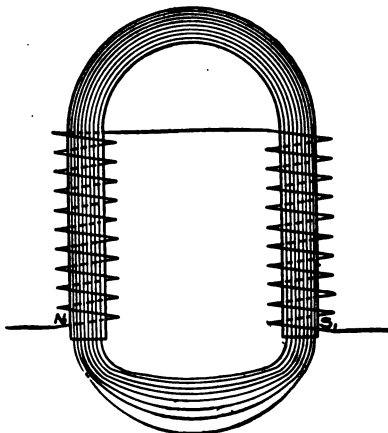

FIG. 27.—Horse-shoe electromagnet.

of explaining the action of the iron is to say that it offers a much smaller resistance to the passage of the magnetic lines, and ac-

cordingly the same current will send many more lines through the iron than through the air alone.

If the magnetic circuit is composed wholly of iron, the opposition to the building up of a magnetic field is much less than when the circuit is part iron and part air. Under such conditions the same current will develop an even stronger magnetic field. Thus, an electromagnet in which the magnetic circuit contains only a small air gap is more effective than one in which the air gap is large, Fig. 27.

22. Magnetic Field Inside of an Anchor Ring.—Suppose a long

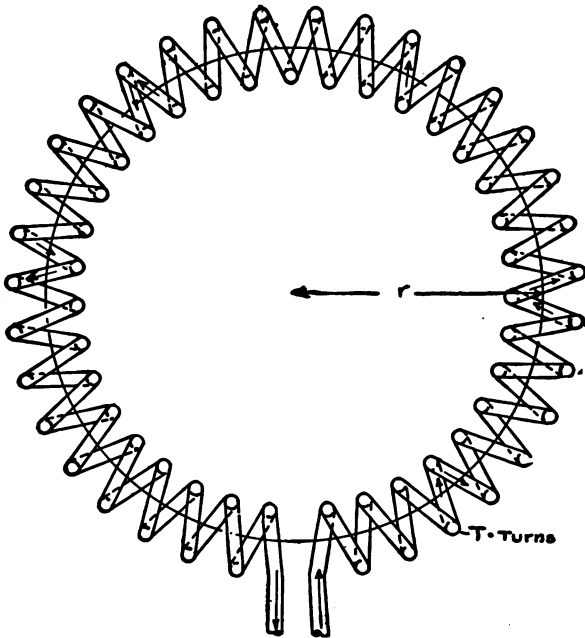

FIG. 28.—Anchor ring.

helical coil of wire is bent into a ring, Fig. 28. When a current is passed through the wire of such a solenoid, the magnetic field is confined to the interior of the spiral ring and in the direction of its length. The work required to move a unit magnet pole around the magnetic circuit, that is, length of the ring, can readily be calculated. A straight conductor is surrounded by a magnetic field whose strength at any point is $\frac{2I}{d}$. When a unit magnet pole

is moved around the wire at a distance d against the magnetic field, the numerical value of the work done will be

$$2\pi d \times \frac{2I}{d} = 4\pi I.$$

If a unit magnet pole is moved along the circular axis of the anchor ring of N turns one complete revolution, it will have made one complete turn around each turn of wire. The total work will then be N times the work done in moving the unit pole around one conductor. Hence the work done in moving the magnet pole one complete revolution along the circular axis of the coil is

$$W = 4\pi NI.$$

If H is the force exerted by the magnetic field on a unit magnet pole within the anchor ring, then by definition $W = Hl$, where l is the length of the path along which the magnet pole was moved. Equating these expressions for W we have

$$\begin{aligned} Hl &= 4\pi NI, \\ H &= \frac{4\pi NI}{l} \end{aligned}$$

where H is numerically equal to the strength of the magnetic field inside of the anchor ring solenoid. If I is measured in amperes, then

$$H = \frac{4}{10} \frac{\pi NI}{l}.$$

23. Magnetic Field Inside of a Long Straight Solenoid.—

It is evident that if the radius of the anchor ring is increased greatly, a part of the anchor ring will approach a straight solenoid. A long straight solenoid may be considered as a portion of an anchor ring with an infinite radius. The magnetic field near the center of a long solenoid will be the same as in the anchor ring, viz.,

$$\begin{aligned} H &= \frac{4\pi NI}{10l} \\ &= \frac{1.257NI}{l} \text{ gilberts per centimeter.} \end{aligned}$$

A more accurate expression for the field intensity inside of any solenoid is

$$H = 1.257NI \left[1 - \frac{r^2}{4(l-x)^2} - \frac{r^2}{4x^2} \right],$$

where l = length of solenoid,
 x = distance of point inside of the solenoid from one end,
 $l - x$ = distance of the point from the other end,
 r = radius of the solenoid.

24. Magnetomotive Force and Magnetizing Force of a Solenoid.—The magnetomotive force is defined as numerically equal to the work expended in moving a positive unit magnet pole around the magnetic circuit against the magnetic field. It has been shown that this, in both the anchor ring and long solenoid, is

$$\text{m.m.f.} = Hl = 1.257NI \text{ gilberts,}$$

when I is in amperes. H , the magnetizing force of the solenoid, is equal to the magnetomotive force per unit length. The student should remember, however, that neither the magnetomotive force nor the magnetizing force is of the physical nature of a force. They are of the nature of work per unit magnet pole.

If an iron core be inserted into the anchor ring or solenoid, the flux density B is μH , where μ = permeability. Then

$$B = \frac{1.257NI\mu}{l}$$

The total flux

$$\begin{aligned} \Phi &= BA = \frac{1.257NI}{\frac{l}{\mu A}} \\ &= \frac{\text{m.m.f.}}{\frac{l}{\mu A}} \end{aligned}$$

The quantity $\frac{l}{\mu A}$ is called the reluctance, R . We may then write

$$\begin{aligned} \Phi &= \frac{\text{magnetomotive force}}{\text{reluctance}} \\ \Phi &= \frac{1.257NI}{R} \text{ maxwells.} \end{aligned}$$

As the reluctance $R = \frac{l}{\mu A}$ it is evident that the reluctance of a magnetic circuit varies directly as the length and inversely as the product of the permeability by the cross-sectional area of the circuit. μ for air is practically unity.

If a magnetic circuit consists of several parts in series, each having a different length, cross-section, and permeability, the total reluctance is the sum of the reluctances of the several parts. Thus if $l_1 A_1 \mu_1$, $l_2 A_2 \mu_2$, and $l_3 A_3 \mu_3$ are the lengths, cross-

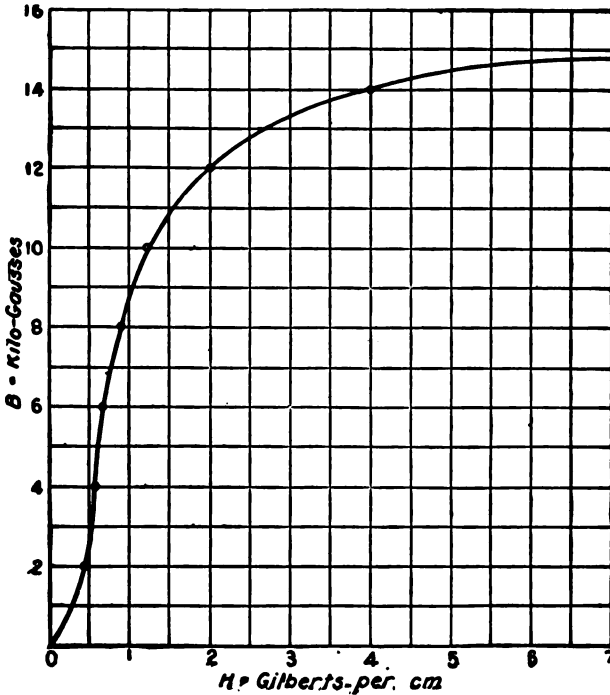

FIG. 29.—Relation between flux density and magnetizing force.

sectional areas, and permeabilities of three parts respectively, the total reluctance is

$$R = \frac{l_1}{\mu_1 A_1} + \frac{l_2}{\mu_2 A_2} + \frac{l_3}{\mu_3 A_3},$$

and if a magnetomotive force of $1.257NI$ units is applied, the flux resulting is

$$\Phi = \frac{1.257NI}{\frac{l_1}{\mu_1 A_1} + \frac{l_2}{\mu_2 A_2} + \frac{l_3}{\mu_3 A_3}}$$

$$= \frac{\text{m.m.f.}}{R}$$

25. **Magnetic Properties of Iron.**—As iron in some form enters

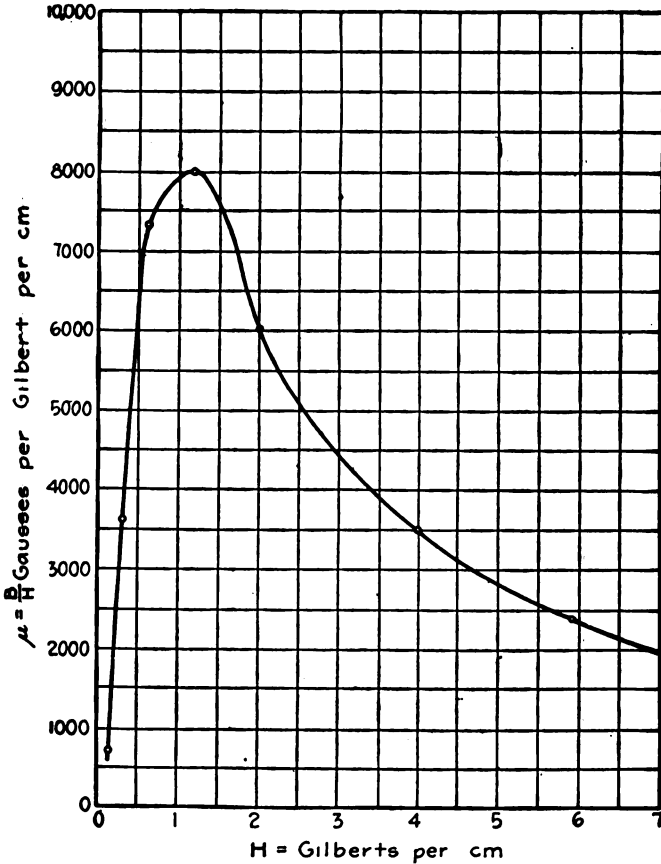

FIG. 30.—Permeability curve.

into all electrical machinery, its magnetic properties are of great importance. When a sample of iron is subjected to the influence of a magnetic field, it becomes magnetized. The relation between the flux density B and the strength of the magnetizing force H , producing the flux density, is usually shown by means of

a magnetization curve commonly called B - H curve. A typical B - H curve is shown in Fig. 29. An examination of this curve shows that for values of H below 0.5 gilbert per centimeter the flux density increases very slowly. As the strength of H increases from 0.5 to 2 gilberts per centimeter the flux density increases

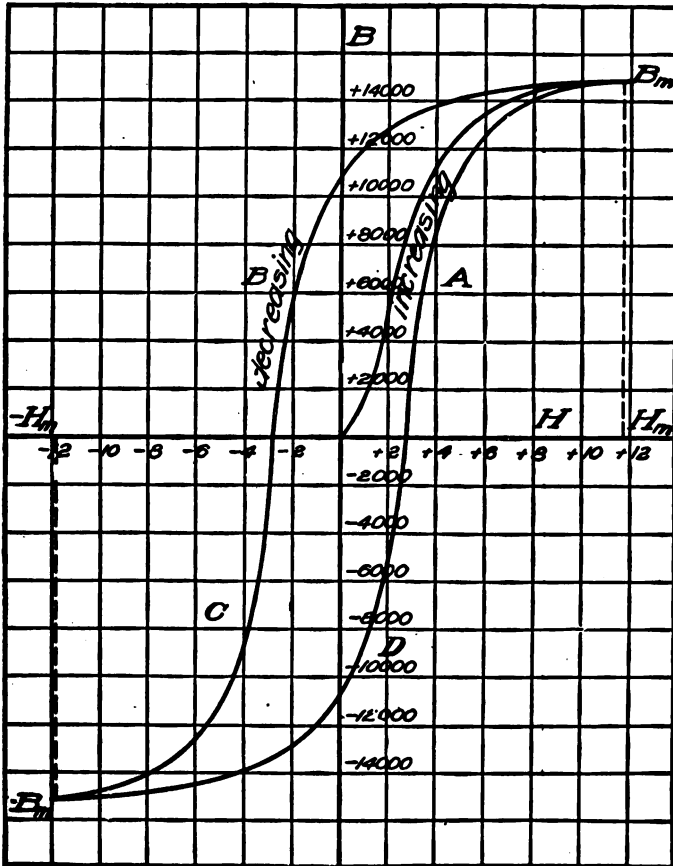

FIG. 31.—Hysteresis loop.

rapidly from about 2000 to 12,000 lines per square centimeter. For higher values of H the flux density again increases at a much slower rate. This is a typical B - H curve for iron. The absolute values of B for corresponding values of H will be different for different samples of iron, but the general form in every case will

be the same. Such curves are of extreme importance in the design of electrical machinery. The μ - H , or permeability, curve, Fig. 30, is easily obtained from the B - H curve. The value of μ at any value of H is obtained by dividing the value of B by the corresponding value of H . Thus when $B = 10,000$, $H = 1.25$ and accordingly $\mu = 10,000 \div 1.25 = 8000$. Other values of μ are calculated in the same way, and from these the μ - H curve is plotted. This curve shows that the permeability of iron is not a constant quantity. This is an important fact. The sharp bend of the B - H curve, in this case that portion of the curve between $B = 10,000$ to $B = 12,000$, is known as the knee of the curve. For practical purposes, this is the point of saturation of the iron. Fig. 29 shows that as the magnetizing force increases, the flux density increases, although not uniformly.

26. Hysteresis.—When a sample of iron is subjected to the influence of a magnetizing force which can be increased by steps and the magnetizing force and flux density are plotted, the curve shown in Fig. 29, results. If the magnetizing force be increased to any value, such as 4 gilberts, the flux density will reach a corresponding value of 14,000. If now the magnetizing force be decreased step by step, the flux density will not decrease along the magnetization curve, but will remain higher. This is illustrated by Fig. 31. This figure shows that when the magnetizing force has been reduced to zero, the flux density is still about 10,800 lines per square centimeter. This value is called *remanent* or *residual* magnetism. The flux density drops to zero only after the magnetizing force has been reversed and, in the illustration shown, increased to about 3 gilberts per centimeter in the negative direction. The magnetizing force required to reduce the residual magnetism to zero is called *coercive* force. It is thus evident that work must be done in causing the molecules to turn around and point in the opposite direction. The decreasing values of the flux density are higher than the increasing values of the flux density corresponding to the same magnetizing force. This lagging behind has, therefore, been given the name *hysteresis* which means "lagging behind," and the area bounded by the four lines *A*, *B*, *C*, and *D* is called a *hysteresis loop*. This loop is due to the fact that some work must be done in magnetizing the iron first in one direction and then in the other direction. The wider the loop the greater the amount of energy spent in the process of reversing the magnetization. This energy appears as

heat in the iron, and is lost for all practical purposes. For electrical machines in which the magnetization is variable, or alternates, it is of great importance to use iron whose hysteresis loop is very narrow and consequently has small hysteresis loss. Hysteresis loops give valuable information in regard to the magnetic qualities of iron.

27. Electromagnetic Induction.—Although even an approximately complete discussion of the processes of generating an electromotive force, or electrical pressure, is beyond the scope of this text, nevertheless the more elementary principles must be given since knowledge of these is necessary for an understanding of inductance and impedance which will be taken up later. In preceding chapters it has been shown that when an

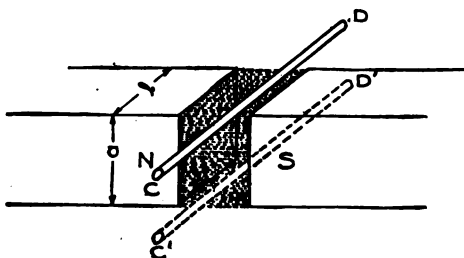

FIG. 32.—Illustrating electromagnetic induction.

electric current flows along a wire a magnetic strain is present in the ether surrounding the wire. The question naturally arises, will a current of electricity be produced in the wire if it is suddenly plunged into a magnetic field, or if a magnetic field of a neighboring wire is suddenly built up. That is, if some other means are used to produce the magnetic strain around the wire, will this result in a current of electricity in the wire? This question can be answered only by an experiment.

Faraday showed that when a wire cuts across a magnetic field, or when a magnetic field is suddenly built up around a wire, an electric current will flow if the wire forms a closed coil. When the coil is open, of course, no current can flow, but the tendency for a current to flow is present nevertheless. Thus whenever a wire cuts across a magnetic field, or when there is relative motion between a wire and a magnetic field, or a magnetic field is suddenly built up around a wire, there is also built up around the wire

an electric field or strain as already explained. If the two ends of the wire be brought together, the lines of the electric field will move along the connecting wires as explained in connection with Fig. 23, and we say a current flows in the wire. The relative motion of the wire and magnetic field thus produces a difference of potential between the two ends of the wire. This difference of potential is commonly called electromotive force, or electrical pressure. The current is the result of the development of this electromotive force. Electromotive force may also be developed in other ways.

The significance of Faraday's experiments will be more easily understood from a consideration of Fig. 32. In this figure two opposite magnetic poles are shown near each other. Between them is the magnetic flux Φ which we shall assume as being cut by the conductor CD moving downward. If the conductor starts from the position CD and moves to the position $C'D'$, it will cut across the flux Φ . A galvanometer or other sensitive current detecting device connected to the ends of the conductor will show that during the motion of the conductor from CD to $C'D'$ an electromotive force is induced, that is, a current flows through the galvanometer. Experiment thus answers the question in the affirmative, and it remains to consider the relation between the rate of cutting and the induced electromotive force.

It is worth while to point out that the magnetic lines must be actually cut by the conductor before an electromotive force will be induced. The conductor must move across the lines, and it is immaterial whether the magnetic field is stationary and the conductor moves, or whether the conductor is stationary and the magnetic field moves across it, or is suddenly built up around the conductor. The relative motion will result in an electromotive force being produced in the wire.

Experiment further shows that if the conductor be moved rapidly across the magnetic field, the deflection of the galvanometer will be greater. This means that the more rapidly the magnetic lines are cut, the higher will be the induced electromotive force. Likewise, it can be shown that if the speed of the conductor remain constant, but the number of magnetic lines be increased, the induced electromotive force, or e.m.f., is also increased. All of these facts can be summarized into one statement—namely, the e.m.f. induced by a conductor moving across a magnetic

field is proportional to the number of lines cut per second, or in other words the rate at which the lines are cut. If we represent the total number of magnetic lines cut in time t by Φ , then the rate of cutting is $\frac{\Phi}{t}$ and the e.m.f. for one conductor is

$$E = \frac{\Phi}{t}.$$

Φ is called the magnetic flux. If there are n conductors cutting the same flux at the same rate, and if these are connected so that the e.m.f. induced in one is added to that induced in the others, then the total e.m.f. is $E = \frac{n\Phi}{t}$. The practical unit of electromotive force or electrical pressure is the *volt*, which is the e.m.f. developed when the conductor is cutting the flux at the rate of $10^8 = 100,000,000$ lines per second. It may be due to a single conductor cutting 10^8 lines per second, or to a large number of conductors, properly connected, each cutting a correspondingly reduced number of magnetic lines. If E is to be expressed in volts, we divide by 10^8 , hence

$$E = \frac{n\Phi}{t \times 10^8}.$$

Examples

1. If the total flux between the pole faces, Fig. 32, is 4,000,000 lines and the conductor moves across it in $\frac{1}{2}$ second, what is the pressure between the ends of the conductor?

Solution

$$E = \frac{n\Phi}{t \times 10^8} \text{ volts.}$$

$$\Phi = 4,000,000$$

$$n = 1$$

$$t = 1/2 \text{ sec.}$$

$$\begin{aligned} E &= \frac{4,000,000 \times 1}{\frac{1}{2} \times 10^8} \\ &= 0.08 \text{ volts.} \end{aligned}$$

2. Suppose one side of a coil of 1000 turns cuts the flux specified in Example 1 in 0.1 second, what will be the pressure between the terminals of the coil?

5

Solution

$$E = \frac{n\Phi}{t \times 10^8}$$

$$n = 1000$$

$$\Phi = 4,000,000$$

$$t = 0.1$$

Then

$$E = \frac{4,000,000 \times 1000}{0.1 \times 10^8}$$
$$= 400 \text{ volts.}$$

CHAPTER IV

UNITS OF MEASUREMENT

28. Measurement.—In order that physical quantities may be compared and that their effects and relations may be calculated, they must be measured and their magnitudes or relative sizes determined. For the purpose of measurement, units are necessary. The unit is always some arbitrarily chosen magnitude of like quantity. For instance, the fundamental unit of length in most electrical calculations is a fractional part of the meter. The meter is defined as the distance, at the temperature of melting ice, between two points on a certain platinum iridium bar deposited at the International Bureau of Weights and Measures at Sevres, France. One one-hundredth of this length is the centimeter which is the unit of length used in most scientific calculations. In the British system of units the fundamental arbitrary unit of length is the yard, one-third of which, the foot, is commonly used in engineering calculations.

What is true with respect to the arbitrary nature of the unit of length is true with respect to the units of other quantities.

The measurement of a physical quantity consists in comparing its magnitude, or effect, with the magnitude, or effect, of the arbitrarily chosen unit as the standard of comparison. The magnitude of the quantity measured is then expressed in terms of that unit, and the expression consists of two parts; a numerical part, and the part which names the unit with which it has been compared. Thus we may give the length of a wire as 1000 *feet* or as 1000 *meters*. Merely the number 1000 will give no idea of the length, but the number must be followed by the name of the unit of measure. The numerical part will vary inversely with the size of the unit employed. Thus a distance may be expressed as 1 *mile*, 1760 *yards*, or 5280 *feet*. The distance is the same in each instance, but as the size of the unit of measure decreases the numerical part of the expression increases.

Systems of Units.—Fundamental concepts of physical quantities are those of *length*, *mass*, and *time*, and most physical quanti-

ties may be expressed in terms of these. For this reason the units of *length*, *mass*, and *time* are called *fundamental units*, and all other units which can be expressed in terms of these are called derived units. A system of units which consists of the fundamental units and derived units based on these is called an *absolute system*. In the absolute system commonly used the fundamental units are the *centimeter*, the *gram*, and the *second*, and the system is for this reason called the c.g.s. system. The corresponding units in the English system are the *foot*, the *pound*, and the *second*.

The *gram* is the $\frac{1}{1000}$ part of a mass of metal called the kilogram. It was intended that the gram should represent the mass of 1 cubic centimeter of distilled water at the temperature of 4°C. Although this is not quite correct, nevertheless, for all practical purposes we may regard the mass of 1 cubic centimeter of distilled water at 4°C. as equal to 1 gram.

The *second* is defined as the $\frac{1}{86,400}$ part of a mean solar day. By mean solar day is meant, the average time for a year between the successive passages of the sun across the meridian. The *meter* has already been defined.

29. Derived Units.—Units of quantities depending on powers greater than unity of the fundamental units of length, mass, and time, are called derived units. Thus the units for the measurement of surface, volume, velocity, force, work, current, electromotive force, etc., can all be expressed in terms of the fundamental units, and are, therefore, derived units. The number of derived units is limited solely by the number of physical quantities to be measured. In electrical measurements and calculations, with which we are at present concerned, two kinds of derived units are commonly used. These are *absolute* units and *practical* units. The absolute units are those based directly upon the three fundamental units. They can be expressed directly in terms of the fundamental units without any multiplying or conversion factors.

The absolute units are, however, too small in some cases, and too large in others for convenient use, and hence, for practical calculations and measurements, certain multiples of the absolute units have been chosen and named. These are called practical units. These will be defined later.

30. Magnetic and Electrical Units.—The absolute units employed in electrical and magnetic measurements are based on two different fundamental assumptions. In one system the repulsive

force between two electrical charges is made the basis. This system is known as the *electrostatic system of units*. In the other the repulsion between two magnetic poles, or quantities of magnetism, is taken as the basis. This is known as the *electromagnetic system of units*. Most electrical measurements are made with the electromagnetic units. There are certain relations between these two systems of units the values of which have been determined by experiment.

The fundamental bases of both the electrostatic and electromagnetic systems of units are force and work. The absolute unit of force the *dyne* is defined as that force which when applied to a gram mass will give it an acceleration of 1 centimeter per second. This is known as the absolute or c.g.s. unit of force. A pound force is approximately equal to 444,800 dynes.

The absolute unit of work is the *erg* which is defined as the work spent or done by a force of 1 dyne acting through a distance of 1 centimeter.

31. Electrostatic Units.—The more common electrostatic units are those of quantity of electricity, difference of electrical potential, and of capacity.

(a) *The Unit of Quantity.*—The unit of quantity of electricity is that quantity which will exert a force of 1 dyne upon an equal and like quantity at a distance of 1 centimeter in air.

(b) *The Unit Difference of Potential.*—A unit difference of electrical potential exists between two points when it requires an expenditure of 1 erg of work to bring a plus unit of electrical quantity from one point to the other point.

(c) *A unit capacitance* is that electrical capacitance of a conductor which requires a charge of one electrostatic unit of quantity to produce a unit difference of potential. These electrostatic units have no names, and will be little used by the student. They are given here mainly for reference and comparison.

32. Electromagnetic System of Units.—As already pointed out the electromagnetic units are based on the force exerted between two like magnetic poles. These units may be considered under two heads, *magnetic* and *electrical*. The magnetic units are those used in the measurement of magnetic quantities and the electrical units are those used in measuring electrical quantities.

33. Electrical Units.—The electrical quantities for the measurement of which units are necessary are current, quantity of electricity or charge, electromotive force, resistance, power,

work, capacitance also called capacity, or permittance, and inductance. The units of power and work are discussed later.

(a) *The Unit of Current.*—Whenever a current of electricity flows through or along a wire, a magnetic field is built up around the wire. This magnetic field is capable of exerting a force upon a magnetic pole. The unit current is defined in terms of the work spent in moving a unit magnetic pole around a current-carrying wire as follows:

An absolute unit of current is that current which requires an expenditure of 4π ergs to carry a unit magnetic pole once around the current.

Another definition which has already been given is the following: The absolute electromagnetic unit of current is that current which when flowing through a conductor bent into a circle of 1 centimeter radius, exerts a force of 2π dynes on a unit pole at the center of the circle of which the conductor is the circumference. The two definitions are equivalent.

This unit of current is too large for practical purposes. It has no name but is sometimes called the *abampere*. The prefix *ab* is the first syllable of the word *absolute*.

(d) *The absolute unit of quantity* is that quantity of electricity transferred by 1 abampere in 1 second. It is sometimes designated the *abcoulomb*. This unit is also too large for practical purposes.

(c) *Difference of Electrical Potential or Electromotive Force.*—A difference of electrical potential is said to exist between two points if, when the two points are joined by a conducting material, an electric current will flow between the points. Every electric generator is primarily a device for developing and maintaining a difference of potential or electromotive force. Electromotive force may then be considered as the real cause of an electric current. It may be produced or maintained in several different ways, only one of which is of interest at present and this has been explained in the previous chapter. The essential principle is that whenever a wire is moved across a magnetic field an electromotive force is induced in the wire. One *absolute unit* of electromotive force is induced in the wire when it cuts 1 magnetic line per second. This unit is the *abvolt*. It is entirely too small for practical calculations and measurements.

(d) *The absolute unit of resistance* is that resistance which requires an electromotive force of 1 abvolt to force 1 abampere

through the resistance. This is also a very small unit and for practical purposes another one is used.

(e) *The absolute unit of capacitance* is the capacitance of a conductor whose potential will be raised one abvolt by a charge of one abcoulomb.

(f) *The absolute unit of work* is the erg. This has been defined in Art. 30. The absolute unit of power is the rate of doing 1 erg per second.

(g) *Inductance*.—This is a property of the electric circuit that is of great importance in radiotelegraphy. The physical connection between the magnetic field surrounding the current-carrying wire and the electric current has been explained. It has been shown that when the lines of the electric field are in motion they develop lines of magnetic strain at right angles. Again when there is relative motion between a conductor and a magnetic field, or when a magnetic field is suddenly built up around a conductor, lines of electric strain are developed in a direction at right angles to the magnetic lines. The change in one condition is accompanied by the development of the other condition. The interaction between a magnetic field and an electric field is called electromagnetic induction.

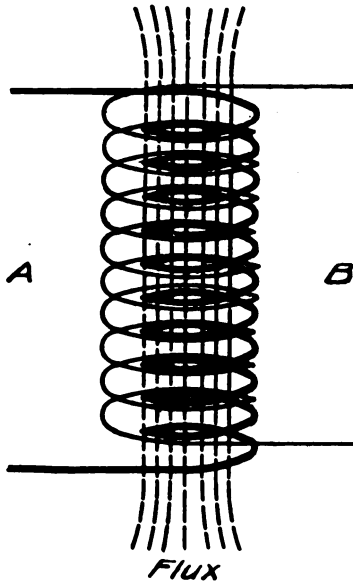

FIG. 33.—Principle of induction coil.

The source of the magnetic field is immaterial. Whenever a circuit is closed so that a current can flow, the flow of current establishes a magnetic field around the conductor. This building up of the magnetic field has the same effect as if the conductor were moved across a magnetic field, that is, an electromotive force is developed in the conductor. The electromotive force induced by the building up or decay of the magnetic field within a coil, due to the variations of current in the same coil, is called electromotive force of *self-induction*.

When two coils are situated so that the magnetic flux developed

by a current in one coil threads through an adjacent coil, Fig. 33, an electromotive force is also induced in the adjacent coil by a variation of current in the first coil. The electromotive force induced by such a process is called electromotive force of *mutual-induction*. The electromagnetic reaction between two adjacent coils is called mutual-induction. The *inductance* of a coil is the ratio between the flux threading through a coil and the current producing it. If the flux is due to the current in the coil itself, this ratio is called *self-inductance*. If the flux is due to a current in an adjacent coil, the ratio is called *mutual-inductance*. Self- and mutual-inductances are like physical quantities. Their magnitudes will depend upon the physical properties of the coils, such as number of turns, cross-

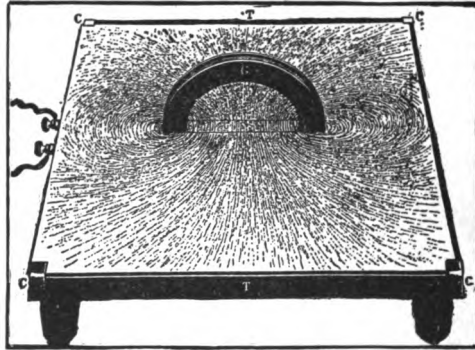

FIG. 34.—Magnetic field in a coil.

sectional area, and presence of magnetic material. This will be readily understood by the aid of Fig. 34, which shows a magnetic field in one plane due to a current in a coil G .

It is evident that each magnetic line through the center of the coil is linked with each turn; or what amounts to the same thing, the lines due to each turn are linked with every other turn as well. If ϕ is the flux due to one turn through the coil, and if N is the number of turns, the total flux is $N\phi$. This total flux is proportional to the current and hence we may write

$$\Phi = N\phi = LI.$$

The constant L is called the coefficient of self-induction, or simply the *self-inductance* of the coil. Dividing by I we have

$$L = \frac{\Phi}{I}.$$

From this expression the self-inductance or coefficient of self-induction of a coil may be defined as the ratio of the flux threading through the coil to the current producing it.

Referring to Fig. 33, if current I_A in circuit A produces a flux Φ_B which threads through circuit B , then the relation may be expressed by

$$\Phi_B = MI_A$$

and

$$M = \frac{\Phi_B}{I_A}$$

where M is the mutual-inductance of the coils. An absolute *unit of inductance* is that in which unit flux is produced by one ab-ampere. This is a small unit and has no distinctive name.

34. Electromotive Force of Self-induction.—If a current in a circuit varies, that is, increases or decreases, the magnetic field accompanying the current will increase with increasing current, and decrease with decreasing current. The variation in current is accompanied by a variation in flux. But it has been shown that when the magnetic flux around a conductor varies, an electromotive force is induced in the conductor. It thus follows that a variation in the current in a circuit is accompanied by the development of an electromotive force in the same circuit. This electromotive force is called electromotive force of self-induction.

The electromotive force of self-induction is determined by the time rate of change of flux in exactly the same way as when a conductor is moved across a magnetic field.

Suppose a current I_0 is flowing in a circuit without iron and that it produces a flux Φ_0 in the same circuit. Then the relation between this flux and current is given by

$$\Phi_0 = LI_0.$$

If now the current in time t changes to I_1 , the flux will also change and may be represented by $\Phi_1 = LI_1$. The change in flux has been $\Phi_1 - \Phi_0 = L(I_1 - I_0)$ and the rate of change of flux, if this change has been uniform, is given by

$$\frac{\Phi_1 - \Phi_0}{t} = \frac{L(I_1 - I_0)}{t}.$$

But the rate of change of flux produces an e.m.f. which in abvolts or absolute units is given by

$$e = \frac{\Phi_1 - \Phi_0}{t} = \frac{L(I_1 - I_0)}{t}.$$

I_1 and I_0 must also be in absolute units.

This gives

$$e = \frac{L(I_1 - I_0)}{t}$$

and

$$L = \frac{e}{\frac{I_1 - I_0}{t}}$$

The denominator of the right-hand member is the rate of change of current; the numerator is the electromotive force of self-induction produced by this rate of change of current. This relation is the basis for another definition of the unit of self-inductance L .

The *unit of self-inductance* is defined as that inductance in which the induced electromotive force is one abvolt when the current changes at the rate of one abampere per second. The unit of mutual-inductance is exactly the same.

In the foregoing discussion we have assumed the current to change at a uniform rate. This is merely for simplicity. The current seldom changes at a uniform rate but the principles are the same nevertheless.

35. Practical Electrical Units.—The absolute units defined in the preceding articles are not of a convenient magnitude to be used in practical measurement, and furthermore they are not readily determined. For these reasons multiples of these units have been chosen for engineering calculations and measurements. The practical units have also been defined in terms of certain definite concrete standards which can be reproduced with reasonable accuracy.

36. Electric Current.—The transference of energy by water through pipes is in many ways analogous to the transference of energy by electricity, the terminology of the former method is, therefore, to some extent used in the latter.

When water flows through pipes, the energy transferred by it in a given time depends upon the current and head, or pressure. The current is the number of gallons or cubic feet of water flowing per second or some other unit of time. The current is then the rate of flow of water.

Electrical energy may be transferred along a conductor, and while the energy is being transferred the conductor is surrounded by a magnetic field. The transfer of energy is said to be by means of a current of electricity. Thus, the rate of flow of electricity is also called a current. The two cases are evidently analogous.

In measuring a water current it is possible to measure the quantity of water discharged during a given time, and thus the rate of flow. It is not practical to measure an electric current in this way. The electric current is measured by means of its effect, and any effect which is proportional to some power of the current strength may be used for determining unit current, and hence, for measuring the current. The practical unit current has been defined in accordance with Faraday's first law.

Practical Unit of Electric Current.—It is a well-known fact that when an electric current is passed through a solution of some chemical salt such as copper sulphate or silver nitrate the salt is decomposed. The relation between the weight of the metal deposited and the electric current causing the decomposition was first determined by Faraday. He showed that the weight of the metal deposited was directly proportional to the current strength and time of current flow. The practical unit of current has been defined in accordance with this law as follows:

The *ampere* is the unvarying electric current which, when passed through a standard solution of nitrate of silver in water, deposits silver at the rate of 0.00111800 gram per second. An ampere will thus deposit 4.025 grams of silver per hour.

The ampere is one-tenth of the absolute electromagnetic unit of current.

37. Practical Unit of Quantity.—The quantity of water flowing through any given pipe in a given time may be expressed as the strength of current multiplied by the time. That is, if a unit current gives a pound of water per second, a two-unit current would give 2 pounds per second, or 4 pounds in 2 seconds

Similarly, a unit current of electricity flowing for 1 second gives a definite quantity of electricity. This quantity is called the *coulomb* and is defined as the quantity of electricity conveyed by a current of 1 ampere in 1 second of time. The total quantity conveyed by a current of I amperes in t seconds is then given by

$$Q = It, \text{ assuming } I \text{ to be constant.}$$

A coulomb is also equal to $1/10$ or 10^{-1} times the absolute electromagnetic unit of quantity.

38. Resistance.—Every electrical conductor offers a resistance to the flow of electricity. This resistance depends upon the material of which the conductor is made, the length of the conductor, and its cross-sectional area. The resistance of a con-

ductor is analogous to the resistance a water pipe offers to the flow of water. This resistance will depend upon the roughness of its surface, or upon the material of which it is made. A long pipe will offer more resistance than a short pipe of the same diameter, and a pipe of large diameter will offer less resistance than one of the same length but of smaller diameter. It must be remembered, however, that the cause of the resistance of a conductor to the flow of electrical current is not the same as the cause of the resistance of a water pipe to the flow of water. They are analogous only.

The resistance of any conductor can then be written in the following form:

$$R = \frac{rl}{A},$$

where R is the total resistance, r the resistance of a piece of the conductor of unit length and of unit cross-section, A its cross-sectional area, and l its length.

The *ohm* is the unit of resistance and is defined as the resistance offered to an unvarying electric current by a column of mercury at the temperature of melting ice, 14.4521 grams mass, of a constant cross-sectional area and of a length of 106.3 centimeters. The ohm is equal to $10^9 = 1,000,000,000$ times the absolute electromagnetic unit of resistance.

The ohm is thus a definite quantity and the resistance of any conductor is expressed in terms of it. In the formula $R = \frac{rl}{A}$, l and A may be expressed in any units, provided r expresses a resistance based on these units. The definition given for the ohm assumes l to be in centimeters and A in square centimeters. In this country the American wire gage (Brown and Sharpe) has been generally adopted where a gage is to be used. In many cases it is better to specify the actual diameter or cross-sectional area of a wire, and for this purpose the "mil system" has been introduced. In this system the *mil* is the unit of length and is equal to 0.001 inch.

Since the areas of any two circles are proportional to the squares of their diameters, if the area of a circle 1 mil in diameter be taken as the unit area, the area of any other circle may be expressed as the square of its diameter in mils. The unit area is called the circular mil and is, as above expressed, the area of a circle 0.001 inch in diameter. Area in circular mils is equal to diameter in

mils squared, and the area expressed in square measure is equal to $0.7854 \times d^2$. The circular mil is, therefore, equal to 0.7854 of a square mil.

It is seldom necessary to convert the area of round conductors into square measure. The wire tables which are in common use usually give the sizes in the American wire gage (A.w.g.), its diameter in mils, its area in circular mils, and various other properties of wire depending on the completeness of the tables.¹

Wires larger than No. 0000 A.w.g., that is, of a greater diameter than 0.46 inch, are usually designated by their diameters in mils or their cross-sectional area in circular mils.

The unit of a conductor most commonly used is a conductor 1 foot long and 1 mil in diameter called the mil-foot. The resistance of a mil-foot of copper of 98 per cent. conductivity is 9.61 ohms at 0°C. or 32°F. This value may be used in our resistance formula which then becomes

$$R = \frac{9.61l}{A}$$

l being expressed in feet and A in circular mils.

Examples

1. What is the cross-sectional area of a wire $\frac{1}{8}$ inch in diameter?

Solution

$$\begin{aligned} \frac{1}{8} \text{ inch} &= 0.125 \text{ in.} \\ 0.125 \text{ in.} &= 125 \text{ mils} \end{aligned}$$

Area in circular mils equals diameter squared.

Hence

$$\text{Area} = 125 \times 125 = 15,625 \text{ circular mils.}$$

2. What is the resistance of 500 feet of No. 20 A.W.G. copper wire at 0° C.?

Solution.—By formula

$$\begin{aligned} R &= \frac{rl}{A} \\ r &= 9.61 \\ l &= 500 \text{ ft.} \\ A &= 32 \times 32 = 1024 \text{ circular mils.} \\ \text{Then } R &= \frac{9.61 \times 500}{1024} = 4.69 \text{ ohms.} \end{aligned}$$

39. The Practical Unit of Electromotive Force.—Since the resistance of a conductor is comparable to the resistance offered by a pipe to the flow of water, and the electrical current is com-

¹ Circular No. 31, Bureau of Standards.

parable to the current of water, we may compare the electromotive force or electrical pressure to the water pressure causing a flow of water. Although this comparison is not exact, it still serves to give a better understanding of the relation of the electrical quantities involved. Water pressure can be measured in terms of pounds per square inch, but usually it is expressed as a head of so many feet. In the same way, the difference of electrical pressure between the terminals of a battery may be considered as a difference of electrical level. The current will then flow from a point of higher to a point of lower electrical level, when the circuit is closed. This difference of electrical pressure or electromotive force, is expressed in volts, and the *volt* is defined as that difference of pressure which will cause a current of 1 ampere to flow through a resistance of 1 ohm. More concretely the *volt* may be defined as $\frac{100,000}{101,830}$ of the electromotive force of the Weston normal cell at a temperature of 20°C. One volt is equal to 10^8 absolute units of electromotive force.

40. Practical Unit of Inductance.—The practical unit of inductance is the *henry*. It is defined as the inductance in a circuit in which the induced electromotive force is 1 volt, when the current changes at the rate of 1 ampere per second. The henry is is equal to 10^9 absolute electromagnetic units.

41. Practical Unit of Capacitance.¹—If two metal plates be separated by a good insulator and the two plates be connected to a source of electrical pressure, a momentary current will flow into the plates. The intensity of the current will depend upon the ability of the plates to hold a charge of electricity. This ability of a conductor, or a system of conductors, to store electricity is called electrical capacitance. The capacitance of a system of conductors is determined by their arrangement, number, and material separating them. The quantity of electricity that a condenser will hold is determined by the capacitance of the condenser and by the electrical pressure applied. Algebraically this is expressed by

$$Q = EC,$$

where Q is the quantity of electricity, E the pressure, and C the capacitance.

¹The term capacitance is sometimes used in the sense of capacity reactance, here it is used in place of capacity to harmonize with resistance and inductance.

Farad.—The unit of capacitance is called the *farad* and is the capacitance of a condenser which is charged to a difference of pressure of 1 volt by 1 coulomb.

The farad is equal to $10^{-9} = \frac{1}{1,000,000,000}$ of the absolute electromagnetic unit of capacitance. But even the farad is far too large for ordinary use, and it is customary to express capacitance in terms of *microfarads*, a microfarad being (10^{-6}) one-millionth of a farad. A microfarad is thus 10^{-15} of the size of the absolute electromagnetic unit of capacitance.

42. Ohm's Law.—The fundamental relation between current and electromotive force was enunciated by Dr. G. S. Ohm in 1827, and is known as Ohm's law. It may be stated as follows:

The current strength in any circuit is directly proportional to the sum of all the electromotive forces in the circuit. This relation expressed algebraically is

$$E = KI,$$

or

$$\frac{E}{I} = K, \text{ a constant.}$$

This holds for both direct- and alternating-current circuits so long as the physical conditions surrounding the circuit remain unchanged. For direct-current circuits K is equal to what is called the resistance of the circuit and under these conditions

$$E = RI,$$

or

$$\frac{E}{I} = R.$$

Thus the ratio of the electromotive force to current is constant so long as physical conditions remain constant. If, for instance, the temperature changes, this ratio will change. This is explained by saying that the resistance changes.

On the alternating-current circuits the total electromotive force must include the electromotive forces of mutual induction, self-induction, and capacitance. When these are considered, Ohm's law as stated still holds.

43. Change of Resistance with Temperature.—The resistance of most conductors changes with the temperature. The resistance of pure metallic conductors increases with increase in temperature. For pure metals the increase per ohm per degree

is practically the same for all. This increase per ohm per degree change in temperature is called *temperature coefficient of resistance*, and for copper it is nearly 0.00393 per ohm per degree at 20°C. The resistance of a conductor at any temperature $t^\circ\text{C}$. is given by the following:

$$R_t = R_{20} [1 + a(t - 20)].$$

R_{20} is the resistance of conductor in ohms at 20°C., a the temperature coefficient, and t the temperature, in degrees Centigrade. The resistance of most alloys also increases with increase in temperature, but to a much smaller extent than pure metals. Thus an alloy of 84 parts by weight of copper, 12 parts by weight of nickel, and 4 parts by weight of manganese, called manganin, has a temperature coefficient of resistance which is negligible for practical purposes. Although the temperature coefficient of manganin is very slight, it is positive between 0° and about

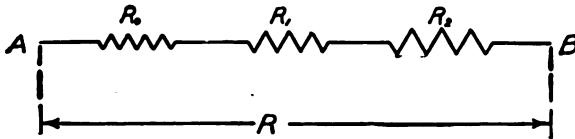

FIG. 35.—Resistances in series.

50°C. When the temperature is increased above 50°C. the resistance of manganin slightly decreases.

Carbon and all acid and salt solutions have negative temperature coefficients of resistance. That is, the resistance of these decreases as the temperature increases.

44. Conductors in Series.—When several conductors are connected in series, that is, end to end, the combined resistance is the sum of the resistance of the several conductors. Thus the resistance R , Fig. 35, between the points A and B is equal to $R_0 + R_1 + R_2$.

45. Conductors in Parallel.—The conductance of a conductor is defined as the reciprocal of the resistance of the conductor. If R is the resistance then $\frac{1}{R}$ is the conductance. When conductors are connected in parallel, the resultant or joint conductance is equal to the sum of the conductances of the several conductors. The manner of computing the joint resistance will then be readily understood from Fig. 36. If R_1 , R_2 , and R_3 are the several re-

sistances connecting the points *A* and *B*, the conductances of these branches are $\frac{1}{R_1}$, $\frac{1}{R_2}$, and $\frac{1}{R_3}$ respectively. Calling the joint resistance *R*, the joint conductance is $\frac{1}{R}$, and according to what has just been said above we have

$$\frac{1}{R} = \frac{1}{R_1} + \frac{1}{R_2} + \frac{1}{R_3}$$

$$= \frac{R_2R_3 + R_1R_2 + R_1R_3}{R_1R_2R_3},$$

and

$$R = \frac{R_1R_2R_3}{R_1R_2 + R_1R_3 + R_2R_3}.$$

In general, the joint resistance of several conductors connected in parallel is equal to the product of the several resistances divided by the sum of the partial products formed by multiplying together all of the resistances less one. The same resistance must not appear in any product more than once.

Example

Five resistances of 10, 15, 20, 25, and 30 ohms are connected in parallel. Calculate the joint resistance.

Solution.—Given

- $R_1 = 10$ ohms,
- $R_2 = 15$ ohms,
- $R_3 = 20$ ohms,
- $R_4 = 25$ ohms
- $R_5 = 30$ ohms,

$$R = \frac{R_1R_2R_3R_4R_5}{R_1R_2R_3R_4 + R_1R_2R_3R_5 + R_1R_2R_4R_5 + R_1R_3R_4R_5 + R_2R_3R_4R_5}$$

$R_1R_2R_3R_4R_5$	$= 10 \times 15 \times 20 \times 25 \times 30$	$= 2,250,000$
$R_1R_2R_3R_4$	$= 10 \times 15 \times 20 \times 25$	$= 75,000$
$R_1R_2R_3R_5$	$= 10 \times 15 \times 20 \times 30$	$= 90,000$
$R_1R_2R_4R_5$	$= 10 \times 15 \times 25 \times 30$	$= 112,500$
$R_1R_3R_4R_5$	$= 10 \times 20 \times 25 \times 30$	$= 150,000$
$R_2R_3R_4R_5$	$= 15 \times 20 \times 25 \times 30$	$= 225,000$
Sum of partial products		$= 652,500$

$$R = \frac{2,250,000}{652,500} = 3.46 \text{ ohms.}$$

46. Divided Circuits—Kirchoff's Laws.—In addition to the simple series and parallel connections shown in Figs. 35 and 36, conductors may be connected in various and much more compli-

cated ways. The several electrical quantities involved in such a network can be evaluated by the aid of what are known as Kirchoff's laws; these are two in number as follows:

(a) If several conductors carrying currents of different intensities meet at a point, the sum of the intensities of all the currents which flow toward the junction point through these conductors is equal to the sum of all those which recede from it; or, in other words, the algebraic sum of all the currents which approach the point through the wires which meet there is zero.

(b) If out of any network of wires which form a complex conductor a number of wires which form a closed circuit be chosen, and if starting at any point, we follow around the closed circuit in either direction, calling all currents positive which flow in the

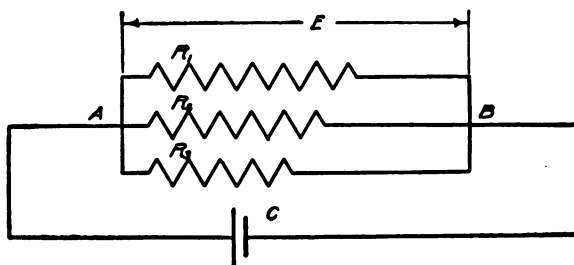

FIG. 36.—Resistances in parallel.

direction that we trace the circuit, and all those which flow in the opposite direction negative; and also calling all sources of electromotive force positive that we encounter in the circuit positive when they tend to send the current in the direction of motion, and when they tend to send the current in the opposite direction negative, then the algebraic sum of all the products formed by multiplying the resistance of each conductor by the current flowing through it and all the electromotive forces encountered is zero. In brief, the algebraic sum of the electromotive forces and IR drops in a closed circuit is zero.

These two laws are merely the statements of experimental facts. The first is an immediate consequence of the fact that there can be no growing accumulation of electricity anywhere in a circuit through which a steady current is flowing.

That the second law is also true will be quite evident if we compare the voltage drops and rises in potential around a circuit with the descents and ascents in a road which traverses a country

making a complete circuit. It is very evident that a traveller following such a road will descend just as far as he ascends when he returns to the starting point. Thus if we call a descent a negative elevation and an ascent a positive elevation, the algebraic sum of the elevations is zero. Examples will serve to make the applications of these two laws more clear.

Example

Fig. 37 shows a network of conductors connected to two sources of e.m.f. $A = 50$ volts and $B = 25$ volts. If the resistances of the several branches are as follows:

$$adeb = 50 \text{ ohms}$$

$$afgb = 10 \text{ ohms}$$

and $achb = 6$ ohms, find the currents in the several branches.

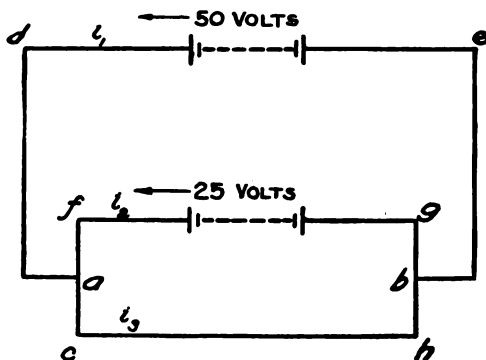

FIG. 37.—Kirchoff's laws.

Solution

Let $R_1 =$ resistance of $adeb$.
 $R_2 =$ resistance of $afgb$.
 $R_3 =$ resistance of $achb$.

also let $i_1 =$ current in de .
 $i_2 =$ current in fg .
 $i_3 =$ current in eh .

Then by Kirchoff's first law at point a ,

$$i_1 - i_2 - i_3 = 0 \tag{1}$$

According to the second law in the circuit $adebfga$ we have

$$i_1 R_1 + i_2 R_2 + 25 - 50 = 0 \tag{2}$$

and in the circuit $dachbe$ we have

$$i_1 R_1 + i_3 R_3 - 50 = 0 \tag{3}$$

Substituting the values of R_1 , R_2 , and R_3 in equations (2) and (3), we have

$$50i_1 + 10i_2 = 25$$

whence
$$i_2 = \frac{25 - 50i_1}{50} = 0.5 - i_1$$

and
$$50i_1 + 6i_3 = 50$$

whence
$$6i_3 = 50 - 50i_1$$

$$i_3 = \frac{50 - 50i_1}{6}$$

Substituting in equation (1), we have

$$i_1 - 0.5 + i_1 - \frac{50 - 50i_1}{6} = 0$$

$$12i_1 - 3 - 50 + 50i_1 = 0$$

$$62i_1 = 53$$

$$i_1 = 0.855 \text{ ampere}$$

$$i_2 = 0.5 - i_1$$

$$= -0.355.$$

The minus sign means that i_2 flows in the opposite direction to that indicated.

$$i_3 = \frac{50 - 50 \times 0.855}{6} = 1.21 \text{ amperes.}$$

47. Work.—Every one has some notion of the meaning of the word "work." We say that a man has worked hard when he has spent much mental effort in solving some problem. Likewise we say a hod-carrier works hard when he carries bricks or mortar from the ground to the top of a building. The two cases are, however, evidently not the same. The degree of fatigue resulting may be the same, but it is plainly not like in kind. There is no way of physically measuring the mental effort, while the measure of the physical effort of the hod-carrier is the number of bricks and the elevation to which he has carried them. In mechanics the meaning of work is restricted and has reference solely to physical quantities.

In the second illustration there are two factors that cause the fatigue of the hod-carrier: one is the force he must exert to raise the bricks, and the other is the distance through which he carries them. The work done thus contains the two elements, force and distance. Work, therefore, is that which is accomplished by a force acting through a distance and is measured by the product of the intensity of the force and the distance through which the force acts. Algebraically this is expressed by

$$\text{Work, } W = Fd \cos \alpha,$$

where α is the angle between the direction of motion and the direction of the force. $F \cos \alpha$ is the component of the force in the direction of motion. If the body moves in the direction of the force, $\alpha = 0$ and we have

$$W = Fd.$$

It is worth noting that time does not enter into work. Work is merely the accumulated result, and the time required to accomplish it is not considered.

48. Unit of Work.—In the English system of units, the unit of work is the *foot-pound* and is represented by the quantity of work done in raising a pound weight 1 foot against the force of gravity. In the metric system, the unit of work is called the *erg* and is the quantity of work done by a force of 1 dyne acting through a distance of 1 centimeter. The erg is a very small quantity and hence 10,000,000 ($= 10^7$) ergs are taken as the practical unit. The practical unit is called the *joule*, and 3,600,000 joules are equal to 1 kilowatt-hour. The *kilowatt-hour* is extensively used in electrical calculations.

49. Relation between English and Metric Units of Work.—The unit of force in the metric system is the *dyne*. The dyne has been defined, Art. 34.

In the English system of units the unit of force is the pound. It is the pull of gravity upon a pound mass. Thus a pound force is capable of giving an acceleration of 32.2 feet per second to a pound mass.

$$\begin{aligned} \text{As the pound mass} &= 453.59 \text{ grams mass} \\ 1 \text{ pound force} &= 32.2 \times 30.48 \times 453.59 \text{ dynes} \\ &= 445,000 \text{ dynes, approximately} \\ 1 \text{ foot-pound} &= 1 \text{ pound} \times 1 \text{ foot} \\ &= 445,000 \times 30.48 \text{ ergs} \\ &= 13,563,600 \text{ ergs} \\ \text{But } 10,000,000 \text{ ergs} &= 1 \text{ joule} \\ \text{Hence } 1 \text{ foot-pound} &= 13,563,600 \div 10^7 = 1.356 \text{ joules.} \end{aligned}$$

Examples

1. The diameter of the cylinder of a steam engine is 24 inches. The piston moves a distance of 24 inches at each stroke. What work in foot-pounds will be done at each stroke if the average steam pressure is 125 pounds per square inch?

Solution

$$\text{Work} = Fd$$

$$F = \text{total pressure on the piston}$$

$$= \pi \times 12^2 \times 125$$

$$d = 24 \div 12 = 2 \text{ feet}$$

Hence

$$W = 2 \times \pi \times 12^2 \times 125$$

$$= 113,098 \text{ foot-pounds.}$$

2. How many joules, and how many kilowatt-hours of work will be done at each stroke of the piston mentioned in Example 1?

Solution

$$1 \text{ foot-pound} = 1.356 \text{ joules}$$

Hence

$$113,098 \text{ foot-pounds} = 113,098 \times 1.356$$

$$= 153,361 \text{ joules}$$

$$1 \text{ kilowatt-hour} = 3,600,000 \text{ joules}$$

Hence

$$153,361 \text{ joules} = 153,361 \div 3,600,000$$

$$= 0.0426 \text{ kilowatt-hours.}$$

50. Energy.—Energy and work are closely related. When a body has been lifted to a certain height, a definite amount of work has been done upon it. This work in foot-pounds is equal to the product of the height in feet by weight in pounds. The body, when elevated, possesses something which it does not possess at a lower level. Again, water at the top of Niagara Falls is capable of doing work by being run through a water-wheel. When it leaves the waterwheel and enters the river at the bottom of the falls, it is no longer capable of doing work. That is, it has parted with its ability to do work in descending from the top to the bottom of the falls. The energy of a body or a system of bodies is its capacity for doing work. It is measured by the work which can be performed.

Energy is classified under two heads *potential* and *kinetic*. The energy that a body possesses by virtue of its position is called *potential*. Thus, the water at the top of the falls is capable of doing work on descending to a lower level. It thus possesses energy of position. Similarly, a body lifted to a given height possesses energy of position. If the body be dropped, the elevation will decrease, but its energy will not decrease until it strikes the earth and transfers its energy to some other body. When only a short distance, say 1 inch, from the lowest point in its fall, its energy of position is very small, and just before it strikes, the energy of position is practically zero. The velocity of the body is maximum or greatest at the time of striking, and zero at its highest point. The total energy of the body thus

consists of energy of position and energy of motion. The energy due to the velocity of the body is called *kinetic*. The simple pendulum will help make this clear. The simple pendulum at the extreme position of its swing, possesses energy due to its elevation. When released, this elevation decreases until the pendulum reaches the lowest point of its swing when its elevation is zero, but its velocity is a maximum. The potential energy has all been changed to kinetic. As the pendulum passes beyond the middle point of its swing, the velocity decreases, hence its kinetic energy decreases; the elevation of the pendulum increases and, therefore, the potential energy increases. This change continues until the pendulum reaches the other extremity of its swing, when the energy is again wholly potential. The sum total of the energy of the pendulum is constant at any point of the swing. That is, the sum of its kinetic and potential energy is a constant quantity.

As already stated, the unit of energy is the same as the unit of work, and the energy of a body is equal to the amount of work expended upon the body. This is a simple statement of the fundamental principles of dynamics, viz., the principle of the conservation of energy. Newton limited his laws to motion. In reality this third law may be considered as applying to energy as well. Thus, the statement "action is equal to reaction" is also true with reference to the expenditure of energy. No body is capable of doing work unless work is first done upon it. All machines act simply as means of transferring energy from one system to another system. The full appreciation of this principle is of comparatively recent date. Perhaps the most important discovery in the realm of mechanics is the following: *The sum of kinetic and potential energies of a body or system of bodies is a constant quantity, unless it be changed by some external influence.* In other words, the energy of a system cannot be created or annihilated. No human being can create or destroy energy. A distinction must, however, be made between the total amount of energy of a body or system of bodies, and the amount of energy that the system is capable of transferring to another system. In all mechanical operations some energy is dissipated or wasted or becomes unavailable. For instance, a simple pendulum released at the extreme position of its swing, will not of itself reach the same point on its return. This is due to the fact that some of its energy has been transferred to the air, and another portion has

been dissipated on account of the friction and stiffness of the string supporting it, etc. Similarly some of the energy delivered by a steam engine to an electric generator is wasted in friction of the air, at the bearings, brushes, etc. The law of the conservation of energy is fundamental in all energy transformations.

51. Power.—In everyday usage, the word power has many different meanings. It is often confused with work. Power is not work, but the time rate of doing work. As an illustration suppose that one man carries 2000 bricks to the second story of a building in 1 day while it takes another man 2 days to do the same work. Evidently, the total amount of work done in the two cases is the same although the rate at which the work is done is different. The second man's rate of doing the work is only one-half that of the first man's rate. Technically, this is explained by saying that the powers of the two men are different. The power of the first man is double that of the second man. Power is then the amount of work done in some unit of time. In engineering practice the unit of time is usually the minute or second. In algebraic symbols power is expressed by

$$\begin{aligned} \text{Power, } P &= \frac{\text{work}}{\text{time}} = \frac{W}{t} \\ &= \frac{F \times d}{t}, \end{aligned}$$

$$P \times t = F \times d = \text{work.}$$

52. Units of Power.—In the British system of units, the unit of power is the rate of doing 33,000 foot-pounds of work in 1 minute. This unit is called the *horsepower*. In the metric system the corresponding unit is the *kilowatt*. The *kilowatt* is the rate of doing 1000 joules per second. One joule per second is called the *watt*.

It has been shown that 1 foot-pound equals 1.356 joules; therefore, 33,000 foot-pounds equal $33,000 \times 1.356 = 44,748$ joules, and, 1 horsepower equals 44,748 joules per minute. One kilowatt equals 60,000 joules per minute, hence

$$\begin{aligned} 1 \text{ hp.} &= \frac{44,748}{60,000} = 0.746 \text{ kilowatt} \\ &= 746 \text{ watts.} \end{aligned}$$

Approximately, 1 horsepower equals $\frac{3}{4}$ kilowatt, or conversely 1 kilowatt equals $\frac{4}{3}$ horsepower. A knowledge of these relations is useful and they should be remembered.

Examples

1. How much energy is stored in a tank of water containing 1,000,000 gallons if the average weight to which the water has been pumped is 100 feet?

Solution.—One gallon of water weighs about 8.35 pounds. One million gallons weigh $1,000,000 \times 8.35 = 8,350,000$ pounds. To raise 8,350,000 pounds of water 100 feet high will require an expenditure of energy of $8,350,000 \times 100 = 835,000,000$ foot-pounds. This is the stored or potential energy of the water.

2. What must be the horsepower of an engine to pump the water in Question 1, in 5 hours?

Solution.—One horsepower = 33,000 foot-pounds per minute. In 1 hour an engine of 1 horsepower will perform

$$33,000 \times 60 = 1,980,000 \text{ foot-pounds.}$$

In 5 hours it will do $5 \times 1,980,000 = 9,900,000$ foot-pounds. To do 835,000,000 foot-pounds will require $835,000,000 \div 9,900,000 = 84 +$ horsepower.

3. If an electric motor were used in place of the engine, what would its rating be in kilowatts (neglecting losses)?

Solution.—One horsepower = 746 watts
= 0.746 kilowatts.

Hence $84 \text{ horsepower} = 84 \times 0.746 = 62.66$ or 63 kilowatts.

53. Electricity and Electrical Energy.—It is impossible at present to explain electricity in terms of anything more elemental than itself. We know electricity only through its manifestations or effects. It matters not, so far as practical results are concerned, whether electricity is a form of energy or only a vehicle of energy. The fact is that energy is always manifest in connection with the electrical current, and that this energy can be transformed into other forms of energy. It may also be transferred from point to point along a conductor without the necessity of mass motion. It is this ability to transfer energy without the motion of masses of matter that makes electricity the most successful medium for transforming energy over long distances. The transformation of electrical energy is electrical work and is accomplished in many ways. The rate of transformation is power just as in the case of other forms of energy.

54. Electrical Work.—The derivation of the principles of electrical work or energy will undoubtedly be better understood if analogies are used. The quantity of water flowing through any pipe in a given time may be expressed as the strength of current multiplied by the time. A unit current of water has no name. If a unit current gives a pound of water in 1 second, a

two-unit current will give 2 pounds of water per second or 10 pounds in 5 seconds.

Similarly, a unit current of electricity flowing for 1 second gives a definite quantity of electricity. This quantity is called the coulomb. The total quantity conveyed by a constant current of I amperes in t seconds is then given by $Q = It$. Again, referring to the analogy of water flowing through pipes one may consider unit work to be done when 1 pound of water is delivered under a head of 1 foot. The amount of work done by a head of h feet, delivering q cubic foot of water will be hq . But electrical pressure is analogous to water pressure, or head; and the quantity of water is analogous to the quantity of electricity or coulombs. A current delivering Q coulombs of electricity under a pressure of E volts will then do EQ units of work. This may be expressed algebraically, thus:

$$\begin{aligned}\text{Work} &= E(\text{volts}) \times Q(\text{coulombs}) \\ &= EQ \text{ joules.}\end{aligned}$$

The relations between volts, coulombs, and joules are such that the product of 1 volt by 1 coulomb gives 1 joule. It has been shown, however, that Q , the quantity, is equal to It , the current by the time. We may then write the expression for work thus:

$$\text{Work, } W = EIt.$$

When E is in volts, I in amperes and t in seconds, the result is in joules. If t is 1 second, we have

$$W = EI \text{ joules per second.}$$

One joule per second is 1 watt, hence in direct-current calculations, volts times amperes gives watts. In electrical work the joule is a small unit of energy so 1000 watts for 1 hour is usually used. This unit is called the *kilowatt-hour*.

Examples

1. What power is being developed by a direct-current generator when it is delivering 84 amperes under a pressure of 250 volts?

Solution

$$\begin{aligned}\text{Power in watts} &= \text{volts} \times \text{amperes} \\ &= I \times E\end{aligned}$$

$$I = 84 \text{ amperes}$$

$$E = 250 \text{ volts}$$

$$P = 250 \times 84 = 21,000 \text{ watts}$$

Hence

$$1000 \text{ watts} = 1 \text{ kw.}$$

Then

$$P_{\text{kw.}} = 21,000 \div 1000 = 21 \text{ kilowatts.}$$

2. An electric heater takes 7.5 amperes at a pressure of 110 volts. How much will it cost to operate the heater for 1 month, 30 days, if it is operated on an average of 8 hours per day, at 5 cents per kilowatt-hour?

Solution

$$\text{Energy consumed} = \frac{IEt}{1000} \text{ kilowatt-hours}$$

$$I = 7.5 \text{ amperes}$$

$$E = 110 \text{ volts}$$

$$t = 8 \times 30 \text{ hours}$$

$$\text{Hence energy} = \frac{7.5 \times 110 \times 8 \times 30}{1000} = 198 \text{ kilowatt-hours.}$$

$$\text{Cost} = 198 \times 0.05 = \$9.90.$$

3. A direct-current generator supplies energy to a street railway motor. If the pressure at the generator is 550 volts and that at the motor 500 volts, what power is lost on the line when 75 amperes are flowing?

Solution.—The loss in pressure is 50 volts, hence the power lost is

$$75 \times 50 = 3750 \text{ watts}$$

$$= 3.75 \text{ kilowatts.}$$

55. Heating Value of the Electric Current.—The power loss in a conductor is given by I^2R . This is all converted into heat and the exact relation was first determined by James Prescott Joule, an English physicist. He did this by immersing a conductor of known resistance into a known weight of water and measuring the current, time, and temperature. The results of his experiments show that the heat generated in a conductor is proportional to the time the current flows, to the resistance, and to the square of the current. This condition may be written in algebraic form as follows:

$$\text{Heat} = KI^2Rt.$$

This is evidently the energy loss in a conductor multiplied by a conversion factor K . This factor is introduced on account of the fact that the unit for the measurement of heat is not the same as that for the measurement of electrical energy. The unit for heat measurement is the quantity of heat required to raise the temperature of 1 gram of water from 15° to 16°C., and is called a calorie. The calorie is equal to 4.181 joules. That is, the heat unit is 4.181 times the electrical unit. To convert joules to calories we must multiply the joules by $\frac{1}{4.181} = 0.24$. This 0.24 is the constant K which we can replace and get

$$\text{Heat, in calories,} = 0.24I^2Rt,$$

where I is in amperes, R in ohms, and t in seconds.

The mechanical engineering unit of heat is called the British thermal unit, which is abbreviated to B.t.u. A B.t.u. is the heat required to change the temperature of 1 pound of water 1°F. One B.t.u. = 252 calories.

Example

1. How many calories of heat per hour are developed in an electric heater which takes 7.5 amperes at 110 volts pressure?

Solution

$$\begin{aligned}\text{Heat, in calories} &= 0.24I^2Rt \\ &= 0.24EI t\end{aligned}$$

$$I = 7.5 \text{ amperes}$$

$$E = 110 \text{ volts}$$

$$t = 3600 \text{ seconds}$$

Hence,

$$\begin{aligned}\text{Heat} &= 0.24 \times 7.5 \times 110 \times 3600 \\ &= 712,800 \text{ calories.}\end{aligned}$$

56. Conversion Factors.—Although it is not often necessary to convert the electrostatic units into the electromagnetic or practical units, it is sometimes essential. Likewise many calculations are still made in the English system of units. To facilitate these calculations the following conversion factors are appended:

ELECTRICAL UNITS

Practical units	Absolute electromagnetic units.	Absolute electrostatic units
1 ampere.....	10^{-1} abampere	3×10^9 units
1 coulomb.....	10^{-1} abcoulombs	3×10^9 units
1 volt.....	10^8 abvolts	$\frac{1}{3} \times 10^{-2}$ units
1 ohm.....	10^9 abohms	$\frac{1}{9} \times 10^{-11}$ units
1 henry.....	10^9 abhenrys	$\frac{1}{9} \times 10^{-11}$ units
1 farad.....	10^{-9} abfarads	9×10^{11} units
1 joule.....	10^7 ergs	
1 watt.....	1 joule per second	10^7 ergs per second

CHAPTER V

ELECTROMAGNETIC WAVES

57. Cyclic Changes.—Physical quantities may vary in many different ways, thus the temperature of a body may be increased gradually or uniformly and after a certain temperature has been reached it may be decreased uniformly, finally reaching the original temperature. Again, if a closed rubber bag in which there is some gas be placed under the receiver of an air pump and the air in the receiver be exhausted, the volume of the rubber bag will gradually increase. If when the bag has reached a certain maximum volume, air be admitted to the receiver, the gas bag will shrink until it reaches its original volume. The volume of the gas in the bag goes through a cycle.

The electric current in a circuit by Ohm's law is

$$I = \frac{E}{R}$$

If R is fixed in value, and E is gradually increased, it is evident that I will increase in the same way. If E is increased from zero to a certain maximum value and then gradually decreased to zero, I will increase to a maximum value and then decrease to zero. Thus a change in one quantity is accompanied by a change in another quantity, and when one goes through a cycle of changes the other goes through a like cycle. To change the physical properties of a body through a cycle takes time, and in many instances the time variations of physical quantities are extremely important.

One of the simplest changes with time is the variation in the position of a body, that is, motion. Many of the laws of motion apply when the variations with time of other quantities are considered, hence some of the simpler motions will be considered.

58. Electromagnetic Pulse.—In Art. 17 it was pointed out that the motion of the electric lines connecting the two branches of an electric circuit produces a magnetic field around the conductors. As long as the electric lines move or disappear at a

uniform rate, the magnetic field is constant in strength and fixed in space. If, however, the e.m.f. which produces the electric strain be connected to, and disconnected from the conductors at regular intervals, it is evident that both the electric strain and resulting magnetic field will undergo periodic changes. These periodic changes or fluctuations are in the ether. At the time the e.m.f. is first connected to the circuit there is no electric field nor magnetic field present, but the instant connection is made the electric lines begin to increase and move along the conductors, and as their number increases, which means as the current increases, the lines of magnetic flux increase in number and spread out in space. When the circuit is opened, the magnetic and electric fields both disappear. It is thus clear that successive interruptions of the circuit produce electric and magnetic pulses which spread in the ether. When these pulses are regular and periodic, they are called electromagnetic waves. Before studying their production and propagation, some general properties of waves will be considered.

59. Waves in General.—In a general way every observer knows what is meant by a wave. Waves are of different kinds, but for our purpose we may define a wave as a disturbance in an elastic medium which is transferred by periodic variations in the physical conditions of the portions of the medium involved. Waves may exist in either one, two, or three dimensional space. That is, waves may be propagated along lines, surfaces, or solids.

60. Production of Waves.—Fig. 38 represents a wave motion produced by the to and fro motion, or vibration of one end of a rope. As the hand moves up and down, waves are started which travel from the hand to the other end of the rope. When the wave reaches the end fastened to some fixed object it is reflected back to the hand. A distinction must be made between the motion of the rope and that of the wave. It is clear that the rope does not move from *A* to *B* and back again. Particles of the rope vibrate up and down only. That is, they have a transverse motion while the wave moves longitudinally, or from *A* to *B*. We have here a vibration of the rope at *A* causing a wave motion in the rope.

A brief analysis will show that a similar periodic variation in the position of water particles takes place when waves are produced on the surface of a body of water. If the surface of a body of water is disturbed at any point by the sudden dropping

of a stone or the up and down motion of a stick dipping in the water, the water is displaced and rises above its normal level. As gravity pulls it down, its inertia carries it below the normal level and, hence, the adjacent water is displaced and rises above the normal level. This up and down motion of the water causes a wave to move out from the point of disturbance.

The vibrations at the center of disturbance must be of such a nature as to produce in the medium a displacement or change which can be propagated by it. A slowly moving body will not produce a wave for the water will flow around it. In order that a wave may be produced, the vibration must be so rapid, or the motion so sudden, that the fluid does not have time to flow, and is, therefore, compressed on one side and expanded on the other. In order that a medium may carry waves, forces of restitution must be developed when parts of the medium are displaced. These forces are due to the interaction of the

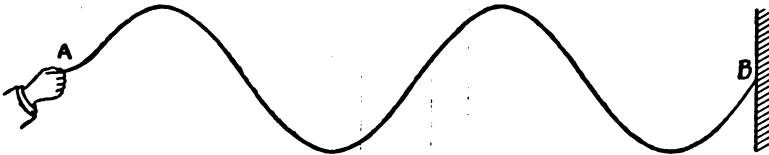

FIG. 38.—Wave motion in a rope.

neighboring parts on each other. The action of the displaced parts on those in contact with them displaces the latter also and so the waves are produced and propagated.

The waves just described occur on the surface of the liquid; but any medium that is elastic can also carry waves through its interior, or can transfer energy by compressional waves, that is, waves sent out by a disturbance which compresses and expands the medium. A good example of this is sound. When a bell is struck, the sound produced can be heard in every direction from it. The vibrations of the bell are transmitted to the air in contact with the bell. These particles of air transfer their vibration to other particles and the sound travels out in ever-widening spheres. The bell vibrates back and forth in the direction of the wave motion, and not at right angles to it as in the other two cases.

In every case considered there is some vibrating body as the source of the wave, and some medium for its propagation. First, there is a disturbance at some point in a certain medium; second, this disturbance is transferred to other points of the

medium. If these conditions as to the medium and the center of disturbance are satisfied, and if the motion at the center of disturbance is vibratory, the different portions of the surrounding medium will in turn be set in vibration or periodic disturbance. If the motion of the vibrating center ceases, that in the medium will persist until friction or other forces bring it to rest. It is very clear that at the center of disturbance energy is spent in causing the vibration and that at a distant point in the medium, when the wave reaches that point, this energy is manifest in the motion of the medium. The wave thus transfers energy from the center of disturbance to other points in the medium.

Although the common waves discussed are complex, the idea of a wave and the manner in which energy is transferred by wave motion are most readily acquired by their consideration.

61. Graphical Representation of Wave Motion.—A simple

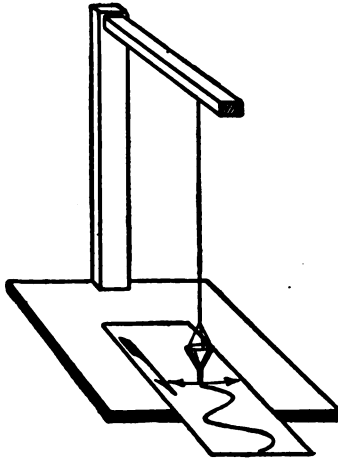

FIG. 39.—Wave produced by a sand pendulum.

way of showing the manner in which a vibratory motion produces a wave is indicated in Fig. 39. The funnel is filled with dry sand and the pendulum is set in vibration above a sheet of paper. While the pendulum is vibrating, the paper is drawn forward at a uniform speed, and at right angles to the direction of motion of the pendulum. The sand flows out of the funnel producing a wavy line. This wave is plainly the result of two motions at right angles to each other; one a uniform linear motion, that of the paper; and the other a vibratory motion, that of the pendulum. The former corresponds to the motion of the wave

through the medium and the latter to the vibratory motion of the parts of the medium. Since many properties of electric or magnetic quantities fluctuate or vary in a manner which may be represented by the curve, Fig. 39, its properties will be considered more fully.

62. Periodic Motion.—A periodic motion is one that is repeated at successive equal intervals of time, that is, it is a cyclic phenomenon. This is the most common type of motion and is present in every machine that has movable parts. Thus the piston of a steam engine, the shuttle of a sewing machine, the motion of a flywheel each repeats itself at regular and equal intervals of time when the machine is operating at constant speed. The motion of the machine parts named is not always simple although it is

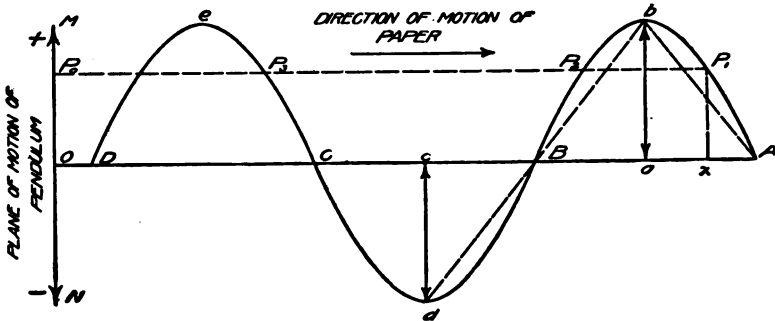

FIG. 40.—Graphical representation of the motion of a pendulum.

periodic. The simplest periodic motions are those of the rim of the flywheel, and of a pendulum. The former is called uniform circular motion and the latter simple harmonic when the arc through which the pendulum swings is small in comparison with the length of the pendulum. There are certain relations between these two types of motions which we shall presently point out. A close attention to the motion of a pendulum will show that it moves with the greatest speed at the center of its swing, and that this speed gradually decreases toward either extreme position where it momentarily comes to rest. On its return the speed of the pendulum increases until the lowest point has been reached. The motion of a pendulum when the arc through which it moves is small in comparison with the length of the pendulum is called simple harmonic. When this motion is combined with a uniform motion at right angles to the plane in which the pendulum swings, we get the curve, Fig. 40, which is merely

an enlarged drawing of the curve produced by the sand, Fig. 39. From this curve certain properties of the motion of the pendulum, and hence of any physical phenomena which vary in the same way, may be deduced. Suppose the pendulum is swinging through O upward, when A on the movable sheet is on O , and suppose the paper to start moving at a uniform speed, s , toward the right at this time. After a definite interval of time the pendulum will reach a position P_0 which corresponds with the point P_1 on the curve. If this interval of time be represented by t , then $Ax = st$. The distance $xP_1 = OP_0$ and represents the distance the vibrating particle in a medium producing wave motion is from its center of oscillation. It has reached this displacement at a varying speed while the wave has moved the distance Ax at a uniform speed. The point in the curve also shows in which direction the pendulum is moving. The point P_1 on the ascending portion of the curve shows that the pendulum is moving away from O upward, while the point P_2 at the same distance from DA , the horizontal axis, shows that the pendulum is returning toward O from its extreme position.

The shape of the curve shows plainly that the speed of the pendulum is not uniform but constantly changing. If the pendulum moved from O to M at a uniform speed, its path would be represented by the dashed line Ab and its return by bB . The greatest speed is plainly indicated at points where the curve crosses the axis, that is, at points A, B, C , etc., and the minimum speed at b, d , etc. The rate at which the speed varies is a variable one and not easily deduced from the curve.

63. Definitions.—In the further discussion of wave motion, some new terms will be used which it is necessary to define.

Amplitude.—The maximum distance that the pendulum swings in one direction from O is called the amplitude of vibration. In the wave this distance is represented by ab above and cd below the axis AD .

Period.—The time required for the pendulum to make a complete vibration is called its period. With reference to the wave this is the time required to trace the wave from A to C , or B to D , or from any point such as P_1 on the wave to the next point P_2 on a corresponding part of the wave.

Cycle.—A cycle with reference to the wave is a complete set of positive and negative values, one positive and one negative loop such as $AbBdC$; or $BdCcD$.

Frequency.—By frequency is meant the number of vibrations the pendulum makes in one second. With reference to the wave by frequency is meant the number of cycles per second.

The human ear is unable to detect sounds whose frequency is higher than 20,000 cycles per second. Electromagnetic wave frequencies below 20,000 are called *audio-frequencies* while higher frequencies are called *radio-frequencies*.

Wave Length.—By wave length is meant the distance the wave advances in the medium in 1 second.

The relations between these quantities can be expressed algebraically as follows:

Let λ = wave length

T = period

f = frequency

s = speed of wave in the medium = the distance the wave travels in 1 second,

$$\text{Then } f = \frac{1}{T}$$

$$s = \lambda f$$

$$\lambda = \frac{s}{f} = sT.$$

Examples

1. A pendulum makes 15 vibrations in 3 seconds, what is its period?

Solution

T = time of one vibration

Hence

$$T = \frac{3}{15} = \frac{1}{5} \text{ second.}$$

2. A tuning fork makes 256 vibrations per second. If sound travels 332 meters in 1 second, what is the wave length of the sound due to the tuning fork?

Solution.

$$\lambda = \frac{s}{f}$$

$$f = 256 \text{ per second}$$

$$s = 332 \text{ meters per second}$$

$$\text{Then } \lambda = \frac{332}{256} = 129.6 \text{ centimeters.}$$

3. The wave length of sodium light is 0.0005896 cm. What is the frequency of vibration of the ether corresponding to this wave length if the speed of light is 3×10^{10} cm. per second?

Solution

$$\begin{aligned}
 f &= \frac{s}{\lambda} \\
 &= \frac{3 \times 10^{10}}{5.896 \times 10^{-5}} \\
 &= \frac{30 \times 10^{14}}{5.896} = 5.1 \times 10^{14}.
 \end{aligned}$$

4. The frequency of a radiotelegraph sending station is 50,000 cycles per second. What is the length of the electromagnetic wave assuming that it travels with the speed of light?

Solution

$$\begin{aligned}
 \lambda &= \frac{s}{f} \\
 &= \frac{3 \times 10^{10}}{50,000} \\
 &= 6 \times 10^5 \text{ centimeters} \\
 &= 6 \text{ kilometers} \\
 &= 3.73 \text{ miles.}
 \end{aligned}$$

64. Generation of Electromagnetic Waves.—The conditions that must be fulfilled in order that a wave may be produced in and propagated by a material medium have been mentioned in Art. 60. In an analogous way, or perhaps we may say, the same or similar conditions determine the production and propagation of waves in the ether. A vibratory disturbance must be produced, and the nature of this must be such as to produce a displacement in the ether, or a change which can be propagated by it. Since any disturbance in the ether travels with the speed of light, it follows that if waves are to be produced, the displacements at the center of disturbance must be very rapid. How the rapid vibration in the ether at a center of disturbance may be produced we shall consider later. Assuming that this can be done, let us now consider how an electromagnetic wave may result.

In Figs. 5, 6, and 7, the electric charge is shown as having associated with it certain lines of strain in the ether. In Fig. 41¹ let *A* represent a charge with only two lines radiating from it. Suppose the charge be suddenly moved from *A* to *B*, owing to the inertia of the ether the line cannot instantaneously move parallel to itself throughout its whole length, but the portions near the charge are displaced first, and the portions farther away will be displaced later. The sudden motion of the charge pro-

¹ Minton, *General Electric Review*. Vol. 18, p. 389.

duces a bend or curve in the electric line which moves away from the charge just as the sudden movement of the end of the rope, Fig. 38, produces a bend which moves away from the hand. A motion of the charge in the direction of the line will not produce a bend in it, and hence no disturbance of the ether in that direction takes place.

If we consider the effect of the motion of the charge on all of the lines radiating from it, we shall find that the greatest bends occur in those lines that are at right angles to the direction of motion of the charge. This will become clear if we consider *A* and *B* to be the initial and final positions of a charge which has been suddenly moved. When the charge is at *A*, Fig. 42, the electric lines radiate along straight lines. A sudden movement, as explained above, will cause a deflection or bend in the lines which will travel at a uniform speed along them, and hence after a small interval of time these bends or pulses will all be at the same

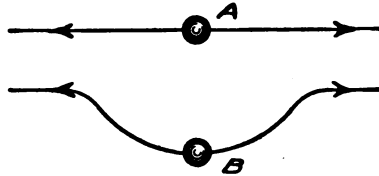

FIG. 41.—Motion of an electric charge producing a wave.

distance from the charge. That is, the bends of the lines will be situated on the surface of a sphere whose center is the charge. Fig. 42 is the section of such a sphere by the plane of the paper. The maximum deflection is found in the lines *CA* and *AD*, or those lines which are perpendicular to the direction of motion *AB*, of the charge. A backward motion of the charge from *B* to *A* will deflect or bend the electric lines in the other direction, Fig. 42, and these bends will travel outward in exactly the same way as the first. The distance between the pulses will be determined by their speed and the period of vibration, or to and fro motion of the charge.

In Chapter III it was shown that magnetic lines were developed when electric lines moved, and that the direction of the magnetic lines is at right angles to the electric lines and also at right angles to their direction of motion. Referring to Fig. 42, the arrow-heads show the direction of motion of the bends in the electric lines. The magnetic lines will, therefore, be perpendicular to

the plane of the paper. In accordance with the convention previously explained, when the charge moves from *A* to *B*, the magnetic lines will extend downward or into the paper below the horizontal axis *MN*, and up or out of the paper above this axis. This is represented by \oplus and \ominus respectively. When the charge moves from *B* to *A*, the direction of the magnetic lines is reversed. In Fig. 42 they are shown as penetrating the paper above the axis and emerging below the axis.

It is thus clear how the vibration of an electric charge may produce electromagnetic pulses or waves which radiate in the

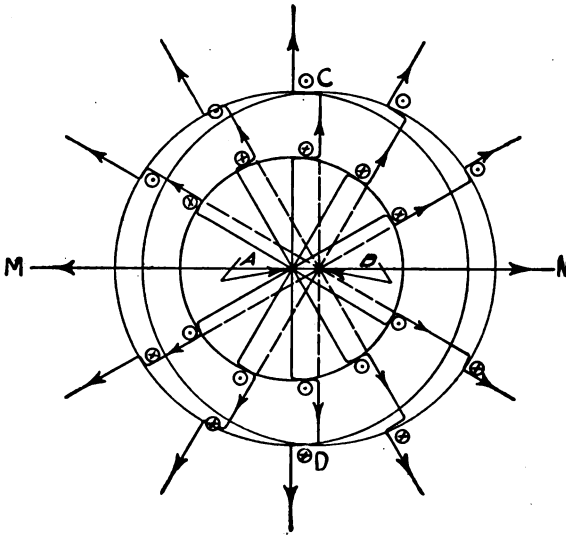

FIG. 42.—Oscillating electric charges.

ether from the source of disturbance just as waves in a material medium. It is also to be observed that the amplitude of these waves is greatest along a direction perpendicular to the direction of motion of the charge.

To apprehend clearly the application of the foregoing to radiotelegraphy, let us consider a little more fully the electromagnetic condition of the ether in a plane perpendicular to the direction of motion of the electric charge, that is, in the plane *CD*, Fig. 42. Let *A*, Fig. 43, be a vibrating or oscillatory charge of electricity, and let its amplitude of vibration be *Aa*. As the charge oscillates between *a* and *a'*, loops or bends are made in the electric line. These loops are propagated in all directions in a plane perpen-

dicular to aa' through A . The motion of these loops develops magnetic lines whose projections on the plane are circles around aa' . The dots represent the end on view of the magnetic lines and the circles show them in the reverse direction. When the charge moves from a to a' the direction of the magnetic lines viewed from a is clockwise. When the charge moves from a' toward a , the direction of the magnetic lines is reversed.

As the charge oscillates, there is a train of waves along the lines of electric strain. This train of waves moves out radially from the line aa' . Mingled with these, and at right angles to them, are the circular lines of magnetic strain. These circular magnetic lines expand outwardly in much the same way as ripples on water expand when a stone is dropped into it. At any point

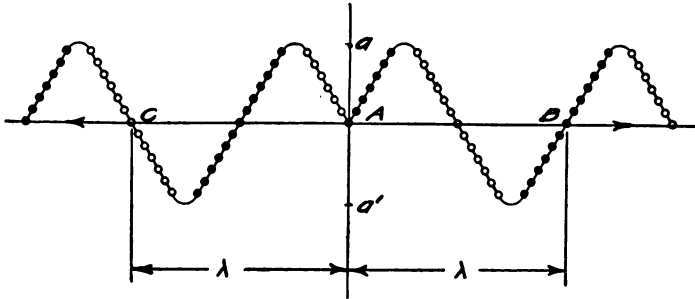

FIG. 43.—Oscillating electric charge producing an electromagnetic wave.

in space, not too near the oscillating charge, there is an alternating electric strain parallel to the direction of oscillation, and an alternating magnetic strain at right angles to it and to the line of its propagation. These two strains are periodic and pulsate together, coming to their maximum values at the same instant at points not too near the wire. The result is the propagation of what is called an electromagnetic wave with a certain definite velocity. In free space this velocity is equal to that of light, namely, 3×10^{10} cm. = 186,000 miles per second.

The wave length is the distance the disturbance or wave travels in the time required for the charge to make one oscillation. In Fig. 43 it is the distance represented by AB or AC .

65. Electromagnetic Waves and Radiotelegraphy.—Reserving for future discussion the methods used to make an electric charge oscillate, let us now briefly consider the application of the theory of the preceding article to wireless or radiotelegraphy. In

Fig. 44, let *A* be a tall mast of conducting material insulated from the earth and separated by an air gap from a wire grounded through a plate *E*, and let the mast commonly called aerial or antenna be charged positively. While the charge is static, only electric lines extend from the charged aerial to the ground as indicated in the figure. One end of each electric line is connected to the aerial while the other end ultimately reaches the earth although it may be at a great or infinite distance from the aerial. If the potential of the charged antenna is raised, or if the air gap is decreased, an electrical discharge will finally take place across the air gap. This discharge is oscillatory. That is,

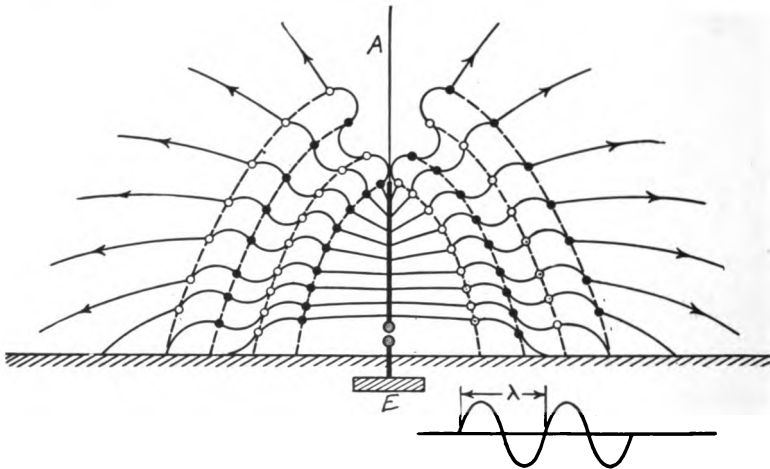

FIG. 44.—An oscillating charge in an antenna producing an electromagnetic wave.

the charge does not jump the air gap from the aerial to earth only, but some of it returns. There is thus a series of discharges, first in one direction and then back again. The oscillations of the charge move the ends of the electric lines back and forth just as has been explained in connection with Fig. 43. This backward and forward movement of the electric lines produces magnetic lines and an electromagnetic wave is propagated into space. A graphical representation of the wave is shown in Fig. 44. It is interesting to observe that the wave is propagated through the lower layers of the ether. In other words, the wave follows the contour of the earth.

While the foregoing is based on a mechanical conception of

the ether, and in some respects may be weak and incomplete, nevertheless it contains the essential facts of electromagnetic wave propagation, and will undoubtedly aid in giving the student a clearer notion of the manner in which energy is transferred through space by electromagnetic waves. The next question of importance is the consideration of practical methods of producing and detecting electromagnetic waves.¹

¹Note.—The above theory is essentially that given by J. P. Minton, *General Electric Review*, Vol. 18, pp 387 and ff, and is based on the electron theory of electricity. The shape of the electromagnetic waves obtained by this theory is the same as that derived from Hertz's solution of the general equation of the electromagnetic field in the neighborhood of a small oscillator.

CHAPTER VI

ELEMENTARY ALTERNATING CURRENTS

66. Oscillatory Motion.—An oscillatory motion with which every one is familiar is that of the simple pendulum, some properties of which have already been discussed. Other interesting properties of oscillatory motion can be more readily derived from a consideration of uniform circular motion. Thus, in Fig. 45 assume the point P to move around the circle at a uniform speed; that is, let it move so as to pass over equal arcs in equal

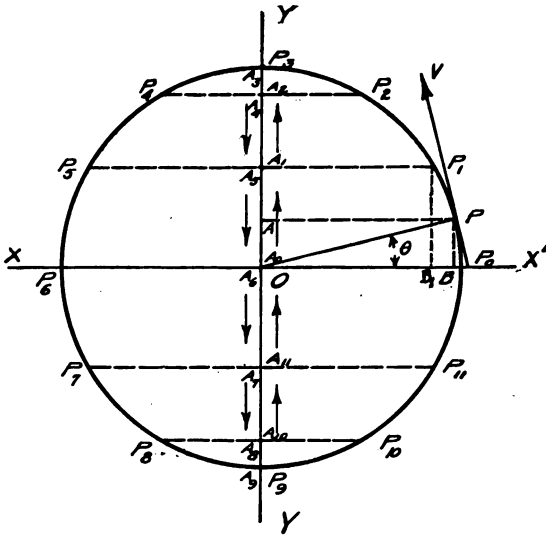

FIG. 45.—Simple harmonic motion.

intervals of time. From any position of P , such as P_1 , draw a line perpendicular to YY' . Then, if P_1A_1 moves parallel to itself as P moves from P_1 to P_2 , A_1 will move to A_2 ; and when P moves from P_2 to P_3 , the foot of the perpendicular will move from A_2 to A_3 . It is very evident that while the speed of P on the circumference of the circle is uniform, the speed of A , the foot of the perpendicular, is variable. When P is at P_0 , the

point A is at A_0 and is moving parallel to P . At this instant the speeds of A and P are equal. The speed of A from A_0 to A_3 decreases until at A_3 it reverses its direction. When P is at P_4 , A is at A_4 on the downward path. When P is at P_6 , A is at A_6 and is again moving parallel to the motion of P and at the same speed. A close inspection of the motion of A will show that at the center of the circle the speed of A is a maximum, and that as it passes the center moving in either direction, its speed decreases until it reaches the extremity of the diameter along which it is moving, where its speed is zero. This, however, is the same as the motion of the pendulum previously considered; hence, by projecting the uniform motion of a point on the circumference of a circle upon a diameter we have an oscillatory motion. The amplitude of the oscillation is the radius of the circle OP_3 . The period of the oscillation is the time required for the point P to move once around the circle, or the time required for the point A to move from A_0 to A_3 , from A_3 to A_6 , and back to A_0 .

We wish to consider the properties of the motion of A . In order to do this we transfer its motion to the circumference of the circle. As already pointed out, the physical properties of certain physical quantities and circuits vary in the same way as the motion of A . A knowledge of the manner in which the motion of A varies is important. The motion of A is called *simple harmonic*.

67. The Displacement of a Point in Simple Harmonic Motion.

—The distance that the point A is from O at any instant of time is called its displacement. This will change with time, but it evidently depends upon the amplitude of vibration, *i.e.*, the radius of the circle, and the time. If at the instant that P passes through P_0 , Fig. 46, in a counter-clockwise direction we note the time t_0 , and if when P has reached P_1 we again note the time, t_1 , then the interval of time required for P to pass from P_0 to P_1 is $t_1 - t_0$. During this interval of time A has moved from O to A , or OA is the displacement required. This is evidently equal to P_1B which in turn equals $OP_1 \sin \theta$. Hence,

$$OA = P_1B = OP_1 \sin \theta,$$

or $OA = R \sin \theta$, where $R = OP_1 =$ the radius of the

circle. Suppose that the speed of the point P is such that it will move from P_0 to P_3 in 1 second. Then the arc $p_0p_1p_3$ on

a circle of unit radius is called the angular velocity and is usually expressed by ω . The angle θ in radian measure is equal to the arc p_0p_1 , but

$$\frac{p_0p_1}{\omega} = \frac{t_1 - t_0}{1}.$$

Hence

$$p_0p_1 = \omega (t_1 - t_0),$$

or

$$\theta = \omega (t_1 - t_0).$$

Substituting this in the expression for displacement which we may represent by y , we have

$$\begin{aligned} OA = y &= R \sin \omega (t_1 - t_0), \\ &= R \sin \omega t, \text{ where } t = t_1 - t_0. \end{aligned}$$

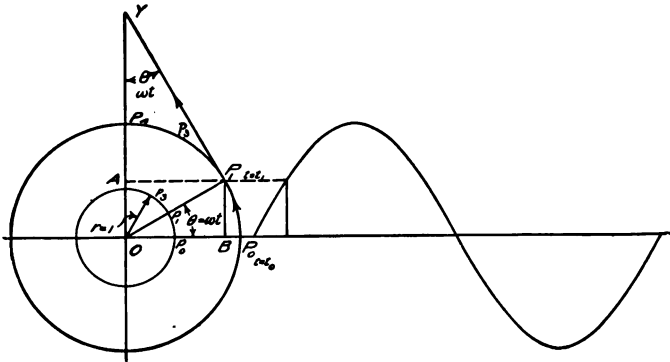

FIG. 46.—Analysis of simple harmonic motion.

This expression gives us the displacement at any time t after the point has passed the middle point O of its oscillation in the upward or positive direction. We may transform this so as to get the displacement in terms of its frequency, time, and period thus:

Let T = period of oscillation.

Then T is the time required for the point P to move once around the circle, or to describe an arc equal to 2π on the circle of radius 1. In 1 second the arc described will be $\frac{2\pi}{T}$, and, as ω is the arc described in 1 second, then

$$\omega = \frac{2\pi}{T},$$

whence

$$\omega t = \frac{2\pi t}{T} = 2\pi ft.$$

and

$$y = R \sin 2\pi ft.$$

This is an important result because the expressions for simple alternating current and electromotive force are exactly of the same form, namely,

$$i = I_m \sin 2\pi ft. = I_m \sin \omega t$$

$$e = E_m \sin 2\pi ft. = E_m \sin \omega t.$$

In fact these two equations may be considered as defining an alternating current and an alternating electromotive force.

Example

1. A body oscillates through an amplitude of 4 centimeters at a frequency of 40 cycles per second. How far is it from the central point of its vibration and in which direction is it moving 0.01 and 0.05 second after its passage in the upward direction, Fig. 46?

Solution

The distance from the center is given by $y = R \sin 2\pi ft.$

DATA

(a) $f = 40.$	(b) $f = 40$
$t = 0.01$ second	$t = 0.05$ second
$R = 4$ cm.	$R = 4$ cm.
(a) $y_1 = 4 \sin 2\pi \times 40 \times 0.01$	
$= 4 \sin 0.8\pi$	
$= 4 \times 0.588 = 2.35$ cm. downward.	
(b) $y_2 = 4 \sin 2\pi \times 40 \times 0.05$	
$= 4 \sin 4\pi$	
$= 4 \times 0 = 0.$ The point has made two oscillations and is moving upward.	

68. Speed of a Body Having Simple Harmonic Motion.— It has been shown that the speed of an oscillating body is constantly changing. The speed at any given instant of time is thus an important and interesting property. Referring to Fig. 46, if we draw a tangent at P_1 such as P_1Y , the velocity of the point P at this instant is directed along P_1Y . The component of this velocity along OY is the speed of the point A . If V is the velocity of P_1 , then the component of this velocity in the direction of OY is

$$V_A = V \cos \theta$$

$$= V \cos \omega t$$

$$= V \cos 2\pi ft.$$

When $\omega t = 0$, that is, when P is at P_0 , we have

$$V_A = V \cos 0 = V.$$

That is, the point A is moving with the same speed as the point P .

When $\omega t = \frac{\pi}{2}$ we have

$$V_A = V \cos \frac{\pi}{2} = 0.$$

At this instant P is at P_4 and is moving at right angles to OP_4 . Since V is the linear velocity of P we can express its value in terms of the amplitude and the period of vibration thus:

Let C = circumference of circle

T = period

Then

$C = 2\pi R$

$$V = \frac{C}{T} = \frac{2\pi R}{T},$$

$$= 2\pi fR = \omega R,$$

for $\frac{2\pi}{T} = \omega$. Substituting, we get

$$V_A = \frac{2\pi R}{T} \cos 2\pi ft.$$

$$= \omega R \cos \omega t.$$

69. Rate of Change of Speed in Simple Harmonic Motion.—

Since the speed of the point A , Figs. 45 and 46, is a variable quantity, it is of interest to determine the rate at which it changes with time. The time rate of change of a velocity is called an acceleration. A velocity is defined as the time rate of change of motion in a specified direction. A velocity thus has two properties, magnitude and direction. By magnitude of a velocity is meant the numerical value of the velocity; thus 60 miles per hour, 5 feet per second, 30 knots, etc., mean that the body if moving at a uniform velocity would move 60 miles in 1 hour, etc. There is no indication in which direction the body is moving. A velocity of 60 miles per hour north is different from a velocity of 60 miles per hour east, for in this case the direction in which the body is moving is specified. Either or both of these properties of a velocity may change with time. If the magnitude changes, we have what is called linear acceleration, and if the direction of the velocity changes, we have centripetal acceleration. A good example of linear acceleration is the change in velocity of falling bodies, or of a locomotive starting from rest on

a straight track and increasing its speed to a given value such as 40 miles per hour.

In Fig. 46 the point P was assumed to move at a constant speed around the circumference of the circle. It is evident that when the point P is at P_0 it is moving in a vertical direction and that when it has reached P_1 it is moving in the direction P_1Y which makes an angle $\theta = \omega t$ with the vertical line. That is, during the time t the direction of the velocity has changed through an angle θ . The question is at what rate is this change of direction taking place, for the change in speed or acceleration of the point A is determined by the change in the direction of the velocity of the point P . Since it has been assumed that the point P revolves at a uniform speed, it will change its direction by 2π in one revolution or in the time T . Hence, the rate at

which it is changing its direction is $\frac{2\pi}{T} = \omega$. The linear velocity is

equal to ωR . The rate of change of this velocity, or the acceleration toward the center, is equal to the product of its linear velocity by the rate at which it is changing its direction, or centripetal acceleration = $\omega \times \omega R = \omega^2 R$. This is directed from P_1 toward the center O . The rate at which A is changing its velocity is the component of the centripetal acceleration, $\omega^2 R$, in the direction AO . This component is equal to $\omega^2 R \sin \omega t$, and is directed from A toward O , while the point A is moving away from O . If the direction from O to A is considered positive, then the direction from A toward O is negative and we may write

$$\text{acceleration of } A = -\omega^2 R \sin \omega t.$$

But $OA = R \sin \omega t$, then

$$\text{acceleration of } A = -\omega^2 \times OA.$$

If we represent OA by y , the acceleration of point A may be

written symbolically $A \left[\frac{y}{t} \right]$; $\frac{y}{t}$ may be considered a velocity, and

the $A \left[\frac{y}{t} \right]$ may symbolically represent the acceleration of point A

having simple harmonic motion. With this modification we may write

$$A \left[\frac{y}{t} \right] = -\omega^2 y \text{ for the acceleration. This is an important ex-}$$

pression for if the acceleration of the rate of change of any physical quantity with time is given by a similar expression, namely,

$$A \left[\frac{Q}{t} \right] = -K^2 Q,$$

we can at once conclude that the quantity oscillates and that its period of oscillation is

$$T = \frac{2\pi}{\sqrt{K^2}} = \frac{2\pi}{K}.$$

This is obtained by analogy, for K^2 corresponds to ω^2 , and Q to y .

But $\omega = \frac{2\pi}{T}$ or $T = \frac{2\pi}{\omega}$. Hence the period of oscillation of the physical quantity represented by Q is

$$T = \frac{2\pi}{K}$$

70. Alternating Current and Electromotive Force.—If a dry cell or a storage cell be connected to a coil of wire, the resulting current will remain at a constant fixed value as given by Ohm's law as long as E , the electromotive force, and R , the resistance, remain constant. If, however, an electromotive force whose value fluctuates with time be connected to a coil of a fixed resistance, the resulting current will at each instant be given by Ohm's law and hence will fluctuate as the e.m.f. In the elementary theory of alternating currents it is always assumed that an alternating electromotive force may be represented by

$$e = E_m \sin \omega t,$$

where e is the numerical value of the e.m.f. at any time t , and E_m is the maximum value of the e.m.f., ω is equal to 2π times the frequency. This expression means that the e.m.f. applied to the two terminals of a circuit increases and decreases in time in exactly the same way as the displacement of a body moving with simple harmonic motion. If this e.m.f. is applied to a circuit whose resistance is R , the resulting current is given by

$$\frac{e}{R} = \frac{E_m}{R} \sin \omega t$$

or

$$i = I_m \sin \omega t.$$

If we collect in parallel columns the expressions for the displacement and the velocity of a body having simple harmonic motion,

and the expressions for alternating current and electromotive force we have:

Harmonic motion.	Alternating currents
$y = R \sin \omega t.$	$e = E_m \sin \omega t.$ $i = I_m \sin \omega t.$
Velocity = $\left[\frac{y}{t} \right] = \omega R \cos \omega t.$	Rate of change of e and i with time, $\left[\frac{e}{t} \right] = \omega E_m \cos \omega t.$ $\left[\frac{i}{t} \right] = \omega I_m \cos \omega t.$
Acceleration = $A \left[\frac{y}{t} \right] = -\omega^2 R \sin \omega t$ $= -\omega^2 y.$	Acceleration of the rate of change of e and i . $A \left[\frac{e}{t} \right] = -\omega^2 E_m \sin \omega t$ $= -\omega^2 e.$ $A \left[\frac{i}{t} \right] = -\omega^2 I_m \sin \omega t$ $= -\omega^2 i.$

71. Phase Difference.—It is very evident that if two points some distance apart are moving at a uniform speed around the circumference of a circle, Fig. 47, then A_1 and A_2 are each moving with simple harmonic motion, but there is an interval of time between their passage through O in the same direction. For instance if A_2 is on O , A_1 is below and some time must elapse before A_1 reaches O . By phase difference is meant this interval of time that elapses between the passage of two points in the same direction across any point in their path. This interval of time plainly determines the angle $P_2OP_1 = \theta$, for if ω is the angular velocity, this interval of time is evidently $t_1 = \frac{\theta}{\omega}$ which is constant as long as the speeds of P_1

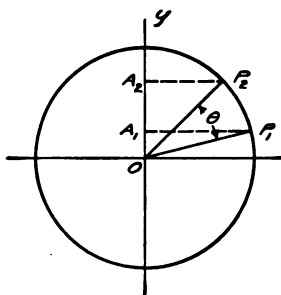

FIG. 47.—Phase difference.

and P_2 are constant and equal. If the displacement OA_2 is represented by $y = R \sin \omega t$,

then

$$\begin{aligned}
 OA_1 = y_1 &= R \sin (\omega t - \theta) \\
 &= R (\sin (\omega t - \omega t_1)) \\
 &= R \sin \omega (t - t_1).
 \end{aligned}$$

The phase difference may be considered as the angle θ or as the interval of time, t_1 . When dealing with alternating currents and electromotive forces, there may likewise be an interval of time between their maximum values. For instance if the e.m.f. is given by

$$e = E_m \sin \omega t$$

the current i may be $i = I_m \sin \omega(t - t_1)$

$$\begin{aligned} \text{or} \quad i &= I_m \sin (\omega t - \omega t_1) \\ &= I_m \sin (\omega t - \theta); \end{aligned}$$

or we may have

$$\begin{aligned} i &= I_m \sin \omega(t + t_1) \\ &= I_m \sin (\omega t + \theta). \end{aligned}$$

The current given by the expression $i = I_m \sin \omega(t - t_1)$ is said to be a lagging current because it will not reach a maximum value until t_1 seconds after the e.m.f. to which it is due has passed through its maximum value.

The current given by $i = I_m \sin \omega(t + t_1)$ is said to lead or to be a leading current because it reaches its maximum value before the e.m.f. to which it is due. It must be remembered that the current in a circuit does not lead or lag by an angle, but that the phase difference is an interval of time, which is usually expressed as an angle or fractional part of the period.

72. Phase Relation Between the E.m.f. and Current in an Inductive Circuit.—Let an alternating current of the form

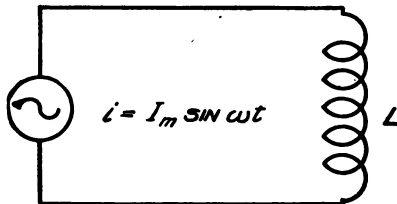

FIG. 48.—Inductive circuit.

$i = I_m \sin \omega t$ be flowing in a circuit of pure inductance, Fig. 48. It is desired to determine the fluctuations and phase relation of this current with reference to the e.m.f. causing it. It has been shown that a current-carrying conductor is surrounded by a magnetic field, and that where the magnetic field changes in intensity an e.m.f. is induced in the conductor. The induced e.m.f. depends upon the constant of the circuit known as the inductance, Art.

33, and the rate at which the current changes. It has been shown that the rate at which the current changes is $\omega I_m \cos \omega t$, and hence the induced counter e.m.f. is given by

$$e_c = L\omega I_m \cos \omega t.$$

This induced e.m.f. is at each instant opposed to the applied e.m.f., but the current is given by

$$\begin{aligned} i &= I_m \sin \omega t \\ &= I_m \sin \frac{2\pi}{T}t \end{aligned}$$

and counter-pressure $e_c = L\omega I_m \cos \frac{2\pi}{T}t$.

When $t = 0$, $i = I_m \sin 0 = 0$,
and $e_c = L\omega I_m \cos 0 = L\omega I_m$ a maximum.

When $t = \frac{T}{4}$, $i = I_m \sin \frac{2\pi}{T} \cdot \frac{T}{4}$
 $= I_m \sin \frac{\pi}{2} = I_m$ a maximum,

and $e_c = L\omega I_m \cos \frac{2\pi}{T} \frac{T}{4} = 0$.

Hence, i and e_c differ by one-quarter period. That is, e_c passes through its maximum value one-quarter of a period behind i . But e_c is always opposed and equal to the applied e.m.f. Hence, the applied e.m.f. leads the counter e.m.f. by one-half a period, and the current by one-quarter period. The expressions for these quantities may be written:

$$\begin{aligned} \text{Applied e.m.f., } e_a &= E_m \sin \omega(t + \frac{T}{4}) \\ &= E_m \sin (\omega t + \frac{\pi}{2}). \end{aligned}$$

Resulting current, $i = I_m \sin \omega t$.

$$\begin{aligned} \text{E.m.f. of self-inductance, } e_c &= \omega L I_m \sin \omega(t - \frac{T}{4}) \\ &= E_m \sin (\omega t - \frac{\pi}{2}). \end{aligned}$$

The important fact to remember is that in an inductive circuit without resistance the current lags one-quarter of a period behind the e.m.f. causing it.

73. Mechanical Analogy.—The effect of self-induction in preventing the sudden increase or decrease of a current may be considered as analogous to the action of the inertia of the flywheel of an engine. When the steam is first admitted to the cylinder, the speed of the flywheel increases gradually. Even if the throttle or steam pipe were fully opened, the speed of the flywheel would not jump suddenly from standstill to full speed.

While the speed of the flywheel is increasing, the flywheel is pushing against the pressure of the steam, and the energy of the steam is being transferred to the flywheel. Only by reacting against the steam pressure can this energy be transferred. This reaction prevents a sudden increase in the speed.

When the flywheel has acquired full speed, and the speed has become constant, a pressure only sufficient to overcome friction is necessary, and no more energy is being absorbed or taken up by the wheel.

If the steam be shut off suddenly, the engine will not come to an instantaneous stop, but the energy that has been stored in the flywheel will keep it running in the same direction for some time. The motion will continue until all of the energy stored in the flywheel has been returned to the driving mechanism of the engine and dissipated as heat.

Although the flywheel is not assumed to oscillate, and hence, the period does not enter, nevertheless it is evident that the speed of the flywheel reaches a maximum value later than the applied pressure. If the pressure applied be considered as analogous to the electromotive force applied to an inductive circuit, then the speed of the flywheel is analogous to the electric current in the circuit. The pressure required to accelerate the flywheel is a maximum at the beginning when the speed is zero and it is a minimum when the speed is a maximum. In an inductive circuit the e.m.f. necessary to increase the current is a maximum when the current is a minimum and a minimum when the current is a maximum. This, however, is true also of two simple harmonic motions one-quarter of a period out of phase.

74. Clock and Wave Diagrams.—The relations explained in Art. 72 may be more clearly apprehended if shown graphically. Thus in Fig. 49, if OE_a , OE_e , and OI_m be rotated together counter-clockwise at a uniform speed, the projections of E_a , E_e , and I_m on OY will each move along OY with simple harmonic motion, and $Oe_e = OE_e \sin \omega t$. But if OE_e represents the maximum

applied e.m.f., then $Oe_a =$ the instantaneous e.m.f., and we may write

$$e_a = E_{am} \sin \omega t.$$

Similarly

$$i = I_m \sin \left(\omega t - \frac{\pi}{2} \right) \\ = I_m \sin \omega \left(t - \frac{T}{4} \right),$$

and

$$e_c = E_{cm} \sin (\omega t - \pi) \\ = E_{cm} \sin \left(\omega t - \frac{T}{2} \right).$$

e_a is the instantaneous applied e.m.f. which is assumed to vary in time just as the displacement in simple harmonic motion, i is

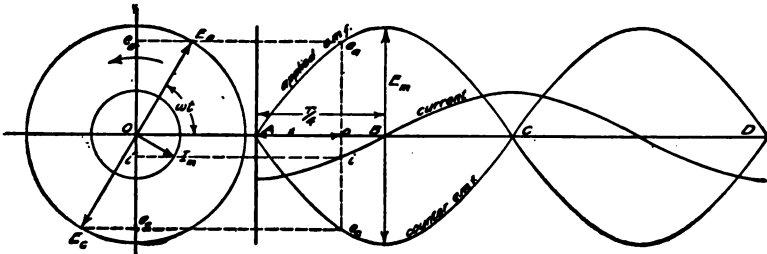

FIG. 49.—Clock and wave diagram for inductive circuit.

the resulting instantaneous current, and e_c is the instantaneous counter-pressure of self-inductance; that is, e_c is the pressure induced by the variations in the current i . If the horizontal axis AD be divided, and if each division represents some interval of time, *i.e.*, some fraction of a second, then the value of e_a , i , and e_c at any instant are represented by the distances from the horizontal axis to the corresponding curve at that particular instant. Thus, let 1 second be the time required for OE_a to make one rotation, that is, let the period of oscillation of e_a , i , and e_c be 1 second. The AD on the horizontal scale will be 1 second, AC will represent $\frac{1}{2}$ second, and AB , $\frac{1}{4}$ second. If T is the period, $AB = \frac{T}{4}$, $AC = \frac{T}{2}$, and $AD = T$. If at O on the horizontal axis corresponding to any interval of time $AO = t$, a vertical line be drawn, then the distances from O to the curves represent the values of e_a , i , and e_c at that instant of time. The diagram shows that the curve representing the fluctuations of current

crosses the axis in an upward direction $\frac{T}{4}$ seconds later than the curve for the applied e.m.f. The counter-pressure is a maximum where the current changes at the greatest rate, that is, when the current is crossing the axis. As the pressure of self-inductance opposes the applied pressure, it is drawn below the axis, and as we have assumed the circuit to be a pure inductance, the counter-pressure must at each instant equal the impressed pressure. In the clock diagram to the left, the phase difference between the applied pressure and current is the angle $E_a O I_m = \frac{\pi}{2}$, and the phase difference between the applied pressure and counter-pressure is the angle $E_a O E_c = \pi$. In the sine wave diagram the phase difference between current and applied pressure is the distance $AB = \frac{T}{4}$, and the phase differences between applied and counter-pressure is the distance $AC = \frac{T}{2}$.

75. Phase Relation of E.m.f. and Current in a Circuit Containing Resistance and Inductance.—In the preceding article an ideal case was assumed. No circuit is entirely free of resist-

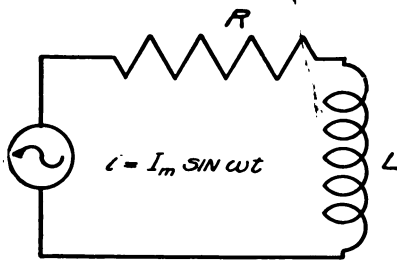

FIG. 50.—Circuit containing resistance and inductance.

ance, hence the practical problem is to determine the phase relation between current and applied e.m.f. when the circuit contains both resistance and inductance, Fig. 50. As before, let us assume that a current of the form $i = I_m \sin \omega t$ is circulating in the circuit. According to Ohm's law this current causes a pressure drop $e_R = I_m R \sin \omega t$. This may be considered as a pressure directly opposed to the flow of current and fluctuating with it. With reference to the current this iR drop is half a period out of phase, and a component of the applied pressure in phase with the current.

is necessary to compensate for e_R . Then, as has just been shown, there will be developed a pressure of self-inductance which is equal to $e_L = \omega I_m \cos \omega t$. This lags one-quarter of a period behind the current. The applied e.m.f. must contain a component to compensate for this e.m.f. of self-inductance. Hence, the total applied e.m.f. must numerically at each instant be equal to the sum of e_R and e_L and oppositely directed. That is, it must be one-half period out of phase with the sum of e_R and e_L . In Fig. 51 the alternating current is shown by the heavy wave. The opposing resistance drop e_R is shown by the lighter line wave, and the counter-pressure of self-inductance is shown by the dashed wave. The wave marked e_a is at each instant numerically equal to the sum of e_R and e_L , and as it is oppositely

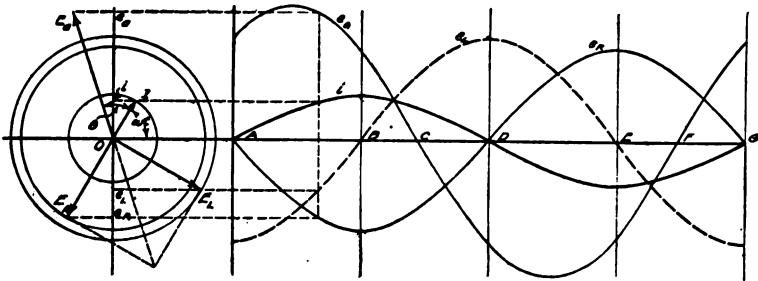

FIG. 51.

directed, it contains the necessary components for compensating for e_R and e_L and is the necessary applied e.m.f. It will be observed that curve e_a does not lead the current by one-quarter of a period, but only by the interval of time represented by CD or FG .

Referring to the clock diagram to the left, the maximum value of the applied e.m.f. must equal the vector sum of E_L and E_R and be oppositely directed. It is represented by OE_a which is ahead of the current by the angle θ .

76. Impedance of a Circuit.—The influence of the inductance, frequency, resistance, and capacitance of a circuit in determining the current and its phase is called the impedance of the circuit. It is thus necessary to be able to calculate the value of the impedance and also the phase angle θ as indicated above. The influence of capacity will be considered later. In this article we shall consider the impedance due to resistance, inductance, and frequency.

The component of the applied e.m.f. necessary to compensate for the resistance drop is $e_R = iR = I_m R \sin \omega t$. The maximum value of this is when $t = \frac{T}{4}$, or when $e_R = I_m R$. The component of the applied e.m.f. necessary to compensate for the pressure of self-inductance is $e_L = L\omega I_m \cos \omega t$, and its maximum value is $e_L = \omega I_m L$. This leads the current by $\frac{T}{4}$. Referring to the clock diagram, $I_m R$ is in phase with the current and $L\omega I_m$ is $\frac{\pi}{2}$ or 90° ahead of the current. The relation between these two quantities, when the phase difference is expressed as an angle, is the same as two sides of a right-angled triangle. In Fig. 52,

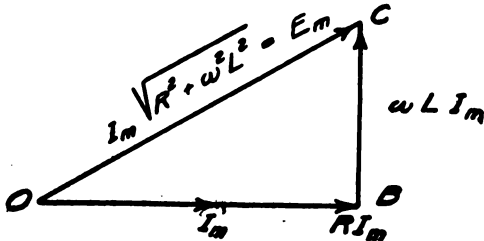

FIG. 52.—Vector diagram for an inductive circuit.

if OI_m represents the magnitude and phase position of I_m , then OB represents RI_m and BC represents ωLI_m .

But
$$\begin{aligned} OC &= \sqrt{OB^2 + BC^2} \\ &= \sqrt{R^2 I_m^2 + \omega^2 L^2 I_m^2} \\ &= I_m \sqrt{R^2 + \omega^2 L^2} = E_m. \end{aligned}$$

Dividing by $\sqrt{R^2 + \omega^2 L^2}$ we get
$$I_m = \frac{E_m}{\sqrt{R^2 + \omega^2 L^2}}.$$

This is an expression for current in the form given by Ohm's law, namely, $I = \frac{E}{R}$. The denominator $\sqrt{R^2 + \omega^2 L^2}$ is called the impedance of the circuit. It is evident that the impedance contains two terms, R the resistance and ωL the inductive reactance. The reactance depends upon ω and L . But $\omega = 2\pi f$,

hence ω varies with the frequency f , and the reactance varies with the frequency and inductance.

The phase difference between the impressed e.m.f. and the resulting current, when expressed as an angle, is equal to the

angle COB . The tangent of angle COB is $\frac{\omega LI_m}{RI_m} = \frac{\omega L}{R}$.

Hence,
$$\tan \theta = \frac{\omega L}{R}.$$

When ω , L , and R are known, the phase difference can be calculated by the aid of the above relation.

If it is desired to express the phase difference as an interval of time, this can readily be done, for it has been shown that $\theta = \omega t_1$, where t_1 is the time interval desired.

Examples

1. An alternating electromotive force of 1500 maximum volts and of a frequency of 1000 cycles per second is impressed upon a circuit of 100 ohms resistance and 0.004 henry inductance. What is the impedance and what is the current?

Solution

The impedance
$$Z = \sqrt{R^2 + \omega^2 L^2}.$$

DATA

$R = 100$ ohms

$\omega = 2\pi f = 2\pi \times 1000$

$L = 0.004$ henry = 4×10^{-3} henrys.

Then
$$Z = \sqrt{100^2 + 4\pi^2 \times 4^2} = \sqrt{10,630}$$

 $= 103.1$ ohms.

The maximum current is given by
$$I_m = \frac{E_m}{\sqrt{R^2 + \omega^2 L^2}}$$

 $= \frac{1500}{103.1} = 14.5$ amperes.

2. What is the phase difference between current and impressed pressure of Problem 1?

Solution

$$\tan \theta = \frac{\omega L}{R}$$

DATA

$R = 100$ ohms

$\omega = 2\pi f = 2\pi \times 1000$

$L = 0.004$ henry.

$$\begin{aligned} \text{Then} \quad \tan \theta &= \frac{0.004 \times 2\pi \times 1000}{100} \\ &= 0.2514 \\ \theta &= 14^\circ 7', \end{aligned}$$

$$\text{or} \quad t_1 = \frac{\theta \text{ radians}}{\omega} = \frac{0.247}{2\pi \times 1000} = 3.9 \times 10^{-5} \text{ sec.}$$

3. What is the impedance of a circuit of negligible resistance and of 0.0002 henry inductance at a frequency of 1,000,000 cycles per second?

Solution

$$Z = \sqrt{R^2 + \omega^2 L^2}.$$

When R is small in comparison with ωL , it may be omitted and we have

$$\begin{aligned} Z &= \sqrt{\omega^2 L^2} \\ &= \omega L. \end{aligned}$$

DATA

$$\begin{aligned} f &= 10^6 \\ L &= 2 \times 10^{-4} \\ \pi &= 3.1416 \\ Z &= 2\pi \times 10^6 \times 2 \times 10^{-4} \\ &= 628 \text{ ohms.} \end{aligned}$$

77. Analogy for a Condenser.—A better understanding of the action of a condenser may be had by considering an analogy. Suppose we have an air tank that under 1 atmospheric pressure holds a certain definite quantity of air, say 5 pounds. We can define the capacity of the vessel in terms of the number of pounds of air it holds, and call it a 5-pound tank.

If the pressure is doubled, the tank will hold 10 pounds of air. Since we have defined the capacity of the tank in terms of unit—1 atmosphere—pressure, we cannot call it a 10-pound tank. A 10-pound tank under the same conditions will hold 20 pounds of air.

Furthermore, if the tank be exhausted, evidently no back pressure will be exerted when air is first admitted to the tank. As soon as some air is admitted to the tank, back pressure begins to manifest itself, and when the back pressure equals the maximum applied pressure, no more air enters the tank. We thus see that the amount of air entering per unit of time depends upon the back pressure, and this back pressure will depend upon the capacity of the tank. For instance, if we put 5 pounds of air in a 10-pound tank, the back pressure will be one-half as great as when 5 pounds of air are put into a 5-pound tank. We can then say

that the unit capacity of a tank is such that when 1 pound of air is forced into it the pressure will be equal to 1 atmosphere. Evidently a certain amount of work will be done in forcing the air into the tank, and we could define unit capacity in terms of the work expended.

The capacitance of electrical conductors is analogous to the capacity of the air tank discussed above. The capacitance of a condenser or system of conductors is usually defined in terms of the quantity of electricity required to raise the difference of pressure between the terminals 1 volt. In accordance with this definition the quantity of electricity that a condenser will contain is equal to the product of the capacitance and pressure.

78. Action of a Condenser.—If a condenser has one of its plates connected to each side of a battery circuit, it will become charged; that is, a quantity of electricity will flow into the condenser due to the battery pressure, and one plate will become positively and the other negatively charged. After a condenser has been connected to a direct-current circuit for a short time, there will be no flow of current to or from the condenser since the condenser becomes fully charged almost instantaneously, and when charged, the difference in pressure between its plates is the same as that of the battery or other source of charging current. If the pressure in the circuit be decreased or reversed, the charge will flow out of the condenser and back through the circuit.

When an alternating pressure is impressed upon a condenser, the action is somewhat different. As the pressure increases from zero to a maximum, a current flows into the condenser, one side becoming charged positively and the other side negatively. The current flows as long as the pressure is changing, and the back pressure of the condenser is always just equal to the applied pressure. When the applied pressure begins to decrease, the current begins to flow out of the condenser. When the applied pressure is reversed, the current flows into the condenser in the opposite direction. This continues until the applied pressure again attains a maximum value, when the current is reversed. These fluctuations of current continue as long as the applied pressure fluctuates or changes. An alternating current may thus flow in a circuit containing a condenser. The exact value of such a current will depend upon the applied

e.m.f., the frequency, the capacitance, and the resistance of the circuit. The algebraic expression for a current in a circuit having capacitance and resistance is

$$I = \frac{E}{\sqrt{R^2 + \frac{1}{(2\pi fC)^2}}}$$

where

E = applied e.m.f.

R = resistance in ohms

f = frequency of the applied e.m.f.

π = 3.1416

and

C = capacity in farads.

The derivation of this expression is given later.

Examples

1. A pressure of 110 volts at 60 cycles is impressed upon a circuit whose resistance is 5 ohms and capacity $\frac{1}{3}$ microfarad, what is the current?

Solution

Given

$$E = 110 \text{ volts}$$

$$R = 5 \text{ ohms}$$

$$f = 60$$

$$C = \frac{1}{3} \times 10^{-6} \text{ farads.}$$

To find I

$$\begin{aligned} I &= \frac{110}{\sqrt{5^2 + \frac{1}{(2\pi \times 60 \times \frac{1}{3} \times 10^{-6})^2}}} \\ &= \frac{110}{\sqrt{25 + \left(\frac{10^6}{21 \times 20}\right)^2}} \\ &= \frac{110}{\sqrt{25 + (7955)^2}} \\ &= \frac{110}{\sqrt{(7955)^2}} = \frac{110}{7955} \end{aligned}$$

as 25 is negligible in comparison with $(7955)^2 = 0.013$ ampere.

2. Suppose that in Problem 1 the frequency were increased to 600, what would the current be then?

Solution

The solution is exactly the same as the foregoing, except for f we substitute 600. The equation for current becomes

$$\begin{aligned}
 I &= \frac{110}{\sqrt{25 + \left(\frac{3 \times 10^6}{2\pi \times 600}\right)^2}} \\
 &= \frac{110}{\sqrt{25 + (795.5)^2}} \\
 &= \frac{110}{796} = 0.13 \text{ ampere, nearly.}
 \end{aligned}$$

This shows that when the resistance is small, the current increases or varies directly as the frequency as long as the pressure remains constant. Both the voice currents and ringing currents in a wire telephone are of high enough frequency to give an appreciable current through a condenser. The frequencies of voice currents range between 100 and 2500 cycles per second in ordinary telephonic communication.

79. Current in a Circuit Containing Capacitance.—Condensers are of great importance in radiotelegraphy. Some elementary principles have already been given. We shall now examine the

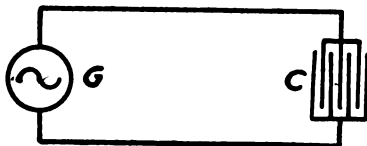

FIG. 53.—Circuit containing capacitance.

phase relation between a current in a circuit containing a condenser and the e.m.f. causing it as well as the value of the current.

Let Fig. 53 represent a circuit consisting of a high frequency generator, G , and a condenser of capacitance of C farads. Since the difference of potential across a condenser is determined by the capacitance and charge, if e expresses the difference of potential, q the charge, and C the capacitance, then by definition

$$q = eC$$

We will assume that q is a fluctuating quantity, increasing and decreasing in exactly the same way as the displacement in simple harmonic motion, that is,

$$q = Q \sin \omega t.$$

The rate at which q changes is $\left[\frac{q}{t}\right] = \omega Q \cos \omega t$ as has been shown.

But the rate at which q , the charge, is changing is the current; hence,

but $i = \omega Q \cos \omega t$
 $i = I_m \cos \omega t$

hence $\omega Q = I_m$

and $Q = \frac{I_m}{\omega}$

Substituting $\frac{I_m}{\omega}$ for Q in the expression for q , we have

$$q = \frac{I_m}{\omega} \sin \omega t.$$

But $eC = q$,

or $e_c = \frac{q}{C} = \frac{I_m}{C\omega} \sin \omega t$ is the expres-

sion for the difference of potential across the condenser when a current $i = I_m \cos \omega t$ is circulating through it. The difference of potential as expressed above

$$e_c = \frac{I_m}{C\omega} \sin \omega t \text{ is the counter-}$$

pressure, as it is due to the charge q . As is evident from the preceding discussion, the current given by $i = I_m \cos \omega t$ lags

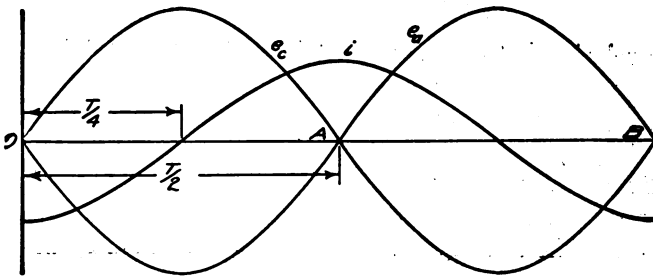

FIG. 54.—Sine wave diagram for a circuit containing capacitance.

one-quarter of a period behind e_c . The applied pressure which compensates for the counter-pressure must at each instant equal and oppose the counter-pressure; hence, the applied pressure must lag one-half period behind the counter-pressure, and one-quarter of a period behind the current. This phase relation is shown in Fig. 54. The fact that a condenser takes a leading current is of great practical importance as will be shown later.

80. Current in a Circuit Containing Resistance and Capacitance.—When the circuit contains capacitance only, the current leads the pressure by one-quarter period. If resistance is also present, the applied pressure must contain a component to

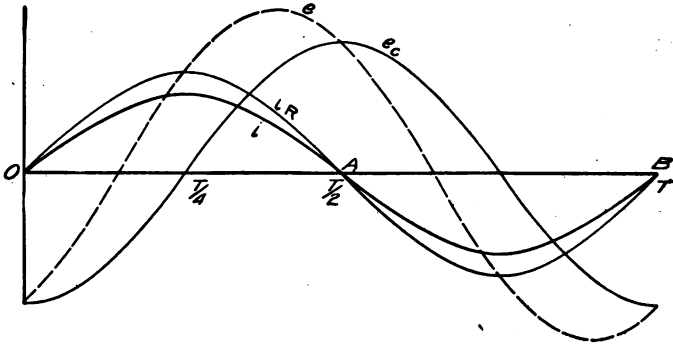

FIG. 55.—Sine wave diagram for circuit containing resistance and capacitance.

compensate for the iR drop. This component will be in phase with the current. These phase relations are shown in Fig. 55 where i is the current curve; iR is the e.m.f. required to compensate for the resistance drop, or e.m.f. consumed in the resistance; and e_c is the component of e.m.f. necessary to compensate for the counter-pressure of the condenser. The sum of these two components is curve e , the necessary applied pressure.

It is evident that these relations are the same as when a current flows in a circuit containing resistance and inductance with the

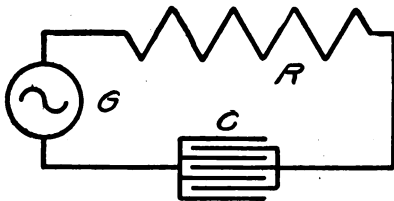

FIG. 56.—Circuit containing resistance and capacitance.

difference that the current leads instead of lags the applied electromotive force.

81. Relation Between Maximum Current and Pressure in a Circuit Containing Capacitance.—If the pressure applied to a circuit containing resistance and capacitance, Fig. 56, is given by

$$e = E_m \sin \omega t$$

then the current is given by

$$\begin{aligned} i &= I_m \sin (\omega t + \theta) \\ &= I_m \sin \omega (t + t_1), \end{aligned}$$

where $\theta = \omega t_1$, is the angle by which the current leads the pressure. The e.m.f. consumed in the resistance is $iR = I_m R \sin \omega (t + t_1)$. This component of the applied e.m.f. is in phase with the current and its maximum value is $E_R = I_m R$.

The component required to compensate for the counter-pressure of the capacitance is

$$\begin{aligned} e_c &= \frac{I_m}{\omega C} \cos \omega \left(t + \frac{T}{4} \right) \\ &= \frac{I_m}{\omega C} \cos \left(\omega t + \frac{\pi}{2} \right). \end{aligned}$$

This component lags one-quarter of a period behind the current and its maximum value is $E_c = \frac{I_m}{\omega C}$. These two components are out of phase by one-quarter of a period which is the equiva-

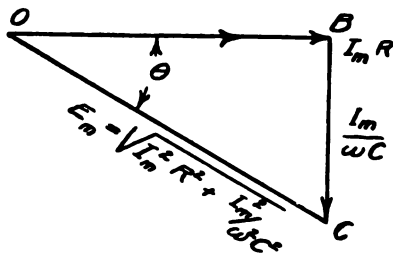

FIG. 57.—Vector diagram for a circuit containing resistance and capacitance.

lent of a right angle when the phase difference is expressed as an angle. This again is the relation between the sides of a right-angled triangle, Fig. 57. The resistance component of the applied e.m.f. is represented by $OB = I_m R$, and the capacitance component is represented by $OC = \frac{I_m}{\omega C}$ which is drawn from B toward C . The maximum applied e.m.f. is then represented

$$OC = E_m = \sqrt{I_m^2 R + \frac{I_m^2}{\omega^2 C^2}}$$

or
$$E_m = I_m \left(\sqrt{R^2 + \left(\frac{1}{\omega C}\right)^2} \right)$$

and
$$I_m = \frac{E_m}{\sqrt{R^2 + \left(\frac{1}{\omega C}\right)^2}}$$

$$\tan \theta = \frac{I_m}{\frac{I_m}{\omega C}} = \frac{1}{\omega CR} \cdot \frac{I_m R}{I_m}$$

This is again an expression for current in the form of Ohm's law. The denominator, $\sqrt{R^2 + \left(\frac{1}{\omega C}\right)^2}$, is called the impedance; R is the resistance; and $\frac{1}{\omega C}$ is the capacitance reactance.

Examples

1. An alternating e.m.f. of 1000 volts maximum is impressed upon a circuit containing a condenser of 2 microfarads and a resistance of 100 ohms. What is the maximum current,

- (a) When the frequency is 60 cycles?
- (b) When the frequency is 1000 cycles?

Solution

(a)
$$I_m = \frac{E_m}{\sqrt{R^2 + \left(\frac{1}{\omega C}\right)^2}}$$

DATA

- $E_m = 1000$ volts
- $R = 100$ ohms
- $\omega = 2\pi \times 60 = 377$
- $C = 2 \times 10^{-6}$ farads.

Then
$$I_m = \frac{1000}{\sqrt{100^2 + \left(\frac{1}{377 \times 2 \times 10^{-6}}\right)^2}}$$

$$= \frac{1000}{\sqrt{100^2 + \frac{10^{12}}{4 \times 377^2}}}$$

$$= \frac{1000}{100 \sqrt{1 + 176.2}}$$

$$= 0.75 \text{ ampere, about.}$$

(b) In this case the conditions are the same except the change in frequency, hence,

$$\begin{aligned}
 I_m &= \frac{1000}{\sqrt{100^2 + \frac{10^{12}}{(6.28)^2 \times 4 \times 1000^2}}} \\
 &= \frac{1000}{\sqrt{100^2 + \frac{10^6}{158}}} \\
 &= 100 \frac{100}{\sqrt{1 + \frac{100}{158}}} = 7.82 \text{ amperes.}
 \end{aligned}$$

This shows that the current in a circuit containing capacitance increases with the frequency.

2. What is the angle of lead in cases (a) and (b) of Example 1?

Solution

$$(a) \quad \tan \theta = \frac{1}{\omega CR}$$

DATA

$$\omega = 2\pi \times 60$$

$$C = 2 \times 10^{-6} \text{ farads}$$

$$R = 100 \text{ ohms.}$$

Then

$$\begin{aligned}
 \tan \theta &= \frac{1}{2\pi \times 60 \times 2 \times 10^{-6} \times 100} \\
 &= \frac{10^3}{75.4} = 13.26
 \end{aligned}$$

and

$$\theta = 85^\circ 41', \text{ nearly.}$$

(b)

$$\begin{aligned}
 \tan \theta &= \frac{1}{2\pi \times 1000 \times 2 \times 10^{-6} \times 100} \\
 &= \frac{10^3}{4\pi \times 10^3} = \frac{10}{12.566} \\
 &= 0.796 \\
 \theta &= 38^\circ 32', \text{ nearly.}
 \end{aligned}$$

82. Current in a Circuit Containing Resistance, Inductance, and Capacitance.—The important circuit in radiotelegraphy, is one containing resistance, inductance, and capacitance. Let such a circuit be represented by Fig. 58. When an alternating e.m.f. is impressed upon such a circuit it must contain three components: one to compensate for the resistance drop iR ; another to compensate for the inductive-reactance, ωLi ; and a third to compensate for the condenser reactance, $\frac{i}{\omega C}$. The maximum values of these components are $I_m R$, $\omega L I_m$, and $\frac{I_m}{\omega C}$.

leads $I_m R$ by a right angle and $\frac{I_m}{\omega C}$ lags $I_m R$ by a right angle. The phase relations are then expressed by Fig. 59 where $OB = I_m R$, $BD = \omega LI$, and $BC = \frac{I_m}{\omega C}$. It is evident that as ωLI_m and $\frac{I_m}{\omega C}$

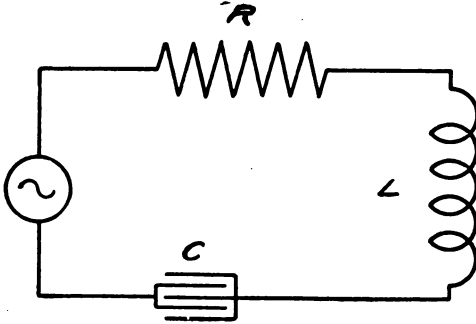

FIG. 58.—A circuit containing resistance, inductance and capacitance.

are in opposition, they have a tendency to neutralize each other. A smaller e.m.f. is thus necessary to send a certain current through a circuit containing an inductance and capacitance in series than through the same circuit when only one is present.

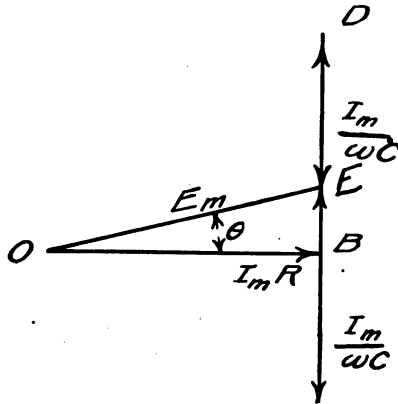

FIG. 59.—Vector diagram for a circuit containing resistance, inductance and capacitance.

The resultant reactance pressure is the difference between ωLI_m and $\frac{I_m}{\omega C}$. This resultant is represented by $BE = \omega LI_m - \frac{I_m}{\omega C}$, Fig. 59. The maximum applied e.m.f. necessary to send current I_m through the circuit is $E_m = OE$.

$$OE = \sqrt{OB^2 + BE^2}$$

or

$$E_m = \sqrt{(I_m R_m)^2 + \left(\omega L I_m - \frac{I_m}{\omega C}\right)^2}$$

$$= I_m \sqrt{R^2 + \left(\omega L - \frac{1}{\omega C}\right)^2}$$

and

$$I_m = \frac{E_m}{\sqrt{R^2 + \left(\omega L - \frac{1}{\omega C}\right)^2}}$$

which is a more general expression for the maximum current through a series circuit containing resistance, inductance, and capacitance. The quantity $\sqrt{R^2 + \left(\omega L - \frac{1}{\omega C}\right)^2}$ is called the impedance of the circuit. It is evident that if $\omega L = \frac{1}{\omega C}$, the impedance is $\sqrt{R^2} = R$. The reactance $\omega L - \frac{1}{\omega C}$ depends upon the frequency, and in order that the reactance may be zero, $\omega L - \frac{1}{\omega C}$ must equal 0.

or

$$\omega L = \frac{1}{\omega C}.$$

Then

$$\omega^2 = \frac{1}{LC},$$

and

$$\omega = \frac{1}{\sqrt{LC}}.$$

But

$$\omega = 2\pi f.$$

Then

$$f = \frac{1}{2\pi\sqrt{LC}}.$$

83. Effective and Average Values of Alternating Current and Pressure.—Since an alternating current or pressure has been defined as one whose intensity or value varies with time, as the displacement in simple harmonic motion, it follows that the expression, an alternating current of 10 amperes, is meaningless unless we define what is meant by an alternating-current ampere. As an electric current heats a conductor through which it passes, an alternating-current ampere is defined in terms of its relative heating effect as compared with the heating effect of a direct current. It has been shown that the rate at which the energy

of a direct current is converted into heat by the resistance of a conductor is—Heat = I^2R joules per second—where I is in amperes and R in ohms. If an alternating current be passed through the same resistance, its energy will also be converted into heat, but at a variable rate. We have defined the simple alternating current by the equation

$$i = I_m \sin \omega t.$$

At any instant the rate at which heat is developed in the resistance R will be $i^2R = RI_m^2 \sin^2 \omega t$. An alternating-current ampere is such a value of the alternating current as will develop the heat at the same rate in a given resistance as a direct-current ampere. Thus, if we represent an alternating current by $I_{a.c.}$ amperes and a direct current by $I_{d.c.}$ amperes, $I_{a.c.}$ is said to equal $I_{d.c.}$ when $I_{a.c.}^2 R = I_{d.c.}^2 R$. But it was shown above that at any instant the heat developed by an alternating current is given by $I_m^2 R \sin^2 \omega t$. The rate at which the heat is developed is the average of this expression per second. Hence,

$$I_{a.c.}^2 R = \text{average } RI_m^2 \sin^2 \omega t$$

and
$$I_{a.c.} = I_m \sqrt{\text{average } \sin^2 \omega t}$$

It can be shown that the average of $\sin^2 \omega t = \frac{1}{2}$; hence,

$$I_{a.c.} = \frac{I_m}{\sqrt{2}} = 0.707I_m.$$

That is, a steady current whose value is 0.707 times the maximum value of the alternating current will develop the same amount of heat in a given resistance as the alternating current. This is known as the *effective* or *root mean square* value of the alternating current and is the value usually used in alternating-current calculations.

Example

An alternating current is given by the expression

$$i = 50 \sin \omega t.$$

What are the maximum and effective values of the current?

Solution

$$i = I_m \sin \omega t$$

and
$$I_{eff} = 0.707I_m.$$

Evidently
$$I_m = 50$$

and
$$I_{eff} = 0.707 \times 50 = 35.35 \text{ amperes.}$$

The effective value of an alternating electromotive force is likewise defined as equal to 0.707 times the maximum value. Alternating-current ammeters and voltmeters indicate effective values.

The average value of an alternating current or pressure is the average for one cycle of the expression $I_m \sin \omega t$. It can be shown that the average of $\sin \omega t$ is $\frac{2}{\pi} = 0.636$; hence, the average alternating current is given by

$$I_{av} = 0.636I_m.$$

Likewise $E_{av} = 0.636E_m.$

Hereafter the symbols I and E will be used to represent effective current and electromotive force respectively.

In a preceding article it was shown that the maximum current in a circuit is given by

$$I_m = \frac{E_m}{\sqrt{R^2 + \left(\omega L - \frac{1}{\omega C}\right)^2}}.$$

Since the effective current is equal to $0.707I_m$ and the effective pressure equals $0.707E_m$, we have

$$\begin{aligned} I_m &= 0.707I_m = \frac{0.707E_m}{Z} \\ &= \frac{E}{Z}, \end{aligned}$$

where I and E are effective values and Z is the impedance of the circuit.

84. Influence of Frequency upon Impedance.—The impedance $Z = \sqrt{R^2 + \left(\omega L - \frac{1}{\omega C}\right)^2}$ of a circuit varies with the frequency, for ωL increases with the frequency and $\frac{1}{\omega C}$ varies inversely with the frequency. This, however, is not the whole effect of frequency upon impedance. The resistance of metallic conductors for alternating currents of relatively high frequencies is also dependent upon the frequency. In the case of alternating currents the current density is not uniform over the entire cross-section of the conductor, but there is a concentration of current

near the surface. This is known as "skin effect." The result is the same as if the cross-section of the conductor were reduced. This reduction in the active cross-section of the conductor results in an increase in its resistance. If R_0 is the resistance obtained by direct-current measurements, then the resistance of copper wires to alternating currents of very high frequencies is given approximately by

$$R = 0.0381 R_0 d \sqrt{f},$$

where d is the diameter of the wire in centimeters and f is the frequency. If d , the diameter, is measured in mils, the formula reduces to

$$R = 9.68 \times 10^{-5} R_0 d \sqrt{f}.$$

This formula applies only when the frequency is very high. That is, $9.68 \times 10^{-5} d \sqrt{f}$ must be larger than unity, of the order 10 or more.

Example

The direct-current resistance of a certain length of No. 20 copper wire is 10 ohms. What is the alternating-current resistance when the frequency is 500,000 cycles per second?

Solution

$$R = 0.0381 R_0 d \sqrt{f}.$$

DATA

- $R_0 = 10$ ohms
- $d = 0.08118$ centimeter
- $f = 500,000$.

Then

$$\begin{aligned} R &= 0.0381 \times 10 \times 0.08118 \times \sqrt{500,000} \\ &= 0.0381 \times 10 \times 0.08118 \times 707.1 \\ &= 21.86 \text{ ohms.} \end{aligned}$$

The increase is 118.6 per cent.

It is very evident from the above formula that the increase in resistance, due to high frequencies, is greater in large than in small conductors. Hence, to reduce the skin effect stranded wire may be used. The individual strands must be insulated and braided so that each strand is on the surface for the same portion of its length.

Since the effect of high frequencies is to concentrate the current in the surface layers of the conductor, the self-inductance, L , of the wire will likewise be affected. In general, the inductance

of wires and coils is reduced with increase in frequency. At high frequencies the inductance of straight wires is reduced by approximately $\frac{l \times 10^{-9}}{2}$ henrys, where l = length of wire in centimeters. The expression for the decrease in the inductance of coils with frequency is much more complicated.¹

¹ Coffin, Bull. Bureau of Standards, Vol. 2, p. 275.

CHAPTER VII
OSCILLATORY CIRCUITS

85. Condenser Discharge.—When two plates separated by a dielectric are connected to a battery or to any other source of e.m.f. a quantity of electricity will flow into them. When the difference of potential between the plates equals the applied e.m.f. no more electricity flows into the condenser and it is said to be charged. If now the source of e.m.f. be disconnected, the charge remains in the condenser, one plate being charged

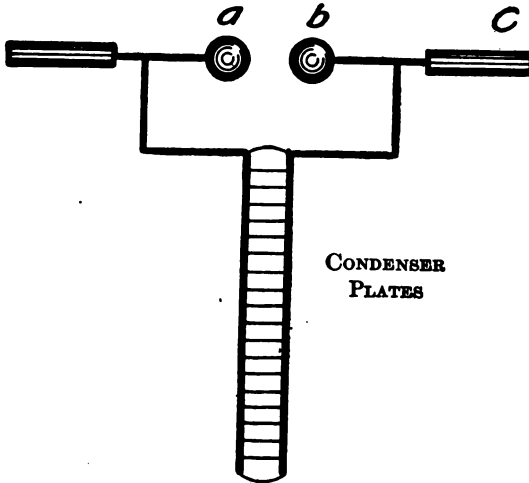

FIG. 60.—Principle of condenser discharge.

positively and the other negatively. The dielectric between the two plates is strained electrically. Such a condition is represented in Fig. 60. If, when the condenser is charged, the two knobs *a* and *b* are gradually pushed toward each other by the insulated handle *C*, a limiting distance will be reached at which a spark will pass between them. This distance varies with the difference of potential between the plates. The greater this is the longer the air gap between the knobs across which the spark will jump. The discharge of the condenser is so rapid

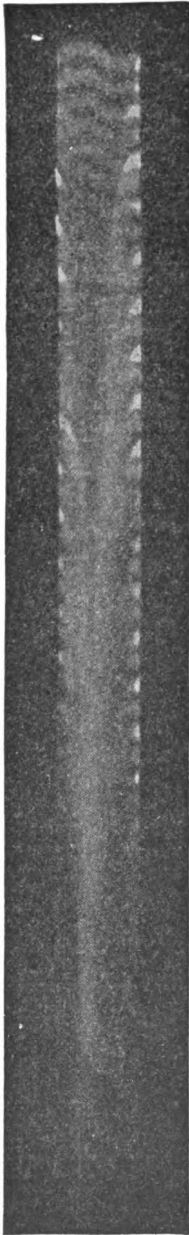

FIG. 61.—Oscillatory discharge of a condenser.

that it appears to consist of one spark only. If, however, the spark is viewed as projected on a screen, by means of a revolving mirror, it will be seen to consist of a series of distinct sparks first from *a* to *b*, and then from *b* to *a*, etc., Fig. 61. The discharge of a condenser across an air gap is thus shown to be oscillatory. That is, the current flows from one side of the condenser into the other side, and back again. Before equilibrium is finally attained all of the energy of the charge must be dissipated as heat, and hence the discharge oscillates.

A condenser can be made to discharge in only one direction if the two plates be connected by a high resistance such as a wet thread. When this is done the discharge is much slower, and the energy is dissipated more slowly.

It is thus evident that a condenser may be used to produce the oscillatory discharge which is the necessary condition for producing electromagnetic waves. In fact two similar condensers were first used for the production and detection of electromagnetic waves. These waves were first investigated by Joseph Henry in 1842. The condenser is a necessary piece of apparatus in all systems of radio-telegraphy.

86. Mechanical Analogy for Discharge of Condenser.—When a condenser is charged, the dielectric between the plates is strained. This is analogous to the strained condition of a spring when compressed or extended beyond its point of equilibrium *O*, Fig. 62. Such a spring when released will swing past the point *O* to *b* and then back again nearly to *a*. Neglecting the resistance offered by the air, the spring will oscillate until all of the energy acquired in extending it is spent in molecular friction of the spring. If the spring be very

elastic but of small mass, the oscillations will be very rapid. The discharge of a condenser is a process by which the potential energy of the charge is dissipated gradually in heat. A very small part of this energy is spent in the dielectric while the major portion is dissipated in the air gap. The behavior of the spring and the behavior of the condenser are plainly analogous.

87. Energy of a Charged Condenser.—The analogy of the spring will aid in determining the energy spent in charging a condenser. Suppose the spring, Fig. 62, is stretched from O to a , a distance d , and that the force required to hold the spring at a is F . According to Hooke's law, this force is proportional to the distance the spring has been stretched, namely, $Oa = d$.

We may then write $F = Kd$. The force F evidently varies uniformly from zero to F and hence the average force is $\frac{1}{2}F = \frac{1}{2}Kd$. The work done by a force $\frac{1}{2}F$ acting through a distance d is $W = \frac{1}{2}Fd = \frac{1}{2}Kd^2$. Hence, the potential energy of the stretched spring is $\frac{1}{2}Fd$, or $\frac{1}{2}Kd^2$.

It has been shown that the work done in moving an electric charge Q from one point in space to another point is equal to the product of the charge by the difference of potential between the two points. The difference of potential between the plates of the condenser is proportional to the charge. Hence, in charging the condenser the difference of potential increases from zero to the maximum which we may represent by E_m . The average difference of potential is $\frac{1}{2}E_m$, and if Q is the charge the energy spent in charging it must be $\frac{1}{2}QE_m$. But $Q = CE_m$, where C is the capacitance. Substituting for Q , we have

$$\text{Energy of condenser} = \frac{1}{2}CE_m^2.$$

Or since $E_m = \frac{Q}{C}$, another expression for the energy of a charged condenser is $\frac{1}{2} \frac{Q^2}{C}$.

88. Condensers in Series and in Parallel.—In practice it may sometimes be necessary to connect more than one condenser to a circuit, and when this is done the joint capacitance must be known. Suppose condensers are connected as indicated in Fig.

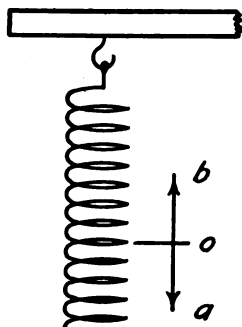

FIG. 62.—Analogy for condenser discharge.

63, and that the difference of potential between a and b is E volts. If C_1 , C_2 , and C_3 are the capacitances of the several condensers what is their joint capacitance and what is the charge?

Let C = joint capacitance.

Then

$$Q = CE$$

is the charge taken from the battery B . But if $+Q$ units flow in at a , then $-Q$ units are attracted at C , etc. That is, each condenser holds Q units of electricity. The difference of potential between a and c is $V_1 = \frac{Q}{C_1}$, that between d and e is $V_2 = \frac{Q}{C_2}$, and that

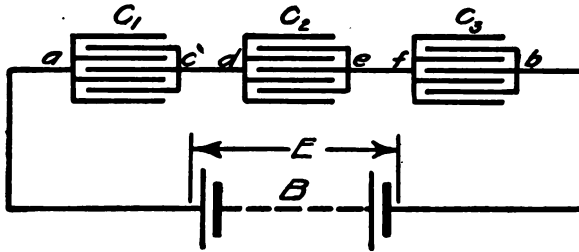

FIG. 63.—Condensers in series.

between f and b is $V_3 = \frac{Q}{C_3}$.

Then

$$E = V_1 + V_2 + V_3$$

or

$$\frac{Q}{C} = \frac{Q}{C_1} + \frac{Q}{C_2} + \frac{Q}{C_3}$$

Cancelling Q

$$\frac{1}{C} = \frac{1}{C_1} + \frac{1}{C_2} + \frac{1}{C_3}$$

whence

$$C = \frac{C_1 C_2 C_3}{C_1 C_2 + C_1 C_3 + C_2 C_3}$$

That is, the joint capacitance is equal to the product of the several capacitances divided by the sum of the products obtained by multiplying together all of the capacitances less one.

Examples

1. Four condensers of 0.2, 0.4, 0.3, and 0.6 microfarads are connected in series. What is the combined capacitance?

Solution

$$C = \frac{C_1 C_2 C_3 C_4}{C_1 C_2 C_3 + C_1 C_2 C_4 + C_1 C_3 C_4 + C_2 C_3 C_4}$$

DATA

$$\begin{aligned}
 C_1 &= 0.2 \text{ microfarad} \\
 C_2 &= 0.4 \text{ microfarad} \\
 C_3 &= 0.3 \text{ microfarad} \\
 C_4 &= 0.6 \text{ microfarad} \\
 C_1 C_2 C_3 C_4 &= 0.2 \times 0.4 \times 0.3 \times 0.6 = 0.0144 \\
 C_1 C_2 C_3 &= 0.2 \times 0.4 \times 0.3 = 0.024 \\
 C_1 C_3 C_4 &= 0.2 \times 0.4 \times 0.6 = 0.048 \\
 C_1 C_2 C_4 &= 0.2 \times 0.3 \times 0.6 = 0.036 \\
 C_2 C_3 C_4 &= 0.4 \times 0.3 \times 0.6 = 0.072 \\
 & \underline{\hspace{10em}} \\
 & 0.180
 \end{aligned}$$

Then $C = \frac{0.0144}{0.18} = 0.08 \text{ microfarad.}$

It is thus evident that when condensers are connected in series the resulting capacitance is less than that of the smallest condenser.

2. A pressure of 500 volts is applied to two condensers of 5 and 10 microfarads connected in series. What is the charge on the condensers?

Solution

$Q = CE$
 and $C = \frac{C_1 C_2}{C_1 + C_2}$

DATA

$$\begin{aligned}
 E &= 500 \text{ volts} \\
 C_1 &= 5 \times 10^{-6} \text{ farads} \\
 C_2 &= 10 \times 10^{-6} \text{ farads.} \\
 \text{Then } C &= \frac{5 \times 10^{-6} \times 10 \times 10^{-6}}{5 \times 10^{-6} + 10 \times 10^{-6}} \\
 &= \frac{50 \times 10^{-6}}{15} = 3.33 \times 10^{-6} \text{ farads.} \\
 Q = CE &= 3.33 \times 10^{-6} \times 500 \\
 &= 16.65 \times 10^{-4} \text{ coulombs.}
 \end{aligned}$$

Condensers may be connected in parallel as shown in Fig. 64. When this method of connection is employed it is evident that the potential difference between *a* and *d* equals that between *b* and *c*, etc., or that the condensers are charged to the same difference of potential. Let

$$\begin{aligned}
 Q_1 &= \text{charge on } C_1 \\
 Q_2 &= \text{charge on } C_2 \\
 Q_3 &= \text{charge on } C_3 \\
 \text{Then } \frac{Q_1}{C_1} &= E, \text{ or } Q_1 = C_1 E \\
 \frac{Q_2}{C_2} &= E, Q_2 = C_2 E
 \end{aligned}$$

and
$$\frac{Q_3}{C_3} = E, Q_3 = C_3 E.$$

If the joint capacity is C and the total charge is Q , then

$$Q = CE \text{ also.}$$

But
$$Q = Q_1 + Q_2 + Q_3.$$

Hence
$$CE = C_1 E + C_2 E + C_3 E$$

and
$$C = C_1 + C_2 + C_3.$$

This shows that when several condensers are connected in parallel the joint capacitance is the sum of the capacitances of the individual condensers.

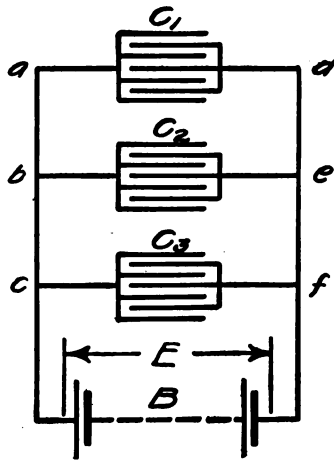

FIG. 64.—Condensers in parallel.

Example

Three condensers whose capacitances are 0.5, 0.33, and 3 microfarads are connected in parallel across a 110-volt d.-c. circuit. What is the charge?

Solution

$$C = C_1 + C_2 + C_3$$

and
$$Q = EC.$$

DATA

$$C_1 = 0.5 \text{ microfarad}$$

$$C_2 = 0.33 \text{ microfarad}$$

$$C_3 = 3 \text{ microfarads}$$

$$E = 110.$$

Then
$$C = (0.5 + 0.33 + 3)10^{-6} = 3.83 \times 10^{-6} \text{ farads}$$

and
$$Q = 110 \times 3.83 \times 10^{-6} = 4.213 \times 10^{-4} \text{ coulombs.}$$

89. Energy stored in Magnetic Field.—In Art. 33 it was shown that $\Phi = LI$, where Φ is the total flux threading through a circuit and I is the current producing it. The e.m.f. of self-induction is $\frac{\Phi}{t} = \frac{LI}{t}$. If Φ changes uniformly, the e.m.f. is constant. The work done by the applied e.m.f. against this counter-pressure is EQ units of work, where Q is the quantity of electricity moved. Assuming for simplicity that the current increases uniformly from 0 to I in time t , then $Q = \frac{1}{2}It$, and the work done against the e.m.f. of self-induction is

$$W = QE = \frac{1}{2}EIt.$$

But

$$E = \frac{LI}{t}, \text{ hence}$$

$$\begin{aligned} W &= \frac{1}{2}EIt = \frac{1}{2} \frac{LI}{t} \times I \times t \\ &= \frac{1}{2}LI^2. \end{aligned}$$

Since the counter-pressure of self-induction is due to the reaction of the magnetic field threading through the circuit, this work is stored as potential energy of the magnetic field.

The foregoing demonstration is based on the assumption that the current changes at a uniform rate from zero to a maximum value. The result is not subject to this limitation, for it can be shown by calculus that the result is true no matter how the current varies.

Example

A circuit has an inductance of 0.45 henry. What is the potential energy of the magnetic field if the current in the circuit is 100 amperes?

Solution

$$\text{Energy} = \frac{1}{2} LI^2.$$

DATA

$$L = 0.45 \text{ henry}$$

$$I = 100 \text{ amperes.}$$

Then

$$\begin{aligned} \text{energy} &= \frac{0.45}{2} \times 100^2 \\ &= 2250 \text{ joules.} \end{aligned}$$

90. Closed Electric Oscillator.—While it is true that the discharge of a condenser is oscillatory, the period of the oscillations is extremely rapid and not subject to control. A condenser by itself is thus not suitable for producing oscillations for radio-telegraphy. A condenser and some form of an inductance are,

however, invariably used. A simple diagram of what is known as a closed oscillator consisting of an inductance and condenser is shown in Fig. 65. The diagram represents an uncharged condenser C connected in series with an inductance L and battery B . At the instant of closing the circuit by means of the switch S , the full e.m.f., E , of the battery is impressed upon the circuit. Since at the instant of closing the switch there is no charge on the condenser, there is no counter-pressure due to it, and the current increases at a maximum rate. But the counter-pressure of self-inductance is equal to the inductance, L , times the rate of change of current; hence, the moment a current starts

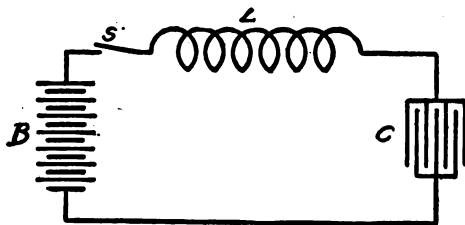

FIG. 65.—Simple closed oscillatory circuit.

in the circuit, the counter-pressure of self-inductance is equal to the applied e.m.f.

As soon as the condenser acquires some charge, q , a counter-pressure equal to $\frac{q}{C}$ is developed, and the current necessarily increases at a lower rate. This is accompanied by a decrease in the counter-pressure of self-inductance. On increasing current the relation between E , the applied pressure; the counter-pressure of self-inductance, e_L ; and the counter-pressure of the condenser, e_C is given by

$$E = e_L + e_C.$$

e_L and e_C change. As one increases the other decreases, but at all times their algebraic sum is equal to E . As the charge on the condenser increases, e_C increases and e_L decreases. This continues until the charge Q on the condenser is such that $\frac{Q}{C} = E$, when the current ceases to increase and e_L is zero. But at this instant the current is a maximum and the energy of the magnetic field around the inductance is a maximum as it is equal to $\frac{1}{2}LI^2$.

As the current begins to decrease, the magnetic field around the inductance begins to decrease in intensity. Since the building up of the magnetic field developed an opposing electromotive force with reference to the applied electromotive force, a decrease or decay of this magnetic field will again develop an electromotive force, but this will act with, and not against, the applied e.m.f. The effect of the inductance is to oppose any change in the current flow. The relation between the applied e.m.f., the e.m.f. of self-induction, and the counter-pressure of the condenser becomes

$$E + e_L = e_C,$$

and as long as e_L increases the charge on the condenser increases, e_L continues to increase as the current decreases and when the current is 0, $e_L = E$ and the condenser is charged to a difference of potential equal to $2E$, and with a quantity of electricity equal to $2Q$. At this instant there is no energy in the magnetic field but the energy in the charged condenser is $2QE = 2CE^2$.

When this state has been reached, the condenser begins to discharge through the inductance and battery. The current, therefore, surges back and forth through the circuit until it finally dies away with the condenser remaining charged with a quantity, $Q = CE$, such that its reacting e.m.f. is equal to the e.m.f. of the battery. A circuit consisting of an inductance and condenser is called an oscillating circuit, for under certain conditions there is an interchange of energy between the inductance and condenser. A mechanical analogy will aid in understanding the characteristics of such a circuit.

91. Analogy for Oscillatory Circuit.—Let us consider the motion of a mass M suspended from a spring as indicated in Fig. 66. Assume that the mass is supported by the shelf B in a position so that the spring is not stretched. At a given instant the shelf is dropped, releasing the mass. The dropping of the shelf corresponds to the closing of the switch S of the electric circuit. As soon as the shelf is dropped the mass begins to move under the force of gravity which corresponds to the applied e.m.f., E . But at this instant there is no tension on the spring; hence, the force of gravity is balanced by the force of inertia of the mass. This corresponds to the beginning of current flow in the electrical circuit. The force of gravity is analogous to the applied e.m.f.; the tension in the spring is analogous to the counter-pressure of the

condenser; the force of inertia is analogous to the counter-pressure of self-induction; and the speed of the mass is analogous to the current. As the mass moves downward, the speed increases, the tension on the spring increases, and the force of inertia decreases. When it has moved a certain distance, the tension of the spring is equal to the weight of the body and it ceases to accelerate. Let this distance be represented by d in the figure. It is evident that

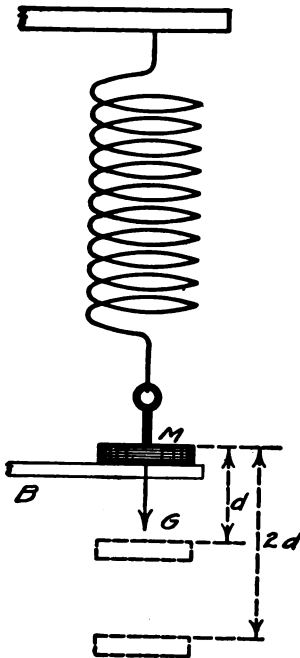

FIG. 66.—Analogy for simple oscillatory circuit.

although the tension on the spring is equal to the weight of the body it does not at once come to rest for at that instant it is moving with maximum velocity. This corresponds to the conditions in the condenser circuit when the charge on the condenser develops a counter-pressure equal to the applied pressure. At this instant the current which corresponds to the velocity of the body is a maximum.

A further consideration of the motion of the body makes it evident that the kinetic energy of the mass is a maximum when it is moving with maximum speed, that is, at the instant the tension on the spring becomes equal to the weight of the body. At this instant the kinetic energy equals $\frac{1}{2}MV^2$.

As the body passes beyond this point the tension on the spring increases and the speed decreases. This continues until the kinetic energy of the body is converted into potential energy of the spring; that is, the spring will be extended beyond this point another distance d . Hence, the total extension of the spring is $2d$, and the potential energy of the spring is $2Kd^2$, which is analogous to the energy of the charged condenser which was shown to be equal to $2CE^2$.

When the spring has been extended through a distance $2d$, the tension of the spring is equal to twice the weight of the body and hence the body begins to move in the opposite direction. The return motion is in every respect like the forward motion and the body oscillates until all of the energy is dissipated in the resistance

offered by the air and molecular friction of the spring, when it will come to rest a distance d below the shelf. Were it not for the friction of the air and spring, the body would oscillate indefinitely through a distance $2d$. We have seen, however, that this type of motion when not retarded is simple harmonic. Since the analogy between this type of motion and the fluctuation of the charge in the condenser in an electric circuit is so exact, it is proper to conclude that the fluctuation of the charge in the electric circuit is simple harmonic when no resistance is present to dissipate the energy.

Since the fluctuation of the charge in the condenser is simple harmonic, the expression for the charge may be written in the form

$$q = Q \sin \omega t$$

and

$$i = \omega Q \cos \omega t,$$

where i is the instantaneous value of the current.

92. Period of Electric Oscillation.—In discussing Fig. 65 it was shown that the current is a maximum when the charge on the condenser is such as to cause a back pressure equal to E , the voltage of the battery. Representing the maximum current by I_m , the energy of the magnetic field at the time of maximum current is $\frac{1}{2}LI_m^2$ and the energy of the condenser is $\frac{1}{2}CE^2$. But these two energies are equal as can readily be shown. The total amount of energy must have come from the battery. The e.m.f. of the battery is assumed to remain constant and equal to E , and as Q coulombs have been moved under this e.m.f. it is evident that EQ is the total amount of energy given out by the battery. We then have

$$EQ = \frac{1}{2}LI_m^2 + \frac{1}{2}CE^2.$$

But

$$Q = EC.$$

Therefore,

$$C = \frac{Q}{E}. \text{ Substituting, we get}$$

$$EQ = \frac{1}{2}LI_m^2 + \frac{1}{2} \frac{Q}{E} \times E^2$$

$$= \frac{1}{2}LI_m^2 + \frac{1}{2}QE.$$

Hence,

$$\frac{1}{2}LI_m^2 = EQ - \frac{1}{2}EQ$$

$$= \frac{1}{2}EQ.$$

But $\frac{1}{2}EQ$ is the energy of the charged condenser. Therefore, at this instant the energy of the condenser is equal to that of the magnetic field and we have

$$\frac{1}{2}LI_m^2 = \frac{1}{2} \frac{Q^2}{C}.$$

It has been shown Art. 91 that if the charge fluctuates as simple harmonic motion it may be represented by

$$\begin{aligned} q &= Q \sin \omega t \\ \text{and} \quad i &= \omega Q \cos \omega t. \end{aligned}$$

The current is a maximum when $\cos \omega t = 1$. At this instant $I_m = \omega Q$. Substituting in the energy equation above we get

$$\frac{1}{2} L \omega^2 Q^2 = \frac{1}{2} \frac{Q^2}{C}$$

$$\text{Hence,} \quad \omega^2 = \frac{1}{LC}$$

$$\omega = \frac{1}{\sqrt{LC}}$$

$$\text{But} \quad \omega = \frac{2\pi}{T} = \frac{1}{\sqrt{LC}}$$

Hence, $T = 2\pi \sqrt{LC}$, where T is the period in seconds, L is the inductance in henrys, and C is the capacitance of the condenser in farads.

This is a very important result as it shows that the period of oscillation of such a circuit as shown in Fig. 65 is determined by the inductance and capacitance of the circuit. By varying either the capacitance or the inductance, the period can be changed.

Examples

1. The capacitance of the circuit, Fig. 65, is 0.001 microfarad and the inductance is 0.002 henry. What is the period of oscillation?

Solution

$$T = 2\pi \sqrt{LC}.$$

DATA

$$L = 0.002 \text{ henry}$$

$$C = 0.001 \times 10^{-6} \text{ farads.}$$

$$\begin{aligned} \text{Then} \quad T &= 6.28 \sqrt{0.002 \times 0.001 \times 10^{-6}} \\ &= 6.28 \times 10^{-5} \sqrt{2} \\ &= 6.28 \times 1.414 \times 10^{-5} \\ &= 8.89 \times 10^{-5} \text{ seconds.} \end{aligned}$$

2. How many complete oscillations per second does the charge make?

Solution

$$\begin{aligned}
 f &= \frac{1}{T} \\
 &= \frac{1}{8.89 \times 10^{-6}} \\
 &= \frac{10^6}{8.89} = 112,500 \text{ cycles per second.}
 \end{aligned}$$

93. **Undamped and Damped Oscillations.**—In the discussion of the motion of the simple pendulum, harmonic motion, and

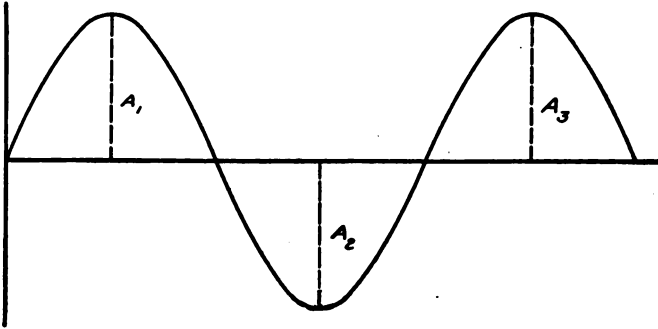

FIG. 67.—Undamped wave.

that of the oscillating pendulum, Fig. 66, it was assumed that the amplitude of oscillation remained constant, or in other words, that no retarding resistance was present. The oscillation of

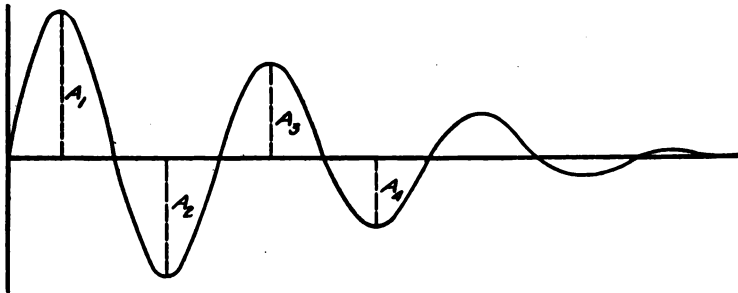

FIG. 68.—Damped wave.

such a pendulum when represented by a wave is exemplified by Fig. 67, where A_1 , A_2 , A_3 , etc., the successive amplitudes, are equal to each other. Oscillations in which the successive amplitudes are equal are called *undamped* oscillations and the resulting wave is called an *undamped* or *sustained* wave.

It is very evident that if a pendulum be permitted to oscillate freely, that is, without reinforcing impulses, the amplitude will decrease gradually until the pendulum comes to rest. The energy originally stored in the pendulum is dissipated in the frictional resistance of the air, and of the molecules of the suspension. Exactly a similar decrease in the successive amplitudes is found to exist in any oscillating system whose energy is dissipated into the surrounding medium. When an oscillation of this type is represented by or produces a wave, it is typified by Fig. 68, where A_1, A_2, A_3 , etc., again represent successive amplitudes. Such an oscillation or wave is called a *damped* oscillation or *wave*. A damped oscillation or wave is one in which the successive amplitudes decrease according to some law.

94. Effect of Resistance in An Oscillatory Circuit.—Let an electrical circuit be diagrammatically represented by Fig. 69, in which R, L , and C represent the resistance, inductance, and

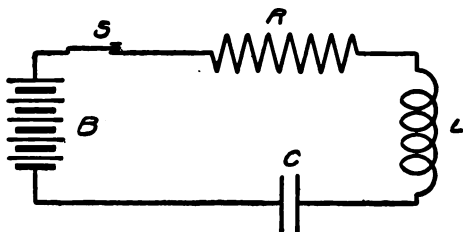

FIG. 69.—Damped oscillatory circuit.

capacitance respectively. Upon closing the switch S a current will begin to flow in the circuit just as in the circuit of Fig. 65, but there will be this difference. The e.m.f. of the battery will have to compensate at each instant the voltage drop, iR , across the resistance on increasing charge, and the current will cease to increase when the counter-pressure of the condenser plus the voltage drop across the resistance are equal to the e.m.f. of the battery. At this instant the current is a maximum and accordingly $I_m R$ is a maximum and the condenser is charged to a difference of potential equal to $E - I_m R$, where E again represents the e.m.f. of the battery. At this instant the charge is equal to $(E - I_m R)C$ which is evidently less than it would be were $R = 0$. The energy in the magnetic field is again $\frac{1}{2}LI_m^2$, but as I_m is less than in the case where $R = 0$, this energy is less. In addition, some energy has been dissipated as heat in the resistance. This energy is lost to the circuit. The

charge on the condenser will, however, continue to increase until the current reduces to zero. When the voltage drop across the resistance is zero the condenser is charged to a difference of potential equal to that of the self-inductance and battery. As the current decreases from its maximum value to zero some more energy is lost so that the final energy charge on the condenser is considerably less than when $R = 0$, and other conditions remain the same. When the charge on the condenser is a maximum its potential is higher than that of the battery and it will begin to discharge. That is to say, a current will flow in the opposite direction. As this current flows through the resistance more energy is lost and the current will not reach so high a value as on charge. The amplitude of the oscillation is thus a constantly decreasing one.

Not only the amplitude is decreased, but the period of oscillation is also affected. It is difficult to show this effect without using higher mathematics. It can, however, be shown that the influence of the resistance on the period is given by

$$T = \frac{2\pi}{\sqrt{\frac{1}{LC} - \frac{R^2}{4L^2}}}$$

If $\frac{R^2}{4L^2} = \frac{1}{LC}$,

then $\frac{1}{LC} - \frac{R^2}{4L^2} = 0$, and T is infinite. That is, the charge does not oscillate. It is thus evident that when R is equal to or is greater than $2\sqrt{\frac{L}{C}}$, the circuit is not oscillatory. If R is less than $2\sqrt{\frac{L}{C}}$ the circuit is oscillatory, but its period is longer than when $R = 0$. Since the frequency is the reciprocal of the period, it is given by

$$f = \frac{1}{T} = \frac{1}{2\pi} \sqrt{\frac{1}{LC} - \frac{R^2}{4L^2}}$$

When $R = 0$, $f = \frac{1}{2\pi\sqrt{LC}}$

Examples

1. A given circuit has a capacity of 0.004 microfarad, an inductance of 0.02 millihenry, and a resistance of 1000 ohms, will the circuit oscillate and if so what is the period of oscillation?

Solution.—The condition that must be fulfilled in order that the charge in such a circuit may oscillate is

$$R < 2\sqrt{\frac{L}{C}} < \text{means less than.}$$

DATA

$$\begin{aligned} L &= 0.02 \times 10^{-6} \text{ henrys} \\ C &= 0.004 \times 10^{-6} \text{ farads} \\ R &= 1000 \text{ ohms.} \end{aligned}$$

Hence

$$\begin{aligned} 2\sqrt{\frac{L}{C}} &= 2\sqrt{\frac{2 \times 10^{-6}}{4 \times 10^{-9}}} \\ &= 2\sqrt{\frac{1}{2} \times 10^{+4}} \\ &= 100 \times 2 \times 0.707 \\ &= 141. \end{aligned}$$

Hence $R > 2\sqrt{\frac{L}{C}}$ and the circuit is nonoscillatory. $>$ means greater than.

2. The resistance of the circuit of Example 1 is reduced to 10 ohms and the inductance is increased to 0.4 henry. What is the period and frequency of the oscillation?

Solution

$$T = \frac{2\pi}{\sqrt{\frac{1}{LC} - \frac{R^2}{4L^2}}}$$

DATA

$$\begin{aligned} 2\pi &= 6.28 \\ L &= 0.4 \text{ henry} \\ C &= 0.004 \times 10^{-6} \text{ farads} \\ R &= 100 \text{ ohms.} \end{aligned}$$

Then

$$\begin{aligned} T &= \frac{6.28}{\sqrt{\frac{1}{.04 \times 0.004 \times 10^{-6}} - \frac{10,000}{4 \times 0.16}}} \\ &= 0.00025 \text{ second.} \end{aligned}$$

The value of $\frac{R^2}{4L^2}$ is so small in comparison with $\frac{1}{LC}$ that it may be neglected.

94. Calculation of Wave Length.—It has been shown that the wave length of the wave train is the distance the disturbance travels during one complete oscillation. If V is the speed of the electromagnetic wave and T is the period of one oscillation of the electric charge producing it, then VT is the wave length. The speed of an electromagnetic wave is the same as that of light, namely, 3×10^8 meters or approximately 186,000 miles per

second; hence the wave length of the electromagnetic wave produced by an oscillator is given by

$$\begin{aligned} \lambda &= 3 \times 10^8 T = 3 \times 10^8 \times \frac{2\pi}{\sqrt{\frac{1}{LC} - \frac{R^2}{4L^2}}} \text{ meters} \\ &= 186,000 \times \frac{2\pi}{\sqrt{\frac{1}{LC} - \frac{R^2}{4L^2}}} \text{ miles.} \end{aligned}$$

Or, if $\frac{R^2}{4L^2}$ is negligibly small it may be omitted and the wave length becomes

$$\begin{aligned} \lambda &= 3 \times 10^8 \times 2\pi\sqrt{LC} \text{ meters} = 1.885 \times 10^9 \sqrt{LC} \text{ meters} \\ &= 186,000 \times 2\pi\sqrt{LC} \text{ miles} = 1.169 \times 10^6 \sqrt{LC} \text{ miles.} \end{aligned}$$

Example

An electric oscillating circuit has an inductance of 0.04 henry, a condenser of 0.004 microfarads capacitance and negligible resistance. What is the wave length produced?

Solution

$$\lambda = 3 \times 10^8 \times 2\pi\sqrt{LC} \text{ meters.}$$

DATA

$$L = 0.04 \text{ henry}$$

$$C = 0.004 \times 10^{-6} \text{ farads}$$

$$R = 0.$$

Then

$$\begin{aligned} \lambda &= 3 \times 10^8 \times 2\pi \times \sqrt{0.04 \times 0.004 \times 10^{-6}} \\ &= 6\pi \times 10^8 \times 1.265 \times 10^{-6} \\ &= 23,800 \text{ meters.} \end{aligned}$$

It is customary to distinguish between electromagnetic waves by their lengths rather than by their periods or frequencies.

95. Practical Oscillatory Circuit.—While the circuits described in the preceding articles and illustrated in Figs. 65 and 69 are very helpful in forming an idea of an oscillatory circuit, and in deriving the expression for period and frequency of such a circuit, they are never used in practice for generating electromagnetic waves.

One of the simplest and earliest oscillating circuits or electric oscillators, as such circuits are called, is the open oscillator of Hertz shown in Fig. 70. Two metal rods *A* and *B* with a small air gap *G* are mounted on insulating stands. These rods are

then connected to the secondary terminals of an induction coil or high voltage transformer. At each interruption of the primary circuit of the induction coil the voltage of the secondary circuit increases to a value great enough to cause a discharge across the air gap. On account of the small capacitance of the two rods, the small inductance of the circuit, and the high resistance of the

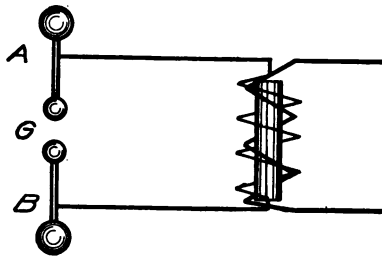

FIG. 70.—Open electric oscillator.

air gap the oscillations of such a circuit are highly damped. In the circuit represented by Fig. 69 most of the energy is dissipated as heat in the resistance. Such a circuit is not very efficient as a generator of electromagnetic waves. In the simple open oscillator of Fig. 70 most of the energy is dissipated in the air gap. While a large part of this is converted into heat, still a greater

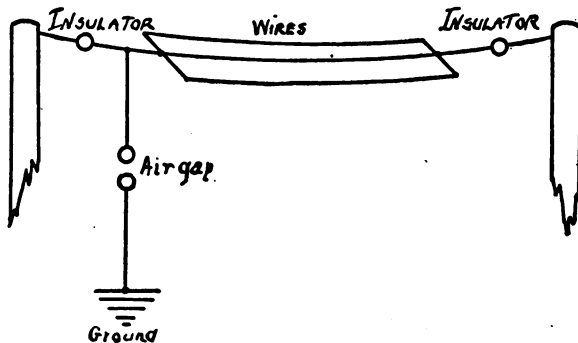

FIG. 71.—Part of one form of radio transmitting circuit.

per cent. is utilized in generating electromagnetic waves. The effectiveness of such an oscillator can be increased still further by increasing the capacitance of the two rods. This is done by adding wires or plates to the rods, or by connecting the lower rod to the earth and attaching wires to the upper one and stringing them over insulators, as shown in Fig. 71. This is a part of one

form of wireless transmitting circuit in practical use. Other forms will be explained later.

97. Properties of Damped Waves.—A damped wave has been

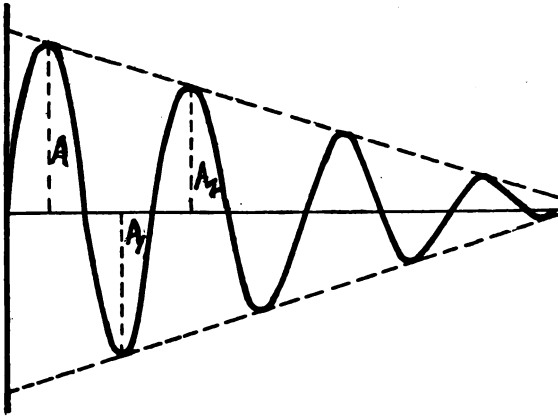

FIG. 72.—A damped wave in which successive amplitudes decrease by a constant factor.

defined as one whose amplitude decreases according to some law. Graphically, two types of damped waves are represented by

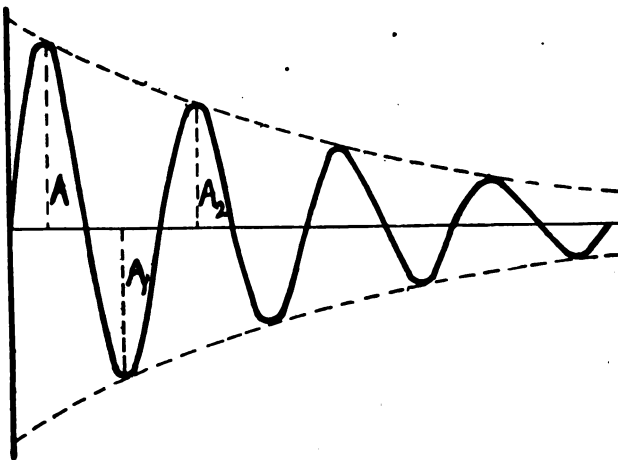

FIG. 73.—Damped wave.

Figs. 72 and 73. The two waves resemble each other but it is evident that the rates at which the amplitudes decrease are not the same. The amplitude in each case decreases according to a

separate law. A periodic quantity which fluctuates according to the law of simple harmonic motion has been expressed by

$$a = A \sin \omega t.$$

In a damped oscillation the amplitude A is not constant but decreases. To get an expression for a damped oscillation it is necessary to multiply A , the amplitude, by such a factor as will give the correct rate of decrease. By higher mathematics it can be shown that this factor is ϵ^{-bt} , where $\epsilon = 2.718$ + or the base of natural logarithms, b is a constant depending upon the constants of the oscillating system, and t is the time in seconds. It is evident that $\epsilon^{-bt} = \frac{1}{\epsilon^{bt}}$ decreases as t increases, and hence if we multiply A by this factor the product of $A\epsilon^{-bt}$ decreases with time. The expression for the instantaneous amplitude of a damped oscillation may be written in the form $a = A\epsilon^{-bt} \sin \omega t$.

If the intensity of the electric current decreases with time in the same way as the damped oscillation, the expression for the current may be written

$$i = I_m \epsilon^{-bt} \sin \omega t.$$

The constant b depends upon the constants of the circuit, namely, upon the resistance and inductance of the circuit. It can be shown that if R and L represent the resistance and inductance respectively, then $b = \frac{R}{2L}$. In an oscillating electric circuit the damping factor is

$$\epsilon^{-\frac{R}{2L}t}$$

Examples

1. An oscillating electric circuit has a resistance of 16 ohms and an inductance of 0.4 henry. If I_m is the maximum possible intensity of the current in the circuit, what will the intensity be 0.01 second after closing the circuit?

Solution

$$i = I_m \epsilon^{-\frac{R}{2L}t} \sin \omega t$$

$$\omega = \sqrt{\frac{1}{LC} - \frac{R^2}{4L^2}}$$

$$R = 16 \text{ ohms}$$

$$L = 0.4 \text{ henry}$$

$$C = 0.3 \text{ microfarad}$$

$$\epsilon = 2.718$$

$$t = 0.01 \text{ second}$$

$$\frac{R}{2L} t = \frac{1000}{0.8} \times 0.01 = 12.5.$$

$$\text{Log } \epsilon = 0.434294$$

$$\text{Log } \epsilon^{-12.5} = \text{Log } 1 - \text{Log } \epsilon^{12.5}$$

$$\text{Log } \epsilon^{12.5} = 12.5 \times \text{Log } \epsilon = 12.5 \times 0.434294 \\ = 5.428675$$

and

$$\text{Log } \epsilon^{-12.5} = \bar{6}.571325$$

$$\epsilon^{-12.5} = 0.00000373.$$

$$\omega = \sqrt{\frac{10^6}{0.4 \times 0.3} - \frac{10^6}{0.4 \times 0.16}}$$

$$= 10^3 \sqrt{6.78}$$

$$= 2.6 \times 10^3$$

$$\sin \omega t = \sin 2.6 \times 10^3 \times 0.01$$

$$= \sin 26$$

$$= 0.77$$

$$i = 0.00000373 \times 0.77 \times I_m$$

$$= 0.00000281 I_m.$$

This shows that if R is large the amplitude decreases very rapidly.

2. Given the circuit of Example 1, but the resistance is short-circuited, i.e., $R = 0$. What is the frequency?

Solution

$$\omega = \sqrt{\frac{1}{LC}}$$

$$= \sqrt{\frac{10^6}{0.12}}$$

$$= 10^3 \sqrt{8.34}$$

$$= 2.89 \times 10^3$$

$$f = \frac{\omega}{2\pi} = \frac{2.89 \times 10^3}{6.28}$$

$$= 4.5 \times 10^2 \text{ per second.}$$

The frequency in the circuit of Example 1 is $\frac{2.6 \times 10^3}{6.28} = 4.14$ per second. This shows the effect of resistance on frequency.

98. Decrement of Damped Waves.—It is often essential to know the per cent. decrease in the amplitude per cycle. Assuming that the law of damping is given by the expression

$$a = A_m \epsilon^{-bt} \sin \omega t$$

the decrease in the amplitude may be calculated as follows:

Let $A_1 = A_m \epsilon^{-bt_1} \sin \omega t_1$ be the maximum amplitude and let t_1 be the time after closing the circuit at which this amplitude

occurs. At some time, t_n seconds later, another maximum amplitude will occur. Let this be represented by

$$A_n = A_m \epsilon^{-bt_n} \sin \omega t_n.$$

But if there are n complete oscillations during the interval of time $t_n - t_1$, $\sin \omega t_1 = \sin \omega t_n$, and the ratio of A_1 to A_n is

$$\begin{aligned} \frac{A_1}{A_n} &= \frac{A_m \epsilon^{-bt_1} \sin \omega t_1}{A_m \epsilon^{-bt_n} \sin \omega t_n} \\ &= e^{b(t_n - t_1)}. \end{aligned}$$

Since we have assumed n to be the number of complete oscillations during the interval $t_n - t_1$, then $t_n - t_1 = nT$, where T is the period. This when substituted gives

$$\frac{A_1}{A_n} = e^{bnT}.$$

Taking the logarithm of both sides we get

$$\begin{aligned} \text{Log}_e \frac{A_1}{A_n} &= bnT \text{Log}_e \epsilon \\ &= bnT, \text{ since } \text{Log}_e \epsilon = 1, \end{aligned}$$

$$\text{whence } bT = \delta = \text{Log}_e \frac{A_1}{A_n}.$$

δ is known as the logarithmic decrement of the damped oscillations. If n is 1, δ is evidently the logarithm to the base ϵ of the ratio of an amplitude in one direction to the next succeeding amplitude in the same direction. Furthermore, since b

$= \frac{R}{2L}$ and T is the period, δ , the logarithmic decrement is equal to $\frac{R}{2L}T$. The larger this value the greater the decrement and the more rapidly the wave dies out.

Since T , the period, can be expressed in terms of the constants of the circuit,

$$T = \frac{2\pi}{\left(\frac{1}{LC} - \frac{R^2}{4L^2}\right)^{\frac{1}{2}}}$$

and

$$\delta = \frac{\pi R}{L\omega}$$

$$\delta = \frac{\pi R}{L \left(\frac{1}{LC} - \frac{R^2}{4L^2} \right)^{1/2}}$$

$$= \pi R \sqrt{\frac{C}{L}}, \text{ when } \frac{R^2}{4L^2} \text{ is negligible. If } R, L,$$

and C are known, δ , the logarithmic decrement, can be calculated. According to statute law, the logarithmic decrement per complete oscillation in the wave transmitted by a radio-transmitter must not exceed 0.2 except when sending distress signals or messages relating thereto.

Examples

1. If the logarithmic decrement is 0.2, how many complete oscillations will be made before the amplitude decreases 99 per cent.?

Solution

$$\delta = \frac{\text{Log}_e \frac{A_1}{A_n}}{n}$$

DATA

$$\delta = 0.2$$

$$A_1 = 100$$

$$A_n = 1$$

$$n = \frac{\text{Log}_e \frac{A_1}{A_n}}{0.2} = \frac{\text{Log} \frac{100}{1}}{0.2}$$

$$= \frac{4.605}{0.2} = 23 \text{ Ans.}$$

2. An oscillating circuit contains a resistance of 100 ohms, an inductance of 0.5 henry, and a capacitance of 2 microfarads. What is its logarithmic decrement?

Solution

$$\delta = \pi R \sqrt{\frac{C}{L}}$$

DATA

$$R = 100 \text{ ohms}$$

$$C = 2 \times 10^{-6} \text{ farads}$$

$$L = 0.5 \text{ henry.}$$

Then

$$\delta = \pi \times 100 \sqrt{\frac{2 \times 10^{-6}}{0.5}}$$

$$= \pi \times 100 \sqrt{4 \times 10^{-6}}$$

$$= 2\pi \times 100 \times 10^{-3}$$

$$= 0.0628.$$

3. What will be the ratio of the first to the tenth amplitude in the circuit of Example 2?

Solution

$$\frac{A_1}{A_n} = e^{\delta n T}$$

$$= e^{\delta n}.$$

DATA

$$\delta = 0.0628$$

$$n = 10$$

$$e = 2.718.$$

Then

$$\frac{A_1}{A_{10}} = 2.718^{10 \times 0.0628}$$

$$= 2.718^{0.628}$$

$$= 1.874.$$

or

$$A_{10} = 0.53A_1 = 53 \text{ per cent. of } A_1.$$

More will be said of logarithmic decrement when coupled circuits are discussed.

CHAPTER VIII

RADIOCIRCUITS

100. Definition.—A radiocircuit may be defined as an oscillatory circuit capable of producing electromagnetic waves. These circuits are quite numerous but in general they may be classed under two heads, (a) simple, (b) coupled.

(a) *Simple radiocircuits* are of two types, series and parallel. A simple series circuit is illustrated in Fig. 58 and its characteristics have been described. It has been shown that the impedance of such a circuit is given by

$$Z = \sqrt{R^2 + \left(L\omega - \frac{1}{C\omega}\right)^2}.$$

If R is small, the impedance is approximately

$$Z = L\omega - \frac{1}{C\omega}.$$

If an alternating e.m.f. be impressed upon such a circuit, the reactance, and hence the resulting current, varies with the frequency. As the frequency increases $\omega L = X_L$ increases and $\frac{1}{\omega C} = X_C$ decreases. At some frequency $X_L = X_C$ and the impedance becomes $Z = \sqrt{R^2 + (X_L - X_C)^2} = \sqrt{R^2 + 0} = R$. At the frequency which makes $X_L = X_C$ the current is determined by the resistance of the circuit and the impressed e.m.f., and for given values of these it is a maximum. The frequency at which the current under a given impressed e.m.f. is a maximum is called *resonant frequency*.

The equality between X_L and X_C can be also obtained by varying the inductance or capacitance. Thus the condition of resonance may be secured by varying f, L , or C . At a given frequency, resonance may be secured by varying L or C , or both. The series circuit is the principal circuit used in radio-transmitting and receiving sets, and in wavemeters.

Tuning.—The term tuning in radiotelegraphy means the adjustment of the circuit, simple or coupled, so as to produce reso-

nance. Circuits are tuned when their natural or free periods are equal, that is, when $L_1C_1 = L_2C_2$. Tuning consists in varying the inductance, or capacitance, or both in order that $f = \frac{1}{2\pi\sqrt{LC}}$, the frequency of the circuit, may have the desired value, usually that of some other circuit.

101. Reactance Diagrams.—The impedance of a circuit is the

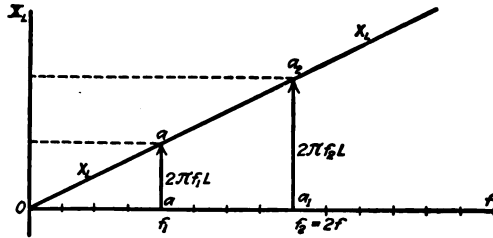

FIG. 74.—Variation of inductive reactance with frequency.

resultant of the resistance, inductive reactance, and capacitance, or condenser reactance. The inductive reactance is equal to ωL or $2\pi fL$, which for a given value of L evidently increases directly with f , the frequency. Representing the variation of inductive reactance with frequency graphically, we have the straight line marked X_L , Fig. 74. When $f = 0$, $2\pi fL = 0$. When

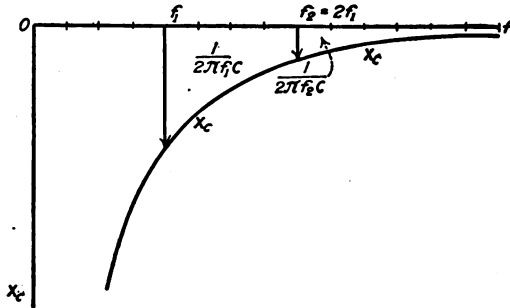

FIG. 75.—Variation of capacitance reactance with frequency.

$f = f_1$, the reactance = $2\pi f_1 L$ and is represented by the line o_a . If the frequency is doubled so that $f = f_2 = 2f_1$, then the reactance is $2\pi f_2 L = 4\pi f_1 L$ and is represented by $a_1 a_2$ which equals $2o_a$. Evidently the distance from any point on line Of to line X_L gives the inductive reactance for the frequency corresponding to that point.

The capacitance reactance is given by $X_c = \frac{1}{\omega C}$. When f is 0, $\omega = 0$, and X_c is infinite. As f increases X_c decreases. The change in X_c with changes in f is shown by the curved line, Fig. 75. Since $\frac{1}{\omega C}$ is subtracted from $L\omega$, values of X_c are plotted below the axis Of . If, now, we combine Figs. 74 and 75 so that the axes Of coincide, we get Fig. 76, to which has been added the curve marked X . This is obtained by adding the corresponding ordinates of the line X_L and curve X_c . Curve

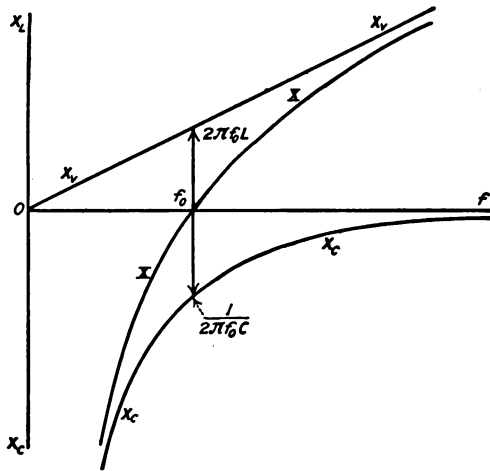

FIG. 76.—Variation of inductive and capacitive reactance with frequency.

X shows how $X_L - X_c$ varies with frequency. The point where this curve crosses the axis Of corresponds to the resonant frequency. At this frequency $X_L - X_c = 0$, and the current in the circuit is determined by the applied e.m.f. and the resistance.

The value of the resonant frequency, in terms of the inductance and capacitance, may be calculated as follows:

For resonant frequency

$$\omega L - \frac{1}{\omega C} = 0 .$$

Then

$$\omega^2 = \frac{1}{LC} .$$

and

$$\omega = \frac{1}{\sqrt{LC}} .$$

But

$$\omega = 2\pi f.$$

Hence

$$2\pi f = \frac{1}{\sqrt{LC}}$$

and

$$f = \frac{1}{2\pi\sqrt{LC}}$$

which is the natural frequency of the circuit as has been shown.

Much valuable information concerning the properties of resonant circuits can be obtained from such reactance diagrams. Fig. 77 is a reactance diagram for a series circuit whose constants are $L = 377 \times 10^{-6}$ henry and $C = 0.00235 \times 10^{-6}$ farads.

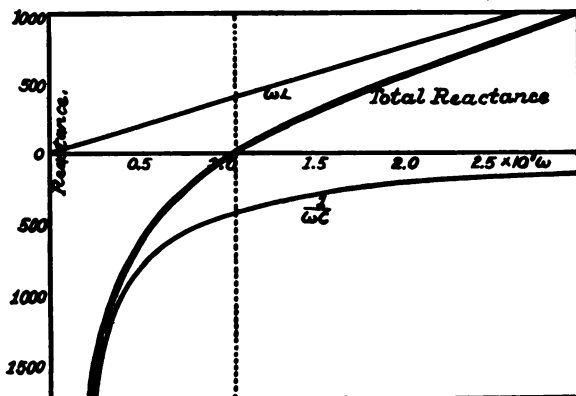

FIG. 77.—Reactance diagram for a circuit whose inductance, $L = 377 \times 10^{-6}$ henry and capacitance, $C = 0.00235 \times 10^{-6}$ farad, $\omega = 2\pi f$.

102. Simple Parallel Circuit.—In a series circuit the same current must flow through each element composing it. In a parallel circuit the elements are connected so that the reactance of each determines the current through that element, and the total current is the resultant of the several component currents. A simple parallel circuit containing resistance, inductance, and capacitance is shown in Fig. 78. Since the branches or elements ab , cd , and ef are in parallel across the line, the current in each will be determined by E , the applied e.m.f. and the reactance of that branch. Thus if we assume E to be the effective value of an alternating e.m.f., the current in the condenser branch is given by $I_c = \omega CE$. This current leads the impressed pressure by $\frac{T}{4}$, or 90° . Similarly, the current through the resistance is given

by $I_R = \frac{E}{R}$ which is in phase with the impressed e.m.f., and at low frequencies it is independent of the frequency. At high or radio-frequencies, the resistance increases and hence the current decreases with frequency. This relation was given in Art. 84.

The current through the inductance is given by $I_L = \frac{E}{\omega L}$ and it lags by $\frac{T}{4}$, or 90° behind the impressed pressure. The total current supplied by the applied e.m.f. is the result of these three

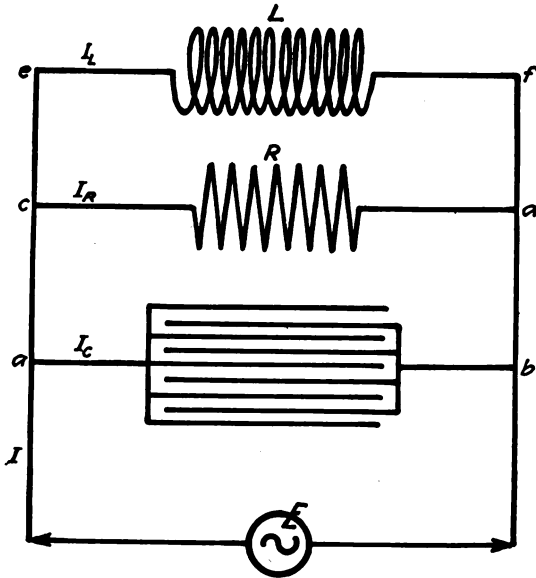

FIG. 78.—Simple parallel circuit.

currents. This resulting current can be found by combining geometrically the several component currents as indicated in Fig. 79. Thus let OE be taken as the reference vector. Since I_R is in phase with E its vector will lie along OE . Let OI_R represent the effective current through the resistance. Since the current through the inductance lags one quarter of a period or 90° behind the pressure, it will be represented by OI_L . Similarly, the condenser current is represented by OI_C . Since these two currents are opposed their sum is equal to $Oa = I_C - I_L$. This resultant combined with I_R gives I , the current in the supply wires. Since I_L decreases with increase in frequency and I_C increases

with increase in frequency, at some frequency $I_C = I_L$ and the current in the supply mains is equal to I_R . If the circuit consists of inductance and capacitance only, then at this frequency I_L and I_C may both be very large, but as they are equal the current in the supply wires is zero. Under these conditions the circuit has infinite reactance. The frequency producing this condition is likewise known as resonant frequency.

A series circuit of inductance and capacitance has zero reactance at resonant frequency, while a parallel circuit of inductance and capacitance has infinite reactance at resonant frequency. The student must not conclude that no current is flowing in the inductance and condenser of a parallel circuit at resonant frequency.

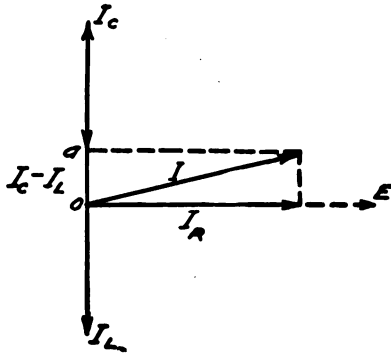

FIG. 79.—Vector diagram for simple parallel circuit.

In these branches the current may be very large but it merely circulates from one to the other and back again. The applied e.m.f. merely supplies the losses. As in a series circuit, the energy surges back and forth at a frequency that is determined by the constants of the circuits.

By the aid of the vector diagram, Fig. 79, we can calculate the impedance of the parallel circuit, thus:

The current through the inductance

$$I_L = \frac{E}{\omega L}$$

The current through the condenser is

$$I_C = \omega C E$$

and the current through the resistance is

$$I_R = \frac{E}{R}$$

The total current is

$$I = \sqrt{I_R^2 + (I_L - I_C)^2}$$

$$= E \sqrt{\frac{1}{R^2} + \left(\frac{1}{\omega L} - \omega C\right)^2}$$

The impedance of a circuit is the ratio of the impressed e.m.f. to the current, or $\frac{E}{I}$. In this instance

$$\frac{E}{I} = \frac{1}{\sqrt{\frac{1}{R^2} + \left(\frac{1}{\omega L} - \omega C\right)^2}}$$

Hence

$$Z = \frac{1}{\sqrt{\frac{1}{R^2} + \left(\frac{1}{\omega L} - \omega C\right)^2}}$$

The quantity $\sqrt{\frac{1}{R^2} + \left(\frac{1}{\omega L} - \omega C\right)^2}$ is called the admittance of the circuit. It is evidently that quantity by which the impressed e.m.f. must be multiplied to give the current.

Upon comparing the expression for admittance of a parallel circuit with the expression for impedance of a series circuit, it is seen that $\frac{1}{\omega L}$ corresponds to ωL , and ωC corresponds to $\frac{1}{\omega C}$.

The quantities $\frac{1}{\omega L}$ and ωC are called the susceptances of the inductance and condenser respectively. Since the susceptances of the inductance and capacitance enter the expression for current in a parallel circuit in the same way that the corresponding reactances enter the expression for current in a series circuit, a susceptance diagram, similar to the reactance diagram, Fig. 77, may be drawn.

If R is infinite, that is, if the resistance branch be opened, then the admittance of the parallel circuit is

$$\sqrt{\left(\frac{1}{\omega L} - \omega C\right)^2} = \frac{1}{\omega L} - \omega C.$$

If values of $\frac{1}{\omega L}$ and $-\omega C$ be plotted, and the corresponding ordinates of the susceptance curves be added, there results a curve which shows the variation in the admittance of a parallel circuit

with variations in frequency, Fig. 80. At resonant frequency, $f_o = \frac{\omega_o}{2\pi}$, the admittance is zero, and as the impedance is the reciprocal of the admittance,

$$Z = \frac{1}{\text{admittance}} = \frac{1}{0} = \text{infinity.}$$

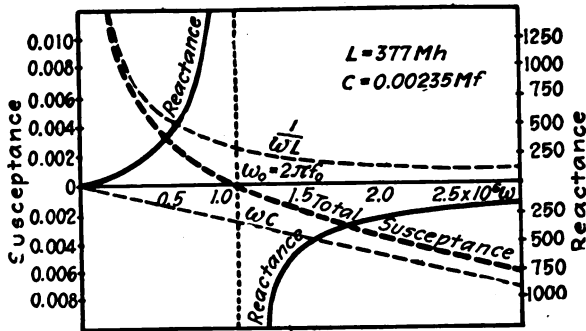

FIG. 80.—Susceptance diagram for a parallel circuit, curve marked total susceptance, is the admittance curve.

103. Coupled Circuits.—When two or more simple circuits are so related that they interact, the combination is called a *coupled circuit*. The desired interaction may be secured by direct connection or by inductive action. The first is known as *direct coupling*. In this type of coupling the component circuits have

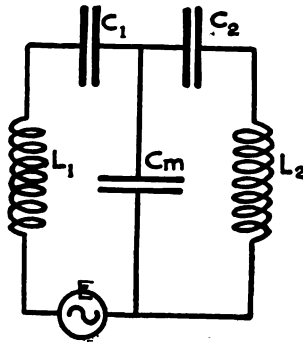

FIG. 81.—Direct coupled circuit, capacitive coupling.

some part in common. Figures 81 and 82 show two direct coupled circuits. In the first the condenser is the common branch and in the second the inductance coil M is common to both,

Inductive coupling is also of two kinds, electromagnetic and electrostatic, or capacitive as it is sometimes called. In the electromagnetic coupling, Fig. 83, the energy is transferred from one circuit to the other by mutual induction. In the capacitive coupling, Fig. 84, the energy is transferred from one circuit to the other by electric induction.

104. Properties of Coupled Circuits.—The fundamental characteristic of coupled circuits is their interaction by means of which energy supplied to one is transferred to the other. The com-

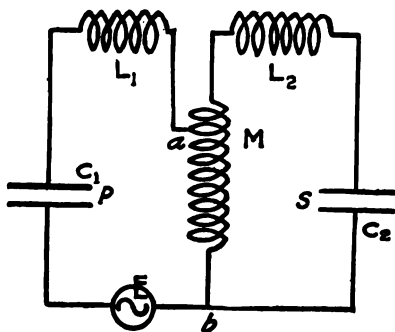

FIG. 82.—Direct coupled circuit, inductive coupling.

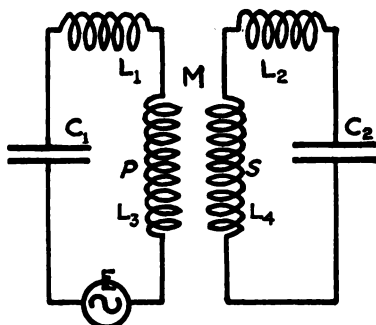

FIG. 83.—Inductively coupled circuit.

ponent of a coupled circuit to which energy is supplied is called the *primary* and the component that receives it by transfer is called the *secondary circuit*.

The transfer of energy from the primary circuit to the secondary circuit can be accomplished only by a reaction of the receiving, or secondary, upon the primary. This is a perfectly general

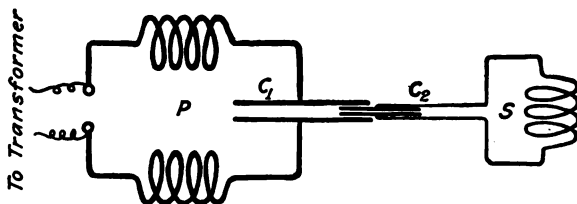

FIG. 84.—Capacitively coupled circuit.

physical principle and applies whenever there is work being done or energy being transferred. Furthermore, the reaction must be of such a nature as can be manifest in the primary circuit or source from which energy is abstracted. This principle

may seem self-evident, yet its full significance is not always apprehended.

If the energy is transferred mechanically, as when a steam engine drives a generator the reaction is mechanical. If the energy is transferred by electromagnetic induction the reaction is electromagnetic in nature, etc. A necessary and indispensable condition for the physical transfer of energy from one system or agent to another is a reaction between the two.

In the direct coupled circuit, Fig. 82, the alternating electric current circulating in the common branch sets up an alternating difference of potential between its terminals *a* and *b*. This difference of potential causes an alternating current to flow in the secondary circuit. If the secondary circuit contains a condenser of capacitance C_2 , the energy delivered to it is $\frac{1}{2} C_2 E_m^2$ in one direction and $\frac{1}{2} C_2 E_m^2$ in the other direction when the primary current reverses. The total energy circulating in the secondary circuit is thus $f C_2 E_m^2$, where E_m is the maximum difference of potential between the terminals of the common branch, and f is the frequency.

If the secondary circuit contains an inductance L , then the total energy circulating in it is $f L I_m^2$, where I_m is the maximum secondary current. This secondary current is determined by the e.m.f. across the common branch and the impedance of the secondary circuit.

Where the circuits are coupled inductively, as shown in Fig. 83, the magnetic flux produced by the oscillatory current circulating in the primary penetrates the secondary, and as it cuts the windings of the secondary an e.m.f. is induced which causes a current to circulate in them. This secondary current tends to develop a magnetic flux opposing the flux due to the primary. This is the electromagnetic reaction mentioned above. The primary and secondary currents thus flow in opposite directions. That is to say, when the current in the windings of the primary coil is flowing in a clockwise direction the current in the secondary windings is flowing in a counter-clockwise direction. The e. m. f. induced by the flux threading through the secondary coil is also 180 degrees or one-half period out of phase with reference to the e.m.f. applied to the primary.

The magnitude of the current circulating through the second-

ary will depend upon the amount of the primary flux that penetrates the secondary and upon the constants of the secondary circuit, namely, its resistance, inductance, and capacitance.

105. Close and Loose Coupling.—When the coupled circuits

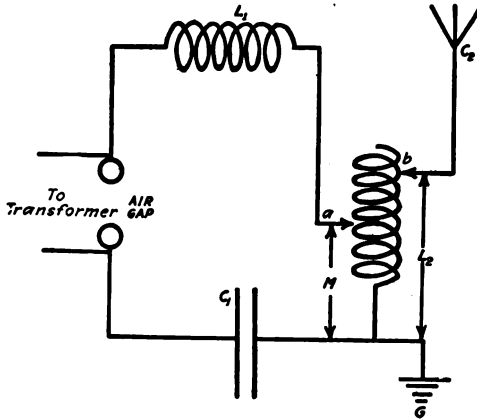

FIG. 85.—Inductively coupled aerial.

are related so that the reaction of the secondary upon the primary is comparatively large the coupling is said to be *close*. On the other hand, circuits are said to be *loose* or loosely coupled when

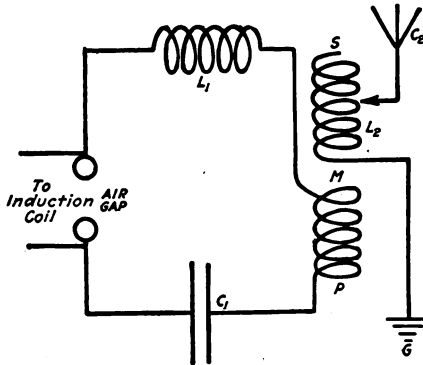

FIG. 86.—Circuit showing method of varying degree of coupling.

the reaction is relatively small. In direct coupled circuits the closeness of coupling can be changed by varying the amount of inductance or capacitance common to the two circuits. This is exemplified in Fig. 85 which shows a primary oscillatory circuit

connected to an aerial. The two connections a and b are movable so that both M , the common inductance, and L_2 , the inductance in the secondary, may be varied.

The degree of inductive coupling is varied by changing the relative position of the branches that interact, or by changing the number of turns on the interacting coils. This is illustrated in Fig. 86. If the distance between the two coils P and S is increased it is evident that a smaller number of the magnetic lines produced in P will penetrate S , and accordingly the mutual inductance is smaller. The relative position of the two coils may be changed in several ways: the distance between them may be varied, the angle that the plane of one coil makes with the plane of the other coil may be changed, or S may be moved to a different position with reference to P . The result in each case is the same; namely, a change in the relative number of magnetic lines threading through the two coils is produced.

106. Coefficient of Coupling.—The intensity of the reaction between two coupled circuits is dependent upon the relative values of the physical constants of the several branches. This relation between the physical constants is called *coefficient of coupling*.

In circuits of negligible resistance, the coefficient of coupling is defined as the ratio of the reactance at a given frequency of the common branch to the square root of the product of the reactances at the same frequency, of the component circuits.

When the circuits are coupled directly or inductively as represented in Figs. 82 and 83, the coefficient of coupling is given by

$$k = \frac{\omega M}{\sqrt{\omega L_p \times \omega L_s}} = \frac{M}{\sqrt{L_p L_s}}$$

where M is the common inductance and L_p and L_s are the inductances of the primary and secondary circuits respectively. In direct coupling, Fig. 82, $L_p = L_1 + M$, and $L_s = L_2 + M$. In inductive coupling, Fig. 83, M is the mutual-inductance, $L_p = L_1 + L_3$, and $L_s = L_2 + L_4$,

When a condenser is used as the common branch of a coupled circuit, the coefficient of coupling is $k = \sqrt{\frac{C_p C_s}{C_m}}$, C_p and C_s are the capacitances of the primary and secondary circuits and C_m is the capacitance common to both,

Examples

1. In the circuit of Fig. 82, $C_1 = 0.001$ and $C_2 = 0.001$ microfarads; $L_1 = 0.00024$ henry, $L_2 = 0.0033$ henry, and M is 0.0023 henry. Find the coefficient of coupling.

Solution

$$k = \frac{M}{\sqrt{L_p \times L_s}}$$

DATA

$$\begin{aligned} M &= 0.0023 \text{ henry} \\ L_p &= 0.0023 + 0.00024 \\ &= 0.00254 \text{ henry} \\ L_s &= 0.0023 + 0.0033 \\ &= 0.0056 \text{ henry.} \end{aligned}$$

Then

$$\begin{aligned} k &= \frac{0.0023}{\sqrt{0.00254 \times 0.0056}} \\ &= 0.617. \end{aligned}$$

2. Given an inductively coupled circuit as represented in Fig. 83. Calculate the coupling coefficients. When $L_p = 297 \times 10^{-6}$ henries $L_s = 450 \times 10^{-6}$ henries; and $M = 241 \times 10^{-6}$ and 25×10^{-6} henries successively.

Solution

$$k = \frac{M}{\sqrt{L_p \times L_s}}$$

DATA

$$\begin{aligned} \text{(a) } L_p &= 297 \times 10^{-6} \text{ henries} \\ L_s &= 450 \times 10^{-6} \text{ henries} \\ M &= 241 \times 10^{-6} \text{ henries} \end{aligned}$$

$$\begin{aligned} \text{(b) } L_p &= 297 \times 10^{-6} \text{ henries} \\ L_s &= 450 \times 10^{-6} \text{ henries} \\ M &= 25 \times 10^{-6} \text{ henries} \end{aligned}$$

$$\begin{aligned} \text{Then } k_1 &= \frac{241 \times 10^{-6}}{\sqrt{297 \times 450 \times 10^{-12}}} \\ &= 0.659 \end{aligned}$$

$$\begin{aligned} \text{Then } k_2 &= \frac{25 \times 10^{-6}}{\sqrt{297 \times 450 \times 10^{-12}}} \\ &= 0.068 \end{aligned}$$

107. Resonance of Simple Circuits.—It has been shown that the natural frequency of a simple oscillatory circuit depends upon the constants of the circuits. This frequency is given by $f = \frac{1}{2\pi\sqrt{LC}}$ when the resistance is negligible. Since both the components of a coupled circuit possess inductance and capacitance each will have a natural frequency of its own. The natural frequency of the primary is given by

$$f_p = \frac{1}{2\pi\sqrt{L_p C_p}}$$

and likewise the frequency of the secondary is $f_s = \frac{1}{2\pi\sqrt{L_s C_s}}$. Unless $L_p C_p = L_s C_s$, these two frequencies are different and complications arise. It is of interest, therefore, to examine somewhat more in detail the reactions of such a circuit.

In Art. 82 it was shown that at resonant frequency, that is, when the frequency of the supply circuit is equal to the natural

frequency of a simple series circuit, the impedance of the circuit is a minimum and hence the current circulating is a maximum. If we plot a curve showing the relation between the intensity of current and frequency of the supply circuit, it will be found that the current increases as the supply frequency approaches resonance. At resonant frequency the current is a maximum. If the frequency be increased beyond resonance the current falls off

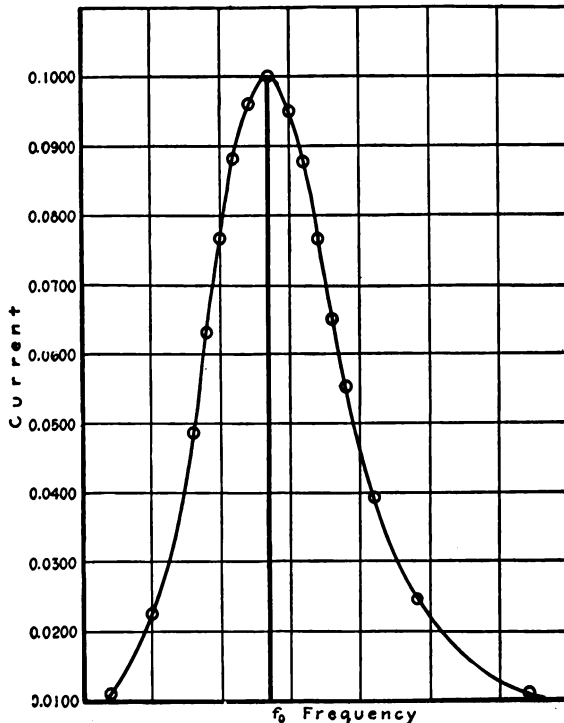

FIG. 87.—Variation of current in a simple circuit with frequency.

rapidly. Such a curve is shown in Fig. 87. Since at a given applied e.m.f. the energy that may be delivered to a circuit varies with the current it follows that more energy can be delivered at resonant frequency than at any other.

That for a given e.m.f. the current in a series circuit will vary with frequency is at once evident from Fig. 76 in which the distance from the axis Of to the curve marked XX represents impedance. The minimum impedance is at f_0 , resonant frequency.

Similarly, for a simple parallel circuit, the energy flowing back and forth between condenser and inductance is a maximum at resonant frequency.

108. Analogy for Resonance of Simple Circuits.—A simple pendulum of a given length at a given position on the earth will, if free, vibrate at a definite frequency. In terms of the length of the pendulum and the acceleration of gravity this frequency is given by

$$f = \frac{1}{2\pi} \sqrt{\frac{g}{l}}$$

If small impulses of the same frequency be applied to the pendulum at proper instants and in the direction of motion it can be made to vibrate through a wide arc. On the other hand, if the frequency of the impulses differs from that of the pendulum, some of them will reinforce or assist in producing motion, while others will oppose the motion. The net result will be to cause the pendulum to vibrate irregularly and at a frequency which differs from its normal frequency.

109. Oscillations of Coupled Circuits.—An electric charge oscillating in the primary of a coupled circuit will cause an electromagnetic reaction in the secondary. For instance, if the voltage across the air gap, Fig. 86, is raised high enough to cause a discharge, the resulting oscillating charge in the primary will produce, by mutual induction, a current in the secondary. If the natural free periods of oscillation of the two circuits are equal, the oscillations in the secondary are synchronous with those in the primary and as a consequence the secondary will absorb a maximum amount of energy. If the amount of energy in the primary is limited to that contained in the maximum charge of the condenser, then at every oscillation some of this energy is absorbed by the secondary whose store of energy increases while that of the primary decreases. This gradual transfer of energy will continue until the secondary has absorbed all of the energy of the primary. When this condition has been reached, the secondary becomes the acting and the primary the reacting circuit. The conditions being reversed the energy is retransferred to the primary. This exchange of energy continues until it is all dissipated as heat and electromagnetic waves.

110. Analogies for Coupled Circuits.—To understand more clearly the interactions between coupled circuits let us consider the interaction between two pendulums which are attached to a

common flexible support such as a string, Fig. 88. If pendulum *A* is started swinging its motion will be transmitted to the suspension of *B* through the string *ab*. The point of support *b* will thus be moved to and fro with simple harmonic motion. Since the point of support is oscillating, the pendulum *B* will also be caused to oscillate. The motion of the pendulum is the resultant of two motions, one the motion of the point of support, and the other, its own natural motion. If the latter be greatly damped by attaching a sheet of paper to the pendulum, or if the pendulum move in a viscous medium, it soon dies down and the final motion is that due to the harmonic motion of the support. Such a vibration is called a "forced vibration" to distinguish it

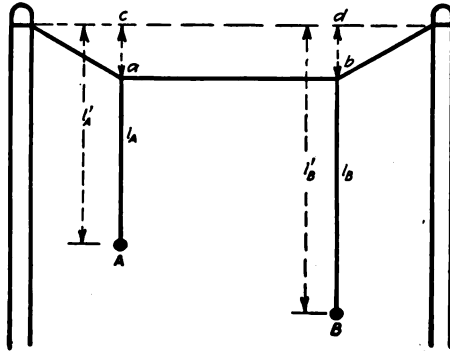

FIG. 88.—Pendulum analogy for resonance.

from the natural free vibration. The amplitude of the forced vibration depends to a great extent upon how closely the period of the forced vibration agrees with that of the natural vibration; if they are exactly equal, the amplitude is very large. This condition is called resonance.

Resonance is present when the two pendulums are of equal length. When this condition exists, the impulses from pendulum *A* are received by pendulum *B* at just the right time to reinforce its motion. At every impulse *B* absorbs some energy and *A* loses a corresponding amount. On account of this transfer of energy the amplitude of *B* increases and that of *A* decreases until *A* comes momentarily to rest, when *B* becomes the acting pendulum. We have assumed the *pendulums* to be simple. In reality the combination is very complex, as is evident from Fig. 88. The motion of *A* and *B* is the resultant of their own natural free motions and of the motion of the supporting string which transmits

the impulses from one to the other. Since the motion of the supporting string is also harmonic, the motion of A and B can be resolved into two simple harmonic motions of two different frequencies.

Another, and in some respects perhaps a more exact, analogy for an inductively coupled circuit is a mechanism represented in Fig. 89. This mechanism consists of three parts corresponding to the three parts of a coupled circuit. The lower carriage and springs correspond to the inductance and condenser of the primary circuit, and the upper carriage and springs correspond to the inductance and condenser of the secondary circuit. Corre-

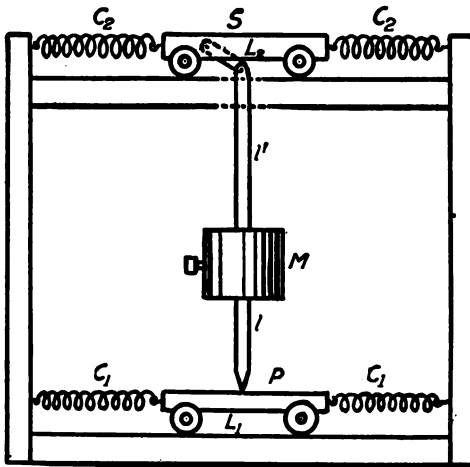

FIG. 89.—Analogy for coupled circuits.

sponding to the mutual-inductance which couples two oscillatory circuits is the weight M and the lever connecting the upper and lower carriages. It is very evident that when the primary system P of such a mechanism is caused to oscillate, the connecting lever, by means of the inertia reaction of the mass M , will transmit force impulses to the secondary system and cause it to oscillate. It is interesting to notice that as P moves to the left S moves to the right and *vice versa*, that is, the motions are one-half period out of phase. This is analogous to the e.m.f. and current in the secondary of a coupled circuit.

When the mass M is very large in comparison with the masses of the carriages P and S , its inertia will be large and it will act as a pivot when P is caused to oscillate rapidly. The motion

of P will then be transmitted to S by the lever and the amplitude of S will be to the amplitude of P as l' is to l . This corresponds to close coupling of electric circuits.

When the masses of P and S are large in comparison with that of M , the reaction of M to the motion of P will be slight, and consequently the oscillations of P will be weakly transmitted to S . This corresponds to loose coupling in an electric circuit.

When the primary and secondary systems are in tune, that is, when the masses and springs of the upper system are adjusted, so that the period of its oscillation is exactly equal to that of the

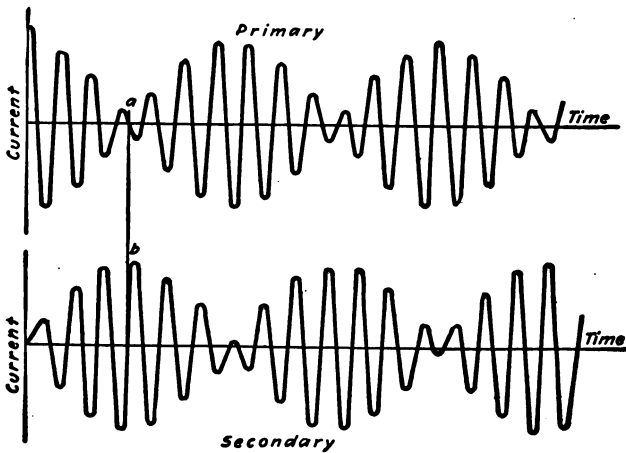

FIG. 90.—Showing interaction of primary and secondary of a coupled circuit.

lower system, all of the energy of the oscillating primary system is transferred to the secondary system, and the primary system comes momentarily to rest. The secondary system now becomes the acting or driving system and retransfers the energy back to the primary system and so on repeatedly.

When the primary and secondary systems are not in tune, only a fractional part of the energy is transmitted from the primary to the secondary. This fraction depends upon the closeness of coupling and the exactness of tuning of the two systems.

111. Damping of Oscillation.—Part of the energy supplied to the primary circuit is transmitted to the secondary and part of it is dissipated as heat in the resistance of the primary. Since no

energy can be transmitted without a reaction, the resulting reaction damps or decreases the amplitudes of the oscillations. This damping is especially pronounced if the circuits are tuned. Of the energy that is transmitted to the secondary, part is converted into heat, part is radiated as electromagnetic waves, and part is returned to the primary circuit. In radiotelegraphy it is important to reduce to a minimum the part wasted as heat, and the part returned to the primary. The part radiated as electromagnetic waves should be as great a per cent. as possible of the energy transmitted to the secondary circuit.

If the circuits are closely coupled the reaction of the primary is so active that much of the energy is returned to it. The in-

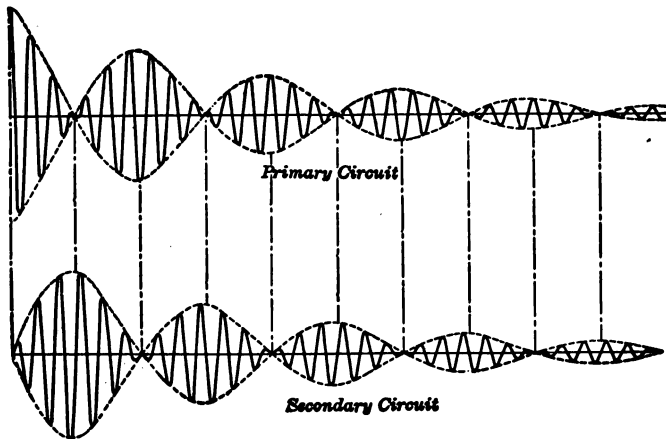

Fig. 91.—Damped primary and secondary currents.

terchange of the energy between the primary and secondary is illustrated in Fig. 90. An examination of the curves shows that the current in the primary dies out as that in the secondary increases, and *vice versa*. It is evident that while both are highly damped, if the conditions are as assumed, the energy is not dissipated very rapidly. If a greater per cent. of the energy is radiated, then the amplitudes of the successive groups of oscillations will be smaller as shown in Fig. 91. Nevertheless, there is still an exchange of energy between the two component circuits. It is evident that energy is returned to the primary circuit because it is in a condition to absorb it. By changing this condition no energy can be returned to it and, consequently, the dissipation of the energy will be confined to the secondary circuit. Such a

state of affairs is represented by Fig. 92. The oscillations in the primary after once dying out are not built up. Since no energy is reabsorbed by the primary, the current in the secondary continues to oscillate until the energy is dissipated as heat and electromagnetic waves.

One method of changing the conditions so as to prevent the return of the energy to the primary circuit is to open it at the instant it ceases to transmit energy to the secondary circuit. This open-circuiting must obviously be automatic. This is accomplished by using a small gap of special design and high resistance. This is known as a "quenched gap."

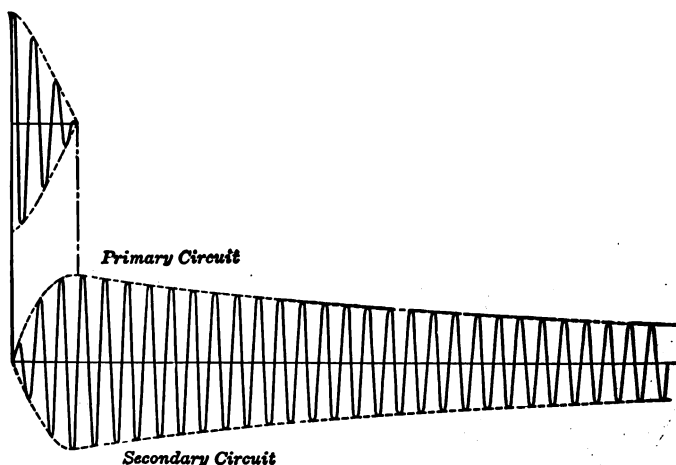

FIG. 92.—Diagram showing how a "quenched gap" prevents the return of energy from the secondary to the primary.

112. Frequencies of Coupled Circuits.—To give even approximately a complete discussion of coupled circuits¹ is beyond the scope of this elementary text. Some of the important principles can only be stated.

It has been shown that two coupled pendulums have two resonant frequencies. Likewise, two oscillatory circuits in which the damping is prominent will respond to two frequencies, neither one of which is the same as the natural frequency of the component circuits.

That the oscillations of a closely coupled circuit are complex can be shown by placing near the primary or secondary a third

¹The Theory of Coupled Circuits by LOUIS COHEN, *Bulletin Bureau of Standards*, Vol. 5, p. 511.

circuit which contains a variable capacitance for varying the frequency and a hot wire ammeter for measuring the current flowing in it. When oscillations are set up in the coupled circuit, and the capacitance in the third circuit is varied until resonance is secured, it is found that there are two values of the capacitance for which the current is a maximum. This means that the oscillations in the coupled circuit have two frequencies which cause resonance in the third circuit. If the cur-

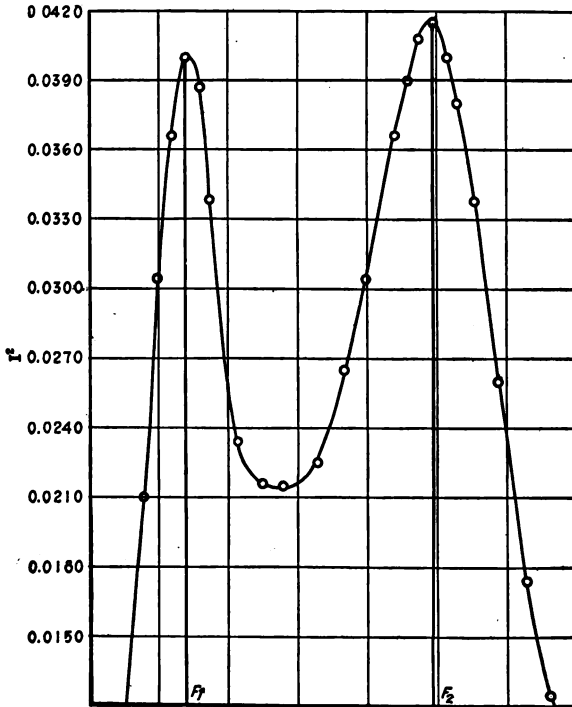

FIG. 93.—Variation of current in coupled circuit with frequency.

rent be plotted as ordinates and the corresponding frequency of the third circuit be plotted as abscissas a double humped curve results, Fig. 93. The two peaks correspond to the two frequencies of the coupled circuit.

For radiotelegraphy this is an undesirable condition for evidently the electromagnetic waves radiated are of two wave lengths, and as the receiving apparatus can be tuned to one only, the energy in the other is wasted. The exact values of the two

frequencies are determined by the constants of the component circuits and the coefficient of coupling.

(a) *Direct Coupled Circuits.*—The mathematical derivation of the formulas for calculating the frequencies of coupled circuits is too difficult for this elementary text.¹ The relation between the natural frequencies of the component circuits and the resultant frequencies may, nevertheless, be expressed as follows:

Let f_1 = natural frequency of primary circuit
 f_2 = natural frequency of secondary circuit
 F_1 = one of the resonant frequencies
 F_2 = the other resonant frequency
 k = coefficient of coupling.

Then

$$F_1 = \sqrt{\frac{f_1^2 + f_2^2 - \sqrt{(f_1^2 - f_2^2)^2 + 4k^2 f_1^2 f_2^2}}{2(1 - k^2)}}$$

and

$$F_2 = \sqrt{\frac{f_1^2 + f_2^2 + \sqrt{(f_1^2 - f_2^2)^2 + 4k^2 f_1^2 f_2^2}}{2(1 - k^2)}}$$

When the circuits are tuned, $f_1 = f_2 = f_0$, the natural frequency of either of the component circuits, and the above expressions

reduce to

$$F_1 = \frac{f_0}{\sqrt{1 + k}}$$

$$F_2 = \frac{f_0}{\sqrt{1 - k}}$$

and

$$\frac{F_1}{F_2} = \frac{\sqrt{1 - k}}{\sqrt{1 + k}}$$

Since wave lengths vary inversely as the frequency,

$$\frac{F_1}{F_2} = \frac{\lambda_2}{\lambda_1} = \frac{\sqrt{1 - k}}{\sqrt{1 + k}},$$

where λ_1 and λ_2 are wave lengths corresponding to F_1 and F_2 respectively.

The influence of closeness of coupling can be deduced from these relations as well as determined experimentally. If k is negligibly small, $1 - k = 1 + k$, approximately, and $F_1 = F_2 = f_0$. That is, when the circuits are loosely coupled there is

¹Circular No. 74 of The Bureau of Standards, p. 52.

only one resonant frequency and that is the natural frequency of either component circuit when they are in tune. The influence of coupling is shown by the curves, Fig. 94. These curves were obtained by changing the distance between the primary and secondary of an inductively coupled circuit. The coefficient of coupling for the double peaked curve is 0.1371 and for the curve with the single peak it was reduced to 0.0512.

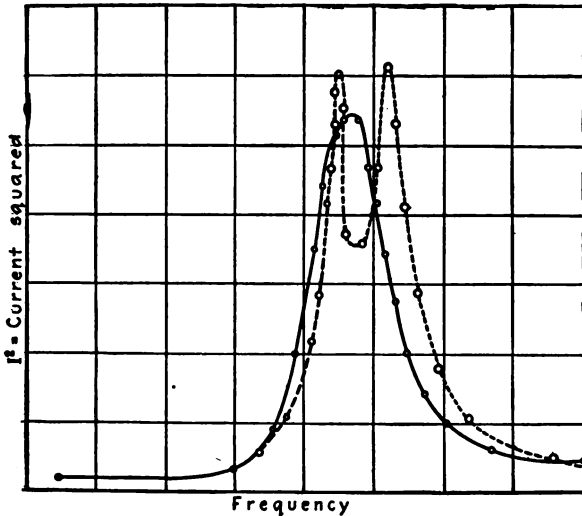

Fig. 94.—Resonant current values produced in same circuit by changing coefficient of coupling.

Example

Given a direct coupled circuit as shown in Fig. 95. Calculate the two resonant frequencies when the constants are as follows:

- $C_1 = 23 \times 10^{-10}$ farads
- $C_2 = 9.3 \times 10^{-10}$ farads
- $L_1 = 56 \times 10^{-6}$ henries.
- $L_2 = 209 \times 10^{-6}$ henries.
- $M = 241 \times 10^{-6}$ henries.

Solution

$$f_1 = \frac{1}{2\pi\sqrt{L_p C_1}} = \frac{1}{2\pi\sqrt{(L_1 + M)C_1}}$$

$$f_2 = \frac{1}{2\pi\sqrt{L_s C_2}} = \frac{1}{2\pi\sqrt{(L_2 + M)C_2}}$$

$$k = \frac{M}{\sqrt{L_p \times L_s}} = \frac{M}{\sqrt{(L_1 + M)(L_2 + M)}}$$

$$F_1 = \sqrt{\frac{f_1^2 + f_2^2 - \sqrt{(f_1^2 - f_2^2)^2 + 4k^2 f_1^2 f_2^2}}{2(1 - k^2)}}$$

The expression for F_2 is the same as for F_1 except that the sign — preceding the third term is +.

By substituting the given values we have

$$f_1 = \frac{1}{2\pi\sqrt{(56 + 241)10^{-6} \times 23 \times 10^{-10}}} = \frac{10^8}{2\pi\sqrt{297 \times 23}}$$

$$= 1.926 \times 10^5 \text{ cycles per second}$$

$$f_2 = \frac{1}{2\pi\sqrt{(209 + 241)10^{-6} \times 9.3 \times 10^{-10}}} = \frac{10^8}{2\pi\sqrt{450 \times 9.3}}$$

$$= 2.46 \times 10^5 \text{ cycles per second}$$

$$k = \frac{241}{\sqrt{297 \times 450}} = 0.659$$

$$f_1^2 = 3.71 \times 10^{10}$$

$$f_2^2 = 6.05 \times 10^{10}$$

$$k^2 = 0.4345$$

$$F_1 = 10^5 \sqrt{\frac{3.71 + 6.05 - \sqrt{(3.71 - 6.05)^2 + 4 \times 0.4345 \times 3.71 \times 6.05}}{2(1 - 0.4345)}}$$

$$= 1.655 \times 10^5 \text{ cycles per second}$$

$$F_2 = 10^5 \sqrt{\frac{9.76 + 6.67}{1.131}} = 3.81 \times 10^5 \text{ cycles per second.}$$

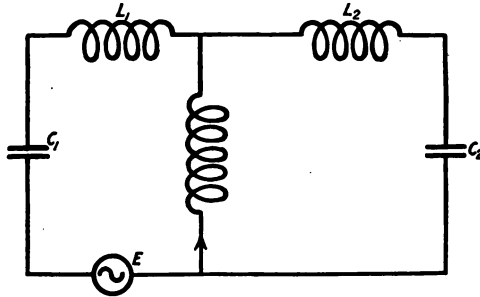

FIG. 95.

(b) *Inductively Coupled Circuits.*—It can be shown that the expressions for the resonant frequencies of inductively coupled circuits are the same as for direct coupled circuits. In making calculations, however, care must be exercised in substituting the proper values of the inductances. For instance, if the circuits are coupled as represented in Fig. 83, $L_p = L_1 + L_3$ and $L_s = L_2 + L_4$. M does not enter into the expression for f_1 or f_2 .

Examples

1. Calculate the resonant frequencies for an inductively coupled circuit the constants of which are

$$C_1 = 100 \times 10^{-12} \text{ farads}$$

$$C_2 = 144 \times 10^{-12} \text{ farads}$$

$$L_p = 169 \times 10^{-6} \text{ henries}$$

$$L_s = 121 \times 10^{-6} \text{ henries}$$

$$M = 25 \text{ and } 2.5 \text{ microhenries, successively.}$$

Solution

$$(a) f_1 = \frac{1}{2\pi\sqrt{L_p C_1}}$$

$$f_2 = \frac{1}{2\pi\sqrt{L_s C_2}}$$

$$k = \frac{M}{\sqrt{L_1 L_2}}$$

$$F_1 = \sqrt{\frac{f_1^2 + f_2^2 - \sqrt{(f_1^2 - f_2^2)^2 + 4k^2 f_1^2 f_2^2}}{2(1 - k^2)}}$$

$$F_2 = \sqrt{\frac{f_1^2 + f_2^2 + \sqrt{(f_1^2 - f_2^2)^2 + 4k^2 f_1^2 f_2^2}}{2(1 - k^2)}} = 2\pi f$$

Substituting the given values we have

$$f_1 = \frac{1}{2\pi\sqrt{100 \times 10^{-12} \times 169 \times 10^{-6}}} = \frac{10^9}{2\pi \times 10 \times 13} = 1.224 \times 10^6 \text{ cycles per second}$$

$$f_2 = 1.5 \times 10^{12}$$

$$f_2 = \frac{1}{2\pi\sqrt{144 \times 10^{-12} \times 121 \times 10^{-6}}} = \frac{10^9}{2\pi \times 12 \times 11} = 1.206 \times 10^6 \text{ cycles per second}$$

$$f_1^2 = 1.455 \times 10^{12}$$

$$k = \frac{25}{\sqrt{169 \times 121}} = \frac{25}{143} = 0.1748$$

$$k^2 = 0.0306$$

$$F_1 = 10^6 \sqrt{\frac{1.5 + 1.455 - \sqrt{(1.5 - 1.455)^2 + 4 \times 0.0306 \times 1.5 \times 1.455}}{\sqrt{2(1 - 0.0306)}}}$$

$$= 10^6 \sqrt{\frac{2.955 - 0.518}{1.94}} = 1.121 \times 10^6 \text{ cycles per second}$$

$$F_2 = 10^6 \sqrt{\frac{2.955 + 0.518}{1.94}} = 1.338 \times 10^6 \text{ cycles per second.}$$

(b) In this case the conditions are as before except M is 2.5×10^{-6} henries. Then

$$k = \frac{2.5}{\sqrt{169 \times 121}} = 0.01748$$

and

$$F_1 = 10^6 \sqrt{\frac{2.955 - 0.068}{2(1 - 0.000306)}} = 1.443 \times 10^6 \text{ cycles per second}$$

$$F_2 = 10^6 \sqrt{\frac{2.955 + 0.068}{2(1 - 0.000306)}} = 1.5 \times 10^6 \text{ cycles per second.}$$

2. In the secondary circuit of Example 1, the capacitance is varied so that $L_p C_1 = L_s C_2$. That is, C_2 is made equal to 139.6×10^{-12} farads. What are the resonant frequencies when $M = 25$ and 2.5 microhenries, successively?

Solution

(a) Since the two circuits are tuned,

$$f_1 = f_2 = \frac{1}{2\pi\sqrt{L_p C_1}} = 1.224 \times 10^6 \text{ cycles per second}$$

$$k_1 = \frac{M}{\sqrt{L_p C_1}} = \frac{25}{\sqrt{169 \times 121}} = 0.1748$$

$$k_2 = \frac{2.5}{143} = 0.01748.$$

Then

$$F_1 = \frac{f_o}{\sqrt{1 + k_1}} = \frac{1.224 \times 10^6}{\sqrt{1.1748}} = 1.128 \times 10^6 \text{ cycles per second}$$

$$F_2 = \frac{f_o}{\sqrt{1 - k}} = \frac{1.224 \times 10^6}{\sqrt{1 - 0.1748}} = 1.345 \times 10^6 \text{ cycles per second}$$

(b) In this case $k = 0.01748$.

Then

$$F_1 = \frac{1.224 \times 10^6}{\sqrt{1.01748}} = 1.214 \times 10^6 \text{ cycles per second}$$

and

$$F_2 = \frac{1.224 \times 10^6}{\sqrt{1 - 0.01748}} = 1.234 \times 10^6 \text{ cycles per second}$$

It is very evident that the resonant frequencies are more nearly equal in case (b) than in case (a).

(c) *Capacitive Coupling*.—When a condenser is the common branch of two coupled circuits, Fig. 84, the closeness of coupling varies inversely with the capacitance of the common condenser. The coefficient of coupling is

$$k = \sqrt{\frac{C_1 C_2}{(C_1 + C_m)(C_2 + C_m)}}.$$

It is evident that the natural frequency of each component circuit is influenced by C_m . The total capacity in the primary circuit is

$$C_p = \frac{C_1 C_m}{C_1 + C_m}.$$

Hence, the natural frequency is

$$f_1 = \frac{1}{2\pi \sqrt{L_1 \frac{C_1 C_m}{C_1 + C_m}}} = \frac{\sqrt{C_1 + C_m}}{2\pi \sqrt{L_1 C_1 C_m}}.$$

In the same way it can be shown that

$$f_2 = \frac{\sqrt{C_2 + C_m}}{2\pi \sqrt{L_2 C_2 C_m}}.$$

The resonant frequencies are given by

$$F_1 = \sqrt{\frac{f_1^2 + f_2^2 + \sqrt{(f_1^2 - f_2^2)^2 + 4k^2 f_1^2 f_2^2}}{2}}$$

and
$$F_2 = \sqrt{\frac{f_1^2 + f_2^2 - \sqrt{(f_1^2 - f_2^2)^2 + 4k^2 f_1^2 f_2^2}}{2}}$$

when $f_1 = f_2$, that is, when the circuits are tuned these expressions reduce to

$$F_1 = f_o \sqrt{1 + k}$$

and

$$F_2 = f_o \sqrt{1 - k}$$

where f_o is the common natural frequency. When the coupling is very loose, k is negligibly small, and $F_1 = F_2 = f_o$ and there is only one resonant frequency.

Example

Calculate the resonant frequencies in a capacitatively coupled circuit whose constants are as follows:

$$\begin{aligned} C_1 &= 25 \times 10^{-10} \text{ farads} \\ C_2 &= 23.5 \times 10^{-10} \text{ farads} \\ L_1 &= 175 \times 10^{-6} \text{ henries} \\ L_2 &= 377 \times 10^{-6} \text{ henries} \\ C_m &= 30 \times 10^{-10} \text{ farads.} \end{aligned}$$

Solution

$$\begin{aligned} k &= \sqrt{\frac{C_1 C_2}{(C_1 + C_m)(C_2 + C_m)}} \\ f_1 &= \frac{\sqrt{C_1 + C_m}}{2\pi\sqrt{L_1 C_1 C_m}} \text{ cycles per second} \\ f_2 &= \frac{\sqrt{C_2 + C_m}}{2\pi\sqrt{L_2 C_2 C_m}} \text{ cycles per second.} \end{aligned}$$

Substituting the given values we have

$$k = \frac{\sqrt{25 \times 23.5}}{\sqrt{(55)(53.5)}} = 0.447$$

$$\begin{aligned} f_1 &= \frac{10^{-5}\sqrt{55}}{2\pi\sqrt{175 \times 10^{-6} \times 25 \times 30 \times 10^{-20}}} \\ &= \frac{10^5\sqrt{55}}{2\pi\sqrt{175 \times 25 \times 30}} = 3.27 \times 10^5 \text{ cycles per second} \end{aligned}$$

$$f_2 = \frac{10^5\sqrt{53.5}}{2\pi\sqrt{377 \times 23.5 \times 30}} = 2.215 \times 10^5 \text{ cycles per second}$$

$$\begin{aligned} F_1 &= \sqrt{\frac{f_1^2 + f_2^2 + \sqrt{(f_1^2 - f_2^2)^2 + 4k^2 f_1^2 f_2^2}}{2}} \\ &= 10^5 \sqrt{\frac{10.75 + 4.9 + \sqrt{(10.75 - 4.9)^2 + 4 \times 0.2 \times 10.75 \times 4.9}}{2}} \\ &= 3.48 \times 10^5 \text{ cycles per second} \end{aligned}$$

and

$$F_2 = 1.875 \times 10^5 \text{ cycles per second.}$$

113. Damping in Coupled Circuits.—In the foregoing discussion of frequencies in coupled circuits the influence of the resis-

tance has been neglected. While the resistance may have a small effect upon the frequency, it is an important factor in damping. Cohen¹ has shown that when the resistance of the primary of a direct coupled circuit is negligible in comparison with the resistance of the secondary there is only one damping factor, and that is the damping factor of the secondary circuit, namely, $b = \frac{R_2}{2L_2}$.

When the circuits are inductively coupled there will be two damping factors corresponding to the two resonant frequencies. If $a_1 = \frac{R_1}{2L_1}$, $a_2 = \frac{R_2}{2L_2}$, and k is the coefficient of coupling the two damping factors are given by

$$b_1 = \frac{a_1 + a_2 + \sqrt{(a_1 - a_2)^2 + 4a_1a_2k^2}}{2(1 - k^2)}$$

and

$$b_2 = \frac{a_1 + a_2 - \sqrt{(a_1 - a_2)^2 + 4a_1a_2k^2}}{2(1 - k^2)}$$

When k is zero, or when the coupling is very loose $b_1 = a_1$ and $b_2 = a_2$. That is, the damping factors at resonant frequencies are the same as the natural damping factors of the primary and secondary circuits. By damping factor is meant the exponent of ϵ , the base of the natural logarithms, Art. 95. This exponent we have designated by b . It has been shown that the logarithmic decrement, or decrement is $\delta = bT$, where b is the damping factor and T the period. Since there are two resonant frequencies, there will be two decrements for closely coupled circuits. These in general are:

$$\delta_1 = \frac{b_1}{F_1}$$

and

$$\delta_2 = \frac{b_2}{F_2}$$

¹ COHEN, *Bulletin Bureau of Standards*, Vol. 5, p. 538.

CHAPTER IX

PRACTICAL TRANSMITTING APPLIANCES AND METHODS

114. Radiotelegraphic Systems.—Modern sending stations are of two distinct types: (a) the spark or damped wave system and (b) the continuous or undamped wave system. The appliances and apparatus used for transmitting are determined by the type of station employing them. In general the apparatus may

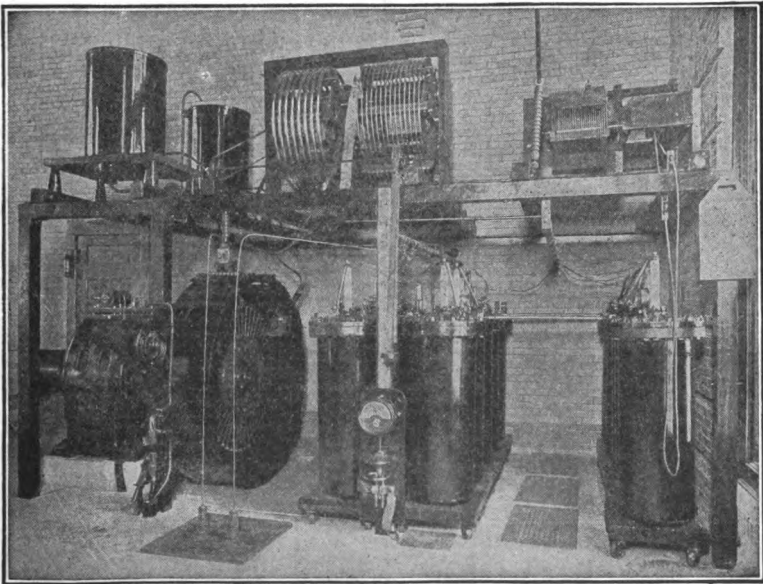

FIG. 96.—Arlington transmitting station equipment.

be classed under three heads: (a) generating, (b) transmitting or sending, (c) receiving. Sometimes the first two are classed together as transmitting. The actual arrangement of transmitting apparatus in the Arlington station is shown in Fig. 96. This comprises a generator shown in the lower left-hand side of the illustration; a transformer, not shown in the figure; the two

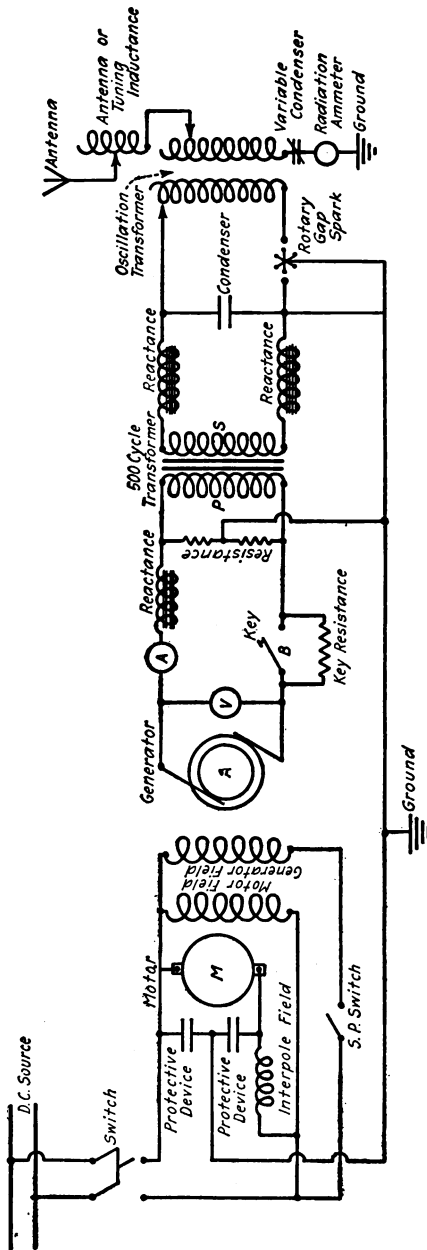

Fig. 97.—Diagram of connections, Arlington transmitting station.

leads in the foreground coming up through the floor are the high tension wires from it; the compressed air condensers are shown in the lower middle and right-hand portion of the illustration. The two tanks at the left upper part of the figure are cooling tanks from which water is circulated through the stationary electrodes of the gap. The two spiral coils are the primary and secondary of the oscillation transformer. The coil at the right above the condensers is an inductance coil in series with the antenna. The heavy wire from the inductance coil is the lead to the aerial. The ammeter on the post is on the ground end of the antenna and indicates the current charging up and down the antenna. A diagrammatic sketch of the installation is shown in Fig. 97.

115. Generating Apparatus for Damped Waves.—The apparatus and connections

usually employed in damped wave-sending stations are shown diagrammatically in Fig. 97. The generating apparatus consists

of a variable speed direct-current motor *M*, or some prime mover either belted or direct connected to a single phase alternating-current generator, together with the necessary switchboard and control apparatus. The generator is commonly wound for about 110 to 220 volts and generates a current of 500 cycles per second.

116. Transmitting Apparatus for Damped Waves.—The transmitting apparatus consists of the key *B*, the transformer, the spark gap, battery of condensers, oscillating transformer and aerial or antenna.

117. Key.—In order to transmit intelligence by means of radiotelegraphy a signal code consisting of dots and dashes as in wire telegraphy is necessary. These signals are formed by short and long trains of oscillations. To form these short and long trains of oscillations in damped wave transmission, the primary

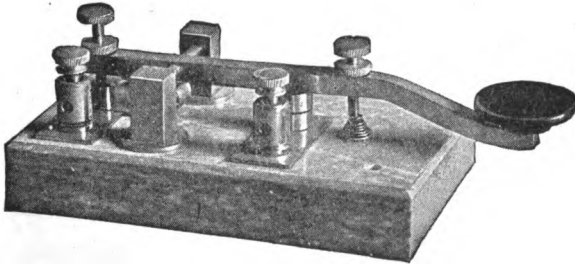

FIG. 98.—Transmitting key.

circuit of the transformer is opened and closed for relatively short and long periods of time by the key *B*. This key is of the same general design as that used in wire telegraphy, with the exception that it is heavier, especially the contacts, which are of platinum or silver. Fig. 98 shows a modern key. When large currents at comparatively high voltage are interrupted, arcing and burning of the contacts result. To avoid this objectionable feature, the key may be shunted by a resistance, inductive reactance, or condenser. The diagram shows the key shunted by a resistance. Another means of overcoming the difficulty is the use of a relay key. The relay which carries extra heavy contacts for interrupting the alternating current is operated by direct current and an ordinary key. The circuits for such a relay are shown in Fig. 99.

Another type of key used is called the "break key." This permits the receiving operator to signal the sending operator as in ordinary wire telegraphy. One method of accomplishing

this is to provide the transmitting key with an extra set of contacts so that when the arm of the key is released after a dot or dash, it connects the receiving set to the aerial and ground. The sending operator can thus hear the signal of the receiving operator should he desire to be heard.

118. The Transformer.—The transformer is an instrument for changing by mutual induction the comparatively low voltage of the alternating current generator to the high voltage necessary to cause the condenser charge to jump across the spark gap. Induction coils were formerly used for this purpose, but their

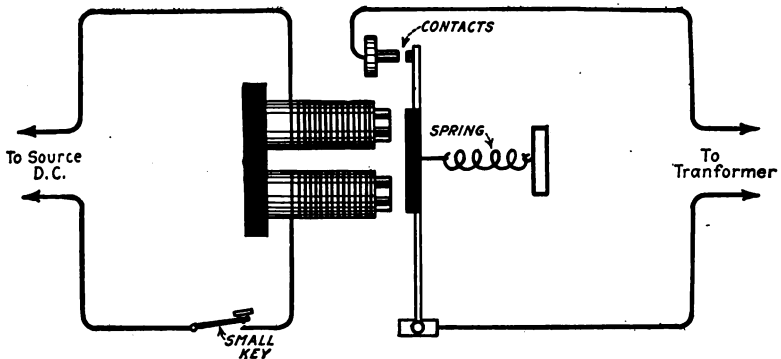

FIG. 99.—Relay.

power output was limited and their operation was not entirely satisfactory.

The transformer consists of two distinct windings or coils around an iron core. The primary winding, P , Fig. 97, is connected to the generator while the secondary, S , is connected in series with the condenser and oscillation transformer. The current in the primary magnetizes the iron core. The magnetic flux cuts the secondary winding and develops in it an electromotive force. This flux will develop an electromotive force in the primary also. Assuming that there is no magnetic leakage between the turns, if the e.m.f. induced in one turn is e , then in N_1 primary turns it will be $N_1e = E_1$. Since the secondary encloses the same flux, the same e.m.f. will be induced in each secondary turn and the total secondary e.m.f. will be $N_2e = E_2$. The ratio between the e.m.f. induced in the primary and that induced in the secondary is evidently $\frac{E_1}{E_2} = \frac{N_1e}{N_2e} = \frac{N_1}{N_2}$. If we neglect the

resistance of the primary, the applied e.m.f. E_a will equal E_1 ;

hence we have $\frac{E_a}{E_2} = \frac{N_1}{N_2}$ or

$$E_2 = \frac{N_2}{N_1} E_a.$$

The secondary voltage is thus increased in proportion to the ratio between the number of turns in the secondary and primary

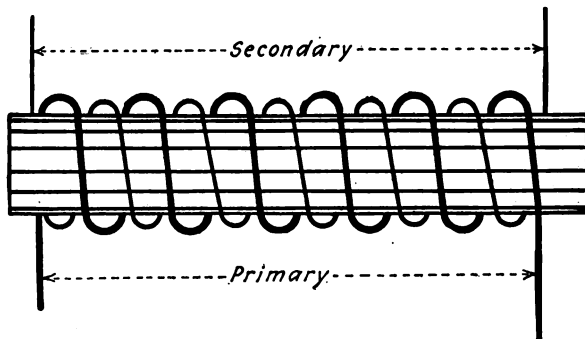

FIG. 100.—Simple open core transformer or induction coil.

windings. To raise the primary of 500 volts to 20,000 volts this ratio must be 40 to 1. In practice, the primary voltage employed may be 110 to 220 volts, while the secondary pressures may range from 10,000 to 25,000 volts.

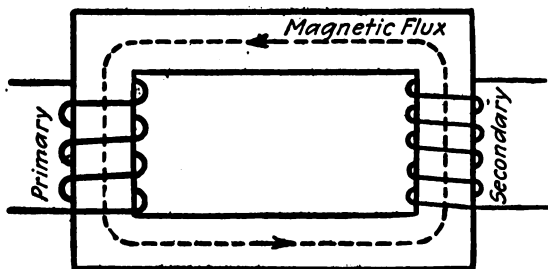

FIG. 101.—Closed core transformer.

There are two types of transformers in general use, the open and closed core types. The open core type is represented in diagram by Fig. 100. It consists of an iron core which does not form a closed magnetic circuit, wound with two separate coils. The primary, which has a relatively small number of turns of large wire, is wound over the core but carefully insulated from it.

Over the primary is wound the secondary which consists of a great number of turns of fine wire. The closed core transformer is represented by Fig. 101. It consists of an iron core which forms a closed magnetic path, and is usually rectangular in shape. The primary is wound on one leg of the iron core, and the secondary

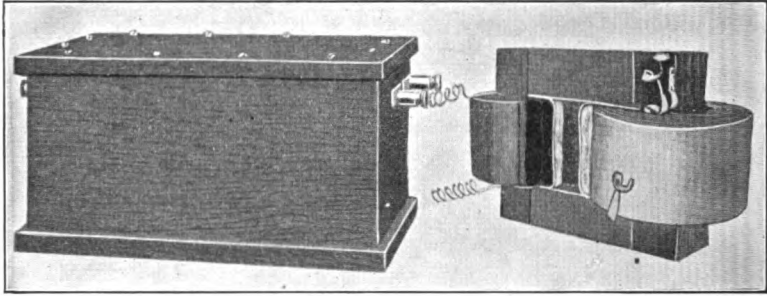

FIG. 102a.—Blitzen closed core transformer mounted and unmounted.

is wound over the leg, or one-half of the primary is wound on each leg and the secondary is wound over these. Two forms of complete transformers are shown in Fig. 102a and 102b.

Owing to the high secondary voltages developed, special pre-

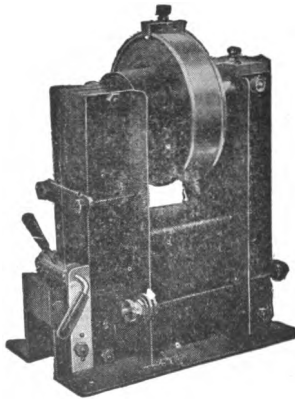

FIG. 102b.—Thordarson closed core transformer with magnetic shunt control.

cautions must be taken to insulate the coils. Both types of transformers are used in practice, and there is not much choice between them. Owing to its compactness, the closed core type is used more extensively at the present time.

119. Spark Gap.—The function of the gap is to serve as a trigger for starting the oscillations and for limiting the voltage applied to the condensers.

In the development of radiotelegraphy, the spark gap has undergone about as many changes as any other part of the equipment. The old spark gap consisted of two stationary electrodes whose distance apart could be varied. This is known as the straight gap. The plain or straight gap was used by Marconi and Hertz in their early experiments. They used an induction coil and this discharged sparks which caused damped oscillations to surge up and down in the aerial circuit. The connections are shown in

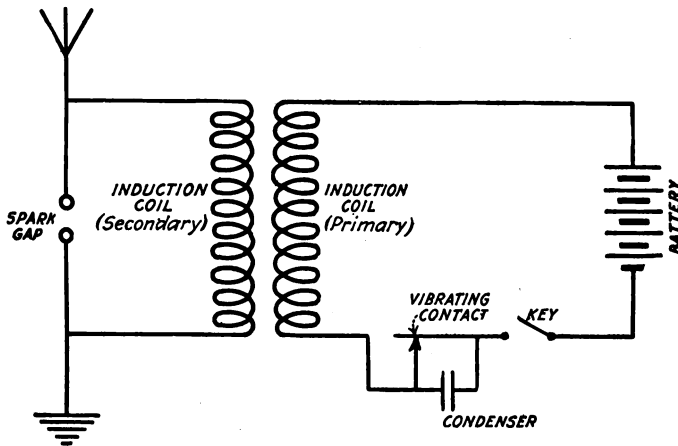

FIG. 103.

Fig. 103. With this type of simple transmitter it was found that the great damping of the oscillations was disadvantageous and that, in order to transmit any considerable distance, the voltage has to be increased to such high values that great difficulty was encountered in insulating the antenna properly, especially if continuous communication was attempted.

Next the straight gap was employed to excite a tuned circuit coupled inductively to the aerial. This system is shown in Fig. 104. Larger amounts of power were employed in this system and greater distances covered. The transformer replaced the induction coil. There were quite a number of drawbacks to this type of transmitter. One of the disadvantages was that the note of the received signals was very low and rough and it was extremely difficult to read the signals during atmospheric disturbances

because of the identity of tones. The real cause for its abandonment came with the enforcement of the act of Congress of August 13, 1912, to regulate radiocommunication which stated that "at all stations the logarithmic decrement per complete oscillation in the wave trains emitted by the transmitter shall not exceed two-tenths." It was almost impossible to obtain satisfactory results with this system and also obey the law; hence its abandonment. In the discussion of coupled circuits it was shown that energy is transferred from the secondary to the primary unless the gap prevents the oscillations in the primary. In the straight gap without air blasts or other quenching devices, the oscillations continue

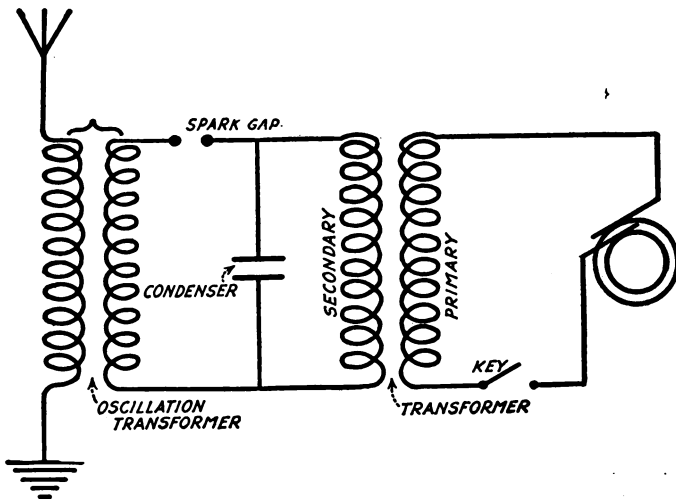

FIG. 104.

permitting this reaction. Incidentally more power is consumed, which is dissipated in the heating and burning away of the electrodes. This is the chief objection to the straight gap, and an improved design must not permit this action. There are two designs of spark gaps which meet this requirement—the synchronous rotary gap and the quenched gap.

The synchronous rotary spark gap, Fig. 105, is a rotatable wheel mounted on the alternator shaft or on the shaft of a synchronous motor operated from the same supply as the transformer. The rotating wheel has projections or sparking points on its periphery and there are two adjustable stationary electrodes. The size of wheel, number and location of the sparking points are

varied but so designed that the stationary and rotating electrodes are nearest together at the instant when the alternating, high potential voltage is at its maximum value. The oscillations in the closed circuit continue as long as the discharge exists, but the gap length increases very rapidly and the spark stops and the oscillations fall off very rapidly in this circuit. The open circuit has, however, been caused to oscillate at its natural period and there is less interference as in the case when the oscillations in the closed circuit persist. In this manner the damping is reduced which is called quenching, and there is a musical note

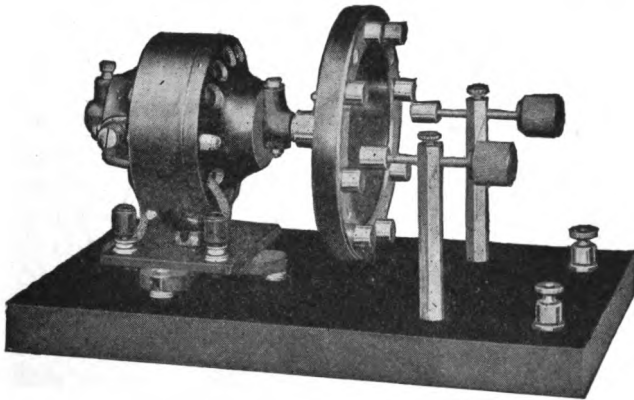

FIG. 105.—Synchronous rotary gap.

produced in the telephones of the receiving outfit which is an advantage over the straight gap.

In order to secure correct adjustments of a synchronous gap the stationary electrodes should be adjusted to give only a small clearance, $\frac{1}{32}$ inch or less, and then they should be adjusted in the direction of rotation until the spark ceases to waver. If the discharge does not occur at the peak of the e.m.f. wave, the spark has a wavering appearance. When the discharge takes place at the peak of the wave there is no apparent wavering and at the same time the note of the spark will become much clearer.

There is another type of gap which is more efficient than either of those mentioned above and which at the present time bids fair to replace completely the other types as a transmitter of damped oscillations. It is called the quenched gap and is a series gap made up of several plates usually of copper placed very

close together and separated by insulating rings of mica or rubber which form air-tight chambers between the plates.

120. Quenched Gap.¹—"It was found by M. Wien that if a series of short spark gaps be substituted for a single long gap and a discharge passed through them, the discharge path returns

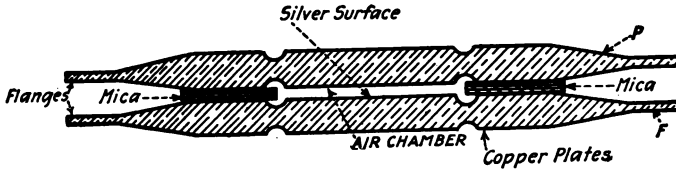

FIG. 106.

much more quickly after discharge to its initial condition of high resistance. This is a result of the more rapid deionization of the gap and is called the quenching action. The quenching action is increased if the surfaces of the gaps are of silver or copper and the gap is kept cool and air-tight. In Fig. 106 is shown a cross-section of a single gap showing the insulating gasket between the plates which renders the gap air-tight, the silver sparking surfaces and the flanges to provide a large cooling surface. The insulating gasket may be of paper, mica, or rubber, and is about 0.2 mm. thick. Its thickness is exaggerated in the figure. A



FIG. 107.

number of such gaps are stacked in series and clamped together, and either the leads to the gap are provided with clips so that the number of gaps used may be varied or means are provided for short-circuiting as many of the gaps as desired. A plate of an improved quenched gap designed at the Bureau of Standards is shown in Fig. 107. The construction is such as to permit air circulation on both sides of each gap. This is accomplished by inverting alternate plates."

While close coupling with the secondary circuit in the case of ordinary spark gaps is to be avoided, since it causes the generation of two frequencies of which only one can be utilized, good working of the quenched gap, on the other hand, requires a fairly close coupling between the primary and secondary circuits. This secures high efficiency and still permits a single wave to be ob-

¹ Circular 74, Bureau of Standards.

tained. The effect of the quenched gap upon the oscillating discharges will be understood when the resulting waves are compared with those of a straight gap, Fig. 90.

In the plain gap there is a transfer of energy from primary to secondary and back again and all of the energy is not radiated into the aerial. However, in the quenched gap the spark is quickly extinguished because of the cooling action of the gap and there is no transfer of energy back to the primary, Fig. 91. There are two advantages of the quenched gap, greater efficiency and less interference between the primary and secondary circuits, which means the radiation of more energy on a purer wave. In addition, on account of the quenching effect, the transmission may be at a greater speed. This facilitates the receiving of signals under atmospheric disturbances. The connections for the quenched gap are similar to those for a straight spark gap, using a transformer. Best operation

is generally obtained when the inductance in the primary circuit is somewhat greater than that required for resonance. On account of the rapid quenching of the gap, the supply alternator may have a frequency of 500 cycles and adjustments made so as to obtain one spark per alternation.

Proper coupling of two circuits using a quenched gap is very important. If the coupling of a tuned quenched gap circuit be varied, and simultaneous readings of current be taken in both the primary and secondary, it will be found that the primary current is a minimum when the secondary current is a maximum. This is evident from Fig. 91. Under these conditions the oscillations in the primary cease at the moment it ceases to deliver energy to the secondary and as the secondary cannot return any energy it continues to oscillate in the secondary. Fig. 108 shows the variation in primary and secondary current intensity with coupling.

Proper coupling of two circuits using a quenched gap is very important. If the coupling of a tuned quenched gap circuit be varied, and simultaneous readings of current be taken in both the primary and secondary, it will be found that the primary current is a minimum when the secondary current is a maximum. This is evident from Fig. 91. Under these conditions the oscillations in the primary cease at the moment it ceases to deliver energy to the secondary and as the secondary cannot return any energy it continues to oscillate in the secondary. Fig. 108 shows the variation in primary and secondary current intensity with coupling.

121. The Condenser.—There are many kinds of transmitting condensers used in wireless telegraphy and each has its own field.

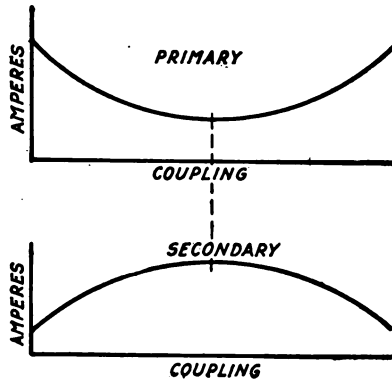

FIG. 108.

All types consist of two conducting surfaces separated by a dielectric which is some insulating material that will withstand the high voltages necessary to produce a spark without breaking down itself. For small size sets a Leyden jar or jars are used. These consist of a glass jar coated inside and out with metal foil to a height somewhat below the top. However, the volume occupied is larger for the capacity than some other kinds of condensers.

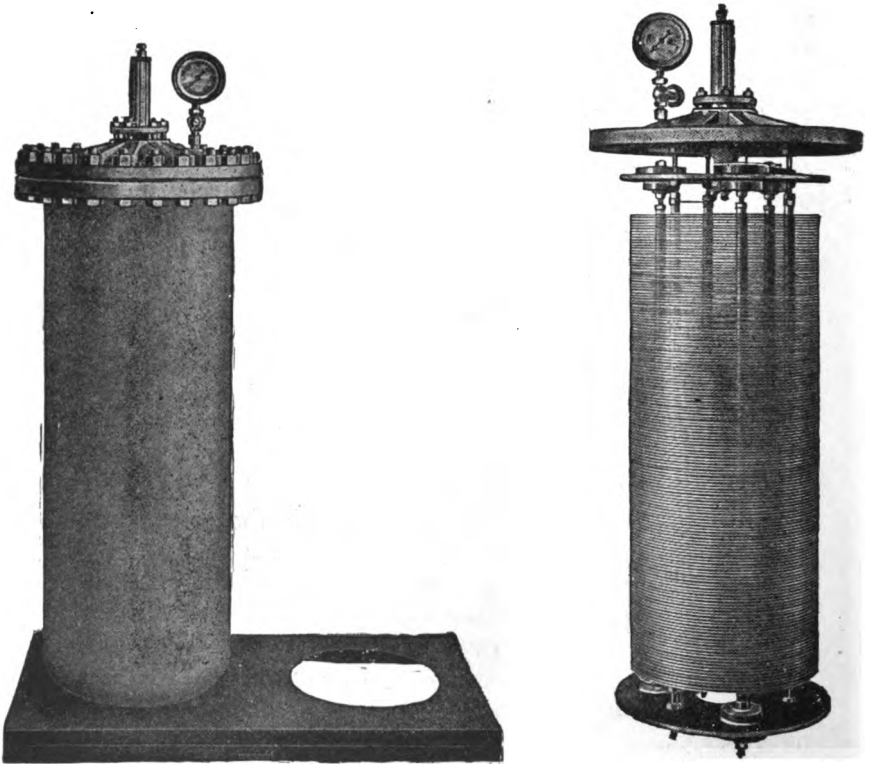

FIG. 109.—Compressed air condensers.

Plate condensers are also made. These have glass plates for the dielectric and are coated with metal or foil. Others are made of sheet metal separated by insulators and immersed in oil as the dielectric. In the ordinary air condenser the spaces are comparatively short and the air is subjected to a pressure of only one atmosphere. Such condensers cannot, however, be used when the transmitting voltages are high. The dielectric strength of air increases with pressure. This fact is utilized in making air

condensers for high-power stations, Fig. 109. Such condensers are made of a large number of circular metal plates each separated from the others by insulating spacers. Alternate plates are connected together electrically, thus forming two sets. One of these sets is connected to the enclosing metal tank and the other to a terminal brought out through the top cover. The air in the tank is compressed up to 200 or 300 pounds per square inch. A gauge on the tank cover indicates the pressure. Such condensers have the advantage of low energy loss, but the disadvantage of being quite bulky. A size commonly used has a capacity of about 0.005×10^{-6} farads.

To increase the capacity without increasing the volume of the condenser, the same type of construction may be employed, but instead of air, ordinary petroleum oil may be used for the dielectric. The increase in capacity is due to the higher dielectric constant of oil.

122. Oscillation Transformer.—The purpose of the inductance, together with the condenser, is to produce electric oscillations in the primary or closed circuit, and to transfer oscillating energy from this closed circuit to the open or aerial circuit. This transfer is accomplished by induction by means of the oscillation transformer.

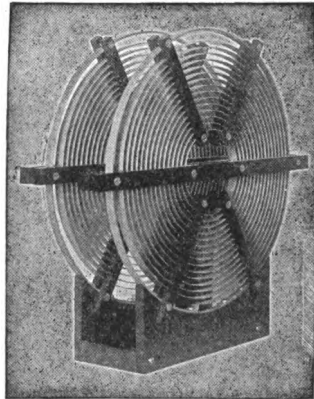

FIG. 110.—Bureau of Standards spiral oscillation transformer.

The oscillation transformer consists of two coils both either helical or spiral and so constructed that their relative positions can be adjusted. In the case of the helical coils one may slide inside of the other and with the spiral coils they may slide or rotate on axes outside of the coils, Figs. 110 and 111. One coil of the oscillation transformer called the primary is connected to the closed oscillatory circuit and the other called the secondary is connected to the open oscillatory circuit. It is usually found necessary to connect an additional inductance coil which is called a loading coil in series in the open circuit.

A helical coil transformer is shown in Fig. 112. This particular design is wound with copper ribbon or strip—the primary turns

being $\frac{1}{2}$ inch wide and the secondary $\frac{5}{16}$ inch wide. Four clips are included so that either inductive or direct coupling may be used. An oscillation transformer whose coupling may be varied by sliding the secondary along the common axis is shown in Fig. 113.

123. The Antenna.—The antenna is the radiator by means of which a portion of the energy of the oscillating system is radiated into space. The antenna consists of a system of wires in the air called the aerial, a variable inductance, the secondary of the oscillation transformer, a variable condenser, and the ground connections. These parts are shown diagrammatically in Fig. 97.

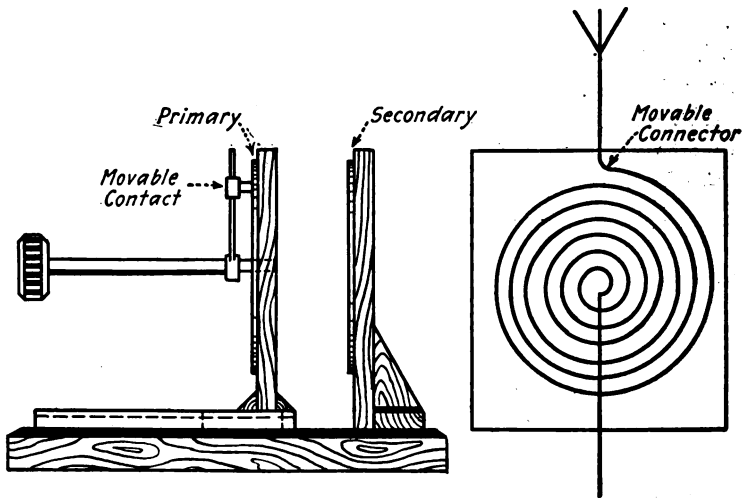

FIG. 111.—Spiral oscillation transformer.

The aerial and the ground are the equivalent of two plates of a condenser which connected in series with the inductance form an oscillatory open circuit. In some instances the ground may be a poor conductor, or for other reasons it may be impossible or inadvisable to connect the aerial with the ground. Under such circumstances a network of wires, corresponding to the aerial, is supported above the ground upon insulators. This network of conductors is known as the *counterpoise*.

The most effective radiator has an elongated form because in this case the oscillations of the electromagnetic field surrounding it are of large amplitude and pass out into space more freely than in the case of a short circuit.

The aerial used in early experiments consisted of a single vertical wire. This was suitable only for small amounts of power

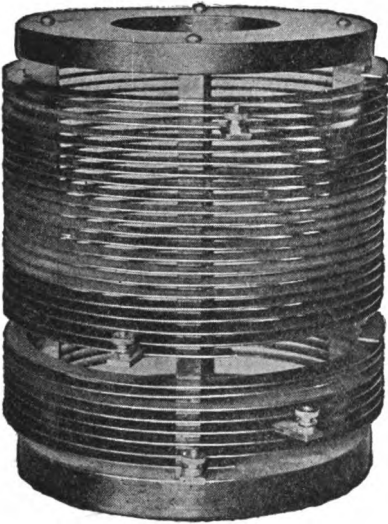

FIG. 112.—Helical oscillation transformer.

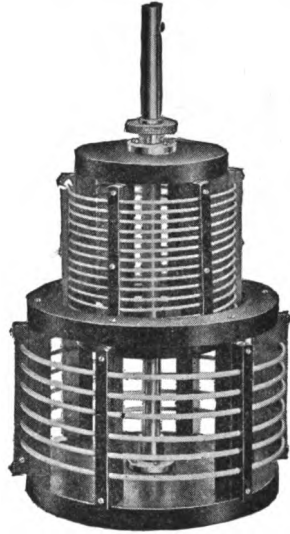

FIG. 113.—Helical oscillation transformer.

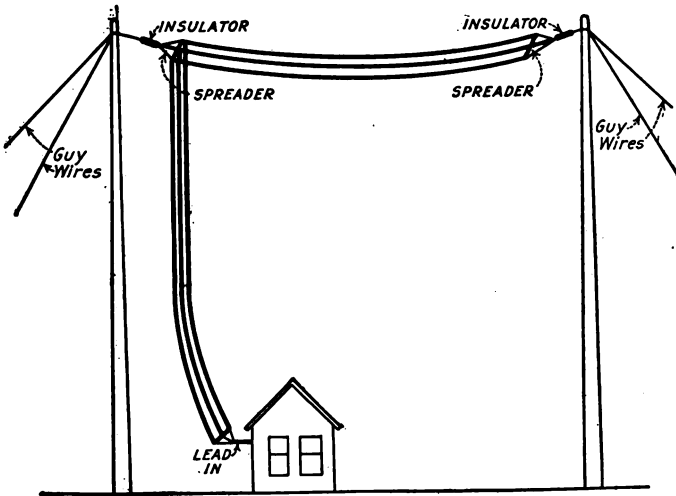

FIG. 114.—Inverted L-type aerial.

and for transmitting short distances, but when greater range was sought and the power increased, it became necessary to modify

the design by increasing the number of wires and suspending them at a greater height. The greater the height, the greater will be the energy content of the electromagnetic waves which it can radiate. The larger it is, the greater will be its capacitance and the more energy can be oscillated in it for a given charging voltage. A great many different types of aerials have been used depending upon the conditions of the installation. There are three general types of aerials at present: the flat-top aerial, Fig. 114, used on land and ship stations having two or more masts

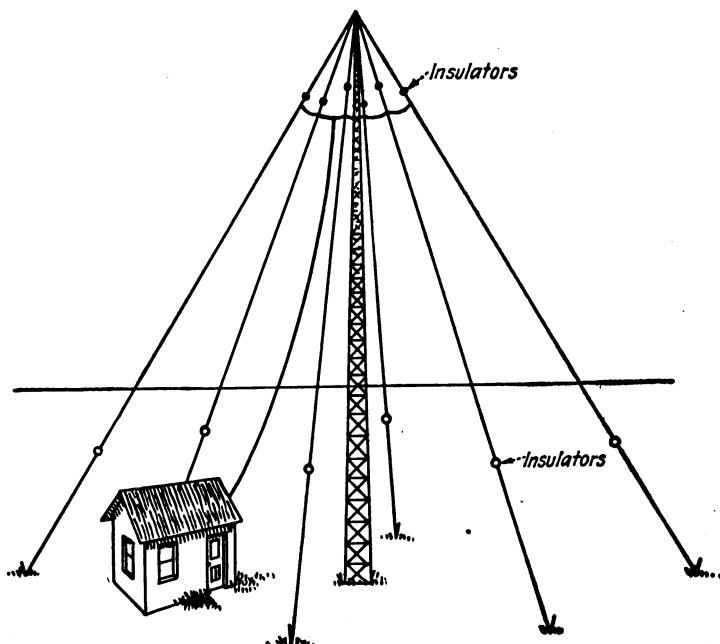

FIG. 115.—Umbrella type aerial.

to support it; the umbrella aerial, Fig. 115, used for portable stations or those having a single mast with plenty of surrounding land; and lastly, the ungrounded aerial employed on aeroplanes.

The flat-top aerial is either inverted L or T type, depending upon whether the connection to the station or "lead-in," as it is termed, is taken from one end or in the middle. Fig. 114 illustrates the inverted L, and Fig. 116 shows the T type aerial, respectively. The umbrella aerial is shown in Fig. 115. This is a very important type and is being employed at present in the

Signal Corps to a very great extent.¹ The aerial on an aeroplane consists of a single wire suspended from the machine. The metal parts such as motor and frame serve as counterpoise.

There is also another type of antenna upon which considerable experimentation has been done recently. This is known as the ground antenna. Up to the present time this has been used principally for receiving, although quite a number of experiments have been made employing it for transmitting purposes. The antenna consists simply of two long wires extending in opposite directions from the station and supported at a height varying from 1 to 10 feet and insulated from the ground. For re-

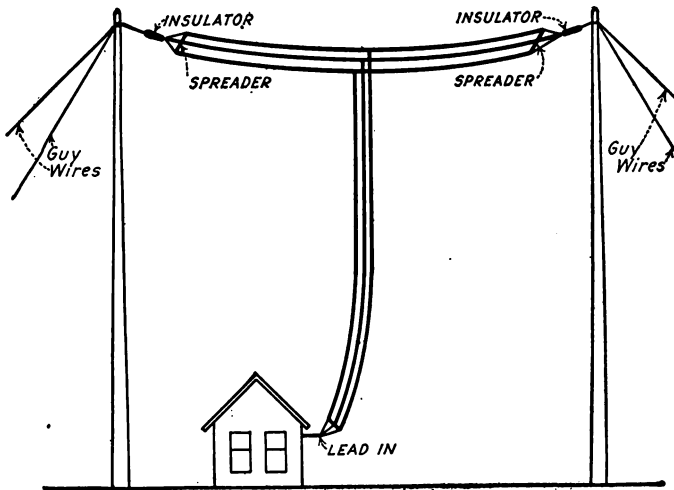

FIG. 116.—T-type aerial.

ceiving purposes only, the wires may be stretched on the ground. One of these wires serves as the aerial and the other as the ground or counterpoise. This type of antenna is equal to the vertical antenna of the same dimensions in radiating and receiving properties. It has one very marked characteristic, directivity, that is, the radiation from the aerial is confined to a narrow angle, and if reception is attempted beyond this narrow zone there is a very great diminution in the energy received. The inverted L type of aerial possesses this characteristic but the effect is not so distinct.

¹ Recent reports convey the information that it is being discarded.

There are a great number of advantages of this directive effect. As a transmitter, it permits the maximum energy to be transmitted in one direction; it permits partial secrecy of messages, an important consideration in war times. As a receiver, it decreases the interference from stations not in the direction of maximum sensibility, and serves as a means of determining the direction of the transmitter.

124. Grounding.—The antenna must be well insulated especially at the ends of the wires to prevent large leakage currents to ground which decrease the efficiency of the station. These insulators must be constructed to withstand the high potentials employed in transmitting. At the point where the aerial "lead-in" enters the station a good insulator must also be employed. If the aerial is supported by masts the guy wires should be insulated from the ground and the aerial also insulated from the mast. It is also advisable to insulate steel towers from the ground. The towers at the Arlington station, Radio, Va. are insulated by marble and concrete slabs securely anchored in the ground. For grounding, by-passes are provided which may be connected to the towers by switches when it is desired as in the case of severe lightning storms.

The ground connection, or its equivalent, is just as important as the aerial in the propagation of electromagnetic waves. The best ground consists of plates of large area buried in the earth and connected to the station apparatus by soldered connections or a large number of wires radiating from the station beneath the surface of the earth. Ground connections for a ship station are made by connecting the aerial to any portion of the steel structure of the ship. The connections must be of very low resistance because the ground is a part of the open oscillating circuit, and increasing the ground resistance will decrease the high currents used in transmitting, and damp the emitted waves. If the ground is poorly conducting or nonconducting, which is true of dry sandy soil, nonconducting rocks such as marble or slate, or if ground water is absent or at a great depth, the counterpoise, which is a wire network parallel to but insulated from the ground, will perform the function of a direct ground connection. The counterpoise is used also for portable sets. In the Signal Corps pack sets the counterpoise consists of long rubber-covered wires laid radially from the station on the ground. The rubber covering insulates the counterpoise from the ground and the wires

taken together serve as the plates of a condenser. The use of the counterpoise on an aeroplane has been referred to above.

125. Wave Length of Antenna.—The wave length as given by the formula $\lambda = 1.884 \times 10^9 \sqrt{LC}$ meters, Chapter VI, was derived on the assumption that the capacitance and inductance were concentrated at two definite parts of the circuit. This is not the case with an antenna whose capacitance and inductance are distributed. As every part of the antenna is separated from the ground by a dielectric; the capacitance is distributed from the base to the end of the antenna. Likewise every part of the antenna carries a current, although the magnitude of this current may be different at different points, and hence the inductance is distributed over the whole length. A circuit analogous to a simple antenna is shown in Fig.

117. It is very evident that the magnitudes of the currents are different in different portions of such a circuit. Part of the main current is shunted by condenser C_1 , another part by condenser C_2 , etc. It is also clear that this is merely an assembly of coupled circuits each one of which will

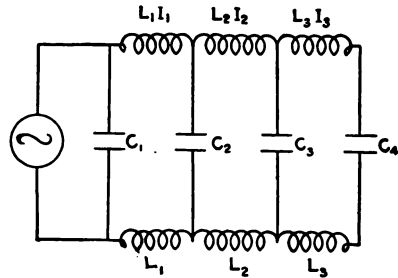

FIG. 117.

have its own resonant frequency; hence, the current values in the different parts of the circuit will vary greatly with frequency. While there is some frequency at which the current I is a maximum, this is not the frequency of either of the separate circuits. In fact such a circuit will have several or many resonant frequencies, none of which will give the wave length mentioned above.

The similarity between the circuit, Fig. 117, and an antenna will be evident if we consider Fig. 118. This shows a single wire separated from a ground connection by an air gap. The earth is one plate of the condenser and the wire is the other. Between these is the air of varying thickness. The capacitance of the antenna per unit length varies from the base up. The dotted condensers connected to earth and to different points on the antenna represent this. The similarity between this and Fig. 117 is very evident. There is this difference, however, the capacitance of the simple antenna per unit length changes continuously while in Fig. 117 the changes are abrupt.

If we consider the simple antenna to be excited by an adjacent circuit and a current flowing up into it, than it is evident that some of the current is shunted by the capacitance path to the

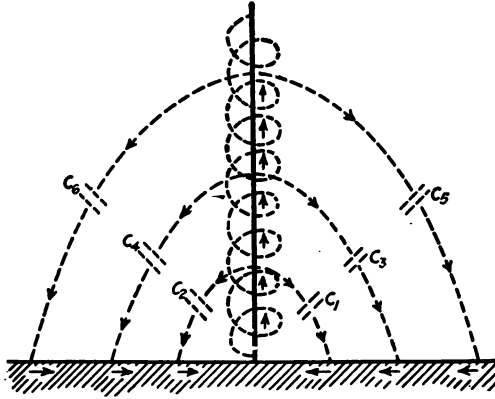

FIG. 118.—Diagrammatic representation of distributed capacitance and inductance of an antenna.

ground, that is, through the phantom condensers C_1, C_2, C_3 , etc. The consequence is that the current intensity or amplitude will be a maximum at the ground and zero at the top. If we represent the current intensity at any point on the antenna by a line

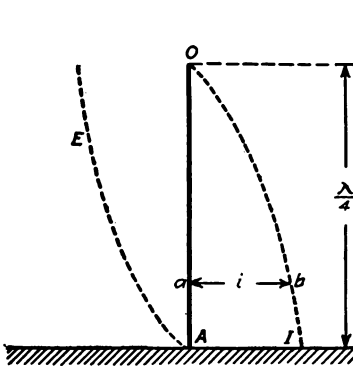

FIG. 119.—Relative magnitude of current at different points of an antenna.

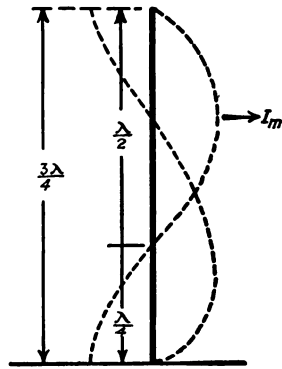

FIG. 120.—Relation between wave length of first harmonic and height of simple antenna.

at right angles to the antenna, such as ab , Fig. 119, and join the ends of such lines we get the curve OI . Similarly, the voltage distribution along a simple antenna is shown by curve AE .

These two curves are approximately sinusoids, and it is evident that the length of the antenna is equal to one-fourth of a wave length, or if h represents the height and λ the wave length, the conditions for the simplest oscillations of a simple antenna are

$$\lambda = 4h, \text{ approximately.}$$

If h is measured in meters, λ will also be in meters.

The frequency which gives $\lambda = 4h$ is, however, not the only frequency to which such an antenna will respond. In every case the current amplitude at the top will be zero and at the base a maximum. The next simplest oscillation is that shown in Fig. 120. In this case

$$h = \frac{3}{4}\lambda \text{ or } \lambda = \frac{4}{3}h$$

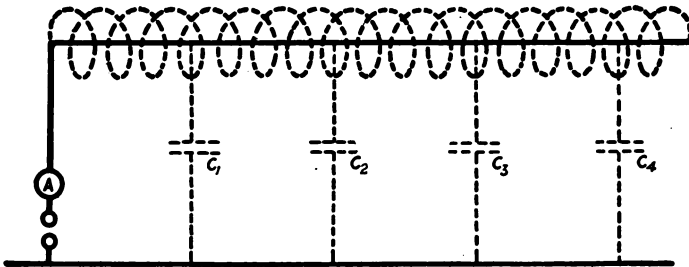

FIG. 121.—Distributed capacitance and inductance of a flat top aerial.

which is one-third of the fundamental wave length. Since λ varies as $1/f$, the second frequency must be three times the fundamental. An exact analogy is found in the oscillations of air in an organ pipe closed at one end and open at the other.

A more exact similarity exists between the circuit of Fig. 117 and a flat top antenna, Fig. 121. The fundamental wave length of such an antenna is roughly approximate to four times the length of the horizontal portion of the aerial.

126. Wave Length of Loaded Antenna.—In practice it is necessary to insert a variable inductance or a condenser in series with the aerial for the purpose of modifying the natural frequency of the aerial. The increase of inductance in the antenna circuit will reduce the frequency or increase the wave length, while the insertion of a capacitance has the opposite effect. An antenna to which a coil or condenser has been added is called a loaded antenna. The natural fundamental frequency of such

an antenna will depend to a great extent upon the loading, and as the loading is increased the more accurate is the value of the frequency calculated by the formula

$$f = \frac{1}{2\pi\sqrt{LC}}$$

assuming L and C concentrated.

If L_o and C_o are the distributed inductance and capacitance¹ of an antenna, then at low frequencies the equivalent concentrated inductance is, with close approximation, given by $\frac{L_o}{3}$. If L is the loading coil inductance, the total inductance is $L + \frac{L_o}{3}$; hence, the resulting fundamental frequency is

$$f = \frac{1}{2\pi\sqrt{\left(L + \frac{L_o}{3}\right)C_o}}$$

and the wave length $\lambda = 1.884 \times 10^3 \sqrt{\left(L + \frac{L_o}{3}\right)C_o}$ meters, where L and L_o are in henries and C_o in farads.

127. Constants of Antennas.—It has already been mentioned that the energy supplied to the secondary of a coupled circuit is spent in three ways: namely, (a) Radiation, (b) Heat, due to resistance of conductors; (c) Reaction, due to the primary or other circuits. To these may be added heat generated in the dielectric, or dielectric hysteresis, and at high voltages discharges from the wires. Since the antenna forms the secondary of a coupled circuit, energy supplied to it is dissipated in exactly the same way.

(a) *Energy Radiated.*—For efficient transmission the amount of the energy radiated should be a large per cent. of that supplied to the antenna. The ideal antenna would be one that would radiate 100 per cent. of the energy received. This is obviously impossible; nevertheless like all appliances for transformation of energy great improvement in this respect has been made in antenna design. The amount of energy that an antenna will radiate depends upon its form; it is proportional to the square of the effective current at the air gap; and proportional to the square of the frequency of oscillations, or in other words, in-

¹ Formulas for calculating these are given in *Circular* of the Bureau of Standards No. 74.

versely proportional to the product of the inductance and capacitance of the antenna.

Radiation Resistance or Coefficient.—Since the energy transferred by the antenna to the electromagnetic waves is proportional to the square of the effective current, the process by which the energy is transferred is considered analogous to the transformation of electrical energy into heat by the resistance of a wire. The factor by which the square of the current is multiplied to give the energy radiated is by analogy called the *radiation resistance*. A better term for this is “radiation coefficient.” The student must be careful and not confuse radiation resistance with the ordinary resistance which converts the energy of the current into heat.

The radiation resistance is equivalent numerically to that resistance, which, if inserted in the gap in an antenna would dissipate, in heat, the same amount of energy as that radiated by the antenna. The radiation resistance depends upon the physical constants of the antenna. Briefly it may be stated that it depends upon the height of the antenna above ground and frequency of the transmitted wave. More exactly it can be shown by higher mathematics that the radiation resistance of a simple grounded oscillator is approximately equal to $R_r = \frac{1580 \times h^2}{\lambda^2}$,

where h is the height of the antenna above ground and λ is the length of the transmitted wave. Since both h and λ vary with the type of antenna used in practice, it is found necessary to multiply h by a factor α called the form factor of the antenna. The product αh is called the effective height. The effective height is also defined as the distance from the ground to the center of the capacitance. This may in practice be difficult to determine. For example Fuller¹ in describing the antenna of the Federal Telegraph Company at Honolulu gives the following data:

Triangular flat top antenna, supported on two 440 ft. and one 608 ft. towers. The towers are at the vertices of an equilateral triangle 600 ft. on a side. In addition, an umbrella antenna is strung from the back side of the 608 ft. tower approximately around an arc of 135°. The center of capacity is very close to 394 ft. It is very evident that the determination of the effective height of such an antenna is a difficult and laborious process.

¹ L. F. FULLER, Transactions A.I.E.E., Vol. XXXIV, p. 814.

Examples

1. What is the radiation resistance of the Honolulu antenna mentioned above when sending on 1000 meters?

Solution

$$R_r = 1580 \frac{h^2}{\lambda^2}$$

DATA

$$h = 394 \text{ ft.} = 120 \text{ meters}$$

$$\lambda = 1000 \text{ meters.}$$

Then
$$R_r = 1580 \times \frac{120^2}{1000^2}$$

$$= 23 \text{ ohms approximately.}$$

2. How much energy per second is radiated by the antenna when the current at the base is 25 amperes?

Solution

$$\text{Energy} = I^2 R_r$$

$$= 25^2 \times 23$$

$$= 14.3 \text{ kw. approximately.}$$

The variation of radiation resistance with wave length of antenna is shown by curve (a) Fig. 122.

(b) *Heat Loss.*—The energy converted into heat by the electrical resistance is also proportional to the square of the effective current and varies somewhat with frequency, but this variation is slight in comparison with other variations; hence the electrical resistance for approximate calculations may be considered constant. This relation is shown by the straight line (b) Fig. 122.

Energy is also wasted by dielectric absorption, that is, the medium intervening between the aerial and the ground. The amount of this energy loss depends upon the presence of trees, buildings, hills, rocks, etc. When imperfect dielectrics are present the energy absorbed by them is approximately proportional to wave length. If we consider this energy as dissipated by a resistance, the variation in the energy dissipated may be considered as due to a resistance which varies with wave length. Such a relation is shown by the straight line (c), Fig. 122.

Assuming that all of the energy spent or dissipated by the antenna is due to a resistance, then the curve representing the variation in this resistance with frequency is obtained by combining curves (a), (b), and (c), Fig. 122. The resultant curve is (d). This curve shows that there is one frequency at which the antenna resistance is a minimum. At this frequency the energy

radiated at a given impressed voltage is a maximum. It has been determined experimentally that for modern quenched gap transmitters the most efficient wave length for transmission is between 1.75 and 2 times the fundamental of the antenna. Thus, if the natural wave length is calculated by the formula

$$\lambda = 1.884 \times 10^9 \sqrt{C_o \left(L + \frac{L_o}{3} \right)}$$

the most efficient wave length for quenched spark gap transmission is about 2λ .

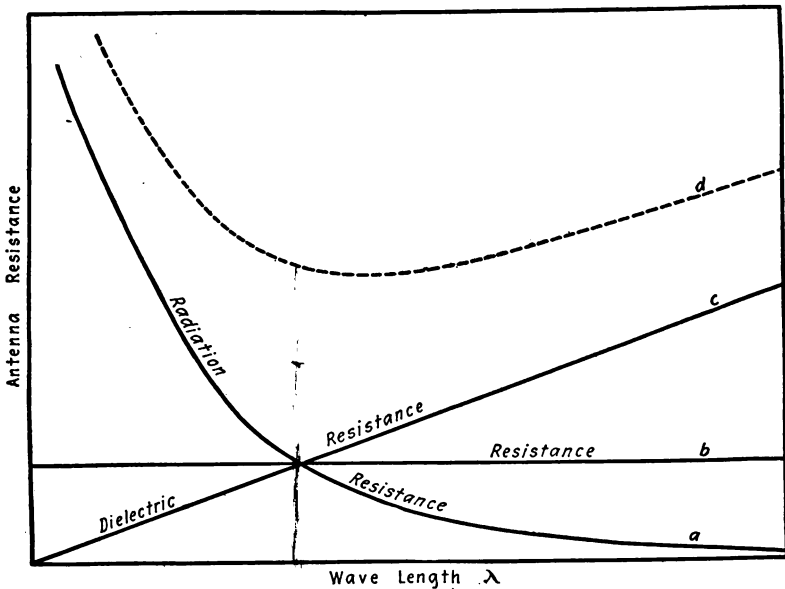

FIG. 122.—Variation in antenna constants with wave lengths.

128. Undamped Wave Transmission.—When the spark method of transmission is used the resulting oscillations in the antenna circuit are damped due to the dissipation of energy. The manner in which energy is dissipated has been explained. If energy is supplied to the antenna circuit as rapidly and synchronously as it is dissipated, there results a sustained or undamped oscillation and wave. The continued oscillations of a clock pendulum or of the balance wheel of a watch are analogous. Just enough energy to compensate for that dissipated in friction is supplied by the clock mechanism and as this energy is supplied at the

proper time, the pendulum continues to vibrate through the same amplitude. That is, its vibrations are undamped.

To produce undamped oscillations the impulses must come at regular intervals and be of equal magnitude. There are in practice several distinct methods of producing undamped oscillations, three of which will be described. These may be classed under the following heads: (a) Alternator method; (b) Arc

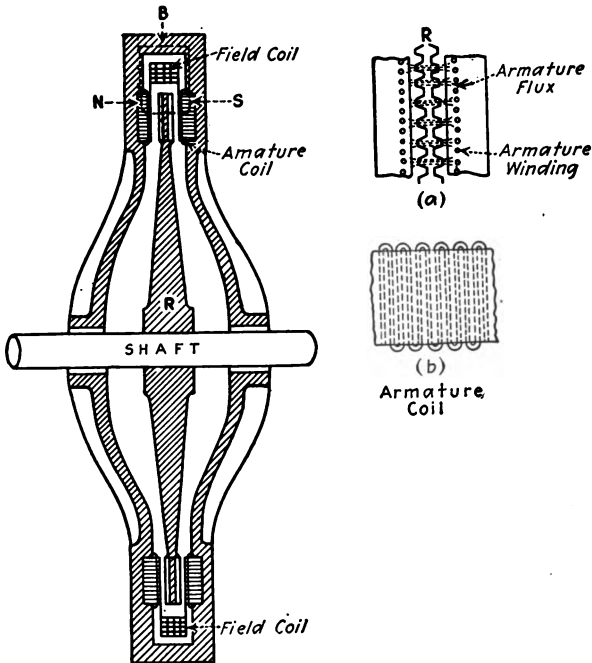

FIG. 123.—Section of Alexanderson alternator.

method, and (c) Vacuum tube method. The last will be explained separately in a later chapter.

129. (a) Alternator Method.—The alternator is an electric generator which develops an alternating electromotive force. An alternating electromotive force and current have been explained in Chapter V. The ordinary commercial alternator is not suitable for radiotelegraphy on account of its low frequency, which is given by $f = \frac{p}{2} \times \frac{\text{r.p.m.}}{60}$ cycles per second, where p is the number of field poles and where r.p.m. is rotations per minute. An alternator for radio-frequencies of the same design

as the commercial alternator would require an enormous number of poles, and would have to be operated at an excessively high speed. In short, the commercial type of construction for an alternator of radio-frequency is impractical.

The high frequency alternator differs from the commercial machine in design although the principles of operation are the same. Radio-frequency alternators are of two types commonly known by the names of their inventors.

130. The Inductor Alternator.—This alternator was first designed by Professor Fessenden and perfected by Mr. Alexander, and hence is commonly known by the latter's name. The principle of operation of this alternator will be more readily

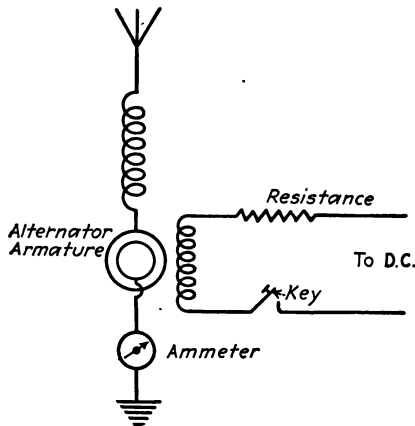

FIG. 124.—Alternator connected to aerial.

understood by reference to Fig. 123. The essential features are a rotor *R* and a stator *S*. The rotor is a steel disk with an enlarged rim. The rim is milled radially as shown in section (a). The stator contains both the field and armature windings. The field coil is concentric with the shaft and completely surrounds the rotor. When direct current is sent through this coil, it magnetizes the stator as indicated, making a north pole on one side of the disk and a south pole on the other side. The armature winding is a single-turn wave winding threaded through the armature faces *A* as shown in section (b). Since the reluctance through the teeth of the rotor disk is less than through the slots, the distribution of the magnetic field will not be uniform. The magnetic lines will be bunched as indicated in (a). As the rotor turns, the flux will shift with it and as the flux cuts the armature

windings an alternating e.m.f. is induced. The armature terminals are connected directly into the antenna circuit as indicated in Fig. 124.

It is obvious that so long as the excitation and speed remain constant undamped oscillations are produced in the antenna. Variations in the excitation will produce variations in the amplitude of the oscillating currents, hence the sending key is placed in the exciting or direct current circuit. The normal frequency

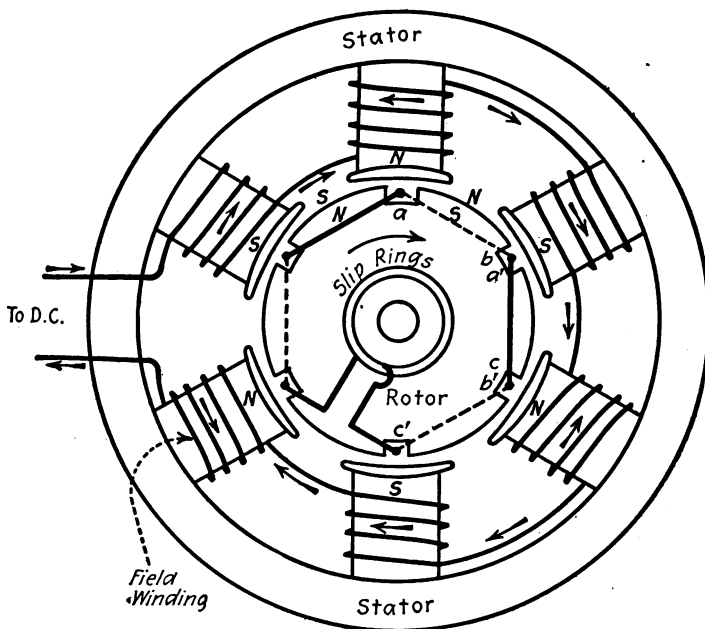

FIG. 125.—Diagram to illustrate principle of Goldschmidt alternator.

of the Alexanderson alternator is $\frac{\text{r.p.m.}}{60} \times T$ where T is the number of teeth on one side of the disk. The Alexanderson alternator is being built for frequencies up to 200,000 and over.

131. Goldschmidt Alternator.—The Goldschmidt undamped wave generator operates on a quite different principle. This alternator is in reality a frequency changer whose principles of operation may be briefly explained as follows: The essential parts of a stationary field common power-alternator are shown in Fig. 125. The field is excited by direct current so that the magnet poles are alternately north and south.

Assuming a clockwise rotation of the armature, each conductor under a north pole such as a will have an e.m.f. induced in it, whose direction is into the paper. When conductor a occupies the position of a' the e.m.f. induced will be out of the paper. When it has reached position c' , the induced e.m.f. is again in or from the front of the armature toward the back. Thus the e.m.f. has passed through a cycle during the passage of a conductor from under one pole to a corresponding position under the next like pole.

The frequency of the induced voltage evidently depends upon the number of pairs of poles composing the stationary field and angular speed of the armature, or what amounts to the same thing, relative speed between field poles and armature. If the rotating part or rotor windings form a closed circuit, evidently a current of a frequency $f = \frac{p}{2} \times \frac{\text{r.p.m.}}{60}$ will flow in it. This current is surrounded by a magnetic field which alternates with it and which by its alternations induces e.m.f. in the stator. That is, the alternating current in the rotor reacts upon the stator according to the fundamental principle of energy transfer previously explained. The interesting question arises: What is the frequency of this e.m.f. induced in the stator? We saw that the current in the rotor winding changes direction every half cycle. If the current in conductor flows in at a and out at b , that part of the rotor between a and b is a south pole and that part between b and c is a north pole. One-sixth of a revolution later conductor a is at a' and b is at b' . During the time required for this one-sixth revolution the current in the armature has reversed; that is, from a maximum in one direction it has changed to a maximum in the other direction. The resulting magnetic field has likewise been reduced to zero and back to its former magnitude. By applying the rule for determining the direction of magnetic field around a current-carrying wire we find that the space ab is again a maximum south pole. The magnetic field thus passes through a complete cycle while the rotor current passes through one-half a cycle. The frequency of the e.m.f. induced in the stator winding by this fluctuating flux will have the same frequency, namely, twice the frequency of the rotor currents. Thus, starting with a direct current in the stator, the reaction of the rotor currents produces an e.m.f. of twice their frequency in the stator windings. Ordinarily this alternating e.m.f. in the stator is small, and in power machinery

would be suppressed, but in the Goldschmidt alternator the current produced by it is amplified and reacts upon the rotor producing in its windings an e.m.f. of the same frequency, which by the motion of the rotor is increased to three times the fundamental frequency. The resulting current of triple frequency is again amplified and by its action on the stator winding produces an e.m.f. of four times the fundamental frequency. The student must understand that Fig. 125 illustrates principles only, but not actual construction.

It has been stated that currents of double and triple frequency are amplified. The manner in which this is done may be understood from the diagram Fig. 126. The coils R and S corre-

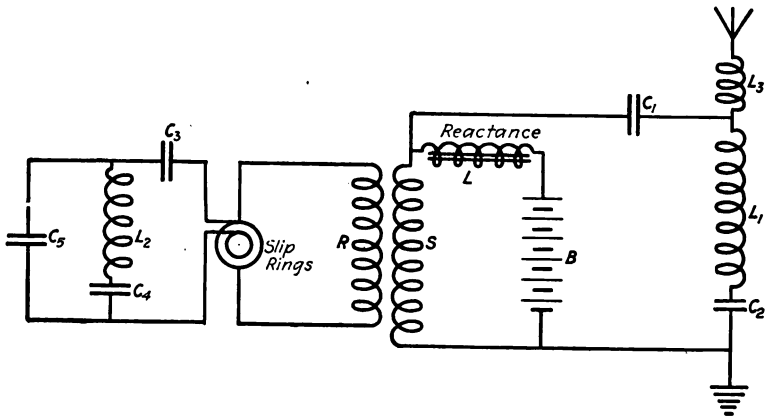

FIG. 126.—Diagram of circuits of Goldschmidt alternator.

spond to the rotor and stator windings of the alternator. The stator is magnetized by a current from the battery B through a reactance which prevents the high frequency currents from flowing through the battery. The rotor winding is connected in series with a condenser C_3 , inductance L_2 and condenser C_4 . These are adjusted until the circuit consisting of R , C_3 , L_2 and C_4 is resonant to the fundamental frequency of the rotor currents. That is, the reactance of this circuit is zero to the currents of fundamental frequency. As a consequence, a comparatively small e.m.f. produces a relatively large current in the resonant circuit. These currents produce an e.m.f. of double frequency in the stator winding S , which is tuned to this double frequency by means of the condenser C_1 , inductance L_1 and condenser C_2 .

These double frequency currents produce triple frequency currents in the circuit RC_3C_5 , which is made resonant by means of condenser C_5 . The reaction of these triple frequency currents on the stator produces quadruple frequency currents in the circuit consisting of the stator windings and the antenna which is made resonant to them. The amplification is secured by making the parallel circuits resonant to the different frequencies.

Example

A Goldschmidt alternator has 360 poles and is driven at a speed of 4000 r.p.m. What is the frequency of the currents supplied to the antenna?

Solution

$$f = \frac{p}{2} \times \frac{\text{r.p.m.}}{60} \times 4 = \frac{360}{2} \times \frac{4000}{60} \times 4$$

$$= 48000 \text{ cycles per second.}$$

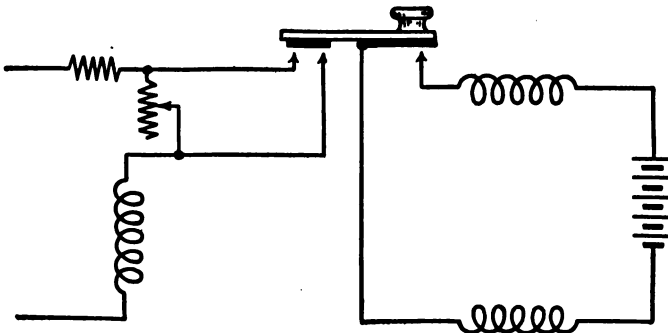

FIG. 127.—Double contact key for Goldschmidt alternator.

The transmission key is inserted in the battery or exciter circuit. Since the variation in the load on the motor during sending will change its speed, a special form of sending key is used. This is a double contact key, Fig. 127, the back contact automatically opening and closing a short circuit to the motor speed regulating rheostat. When the shunt to the rheostat is opened, *i.e.*, when the key is depressed, the resistance of the motor field winding is increased. This weakens the field and the speed tends to increase. When the key is released the rheostat is short-circuited, the motor field is strengthened and the speed tends to decrease. The rheostat is adjusted so that the changes in speed produced by the variations in the load are compensated

by the successive and synchronous changes in motor field strength.

132. The Arc Generator.—When two carbon electrodes are connected to an e.m.f. of at least 50 volts and if after contact they are separated slightly, Fig. 128, an arc will form at the point of separation. The current is carried across the space between the electrodes by a stream of vapor which issues from one electrode.

As the arc conductor is a vapor stream of electrode material, energy must be expended before arc conduction can take place. The arc, therefore, does not start spontaneously if sufficient voltage is supplied to maintain it, but the arc must first be started. This is done by bringing the electrodes together and then when the current has started to flow separating them. The

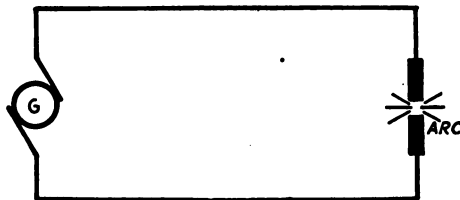

FIG. 128.—Simple arc.

characteristics of the arc are such, however, that if only the simple connections shown in Fig. 128 are used, it will not be steady. That is, the current will not remain constant. This is due to the fact that the voltage necessary to maintain the arc decreases as the current increases, or what amounts to the same thing, the voltage across the arc varies inversely as the current. This relation between the voltage and current across a $\frac{1}{2}$ inch arc is shown by the curve in Fig. 129. This characteristic of the arc is utilized in producing undamped oscillations of radio-frequency.

The principles of producing oscillations by the arc method can be readily understood by reference to Fig. 130. An inductance and condenser are connected in ~~parallel~~ with the arc; a variable resistance to control the current, and a choke coil to check surges of oscillations from flowing back through the mains are placed in series with it across the direct-current supply of 500 volts or more. When the shunt condenser circuit is closed, a portion of the current charges the condenser and thus reduces the current flowing through the arc. However, owing to the

falling characteristic of the arc, as the current decreases the potential across the arc increases and the condenser continues to charge. When equilibrium has been reached, the condenser begins to discharge across the arc. This increases the arc current and decreases the pressure across it. The character of the discharge will be much the same as that described in Art. 90 and an alternating current will flow in the condenser circuit the frequency of which is determined by the constants of the circuit.

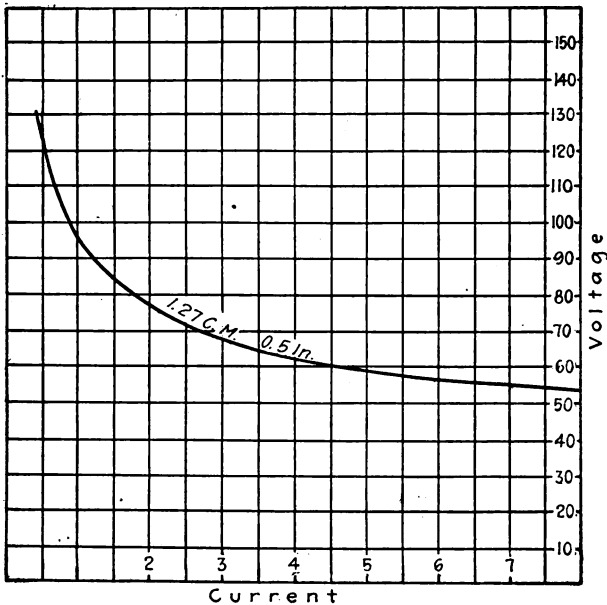

FIG. 129.—Variation of voltage across arc with current.

The Poulsen arc system is shown in Fig. 131. The arc is composed of a positive electrode of copper which is water cooled and a negative electrode of carbon which revolves slowly in order to insure an even burning down of the carbon which has to be replaced frequently. The whole arc is enclosed in an atmosphere of hydrogen which cools the arc and keeps the air from the electrodes and reduces the burning away. In many cases alcohol is used and the alcohol drips into the arc chamber. There is also a strong magnetic field at right angles to the arc which keeps the arc steady. This, however, is not absolutely necessary.

The connections for the transmitting key in this system are shown in Fig. 131. The characteristics of the arc are such that the key cannot be used to make and break the arc circuit. If this were done, the arc would go out at the first break and would not reignite until the electrodes were brought together again. The arc circuit must, therefore, be kept closed during transmission. As shown in Fig. 131, the method employed is to short-circuit successively a few turns of the antenna inductance coil and thus change the transmitting wave length by only a few per cent. If the receiving station is tuned sharply to the wave

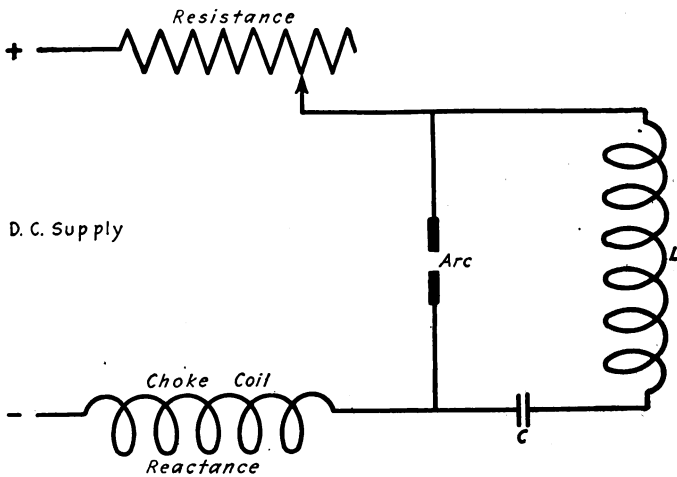

FIG. 130.

produced when key is closed, with the key open no signal will be heard, and thus it is possible to send messages by means of dots and dashes. The waves transmitted are of two frequencies and lengths. The wave produced when the key is open is commonly called the "compensation" wave, a term which is a misnomer. A better name would be "asynchronous," wave, for it is not in tune with the receiving circuit or if musical terms are preferred, "dissonant" or "discordant" is to be preferred. When the tuning at the receiving station is not sharp, it is frequently difficult to distinguish between the synchronous or transmitting, and asynchronous waves, and difficulty of communication is experienced.

The undamped oscillations have a great many advantages over

the damped oscillations for radiotelegraphy. Observations show that in the propagation over the earth's surface undamped oscillations are absorbed less rapidly than damped oscillations and thus for the same power at the transmitting station the distance covered by the undamped system is greater than that by the damped, other conditions being equal. Also undamped oscillations permit greater sharpness of tuning and looser coupling can be employed at the receiving station. This reduces the interference from other stations and from atmospheric conditions. As indicated previously, the undamped systems are more

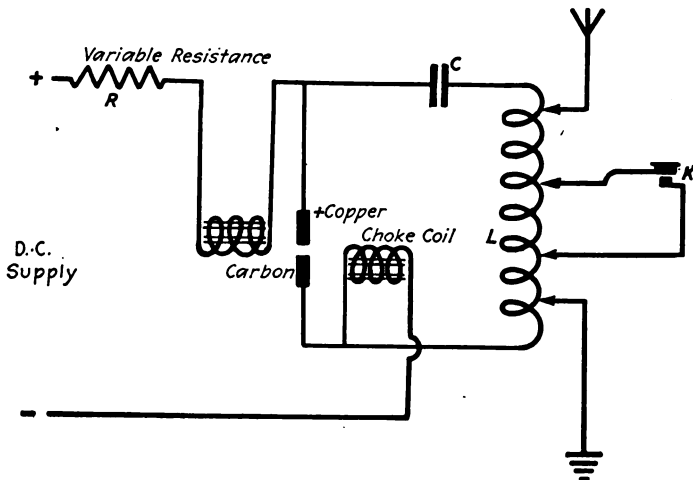

FIG. 131.

efficient than the damped. The voltage induced in the antenna in the undamped is much less than for the damped and consequently larger amounts of power can be employed with the same insulation. The most efficient wave length for undamped wave transmission is approximately three times the fundamental wave length of the antenna.

Up to about ten years ago practically all radio stations were transmitters of damped oscillations of the spark type but since that time the undamped systems have been developed and used more and more until at the present time all the high power stations such as those for transatlantic and transcontinental service and a great number of smaller stations are of this type and this system is rapidly replacing the spark system stations.

133. Operation of the Transmitting Set.—The tuning of the transmitting set to a given wave length is very essential after the set has been connected up and before lawful communication can be carried on. This operation in order to be complete should include four separate and distinct steps, adjustment of primary circuit to given wave length, adjustment of secondary circuit to the same wave length, measurement of the wave length of both circuits coupled together and the making of a resonance curve of the emitted wave, and the measurement of the logarithmic decrement.

The diagram for measuring the wave length of the closed circuit is shown in Fig. 132.¹ The closed circuit is shown at the right. The wavemeter or measuring instrument which consists of an inductance, variable condenser, and some detecting and indicating device such as a crystal detector and telephones, or hot wire

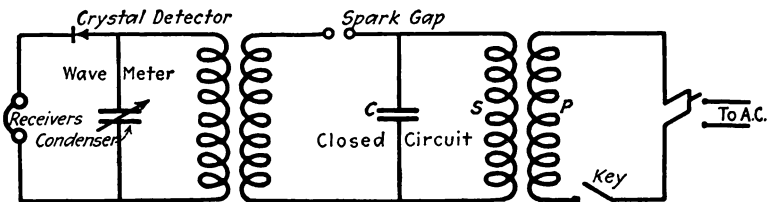

FIG. 132.—Diagram of wave meter connections. Coils *S* and *P* are wound on an iron core.

milliammeter, hot wire wattmeter, or helium tube. The wavemeter must be calibrated previously and the calibration curve available. Usually there are a number of different size inductances furnished with the wavemeter in order to cover a wide range of wave length and calibration curves made for each coil. These curves are ordinarily plotted with wave lengths as ordinates and variable condenser settings as abscissæ.

The closed circuit is excited by producing a spark at the gap which has been reduced to the shortest sparking distance to maintain a spark and not an arc. The inductance of the wavemeter is brought up to the primary of the oscillation transformer and the capacity of the wavemeter condenser varied until the greatest indication is obtained, either the loudest signal in the telephone, or the highest current, or maximum watts or the maximum brilliance

¹ Only a simple diagram of wave meter connections is shown. Many others, some more efficient are shown on page 105 circular of the Bureau of Standards, No. 74 Radio Instruments and Measurements.

of the helium tube. This point of maximum intensity or resonance, as it is called, will be very sharply defined if the coupling between the closed circuit and the wavemeter is not too close. If this resonance point is not very sharply defined the coupling should be loosened somewhat. The wave length corresponding to the point of resonance can then be read off the calibration curve. If this wave length is not the desired value the inductance of the closed circuit can be raised or lowered as the case may be by increasing or decreasing the number of turns on the

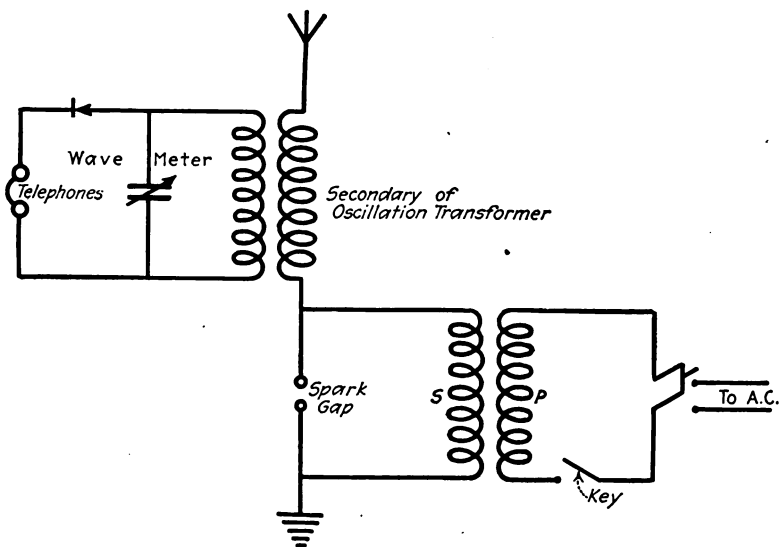

FIG. 133a.—Wave meter coupled to oscillation transformer.

primary of the oscillation transformer, and repeating the operations until the circuit is properly tuned.

Next the connections are made as shown in Fig. 133a and the open circuit excited by a small spark gap as shown. The inductance of the wavemeter is coupled inductively with the secondary of the oscillation transformer and care should be taken to disconnect the primary and thus have the closed circuit, previously tuned, open while tuning the secondary circuit. The open circuit is tuned in the same manner as described above to the same wave length as that of the primary circuit. The case sometimes is encountered where the inductance in the secondary of the

oscillation transformer is not great enough to reach this wave length and it is necessary to load this circuit by putting an additional inductance, called a loading coil, in series.

Another and in some respects a more satisfactory connection for exciting the aerial for tuning purposes is shown in Fig. 133b. As here shown, one side of the power transformer secondary is connected through a rotary spark gap to the upper end of the secondary of the oscillation transformer while the other end of the power transformer secondary is left disconnected. The operation of the key then produces oscillations of sufficient magnitude to permit sharp tuning.

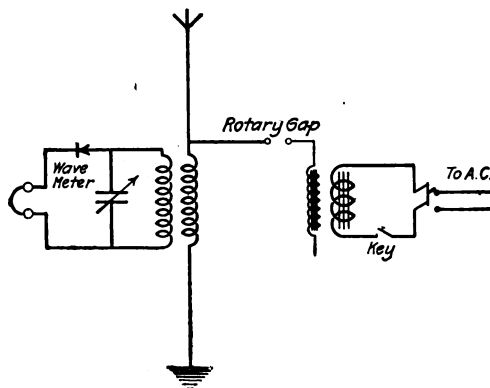

FIG. 133b.—Tuning circuit.

The measurement of the radiating wave is then made as shown in Fig. 134, in which the transmitting set is coupled up in the regular manner and the wavemeter is then coupled with a single turn in the antenna circuit. The hot wire milliammeter is used as the indicating device in this measurement. The transmitting key is depressed and readings of the ammeter and condenser settings taken as the capacity of the wavemeter condenser is varied throughout its range. Then a curve is plotted with millamperes as ordinates and wave length or condenser settings as abscissas as in Fig. 93. It will be observed that there are two peaks in this curve due to the reaction of the magnetic fields of the closed and open circuits one upon the other causing the antenna to have two periods of oscillation, one of which is shorter

than the individual adjustment of the circuits and the other longer. No readjustment of the tuning of the circuits can be made which will give a single peak in both of the same wave length as before, and the only method of obtaining a single peak, or a wave of two peaks in which the amplitude of the smaller is less than 10 per cent. of the greater as prescribed in the law, is to loosen the coupling. Such a single peak at the same wave length to which both circuits were tuned individually is shown by the solid line curve, Fig. 94.

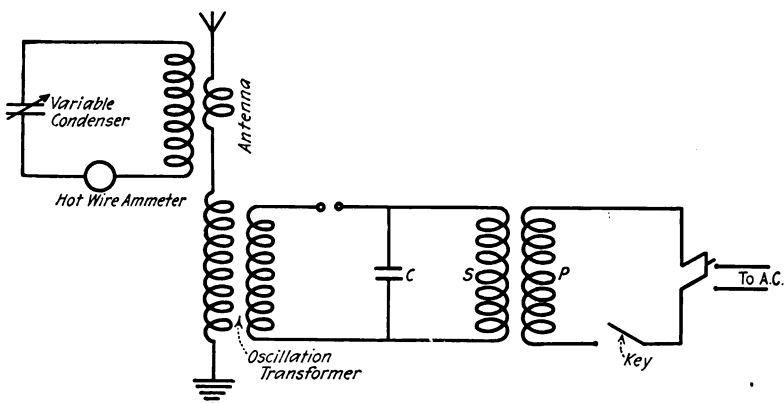

FIG. 134.—Measuring wave length in antenna. *S* and *P* are coils of an iron core transformer.

Having obtained the resonance curve it is possible to calculate the logarithmic decrement for complete oscillation of the antenna circuit by the following formulas,

$$(1) \quad \delta_1 + \delta_2 = 3.14 \frac{C_r - C}{C_1} \sqrt{\frac{I^2}{I_r^2 - I_1^2}}$$

$$(2) \quad \delta_1 + \delta_2 = 3.14 \frac{C_2 - C_r}{C_2} \sqrt{\frac{I_2^2}{I_r^2 - I_2^2}}$$

where δ_1 is the decrement of the antenna circuit, δ_2 the decrement of the wavemeter, which is usually negligible and may be omitted, C_r and I_r are condenser setting, or wave length, and current at resonance, C_1 and I_1 are the same for a point below resonance,

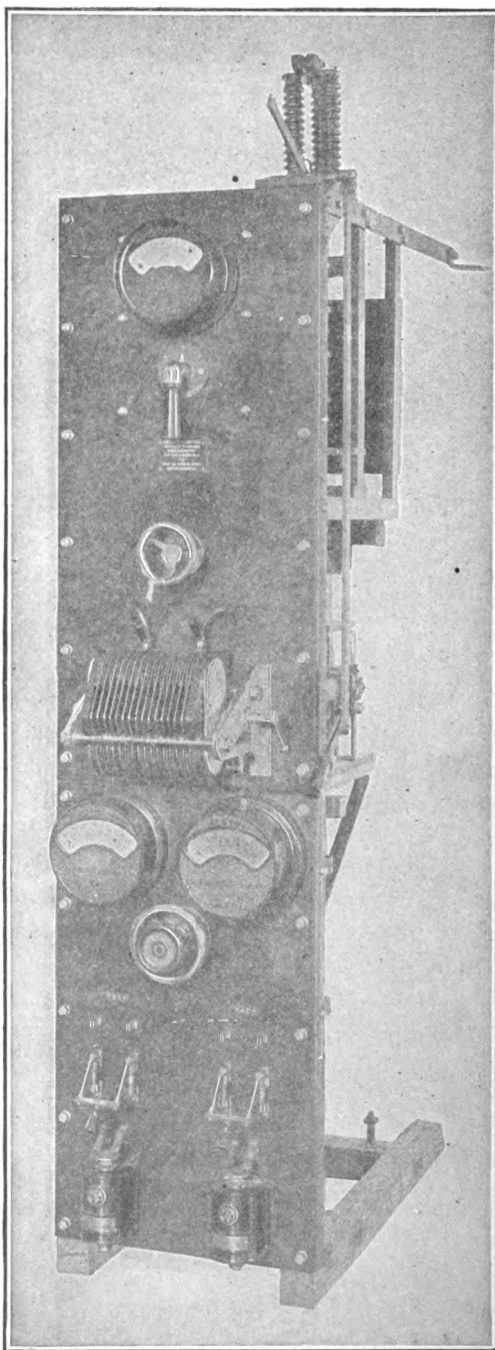

FIG. 135.—Bureau of Standards transmitting set, front view.

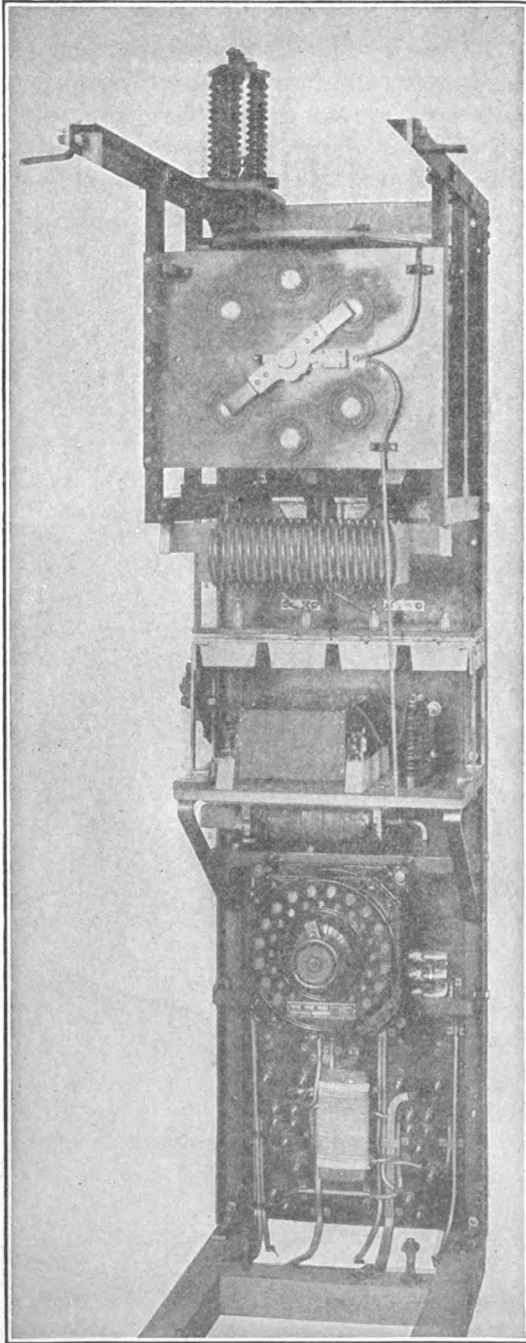

FIG. 136.—Bureau of Standards transmitting set, back view.

and C_2 and I_2 are the same for a point above resonance. The values obtained by the two formulas should be averaged in order to obtain the most accurate value. This value should be less than two-tenths in order to comply with the law. An actual transmitting set designed by the Bureau of Standards is shown in Figs. 135 and 136.

CHAPTER X

PRACTICAL RECEIVING APPLIANCES AND METHODS

134. General.—Radiotelegraphy receiving apparatus is a combination of appliances for converting the energy of the electromagnetic waves produced at the transmitting station into signals that can be perceived by one of the senses. As has been explained, the energy from the transmitting station is radiated by the antenna and as it spreads out into space the amount passing across a unit area at right angles to its line of propagation decreases with the distance from the source.

Since these waves are propagated close to the earth, irregularities in the surface of the earth as mountains will have the effect of decreasing the energy still further because of absorption. It can readily be seen that at any considerable distances, as those covered in wireless telegraphy, there is an exceedingly small amount of energy available at the receiving station.

In order to detect the waves at the receiving station it is essential to have an antenna system similar to that employed for transmitting, and in most cases the same antenna is used for both transmitting and receiving. The waves, which as previously described consist of an electric field and a magnetic field at right angles to each other, cut the receiving antenna and induce alternating currents in it. These currents have the same frequency as the high frequency currents oscillating in the transmitting antenna, provided that the receiving antenna system is tuned to the same period of oscillation or wave length as the sending antenna, or in other words, provided there is resonance between the two circuits. It is nearly always the case that the natural periods of the two systems are not the same; in fact it may be said that it is universally true that they are not the same. Thus it is necessary to make them the same. The transmitting wave length is fixed by law and the receiving apparatus must be adjusted to this wave length. This adjustment is called tuning. As it is true in a number of things, the tuning can be carried to any degree of refinement required, depending upon the conditions

and upon the instruments available. Corresponding to the two types of transmitters—namely, damped or spark and undamped wave transmitters—there are two types of receivers, if by receiver we mean the receiving appliances as a whole.

In spark transmission the signals are made by short and long trains of sparks at the gap. Each spark, however, has a frequency far above audibility, but a group of sparks may follow each other at intervals ranging from 0.02 to 0.001 second, or in other words the spark frequency ranges in practice from 50 to 1000. This frequency is low enough to operate a telephone receiver. If the method of producing the sparks is carefully adjusted so that the sparks follow each other at equal intervals, a musical tone is heard in the telephones. A necessary condition for detecting signals from a spark transmitter is close or accurate tuning.

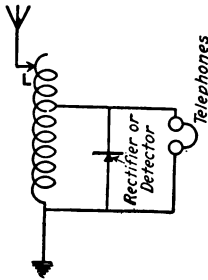

FIG. 137.—Simple receiving circuit.

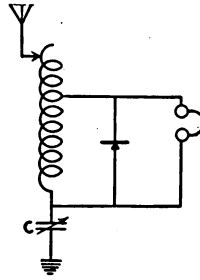

FIG. 138.—Simple receiving circuit with condenser in antenna.

The receiving antenna circuit must respond to the frequency of the sending antenna circuit. In addition appliances must be provided which will translate the electric energy received into signals that can be perceived by some one of the senses, at present this is the sense of hearing but attempts have been made to transform the received oscillations into visual signals. Fig. 137 shows a diagram of a simple receiving circuit in which the adjustable inductance is inserted in the antenna to increase the wave length above its natural value. Fig. 138 shows a simple circuit containing a variable condenser in series with the antenna for tuning to lower frequencies. In addition the circuit contains a device for rectifying the alternating current and a pair of telephone receivers for translating the oscillating energy into audible signals.

135. Cymoscopes or Detectors.—In general detectors may be divided into two general classes:

Those operating a detecting device directly by means of the energy received from the sending station, thus getting proportional responses and those operating as triggers or relays. This type is operated by the energy received from the sending station merely to influence a local circuit which supplies the energy to operate some signalling device.

At present the use of the former type is limited to the receiving of signals from spark stations, while both types are used in undamped wave receiving stations. A detector is defined by the standardization committee of the Institute of Radio Engineers as follows: "A detector is that portion of the receiving apparatus which is connected to a circuit carrying currents of radio frequency and in conjunction with a self contained or separate indicator translates the radio frequency energy into a form suitable for operation of the indicator. This translation may be effected either by the conversion of the radio frequency energy or by means of the control of local energy by the received energy."

It would be useless to describe all of the different types of detectors used at various times in the very rapid development of radiotelegraphy and therefore we shall limit ourselves to a discussion of those types which have been the most widely used and the most successful. The earliest detector was the coherer. It was employed by Marconi and several other experimenters but was soon abandoned in favor of other types. The magnetic and electrolytic detectors followed the coherer and were likewise superseded by the crystal detector. The crystal detector was very widely used and very successful up to the advent of the vacuum tube detector which at the present time is used practically universally. The operation of this will be explained later.

Certain crystals have the property of offering a much higher resistance to the flow of current in one direction than in the other direction. This property is termed unilateral conductivity, and the crystals possessing it are called rectifiers. There are quite a number of different crystals that have this property; such as silicon, galena, carborundum, molybdenite, with a metallic contact and zincite-chalcopyrite, zincite-boronite, zincite-tellurium, silicon-arsenic, iron pyrites-antimony and numerous other combinations. Some of these are used with a local battery and others employ merely the rectified current to operate the

detecting device, which is usually a pair of telephone receivers.

The action of the detector is as follows: The received energy which, upon collection by the aerial develops oscillating currents, is passed through the detector, either directly or in a derived

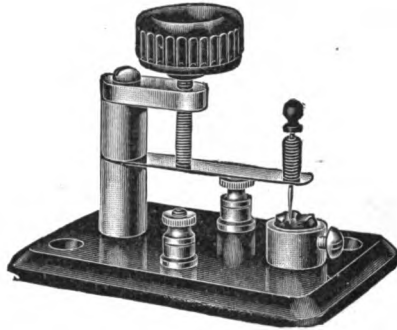

FIG. 139.—A mounted crystal detector.

circuit by means of a transformer, and the detector acts as a rectifier by changing the oscillating current to a unidirectional, intermittent current. This unidirectional current can be used directly in the telephone receiver. One group of these rectified currents produces but one movement of the telephone diaphragm,

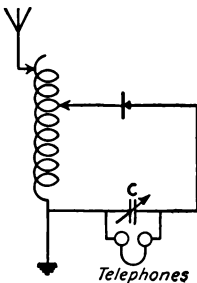

FIG. 140.—Simple receiving circuit with telephones across condenser.

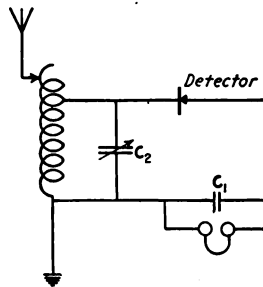

FIG. 141.—Possible connection for crystal detector.

that is each spark produces a movement, and not the individual waves of the spark. Fig. 139 shows one form of crystal detector. Various connections are possible with crystal detectors; some of these are shown in Figs. 140, 141 and 142. Silicon and galena crystals are sensitive detectors and do not require a local battery.

Carborundum and zincite-chalcopyrite detectors require a battery, the latter forms the most sensitive detector but the former is very rugged and holds its adjustment a long time. Ordinarily all points on a crystal are not equally sensitive, it is thus necessary to adjust for maximum sensibility and it is extremely diffi-

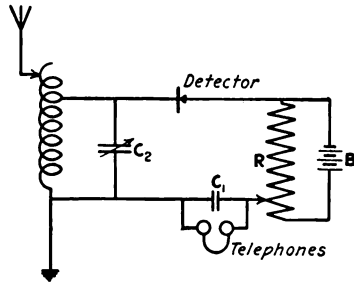

FIG. 142.—Possible detector circuit with battery.

cult to maintain a good adjustment with a galena detector. The adjustment of the detector for maximum sensibility can be made either while receiving signals or before actual reception by exciting the receiving set by means of weak local oscillations from

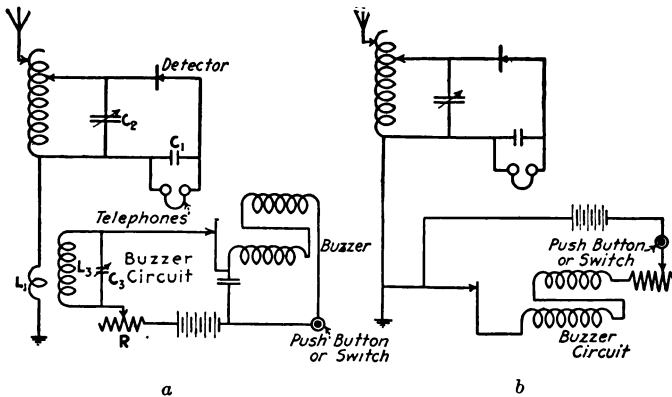

FIG. 143 (a) and (b).—Receiving circuits with buzzer test circuits.

a buzzer. Figs. 143 and 144 show the connections for such a buzzer test outfit. The buzzer circuit is coupled inductively to the antenna circuit as shown. A small coil L_1 of 5 to 6 turns about 1.25 to 1.75 in. in diameter is connected in series with the antenna. Around this coil is wound another coil L_3 of the

buzzer circuit. As the buzzer is operated, electric oscillations are set up in the circuit consisting of coil L_3 and condenser C_3 . These oscillations are tuned to the antenna frequency and thus excite oscillations in it.

The buzzer and its circuit are for the purpose of determining the condition of sensitiveness of the detectors. For instance if the received signals suddenly cease, the receiving operator must be in a position to determine whether the break is due to a fault at the sending or receiving station. If he hears signals when the buzzer is operated, he knows at once that his detector is all right, and that the interruption is due to some other cause, while an absence of signals indicates that his detector is at fault.

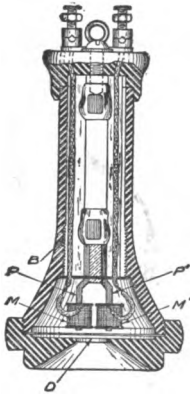

FIG. 144.—Telephone receiver.

The buzzer circuit is also employed for adjusting the crystal detector for the most sensitive operating condition. It is generally necessary after a period of operation to adjust the detector to its maximum degree of sensitiveness. This is done by exciting the buzzer circuit and changing the points of contact on the crystal until the loudest signals are heard in the telephones.

136. Telephone Receivers.—The principles of operation of the telephone receiver will be understood from Fig. 144, which is a section of the ordinary instrument. The essential parts are a case of hard rubber, two permanent bar magnets or a horseshoe magnet, coils, and a diaphragm.

Two permanent bar magnets are employed, being fastened together so as to form a single horseshoe magnet. Two soft-iron pole pieces P and P' are attached to the ends of the magnet near the diaphragm. Each one of the soft-iron poles is surrounded by a coil of very fine insulated copper wire, marked M and M' in the figure. Immediately in front of the poles is placed the sheet-iron diaphragm D which must not touch the pole pieces even when vibrating through its widest range. One of the magnet poles is a north pole and the other is a south pole. The diaphragm forms a part of the magnetic circuit, and where the lines enter the diaphragm a south pole is formed, and where the lines leave the diaphragm a north pole is formed. Thus the diaphragm acts

as an armature and by the attraction of the magnet is constantly bent or dished toward the pole pieces.

The coils on the pole pieces are connected so that the magnetic lines set up by a current passing through them will make one a north pole and the other a south pole. The currents flowing through the coils in one direction tend to strengthen the field of the permanent magnet, and currents flowing in the opposite direction tend to weaken the field of the permanent magnet. The diaphragm will spring away from the pole pieces when they

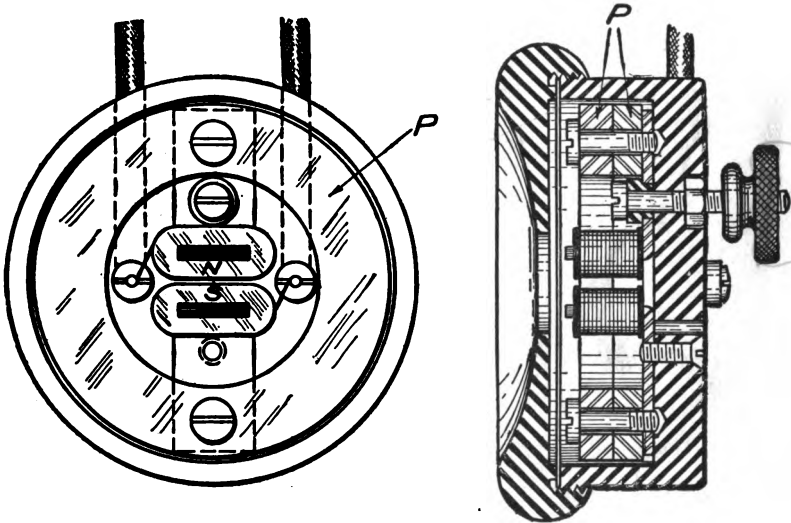

FIG. 145.—Principles of radio telephones.

are weakened, and when the current ceases the diaphragm will be drawn back toward the pole pieces. When the magnetic field set up by the coils assists the field of the magnet, the diaphragm will be drawn nearer to the pole pieces, and when the current stops the diaphragm will again spring back to its normal position.

The construction of radio telephone receivers is shown in Fig. 145. This instrument is a double pole receiver, hence, the operation is the same as that of the hand receiver described above. The permanent magnets consist of steel rings *P*, which are cross magnetized so that a north pole exists on one side and a south pole on the other. The soft-iron pole pins are clamped between the bottom ring and the case, as shown in the sectional view. The

essential difference between the ordinary wire telephone receiver and the receiver for wireless telephony is in the resistance of the coils, the latter having much the higher resistance. Those shown in Fig. 146 are wound to 3200 ohms resistance.

137. Sensitiveness and Amplitude of Vibration.—The sensitiveness of telephone receivers depends upon the strength of the permanent magnets and upon the diameter and thickness of the diaphragm. A thin diaphragm responds very readily to currents of high frequency and gives clear, sharp tones, while a thicker one is more rigid and responds readily only to low frequencies. The chief objection to a very sensitive receiver is that it reproduces any local disturbance as faithfully as it does the waves from the transmitting end.



FIG. 146.—A pair of radio telephones.

It is incredible what small quantities of energy are required to operate a receiver to produce audible sounds. Kennelly's tests show that a current as small as 0.00000044 ampere is sufficient to produce audible signals. The amplitude of vibration of the diaphragm is likewise very small. Investigators do not agree but Bosscha reported the amplitude for the most faintly audible tone to be an amplitude of 0.000002 centimeter. Weillischbach concluded that the "amplitude for speaking must certainly be considerably greater than for a mere hum, and it is fair to estimate it at from 0.001 to 0.0001 centimeter."¹

¹SHEPARDSON, Telephone Apparatus, p. 58.

138. Natural Period of Diaphragm.—Since the diaphragm is an oscillating body, it has a natural period of its own. This may be of considerable importance when the frequency of the current in the telephone circuit is nearly the same. Another effect of the motion of the diaphragm is to vary the magnetic reluctance of the magnetic circuit, and indirectly the impedance of the windings. This, however, is of more importance in telephony than in telegraphy and in cases where the receiver is used as a detector.¹

139. Adjustments of Damped-wave Receiving Circuits.—A diagram of the electrical circuits of a typical damped-wave

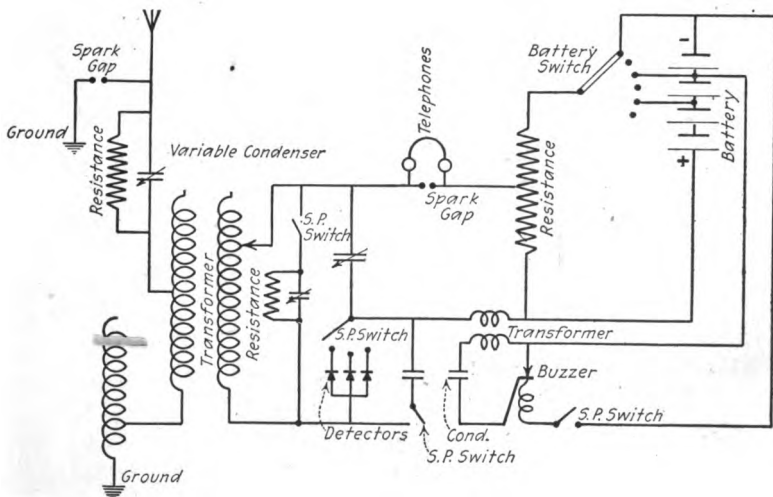

FIG. 147.—Typical connections of a receiving station.

receiving station is shown in Fig. 147. The student will observe that this is merely a combination of the simple circuits into a practical working set.

“The spark-gap shown connected between the antenna and ground is really a lightning arrester. The resistances, shown shunted around the condenser in the antenna and the condenser in the closed oscillating circuit, are for protective purposes and serve as a leak for high voltage charges. They are generally made of graphite rods and have a very high resistance. The detectors shown are of two types, liquid barretters and crystals, two of the former and one of the latter being mounted in the

¹ See SHEPARDSON, *Telephone Apparatus*, *loc. cit.*

particular installation represented in the sketch. These detectors are provided with a condenser which can be shunted around them as a protection against too strong currents, such as are apt to be picked up during the sending on a nearby set. This condenser is cut out during the receiving operations. The test buzzer and its circuits are for the purpose of determining the condition of sensitiveness of the detectors."¹ In operating a receiving set of this type the antenna circuit is first tuned to the frequency of the transmitting station with which it is desired to establish communication. This tuning is accomplished by the adjustment of the variable inductance and condenser. The necessity for sharp tuning can be appreciated by remembering that in normal times there are hundreds of commercial land and ship stations and naval and army stations, and thousands of

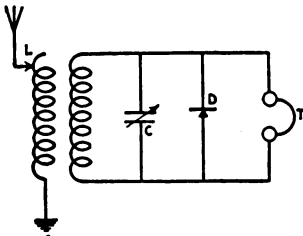

FIG. 148.—Loosely coupled detector circuit.

private ones. The allowable wave length at which these stations can operate has been fixed by the International Radio Congress and by law, and this has resulted in a very confused state of affairs. The condition at present is that certain wave lengths are very congested, and this is particularly true in certain parts where there are a great number of stations, both land and ship, of

moderate power and all operating on the same wave length. Under actual operating conditions it must be possible to select the station with which it is desired to communicate and to weed out all of the others so as to reduce the interference to a minimum. The best method of obtaining this extreme selectivity is by loose coupling of the antenna and detector circuits. A simple loose coupled receiving circuit is shown in Fig. 148. Both the primary and secondary circuits can be tuned and the coupling varied. In tuning to a certain station, both circuits should first be tuned to approximately the desired wave length, then the primary or open circuit is tuned to the incoming wave and the secondary tuned exactly, the final adjustments being made by varying the coupling and the variable condenser *C*, until the signals are the maximum or the interference reduced to the minimum. It will be found in many cases that it is wise to cut

¹ KINTNER, *Electric Journal*, Vol. 10, p. 826.

down the strength of the received signal if the interference can be reduced because the point of maximum intensity and that of minimum interference do not ordinarily occur at the same adjustment.

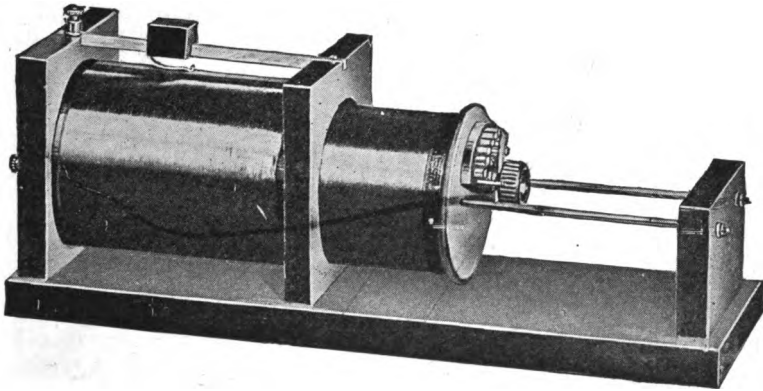

FIG. 149.—Receiving transformer.

The loose coupler, Figs. 149 to 150, or receiving transformer, usually consists of two coils so constructed that one slides inside of the other, the primary coil being outside and wound with relatively large wire and the secondary being inside and wound

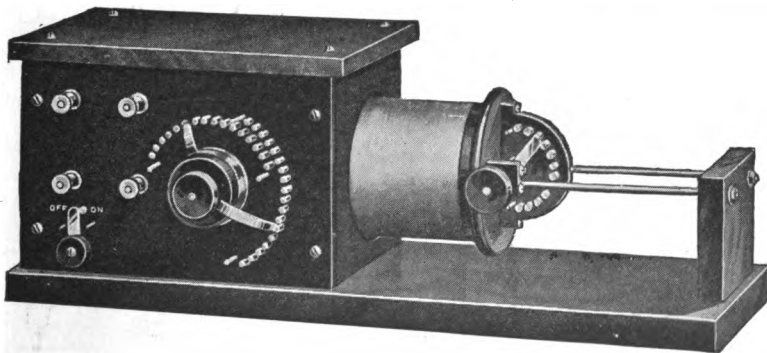

FIG. 150.—Receiving transformer.

with many turns of fine wire. Taps are taken from the windings to button switches or the number of active turns may be varied by sliding contacts. Sliding contacts are not very satisfactory because the contact is poor and the wire becomes worn down with

use. Taps are very much more desirable because soldered connections can be used and the entire instrument can be mounted in a cabinet or panel.

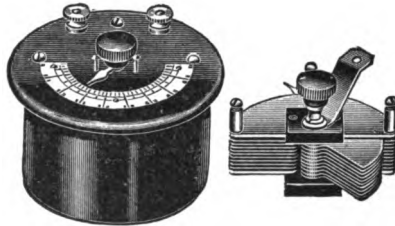

FIG. 151.—Receiving condenser.

The variable condensers employed in receiving are of much smaller capacity than those employed for most purposes and may be of many and varied designs. There is one type of condenser that is coming to be used as the standard, Figs. 151 and 152.

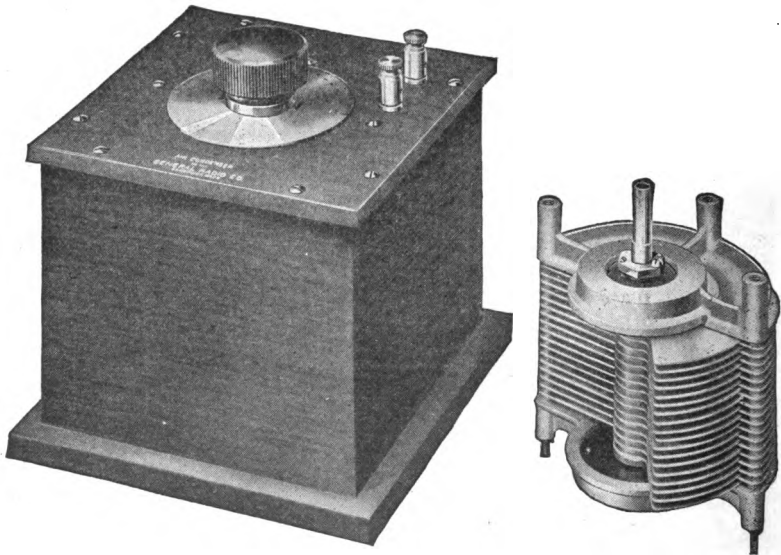

FIG. 152.—Receiving condenser.

This consists of a large number of metal disks usually semicircular in shape. One half of these metal disks are fixed and mounted parallel and close together. The other half is mounted on a shaft which can be rotated and placed between the fixed plates.

The movable plates are separated from the fixed ones by an air space and are insulated from them. The capacity of the condenser can be varied by rotating the movable plates. A receiving set designed by the Bureau of Standards is shown in Fig. 153.

140. Receivers for Undamped Waves.—Receivers of the type described above are for spark or damped-wave signals only as the sound the receiving operator hears corresponds quite closely to the sound of the spark heard at the sending station. If transmission is carried on by means of undamped waves, no signal will be heard by a receiving operator using a set like those described; for the undamped wave frequency is far above the

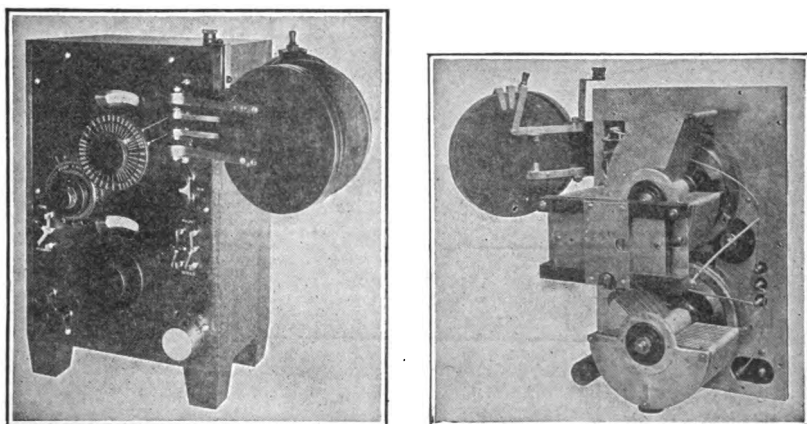

FIG. 153.—Bureau of Standards receiving set.

limit of audibility, and further, the telephone diaphragm cannot respond to such rapid vibrations.

There are two methods employed in practice for detecting undamped or continuous wave signals. These may be called the *discontinuous* and *interference* methods, although the more common names are *tikker* and *heterodyne* methods.

141. Discontinuous or Tikker Method.—In the spark system the signals are heard at the receiving station because the sparks are groups or waves. That is, the spark makes the waves discontinuous at the sending station. In the discontinuous or tikker system of detecting continuous waves the discontinuity is made at the receiving station instead of at the sending station. The continuous waves are broken up into groups of waves which a telephone receiver is capable of detecting. The discontinuity

is produced by a rotating switch called a tikker which alternately closes and opens a circuit around part of a resonant circuit. This breaking in on the resonant circuit breaks up the continuous waves into groups of cycles which can be made to operate the telephone receiver. A typical tikker circuit is shown in Fig. 154. The tikker is a wheel mounted on the shaft of a constant speed motor or is driven in some other way at a constant speed. The wheel is made of conducting material in the rim of which are inserted insulating sectors. The wheel is connected to a resonant circuit by two sliding contacts, one, *A*, on the face or shaft of the wheel and the other, *B*, on the rim. It is evident that as the wheel rotates it alternately connects and disconnects C_2 in parallel with C_1 . When the tikker closes the circuit, C_2 receives a charge from the secondary of the receiving trans-

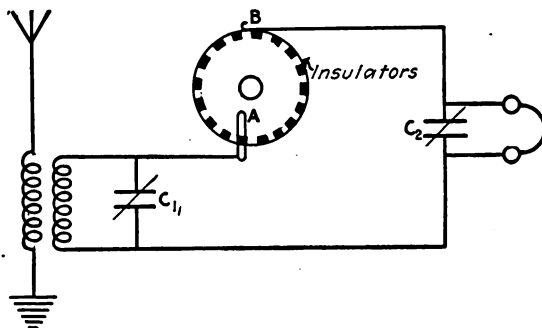

FIG. 154.—Connections for tikker.

former provided current is surging up and down the antenna. When sliding contact *B* makes contact with an insulating sector, condenser C_2 discharges through the telephones producing a click. The frequency or number of these clicks per second is determined by the speed of the tikker and the number of insulating teeth; the frequency may thus be adjusted so as to produce an audible note in the telephone.

A modification of the tikker method is the so-called *tone-wheel* method. In this method a rotating switch is also employed, but the wheel is rotated at such a speed that the interruptions of the circuit at *A* are nearly synchronous with the frequency of the alternating current in the resonant circuit. The telephones are connected directly in series with the wheel and condenser C_2 is omitted. If the interruptions at *A* were exactly in synchronism, or of the same frequency as the alternating current in the antenna,

no sound would be heard in the receiver on account of the high frequency. If the frequency of the interruptions is constant but slightly different from the frequency of the alternating current, then impulses will be imparted to the receiver diaphragm whose frequency is equal to the difference between the frequencies of alternating current and that of the interruptions. To understand the reason for this, assume that the circuit is first closed at the instant the alternating e.m.f. is passing through its zero value. At this instant no current will flow through the telephone. There may be a phase difference between current and pressure, but for the present we neglect this. If the interruptions are slower than the frequency, the next contact will be higher up on the succeeding e.m.f. wave. The third contact will be still higher up etc. so that by the time the e.m.f. has gained one

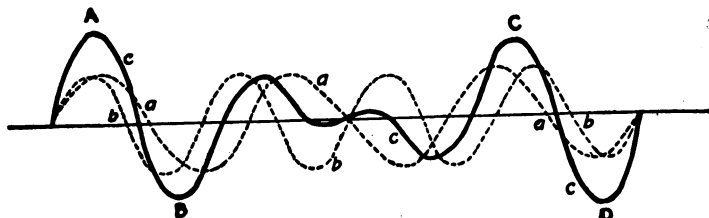

FIG. 155.—Interference of sound waves.

cycle on the interruptions, a cycle of current has passed through the receiver and the diaphragm has made one complete oscillation. If f_1 is the frequency of the e.m.f., and f_2 the frequency of the interruptions, then $f_1 - f_2$ is the number of cycles gained per second by the e.m.f. on the interruptions; and $f_1 - f_2$ is the frequency of the telephone diaphragm. It is evident that by adjusting f_2 , sounds in the telephone receiver may be made audible.

Interference or Heterodyne Method.—The principle of the interference method has its counterpart in sound. If two like tuning forks be mounted on resonant bases near each other, and if while in this position they be caused to vibrate, a musical tone of definite pitch will be heard. If next a small weight be attached to a prong of one of the forks, and the two are again sounded together, the tone produced will no longer be simple, but at successive intervals the sound will be intensified and weakened or it will be characterized by what are known as beats. That is, the loudness of the sound fluctuates; it rises and falls at

regular intervals. These beats are due to interference of the sound waves produced by the tuning forks. The sound waves produced by the tuning forks may also be represented by sine waves. Let (a), Fig. 155, represent a wave due to one fork and (b) be a wave due to the other fork. The motion of a particle of air in which these waves are produced will be the resultant or sum of the two waves. Combining (a) and (b) we get (c) which shows the increase in amplitude at points marked *A*, *B*, *C*, and *D*. At other points the amplitude of the resultant curve is less than the amplitude of either component. The intensity of sound due to the vibrations at *A*, *B*, *C*, and *D* is greater than at other points in the sound waves and accordingly the sound is characterized by beats.

143. Relation Between Frequencies and Beats.—Suppose the two forks mentioned in the preceding article have frequencies of 250 and 251 cycles per second. If the two forks are started vibrating together and in the same direction, then after 250 vibrations of one and 251 of the second they will be exactly in the same relative position as at the beginning. That is, the second fork will gain one vibration in every 250 vibrations of the first, or one vibration per second. Since the speed of the sound from the two forks is the same, the sound due to the second

fork gains its own wave length in $\frac{1}{251 - 250} = 1$ sec. or there will be one beat per second. In general, if the frequencies are f_1 and f_2 , then one will gain its own length in $\frac{1}{f_1 - f_2}$ seconds, and there will be $f_1 - f_2$ beats per second. This is plainly the same as the frequency of the tone wheel described above. The interference method of receiving undamped waves is analogous to or an exact counterpart of the interference method of producing beats. To the receiving antenna circuit is connected an undamped-wave generator of a form which will generate waves of nearly the same frequency as the generator at the sending station, Fig. 156 shows an arc generator at the receiving station. The received waves interfere with the locally generated waves producing beats whose frequency may be varied by varying the frequency of the local generator. The frequency of the beats is adjusted so that they produce an audible tone in the receiver.

With the heterodyne system, interference from an undesired signal of slightly different frequency can be avoided by adjusting the beats due to the undesired wave to zero or above audibility.

For some time the use of the interference or heterodyne system was limited on account of the lack of a suitable local generator whose frequency could be readily varied. The two available methods of generation were more or less unsatisfactory—the alternator because its frequency could not be varied quickly and

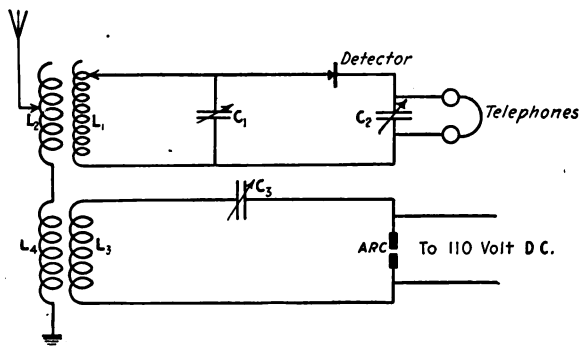

FIG. 156.—Heterodyne receiving circuit.

easily, and the arc because its current gave disturbing noises in the telephones making difficult the recognition of signals. But the more recent discoveries of the properties of vacuum tubes have obviated these difficulties and the heterodyne method has become commercially feasible. The vacuum tube and some of its many applications will be given in the next chapter.

CHAPTER XI

VACUUM TUBES AND THEIR USE IN RADIOTELEGRAPHY

144. General.—The vacuum tube in the form of Geissler's tube has been known for a long time, but its practical application has been very limited. It is only within the last few years that the properties of these tubes have become more fully known and that their practical application has extended to fields which in war times cannot be discussed. In 1906 DeForest presented a paper before the American Institute of Electrical Engineers on a *New Receiver for Wireless Telegraphy* which he called the Audion. It is the modification and improvement in this which have enormously increased the efficiency of radio-communication, both telegraphic and telephonic. As the theory of operation of this type of vacuum tube is based on the electron theory of electricity, a brief abstract of the theory will first be given.

145. Electron Theory of Electricity.¹—In the preceding discussion of electromagnetic phenomena attention was concentrated on the phenomena without reference to any theory as to the essential nature of electricity nor of its relation to matter. In fact matter was treated as though it were a vehicle for conveying or a vessel for holding electricity. As early as the middle of the eighteenth century, Prokop Divis made what then seemed a fantastic guess that electricity is the soul of the elements. In other words this is the one fluid theory suggested by Benjamin Franklin to which has been added the suggestion that matter is fundamentally electrical. The electron theory is in accordance with the statement or guess of Divis to the extent that it asserts the atoms of all substances to consist of negative and positive electricity, the former existing in the form of very minute corpuscles or electrons, each of which has a mass of about $\frac{1}{1800}$ of that of the hydrogen atom. Every atom is supposed to consist of a nucleus of positive electricity around which the negative charges are grouped, and the electrical effect of the positive

¹ An elementary and interesting discussion of the electron theory is found in KENNEDY DUNCAN'S "New Knowledge."

electricity just neutralizes that of the electrons and in the normal condition the whole atom is electrically neutral. The positive electricity is immovable, that is to say an atom cannot be deprived of its positive charge; but in conductors the negative corpuscles or electrons are continually getting loose from the

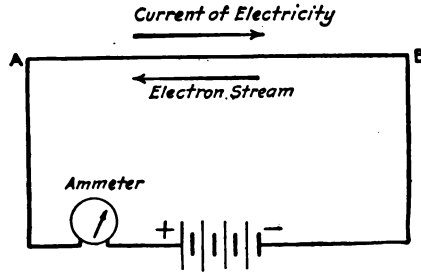

FIG. 157.—Circuit showing direction of current and stream of electrons.

atoms and reentering other atoms. When these electrons are driven off from the conductor, it is left with an excess of positive electricity and is said to be charged positively. Again, if the conductor contains an excess of electrons, it has a preponderance of the property of these negative corpuscles and is said to be

negatively charged. The charge of one electron is called the elementary electrical charge. A current of electricity, according to the electron theory, is a stream of electrons guided by a conductor. The interesting fact must here be noted that this stream of electrons is in a direction opposite to that in which the current of electricity is assumed to be flowing. This is due to the fact that the convention with reference to the direction of current flow was established

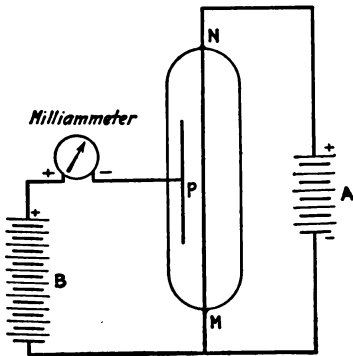

FIG. 158.—Vacuum tube showing how an electron stream may be produced.

before the recognition of the validity of the electron theory. It is believed that in a metallic conductor many of the electrons are so loosely bound that they are easily set in motion by electric forces. There is evidence that the electrons are moving in random directions with high velocities when no

e.m.f. is impressed upon the conductor. This velocity can be increased in several ways, especially by the application of heat, to such an extent that they can be ejected from the surface of the metal. When they are subjected to the influence of an electromotive force or difference of potential, their direction of motion is controlled by the applied e.m.f. The random motion of the electrons is changed into directed motion or drift, and this drift constitutes the electric current.

146. Theory of Vacuum Tubes.—We have seen that what we consider as a current of electricity flowing from a positive to a

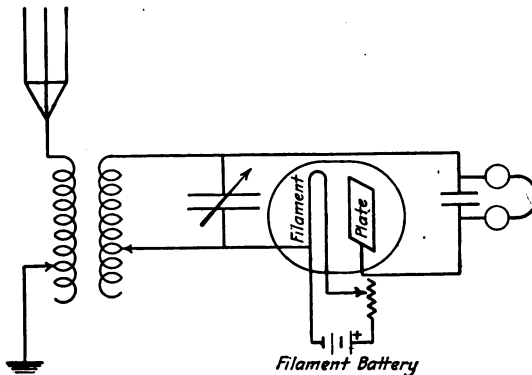

Fig. 159.—A simple Fleming valve receiving circuit.

negative potential is in reality a stream of negative charges flowing from a negative to a positive potential. The negative charges or electrons have a mass of about $\frac{1}{1800}$ the mass of a hydrogen atom. When we speak of a current of electricity flowing from *A* to *B*, Fig. 157, we are really speaking of the passage of a stream of electrons from *B* to *A*. This in general holds true whether the material through which the stream of electrons moves is a solid, a liquid, a gas, or even a pure vacuum.

Consider a tungsten wire (*M-N*) sealed into a glass tube, Fig. 158, from which the air has been exhausted, and let this wire be heated by an electric current from a battery *A*. Such a bulb is analogous to an ordinary incandescent electric lamp. A certain number of electrons flowing along the wire from *M* to *N* make up this heating current. Not all of the electrons in the wire, however, are used for this purpose. As the wire is raised in temperature, the remaining electrons are free to vibrate with increased

energy. If heated hot enough, the vibration of these electrons will become violent enough to break through the surface tension of the metal and permit them to escape. Thus we have the space around the filament filled with electrons. These electrons in the space immediately around the filament will tend to repel others coming out and equilibrium will be reached when no more electrons will be given off due to the repulsion of those already outside.

Suppose that in addition to the filament we seal into the glass tube a metal plate *P* and make the plate positive with respect to the filament by means of a second battery *B*. A milliammeter in this circuit will show that a small current is flowing toward the plate when the filament is hot. This is due to the fact that the free electrons which have been expelled from the hot filament are attracted by the positive plate. This stream of electrons from filament to plate constitutes a flow of current in the opposite direction, just as a stream of electrons through a wire constitutes an electric current. In this case the flow of electrons is from filament to plate, from the plate through the battery, and back again to the filament. This circuit is called the *B* circuit.

If the connections of the battery *B* are reversed thus making the plate negative with respect to the filament, no current will flow as the plate repels the electrons which are emitted from the filament and tends to drive them back into it. If an alternating e.m.f. be supplied in place of the battery *B*, there will be a current flowing toward the plate only when the plate is positive. It is, therefore, evident that the bulb in Fig. 158 may be used as a rectifier for alternating currents, and, therefore, can be substituted in place of a crystal detector in a radio-receiving circuit. Such an instrument is called a Fleming valve. A simple Fleming valve receiving circuit is shown in Fig. 159.

147. Factors Affecting Operation.—The magnitude of the current in the plate circuit depends upon several factors. In gen-

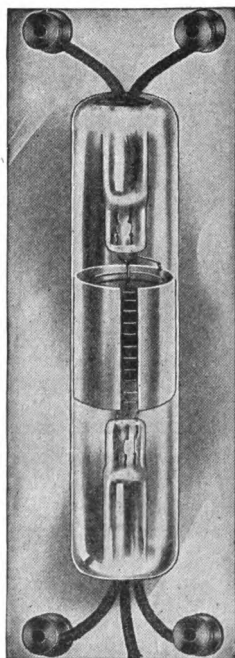

FIG. 159a.—A common type of detector bulb.

eral, for a given temperature of the filament and a given voltage applied to the plate, the current in the *B* circuit will be greater, the closer the plate is to the filament. For a given bulb at a constant temperature, the plate current will vary with the voltage of the battery *B*. For a given filament temperature this varia-

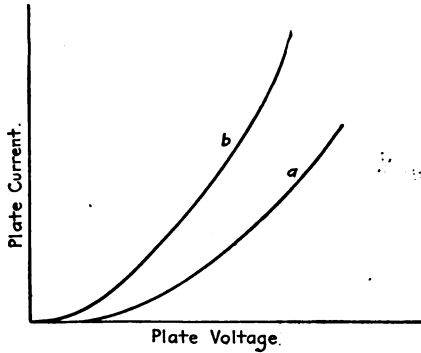

FIG. 160.—Variation of plate current with plate voltage.

tion will be like curve *a*, Fig. 160; for a higher temperature it will be like *b*.

The plate current also varies with the temperature of the filament. Fig. 161 is a curve showing the nature of this variation.

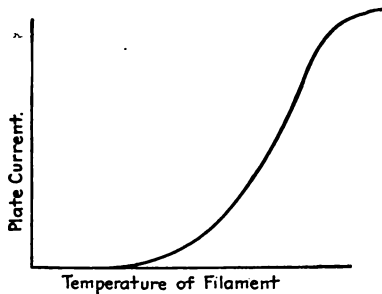

FIG. 161.—Variation of plate current with temperature.

The temperature of the filament may be taken as approximately proportional to the square of the heating current.

There is a third factor upon which the current in the plate circuit depends very markedly and this is the potential of the

space between plate and filament. As has been stated before, electrons which have just left the filament and are moving away from it, give a "space charge" as it is called to the vacuous space in the vicinity of the filament. This space charge is greatest close to the filament and will limit the flow of electrons between filament and plate. If a fine wire grid is put close to the filament, the influence of this space charge may be controlled by varying the potential of this grid. If the grid is made positive, it will tend to neutralize the effect of the electronic space charge which is negative and the result will be an increase in the flow of electrons from filament to plate. If the grid is made nega-

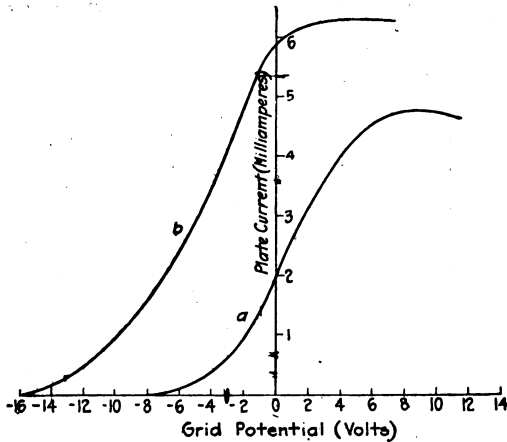

FIG. 162.—Variation of plate current with grid potential.

tive, it adds to the effect of the electrons in the space, and decreases the flow of electrons in the plate circuit. Thus if the temperature of the filament is kept constant, and the potential applied to the plate is kept constant, the current in the plate circuit may be varied also by varying the potential of the grid. *a* Fig. 162 shows such a curve, while *b* Fig. 162 is a curve taken for the same bulb with a higher plate voltage. These curves are called the characteristic curves of the bulb and they have a very important bearing upon the use to which the bulb is to be put. The connections for getting the characteristic curves are shown in Fig. 163. The notation of the various circuits should be noted as it is standard.

The circuit which heats the filament is called the *A* circuit;

the circuit to the plate is called the *B* circuit, and the circuit to the grid is called the *C* circuit. The voltage applied to the plate is called E_B and the current is called I_B . Similarly E_C denotes the voltage of the grid and I_C the current in the grid circuit. E_A and I_A are the corresponding quantities in the *A* circuit. In accordance with this notation Fig. 162 shows the variation of I_B with E_C for constant values of E_B and I_A , while Fig. 160 shows an E_B - I_B curve for $I_A =$ a constant, and $E_C = 0$.

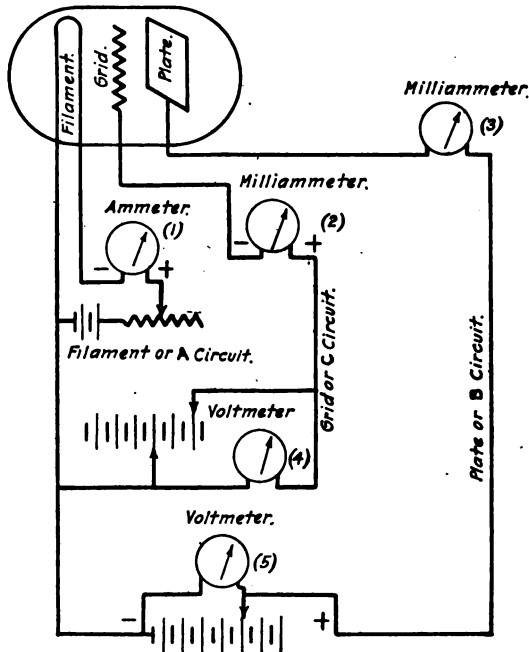

Fig. 163.—Connections for determining vacuum tube characteristics.

Note that when E_C is positive, the grid will attract electrons just as the plate and consequently there will be a current I_C in the grid circuit. When E_C is negative, $I_C = 0$. In Fig. 164

- Meter 1 shows I_A
- Meter 2 shows I_C
- Meter 3 shows I_B
- Voltmeter 4 shows E_C .
- Voltmeter 5 shows E_B .

noted
11/11/24
SP

INDEX

- A
- Abampere, 25
Acceleration, centripetal, 81
Action of condenser, 93
Adjustments of receiving circuits,
209
Admittance, 137
Aerials, 173
Alexanderson alternator, 184
Alternating current, 82
 average value, 102
 effective value, 102
Alternating e.m.f., 82
Alternator, Alexanderson, 184
 Goldschmidt, 186
American wire gage, 46
Ampere, 45
Amplifier, vacuum tube, 225
Amplitude, 68
Analogy for, coupled circuits, 145
 discharge of condenser, 108
 oscillatory circuit, 115
Analogy, phase difference, 86
 condenser, 92
Antenna, grounding, 172, 176
 capacitance, 180
 constants, 180
 inductance, 180
 wave length, 177, 179
Apparatus for damped waves, 160
 generating, 160
 key, 161
 transmitting, 161
Appliances, receiving, 201
 transmitting, 159
Arc circuit, 192
Arc generator, 190
 characteristic, 191
Audio-frequencies, 69
- B
- Bulb, vacuum, 221
Buzzer circuit, 205
- C
- Calculation of decrement, 197
 of wave length, 122
Capacitance, 13
 of antennas, 180
 unit, 15, 48
Capacitative coupling, frequency,
156
Centripetal acceleration, 81
Characteristic of arc, 191
Characteristics of vacuum tubes,
222, 225, 227, 232
Charge, electric, 8
 unit, 12
Circuits, detector, 205
 divided, 51
 for arc generator, 192
 impedance, 89
 magnetic, 6
 oscillatory, 107
 radio-, 131
 coupled, 138
 parallel, 132
 primary, 139
 secondary, 139
 simple, 131
Circular mil, 47
Clock diagrams, 86
Closed core transformer, 163
Closed electric oscillator, 113
 effect of resistance, 119
Coefficient of coupling, 142
Coefficient, radiation, 181
 temperature, 50

- Combined telephone and telegraph circuit, 235
 Condensers, 13
 Condenser, analogy, 92
 action, 93
 Condenser, discharge, 107
 analogy, 108
 energy, 109
 in parallel, 109
 in series, 109
 transmitting, 169
 Condenser in grid lead, 228
 Condenser, receiving, 212
 Conductors in series, 50
 in parallel, 50
 Connections of a receiving station, 209
 Constant, dielectric, 14
 Constants of antennas, 180
 Conversion factors, 62
 Coulomb, 45
 Counterpoise, 172, 176
 Coupled circuits, 138
 analogies, 145
 capacitative coupling, 139
 close coupling, 138
 coefficient, 142
 damping, 157
 direct coupling, 138
 frequencies, 150
 inductive coupling, 140
 loose, 141
 oscillations, 145
 primary, 139
 properties, 139
 secondary, 139
 Crystal detectors, 203
 Current, alternating, 82
 Current distribution in an antenna, 178
 Current, electric, 17
 Current in a circuit with capacitance, 95
 in a circuit with resistance and capacitance, 97
 phase relation, 97
 in a circuit with resistance, inductance, and capacitance, 100
 Cycle, 68
 Cyclic changes, 63
 Cymoscopes, 203

D

 Damped oscillation, 119
 Damped waves, 119, 125
 decrement, 127
 properties, 125
 Damped waves, generating apparatus, 160
 receivers, 202
 transmitting apparatus, 161
 Damping factor, 125
 Damping in coupled circuits, 157
 Damping of oscillations, 148
 Decrement of antenna, 197
 Decrement of damped waves, 127
 logarithmic, 128
 Detector circuits, 205
 loosely coupled, 209
 Detectors, 203
 crystal, 203
 vacuum tube, 226
 Diagrams, clock, 86
 Diaphragm, 209
 Dielectric constant, 14
 Difference in phase, 83
 Direct coupled circuits, frequency, 152
 Direct coupling, 138
 Discharge, condenser, 107
 Displacement, 77
 Distribution of current in an antenna, 178
 Distribution of voltage in an antenna, 178
 Divided circuits, 51
 Dyne, 7

E

 Effective value of A. C., 102
 Electric and magnetic fields, 19
 Electric charge, 8
 Electric current, 17
 heating value, 61
 unit, 45

- Electric field, 9
 between like and unlike charges,
 10
 between parallel plates, 10
 properties, 11
- Electric oscillator, closed, 113
- Electric potential, 12
- Electrical work, 59
- Electricity and energy, 59
- Electromagnetic induction, 33
- Electromagnetic pulse, 63
- Electromagnetic unit current, 24
- Electromagnetic waves, 63
 generation, 70
- Electromagnetic waves and radio-
 telegraphy, 73
- Electromagnetism, 17
- Electromagnets, 25
- Electromotive force, 35
 unit, 35
- Electromotive force, alternating, 82
- Electromotive force of self-induc-
 tion, 43
- Electron stream, 219
- Electron theory, 218
- Electrostatic phenomena, 8
- Energy, 56
 kinetic, 56
 potential, 56
- Energy in charged condenser, 109
 magnetic field, 113
- Energy radiated, 180
- English and metric units, 55
- Erg, 41
- Ether, 1
 elasticity, 2
 omnipresence, 2
 properties, 2
- F
- Factors, conversion, 62
- Farad, 15, 49
- Frequency, 68
 audio-, 69
 coupled circuits, 150
 influence on impedance, 104
 of direct coupled circuits, 152
 22
- Frequency of inductively coupled
 circuits, 154
 radio-, 69
 resonant, 131
- G
- Gap, spark, 165
 quenched, 168
 straight, 165
 synchronous, 166
- Generating apparatus for damped
 waves, 160
- Generator, arc, 190
 Goldschmidt, 186
 inductor, 185
 vacuum tube, 234
- Gilbert, 27
- Goldschmidt, alternator, 186
- Graphical representation of wave
 motion, 66
- Grounding antenna, 176
- H
- Heat loss, 182
- Heating value of electric current, 61
- Henry, 48
- Heterodyne, receiving, 215
 circuit, 217
- High frequency alternators, 183, 186
- Hysteresis, 31
- I
- Impedance, 89
 influence of frequency, 104
- Inductance, 41
 unit, 48
- Inductance of antenna, 180
- Induction, electromagnetic, 33
- Inductive circuit, 84
 phase difference, 84
- Inductive coupling, 140
- Inductively coupled circuits, fre-
 quency, 154
- Inductor alternator, 185
- Influence of stopping condenser, 229

- Interaction of primary and secondary, 148
- Interference method of receiving, 215
 relation between frequencies and beats, 216
- Iron, magnetic properties, 30
- K
- Key, 161
 double contact, 189
- Kinetic energy, 56
- Kirchoff's laws, 51
- L
- Light, 2
 speed of, 2
- Loaded antenna, wave length, 179
- Logarithmic decrement, 128, 197
 calculation of, 197
- Loose coupling, 141
- Loosely coupled detector circuit, 209
- Loss in antenna, 181
- L-type aerial, 173
- M
- Magnetic and electric fields, 19
- Magnetic circuit, 6
- Magnetic field, 2
 around current carrying wire, 18, 23
 energy in, 113
 inside of a long solenoid, 27
 inside of an anchor ring, 26
 unit, 24
- Magnetic phenomena, 1
- Magnetic poles, 3
 unit, 7
- Magnetic properties of iron, 30
- Magnetic reluctance, 28
- Magnetizing force, 28
- Magnetomotive force, 28
- Measuring transmitted wave, 194
- Metric and English units, 55
- Mil, 46
- Motion, pendulum, 66
- Motion, oscillatory, 76
 periodic, 67
 simple harmonic, 77
- N
- Natural period of diaphragm, 209
- O
- Ohm, 46
- Ohm's law, 49
- Open core transformer, 163
- Operation of transmitting sets, 194
- Oscillation transformer, 171
- Oscillations, 117
 coupled circuits, 145
 damped, 119
 damping, 148
 undamped, 119
- Oscillator, vacuum tube, 231
 characteristic, 232
 uses, 233
- Oscillatory circuits, 107, 113
 period, 117
 practical, 123
- Oscillatory motion, 76
- P
- Parallel arrangement of conductors, 50
- Parallel condensers, 109
- Pendulum, vibration, 66
- Period, 68
- Period of oscillatory circuit, 117
- Periodic motion, 67
- Permeability, 28
- Phase difference, 83
 in an inductive circuit, 84
 in circuit containing resistance and inductance, 88
 in circuit with resistance and capacitance, 97
 mechanical analogy, 86
- Phenomena, magnetic, 1
 electrostatic, 8
- Poles, magnetic, 4
 unit, 7

Potential, electric, 12
 Potential energy, 56
 Power, 58
 Power tube, 235
 Practical oscillatory circuits, 123
 Primary and secondary interaction, 148
 Propagation of waves, 64
 Properties of an electric field, 11
 Pulse, electromagnetic, 63

Q

Quantity, unit, 45
 Quenched gap, 168

R

Radiated energy, 180
 Radiation resistance, 181
 Radio-circuits, 131
 simple, 131
 Radio-frequencies, 69
 Radiotelegraphic systems, 159
 Radiotelegraphy waves, 73
 Radiotelephones, 207
 circuit, 235
 Reactance diagram, 132
 Receivers for undamped waves, 202, 213
 telephone, 206
 Receiving appliances, 201
 Receiving condenser, 212
 Receiving station circuits, 209
 Receiving transformer, 211
 Relation between magnetic and electric fields, 19
 Reluctance, magnetic, 28
 Resistance, 45
 change with temperature, 49
 radiation, 181
 temperature coefficient, 50
 unit, 45
 Resistance, effect on oscillations, 119
 Resonance of simple circuits, 143
 analogy, 145
 Resonant frequency, 131

S

Self-induction, 41
 Sensitiveness of receivers, 208
 Series arrangement of conductors, 50
 Series, condensers, 109
 Simple antenna, wave length, 178
 Simple circuits, resonance, 143
 Simple harmonic motion, 77
 Simple parallel, 134
 Spark gap, 165
 quenched, 168
 straight, 165
 synchronous, 166
 Speed in simple harmonic motion, 79
 rate of change, 80
 Speed of light, 2
 Stopping condenser, 228
 Strength of magnetic field, 23
 Susceptance, 137
 Synchronous gap, 166

T

Telephone receivers, 206
 circuit, 236
 radio-, 207
 sensitiveness, 208
 Temperature coefficient of resistance, 50
 Temperature effect on resistance, 49
 Theory of vacuum tubes, 220
 Tikker, 213
 Time, unit, 38
 Tone wheel, 214
 Transformer, 162
 closed core, 163
 open core, 163
 oscillation, 171
 receiving transformer, 211
 voltage relation, 162
 Transmission, undamped, 183
 Transmitting appliances, 159, 161
 operation, 194
 sets, 198
 Transmitting condenser, 169
 T-type aerial, 175
 Tuning, 131
 of transmitting set, 194

U

- Umbrella type aerial, 174
- Undamped oscillations, 119
- Undamped wave, transmission, 183
 - alternator method, 184
 - receivers, 213
- Unit charge, 12
- Unit magnet pole, 7
- Unit magnetic field, 24
- Unit of electromotive force, 35
- Units of measurement, 37
 - absolute, 38
 - derived, 38
 - electrical, 38
 - fundamental, 38
 - gram, 38
 - magnetic, 38
 - meter, 37
 - practical, 38
 - systems, 37
- absolute, 38, 40
- capacitance, 41
- current, 24, 40
- dyne, 7, 39
- electromagnetic, 39
- electrostatic, 39
- inductance, 41
- potential, 40
- resistance, 40
- work, 41
- practical electrical units, 44
 - capacitance, 48
 - current, 44
 - electromotive force, 48
 - inductance, 48
 - power, 58

- Units, practical electrical, quantity, 45
 - resistance, 45
 - work, 55

V

- Vacuum tubes, 218
 - amplifier, 225
 - bulb, 221
 - characteristics, 222
 - circuits, 230
 - connections for determining characteristics, 224
 - detector, 226
 - operation, 222
 - oscillator, 231
 - power, 235
 - receiving circuit, 220
 - theory of, 220
- Volt, 35, 43
- Voltage across arc, 191
- Voltage distribution in an antenna, 178

W

- Wave length, 69, 122, 177
 - measurement, 194
- Wave meter, 194
- Wave motion, 66
- Waves, electromagnetic, 63
- Waves, general, 64
 - production, 64
 - propagation, 64, 65
- Wisconsin circuit, 234
- Work, unit, 41, 54
 - electrical, 59

APR 13 1922



