

TEE
P

PITMAN'S COMMON COMMODITIES
AND INDUSTRIES SERIES

TELEGRAPHY, TELEPHONY
AND WIRELESS

BY

^{Joseph}
J. POOLE, WH.SCH., A.M.I.E.E.

AUTHOR OF "THE PRACTICAL TELEPHONE HANDBOOK"



465974
15.9.47

LONDON
SIR ISAAC PITMAN & SONS, LTD.
PARKER STREET, KINGSWAY, W.C.2
BATH, MELBOURNE, TORONTO, NEW YORK

COMMON COMMODITIES
AND INDUSTRIES



3 1761 06706417 0

TELEGRAPHY
TELEPHONY AND
WIRELESS

J. Poole

"LITTLE GEEKO"

DIRECT WORKING

TELEPHONES

For operating on existing bell circuits in Shops, Offices, Warehouses, Factories, Private Houses, etc. Easily installed. Efficient in working.

G.E.C. Telephones have many years of unequalled reputation behind them and can be recommended with the utmost confidence. Sound construction, combined with expert workmanship, and the use of the finest materials, has resulted in the production of instruments of first class quality.

Full particulars and expert advice can always be obtained on application.



K7765



K7730

**The GENERAL ELECTRIC
CO., LTD.**

Principal Showrooms and Sales Depot
67 Queen Victoria Street, London, E.C.4

Branches throughout the United Kingdom

YOUR ORGANISATION is incomplete without THE RELAY AUTOMATIC TELEPHONE SYSTEM, which is *entirely* AUTOMATIC and requires NO OPERATORS.

In four seconds you are either connected and can speak to the desired number, or informed by a low buzzing sound in the receiver that the line is engaged.

Call and see the system demonstrated or write *to-day* for an illustrated booklet.

The Relay Automatic Telephone

Co., Ltd.

Marconi House
Strand, London
W.C.2

Telephone City 281

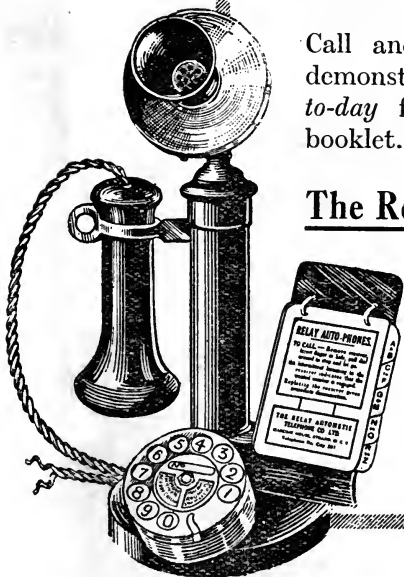



"STERLING" SYSTEM

PRIMAX

OF

AUTOMATIC INTERPHONES

THE present-day perfection of STERLING TELEPHONES is the direct result of twenty years practical experience in the manufacture of Telephones for every purpose. The STERLING "PRIMAX" SYSTEM is unequalled for simplicity and efficiency. Selecting and ringing are performed at one operation—there are no buttons to push. Made throughout at the STERLING WORKS, DAGENHAM, Essex, by skilled British labour using the best obtainable material.

Write for latest lists—

STERLING TELEPHONE & ELECTRIC Co. Ltd.
210-212 Tottenham Court Road, London, W.1

Telegrams—
"Cucumis, Ox, London."

Telephone—
Nos. 4144 Museum (7 Lines).

Works—
CARDIFF,
8 Park Place.

Works—
DAGENHAM,
Essex.

Works—
NEWCASTLE-ON-TYNE
42 Westgate Road.

SERVICE
ON
SILENT
CIRCUITS

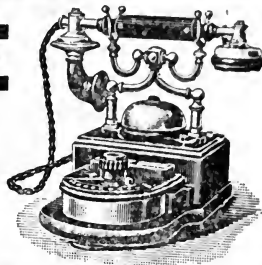

Standard Desk
Instrument

WITH
PARSONS-SLOPER
SECRET SINGLE LINE INTERPHONES

NO -

LONDON
25 VICTORIA ST.
S.W.1

CROSS-TALK
OVERHEARING
EXTRANEIOUS NOISES

NEWCASTLE-ON-TYNE
52 BLACKETT ST.

ALL -

CONVERSATIONS
SECRET AND
UNINTERRUPTED

— WRITE —



Standard Wall
Instrument

GENT & CO. L^{TD.} FARADAY WORKS

MANUFACTURING
ELECTRICAL
ENGINEERS

LEICESTER

COMMON COMMODITIES AND INDUSTRIES SERIES

Each book in crown 8vo, cloth, with
many illustrations, charts, etc., 3/- net

- TEA.** By A. IBBETSON
COFFEE. By B. B. KEABLE
SUGAR. By GEO. MARTINEAU, C.B.
OILS. By C. AINSWORTH MITCHELL,
B.A., F.I.C.
WHEAT. By ANDREW MILLAR
RUBBER. By C. BEADLE and H. P.
STEVENS, M.A., Ph.D., F.I.C.
IRON AND STEEL. By C. HOOD
COPPER. By H. K. PICARD
COAL. By FRANCIS H. WILSON,
M.Inst., M.E.
TIMBER. By W. BULLOCK
COTTON. By R. J. PEAKE
SILK. By LUTHER HOOPER
WOOL. By J. A. HUNTER
LINEN. By ALFRED S. MOORE
TOBACCO. By A. E. TANNER
LEATHER. By K. J. ADCOCK
KNITTED FABRICS. By J. CHAM-
BERLAIN and J. H. QUILTER
CLAYS. By ALFRED B. SEARLE
PAPER. By HARRY A. MADDOX
SOAP. By WILLIAM A. SIMMONS,
B.Sc. (Lond.), F.C.S.
THE MOTOR INDUSTRY. By
HORACE WYATT, B.A.
GLASS AND GLASS MAKING. By
PERCIVAL MARSON
GUMS AND RESINS. By E. J.
PARRY, B.Sc., F.I.C., F.C.S.
THE BOOT AND SHOE INDUSTRY.
By J. S. HARDING
GAS AND GAS MAKING. By
W. H. Y. WEBBER
FURNITURE. By H. E. BINSTED
COAL TAR. By A. R. WARNES
PETROLEUM. By A. LIDGETT
SALT. By A. F. CALVERT
- ZINC.** By T. E. LONES, M.A., LL.D.,
B.Sc.
PHOTOGRAPHY. By WM. GAMBLE.
ASBESTOS. By A. LEONARD
SUMMERS
SILVER. By BENJAMIN WHITE
CARPETS. By REGINALD S BRINTON
PAINTS AND VARNISHES. By
A. S. JENNINGS
**CORDAGE AND CORDAGE HEMP
AND FIBRES.** By T. WOODHOUSE
and P. KILGOUR
ACIDS AND ALKALIS. By G. H. J.
ADLAM
ELECTRICITY. By R. E. NEALE,
B.Sc., HONS.
ALUMINIUM. By Captain G.
MORTIMER
GOLD. By BENJAMIN WHITE.
BUTTER AND CHEESE. By C.
W. WALKER-TISDALE and JEAN
JONES.
THE BRITISH CORN TRADE. By
A. BARKER.
LEAD. By J. A. SMYTHE, D.Sc.
ENGRAVING. By T. W. LASCELLES.
STONES AND QUARRIES. By J.
ALLEN HOWE, O.B.E., B.Sc.,
M.I.M.M.
EXPLOSIVES. By S. I. LEVY, B.A.,
B.Sc., F.I.C.
THE CLOTHING INDUSTRY. By
B. W. POOLE, M.U.K.A.
**TELEGRAPHY, TELEPHONY, AND
WIRELESS.** By J. POOLE,
A.M.I.E.E.
PERFUMERY. By E. J. PARRY.
THE ELECTRIC LAMP INDUSTRY.
By G. ARNCLIFFE PERCIVAL.
ICE AND COLD STORAGE. By B. H.
SPRINGETT.

OTHERS IN PREPARATION

Digitized by the Internet Archive
in 2007 with funding from
Microsoft Corporation



By courtesy of the proprietors of "The Daily News"

SENATORE MARCONI

Born 25th April, 1874

In the Wireless Cabin of his yacht Elettra

Frontispiece

PRINTED BY
SIR ISAAC PITMAN & SONS, LTD.
BATH, ENGLAND

PREFACE

THIS book is intended as a short general introduction to the three industries, or vocations, dealing with the electrical transmission of intelligence, which have now assumed such very great importance in the intercourse between the peoples of all civilized nations. They are all really different branches of the oldest of them, telegraphy, which was commercially born about 1834; the telephone industry commencing about forty-five years later, in 1878-9, and that of "wireless" in 1904, when an arrangement was made by which the British Post Offices received messages for transmission by Marconi wireless stations.

The historical method has been used, as it was considered best adapted to impress the principles of working on readers new to the subjects dealt with, by leading up from the simpler to the more complex apparatus.

A somewhat larger share of space in the book has been given to the wireless than to the other two sections, as it, no doubt, attracts more general interest at the present time, but it is believed that no important feature of the other two sections has been neglected.

The writer is indebted to the following books for borrowed illustrations, viz., Herbert's *Telegraphy*, 3rd edition, Pendry's *Elementary Telegraphy*, 2nd edition, Marchant's *Wireless Telegraphy*, 2nd edition, and to Mr. T. Sherratt, A.M.I.E.E., for kindly correcting the proofs.

J. POOLE & Co.

104 Charing Cross Rd., W.C.2

ESTABLISHED 1854

ALWAYS A LARGE STOCK OF
EDUCATIONAL AND
TECHNICAL BOOKS



*All enquiries answered. Orders by post receive
immediate attention*

BOOKS

SCIENTIFIC-ELECTRICAL-ENGINEERING

OVER 1,000,000 Volumes in stock on every conceivable subject in strictly classified order. Second-hand and New. Books sent on approval. We have the books you want. There are always Bargains on our shelves. Catalogue No. 273 free. State wants. Books bought; best prices given.

W. & G. FOYLE, LTD. 121-125 Charing Cross
Road, London, W.C.2

CONTENTS

CHAP.	PAGE
PREFACE	V
I. INTRODUCTORY	1
II. SOURCES OF ELECTROMOTIVE FORCE ; ELEC- TRIC BELLS AND RELAYS	13
III. TELEGRAPHY	26
IV. TELEPHONY	51
V. TELEGRAPH AND TELEPHONE LINES	81
VI. WIRELESS TELEGRAPHY	89
VII. WIRELESS TELEPHONY	113
INDEX	118

TELEGRAPHY, TELEPHONY AND WIRELESS

CHAPTER I

INTRODUCTORY

IN order to render the subject matters treated of in this book clear to the general reader a few introductory remarks and definitions are considered desirable as to the nature or effects of the imponderable something which we call electricity.

Frictional Electricity. The first recorded fact in connection with it was that if the substance amber was rubbed by the hand or a cloth, it would attract very light bodies to its surface and in the dark give off sparks. These facts were known in the very early ages, and it was not until the beginning of the seventeenth century that Dr. William Gilbert found that many other substances also became "electrified" when rubbed. He also found that there were two kinds of "electricity" which were always produced together, one kind on the rubbed and the other kind on the rubber, and that bodies electrified with the same kind repelled each other and bodies electrified or "charged" with different or opposite kinds attracted each other.

Conductors and Insulators. Some of the substances thus electrified were found to lose their charges very rapidly when touched and others retained their charges after being touched; the former were called conductors and the latter insulators, but there is infinite variety

in the various substances in regard to these properties of conductivity and insulation. In order to retain a charge of electricity on a good conducting body, such as a metal, it is necessary to support it by means of a good non-conducting or insulating body, such as glass, porcelain, silk, indiarubber or such like; but unless the air surrounding the conductor is also dry even the insulators will not succeed in retaining the charge. The insulators are, therefore, said to have a high or great *resistivity* to the passage of electricity and the conductors offer small resistance to the escape or passage of the electricity.

Potential. Bodies may be feebly or powerfully charged with electricity and the intensity of such charge is called its "potential," which is measured by units called *volts*. Potential is analogous to head of water in connection with a turbine, or pressure of steam in a steam engine boiler and is a gauge of the intensity of the effects it can produce.

Electrical Current. When two points in a conducting body become charged with electricity at different potentials a *current* of electricity is caused to pass through the conductor. This current may be only momentary if there is nothing to maintain the difference between the potentials of the two points, or it will be a "continuous" one if such points can be maintained at a "difference of potential" or "P.D.," by some source of *electro-motive-force*, such as a "battery" or a "dynamo machine." These will be described later.

Effects of Current. The circulation of a current through a conductor—usually a copper wire—gives rise to certain effects either in or about the conductor, such as heat, attraction and repulsion, magnetism, chemical changes, etc., and it is on such effects—principally the magnetic effects—that the science and

practice of modern electric telegraphy and telephony depend.

Ohm's Law. The magnitude of the effects produced by a current in a given time depends on its "strength" and this is proportional to the electromotive force (E.M.F.) producing the potential difference in the conducting circuit, and the *conductivity* of the circuit, or inversely as the resistance of the circuit. The above paragraph is a bald statement of what is known as "Ohm's law," which in the shape of the formula $I = \frac{E}{R}$ gives the relation between strength of current (I), electromotive force (E) and the resistance (R) when these are expressed in proper units such as "amperes," "volts" and "ohms" respectively. The law holds good for any part of a circuit through which a current is passing, but the volts (E) must then be the potential difference between the ends of the part of the circuit and the resistance of the part itself.

Earth and Metallic Circuits. An electric circuit may be wholly metallic (with the exception of the battery), as in the case of telephone circuits, or, it may be made up partly of a metal wire with a connection at each end to some conductor which is in intimate connection with the ground, such as the water supply pipes of a town or plates buried in damp soil. With the latter construction, which is generally adopted for telegraph circuits, it has been found that the earth itself between the points of connection will serve to complete the circuit, with the advantage of a great saving in cost of line and a halving of the resistance of the circuit, as the earth itself offers practically no resistance. Therefore a smaller battery is required to do the necessary work in the form of electromagnetism, etc.

Magnetism. Most people are familiar with the

attractive power of each end of a magnet for iron or steel, and that if it is suspended so as to be free to move, as in the form of a magnetic needle, it will set itself nearly in a north and south line. Fewer people know that there are two "poles" or points on a magnet, one a north seeking or "north" pole and the other a

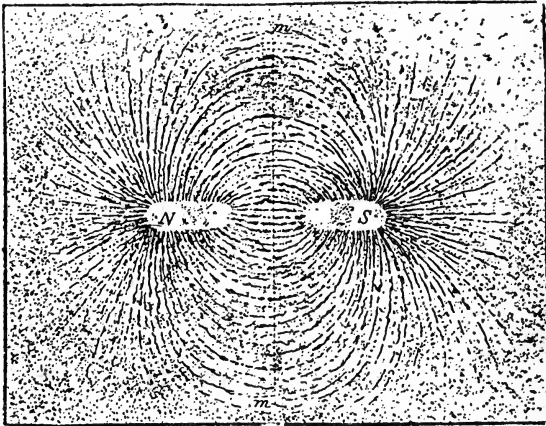

FIG. 1

LINES OF FORCE ROUND POLES OF HORSESHOE
MAGNET

south seeking or "south" pole (the north pole only being generally marked with an "N" on the magnets) and that, as in the case of electric charges, unlike poles attract each other and like poles repel each other. The directive effect of the earth on a magnetic needle is due to the earth itself being a magnet, with its magnetic poles near to its geographical poles, but not corresponding to them. In this country the "declination" of the

magnetic needle from true north and south is now about 14° to the east, but it is getting a little less every year.

Induced Magnetism and Lines of Force. When a piece of iron is attracted by a magnet, even without actually touching, the iron itself becomes a magnet with two poles, but the magnetism is only of a temporary nature and disappears when the magnet is withdrawn. When iron filings

are dusted over a card covering a magnet each of the filings becomes a magnet, and if the card is gently tapped they arrange themselves into the form of curves, as shown in Fig. 1. The curves represent the direction in which the magnetic forces act in what is called the "magnetic field" round a magnet, the curves themselves being evidence of what the great Faraday called "lines of force."

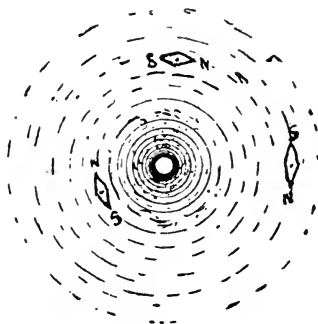

FIG. 2

MAGNETIC LINES ROUND
CONDUCTOR OF ELECTRIC
CURRENT

Although we do not know what actually happens or exists round a magnet this conception of the lines of force has proved of the greatest utility in connection with the science.

Electro-magnetism. There is an intimate connection between magnetism and electricity, indeed one cannot be produced without the other, although one may not be in evidence. A wire conveying a current is in fact surrounded by a field of magnetic force, but the direction of the forces acting, or the lines of magnetic force, are in the form of circles in planes at right angles to the

wire, as shown in Fig 2, which shows how iron filings and magnetic needles would arrange themselves round a conducting wire penetrating the paper. If the wire be bent into a circle or wound into a coil it is easy to see that a large number of these "rings of magnetic force" will meet in the internal portion of the circle or coil, and if a soft iron rod is inserted in this space a number of the rings-of-force will pass through it and will make it an "electro-magnet" with poles and attractive forces like an ordinary magnet, and the more lines of force passing through a given space the greater will be its magnetic influence, or the stronger the "magnetic field."

An electro-magnet is therefore made by winding a number of turns of current conducting wire, insulated by being covered by windings of cotton or silk or by layers of varnish, round a bar of iron. Such an electro-magnet will act as an ordinary magnet as long as the current circulates, but directly the current is cut off the magnetism in the bar disappears if it be made of soft iron, but will persist for a time if it be made of harder iron, and will become permanent if the bar is made of hard steel. The softer or more "permeable" the iron cores are the greater also will be the magnetic intensity produced by the same strength of current in the coil.

Electro-magnets are usually constructed with a number of turns of wire wound on bobbins which can be slipped over the iron cores. The cores may be in the form of a single straight bar or of the double or "horse-shoe" form on which two bobbins are used, with the ends of the wires so joined up, as shown in Fig 3, as to give a continuous spiral if the horse-shoe were imagined to be straightened out into a bar. Such electro-magnets are used in large numbers

for the practical purposes of telegraphy and telephony and in all the other branches of electrical engineering. Fig. 4 shows a practicable electro-magnet with *armature*. The cores have small brass pins inserted to prevent actual magnetic contact between the cores and armature, which would cause a persistence of the magnetism after the current had ceased.

Magneto-Electricity. The very close relation between magnetism and electricity was further exemplified by Faraday's discovery that transient currents could be set up in a conductor by the relative movements of a magnet and a conductor in the form of a coil of wire. Such currents only lasted

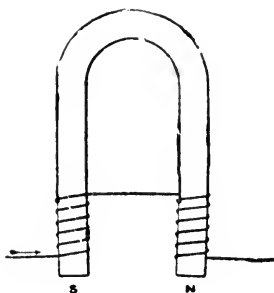

FIG. 3
CORRECT METHOD OF
WINDING ELECTRO-
MAGNET.

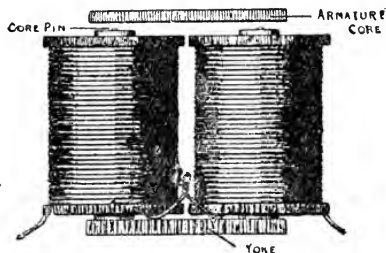

FIG. 4
ELECTRO-MAGNET

as long as the movements continued and a complete circuit existed, or the ends of the circuit were sufficiently

near together to allow an electric spark to pass across. Faraday showed that to produce such currents it was necessary that the lines of force due to the magnet should be cut through by the wires. From this important discovery has arisen the very great and important industry of the production of electric currents by magneto and dynamo machines.

Current Induction. When a current in a wire is started the magnetic rings of force are thrown out at right angles from every part of the circuit, and if there is another wire running in the same direction in the neighbourhood, such wire will be cut by the lines of force and this will give rise to a momentary or inductive current in the second wire (if that forms part of a complete circuit in a direction opposite to that of the originating current). When the current in the first or "primary" wire is stopped the rings of force are, as it were, drawn in again to the wire, and will again cut the wire of the "secondary" circuit in the opposite direction, giving rise to another momentary induced current, in the second circuit, in the opposite direction to the first, that is, in the same direction as the inducing current itself.

Induction Coil. By winding the "primary" wire into the form of a coil and winding the "secondary" wire in another coil over, or close to the primary, the inductive effects are greatly enhanced, and still more so if a soft iron core is inserted in the axis of the primary coil. This construction constitutes an "induction coil" or "transformer," much used in the electrical industries when one circuit is desired to influence another one without actually being in conductive contact with it. By constructing the secondary coil with a much larger number of turns than that of the primary coil through which the inducing current is

sent, the intensity or E.M.F. of the currents in the secondary can be made much higher than that of the primary current, in fact in about the same proportion as the number of turns in the two coils respectively, but at the same time the actual strength of the current in the secondary coil will be *reduced* in the same proportion.

Action of Current on Magnetic Needle. If a wire conveying a current be brought over a pivoted compass needle so as to run north and south, the needle will be deflected to some extent from its normal position. If the current is from south to north in the wire the *N* end of the needle will be deflected towards the left or west, the amount of the deflection depending on the strength of the current and the closeness of the wire. If the direction of the current in the wire be reversed, so as to run from north to south, the deflection of the *N* end of the needle will then be to the right or east. The simple rule with regard to these deflections is, that, if you imagine the small figure of a man to be swimming with the current so as always to face the magnetic needle, the *N* end will always be deflected to his left. This rule may be reversed so as to find in which direction the current in a wire is flowing when a magnetic needle is deflected by the current, by imagining the same small figure floating with the current with its face always to the needle.

Galvanometer. By sending the current through a coil of wire provided with two marked terminals and having within it a magnetic needle, pivoted to move either in a vertical, or in a horizontal plane, we get a "galvanometer" or "detector" in which the deflection effect is increased according to the number of the turns of wire in the coil. The back part of a common form of one of these is shown in Fig. 5, with one of the two coils

used in this construction removed to show the pivoting of the magnetic needle.

Self-Induction. We have seen that a current in a wire affects other wires in its neighbourhood by induction, and a single wire carrying a current may be looked upon as made up of a bundle of small parallel wires each conveying a portion of the current and each one acting

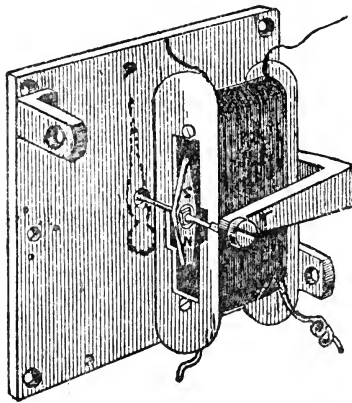

FIG. 5

CONSTRUCTION OF DETECTOR
GALVANOMETER

inductively upon the others. The effect of this is that the current in a wire, and especially if this wire is wound into a coil, is hindered or weakened in starting and also retarded in stopping by its own "self-induction" or inertia, analogous to the starting and stopping of a material mass by its inertia. If the wire is in the form of an electro-magnet with a soft iron core the self-induction effect is greatly increased and

the coil is said to have high "inductance," this being measured by a unit called the "Henry."

Static Electric Induction. We have so far dealt with the electro-magnetic effect of current induction, but there is also a "statical" electric effect from a wire carrying a current which acts upon conductors in its neighbourhood. Every part of such a wire has an electric charge proportional to its potential, and this charge can act through intermediate insulating

substances upon other wires or conductors, causing a change in their potential which may give rise to currents. This action is stronger through certain intermediate materials than others, mica, for example, having a high "inductive capacity," whilst dry air has the lowest of any of the insulators, and the great importance of this fact will be appreciated when we come to deal with telephone and telegraph "dry-air" cables.

Inductive Capacity. In many cases it is of importance to reduce the inductive effects of one wire on another, both the statical and dynamical effects, and it is then that the substances having a low "dielectric constant" or low "inductive capacity" are used for the insulating or separating materials between the wires. The dielectric constant of dry air is taken as the unit, and we give below that of a few other substances used as insulators, viz., resin 1.7, paraffin (solid) 2, vulcanised india-rubber 2.5, guttapercha 2, manilla paper 1.8 to 2.5, ebonite 2.3, glass 3.3, mica 5.

Condensers. The latter of these substances, having a high inductive capacity are used when it is required to obtain a large electric capacity in a small space, so as to form "condensers" which are made up of two sheets or two sets of sheets of thin ductile metal, usually tinfoil, separated by paraffined paper or mica sheets. The well known Leydon jar, made up of a glass jar lined inside and covered outside with tinfoil, is another type of condenser. If sets of sheets are used the sheets of each set are joined together and then connected to two separate insulated terminals. Of late years a large number of condensers have been made up with double rolls of tinned paper, such as that employed in the coverings of small tea packages.

Microfarad. The capacity of condensers is in practice measured in units called "microfarads" or millionths

of a "farad." The farad is the real scientific unit, but is, however, too large for ordinary practical purposes.

It will be seen in later pages that condensers are extensively employed in all the arts dealt with in this book.

Effects of Condensers. When one of the terminals of a condenser is connected to some source of electricity so that its potential is raised, and the other terminal is connected to earth, or to some source of lower potential electricity, there is an accumulation of electricity on the surfaces of the two sets of tinfoil sheets in proportion to the capacity of the condenser and the difference of potential between the two terminal connections. The "charges" will remain in the condenser, if the insulation is good, after the removal of the charging source until they are "discharged" by connecting, or nearly connecting, the terminals together through some conducting circuit, when sparking will occur and a momentary current, or a series of alternating currents, will pass through the connecting circuit. If, on the other hand, whilst the charging source is connected the potential of the source is lowered, the charges on both the sets of tinfoil or "plates" of the condenser are partly set free and produce momentary currents in the connecting circuits or circuits. If the potential is constantly varying, currents will be surging in the two connecting wires, so that if a source of rapidly varying or alternating current be connected to one of the terminals similar variations will appear in the wire connecting the other terminal. It will thus appear as though the alternating currents passed through the insulating material between the tinfoil plates, although, as a matter of fact, none pass through the insulation.

CHAPTER II

SOURCES OF ELECTROMOTIVE FORCE, ELECTRIC BELLS, AND RELAYS

ALL the inter-communication industries dealt with in this book require some source for the production of the currents which are necessary for working, and it therefore appears to be desirable to describe these before proceeding to the industries themselves.

The sources principally relied upon in these industries are (1) Chemical action in the various voltaic cells, both primary and secondary or storage; and (2) Mechanical Power based on Faraday's discovery of the production of magneto-electricity by the relative movements of magnets and coils of wire.

Primary Cells. When two electrical conductors of different material are dipped into a conducting solution (called an electrolyte), they are acted upon chemically to a different degree and will each show evidence of an electrical charge, one being negatively and the other positively charged. If the plates are now connected on the outside, by touching together or by means of a wire, an electric current will be found to circulate through the circuit thus formed, passing through the liquid from the high potential or electro-positive conductor to the other or electro-negative conductor and through the outside wire from the electro-negative to the electro-positive conductor. Such an arrangement constitutes a simple voltaic cell in which, usually, a plate of zinc is the electro-positive conductor and a plate of copper the electro-negative, and the electrolyte is a very dilute solution of sulphuric acid. Fig. 6 shows four of these

simple cells joined up in the proper manner to form a "battery."

Polarization. The result of the chemical action which takes place in a cell is that the zinc plate is oxidized and that bubbles of hydrogen gas appear on the copper plate and rise to the surface when large enough, but generally adhere to the face of the plate and reduce its

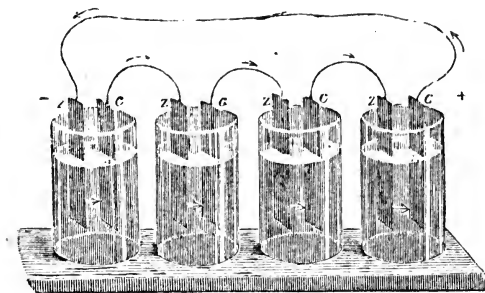

FIG. 6

BATTERY OF SIMPLE VOLTAIC CELLS

active surface. Not only do we get this kind of interference with the working of the cell by an increase of resistance, but the gas so liberated is in a very active or "nascent" condition and tends to produce a current in the opposite direction to that proper to the cell, so reducing its effective E.M.F. This effect is called the *polarization* of the cell, and renders the simple cell of no practical use. All types of cells in practical use have some method of preventing or reducing the effect.

The Leclanche Cell. In this cell the trouble of polarization has been prevented to an almost perfect extent by surrounding the electro-negative plate, which in this case consists of a hard gas carbon plate,

by a solid de-polarizer in the form of small crystals of binoxide of manganese, and using a single solution of sal-ammoniac (chloride of ammonium) for the electrolyte or exciting fluid, instead of the dilute sulphuric acid. This electrolyte is a compound of nitrogen, hydrogen and chlorine. In action the chlorine combines with the zinc to form zinc chloride, which is dissolved, and the hydrogen instead of being liberated combines with part of the oxygen of the binoxide to form water; ammonia gas is also liberated but being readily soluble in the solution does not give trouble unless the cell is hard worked, when it is not dissolved as fast

as it is formed and again gives rise to the polarization trouble ; for this reason the Leclanché cell is not a good one to use where a strong current is needed constantly and for a long time, but where current is needed intermittently for such purposes as electric bells and telephonic signalling the cell serves its purpose excellently.

Forms of Leclanché Cell. The Leclanché cell is made up in many different forms, the chief of which are the "wet" porous pot and the so-called "dry" cell, which

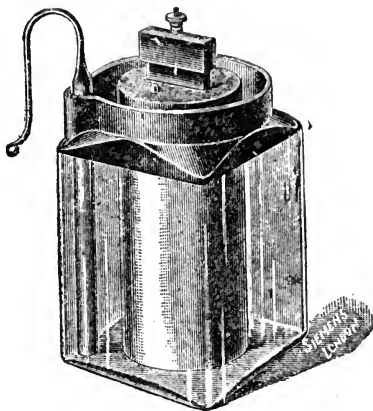

FIG. 7
POROUS POT FORM OF
LECLANCHÉ CELL

is not really dry or it would not work. Fig. 7 gives a view of a "wet" cell of a common form in which the carbon plate, provided with a metal cap and terminal, is placed in a porous pot packed with a mixture of about equal parts of pulverized carbon and black oxide of manganese. The cell is then sealed up with pitch or marine glue, in which two ventilating holes are left for the escape of the gases. This is then placed in a glass jar of the shape shown, into which is also inserted the zinc in the form of a rod provided with a wire and loop to fit under a terminal. The glass cell is then nearly filled with a strong solution of sal-ammoniac. In other forms the depolarizing substance is compressed solidly round the carbon block or packed into a canvas bag, so as to dispense with the high resistance porous pot.

Dry Cells. These are generally some form of Leclanché cell in which the space between an inner carbon plate or rod and an outer containing vessel of zinc is filled with some absorbent substance, such as plaster of Paris or even sawdust, with which the depolarizing substances are mixed and in which the solution of sal-ammoniac is entirely absorbed, so that there is no free liquid in evidence. They are therefore more convenient and cleanly to use and are also more compact than the wet cell.

Secondary or Storage Cells. These cells are the result of experiments of M. Plante, about 1860, who found that a current could be obtained from two thin plates of lead dipped into a dilute acid solution, which arrangement had previously had a current from another source sent through it for a time, the secondary current obtained from the lead plates being in the opposite direction to that of the primary or charging current. The result on the plates of the primary current was that one of

the lead plates became coated with a covering of brown peroxide of lead and the surface of the other plate was made into a spongy condition. To obtain the best effect from the cells it was necessary to put them under a "forming" process which consisted in charging and discharging them several times over, at the end of which both lead plates were brought into a spongy condition but one of them was pure lead and the other, which afterwards acted as the electropositive plate (and equivalent to the zinc in a primary battery), was coated with the brown peroxide of lead. This preliminary process of "forming" was much facilitated by Faure, who coated both of the lead plates with red-lead, which under the forming process became converted to spongy lead on one plate and spongy peroxide of lead on the other. It has been still further facilitated by making the lead plates into a cellular or grid pattern and filling the recesses in the plate so formed with the red-lead preliminary to the forming process, and all the varieties of the modern storage cells are only so many different methods of making the lead plates to get the spongy effect and retain the active materials in position.

Magneto-electric Generators. Following the discovery of magneto-electricity by Faraday, in 1831, machines were very soon invented for the practical utilization of the discovery; the machine of Pixii being the first. In this the poles of a horse-shoe permanent magnet were revolved close to, and in front of, the ends of a similar electro-magnet with two coils, and this gave rise to two waves of opposite currents in a circuit through the coils for each complete revolution of the permanent magnet, due to the inductive effect of two reversed polarities in the core of the electro-magnet. In Clarke's machine, the electro-magnet was mounted on a pivot and revolved near the sides of the poles of a large flat

permanent magnet, and this machine is still in use in the portable medical magnetos often used to give alternating current.

Siemens Armature. A great improvement was made in these machines when, in 1857, Dr.

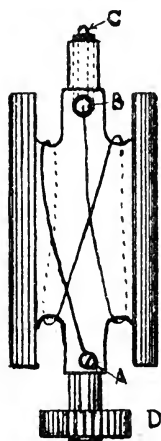

FIG. 8



FIG. 9.

(Scale $\frac{1}{2}$)

GENERATOR
ARMATURE

W. Siemens devised the "cylindrical armature," an electro-magnet in a very compact form, which could be made to revolve between the poles of a powerful compound permanent magnet. Fig. 8 shows a longitudinal view and Fig. 9 an end view of one of these armature cores as used in the magneto machines so commonly employed in telephony for generating ringing currents and also for generating the sparks for exploding petrol gases in motor engines. The core is an iron cylinder out of which has been cut or formed two deep and wide slots, one on each side, leaving only a comparatively thin web and bearings at each end on which it can be made to revolve. The web at each end is cut away to provide room for the wire coil which is wound on longitudinally in the recesses until they are filled up again to form a nearly complete cylinder. Only two turns of the wire are shown in Fig. 8 to illustrate the method of winding. When the winding is completed the ends of the coil are connected to the pins A and

B, the former connecting direct to the metal and the latter to an insulated wire pin which passes through the centre of the bearing and projects at C, the screw

pin B being also insulated from the iron. D is a toothed pinion wheel for turning the armature.

The magnet and cast-iron pole-pieces between which the armature revolves without touching are shown in Fig. 10. The space between these pole-pieces is a powerful magnetic field, which at every half revolution reverses by induction the magnetism of the web of the soft iron armature, each of the reversals inducing a current in the surrounding coil which is opposite in direction to that produced by the preceding reversal. Of course, this is assuming that the circuit of the coil is completed outside the machine in some manner as well as through the metal frame and a spring bearing on the insulated pin C.

The current obtained from such a machine is in the nature of a double wave, a gradually increasing and then diminishing flow of, say, positive current, and then a similar one of negative current, for each complete revolution of the armature.

Commutators. If currents in one direction only are required it is necessary so to arrange that at the moment the machine is in the neutral position the connections of the collectors shall in some manner be reversed, so that, say, two positive undulations are obtained for each revolution. The currents from such a machine if sent through a telephone would give rise to a loud musical note if the machine was turned sufficiently rapid, owing to the variations in strength,

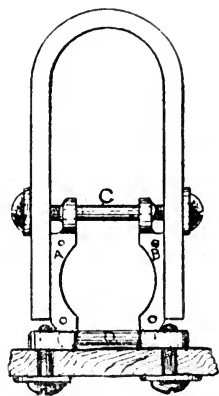

FIG. 10
(Scale $\frac{1}{2}$)
MAGNETO
GENERATOR

If a steady current is required, it is necessary to use an armature of a different type, having a number of coils wound over and round its whole circumference, or wound over and under the "rim" of its circumference, and having connections from the ends of each coil to the plates of a compound "commutator."

Dynamo Machine. It was discovered by Wheatstone and by Siemens in 1867 that machines could be made to produce electric currents without permanent magnets being employed, by simply using electro-magnets instead, and relying on the small amount of "residual" magnetism left in the iron cores after a previous magnetization to start a current in the armature on the latter being revolved between the poles of the electro-magnet. The current thus obtained was passed through the electro-magnet coils, thus increasing the magnetism and this again reacting on the armature, and so on, until the full power of the machine was obtained. Such machines are called "dynamos."

Motors. The dynamo machines as described above are reversible machines, so that if current from some other dynamo, or other source, is sent through its magnet and armature coils the armature will revolve, and the machine will become a motor to be used for driving other machines.

Electric Bells. For signalling purposes, electric bells of one form or another are almost invariably used, except in such places as telephone exchanges and telegraph centres. There are three types of electric bells which may be made up in many different forms, viz: (1) the single stroke; (2) the trembler and (3) the polarized ringer for alternating current working.

The *single-stroke* bell is merely an electro-magnet with an armature to which is attached a hammer which

is arranged to strike on a bell gong every time a current is sent through the coils of the electro-magnet.

The *trembler bell* has in addition to the above a spring contact attached to the armature and through which the current has to pass to the coils. By means of an adjusting screw it is so arranged that when the armature has been attracted by a current, and before it touches the magnet cores, the spring contact is broken and the armature falls back, again making contact, and again being attracted, and so on, as long as there is a current connection to the terminals. Fig. 11 shows a common form of bell with the cover removed.

Polarized Ringer Bell. This form is nearly always used when alternating currents are employed for the signalling, which is now the general practice in telephone working.

Figs. 12 and 13 give two views of a common form, which differs from the single-stroke and trembler bells in having its armature pivoted at its centre, between the poles of the electro-magnet AB, and in having a permanent magnet NS attached at its N end to the centre of the yoke of the two coils. This induces a N. polarity in the far ends of the two cores and a S. polarity is induced in the two ends of the armature by the proximity of the S end of the magnet to its centre.

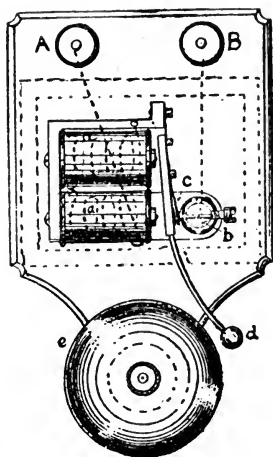

FIG. 11
ELECTRIC BELL
(ORDINARY PATTERN)

Action. The effect of passing a current through the coils is to strengthen the N. polarity of one core and to weaken, or altogether neutralize, the N. polarity of the other core, the result being that the armature is strongly attracted to one core and not at all to the other. The next reversal of current causes the core which was strengthened before to be weakened,

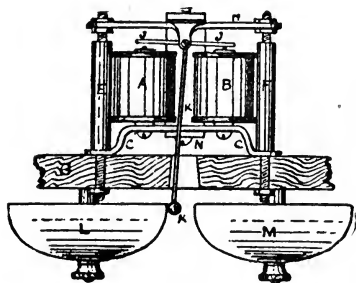

FIG. 12. (Scale $\frac{1}{3}$)
MAGNETO RINGER

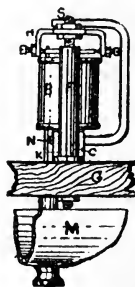

FIG. 13

and vice versa, so that the armature vibrates over to the opposite core, and in doing so causes the hammer to strike on the gongs, and so on repeatedly. Sometimes two polarizing magnets are used, one to each core, but the action and effect are similar.

Relays. In the working of electrical apparatus it is often necessary to operate instruments from a distance. To send a sufficiently strong current from the distant point would entail the use of powerful batteries or other generators, a large proportion of the energy of which would be lost on the line. In such cases it is found to be more economical and satisfactory to employ what are termed *relays*, which are simply electro-magnets wound generally with a large number of turns of wire, and fitted

with light and sensitive armatures. When attracted, the armatures cause the closing of local circuits of comparatively small resistance, in which are included local batteries, which will give sufficiently powerful currents to effect the desired operation.

Fig. 14 shows a simple form of relay much used in telephony, in which a bent armature A when attracted at C lifts the centre spring at D from an under contact

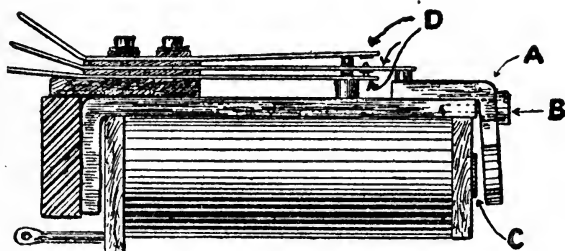

FIG. 14
KELLOGG RELAY
(Full size)

spring to an upper contact. Several similar sets of springs may be fitted side by side and all be operated by the same armature.

Polarized Relays. This is another class of relay in which the inductive effect of a permanent magnet is used to enhance the electro-magnetic effect of the current so as to give more rapid and efficient working. It also differentiates in its action between currents in one direction and currents in the opposite direction through its coils.

Siemens Polarized Relay. There are a number of different types of polarized relays in use, the first to be put into general use having been invented by W.

Siemens, of which the principle is illustrated in Fig. 15. The centre of the electro-magnet is fitted on one pole N of a permanent magnet NS and one end of a soft iron armature is pivoted in a gap in the S end of the magnet with its other end free to move between the extended pole pieces of the electro-magnet. This end is prolonged with a light metal lever, the end of which plays between two contact screws.

With this construction the two poles of the electro-magnet will both be induced into N. polarity and the

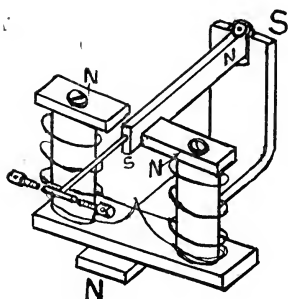

FIG. 15

PRINCIPLE OF SIEMENS
POLARIZED RELAY

free end of the armature will be induced to S. polarity. Current in one direction through the coils will weaken the N. polarity of one core end and strengthen that of the other, so that the armature is attracted to the strengthened pole, whilst current in the opposite direction reverses the effect on the cores and the attraction is then to the other pole. In this manner a very sensitive relay results, which may be made to work

with both directions of current by holding the armature in the centre by a light spring, when it is called a "neutral" relay. It is usually, however, actuated by current in one direction only, by holding the armature normally to one side by spring or otherwise.

There are many other forms used by the B.P.O. but they are all based on similar principles.

Differential Winding. When each of the coils of an electro-magnet of a relay or other electrical instrument

is wound with two equal fine wire windings, which can be connected so that current from a single source can be passed in opposite directions so as to oppose each other's effect, the instrument is said to be wound differentially. With such construction the windings may also be connected up so as to assist each other. Such instruments are frequently employed in the arts we are dealing with.

CHAPTER III

TELEGRAPHY

A MEANS of communicating between persons situated beyond the range of the direct sound of the human voice or of eye-sight has from the earliest recorded ages been a dream of the best minds, but nothing appears to have been really successful before electricity was utilized for the purpose. In the latter half of the eighteenth century many attempts were made to signal between distant points by means of frictional electricity, generally using a charge sent along an insulated wire to cause a divergence of light pith balls suspended at the far end of the wire. In one case, that of Le Sage at Geneva in 1774, as many as twenty-four wires were used, each with a pair of pith balls, so as to signal all the letters of the alphabet separately. It was not, however, until after the discovery by Oersted, in 1819, that a current passing through a wire would deflect a suspended magnetic needle, that anything of a practical nature resulted. Ampere in 1821 was the first to suggest and describe a method for the purpose of telegraphing, and Schilling and Weber appear to have been the first to have carried out the suggestion practically with a single magnetic needle instrument at each end of the line. For signalling they used a code made up by a combination of deflections of one end of needle to the right and to the left, to signal the letters of the alphabet. This arrangement was an experimental one between departments of the Göttingen University.

Cooke and Wheatstone's Needle Telegraph. W. F. Cooke, a retired Indian surgeon, in 1836 saw at the

Heidelberg University a single-needle telegraph, and on reaching London in the same year took out a patent with Professor Wheatstone of King's College (who was afterwards responsible for so many valuable inventions in telegraphy, etc.) for a different form of needle telegraph in which five magnetic needles were used at each end, each needle actuated by a coil of wire connected to a separate line wire. Two of the needles were deflected for each signal, and by a clever form of dial, forming the face of the instrument, on which the letters were painted, each double signal pointed directly to the letter to which it corresponded. This was the first form of telegraph opened for public use in this or any other country, and was operated on a line running from Paddington to Slough by the side of the Great Western Railway. It attracted much public notice because it was the means of bringing to justice a man dressed as a quaker (or "kwaker" as it was telegraphed, because the letter *q* was not used in the signals) at London for the murder of a woman at Slough. The number of wires required for the line, however, was an obstacle and the system soon became obsolete.

Henry's Sounder Telegraph. Henry in New York, in 1852, made use of the sounds of the armature of an electro-magnet when attracted against a stop and when released and drawn back by a spring against the limiting screw, to form a code of signals, but did not bring the system into practical use. He was the first to show that electro-magnets, which are required to work from the feeble current sent through a long line, must be wound with a large number of turns of wire to make them sufficiently sensitive.

The Morse Telegraph was conceived in 1832 by Samuel Morse, an American artist whilst on a voyage from Havre to New York, and was the result of an idea

suggested by Dr. Jackson a fellow passenger on the same boat. Morse's first arrangement was of an electro-chemical nature, in which at the receiving end an electrical contact in the line circuit was pressed on to a moving strip of paper impregnated with a chemical solution, such as of the acetate or carbonate of lead, which when a current passed through it, from the contact to a metal cylinder beneath, would be electrolyzed and leave a legible mark on the paper.

A later form of receiver used by Morse was one in which a pencil was attached to a sort of pendulum bob, which when attracted, by a current impulse sent

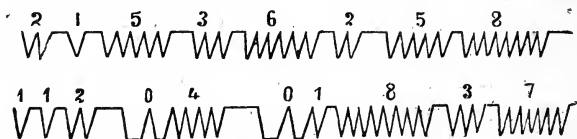

FIG. 16

MORSE'S EARLY CODE

through an electro-magnet, made a V shaped mark on a strip of paper moving in a lateral direction to the moving pencil. These V's represented units of numbers and the various letters were denoted by combinations of the figures. Fig. 16 gives a facsimile of the first practical Morse message which represented, by the code arranged, the words "Successful attempt with telegraph Sep. 4, 1837."

Afterwards a different code of signals was arranged by Morse, which consisted of combinations of short contacts to form dots and longer contacts to give dashes, separated by non-contact spaces between each contact part of a letter, longer spaces between each letter and still longer spaces between each word. For sending the signals

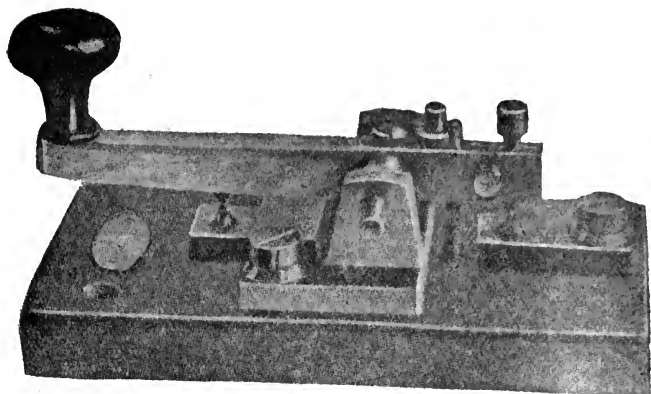

FIG. 17
SINGLE-CURRENT MORSE KEY

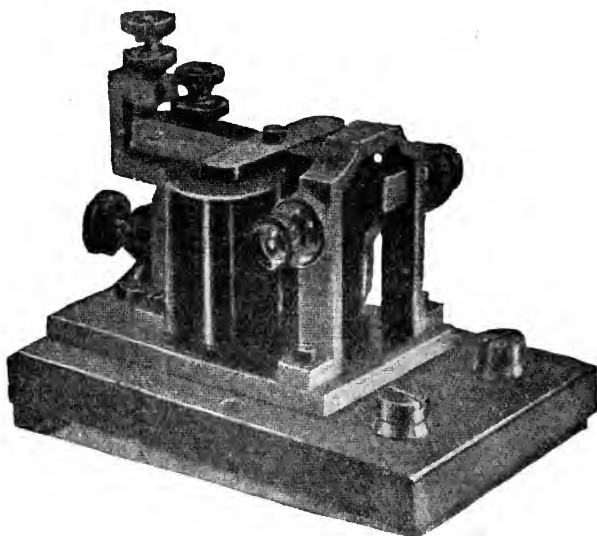

FIG. 18
P.O. "PONY" SOUNDER

metal type was at first used for each letter, and was set up in a line to form the message, the line of type being then passed between two electrical contacts in the line circuit.

The above system was only used experimentally, and it was in 1837 that the Morse system as known at present was brought into use. In this later system, the messages are printed on a strip of paper in the dot-and-dash code in ink, and the sending instrument is merely a contact key which is used to close and open the battery circuit to the line, the skill of the manipulator of the key being relied upon to give the correct duration for the dots, dashes, etc., for the various letters and words of the messages.

Modern Morse Systems. In the simplest form of the Morse system now employed a sending key is used, which is merely a hinged brass lever with front and back contacts as shown in Fig. 17, the lever being normally kept on the back contact by an adjustable spring. This is worked in connection with a simple "sounder," called a "pony" sounder, shown in Fig. 18. This consists of a two-coil electro-magnet with an armature attached to a heavy brass lever which works between two adjustable contacts, the frame of the magnet being mounted on a resonant wooden base.

In connection with these instruments a single needle or galvanometer is used as a check to show the presence and direction of the line currents, although it is not absolutely necessary for the working.

When the sending key at the "Up" station is depressed a positive current is sent through the line and through all the other station instruments connected to the line (see Fig. 19), attracting the armatures of the sounders and causing a clicking sound, and giving another click of a rather different character when the

armatures are released by the lifting of the key, so that the sound due to long duration currents for dashes are readily distinguished from the sounds given by the short dot impulses. In this country the messages are sent in the International Morse code, shown in Fig. 20, which differs slightly from the code used in America.

The sounder system, shown in Fig. 19, is known as the open "single current" system, only current of one

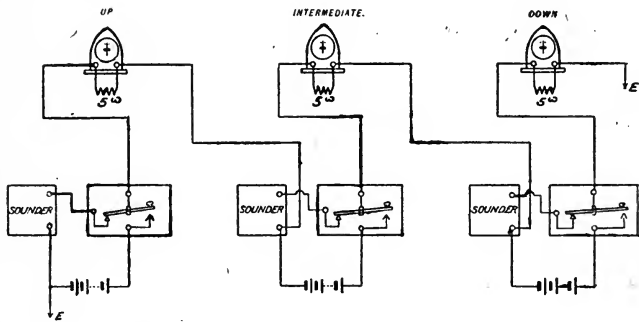

FIG. 19

"SOUNDER" SINGLE-CURRENT LINE CIRCUIT

polarity being used and there being no current on the line except when messages are being actually transmitted.

In the *Double Current System* the Morse keys are so constructed that directly a dot or dash has been sent by a current impulse in one direction it is immediately followed on the restoration of the key by a current in the opposite direction, which remains until again reversed by another dot or dash current. This gives much more rapid and satisfactory results than the single current system and is much more extensively used. The explanation of this superiority is that when a current passes through a line there is always a certain

<i>Letters.</i>	
a	— —
ä	— — — —
à or ä	— — — — —
b	— — — —
c	— — — —
ch	— — — — —
d	— — —
e	—
é	— — — —
f	— — — —
g	— — — —
h	— — — —
i	— —
j	— — — — —
k	— — —
l	— — — —
m	— — —
n	— — —
ñ	— — — — —
o	— — — —
ö	— — — —
p	— — — —
q	— — — — —
r	— — — —
s	— — —
t	—
u	— — — —
ü	— — — — —
v	— — — — —
w	— — — —
x	— — — — —
y	— — — — —
z	— — — — —
<i>Figures.</i>	
1	— — — — —
2	— — — — —
3	— — — — —
4	— — — — —
5	— — — — —
6	— — — — —
7	— — — — —
8	— — — — —
9	— — — — —
0	— — — — —
<i>Bar indicating Fraction.</i>	
— — — — —	

FIG. 20

“INTERNATIONAL”
MORSE CODE SIGNALS

amount of stoppage or retardation of the electricity due to the “condenser effect” between the line and neighbouring conductors or the earth, and a charge is held all along the line, which slows and weakens the charging impulse; which when discharging interferes with the starting of the next current impulse. It is found much quicker and more satisfactory to neutralize the line charge by sending an opposite charge of electricity by reversing the current, than by discharging the line to earth through the ends of the line. This is especially the case with lines passing through cables where the condenser effect is very pronounced.

For double current working it is necessary that the receiving instruments shall be polarized ones, so that they are only actuated by the depressed key currents. It is usual, therefore, to employ polarized relays, the sounders or other instruments being included in a local circuit with a separate

battery. Some sounders, however, are made up with polarized magnet cores and can then be worked directly by the received line currents, provided the line is not very long.

The Morse Ink Writer. This is a clockwork arrangement for moving a paper tape between rollers at a uniform speed, with an electro-magnet which, by means of a long and light attachment to its pivoted armature, can lift a small rotating roller from an ink well into contact with the paper strip, every time and for as long as the electro-magnet is energized. The message thus appears as long and short ink marks on the paper strip.

The Single Needle Telegraph is one of the simplest forms now in use. It is employed on railway lines where it has not yet been supplanted by telephones ; its manipulation

is easily learnt and it will work under difficult circumstances and requires no adjustment. The arrangement consists of a pointer needle attached to a magnetic needle pivoted inside two coils similar to the galvanometer shown in Fig. 5. The latter needle may be magnetic in itself or be an iron one inductively magnetized by a fixed permanent magnet.

The pointer needle works between two fixed stops and the letters, etc., of messages are indicated by movements to right or left of the top part of the needle, the movements for each letter being indicated on the dial, as shown in Fig. 21, the long ticks representing deflections to the right and the short ones deflections to the left.



FIG. 21

SINGLE-NEEDLE DIAL

The transmitting apparatus is of two forms, one called the "drop handle" consists of a pendant handle connected to a horizontal shaft on which are fitted two insulated contact pieces shown at p and p^1 in Fig. 22, one of these being connected to the negative pole and the other to the positive pole of a battery. These are

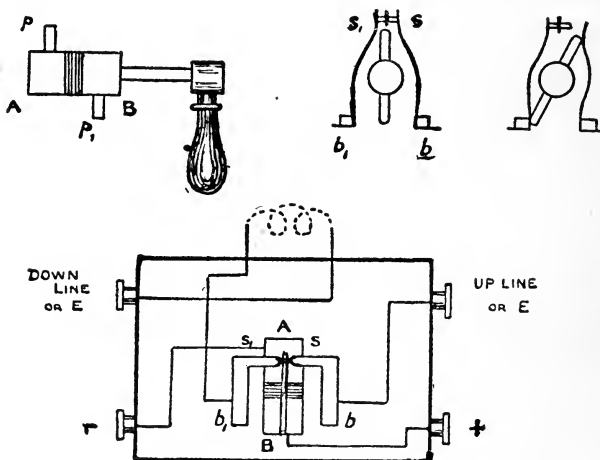

FIG. 22

CONNECTIONS OF " DROP-HANDLE " SINGLE NEEDLE

fitted between, but not touching, a pair of springs which normally press on a contact bridge and gives a through connection to the up and down parts of the line.

When the handle is moved to the left the connection of the right spring with the bridge is broken and the up line is connected to, say, the negative pole of the battery, and the down part of the line to the positive pole, through the lower contact piece, thus sending a current through the line which produces a left deflection of the needles at all the stations on the line, including

its own. A movement of the handle to the right, in like manner, makes contact with and presses aside the left spring, and causes a right deflection on all the station needles. Thus, by manipulation of the handle messages may be sent and indicated at all the stations but will generally only be read at the station whose special call code has been previously signalled and acknowledged.

In place of the drop handle, two flat keys called "tappers," like pianoforte keys, are much more commonly used. These keys work on a central pivot at the back part and normally press upwards against two contacts on the same metal bridge, the keys being connected to the up and down lines respectively. A depression of the left key causes a left deflection on the station needles and a depression of the right key a right hand deflection of the needles at all the stations on the line.

Needle Double Sounder. If the two stops between which the indicating needle works in the single needle instrument are attached to two thin metal plates or tubes, supported in such a manner that they will emit a sound when struck by the needle, and if the sounds given by the plates or tubes are made different so as to be readily distinguished one from the other, the messages can then be received by sound alone, and the instrument has become a "needle double sounder."

By passing the received currents at each station through a "neutral polarized relay" (which is a polarized relay in which the moving contact arm is, by light springs, kept midway between the fixed contact stops) as well as through the needle instrument coils, then connecting the moving contact of the relay to a local battery and the two fixed contacts to two electro-magnet sounding arrangements, such as single-stroke electric bells giving out different tones, the instrument has become a "double sounder," a very satisfactory

and much employed instrument in the B.P.O. Service. All the parts of such instruments are fitted in a kind of canopy box, as shown in Fig. 23, which serves as sound intensifier and also screens the operator from the sounds of other instruments of a similar character in the same room.

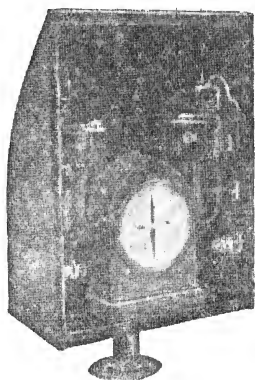
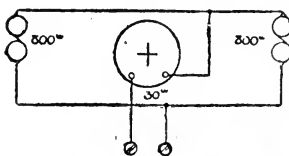

FIG. 23

POLARIZED DOUBLE-
PLATE SOUNDER

Wheatstone Automatic.

When the same message is required to be sent from some one point or station to a number of other stations a great advantage is obtained by an automatic transmitting machine which will take, as it were, a master record of the message punched in a machine by hand (or, as a matter of fact, by a number of hands, each taking a portion of the message), and if continuously fed with the punched record will transmit the message to the many stations, all joined on to the machine by their lines, at a rate of from ten to twenty times that which could be obtained from ordinary manual working. This is the principle on which the Wheatstone automatic tele-

graph is based, which apparatus has been of the greatest utility to the British telegraph service.

The punching mechanism is a small machine with three buttons, as shown in Fig. 24. The left hand button when struck by a small mallet causes the punching of holes in a paper tape necessary to produce

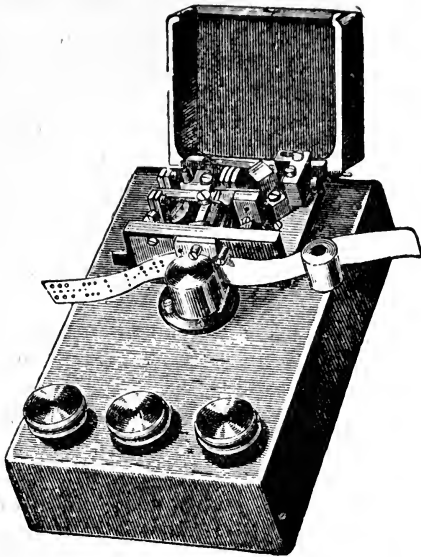

FIG. 24
WHEATSTONE PERFORATOR

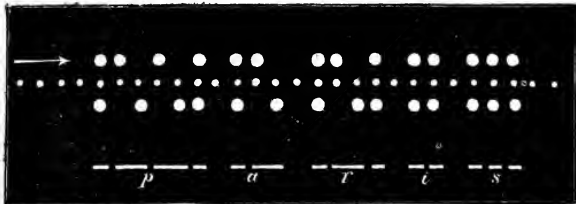

FIG. 25
PERFORATIONS FOR WHEATSTONE AUTOMATIC

a dot ; the right button gives the holes necessary for a dash, and the centre button produces a small central hole to give a space by moving on the paper tape, the other buttons also cause the moving on of the tape when struck. The holes when punched appear as shown in Fig. 25, which also gives the interpretation " Paris " in Morse code of the punched portion shown.

The tape, which is a little wider than the width between the large holes, is passed through a special transmitting machine, capable of very rapidly converting the outer large holes into short and long current impulses necessary to give the dots and dashes of the Morse code at the receiving instruments, which are specially rapid working instruments of the Morse inking type.

The action of the transmitting instrument is principally based on two reciprocating rods, which, as it were, rapidly " mark time " one on the upper and the other on the lower parts of the perforated tape, which is moved along in very rapid jerks by a small toothed wheel gearing into the small centre holes of the tape. When, in marking time, the upper rod falls into one of the top holes an impulse current is sent to line. If it is for a dot it is immediately reversed by the other rod falling into one of the lower holes, but if for a dash the impulse current is continued longer, until the lower rod has reached the reversing hole in the lower row.

With such an arrangement as the above a speed of 2,400 letters per minute has been obtained under actual working conditions.

Duplex, Diplex, etc., Telegraphy. Any device or system which will increase the working capability of a line between distant and important business centres is of the greatest service because of the excessive cost of running new lines between such centres. One

such new line might necessitate the entire reconstruction of portions of the line of poles along the route, or an additional new route of poles, owing to the old route being overloaded with lines ; and even if there were no special difficulties of the kind mentioned the ordinary cost of running a long new line is a very heavy one.

The various systems, therefore, which allow more than one message to be sent through a single line at the same time—such as “duplex,” which allows a message to be sent in each direction at the same time ; “diplex,” which enables two messages to be sent in the same direction at the same time ; “quadruplex,” which combines the two former systems and enables two messages to be sent at the same time in both directions through a single line ; and “multiplex,” working, by which ten or more messages may be transmitted through a single line at the same time—have of late years made much progress in busy communities. We will deal very briefly with these systems in the following pages.

Duplex Telegraph Working. There are two principal methods of duplex working ; one, called the “differential” method, depends on the principle of using a differentially wound receiving instrument at each end of the line, and sending the transmitting current through both coils at the transmitting end, so as to have opposing effects, whilst at the distant, or receiving station, the current passes through only one of the coils and therefore produces its full magnetic effect on the receiving instrument.

Fig. 26 shows the principle of working, the differential windings being indicated by two loops. The receiving instrument may be of any type, single needle, sounder or Morse, or may be a relay for working any of those instruments, but whatever it is it must be differentially

wound. In order to produce the same effect in the two coils of the receiving instrument it is necessary to balance the resistance of the line and the instruments at the other end by an artificial resistance, which is indicated by "rheo" in the figure, this meaning "rheostat," an adjustable resistance.

The above remarks apply to whichever end of the line may be taken. If it should happen that the

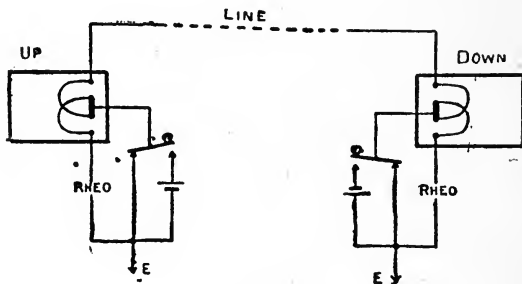

FIG. 26

THEORETICAL DIAGRAM OF DIFFERENTIAL DUPLEX

transmitting keys at both ends of the line are depressed at the same time the effect will be that the current in the line will be doubled in strength, because the batteries at the two ends are connected so as to assist each other, the positive end being connected to line at one end and the negative end of the other battery at the other end. The result on the receiving instruments at both ends is that a double strength of current passes through that coil winding which is connected to the line, whilst there is only a single strength of current passing through the coil which is connected to the artificial resistance and earth. The effect on the receiving instruments is, therefore, just the same as

if the messages were being transmitted over two independent lines, and the working is the same whether one or both stations are transmitting at any time.

The Bridge Duplex. The Wheatstone bridge is a well-known instrument much used for measuring electrical resistances. It is an arrangement of circuits with a rheostat, and is based on a balancing effect produced when two points, in two separate circuits,

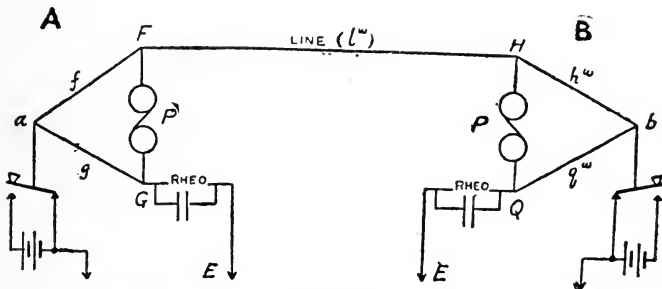

FIG. 27

THEORETICAL DIAGRAM OF BRIDGE DUPLEX

supplied with current from the same battery, are bridged across by a conductor. When the two points have the same potential there will be no current through the bridging conductor, but if this balance is altered, as by connecting a second battery to one of the circuits, a current will pass through the bridge in one way or the other, depending upon how the second battery is joined to the circuit.

Fig. 27 shows the theoretic arrangements for a "bridge" duplex line, which is made up of a Wheatstone bridge at each end. P is the receiving instrument at the A station and the bridge conductor is connected to points F and G , whilst f and g represent two equal

resistances inserted in the line and earth circuits respectively. If the resistance in the rheostat is such as to be equal to the resistance of the line and the instruments at the other end of the line the potential at the points F and G will be equal when the home key is depressed, and no current will pass through the receiving instrument at the A station which is inserted in the bridge. The current, however, passing through the line to the instrument at the other end will raise the potential at the point where the bridge is connected, and a current will flow through the bridge and the receiving instrument in it.

The same remarks will apply when the B station is transmitting alone to the A station, the bridge being connected at H and Q and the equal resistances being h and q respectively. There is however, no absolute necessity that these resistances at either or both ends of the line should be equal; f for example may be made ten times the value of the g resistance, and then a balance will be obtained when the resistance in the rheostat is made one-tenth the total resistance of the line and distant station instruments; the principle to be followed being that the point F must divide the resistances f and the line, etc., taken together, in the same proportion that the point G divides the resistances g and that in the rheostat taken together.

We will now assume that the transmitting keys at both ends of the line are depressed at the same time. As the batteries at the two ends are so connected up to the line as to assist each other (although this is not absolutely necessary) the current in the line will be doubled in strength, and the points in the bridges at both ends which are included in the line circuit will have their potentials doubled, but the other points of the bridges in the rheostat circuits will not be affected,

and a current will therefore flow through the bridges and the receiving instruments and the latter will be actuated just as if the signals were sent singly through the line.

In the figures showing the duplex methods of working it will be observed that the rheostats have each a condenser connected across its terminals. This, especially in the case of cable line working, assists very materially in raising the speed of working, by more rapidly neutralizing the static electric charges accumulated in the line by the condenser effect when a current passes through the line, as mentioned in connection with double current working. With the addition of the condensers the artificial resistance is converted into an artificial line with which to give a more perfect balance to the natural line.

Diplex Working. The methods used for sending two signals in the same direction through the same line at the same time are based on the principle of working one of the receiving instruments by changes in direction of a comparatively weak current, to cause the actuation of a polarized relay, and the other receiving instrument being actuated only by a stronger current, in either direction, a non-polarized relay being employed to actuate the latter receiving instrument, the relay being "biased" by a spring adjusted so that the relay will not operate with a less current than about double that necessary to actuate the polarized relay.

If the current sent to operate the non-polarized relay is of the polarity which will not actuate the polarized relay, but of a strength equal to three times that which is needed for the latter relay, the non-polarized relay will be actuated, but the polarized one will not. If the direction of the current be reversed and if the strength remains the same, both relays will be actuated; but

if the current is reduced to about one-third its previous strength, only the polarized relay will respond. Thus, the two relays will work quite independently of each other, whether worked separately or together.

At the transmitting end two different kinds of keys are used for sending the signal currents, one for reversing the connections of the battery for operating the polarized relay and the other, called an "increment" key, for increasing the current strength by adding on another battery of about twice the strength of the other one, this key being used to work the non-polarized relay.

Quadruplex Working. Referring to duplex and diplex working, there is nothing to prevent the receiving instruments used in the diplex method from being each wound differentially with opposing coils, and being included in series in the diplex circuits; or, instead of this, the ordinary diplex receiving instruments may be included in series in a "bridge" of the ordinary duplex type at both ends of the line, with, of course, the balancing artificial line resistances in the earth circuit. When either of these plans is followed we then have "quadruplex" working and the power of being able to transmit two messages in each direction through a single line at the same time, thus transmitting four messages at the same time and employing eight operators on the same line. Quadruplex working is now of the greatest importance on all busy routes.

Multiplex Telegraphy, which allows a number of messages to be successfully sent through one line at the same time, has been extensively adopted in this country and many systems have been tested, as the result of which the "Baudôt" and others are now extensively employed in the B.P.O. Service.

The principle of working of these instruments is that instead of allowing each pair of working instruments,

one at each end of the line, to have connection to the line all the time, such a pair has connection for only very short but rapidly repeated intervals, the connection lasting but one-quarter or one-sixth or one-eighth, or so on, of the whole time, depending on the system; whilst three or five or more other pairs of instruments may also have their own one-quarter or one-sixth, etc., periods of exclusive connection with the same line. In the Baudôt system, as generally used in this country, the connections are for one-twelfth of a second, repeated at intervals of one-third of a second, four pairs of instruments being connected to a single line.

The systems depend for their satisfactory working on being able to produce exactly synchronous rotations of two arms carrying brush contacts, and situated one at each end of the line, which sweep over the surfaces of two similar discs, each fitted with a number of groups of contact plates insulated from each other, so that at any moment of time two or more correspondingly situated contact plates, one or more on each disc, will be connected in the line circuit by the two rotating contact arms or "trailers."

In the **Baudôt System**, which is the most used of the multiplex systems in the B.P.O. Service, the rotating discs are part of what are called "distributors" and there are six concentric ring sets of contact plates, as shown in Fig. 28, the second set having twenty-four plates, these being divided into five groups which are opposite the five divisions shown in the fourth ring. The first four groups, numbered up to twenty, of the contact plates are allotted to the four different pairs of working telegraphs, and the fifth group, of four plates, is for the purpose of regulating the synchronization, etc., of the brush arm revolutions and other purposes.

The sending instrument is made up of a set of five

double current tapper keys, which are depressed when transmitting, either singly or in different combinations,

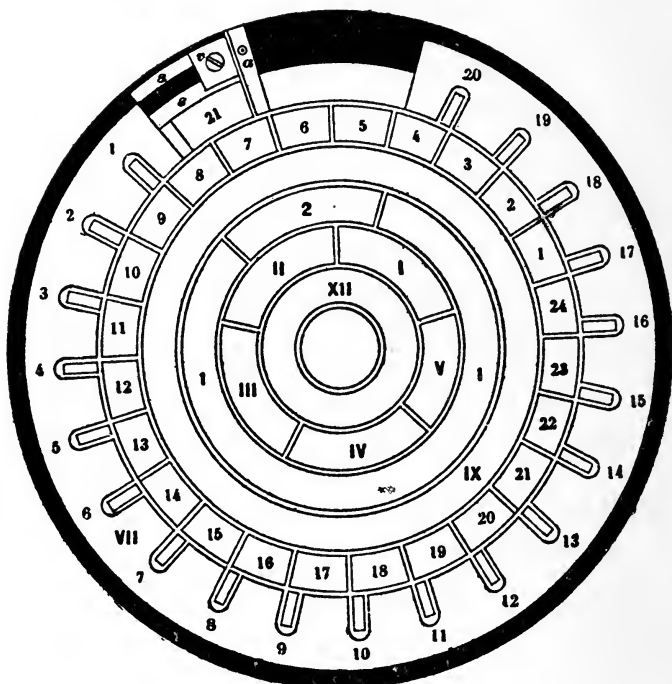

FIG. 28
BAUDÔT MULTIPLEX
FRONT PLATE RINGS AND SEGMENTS

like the playing of single notes or of chords of two or more notes on a pianoforte, there being with the five keys the possibility of thirty-one different single keys or combinations of keys with which to signal letters,

TELEGRAPHY

figures, etc., as shown in Fig. 29. Each of the five keys has a contact plate on the distributor disc at the sending station allotted and connected to it, and whenever a key is depressed, whether singly or in a set, the corresponding plate on the disc is connected to a battery, which, when the brush sweeps over it, sends a short current impulse through the line and the revolving brush arm at the other end, which will, if the synchronization is correct, be on the corresponding contact plate of the receiving distributor disc at the same moment. Usually more than one key will be depressed at the same time and the brush takes them in their order and sends "marking" impulses for each pressed key at each revolution, which takes place in one-third of a second, an audible sound called the "cadence" signal being given in a telephone at each revolution of the brushes as a guide to the operator when to press the keys for each successive letter, etc. Even, however, with this guide, a well-trained and skilful operator is necessary for the working, owing to the speed.

At the receiving end the current impulses received by the contact

1	⊗				
2		⊗			
3			⊗		
4				⊗	
5					⊗
6	⊗	⊗			
7	⊗		⊗		
8	⊗			⊗	
9	⊗				⊗
10		⊗	⊗		
11		⊗		⊗	
12		⊗			⊗
13			⊗	⊗	
14			⊗		⊗
15				⊗	⊗
16	⊗	⊗	⊗		
17	⊗	⊗		⊗	
18	⊗	⊗			⊗
19	⊗		⊗	⊗	
20	⊗		⊗		⊗
21	⊗			⊗	⊗
22		⊗	⊗	⊗	
23		⊗	⊗		⊗
24		⊗		⊗	⊗
25			⊗	⊗	⊗
26	⊗	⊗	⊗	⊗	
27	⊗	⊗	⊗		⊗
28	⊗	⊗		⊗	⊗
29	⊗		⊗	⊗	⊗
30		⊗	⊗	⊗	⊗
31	⊗	⊗	⊗	⊗	⊗

FIG. 29

PLAN OF 5-UNIT SIGNALS

plates from the revolving brushes act upon corresponding sets of relays and electro-magnets, and each different letter, etc., combination affects a similar combination of the relays, so that by means of a combination of circuits it will only act on a special electro-magnet to raise a strip of paper against an inked type-wheel, revolving synchronously with the distributor disc, when the wheel is in such a position as to print the letter, etc., corresponding to the set of keys depressed at the sending end at that particular moment. The messages are thus given out in typed letter strips, and in some of the later arrangements even printed in paged form like an ordinary typewritten letter.

Each of the other three sets of telegraph instruments will be worked in a similar manner quite independently of each other, and each of the sets may be arranged for duplex working, so that eight circuits employing sixteen operators may all be working on the same single line at the same time, and all be using rapid working automatic machines such as the Wheatstone automatic. Also the machines may all be worked in the same direction or any combination can be used to suit the business demands as they arise, this flexibility contributing greatly to the popularity of the system.

The forerunner of the automatic type-printing instruments was the *Hughes' Type Printer Telegraph*, which has been very extensively used in continental countries since its invention in 1855. It also had the synchronous wheel arrangement, the one at the receiving end being a type-wheel; the sender was similar to a pianoforte keyboard of twenty-eight keys for the letters, figures, etc. One key was pressed at each revolution of the wheels, this resulting in a current impulse passing through the line and through an electro-magnet at the other end at the exact moment

to cause the armature to lift a strip of paper against the letter corresponding to the depressed key at the sending end.

Submarine Telegraphy. When long submarine cables are used for telegraphy the condenser effect trouble becomes very serious, and so weakens the received currents that the ordinary type of receiving instruments cannot be used. What is known as the "siphon recorder" was invented by the late Lord Kelvin for this purpose, for use with the newly laid Atlantic cable.

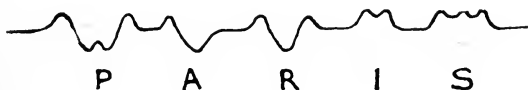

FIG. 30

SIPHON RECORDER DIAGRAM

The instrument may be likened to a very delicate single needle receiver in which the pointer needle is a very small and long glass tube, one end of which, near its pivoted point, dips into an ink well, and the other pointed end at a lower level moves very near to, and across, a moving strip of paper on which the ink is spurted in a thin line. As a matter of fact the magnet of the receiver is a large horseshoe fixed one, between the poles of which is suspended by a double silk thread suspension a very fine and light coil of wire, to which the siphon tube is connected by a silk fibre. The ink is caused to spurt on to the paper by being electrified. The senders are the double tapper keys and the current impulses are of both polarities, as in the single needle working, but sent at a slower rate. The letters are read at the receiving end by the undulations of the inked record line above and below the normal level line, as

shown in Fig. 30, these corresponding to the left and right deflections of the single needle instrument, the undulations being caused by the movements of the coil in the magnetic field when the weak received currents pass through it.

CHAPTER IV

TELEPHONY

Reis's Telephone. The first transmission of sounds electrically was accomplished by P. Reis in 1861, and the apparatus used was called a "telephone," and although only really intended for the transmission of musical sounds, it would appear that on some, as it were, accidental occasions actual speech sounds were transmitted and reproduced. The instrument consisted of a thin vibrating plate or membrane with a conducting point or surface (connected to a line) which, when the sounds were directed on to it, vibrated against a fixed contact connected to a battery and thus sent currents through the line corresponding to the sounds directed on to the membrane or diaphragm. At the receiving end the line was connected to an electro-magnet with a long iron core fitted on a sounding board or box, which every time the long core was magnetized or demagnetized gave out an audible sound and so the pitch and rough characteristics of the sound sent was given out by the receiving instrument.

Bell's Telephone. Speech waves, however, consist of a smooth combination of sound waves of complicated character which cannot be imitated by electrical waves in which breaks occur in the circuit, as in the case of the Reis apparatus; and it was only when, in 1876, Alexander Graham Bell invented a magneto-electric apparatus which converted speech sound waves into equivalent electrical current waves, and used a similar electro-magnetic apparatus to reconvert into sound

waves, that electric speech telephony became possible and practicable.

Sound is transmitted through air by a wave motion due to movements of the particles of the air backwards and forwards in a line with the direction in which the sound is travelling, as contrasted with wave motion in water, which is caused by an up and down motion of

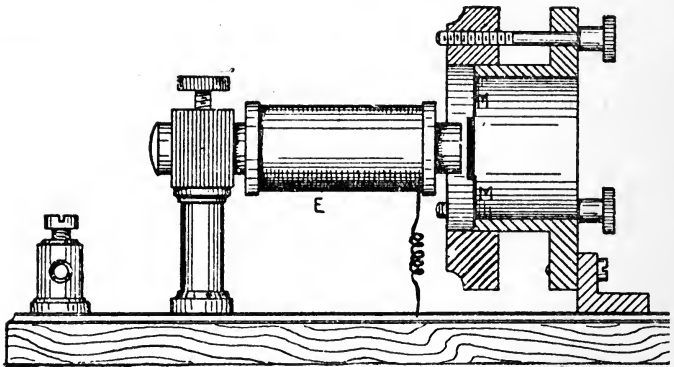

FIG. 31

BELL'S ORIGINAL TELEPHONE

the particles of water, or at right angles to the direction in which the wave progresses. Every different sound needs a different motion of the air particles for its conveyance, and if the characteristic motion of any sound can be impressed upon the air particles at any place, that sound will be produced.

The instrument with which Prof. Bell first succeeded in doing this is shown in Fig. 31, where E is an electromagnet mounted so as to be adjustable near the centre of a membrane, M, of goldbeater's skin, stretched over the end of a hollow cylinder. A small piece of

clock-spring is cemented to the centre of the membrane. Two of these instruments, some distance apart, were joined in a circuit, including a battery, one being used as transmitter and the other as receiver.

The action was as follows: On speaking into the cylinder, the membrane moved in unison with the movements of the air particles. These movements of the magnetic substance in front of the magnet produced

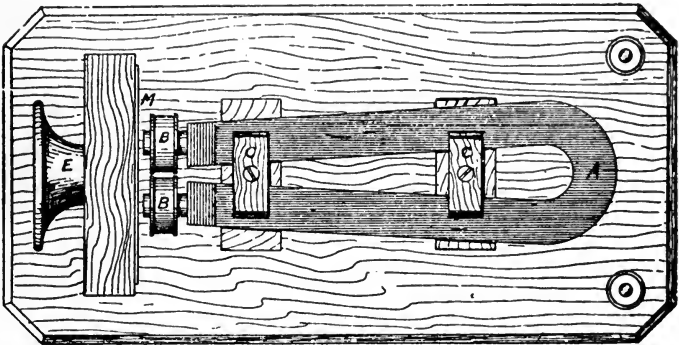

FIG. 32

BELL'S DOUBLE-POLE TELEPHONE

alterations in the magnetic field in which the coils were situated. The effect was to cause electrical pulsations or waves to pass through the coils, the connecting wires, and the coils of the receiving instrument at the distant end, of such a nature that they so affected the attraction between the magnet and the steel spring of the receiver as to set up exactly corresponding movements in its diaphragm to those impressed upon that of the transmitter. These movements being impressed upon the air, a person listening at the end of the cylinder would hear the original sound reproduced, but in a much

fainter degree. The characteristics of any sound could thus be transmitted and reproduced.

Gradually improvements were made by Prof. Bell, until he arrived at the much more efficient instrument shown in Fig. 32, where a compound horseshoe permanent magnet, A, took the place of the original electro-magnet, two small coils of wire, B B, being fixed on soft-iron pieces attached to its poles. It had been found that no battery was required, its only use being to produce a magnetic field by means of the electro-magnet. The gold-beater's skin membrane had also been discarded, one of thin sheet iron being substituted.

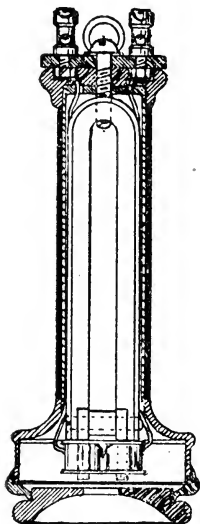

FIG. 33

(Scale $\frac{1}{2}$)

METAL-CASED
D.P. RECEIVER

The action of this form is similar to that of the original form, except that the pulsatory currents are, when transmitting, wholly developed by the movements of the diaphragm, instead of the movement simply varying a current already existing.

With this instrument much louder effects were produced, but it lacked portability, to attain which the much more compact form shown in Fig. 33

has been adopted and may be considered the final type of receiving instrument. It is made up in a metal and ebonite case, in the handle part of which is fitted a double-pole magnet. On each of the two free ends of this magnet a bobbin of wire is fitted, the ends of the coils being connected together and to the terminals at the end of the instrument. A diaphragm of thin

ferrotype iron is clamped close in front of the magnet by a cap in which is fitted a funnel shaped mouth or ear piece with a small opening in the centre.

At first the instruments served both as transmitters and receivers and came practically into use in this form. The instruments were joined up on a single line and earth circuit, as shown in Fig. 34, but two instruments

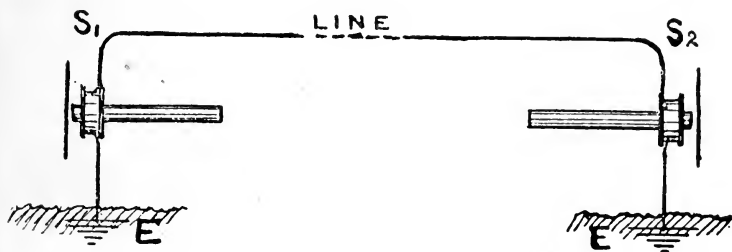

FIG. 34

TELEPHONE SINGLE-LINE AND EARTH CONNECTIONS

were used at each end to save the constant changing from ear to mouth and vice versa.

Transmitters. It had been pointed out by Prof. Bell that the necessary waves of electricity might be produced in another way than the one employed in his *magneto-telephone*, in which the waves were produced by a varying E.M.F., caused in the transmitter by the movement of the diaphragm. The second method of producing the waves was by *varying the resistance* in the circuit in proportion to the amplitude of the vibrations of the air particles, whilst the E.M.F. remained constant.

Edison's Carbon Transmitter.—Edison, in 1878, was the first to produce a successful instrument based on the variation of resistance principle. He took advantage

of the fact discovered by Du Moncel, "that the increase of pressure between two conductors in contact produces a diminution in their electrical resistance." This is eminently the case with carbon, which was the substance chosen by Edison, its great variation of resistance under pressure having been independently discovered by him.

The instrument shown in Fig. 35 was known as the "button" transmitter. D is a mica diaphragm

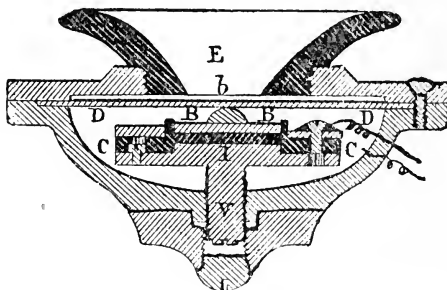

FIG. 35

EDISON'S CARBON TRANSMITTER (SECTION)

clamped to the iron case by the iron cap, in which is screwed the ebonite mouthpiece E. Pressing against the centre of D is the ivory button *b*, attached to a small disc of platinum, B B. This forms the loose cover of a chamber, with ebonite sides, in which is placed a quantity of lamp-black, I.

Speaking on the diaphragm causes it to vary its pressure on the carbon, producing corresponding variations in the resistance of a circuit containing also a Bell receiver and a battery.

Induction Coil.—Edison still further augmented the power of the instrument, especially when used over

long distances, by using an induction coil in conjunction with his transmitter. The carbon and battery were connected in series with the primary wire of an induction coil, and the line wire and receiver coils were included in another circuit with the secondary coil, as shown in Fig. 36. The improvement resulted as follows: As stated above, the working of a carbon transmitter depends upon the variation of the resistance of the circuit in which it is included, when the sound waves impinge upon the diaphragm; the greater the proportional

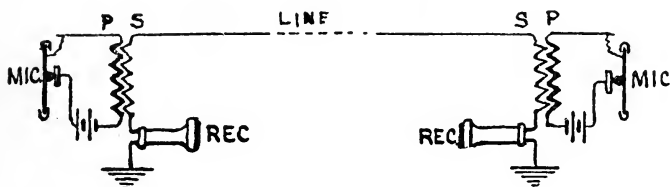

FIG. 36

TELEPHONE LINE CONNECTIONS WITH INDUCTION COIL

variation to the total resistance of the circuit the louder will be the reproduced sound from the receiver. The variation will be the greater the smaller the resistance of the circuit apart from the transmitter itself. It therefore follows that the efficiency will decrease as the distance is increased if the transmitter is included directly in the line circuit. For example, the resistance of a certain sound transmitted is about 5 ohms, and the variations of resistance caused by a certain sound is say, 1 ohm; assuming that the rest of the circuit is 15-ohms resistance, the variation would then represent $\frac{1}{20}$ th, or 5 per cent., of the whole resistance. But suppose, now, it is directly in the circuit of a long line the total resistance of which is 1,000 ohms, a variation

of only $\frac{1}{1000}$ th part, or 0.1 per cent., would then be obtained, and the effect on the receiver would be comparatively feeble. If the resistance of the transmitter were increased to, say, 100 ohms, and the variation was increased in the same proportion to 20 ohms, then in a 1,000-ohm circuit we should have a variation of $\frac{1}{50}$ th, or 2 per cent., which is twenty

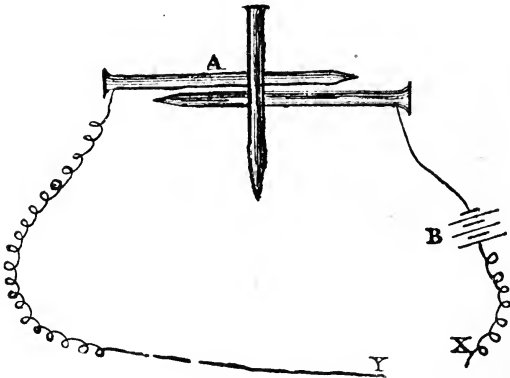

FIG. 37

HUGHES'S "NAIL" MICROPHONE

times as great. (This latter is the principle followed when a common battery is used for exchange working, the current for working the subscriber's transmitters being sent from the exchange.) By making use of an induction coil, the resistance of the circuit containing the transmitter can thus be kept very low, and the relative variation made very large. By making a secondary coil of a great number of turns of wire, the currents induced in it by the variations in the primary coil will have a high E.M.F., and will be able to overcome much resistance in the line and instruments

at the other end with comparatively little loss of strength.

Microphones.—The next step in the direction of improvement was the discovery by Prof. Hughes at London in 1878 of the fact that *any loose contact* between conductors would act as a telephonic transmitter, owing to the variations of resistance caused between

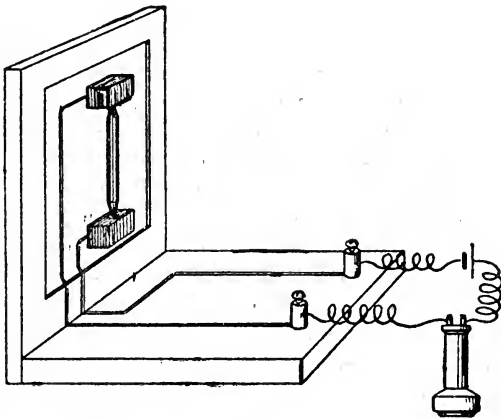

FIG. 38

HUGHES'S "PENCIL" MICROPHONE CONNECTIONS

them by the impact of the sound waves. The simple means he employed caused much astonishment. Three nails arranged as in Fig. 37, and joined up with a battery and a Bell receiver, were found to be sufficient to respond to speech, and were even so sensitive as to render audible the most minute sounds, such as those caused by the walking of a fly, etc. The best effect was obtained with carbon in one shape or another, that given in Fig. 38 being one of the best forms. Two

carbon blocks having a cup-shaped hollow made in each, in which the carbon pencil is loosely held, are attached to a sounding-board of thin deal, wires being connected for joining up the battery and receiver.

Granulated Carbon Transmitters.—One of the forms of microphone shown by Prof. Hughes consisted of a wooden pill box filled with carbon granules of hard carbon or graphite of about the size of fine gunpowder, the bottom of the box and the lid having conducting electrodes for the battery current. This simple instrument was the pioneer of a very numerous class of practical telephone transmitters which have now superseded all the other forms of microphone, owing to the fact that they form the most powerful and most compact transmitters. The earlier forms of this transmitter laboured under the disadvantage of what is known as "packing," which resulted from the gradual settling down and consolidating of the carbon granules, so that the loose contacts, upon which their efficiency depended, were no longer existent, and the carbon conducted as an ordinary solid conductor.

Many different forms of granular microphones have been devised, but nearly all represent different methods of getting rid of the packing difficulty. They all contain crushed retort carbon or oven-coke sifted through wire gauze so as to obtain even grains of about the size of those of fine gunpowder. A quantity of this is enclosed in a cell between a flexible diaphragm and a fixed block of carbon. Probably the best method adopted for the prevention of packing is repeated sifting, to ensure that all the granules used in a transmitter are as nearly of the same size as is practically possible.

On account of the number of loose contacts the variation of resistance is very great, which explains their power.

The Solid-back Transmitter.—Of the transmitters now used in the public services nearly all are of what is known as the “solid-back” type, which was invented by A. C. White in America in 1892. This achieved such great success, owing to its great power and freedom from packing, that many other transmitters

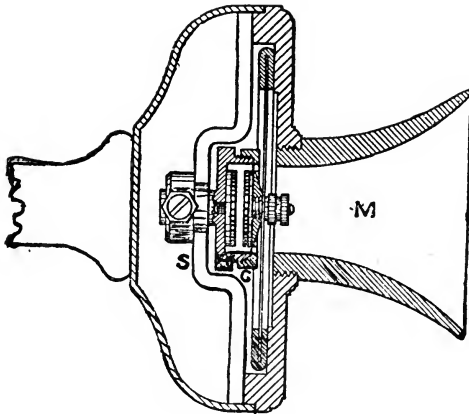

FIG. 39

(Scale $\frac{2}{3}$)

WHITE'S SOLID-BACK TRANSMITTER

having the same general features have been made by the larger manufacturing firms and have come into general use.

Fig. 39 shows a section of the original instrument. The small brass cell G is provided with a screwed cover, which serves to clamp a small flexible mica disc, to the centre of which is clamped a thin carbon electrode rather smaller than the inside of the brass cell. This electrode is faced by another one of carbon, fixed

to the back of the cell. Both electrodes are electro-plated, and soldered to their supports.

The cell is rigidly fixed to the arm *s*, which extends across the instrument. The mica disc is clamped by



FIG. 40
OPERATOR'S SET
(ERICSSON PATTERN)

the screw shown to a comparatively large ordinary aluminium diaphragm with an india-rubber ring round its edges, held in position and damped by means of two flat springs clamped to the rim of the casting, and having their ends tipped with felt or rubber pads, which bear on the outer part of the diaphragm. The sides of the cell *G* are lined with paper, and the space left (shown in white in the figure) is filled about three-fourths full with carbon granules. If, however, the trans-

mitter is to be used for common battery working, only about one-half the amount of granules is used, in order to increase the resistance.

Operator's Telephone Sets. For operators in telephone exchanges and others who require both hands to be at liberty whilst using the telephone, special sets of instruments are made, such as shown in position in Fig. 40. They consist of "head-gear" or "watch" receivers,

provided with springs to fit over the head, and of "breast-plate" transmitters with adjustable mouth-piece and necessary switches for cutting off the current when not in use ; and the conducting cords for joining up the different parts.

Office Sets. For the proper utilization of the telephone instruments so far described certain auxiliary

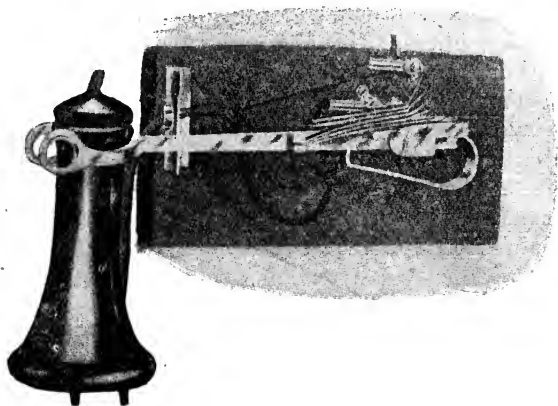

FIG. 41

AUTOMATIC PRONG-SWITCH AND RECEIVER

instruments are desirable, such as signalling bells and switches for changing the line circuit connection from such bells to the speaking telephones when ready for talking. The signalling bells used are the polarized ringers already described in Chapter II, and the *Switches* are made in a large number of different patterns, the most popular of which are similar to the one shown in Fig. 41, in which a projection on the pronged lever support for the receiver presses against a centre spring of a group of five springs ; this centre spring

presses two lower springs together when the receiver is on the prong to connect up the signalling circuit and presses the two upper springs together when the receiver is lifted to complete the speaking circuit.

Magneto Generator. In all cases other than with common battery working, a magneto generator would also be required as part of a set of instruments in order to signal the exchange or ring the stations at the other end of the line. Such a generator has already been described in Chapter II.

Telephone Exchanges. The telephone was at first used almost exclusively for private communications, but very early it was recognized by Mr. Hubbard, the father-in-law of Bell, that its usefulness would be greatly increased by the establishment of telephonic exchanges. Each member of such an exchange pays a certain subscription, for which he is supplied with a set of telephonic instruments, including the necessary switches and signalling apparatus and the use of a line wire which joins him to a central office. This office was provided with switchboards and with operators in attendance at them to answer any call signals from the subscriber and connect the line of any one subscriber to the line of any other one desired by the caller, so that the subscribers might converse together just as though they had a private wire between their respective offices.

Very few towns in civilized countries are now without their telephonic exchange, and in most large towns business would be completely disorganized by the cessation of its service for a few days.

The simplest and oldest system still in use is known as the "magneto," because it relies on the use of magneto-electric generators as described in Chapter II for all the signalling, etc., between the subscribers and operators. The system is only now used in

comparatively small districts and is rapidly being supplanted by the "common battery" system or by "automatic" systems.

The general features of the different systems of telephone exchange working will be given in the following pages.

Magneto Exchanges are of two kinds, according to whether the number of subscribers' lines to be served is likely to exceed 400 or not. If it is not likely to exceed that number a form of "standard" switchboard is used which is made up for either fifty or 100 subscribers.

Standard Magneto Switchboards.—Each of these switchboards has an equipment for each line connected to it consisting of a call signal, in the shape of an electric drop or annunciator, and a means of easy connection to it, which is called a "switch-jack," or shortly a "jack." In addition to these there is a set of a number of pairs of long flexible conducting cords, each containing two insulated conductors. Each cord of a pair is fitted at one end with a connecting "plug" to fit into the subscribers' line jacks and at the other end is connected to a "listening and ringing key," common to the two cords of a pair, by means of which the operator can connect her telephone set into connection with either of the lines connected by the pair of cords corresponding to the key.

Fig. 42 gives a front and a sectional view of a standard switchboard for fifty lines. The switch-jacks are fitted in strips of ten in the upper panel, and the signal drops in five rows of ten in the middle panel. Below the subscribers' line drops are five similar drops connected to junction lines used when a line has to be connected through to a line in another exchange. At the bottom of this panel is another row of ten drops which are the "clearing" signals used in connection with the

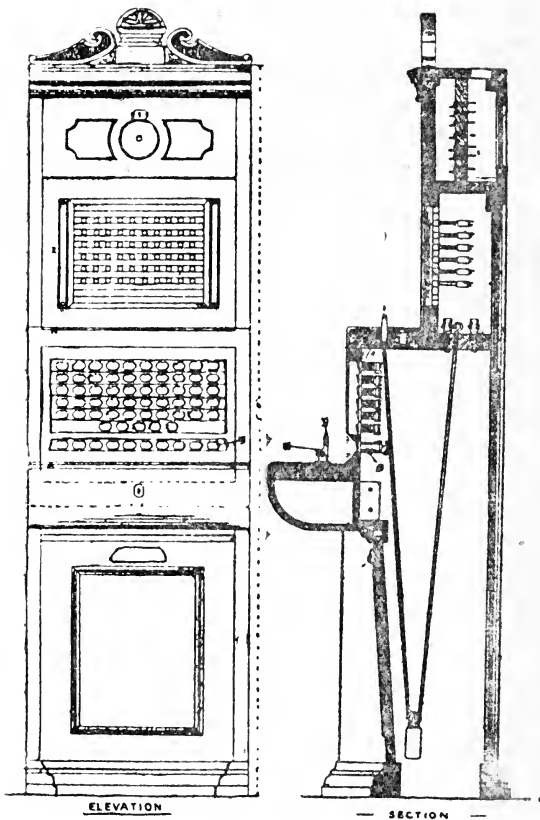
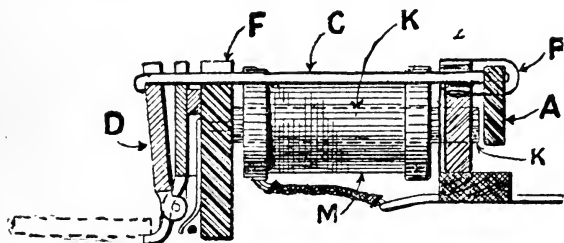

FIG. 42
(Scale $\frac{1}{16}$)
STANDARD SWITCHBOARD

pairs of connecting cords and plugs accommodated on the horizontal shelf above (only one cord of the twenty used is shown in the figure) with weighted pulleys to keep the cords straight and tidy when pulled up for connection.

The ten operators' listening-and-ringing keys, corresponding to the ten pairs of cords, are accommodated on the lower shelf, each pair opposite its respective clearing drop.

Drops.—The signal drops or "indicators" used on



SECTIONAL ELEVATION AT *x.y.*

FIG. 43

TWO-COIL DROP (FULL SIZE)

the boards consist of an electro-magnet, of one or two coils, with an armature (A in Fig. 43) which when attracted releases a shutter D, normally held in position by a long light arm C attached to armature, thus exposing a number corresponding to that of the line to which the drop belongs. The figure is a sectional side view showing only one of the two coils K. These drops are used for the calling signals, and another kind, called "tubular" drops, of a single coil enclosed in an iron tube, are used for the clearing signals on the lower row.

Switch-Jacks.—These are built up in strips of ten

or twenty jacks and are very important items in connection with all kinds of switchboards operated manually. As will be seen from Fig. 44, which shows the two end jacks of a row of twenty, they are formed of sets of flat springs (shown sideways only) with their ends projecting at the back so as to form soldering tabs for the connection of the wires, and with the two outer springs of the four of each jack, making contact normally with the two inner and shorter springs. The outer springs project near the end of a metal socket

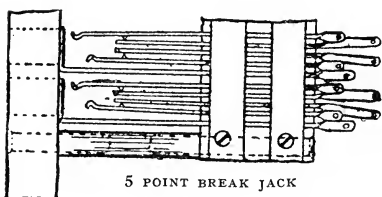

5 POINT BREAK JACK

FIG. 44

(Scale $\frac{1}{2}$)

SPRING JACKS

(shown in dotted lines) through which the connecting plugs are inserted in such a manner as to lift the outer springs from the inner springs and change the connection on to the two conductors of the cord to which the

plug is attached. Such jacks as the above are called "break-jacks" but there are others with no inner spring contacts, called "branching-jacks," which are used in connection with C.B. working.

Switch-plugs.—These are also made in many forms: those used in the type of board we are now describing would be called "two-way" plugs, but when a separate connection is required to the socket of the jack a "three-way" plug is then used, such as shown in Fig. 45.

When a plug is fully inserted into a jack the shorter of the two long springs makes contact on the back of the rounded end of the tip of the plug and is, therefore, called the "tip-spring," the longer spring presses on

the metal sleeve, which is, of course, insulated from the tip.

The 3-way plug has in addition to the tip and sleeve an insulated metal collar or ring, R, on to which the long spring of the jack presses when in use, and a connection

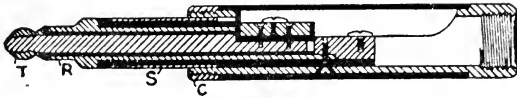

FIG. 45

THREE-WAY PLUG (FULL SIZE)

to the inner part of the plug. This is only required for "multiple" working, where it is necessary that the socket and long spring of the jack should be insulated from each other.

Listening and Ringing Keys.—There are many

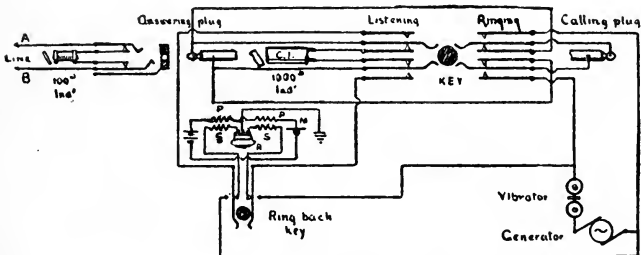

FIG. 46

CONNECTIONS OF STANDARD BOARD

different types of these made, but the type roughly shown in Fig 46 is a very simple and effective one. When a lever at the top is pressed to the left (really drawn forward), the cylindrical insulating piece, shown as a black circle, moves to the right and pushes the

springs from the inner springs which are connected to the cords, on to the outer springs which are connected to the operator's telephone set, and thus enables her to talk to a calling subscriber whose line has been connected to the "answering" cord. In a similar manner, when the lever is pressed to the right (backwards) the conductors of the other cord connected to the two similar springs are changed from the inner to the outer springs, which are connected to a battery or a generator for ringing the called-for subscriber's bell.

In later practice the ringing keys or buttons are held down, after being pressed, by an electro-magnet until the subscriber answers, or for a certain predetermined time in case of no answer to the ring.

Connections.—The full connections of the Standard switchboard are given in Fig. 46, and should be readily understood from what has been already described. The connections of the operator's telephone set are shown, including a double-wound induction coil PS, microphone M, and receiver R. The ring-back key shown is used for ringing the calling subscriber if he should have hung up his receiver after calling and before getting a reply.

Operation.—On the ringing of a calling subscriber his drop indicator (shown on left) falls. The operator inserts the answering plug of a pair of cords into the corresponding jack and pulls the listening key to connect her telephone to the calling line. On ascertaining the number wanted she inserts the calling plug into the jack of that number, and pushes her key to the ringing position for a few moments. The "vibrator" shows the operator if ringing current is passing to the line.

Clearing.—When finished the subscriber gives a clearing ring which drops the clearing indicator, CI,

and the operator seeing this takes out the plugs and restores all to normal conditions.

Multiple Switchboards. It is evident that if the exchange is so large as to require more than three, or at most four, of the "Standard" boards it will not be easy to get cords to reach from a board at one side to the board on the other side of the group, and in whatever manner such a connection might be accomplished it would be delayed, and the risk of connecting wrong numbers would be much increased.

To overcome such difficulties the "multiple" switchboard (invented by Scribner in 1880) is used, which enables a connection to be made to any one line at as many different points in the exchange as there are sections of the switchboard. Each section is made complete in itself, of from 5 to 6½ ft. in width, and is usually operated by three operators, each one of whom has a complete equipment of keys and cords and telephone sets for her own use, such as the single operator on a standard board is supplied with. The sections in an exchange are fitted end to end and in a large exchange may extend to quite a long length.

Each of the sections may be compared to three standard boards joined together end by end, with the indicators and jacks as described, but with an addition at the upper part, of a large panel of what are called "multiple" jacks, in which is provided a jack for every line in the exchange, however large the exchange may be, so that any one of the three operators can herself connect any one of the lines whose calls she specially attends to, to any other line in the exchange without moving from her position.

Any one line is connected to, or through, a jack in the multiple panel on each one of the sections of the complete switchboard, and usually finishes up by

connection to the ordinary jack and drop on the special one of the sections on which its calls are attended to, as shown in Fig. 47, which gives the connections of a line at the exchange.

Engaged Test. It will be evident that if any line can have a connection made to it at any one of, say, twenty sections much confusion would result, owing to two or more connections being made to the same line, unless there was some simple and rapid method of finding out if a wanted line was in use on some other

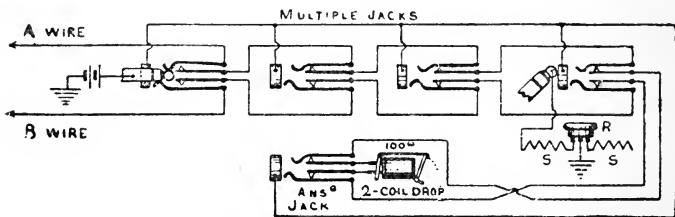

FIG. 47

LINE CONNECTIONS OF MULTIPLE BOARD

section. This is accomplished by connecting all the sockets of all the jacks appertaining to any one line together, and connecting a battery to all the sleeves of all the connecting plugs. Then before connecting a wanted line the operator touches the tip of the plug on to the socket of the wanted number jack and, if the line is already engaged, she will hear a click in her receiver and will tell the caller that the line is engaged. The connections for this test are shown in Fig. 47. The line is shown engaged at the first section of the multiple jacks, on the left, and being tested at the fourth section.

Common Battery Exchanges. With the main object

of reducing the cost of maintenance of subscribers' instruments in connection with exchanges many arrangements have been devised for dispensing with the batteries and the magneto generators at the subscribers' offices, and the "common battery" or "central energy" system is now the universal practice in all but small exchanges. The adoption of the system results in a reduction in the apparatus required and in the maintenance costs at these offices, and at the same time reduces the labour of the subscriber to a minimum, by making the calling and clearing operations automatic on the lifting of the receiver from, and the hanging up on, the prong-switch of the instrument.

As the name suggests, a large battery situated at the exchange itself is used to supply all the energy required for the working of all the signalling and talking apparatus of the exchange. The battery is nearly always a storage battery of either eleven or twenty cells, giving a voltage of about twenty-two or forty according to the one or other of two systems adopted.

To prevent too much current being supplied to the shorter lines and too little current to the longer lines, when such lines are coupled together for speaking at the exchange, and also to prevent overhearing from one pair of connected lines to another pair through the battery, it is necessary to supply the current to each pair of cords through a rather high resistance or impedance. It is the special means of providing these impedances in the current supply that has given rise to the various systems of common battery working.

The Hayes C.B. System.—This, invented in 1892, and introduced by the Western Electric Co., was the first practical suggestion for a complete C.B. system and has attained the greatest measure of success all over the world. The current in this case is supplied

to each pair of connecting cords through two complete induction or repeating coils, one connected to the positive side of the battery and the other to the negative side, as shown in the simplified diagram Fig. 48, which shows a connection made between two subscribers' speaking instruments by means of a pair of connecting cords. It will be seen that the two ends of each repeating coil are joined together and also to a pole of the battery; the figure also shows two supervisory relays, the purpose of which will be explained later. As a matter of fact,

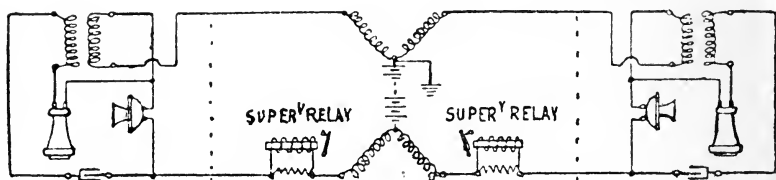

FIG. 48

CONNECTIONS OF HAYES'S C.B. SYSTEM

in the system as used to-day all the four coils of the two repeaters are wound together on one iron core.

The Stone C.B. System.—This is another extensively used system, invented in 1893. It differs from the Hayes system in having a continuous line connection between two subscribers connected for speaking at the exchange. The current is fed to the connected lines through two electro-magnets, otherwise called "retardation" coils, of which two are used for every pair of connecting cords. The speaking current waves generated at the subscribers' transmitters being very rapid are opposed by the self-induction or "inductance" of the retardation coils so much as to prevent overhearing due to leakage, at the same time allowing the steady

feeding current to pass to the lines. Fig. 49 gives a simplified diagram showing the speaking connections between two subscribers' instruments. The arrowed lines show connections to other retardation coils for other connecting cords.

Exchange Operations.—When a subscriber lifts his receiver from the prong-switch, the break in the line circuit, caused by the condenser, is bridged over and a current from the battery shown on the right then passes through the line relay, and this on actuation closes a circuit through a small electric calling lamp shown,

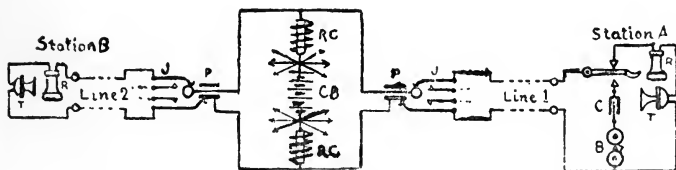

FIG. 49

STONE'S C.B. SYSTEM

which lights up and calls the attention of the operator, who, to answer the call, thereupon inserts the answering plug of a pair of cords into the jack shown.

The call having thus been made to the operator the latter tests the jack of the wanted number in the multiple panel above, and if disengaged, inserts the calling plug in the jack and turns over her listening key to the ringing side. The principal connections will then be as already shown in Fig. 48, the supervisory relays shown serving to short-circuit the two "supervisory lamps" in connection with the pair of cords, and prevent them lighting up. Immediately either of the receivers is hung up the corresponding relay is released and its lamp glows, as the short-circuit is removed

from it. When both lamps glow the operator knows that the conversation has finished and removes the connecting plugs and cords.

Lamp Signals.—The calling lamps referred to above are now used in nearly all C.B. exchanges in place of the ordinary drop signals, and have proved a great success, because they attract attention more certainly than drops, they occupy much less space, they are completely self-restoring and they can be fixed in any position. They are fitted in strips similar to and of the same size as strips of jacks, and are fitted directly below the answering jacks to which they correspond so that there is very little risk of mistake in connection.

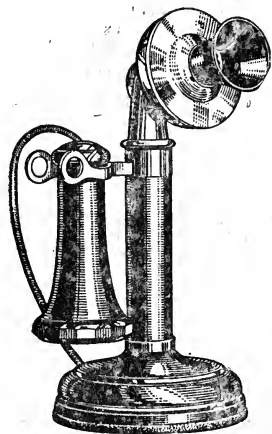

FIG. 50
TABLE PEDESTAL
TELEPHONE

The general appearance of a C.B. table set is shown in Fig. 50, the ringer and condenser are fitted in a separate case which can be fixed on the wall or under a table or desk. The pedestal for the table has provision for the transmitter and the receiver prong-switch, the springs of the latter being accommodated vertically inside.

Automatic Telephone Exchanges. Within the last few years the method of making connections between pairs of subscriber's lines at an exchange by mechanical and electrical means, without the aid of an operator, has made much progress in this country, and a number of such exchanges have been installed by the B.P.O.

The principle of working is that of dividing all the subscribers' lines into groups usually of 100 each; tens of such 100 groups are combined to make other larger groups of 1,000 lines each, and, if the exchange is large enough, tens of the 1,000 groups are combined to form still larger groups of 10,000 each. Each of the groups has distinctive numbers allotted to the lines of which it is comprised.

In addition to an ordinary telephone set each subscriber is furnished with a "finger-hole dial" or "impulse transmitter" (see Fig. 51), by the aid of which he can send, in steps, a number of current impulses through the line to the exchange, for the purpose of actuating the working magnets of switching machines, called "selectors," an equivalent number of times and so obtain access, first, by another selector to the large group of lines represented by the first left hand digit of the wanted number, which we will assume is 9546, so that the first set of impulses would be nine giving connection to a selector associated with the ninth 1,000 group of lines. The next set of impulses would be five, operating the last named selector to make a connection with another selector, or, as it is the last required in this case it is called a "connector," connected to the fifth of the 100-line groups.

The changes from one selector to another at the end of each of the sets of current impulses corresponding to the digits is caused by the operation of relays, which are so constructed as to be much slower in releasing their armatures after the current has ceased than the ordinary class of relays. These relays are released only after the comparatively long interval which occurs between the different sets of digit impulses whilst the sending instrument is being prepared for the next digit set.

The *Selectors* are switches with a number of fixed sets of line contacts, made up usually in ten circular



FIG. 51

TABLE SET FOR AUTOMATIC WORKING

arc tiers, one above another, and also of a set of movable contacts or brushes, which become part of the circuit of the calling line when the selector is in use. The arm (or arms) carrying these brushes is, by cause of the

current impulses sent from the calling station, lifted from the bottom to the tier of contacts represented by the impulses sent, and then by an automatic process, it is made to sweep round over the contacts fitted on that tier until an idle, or not-in-use, selector is found, one out of ten or more, connected to the group required. This process is continued until the last required, *i.e.*, the connector, is reached, as in the case taken, after the second set of impulses has been sent. The action of the connector differs from that of a selector in that the sweeping round of the brushes, after they have been raised to the proper tier, is not altogether automatic, but is governed entirely by the last set of impulses sent from the calling station. The third set of impulses therefore lift the connector brushes to the fourth tier and the fourth set of six impulses causes the brushes to revolve six steps over the sets of contacts on that tier, when it will have arrived at the set of contacts directly connecting the line of the No. 9546 subscriber. If the line is disengaged the brushes are connected to the contacts and a ringing current is joined on to the line to call the subscriber. If, on the other hand, the wanted line is found to be already engaged, which is indicated by a certain battery connection, this same battery connection will cause a signal to be given to the calling subscriber and at the same time cause the undoing of all the connections that have been set up, as described above, so as to restore all parts concerned to their normal condition.

It ought perhaps to be stated, that in addition to the selectors, etc., at the exchange each subscriber's line is, in most of the automatic systems, connected to another small switch called a "line" or "hunting" switch, which is set in action immediately on the lifting of the receiver telephone from the hook by the calling

subscriber and the consequent closing of the line circuit. The hunting switch is similar to one tier of contacts of a selector, with an arm carrying brushes, which immediately the line circuit is closed, by the lifting of the receiver from the prong, sweeps over the contacts to find an idle junction line to a sort of central clearing house, where a number of junction lines to selectors connected to all the large groups of lines are centred and available. All this will have been done before the caller has operated the dial impulse transmitter.

The system outlined above is known as the "Strowger," which was first in the field, and has so far been used for most of the automatic exchanges which have been established by the Automatic Telephone Manufacturing Co. and Siemens Bros. & Co. in this country, and by the Automatic Electric Co. in America, but there are several other systems which have lately come into use, some of which are equally promising, such as those of the Western Electric Company and of the Relay Automatic Telephone Company. These systems are mostly based on the same general principles with regard to the grouping of the lines, etc., but differ in regard to the mechanism of the selectors, etc., employed in making the connections. The latter mentioned Company's connecting system being entirely worked by the aid of simple relays, which having, practically speaking, no parts subjected to wear, are considered more reliable than ordinary electro-mechanical devices of the ordinary selector type which are subject to a good deal of wear on some of the working parts.

CHAPTER V

TELEGRAPH AND TELEPHONE LINES

CONDUCTING lines for the connection of the various stations, in both telegraph and telephone systems, are of three different kinds, "overhead" or "aerial," "underground," and "submarine." Until recent years a very large proportion of the land lines were run overhead, because of the cost and the difficulty of working underground lines, especially if long ones, owing to the condenser effect being excessive with the old types of cable then used. The introduction, however, of what is variously known as "dry-core," "paper" and "air-space" cables, which are comparatively cheap and also have much less condenser capacity effect, has considerably modified the practice. In telephone working, which was most affected by the condenser effect, the dry-core cables, with the aid of Pupin's scheme for the "loading" of the lines by connecting inductance coils in series with them at regular distances along the route, has made the working of long underground or submarine telephone lines quite feasible.

Aerial Lines should be erected so that the line route is as straight as practicable in order to lessen the strains on the supports, which under conditions of heavy snow and wind storms are very severe in exposed situations.

Wire.—Galvanized iron wire is generally used for all the shorter telegraph lines, but for long and important ones hard-drawn copper wire is now extensively employed, both for telegraph and telephone lines, whilst

for the shorter telephone lines bronze wires are used, as they resist the corrosive effects of the town atmospheres better and are of greater strength than copper wires of the same diameter.

Joints of one length of wire to another length are made by winding over the overlapped wires a length of smaller copper binding wire in the manner shown in Fig. 52, and then soldering the whole together. This is known as the "Britannia" joint.

Poles.—The poles used in this country are mostly Norwegian or Swedish fir, subjected before use to a preservative process of impregnating the timber with creosote. They vary in length from 18 to 85 ft., and



FIG. 52

BRITANNIA JOINT

from 4 to 8 ft. of the length of the butt-end is planted in the ground when erected, according to the size of the pole.

The appearance of an ordinary pole as used in the country is shown in Fig. 53, which also shows the method of "staying" to prevent the pole falling over to the right or "opposite" side.

The insulator supporting arms are of oak or hollow cylindrical iron, fitted into slots cut in the pole, and secured by a bolt through the arm and pole.

Double poles, shaped like an A or an H, are used for important routes where a large number of wires have to be carried being much stronger than single poles and not requiring so much staying.

Insulators.—As the wire used for overhead lines is usually bare and must be supported at many points, it is necessary to provide special insulating supports

which, even in the worst of weather conditions, will allow but a very small proportion of the working currents to leak to the earth or to other lines.

The best "insulators" for this purpose have been found to be those made of porcelain or of well glazed

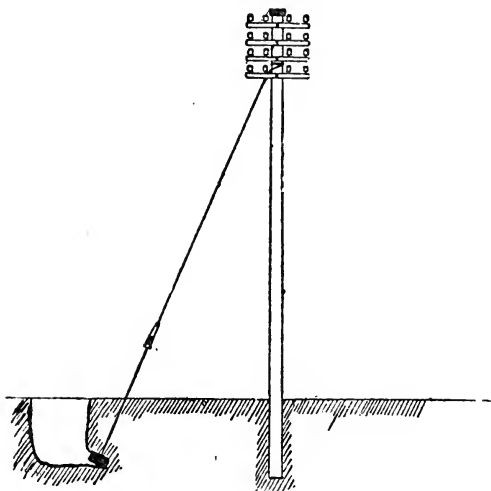

FIG. 53

POLE WITH STAY

earthenware, of the shape and section shown in Fig. 54, and known as the "Cordeaux" insulator. This has two inverted cup surfaces (therefore called "double-shed") protected from the rain, and as the leakage which takes place at these insulators is nearly all over the surface and not through the substance of the insulator, the dry surfaces of the cups give very good insulation when clean.

The insulator is screwed on top of an iron bolt, the lower portion of which passes through a hole in the arm, and the line wire is secured in the channel recess in the insulator by a length of copper binding wire passed round the insulator and the line wire. This form of insulator is used for most line work, but several other forms are used for special purposes such as terminating, etc., but all have the inverted "double-shed" principle for giving a long dry surface between the supporting bolt and the line wire.

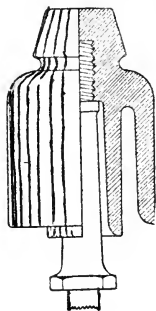

FIG. 54
CORDEAUX
INSULATOR

Overhouse Lines.—When a route of lines reaches a town it is necessary to adopt another type of construction for the wire supports, as the poles are not allowed to be erected along the streets as they are in many American towns. The lines are in overhouse work supported on iron poles resting on the walls or ridges of buildings and well "stayed" in many directions to make them firm. The arms are also made of iron clamped to the iron tube pole as shown in Fig. 55.

In late years, however, it has been the more general practice to run a route of lines through a town in the form of a cable of small wires enclosed in a lead tube for protection, this cable being preferably run underground; but if this cannot be arranged, then by somewhat lighter cables supported on the lower parts of the overhouse poles. The cables are supported by suspensor wires consisting of one or more galvanized steel wires, the cable being supported from the suspensor at about every yard by "cable-slings" of raw hide as shown in Fig. 56.

Underground Work. The initial cost of laying a

group of lines underground is considerably higher than that of erecting the same number overhead, but a good system of underground lines is much more

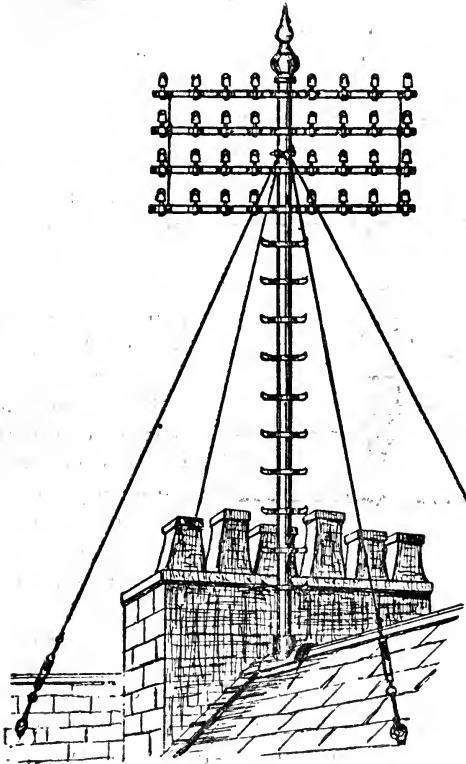

FIG. 55

IRON POLE COMPLETE WITH ARMS, STAYS, ETC.

economical as regards maintenance costs, for which reason it is probable that in the near future the lines in all busy districts will be run underground.

Cables.—The cables used for underground work are of the paper and air insulation type, already mentioned, protected by a lead tube and usually called “dry-core” cables. The wires are kept apart by a loose wrapping of Manilla paper strip, but it should be understood that it is the dry air enclosed with the paper and not the paper itself that gives the very low capacity and high insulation properties which are so valuable and characteristic of this type of cable.

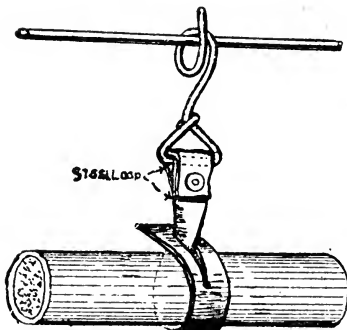

FIG. 56

CABLE SUPPORT

For telephonic purposes cables of about 2 ins. diameter are sometimes made up with as many as 1,000 pairs of small wires to be used for short telephone lines.

The conductors, or pairs of conductors, in the various layers of wires in a cable are distinguished from each other, and any one traced, by the

colours of the few cotton fibres which are used to hold the loose wrappings of the paper on the wires, or by the colour of the paper itself.

Conduits are made up of “ducts” which are the receptacles for the cables laid under the roadways or footways of the streets. There are several types of them in use, the most common being made up of cast iron or of earthenware ducts, and they all amount to different methods of forming watertight and smooth cylindrical holes of from 3 to 4 ins. diameter in the earth, for the easy “drawing-in” of one of the larger, or two or more

small cables. To provide for this drawing-in and also for the jointing, testing, etc., of the wires "manholes" are constructed below the surface of the roads, into which workmen can enter. When the cables are being drawn in they are smeared with crude vaseline as a lubricant, to prevent damage and make the work easier.

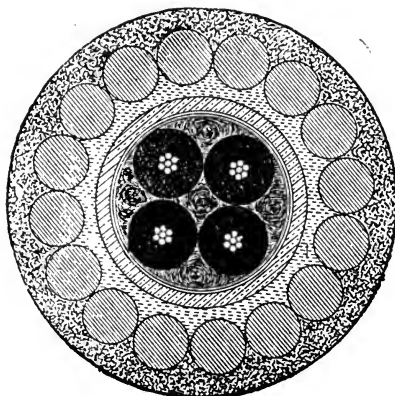

FIG. 57

SECTION OF ANGLO-BELGIAN SUBMARINE
CABLE (FULL SIZE)

Submarine Cables. The very great strains to which submarine cables are subjected when being laid in deep water, and when laid at comparatively shallow depths, by the anchors of vessels, etc., necessitate a very much stronger form of construction than for cables used for underground work. Fig. 57 shows a full sized section of a type of submarine cable having two pairs of 7-wire stranded conductors for telephone use or four separate line conductors for telegraphic use. Each of the

conductors is separately insulated with gutta percha and Chatterton compound, as shown in black, a spiral tube of brass being wound outside this insulation to protect the conductors from the destructive attacks of the small submarine animal—the “teredo.” Over other coverings of tarred tape and hemp is wound an armouring sheath of sixteen galvanized iron wires, the whole being then covered with tarred hemp and tape.

It appears probable that the late pronounced success of wireless telephony will restrict to some extent the numbers of such cables laid in the future for telephonic purposes owing to their heavy cost.

CHAPTER VI

WIRELESS TELEGRAPHY

THE subject of wireless or "radio" telegraphy deals with the matter of signalling through space between distant points by means of electric waves, without the aid of wires or other metal conductors between the signalling points. Such signalling is analogous to the propagation of sound through the air between points comparatively close together, by means of bells or sirens; in this case the sound waves are known to be carried through the air in all directions at a certain speed depending upon the density and elasticity of the air, but usually about 1,090 ft. per second. The medium of propagation dealt with in wireless working, and called the "aether," is a very much more mysterious one than the air, and no direct proof of its existence has yet been produced, but its existence is believed in by practically all the more eminent scientists, because such a medium appears to be absolutely necessary to account for many of the known facts in connection with electricity, light, heat, gravity, etc.

As acoustics deals with vibrations or oscillations of matter causing sound and their propagation through the air, so wireless telegraphy deals with the electric oscillations and their propagation through the aether, generally in all directions, by electric waves travelling at the immense speed of 186,000 miles per second. These waves although imperceptible to any human sense can, by suitable apparatus, be intercepted and interpreted at receiving stations.

Oscillations. There are many means of producing the

electric oscillations and there are two types of oscillations used for signalling, one called "damped" and the other "undamped" oscillations. These types may be compared to the sound vibrations sent through the air by a bell struck at frequent intervals and to the vibrations set up by a siren respectively. From the bell we obtain a loud sound at the moment of striking which rapidly falls off until the next blow is struck, and so on, whilst from the siren the sound may be loud, steady and continuous. Damped electric oscillations, corresponding to the bell vibrations, are obtained as the result of the discharge of highly charged condensers through a circuit having but a moderate amount



FIG. 58

OSCILLOGRAM OF DAMPED ELECTRIC SPARK WAVES

of resistance; if the resistance of the discharging circuit is very high there will be no oscillation, but only a single wave of discharge in one direction. Fig. 58 gives a graphic idea of a series of eight sets or "trains" of damped oscillations obtained from the rapid charging and discharging of a condenser eight times in succession, the condenser being of course charged up again after each discharge; the same figure might also represent the air vibrations caused by the striking of a bell eight times in succession. In the case of the bell the number of oscillations of the air particles may be about 800, but in the case of the electric oscillations they may be anything from, say, 1,000 up to millions per second.

Resonance. One of the facts well known in acoustics and music is that a stretched string, or a metal reed,

or an organ pipe, which is tuned to a certain note will set up vibrations of that note on its own account if a note of the same pitch is sounded in its vicinity. In the same manner an electric circuit, tuned by its capacity and inductance to respond to or give out electric oscillations of a certain periodicity, will have oscillations of that periodicity set up in its own circuit with increased effect if electric waves of the same periodicity, produced by other means, come within its field of action. This effect is called "resonance," and it was by taking advantage of this effect that Hertz in 1888 proved the existence of electric waves, and of Maxwell's theory that light was due to electro-magnetic waves of very high periodicity propagated through the aether.

Radiation. The discharge and oscillations produced in the plates and the wire joining the plates of a condenser, do not give rise to electric waves travelling into space, as the strain effects on the aether brought into play by the attraction of the two electric charges are too much localized, being mostly confined to the spaces between the plates. Such a circuit is, therefore, called a "non-radiative" circuit. To obtain radiation and electric waves it is necessary to increase the distance between the conductors acting as plates, and, in order to obtain the best effects, make use of the earth's surface to serve as one of the two plates. So that the latest arrangements for radiation consist of one plate, which really consists of a network of wires, elevated in the air and the other the practically limitless surface of the earth along which a strain on the aether can flow, and carry with it a similar aether strain, or electric charge, in the air above the earth, the earth's surface acting as a sort of guide to the electric waves in the neighbouring air spaces. It will, however, be well to give the steps which led to this final arrangement.

Hertz's Researches. In 1888 Hertz experimented with a sort of condenser in which two flat plates were fitted in the same plane, each with a wire and sparking knobs as shown in Fig. 59. This apparatus was called an "oscillator," and each of the plates was connected to the terminal of a large sparking induction coil. Even with such an arrangement there is a certain capacity and inductance between the two plates and the connecting wires to the knobs, and oscillations arise whenever a spark passes between the knobs. Such an oscillator as this is a radiating one, and projects electric waves into space, which waves were detected by the use of resonators in the form of wire rings of a certain size with a very small air gap left in, faced

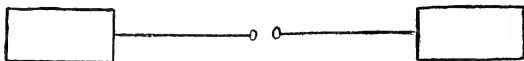

FIG. 59

HERTZ'S OSCILLATOR

by sparking balls. Such a resonator would show very small sparks whenever set in such a position opposite the centre of the oscillator, that the spark obtained was parallel to the spark of the oscillator. The oscillator and resonator might be many yards apart and with brick walls intervening. Hertz also proved that the electric waves could be reflected and refracted just as light rays can be.

Marconi. In 1895, G. Marconi, an Italian, used as a Hertz oscillator two short cylinders in place of the plates, and adopted as the receiver, in place of the ring resonator, a kind of microphone, called a "coherer," which consisted of a sealed glass tube (see Fig. 60), inside which were two silver buttons furnished with connecting wires fused through the ends of the tube.

Between the buttons or plugs, which were only separated by about one millimeter, there was a wedge-shaped space in which were loosely packed a few fine mixed filings of nickel and silver. Such a coherer, if included in a circuit with a small battery and a telephone receiver, is normally of very high resistance, so that a current will not pass, but it is very sensitive to electric wave impulses, which immediately render it conducting to the battery current, thus causing a click in the telephone receiver. As, however, the conductivity of the filings of the coherer persists until the filings are mechanically disturbed, an arrangement had to be made by which the instrument was automatically shaken; this was done by means of a sort of electric trembler



§ FIG. 60

MARCONI'S COHERER

bell vibrator, which kept the coherer continually shaken, so that the conductivity should fail immediately the electric waves ceased to impinge on it.

A great improvement was obtained by Marconi when he used a vertical wire, some meters in length, topped by a sort of large biscuit tin, and connected at the bottom to one of the spark balls, and with the other ball connected to earth. Using a similar arrangement at the receiving end, but with a coherer in place of the spark gap and induction coil, he was able to obtain signals over many miles of space, the higher the vertical wires or "aerials" used, the longer the distance that could be signalled over. The connection to earth also constituted an improvement of the utmost value

and proved a turning point in the practical success of wireless working. Such an arrangement without the biscuit box (which could be dispensed with without much effect on the working) is known as "plain aerial" working.

The Morse code was adopted for signalling, the dots and dashes being sent by a Morse key in the primary coil of the induction coil, the secondary coil being connected to the spark balls and the aerial, as shown in

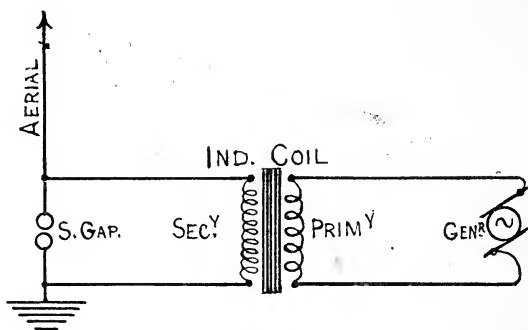

FIG. 61
MARCONI'S "PLAIN-AERIAL" ARRANGEMENT

Fig. 61. The current fed to the primary coil would, of course, be continuous and that obtained from the secondary coil to the spark balls would be alternating, the frequency depending on the speed of the interrupting vibrator in circuit with the primary coil. As the process of using the key is a comparatively slow one, there would be at least one make and break in the vibrator, and one train of oscillations and corresponding electric waves, in the duration of even a very short Morse dot, so that the fact of the waves being broken up into trains has little or no influence on the code

transmission; the coherer vibrator also being sufficiently rapid in action to distinguish the dots, dashes and spaces very readily. Arrangements were also made to print the messages by Morse printer actuated by the coherer, and also to sound an alarm bell by the same means when a message was to be sent.

Coupling. Such a system as the above, although very simple and effective, as compared with the results obtained with the Hertz oscillator, had several faults, the chief of which were, that its range was limited, and it could not be used for selective systems, which latter reason became of much importance as the number of wireless stations increased. For these reasons it was soon replaced by Marconi by the "coupled" system, in which the oscillations due to the sparking were gener-

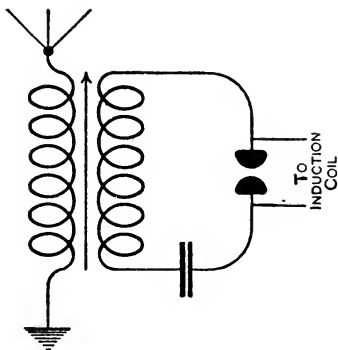

FIG. 62
"INDUCTIVE" COUPLING

ated in a circuit separate from the aerial and earth circuit, but inducing oscillations in the latter circuit by means of another induction coil or "transformer" as it is more often called. Fig. 62 shows the principal connections to the spark gap. In order to obtain the best results it is necessary that the two transformer circuits shown should be tuned to the same natural frequency for the oscillations, so that they will react upon each other and so enhance the effects. Some "tuning" arrangement is therefore necessary in one

or both of the circuits, and this generally takes the form of an adjustable inductance or an adjustable condenser, or both. There are several methods of coupling, the one shown above being called an "inductive" coupling, whilst another method, called "direct" coupling, is shown in Fig. 63. In this, only a single *inductance* coil is used, with an arrangement for connecting either the whole coil or a portion only at the same time to two different circuits, so that a proportion of the turns

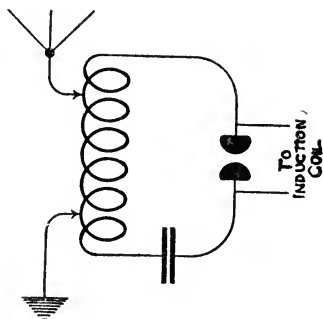

FIG. 63
"DIRECT" COUPLING

of the coil will be common to both the aerial and the spark-gap circuits, as shown in the figure, the two circuits working apparently quite independently of each other, just as though they had been inductively coupled by two separate coils.

Undamped Wave Generators. Undamped wave systems are coming into use to a considerable

extent for wireless transmission, and have several advantages over systems using the damped waves. They have more effect on resonant receiving circuits owing to their regular, continuous and cumulative effect. Selective working is also much more certain and efficacious. The undamped system is also the only one which can be used for wireless telephony.

There are four methods of producing undamped oscillations : (1) by magneto-electric generators ; (2) by the "singing arc" method ; (3) by what is known as the "quenched spark" method ; and (4) by means

of the Fleming or "thermionic valve," a special arrangement of an electric lamp, which appears likely to prove by far the most important of all the methods.

Magneto-Electric Generators. Machines to be used for generating the alternating currents to produce the oscillations directly must be provided with as large a number of field magnets, or pairs of alternate poles, as practicable, so as to give as many reversals as possible in one revolution of the armature shaft. To avoid excessive driving speeds various methods have been adopted, such as to use the alternations generated in one machine to generate double the number of alternations in another generator by passing them through the field magnets of the second machine, and so on, each machine doubling the alternations of the last one. By such or somewhat similar methods machines giving 100,000 alternations per second have been produced.

The Singing Arc. Prof. E. Thomson showed, in 1892, that an electric arc, if shunted by a suitable circuit containing capacity and inductance, would be set into regular oscillation, which would continue until the circuit was broken, and this was independently brought to notice again by Duddell in 1900, who called it the "singing arc" and by its means opened up a very promising field for wireless transmission. The arrangement was soon put to practical uses, but there were many difficulties in connection with its practical success, such as the irregularity of starting the arc and its varying resistance, so that it was not until Poulsen had improved the arrangement that it became a complete success. His improvements consisted in producing the arc in an enclosed space containing hydrogen or hydro-carbon gases under high pressure, so that there was no consumption of the carbon; and cooling the electrodes as

much as possible by making one of them of heavy copper with water circulating inside. He also used a powerful electro-magnet with its poles near the arc in order, by the repulsion of the electrified gases, to obtain a very rapid cooling circulation round the electrodes. By such means steady and high power oscillations at a rate up to a million or more per second were successfully obtained, and the Poulsen system of working is now in use over distances exceeding 4,000 miles. The frequencies of the oscillations thus produced are, of course, much above the audible range of the human ear, and the arrangement is, therefore, not, correctly speaking, a "singing" arc.

The Quenched Spark System. This is merely a modification of the ordinary coupled spark system, in which, by certain means, the train of oscillations across the spark gap and the primary circuit, is made as short as possible by a very rapid damping effect. The result on the secondary circuit is to prolong the oscillations in the aerial and render them of a more uniform strength, and also to transform a larger proportion of the energy received from the primary circuit into space-wave energy. The oscillations set up in the aerial circuit by the effect of the few (about three or four) very powerful oscillations in the primary circuit, are nearly uniform in strength, being only reduced by the damping due to the impedance in its own circuit and to the power radiated out into space.

The rapid damping of the spark and primary oscillations is managed in various ways, the method used by the Telefunken Co. in Germany being to break up the primary spark into a number of very minute sparks across very small gaps left between a number of heavy copper discs, so as to carry off the heat of the sparks as rapidly as possible, this being assisted

by a strong draught of air forced between the discs at the same time.

The Marconi Co.'s "Disc-Discharger" may also be used to give a "quenched spark." In it a metal disc is used, on the rim of which are fitted a number of radiating spokes like the handles of the steering wheel of a vessel. This disc is made to revolve very rapidly between two metal electrodes so arranged that two of the spokes come very close at the same instant to the two electrodes. By revolving the disc at a very high speed the sparking between the spokes and the electrodes, when they come nearest together, can be cut down to a very few oscillations by the rapid increase in the distance between the sparking points, and the strong current of air generated by the revolutions of the disc and spokes.

The fourth method of producing undamped oscillations is by means of the "thermionic valve oscillator." but the importance of this thermionic working is so great that it is considered desirable to give a separate section to it and its connection with the electronic theory of electricity.

Receiving Circuits. The most important detail in which improvement has been made in the receiving arrangements is the superseding of the coherer, decoherer, etc., by other forms of detectors or receiving devices, such as the "electrolytic," the "crystal rectifier," the "thermionic lamp rectifier" and the Marconi "magnetic detector," which are much more sensitive and reliable, and also the including of these devices in a coupled circuit similar to that adopted at the transmitting end for the transmitting devices.

The Electrolytic Detector.—This is a rectifying receiver of great sensitiveness; it is made up in several different forms, one of which consists of a very fine platinum

wire (called a Wollaston wire) sealed into a glass tube, the end of the wire just dipping into a weak acid solution contained in a sort of lead thimble. The wire forms one electrode and the container the other, of the current from a small battery. When the potential difference is correct and a circuit with an oscillatory current is joined to the electrodes, the instrument is found to be, in some way not quite understood, extraordinarily sensitive to the oscillations, which are super-imposed on the direct current from the battery, a telephone being used to detect the variations.

The Crystal Detector.—In this instrument advantage is taken of the fact that certain crystals, and especially carborundum, will only conduct currents passing in one direction or polarity through certain diameters of the crystal, and so become rectifiers of alternating currents. The crystals are especially sensitive, as in the case of the electrolytic rectifier, with a certain strength of permanent current in the proper direction.

The Thermionic Rectifier is dealt with in a later section, and is the one which gives promise of the greatest development in the future.

The Marconi Magnetic Detector.—This instrument, which was introduced in 1901, superseded the metal filings coherer and has proved a sensitive and reliable instrument, so that it has probably been more extensively used than any other form of detector. The complete instrument is shown in Fig. 64, and is made up of an endless band of soft iron, of about seventy strands of very fine wire, which is moved at a steady rate, by clockwork and pulleys, in front of the poles of the two permanent magnets shown and through the centre of a sort of induction coil. The electric oscillations passing through the inner coil have the effect of nullifying the magnetism induced in the iron band by

the inductive effect of the first magnet pole reached which would otherwise have persisted until it had passed through the coils, so that every time a train of oscillations passes through the inner coil a click is heard in the telephone, and the coded signals can be read by the soundings of the musical note due to the combination of the clicks.

There are other forms of receiving detectors in use, but those described above are the most important.

Modern Marconi Installation. The apparatus, etc., generally comprised in an up-to-date Marconi installation consists of

the following:

The mast or masts for supporting the carefully insulated aerial wire arrangement; an almost equally elaborate earth wiring system; a generator of

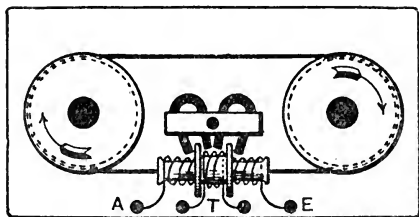

FIG. 64

MARCONI MAGNETIC DETECTOR

either direct or alternating current for charging the condenser; the condenser and the coupling transformer (usually called the "jigger"); and the discharger, with the aerial tuning inductance connected to the jigger secondary coil on one side, and to earth on the other.

The receiving instruments usually comprise: the detector, the coupling jigger, the tuning circuits, the lightning protectors, and the telephone.

Masts and Aerials.—The masts for important stations are mostly of open lattice work, iron or steel, and run to between 200 ft. and 400 ft. in height. There may be as many as ten of these masts required to support the

aerial wires where special directive working is concerned, such as for the important Atlantic stations. At such stations a number of raised parallel horizontal wires are run, for perhaps a mile in length, in a direction from the transmitting station opposite to that in which the electric waves are to be sent. This is on the principle of Marconi's invention of the inverted L form of aerial which appears like this " **┐** " and has the property of sending out the electric waves most strongly in the direction opposite to that in which the free end of the horizontal part points, and also of receiving the waves best when they come from that same opposite

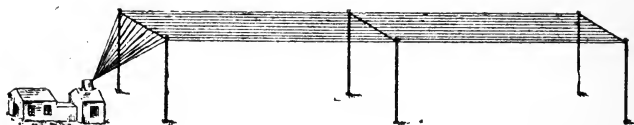

FIG. 65

MARCONI DIRECTIVE AERIAL

direction. Fig. 65 gives a rough idea of the construction of a large directive aerial for an Atlantic station.

In other stations intended for all round working, there is a high central mast for the central support of an "umbrella" aerial, subsidiary masts being erected round this to support the ends of the ribs, as it were, of the umbrella.

Earth Connections.—On account of their importance the earth connections are often almost as elaborate as the aerials, a system of wires being laid in the ground similar to that of the aerials to assist the directional working, etc. The earth wires end up in plates laid in damp ground or water, may be, a mile or more from

the station. For directive working the earth wiring system is run in an opposite direction to the aerial, that is, towards the station it is desired to work with.

The Generator for charging the condenser is usually some form of alternator, driven by an engine, or by an electric motor when an electric supply is available. The alternations from the generator are sent through a static transformer which raises the voltage to as much as 20,000 before the current is used for charging the condenser. Tuning arrangements are used with this transformer-condenser circuit so that it may be put into resonance. The frequency of the generator, and of the sparking, runs from 200 to 1,000 per second, and gives rise to a musical note in the receiving telephone which is readily distinguished from the interference noises which are always heard when receiving.

The Condenser.—This is usually made up of alternate glass and metal plates immersed in oil ; or in the case of an air condenser, of large sized sheets of zinc only ; these being suspended in the air from heavy insulators. Alternate sheets are connected together in two sets to form the two plates of the condenser. Such condensers as these have the advantage that they cannot be destroyed by sparking between the plates, as is the case with other forms.

The Transformer or Transmitting "Jigger."—The primary coil of this consists of a few turns of a thick copper stranded wire cable on an insulating core, and the secondary consists of a much larger number of turns of a smaller copper stranded cable. The two coils are so arranged that one can be hinged, or slid, or rotated away from the influence of the other, so as to be able to vary the inductance between them, to make the coupling more or less effective (*tight* or *loose*) as desired.

Adjustable Tuning Inductances are provided in the

aerial and secondary circuits, these being also made up of stranded copper cables wound on a core and furnished with heavy sliding contacts for adjusting purposes.

The Sparking Dischargers used in large Marconi stations are almost invariably of the rotary disc type, the later ones being multiple disc ones, the discs being so geared to the generator that the sparking follows in series through the different discs and always takes place at the most favourable moment for the discharge.

Operating Key.—In small stations the Morse key may be directly inserted in the primary circuit of the transformer, but it is more usual to employ a separate key to operate a relay having contact points in the primary circuit, and in large stations, where the current and voltages are very high, the key is a specially insulated one, used to operate electrically a heavy and very well insulated key fitted in the secondary circuit.

Receiving Stations. For all the most modern Marconi stations separate receiving aerials and stations are used, these aerials being similar to those at the transmitting stations. The stations are at least 10 miles apart, so as to get rid of a great proportion of the interfering effects and allow transmitting and receiving operations to be carried on at the same time. This also removes the danger of injury to the comparatively very delicate receiving instruments from the heavy currents and voltages used with the transmitting instruments.

The Standard Receiving Instrument used is the Marconi magnetic detector, which has been found the most reliable and substantial instrument to use under all adverse atmospheric conditions. If, however, special sensitiveness is required for special conditions a detector of the crystal carbonundum or of the thermionic valve type is used.

The coupling jiggers and the tuning devices are similar to, but smaller, than those used in connection with the transmitting instruments, and all the apparatus is well protected from lightning and other heavy electric discharges by protectors of various types.

The Electron Theory. Since the discovery of radium and its emanations by Prof. and Madam Currie in 1898, the effect of many other investigations has led to a belief that the atom, which was formerly considered the smallest body that could have a separate existence, constitutes a small constellation in itself; the smallest atom, that of hydrogen, being made up of some 2,000 or so of some other bodies called "electrons," each of which has a diameter of only about the 100,000th part of that of an atom. Each of these electrons carries, or constitutes, a certain charge of negative electricity, and when any electrons have, by some means or other, been separated from an ordinary atom, the remaining part gives evidence of a charge of positive electricity, the stronger according to the number of electrons lost; the part left of the atom is then called a positive "ion," this word meaning "wandering part." A negative "ion" is also formed when one or more electrons are added to an atom, and it then shows a negative charge.

Free Electrons.—In conducting substances there are always a large number of electrons which are not attached to any of the atoms of the substance but are moving about in all directions between them, but when a conductor is made to form part of an electric circuit many of the free electrons are made to flow all in one direction and this then constitutes an electric current, the strength of the current being in proportion to the number of electrons thus flowing. The hotter the conducting substance is, the more active are the

movements of the free electrons, and when the substance becomes very hot the electrons, which are ordinarily confined within the surface of the body, are able to penetrate the skin of the conductor and attach themselves to other bodies in the neighbourhood. If there happens to be a body near charged with positive electricity, the stream of electrons thus thrown off, as it were, will be directed towards it, and give rise to a current from the hot body to the positively charged body. If this operation can take place in a space exhausted of air the action will be much more intense, as, otherwise, the atoms of air oppose the free movements of the electrons.

This direction of the flow of the electrons in a current given above appears to contradict the previous ideas of the direction of flow of a current, which has hitherto been taken as from the positive to the negatively charged electrodes. It would seem to be desirable to have a fresh definition on the subject.

Fleming Valve. The action described above is the principle of action of an appliance invented by Prof. Fleming in 1904, in which the filament of an electric lamp is used as the heated conductor and a small metal plate supported by a conducting wire fused through the glass bulb of the lamp and connected to the positive pole of a battery constitutes the positively charged conductor. When the lamp filament is heated and a separate circuit is formed, including the filament and the plate, as shown in Fig. 66, a current is found to flow from the filament to the plate of a strength depending upon the original charge of the plate, the surface area, the proximity of the plate to the filament, and the temperature of the latter. The figure shows a coupled receiving circuit for wireless, D being the secondary coil of the coupling; it also shows an

adjustable condenser joined up as a shunt for tuning purposes.

If a circuit conveying an alternating current is connected to the plate and filament, only that half of the alternating current which passes in direction from the filament to the plate will be passed through, the other half in the opposite direction being suppressed completely, so that the instrument is called a "rectifier," as it converts an alternating current into an intermittent direct current, and it does this, however rapid the alternations may be, so that if such a "valve" is connected in the circuit of a receiving aerial, or to a circuit coupled to a receiving aerial, the alternate oscillations in it, which are much too rapid to affect a telephone receiver diaphragm, will be converted into a direct current, which will affect the telephone when the rapidity of starting and stopping or varying in strength are within the audible limits of the human ear. Such an instrument is known as a "two-electrode thermionic valve" or a "Fleming valve."

It is necessary that the vacuum in lamps to be used for these thermionic valves shall be of a much more perfect nature than that which suffices for ordinary electric lamps.

Three-Electrode Thermionic Valve. A still more sensitive and important instrument is obtained by

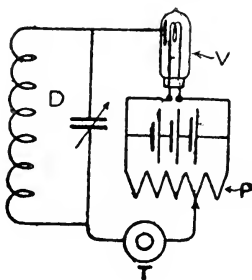

FIG. 66

FLEMING VALVE
DETECTOR

- V = Valve
P = Potentiometer
T = High-resistance tele-
phones
D = Detector circuit of
tuner

inserting between the plate and filament of a Fleming valve a perforated plate or "grid," supported by a separate connecting wire also fused through the glass bulb (see Fig. 67). If this "grid," as it is termed, be slightly negatively electrified it will considerably diminish any thermionic current which may be passing from filament to plate through the openings of the grid, whilst if the grid is positively electrified it will considerably increase such a thermionic current according

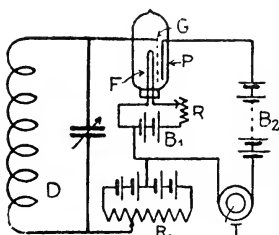

FIG. 67

THREE-ELECTRODE
THERMIONIC VALVE
AMPLIFYING CIRCUIT

to the degree of such positive electrification. Thus by connecting the grid to some circuit which carries a varying current (and therefore a varying potential and electrification at the point of connection) the current in the filament and plate circuit will be varied to a much greater extent whilst keeping the same general form, and the instrument thus becomes an "amplifier" for magnifying feeble currents, such as

those received by a wireless aerial, or feeble telephone currents. The arrangement, as above, was invented by Lee de Forrest in 1907, and he gave the name "audion" to the instrument, which has proved of great utility in wireless working. Even though the received current should vary or reverse millions of times in a second, the amplified and rectified current in the filament and plate circuit follows the same general form as that impressed on the transmitting instrument.

In the actual working instruments the plate is usually made in the form of a metal cylinder fitted round the

filament, with the grid in the form of a wire spiral or a perforated cylinder, fitted between, but insulated from, the plate cylinder and the filament, the later being usually a tungsten one.

Cascade Working. A very important property of three-electrode valves is that they can be worked in series, so that the amplified current in the filament and plate circuit of one valve can be applied to the grid circuit of another one, either directly, or better still, through a transformer coupling; the still more amplified thermionic current of this second valve can then be applied to the grid of a third valve, and so on, a large magnification of the effects being obtained with each valve added, and there appearing to be no limit to the number that can be used in this so-called "cascade" arrangement.

Thermionic Valve Oscillator. Another highly important application of the three-electrode valve was made in 1913, when it was discovered that if the plate circuit was connected through one winding of a transformer and the grid circuit through the other winding, a battery being in the plate circuit, and with the circuits connected up in a suitable manner, the instrument would of itself generate electric oscillations of any frequency desired, up to even millions per second, according to the tuning conditions, etc., and would continue to give these out as long as the conditions remained the same. The effect is due to the reaction of the two circuits on each other and is analogous to the singing arc.

TRANSMISSION CONDITIONS

Atmospheric Absorption. A difficulty met with in connection with long distance radio transmission is caused by the fact that the energy of the electric

waves is excessively absorbed by certain abnormal conditions of, or in, the atmosphere. These conditions are not properly understood, but they appear to be mostly due to the ionization of the layers of the upper atmosphere, that is, the presence in these layers of excessive numbers of electrons and electric ions probably due to eruptive discharges sent out from the sun. As might be inferred from this the absorption is found to take place more extensively in the daytime than at night, and both sunrise and sunset are found to have a marked effect on the transmission. Generally the transmission at night is much stronger than in the daytime, but at the same time may be more irregular; this, however, depends to a large extent on the length of the electric waves employed in the transmission, long waves being much more regular and effective in their results both by day and night time, so that with very long waves there is very little difference in day and night working.

The length of the wave depends, of course, on the frequency, and is obtained, in any case where the frequency is known, by dividing the velocity of transmission, viz., 186,000 miles per second, by the frequency per second, thus giving the wave length in miles.

Direction Finder. It is of much importance, especially to shipping and to aircraft generally, to be able to find out from what direction electric waves, which are being received, are coming, as, if this can be accurately read at two shore stations a few miles apart, it is easy to give information to the vessel (which may have lost its reckoning through fog, storms, etc.), as to its exact location. The ideal method of finding this direction would be to swing round one of the large Marconi inverted L aerials until the point was reached at which the

received sounds were the loudest ; but as this is impracticable, a modification in the shape of a nearly

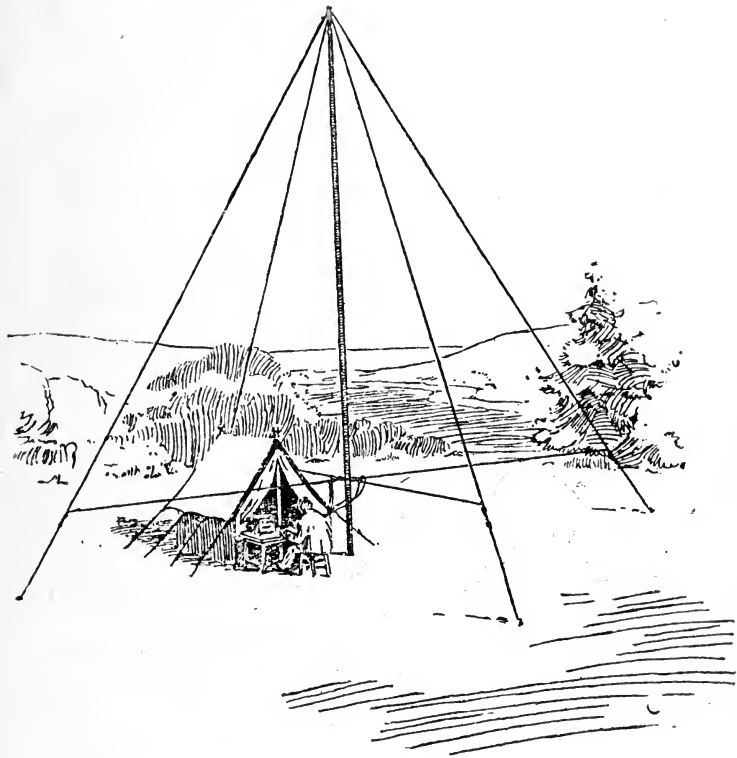

FIG. 68

MARCONI DIRECTION FINDING STATION

complete vertical loop of wire is used for the purpose. The loop may be of any shape—square, triangular or rectangular. Such a loop will receive best when its

plane lies in the direction from which the electric waves are coming, and if the loop can be swung round until the sounds heard in the receiving telephone are the loudest the direction of the transmitting point will be indicated ; but if this cannot be done, then two such loops are erected with their planes at right angles and cutting each other at their centres, and a small vertical coil with handle and a pointer attached is fitted at the centre of the two fixed loops, and the direction is indicated by the pointer on a scale, when the small coil is turned to a position which gives the best receiving results. Fig. 68 shows a direction finding station of this kind using two triangular loops. Such an arrangement as this can be used on board a ship or on a dirigible airship or a large aeroplane, and is, in fact, almost indispensable to air navigation. This directional working has been developed to a very marked extent during the war.

Frame Aerials. A development of the above directional aerial which has been much used recently is the " frame " aerial, which is usually a square frame from about 3 ft. to 10 ft. sides, on the outer run of which, are wound a number of loops of wire. This frame, properly connected, can be used in all sorts of situations, inside or outside, in place of the usual elevated aerial for reception or transmission, the most sensitive position for it being when the plane of the loops is set in the direction of the waves.

CHAPTER VII

WIRELESS TELEPHONY

ALTHOUGH many arrangements have been invented, and some put into use on a very limited scale, the only system of wireless telephony which appears likely to become a practical success is based on a modification of radio-telegraphy and makes use of the same kind of electro-magnetic waves at radio frequency, except that the damped waves resulting from the ordinary spark methods of propagation cannot be used, or at any rate do not give satisfactory results.

Radio-Telephony. The electrical vibrations produced by the voice in a telephone transmitter are of too low a frequency to give rise to electro-magnetic waves in the aether, to correspond to the electric waves which pass through a conducting line in ordinary telephony, even if they could be made of sufficient power. It is therefore necessary for radio telephonic transmission that there should be some carrying medium, and that employed is in the form of steady undamped radio waves of a frequency sufficiently high to be well above the human audible limit (which Helmholtz gave as about 33,000 alternations per second), and the variations caused by the voice sound waves, in an ordinary or modified microphone transmitter, are then, by some means or other, superimposed on the steady radio waves, or rather the oscillations producing the waves, so that the strength of the latter

will be made to vary in proportion to the vocal air sound vibrations.

If the varied radio oscillations produced in a receiving aerial, by the impact of the varied waves, as above described, sent from the transmitting station, were received by an ordinary telephone receiver, they would not affect it, because they would consist of alternating currents of much too rapid a frequency directly to affect the receiver diaphragm, and so nothing whatever would be heard in the instrument, except an occasional click. As in radio-telegraph receiving, when undamped waves are used, it is necessary to use a valve or other device to rectify the received radio oscillations with the audio variations superimposed on them ; and then, although half of the waves are cut off and lost, the remaining half has become the equivalent of a fluctuating current of one polarity or direction, which, when passed through the telephone receiver coils, will affect the diaphragm as the diaphragm of the sending transmitter was affected by the voice waves, except, of course, with regard to the intensity of the effects.

The real commencement of practicable radio-telephony came as a result of the discovery of the "singing-arc" by Duddell in 1900 (see page 97), which gave smooth oscillations and carrier waves up to a frequency of about 10,000 per second, which, however, was not sufficiently rapid for altogether satisfactory results. The improvements made in the singing-arc by Poulsen (as described on page 97), gave the requisite frequency, and radio-telephony became a practical success over comparatively long distances, as it gave steady carrier waves above the human audible limit and did not in itself, even after rectification, affect a receiving telephone, except to the extent of giving some slight noises

owing to imperfections in the carbons and other parts of the transmitting mechanism, which, however, did not materially affect the speech reception.

The **Telephone Transmitter** required for use in radio telephony before the advent of the amplifying thermionic valve was one which would carry a much larger working current than the usual type of telephone transmitter, so that the variations in strength of the transmitting oscillations might be made as large as possible. The radio carrier waves must necessarily be of sufficient strength to carry to the distance required, so that to vary the strong oscillations required for long distances to any sensible degree, comparatively strong variable telephone currents must be available. This has been one of the great difficulties, because ordinary carbon telephone transmitters will not bear much above their normal current of about 20 or 30 milliamperes without rapid deterioration, due to the burning of the carbon granules, so that if such transmitters are to be used, some means of keeping the transmitter cool is required, such as by enclosing the carbon in a water-jacket with a circulation of cold water. With a number of transmitters of this type, all acted upon through a single mouthpiece, it was found practicable to vary a current of about 15 amperes in the microphonic circuit.

Thermionic Valve Transmitters. Even with the best arrangements of such telephonic transmitters as above described, however, the power available had but a small proportion to the power necessary for the carrier waves when required to transmit to long distances, and although it was possible with such arrangements to transmit to stations 200 or 300 miles distant, the successful use for much longer distances would hardly have been feasible but for the utilization of the thermionic

valve as an amplifier at the transmitting end, and as rectifier and amplifier at the receiving end, with its cascade arrangements for both purposes.

Advantages of Radio Telephony. With the last mentioned devices there seems no difficulty, except, perhaps, from a pecuniary point of view, why distances as great as those surmounted by radio telegraphy should not be overcome by radio telephony. This would mean a very distinct advantage to telephony generally, as at present no wire telephony can be carried on over more than about 50 miles of submarine cable, owing to the condenser effect, which, to overcome by Pupin coil or other methods would, if at all practicable for long distances, cost a fabulous amount. Not only, however, is wireless telephony feasible under such circumstances, but it is much better in quality than any wire telephony could be if transmitted a long distance by cable, if such were practicable. This is because the proportion of the tones and overtones of many frequencies of vibration which give quality and distinctness to speech is retained to the fullest extent after long distance transmission by radio waves, so that the words are given out remarkably clearly even though they may be somewhat faint. On the other hand, the proportion of the tones and overtones is altered to a more or less extent by wire transmission, and especially if the wires are in submarine or other cables, even where the conductors have been Pupinized.

Recent Successes. The most sensational work done in wireless telephony was that accomplished by the American Telephone and Telegraph Co. in September, 1915, when, by a very large combination of oscillation three-electrode thermionic valves together with a very large cascade arrangement of amplifying valves connected to an ordinary carbon transmitter, the human

voice tones were transmitted from Arlington, U.S.A., to Honolulu and Paris (the longest distance being 4,500 miles), and heard at these places, although they were not able to reply telephonically to the messages received. The Marconi companies have more recently been very successful with experimental work over the Continent, from Chelmsford to Rome and other cities, and also to America.

INDEX

- ADVANTAGES of radio-telephony, 116
Aerial, directive, 102
—, frame, 112
—, plain, 94
—, wireless, 93, 102
Amperes, 3
Armature, generator, 18
Atmospheric absorption, 109
Audion, Lee de Forrest's, 108
Automatic telegraphs, 36
— telephone exchanges, 76
- BAUDÔT multiplex telegraph, 45
Bell, electric, 20
— polarized, 21
—, single-stroke, 20
— trembler, 21
Bell's telephone, 51
- CABLES, dry-core, 81, 86
—, submarine, 87
—, supports for aerial, 86
Capacity, inductive, 11
Cascade working of thermionic valves, 109
Cells, dry, 16
—, primary, 13
—, Leclanché, 14
—, secondary, 16
—, storage, 16
Code, Morse, 27, 32
Common battery telephone exchanges, 72
Coherer, 92
Commutators, 19
Condensers, 11, 101, 103
Conductors, 1
Conduits, 86
Cordeaux insulator, 83
Coupling of wireless circuits, 95
Crystal detectors, 99, 100
Current induction, 8
- DAMPED wireless oscillations, 90
Detector, crystal, 99
—, galvanometer, 9
—, electrolytic, 99
—, thermionic, 99
Difference of potential, 2
Differential duplex telegraph, 39
— windings, 24
Diplex telegraphy, 38, 43
Direction finder, wireless, 110
Directive aerial, 102, 110, 112
Disc discharger, 99
Double-current telegraph system, 31
Double-plate sounder, 36
Dry-core cables, 81, 86
Duplex telegraphy, 38, 41
Dynamo generators, 20
- EARTH circuits, 3
— connections for aerial, 102
Edison's telephone transmitter, 55
Effects of condensers, 12
— of current, 2
Electric bells, 20
Electricity, 1
Electro-magnetism, 5
Electron theory, 105
Engaged test for telephones, 72
Exchanges, telephone, 64
—, switchboards for, 65, 71
—, common battery, 72
- FLEMING'S thermionic valve, 106
Frame aerials, 112

- Free electrons, 105
Frictional electricity, 1
- GALVANOMETER, 9
Generators, dynamo, 20
—, magneto-electric, 17, 64, 97, 103
Granulated carbon transmitter, 60
Grid of thermionic valves, 108
- HAYE'S common battery telephone system, 73
Hertz's wireless researches, 91, 92
Hughes's microphone, 59
— type-printing telegraph, 48
- IMPULSE transmitter, 77
Inductance, 10
Induction coil, 8, 56
— current, 8
—, statical, 10
Inductive capacity, 11
Installation, modern wireless, 101
Insulators, 1
— for aerial lines, 82
- JACKS, connecting, 67
Jigger, wireless, 103, 105
Joints for line wires, 82
- KEYS, listening and ringing, 69
- LAMP signals for telephones, 76
Leclanché cell, 14
Length of electric wave, 110
Lines of force, 5
—, telegraph and telephone, 81
Listening and ringing keys, 69
- MAGNETIC detector, 99, 100
— field, 6
Magnetism, 3
— Electro-, 5
- Magnetism, induced, 5
Magneto-electricity, 7
— -electric generators, 17, 64, 97, 103
— telephone exchanges, 65
Marconi's coherer, 92
— coupled circuit, 95
— disc-discharger, 99
— magnetic detector, 99
— plain aerial, 94
Metallic circuits, 3
Microfarad, 11
Microphone, 59
Morse code signals, 32
— ink-writer, 33
— telegraphs, 27, 30
Motors, electric, 20
Multiple telephone switchboards, 71
Multiplex telegraphy, 39, 44
— —, Baudôt's, 45
- NEEDLE telegraph, 26, 33
—, single, telegraph, 33
— sounder, 35
- OFFICE telephone sets, 63
Ohms, 3
Ohm's Law, 3
Operating of telephone switchboards, 70, 75
Operator's telephone sets, 62
Oscillations, electric, 89, 109
Overhouse lines, 84
- PACKING of carbon transmitters, 60
Plugs for switching, 68
Polarization of cells, 14
Polarized relay, 23
— ringer bell, 21
Poles for aerial lines, 82
— for overhouse lines, 84
Potential, 2
Poulsen's spark oscillator, 97, 114
Primary cells, 13

- QUADRUPLEX telegraphy, 39, 44
 Quenched spark wave generators, 96, 98

 RADIATION of electric waves, 91
 Radio-telegraphy, 89
 — telephony, 113, 116
 Receiving instruments, wireless, 99, 104
 — stations, 104
 Reis's telephone, 51
 Relay Automatic Telephone Co.'s system, 80
 Relays, 22
 —, polarized, 23
 Resistivity, 2
 Resonance, electric, 90
 Ringers, polarized, 21, 63
 Rings of electric force, 5
 Rotary-disc dischargers, 99, 104

 SECONDARY cells, 16
 Selectors for automatic telephony, 77, 78
 Self-induction, 10
 Siemens armature, 18
 — polarized relay, 23
 Signal drops, 67
 — lamps, 76
 Siphon recorder, 49
 Singing-arc, 96
 — -wave generators, 96, 97, 114
 Single needle telegraph, 33
 Solid-back transmitter, 61
 Sounder, pony, 30
 — telegraphs, 27, 35, 36
 Statical induction, 10
 Stations, wireless receiving, 104
 Storage cells, 16
 Strowger automatic telephone system, 80
 Submarine cables, 87
 Submarine telegraphy, 49
 Switchboard, telephone, 65, 71
 Switch-jacks, 67
 — -plugs, 68

 TELEFUNKEN Co.'s wireless system, 98
 Telegraphs, early forms of, 26
 —, Morse, 27, 30
 Telephone, Bell's, 51
 — exchanges, 64
 — receivers, 55
 —, Reis's, 51
 — transmitters, 55, 115
 Terebo, 88
 Test for telephone lines, 72
 Thermionic valve, 97, 99, 106, 115
 Transmitters, telephone, 55, 60, 115
 —, thermionic valve, 115
 Trembler bell, 21
 Tuning inductance, 103
 Type-printing telegraphs, 45, 48

 UNDAMPED wireless oscillations, 90, 96
 Underground line work, 84

 VALVE thermionic, 97, 99, 106, 115
 Volts, 2

 WAVE, electric, 91, 96
 —, —, length of, 110
 Wheatstone bridge, 41
 — telegraph, 26, 36
 Windings, differential, 24
 Wire for aerial lines, 81
 Wireless telegraphy, 89
 — telephony, 113
 — wave generators, 96
 Wollaston wire, 100

A LIST OF BOOKS

PUBLISHED BY

Sir Isaac Pitman & Sons, Ltd.

(Incorporating WHITTAKER & CO.)

1 AMEN CORNER, LONDON, E.C. 4

A complete Catalogue giving full details of the following books will be sent post free on application.

ALL PRICES ARE NET.

	s. d.
AERONAUTICAL ENGINEERING. A. Klemin. (<i>In preparation.</i>)	
ALTERNATING CURRENT MACHINERY. Papers on the Design of. C. C. Hawkins, S. P. Smith, and S. Neville . . .	18 0
ALTERNATING-CURRENT WORK. W. Peirten Maycock . . .	7 6
ARITHMETIC OF ELECTRICAL ENGINEERING. Whittaker's	3 6
ARITHMETIC OF ALTERNATING CURRENTS. E. H. Crapper .	3 0
ARCHITECTURAL HYGIENE, OR SANITARY SCIENCE AS APPLIED TO BUILDINGS. B. F. and H. P. Fletcher . .	6 0
ARMATURE CONSTRUCTION. H. M. Hobart and A. G. Ellis	18 0
ART AND CRAFT OF CABINET MAKING. D. Denning . . .	6 0
ASTRONOMY, FOR GENERAL READERS. G. F. Chambers . .	4 0
ATLANTIC FERRY: ITS SHIPS, MEN AND WORKING, THE. A. G. Maginnis	3 0
BAUDÔT PRINTING TELEGRAPHIC SYSTEM. H. W. Pendry	3 0
CALCULUS FOR ENGINEERING STUDENTS. J. Stoney . . .	3 6
CARPENTRY AND JOINERY: A PRACTICAL HANDBOOK FOR CRAFTSMEN AND STUDENTS. B. F. and H. P. Fletcher	7 6
CENTRAL STATION ELECTRICITY SUPPLY. A. Gay and C. H. Yeaman	12 6
COLOUR IN WOVEN DESIGN: A TREATISE ON TEXTILE COLOURING. R. Beaumont	21 0

	s.	d.
COMMERCIAL AND TECHNICAL TERMS IN THE ENGLISH AND SPANISH LANGUAGES. R. D. Monteverde	2	6
CONVERSION OF HEAT INTO WORK. Sir W. Anderson	6	0
CONCRETE STEEL BUILDINGS: BEING A CONTINUATION OF THE TREATISE ON CONCRETE-STEEL. W. N. Twelvetrees	12	0
CONTINUOUS-CURRENT DYNAMO DESIGN, ELEMENTARY PRINCIPLES OF. H. M. Hobart	9	0
REINFORCED CONCRETE. W. N. Twelvetrees. (<i>In preparation.</i>)		
CONTINUOUS CURRENT MOTORS AND CONTROL APPARATUS. W. Perren Maycock	7	6
DESIGN OF ALTERNATING CURRENT MACHINERY. J. R. Barr and R. D. Archibald	15	0
DIRECT CURRENT ELECTRICAL ENGINEERING. J. R. Barr	12	0
DISSECTIONS, ILLUSTRATED. C. G. Brodie	21	0
DRAWING AND DESIGNING. C. G. Leland	2	6
DYNAMO: ITS THEORY, DESIGN AND MANUFACTURE, THE. C. C. Hawkins and F. Wallis. In two vols.	12	6
ELECTRIC LIGHT FITTING: A TREATISE ON WIRING FOR LIGHTING, HEATING, &c. S. C. Batstone	6	0
ELECTRO-PLATERS' HANDBOOK. G. E. Bonney	3	6
ELECTRICAL INSTRUMENT MAKING FOR AMATEURS. S. R. Bottone	3	6
ELECTRIC BELLS AND ALL ABOUT THEM. S. R. Bottone	2	6
ELECTRIC TRACTION. A. T. Dover	21	0
ELECTRICAL ENGINEERS POCKET BOOK. (<i>New Edition preparing.</i>)		
ELECTRIC MOTORS AND CONTROL SYSTEMS. A. T. Dover.	16	0
ELECTRIC MOTORS—CONTINUOUS, POLYPHASE AND SINGLE-PHASE MOTORS. H. M. Hobart	21	0
ELECTRIC LIGHTING AND POWER DISTRIBUTION. Vol. I. W. Perren Maycock	7	6
ELECTRIC LIGHTING AND POWER DISTRIBUTION. Vol. II. W. Perren Maycock	10	6
ELECTRIC MINING MACHINERY. S. F. Walker. (<i>In preparation.</i>)		
ELECTRIC WIRING, FITTINGS, SWITCHES AND LAMPS. W. Perren Maycock	9	0
ELECTRIC WIRING DIAGRAMS. W. Perren Maycock	3	0
ELECTRIC WIRING TABLES. W. Perren Maycock	4	0
ELECTRIC CIRCUIT THEORY AND CALCULATIONS. W. Perren Maycock	6	0
ELECTRICAL INSTRUMENTS IN THEORY AND PRACTICE. Murdoch and Oschwald	12	6

	<i>s. d.</i>
ELECTRIC TRACTION. J. H. Rider	12 6
ELECTRIC LIGHT CABLES. S. A. Russell	10 6
ELECTRO MOTORS; HOW MADE AND HOW USED. S. R. Bottone. (<i>New edition preparing.</i>)	
ELEMENTARY GEOLOGY. A. J. Jukes-Browne	3 0
ELEMENTARY TELEGRAPHY. H. W. Pendry	3 6
ELEMENTARY AERONAUTICS, OR THE SCIENCE AND PRACTICE OF AERIAL MACHINES. A. P. Thurston. <i>New Edition preparing.</i>)	
ELEMENTARY GRAPHIC STATICS. J. T. Wight	5 0
ENGINEER DRAUGHTSMEN'S WORK: HINTS TO BEGINNERS IN DRAWING OFFICES	2 6
ENGINEERING WORKSHOP EXERCISES. E. Pull	2 6
ENGINEERS' AND ERECTORS' POCKET DICTIONARY: ENGLISH, GERMAN, DUTCH. W. H. Steenbeek	2 6
ENGLISH FOR TECHNICAL STUDENTS. F. F. Potter	2 0
EXPERIMENTAL MATHEMATICS. G. R. Vine	
Book I, with Answers	1 0
,, II, with Answers	1 0
EXPLOSIVES INDUSTRY, RISE AND PROGRESS OF THE BRITISH FIELD WORK AND INSTRUMENTS. A. T. Walmisley	18 0
FIRST BOOK OF ELECTRICITY AND MAGNETISM. W. Patten Maycock	6 0
GALVANIC BATTERIES: THEIR THEORY, CONSTRUCTION AND USE. S. R. Bottone	5 0
GAS, OIL AND PETROL ENGINES: INCLUDING SUCTION GAS PLANT AND HUMPHREY PUMPS. A. Garrard	7 6
GAS AND OIL ENGINE OPERATION. J. Okill. (<i>In preparation.</i>)	6 0
GAS SUPPLY, IN PRINCIPLES AND PRACTICE: A GUIDE FOR THE GAS FITTER, GAS ENGINEER AND GAS CONSUMER. W. H. Y. Webber	4 0
GERMAN GRAMMAR FOR SCIENCE STUDENTS. W. A. Osborne	3 0
HANDRAILING FOR GEOMETRICAL STAIRCASES. W. A. Scott	2 6
HIGH-SPEED INTERNAL COMBUSTION ENGINES. A. W. Judge	18 0
HISTORICAL PAPERS ON MODERN EXPLOSIVES. G. W. MacDonald	9 0
HOW TO MANAGE THE DYNAMO. S. R. Bottone	1 6
HYDRAULIC MOTORS AND TURBINES. G. R. Bodmer	15 0
INDUCTION COILS. G. E. Bonney	6 0
INSPECTION OF RAILWAY MATERIAL. G. R. Bodmer	5 6

	s.	d.
PRACTICAL ELECTRIC LIGHT FITTING. F. C. Allsop	6	0
PRACTICAL EXERCISES IN MAGNETISM AND ELECTRICITY. J. R. Ashworth	2	6
PRACTICAL SHEET AND PLATE METAL WORK. E. A. Atkins	7	6
PRACTICAL IRONFOUNDING. J. Horner	6	0
PRACTICAL EDUCATION. C. G. Leland	5	0
PRACTICAL TESTING OF ELECTRICAL MACHINES. L. Oulton and N. J. Wilson	6	0
PRACTICAL TELEPHONE HANDBOOK AND GUIDE TO THE TELEPHONIC EXCHANGE. J. Poole	12	6
PRACTICAL ADVICE FOR MARINE ENGINEERS. C. W. Roberts	5	0
PRACTICAL DESIGN OF REINFORCED CONCRETE BEAMS AND COLUMNS. W. N. Twelvetrees	7	6
PRINCIPLES OF FITTING. J. Horner	6	0
PRINCIPLES OF PATTERN-MAKING	4	0
QUANTITIES AND QUANTITY TAKING. W. E. Davis	4	0
RADIO-TELEGRAPHIST'S GUIDE AND LOG BOOK. W. H. Marchant	5	6
RADIUM AND ALL ABOUT IT. S. R. Bottone	1	6
RAILWAY TECHNICAL VOCABULARY. L. Serraillier	7	6
RESEARCHES IN PLANT PHYSIOLOGY. W. R. G. Atkins	9	0
ROSES AND ROSE GROWING. Kingsley, R. G.	7	6
ROSES, NEW	9	
RUSSIAN WEIGHTS AND MEASURES, TABLES OF. Redvers Elder	2	6
SANITARY FITTINGS AND PLUMBING. G. L. Sutcliffe	6	0
SIMPLIFIED METHODS OF CALCULATING REINFORCED CON- CRETE BEAMS. W. N. Twelvetrees	9	
SLIDE RULE. A. L. Higgins	6	
SLIDE RULE. C. N. Pickworth	3	0
SMALL BOOK ON ELECTIC MOTORS, A. C. C. AND A. C. W. Perren Maycock.	5	0
SPANISH IDIOMS WITH THEIR ENGLISH EQUIVALENTS. R. D. Monteverde	3	0
SPECIFICATIONS FOR BUILDING WORKS AND HOW TO WRITE THEM. F. R. Farrow	4	0
STEEL WORKS ANALYSIS. J. O. Arnold and F. Ibbotson	12	6
STORAGE BATTERY PRACTICE. R. Rankin. (<i>In preparation.</i>)		
STRUCTURAL IRON AND STEEL. W. N. Twelvetrees.	7	6
SUBMARINES, TORPEDOES AND MINES. W. E. Dommett	3	6
SURVEYING AND SURVEYING INSTRUMENTS. G. A. T. Middleton	6	0
TABLES FOR MEASURING AND MANURING LAND. J. Cullyer	3	0

	<i>s. d.</i>
TEACHER'S HANDBOOK OF MANUAL TRAINING; METAL WORK. J. S. Miller	4 0
TELEGRAPHY: AN EXPOSITION OF THE TELEGRAPH SYSTEM OF THE BRITISH POST OFFICE. T. E. Herbert	10 6
TEXT BOOK OF BOTANY. Part I—THE ANATOMY OF FLOWERING PLANTS. M. Yates	2 0
TRANSFORMERS FOR SINGLE AND MULTIPHASE CURRENTS. G. Kapp	12 6
TREATISE ON MANURES. A. B. Griffiths	7 6
TRIGONOMETRY, PRACTICAL. H. Adams	3 0
VENTILATION OF ELECTRICAL MACHINERY. W. H. F. Murdoch	3 6
VENTILATION, PUMPING, AND HAULAGE, THE MATHEMATICS OF. F. Birks	3 6
WIRELESS TELEGRAPHY AND HERTZIAN WAVES. S. R. Bottone	3 0
WIRELESS TELEGRAPHY: A PRACTICAL HANDWORK FOR OPERATORS AND STUDENTS. W. H. Marchant	6 0
WIRELESS TELEGRAPHY AND TELEPHONY. W. J. White	4 0
WOODCARVING. C. G. Leland	5 0

Catalogue of Scientific and Technical Books post free.

465974

TEE
P
Poole, Joseph
Telegraphy, telephony and wireless

**University of Toronto
Library**

**DO NOT
REMOVE
THE
CARD
FROM
THIS
POCKET**

Acme Library Card Pocket
LOWE-MARTIN CO. LIMITED

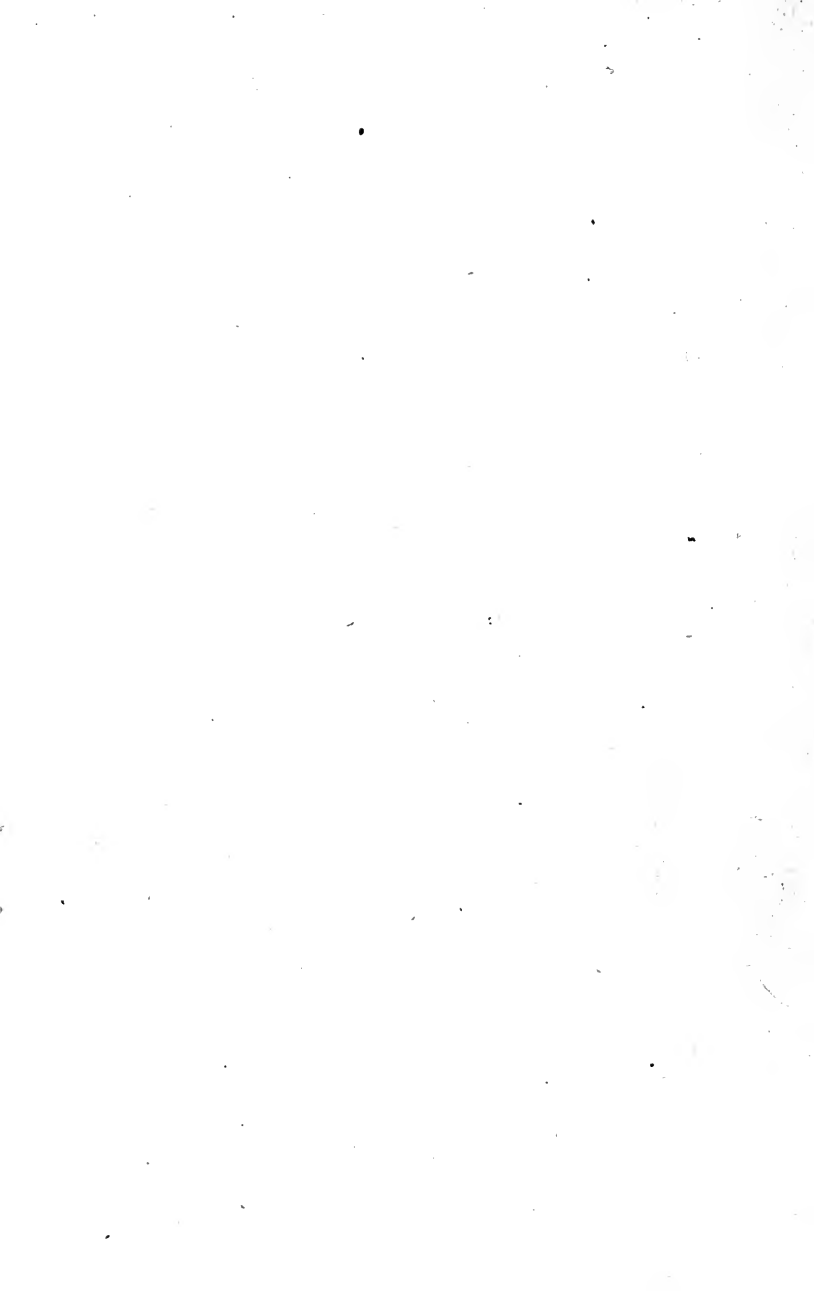

AUTOMATIC TELEPHONES



Telegrams :
"SIEMENS, WOOLWICH"

Telephone :
CITY 6400



SIEMENS BROTHERS & CO., LIMITED, Woolwich, London, S.E.18

TELEPHONE APPARATUS MINING TYPES

For : MINES,
RAILWAY
SIDINGS,
DOCKS,
ENGINE
ROOMS,
Etc.

Suitable for all positions where atmospheric
and other conditions are detrimental to
apparatus of the ordinary type.

Manufactured by
SIEMENS BROTHERS & CO., LTD.
Woolwich, London, S.E.18

Telegrams :
"SIEMENS, WOOLWICH"

Telephone :
CITY 6400

Complying with HOME OFFICE REGULATIONS

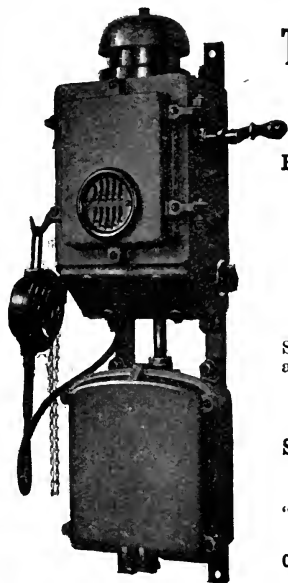

ERICSSON

Apparatus is the best.
If you are requiring
a reliable System of

TELEPHONES

in your Offices, Fac-
tories, Yards, Ships,
or for use in your
Mines, we can suit your
particular requirements

|||||

*Write for prices and
— particulars to —*

**BRITISH L. M. ERICSSON
MANUFACTURING Co. Ltd.**

**60 Lincoln's Inn Fields
LONDON, W.C.2**

WORKS: BEESTON, NOTTS, ENGLAND

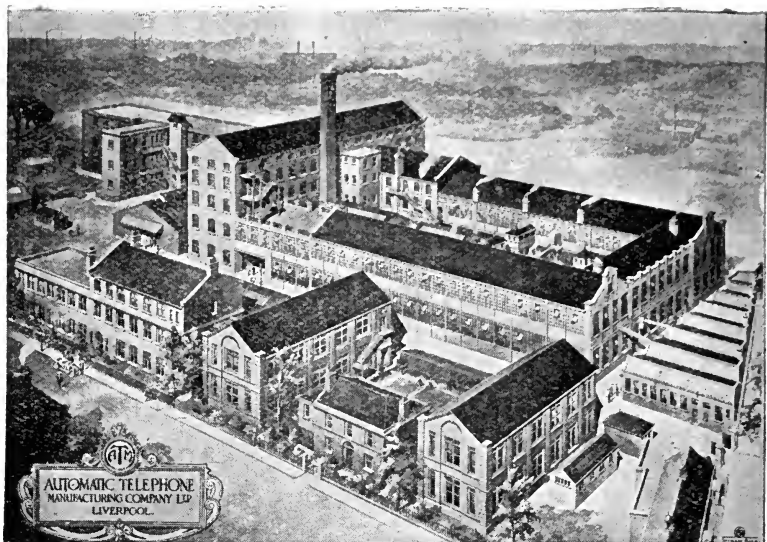

AT THESE WORKS

We manufacture all classes of Telegraph and Telephone Apparatus and Accessories.

Our Specialities include :—Strowger Automatic Telephone Equipment (Public and Private Exchanges of any size) ; The A.T.M. Gulstad Relay ; The A.T.M. Undulator ; The A.T.M. Wheatstone Transmitter ; The A.T.M. Palmer Keys, etc., etc.

LOOK FOR THE
TRADE MARK



THE GUARANTEE
OF QUALITY

Automatic Telephone Manufacturing Co., Ltd.

Milton Road, Edge Lane, Liverpool

London Address : 60 Lincolns Inn Fields, London, W.C.2

