

# TEXT BOOK ON WIRELESS TELEGRAPHY

BY

RUPERT STANLEY, B.A., M.I.E.E.

LECTURER IN PHYSICS AND ELECTRICAL ENGINEERING, MUNICIPAL TECHNICAL  
INSTITUTE, BELFAST; EXTRA MURAL PROFESSOR OF ELECTRICAL  
ENGINEERING, QUEEN'S UNIVERSITY, BELFAST



*WITH ILLUSTRATIONS*

LONGMANS, GREEN AND CO.

39 PATERNOSTER ROW, LONDON

FOURTH AVENUE & 30TH STREET, NEW YORK

BOMBAY, CALCUTTA, AND MADRAS

1914

## A SELECTION OF BOOKS ON ELECTRICITY AND MAGNETISM

---

- TELEGRAPHY.** By the late Sir W. H. PREECE, K.C.B., F.R.S., formerly Engineer-in-Chief and Electrician, Post Office Telegraphs; and Sir J. SIVEWRIGHT, M.A., K.C.M.G. New Edition, revised and partly re-written by W. LLEWELLYN PREECE, Mem.Inst.C.E., Mem.Inst.E.E. With 256 Illustrations. 8vo, 7s. 6d. net. (*Text-books of Science.*)
- THE PRINCIPLES OF ELECTRIC WAVE TELEGRAPHY AND TELEPHONY.** By J. A. FLEMING, M.A., D.Sc., F.R.S. With 7 Plates and numerous other Illustrations. 8vo, 28s. net.
- AN ELEMENTARY MANUAL OF RADIOTELEGRAPHY AND RADIOTELEPHONY FOR STUDENTS AND OPERATORS.** By J. A. FLEMING, M.A., D.Sc., F.R.S. 8vo, 7s. 6d. net.
- X RAYS: An Introduction to the Study of Röntgen Rays.** By G. W. C. KAYE, B.A., D.Sc., Head of the Radium Department at the National Physical Laboratory. With 97 Plates and Diagrams and 28 Tables. 8vo, 5s. net.
- MAGNETISM AND ELECTRICITY.** A Manual for Students in Advanced Classes. By E. E. BROOKS, B.Sc. (Lond.), A.M.I.E.E., and A. W. POYSER, M.A. (Trinity College, Dublin). With 413 Illustrations. Crown 8vo, 7s. 6d.
- VECTORS AND VECTOR DIAGRAM, APPLIED TO THE ALTERNATING CURRENT CIRCUIT.** With Examples on their use in the Theory of Transformers, and of Single and Polyphase Motors, etc. By WILLIAM CRAMP, M.I.E.E., and CHARLES F. SMITH, M.I.E.E., Assoc.M.Inst.C.E., Whit. Schol. With 114 Diagrams. 8vo, 7s. 6d. net.
- INSULATION AND DESIGN OF ELECTRICAL WINDINGS.** By A. P. M. FLEMING, M.I.E.E., and R. JOHNSON, A.M.I.E.E. With Diagrams. Medium 8vo, 7s. 6d. net.
- ELEMENTARY TREATISE ON ELECTRICITY AND MAGNETISM.** By G. CAREY FOSTER, F.R.S.; and ALFRED W. PORTER, B.Sc. Founded on JOUBERT'S "Traité Élémentaire d'Electricité." With 376 Illustrations and Diagrams. 8vo, 10s. 6d. net.
- ELEMENTARY EXPERIMENTAL MAGNETISM AND ELECTRICITY: a Combined Lecture and Laboratory Course.** By WILLIAM ALLANACH, B.Sc. (Lond.), Principal of the Technical School, Southport. Crown 8vo, 3s. 6d.
- ELEMENTARY ELECTRICAL CALCULATIONS.** A Book suitable for the use of First and Second year Students of Electrical Engineering. By W. H. N. JAMES, A.R.C. Sc. (Lond.), A.I.E.E., and D. L. SANDS. Crown 8vo, 3s. 6d. net.
- 

WORKS BY JOHN HENDERSON, D.Sc., F.R.S.E.

- PRACTICAL ELECTRICITY AND MAGNETISM.** 157 Illustrations and Diagrams. Crown 8vo, 7s. 6d.
- PRELIMINARY PRACTICAL MAGNETISM AND ELECTRICITY.** Crown 8vo, 1s.
- ELECTROTECHNICS.** With 31 Diagrams. Crown 8vo, 3s. 6d.
- 

LONGMANS, GREEN, & CO. 39 Paternoster Row, London,  
New York, Bombay, Calcutta, and Madras.

## ELECTRICITY AND MAGNETISM—*continued.*

- EXAMPLES IN ELECTRICAL ENGINEERING. By SAMUEL JOYCE, A.I.E.E. Crown 8vo, 5s.
- THEORY AND CALCULATION OF ELECTRIC CURRENTS. By J. L. LA COUR, Vesteras, and O. S. BRAGSTAD, Trondhjem. Translated by STANLEY P. SMITH, D.Sc., A.M.Inst.C.E., A.M.I.E.E. With Diagrams. 8vo, 16s. net.
- ELEMENTARY QUESTIONS IN ELECTRICITY AND MAGNETISM. Compiled by MAGNUS MACLEAN, D.Sc., M.I.E.E., and E. W. MARCHANT, D.Sc., A.I.E.E. Crown 8vo, 1s. 6d. net.
- AN ELEMENTARY COURSE ON PRACTICAL APPLIED ELECTRICITY AND MAGNETISM. By DANIEL H. OGLE, B.Eng. (1st Hons.), late Rew Research Scholar, Liverpool; Lecturer in Electrical Engineering, Royal Technical Institute, Salford. With Diagrams. Crown 8vo, 2s. 6d. net.
- PRACTICAL ELECTRICAL TESTING IN PHYSICS AND ELECTRICAL ENGINEERING. By G. D. ASPINALL PARR, M.Sc., M.I.E.E., A.M.I.Mech.E. With 231 Illustrations. 8vo, 8s. 6d.
- MAGNETISM AND ELECTRICITY. Stage 1. By ARTHUR W. POYSER, M.A. With 235 Illustrations. Crown 8vo, 2s. 6d.
- ADVANCED MAGNETISM AND ELECTRICITY. By ARTHUR W. POYSER, M.A. With 317 Illustrations. Crown 8vo, 4s. 6d.
- A LABORATORY MANUAL OF ALTERNATING CURRENTS. By JOHN H. MORECROFT, E.E., Member A.I.E.E., Assistant Professor of Electrical Engineering, Columbia University. 8vo, 7s. 6d. net.
- A PRIMER ON ALTERNATING CURRENTS. By W. G. RHODES, D.Sc., Head of the Electrical Engineering Department, The Royal Technical Institute, Salford. With Diagrams. Crown 8vo, 2s. 6d. net. (*Longmans' Technical Handicraft Series.*)
- ELECTRICAL ENGINEERING FOR ELECTRIC LIGHT AND POWER, ARTISANS AND STUDENTS (embracing those branches prescribed in the Syllabus issued by the City and Guilds Technical Institute). By W. SLINGO, A. BROOKER, Engineer-in-Chief of the General Post Office, and T. F. WALL, M.Sc. With 389 Illustrations. Crown 8vo, 12s. 6d.
- PROBLEMS AND SOLUTIONS IN ELEMENTARY ELECTRICITY AND MAGNETISM. By W. SLINGO and A. BROOKER, Engineer-in-Chief of the General Post Office. With 98 Illustrations. Crown 8vo, 2s.
- THE PRINCIPLES AND PRACTICE OF ELECTRIC WIRING. With 166 Illustrations. By ARCHIBALD BURSILL, A.M.I.E.E., Lecturer in Physics and Electrical Engineering at Paddington Technical Institute. Crown 8vo, 3s. net. (*Longmans' Technical Handicraft Series.*)
- POWER HOUSE DESIGN. By JOHN F. C. SNELL, M.Inst.C.E., Vice-President of the Institution of Electrical Engineers. With 17 Folding Plates and 186 Illustrations. 8vo, 21s. net. (*Longmans' Electrical Engineering Series.*)
- ELECTRICITY AND MAGNETISM. For Advanced Students. By SYDNEY G. STARLING, B.Sc., A.R.C.Sc., Head of the Physical Department in the West Ham Municipal Technical Institute. With Diagrams. Crown 8vo, 7s. 6d. net.

---

LONGMANS, GREEN, & CO., 39, Paternoster Row, London,  
New York, Bombay, Calcutta, and Madras.

# WIRELESS TELEGRAPHY



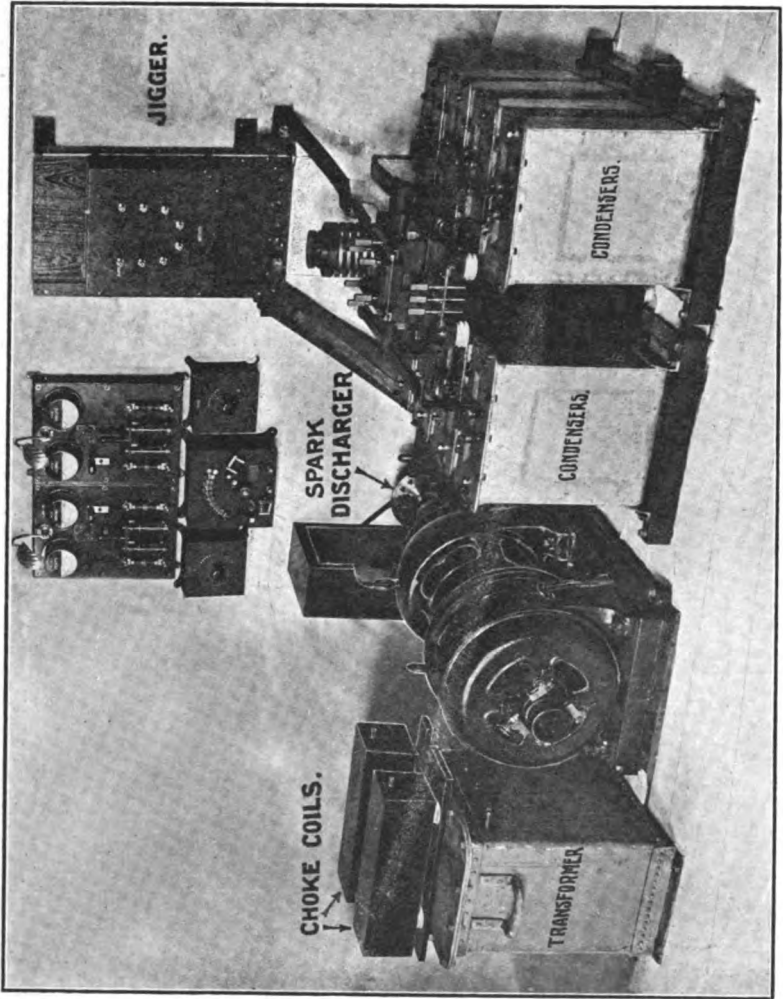

MARCONI TRANSMITTER APPARATUS

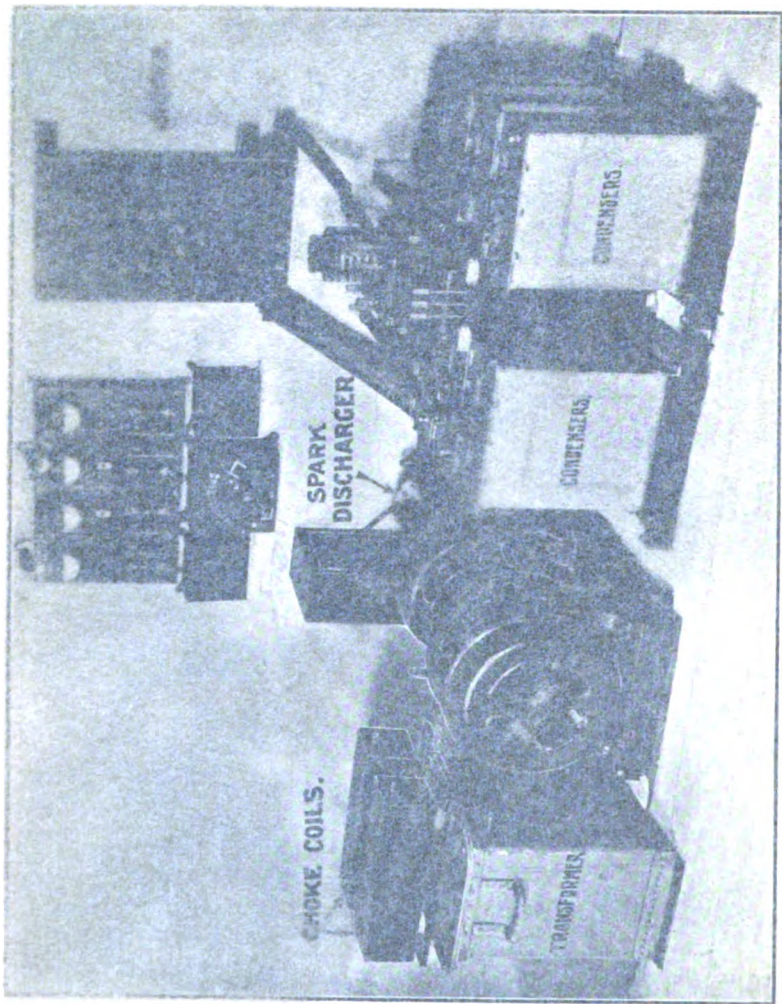

MARCONI TRANSMITTER APPARATUS

# TEXT BOOK ON WIRELESS TELEGRAPHY

BY

RUPERT STANLEY, B.A., M.I.E.E.

PROFESSOR OF PHYSICS AND ELECTRICAL ENGINEERING, MUNICIPAL TECHNICAL  
INSTITUTE, BELFAST; EXTRA MURAL PROFESSOR OF ELECTRICAL  
ENGINEERING, QUEEN'S UNIVERSITY, BELFAST



*WITH ILLUSTRATIONS*

LONGMANS, GREEN AND CO.

39 PATERNOSTER ROW, LONDON

FOURTH AVENUE & 30TH STREET, NEW YORK

BOMBAY, CALCUTTA, AND MADRAS

1914

192312

FEB 20 1915

~~T&W~~  
~~STR~~

TK  
5742  
S7

## PREFACE

MANY of those attending classes with the intention of becoming wireless operators have little, if any, preliminary knowledge of electrical matters, or indeed of scientific phenomena in general. Many amateurs, who are quite expert in the ordinary manipulation of radio apparatus, miss much of the fascination of this interesting hobby because they do not understand the fundamental principles on which it is based.

The author, in the course of writing this Text-Book on Wireless Telegraphy, has always kept before his mind the special requirements of such students.

Several excellent treatises on Radio-Telegraphy are at present available; as a general rule, however, these deal with theoretical considerations in a manner which can be thoroughly understood only by those who have already become acquainted with the theory of electrical science, and who understand, to some extent, the significance of the technical terms associated therewith.

Time after time the author has been requested by students of this subject to recommend to them an elementary text-book on Electricity and Magnetism. It has always been with great reluctance that the author has made any recommendation, and that for several reasons:—

In the first place our elementary text-books are, for the most part, hopelessly out of date; they juggle with one fluid, two fluid, and atomic theories; they labour over Faraday's crude though pioneer experiments, and fog the practical student with long dissertations on potential gradients or moments of complex arrangements of magnets.

In the second place our elementary text-books are written to serve as a preliminary to the study of general electrical engineering, and are not at all adapted to the elucidation of the principles of energy radiation.

Lastly, no elementary text-book on magnetism and electricity adequately introduces some of the most important phenomena

applied to radio-telegraphic circuits, such as self-induction, mutual induction, oscillatory currents, and the true significance of magnetic or electric lines of strain in the all-pervading ether.

Therefore, in the opening chapters, the author has tried to introduce the subject of radio-telegraphy by demonstrating its place in the natural order of things, and its intimate relation to other branches of science.

The electron theory has been used; on it has been based all theoretical considerations, the author believing that this theory, modern, simple, direct, and well established, will present fewer difficulties to the student than the vague fluid theories which it has replaced.

In dealing with the technical portion of the subject, calculations and formulæ have been made as simple as possible, while long accounts of historical developments and researches have been avoided. Only the best types of modern radio apparatus have been fully described, and the author has tried, at each point, to explain fully the theory governing each system of connection or the development of each design.

The author has been indebted to the Marconi Wireless Telegraphy Co. and to Captain R. Sankey for much valuable information on Marconi apparatus, also for the loan of blocks and photos for the purposes of illustration, on which the value of such a text-book materially depends. A like remark applies to Messrs. Siemens Bros. & Co., who placed at the disposal of the author blocks, photos, and many particulars concerning the Telefunken System; to the Compagnie Universelle de Télégraphie et de Téléphonie sans Fils for photos and particulars of the Goldschmidt apparatus. To Messrs. The Electrical Co., Ltd., Messrs. The Cambridge Scientific Inst. Co., Messrs. Isenthal & Co., Messrs. The Union Electric Co., and to Mr. S. G. Brown like acknowledgments are due. The author has also to thank Prof. J. Earls and Mr. W. J. McCracken, B.A., B.L., for much assistance and advice in the compilation of the work. Lastly, the author wishes to place on record how much he is indebted to Mr. James Craig, Sirocco Works, Belfast, for preparing all the diagrams with which the book is illustrated. There are undoubtedly many literary faults in the text, perhaps many descriptions and explanations which are vague and insufficient; it is therefore hoped that any failings of this description may be outweighed by the merit of the help which Mr. Craig has given to the author.

In conclusion, a word of advice may be given to those who wish to obtain an intimate knowledge of this engrossing subject.

When they have mastered the fundamental principles of radio-telegraphy they will only be in a position to really appreciate the interest which further reading will open up to them. Valuable information can then be gained by reading the papers and contributions of such well-known authorities as Signor Marconi, Dr. J. A. Fleming, Dr. W. Eccles, Dr. Erskine Murray, Dr. Austin, and many others.

Reprints of these papers, contributed to such learned institutions as the British Association and the Physical Society, can constantly be found in the pages of *The Electrician*, *The Wireless World*, and other well-known periodicals.

It is hoped that this text-book may serve as an introduction to a full appreciation of the work of scientists who have done, or are doing, so much to elucidate the outstanding problems of radio-telegraphy.

RUPERT STANLEY.

BELFAST,  
*July, 1914.*

# CONTENTS

CHAPTER	PAGE
I. THE EARTH, THE ATMOSPHERE AND THE ETHER . . . . .	1
II. MATTER AND ELECTRONS . . . . .	5
III. MAGNETISM AND MAGNETIC STRAINS IN THE ETHER . . . . .	11
IV. ELECTRICITY AND ELECTRIC STRAIN IN THE ETHER . . . . .	18
V. ELECTRICAL MEASUREMENTS AND CALCULATIONS . . . . .	29
VI. CAPACITY AND INDUCTION EFFECTS . . . . .	41
VII. INDUCTION COILS, ALTERNATORS, AND TRANSFORMERS . . . . .	61
VIII. OSCILLATORY DISCHARGES . . . . .	75
IX. HISTORICAL DEVELOPMENT OF RADIO-TELEGRAPHY . . . . .	90
X. HOW ETHER WAVES ARE PROPAGATED AND RECEIVED . . . . .	101
XI. COUPLING OF CIRCUITS . . . . .	118
XII. TRANSMITTER CIRCUITS FOR SPARK SYSTEMS . . . . .	187
XIII. TRANSMITTING APPARATUS . . . . .	150
XIV. AERIALS, INSULATORS AND EARTH CONNECTIONS . . . . .	178
XV. RECEIVER CIRCUITS . . . . .	200
XVI. DETECTORS . . . . .	216
XVII. RECEIVING CIRCUIT APPARATUS . . . . .	242
XVIII. UNDAMPED WAVE SYSTEMS . . . . .	268
XIX. MISCELLANEOUS APPARATUS . . . . .	288
XX. MEASUREMENTS IN RADIO-TELEGRAPHY . . . . .	305

## APPENDICES

I. INTERNATIONAL MORSE CODE . . . . .	335
II. CALL LETTERS OF BRITISH STATIONS . . . . .	337
III. EXTRACTS FROM THE INTERNATIONAL RADIO-TELEGRAPHIC REGULATIONS . . . . .	338
IV. EIFFEL TOWER TIME SIGNALS AND WEATHER REPORTS . . . . .	339
INDEX . . . . .	341

# TEXT-BOOK ON WIRELESS TELEGRAPHY

## CHAPTER I

### *THE EARTH, THE ATMOSPHERE AND THE ETHER*

IN its first state the earth was a mass of gaseous matter or "nebulae" at a very high temperature, revolving round the sun. Through the æons of time it was gradually cooling down, until about 200,000,000 years ago, as calculated by Lord Kelvin, it began to be solid on the outer surface, just as the surface of water turns into ice when cooled. This solidification of the earth's surface continued until it became an irregular solid mass, in the aggregate shaped nearly like a sphere; but the surface is all uneven with high ridges and points called mountains, and deep depressions where the seas and oceans have collected. The cooling of the earth is going on continuously, and the surface is cooler than the interior, as can be easily proved by taking the temperature when one descends a mine. The lower we go the more the temperature rises, and the middle of the earth is still at a very high temperature, as shown by volcanic eruptions.

The earth is a ball 8000 miles in diameter, and is surrounded by a mixture of gases called the atmosphere. The principal gases in the atmosphere are nitrogen and oxygen. This atmosphere covers the earth like the chamois skin of a tennis ball, and forms a layer probably about 200 miles thick. It is most dense at the surface of the earth, and gets lighter and lighter until the gases which compose it fade away into nothing; just as a vertical column of smoke which is dense at the bottom gradually spreads out and lightens more and more as it ascends.

In the atmosphere of the earth float clouds and vapours formed from dust, water vapour, and gases which have risen from the earth's surface; but the highest of these is never much farther than 4 or 5 miles from the earth's surface.



The earth and its atmospheric envelope is always spinning round on its axis and at the same time is travelling round the sun in a big circle, whose radius is about 93 millions of miles. These rotations of the earth are similar to those of a spinning top, which spins on the floor and at the same time travels round and round in a circle on the floor. It is the spinning of the earth on its axis which causes night and day, and the travel of the earth round the sun which causes winter and summer.

Now we must not forget that the earth is only a very small portion of the universe; there are lots of other planets travelling in circles or in elliptical orbits round the sun. We have to ask ourselves: what fills all the space of the universe in which these planets move? Is there anything in that space? The fact that we can see nothing in it does not justify us in assuming that there is nothing. We cannot see the air, *i.e.* the atmosphere, but we know it is there, and we know many facts concerning it.

There is indeed another medium which pervades the whole universe. Evidence of the existence of this medium will accumulate as we proceed, but for the present we will consider one or two very elementary facts which show that such a medium does exist. We know that light and heat come to us from the sun; they travel millions of miles before they reach our atmosphere, and then they travel through the atmosphere until they affect our eyes or sense of touch. We know that light and heat travel in the form of lines or rays: if we let the light come through a hole in a shutter into a darkened room, we see it in the form of what are called rays of light, traced out in the dust particles of the room. Now every student of science knows that light and heat are forms of energy, and energy implies movement of something, so that the light and heat which come to us from the sun across space imply movement of something in that space.

It cannot be the atmosphere, for the atmosphere extends a comparatively short distance into that space. There must therefore be some other medium in that space, whose motion conveys these forms of energy to us. It is easy to prove that atmosphere or air has nothing to do with the conveyance of light and heat. If we put an electric bell into a glass globe we can hear it ringing, but if we exhaust all the air out of the globe we can no longer hear the bell, so that the air is necessary for the conveyance of sound. But if we put a lamp into a glass globe from which all the air or atmosphere has been exhausted we shall still see the light of the lamp, and feel the heat radiated from it. It is thus evident that air is not the medium by which light and radiant heat are conveyed.

The Dutch philosopher Huyghens first propounded the theory of the existence of an all-pervading medium, through which heat and light travel with a definite velocity of 300,000,000 metres per second, or roughly 186,000 miles per second.

All the accumulated evidence of modern science confirms the theory that such a medium does exist, and the demand for a rational explanation of many phenomena in nature makes it easier to believe in such a universal ether rather than to believe that interplanetary space is void or entirely empty.

We may now consider how heat and light travel through the ether. Sound is caused by the vibrations of the sounding body setting up waves in the air, the length of a wave depending upon the number of vibrations per second which excite it. These waves are detected by the ear and a sensation of sound is conveyed to the brain. A number of sounding bodies may all be vibrating at different frequencies, setting up waves of different wave lengths in the air, and the ear will detect that there are different sets of waves arriving at it. Also we know that a body may vibrate so slowly, setting up long air waves, or so fast, setting up short wave lengths, as to cause no impression on the ear; in other words the air waves may be too long or too short for the ear to detect them. Thus one can set up waves in the air of all wave lengths; all exactly identical in character, but our sense of hearing can only detect a certain limited range of them.

Now every elementary student in science knows that heat is due to motion of the molecules of a body. Heat can be excited by friction or by collision, and if a moving body is suddenly stopped it is heated because the energy of its motion is transferred to the atoms of its structure. Again, radiant heat and light have many properties in common, which show that they are identical in their natures.

We do not believe that heat and light are shot from the sun through space, like a bullet shot from a ship to disturb a target; but rather that disturbances in the sun set up waves in the ether medium. These waves excite our senses of touch and sight, in the same way as a ship by violent movement might set up waves in the water to disturb a distant target. And just as the sense of hearing can only detect a limited range of air waves, so our sense of touch can only detect ether waves of lengths which lie within a limited range, *i.e.* the heat waves; and our sense of sight detects ether waves of another range,—the light waves. But some heat waves affect our sense of touch as well as our sense of vision, which leads us to conclude that light waves and heat waves are identical in nature and only differ in the lengths of the waves. Also, as it is

possible for air waves to be too long or too short to affect the sense of hearing, so there are ether waves too long or too short to affect either our sense of touch or our sense of vision.

Air waves from  $\frac{1}{3}$  inch long to 12 or 13 yards long affect the sense of hearing, ether waves  $36 \times 10^{-6}$  cms. long give the sensation of violet light,  $45 \times 10^{-6}$  cms. long the sensation of blue light, and as they increase in length we receive the different colours of the spectrum until waves  $80 \times 10^{-6}$  cms. long give the sensation of red light; ether waves longer than these do not affect the eye. If waves of all these different lengths arrive at the eye together, we get the sensation of white light, as in sunlight, whilst waves from  $80 \times 10^{-6}$  cms. long to  $80 \times 10^{-4}$  cms. long give the sensation of heat. Ether waves longer than  $80 \times 10^{-4}$  cms. or shorter than  $36 \times 10^{-6}$  cms. do not affect the human senses of sight and touch, at the same time ether waves shorter than violet light waves have chemical effects, and can act on photographic plates. These waves carry what is sometimes called the invisible or actinic rays, whilst waves  $2 \times 10^{-8}$  cms. long are what are known as X rays, discovered by Sir Wm. Crookes.

Thus we see that as waves of varying lengths can be set up in air, so in the all-pervading ether medium various lengths of waves can be set up, and are being continually set up by natural means; also that we can detect many of these waves by their direct effect on the human senses of touch and sight, and can detect others by artificial means.

As we proceed we shall find that the problem of Wireless Telegraphy is simply to make and arrange apparatus so that long waves will be set up in the ether, and to make and arrange other apparatus to detect these waves, for they are far too long to be detected by the senses of sight or touch. Waves in any medium are caused by setting up strains in the medium, and we must first study how strains can be set up in the ether, and how they can be combined to cause a wave motion.

#### QUESTIONS ON CHAPTER I.

1. How would you demonstrate the difference in the natures of light waves and sound waves?
2. What is the evidence for the existence of an all-pervading medium in the universe?
3. What range of ether wave lengths can be received, using the eye as a detector?
4. If waves are set up in the ether shorter than those which affect the eye, how can they be detected, and what use is made of them?
5. Describe the changes which take place in the ether disturbances set up round an iron ball, as the latter is slowly heated from a cold state to a white heat.

## CHAPTER II

### MATTER AND ELECTRONS

WE know that any portion of a substance, be it a solid, liquid, or gas, contains innumerable smaller portions, each of which can act on other bodies. The smallest portion of any substance which can take part in chemical action is called an *atom*. It is far too small to be seen by the most powerful microscope. There is a form of fine dust which can be taken from the bed of the ocean called globigerina; it looks like a very fine powder and a few particles of it could not be seen by the naked eye. Yet if put under a powerful microscope each particle is seen to be a beautiful structure in appearance like a miniature sea shell. Thus it could be broken up into smaller portions; the little globigerina can only be seen under a powerful microscope, and an atom of any elementary constituent of it cannot be seen under any circumstances. Thus it is with an atom of any element, there are billions of them in one cubic centimetre: In ancient times atoms were considered to be hard like miniature pellets of shot; as Dr. Preston wrote:—"The hard atom was conceived by the Greek philosophers Democritus and Leucippus, and was subsequently glorified in the poetry of Lucretius." But modern science has conclusively proved to us that the structure of an atom of any form of matter is in itself very complicated; our knowledge of the subject has been largely increased during the last few years by the brilliant researches of Sir J. J. Thomson and others on electricity passing through gases, and by the equally brilliant discovery of Professor and Madame Curie of radium and radioactive substances. The work of these modern scientists has proved the truth of what was already suspected—that an atom of matter contains within it still smaller forms, which by Sir J. J. Thomson are called "corpuscles," but by many scientists "electrons." We shall speak of them as electrons in this treatise.

Modern science teaches us that an atom of matter consists of a number of electrons in motion round a central nucleus. To a

person who is accustomed to think of the *molecules* of a body as being in a constant state of vibration, the rate of which depends on their temperature and rises as they are heated, it may not be difficult to appreciate the existence of electrons moving in the atoms of matter. But others, who chiefly realise the fact that atoms are far too small to be seen, may find it difficult to believe in the existence of electrons. Yet Sir J. J. Thomson and other scientists of the present day have carried out experiments to prove the existence of "electrons." They have discharged them through vacuum tubes and measured their velocity and their mass; they have by these experiments discovered that *electrons are identical with what was called negative electricity*. It has been proved by them that an atom of any matter consists of electrons moving in a central nucleus, that one or more of these electrons can be torn out of the atoms of one form of matter and placed on another. A body which is negatively electrified is simply one on which free electrons have been placed; a body which has lost electrons from some of its atoms is positively electrified. This explains the phenomenon that when two substances are rubbed together, one is found to be positively electrified, the other negatively electrified, and the positive electrification of the one is equal to the negative electrification of the other. There are several methods of making electrons move from one body to another, or move from the atoms of one portion of a body to those in another portion. The radiations from radium and radio-active substances are simply due to the fact that some of their atoms are always spontaneously breaking up, and electrons flying off into space.

The difference between an atom of copper, for instance, and an atom of lead is simply that there are a different number of electrons in the atom, and probably that the motion of the electrons in the atom is also different. If electrons are taken out of the atoms of any form of matter the structure of the atom changes, and if all the atoms were thus changed the matter would be changed into something else. If four people stand so as to form a square, and one drops out, then, in order to form a new symmetrical figure, the remaining three would arrange themselves in an equilateral triangle. In the same way it is found that when Thorium has given out radiations for some time (owing to discharge of electrons) a new substance is formed which has been called Thorium X. The old alchemists who were seeking for a method of turning lead into gold were working on a hypothesis which modern science seems to confirm, though at present no one is likely to follow their pursuit, for Sir J. J.

Thomson has calculated that a piece of radium, continuously throwing off electrons, would take 50,000 years to change into another form of matter.

Fig. 1 (a) is a picture of an atom of hydrogen on this modern theory. The white specks represent the electrons in the atom, Fig. 1 (b) similarly shows an atom of radium in which electrons are seen to be flying off, some escaping into space, others being pulled back into the atom by the attractive force which acts towards its centre.

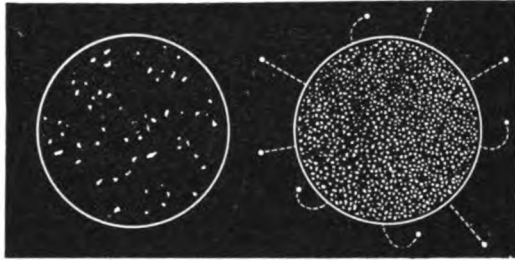

(a) FIG. 1. (b)

Fig. 2 shows a glass globe exhausted of air, with a glass stem holding a small plate of platinum at the centre, and two electrodes

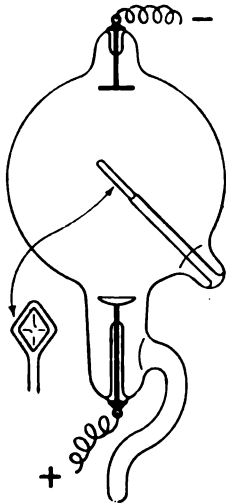

FIG. 2.

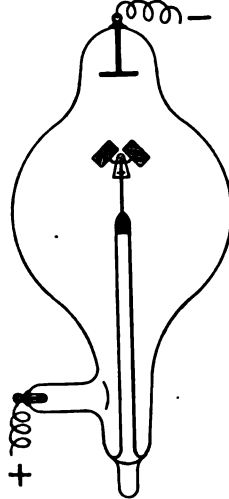

FIG. 3.

sealed through the glass. If wires from an induction coil which is generating a very high electric pressure, or difference of potential measured in volts, are joined to the electrodes, the negative wire to the top terminal and the positive wire to the bottom a discharge

of electrons will be driven from the top terminal and will strike against the platinum plate. The plate will be seen to become red hot. This proves that the electrons, though so small as to be quite invisible, yet travel in such numbers and with such velocity that their bombardment heats the platinum.

In like manner one might heat a target by bombarding it with a rain of bullets; the energy of the high velocity bullets would be turned into heat on the target, though here again one does not see the bullets.

Fig. 3 shows another vacuum tube with electrodes, and in the centre is pivoted a small wheel with very light vanes. If the electrodes of this tube are suitably joined to a source of high electrical pressure, the discharge of electrons will be seen to turn the little wheel rapidly, and at the same time make its vanes phosphoresce.

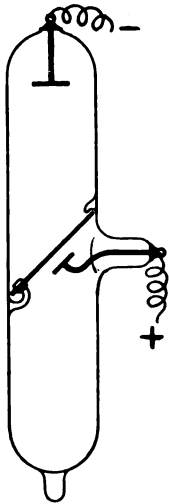

FIG. 4.

Fig. 4 shows another such vacuum tube, having at the centre a plate covered with barium sulphide. When electrons are made to discharge across it and strike the plate the latter is seen to give off a brilliant light. Indeed, in all these experiments the glass of all the vacuum tubes is seen to glow with phosphorescent light. Since light is due to waves of definite length set up in the ether, we have here a proof that a sudden stoppage of electrons may so disturb the ether that there is set up in it those small ripples or waves which give the sensation of light; the length of the waves, in other words the colour of the light, depending upon the form of matter (whether glass, barium sulphide, etc.) in which the ether was as it were entrapped where the waves started.

These experiments are carried out in vacuum tubes, that is in tubes in which the air is very attenuated, or at a very low pressure, because the electrons are so tiny that their motion would be quickly stopped in air at ordinary pressure unless very high voltages were used, and even then they would heat up the air so much that it would itself become incandescent and thus obscure the other effects.

Thus lightning is a discharge of electrons, generally from one cloud which is highly negatively charged to one highly positively charged. The electrical pressure or voltage is so great as to make the electrons burst their way through the resistance of the air, and raise it to a white heat as they pass through it. An electric spark discharge from an induction coil is similarly a discharge of

electrons ; a current of electricity through a wire is a steady flow of electrons from atom to atom through the wire.

The student will now see the importance of a knowledge of the electron theory, because it not only shows him how different forms of matter are related to each other, but also explains the nature of electricity ; he will also realise that electron discharges can be made to set up light waves in the all-pervading ether medium. If electrons were not constituents of matter, and had not mass, their discharge like little invisible bullets would not make the platinum red hot, or turn the wheel of the second vacuum tube. Besides the experiments already described there are many other facts in science to show that the atoms of matter are complex structures, and that they all have something in common.

For instance, whether we produce electrons from radio-active substances such as radium, or from incandescent metals, or from light sources giving rays beyond the violet (ultra violet light), or by discharges from electrodes in vacuum tubes, using various metals for the electrodes or various gases in the tubes, we always get the same kind of electrons, with exactly the same properties in each case. Again, in chemistry we have what is known as Mendeleeff's Periodic Law, according to which if we arrange the elements according to the weights of their atoms, we find that an element (say lithium) has certain properties which are not shared by the elements which follow it immediately, but that similar properties appear again in some element further on, in this case sodium, only to disappear again in the immediately succeeding elements and reappear in potassium, and so on. This would seem to show that these elements have something in common, as in the case of octave notes in music—one note has twice the frequency of the last and so on. In lithium, sodium, and potassium, sodium may have twice the number of electrons which lithium has, or the arrangements of the electrons in the atom may be something similar.

Again spectroscopic work with the elements show that there is some similarity between elements which follow each other at regular intervals in the periodic series.

Thus we are led to conclude that electricity is a constituent of all forms of matter, and that it is of a material nature ; that it has mass, and by its motion can convey energy ; while by a change of its motion it can cause disturbances in the ether medium.

It is possible that the whole universe may consist only of two essentials, ether and electrons.



## NOTES.

The mass of a hydrogen atom is  $\frac{1.64}{10^{24}}$  grams.

The charge corresponding to an electron is  $\frac{1.57}{10^{19}}$  coulomb.

The number of electrons equal in mass to an atom of hydrogen is 1835.

## . QUESTIONS ON CHAPTER II.

1. Define "matter," "atom," "electron," "radio-activity."
2. Deduce some evidence of the fact that electrons have mass.
3. Write a short account of the structure of the atoms of matter.
4. On the electron theory how does an atom of copper differ from an atom of hydrogen?
5. If the electron theory is taken as the correct one, what is electricity?

## CHAPTER III

### *MAGNETISM AND MAGNETIC STRAINS IN THE ETHER*

IRON is the most abundant metal in the world; how interesting then to think that it is practically the only metal which can be magnetised, and if it is hard iron or steel it will retain its magnetic properties when magnetised. A magnetised bar of steel if pivoted at its centre of gravity will point in the magnetic N. and S. direction; the end pointing N. is called the *N. pole*—the other end the *S. pole*. Either pole of a magnet will attract iron or steel, but there is no property of attraction at the middle of the magnet. Now if we suspend a straight steel bar magnet through its centre of gravity, and bring a pole or end of another magnet near one of its poles, we find that the latter is either attracted or repelled and the suspended magnet moves round. Like poles repel each other, unlike poles attract each other. But fix your attention on the fact that while the approaching magnet is still at a distance of perhaps a foot or more from the suspended one the latter moves. Some force is making it move, a force due no doubt to the approaching magnet, but what conveys that force to the suspended one and makes it move? If we wish to move something we can do so by pushing it with a rod, or pulling it with a string, or by directly acting on it; but there must always be some connecting medium between the force applied and the thing moved, a fact which holds throughout the whole range of mechanics. In the case of the magnets there must be a medium conveying the force from the one magnet to the other. It is an invisible medium and it is not the air, as the experiment will take place equally well across a space from which all air has been exhausted.

We must conclude it is the ether medium which acts in this case; just as it conveys light energy, and radiant heat energy: so here we have it conveying force, acting as a connecting link between the applied force and the body on which it acts. Now we know that when we apply a force by pulling a string or

chain, or by pushing through a lever, the string or chain or lever is strained in a definite way. How is the ether strained around a magnet so that the magnet can attract iron, or cause a

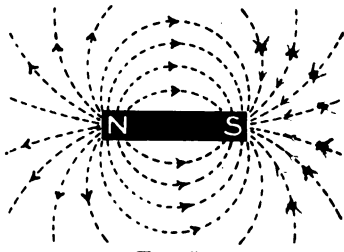

FIG. 5.

a motion of other pivoted magnets near it? If we put a magnet under a sheet of thick paper, and sprinkle fine iron filings over the paper, we find that the filings arrange themselves as shown in Fig. 5.

The filings arrange themselves in definite symmetrical lines around the magnet showing that the ether all round a magnet

is in this peculiar state of strain.

These lines of strain in the ether are called "magnetic lines of force," and we should find that the extent to which the ether round a magnet is strained depends on the degree to which the steel has been magnetised, or, as we say, on the strength of the magnet. We see that the lines of magnetic strain in the ether stretch from one pole to the other outside the magnet, and no doubt the ether in the steel magnet is also strained. The direction of the lines is for convenience taken as the direction in which a north pole of a magnet would be urged, and since we know by experiment that a north pole will be repelled from a north pole and attracted towards a south pole, *the lines of force therefore emerge from N. poles of magnets and enter at S. poles.* Each line of force coming from a N. pole and entering a S. pole is completed through the magnet itself from the S. pole to the N. pole, so that the lines are really links which have no end.

If the student wishes to see why two like poles of two magnets repel each other and two unlike poles attract each other, he has only to repeat the experiment with the iron filings using two magnets. The result will be as shown in Fig. 6.

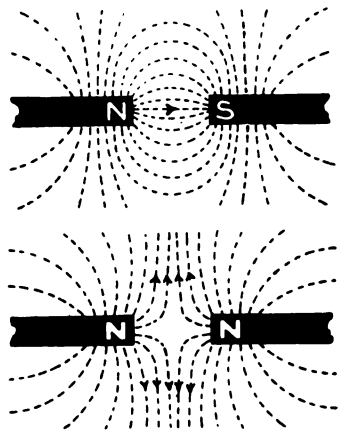

FIG. 6.

The result will be as shown in Fig. 6.

These lines of magnetic strain set up in the ether are always

tending to shorten themselves. That is why the S. pole of one magnet is pulled towards the N. pole of another near it, as if they were connected by invisible elastic strings. The lines never cross each other, for if one places poles in any position near each other the lines peculiar to each disappear and new irregular curves of ether strain take their place, just as in mechanics a number of forces gives a resultant force which has the same effect.

The lines of magnetic strain are self-repellent, that is why those farthest out in what is termed the "MAGNETIC FIELD" are pushed into curves by those inside them in the field. Thus the ether can be strained in a peculiar way, known as a magnetic strain; we represent this magnetic strain by "magnetic lines," and any space in which magnetic lines exist is called a "magnetic field." The "strength of a magnetic field" at any point is measured by the number of magnetic lines which cross a square centimetre at that point, the square centimetre being taken at right angles to the direction of the magnetic lines. This strength of field is usually denoted by the letter H.

We must now consider the difference between an ordinary bar of iron and one which is magnetised. They may be alike in appearance but the latter has got properties of attraction and repulsion not possessed by the former. The difference is in the arrangement of the atoms of iron in the bar; in an ordinary bar of iron the atoms are all massed together without any order; in a magnetised bar some of the atoms are arranged in definite lines or chains along the bar, and the more of these chains formed, the stronger is the magnet. The bar would be completely magnetised, or as we say "saturated," if all the atoms were arranged in definite lines. It is much the same as the difference between an irregular heap of bricks and a brick wall or another heap of bricks, in which at least the outside ones were arranged in definite order.

Again we must remember that an atom of iron consists of electrons in motion, the motion being in definite directions in each atom, and when the atoms are rearranged in magnetising a bar they are not only arranged in definite lines, but are also arranged so that the motions of the electrons in the atoms synchronise with each other. We cannot say how electrons revolve or move round the centre of an atom, but a chain of atoms in a magnetised bar of iron may be compared with a row of pulleys on a long shaft. When driven the pulleys all revolve in the same sense, and from them a line of belts will move in the same direction conveying forces to machinery placed beneath.

The scientist Ampère many years ago propounded the idea that

each atom of iron had electric currents flowing round it. Before magnetisation the atoms were in disorder and hence the currents moved irregularly; but when magnetised some of the atoms become parallel to each other and are arranged in chains along the bar so that the currents round these atoms are flowing round in the same direction or sense. Thus order is established out of disorder and the magnetic properties appear. We see how well this hypothesis agrees with the more definite knowledge we have obtained in later years regarding the constitution of an atom. Fig. 7 illustrates this conception of the magnetisation of iron, and the student is referred to works on Magnetism and Electricity, where experiments are described which go to prove the correctness of this explanation.

Let us now consider how iron can be magnetised, in other words, how some of the atoms in an ordinary bar of iron can be properly rearranged so that the bar evinces magnetic properties,

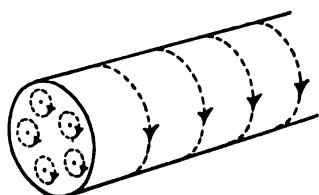

FIG. 7.

and magnetic lines of strain are set up in the ether around it. This can be done by simply laying the bar or rod of iron on the table and drawing a pole of a magnet along the bar from end to end, taking care always to rub along the bar in one direction. The more we rub the more strongly will the bar become magnetised, and we shall find that the end where we leave off rubbing is of opposite polarity to the pole used for rubbing, in consonance, as it were, with the rule that unlike poles attract each other. Note that nothing goes out of the magnet into the bar of iron. It is simply that the magnetic lines of strain in the ether at the pole of the magnet affect the atoms of iron in the bar so that some of these atoms are turned into definite directions along its length, in line with the path of the ether strain lines of force, which move along the bar as the pole is pulled along it.

But there is a more interesting and instructive method of magnetising iron. If we coil a long piece of insulated wire into a cylindrical coil, called a *solenoid*, and pass a current of electricity through the wire, we shall find that the coil behaves like a magnet. If free to move, one end of it will be repelled by one pole of a magnet and the other end attracted; if threaded through a sheet of cardboard and iron filings sprinkled on the cardboard, we shall find the filings arrange themselves just as they do with a steel magnet. These experiments show that there are magnetic lines of strain all round and through the coil. One end of the coil repels

the N. pole of a magnetic needle, the other end repels the S. pole showing that the coil has N. and S. poles. If the direction of the current is reversed, the polarity of the coil is reversed, so that the direction of the magnetic lines, which indicates the direction of the strain in the ether, depends on the direction of the current. To distinguish the N. and S. poles of such a coil the following rule can be applied:—look at one end of the coil, if the current is flowing round that end in the same direction as the hands of a watch move, that end is a S. pole; if the current is flowing round that end in the opposite direction to the hands of a watch it is a N. pole; see Fig. 8.

Now, if the core of the coil is filled with iron or if a bar of iron is placed in the coil, the iron will be found to be strongly magnetised, its polarity agreeing with the rule given above. There will be far more magnetic lines now passing through the coil than when it had no iron core, for the magnetic strain lines of the ether inside the coil have rearranged many of the atoms of iron, so that the iron is now a magnet, setting up magnetic lines in the ether in addition to those set up by the coil. In this way the iron multiplies the magnetic lines, its multiplying power for magnetic lines being called its *Permeability*, which will depend (1) on the quality of the iron, (2) on the extent to which it has been magnetised, (3) on its temperature.

We shall find that hard iron or steel retains much of its magnetism after being taken out of the coil, and retains it for a long time; in other words many of the atoms remain rearranged: after the influence of the current-carrying coil has been removed. If, however, the iron core is soft iron, it will lose most of its magnetism as soon as the current is stopped. Thus, if we wind insulated wire on a soft iron core we can have a magnet which will be very strong even with a small current, and whose magnetism is stopped by

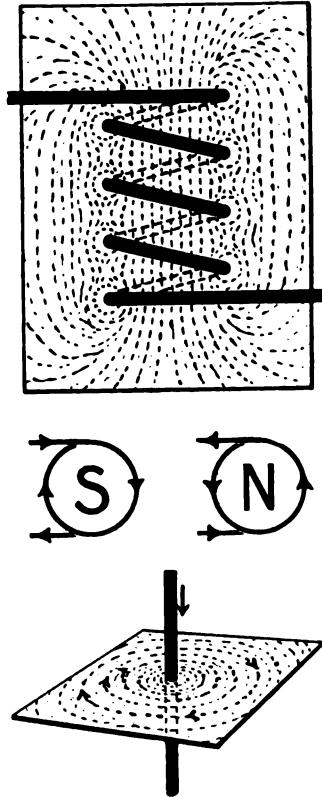

FIG. 8.

switching off the current. This effect is made use of every day in bells, arc lamps, motors, dynamos, etc. The strength of the magnet depends on the magnetising force of the coil, and this is directly proportional to the current flowing in it; also to the number of turns in the coil per centimetre of length: Thus 1 ampere of current through 200 turns of wire has the same effect as 2 amperes through 100 turns of wire wound on the iron; the magnetising effect depends on what is called the "ampere turns," current multiplied by turns of wire per centimetre of length.

Now a current of electricity is simply a regular movement or flow of electrons from atom to atom along the wire. Thus when electrons flow or move round a bar of iron the iron becomes magnetised, and its atoms or some of them are rearranged in definite chains. The atoms thus rearranged are set in such directions that the electrons in the atoms are all moving round the centres of the atoms in the same sense. It was this effect of a current-carrying coil which caused Ampère to formulate his hypothesis of magnetisation which so closely agrees with the facts brought out by more recent investigations (see Fig. 7).

Magnetic lines of strain are set up in the ether by movement of electrons. The particular way in which electrons move in iron atoms sets up these magnetic lines in the ether; if the atoms are so arranged that they do not annul each other's effects, the iron becomes a magnet. But any motion of electrons sets up magnetic strains in the ether. If we pass a wire through a sheet of cardboard and sprinkle iron filings on the cardboard, when a flow of electrons takes place along the wire (such as occurs when a current of electricity is passed through the wire), we shall see the filings rearrange themselves in such a way as to show that the ether round the wire is in a state of magnetic strain. The lines of strain will be concentric circles round the wire. If the wire is made into a long coil and a current passed through it, the magnetic lines of ether strain now pass up through the coil, in just the same way as ether strain is set up by parallel chains of iron atoms in a magnetised bar of iron. The direction of the magnetic lines depends on the direction in which the electrons move. If we reverse the current in the wire, or in the coil, we shall find the direction of the magnetic lines reversed, as shown by the direction in which the N. pole of a small magnetic needle points when placed in the magnetic field or magnetically strained ether. These effects are illustrated in Fig. 8.

That ether can be strained in this peculiar way, known as the magnetic strain, is of supreme importance in Wireless Telegraphy, as indeed it is in all commercial applications of electricity. The

design of most electrical machinery and apparatus is based on the use that can be made of this ether strain. It must never be forgotten that the principal use of magnets, either permanent or electro magnets, is to provide magnetic lines, and although they are invisible, roughly pictured to us by iron filings, as one pictures rays of light by letting them flow through a hole in a shutter into a dusty room, the student must always remember that the actual magnet is only a means to an end. The thing he is really concerned with is the magnetic strain in the ether, which is represented by the magnetic lines in front of the poles of the magnet, or in the centre of the current-carrying coil, or around the current-carrying wire, as the case may be.

## EXPERIMENTS AND QUESTIONS ON CHAPTER III.

1. Suspend a magnet by its centre of gravity, and try the effect of bringing a pole of another magnet (*a*) near its N. pole, (*b*) near its S. pole.

2. Place a bar magnet under a sheet of white cardboard. Dust soft iron filings lightly over the cardboard; tap the cardboard lightly with a pencil and note how the iron filings map out magnetic lines.

3. Place two magnets in a line with their N. poles opposite each other and about two inches apart. Repeat experiment 2 and note how the magnetic lines show why N. poles repel each other.

Repeat experiment with two S. poles opposite each other, and with a N. pole opposite a S. pole; note why unlike poles attract each other.

4. Fill a glass tube loosely with hard iron filings; proceed to magnetise it as if it were a bar of iron, using a pole of a magnet; note how the filings rearrange themselves, see if the tube has magnetic properties. Shake up the tube and test again.

5. Carry out the experiments described in this chapter with a current-carrying wire, and a current-carrying coil.

## QUESTIONS.

1. What are "magnetic lines"? What is meant by the direction of a magnetic line?

2. Explain how a current-carrying coil of wire sets up a magnetic strain in the ether.

3. Draw an iron core wound with insulated wire; show the direction of a current of electricity through the coil and the resulting N. and S. poles of the iron.

4. Show how a coil could be wound and a current passed through it so that it would have a N. pole at each end of the coil and a S. pole in the middle?

5. The magnetising force of a current-carrying coil is  $\frac{4\pi}{10} \times \frac{CT}{l}$ ; if a coil, 10 inches long, has 200 turns of wire, and the current flowing in it is 0.6 ampere, what is the magnetising force of the coil? In the formula given C is the current in amperes, T is the number of turns in the coil, and *l* is its length in cms. 1 inch = 2.54 cms.



## CHAPTER IV

### *ELECTRICITY AND ELECTRIC STRAIN IN THE ETHER*

IF an ordinary ebonite ruler is rubbed with a piece of fur or flannel, and the rubbed part held near light objects, such as small pieces of tissue paper, the latter will be attracted to the ebonite. A dry glass rod rubbed with silk shows the same phenomena, and a like result can be obtained with an amber mouthpiece of a pipe, or a stick of sealing-wax rubbed on the sleeve of a coat. These bodies are then said to be electrified.

When a rod of brass, or of any metal, is held in the hand and rubbed in a similar way it evinces no such property of electrification; however, if we mount the brass or other metal on a support of ebonite, amber, or sealing-wax, and flick it with a piece of fur, we find it has now the property of attracting light substances; in other words it is electrified. Thus bodies can be divided under two headings: those in which the electrified portion remains isolated or insulated, termed "Insulators," and those over which the electrification passes freely, and can pass into other similar bodies in contact with them, termed "Conductors."

Ebonite, sealing-wax, amber, silk, shellac, dry glass, and air are good insulators; metals and alloys, the human body, and most vegetable matter are good conductors.

A brass rod held in the hand is electrified by friction, but the electrification can spread all over the brass into the body through the hand, and into the earth through the body, so that no signs of electrification appear; when the brass is insulated, while the electrification can spread all over the brass, it cannot spread any farther, so that the brass as a whole shows signs of electrification.

All bodies can be electrified by friction or other processes. What is meant by electrification? Taking the case of the ebonite and fur, when they are rubbed together some of the atoms are disturbed, and electrons torn out of them in such a way that, after the rubbing, a number of free electrons, independent of atoms, are found on the ebonite, and a number of atoms of fur which have not

their proper number of electrons remain in the fur. If the fur were insulated, it also would be found to have the property of attracting light bodies. This statement would seem to show that there are two ways of electrifying a body, a fact amply proved by experiment.

If one electrified ebonite rod is suspended at the centre by a thread, and another electrified ebonite rod is brought near the electrified end of the suspended one, the latter is seen to be repelled. But if a glass rod, electrified by rubbing it with silk, is brought near the suspended electrified ebonite, the latter will be attracted and move round towards the electrified glass rod. The rubbed glass and the rubbed ebonite will each attract light neutral bodies; they are each electrified, but there is evidently some difference in their electrification. If the fur which rubbed the ebonite rod had been insulated, it would have attracted the electrified ebonite rod as the glass did; and, indeed, it can be easily proved that if two insulators, or insulated conductors, are rubbed together, they both become electrified to exactly the same extent but with different states of electrification, one repelling another electrified body, the other attracting it with exactly the same force. Franklin tried to explain this, in his "One Fluid Theory," by saying that when two bodies are rubbed together one loses something which the other gains; the first was negatively electrified and the second positively electrified, the negative and positive electrifications being necessarily equal.

With our modern knowledge of the structure of atoms we can explain it by saying that one body has gained free electrons, the other is left with some atoms which have not their proper quota of electrons. Experiment proves that a body on which free electrons are placed has the same effect as what is called a negatively charged body, and a body robbed of electrons acts as a positively charged body; thus to put free electrons on a body is to charge it with negative electrification, to rob a body of electrons is to charge it with positive electrification.

In other words it would seem that the atoms of any form of matter are made up partly of electrons or negative corpuscles and partly of positive charges; the latter probably constituting the nucleus of the atom mentioned in the previous chapter. In ordinary neutral matter the positive and negative charges in each atom neutralise each other, but *if electrons can be taken from some of the atoms, or added in excess as free electrons, the body is positively or negatively charged respectively.*

Some bodies are more easily electrified than others; this will depend upon the structure of the atom, how many electrons it

contains, and how the electrons are arranged in the atom. Sir J. J. Thomson has shown that from some atoms only one electron can be freed, from others two, and so on. The difference between electrons and the positively charged residue of the atoms from which the electrons are obtained is beautifully shown by experiment, with a special form of vacuum tube which is shown in Fig. 9.

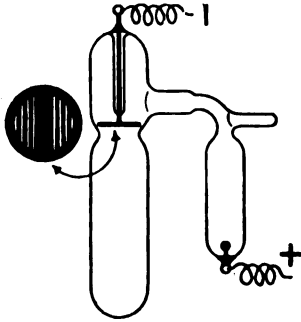

FIG. 9.

There are two plates or electrodes in the tube, one of which is joined to a source of great positive electrical pressure, the other is joined to a source of great negative pressure. This may be effected by joining the terminals to the secondary wires of an induction coil. The negative electrode

plate is cut in the form of a grid, with horizontal slits or openings in it.

When joined to a sufficiently great difference of electrical potential or pressure, a discharge will take place between the electrodes in the tube; electrons will be torn out of the atoms of gas in the tube near the negative electrode, and shot with great velocity towards the positive electrode. They will be like little invisible pellets flying across this space in the tube, and will make it phosphoresce with the usual yellowish-green coloration.

Now when a shot is fired from a gun, the gun itself recoils, and similarly in this case when electrons fly forward from atoms, the robbed atoms themselves fly backward; they will pass through the openings in the negative electrode and there will be seen behind it rays of quite a different colour to those due to the flying electrons in front. These rays will be of a reddish colour, and are due to the positively charged atoms flying backwards from the recoil.

One insulated conductor can be charged by bringing it into contact with another charged conductor, or by joining them together with a conducting wire. A simple little instrument for studying effects of electrical charges is the Gold Leaf Electroscope (Fig. 10).

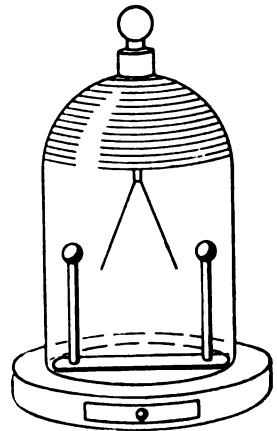

FIG. 10.

It consists of two little gold leaves hanging side by side on a metal bar connected by a metal rod to a disc, and the whole well insulated by ebonite, paraffin wax, or glass, from a case which surrounds the leaves, the case having glass windows through which the leaves can be seen ; it may be of glass and wire netting.

If the electroscope is charged, the leaves will stand apart, for being electrified in a similar sense (both positively or both negatively charged) they repel each other. Thus, if joined to a conductor and the conductor is charged the leaves stand apart.

If the electroscope is charged, say positively, and another charged conductor is brought near it, the leaves will collapse if the conductor has a negative charge but will stand still further apart if the conductor is positively charged. This instrument can only be used for dealing with very small charges, as the little gold leaves would be torn off if the effects are too strong ; we shall use it later in studying the action of condensers.

**Potential.**—When a body is charged positively or negatively, it is said to have a positive or negative electric pressure. When one puts water into a tank there is a certain pressure of water in the tank which could be measured by the height of water in the tank.

Water will flow through a pipe connecting two tanks if one tank has a greater height of water than the other ; that is to say if the water pressure in one is greater than in the other ; the first would have positive pressure with regard to the second ; the second negative pressure with regard to the first. Sea level is taken as the zero of water pressure ; and a tank in which the water level was lower than sea level might be said to have negative water pressure. The case of electricity is exactly analogous to these effects ; but instead of using the word "pressure," we more often use the word "potential," so that potential means pressure when applied to electrical effects. The earth is considered to be always at zero electrical potential just as the sea is the zero of water pressure. A body with negative electrification is at negative electrical potential analogous to a tank in which the level of water is below sea level ; a body with positive electrification is at positive potential, analogous to a tank in which the water level is above sea level. Two bodies may be both at positive potential or both at negative potential, or one at positive potential and

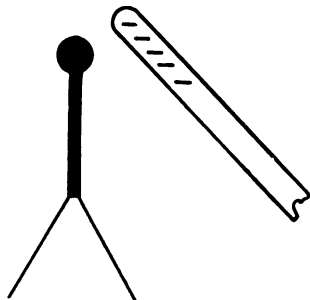

FIG. 11.

the other at negative potential; but if in either case there is a difference of potential, electricity will flow from the one to the other when they are joined by a conductor of electricity, just as water will flow through a pipe from one tank to another if the water pressures in the tanks are different, no matter how the tanks are situated as regards sea level. And the flow of electricity between two bodies tends to equalise their potentials, ceasing when there is no difference of potential, as water will flow between two tanks until the pressure, as seen by the surface levels, is the same in both tanks.

A body charged with electricity has therefore a certain electrical potential, and to obtain a discharge of electricity along a conductor it is necessary that the conductor should have applied to its ends different electrical potentials; or as we say, a difference of potential is applied to it.

Such a difference of potential might be set up by electrifying two conductors as already described; one might be positively electrified, the other negatively electrified, or one might be electrified to a greater positive (or negative) potential than the other. A conductor joining the two would then have applied to it a difference of potential, and a discharge of electricity will pass through it until they are at the same potential. This would only take an instant of time, and is nothing else but a redistribution of electrons, which pass along the conductor until as many of the disturbed atoms in the two bodies as possible are in a neutral condition again. If one could, by continuous rubbing, keep up the difference of potential, then the discharge would be continuous, and would constitute what is called a "current of electricity." In commercial practice we do not employ this frictional method of obtaining a difference of potential. The plates of a primary cell, such as a Leclanché cell, are at different potentials, the zinc being lower in potential than the other plate, so that a discharge would take place along a wire joining the terminals of these plates; the cell has the advantage that the chemical action of the liquid on the zinc keeps up the difference of potential; thus the discharge is continuous, and we therefore obtain a current of electricity in the wire. If a number of cells are joined in series:— the high potential plate of the first joined to the low potential plate of the second, and so on, the difference of potentials of the cells are added together; in this way a greater difference of potential is obtained, with consequent increase in the strength of the current. As in the water analogy, one might have tanks on all the floors of a house with pumps sending the water up from tank to tank; the rate of water current in a pipe leading from

the top tank back to the bottom one will depend upon the sum of all the pressures due to the several tanks; each tank is like a cell, and each pump has a similar effect to the chemical action in a cell. Again in a dynamo the ends of each wire on the armature are at different electrical potentials, and as a number of wires are joined in series the resultant difference of potential is the sum of all those due to the several wires. In practice, therefore, it is more convenient to obtain a suitable difference of potential by using a battery of cells, or a dynamo, than by the frictional method.

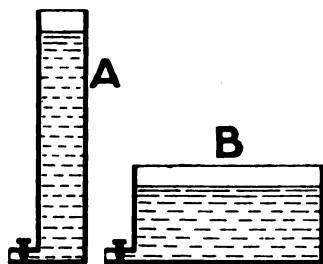

FIG. 12.

**Capacity.**—Now, when a tank is filled with water the resulting water pressure depends not only on the quantity of water put in, but also on the size of the tank, and on the shape of the tank. This if equal quantities of water are put into the vessels A and B. The pressure at the tap in A is greater than that at the tap in B (Fig. 12).

Similarly, when a conductor is electrically charged, negatively or positively, the resulting electrical potential depends not only on the charge, but on the size of the conductor, on the shape of the conductor, and, unlike the water analogy, on the position of other conductors near it. These considerations define what is called the electrical capacity of the conductor, so that the potential depends on the charge put on the conductor and on its capacity. We shall return to this in the subsequent chapter, when methods and formulæ for calculating capacity will be given.

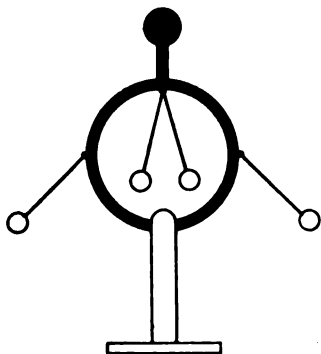

FIG. 13.

**Electric Strain in the Ether.**—We have seen that an electrified body attracts neutral bodies; that one electrified body will attract or repel another electrified body even though some distance apart; that two gold leaves will stand apart from each

other when similarly electrified.

If a brass ring is insulated and has attached to it some little balls of pith by light threads, as shown in Fig. 13, when the ring

and balls are electrified it will be found that the balls rise up in the air and stand well away from the ring. An invisible force has lifted them up, acting against their weight, similar to the invisible force which acts on the neutral bodies, or across space between electrified bodies, in the experiments already described.

As was the case in magnetism, the air has nothing to do with this force, for the actions described would take place in a vacuum. Thus we learn that the ether round an electrified body is in a state of strain, and as we have pictured the magnetic strain in the ether in the form of magnetic lines of strain, so round an electrified body there are said to be *electric lines of strain* in the ether. This electric strain in the ether conveys the force with which an

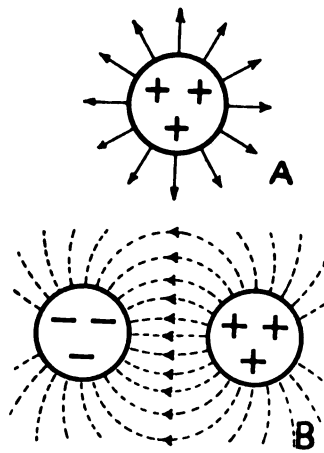

FIG. 14.

electrified body acts on a neutral body or another electrified body near it: each line represents a unit of strain force in the ether. Since a force acts always in a definite direction it is convenient to assume the direction of an electric line of force as the direction in which a positive charge would be urged along it. In magnetism we assume the direction of a magnetic line of force to be that in which a N. pole would be urged along it and as it is repelled by N. poles and attracted by S. poles, the magnetic lines of strain in the ether are said to be directed from N. poles to S. poles. Similarly a unit of positive

charge would be repelled by positively charged bodies and attracted by negatively charged bodies, hence the electric lines of force in the ether issue out from positively charged bodies and go in at negatively charged bodies.

Each electric line of force or strain in the ether starts at a unit of positive charge and ends at a unit of negative charge; they issue out and enter conductors always at right angles to the surfaces of the conductors, and their shape in space depends on the arrangement of charged bodies in the vicinity.

Thus if an insulated metallic sphere is isolated from other conductors and charged, the electric lines of strain in the ether round it are as shown in Fig. 14 (A). The arrows on the lines show the direction of the strain.

If two insulated spheres are charged, one positively and the other negatively, and placed near each other, the electric lines of

strain in the ether will be shown in Fig 14 (B). Note that though the lines are curved between the spheres, yet they are at right angles to the surfaces of the spheres where they enter or leave.

If an insulated metal plate A is charged positively, and a similar metal plate B is charged negatively and placed near A, the electric lines of strain between the plates will be as shown in Fig. 15. In this case the electric lines are straight except near the edges, and are uniformly distributed in the space between the



FIG. 15.

plates; that is to say there are a uniform number of lines per sq. cm. in the space between the plates. This is an example of what is called a "uniform electric field." In each of the cases described only a few electric lines are drawn, the actual number which exist in the ether space will depend upon the amount of the positive or negative charges on the bodies which are causing the strain. The electric field is the space in which the ether is strained, the strength of the field being measured by the number of strain lines per sq. cm. at any point. We cannot have free electrons without having atoms which have lost electrons, and electric lines of strain which start from positive charges, due to atoms which have lost electrons, end on negative charges which are the complementary number of free electrons. We can thus see why a neutral body is attracted by a charged body; some lines of ether strain stretch from the positively charged body in Fig. 16 to the neutral body;

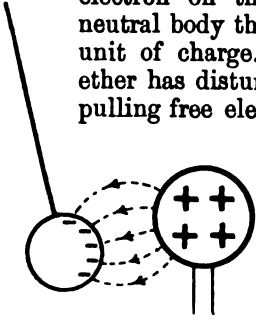

FIG. 16.

each line issues from an atom which has lost an electron on the charged body, and where it enters the neutral body there is a free electron constituting a negative unit of charge. In other words the electric strain in the ether has disturbed some of the atoms of the neutral body pulling free electrons to that side of it nearest the charged body; then the lines of strain being like elastic strings tend to shorten, and if their number is great enough this force of contraction will pull the neutral body up to the charged body. We see, then, that before a neutral body is attracted by a positively charged body it is really negatively charged on the nearest side, by the influence of the electric lines of force set up in the ether, and then the positive charge attracts the negative charge. The attraction of a negatively charged body for a neutral body is explained in a similar manner.

The forces of attraction and repulsion round bodies electrically



charged are therefore due to the strain set up in the ether around them. We picture this strain as lines of electric forces which have the peculiar property of being like stretched elastic strings, and therefore always tending to shorten themselves, or to pull their positive and negative ends towards each other until they disappear. In the same way a N. pole of one magnet attracts a S. pole of another, because the magnetic lines of force in the ether between them tend to contract, pulling the poles towards each other. There is therefore much similarity between magnetic lines of strain and electric lines of strain, and that some relationship exists between them will now be considered.

It has been already noted that when a current of electricity flows in a wire, or through a coil of wire, a state of magnetic strain exists in the ether near the wire or coil; but a current of electricity is simply a continuous flow of electrons,

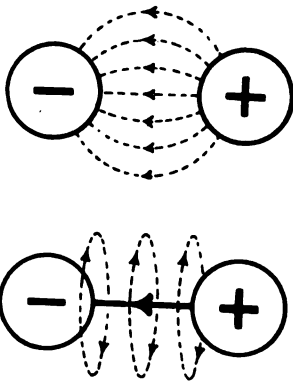

Fig. 17.

and can only take place when the wire or coil is connecting two conductors which are charged to different electrical potentials. A body charged with electricity is surrounded by ether in a state of electric strain; if the charge disappears the electric strain disappears, but for the charge to disappear there must be a flow of electrons either to or from the body, according as it is positively or negatively charged. This flow of electrons constitutes a discharge, or current,

which is surrounded by a magnetic strain in the ether.

*Hence we see that when an electric strain in the ether disappears a magnetic strain is immediately set up.*

Also it will be evident that these two states of strain act in directions which are at right angles to each other.

Thus in Fig. 17, if the two spheres are at different potentials (and note that this may mean that one of them is not charged at all, or neutral) the electric lines of strain in the ether will be somewhat as shown in the upper diagram.

If a discharge passes across the air gap from the one to the other, or if they are joined by a wire to obtain a discharge, then magnetic lines of force are set up in the ether round the discharge as shown in Fig. 17, the direction of these lines being at right angles to that of the electric lines which they replace.

*Thus electric lines of strain owing to a charge, or charges, act at*

right angles to the magnetic lines of strain which replace them at the discharge.

The existence of electric and magnetic strains in the ether owing to the electrical charges and discharges, and the fact that they act at right angles to each other, are of supreme importance in connection with radio-telegraphy, therefore a preliminary idea will now be given of how these strains cause wave motion in the ether, by which energy is conveyed through it in a similar manner to the energy conveyed in the form of heat and light.

An analogy with wave motion set up in a familiar fluid will simplify the explanation, so let us consider what happens when waves are set up in water. When the surface of some water is disturbed, so as to change the shape of the surface, it tends to resist that change by its elasticity; if its surface shape is changed its force of elasticity brings it back to its original shape unless prevented from doing so. This force is generally called the force

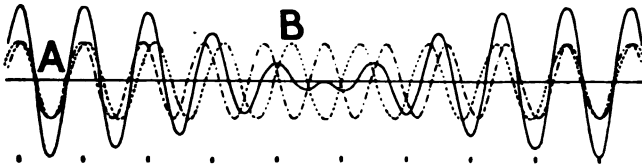

FIG. 18.

of surface tension. Also water, like all material substances, has a certain amount of the property of inertia, and when in a state of rest or motion, a force of inertia tries to prevent any change in that state. In large waves gravity takes the place of surface tension.

We might here consider with advantage the action which takes place when two different wave motions are set up in a medium at the same time. If we throw into some water two stones close to each other the resulting rings of wave motion will intermingle with each other and provide us with an example of what we are now discussing.

Suppose two wave disturbances are set up simultaneously in the same medium, one of which swings backwards and forwards at a slightly quicker rate than the other. The resulting effect is shown in Fig. 18, where the two waves are shown dotted. If they start in step, as at A, they will gradually get out of step until one is swinging upwards when the other is swinging downward, as at B. These effects will therefore annul each other at B, and in fact the result of the two is a slow wave motion as shown in the figure by a thick line wave.

We shall see later that this action is made use of in wireless telegraphy ; on it is based the working of Fessenden's heterodyne receiver and of Goldschmidt's tone wheel, described in Chap. XVI.

A discussion of how the waves spread out in the ether will not be undertaken at present, the above explanation being given at this stage in order that the student may realise how important it is that he should familiarise himself with the phenomena of magnetic and electric strains in the ether, as a knowledge of them is all important when dealing with ether waves.

From what has been said it will be clear to the student that bodies are charged, or electrical potentials set up, in order that two results should be obtained (1) that the ether should be put in a state of electric strain, or (2) that currents of electricity should be made to flow along wires or circuits to set up the accompanying magnetic strains in the ether. It may be that some subsidiary property of the currents is turned into service, such as their heating effects to give light, or their chemical effects to charge batteries or electroplate objects ; as far as radio-telegraphy is concerned our attention must be concentrated on the electrical and magnetic strains in the ether.

#### QUESTIONS AND EXERCISES.

1. Explain the difference between positive and negative electrification.
2. Mention some good insulators ; in what way do they differ from conductors ?
3. What is meant by the " electrical potential " of a charged conductor ? On what two things does it depend ?
4. " Around an electrified body a state of strain is set up in the ether ; " what experimental facts support this statement ?
5. What is meant by the direction of an electric line of force ?
6. Show that when electric strain in the ether disappears a state of magnetic strain is set up, and that the latter acts at right angles to the original electric strain.
7. What is meant by joining cells in series ? If the difference of potential between the plates of a cell is 2 volts, what is the difference of potential between the terminals of a battery consisting of 10 such cells in series ?
8. What is a " uniform electric field " ?

## CHAPTER V

### ELECTRICAL MEASUREMENTS AND CALCULATIONS

ALL units of measurement used in electrical calculations are based on the Metric, or, as they are usually called, the C.G.S. units. In this system of units the centimetre is the unit of length, the gramme is the unit of mass, and the second is the unit of time—hence the name—C.G.S. units.

**Force.**—In the British system of units, a unit of force is the force which would give a mass of 1 lb. an acceleration of 1 foot per second every second. In the C.G.S. system the unit is that force which would give a mass of 1 gram. an acceleration of 1 cm. per second every second. This is called a “*dyne*.”

A weight of 1 gram. exerts a force of 981 dynes, i.e. gravity would give a mass of 1 gram. in falling an acceleration of 981 cms. per second every second.

**Work.**—Work is always done or energy is expended when a force is moved through a distance, and the work is measured by the *product of the strength of the force and the distance through which it has been moved*. Thus if a force of 1 lb. is moved through 1 foot, the work or energy is said to be 1 ft. lb.; if a gallon of water (weighing  $62\frac{1}{2}$  lbs.) is raised 20 feet the work done is  $62\frac{1}{2} \times 20$  ft. lbs. = 1250 ft. lbs. 1 cu ft

Similarly in the C.G.S. system if a weight of 2 grams is raised through 6 cms. the work done is 12 gram. cms. and the unit of work is the work done when unit force (1 dyne) is moved through unit distance (1 cm.), that is to say, the unit of work is a *dyne-cm.*; this is called an “*erg*.”

Hence unit of work or energy = 1 erg = 1 dyne-cm.

Ten million ergs ( $10^7$  ergs) is called a joule.

**Power.**—Power is the rate of doing work—in British units we measure power by the number of *ft. lbs. of work done per second*: if there are 550 ft. lbs. of work done per second, we call that a horse-power. Thus power =

$$\text{power} = \frac{\text{work done in ft. lbs.}}{\text{seconds of time it took to do it}}$$

$$\text{and horse-power} = \frac{\text{work done in ft. lbs.}}{\text{seconds taken} \times 550}$$

In the Metric System power is also measured by the number of units of work done per second.

Hence power unit = 1 erg per second.

In electrical calculations a larger unit is adopted. If work is being done at the rate of 10 million ergs ( $10^7$  ergs), or 1 joule per second, we say the power is 1 watt.

$$\text{Watts} = \text{joules per second} = \frac{\text{ergs per second}}{10^7}.$$

Thus there are the "absolute" units and, in general, larger units based on them which may be used if found more practical.

**Length.**—absolute unit—a centimetre.

larger units—metre = 100 cms.; Kilometre = 1000 metres.

**Time.**—absolute unit—a second.

**Mass.**—absolute unit—a gramme.

**Force.**—absolute unit—a dyne.

larger unit—weight of 1 gramme = 981 dynes.

**Work.**—absolute unit—an erg.

larger unit for electrical purposes—a joule =  $10^7$  ergs.

**Power.**—absolute unit—an erg per second.

larger unit for electrical purposes—a watt =  $10^7$  ergs per second = 1 joule per second.

The units used for electrical and magnetic measurements are based on the above; unfortunately there are two sets of absolute units in use, called the electro-static and electro-magnetic units: there are also practical units used for ordinary commercial applications.

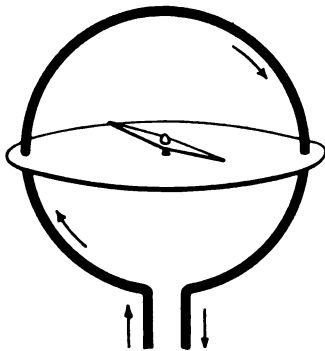

FIG. 19.

For our purposes it will be sufficient to consider the absolute or C.G.S. electro-magnetic units and their relation to the practical units.

**Current.**—When a current of electricity flows round a circle of wire magnetic lines of strain are set up as already described, and it will deflect a magnetic needle placed at the centre of the circle. When the circle is in the first place parallel

to the needle the current acts on the needle with a certain force, which can be measured in "dynes," and which will depend

directly on the strength of the current and inversely on the radius of the circle. (See Fig. 19.) Current is quantity of electricity flowing per second, and it is found by experiment that the force in dynes with which the current acts on the magnet is given by the formula

$$F \text{ dynes} = \frac{2\pi \cdot C \cdot m}{r}$$

where  $m$  = strength of magnet's pole,  $r$  = radius of the circle, and  $C$  is the current.

Now if  $m = 1$ ,  $r = 1$  cm.,  $C = 1$ , then  $F = 2\pi$  dynes, or 1 dyne for each centimetre of the circumference (which =  $2\pi$  cms. when  $r = 1$  cm.).

Thus we see that *unit current is that current which, flowing in a circle of unit radius, acts on unit magnet pole placed at the centre with one unit of force per each unit of length in the circle.*

It is evident why the unit is called an electromagnetic unit, as its definition is based on the magnetic effects of a current in a wire.

There is no special name given to this absolute or C.G.S. unit of current, but, being too large for ordinary purposes, one-tenth of it is used as a practical unit, and is called an "ampere." One-millionth part of an ampere is called a "microampere."

**Quantity or Charge.**—A current is quantity per second, or discharge per second; thus the C.G.S., or absolute unit of current, is the C.G.S. or absolute quantity of electricity flowing per second, and a current of 1 ampere is  $\frac{1}{10}$ th of an absolute unit of quantity or charge per second. This practical unit of quantity is called a "coulomb." For some purposes a much smaller unit is required and the millionth part of a coulomb is called a "microcoulomb." Just as a current of water is measured in gallons per second, so a current of electricity is measured in coulombs per second, but a coulomb per second is called an ampere.

**Potential and E.M.F.**—When water flows through a pipe the force causing it to move is the water pressure, which might be called the "water motive force"; in the same way a current of electricity flows when a difference of potential is applied to a circuit, and this *difference of potential is called the Electro Motive Force, or, shortly, the E.M.F.*

When water flows through a pipe, we know that for a given rate of flow, or current, the work which can be done by the water depends on its pressure; thus, if the current is at the rate of 1 lb. of water per second and it flows with a force which is due to a difference of level of 20 feet, then the water-flow can do  $1 \times 20 = 20$  ft. lbs of work per second. If the force is due to a difference of

level of 50 feet, the work done by a current of 1 lb. of water per second is 50 ft. lbs. : thus, the work done per second by what might be called unit strength of water current is a measure of its pressure, or the difference of level which constitutes the force acting on it: 20 feet lbs. of work on unit current represents 20 feet difference of level, 50 feet lbs. of work on unit current represents 50 feet difference of level.

In the same way, if water is raised to a height, the height to which it is raised can be measured by the work done on each lb. of water per second.

An exactly similar method is adopted in electrical science for measuring difference of potential : the units of work here used are ergs and the C.G.S. unit of current is one C.G.S. unit of quantity per second.

If one erg of work is done by one C.G.S. unit of current in flowing from one point to another, we say that the difference of potential between the two points is one absolute, or C.G.S. electro-magnetic, unit of potential. This is much too small a unit of potential for practical purposes, and one hundred million of these units (or  $10^8$  ergs) are used to form the practical unit of difference of potential or E.M.F., which is called a *volt*.

Thus, if the difference of potential between two points in a circuit is 1 volt it means that on each C.G.S. unit of current flowing between the points  $10^8$  ergs of work are done : since an ampere =  $\frac{1}{10}$  C.G.S. unit, on each ampere of current flowing between the two points  $10^7$  ergs of work are done.

Thus a volt represents  $10^7$  ergs of work done per second on each coulomb of charge or discharge, it being always remembered that "Coulombs per second" means the same thing as "amperes."

**Electrical Work.**—The C.G.S. unit of work is, of course, the "erg," and it has been shown that this is the work done by the C.G.S. unit of current when it flows from one point to another; between which unit difference of potential exists.

A larger unit is  $10^7$  ergs, called a joule; it is the work done by one ampere of current in flowing between two points, A and B, when the difference of potential between A and B is one volt.

Now  $V$  volts represent  $V$  joules of work by each ampere of current, therefore if the current is  $C$  amperes the work done per second is  $VC$  joules, and if the current flows for  $t$  seconds the total work done equals  $= VCt$  joules.

Thus, if an electromagnet takes 2 amperes of current when 8 volts are applied to it and the current is kept up for ten minutes (600 seconds), the total electrical work done, or energy expended on the coil is—

$$\begin{aligned} VCI &= 8 \times 2 \times 600 = 9600 \text{ joules} \\ &= 9600 \times 10^7 \text{ ergs.} \end{aligned}$$

The flow of electricity (2 amperes) = 2 coulombs per second  
 =  $\frac{1}{3}$  C.G.S. unit per second.

**Electrical Power.**—Power is the rate of doing work ; the C.G.S. unit is 1 erg per second ; so that the power in C.G.S. units is the ergs of work done divided by the time in seconds taken to do it. The practical unit of work is a joule, and therefore of power is a joule per second.

The *joules per second* are obtained by multiplying the volts and amperes together, and a joule per second has been given a name, *i.e. a watt*, which is therefore the practical unit of measuring electric power.

$$\begin{aligned} \text{Thus watts (W)} &= VC = \text{volts} \times \text{amperes} \\ &= \text{joules per second.} \end{aligned}$$

A larger unit—the kilowatt = 1000 watts.

**Electrical Resistance.**—When water flows through a pipe the resistance it meets with depends directly on the length of the pipe, inversely on the cross section of the pipe, and directly on the conditions of the pipe, that is the number of bends in it, and how much obstruction there is in it due to leaves, roughness, or other cause.

When a difference of potential is applied to any electrical circuit, a current flows through the circuit, and the ratio of the volts applied to the current that flows,  $\left(\frac{V}{C}\right)$ , is called the resistance of the circuit measured in units called *ohms*. Thus if 10 volts are applied and 2 amperes of current flow, the resistance (R) is  $\frac{10}{2} = 5$  ohms. An ohm is therefore the practical unit of electrical resistance ; it is the resistance of a circuit through which 1 ampere will flow when 1 volt is applied, or 6 amperes will flow, when 6 volts are applied, etc.

As in the water analogy it is found by experiment that the electrical resistance of a circuit depends—

(1) Directly as its length—the greater the length the greater is R.

(2) Inversely as its cross section—the greater the cross section the less is R.

(3) Directly on the conditions of the circuit, that is to say on the materials of which the circuit is made, for different materials allow electrons to pass along them at different rates.

The resistance effects of different materials are compared by



calculating, from experiments, the resistance of a piece of each material 1 inch long and 1 sq. inch section (or 1 cm. long and 1 sq. cm. section in some Tables). The resistance of such a piece of a material is called its *specific resistance*. Then to find the resistance of any piece it is only necessary to multiply the specific resistance by the length in inches (or cms.) and divide by the cross section in sq. inches (or sq. cms.), using the English or metric units according to the system on which the specific resistance is calculated.

$$\begin{aligned} \left. \begin{array}{l} \text{Thus the specific resistance} \\ \text{of copper} \end{array} \right\} &= 0\cdot00000066 \text{ ohm per inch cube} \\ \rho &= 0\cdot00000066 \text{ ohm} \\ \text{Then } R &= \frac{\rho \times l}{A} \text{ ohms.} \end{aligned}$$

The resistance of a piece of copper wire 100 yards long and 0·92 sq. inch section is

$$R = \frac{0\cdot00000066 \times 100 \times 36}{0\cdot02} = 0\cdot1188 \text{ ohm.}$$

The specific resistance of German silver is 0·00001181 ohm, of iron is 0·000003569 ohm; the values for any materials can be found in electrical pocket-books and text-books.

It will be pointed out in a later chapter that the above method of calculating resistance is only applicable when steady currents are used; with oscillating discharges or currents, the resistance will be higher than for steady currents.

**Resistance in Series.**—When resistances are joined in series the resulting resistance is the sum of their resistances.

$$R = (r_1 + r_2 + r_3 + \text{etc.}) \text{ ohms}$$

and the current will be of the same strength in all parts of the series circuit. If a long thin wire is joined in series with a short thick one, and an E.M.F. applied across the terminals, the current will be of the same strength in both wires, just as a water current must be of the same strength in a row of pipes joined in series no matter how their diameters may vary. But the volts used up in the first resistance is  $C \times R_1$  and in the second resistance is  $C \times R_2$ ; these are called the drops of potential across the resistances, and we see that *the drop of volts (or volts required) to send a current through a resistance is directly proportional to the current and to the resistance, and is equal to their product.* ( $V = CR$ ). This relationship is known as Ohm's Law.

The current flowing in a circuit is measured by an ammeter, which is joined in series with the apparatus or circuit, just as a gas meter is joined in series with the pipes through which the gas flows. A gas meter offers little resistance to the flow of gas, so that not much pressure is wasted in it, similarly an ammeter has a very low resistance, so that the drop of volts in it will be very small even if the full current is flowing. It usually consists of two parts, a shunt of manganin strip through which most of the current flows and a small working coil joined in parallel with the shunt through which a definite fraction of the current flows, the current dividing between them inversely as their resistances, or—

$$\frac{\text{current in coil}}{\text{current in shunt}} = \frac{\text{resistance of shunt}}{\text{resistance of coil}}$$

The resistance of the shunt is low and depends on the current to be carried; thus if the ammeter measures up to 5 amperes, the resistance of the shunt part of it might be about 0.0145 ohm. The coil has a small resistance of not more than 2 ohms, and, as the coil and shunt are joined in parallel, it is easily seen that the resistance of the whole instrument is very small.

A voltmeter is very similar in design to an ammeter, but is a high resistance instrument: its coil works exactly in the same manner as that of an ammeter, but instead of being shunted with a low resistance it is joined in series with a very high resistance, which usually consists of a long thin insulated manganin wire wound on a frame which is fixed at the back, inside the instrument. Thus a Weston voltmeter to measure up to 220 volts may have a resistance of 16,000 ohms, of which 3 ohms is the resistance of the little working coil and the remaining 15,997 ohms is the resistance joined in series with it. A voltmeter is never joined into the main circuit, but is always joined across the points in any circuit whose difference of potential it is desired to measure. It is made

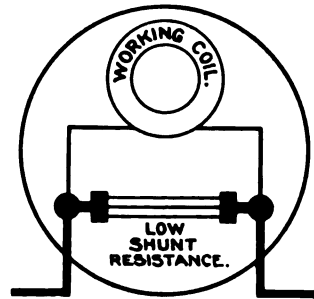

**AMMETER.**

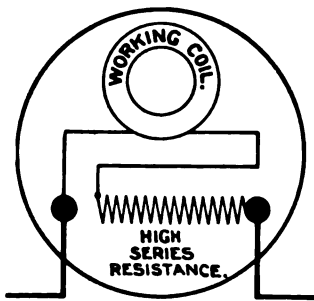

**VOLTMETER.**

FIG. 20.

whose difference of potential it is desired to measure. It is made

to have a high resistance because in measuring a difference of potential we wish to do so with an instrument which takes the least possible current. One does not measure the steam pressure going to an engine by diverting a lot of the steam and bringing it to the steam gauge: if this were done the pressure in the engine cylinders would be seriously reduced. A small pipe leads a small quantity of the steam to the steam gauge, and for a similar reason a voltmeter has a high resistance so that very little current will be used in it when measuring the voltage; the wires connecting the voltmeter to the points desired can therefore be of small diameter. The difference between an ammeter and a voltmeter is shown in Fig. 20.

An ammeter is joined in series with the circuit or apparatus,

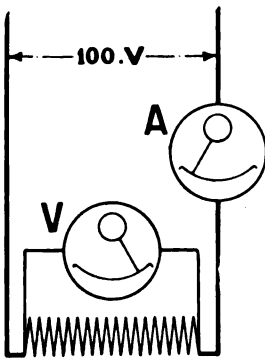

FIG. 21.

a voltmeter in shunt across it as shown in Fig. 21. If an ammeter is joined in shunt across a circuit by mistake it is likely to be burnt out. Thus in Fig. 21 suppose there are 100 volts applied to the apparatus and that the ammeter, of 0.03 ohm resistance say, is joined across the circuit instead of the voltmeter, then by Ohm's Law the current which flows through it

$$= \frac{V}{R} = \frac{100}{0.03} = 3333 \text{ amperes, which would burn it out.}$$

If a voltmeter is joined by mistake in series in a circuit, nothing would happen, for it has such a high resistance

that only a very small current would flow.

The author has seen a student join an ammeter to a battery, nothing else being in the circuit, to see what the current of the battery was! Naturally the current was that which flowed through the low resistance ammeter, and promptly burnt it up.

It is not intended here to describe the different designs of ammeters and voltmeters, as these can be studied in any electrical engineering text-book; a special design much used in radio telegraphy, known as the hot-wire ammeter, will be described in Chap. XIX.

When resistances are joined in parallel, the combined resistance can be found from the formula

$$\frac{1}{R} = \frac{1}{r_1} + \frac{1}{r_2} + \frac{1}{r_3} + \frac{1}{r_4} + \text{etc.}$$

where R is the combined resistance.

Thus, suppose A and B, in Fig. 22, are two mains which are at a difference of potential  $V$  volts, and are joined by three resistances  $r_1$ ,  $r_2$ , and  $r_3$  in parallel.

Then by Ohm's Law

$$\text{Current in } r_1 = \frac{V}{r_1}$$

$$\text{Current in } r_2 = \frac{V}{r_2}$$

$$\text{Current in } r_3 = \frac{V}{r_3}$$

$$\begin{aligned} \text{Total current} &= \frac{V}{r_1} + \frac{V}{r_2} + \frac{V}{r_3} \\ &= V \left( \frac{1}{r_1} + \frac{1}{r_2} + \frac{1}{r_3} \right) \end{aligned}$$

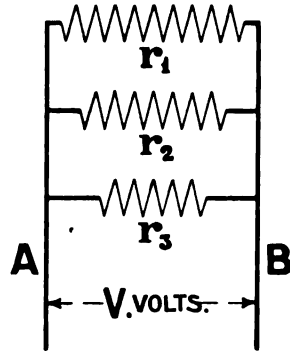

FIG. 22.

But if  $R$  is their combined resistance by Ohm's Law also  $C = \frac{V}{R} = V \left( \frac{1}{R} \right)$ .

$$\therefore \frac{1}{R} = \frac{1}{r_1} + \frac{1}{r_2} + \frac{1}{r_3}.$$

It is very usual to have two resistances in parallel, in which case

$$\frac{1}{R} = \frac{1}{r_1} + \frac{1}{r_2} = \frac{r_1 + r_2}{r_1 \times r_2}; \text{ or } R = \frac{r_1 \times r_2}{r_1 + r_2}.$$

Thus, if  $r_1 = 5$  ohms and  $r_2 = 50$  ohms  $R = \frac{5 \times 50}{5 + 50} = \frac{250}{55} = 4\frac{1}{11}$  ohms.

It will always be found that the combined resistance is less than the least of the resistances in parallel: if 1 ohm is joined in parallel with 10,000 ohms, the combined resistance

$$= \frac{1 \times 10,000}{1 + 10,000} = \frac{10,000}{10,001} \text{ ohm}$$

which is less than 1 ohm.

If a number of equal resistances are joined in parallel, the combined resistance is that of one divided by the number in parallel. Thus, if a Tungsten Lamp has 1600 ohms resistance, and ten such lamps are joined in parallel, the resulting resistance

$$= \frac{1600}{10} = 160 \text{ ohms.}$$

Again, if two resistances are joined in parallel, the main current divides between them into two parts which are inversely proportional to their resistances, or—

$$\frac{\text{current in } r_1}{\text{current in } r_2} = \frac{\text{resistance of } r_2}{\text{resistance of } r_1}$$

When a current  $C$  flows through a resistance  $R$ , the drop of potential across the resistance ( $V$ ) =  $CR$ , thus the watts used up in the resistance =  $VC = CR \times C = C^2R$  and the joules expended in it in  $t$  seconds =  $C^2Rt$ .

Therefore, watts in any circuit or portion of a circuit equals current  $\times$  volts drop across it, or equals (current)<sup>2</sup>  $\times$  its resistance.

Joules of work expended in any circuit equals volts across it  $\times$  current  $\times$  time in seconds, or equals (current)<sup>2</sup>  $\times$  its resistance  $\times$  time in seconds.

In order that the student may become familiar with the methods of working electrical calculations, a few examples will now be given:—

1. A current of 5 amperes is required to drive a 100 volt motor; what is the power given to the motor, the total energy used in half an hour, and, if the efficiency of the motor is 80 per cent., what is its horse-power?

Power given to motor in watts =  $VC = 100 \times 5 = 500$  watts.

Watts are joules per second, therefore energy used in half an hour equals  $500 \times 30 \times 60 = 900,000$  joules =  $900,000 \times 10^7$  ergs.

Power given out by motor is 80% of 500 watts

$$\frac{500 \times 80}{100} = 400 \text{ watts} = \frac{400}{746} \text{ H.P.} = 0.53 \text{ H.P.}$$

2. If 2 amperes of current flowing in a circuit do 600 million ergs of work per second in that circuit, what is the applied voltage?

600 million ergs =  $600 \times 10^6 = 60 \times 10^7$  ergs. Now 1 volt represents  $10^7$  ergs of work (1 joule) done per second per ampere of current, therefore  $2 \times 10^7$  ergs on 2 amperes: thus voltage applied =  $\frac{60 \times 10^7}{2 \times 10^7} = 30$  volts.

3. If 300 microcoulombs of electricity flow per minute in a circuit across which a difference of potential of 100 volts exists, what is the electric power in the circuit, and the electrical work done in each minute?

300 microcoulombs per minute = 5 microcoulombs per second, therefore the current is 5 microamperes.

Power =  $VC = 100 \times 5 = 500$  microwatts.

Work done per minute =  $VCI = 100 \times 5 \times 60 = 30,000$

microjoules =  $\frac{30,000}{10^6}$  joules =  $\frac{3}{10^3} \times 10^7$  ergs = 300,000 ergs.

4. If the resistance per 1000 yards of a 7/22 S.W.G. copper cable is 5.672 ohms, what is the resistance of (a) 350 feet of it, (b) four lengths of 350 feet joined in parallel?

Resistance is directly proportional to length,

$$\therefore \frac{\text{Res. of 350 ft.}}{5.672} = \frac{350}{1000} = \frac{7}{20}$$

$\therefore$  resistance of 350 feet of  $\frac{7}{22}$  =  $5.672 \times \frac{7}{20} = 0.6617$  ohm.

Resistance of four such lengths in parallel

$$= \frac{0.6617}{4} = 0.1654 \text{ ohm.}$$

5. What is the combined resistance of three resistances in parallel, these being of 5, 10, and 100 ohms respectively?

$$\frac{1}{R} = \frac{1}{5} + \frac{1}{10} + \frac{1}{100} = \frac{20 + 10 + 1}{100} = \frac{31}{100}$$

$$\therefore R = \frac{100}{31} = 3.236 \text{ ohms.}$$

6. The working coil of an ammeter has a resistance of 2 ohms and can safely carry  $\frac{1}{20}$  ampere. What must be the resistance of its shunt if the instrument is to measure up to 15 amperes?

When the maximum current is flowing through the instrument, *i.e.* 15 amperes, the current through its coil is not to be more than  $\frac{1}{20}$  ampere, therefore the current in its shunt must be  $14\frac{19}{20}$  ampere.

$$\therefore \frac{\text{Res. of shunt}}{\text{Res. of coil}} = \frac{C_s}{C_c} = \frac{\frac{1}{20}}{14\frac{19}{20}} = \frac{1}{299}$$

$$\therefore \text{Resistance of shunt} = 2 \times \frac{2}{299} = \frac{4}{299} \text{ ohm.}$$

7. How could the above instrument be arranged to measure up to 30 amperes? By changing its shunt to one of lower resistance,  $\frac{1}{20}$  ampere going through the coil when  $29\frac{19}{20}$  amps. goes through shunt.

$$\therefore \text{Resistance of new shunt} = 2 \times \frac{\frac{1}{20}}{29\frac{19}{20}} = \frac{2}{599} \text{ ohm.}$$

## EXERCISES ON CHAPTER V.

1. A lamp of 400 candle power takes 1.5 watts per candle power; how many amperes of current flow through it if the applied voltage is 220?
2. Find the combined resistance of four wires connected in parallel, their resistances being 6.25, 8, 20, and 100 ohms respectively.
3. If a current of 10 amperes flows along a wire of 0.015 ohm resistance to an instrument of 20 ohms resistance, find the drop of volts across the wire, across the instrument, and across the whole circuit.
4. If the voltage applied to a potentiometer wire of uniform section is 4 volts what is the drop of volts across  $\frac{1}{10}$ th of the wire?
5. An oscillating current of 10 microamperes effective flows in a receiver aerial of 25 ohms resistance; find the watts of oscillating energy.
6. When a volt is applied across a carborundum crystal the current flowing in it is found to be 8 microamperes; what is the resistance of this crystal? Draw the connections of ammeter and voltmeter to make the above measurements.
7. What is the resistance of 1200 yards of a conductor  $\frac{1}{8}$ th inch diameter if the resistance per mile of a wire of the same material  $\frac{1}{4}$  inch diameter is 2 ohms?
8. If 800 watts are used in a transmitter find the joules of work done in half an hour, and the ergs of work done in  $\frac{1}{100}$  second.
9. Two points A and B are at a difference of potential of 5000 volts. How many ergs of work are done on each coulomb of electricity passing between A and B, and how many joules of work are done per second, if the quantity per second is 5 coulombs?
10. Calculate the resistance of 220 yards of a copper cable made of 7 strands of No. 22 S.W.G. wire, the cross section of No. 22 wire being 0.0006 sq. inch.
11. Define a volt, a watt, a coulomb, an erg, and specific resistance.
12. What is the relation between the C.G.S. electromagnetic units, and the practical units of (a) current, (b) potential, (c) work, (d) power, (e) quantity or charge?

## CHAPTER VI

### CAPACITY AND INDUCTION EFFECTS

**Capacity Effects.**—When a vessel is filled with water the pressure in the vessel depends on how high the level of the water is raised; the pressure will be directly proportional to the quantity of water put into the vessel, and inversely proportional to its size and shape. The size and shape will qualify what we might call the capacity of the vessel. If the vessel is connected to a tank containing water, a discharge will flow into it until the levels or pressures are the same in both, and the greater the capacity of the vessel the more water will flow in to equalise the pressures.

Similarly, if we have an insulated conductor, with no other conductors near it, and we proceed to charge it, connecting it by contact or by a wire to a charged conductor, a charge will flow into it until the two are at the same potential. Every conductor has a certain electrical capacity depending on its size and shape, and the larger this capacity the more charge is required to bring it to a given potential. Thus the potential is directly proportional to the charge, and inversely proportional to the capacity, as in the water analogy; or in symbols  $V = \frac{Q}{K}$ , where  $V =$  potential,  $Q =$  quantity or charge, and  $K =$  capacity.

Unity capacity would be that of a conductor which is raised to unit potential by unit charge. The practical unit of capacity is called a *farad* (after Faraday). A conductor whose capacity is 1 farad would be raised to a potential of 1 volt by a charge of 1 coulomb. Unfortunately, a farad is far too large a unit for ordinary purposes, so we use a millionth part of it as a working unit, called a *microfarad* ( $10^6$  microfarads = 1 farad). Thus a capacity of 1 microfarad is charged to a potential of 1 volt by 1 microcoulomb of electricity. There are, of course, scientific or absolute units of capacity, based on the C.G.S. units of measurement. In these units a sphere of 1 cm. radius has a capacity of 1 unit, called a centimetre; 900,000 of these scientific units



equals 1 microfarad, and since all formulæ for calculating capacity are based on the centimetre as a unit of length, and give the capacity in absolute units, we shall have to divide by 900,000 when it is desired to express the capacity in microfarads.

If a conductor is positively charged and some one brings near it another body negatively charged, or even a body at zero potential, such as the hand, the potential of the first body is immediately lowered. This can easily be seen by experiment. Attach an insulated conductor to a gold-leaf electroscope by a wire, and charge the whole system, gradually raising its potential and noting its value by the increasing divergence of the gold

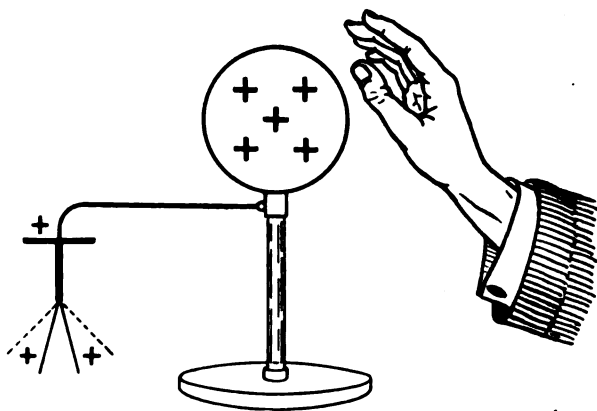

**SHEWING HOW A NEUTRAL BODY BROUGHT NEAR  
LOWERS THE POTENTIAL OF A CHARGED BODY,  
DOTTED LINES SHEW POSITION OF LEAVES IF  
HAND IS TAKEN AWAY**

FIG. 23.

leaves (Fig. 23). Having raised it to a certain potential, bring the hand close to any part of the charged system, and note that immediately the divergence of the leaves is decreased. If the system is positively charged, bring near it a negatively charged body, and the effect is seen to be still greater. If the negatively charged body is taken away the potential rises to its former value, but if left there the potential is permanently lowered.

To bring it to its former potential while under the influence of the negatively charged body, we would have to put a greater positive charge on it, therefore *its capacity is greater than it was before*. It is just as if one had a tank filled with water up to

a certain level or pressure, and suddenly the tank became lowered in its position so that it was not so high above sea-level; to get the same water pressure as before more water will have to be put into the tank. Considering the question from another point of view we must remember that a charged conductor is surrounded by a strain in the ether in the shape of electric lines of force; if the conductor is of symmetrical shape the strain in the ether round it will be symmetrical, the electric lines leaving the conductor everywhere at right angles to its surface. But if we bring another conductor near the charged conductor, the ether between the two will be more strained than that around other parts of the charged conductor. Thus, if the charged conductor is a plate, and another plate joined to earth is brought parallel to it and near it, almost all the ether strain will exist in the space between the two conductors; that is to say, this space will be filled with electric

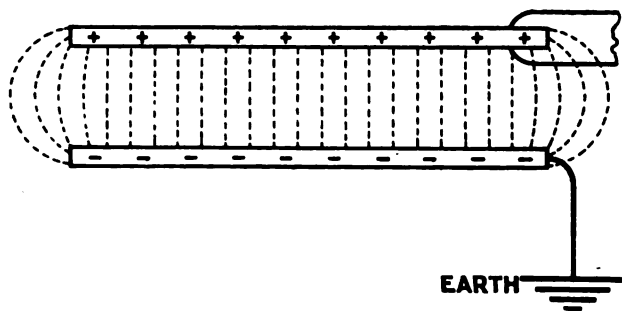

FIG. 24.

lines of force, as shown in Fig. 24. This condensing of the electric lines into a smaller space is accompanied by a fall of potential for a given charge, or, what is the same thing, an increase of the capacity of the system. This change will be greater the smaller the distance across the space. It is found that the effect also depends on the insulating material filling the space between the conductors. So far we have only considered the case of air in the space, but if we fill it with ebonite, or glass, or paraffin wax, we shall find the capacity is increased by using one of these substances, the increase depending on which we use.

**Dielectrics.**—An insulator used in this way is called a “*dielectric*,” and the ether strain set up by the system, and therefore the capacity of the system, depends on the material in which the ether is strained or the electric lines of force set up; in other words, it

depends on the dielectric used. Thus the capacity of a conductor depends—

1. On its size.
2. On the presence of other conductors.
3. On the dielectric in which the electric lines are set up between the charged conductors and neighbouring conductors.
4. On the distance between the charged conductor and the neighbouring conductors—that is on the thickness of the dielectric; the thinner it is the greater the effect.

If we experiment with the effects of ebonite and air as dielectrics we shall find that an ebonite dielectric increases the capacity 2·5 times as much as air. This number is called the “specific inductive capacity” or “dielectric constant” of ebonite. Similarly the dielectric constant of glass varies from 6 to 10, depending on the kind of glass used; of paraffin oil is 2; that of air being 1.

*The “dielectric constant” of a substance is therefore its effect when used as a dielectric as compared with an air dielectric.*

**Condensers.**—Conductors placed parallel to each other and separated by a suitable dielectric constitutes a “condenser”; it usually takes the form of one metallic plate, or set of plates joined together, separated from a similar plate or set of plates by a dielectric of glass, ebonite, paraffin oil, or air. The plates may be flat rectangular or circular sheets, or may be in the form of tubes.

If  $A$  = area in sq. cms. of one set of plates or surfaces,  
 $k$  = dielectric constant, or specific inductive capacity, of the dielectric used,  
 $t$  = thickness of the dielectric between the plates, or surfaces, measured in cms.,

then the capacity of the condenser—

$$K = \frac{A \times k}{4\pi \times t \times 900,000} \text{ mfd.}$$

A simple form of condenser is the Leyden jar; it consists of a glass jar, coated to about halfway up the sides both inside and out with tinfoil, the inside coating being connected to the circuit by a metallic rod ending in a small sphere above the jar, and fitting into an ebonite cover on the jar which aids the insulation of the rod and inside coating. The glass above the coatings is generally coated with shellac for the same reason. To apply the above formula to a Leyden jar— $A$  is the area of one of the tinfoil coating in sq. cms.,  $k$  has a value varying between 6 and 10,

depending on the quality of glass, and  $t$  is the thickness of the glass measured in cms.

A Leyden jar of what is known as pint size has a capacity of about 0.001 microfarad, a quart size has a capacity of about 0.0017 microfarad. Special tubular forms of Leyden jar condensers are used in wireless telegraphy, as shall be described hereafter, but ordinary Leyden jars can be used as condensers for obtaining oscillatory discharges.

Another form of condenser, much used for ordinary electrical purposes, consists of sheets of tinfoil separated by thin sheets of paper well soaked in melted paraffin, alternate sheets being joined together to form as it were one large sheet, and the other alternate sheets joined together to form the other large sheet with the

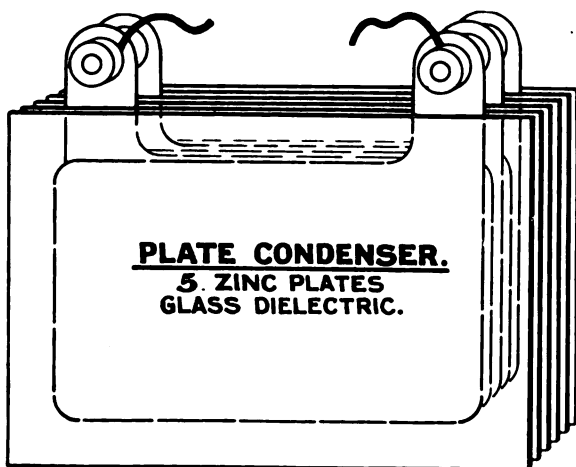
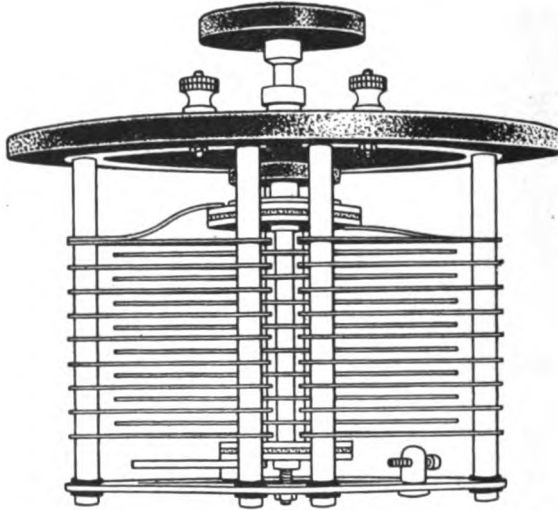

FIG. 25.

paraffined paper as dielectric. The whole is inclosed in a hard wood or ebonite box. In this way a condenser can be made to have a comparatively large capacity, though its bulk is quite small. Such condensers are not much used in wireless telegraphy for reasons which shall become apparent later.

A transmitter condenser might be made of zinc plates separated by sheets of glass, the glass sheets being much larger than the zinc plates, so as to avoid any likelihood of a discharge taking place round the edges of the glass. Suppose each zinc plate has an area of  $A$  sq. cms. and that the condenser consists of 2 zinc plates joined together, separated by the glass sheets from 3 similar zinc plates joined together as shown in Fig. 25. Then it must be noted

that the total active area is 4 A sq. cms. for each side of the two zinc plates is acting as a surface separated by the dielectric from a similar surface. Thus if each zinc plate is 5.4 cms. by 6.5 cms. and



**MOVING VANE VARIABLE CONDENSER.**

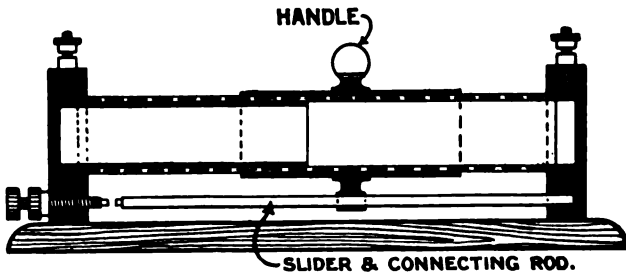

**TUBULAR VARIABLE CONDENSER.**

FIG. 26.

the glass is 0.4 cm. thick (it would be about 11 cms. by 10 cms. in area), then, taking the dielectric constant of glass as 8, we would have for the capacity of the condenser—

$$K = \frac{4 \times 5.4 \times 6.5 \times 8}{4\pi \times 0.4 \times 900,000} \text{ mfd.} = 0.000248 \text{ mfd.}$$

Small condensers, used as shunts across telephone receivers, may be made with tinfoil and paraffined paper embedded in paraffin wax, and enclosed in wooden boxes with ebonite tops, on which are mounted the terminals to which the two sets of plates are joined.

Thin mica sheets whose dielectric constant is 6·7 would be preferable to paraffin paper as a dielectric; thus a small condenser having 41 plates joined in groups of 20 and 21, each 2 cms. by 4·35 cms. and separated by mica 0·1 mm. thick would have a capacity—

$$K = \frac{40 \times 2 \times 4.35 \times 6.7}{4\pi \times 0.01 \times 900,000} = 0.029 \text{ mfd. (approx.)}$$

In making plates for condensers, it is well to round off the corners of the plates slightly, as an accumulation of electric strain always takes place at sharp points or corners on charged conductors, and in all electrical apparatus which is required to be charged to high potentials it will be noted that sharp corners, points, or edges are always avoided.

Condensers whose capacity may be varied are made by having a set of fixed plates and a set of movable plates, separated by air, paraffin oil, glass, ebonite, or mica. The movable plates are mounted on a spindle, so that by turning it round, all or only a portion of the movable plates may be placed opposite the fixed plates. Such a condenser is shown in Fig. 26. Another form is a tube of metal, over which is fixed a tube of ebonite and on the ebonite another tube of metal slides, having fixed to it an insulating handle. By sliding the outer tube over the ebonite more or less of its surface can be made to cover, or be opposite, the fixed tube inside, and thus the capacity can be varied. These variable condensers are, however, only used in small sizes for dealing with small potentials.

Other forms of condensers will be described in connection with the different systems of radio-telegraphy; for the present we shall confine ourselves to a study of the general theory underlying the design of a condenser.

Returning to the consideration of the capacity of a condenser, we note that the thinner the dielectric, everything else being equal, the greater the capacity. But we must not make the dielectric too thin, or we shall be limited in the potential to which we can charge it. If we raise the potential too high, a discharge will take place through the dielectric, puncturing it, and thus the plates would no longer be efficiently insulated from each other. In much the same way, a great potential strain between two clouds charged with electricity of opposite kinds, finally breaks

down the insulation of the dielectric (air) between them, and we see a discharge, in the form of lightning, forcing its way through the air. Similarly when a great difference of potential exists across a spark gap, the insulation of the air dielectric between the spark balls breaks down, and a spark passes. The breaking down potential for any dielectric depends on its thickness as well as on the material; consequently the thickness of the dielectric which must be used in a condenser depends on the potential strain it will be required to stand, also on the material used as a dielectric. Thus the *dielectric strength* is measured by the voltage which will break down the insulation of unit thickness of the material.

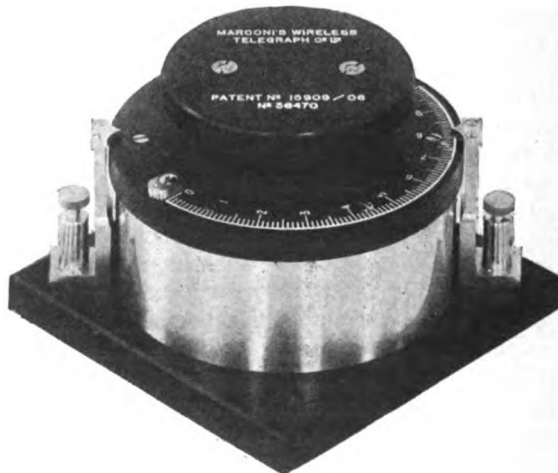

FIG. 26 (a).—Marconi variable condenser for receiver circuits.

For instance, 3000 volts will discharge across 1 mm. of air, but it would take 200,000 volts to discharge across 1 mm. of mica, and about 50,000 volts to discharge across 1 mm. of ebonite. These values vary according to the shape of the electrodes between which the dielectric is placed. Thus, while capacity is increased by decreasing the thickness of the dielectric, for a given potential there is a certain minimum thickness for each dielectric that may be used, and the best dielectric has not necessarily the highest dielectric strength.

Another important consideration in choosing a dielectric for a condenser, is what is known as "dielectric hysteresis." If a charged Leyden jar is discharged and left undisturbed, for, say,

30 seconds, a second small discharge can be got from it, and sometimes even a third one. This is due to the fact, that when charged, the strain across the dielectric causes the charges to leave the plates and really settle on the surface of the dielectric, through which they are tied by the electric lines of force, or ether strain, in the dielectric. When the opposite sets of plates are suddenly discharged through a circuit joining them, such as a piece of wire or a spark gap, the flow of electrons rushing round the circuit neutralises the positive and negative charges, but some are still left straining across the dielectric, trying as it were to get across that way instead of taking the easier path that has suddenly been provided for them; thus the dielectric does not entirely recover from the strain when the discharge takes place.

This effect will be again referred to when dealing with transmitter condensers.

We must now obtain an expression for the amount of energy stored in a condenser. The energy of a flow of water is determined by the product of the quantity of water that flows and the pressure at which it flows; thus the power of a waterfall is the product of the quantity of water flowing per second, and the pressure of the water, calculated from the height of the fall. If  $W$  lbs. equals the weight of the water discharged per second, and  $h$  equals the height of the fall in feet; the energy per second =  $Wh$  lb. feet, and 550 ft. lbs. per second equals one horse-power.

Again, if a tank is filled with  $W$  lbs. of water to a height of  $h$  feet, and the water is allowed to flow out at the bottom, the quantity of water discharged is  $W$  lbs., but the pressure of the water is due to a height of  $h$  feet at the commencement of the discharge, and falls to 0 when the discharge is complete, so that the average pressure is that due to  $\frac{1}{2} h$  feet of water. Thus the total energy of the discharging water is  $W \times \frac{1}{2} h$  lb. ft., and this must be a measure of the energy stored in the tank before the discharge. Similarly, when a condenser is discharged its potential at the commencement of discharge is  $V$  volts, at the end is zero, therefore the average potential is  $\frac{1}{2} V$  volts, and thus if the quantity of electricity is  $Q$  coulombs, the total energy of discharge is  $\frac{1}{2} QV$  joules. This must also equal the energy stored in the circuit before the discharge.

In a circuit charged to  $V$  volts with a charge of  $Q$  coulombs the energy stored =  $\frac{1}{2} QV$  joules.

If the charge is  $Q$  microcoulombs this equals  $\frac{Q}{10^6}$  coulombs.

$$\therefore E = \frac{1}{2} \frac{Q_{\text{mc.}} \cdot V_{\text{volts}}}{10^6} \text{ joules.}$$

E



Now 1 microfarad is charged by 1 microcoulomb to a potential of 1 volt.

∴ K mfd. is charged by K microcoulombs to a potential of 1 volt.

∴ K mfd. is charged by KV microcoulombs to a potential of V volts.

∴ If a condenser of K mfd. is charged to V volts, the charge  $Q = KV$ .

$$\therefore E = \frac{1}{2} \frac{Q \times V}{10^6} = \frac{1}{2} \frac{KV \times V}{10^6} = \frac{1}{2} \frac{K_{\text{mfd.}} \times V^2_{\text{volts}}}{10^6} \text{ joules.}$$

In diagrams a condenser is usually denoted as shown in Fig. 27 ;

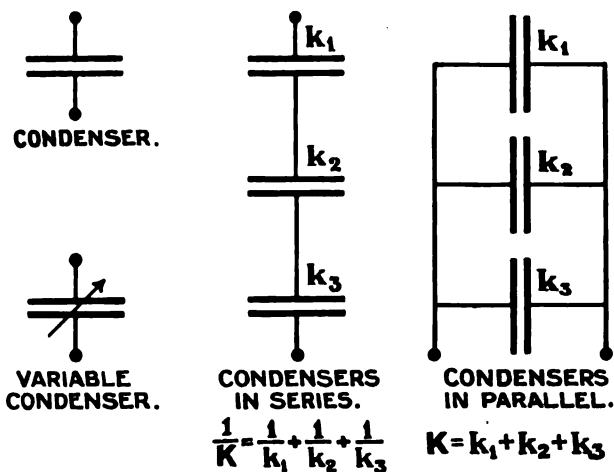

FIG. 27.

if its capacity is variable an arrow is generally drawn across it.

If we join condensers in parallel, as shown in the figure, the combined capacity is equal to the sum of their capacities,  $K = K_1 + K_2 + K_3$ .

It is easily seen that by joining them in parallel we are simply adding the size of their plates together if they are similarly constructed, and has just the same effect as if we had increased the size of the plates of one of the condensers to the same extent. If three condensers of 1 mfd. each are joined in parallel the resulting capacity is 3 mfd.

If condensers are joined in series, as shown in the figure, the capacity of the series is less than that of one alone, and is given by the formula

$$\frac{1}{K} = \frac{1}{K_1} + \frac{1}{K_2} + \frac{1}{K_3}.$$

If each has a capacity of 1 microfarad the capacity of the three in series is obtained thus

$$\begin{aligned} \frac{1}{K} &= \frac{1}{1} + \frac{1}{1} + \frac{1}{1} = \frac{1}{3} \\ \therefore K &= \frac{1}{3} \text{ mfd.} \end{aligned}$$

Thus the capacity of any system of electrical conductors for storing electrical energy can be decreased by joining a condenser in series with the system. We shall see later that the capacity of an aerial circuit in radio-telegraphy is often thus decreased.

If a condenser of 0.02 mfd. capacity is joined in series with one of 0.04 mfd. capacity, the resulting capacity is given by

$$\begin{aligned} \frac{1}{K} &= \frac{1}{0.02} + \frac{1}{0.04} = \frac{0.04 + 0.02}{0.02 \times 0.04} = \frac{0.06}{0.0008} = \frac{6}{0.08} \\ K &= \frac{0.08}{6} = 0.0133 \text{ mfd.} \end{aligned}$$

It is seen that this is less than the capacity of either condenser.

Every circuit or wire has some capacity, and while that of wires or isolated conductors is very small compared with a condenser arrangement, yet in wireless telegraphy they must be taken into consideration. For instance, there are circumstances when we may wish to increase the number of turns in a coil to increase what is known as the inductive effect, yet by so doing we are increasing the capacity of the coil; for this reason it is better to attain our object by some other means. We shall discuss these circumstances later in connection with Wireless Telegraphy Receivers.

The capacity of a straight vertical wire, far removed from other conductors,—

$$= \frac{l}{4.6052 \log \frac{2l}{d}} \text{ mfd.}$$

where  $l$  is its length in cms., and  $d$  its diameter in cms.

The capacity of a straight horizontal wire, raised high above the earth and not close to other conductors,—

$$= \frac{l}{4.6052 \log \frac{4h}{d} \times 900,000} \text{ mfd.}$$

where  $l$  and  $d$  are its length and diameter in cms., and  $h$  is its height in cms. above the earth.

If two or more such wires are joined in parallel, their combined capacity is not quite the sum of their capacities, but no simple formula can be given for the resultant capacity since it depends very largely on how close they are together, and on local circumstances such as the presence of other conductors near them.

An aerial, or antennæ, used in radio-telegraphy, consists of one or more wires stretched horizontally, at as great a height as possible, with vertical wires leading down from each, all joined together at the bottom, to apparatus which either charges the aerial or through which it may discharge. A ship's aerial of ordinary dimensions would have a capacity of the order of about 0.0012 mfd.

**Induction Effects.**—We have already seen in Chapter III. that when a current of electricity flows along a wire the surrounding ether is subject to a magnetic strain; in other words, the wire is surrounded by magnetic lines in the form of concentric circles, and if the wire is coiled up the magnetic lines pass along the axis of the coil, their number and direction depending on the strength and direction of the current in the coil. An iron core will greatly increase the number of magnetic lines through the coil for a given current.

There is a converse effect which we shall now proceed to study. If a wire is surrounded by ether in a magnetic state of strain, and that magnetic strain suddenly changes in value, electrons will flow along the wire, and one end of it will momentarily be at a higher electrical potential than the other end. A wire surrounded by magnetic lines of force, or placed in a magnetic field of lines of force, is said to be interlinked with the magnetic lines, so that we can describe the above phenomena in this way:—if a wire is interlinked with a magnetic field, and the number of magnetic lines interlinked with the wire changes, a momentary difference of potential is set up between the two ends of the wire.

If the magnetic field interlinked with the wire continues to change, the difference of potential set up in the wire will continue, and *its value at any moment will depend upon the rate of change*

of the magnetic field at that moment. We can insure this continuity by having a magnetic field which is not uniform in strength across which the wire can be moved; if it moves from a position where the field is weak to one where the field is stronger, the induced difference of potential will increase, and *vice versâ*. If we keep the wire stationary and move the magnetic field we obtain just the same effect. It is not sufficient simply to make the wire move through magnetic lines, for if the wire is interlinked with the same number of magnetic lines every instant there would be no difference of potential in the wire. The wire must be interlinked with a magnetic field, and one or other must move in such a way that the number of magnetic lines interlinked with the wire, cut by the wire, or cutting through the wire, is changing.

There may be a number of such wires all interlinked with magnetic lines, and moving in such a way that an E.M.F. or difference of potential is induced in each wire; if then all the wires are properly joined in series with each other, an E.M.F. is obtained which is the sum of their individual E.M.F.s.

This explains what happens in a dynamo or generator; in it we have a magnetic field of ether strain between the N. and S. poles of one or more electro-magnets and constrained to act in the space between the poles by filling the centre of the space with a core of soft iron, so that between this core and each pole there exists a field of invisible magnetic lines. Copper wires are made to move through this field between the core and the poles, the method adopted being to fasten the wires on the surface of the core and make it revolve, carrying the wires with it, therefore making them cut through the magnetic lines. Such an arrangement is shown in Fig. 28. The core with its wires is called the armature of the machine. Consider any wire A; at the moment shown, it is not cutting any magnetic lines, but as it revolves it begins to cut them in a slanting manner, the angle at which it cuts them getting steeper and steeper until it cuts them

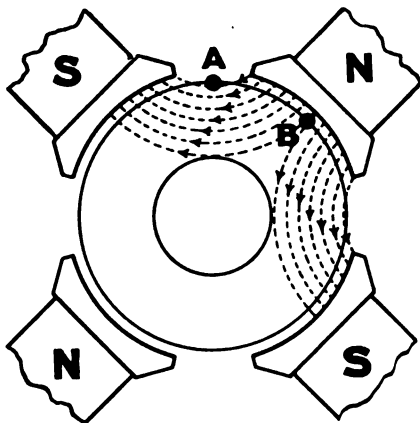

FIG. 28.

straight down, as at B, after which the reverse action takes place.

Thus we see that the number of magnetic lines cut through by the wire is continually changing, therefore the induction of an E.M.F. in the wire will be continuous, but its value will rise and fall. When a number of such wires are suitably joined in series with each other the resultant E.M.F. will be increased. Thus we can get 200 or 400 volts, or whatever is desired by such an arrangement. The free ends of the two wires (at the ends of the series) are joined to two insulated conducting rings on the shaft of the revolving armature, and the circuit (through which a current is required) is connected to these rings by sliding contacts of copper or carbon, called brushes; thus the E.M.F. obtained by induction effects can be utilised, just as we use the E.M.F. of a battery of cells.

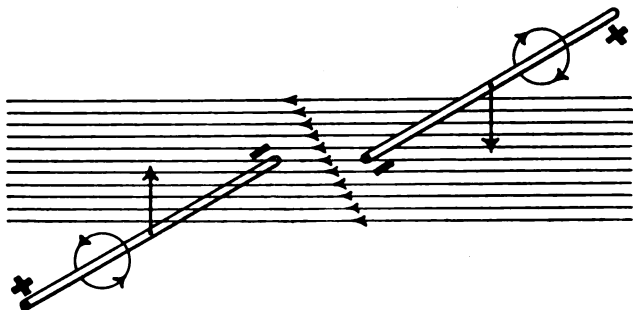

FIG. 29.

Now the question at once arises—which is the positive and which is the negative end of a wire which cuts through a magnetic field? A simple experiment will help us to answer it: join a wire to the terminals of a galvanometer, or, better still, a number of wires in series with each other in the form of a coil, so as to increase the effect; make the wires of one side of the coil cut down through the magnetic field between the poles of a horseshoe magnet. Immediately it will be seen the galvanometer deflects to one side, showing that a current has flowed through the galvanometer coil, and therefore an E.M.F. must have been applied to the circuit. This was the E.M.F. induced in the wires in series with each other which cut through the magnetic field. The deflection is only a momentary one; therefore the current and therefore the E.M.F. induced is only momentary.

Now make the wires cut *up* through the magnetic field; again

the galvanometer deflects, but this time in the opposite direction, therefore the current is flowing in the opposite direction, and thus the E.M.F. is induced in the opposite direction. So that the direction of induced difference of potential in a wire depends on the relative directions of the motion of the wire and of the magnetic lines. Fig. 29 shows the result when the wire cuts down through the field there shown, the direction of induction is such that the front end is negative, and when it cuts up through the field the front end is positive. To find the current direction, imagine the magnetic lines to bend round the wire as it cuts through them as shown in Fig. 30, and imagine a corkscrew to be turned in the same direction as the curve of the magnetic line shows. Then the current will flow along the curve of the wire to the outside circuit, when joined to it, in the same direction as the corkscrew would move in a cork if screwed as shown. In the figure the

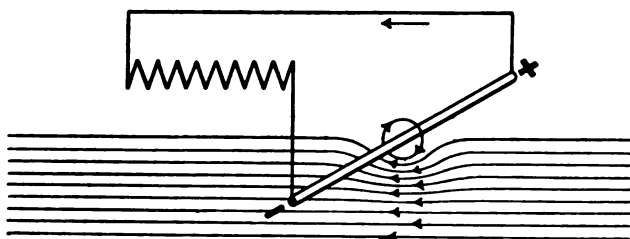

FIG. 30.

current flows from front to back ; therefore the current goes to the outside circuit from the back, which is thus the positive end of the wire.

In the armature wires of a dynamo the E.M.F.s are induced in one direction when they pass through the magnetic lines coming out of a N. pole and in the opposite direction when they pass through the magnetic lines going into S. poles. Thus the resulting current in the wires and outside circuit will be continually reversing its direction ; this is called alternating current, and the E.M.F. an alternating E.M.F. If the current is required to flow only in one direction in the outside circuit, this can be accomplished by connecting it through brushes, not to two insulated rings on the shaft, but to a number of insulated contacts joined to the wires, which constitute what is called the commutator. In this way we get what is called direct current, making the machine a direct current generator.

Returning to our experiment with the galvanometer, if the

side of the coil in the magnetic field between the poles of the horseshoe magnet is not moved, there will be no deflection on the galvanometer, so that it is not enough to put a wire, or wires in series, in a magnetic field. Only when the wires are moved into or out of the field is an induced E.M.F. obtained; the wires must interlink with the magnetic field, and the number of interlinkages must change per instant of time. The wires may move from a stronger field to a weaker one or *vice versa*, or the strength of the field may increase or decrease to produce the effects.

The experiment can be repeated by joining a stationary coil of wire to the galvanometer, and bringing near it, or inserting in it, a pole of a magnet. When the pole is inserted or brought up, induction takes place in one direction, when it is taken out or removed induction takes place in the opposite direction. A N. pole will set up induction in one direction, a S. pole will set up induction in the opposite direction, because the direction of induction depends on the direction of the magnetic lines with respect to the wires of the coil; magnetic lines come out of N. poles, they go in to S. poles.

Again it will be noted that the strength of the induced E.M.F., as shown by the deflections, depends on how quickly the magnet pole is moved; the faster the magnetic lines interlink with the coil, the stronger the induced E.M.F. The E.M.F. is set up by change in the number of magnetic lines interlinked with each wire, and its strength is proportional to the rate of change; thus of the number of magnetic lines interlinked with one wire or turn *changes at the rate of M lines per second*, the voltage induced in the wire or turn is  $\frac{M}{10^8}$  volts. In the case of a coil, if there are T turns in series and each turn experiences the same rate of change of M lines per second, then the E.M.F. induced at the terminals of the coil is  $\frac{MT}{10^8}$  volts. Note carefully that M is not the number of magnetic lines which has interlinked with the coil, but is the change per second in the number of magnetic lines so interlinked.

**Self-induction.**—A wire carrying a current is surrounded by magnetic lines in the form of concentric circles all along its length; forget for a moment what causes these magnetic lines, that is to say, do not think of the current, but think only of the magnetic lines and the wire. The wire is interlinked with these magnetic lines, therefore any change in their number will cause an E.M.F. to be induced in the wire; if their number decreases, in other words if some of them collapse into the wire, an E.M.F. will

be induced in it in one direction, but if they increase an E.M.F. will be induced in the wire in the opposite direction, and this will happen no matter what causes the decrease or increase of the magnetic lines. A decrease or increase of current in the wire will decrease or increase the number of magnetic lines interlinked with it, *thus any change of current in a wire will induce in it an E.M.F.* If there is no change of current there will be no induction. This effect set up in a circuit by a change in its own current is called *self-induction*.

*The self-induced E.M.F. will always be in such a direction as to oppose the change of current which produces it*; if the current decreases, the induced E.M.F. will be in the same direction as the E.M.F. applied to the circuit; it as it were increases it so as to stop the decrease of current. If the current is increasing, the induced E.M.F. is in the opposite direction to the applied E.M.F., thus tending to decrease the effective E.M.F. and stop the increase of current.

Self-induction in electricity is like *inertia* in mechanics; if a truck is moving along a set of rails and we try to decrease its velocity, or rate of displacement, its inertia will tend to make it go on just as before, and the inertia will have to be overcome before any decrease in its velocity can be accomplished. If the truck is at rest, or moving only slowly, and we desire to increase its velocity, its inertia will oppose the change and must be overcome before the velocity can be increased. But once the inertia is overcome, once the truck is started and moving with a uniform velocity, there will be no inertia. So it is with self-induction, if the current, or rate of displacement of electricity, is flowing steadily there is no self-induction, for there is no change in the number of magnetic lines interlinked with the circuit; but if the current is decreased or increased, stopped or started, then an inductive effect is set up.

With direct current, self-induction effects are only produced at switching on or off, or when the current is increased or decreased, but with alternating current which is not only flowing backwards and forwards in the circuit but is also continually rising and falling in value, self-inductive effects are also continually rising and falling, and reversing in direction as the current reverses; always opposing the change of current. Oscillating currents or discharges are alternating currents changing at a very high rate, so that with these also self-induction effects are ever present, and have an important bearing on the electric conditions of the circuit.

If a wire carrying a current is made up into a coil, the magnetic lines which were strung out along the wire are now congregated



together, threaded along the axis through the coil, and the magnetic lines due to the length of one turn will not only interlink with that turn, but with others near it, so that any change of current in the coil will set up a greater E.M.F. of self-induction than would be the case if the same length of wire were stretched out straight. The presence of an iron core in a coil greatly increases the number of magnetic lines through it for a given current, therefore will cause an increased change in the number of magnetic lines interlinked with the coil if the current changes.

Thus the self-induction effect in a coil of wire is much greater than that of the same length of wire stretched out straight; also the presence of an iron core in a coil greatly increases its self-inductive effect, except in the case of a coil carrying a current or discharge oscillating at a very rapid rate. With rapidly oscillating currents an iron core does not increase the self-inductive effects.

The amount of self-induction effect set up in a wire or coil depends on the rate of change in the number of magnetic lines interlinked with it, either decreasing or increasing; and this we know depends on the rate at which the current is changing since the number of magnetic lines depends directly on the strength of the current. Thus, if the current is changing at the rate of one ampere per second in any wire, coil, or circuit, there will be a certain amount of self-induction effect, or, as it is sometimes called, inductive effect, depending on whether it is a wire, or a coil, or on the shape of the circuit. In order to be able to compare the self-induction effects in different circuits, we calculate, or find by experiment, *its amount in any circuit when the current is changing at the rate of one ampere per second and call this "The Coefficient of self-induction"* of the circuit. Such a change of current can be produced by suddenly switching on or off one ampere of direct current. If an alternating current of  $C$  effective amperes is flowing in a circuit at a frequency of  $f$  cycles per second, the rate of change of the current is  $2\pi fC$  amperes per second. The coefficient of self-induction is measured in units called *henrys*—if a circuit has a "coefficient of self-induction," sometimes called "inductance" of 1 henry, it means that if the current in the circuit is changing at the rate of 1 ampere per second there will be induced in that circuit an E.M.F. of 1 volt. If the circuit consists of one turn of wire, the change of magnetic lines would in this case be 100,000,000 or  $10^8$  per second, if there are  $T$  turns the change in the number of magnetic lines is  $\frac{10^8}{T}$  per second.

If a coil of  $T$  turns has an inductance of  $L$  henrys and the current in it is changing at the rate of  $C$  amperes per second, the volts induced in it by the change of current =  $LC$  and the change of magnetic lines through it per second =  $\frac{LC \times 10^8}{T}$ .

When, therefore, we wish to introduce a self-induction effect into a circuit, a condition necessary in wireless telegraphy circuits, we do so by making part of the circuit in the form of a coil, as it has a greater inductance than a straight wire. With the high frequency currents used in radio-telegraphy the inductance of a coil would not be increased by inserting in it an iron core, nor would it be worth while to wind the coil in more than one layer, as high frequency oscillating currents would, in the case of more than one layer in the coil, confine themselves mostly to the top layer.

The symbol used for the "inductance" of a coil or circuit is the letter  $L$ , and as already noted it is measured in units called henrys. This is the practical unit, the scientific unit being very much smaller and called a centimetre; there are  $10^9$  cms. in a henry. The henry is really too large a unit for most practical purposes, so we have smaller subdivisions of it,  $\frac{1}{1000}$  part called a millihenry, and  $\frac{1}{1000000}$  part called a microhenry.

$$\begin{aligned} 1 \text{ henry} &= 1000 \text{ millihenry or } 10^3 \text{ mhy.} \\ &= 1,000,000 \text{ microhenrys or } 10^6 \text{ microhys.} \\ &= 1,000,000,000 \text{ centimetres or } 10^9 \text{ cms.} \end{aligned}$$

Thus 0.02 Mhy. = 0.00002 hy. = 20 microhys. = 20,000 cms.

The inductance of a straight wire  $l$  cms. long and  $d$  cms. diameter

$$L = 2l \left( 2.3026 \log_{10} \frac{4l}{d} - 1 \right) \text{ cms.}$$

The inductance of a coil, or helix, of one layer of  $D$  cms. diameter,  $l$  cms. long, and having  $N$  turns *per cm.*—

$$L = (\pi DN)^2 l \left[ 1 - 0.424 \left( \frac{D}{l} \right) + 0.125 \left( \frac{D}{l} \right)^2 - 0.0156 \left( \frac{D}{l} \right)^4 \right] \text{ cms.}$$

If the coil is long compared to its diameter, its inductance is approximately  $L = (\pi DN)^2 l$  cms.

If a coil is wound in the form of a flat spiral, let  $\bar{D}$  cms. be the mean of the diameters of its various turns,  $N$  the number of turns, and  $l$  the width of the spiral in cms., then the above formula for helix coils can be applied to a spiral coil. For greater accuracy in the case of spiral coils increase the result by 3.5 per cent.

To reduce any of above values to millihenrys divide by  $10^6$ .

**Mutual Induction.**—If the lines set up by a current in one circuit, interlink with a second circuit in such a way that they produce inductive effects in this circuit, we have what is known as mutual induction between the circuits. This effect will be dealt with when we come to consider the magnetic coupling of circuits.

#### QUESTIONS AND EXERCISES ON CHAPTER VI.

1. A condenser has a capacity of 0.002 microfarad. If the number of the plates was doubled and the thickness of the dielectric also doubled, what would be its new capacity?

2. If the above-mentioned condenser were charged to 10,000 volts, what is the energy stored in it?

3. What is meant by the "dielectric constant" and the "dielectric strength" of a material? What are their values for air?

4. If an aerial has a capacity of 0.0015 mfd., what is the new value of capacity when a condenser of 0.0004 mfd. is joined in series with it?

5. The capacity of a condenser used in the primary circuit of a Marconi Half Kilowatt transmitting set is found to be 0.0074 mfd. It has 16 pairs of plates and the dielectric is glass 2 mms. thick. Taking the dielectric constant of glass as being 8, what is the size of each zinc plate?

6. An aerial consists of two wires each raised 120 feet vertically and then 300 feet horizontally, the diameter of the wires being 2.743 mms. If the capacity of the two wires is 40 per cent. greater than that of one used alone, find the capacity of the aerial.

7. What is meant by the "coefficient of self-induction" of a circuit? If a coil has 20 turns and a coefficient of self-induction of 0.001 henry, what is the change in the number of magnetic lines interlinked with it when the current flowing in it is changing at the rate of 1 ampere per second?

8. Find the coefficient of self-induction of a coil consisting of 375 turns of enamelled copper wire: the diameter of the coil being 6.5 cms. and its length 36 cms.

9. In Question 8 calculate the change of magnetic lines in the coil when the current changes at the rate of 10 amperes per second.

10. Describe how a coil used to give inductance effects with rapidly changing oscillatory currents differs in design from one used with alternating currents at ordinary low frequencies.

11. The coil of a Wavemeter has a coefficient of self-induction equal to 150 microhenrys. What is its value in (a) millihenrys, (b) cms.?

12. A condenser has a capacity of 10,000 cms.; what is its capacity in microfarads?

## CHAPTER VII

### *INDUCTION COILS, ALTERNATORS, AND TRANSFORMERS*

THE Induction Coil has a core built up of soft iron wires over which is wound a coil, 200 or 300 turns, of insulated copper wire, whose size depends upon the size of the induction coil. This is called the primary coil, and when joined in series with an interrupter to a battery a current flows in the coil, setting up a great number of magnetic lines in the iron core, but the interrupter immediately breaks the circuit, and so the magnetic lines disappear. The interrupter makes and breaks the circuit alternately with great rapidity, and thus magnetic lines are set up and collapse in the iron core with an equal rapidity.

It is these magnetic lines which we wish to make use of to obtain a high voltage. Over the primary is put a good coating of insulation; mica, ebonite, or paraffin wax—the former two being best—and over all is wound a secondary coil, consisting of many thousands of turns of wire, double silk covered, and much thinner than the primary wire.

Now it has already been explained that when magnetic lines interlink with a coil of wire there is an E.M.F. set up in each turn of the coil, and the value of this E.M.F. depends on the rate of interlinkage per second. That is to say, it depends on how many magnetic lines there are, and how fast they start up or collapse inside the coil. In Fig. 31 we have magnetic lines set up in the core and collapsed every time the current in the primary is made and broken. These magnetic lines, when starting up and collapsing, interlink with the secondary coil, and thus induce in each turn of it an E.M.F.; all the turns are in series with each other, therefore all the induced E.M.F.s are added together, and thus between the two terminals of this coil we can get a great E.M.F. by putting a sufficient number of turns in it.

Each time the magnetic lines start up in the coil, there will be induced in the secondary an E.M.F. in one direction, and each time they collapse an E.M.F. induced in the opposite direction.

In the case of an Induction Coil these induced E.M.F.s are not equal; their values depend on the turns in the secondary coil, on the number of magnetic lines, and on how rapidly the lines interlink with the coil—that is, how rapidly they start up and collapse. Now they collapse much more suddenly than they start up, therefore the E.M.F. induced in the secondary is very much greater at the break of the current by the interrupter than at the make; in fact, so great is the E.M.F. at break compared to that at make, that we neglect the latter effect altogether, and simply consider that *a high E.M.F. is induced in the secondary coil each time the current is broken.*

To understand why there is this difference, we must consider the effect of the magnetic lines on the primary coil itself; they interlink with it as with the secondary. Each time the current starts, the magnetic lines interlinking with the primary

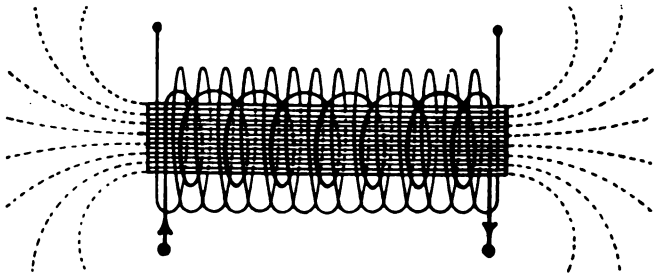

FIG. 31.

induce in it a voltage which is opposed to the current, and therefore prevent the current from rising to its full value quickly. As the increase of magnetic lines depends on the increase of current, it is seen that the magnetic lines do not start up quickly, hence the induced voltage in the secondary is not very great. On the other hand, when the interrupter stops the current, the collapsing magnetic lines induce in the primary a voltage which hastens the break of the current; hence there is a sudden stoppage of current and a rapid collapse of the magnetic lines, which causes a high voltage to be induced in the secondary coil.

When a hammer or interrupter breaks the circuit, another effect arises and has to be dealt with; it is that the voltage induced in the primary coil by the collapsing magnetic lines, and acting with the current, tends to drive the latter across the break at the interrupter in the form of a spark or arc. This arc is a conductor of electricity, and if it is allowed to form, the current

is never completely stopped at all; hence the magnetic lines are not all swept out, and the voltage induced in the secondary coil is not anything like as great as it should be. To avoid this arcing at the interrupter contacts, a condenser is joined across them, so that the moment the break occurs the extra current due to the induction in the primary flows into the condenser and does not arc across. Also the condenser, in immediately discharging through the circuit formed by the battery and primary coil, tends to complete the collapse of the magnetic lines in the core.

The connections of the complete induction coil are shown in Fig. 32.

The secondary coil is wound in sections, each section consisting of a spirally wound coil on a thin ring of paraffined paper, and

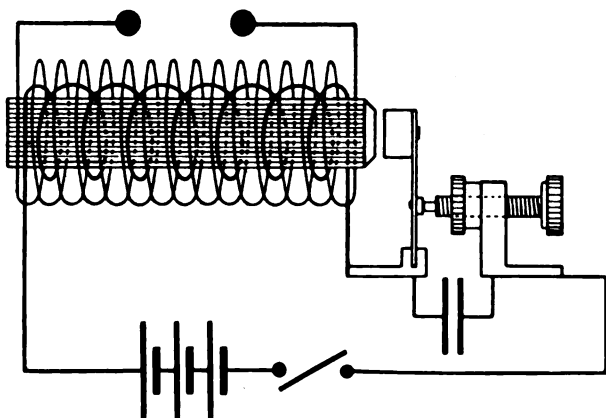

FIG. 32.

brushed over with hot paraffin so that it sticks to the paper. All these sections are then threaded over the insulating cover on the primary, joined in series with each other, as shown in Fig. 33, pressed close together, and hot paraffin run in to impregnate the whole mass. It is important to make certain that the sections are joined as shown, so that the current will flow in the same direction round each section, and that there will be no undue potential strain between the end of one section and the end of the next section to which it is joined.

Coils used for radio-telegraphic purposes are specially designed, in that the secondary is wound with thicker wire than usual; this is because the coil is used to charge up a condenser, and if the secondary resistance is too high, we shall not be able to charge the condenser to a voltage great enough to give an effective

spark length, even though the coil may give a very long spark, showing high voltage, when the condenser is disconnected. It takes about 3000 volts to spark across 1 mm. of air, therefore a 1-inch spark coil has about 70,000 volts induced in its secondary; if, however, this is joined to a condenser, we shall find that the condenser can only be charged to a few thousand volts, and hence will only discharge across a spark gap whose length is a small fraction of an inch. The resistance of the secondary is partly responsible for this, hence it is kept lower than usual.

The condenser joined across the make and break of the interrupter generally consists of sheets of tinfoil separated by paraffined paper. It should have a capacity of  $\frac{1}{4}$  to 1 microfarad

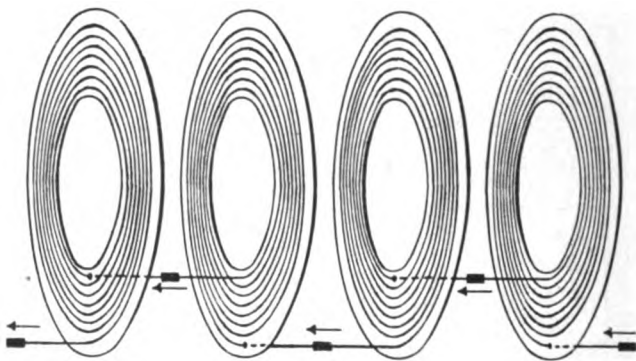

FIG. 83.

according to the size of the induction coil, and is designed by applying the formula given for a plate condenser—

$$K = \frac{AK}{4\pi t \times 900,000} \text{ mfd.}$$

The interrupter should have good platinum contacts, and should make and break the primary circuit as rapidly as possible. Various new rapid working interrupters, giving up to 100 breaks per second, have been designed for coils used in radio-telegraphy and this rate of sparking gives satisfactory results. Besides the contact or hammer interrupter there are other designs, such as the Wehuel electrolytic interrupter, and the mercury jet driven by a motor; these are very suitable when the induction coil is used for X-ray work, but are too troublesome to use for ordinary radio-telegraphic purposes, and therefore will not be described here.

There is another very important physical phenomenon made use of in the design of induction coils for radio-telegraphic purposes; it is the phenomenon of *electrical resonance*. When a current pulsates or alternates in a circuit containing inductance and capacity effects as well as resistance, its value is not generally given by Ohm's Law, *i.e.*  $C$  is not generally equal to  $\frac{V}{R}$ .

If the frequency of the current pulsations is  $f$ , and the inductance is  $L_{\text{hrs}}$ , the voltage set up across the inductance is  $2\pi fLC$ . Similarly, if there is capacity  $K_{\text{ids}}$ , in the circuit, the volts set up across the capacity is  $\frac{C}{2\pi fK}$ . These voltages act in opposition to each other (capacity effect acting like a spring, inductance effect like inertia), hence the resultant voltage effect due to these reactions is  $(2\pi fLC - \frac{C}{2\pi fK})$ . It can be seen that both these reactance voltages in the circuit may be very great, but if they are equal the resultant voltage is zero, and the only volts required to be impressed in the circuit is the  $CR$  volts required to send the current through its resistance. Under these conditions a circuit is said to be in a state of resonance. A circuit in a state of resonance is, then, one containing capacity, inductance, and resistance effects, but supplied with current alternating or pulsating at such high frequency that—

$$2\pi fLC = \frac{C}{2\pi fK}, \text{ or } 2\pi fL = \frac{1}{2\pi fK}, \text{ or } f = \frac{1}{2\pi\sqrt{LK}}$$

In such a circuit there may be great potentials set up across the inductance and across the capacity, but they are balancing each other, hence a much smaller voltage applied may send currents through the circuit to give these effects. An induction coil has considerable capacity effects in its circuit as well as inductance effects, hence if designed so that resonance is produced by the intermittent current impulses, much greater potential strain or voltage will be set up across the secondary coil than would otherwise be the case. The pulsating current flowing in a circuit containing inductance and capacity as well as resistance is not equal to  $\frac{V}{R}$  but is given by the formula—

$$C = \frac{V}{\sqrt{R^2 + \left(2\pi fL - \frac{1}{2\pi fK}\right)^2}}$$

F



We see that the denominator of this fraction is least and the current greatest when  $\frac{1}{2\pi fK} = 2\pi fL$ , *i.e.* when a state of resonance exists.

To understand why an induction coil, which would ordinarily give, say, a 10-inch spark, gives a very small one when a condenser is joined across its secondary terminals, we have to remember that the condenser must first be charged before a spark can take place, and that the voltage to which the condenser is charged is the voltage which sends a discharge across the spark gap. Now the voltage induced in the secondary of the induction coil rises very suddenly at the break, but it also falls very quickly to zero again; also the charging current which it sends into the condenser must flow through the resistance of the secondary and connecting wires, which means that it takes an appreciable time to build up the condenser potential. Suppose the voltage induced in the secondary rises to 100,000 volts, this would instantly send a discharge across a long spark gap; if, however, there is also a condenser joined across it, the secondary voltage first sends a current into the condenser, and before this has time to charge the condenser to more than 20,000 volts, the 100,000 volts have decreased to 20,000. Thus, under these circumstances, unless the spark balls are placed close enough to allow 20,000 volts to send a discharge across, no spark passes.

This shows two things: (1) the necessity of having the secondary wound with comparatively thick wire, so that the current encounters little impedance to its rush into the condenser before the volts fall away too much; (2) the necessity of not putting too large a condenser across the given size of coil, for the larger the condenser the less the voltage to which it will be charged by the current from the induction coil.

If the resistance of the secondary is high, or the condenser too large, we shall obtain only a very short spark at discharge if we obtain one at all.

**Alternators.**—An alternator is a machine in which a difference of potential, or voltage, is induced which has not a constant value, as in an ordinary direct current generator, but which rises and falls and reverses in direction many times per second. Let us consider the potential changes in any wire, *W*, on the armature as the armature rotates. Fig. 34 shows some of the poles, and magnetic lines coming out of *N.* poles, passing through the armature iron core, and going into *S.* poles; we will suppose the armature to rotate in the direction of the arrow, so that the wire *W* cuts through these magnetic lines.

Starting from the position shown, as the wire passes to A the voltage induced in it will rise to a maximum value: this is represented on the curve below by the height of the line  $V_m$ ; when the wire goes on from A to B, passing out of the magnetic field the voltage dies away to zero again, as shown at  $V_0$  on the curve. Then, as it goes on from B to C, the voltage will rise in it again to a maximum, but since the magnetic lines are going up into the S. pole, whereas they were coming down from the N. pole, the voltage is now induced in the opposite direction along the wire; this is shown by drawing the voltage below the line instead of above it. As the wire passes on from C to D, out of the magnetic field, the voltage dies away to zero again as shown on the curve. From D

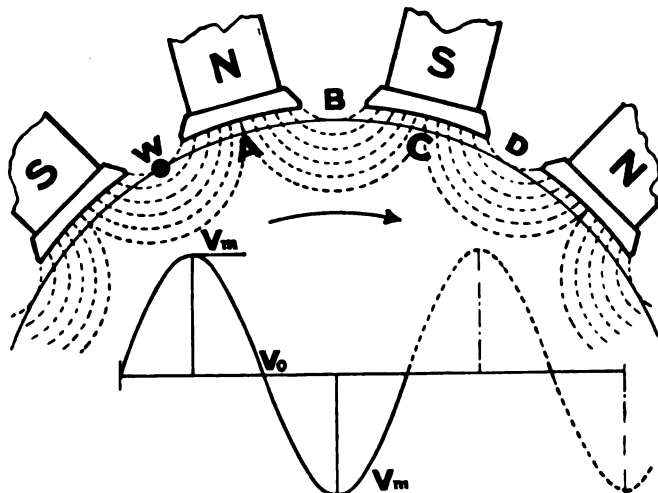

FIG. 34.

as it goes on in front of another N. pole a new wave of voltage is started exactly similar to that drawn, so that in each wire we get a complete wave of voltage for every pair of poles on the machine.

There are a great many wires on the armature, and induction is taking place simultaneously in each of them; they are all joined properly in series with each other, so that all their voltages are added together like that of cells in a battery. Thus between the end terminals of the armature we get a big wave of voltage as its wires pass in front of each pair of poles, and in this way an alternating voltage of 100, or 200, or 5000 volts is obtained, depending on the number of magnetic lines per pole, the speed at which they are cut by the wires, and the number of wires in series.

The end wires are joined to two insulated rings on the shaft, and connection of the outside circuit is made to these through brushes bearing on them. Direct current must be used in the coils on the poles of the alternator to provide the magnetic field: this may either be obtained from a battery, or some of the alternator's own armature current may be led to a commutator mounted on its shaft, and so turned into direct current for use in the pole coils. The latter are generally all joined in series with each other.

Since the voltage is at one moment a maximum and the next moment zero, a question at once arises as to what is meant by saying the voltage is 100, or 200, or 500. These values denote the effect which the voltage will have on a voltmeter, or lamp, or other apparatus to which it is applied; this effective value of the voltage is 0.707 of the maximum value; *i.e.* 200 volts = 0.707  $V_{\max.}$ , so that if the voltmeter reads 200, the maximum value of the voltage wave is  $200 \div 0.707 = 283$  volts.<sup>1</sup>

Now, since the voltage is varying in value and alternating in direction, if a circuit is joined to the terminals of the rotating armature the current which will flow in the circuit acts similarly; hence an alternating current follows the same shape of curve as an alternating voltage.

Referring again to Fig. 34, it is seen that a complete wave of voltage is obtained for each pair of poles on the machine; such a complete wave is called a *cycle* and the number of cycles per second is called the *frequency* of the machine or circuit in which its current flows.

It is very easy to calculate the frequency, for if there are  $p$  pairs of poles, there are  $p$  cycles in each revolution, and if there are  $n$  revolutions per second there are  $pn$  cycles per second, which is the frequency. Thus if an alternator has 8 poles and runs at 1500 revolutions per minute, there are 4 pairs of poles and 25 revolutions per second, therefore there are 4 cycles per revolution, or 100 cycles per second—the frequency is 100. Alternators for ordinary commercial work in this country are usually made for a frequency of 50, but when used for radio-telegraphy they are designed for a frequency of 100–500.

Alternators used for radio-telegraphy generate from 200 to 2000 volts; these voltages are much too low to charge condensers in order that the latter may discharge across spark gaps. As already

<sup>1</sup> NOTE:— $0.707 = \frac{1}{\sqrt{2}}$  and  $\frac{1}{\sqrt{2}} V_{\max.}$  is the root of the (average value of voltage)<sup>2</sup>. The effective volts are therefore often called the root mean square volts, so that  $V_{r.m.s.} = \frac{1}{\sqrt{2}} V_{\max.}$ ; similarly  $C_{r.m.s.} = \frac{1}{\sqrt{2}} C_{\max.}$

mentioned, it requires about 3000 volts to spark across 1 mm. of air. Therefore the voltage is transformed up by a step-up transformer, which in some respects is similar in design to an induction coil; the alternator is connected to the primary coil of the transformer, and as the secondary coil has a great many more turns in it than the primary, the voltage obtained from the secondary will be an alternating one, but very much higher than that applied to the primary. In this way from 20,000 to 70,000 volts can be obtained for charging condensers, and, as we shall see, this is the method of excitation usually adopted for all wireless telegraphy transmitters from  $\frac{1}{2}$  KW size upwards.

It will be remembered that with an induction coil the high voltage was induced every time the primary circuit of the coil was broken; if the interrupter vibrates at the rate of 100 per second

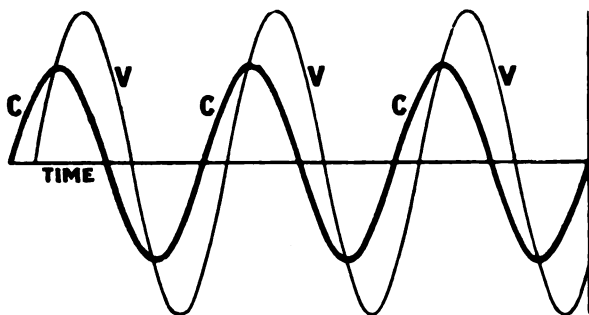

THREE CYCLES OF A "LEADING" CURRENT.

FIG. 35.

we get a high voltage to charge the shunted condenser 100 times per second, and thus obtain a spark discharge 100 times per second.

With an alternating generator and transformer, we obtain a high voltage twice in each cycle, therefore if there are 200 cycles per second we have a maximum of voltage 400 times per second, which gives 400 sparks per second.

If the inductance and capacity effects are negligible in a circuit joined to an alternator the current will rise, fall, and reverse in step with the volts; *the current and volts are then said to be in phase with each other.* If the circuit has got inductance effects the current will rise to its maximum, and pass through its zero values, later than the similar changes in the voltage; the current is then said to *lag* behind the volts. On the other hand, if capacity effects preponderate in the circuit the current wave will *lead* the voltage wave. Fig. 35 shows waves of alternating voltage and of the resulting

current which flows in a circuit to which the voltage is applied, and in which capacity effects preponderate. Here we see that the current is zero before the volts is zero, and a maximum before the volts is a maximum. In this case the current is said to lead the volts, and also to be out of phase with it. Thus if an alternating voltage is applied to a condenser the current is a maximum when the volts are nearly zero; it is then said to lead the volts by nearly  $90^\circ$ , a complete cycle representing  $360^\circ$ , the conditions in this case being shown in Fig. 36. When the volts are zero, as at X, the current is nearly at its maximum; the complete wave from A to B represents  $360^\circ$ , and from X, where the current is a maximum, to Y where the volts are a maximum, the distance is nearly one quarter AB. The distance XY therefore represents nearly  $90^\circ$ , or the current

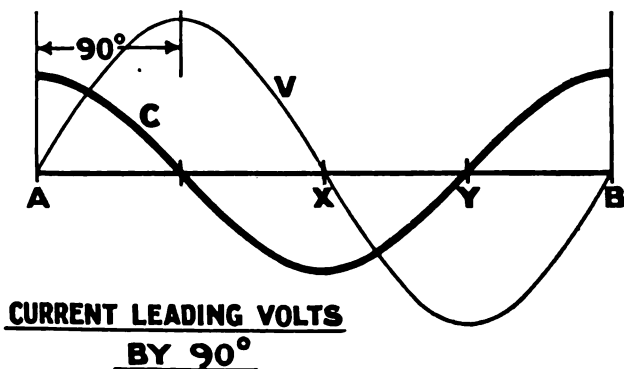

FIG. 36.

leads the volts by nearly  $90^\circ$ . The importance of this effect will be seen when we come to consider the Marconi Disc Discharger.

Sometimes an alternator's armature has three distinct and equal windings connected to each other at one point, giving three equal alternating voltages; this is called a three-phase alternator, but as it is not used in radio-telegraphy we need not further consider it.

**Transformers.**—The function of an interrupter on an induction coil was to make and break the magnetising current in the primary, so that the magnetic lines set up in the iron core would collapse through the secondary, inducing impulses of high voltages in it at a speed of, say, 100 impulses per second. An alternating current is one which rises to a maximum, falls to zero, reverses its direction, falls to zero, and so on, at a rate which depends on the frequency, or number of cycles per second; if

such a current is available, we can get the magnetic lines in the core to rise and fall without an interrupter, and so generate high voltages in the secondary coil. Such an arrangement of coils, for use with alternating currents, is called a transformer; its construction will be briefly described.

An iron core made of thin sheets or laminations of iron, averaging about 0.012 inch thick, is built up; each sheet being slightly japanned or oxidised. On this core is wound a coil of double cotton-covered copper wire, called the primary, through which the alternating current used will flow. The primary is covered with good insulation:—micanite, presspahn, or mica; and over this again is wound the secondary coil which is of smaller wire than the primary, but consists of a great many more turns if it is desired to obtain a high voltage from it. The ends of the secondary are brought to two terminals heavily insulated with ebonite or porcelain. If the transformer is a small one, dealing with energies up to 5 KW, it is put in a perforated iron case and is then said to be air-cooled; a large transformer is enclosed in a cast-iron case which is filled with special transformer oil. The core and coils of a transformer get hot when in use, and the oil serves to convey the heat from them to the iron case from which it is radiated away.

With very large transformers an air blast may be blown through for the same purpose.

The design of a transformer differs from that of an induction coil in that the magnetic lines have a complete iron circuit or path. The magnetic lines of an induction coil, issuing from one pole of the core, have to pass through the air to the other pole as they do in the case of an ordinary bar magnet; in a transformer the iron path is continuous, so that the magnetic lines, set up in the core on which the coils are wound, continue their paths in the iron which connects, as in Fig. 37, one end of the core to the other. This arrangement ensures that magnetic strain lines are easily set up in the iron, and that more magnetic lines are set up by any given value of primary current than would otherwise be the case.

When the alternating current flowing into the primary rises to a maximum, the resulting magnetic lines in the core has induced a voltage in the secondary coil which also rises to a maximum. When the current dies away and rises to a maximum in the opposite direction the magnetic lines die away, and new ones are set up, in the opposite direction, so that a voltage is now induced in the secondary coil in an opposite direction to that induced at first.

Thus it can be seen that the secondary induced voltage will be alternating, having the same frequency as the applied voltage and current. If the applied voltage goes through 100 complete cycles per second the voltage induced in the secondary will do likewise, and as in each complete cycle there are two maximum values in opposite directions, we see that a frequency of 100 cycles per second means 200 maximum values of voltage per second. With an induction coil we only get a secondary high

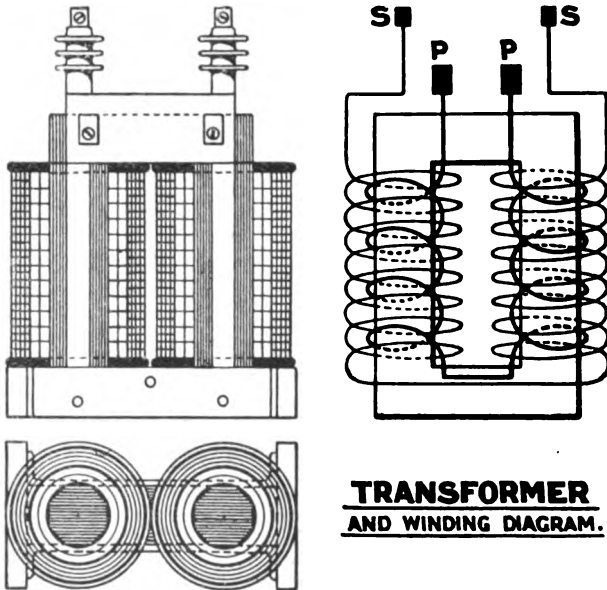

**TRANSFORMER**  
**AND WINDING DIAGRAM.**

FIG. 37.

voltage at each break of the primary current; with a transformer we get a secondary high voltage twice in each cycle of primary current.

The ratio of the voltage induced in the secondary to that applied to the primary is practically equal to the ratio of the turns in each coil— $\frac{V_s}{V_p} = \frac{T_s}{T_p}$  and if current is taken from the secondary, the ratio of the secondary and primary currents is inversely as the number of turns— $\frac{C_s}{C_p} = \frac{T_p}{T_s}$ .

Thus  $\frac{V_s C_s}{V_p C_p} = \frac{T_s}{T_p} \times \frac{T_p}{T_s} = 1$ , that is Watts taken from the secondary ( $V_s C_s$ ) equals Watts put into the primary ( $V_p C_p$ ).

This is very approximately true, as the transformer is a very efficient piece of apparatus, and not much energy is lost in it. If  $M$  is the maximum value of the number of magnetic lines set up in the core,  $T_p$  the turns in the primary,  $V_p$  the voltage applied, and  $f$  the frequency; we have the following relation:—

$$V_p = \frac{4.44 M \cdot T_p \cdot f}{10^8}$$

Thus if the voltage, frequency, and number of turns in the coil are known, we can find the number of magnetic lines set up in the core. A similar formula holds for the secondary coil—

$$V_s = \frac{4.44 M \cdot T_s \cdot f}{10^8}$$

Transformers designed for radio-telegraphy purposes are made to give a secondary voltage of from 20,000 to 70,000 volts.

If the core of an induction coil, or of a transformer, were made of solid iron voltages would be induced in the iron, (which is a conductor of electricity), by the changing magnetic field in it, and currents would flow in it which cannot be used and would only heat up the core. This explains why the cores are built of iron wires, or iron laminations, japanned or oxidised—the japanning offers resistance to these currents so that their values are small. Such currents are called eddy currents.

**Alternating Current Power and Power Factor.**—If  $V$  is the effective value of an alternating voltage applied to a circuit,  $C$  the effective value of the resulting current, and  $\theta$  the angle of phase difference between the volts and the current, then the watts of energy in the circuit is given by:—  $W = VC \cos \theta$ . “ $\cos \theta$ ” is called the *Power Factor*.

RESONANCE EFFECTS.

NOTE.—In the primary circuit of an induction coil, the resistance and capacity effects are small, and the oscillation constant is practically determined by its inductance, ( $L_p$ ).

In the secondary circuit, the large number of turns has resistance ( $R_s$ ) and inductance ( $L_s$ ), while the condenser to which it is joined has capacity ( $K$ ).

If the frequency of the impulses in the induction coil is  $f$ , the impedance of the secondary circuit is—

$$\sqrt{R_s^2 + \left(2\pi f L_s - \frac{1}{2\pi f K}\right)^2}$$



This is least when  $2\pi fL_s = \frac{1}{2\pi fK}$ , for then the part under the bracket is zero ; that is when—

$$L_s = \frac{1}{4\pi^2 f^2 K}$$

But  $L_s$  is to  $L_p$  approximately in the same ratio as that of the number of turns in the coils  $\frac{L_s}{L_p} = \frac{T_s}{T_p}$

$$\therefore L_s = \frac{T_s}{T_p} L_p$$

Thus

$$\frac{T_s}{T_p} L_p = \frac{1}{4\pi^2 f^2 K}$$

or

$$\frac{T_s}{T_p} = \frac{1}{4\pi^2 f^2 L_p K}$$

In this way the best number of turns to put on the secondary winding to give resonance effects can be approximately found.

With a transformer, the ratio  $\frac{T_s}{T_p}$  is determined by the voltage required at the secondary terminals. If we apply 200 volts to the primary and wish to obtain 40,000 volts at the secondary then—

$$\frac{T_s}{T_p} = \frac{40,000}{200} = \frac{200}{1}$$

The formula—

$$\frac{T_s}{T_p} = \frac{1}{4\pi^2 f^2 L_p K}$$

then shows us that with a given frequency ( $f$ ) and condenser ( $K$ ), to obtain resonance effects the transformer primary circuit should have an inductance ( $L_p$ ). If, in itself, it has not got this value an auxiliary small inductance coil is joined in series with it. We shall see later that this auxiliary inductance coil is used in the Marconi Transmitters.

### QUESTIONS AND EXERCISES.

1. Why is the core of a transformer made of jappaned laminations instead of solid iron?
2. Explain the function of a condenser when joined across the make and break contacts of an induction coil.
3. Why is the secondary of an induction coil used for wireless telegraphy purposes made of thicker wire than usual?
4. A transformer is supplied with alternating current at a voltage of 100, and a frequency of 50 cycles per second. If it has got 400 times as many turns in the secondary as are in the primary, what voltage will be induced in the secondary, and how many times in a second will this voltage rise to a maximum?
5. If an induction coil has 300,000 volts induced in its secondary what is the approximate length of spark it will give?
6. If a condenser is joined across the secondary terminals of an induction coil why is the spark obtained very much shorter than if the condenser were not connected?
7. An alternator has 8 poles : at what speed must it run to generate voltage at a frequency of (a) 100, (b) 200 cycles per second?
8. What is meant by saying that an alternating current is not in phase with the volts? Draw curves of alternating voltage and current in which the current leads the volts by  $45^\circ$ .
9. If the voltage of an alternator is 400, what is the maximum value to which the voltage wave rises twice in each cycle?

## CHAPTER VIII

### *OSCILLATORY DISCHARGES*

WE know that an electric strain is set up in the ether round or near conductors charged with electricity, positively or negatively, its extent depending on the amount of charge, on the capacity of the charged system, and on the nature of the dielectric in which the ether is strained. A disappearance of electric strain in the ether sets up in it a magnetic strain, round the wire or circuit through which the discharge takes place.

The amount of electrification and of electric strain can be increased by using condensing effects, and will increase as the difference of potential applied is increased. Large differences of potential can be obtained by using an induction coil or a transformer, and the amount of charge is equal to the product of the potential applied and the capacity of the system charged; ( $Q = VK$ ).

The rate of discharge varies directly as the difference of potential across the circuit in which the discharge takes place, and inversely as the Impedance effects present in the circuit. Inductive effects always oppose any change in the rate of discharge; these effects will depend upon the shape of the circuit and the rate at which the current, or discharge, is changing. Thus the amount of charge depends on the potential applied and on the capacity of the charged system; the rate, and nature of the discharge depends on the potential, capacity, resistance, and self-induction in the discharging circuit. See Chap. VII.

In 1838, Prof. Henry, of Princeton University, discovered that when a condenser is discharged across a small spark gap the discharge is not simply in one direction across the gap, but oscillates backwards and forwards across it, so that what appears to be a single discharge spark is really a rapid succession of sparks; we cannot distinguish between the separate sparks with the eye, so rapidly do they follow each other, but if photographed on a plate which is falling rapidly in front of the spark, we shall

find not a picture of a single flash, but of a number of flashes. Fig. 38 shows the result of passing the discharge from a condenser through a special instrument, called an oscillograph, and

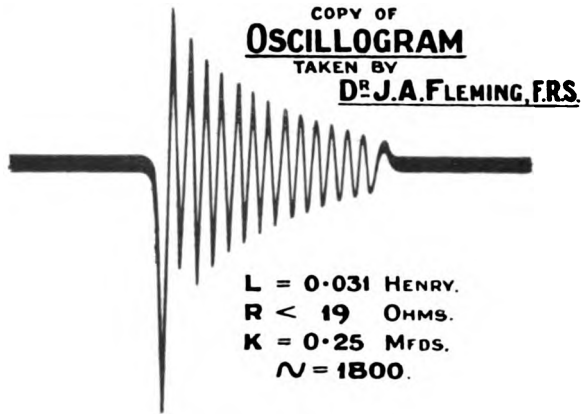
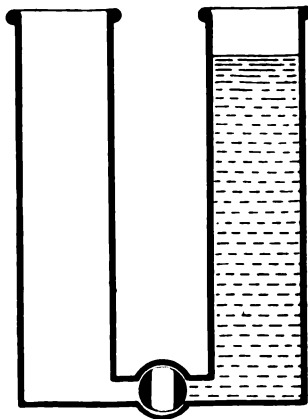

FIG. 38.

its effects photographed. If the spark is photographed on a plate rapidly falling in front of it, the photograph will show that it is not one single flash, but a rapid succession of flashes.



WHEN THE TAP IS OPENED THE WATER OSCILLATES BETWEEN THE TUBES BEFORE COMING TO REST.  
IF THE CONNECTING PIPE IS SMALL THE WATER DOES NOT OSCILLATE.

FIG. 39.

Turning to the water analogy we can find an exactly similar action when two long glass tubes are connected by a pipe whose bore is not too small, and fitted with a stop cock. The tubes are

filled with water coloured so that it can be easily seen, and one tube is filled to a greater height than the other one. Then, if the tap is suddenly opened, the water will flow, or discharge, along the pipe from the tube in which the greatest pressure exists to the other one. We would expect that the flow would take place in the one direction until the water stands at the same height in both tubes, but it will be found that under suitable conditions this is not the case. The water will overflow into the second tube, raising the level in it too high; then it will flow back again into the first tube to produce the same effect in it; thus we shall see the water surging backwards and forwards between the tubes several times. The surges will gradually die down until

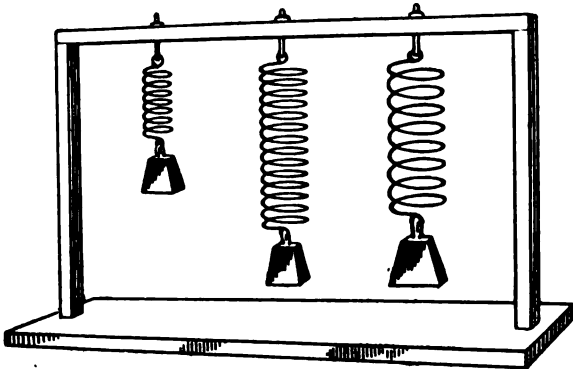

**DIFFERENT SPRINGS AND WEIGHTS  
HAVE DIFFERENT PERIODS OF OSCILLATION.**

FIG. 40.

the water settles at the same level in each tube, when there will be no difference of pressure between them.

This is analogous to the action occurring when a condenser is discharged under suitable conditions; the discharge surges backwards and forwards across the spark gap in the circuit, its amplitude decreasing until it has died away, leaving no difference of potential between the two sides of the circuit. Some interesting questions at once arise in connection with this new phenomenon;—what are the suitable conditions? what bearing has the inductive action of the circuit on the surges? and how does the resistance of the circuit control the effects?

Before answering the questions we shall turn our attention to a similar phenomenon in mechanics. Make three or four springs with steel wire wound loosely, about 2 or 3 inches diameter and,

say, 6 inches long; the springs should be made of different gauges of wire, in which case the elasticity, or what we might call the springiness of each spring, will depend upon the gauge of the wire. As shown in Fig. 40, suspend the springs from a beam and attach a weight to the bottom of each. If one of these springs is, as it were, charged, either by pressing the weight up or pulling it down, and then discharged by letting go, we shall find the weight does not simply return to its original position, but oscillates up and down past it; the oscillations gradually dying down until the weight is again settled in its original position. If we do this experiment with all the springs, we shall find that, in each case, the resulting motion is oscillatory, but that the *rates of oscillation are all different*. Now there are two forces which are causing the oscillatory motion—the springiness of the spring and the force of inertia; the rates of oscillation are different with the different springs because the force of elasticity or the force of inertia or both, is, or are, different in each case.

It is exactly the same in the electric circuit; capacity effects are analogous to the springiness of the spring, inductive effects are analogous to the inertia of the moving system; the discharge will be oscillatory owing to the capacity and inductive effects, and the rate at which the oscillations take place will depend upon the values of the capacity and inductive effects present in the circuit.

What are the conditions necessary for a discharge to be oscillatory? and what is the effect of the resistance of the circuit? Returning to the weighted springs, if we gradually increase the weight on one of them, we shall find the result is to lessen the number of oscillations which will take place after it is charged; the extent of the motion of each oscillation, or, as we call it, the amplitude of the oscillations, will rapidly decrease, and the number of oscillations made before the system comes to rest will be less than before. That is to say, the greater the weight, the greater is the damping effect on the oscillations, decreasing the amplitude of each successive oscillation and decreasing the number of oscillations. If we go on increasing the weight, we shall finally arrive at one which will entirely prevent oscillations taking place, so that if the weight is greater than a certain value, there will be no oscillations.

Similarly, in the electric circuit, the resistance of the circuit determines the damping effect on the amplitude and number of oscillations in the discharging current; if the resistance effect exceeds a certain value, the discharge will not oscillate at all, but will simply be a direct discharge of a single movement of electricity across the circuit. In our analogy of water flowing

from one vessel to another through a connecting pipe, if the pipe is of small diameter, or is obstructed by sand, leaves, etc., it offers a resistance to the flow of water, which will therefore take place at a small and steady rate, raising the pressure in the second vessel until it is equal to that in the first without any oscillatory motion taking place.

Thus the suitable conditions are that the resistance be of a low value; we know that the resistance of a circuit is directly proportional to its material and its length, and inversely proportional to its cross section, whether the circuit be a wire, a liquid, a vacuum tube, or the air between two spark balls. When, therefore, a discharge takes place between two spark balls in a circuit which contains capacity and inductance, the discharge will be oscillatory if the materials of the circuit are good conductors, and of good cross section, and *if the spark gap is not too long*. In circuits where discharges take place across a spark gap most of the resistance is in the gap, because air is a very bad conductor; hence to keep the resistance low we must have a low spark gap resistance, *i.e.* the gap must be comparatively short.

One cannot have an oscillating spring system that has not some weight, nor an electric circuit that has not some resistance; but if the weight is kept small in the one case, and the resistance kept low in the other, their damping effect on the oscillations will be small, and there will be a greater number of oscillations at each discharge.

It is, however, necessary to point out that the spark gap must not be made too small, for then the discharge would take place before the capacity had been charged to any great potential; also there would be the likelihood of the spark gaps being bridged by an arc discharge instead of a true spark discharge. An arc discharge can be distinguished from a spark by the fact that it is more like a flame and yellowish in colour, whereas a good spark discharge is white, sharp, and, as it were, vicious in its action.

Now there is a second condition which will cause damping of the oscillations, besides the effect of resistance. In the oscillating spring system the damping of the oscillation will depend not only upon the weight, but also on how much energy is communicated from the oscillating system to its surroundings. The air near the spring will be set in motion, and motion of anything, even of air, implies that energy has been given to it; in this case the energy has been taken from the oscillating spring system, and a loss of its energy means that its own state of motion will be decreased. We know that if the spring oscillated in water instead of air, it would come to rest sooner; water is

heavier than air, hence to set water in motion more energy will be abstracted from the spring. If the spring oscillated in treacle its oscillations would be still more quickly damped. Thus the damping also depends on the rate of loss of energy communicated to, or, as we might say, radiated to the surrounding medium. Similarly with an oscillatory discharge in an electric circuit, the damping of the oscillations, while principally due to, and dependent on, the resistance of the circuit, will also depend on the rate of loss of energy radiated to the surrounding medium, in this case the ether, set in motion by the oscillating discharge. As we shall see later, in wireless telegraphy the object of an oscillatory discharge is to radiate energy in the form of motion of the ether, *i.e.* ether waves; in transmitter circuits we do not avoid this damping effect, and in fact our object will be to

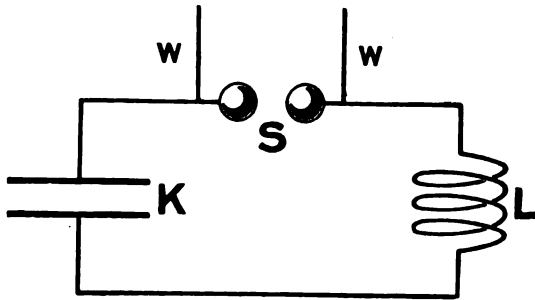

**OSCILLATORY DISCHARGE CIRCUIT.**

**FIG. 41.**

radiate a certain amount of the energy put into the oscillating discharge circuit. Again, an oscillating spring system can lose energy by giving it to another spring system, against which it may strike at each oscillation. The second spring system would thus start oscillating with energy taken from the first one. In a similar manner oscillating electric energy in a circuit may be decreased by inducing oscillations in a second circuit placed near it, an effect which is much used in wireless telegraphy. This transfer of energy constitutes a third damping effect on the oscillations, so that damping or loss of energy can be summed up under three headings: (1) Resistance; (2) Radiation; (3) Transfer. Fig. 41 is a diagrammatic view of a simple oscillatory discharge circuit, K being the condenser, L representing the inductance effect, and S the spark gap, while the wires WW lead to the source of charging potential, such as an induction coil.

We must now consider in detail what actually happens when an oscillatory discharge takes place across a spark gap.

I. Let the circuit consist of a condenser joined in series with a coil to a spark gap, the coil providing a certain amount of inductive effect. An induction coil charges up the circuit until a great difference of potential exists across the spark gap, one ball being at positive potential the other at negative potential, as shown in the Fig. 42, and the ether between the condenser plates and all round the spark gap being in a state of electric strain.

II. As the charge is completed the difference of potential becomes so great that the insulation of the air in the spark gap breaks down and a discharge starts, gathering strength as it goes on. This discharge from one side to the other tends to equalise the potentials and decrease the ether strain. After a small fraction

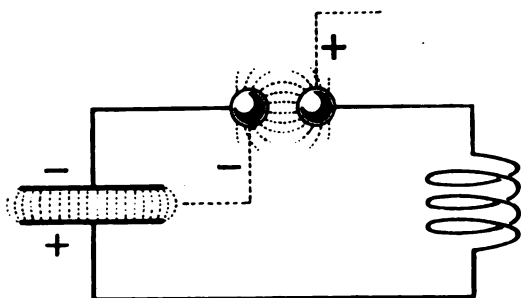

**CHARGE:**  
ELECTRIC STRAIN IN CONDENSER DIELECTRIC.

FIG. 42.

of time the discharge will have equalised the potentials, and the electric strain will have disappeared. But the flow of electrons across the gap will set up a magnetic strain in the ether, which strain takes the form of whirls of magnetic lines round the path of the flow. At the end of this small interval of time the conditions will be as shown in Fig. 43, and the rate of discharge will have risen in value to a maximum as shown in the curve below the Figure, just as the motion of a spring system is a maximum when it is passing through its position of rest, where it ought to stop.

III. Now, just as the spring system swings too far owing to inertia, so the discharge of our circuit persists owing to induction, until a difference of potential is again built up in the opposite direction to that existing before; the ball which was at positive potential is now at negative potential and *vice versa*. When this

G



state is attained the discharge has fallen to zero, the magnetic strain has disappeared, and an electric strain exists again in the ether ;

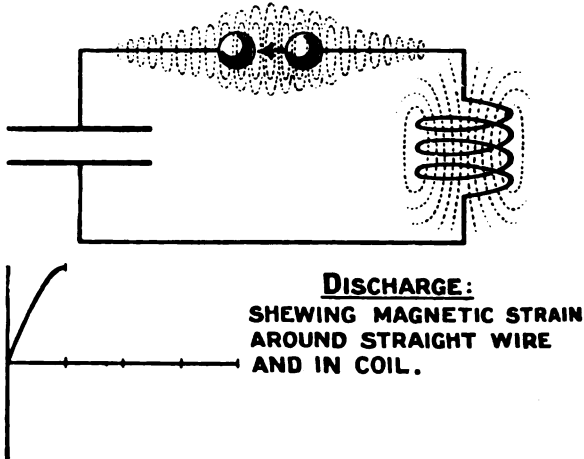

FIG. 43.

the conditions now being as shown in Fig. 44. The time taken by the discharge in dying down from its maximum value to zero is

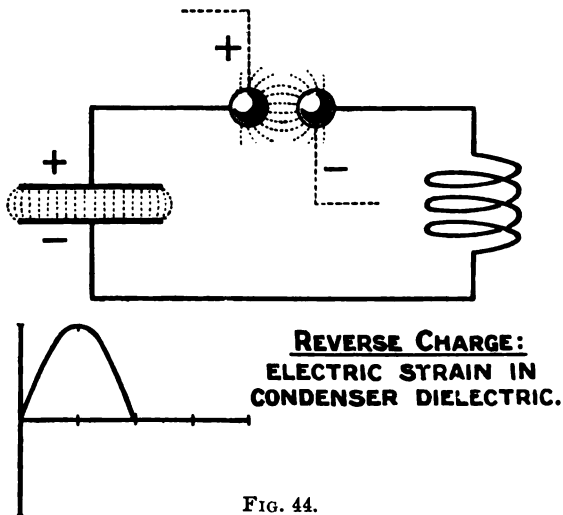

FIG. 44.

equal to the time it took from its start to attain its maximum value.

IV. The difference of potential being thus again built up, the

circuit again discharges across the spark gap, but this time in the opposite direction to the first discharge: see Fig. 45. As before, after an interval of time the difference of potential and the electric strain have disappeared, the discharge has risen to a maximum, and a magnetic strain exists in the ether round it. The discharge being in the opposite direction to the first one, we represent this by drawing the curve below the axis of time as shown in the curve.

V. The reversed discharge builds up a difference of potential again, similar to that with which we started, at the same time the discharge itself dies away, as shown in Fig. 46. The magnetic strain in the ether gives place again to an electric strain.

VI. The whole procedure is repeated several times in

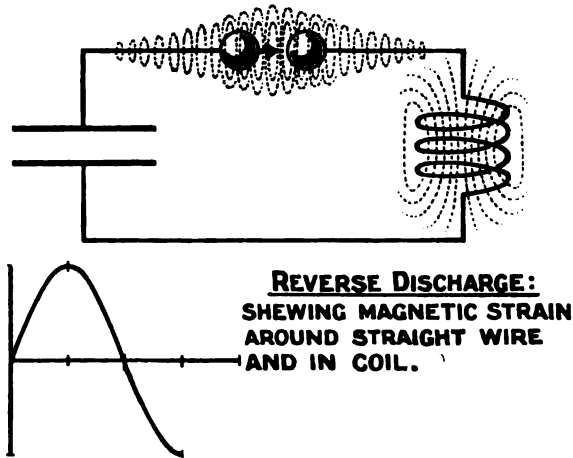

FIG. 45.

exactly the same manner, and we thus get a series of discharges, oscillating backwards and forwards, just as the spring system oscillates up and down. Each discharge has a maximum value a little smaller than the one preceding it; of the original energy in the circuit, which is equal to  $\frac{1}{2} \frac{V^2 \text{ volts } K_{\text{mfd.}}}{10^6}$  joules, a part is used up in the resistance of the circuit, including that of the spark gap (this part being turned into heat, as is evident in the spark gap), and a small part sets up the strains in the ether. At each swing of the discharge portions of the energy will be lost in these forms, so that the swings of discharge gradually die down.

The time taken by the circuit to pass from a condition as shown in Fig. 42, until it comes again to a similar condition, as shown in Fig. 46 (*i.e.* while it discharges completely, first in one direction and then in the opposite direction), is called the "time of a complete oscillation" or the "periodic time." *All the oscillations take equal times*, the small ones near the end of the discharge taking the same time as the large ones at its commencement, this being similar to what takes place in the oscillating spring system. Thus, a complete oscillatory discharge might be represented as shown in Fig. 38, in which the *amplitude* or maximum values of the oscillations is seen to gradually die away, owing to the energy

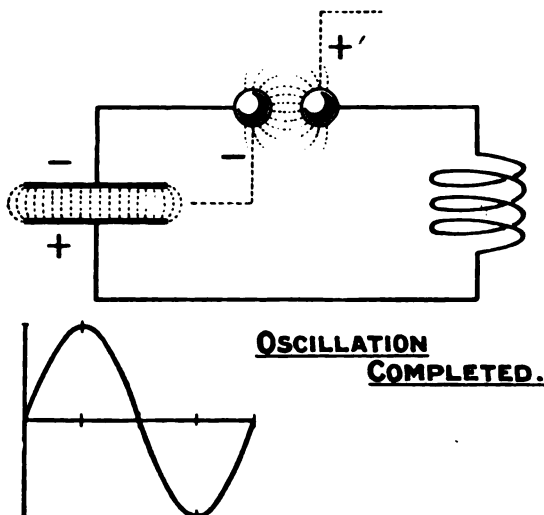

FIG. 46.

lost at each oscillation, and in which the times for complete oscillations are shown to be equal.

If the loss of energy is too great, in other words, if the resistance of the circuit is too large, there will be no oscillations, but the circuit will discharge itself only in one direction, as shown in Fig. 47; this is called a "uni-directional discharge," and is obtained when, for instance, the spark gap is too long.

Now we have already noted that the time of an oscillation depends on the amounts of capacity effect and inductive effect in the discharging circuit; in 1853 Lord Kelvin proved that the

number of oscillations per second was approximately equal to  $\frac{1}{2\pi\sqrt{L \times K}}$  if the resistance of the circuit is small, where L is the coefficient of self-induction of the circuit measured in henrys and K is the capacity of the circuit measured in farads. The number of oscillations per second is called the "frequency" ( $n$ ), and we see that the time taken for one oscillation, or the "Periodic Time,"  $T = 2\pi\sqrt{LK}$ ; the quantity  $\sqrt{LK}$  being called the "oscillation constant" of the circuit.

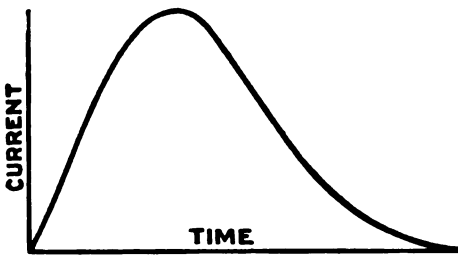

DIRECT DISCHARGE WHEN RESISTANCE OF CIRCUIT IS TOO GREAT.

FIG. 47.

As, however, it is more convenient to measure inductance in centimetres (1 cm. =  $\frac{1}{10^9}$  henry) and the capacity in microfarads (1 mfd. =  $\frac{1}{10^6}$  farad) we shall find it more convenient to deduce the following formulæ :—

$$\begin{aligned} \text{Frequency } (n) &= \frac{1}{2\pi\sqrt{\frac{L_{\text{cms.}}}{10^9} \times \frac{K_{\text{mfd.}}}{10^6}}} = \frac{\sqrt{10^{15}}}{2\pi\sqrt{L_{\text{cms.}} \times K_{\text{mfd.}}}} \\ &= \frac{\sqrt{1000} \times 10^6}{2\pi\sqrt{LK}} = \frac{5 \cdot 033 \times 10^6}{\sqrt{LK}} \\ &= \frac{5 \times 10^6}{\sqrt{L_{\text{cms.}} \times K_{\text{mfd.}}}} \text{ approximately.} \end{aligned}$$

$$\text{Periodic time} = \frac{\sqrt{L_{\text{cms.}} \times K_{\text{mfd.}}}}{5 \times 10^6} \text{ second.}$$

$$\text{Oscillation constant} = \sqrt{L_{\text{cms.}} \times K_{\text{mfd.}}}$$

The periodic time is proportional to the product of capacity and the inductance in the circuit; as regards the individual effect of each, increase of capacity will increase the amplitude of the discharge, while increase of inductance will diminish the amplitude but increase the momentum of discharge: the analogy with the similar effects in an oscillating spring system may be left to the student for consideration.

Now, let us turn our attention to the damping of the oscillations, and study the conditions under which the discharge will be uni-directional.

Lord Kelvin's complete formula for oscillation frequency is  $\frac{1}{2\pi} \sqrt{\frac{1}{LK} - \frac{R^2}{4L^2}}$ , which decreases in value with increase of the resistance (R) of the circuit. If  $\frac{R^2}{4L^2} = \frac{1}{LK}$  the oscillation frequency is zero; in this case  $R^2 = \frac{4L}{K}$  or  $R = 2\sqrt{\frac{L}{K}}$ . Thus, the number of oscillations is reduced by increasing R, and there will be no oscillations at all if R is equal to or greater than  $2\sqrt{\frac{L}{K}}$ .

Capacity and inductance are necessary to make the discharge oscillate; resistance damps out the amplitude and number of the oscillations. From Kelvin's formula we see that increase of resistance will greatly increase the damping; it may be here noted that an increase of capacity decreases the resistance of the circuit, while an increase of inductance increases the resistance. These effects are, however, slight compared to the resistance effects in other parts of the circuit, particularly in the spark gap.

We have seen that when the resistance exceeds a certain value, the oscillations are entirely damped out and the discharge is only a uni-directional one. This takes place when the resistance R exceeds the value  $2\sqrt{\frac{L}{K}}$ , L being measured in henrys and K in farads: if L is measured in millihenrys and K in microfarads then the critical value of the resistance is given by

$$R = 2\sqrt{\frac{\frac{L}{1000}}{\frac{K}{10^6}}} = \left(2\sqrt{\frac{1000 L_{\text{mhy.}}}{K_{\text{mfds.}}}\right) \text{ ohms.}$$

Here the student must be reminded that high frequency currents, such as these oscillatory discharges, do not flow uniformly

through the cross section of a wire, but are most dense near the surface, owing to inductive effects which are proportional to the frequency. Hence the resistance of a conductor to oscillatory discharges is reduced, not necessarily by increasing its diameter, but by increasing its surface. The surface may be increased by increasing the cross section of the conductor; without increasing the effective cross section we may increase the surface by making the conductor in the form of a tube, or by making it of several strands of wire instead of one single thick wire. The fact that a wire has a greater resistance to oscillatory currents than to direct currents is called the "skin effect"; the oscillatory currents flow mostly on the outer layers of the wire, so that the cross section of the wire is, as it were, reduced to them. At very high frequencies a hollow tube would have just the same resistance as a solid tube of the same section, because the current is practically all flowing on the surface. The effect will be greater with iron wires than copper ones because the induction effects are greater. In wireless telegraphy apparatus we shall find coils made of copper tubes and copper strip, giving a greater surface area than round wires of the same effective cross section, and we shall find that conductors are made up of many strands rather than one thick single strand.

Lord Rayleigh has shown that if the resistance of a wire to uni-directional currents is  $R_0$ , its resistance to oscillatory currents of high frequency is  $R_0 = R_0 \times \frac{\pi d}{80} \sqrt{n}$  approximately,  $d$  being the diameter of the wire in cms., and  $n$  the frequency.

A No. 22 S.W.G. copper wire has a resistance of 0.0431 ohm per metre length for a direct current, but its resistance is 0.1207 ohm per metre length for a current oscillating at a frequency of one million ( $n = 10^6$ ).

**Damping Decrement.**—In Fig. 74 is shown the decreasing amplitudes of an oscillatory discharge.

The damping of the oscillations is measured by the ratio of the amplitude of any oscillation to that of the one which has preceded it in the opposite sense, *i.e.* succeeding amplitudes, one in the positive the other in the negative direction.<sup>1</sup> It is, however, more usual to measure what is called the logarithmic decrement or simply the "*Decrement*" of damping, which is found by taking the Napierian logarithm of the reciprocal of the ratio given above. Since the Napierian logarithm of any number is 2.303 times its ordinary

<sup>1</sup> In some cases the ratio of an amplitude in one direction to the immediately preceding one in the same direction is taken to measure the damping factor.

logarithm to the base 10, if  $A_1$  and  $A_2$  are the *amplitudes of two successive oscillations in opposite directions* the Decrement =  $2.303 \log_{10} \left( \frac{A_1}{A_2} \right)$ . This is usually denoted by the symbol ( $\delta$ ).

In Chapter I. of Dr. Fleming's "Elementary Manual of Radio-Telegraphy," it is proved that if  $\delta$  is the decrement of a train of oscillations of this nature, the number of complete oscillations in the train is  $\frac{4.605 + \delta}{\delta}$ .

Since the damping is partly due to resistance, partly due to radiation, and to transfer of energy, the decrement has then three components; as we proceed we shall note its importance, especially of that component of the damping effect which represents energy conveyed to the surrounding ether medium from the oscillatory discharge. We shall also subsequently consider methods of setting up oscillatory discharges which are undamped, and shall find that different systems of wireless telegraphy use electrical oscillatory discharges which are highly damped, moderately damped, or undamped. Much of the pioneer work in radio-telegraphy has been carried out with damped oscillations, but it will be shown that, as far as radio transmitters are concerned, in closed oscillatory circuits great damping may be desirable, whilst in aerial circuits damping effects are avoided. The most modern systems of radio-telegraphy use oscillating currents which are quite undamped.

#### QUESTIONS AND EXERCISES ON CHAPTER.

1. Under what circumstances will the discharge from a condenser be oscillatory?
2. In an oscillatory discharge circuit, how will the periodic time be modified—
  - (a) By an increase in the capacity.
  - (b) By an increase in the inductance effect.
  - (c) By an increase in the resistance.
3. A circuit made up for oscillatory discharges consists of a condenser with 5 zinc plates, each 5.4 cms.  $\times$  6.5 cms., separated by glass plates, each 0.4 cm. thick; also a coil of copper tube, 18 cms. long and 10.5 cms. mean diameter, consisting of 11 turns. A spark gap is joined across the condenser. Calculate
  - (a) The capacity of the condenser.
  - (b) The inductance of the coil.
  - (c) The oscillation constant of the circuit.
  - (d) The number of oscillations per second in a discharge.
4. In Question 3, if only 3 turns of the coil are used in the oscillatory circuit, find the number of oscillations per second in the discharge.
5. Under the conditions given in Question 4, find the maximum value of the resistance of the circuit which would allow of the discharge being oscillatory assuming radiation loss to be negligible.

6. Why is the coil in the above-mentioned oscillatory circuit made of copper tube rather than of solid copper wire of same section?

7. A piece of No. 22 copper cable has a resistance of 4.31 ohms for direct currents. Calculate by the Raleigh formula its resistance to currents oscillating at a frequency of 500,000. The diameter of a No. 22 wire is 0.07 cm.

8. In an oscillatory discharge the amplitude of an oscillation is 0.9 of the amplitude of the one preceding it in the same sense. Find the "decrement of damping" of this discharge.

9. How many oscillations take place in the discharge of Question 8 before it is complete?

10. In the oscillatory discharge circuit of a Telefunken transmitter the number of complete oscillations in each discharge is about 5. What is the decrement of damping of this circuit?



## CHAPTER IX

### *HISTORICAL DEVELOPMENT OF RADIO-TELEGRAPHY*

IN the last chapter it was noted that, when an oscillatory discharge took place, part of the stored up energy was spent at each oscillation in setting up ether strains. On this radiation of energy is based the whole development of radio-telegraphy, therefore consideration must be given as to how it can be increased.

The oscillatory circuit which has been described is called a "closed oscillatory circuit," and it has been pointed out that, in discharging across such a circuit, most of the damping effect on the oscillations is due to energy lost, or wasted, in heating the resistance of the circuit, principally in the spark gap. Very little energy is, in this case, transformed into ether strain. Strains in the ether set it in wave motion and this wave motion spreads out in all directions; if more energy can be put into these waves, and if at the same time they are made larger, their presence in space can be detected at great distances.

The development of radio-telegraphy, from the fundamental fact that under certain circumstances an electric discharge will oscillate at a high frequency, may best be explained by treating it in a historical manner. In order that the student should not be wearied by dates, and by details of experimental methods which are now obsolete, only important steps in the development will be mentioned, and only those experiments described which bear directly on the development.

As already pointed out, **Prof. Henry** in 1838 (and later Feddersen in 1857) discovered that under suitable circumstances the discharge of a Leyden jar, or condenser, would be oscillatory, and would oscillate at high frequency. **Kelvin** (1853) proved the laws under which these oscillations took place; showed that the time of oscillation depended on  $\sqrt{LK}$ , and that the effect of resistance was to damp the oscillations. The conception of electric and magnetic strains in the ether was due to **Faraday**; but **Faraday**, while a brilliant experimentalist, was not a mathe-

matician, and thus did not foresee the far-reaching results of some of his experiments.

In 1873 Clerk Maxwell, by mathematical reasoning, formulated the theory that light and radiant heat were electro-magnetic phenomena, caused by strains set up in the all-pervading medium, similar to the electric lines and magnetic lines which we have already discussed. He said that electro-magnetic disturbances travelled in the ether at a definite velocity, that is to say the known velocity of light and radiant heat—186,000 miles, or 300,000 kilometres, per second. Clerk Maxwell was a mathematician, not an experimentalist, and his theories lacked experimental proof for 25 years.

However, in 1888, Heinrich Hertz, a young German Professor, issued the results of his experiments, which proved conclusively the correctness of Maxwell's theory. Hertz had set up electro-magnetic wave disturbances in the ether, had detected them, had proved that they possessed all the properties of light and radiant heat. They could be reflected, refracted, and polarised, and their velocity was 300,000 kilometres per second.

It will be remembered that when an electrical discharge takes place in an oscillatory circuit, a portion of the oscillating energy is communicated to the surrounding ether, causing electric and magnetic strains in it, which sets it in wave motion. With a closed oscillatory circuit the energy thus conveyed to the ether is a very small portion of the whole, and before the experiments of Hertz no method of detecting the ether energy was known.

Hertz increased the relative amount of radiated energy by arranging the capacity effect in the circuit, not in the form of a condenser with plates close together, but with plates or spheres separated widely from each other on each side of the spark gap. Of course the capacity of such an arrangement is not so great as when the plates are close together, but by making the plates large enough it was sufficient for the purpose.

Thus the arrangement of circuit made by Hertz was the first *open type of oscillator*. It consisted of a spark gap on each side of which were copper rods, 30 cms. long, terminating in large square brass plates of 40 cm. side, or round discs of copper, brass, or zinc. Such a Hertzian oscillator is shown in Fig. 48. Each side of the spark gap is joined to the high potential terminals of an induction coil, by which the oscillator is charged; the plates provide a suitable amount of capacity effect in the circuit; inductance effect is present in every circuit, even with straight wires. Using a suitable length of spark gap the discharge of this Hertzian open circuit is oscillatory. When the capacity plates are close together the

greatest ether strain, on charge, occurs between the plates; when they are separated far apart on each side of the circuit, it follows that the volume of strained ether is increased, and the electric lines of force are longer, since they stretch from plate to plate.

If waves are set up in air to form sounds, we find that a portion of the air more condensed than usual is followed by a portion more rarefied than usual, and this alternate condensation and rarification spreads out in all directions as the sound travels, just as water waves spread out when a stick is plunged up and down in a pond. At any place the air is alternately rarefied and condensed along the direction of wave propagation, so that air waves are an example of what is called *longitudinal wave motion*.

When an oscillating discharge of electricity occurs, the ether near it is alternately electrically and magnetically strained. The flow of electricity, corresponding to a building up or collapse of electric strain in the ether, produces magnetic strain lines, and, as we have already seen, these strains act nearly at right angles to each other.

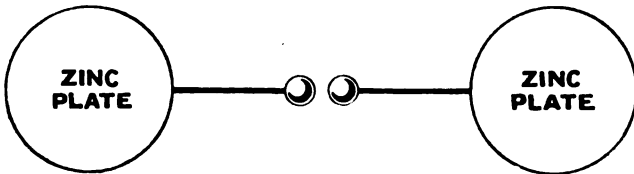

FIG. 48.

The oscillatory discharge corresponds to the stick plunged up and down in water; it sets up wave motion in the ether just as waves are set up in water. But whereas air wave disturbances follow each other in the direction of the wave motion, that is to say, are longitudinal, the disturbances set up in the ether are *transverse*, or across the direction in which the waves travel.

Hertz detected the presence of ether disturbances, or ether energy, in the space around his apparatus by using what he called a "resonator," corresponding to a receiver in radio-telegraphy. It simply consisted of a stout copper wire circle, of about 35 cms. radius, with a very small spark gap in the circle. When he held this circle parallel to his oscillator, in such a way that the small spark gap was turned towards it, he obtained minute sparks across the resonator gap.

By placing his oscillator (made smaller for the purpose) and his resonator in parabolic mirrors, he proved that the ether waves set up by the oscillatory discharge could be reflected, refracted, polarised, and had, in fact, all the properties of light and radiant

heat. He reflected the waves from a large conducting surface, and by the interference of the advancing and reflected waves set up stationary waves. This is analogous to the apparently stationary waves which can be set up in a stretched string when it is bowed anywhere along its length; the string will be seen to vibrate in loops, and points along it, called *nodes*, appear to be at rest. The distance between two consecutive nodes is half the wave length of vibration of the string.

Hertz, experimenting with the stationary waves, measured the distance between two consecutive nodes, or between two consecutive *antinodes*, which are points of maximum disturbances. He thus measured the wave length. Knowing the frequency of the oscillations, he calculated the velocity with which these ether waves travelled, for velocity = frequency  $\times$  wave length ( $v = n \cdot \lambda$ ); no matter what frequency or wave length was used, he found the velocity to be 300,000 kilometres, or  $3 \times 10^8$  metres, per second.

The experiments of Hertz proved the accuracy of Clerk Maxwell's theories, set at rest all doubts as to the nature of light and radiant heat, and opened up a new and delightful field of scientific investigation.

Ether waves similar to light waves had now been set up by electric means, and many scientists devoted themselves to a study of these new waves. The shortest ether waves set up by Hertz's small oscillator were about 60 cms. long, while the longest light wave is about  $\frac{8}{10^5}$  cm. long, and the longest radiant heat wave measured is only 0.0025 cm. It is interesting to note that the scientists who first followed Hertz devoted their efforts to the construction of apparatus which would set up and detect waves shorter than his, hoping to produce and detect ether waves more nearly approaching, in length, those already known in the form of heat and light. Following this idea Professor Chundar Bose, by a development of apparatus, produced and detected ether waves 0.6 cm. long.

Thus, as far as radio-telegraphy was concerned, the progress at first was all in the wrong direction; we realise now that the longer the waves the greater the distance at which they can be received.

Before the work of Hertz was published Professor Hughes had proved it was possible to send signals to some distance, using an induction coil as oscillator and a microphone as resonator. Unfortunately, his scientific friends persuaded him that this was due to inductive effects, such as we have when one magnet acts on another at a distance. For this reason Hughes did not follow

up a discovery which, had he been encouraged as to the true significance of it, would have made him famous.

Sir Oliver Lodge also had made discoveries which were of vast importance in their application to radio-telegraphy, and no doubt his syntonized Leyden jars experiment was known to Hertz.

In this experiment an oscillatory discharge is made to take place across a Leyden jar whose inside and outside coatings were connected by a rectangle of wire, the knob of the inside coating and the knob at the end of the wire formed the spark gap, as shown in Fig. 49. At a short distance from this is placed a resonator, consisting of a Leyden jar with a similar circuit of wire, whose length could be adjusted by moving the bridging-piece AB. A very small spark gap is joined across the jar.

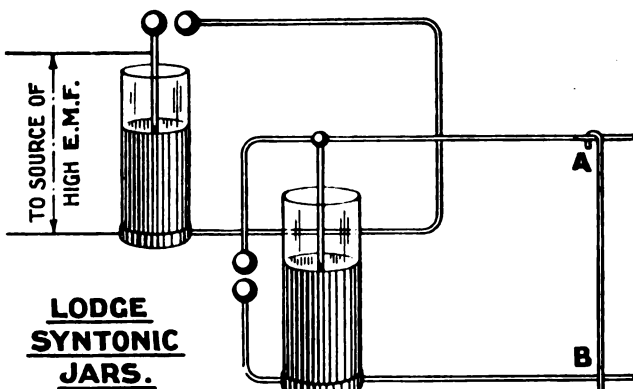

FIG. 49.

When the circuits are placed parallel and the resonating circuit is suitably adjusted a small spark is obtained in the latter when a discharge takes place in the oscillating circuit. As the bridging-piece AB is moved about, it is found that for one position only would the small spark discharge appear; this was called by Sir O. Lodge the position of syntonny, *i.e.* the two circuits were syntonised or tuned to each other.

Moving the bridging-piece AB changed the inductance ( $L$ ) of the second circuit, and its position when the sparks appeared was that which gave this circuit the same oscillation constant as the oscillating circuit—in other words, the inductance was changed until it had a value  $L_2$ , such that  $\sqrt{L_2 K_2} = \sqrt{L_1 K_1}$ . However, this experiment was carried out with a closed oscillating circuit, which is always a poor radiator, so that further development

did not come until Hertz demonstrated how to make and use an open oscillator.

When the account of Hertz's work was published many scientists took up the research ; but, as far as radio-telegraphy is concerned, the next important development was in the detector of the ether waves. The small spark gap of Hertz in his circle of wire, and that of Lodge in his syntonic jars, were very crude detectors, and could only make manifest etheric disturbances at very short ranges.

Prof. Branly, in 1890, found that a coherer was sensitive to ether wave disturbances. A coherer consists of a short gap in an electric circuit which is filled with metal filings; under ordinary conditions, the coherer will not conduct a small current, such as would ring a bell or make a galvanometer deflect. When, however, it is connected in a resonating circuit, taking the place

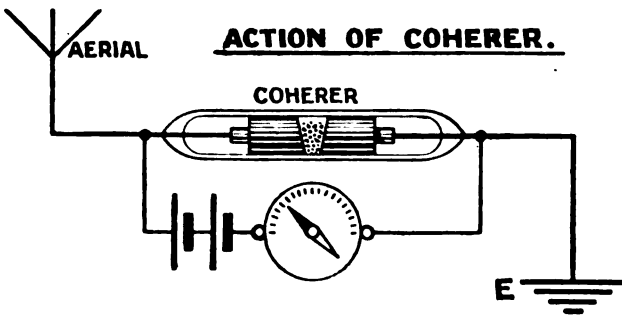

FIG. 50.

of the little spark gap, and ether waves act on the resonator, the coherer becomes a conductor. Fig. 50 explains the action; the coherer is shown in a circuit which contains a galvanometer and a battery, but under ordinary circumstances no current will flow, for the coherer is nearly a non-conductor. Branly showed that if the coherer is made part of an open resonating circuit, which is joined to an oscillating discharge circuit, when ether waves strike the resonator the resistance of the coherer is broken down, and it now conducts the battery current through the galvanometer. This was really only a rediscovery, as the same effect had been noted by Munk in 1839. When the ether waves are set up, the metal filings seem to cling together, or cohere (hence the name); the circuit is no longer broken by the little films of gas or air between the filings, and thus the local circuit is a closed one.

Branly did not use the coherer for receiving signals. When it

coheres and closes the local circuit it remains cohered until it is shaken up, and it probably never occurred to Branly that a coherer might be used to receive a succession of signals. The next important development was that of Prof. Popoff, of Kronstadt, who conceived the idea of making a Resonator with one side taking the form of a wire raised high into the air. By this arrangement his resonator or receiver responded to ether waves caused by lightning storms, and thus recorded such disturbances. We first hear of his work in 1895, and in that year Marconi, encouraged, no doubt, to investigate this new field by Professor Righi, made rapid progress in the application of Hertzian waves to radio signalling of a commercial value. He was the first to make one side of the oscillator consist of a wire stretched upwards into the air, and the first to join the other side of the oscillator to earth. By so doing he found that, with the same oscillating energy, he could detect the ether waves at much greater distances than had hitherto been accomplished.

He also improved the coherer, and was the first to devise a scheme for sending intelligible signals by the ether waves, using for this purpose a decohering arrangement.

As already described, when the ether waves act on a receiver with a coherer in its circuit the coherer closes the local circuit attached to it, and the latter will remain closed unless the coherer is shaken up. Marconi included in the local circuit a little electro magnet, so that when the local current flowed the magnet attracted an armature of soft iron, to which was attached a little hammer; this hammer striking against the coherer caused it to decohere, and thus it was ready to be again affected by another impulse, or train of ether waves. The time of action could be made long or short according to the length of time the oscillator switch was closed; thus a scheme of signals, such as the Morse Code, could be used. The connections of Marconi's first receiver are shown in Fig. 51.

In 1896 Marconi, then only twenty years of age, came to England, and was sympathetically received by Sir Wm. Preece, Engineer-in-Chief of the Post Office Department, who encouraged him in his work, and allowed him to carry out experiments on the premises of the General Post Office. Marconi, backed by influence and capital, rapidly developed his wireless system, and signalled over greater and greater distances; at the same time he enlarged the theories of Hertzian wave action, and developed the idea of tuning his receiver to the transmitter.

In 1897, returning to Italy, he signalled over 18 kilometres in the presence of the King and Ministers of State, and in 1898 the

Italian Navy had established two stations 72 kilometres apart. Marconi had by this time discovered that the distance of transmission was increased by increasing the height of the aerial wire, (or antenna), and in 1901 signalled from Cape Lizard to St. Katherine's, a distance of 200 miles, with antennæ only 300 feet high. The significance of this result was that the curvature of the earth, which raises its surface high up between these two stations, was no barrier to the ether waves. Fig. 52 shows the first form of a Marconi Transmitter. Now a single wire has a very small

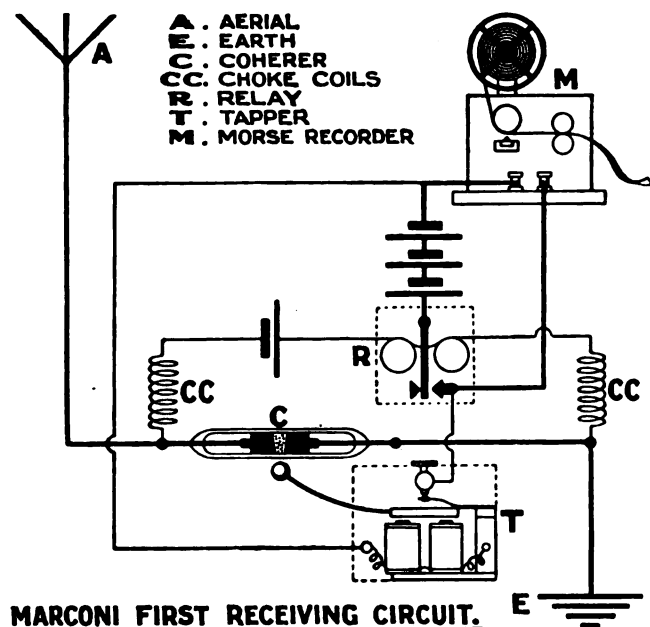

FIG. 51.

capacity, therefore not much energy could be stored in it; when the distance of transmission was increased the energy required in the oscillator, or radiating circuit, had to be increased; hence the aerial, instead of being a single wire, developed into a number of wires in parallel, by which construction its capacity was increased. Thus more energy could be oscillated in it at a given charging voltage, since the energy in it =  $\frac{1}{2}KV^2$ , therefore varies directly as the capacity. This was known as a fan aerial, and we must note that by increasing the capacity not only was the oscillating energy increased, but the wave length was also increased.

H



The wave length ( $\lambda$ ) multiplied by the number of waves per second must equal the velocity of propagation ( $v$ ).

Thus  $v = n\lambda$ ;  $v = 300,000$  metres per second,

$$n = \frac{5.3 \times 10^6}{\sqrt{L_{\text{cms.}} K_{\text{mfds.}}}} \quad \therefore 300,000 = \frac{5.3 \times 10^6}{\sqrt{L_{\text{cms.}} K_{\text{mfds.}}}} \times \lambda.$$

$$\therefore \lambda = 59.6 \sqrt{L_{\text{cms.}} K_{\text{mfds.}}} \text{ metres.}$$

In 1901 Marconi was able to signal from his large station at Poldhu in Cornwall to Glace Bay, Cape Breton, at night; his aerial at Poldhu consisting of 400 wires, and the wave length ( $\lambda$ ) employed was 3600 feet.

In the mean time an officer in the Italian Navy had discovered that a drop of mercury between two steel or carbon plugs in a

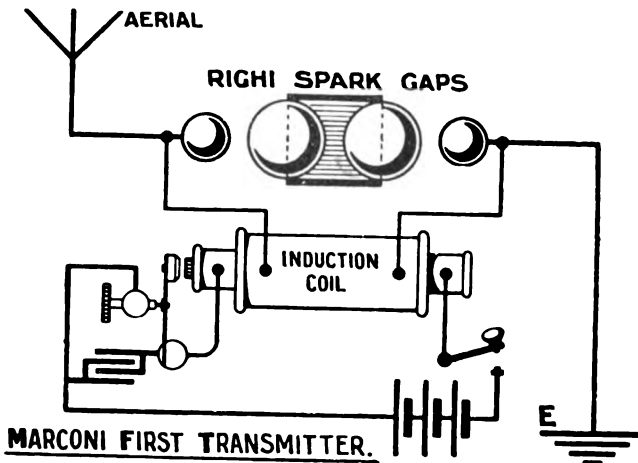

FIG. 52.

small glass tube acted as a coherer; and, when a signal ceased, it decohered itself, so that no tapping arrangement was necessary. Soon after Poldhu station was completed Marconi evolved his magnetic detector which also was a self-restoring device, much more reliable and delicate in its action than the coherer. It will be described in a later chapter.

In 1900 Marconi adopted a tuning arrangement, more efficient than any in use up to that time; it is the subject of his famous patent No. 7777, sometimes called the four sevens patent. With his new arrangement he demonstrated that it was possible to transmit or receive two messages of different wave lengths

simultaneously on the same aerial without any confusion due to mutual interference.

His first station at Poldhu employed 20 KW. of power, and though, after his apparatus was more perfected, he could signal from Cape Cod to Poldhu (a distance of 2669 miles) with 5 KW. of energy *at night*, yet he soon found that for a satisfactory and reliable service during daylight much greater power was necessary. He therefore built larger stations at Clifden, Ireland, and at Glace Bay, Cape Breton, equipping them with plant of 370 KW. (500 H.-P.); it was, however, possible to use only 150 KW. efficiently, and at present the average power used in these stations is about 80 KW.

In 1905 he patented the horizontal directional aerial, by means of which a maximum amount of the total radiated energy can be sent in any desired direction. From experiments made by Dr. Austin, U.S.A., in 1912, it would appear that the directional aerial increases the radiation in the maximum direction about five times, so that this invention proved to be a great step forward in the solution of the problem of long distance transmission.

With his Clifden and Glace Bay stations Marconi studied the effect of daylight in absorbing the radiated energy. As stated by him before the House of Commons Select Committee, 1913, he found that in the morning and evening, when darkness only extended part of the way across the ocean, the received signals were at their weakest, and the variations seem to be less in a north-southerly direction than in an east-westerly one.

In 1907 Marconi patented his high-speed disc spark discharger, by means of which trains of waves at high frequency and good regularity could be transmitted. This invention was one of the first to open up the possibilities of high-speed signalling.

Radio-telegraphy was thus firmly established on a commercial basis, largely by the genius and enterprise of Marconi. At the same time there were other investigators whose labours have contributed much to its development. Sir Oliver Lodge and Dr. Muirhead perfected many pieces of apparatus, including a self-decohering device and an automatic transmitter.

Sir O. Lodge did not adopt the arrangement of earthing one side of the transmitter, but worked on a symmetrical oscillator such as was used by Hertz. His aerial consisted of a network of wires, placed horizontally and high in the air, with the other side of his transmitter joined to a similar network raised about a foot above the ground. Such an arrangement is shown diagrammatically in Fig. 53.

Dr. Braun, of Berlin, developed a system for Messrs. Siemens

and Halske; **Count Arco** and **Prof. Slaby** developed the Arco-Slaby system. These systems have now been combined into one system known as the **Telefunken** system. **Dr. Lee De Forest**, U.S.A., did much good pioneer work, and brought out a new form of electrolytic detector which is not now employed. The work of modern inventors, including Poulsen, Goldschmidt, Fessenden, and Wein, will be considered in later chapters.

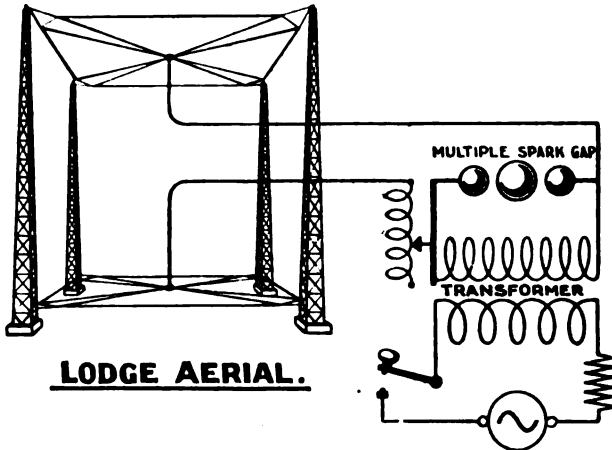

FIG. 53.

This brief survey of the historical development of radio-telegraphy will enable the student to follow the lines of progress after the publication of the results of Hertz in 1888. Since the laboratory experiments of his time, when ether waves of about 100 cms. long were employed, and the distance at which they could be detected was only a few metres, rapid development has taken place; at the present time waves of 20,000 feet are used, and the distance over which they can be detected is 6000 miles.

## CHAPTER X

### HOW ETHER WAVES ARE PROPAGATED AND RECEIVED

WHEN a simple Hertz oscillator, such as in Fig. 54, is charged, one side is at positive potential, the other at an equal negative potential, and lines of electric strain are set up in the ether around it. The ends of these lines represent units of positive and negative charge on the two sides of the oscillator. Let us briefly review what happens when an oscillatory discharge takes place across the spark gap. At a certain difference of potential the insulation of the spark gap breaks down and the discharge commences; the flow sets up magnetic lines in circles round the circuit, and the self-inductive effect of these magnetic lines keeps the discharge from rising to a maximum instantaneously. During this building up of the discharge and of the magnetic field the electric lines are collapsing; their feet rushing together as the positive and negative charges neutralise each other. When the discharge is a maximum it should be complete, with no difference of potential between the two sides; but the magnetic lines set up round the circuit collapse on it, and their inductive effect is to set up a difference of potential in the circuit, which sends an extra current across the gap, until what was before negatively charged is now positively charged, and *vice versa*. As the magnetic strain dies away so also does the extra discharge, but on account of it the circuit is now charged in the opposite sense to what it was before; electric lines of strain are set up in the ether near it in the opposite direction to their former direction, and a fresh discharge takes place with similar results. Thus the discharge oscillates backwards and forwards, losing energy at each swing, in radiation and resistance, until it eventually dies out; the whole process, however, only taking a fraction of a second and constituting what is called a spark. That there is energy in the discharge is seen by the heat and light set up in the spark gap, and by the effects of the ether strains set up round the circuit.

Let us concentrate our attention on the electric strain in the

ether round the oscillator. A discharge means the collapse of this strain, the positive and negative charges neutralising each other. The shorter electric strain lines collapse completely, as it were, into the spark gap, as each positive unit of charge meets a negative unit. The unit charges which exist in the two sides of the oscillator at the ends of the longer strain lines also rush to meet each other in the discharge; these strain lines also tend to shorten into the gap and vanish. But, owing to the good conductivity of the metal oscillator, the feet of these lines have met before the loops of the lines have collapsed; thus a closed loop of electric strain is set up in the ether all round the oscillator, sections of this loop being diagrammatically shown in Fig. 54.

At the instant represented in Fig. 54 the discharge current has passed its maximum value, and, as it dies away, is charging up the sides of the oscillator in the opposite sense to their former

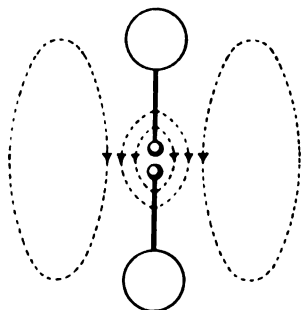

**LOOPEO STRAINS  
AROUND HERTZ OSCILLATOR.**

FIG. 54.

charges; hence new lines of electric strain in the ether are being set up round the spark gap as shown. As the discharge oscillates backwards and forwards, successive loops of strain in the ether round the oscillator are thus set up, the strain force represented by any loop acting in the opposite direction to that of the loop just preceding it.

Now let us consider the magnetic strains set up in the ether. We know that when a discharge takes place across the oscillator, the ether round it is strained magnetically, that is to say concentric circles of magnetic lines are set up owing to the discharging current. One would think that, when the magnetic strain is a maximum, the electric strain in the ether should have disappeared, and the discharge would be finished if it were not for the inductive effect of the magnetic strain lines when collapsing. But is it true that the electric strain is zero when the magnetic strain is a maximum?—is the difference of potential of the two sides of the oscillator zero when the current in it is a maximum and *vice versa*?

Such conditions would be as represented in the diagram of Fig. 55. As the current rises to a maximum value (from A to B) the potential difference falls to zero, but when the discharge current dies away to zero (from B to D) the potential is being built up again in the opposite direction, (shown by drawing the

potential curve below the horizontal line at F (Fig. 55)). Similarly when the current in the opposite direction rises to a maximum and falls to zero (from D to E) the potential is reduced to zero again and then raised to a maximum in the opposite direction (at E). Thus the oscillator at E would be just in the same condition as it was at A; the changing conditions from A to E represents a complete cycle, and the distance AE is said to represent  $360^\circ$ . Thus, AF represents  $90^\circ$ , or the maximum of current occurs  $90^\circ$  from the maximum of volts.

Now, if the current and volts were at  $90^\circ$  to each other, there would be no energy available from the discharge, for the energy represented by the current in rising, and discharging the oscillator, would be just equal to the energy of recharge of the circuit in the opposite direction, when the current is dying away to zero. Any student familiar with the elementary theory of alternating current

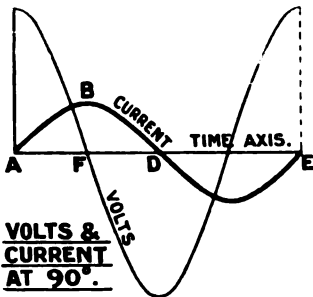

FIG. 55.

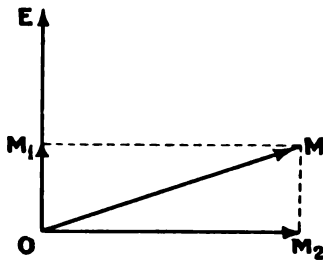

FIG. 56.

knows that when current and potential in a circuit are at  $90^\circ$  to each other no energy is available, or expended, in that circuit.

Yet, with our oscillatory discharge, we know energy is available in the circuit, for some is turned to heat and light in the spark gap, some heats the wires or conductors, and some is given to the ether. Therefore the current and potential cannot be exactly at right angles to each other, and around the oscillator the electric strain is not zero when the magnetic strain is a maximum, or *vice versa*. The strains are nearly at right angles to each other, and the nearer they are to this condition the more oscillations there will be at each discharge, while less energy will be given out at each oscillation. The actual conditions of strain at each oscillation might be represented in a vector diagram, as shown in Fig. 56. Here OE represents the electric strain force and OM represents the magnetic strain not exactly at right angles to OE. Any force

such as  $OM$  can be resolved into two components at right angles to each other, hence we can resolve  $OM$  into a component  $OM_1$ , acting with the electric strain, and  $OM_2$  acting at right angles to the electric strain. The component of the magnetic force  $OM_2$  at right angles to the electric strain acts with the latter to make the discharge oscillatory; the other component  $OM_1$  in phase with the electric strain represents the energy produced by an oscillation.

The important conclusion to remember is that, round the oscillator, the magnetic and electric strains are not set up in the ether exactly at right angles to each other; if they were no energy would be radiated.

One of the first steps in the development of radio-telegraphy by Marconi was to join one side of the transmitter to earth, while the other side was a wire (the aerial) raised high in the air. The action in such a circuit when the discharge takes place is very

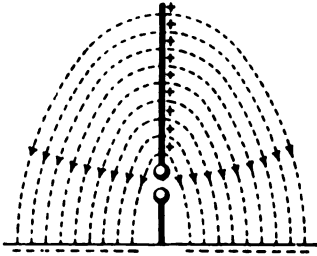

FIG. 57.

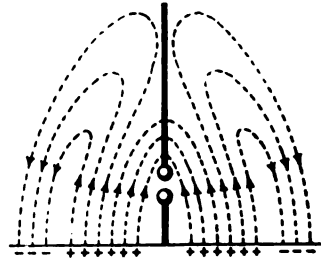

FIG. 58.

similar to that already described. When the oscillator is charged up the electric strain in the ether is as shown in Fig. 57, the lines stretching from the aerial to the earth which is at zero potential.

When it is statically charged electric lines enter or leave a conductor at right angles to its surface; note that the ether all round the oscillator is strained, hence what is shown in the figure is only a section of the strain. It will be seen later that elaborate arrangements are made to provide good conductivity on the earth's surface all round the aerial circuit.

When a discharge starts the upper ends of the strain lines rush down to meet the lower ends; the latter move comparatively slowly as they pass along the earth's surface, which offers a certain amount of electrical resistance effect to their progress. By the time the upper ends of the electric strain lines have reached the bottom of the aerial, the discharge current has reached its maximum and, as it dies away to zero, is charging the aerial circuit up in the reverse direction, as shown in Fig. 58. Hence, loops of electric

strain are formed round the oscillator with their feet on the earth, and new strain lines formed by the completion of a discharge in one direction. The looped strains die away as the new strains reach their maximum, but loops are set up in the ether beyond.

If the direction of the strain, as shown by the arrow heads, is studied, (the direction of an electric line being from a positive charge to a negative charge), it will be seen that the ether near the oscillator is electrically strained vertically in one direction; while farther out it is strained vertically in the opposite direction: each loop of strain close to the oscillator being completed by a portion of the oscillator and earth, while each loop farther out is completed by the earth's surface. At the next discharge the direction of the vertical strains of the ether round the oscillator will be reversed, the first strains having in the mean time died away.

Now we must try to realise how the ether strains are propagated outwards in all directions to great distances. This is one of the problems in radio-telegraphy least understood by scientists of the present day, and the student is warned that any attempt here made to explain the propagation of waves in the ether is simply an application of first principles to ideal conditions which hardly exist. At the same time, the explanations given here may enable him to take an intelligent interest in the discussions on this problem, which at present fill the scientific periodicals.

There are four considerations on which an explanation of ether wave propagation may be based—

I. A charged conductor is surrounded by lines of electric strain, which die away when a discharge current flows, and are set up when a charge current flows; thus an increasing or decreasing electric strain is identified with a current in one direction or the other.

II. Clerk Maxwell has shown that a diminishing electric strain in the ether is equivalent to an electric current in the opposite direction to the strain, and an increasing electric strain is equivalent to an electric current in the same direction as the strain.

III. A straight current of electricity is surrounded by concentric magnetic circles of strain in the ether around the current path.

IV. Since the electric ether strains set up by an oscillating discharge have never a steady value, but are always rising or falling in magnitude, it follows from Clerk Maxwell's principle that their effects are equivalent to a continually changing displacement current in the ether, and therefore their rise and fall will be accompanied by rising and falling magnetic strains. Thus,



while the magnetic strains round the oscillator are nearly at right angles to the electric strains, farther out, if oscillating electric strains exist in the ether, they are accompanied by oscillating magnetic strains whose values are in phase or unison with them, and whose planes of action are at right angles to those of electric strain.

Round the oscillator, if we neglect the top of the loops, the electric strains in the ether are vertical cylinders of strain, and the magnetic strains are horizontal circles. Such conditions are seen in Fig. 59, which shows only a section of the strains conditions; the lines being sections of the cylindrical electric strains, the dots sections of the circular magnetic strains. Of course, in each case, only a very few of the strain lines are shown, and the diagrams are not to scale.

Consider a section of one of the loops of electric strain formed in the ether near the transmitter, its direction being as shown in Fig. 60, dots representing sections of magnetic strains. Suppose it is a decreasing strain then it is equivalent to currents flowing

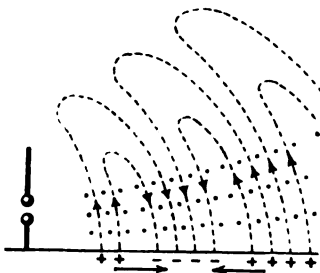

FIG. 59.

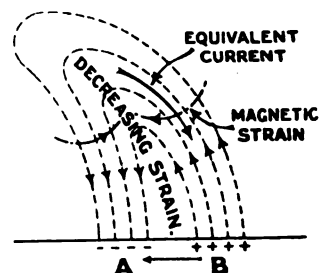

FIG. 60.

in the opposite direction to the electric strain lines; these currents are represented by an arrow, and earth currents will flow from B to A completing the circuit.

The direction of the magnetic loops of strain will then be as shown in the diagram. A moment later the electric strain at B will have fallen to zero, but the collapse of the magnetic strain lines will induce at B electric strains in the opposite direction to those existing before, and these will rise to a maximum, as shown in Fig. 61. At the same time the oscillator being charged up again, has set up electric strains at A, so the strain lines at B loop over outwards, and thus a strain is set up at C. The same effects will take place at C, and when the strain there is reversed and rises to a maximum it will loop over outwards. Thus the electric strains with their accompanying magnetic strains are

spread outwards in the ether. The distance from A to B, or B to C represents one half cycle or half wave disturbance; that is  $\frac{\lambda}{2}$ .

At any place B the electric strains in the ether are approximately vertical to the earth's surface, acting alternately downwards and upwards; the magnetic strains are parallel to the earth's surface, the maximum values of the magnetic and electric strains occur together, as do their zero values. Alternating currents will flow on the earth's surface between A and B, B and C, etc., and the resistance of the surface to these currents will waste some of the energy in the waves. At a given instant the strains in the ether might be represented as shown in Fig. 62; at the instant taken, the ether strains are a maximum at A, C, and E, and zero at B and D; an instant later the strains will be a maximum at B

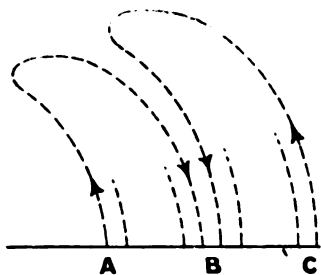

FIG. 61.

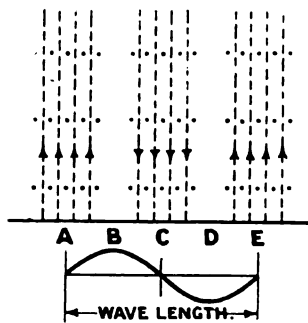

FIG. 62.

and D, and zero at the other points. The direction of propagation of the wave disturbance is at right angles to both the electric and magnetic strains.

The wave motion spreads out through the ether at a velocity of 300,000 kilometres, or  $3 \times 10^8$  metres per second. If  $n$  is the number of waves set up at a given point per second, and  $\lambda$  is the length of the wave, then  $n\lambda$  must be the distance that would be traversed by a wave in one second if its energy were not dissipated, that is  $n\lambda = v$ . The number of waves passing any point per second is equal to the number of oscillations per second in the discharge of the transmitter, and the wave length  $\lambda$  depends, as we have seen, on the electrical capacity and inductance effects in the oscillating circuit—

$$(\lambda = 59.6\sqrt{L_{\text{cms.}} K_{\text{mfds.}}} = 1885\sqrt{L_{\text{michys.}} K_{\text{mfds.}}}).$$

In practice we do not have a plain vertical aerial so that the electric strain lines in the ether are not vertical to the earth's surface. Indeed, we shall presently see that even if the strain at starting was vertical to the earth's surface, it does not remain so. Fig. 63 shows the form of radiation from an inverted L or directional aerial. It will be seen that at the aerial the electric strain or wave front is roughly in the form of a sector of a circle, whose centre is the foot of the aerial.

As the disturbance spreads out in the ether, it penetrates higher and higher, as shown in the figure: in this respect it is similar to the rings of disturbance set up in water when, for instance, a stone is thrown into it. How high up into the atmosphere does the disturbance penetrate? Water is a uniform medium, and the rings of wave disturbance set up in it spread out symmetrically to infinite distance. Ether may be a uniform medium, but the ether in which our strains are set up is intimately

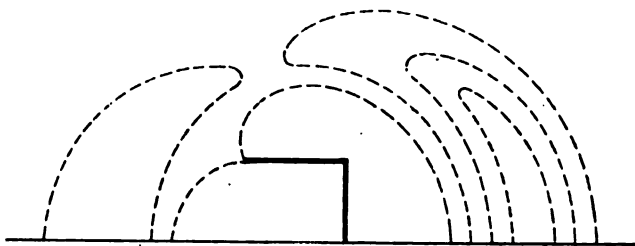

FIG. 63.

associated with the earth and its atmosphere; these in various ways abstract energy from the strain forces. We shall presently discuss these effects of the earth and atmosphere; at present we will note that on account of them the radiation of energy outwards through the ether, in the form of electric and magnetic strain lines, does not remain symmetrical. The height to which the strains, or waves, can penetrate is limited, and the wave front changes in direction and shape as the waves spread to greater and greater distances. In fact we shall see that at great distances the strain loops, instead of being bent backward as they leave the transmitter, are probably bent forward in the direction of propagation.

When a stone is thrown into a pond and waves set up the energy in the waves gets less and less as the distance from the point of disturbance increases, finally disappearing, so that no waves are formed far out in the pond. Similarly the energy

in the ether waves spreads out along larger and larger wave fronts, so that at any point the amount of ether wave energy will be less the greater its distance from the origin, or transmitter. The energy, at any point, would be inversely proportional to the square of the distance from the transmitter if the ether energy became attenuated by distance effects alone. But there are several other effects which go to dissipate the energy in the ether waves, and these we must now consider. Let us start at the feet of the strain lines and consider the dissipating effects as we go towards the top.

**Earth and Sea Effects.**—The feet of the loops travel on the earth or sea; and, as the electric strains rise and fall, alternating currents flow along the surface of the earth or sea, from foot to foot of each loop. But the earth and sea are not perfect conductors; they have resistance, and we know that when a current flows through a resistance, energy is used up in it, (watts used in a resistance =  $C^2R$ ). Thus these conduction currents on the surface of the earth or sea, over which the waves travel, represent a loss of energy. Each succeeding loop has less energy than the one behind it, and, of course, the loss depends on the resistance of the surface over which the loops travel. The greater the resistance of the surface path of the waves the more energy will be dissipated, and the less will be the range of transmission.

Brylinski has calculated the resistance of damp earth to be 6600 ohms per cm. cube, and of the sea 373 ohms per cm. cube; thus we realise one reason why much longer distances can be attained over sea than over land. Dry land has a much greater resistance than marshy land, and this accounts for the great difficulty experienced in wireless signalling during the South African and Russo-Japanese wars.

Brylinski also demonstrated that the surface currents flow in a section which in land may penetrate to about 15 metres deep, but over sea the penetration is probably not more than 2 or 3 metres. Thus we have to take into consideration not only the qualities of the surface, but the material of the underlying strata. Limestone has a greater resistance than sandstone, and both have a much greater resistance than damp soil or sea water.

Now, it will be remembered that one of Marconi's earliest experiments was to signal from Cape Lizard to St. Katherine's, a distance of 300 miles with aerials only 200 feet high. Between these the curvature of the earth raised its surface high up between the aerials, and the experiment proved that ether waves went round the curvature of the earth. This brings us to consider the effect of obstructions such as buildings, forests, and mountains. Energy is dissipated by these obstructions. Mr. Duddell, experimenting

in Bushey Park near London, found that when the receiver was placed close up behind a plantation of trees the received currents were much weakened, but when he removed it to a greater distance behind the plantation they increased again to something less than what would have been their normal value if the plantation had not been there. An Officer of the United States Army is said to have received signals using a tall tree only as a receiver aerial; this shows that considerable energy was absorbed from ether waves by trees directly in the path. The student can picture the analogy of water waves meeting a post which sticks up out of the surface of the water. Yet, since ether waves follow the curvature of the earth's surface, they may be made to travel over mountains, and radio-telegraphy is carried on successfully between Switzerland and Italy across the Alps.

At the same time it is easy to see that a considerable dissipation of energy must take place in obstructing mountains, because, in the first place their substrata is usually of a rocky nature which has a relatively high specific resistance. Secondly, when loops are travelling on an inclined surface, either the length of surface between their feet is greater than when travelling on a horizontal surface, which increased length increases the resistance and therefore the dissipation of energy, or the waves are bent backwards thus interfering with those following. Also it is possible that the ether wave fronts, guided or refracted upwards by the mountain, may pass over the valley beyond without effecting it, unless the wave length is very long compared to the depression of the valley.

Now let us turn our attention to the portion of the ether waves travelling through the atmosphere. If the atmosphere were a perfect dielectric there would not be dissipation of energy in it; unfortunately it is not a perfect dielectric, nor are its dielectric qualities uniform at all heights, so that its effect on the ether waves is a complex one; complicated by the fact that sunlight has a peculiar influence upon the conditions.

We know that the density of the atmosphere decreases with the height, and Sir J. J. Thomson has shown, in his "Recent Researches on Electricity," that while the atmosphere is nearly a perfect dielectric, or non-conductor, near the earth's surface where its density is greatest, yet at a height of about 35 miles it becomes conductive for high-frequency currents, and immediately above that it is a very much better conductor for these currents than sea water. Therefore the ether waves must travel within a belt of atmosphere 35 to 40 miles thick, and it is probable that at least long distance waves, which are 4-5 miles long, have the upper ends

travelling on the upper plate of conducting atmosphere, just as their lower ends travel on the conducting sea. If this be so, then alternating currents will flow on the upper conducting layer of atmosphere, as they do on the earth or sea surface; energy will therefore be dissipated in this layer. Since its resistance is very low the energy thus lost will not be so great as that due to the earth currents.

It has already been noted that, owing to resistance, conduction current impulses do not travel as fast through a conductor as the corresponding displacement current impulses travel in a dielectric. If we consider the effect of this on ether waves, we see that the feet of the waves, travelling on the resistance of the earth or sea, will not travel as fast as the loops in the atmosphere. Thus, if the loops are set up vertically round the transmitter, after a distance has been covered they will be bent over in the outward direction, as shown in Fig. 64. Even if the upper ends of the loops travel on the conducting layer of atmosphere its resistance is so much less than that of the earth or sea that they will still travel faster than the lower ends, and the waves will bend over.

The waves may become so bent as to be horizontal for a great portion of their length; this is one reason why receiver aerials are made with long horizontal wires, which are not necessarily at any great height. For

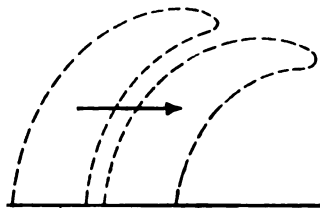

FIG. 64.

transmission to great distances the waves are not set up vertically at the transmitter but the aerial is bent backwards; this ensures that more energy is propagated in the forward direction than in any other; at the same time the waves at starting are bent backwards, which no doubt compensates for an excessive forward inclination of the tops of the waves at a great distance from the transmitter.

**Day and Night Effects.**—It is well known that the distance to which signals can be sent is much less in the daytime than at night; Marconi stated that a range of 1000 miles at night would probably correspond to 500 miles by day. The Telefunken Co. guarantee, with their Type E transmitting outfit, a range over sea of 280 miles by day, and 550 miles by night; over flat land a range of 350 miles by day and 470 miles by night; the land figures being comparatively high in this case owing to better aerial and earthing facilities.

In a lecture given at the Royal Institution in 1911, Mr.

Marconi stated that the strength of the signals received at Clifden from Glace Bay was a minimum about an hour and a half after sunset at Clifden, it being then daylight at Glace Bay. The strength was a maximum four hours later at Clifden, it being then sunset at Glace Bay. Just after sunrise at Clifden, they are again a maximum; an hour and a half later a minimum; and then before sunrise at Glace Bay they return to their usual strength. The effect of daylight is found to dissipate the energy of short waves more than that of long waves.

Though many theories have been given, from time to time, of this peculiar effect of daylight, it is by no means clear that they completely explain the phenomenon; this is partly because we are not at all certain of the manner in which the radiated energy travels to great distances. We will consider some of the scientific explanations of daylight effects; though they may not fully meet the case, and though at present there is not unanimity among scientists regarding these explanations, yet from them the student can note the interesting problems which await solution.

In the first place, the violent disturbances at the sun are continually throwing off electrons and charged particles, the latter being called "ions" (from the Greek word "ion" = a wanderer). Thus, in daylight, when a certain portion of the atmosphere is exposed to the sun, it experiences a bombardment of ions and electrons; these are very small, and their different powers of penetration into the atmosphere will depend upon their different sizes and velocities. We know how easily electrons are stopped by air at ordinary pressure, and that a vacuum space must be used if we are to study their motion, as in Chapter II. Now the density of the atmosphere increases from its outer bounds to its inner surface on the earth, hence at some height above the earth its density will be such as to stop the charged particles shot from the sun. There will thus be an accumulation, or layer, of these particles, or at least of one class of them, at a definite height; this may account for the conducting layer of atmosphere already referred to—35 or 40 miles above the earth's surface. (A few writers have assumed that this layer is due to cosmic dust accumulation, so that its action is not altogether dependent upon the sunlight.) Some of the electrons and ions will penetrate beyond this layer of atmosphere, into what is called the middle atmosphere, where the positive and negative charges may become separated, or driven along different paths, by the earth's magnetic field when they arrive within its influence.

We have already noted the fact that the feet of the strain loops, or ether waves, are retarded by the ohmic resistance of the

earth or sea. But apart from this, it would be quite possible for the waves to bend over owing to the varying densities of the atmosphere; in other words, they are refracted, the top portion travelling faster in the rarer atmosphere than the bottom portion. Just as a ray of light, which is also an ether wave motion, bends as it goes from a rarer to a denser medium, owing to a change of its velocity. This is called refraction; twilight is a phenomenon due to it, the light waves from the sun being bent round in the atmosphere to us, even when the sun is below our horizon.

In the daytime, therefore, we have to picture to ourselves a layer of atmosphere 35 to 40 miles thick, the sea or land being one boundary and an upper conducting layer the other boundary. The upper portions of this layer is partially ionised by the electric charges shot from the sun, which have penetrated beyond the upper conducting limit; the lowest portions have clouds, vapour and dust floating in them. The partial ionisation of the atmosphere lowers its dielectric strength, hence the energy of electric strains set up in the ether will be depreciated. Now if ether waves are formed they spread upwards and outwards, the tops travel faster than the feet, and will thus bend over in the direction of propagation; also the tops of the waves may reach the upper conducting layer of atmosphere but cannot penetrate beyond it. The effect of the ionised condition of the middle atmosphere is twofold: it will dissipate some of the energy in the waves, and at the same time increase their refraction. Thus the wave motion may finally arrive at the receiving station weak, and bent at such an angle as will not affect its aerial.

After sunset the positive and negative ions in the middle atmosphere combine together to neutralise each other, the atmospheric belt is cleared and it becomes a better dielectric. Ether waves now transmitted through it spread upwards, and are refracted forward; the good conductivity of the upper layer increasing the refracting effect to such an extent that it is practically a reflection of energy. At the same time the belt through which the waves travel is not ionised to the same extent as in daylight, hence less energy is abstracted from the ether waves.

It must be emphasised that the decreased effect of ether wave energy in daylight is not due only to the absorption of energy by the ionised condition of the atmospheric belt in which it travels; it is partially due to the fact that the waves are refracted so that they wholly or partially miss the receiving aerial. Thus Professors Pierce and Zenneck have shown that the energy absorption due to the ionisation of the atmosphere is small,



and does not account for the total attenuation effect obtained in practical work. Dr. Austin has pointed out that much greater increases of ground absorption effects, than those possible by an ionised atmosphere, vary the strength of signals very slightly.

Sir O. Lodge has suggested that the ether waves would sweep the ions in the atmosphere before them; thus the energy of motion given to the ions represents energy abstracted from the waves. Dr. Fleming considers that the ions, shot into the atmospheric belt with which we are concerned, may form the nuclei for small condensations of moisture, thus retarding the velocity of the waves travelling through them. On the other hand greatest ionisation must be at heights to which moisture does not penetrate. That the diminution of energy in daylight is partly due to refractive effects accounts for its variation at different wave lengths. The energy conveyed at one wave length may be seriously diminished while that at another wave length may not be affected appreciably; a result which has been observed by Mr. Marconi in his trans-Atlantic work.

This selectivity of wave length shows that the phenomena is partly due to refraction: we know that light waves of different lengths are refracted, or bent, by different amounts in the same medium: we can use a glass prism to break up white light into its constituent colours on account of this fact. In a similar way, telegraphic ether waves are refracted in the ionised atmospheric medium to different extents, according to the wave length.

The difference between day and night effects on the transmitted ether energy might possibly be caused by a change in the position of the upper conducting layer of atmosphere. In sunlight it may approach closer to the earth's surface; in other words, the aggregate of charged ions may penetrate deeper into a warm and expanded atmosphere.

Another problem in atmospheric conduction relates to the freak distances, or ranges, which are often attained. Ships, whose normal range is 300 or 400 miles, have been able to communicate over 1000 to 2000 miles without difficulty at certain times and places. The effect is more prevalent in the Pacific than in the Atlantic Ocean, and is no doubt caused by some advantageous temporary refracting power of the atmosphere.

The whole question of ether wave propagation is one of the outstanding problems in radio-telegraphy; on it many well-known scientists are at present carrying out investigations. A very valuable contribution on this subject was given by Dr. Eccles to the British Association in 1912 (see *Electrician*, September 27th, 1912).

We shall now discuss the action of the ether waves on the distant receiver, which for simplicity we shall assume to be a vertical wire, with some form of detecting instrument in series with the wire and earth, as shown in Fig. 65. Here a state of electric ether strain is shown, arriving in the ether at the receiver. Now the action on the receiver will be the added results of two effects—that due to the electrostatic strain and that due to the electro-magnetic strain. Suppose, at the instant considered, that the electric strain is increasing in the ether at the receiver; then that portion of it which is on the receiving wire will have the effect of setting up a difference of potential between its ends. This means that a flow of electrons,

(a current of electricity), takes place from the one end to the other, due to the electric strain. At the same time the magnetic strain will be increasing, in other words, magnetic lines will circle round the wire, and we know that the inductive action of a magnetic field increasing and interlinking with a conducting wire, is to induce a difference of potential between the ends of the wire. This causes a displacement of electrons, *i.e.* a current flows from one end to the other.

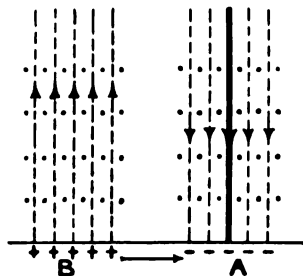

FIG. 65.

Thus, when an ether wave acts on the receiver it causes a current to flow from one end of it to the other, the effect being partly due to the electric strain and partly due to the magnetic strain. Since the energy transmitted is equally divided between the magnetic and electric strains, the energy of the current set up in the receiver will be equally due to each of these strains under the circumstances considered; its amount will depend on the amount of energy which exists in the ether waves set up at the receiver.

In an instant later than that considered, the electric and magnetic strains in the ether at the receiver will be reversed, therefore the current set up in the receiver will be reversed; thus the current set up in it will be an oscillating one of the same frequency as the waves, which is the same as the frequency of the oscillating discharge at the transmitter. The student will easily realise that the higher the receiver aerial the more energy will it absorb from the ether wave set up at it; a greater vertical length of electric strain will be coincident with it, giving a greater difference of potential between its ends; also more of the magnetic lines of strain will interlink along it.

It might here be noted that if the wire of the receiver were at right angles to the electric strain lines, theoretically, no energy would be imparted to it from the ether waves. The wire is now in the same plane as the magnetic strain, and we know that no induction takes place in a wire along which magnetic lines move—the lines must interlink with the wire; at the same time the electric strain would only give rise to a difference of potential

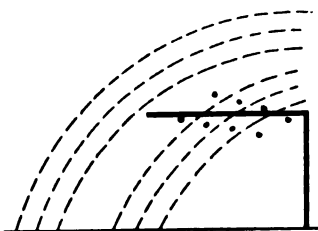

FIG. 66.

between the bottom and top sides of the wire, whose value would depend on the length of the electric strain lines which coincide with the wire; this, in Fig. 66, is seen to be practically nothing.

We have seen that the ether waves do not in general remain vertical, for reasons already described. Thus it becomes important that a portion of the receiver aerial

should be horizontal; the greater the distance which the ether waves travel the less becomes the advantage of great vertical height in the receiver aerial. As pointed out elsewhere, signals may be received on horizontal wires raised only a few feet above the ground. This is partly due to the fact that the waves, being bent over, have a strong horizontal component; the effect may also be partly caused by induction from the earth currents, set up on the surface over which the waves travel.

The strength of the currents induced in the receiver aerial will be very small, and delicate apparatus must be used to detect them. The smallest current that can be thus detected with modern apparatus is probably about 5 microamperes; in good commercial working the currents set up in the receiver aerial will be from 40 to 50 microamperes.

From the explanations given it is readily seen that there are many factors which qualify the strength of the receiver currents, such as distance, curvature of the earth, conductivity of the earth or sea, changing dielectric capacity of the atmosphere, latitude, and magnetic storms.

#### QUESTIONS AND EXPERIMENTS ON CHAPTER.

1. Show that the magnetic and electric strains in the ether round an oscillating discharge cannot be exactly at  $90^\circ$  out of phase with each other.
2. Explain how the ether waves are sent out with their feet on the surface of the earth. What effect has this on the shape of the waves when the wave motion has been propagated to some distance?

3. How is the energy of the wave-motion in the ether attenuated as it spreads out further and further?
4. Why is the range of transmission much less over land than over sea?
5. Write a short account of the effect of daylight on the transmission of ether waves.
6. What is meant by the refraction theory of the effect of daylight on ether waves?
7. Explain shortly how the ether waves induce currents in the receiver aerial, and what is the best form of this aerial.
8. A receiver station is 3000 miles from the transmitting station; find the time taken by the ether wave disturbance in traversing the distance between the stations.
9. Explain why ether waves cannot penetrate to a greater height in the atmosphere than 35 to 40 miles.

## CHAPTER XI

### COUPLING OF CIRCUITS

WHEN a current of electricity flows through a coil of wire magnetic lines of force are set up through the axis of the coil. If the current changes the number of magnetic lines interlinked with the coil changes, thus giving an inductive effect in the circuit. If the current is an oscillating one there will then be a continuous inductive effect, the magnetic strain lines oscillating backwards and forwards whilst their number varies. We know that this inductive effect helps to make the discharge in a closed circuit, such as Fig. 67, an oscillating one, the frequency of the oscillations

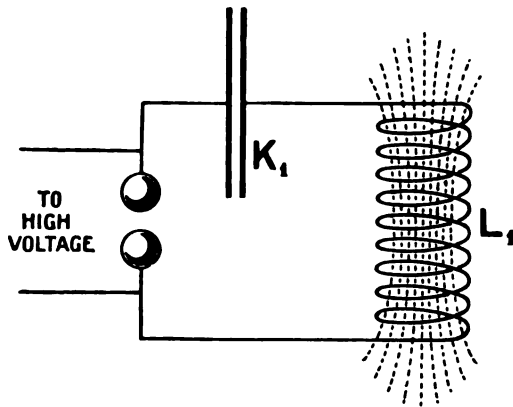

Fig. 67.

being determined by the value of  $\frac{5 \times 10^6}{\sqrt{L_1 K_1}}$  and the wave length is  $59.6 \sqrt{L_{1\text{cms.}} K_{1\text{mfds.}}}$  metres.

Let an aerial and an earth wire be joined to the closed circuit, as shown in Fig. 68. As the oscillating discharges of the closed circuit go through the portion AB of the coil, oscillatory magnetic

fields will be set up, giving an inductive effect in the closed circuit, and if  $L_1$  is the inductance of this portion of the coil the wave length is, as before,  $59.6\sqrt{L_1K_1}$ . Now it is seen that a great many of the magnetic lines, set up through the portion AB of the coil, extend through, or interlink with, the remainder of the coil BC, so that the whole coil AC has inductive effects set up in it by the magnetic strains which are produced in a portion of it. Thus, since there are more turns in AC than AB, and a different number of magnetic lines interlinked with it (for not all the magnetic lines set up in AB will extend through all the turns AC), the inductance of AC is different to AB,—let us call it  $L_2$ .

Now the effect of magnetic lines interlinking with turns of wire is to induce an E.M.F. in the turns, and if the magnetic field is oscillatory, the induced E.M.F. will be oscillatory. In this case the magnetic field is oscillating as fast as the oscillations of the discharge, thus a high frequency, or oscillating, E.M.F. is induced in the coil AC. It is joined to the capacity of the aerial at one side and to the capacity of the earth at the other; hence the oscillating E.M.F.s induced in it will cause oscillating currents to flow up and down the whole open circuit.

If a swinging pendulum is tapped, it may be kept in motion in an irregular sort of way, but if the taps are properly timed to hit the pendulum at regular intervals, and always at the same point of its motion, the swings of the pendulum can be made both regular and greater in extent. Thus, with the same strength of taps, when the taps are in tune with the pendulum we get much better effects in the resulting motion of the pendulum. Similarly with a child's swing; the force applied must be in step, or in tune, with the swing, to realise the full effects of the force, or make the amplitude of the swing motion a maximum. Again, if the front is taken out of the piano and a tuning-fork sounded in front of it, the air waves set up will affect, more or less, all the strings, but the greatest effect will act on the string which happens to be in unison, or tune, with the tuning-fork; the effect on it will set it vibrating to such an extent that it will be heard to sound the same note as the tuning-fork.

So it is with electrical circuits; if we apply oscillating electrical or magnetic forces to them the effect will be a maximum if the forces are applied at the same frequency as the natural electrical frequency of the circuit; or if the circuit is arranged so that its electrical frequency is the same as that of the forces applied.

In the case before us, if  $K_2$  mfd. is the capacity of the open, or aerial to earth circuit, and  $L_2$  cms. is its Inductance, (mostly in the

coil AC); then its electrical frequency is  $\frac{5 \times 10^6}{\sqrt{L_2 K_2}}$ , and the oscillating currents set up in it will be a maximum if this frequency is equal to that of the forces acting on it; *i.e.* if  $\frac{5 \times 10^6}{\sqrt{L_2 K_2}} = \frac{5 \times 10^6}{\sqrt{L_1 K_1}}$ , or if the wave lengths are equal— $59.6\sqrt{L_1 K_1} = 59.6\sqrt{L_2 K_2}$ .

Such electrical circuits are said to be in tune with each other, and it is easy to see that two circuits are in tune when  $L_1 K_1 = L_2 K_2$ . Generally the capacity of the open circuit is less than that of the closed circuit, *i.e.*  $K_2$  is less than  $K_1$ ; therefore  $L_2$  is greater than  $L_1$  when the product  $L_2 K_2$  is equal to  $L_1 K_1$ .

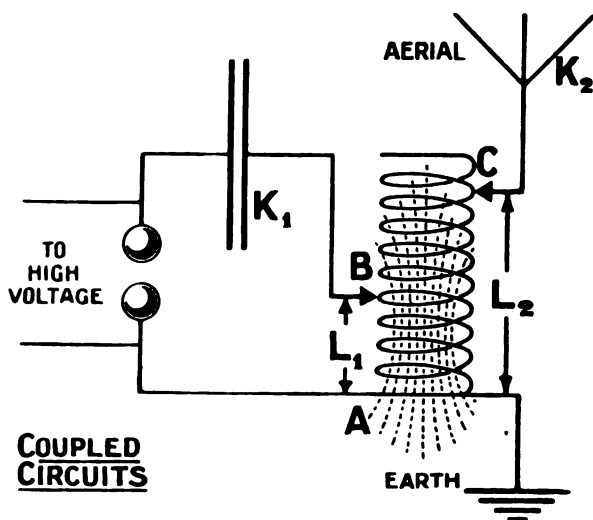

FIG. 68.

That is to say, capacity effects predominate in the closed circuit and inductance effects in the open circuit; thus we always find more of the coil included in the open circuit than in the closed one as shown in Fig. 68. This method of joining syntonised circuits to each other is called "auto-transformer coupling."

But there is another method by which the circuits can be coupled; it seems to have been developed and first applied to radio-telegraphic circuits by Dr. Braun. In this method the closed oscillatory circuit of a transmitter is coupled to the open, aerial, or radiating circuit by electro-magnetic effects alone.

Referring to the use of an Induction coil for producing high voltages, it was seen how the action of intermittent direct current

in a primary winding could induce E.M.F.s in the turns of a secondary winding, due to the sweeping of the magnetic lines out of the iron core every time the current was suddenly reduced to zero. The same action occurs in a transformer, where the currents flowing in the primary are alternating currents of ordinary slow frequency, such as 50 cycles per second.

Nikola Tesla discovered that similar effects could be produced by oscillating discharges of electricity, or high frequency currents, (the frequency of which might be a million cycles per second), and he introduced the Oscillation Transformer, sometimes called the Tesla Transformer. Its primary consists of a few turns of thick

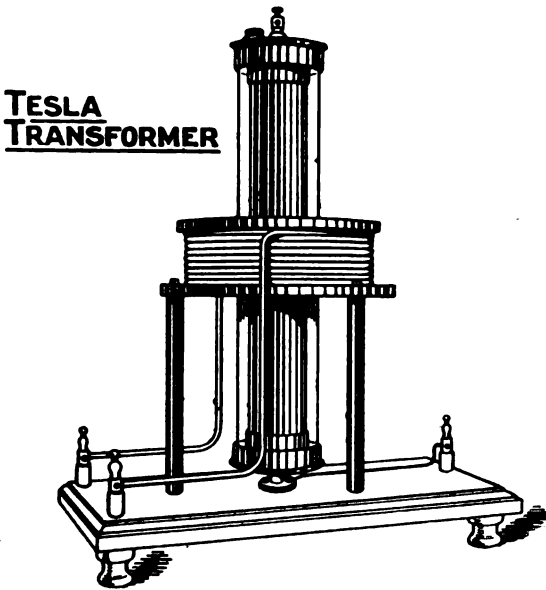

FIG. 69.

copper wire; the secondary of many turns of much thinner wire, separated from the primary by a thick cylinder of ebonite, or glass, or by an air space. They must be well separated so that there is no possibility of a direct discharge passing from the primary to the secondary. In some cases the whole arrangement of coils is immersed in a glass case filled with purified paraffin oil to increase the insulation. Fig. 69 shows such a Transformer. The primary coil forms part of an ordinary oscillating discharge circuit, containing condensers, such as Leyden jars, and a spark gap. High frequency oscillating currents flow in the primary, setting up through it an



oscillating magnetic field; this induces a high frequency E.M.F. in the secondary winding, and, as there are many turns on this winding, the induced E.M.F. in it can be made to have a very high value, even up to a million volts. Thus it can give powerful brush discharges, and a vacuum tube held near it in the hand will light up. If such a high frequency high voltage circuit is touched it will not be felt, nor have any harmful effects, so that one can grasp the terminals of such a circuit with the hands without feeling any sensation of shock. An iron core would be of no service in such a transformer; rather the reverse, for the oscillating magnetic fields would heat it up seriously. Also, there is no

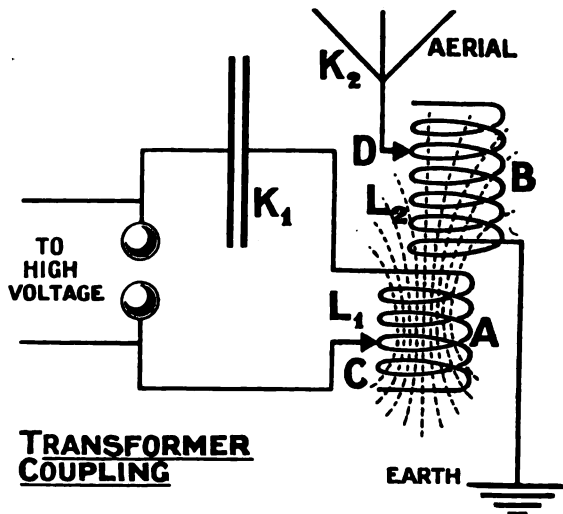

FIG. 70.

advantage in having more than one layer of winding in either the primary or secondary, as the inductive effects at high frequencies would prevent the current flowing into the inner windings. *All coils used for radio-telegraphy purposes on high frequency currents have only one layer of winding.*

Oscillation transformers used in the transmitting circuits of radio-telegraphy are not exactly of the same design as that just described, for reasons which will be apparent later, but their action is much the same.

In Fig. 70 is seen the usual form of closed oscillating circuit, and the time depicted is that at which the discharge current, through the circuit and across the spark gap, is a maximum, so

that a magnetic field is built up through the coil A. Close to A is another coil B joined to the aerial and earth; it is seen that the magnetic lines of A are to some extent interlinked with the coil B, so that the two circuits are coupled together by these magnetic lines, or, as we say, by electro-magnetic induction. Just as in the case of a single coil, when the magnetic lines are set up through, or shrink back into, coil A as the discharge oscillates, they will induce oscillating E.M.F.s in coil B, which will send oscillating currents surging up and down the aerial to earth circuit. The inductive effect in B will depend on the size and number of turns in it, that is to say, on its coefficient of self-induction  $L_2$ : and the surges in the open circuit will have maximum values when  $L_2 \times K_2 = L_1 \times K_1$ , *i.e.* when it is in tune with the closed circuit. The two circuits can be brought into tune by changing  $L_1$ , or  $L_2$ , or both: this can be accomplished by having moving contacts at A and B, so that more or less turns of the coils can be included in the circuits as required. If the frequency or wave length of one circuit is changed, that of the other circuit can then be tuned to it, and should be so tuned; with reservations, however, which shall be dealt with later.

In the Marconi system the oscillation or coupling transformer is called the "jigger"; it is used in all except the smallest of the Marconi equipments.

It is evident from the foregoing that energy is conveyed to the opened circuit from the closed circuit by the magnetic lines of strain coupling them, and of course the object aimed at is to get as much energy as possible oscillating in the open circuit. Also, the main object of oscillating energy in the closed circuit is to turn as much of it as possible into radiated energy in the form of ether waves, so that the transmission of energy shall be of maximum efficiency.

It would, therefore, seem desirable to use every magnetic line set up in the closed circuit, and make it transfer energy to the open one by coupling the two circuits as closely as possible; such close coupling takes place in an induction coil, in an ordinary transformer, and in an ordinary Tesla transformer, and would be effected in this case by placing the inductance coil of the open circuit so that all the magnetic lines, oscillating in the coil of the closed circuit, interlink with and act upon it.

Thus in the first method of coupling, shown in Fig. 68, this would be accomplished by having as many of the turns in the coil as possible common to both the open and closed circuits; and in the second method of coupling by having the coil B wound over coil A, so that all the magnetic lines oscillating in coil A will

act on all the turns of coil B. Unfortunately, however, when two circuits are thus magnetically coupled, complications arise which prevent us making use of this method of obtaining maximum efficiency; effects which we must now consider. They involve the damping effect, the amount of energy radiated, the purity of the wave length, in other words the tuning; also the question of interference with other stations.

In the first place, the oscillating currents set up in the open circuit will produce lines of magnetic force in its coil B, Fig. 70, which will interlink with coil A, and when the current flowing in the closed circuit has filled the spark gap with gases, and made the circuit one of good conductivity, the magnetic lines from coil B will set up an extra induced current through the closed circuit; in other words *energy will be transferred back from the open circuit to the closed one*. Now we know that one of the advantages of using an open circuit, as shown, is that there is no spark gap in it to introduce resistance, and its resistance can be kept small by using suitable aerial and connecting wires. Thus when oscillating currents are set up in it there is very little damping effect due to resistance; no doubt it radiates more energy than a closed circuit, and the radiation damping will be greater than that of a closed circuit, yet, on the whole, the damping decrement would be small. When oscillations are set up in it, they should be still swinging backwards and forwards even after the closed circuit discharge has been damped out. If, however, the aerial circuit returns some energy to the closed one at each oscillation we have here a new damping effect, and the closer the circuits are coupled the more will this damping of the open, or radiating circuit, be increased.

A wave train, started in the ether by the first oscillation, will require further contributions of energy, radiated into the ether behind it if it is to spread to any distance; these it will not get if the oscillations in the radiating circuit are quickly damped out. The less damped the oscillations the farther will the radiated energy travel; also more of it will travel at a definite wave length to which receivers can be tuned, and less energy may be expended in the transmitter in order that reception may take place at a given distance. Hence the rival systems of radio-telegraphy use methods and apparatus to decrease the damping of the oscillations in the aerial circuit. The Poulsen System uses wave trains which are practically undamped; the Telefunken System is such that its aerial circuit oscillates freely with very slight damping, though the oscillations of each discharge in the closed circuit are quickly damped out; the Marconi Co. have

perfected their apparatus to attain a like result, without the same extreme damping effect in the closed circuit as takes place with the Telefunken apparatus.

We note, therefore, that if circuits are closely coupled there will be a large damping effect on the radiating circuit, and the amount of energy radiated will be relatively small; referring here only to spark systems. Incidentally it may be noted that the transfer of energy from the radiating circuit, back to the closed circuit, would be diminished if the resistance of the closed circuit spark gap could be automatically increased at the moment its discharge had ceased. Then the inductive effects of the radiating circuit would not be great enough to send currents through this extra resistance, and so energy would not be transferred back. We shall see later that such automatic action is claimed for the Marconi Rotating Disc Discharger, and for the special spark gaps of the Telefunken Co.

Now let us consider the question of tuning, and the effects produced on the tuning of circuits according as the coupling is fast or loose. To say that a circuit radiates energy at a certain wave length means that, if electrical oscillations are allowed to take place freely in it, some of its energy is carried away by ether waves, and a greater amount of the energy will be carried by ether waves of the length calculated from the electrical constants of the oscillating circuit than by waves of any other length. The oscillating discharge will set up ether waves of many different lengths, but the principal wave length will be that which carries most energy. In a similar way the disturbances at the sun set up many different lengths of ether waves, the one carrying most energy being a heat wave; a note struck on the piano sets up different lengths of air waves, the one of most energy corresponds to the fundamental note, the others are called harmonics. If the aerial and earth wires in a radio-transmitter are directly connected to the closed circuit in which oscillating discharges are taking place, and a curve is plotted, showing the energy transmitted to the ether in any one direction at different wave lengths, it would be of a shape such as shown in Fig. 71. Most energy in the particular case shown is transmitted at 300 metres wave length, but at the same time a considerable amount of energy is transmitted at 200 metres and 400 metres wave length. A receiving station closely tuned to 300 metres wave length would only be acted upon by a small portion of the energy, such as that shown shaded; all the remainder of the radiated energy would not affect it. At the same time a receiving station, tuned to any wave length between 100 and 500 metres, would probably receive

signals from such a transmitting station in its neighbourhood, for the curve shows that there may be sufficient energy at any of these wave lengths to affect the corresponding receivers. Such a transmitting station is not a tuned one at all, and will interfere with all the stations near it.

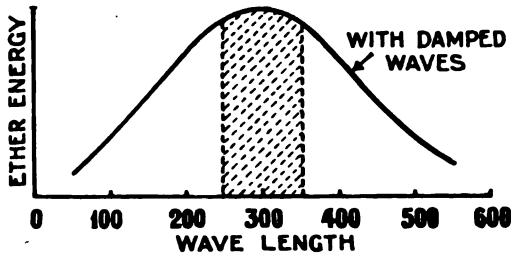

FIG. 71.

The object to be aimed at is to get as much of the energy as possible radiated at, or near, one definite ether wave length, so that if a receiving station is tuned to that wave length most of the radiated energy will act upon it. At the same time receiving

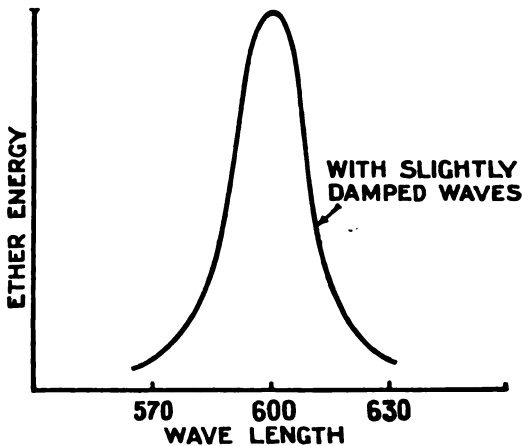

FIG. 72.

stations not in tune will not receive the signals. Thus Fig. 72 would show an ideal case. Most of the energy radiated into the ether is carried at 600 metres ether wave length, and nearly all the energy radiated in any one direction would act upon a receiving station, in that direction, tuned to 600 metres, but

stations tuned to 500 or 700 metres would not be acted on by sufficient energy to work their receiving apparatus. Of course it is only the shape of the curve of energy that need be considered, for the actual amount of energy at any point depends on the distance from the transmitter, and it gradually dies away with increasing distance; also the energy is spread in all directions round the transmitter. Thus the curves simply show the ether wave lengths which are conveying the energy at any place.

Now, if the aerial, or radiating circuit, of the transmitter is magnetically coupled to its closed, or primary circuit, by either of the methods described, and if the coupling is loose, then it is found that most of the energy is radiated at one principal wave length. This wave length is that of the aerial circuit, to which

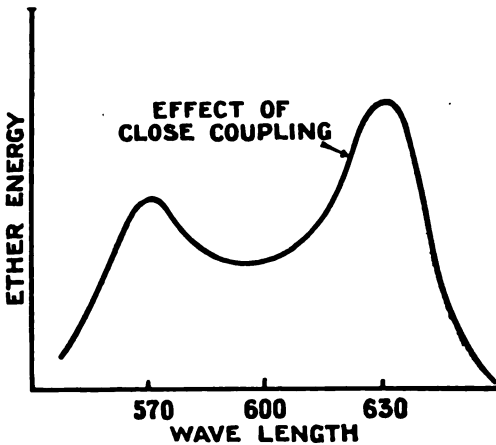

FIG. 73.

also the closed circuit has been tuned. If, however, the circuits are close coupled, then the curve connecting radiated energy and wave length will be shown in Fig. 73. It will be seen that there are two points of maximum value on the energy curve, showing that the circuit is radiating energy at two principal wave lengths, neither of which is the natural wave length of the oscillating circuits. These wave lengths can be easily discovered by the use of a wavemeter, as shall be described in a later chapter. Referring to Fig. 73, a receiving station tuned to a wave length of 630 metres would in this case be unaffected by all the energy carried at 570 metres wave length; that is to say, efficient use is not being made of all the radiated energy. The closer the open and closed transmitter circuits are coupled, the greater will be the

difference of the two radiating wave lengths, until with tight coupling one is practically reduced to zero and the radiated energy is spread out to the other wave length, as shown in Fig. 71. Thus, with tight, or direct, coupling, though the closed and open circuits are both tuned to a certain wave length, the energy is radiated from them at no definite wave length, and a receiving circuit will be affected by only a very small fraction of the ether energy at any place. On the other hand, if the coupling of the tuned open and closed circuits is made loose, the two resulting wave lengths come nearer to each other in value, until with sufficiently loose coupling the phenomenon of two wave lengths does not arise, and the greater part of the radiated energy occurs at one definite wave length, as shown in Fig. 72.

Before proceeding further, let us consider why two wave lengths are obtained with close coupling, neither of which is the wave length to which both the open and the closed circuits are tuned; one being greater and the other less than the electrically calculated wave lengths of the circuits. The effect is due to the mutual action of the one circuit on the other. It has been pointed out that the magnetic lines due to the oscillating currents in the aerial circuit may transfer energy back again to the closed circuit, and the effect will be greater the closer they are together. This action occurs at a regular periodicity, alternately acting with and against the oscillating energy in the closed circuit, so that its inductive value ( $L$ ) is alternately increased and reduced by very small amounts, but sufficient to change the wave length from one value to another during each surge of the oscillating current. The inductive effect of one circuit on another is called "mutual induction," and the *coefficient of mutual induction* ( $M$ ) between two circuits is the inductive effect produced in one when the current in the other is changing at the rate of 1 ampere per second. It is measured in henrys, millihenrys, or centimetres. The closer two circuits are coupled the greater will  $M$  be, and in these radio-telegraphy circuits, the mutual induction is at one moment added to the self-induction and at the next opposed to it. Thus if  $L$  is the self-induction, the total inductive effect in the circuit at one moment is  $(L + M)$  and at the next is  $(L - M)$ . Therefore two frequencies are impressed on each oscillation, and two wave lengths are set up in the ether, *i.e.*  $59.6\sqrt{(L + M)K}$  and  $59.6\sqrt{(L - M)K}$ .

**Damping.**—We are now in a position to study the various damping effects in more detail, and note both how and why they should be avoided.

Let us consider the effects of damping in the two circuits of the

transmitter separately. In the primary circuit the oscillations decrease in amplitude very rapidly, as shown in Fig. 74. The meaning of amplitude has already been defined, and it has also been noted that the small oscillations take exactly the same time as the large ones. A train of oscillations of decreasing amplitude is said to be damped, and this damping is due to loss of energy. The damping in the primary circuit is caused by three effects: (1) Energy lost in resistance, especially in that of the spark gap, which, as we have seen, must not be too long for this reason. The oscillating energy in the primary circuit may be stopped by an automatic increase of spark resistance. (2) Energy given to the aerial circuit through the medium of the magnetic lines set up

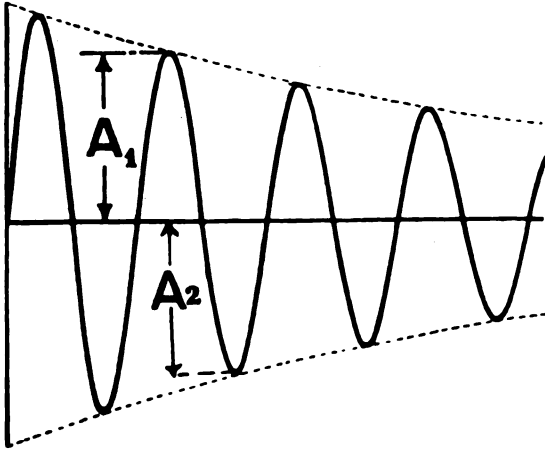

FIG. 74.

in the primary of the coupling coil. They set up oscillating currents in the secondary coil. This may be the largest damping effect in the primary circuit, except where quenched sparks are used, as described later. (3) Energy lost by radiation—this is a very small effect in the primary circuit as it is but a poor radiator, most of the electric strain occurring chiefly in the ether involved in the dielectric of the condenser, therefore it is not a strain which is widespread round the circuit.

As already explained the total damping effect is measured by obtaining the *damping decrement*  $(\delta) = 2.303 \log \frac{A_1}{A_2}$ .

The damping in the aerial circuit is due to three causes also: (1) Energy lost in resistance; this can be kept very small by

K



using wires with sufficient surface area and stranded as much as possible, (cables of 500 strands being often used in some of the apparatus); also by having good earth contacts. In the aerial circuit there is no spark gap resistance to consider. (2) Energy lost due to radiation; this of course cannot be avoided as it is the object of the transmitter to radiate energy, but the aerial circuit can be so designed that this radiation of energy is spread over a number of oscillations rather than taken from a few, so decreasing the damping per oscillation, and ensuring that there will be more oscillations than would otherwise be the case. Such aerials are called slow radiating ones; a familiar type is the umbrella aerial much favoured by the Telefunken Co. for their land stations. (3) Energy transferred back to the primary circuit from the secondary coil of the coupling transformer; this results in two waves being set up, as already described; it can be obviated by loose coupling between the coils, in conjunction with an automatic increase in the resistance of the primary circuit, at the proper moments of time, by means of rotary disc dischargers or quenched sparks as shall be hereafter described.

Thus the damping effect in the aerial circuit can be made very much less than that in the primary circuit, so that at each spark the aerial oscillations go on after those in the primary have ceased.

Here again the damping decrement ( $\delta$ ) =  $2.303 \log \frac{A_1}{A_2}$  and the

damping factor is equal to  $\frac{A_2}{A_1}$ . Each oscillation in the aerial circuit radiates energy in the form of an ether wave, so that each ether wave conveys away energy. The energy per wave decreases at a rate depending on the damping effects in the coupled circuits; thus it is seen that the *damping of the radiated waves depends on the degree of coupling (k), on the form of spark gap used, and on the design of the aerial.*

The disadvantages of damped waves are:—(1) the first wave sent out is not followed by much energy in the waves behind it, so that it must itself carry a large amount of energy which can spread across a good range before it is dissipated. This means that the transmitting apparatus, to give a large initial impulse, must be larger than if the same energy was conveyed by a number of smaller but more equal impulses; in other words, with slightly damped waves a given range can be covered with much smaller apparatus. (2) Damped waves imply that, instead of most of the energy being radiated at one wave length, it is spread more or less over a wide range of wave lengths. A receiver station, tuned to one wave length, loses the energy which

is conveyed by waves not in tune with it, and all the receiving stations of different wave lengths within the shortened range of the transmitter are affected by it, causing the nuisance of interference. (3) If the damping is mainly due to a tight coupling, the energy is radiated at two principal wave lengths, and as a receiver can only be tuned to one of them it misses all the energy conveyed by the other; this also decreases the range of transmission.

When dealing with interference effects, the International Radio Conference made the regulation that the damping decrement should not be greater than 0.2; this means that in any two consecutive oscillations, the second amplitude equals at least 0.82 of the first ( $A_2 = 0.82A_1$ ). In good slightly damped systems the damping decrement is very much less than this; for example, in the Telefunken System, if the radiated waves are 3 to 4 times the natural wave length of the aerial, the decrement of radiation is not greater than 0.05.

The question at once naturally arises:—if the primary has a certain damping decrement, and the aerial circuit a different damping decrement, how is the decrement of transmission related to these two? Now, in the general case of two coupled circuits, the energy radiated has two maxima at two different wave lengths; with tight coupling one of these is very nearly zero, with close coupling, the two wave lengths are very distinct and can easily be found with a wavemeter, with very loose coupling they practically merge into one principal wave length. The damping decrements of transmission for the two wave lengths are given by the formulæ—

$$\delta_1 = \frac{\delta_p + \delta_a}{2} \times \frac{\lambda}{\lambda_1}$$

$$\delta_2 = \frac{\delta_p + \delta_a}{2} \times \frac{\lambda}{\lambda_2}$$

In these formulæ  $\delta_p$  and  $\delta_a$  are the decrements of the primary and aerial taken separately,  $\lambda_1$  and  $\lambda_2$  the two wave lengths at which maxima of radiation takes place— $\lambda_2$  being the longest,  $\lambda$  is the wave length to which both the primary and secondary are tuned, and  $\delta_1$  and  $\delta_2$  are the two decrements for the two principal radiation wave lengths  $\lambda_1$  and  $\lambda_2$ . With *proper loose coupling*, when  $\lambda_1$  and  $\lambda_2$  are approximately equal (and equal to  $\lambda$ ) it is easily seen that  $\delta_1$  and  $\delta_2$  are equal—

$$\delta = \frac{\delta_p + \delta_a}{2}$$

The measurement of decrement is dealt with in Chapter XX.

**Coupling.**—What is called the “Coefficient of Coupling” is given by the formula  $\frac{M}{\sqrt{L_1 \times L_2}}$ , but it is more usual to speak about the “Degree of Coupling” which depends not only on the Coefficient of Coupling, but also on the decrements of damping in the two circuits. If, as is usual, we denote “degree of coupling” by  $k$  then—

$$k^2 = \left( \frac{M}{\sqrt{L_1 L_2}} \right)^2 - \left( \frac{\delta_p - \delta_a}{2\pi} \right)^2$$

Drude has shown that theoretically a single wave length is obtained if  $\frac{M}{\sqrt{L_1 L_2}} = \frac{\delta_p - \delta_a}{2\pi}$ ; i.e. if  $k = 0$ .

Thus, to approach single waveness,  $k$  must be kept very small, and in practice it is never more than about  $\frac{1}{5}$ , or, as it is more often written, 20 per cent.

Examining the formula for  $k$ , we know that  $\delta_p$  and  $\delta_a$  are both very small, therefore the second part of the formula which is subtracted from the first is very small. Hence, if  $k$  is to be small it is easily seen that  $M$ , the mutual induction effect, must be small.

Now, in general, when two circuits are coupled, energy is radiated at two lengths; these are—

$$\lambda_1 = \lambda\sqrt{1 - k} \text{ and } \lambda_2 = \lambda\sqrt{1 + k}$$

$\lambda$  being the wave length to which the circuits are tuned, and  $\lambda_2$  being longer than  $\lambda_1$ . In order that  $\lambda_1$  should nearly be equal to  $\lambda_2$ , i.e. that we should have single waveness, it is easily seen that

$$\sqrt{1 - k} \text{ should be equal to } \sqrt{1 + k} \text{ approx.,}$$

and this can only happen if  $k$  is very small.

In practice the degree of coupling ( $k$ ) varies from 10 to 20 per cent.; the Telefunken system use a coupling of about 20 per cent., which is a relatively high value made possible by the automatic action of their quenched spark.

With a wavemeter it is easy to measure the two resultant wave lengths of coupled circuits, and thus we have a means of measuring the degree of coupling.

$$\begin{aligned} \text{For } \lambda_1 &= \lambda\sqrt{1 - k} \text{ and } \lambda_2 = \lambda\sqrt{1 + k} \\ \therefore \lambda_1^2 &= \lambda^2 - \lambda^2 k, \quad \lambda_2^2 = \lambda^2 + \lambda^2 k \\ \therefore \frac{\lambda_2^2 - \lambda_1^2}{2\lambda^2} &= k. \end{aligned}$$

This can be written  $\frac{(\lambda_2 - \lambda_1)(\lambda_2 + \lambda_1)}{2\lambda^2} = k$  and  $(\lambda_1 + \lambda_2)$  is very nearly equal to  $2\lambda$  for a transmitter fairly loosely coupled, therefore, cancelling these, we have—

$$\frac{\lambda_2 - \lambda_1}{\lambda} = k \text{ approximately.}$$

With an ordinary sparking transmitter the degree of coupling should not be greater than 15 per cent. if the regulations of the International Radio Convention are to be complied with and tuning out made possible, thus avoiding interference with other stations. For a similar reason the British Post Office Authorities will not allow a licensed station to have the aerial circuit direct coupled to the primary circuit of the transmitter, except when signals of distress are being sent, or when the power in the transmitter is less than 50 watts.

If energy could be prevented from returning to the primary circuit by an automatic increase of its resistance, then, even with a tighter coupling than usual, the aerial circuit will oscillate freely without much damping, and energy will be radiated at a pure wave length. This effect has been attained in practice by modifying the design of the spark gap in the primary circuit. The resistance of an ordinary spark gap is actually decreased after the first oscillation of discharge, owing to the ionisation of the air in the gap; with the Marconi disc discharger and the Telefunken quenched spark the resistance is greatly increased just when the oscillations in the aerial circuit have attained their maximum, thus preventing a return of energy to the primary circuit. With these dischargers the coupling may be made tighter than usual, thus transferring more energy to the aerial circuit without an increase of damping. Their use will mean that the decrement of damping in the aerial circuit is small, and the decrement in the primary circuit is relatively larger than usual.

If the circuits are coupled too loosely the energy will be radiated from the aerial sharply to one wave length, but its amount will be small, because few of the magnetic lines of the primary coupler will interlink with the aerial circuit coil, and thus very little energy will be transferred to the latter circuit. Much of the energy oscillating in the primary circuit would then be wasted, and the transmitter is again inefficient. Fig. 75 shows the resonance curves of a properly coupled circuit (*a*); one too tightly coupled (*b*) and one too loosely coupled (*c*).

In explaining the tuning of coupled circuits, and the coupling conditions necessary to obtain maximum radiation effects at a

sharply defined wave length, it was assumed that two circuits, primary and aerial, were tuned to the same wave length. As a matter of fact with spark systems one cannot get zero damping effect in the aerial circuit, so that the maximum resonance is obtained when the frequencies of the two circuits are slightly different, and this difference will increase with the resistance of either circuit. Thus we find that in the Telefunken transmitter the circuits are slightly mistuned, the aerial circuit having a free wave length about 2 per cent. higher than that of the primary circuit, and this mistuning is increased with the closeness of coupling. It is claimed for this arrangement that it aids the quenching of the oscillations in the primary circuit, thus leaving

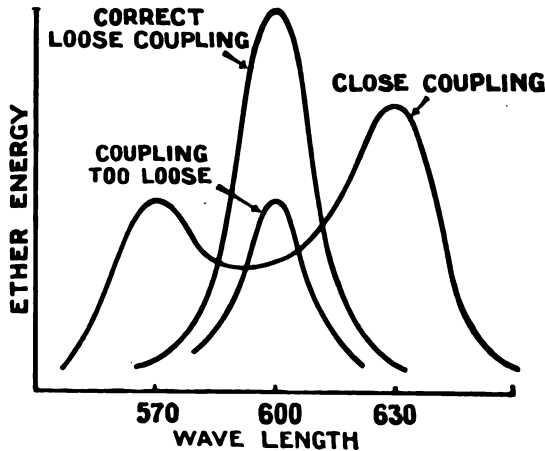

FIG. 75.

the aerial circuit free to oscillate at its own frequency, and giving a well-defined maximum of radiated energy at that wave length.

Before leaving the question of tuning and coupling, there are one or two particular cases which may be noted. It will be remembered that the complete Kelvin formula for frequency is—

$$n = \frac{1}{2\pi} \sqrt{\frac{1}{LK} - \frac{R^2}{4L^2}} \text{ or } = \frac{1}{2\pi} \sqrt{\frac{1}{LK} - \left(\frac{R}{2L}\right)^2}$$

If the primary circuit is such that  $\frac{R^2}{4L^2} = \frac{1}{LK}$  then its discharge is a direct one and not oscillatory; if it is coupled to an aerial circuit the latter will oscillate at its own natural frequency, no matter what may be the values of  $K$  and  $L$  in the closed circuit.

If, on the other hand, the open circuit resistance is increased while the closed circuit has its usual low resistance, both circuits will oscillate, and the open circuit will never cease to oscillate before the closed circuit; its oscillations will, however, be forced oscillations of the frequency of those in the closed circuits.

These results were obtained by Dr. Fleming in a valuable series of oscillograph records on oscillatory circuits.

Whether the auto-transformer or Tesla-transformer method of coupling should be adopted largely depends on the design of other portions of the apparatus, such as the spark gap; the desired distance of transmission, and the closeness of tuning required.

The jigger, or two-coil coupler, gives the sharpest tuning, and thus best avoids interference with, or by, other stations, but the auto-transformer would for a given amount of energy transmit farther. Thus the Telefunken Co. use the auto-transformer coupling for long distance transmission, and the two-coil coupling for shorter distances when interference with neighbouring stations is likely to occur.

From the foregoing it will be seen that damping effect, efficiency, tuning, and interference are all involved in each other, and in the degree of coupling. If the coupling is too close the damping effect becomes great, less energy is radiated, and there is no definite wave length. If the coupling is loose enough, and the spark gap of such a design that little energy is transferred back from the aerial to the primary circuit, then the radiation of energy occurs sharply at the fundamental wave length of the circuit, and tuning is good. Stations of other wave lengths are not interfered with; there will be more oscillations at each discharge, and the radiated energy is more persistent; finally, the transmitter need not be as powerful as would otherwise be required.

#### QUESTIONS AND EXERCISES ON CHAPTER.

1. Describe an oscillation transformer or jigger. Why has it not got an iron core?
2. The closed circuit of a transmitter has an inductance of 10 mhs. and a capacity of 0.0074 mfd. If the radiating, or aerial, circuit has an inductance of 63.4 mhs. what must be the capacity of the aerial so that the two circuits shall be in tune?
3. What is the wave length of the transmitter described in Question 2 if the circuits are loose coupled?
4. Why are two wave lengths of maximum resonance obtained when two tuned circuits are close coupled?
5. Explain how the degree of coupling influences the effects of interference on stations not in tune with the transmitting station.

6. Why does the International Radio-Telegraphy Congress specify that the degree of coupling of the two circuits of a transmitter shall not be greater than 15 per cent. ?

7. A circuit has an inductance of 0.018 henrys, a capacity of 0.75 mfd., and a resistance of 16.5 ohms. Calculate its natural frequency, its damping factor, and the decrement of damping.

8. When the two circuits of a transmitter are coupled and oscillatory discharges sent through them, each being tuned to 600 metres wave length, the radiated energy is found to have two maxima, at 630 metres wave length and 570 metres wave length respectively. Calculate the degree of coupling of the circuits.

9. What modification of the closed circuit spark gap of a transmitter would enable closer coupling to be adopted without increasing the damping of the radiated energy ?

10. Explain why maximum resonance is obtained by slightly mistuning the closed and aerial circuits of a transmitter.

11. What is meant by sharp tuning ?

12. The Marconi Transatlantic transmitter use wave lengths of 6000 metres ; what is the frequency of this radiation ?

13. A station transmitter sharply tuned to one wave length of radiation has a radiation decrement of 0.1. If the decrement of its aerial circuit is 0.08 what is the approximate value of the decrement of its closed circuit ?

## CHAPTER XII

### *TRANSMITTER CIRCUITS FOR SPARK SYSTEMS*

A TRANSMITTER consists of three circuits: (1) a generating circuit for giving high voltages, either intermittent or alternating; (2) a closed circuit to which the high voltages are applied, and in which oscillating discharges take place; (3) an open or radiating circuit linked, or coupled, to the closed circuit.

For small power stations, up to 300 watts, the generating circuit consists of an induction coil joined to a battery through a manipulating key of the Morse pattern. As already described the induction coil should be specially designed with a low resistance secondary, and wound to produce resonance effects, so that a relatively large current will flow at each rise of secondary voltage. The induction coil will be fitted with a specially rapid make and break, giving a maximum of about 100 pulsations per second.

It is preferable to join choke coils in the leads connecting the secondary of the induction coil to the oscillating circuit. These are coils having such inductance values that they prevent the high frequency oscillating discharge currents from flowing back into the secondary of the induction coil, where they might cause such great potential strains as would damage the insulation of the secondary. The choke coils do not appreciably stop the currents which flow from the induction coil secondary to charge the oscillating circuit.

Choke coils for this purpose can be made by winding a single layer of copper wire (No. 20 to 40, according to the current to be carried) on flanged and glazed porcelain cylinders, three inches diameter and about four inches long.

If such a coil has an inductance of "L" henrys the reactance it offers to a current oscillating or alternating at a frequency of "f" cycles per second is  $2\pi fL$  ohms. Since the oscillating discharges in the closed circuit have a frequency of  $\frac{3 \times 10^8}{\lambda}$



( $f = 1,000,000$  when  $\lambda = 300$  metres) it is easily seen that the reactance of the choke coils ensures that the oscillating currents will stay in the closed circuit, and cannot stray into the secondary of the induction coil. The frequency of the current which flows from the induction coil to the closed circuit is only 50 to 100, depending on the rapidity of the make and break, hence to these pulsating currents the choke coils offer little reactance. For small equipments the reactance of the induction coil secondary is relied upon to choke back the oscillating currents, but the end turns of the secondary are then subjected to undue potential strains, and the use of auxiliary choke coils is to be preferred.

The complete generating circuit will be as shown diagrammatically in Fig. 76.

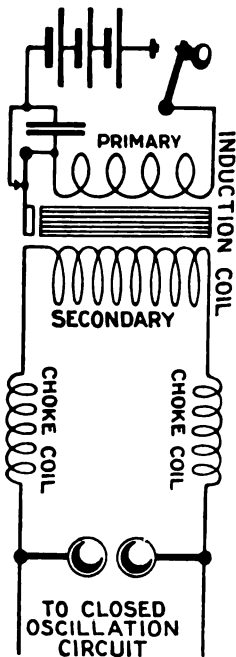

FIG. 76.

through it from the alternator to the primary of the transformer. It has been already explained that an alternating current flowing in a capacity circuit leads the volts in phase, therefore the current flowing from the secondary coil of the transformer into the condenser of the oscillating circuit will be nearly 90 degrees before the secondary volts. This current would be counterbalanced, as it were, by an equivalent current flowing into the transformer primary from the alternator, its phase leading that of the alternator's voltage. With given values of current and voltage the energy delivered from the alternator

will be a maximum if the current and volts are in phase. Remembering, then, that capacity and inductance reactance can be made to neutralise each other, we see that by joining a coil of suitable inductance value in the alternator or low voltage circuit,  $2\pi fL$  can be made equal to  $\frac{1}{2\pi fK}$  in the formula for current given in

Chapter VII. Then  $C = \frac{V}{R}$ ; the current is not only a maximum, but is also in phase with the volts, so that the generator is being most efficiently used.

When resonance is set up the voltage across the condenser will build up to a much higher value than would otherwise be the case; in fact, it is now only limited by the spark gap length. *If we use resonance effects we may only get one discharge, or spark, for every 3 or 4 cycles of primary voltage* as these may be required to build up the secondary voltage.

The inductance coil joined in the low voltage circuit has generally got severalappings, so that the inductance can be chosen of a suitable value to give resonance. A state of resonance can finally be obtained by adjusting the speed of the alternator, and therefore the value of the frequency "*f*." It will be remembered that  $f = \frac{\text{poles} \times \text{r.p.m.}}{120}$ ; it is therefore directly proportional to the speed, and can be thus adjusted in value. In the leads from the transformer secondary to the oscillatory circuit are joined choke coils, to guard the secondary from undue potential strains; their construction and action being similar to those already described in connection with the use of a spark, or induction, coil. As a further precaution against oscillatory effects in the alternator it is usual to shunt its terminals with a non-inductive shunt, such as a graphite resistance or a carbon filament lamp; oscillatory impulses of voltage will expend themselves in these resistances rather than through the inductive windings of the machine.

The alternator may be driven by a steam, gas, or oil engine, or by an electric motor. If it is a motor drive the speed of the alternator can be raised by putting resistance in the field circuit of the motor, and the speed decreased by lowering the resistance in the motor's field; the motor is therefore provided with a field rheostat. Thus the frequency of the alternator can be adjusted to give resonance, or to the spark rate desired; the discharges in the oscillatory circuit occurring at a rate which is twice the frequency, *i.e.* a frequency of 200 gives 400 sparks per second.

But the voltage of the alternator also depends on the speed

of rotation of the armature, and it may be desirable to change the speed or frequency without changing the voltage. If  $V$  = volts generated,  $M$  = magnetic lines per pole,  $Z$  = wires in series on the armature,  $f$  = frequency, then  $V = \frac{2.22 MZf}{10^8}$ . We see that the voltage can be changed by varying the strength of

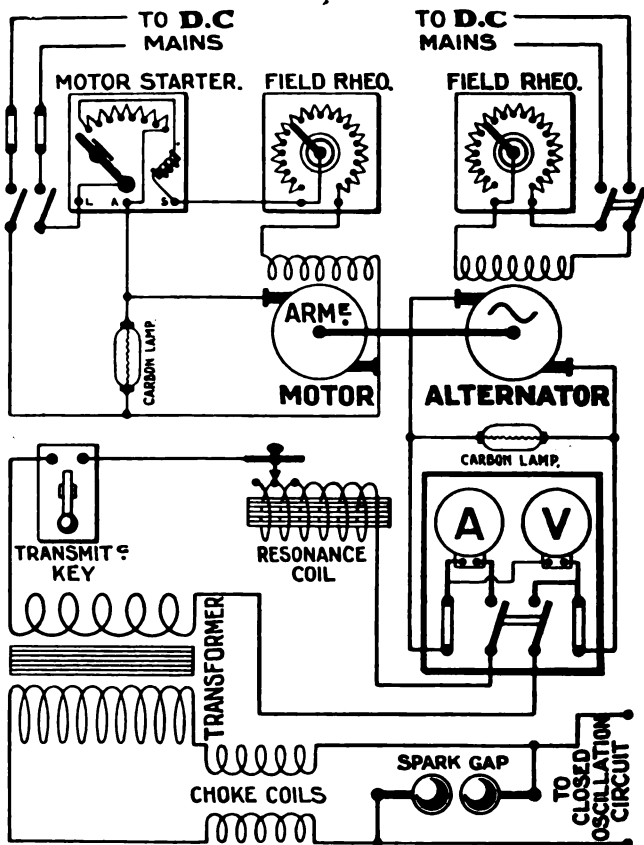

Fig. 77.

the magnetic field ( $M$ ), and this can be accomplished by changing the field current flowing in the coils on the poles. Thus a field rheostat is joined in series with the field coils of the alternator, by changing the resistance of which the generated volts can be adjusted to the desired value. Our complete high voltage generating circuit will then be as shown in the diagram in Fig. 77.

If a public alternating current supply is available, as in many parts of the United States and Canada, an alternator is not required, and the high voltage step-up transformer is directly connected to the supply mains, choke coils being joined in series with the leads to the primary coil. An adjustable iron core inductance coil should also be joined in series with the primary to bring the current into phase with the volts and thus give resonance. In this case the frequency, and hence the spark rate, cannot be adjusted, and as the frequency of the public alternating supply in North America is never more than 125, the spark rate will not be high enough to give a musical note.

The closed oscillatory circuit consists of a condenser, a few turns of inductance, and a spark gap or other form of discharger. The values of capacity and inductance in this circuit are chosen so that the oscillatory discharges will take place at a desired frequency—

$$f = \left( \frac{5 \times 10^6}{\sqrt{L_{\text{cms.}} K_{\text{mfds.}}}} \text{ approx.} \right)$$

corresponding to a radiation wave length

$$\lambda = 59.6 \sqrt{L_{\text{cms.}} K_{\text{mfds.}}} \text{ approx.}$$

metres

This closed, or oscillatory, circuit is coupled to an aerial radiating circuit, the coupling being by direct connection when the energy applied to the transmitter is not more than about 30 watts: with larger energies the circuits will be coupled inductively by means of an auto-transformer or a jigger transformer. The coupling of these circuits has been dealt with in the preceding Chapter, and it was there shown that the two circuits should be arranged to have similar oscillation constants; *i.e.*  $L_1 K_1 = L_2 K_2$ . The capacity ( $K_2$ ) in the aerial circuit is generally much less than that in the closed circuit ( $K_1$ ), hence the inductance ( $L_2$ ) in the aerial circuit must be greater than that in the closed circuit. Up to a certain point this can be arranged by having more turns in the secondary than in the primary of the oscillation transformer, or "jigger." This ratio of secondary to primary turns qualifies the degree of coupling, hence with a certain number of primary turns, which is fixed for a given wave length, we are limited in the number of secondary turns it is desirable to employ. Therefore, further increase of inductance in the aerial circuit must be made by a coil quite distinct from the oscillation transformer. This is called the aerial inductance coil; it is usually joined in series between the secondary of the oscillation transformer and

the aerial. Its inductance may be varied, either by having adjustable connections on its coils (Marconi), or by having its coils so that they can be displaced relatively to each other (Telefunken). The aerial itself will consist of two or more wires and the capacity in this circuit will be that of the aerial relative to the earth. The inductance  $L_2$  consists of three parts: that of the aerial itself, that of aerial inductance coil, and that of the secondary of the oscillation transformer.

The fundamental, or natural, wave length of the aerial is that given by its own capacity and inductance, and if the aerial could be arranged so that its *natural wave length is that at which radia-*

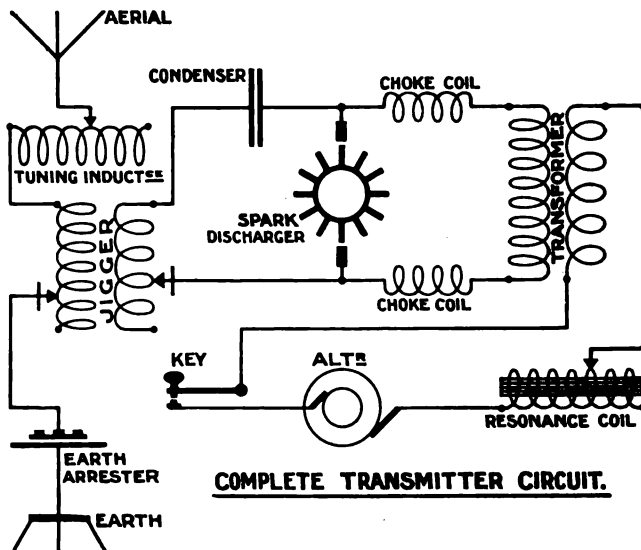

FIG. 77A.

tion is desired, it would then be most efficient as a radiator. Of course we must couple it to the closed circuit which means the addition of artificial inductance, but the point to be remembered is that the less artificial inductance added to the aerial, in the form of loading coils, the more efficient it will be as a radiator.

In general, it is not possible, owing to limitations of space, to make the aerial large enough to give the desired wave length: hence inductance coils must be added. By the use of inductance coils it is not practicable to increase the wave length to more than 4.5 times the natural aerial wave length; beyond that it loses radiation efficiency. Hence it is most important that the natural wave length of the aerial should be known; thus, if it is

desired to transmit on a 600 metre wave length, and the aerial wave length is only 150 metres, the aerial should be changed. Its height or length should be increased, so increasing both the capacity and inductance; the wires may be placed farther apart increasing its capacity (the inductance will be decreased, but this change is not important); or more wires may be used in parallel on the aerial, increasing its capacity.

On the other hand, it may sometimes happen, especially with amateur stations, that the natural wave length of the aerial is larger than that at which it is desired to transmit, owing perhaps to limitations of Post Office Licence. The aerial may be required to receive messages on long wave lengths, and thus a decrease of its dimensions is not practicable nor desirable. In this case the only thing to be done is to join a condenser of suitable capacity in series with the aerial instead of an inductance coil. The condenser is usually connected in the earth lead, and can be provided with a short circuiting switch, by means of which it can be cut out of action when messages are being received. In fact a short circuiting switch is absolutely necessary, because the condenser insulates the aerial from earth and therefore the aerial may become statically charged. A better method is to join the condenser in parallel with the aerial inductance.

Shortening an aerial wave length by means of a series condenser has two disadvantages: first, there is danger from lightning discharges which may strike the aerial while transmission is taking place, and while therefore it is insulated from the earth: in the second place, it is not an efficient radiator, for that part of the energy oscillated in the series condenser does not contribute to the radiation.

In the aerial circuit a special type of hot-wire ammeter may be joined by means of which the effective value of the current oscillating in the circuit is measured. It is to be noted that, whereas the maximum of potential will be at the far end of the aerial, the maximum current will occur at the earthed end, hence the ammeter should be joined in the earth lead from the coupling transformer. The reading on the ammeter will be a maximum when the closed and open circuits are properly tuned and properly coupled to each other; such an instrument should therefore be included in every transmitter equipment.

The aerial circuit will also include a long break highly insulated switch, by means of which it can be connected either to the transmitting apparatus or to the receiving apparatus: in the Marconi equipments an earth arrester takes the place of the aerial switch.

The complete closed and open circuits of the transmitter will thus be as shown diagrammatically in Fig. 78.

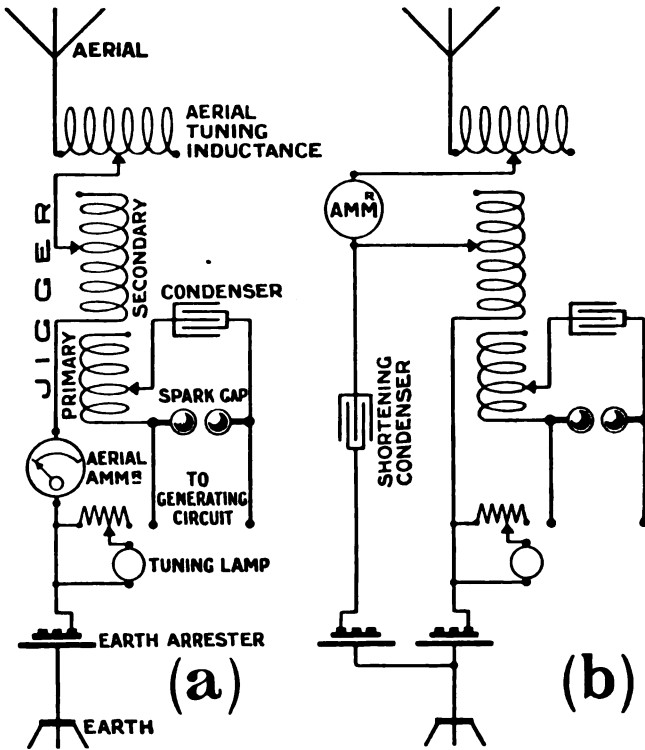

(a) Transmitting on long waves. (b) Transmitting on short waves.

FIG. 78.

Let us now consider the actual conditions of oscillating energy in the primary and aerial circuits. The simplest method is to work to an example, so we shall assume that the transmission wave length is 600 metres, then—

$$n = \frac{v}{\lambda} = \frac{300,000,000}{600} = 500,000,$$

or the time of one oscillation is  $\frac{1}{500,000}$  second.

If there are 10 oscillations of energy in the primary circuit at each spark then the duration of a spark is  $\frac{1}{50,000}$  second.

The make and break of an induction coil will vibrate at, say, 100 times per second, and usually a spark does not take place at each break of the primary current; however, let us assume that there are 100 sparks per second, so that one spark is obtained in each  $\frac{1}{100}$  second.

Under these circumstances the oscillating currents of the primary circuit are shown in Fig. 79 (a). We see that, while a spark is obtained in each  $\frac{1}{100}$  second, the spark itself only lasts  $\frac{1}{50,000}$  second; during a considerable portion of the complete time of transmission there is no oscillation of energy.

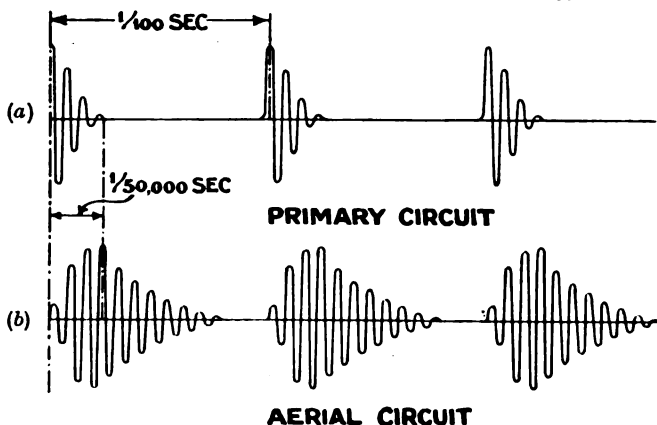

FIG. 79.

If an alternator and step-up transformer is used, the frequency will probably not be lower than 200 cycles per second, giving 400 sparks per second, or a spark in each  $\frac{1}{400}$  second. In this case energy will be oscillated four times as often as is shown above, at the same time the difference between  $\frac{1}{50,000}$  second, which is the duration of a spark, and  $\frac{1}{400}$  second, the interval between sparks, is still very great.

Now let the closed, or primary, circuit be coupled to an aerial circuit with not more than 15 per cent. degree of coupling; close enough to cause the transference of about 30 per cent. of the energy

L



to the aerial circuit, but loose enough to avoid much damping effect in the latter owing to re-transfer of energy. Oscillations are then set up in the aerial circuit; these are slightly damped, chiefly on account of radiation of energy to the ether at each oscillation. If the radiation of energy is fairly slow, *i.e.* if it radiates only a comparatively small amount of energy at each oscillation, then, with proper coupling and a suitable spark gap, damping of the aerial oscillations will be small. Energy will continue to oscillate in the aerial, at each spark, after the corresponding oscillations have ceased in the closed circuit. This is shown in Fig. 79 (b). In Chapter XIV. it will be shown that slow radiation, and a slightly damped aerial, can be obtained by using a suitable design—such as the umbrella type; but even with an L or T aerial the oscillations in the aerial circuit will continue after the spark is over, provided a suitable design of spark gap and suitable coupling conditions are employed.

Yet even in the aerial circuit, when transmission is taking place, there are comparatively long intervals between each train of oscillations. At first sight it might appear as if these intermittent trains of oscillations should cause irregularity in the sending of dot and dash signals; a little consideration will remove this idea.

If the rate of signalling is, say, 20 words of 5 letters each per minute, that is 100 letters in 60 seconds or  $\frac{5}{3}$  second per letter. Let the letter consist of four dashes separated by four intervals of equal duration; this would give us  $\frac{5}{30}$  second per dash. Then 100 sparks or oscillation trains per second will give nearly 8 trains of oscillations to each dash; thus each signal sets up a great many oscillations in the aerial circuit, and sends out a great many ether waves to act on the distant receiver.

With an ordinary spark gap in the closed circuit it is probable that the degree of coupling, suitable to obtain a sufficient amount of energy in the aerial circuit, will not prevent some of this energy from being transferred back to the closed circuit, with consequent damping of the aerial oscillations. But when a Marconi rotary spark or a Telefunken quenched spark is used this re-transfer of energy does not take place, and thus the aerial currents are free to oscillate without much damping. Also in the Marconi and Telefunken Systems the spark frequency is very high, giving what is called a "musical note." The Telefunken System spark frequency is often 1000 (alternator generating frequency 500); also the oscillations in the closed circuit are rapidly damped out so that only about 5 oscillations of energy take place at each spark. Let us consider these

conditions for a 600 metre wave length. The time of oscillation is  $\frac{1}{300000}$  second, therefore each spark of 5 oscillations takes  $\frac{1}{100000}$  second while the interval between sparks is only  $\frac{1}{1000}$  second; thus we obtain 50 oscillations in  $\frac{1}{100}$  second. In the example of Fig. 79 we had only 10 oscillations in each  $\frac{1}{100}$  second. Thus with high sparking frequency we have far more oscillations of energy in the closed circuit at each signal than with an ordinary spark, and since the aerial currents are now oscillating freely without much damping the effect is still more magnified in it. Instead of what might be called spasmodic oscillations we have now persistent oscillations: these may have a smaller amplitude than before, but since they are more numerous the total energy radiated to the ether is increased.

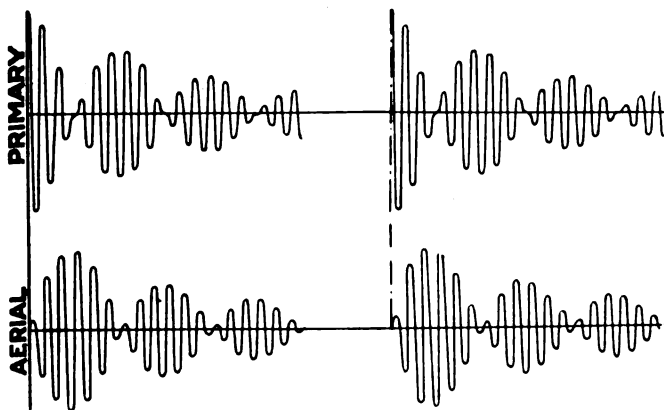

FIG. 80.

Therefore, with less energy applied to the primary circuit (less watts delivered from the battery or alternator), the use of a rotary or of a quenched spark may increase the radiation of energy—not only that, but, owing to the small aerial damping the energy is radiated at a more closely defined wave length, therefore will have more effect on a receiver tuned to that wave length.

In Fig. 80 may be seen the effect of close coupling on the oscillations in the closed and aerial circuits.

We know that with close coupling energy is lost from the aerial circuit, in that it is transferred back to the closed one. This results in the propagation of ether energy at two principal wave lengths, or what amounts to the same thing, the aerial oscillates at two frequencies, the frequency changing from one value to the other rhythmically.

Dr. Fleming has obtained oscillograph curves of the current changes under the conditions of close coupling, the curves are similar to Fig. 80. It will be seen that the energy surges between the two circuits: the amplitude of the current in one circuit suddenly falls while that in the other rises, then the reverse action takes place, and this is repeated throughout an oscillation train.

Such transmitting conditions are inefficient for two reasons: (1) energy is unnecessarily lost from the aerial, (2) radiation is not taking place at a pure wave length.

We will conclude this chapter by a short consideration of the calculations involved in the transmitter circuits.

If  $K$  is the capacity of the condenser in the primary, or discharge, circuit measured in microfarads, and  $V$  the sparking voltage, then the energy discharged at each spark is  $= \frac{1}{2} \frac{KV^2}{10^6}$  joules. If the spark frequency  $= s$ , then *power in the discharge circuit* is given by  $W_p = \frac{1}{2} \frac{sKV^2}{10^6}$  watts.

The power rating of the alternator will generally be considerably more than this to allow for losses in transformer, chokes, etc., and to ensure the certainty of a spark at each maximum of voltage.

The current in the primary circuit is obtained by considering the reactance of capacity which we know to be  $\frac{10^6}{2\pi nK}$  where  $n$  is the oscillation frequency; the sparking voltage is the maximum voltage, hence *maximum current in primary circuit* :—

$$C_p = \frac{V}{\frac{10^6}{2\pi nK}} = \frac{2\pi nKV}{10^6} \text{ amperes}$$

but  $n = \frac{3 \times 10^8}{\lambda} \therefore C_p = \frac{6\pi \times 10^2 KV}{\lambda}$  amperes

The decrement of the closed circuit— $\delta_p = \frac{R_1}{4nL_1}$ ,  $R_1$  being the high frequency resistance, including the spark gap, and  $n$  the oscillation frequency. The effective current  $C_e = \frac{1}{\sqrt{2}} C_p$  and the *energy lost*—

$$C_e^2 R_1 = C_e^2 \times 4nL_{1\text{cms}} \delta_p = C_e^2 \times \frac{10^6 \cdot \lambda \cdot \delta_p}{3K_{1\text{mfd}}} \text{ watts.}$$

Thus *energy available for the aerial circuit is*—

$$\left( \frac{1}{2} \frac{sKV^2}{10^6} - C_s^2 \times \frac{10^6 \cdot \lambda \cdot \delta_p}{3K} \right) \text{ watts.}$$

The amount of this transferred to the aerial depends upon the degree of coupling. We may assume the current induced in the aerial is distributed along it as a sine wave, as shown in Fig. 101; thus, if a hot wire ammeter in the aerial, at its base, shows  $C_a$  amperes, the average of mean square of current is  $\frac{1}{2}C_a^2$ , and the energy wasted in the aerial is  $\frac{1}{2}C_a^2R_a$ , where  $R_a$  is its high frequency resistance. Therefore the *energy radiated* is—

$$A \left\{ \frac{1}{2} \frac{sKV^2}{10^6} - C_s^2 \times \frac{10^6 \cdot \lambda \cdot \delta_p}{3K} \right\} - \frac{1}{2}C_a^2R_a \text{ watts,}$$

where  $A$  is a constant which varies with degree of coupling. This expression for radiated energy may be compared with that given in Chapter XIV., *i.e.*  $400C_a^2 \left( \frac{\text{aerial length}}{\text{wave length}} \right)^2$  watts.

QUESTIONS AND EXERCISES ON CHAPTER XII.

1. Do high and low frequency waves travel at the same speed?
2. The Telefunken Co. use alternators at 500 cycles frequency giving a spark frequency of 1000. Does the spark frequency affect the wave-length? if not, why not?
3. Name some of the advantages of a high spark frequency.
4. A transmitter is supplied with alternating current at 200 cycles frequency. If the condenser has a capacity of 0.0074 mfd., and the sparking voltage is 20,000 volts, what is the power oscillated in the primary circuit?
5. What is meant by a resonance state in the alternator circuit of a transmitter? How is it obtained?
6. What is the disadvantage of having a condenser in series with the transmitting aerial? What then is the best method of reducing aerial wave length?
7. Find the maximum current of discharge in the conditions described in Question 4.
8. Describe the auxiliary equipment of a motor-alternator generating set.
9. Why should the aerial hot-wire ammeter be joined into the circuit near the earth connection?
10. A wireless operator is always required to transmit with minimum effective power in his aerial. How is aerial energy most easily reduced?

## CHAPTER XIII

### *TRANSMITTING APPARATUS*

HAVING dealt with the theoretical considerations under which transmission is carried out, in this chapter a description of the apparatus used in transmitting circuits will be given.

For small stations, or as a stand by to larger outfits on ships, the source of high voltage for charging the primary circuit consists of an induction coil and battery—the design of such coil has already been described.

In places where alternating current supply is available, as in many American towns, an ordinary step-up transformer can be used; its secondary delivering current at say 10,000 to 20,000 volts, and at the frequency of supply, 50 to 125 cycles per second. Nothing more than this is needed to charge the primary circuit condensers and give the spark. The secondary coil must be well insulated owing to its high voltage, and should be specially well insulated from the primary winding. Such transformers, made by the Clapp Eastham Co. of Cambridge, Mass., cost £3 for  $\frac{1}{4}$  KW. size, £4 10s. for  $\frac{1}{2}$  size, and £7 10s. for 1 KW. size. Choke coils should be joined in the leads from the transformer secondary as described in the previous chapter.

In all ship stations of  $\frac{1}{2}$  KW. size and over, and in all large commercial stations, an alternating generator is connected to a step-up transformer, and these give the necessary high voltage.

The generator of a Marconi portable outfit is driven by a petrol engine, and the armature of the generator has a commutator at one end, through which the machine supplies direct current; this is used in the exciting coils on the pole pieces, also for charging the small batteries required in connection with the receiving circuit. To the generator shaft is also connected the rotary disc discharger, used by the Marconi Co. as a sparking arrangement. Such a Marconi generating unit is shown in Fig. 81. The Telefunken Co. also use alternators and transformers to supply energy to their larger transmitting outfits; the alternators having a frequency of 500 cycles per second, which gives high rate of sparking, and therefore a musical note in their patented form

of spark discharger. The frequency of the generator can be changed by varying its speed up or down, and in this way the pitch of the spark note can be raised or lowered. For their smaller stations the Telefunken Co. use induction coils.

Where alternators are used it is important that the motor or engine which drives it should do so at absolutely constant speed, in order that the frequency should not vary. For this reason the driving motor or engine should be of much larger output than the alternator, so that, having an ample margin of power, the load put on it every time the transmitting key is depressed will not affect its speed.

A direct current motor requires to have a resistance in series with its armature at starting up. This is because the armature

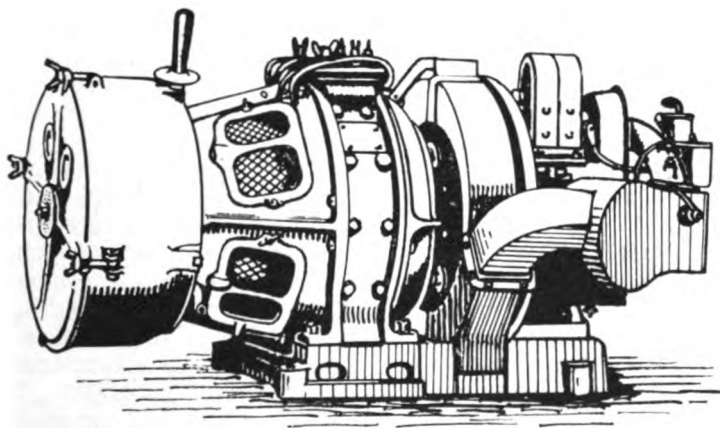

FIG. 81.

has a low resistance, generally less than an ohm; thus if it were switched directly on to, say, 220 volts, the current which would flow into it would be so excessive as to either blow the fuses or damage the motor. The field coils of the motor are, however, switched directly on to the mains, as they have a high resistance and take only a small current. When the motor armature gets up speed there is induced in it an E.M.F., exactly as if it were a generator, but this E.M.F. opposes the entering current; *i.e.* acts in opposition to the applied E.M.F. Thus the current is cut down as the motor speed rises, and the resistance in series with the armature can now be cut out as it is no longer necessary. This resistance is therefore a variable one, known as the starting rheostat, or simply—the starter. Again if the current round the

pole pieces of the motor is weakened, by inserting a resistance in series with the field coils, the number of magnetic lines crossing the armature will be decreased; that is to say, the field is weakened, and this has the effect of making the motor run faster. Similarly if the field is strengthened by increasing the field current the speed of the motor is reduced. Thus a variable resistance called the field rheostat is always joined in series with the field coils, and by means of it the speed of the motor can be varied.

The equipment of a driving motor will therefore consist of a double pole switch and double pole fuse to connect it to the mains, a field rheostat in series with its field coils, and a starting rheostat in series with its armature. An ammeter may be joined in series with the mains and a voltmeter across them, in order that the current and voltage supplied to the motor may be known. To start up the motor, the double pole switch is first closed, then the starter handle is pulled over on to the first or second contact and the motor starts. As the motor gets up speed, the starting handle should be pulled quietly over, cutting out the resistance until all is cut out, and the handle is held over by the attraction of an electro-magnet through which the current going to the field coils is flowing. Then the speed can be adjusted by means of the field rheostat. A diagram of motor connections is shown in Fig. 77. Generally a tubular form of carbon filament lamp or a graphite resistance is joined across the motor terminals; any oscillations of potential which may be set up in the circuit, by the inductive action of the oscillating discharges in the transmitter circuits, are absorbed by this lamp or graphite resistance, and thus will not affect the motor.

**Spark Gap.**—The design of the spark gap, or gaps, is of supreme importance, and much of the rapid development of radio-telegraphy has been due to a proper appreciation of this fact by Signor Marconi, Prof. Wein, Dr. Fleming and other pioneers.

Electricity always tends to discharge from or to points, a fact applied commercially in the pointed ends of lightning conductors; when, however, a circuit has to be charged up to a high potential before a discharge takes place, points must be avoided, hence spark gaps were originally made with two spherical electrodes of polished conducting metal.

For small radio-transmitters the spark gap consists of two electrodes, generally of zinc, though brass or copper may be used. These are mounted on ebonite insulating supports, and are spherical on the sparking surface; sometimes broadening out into circular plates with rounded edges at the back—these plates are called radiation fins, because they serve to radiate away the heat

caused by the spark discharge. The sparking surfaces of these electrodes become pitted and blackened by the discharge, and in the case of heavy discharges are worn away rapidly; they must be kept well polished and clean, otherwise the spark will not be a good one.

The distance between the spark electrodes must be very carefully adjusted. If the spark is too long it acts as a considerable resistance in the discharging circuit, and this causes great damping of the oscillations. If the spark gap is too short it either causes arcing to take place, which is simply a direct discharge without oscillations, or the condenser discharges across it before it has been charged up to the full voltage, with the full available amount of energy, so that the oscillations are unnecessarily weak.

Now the first oscillation of discharge ionises the air in the spark gap, which makes it a better conductor; in other words the resistance of the air is broken down, hence there is a tendency for a direct, or arcing, discharge to take place continuously across the gap.

In the early days of radio-telegraphy this tendency was combated by putting the spark gap in compressed air or in vaseline oil, but these methods are now discarded. In 1912 Dr. Eccles, London, described experiments he had carried out, in which he had passed heavy discharges across spark gaps immersed in running liquids, such as oil, or even water, without any tendency to arcing. No commercial development on these lines has yet taken place. If we put an open sparking device in the same room as the receiving apparatus, the noise made by the spark will lessen the operator's acuteness of hearing for the faint signals he picks up in the receiver telephones, possibly also the signals transmitted by the sparks might be overheard. Therefore it is enclosed in a sound proof box of heavy wood, well padded, though the front may have a glass window through which the operator may see that the sparks are passing properly.

Now the sparks combine some of the oxygen and nitrogen of the air into nitrous and nitric acids, which would deteriorate the insulating supports of the electrodes; thus these acid fumes must be got rid of, either by putting some quicklime in the box to absorb them, or by a fan arrangement which will carry off the vitiated air. At least one, if not both, the spark electrodes should be fitted with handles of insulating material by means of which the spark gap can be adjusted; when properly adjusted a good spark should give a sharp, crackling sound, and be of an intense



bluish white colour; an arcing spark will be more yellow in colour, and without what might be called viciousness.

Fig. 82 shows the spark gap used by the Marconi Co. on small outfits. The spark electrodes are of zinc hemispherical in shape, mounted in a padded case through which the terminal rods pass in ebonite tubes, the distance between the electrodes being varied by rotating them. Below the main electrodes are seen two point electrodes, fixed at a constant distance apart which is somewhat greater than the usual working position of the main electrodes. This gap protects the condenser and other apparatus from injury due to excessive voltages, which would be set up if the

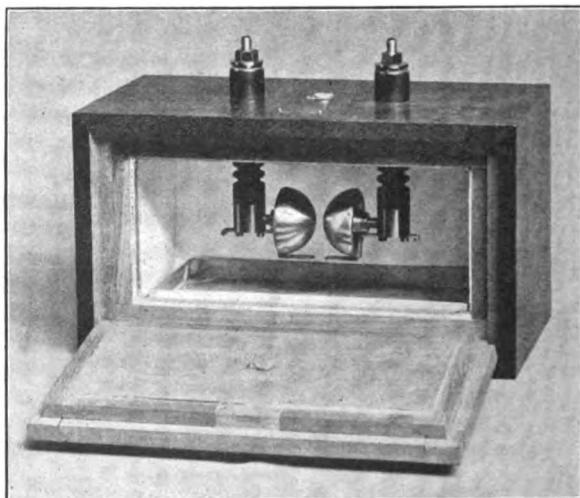

FIG. 82.

operator, by inadvertence, left the main electrodes too far apart and started to work the circuit. The condensers might then be raised to such a high voltage that their dielectric would be pierced by a discharge, or the insulation of some other portion of the circuit broken down: the auxiliary point electrodes act as a safety valve to guard against these risks.

When it is desired to raise the closed circuit to a high potential, before a discharge takes place, it is better to use two or more short spark gaps in series rather than have one long spark gap.

As long distance transmission developed, with consequent

increasing amounts of energy to be oscillated, as discharges, in the closed circuit, it became more and more difficult to operate these heavy discharges efficiently across the ordinary design of spark gap. Arcing took place or the insulation of the apparatus broke down; it became necessary to design some better form of discharger. Thus we find that an early development was to have one electrode in the form of a disc, rotated rapidly in front of the other electrode; by this arrangement a new surface was exposed to the discharge at each oscillation of current, preventing arcing and providing a fan effect to dissipate the vitiated air. Dr. Fleming designed an arrangement of this sort when the Marconi Co., transmitting across the Atlantic in 1901, found that ordinary spark dischargers would not handle the great energy (20 to 80 KW.s) required for signalling across this distance. Signor Marconi developed the rotary spark arrangement, and in 1907 patented his high speed disc discharger which has since been brought to great perfection. It not only gets over all difficulties of arcing, but also gives a high spark rate, the advantages of which for tuning and efficiency will become more apparent as we proceed.

**Disc Discharger.**—The disc discharger fitted by the Marconi Co. to their 25 KW. transmitter outfit is shown in Fig. 83, and its action is more or less similar to those used on the smaller outfits. It consists of a large disc, mounted on the end of the shaft of the alternator, and insulated by a thick coupling disc of rubber. The disc has a number of metal projecting teeth, the number depending on the frequency of the alternator, on the number of poles on the alternator, and on the spark frequency desired. Two fixed electrodes are mounted on insulators, and the teeth pass in front of these as the disc revolves, thus providing two spark gaps in series. The fixed electrodes here consist of metal discs rotated slowly by a chain gear, which is itself driven by a worm gear from the shaft. This is clearly seen in the illustration. Also, the position of the fixed electrodes can be changed by means of a worm screw, operated by the handwheel at the right; thus the timing of the spark can be adjusted.

In smaller disc dischargers, the rotating disc is of ebonite with a metal ring on which the teeth are fixed; the stationary electrodes are two copper teeth projecting from a plate of ebonite.

Owing to the capacity effect in the high potential circuit the maxima of voltage in it occur when the voltage wave of the generator is nearly at its zero value; the effect of capacity being to make the voltage in its circuit lead the primary voltage by nearly  $90^\circ$ , hence the spark discharges take place when the

alternator's voltage is very small, and so throws no strain on the

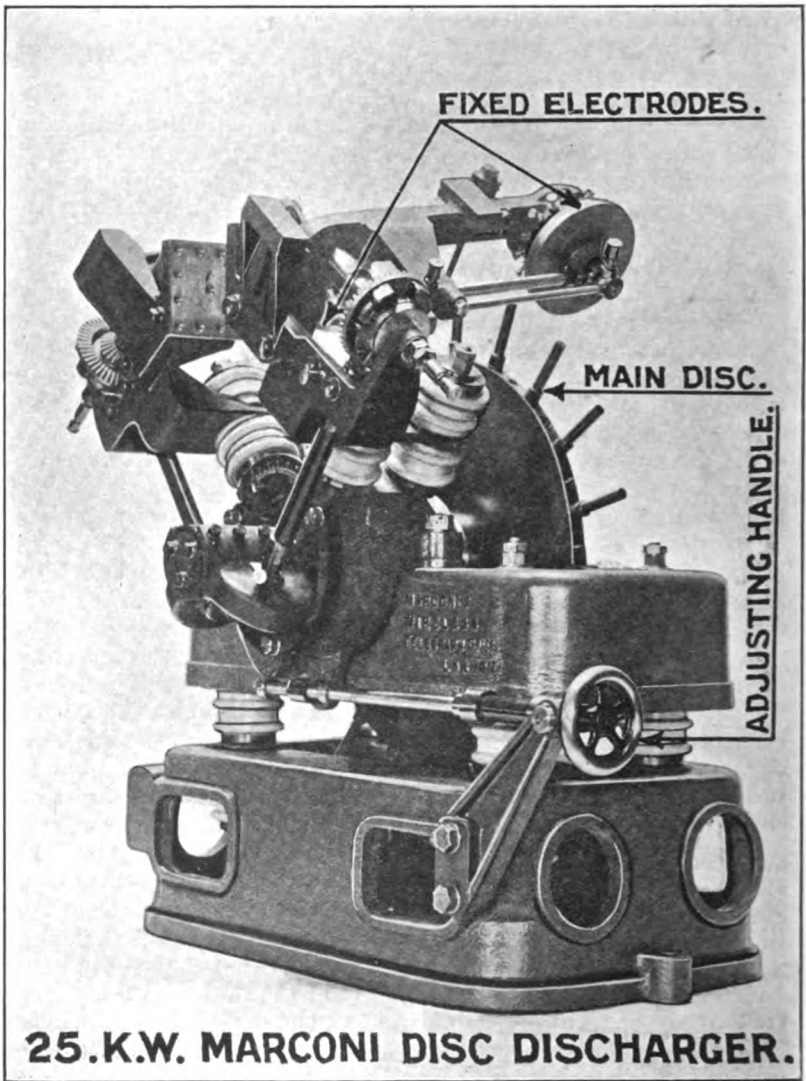

FIG. 83.

machine. The current from the alternator is nearly in phase with

its volts, since the reactance coil included in its circuit balances in it the capacity effect.

The advantages of a disc discharger are as follows :—

I. The discharge will commence when the distances between the revolving and fixed electrodes will be short enough to allow it, a distance which depends on the potential used and the capacity of the condensers ; it will commence *before the two gaps are short enough to allow of arcing*, and at the same time there will be *no missing of sparks*, for if the voltage is lower than usual the discharge simply commences a little later, when the electrodes are a little nearer to each other.

II. After the discharge commences the moving electrodes are passing the fixed ones ; the spark gaps are then shortened and have less resistance, thus decreasing any damping effect which would be due to spark gap resistance in the primary circuit. There will be no arcing with the shortened gaps, for the voltage has now fallen from its maximum, and is not, therefore, of a sufficiently high value to cause arcing.

III. By the time the maximum oscillation has been established in the aerial circuit the rotating electrodes are moving away from the fixed electrodes ; the spark gaps are thus automatically increased in length and resistance, so that no energy can return to the primary circuit from the aerial circuit ; the latter is, therefore, left free to oscillate at its own natural frequency, without its oscillations being damped by giving back energy. The only damping in the aerial circuit is then that due to its own resistance and to radiation.

Thus we get regular sparking without any misses, therefore a pure musical note ; no danger of arcing if the volts are too high ; automatic prevention of return energy from the aerial circuit, allowing of closer coupling than with an ordinary spark ; this means more energy delivered to the aerial, or a better efficiency obtained.

In disc dischargers of smaller size an iron casing encloses the electrodes and the revolving disc, and thus acts as a silencer to the spark ; it is fitted with an inspection door and provided with a fan arrangement which circulates the air inside the casing, driving off the nitrous gases through outlets in the casing fitted with sound proof material.

Small rotary discharges on the above principle, driven by electric motors, can be used on small sets with an induction coil if it has electrolytic or a motor-driven make and break ; with the ordinary hammer break a rotary discharger will not give a musical note, as the interruptions of primary current are too slow. As a matter of fact, a rotary discharger is not a suitable one to use

with an induction coil, for the voltage induced in the secondary of the coil rises to its maximum and falls from it very suddenly, so that it is most difficult to synchronise this voltage with a suitable spark length of a rotary discharger.

A motor-driven rotary discharger will give a good note if the source of voltage is an ordinary step-up transformer on an alternating current supply of say 100 cycle frequency, such as is obtainable in many towns in the United States. For satisfactory working, however, the frequency should not be less than about 200 cycles per second.

Fig. 81 shows a Marconi portable outfit, the alternator being driven by a petrol engine seen on the right; the disc discharger enclosed in a case on an extension of the alternator shaft, is seen on the left of the picture.

The fixed electrodes of a Marconi disc discharger in their insulating plate can be moved round by hand, so that the actual time at which sparking will take place can be adjusted to give the best effect, according to the individual conditions of the apparatus of each transmitting equipment when assembled. For this purpose graduations are marked on the enclosing case; the adjustment is generally made at the Marconi factory when the apparatus is being tested before delivery.

**Telefunken Quenched Spark.**—The quenched spark, or “singing spark” as it is sometimes called, invented by Prof. Max

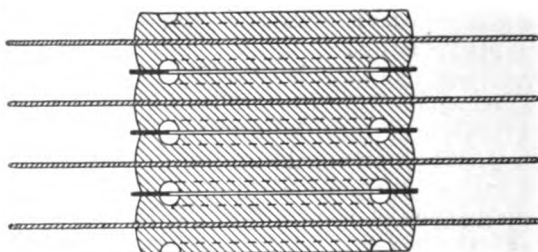

FIG. 84.

Wien in 1906, has been adopted by the Telefunken Co. as a characteristic part of their system. As made by them it consists of a number of metal discs, with grooves cut in them as shown in Fig. 84, each disc slightly recessed at the centre. The discs are separated by very thin insulating washers of mica, which extend only a little way across the grooves. The thinner these washers are the purer the wave at which the energy is radiated, so that the mica is only from  $\frac{1}{10}$  to  $\frac{3}{10}$  mm. thick. The metal discs are ground

dead true, and it is seen that instead of the energy being discharged in one large spark, it is distributed over several in series with each other. The spark will start at any part of the inner portions of the discs, and, owing to the electromagnetic action of the magnetic fields which are set up round the discharging current, it is rapidly driven outwards towards the grooves where it becomes lengthened and extinguished. This constitutes the quenching action, which is similar to that which takes place in a horn type lightning arrester. Fig. 85 shows a complete Quenched Spark Gap consisting of seven units; some of the units, if necessary, may be cut out of action by short circuiting them with metal

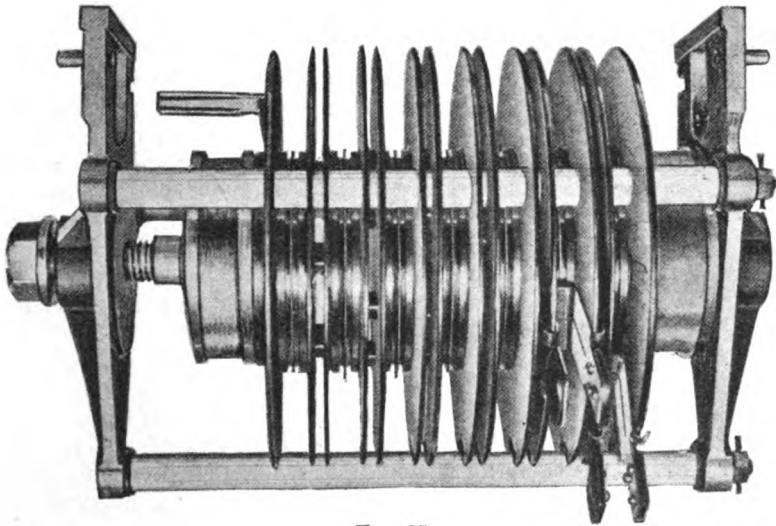

FIG. 85.

spring clips, seen in the illustration. The number of units employed depends upon the amount of energy to be handled; for instance, if half the spark gaps are only employed, then the condenser will discharge when only one quarter of the original energy has been stored in them, for energy stored in  $\frac{1}{2} KV^2$  and  $V$  depends on the total spark length. The Telefunken discs are of copper, faced with silver plates, the latter forming the spark gap proper.

Owing to the rapidity with which the sparks are quenched, *i.e.* the discharge is completed, the condensers will charge and discharge a much greater number of times per second with a quenched spark than with an ordinary spark; that is to say, the spark

frequency can be made very much higher, so that the sparks give out a musical note. The Quenched Spark discs are mounted on heavy porcelain insulating supports, clamped between metal end plates by means of a screw handle, or bolt, which can be easily released to permit of cleaning and generally overhauling the spark units.

The larger discs seen in the illustration are of thin copper, placed between each spark unit to radiate away the heat caused by the sparks. The units should be inspected about once in six weeks, as the sparks are likely to wear away the inner edges of the mica insulating washers.

Quenched spark gaps, made on the above lines, can be used with induction coil and battery excitation, but will only give a musical note if the coil is fitted with a rapid make and break; otherwise the spark will be of a hoarse sound which is not heard well in the receivers. The Telefunken Co. have designed a rapid make and break for their induction coils, used in the smaller stand-by transmitting outfits. The quenched spark will not work well on alternating current supply of ordinary low frequencies, where the transmitter is excited by a high voltage transformer. For use in commercial stations the Telefunken alternator is generally built for a frequency of 500 cycles per second, which, through the step-up transformer, gives 1000 sparks per second in the spark gap, so that a musical spark results.

Now let us consider and analyse the advantages claimed for the "quenched spark discharger."

I. A pure wave is radiated, in other words, most of the energy radiated is at one wave length. This is due to the fact that the spark is rapidly quenched so that it is extinguished by the time the oscillations in the aerial circuit have reached their maximum; hence no back transfer of energy can take place from the aerial circuit to the closed circuit through the coupling coils, whether the latter are of the auto-transformer or tesla transformer pattern. Therefore no damping of the aerial oscillations is caused by the coupling, and the aerial energy oscillates at its own natural frequency, thus emitting a pure wave. The degree of coupling used is about 20 per cent., and the best effects are obtained when the aerial circuit is tuned to a little longer wave length than the primary circuit; the difference increasing as the coupling is made tighter. This mistuning causes a slight reaction of the aerial circuit on the primary circuit which assists the quenching of the spark. The aerial energy thus oscillates with a very small decrement of damping after the primary circuit discharge is quenched as shown in Fig. 85A.

The Telefunken Co. claim that the damping decrement of the waves radiated is only about 0·8 to 0·1, with slow radiating umbrella and T antennae if they are working at their natural wave length, and is only 0·05 to 0·03 if the wave length is increased to three or four times the natural wave length by the help of inductance coils.

II. The range of existing stations using ordinary spark gaps can be doubled if a quenched spark gap is used.

This immediately follows from the above reasoning, for if a quenched spark gap decreases damping, and the oscillations in the aerial are free and persistent, the energy radiated, which with an ordinary spark gap would be spread over a range of wave lengths, and probably have two maximum values at two different

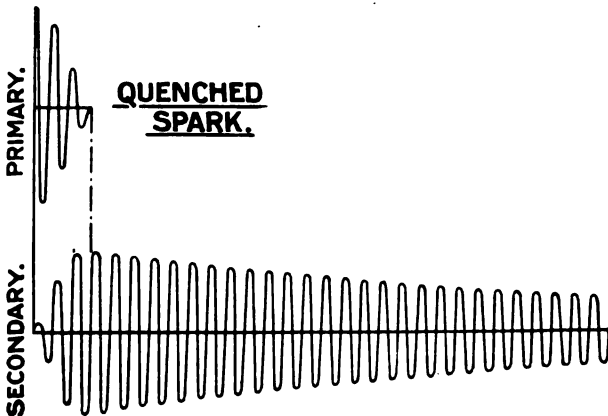

FIG. 85A.

wave lengths, is now nearly all radiated at one distinct wave length. It will therefore at that wave length be more than doubled in value; hence a receiver, tuned sharply to this wave length, will pick up the signals at a much greater distance than usual.

III. High efficiency of transmission, or much less power required for a given range.

This, in the first place, is owing to the small damping in the aerial, on account of which a large number of oscillations of energy takes place at each spark. Thus energy is sent out, radiated by the aerial, in persistent impulses rather than in one large impulse followed by a few smaller and decreasing ones. Instead, therefore, of having to provide power to set up the large impulse of energy,

M



a small power unit, capable of giving the persistent impulses, will suffice; also there will be more total energy in persistent oscillations of a given value than in larger oscillations which are damped. In the second place the receiver telephones are much more sensitive to high frequencies than low ones, and will give the same effective sounds with a very much smaller amplitude of receiver current at a higher frequency, provided it is within the range of audibility. This effect will be referred to again when dealing with receiver telephones.

IV. Small transmitter apparatus and aerials.

V. Large ranges compared with ordinary spark system. These advantages are involved in those already explained.

VI. High speed of signalling.

This is owing to the high rate of sparking, thus it can be calculated that the usual rate of 1000 sparks per second would enable signalling to be done at the rate of 240 words per minute, allowing 5 sparks to a dot and 10 to a dash.

VII. Less interference at the receiving station due to atmospherics or to other transmitters.

This is partly because of the musical pitch of the spark, which can easily be distinguished from other sparks even if the latter cannot be entirely tuned out, and partly owing to the sharp wave length radiation, which prevents stations not exactly in tune from causing interference at the sharply tuned receiving station.

Now if the student will study each of the considerations set out above and apply them to a Marconi disc discharger he will find that it also can claim these advantages; in fact the quenched spark and the rotary spark are simply two different means of attaining the same object. The object is to allow the aerial circuit to oscillate freely without the damping effect of transferring energy back to the primary circuit; also to have a high spark frequency giving a musical note, which will be easily distinguished amongst interfering disturbances, and will make high speed signalling possible.

It does not follow that these dischargers are equally good in all cases; the Marconi disc discharger would seem to be the best for dealing with the large energy values required for trans-oceanic work; for instance, it is a better design for radiating away the heat losses, and would not require the frequent renewals and overhauling which are necessary to a quenched spark gap.

The Telefunken quenched spark gives sharp tuning with coupling which is closer than that used with the Marconi apparatus; in this respect it is a more efficient transmitter. The high

spark frequency gives a high note in the receivers, which is easily discernible through atmospherics or interfering signals.

The new equipment at the Nauen station includes engines of 500-600 horse power, and this would seem to prove that no difficulty is experienced in handling large amounts of energy with the quenched spark. The new tower at Nauen for the umbrella aerial is 900 feet high, and the range is 4000 miles, a range which may be commercially accomplished, as the station has been in communication with transatlantic stations well over 2000 miles away, when the power available was only 35 KW. and the mast only 400 feet high. Indeed it is said that communication had already been established between Nauen and the German West African station 4000 miles away.

**Condensers.**—The simplest form of condenser is the Leyden jar, which is made up in various sizes; the capacity of a pint Leyden jar being about 0.001 microfarad. Condensers used in the transmitting circuits of wireless telegraphy have to stand very high potentials, and if the Leyden jar type is used, it is usually of a design specially adapted for this purpose. Thus the Telefunken system use the form of a Leyden jar shown in Fig. 86. The inside and outside coatings are of specially prepared tinfoil, and the glass dielectric extends considerably above the coatings, to prevent any risk of brush discharge loss, which depends on the length of the metallic edge of the coating in each jar. This type of condenser has the advantage of taking up very little floor space for the amount of capacity in each jar.

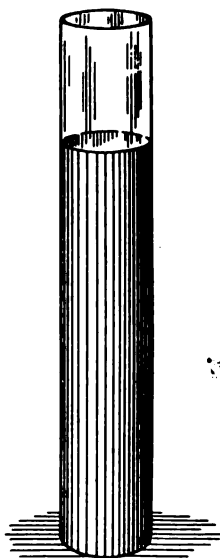

FIG. 86.

In ordinary ship and land outfits the Marconi Co. use a plate condenser. For those of  $\frac{1}{2}$  KW. size the plates are made of zinc 14 cms.  $\times$  34 cms., separated by glass dielectric, the glass being 0.3 cm. thick and extending about 6 cms. beyond the zinc in each dimension. The zinc plates are made with lugs, so that they can be easily attached to the connecting-rods joining alternate plates together, and plates can be quickly added to or subtracted from the condenser. The whole is contained in a stout teak box and filled with transformer oil, so as to eliminate any danger of direct arcing, while the terminals of the condenser are heavily bushed with ebonite. The capacity of the condenser here described

having 32 zinc plates, is 0.0074 microfarad; the addition of an extra zinc plate increasing the capacity by 0.00092 microfarad.

The whole system of zinc and glass plates can be easily lifted out of the tank for the purpose of renewing a glass plate, should one break down in the process of working. The condenser can be protected by a pair of spark points from any heavy strain of potential put across it, and the discharge of these spark points will notify to the operator the necessity of making better adjustments in his circuit.

For larger stations a battery of similar or larger condensers of the same pattern is employed. When a single condenser is used the capacity is changed by putting in or taking out one or more of the zinc plates and glass dielectrics, but on stations of, say, 5 KW. size, where a battery of these condensers is installed, a commutating switch can be used to vary the number of condensers in the circuit, according to the length of the wave it is desired to transmit. Where it is desired to transmit short waves by putting a condenser in the aerial circuit, this condenser may be of the same design as that here described.

With the  $1\frac{1}{2}$  KW. military (cart.) station of the Marconi Co., the transmitting condenser consists of 22 tube Leyden jars 24 ins. high, the coatings being of electrolytically deposited copper. Similar condensers, though smaller and, of course, less in number, are used in the Marconi cavalry type station, and in the special portable station of  $\frac{1}{2}$  KW. size for landing from warships.

It might here be noted that in ship outfits, the size and height of the aerial are necessarily limited, therefore the potential to which it can be charged is also limited. Thus it is usual to employ larger condensers than would be necessary in a land station of same range having a higher and larger aerial. By this means more energy can be utilised at the lower potential, and the wave length is increased; both effects conducing to increase of range.

For small transmitting outfits a suitable condenser can be made with zinc plates, using crown glass sheets as dielectric; ordinary soda glass should not be used, as the dielectric hysteresis loss in it would heat up the condenser. The zinc plates should be cut with rounded corners, and the glass should extend two or three inches beyond the zinc on every edge; the whole can then be tied together with tape and placed in a box which should be filled with melted paraffin wax. The higher the voltage at which it is desired to charge the condenser, the thicker should be the glass.

**“Dielectric Hysteresis.”**—When a condenser is charged we

know that positive charges are accumulated on one set of plates and negative charges on the other set, while electric strain lines are set up in the ether between the positive and negative charges, that is to say, in the dielectric between the plates. When a discharge takes place these lines should disappear, but it is found that, to a different degree with different dielectrics, all the electric strain does not disappear when the discharge should be complete. This means that all the electrostatic energy of charge is not turned into electromagnetic energy of discharging current, and hence a loss of energy occurs; before the condenser can be charged up again in the opposite direction, as it is by the oscillating currents, remaining electric strain lines must first be wiped out, and some energy of charge is wasted in doing this. The effect is called dielectric hysteresis: it is negligible with air dielectric, and is very small with oil dielectrics or flint glass; but may be considerable with ordinary glass or mica.

The effect of dielectric hysteresis is to heat up the condenser, just as all wasted energy is turned into heat; also since the dielectric hysteresis loss increases with the temperature it is easily seen that the effect becomes cumulative, and *the condenser may become very hot.*

When the Marconi Co. first set up their transatlantic stations the condensers in the primary discharging circuit consisted of large metal plates separated by glass sheets, but the loss of energy due to "dielectric hysteresis" in the glass was found to be appreciable, therefore the condensers now consist of large metal sheets, suspended from insulators side by side, so that air is used as a dielectric, and there is no hysteresis loss of energy.

**Teala Type Coupling Transformer.**—In the Marconi system the coupling transformers are termed "jiggers," and much experimental work, which it is unnecessary to describe here, was carried out by Signor Marconi and his scientific staff before the present form of jigger was evolved. The primary consists of a thick copper ribbon wound on edge as a square shaped spiral, mounted on an ebonite support which is held in a wooden frame with metal supporting legs. Over the primary there is an insulating sheet of ebonite, and on top of this is placed the secondary, which consists of insulated copper stranded cable, wound in one layer on a square wooden box with ebonite top. Tappings are taken from several points on the secondary winding to brass sockets mounted on the ebonite top. One end of the secondary is joined to the aerial by means of a plug inserted into a socket, and the connection to the earth plate is made by plugging into one of the other sockets, so that the number of turns of the secondary in use can be varied.

If a separate aerial inductance is also used the aerial plug is inserted in its terminal socket, and a flexible cable, with a plug at each end, connects one of the other tappings of the tuning inductance to one of the tappings of the transformer secondary. The connections to the transformer primary are made by spring clips, so that the inductance effect in use on it can also be chosen to give the best tuning effect. A Marconi jigger is shown in Fig. 87.

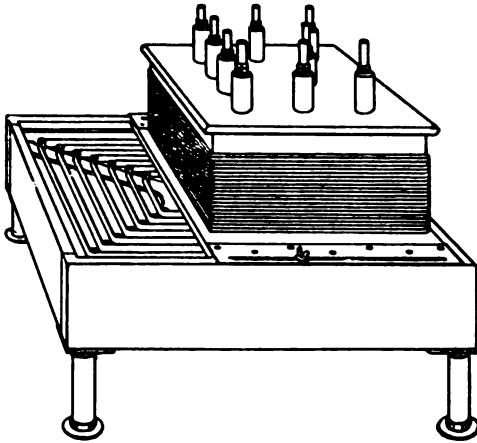

FIG. 87.

The secondary frame is made to slide in graduated grooves on the primary frame, so that it can be placed in the best position to give efficient coupling; the degree of coupling used being from 15 to 20 per cent. In the  $\frac{1}{2}$  KW. station the primary spiral has 7 turns of copper ribbon  $\frac{3}{4}'' \times \frac{1}{10}''$ , and the secondary has 21 turns of insulated stranded cable, the whole being mounted on a frame about 20'' square.

The Marconi 1.5 KW. military station has a tuning inductance square spiral in the closed circuit: the jigger primary consists of one turn, made of a number of wires insulated from each other in order to provide a large surface for the oscillations; the secondary has 15 turns of stranded cable with 3 tappings to a 3-way switch, by which it is joined to the aerial tuning inductance; as before the coupling is varied by sliding the secondary over the primary.

In a smaller Marconi outfit, where again an adjustable tuning inductance is used in the closed oscillating circuit, the jigger primary is a square spiral of  $3\frac{1}{2}$  turns; the secondary is a similar coil of 6 turns with 3 tappings.

The Telefunken Co. have also developed various forms of Tesla transformer for electromagnetically coupling the closed primary oscillating circuit to the aerial circuit, but this inductive coupling is used by them, as a general rule, only for stations of 15 KW. or over. It consists, in both primary and secondary, of

spirally wound circular coils of copper ribbon, wound on edge and mounted on the back of a switchboard; the degree of coupling being adjusted by moving the secondary nearer to or farther from the primary.

**Auto-Transformers for Direct Coupling.**—These transformers, or couplers, consist of only one coil, two or three turns of which are included in the primary or closed circuit, and several turns included in the aerial circuit; the number of turns being adjusted so as to tune the circuits to each other.

For small outfits they can be made by winding 8 to 10 turns of copper ribbon, or copper tube, on a rectangular frame, with four ebonite supports screwed to end plates of mahogany, teak, oak, or other hard wood; the coil being about one foot square, or one foot in diameter, and the tube or ribbon being held in place on the ebonite by cleats or screws.

The Marconi Co. do not use this method of coupling on any of their outfits, but it is used by the Telefunken Co. on stations up to 15 KW. size. The Telefunken stations are rated according to the power in the aerial circuit, not by the primary power, so that a 15 KW. station means one in which 15 KW.s are oscillating in the aerial.

The Telefunken coupling coil is a spiral of copper strip, wound on edge, and mounted in a wooden or ebonite frame of radial arms. On the spiral is fixed a number of sockets, into which can be fitted plug connectors from the other apparatus in the circuit, so that three or more definite wave lengths can be chosen. Fig. 88 shows the coupling coil, together with the condensers and spark gap of the Telefunken E type station, whose range over sea is 550 miles at night. The wave length can be adjusted to 300, 450, 600 and 900 metres, with an aerial 300 feet long on masts 100-120 feet high.

**Aerial Tuning, or Loading, Coils.**—These coils are for adjusting the wave length of the aerial circuit independently of the tappings on the coupling coil or coils, which are used only to give the proper degree of coupling. In the ship outfits made by the Marconi Co., the aerial tuning inductance is made of stranded cable well insulated and braided, wound in one layer on a square box former: its design being similar to the secondary of the coupling transformer. Tappings are taken from the coil to brass sockets on the front of the frame, into which brass plug connectors can be inserted, one from the aerial, the other to the coupling transformer secondary. Fig. 89 shows the aerial inductance coil for a  $\frac{1}{2}$  KW. station, having 13 turns of cable on a box frame.

In the Telefunken equipments the aerial tuning inductance

consists of two or more spirals of copper strip, with plug sockets; the design being similar to that of their coupling coils. One of

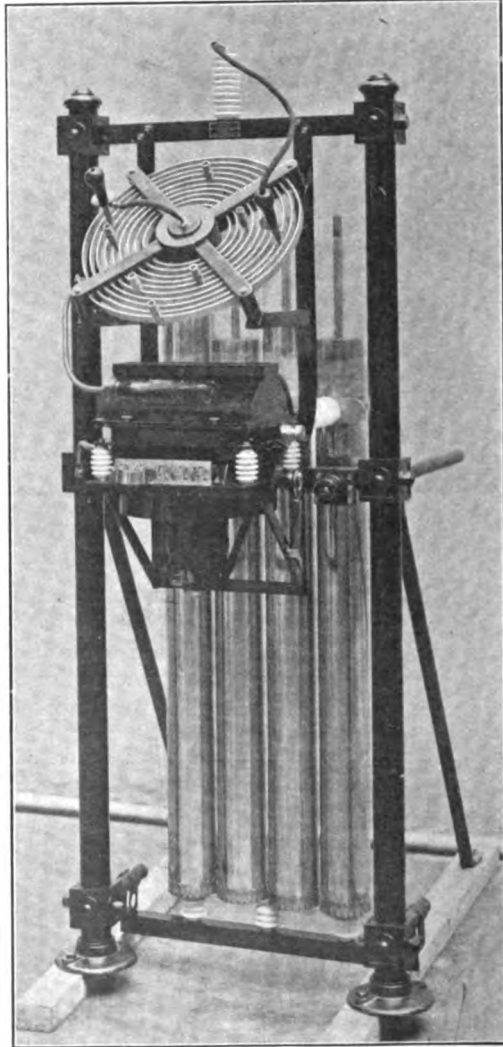

FIG. 88.

the spiral coils is on a hinged frame; by altering the position of this coil with respect to the others their combined inductance

effect can be changed, so that the tuning can be done by this method as well as by using the plugs.<sup>1</sup> These tuning coils are seen in the illustrations of Telefunken apparatus given later, the movable coil being the one which is shown fitted with a handle.

The Telefunken Co. have also developed an arrangement of tuning coils which they call a "Variometer," or variable inductance. It consists of two circular flat plates of ebonite placed coaxially, one being fixed, the other capable of rotation about its axis. Each plate has two flat coils on it wound as shown in Fig. 90 and, by means of a switch, the four windings can be joined in series or in parallel. If the plates are so placed that the magnetic fields, set up in the coils by the oscillating currents, are all at any moment acting in the same direction, *i.e.* are added, then

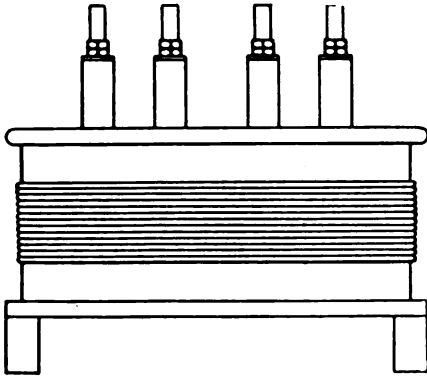

FIG. 89.

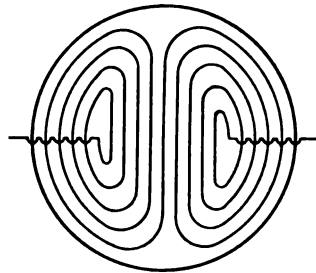

FIG. 90.

the inductance effect is a maximum; if the movable plate is now turned through an angle of  $180^\circ$ , the magnetic fields in its coils oppose those in the fixed coils, and the inductance effect is a minimum.

By joining the coils in series or in parallel, and by rotating the movable plate, a large range of wave lengths can be obtained; the movable coil is graduated to show the wave length corresponding to each position of it, so that the transmitting apparatus can be quickly set to any desired wave length. This is an advantage which is of importance in naval and military outfits, as by changing the wave length at pre-arranged intervals, it becomes more difficult for unauthorised stations to pick up the messages by

<sup>1</sup> The advantage of this is that the aerial resistance can be kept constant, and thus damping decrement is not changed by adjustment of wave length.



tuning in. The message would be in secret code, and the variation of wave length is only an extra precaution. In the Marconi military outfits the same object is attained by having three tappings, or switches, on the tuning coils, so that three different wave lengths may be used.

**Transmitter Key.**—This is always joined in the low potential side of the induction coil or transformer, and, if the outfit is a small one, it may be a simple key of the Morse pattern with good platinum contacts.

When an aerial switch is used to change over from receiving to sending, it has generally got auxiliary contacts which open the circuit across the detectors and telephones when in the sending position, thus avoiding any heavy inductive effects in these from the transmitter oscillations. In the Marconi system there is no aerial switch, an earth arrester taking its place as already described, hence, when sending, the receiver telephones have to be protected from the effects of the sending circuit. The receiver apparatus, as a whole, is protected by a micrometer spark gap joined as a shunt across it, but this would not prevent the telephones from responding loudly to each sending spark, thus dulling the aural sensitiveness of the operator for the received signals.

Therefore the Marconi Morse transmitting key has small auxiliary spring contacts at the side, and each time the key is depressed an ebonite bar, projecting from its side, presses the auxiliary contacts together. These are joined across the receiver telephones, which are thus short circuited each time the key is closed. (The contacts may also be used to open the receiver circuit at each side of the detector.) The Marconi key is shown in Fig. 91; the switch at the left-hand side breaks the circuit completely, thus cutting the transmitter key out of action. Even when such arrangements are adopted it is best to have a switch which will disconnect the receiver from the aerial while transmission is taking place. When large amounts of energy have to be dealt with in the transmitter the sending key is more elaborate, and its make and break contacts may be enclosed in oil, or acted upon by an air blast, to extinguish or avoid heavy arcing which would rapidly burn away the contacts. In larger outfits the sending key may not be in the main generator circuit, but may be used to close and open an auxiliary low voltage circuit. The current in this circuit flows through the coils of electro-magnetically operated switches, which open and close the main circuit.

A simple arrangement of this type is shown in Fig. 92, the sending key K, when closed, energises the electro-magnet M by the current from the 6-volt battery B. The magnet attracts its

soft iron armature A, thus closing the contacts C, it in turn closing the circuit of the coil D, which may be the primary of an

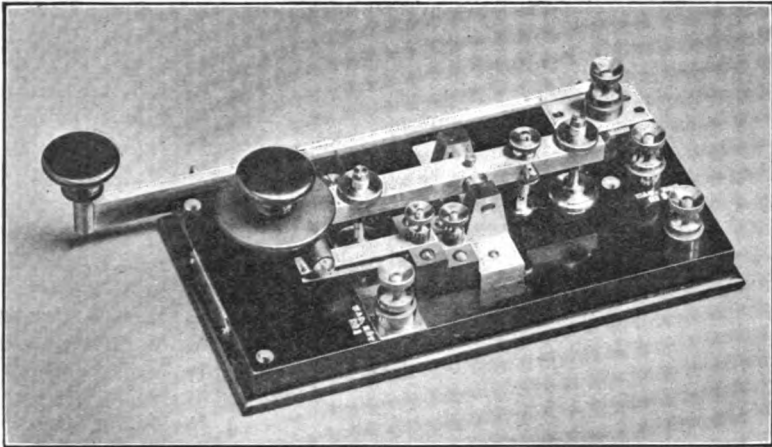

FIG. 91.

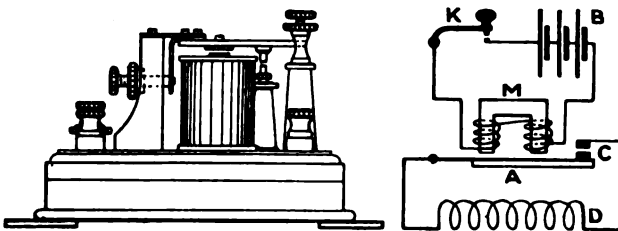

FIG. 92.

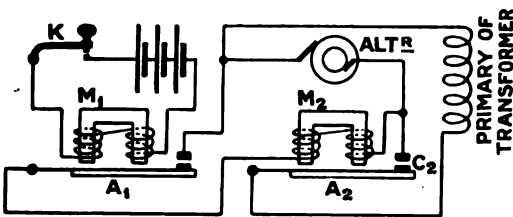

FIG. 93.

induction coil, or of a step-up transformer. The Marconi Co. use a double magnetic key working on this principle, a diagram of which is shown in Fig. 93. When the key is depressed the

low voltage electro-magnet attracts its armature  $A_1$  which closes a circuit from the alternator through the second electro-magnet. This attracts its armature  $A_2$ , closing the circuit from the alternator through the primary of the step-up transformer. When the second key is opened  $A_2$  will not fall away from  $M_2$  until the alternator's voltage is going through its zero value, and when, therefore, its current is also very small, so that there will be little current and little arcing at the contacts  $C_2$  when they break away from each other. The frequency being comparatively high the difference in time between the opening of  $K$  and the opening of  $C_2$  is inappreciable and does not affect the signals.

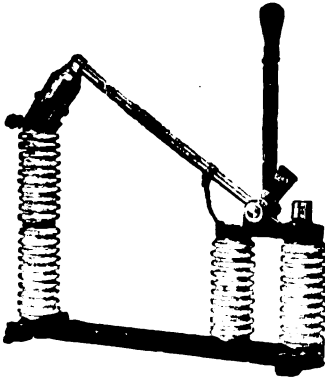

Fig. 94.

Fig. 94 shows a Telefunken Aerial Switch: it is of the change-over pattern, and when in the sending position it breaks the receiver circuit at each side of the detector.

Fig. 95 is a diagram of a Marconi  $\frac{1}{2}$  KW. transmitter, the various pieces of apparatus being shown in plan and properly connected up.

**Telefunken Stations.**—In January, 1914, the official list of radio-telegraphy stations gave a total number of 3865 then licensed. Of these about one-half are equipped on the Telefunken system, including 86 British vessels, 1204 other vessels, 381 land stations, and a great number of naval and military stations of which there are no particulars. Messrs. Siemens Bros. & Co., of London and Woolwich, control the British rights of the Telefunken or Quenched Spark system, the outstanding peculiarities of which are the quenched spark discharger, the high note signals which it gives, the use of umbrella, or slow radiating, antenna for their land stations; also the fact that their stations are rated by the energy in the aerial, and not by the output of the generator. An efficiency in the aerial of from 50 to 75 per cent., according to the size of the station, is claimed for this system.

Much of the Telefunken transmitting apparatus has already been described, and it remains only to give a short description of some of the complete equipments, as used on ships.

The smallest set made up for ship work takes 300 watts of energy, using battery and induction coil; its range being 18–30 miles. The other equipments for ships are made up in four sizes, known as Types A, B, C, and D respectively.





Type A takes 400 watts, uses an induction coil to obtain the charging voltage, and has a guaranteed range of 45 miles day and 60 miles night with 50 ft. masts, and 90 miles day, 125 miles night with 100 ft. masts.

Type B has a motor-driven alternator giving 0.4 KW. at 220 volts and 500 frequency. The range is about double that of Type A.

Type C has a 1 KW. alternator; Type D a 1.5 KW. alternator, and Type E, suitable for land or ship stations, a 5 KW. alternator.

Type D is the size suitable for passenger vessels, and is shown in Fig. 97. The alternator's voltage (220 volts) is transformed up to 8000 volts, and the current led to the primary circuit, consisting of tubular jar condensers, as already described, primary inductance flat spiral coil, seen on the right of the picture, and a 8-gap quenched spark, seen just above the inductance. To the left of the primary inductance is a hot wire aerial ammeter; on the wall, in the centre, is seen the three-coil aerial inductance, of which the centre coil, fitted with a handle, is hinged and movable. The normal ~~wave length range~~ range of this station is 200-600 miles. In the centre of the table is the transmitter key, which operates an electro-magnetic relay in the armature circuit of the alternator. At the extreme left of the table is the receiver apparatus.

Fig. 98 show condensers and inductances for the aerial circuit of Type E station. The tuning of the aerial transmitting circuit is accomplished by moving two coils, which are mounted between the three fixed coils. The condensers are joined in series with the aerial if it is desired to shorten the wave length.

With umbrella aerial, 200 feet high, this equipment has a range of 470 miles day and 950 miles night over sea, if installed in a land station with good earthing facilities over a space of 800 feet in diameter.

We will conclude this chapter by briefly considering the question of short distance transmission. The shortest range occurring in practice is that used when a buzzer is put in the transmitting aerial circuit to excite it, and the signals are heard in a wavemeter when held near and tuned to it. This at once suggests that messages can be transmitted with an aerial and earth connected to the terminals of a simple buzzer; the necessary capacity and inductive effects being in the wires, the wave length that of the aerial circuit, while the spark is the make and break of the buzzer. With a fairly large buzzer, worked by a

4-volt battery, it is possible in this way to signal over several hundred yards.

If an ordinary motor-car ignition coil is joined to an aerial

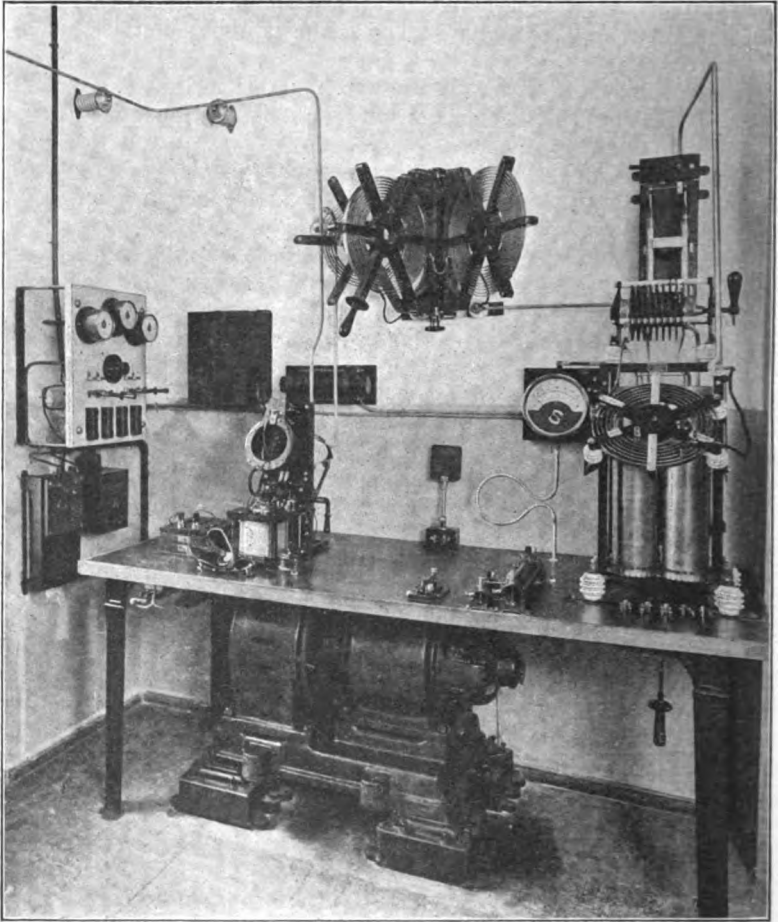

FIG. 97.

earth circuit in open country, the aerial being umbrella type and about 30 feet high, it is possible to signal over five miles of country. Similarly, if what is called an inch spark coil is used with a 6-volt battery, the range of signalling may be 10-12

miles. But this implies that the receiving apparatus is suitably

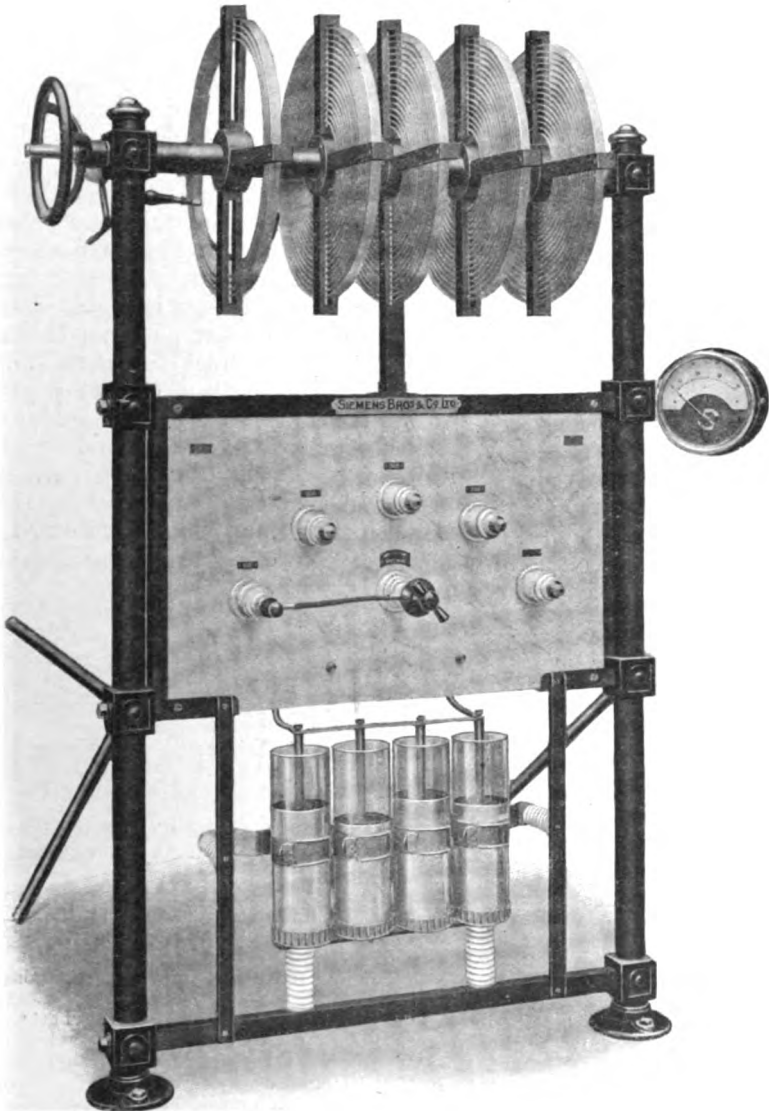

FIG. 98.

designed to be capable of tuning to short wave lengths, and to



be accurately adjusted. Direct connection of the sending aerial to the discharge circuit is best for these small ranges.

The United States Navy Signal Corps have carried out experiments on signalling with buzzers. The buzzer used was of a size corresponding to that of a fairly large bell, and is shown in Fig. 99. A receiver blocking condenser of about 0.008 mfd. was connected in series with the aerial and earth, and the buzzer make and break connected directly across the condenser, as shown in the figure. The soft iron armature of the buzzer is mounted on a piece of thin sheet phosphor bronze strip, fixed in bracket-holders, and carrying a good silver contact piece; a similar contact piece being soldered to the screw of the make and break.

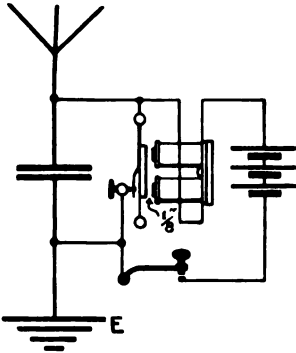

FIG. 99.

The self-induced E.M.F. in the buzzer at break of current charges the condenser, which immediately discharges into the aerial. It is claimed that with an aerial 300 ft. long and 125 ft. high, using 6-volt battery and  $\frac{1}{2}$  ampere of current, signals were received at a distance of 30 miles.<sup>1</sup>

#### QUESTIONS AND EXERCISES ON CHAPTER XIII.

1. Discuss the possibility of using (a) a rotary discharger; (b) a quenched spark discharger, when the oscillating circuit is charged from an induction coil.
2. What is the object of fitting the alternators used on Marconi portable outfits with commutators as well as slip rings?
3. How can the pitch of the spark note be varied; how can you tell if the spark is a good one; and why should the spark chamber have a ventilating draught through it?
4. What are the advantages claimed for a Marconi disc discharger?
5. With a Marconi disc discharger the actual time of sparking is not the time of shortest distance between the fixed and moving electrodes. Explain why.
6. From the particulars given in this chapter of the condenser used in a Marconi  $\frac{1}{2}$  KW. outfit, calculate the specific inductive capacity of the glass dielectric used.
7. Describe the construction and advantages of a quenched spark discharge.
8. If a Marconi disc discharger has got 8 rotating teeth, how many poles are on the alternator, and what is the spark frequency, if the speed of the alternator is 3000 revolutions per minute? Neglect Resonance effects.
9. What are the advantages of transmitting with a musical note?
10. Explain why it is that if the closed circuit is quickly damped, and the

<sup>1</sup> Modern Electrics.

aerial feebly damped, much less power is required at the transmitter for a given range.

11. What are the conditions necessary for high-speed signalling?

12. Describe the condenser in the oscillating circuit of a Marconi ship outfit, and of a Telefunken ship outfit.

13. A condenser on a small transmitting outfit is found to get warm when in use. Explain the cause of the heating and how the fault can be remedied.

14. Describe the construction and action of a variometer.

15. What are the disadvantages of using a condenser in series with the aerial to shorten the wave length? What is the best method of shortening the aerial wave length?

16. How would you make an oscillation, or coupling, transformer for radio-telegraphic purposes?

17. Describe, with the aid of a sketch, an electromagnetic transmitting key.

## CHAPTER XIV

### *AERIALS, INSULATORS AND EARTH CONNECTIONS*

AN aerial consisting of one vertical wire only is rarely used, except for experimental purposes or small portable stations. It was discovered that the aerial must have capacity to enable it to store oscillating energy before radiation commences, and incidentally serve for tuning purposes; thus, quite early in the development of wireless telegraphy, we find Sir Oliver Lodge advocating the use of a horizontal network of wires at the top of the aerial, and in Marconi's early experiments, on the voyage of the *Carlo Alberto* to the Baltic, the aerial consisted of a number of vertical wires, suspended in the shape of a fan from a support stretched between two masts. When the Marconi Station at Poldhu was first opened the aerial consisted of 400 wires, supported in the shape of an inverted pyramid from 4 steel towers.

In 1905 Marconi patented his horizontal directional aerial, and, as he himself said before the Marconi Agreement Committee (1913), the real progress in long distance transmission dated from this development. A simple vertical wire or symmetrical system of wires radiates energy equally in all directions, and as regards reception of energy, such a system would be equally effected by energy arriving from any direction. Marconi discovered that if, from the top of the vertical aerial, horizontal wires were stretched backwards, the amount of energy radiated was greater in a forward direction than in any other. To a certain extent the signals by this means could be directed, or at least strengthened, in a selected direction, thus ensuring greater reliability and enabling greater distances to be covered in that direction. Similarly, at the receiving station, if horizontal wires are stretched *backwards* from the top of the vertical portion of the aerial, ether waves coming forward will affect the receiving apparatus more than those coming from any other direction.

Professor Zennick has shown that since the electric strain lines

in the ether travel along the earth or sea, which are of comparatively high resistance, the lower ends are retarded by this resistance, so that the upper parts of the waves become inclined forward, and when they reach the receiving aerial a considerable portion of the waves are horizontal; thus an aerial which has a horizontal portion parallel to these will be most affected by them.

As for the transmitting aerial, since the waves acting on the receiver consists of considerable portions which have been bent downwards from the upper regions of the ether, it is necessary to shape the sending aerial so that a considerable portion of the radiated energy will be thrown upwards rather than outwards. According to this explanation Fig. 100 will serve to illustrate the effect of directional aerials at the sender and at the receiver.

Now, in the first place, the aerial must have a low resistance and good insulation. If its ohmic resistance is too high the damping effect will be serious, and thus the radiating power is diminished; in connection with this consideration it must be remembered that the heaviest currents are near the bottom of the aerial. When



FIG. 100.

oscillations take place in the aerial circuit the top extremity is first charged to a high potential and then discharged by a flow of electrons, which is a maximum at the bottom of the aerial for the earth is the other side of the oscillating circuit. Compare this with the oscillating discharge of a Leyden jar or a Hertz oscillator as already described.

Thus, if the aerial circuit oscillations are taking place at its natural frequency, the condition of affairs will be as shown in Fig. 101 where a potential strain is succeeded by a current strain, the current being a maximum at the bottom of the aerial while the potential strain is a maximum at the top. If anything, therefore, the lower portion of the aerial should have a larger surface and less resistance per unit length than the top portion. In general, the aerial of a ship station has less than 2 ohms resistance. Again the insulation of the aerial must be perfect, otherwise, in transmitting, energy will be lost by current leaking from the aerial at the high voltages used; and, in receiving, the small oscillating currents set up in the aerial will be lost before they arrive at the receiving

apparatus. The insulation, especially at the top, or—if the aerial has a horizontal portion—at the farthest end, must be extremely good, and such that it remains good in all weathers. The wires must not be too small, otherwise at high voltages a brush discharge, seen as a bluish light at night, will take place from them into the atmosphere. This, of course, represents a dead loss of energy; it is avoided by making the aerial with wires of good surface area, and designing it to have no sharp points, bends, or corners.

The brush discharge loss from a wire of given surface area depends upon the voltage; beyond a limiting value of working voltage the brush discharge will increase rapidly and becomes a serious loss. Thus, for any size of aerial cable, the efficient voltage to which it can be charged is limited.

Referring again to Fig. 101 it is seen that the length of the aerial corresponds to a half loop of voltage or current, and there-

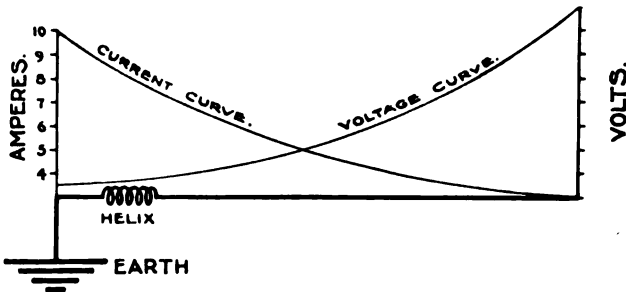

FIG. 101.

fore to a quarter of a complete oscillation, or wave. Thus, theoretically, the natural electrical wave length of an aerial is four times its geometrical length; in practice, however, where an aerial consists of more than one wire and part of it is horizontal, or where masses of earthed conductors, such as lead roofing, telegraph wires, etc., are in its vicinity the natural wave length varies with the local conditions. Under normal conditions the natural wave length of an aerial may be approximately 4.9 times the length of the aerial: only in the case of a long thin vertical wire is the factor 4 used, while for umbrella aerials this factor may be as much as 8.

The student will, of course, remember that the aerial wave length is artificially increased to couple and tune it to the closed circuit; this is effected by joining inductance coils in its circuit, and its wave length is then given by the formula  $\lambda = 59.60 \sqrt{LK}$  metres; he must also note that *it becomes an inefficient radiator*

*if, by loading it with inductance, its wave length is made more than four times its natural wave length.*

Increase of inductance only increases wave length, and does not increase the amount of energy oscillating in the aerial circuit. Up to a certain point increase of radiation wave length will increase the range of signalling, but unless the capacity of the aerial, and with it the energy in it, is increased, further addition of inductance coils decreases the relative efficiency of radiation, because they increase the resistance of the aerial circuit and so increase the damping effect.

The design of an aerial is based on three main considerations:—

1. The higher it is the farther will ether energy be radiated from it, and the better will it receive signals, though height is not the most important consideration in the reception of signals.

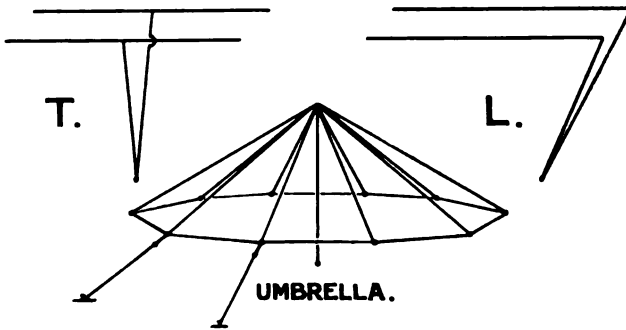

FIG. 102.

2. The larger it is (or the more wires there are in it) the greater its capacity, and the more energy can be oscillated in it for a given charging voltage.

3. High frequency, or oscillating, currents travel only on the surfaces of wires, hence it is surface and not cross-section that is of importance, and it is better to use a number of wires in parallel rather than one wire of the same total cross-section.

The wire used is generally bare hard drawn copper or silicon bronze wire, which even for the smallest stations should preferably be stranded. For stations of over  $\frac{1}{2}$  KW. size the Marconi Co. use bronze wires pleated on a flexible core of non-conducting material. To provide sufficient capacity effect wires radiate from the top of the vertical lengths to form either an umbrella, an L, or a T type of aerial as in Fig. 102—these being the types chiefly employed in practice.

It can be seen that the L type gives a certain amount of directional effect; the horizontal portion of the aerial should therefore be turned backwards from the direction in which the strongest effects are required, either in sending or receiving.

The umbrella type of aerial is used with portable outfits and military stations; one made by the Marconi Co. consists of a single light telescopic mast 30 feet high, having a porcelain insulator on the top. This supports the aerial, consisting of a single vertical cable terminating in 6 ribs, all joined into a ring which slips over the insulator at the top of the mast. The ribs act themselves as stays for the mast, being fitted at their lower ends with eyes, by means of which they are attached through spring hooks and flexible rubber cord insulators to anchor stays, the latter terminating in pegs driven into the ground. Each rib of this umbrella aerial is about 40 feet long. For larger stations a similar construction could be used with a higher mast and more extended design.

The capacity of an aerial such as above would be of the order of about 0.0005 microfarad; its most efficient use would be for small power and short wave lengths, when it would be directly connected to the spark gap, the other side of the spark gap being directly connected to earth. Of course a larger umbrella aerial would be inductively connected to the oscillating closed circuit in the usual manner.

Aerials of the L or T types are more used than any other, and for ordinary purposes and ship outfits are standard practice. In these types of aerial from one to eight wires are stretched horizontally at as great a height as possible, then brought vertically downwards at one end where they may be connected into one or two groups, and thus one or two cables form eventually the vertical portion of the aerial; it is better, however, to bring all the wires down to the insulating tube through which they enter the wireless station.

The spacing of the wires, that is to say their distance apart in the horizontal portion of the aerial, is an important factor in its working. Currents flowing in parallel wires set up round them magnetic strains, in other words there is a mutual inductive action between them, owing to the fact that they are surrounded by magnetic fields which interact on each other if they are close together. Thus if two wires are used the wires should be kept as far apart as possible, from 5 to 10 feet apart being standard practice.

The aerial wires are spaced by means of pine or oak spreaders which should be spar varnished; if the aerial consists of four

wires, these are best spaced by making them the sides of a rectangle, using wooden spreaders in the form of a cross.

It is important that the wires should all be exactly the same length from the coupling transformer to the end of each wire, otherwise each branch of the aerial will have a wave length differing from that of the others, so that, accurate tuning being impossible, radiating and receiving efficiency is decreased.

Each wire of the aerial should be stranded; for amateur stations not less than  $\frac{3}{16}$  wire should be used, while ship stations would use not less than  $\frac{7}{16}$  hard drawn copper or phosphor bronze. All joints to leading down wires should be well made and soldered. The bridles for supporting the aerial from the masts, and the raising tackle, should be of ratline (tarred hemp rope), as this is found to withstand the weather better than steel rope. Fig. 103 shows how the aerial may be attached through insulators to the spreaders and bridles. Sometimes the horizontal portion of the

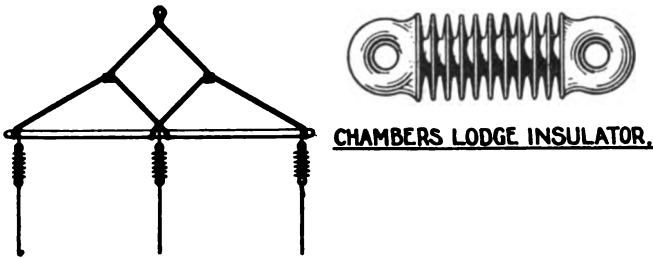

FIG. 103.

aerial has its wires connected together at the farthest end. Where the aerial is very long compared with its breadth it is best to leave the far ends of the wires unconnected.

If one end of the aerial is higher than the other the leading down wires should be taken from the highest end. A T aerial differs from the inverted L type only in the fact that the vertical leading down wires are taken from the centre of the horizontal wires instead of from one end. It is to be noted that the leading down wires *must be taken from the exact centre*, otherwise each branch of the T would have a different wave length. This assumes of course that the upper part of the T is horizontal; if one end of it is higher than the other the capacity and inductance effects are probably not balanced at the exact centre; the proper point of connection is then best found by using a wavemeter to measure the wave length of each side of the T whilst the other side is disconnected.



It is not necessary that the top arms of the T should be in the same straight line, and the ends of the top arm need not be as high as the centre; it is best, however, to keep them as high as possible. If the T aerial consists of two wires the extremities should be left open as in the L type, *i.e.* the wires should not be connected together except at the insulator entering the operating room. This does not apply to special aerials used on ships.

If an L type of aerial is changed to a T type, by taking the leading down wires from the centre instead of from one end, the wave length is reduced, as the effective aerial length is the vertical height plus one arm of the T. Similarly the wave length can be increased by changing from a T type to an L type aerial with the same height and length of wires.

It will be gathered from the foregoing that the number of wires to be used in an aerial, and its total length, will depend upon the amount of energy it is required to use in the transmitter, and the wave length it is desired to transmit or receive. Each of these varies as the capacity, which depends upon the number and length of the wires and their distance apart.

Generally one may say that, for sending, an increase in the number of wires in the aerial increases its capacity, therefore increases the amplitude of the current oscillating in the vertical portion with a corresponding increase in radiated energy; for receiving increase of capacity is not so necessary and a two wire aerial may receive as well as a four wire one, but the greater number of horizontal wires may pick up more energy from the ether waves. As a matter of fact, everything else being equal, practical working has proved that the more the aerial is split up into parallel wires the better it is for both sending and receiving.

If an aerial consists of 6 wires they may be arranged all parallel to each other in the same horizontal plane or spaced round the periphery of wooden hoops fixed at intervals along their lengths. As many as 10 wires are often used, in which case they are generally stretched parallel to each other in a horizontal plane, with about 2 feet spacing between the wires. Such an aerial, if about 100 feet long on top and 80 feet above the ground, would have a capacity of the order of 0.001 mfd.; if the wires were spaced 6 feet apart instead of 2 feet, the capacity would be increased from 15 to 20 per cent.

It might be well to consider more fully here the effect which spacing and size of aerial has on its capacity. Neglecting resistance and considering the horizontal portion of a two wire aerial, if  $L$  is the inductance of each wire, and  $M$  is the mutual inductance

between them, then the effective inductance of the system is  $\frac{L + M}{2}$ ,  
 $L = 2(2.303 \log_{10} \left( \frac{2h}{r} - 1 \right))$  cms. per cm. and  $M = 2.303 \log_{10} \frac{4h^2}{d^2}$  cms.  
 per cm., where  $h$  and  $d$  are the height of the wires above earth, or  
 earthed conductors, and their distance apart respectively, both  
 measured in the same units.

We see then that the farther apart the wires are (*i.e.* the  
 greater " $d$ " is) the less is the mutual inductance and therefore  
 the less is the effective inductance which we will call  $L_e$ . Now  
 the effective inductance multiplied by the capacity is a constant—

$L_e K = \frac{1}{v^2}$ , where  $v$  = velocity of high frequency wave propaga-  
 tion along wires,  $L$  = inductance in cms. per cm.,  $K$  = capacity  
 in cms. per cm.; therefore the smaller  $L_e$  is the greater is the  
 capacity, hence by spacing the wires further apart the mutual  
 inductance between them is reduced, thus the effective inductance  
 is reduced so that the capacity of the aerial is increased.

In ship stations there are comparatively large inductance  
 effects which can be avoided in land stations and thus the capacity  
 of a given aerial will be less than in land stations, but this is well  
 compensated for by the good transmission effects over sea.

Let us now study the effect of aerial design on the trans-  
 mission, apart from questions of wave length. When an aerial  
 is charged to a certain voltage the amount of current oscillating  
 in it will depend upon the capacity it has for storing energy, and  
 the amount of energy radiated from it will depend upon the  
 square of this current. We remember that resistance damps out  
 the oscillations, and that radiation, representing loss of energy  
 to the ether, has the same effect. Thus the radiating power of  
 an aerial can be expressed as an equivalent "radiation resist-  
 ance" and as resistance loss is given by the formula  $C_a^2 R$  we can  
 similarly express radiation loss. Thus if  $C_a$  is the effective aerial  
 current and  $R_r$  is the equivalent radiation resistance, the energy  
 radiated is  $C_a^2 R_r$  watts.

Rüdenberg deduced a formula for equivalent radiation resist-  
 ance, which has been experimentally verified by Austin, and is as  
 follows:—

$$R_r = A \frac{h^2}{\lambda^2}$$

in which  $A$  is a constant,  $\lambda$  is the working wave length, and  $h$  is  
 the effective height of the aerial. The value of  $A$  is about 400,  
 the effective height for L or T aeriels is about 80 per cent. of the

true height, while for umbrella aerials it is the mean height of the oblique wires.

$$\text{Thus the radiated energy} = 400 \frac{h^2}{\lambda^2} \times C_a^2 \text{ watts.}$$

Therefore we increase the capacity of an aerial, either by putting more wires on it or by spacing the wires farther apart, so that for a given voltage we shall have a greater amount of oscillating current; with it a greater amount of energy radiated. Increasing the capacity by greater spacing of the wires decreases the effective inductance; adding more wires and placing them too close together may not increase the capacity to any effective extent. Increasing the height will increase both capacity and inductance, as well as increasing the radiation effect as shown by Rudenberg's formula. With more wires used in parallel they need not be so far apart because the current is divided up, there is less current in each wire and therefore the mutual inductance effect is decreased.

In the words of Sir Oliver Lodge "all increase of capacity combined with height in the aerial goes to increase both the electric and magnetic fields at a distance, and therefore will be advantageous, because both increase the power.

"Insertion of inductance coils in the aerial will have the effect of lengthening the wave without strengthening the field at a fixed distance, and so must act deleteriously on radiation intensity" (see above formula) "though such coils will promote persistent oscillation and tuning, and may therefore be advantageous up to a point. Their use will always be in the nature of a compromise, and so they should be kept at a reasonable minimum."

The student must be careful to note the difference between aerial resistance and "radiation resistance." Aerial resistance is its actual resistance measured in ohms; multiplied by the square of the aerial current it represents lost energy and the greater it is the less effective is the aerial. The aerial wires themselves may not have a greater resistance than 1 or 2 ohms, but aerial resistance includes that part of the earth under the aerial on which oscillating currents also act, and thus the total aerial resistance may be from 20 to 40 ohms if there are bad earthing arrangements.

On the other hand "radiation resistance" multiplied by the square of the aerial current represents energy radiated; this is the whole object of the transmitter. Radiation resistance is sometimes called "radiation coefficient"; this is a term not,

perhaps, so puzzling to the student. It must not be too great, in other words, radiation must not be too rapid; otherwise the waves will be damped and the tuning not sharp. It is useless to radiate more energy if we do so at a wider range of wave lengths since the receiver can only pick up the energy at one wave length.

Comparing the different forms of aerials, the umbrella type is most convenient for portable stations while its radiation coefficient is less than that of any other form, especially if its ribs approach the ground. In other words it is a slow radiator, therefore aids close tuning. As Sir O. Lodge explains it, the charge has to rise up the vertical wires before it falls down the ribs, so that it fails to exert its full magnetic force at a distance, and conserves some energy which it might radiate; thus its radiation coefficient is comparatively small. At the same time, the fact that the oscillations are not too quickly damped out by radiation means that it will oscillate at a pure wave length more persistently, and hence it will require sharper tuning at the receiving station, a condition which is favoured by the Telefunken Company. With the damped oscillations which are obtained from an ordinary spark discharge such an aerial would perhaps be best if very sharp tuning is desirable, but with undamped oscillations or feebly damped oscillations, such as are obtained from a quenched spark or rotating disc discharge, the natural oscillations will be persistent enough for sharp tuning purposes without curtailing the amount of radiated energy. Besides the sharp tuning given by an umbrella aerial may be more than counterbalanced, as far as range is concerned, by the directional effect which an L type aerial would give.

The umbrella aerial requires more height than others for a given range, and requires also a larger area of flat land accessible around it for earthing purposes. If the tower is 100 feet high then earthing ground embraced in a circle of 800 feet should be accessible all round it. It is a cheap aerial to construct, the rib wires themselves acting as stays to the mast.

The fan aerial has good radiating properties; the L and T have not, perhaps, as high a radiation coefficient, but they have a certain amount of selective direction property which increases their efficiency as radiators. The T type is particularly suitable for ship work, though if the distance between the masts is not great enough the L type has to be used in order to get a sufficiently long natural wave length.

The objects to be aimed at are—(1) to get oscillations in the aerial with amplitudes as large as possible and not too quickly damped out; (2) to have an aerial whose natural wave length is

as nearly as possible equal to the wave length at which it is desired to radiate energy, for it is then most efficient. The natural wave length must, if anything, be smaller than the radiation wave length since it will have the secondary of the coupling coil in series with it. To be most efficient for sending the aerial should be of such dimensions that, beyond the inductance of the coupling coil or jigger, no further aerial inductance has to be joined in series with it to give the necessary radiation wave length. Its natural wave length must not be longer than the radiation wave length, as this would require the use of a condenser in parallel with the coupling coil, an arrangement which is inefficient because the energy oscillated in the condenser does not contribute to radiation.

It has been found that, for a given radiation wave length, there are values of sending and receiving aerial heights which will give the best effects over a fixed signalling distance. Thus, Dr. Kimura has calculated that if the transmitting aerial is 200 feet high and the receiving one 150 feet high, for a day range of 300 miles, the best wave length to adopt is 640 metres with 2.9 amps. in the sending aerial, but for a range of 500 miles the best wave length is 800 metres with 9.7 amps. in aerial: these figures apply to transmission from shore to ship. For ship to ship work the aerials may be of less height, and the same ranges obtained using shorter wave lengths but stronger aerial currents.

Dr. Kimura also deduces that the length of the horizontal portion of the aerial should never be less than its effective height, and if it has the minimum value  $l = h$  the wave length proper to such an aerial ( $\lambda$  metres) =  $3.5 \times ht$  in feet.

Dr. Austin, after a long series of experiments between a shore and ship station deduced the following important formula:—<sup>1</sup>

$$I_r = \frac{3.92I_s h_1 h_2}{\lambda D \cdot \epsilon^{\frac{1}{\sqrt{\lambda}}}}$$

$I_r$  = current in receiver aerial in microamperes; about 5 microamperes for a just audible signal with modern delicate detectors.

$I_s$  = current in sending aerial in amperes.

$h_1$  and  $h_2$  = sending and receiving aerial heights in feet.

$D$  = distance of transmission in kilometres.

$\lambda$  = wave length in metres.

$\epsilon$  = Napierian base.

<sup>1</sup> Article by J. Hogan in *Electrician* for August 8, 1913.

This formula has been given here to show how aerial height at the sending and receiving stations qualifies the amount of energy received at a given distance and wave length.

Some special forms of aerials will now be described as used at Marconi and Telefunken stations. At the Glace Bay station of the Marconi Co. the original aerial consisted of a vertical inverted pyramid of wires supported to the tops of 4 steel towers 200 feet high, the vertical wires being connected to 200 radiating wires each 1000 feet long, supported on two outer circles of masts, the extreme ends being 180 feet above the ground. The natural wave length of this aerial was 12,000 feet. The aerial has now been changed to the Marconi directional pattern, all the wires rising vertically in one plane and stretching back horizontally from the Atlantic, or east, side so that a maximum of energy may be radiated in the eastern direction.

The specification for the long distance Imperial Wireless Stations states that they are to be of the directional type, each wire to be composed of 7 strand No. 19 S.W.G. silicon bronze wire over 3000 feet long. The aerial to be supported by ten tubular steel masts each 300 feet high, and be suspended from them by threading the wires through porcelain reel insulators, attached to the bottom of porcelain rod insulators. The masts to be of 2 feet 6 inches section. The wave length used with this aerial to be 30,650 feet.

With the Marconi  $1\frac{1}{2}$  KW. military station, the aerial is of the two wire L type, the cables consisting of bronze wires pleated on a light, but strong, flexible nonconducting core. The masts 70 feet high are each made on six sections, stayed at three heights, the sections being made of hollow hexagonal wood boxing, with sockets and solid drawn steel plugs. This construction of the masts is shown in Fig. 104. The aerial is 525 feet (160 metres) long, that is to say the masts are about 130 metres apart.

The Marconi cavalry station with a range of about 25 miles has light masts 30 feet high, 350 feet apart, and a two wire L type aerial. A smaller umbrella type of Marconi aerial has already been described.

The larger Telefunken stations use umbrella type aerials, supported from a single girder steel mast. The Nauen station near Berlin has a steel mast of this type 900 feet high, supporting a large umbrella aerial with a sending range of 4000-5000 miles. Several Telefunken stations in South America with a range of 200 kilometres over land use similar aerials, the masts in these

cases being about 45 metres high. Fig. 105 shows typical ship aerials installed by the Telefunken Co.

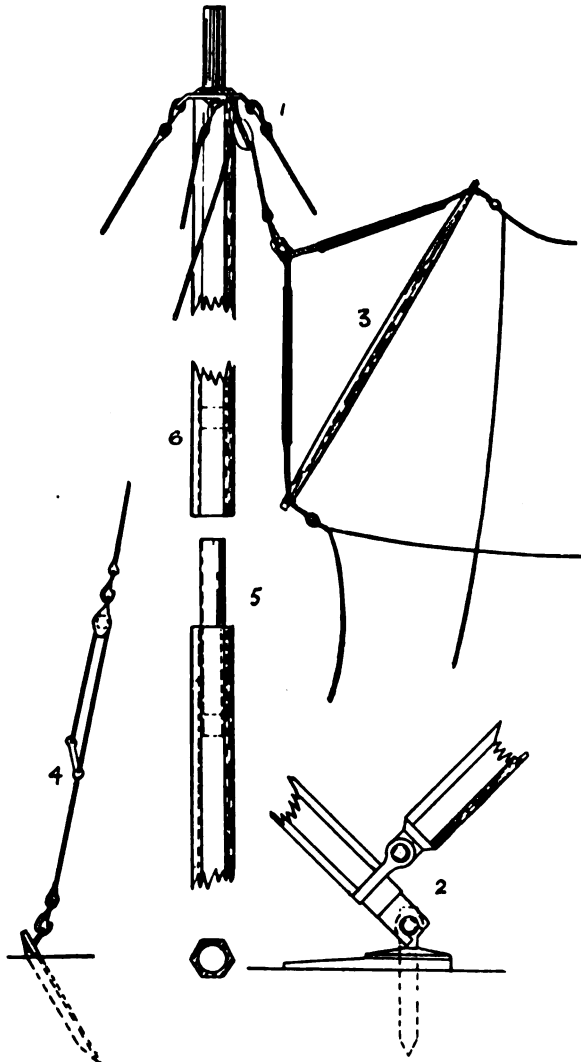
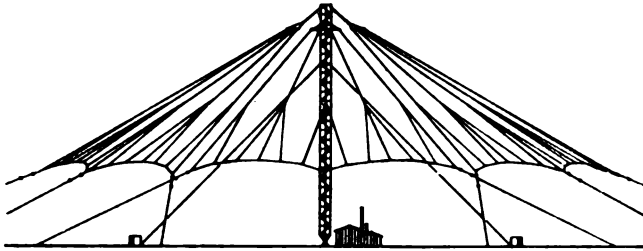

FIG. 104.—Marconi Military Mast.

For portable or military stations the Telefunken Co. use

wooden masts made up of socketed sections, something similar to



AERIAL AT NAUEN STATION NEAR BERLIN.

FIG. 105.

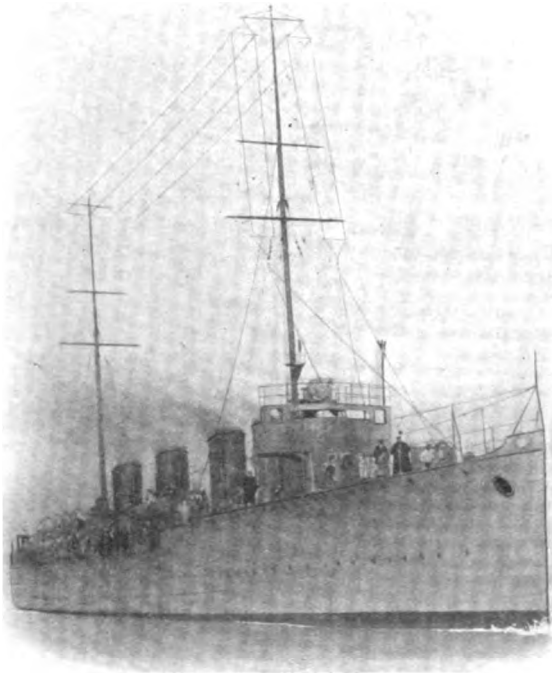

FIG. 105A.—Torpedo-boat Destroyer *Almirante Lynch*. Telefunken L Aerial.  
Day Range 250 Miles.

those of the Marconi Co.; they have also a special form of steel



mast invented by Mr. Rendahl, the construction of which is shown in Fig. 106. The stays are fitted with Rendahl insulators which will be described later.

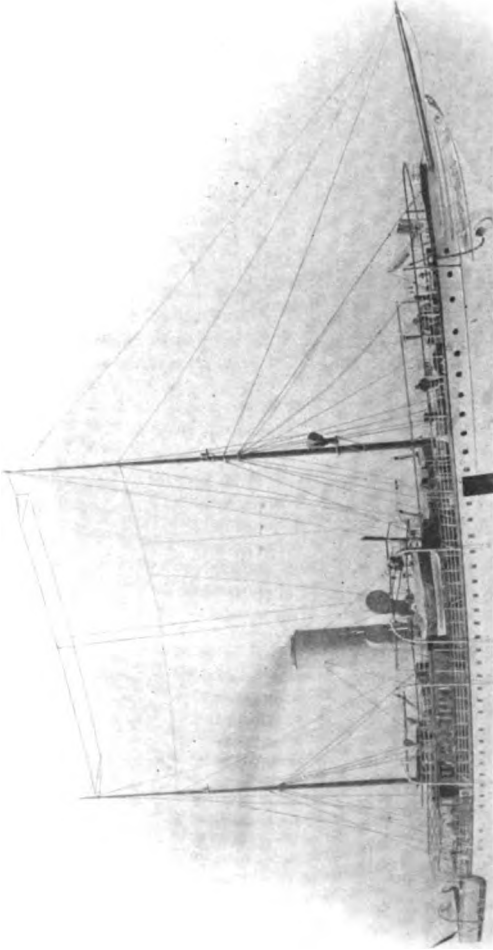
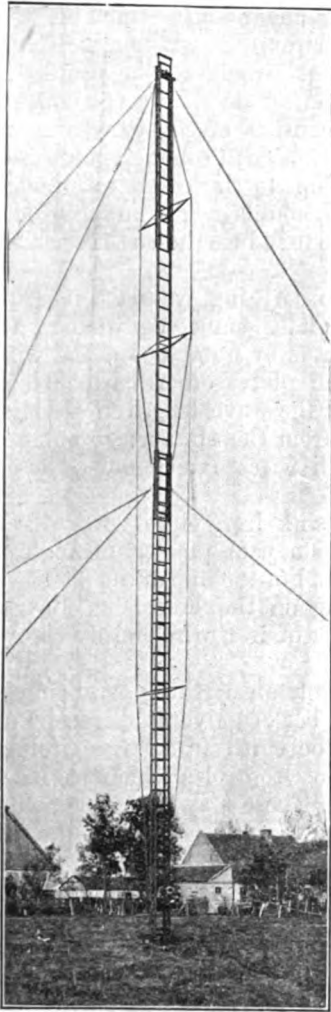

FIG. 105B.—S. S. *Mekoong*. Telefunken T Aerial. Day Range 800 Miles.

**Earthing.**—It will be remembered that Marconi's first important development of Hertzian wave transmission was to

join one side of the spark gap to earth ; by so doing he found the distance of transmission for a given height of aerial was much



(a) Telefunken Ladder Mast.

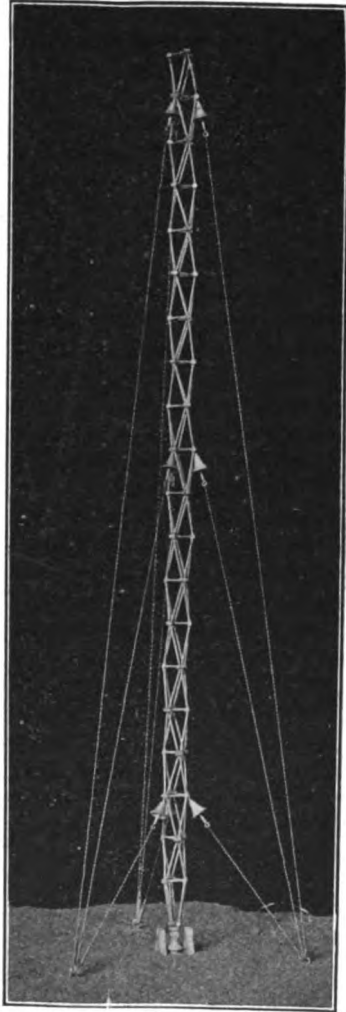

(b) Telefunken Rendahl Mast.

FIG. 106.

increased. Considerable care and attention must be given to the earthing of one side of the aerial circuit ; if possible the earth

wire, or wires, should go straight down from the coupling transformer, and no part of it should run parallel to the aerial connections if it can be at all avoided.

As regards proper earthing the student must remember that this earthing is a part of the aerial circuit, and if not well done it will increase the resistance of that circuit to the oscillating currents, with consequent damping effect on the waves emitted. For portable stations, the earthing consists of copper wire gauze or netting pegged down on the ground, a good soldered connection being taken from each sheet of netting to the earth terminal of the transmitter. The earthing sheets should cover as much ground round the transmitter as possible so as to reduce the earth resistance to the first wave.

At land commercial stations the earthing system consists of a wide circle of zinc rectangular plates sunk edgewise in the ground, and connected to the apparatus by numerous radial wires soldered to the ring; from the zinc plates other wires stretch out under the ground. The longer the wave length the farther out should the earth wires extend from the station; at some of the large Marconi stations the earth wires extend outwards for hundreds of feet.

Another method adopted is to sink iron pipes vertically in the ground, in a circle round the station, each pipe connected by a thick copper wire to the earth terminal of the apparatus.

At Macrihanish station (working on the Fessenden system) the earth consisted of a large network of iron wire simply thrown on the rocks, and washed by the sea.

With the Marconi Co. 5 KW. set, an earthing arrangement sometimes adopted is to have a number of galvanised iron plates, No. 24 gauge, buried on edge in the earth in a large circle of 50 feet radius, and connected by wires to cables which are led to the earth terminal of the apparatus. These may be supplemented by long wires buried in the earth and radiating out from the iron plates.

For small amateur stations the water pipes may provide a good earth, especially if no part of them rises higher in the house than that joined to the apparatus—on no account should gas pipes be used as an earth, for leakage or explosion may ensue, owing to the danger of sparking at bad contacts.

The aerial should always be left connected to the earth wires when the apparatus is not in use, and amateur aerials should be fitted with a long bladed knife switch, which can be used to short circuit all the apparatus, so that if atmospheric or lightning discharges strike the aerial they can pass direct to earth.

The Marconi Co. use a device called an earth arrester, which consists of two heavy brass plates clamped together, and separated from each other by a very thin mica washer. This is joined in series in the aerial and is shown in Fig. 107. A circular groove is cut in each brass disc, coinciding with the edge of the mica, to ensure that the sparking will not take place at the mica edge and burn it; the sparking then takes place across the outer edge of the upper plate. The gap is so short that it does not stop the transmitting aerial currents, which flow in sparks across it, but it acts as an insulator to the tiny received currents which must therefore flow through the receiving apparatus. Strong atmospheric or lightning discharges can flow across the gap, so that to such the aerial is constantly earthed. This arrangement does away with the necessity of having a change over switch connecting

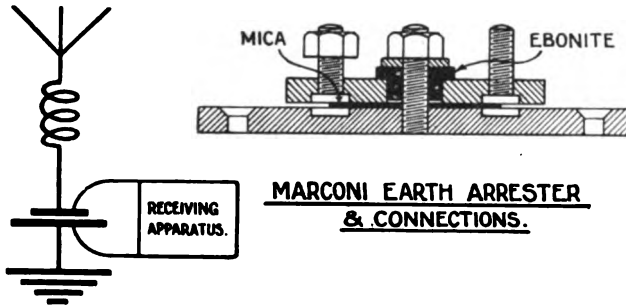

FIG. 107.

the aerial to the sending or receiving apparatus according as each is required. Fig. 107 shows how the receiver is joined up.

The earthing arrangement at the Marconi transoceanic stations, on the shores of the Atlantic and Pacific, are very elaborate and costly. The sending and receiving units are in separate buildings from 20 to 30 miles apart; each of course with their own directional aerial system. In order that the interaction between the sending and receiving aerials should be as small as possible they are placed parallel to each other.

At the sending station a continuous circle, of 100 feet radius, is made by large zinc plates, all bolted together and buried in the ground on edge, the transmitting apparatus being at the centre of the circle. Soldered to the top edge of the plates are 224 stranded copper cables, all of same length and size, stretching out radially from the earthing side of the transmitter.

From the zinc ring 112 copper cables, 300 feet long, stretch out

radially, each terminating in another zinc plate placed vertically in the ground. Some of these latter zinc plates will be under the aerial, and from these copper cables extend, in the ground under the aerial, to a point a little further than the span of the aerial itself. If the station is near a river or marsh this symmetrical system of earthing may be modified, so that a good number of the plates may be in the bed of the river or in the marshy ground.

At the receiving station a continuous circle of 50 feet radius is made of zinc plates and, as before, joined by copper cables to the earthing side of the receiving apparatus. From this circle of buried zinc plates other cables extend out to marshy ground or a water way in the vicinity, each terminating in another zinc plate buried on edge.

At the new transatlantic Marconi station on Cefndu Mountain in Wales the earthing arrangements are as here described. The aerial consists of 32 silicon bronze cables supported on 10 tubular steel masts each 400 feet high.

**Insulators.**—The strain insulators used in the aerial must be of such a design that they will not break under heavy mechanical strain, and their insulating properties must not deteriorate by exposure to the weather. The Marconi Co. use a special type of flexible insulator consisting of a core of special cord, completely covered with vulcanised india-rubber. The surface of the rubber is treated with a special bitumen compound which, though flexible, has a smooth surface; this causes moisture to separate into drops, so that in wet weather there will not be a continuous surface of moisture on the insulator. The insulator is made up in two different lengths, 3 feet for a working strain of 15 cwt. and 5 feet for a working strain of 30 cwt., while, of course, the longer insulator has the greatest dielectric strength.

The Telefunken Co. use the Rendahl insulator shown in Fig. 108. The high pressure end is made of aluminium, funnel shaped, the effect of which is to spread the potential stress more uniformly along the stalk of insulating material than would otherwise be the case. The stalk is made of wood, impregnated with oil and protected by a porcelain tube.

Strain insulators can be made by screwing metal eyes into the ends of ebonite rods, from 9 inches to 12 inches long. The end of the rod and the metal eye should first be put in boiling water for some time, and it will then be found easy to screw the eye into the rod, after which the end should be plunged in cold water. Such insulators will stand a strain of 500 to 700 lbs. and, for a high voltage, two or more can be joined in series. They are suitable for

use in stay ropes; which anchor each end of the spreaders, to prevent the aerial swaying or turning round in the wind. Other strain insulators of porcelain or special composition, capable of withstanding large mechanical strain, can be seen in the lists of wireless supply firms.

A good roof or wall insulator, for use where the aerial enters

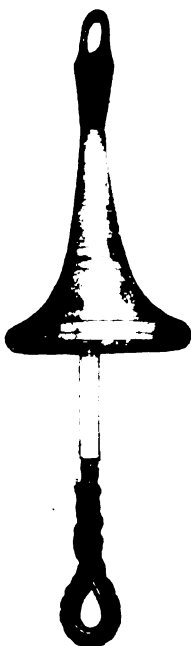

FIG. 108.

the operating room, can be made by threading an ebonite tube 36 inches long over a brass rod, the ebonite being  $\frac{3}{8}$  inch thick. The brass rod is screwed at each end, and fitted with nuts by means of which the aerial wires, inside and outside, can be connected to it. For leading in purposes the Marconi Co. use the Bradfield Insulator shown in Fig. 109. It consists of a stalk of

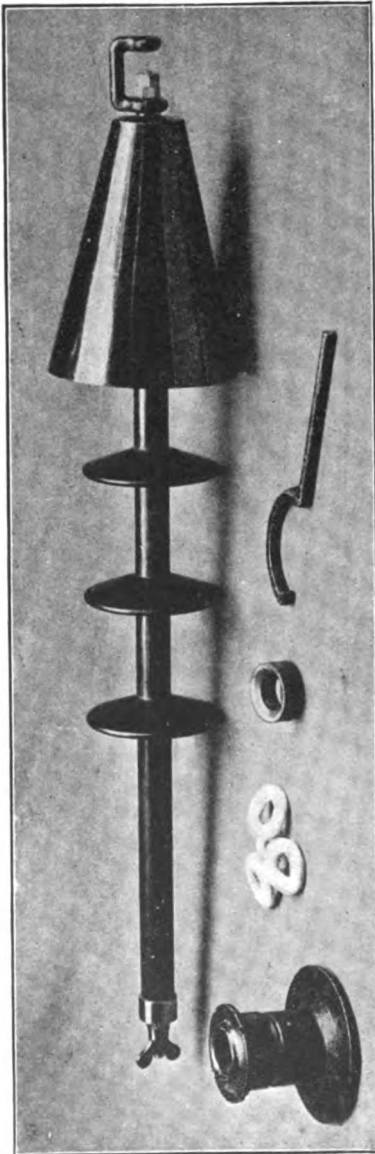

FIG. 109.

ebonite with an iron rod running through it, the ebonite having three petticoat enlargements to give a longer insulating or leakage path. The whole is surmounted by a metal cone, which serves to keep off the rain and distribute the potential gradient. The insulator fits in a stuffing-box in the cabin roof, the box having an ebonite core and asbestos ring washers.

For small stations a glazed porcelain tube, such as is stocked by most electrical supply companies, might be used; the tube should be of such a length that it extends well beyond the inside and outside surfaces of the wall, and it should be filled with bitumen so that moisture is prevented from lodging in it.

#### QUESTIONS AND EXERCISES ON CHAPTER XIV.

1. What is a directional aerial and how is it used?
2. Why is it that the natural wave length of an aerial may be taken as about 4.9 times its actual length?
3. Explain why an aerial should not be loaded with inductance to produce a wave length greater than 4 times its natural wave length.
4. How would you produce a radiating wave length which is less than the natural wave length of the aerial?
5. An aerial has a capacity of 0.0005 mfd. What inductance placed in series with it will produce a radiation wave length of 100 metres?
6. An aerial is 80 feet high and

its horizontal portion consists of 10 wires 110 feet long, spaced 2 feet apart. Its capacity is 0.00035 mfd. and its inductance 0.0005 mhy. What is the natural wave length of this aerial?

7. Calculate the inductance of the transformer coil placed in the aerial in Question 6, to produce a radiation wave length of 800 metres.

8. What considerations determine the proper spacing of the wires of a horizontal aerial?

9. Why are aerials put as high above the ground as possible?

10. What is meant by "radiation resistance"? How is it determined for any radio-telegraphic aerial?

11. Why is it necessary to have a large spread of earthing connections at a transmitter station?

12. What is the principal advantage of an umbrella type aerial?

13. If the effective current is 10 amperes at the base of a T aerial 120 feet high, and the wave length is 2000 ft., find the approximate amount of radiated energy.

14. Calculate the approximate wave length of the aerial used with the Marconi cavalry outfit described in this chapter.

15. What effect has (a) increase of aerial capacity, (b) increase of aerial inductance, on the amount of energy radiated from the aerial?



## CHAPTER XV

### RECEIVER CIRCUITS

WHEN energy is applied to the closed, or primary, circuit of a transmitter, either from a battery through an induction coil, from an alternator through a transformer, or by any other arrangement now in use on the different systems, in general not more than 20 or 30 per cent. of that energy is radiated from the aerial with proper coupling (say 20 per cent.) between the two circuits. The Telefunken Co. claim a much higher radiation efficiency than this for their quenched spark system, however the above figure will apply to ordinary spark systems.

The energy is radiated in all directions, and therefore, as it spreads out, in any given direction it gradually diminishes, decreasing approximately as the square of the distance from distance effect alone. Obstructive effects of large conductors, mountains, etc., will still further decrease it, also the effects of absorption by the land or sea over which the feet of the waves travel, and, especially in daylight, the ionised condition of the upper atmosphere.

Thus at the receiving aerial a very small amount of energy will be available, so that we shall have oscillating energy set up in it of value somewhere near  $\frac{1}{10^8}$  watt. At a good working maximum range the receiver energy would be about  $\frac{4}{10^8}$  watt, and the least energy which would act on the modern forms of detectors to produce signals would be about  $\frac{0.25}{10^8}$  watt.

The aerial has got capacity and inductance which, as mentioned in an earlier chapter, correspond to elasticity and inertia in mechanics. Suppose we consider the ether wave energy to be little forces causing an electron current to flow back and forth along the aerial. Referring to Fig. 65, Chap. X., the ether

wave at A gives it a small push upwards, and if, on account of the inertia, it has not stopped moving upwards before the wave reverses and gives it a small push downwards the resultant motion will be very irregular. It will not be nearly as great as might be obtained by tuning the vibration period of the circuit to the forces acting on it. Thus it is evident that for real effectiveness the receiver aerial must be tuned to the frequency of the ether waves, *i.e.* have the same wave length. It is also evident that if the aerial resistance is very great the currents produced would be too small to be effective. The aerial used for receiving is the same as that used for transmitting (except at large stations), a change over switch being provided to connect it to the receiving instruments or transmitting instruments; or an earth arrester may be used as already described. If, then, the natural wave length of the aerial is longer than the arriving ether waves, it can be shortened by joining an adjustable condenser in series with the aerial, since this will decrease the capacity of the whole circuit, and will thus decrease the value of  $59.6\sqrt{LK}$ . More often, however, the ether waves are longer than the natural wave length of the receiving aerial, and thus it is necessary to increase the latter by means of an inductance coil joined in series with the aerial.

It is best to have both an adjustable condenser and an adjustable inductance coil in series with the aerial, because, not only do they allow of tuning to wave lengths both greater and less than the natural wave length of the aerial, but with the variable condenser we can obtain finer adjustments in the value of  $\sqrt{LK}$  than by tappings from a coil. We would tune in by first short circuiting the condenser, and adjusting the inductance coil to give a wave length a little too long; then by putting in some capacity from the condenser the accurate wave length can be arranged. The condenser may be joined in parallel with the inductance to produce the same effect; with this connection the capacity will increase the wave length. If the wave lengths to be received are longer than that of the aerial, and if sufficient contacts can be arranged on the inductance coil to give close adjustment, a variable condenser in series or parallel is not used. Thus the simplest forms of receiver aerial circuits are those shown diagrammatically in Fig. 110; if an earth arrester is used instead of a change over switch it may be that the secondary of the transmitter jigger and the aerial inductance of the transmitter will remain in the aerial circuit, thus the receiver aerial circuit will be as shown in Fig. 111. In the aerial, if properly tuned, small currents will oscillate at the same frequency as the oscillations of discharge in the transmitter; to detect them, we might, like Hertz,

put a very short spark gap in the receiver aerial circuit, but a spark gap, even the smallest, introduces a high resistance, so that the effects set up in the aerial would give rise to very tiny sparks only when the receiving circuit was a very few feet away from the transmitter. We might connect a delicate galvanometer, of suitable working principle to measure oscillating currents, in series with the receiving aerial circuit, and note its deflections. But the currents set up in the aerial when at a good distance from the transmitter are only a few microamperes, and it requires a very delicate galvanometer indeed to give suitable deflections with such a small current. In any case it would be practically impossible to interpret signals by means of a

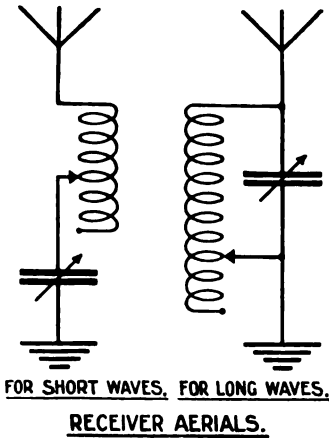

FIG. 110.

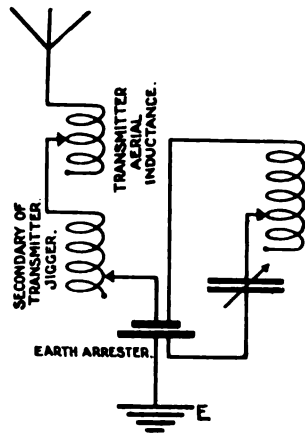

FIG. 111.

galvanometer connected in series at the base of the receiver aerial. None of the modern forms of detectors, used with telephones for receiving signals, are suitable for direct connection in the aerial circuit, with the exception of the Marconi Magnetic Detector and possibly the Fleming Valve. These are sometimes joined in series with the aerial tuning inductances, aerial tuning condenser, and earth, and will in this position pick up signals, but in the Marconi outfits they are only thus connected when "standing by," as will be described in Chapter XVII.

One reason why a detector should not be connected in series in the aerial circuit is that if so placed it will be affected by every atmospheric disturbance; these would injure the detector, or at least impair its sensitiveness. In the second place, if several

stations are signalling within range, it will be almost impossible to tune the receiving aerial circuit so that only one station is heard—except it be a station of very long wave length. It will, therefore, be found that there are, in general use, three methods of connecting the detecting apparatus to the receiving aerial circuit; they are—

I. Joining them in shunt across the inductance coil in the aerial circuit.

II. Joining them in a circuit which is inductively coupled to the aerial circuit.

III. Joining them in a circuit which is inductively coupled through one or more intermediate circuits to the aerial circuit. The different methods will be discussed in the above order.

**Direct Coupling across the Receiver Inductance.**—This method

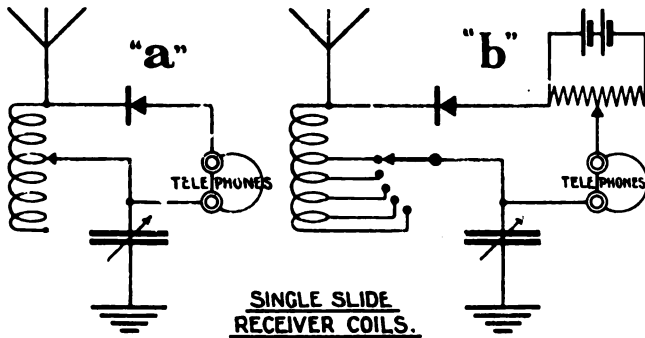

FIG. 112.

will be suitable for small outfits; or where the receiving station is well within the range of the transmitting station; or when the receiving aerial is used to pick up wave lengths much longer than the natural wave length of the aerial, in which case the tuning coil comprises the major portion of the inductance effect in the receiving aerial circuit. Fig. 112 (a) explains the method of connection. There are two terminals on the inductance coil, one of which is joined to a sliding contact which acts on a bared portion of the insulated wire of the coil, and by means of which the amount of inductance in the aerial circuit can be adjusted to tune it to the proper wave length. Instead of a sliding contact on the coil, tappings may be taken from the windings of the coil to the studs of a multiple way switch, as shown in Fig. 112 (b); indeed this is a better method of construction. The detector and telephones are then joined in series across the inductance, as shown;

the second figure showing a potentiometer joined in series with them, and it will generally be found that such a potentiometer improves the working of most detectors as will be explained in the next chapter.

With such a connection the little oscillating currents, set up in the aerial circuit by the ether waves, will give rise to an oscillating difference of potential across the inductance coil; this will tend to send oscillating currents through the circuit joined across it, *i.e.* through the detector and telephones. The frequency of the detector and telephone currents may be here explained. Each spark at the transmitter sends out a train of waves (*as many waves in a train as there are oscillations in the transmitter aerial at each spark*) and each train of waves acts on the telephone circuit with a cumulative effect, in such a way that one impulse of current acts on the telephones or other receiving device. *The frequency of the current impulses in the telephones is not that of the ether waves, but of the wave trains, and the wave train frequency is the transmitter spark frequency.*

Referring back to the chapter on transmitters we see that the oscillation frequency for a 600 metre wave length is 500,000 per second; now a telephone receiver would give no sound if it vibrates at a greater rate than 40,000 per second, for this is the highest rate of vibration audible to the human ear. Thus the telephone diaphragm does not oscillate at the wave frequency. If the transmitter is so arranged that a spark takes  $\frac{1}{1000}$  second, then the spark frequency is 1000, the wave train frequency is 1000, and the telephone diaphragm vibrates at the rate of 1000 per second. The sound heard in the telephone has the same pitch as the sound given out by the spark, in the case considered approximately a note in unison with the C two octaves higher than the middle C on a piano. A high note is obtained if there are a great number of sparks per second, and this is an object aimed at in all sparking systems, as it is very easy to discriminate between a musical note and a chance discharge or atmospheric. A high musical note can be distinguished even if an ordinary low frequency note is not entirely tuned out from the receiver, also it is a fact that telephone receivers are most sensitive to high frequency impulses. An alternator frequency of 500 gives 1000 sparks per second, and the alternator frequencies usually employed vary from 200 to 600 cycles per second.

If the wave length of the aerial is longer than that of the ether waves a condenser must be put in series with the tuning coil, and less inductance used to tune the receiver circuit. Such an

arrangement will not give strong signals unless the receiving station is well within the range of the transmitting one, for it is seen that the detector-telephone circuit is applied across less inductance, therefore less energy would be imparted to it.

The connections shown in Fig. 112, *a* and *b*, will work very well when picking up long waves, the series condenser then being short-circuited, or not provided at all, while the inductance coil is relatively large. Most of the inductance effect in the circuit is located in the coil, and practically all the energy available acts across the detector circuit. We must note that the energy oscillating in the aerial is at one instant stored up in its capacity, and at an instant later is sending currents through the inductance thus setting up inductance effects; it is when the energy is in the form of inductive effects that we transfer it to the detector circuit.

**Two-Slide Inductance.**—For efficient reception over a good range of wave lengths it is better to have two adjustable contacts on the inductance coil, either by using two sliders, or tappings taken to two multiple way switches.

With such a coil the inductance applied across the detector circuit may be made different to that added into the aerial circuit; for instance, more turns can be applied to the detector circuit than are included in the aerial circuit, thus giving a transforming up effect. It will be at once seen that, with such an arrangement, the two circuits are inductively coupled together, and the same precautions must be taken as those which apply to the coupled circuits of the transmitter; that is to say, for good efficiency the coupling must not be too tight, neither must it be too loose, and the circuits must be tuned to each other. For instance, if it is found that only two or three turns of the coil are required to be added into the aerial circuit to tune it to the on-coming waves, and that a good many turns are required in the detector circuit, then the coupling will probably be too loose to make the receiver really efficient.

In order that the secondary circuit may be accurately tuned to the aerial circuit, it is usual to join a variable condenser as a shunt to the portion of the tuning coil across which the detector circuit is connected. This condenser must be of very small capacity, with a maximum value of about  $5000$  microfarad. We must realise that there will be many inductance turns in the secondary circuit, and these turns will have a self-capacity value which in most cases may be quite sufficient for tuning purposes. If, however, low resistance detectors and telephones are used the secondary condenser would be larger than usual; also when tuning to very long wave lengths larger values may be

necessary to bring the secondary into tune; thus 0.002 to 0.005 mfd. may be required in these cases.

The small variable condenser is used to give very small gradations of capacity, so that, acting with the secondary portion of the coil, accurate tuning of the secondary circuit is made possible. It is easy to see that if this variable condenser has too high a value, it is worse than useless on ordinary wave lengths up to 600 metres, because the necessary very small adjustments of capacity tuning cannot be obtained. Also it must not be forgotten that we are working with very tiny currents which would not charge up relatively high capacities to an appreciable potential. As a matter of fact, the receiver will be most efficient when so designed that no capacity effect is necessary across the secondary circuit beyond that of the secondary coil itself.

In some cases a small fixed or variable condenser is joined as a shunt across the telephone receivers; though it is not absolutely necessary, yet often it will make the sounds in the telephones clearer and stronger, if of suitable value. Its action is to strengthen certain harmonics in the oscillations set up in the receiver and suppress others, so that the sounds heard in the telephones will be distinct because they are, as it were, clarified.

We know that sound, or air waves, of any fundamental length are always accompanied by other wave lengths whose frequency bears definite relations to that of the fundamental wave; thus in a note struck on the piano one can distinguish the sound of a note which is an octave higher—this accompanying note being called a harmonic; and the peculiar difference of notes as heard on a flute, or violin, or piano, is due to the presence of different harmonics in the note, according to which instrument is used.

In the same way ether waves of any fundamental length are accompanied by harmonics, and when there are several circuits tuned to each other, as in a receiver, there are likely to be small disturbing oscillations set up which would confuse the sound in the telephone. The function of the telephone condenser is to suppress at least some of these small oscillations, making *all the little irregular currents join with the main impulses of current to flow into the condenser and charge it; they are thus all integrated and made into one whole before flowing from the condenser plates through the telephone receivers.* In the same way a reservoir gathers up all small contributions of mountain streamlets, and perhaps one large rivulet, before it sends a steady flow of water through the delivery pipes.

The size of condenser necessary partly depends on the detector used, but chiefly depends on the telephone receivers

used, or rather, the mechanical diaphragm frequency of the latter. The telephone condenser used should therefore be a variable one, with a maximum value of about 0.002 mfd. By suitably choosing the value of the capacity of the condenser, it can be made to discharge into the telephones at each main impulse of current from the detector, that is to say, a discharge for each train of waves received, *i.e.* for each spark at the transmitter, so that the "note frequency" in the telephones is the spark frequency. If the condenser has too large a capacity, the effect will be very irregular, and the note in the telephone not a good one; while if the condenser has too small a capacity, it will not carry out the functions required of it, and may cause the note heard in the telephone to have a frequency not that of the pure fundamental note, but of one of its harmonics.

With a two-slide inductance or tuning coil the receiving circuit will therefore be as shown in Fig. 113. The condenser A must be a small one, having a capacity of  $\frac{1}{5000}$  microfarad, and be continuously adjustable, an effect most simply accomplished by making one set of its plates so that they can be moved relatively to the other set.

In the next chapter will be found a description of the Billi condenser used by the Marconi Co. for this purpose. The telephone condenser, if used, should either be variable or have a capacity to suit the particular telephone receivers with which it is used.

**Use of Inductance Tuning Coil with Separate Primary and Secondary Windings.**—We have seen that, on account of the design of the apparatus, the two receiver circuits may be in tune only when the coupling between them is too loose to be really effective or efficient. Again, if the coupling is too fast, then both circuits will have the currents oscillating in them at two very different wave lengths, neither of which is that of the ether waves received, (a result analogous to what occurs in a tightly coupled transmitter), so that only about half the energy available can act on the telephones. For confirmation of this see Fig. 190, Chap. XX., and the experiment which it illustrates. It is best, therefore, to arrange the connections so that the degree of coupling is to some extent independent of the tuning adjustments; this can be accomplished

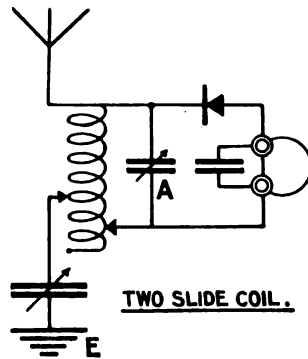

FIG. 113.



by making the tuning coil in the aerial act inductively on another tuning coil, shunted by a variable condenser and joined across the detector circuit. The primary and secondary windings are of different linear dimensions; the secondary has many more turns than the primary, and is generally wound with finer wire. Both may be fitted with sliding contacts, or, preferably, with multiple switch tappings, for tuning purposes. The coupling between the two receiver circuits can be made fast or loose by moving the secondary winding up to or away from the primary, or by rotating the primary so that its magnetic axis is not in line with that of the secondary; thus a degree of coupling can be chosen quite independent of the tuning arrangements.

The diagram of such a receiving circuit is shown in Fig. 114,

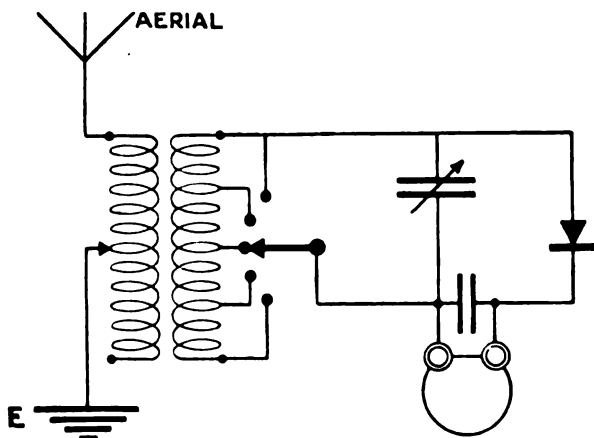

FIG. 114.

where sliding contacts are used, while Fig. 115 shows similar methods of coupling and tuning. In some cases the secondary slides into the primary; in the Telefunken Receiver the primary is hinged on a board over the secondary, so that by pulling it up or out the axis of the two coils are not in line, and thus the coupling between them is made loose; in the Marconi Receiver, the secondary is wound on a cylinder form, while the primary is wound on a spherical form fitting into one end of the secondary; by turning the spherical primary relatively to the axis of the cylindrical secondary, the coupling is made loose.

Fig. 116 shows the connections in a portable receiving station made by the Marconi Co. for scout work and military purposes;

no tuning adjustments are provided except in the small condenser as the outfit is used only to receive from a short wave length

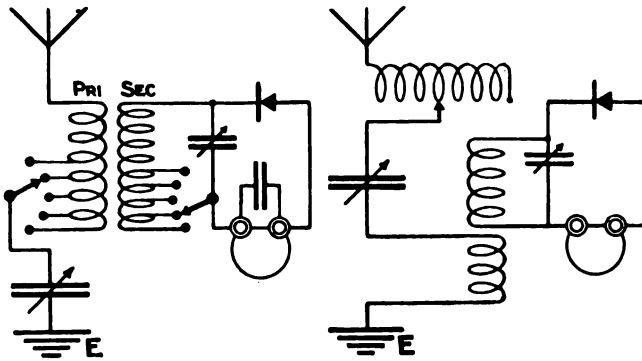

FIG. 115.

transmitter, over distances of from 5 to 7 miles, with aerials about 30 feet high.

Fig. 117 shows the connections used in the Telefunken system; it will be observed that for short waves an adjustable condenser is used in series with the aerial circuit inductance, but for long waves this condenser is switched over to be in parallel, or shunt, across the inductance.

Where a Fleming valve detector is used, the connections would be as shown in Fig. 127, Chap. XVI., and are there fully described.

Fig. 118 shows the connections in a Marconi Crystal Receiver used for waves up to 1200 metres long. The turns of wire in both primary and secondary of the coupling coil are fixed, *i.e.* there are no variable contacts. The aerial circuit is tuned by having in series with the primary a variable inductance coil with tappings taken to a multiple way switch; a variable condenser is also joined in series, and is used to obtain finer adjustments of tuning. The secondary coil being of a fixed value, tuning of the secondary circuit is carried out by means of a small adjustable Billi condenser, joined across the secondary coil. Since the primary and secondary

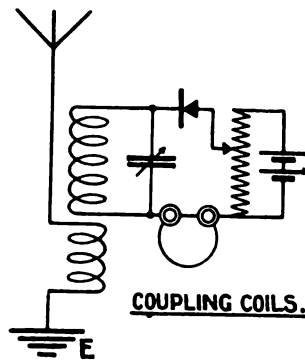

FIG. 116.

coils have each a fixed number of turns the maximum coupling is fixed, but the "degree of coupling" can be varied by turning the

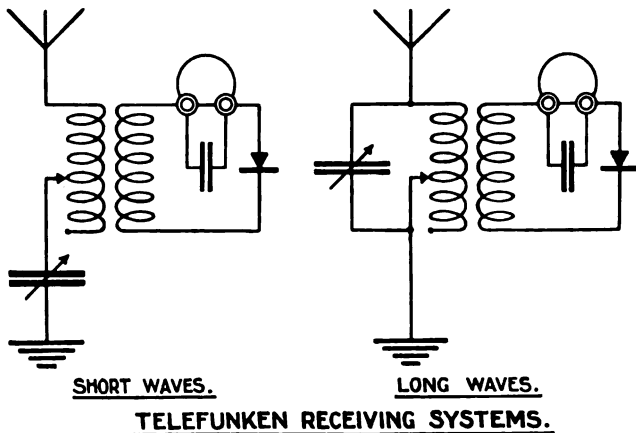

FIG. 117.

axis of the primary coil out of line with that of the secondary, as shall be further described in Chap. XVII.

Across the whole primary circuit from aerial to earth is joined

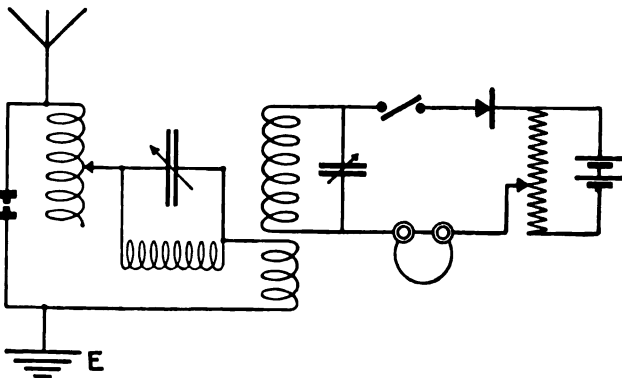

FIG. 118.

a small spark gap  $\frac{1}{100}$  inch long, through which abnormal discharges can pass, such as those induced by the station transmitter; it thus acts as a safety valve. Across the aerial condenser is

shunted a coil whose inductance value is so high (up to 80 mhs.) that the ordinary oscillating currents in the receiver aerial circuit do not pass across it, but through it the aerial is permanently earthed, so that it cannot become statically charged from atmospheric electricity. If such static charges were allowed to accumulate, they would, on discharging through the apparatus, injure the detector or telephones.

The detector used is a carborundum crystal with potentiometer and 4 to 6 volt battery. The construction of this Marconi crystal receiver will be further described in Chap. XVII.

It may here be noted that in some of the Marconi receiving sets, the primary and secondary of the coupler have each a fixed number of turns, and no tappings are taken from them. They are simply used for coupling, and each of the circuits are tuned by variable

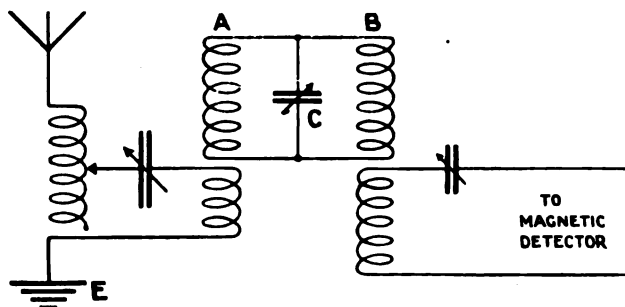

FIG. 119.

inductances and capacities which are quite separate and distinct from the coupling coils.

We must now consider the use of a closed intermediate circuit between the aerial circuit and the detector circuit, inductively coupling them together. It may be stated at once that the function of this extra circuit is to filter the received ether waves, so that the detector circuit may be actuated by signals of only one wave length, all others being tuned out. The intermediate circuit also decreases the effect of atmospheric discharges on the detector circuit; these discharges are sometimes called Xs.

Fig. 119 shows the connections of such a multiple tuner, as used by the Marconi Co. with a magnetic detector. The aerial circuit contains, as usual, tuning inductance, tuning condenser, and a coupling coil. An intermediate circuit AB is coupled to the aerial circuit as shown, and is tuned to it by means of the variable condenser C. Oscillating currents induced in A will flow through B.

These currents in B will induce currents in the detector circuit, the latter being coupled to coil B in the usual manner.

A similar arrangement can be used with valve or crystal detectors, and further particulars of its construction will be given in Chap. XVII.

It will be remembered that the receiver circuit is most sensitive when accurately tuned to the arriving ether waves. In the receiver here described we have three circuits, each of which must be tuned to each other and to the transmitted wave length; it will be seen, therefore, that energy arriving at a different wave length will act on the aerial circuit, but its effect will be diminished in the intermediate circuit, and be not apparent at all in the detector circuit, since all three circuits are out of tune with it. Similarly the effect of strong atmospherics will be weakened, the impulses from them charging the condenser C, which is then discharged partly through A and partly through B. The whole arrangement forms a very weak coupling with a condenser filter

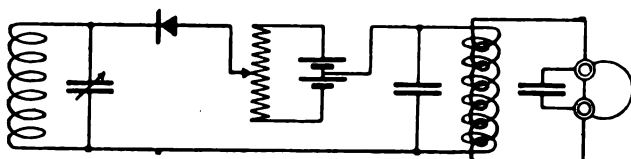

**SECONDARY CIRCUIT WITH STEP-DOWN TELEPHONE TRANSFORMER  
AND LOW RESISTANCE RECEIVERS.**

FIG. 120.

in the middle of it, so that the receiver only responds strongly to waves with which it is in accurate tune.

In some cases it is desirable to use low resistance telephone receivers, connected to the detector circuit through small step-down transformers; the connections will then be as shown in Fig. 120.

Before concluding this chapter there are two or three considerations which demand attention. In the first place, when the oscillating currents are set up in the receiver aerial circuit, similar conditions to those in a transmitter aerial are produced on a small scale; that is to say, a part of the oscillating energy will be wasted or used up, in the resistance of the aerial, being the usual  $C^2R$  loss in resistance; a part will also be re-radiated again, for even though the oscillating currents are small yet there will always be some radiation from an aerial in which currents are oscillating. Thus, all the energy which is given to the receiver

aerial by the oncoming waves is not available to work the receiving apparatus; some is lost in resistance of wires, connections, and contacts, while some is re-radiated from the aerial. Rudenberg has proved that "*a receiver is most efficient when the energy re-radiated is equal to that available at the detector.*"

Again, in the coupled receiver circuits, just as in those of the transmitter, the energy will oscillate at two wave lengths which may have widely different values if the coupling is too tight, but which can be brought into close agreement by suitably adjusting the degree of coupling—this effect has already been referred to, and can be proved by means of the wavemeter, as shall be hereafter described in the Chapter on Measurements.

When a condenser is used in series with the aerial, to shorten the wave length, it must be remembered that the plates of the condenser are separated by air, or other dielectric, which is a good insulator; thus, the aerial is insulated from the earth, and, as a precaution against lightning discharges, some form of safety valve or gap should be connected in parallel across the condenser so that abnormal discharges can pass through it to the earth. The potentials set up in the aerial by the ether waves will be too small to send the currents across this gap, but strong discharges will cross it and not go through the receiver apparatus. This safety gap may be the earth arrester as used with Marconi apparatus, but a micro-meter spark gap is fitted to all Marconi receivers to protect them from abnormal discharges. If such a safety gap is not provided the aerial condenser terminals should be short-circuited when not in use. The highly inductive shunt coil used by the Marconi Co. across this condenser prevents the aerial from becoming statically charged with electricity.

If it is desired to receive long waves the inductance in the aerial circuit can be increased, and the coupled circuit tuned to it by increasing the number of turns used in its coil or increasing the capacity joined across it. In practice it is found that the value of the capacity in the secondary circuit cannot be increased beyond a certain limit without making the receiver inefficient. If the condenser is too large the tiny currents, set up in the secondary circuit, would not charge it up to a potential high enough to act through the detector. It may be reiterated that a coil of wire has not only inductance but also capacity; a coil is most efficient when its self-induction and self-capacity values are such that its natural wave length is equal to that which is to act upon it. Thus, if a receiver is to be designed to receive on 600 metre wave length, the secondary of the tuning coil should be so designed that its natural wave length is 600 metres, when it can be used

*without a variable condenser across it. This will be the most efficient receiving arrangement.*

When it is desired to receive longer wave lengths more inductance can be used on the secondary if it has an adjustable switch or sliding contact. If the whole coil is in the circuit, or if, as in the Marconi receivers, it is simply a coil of a fixed number of turns with no adjustable contacts, the circuit can be tuned to longer waves by joining a variable condenser across it and adjusting the capacity. As the capacity of this condenser is increased the receiver becomes less efficient, and the working limit is reached when, by means of the condenser, the wave length has been raised to 2.5 times that of the coil alone.

Thus, if the secondary coil will of itself provide tuning up to 600 metre wave length, by joining a variable condenser across the coil will work up to 1500 metre wave length; for greater wave lengths it is best to replace it by another secondary of greater axial length, or greater diameter, or with a greater number of turns of finer wire.

The author has known amateurs to make combined coupling and tuning coils for receivers with large primaries and secondaries up to 15 inches diameter, which enabled them to receive the signals from Clifden, Poldhu, Paris; also from local stations. The latter are chiefly carried to them by earth currents for which no tuning is necessary. These amateurs were puzzled by the fact that no method of arranging their apparatus would enable them to pick up signals from stations of 600 metre wave length; then, not understanding the conditions, they tried the effect of using condensers; of course, with no result. Their coils are too large and when the number of turns in use on the primary are brought down to suitable tuning values, there are too few of them in the circuit and practically no coupling results. Copying a diagram which shows a variable condenser across the circuit they try this arrangement, forgetting or being ignorant of the fact that a condenser so used increases the wave length. Also, with such large coils, a small condenser across the secondary is useless, since there is a large capacity effect between the primary and secondary coils. By moving the secondary into or out of the primary this capacity effect will change the wave length by 200 or 300 metres.

It is hoped that the explanations and diagrams given here will enable all amateurs, who may read them, to design their receiving circuits intelligently, and know exactly the function for which each piece of apparatus is provided. For amateur stations, using crystal detectors, a wise maxim would be that "the less condensers used in

the receiving circuit, the better its efficiency." Some hints on the construction of amateur apparatus will be given in Chap. XVII.

The receiving aerial has already been dealt with, and it is sufficient to remark here that good horizontal length is of more importance for receiving than vertical height. The aerial should be kept clear of surrounding conductors, such as houses, trees, etc.; it will be necessary to raise it well above the houses to obtain this result in the neighbourhood of towns. The aerial will be most efficient when its natural wave length is from a half to three-quarters that of the wave length to be received. It may be recalled that, if a sending aerial is loaded with inductance to increase the wave length, it becomes inefficient when this artificial wave length is about four times the natural wave length. A receiving aerial can, however, be loaded with inductance, to increase its wave length for tuning purposes, without greatly impairing the efficiency, provided always that the horizontal portion of the aerial is long enough to entrap a sufficient amount of energy from the ether waves.

#### QUESTIONS AND EXERCISES ON CHAPTER XV.

1. What is the frequency of the currents in the telephones of a radio-receiver if the primary alternating current supplied to the transmitter circuit has a frequency of 300 cycles per second? Neglect transmitter resonance effects.
2. What is the function of the highly inductive coil joined across the aerial condenser in a Marconi receiver? How does its action differ from that of the micrometer spark gap joined across from aerial to earth?
3. The secondary of a receiver coupling has a coefficient of self-induction of 500 mhys. when adjusted to receive signals on 1200 metre wave length. What value of capacity should be shunted across it to make the tuning accurate?
4. What is the object of an intermediate circuit in a multiple tuner receiver? Point out the possible disadvantages of such an intermediate circuit.
5. Explain the object of joining a condenser across the telephones in a receiving circuit.
6. If the inductances in a receiving circuit consist only of the variable primary and secondary windings of the coupler, and if these coils are of relatively large diameter, it is found impossible to tune to (a) short wave lengths, (b) very long wave lengths. Explain the reason of failure in each case.
7. If a receiver coupler consists of a cylindrical secondary coil sliding into a primary one it is bad practice to have the secondary of such a diameter that it fits closely into the primary. Explain the inefficiency of such a design?
8. Draw a diagram of the connections of a loose-coupled receiver, with primary and secondary coupling coils, and a potentiometer voltage in series with the detector.
9. If the inductance in a receiver aerial circuit is 90 millihenrys when it is tuned to Clifden wave length of about 6000 metres what is the combined capacity of the aerial and aerial inductance coils?
10. The inductances of a receiver consists of a secondary coil sliding into a primary coil. When the secondary is pushed into the primary the two provide a capacity effect. If the secondary is moved out of the primary, how are the wave lengths of the receiver circuits modified?



## CHAPTER XVI

### DETECTORS

LIGHT waves in the ether are detected by means of the eye and the sensations are conveyed to the brain receiver. However, the eye, though so delicate and sensitive, is not affected by long ether waves, whilst our radio-telegraphy detectors are far too crude to detect the short ether waves of light or radiant heat. Telegraphy by short ether ripples, such as the light of a heliostat, uses the eye as a detector, but we must use artificial detectors when dealing with longer ether waves.

The first detector, in the form of a tiny spark gap, was used by Hertz in his experiments, and by Sir O. Lodge with his Syntonic Leyden jars. But this was not a very sensitive arrangement and a more delicate detector was evolved in the improvement of Branly's coherer by Marconi, already referred to in Chapter IX.

**Coherers.**—The coherer consists of a small glass tube having two silver plugs cut as shown in Fig. 121. The plugs are

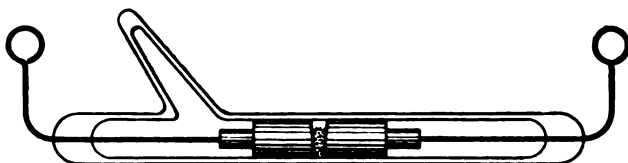

FIG. 121.

separated about 1 millimetre, and in the space between them metallic granules are placed, 5 per cent. silver and 95 per cent. nickel. The silver plugs are attached by wires, one to the aerial, the other to the earthed side of the receiving circuit; preferably the glass tube is sealed and exhausted of air, the tube being about 5 mms. diameter. To the coherer is joined a circuit consisting of a single primary cell and a relay. Under ordinary circumstances the resistance of the loosely packed filings in the

coherer is so great that it does not complete the circuit of the cell to the relay, and consequently the latter does not act; when ether waves act on the receiving circuit the oscillating electrical potentials set up in it act across the coherer. This has the effect of breaking down its resistance, so that it now completes the cell and relay circuit, and the latter is actuated by the current of the cell. The coherer acts like an open switch which becomes closed by the effect of the ether waves; the filings stick together, or cohere, so as to form a bridge to conduct the current across from one plug to the other; the name "coherer" was given to this device by Sir Oliver Lodge, and Dr. Erskine Murray proved that its sensibility depended upon the difference of potential acting across it.

When it has cohered it remains in that condition, therefore in order that it may detect a train of signals it must be decohered after each signal. This is accomplished by tapping it with a little hammer attached to the soft iron armature of an electromagnet, and actuated by the current of a circuit closed through the relay. The relay also closes at each signal a local circuit, consisting of a battery and either a sounder or a Morse Tape machine. Fig. 51, Chap. IX., shows the connections of the coherer, the tapping device and the local circuit.

The disadvantages of the coherer are:—(1) it is erratic in its sensitiveness, which may be much decreased by local discharges, such as the spark discharges of the transmitter; (2) it responds to atmospheric disturbances or discharges, and consequently cannot be relied upon even as a calling-up apparatus. With strong impulses of energy in the receiver it enables one to print the received message, but for long-distance work it is not as sensitive as some other detectors which are of more modern development.

The **Italian Navy Coherer**, discovered by Lieutenant Solari, consists of a small glass tube with two iron or steel plugs between which is a small drop of mercury. This form of coherer has the advantage of being self-decohering, the mercury making good contact with the iron plugs only when the ether waves are acting on the aerial circuit.

The **Lodge Muirhead Coherer** is also self-restoring; it consists of a small steel wheel with a sharp edge, revolved by clockwork at a suitable speed, and just touching a little pool of mercury in a cup at the top of a brass terminal pillar. The mercury is covered with a thin film of oil so that in ordinary circumstances the oil insulates the wheel from the mercury; when oscillating potentials are set up in the receiving circuit the oscillations

break down the insulation of the oil, and a local circuit of which the coherer forms a part is then completed. As the wheel revolves a new portion of it immediately comes into action and thus decoherence takes place. The resistance of this coherer when coherence takes place is very low, therefore it has the advantage *that no relay is required*; the battery and Morse tape or other recording apparatus can be joined directly in a series circuit with the coherer.

A coherer made on what is called the Stone system is employed in some of the portable wireless outfits of the United States Army. The **Stone coherer** has two small steel plugs between which are placed loosely packed carbon granules. This is a self-decohering device; though not as sensitive as other forms of detectors it is well suited to the rough usage of portable outfits.

Before proceeding further with a description of various detectors it will be necessary here to digress into theory for a moment. It will be remembered that when electrical oscillations occur in an aerial circuit, and when these oscillations occur at the fundamental wave length of the circuit, maximum potential strains occur at the top, or outer end, of the aerial, and maximum current disturbances occur at the earthed end (see Fig. 101, Chap. XIV.). Now the action of a coherer depends on potential strains acting across it, and we therefore see that, when joined into the aerial circuit near the earthed end, it is not placed where the potential strains have their maximum effect. This was early realized by Marconi in the development of wireless telegraphy, and led to his joining the coherer in a secondary circuit inductively coupled by the Braun method to the aerial circuit. This secondary circuit can be so arranged that the coherer is at a point of maximum potential strain in it, that is to say at an antinode of potential. By this means not only is the high initial resistance of the coherer removed out of the aerial circuit, but it is also placed in a position where the action of the induced oscillations on it will be most effective. In passing we may note that the distribution of potential strains and current values in the aerial circuit can also be modified by joining inductance coils or condensers, or both, near the earthed end. This changes the wave length, making it longer or shorter than the fundamental, hence produce new positions for the nodes and antinodes of potential and current. In the consideration of detectors the student will find that while some of them are actuated by potential strains, others, such as the magnetic detector, are current actuated devices. He will find that the latter are generally of comparatively low resistance, and will work well if joined directly into the aerial circuit near the bottom,

where maximum current disturbances occur. Other considerations, however, such as tuning and avoidance of interference, make it advisable to use secondary circuits even with current actuated detectors; the student will learn this in what follows, but the above considerations may help him to understand why receiver circuits may differ from each other according to the detector used.

**Marconi Magnetic Detector.**—The erratic behaviour of the coherer led Marconi to develop and perfect his Magnetic Detector, based on the results of experiments by Rutherford and other scientists. It consists of a band, made of fifteen or more slightly insulated soft iron wires, passing over two small wooden discs which are revolved by clockwork. In this manner the band continually passes in front of the poles of two small permanent magnets arranged as shown in Fig. 122. The band passes through a small glass tube

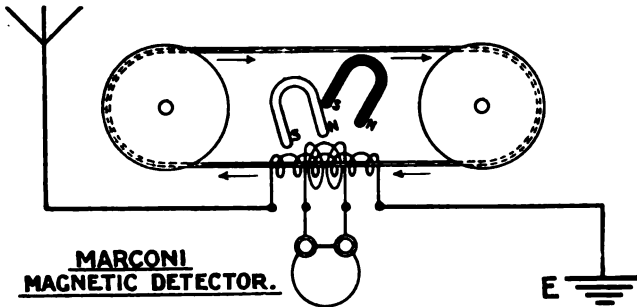

FIG. 122.

in front of the magnets; on this is wound two coils, one being joined in the aerial circuit, or in the coupled secondary circuit as the case may be, the other joined to the telephone receivers as shown. The action of the detector is very simple. As the iron wires pass in front of the magnets they become magnetised, their magnetic condition depending upon the arrangement of the magnets. When iron or steel is magnetised it does not lose all its magnetism if the magnetising force is removed. This retention of magnetism depends in amount on the quality of the iron, and is due to what is called its "magnetic hysteresis." Thus the portion of the iron band passing away from the front of the magnets retains some magnetism or magnetic lines, but when the ether waves set up oscillating currents in the receiver circuit, and therefore in the coil through which the band is passing, these oscillating currents have the effect of suddenly diminishing the number of magnetic lines in the band. Now consider the coil on the glass tube joined to the telephone receivers; if the number of magnetic lines threaded

through or interlinked with it is suddenly reduced an E.M.F. is induced in it; this sends an impulse of currents through the receivers. Thus at each train of oscillations set up in the receivers circuit the band suddenly loses magnetic lines, and the resulting induced current causes a sound in the telephones. As the band is driven forward a new portion of it comes into action, so that the arrangement is self-restoring. Note also that it is a current actuated device. This detector is most reliable, and is fitted to practically all Marconi outfits on board ships; by means of it signalling across the Atlantic was first made possible. It is not as sensitive as some other detectors of more modern development, but probably no other form of detector is more reliable, and, as Mr. Duddell remarked, it is almost fool proof. Its sensitiveness is not affected by "atmospherics" or strong transmitter discharges in its neighbourhood; when once adjusted by the Marconi Co. no further adjustment is necessary. It is specially suitable for long wave long distance reception, that is to say for comparatively low

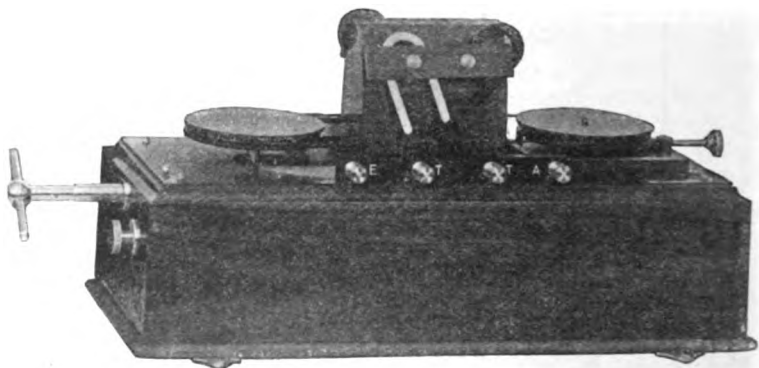

FIG. 123.

frequencies; being a low resistance detector and current actuated it may be joined directly into the receiver aerial circuit. In the Marconi equipments it is so joined when standing by, or when it is desired to pick up signals from any transmitter, irrespective of wave length. Fig. 123 shows the appearance of the magnetic detector; it does not require a potentiometer E.M.F. to be used in conjunction with it. A possible disadvantage is the necessity for clockwork mechanism; this may go out of order or run down in the middle of a message, therefore vessels are generally equipped with a more sensitive form of detector, but have in addition a magnetic detector to serve as a stand by or for the use of comparatively

inexperienced operators. It is quite possible that magnetic detectors could be further developed by more experimental research; for instance the action of nickel or Heusler alloys might be tried, or the detector in a new form might with advantage be used in conjunction with the lately developed gas relays. It is usual to have a second set of magnets and coils to work on the other side of the band; one set will then serve to replace the other, and when receiving on long wave lengths the strength of signals is often increased by using the two sets of coils in series. For rapid sparking, or high note, signals the band should be driven slightly faster than usual to obtain best effects.

**Use of Potentiometer.**—We have referred above to the fact that a potentiometer is not required with a magnetic detector, and before proceeding further it will be necessary to explain the use of a potentiometer in wireless telegraphy receivers.

If a battery (say of 4 volts) is joined to a long uniform wire there will be a uniform drop of potential along the wire. The wire should be of high resistance so that the current taken from the battery is a small one. If a voltmeter is now joined across two points on the wire which are exactly half the length of the wire apart it will read 2 volts; if the points are exactly one quarter of the length of the wire apart the voltmeter will read 1 volt, and similarly we can tap any voltage from 0 to 4 volts off the wire. Such an arrangement of battery and wire is called a potentiometer; by means of it we can obtain any voltage, to apply to our apparatus, from zero up to the full voltage of the battery.

For wireless telegraphy receiver circuits a potentiometer usually consists of a long fine german silver or platinoid wire having 200 to 400 ohms resistance, wound on a slate form, the turns being insulated from each other. It has a terminal at each end, and a third one joined to a sliding contact on the wire; by means of this sliding contact we can tap off whatever voltage we desire or find suitable, up to the full voltage across the whole wire. If the wire has 400 ohms resistance, and we apply 4 volts to it, the current taken from the battery is  $\frac{4}{400} = \frac{1}{100}$  ampere; thus the battery can be used for a long time before it is discharged. Of course the battery may be switched off when the apparatus is not in use. Fig. 124 shows a potentiometer made by Messrs. Isenthal & Co., Neasden, London; if desired the

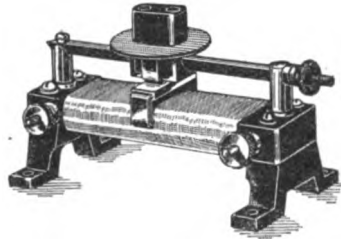

FIG. 124.

potentiometer may be wound *non-inductively* by doubling the wire back on itself at each turn, but this is a refinement which is scarcely necessary.

Now it is found that some forms of detectors, such as valve or carborundum crystal detectors, are made more sensitive by having in series with them a small steady voltage such as can be tapped from a potentiometer wire. The reason of this may be explained as follows:—If a direct current flows in a circuit kept at a steady temperature Ohm's law applies to it, that is to say

$C = \frac{V}{R}$ , or the current is directly proportional to the impressed

volts. Thus if we plot a curve connecting current and volts we shall get a straight sloping line, as shown at A in Fig. 125. If we take *any* point on the curve, such as *x*, and divide the current at *x* into the corresponding applied volts we obtain the resistance R of the circuit—( $C = \frac{V}{R} \therefore \frac{V}{C} = R$ ).

But when a current flows in a circuit it heats the circuit; if the circuit is of metal its resistance increases with the temperature, so that as the volts are raised and the current increases the

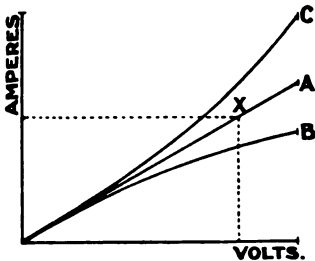

FIG. 125.

temperature rises and the resistance increases. On account of this increase of resistance the current at any voltage will be less than usual. Hence for a metal the current voltage curve will not be a straight line, but will curve downwards as shown at B, Fig. 125. On the other hand, if the circuit is a carbon, mineral, or liquid one, its resistance will decrease with rise of temperature; therefore the current voltage curve will rise above the straight line as shown at C. The student should obtain the current voltage curves of carbon and metal filament lamps and verify the above remarks.

To sum up we may say that in general temperature variations change the resistance of a circuit and thus modify the amount of current flowing in it when a certain voltage is applied.

Again, if a circuit contains a contact between two dissimilar materials, such as a junction of two different metals or a contact of a metal and a crystal, a current flowing across this contact or junction will set up at it either a small evolution or small absorption of heat. Whether it is an evolution or an absorption depends on the material used and the direction of the current across the contact. This effect was discovered by Peltier and

is called "*The Peltier Effect.*" Since a crystal detector always contains a contact between a crystal and a metal or another crystal, it is easily seen that, if a voltage is applied across it, the resulting current will depend, partly upon the decrease of resistance of the crystal or crystals due to rise of temperature, and partly upon the amount of Peltier effect set up at the detector contacts. If, therefore, we apply small increasing voltages across a crystal suitable for detector purposes, and measure the resulting currents by means of a microammeter or galvanometer joined in series with the crystal, we shall find that the current voltage curve of the crystal has departed very considerably from a straight sloping line and that it bends upwards. Fig. 126 shows curves obtained

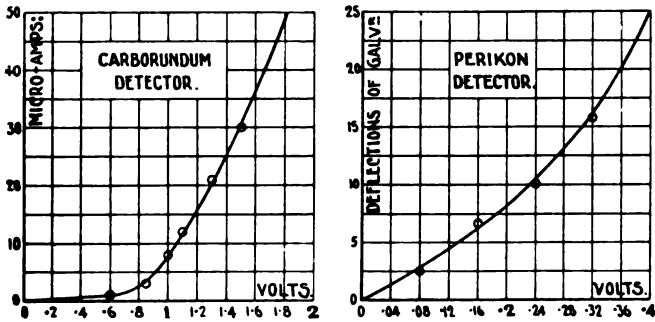

FIG. 126.

by the author with a Carborundum and a Perikon detector respectively.

By means of these curves we see at once how a potentiometer voltage may increase the sensitiveness of a detector in some cases. Thus the curve for the carborundum crystal shows that a small increase of voltage above 0.8 volt will increase the current through the crystal very greatly. Studying the curve we see that if 0.6 volt acts across the crystal the resulting current through it is 1 micro-ampere, but if we had already across the crystal 0.8 volt and add another 0.6 volt the resulting current through it is 26 micro-amperes; an increase of current out of all proportion to the increased voltage.

Thus to make such a detector sensitive we apply across it, by means of a potentiometer wire, such voltage as will bring the current through it just to the bend of the curve; then, when ether waves act on the receiver aerial and set up a small additional potential across the detector, the resulting current increase through its circuit will have a much higher value than if no voltage acted



on the detector except the small one set up by the ether waves. In other words, instead of starting from the zero point of the curve, we start from the bend where it is in its most sensitive condition. If we apply too much potentiometer voltage then the steady current due to it, through the detector and telephones, is on the steep part of the curve; in this case the additional rectified current impulses, due to the oscillating voltage set up by the ether waves, will be less effective in promoting vibration of the telephone receiver diaphragms. The large resulting current may burn or jam the detector contacts, and in any case the crystal will now conduct current in either direction, hence will not rectify the oscillations. The proper adjustment of potentiometer voltage is obtained by listening in the telephone receivers when oscillations are being set up across the detector—a small buzzer transmitting circuit is usually fitted up for this purpose as described in Chap. XX.

It is to be noted that the received ether waves set up oscillating potentials across the detector; at one instant this potential is added to the potentiometer voltage to increase the current, at the next the potentials oppose each other and practically a negligible current flows. Thus the detector rectifies the oscillating currents set up in the receiver circuits and the current impulses through the telephone receivers are always in the same direction.

The curve shown in Fig. 126 for a Perikon detector is fairly regular with no decided bend, thus demonstrating that no great advantage would be gained by using a potentiometer voltage in series with this detector.

A potentiometer is used with valve detectors and some crystal detectors: this will be noted when dealing with the detectors in detail.

**Fleming Valve Detector.**—The Fleming Valve Detector was patented by Dr. J. A. Fleming in 1904; its action is reliable and sensitive so that it is much used by the Marconi Co. The detector consists of a small electric lamp having a single loop filament of carbon or of tungsten. Inside the lamp and surrounding the filament is a cylinder of sheet or gauze copper, joined by a platinum wire passing through the glass to a third terminal on the lamp. The filament is lighted up or raised to incandescence in the ordinary way by means of a battery of 4 or 12 volts (according to the size of valve used) in series with a voltage regulating resistance. The *negative* terminal of the filament is joined in series with a potentiometer voltage and the telephone receivers to one side of the secondary circuit of the receiver, while the copper cylinder is joined to the other side;

when ether waves act on the receiver aerial oscillating voltages act across the space between the filament and its surrounding cylinder. An incandescent filament discharges electrons into the space around it, and in a lamp this space is a vacuum, *i.e.* contains highly rarefied air in which ions and electrons can move



FIG. 127 (a).—Fleming Valves.

fairly freely if acted upon by electrical potentials. These electrons correspond to negative electricity and are therefore attracted by

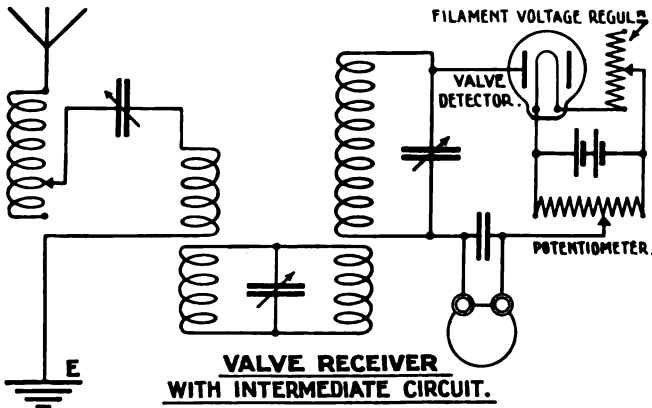

FIG. 127 (b).

the cylinder when it is at positive potential, but repelled from it when at negative potential; also a flow of electrons from the filament to the cylinder represents a current of electricity. The valves, as made up, are shown in Fig. 127 (a).

A diagram of the connections of the valve detector is shown in Fig. 127 (b), in which it will be seen that the battery which lights

Q

the filament is also used to provide voltage across the potentiometer.

When ether waves act on the receiver aerial they set up small oscillating currents in it; these induce oscillating voltages in the secondary circuit so that the copper cylinder alternates rapidly between positive and negative potentials. When it is at positive potential electrons flow across to it from the filament; that is to say, a current flows through this space and therefore through the whole circuit, including the telephone receivers. But when the cylinder is at negative potential the electrons are repelled by it so that they do not flow across and no current ensues. Thus the valve detector conducts current only in one direction, half of each oscillation (set up in the receiver circuit by the ether waves) sending an impulse of current through the detector and telephones, the other half of the oscillation being as it were inoperative. The resulting current through the telephones is called "rectified" current; it flows only in one direction, but unlike ordinary direct current it rises from zero to a maximum value and falls again with regular frequency, and is intermittent. The valve detector is said to have "unilateral conductivity," *e.g.* it conducts current only in one direction through it, a property peculiar also more or less to many mineral crystals, which for this reason can be used as detectors. The sensitiveness of the valve detector depends on the potentiometer voltage joined in series with it; also on the voltage used to light the filament, for the liberation of electrons from the filament will depend upon the latter voltage. A resistance is joined in series with the battery and filament to regulate the lighting voltage; if a sensitive galvanometer is used instead of the telephones, its readings, when oscillations are set up by a buzzer circuit, will enable the filament lighting voltage to be set to its most suitable value.

The valve detector is very reliable and its sensitiveness is not impaired by strong atmospherics or strong signals. When properly adjusted it requires little attention, and compares favourably with crystal detectors in this respect. It is usual to cover the outside of the glass with copper gauze which is earthed to prevent the glass from becoming statically charged, as such a condition decreases the sensitiveness of the detector. More information concerning it will be given when dealing with valve receivers in the next chapter.

**Audion Detector.**—This detector evolved by Dr. de Forest (United States) is very similar to the Fleming valve. Dr. de Forest prefers to use a tantalum filament and has introduced a second perforated plate or cylinder between the filament and the

other plate. The distance between the filament and the perforated plate, or grid, G in Fig. 128, is about  $\frac{1}{16}$  inch, and a similar distance separates the perforated plate and the other plate W. The filament requires 4 to 15 volts to light it according to the size of the valve used. Fig. 128 shows the connections; T is the telephone

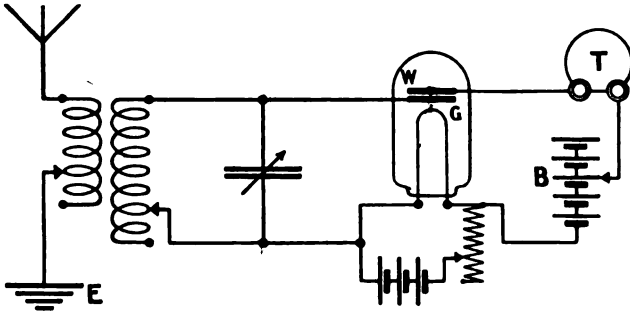

FIG. 128.

receiver (or a relay), G the perforated plate or grid, W the other plate, and B a battery with adjustable switch which takes the place of a potentiometer voltage. It is seen that the electrons given off by the filament pass through the grid G to the plate W and that the rate of flow of these electrons is determined by the potential to which the oscillating currents of the receiver circuit raise G. If the electrons flowed from G to W by means of a connecting wire between them instead of through the rarefied gas, this detector would be identical with the Fleming valve, but Dr. de Forest claims that his arrangement is much more sensitive than that of the ordinary valve. He is particular in pointing out that the plate W in the "Audion" must be joined to the *positive* terminal of the battery or potentiometer, whereas in the Fleming valve the corresponding plate or cylinder is joined to the negative terminal.

This detector can be used as a relay to magnify the received currents. For this purpose a small step-up transformer is used; its primary joined, in the circuit shown in Fig. 128, instead of the telephone receivers, its secondary joined across the filament and grid G of a second Audion to which a battery and telephone receivers are connected in the usual manner.

**Crystal Detectors.**—Certain crystals, when joined in series in an electric circuit, offer more resistance to the flow of the current in one direction than when the current flows in the opposite direction; in other words, they possess to a certain extent the property of "unilateral conductivity"; hence they will act as

rectifiers of weak electrical oscillations in a similar manner to the Fleming valve. If an E.M.F. is applied in one direction across a carborundum crystal, the current which flows may be 100 times stronger than if the E.M.F. is applied across the crystal in the opposite direction. The student can prove this for himself, using small E.M.F.s up to 4 volts, and having a delicate galvanometer in series with the crystal to measure the currents: the crystal itself being held between two metal contacts.

A similar property is possessed by many other crystals, such as silicon, galena, iron pyrites, zincite, molybdenite; or is possessed by a contact between two different crystals such as that between zincite and bornite. Several scientists, notably Eccles,<sup>1</sup> Pierce, and Austin have investigated the action of oscillating currents on crystals; so far not much unanimity of opinion has been reached, but the results of their labours seem to show that the effects are mainly due to change of resistance at the contact point on the crystal. This is partially caused by the heating effect of the current, and partially also due to absorption or evolution of heat owing to the Peltier effect set up. The unilateral conductivity effect is best obtained when *small point contacts* are used between the crystal and the other portion of the detector, whether it is metal or another crystal; the small contact localises the physical changes set up by the current to a small area and thus intensifies the effects produced.

**Carborundum Detector.**—Probably the most satisfactory crystal

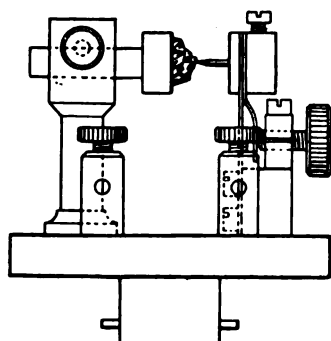

FIG. 129.

detector, as regards reliability, and freedom from deterioration of action due to the mechanical vibration or strong discharges across it, is the *Carborundum Detector*, much used by the Marconi Co. in their ship outfits, portable outfits and wave-meters. The carborundum detector as made by the Marconi Co. is shown in Fig. 129. The crystal is fixed by means of Wood's Metal in a small metal cup supported at the end of an arm on a metal pillar. In front of this is a light spring support in which a hardened steel point is clamped, and by a screw action the steel point can be brought into

<sup>1</sup> Dr. W. H. Eccles read a paper on this subject before Section A, British Association, Birmingham, 1913, published in *Electrician* of September 5, 1913; also one before the Physical Society published in the *Electrician* of October 3, 1913.

contact with the crystal in front of it, with whatever pressure is necessary to give sensitive working. The base is of ebonite and terminals are connected to the crystal pillar and spring support. The ebonite base can be made like the cap of an incandescent lamp, so that it may be inserted into an ordinary type of bayonet holder like a lamp or a Fleming valve; in this way a crystal detector may be used to replace a Fleming valve or *vice versa*.

While a carborundum detector will act alone, if a good crystal is used, its sensitiveness in most cases is increased by having in series with it a steady E.M.F. from a potentiometer, to which the oscillatory E.M.F.s can be superimposed as already described. A 400 ohm potentiometer wire with a 4 volt battery will be found suitable for use with such a detector. The connections of a crystal detector, potentiometer and telephones are shown in Fig. 130 (a).

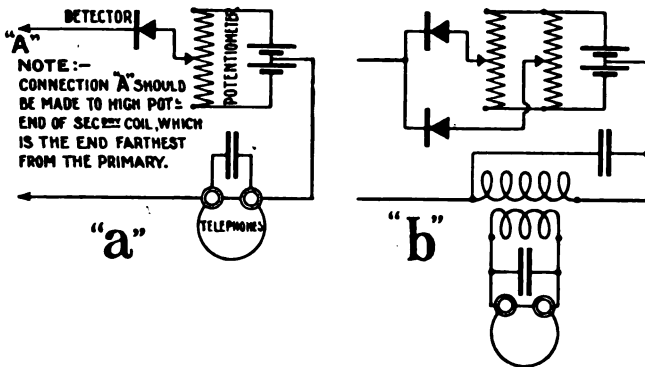

FIG. 130.

The Marconi Co. have lately patented an arrangement, invented by Signor Marconi, in which two balanced crystals with opposing effects are used together, connecting them as shown in Fig. 130 (b) and using a small step-down telephone transformer with low resistance (150 ohm) telephones. This use of balanced crystals reduces the effects of atmospheric and strong jamming without reducing the strength of signals. It is quite independent of tuning and easy to obtain with properly selected crystals. This use of balanced crystals will be referred to again in Chap. XIX.

The amount of potentiometer voltage required will depend on the crystal used as different crystals vary very much both in sensitiveness and resistance. Out of a batch of a dozen crystals tested only perhaps one or two may be found sensitive enough for

detector purposes. Only good crystals should be selected, and the student must remember that while a crystal may conduct practically no current in one direction it may prove to be quite a good crystal if the current or testing E.M.F. is reversed.

Carborundum is a silicate of carbon and the crystals are not expensive; they are, as a class, of high resistance and will therefore necessitate the use of sensitive or high resistance telephone receivers. Receivers of 4000 ohms resistance will be found to be most suitable for use with carborundum detectors. Since carborundum is very hard a good pressure of contact can be maintained on it, and thus it is not as easily knocked out of adjustment by mechanical vibrations as some other crystal detectors. In wavemeters and portable receivers a good crystal can be simply clamped between two spring metal supports to serve as a detector.

**Galena Detector.**—The Galena detector has been much used by the Telefunken Co. and in the United States, but it is likely to be universally discarded at an early date; though sensitive, it is not very reliable and is easily knocked out of adjustment.

It consists of a crystal of galena on which a light contact is made by the pointed end of a small rod of graphite such as is used in pencils. The pressure at the contact is adjusted by a spring and screw arrangement; unlike the carborundum detector the contact must be very light, hence the detector is easily thrown out of adjustment by mechanical vibrations such as would occur on board ship; also "atmospherics," or strong inductive discharges, easily destroy the sensibility of a contact point, and necessitate frequent adjustment of the latter.

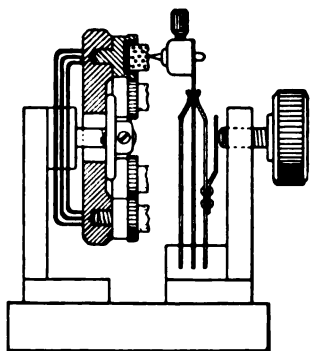

FIG. 131.

Galena belongs to the cubic system of crystal, it therefore occurs in square shape, breaking up into pieces with rectangular sides and flat surfaces. Since the face of a crystal is flat, it provides innumerable points on which sensitive contacts can be made. Galena is bluish black in colour, has a metallic lustre, and is fairly heavy. Instead of using graphite, contact can be made by means of a tiny copper spring, its end lightly resting on the face of the crystal; a fine platinum wire can be used for the same purpose, or a pointed crystal of tellurium.

Fig. 131 shows a galena graphite detector made by the British

Insulated Wire Co., Helsby; on it six galena crystals are mounted in cups fixed on a circular plate; this plate can be rotated so that a sensitive crystal can quickly be selected for use.

Galena graphite detectors are of comparatively low resistance and are not made more sensitive by a potentiometer voltage impressed across them; they are not suitable for short range work, as strong signals destroy the sensitiveness of contact. In fact though very sensitive to weak signals, they are very troublesome to keep in adjustment and not at all suited for commercial practice.

**Perikon Detector.**—This is a detector much favoured by amateurs because it is exceedingly sensitive and easy to adjust, though it requires continual adjustment. In its original form it consisted of a crystal of zincite (oxide of zinc) in contact with a crystal of copper pyrites (sulphide of copper), or of bornite (a compound of copper and iron sulphides— $\text{Cu}_2\text{S.CuS.FeS}$ ), or of chalcopyrite ( $\text{Cu}_2\text{SFe}_2\text{S}_8$ ).

Zincite is of reddish brown colour, copper pyrites yellow grey, and bornite bluish grey. The crystals are mounted in little brass cups either by means of clamping screws or soldered in with Wood's metal, and they are brought into contact by spring and screw adjustments. The sensitiveness depends on the pressure of contact so that delicate adjustment is necessary; it will also be found that small pieces of crystals give better results than large pieces. Some crystals will be found to have apparently no sensitive point, others will make sensitive contact at almost any point chosen; if a crystal is found to give poor results, a piece may be fractured off it to expose a new crystalline surface.

The detector can be made up in various designs as seen in the advertisements of wireless apparatus; some of these designs are very poor, especially in their arrangements for choosing and adjusting the pressure of contact. A design which has been found to give excellent results is shown in Fig. 132; it is very cheap to construct and can be made by most students. On a round base of ebonite,  $1\frac{1}{4}$ " in diameter, is mounted two brass plug contacts. One of these ends in a cup on the top of the ebonite and carries

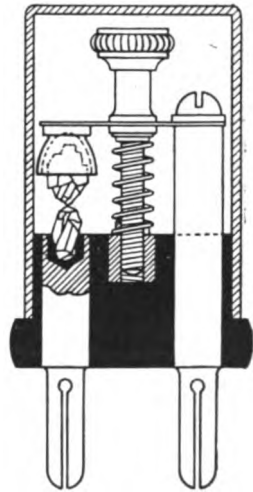

FIG. 132.



a small piece of tellurium. The other plug is extended to a pillar which carries a spring arm; on the extremity of the latter is mounted the zincite crystal in its cup. The adjustment of the crystals is made by means of a screw which carries a steel spring, and which screws into a brass receptacle on the ebonite base. The whole is covered by a brass cap held by bayonet joints on the ebonite base. It is seen that the detector plugs into a socket receptacle and can be easily disconnected or replaced.

A contact between a crystal of zincite and one of tellurium has been found to give better results than the original form of Perikon detector. The Perikon or zincite detector is very sensitive and does not require a potentiometer voltage in series with it;

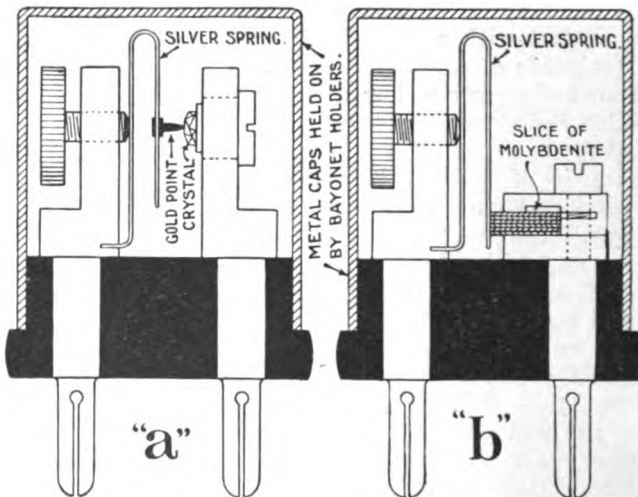

FIG. 133.

unfortunately it is easily made insensitive by transmitter discharges close to it. It should always be short circuited or open circuited when transmission is going on, and should preferably be covered with an earthed metallic cup as an additional precaution. Though more sensitive than a carborundum detector it is not as reliable as the latter for commercial purposes. Zincite is not very hard and crumbles away easily at the point of contact.

**Iron Pyrites Detector.**—In this detector a gold point makes contact with a selected crystal of iron pyrites. Fig. 133 (a) shows this detector as made and used by the Telefunken Co. The base is of ebonite about  $1\frac{1}{4}$ " diameter; on this is mounted a metal pillar

into the top of which is screwed the crystal cup, the crystal being fixed in the cup by Wood's metal. In front of the pillar is a silver U-shaped spring carrying a little gold point. The spring is pressed forward by means of a screw until the gold point makes sensitive contact with the crystal. A light metallic cover is held on the base by a bayonet holder and sockets as on an ordinary incandescent lamp-holder. Instead of terminals the detector is fitted with plug contacts; thus it can be quickly plugged into socket terminals in the receiver apparatus. A pointed crystal of antimony may be used to make contact instead of the gold point, and indeed the sensitiveness is said to be increased by this means.

**Molybdenite Detector.**—This detector is also made and used by the Telefunken Co.; it is not as sensitive as the iron pyrites detector but is very reliable and robust. As shown in Fig. 133 (b) a flat piece of molybdenite is firmly held by screws between two brass plates, only its front edge projecting. Contact is made on this edge by a U-shaped silver spring, pressed towards it by means of an adjusting screw. If the detector becomes insensitive with use the molybdenite face is lightly cleaned with sandpaper, when a new sensitive surface will be exposed. The design of this detector, as regards shape and size, is uniform with the iron pyrites detector so that they can be readily interchanged on the receiving apparatus. This detector is suitable for short range work, for strong signals, and for use with portable outfits.

**Silicon Detector.**—This consists of a gold point resting lightly on a crystal of silicon, though in cheap forms brass is used instead of gold. The sensitiveness depends on the contact point chosen on the crystal and the pressure of the contact; the general arrangement of the detector may be similar to some of those already described. On any given crystal of silicon there are not many points of sensitiveness to be found, and probably for this reason the silicon detector has not become popular.

In comparing the different forms of crystal detectors one must bear in mind that reliability is almost of as much importance as sensitiveness; for this reason it must be concluded that the carborundum detector is probably the best for all-round work though a good pair of crystals in a Perikon is the most sensitive. The iron pyrites detector is more reliable than the Perikon, and probably more sensitive than the carborundum detector, while, like the Perikon, it can be used without auxiliary potentiometer and battery. It is to be carefully noted that the unilateral conductivity of any crystal is only partial, hence if strong signals act on the receiver both loops of each current oscillation set up may

pass through the detector, hence no sound will be heard in the telephones as they will not act on rapidly oscillating currents.

A good soft metal for fastening the crystals in the cup can be made by melting down equal parts of ordinary lead fuse wire and tinfoil, and adding a little mercury—if too much mercury is added the metal will not have good holding properties. Wood's metal is a mixture of lead and tin with bismuth and cadmium in the proportions—2 lead, 1 tin, 4 bismuth, 1 cadmium; its melting point is about 60° C. In making it the lead should first be melted and then the other metals added.

**Electrolytic Detectors.**—If a current of electricity is passed, by means of two electrodes, through water diluted with sulphuric or nitric acid, hydrogen and oxygen gases are set free, the oxygen being deposited on the anode or plate joined to the positive terminal of the battery, and the hydrogen deposited on the kathode or plate joined to the negative terminal. Since oxygen is a very active gas, the positive plate or anode should be of a material such as platinum, which the oxygen cannot attack. This action of a current of electricity is called electrolytic action.

When the plates are coated with the gases they are said to be polarised, and this polarisation not only increases the resistance of the circuit, since the gases are bad conductors, but also sets up a difference of potential between the plates which acts in the opposite direction to the applied E.M.F. and has a value of about 1.48 volts. Thus when polarisation takes place the current flowing in the circuit is reduced, and if the applied E.M.F. is adjusted to be nearly equal to the E.M.F. set up by the polarisation the current is reduced to almost zero value.

For detecting small electrical oscillations a very small electrolytic cell is made up, one plate of which consists of an extremely fine platinum or wollaston wire of about 0.001 mm. diameter, sealed in a small glass tube drawn down to a capillary point at the end, and exposing just a tiny speck of the platinum or wollaston to serve as a plate for the cell. The other plate may be of silver or mercury at the bottom of the cell, and the liquid a 1 : 5 solution of sulphuric or nitric acid in distilled water.

A battery of 3 or 4 volts is joined across a potentiometer resistance wire; a portion of the drop of volts across this potentiometer is tapped off and joined in series with the cell and a telephone receiver. A current will then flow in this circuit, but will immediately polarise the small platinum point, and if the E.M.F. tapped from the potentiometer wire is suitably adjusted no sound will be heard in the telephone receiver: if the E.M.F. is too great a bubbling sound will be heard.

When the oscillations set up in a receiving circuit by the ether waves are passed across such a cell, one-half of each oscillation of E.M.F. will depolarise the platinum electrode so that a current impulse is allowed to pass through it. Since the oscillations rapidly succeed each other, in each train of waves, the polarising and depolarising effects in the detector will set up a train of current impulses which will vibrate the telephone dia-

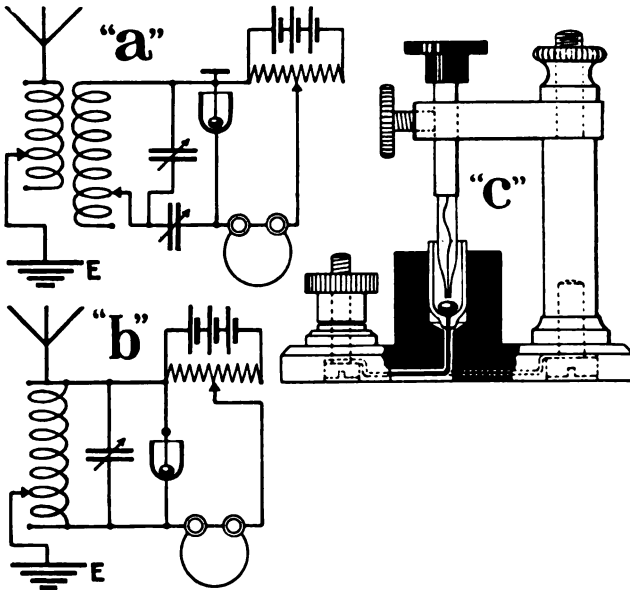

FIG. 134.

phragm, and the pitch of the sound heard will correspond to the frequency of the wave trains received.

The connection of such a detector to the receiving circuit are shown in Fig. 134 (a). Some difference of opinion exists as to whether the small point electrode should be the anode or kathode; Fessenden, who seems to have originated its use as a detector, made the point electrode the anode, joining it to the positive pole of the battery. Fessenden also explained its action by stating that it was due to change of resistance at the point electrode, while others considered that the polarisation E.M.F.s are responsible—it is possible that both resistance and back E.M.F. of polarisation are taking part in the effects which produce the change of current. Fig. 134 (c) shows an electrolytic detector made by the

British Insulated Wire Co., Helsby. The glass-covered platinum wire is connected to a brass terminal, clamped by a screw to a brass arm and pillar. The base is of ebonite and supports a small glass-lined cup of ebonite, at the bottom of which is a small quantity of mercury connected to one of the terminals; the liquid used being a 1 : 5 solution of sulphuric acid in water.

Sometimes the detector is joined as shown in Fig. 134 (b); this would apply to small amateur stations using a single slide tuning coil as shown in the figure.

The electrolytic detector ranks among what are called high resistance detectors, and as such requires that the telephone receivers used with it should be very sensitive with a great number of turns on the coils, therefore these should be of about 8000 ohms resistance. It is not much used in British wireless stations but has considerable vogue in the United States, where it was first introduced by De Forest and by Fessenden; probably, it will soon be universally discarded, owing to the simplicity and sensitiveness of the more modern crystal and valve detectors.

**Detectors for Use with Undamped Wave System.**—When the waves are undamped the small oscillating currents set up in the receiver apparatus are not broken up into groups of impulses, corresponding to each spark at the transmitter, but persist at uniform amplitude and at the wave frequency. This frequency is a million for waves of 300 metres length, 500,000 for waves of 6000 metres, and even if the waves are 6000 metres long the frequency is 50,000. Currents at these high frequencies would not cause audible vibration of the telephone diaphragm, therefore in systems using undamped waves apparatus must be included which will receive these rapidly oscillating currents, store them up, and only send a discharge through the telephones at a rate which will cause them to give out audible sounds of musical pitch. For this purpose a piece of apparatus, called a "tikker," is included in the receiver circuit of a Poulsen outfit; it will be described in a later chapter when the Poulsen system as a whole will be considered.

New detecting arrangements have now been developed which can be used with either damped or undamped waves to insure audible sounds in the receiver telephones. To understand the principles on which these are based we may consider an analogy in air or sound waves. When two musical notes which have nearly the same vibration frequency are sounded together their mutual interference sets up a new set of resultant impulses. The frequency of these is equal to the difference of the two fundamental frequencies, and "beats" are heard. These beats are sometimes very effective and noticeable, especially in organ music.

**Fessenden's Heterodyne Detector System.**—In this arrangement Fessenden generates at the receiving station a small current of high frequency which differs slightly from the frequency of the receiver circuit currents—it may be higher or lower than the received frequency. Thus, if receiving 6000 metre waves at a frequency of 50,000, the auxiliary currents are generated at a frequency of 49,000 or 51,000. Both the auxiliary generated currents and the received currents are allowed to act on the telephone receivers; thus when signals are received, owing to the slight difference of frequency, beats or impulses of current act on the telephones at a low frequency. In the example given the telephone currents would have a frequency of 1000 per second, giving therefore a high musical note.

One method of applying this arrangement is to have a specially designed telephone receiver as shown in Fig. 135. This has a central core of fine iron wires on which is wound a coil joined to the small generator of high frequency current. The diaphragm is a light disc of mica attached to the centre of which is a small light coil of fine wire, joined in series with the secondary circuit of the receiver.

When signals arrive the diaphragm coil carries current at one frequency, the fixed coil currents of a slightly different frequency, and the magnetic attractions and repulsions between these two current-carrying coils causes the diaphragm to vibrate at the frequency of the beats set up.

The heterodyne arrangement will act on slightly damped waves, and interesting experiments have been carried out with it between the U.S. Station at Arlington and the U.S.S. *Salem*, when the latter crossed the Atlantic to Gibraltar. According to the published reports of these tests the heterodyne receiver produced, with spark signalling, a telephone current 4.65 times as great as that due to an electrolytic detector, and under favourable conditions the current may be increased 12 or 15 times by its use. And, whereas signalling from Arlington to the *Salem* could be carried out by the detector up to 2900 kms., with the heterodyne arrangement the signals were received up to 3830 kms. With undamped waves its advantages would prove to be even greater, and a point worth noting is that atmospheric discharges are highly

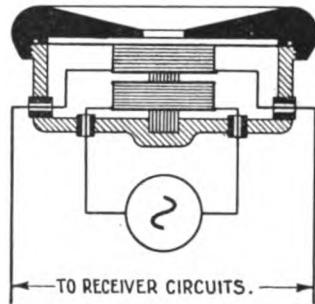

FIG. 135.

damped ones, therefore have only a small effect on telephone receivers when a heterodyne arrangement is used.

**Marconi Receiver for Undamped Waves.**—The Marconi Co. use a method developed by Mr. H. I. Rounds for the reception of signals on undamped or slightly damped ether waves. As with the heterodyne receiver, an auxiliary high frequency current is generated in the receiving station, and impressed on the receiver circuit; in this case the auxiliary currents act in impulse trains on Marconi balanced detectors.

Two balanced crystal detectors with potentiometers are employed in the usual manner, as already described and shown in Fig. 130 (b); arranged so as to oppose their effects, and adjusted so that they can only receive signals which are very strong. Thus they would not act on ordinary weak oscillations, and no sounds

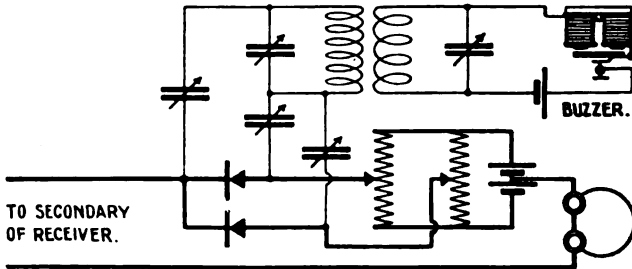

FIG. 196.

would be heard in the telephones. But by means of coupling coils and condensers the detectors are acted upon strongly by a buzzer circuit as shown in Fig. 136, so that each train of oscillations set up by the buzzer makes the detectors conducting. The detectors thus act at intervals of low frequency, therefore the undamped oscillations set up in the receiver circuits are stored, and only discharged through the detectors at a frequency depending upon the oscillation frequency of the receiver circuits and the frequency of the buzzer interruptions. The frequency of the buzzer should not be a sub-multiple of the receiver circuit frequency, otherwise beats may not be produced. Thus, if the buzzer makes 4900 impulses per second, and the receiver frequency is 50,000 per second, the beats of current through the detectors and telephones will occur at about 1000 per second, and hence give a musical note.

**Goldschmidt Tone Wheel.**—Dr. Rudolf Goldschmidt has designed an arrangement, called by him a Tone Wheel, for detecting

undamped oscillations ; it has worked satisfactorily on long wave transmission of low frequency. It consists of a toothed wheel disc, rotated at a constant speed, the tooth pitch being about 1 mm. Small brushes consisting of copper wire or foil, encased in insulating material, make contact with the toothed edge, and by means of them high frequency alternating currents can be led through the rotating toothed disc and rectified. Suppose alternating current of frequency 50,000, corresponding to 6000 metre wave length, is led through the disc, then its speed can be so adjusted that a brush makes contact with a tooth during one half of a cycle of current, and is between two teeth, not making contact, during the other half of the cycle ; thus only a half of each cycle of current is obtained ; in other words rectified current. This speed of rotation of the wheel is called synchronous speed. It would be very difficult to run the wheel at absolutely synchronous speed, but it is not necessary to do so, for if it is rotated at a little lower or a little higher than synchronous speed, then what might be called a beat of low frequency partially rectified alternating current is obtained. Since it is partially rectified it has the same effect as if it had a direct current component ; thus with such a rotating wheel, joined as a detector arrangement in a receiver circuit, it will obtain a direct current component from the small oscillating currents set up in the circuit, and this will affect the telephones in the usual manner ; a musical note being obtained by adjustment of the speed of the wheel. It has been tried with success on transatlantic work, between the Goldschmidt stations in Germany and at Tuckerton, U.S.A. Among the advantages claimed for it are the following :—

1. Ordinary damped waves will only make a noise in it.
2. The tone can be clearly distinguished from atmospherics.
3. It can be arranged to give the note best suited to the vibration frequency of the diaphragm of the telephone used, thus making the latter much more sensitive than it would be otherwise.
4. Stations with slightly different wave lengths give two very different notes on the telephones. Thus, if the wheel makes 49,000 interruptions per second, a station sending out waves of 6000 metres at 50,000 frequency gives a note corresponding to 1000 periods ; a station sending out waves slightly shorter at, say, 51,000 frequency gives a note of 2000 periods.
5. The wheel can be joined in series with a suitable high frequency alternating current galvanometer, and the deflections of the latter photographed on a tape ; it will be found to give a straight line record of the Morse code signals received.

Fig. 137 shows how the interrupted contacts of the brushes on the disc breaks up the oscillating currents, and give rise to a



low frequency wave of current impulse. The shaded portions represent the breaks in the contacts. In Fig. 137 (a) the wheel is running synchronously so that the oscillating currents are rectified; in (b) the wheel is out of slip and a current wave of low frequency (shown dotted) is obtained which will vibrate the telephone diaphragm. With such a Tone Wheel some trouble

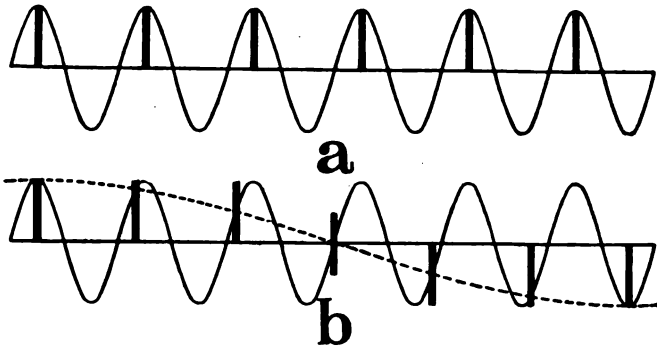

FIG. 137.

may be experienced in maintaining constancy of speed; also in avoiding induction effects from the currents in the driving motor. It would probably be difficult to make such a wheel for dealing with 300 metre waves, having a frequency of a million per second.

#### QUESTIONS AND EXERCISES ON CHAPTER XVI.

1. Explain the action of a coherer when used as a detector.
2. Describe the use of a potentiometer wire with crystal detectors, and mention those detectors whose sensitiveness is increased by a steady voltage across them.
3. How would you experimentally determine the best voltage for lighting the filament of a Fleming valve, and how are small variations of voltage obtained in practice for this purpose?
4. How would you use two Audion detectors to increase the intensity of the received signals? Illustrate your answer with a sketch.
5. What is meant by "unilateral conductivity" and by "rectified current"? Under what circumstances will the unilateral conductivity of a crystal not be apparent when used with a potentiometer?
6. What are the advantages and disadvantages of a galena graphite detector?
7. Draw a sketch showing the shape of the current voltage curve of a carborundum detector; explain its shape, and the effect of suitable potentiometer voltage joined in series with the detector and telephone.
8. What would happen if the potentiometer voltage in series with a carborundum detector were reversed? How are two carborundum detectors arranged in a circuit so that when strong oscillations of current flow in the circuit no sounds or extremely weak sounds are heard in the telephone receivers?

9. A carborundum detector is joined up to a receiving circuit, but no sounds are heard in the telephone. Explain why this does not necessarily mean that the crystal is a bad one.

10. Explain the action of Fessenden's heterodyne receiver.

11. A simple detector arrangement will not work in a circuit which is receiving energy from undamped waves. Why is this?

12. How would you adjust (a) a Fleming valve detector, (b) a carborundum detector?

13. Compare the advantages and disadvantages of a Marconi magnetic detector with those of a carborundum detector.

## CHAPTER XVII

### *RECEIVING CIRCUIT APPARATUS*

IN this chapter descriptions will be given of the designs of the different pieces of apparatus used in receiving circuits; it will also give more detailed information as to the particular function of each, and the best methods of using them. There are many amateur installations in this country and some of them work very well, but many of them could be made more successful if the elementary principles of the action in the circuits received attention. It is safe to say that the majority of amateur stations, though perhaps giving their owners satisfaction, are working inefficiently, through wrong design of apparatus, or faulty connections, or both. In many amateur receivers we find tuning and coupling both involved in the one piece of apparatus, and if it is necessary to change one of these the other is also changed, which for efficiency may be quite undesirable. Undoubtedly, then, it is better to have coupling, as far as possible, of fixed inductance, and tune the capacity and self-inductance quite independently by means of further adjustable coils and condensers. The degree of coupling, *i.e.* the mutual inductance, can be easily changed by displacing one of the coupling coils relatively to the other, by rotation or otherwise; it may be kept the same for short wave lengths as for long wave lengths, a result impossible to satisfactorily achieve if the primary of the coupling coil is tapped to permit of tuning by it. The diagrams of commercial receivers, shown in this and preceding chapters, will illustrate the efficient grouping and design of apparatus here mentioned.

Even if it is desired to pick up all wave lengths, from those of the local amateur to those of the Eiffel Tower, Poldhu, or Clifden, the receiving station is most efficiently designed when coupling is not rigidly involved with tuning, and capacity with inductance. True the Telefunken and Marconi systems use tappings on the primary coil of the coupler, but this is done only to a limited extent, and a wide wave length range is obtained by independent aerial inductance and capacity, or by interchangeable coils.

**Receiving Aerials.**—The aerial has already been dealt with in a previous chapter, and in most commercial and all ship stations the same aerial is used for sending and receiving; but we find that, in the modern large power stations, it is becoming customary to have the receiving station quite distinct from the sending one and at some distance from it.

It has already been explained that, owing partly to the retarding effect of the resistance of the earth or sea on the feet of the ether waves, and partly to the reflecting effect of the upper partially conducting layer of the atmosphere on the upper portion of the waves, the ether waves become bent over at the top in the direction of propagation. Hence, when long distances have been traversed, the greater portion of the electric strain lines of each wave are nearly parallel to the earth's surface. Thus a good receiving aerial should be large horizontally, and need not necessarily be of very great vertical height.<sup>1</sup>

The horizontal wires should be placed parallel to the direction in which the waves travel; thus, with inverted L type aerial the upper wires should stretch back, from the apparatus, in the opposite direction to that from which the waves are likely to approach it; when the waves do arrive the electric strain lines, coinciding in direction with the horizontal wires, collapse into them, setting up small oscillating currents with a maximum of efficiency. Fig. 65, in Chap. X., makes this clear. The umbrella aerial will of course receive equally well from all directions, though naturally waves may travel better from one direction than another; for instance, the wave energy becomes less attenuated over sea than over land.

If possible the aerial should be run at right angles to current carrying wires near it, so as to avoid inductive effects.

Rudenberg's rule for maximum efficiency is that the energy passed through the detector circuit should be equal to that re-radiated by the aerial; it implies that, according to the amount of energy oscillating in the circuits, the detectors and coupling should be adjusted anew at each reception of signals. By so doing we obtain in the detector circuit that fraction of the energy which gives maximum efficiency.

The Marconi Short Wave Multiple Tuner, for use with the magnetic detector, differs from the usual connections in the fact that the condenser in the secondary, or detector, circuit is in series

<sup>1</sup> Re-radiation loss is proportional to "radiation resistance" and this  $R_r \sim \frac{h^2}{\lambda^2}$ , in other words increases with the square of the effective height: another argument against making a receiver aerial very high.

with the secondary of the tuning coil. The connections of this receiving set are shown in Fig. 138, in which it will be seen that the aerial is joined in series with the aerial tuning inductance

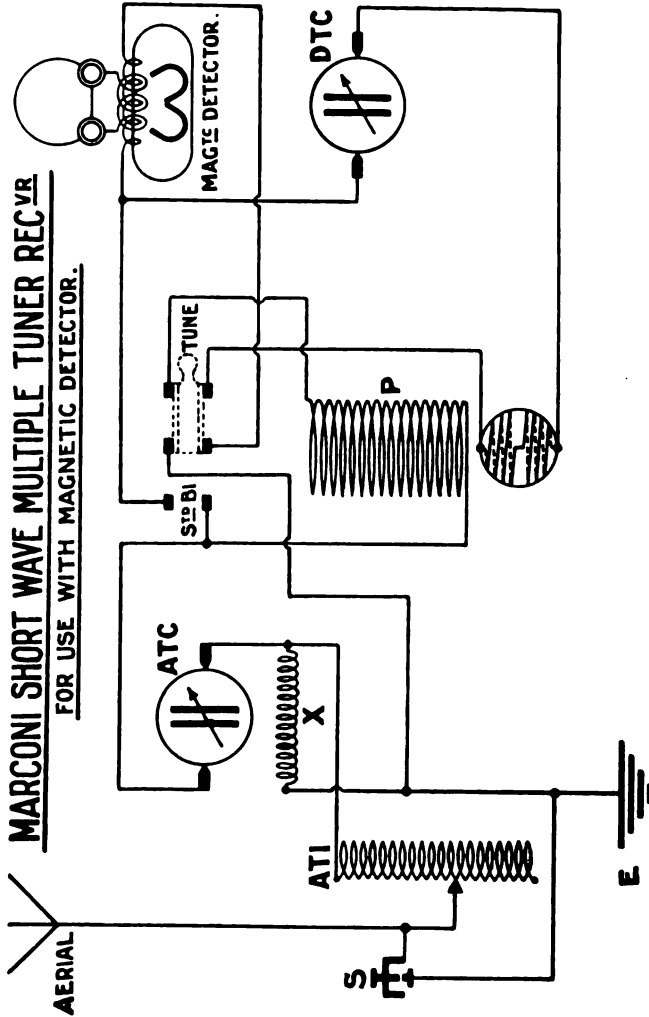

FIG. 138

ATI, the aerial tuning inductance ATC, primary coil of coupler P, and earth. A micrometer spark gap S is joined from aerial to earth to save the apparatus from lightning effects or

strong inductive effects produced by a neighbouring transmitter ; also a coil X, of high inductance, is joined across the aerial condenser to provide a continuous wire circuit from aerial to earth. As there are no tappings on the secondary of the tuning coil, all tuning of the secondary circuit is done with the condenser. Similarly the primary coupling coil is not variable, hence all tuning of the aerial circuit is done with the aerial inductance and condenser.

When standing by a switch is thrown over so that the detector is joined directly in series with the aerial inductance and condenser to earth ; the magnetic detector is of low resistance so that it

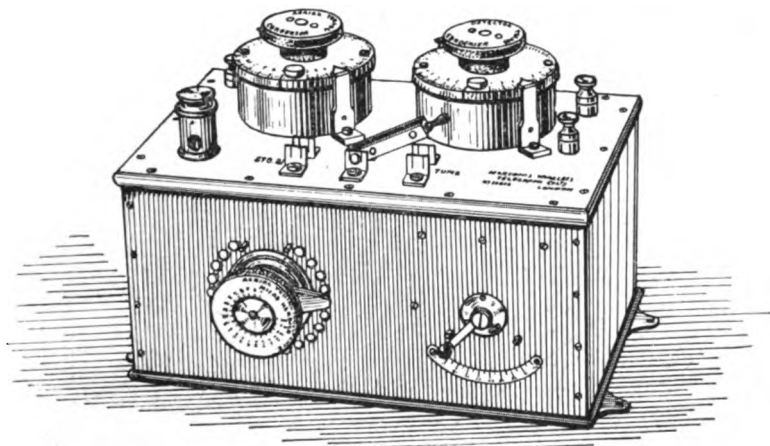

FIG. 139.—Marconi Short Wave Multiple Tuner.

will work well in this position, and will be certain to pick up any station within range. But it is not possible to cut out interfering stations with these connections, so that when a station is picked up the switch is thrown over to the connections shown in Fig. 138, the detector circuit tuned by means of its condenser, and interfering stations cut out by varying the degree of coupling, *i.e.* varying by means of an ebonite handle the position of the axis of the primary coil with respect to that of the secondary. The "stand by" connections are easily traced, while the receiver itself is shown in Fig. 139. It is suitable for wave lengths from 250 to 1750 metres.

**Marconi Short Wave Crystal Receiving Set.**—The connections of this set have been already described in the last chapter. Its normal range is 200–1200 metres of wave length, but it can be

used for longer wave lengths if an additional loading, or tuning, coil is placed in the aerial circuit.

The aerial inductance is a coil of about 100 turns of No. 20 S.W.G. Copper wire, 4 inches long and  $3\frac{1}{4}$  inches diameter, with tappings taken to a multiple way switch on the top of the case. The aerial tuning condenser is of the moving vane type with ebonite dielectric: it has contacts which short circuit it when set to zero on the scale of graduations, and its maximum capacity value is about 10,000 cms. It is about 4 inches in diameter and  $1\frac{1}{4}$  inches high.

The coupling coils consist of a primary of 24 turns, wound on a spherical former which is embraced by one end of the cylindrical secondary. The secondary coil is wound on a cylinder and is about 3 inches long by  $3\frac{1}{2}$  inches diameter, consisting of a small

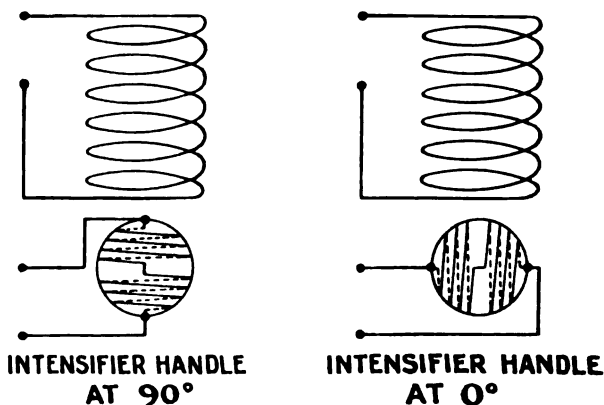

FIG. 140.

size copper wire—about No. 27 S.W.G. The primary can be rotated by means of an ebonite handle on the top of the case; this handle is called the Intensifier and simply loosens or closes the coupling. When set to zero the coupling is zero, for the magnetic axis of the primary is then at right angles to that of the secondary, but when the intensifier handle is at 90, the coupling effect is then a maximum, the axes of the coils being then in line, as shown in Fig. 140.

The coupling can be varied between maximum and zero, *i.e.* between 0 and 90, and by so varying it the interference of stations, slightly out of tune with the one it is desired to receive, may be minimised.

Neither the primary nor secondary coupling coils are tapped,

tuning being effected by means of the aerial inductance, aerial condenser, and secondary condenser.

The secondary condenser is a Billi condenser, and consists of two parallel sets. Each set consists of metallic tubes,  $2\frac{1}{4}$  inches long, separated by thin ebonite, the outer tubes being 0.8 inch in diameter. The whole condenser is only  $4\frac{1}{2}$  inches long, and the outer tubes can be made to embrace more or less of the inner tubes by sliding them along the ebonite, an ebonite handle being fixed to them for this purpose. Thus the capacity can be adjusted; its capacity at any adjustment being given by the formula—

$$K = \frac{l \cdot k}{4.6052 \log \frac{R}{r} \times 900,000} \text{ mfd.}$$

(see Chap. VI.). Two carborundum detectors are mounted on the case and a german silver coil, of 400 ohms resistance, acts as a potentiometer to use with the one selected. In the centre of the top of the case are the telephone terminals, so arranged that one telephone set may be used alone or two telephone sets may be used in series. A two-way detector switch, micrometer spark gap, and high inductance aerial earthing coil completes the equipment of this receiver.

To use the receiver we shall suppose it is desired to pick up signals at 600 metre wave length. Having a 4-6 volt battery joined to the potentiometer, send current through a buzzer near the receiver and set the potentiometer to give best sounds in the telephones. It may be necessary to reverse the direction of the current through the crystal in use, as carborundum conducts much better when the current is flowing in one direction through it than if it is reversed and there is no means of knowing which is the best direction except by trial. To reverse the crystal in this receiver it is only necessary to give the whole detector a half turn on its base. Having got the detector into a sensitive condition, set the Billi condenser to the adjustment corresponding to 600 metres—it is provided with graduations by means of which this can be done. Place the aerial condenser in its short-circuited position, the intensifier handle at 90, and tune in with the aerial inductance. When the signals are obtained, vary first the aerial condenser, and then the secondary condenser until the strongest signals are obtained. If there is interference, loosen the coupling by means of the intensifier handle and tune again with the condensers. This receiver can also be used with valve detectors.

**Marconi Universal Crystal Receiver for Low Resistance Crystals.**—This receiver has been designed to work with crystal detectors,



such as zincite-bornite, zincite-tellurium, and others of comparatively low resistance; its range being for wave lengths from 300 to 3000 metres.

The receiver differs from the one already described in that the primary of the loose coupler has three tappings, and the secondary of the loose coupler is made in three separate sections, fitted with a switch so that one section can be used alone, two in series, or three in series, according as the wave length increases. It will be remembered that in the first Marconi crystal receiver described, the tuning of the secondary circuit was done by means of the small Billi condenser joined across it. This method of capacity tuning is suitable if only a comparatively small range of wave lengths is desired; but we have noted that a crystal receiver is most efficient when the capacity effects are small, therefore when tuning to long wave lengths it is better, indeed necessary, to increase the inductance effect in the secondary circuit rather than the capacity effect. At the same time if the secondary is made large enough to tune by inductance to very long wave lengths, when short ones are received it is not only necessary to decrease the turns used on the secondary, but also very desirable to disconnect altogether the unused portion of the secondary coil; *i.e.* "dead end." By this means we avoid the loss of energy in these turns, called the "dead end loss." In other words, instead of simply taking tappings from the secondary to a multiple way switch, it is better to wind it in separate sections, and have a switching arrangement which will join in series the sections which are required, leaving the others quite disconnected. Such an arrangement is fitted to the Marconi universal crystal receiver.

Another point of novelty about the universal receiver is that the detector is disconnected at both sides by means of relays when the transmitting key is depressed, thus avoiding the danger of burning it out by the strong currents induced when transmission takes place. The side contacts on the transmitting key are used to close the circuits of the relay coils. The crystal detector is enclosed in a metal screening box to further protect it from induced currents.

The connections of the receiver are shown in Fig. 141. It will be noticed that both primary and secondary coupling coils have three points of working, marked 1, 2, and 3, corresponding to wave lengths, (1) below 600, (2) 600 to 1600, (3) 1000 to 3000 metres respectively. If the primary is on stud 2 the secondary should be on the corresponding stud. The only points calling for remark are the secondary switch, the detector relays, and the telephone condenser.

When the switch is on contact 1, the detector is joined to the high potential end of the section  $I_1$  of secondary inductance, the sections  $I_2$  and  $I_3$  being then completely disconnected. When

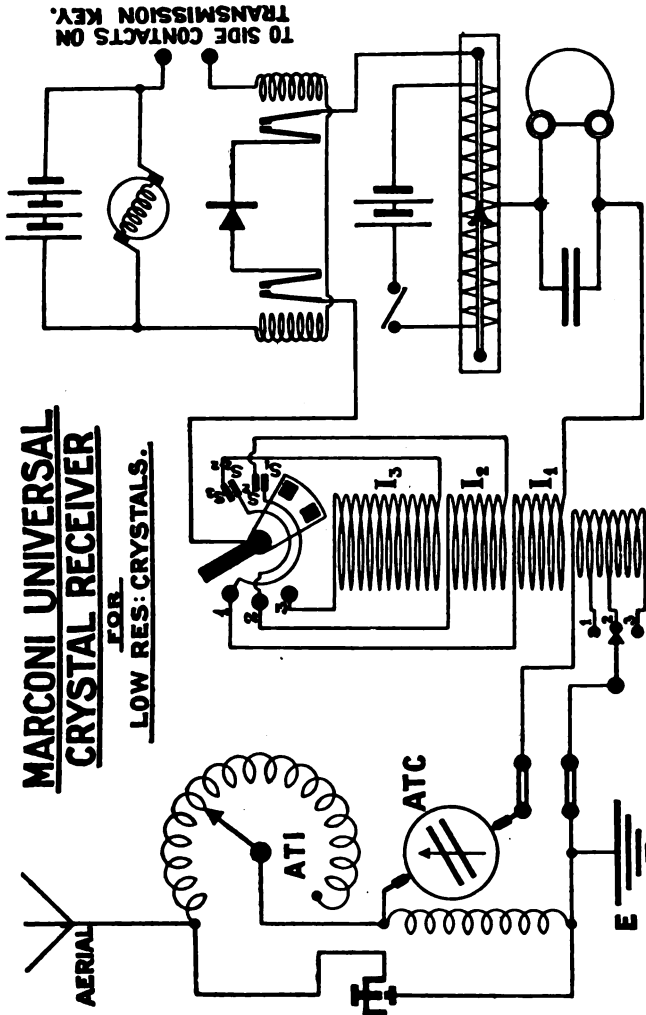

FIG. 141.

the switch is on contact 2, the detector is joined to the high voltage end of  $I_2$ , the other end of this section being joined to the top of  $I_1$  by a bridging piece carried on the switch—short

circuiting the springs  $S_1 S_2$ . Similarly when the switch on contact 3, the springs  $S_1 S_2$  are shorted, also  $S_2 S_3$ , and the whole of the secondary coils are then in series.

The relay connections of the detector are easily followed, the relays being worked by three or four primary cells, through the side contacts of the transmitting key. A potentiometer is mounted on this receiver; if a carborundum detector is used, three or four volts will be necessary for the potentiometer, but if a perikon or any zincite combination is used a very small voltage, if any, is necessary.

Fig. 142 is a view of the receiver, the aerial tuning induct-

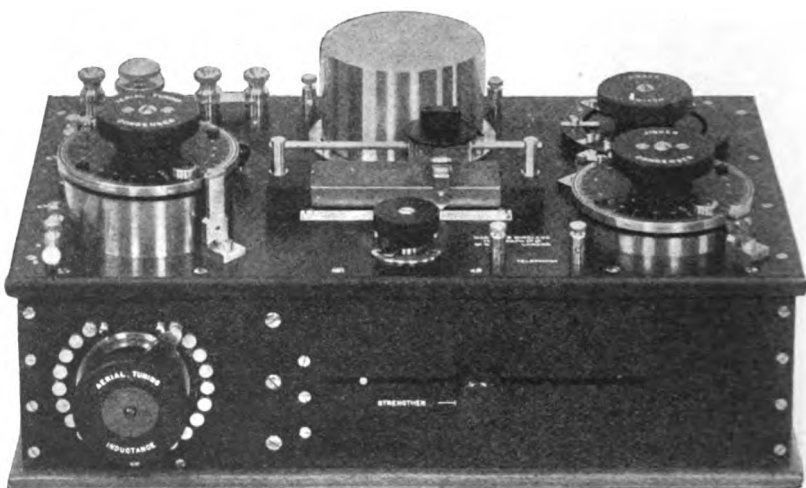

FIG. 142.

ance being on the left front, above it on the top is the aerial condenser; in the centre is the potentiometer, behind it the detector box, and in front of it the three-way primary switch. On the top right front is the secondary circuit condenser of small disc form, and behind it the secondary three-way switch. In the front on the right is a handle sliding in a slot, by which the primary is moved to loosen or tighten the degree of coupling for the purpose of cutting out interfering stations. The telephone condenser is a fixed one, chosen to suit the receiver apparatus. If a carborundum detector is used with this receiver the crystal should be one of low resistance.

**The Marconi Valve Receiver.**—The connections of a simple valve receiver have been given in the previous chapter, and the

one here described differs from it only in having an intermediate circuit. A diagram of the connections is shown in Fig. 143, from

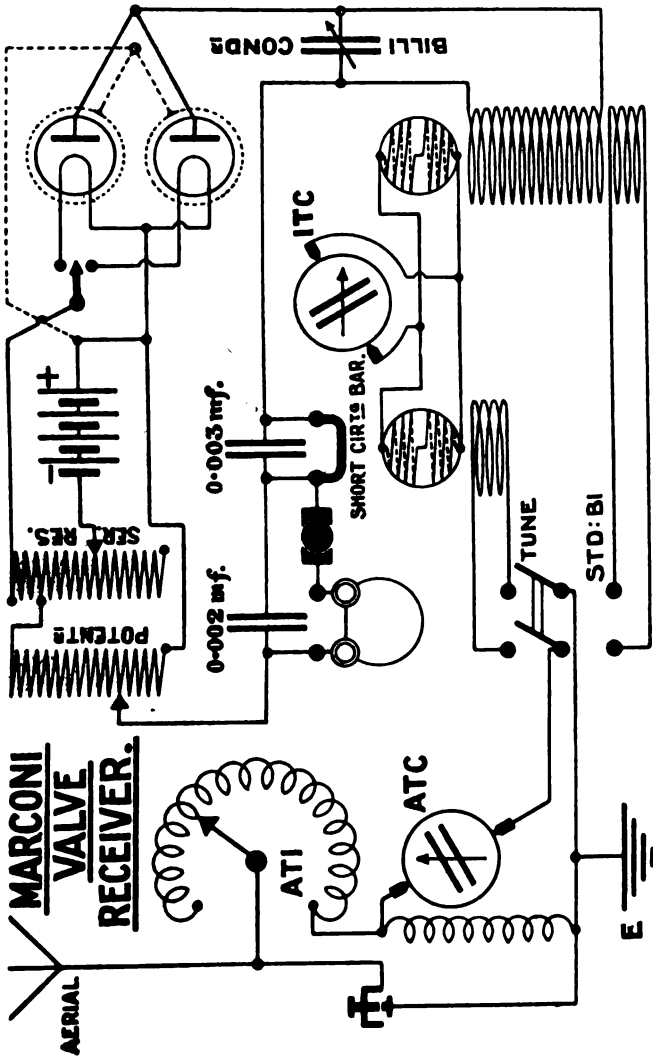

FIG. 143.

which it will be seen that the aerial circuit is fitted with a throw-over switch, so that when "standing by" it is magnetically coupled direct to the valve circuit, but when switch is thrown over to

"tune," the aerial and valve circuits are coupled through an intermediate circuit. The aerial and intermediate circuits are of the usual Marconi pattern; the valve circuit is slightly more complicated than a crystal detector circuit, owing to the necessity of having the valve filament incandescent with an adjustable voltage impressed on it. This voltage is adjusted by means of the battery, potentiometer, and series resistance joined as shown. It is most important that the + and - terminals of the battery should be joined to the corresponding terminals marked on the case. The wire gauze shields, put over the two valves to protect

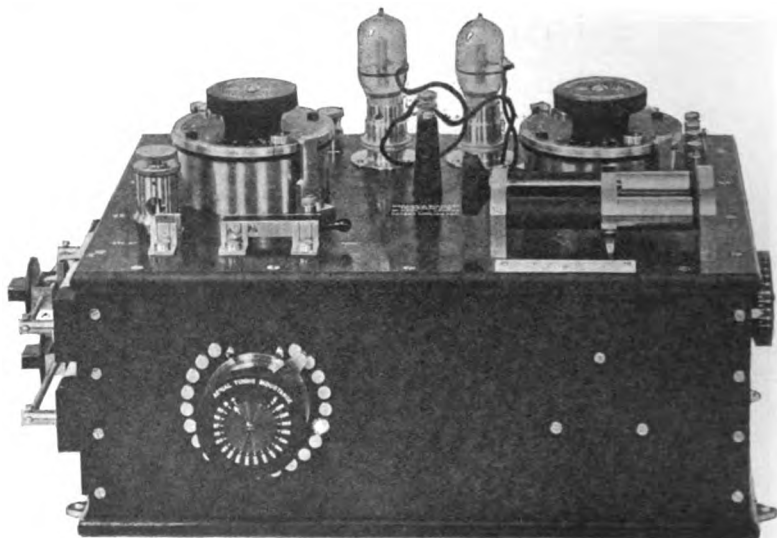

FIG. 144.

them from static charges, are connected to the positive terminals of the battery, these connections being shown dotted. If no potentiometer and series resistance are used the short circuit bar across the 0.003 mfd. in the telephone circuit must be replaced by a special value of resistance coil.

The appearance of this receiver is shown in Fig. 144, and the student will easily recognise the usual apparatus. The potentiometer and series resistance are on the left side of the case, the valve condenser is the tubular, or Billi, condenser near the front, while the handle just seen on the right side of the case is connected to the intermediate circuit coupling coils. By rotating the handle from 90° the coupling can be loosened, and interfering

circuits cut out; after such adjustment of coupling, tuning will have to be made sharper by means of the condensers.

The strength of the signals at any time will greatly depend on the proper adjustment of the potentiometer and series resistance, and this will depend on the valve used. The adjustment for any valve should be carefully made with the aid of a buzzer circuit.

**The Marconi Multiple Tuner for use with Magnetic Detector.**— This is a type of receiver much used on Marconi Ship Outfits, for the magnetic detector, though not so sensitive as valve or crystal detectors, is very reliable, requires no adjustments when once well set, does not jam with strong discharges, and is almost

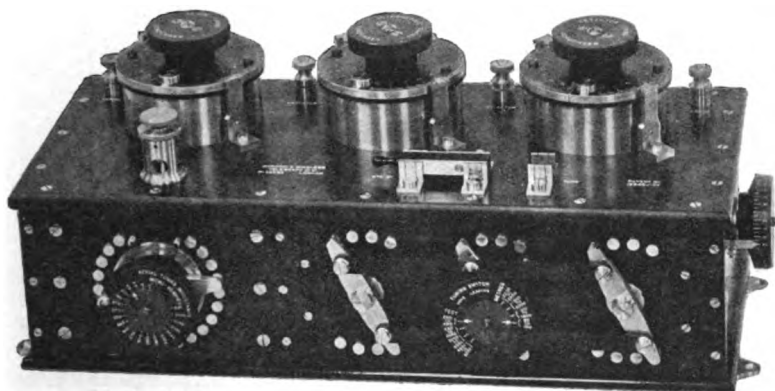

FIG. 145.

fool proof. Since it is a low resistance detector, it works on current rather than voltage effects, and hence the receiver circuits are designed differently, for use with it, than if they were to be fitted with valve or crystal detectors. Thus it will be found that, in this receiver, capacity effects predominate and inductance effects are small, so that the condensers used are much larger than in other receivers. As the name "multiple tuner" implies, the receiver has three circuits, aerial, intermediate, and detector, each of which must be tuned, and the tuning switches are so connected together that the three circuits can be tuned simultaneously.

The appearance of this tuner is shown in Fig. 145; the coupled switch handle, which tunes the coupling inductances in the three circuits simultaneously, is seen on the front of the case; finer adjustments of tuning being made by means of the variable

condensers in the aerial, intermediate, and detector circuits, seen on the top of the case. The aerial loading inductance is adjusted by means of the multiple contact switch seen on the top

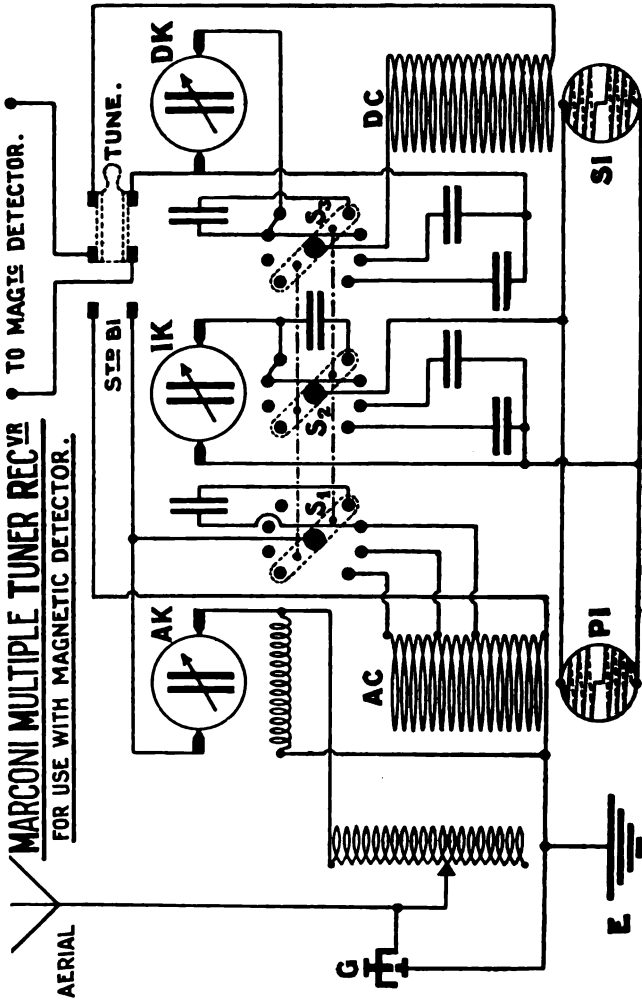

FIG. 140.

left front of the case. A two-way throw-over switch is mounted on the top of the case; in the "stand by" position it connects the magnetic detector directly into the aerial circuit; when signals are received it is thrown over to the "tune" position so that the

detector circuit is now coupled to the intermediate circuit, and accurate tuning can take place.

A diagrammatic sketch of the connections of this receiver is shown in Fig. 146. Across the aerial condenser is the high inductive coil which prevents static charges accumulating in the aerial circuit; a small gap *G* is also provided. It is seen that when the detector switch is thrown over to "Std. Bi," the detector is joined directly into the aerial circuit. This method of use is possible with a magnetic detector since its primary coil has low resistance. When the switch is thrown over to "Tune" the detector is no longer in the aerial circuit, but the aerial current now goes through the coupling coil *AC* and switch *S* on its way to aerial condenser, inductance, and earth. The aerial coupling coil couples to the primary coil *PI* of an intermediate circuit the secondary coil *SI* of which couples to the coil in the detector circuit. The intermediate circuit is tuned by its variable condenser *IK* and other condensers, the rough adjustment being made by the switch *S*<sub>2</sub>. The detector circuit, which consists of the coil (coupled to the intermediate circuit), detector, detector condenser *DK*, and auxiliary condenser, is roughly tuned by means of the switch *S*<sub>3</sub>. The switches *S*<sub>1</sub>, *S*<sub>2</sub>, and *S*<sub>3</sub> are all linked together so that the approximate tuning of all the three circuits to any wave length takes place simultaneously. Any finer tuning can be carried out by varying the condenser *AK*, *IK* and *DK*, on the top of the case. The degree of coupling can be changed by moving the axis of the coils of the intermediate circuit relatively to the aerial and detector circuits coils; this is effected by rotating a handle at the side of the case. The four steps of the tuning switches *S*<sub>1</sub>, *S*<sub>2</sub>, and *S*<sub>3</sub> are marked in wave lengths, the instrument being proportioned to tune to all wave lengths from 300 to 8000 feet.

**Telefunken Receiving Set.**—The connection of this set has already been described in the last chapter, and its appearance is shown in Fig. 147. The aerial, or antenna, switch, whose handle is seen at the right extending from the back, can be switched to sending or receiving position. When switched over for sending it opens the circuit at each side of the detector, also at each side of the telephones, so that the strong inductive effects set up while sending will not act upon these delicate parts of the receiver. When the aerial switch closes to the receiving circuit the aerial is joined to the primary coil of the tuning inductance, which can be varied in three steps by means of a plug, inserted into corresponding socket connections on the front of the primary coil frame. Two or three interchangeable primary coils of different



inductance values are provided so that a long range of wave lengths can be obtained. The spare coils are seen at the side of the receiver.

The secondary of the tuning inductance is hinged over the primary, and can be moved outwards to loosen the degree of

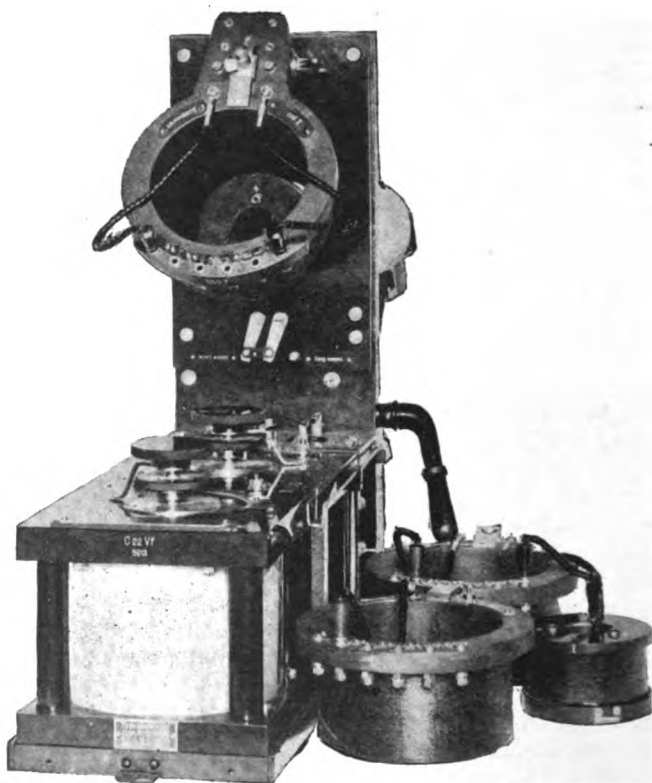

FIG. 147.

coupling; it can also be turned round on a horizontal axis when moved outwards, so that a large range of coupling is obtained. The secondary can be varied in six steps by means of the plug and socket contacts seen on its flange, and for any given wave length a certain value of primary and secondary is always used. Thus fineness of tuning is effected simply by adjusting the condenser seen in the front of the set, which is of the usual movable plate design, and can be joined in series or in

parallel with the primary tuning coil by means of a small two-way switch which is just below the primary. Two detectors are mounted behind the condenser; also terminals for the telephones or call apparatus. A continuous wave range of 250 to 2500 metres can be got by varying the condenser and a single interchange of primary coils. With highly damped aerials of large capacity the effect of atmospheric disturbances with this arrangement would be serious, and likely to destroy the sensitiveness of the detector; in such circumstances it is usual to provide an intermediate circuit, loosely coupled to the aerial circuit and not too closely coupled to the detector circuit.

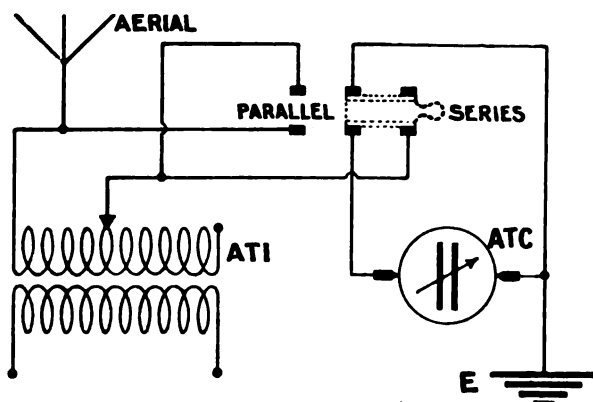

FIG. 148.

**Aerial Circuit Condensers.**—As has been already explained, a condenser is joined in series with aerial and aerial tuning inductance to shorten the wave length of this circuit; it may be joined in parallel with the primary, or aerial, coil of the tuner to increase the wave length. A small two-way switch can be used to join it in series or in parallel for short or long waves respectively, the connections being as shown in Fig. 148.

The capacity of the condenser will depend upon the detector used; for instance, when a Marconi magnetic detector is used the capacity values in the receiving circuit are larger and the inductive values smaller than when crystal detectors are used. A suitable condenser for crystal detector receivers would be one having a maximum capacity of 0.01 – 0.015 microfarad. For compactness it may be made with ebonite dielectric between the vanes, but mica and paraffin paper are unsuitable owing to their “dielectric hysteresis” values. Paraffin oil (specific inductive

capacity = 2) has small dielectric loss, but it is likely to spill and tends to creep over on to the outside case; air, of course, would be the best dielectric, but for a given capacity the bulk of an air condenser is much greater than an ebonite one.

**Secondary Circuit Condensers** have already been described, and do not call for further comment. Their capacity should be kept as small as possible and they should always be variable. It has already been noted that the coupling between the secondary and primary coils gives a capacity effect which, in some cases, is appreciable and varies as the coupling is varied.

**Telephone Receivers.**—A telephone receiver shown diagrammatically in Fig. 149 consists of a small permanent steel magnet

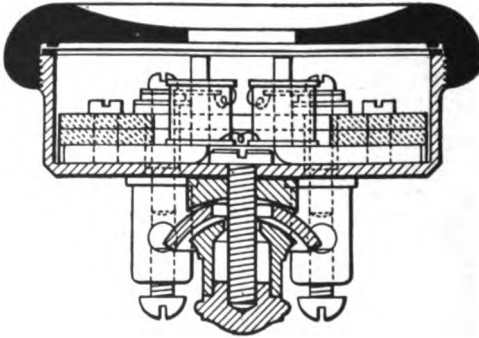

FIG. 149.

round the poles of which are wound coils of fine insulated copper wire, the coils being joined in series with each other. Held in equilibrium in front of the poles of the magnet is a thin disc of special iron called the diaphragm, the centre of which is attracted by the poles. If a small current flows through the coils it either

strengthens or weakens the strength of the magnet so that the iron disc is either more attracted or less attracted. Thus if the current comes in impulses the disc will vibrate up and down, and we know that the currents which flow through a detector are impulses of current, at the same frequency as the trains of waves, or the number of sparks per second at the transmitter. Therefore the disc of the telephone receiver will undergo as many vibrations per second as the number of transmitter sparks per second, so that the sound caused by the vibrations in the telephone will be of the same pitch as that of the transmitter spark. This of course assumes that the condenser, usually shunted across the telephones, has tuned them to the fundamental note and not to one of the harmonics in it.

Now we remember that the magnetic effects produced by a current in a coil is proportional to the number of ampere turns; 0.2 microampere flowing through a coil of 400 turns will produce the same magnetic effect as 0.8 microampere flowing through a

similar coil having only 100 turns, for in each case the value of the microampere-turns is 0.800. With most forms of crystal detectors the resistance of the detectors are very high, therefore only minute currents flow through them into the telephone receiver coils. Thus, to get any appreciable magnetic effect with these small currents, it is necessary to make the receiver coils with a great many turns, winding them with a great length of wire, which must be very fine in diameter to go into the small space of the receiver.

Unfortunately a great length of fine wire means that the coils will have a high resistance; this cannot be helped, as we must obtain the necessary magnetic effect to vibrate the disc, and, as a matter of fact, the resistance of the detector is so high that the telephone receivers' resistance is not of any great consequence as far as the total resistance of the circuit is concerned.

This may remove a misconception in the minds of some amateurs, who seem to think that the telephone receivers must have a high resistance and therefore think they should be wound with high resistance wire. That they must have a high resistance, when high resistance detectors are used, is an unavoidable evil, due to the fact that their coils must be wound with a great many turns of very fine copper wire. The most sensitive telephones have the highest resistance.

The receiver usually employed consists of two ear pieces joined in series on a head piece; sometimes the wires from each ear piece are brought out so that they may be joined in series, or may be joined in parallel if low resistance detectors are employed. Thus if a Perikon or a carborundum detector is used the two ear pieces would each have say 4000 ohms resistance, or 8000 ohms in all when joined in series. If only one of the ear pieces is used, it will of course be just as sensitive as before and we are now putting only 4000 ohms in the circuit, so that the current will if anything be a little stronger. If the detector has not too high a resistance it may prove better to join the two ear pieces in parallel in which case the total resistance of the telephones is now only  $\frac{4000}{2} = 2000$  ohms.

High resistance (very sensitive) telephones are not required for use with low resistance detectors, such as the Marconi magnetic detector or the galena graphite detector. The resistance to which telephones are wound depends, as we have seen, on the currents available to work them, and these not only depend upon the resistance of the detectors, but also on the distance from the transmitting station over which it is desired to work. Thus

no hard-and-fast rule can be laid down as to the telephones which should be employed, beyond saying that with valve and with most crystal detectors the telephone receivers should be wound to a resistance of from 2000 to 8000 ohms; with magnetic detectors 80-250 ohms, and with electrolytic detectors 8000 ohms. The greater the distance over which it is desired to receive the more sensitive the receivers must be, to work with the very small currents then available.

The working parts of the telephone receivers are usually enclosed in ebonite casings, which should be of such design that dust and damp cannot easily penetrate beyond the diaphragm; dampness especially is to be avoided, as it is sure to lower the insulation of the little coils and thus the sensitivity of the instruments. The design should be such that the diaphragm is as close as possible to the magnets, just leaving it room to vibrate; thus the magnetic lines which go from one pole of the magnet across the air, and through the diaphragm and air to the other pole, will have very short air gaps to traverse. It is found that, for any given current, the change of magnetic conditions causing the diaphragm to vibrate will be greater the smaller the air gaps; *i.e.* the closer the diaphragm is to the magnets. The receivers should be periodically overhauled to see that they are not damp or dusty, and that the caps are screwed up tight.

The diaphragms should be as light as possible, and for maximum sensitivity should have a "natural period of vibration" equal to that of the received currents. It is perhaps necessary to explain what this means; the student is aware that different gongs give out different notes when struck with a stick depending on their size, material, shape, etc.; in the same way the different wires on a piano give different notes depending on their length and weight. Everything has what is called its natural period of oscillation or vibration. If we start something vibrating the amplitude, or extent, of the vibrations will be a maximum if the impulse forces, which are applied to it, act at its natural period of vibration, *i.e.* if the body itself is so designed that its natural period of vibration is in tune with the impulse forces which will act on it. It is easily seen that this is analogous to the tuning of an electric circuit; it has the same electrical frequency as that of the oscillating currents flowing in it.

Thus if our receiver diaphragm is of such a thickness, diameter, and density, that its "natural period of vibration" is the same as that of the little currents acting on it, through the coils, it will be most sensitive, and will vibrate best to currents of that frequency. If the transmitter generator has a frequency of 500 per second

giving 1000 sparks per second, the receiver currents will have a frequency of 1000 impulses per second, and that diaphragm if possible should be selected which has a natural vibration frequency of 1000 per second.

The necessity of using the telephone diaphragm whose natural frequency of vibration is in tune with that of the transmitter sparks is greatest when no condenser is used in shunt with the telephones, as when using a Marconi magnetic detector.

Wein and Austin have each carried out experiments on the sensibility of telephone receivers at different frequencies; they have proved that currents at a frequency of 800 to 1000 give the same effect in the receivers as currents many hundred times greater when the frequency is only 100. Duddell carried out experiments to find the minimum power required to produce audible signals in a telephone receiver at different frequencies, and found that, while 430 microwatts were required at 300 frequency, only 7.7 microwatts were required at 900 frequency; also at higher frequencies the necessary power increased again (*vide* his Presidential Address to the I.E.E. 1912).

We have here a great argument for high spark frequencies at the transmitter, giving what is called a musical note; this also explains why much less energy per spark is necessary, under these conditions, for a given range of signalling.

Dr. Austin stated in 1910 that 10 microamperes of received aerial current through 25 ohms resistance, or a power of  $\frac{2.5}{10^9}$

watts gave a just audible signal, while  $\frac{40}{10^9}$  watts were necessary for good working. Mr. J. L. Hogan of the National Signalling Co., U.S.A., on tests made between the U.S. station at Arlington and the U.S.S. *Salem* found that by using Fessenden's heterodyne receiver the above values of received current could be halved, and gives the following figures:—for reading messages 12.5 microamperes, for good intercommunication 25 microamperes, and for commercial work 56 microamperes.

**Combined Tuning and Coupling Coils.**—Where these are employed they consist of a primary winding to join in the aerial circuit, and a secondary winding to join to the detector circuit; both primary and secondary windings having tappings taken from them or sliding contacts, so that each can be tuned.

The use of sliding contacts is to be deprecated, for they gather dirt, make imperfect contact, and wear the wires so that copper dust lodges between the windings, where they are bared, and is likely to short circuit the turns. It is better to take tappings

from both coils to the studs of multiple way switches, by which the proper number of turns required for tuning, on both primary and secondary, may be selected. If the number of tappings taken from the primary coil are not sufficient to give accurate selectivity for tuning, then a variable condenser should be joined in series or in parallel.

The tappings taken from the coils to the switch contacts should be as short as possible to avoid extra resistance and inductive loss in them, and should be soldered both to the coils and to the switch contacts. They should not be allowed to lie about loosely but should be arranged symmetrically between the coils and the switches, otherwise a loss of efficiency will occur. The secondary should fit loosely into the primary (if both cylindrical), otherwise, if fitting closely there will be a capacity effect between them which is not desirable. The coils must not be made too large; better to design the coil for an ordinary range of wave lengths, and obtain the longer waves by an auxiliary tuning or loading aerial coil, helped by a variable condenser in parallel with the primary of the tuning coil.

A cheaper form of apparatus is the two-slide tuning coil without a secondary, the connections of which have already been given. This will work very well for picking up long waves, but does not give an adjustment of the "degree of coupling" necessary for tuning out stations on say 600 metre wave length, and certainly will not cut out nor minimise in any way the irritating discharges of atmospherics.

The primary of a tuning coil may be wound with No. 22 to No. 24, S.W.G. copper wire, enamelled or double cotton covered. The cylinder of wood on which it is wound should receive first if possible a coating of linen tape and over it a coating of shellac varnish or paraffin; if an ebonite cylinder is used these are not necessary. The wires used for tappings should preferably be of stranded flexible, such as is used for electric light pendants (say  $\frac{3}{4}$  size), soldered to the turns and to the switch contacts. The secondary coil may be wound with double silk-covered copper wire, size No. 26 to No. 30, and it is well in this case to put a coating of shellac varnish or paraffin wax on the cylinder first and wind the coil while this coating is still liquid; the coating will then hold the turns firmly in place and they will not become loose during construction. Too much shellac or paraffin must not be used or the capacity effects will be increased, for it must be remembered that the secondary and primary will act as plates of a condenser.

It is scarcely necessary to say that only one layer of winding

is put on each coil. The studs and contacts should be preferably of brass, or copper, or silver plated; but not nickel plated, as nickel is slightly magnetic and is not as good a conductor as the other metals named. As regards the size of the coils, a primary 8 inches diameter and 10 inches long with a secondary about 7 inches diameter and 9 inches long will, without condensers, tune easily to Poldhu, Norddeitch, Paris, and other long wave stations.

The following examples of receiving apparatus made by students at Belfast will illustrate the performance of amateur apparatus:—

I. This receiver has no aerial tuning coil nor condenser. It consists of a primary coil, about 8 inches diameter and 10

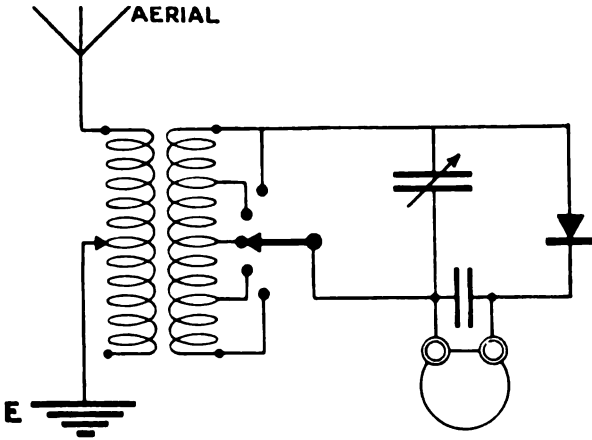

FIG. 150.

inches long, wound with No. 24 enamelled copper wire with a sliding contact. The secondary slides into the primary, is about 7 inches diameter, and is wound with No. 40 silk-covered copper wire. Tappings are taken from it to a 12-way contact switch mounted on the end of the cylinder. The secondary circuit condenser is a variable one (up to 0.004 mfd.) with air dielectric, and the telephone condenser a small fixed one of 0.002 mfd. capacity. The telephones are wound to 4000 ohms and a Perikon detector is employed. The connections are shown in Fig. 150; the receiver is used on a two-wire aerial 300 feet long and about 30 feet high, the aerial being stretched across an open space. This set receives regularly at Belfast from Poldhu, Eiffel Tower, Norddeitch; and all the principal English stations at 600 metre wave length.



II. This receiving set is only used for long wave lengths, the connections being similar to those shown for Set I. except that, owing to the size of the coils, a secondary condenser is used only when tuning to Clifden. The primary is 8 inches diameter and  $8\frac{1}{2}$  inches long, wound with No. 20 enamelled copper wire; the secondary is 8 inches long and 6 inches diameter, wound with No. 26 silk covered copper wire and sliding on brass rails into the primary. Being only used for the long wave signals from Poldhu, Eiffel Tower, and Norddeitch tapplings are taken from the primary coil at several consecutive turns near the points at which each of these stations tune, and brought to switch contacts on the front of the case. The secondary has 10 tapplings taken to switch contacts on the ebonite end plate. The telephones are wound to 8000 ohms, the detector is a Perikon one, and the telephone condenser is 0.008 mfd. On this set the Eiffel Tower weather reports are received every morning at Belfast; also Poldhu night signals, and those of Norddeitch very strongly. For tuning to Clifden an extra aerial inductance is joined in series with the coil, its value being about 15 mhys.; also a variable condenser (0.008 mfd. maximum) is joined in shunt across the whole aerial circuit inductance, and a smaller variable condenser across the secondary of the coupling coil. A view of this set is shown in Fig. 151. The aerial is a two-wire one, 150 feet long and 100 feet high, placed on the top of a very high building.

The receiver just described is by no means perfect, and it will perhaps be instructive to consider how it could be improved.

In the first place, the primary is a large coil of No. 20 wire with the turns in the coil close to each other; it will therefore have considerable self-capacity. This capacity effect could be decreased by spacing the turns a little apart from each other; one method of doing so would be to wind on a thin string at the same time as the coil was wound, so that the string will separate the turns.

Again, with such a large primary, it is best to have its windings in distinct sections, joining in series just so many sections as are required for tuning purposes, the remainder of the coil, or "dead end," being then disconnected. As a matter of fact the primary coil under consideration is thus divided into 4 sections, which can be connected in series by means of three plug switches. One section corresponds to tuning for Norddeitch, two in series for Eiffel Tower, three for Poldhu, and the whole coil, with extra aerial inductance, for Clifden. The necessary length of each section, required to tune to the stations named, was first found by experimental tuning, and each section has a dial of 8 tapplings to ensure close tuning.

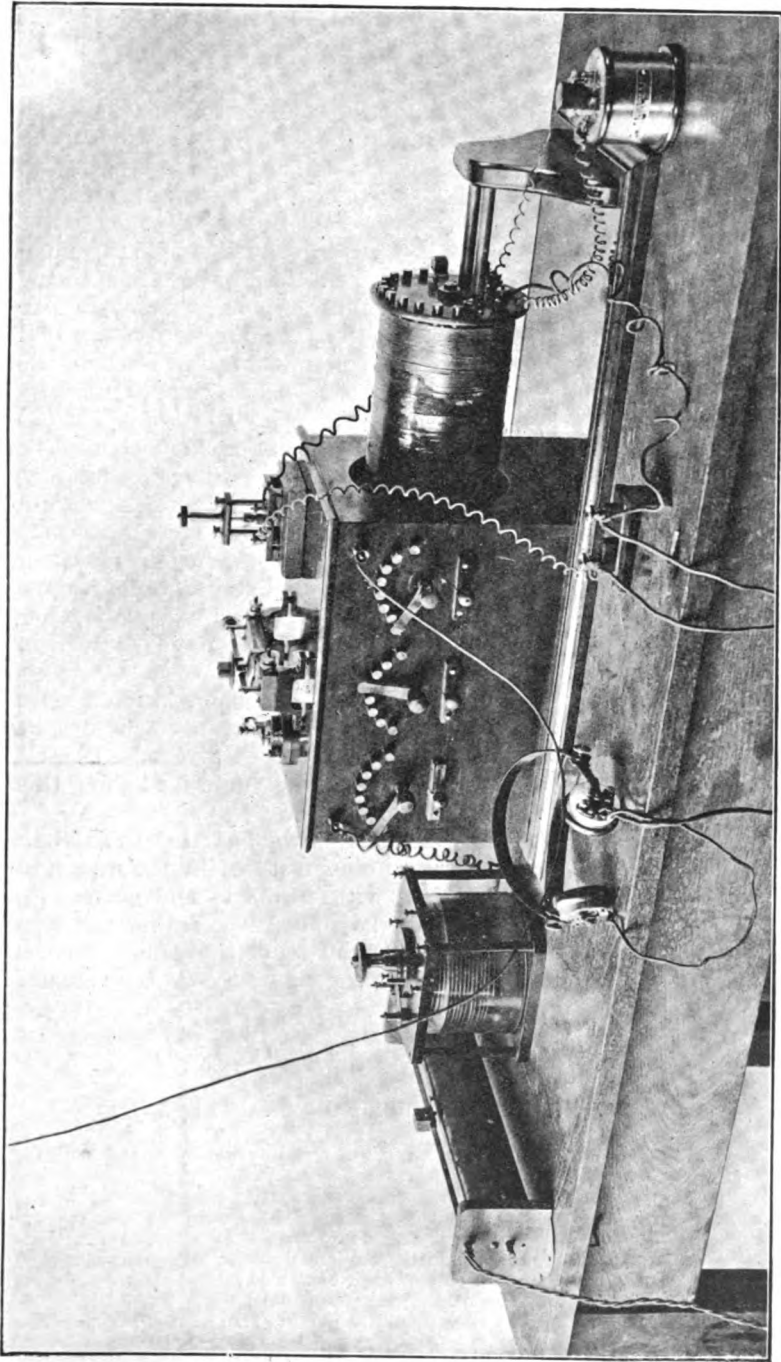

FIG. 151.

Dealing with the secondary of the coupler, it also would be much improved by dividing it, at the tappings to the tuning

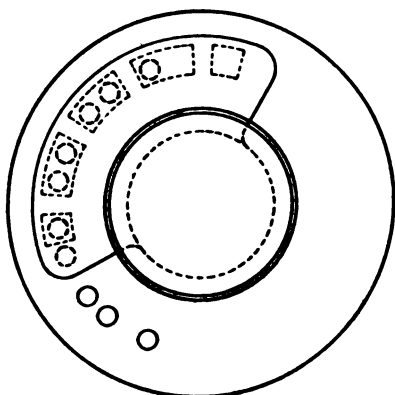
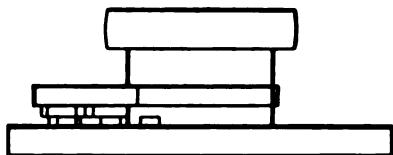

FIG. 152.

switch, into distinct sections, thus avoiding "dead end loss" when tuning to short wave lengths. A simple arrangement of switch for effecting this purpose is shown in Fig. 152; each section of the coil is brought to two studs, the studs being arranged in pairs as shown. The switch consists of a semi-circle of ebonite on which are fixed contactors, spaced at the proper distance apart. The first contact is only wide enough to cover one stud, those which follow it bridge over two studs, thus joining sections of the coil in series.

The student is referred to a similar arrangement on the Marconi Universal Crystal receiver described in this chapter.

In conclusion, stress must be laid on the fact that bad switch contacts will annul all other desirable features in the design of a receiver. Avoid unnecessary switch contacts and make connections by plug and socket where possible. The author has seen amateur receivers in which the intensity of the sounds in the telephones was doubled by simply pressing on the switch contacts of the primary or secondary coil.

#### QUESTIONS AND EXERCISES ON CHAPTER XVII.

1. Explain the arguments against the use of coupling coils as tuning coils for the aerial and detector circuits.
2. Give a detailed account of what happens to the energy set up in the receiver aerial by the transmitted waves, and state the reason why transoceanic stations have separate transmitting and receiving aerials.
3. Kieblitz was able to receive signals from long distances with wires stretched only a few feet above the ground. How is this explained?
4. State Rudenberg's rule for maximum receiver efficiency.
5. Marconi receivers have an inductive shunt across the aerial series

condenser. Why do not the aerial currents go through this coil rather than through the condenser?

6. A magnetic detector is joined in series in the receiver aerial circuit, when listening for a call or for signals. Could this be done with any other form of detector—if not, why not?

7. Calculate approximately the capacity of the Billi condenser described in connection with the Marconi short wave crystal receiver, if the ebonite dielectric is 0.5 millimetre thick. The dielectric constant of ebonite may be taken as 2.5.

8. Describe how you would pick up and tune to a station with a Marconi multiple tuner, using a magnetic detector.

9. Why are high resistance telephone receivers used with most crystal detectors?

10. How does the sensitiveness of a telephone receiver depend on the frequency of the currents flowing in it, and what is meant by saying that the receiver is most sensitive when the period of the currents is equal to the natural vibration period of the telephone diaphragm?

11. A ship's aerial has a capacity of 0.002 mfd. and an inductance of 0.08 millihenry. Calculate the length of a coil, 6 inches diameter wound with No. 20 enamelled copper wire giving 25 turns to the inch, which would tune this aerial to the 1200 metre wave length of the Eifel Tower signals.

## CHAPTER XVIII

### UNDAMPED WAVE SYSTEMS

It will have become obvious to those who have read the preceding chapters that radio-telegraphy signalling becomes more and more efficient, and the range increased for a given amount of energy used, the less the waves are damped. We have seen how such considerations have evolved the rotary disc discharger, the quenched spark gap, and the loose coupling; how with these radio-telegraphy on a commercial scale has rapidly developed. It follows, then, that an ideal system would be one in which the waves are not damped at all, and in this chapter we shall review some methods which have been developed to attain this result.

Suppose it is desired to set up waves 6000 metres long; the frequency of the aerial oscillating currents would be—

$$\frac{V}{\lambda} = \frac{3 \times 10^8}{6000} = 50,000;$$

thus if a uniform alternating voltage could be generated at 50,000 frequency and applied, either directly or through coupling coils, to the aerial, we should have oscillating currents flowing in the aerial of uniform values, the amplitudes would all be equal, and there would be no damping. We, therefore, see that this involves the design of apparatus which will generate alternating voltage at a frequency of 50,000 cycles per second, or at greater frequencies if the wave length is less than 6000 metres. It is easy enough to design an alternator, on similar lines to those used in ordinary electrical engineering practice, in which the frequency is 10,000 cycles per second, but the design of an ordinary alternator has to be discarded when we want 50,000 to 100,000 cycles per second.

It will be remembered that the frequency of an alternator is equal to the revolutions per second multiplied by the number of pairs of poles. Now, suppose that we could drive the machine at a peripheral speed of 80 metres per second, and wish to have a frequency of 50,000, the distance between the poles would only be  $\frac{80,000}{2 \times 50,000} = 0.8$  mm., this distance would have to accommodate

the iron of the core, the copper of the winding, and the insulation. Therefore it is easily seen that ordinary alternator designs are not feasible.

Several methods of generating undamped oscillations are at present commercially in use; of these the system developed by Dr. Goldschmidt is one of the best, and is most likely to take the place of spark discharge systems in the near future. The development of this system has been rapid and reliable, and important concessions from the company controlling it have been secured by the powerful Marconi Co., so that within a very short space of time we may anticipate that it will come into great prominence.

**Goldschmidt System.**—The essential part of the Goldschmidt system is the high frequency alternator which Dr. Goldschmidt has developed and patented, a machine which has not a great number of poles, and which does not require to be run at dangerously excessive speeds to attain the necessary high frequency.

To understand the principles of the machine let us return for a moment to fundamental facts. In an ordinary alternator we get a complete cycle of induced voltage in any wire when it has passed through the magnetic field corresponding to a pair of poles, consequently the number of cycles per second depends on how quickly the wires cut through this magnetic field. Now it is easily seen that if the poles, or the magnetic field, could be rotated backwards as fast as the wires rotate forward, a cycle of voltage would be obtained in half the time, or the frequency would be doubled.

This is very easily managed, for if, instead of pole pieces, we make the stationary portion of the machine of laminated iron with slots on the inner periphery, put coils suitably joined up in these slots, and pass alternating current through the coils, we can obtain a magnetic field of invisible lines which rotates, round the inner periphery of the stationary iron and coils, at a speed equal to the frequency of the alternating current. An electrical engineering student will recognise that this is a description of the stator of an ordinary induction motor. Thus, if we have wires suitably joined up on the armature, or rotor, of the machine, and drive this in the opposite direction to that in which the magnetic field is rotating and at the same speed, we induce in the rotating winding an alternating voltage which is at double the frequency of that applied to the stationary winding. The stationary part of such a machine is called the stator and the rotating part the rotor. The voltage of the rotor at the doubled frequency could be applied to the stator of a similar machine, and from its rotor current at

increased frequency obtained; by connecting up several machines in this manner we could obtain a high frequency current, but the method would be inefficient as there would be serious iron and copper energy losses in each machine.

This is the principle on which the Goldschmidt high frequency machine is designed, but, as we shall see, there is only one stator and rotor; not several joined in cascade to obtain the high frequency. The machine consists of a stator and a rotor, the stator being magnetised, in the first place, by direct current as in ordinary alternators, and the rotor being so designed that, when driven at a speed which is within ordinary safe limits, the frequency in it is about 15,000 cycles per second.

The rotor has an oscillating circuit consisting of condensers and inductance coils joined across it, and tuned to this frequency, hence currents at 15,000 frequency flow in this circuit. Now the rotor is magnetically coupled to its own stator, so that in the stator currents at 30,000 frequency are set up, due to the inductive effect of the rotating magnetic field set up by the high frequency rotor currents. The rotation of the rotor in the magnetic field which is induced by currents at 30,000 frequency in the stator induces in it currents at a new frequency of 45,000; these currents have provided for them an oscillating circuit, joined to the rotor and tuned to this frequency. Again the reaction of these rotor currents induces currents in the stator at a frequency of 60,000, and these swing in a closed circuit to which the aerial and earth are directly coupled. The diagram of connections is shown in Fig. 153. Currents at still higher frequencies might be generated by this method, but the efficiency of generation would decrease with higher frequencies; magnetic, or hysteresis, losses of energy in the iron parts of the machine increase rapidly with the frequency, also the eddy current losses both in the copper and iron. Thus, at present, the Goldschmidt machine is only adapted for long-distance long-wave transmission, and it may be some time before an efficient machine is designed for 600 metre waves at 500,000 frequency.

In Fig. 153 it is seen that the stator is, in the first place, excited or magnetised by current from a battery or other D.C. supply; this current cannot pass to the oscillating circuit owing to the condenser  $C_1$ , while the choke coils,  $MM$ , prevent the oscillating currents from getting back through the supply mains. Oscillating circuits, made up of the condensers  $C_2, C_3, C_4$ , and the inductance coil  $L$ , are joined to the rotor, and in these flow the currents of the rotor at the different frequencies to which these circuits are tuned, *i.e.* 15,000 and 45,000.

Hanover station, using a Goldschmidt machine of 150 KW.s at 50,000 frequency, has succeeded in sending messages to Tuckerton, U.S.A., the aerial being of the umbrella type on a high lattice steel tower. A point of importance in working with the high frequency generator is the necessity of keeping absolutely constant speed, in order that the frequency, and therefore the wave length, should be constant. It will be noted that transmission is effected by manipulating the exciting current of the generator; every time the key is depressed load is thrown on, and when the key is released the load is taken off; the generator is driven by a steam engine or motor, and it is

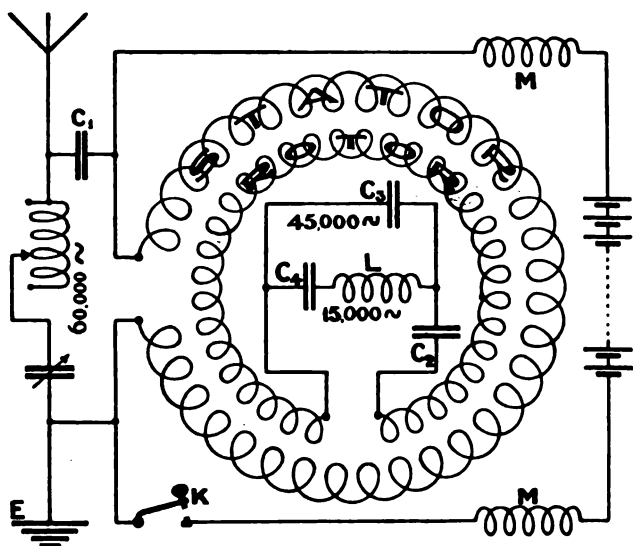

FIG. 158.

evident that some very accurate method of governing the speed must be used under these conditions. As a matter of fact the transmitting key not only changes the exciting current of the generator, but simultaneously changes the field current of the driving motor by such an amount that it does not lose speed when the load is thrown on it. The student will remember that the speed of a motor under increased load can be kept up by weakening its field, *i.e.* decreasing the current round its poles by putting more resistance in series with them.

The Advisory Scientific Committee, appointed by the Postmaster General, reported last year that the Goldschmidt machine



installed in the Hanover station was admirable both in design and workmanship. Fig. 154 is a view of the 150 KW. Gold-

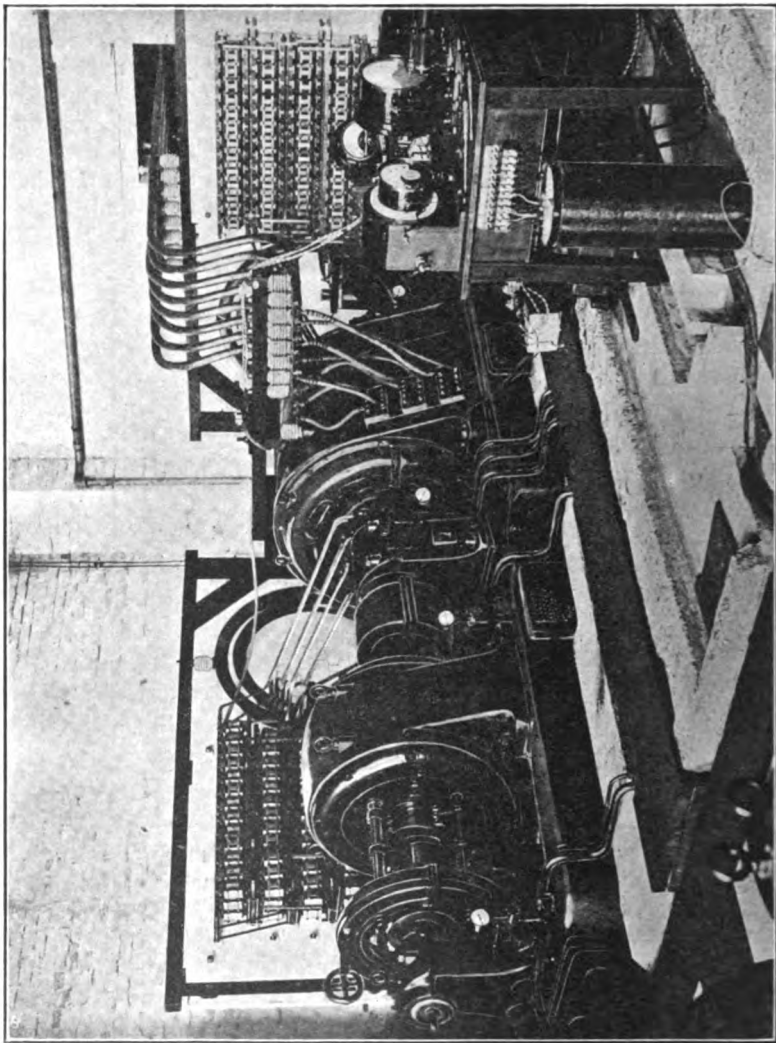

FIG. 154.

schmidt high-frequency transmitter outfit installed at Eilvese, near Hanover, from which communication is carried on with a similar station at Tuckerton, New Jersey; while Fig. 155

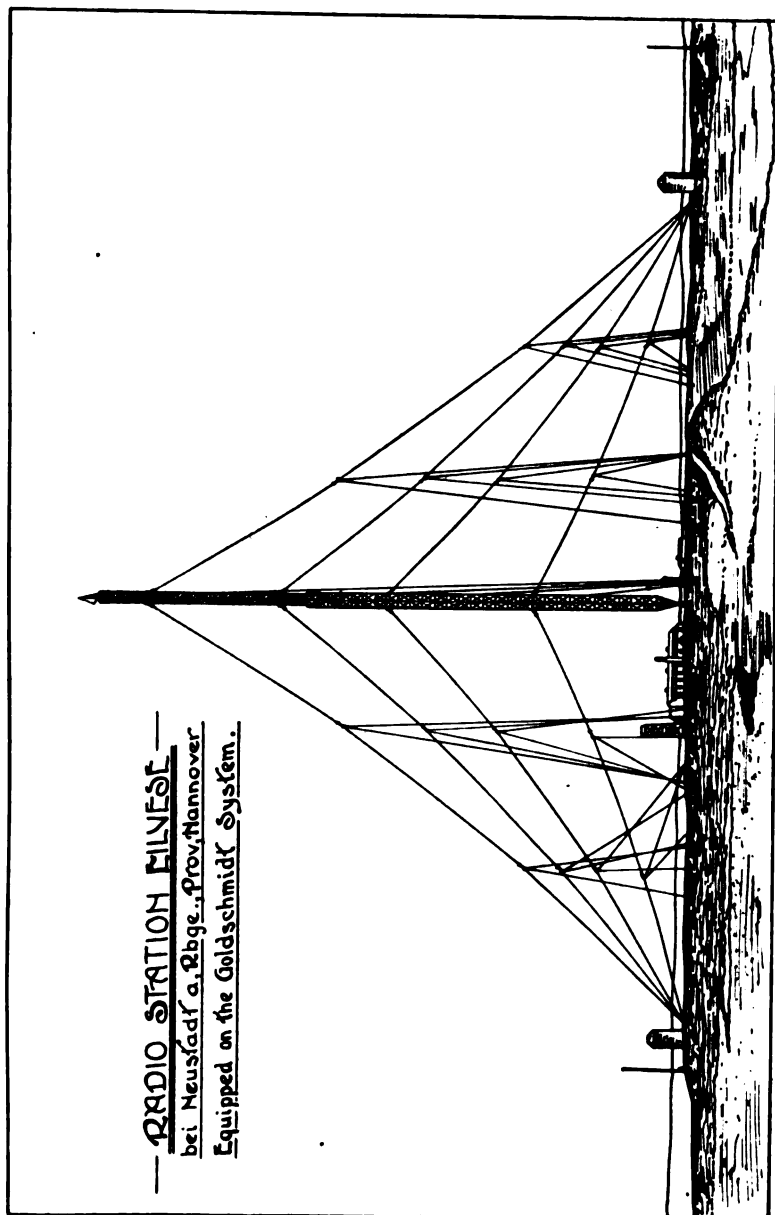

Fig. 155.

T

is an exterior view of the Eilvese station. These views were kindly placed at the disposal of the author by the "Compagnie Universelle de Télégraphie et de Téléphonie sans Fil," who control the Goldschmidt patents. The author is also indebted to them for the following interesting details of construction and apparatus used at these stations:—

The high frequency machine has similar dimensions to ordinary electrical generators of the same output, the 150 KW. size running at 3100 r.p.m. while the 5 KW. size runs at 8000 r.p.m. They are specially ventilated and are lubricated by oil under pressure, the oil being itself cooled by water circulation. All iron cores of the machine are built of very thin laminations (0.05 mm. thick), with paper insulation between them, the iron being specially prepared. The winding consists of one conductor per slot, the conductor being made of many-stranded wire and wound backwards and forwards in the slots, in the simple manner shown in Fig. 156, so as to produce alternate N.

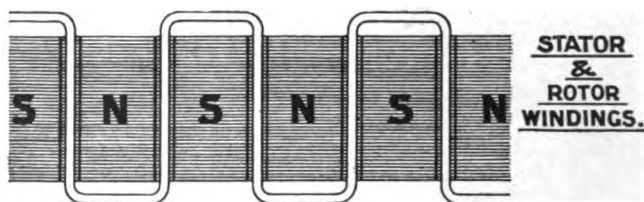

FIG. 156.

and S. poles. The stator and rotor are electrically identical, with the same number of poles and the same winding; each winding is divided into several sections so that grouping may be made in series or in parallel, in order to vary the current and the voltage as desired. The 150 KW. machines are driven by steam turbines, but small sizes can be driven by electric motors; as mentioned already the Wheatstone type transmitting key manipulates the excitation current of the machine, but for large sets it would be practicable to make the key manipulate the field circuit of the D.C. machine which supplies the exciting current to the high-frequency alternator.

As accessory apparatus for transmission it is only necessary to have inductance coils, condensers, aerial and earth connections. The inductance coils are of the usual type and do not require special description; the condensers are built up with tinfoil sheets and mica dielectric, and have, of necessity, large dimensions when dealing with 150 KW.s of power. Since there can

be no damping the aerial and earth are connected directly to the stator oscillating circuit: the aerial is supported on a steel tower 250 metres high, and is a combination of double cone and umbrella, made up of 36 bronze cables of 8 mms. diameter, and extending over a radius of 500 metres. The tower is insulated at the base and halfway up, while steel cables, sectioned themselves by insulators, serve to support it. The construction of tower and aerial is well seen in Fig. 155, while it is shown diagrammatically in Fig. 157. Earthing is carried out by a network of wires, extending around the foot of the mast to a radius of 500 metres.

As regards the receiver, any system of apparatus and connections suitable for undamped wave systems can be employed, but Dr. Goldschmidt has invented a special form of interrupter

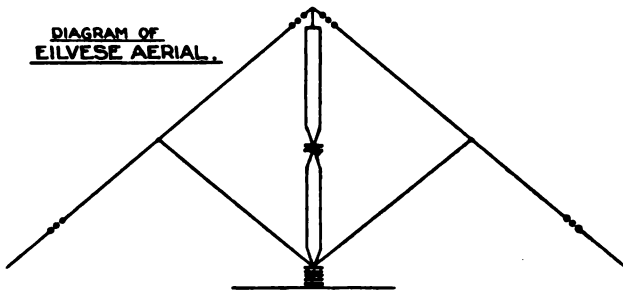

FIG. 157.

for use in the receiving circuit, which has been fully described in Chap. XVI.

**Poulsen System.**—Fourteen years ago Mr. Duddell discovered that if an oscillating circuit, *i.e.* one containing inductance and capacity with low resistance, is joined across the carbons of an arc lamp oscillating currents will flow through this circuit and across the arc when it is lighted. The suitable conditions under which such oscillations can take place are that the carbons should be solid, the arc short, the condenser of about 1 mfd. capacity, and that the arc should have a resistance in series with it to steady it.

According to the values of capacity, inductance, and resistance in the oscillatory circuit the arc column will give out a note of higher or lower pitch, and by changing the value of the inductance, or of the capacity, by means of plugs or contacts the note can be changed, so that the arrangement was called "Duddell's Musical Arc." It is shown diagrammatically in Fig. 158. The note given out depends on the frequency of the oscillating currents which flow across the arc from the oscillating circuit; this current, as it

rapidly rises and falls in its oscillations, increases or decreases the thickness of the carbon vapour column which forms the arc; thus it sets up waves in the air around it, and a note, or sound, is heard whose pitch depends on the frequency of these currents. When we have currents oscillating in a circuit they set up waves in the ether round it, and the frequency of these waves is given by the usual formula—

$$n = \frac{1}{2\pi} \sqrt{\frac{1}{KL} - \frac{R^2}{4L^2}}$$

where  $K$ ,  $L$ , and  $R$  are measured in farads, henrys, and ohms, respectively.

The resistance of the oscillating circuit includes the resistance of the arc, and this varies with the current which flows across it

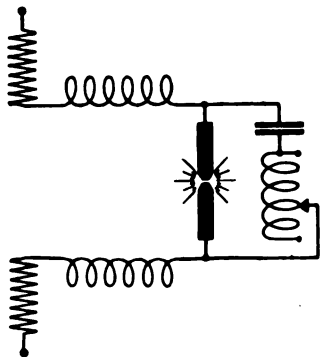

FIG. 158.

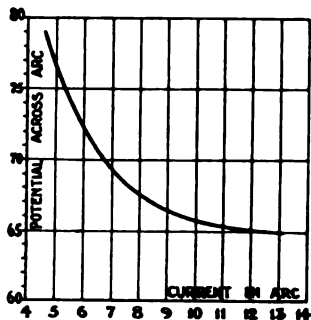

FIG. 159.

from the mains; if the arc is short and thick, so that  $R$  is small, the frequency is, as usual, approximately equal to—

$$\frac{1}{2\pi\sqrt{K_f L_h}} \quad \text{or} \quad \frac{5 \times 10^6}{\sqrt{L_{\text{cms.}} K_{\text{mfds.}}}}$$

In addition to the resistance joined in series with the arc a choking coil should also be joined in series in each main, so that the oscillating currents will flow across the arc and are choked back from the direct current supply mains.

Why does an oscillatory current flow through the circuit and across the arc lamp under the conditions described? It is very simply explained if the relations between the voltage across the arc and the current in it are realised. Briefly, the volts across the arc automatically rises if the current falls, and falls if the current rises in value, as shown in the curve Fig. 159; in other words an

arc does not obey Ohm's law; it thus differs from most electrical circuits. The current oscillations are produced as follows:—

(a) When the condenser circuit is joined across the arc current flows into it, therefore less current is left to flow across the arc and the volts rise until the condenser is charged.

(b) When the condenser is charged the current across the arc now rises to its normal value, and the increased current means that the volts fall; but the condenser was charged to the higher voltage, therefore it discharges across the arc.

(c) Owing to the oscillatory nature of the circuit and the shortness of the arc the discharge is an oscillatory one.

(d) At each oscillation of current the volts rise and fall as described above, therefore the oscillations are indefinitely kept up as long as the current flows; in other words, there is a fresh impulse of energy at each oscillation, and the oscillations are consequently entirely undamped.

This provides us with a method of setting up undamped waves, and a system of radio-telegraphy based on arc generation of waves has been developed by Dr. Poulsen.

The student will readily realise that the length of the arc must be kept very constant, for if its length varies its resistance would vary and this would change the wave length. Also, if the waves are to be propagated to long distances, the arc will have to deal with large amounts of energy, the electrodes must be thick, and some method provided for dissipating the heat.

In the Poulsen system the arc is struck between a copper positive, (anode), and a carbon negative, (kathode), in a chamber which is kept cool by circulation of water. This chamber is filled with coal gas, or preferably with hydrogen, which enters at the bottom and passes out by a tube at the top; the consumption of gas per hour depending on the size of the arc used. This gas cools the arc, and has the effect of modifying its current voltage curve in such a way that the oscillation effects are accentuated; that is to say, it makes the curve more steep than if the arc were an ordinary open one. At the same time the gas prevents access of air to the electrodes, thus stopping oxidising or burning away effects.

Extending into the arc chamber are the poles of a strong electro-magnet, the coils of which are in series with the arc so that their exciting current is the arc current; indeed the electro-magnet coils act as choke coils in the supply leads and other choke coils are not required. The strong magnetic field which exists between the poles of the magnets acts on the arc and keeps it steady, while the length of the arc is kept constant by rotating

the carbon kathode, or by making the arc rotate round it. The carbons have to be frequently renewed but the copper anode will last for two or three months.

The connections are very simple, for since the oscillating currents are undamped the aerial circuit can be direct coupled to the oscillating circuit, as shown in Fig. 160 (a). Poulsen arc transmitters have been made which take 40 KW.s of power, and, with this power, communication with the Poulsen system has been established between San Francisco and Honolulu, a distance of 2100 miles.

According to the report of the Advisory Scientific Committee to the Postmaster-General (1913) there was then no evidence that such communication was reliable and constant, and it

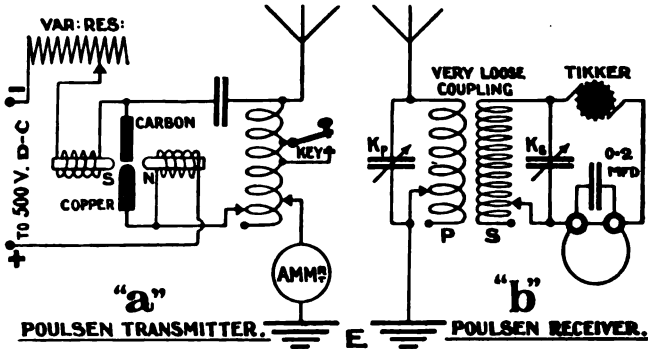

FIG. 160.

expressed the opinion that a greater power would be necessary to give reliability of service over this distance.

One interesting feature of this apparatus is the connections of the transmitting key. This cannot be put in the primary circuit, as is the case in spark systems, for if the primary circuit were broken by the key the arc would go out, and would not light up again until the electrodes are brought into contact. Hence the arc must be kept lit all the time. The waves being undamped very sharp tuning is necessary between the sending and receiving stations, and if the wave length at the sending station is changed by only 1 per cent. or 2 per cent. no signals are heard in the receivers. Thus the sending station is arranged to be slightly out of tune with the receiving station, and the transmitter key is connected across a few turns of the aerial tuning coil; when the key is depressed it short circuits these turns, and, by changing

the wave length of the transmitting aerial, the latter is put in tune with the receiver so that the signals are heard in the latter. There are other methods of joining the transmitting key to obtain the same effect, but they are scarcely so reliable. Fig. 160 (a) shows the transmitting key connected as here described.

The Poulsen system, being one employing undamped waves, is adapted to a speed of transmission as high as 120 words a minute. Dr. Pedersen has invented an automatic high speed transmitter which is used in conjunction with the Poulsen system. The dots and dashes of a message are punched on a tape and this is fed into a machine with revolving commutator contacts and pin contacts. When a pin contact pass through a hole on the tape, corresponding to a dot or dash suitable connections are made on the commutator to send the dot or dash signal. The speed of transmission with such an automatic arrangement could be made very high but there is no evidence to show that higher speeds than seventy words a minute have been used, and the Post Office Commission of 1913 had a speed of sixty words a minute demonstrated to them at the Clifton station of the Marconi Co., using the patent Marconi Undamped Wave system with an automatic transmitter.

In connection with any system using undamped waves we may note that the ether waves are not set up in groups, or trains; when trains of waves are sent out they act with a cumulative effect on a receiver tuned to them so that one impulse of current is built up per train to be discharged through the telephones. With undamped waves we do not get this cumulative effect; thus in an ordinary receiver the currents flowing through the detector and telephones would have a frequency equal to the oscillation frequency. Currents discharged through the telephones at this frequency would not give audible vibrations of the diaphragm, so that some means must be devised for breaking up these oscillating currents into groups, say 900 groups per second, and causing discharges to take place through the telephones at the group frequency.

In the Poulsen system the special device used for this purpose is called a "tikker"—it is simply a very delicate interrupter which makes and breaks the telephone circuit. In one form the "tikker" consists of two fine gold wires crossing each other and vibrated into contact by clockwork; in another form the contacts can be vibrated by a buzzer arrangement. A tikker arrangement can be made by having a light contact wire resting on an insulated metal disc mounted on the shaft of a small motor which rotates at high speed; the vibrations of the motor can be made to vibrate



the contact between the wire and the disc at a frequency depending on the speed of the motor.

The connections of a Poulsen receiver are shown in Fig. 160 (b); it will be seen that no detector is required other than the tikker arrangement, and that a relatively large condenser of 0.2 mfd. is shunted across the telephone receivers. The primary and secondary coils are of relatively large diameter and few turns; they are coupled very loosely, being separated by 20 to 30 inches, so that full effect is taken of the sharp tuning possible with undamped waves. While the tikker circuit is broken the ether waves set up oscillating currents in the secondary circuit of the receiver (S and K<sub>s</sub>) and by resonance effects the energy in this circuit is built up; when the tikker closes the telephone circuit the energy is discharged into the telephones and their condenser, which together form a circuit whose natural frequency is that of the tikker discharges. This action is similar to that which would take place if one built up oscillations in a pendulum by striking it with little uniform taps, at a frequency equal to the natural frequency of the pendulum; then allowing the pendulum to strike against a gong, which has a low frequency of vibration. This sequence could be repeated automatically, so that at definite intervals, when the pendulum has got up a good swing, it strikes against the gong and gives up all its energy to it.

**Marconi System of Continuous Oscillations.**—It is not generally realised at present that the Marconi Co. have developed and brought to a high degree of perfection a system for setting up continuous oscillations and transmitting undamped waves. In the report of the Technical Committee, appointed by the British Government in 1913 to investigate the merits of existing long-distance radio-telegraphic systems, we find it stated that the Marconi system was the only one which they had seen in successful operation over long distances. Signor Marconi has described this system in a paper communicated to a scientific society in Rome. The student will remember that the ordinary Marconi system, with a disc discharger, sets up groups of oscillations at great regularity, and that the oscillations in the transmitter aerial circuit are not very damped for a spark discharge system. Yet these oscillations, and the resulting ether waves, are in groups separated by intervals of time, and the idea underlying the Marconi continuous wave system is to fill up these intervals of time with other groups of oscillations, set up by other discharge circuits. It is something like using a four-cylinder engine instead of a single cylinder one; Fig. 161 explains the idea. The lines A, B, C, D, show groups of oscillating discharges set up in four

different circuits, arranged in such a manner that the discharges of the different circuits follow each other in a regular sequence. If, then, these discharges are all made to act inductively on a fifth circuit, the resulting oscillations in this circuit will be as shown at E. Attention must here be drawn to an important point in the working of such an arrangement—the discharges must overlap each other *in phase*.

A four-cylinder engine would be useless if the impulses of steam or gas in the cylinders were not properly timed; timed to occur in sequence and to occur at the proper point of the stroke. Similarly, our oscillating discharges must overlap in phase, that is to say, referring to Fig. 161,  $y$  must be in the same phase as  $x$ ,

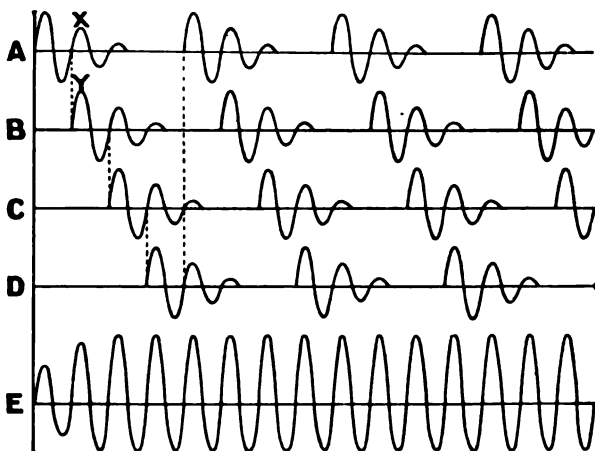

FIG. 161.

otherwise their effects would neutralise each other. The method adopted by the Marconi Co. to obtain these results is diagrammatically illustrated in Fig. 162. It will be seen that four primary circuits are charged in parallel from the source of voltage, or generator G. The spark gaps are metallic wheels with projecting teeth, these wheels being insulated from each other though rigidly mounted on the same shaft by which they are rotated. The primary circuits are inductively coupled, by four jigger secondaries in parallel, to the aerial circuit, and the discs are so arranged that discharges in the four circuits take place in regular succession. Thus, the discs having a certain velocity, the interval between a discharge from one circuit and that of the circuit which follows it is *exactly equal to one or more periods of*

complete oscillations in the aerial circuit. At a certain disc speed the oscillation impulses overlap each other in exact phase. The aerial circuit may be coupled to the four primary circuits through the medium of an intermediate circuit; the timing in either case is done by small auxiliary spark gaps and circuits joined to the main discharge circuits; to avoid confusion these are not shown in the diagram of Fig. 162.

**Lepel System.**—This system was invented by Baron Von Lepel of Berlin, and stations equipped on the Lepel system in Belgium, France, and the West Indies have attained a considerable success

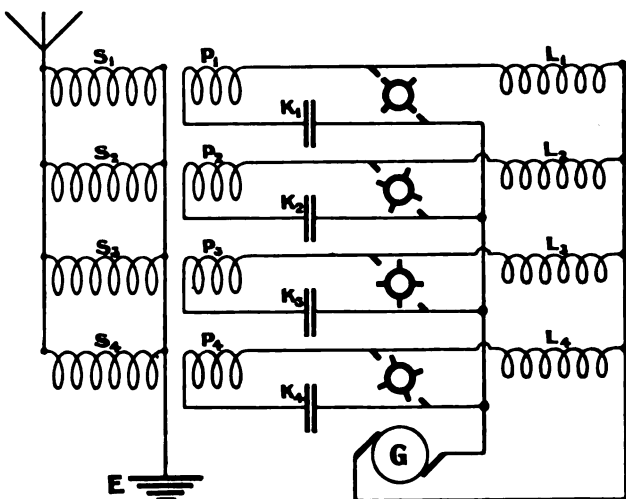

FIG. 162.

in operation, so that a short description of the particular apparatus used may prove interesting.

The Lepel discharger is really a form of quenched spark gap, and in the patent specification it is stated that the electrodes are a very small distance apart and equal at all points of the same. They may be made of two metallic discs or two metallic cone surfaces as shown in Fig. 163, the distance between the electrodes being so small as to be broken down by a discharge at the working voltage, so that the action would seem to be a mixture of spark and arc discharge. Thus, if 220 volts are used, the electrodes are only a fraction of a millimetre apart. The discharge is prevented from coming to the edges of the electrodes by very thin paper washers which project out beyond the edges of the electrodes;

these washers are gradually burnt away on their inner edges and have to be renewed. For small power the electrodes need not be cooled; otherwise they can be cooled by water circulation, and in any case cooling will aid the oscillation characteristics as it does in the Poulsen arc. The aerial circuit may be direct coupled to the spark gap, or coupled by an oscillating transformer; in either

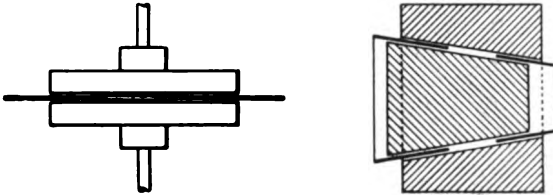

FIG. 163.

case the power in the oscillating circuit is found to be increased by having an auxiliary oscillating circuit in parallel with it. The connections would then be as in Fig. 164 (a) for direct, (b) for inductive coupling of the aerial, the auxiliary oscillating circuit being shown dotted in each case.

It is to be noted that when the auxiliary circuit is not used the oscillations in the aerial are practically undamped, the spark gap giving off a faint hissing sound; when, however, the auxiliary circuit is connected up, the values of its inductance and capacity can be so chosen that the oscillations across the spark gap causes it to give out a musical note—it is then identical with a Duddell musical arc and the transmitter acts like a high note

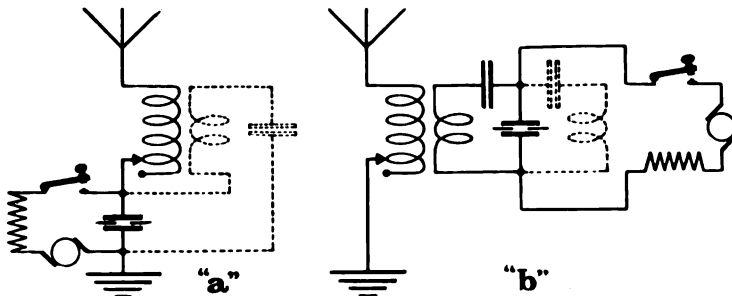

FIG. 164.

sparkling transmitter. Thus the Lepel system can be used on either practically undamped waves or highly syntonised damped waves, and the Lepel receivers are fitted with alternative apparatus suitable for the reception of signals on either system

In Duddell's musical arc the note given out depends on the frequency of the oscillating circuit shunted across it; if its inductance or capacity is changed the note given out by the arc is changed. In the Lebel transmitter the inductance of the auxiliary circuit is fitted with a switch keyboard, so that by manipulating these keys the spark note can be changed; indeed a tune could be played in the transmitter and heard in the receiver.

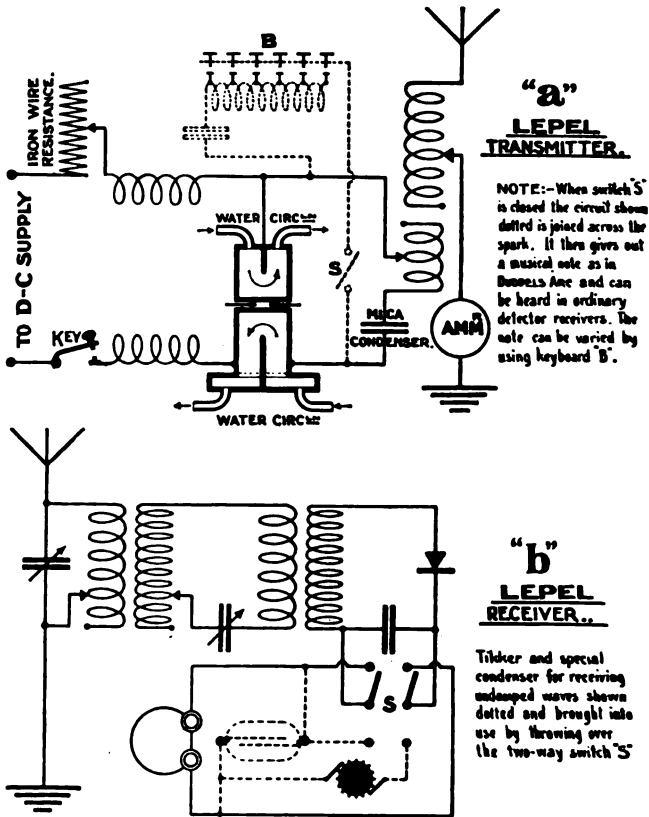

FIG. 165.

The transmitter apparatus actually employed is shown diagrammatically in Fig. 165 (a). The spark gap is joined in series with choke coils, manipulating key, and special iron wire resistances, to a 500 volt DC. supply. The iron wire resistances are enclosed in glass tubes filled with hydrogen; their resistance

rises if the current in the circuit increases, hence they tend to steady the supply and prevent damage if the spark should become short circuited. The spark electrodes are of copper and delta metal, made hollow and cooled by water circulation. The main oscillating circuit consists of a condenser with mica dielectric and an inductance coil of copper strip wound cylindrically; coupled to it is the aerial circuit. This is all that is required to emit feebly damped waves, but the auxiliary circuit, shown dotted in the diagram, is also provided, consisting of a condenser with mica dielectric and an inductance coil with keyboard switch contacts. The use of mica dielectric in the condensers considerably reduces their size for a given capacity, hence the Lepel apparatus is small and compact; while the apparatus is thus simple and comparatively inexpensive the efficiency of transmission is certainly very high, and long distances have been covered with comparatively small transmitter energy.

The Lepel receiver is shown diagrammatically in Fig. 165 (b), and is seen to consist of three circuits; the aerial circuit coupled inductively to an intermediate circuit, and the latter coupled inductively to the detector circuit. For receiving damped waves, either from a Lepel musical note transmitter, or from a station using spark or disc discharger, a crystal detector and telephones with blocking condenser are used; when receiving Lepel or other undamped waves a tikker interrupter is joined in series with the telephones and an extra condenser of special construction shunted across them. This change of connections can be quickly effected by means of the throw-over switch shown in the diagram. The special condenser used across the telephones when receiving on undamped waves is known as an "electrolytic condenser;" it consists of two little plates sealed in a glass tube, which is filled with an electrolyte. When current flows across the electrolyte a film of gas is deposited between the plates forming the dielectric of a condenser and since this film dielectric is very thin quite an appreciable extra capacity is shunted across the secondary circuit. The energy is stored up in this condenser until the interrupter allows it to be discharged through the telephone receivers.

Before concluding this chapter, it may be profitable to review the advantages which are obtained by an efficient method of generating and utilising undamped electrical oscillations of high frequency. These advantages can be set out under the following six headings:

(a) **More Power Employed.**—The amount of power which can be handled at transmitting stations using condenser discharges to

set up oscillations cannot be increased much further than that at present in use in large stations; thus, if more power is to be employed and longer ranges covered with certainty, a machine of the Goldschmidt type is the only oscillation generator which gives promise of efficient development.

(b) **Less Interference.**—The perfect syntonisation obtainable with undamped waves reduces interference troubles between stations, and would certainly safeguard commercial stations from any annoyance, caused by smaller stations in their vicinity equipped with spark transmitters.

(c) **Simpler Apparatus.**—The transmitting and receiving apparatus for undamped waves are less intricate and less costly than those required for spark systems; in the receiving station the detector arrangement has better mechanical features, and is not so easily put out of adjustment.

(d) **High Speed of Signalling.**—In sparking systems we have groups of oscillations separated by comparatively long intervals of inactivity (see Chapter XII. and Fig. 79), so that if high speed of transmission is attempted we may not have more than one or two trains of oscillations per dot or dash. With undamped oscillations these periods of inactivity are absent, hence high-speed work is possible as soon as reception apparatus has been developed which will be automatic, reliable, and efficient.

(e) **Wireless Telephony** is only possible with undamped waves, for the variations of the human voice are much more rapid than the succession of wave trains which could be obtained with any sparking system. Besides, even if sparking frequency could be speeded up, the sound of the sparks would be heard superimposed on those of the voice. Since wireless telephony is under rapid development at present we may be certain that it will cause a concurrent development of undamped wave systems.

(f) **Use of Special Directive Aerials.**—Undamped wave systems lend themselves specially to the use of directive aerials, in which direction of radiated energy is controlled by making the waves of two different aerials interfere with each other.

In conclusion, we might remind the student that a station fitted up for receiving signals on a spark or damped wave system will not receive signals carried by undamped waves. An undamped wave transmitter can only affect an ordinary detector receiver if an interrupter is actuated in one of the transmitter circuits, so as to break up the undamped waves into groups which will cause the receiver telephones to vibrate at an audible rate. Otherwise the receiver station should be equipped with two sets of apparatus; one with the ordinary detector arrangements, and the

other having a heterodyne, tikker, tone wheel, or other device which will respond to undamped waves.

## QUESTIONS ON CHAPTER XVIII

1. Explain clearly why an arc lamp can be used for the generation of oscillating currents.
2. What are the advantages of undamped wave transmission?
3. In an ordinary spark transmitter direct connection of the aerial circuit to the closed oscillating circuit is not permissible nor desirable, except for small outfits. Why is this? And why is such a connection permissible with undamped wave transmitters?
4. Why is it that a receiver equipped with ordinary detector arrangements will not respond to undamped waves?
5. Explain the theory of the Goldschmidt high frequency generator.
6. In the Marconi undamped wave system the primary oscillations must overlap each other *in phase*. Why is this, and what would happen if they did not so overlap?
7. Explain why it is that high-speed radio-telegraphy is only possible with undamped wave systems.



## CHAPTER XIX

### *MISCELLANEOUS APPARATUS*

WE have seen that the energy radiated from a transmitting aerial spreads out through the ether in all directions, and that consequently only an extremely small fraction of it will act on any given receiver. In other words, the over-all signalling efficiency between a given transmitter and a given receiver is only a fractional percentage, while the currents dealt with, and utilised in, the receiver are very much smaller than those employed in any other commercial application of electricity.

It is therefore evident that two important fields, at least, remain open for further investigation and development; two important problems yet to be fully solved. The first: how to prevent the spreading out of the ether energy in all directions round the transmitter; how best to augment, or, as it were, concentrate, its action in one particular direction. The problem was responsible for the development of the Marconi directional aerial; this, at the best, is only partially successful and does not direct telegraphic ether waves with the same certainty and completeness as that which a parabolic mirror produces on the short ether waves of light.

The second problem entails the development of cheap commercial apparatus which will work with, and make correct quantitative measurements on, the extremely small currents in a radio receiver. The many forms of crystal detectors so popular in radio receivers cannot be included in the category of reliable commercial apparatus; they are uncertain in their action and with them sensitiveness has to be sacrificed if reliability is increased. In its present design a crystal detector is not even a scientific apparatus; its action is not completely understood, and there is such a happy-go-lucky chance in its probable behaviour as to make its use distasteful to the scientific investigator. Undoubtedly the behaviour of crystals to small oscillating currents has been instructive, in the pioneer possibilities which it opened up; it is equally undoubted that future development will not include the use of crystals, but will involve the design of apparatus having perhaps the characteristics of crystals but with sound mechanical features while giving reliable and quantitative indications.

The object of this chapter is shortly to describe some of the first steps which have been taken in the solution of the above problems, and the methods by which it is hoped to develop the commercial utility of ether wave telegraphy.

**Bellini-Tosi Aerial Compass.**—This is a particular form of directional aerial, by the use of which stations can discover the direction from which signals are being sent to them, or by which they can send signals in a definite direction. Thus in foggy weather a ship station can tell the bearing of a land station with which it is in communication, and check its own position, if fitted with one of these aerials. The aerial consists of two fixed equilateral triangles whose planes are at right angles to each other,

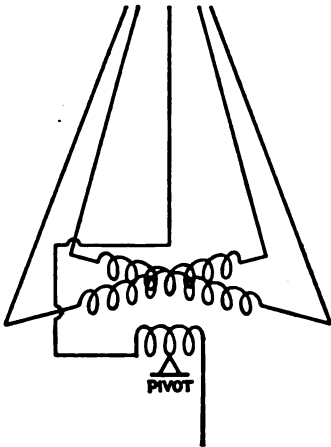

FIG. 166.

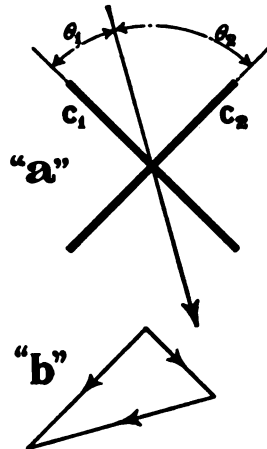

FIG. 167.

the triangles being open at the top and each including in its base a coil of a few turns, as shown in Fig. 166. There is also a single vertical wire with a coil of a few turns in its circuit; this coil is placed immediately below the cross formed by the other two coils, and is pivoted to rotate on its centre. To transmit in any given direction, the pivoted coil is turned round to point in that direction. To find out the direction from which signals are coming, the pivoted coil at the receiver aerial is turned round until the signals have a maximum strength; the coil is then pointing along the direction of the transmitting station. This type of aerial has worked very successfully at some French coast stations.

The theory of the arrangement is briefly as follows: Let the two coils at right angles to each other be represented in Fig. 167 (a) by the two lines  $C_1$  and  $C_2$  and let the direction of the waves be as

U

shown. Then the currents induced in  $C_1$  by the wave energy will depend upon  $\cos \theta_1$ , and the magnetic field set up by these currents will also vary as  $\cos \theta_1$  and will act along the axis of  $C_1$ , i.e. along  $C_2$ . Similarly the magnetic field set up by the currents induced in  $C_2$  will be proportional to  $\cos \theta_2 (= \sin \theta_1)$  and will be at right angles to  $C_2$ . These magnetic fields are shown in Fig. 167 (b) and the resultant induced field is seen to be at right angles to the direction of transmission of the waves. If the exploring coil is to embrace all this resultant field and give the strongest signals in the telephones its plane must be at right angles to the resultant field, therefore it must be lying along the direction of transmission.

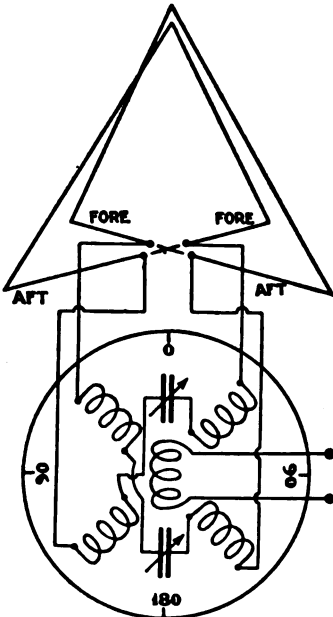

FIG. 168.

From the above it will be seen that maximum current and field is induced in one of the triangular aerial circuits when its plane coincides with the direction of transmission; in this case the plane of the other is at right angles to the direction of transmission, hence no current or field will be induced in it.

**Wireless Direction Finder.**—The Marconi Co. have designed an instrument for use on board ships called the "Wireless Direction Finder" which is based on the Bellini-Tosi system. The aerials are two triangles as already described, with their planes at right angles to each other, each being at  $45^\circ$  to the centre line of the ship. The four wires of the two triangles are insulated from each other at the top, the insulators being hung from fore and aft stays to the tops of masts.

The centre of the bases of the two triangles pass through the instrument room and the coils which form the centre of the bases are mounted in an apparatus case. These coils are fixed at right angles to each other; at the centre of each coil is a variable condenser for tuning the two triangular aerials to different wave lengths.

The two condensers are varied simultaneously by a rotation of a single handle, their connections to the coils being shown diagrammatically in Fig. 168. Inside the fixed coils is mounted on a vertical spindle the exploring coil, whose terminals are joined to a carborundum detector, potentiometer, and telephones in the

usual manner. A more elaborate tuned receiver may be joined to the terminals of the coil, thus increasing the range.

As already explained the signals will be strongest when the plane of the exploring coil is coincident in direction with that of the transmitting station. The handle which rotates the exploring coil is fitted with a pointer which moves over a scale and thus indicates the line of direction of the transmitting station. The instrument will be accurate within 2 or 3 degrees, and is useful for Channel ships in thick fog. Of course the instrument only shows the direction line of the transmitting station as compared with the course of the ship—it does not tell if the station is, say, off the port bow or off the starboard quarter; this, if not already known from local conditions, can be found by taking a second reading after the ship has kept on her course for a short time. Two successive readings will also enable the operator to determine the distance of the ship from the transmitting station, and if the signals are increasing in strength it shows that that distance is being lessened.

**Fessenden's Interference Preventer.**—Dr. Fessenden has designed many pieces of wireless telegraphy apparatus, his system being used by the National Electric Signalling Co., U.S.A. Many of the United States stations and ships use his patents, and a large station at Arlington, U.S.A., is equipped with his apparatus. His heterodyne detector has already been described in these pages. Dr. Fessenden has patented an arrangement for cutting out atmospherics, or Xs; also stations interfering with the signals from the station whose message it is desired to receive. A diagram of connections is shown in Fig. 169. The aerial is joined to the primaries of two coupling coils A and B in parallel with each other, and thence to earth. The primaries and secondaries of the two couplers are alike in all respects, but the secondaries are so joined that their actions oppose each other. The detector D, potentiometer P, telephones T, and secondary condenser K, are joined up in the usual manner.

The side A is tuned to the wave length which is to be received, side B being disconnected while this tuning is carried out; side B is then switched in parallel with A, and its aerial condenser varied until disturbing signals are cut out. When this takes place the currents induced in the aerial by ether waves not in tune with side A divide equally between  $P_A$  and  $P_B$ ; but the secondaries being opposed to each other the detector and telephones are not affected. When waves are received to which A is tuned, the current passes almost entirely through the tuned side A, therefore currents are induced in its secondary circuit, and act in the

detector and telephones; the coil  $S_B$  under these conditions simply acting as a portion of the wiring of the detector circuit. Atmospheric effects will divide equally between the two sides, and thus their action on the telephones is greatly weakened. It can easily be realised that tuned signals would be weakened by this arrangement if the tuning of A and B did not differ by a certain minimum percentage, and thus the selectivity obtained is limited; in other words, stations differing by about 2-3 per cent. in wave length from the one in communication cannot be tuned out without weakening the signals from the station in communication.

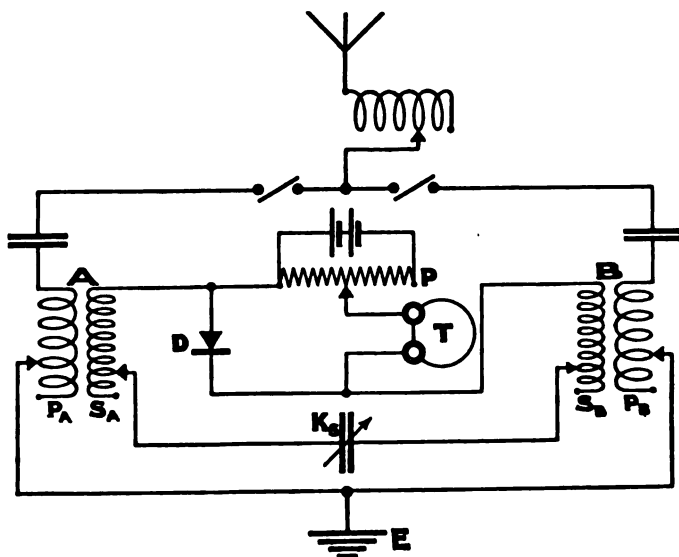

FIG. 169.

Marconi patented an interference preventer which involved the use of two aerials and a rotating machine, but it does not appear to have come into commercial use. Undue interference is avoided by the observance of the International Radio Laws, and any method of supplementing these by the use of interference preventers is calculated to make the receiver less efficient and less reliable while rendering more difficult the free inter-communication between ships of all nations. If the International Rules are duly observed an interfering station should be one which considers itself out of range, either on account of distance or on account of widely different wave length; in these circumstances its signals would be weak, and can be sufficiently avoided

by means of an intermediate circuit in the receiver. Such a multiple tuner receiver may not, and generally does not, eliminate altogether the sounds caused by atmospherics, or Xs, which at times are so persistent as to render communication difficult, but the modern practice of high spark frequency and musical note signalling has mitigated this nuisance considerably. The student should note that the Marconi patented system of "balanced detectors," already described, reduces very considerably the effects of strong atmospherics and of flat wave interference.

**Telefunken Double Receiving Switch.**—It is usual to have a pair of telephone receivers, one for each ear, mounted on a head piece; the receivers being joined in series or in parallel according to the resistance and detector used. If it is desirable that two persons can receive the message simultaneously, one receiver can be mounted on each of two head pieces, but of course this decreases the audibility for each person. Two complete receiver sets can be joined in series across the telephone terminals on the receiver apparatus, but this also will decrease the loudness of the signals to each listener.

The reception of two different messages simultaneously on the same aerial is a more difficult problem; this will require that two different receiver sets should be connected to the aerial, and that the messages be transmitted at different wave lengths. Any given aerial will only receive one wave length with maximum efficiency, and the more the two received wave lengths differ from each other the less efficient is the reception of one of them. Also if two receivers are joined to the same aerial they are electrically coupled, and must therefore interfere with each other to some extent.

The Telefunken Co. have designed an arrangement by means of which two different messages at different wave lengths can be received on the same aerial simultaneously, or one message received by two operators on two different receivers. A diagram of this double receiver switch is shown in Fig. 170, and its action is very simple. A tongue T is caused to vibrate very rapidly (about thirty times a second) by means of a magnet M and local battery, the tongue itself providing the intermittent contact. At the end of

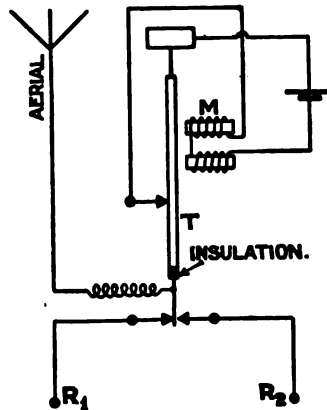

FIG. 170.

the tongue is an insulated spring piece joined flexibly to the aerial, and as the tongue vibrates this spring piece joins the aerial to each of the two receivers alternately. The vibration is so rapid that each receiver is joined to the aerial three or four times during the reception of a dot, so that the intensity of sound in the telephones is almost as great as if one receiver alone were

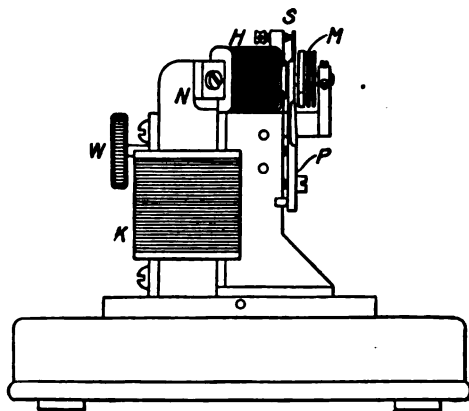

FIG. 171.

permanently connected to the aerial. Thus the receivers, not being electrically connected, have no interfering action on each other, and the same message is received equally well on both of them. Two different messages at different wave lengths can be received simultaneously, but of course the aerial is more efficient to one of these wave lengths than to the other.

#### Brown Telephone Re-

**lays.**—These relays have been designed by Mr. S. G. Brown, 4, Gt. Winchester Street, London, E.C., and will magnify receiver circuit currents about twenty times. That known as type "G" is designed to manipulate, with relay action, action local currents of 25-35 milliamperes, while a design with a single magnet is specially suitable for small currents in radio receivers. An outline of the "G" type is shown in Fig. 171, its circuits and connections in Fig. 172.

The relay consists of a permanent magnet, N, with pole pieces H, the latter being wound with coils, H, through which the receiver current flows from the terminals, A; a 2 mfd. condenser is connected in series with A to keep out steady currents. A steel reed, P, held by a screw, is fixed in front of the poles of the magnet; its distance from the poles being adjusted by means of the screw W. When the reed is on the point of dropping against the magnets, that is to say, when its elasticity is just balanced by the magnetic pull, it is in its most sensitive position. S is a stop screw to prevent the reed from coming into contact with the pole faces, as it would then stick to them; the reed, when in use must not touch S, otherwise its oscillations would be damped.

M is a sealed microphone chamber containing two carbon faced electrodes and nearly filled with fine carbon granules. The

front of this chamber is screwed firmly into the reed, and the back is held by three grub screws in the insulated arm. The microphone is in series with a regulating winding K on the limbs of the magnet; by the telephonic reaction of this coil the magnifying power of the instrument is intensified.

The accessories to be used with the instrument are a 6-volt battery, a small transformer, a condenser of tinfoil and paper pattern, and the telephone receivers of about 120 ohms resistance.

The diagram of connections shows that the receiver currents flow through the coils H on the poles of the permanent magnet;

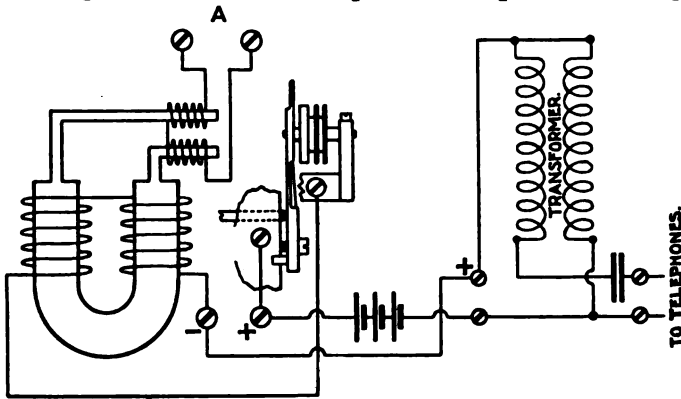

FIG. 172.

these coils, as it were, taking the place of the coils of the telephone receivers. In this case, however, instead of a diaphragm in front of the poles, we have the steel reed. The contacts in the microphone (at the back of and fixed to the reed) are joined in series with the local battery, the primary of the transformer, and the intensifying coils on the magnet. The vibrations of the reed act on the carbon granules in the microphone and cause telephonic changes of the current in the local circuit, which currents flow through the primary of the transformer. Currents are therefore induced in the secondary of the transformer, which act on the telephone receivers joined to it.

Thus very weak receiver currents cause vibrations of the reed, and through it much stronger impulses of local current are made to act on the telephones. A second relay may take the place of the telephones; that is to say, two or even three relays may be joined in series, and thus the magnification of current effects greatly increased. Mr. A. Campbell Swinton, using three Brown relays in series at a demonstration before the London Radio-telegraphic Society, made the Eiffel Tower signals audible to the



whole audience in a large room. By the use of Brown relays, feeble receiver currents can be so magnified that the message may be printed on a tape machine or otherwise recorded.

While the type "G" relay just described is best adapted for commercial work, another type "A" has been designed which will make distinctly audible signals which are quite inaudible in telephone receivers used alone. Referring to the diagram of this relay, shown in Fig. 173, the reed P is set as closely to the magnet HK as possible, if necessary thin tissue paper being used to ensure that they are slightly separated. Screwed to the reed is a flat contact O of carbon, highly polished, while carried on the hinged arm L is the top contact consisting of a blunt point of iridium

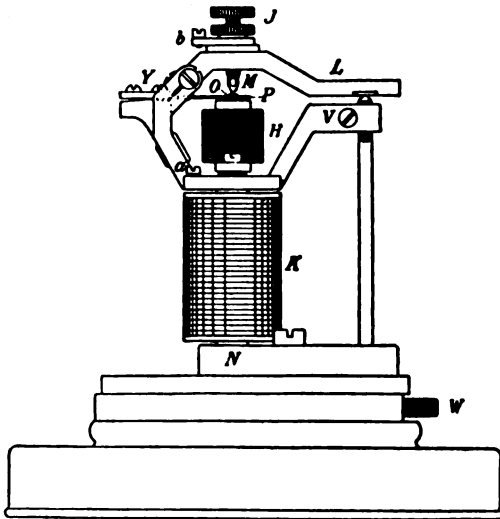

FIG. 173.

screwed into the coarse adjusting screw J. The contact pieces are opened to an infinitesimal amount to form the microphone by means of a fine adjusting screw W, also by the action of the local current which passes through the contacts and the self-regulating winding K. The local current thus assists to form the microphone and steady the adjustment, its amount being regulated by the fine adjusting screw worked from the mill head W.

The auxiliary apparatus and the connections of this relay are similar to those required for the type "G," a blocking condenser with variable capacity from 0.0025 to 0.01 mfd. being joined across winding H, (terminals A), 1½ volt being used in the local circuit; a milliammeter is also used in the circuit so that the relay may be adjusted until the local circuit current is from 8 to 12 milliamperes; then the relay should be in its most sensitive condition. The telephone receivers are of 120 ohms resistance.

A third type of relay (type W) has been designed which is the most sensitive of all, and can be used for recording; it, however, requires more attention than the "G" or "A" types, and has to be

very carefully protected from vibration. Indeed with all the relays we must avoid vibration effects, otherwise it will be impossible to adjust them to their most sensitive condition.

**The Lieben and Reisz Current Relay.**—This relay has been described by E. Reisz in the *Electrician*, February 6, 1914. It is a gas, or valve, relay, something similar in action to Dr. de Forest's "audion" detector, but with new distinctive features of construction.

A diagram of the relay with its connections is shown in Fig. 174. It consists of a glass bulb cell exhausted of air, but filled with attenuated vapour of mercury at a pressure of 0.001 mm. ( $20^{\circ}$  C.), this vapour rising from a small quantity of mercury amalgam placed at the bottom of the bulb.

The cathode (K) consists of a platinum strip 1 metre long,

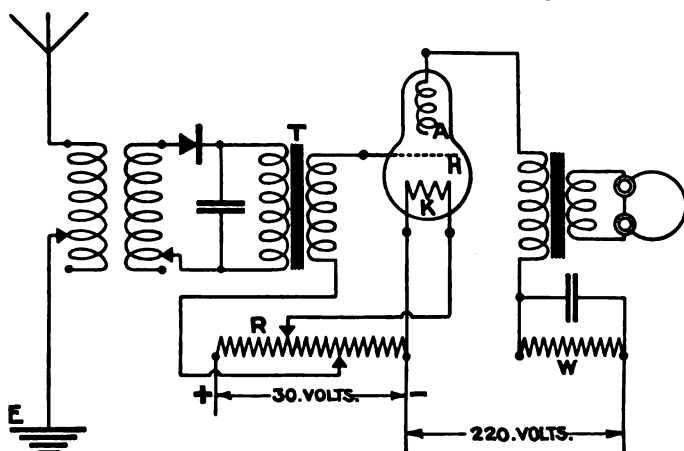

FIG. 174.

1 mm. wide, and 0.5 mm. thick, wound zigzag on a glass supporting stem; the strip being coated with a thin layer of barium and calcium oxides. The anode (A) is a spiral of aluminium wire wound on the top of the glass central stem, while the auxiliary electrode (H) is a thin plate of aluminium, extending right across the bulb between the cathode and anode, with apertures of  $3\frac{1}{2}$  mms. diameter uniformly distributed all over it.

The cathode is raised to a bright red heat by an electric current, being connected with adjustable contacts across a resistance R which has applied to it 30 volts from a battery. This voltage must be kept quite steady, hence a battery is used. Between the cathode and the anode is impressed a difference of potential of 220 volts from a dynamo or mains, this voltage also

being kept as steady as possible. In series with the anode and kathode is a high resistance ( $W$ ) shunted by a suitable condenser, also the primary coil of a telephone transformer.

Wehnelt discovered that heated metallic oxides emit electrons, and thus from the heated kathode described above, electrons, cathode rays, or ionic currents, flow to the anode owing to the difference of potential existing between it and the kathode. This ionic discharge has to pass through the apertures in the auxiliary electrode ( $H$ ) and the strength of the discharge that passes through the apertures depends upon the potential of this auxiliary electrode.

It is seen that the electrode  $H$  is joined to an adjustable contact on the series resistance  $R$ , so that the difference of potential between it and the kathode can be adjusted to bring the relay to its most sensitive condition. In series with the auxiliary electrode ( $H$ ) is the secondary of a transformer ( $T$ ) whose primary would be joined to the receiving circuit instead of the telephones. The currents induced in the receiver by the ether waves will induce potentials in the secondary of the transformer  $T$ , which will alter the potential of the auxiliary electrode  $H$ . Thus the vapour currents flowing between anode and kathode will be changed, causing inductive effects in the primary of the transformer  $T_2$ , whose secondary would be joined to a telephone receiver, galvanometer, or relay.

It will thus be seen that this is a relay in the true sense of the word, the receiver currents causing changes in the strength of local currents. It is claimed that the relay will thus give currents of thirty-three times the amplitude of the receiver currents; two or more relays can also be joined in cascade to give still further amplification.

The appearance of the relay as made by the A. E. G. Company is shown in Fig. 175. The auxiliary transformers, condenser, resistances, etc., are mounted in a case provided with a lamp holder contact into which the relay lamp fits. The high resistance  $W$  limits the value of the current carried by the vapour; it is bridged by a condenser through which the intensified high frequency currents can flow.

The sensitiveness of the relay depends chiefly on the voltage applied to heat the kathode, which voltage must be kept constant; the sensitiveness also depends upon the difference of potential between the kathode and the auxiliary electrode.

**Telefunken Sound Intensifier.**—This is an instrument which was developed some years ago by the Telefunken Co. The theory of its action is very similar to that of the Brown relay just described; it is, however, much more elaborate in construction,

and requires more delicate adjustment. It consists practically of three tuned microphones in series with each other, as shown in the diagram of connections in Fig. 176.

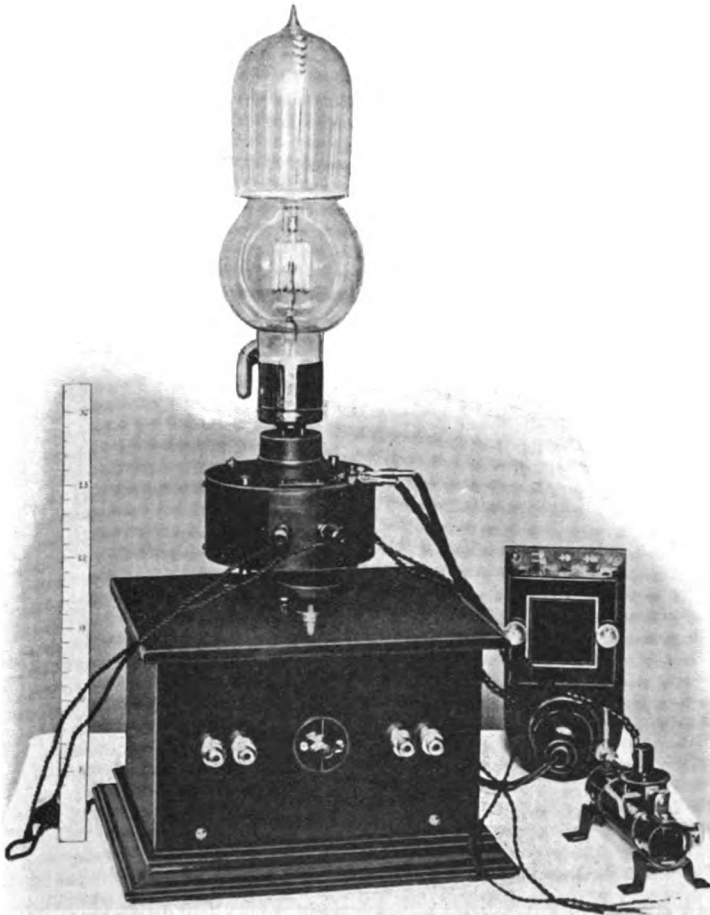

FIG. 175.

The terminals (A, B) are joined to the receiver circuit instead of the usual telephone receivers, the receiver currents thence flow into the high resistance windings (F) of an electromagnet. In

front of this magnet is a small armature which has the same vibration frequency as the sounds to be magnified, and the vibrations of the armature opens and closes a small microphonic contact ( $M_1$ ). It will be seen that the magnet and armature correspond respectively to the coils and diaphragm of a telephone receiver. The microphonic contact ( $M_1$ ) interrupts a local current flowing from a battery to a second electromagnet ( $F_2$ ), so that larger currents are caused to pulsate in  $F_2$  than those in  $F_1$ . The currents in  $F_2$  act on a tuned armature and contact ( $M_2$ ), and the action is repeated through a third set.

Thus the receiver currents can be made to cause large impulses of local currents, and the last of these acts on a loud speaking telephone, or on a Morse inker outfit. Since the armatures respond best to currents whose frequency is equal to their own vibration frequency, this instrument can be used to give good selectivity and cut out stations not in tune; two intensifiers can be used

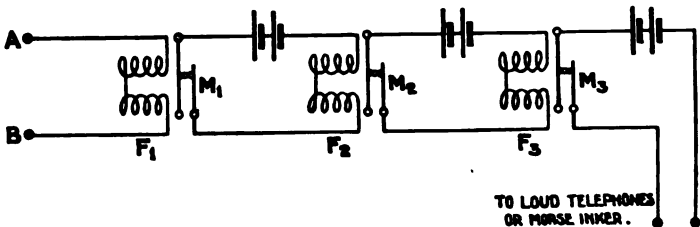

FIG. 176.

simultaneously on the same aerial to receive messages if the notes differ in pitch by 20 per cent. or over.

The instrument must not be subjected to vibration, therefore in mounting it for use elaborate precautions are taken; on board ship it is suspended from a well-sprung and damped universal joint.

**Einhoven String Galvanometer.**—The range of a given size of radio transmitter has been greatly increased since the time when coherer detectors were used in conjunction with a Morse tape machine or siphon recorder. This increase of range is partly due to the development of very sensitive detectors and telephones, operating on infinitesimal currents, but we must note that, when these are used, the speed and accuracy of reception is dependent on the skill of the operator. Much time is often wasted in the repetition of messages or phrases not properly understood at the receiving end; also fast transmitting is not feasible with code or cipher messages. Therefore at the present time there is a great demand for some method of automatic reception which can be used

with the most sensitive detectors; a demand which has brought about the development of the Brown telephone relay and the Telefunken sound intensifier, with either of which the received currents are made to control local currents in such a way that a siphon recorder can be used. It would be more desirable, however, to have an instrument which could simply take the place of the telephones, or of both detector and telephones; an ordinary sensitive mirror galvanometer will not do, because its moment of inertia would prevent it from responding to the rapid pulsations of current set up in the receiver circuits. An instrument, suitable for the purpose, must be so delicate as to give a clear deflection, or reading, on currents of one microampere or less; its moving part must have negligible moment of inertia, and the part of the instrument through which the current flows should have negligible self-induction and capacity. It should be absolutely aperiodic in its moving system, so that it will respond clearly to each impulse of a rapid pulsating current.

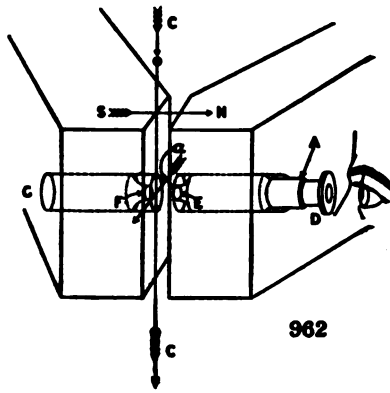

Fig. 177.

So far the only instrument designed to meet the above conditions, and give satisfactory results, when directly working on receiver currents, is the Einthoven galvanometer. By means of it the Marconi Co. have received transatlantic messages at Clifden, automatically recording them on a photographic strip, with a clearness and definition at high speeds which fulfils all requirements. This Galvanometer was designed by Prof. Einthoven of Leyden, and is made by the Cambridge Scientific Instrument Co., England, to whom the author is indebted for the illustrations and particulars herewith given.

A diagram of the instrument is shown in Fig. 177: it consists of a very powerful electromagnet with poles (N) and (S) separated only by a very narrow gap. In this gap is fixed the string CC through which the detector current passes. This string, therefore, takes the place of the coils on the telephone receivers, or of an ordinary galvanometer. When a current passes through the string it is deflected across the field in the direction shown by the arrow. The small movement of the string can be observed by means

of a microscope A, passing through a circular aperture bored in the poles. For wireless telegraphy purposes, a beam of light is passed through the hole from an arc lamp or lantern, so that the string stretches across the beam. Its motion, or instantaneous position, can then be photographed by making a photographic film pass in front of the aperture from which the beam emerges at the other side of the magnet. A view of the Einthoven galvanometer is given in Fig. 178.

In the most sensitive designs the string is made of a fibre of quartz or glass, on which is put a light coating of silver; the periodic time of vibration of the string depends on its tension, which can be adjusted by means of a micrometer screw, and, with glass or quartz fibres, can be varied between the aperiodic state

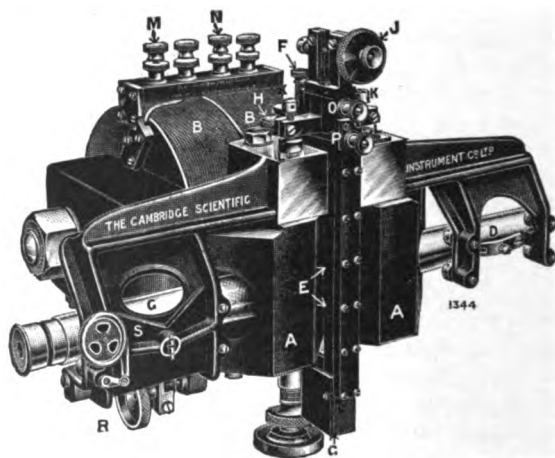

FIG. 178.

and  $\frac{1}{300}$  second. The resistance of these fibres is from 2000 to 10,000 ohms. A less sensitive design is fitted with silver or aluminium wire strings; these have a resistance of 6 or 8 ohms and have a longer periodic time, hence they are not so suitable for work with rapid current pulsations.

As seen through the microscope a quartz fibre instrument gives a deflection of 6 mms. with one microampere, so that when lantern and photographic films are used the instrument is readable with still smaller currents. Unfortunately the Einthoven galvanometer is rather too delicate for ordinary commercial usage; it is also expensive, a complete outfit costing about £100. Its great field of usefulness will probably be in the accurate measurements of receiver currents, and research work on atmospherics, daylight

effects, or other phenomena of like nature. Many of the instruments are at present employed for these purposes.

**Hot-wire Ammeter.**—This is the only type of instrument suitable for joining in the aerial circuit to measure the effective value of the currents oscillating in the aerial. The construction of an ordinary form of hot-wire ammeter is shown in Fig. 179, from which it can be seen that most of the current to be measured flows through a manganin shunt (*S*) and a small definite fraction of the current flows through the fine platinum silver wire *W*. The current flowing through this wire heats it slightly so that it increases a little in length and sags. Attached to the hot wire is a phosphor bronze wire (*B*), whose other extremity is fixed; attached to the phosphor bronze wire is a single fibre of silk, which passes round a small ivory or brass pulley and has its other end fixed to a steel spring *X*. The pulley is mounted on a spindle pivoted in jewelled screws: the spindle also carrying the index pointer and a light sheet of aluminium *A*.

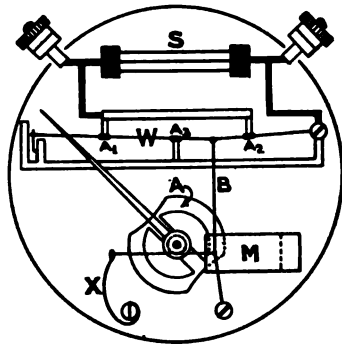

FIG. 179.

The action of the instrument is very simple: when current flows through the wire *W* it sags slightly, the sag is taken up by the phosphor bronze wire which in its turn sags, lessening the pull on the silk fibre attached to it, so that the latter is pulled a little to the left by the steel spring. As the silk fibre moves to the left it causes a slight turning movement on the little pulley, and the spindle in turning carries the index across the scale of the instrument.

The heating effect, the sag, and therefore the turning movement are directly proportional to the square of the current; hence the movement of the pointer across the scale is proportional to the square of the current, and thus the scale can be calibrated to read amperes. The heating effect is independent of the direction of the current through the wire, so that the instrument can be used on direct current or current alternating at any frequency. It is seen that magnetic effects or electrostatic effects do not disturb, or enter into, the working of the instrument. As the pointer moves across the scale, the aluminium disc moves between the poles of a strong permanent magnet *M*; this causes eddy currents to be produced in the disc which have a braking effect on any movement,



and prevent any unnecessary vibratory motion of the moving system; thus the pointer when deflected remains steady and the reading can be taken accurately.

The type of hot-wire ammeter described is suitable for alternating current measurements if the frequency is not too high, but with high frequency currents, such as obtain in the aerial circuits of wireless transmitters, some modification of the design is necessary to obtain accuracy. For currents above 5 amperes the hot wire would be subdivided into two or three portions in parallel with the shunt, current being led into it as shown at  $A_1$ ,

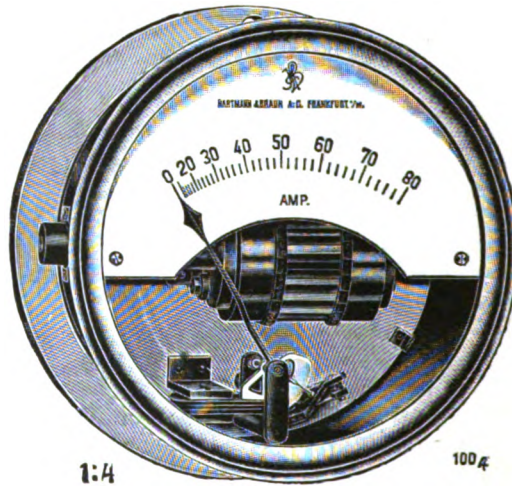

FIG. 180.

$A_2$ , and  $A_3$ ; on high frequency currents this would cause the instrument to read too low.

It is better, then, to have no shunt, and instead of a hot wire, have a number of extremely thin (0.01 mm.) platinum-iridium strips, arranged in parallel; the whole of the current to be measured dividing evenly through the strips, which are carried on a heavy block of metal to absorb the heat and prevent the temperature from rising above a fixed maximum value.

Fig. 180 shows such an instrument made by the Union Electric Co., Ltd., in which the parallel strips can be seen, also the arrangement of permanent magnet and aluminium damper. The pointer can be adjusted to zero by a screw, accessible from the outside of the case, and the working parts of the instrument are mounted on a marble base.

## CHAPTER XX

### MEASUREMENTS IN RADIO-TELEGRAPHY

IN this chapter a description will be given of some of the important tests and measurements which can be made on transmitting and receiving circuits. It is not intended to deal with ordinary electrical measurements such as those of insulation, resistance, voltage drop, and detection of broken circuits or faults; descriptions of these can be found in any electrical text-book. It may be observed that most of the testing work to be done in radio-telegraphy can be carried out with a wavemeter and its accessories, so that nearly all the measurements described in the following pages are carried out with this instrument.

**Capacity.**—For the measurement of a capacity a ballistic galvanometer may be used. A ballistic galvanometer is one whose moving system is comparatively heavy; that is to say, it has a larger moment of inertia than usual, so that when electricity is discharged through its coil the moving system does not start to move until the discharge is at its full value; thus the resulting deflection is proportional to the full discharge.

The simplest, though perhaps not the most accurate, method of measuring a capacity is to first charge a standard condenser by joining it to a standard cell, such as a Clark's cell, whose E.M.F. is accurately known. The charge  $Q = KV$  microcoulombs, if  $K$  is in microfarads and  $V$  in volts. Discharge the condenser through the galvanometer and note the deflection ( $d$ ). Then the discharge

which will give unit deflection =  $\frac{KV}{d}$  microcoulombs. Now join the unknown capacity ( $K_x$ ) to a known E.M.F., and since capacities used in radio-telegraphy are generally very small this E.M.F. may have to be fairly high, in order to obtain a readable deflection on the galvanometer when the condenser is discharged through it. An accurate voltmeter will be required to measure this E.M.F. Then discharge the condenser through the galvanometer

and note the deflection ( $d_2$ ). The discharge ( $Q$ ) =  $K_x V_2$ ; it is also equal to  $d_2 \times$  microcoulombs to give unit deflection—

$$\therefore K_x V_2 = d_2 \times \frac{KV}{d_1} \quad \therefore K_x = \frac{d_2 V}{d_1 V_2} K \text{ microfarads.}$$

Note that if the same E.M.F. is used to charge both the standard and the unknown condenser—

$$K_x = \frac{d_2 V_1}{d_1 V_1} K = \frac{d_2}{d_1} K \quad \text{or} \quad \frac{K_x}{K} = \frac{d_2}{d_1}$$

Thus the calculations are simplified, and indeed the experiment made more accurate, if a standard condenser of small capacity is available, so that the same E.M.F. may be used to charge both the known and the unknown capacity. Therefore it is advisable to make a standard small capacity with air dielectric, the plates being exactly parallel and as symmetrical as possible, so that the capacity can be accurately calculated from the formula

$$K = \frac{A \text{ sq. cms.}}{4\pi t_{\text{cms.}} \times 900,000} \text{ mfd.}$$

The standard capacity may be made with stiff brass or aluminium sheets, square or circular; separated by thin small washers of ebonite, mica or glass, the washers being all of exactly the same thickness. Leads should be soldered to the plates and to terminals mounted on a mahogany or other hard wood case which encloses the condenser. Three or four of such condensers, ranging from 0.001 to 0.005 microfarad should, if possible, be kept for testing purposes.

As a matter of fact, the foregoing method of measuring capacity is not the best one to use on condensers which are required for radio-telegraphic purposes, since the capacity values for direct and high frequency currents are different. However, the method has been given in order that the student may revise his knowledge of the relationship which exists between quantity, capacity and potential.

The capacity of a condenser can be measured by a bridge method which is a modification of De Sauty's method. The condenser of unknown capacity, a standard condenser ( $K_s$ ) of approximately similar capacity, and two *non-inductive* resistance boxes are joined as shown in Fig. 181; an arrangement which is similar to the usual Wheatstone bridge connections for measuring resistance. A telephone receiver is used instead of a galvanometer, and a buzzer, worked by a battery and key, joins the other two corners of the bridge. The resistances,  $R_1$  and  $R_2$ , are variable by

means of plugs or contacts, and their values are changed until the least sound is heard in the telephone.

Then— 
$$\frac{K_x}{K_s} = \frac{R_1}{R_2}, \text{ or } K_x = K_s \times \frac{R_1}{R_2}$$

The connecting wires should be short and the contacts good, so that the resistance of these is negligible. If the condensers have different dielectrics, it will be impossible to balance so as to get complete silence in the telephone, owing to the fact that their dielectric hysteresis effects are unequal, but it should be possible to get a result correct to within a very small percentage. The buzzer should be a high note one, requiring small battery power to work it. The capacity of an aerial circuit may be measured by this method, replacing the condenser  $K_x$  by the aerial and earth wires as shown dotted in Fig. 181.

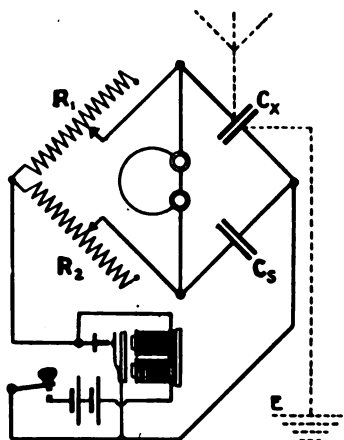

FIG. 181.

Since condensers have not exactly the same capacity for high frequency charges as they have when a direct voltage is applied to them it is preferable to use this method for radio condensers rather than the one previously described. A good method of measuring capacity by means of a wavemeter will be described later.

**Inductance.**—The most satisfactory method of measuring inductances of coils used in radio-telegraphy is probably that known as Anderson's method, with modifications introduced by Prof. Fleming.

The coil, whose coefficient of self-induction is to be measured, is first balanced in a Wheatstone bridge box, so that its resistance for steady currents is obtained in the ordinary way—see Fig. 182 (a). In obtaining this balance the precaution should be taken to close the battery key before the galvanometer key, otherwise a kick of the galvanometer will take place when the battery key is closed, this kick being caused by inductive action in the coil.

When the galvanometer shows no deflection

$$\frac{\text{res. of coil}}{\text{res. S}} = \frac{\text{res. P}}{\text{res. Q}}$$

When balance has been obtained, modify the circuit as shown in Fig. 182 (b), i.e. replace the galvanometer by a telephone receiver, and join in series with it an adjustable resistance ( $r$ ), which should be a plug-box resistance, or at least one which is non-inductive.

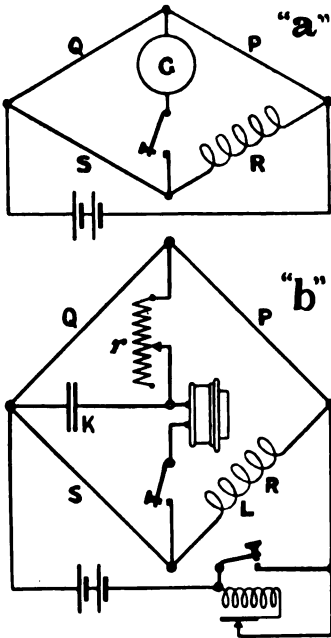

FIG. 182.

Join a standard condenser (say  $\frac{1}{2}$  microfarad) as shown: most laboratories will contain such a standard, or, if not, a standard can be made with metal plates and ebonite dielectric as already described. Join an ordinary buzzer in series with the battery, and with some resistance in  $r$ , note the sound heard in the telephone when its key is closed. It may be necessary to increase the battery volts for this part of the experiment, but not more than 4 or 5 volts should be used owing to the small sizes of wires in the resistance boxes.

Now adjust the resistance  $r$  until the least sound is heard in the telephone—this will easily be discernible, and it is not necessary that there should be no sound;

when the least sound is obtained the bridge is then balanced for inductive currents, and the self-induction coefficient is calculated from the formula

$$L = K_{\text{mfd.}} \{ r(R + S) + QR \} \text{ microhenrys.}$$

This method can be used both for the inductances of sending coils and receiving coils; the proof of the formula is rather complicated and need not be given here, but the student should check his results by calculating the inductance of the coil, using a suitable formula, based on the dimensions and shape of the coil, as already given in a preceding chapter.

**Wave Length.**—The length of the waves set up in the ether is approximately  $59.6 \sqrt{L_{\text{cma.}} K_{\text{mfd.}}}$  metres, where  $L$  and  $K$  are the electrical constants of the wave generating circuit. Also, any circuit which has been tuned to respond to the ether waves has the same electrical periodicity as the waves; therefore the same wave length.

Thus if a small closed circuit is made up consisting of an inductance coil and a condenser, either or both of which are variable, it can be electrically tuned to the oscillating circuits of a radio transmitter or a radio receiver. When loosely coupled to an oscillating circuit and tuned to it the wave length can be determined from the calibrated values of the inductance and capacity of the small tuned circuit.

**Marconi Wavemeter.**—A wavemeter is, therefore, of simple construction and not difficult to use; one of the Marconi wavemeters consists of a square wooden frame 5" x 5" x 0.7", wound with 25 turns of No. 24 silk covered wire, the coil having an inductance (L) = 0.175 mhy. approx. This coil is joined across a variable condenser of the moving vane type with ebonite dielectric, whose capacity has a maximum value of about 0.011 mfd. The condenser is about 2" deep and 4" diameter, and has graduations on the ebonite top, a brass pillar carrying an index finger which indicates the value of capacity in use as the vanes are rotated. Across the terminals of the condenser is joined a carborundum crystal detector in series with a pair of telephone receivers; the crystal being simply held between two spring brass fingers. The whole apparatus is mounted in a box 9" x 6" x 4½" deep.

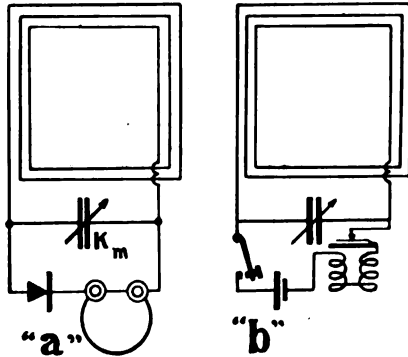

FIG. 183.

The connections are shown in Fig. 183 (a), the coil is in two sections so that either the whole or only a part of the inductance can be used. When the whole coil is used with the maximum value of the capacity the wavemeter will have a certain maximum wave length and a certain range, but, since wave length depends on  $\sqrt{L}$ , we see that if  $\frac{1}{4}$  of the coil is used the range of the meter will be  $\frac{1}{2}$  of its first range, hence we note how the meter can be arranged to give two ranges.

When arranged as shown in Fig. 183 (a), the wavemeter acts as a receiver; as thus arranged it will respond to and measure the wave length of a transmitting circuit near which it is held.

If the detector and telephones are replaced respectively by a cell and small buzzer as shown in Fig. 183 (b), the meter will then act as an oscillator or transmitter; this can be held near a

receiver circuit so that the wave length of the latter may be obtained by noting the value of the wavemeter circuit when tuned to it.

Since wave length =  $59.6\sqrt{LK}$  if  $L$  is kept constant  $59.6\sqrt{L}$  is a constant for the instrument. Thus if  $L = 175,000$  cms.  $59.6\sqrt{L} = 24,900$  approx. therefore wave length =  $24,900\sqrt{K}$  metres, so that each value of capacity of the meter condenser corresponds to a certain wave length. The graduations of the condenser could therefore be marked directly in wave length values, but it is more usual to number the divisions 1, 2, 3, etc.,

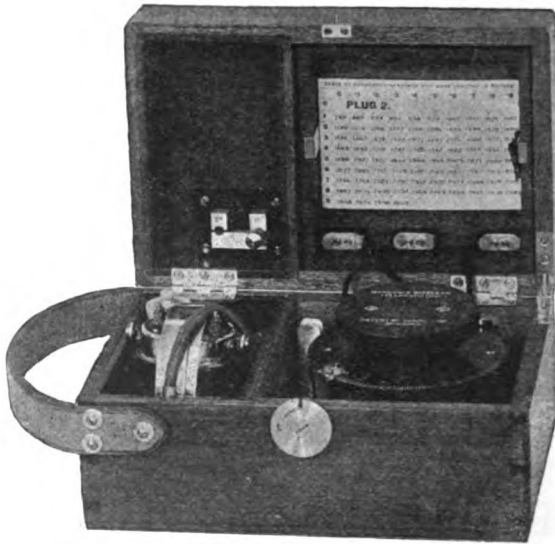

FIG. 184.

and obtain the corresponding wave lengths from a card or curve. The range of the meter might be varied by changing the inductance coil, having a set of coils for the purpose and a card of wave length values for each coil.

The wavemeter as used by the Telefunken Co. is shown in Fig. 184 and a diagram of the connections in Fig. 185. The variable capacity  $K$  is connected to an inductance  $L_1$  in the case of the instrument, this inductance consisting of four coils of fine enamelled wire, and connected to a switch whose handle is seen on the near side of the case, by means of which one or more of the

coils can be joined in series with the condenser. This closed circuit is inductively coupled to the circuit, whose wave length is to be measured, by means of the closed circuit consisting of the



FIG. 184 (a).

two coils  $L_2$  and  $L_3$  joined together by means of leather insulated leads. These are flat coils embedded in ebonite, sliding into grooves at the side of the instrument;  $L_2$  is coupled to  $L_1$  while  $L_3$  is held near the circuit under test.

A helium tube  $H$  glows when the circuits are in resonance, and if  $L_2$  is loosely coupled to  $L_1$  a sharp indication will be obtained. A buzzer, mounted on the top of this wave-meter, is seen in the top right-hand corner; with this buzzer the meter can be used for such measurements as wave length of receiver circuits, sensitiveness of detectors, coupling, and pitch of note. These tests will be described later.

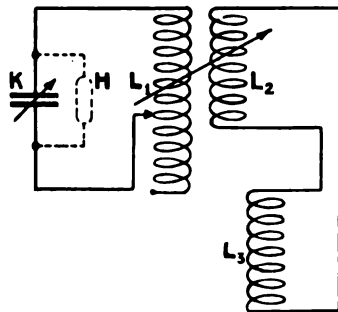

FIG. 185.

The Telefunken Co. also make a more elaborate instrument, as shown in Fig. 186; the black disc, mounted on a flexible support seen on the right, is the flat spiral inductance coil encased in ebonite, and connected by flexible



leather-covered leads to the variable condenser. Six such coils of different inductances are supplied with each instrument; some of these are seen in the foreground of the picture.

The diagram of connections is as shown in Fig. 187, in which it is seen that resonance is obtained by changing the capacity until a maximum reading occurs on the hot-wire ammeter A, which is joined as a shunt to a part of the inductance.

Besides the hot-wire ammeter a helium tube H can be used to note the point of resonance, or through the point 4 of the

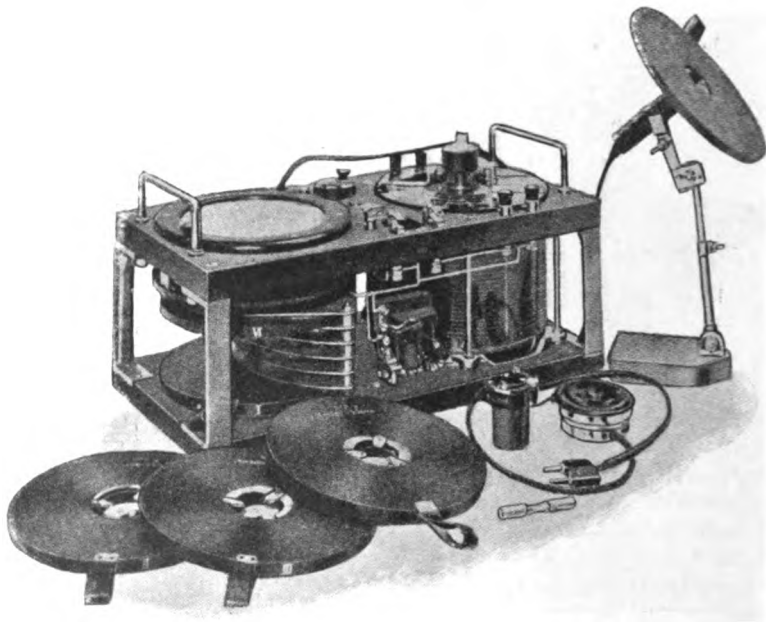

FIG. 186.

switch K a detector D and telephones G can be used. S is a micrometer spark gap to protect the condenser which it shunts. When the switch K is on point 2 a buzzer B is connected to a battery to supply intermittent currents to the condenser circuit, and when the switch is on point 3 it can be used as an ordinary tapping key to send Morse signals, using the buzzer and battery. Thus this wavemeter can also be used for other auxiliary purposes such as those already referred to in connection with the simpler instrument.

It will be seen that a wavemeter is very easy to construct, in

its simplest form consisting only of a fixed coil, a variable condenser, a detector and telephone receivers; all who work at radio-telegraphy should try to possess one, as the experiments which can be carried out with it are both interesting and instructive, while its use will lead to a very clear knowledge of the actions taking place in transmitter and receiver circuits.

The amateur should certainly try to possess a wavemeter; he could use the detector, the telephones, and the moving plate variable condenser of his receiver circuit for this purpose, and thus would only require to have in addition two or three inductance coils of various sizes, which would enable him to deal with a wide range of wave lengths.

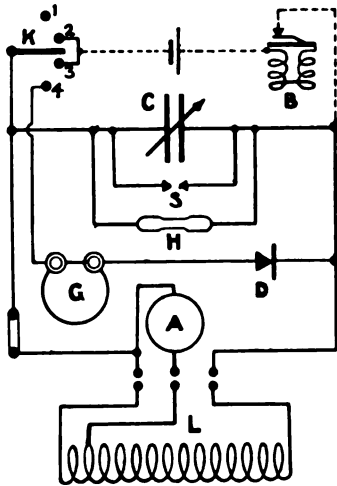

FIG. 187.

We shall now consider how various experiments with the wavemeter are carried out.

**1. To Measure the Natural Wave Length of a Closed Oscillating Circuit, such as the Closed Circuit of a Transmitter.**—Remove the connections of aerial and earth, and, if coupled through an oscillation transformer or jigger, remove the jigger secondary. Then send oscillating discharges through the closed transmitter circuit in the usual manner, and hold the coil of the wavemeter near enough to it to be loosely coupled; the wavemeter being fitted with detector and telephones. Tune in the wavemeter until sounds of maximum intensity are heard in its telephones, and obtain the wave length from the card. The more loosely the wavemeter is coupled to the circuit under test the sharper will be the tuning, and the less will its inductive action interfere with the frequency of the tested circuit.

**2. To Measure the Natural or Free Wave Length of a Transmitter Aerial Circuit.**—Do not use the closed oscillating circuit but join a spark gap directly in the aerial and earth circuit, and send a discharge across it from an induction coil—a small coil and spark gap will be sufficient for this purpose, so that the oscillating energy is small and will not interfere with neighbouring stations while the experiment is carried out. If a Marconi earth arrester is in the circuit it can be made to serve as the spark gap. Of

course if the aerial circuit is usually coupled to the discharge circuit through a jigger transformer the secondary of this must be included in the aerial circuit for the purpose of the test, but must be removed from, or very loosely coupled to, the primary. Use the wavemeter as already described and thus obtain the natural wave length of the circuit. This should be equal to that of the closed circuit of the transmitter so that maximum energy will be radiated when they are suitably coupled.

Some difficulty may be experienced in measuring the wave length of an aerial by this method, owing to the flatness of the wave when the spark discharge is directly in the circuit. The wave length of the aerial circuit may be obtained by coupling it very loosely to the primary circuit and setting up oscillations in the latter. With loose coupling and a quenched spark or disc discharger the aerial will oscillate at its own wave length. The wavemeter should then be held near a part of the aerial circuit which is at some distance from the primary circuit, and the wave length measured as before. A third method, involving the use of a shunted buzzer, will be described later when dealing with buzzers generally.

The wavemeter can be used to prove that when the closed and open circuits are adjusted to the same wave length and are coupled, two wave lengths are set up in the ether, one longer and one shorter than the fundamental wave length. The closer the coupling the greater is the difference between these two wave lengths, until, with direct coupling, one is very small and the other is  $\sqrt{2}$  times the fundamental wave length. With very loose coupling one resultant very sharp wave length is obtained, as already explained in Chapter XI.

**3. Calibration of the Transmitter Circuits.—(a) Closed circuit.** The closed circuit of a transmitter has generally a fixed condenser, and its wave length is changed by changing the position of the connection on the primary of the jigger or coupling coil. Use the wavemeter as in Experiment 1; having removed the aerial circuit connections find the wave lengths of the closed circuit corresponding to various values of jigger primary turns. Plot a curve on squared paper connecting primary turns with corresponding wave lengths. While the wavemeter should be held in such a position near the oscillating circuit that the signals can be heard in its telephones, it should be used as far away as possible; *i.e.* the sounds should just be heard when the wavemeter is in tune. This will not only ensure accuracy of measurement, but will also avoid the introduction of an inductive effect, which would be caused by the wavemeter coil reacting on the transmitter circuit.

(b) *Aerial circuit.* As in Experiment 2, remove or weaken as much as possible the coupling between the transmitter closed and aerial circuits, and measure the wave length of the aerial circuit for different values of jigger secondary and of aerial inductance. Plot, on the same squared paper as used for the primary circuit, curves connecting aerial wave length with turns on aerial inductance and jigger secondary. From these curves it will be easy at any time to find what value of primary and secondary turns are required to tune the transmitter to any given wave length.

Every transmitter set has some definite wave length at which its efficiency is a maximum; this will be shown by the maximum reading of a hot-wire ammeter in the aerial circuit.

**4. To Calibrate the Circuits of a Receiver in Wave Lengths.—**

Replace the detector and telephones in the wavemeter by a buzzer, cell, and key in series, so that the instrument may be used as a transmitter; the receiver circuits are joined up as for ordinary reception.

(a) Find the effect of inductance in the aerial, or primary, circuit of the receiver. Set the secondary inductance and capacity to some fixed value, and do not vary them during the course of this experiment; also keep the coupling between primary and secondary circuits at a constant value. Now place the wavemeter in a position where it is loosely coupled to the primary circuit only of the receiver; be very careful that the wavemeter is not placed so that it will only act directly on the receiver secondary. By manipulating the key set up oscillations in the wavemeter, and vary its wave length until the sounds heard in the receiver telephones are a maximum, showing that the receiver primary and the wavemeter are in tune. Note the wave length: if the wavemeter has a sufficient range it will in general be found that the receiver will respond to two wave lengths with maxima of telephone sounds. Repeat the experiment for different values of receiver primary, or aerial, inductance, and plot on squared paper curves showing how the two wave lengths vary with the primary turns. It will be found that the curves are as shown in Fig. 188, the longer wave length varying almost directly with the primary turns, the shorter wave length scarcely varying at all, though it will decrease slightly if the increase of primary turns has increased the coupling with the secondary circuit.

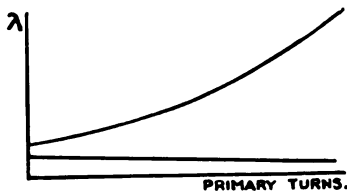

FIG. 188.

(b) Repeat the experiment, keeping the primary constant, and

coupling the meter to the secondary; vary the secondary inductance, and plot wave lengths against secondary turns; the curves will be very similar to those already obtained for the primary circuit.

(c) Repeat the experiment again, this time keeping the primary and secondary inductance and the coupling constant, while the condenser joined as a shunt across the secondary is varied. As before, two values of wave length may be obtained for each capacity value, and curves should be drawn connecting these with the graduations on the condenser. It will be found that both wave lengths increase as the capacity is increased.

In carrying out this calibration of the receiver circuits it is quite possible that the two wave lengths corresponding to each step may not be obtained—this is because the coupling has been loose, or because one of the waves is beyond the range of the wavemeter, or because it is not a point of very marked maximum. Many amateurs seem to be under the impression that they should put up as large an aerial as possible with which to use their receivers; the author has recently tested a receiver which was palpably joined to an aerial too large for it. The wave length of the aerial circuit could be varied from 1050 metres to 3380 metres, while that of the secondary circuit had a range from 500 to 1200 metres. The efficient range of the receiver was thus only from 1000 to 1200 metres.

**5. To find how Condensers in the Aerial Circuit affect the Wave Length of a Receiver.**—The experiments are carried out in a similar manner to those described above; the primary coil, secondary coil, secondary condenser, and coupling being kept constant.

If the condenser is joined in shunt across the aerial inductance the wave length with zero capacity will be the same as found in Experiment 4, but it will increase as the capacity is increased.

If the condenser is joined in series with the aerial the wave length will be much less than before, and will decrease as the capacity is decreased.

When experimenting on the wave length of the aerial circuit we tune the wavemeter to it, but sounds will also be heard in the telephones when the wavemeter is in tune with the secondary circuit, this being kept constant during the experiment, and coupled loosely to the primary. As carried out by the author the results of such an experiment were as follows:—

(a) Wave length of receiver aerial circuit without any added capacity—1984 metres.

(b) Capacity joined in parallel across the inductance in the aerial circuit:—

Value of condenser graduation—	0	2	4	8	10
Corresponding wave length—	1984	2071	2223	2232	2473 metres.

(c) Capacity joined in series in the aerial circuit:—

Value of condenser graduation—	9	7	5	3	2
Corresponding wave length—	2322	2154	2028	1871	1670 metres.

When the capacity in series has a small value it stops all sounds in the telephones as it practically amounts to a broken aerial circuit. While taking the measurements in (a), (b), and (c) the receiver telephones showed an additional maximum value of current when the wavemeter was adjusted to a wave length of 460 metres; this was the wave length at which the secondary circuit was kept constant.

(d) Primary circuit kept constant while the capacity joined across the secondary is varied:—

Value of condenser graduation—	500	600	800	1000	1200
Corresponding secondary wave length—	460	562	779	1018	1180 metres.

Experiment (d) was carried out on a Marconi crystal receiver, and during this experiment the telephones also showed a maximum of current when the wavemeter was set to the wave length at which the aerial circuit was kept constant. It will be noted that in the above experiment the wave lengths of the primary and secondary circuits were widely different; of course, such would not be the case in ordinary practice. The experiment was thus arranged for the purpose of demonstrating clearly to students the distinction between primary wave length and secondary wave length.

**6. To find the Wave Length of a Distant Transmitting Station.**

—Tune the receiver until the waves from the distant station produce the loudest sounds in the telephones. With the detector and receivers removed from the wavemeter, connect the buzzer and battery to it as before, using it as a transmitter; adjust its wave length until it is heard loudest in the tuned receiver circuit. The wavemeter is then adjusted to have the same wave length of the distant station.

The wavemeter may show two wave lengths to which the receiver responds; either of these is then the wave length of the

distant station. To find out which is the correct value cut a few turns out of the receiver primary; if the distant station cannot now be heard the highest wave length is the correct one, as it is the one affected by the primary turns (see curves of Experiment 4 (a)).

**7. Using Wavemeter to obtain Resonance Curves of Receiving Circuit.**—Connect up a buzzer to the wavemeter so that it may be used as a transmitter; instead of the usual receivers in the receiving set join up a thermal galvanometer, or receivers shunted by an adjustable graduated resistance such as a graduated potentiometer wire; the connections are shown in Fig. 189.

(a) The receiver is first tuned to any special wave length, *i.e.* adjusted as it would be when receiving messages at that wave length, with fairly close coupling.

(b) With the buzzer in action the wavemeter is adjusted until

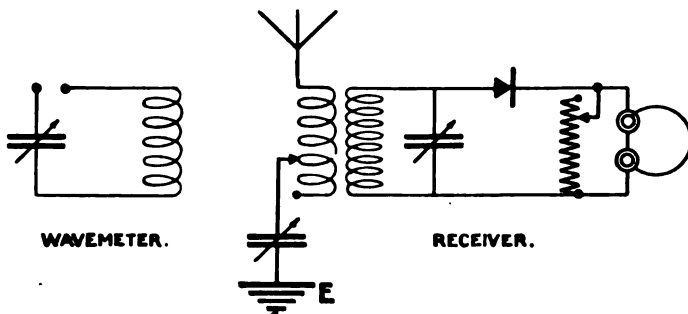

FIG. 189.

the sound is strongest in the receiving set, using the full resistance of the potentiometer across the receiver telephones. The resistance across the telephones is now reduced until the sounds are just heard; the value of the resistance then in use is noted.

(c) The wavemeter is now adjusted to a low wave length and, as before, the shunt resistance varied until the sound is just heard in the receivers. *The current flowing in the telephones at each adjustment is inversely proportional to the corresponding value of the shunt resistance.*

(d) The wavemeter is adjusted to a higher wave length and the receiver current measured as above. This is repeated with the wavemeter adjusted to various wave lengths, both increasing and decreasing, until no sound is heard in the receivers even with full value of resistance shunt.

(e) A curve is now plotted on squared paper; it will be

similar to that in Fig. 190 (A) showing that with close coupling there are two wave lengths of widely different values at which the currents in the receiver are a maximum. The experiment should now be repeated with looser coupling, and after two or three couplings have been thus plotted one will be found, as at (B), in which the two wave lengths have nearly the same value.

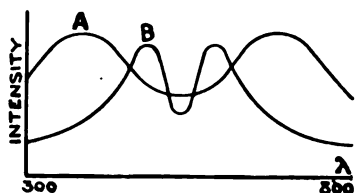

FIG. 190.

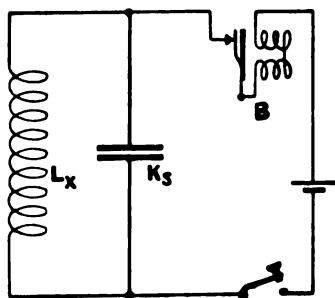

FIG. 191.

**8. To measure the Inductance of a Coil using the Wavemeter.**—Join the coil in shunt with a standard known capacity, and send intermittent currents through this circuit by means of a buzzer (B), battery (C), and key as shown in Fig. 191. If a standard condenser is not at hand one can be constructed as already described. With detector and telephones in the wavemeter tune it to this circuit, and read the wave length ( $\lambda$ ).

$$\text{Then } \lambda = 59.6 \sqrt{L_x} \times \sqrt{K_s} \quad \therefore L_x = \frac{\lambda^2}{(59.6)^2 K_s} \text{ cms.}$$

**9. To measure a Capacity by means of the Wavemeter.**—Join the condenser (K) to a coil of known inductance (L cms.) and a buzzer circuit as in Experiment 8. Tune the wavemeter to resonance with this circuit, and obtain the wave length ( $\lambda$ ).

$$\text{Then—} \quad K = \frac{\lambda^2}{(59.6)^2 L_{\text{cms.}}} \text{ mfd.}$$

If a coil of known inductance is not available but a condenser of known capacity is at hand, the unknown capacity can be measured by a substitutional method. Join the unknown capacity ( $K_x$ ) to any suitable coil and buzzer circuit and find the wave length  $\lambda_1$ ; then replace the unknown capacity by the known one ( $K_s$ ) and find the new wave length  $\lambda_2$ .

$$\frac{\lambda_1}{\lambda_2} = \frac{59.6 \sqrt{L} \sqrt{K_x}}{59.6 \sqrt{L} \sqrt{K_s}} = \frac{\sqrt{K_x}}{\sqrt{K_s}} \quad \therefore \frac{K_x}{K_s} = \frac{\lambda_1^2}{\lambda_2^2}.$$



**10. To measure the Degree of Coupling of Two Tuned Circuits.**

—If  $\lambda$  = free wave length of each of the two circuits,  $\lambda_1$  and  $\lambda_2$  = the two resultant wave lengths when they are coupled, and  $k$  = percentage degree of coupling,—

$$k = \left( \frac{\lambda_2 - \lambda_1}{\lambda} \times 100 \right) \text{ per cent. approx.}$$

The wave length measurements can be made with the wavemeter, and thus the percentage degree of coupling obtained. In transmitting circuits it is not usual to have tight couplings, and anything over twenty per cent. would be considered close coupling; receiving circuits are also coupled as loosely as possible to obtain good syntony and avoid interference.

When the two circuits are coupled the two resultant wave lengths are— $\lambda_1 = \lambda\sqrt{1 - k}$  and  $\lambda_2 = \lambda\sqrt{1 + k}$ .

$$\begin{aligned} \text{Hence} \quad \lambda_2^2 - \lambda_1^2 &= 2\lambda^2 k \\ \therefore k &= \frac{\lambda_2^2 - \lambda_1^2}{2\lambda^2} \end{aligned}$$

This can be written— $k = \frac{(\lambda_2 - \lambda_1)(\lambda_2 + \lambda_1)}{2\lambda^2}$ , but  $\frac{\lambda_2 + \lambda_1}{2}$  is approximately equal to  $\lambda$  since the fundamental wave is nearly the mean of the two resultant waves.

$$\text{Hence} \quad k = \left( \frac{\lambda_2 - \lambda_1}{\lambda} \times 100 \right) \text{ per cent.}$$

The student should study the relation between the two resultant wave lengths and the fundamental wave length, and is referred back to the curves shown in Chap. XI.

**Buzzers.**—The delicacy of the adjustment of detectors can be tested by placing near the receiving circuit a small transmitter consisting of a buzzer, key, and primary or secondary cell, all joined in series.

A suitable buzzer can be bought for about 2s., or one can be made from an old bell by simply taking off the gong, and cutting off the hammer. When the cell, key, and buzzer are joined in series and the key closed, intermittent currents will flow in this circuit, owing to the vibration of the buzzer's armature making and breaking the circuit. These will act inductively on the neighbouring receiving circuit, and so cause currents to flow through the receiver telephones if the detector is properly adjusted. The detector can then be adjusted until the sounds are heard in the telephones and are of maximum strength.

If the buzzer cannot be placed close to the receiving circuit, its

effect will be strengthened by joining one side of the buzzer contact (*i.e.* one of its terminals) to earth, and attaching a short vertical wire about a foot long to the other terminal, thus making it a miniature direct coupled oscillating circuit.

If the buzzer is made out of an old bell its period of vibration may be slow, so that it only gives a low harsh note; in such a case the frequency can be increased, and the pitch of its note made higher, by putting a small piece of soft cloth or felt between the soft iron armature and the spring contact attached to it, or by soldering the spring contact to the armature so that the spring breaks contact quickly. The buzzer which forms part of the Telefunken wavemeter can, as already explained, be used to test detectors. Fig. 192 shows one method of making a high-note buzzer. In it the core of soft iron is wound with silk-covered wire and mounted on an iron frame. A thin sheet of steel is fixed in front of one end of the core by screws in two bracket

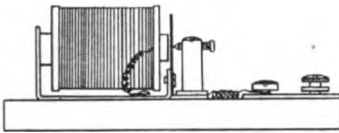

FIG. 192.

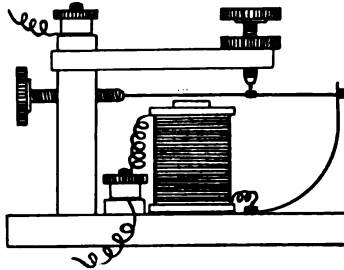

FIG. 193.

pillars; this has fixed on it a platinum contact, and a similar contact at the end of an adjustable screw provides the interrupting device. In Fig. 193 a steel piano wire is stretched in front of the electro-magnet; one end of the wire is attached to a piece of clock spring steel, while the other end is connected to a tension adjusting screw in a pillar of wood or ebonite. The steel wire may be about 3 inches long; it has a small platinum or silver contact folded round it at the contact screw, the latter being arranged in the usual manner. This buzzer will give a very high note, the pitch of which can be adjusted by means of the tension screw.

A *shunted* or *tuned* buzzer is made by joining a non-inductive resistance across the interrupter of an ordinary buzzer as shown in Fig. 194. This will prevent sparking at the contacts when the current is broken so that the current of the circuit is sharply interrupted at the frequency of the buzzer vibrations. A "shunted" buzzer can be used to set up currents in a circuit

Y

which will oscillate in it at the natural frequency of the circuit. For example, if we wish to measure the wave length of a transmitter aerial circuit, the connections would be made as shown in Fig. 194. The earth arrester is shorted by a piece of wire and the buzzer circuit is joined in series with a few turns of the aerial inductance, or of the jigger secondary. At each interruption of the current the magnetic lines, set up by the current through these few turns, collapse; hence induced currents are set up, and these oscillate in the circuit at its natural frequency. Thus a wavemeter can be coupled to the circuit and the wave length obtained.

The buzzer can also be used as a vibrating switch to interrupt the current of a circuit, as shown in Fig. 195. The vibrating spring of the buzzer interrupts the current of the cell B, setting up oscillations in the aerial circuit, of which a few turns of inductance has been included in the circuit of the cell. The two portions of the vibrator can be insulated from each other at M, but this, while giving better results, is not absolutely necessary.

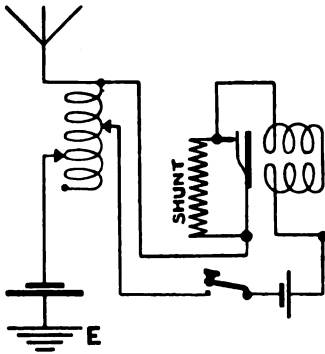

FIG. 194.

To obtain the Current Voltage Curves of a Crystal Detector.—A battery of about 4 volts is joined across a potentiometer wire, and the detector is joined in series with a microammeter and a portion of the potentiometer. If a micro-

ammeter is not available a galvanometer can be used. The deflections on the ammeter or galvanometer are read corresponding to different voltages tapped off the potentiometer. These voltages can be read by joining a low reading voltmeter across the detector, but the voltmeter circuit must not be closed while the currents are being read.

The students should draw a graph connecting the current through the detector with voltages applied to it; he will thus become familiar with the necessity of using a potentiometer voltage with some crystals, and at the same time note how widely different are the resistances of different crystals.

**Measurement of Damping Decrement.**—In a wireless transmitter we have two circuits; each has its own decrement of damping, and the damping decrement of the radiated waves is different from both the component decrements. In general, when two

Circuits are coupled, waves are radiated at two wave lengths, which differ according to the degree of coupling, and it can be proved that the train of shortest wave length is the most damped. We have seen that in practice the coefficient of coupling is chosen so that the two wave lengths very approximately coincide.

Now, according to Wien, if the decrements of the closed and open circuits are  $\delta_1$  and  $\delta_2$  respectively, and  $k$  is the coefficient of coupling, the decrements of the two radiated wave lengths are—

$$D_1 = \frac{\delta_1 + \delta_2}{2\sqrt{1 - k}} \quad \text{and} \quad D_2 = \frac{\delta_1 + \delta_2}{2\sqrt{1 + k}}$$

Thus, suppose the closed circuit has a decrement of 0.18 and the aerial circuit a decrement of 0.05 while the coefficient of coupling is 20 per cent. or 0.2; then

$$D_1 = \frac{0.18 + 0.05}{2\sqrt{1 - 0.2}} = \frac{0.23}{1.78} = 0.13$$

$$D_2 = \frac{0.18 + 0.05}{2\sqrt{1 + 0.2}} = \frac{0.23}{2.2} = 0.105.$$

The longest wave has the smallest decrement; the smaller the coupling the more nearly do the wave decrements and wave lengths coincide to one value in each case.

It will be seen from the above that, to obtain the damping decrement of any train of waves, it is necessary to find the coefficient of coupling, and the sum of the decrements of the closed and aerial circuits. The coupling coefficient can be found by means of a wavemeter, using the method already described; it therefore remains to find some method for determining  $(\delta_1 + \delta_2)$ .

Unfortunately this is difficult to obtain accurately with ordinary sparking systems, because the frequency is never quite constant, and the decrements do not exactly follow a logarithmic law. With arc or other undamped oscillators  $\delta_1 = 0$ , and the determination of radiation decrement can be made with some accuracy in such a case. Damping decrement can be determined with sufficient accuracy for practical purposes by the following method:—

Obtain a resonance curve of the circuit, in other words find

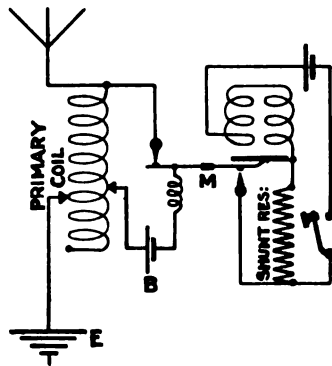

FIG. 195.

the strength of the currents received in a wavemeter on various wave lengths. These will be proportional to the ether energy carried at the various wave lengths: if the circuits of the transmitter are well tuned and loosely coupled the curve of energy will be a sharp peaked one, as described in the chapter on "Coupled Circuits" or as shown in Fig. 190 (B).

To find the resonance curve a special form of wavemeter is used; in this the telephone receivers and detector are joined across the inductance by a sliding contact, as shown in Fig. 196.

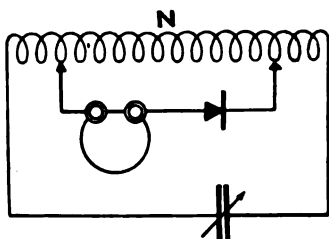

FIG. 196.

When such a circuit is inductively coupled to a transmitter circuit, and tuned to it, oscillating currents will flow through the wavemeter circuit; as they flow through the turns of the induction coil they will cause a difference of potential to be set up across its turns. This difference of potential will send currents through the detector and telephones, and sounds will be

heard in the latter. The less current oscillating in the wavemeter coil the less is the potential induced in each turn, therefore more turns must be joined across the telephone circuit to give a certain strength of sound. *In other words, for a certain strength of sound in the telephones the strength of the currents in the wavemeter are inversely proportional to the number of turns of the coil used across the telephones* ( $C \sim \frac{1}{n}$ ).

The strength of sound usually adopted is that which can be just heard. The experiment is carried out as follows:—

(a) Tune wavemeter to the transmitting circuit and adjust the slider on the coil until the sound is just heard in the telephones; let the number of turns tapped be  $n_1$ , then current strength in wavemeter  $\sim \frac{1}{n_1}$ . Also wave length =  $59.6 \sqrt{LK}$ , but L is a constant,  $\therefore \lambda \sim \sqrt{K}$ .

(b) Decrease K a little, and adjust slider again to just get a sound in the telephones—it will require more turns now, since the wavemeter is slightly out of tune and hence the oscillating currents in it are decreased; note  $n_2$  and  $K_2$ .

(c) Repeat for different values of K above and below sharp tuning value. The currents in the meter are proportional to  $\frac{1}{n_1}$ ,

$\frac{1}{n_2}, \frac{1}{n_3}$ , etc., and are set up by tuning to wave lengths which are proportional to  $\sqrt{K_1}, \sqrt{K_2}, \sqrt{K_3}$ , etc.; hence if we plot a curve having  $\sqrt{K_1}, \sqrt{K_2}$ , etc., as abscissæ and  $\frac{1}{n}, \frac{1}{n_2}$ , etc., as ordinates, it will be of the same shape as the currents set up in the meter plotted against wave lengths, therefore it shows relatively the amounts of energy in the ether at different wave lengths. We shall see presently that it is not necessary to plot the actual values of the receiver (*i.e.* wavemeter) currents, nor of the wave lengths. The curve when plotted is as shown in Fig. 197.

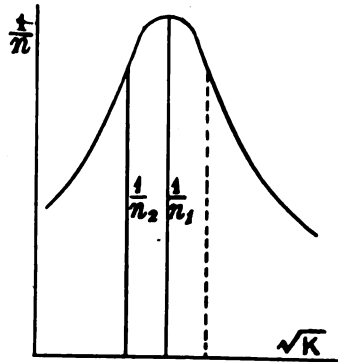

FIG. 197.

Now V. Bjerknes has proved that if  $D_1$  is the transmitter decrement, and  $d_m$  the wavemeter decrement, and if  $C_1$  is the resonating current in the wavemeter when in tune at  $\lambda_1$ , and  $C_2$  the current in the wavemeter when it is a small percentage out of tune then—

$$D_1 + d_m = \pi \left(1 - \frac{\lambda_1}{\lambda_2}\right) \frac{1}{\sqrt{\left(\frac{C_1}{C_2}\right)^2 - 1}};$$

since the wavemeter decrement can be made very small we may in such case neglect it, so that we may say—

$$D_1 = \pi \left(1 - \frac{\lambda_1}{\lambda_2}\right) \frac{1}{\sqrt{\left(\frac{C_1}{C_2}\right)^2 - 1}}$$

but  $\frac{\lambda_1}{\lambda_2} = \frac{\sqrt{K_1}}{\sqrt{K_2}} = \sqrt{\frac{K_1}{K_2}}$ , and  $C_1 = \frac{1}{n_1} = \frac{n_2}{n_1}$

therefore  $D_1 = \pi \left(1 - \sqrt{\frac{K_1}{K_2}}\right) \frac{1}{\sqrt{\left(\frac{n_2}{n_1}\right)^2 - 1}}$

The difference of wave length chosen from the resonating curve should not be more than 4 per cent.; a smaller wave length may

be taken, then another greater than the tuned wave length, so that an average value of  $D_1$  may be found from the two results obtained.

The instrument has been called up to the present a wave meter and could be used as such, but since this special design is suitable for measuring decrements it may be called a "decrementer."

Instead of the telephone and detector some special form of high frequency galvanometer, such as a thermo-galvanometer, might be used; in general it is not so sensitive as the telephone and detector arrangement, and the decrementer would have to be held close to the oscillating transmitter to obtain suitable readings. In the above formula it is seen that we require only ratios of currents and ratios of wave lengths, also it is not necessary to know the actual currents and wave lengths, since the ratios are

equal to  $\frac{n_2}{n_1}$  and  $\sqrt{\frac{K_1}{K_2}}$  respectively.

**Marconi Decrementer.**—This instrument, as its name implies, is used for measuring the decrement of damping in an oscillating

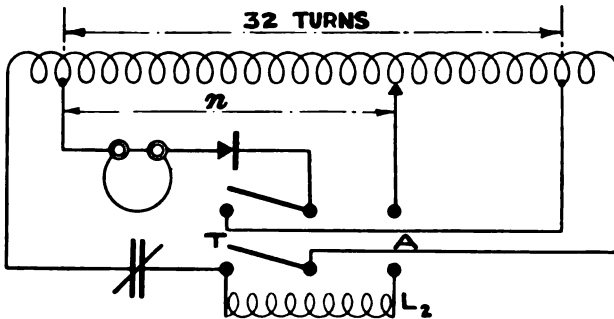

FIG. 198.

circuit. At the same time, it is constructed so that it can be used as a wavemeter; also for the determination of capacities, self-induction coefficients, mutual induction, and degree of coupling. It is, in fact, a combination of wavemeter and decrementer, with special terminals for inserting inductances and capacities when it is desired to measure them. The connections as a decrementer are shown in Fig. 198.

To use the instrument:—(a) Turn the switches over to side A, and tune the meter by means of the condenser as accurately as possible; do not touch the condenser afterwards. (b) Turn the switch to side T; this cuts out small inductance coil  $L_2$ , which changes the wave length of the meter 4 per cent.; the telephones are now across 32 turns of the main coil, and the meter is put

in such a position that weak signals are heard in it. (c) Turn switch over to A again; the meter is again in tune and the slider is varied until the signals in the telephones are of same strength as in (b). Let the number of turns now tapped by the slider be  $n$ , then, neglecting decrement of the meter—

$$D = \pi \left(1 - \frac{\lambda_1}{\lambda_2}\right) \frac{1}{\sqrt{\left(\frac{32}{n}\right)^2 - 1}} = 0.04\pi \frac{1}{\sqrt{\left(\frac{32}{n}\right)^2 - 1}}$$

It is easily seen that each number of turns ( $n$ ) tapped by slider corresponds to a certain decrement, since it is the only variable in the above formula; therefore the slider can be provided with a scale from which the decrement can be read off directly.

When the signals are very damped, or with coupled circuits, it is best to obtain the decrement by plotting the resonance curve, which can be done in the usual manner with the Marconi decremeter. In this case the switches should be kept in the position A all the time, the position of the slider and the capacity being varied as already described for this test.

The diagram of the latest type of Marconi decremeter is shown in Fig. 199. A portion of the inductance is in the form of a square coil, by which the meter can be inductively coupled to the circuit under test. Switch S is a double throw reversing switch, while the double two-way key (K) on one arm changes the decrement circuit, and on the other changes the telephone circuit.

(a) With switch at F and key at 1,  $L_3$  is cut out and the telephones are across  $n$  turns.

(b) With switch at F and key at 2,  $L_3$  is in and telephones are across 32 turns.

(c) With switch at A and key at 1,  $L_3$  is in and telephones are across  $n$  turns.

(d) With switch at A and key at 2,  $L_3$  is out and telephones are across 32 turns.

To measure a small capacity: Tune up for wave length with switch at A and key at 1 or 2; then join unknown capacity in parallel with variable capacity and vary latter until resonance occurs again, but do not vary slider. Since the wave length is the same in each case  $60\sqrt{LK_1} = 60\sqrt{L(K_2 + K_x)}$

$$\therefore K_x = K_1 - K_2.$$

Larger capacities can be measured by taking the link out at  $ab$  and joining them in series with C; do experiment as before;

$$\text{then } K_1 = \frac{1}{K_2} + \frac{1}{K_x}.$$



To measure a self-induction take the link out at *ab* or *cd*, join the self-induction to be measured in the break thus made, and repeat as for finding a capacity, then—

$$LK_1 = (L + L_x)K_2 \quad \therefore L_x = L\left(\frac{K_1}{K_2} - 1\right).$$

To measure the coefficient of mutual induction of two coils join one in *ab*, the other in *cd*, and measure the inductance

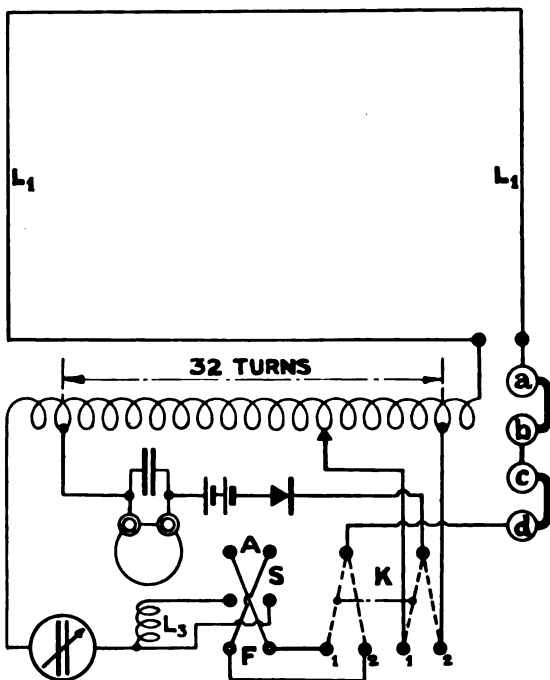

FIG. 199.

$L_x$  as in previous paragraph;  $L_x = L_1 + L_2 + 2M$ . Then reverse the connections of the coil in *cd* and measure again; the new result  $L_y$  is equal to  $L_1 + L_2 - 2M$ . Thus  $L_x - L_y = 4M$ , so that  $M$  can be calculated. Fig. 200 shows the Marconi Decremeter.

**Secondary Cells or Accumulators.**—The plates of these cells are made of lead; the positive plates have a corrugated surface and the negative plates are made in grid form, the grids being filled with a soft paste of lead. When the cells are charged, by passing a current of electricity through them, the positive plates become

covered with reddish brown peroxide of lead, the negative plates remain a pale grey colour. The number and size of plates in each cell depends on the current to be taken from the battery, a safe rule being to allow four amperes of current per square foot of positive active surface.

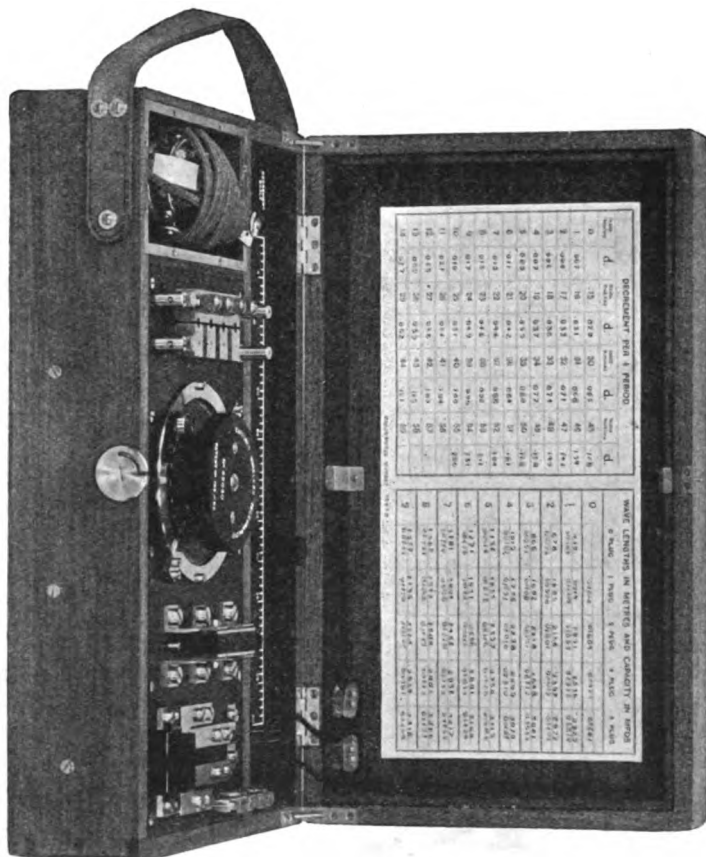

FIG. 200.

When cells are first received they have to be filled with a solution of sulphuric acid in water—the acid should be quite free from impurities and the water distilled. In making the solution *pour the acid into the water* until the density is 1·180 as measured by putting a hydrometer into the solution. Never put the acid into the cells until the first charge is about to commence, the

cells being in series, positive of one to negative of the next and so on; leaving one positive and one negative terminal of the battery. Join the *positive of the battery to the positive of supply* and the negative to the negative of supply; the positive terminals are usually coloured red; if not so coloured they can be easily distinguished, as the positive plates are the dark ones. Start the first charge the moment the acid is put into the cells and do not stop it for at least the first twelve hours. Continue the first charge for 50 to 70 hours, or until gases are seen to rise steadily from all the cells; these are hydrogen and oxygen gases set free when the cells are fully charged. The charging current used should be the normal current of the battery, as calculated by the rule given above or marked on the cells. When the cells are fully charged each cell should give 2.5 volts on a voltmeter joined across it; this falls quickly to 2.2 volts per cell, and then, on using the battery, to 2 volts per cell. The voltage gradually falls as current is taken from the battery, and when it has fallen to 1.85 volts per cell it is time to charge the battery again.

If the voltage of the battery is allowed to fall too low the plates become "sulphated," *i.e.* a white hard substance (lead sulphate) forms on the plates which is very difficult to remove, and which decreases the active surface of the plates, therefore decreases the current output of the battery. The surface of the solution should always be kept about half an inch above the top of the plates; if it falls below this at any time *fill up with pure water*; do not use acid for this purpose. The voltage to be applied to a battery to charge it must be 5 to 8 per cent. greater than the full voltage of the battery.

Cells may be charged with less current than the normal charging current, in which case they will take a longer time to charge; similarly, they may be charged quickly by using more than normal current, but it is not advisable to do this, as the plates will heat up and may bend or "buckle." More than normal current up to 50 per cent. may be drawn from the cells on discharge, but they will then require to be charged up again much sooner than would otherwise be the case.

A small battery may be charged by joining it in series with a number of incandescent lamps joined up in parallel, such as the lamps lighting a room. To do this, break one of the wires going to the lamps and join the battery in the break, taking care always that the positive terminal of the battery is joined to the positive side of the break. No matter what voltage is supplying the lamps, the battery will take the voltage necessary for it, the lamps getting the remainder.

The positive and negative side of the break can be found by joining across it a moving coil ammeter, which has marked positive and negative terminals, and switching on the current; if the ammeter pointer moves over the scale, its positive terminal must then be joined to the positive side of the break. The connections for thus charging a small battery are shown in Fig. 201.

**Location of Faults in Transmitters.**—We will conclude this chapter by considering some of the faults which may develop in a transmitter, and how they may be located. For this purpose it may perhaps be best to describe how a transmitting set is started, and deal with faults in each circuit as they are manipulated.

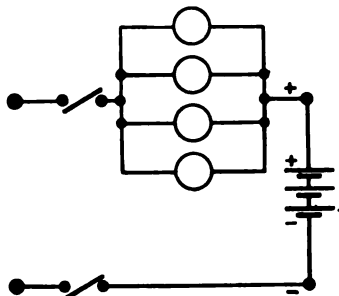

FIG. 201.

To start up the motor the double pole switch connecting it to the mains is first closed and the starting handle pulled quietly over. If the motor does not start when the handle is on the second or third notch the handle must be released, and on no account pulled further over, otherwise the motor may be damaged by an excessive current.

The motor will not start if:—(1) one or both fuses are blown; (2) the brushes are not making contact on the commutator; (3) the field connection is broken, either on the machine, at the starter, or at the field rheostat; (4) the connections of the motor are loose in the starter or the motor terminals; (5) there are loose connections on the motor switchboard panel.

The fault should be looked for in the order given above.

It may be that the motor starts up but attains an excessive speed as the starting handle is pulled over; the starting handle should be at once released, as the field circuit is either broken or joined by mistake in series with the armature.

When the motor starts up all right and attains its proper speed the carbon filament lamp joined across the motor mains should be glowing bright; if it does not glow the lamp should be examined. Either (1) its filament is broken; (2) the glass is punctured so that there is no vacuum; (3) there are dirty or broken contacts in the lamp circuit or at its terminals.

The motor drives the alternator, which should therefore develop its proper voltage, and the carbon filament lamp joined across its armature should be glowing. If the lamp does not glow

then:—(1) the lamp or its connections are defective; (2) the alternator's brushes are not bearing on the slip rings; (3) the alternator's field circuit is broken or faulty. Therefore, before proceeding further, look for the possible fault in the above order.

The lamp should first be examined, and, if doubtful, replaced by a new one. If the motor and generator lamps are rated at the same voltage they can be interchanged to see if the good lamp will light across the alternator. If the lamp circuit is not faulty examine the brushes and see that these are bearing well on the slip rings with clean contact surfaces. Then see that the field circuit is not faulty; the field switch, if there is one, may have been inadvertently left open, or connections may have become loose at the switch, at the field rheostat, or at the poles of the machine. If the unit is a rotary converter the field is common to both motor and alternator, hence if in good order for the motor there can be no fault in the field circuit.

If the motor and alternator, or the rotary converter as the case may be, are running properly and both lamps are glowing, it is certain that there is no fault in this portion of the apparatus; care, of course being taken that the bearings are properly lubricated, and that no oil or dirt is allowed to remain on any portion of the machines. Now, if no sparks ensue when the transmitter key is closed, the fault must be in the primary transformer circuit, or in the closed oscillatory circuit. First examine the transformer primary circuit: (1) see that the A. C. switch is closed and the fuses have not blown; (2) see that the leads are intact and the contacts good at the transformer primary terminals, at the terminals of the resonance coil, and at the terminals of the transmitter key; (3) see that the leads are joined to the proper terminals of the transmitter key; (4) see that the platinum contacts of the transmitter key are clean and not blackened with dirt or sparking.

When satisfied that the primary transformer circuit is in good order, if the fault still exists examine the closed oscillatory circuit as follows: (1) see that the secondary terminals of the transformer are connected to the choke coils; (2) see that there is no break in the fine wire winding of the choke coils, especially at the terminals; (3) see that the spring connections to the jigger primary have not been inadvertently left open; (4) examine the connections to the condensers and disc discharger; (5) see that the fixed electrodes of the disc discharger have not been moved too far away from the teeth of the disc.

It will be seen from the above that the surge preventing lamps are most useful for locating faults to either the rotating or

stationary parts of the transmitter apparatus, though of course there may be simultaneous faults in each part.

If the transmitter is giving poor sparks the most likely causes are: (1) dirty contacts on the transmitting key; (2) spark gaps too long; (3) fixed and disc electrodes burnt away on the leading side, or blackened; (4) fixed electrodes not properly set, so that the spark is not timed for the maximum value of voltage in each cycle.

When the fixed or disc electrodes have been burnt down to an angle at the sparking surface they should be filed to a true surface, and the spark length properly adjusted again by rotating the brass terminals of the fixed electrodes. If the sparking is still bad, the timing of the spark should be *slightly* changed, forwards and backwards, by slightly rotating the ebonite disc on which the fixed electrodes are mounted until a satisfactory spark is obtained. The disc should then be clamped in this position by means of the locking screws, and the angle of position noted on the scale affixed to the discharger.

If the spark is advanced or occurs too soon, an arc discharge will take place from the transformer secondary as the voltage passes over the maximum value. The ammeter in the alternator circuit will then show a high reading; this is due to the partial short circuit caused by the thick and arcing spark, while the oscillating energy is really less than it should be.

If the spark lags too much the voltage has passed its maximum value before the spark takes place. Hence some of the energy which was stored in the condenser has been already discharged through the transformer secondary and the remainder gives only a weak and ragged spark.

It will thus be seen that timing of the spark is very important, and that a very thick spark is to be avoided as much as a thin one. The only instrument which really shows the conditions of oscillating energy is the aerial hot-wire ammeter.

A change of the timing of sparking should only be done as a last resort, since this is always properly set before the apparatus, is delivered by the Marconi Co. Care must always be taken to see that the sparking gaps are not too long; this would expose the dielectric glass of the condensers to risk of puncture, owing to the high voltages which might be set up when no discharge takes place.

In the examination of students who wish to qualify as wireless operators location of faults in the transmitter is always included, therefore students should learn to look for these intelligently and in a proper sequence.



## APPENDIX I

### INTERNATIONAL MORSE CODE

a ■■■	ä ■■■■■■	<i>Punctuations.</i>
b ■■■■■	á ■■■■■■	Full stop ■■ ■■ ■■
c ■■■■■■	ch ■■■■■■	Semicolon ■■■■■■■■
d ■■■■	é ■■■■■■	Comma ■■■■■■■■
e ■	ñ ■■■■■■	Colon ■■■■■■■■
f ■■■■■■	ö ■■■■■■	Interrogation ■■■■■■■■
g ■■■■■■	ü ■■■■■■	Hyphen ■■■■■■■■
h ■■■■■■		Apostrophe ■■■■■■■■
i ■■		Inverted commas ■■■■■■■■
j ■■■■■■		
k ■■■■■■	<i>Figures.</i>	<i>Short Figures.</i>
l ■■■■■■	1 ■■■■■■	1 ■■■
m ■■■■	2 ■■■■■■	2 ■■■■
n ■■■■	3 ■■■■■■	3 ■■■■■■
o ■■■■■■	4 ■■■■■■	4 ■■■■■■
p ■■■■■■	5 ■■■■■■	5 ■■■■■■
q ■■■■■■	6 ■■■■■■	6 ■■■■■■
r ■■■■	7 ■■■■■■	7 ■■■■■■
s ■■■■	8 ■■■■■■	8 ■■■■■■
t ■■■	9 ■■■■■■	9 ■■■■■■
u ■■■■	0 ■■■■■■	0 ■■■■
v ■■■■■■		
w ■■■■■■		
x ■■■■■■		
y ■■■■■■		
z ■■■■■■		

#### *Other signals.*

- Repeat (something not understood) ■■■■■■
- Underline (before and after words or phrase) ■■■■■■■■
- Preliminary call signal ■■■■■■



Understood ■■■■■■  
 Error ■■■■■■  
 Cross (+), also end of transmission ■■■■■■  
 Invitation to transmit ■■■■  
 Wait ■■■■  
 "Received" signal ■■■■  
 Double dash (=) ■■■■■■  
 End of work ■■■■■■

*Spacing and length of signals.*

1. A bar is equal to 3 dots.
2. Space between signals in one letter is equal to 1 dot.
3. Space between letters is equal to 3 dots.
4. Space between words is equal to 5 dots.

## APPENDIX II

### CALL LETTERS OF BRITISH STATIONS

THE Bureau International have allotted to stations of Great Britain and Ireland all combinations commencing with B, G, and M.

Aberdeen . . . .	BYD	Dover . . . . .	BYL	*North Foreland	GNF
*Ballycastle . . .	GSL	*Fishguard . . .	GRL	Parkeston Quay	GPQ
*Caister-on-Sea .	GCS	*Folkestone		Pembroke . . . .	BYF
Carnarvon . . . .	—	Hbr. . . . .	GUR	Poldhu . . . . .	MPD
Chelmsford . . . .	MZX	The Haven . . .	MHH	*Rathlin Island.	GRN
Cleethorpes . . .	BYB	Heysham		*Seaforth	
Clifden . . . . .	MFT	Hbr. . . . .	GHH	(Liverpool) . .	GLY
Corkbeg . . . . .	BYQ	*Hunstanton . .	GHC	*Skegness . . . .	GSN
Cromarty . . . . .	BZV	*Lands End . . .	GLD	*Tobermory . . .	GCA
*Crookhaven . . .	GCK	*Malin Head . .	GMH	Whitehall . . . .	BYA
*Cullercoats . . .	GCC	Newhaven . . .	GNV	Yarmouth . . . .	BZX

#### *Continental Stations*

Eiffel Tower . . . .	FL	Norddeich . . . .	KAY	Scheveningin . .	PCH
Dieppe . . . . .	FFI	Cuxhaven . . . .	KCX	Nieuport . . . .	OST
Cherbourg . . . . .	FFC	Gibraltar . . . .	{ BYW BYX	Dunkerque . . . .	FFD

\* Stations controlled by the Post Office Authorities.

Stations whose call letters commence with B are controlled by the Admiralty and those commencing with M by the Marconi Co.

Eiffel Tower sends out time signals and weather reports daily at 9.55 a.m., 10.45 a.m., 5 p.m., and 11.44 p.m. Greenwich time ; wave length 2500 metres (see Appendix IV.).

Norddeich sends out time signals and weather reports daily at 12 a.m. and 12 p.m. Greenwich time on a wave length of 1650 metres.

They start with preparatory signals √ √ √ √ ■ ■ ■ ■ from 11.53 to 11.55.

## APPENDIX III

### EXTRACTS FROM THE INTERNATIONAL RADIO-TELEGRAPHIC REGULATIONS

THE system used must be a "syntonised" or "tuned" system.

The speed of transmission or reception must not be less than 12 words of five letters each per minute.

The power used in normal circumstances for ship stations should not exceed 1 kilowatt.

Every ship station must be capable of using the standard ship wave lengths of 300 and 600 metres. Other wave lengths not exceeding 600 metres may also be used for transmitting.

Small cargo steamers which transmit at 300 metres must be capable of receiving at 600 metres.

Ships may receive from coast stations at wave lengths greater than 1600 metres.

Coast stations may use wave lengths up to 600 metres, or exceeding 1600 metres.

Ship or coast stations must intercommunicate with all coast or ship stations of countries who have adhered to the International Convention, without regard to the system of radio-telegraphy employed. British ships are not bound at present to intercommunicate with any other *ship*, British or foreign, except in case of distress.

A ship station wishing to communicate with a coast station must select the nearest one as given in the official list of stations.

The ship station always calls the coast station, and only when well within the normal range of the smallest station.

#### *Method of calling.*

If the coast station's call signal is GLV and that of the ship GPR, the ship first ascertains that the coast station is not communicating and then calls :—

— — — — — GLV GLV GLV — — — — — (de) GPR GPR GPR.

The coast station replies — — — — — GPR GPR GPR — — — — — GLV — — — — —. The ship then makes known (1) its distance from the coast station in nautical miles, (2) its true bearing from the coast station in degrees, (3) its true course in degrees, (4) its speed in nautical miles per hour, (5) the number of words it has to transmit.

The bearing and course of a ship are signalled in degrees, thus NE is 45°.

A radio telegram is always preceded by the signal — — — — — and terminated by the signal — — — — — followed by the call signal of the transmitting station.

The end of work between two stations is indicated by each station signalling — — — — — followed by its own call signal.

## APPENDIX IV

### EIFFEL TOWER TIME SIGNALS AND WEATHER REPORTS

THE time signals are sent out daily on a wave length of about 2500 metres, and commence at 9.55 a.m., and 11.44 p.m. Greenwich time. Irish time is approximately 25 minutes behind Greenwich time, so that in Ireland reception of the signals would commence at 9.30 a.m. and 11.19 p.m.

Time signals followed by meteorological reports are sent out at 10.45 a.m. and 5 p.m.

The signals are sent as follows:—

At 9.55 a.m. —  
 9.57 — — — — — eighteen times followed by — — — — —, the  
 last dash marks 9.58 a.m.  
 — — — — — five times followed by — — — — —, completion of  
 last dash marks 9.59 a.m.  
 — — — — — five times followed by — — — — —, completion  
 of last dash marks 10.0 a.m.

10.45 a.m.—Time signals sent out again.

10.49 a.m.—Weather reports starting with BCM (Bureau Central Meteorologique). The weather reports starts with R (representing Reykiavik) followed by 8 figures, followed by similar groups for V (Valentia), O (Ushant), CO (La Carogne, Spain), HO (Horta, Azores), SP (St. Pierre, America). The meaning of the figures will be presently described. (When no report has been received from a station Xs are sent.)

Then follows a short message in French words describing European weather, such as “Dépression sud ouest Europe forte pression nord Europe.”

After this, letters followed by groups of figures give the morning weather conditions at Paris, C (Clermond Ferrand), BI (Biarritz), M (Marseilles), N (Nice), A (Algiers), SY (Stornoway), SH (Shields), HE (Helder), SK (Skudesnaes), ST (Stockholm), P (Prague), T (Trieste), R (Rome).

Then follows a forecast of probable state of sky and wind in France for the day, then FL (Eiffel Tower), followed by direction and velocity of wind in metres per second at the Eiffel Tower.

To interpret the figures suppose we receive V67420544, this means

that at Valentia the barometer stands at 767.4 mms., the first 7 being taken as understood (since it does not vary), the wind is from 20, its strength is 5 ; the state of the sky is 4 and of the sea is 4. The meaning of these figures is as follows :—

<i>Direction of wind.</i>		<i>Strength of wind.</i>	
00	no wind	0	Calm
04	NE	1	Almost calm
08	E	2	Slight breeze
12	SE	3	Little breeze
16	S	4	Moderate
	. . . .	5	Good breeze
	up to	6	Strong wind
32	N	7	Very strong
		8	Windy
		9	Storm

<i>State of sky.</i>		<i>State of sea.</i>	
0	Fine	0	Calm
1	Light clouds	1	Very smooth
2	Cloudy	2	Smooth
3	Very cloudy	3	Slight choppy
4	Overcast	4	Choppy
5	Rain	5	Rough
6	Snow	6	Very rough
7	Mist	7	High seas
8	Fog	8	Very high seas
9	Storm	9	Storm

The weather report sent out at 5 p.m. is a short one on similar lines to the morning report, but adding forecasts of the weather for the following day.

The time signals at night start at 11.44 p.m. with — — — — —  
 — — — — — — — — — —, then “scientific time signals,” followed at 11.45 p.m. by 300 dots of which the 60th, 120th, 180th and 240th are suppressed in order to allow of counting, for purposes of comparison with the tickings of a clock in the observatory in Paris.

# INDEX

- A**BSORPTION of energy, 110  
Accumulators, 328  
Aerials, 178  
    capacity of, 182, 194  
    directive, 99, 108, 178  
    Goldschmidt, 272  
    insulators for, 183, 196  
    loading coils, 167  
    Lodge, 99  
    multiple wire, 182  
    Nauen station, 191  
    transatlantic stations, 189  
    voltage and current in, 180  
    wave length of, 180  
Alternators, 66  
    Goldschmidt High Frequency, 269  
Ammeter, hot wire, 308  
Amplitude, definition of, 84  
Arc, characteristics of, 276  
    Duddell musical, 275  
    Poulsen, 275  
Arcing, 79, 153  
Atmosphere, the, 1  
    conductive layer in, 110  
    ionisation of, 112  
Atmospherics, 211, 229, 292  
Audion detector, 226  
Austin, Dr., on receiver currents, 183  
Auto-transformers, 167
- B**EAT currents, 236  
    Beats, 236  
Bellini Tosi aerial, 289  
Blocking condenser, 206  
Bornite, 231  
Bradfield insulator, 197  
Branly, coherer, 95  
Brown relays, 294  
Brylinski, 109  
Buzzers, 176, 320  
    shunted or tuned, 321
- C**ALL signals of stations, 337  
    Calling up, methods of, 338  
Capacity, 41  
    Capacity—*continued.*  
        in receiver aerial, 200  
        in receiver secondary, 207, 247  
        measurement of, 305  
        of conductors, 51  
        transmitter, 163  
Carborundum detector, 228  
Chalco pyrites, 231  
Choking coils, 137  
Clerk Maxwell, theory of, 91, 105  
Coherer, 216, 95  
    Italian navy, 217  
    Lodge, 218  
    Marconi, 216  
    Stone, 218  
Compass, Marconi wireless, 290  
Condensers, 44  
    Billi, 247  
    for receivers, 205, 257, 46  
    for transmitters, 45, 163  
    Lepel electrolytic, 285  
Coupling of circuits, 118  
    close, 123, 127  
    receiver circuits, 203  
Coupling coefficient, 132, 320  
Crystal detectors, 227  
    testing of, 322  
Cycles of potential and current, 69
- D**AMPING, of oscillations, 78, 128  
    Day, transmission range, 111  
Decrement, 78, 322  
    due to radiation, 130, 185  
    due to resistance, 78, 129  
    logarithmic, 89, 129  
    measurement of, 322  
    of ether waves, 109  
De Forest, Dr. L.'s "Audion," 226  
Degree of coupling, 132, 320  
De Sauty, bridge measurement, 306  
Detectors, 216  
Dielectric constant, 44  
    hysteresis, 48, 164, 257  
Direct coupling of transmitter, 120, 167  
Directive aerial, 99, 108, 178

Disc discharger, 151, 155  
 Discharge, oscillatory, 75  
   non-oscillatory, 84  
 Dissipation of energy, 109, 200  
 Duddell musical arc, 275  
   and Taylor, experiments, 109

**EARTH**, and sea effects, 109

  arrestor, 195  
   connections, 192  
   currents, 107  
   resistance of, 109

Eccles, Dr. W. H., atmospheric effects, 114

Effective currents and volts, 68

Eiffel Tower, time signals, 339

Einthoven galvanometer, 300

Electrical resonance, 65, 73  
   strains in the ether, 18  
   units of measurement, 29

Electrolytic condenser, 285  
   detector, 234

Electrons, 5

Energy stored in a condenser, 49  
   radiated from aerial, 149  
   received by aerial, 200

Ether waves, how set up, 101

**FAULTS** in transmitters, 330

  Fessenden, heterodyne detector, 237

  interference preventer, 291

  Field rheostats, 140, 152

  Fleming, Dr. J., valve detector, 224

  measurement of inductance, 307

  Frequency of an alternating circuit, 68  
   of an oscillating circuit, 85

  Fundamental wave length, 180

**GALENA**-graphite detector, 230

  Gases due to discharge sparks, 153

  Gas, use in Poulsen arc, 277

  Generator, Goldschmidt, 269

  Goldschmidt, transmitter, 271  
   Tone wheel, 239

**HELSEBY** detector, 230

  Hertz Henrich, work of, 91

  Hertzian oscillator, 91

  resonator, 92

  High frequency alternator, 269  
   resistance, 87

  Horizontal aerial, 178

  Hot wire ammeter, 303

  Hysteresis dielectric, 48, 164, 257  
   magnetic, 219

**INDUCTANCE**, aerial loading, 143,  
 167  
 definition of, 58  
 effect in trans-  
   mitter, 118  
 formula, 59  
 measurement of, 307

Induction coil, 61

Inductive coupling, 122

Insulators, 196

  aerial, 196

  Bradfield, 198

  Rendahl, 197

Ionisation, of spark gap, 153  
   of the atmosphere, 112

Interference, prevention of, 292

International regulations, 338

Iron pyrites detector, 232

Italian navy coherer, 217

**LEIBEN** and Reisz Relay, 297

  Lepel system, 282

Leyden jars, 44, 163

Loading coils, 142, 167

Lodge coherer, 217

Lodge, Sir O., syntonio circuits, 94

Lodge-Muirhead system, 100

Logarithmic decrement, 87, 129  
   measurement of, 322

**MAGNETIC** detector, Marconi, 219  
   keys for transmitter,  
   170  
   strains in ether, 12,  
   101

Magnetism, 11

Marconi, balanced crystals, 229

  coherer, 216

  decrement, 326

  directive aeriels, 99, 108, 178

  disc discharger, 151, 155

  earth arrester, 195

  first receiver, 97

  first transmitter, 98

  jigger, 165

  magnetic detector, 219

  receivers, 208, 238, 243

  spark gap, 154

  transmitters, 137, 172

  transmitting keys, 170

  undamped system, 280

  wavemeter, 309

Masts for aeriels, 190

Measurements, 305

  capacity, 305

  capacity of aerial, 182, 184, 305

  coefficient of coupling, 320

  damping decrement, 322

  high frequency currents, 303

- Measurements—*continued*.  
 self-induction, 307  
 wave length, 313
- Mistuning, Telefunken, 134, 160
- Molybdenite detector, 233
- Morse Code, 335
- Musical Arc, Duddell, 275
- N** **AUEN** aerial, 191  
 Night and day ranges, 111
- Non-oscillatory discharge, 84
- Norddeitch time signals, 337
- O** **SCILLATION** constant, 85  
 Oscillatory discharge, 75
- P** **ERIKON** detector, 231  
 Periodic time, 84
- Phase and phase difference, 69
- Poldhu station, 99
- Popoff, work of, 96
- Potentiometer, 221
- Poulsen receiver, 280  
 system, 275  
 tikker, 279  
 transmitter, 277
- Propagation of waves, 105
- Q** **UENCHED** spark, Lepel, 282  
 Telefunken, 158
- R** **ADIATION** coefficient, 185  
 decrement, 131  
 efficiency, 148, 200  
 energy, 148, 200  
 resistance, 125, 185
- Ranges, day and night, 111
- Rayleigh, Lord, formula, 87
- Receiver apparatus, 242  
 circuits, 200
- Receivers, amateur, 214, 261  
 Goldschmidt, 238  
 Lepel, 285  
 Marconi crystal, 208, 209,  
 245  
 Marconi multiple, 253  
 Marconi short wave, 243  
 Marconi valve, 225, 250  
 Marconi, for undamped  
 waves, 238  
 Poulsen, 278  
 Telefunken, 210, 255
- Receiving aerial, 243
- Reflection of waves, 92
- Refraction of waves, 113
- Regulations, International, 338
- Relays, Brown, 294  
 on Marconi receiver, 248  
 Reisz gas, 297
- Rendahl steel mast, 193
- Re-radiation, 212
- Resistance, examples on, 33  
 high frequency, 87  
 losses in transmitter, 148  
 of earth and sea, 109  
 starting for motors, 151
- Resonance coil, 138  
 curves, 325  
 state of, 65, 73
- Rheostats, field, 140, 152
- S** **EA**, transmission over, 109  
 Secondary cells, 328
- Sharp tuning, 125, 133
- Signalling, rate of, 146, 279, 286
- Silicon detector, 233
- Single slide receiver coil, 203
- Solari coherer, 217
- Sound intensifier, Telefunken, 298
- Spark frequency, 139  
 gaps, 152
- Stone's coherer, 218
- Switch, aerial, 172  
 condenser, 257  
 secondary section, 249, 266  
 Telefunken double receiving,  
 293
- Syntonic Leyden jars, 94
- T** **ELEFUNKEN** aerials, 190  
 aerial switch, 172, 255  
 condensers, 168, 173  
 detectors, 232  
 double receiving switch, 293  
 quenched spark, 158  
 receiver, 255  
 sound intensifier, 298  
 transmitters, 168, 172  
 wave meters, 310
- Telephone condensers, 206  
 receivers, 258
- Tellurium in detectors, 232
- Tesla transformer, 121, 165
- Tikker, Poulsen, 279
- Time signals, 339
- Timing of spark, 333
- Tone wheel, Goldschmidt, 239
- Transatlantic stations, 189
- Transformers, 70
- Transmitters, aerials, 178  
 apparatus, 150  
 calculations, 148  
 circuits, 137



- Transmission, Austin's formula, 188  
     speed of, 146, 279, 286  
 Transmitter, 119  
 Tuning of receiver, 201  
 Two slide receiving coils, 205
- U**MBRELLA ariels, 181, 197, 191  
     Undamped oscillations, 268  
 Unidirectional conductivity, 226
- V**ACUUM tubes, 7  
     Valve detectors, 224, 297  
 Variometer, 169  
 Velocity of ether waves, 91
- W**ATTS, power units, 30  
     Wave length, formula, 98  
 Wave meter, measurements with, 313  
 Wave meters, 309  
 Waves, light, 3  
     radiant heat, 3  
     superimposed, 27
- X**S, or atmospherics, 211, 229, 292
- Z**INCITE in detectors, 231

THE END



A9048529614



b89048529614a

TK  
5742  
S7

89048529614



b89048529614a