

*Wilson*  
FOR OFFICIAL USE ONLY

# VISUAL SIGNALING

*(Confidential)*

Training Pamphlet  
No. 4

Signal-Corps, U. S. Army  
6-2-18

# **VISUAL SIGNALING**

**Lamp, Fireworks and Panel Liaisons Analyzed as to  
When, Where and How Used.**

# TABLE OF CONTENTS

	Page
Chapter I—The Scope of Visual Signaling.....	3
Chapter II—Signaling by Means of Lamps.....	7
Description of Signaling Lamps.....	7
Method of Operating Lamps.....	8
Adjustment of Lamps.....	9
Precautions in Lamp Signaling.....	9
Signaling Range of Lamps.....	10
Code and Conventional Signals for Use with Lamps.....	10
Conventional Lamp Signals for the Infantry.....	10
Conventional Lamp Signals for the Artillery.....	11
Conventional Service Signals.....	11
Manner of Sending Messages by Lamp.....	12
Example of a Message Transmitted by Lamp.....	13
Giving Notice of Moving a Station.....	13
Tactical Use of Signal Lamps.....	13
Table of Lamp Liaisons.....	15
Schematic Diagram of Lamp Liaisons, Ideal Sector..	24
Station Calls .....	15
Lamp Centrals .....	16
Distribution of Lamps.....	18
Chapter III—Signaling by Means of Fireworks.....	19
The Fireworks Code.....	19
Considerations in Preparing a Code of Fireworks Signals .....	20
Classification of Fireworks.....	21
Very Pistol Cartridges.....	21
VB Cartridges .....	22
Rockets .....	22
Flares .....	23
Uses of Various Classes of Fireworks.....	23
How Various Fireworks Signals Are Obtained.....	27
Chapter IV—Signaling by Means of Panels.....	29
Classification of Airplanes.....	30
Work of the Artillery Airplane.....	31
Work of the Infantry Contact Airplane.....	32
Description of Signaling Panels.....	33
Allowance of Panels.....	36
Specification of Panels.....	37
Chapter V—Example in the Use of Visual Signaling within a Division in a General Advance of an Army Corps.....	42
Chapter VI—Miscellaneous Methods of Visual Signaling....	46

## THE SCOPE OF VISUAL SIGNALING

**V**ISUAL SIGNALING, as the name implies, consists of all signals received by the eye, regardless of how transmitted. Although in some cases it is the primary means of communication, it is more generally used to supplement other methods should they fail in an emergency. Visual signaling must be studied by the troops of all arms. All soldiers should be at least familiar with the devices employed. Those specially detailed as visual signalers must have constant training in the technical operation of the devices employed and the methods of transmission. It is not enough for them to be able to read signals with the naked eye at close range. They must have practice in receiving through various atmospheric conditions over long distances with the aid of field glasses, duplicating as far as possible the work they will later be called upon to perform.

Visual signaling differs from other methods of communication in that it is seldom used for sending long messages, but principally for sending signals, codes, or brief information from the front to the rear. Such messages are generally requests for artillery barrage, for ammunition, reinforcements, etc.

In trench warfare it is used principally to duplicate important telephone lines and to provide communication means for the infantry, the airplanes, and the artillery. During heavy enemy shelling telephone lines are continually cut and other methods of communication interfered with. Under these conditions, the visual signaling suffers the least interruption.

In an attack the problem of communication would be almost hopeless without this method of signaling. It is often the only means of communication for several hours after an advance. Of course no possible channel of transmitting intelligence should be neglected and several means should be employed simultaneously. It must be constantly borne in mind that the commander is waiting impatiently for any information and that he can act intelligently and strategically only when he knows the true situation.

In an attack the whole success of the visual signaling sys-

tem depends upon previous preparation. Particular attention to the subject during training and careful preparations before the assault are the only means of assuring this success. All details should be carefully worked out and proposed points in the enemy territory for establishing new stations selected beforehand. Consideration of topography and the layout of our own and hostile territory, as learned from a study of maps, aerial photographs, personal reconnaissance, etc., must govern the choice of methods which will give best promise of success. On these methods, every effort should be concentrated. Each unit must understand the probable location of its own new station and that of the stations with which it will work. The calls of these stations must of course be learned in advance.

When completed, the scheme of visual signaling in the form of a program should be issued to all concerned, including battalion and company commanders. The signaling personnel, previously detailed and specially instructed, should be lightly equipped. The signal equipment must be carried in as inconspicuous a manner as possible and allow a free use of weapons if necessary. The signaling personnel will assemble at the designated headquarters prior to the assault. They will be sent forward to their new station by the commander as soon as sufficient progress in the advance will permit.

While signals sent toward the front may be seen by the enemy and draw his fire, it often happens that a careful study of the ground to be occupied will allow a method of acknowledgment to be used which, although seen by the enemy, will either be misinterpreted or not especially noticed. The possibilities of acknowledgment should be carefully worked out as there can be no certainty that a signal has been received unless it is acknowledged. Visual receiving stations should be concealed as well as possible by placing them so they will have a background of hedges or clumps of trees, avoiding sky lines, white surfaces, open ground, and rivers or whatever might reflect images.

The advantages of visual signaling are—

1. The rapidity with which stations can be installed.
2. The ability to send prearranged signals or short messages almost instantaneously.
3. The absence of need for metallic connection between stations.

The disadvantages are—

1. The likelihood of observation by the enemy.
2. The limited range of transmission.
3. The dependency upon weather conditions.
4. The impracticability of sending long messages.

Snow, rain, mists, smoke, too bright sunlight, poor background, etc., may completely interrupt visual communication. The difficulty of sending without being able to get acknowledgment unobserved by the enemy constitutes probably the greatest objection. But the problem of maintaining systems of communication is so difficult that no means can be neglected. The services which the telephone, radio, T. P. S., etc., render may be more far-reaching and important at times, but in numerous cases during the present war messages have been sent visually when all other means of communication were inoperative.

During and immediately after an attack, the whole intelligence service of the army may be forced to depend upon visual signaling. Continuous training must therefore be given in these means of communication, always remembering that some day it may be necessary to fall back upon them entirely. When this time comes they must be ready and absolutely reliable, for it may be a question of life and death for many soldiers and possibly a question of defeat or victory.

Visual signaling is used to provide the following liaisons:

1. Within the infantry as far as the most advanced elements.
2. Within the artillery, as far as the advance observing station.
3. Between the infantry and artillery.
4. Between the infantry and airplane.
5. Between artillery and airplane.
6. Between infantry and observation balloon.
7. Between artillery and the observation balloon.

The three principal means of visual signaling used by the American Expeditionary Forces are:

1. Lamps (also called projectors; French lamps and searchlights).
2. Fireworks.
3. Panels.

These three means will now be dealt with in detail, showing

the technical operation and also the tactical use of each in all the above liaisons.

Other means of visual signaling include the wig-wag, semaphore, heliograph, etc. Their limited use in the present war will be outlined in Chapter V.

## CHAPTER II.

### SIGNALING BY MEANS OF LAMPS

Visual signaling by means of the lamp has been found to be very important and efficient. Experience has shown that during the first hours of a battle, particularly in an advance, before it has been possible to establish the telephone systems, the lamp has furnished the most dependable means of communication both by day and night. Even in stationary or trench warfare in sectors with well organized systems of communication, the lamp is most serviceable in transmitting short messages such as calling for a barrage, reinforcements, etc., for which arbitrary signals are used. In fact, this method is more precise than the use of rockets and more rapid than

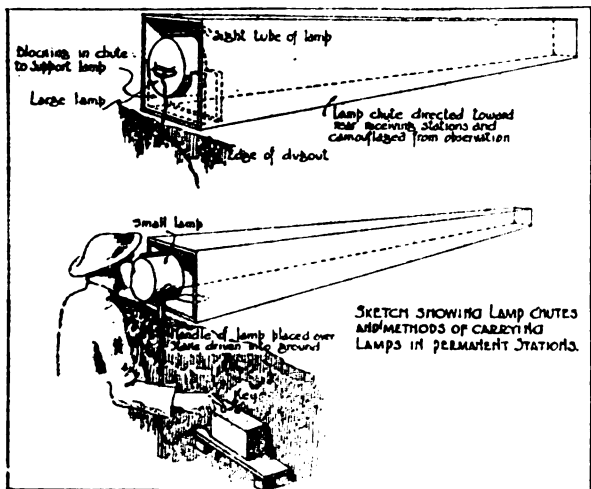

the telephone in transmitting information covered by these arbitrary signals. For these reasons, all important telephone lines near the front are paralleled by the lamp system.

**Description of the Lamps.**—The signaling lamps are made in three sizes called the 14, 24 and 35 centimeter lamps. These dimensions indicate the diameter of the reflector. The 24-cm. lamp consists of a portable searchlight, similar in principle to an automobile headlight, but equipped with a sighting



or aiming tube on top, a hinged lid to cover the glass reflector, and a two-wire cable used to connect the batteries for operating the bulb. The battery comprises eight dry cells in series, carried in two leather pouches, each holding four cells. These pouches are attached to a leather belt supported by shoulder straps. The belt also has an additional pouch in which three extra lamp bulbs are carried. A brass push button which projects through this pouch is used as a key in completing the battery and lamp circuit to make signals of short and long flashes. Connection between the lamp and battery is completed by the two-wire cable and the plug and socket connector.

The complete apparatus comprising the lamp and belt and three spare light bulbs and eight dry batteries is furnished in a wooden carrying case. The 14-cm. lamp is similar to the 24-cm., but smaller, using a battery of four dry cells and being slightly different in the manner in which it is carried. The 14-cm. lamps come three in a wooden carrying case with extra batteries and lamp bulbs. The 35-cm. lamp is a larger model of the 24-cm. lamp, is not as readily portable and employs a storage battery. It is used only for permanent installations.

**Method of Operation.**—The lamp and battery circuit is completed by means of the plug and socket connector. The lid covering the reflector is then opened and the operator sights through the sighting tube to locate the station with which he is to communicate, and signals by means of the push-button key. It is essential that the lamp be held rigidly and the sighting tube be continuously aimed exactly at the receiving station during signaling. A slight movement of the lamp makes the signals appear blurred or entirely invisible to the receiving station.

A lamp station should always be located in the shade or protected from direct sun rays, which would otherwise produce a continuous glare from the reflector and make the electric light signals invisible. A lamp may be held in the hand while signaling or fastened to anything that will aid stability.

In permanent and semi-permanent stations an arrangement for holding the lamp in a fixed position, directed at the receiving station, should be installed. In addition, a wooden tube tapering down in size toward the outer end and being 6 ft. to 9 ft. long and approximately the size of the lamp at the inner end, should be constructed and also permanently aligned

on the receiving station. This reduces the diffusion of the rays of the lamp, and also minimizes the possibility of the signals being read where not intended.

**Adjustment of Lamps.**—The reflecting apparatus of a lamp is carefully adjusted before it is issued. However, it is possible that a slightly different adjustment will give better results when a new bulb is inserted. To focus the lamp, the light is flashed on some dark background, such as a wall a few yards away and the screws supporting the parabolic mirror carefully turned until the light becomes concentrated in the smallest possible circle. The adjustment screws are then tightened, but they should never be set tight.

If the receiving operator is having difficulty in receiving signals, he will inform the sending station by sending a series of dots. The sending operator will then examine his apparatus to see if the lamp is properly directed at the receiving station, if the reflector is out of focus, or if the battery has become weak. The receiving operator indicates the manner in which he is receiving the signals by the method in which he sends the series of dots. If the signals become worse, the dots are made more rapidly. As the adjustment becomes better, the dots are made more slowly. When a good readable adjustment has been obtained, he will signal BR, meaning "go ahead."

#### **Precautions in Lamp Signaling.**

Don't leave the lamp cover open when not in use.

Don't forget to open it when you start to transmit.

Don't touch the mirror. If necessary, it should be cleaned by wiping with gauze or cotton or wiped with clean water.

Don't pull the wire cable fastened to the bottom of the lamp when removing from the box.

Don't return broken or burned-out globes to the pouch, but throw them away unless ordered to turn them in.

Don't use the lamp for illuminating purposes.

Don't neglect to keep a constant watch on the stations with which you are supposed to communicate.

### Signaling Range of Lamps.

	DAY.	NIGHT.
14 cm.....	1 to 3 kilometers	2 to 6 kilometers
24 cm.....	1 to 6 kilometers	3 to 10 kilometers
35 cm.....	5 to 10 kilometers	8 to 15 kilometers.

Signals may be transmitted by using either white or red bulbs, but the range when using red bulbs is reduced approximately 50 percent.

### General Service Code and Conventional Signals

A .—	J .— — —	S ...	1 .— — — —
B — . . .	K — . —	T —	2 . . — — —
C — . . . .	L . . . .	U . . —	3 . . . . .
D — . .	M — — —	V . . . —	4 . . . . .
E .	N — .	W . — — —	5 . . . . .
F . . . .	O — — — —	X — . . . —	6 — . . . .
G — — .	P . — . .	Y — . — — —	7 — — . . .
H . . . .	Q — — . . —	Z — — . . .	8 — — — . .
I ..	R . — .		9 — — — — .
			0 — — — — —

### Conventional Lamp Signals for the Infantry.

The objective is reached.....A series of GM, — . . . . —

Request for barrage.....A series of O, — — — —

Request for artillery fire in

preparation for an attack...A series of ND, — . . . .

Field artillery fire falling

short .....A series of S, ...

Heavy artillery falling short...A series of V, ... —

We are ready to attack.....A series of I, ..

We will not be ready to

attack at the time des-

ignated .....A series of GW, — . . . . —

Increase the artillery range

we are going to advance...A series of H, ....

Request for rifle ammuni-

tion .....A series of Y, — . — . — .

Request for grenades.....A series of Q, — . — . — .

### Conventional Lamp Signals for the Artillery.

I want to talk.....	Dash held for 10 seconds.
Adjust on target you designate .....	A series of D, ---
Observe on target.....	A series of K, ---
Battery ready .....	A series of A, .---
Wait at least ten minutes.....	A series of Z, ----
Fired .....	A series of dashes, -----
Your radio works, but is not readable.....	A series of ?, ..----
Can't hear you.....	A series of dots, .....
No .....	A series of OG, -----
Continue to adjust.....	A series of OD, -----
Continue to adjust piece.....	A series of OS, -----
Salvo .....	A series of OE, -----
Amelioration .....	A series of B, ----
Series of 24 rounds.....	A series of MH, -----
Fire for effect.....	A series of 1, .-----
Fire for control.....	A series of 4, .....
Attack commences; be guided by previous arrangements .....	A series of P, .----
No further need for you.....	A series of BV, -----
Enemy airplane near you.....	A series of 2, ..----
Optional .....	A series of 3, ..----

### Service Signals Used with Lamp.

AS	Wait (. --- . . .)
AR	End of message (. --- . . .)
BR	Go ahead (--- . . . ---)
BT	Space (--- . . . ---)
CL	Am closing station (--- . --- . . .)
CQ	Signal of inquiry employed by a station which desires to communicate (--- . --- . ---)
FM	From (. . --- . ---)
SN	Understood (. . . ---) A single dot is invariably used for this signal.
?	Repeat (. . --- ---) Two dots are invariably used for this signal.
OFM	Official message.
QRA	This station is -----

- QRT Stop transmitting.  
 QRU I have nothing for you.  
 QRV I am ready; all is in order.  
 QRW I am busy with another station.  
 QRY Your turn is No. \_\_\_\_\_  
 QSC Your intervals of transmission are bad.  
 QSO I am in communication with \_\_\_\_\_.  
 QSP Inform \_\_\_\_\_ that I am calling him.  
 QSQ You are being called by \_\_\_\_\_.  
 QSR I will forward the message.  
 QSU I will call you when I have finished.

### Manner of Sending Messages

Messages are sent by using the General Service Code and should always be as short as possible. Every time a letter can be omitted, the chance of error is reduced.

A dot is made by a short flash of about  $\frac{1}{4}$  second duration.

A dash is a longer flash of about 2 seconds duration.

The interval between dot and dash is of about  $\frac{1}{4}$  second duration.

The interval between letters is of about 2 seconds duration.

The interval between words is of about 4 seconds duration.

In order that lamp signals may be easily read, it is necessary that the signals be not too rapid. Fifteen to twenty characters per minute should be taken as the upper limit. Successive letters must be well spaced. An interval of two seconds between letters will enable the receiving operator to call off each letter to his assistant as he receives it. In general, two men for each shift are necessary to operate a lamp station. At the sending station one man dictates the message letter by letter, and watches the receiving station for breaks. The other sends the message. At the receiving station, one man receives the message and calls it off by letter to his helper, who writes it down.

To call a station, its call letter should be sent several times and at intervals the station calling should signal its own call letter. As soon as a station observes that it is being called, it will answer by signaling its call letter and (the signal BR, "go ahead." The message is then transmitted and the receiv-

By one dot, if it has been understood.

By the interrogation mark, if it has not been understood and repetition is desired. (While the interrogation mark is official, two dots are invariably used for this signal.) At the end of a message the sending station signals AR, meaning, "end of message." The receiving station sends a dot if the message has been understood.

**Example of a Message.—**

Call signal of sending station C3.

Call signal of receiving station F4.

Signals transmitted by sending station.	Signals transmitted by receiving station.	Remarks.
F4 F4 F4 C3 F4 F4 F4 C3	C3 BR	
F4 FM C3		
Help	dot	
Sent	dot	
Hill	two dots	(3rd word not understood)
Hill	dot	
Sixty	dot	
AR	dot	

If the likelihood of observation by the enemy prevents the receiving station from answering with the brief signals above, some simple scheme of using signal fireworks, not in conflict with the general rocket scheme, must be determined upon to take its place. All visual signalers need special training to give them confidence in repeating a message several times to a known back station which may not be able to reply forward. However, it is most desirable that the back stations should acknowledge whenever possible.

**Moving a Station.—**A station which is about to move, calls each of its connecting stations in turn and signals CL, meaning, "close." This is followed if possible by the hour when it will again set up and the new location. For example—  
CL 530 PM Hill 140

This means, "we are closing station and will set up again at 5.30 p. m. on Hill 140."

### Tactical Use of the Lamp

The following table and the corresponding diagram at the center of the pamphlet indicate the lines of lamp communication as they would exist in an ideal sector. For obvious

reasons it is impossible to establish all of these liaisons on account of the topography of the ground. However, as many as possible of the lines indicated should be established.

Lamp communication in general should be direct, but in order to afford the proper concealment of stations or to work around hills, woods, houses and other obstructions, lamp relay stations are sometimes installed. The lamp liaison diagram takes no account of relay stations. Relay stations between

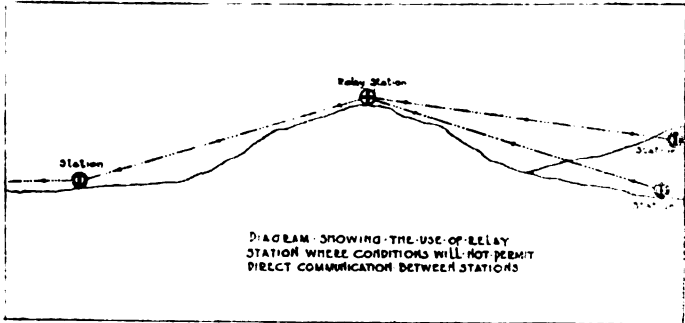

two commands are equipped by the lower command. Whether or not a relay station will be necessary in signaling between two given points can generally be determined by studying contour maps of the territory. This is done by drawing a profile of the ground between any two proposed lamp stations, taking the elevation readings off the contour map, and this will show at once if there is a hill or other intervening object high enough to obstruct the vision.

Before an advance, a new lamp system diagram should be worked out by the division signal officer for all elements concerned so that the detail for each lamp station will be able to locate its own position and that of the stations with which it will work. This is done by a study of the maps, aerial photographs and other information available. Enemy machine gun emplacements have often been found to be suitable for lamp stations. The compass readings of the new stations in reference to the stations with which they are to communicate should be learned in advance so that no time will be lost in establishing communication. The proper use of the compass must necessarily be a part of the instruction of all signal men.

## Lamp Liaisons

Location	Size	Personnel	Receives from	Transmits to
Div. Hdq.	24 cm.	From Field Signal Bn.	Its Inf. Brig.	Corps Hdq. (seldom)
Art. Brig. Hdq.	24 cm.	From Hdq. detachment of Art. Brig.	Its Art. Regs. The Infantry Brig.	
Inf. Brig. Hdq.	24 cm.	From Field Sig. Bn.	Its Inf. Regs. Its Inf. Bns. The Art. Regs. The Art. Bns. The Art. Obsv. Sta. Its Mach. Gun Bn.	The Div. Hdq. The adjoining Inf. Brig. The Art. Brig. Hdq. The Art. Reg. Hdq.
Art. Reg. Hdq.	24 cm.	From its Sig. Detachment	Its Art. Bns. and their Obsv. stations. Inf. Brig. Hdq.	The Art. Brig. The adjoining Art. Regs. The Inf. Brig. Hdq.
Inf. Reg. Hdq.	24 cm.	From its Sig. Platoon	Its Bns. The adjoining Inf. Regs.	Its Inf. Brig. The adjoining Inf. Regs. Art. Reg. Hdq.
Artillery Bn.	24 cm.	From Art. Bn. Signalers	Its Art. Bats. Its Art. Obsv. Station	Art. Bats. Art. Reg. Inf. Brigade
Art. Obs. Sta.	24 cm.	From Art. Bn. Signalers	Its Inf. Bns.	Artillery Bns. Inf. Brigade
Inf. Bn. Hdq.	24 cm.	From Inf. Reg. Sig. Pl.	Its Companies	Art. Obsv. station of its supporting artillery. Its Inf. Reg. Hdq. Its Inf. Brig. Hdq.
Trench Mortar Battery	14 cm.	From Trench Mortar Bn.	Works with the other Art. to which it is assigned.	
Mach. Gun Bn.	14 cm.	From Mach. Gun Bn. Signalers	Its Mach. Gun Cos.	Two Bns. to the nearest Inf. Brig. Hdq. and one Bn. to Div. Hdq.
Art. Battery	14 cm.	From Art. Battery	Its Art. Bn.	Its Art. Bn. Its Art. Reg.
Mach. Gun Co.	14 cm.	From Mach. Gun Co.	The Inf. Cos. that it supports.	Its Mach. Gun Bn.
Inf. Company	14 cm.	From Inf. Co.		Its Inf. Bns. and its supporting Machine Gun Company.

**Station Calls.**—On account of the large number of lamps which may be operating simultaneously, it is essential that a call be assigned to each station. These calls are fixed by the division signal officer. In general, they consist of either



two letters, two figures, or a letter and a figure, and they always conform with the call letters of the corresponding radio and T. P. S. stations. Battalion calls are derived by using the last letter or figure of the regimental call supplemented by the number of the battalion. For example, the second battalion of a regiment whose call is AG would be G2. The third battalion of a regiment whose call is F4 would be 43.

**Lamp Centrals.**—It will be noticed that the infantry brigade stations and the artillery regimental stations receive from a large number of forward stations. These stations are called

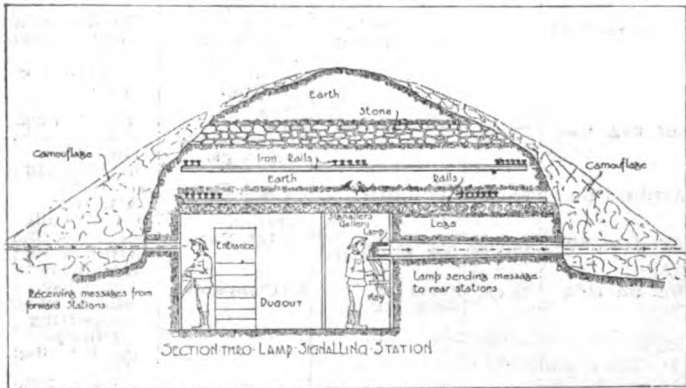

Central Receiving Station, Vertical Section.

“central lamp stations.” They are not necessarily located at headquarters, but at the nearest point to headquarters where they can command a good view of the entire forward territory. They are always equipped with good telephone communication to the higher commands.

**Summarizing.**—The principal liaisons to be established by lamp stations are those—

1. Within the infantry from company to battalion; from battalion to regiment; from regiment to brigade (central lamp station).
2. Within the artillery from observation post to battalion; from battalion to battery; from battalion to regiment (central lamp station).
3. Between infantry and artillery from infantry battalion to supporting artillery observation station.

The signal lamp personnel must have thorough instruction in (1) setting up and operating lamp stations, (2) pro-

viding protection and concealment, (3) the use of field codes and ciphers, (4) the care of equipment, (5) operating with other stations by day and night and with or without the use of field glasses, (6) the routine of handling business.

Although experiments are still being conducted in the hopes of establishing lamp liaison between the air and the ground, no very satisfactory method has yet been developed.

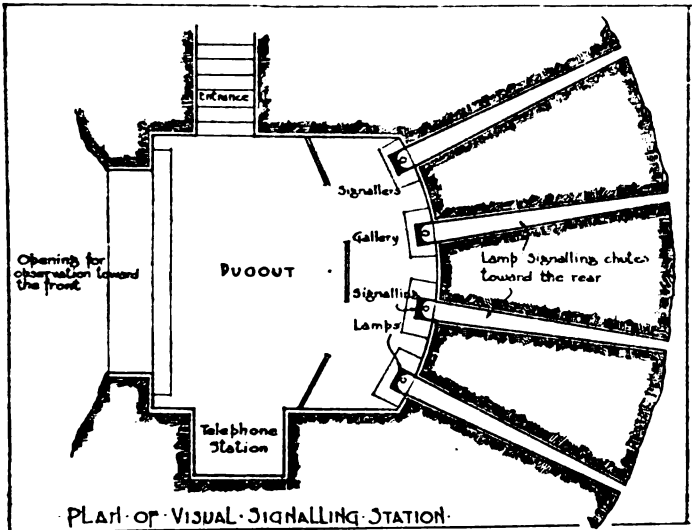

Central Receiving Station, Horizontal Section.

As a rule, lamp liaison is established from front to rear, but nothing should be left undone in attempting to establish a safe method of acknowledgment from rear to front.

Lamp signaling by using red bulbs is generally limited to communication within the artillery, and between the artillery and infantry. Communication by lamp within the infantry is invariably done with the white bulb.

The use of the lamp system, as previously stated, may be the only means of communication in a very heavy bombardment. But even the lamp system may be put out of commission. In such an event any possible means of establishing communication must be used. Even the ordinary pocket flashlights have been used several times in emergencies to keep the lamp system operative.

### Distribution of Lamps

The 14-cm. lamps are distributed within an infantry division as follows:

#### Infantry Regiments

12 rifle companies, 2 lamps each.....	24	
1 machine gun company, 2 lamps.....	2	
1 regimental headquarters company, 12 lamps.....	12	
Total for one infantry regiment.....	38	
Total for 4 regiments.....		152

#### Machine Gun Battalions

10 machine gun companies, 2 lamps each.....	20	
(Two battalions of three companies and one of four companies.)		
3 machine gun headquarters companies, 2 lamps each .....	6	
Total for machine gun battalions.....	26	26

#### Field Artillery

1 trench mortar battery, 3 lamps.....	3	
2 regiments of 75-mm. guns, 18 lamps each.....	36	
(Each regiment has six batteries, which are supplied three lamps each.)		
1 regiment of 155-mm. guns.....	18	
(Six batteries, three lamps each.)		
Total for field artillery.....	57	57

#### Field Signal Battalion

1 headquarters company, 3 lamps.....	3	
Total for Division.....		238

The 24-cm. lamps are distributed within an infantry division as follows:

#### Infantry

4 regimental headquarters companies, 4 lamps each .....	16	
---	----	--

#### Field Artillery

2 regimental headquarters companies of 75-mm. guns, 10 lamps each.....	20	
1 regimental headquarters company of 155-mm. guns, 13 lamps .....	13	
1 artillery brigade headquarters, 5 lamps.....	5	
Total for field artillery.....	38	38

#### Field Signal Battalion

1 headquarters company, 3 lamps.....	3	
Total for Division.....		57

(This distribution is in accord with the Provisional Signal Unit Equipment Table for Infantry Division, April 23, 1918, A. E. F., France.)

## CHAPTER III.

### SIGNALING BY MEANS OF FIREWORKS

The use of fireworks in modern battles for sending signals has been greatly developed and is now one of the most important means relied upon to send a few fundamental signals from the front line of the infantry to the supporting artillery within the division and between the ground and the airplanes.

#### The Fireworks Code

As the signals that are made by fireworks are always of the most important character, it is essential that the system for their use should be so perfectly worked out that there will be no chance of confusion. The smaller the number of signals<sup>o</sup> to be sent by fireworks, the less chance there is of confusion. The watchword of the fireworks code must be simplicity. Consequently the information which fireworks are to convey is reduced to fundamental items of the following character:

#### SENT BY AN AIRPLANE.

I am the airplane of the X Division.  
I am the airplane of the Y Division.  
Understood.  
Where are my front line troops?  
The enemy is preparing to attack you.

#### SENT BY THE INFANTRY.

Request for artillery barrage fire.  
We are going to advance, lengthen fire.  
Objective reached.  
Request for artillery fire in preparation for an attack.  
We are ready to attack.  
We will not be ready to attack at the set hour.  
Our heavy artillery fire is falling short.  
Our field artillery fire is falling short.  
Request for ammunition.  
Request for grenades.  
Understood (same as for airplane).

The code of signal fireworks is drawn up by the staff of the army. In drawing up the code, signals are selected which will be easily distinguished from one another where there is any chance that they may be used in either the same place or at the same time, using the most effective fireworks for the most important signals.

Experience has taught that the differentiation between signals on the basis of color alone is unreliable. One code, in white only, with the exception of red and green light, should be used. This same code in green, with white and red light or in red with white and green light, may be employed for an instantaneous change in the whole code if this should become necessary in order to cope with the enemy's attempts to confuse our signals by projecting similar signals of his own. At present, fireworks are furnished in the colors shown in tables which follow, but attempts are being made to satisfactorily reproduce the entire code in the three different colors.

#### **Considerations in Preparing a Code of Fireworks Signals.**

In preparing a code of fireworks it is necessary to bear in mind the following:

1. Those fireworks that are most visible and most easily distinguishable from each other should be used for the most important signals. For instance, if illuminating lights are to be used, the one white star signal should be avoided as it might be readily confused. It could be used, however, as a signal by the airplane.

2. The use of one, two, three and six star signals, without parachute, is preferable to that of single star signals with parachute, if it is desirable that the observer should be able to determine the place from which the signal was fired. This can be done by noting the descent of the stars.

3. The signal code must be varied frequently. Experience has proved the inadvisability of having a permanent code.

4. The signal code must be made long enough in advance so that it may be known to all units of the army, as well as to all interested units of adjacent armies.

5. It is necessary to designate, according to the situation, the authority in each sector (battalion, company and occasionally platoon commanders) having the right to order the use of fireworks signals. Otherwise there is the risk of giving

false alarms and causing waste of ammunition. It has been found that in the event of a retreat where non-commissioned officers have been authorized to give signals, undue alarm is given many times, disclosing the position of the unit which otherwise might not have been attacked.

6. All fireworks classed as signal fireworks are visible, in different degrees, by day and night, with the exception of the yellow smoke and flag signals, which are visible in day only.

### Classification of Fireworks

The fireworks now being used by the American Army are divided into the following classes:

1. Very pistol cartridges.
2. VB cartridges (commonly called "Tromblons").
3. Rockets.
4. Flares.

The complete directions for firing these various fireworks are generally attached to the container or box in which they are packed. They are fully discussed in Annex 14, Translation of the 1917 *Instruction on Liaison for Troops of all Arms*, A. E. F.

#### 1. VERY PISTOL CARTRIDGES.

The Very pistol cartridges are made in two sizes, a 25-mm. size, which is issued to the companies of infantry, and a 35-mm. size, which is used by the airplanes. These Very pistols fire both signal and illuminating cartridges. The 25-mm. Very pistol cartridges are now furnished as follows:

##### 25-mm. Signal Cartridges.

FRENCH.	AMERICAN EQUIVALENT.
Red	Very star cartridge, red.
Green	Very star cartridge, green.
Three stars	Very star cartridge, white, 3 stars.
Six stars.	Very star cartridge, white, 6 stars.
Yellow smoke	Very parachute cartridge, yellow smoke.

##### 25-mm. Illuminating Cartridges.

FRENCH.	AMERICAN EQUIVALENT.
Illuminating without parachute.	_____

The 35-mm. Very pistol cartridges are now furnished as follows:

**.35-mm. Signal Cartridges.**

<b>French</b>	<b>AMERICAN EQUIVALENT.</b>
<b>One star</b>	Signal cartridge, mark 1 aviation, white, 1 star.
<b>Two stars</b>	Signal cartridge, mark 1 aviation, white, 2 stars.
<b>Three stars</b>	Signal cartridge, mark 1 aviation, white, 3 stars.
<b>Six stars</b>	Signal cartridge, mark 1 aviation, white, 6 stars.
<b>Chenille</b>	
(caterpillar)	Signal parachute cartridge, white caterpillar.
yellow smoke	Signal parachute cartridge, yellow smoke.

There are no illuminating cartridges supplied in the 35-mm. size.

**2. VB CARTRIDGES.**

The VB cartridges are fired from a cylinder which is attached to the end of a rifle. This cylinder, on account of its resemblance to the old-fashioned blunderbuss (which the French call "Tromblon") has taken the name of Tromblon and now even the VB cartridges, which are fired from this cylinder, are often spoken of as Tromblons. They are now furnished with VB cartridges of the following types:

**Signal Cartridges.**

<b>FRENCH.</b>	<b>AMERICAN EQUIVALENT.</b>
White parachute	VB parachute cartridge, white.
Red parachute	VB parachute cartridge, red.
Green parachute	VB parachute cartridge, green.
One star	VB star cartridge, white, 1 star.
Three stars	VB star cartridge, white, 3 stars.
Six stars	VB star cartridge, white, 6 stars.
Chenille	VB parachute cartridge, white, caterpillar.
Yellow smoke	VB parachute cartridge, yellow smoke.

**Illuminating Cartridges.**

<b>FRENCH.</b>	<b>AMERICAN EQUIVALENT.</b>
* White parachute	VB parachute cartridge, white.
* One star	VB star cartridge, white, 1 star.

**3. ROCKETS.**

The rockets comprise fireworks which are made in the form of cartridges attached to a wooden stick and fired from a tube or trough. They are used both for signaling and illuminating. The following varieties are now used by the American troops in France:

- \* Also listed under VB Signal Cartridges.

### Signaling Rockets.

FRENCH.	AMERICAN EQUIVALENT.
Large white star	1Signal star rocket, white, one flash.
Large red star	1Signal star rocket, red, one flash.
Large green star	1Signal star rocket, green, one flash.
Chenille	Signal parachute rocket, flag.
Yellow smoke	Signal parachute rocket, yellow smoke.
Drapeau (flag)	Signal parachute rocket, flag.

### Illuminating Rockets.

FRENCH.	AMERICAN EQUIVALENT.
34-mm. illum- inating rocket	Signal illuminating, mark 1, white parachute.

### 4. FLARES.

Flares are used only in the front lines to mark the position of the advanced troops when called for by an airplane. They are now furnished as follows:

FRENCH.	AMERICAN EQUIVALENT.
Bengal flare, white	*Position light, mark 1, white ground.
Bengal flare, red	Position light, mark 2, red ground.

### The Uses of Various Classes of Fireworks

It will be seen that the above classification of fireworks is an arbitrary one, made according to the method of projecting them. The same signal can be made by several different means. The means employed depend upon the type of fireworks issued to the particular unit using them and also upon the distance through which the signal must be read.

Flares are not projected at all and consequently have the most limited range of visibility in any but a perpendicular direction.

The 25-mm. Very pistol projects its signals about 200 ft. and can be seen from the immediate vicinity.

The tromblon projects its signals to a height of about 300 ft. and is next in range of visibility.

The rockets which project signals at a height of 1000 ft. or over have the maximum range of visibility.

The 35-mm. very pistol projects signals which are larger than those of the 25-mm. pistol, but throws them a shorter distance (about 150 ft.) As its use is confined to the airplane this is not a factor in its visibility.

<sup>1</sup>Will be made with or without parachute.

\*Also position light, mark 2, white hand flare may be furnished.



# LAMP · SIGNALLING · LIAISON · · WITHIN · A · DIVISION ·

Prepared in  
THE OFFICE OF THE CHIEF SIGNAL OFFICER.

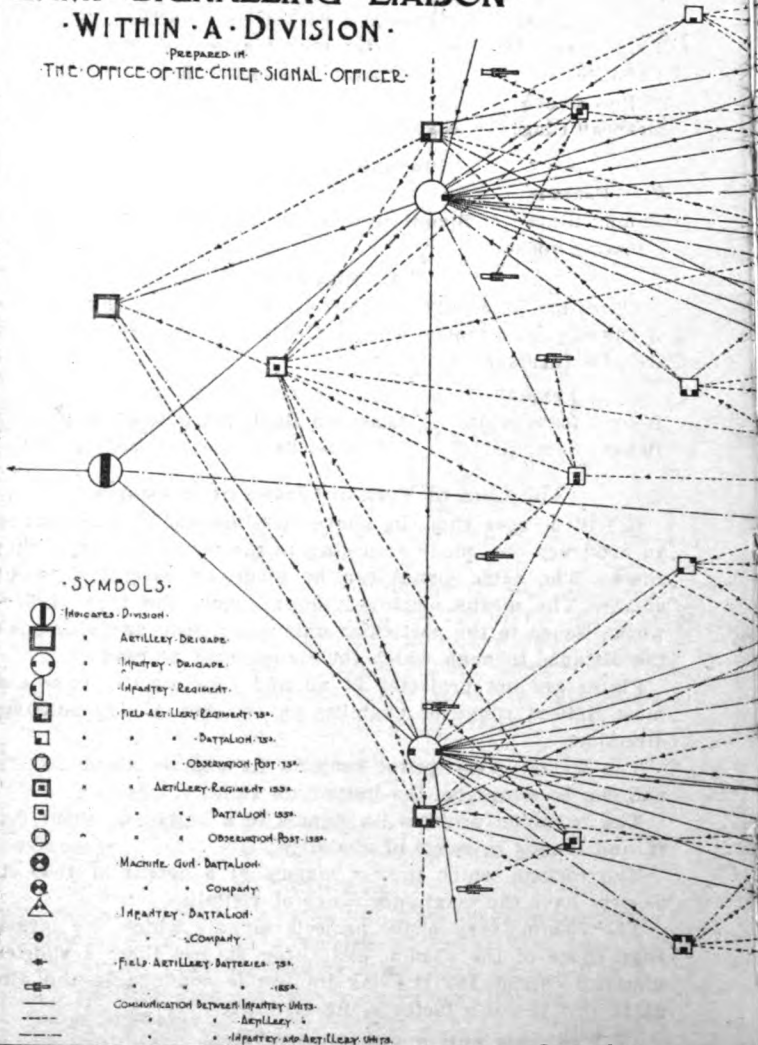

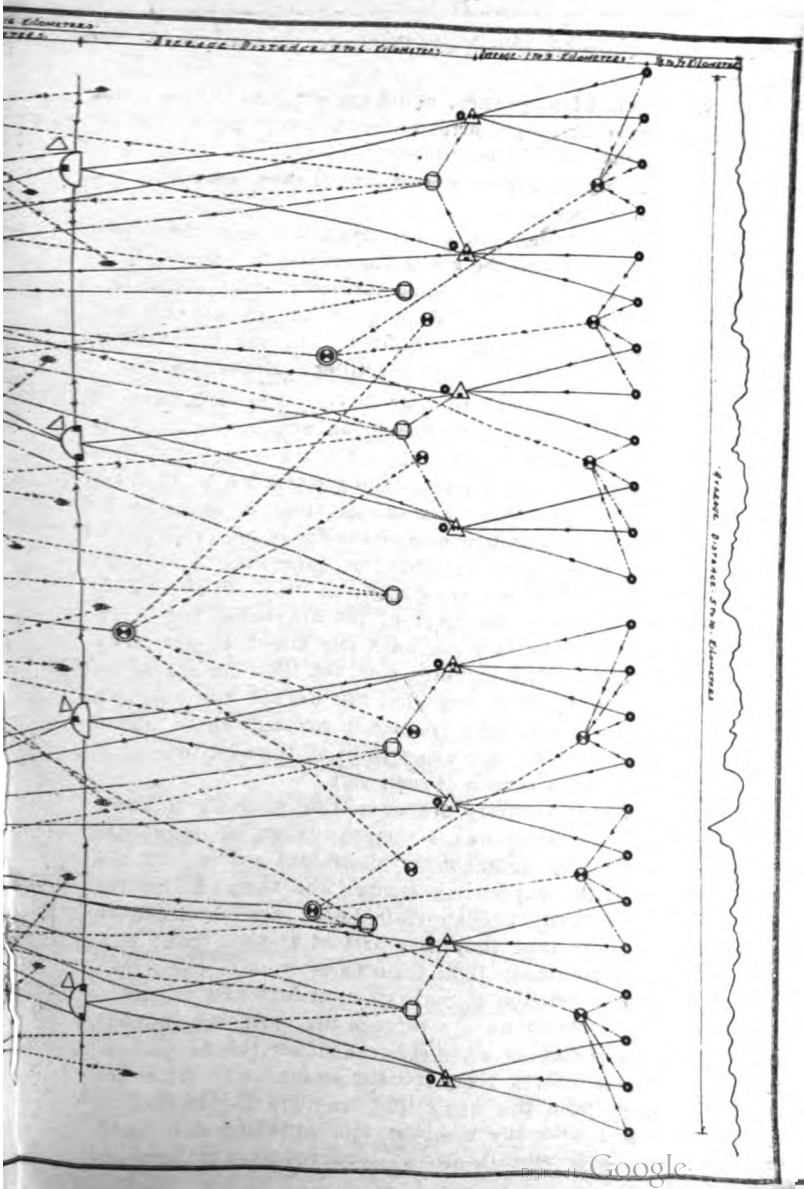

The following are important uses that may be made of fireworks:

1. By the infantry platoon, company or battalion commander in signaling to the artillery for a barrage, or otherwise directing the fire of the artillery.
2. For signaling between the front line troops and the contact airplane in an advance.
3. Warning of enemy gas attack given by the fireworks signaler nearest to where the gas is discovered.
4. As a method of acknowledging various visual signals.
5. Occasionally, during the preparation of an attack and upon orders from the General Staff, fireworks may be used in liaison between the artillery and the artillery airplanes.

The use of flares is always reserved for the infantry to mark the location of its front line in an advance, upon request from the contact airplane. The white flare may be used to indicate the position when all is going well, while the red would indicate the position when the advance is stopped by enemy artillery fire. The grouping of the flares by ones, twos or threes might be used for different information. They should be distributed evenly along the front line. They should never be lighted unless requested by the airplane, but a request from the airplane is a command and must be acknowledged immediately. The infantry does not like to mark its position in this way, as it feels that this draws the enemy's fire. However, it is generally possible to conceal these lights from the enemy's view by placing them at the bottom of a shell hole or behind a screen of some sort.

Before asking for artillery fire, or making signals to show the position of the front line, a company must be sure that there are no friendly detachments in advance of it. In the confusion of battle, supporting troops, who may be poorly informed and excited through their losses, are inclined to prematurely believe that they have arrived at the front line. If they then blunderingly light their flares or call for a barrage it may be disastrous to our own most forward troops.

It is only possible to have a barrage fire open up immediately by fireworks signals when the lookout service is well informed and the necessary relay stations established. After the signals are sent from the firing line, they are duplicated by observers located with the company and battalion commanders. They should be simultaneously observed by artillery ob-

servers detailed in observation posts as near as possible to the artillery battalion. These observers must be men of keen eyesight and intelligence, trained to interpret and locate signals of all kinds along the front. It is also their duty to note carefully the enemy signal rockets, the time when they appear and any particularly unusual circumstance connected with them. This information should be given to their immediate commanders who will transmit it to the intelligence section. An example of the use of fireworks for signaling is given in Chapter V.

The only fireworks used by the airplanes are the 35-mm. Very pistol cartridges and these are displayed only by the contact airplane when communicating with the advance elements of the infantry. This rule is necessary to avoid confusion, and moreover, the artillery airplane can communicate with the rear elements by dropped messages and by radio. In order that these signals will not be confused with fireworks signals made by the infantry, they must be made by the airplane at an elevation of not less than 1000 ft.

The amount of fireworks signaling required varies greatly. The tables of organization equipment state the different amounts furnished to each unit, but these amounts should be considered as a minimum to be kept on hand at all times. Future demands should be anticipated and the supply procured accordingly.

### Fireworks Signals—How Obtained

**Type of Signal Desired. Means by Which it May Be Secured.**

**White light, illuminating.**—Very pistol, 25-mm., illuminating cartridge without parachute.  
Tromblon, VB white parachute.  
Tromblon, VB one star.  
Rocket, large white star.  
Rocket, 34-mm. illuminating.

**Red light, one-star**-----Very pistol, 25-mm., red cartridge.  
Tromblon, red parachute VB.  
Rocket, large red star.  
Flare, Bengal flare, red.

**Green light, one-star**----Very pistol, 25-mm., green cartridge.  
Tromblon, VB green parachute.  
Rockets, large green stars.

**White signal, one-star**---Very pistol, 35-mm., star cartridge, white one star.  
Tromblon, VB parachute, white.  
Tromblon, VB one star, white.  
Rocket, large white star.

White signal, two-star	Very pistol, 35-mm., 2-star cartridge, white.
Three-star, white	Very pistol, 25-mm., 3-star cartridge, white. Very pistol, 35-mm., 3-star cartridge, white. Tromblon, VB cartridge, 3-star, white.
Six-star, white	Very pistol, 25-mm., 6-star cartridge, white. Very pistol, 35-mm., 6-star cartridge, white. Tromblon, VB 6-star, white.
Yellow smoke	Very pistol, 25-mm., yellow smoke cartridge. Very pistol, 35-mm., yellow smoke cartridge. Tromblon, VB cartridge, yellow smoke. Rocket, yellow smoke.
Chenille (caterpillar)	Very pistol, 35-mm., chenille cartridge. Tromblon, VB cartridge chenille. Rocket, chenille rocket.
Drapeau (flag)	Rocket, flag rocket.

Note: It will be seen that for illuminating and signaling the same rockets may be used. This should be given attention, in making up a rocket code, in order to avoid using any illuminating rockets which might be confused with a signaling rocket.

## CHAPTER IV.

# SIGNALING BY MEANS OF PANELS

The increasing use of the airplane in modern warfare has necessitated the development of reliable communication between it and the earth. This has gradually been worked out in the following methods:

1. The direct dropping of messages by the airplane.
2. The use of radio apparatus.
3. The use of visual signaling by means of lamps, fireworks and panels.

As this pamphlet deals primarily with visual signaling, the first two methods will not be taken up. The use of lamps and fireworks has been covered in Chapters II and III. The present chapter is devoted to the use of panels—an entirely new development of the present war.

Panels are pieces of cloth or other materials of various designs which are spread out on the ground in a manner to be easily seen by the airplane. They are used for three purposes:

1. To signal to an airplane the identity and location of a unit's headquarters by the use of its distinctive panel, called its "identification panel." This is displayed either when the airplane requests it (by means of radio) or when the headquarters desires to attract the attention of the airplane.
2. To signal to the airplane other brief information by the use of rectangular panels known as "signaling panels" and arranged in various ways, either by themselves or in conjunction with the unit's identification panel.
3. To signal to the airplane the position of the front line in a daylight advance by the use of special panels called "marking panels." These are displayed only when called for by the airplane.

All panels are removed as soon as an acknowledgment is received from the airplane.

As the use of panels is always in conjunction with airplanes, all panel signalers should understand the different uses and the general disposition of the various airplanes employed. In modern warfare we find the following airplanes:

## **Classification of Airplanes**

### **TO WORK WITH A DIVISION.**

(Assigned from the nearest airdrome.)

**Infantry Airplane (Also Called "Contact Airplane").**—One or two airplanes per division are used to locate the exact position of our troops, especially the front line, and furnish this information to the different headquarters concerned by means of dropped maps having the positions marked on them, or by radio giving the map co-ordinates of the troop positions. If the front is easy to survey only one plane per division is necessary. The contact airplane is used only in case of our own or an enemy's attack. It is equipped with radio.

**Artillery Airplane.**—One or two airplanes per division are used to direct the fire of the regular divisional field artillery. If an added amount of field artillery is employed, more artillery planes per division may be necessary. Artillery planes also locate targets (enemy batteries, material dumps, massed troops, etc.) in enemy territory. They are used both in a quiet sector and in an attack and are equipped with radio.

**Messenger Airplane.**—One airplane per division if found necessary is used to carry messages from division headquarters to brigades or regimental commanders. These messages are dropped over the designated headquarters. The messenger plane is used only in an attack and then only in exceptional cases. It is not equipped with radio.

### **TO WORK WITH AN ARMY CORPS.**

(Assigned from the nearest airdrome.)

**Staff Airplane.**—One airplane to an army corps is used to survey the enemy in the territory opposite its particular corps, especially in cases of expected counter attacks. Its function differs from that of the infantry plane in that it watches the enemy's movements rather than the movements of its own troops. However, it will transmit any messages it may happen to pick up. It is never used except in an attack. It is equipped with radio.

**Army Corps Artillery Airplane.**—One airplane per battalion or regiment of heavy artillery is used to direct the fire of this artillery and to locate targets in enemy territory. It is used both in quiet sectors and in an advance, and is equipped with radio.

**Reconnaissance Airplane.**—One or more airplanes per army corps are equipped with a camera for making photographs of the enemy's territory from which maps are made and other information gathered. These planes operate every clear day. They are not necessarily equipped with radio.

#### TO WORK WITH AN ARMY.

(Assigned from the nearest airdrome.)

**Army Artillery Airplanes.**—These airplanes are used to direct the fire of the army long range artillery both in a quiet sector and during an attack. They are equipped with long-distance radio apparatus.

**Long-Distance Reconnaissance Airplane.**—These airplanes are used to make patrols far into the enemy's territory, taking photographs and gathering information. They are very speedy and are used generally in a quiet sector previous to an attack. They are not necessarily equipped with radio.

**Pursuit Airplane.**—As many as are necessary of these planes are supplied for each army. They are a small, very rapid fighting plane and are used to keep enemy planes from flying over our territory, and sometimes to protect our artillery and infantry contact planes. They often raid enemy territory, flying in squadrons. They are not necessarily equipped with radio.

**Bombing Airplane.**—These are large airplanes with great carrying capacity and capable of traveling long distances. They are used for raiding enemy territory, destroying railroads, factories, munition plants, supply depots, etc. They generally work in squadrons. They may be equipped with radio telephones for interplane communication.

French, English and American airplanes all carry the same distinctive markings, which are three concentric circles of red, white and blue painted on both the upper and lower surfaces of the wings. The arrangement of these colors indicates to which of these countries the plane belongs.

The visual signaler is concerned principally with the two following kinds of planes.

1. **The Artillery Plane.**—This plane carries the above permanent markings only and is used only in the day time. It will be seen every clear day flying fairly high, probably about 5000 or 6000 ft. over our own lines and occasionally slightly into those of the enemy, observing and regulating



the fire of the divisional artillery. It communicates its observations and information to the artillery by means of its radio set. Its only communication from the ground is from different artillery unit headquarters and artillery observation posts. It receives information from them by means of their identification panels in conjunction with their signaling panels. Its work is quite distinct from that of any other plane.

2. **The Infantry Contact Plane.**—This plane is used only during an attack of our own forces or while an attack is being made by an enemy. It must be able to work both by day and night. In addition to its permanent markings it carries one or two identification streamers in the day time and various arrangements of colored lights at night. The arrangement of these streamers and lights must be determined upon and understood by the troops with which it is co-operating. These means of identification are necessary to distinguish it from the contact airplane of adjoining divisions which sometimes necessarily fly over the same territory. The contact plane is the eye of the infantry. It constantly endeavors to aid the infantry, noting its needs and changes in location and communicating these by radio to the headquarters concerned, including the artillery. Its special duty is to watch out for the advance element, being always on the alert to understand and transmit any signal which it may see, and to furnish any useful information about the enemy it has been able to observe. When impossible to transmit this information by radio it does so by means of dropped messages. These are often in the form of a map prepared in advance showing the general contour of the sector. The precise position of the firing line or of new headquarters positions which have been identified can be quickly shown upon this map. In order to avoid jamming the different divisional radio sets, radio transmission of signals from the contact plane is generally used only for messages of an urgent character.

The contact airplane circles above the advance elements of the infantry at a lower altitude than other airplanes, never above 3500 ft. and only exceptionally below 1000 ft. In addition to communicating with infantry or artillery headquarters by radio, it communicates with the advance infantry elements by means of a small number of fireworks signals made by cartridges of a 35-mm. Very pistol. These fireworks signals are generally preceded by a sound signal—klaxon horn,

compressed-air whistles, etc. Upon arriving over the advance infantry troops and attracting their attention by the sound signal, it signals by fireworks, either one or two white stars, to announce, "I am the airplane of the X Division." Another fireworks signal of six white stars might then be fired meaning, "Where are my front line troops?" This is a demand that the front line make known its position in daytime by its marking panels, and at night by lighting red or white flares. As soon as the airplane has obtained the desired information, it signals acknowledgment by a fireworks signal of three white stars. These three fireworks signals given above are the fundamental signals used by the contact airplane.

### Description of Panels

#### Infantry Division Identification Panel Set.—

- 1 Infantry Division Identification Panel, white, this being a circular disc of white cloth, 9 $\frac{3}{4}$  ft. in diameter with a batten 1 $\frac{1}{2}$  in. x 1 $\frac{1}{2}$  in. x 9 $\frac{3}{4}$  ft. fastened along a diameter of the disc.
- 4 Designator Strips, black.
- 3 Infantry Signaling Panels, white.

#### Infantry Brigade Identification Panel Set.—

- 1 Infantry Division Identification Panel, white (same as above).
- 5 Infantry Designator Squares, black.
- 3 Infantry Signaling Panels, white.

#### Infantry Regimental Identification Panel Set.—

- 1 Infantry Regimental Identification Panel, white, this being a semi-circular disc of white cloth, 9 $\frac{3}{4}$  ft. in diameter and fastened along the diameter to a wooden batten 1 $\frac{1}{2}$  in. x 1 $\frac{1}{2}$  in. x 9 $\frac{3}{4}$  ft.
- 3 Infantry Designator Squares, black.
- 3 Infantry Signaling Panels, white.

#### Infantry Battalion Identification Panel Set.—

- 1 Infantry Battalion Identification Panel, white, this being a 6 $\frac{1}{2}$ -ft. equilateral triangle of white cloth with a wooden batten 1 in. x 1 in. x 6 $\frac{1}{2}$  ft., fastened along one of the sides.
- 3 Infantry Designator Squares, black.
- 3 Infantry Signaling Panels, white.

#### Artillery Identification Panel Set.—





- 1 Artillery Identification Panel, white, this being a square of white cloth, 13 ft. on a side, fastened on two opposite sides to wooden battens, 1 $\frac{1}{2}$  in. x 2 in. x 13 ft.
- 3 Artillery Designator Squares, black.
- 3 Artillery Signaling Panels, white.

The designators and signaling panels above referred to are made up as follows:

The Infantry Designator Square, black, is a square of black cloth, 16 in. on a side, fastened on two opposite sides to  $\frac{3}{4}$ -in. x  $\frac{3}{4}$ -in. x 16-in. wooden battens.

The Artillery Designator Square, black, is a square of black

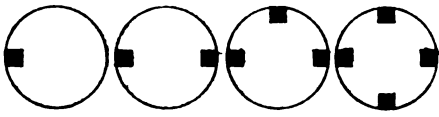
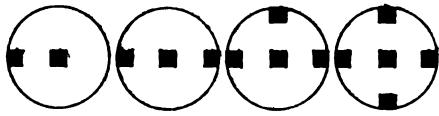
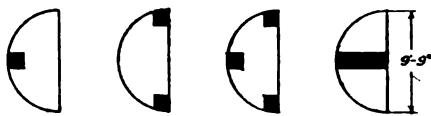
## IDENTIFICATION PANELS USED BY THE INFANTRY

For the Army Corps	
For the Division (Adjoining Divisions should have their designator strips placed differently.)	 <p style="text-align: center;">X Division    Y Division    V Division    Z Division</p>
For the first brigade of various divisions	
For the second brigade of the corresponding divisions	
For the Regiment (Adjoining regiments should have their designators placed differently)	
For the Battalion (Adjoining Battalions should have their designators placed differently)	

## ARTILLERY IDENTIFICATION PANELS

Panels for Brigade Headquarters, Regimental Headquarters  
and Battalion Headquarters of Divisional Artillery



Artillery  
Brigade  
Headquarters



1



2



3



4



5



6



7



8



9



10



11



12



13



14



15

Panels for Brigade Headquarters, Regimental Headquarters  
and Battalion Headquarters of Heavy Artillery



Heavy  
Artillery  
Brigade  
Headquarters



16



17



18



19



20



21



22



23



24



25



26



27



28



29



30

cloth, 52 in. on a side, fastened on two opposite sides to 1-in. x 1-in. x 52-in. wooden battens.

A Designator Strip, black, is a 16-in. x 9½-ft. rectangle of black cloth fastened on the two 16-in. ends to ¾-in. x ¾-in. x 16-in. wooden battens.

The Infantry Signaling Panel, white, is a 2-ft. x 6½-ft. rectangle of white cloth fastened on the two 2-ft. ends to 1-in. x 1-in. x 24-in. wooden battens.

The Artillery Signaling Panel, white, is a 3¼-ft. x 13-ft. rectangle of white cloth, fastened on the 3¼-ft. ends to 1-in. x 1-in. x 3¼-ft. wooden battens.

The Marking Panel, white, for the companies, is a 16-in. x 20-in. rectangular sheet of oil-cloth or canvas with a wooden batten fastened along each 16-in. side. These battens serve the double purpose of preventing the canvas from turning up at the edges and facilitating folding up and handling when not in use.

For use in snow, the colors of all the above panels are just reversed.

### Allowance of Panels

The following is the allowance and distribution of panels within an Infantry Division:

Infantry Division Identification Panel Set, white	
1 to Radio Company, Field Signal Battalion-----	1
Infantry Brigade Identification Panel Set, white	
2 to Radio Company, Field Signal Battalion-----	2
Infantry Regimental Identification Panel set, white	
1 to each Infantry Regimental Headquarters Company----	4
Infantry Battalion Identification Panel Set, white	
1 to each Infantry Battalion Headquarters-----	12
Artillery Identification Panel Set, white	
1 to Artillery Brigade Headquarters-----	1
1 to each Artillery Regimental Headquarters Company----	3
1 to each Artillery Battalion Headquarters-----	7
	<hr/>
	30
Marking Panels, white	
768 to each Infantry Regiment, 64 to each Rifle Company--	3072

These above panels are not listed in this same manner in the Signal Unit Equipment Table for an Infantry Division issued by A. E. F. April 23, 1918. They are listed under the following names:

Infantry Division Identification Panel Set, white, is listed as Panels, Infantry Division, white.  
 Infantry Brigade Identification Panel Set, white, is listed as Panels, Infantry Brigade, white.  
 Infantry Regimental Identification Panel Set, white, is listed as

- Panels, Identification.** When ordering ask for Panels, Identification for Regiment, white.
- Infantry Battalion Identification Panel Set, white,** is listed as Panels, Identification. When ordering ask for Panels, Identification for Battalion, white.
- Artillery Identification Panel Set, white,** is listed as Panels, Artillery Type, white.
- Marking Panels, white,** listed as Panels, marking. When ordering specify white.
- Panels, Artillery Brigade, and Panels, rectangular,** which are listed in this table, are included in the make-up of the various panel sets and do not have to be ordered separately.

### Specification of Panels

The panel specifications as listed in the Signal Unit Equipment Table for an Infantry Division, issued by A. E. F. April 23, 1918, may be complied with as indicated in the following:

- Item No. 63—Panels, Artillery Brigade, white.**  
For this, supply Item No. 64, Panels, Artillery Type, white.
- Item No. 64—Panels, Artillery Type, white.**  
For this, supply Artillery Identification Panel Set, white.
- Item No. 66—Panels, Identification.**  
For this, supply either the Infantry Regimental Identification Panel Set, white, or the Infantry Battalion Identification Panel Set, white, as specified. If not specified, supply one Infantry Regimental Identification Panel Set, white, and three Infantry Battalion Identification Panel Sets, white.
- Item No. 67—Panels, Infantry Brigade, white.**  
For this, supply the Infantry Brigade Identification Panel Set, white.
- Item No. 69—Panels, Infantry Division, white.**  
For this, supply the Infantry Division Identification Panel Set, white.
- Item No. 71—Panels, marking.**  
For this, supply Marking Panel in the same required number.
- Item No. 72—Panels, rectangular.**  
These panels are the signaling panels included in the various Identification Panel Sets.

SIGNALS	CODE OF INFANTRY PANEL SIGNALS			Additional Signals
	For Signalling to Contact Airplanes			
	Battalion	Regiment	Brigade	
The objective is reached				Numbers made by panels. Various meanings may be assigned
Request for barrage fire				0
Request for artillery fire to prepare the attack				1
Our own field artillery firing on us.				2
Our own heavy artillery firing on us				3
We are ready to attack				4
We are not ready to attack at the prearranged hour				5
Increase the artillery range we are going to advance				6
Request for rifle ammunition				7
Request for grenades				8
Understood, or message received				9









## CODE OF ARTILLERY PANEL SIGNALS

The following is the standard conventional code of signals used by the artillery in communicating with the fire control airplanes. It must be remembered that the different artillery units are distinguished from each other by their designator squares arranged on their identification panels in accord with the number assigned to them.

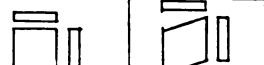
		Divisional Artillery	Heavy Artillery
1	Observe fire of the battalion whose identification panel has its designator squares arranged as mine are now arranged. (Shows proper arrangement of designators and points the signalling panels in the direction of battalion referred to.)		
2	Request for adjustment		
3	Adjust on target you just indicated		
4	Observe fire on target No. —, or shift target (followed by number of new target)		
5	First battery ready - - - - - Second battery ready - - - - - Third battery ready - - - - -		
6	Wait a few minutes		
7	Battery not ready. Delay of at least ten minutes		
8	Battery has fired		
9	Your wireless works but signals confused. Repeat.		
10	Do not hear you. Fire not adjusted.		
11	Yes or Understood or Message Received		

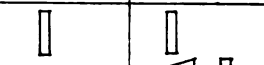
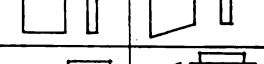
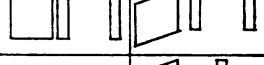
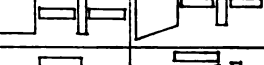
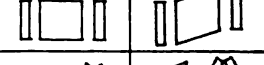

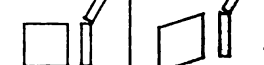





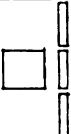

## CODE OF ARTILLERY PANEL SIGNALS (continued)

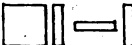



		Divisional Art'y	Heavy Artillery
12	Ho		
13	Continue to adjust		
14	Fire by piece		
15	Fire by salvo		
16	Amelioration		
17	Series of 24 rounds		
18	Continuous fire for effect		
19	Fire for control		
20	Enemy attacks. Be guided by previous agreement		
21	No further need of you		
22	Hostile airplane near you		
23	Optional		

**EXAMPLES OF THE USE OF ARTILLERY PANELS**

**1. Designation of Target to Aerial Observer**

The receiving station signals - - - - - The observer answers "understood"	
The receiving station signals - - - - - The observer repeats "one"	
The receiving station signals - - - - - The observer repeats "three"	
The receiving station answers - - - - - The observer answers "understood"	
The receiving station repeats - - - - - The observer repeats "four"	
The receiving station takes off the signal at once, then repeats - - - - - The observer repeats "four"	
The receiving station signals - - - - - The observer repeats "seven"	
Then the observer sends "Adjust 1447" The receiving station answers - - - - -	
Or the receiving station may answer - - - - -	

**2. Commands to Aerial Observers in Case of Open Warfare.**

The Artillery Brigade station (call XA) signals, "Artillery Brigade headquarters here" - - - - - The airplane answers "XA, observer ready to work."	
The artillery station arranges panels thus - - - - - indicating the order, "Observe fire of the battalion with this identification panel, which is in the direction of my signalling panels."	
The observer announces, "XA, understood XC". (XC is the station call of the battalion to which that panel is assigned) The Artillery Brigade station answers - - - - -	
The airplane flies away in the indicated direction and signals "XC XC" continuing until XC displays its identification panel, and indicates that it is ready to work - - - - -	

**AN EXAMPLE IN THE USE OF VISUAL SIGNALING WITHIN A DIVISION IN A GENERAL ADVANCE OF AN ARMY CORPS.**

An attack has been decided upon by the general commanding the —th Army Corps to commence June 5, 1918, at zero hour, which will be some time in the morning between 7 and 9 o'clock. In addition to the standard signals, the following special code to be used in the attack has been drawn up by the chief signal officer of the army corps and approved by the staff of the army and issued by the commanding general to the divisions for the guidance of their chief signal officers in drawing up their specific instructions. When these instructions are drawn up they are submitted to the commanding general of the army corps for final approval and then issued to the adjoining army corps for their information and also to the various unit commanders within the corps concerned. It is understood that the standard conventional signals will be used in all cases where no new special code has been issued.

The following special lamp signals are reserved by the army corps for corps uses only—series of D, F, G and L.

The fireworks code is worked out as follows:

For use by the contact airplane—

- I am the airplane of the 39th Division.....1 white star
- I am the airplane of the 40th Division.....2 white stars
- I am the airplane of the 41st Division.....1 white star
- I am the airplane of the 42nd Division.....2 white stars
- Where are my front-line troops.....3 white stars
- Understood .....6 white stars
- The enemy is preparing to attack.....Yellow smoke

For use by the infantry—

- Request for artillery fire in preparation for our attack.....1 green star
- Request for ammunition.....3 white stars

- Request for grenades..... { 3 white stars  
1 white caterpillar

- Field artillery fire is falling short... { 6 white stars  
1 red star

- Heavy artillery fire is falling short { 3 white stars  
1 red star

We are ready to attack.....	} 1 green star 1 red star
We shall not be ready to attack at the set hour... Yellow smoke	
We are going to advance; lengthen fire.....	Caterpillar
Objective reached.....	Flag
Understood .....	6 white stars
Request for artillery barrage.....	1 red star
We are stopped before reaching objective....	} Yellow smoke Caterpillar
Our front line position, all is going well.....	
Our front line position, we are held up.....	Red flares
The panel code determined upon, follows:	
Panel numeral "1"—Where are my front line troops?	
Panel numeral "2"—Explain the situation by dropped message.	
Panel numeral "3"—Where are the headquarters of my subordinate units?	
Panel numeral "4"—Tell me what you can see on my left?	
Panel numeral "5"—Tell me what you can see ahead?	
Panel numeral "6"—Tell me what you can see on my right?	
Panel numeral "7"—The enemy's artillery prevents my advance. Send artillery airplane.	
Panel numeral "8"—Send infantry airplane.	
Panel numeral "9"—Report to the higher unit that I am going to attack.	

Working with this chart as a basis the division signal officer has accordingly drawn up complete signals and codes for all means of communication within his division including station calls for radio, T.P.S., lamp stations, etc. It is not necessary to show here the final detailed signal instructions that are issued to the various unit commanders, as the visual system has been practically covered by the above general army corps instructions.

On June 4 these instructions are issued to the commanding officers down to the company commanders with the information that an attack is to begin some time early in the morning on June 5 in order that everything may be prepared in advance. The division commander is notified early on the morning of June 5, about an hour before the artillery preparation is to commence, the exact time of zero hour. This artillery preparation commences four hours before zero increasing in violence and

intensity. A few minutes before zero hour the contact airplane arrives, passing over division headquarters and continuing toward the front, where it takes up its work. The commanding officer of the 168th Regiment, on account of the injury his regiment has sustained through the counter artillery fire of the enemy, decides that it is hopeless for his regiment to attempt an attack. He signals this information back to the higher command by all means still available, including lamps, panels and fireworks. This is sent by the lamps, by the conventional — — . — —, by the yellow smoke rocket or yellow smoke VB cartridges. These attract the attention of the contact airplane which flies over the place where the observer saw the signal. Here he sees the identification and signaling panels of the regiment spread out on the ground forming the same signals; i. e., "We will not be ready to attack at the set hour." The airplane observer signals "understood" with his white-star cartridges and at once transmits this information by radio to the division headquarters, in the meantime preparing a message to be dropped as soon as he can fly there. These same signals have been perceived by the central lamp receiving station which also transmits them to division headquarters. As soon as the division commander receives this message he transmits it to the corps headquarters. But as it is an unusual case, being the only regiment along the entire front not able to advance at the set hour, the attack will take place and reserves will be rushed to the area of this regiment.

At zero hour minus four minutes, in accord with previous orders, the artillery barrage fire commences. At zero hour the advance starts, the barrage lifting and advancing in keeping with the same slow speed of the advancing columns. After several minutes of the advance one company runs into its own heavy-artillery fire. It at once signals with three white stars and one red star, meaning "heavy artillery fire is falling short." These signals, although plainly visible to artillery observers, are repeated by the infantry battalion headquarters, which is not only authority for the observation post to relay them to the battery, but is double assurance that the artillery observation station will see the signal.

After several minutes more of the advance, Company C, 165th Regiment, is held up by enemy machine gun fire. It signals with yellow smoke and caterpillar fireworks, meaning "we are stopped before reaching objective," which is a notice

to the artillery to hold back the barrage fire at that point and to the regimental commander to take the necessary action. As soon as this enemy resistance has been overcome the company sends up a caterpillar signal, meaning "we are going to advance; lengthen fire."

In the meantime the division commander is getting impatient to know what is happening up front. He knows that he will receive a report from the contact airplane every hour, but he desires to get into communication with it at once. As this airplane is up towards the front he communicates with all his regimental headquarters, ordering them to display their signaling panels to make numeral "1," meaning "where are my front line troops?" As soon as the airplane sees one of these panels it proceeds to the spot and acknowledges it with a six-star cartridge, and then flies over the advanced elements and attracts their attention by means of its klaxon horn. It then fires a two-star white cartridge, meaning "I am the airplane of the 42nd Division," and then a three-star white cartridge, meaning "where are my front-line troops?" This is a demand for the infantry of the front line to open its marking panels. When the airplane has located the position of the front line and marked it on a map it fires the six-star acknowledgment signal. If the location of the front line has not been observed, the airplane fires another three-star white cartridge. As the morning is hazy, and it is not possible to see the panels well the infantry men this time light their white flares, indicating their position and that all is going well. This is seen by the airplane and acknowledged by the six-star white cartridge. The airplane then flies over in the direction it believes division headquarters to be, asking it by radio to show its location. Division headquarters does this by displaying its identification panel, which enables the airplane to know where to drop the map with the desired information. The airplane then proceeds to the front line and continues to watch the advance. The advance continues until the objective is reached, when the infantry makes this known by firing the flag signal. This signal is acknowledged by the airplane, which again calls for the marking of the new front position and proceeds as before to transmit this information back to division headquarters.

## MISCELLANEOUS METHODS OF VISUAL SIGNALING

There are numerous other forms of visual signaling, many of which are capable of being developed into useful means of communication under some conditions. All of the following signaling methods, with the exception of the wig-wag disc have been tried out in the present war, and while each has its advocates none has as yet been of general use. It is highly probable that in the future some of these means may be developed and become highly serviceable, or the methods of warfare may become such as to permit the use of some of these even in their present form.

**Wig-Wag Flags.**—Flags for use in wig-wagging are now issued to infantry divisions under the name of "kits, flag, combination, standard." Each kit includes one wig-wag staff and two wig-wag flags, and also two semaphore staffs and two semaphore flags. A division is supplied with 1022 of these kits. The use of the wig-wag flags is already fairly well known in the American Army. Signals are transmitted by describing an arc of 90 deg. to the right and left to form dots and dashes, and spaces by a downward front motion. The general service code can be transmitted by this means. Wig-wag flag signaling should be thoroughly understood and practiced by all signal men, as it forms an excellent method for becoming familiar with the code. Signals can be sent by this means merely by the use of the hand, and consequently the system forms an excellent way for troops to put in their time when traveling by train or on shipboard. Its use in the present war has been limited, but it will undoubtedly be used more and more, especially when open warfare is resumed.

**Wig-Wag Discs.**—This form of communication is very similar to wig-wag signaling. The method is the same, but a stiff white or black disc from 6 to 12 in. in diameter, rigidly fastened to a light wooden staff about 20 in. long is used instead of the flags. Its advantage over the flag wig-wag is that the visibility of an 8-in. disc is as great as the standard wig-wag flag, while the speed of transmission may be three times as great.

**Semaphore.**—Signals by semaphore are transmitted by the arms, either alone or with the semaphore flags that are issued in the standard combination flag kits. It is a standard means of communication in the American Navy and well known in the Army. It is not used by the armies of Europe, but it might serve a useful purpose to linemen and others for intercommunicating.

**Shutter Signaling Panel.**—This consists of a framework 5 ft. wide and 9 ft. 6 in. long resembling an old-fashioned adjustable outside window shutter. By pulling and releasing a cord the "slats" are closed or opened, thus making the rectangle to appear white or disappear. Signals are sent by using the general service code, the dots and dashes corresponding to the length of time the white rectangle is exposed. Thus far, its use has not proven very satisfactory, and is limited to communications between the ground and observing balloons, in making simple signals such as "understood" or "repeat."

**Folding Cylinder.**—This form of signaling consists of black or white cloth sewed to the outside of five parallel hoops. It is used only by an observing balloon in communicating with the ground. The top ring is attached to a cord which runs up to the observers' basket in the balloon. The lower ring is fastened to a cord, which is attached to the balloon cable at some distance under the basket. The upper and lower rings are connected by a spring which tends to pull all the rings together. The observer in the balloon by pulling on the cord and releasing it can send the general service code by the accordion-like action of the cylinder as it expands and contracts. Its use has now been practically discontinued as a method of communication.

**The Aldis Lamp (British).**—This form of signaling consists of a 1000 candle-power projector placed under the wing of an airplane and supplied with energy by a storage battery. It is sighted by means of a telescope mechanically connected to the projector, which causes the light beam to focus on the same object as the telescope. Its range is from 5000 to 7000 ft. It is used by the French and English for sending signals from the airplane to the ground.

**Heliograph.**—The heliograph is a device for sending general service code signals by means of mirrors which reflect



the rays of the sun. The lamp has almost entirely superseded this means of communication in the A. E. F., as it is equally portable and much more flexible in its adaptability to light and weather conditions. The heliograph has a much greater range of transmission than the lamp.

**Shrapnel Signaling.**—The artillery can send one or two signals to the front-line infantry such as "repeat" and "understood" by firing shrapnel timed to burst directly ahead of the front line in a certain manner. For example, four simultaneous bursts of shrapnel, one above the other might mean "understood."

---





FOR OFFICIAL USE ONLY

**ELEMENTARY PRINCIPLES  
OF  
RADIO TELEGRAPHY  
AND TELEPHONY**

**Radio Pamphlet  
No. 1**

**Signal Corps, U S. Army  
Second Edition Revised to  
10-28-18**



# ELEMENTARY PRINCIPLES OF RADIO TELEGRAPHY AND TELEPHONY

**The Underlying Electrical Theory Involved in Radio Communication Work is Simply and Briefly Covered. The More Common Means of Transmitting and Receiving Radio Employed for Military Purposes are Analyzed in Terms Comprehensible to the Non-Technically Educated but Technically Inclined Personnel.**

It is expected that the officers and non-commissioned officers who are better qualified to understand the theory involved in radio work, will explain the contents of this pamphlet to the enlisted personnel who must have some knowledge of the work, by enlarging upon the points presented herein and by giving analogs and in general by going over the pamphlet, sentence by sentence, with these men and fully explaining each step and answering all questions.

## PART 1

	Page
<b>CHAPTER I.—THE THEORY UNDERLYING THE RADIO</b>	
<b>SYSTEM OF COMMUNICATION.....</b>	<b>3</b>
General Survey of the Field of Radio Communication...	3
The Electrical Units Pertinent to Radio.....	5
Definitions of Electrical Units.....	6
Three Systems of Units—Table for Changing from One to Another.....	7
Electromagnetic Induction.....	8
The Alternator.....	8
The Inductor Type Alternator.....	10
The Induction Coll.....	10
The Transformer.....	12
Oscillatory Discharge of a Condenser.....	12
Phenomena of Resonance.....	15
Propagation of Electric Waves.....	17
<b>CHAPTER II.—DAMPED WAVE RADIO TELEGRAPHY.....</b>	<b>19</b>
Principles of Transmission.....	19
Types and Characteristics of Antennae.....	20
Transmission by Direct Excitation.....	22
Transmission by Indirect Excitation.....	24
Principles of Reception.....	28
Tuning of Oscillatory Circuits.....	31
Coupling of Oscillatory Circuits.....	31
Sources of Trouble in Reception.....	31
Influence of Topography on Reception.....	32

## PART 2

<b>CHAPTER I.—UNDAMPED WAVE RADIO TELEGRAPHY.....</b>	<b>33</b>
<b>Vacuum Tubes in Radio Communication Work.....</b>	<b>33</b>
Electron Flow in Vacuum Tubes.....	34
Operation of Two-Electrode Tubes Under Various Conditions.....	35
Characteristics of the Three-Electrode Vacuum Tube	36
Detector Action of Vacuum Tubes.....	38
Amplifier Action of Vacuum Tubes.....	40
Oscillator Action of Vacuum Tubes—Undamped Wave Transmission.....	41
Three-Electrode Tubes used by the United States Signal Corps.....	43
Reception of Undamped Waves.....	44
<b>CHAPTER II.—RADIO TELEPHONY.....</b>	<b>46</b>
<b>Modulator Action of Vacuum Tubes.....</b>	<b>46</b>
Radio Telephone Transmission.....	46
Radio Telephone Reception.....	46

## PART I.

### CHAPTER I.

# THE THEORY UNDERLYING THE RADIO SYSTEM OF COMMUNICATION

## General Survey of the Field of Radio Communication

**V**ERY soon after wire telegraphy became of practical usefulness, conditions were encountered in which the desirability of effecting electrical signaling without connecting wires became apparent. As a result of this need, a number of methods of telegraphing without wires were tried out, based on schemes of utilizing the conduction through the ground, magnetic induction, etc., as the means of sending the signals. All of these methods, however, were very limited as to range of transmission and were therefore of little importance and value as a system of communication.

Radio telegraphy, or the transmission of signals by means of unguided electric waves, was first introduced in 1896 by Marconi, after extensive experiments made by himself and with the help of the discoveries and research work of Hertz and others. In 1899 communication was established between Dover and Boulogne, a distance of 32 miles, and shortly after, information between ships was transmitted as far as 80 miles. The importance of radio communication was by that time universally admitted, and from this it has constantly grown and extended its field to commercial, naval and military pursuits. From these early stages, the art has rapidly progressed until in 1916, Arlington Station could hear Japan working with Honolulu, the distance involved being approximately one half the circumference of the earth.

The application of radio to military uses is the one to which this pamphlet is particularly devoted. In this application, its development has likewise been extremely rapid, and at the present time one of the most important means of communication between armies and units is by means of the unguided radio waves, this assuming greater importance as the intensity of destructive shell fire and hence the difficulty of maintaining wire communications increases.



An entire system of radio communication has been established to supplement the wire system for the forwarding of information between the various headquarters of the armies, divisions, brigades and even to and from the front line trenches. In an attack, when the infantry moves forward, one of the most difficult tasks is to maintain communication with headquarters. A certain element of time is involved in carrying forward wire communication systems and they are continually broken down by shell fire. The radio and ground telegraph apparatus, however, are much more simply carried forward and are usually operative unless destroyed by an almost direct hit. Of course, there are many times when the interference of the enemy and other of our own radio sets is so great as to make receiving of signals extremely difficult and at nearly all times the operator must be able to pick out his own signals from a number heard simultaneously.

Another system of radio communication is in existence between airplanes and artillery. This is called the fire-control system and it is perhaps the most extensive and complex of all the radio organizations in operation at the front. The firing of each battery of light, medium, heavy and superheavy artillery is directed to greater or less degree by radio signals sent out from airplanes flying over enemy positions, particularly that of the last three named. This work is extremely important, and the number of airplanes used for the purpose is large. Great as is the value of the airplanes in extending the range of vision of the army, yet their effectiveness in directing artillery fire onto enemy targets is only made possible by the instantaneous means of communication between plane and battery afforded by the radio apparatus. In the early days of the war, even this scheme of communication was so slow, due to the cumbersome signals and natural sluggishness and difficulties incurred in developing and perfecting the practice, that the batteries were not kept busy enough to hold the interest of the men. The intervals between firing and receiving a range correction from the airplanes were so long that not much confidence was had in this method of directing fire. However, the signal system has been greatly simplified and otherwise improved, so that it is now very effective in directing suitable battery fire on enemy gun positions and movements in such a manner as to frequently effectively silence the guns or destroy supply trains, etc.

Radio is also effectively used on reconnaissance and bomb-

ing airplanes, which sometimes are equipped with high power, long range sets. The radio telephone has found some use on battle planes and fighting machines, although this means of communication has not been extensively used up to the present time. It is now undergoing an intensive development and may come in for a more important part in the airplane and other radio work later on.

Not the least important use of the radio apparatus in military operations is that which the alert operator makes of it as a means of anticipating destructive shell fire on his own battery position. It frequently happens that he will hear a hostile plane sending down to the enemy batteries, the map co-ordinates of his position. He will then warn the battery commander not to fire for a period, as this would further prove the position to the hostile aircraft. Or the operator may hear a shell burst at not great distance from his battery position and then hear the hostile plane send down a correction which denotes to the operator that his battery is the target at which the enemy is firing. A timely warning made to the battery commander under these circumstances has saved the lives of many artillery men.

### The Electrical Units Pertinent to Radio

**Self and Mutual Inductance.**—When an electric current is made to flow through a circuit, a magnetic field is established in the space surrounding it. The strength of this field at any given point is proportional to the current flowing in the circuit, and is dependent on the shape of the circuit and on the nature of the medium surrounding it. The value of the ratio of the field flux to the current in a given circuit is called its self-inductance (also called coefficient of self induction). Thus,

$$\text{Self Inductance} = \frac{\text{Electromagnetic Flux}}{\text{Current}}$$

The self-inductance of a circuit, therefore, is the electromagnetic flux around the circuit when unit current is flowing through it.

If unit current is made to flow through one of two independent circuits A and B, (A for instance), the magnetic field due to that current extends around both circuits A and B, if they are near enough together. That part of the flux due to A which interlinks with circuit B is called the mutual inductance of circuit A upon circuit B. This depends on the shape of each of the two circuits and on their relative positions. Their

mutual inductance is therefore greatest when the two circuits are closest together. Whenever a circuit reacts upon another, the two circuits are said to be coupled, the coupling being close or loose according to whether the mutual inductance is large or small.

As the magnetic field builds up around a wire carrying a current, it is possible to obtain a large inductance by winding the wire into a coil so that many turns will be concentrated in small space. By this means, a considerable flux may be produced through the summation of the fluxes due to each turn.

**Capacitance.**—If an insulated conductor is placed near a grounded conductor, and a charge is given to the former, its potential is found to be proportional to that charge. The value of the ratio of the charge to the potential of the conductor has been called the capacitance (electrostatic capacity) of that conductor. Thus,

$$\text{Capacitance} = \frac{\text{Electrostatic Charge}}{\text{Potential}}$$

A large capacitance may be obtained by placing two sheets of metal very close to each other and insulating them by means of some dielectric (air, mica, glass, etc.). Such a device is called a condenser. Condensers of large capacitance are built by combining a large number of sheets of metal foil separated by glass plates or sheets of mica. All even and all odd numbered sheets are connected together, respectively, each group forming one side of the condenser. The capacitance of a condenser is directly proportional to the area of the plates and inversely proportional to the distance between them.

Condensers of adjustable capacitance are also used. Several semi-circular metal plates are placed parallel and one above the other, and connected by means of metal rods extending through the plates at the two ends of the straight side, and held apart by blocks or washers, the whole group of plates making up one side of the condenser. The other side is made up of a set of similar plates having a semi-circular shape and mounted on a shaft at their centers. By rotating the shaft, the plates move in or out between the stationary plates, and the capacitance of the condenser can thus be continuously varied.

### Definitions of Units

**Resistance.**—The unit of resistance is the international ohm.

It is the resistance of a column of mercury 106.3 cm. high, and weighing 14.4521 grams at a temperature of 0 deg. C.

**Current.**—The unit of current is the international ampere. It is that unvarying current which, when passed through a neutral solution of silver nitrate, will deposit silver at the rate of .001118 gram per second.

**Electromotive Force.**—The unit of electromotive force is the international volt. It is the electromotive force which will cause one international ampere to flow through one international ohm.

**Inductance.**—The unit of inductance or of the coefficient of self-induction is the henry. It is the inductance of a circuit in which a current varying at the uniform rate of one ampere per second will induce an electromotive force of one international volt.

**Capacitance.**—The unit of capacitance is the farad. It is the capacitance of a condenser, such that a potential of one volt will cause the condenser to store a charge of one coulomb. (A coulomb is the quantity of electricity transported by a current of one ampere flowing for one second).

### Three Systems of Units

There are three systems of units commonly used in practice. These are the electrostatic, the electromagnetic and the practical units. A table is given below for changing these units from one system to another.

#### CAPACITANCE.

Electrostatic Units (cgs.).		Electromagnetic Units (no name).		Practical Units (mfd.).	
To Magnetic.	To Practical.	To Static.	To Practical.	To Static.	To Magnetic.
Divide by $9 \times 10^{20}$	Divide by $9 \times 10^5$	Multiply by $9 \times 10^{20}$	Multiply by $10^{15}$	Multiply by $9 \times 10^5$	Divide by $10^{10}$

#### INDUCTANCE.

Electrostatic Units (no name).		Electromagnetic Units (cgs.).		Practical Units (henrys).	
To Magnetic.	To Practical.	To Static.	To Practical.	To Static.	To Magnetic.
Multiply by $9 \times 10^{20}$	Multiply by $9 \times 10^{11}$	Divide by $9 \times 10^{20}$	Divide by $10^9$	Divide by $9 \times 10^{11}$	Multiply by $10^9$

## CURRENT.

Electrostatic Units (no name).		Electromagnetic Units (no name).		Practical Units (amperes).	
To Magnetic	To Practical.	To Static.	To Practical.	To Static.	To Magnetic.
Divide by $3 \times 10^{10}$	Divide by $3 \times 10^9$	Multiply by $3 \times 10^{10}$	Multiply by 10	Multiply by $3 \times 10^9$	Divide by 10

## POTENTIAL.

Electrostatic Units (no name).		Electromagnetic Units (no name).		Practical Units (volts).	
To Magnetic.	To Practical.	To Static.	To Practical.	To Static.	To Magnetic.
Multiply by $3 \times 10^{10}$	Multiply by 300	Divide by $3 \times 10^{10}$	Divide by $10^8$	Divide by 300	Multiply by $10^8$

## RESISTANCE.

Electrostatic Units (no name).		Electromagnetic Units (no name).		Practical Units (ohms).	
To Magnetic.	To Practical.	To Static.	To Practical.	To Static.	To Magnetic.
Multiply by $9 \times 10^{20}$	Multiply by $9 \times 10^{11}$	Divide by $9 \times 10^{20}$	Divide by $10^8$	Divide by $9 \times 10^{11}$	Multiply by $10^8$

It will be noted that in many cases the units have received no name in some of the systems in which they are expressed, so that the name of the system must be given. Thus a current of 1 amp. is a current of 3,000,000,000 units of current in the electrostatic system, or 3,000,000,000 electrostatic units of current.

### Electromagnetic Induction

When a conductor is moved across a magnetic field so that it cuts lines of force, an emf. is generated in the conductor. If the conductor is part of a closed circuit, a current will flow in it due to this induced emf. As this induction effect is due to the cutting of lines of force by the conductor, it will be greatest at the instant of the highest rate of cutting the magnetic lines of force (greatest number of lines cut per second). This phenomenon has many practical applications, some of which are studied below.

**Alternator.**—Consider a loop of wire closed on an ammeter.

and placed near a permanent bar magnet, Fig. 1. If either the magnet or the loop is moved, a current will be observed through the ammeter, the direction of the current depending upon the direction of motion and the polarity of the magnetic pole. If then the loop is held stationary and the magnet rotated around its axis *aa*, the direction of the magnetic field through the loop will be alternately in opposite directions, and an alternating current will be generated in the stationary loop circuit.

As the current is a maximum when the number of magnetic lines of force cutting the wire per unit of time is greatest, this

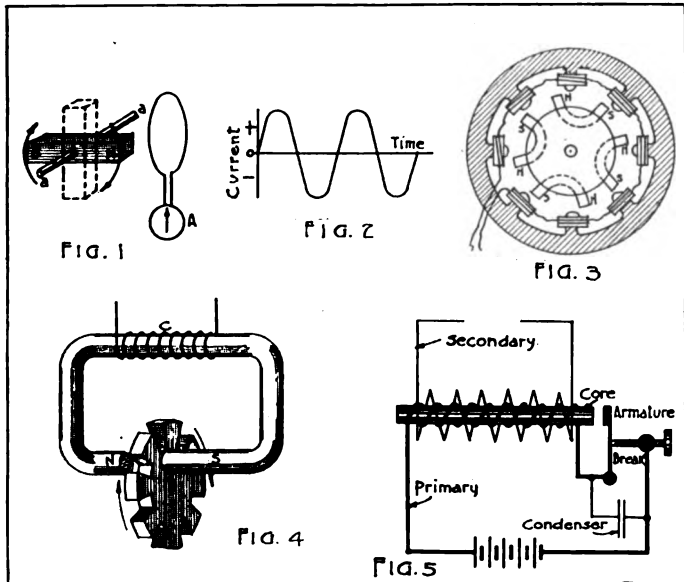

will occur when the magnetic pole passes directly in front of the loop. The current then decreases as the magnet pole is moved away, becomes zero for the position of the magnet shown in dotted lines, and increases again, but in the other direction, as the other pole of the magnet revolves toward the loop. The duration of one complete cycle, that is, of one complete revolution of the magnet, is called the "period" of the alternating current. The number of periods per second is called the "frequency."

A graphical representation of an alternating current may be

obtained by plotting off the value of the current at each instant. time being counted on one axis, and current on the other. This produces what is known as a "sine" curve, as shown in Fig. 2. In order to obtain currents of higher frequency, it is simply necessary to rotate the magnet at a higher speed, or to use a number of magnets mounted on a frame locked to the shaft, Fig. 3. Also, rotating the magnet, Fig. 1, at higher speed, or increasing the number of magnetic fields cut through per revolution, Fig. 3, increases the rate of cutting the lines of force and therefore produces higher voltage.

The permanent magnets may be replaced by electromagnets energized by a direct current derived from an auxiliary dynamo called an exciter, or from a battery. The field magnets, either permanent or electromagnets, may be stationary and the alternating current winding rotary.

The rotating portion of an alternating current generator is called the "rotor" and the stationary portion, the "stator." The more common construction is to make the field windings (d. c.) rotary.

**Inductor Type Alternator.**—Another method of producing an alternating current is to wind a coil of wire C, Fig. 4, around a magnet of special shape, the two poles of which face each other and are separated by an air gap. A toothed iron disk is then made to rotate between the jaws of the magnet, so that the gap between the poles is alternately open and then practically closed with iron. The result is that the flux between the two poles, and hence the magnetic flux in the entire magnet, alternately increases and decreases. This periodically varies the number of magnetic lines of force inside the coil C where an alternating emf. is thus generated. This type of generator is called an "inductor type alternator." It is quite widely used in supplying high frequency current to airplane radio apparatus. Instead of using a permanent magnet, it is of course possible to use an electromagnet energized by a direct current derived either from a storage battery or from a separate exciter dynamo.

**Induction Coil.**—Another form of electromagnetic induction is that involved in the operation of the ordinary induction coil, Fig. 5. This consists essentially of an iron core on which are wound two coils of wire. These are called the primary and secondary windings and the latter usually has a much larger number of turns of wire than the primary coil. Inserted in the circuit of the primary coil is a vibrator which, upon closing the circuit through the primary coil, is attracted toward the iron

core of the coil, opening the circuit. It is then immediately released by the demagnetized coil and it returns to its former position to again close the circuit, the operation being very similar to that of the ordinary buzzer. The vibrator thus serves to very rapidly make and break the circuit through the primary coil.

In the induction coil method of producing current by induction, the coils remain stationary, but the function of the vibrator in alternately making and breaking the circuit through the primary, is to produce a rapid change in the number of lines of force resulting from the current in the primary coil. These lines of force also penetrate and surround the secondary coil and induce in it an emf. corresponding in magnitude to the rate of change of the number of lines of force produced by the primary coil. When the circuit of the primary coil is closed, the magnetic field rapidly builds up but is retarded from reaching its maximum value by the counter emf. due to the self-inductance of the primary coil. As this field increases, it induces an emf. in the secondary coil of higher voltage and in the opposite direction than that in the primary. When the current in the primary has reached a certain value, the field becomes strong enough so that the vibrator armature is attracted toward the core, suddenly opening the primary circuit. This is followed by a rapid decrease in the number of lines of force cutting the secondary circuit, this change inducing an emf. of opposite polarity to the first, in the secondary coil. It is important to note that the opening of the primary circuit by the vibrator introduces a condenser in the primary circuit which serves the purpose of causing the primary current to fall to zero value with great rapidity. This is accompanied by a correspondingly high rate of decrease in the magnetic field, with the result that a very much higher emf. is generated in the secondary coil upon opening the primary circuit than upon closing it. This is clearly illus-

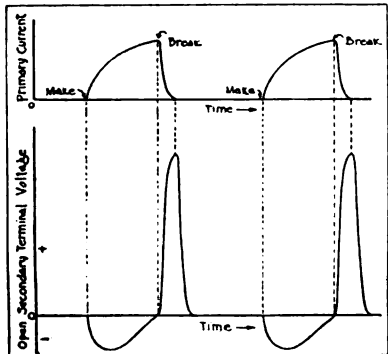

Fig. 6—Current and Voltage Relations in Primary and Secondary of an Induction Coil



trated by the curves of Fig. 6 where primary current and secondary voltage are plotted against time.

**Transformer.**—The operation of the alternating current transformer is based on a very similar principle to that of the induction coil. The principal difference between the two is that an alternating current is fed into the primary winding of the transformer instead of a direct current, as in the induction coil, which is broken up by the vibrator to produce a pulsating current.

The current in the primary of the transformer is then periodically reversed in direction. This produces a magnetic field periodically reversing in direction through the primary circuit, and also through the secondary coil which is generally wound over the primary on a common iron core. The reversals of the magnetic field induce in the secondary winding an opposite emf., the polarity of which is reversed at each reversal of the field. If the secondary terminals are connected to some external circuit, an alternating current of frequency equal to that of the primary current will then flow through this circuit. The ratio of the emfs. at the terminals of the two windings (primary and secondary) is equal to the ratio of their number of turns. Thus, if the primary consists of 20 turns of wire and the secondary of 1200 turns, the secondary voltage will be 60 times the primary voltage. The current will be roughly  $1/60$  as large, assuming unity power factor, since the power induced in the secondary cannot be greater than the power input to the primary. On account of the relative currents carried, the low voltage winding is made of heavy wire, while the high voltage winding is generally made of much finer wire.

Transformers used in radio apparatus are generally for the purpose of transforming a low voltage alternating current into a high voltage alternating current. Such transformers are called "step-up" transformers.

### Oscillatory Discharge of a Condenser

As outlined above, currents may be induced in a circuit by another entirely independent circuit in which an alternating or pulsating current is made to flow. As the inductive effect is due to a change of the magnetic flux in the circuits, it increases with increasing rate of change. In other words, the greater the number of reversals of flux per second, the greater the inductive effect at a given point, or the greater the distance

through which this effect may be evidenced. In radio telegraphy, where these effects must be transmitted great distances, it is therefore necessary to generate alternating currents in the transmitting circuit of a very high frequency—something of the order of 30,000 to 3,000,000 cycles per second. A number of methods have been used to attain this result, a very important one being the oscillatory discharge of a condenser. This is explained below.

Consider a condenser C, Fig. 7, with its plates connected to an inductance coil L and a spark gap G. The condenser

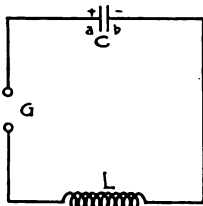

FIG. 7

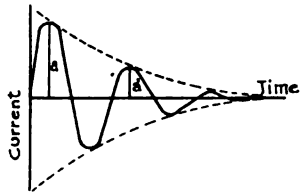

FIG. 8

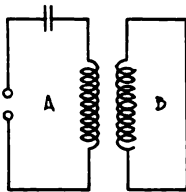

FIG. 9

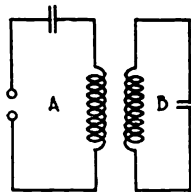

FIG. 10

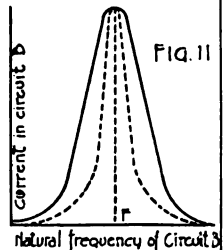

FIG. 11

is charged by some outside source of energy; that is, a difference of potential is established between the two plates, giving them opposite polarities. If this potential is made high enough, a spark will jump across the gap, momentarily short-circuiting the condenser through the inductance coil. The condenser will then discharge, and the quantity of electricity which had been accumulated on one of its plates will spread over the circuit in a tendency to equalize the charge on the two plates of the condenser. This will create a current in the circuit, flowing for instance from a to b in the direction aGLb. The

effect of this current is to produce a magnetic field in the coil L. After a very short time, the condenser is entirely discharged, and there is no potential difference between its plates. There being no further charge on the condenser to maintain the current in the circuit, the latter will die out. This is accompanied by the collapse of the electromagnetic field in the coil. This change of magnetic flux, however, generates a current in the coil, in the same direction as the discharge current of the condenser, so that the current in the circuit, instead of dying out suddenly at the moment the condenser is discharged, will continue to flow in the same direction for an instant and accumulate electricity on the condenser plate which was originally at the lower potential. When the current has ceased to flow, the condenser will be charged again, but with a polarity opposite to its original polarity. It will therefore start discharging in the opposite direction, the phenomena occurring as above described, but with the current flowing this time in opposite direction. A series of current reversals will thus take place, the initial energy which was stored in the condenser being alternately stored in the electrostatic and in the electromagnetic fields of the circuit, this producing an alternating current of a frequency depending on the value of the inductance L and capacitance C, in the circuit. The relation between the frequency and the constants of the circuit is

$$f \text{ (cycles per second)} = \frac{159,200}{\sqrt{L \text{ (microhenrys)} C \text{ (microfarads)}}$$

This frequency is called the "natural frequency" of the circuit.

This alternating current would maintain itself indefinitely if there were no energy losses during the cycle. However, the wires making up the circuit have resistance, in which a certain amount of the energy is dissipated in the form of heat. Also, there are heat losses in the spark gap, the radiation losses, and some other losses, generally of less importance, such as leakage losses in the condenser, etc. The result is that at each cycle, the intensity of the current grows less, until after a few cycles, the energy is practically entirely dissipated and the current is consequently "damped" out. These few cycles as a group are called a "train" of oscillations. In order to produce a new train of oscillations, it is then necessary to recharge the condenser by means of some outside

source of potential. Such a train of oscillations may be represented as in Fig. 8 where current is plotted against time.

**Decrement.**—The number of cycles taking place in the circuit before the current is damped out is dependent on the resistance of the wire making up the circuit, being greatest for circuits of low resistance. The damping varies directly with the resistance of the circuit. The rate of damping of the current of such a discharge may be expressed mathematically by the ratio of the maximum amplitude of two consecutive cycles of a wave train. This ratio is a constant for a given circuit and is called the "arithmetic decrement" of the oscillation. Thus, the arithmetic decrement of the wave shown in Fig. 8, would be  $\frac{a}{a'}$ . The greater the value of this decrement, the more rapid the damping of the oscillation. For a true, undamped alternating current, Fig. 2, the decrement is equal to 1.

In practice the arithmetic decrement is of little interest, and the term used most frequently to express the damping is the "logarithmic decrement," which is the Napierian logarithm of the arithmetic decrement. Hence, the logarithmic decrement of an undamped oscillation is zero.

The frequency of oscillation of the condenser discharge may be very great—from 50,000 to 3,000,000 cycles per second, depending on the values of inductance and capacitance in the circuit. But the number of cycles in one train taking place before complete damping out is comparatively small. Hence, by recharging the condenser after each wave train, it is possible to produce a large number of trains of oscillations per second. This may be done by means of an induction coil or an alternator, and will be taken up later.

### Phenomena of Resonance

Due to the very high frequency of the discharge oscillations of a condenser through an inductance, the inductive effects are considerable. If an inductance coil B, Fig. 9, is placed near an oscillating circuit A, an alternating emf. is induced in coil B, exactly in the same way as in an ordinary transformer. If the coil is short circuited by means of a piece of wire, an alternating current will flow in the circuit. This will be of the same frequency as the current in circuit A, whatever that frequency may be, as determined by the values of capacitance and inductance in the generating circuit A.

Circuit B is then said to be "aperiodic" as it has no natural oscillation period of its own.

If, however, instead of short circuiting coil B, a condenser is connected across its terminals, Fig. 10, phenomena of a somewhat different nature will take place, so-called resonance phenomena. The alternating current flowing in circuit A, at the natural frequency of that circuit, induces, as before, an alternating emf. of the same frequency in coil B. This emf. produces in circuit B an alternating current of the same frequency. As a result of this alternating current, the condenser of circuit B is charged every half cycle, and will therefore, independently of the current induced by circuit A, discharge through the inductance coil B at the natural frequency of circuit B. Two alternating currents of the natural frequencies of circuits A and B will thus flow in circuit B, and will combine, successively adding and subtracting their effects. If the two frequencies are made equal by a suitable adjustment of the natural period of circuit B, the two currents in that circuit will be in phase and will always add their effects to produce the maximum current in the circuit B. To obtain this condition, it is necessary that the product of the capacitance and inductance of one circuit equal that of the same constants of the other circuit. When this condition prevails, the two circuits are said to be "resonant," or "in tune." Circuit B may be tuned to circuit A by varying the capacitance of the condenser or the inductance of the coil B. Circuits which require a change in frequency are generally equipped with a variable air condenser or a multi-tap inductance coil, or both.

If the current in circuit B is plotted against the natural frequency of that circuit, a "resonance curve," Fig. 11, is obtained which shows that the maximum current exists in B when its frequency is equal to that of circuit A. This curve may in some instances be of a very peaked shape (dotted curve), which means that under certain conditions, circuit A may produce an appreciable current in circuit B only when the latter is almost exactly in tune. Such a result may be attained by loosening the coupling of the two circuits; that is, by separating them so that the induced current in B will not react appreciably on circuit A. Also, the trains of oscillations in circuit A should be damped as little as possible, so that each train will act on circuit B for a comparatively great

length of time. This object is attained by making the circuits of large size copper wire and consequent low resistance.

The fact that the current produced in circuit B by the oscillations of circuit A is considerably greater when the two circuits are in tune, is used in radio telegraphy, as will be shown later, in order to make it possible to receive signals of a given frequency and practically eliminate those of other frequencies.

### Propagation of Electric Waves

The flow of electric current in any circuit is accompanied by the existence of interlinked magnetic and static fields which surround the conductors carrying the current and extend throughout space. Whenever the direction of current flow in the circuit is reversed, these fields reverse also. This reversal does not take place, however, throughout space instantaneously. The phenomenon is somewhat similar to the ripples taking place on the surface of water when a pebble is thrown into it. The disturbance gradually propagates itself at a uniform speed, keeping its shape and characteristics until it dies out due to friction losses. The disturbance or reversal in the electric field surrounding a conductor propagates itself in much the same way, but at a speed of 300,000,000 meters (186,500 miles) per second. That is, at a point 300,000,000 meters distant from the circuit under consideration, the reversal of the electric field will occur one second after the reversal of current has been made in the circuit. On account of the similarity with the ripples in the water, this phenomenon has been called an electromagnetic wave. Such waves, however, travel outward not only in one plane as the ripples on the surface of the water, but they radiate out into space in a spherical progression. The medium in which this propagation is assumed to take place is called the "ether." This hypothetical medium is, for theoretical reasons, assumed to be present throughout space, whether matter is present or not; it is the medium in which all electromagnetic disturbances, light waves and heat radiations occur.

If now a frequently reversed current or alternating current is sent through a circuit, the interlinked magnetic and static fields will alternately reverse at the same frequency. This constitutes a series of waves progressing from the current carrying circuit outward into space in all directions. The length of the waves radiated is measured by the distance

between two consecutive points at which the electric field has the same amplitude and direction. This distance is therefore equal to 300,000,000 meters divided by the frequency of the alternating current.

Fluctuations of magnetic and static fields will produce electric currents in any metallic circuit which happens to be within the range of these fields, energy being thus dissipated in these circuits. As this energy is derived from the oscillating circuit, and conveyed to the various other circuits by the electromagnetic waves, the oscillating circuit is shown to "radiate" energy into space. An appreciable amount of energy is not radiated, however, at frequencies of less than about 10,000 cycles per second. The problem is then to generate high frequency alternating currents in a circuit of such shape as to radiate a large amount of energy and produce fields of sufficient strength that the changes in their intensity and direction may be intercepted at great distances. In the following chapters a study will be made of the application of these phenomena to radio telegraphy.

# DAMPED WAVE RADIO TELEGRAPHY

## Principles of Transmission

From the previous study it has been seen that a radio transmitting set, that is, a set which will emit electromagnetic waves into space, may consist of an oscillatory circuit containing inductance and capacitance, in which trains of damped high frequency oscillations are produced in rapid succession by supplying a certain amount of energy to the system after each wave train. Such a set therefore comprises, in addition to the oscillating circuit, the necessary apparatus to produce the high voltage required for charging the condenser at the beginning of each train of oscillations. This auxiliary apparatus varies greatly with the various sets and is not exclusively applicable to radio work. It comprises ordinary power apparatus used for the production of high potentials and may be an induction coil, transforming the low voltage of a battery into a high pulsating voltage, or an alternator, generating low voltage alternating current which is then stepped up to a high voltage by means of a transformer. This will be studied in a later paragraph.

The oscillatory circuit, however, is a part of the set which is peculiar to radio work. It was seen that such a circuit is made up of an inductance coil, the terminals of which are connected to the plates of a condenser; also, that there are two methods of starting oscillations in such a circuit, one being to introduce a spark gap, charge the condenser, and suddenly close the circuit by producing a spark across the gap, and the other being to couple a circuit without a gap to an oscillating circuit containing a gap. The first may be termed the "direct excitation" and the second, the "indirect excitation" method.

In radio telegraphy it is necessary, in order to increase the range of transmission, to arrange the oscillating circuit so that the electric field will be of suitable shape, and of appreciable strength at great distances. This is accomplished by making either the inductance coil, or (more generally) the condenser of the oscillatory circuit of large physical dimensions. It is then called the "antenna" of the set. The dimensions and shape of the antenna vary greatly in practice and a number of types, some of which are described below are in use at present.



## Types and Characteristics of Antennae

In the very great majority of cases, it is the condenser of the radio circuit which is made the antenna, the inductance coil being wound inside the set box. One reason for this is that such a condenser antenna is much more simply installed or repaired under emergency conditions. The simplest type considered here is the so-called "L" type antenna, Fig. 12. This consists of a horizontal wire, called the "aerial" which forms one side of the condenser. This is connected to one side of the inductance of the oscillating circuit. The other side of the con-

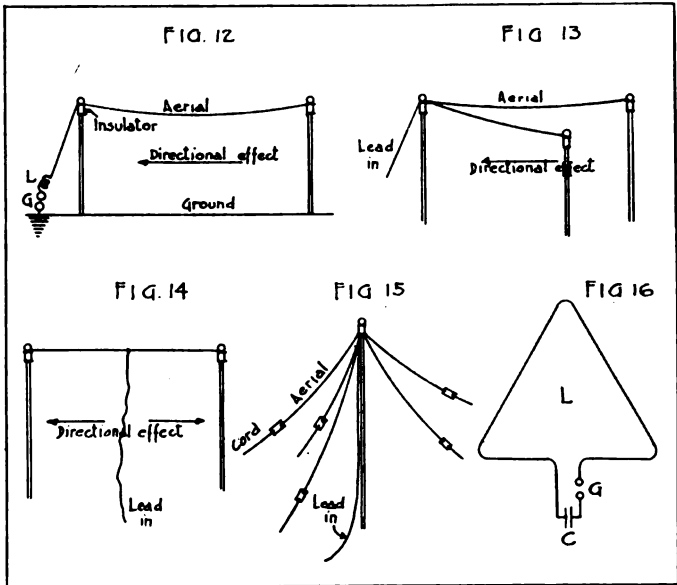

denser is made of a similar wire which is stretched out underneath the aerial wire, either slightly above or laid on the ground. Or the ground itself, if not too dry may be used as the counterpoise side of the condenser. This ground side of the condenser is connected either directly or through a spark gap to the inductance coil, according to the method of excitation used. This is explained below. The connecting wires used to connect the coil and gap to the aerial and the counterpoise (or ground) are called the "lead-in wires." In some cases, no in-

ductance coil is provided with the set, the self inductance of the antenna wire being sufficient.

A very important feature of the antenna is its "directional effect." When the antenna circuit is made to oscillate, the intensity of its electric field and hence the range of transmission is distinctly greater in the direction of the end at which the lead-in wires are connected (direction of the arrow in Fig. 12). Advantage is taken of this characteristic when using such an antenna, by pointing the aerial wire toward the location of the receiving station with which it is desired to communicate, the lead-in wire being connected to that end of the aerial which is nearest the receiving station. It is very important to remember this, since the range of transmission in the other direction is considerably less.

Another type of antenna is the "V" antenna shown in Fig. 13. The aerial consists of two diverging horizontal wires and the lead-in wire is connected at the apex of the "V." If a counterpoise is used, it is generally made of two wires laid on the ground or stretched between masts above ground and underneath the branches of aerial. (See Radio Pamphlet No. 2.) The directional effect of this antenna is toward the point of the "V."

The "T" shaped antenna, Fig. 14, consists of a horizontal wire at the center of which the lead-in wire is connected. The directional effect is in either direction in the vertical plane of the antenna.

The "umbrella" type antenna consists of a number of interconnected wires suspended from the top of a mast and insulated from ground, spreading around the mast like the ribs of an umbrella frame. The free ends are fastened to the ground by means of insulators and ropes, Fig. 15. There is no directional effect with this antenna, the electric waves being radiated with equal strength in all directions.

There are a number of other types in use, but they are generally too difficult to set up in the field for common use. A very important consideration in using antennae is to always well insulate the aerial and lead-in wires from the ground in order to avoid any leakage path which would of course greatly reduce the range and might even completely prevent any radiation.

As was pointed out in the first chapter, the resistance of the oscillating circuit should be as low as possible in order to reduce the heat losses and resulting damping. The lead-in wires con-

necting the counterpoise and antenna to the set should be made as direct and as short as possible. This will also eliminate any superfluous inductance due to possible turns in these wires. If the set is under shelter, the wires should be run through ebonite tubes where they pass through the wall. If these are not available, a bottle may be used, the bottom of which has been broken out.

The ground connection should be made by driving a few metal rods into the ground and interconnecting them, and then connecting them to the set. A ground mat may also be used. This is a small metal netting which is placed on the ground underneath the aerial and connected to the set. It is very useful when the station has to be set up in a short time, and is indispensable when the ground is dry or rocky.

An important use of the counterpoise is to be found on airplane sets where the aerial is generally a single wire let out from a reel on the airplane through an insulating tube, and the counterpoise is all the metallic parts of the airplane motor, gasoline tanks, stay wires, etc., electrically bonded together.

As mentioned before, the antenna sometimes consists of the inductance coil of the set instead of its condenser. The latter is then of small physical size and is mounted within the set box, while the antenna is a loop of wire, Fig. 16, of suitable size and of very few turns, frequently of only one turn, supported on a wooden frame. Such antennae, called "loop antennae," are generally used for short range radio telegraphy and for radiating very short wave lengths—30 to 100-meter waves. They are directional in their plane. This type of antenna is somewhat delicate to repair and is not used very much in the field.

### Direct Excitation Transmission

With the direct excitation method of sending radio waves, the radiating oscillatory circuit comprises the aerial and ground (forming the condenser), an inductance coil  $L$ , and a spark gap, Fig. 17. The two electrodes of the spark gap are connected to the secondary (high voltage) terminals of a transformer, in the primary of which an alternating current may be made to flow by closing the key placed in series with it. When the key is closed, the primary low tension alternating current induces a high alternating voltage in the secondary of the transformer, and an alternating difference of potential is thus established between the aerial and the ground which causes a storing of

energy in the antenna. If this potential is high enough when the maximum of the cycle is reached, the air gap breaks down and the antenna discharges the stored energy through the inductance  $L$ , and a high frequency oscillation is created as explained previously. This is shown in Fig. 18. The upper curve shows the voltage variation in the secondary circuit of the transformer. It rises from zero to the breakdown potential  $e$  of the gap, when the condenser discharges and suddenly equalizes the potential of its two electrodes. When the resistance of the gap breaks down, the voltage of the transformer

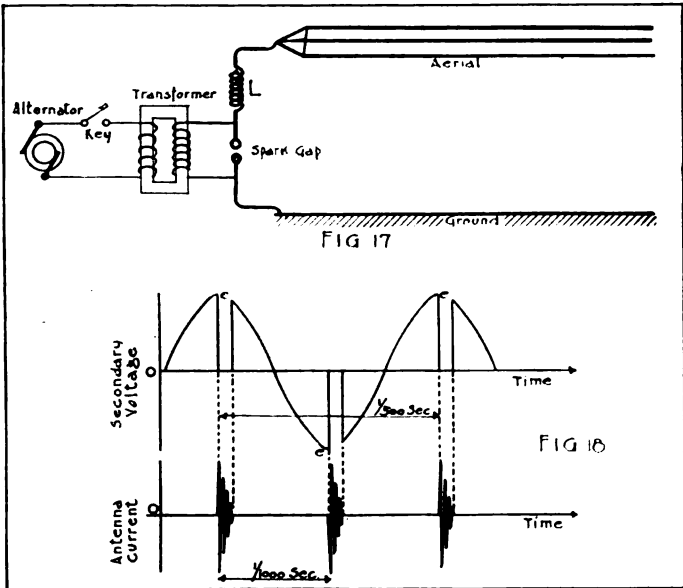

secondary drops practically to zero and a high frequency current oscillates in the antenna circuit, as indicated in the lower curve. When the oscillations have been damped out due to heat losses in the spark, the resistance of the circuit, and the energy losses by radiation, there being no current flow through the gap, the latter opens again, and the voltage of the antenna follows again the cycle of the alternator until the negative maximum is reached, when the same phenomenon takes place. In this way, for every half cycle of the alternator, a high frequency discharge of the antenna takes place which sets up in space, a

train of high frequency oscillations (wave train). The frequency of successive wave trains is thus equal to twice the frequency of the alternator. This, for reasons seen later, is called the "audio" or "wave train" or "spark frequency." The frequency of the oscillations of each individual train is called the "radio frequency" and is entirely independent of the frequency of succession of the sparks or wave trains, as it is determined by the constants (inductance and capacitance) of the antenna circuit. The value of the radio frequency can therefore be regulated by inserting capacitance or inductance in the antenna circuit. Thus, placing an inductance coil in series with the aerial will increase the wave length (decrease the frequency), while a condenser inserted in series with the aerial decreases the wave length (increases the frequency). The frequency of the alternator in practice is of the order of 500 to 1200 cycles per second.

Instead of using an alternator and transformer, an induction coil may be used, as in the SCR-74 trench transmitting set. This supplies a high pulsating voltage at its secondary terminals instead of a high alternating voltage. The operation is the same in principle, the advantage being that such a set is readily portable, and easily set up. However, the wave trains may occur at slightly irregular intervals as the armature does not vibrate regularly as a rule.

The presence of a spark gap in the oscillatory circuit has the disadvantage of introducing quite a high resistance, so that the oscillations are rapidly damped out, and the interval of time between two wave trains, although of the order of  $1/1000$  second, is very much longer than the duration of the various wave trains. The result is that such sets are of low power and small range, as a great part of the energy of the oscillations, instead of being radiated into space, is wasted away as heat in the antenna circuit. Also, due to the rather high decrement, tuning of the receiving set cannot be made very sharp. For long range sets, this method is then replaced by the indirect excitation method of transmission.

#### Indirect Excitation Transmission

By this method, oscillations are started in an oscillatory circuit A, Fig. 19, exactly as with the direct excitation method, only this is a so-called closed oscillatory circuit; that is, both the condenser and the inductance coil are of small physical dimensions.

Coupled to this circuit is the antenna circuit, comprising the large aerial-ground condenser and an inductance through which the coupling to circuit A is made. Oscillations are set up in circuit A, as described above, each train of oscillations being rapidly damped out. Through the transformer action of the two inductance coils, these oscillations induce similar oscillations in the antenna circuit. When the oscillations in circuit A have been completely damped out, the antenna circuit, containing no high resistance such as the spark gap, will continue to oscillate for some time, so that for the same power input, a greater

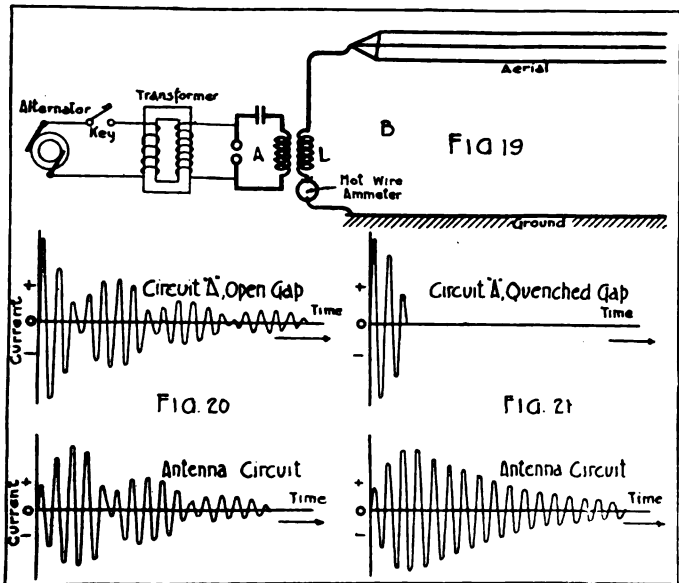

amount of power will be radiated by using this method of exciting the antenna. For the proper operation of such a set it is of course necessary that the antenna circuit be tuned to the period of the closed oscillator circuit A. This is generally done as follows. Circuit A is first given the desired natural period by properly setting its variable condenser and variable inductance. The key is then closed and the antenna circuit adjusted by changing its constants until it is in resonance with circuit A. This condition is indicated by the maximum reading of the hot-wire ammeter inserted in the antenna for this purpose.

As in the previous case, many different arrangements of the circuits are possible. Instead of the alternator and transformer, use may be made of an induction coil. This is done in the SCR-56 airplane transmitting set. In some sets, the coupling of the closed oscillating circuit A to the antenna is made by means of one coil only, Fig. 22. This is called "conductive coupling." The inductance of circuit A is then that part of the coil comprised between the points a and b, the portion of the coil included in the antenna circuit being that between m and n. Such a scheme is used in the SCR-65 airplane transmitter. It will be noticed that this arrangement of one or two inductance coils for effecting the transfer of energy from one circuit to another is, in principle, the same as an ordinary transformer, the only difference being the absence of an iron core. From this similarity, the arrangement has derived the name, "oscillation transformer."

Some auxiliary phenomena take place when indirect excitation is used for setting up oscillations in the antenna. When a train of oscillations is started in a closed oscillatory circuit by the breaking down of the gap, the oscillations quickly damp out, mainly due to energy losses (resistance, gap, etc.) in the circuit itself. However, when such a circuit is coupled to some other oscillating circuit, such as in the case of Fig. 19, the closed oscillator, in addition to wasting away its energy in the usual internal losses, gives up at every cycle a part of it to the other oscillating circuit, so that its damping will be much greater. When the oscillations in the first circuit have died out, the second circuit has then stored a large part of the energy, and high frequency oscillations take place in that circuit. These react on the closed circuit and induce in it an emf. which causes the oscillations to start anew, due to the fact that the conducting gases in the gap were not given time after transfer of energy from the local to the radiating circuit to de-ionize or escape, and open the circuit. The second oscillating circuit thus gives back energy to the first, until it has returned all of it, at which time the first circuit is again in full oscillation. The phenomena then repeat in the same sequence. The result is a series of "beats" in each circuit, as represented in Fig. 20. The practical result is that the antenna circuit, instead of oscillating freely and radiating all its energy into space, feeds back and wastes some of it in the local oscillating circuit A.

To avoid this waste and secure the maximum radiation, it has been found necessary to prevent the transfer of energy

back to the closed oscillating circuit, and a number of methods have been devised, all based on the same principle. The general principle consists of making the spark gap non-conducting after the circuit A has given up all of its energy; that is, after the oscillations taking place in it have been once damped out. If this is done, circuit A is open and an emf. induced back into that circuit by the antenna circuit will be unable to produce any current in it. Excitation by this method is called "impact excitation." This gives conditions shown in Fig. 21. from which it will be seen that after all the energy has been transferred from A to B, it is all spent in circuit B in free oscillations of low damping.

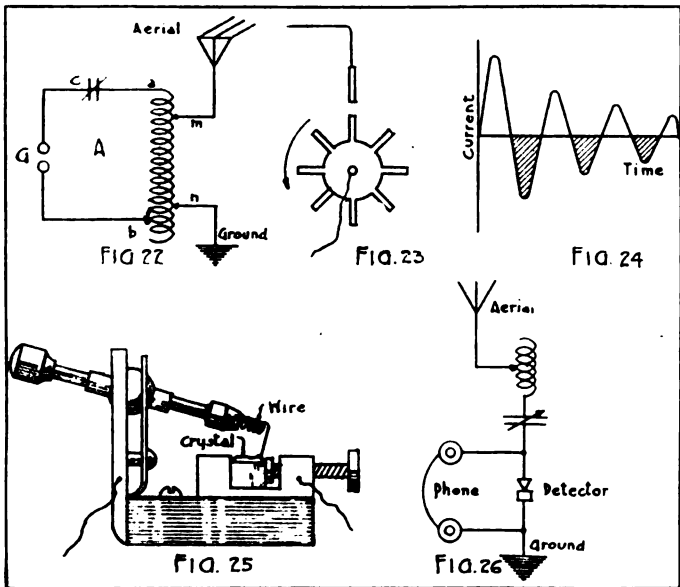

One method of making circuit A non-conducting consists in blowing out the spark in the gap by means of a violent stream of air produced by a blower of some sort. Such an arrangement is called an air blast spark gap. Another method is the use of the "quenched gap," in which the spark occurs in an air tight space between cooled electrodes made of metals such as zinc, aluminum or silver, all of which tend to prevent the spark from maintaining itself after the first energy transfer. A third



method, used on a number of airplane transmitters, is the "rotary spark gap," in which one of the electrodes of the gap is a stationary metal post, at a small distance from which is rotated a toothed metal disk forming the other electrode, Fig. 23. The disk is rotated at high velocity and a spark takes place every time one of the teeth of the disk passes in front of the stationary electrode. Each spark is extinguished very rapidly on account of the increased length of gap as the tooth turns away from the stationary electrode. There are two kinds of rotary gaps, called the "synchronous" and the "non-synchronous" gap. In the former, the disk is driven at such a speed, and has such a number of teeth, that there will be one spark for every cycle of the alternator. In the latter, the disk is driven at a different speed so that there will be more than one spark per cycle, or else one spark in every few cycles. The adjustment of such gaps is somewhat delicate and is not taken up here. While quenched gaps are of use in indirectly excited sets, they should be avoided in directly excited sets, as in this case the oscillations take place only in the antenna circuit and hence want to be prolonged as much as possible.

### Principles of Reception

In the previous paragraphs, a study has been made of the production in an antenna, of high frequency damped oscillations. These oscillations, it was pointed out, produce reversals of the electric field throughout space, and if the antenna is of suitable shape, of greater strength in certain directions than in others. Thus a damped oscillation in the antenna will produce a train of electric waves travelling from the source outward. When such a train of waves sweeps over any conductor, it will induce in this conductor an alternating emf. of proportional amplitude and of the same frequency as the oscillations of the train. If a circuit containing inductance and capacitance is acted upon by the oscillations, the alternating current set up in it will be a maximum when the natural frequency of the circuit is equal to the frequency of the oscillations, or in other words, when the circuit is tuned to the waves received, which means resonant with the transmitting circuit. A radio receiving set then comprises a circuit containing adjustable inductance and capacitance, so that it may be tuned to any frequency within certain limits. As it is of advantage that the receiving set intercept as much as possible of the energy of the incoming waves, it is made to cover as large an area as possible. This

is accomplished by giving large physical dimensions to either the inductance coil or the condenser, in other words, by using an antenna. In such a circuit, for each wave train passing over the antenna there will be induced a train of high frequency oscillations. In order to perceive these oscillations, it is necessary to insert in the circuit some sensitive device which will respond to the extremely small currents induced in the antenna. The telephone receiver forms a very convenient device for this purpose because of its great sensitiveness and ruggedness. Reception of radio telegrams is thus almost universally done by sound.

As the frequency of the oscillations is far beyond the vibration frequency of the telephone receiver diaphragm, no sound would be produced by the latter under the influence of the alternating current induced in the receiving antenna. It is therefore necessary to rectify this current by means of a special device called a "detector." This will conduct electric current fairly well in one direction, but practically not at all in the other. If such a detector is then connected in series with the telephone receivers, a wave train passing over the antenna will induce an alternating current in the circuit, but all the half cycles in one direction will be cut off by the detector, so that instead of a damped alternating current passing through the telephone, a series of unidirectional half-cycle impulses will flow, Fig. 24. As these impulses occur in such rapid succession that the receiver diaphragm will not respond to them, their effect is added, giving one deflection of the diaphragm for each train of waves. When the train of oscillations is damped off, the telephone diaphragm falls back in place until the next wave train arrives at the receiving station. If these trains arrive at a rate (for best results) of 500 to 1200 per second, the successive vibrations of the telephone diaphragm will produce a sound in the operator's ear which will be of a very pure and steady note if the trains arrive regularly, which means that the spark of the transmitting set is occurring at very regular intervals, as determined by the vibrations of the induction coil vibrator, or by the alternating current frequency of the alternator. This wave train frequency is therefore called "audio frequency," as was already pointed out, since it is of a frequency to which the telephone receiver and the ear will respond. The limits of audible frequencies are about 20,000 and 16 cycles per second.

There is quite a large variety of detectors. One used very widely on account of its simplicity is the crystal detector, a

sketch of which is given in Fig. 25. It consists of a crystal of galena (lead sulphide) or iron pyrite (iron sulphide) held in a special support. A fine metal wire is then maintained in position so that its point will rest with a light pressure against a spot of the crystal's surface. Certain points of the crystal surface give better results than others and almost completely stop the current flow in one direction. Such a spot is found by touching the wire point at various points of the surface, until the sound in the telephone receiver is great enough to be readily heard. This adjustment does not have to be repeated often if not disturbed by mechanical vibration. The selection of a good detecting spot on the crystal may be made by exciting the set by means of a small testing buzzer provided for the purpose.

From the previous paragraphs, it may be seen that a receiving set may be constructed by connecting an aerial to ground through an adjustable inductance and condenser, and a telephone receiver shunted by a crystal detector, Fig. 26. The set is tuned by adjusting the inductance and the condenser until maximum response is obtained in the telephone. The high frequency alternating current induced in the antenna will then flow through the receiver in one direction (one half cycle), and through the detector in the other. Such a set, although very simple, has the disadvantage that the detector introduces a high resistance in the antenna, which prevents the latter from oscillating at maximum amplitude.

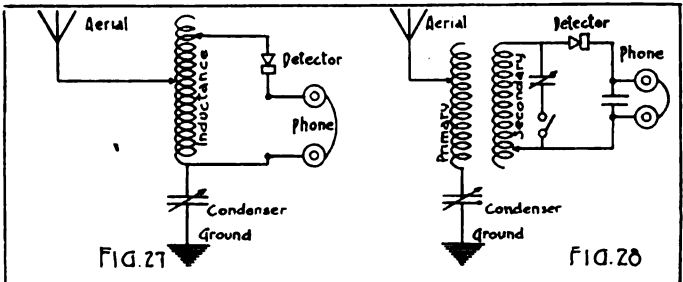

Damped Wave Receiving Circuits. Fig. 27—Inductively and Conductively Coupled. Fig. 28—Inductively Coupled.

A better arrangement is therefore obtained by coupling the telephone and detector circuit to that of the antenna. This coupling may be inductive or capacitive. In case of the former, one or two coils may be used, just as in the case of sending sets. Such sets are shown in Fig. 27 and Fig. 28. With circuits of this kind, the antenna circuit oscillates freely

under the influence of the incoming waves, and induces the high frequency currents in the telephone circuit. The circuit of Fig. 28 is that used in the SCR-54 receiving set, and its operation is fully explained in Radio Pamphlet No. 3.

**Tuning.**—The waves emitted by transmitting stations are propagated in all directions, so that a receiving station may hear not only the signals of a particular station, but also those of all sets working within a good distance of it. It is evident that the reading of telegraphic signals would be absolutely impossible if it were not possible to weaken or eliminate all of the disturbing signals and on the other hand amplify the ones desired. If the disturbing signals are of wave lengths differing from that of the signals to be received, this selection of signals can be made by proper tuning of the receiving set.

When the resonance is very sharp, the receiving station may be sharply tuned. Reception by coupled circuits is almost always employed on account of the good tuning it affords, due to the possibility of double tuning both the antenna and the local oscillating circuits.

**Coupling.**—To maintain good tuning, it is necessary to avoid too close coupling, that is to say, to avoid bringing the two coupling coils too near together since in that case, the mutual reaction between the antenna and the oscillating circuits distorts the waves and decreases the sharpness of the tuning.

Care must be taken in the use of radio apparatus, not to put any metallic mass in the vicinity of the coils as this would be the seat of induced currents, the production of which would take energy from the oscillating circuit and damp the oscillations.

#### Sources of Trouble

It has just been seen that tuning allows the elimination or the weakening of the effect of transmitted waves different in length from the ones to be received. For waves of nearly the same length, this elimination of interference will only be possible when the tuning is very sharp. This depends not alone on the receiving station. If the waves received have high damping, each incoming wave train is made up of only a few oscillations, and does not act very long on the receiving antenna. Sharp tuning requires the rhythmic repetition of the effects of a large number of successive oscillations. Oscillations of the lowest damping should therefore be used when sharp tuning at the receiving station is desired.

If two oscillations have the same or very nearly the same wave length, tuning cannot separate them, but receiving of either is nevertheless possible if the two sending stations have clearly defined tones. This depends on the difference in spark frequency (audio frequency) of the two transmitting sets, the higher this frequency, the higher the pitch of the note heard at the receiving station.

Other causes of serious trouble are electrical atmospheric disturbances, aurora borealis, the passage of electrified clouds, hail storms and drops of electrified rain. The atmospheric electrical discharges produce currents in the antenna, and the telephone receives them giving a series of mixed sounds. These noises are generally a series of impulses of low tone with the result that the high pitched musical signals are the least disturbed by atmospheric interference. This is often very troublesome in long distance receiving from powerful stations which work with long wave lengths. Although less intense on small field antennae, the atmospheric disturbances sometimes cause serious trouble in reading signals.

**Influence of Ground Contour.**—On a great plain, the waves are propagated normally in all directions from an antenna. In hilly regions, on the contrary, steep slopes form screens and deflect the waves. Near the foot of a steep hill, there is a region of shadow which is not reached by the waves coming from the opposite side. The waves reflected from the two slopes of a narrow valley, follow the valley. As it is necessary to avoid placing the receiving antenna in a region of shadow, an exposed position is sometimes preferable.

Telegraph lines and metallic conductors used in the construction of houses absorb the waves and their proximity is usually detrimental. In forests, an antenna receives and transmits badly because the sap of the trees conducts electricity and may be the seat of induced currents. When an antenna must be hidden in a wood, it should be placed as close as practicable to the edge from which the waves are coming, or in the middle of a glade. If possible, it is advantageous to install it above the trees. Interference with the waves by trees and houses is greater, the shorter the waves.

It is also necessary to choose a position for the ground connection where the ground is damp and conducting. An antenna in a position not entirely exposed may be good for transmitting and receiving waves in one direction, but not for another.

## PART 2.

### CHAPTER I.

# UNDAMPED WAVE RADIO TELEGRAPHY

The fact that the efficiency of the transmitting sets is greater, and that the tuning of the receiving sets is sharper for the waves having the smallest damping, gives rise to the desirability of using waves that are not damped at all. This means that an alternating current of constant amplitude and of radio frequency must be generated in the transmitting antenna. The use of alternators for this purpose presents very considerable difficulties, and is absolutely impracticable for portable sets such as are needed for military purposes. However, a new method of generation of undamped wave oscillations has come in for a very extensive application in Signal Corps work, consisting in the use of the three-electrode vacuum tube.

### Vacuum Tubes in Radio Communication

Upon gaining a general idea of the newer apparatus used in the transmission and reception of communications by radio, one soon becomes impressed with the importance of the vacuum tube, as it occurs in nearly all of the principal types of modern radio apparatus. The same tubes may be used to transmit, to receive, to detect, to amplify, to modulate and to serve other important functions necessary to radio communication as it is now known. Their practical application to these numerous uses is an accomplishment of the last few years and the possibilities for further application are by no means exhausted. In fact, the whole field of radio work has been greatly influenced by the development of vacuum tubes, and by virtue of this it is now possible to effect radio communication through greater range with lower power and with greater selectivity than was formerly possible. Also, the tube has enabled the construction of apparatus for these uses, which is readily portable—a most important feature in connection with military communication systems.

How these tubes work and how they can be made to serve such a multiplicity of purpose, are the questions which most naturally arise in the mind of every student. Answer to these

two questions involves much highly theoretical discussion and more than one way of explaining the action in some instances. The following paragraphs, however, are intended to give an explanation general enough to be easily understood, avoiding much interesting and valuable discussion on functions of the tubes not at present utilized by the U. S. Signal Corps, and also avoiding dual explanations of any particular action.

### Electron Flow in Vacuum Tubes

The electron flow in a vacuum tube will first be studied in a bulb containing two metal electrodes; one, a filament which may be heated by a local battery A, and the other, a flat piece of metal, called the plate, Fig. 1. If a battery B is connected across the tube with its negative pole to the filament and its positive pole to the plate, no current will be indicated on the ammeter I inserted in the circuit. However, if a current is passed through the filament by means of a battery A, bringing the filament to a red heat, a current of a few milliamperes will be shown by the ammeter to flow in the circuit BFPIB. Thus, the heating of the filament causes a current to flow across the open space of the bulb. This may be accounted for as follows:

The explanation of phenomena observed in a great number of experiments has led to the assumption that there exist extremely small non-material particles having a definite negative charge of electricity. These particles are called electrons. They move in great numbers between the atoms of any metal. At ordinary room temperatures, they do not escape out of the metal, in most cases, but when the metal is heated, the material atoms vibrate about their mean position of equilibrium with a speed and amplitude which increases with the temperature. The electrons, which follow the atoms in this thermal agitation, likewise acquire increasing speed as the temperature of the metal is raised. When it becomes red hot, the speed of the electrons is so high that they leave the metal. This phenomenon is illustrated by the experiment described above, wherein the filament was made red hot and an electrostatic force was present, due to the connection of the B battery in the plate circuit, which tended to move the negative electrons from the filament to the plate by repulsion from the filament and attraction by the plate. Under these conditions, the electrons travel from the filament to the plate at a speed which may attain tens of thousands of miles per second, and transport negative charges across the space in the bulb from filament to

plate. The passage of electrons, each carrying its charge of electricity from filament to plate, constitutes a flow of electricity which is an electric current. It should be noted that the electron flow is from the negative filament to the positive plate, while the electric current flow is just the opposite—from the positive plate to the negative filament. This is not difficult to explain, as the direction of flow of the electric current from positive to negative poles is a mere assumption which was made before the discovery of the electron flow, and could just as well have been assumed to be in the opposite direction.

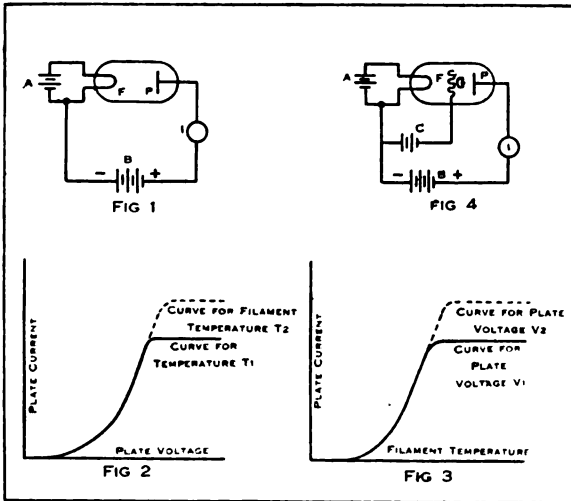

Fig. 1, 2 and 3—Two-Electrode Vacuum Tube and Characteristic Curves  
Fig. 4—Three-Electrode Vacuum Tube

If the polarity of the B battery, Fig. 1, is reversed, no electric current will flow through the ammeter, as the plate will be negative and will repel the negatively charged electrons and thus prevent any flow of electricity across the tube.

#### Operation of Two-Electrode Tubes Under Various Conditions

The two electrode vacuum tube is very frequently called a valve. For a given filament temperature,  $T_1$ , a definite number of electrons is emitted per unit of time. The number of electrons per second which will travel across the tube and reach the plate is the measure of the current in the plate circuit, and it varies



within limits approximately as the square of the voltage across the space between plate and filament. As this voltage is increased, a certain value will be reached at which all electrons emitted by the filament will be absorbed by the plate, so that no increase of current will take place for higher values of the plate voltage. This is shown in Fig. 2, curve for temperature  $T_1$ . In order to increase the plate current, it is then necessary to raise the filament temperature to some higher value,  $T_2$ , when the current curve will rise to a new value before bending over to the horizontal position.

Now, if the plate voltage is kept at a constant value,  $V_1$ , and the filament temperature raised by increasing the current from the battery A, the number of electrons emitted by the filament will vary approximately as the square of the filament temperature figured above the red heat temperature ( $1600^\circ$  absolute for tungsten filament) until a point is reached where the electrostatic field, due to the negative charge of the electrons in motion in the tube, will exactly counteract that due to the positive charge of the plate. This condition is called the "space charge effect." Any further increase of filament temperature would then tend to increase the number of electrons in the tube, and therefore the space charge. The latter then outweighing the charge of the plate, would repel some of the electrons back into the filament. A state of equilibrium is thus reached whereby the current remains constant independently of further increase of filament temperature, and the current curve will bend over and remain at a constant value of plate current, Fig. 3. If there is not potential difference between the filament and the plate, the space charge effect will prevent the flow of electrons to the plate.

To increase the current, it is then necessary to increase the plate voltage to some higher value,  $V_2$ . The upper limit to this voltage increase is that which prevails when a blue glow is observed around the plate. On old and defective tubes, this blue glow may appear at normal operating voltages, and then it is an indication of poor vacuum. It causes a hissing noise in the telephones and prevents good operation of the tubes.

### The Three-Electrode Vacuum Tube

The three-electrode tube used by the U. S. Signal Corps is a highly evacuated bulb containing a filament and a plate like the two-electrode tube already described, but in addition

having a grid or wire screen supported midway between the plate and the filament. The filament is made of some material, usually tungsten, or platinum coated with oxide, which when heated liberates a quantity of electrons from its surface. The plate electrode is placed near to and usually encloses the filament. It may take various forms, such as two flat plates, a cylinder, a cone, etc. The grid is made up of a network of metal wires, sealed into the tube and supported in such a manner as to be interposed between the filament and the plate so that any passage of electrons or current between these electrodes must pass through the grid.

If the plate is made positive with respect to the heated filament, a flow of electrons will take place from the filament to the plate, as explained in connection with the two electrode tube. In their flow, the electrons must pass through the wire mesh of the grid, which can be made to have a controlling influence on the electrostatic field in the tube. Thus the rate of flow of electrons from filament to plate may be regulated by changing the potential of the grid with respect to the filament. If the grid is given a potential slightly negative to the filament, which may be done by a battery C, Fig. 4, it will repel some of the electrons emitted from the filament, but many of them, due to their high velocity, will pass through the mesh of the grid and reach the plate. Now, as the potential of the grid is made more negative, Fig. 5, the plate current will gradually decrease until the negative grid potential will be great enough to prevent all electrons from leaving the filament, thus stopping the plate current flow entirely. This is due to the action of the field created by the grid which has neutralized that created by the plate.

If the grid is made positive instead of negative, more electrons will be attracted toward the plate than would pass without the influence of the grid potential, and the plate current will be increased until saturation of the tube occurs. This saturation may be explained as follows: As the grid is made more and more positive, the plate current increases at a greater rate than the grid voltage, Fig. 5, so that a grid potential will be reached at which the space charge due to the negative electrons passing across the tube will exactly counteract the influence of the positive grid potential. When this condition prevails, the maximum plate current is obtained. Further increase of grid potential tends to increase the plate

current and therefore the space charge, but the latter, increasing at a greater rate, overbalances the influence of the grid and the plate current thus remains practically constant up to a certain grid voltage, beyond which the plate current slowly decreases. The limitation of plate current is due not only to the space charge effect, but also to the absorption of electrons by the grid in increasing numbers as its positive potential is increased. This absorption gives rise to a current flow in the circuit FGCF, called the grid current.

From the last two paragraphs it can be seen that if the grid is made alternately positive and negative, the plate current will be accordingly increased and decreased about its normal value in the absence of the grid. By means of a small dry battery it is possible to fix the mean potential of the grid at any point on the characteristic curve. The value of this mean potential (which is the grid potential existing when no oscillations are taking place) determines the operation of the tube as a rectifier or as an amplifier. The variations of grid potential modify the plate current, and the tube thus acts as a relay controlled by the very small variations of grid potential. The electrostatic capacity of the grid being very small, the variations of its charge involve correspondingly small amounts of energy. It is therefore very sensitive, and having no inertia, it is able to follow the extremely rapid oscillations encountered in radio telegraphy—oscillations of frequency far beyond the range of mechanical or more common electrical devices.

### Detector Action of Vacuum Tubes

A simple connection of the three-electrode tube as a detector is shown in Fig. 6. When a train of damped oscillations strikes the antenna, it produces an alternating voltage in the antenna circuit as represented in Fig. 7-A. This voltage induces a similar voltage in the secondary coil, ab, of the receiving transformer connected in the grid circuit, which is superimposed on the normal grid potential given by the battery C. The component of the grid current due to the alternating voltage will flow only during the positive half cycle of the oscillation, as seen from the grid current characteristic curve, Fig. 5, and indicated in Fig. 7-B. This current flow from grid to filament has a tendency to equalize the potential difference between them, so that the actual grid voltage, instead of

following a symmetrical curve similar to the antenna voltage, will be asymmetrical, the amplitude of the negative half of the wave being greater than that of the positive half, Fig. 7-C, as no current is then flowing.

Referring to the grid current characteristic curve, Fig. 5, again, it will be seen that an asymmetrical change in plate current will result from this asymmetrical change in grid

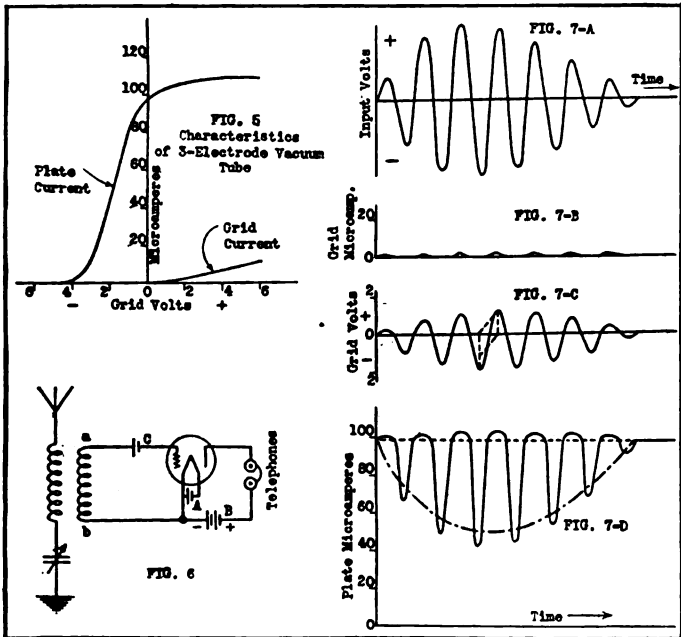

Fig. 5—Characteristics of Three-Electrode Vacuum Tube. Fig. 6—Three-Electrode Tube Used as Detector. Fig. 7—Analysis of Detector Action; (A) Input Voltage Due to Incoming Waves; (B) Resulting Grid Current; (C) Grid Voltage, Resultant of Induced and Counter EMF.; (D) Current in Plate and Telephone Circuit

potential, Fig. 7-D. When flowing through the telephone receivers, this plate current will be smoothed out by the inductance of the telephone into a single unidirectional impulse; and such an impulse being produced for every wave train, a sound will be produced in the telephones at a frequency corresponding to that of the frequency of the trains. The operation of the tube as a detector will be best when the normal grid potential is near the upper bend of the characteristic curve.

and will gradually become less effective as this potential is brought nearer to the lower bend, until a point is reached when rectification does not occur and where the asymmetrical variations of grid voltage produce symmetrical variations of plate current, Fig. 8. This particular part of the curve is used for amplification, as will be explained in a later paragraph. Beyond this point of no detector action, however, the rectifying properties of the tube reappear, so that it may be used as a fair detector on the lower bend of the characteristic curve.\*

**GRID CONDENSER CONNECTION FOR DETECTOR ACTION.**—If the C battery, Fig. 6, is replaced by a small condenser (.0005mfd.), the detector action of the tube is different from that described above. During a period of no oscillations, the plate current assumes a certain value determined by the B battery and the filament temperature. If now an oscillation strikes the antenna, the grid will be made alternately positive and negative. When it is positive, it attracts electrons, and being insulated from the filament, it retains these electrons and acquires a negative charge which lowers the plate current. The negative charge of the grid is then caused to leak off either through the condenser dielectric or through a high resistance shunting the condenser, so that by the time the next train of waves arrives, the grid is again at its normal potential.

### Amplifier Action of Vacuum Tubes

The energy of a signal wave at the receiving station is very often so extremely weak that it is necessary or advantageous to amplify the signals to make them more easily read. In radio telephony, this amplification has a special importance. The problem consists in producing changes in the telephone receiver current which are exactly proportional to the amplitude of the incoming waves, and without distortion. As outlined in the explanation of the detector action of the tube, a symmetrical oscillation in the primary (input) circuit induces an asymmetrical oscillation in the secondary or grid circuit, the voltage amplitude being less for the positive half cycle than for the negative. A point may be found on the characteristic curve of the tube, Fig. 8, where the asymmetrical variation of grid potential produces symmetrical variations of plate current, so that the variations of the plate current will reproduce

---

\*The curves of Fig. 7-B, 7-C and 7-D should lag about 180° behind the voltage curve of Fig. 7-A. This has not been shown because of its tendency to confuse.

exactly those in the antenna without distortion. Furthermore, the very slight energy of the wave acting on the grid, produces very large variations of plate current because of the relay action of the tube, and this explains the amplification of the antenna oscillations.

To separate the amplified alternating current from the steady direct current in the plate circuit, the pulsating plate current

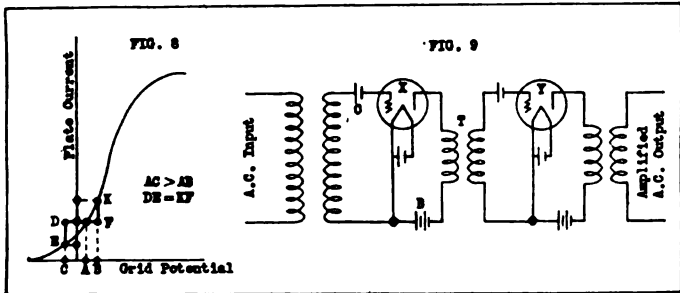

Three-Electrode Vacuum Tube Used as Amplifier. Fig. 8—Point on Characteristic Curve Giving Symmetrical Amplification. Fig. 9—Connection for Cascade Amplification

is passed through a transformer, Fig. 9, which delivers the amplified alternating current at its secondary terminals. A second tube may be used to further amplify this wave if necessary, as tube Y, Fig. 9. When this is done, the process is called cascade amplification. With the VT-1 type vacuum tube, more than two tubes are seldom used for amplification purposes. Two of these tubes give an amplification of about 10,000 times.

### Oscillator Action of Vacuum Tubes—Undamped Wave Transmission

As the vacuum tube can be used as an energy amplifier, it can be made to generate and sustain oscillations by feeding back upon the grid circuit the energy amplified in the plate circuit. This can be done by electromagnetically or electrostatically (or both) coupling the grid circuit to the plate circuit. Such an arrangement is shown in Fig. 10, where the grid circuit  $GL_1FG$  is coupled electromagnetically to the plate circuit  $PL_2FP$  by means of the inductances  $L_1$  and  $L_2$ .

If now a small change is produced in the potential of the

grid, a change in plate current involving a greater amount of energy will result. This plate current, flowing through  $L_2$ , will in turn induce an emf. in  $L_1$  of greater magnitude than the original potential change in the grid circuit. This produces a new change in the potential of the grid so that oscillations

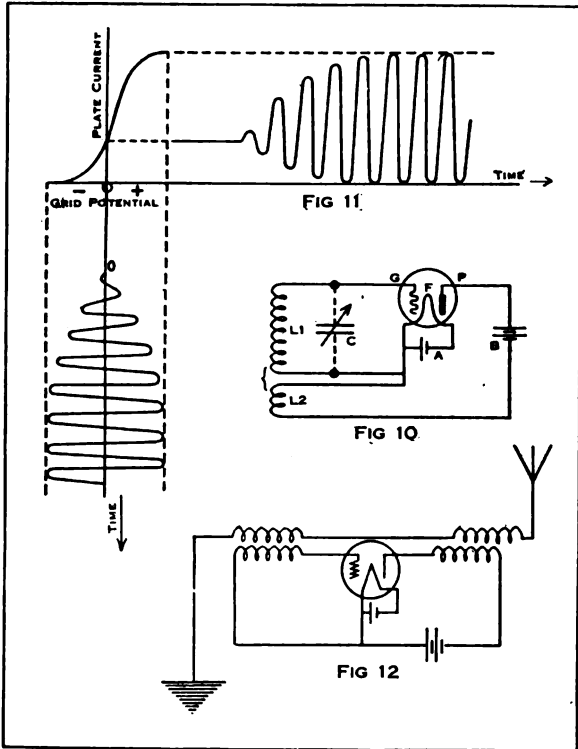

Vacuum Tube Used as Oscillation Generator. Fig. 10—Connection for Undamped Oscillation Generation. Fig. 11—Analysis of Generator Action. Fig. 12—Example of an Undamped Wave Transmitting Set

continue to increase in this manner until the amplitude of the plate current reaches the bends of the characteristic curve of the tube. At this point the oscillations will have reached their final constant amplitude. Fig. 11 is a graphical representation of this phenomenon.

To produce oscillations, it is of course necessary that the values of inductance and capacitance, and the coupling, be chosen of such values that the emf. induced in the grid circuit will be in phase with the alternating component of the plate current. To generate oscillations of any given frequency, it is simply necessary to tune the oscillatory circuit by means of the condenser C, for instance. The circuit  $L_1C$  will then oscillate at its natural frequency, and these oscillations will be sustained by the plate current. The oscillator can then be coupled to an antenna and made to induce undamped oscillations in it which will be radiated into space. Such a circuit is shown in Fig. 12, which shows the principle of the SCR-69 set, but there are any number of connections which will enable the use of the three-electrode tube as an oscillation generator. To use such a set as a radio transmitting set, it is simply necessary to insert a sending key at some point of the circuit. Then whenever the key is depressed, the antenna will radiate undamped waves.

### Signal Corps Three-Electrode Vacuum Tubes

The three-electrode vacuum tubes used by the Signal Corps have the type numbers VT-1, VT-11, VT-21, VT-14 and VT-2. The first three employ platinum filaments coated with an oxide and they are all used for detection and amplification. They operate at the same constants and have practically the same characteristics, the different designations referring to tubes which have different physical construction and are supplied by three different manufacturers. The VT-2 tube is used for transmitting purposes. The VT-14 tube employs a tungsten filament, and is used for transmitting. It operates with a plate potential of 350 volts, a filament current of 1.75 amp. at 7 to 8 volts, a grid potential of negative 20 volts and delivers 3 watts output.

The detector and amplifier tubes operate with an average filament current of 1.1 amp. at 3.6 volts. The plate voltage averages 20 volts. The grid is maintained at the same potential as the negative filament lead, or slightly more negative.

The VT-2 tube operates with an average filament current of 1.36 amp. at 7 volts, and with a plate voltage of 300 volts. It normally operates with about 20 volts negative potential on the grid. The power output as an oscillation generator is approximately 3 watts.

The VT-1 and VT-2 tubes operate with a dull filament. The



VT-11, VT-12, VT-14 and VT-21 tubes operate with extremely bright filaments.

### Reception of Undamped Waves

The reception of such signals is different from that of damped wave signals. The principle of damped wave reception is that every wave train, after being rectified, deflects the diaphragm of the telephone receiver, which then between two wave trains, springs back in place. The succession of wave trains then sets the diaphragm into vibration at the spark frequency of the transmitting set.

In undamped wave telegraphy, the oscillations are not divided into wave trains; they are emitted without interruption, and with a constant amplitude, Fig. 13. Hence, the telephone diaphragm is deflected at the beginning of the signal, and so remains until the end of the signal, for the succession of the

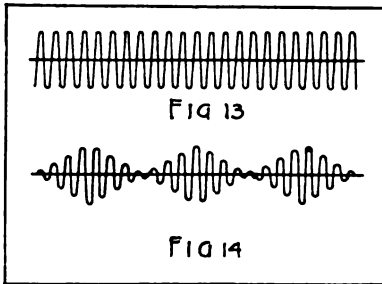

individual waves is so rapid that the diaphragm will not respond to the corresponding high rate of vibration. There is consequently no audible vibration of the diaphragm. However, audible vibrations in the receiver may be obtained by several different methods.

One method consists in utilizing a mechanical interrupter called a "tikker" which is connected in the circuit at the receiving station, in such a way that it periodically interrupts the current through the telephone receivers—the current induced by the incoming radio waves—and thus breaks it up into current-off-and-on periods of a low frequency to which the diaphragm will respond. This method has the disadvantage that all the energy received by the antenna during the current-off periods is lost.

A more recent and better method consists of a scheme for transforming at the receiving station, the continuous waves of constant amplitude into waves the amplitude of which varies periodically, Fig. 14. This end is attained by the application of the phenomenon, familiar in the study of sound wave propa-

gation, called "beats." This is called the "heterodyne" method of reception.

The receiving set is tuned to the frequency of the incoming waves by means of its adjustable inductance coils and condensers. Then, undamped waves of slightly different frequency are generated locally at the receiving station and superimposed upon the oscillations in the detector circuit due to the incoming waves. The result is that the two rectified alternating currents add together algebraically to produce beats in the amplitude of the current through the telephones, of a frequency equal to the difference between the frequencies of the two currents.

Such a set may be constructed by modifying the receiver circuit shown in Fig. 6. It is simply necessary to couple the plate circuit of the detector tube to the grid circuit. The tube then acts simultaneously as a detector for the incoming waves and as a generator for the local undamped oscillations, Fig. 15. Such an arrangement of circuits is called an "autodyne" receiving set.

The frequency of the local oscillations may be changed by adjusting the setting of the condenser C for instance, and this will change the beat frequency and therefore the pitch of the sound in the telephone. A very pure note of any

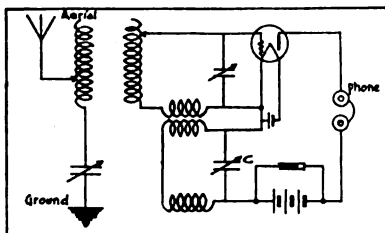

Fig. 15—Schematic Circuit of an Autodyne Receiving Set.

pitch may thus be obtained at the will of the receiving operator. The use of such sets allows exceedingly sharp tuning and practically eliminates all interference from other sending stations.

# RADIO TELEPHONY

Radio telephony has not thus far been extensively used in the war, although recent developments bid fair to make practical a perhaps very important utilization of this form of radio communication. The principles involved in radio telephonic transmission are the same as for undamped wave telegraphic transmission, except that the sending key is replaced by a device for varying the intensity of the energy radiated to produce sounds at the receiving station corresponding to the inflections and modulations of the voice. The device used for this purpose is the three-electrode vacuum tube so connected in the transmitting oscillatory circuit as to act as a modulator of the outgoing energy. The principles involved in radio telephonic reception are the same as for damped wave telegraphic reception. These principles are explained in the following paragraphs.

### Modulator Action of Vacuum Tubes—Radio Telephone Transmission

The three-electrode vacuum tube may be used not only to amplify power, but also to absorb power in a perfectly controllable manner. This may be explained by the characteristic of the tube whereby the space between the plate and filament has a resistance, the magnitude of which is dependent upon the potential of the grid. This was fully shown above in connection with Fig. 5, where, for a given constant plate potential and filament temperature, the plate current was determined by the grid potential. In other words, the action of the vacuum tube may be considered as equivalent to a variable resistance which controls the flow of the current in the plate circuit, the value of this resistance being determined by the potential of the grid.

A common application of this property of the tube is found in radio telephony. For instance, consider the circuit of Fig. 16. The high frequency alternator connected in the antenna circuit generates continuously a high frequency alternating

current of constant amplitude. The antenna is thus made to radiate a continuous stream of undamped oscillations. Inductively coupled to the antenna

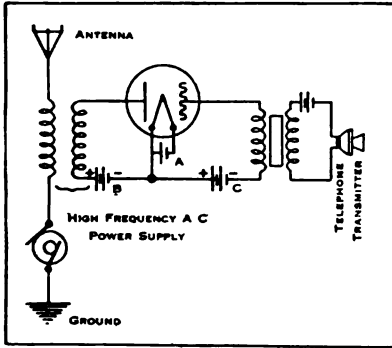

Fig. 16—Three-Electrode Tube Used as Modulator, Showing Connection as Radio Telephone Transmitter

is the plate circuit of a three-electrode vacuum tube, the grid of which is maintained at a considerable negative potential with respect to the filament by means of a battery C. The current passing through the antenna coil induces an emf. in the plate coil coupled to it, and therefore a potential difference between the filament and the plate of the tube. But on account of the strongly negative potential of the grid, this emf. produces only a very small current in the plate circuit. In other words, the power transferred from the antenna circuit to the plate circuit of the tube is very small.

Now if the grid is made less negative, or even positive, the same induced emf. in the plate circuit will produce a larger current, so that there will be a larger transfer of energy from the antenna circuit to the tube. The tube will have absorbed power, so to speak, from the antenna circuit. The result of this absorption is that the normal output of the generator is divided between the two circuits in proportion to their impedances, so that part only of the energy normally radiated by the antenna without the reaction of the plate circuit, will now be radiated. The more positive the grid of the tube, the less the resistance to the plate current flow and the greater the power absorbed by the tube, and therefore the less the amount of energy radiated by the antenna.

It is thus possible to modulate the waves radiated by the antenna into any desired shape. By suitably varying the grid potential by means of the voice, through the medium of the ordinary telephone transmitter coupled to the grid circuit, the changes in the instantaneous amounts of energy radiated will be proportional to the inflections of the voice. At the receiving station, the corresponding oscillations, when rectified, will

have a shape or "envelope" molded to the transmitting speech, and they will therefore induce in the telephone receivers a unidirectional pulsating current similar to that in the ordinary wire telephone which will exactly reproduce the sound of the voice at the sending station.

The vacuum tube may be used not only to modulate the a.c. power output of the high frequency a.c. generator, as explained in the previous paragraph, but to modulate the d.c. supply to that generator, thus accomplishing in another way the same final result—the modulation of the antenna output. This is the scheme of modulation commonly used by the U. S. Signal Corps, the a.c. generator being a vacuum tube oscillator. The modulator tube is connected in parallel with the oscillator tube, across the d.c. supply and the telephone transmitter is connected to the primary of a transformer, the secondary of which is connected in the grid circuit of the modulator tube. As the resistance of the modulator tube is changed by the voice, the amount of d.c. power to be transformed into a.c. power by the oscillator tube will be correspondingly modulated. For fuller explanation, see Radio Pamphlet No. 20.



---

Prepared in the  
Office of the Chief Signal Officer  
Training Section  
Washington

---

**ELEMENTARY PRINCIPLES  
OF  
RADIO TELEGRAPHY  
AND TELEPHONY**

Radio Pamphlet  
No. 1

Signal Corps, U. S. Army  
6-30-18

3





---

ERRATA

Radio Pamphlet No. 1.

Page 5, just below:  
equation should read:

" The self-inductance of a circuit, therefore, is the ... etc."

Page 15, line 13  
"aa" should be  $a/a'$ .

Page 28, Paragraph 2, Line 9  
"current" should read "omf"

Y

lo  
d.  
e-  
re

It is expected that the officers and non-commissioned ~~off~~ better qualified to understand the theory involved in radio ~~v~~ plain the contents of this pamphlet to the enlisted personnel ~~w~~ some knowledge of the work, by enlarging upon the points ~~pre~~ and by giving analogs and in general by going over the ~~pamph~~ by sentence, with these men and fully explaining each step ~~of~~ all questions.

Faint, illegible text on a white sheet of paper, possibly bleed-through from the reverse side. The text is too light to transcribe accurately but appears to be organized into several lines or paragraphs.



# **ELEMENTARY PRINCIPLES OF RADIO TELEGRAPHY AND TELEPHONY**

**The Underlying Electrical Theory Involved in Radio Communication Work is Simply and Briefly Covered. The More Common Means of Transmitting and Receiving Radio Employed for Military Purposes are Analyzed in Terms Comprehensible to the Non-Technically Educated but Technically Inclined Personnel.**

It is expected that the officers and non-commissioned officers who are better qualified to understand the theory involved in radio work, will explain the contents of this pamphlet to the enlisted personnel who must have some knowledge of the work, by enlarging upon the points presented herein and by giving analogs and in general by going over the pamphlet, sentence by sentence, with these men and fully explaining each step and answering all questions.

## PART 1

	Page
<b>CHAPTER I.—THE THEORY UNDERLYING THE RADIO SYSTEM OF COMMUNICATION.....</b>	<b>3</b>
General Survey of the Field of Radio Communication...	3
The Electrical Units Pertinent to Radio.....	5
Definitions of Electrical Units.....	6
Three Systems of Units—Table for Changing from One to Another.....	7
Electromagnetic Induction.....	8
The Alternator.....	8
The Inductor Type Alternator.....	10
The Induction Coil.....	10
The Transformer.....	12
Oscillatory Discharge of a Condenser.....	12
Phenomena of Resonance.....	15
Propagation of Electric Waves.....	17
<b>CHAPTER II.—DAMPED WAVE RADIO TELEGRAPHY.....</b>	<b>19</b>
Principles of Transmission.....	19
Types and Characteristics of Antennae.....	20
Transmission by Direct Excitation.....	22
Transmission by Indirect Excitation.....	24
Principles of Reception.....	28
Tuning of Oscillatory Circuits.....	31
Coupling of Oscillatory Circuits.....	31
Sources of Trouble in Reception.....	31
Influence of Topography on Reception.....	32

## PART 2

<b>CHAPTER I.—UNDAMPED WAVE RADIO TELEGRAPHY.....</b>	<b>33</b>
Vacuum Tubes in Radio Communication Work.....	33
Electron Flow in Vacuum Tubes.....	34
Operation of Two-Electrode Tubes Under Various Conditions.....	35
Characteristics of the Three-Electrode Vacuum Tube	36
Detector Action of Vacuum Tubes.....	38
Amplifier Action of Vacuum Tubes.....	40
Oscillator Action of Vacuum Tubes—Undamped Wave Transmission.....	41
Three-Electrode Tubes used by the United States Signal Corps.....	43
Reception of Undamped Waves.....	44
<b>CHAPTER II.—RADIO TELEPHONY.....</b>	<b>46</b>
Modulator Action of Vacuum Tubes.....	46
Radio Telephone Transmission.....	46
Radio Telephone Reception.....	46

## PART I.

### CHAPTER I.

# THE THEORY UNDERLYING THE RADIO SYSTEM OF COMMUNICATION

## General Survey of the Field of Radio Communication

**V**ERY soon after wire telegraphy became of practical usefulness, conditions were encountered in which the desirability of effecting electrical signaling without connecting wires became apparent. As a result of this need, a number of methods of telegraphing without wires were tried out, based on schemes of utilizing the conduction through the ground, magnetic induction, etc., as the means of sending the signals. All of these methods, however, were very limited as to range of transmission and were therefore of little importance and value as a system of communication.

Radio telegraphy, or the transmission of signals by means of unguided electric waves, was first introduced in 1896 by Marconi, after extensive experiments made by himself and with the help of the discoveries and research work of Hertz and others. In 1899 communication was established between Dover and Boulogne, a distance of 32 miles, and shortly after, information between ships was transmitted as far as 80 miles. The importance of radio communication was by that time universally admitted, and from this it has constantly grown and extended its field to commercial, naval and military pursuits. From these early stages, the art has rapidly progressed until in 1916, Arlington Station could hear Japan working with Honolulu, the distance involved being approximately one half the circumference of the earth.

The application of radio to military uses is the one to which this pamphlet is particularly devoted. In this application, its development has likewise been extremely rapid, and at the present time one of the most important means of communication between armies and units is by means of the unguided radio waves, this assuming greater importance as the intensity of destructive shell fire and hence the difficulty of maintaining wire communications increases.

An entire system of radio communication has been established to supplement the wire system for the forwarding of information between the various headquarters of the armies, divisions, brigades and even to and from the front line trenches. In an attack, when the infantry moves forward, one of the most difficult tasks is to maintain communication with headquarters. A certain element of time is involved in carrying forward wire communication systems and they are continually broken down by shell fire. The radio and ground telegraph apparatus, however, are much more simply carried forward and are usually operative unless destroyed by an almost direct hit. Of course, there are many times when the interference of the enemy and other of our own radio sets is so great as to make receiving of signals extremely difficult and at nearly all times the operator must be able to pick out his own signals from a number heard simultaneously.

Another system of radio communication is in existence between airplanes and artillery. This is called the fire-control system and it is perhaps the most extensive and complex of all the radio organizations in operation at the front. The firing of each battery of light, medium, heavy and superheavy artillery is directed to greater or less degree by radio signals sent out from airplanes flying over enemy positions, particularly that of the last three named. This work is extremely important, and the number of airplanes used for the purpose is large. Great as is the value of the airplanes in extending the range of vision of the army, yet their effectiveness in directing artillery fire onto enemy targets is only made possible by the instantaneous means of communication between plane and battery afforded by the radio apparatus. In the early days of the war, even this scheme of communication was so slow, due to the cumbersome signals and natural sluggishness and difficulties incurred in developing and perfecting the practice, that the batteries were not kept busy enough to hold the interest of the men. The intervals between firing and receiving a range correction from the airplanes were so long that not much confidence was had in this method of directing fire. However, the signal system has been greatly simplified and otherwise improved, so that it is now very effective in directing suitable battery fire on enemy gun positions and movements in such a manner as to frequently effectively silence the guns or destroy supply trains, etc.

Radio is also effectively used on reconnaissance and bomb-

ing airplanes, which sometimes are equipped with high power, long range sets. The radio telephone has found some use on battle planes and fighting machines, although this means of communication has not been extensively used up to the present time. It is now undergoing an intensive development and may come in for a more important part in the airplane and other radio work later on.

Not the least important use of the radio apparatus in military operations is that which the alert operator makes of it as a means of anticipating destructive shell fire on his own battery position. It frequently happens that he will hear a hostile plane sending down to the enemy batteries, the map co-ordinates of his position. He will then warn the battery commander not to fire for a period, as this would further prove the position to the hostile aircraft. Or the operator may hear a shell burst at not great distance from his battery position and then hear the hostile plane send down a correction which denotes to the operator that his battery is the target at which the enemy is firing. A timely warning made to the battery commander under these circumstances has saved the lives of many artillery men.

### The Electrical Units Pertinent to Radio

**Self and Mutual Inductance.**--When an electric current is made to flow through a circuit, a magnetic field is established in the space surrounding it. The strength of this field at any given point is proportional to the current flowing in the circuit, and is dependent on the shape of the circuit and on the nature of the medium surrounding it. The value of the ratio of the field flux to the current in a given circuit is called its self-inductance (also called coefficient of self induction). Thus,

$$\text{Self Inductance} = \frac{\text{Electromagnetic Flux}}{\text{Current}}$$

The unit of self inductance, therefore, is the electromagnetic flux around the circuit when unit current is flowing through it.

If unit current is made to flow through one of two independent circuits A and B, (A for instance), the magnetic field due to that current extends around both circuits A and B, if they are near enough together. That part of the flux due to A which interlinks with circuit B is called the mutual inductance of circuit A upon circuit B. This depends on the shape of each of the two circuits and on their relative positions. Their



mutual inductance is therefore greatest when the two circuits are closest together. Whenever a circuit reacts upon another, the two circuits are said to be coupled, the coupling being close or loose according to whether the mutual inductance is large or small.

As the magnetic field builds up around a wire carrying a current, it is possible to obtain a large inductance by winding the wire into a coil so that many turns will be concentrated in small space. By this means, a considerable flux may be produced through the summation of the fluxes due to each turn.

**Capacitance.**—If an insulated conductor is placed near a grounded conductor, and a charge is given to the former, its potential is found to be proportional to that charge. The value of the ratio of the charge to the potential of the conductor has been called the capacitance (electrostatic capacity) of that conductor. Thus,

$$\text{Capacitance} = \frac{\text{Electrostatic Charge}}{\text{Potential}}$$

A large capacitance may be obtained by placing two sheets of metal very close to each other and insulating them by means of some dielectric (air, mica, glass, etc.). Such a device is called a condenser. Condensers of large capacitance are built by combining a large number of sheets of metal foil separated by glass plates or sheets of mica. All even and all odd numbered sheets are connected together, respectively, each group forming one side of the condenser. The capacitance of a condenser is directly proportional to the area of the plates and inversely proportional to the distance between them.

Condensers of adjustable capacitance are also used. Several semi-circular metal plates are placed parallel and one above the other, and connected by means of metal rods extending through the plates at the two ends of the straight side, and held apart by blocks or washers, the whole group of plates making up one side of the condenser. The other side is made up of a set of similar plates having a semi-circular shape and mounted on a shaft at their centers. By rotating the shaft, the plates move in or out between the stationary plates, and the capacitance of the condenser can thus be continuously varied.

#### Definitions of Units

**Resistance.**—The unit of resistance is the international ohm.

It is the resistance of a column of mercury 106.3 cm. high, and weighing 14.4521 grams at a temperature of 0 deg. C.

**Current.**—The unit of current is the international ampere. It is that unvarying current which, when passed through a neutral solution of silver nitrate, will deposit silver at the rate of .001118 gram per second.

**Electromotive Force.**—The unit of electromotive force is the international volt. It is the electromotive force which will cause one international ampere to flow through one international ohm.

**Inductance.**—The unit of inductance or of the coefficient of self-induction is the henry. It is the inductance of a circuit in which a current varying at the uniform rate of one ampere per second will induce an electromotive force of one international volt.

**Capacitance.**—The unit of capacitance is the farad. It is the capacitance of a condenser, such that a potential of one volt will cause the condenser to store a charge of one coulomb. (A coulomb is the quantity of electricity transported by a current of one ampere flowing for one second).

### Three Systems of Units

There are three systems of units commonly used in practice. These are the electrostatic, the electromagnetic and the practical units. A table is given below for changing these units from one system to another.

#### CAPACITANCE.

Electrostatic Units (cgs.).		Electromagnetic Units (no name).		Practical Units (mfd.).	
To Magnetic.	To Practical.	To Static.	To Practical.	To Static.	To Magnetic.
Divide by $9 \times 10^{20}$	Divide by $9 \times 10^3$	Multiply by $9 \times 10^{20}$	Multiply by $10^{13}$	Multiply by $9 \times 10^5$	Divide by $10^{15}$

#### INDUCTANCE.

Electrostatic Units (no name).		Electromagnetic Units (cgs.).		Practical Units (henrys).	
To Magnetic.	To Practical.	To Static.	To Practical.	To Static.	To Magnetic.
Multiply by $9 \times 10^{20}$	Multiply by $9 \times 10^{11}$	Divide by $9 \times 10^{20}$	Divide by $10^9$	Divide by $9 \times 10^{11}$	Multiply by $10^9$

## CURRENT.

Electrostatic Units (no name).		Electromagnetic Units (no name).		Practical Units (amperes).	
To Magnetic	To Practical.	To Static.	To Practical.	To Static.	To Magnetic.
Divide by $3 \times 10^{10}$	Divide by $3 \times 10^9$	Multiply by $3 \times 10^{10}$	Multiply by 10	Multiply by $3 \times 10^9$	Divide by 10

## POTENTIAL.

Electrostatic Units (no name).		Electromagnetic Units (no name).		Practical Units (volts).	
To Magnetic.	To Practical.	To Static.	To Practical.	To Static.	To Magnetic.
Multiply by $3 \times 10^{10}$	Multiply by 300	Divide by $3 \times 10^{10}$	Divide by $10^8$	Divide by 300	Multiply by $10^8$

## RESISTANCE.

Electrostatic Units (no name).		Electromagnetic Units (no name).		Practical Units (ohms).	
To Magnetic.	To Practical.	To Static.	To Practical.	To Static.	To Magnetic.
Multiply by $9 \times 10^{20}$	Multiply by $9 \times 10^{11}$	Divide by $9 \times 10^{20}$	Divide by $10^9$	Divide by $9 \times 10^{11}$	Multiply by $10^9$

It will be noted that in many cases the units have received no name in some of the systems in which they are expressed, so that the name of the system must be given. Thus a current of 1 amp. is a current of 3,000,000,000 units of current in the electrostatic system, or 3,000,000,000 electrostatic units of current.

### Electromagnetic Induction

When a conductor is moved across a magnetic field so that it cuts lines of force, an emf. is generated in the conductor. If the conductor is part of a closed circuit, a current will flow in it due to this induced emf. As this induction effect is due to the cutting of lines of force by the conductor, it will be greatest at the instant of the highest rate of cutting the magnetic lines of force (greatest number of lines cut per second). This phenomenon has many practical applications, some of which are studied below.

**Alternator.**—Consider a loop of wire closed on an ammeter,

and placed near a permanent bar magnet, Fig. 1. If either the magnet or the loop is moved, a current will be observed through the ammeter, the direction of the current depending upon the direction of motion and the polarity of the magnetic pole. If then the loop is held stationary and the magnet rotated around its axis *aa*, the direction of the magnetic field through the loop will be alternately in opposite directions, and an alternating current will be generated in the stationary loop circuit.

As the current is a maximum when the number of magnetic lines of force cutting the wire per unit of time is greatest, this

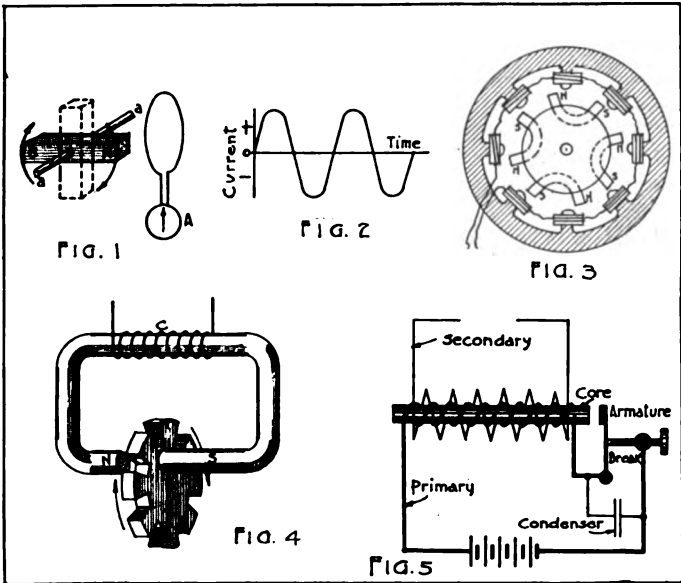

will occur when the magnetic pole passes directly in front of the loop. The current then decreases as the magnet pole is moved away, becomes zero for the position of the magnet shown in dotted lines, and increases again, but in the other direction, as the other pole of the magnet revolves toward the loop. The duration of one complete cycle, that is, of one complete revolution of the magnet, is called the "period" of the alternating current. The number of periods per second is called the "frequency."

A graphical representation of an alternating current may be

obtained by plotting off the value of the current at each instant, time being counted on one axis, and current on the other. This produces what is known as a "sine" curve, as shown in Fig. 2. In order to obtain currents of higher frequency, it is simply necessary to rotate the magnet at a higher speed, or to use a number of magnets mounted on a frame locked to the shaft, Fig. 3. Also, rotating the magnet, Fig. 1, at higher speed, or increasing the number of magnetic fields cut through per revolution, Fig. 3, increases the rate of cutting the lines of force and therefore produces higher voltage.

The permanent magnets may be replaced by electromagnets energized by a direct current derived from an auxiliary dynamo called an exciter, or from a battery. The field magnets, either permanent or electromagnets, may be stationary and the alternating current winding rotary.

The rotating portion of an alternating current generator is called the "rotor" and the stationary portion, the "stator." The more common construction is to make the field windings (d. c.) rotary.

**Inductor Type Alternator.**—Another method of producing an alternating current is to wind a coil of wire C, Fig. 4, around a magnet of special shape, the two poles of which face each other and are separated by an air gap. A toothed iron disk is then made to rotate between the jaws of the magnet, so that the gap between the poles is alternately open and then practically closed with iron. The result is that the flux between the two poles, and hence the magnetic flux in the entire magnet, alternately increases and decreases. This periodically varies the number of magnetic lines of force inside the coil C where an alternating emf. is thus generated. This type of generator is called an "inductor type alternator." It is quite widely used in supplying high frequency current to airplane radio apparatus. Instead of using a permanent magnet, it is of course possible to use an electromagnet energized by a direct current derived either from a storage battery or from a separate exciter dynamo.

**Induction Coil.**—Another form of electromagnetic induction is that involved in the operation of the ordinary induction coil, Fig. 5. This consists essentially of an iron core on which are wound two coils of wire. These are called the primary and secondary windings and the latter usually has a much larger number of turns of wire than the primary coil. Inserted in the circuit of the primary coil is a vibrator which, upon closing the circuit through the primary coil, is attracted toward the iron

core of the coil, opening the circuit. It is then immediately released by the demagnetized coil and it returns to its former position to again close the circuit, the operation being very similar to that of the ordinary buzzer. The vibrator thus serves to very rapidly make and break the circuit through the primary coil.

In the induction coil method of producing current by induction, the coils remain stationary, but the function of the vibrator in alternately making and breaking the circuit through the primary, is to produce a rapid change in the number of lines of force resulting from the current in the primary coil. These lines of force also penetrate and surround the secondary coil and induce in it an emf. corresponding in magnitude to the rate of change of the number of lines of force produced by the primary coil. When the circuit of the primary coil is closed, the magnetic field rapidly builds up but is retarded from reaching its maximum value by the counter emf. due to the self-inductance of the primary coil. As this field increases, it induces an emf. in the secondary coil of higher voltage and in the opposite direction than that in the primary. When the current in the primary has reached a certain value, the field becomes strong enough so that the vibrator armature is attracted toward the core, suddenly opening the primary circuit. This is followed by a rapid decrease in the number of lines of force cutting the secondary circuit, this change inducing an emf. of opposite polarity to the first, in the secondary coil. It is important to note that the opening of the primary circuit by the vibrator introduces a condenser in the primary circuit which serves the purpose of causing the primary current to fall to zero value with great rapidity. This is accompanied by a correspondingly high rate of decrease in the magnetic field, with the result that a very much higher emf. is generated in the secondary coil upon opening the primary circuit than upon closing it. This is clearly illus-

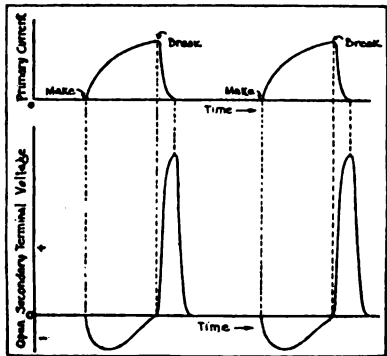

Fig. 6—Current and Voltage Relations in Primary and Secondary of an Induction Coil

trated by the curves of Fig. 6 where primary current and secondary voltage are plotted against time.

**Transformer.**—The operation of the alternating current transformer is based on a very similar principle to that of the induction coil. The principal difference between the two is that an alternating current is fed into the primary winding of the transformer instead of a direct current, as in the induction coil, which is broken up by the vibrator to produce a pulsating current.

The current in the primary of the transformer is then periodically reversed in direction. This produces a magnetic field periodically reversing in direction through the primary circuit, and also through the secondary coil which is generally wound over the primary on a common iron core. The reversals of the magnetic field induce in the secondary winding an opposite emf., the polarity of which is reversed at each reversal of the field. If the secondary terminals are connected to some external circuit, an alternating current of frequency equal to that of the primary current will then flow through this circuit. The ratio of the emfs. at the terminals of the two windings (primary and secondary) is equal to the ratio of their number of turns. Thus, if the primary consists of 20 turns of wire and the secondary of 1200 turns, the secondary voltage will be 60 times the primary voltage. The current will be roughly  $1/60$  as large, assuming unity power factor, since the power induced in the secondary cannot be greater than the power input to the primary. On account of the relative currents carried, the low voltage winding is made of heavy wire, while the high voltage winding is generally made of much finer wire.

Transformers used in radio apparatus are generally for the purpose of transforming a low voltage alternating current into a high voltage alternating current. Such transformers are called "step-up" transformers.

### Oscillatory Discharge of a Condenser

As outlined above, currents may be induced in a circuit by another entirely independent circuit in which an alternating or pulsating current is made to flow. As the inductive effect is due to a change of the magnetic flux in the circuits, it increases with increasing rate of change. In other words, the greater the number of reversals of flux per second, the greater the inductive effect at a given point, or the greater the distance

through which this effect may be evidenced. In radio telegraphy, where these effects must be transmitted great distances, it is therefore necessary to generate alternating currents in the transmitting circuit of a very high frequency—something of the order of 30,000 to 3,000,000 cycles per second. A number of methods have been used to attain this result, a very important one being the oscillatory discharge of a condenser. This is explained below.

Consider a condenser C, Fig. 7, with its plates connected to an inductance coil L and a spark gap G. The condenser

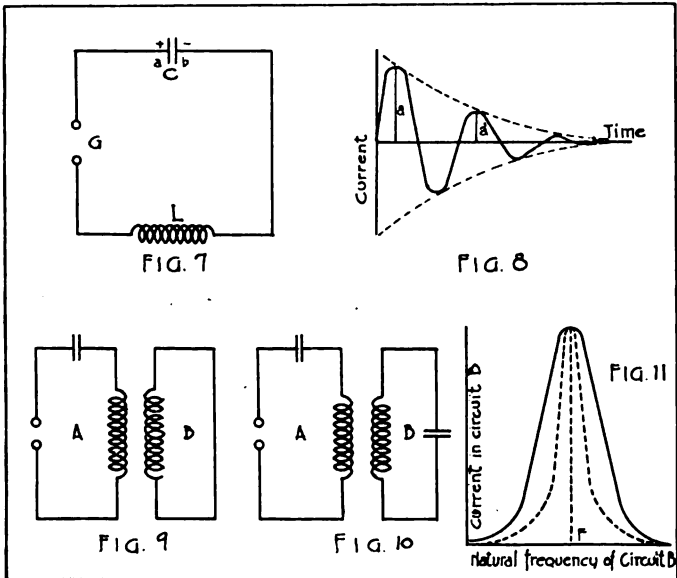

is charged by some outside source of energy; that is, a difference of potential is established between the two plates, giving them opposite polarities. If this potential is made high enough, a spark will jump across the gap, momentarily short-circuiting the condenser through the inductance coil. The condenser will then discharge, and the quantity of electricity which had been accumulated on one of its plates will spread over the circuit in a tendency to equalize the charge on the two plates of the condenser. This will create a current in the circuit, flowing for instance from a to b in the direction aGLb. The



effect of this current is to produce a magnetic field in the coil L. After a very short time, the condenser is entirely discharged, and there is no potential difference between its plates. There being no further charge on the condenser to maintain the current in the circuit, the latter will die out. This is accompanied by the collapse of the electromagnetic field in the coil. This change of magnetic flux, however, generates a current in the coil, in the same direction as the discharge current of the condenser, so that the current in the circuit, instead of dying out suddenly at the moment the condenser is discharged, will continue to flow in the same direction for an instant and accumulate electricity on the condenser plate which was originally at the lower potential. When the current has ceased to flow, the condenser will be charged again, but with a polarity opposite to its original polarity. It will therefore start discharging in the opposite direction, the phenomena occurring as above described, but with the current flowing this time in opposite direction. A series of current reversals will thus take place, the initial energy which was stored in the condenser being alternately stored in the electrostatic and in the electromagnetic fields of the circuit, this producing an alternating current of a frequency depending on the value of the inductance L and capacitance C, in the circuit. The relation between the frequency and the constants of the circuit is

$$f \text{ (cycles per second)} = \frac{159,200}{\sqrt{L \text{ (microhenrys)} C \text{ (microfarads)}}$$

This frequency is called the "natural frequency" of the circuit.

This alternating current would maintain itself indefinitely if there were no energy losses during the cycle. However, the wires making up the circuit have resistance, in which a certain amount of the energy is dissipated in the form of heat. Also, there are heat losses in the spark gap, the radiation losses, and some other losses, generally of less importance, such as leakage losses in the condenser, etc. The result is that at each cycle, the intensity of the current grows less, until after a few cycles, the energy is practically entirely dissipated and the current is consequently "damped" out. These few cycles as a group are called a "train" of oscillations. In order to produce a new train of oscillations, it is then necessary to recharge the condenser by means of some outside

source of potential. Such a train of oscillations may be represented as in Fig. 8 where current is plotted against time.

**Decrement.**—The number of cycles taking place in the circuit before the current is damped out is dependent on the resistance of the wire making up the circuit, being greatest for circuits of low resistance. The damping varies directly with the resistance of the circuit. The rate of damping of the current of such a discharge may be expressed mathematically by the ratio of the maximum amplitude of two consecutive cycles of a wave train. This ratio is a constant for a given circuit and is called the "arithmetic decrement" of the oscillation. Thus, the arithmetic decrement of the wave shown in Fig. 8, would be  $aa$ . The greater the value of this decrement, the more rapid the damping of the oscillation. For a true, undamped alternating current, Fig. 2, the decrement is equal to 1.

In practice the arithmetic decrement is of little interest, and the term used most frequently to express the damping is the "logarithmic decrement," which is the Napirian logarithm of the arithmetic decrement. Hence, the logarithmic decrement of an undamped oscillation is zero.

The frequency of oscillation of the condenser discharge may be very great—from 50,000 to 3,000,000 cycles per second, depending on the values of inductance and capacitance in the circuit. But the number of cycles in one train taking place before complete damping out is comparatively small. Hence, by recharging the condenser after each wave train, it is possible to produce a large number of trains of oscillations per second. This may be done by means of an induction coil or an alternator, and will be taken up later.

## Phenomena of Resonance

Due to the very high frequency of the discharge oscillations of a condenser through an inductance, the inductive effects are considerable. If an inductance coil B, Fig. 9, is placed near an oscillating circuit A, an alternating emf. is induced in coil B, exactly in the same way as in an ordinary transformer. If the coil is short circuited by means of a piece of wire, an alternating current will flow in the circuit. This will be of the same frequency as the current in circuit A, whatever that frequency may be, as determined by the values of capacitance and inductance in the generating circuit A.

Circuit B is then said to be "aperiodic" as it has no natural oscillation period of its own.

If, however, instead of short circuiting coil B, a condenser is connected across its terminals, Fig. 10, phenomena of a somewhat different nature will take place, so-called resonance phenomena. The alternating current flowing in circuit A, at the natural frequency of that circuit, induces, as before, an alternating emf. of the same frequency in coil B. This emf. produces in circuit B an alternating current of the same frequency. As a result of this alternating current, the condenser of circuit B is charged every half cycle, and will therefore, independently of the current induced by circuit A, discharge through the inductance coil B at the natural frequency of circuit B. Two alternating currents of the natural frequencies of circuits A and B will thus flow in circuit B, and will combine, successively adding and subtracting their effects. If the two frequencies are made equal by a suitable adjustment of the natural period of circuit B, the two currents in that circuit will be in phase and will always add their effects to produce the maximum current in the circuit B. To obtain this condition, it is necessary that the product of the capacitance and inductance of one circuit equal that of the same constants of the other circuit. When this condition prevails, the two circuits are said to be "resonant," or "in tune." Circuit B may be tuned to circuit A by varying the capacitance of the condenser or the inductance of the coil B. Circuits which require a change in frequency are generally equipped with a variable air condenser or a multi-tap inductance coil, or both.

If the current in circuit B is plotted against the natural frequency of that circuit, a "resonance curve," Fig. 11, is obtained which shows that the maximum current exists in B when its frequency is equal to that of circuit A. This curve may in some instances be of a very peaked shape (dotted curve), which means that under certain conditions, circuit A may produce an appreciable current in circuit B only when the latter is almost exactly in tune. Such a result may be attained by loosening the coupling of the two circuits; that is, by separating them so that the induced current in B will not react appreciably on circuit A. Also, the trains of oscillations in circuit A should be damped as little as possible, so that each train will act on circuit B for a comparatively great

length of time. This object is attained by making the circuits of large size copper wire and consequent low resistance.

The fact that the current produced in circuit B by the oscillations of circuit A is considerably greater when the two circuits are in tune, is used in radio telegraphy, as will be shown later, in order to make it possible to receive signals of a given frequency and practically eliminate those of other frequencies.

### **Propagation of Electric Waves**

The flow of electric current in any circuit is accompanied by the existence of interlinked magnetic and static fields which surround the conductors carrying the current and extend throughout space. Whenever the direction of current flow in the circuit is reversed, these fields reverse also. This reversal does not take place, however, throughout space instantaneously. The phenomenon is somewhat similar to the ripples taking place on the surface of water when a pebble is thrown into it. The disturbance gradually propagates itself at a uniform speed, keeping its shape and characteristics until it dies out due to friction losses. The disturbance or reversal in the electric field surrounding a conductor propagates itself in much the same way, but at a speed of 300,000,000 meters (186,500 miles) per second. That is, at a point 300,000,000 meters distant from the circuit under consideration, the reversal of the electric field will occur one second after the reversal of current has been made in the circuit. On account of the similarity with the ripples in the water, this phenomenon has been called an electromagnetic wave. Such waves, however, travel outward not only in one plane as the ripples on the surface of the water, but they radiate out into space in a spherical progression. The medium in which this propagation is assumed to take place is called the "ether." This hypothetical medium is, for theoretical reasons, assumed to be present throughout space, whether matter is present or not; it is the medium in which all electromagnetic disturbances, light waves and heat radiations occur.

If now a frequently reversed current or alternating current is sent through a circuit, the interlinked magnetic and static fields will alternately reverse at the same frequency. This constitutes a series of waves progressing from the current carrying circuit outward into space in all directions. The length of the waves radiated is measured by the distance

between two consecutive points at which the electric field has the same amplitude and direction. This distance is therefore equal to 300,000,000 meters divided by the frequency of the alternating current.

Fluctuations of magnetic and static fields will produce electric currents in any metallic circuit which happens to be within the range of these fields, energy being thus dissipated in these circuits. As this energy is derived from the oscillating circuit, and conveyed to the various other circuits by the electromagnetic waves, the oscillating circuit is shown to "radiate" energy into space. An appreciable amount of energy is not radiated, however, at frequencies of less than about 10,000 cycles per second. The problem is then to generate high frequency alternating currents in a circuit of such shape as to radiate a large amount of energy and produce fields of sufficient strength that the changes in their intensity and direction may be intercepted at great distances. In the following chapters a study will be made of the application of these phenomena to radio telegraphy.

## DAMPED WAVE RADIO TELEGRAPHY

### Principles of Transmission

From the previous study it has been seen that a radio transmitting set, that is, a set which will emit electromagnetic waves into space, may consist of an oscillatory circuit containing inductance and capacitance, in which trains of damped high frequency oscillations are produced in rapid succession by supplying a certain amount of energy to the system after each wave train. Such a set therefore comprises, in addition to the oscillating circuit, the necessary apparatus to produce the high voltage required for charging the condenser at the beginning of each train of oscillations. This auxiliary apparatus varies greatly with the various sets and is not exclusively applicable to radio work. It comprises ordinary power apparatus used for the production of high potentials and may be an induction coil, transforming the low voltage of a battery into a high pulsating voltage, or an alternator, generating low voltage alternating current which is then stepped up to a high voltage by means of a transformer. This will be studied in a later paragraph.

The oscillatory circuit, however, is a part of the set which is peculiar to radio work. It was seen that such a circuit is made up of an inductance coil, the terminals of which are connected to the plates of a condenser; also, that there are two methods of starting oscillations in such a circuit, one being to introduce a spark gap, charge the condenser, and suddenly close the circuit by producing a spark across the gap, and the other being to couple a circuit without a gap to an oscillating circuit containing a gap. The first may be termed the "direct excitation" and the second, the "indirect excitation" method.

In radio telegraphy it is necessary, in order to increase the range of transmission, to arrange the oscillating circuit so that the electric field will be of suitable shape, and of appreciable strength at great distances. This is accomplished by making either the inductance coil, or (more generally) the condenser of the oscillatory circuit of large physical dimensions. It is then called the "antenna" of the set. The dimensions and shape of the antenna vary greatly in practice and a number of types, some of which are described below are in use at present.

## Types and Characteristics of Antennae

In the very great majority of cases, it is the condenser of the radio circuit which is made the antenna, the inductance coil being wound inside the set box. One reason for this is that such a condenser antenna is much more simply installed or repaired under emergency conditions. The simplest type considered here is the so-called "L" type antenna, Fig. 12. This consists of a horizontal wire, called the "aerial" which forms one side of the condenser. This is connected to one side of the inductance of the oscillating circuit. The other side of the con-

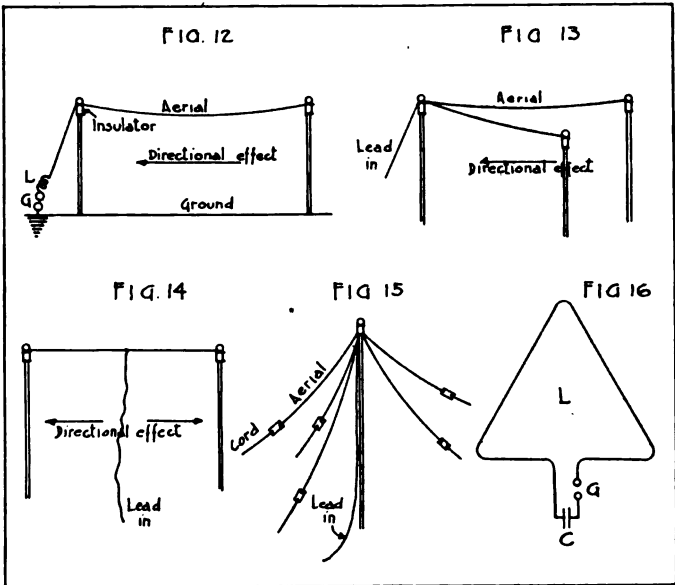

denser is made of a similar wire which is stretched out underneath the aerial wire, either slightly above or laid on the ground. Or the ground itself, if not too dry may be used as the counterpoise side of the condenser. This ground side of the condenser is connected either directly or through a spark gap to the inductance coil, according to the method of excitation used. This is explained below. The connecting wires used to connect the coil and gap to the aerial and the counterpoise (or ground) are called the "lead-in wires." In some cases, no in-

ductance coil is provided with the set, the self inductance of the antenna wire being sufficient.

A very important feature of the antenna is its "directional effect." When the antenna circuit is made to oscillate, the intensity of its electric field and hence the range of transmission is distinctly greater in the direction of the end at which the lead-in wires are connected (direction of the arrow in Fig. 12). Advantage is taken of this characteristic when using such an antenna, by pointing the aerial wire toward the location of the receiving station with which it is desired to communicate, the lead-in wire being connected to that end of the aerial which is nearest the receiving station. It is very important to remember this, since the range of transmission in the other direction is considerably less.

Another type of antenna is the "V" antenna shown in Fig. 13. The aerial consists of two diverging horizontal wires and the lead-in wire is connected at the apex of the "V." If a counterpoise is used, it is generally made of two wires laid on the ground or stretched between masts above ground and underneath the branches of aerial. (See Radio Pamphlet No. 2.) The directional effect of this antenna is toward the point of the "V."

The "T" shaped antenna, Fig. 14, consists of a horizontal wire at the center of which the lead-in wire is connected. The directional effect is in either direction in the vertical plane of the antenna.

The "umbrella" type antenna consists of a number of interconnected wires suspended from the top of a mast and insulated from ground, spreading around the mast like the ribs of an umbrella frame. The free ends are fastened to the ground by means of insulators and ropes, Fig. 15. There is no directional effect with this antenna, the electric waves being radiated with equal strength in all directions.

There are a number of other types in use, but they are generally too difficult to set up in the field for common use. A very important consideration in using antennae is to always well insulate the aerial and lead-in wires from the ground in order to avoid any leakage path which would of course greatly reduce the range and might even completely prevent any radiation.

As was pointed out in the first chapter, the resistance of the oscillating circuit should be as low as possible in order to reduce the heat losses and resulting damping. The lead-in wires con-



necting the counterpoise and antenna to the set should be made as direct and as short as possible. This will also eliminate any superfluous inductance due to possible turns in these wires. If the set is under shelter, the wires should be run through ebonite tubes where they pass through the wall. If these are not available, a bottle may be used, the bottom of which has been broken out.

The ground connection should be made by driving a few metal rods into the ground and interconnecting them, and then connecting them to the set. A ground mat may also be used. This is a small metal netting which is placed on the ground underneath the aerial and connected to the set. It is very useful when the station has to be set up in a short time, and is indispensable when the ground is dry or rocky.

An important use of the counterpoise is to be found on airplane sets where the aerial is generally a single wire let out from a reel on the airplane through an insulating tube, and the counterpoise is all the metallic parts of the airplane motor, gasoline tanks, stay wires, etc., electrically bonded together.

As mentioned before, the antenna sometimes consists of the inductance coil of the set instead of its condenser. The latter is then of small physical size and is mounted within the set box, while the antenna is a loop of wire, Fig. 16, of suitable size and of very few turns, frequently of only one turn, supported on a wooden frame. Such antennae, called "loop antennae," are generally used for short range radio telegraphy and for radiating very short wave lengths—30 to 100-meter waves. They are directional in their plane. This type of antenna is somewhat delicate to repair and is not used very much in the field.

### Direct Excitation Transmission

With the direct excitation method of sending radio waves, the radiating oscillatory circuit comprises the aerial and ground (forming the condenser), an inductance coil  $L$ , and a spark gap, Fig. 17. The two electrodes of the spark gap are connected to the secondary (high voltage) terminals of a transformer, in the primary of which an alternating current may be made to flow by closing the key placed in series with it. When the key is closed, the primary low tension alternating current induces a high alternating voltage in the secondary of the transformer, and an alternating difference of potential is thus established between the aerial and the ground which causes a storing of

energy in the antenna. If this potential is high enough when the maximum of the cycle is reached, the air gap breaks down and the antenna discharges the stored energy through the inductance  $L$ , and a high frequency oscillation is created as explained previously. This is shown in Fig. 18. The upper curve shows the voltage variation in the secondary circuit of the transformer. It rises from zero to the breakdown potential  $e$  of the gap, when the condenser discharges and suddenly equalizes the potential of its two electrodes. When the resistance of the gap breaks down, the voltage of the transformer

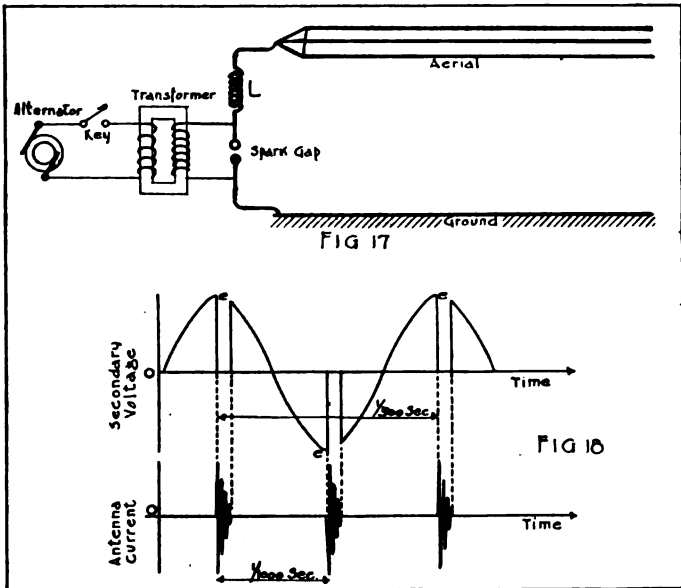

secondary drops practically to zero and a high frequency current oscillates in the antenna circuit, as indicated in the lower curve. When the oscillations have been damped out due to heat losses in the spark, the resistance of the circuit, and the energy losses by radiation, there being no current flow through the gap, the latter opens again, and the voltage of the antenna follows again the cycle of the alternator until the negative maximum is reached, when the same phenomenon takes place. In this way, for every half cycle of the alternator, a high frequency discharge of the antenna takes place which sets up in space, a

train of high frequency oscillations (wave train). The frequency of successive wave trains is thus equal to twice the frequency of the alternator. This, for reasons seen later, is called the "audio" or "wave train" or "spark frequency." The frequency of the oscillations of each individual train is called the "radio frequency" and is entirely independent of the frequency of succession of the sparks or wave trains, as it is determined by the constants (inductance and capacitance) of the antenna circuit. The value of the radio frequency can therefore be regulated by inserting capacitance or inductance in the antenna circuit. Thus, placing an inductance coil in series with the aerial will increase the wave length (decrease the frequency), while a condenser inserted in series with the aerial decreases the wave length (increases the frequency). The frequency of the alternator in practice is of the order of 500 to 1200 cycles per second.

Instead of using an alternator and transformer, an induction coil may be used, as in the SCR-74 trench transmitting set. This supplies a high pulsating voltage at its secondary terminals instead of a high alternating voltage. The operation is the same in principle, the advantage being that such a set is readily portable, and easily set up. However, the wave trains may occur at slightly irregular intervals as the armature does not vibrate regularly as a rule.

The presence of a spark gap in the oscillatory circuit has the disadvantage of introducing quite a high resistance, so that the oscillations are rapidly damped out, and the interval of time between two wave trains, although of the order of 1/1000 second, is very much longer than the duration of the various wave trains. The result is that such sets are of low power and small range, as a great part of the energy of the oscillations, instead of being radiated into space, is wasted away as heat in the antenna circuit. Also, due to the rather high decrement, tuning of the receiving set cannot be made very sharp. For long range sets, this method is then replaced by the indirect excitation method of transmission.

#### Indirect Excitation Transmission

By this method, oscillations are started in an oscillatory circuit A, Fig. 19, exactly as with the direct excitation method, only this is a so-called closed oscillatory circuit; that is, both the condenser and the inductance coil are of small physical dimensions.

Coupled to this circuit is the antenna circuit, comprising the large aerial-ground condenser and an inductance through which the coupling to circuit A is made. Oscillations are set up in circuit A, as described above, each train of oscillations being rapidly damped out. Through the transformer action of the two inductance coils, these oscillations induce similar oscillations in the antenna circuit. When the oscillations in circuit A have been completely damped out, the antenna circuit, containing no high resistance such as the spark gap, will continue to oscillate for some time, so that for the same power input, a greater

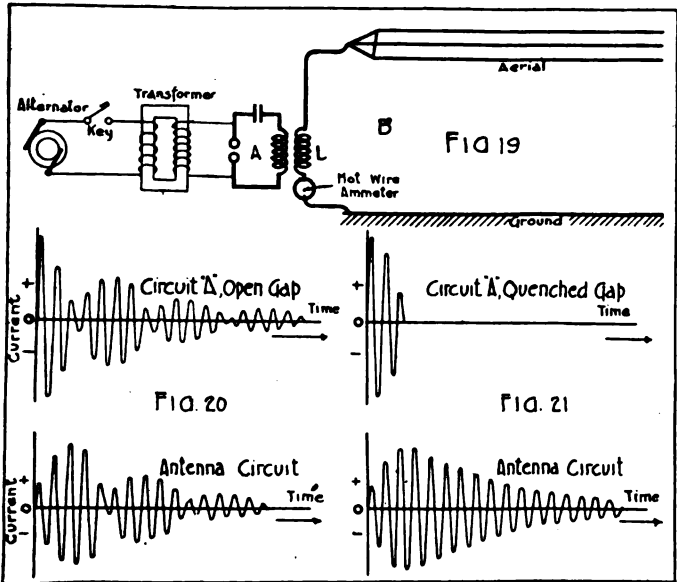

amount of power will be radiated by using this method of exciting the antenna. For the proper operation of such a set it is of course necessary that the antenna circuit be tuned to the period of the closed oscillator circuit A. This is generally done as follows. Circuit A is first given the desired natural period by properly setting its variable condenser and variable inductance. The key is then closed and the antenna circuit adjusted by changing its constants until it is in resonance with circuit A. This condition is indicated by the maximum reading of the hot-wire ammeter inserted in the antenna for this purpose.

As in the previous case, many different arrangements of the circuits are possible. Instead of the alternator and transformer, use may be made of an induction coil. This is done in the SCR-56 airplane transmitting set. In some sets, the coupling of the closed oscillating circuit A to the antenna is made by means of one coil only, Fig. 22. This is called "conductive coupling." The inductance of circuit A is then that part of the coil comprised between the points a and b, the portion of the coil included in the antenna circuit being that between m and n. Such a scheme is used in the SCR-65 airplane transmitter. It will be noticed that this arrangement of one or two inductance coils for effecting the transfer of energy from one circuit to another is, in principle, the same as an ordinary transformer, the only difference being the absence of an iron core. From this similarity, the arrangement has derived the name, "oscillation transformer."

Some auxiliary phenomena take place when indirect excitation is used for setting up oscillations in the antenna. When a train of oscillations is started in a closed oscillatory circuit by the breaking down of the gap, the oscillations quickly damp out, mainly due to energy losses (resistance, gap, etc.) in the circuit itself. However, when such a circuit is coupled to some other oscillating circuit, such as in the case of Fig. 19, the closed oscillator, in addition to wasting away its energy in the usual internal losses, gives up at every cycle a part of it to the other oscillating circuit, so that its damping will be much greater. When the oscillations in the first circuit have died out, the second circuit has then stored a large part of the energy, and high frequency oscillations take place in that circuit. These react on the closed circuit and induce in it an emf. which causes the oscillations to start anew, due to the fact that the conducting gases in the gap were not given time after transfer of energy from the local to the radiating circuit to de-ionize or escape, and open the circuit. The second oscillating circuit thus gives back energy to the first, until it has returned all of it, at which time the first circuit is again in full oscillation. The phenomena then repeat in the same sequence. The result is a series of "beats" in each circuit, as represented in Fig. 20. The practical result is that the antenna circuit, instead of oscillating freely and radiating all its energy into space, feeds back and wastes some of it in the local oscillating circuit A.

To avoid this waste and secure the maximum radiation, it has been found necessary to prevent the transfer of energy

back to the closed oscillating circuit, and a number of methods have been devised, all based on the same principle. The general principle consists of making the spark gap non-conducting after the circuit A has given up all of its energy; that is, after the oscillations taking place in it have been once damped out. If this is done, circuit A is open and an emf. induced back into that circuit by the antenna circuit will be unable to produce any current in it. Excitation by this method is called "impact excitation." This gives conditions shown in Fig. 21, from which it will be seen that after all the energy has been transferred from A to B, it is all spent in circuit B in free oscillations of low damping.

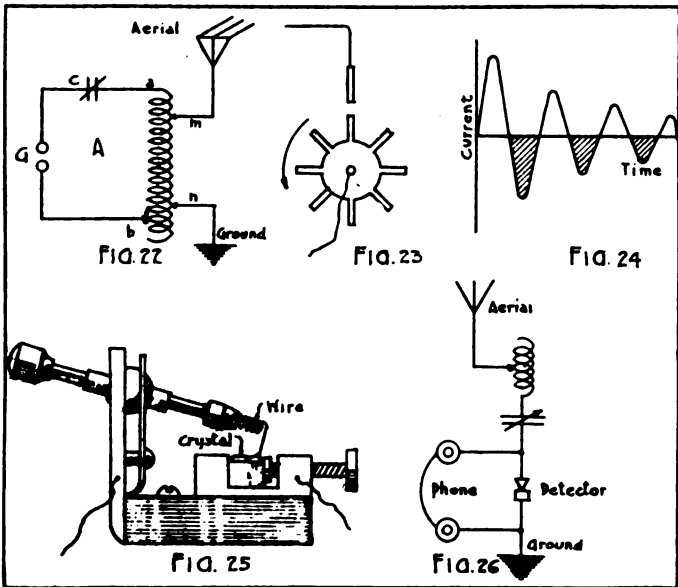

One method of making circuit A non-conducting consists in blowing out the spark in the gap by means of a violent stream of air produced by a blower of some sort. Such an arrangement is called an air blast spark gap. Another method is the use of the "quenched gap," in which the spark occurs in an air tight space between cooled electrodes made of metals such as zinc, aluminum or silver, all of which tend to prevent the spark from maintaining itself after the first energy transfer. A third

method, used on a number of airplane transmitters, is the "rotary spark gap," in which one of the electrodes of the gap is a stationary metal post, at a small distance from which is rotated a toothed metal disk forming the other electrode, Fig. 23. The disk is rotated at high velocity and a spark takes place every time one of the teeth of the disk passes in front of the stationary electrode. Each spark is extinguished very rapidly on account of the increased length of gap as the tooth turns away from the stationary electrode. There are two kinds of rotary gaps, called the "synchronous" and the "non-synchronous" gap. In the former, the disk is driven at such a speed, and has such a number of teeth, that there will be one spark for every cycle of the alternator. In the latter, the disk is driven at a different speed so that there will be more than one spark per cycle, or else one spark in every few cycles. The adjustment of such gaps is somewhat delicate and is not taken up here. While quenched gaps are of use in indirectly excited sets, they should be avoided in directly excited sets, as in this case the oscillations take place only in the antenna circuit and hence want to be prolonged as much as possible.

### Principles of Reception

In the previous paragraphs, a study has been made of the production in an antenna, of high frequency damped oscillations. These oscillations, it was pointed out, produce reversals of the electric field throughout space, and if the antenna is of suitable shape, of greater strength in certain directions than in others. Thus a damped oscillation in the antenna will produce a train of electric waves traveling from the source outward. When such a train of waves sweeps over any conductor, it will induce in this conductor an alternating current of proportional amplitude and of the same frequency as the oscillations of the train. If a circuit containing inductance and capacitance is acted upon by the oscillations, the alternating current set up in it will be a maximum when the natural frequency of the circuit is equal to the frequency of the oscillations, or in other words, when the circuit is tuned to the waves received, which means resonant with the transmitting circuit. A radio receiving set then comprises a circuit containing adjustable inductance and capacitance, so that it may be tuned to any frequency within certain limits. As it is of advantage that the receiving set intercept as much as possible of the energy of the incoming waves, it is made to cover as large an area as possible. This

is accomplished by giving large physical dimensions to either the inductance coil or the condenser, in other words, by using an antenna. In such a circuit, for each wave train passing over the antenna there will be induced a train of high frequency oscillations. In order to perceive these oscillations, it is necessary to insert in the circuit some sensitive device which will respond to the extremely small currents induced in the antenna. The telephone receiver forms a very convenient device for this purpose because of its great sensitiveness and ruggedness. Reception of radio telegrams is thus almost universally done by sound.

As the frequency of the oscillations is far beyond the vibration frequency of the telephone receiver diaphragm, no sound would be produced by the latter under the influence of the alternating current induced in the receiving antenna. It is therefore necessary to rectify this current by means of a special device called a "detector." This will conduct electric current fairly well in one direction, but practically not at all in the other. If such a detector is then connected in series with the telephone receivers, a wave train passing over the antenna will induce an alternating current in the circuit, but all the half cycles in one direction will be cut off by the detector, so that instead of a damped alternating current passing through the telephone, a series of unidirectional half-cycle impulses will flow, Fig. 24. As these impulses occur in such rapid succession that the receiver diaphragm will not respond to them, their effect is added, giving one deflection of the diaphragm for each train of waves. When the train of oscillations is damped off, the telephone diaphragm falls back in place until the next wave train arrives at the receiving station. If these trains arrive at a rate (for best results) of 500 to 1200 per second, the successive vibrations of the telephone diaphragm will produce a sound in the operator's ear which will be of a very pure and steady note if the trains arrive regularly, which means that the spark of the transmitting set is occurring at very regular intervals, as determined by the vibrations of the induction coil vibrator, or by the alternating current frequency of the alternator. This wave train frequency is therefore called "audio frequency," as was already pointed out, since it is of a frequency to which the telephone receiver and the ear will respond. The limits of audible frequencies are about 20,000 and 16 cycles per second.

There is quite a large variety of detectors. One used very widely on account of its simplicity is the crystal detector, a



sketch of which is given in Fig. 25. It consists of a crystal of galena (lead sulphite) or iron pyrite (iron sulphite) held in a special support. A fine metal wire is then maintained in position so that its point will rest with a light pressure against a spot of the crystal's surface. Certain points of the crystal surface give better results than others and almost completely stop the current flow in one direction. Such a spot is found by touching the wire point at various points of the surface, until the sound in the telephone receiver is great enough to be readily heard. This adjustment does not have to be repeated often if not disturbed by mechanical vibration. The selection of a good detecting spot on the crystal may be made by exciting the set by means of a small testing buzzer provided for the purpose.

From the previous paragraphs, it may be seen that a receiving set may be constructed by connecting an aerial to ground through an adjustable inductance and condenser, and a telephone receiver shunted by a crystal detector, Fig. 26. The set is tuned by adjusting the inductance and the condenser until maximum response is obtained in the telephone. The high frequency alternating current induced in the antenna will then flow through the receiver in one direction (one half cycle), and through the detector in the other. Such a set, although very simple, has the disadvantage that the detector introduces a high resistance in the antenna, which prevents the latter from oscillating at maximum amplitude.

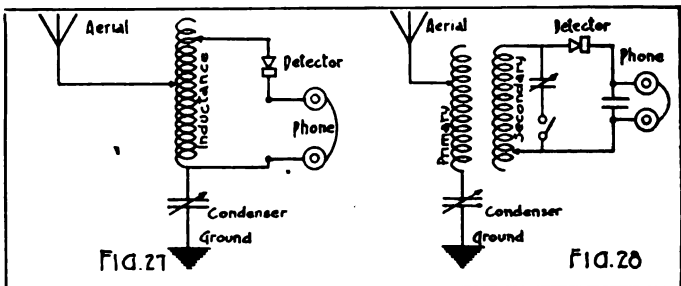

Damped Wave Receiving Circuits. Fig. 27—Inductively and Conductively Coupled.  
 Fig. 28—Inductively Coupled.

A better arrangement is therefore obtained by coupling the telephone and detector circuit to that of the antenna. This coupling may be inductive or capacitive. In case of the former, one of two coils may be used, just as in the case of sending sets. Such sets are shown in Fig. 27 and Fig. 28. With circuits of this kind, the antenna circuit oscillates freely

under the influence of the incoming waves, and induces the high frequency currents in the telephone circuit. The circuit of Fig. 28 is that used in the SCR-54 receiving set, and its operation is fully explained in Radio Pamphlet No. 3.

**Tuning.**—The waves emitted by transmitting stations are propagated in all directions, so that a receiving station may hear not only the signals of a particular station, but also those of all sets working within a good distance of it. It is evident that the reading of telegraphic signals would be absolutely impossible if it were not possible to weaken or eliminate all of the disturbing signals and on the other hand amplify the ones desired. If the disturbing signals are of wave lengths differing from that of the signals to be received, this selection of signals can be made by proper tuning of the receiving set.

When the resonance is very sharp, the receiving station may be sharply tuned. Reception by coupled circuits is almost always employed on account of the good tuning it affords, due to the possibility of double tuning both the antenna and the local oscillating circuits.

**Coupling.**—To maintain good tuning, it is necessary to avoid too close coupling, that is to say, to avoid bringing the two coupling coils too near together since in that case, the mutual reaction between the antenna and the oscillating circuits distorts the waves and decreases the sharpness of the tuning.

Care must be taken in the use of radio apparatus, not to put any metallic mass in the vicinity of the coils as this would be the seat of induced currents, the production of which would take energy from the oscillating circuit and damp the oscillations.

#### **Sources of Trouble**

It has just been seen that tuning allows the elimination or the weakening of the effect of transmitted waves different in length from the ones to be received. For waves of nearly the same length, this elimination of interference will only be possible when the tuning is very sharp. This depends not alone on the receiving station. If the waves received have high damping, each incoming wave train is made up of only a few oscillations, and does not act very long on the receiving antenna. Sharp tuning requires the rhythmic repetition of the effects of a large number of successive oscillations. Oscillations of the lowest damping should therefore be used when sharp tuning at the receiving station is desired.

If two oscillations have the same or very nearly the same wave length, tuning cannot separate them, but receiving of either is nevertheless possible if the two sending stations have clearly defined tones. This depends on the difference in spark frequency (audio frequency) of the two transmitting sets, the higher this frequency, the higher the pitch of the note heard at the receiving station.

Other causes of serious trouble are electrical atmospheric disturbances, aurora borealis, the passage of electrified clouds, hail storms and drops of electrified rain. The atmospheric electrical discharges produce oscillating currents in the antenna, and the telephone receives them giving a series of mixed sounds. These noises are generally a series of impulses of low tone with the result that the high pitched musical signals are the least disturbed by atmospheric interference. This is often very troublesome in long distance receiving from powerful stations which work with long wave lengths. Although less intense on small field antennae, the atmospheric disturbances sometimes cause serious trouble in reading signals.

**Influence of Ground Contour.**—On a great plain, the waves are propagated normally in all directions from an antenna. In hilly regions, on the contrary, steep slopes form screens and deflect the waves. Near the foot of a steep hill, there is a region of shadow which is not reached by the waves coming from the opposite side. The waves reflected from the two slopes of a narrow valley, follow the valley. As it is necessary to avoid placing the receiving antenna in a region of shadow, an exposed position is sometimes preferable.

Telegraph lines and metallic conductors used in the construction of houses absorb the waves and their proximity is usually detrimental. In forests, an antenna receives and transmits badly because the sap of the trees conducts electricity and may be the seat of induced currents. When an antenna must be hidden in a wood, it should be placed as close as practicable to the edge from which the waves are coming, or in the middle of a glade. If possible, it is advantageous to install it above the trees. Interference with the waves by trees and houses is greater, the shorter the waves.

It is also necessary to choose a position for the ground connection where the ground is damp and conducting. An antenna in a position not entirely exposed may be good for transmitting and receiving waves in one direction, but not for another.

## PART 2.

### CHAPTER I.

# UNDAMPED WAVE RADIO TELEGRAPHY

The fact that the efficiency of the transmitting sets is greater, and that the tuning of the receiving sets is sharper for the waves having the smallest damping, gives rise to the desirability of using waves that are not damped at all. This means that an alternating current of constant amplitude and of radio frequency must be generated in the transmitting antenna. The use of alternators for this purpose presents very considerable difficulties, and is absolutely impracticable for portable sets such as are needed for military purposes. However, a new method of generation of undamped wave oscillations has come in for a very extensive application in Signal Corps work, consisting in the use of the three-electrode vacuum tube.

### Vacuum Tubes in Radio Communication

Upon gaining a general idea of the newer apparatus used in the transmission and reception of communications by radio, one soon becomes impressed with the importance of the vacuum tube, as it occurs in nearly all of the principal types of modern radio apparatus. The same tubes may be used to transmit, to receive, to detect, to amplify, to modulate and to serve other important functions necessary to radio communication as it is now known. Their practical application to these numerous uses is an accomplishment of the last few years and the possibilities for further application are by no means exhausted. In fact, the whole field of radio work has been greatly influenced by the development of vacuum tubes, and by virtue of this it is now possible to effect radio communication through greater range with lower power and with greater selectivity than was formerly possible. Also, the tube has enabled the construction of apparatus for these uses, which is readily portable—a most important feature in connection with military communication systems.

How these tubes work and how they can be made to serve such a multiplicity of purpose, are the questions which most naturally arise in the mind of every student. Answer to these

two questions involves much highly theoretical discussion and more than one way of explaining the action in some instances. The following paragraphs, however, are intended to give an explanation general enough to be easily understood, avoiding much interesting and valuable discussion on functions of the tubes not at present utilized by the U. S. Signal Corps, and also avoiding dual explanations of any particular action.

### Electron Flow in Vacuum Tubes

The electron flow in a vacuum tube will first be studied in a bulb containing two metal electrodes; one, a filament which may be heated by a local battery A, and the other, a flat piece of metal, called the plate, Fig. 1. If a battery B is connected across the tube with its negative pole to the filament and its positive pole to the plate, no current will be indicated on the ammeter I inserted in the circuit. However, if a current is passed through the filament by means of a battery A, bringing the filament to a red heat, a current of a few milliamperes will be shown by the ammeter to flow in the circuit BFPIB. Thus, the heating of the filament causes a current to flow across the open space of the bulb. This may be accounted for as follows:

The explanation of phenomena observed in a great number of experiments has led to the assumption that there exist extremely small non-material particles having a definite negative charge of electricity. These particles are called electrons. They move in great numbers between the atoms of any metal. At ordinary room temperatures, they do not escape out of the metal, in most cases, but when the metal is heated, the material atoms vibrate about their mean position of equilibrium with a speed and amplitude which increases with the temperature. The electrons, which follow the atoms in this thermal agitation, likewise acquire increasing speed as the temperature of the metal is raised. When it becomes red hot, the speed of the electrons is so high that they leave the metal. This phenomenon is illustrated by the experiment described above, wherein the filament was made red hot and an electrostatic force was present, due to the connection of the B battery in the plate circuit, which tended to move the negative electrons from the filament to the plate by repulsion from the filament and attraction by the plate. Under these conditions, the electrons travel from the filament to the plate at a speed which may attain tens of thousands of miles per second, and transport negative charges across the space in the bulb from filament to

plate. The passage of electrons, each carrying its charge of electricity from filament to plate, constitutes a flow of electricity which is an electric current. It should be noted that the electron flow is from the negative filament to the positive plate, while the electric current flow is just the opposite—from the positive plate to the negative filament. This is not difficult to explain, as the direction of flow of the electric current from positive to negative poles is a mere assumption which was made before the discovery of the electron flow, and could just as well have been assumed to be in the opposite direction.

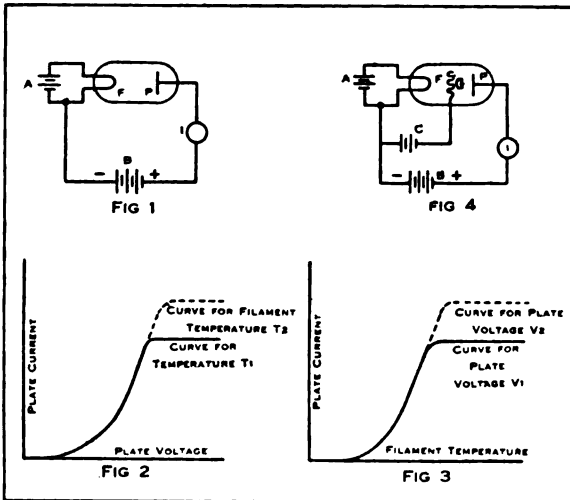

Fig. 1, 2 and 3—Two-Electrode Vacuum Tube and Characteristic Curves  
Fig. 4—Three-Electrode Vacuum Tube

If the polarity of the B battery, Fig. 1, is reversed, no electric current will flow through the ammeter, as the plate will be negative and will repel the negatively charged electrons and thus prevent any flow of electricity across the tube.

### Operation of Two-Electrode Tubes Under Various Conditions

The two electrode vacuum tube is very frequently called a valve. For a given filament temperature,  $T_1$ , a definite number of electrons is emitted per unit of time. The number of electrons per second which will travel across the tube and reach the plate is the measure of the current in the plate circuit, and it varies

within limits approximately as the square of the voltage across the space between plate and filament. As this voltage is increased, a certain value will be reached at which all electrons emitted by the filament will be absorbed by the plate, so that no increase of current will take place for higher values of the plate voltage. This is shown in Fig. 2, curve for temperature  $T_1$ . In order to increase the plate current, it is then necessary to raise the filament temperature to some higher value,  $T_2$ , when the current curve will rise to a new value before bending over to the horizontal position.

Now, if the plate voltage is kept at a constant value,  $V_1$ , and the filament temperature raised by increasing the current from the battery A, the number of electrons emitted by the filament will vary approximately as the square of the filament temperature figured above the red heat temperature ( $1600^\circ$  absolute for tungsten filament) until a point is reached where the electrostatic field, due to the negative charge of the electrons in motion in the tube, will exactly counteract that due to the positive charge of the plate. This condition is called the "space charge effect." Any further increase of filament temperature would then tend to increase the number of electrons in the tube, and therefore the space charge. The latter then outweighing the charge of the plate, would repel some of the electrons back into the filament. A state of equilibrium is thus reached whereby the current remains constant independently of further increase of filament temperature, and the current curve will bend over and remain at a constant value of plate current, Fig. 3. If there is not potential difference between the filament and the plate, the space charge effect will prevent the flow of electrons to the plate.

To increase the current, it is then necessary to increase the plate voltage to some higher value,  $V_2$ . The upper limit to this voltage increase is that which prevails when a blue glow is observed around the plate. On old and defective tubes, this blue glow may appear at normal operating voltages, and then it is an indication of poor vacuum. It causes a hissing noise in the telephones and prevents good operation of the tubes.

### The Three-Electrode Vacuum Tube

The three-electrode tube used by the U. S. Signal Corps is a highly evacuated bulb containing a filament and a plate like the two-electrode tube already described, but in addition

having a grid or wire screen supported midway between the plate and the filament. The filament is made of some material, usually tungsten, or platinum coated with oxide, which when heated liberates a quantity of electrons from its surface. The plate electrode is placed near to and usually encloses the filament. It may take various forms, such as two flat plates, a cylinder, a cone, etc. The grid is made up of a network of metal wires, sealed into the tube and supported in such a manner as to be interposed between the filament and the plate so that any passage of electrons or current between these electrodes must pass through the grid.

If the plate is made positive with respect to the heated filament, a flow of electrons will take place from the filament to the plate, as explained in connection with the two electrode tube. In their flow, the electrons must pass through the wire mesh of the grid, which can be made to have a controlling influence on the electrostatic field in the tube. Thus the rate of flow of electrons from filament to plate may be regulated by changing the potential of the grid with respect to the filament. If the grid is given a potential slightly negative to the filament, which may be done by a battery C, Fig. 4, it will repel some of the electrons emitted from the filament, but many of them, due to their high velocity, will pass through the mesh of the grid and reach the plate. Now, as the potential of the grid is made more negative, Fig. 5, the plate current will gradually decrease until the negative grid potential will be great enough to prevent all electrons from leaving the filament, thus stopping the plate current flow entirely. This is due to the action of the field created by the grid which has neutralized that created by the plate.

If the grid is made positive instead of negative, more electrons will be attracted toward the plate than would pass without the influence of the grid potential, and the plate current will be increased until saturation of the tube occurs. This saturation may be explained as follows: As the grid is made more and more positive, the plate current increases at a greater rate than the grid voltage, Fig. 5, so that a grid potential will be reached at which the space charge due to the negative electrons passing across the tube will exactly counteract the influence of the positive grid potential. When this condition prevails, the maximum plate current is obtained. Further increase of grid potential tends to increase the plate



current and therefore the space charge, but the latter, increasing at a greater rate, overbalances the influence of the grid and the plate current thus remains practically constant up to a certain grid voltage, beyond which the plate current slowly decreases. The limitation of plate current is due not only to the space charge effect, but also to the absorption of electrons by the grid in increasing numbers as its positive potential is increased. This absorption gives rise to a current flow in the circuit FGCF, called the grid current.

From the last two paragraphs it can be seen that if the grid is made alternately positive and negative, the plate current will be accordingly increased and decreased about its normal value in the absence of the grid. By means of a small dry battery it is possible to fix the mean potential of the grid at any point on the characteristic curve. The value of this mean potential (which is the grid potential existing when no oscillations are taking place) determines the operation of the tube as a rectifier or as an amplifier. The variations of grid potential modify the plate current, and the tube thus acts as a relay controlled by the very small variations of grid potential. The electrostatic capacity of the grid being very small, the variations of its charge involve correspondingly small amounts of energy. It is therefore very sensitive, and having no inertia, it is able to follow the extremely rapid oscillations encountered in radio telegraphy—oscillations of frequency far beyond the range of mechanical or more common electrical devices.

### Detector Action of Vacuum Tubes

A simple connection of the three-electrode tube as a detector is shown in Fig. 6. When a train of damped oscillations strikes the antenna, it produces an alternating voltage in the antenna circuit as represented in Fig. 7-A. This voltage induces a similar voltage in the secondary coil, ab, of the receiving transformer connected in the grid circuit, which is superimposed on the normal grid potential given by the battery C. The component of the grid current due to the alternating voltage will flow only during the positive half cycle of the oscillation, as seen from the grid current characteristic curve, Fig. 5, and indicated in Fig. 7-B. This current flow from grid to filament has a tendency to equalize the potential difference between them, so that the actual grid voltage, instead of

following a symmetrical curve similar to the antenna voltage, will be asymmetrical, the amplitude of the negative half of the wave being greater than that of the positive half, Fig. 7-C, as no current is then flowing.

Referring to the grid current characteristic curve, Fig. 5, again, it will be seen that an asymmetrical change in plate current will result from this asymmetrical change in grid

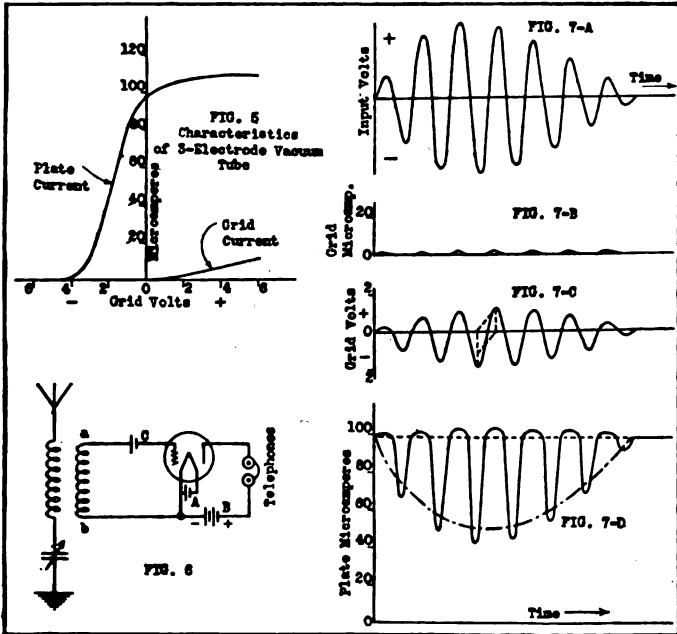

Fig. 5—Characteristics of Three-Electrode Vacuum Tube. Fig. 6—Three-Electrode Tube Used as Detector. Fig. 7—Analysis of Detector Action: (A) Input Voltage Due to Incoming Waves; (B) Resulting Grid Current; (C) Grid Voltage, Resultant of Induced and Counter EMF.; (D) Current in Plate and Telephone Circuit

potential, Fig. 7-D. When flowing through the telephone receivers, this plate current will be smoothed out by the inductance of the telephone into a single unidirectional impulse; and such an impulse being produced for every wave train, a sound will be produced in the telephones at a frequency corresponding to that of the frequency of the trains. The operation of the tube as a detector will be best when the normal grid potential is near the upper bend of the characteristic curve,

and will gradually become less effective as this potential is brought nearer to the lower bend, until a point is reached when rectification does not occur and where the asymmetrical variations of grid voltage produce symmetrical variations of plate current, Fig. 8. This particular part of the curve is used for amplification, as will be explained in a later paragraph. Beyond this point of no detector action, however, the rectifying properties of the tube reappear, so that it may be used as a fair detector on the lower bend of the characteristic curve.\*

**GRID CONDENSER CONNECTION FOR DETECTOR ACTION.**—If the C battery, Fig. 6, is replaced by a small condenser (.0005mfd.), the detector action of the tube is different from that described above. During a period of no oscillations, the plate current assumes a certain value determined by the B battery and the filament temperature. If now an oscillation strikes the antenna, the grid will be made alternately positive and negative. When it is positive, it attracts electrons, and being insulated from the filament, it retains these electrons and acquires a negative charge which lowers the plate current. The negative charge of the grid is then caused to leak off either through the condenser dielectric or through a high resistance shunting the condenser, so that by the time the next train of waves arrives, the grid is again at its normal potential.

### Amplifier Action of Vacuum Tubes

The energy of a signal wave at the receiving station is very often so extremely weak that it is necessary or advantageous to amplify the signals to make them more easily read. In radio telephony, this amplification has a special importance. The problem consists in producing changes in the telephone receiver current which are exactly proportional to the amplitude of the incoming waves, and without distortion. As outlined in the explanation of the detector action of the tube, a symmetrical oscillation in the primary (input) circuit induces an asymmetrical oscillation in the secondary or grid circuit, the voltage amplitude being less for the positive half cycle than for the negative. A point may be found on the characteristic curve of the tube, Fig. 8, where the asymmetrical variation of grid potential produces symmetrical variations of plate current, so that the variations of the plate current will reproduce

---

\*The curves of Fig. 7-B, 7-C and 7-D should lag about 180° behind the voltage curve of Fig. 7-A. This has not been shown because of its tendency to confuse.

exactly those in the antenna without distortion. Furthermore, the very slight energy of the wave acting on the grid, produces very large variations of plate current because of the relay action of the tube, and this explains the amplification of the antenna oscillations.

To separate the amplified alternating current from the steady direct current in the plate circuit, the pulsating plate current

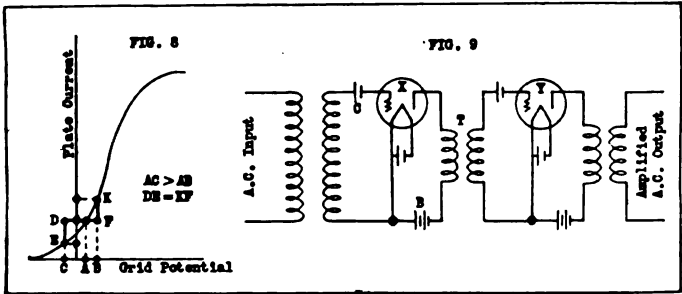

Three-Electrode Vacuum Tube Used as Amplifier. Fig. 8—Point on Characteristic Curve Giving Symmetrical Amplification. Fig. 9—Connection for Cascade Amplification

is passed through a transformer, Fig. 9, which delivers the amplified alternating current at its secondary terminals. A second tube may be used to further amplify this wave if necessary, as tube Y, Fig. 9. When this is done, the process is called cascade amplification. With the VT-1 type vacuum tube, more than two tubes are seldom used for amplification purposes. Two of these tubes give an amplification of about 10,000 times.

### Oscillator Action of Vacuum Tubes—Undamped Wave Transmission

As the vacuum tube can be used as an energy amplifier, it can be made to generate and sustain oscillations by feeding back upon the grid circuit the energy amplified in the plate circuit. This can be done by electromagnetically or electrostatically (or both) coupling the grid circuit to the plate circuit. Such an arrangement is shown in Fig. 10, where the grid circuit  $GL_1FG$  is coupled electromagnetically to the plate circuit  $PL_2FP$  by means of the inductances  $L_1$  and  $L_2$ .

If now a small change is produced in the potential of the

grid, a change in plate current involving a greater amount of energy will result. This plate current, flowing through  $L_2$ , will in turn induce an emf. in  $L_1$  of greater magnitude than the original potential change in the grid circuit. This produces a new change in the potential of the grid so that oscillations

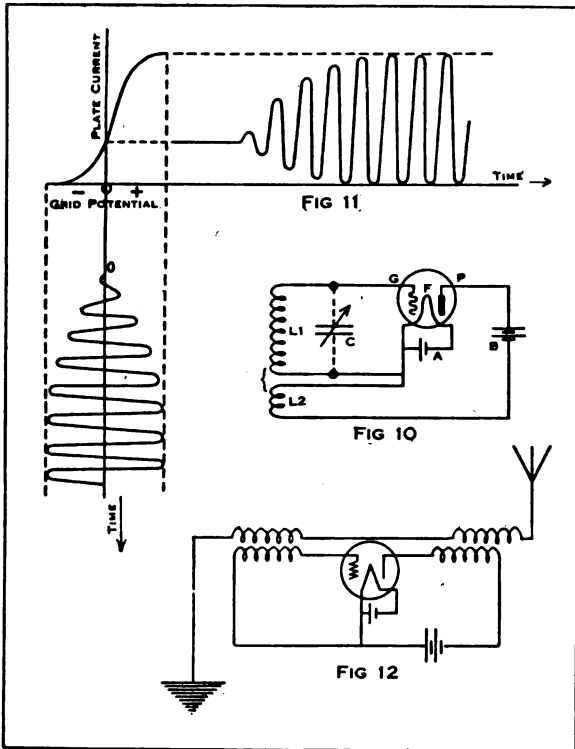

Vacuum Tube Used as Oscillation Generator. Fig. 10—Connection for Undamped Oscillation Generation. Fig. 11—Analysis of Generator Action. Fig. 12—Example of an Undamped Wave Transmitting Set

continue to increase in this manner until the amplitude of the plate current reaches the bends of the characteristic curve of the tube. At this point the oscillations will have reached their final constant amplitude. Fig. 11 is a graphical representation of this phenomenon.

To produce oscillations, it is of course necessary that the values of inductance and capacitance, and the coupling, be chosen of such values that the emf. induced in the grid circuit will be in phase with the alternating component of the plate current. To generate oscillations of any given frequency, it is simply necessary to tune the oscillatory circuit by means of the condenser C, for instance. The circuit  $L_1C$  will then oscillate at its natural frequency, and these oscillations will be sustained by the plate current. The oscillator can then be coupled to an antenna and made to induce undamped oscillations in it which will be radiated into space. Such a circuit is shown in Fig. 12, which shows the principle of the SCR-69 set, but there are any number of connections which will enable the use of the three-electrode tube as an oscillation generator. To use such a set as a radio transmitting set, it is simply necessary to insert a sending key at some point of the circuit. Then whenever the key is depressed, the antenna will radiate undamped waves.

### Signal Corps Three-Electrode Vacuum Tubes

The three-electrode vacuum tubes used by the Signal Corps have the type numbers VT-1, VT-11, VT-21, VT-14 and VT-2. The first three employ platinum filaments coated with an oxide and they are all used for detection and amplification. They operate at the same constants and have practically the same characteristics, the different designations referring to tubes which have different physical construction and are supplied by three different manufacturers. The VT-2 tube is used for transmitting purposes. The VT-14 tube employs a tungsten filament, and is used for transmitting. It operates with a plate potential of 350 volts, a filament current of 1.75 amp. at 7 to 8 volts, a grid potential of negative 20 volts and delivers 3 watts output.

The detector and amplifier tubes operate with an average filament current of 1.1 amp. at 3.6 volts. The plate voltage averages 20 volts. The grid is maintained at the same potential as the negative filament lead, or slightly more negative.

The VT-2 tube operates with an average filament current of 1.36 amp. at 7 volts, and with a plate voltage of 300 volts. It normally operates with about 20 volts negative potential on the grid. The power output as an oscillation generator is approximately 3 watts.

. The VT-1, VT-2 and VT-14 tubes operate with a dull filament.

The VT-11 and VT-21 tubes operate with extremely bright filaments.

### Reception of Undamped Waves

The reception of such signals is different from that of damped wave signals. The principle of damped wave reception is that every wave train, after being rectified, deflects the diaphragm of the telephone receiver, which then between two wave trains, springs back in place. The succession of wave trains then sets the diaphragm into vibration at the spark frequency of the transmitting set.

In undamped wave telegraphy, the oscillations are not divided into wave trains, they are emitted without interruption, and with a constant amplitude, Fig. 13. Hence, the telephone diaphragm is deflected at the beginning of the signal, and so remains until the end of the signal, for the succession of the

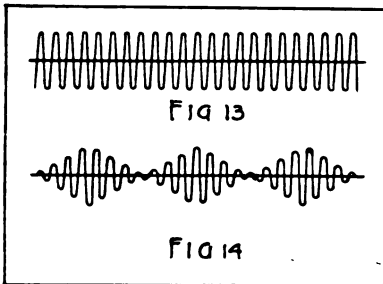

individual waves is so rapid that the diaphragm will not respond to the corresponding high rate of vibration. There is consequently no audible vibration of the diaphragm. However, audible vibrations in the receiver may be obtained by several different methods.

One method consists in utilizing a mechanical interrupter called a "tikker" which is connected in the circuit at the receiving station, in such a way that it periodically interrupts the current through the telephone receivers—the current induced by the incoming radio waves—and thus breaks it up into current-off-and-on periods of a low frequency to which the diaphragm will respond. This method has the disadvantage that all the energy received by the antenna during the current-off periods is lost.

A more recent and better method consists of a scheme for transforming at the receiving station, the continuous waves of constant amplitude into waves the amplitude of which varies periodically, Fig. 14. This end is attained by the application of the phenomenon, familiar in the study of sound-wave propa-

gation, called "beats." This is called the "heterodyne" method of reception.

The receiving set is tuned to the frequency of the incoming waves by means of its adjustable inductance coils and condensers. Then, undamped waves of slightly different frequency are generated locally at the receiving station and superimposed upon the oscillations in the detector circuit due to the incoming waves. The result is that the two rectified alternating currents add together algebraically to produce beats in the amplitude of the current through the telephones, of a frequency equal to the difference between the frequencies of the two currents.

Such a set may be constructed by modifying the receiver circuit shown in Fig. 6. It is simply necessary to couple the plate circuit of the detector tube to the grid circuit. The tube then acts simultaneously as a detector for the incoming waves and as a generator for the local undamped oscillations, Fig. 15. Such an arrangement of circuits is called an "autodyne" receiving set. The frequency of the local oscillations may be changed by adjusting the setting of the condenser C for instance, and this will change the beat frequency and therefore the pitch of the sound in the telephone. A very pure note of any pitch may thus be obtained at the will of the receiving operator.

The use of such sets allows exceedingly sharp tuning and practically eliminates all interference from other sending stations.

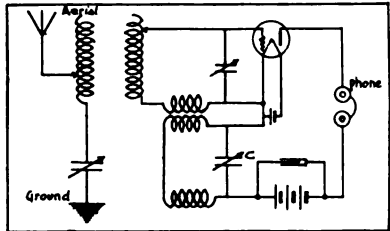

Fig. 15—Schematic Circuit of an Autodyne Receiving Set.



## RADIO TELEPHONY

Radio telephony has not thus far been extensively used in the war, although recent developments bid fair to make practical a perhaps very important utilization of this form of radio communication. The principles involved in radio telephonic transmission are the same as for undamped wave telegraphic transmission, except that the sending key is replaced by a device for varying the intensity of the energy radiated to produce sounds at the receiving station corresponding to the inflections and modulations of the voice. The device used for this purpose is the three-electrode vacuum tube so connected in the transmitting oscillatory circuit as to act as a modulator of the outgoing energy. The principles involved in radio telephonic reception are the same as for damped wave telegraphic reception. These principles are explained in the following paragraphs.

### **Modulator Action of Vacuum Tubes—Radio Telephone Transmission**

The three-electrode vacuum tube may be used not only to amplify power, but also to absorb power in a perfectly controllable manner. This may be explained by the characteristic of the tube whereby the space between the plate and filament has a resistance, the magnitude of which is dependent upon the potential of the grid. This was fully shown above in connection with Fig. 5, where, for a given constant plate potential and filament temperature, the plate current was determined by the grid potential. In other words, the action of the vacuum tube may be considered as equivalent to a variable resistance which controls the flow of the current in the plate circuit, the value of this resistance being determined by the potential of the grid.

A common application of this property of the tube is found in radio telephony. For instance, consider the circuit of Fig. 16. The high frequency alternator connected in the antenna circuit generates continuously a high frequency alternating

current of constant amplitude. The antenna is thus made to

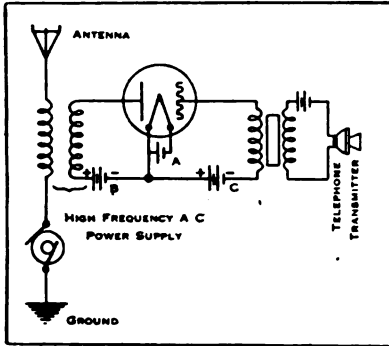

Fig. 16—Three-Electrode Tube Used as Modulator, Showing Connection as Radio Telephone Transmitter

radiate a continuous stream of undamped oscillations. Inductively coupled to the antenna is the plate circuit of a three-electrode vacuum tube, the grid of which is maintained at a considerable negative potential with respect to the filament by means of a battery C. The current passing through the antenna coil induces an emf. in the plate coil coupled to it, and there-

fore a potential difference between the filament and the plate of the tube. But on account of the strongly negative potential of the grid, this emf. produces only a very small current in the plate circuit. In other words, the power transferred from the antenna circuit to the plate circuit of the tube is very small.

Now if the grid is made less negative, or even positive, the same induced emf. in the plate circuit will produce a larger current, so that there will be a larger transfer of energy from the antenna circuit to the tube. The tube will have absorbed power, so to speak, from the antenna circuit. The result of this absorption is that the normal output of the generator is divided between the two circuits in proportion to their impedances, so that part only of the energy normally radiated by the antenna without the reaction of the plate circuit, will now be radiated. The more positive the grid of the tube, the less the resistance to the plate current flow and the greater the power absorbed by the tube, and therefore the less the amount of energy radiated by the antenna.

It is thus possible to modulate the waves radiated by the antenna into any desired shape. By suitably varying the grid potential by means of the voice, through the medium of the ordinary telephone transmitter coupled to the grid circuit, the changes in the instantaneous amounts of energy radiated will be proportional to the inflections of the voice. At the receiving station, the corresponding oscillations, when rectified, will

have a shape or "envelope" molded to the transmitting speech, and they will therefore induce in the telephone receivers a unidirectional pulsating current similar to that in the ordinary wire telephone which will exactly reproduce the sound of the voice at the sending station.

The vacuum tube may be used not only to modulate the a.c. power output of the high frequency a.c. generator, as explained in the previous paragraph, but to modulate the d.c. supply to that generator, thus accomplishing in another way the same final result—the modulation of the antenna output. This is the scheme of modulation commonly used by the U. S. Signal Corps, the a.c. generator being a vacuum tube oscillator. The modulator tube is connected in parallel with the oscillator tube, across the d.c. supply and the telephone transmitter is connected to the primary of a transformer, the secondary of which is connected in the grid circuit of the modulator tube. As the resistance of the modulator tube is changed by the voice, the amount of d.c. power to be transformed into a.c. power by the oscillator tube will be correspondingly modulated. For fuller explanation, see Radio Pamphlet No. 20.



---

Prepared in the  
Office of the Chief Signal Officer  
Training Section  
Washington

---

*AR*

# ANTENNA SYSTEMS

a-2;    a-2-a;    a-2-B;  
a-3;    a-3-a;    a-4;  
a-6;    a-9.

(Confidential)

*Communication*  
Radio Pamphlet  
No. 2

**Signal Corps, U. S. Army**  
Third Edition, Revised to  
10-31-18

---

Prepared in the  
Office of the Chief Signal Officer  
Training Section  
Washington

---

# ANTENNA SYSTEMS

a-2;      a-2-a;      a-2-b;  
a-3;      a-3-a;      a-4;  
a-6;      a-9.

(Confidential)

*Communication*  
Radio Pamphlet  
No. 2

Signal Corps, U. S. Army  
Third Edition, Revised to  
10-31-18





# **Antenna Systems**

**General Theory of Antennae—Data from  
Which to Select Best Antenna for  
a Given Set—General Method  
of Erecting Antennae**



**T**HE UNDERLYING principle of radio communication is the production by a transmitting circuit of an electromagnetic and electrostatic field which will extend far enough to interlink with a receiving circuit, and be strong enough to induce currents in the latter, these being used to produce sound signals. The production of a field of such shape and strength, and the effect of this field upon the receiving circuit, depend to a great extent on the size, shape and position of the transmitting and receiving antenna circuits. Also, the standard radio sets employed by the Signal Corps to transmit and receive signals of definite wave length between certain stations, require that the antennae shall have certain electrical characteristics (inductance, capacitance, resistance, natural wave length) and directional effects. It is the purpose of this pamphlet to outline methods of establishing an antenna of given characteristics, as determined by the type of radio set to be used, taking into account the location of the stations to be communicated with and the limitations of space which may be encountered in the field.

### **Various Types of Antennae**

The antenna of a transmitting or receiving circuit forms part of an oscillatory circuit which comprises inductance, capacitance, and resistance. Although these electrical constants are distributed throughout the oscillatory circuit, this distribution is in most cases unequal, and for small antennae and sets of the longer wave lengths the greatest part of either the capacitance or the inductance is concentrated inside the set box in the form of a condenser or inductance coil of small dimensions, the antenna then performing the function of the inductance coil or condenser of the circuit, respectively, as the case may be. And due to the large dimensions of this inductance coil or condenser, the antenna circuit has an electric field suitable for the establishment of radio communication. For large antennae and sets of short wave length the antenna may form the greater part of the total inductance or capacitance of the open oscillatory circuit.

When the antenna forms the inductance coil of the oscillatory circuit, it is called a "loop" antenna and the resulting radiation of energy is called magnetic radiation. It generally consists of a rectangular or triangular coil of a very few turns (1 to 10 as an average), and of large overall dimensions. The properties of this type of antenna are not taken up here, as its use is restricted to a few sets only for which it takes on definite dimensions and shape. Such antennae are described in

separate pamphlets, in conjunction with the radio set of which they form a part.

When the antenna forms the condenser of the oscillatory circuit, the resulting radiation is called electrostatic radiation. The antenna may be given a large number of different shapes, depending on the conditions of each particular problem. Such antennae are used with most Signal Corps ground radio sets, and on almost all airplane sets. Only ground antennae are taken up here.

Such an antenna is made up of an aerial system and a ground or counterpoise system, each of which is connected to the radio set terminals by means of leading-in wires. This constitutes a so-called open oscillatory circuit, the aerial and ground systems being the two plates of a large air condenser. The aerial system is made up entirely of metallic wires. The other plate of the condenser antenna may be made up of wires, or of the earth itself if it is damp and conducting.

### Distributed Constants of an Antenna

The simplest form of antenna is the single wire vertical antenna, illustrated in Fig. 1. Such an antenna may be made up by suspending a metal wire from an insulator, and grounding the lower end. This wire has a certain amount of inductance which is equally distributed throughout its length. That is, any segment of the wire will have the same inductance as any other segment, provided they have the same length.

Consider now a segment *ab* of the antenna Fig. 1, to the exclusion of the rest of the antenna. This segment is at a certain height above the conducting ground, and is separated from it by a layer of air which is an insulator. The ground and this section of the antenna wire thus form the two sides of a condenser, the dielectric being the air between them. This is shown schematically by the circuit in dotted lines. Similarly, the segment *bc* of the wire, equal in length and immediately below the segment *ab*, will form a condenser with the ground; and so on for the entire wire. However, although the various segments, *ab*, *bc*, etc., are of equal length, their electrostatic capacity to ground, that is, the capacitance of the individual condensers considered above, is not equal. This is due to the fact that the distance of the segments to the ground, and therefore the thickness of the dielectric (air) of each condenser, is not the same for the different segments. And since for various condensers otherwise similar, but differing in the thickness of their dielectric, the capacitance is greater for the condenser having the thinnest dielectric, it follows that the lower sections of the antenna wire have a capacitance to ground greater than the upper sections.

Since such an antenna contains capacitance and inductance, it is possible to produce oscillating currents in it by suitable excitation. This may

be done in a number of ways, one method being to insert a spark gap *S* in the circuit, Fig. 2, and establishing a difference of potential between the aerial (upper part of the antenna) and the ground, great enough to produce a spark across the gap. High frequency oscillations will then take place in the antenna, the process being similar to the oscillatory discharge of a closed (non-radiating) circuit, as explained in Radio Pamphlet No. 1; that is to say, an electric current will flow in the antenna wire, alternately upward and downward. Such a high frequency current will flow through a condenser, and, as is known, the greater the

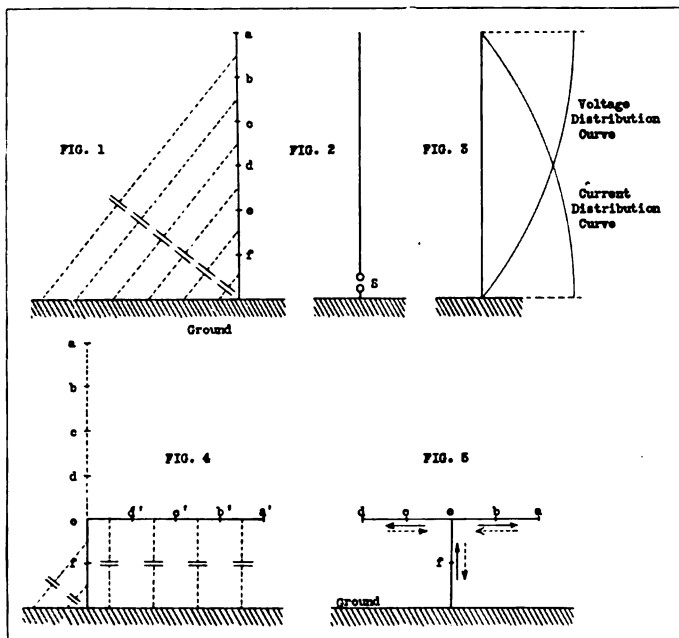

capacitance of the condenser, the greater the current. It follows that the capacitance of the antenna being greatest at its base, the current in the antenna wire is a maximum near the grounded end, and a minimum near the top. This produces an unequal distribution of the current along the antenna wire, which may be represented for a particular instant as in Fig. 3. This current distribution curve is obtained by plotting off horizontally at each point of the antenna wire a length proportional to the instantaneous current flowing in the antenna at this point.

It may be similarly shown that the voltage distribution along the antenna wire is unequal, the greatest voltage point being at the ungrounded end of the aerial, while the voltage of the grounded end is zero.

The practical conclusions to be drawn from the above remarks are that the wire and connections must be made of metal of large capacity or cross section, so that the parts which have to carry the greatest currents, will not have too high resistance. Also, if the wire is supported at various points, the insulation must be made increasingly heavier as the top of the antenna is approached.

### Natural Wave Length of an Antenna

In the previous paragraphs it was shown that an antenna made up of a single vertical wire grounded at its lower end, has capacitance and inductance, the values of which, respectively, are the sum of the capacitances to ground and inductances of the various sections  $ab$ ,  $bc$ , . . . , of the antenna wire. When an oscillating current takes place in the antenna, electric waves are radiated by it (see Radio Pamphlet No. 1), the length of which is numerically expressed by the equation.

$$\text{Wave length} = \text{velocity of light} \times \sqrt{\text{inductance} \times \text{capacitance}}.$$

This wave length is called the "natural wave length" of the antenna.

It has been found that the inductance and capacitance of an antenna of the type described above are of such value that its natural wave length is equal to four times the length of the antenna wire. This is frequently expressed by saying that the antenna oscillates at quarter wave length.

If now instead of using the antenna above described, the same length of wire is given the shape shown in Fig. 4, by suspending a length  $ae$  of the wire horizontally, a so-called "inverted L" antenna is obtained. As a result of this bending of the antenna wire, the sections of the wire above point  $e$  have been brought closer to the ground, so that the capacitance of the corresponding individual condensers, or, which is the same thing, the capacitance to ground of sections  $ab$ ,  $bc$ ,  $cd$ ,  $de$ , has increased correspondingly. The total capacitance of the antenna has therefore increased. Its inductance has similarly increased, but to a lesser degree. These changes result in a longer natural wave length for the inverted "L" antenna, as may be seen from the above equation, so that the quarter wave length rule no longer holds.

Another arrangement is that of Fig. 5, known as the "T" antenna, where the vertical wire  $fe$  is connected to the center of the horizontal wire, instead of the end. If the vertical and horizontal wires are respectively equal to those of the "L" antenna considered above, the total electrostatic capacity will be the same, since the distances to ground of the various segments of the wire have not been changed. The total

inductance of the antenna is however considerably less than before, as the oscillating current always flows in opposite directions in the two horizontal branches of the "T", so that their magnetic fluxes neutralize. The natural wave length of the "T" antenna is thus smaller than that of the "L" antenna considered above.

It may thus be seen, that with a given amount of wire to be used, the shape of the antenna should be so chosen that the natural wave length will be of the order required by the radio set to be used. Also, since various shapes may give the same wave length, or may have the same capacitance or inductance, the choice of antenna which takes up the least space, or which is easiest to erect, etc., should be made, according to circumstances. Other considerations which are of great importance must be taken into account, however; namely, the distance over which radio communication is to be established, and the directive effect of the antenna. These are taken up below. In general, where a low antenna is necessary, one having fairly high capacitance is usually used in order to get sufficient input of power to give appreciable radiation.

### **Directional Effect of an Antenna**

The directional effect of an antenna is a property of the latter whereby the strength of the signals radiated is greater in certain directions than it is in others. This may be illustrated as follows:

A vertical wire antenna, shown in plan view by the point A, Fig. 6, is used as a transmitting antenna; that is, oscillating currents are set up in it, as a consequence of which an oscillating electromagnetic and electrostatic field are built up in the space surrounding the wire. As is known, these varying fields will induce electric currents in a suitable receiving circuit, and these in turn produce sounds in a telephone receiver, corresponding to the signals transmitted. The loudness of the sound may be measured (by means of an audibility meter), and is an indication of the strength of the electric field at the point at which the receiving station is installed. It need not be demonstrated that the strength of the signals emitted by a certain station decreases as the distance to the receiving station is increased.

Using the vertical wire antenna A, Fig. 6, as a transmitting antenna, if a number of observers are scattered around that transmitting station, and equipped with identical receiving circuits, and these observers move toward or away from the station A until the loudness of the signals in the various receiving circuits is the same, all the observers will find themselves on a circle, the center of which is point A. In other words, the strength of the signals emitted by a vertical wire antenna is the same in all directions.



Repeating the experiment, using an inverted "L" antenna AB, with the lead-in end (grounded end) at point A, the observers will find themselves no longer on a circle, but on a curve having the general shape shown in Fig. 7. From this curve, it will be seen that the strength of the waves sent out by an "L" antenna is greatly dependent on the location of the receiving station with respect to the position of the transmitting antenna, and is a maximum in the vertical plane of the "L" antenna, in the direction of the grounded end of the horizontal branch of the "L." The practical conclusion is that when it is desired to transmit to one particular station in a known direction, an "L" antenna should be used, setting it up so that it will point toward the station it is desired to reach, with the free end of the aerial in the direction away from the distant station.

Figs. 8 and 9 similarly illustrate the directive effect of a "T" and a "V" antenna. The latter, which may be considered as two "L" antennae

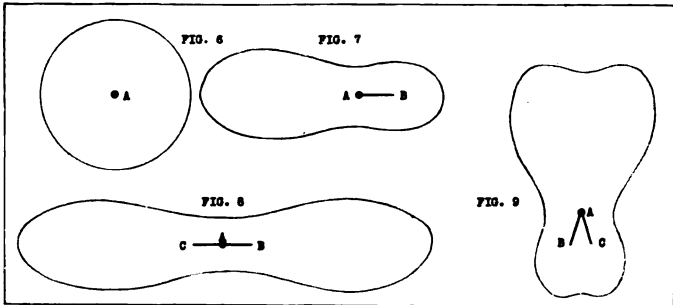

having a common vertical wire, is used instead of the "L" when communication is to be established with a station in motion, such as an airplane, but which remains in the same general direction.

The "V" antenna, while uni-directional in the same general direction as the "L" antenna, has an electric field of fan-like shape which will cover a greater width of the front, permitting a greater lateral movement of the forward station while remaining in the field of the antenna. This will be seen by comparing the fields of Fig. 7 and Fig. 9.

The directive effect of an antenna used for receiving messages is the same as when the antenna is used for transmitting, so that the diagrams of Figs. 6, 7, 8 and 9 may be used. From these, the relative positions of the antennae of various stations which are to communicate with each other are easily established. As an illustration, Fig. 10 shows the correct method of setting up two stations using "L" antennae.

As a general rule, it may be said that any antenna is directive in the direction of its plane of symmetry, and, in that plane, in the direction of the end of the aerial at which the lead-in wire is connected.

### Ground and Counterpoise Systems

In the theory of the antenna explained in the opening paragraphs, it was assumed that the ground surface was a perfectly good conductor of electricity. Actually, the ground is only a partial conductor, especially when dry or rocky. And when wet, its effectiveness depends to a great extent on the manner in which the antenna wire is connected to the ground. Another consideration is, that like any other oscillatory circuit, the resistance should be as low as possible, so that the oscillations will take place satisfactorily.

It is therefore important that the ground connection and ground side of the large condenser making up the antenna, be of low electrical resistance. This condition may be accomplished by either making a good ground connection, or using an insulated counterpoise system.

**Ground Connection.**—A ground connection should be used preferably when the ground is wet or fairly conducting. The best method is to bury one or more copper mats, about 1 ft. deep. When several mats are used, they should be spaced equal to their widths, and placed in the area covered by the aerial wires. When it is not possible to bury the mats, they may simply be laid on the ground. All the mats should be carefully interconnected, and this system used as the ground.

Another method is to drive 10 to 15 stakes into the ground, as deep as possible, and 3 ft. to 6 ft. apart, in the area covered by the aerial system. These should then be carefully interconnected and used as the ground.

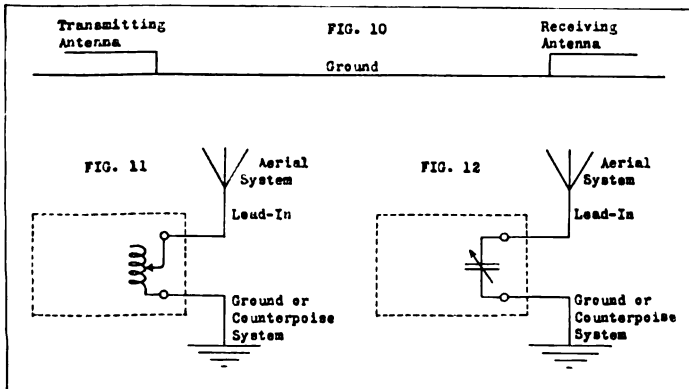

**Counterpoise Systems.**—This is by far the best method of establishing the ground side of the antenna. Instead of using a ground connection, a system of wires insulated from the ground, preferably by supporting them about 1 ft. above the ground, and run parallel and underneath the aerial wires, is employed.

It is not advisable to make simultaneous use of a counterpoise and ground mats or stakes.

### Methods of Changing the Wave Length

When an antenna is set up, it is generally used at a number of different wave lengths, the adjustment being made by means of a loading coil or an antenna condenser connected in series with the antenna, Figs. 11 and 12. This coil or condenser is generally inclosed in the set box and is arranged so that the amount of inductance or of capacitance in the antenna circuit may be readily varied. Adding inductance in series with the lead-in wire lengthens the wave, while similarly adding capacitance shortens it. Hence, to increase the wave length, increase the inductance or decrease the capacitance. To decrease the wave length, decrease the inductance or increase the capacitance.

Radio Set Type No.	ANTENNA CONSTANTS FOR BEST OPERATION OF SET.		Suggested Antenna Construction (Item No)	Antenna Equipment Furnished with Set. (Type No.)
	Electrostatic Capacity (Micro-mfd)	Resistance (Ohms)		
SCR-54	320	-	7	A-2
SCR-54-A	320	-	7	A-2-A & A-2-B
SCR-67	At Least 500	Less than 40	Umbrella, 40 ft. high; 6 aeriials & 6 ctps.wires 50 ft. each or, Item No. 26 or 29	A-4 (Obsolete)  A-9
SCR-69	At Least 500	As Low As Possible	26 or 29	A-6 * (Obsolete)
SCR-70	At Least 500	"	26 or 29	"
SCR-74	About 350 to 500	As Low As Possible	4, 5, or 6; See Radio Pamphlet No 11	A-3
SCR-74-A	"	"	"	A-3-A
SCR-78	-	-	Special Tank Antenna	A-7 A-8
SCR-79	300-600; Best Value 450	Less than 60	7, 21, or 22	A-9
SCR-99	"	Less than 30	11 or 22	A-9

\* Type A-9 Antenna Equipment may be used instead.

## TABLE OF ANTENNA CONSTANTS

ANTENNA TYPE	Item No.	AERIAL SYSTEM			COUNTERPOISE SYSTEM	PLAN VIEW	NATURAL WAVE LENGTH (Meters)	ELECTRO-STATIC CAPACITY (Micro-mfd.)	MINIMUM EFFECTIVE RESIST. (Ohms)
		Length Ft.	Lead-in Rad. Ft.	Height Free End, Ft.					
Inverted "L"	1	100	20	20	1 Wire, insulated 100 ft. long		200	200	42
Inverted "L"	2	100	20	20	4 Ground Stakes (spaced)		220	270	56
Inverted "L"	3	150	27	1 1/2	1 Ground Mat 3 ft. x 6 ft. buried		270	400	57
Inverted "L"	4	150	3	3	1 Wire, insulated 150 ft. long		330	430	46
Inverted "L"	5	150	3	3	1 Ground Mat 3 ft. x 12 ft.		270	450	52
Inverted "L"	6	150	3	3	4 Ground Stakes		330	500	68
Inverted "L"	7	150	20	20	1 Wire, insulated 150 ft. long		325	320	33
Inverted "L"	8	150	20	20	2 Wires, insulated close together 150 ft. long		315	345	32
Inverted "L"	9	150	20	20	2 Wires, insulated 4 ft. apart, 150 ft. long		300	335	23
Inverted "L"	10	150	20	20	2 Wires, insulated 12 ft. apart, 150 ft. long		290	325	27
Inverted "L"	11	150	20	20	3 Wires, insulated 12 ft. to center 150 ft. long		225	350	17
Inverted "L"	12	150	20	20	5 Mats, 3' x 6', spaced 10 ft. between centers		250	350	49
Inverted "L"	13	150	20	20	3 Mats, 3' x 6', spaced 3 ft. between centers		230	320	64
Inverted "L"	14	150	20	20	6 Ground Stakes		255	360	74
Inverted "L"	15	100	20	20	4 Ground Stakes		245	300	60
Inverted "L"	16	100	20	20	2 Ground Stakes		240	370	86
Inverted "L"	17	200	20	20	1 Wire, insulated, 200 ft. long		340	400	39
Inverted "L"	18	200	20	20	1 Wire, insulated, 150 ft. long		340	380	37
Inverted "L"	19	200	20	20	5 Mats, 3' x 6', spaced 15 ft. between centers		300	460	60
Inverted "L"	20	200	20	20	4 Ground Stakes		340	490	54
60-Deg. "Y"	21	100 ft. each side	24	24	2 Wires, insulated 100 ft. each		255	400	32
60-Deg. "Y"	22	100	24	24	3 Wires, insulated 100 ft. each		245	410	23
60-Deg. "Y"	23	100	24	24	3 Ground Mats, 2'10" x 5'6"		265	410	46
60-Deg. "Y"	24	100	24	24	1 Mat, buried, 3 ft. x 6 ft.		235	465	59
60-Deg. "Y"	25	100	20	20	2 Mats, buried, 3 ft. x 12 ft.		240	420	34
60-Deg. "Y"	26	150	24	24	2 Wires, insulated 150 ft. each		340	580	24
60-Deg. "Y"	27	150	24	24	2 Wires, insulated 100 ft. each		330	550	31
60-Deg. "Y"	28	150	24	24	3 Wires, insulated 150 ft. each		300	600	21
60-Deg. "Y"	29	150	24	24	3 Wires, insulated 100 ft. each		360	600	19
60-Deg. "Y"	30	150	24	24	2 Ground Mats, 3 ft. x 12 ft.		310	620	45
60-Deg. "Y"	31	150	24	24	2 Mats, 3' x 12' and 3 Mats, 3' x 6'		335	660	30

KEY

Aerial Wire

Counterpoise Wire

• Stake

□ Mat

## Antennae Used with Signal Corps Apparatus

As explained above, the constants of an antenna depend essentially on its shape. In the Table of Antenna Constants given herewith are the constants of a number of antennae of various designs which may be used with Signal Corps apparatus. They may be altered to suit special conditions. Also, each radio set will give best results when used with an antenna of certain definite constants. This is summarized in the Table of Antenna Requirements, which may be found of use when setting up in the field under various conditions.

The size of the antenna may of course be changed, as desired. If the lead-in wires are short as compared with the length of the aerial and counterpoise wire, it may be said that the lower the aerial, the greater the capacitance. As a general rule, the higher the antenna, the greater the distance over which signals may be transmitted.

### How to Use the Antenna Tables

As an illustration of how to use these tables, assume it is desired to set up an antenna for use with the type SCR-79 set. The requirements of this set are to be found in the Table of Antenna Requirements. Thus, the antenna must have a capacitance of from 300 to 600 micro-mfd., preferably 450 micro-mfd., and a resistance of less than 60 ohms. Referring to the Table of Antenna Constants, it may be seen that several types of antennae fulfil those requirements. Three types are especially recommended in the first table, as found in items 7, 21 and 22. It is seen that item 7 is an inverted "L" antenna, 150 ft. long, and 20 ft. high, using an insulated counterpoise wire of the same length. Items 21 and 22 are "V" antennae. The choice between these three different designs will depend upon the material available (poles, wire, etc.) and upon the degree of directional effect required on the particular occasion. It will be remembered that the "L" antenna is more directional than the "V." If a "V" antenna is suitable for the purpose, and sufficient material is at hand, the item 22 would probably be better than the item 21, since, with almost the same natural wave length and capacitance, the resistance of the former is less than that of the latter, resulting in smaller resistance (heat) losses in the antenna and consequently greater radiation.

### Setting Up Antennae

After having determined the type of antenna to be used, as explained above, it is now necessary to erect it properly. The first thing to do is to choose a location suitably protected from enemy shell fire and observation, and among surroundings which will not cause absorption of the waves in the direction of transmission or reception.

In many instances it may be possible to use trees, houses, etc., to support the aerial. In most cases however, it is necessary to use the

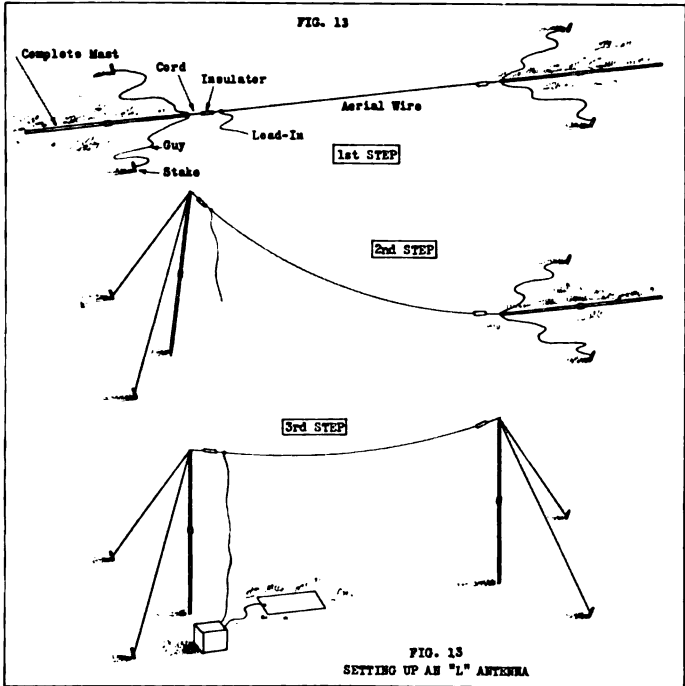

antenna poles or supports furnished with the set. In such an instance, the proper procedure is explained below, this being such as to enable one man to erect the antenna without any assistance.

### Inverted "L" Antenna

1. Stretch out the aerial wire on the ground in line with the direction of the distant station and with the lead-in end nearest that station.

2. Couple the mast sections and lay the assembled masts at each end of the antenna in the same straight line as the wire, Fig. 13.

3. Attach the antenna wire to the insulators and attach the latter to the mast tops by means of cords or snap hooks, etc. Attach two guys to each mast top.

4. Drive two stakes near each mast and at an angle of about 45 deg. to the line of the antenna wire. The distance from the top of the mast must be estimated from the length of the guys and the height of the mast, Fig. 13, 1st Step.

5. One mast is then erected by gradually raising the mast top, keeping the bottom end on the ground at all times and moving it toward the opposite end of the antenna wire, until the mast is in a nearly vertical position, Fig. 13, 2nd Step, where it will stand without having to be held.

6. Proceed similarly with the other mast. Then shift the first mast slightly to bring it in a vertical position, Fig. 13, 3rd Step. It will be noted that the aerial wire is stretched out in the process of erecting the masts.

### "V" Antenna

The method of erecting a "V" antenna is similar to that explained above for the "L" antenna. The antenna is first laid out on the ground as shown in plan view in Fig. 14. The masts A and B are first raised like the first mast of the "L" antenna, after which mast "C" is erected by raising the mast top and moving the bottom of the mast (held on the ground) in the direction of the point of the "V."

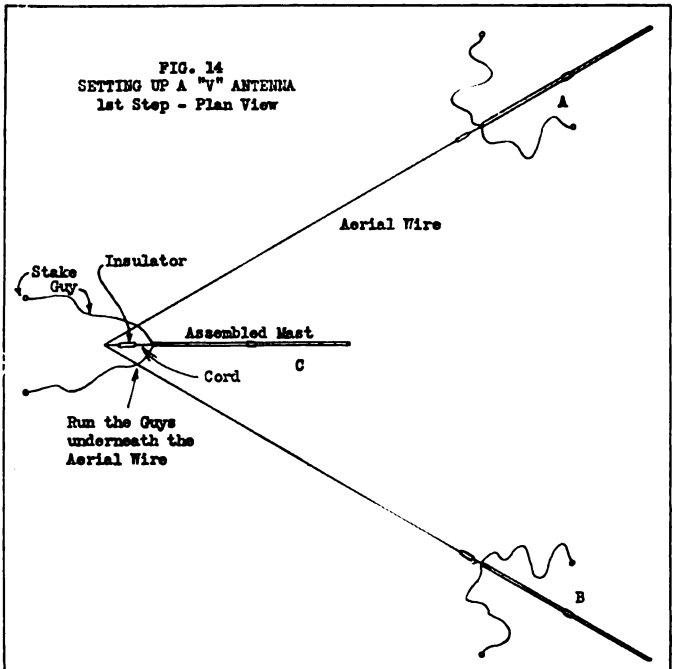

## Parts Lists

---

### EQUIPMENT, TYPE A-2

**2 Mast Sections, Type MS-1;** top; same as type MS-2, but without steel coupling tube.

**8 Mast Sections, Type MS-2;** intermediate.

**6 Guys, Type GY-1;** 43-ft., complete.

**3 Guys, Type GY-2;** 22-ft., complete.

**4 Reels, Type RL-3;** hand; one for antenna and lead-in wire, and one for each set of 3 guys.

**6 Stakes, Type GP-1;** guy; 3 in use for each mast.

**2 Plates, Type MP-2;** upper guy; complete with mast tube; one for each mast.

**1 Plate, Type MP-3;** lower guy; for 29-ft. mast.

**2 Plates, Type MP-1;** antenna, complete with Electrose No. 4500 insulators connected to plate with closed wire link; other end provided with open wire hook to receive antenna wire thimble.

**1 Antenna, Type AN-1;** 150 ft. antenna wire with thimble at each end; the thimble for the 29-ft. mast end has connected to it a 50-ft. lead-in of No. 16 B&S gauge, single conductor, new code lamp cord, weather-proofed.

**2 Connections, Type GD-1;** ground; ground mat with 20-ft. No. 16 B&S gauge single conductor new code lamp cord, weather-proofed; 1 in use, 1 spare.

**2 pr. Bags, Type BG-1;** carrying; for masts.

**1 Bag, Type BG-2;** carrying, for antenna and accessories.

**1 Hammer, Type HM-1;** 2 lb.; two-face engineer's; 16-in. handle.

**1 Twine, Measuring, Type TW-1;** 35-ft.; for measuring distance of guy stakes from masts.

**1 Marker, Type MR-1;** guy stake; for locating direction of ground stakes from masts.

### EQUIPMENT, TYPE A-2-A

**6 Masts, Type MS-5;** bamboo; 13 ft. long; iron tipped at both ends; total weight, 16 lbs.

**6 Insulators, Type IN-6;** mast top; 3- $\frac{5}{8}$  in. x 1 $\frac{1}{2}$  in.

**6 Pins, Type FT-3;** insulators; 4-9/16 in. x  $\frac{3}{8}$  in. square.



**750 ft. Wire, Type W-1;** antenna; 7-strand, No. 22 B&S gauge, soft tinned copper, bare; net weight, 8 lb. 12 oz.; to be in one piece and wound on spool of 6 in. outside diameter.

**75 ft. Wire, Type W-4;** lead-in; modified No. 16 B&S gauge, N.E.C. lamp cord, spec. W-4, wound on 8-in. coil; total weight, 1 lb. 8 oz.

**2 lb. Wire, Type W-2;** No. 14 B&S gauge, soft drawn copper, bare; in one piece wound in 7-in. coil.

**1 Mat, Type MT-2;** ground; 9 ft. x 20 in.; total weight, 3 lb. 4 oz.

**14 Stakes, Type GP-3;** ground; 1 in. x 1 in. x  $\frac{1}{8}$  in. angles; total weight, 35 lb.

**8 Insulators, Type IN-5;** hard rubber;  $5\frac{1}{2}$  in. x  $\frac{5}{8}$  in.; total weight, 10 oz.

**6 Couplers, Type FT-2;** pole; 4 in. x 5 in. x 1 in.; total weight 4 lb.

**150 ft. Rope, Type RP-1;** manila; 1-in. circumference;  $\frac{5}{16}$  in. diameter; tensile strength, 1,000 lbs.; in one piece wound on 8-in. coil; total weight, 3 lb. 12 oz.

**4 Reels, Type RL-3;** hand;  $11\frac{3}{4}$  in. x 10 in.

**1 Pliers, Type TL-20;** universal; 8-in.; similar to Fairbanks' combination pliers No. 70; drop forged steel with blue handle and polished head.

**1 Tape, Friction, Roll, spec. 569-B;**  $\frac{3}{4}$ -in.

**1 Hammer, Type HM-1;** 2 lb. 16-in. handle.

**2 Marlin, Type RP-2, Coils;** 42-ft. lengths.

### EQUIPMENT, TYPE A-3

**2 Supports, Type MS-4;** antenna; complete with guys.

**1 Antenna, Type AN-2;** antenna cord, 150 ft. complete with 20-ft. lead-in wire and 4 Electrose No. 4500 insulators, of which 2 are linked in series at each end of antenna wire; free end of insulator provided with open wire hook.

**1 Counterpoise, Type CP-1;** two 150-ft. lengths counterpoise wire, spec. 416-1, with terminal plug on one end.

**1 Block, Type BL-3;** connecting; at one end of 20-ft. lead-in wire.

**4 Stakes, Type GP-2;** ground, standard.

**3 Reels, Type RL-3;** hand; for antenna and counterpoise wires.

**1 Bag, Type BG-8;** carrying; for ground stakes, antenna and accessories.

**2 Hammers, Type HM-1;** 2 lb.

## EQUIPMENT, TYPE A-3-A

**1 Bag, Type BG-15;** carrying.

**2 Antenna Supports, Type MS-4-A;** each complete with insulator type IN-5, guy rope type RP-5, ground stake type GP-5, and guy rope fastener type FT-9.

**1 Reel, Type RL-3;** hand.

**1 Antenna, Type AN-5;** with snap hooks on both ends.

**1 Mat, Type MT-3;** ground.

**1 Hammer, Type HM-1.**

**1 Pliers, Type TL-19;** pair; combination.

**¼ lb. Tape, Friction;** ¾ in.

**1 Stake, Type GP-6;** ground.

## EQUIPMENT, TYPE A-2-B

**6 Mast Sections, Type MS-5;** bamboo; 13 ft. long; iron tipped at both ends; total weight, 16 lb.

**6 Insulators, Type IN-7;** mast top; 3 in use, 3 spare.

**750 ft. Wire, Type W-1;** antenna; 7-strand, No. 22 B&S gauge, soft tinned copper, bare; net weight, 8 lb. 12 oz.; to be in one piece and wound on spool of 6 in. outside diameter.

**75 ft. Wire, Type W-4;** lead-in; No. 16 B&S gauge, modified, N. E. C. lamp cord, wound on 8-in. coil; total weight, 1 lb. 8 oz.

**2 lb. Wire, Type W-2;** No. 14 B&S gauge, soft drawn copper, bare; in one piece wound in 7-in. coil.

**1 Mat, Type MT-2;** ground; 9 ft. x 20 in.; weight 3 lb. 4 oz.

**14 Stakes, Type GP-3;** ground; 1 in. x 1 in. x ⅛ in. angles; total weight, 35 lb.

**8 Insulators, Type IN-5;** hard rubber; 5½ in. x ⅝ in.; total weight, 10 oz.

**6 Couplers, Type FT-2;** pole; 4 in. x 5 in. x 1 in.; total weight, 4 lb.

**200 ft. Cord, Type RP-3;** sash; No. 5; olive drab.

**4 Reels, Type RL-3;** hand; 11-¾ in. x 10 in.

**1 Pliers, Type TL-20;** universal; 8-in.; similar to Fairbanks combination pliers No. 70; drop forged steel with blue handle and polished head.

**¼ lb. Tape, Friction;** ¾ in.

**1 Hammer, Type HM-1;** 2 lb.; 16-in. handle.

**¼ lb. Marlin, Type RP-2;** wound in two coils.

**EQUIPMENT, TYPE A-4**

- 1 Mast Section, Type MS-1;** top; same as type MS-2, but without steel coupling tube.
- 8 Mast Sections, Type MS-2;** intermediate.
- 1 Mast Section, Type MS-3;** bottom.
- 1 Insulator, Electro, No. 3001.**
- 1 Cap, Mast, Type MP-4;** complete with 50-ft. antenna lead.
- 4 Wires, Type GY-3;** antenna; complete with guys.
- 4 Wires, Counterpoise, SPEC. 416-I.**
- 9 Reels, Type RL-3;** hand; one for each antenna and counterpoise wire, and one for lead-in wire.
- 4 Stakes, Type GP-1;** guy.
- 2 pr. Bags, Type BG-1;** carrying; one pair for 5 mast sections.
- 1 Bag, Type BG-6;** carrying; for antenna and counterpoise.
- 1 Bag, Type BG-7;** carrying; for accessories.
- 2 Hammers, Type HM-1;** 2-lb.
- 1 Box and Cord, Type BL-2;** junction; for counterpoise wires.
- 1 Cord, Type CD-26;** from set box BC-13 to antenna.

**EQUIPMENT, TYPE A-6**

- 3 Mast Sections, Type MS-1;** without tubes.
- 12 Mast Sections, Type MS-2;** with tube.
- 3 Caps, Mast, Type MP-5.**
- 3 Insulators, Type IN-1;** hard rubber, with hooks.
- 9 Reels, Type RL-3;** hand.
- 1 Antenna, Type AN-5;** two lengths of braided antenna cord 150 ft. long, and one length of lead-in wire 40 ft. long, all carried on three hand reels.
- 9 Guys, Type GY-3;** No. 5 sash cord, each 36 ft. long, with metal tent slide and hook; a set of three guys to be carried on each of three hand reels.
- 1 Counterpoise, Type CP-4;** two lengths of wire 150 ft. long, and one lead-in wire 40 ft. long, all joined together at their intersection; to be carried on three hand reels.
- 3 Hammers, Type HM-1.**
- 9 Stakes, Type GP-2;** guy.
- 3 Cords, No. 5 Sash, Pieces, 3 Ft. Long.**
- 1 Chest, Type BC-35;** carrying; used for packing antenna equipment for transportation.

## EQUIPMENT, TYPE A-9

**6 Masts, Type MS-5;** bamboo, 13-ft. long; iron tipped at both ends.

**2 Bags, Type BG-14;** carrying;  $6\frac{3}{4}$  in. x 2 ft.  $7\frac{1}{2}$  in.

**12 Stakes, Type GP-3;** ground.

**1 Bag, Type BG-8;** carrying; 1 ft. 8 in. x 1 ft. 2 in. x 3 in.

**50 ft. Wire, Type W-4;** lead-in; wound in 8-in. coil.

**1 Hammer, Type HM-1;** weight 2 lb.; 16 in. handle.

**1 Marlin, Type RP-2;** coil;  $1/16$ -in. diameter; weight about 8 oz.

**300 ft. Cord, Type RP-3;** sash; No. 5; olive drab.

**6 Insulators, Type IN-6;** mast top;  $3\text{-}\frac{5}{8}$  in. x  $1\frac{1}{2}$  in.; 3 in use, 3 spare.

**6 Insulators, Type IN-5;** hard rubber;  $5\frac{1}{2}$  in. x  $\frac{5}{8}$  in.

**3 Pins, Type FT-3;** insulator;  $4\text{-}9/16$  in. x  $\frac{3}{8}$  in. square.

**6 Couplers, Type FT-2;** pole; 4 in. x 5 in. x 1 in.

**3 Mats, Type MT-3;** ground; 40 in. x 13 ft.

**750 ft. Wire, Type W-1;** antenna; 7 strands, No. 22 B&S gauge, bare, soft tinned copper; net weight, 8 lb. 12 oz.; to be in one piece wound on spool 6-in. x  $5\frac{1}{2}$  in.

**2 Reels, Type RL-3;** hand;  $11\text{-}\frac{3}{4}$  in. x 10 in.

**300 ft. Wire, Type W-6;** counterpoise; on two reels type RL-3.





---

**Prepared in the  
Office of the Chief Signal Officer  
Training Section  
Washington**

---

FOR OFFICIAL USE ONLY

# RADIO RECEIVING SETS

Type SCR-54

Type SCR-54-A

and

# DETECTOR EQUIPMENT

Type DT-3-A

*Confidential*

*Communication*  
Radio Pamphlet

No. 3

Signal Corps, U. S. Army

Third Edition, Revised to  
10-24-18.





**Radio Receiving Sets**  
**Type SCR-54 and**  
**Type SCR-54-A**  
**and**  
**Vacuum Tube Detector Equipment**  
**Type DT-3-A**



**T**HE RADIO receiving sets, type SCR-54 and SCR-54-A form the standard units for the reception on the ground of signals from airplanes, and in general, of all damped wave signals or modulated wave signals. The principal use for these sets may perhaps be said to be that in connection with the work of the fire control airplanes in directing the fire of the artillery. But in addition, they are used for so many other classes of radio work, that they may indeed be considered among the most important radio sets.

The type SCR-54 set is very similar to the French type A-1 receiving set. The type SCR-54-A set is an improved American product, designed along the same general lines as the type SCR-54 but differing in some respects, both mechanical and electrical, to improve the operating characteristics. The type A-2 and A-2-B antenna units are normally furnished as parts of these sets. These antennæ are fully described in Radio Pamphlet No. 2. With their use the receiving sets have a wave length range of approximately from 150 to 650 meters. If properly operated, they afford quite sharp tuning. This feature and their compact, rugged and simple construction have made them of very considerable value on the Western front.

## **Type SCR-54 Set**

As shown in the wiring diagram, Fig. 1, the type SCR-54 receiving set comprises a primary (antenna) circuit and a secondary circuit, both of which may be tuned by means of the variable capacitance and variable inductance comprised in both circuits. The secondary circuit may also be made aperiodic by placing the switch M on the position marked "AP." This connects the condenser in or disconnects it from the circuit. Across the secondary condenser is connected the detector and telephone circuit. A separate buzzer circuit is installed in the cover of the box to excite the set when adjusting the crystal detector.

The adjustable capacitance in each circuit is a variable air condenser which is adjusted by means of an insulating handle, marked "Primary" or "Secondary," mounted directly on the rotating shaft of the condenser. The relative amount of capacitance in the circuit, corresponding to the various positions of

these handles, is indicated by a pointer fastened to the shaft, which moves over a dial graduated from 0 to 90. The position 0 corresponds to the minimum and the position 90 to the maximum capacitance of the condenser. The two condensers are

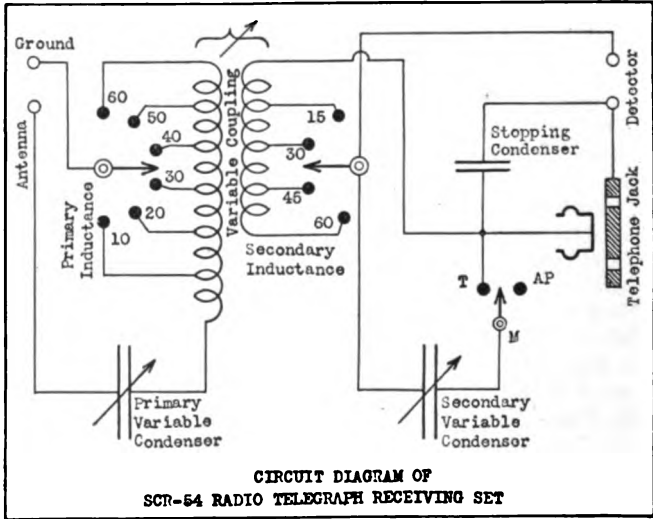

Fig. 1—Schematic Wiring Diagram of the Type SCR-54 Set.

identical in design, and have a maximum capacitance of 500 micro-mfd.

The primary and secondary inductances are varied by means of two dial switches marked "P" and "S," respectively. The primary inductance comprises 60 turns of wire divided into six steps of 10 turns each, while the secondary inductance comprises 60 turns divided into four steps of 15 turns each. These two inductance coils are wound on separate wooden cylinders so arranged that their relative positions may be readily varied.

The coupling of the two circuits, which is accomplished by the mutual induction effect of these two coils, is varied by changing the relative mechanical positions of the coils. The secondary coil may be rotated by means of a handle marked "Coupling," and a pointer moving over a scale graduated from 0 to 90 indicates its position. When in the zero position, the axes of the two coils are at right angles to each other, and the degree of coupling

is zero. When in the position "90," their axes are parallel, and the coupling is a maximum.

The telephone and detector circuit shunts the secondary condenser. This circuit consists of a crystal detector connected in series with the telephone receivers, which are shunted by a so-called stopping condenser. The latter is a .002 mfd. mica condenser. Two crystal detectors are furnished with the set; one of them is enclosed in a glass tube, which protects the crystal from dust or dirt. The other is open, having no such protective casing. Either one may be used by screwing it to the two binding posts of the set marked "Detector."

The buzzer circuit is mounted in a compartment of the set box cover, and consists of a small buzzer connected in series with a dry battery, type BA-4 and a switch. The buzzer is energized when this switch is closed.

A spare dry battery for the buzzer, a screw-driver, the enclosed detector, some spare wire and spare crystals are normally stored in compartments or metal clips in the cover. Two type P-11 telephone head sets are kept in a special compartment in the box. The set box, when closed, may be carried by a leather strap attached to it.

### Method of Operating

The first step in putting the set in operating condition is to select a suitable place and set up the antenna. The set box is then installed in a dry and protected place, and the aerial and ground (or counterpoise) leads are connected to their respective terminals on the operating panel, and the telephone head set plugged into the jack.

With the installation thus completed, the first step is to adjust the crystal detector. To do this, place the "coupling" handle near the maximum position, and connect a short piece of wire from the terminal clip in the buzzer circuit to the "antenna" or "ground" terminal of the operating panel. Close the buzzer switch to energize the buzzer, and carefully explore the surface of the crystal with the spring contact point until a sensitive spot is found, as evidenced by a good audible sound in the telephone receiver. The short wire running from the buzzer to the panel is then removed and the buzzer stopped by opening the buzzer switch. Care should be taken not to disturb the crystal adjustment by mechanical vibration or shock. This adjustment is very delicate, and, if destroyed, it must be restored before any signals can be received.

With the crystal adjusted, the set is then ready for tuning. The procedure varies somewhat according to whether the wave length of the station it is desired to receive is known or not.

(a) **Wave Length of Signals Unknown.**—The switch M in the center of the panel is thrown to the position "AP" (aperiodic). This disconnects the secondary condenser, and makes the secondary circuit responsive to signals of any wave length. The coupling is made a maximum, and the secondary inductance dial switch S placed at the position "60." The primary inductance switch P is then placed successively at the positions marked 10, 20, 30, 40, 50 and 60, and, at each point, the handle of the primary condenser is slowly turned over its full range, until the loudest signals are obtained in the telephone. The station is then identified by its call letters, and if it is the station desired, tuning of the set is completed as explained below. It may happen however, that in this search for signals, several stations are heard, simultaneously or for different positions of the handles. The process of searching is kept up until the desired station, as identified by its call letters, is heard with the greatest intensity.

The coupling pointer is then moved towards the minimum position, so that the signals will be just loud enough to be easily read. The switch M is placed in the position T (tune), which connects the secondary condenser in the secondary circuit. The secondary circuit is then tuned by operating the secondary inductance dial switch S and the secondary condenser in the same way that was followed in tuning the primary. The secondary circuit is in tune when the signals are heard loudest. The set is then ready for operation.

If necessary, the strength of the signals may be increased by increasing the coupling, but this should not be done unless the signals become too faint to be read, since increasing the coupling increases the likelihood of interference by other sending stations. When the coupling is changed, some slight adjustments of the primary and secondary condensers will be found to improve the signals.

(b) **Wave Length of Signals Known.**—When the receiving operator has been advised of the wave length of the signals he is to pick up, the process of tuning in is somewhat facilitated by the use of the table of wave lengths which is pasted in the cover of the box.

The primary circuit of the set is first tuned, as explained above, with the switch on "AP," the secondary inductance on

"60," and with maximum coupling. After the signals have been identified and the primary has been tuned to give maximum loudness, the coupling is reduced as before, and the switch M moved to T. The secondary inductance setting to be used is then given in the table. Thus, for a wave length of 280 meters, the setting may be 30 or 45. It is best to use the higher value 45. The final secondary adjustment is then made as before by means of the secondary condenser.

### **Use of a Vacuum Tube Detector with the SCR-54 Set**

It is sometimes desirable to use a vacuum tube detector in place of the crystal detector supplied with the set. In this case, the telephone stopping condenser of the set must be short circuited by inserting a dummy brass plug in the telephone jack. The crystal detector is then disconnected, and wires are connected from the detector binding posts of the set to the proper terminals of the vacuum tube detector set. The telephone receivers should not be plugged in, as before, in the jack of the set box, but must be connected to the proper terminals or jack of the vacuum tube detector box.

### **Precautions, Sources of Trouble, Maintenance**

In using this set, care should be taken to always keep it in as dry a place as possible. It should be kept in a clean condition, especially the operating panel, the contacts, binding posts, dial switch studs, etc., and the telephone jacks. Oil or grease on these contacts will make the connections uncertain and unsteady and impair or even prevent the satisfactory operation of the set. The set should be handled carefully to avoid warping the condenser plates or otherwise damaging the set. No foreign substance should be placed in the set box.

Care should be taken that the telephone receiver cords do not get wet, for the resulting leakage of current in them would considerably decrease the strength of the signals and introduce annoying noises. The telephones do not require any adjustment, and the ear-pieces should always be kept screwed up tight. The telephone receivers should never be taken apart, since their adjustment at the factory is very accurate and permanent. If it becomes necessary to remove the cord connections from either the telephones or the plug, the wires must be reconnected as found, according to their different colors. This is important since otherwise the permanent magnets will be



partially demagnetized and the efficiency of the telephone receivers will be seriously impaired.

In packing the set for transportation, the telephone head set receivers are placed face to face so that the diaphragms will be

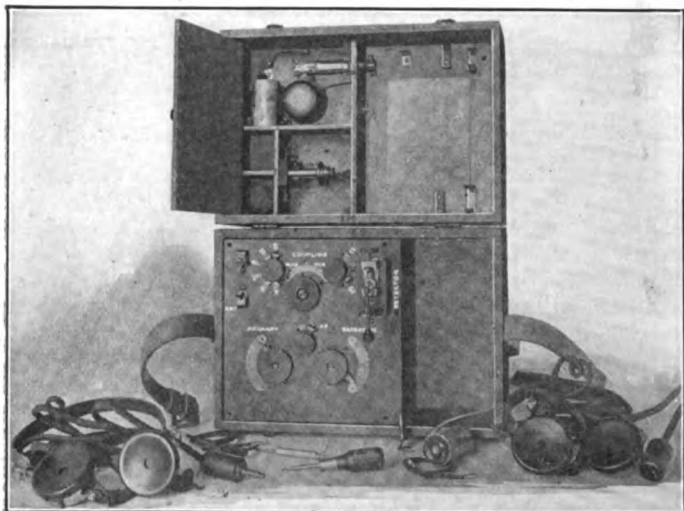

Fig. 2—Operating Panel and Cover Accessories of the Type SCR-54 Set.

protected and kept free of mud and dirt. The telephone cord is then wound around the head band in such a way as to hold the receivers together. The telephone plug is finally slipped inside the coil thus formed by the connection cord, and the entire set is carefully replaced in its compartment in the set box.

Among the troubles most frequently encountered are those considered below.

It may happen that the buzzer does not work. This may be due to a poor adjustment of the buzzer vibrator, or to a run down dry battery.

If the radio set does not work it may be because the crystal detector is not making contact with a sensitive spot. Readjust it with the aid of the buzzer.

No sound in the receivers may be due to the fact that the telephone plug is not all the way in the jack, or that it is dirty. In this case see that the plug is clear in, or remove it and wipe it off with a clean cloth. Also, the dummy brass plug may be

in the telephone jack. This would prevent operation entirely with the crystal detector.

Scratching noises in the telephone may be the result of a wet connection cord, or the connection at the plug or at either telephone receiver may be loose.

If the antenna or ground connection is loose, or if the aerial or lead-in wire is grounded through a branch of a tree, or in some other way, the set will fail to operate. Make sure of good insulation all around.

It sometimes happens that a wire will break inside the set box. This generally occurs to one of the wires connecting the secondary inductance coil to the various taps of the secondary dial switch. One way to discover this fault is to turn the "coupling" handle back and forth; the signals may then suddenly stop for a certain position of the handle, although they will be audible with the handle on either side of this position. Finally, a plate of one of the variable air condensers may become warped and short circuit the condenser. This is generally evidenced by the fact that the condenser, when varied over its whole range, does not change the loudness of the signals.

In active service, receiving sets are required to be in continuous working condition. To insure this, spare parts must be kept on hand at all times in order to replace defective parts with the least possible delay. Such spare parts should include spare crystals, telephones and telephone cords. Complete extra sets should always be in stock at the central radio supply station to provide for replacements promptly when sets are destroyed. The sets in use should also be frequently tested to determine their condition and readiness for an intensive and continuous activity. The condenser and inductance circuits should be tested to make sure that each part of each circuit is in perfect working condition. Testing of circuit parts may be simply done with a head phone and dry cell, a click through closed circuits, and the absence of a click through the condenser circuits, being the indication which should be noted.

### **Reception of Airplane Signals**

When receiving signals from an airplane, such as in fire control work, some special precautions are necessary, due to the constantly changing distance between the sending and receiving sets, and the possibility of the airplane going so far away that the signals become too faint to be read.

In the case of a prearranged shoot, the airplane will always fly above or near his receiving station before starting out over the target, and will send his call letters. This will give the receiving operator an opportunity to tune his set. He should tune in accord with the procedure outlined in an earlier paragraph, but he should not reduce the coupling as much as he would if communicating with a ground station. This rule is followed in order that the signals, which grow fainter as the airplane flies farther away, may be audible for the greatest range which will be needed. The operator thus constantly remains in touch with the airplane without readjustment of his set. Once the airplane has reached the target, and his distance to the battery no longer increases, the operator should reduce the coupling in order to reduce interference with the signals from his airplane.

Another point of importance is that sometimes good reception is obtained with the secondary circuit aperiodic (switch M in the position AP), and the primary alone tuned to the sending station. This may occur when very few stations are working, but that adjustment of the set gives no protection against interference from a nearby station which may start to send while communication is going on. It is therefore absolutely necessary to always tune both the primary and secondary circuits.

## **Type SCR-54-A Set**

As previously stated, the SCR-54-A radio receiving set is in many respects identical with the SCR-54 set. A wiring diagram of the former is given in Fig. 3. The main point in which the newer set differs from the SCR-54 set is that the buzzer circuit, instead of being installed independently in the cover of the box, is mounted on the operating panel, with a pull type switch which closes it on the primary radio circuit. The buzzer circuit consists of a dry battery, type BA-4, a small buzzer, a switch, and the first section (10 turns) of the primary inductance coil. The dry battery used to energize the buzzer is mounted in spring clips in the same compartment in which the telephone head sets are packed. The switch is in the center of the panel, and is closed when the button is pulled up. The buzzer winding is shunted by a 45-ohm resistance.

The switch M, which connects or disconnects the secondary condenser, is placed to the right of the buzzer switch, and is marked as on the SCR-54 set.

Only one glass enclosed crystal detector is furnished with this set, and this is permanently mounted on the operating panel. The two binding posts marked "Detector" are to permit the use of a vacuum tube detector or any other kind of detector

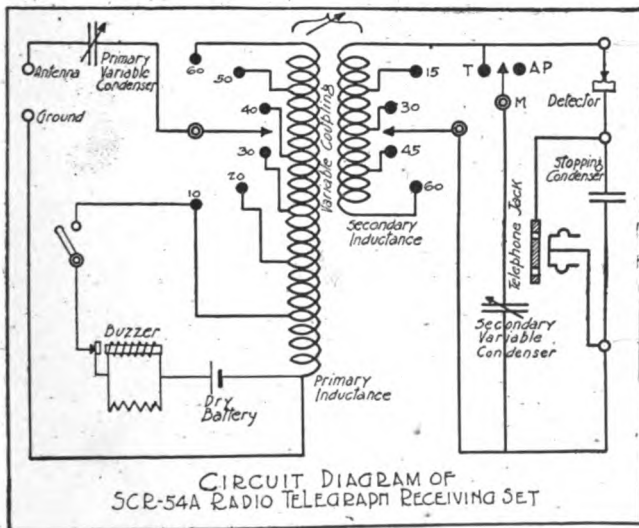

Fig. 3—Schematic Wiring Diagram of the Type SCR-54-A Set.

as explained in a later paragraph. Two emergency telephone binding posts on the operating panel are connected in parallel with the telephone jacks, to allow the use of telephone receivers having no connection plug.

Each set is calibrated individually, throughout the range of wave length, and this greatly facilitates the operation of tuning in, as will be seen below.

In the cover of the box is a screw-driver, a spare dry battery for the buzzer, some spare wire, spare crystals, and replacement parts for the crystal detector. In all other respects, the set is not fundamentally different from the type SCR-54 set.

### Method of Operation

The method of operating the type SCR-54-A set will be explained only wherein it differs from that of the type SCR-54 set. The telephone head set is first plugged in, and the coupling

handle placed near the maximum position. The buzzer is then energized by pulling out the buzzer switch button. The surface of the crystal is explored with the spring point until a sensitive

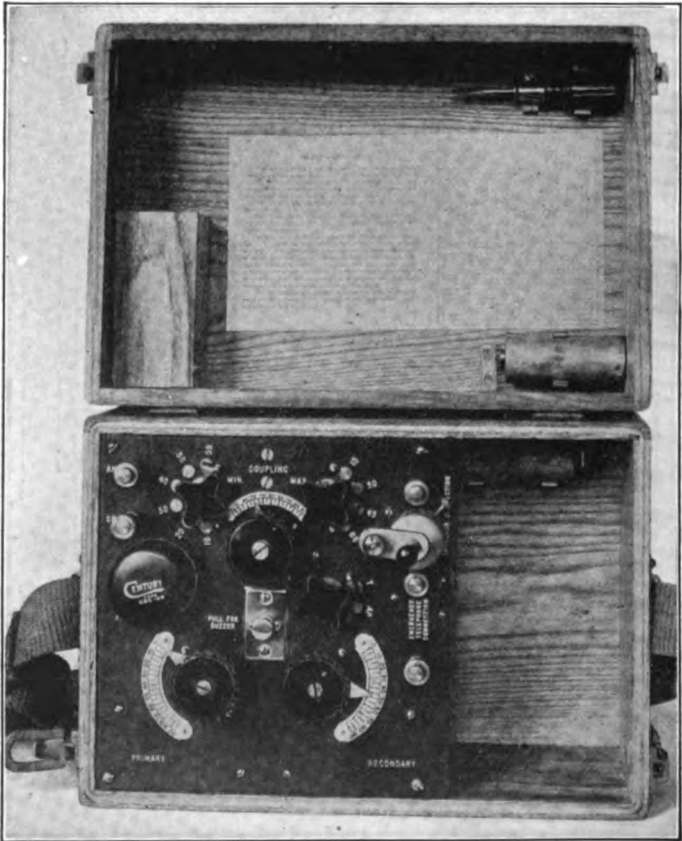

Fig. 4—Operating Panel of the Type SCR-54-A Set.

spot is found. The buzzer switch is then pushed in to stop the buzzer. This should be done gently, so that the vibration will not cause the crystal adjustment to be disturbed.

If the wave length of the signals to be received is unknown to the receiving operator, the method of tuning the set will

be exactly the same as that outlined for the SCR-54 receiving set.

When the wave length of the signals to be received is known, the procedure is quite different. The proper settings of the secondary inductance and of the secondary condenser are obtained from the calibration table pasted in the cover of the set box for the wave length it is desired to receive. The secondary adjustments being thus made, the switch M is placed in the

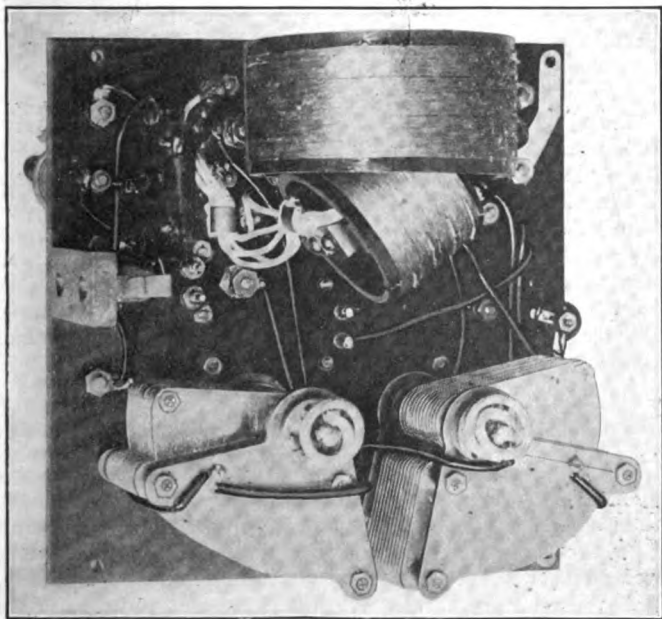

Fig. 5—Mounting of Apparatus on Under Side of Operating Panel, Type SCR-54-A Set.

position T, and the coupling handle turned near the "60" or maximum mark. The primary circuit is then tuned by placing the primary inductance dial switch successively in its various positions, and for each position rotating the primary condenser handle until a maximum sound is produced in the telephone receiver. The coupling handle is then turned toward the minimum mark so that the signals will be just loud enough to be easily read. Some very slight changes in the settings of both variable condensers may then be found to improve the tuning.

This method of tuning is very much more rapid and certain than that used with the SCR-54 set. If the value of wave length it is desired to pick up is not marked in the table, the settings of the nearest wave length should be used. Some slight changes in the final adjustments, after the coupling has been reduced, will bring them to the correct value.

It is also possible to tune the set approximately to the wave length which has been predetermined, even before signals are received. The wave length of the secondary circuit is calibrated for all positions of the secondary inductance and capacitance switches. The secondary circuit may thereby be used as a wavemeter for adjusting the primary circuit. This is accomplished as follows:

The secondary inductance and condenser handles are adjusted to the values indicated in the table opposite the wave length nearest to the one at which it is desired to receive. The buzzer is then started and the primary adjusted to produce the maximum sound in the receivers. This will indicate that the primary and secondary circuits are in tune at approximately the desired wave length. The coupling should then be reduced and the set may be considered ready for the expected signals. When these actually come, a slight readjustment of both primary and secondary will probably produce a sharper tuning.

### **Use of a Vacuum Tube Detector with the SCR-54-A Set**

When it is desired to use a vacuum tube detector, or any other form of detector, with the SCR-54-A receiving set, the wire point of the crystal detector of the set should be lifted off the surface of the crystal, and the emergency telephone binding posts short circuited by means of a piece of wire. (If avoidable, do not use the wire furnished in the cover of the box, as this is intended for repairs in case of trouble in the radio circuits of the set.) Wires are then connected from the "Detector" binding posts of the set to the proper binding posts or clips of the vacuum tube detector box. The telephone receiver should not be plugged into the jack of the set, but, instead, should be connected to the proper terminals or jack of the vacuum tube detector box.

For information on "precautions, sources of trouble, and maintenance," and on the special work of "reception from airplanes" with the SCR-54-A set, see the corresponding sub-heads of the instructions pertaining to the type SCR-54 set, these being identical for both sets.

## Vacuum Tube Detector Equipment Type DT-3-A

When using the SCR-54 or SCR-54-A receiving sets for receiving long distance signals, it may be found that the crystal detector of the set is not sensitive enough and will give only very faint signals. A vacuum tube detector may then be used to advantage. Such a device is provided in the Type DT-3-A equipment. While this detector is used primarily with the two

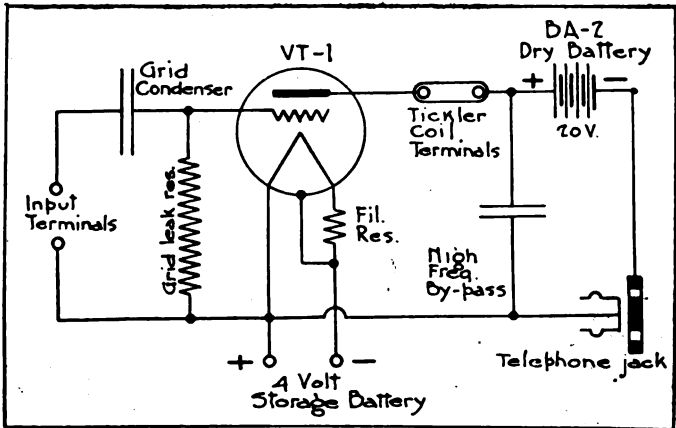

Fig. 6—Schematic Wiring Diagram of the Type DT-3-A Detector Equipment.

receiving sets described in this pamphlet, it does not form a component part of these sets and must be ordered separately, if needed.

A circuit diagram of this equipment is given herewith, from which the principle of operation may be easily understood. The detector comprises an ordinary three-electrode vacuum tube and a grid condenser and grid leak resistance. The filament is heated to the proper temperature by a 4-volt storage battery, and the plate current is furnished by a 20-volt type BA-2 dry battery. The tube used is a type VT-1. No grid battery is required, the grid potential being obtained through the grid leak resistance.

To connect up the vacuum tube detector box to the set box of the type SCR-54 or SCR-54-A set, proceed as directed in the paragraphs under the directions for operating the receiving sets,



which are headed "Use of Vacuum Detector, etc." The two wires are brought from the detector terminals of the SCR-54 or SCR-54-A set box to the "Input" terminals of the vacuum tube detector box. The 4-volt storage battery is connected to the "Battery" terminals, with the proper polarity, and the telephone receivers are plugged into the telephone jacks of the vacuum tube detector box. No detector adjustment is required and the operation of tuning in the receiving set is not altered in any way.

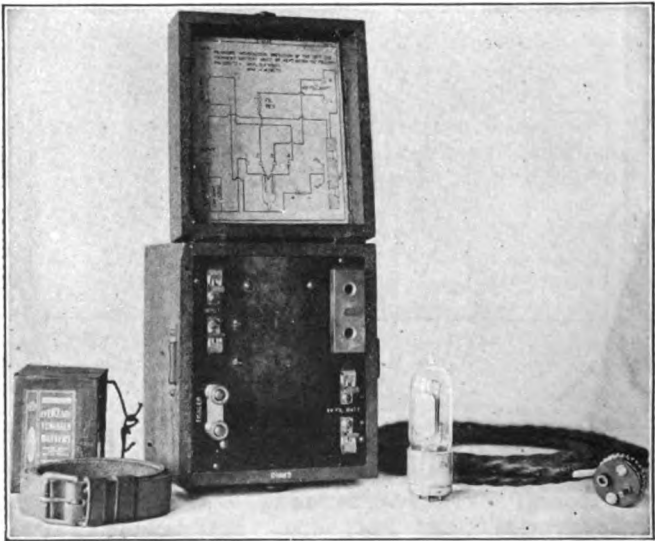
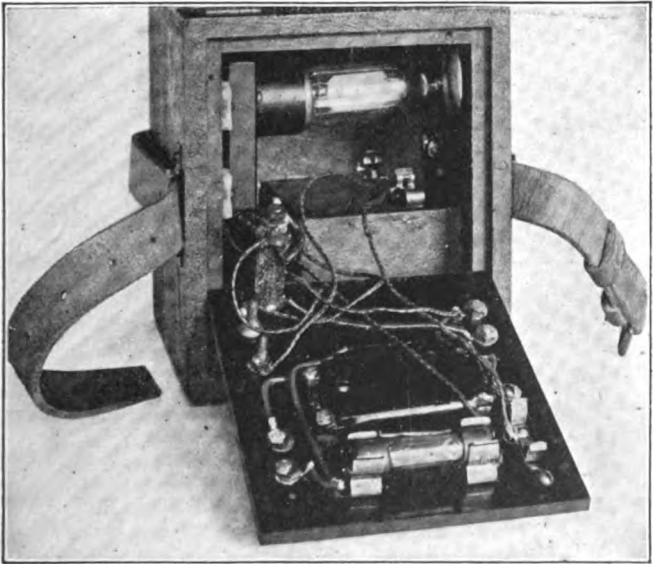

Fig. 7—Operating Panel of the Type DT-3-A Detector.

The DT-3-A equipment also permits the reception of undamped wave signals with the SCR-54 or SCR-54-A receiving set, although this should be considered a makeshift and one not to be depended upon for work of any great importance. To receive undamped waves, connect a suitable tickler coil to the "Tickler" terminals of the detector, after having removed the short circuiting strap which is normally connected across these terminals. Couple this coil with the receiving set inductances with such a degree of coupling that a note will be heard in the telephone receivers. The principle of heterodyne reception is explained in Radio Pamphlet No. 1.



**Fig. 8—DT-3-A Panel Removed Showing Vacuum Tube.**

## Parts Lists

In ordering this set or parts of this set, specification must be made by names and type numbers as listed below, exactly. The designation printed in bold face type *only*, will be used in requisitioning, making property returns, etc.

In ordering *complete* sets, it is not necessary to itemize the parts; simply specify, "2 Sets, Radio Receiving, Type SCR-54." If *all* the parts listed under a group heading are desired, it is not necessary to itemize the parts; simply specify, for example, "1 Equipment, Type RC-1."

The set is not complete unless it includes all of the items listed in the component parts table, below.

### SET, RADIO RECEIVING, TYPE SCR-54

#### EQUIPMENT, TYPE RC-1; Receiving

- 1 **Set Box, Type BC-14**; receiving
- 1 **Strap, Type ST-5**; carrying, for BC-14
- 2 **Head Sets, Type P-11**; telephone
- 4 **Crystals, Type DC-1**; mounted detector; 1 in use, 3 spares
- 2 **Batteries, Type BA-4**; buzzer; 1 in use, 1 spare
- 1 **Screwdriver, Type TL-2**; Stanley No. 25, or equivalent, 4 in. long
- 30 ft. **Wire, 7-Strand, No. 30 B & S Gauge, Rubber Covered, White Silk, Braided**; spare
- 3 **Springs, Detector Contact**; 1 in use, 2 spares

#### EQUIPMENT, TYPE A-2; Antenna

- 2 **Mast Sections, Type MS-1**; top; same as type MS-2, but without steel coupling tube
- 8 **Mast Sections, Type MS-2**; intermediate
- 6 **Guys, Type GY-1**; 43 ft., complete
- 3 **Guys, Type GY-2**; 22 ft., complete
- 4 **Reels, Type RL-3**; hand; one for antenna and lead-in wire, and one for each set of 3 guys
- 6 **Stakes, Type GP-1**; guy; 3 in use for each mast
- 2 **Plates, Type MP-2**; upper guy; complete with mast tube; one for each mast
- 1 **Plate, Type MP-3**; lower guy; for 29-ft. mast
- 2 **Plates, Type MP-1**; antenna, complete with Electrosec No. 4500 insulators connected to plate with closed wire link; other end provided with open wire hook to receive antenna wire thimble

- 1 **Antenna, Type AN-1**; 150 ft. antenna wire with thimble at each end; the thimble for the 29-ft. mast end has connected to it a 50-ft. lead-in of No. 16 B & S gauge, single conductor, new code lamp cord, weather-proofed
- 2 **Connections, Type GD-1**; ground; ground mat with 20 ft. No. 16 B & S gauge, single conductor, new code lamp cord, weather-proofed; 1 in use, 1 spare
- 2 pr. **Bags, Type BG-1**; carrying; for masts
- 1 **Bag, Type BG-2**; carrying, for antenna and accessories
- 1 **Hammer, Type HM-1**; 2 lb.; two-face engineer's 16-in handle
- 1 **Twine, Type TW-1**; coil; 35-ft.; for measuring distance of guy pins from masts
- 1 **Marker, Type MR-1**; guy pin; for locating direction of ground pins from masts

### SET, RADIO RECEIVING, TYPE SCR-54-A

#### EQUIPMENT, TYPE RC-1-A; Receiving

- 1 **Set Box, Type BC-14-A**; radio receiving; weight, 11 lb. 8 oz.
- 1 **Strap, Type ST-5**; carrying, for BC-14-A
- 2 **Head Sets, Type P-11**; telephone
- 6 **Crystals, Type DC-1**; detector, mounted, spare; galena
- 2 **Batteries, Type BA-4**; dry; for buzzer; 1 in use, 1 spare
- 1 **Screwdriver, Type TL-2**; Stanley No. 25, 4 in. long, or equivalent
- 30 ft. **Wire, Type W-20**; wound in coil; 1½ in. outside diameter
- 2 **Springs, Type M-14**; detector contact; spares

#### EQUIPMENT, TYPE A-2-B; Antenna

- 6 **Mast Sections, Type MS-5**; bamboo; 13 ft. long; iron tipped at both ends; total weight, 16 lb.
- 6 **Insulators, Type IN-7**; mast top; 3 in use, 3 spares
- 750 ft. **Wire, Type W-1**; antenna; No. 22 B & S gauge, 7 strand, soft tinned copper, bare; net weight 8 lb. 12 oz.; to be in one piece and wound on spool of 6 in. outside diameter

- 75 ft. Wire, Type W-4;** lead-in; No. 16 B & S gauge, modified N. E. C. lamp cord, Spec. 3040, wound on 8 in. coil; total weight, 1 lb. 8 oz.
- 2 lb. Wire, Type W-2;** No. 14 B & S gauge, soft drawn copper, bare; in one piece wound in 7 in. coil
- 1 Mat, Type MT-2;** ground; 9 ft. x 20 in.; total weight, 3 lb. 4 oz.
- 14 Stakes, Type GP-3;** ground; 1 in. x 1 in. x  $\frac{1}{8}$  in. angles; total weight, 35 lb.
- 8 Insulators, Type IN-5;** hard rubber;  $5\frac{1}{2}$  in. x  $\frac{5}{8}$  in.; total weight, 10 oz.
- 6 Couplers, Type FT-2;** pole; 4 in. x 5 in. x 1 in.; total weight, 4 lb.
- 200 ft. Cord, Type RP-3;** sash; No. 5; olive drab
- 4 Reels, Type RL-3;** hand;  $11\frac{3}{4}$  in. x 10 in.
- 1 Pliers, Type TL-20;** universal; 8 in.; similar to Fairbanks combination pliers No. 70; drop forged steel with blue handle and polished head
- $\frac{1}{4}$  lb. Tape, Friction, Spec. 569-B;**  $\frac{3}{4}$  in.
- 1 Hammer, Type HM-1;** 2 lb.; 16 in. handle
- $\frac{1}{4}$  lb. Marlin, Type RP-2;** wound in 2 coils
- CHEST, TYPE BC-26;** carrying

### Carrying Units

The above parts of the type SCR-54-A set are assembled in two carrying units, as follows:

1. Carrying Chest; 1 ft.  $3\frac{7}{8}$  in. x 3 ft.  $9\frac{5}{8}$  in. x  $11\frac{1}{2}$  in.; containing receiving and antenna equipments, but not including bamboo masts; total weight, 155 lb.
2. Six Bamboo Mast Sections; 13 ft. long; total weight, 16 lb.

### EQUIPMENT, TYPE DT-3-A; Vacuum Tube Detector

- 1 Set Box, Type BC-19-A;** vacuum tube detector;  $7\frac{1}{2}$  in. x  $7\frac{1}{8}$  in. x  $6\frac{5}{8}$  in.; weight, 4 lb. 12 oz.
- 1 Strap, Type ST-6;** carrying; 2 ft. 8 in. x 1 in. x  $\frac{1}{8}$  in.
- 2 Tubes, Type VT-1;** vacuum; 1 in use, 1 spare
- 2 Batteries, Type BA-2;** dry; 1 in use, 1 spare
- 2 Cords, Type CD-40;** extension; 6-ft., No. 16 B & S gauge, 2-conductor, battery plug on one end, spade clips on other end; 1 in use, 1 spare



---

**Prepared in the  
Office of the Chief Signal Officer  
Training Section  
Washington**

---

FOR OFFICIAL USE ONLY

*WRE*

# THEORY AND USE OF WAVEMETERS

SCR-60.

SCR-61.

Radio Pamphlet

No. 21

Signal Corps, U. S. Army

5-21-18





# THEORY AND USE OF WAVEMETERS

## Various Methods of Using the Wavemeter as a Measuring Device—Description of SCR-60 and SCR-61 Wavemeters

The wavemeter is a piece of apparatus by means of which it is possible either to measure the length of electromagnetic waves generated by some outside source, or to emit waves of a known length. It may therefore be used to measure the inductance of a coil, the capacitance of a condenser, or the decrement of electromagnetic waves. It is thus a calibration instrument which finds use in both the field and the laboratory.

The principles upon which all wavemeters operate are the same. A general circuit diagram which might apply to any wavemeter is shown in Fig. 1. It consists of an oscillating circuit containing a condenser  $C$  and an inductance coil  $L$ , having a low ohmic resistance. By varying the capacitance in this oscillating circuit, its natural frequency can be brought into resonance with another oscillating circuit. When used as a measuring instrument, some sensitive device  $A$  is inserted in shunt or in series in the circuit, to indicate the voltage across the condenser or the current in the coil. In practice, this sensitive device may be a telephone receiver and a detector, a neon tube, a hot wire ammeter, or a galvanometer and thermo-couple. When the wavemeter is used as a generator of waves of known length, the device  $A$  is replaced by a buzzer and battery which excite damped oscillations in the wavemeter resonance circuit, at an audible wave train frequency.

The method of adjustment most commonly employed in using a wavemeter is to vary the natural period of the circuit by changing the capacitance of the meter and keeping the inductance constant. This affords a continuous variation of wave lengths between the limits of 0 and  $2\pi\sqrt{LC}$ . The condenser is therefore usually an air condenser, the capacitance

of which may be varied from 0 to a certain maximum by means of a handle on the operating panel. To this handle is attached a pointer which moves over graduated scales,

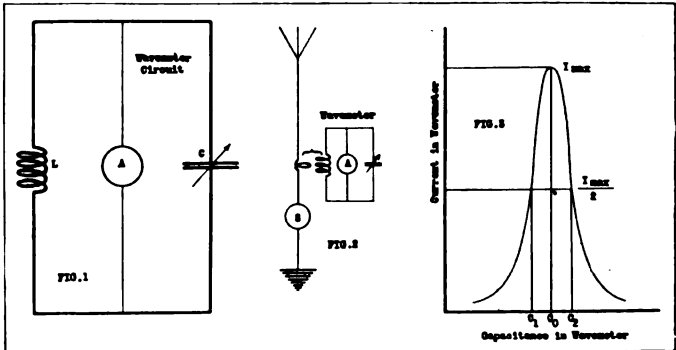

Fig. 1. General Wavemeter Circuit—Fig. 2. Use of Wavemeter—  
Fig. 3. Typical Resonance Curve.

reading directly in wave lengths or in conventional numbers corresponding to calibration curves. Several inductance coils having different numbers of turns are usually provided with a set, any one of which may be connected in the circuit. The apparatus may thus be made to cover a very wide range of wave lengths with reasonable accuracy.

### Using the Wavemeter as a Measuring Instrument

To use a wavemeter for measuring the length of the waves sent out or received by a radio set S, Fig. 2, it is coupled to this set as loosely as its operation will permit so that there will be no appreciable reaction between the two circuits. The coupling is made inductively to the inductance coil of the wavemeter. The capacitance of the wavemeter condenser is then changed until a maximum indication is observed on the instrument A—maximum loudness of sound in the telephone, maximum brightness in the neon tube, maximum reading on the galvanometer, etc. At that time, the wavemeter circuit will be in resonance with the waves to be measured, and the length of waves will be indicated by the reading on the condenser dial scale.

## Using the Wavemeter as a Generator

The wavemeter is used as a generator of electric oscillations when it is desired to calibrate another resonant circuit. It can be made to oscillate at any desired frequency by choosing the proper setting of the wavemeter condenser. For each setting of the wavemeter, the circuit to be calibrated is then tuned to the waves generated by the wavemeter, this establishing a calibration point for which the adjustments of the set under test are noted as corresponding to that specific wave length. This operation is repeated for various settings of the wavemeter condenser to obtain the desired number of calibration points.

## Measuring Inductance and Capacitance

A rapid method of measuring the inductance of a coil or the capacitance of a condenser is to connect the coil or the condenser to a standard condenser or coil, respectively, of known constants, to make an oscillating circuit. This is then made to oscillate by means of a buzzer and its natural period is found by means of the wavemeter. Having determined the period, and knowing one of the constants, either L or C, of the circuit under test, the other constant C or L is easily computed by means of the formula

$$\lambda \text{ (wave length)} = 1884 \sqrt{LC}$$

where L is expressed in microhenrys, C in microfarads and  $\lambda$  in meters.

## Measuring Decrement

If an oscillatory circuit of constant wave length is made to act upon a wavemeter circuit, the wave length of which is varied by changing the value of its capacitance, a so-called resonance curve may be plotted, showing the variation of wavemeter current with the natural frequency of the current in the wavemeter circuit. Such a curve will show a maxi-

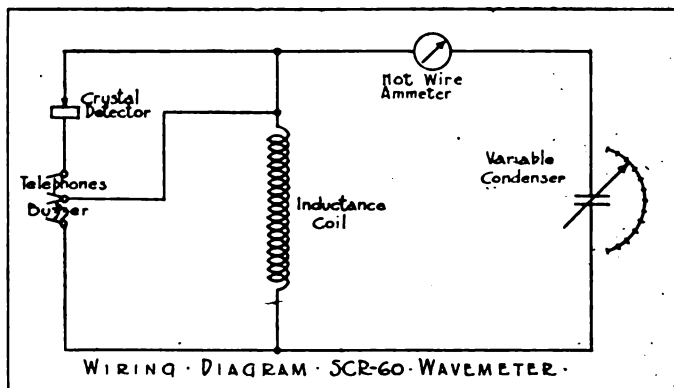

Fig. 4. Schematic Circuit Diagram of the SCR-60 Wavemeter.

imum current at that wavemeter frequency which is equal to the frequency of the circuit under test. The sharpness of the peak of this curve depends on the decrements  $d_1$  and  $d_2$  of the two circuits.

Instead of plotting current against frequency, current may be plotted against the corresponding condenser capacitance of the wavemeter, which is proportional to the frequency. If  $C_0$ , Fig. 3, represents the capacitance value of the condenser at resonance, and  $C_1$  and  $C_2$  the two values corresponding to current equal to one-half the resonance current, it can be shown that

$$d_1 + d_2 = \frac{\pi}{2} \frac{C_2 - C_1}{C_0},$$

or approximately that

$$d_1 + d_2 = \pi \frac{C_0 - C_1}{C_0}, \text{ or}$$

$$d_2 = \pi \frac{C_0 - C_1}{C_0} - d_1.$$

If the decrement  $d_1$  of the wavemeter circuit is known, and  $C_1$  and  $C_2$  determined, it is possible to find the decrement,  $d_2$ , of the circuit under test.

As the decrement of a circuit is a function of its resistance, it is important that the adjustment of the wavemeter should not change its resistance. This is one of the reasons why the condenser is made variable rather than the inductance, since cutting turns of the inductance in or out of the circuit would change the resistance as well as the wave length.

### SCR-60 Wavemeter

The SCR-60 wavemeter is a very simple set designed primarily for use with the SCR-67, SCR-68, SCR-79 and other radio apparatus, particularly airplane sets, in tuning them to emit the desired wave length. It is also extensively used for calibrating newly set up receiving stations. The wavemeter contains a single inductance coil and a variable condenser and hot wire ammeter in the local oscillating circuit, Fig. 4. In calibrating a set, the wavemeter is placed on the set box, or near it, and the condenser handle moved around until the maximum current reading is observed in the ammeter. The reading on the condenser scale then indicates the wave length of the set under calibration.

The SCR-60 set is designed to measure wave lengths ranging from 200 to 700 meters. The SCR-60-A set is an identical wavemeter, except

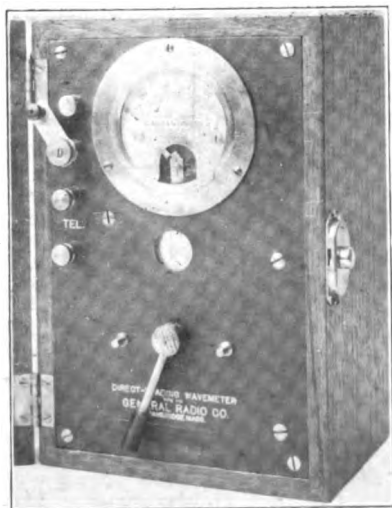

Fig. 5. Operating Panel of the SCR-60 Wavemeter.

that the constants are changed to give a range of from 300 to 1000 meters. The SCR-60-B wavemeter is a similar set but is equipped with connectors for changing the constants of the wavemeter circuit to secure two ranges of measurement. One scale reads from 50 to 200 meters and the other from 200 to 700 meters. All three of the SCR-60 sets are equipped with crystal detectors, and with binding posts for connecting in telephones and a buzzer when it is desired to use these.

### SCR-61 Field Type Wavemeter

A wiring diagram of the SCR-61 wavemeter, which is designed for ground work, is shown in Fig. 6. Three inductance coils are provided with the set and when any one of these is in use, it is clamped in the

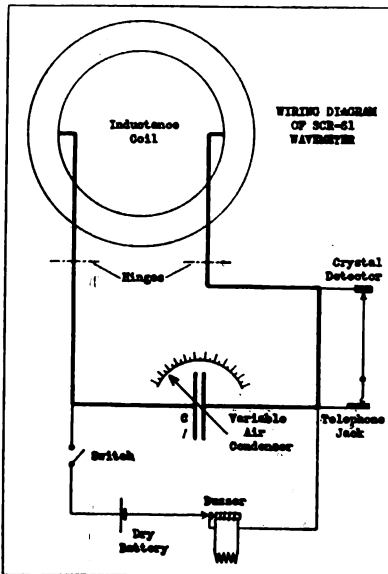
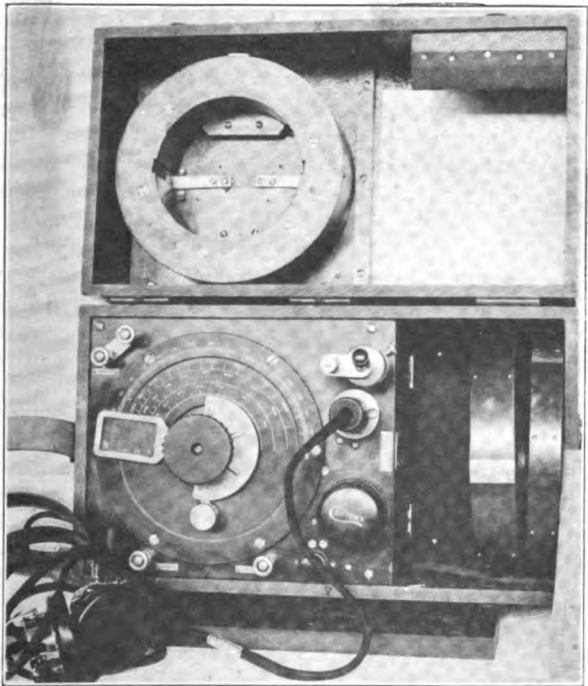

Fig. 6. Schematic Circuit Diagram of the SCR-61 Wavemeter.

cover of the case containing the set, the clamp forming the electrical connection. The circuit from the coil in use to the remainder of the wavemeter circuit in the box, is made through the hinges of the cover. The condenser is varied by means of a handle which moves over scales reading directly in meters, there being a separate scale to correspond with each inductance coil.

Each induction coil is designated by a letter stamped in the wood case, and a corresponding letter is printed on the dial opposite each scale. A telephone jack in series with a crystal detector is connected unilaterally when



**Fig. 7. Operating Panel of the SCR-61 Wavemeter and the Three Inductance Coils.**

using the wavemeter for calibrating purposes. When using the set as a wave generator, the buzzer circuit through the wavemeter inductance coil is closed by a small switch to produce the necessary oscillations. The range of the set is from 150 to 2400 meters. It is intended for field use and is provided with a carrying strap.









CONFIDENTIAL

Directions for Using the  
**TWO-WAY T. P. S. SET**

Type SCR-76

Field Pamphlet  
No. 3

(For enclosure in the Type SCR-76 Set and  
to remain constantly with the set box.  
To be issued only as a component part  
of this set.)

Signal Corps, U. S. Army

8-24-18



**Directions for Using the Two-Way T. P. S. Set  
Type SCR-76.**



## **Directions for Using the Two-Way T. P. S. Set, Type SCR-76.**

The SCR-76 set is a receiving and transmitting set for T. P. S. communication (ground telegraphy). It is to be used at stations when two-way T. P. S. communication is necessary, in place of the SCR-71 T. P. S. power buzzer and the SCR-72 vacuum tube amplifier combination. The set comprises a power buzzer for transmitting, a vacuum tube amplifier for receiving, a 10 volt storage battery for operating both, and the necessary ground rods, leads, etc. For a detailed description of the set, see Radio Pamphlet No. 15.

### **Installation of the Set.**

To set up a station the following steps are necessary:

- I. Proper location of the base line or lines.
- II. Installation of the grounds.
- III. Connection of the set.

These steps can be carried out simultaneously if a sufficient number of men are available.

#### **I. Location of the Base Line.**

The base line of a T. P. S. station is the imaginary straight line joining the two grounded ends of the line wires. When two stations are to communicate with each other, their base lines should be located so that they will make equal angles with an imaginary straight line joining the centers of the two bases, the angles considered being on the same side of this line and on the side of the base lines to-



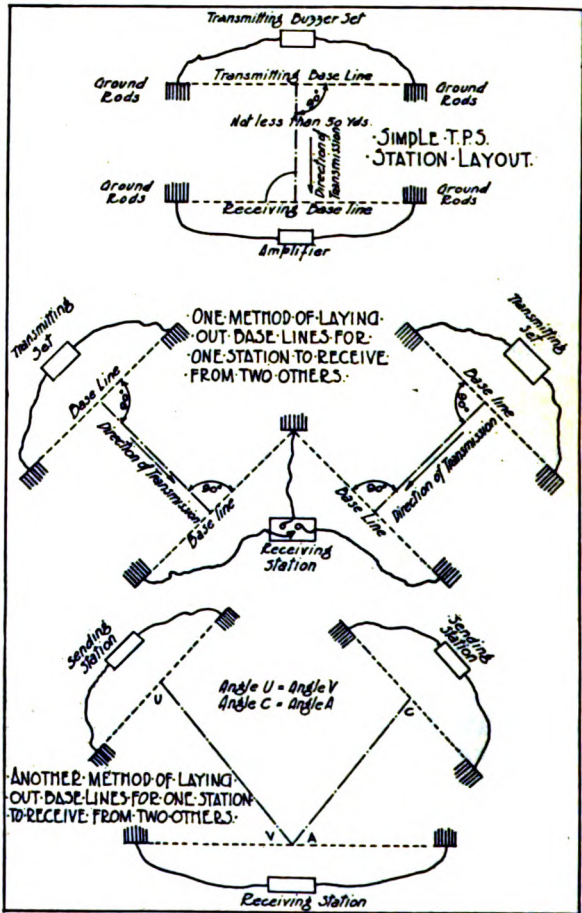

**Fig. 1—How to Lay Out Base Lines.**

ward the opposite station. This arrangement is generally secured with the aid of the compass supplied with the set. The best position of the base lines is that in which the angles are right angles (90 deg.), the two base lines then being parallel and facing each other. This is simply obtained by sighting an imaginary line from one station to the other and placing the base lines perpendicular to that line. The accompanying drawing, Fig. 1, shows the proper arrangement of base lines for several types of station.

When two or more stations are to communicate with one common station, the latter is established first and the other stations are then established according to the general rule given above, and shown in Fig. 1. When one station is to communicate with a number of other stations, a selector switch is used, as shown in Fig. 2. A number of base lines are laid out radially at the one station, and any one of them may be connected to the set box by means of the selector switch. All the other stations establish their base lines perpendicularly to the imaginary line joining them with the central station. The latter then selects, by means of the switch, the base line properly placed relative to any station with which it is desired to communicate.

## II. Installation of the Grounds.

After the direction of the base line has been determined, a ground connection is made at each end of the base, the grounds being separated by a distance of approximately 500 ft.

The base line wire is run out from the set box by means of the breast reel on which is wound 500 ft. of wire. One end of the wire is connected to the set box, as explained below. At the other end, drive four

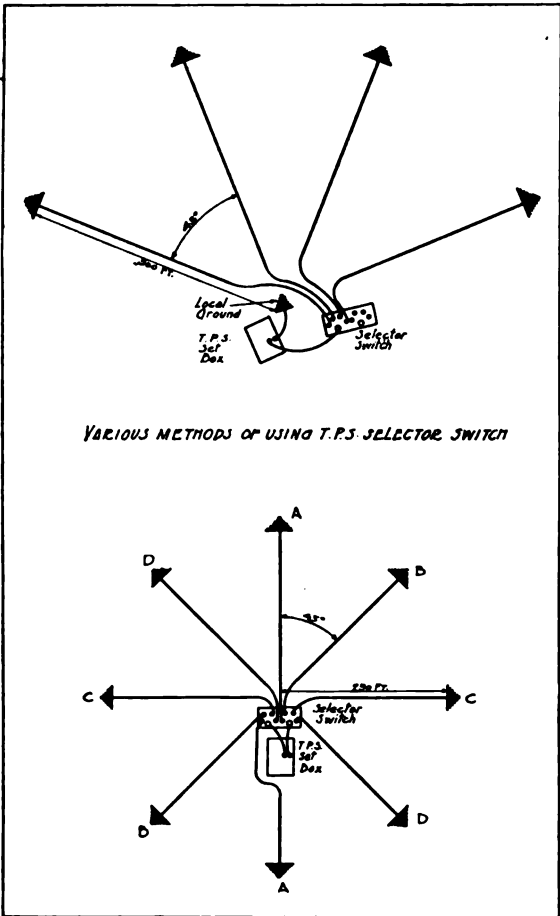

**Fig. 2—Two Ways of Laying Out a Central T. P. E. Station.**

to six ground stakes as deep as possible into the ground, in a straight line coinciding with the line of the base, and with at least 2 ft. separation between adjacent stakes. All the stakes are connected together by means of a wire which is then spliced to the line wire.

Near the set box, drive another group of four to six stakes into the ground and interconnect them similarly. This ground is connected to the other line wire from the set box.

Special care should be taken to use only line wires having perfect insulation for connecting the ground rods to the set box. These line wires may be buried in the ground if desired in order to protect them somewhat from shell fire; this, however, may increase the difficulties in case it is necessary to repair the wire after it has been cut by a shell. Inspect the line wires frequently to see that they are in good condition. If splices have to be made, insulate them carefully. Never use lead covered cable for these leads.

In order to make ground connections of low resistance, it is often useful to bury tin cans, shell cartidges, pieces of pipe, etc., in addition to the ground rods or in place of them, in cases of emergency. All these metallic masses should be carefully interconnected and connected to the line.

If possible, moisten the ground around each ground connection by pouring some water over the ground stakes after they have been driven in.

### III. Connecting Up the Set.

While the base line is being established, the set box can be connected up by one or two men in the following manner:

1. Lay the set box flat on its back side, take the telephone head sets out of the bottom compartment and then carefully lock the latter. Set the box upright and place the 10-volt storage battery beside it.

2. Open the metal front door. Connect the two battery wires which are fastened to the operating panel, to the storage battery terminals, giving due regard to the proper polarity.

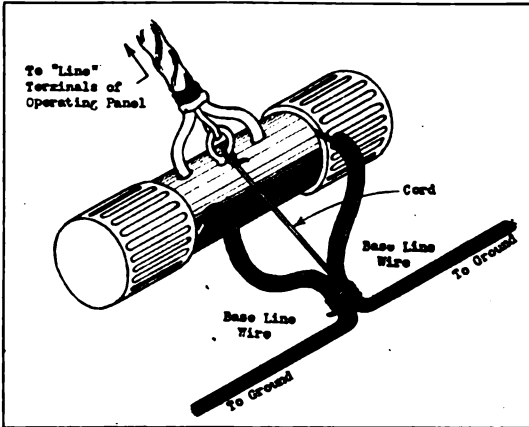

Fig. 3—Method of Tying Line Wire to Special Connector.

3. Connect the free ends of the two base line wires to the special double connector, which is connected to the "Line" binding posts of the operating panel.

4. To relieve any mechanical strain on the special connector, tie the two line wires together with a piece of cord, about 6 or 8 in. away from the connector and tie one end of this cord through or around the metal ring in the center of the connector, Fig. 3.

5. Connect a telephone head set by means of the telephone plug or the telephone binding posts.

## Method of Operation.

After the set is connected up, certain adjustments are required to bring it into operating condition.

### I. Adjustments for Transmitting.

1. Place the switch of the operating panel in the "Transmit" position.

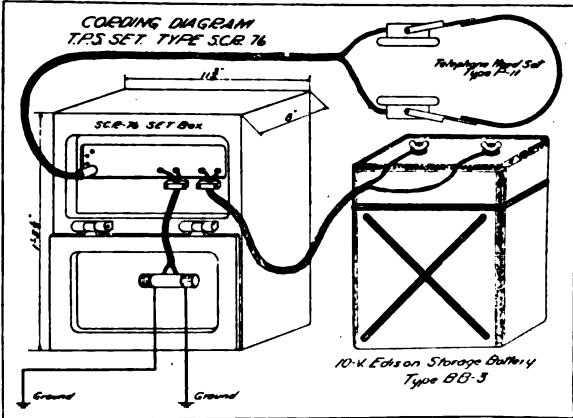
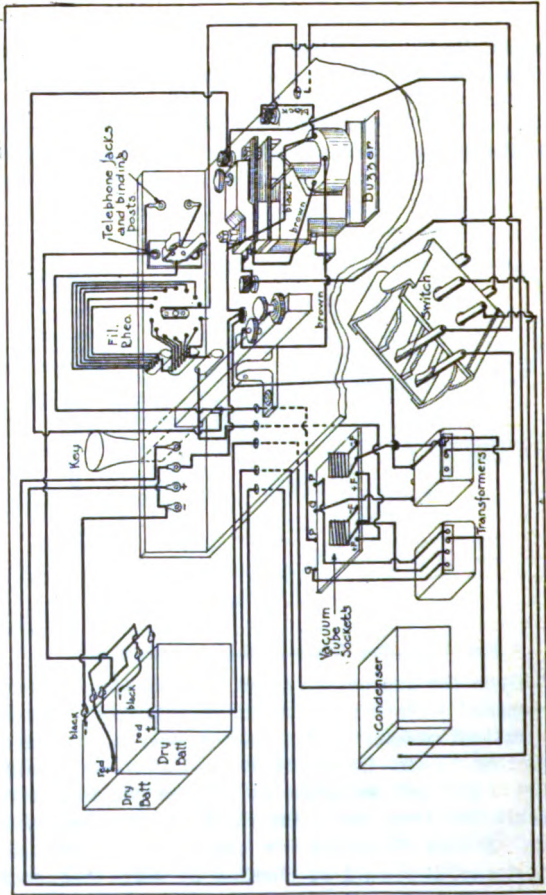

Fig. 4—Cording Diagram of Type SCR-76 Set.

2. Open the top cover of the box and by means of the special wrench to be found in this cover, fasten the desired weight to the power buzzer armature, according to the frequency it is desired to obtain.

The following adjustments of the weights give roughly the frequencies indicated in the following table. Where frequency or tone is of particular importance, it should be checked by some frequency measuring device. A device for this purpose will probably be supplied in the near future.



**Fig. 5—Diagram of Actual Circuit Connections.**

Large weight out.....	630 cycles per second.
Large weight in.....	700 cycles per second.
2 small weights out..	830 cycles per second.
1 small weight out...	980 cycles per second.
1 small weight in....	1150 cycles per second.
No weights .....	1380 cycles per second.

3. Unlock the buzzer adjusting screw. Straighten out the telegraph sending key and depress it so that the buzzer will vibrate. Hold the key down and adjust the buzzer adjusting screw until a good clear note is obtained, then locking the screw in this position. As the current input into the ground is greater, the tighter the adjustment, the screw should be turned down as far as possible and retain a clear tone. If the tone is ragged, it is very difficult to eliminate interference at the receiving station.

4. Close the top cover. The set is now in operating condition for transmitting.

## II. Adjustments for Receiving.

1. Place the switch of the operating panel in the "Receive" position.

2. Observe that both vacuum tubes are glowing by looking through the glass covered openings in the top cover. If not readily seen, move the filament rheostat toward the "maximum" position. In normal reception the filaments should not be heated any brighter than is necessary to obtain sufficient amplification. The life of the tubes is shortened by too bright operation.

3. Check up that the two dry batteries are connected with the correct polarity and close the top cover again.

4. Put on the telephone head set. The set is now in operating condition for receiving.

5. When the reception is very faint, move the fla-



ment rheostat toward the "maximum" position to increase the amplification.

6. While waiting for signals, or listening in for enemy information, check up that the filaments of both vacuum tubes are glowing, frequently, as an assurance that the set is in operating condition and that nothing is being missed.

### Precautions.

When the set is not in use, the transmit-receive switch must be placed in the "off" position so that there will be no possibility of running down batteries unnecessarily.

Always keep the set box dry and waterproof. Keep the rubber gaskets on the covers clean so that they will keep moisture out of the box. In case of rain, cover the operating panel of the set with the rubber curtain furnished for this purpose.

Do not operate the set on run down batteries. Check up the voltage of the storage battery (10 volts) and of each dry battery separately (20 volts) by means of the voltmeter furnished with the set. The lower limit of working voltage for the dry batteries is 17 volts per battery.

It is impossible to operate the set for receiving messages with only one vacuum tube inserted, or with one tube broken or burned out. Two good tubes in place are essential. At least two spare tubes should be kept on hand at all times. This will be a sufficient supply to take care of the requirements between times of getting new supplies from the depot.

Take note that the two contact points on the buzzer vibrator are clean and not pitted or burned. If they require cleaning or truing up, remove them by means of the wrench, and gently rub them against some emery cloth on a plane surface. Do not use the file

unless absolutely necessary. Replace the contacts carefully, with their surfaces in plane contact. Be sure to place the upper contact on the upper armature and the lower one on the lower armature. Do not interchange them.

Keep the connection leads as dry as possible. Frequently inspect the base line wires, as they may be broken by shell fire and this makes communication impossible.

### Parts List

In ordering this set or parts of this set, specifications must be made by names and type numbers as listed below, exactly. The designation printed in bold face type, *only*, will be used in requisitioning, making property returns, etc.

In ordering *complete* sets, it is not necessary to itemize the parts; simply specify, "2 Sets, Two-Way T. P. S., Type SCR-76." If *all* the parts listed under a group heading are desired, it is not necessary to itemize the parts, simply specify, for example, "1 Equipment, Type PE-13."

The Type SCR-76 Set is not complete unless it includes all of the items listed below.

#### SET, TWO-WAY T. P. S., TYPE SCR-76.

EQUIPMENT. (A) TYPE PE-13\* or (B) TYPE PE-11; Power \*

(A)\* 2 Batteries, Type BB-3; Edison storage; 10 volts, 3 amp-hr.; includes powdered electrolyte in separate container; 1 in use, 1 spare, or

(B) 3 Batteries, Type BB-23; lead storage; 10 volts, 20 amp-hr.; electrolyte is not included; concentrated acid for electrolyte supplied separately in carboys; 1 in use, 2 spares.

\* Figures in parenthesis at the right refer to the corresponding part in the illustration on page 14.

\* Not to be shipped overseas.

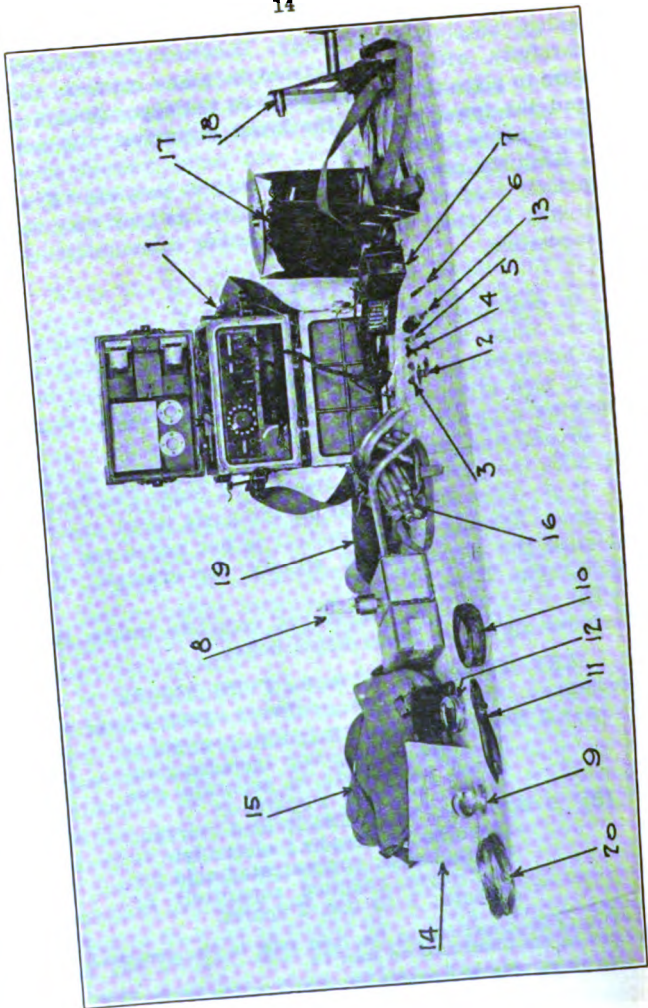

## EQUIPMENT, TYPE RE-3; T. P. S.

- 1 Set Box, Type BC-21; T. P. S.; 15½ in. x 11¼ in. x 8 in.; weight 32 lb.. (1)
- 1 Weight, Type WT-2; large; for vibrator ..... (2)
- 2 Weights, Type WT-3; small; for vibrator ..... (2)
- 2 Contacts, Type CN-1; upper; for vibrator; spare ..... (3)
- 2 Contacts, Type CN-2; lower, for vibrator; spare ..... (3)
- 1 Wrench, Type TL-6; for changing vibrator weights ..... (4)
- 1 Gauge, Type TL-7; air gap; for vibrator ..... (5)
- 1 File, Type TL-5; contact; for vibrator (6)
- 2 Head Sets, Type P-11; telephone.... (Not shown)
- 4 Batteries, Type BA-2; dry; 2 in use, 2 spare ..... (7)
- 4 Tubes, Type VT-1; vacuum; 2 in use; 2 spare ..... (8)
- 1 Switch, Type SW-16; selector; issued as required ..... (Not shown)
- 1 Compass, Type I-1; luminous dial.... (9)
- 1 Tape, Friction, Roll, Spec. 569-B; ¾ in..... (10)
- 1 Pliers, Type TL-19; universal..... (11)
- 1 Voltmeter, Type I-10; d. c.; 0 to 10 volts and 0 to 50 volts; with leads. (12)
- 1 Screwdriver, Type TL-2..... (13)
- 1 Cloth, Emery, Sheet, 11 in. x 8 in.... (14)
- 1 Bag, Type BG-13; carrying; 10 in. x 7¼ in. x 3 in..... (15)

## EQUIPMENT, TYPE GD-3; Ground

- 12 Rods, Type GP-4; ground; 18¾ in. x ½ in.; weight 5 lb. 14 oz..... (16)
- 2 Drums, Type DR-3; for breast reel; 8 in. x 8½ in..... (17)
- 1 Reel, Type RL-6; breast; 9 in. x 11 in. x 4½ in..... (18)

- 1000 Ft. Wire, Type W-4; No. 16 B & S gauge, modified N. E. C. lamp cord; in two 500-ft. lengths, each wound on drum, type DR-3; net weight, 20 lb. .... (17)
- 1 Bag, Type BG-3; carrying; for wire, ground rods, etc. .... (19)
- 60 Ft. Wire, Type W-5; No. 30 B & S gauge, 16 strands, soft copper braided; in two 30-ft. lengths, each wound in 3-in. coil. .... (20)

### Carrying Units

The above parts of the Type SCR-76 set may be assembled in seven carrying units, as follows:

- 1.—One set box, type BC-24, 15½ in. x 11¾ in. x 8 in.; including telephone head sets, dry batteries, vacuum tubes, etc.; total weight, 39 lb.
- 2.—One bag, type BG-3, containing 12 ground rods, 2 spools of wire and 2 coils of wire; total weight, 6½ lb.
- 3 and 4.—Two batteries, type BB-3; 11 in. x 10½ in. x 7 in.; weight, 31 lb. each.
- 5.—One bag, type BG-13, containing compass, volt-meter, tape, screwdriver, pliers, emery cloth, selector switch, and breast reel if desired; total weight, 4 lb. 9 oz.
- 6.—One reel, type RL-6; 9 in. x 4½ in. x 11 in.; weight 4½ lb.
- 7.—Two drums, type DR-3; each with 500 ft. of wire, type W-4; total weight, 24½ lb.

### Renewable Parts Estimated as Monthly Requirements per set in use.

- ½ Set, type SCR-76.  
 6 Rods, type GP-4.  
 1000 Ft. Wire, type W-4.  
 30 Ft. Wire, type W-5.  
 2 Cords, type CO-4, for telephone head sets.  
 4 Batteries, type BA-2.  
 2 Tubes, type VT-1.



---

Prepared in the  
Office of the Chief Signal Officer,  
Training Section,  
Washington

---

FOR OFFICIAL USE ONLY

# THE BUZZERPHONE

Type EE-1

(Confidential)

Wire Communication

Electrical Engineering Pamphlet  
No. 1

(note  
changes in text)

Signal Corps, U. S. Army  
5-21-18





# THE BUZZERPHONE

Type EE-1



## **EE-1 BUZZERPHONE**

### **Makes Possible Secret Telegraphic Communication— Non-Secret Telephone Conversation May be Carried on Simultaneously Over the Same Circuit.**

It is a well known fact that military communication by means of telephone and telegraph, which are widely used at the front, is readily picked up by induction and leakage through quite considerable distances. This fault in these systems has made it possible for both the Allies and the enemy to gain valuable information concerning the movements of the opponent by resorting to what has been termed the "listening in" service. Naturally, a form of communication which would be entirely secret was greatly needed, particularly in the forward positions. This need led to the development by the British of the Fullerphone, the American substitute for which is much improved in compactness and weight and scheme of operation, and is called the "buzzerphone." One of the principal differences of the buzzerphone from the Fullerphone is that the former has no potentiometer and requires no adjustments to compensate for ground potentials. The buzzerphone type of signaling device is coming in for more and more extensive use in and near the front line trenches since it reduces to a minimum the possibility of detection of signals through induction or ground leakage. The transmission of general service code signals is the use for which the set is primarily designed, but it may be used simultaneously, without interference, for carrying on a telephone conversation. Such a telephone conversation, however, may be easily picked up by the usual methods and it is therefore not used for any confidential messages. Because of its characteristics, the buzzerphone may be used to largely replace the ordinary telephone and telegraph instruments in the Infantry telephone network within the regiment. There is now an A. E. F. general order specifying that the telephone

shall not be used forward of one mile behind the lines, and that all wire communication in this area shall be by buzzer-  
phone. This is understood to except the telephone lines from  
artillery battallions to forward artillery observing posts.

### Principle and Description

In general, the system of operation employed in the buzzer-  
phone is the transmission of unvarying direct current, broken  
up by a key at the sending end to form dots and dashes, and  
the reception of these direct current signals at the receiving  
end through a device which breaks up the direct current  
into fairly high frequency impulses which are then audible  
in the ordinary telephone receiver. The device employed  
for breaking up the current in the receiving circuit  
is a combination of two microphones and a receiver  
to produce what is commonly called a "howler." One of  
these howlers is also employed in the transmitting circuit to  
break up the signal current in the local circuit, so that the  
operator can hear his own signals as he sends. To prevent  
these high frequency impulses from passing out on the line  
where they could be detected, a combination of inductances  
and capacitances, called a "filter," is inserted in the circuit  
and is designed to have such constants that all variations  
from the constant output current are smoothed out. The  
filter likewise eliminates the usual click heard at the begin-  
ning and end of the dots and dashes, as it prevents any sud-  
den change in voltage and hence smoothes out the instanta-  
neous rise from zero to normal line voltage, or vice versa,  
into a gradual change approximating a sine wave with a rate  
of change so slow that the inductive effect is practically  
imperceptible. The fact that the current in the line is very  
small in addition to being practically constant, also aids in  
the secrecy of transmission.

The circuits for both sending and receiving are combined  
in one set which is mounted in a wooden box measuring  
5 $\frac{3}{8}$  in. x 8 $\frac{3}{8}$  in. x 6 in. high and having a total weight of 11 lb.  
All apparatus necessary to the operation of the set is self-  
contained in this box except a telephone hand set which is  
used when talking over the line and which adds 1 $\frac{1}{2}$  lb. to the  
weight of the complete set. The howler, various condensers,  
~~inductance coils,~~ induction coil and operating switch are  
mounted on the under side of the panel, which is hinged at

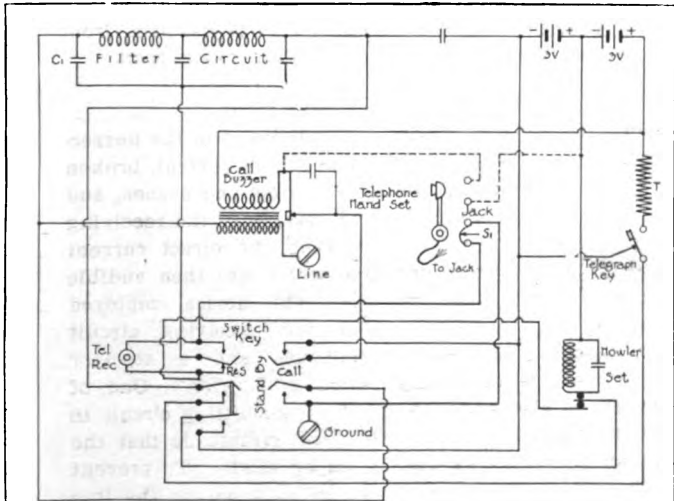

FIG 1

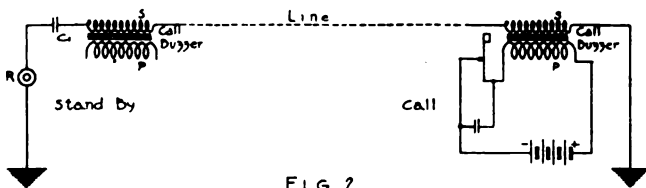

FIG 2

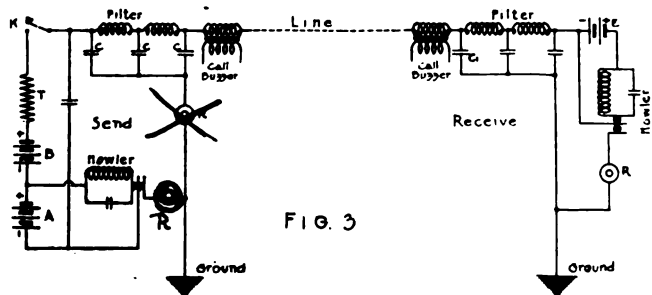
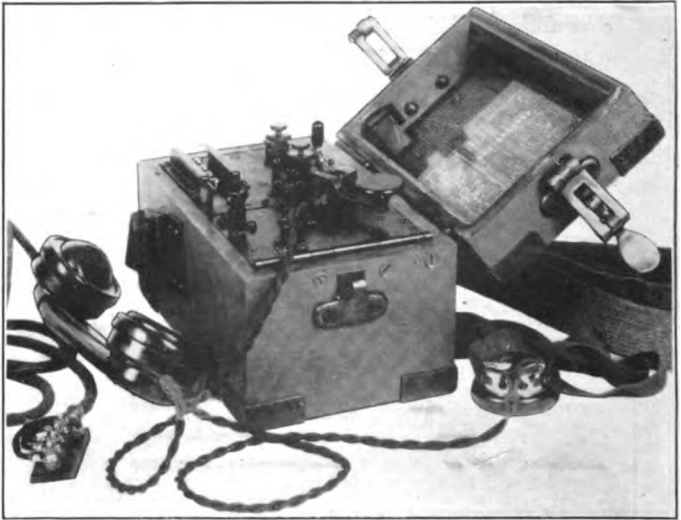

FIG. 3

Fig. 1. Schematic Diagram of Complete Buzzerphone Circuits—  
 Fig. 2. "Stand-By" and "Call" Circuit Elements—Fig. 3. "Send"  
 and "Receive" Circuit Elements.



**Fig. 4. Panel of EE-1 Buzzerphone—Telephone Hand Set Clip-Jack at Left of Panel, Sending Key in "Receive" Position, and Switch Key at Back Right Corner.**

one end of the box and locked when closed by a set screw at the opposite end, Fig. 5. The sending key and the jack for connecting the telephone hand set, and the line and ground binding posts are mounted on top of the panel, Fig. 4. The two, two-cell Signal Corps type A dry batteries producing the 6-volt current to operate the set are installed in the bottom of the box.

The different operating connections of the set are controlled by the three-position switch key and the side-contact switch on the sending key. The switch key is normally in the neutral position which is termed the "Stand-By" position. When receiving or sending, this switch is moved to the "Send-Receive" position. When pulled in the opposite position, the "Call" circuit is completed, but the switch is designed so that it will not remain in this position but will spring back to stand-by. The separation between sending and receiving connections is determined by the position of the jointed sending key. In its normal position it is held over against a side

contact which completes the circuit for receiving signals from another station. When the operator desires to send, he straightens out the key, moving it to the left to the sending position and this opens the receiving circuit. Pressing the key brings the transmitting circuit into play. When he has completed sending signals, he takes his fingers off the key, which then automatically goes back to the receive position.

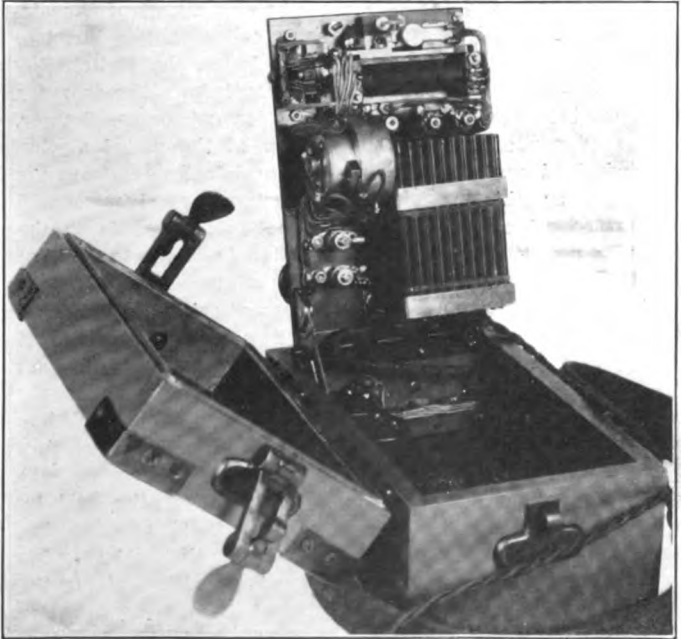

Fig. 5. Howler, Condensers, Switch, Call Buzzer and ~~and~~ <sup>Sending resistance</sup> Mounted on Underside of Panel, EE-1 Buzzerphone.

A complete schematic diagram of the buzzerphone circuits is shown in Fig. 1. For simplicity in explaining the circuits for the different positions of the switch key and sending key, this is separated into its elements in Fig. 2 and Fig. 3.

Stations which are to work together are connected by means of a well insulated single wire line, the other side of the sets being grounded, or preferably by means of a complete metallic circuit, if this is available. Two or more sta-



tions may be used on the same line, all stations being bridged between the line and the ground, or between the two lines in the case of a two-wire metallic circuit. When not in use, all stations should have the switch key in the neutral or stand-by position, which gives the simple circuit between line and ground at each station indicated in the left-hand portion of Fig. 2. When an operator desires to call another station, then, he moves his switch key to the call position, pushing it back and forth to give the call signal of the station wanted, or simply to give any call signal if but two stations are connected on the line. When the switch key is in this position, it completes a circuit from the two dry batteries in series, through the induction coil or call buzzer. This produces a tone in the receiver of the called station which is loud enough to be heard several feet away from the station. For this reason, the telephone receiver should never be kept on the ears when the switch key is in the stand-by position and another operator is likely to call, as the call signal would hurt the ear drums.

The circuit in use during the process of calling is indicated at the right of Fig. 2. The alternating current received at the called station, due to the call connection, passes through the secondary of the call buzzer, the condenser  $C_1$  of the filter, and through the telephone receiver to ground. When a station is called, both the calling and called operators immediately place their switch keys in the send-receive position. The called operator then acknowledges the call by operating his sending key and giving an O. K. or repeating his station call signal. The called operator then releases his sending key, which returns to the receive position, giving the circuit shown at the right of Fig. 3, and the sending operator straightens out his key and proceeds to send, the circuit at the left of Fig. 3 then representing that which is in use in his set. The two connections of Fig. 3 are then alternated back and forth in the two stations, as they communicate.

As soon as the switch key is placed in the send-receive position, a local circuit through one dry cell and the howler is established, causing the latter to vibrate continuously. This howler is made up of a transmitter and receiver element enclosed in a rigid case, the two elements having a common diaphragm. The transmitter element has two microphone capsules, one of which is utilized in causing the howler

to vibrate, while the other is used simply for transforming the direct current signals into a high frequency tone current. This howler does not actually interrupt the current, but it serves to change the resistance in the circuit to produce a current varying between certain limits at a frequency of about 500 cycles per second.

When the sending operator closes his sending key, K, Fig. 3, he completes a circuit from the line through the high impedance coils of the filter, through a high resistance coil T, the two batteries in series and the outer transmitter capsule of the howler to ground. The howler transforms the direct current into a pulsating current which makes the signals audible in the receiver at the sending station. These fluctuations in the current, however, are prevented from going out over the line by the filter, the high impedance coils of which prevent any sudden change in the current, and the condensers absorb the changes which occur in the local circuit.

When the direct current dots and dashes are received at the receiving station, they pass through the impedance coils of the filter, through the outer capsule of the howler to the receiver and ground. Since the howler is constantly vibrating, the constant current signals received are transformed into high frequency impulses which can be heard in the receiver. In both the receiving and sending circuits, the secondary of the call buzzer is in series with the line, but it has no particular function ~~except to add desirable resistance in the circuit.~~ The purpose of this coil comes into play in operating the call signal and also when using the hand telephone set, as it then serves as an ordinary telephone transformer. The coil is in reality an ordinary transformer with a buzzer added.

When it is desired to talk over the line and thus more readily transmit unconfidential matter, the connector fastened to the telephone hand set cord is pushed into position in the clip-jack on the face of the panel. Placing the connector in the jack opens a spring switch which normally short circuits the two terminals of the jack to which the receiver of the hand set is connected. With this connector in place and the switch key in the send-receive or stand-by position, telephone conversation may be carried on in the ordinary manner. It must be remembered, however, that any messages sent over the line by telephone are not confidential and are readily picked up by the enemy. If the switch key is in the

at any other than the calling station

send-receive position at the time a telephone conversation is carried on, there is no interference between the telephone and Morse communication. If the switch key is in the stand-by position, the telephone conversation can be heard in the head set or buzzerphone receiver. When the buzzerphone call signal is used, it causes a loud noise in the hand telephone set and interrupts the talking. The reason that there is no interference between the incoming telephone and Morse messages is that the high frequency voice current coming in from the outside line is stopped by the inductance coils, but readily passes through the first condenser  $C_1$  of the filter circuit, Fig. 1, and thence through the telephone hand set receiver to ground. The constant direct current of the Morse signals is obstructed by the condensers, but passes through the inductances of the filter and is subsequently broken up by the howler as explained above. Telephone and Morse currents originating within the set are likewise separated at the filter so that they do not interfere with each other. If the switch key is in the stand-by position, the buzzerphone receiver is in series with the hand set receiver, and hence the voice current may be heard in the buzzerphone receiver, while the switch key is in this position. When the switch key is at send-receive, and the hand set is plugged in, the hand set receiver is in series with the line or ground where the Morse signal current is constant direct current and hence not audible, while the head set receiver is in a local circuit wherein the current is broken up by the howler to make it audible. This can be clearly seen by drawing in a receiver in series with the line between "ground" and the first branch-off above, in the right-hand portion of Fig. 3.

### Leaky Lines and Ground Potential

The principal causes of interference in the transmission of signals are likely to be leaky lines and ground potential. The presence of ground potential does not affect the secrecy of signals at all, and is not particularly detrimental as long as the sending signals produce a change in the tone heard in the receiver distinct enough so that the signals can be read. With a badly leaky line and a high ground potential, however, the leakage current may be of such value that if it happens to be opposing the line current, it will be stronger than the latter and the signals will come in reversed and be

impossible to read. The EE-1 buzzerphone is designed to transmit satisfactory signals over a one-wire grounded circuit in the presence of a ground potential at any station of as high as 1 volt with a leak of not less than 50,000 ohms resistance. If a ground potential of  $1\frac{1}{2}$  volts is encountered, the line leak must not be less than 100,000 ohms. If the ground potential is but  $\frac{1}{2}$  volt, a line leakage as low as 25,000 ohms will not destroy the secrecy and clearness of the signals.

The indication of the presence of a <sup>of two sets are</sup> ground potential is a steady tone in the head receiver when the switch keys in the send-receive position and the sending keys of all stations bridged on the line are in the receiving position. If the line ~~is~~ <sup>sets</sup> well insulated, this tone will disappear when the sending key is straightened out to open the receiving side-contact, as this cuts the receiver off the exterior circuit. If the tone continues to be heard after the sending key is straightened out, this is an indication that the <sup>contact</sup> line is leaky. Ordinarily, if the line leak is not too great, even if the tone does continue after straightening out the sending key, it will be sufficiently reduced ~~by the signal current~~ to make the signals readily distinguishable. In the absence of appreciable ground potential, satisfactory signals can be obtained over a line with a leak to ground as low as 100 ohms. No adjustment of the set is necessary to compensate for ground potential conditions.

On a well insulated line, satisfactory signals can be obtained through a resistance as high as <sup>50,000</sup> ~~100,000~~ ohms and against ground potentials of any value either steady or varying. In the absence of appreciable ground potential, several stations may receive code signals simultaneously, by having them bridged between the line and the ground, or between the two wires if a two-wire metallic circuit is used. However, each set ~~in the receiving position~~ <sup>receiving position</sup> introduces a leak from line to ground of about 4000 ohms, and hence in the presence of ground potential of any particular moment, not more than one set on a line should be <sup>signals</sup> ~~in the receiving position~~ at a time. For this reason, when considerable ground potential is known to exist, operators should be careful to move the switch key to the send-receive position momentarily, before attempting to use the line for code. If the line is already in use for Morse purposes, the operator should switch back immediately to stand-by in order to avoid having the additional 4000 ohm

leak to ground and possibly so weaken the signals being sent as to make their clear reception impossible.

### Grounding Buzzerphone Lines

The best operation of the buzzerphone will be obtained when the ground has the lowest obtainable resistance. The better the ground, the greater the line leakage and ground potential which can be encountered and still get through satisfactory signals. The grounds at all stations on a line should be made of the same material; that is, they should all be galvanized iron grounds, black iron grounds, or other good grounds, but there should not be a combination of the different types on a single line. Two grounds of different materials produce a ground potential between them which is very undesirable and unnecessary. Under ordinary conditions of moderate line leakage, a black iron ground rod will give the lowest ground potential, or the lowest steady tone in the receiver. Under varying conditions of line leakage, however, galvanized iron ground rods will generally give readable signals through worse conditions of ground potential and poor insulation than other types of grounds. The type of ground rods furnished with a set are the Signal Corps type D rods (S. C. Manual No. 3, page 353). These rods are 9 in. long x  $\frac{1}{4}$  in. thick and are hexagonal in shape. They are pointed at one end and bent into a circular handle at the other. A machine screw on the top of the handle is provided for connecting on the ground wire leading to the set.

It is undesirable to use a ground rod for the buzzerphone which is at the same time in use for any other purpose, as interference of signals will probably result. In ordinary soils, it will generally be sufficient to separate grounds for different purposes by 20 ft. or more. This, of course, does not apply in the case of a good ground of negligible resistance such as a water pipe or gaspipe system which may be used as a common ground for many purposes.

### Testing and Precautions

The normal Morse signal current on a buzzerphone line is about 60 microamp., this varying slightly with ground potential conditions. This current is greater than is necessary to give good signals over a perfectly insulated line, but is necessary in order that readable signals may be received

under the conditions of line leakage and ground potential which frequently prevail.

The telephone hand set which forms a part of the buzzerphone provides a convenient means of testing out the buzzerphone. If tone signals or clicks at the beginning and end of dots and dashes are heard in the hand set during Morse operation, these are due to defects in either the sending or receiving circuits of the set and they should be cleared before further operation. The set should never be used for confidential communication when either the tone signals or clicks are audible in the hand set since under these conditions the signals are readily overheard by induction or ground leakage methods. When this trouble is experienced, the set should be replaced. It is desirable to make a test of this character once a day, to ascertain if the condensers and inductance coils in the filter are all right.

In case there is no hand set with the buzzerphone, the set may be similarly tested by operating the sending key on one station and listening in at the other station while the key at the latter is in the stand-by position, to see if any clicks or tone can be heard. The reverse test is then made, the other station sending while the first station listens with the switch key in the stand-by position. If the buzzerphone is operating properly, there should be no tone or click heard in the buzzerphone receiver when the switch key is in the stand-by position.

Tone signals heard in the head receiver when there is no operator sending from another station, will probably be due to leakage either through the line or through the ground from another buzzerphone or telegraph line in the vicinity. Such signals due to ground leakage will not occur except where the ground rods of the two lines are very close together.

It must be remembered that telephone conversations and calling by means of the switch key are readily overheard at considerable distances by inductive or ground leakage methods, and that the telephone hand set should therefore never be used for transmitting any information of the least confidential nature. The Morse signals should always be used for any message which would be of slightest value to the enemy as these can be picked up only from ground connections within a few feet of the buzzerphone ground or by actually tapping the buzzerphone line. Even tapping the line will not

disclose the signals, except with the help of the very most efficient detecting apparatus.

Operators should not touch or rest their hands or clothing on the terminals of the set at any time, either when sending or receiving or when the set is at stand-by, as this may make the tone signals audible on the line or produce a leak from line to ground which would confuse signals at other stations on the line.

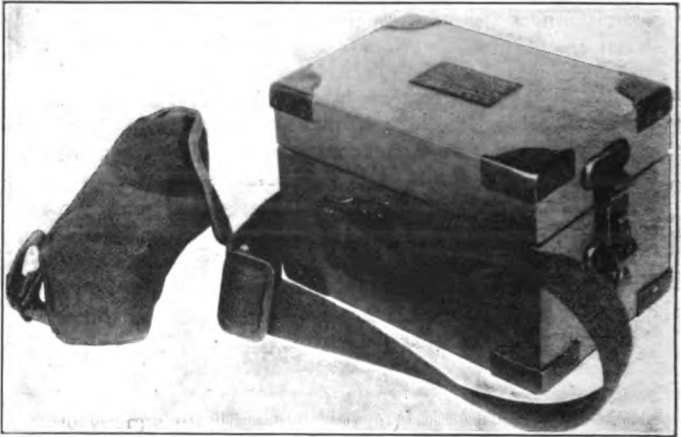

Fig. 6. Buzzerphone Case Closed and Telephone Hand Set in Canvas Case at Left.

When not sending or receiving, the switch key should always be kept at the stand-by position as the set otherwise forms a low resistance leak from line to ground, and also, because any other position makes it impossible for that station to be called.

The line and ground should always be connected to the proper terminals as indicated at the terminals in order to secure the most satisfactory signals under all conditions of ground potential and line leakage. The connections in the set are so chosen as to maintain the line at positive potential to ground, and also in such a manner that the more common ground potentials encountered add their potential to the emf. of the signals, rather than oppose it. This indicates the importance of proper connections.

If the howler fails to operate upon moving the switch key to the send-receive position, it will generally be found that the trouble is at the battery. No attempt should be made to adjust the microphones since the manufacturer's adjustment is not easily disturbed and it is difficult to make adjustment in the field. If the howler is found to be defective, it should be replaced.

### **Specific Details of Operation**

1. Connect the line to the binding post marked "Line." Install the ground and make connections from it to the binding post marked "Ground."

2. Move the switch key to the "Send-Receive" position and listen in the head set to ascertain if the line is already in use for Morse signals. If so, push back to "Stand-By" and wait a short time before listening in again. Repeat until the line is found clear.

3. Move the switch key to "Call", giving just a buzz or two if but one other station is connected on the line, or the proper predetermined signal to call the station wanted if several are bridged on the same line.

4. Move the switch key to "Send-Receive" immediately and listen in the head set for acknowledgment in Morse signals, this being given in a repetition of the call signals of the station called. If no acknowledgment is received, repeat the call.

5. When acknowledgment is received, straighten out the key by moving the handle to the left and proceed to send the desired signals.

6. When finished sending, take the hand off the sending key which will then spring back to close the side or receiving contact, when the set is again ready for receiving any return message.

7. A set not in use should always have the switch key at "Stand-By." When in this position, if your station is called, move the switch key to "Send-Receive," straighten out the sending key and acknowledge the call. Then let go of the sending key and listen.

8. To break in while receiving signals, if they are not understood or if it is more urgent to send signals than to receive the ones being transmitted, move the sending key to the left to open the receiving contact. This will interrupt the incom-



ing signals and on any but a very poor line will so far reduce the tone of the signals in the sending station that the operator there will know the circuit has been opened and will stop sending.

9. The sending operator, in such a case, should immediately release his sending key and listen for signals. If none are received and the conditions prevail for sometime, it is a fair indication that the line has been cut by a shell at some point, or that the receiving operator has been forced to remove his set to another position.

10. When working on a leaky line and it is desired to break in, the change in tone in the sending set upon opening the receiving contact on the receiving set may not be great enough so that the sending operator will notice the reduction. In this case the receiving operator may interrupt by using the call signal. ~~This should never be done unless absolutely necessary, for the call signal will be very unpleasant on the ears of the operator having the head set in place to send~~

~~message~~

---





# RADIO TELEGRAPH TRANSMITTING SET

Type SCR-69

*(Confidential)*

Radio Pamphlet

No. 14

Signal Corps, U. S. Army

8-30-18



**Radio Telegraph Transmitting Set  
Type SCR-69**



## RADIO TELEGRAPH TRANSMITTING SET TYPE SCR-69

The radio telegraph transmitting set, type SCR-69, is an undamped wave set which is intended primarily for use as an instruction unit. It is designed to serve somewhat the same purpose as the French E-3 or E-10 sets and is issued only to organizations in training. Light weight, high efficiency and sharp tuning are its special characteristics. Three kinds of undamped wave sending may be used with the one set, making it possible to communicate with a receiving station whether the latter is equipped with a heterodyne or an ordinary rectifying detector set. This feature makes it more or less universal in character and particularly suited to use under training conditions where several types of receiving sets may be employed. In case the batteries of a heterodyne or autodyne receiving unit working with this transmitting set should fail, it would still be possible to use this same set by sending buzzer-modulated waves and receiving by ordinary crystal detection.

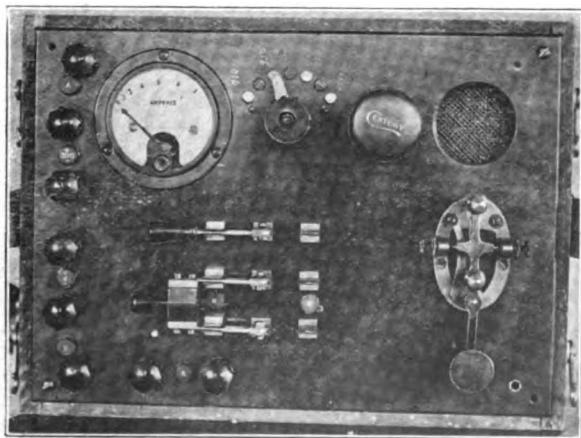

Operating Panel of Type SCR-69 Transmitting Set

As the operating characteristics of this set have not been satisfactory, only a comparatively small number of sets will be manufactured, and it is anticipated that these will be displaced in the near future by the type SCR-79 set.



## Description of the Set

The type SCR-69 set consists essentially of a three-electrode vacuum tube, type VT-12, having its grid and plate circuits inductively coupled together and to the antenna. The three coupling coils (antenna, plate and grid coils) are mounted on the same axis. The antenna and grid coils are about 7 in. in diameter and the plate coil is about 3 in. in diameter, and these coils are so wound that the capacitance between the turns is reduced to a low value. The wave length of the set may be changed by means of the four taps on the antenna coil, whereby four different wave lengths ranging between the limits of about 600 meters and 1500 meters with an SCR-53 antenna, can be secured. A definite specification as to the type of antenna to be used with this set has not been made. Its operation with the type SCR-53 antenna is somewhat improved by opening the "V" to a greater angle than the standard 60 deg., in order to increase the capacitance

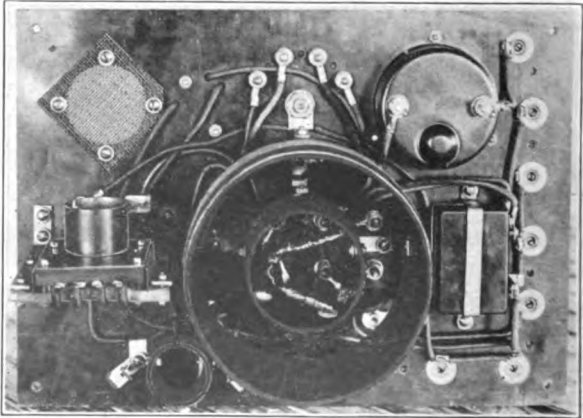

Mounting of Apparatus on Under Side of Panel

of the antenna. The greatest capacitance is obtained when the angle is 180 deg. The three masts should then be erected in a straight line with the station it is desired to signal, the lead-in wires being connected as usual at the center.

The vacuum tube plate current is supplied by a dynamotor running on a 10-volt storage battery to supply 325 volts

potential between the plate and the filament. The high voltage side of this dynamotor is shunted by a condenser which serves the double purpose of smoothing out the small variations in the 325 volt direct current supply, and of providing a path for the high frequency oscillations generated by the tube which would otherwise be choked out by the impedance of the dynamotor windings. A negative grid potential of about 20 volts is supplied by a BA-2 dry battery which is contained inside the case. The filament is heated by a 6-volt storage battery which forms part of the auxiliary apparatus accompanying the set. The filament circuit includes an adjustable rheostat which should be set to limit the filament current to 1.36 amp. This corresponds with the VT-12 tubes to a reddish yellow glow and with the VT-2 tubes, should these happen to be used in emergency, to a dull red glow. The rheostat is not shown in the cut of the panel, but it forms part of the panel equipment on the sets now under construction.

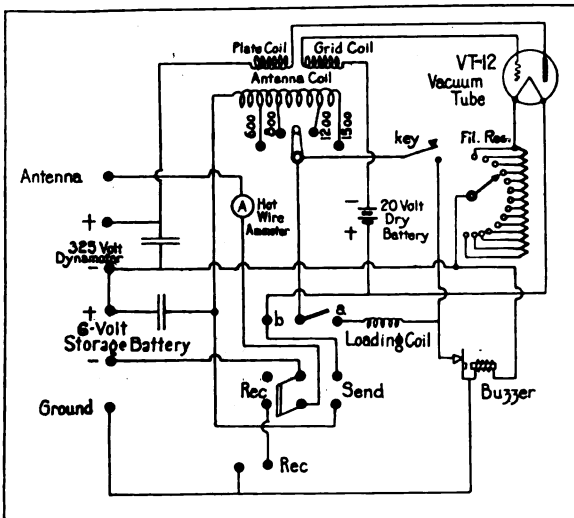

Fig. 1—Wiring Diagram of the Type SCR-69 Set

A sending key and hot wire ammeter are inserted in the antenna circuit. The latter indicates whether or not the vacuum tube is oscillating. A double pole double throw

switch mounted on the panel provides a connection such that the antenna and ground of the sending set may be readily connected to any receiving set which may be connected to the "Receiving" terminals on the panel of SCR-69.

## Method of Operation

The set being properly connected up to the antenna, ground, dynamotor and batteries, and the d. p. d. t. switch closed to the right (sending position), there are three methods of radiating the oscillations generated by the tube which correspond to the three positions of the single pole double throw switch marked ab, Fig. 1, and mounted on the panel of the set. The character of waves radiated corresponding to each of the three positions of this switch is as follows:

### Compensated Wave Sending

**S.P.D.T. SWITCH CLOSED TO THE RIGHT.**—Closing the switch to the right places the small loading coil in parallel with the sending key. The equivalent circuit is shown in Fig. 2, first diagram, for simplicity. With these connections, the oscillations generated by the tube are radiated continuously from the antenna, and are of a wave length  $\lambda_1$ , determined by the size of the antenna and the tap used on the antenna coil. When the key is now closed, in sending signals, the small loading coil is short circuited, thus reducing the inductance of the antenna and shortening the wave length to a value  $\lambda_2$ . This condition is shown in Fig. 3, first series of waves. The small loading coil, which has about ten turns of wire and a diameter of about 2 in., is so calculated that the difference between the wave lengths radiated with the key open and with the key closed is from 5 to 10 meters. As these waves are undamped, they are received by the heterodyne method which affords very sharp tuning and thereby makes it entirely possible to tune the receiving set to the shorter signal wave  $\lambda_2$ , and cut out the interference from the longer wave  $\lambda_1$ , corresponding to the key open. It is also possible to receive both waves simultaneously if so desired. With this adjustment, two notes are heard in the receiver, a high pitched note for the spaces and intervals and a low pitched note for the dots and dashes. This method of sending is called the "compensated wave" or "detuning" method.

### Cut-In Sending

**S.P.D.T. SWITCH OPEN.**—The equivalent circuit for this connection is shown in the second diagram of Fig. 2. In this case, the key is placed directly in the antenna circuit so that it opens and closes that circuit. The result is that the oscillations generated by the tube are radiated from the antenna

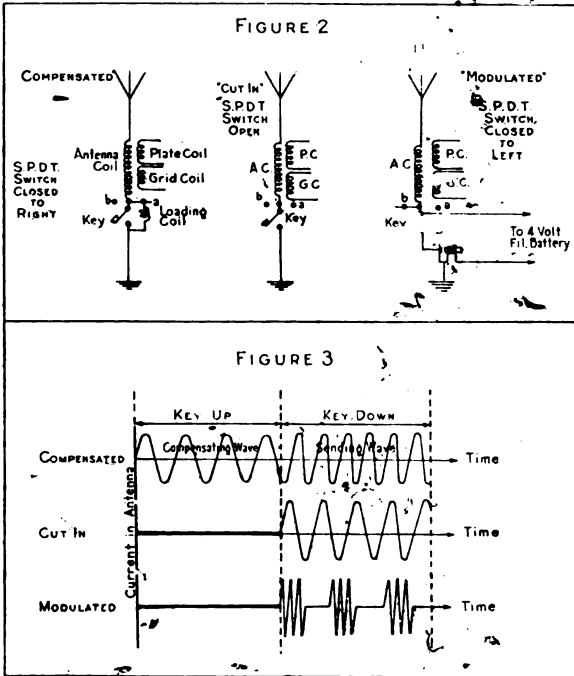

Fig. 2 and 3—Schematic Representation of Different Sending Connections and Waves Radiated

only when the key is closed, no energy leaving the antenna when the key is open. A dot or dash will then be sent out as a train of undamped waves, (Fig. 3, second series of waves), while a space will correspond to no energy sent out. As for the compensated method, reception of these signals must be made by the heterodyne method, the only difference in the signals heard at the receiving station being that no note will be obtained for spaces or intervals. This method of sending is called the "cut-in" method.

### Modulated Sending

S.P.D.T. SWITCH CLOSED TO LEFT.—The equivalent circuit for this position of the switch is shown in the third diagram of Fig. 2. In this case, the antenna circuit is opened when the key is up, and no energy is radiated. When the key is down, energy is radiated in a manner similar to that of the cut-in method, except that the closing of the key not only completes the antenna circuit but also a circuit through a small buzzer, the vibrator of which opens and closes the antenna circuit. The undamped wave thus sent out is interrupted at regular intervals by the buzzer vibrator and a dot or dash is consequently made up of a series of short trains of undamped oscillations (Fig. 3, third series of waves). While the frequency of the oscillations is above audibility, the wave train or group frequency is equal to the buzzer vibrator frequency and therefore within the range of audibility. These waves can therefore be received by an ordinary receiving set and rectifying detector, just as damped wave signals. This method of sending is called the "modulated" method.

### Choice of the Method of Sending

Each of the above sending methods has its respective advantages and disadvantages which determine and limit its use. The compensated method is the best of the three, in that the constants of the various circuits are changed very little by the closing of the key and there is therefore no danger of the tube being stopped from oscillating. The ammeter in the antenna circuit should give a practically constant reading whether the key is closed or open. This method has the disadvantage that it requires a certain amount of skill on the part of the operator, as no sound is produced by the transmitter and he must therefore make his dots and dashes purely by touch and not at all by ear. At the receiving end, it is not always possible to completely tune out the compensating waves, that is, the waves corresponding to the spaces, and the signals may be somewhat harder to read and cause an untrained operator some trouble. In tuning a set to receive waves sent out by the compensated method, it is important that the sending and not the compensating wave should be tuned in, as the former is made up of the signalling dots and dashes, while the latter is made up of the spaces between the dots and dashes.

The cut-in method gives no radiation of electric waves when the key is up. When the key is closed, the antenna circuit is suddenly coupled to the tube circuit. This is generally sufficient to produce an initial change in the potential of the grid of the tube and thus start it oscillating. However, due to various conditions, it sometimes happens that the resulting change is not sufficient, and oscillations may not take place when the key is closed. This method is therefore not as reliable as the compensated method but it may be more easily read at the receiving station, as it produces only one note in the receiver. It has the same disadvantage for the sending operator as the compensated method—no sound to aid the hand.

The modulated method of sending has the same defects and advantages as the cut-in method. It has the additional advantage that the buzzer emits a sound which may assist the operator in sending. However, due to the breaking up of the waves, less energy is radiated by the antenna. The modulated method is the only one of the three by which signals can be received by means of an ordinary crystal detector such as is supplied with the SCR-54 receiver.

Particular care should be taken that the antenna and lead-in wire are completely insulated from the counterpoise and the ground, as a leak from antenna to ground, due to contact with a tree or shrubbery, or even leakage due to rain or damp weather, will not only cut down the radiation considerably, but will also prevent the tube from oscillating. Care should be taken that the counterpoise wire is heavily insulated from ground. A poorly insulated or partially grounded counterpoise will increase the antenna resistance and may prevent the tube from oscillating. The resistance of the antenna and lead-in wires should be kept as low as possible.

## **Parts List of Radio Telegraph Transmitting Set Type SCR-69**

### **POWER EQUIPMENT, TYPE PE-8.**

- 2 Edison Storage Batteries, type BB-1; 7 cells, 10 volts, 37.5 amp-hr. (1 in use, 1 spare).
- 2 Edison Storage Batteries, type BB-2; 3 cells, 4 volts, 75 amp-hr. (1 in use, 1 spare).
- 1 Westinghouse Dynamotor, type DM-1; 10/300 volts, 50 watts.

**TRANSMITTING EQUIPMENT, TYPE RT-6.**

- 1 Radio Telegraph Transmitting Set Box, type BC-34; complete with carrying strap.
- 5 Vacuum Tubes, type VT-12 (1 in use, 4 spares).

**ANTENNA EQUIPMENT, TYPE A-6 (Old Type SCR-53 Set).**

- 3 Mast Sections, type MS-1 (without tube).
- 12 Mast Sections, type MS-2 (with tubes).
- 3 Mast Caps, type MP-5.
- 3 Insulators, type IN-1; hard rubber, with hooks.
- 9 Hand Reels, type RL-3.
- 1 Antenna, type AN-5; two lengths braided antenna cord 150 ft. long and one length of lead-in wire 40 ft. long, all carried on three hand reels.
- 9 Guys, type GY-3; No. 5 sash cord, each 36 ft. long with metal tent slide and hook; a set of three guys to be carried on each of three hand reels.
- 1 Counterpoise, type CP-4; consists of two lengths of wire 150 ft. long and one lead-in wire 40 ft. long, all joined together at their intersection; to be carried on three hand reels.
- 3 Hammers, type HM-1.
- 9 Guy Pins, type GP-2.
- 3 Pieces of No. 5 Sash Cord, each 3 ft. long.
- 1 Carrying Chest, type BC-35; used for packing all of the above material for transportation.









---

Prepared in the  
Office of the Chief Signal Officer  
Training Section  
Washington

---

FOR OFFICIAL USE ONLY

# RADIO TELEGRAPH TRANSMITTING SETS

Type SCR-74

Type SCR-74-A

*(Confidential)*

*Communication*  
Radio Pamphlet  
No. 11

**Signal Corps, U. S. Army**

Second Edition, Revised to

10-18-18



**Radio Telegraph Transmitting Sets**  
**Type SCR-74**  
**Type SCR-74-A**



**T**HE TYPE SCR-74 and SCR-74-A radio telegraph sets are used for the transmission of radio messages between regiment and brigade headquarters. Only in exceptional cases are these sets used at battalion headquarters. They are similar to the French set "*Poste Portatif No. 3.*"

These sets produce damped wave signals. The only way in which the wave length can be changed is to alter the dimensions of the antenna. On account of the broad, non-musical wave emitted, a special inverted "L" antenna, type A-3 or type A-3-A, is used because of its marked directional effect. This antenna also lends itself well to the necessity of having one which can be easily repaired under shell fire. Its characteristics permit the simultaneous use of a comparatively large number of sets within a limited area. It is described in a later paragraph.

The signals emitted by both these sets may be received with any damped wave receiving set of suitable wave length range, but the type SCR-54 or SCR-54-A set is generally used for this purpose.

### **Description of the Sets**

The two sets are identical in their electrical characteristics and operation. They differ only in the arrangement of the various parts within the set box, and in that the cover of the set box of the type SCR-74-A set is equipped with rubber gaskets, to make the box waterproof.

The principle of the sets is illustrated in the circuit diagram of Fig. 3. Both sets comprise an open magnetic circuit induction coil, the primary of which is energized by a 10-volt storage battery when the telegraph sending key is closed. The primary circuit also comprises an ammeter which serves to indicate by its deflection whether or not the set is operating properly. The secondary winding of the induction coil is connected to an adjustable spark gap of the open-gap type. The two electrodes of the gap are connected to the aerial and ground respectively. The vibrator contacts are shunted by a 6-mfd. mica condenser, which greatly reduces the sparking at the vibrator and produces a more abrupt interruption of the primary current.

The set box contains the induction coil with its vibrator, vibrator condenser, telegraph key, ammeter, antenna spark gap, aerial and ground binding posts, and battery binding posts, to which is connected an extension cord with a plug for connection to the 10-volt battery. A screwdriver and file for making adjustments and keeping the vibrator contacts in shape, are also furnished with the box.



All these parts are arranged in the set box as shown on the photographs. A glass covered hole in the cover over the ammeter and over the spark gap, and a rubber covered hole over the key, permit operating the set with the cover closed to exclude the rain or snow, etc.



Fig. 1—Type BC-18 Set Box and Operating Panel of the Type SCR-74 Set

### Installation and Operation

The method of installation is the same for both types of sets, and is given below. The following steps should be followed exactly and in the order given.

1. Choose a location suitable for the installation of the station. This should be done with due regard for the screening effect of trees and houses, and also for protection from enemy shell fire or

observation. The set box itself may be installed under a protected shelter, but precautions must then be taken to thoroughly insulate the lead-in wires at the points where they enter the shelter.

2. Install the antenna, with due regard to its directional effect. The method of setting up the type A-3 antenna, which is the standard antenna for this set, is illustrated in Fig. 5. The length of this antenna is 150 feet, its height about 3 feet. The aerial wire and the two counterpoise wires are unreel, so that their general direction



Fig. 2—Vibrator Mounted in the End of the Type BC-18 Set-Box

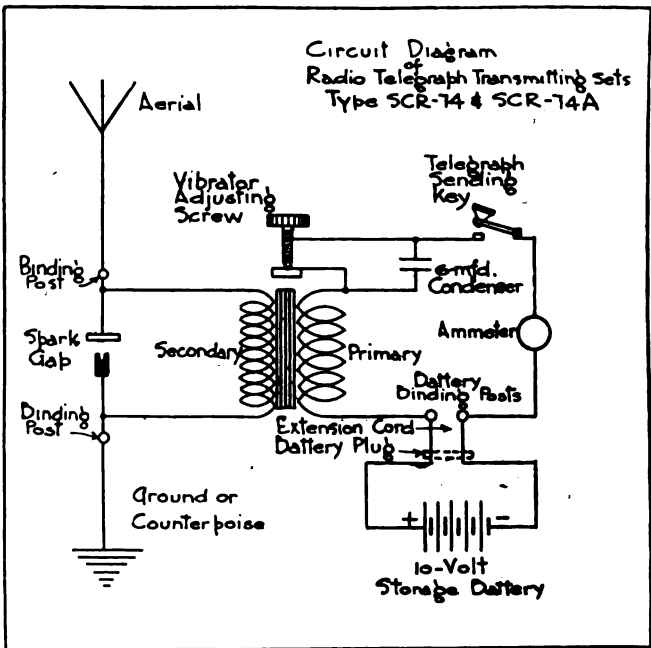

Fig. 3—Schematic Wiring Diagram for the Type SCR-74 and Type SCR-74-A Sets

will point toward the station with which it is desired to communicate, and with the lead-in end of the aerial wire and plug end of the counterpoise wire at the end nearest to that station. Open the two wooden antenna supports, fasten the aerial wire to the insulators, and guy the supports in position by tying the guy ropes to one or two stakes driven in the ground. The counterpoise lead-in wire is then knotted around the strut cord of the wooden support so that the connecting block will be held off the ground. Plug the two counterpoise wires into the connecting block, and bring the free ends of the two lead-in wires to the set box, taking care to keep them separated and off the ground.

The antenna used with the type SCR-74-A set is the type A-3-A, which differs but little from the type A-3 described above in conjunction with the type SCR-74 set. The main difference is that a ground mat is used in place of the two-wire counterpoise. This alters the electrical constants to only a slight degree, and

does not appreciably affect the directional characteristics. When working on a damp ground, it is best to bury the mat about one foot deep, or deeper if possible, and to pack the earth well around and above it. If on dry ground, the mat is simply laid on the surface of the ground. In all cases, the location for the mat is directly underneath the aerial wire.

An advantage of the type A-3-A antenna is the use of snap hooks to fasten the aerial wire to the insulators. This makes the installation more secure. In its general aspect, this antenna appears similar to that shown in the sketch, Fig. 5, the counterpoise being replaced by the mat.

3. Connect the antenna and counterpoise lead-in wires respectively to the "antenna" and "ground" binding posts of the set box.



Fig. 4—Type BC-10-A Set Box of the Type SCR-74-A Set

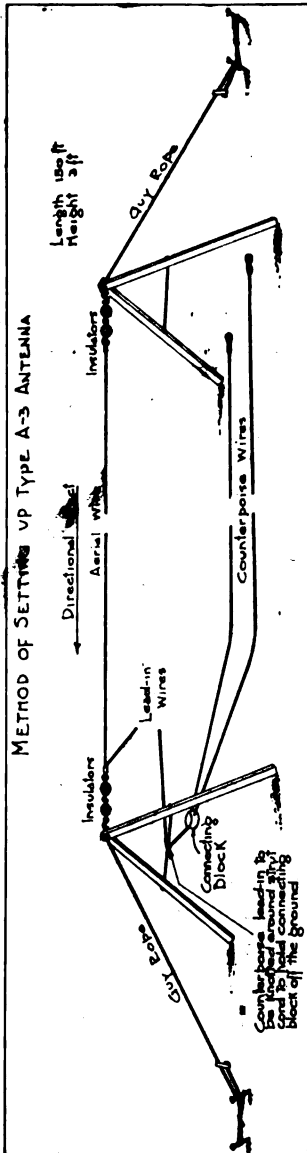

Fig. 5—Method of Setting up the Type A-3 Antenna

4. Connect the 10-volt storage battery by means of the battery plug and connector. If no connector has been furnished with the set, use short and heavy wires, and give due regard to the polarity, as marked on the "Battery" binding posts of the set box, and on the terminals of the battery.

5. Open the antenna spark gap all the way out.

6. Close the telegraph sending key, and adjust the vibrator by means of the vibrator screw until a good, clear, steady note is obtained.

7. Release the key, and gradually decrease the distance between the spark gap electrodes; turning the disc electrode about one turn at a time, and closing the key for each position, until a good spark is obtained across the gap. The adjustment is completed when, upon closing of the key, a rapid succession of fine, white-blue sparks takes place across the gap. The distance between the electrodes should be the smallest distance possible which will give such white blue sparks in abundance, without establishing a "power arc," easily recognizable by its flaming, yellowish aspect.

Care should be taken during the operation, to never touch the spark gap elec-

trodes or lead-in wires, while the telegraph key is held down, as a serious shock will result.

8. The current indicated by the ammeter, with the gap and vibrator properly adjusted, and the battery fully charged, should be from 7 to 11 amp.

### **Special Precautions in Operating and Maintaining the Sets**

The following rules should be strictly observed when operating the SCR-74 and SCR-74-A sets:

1. Never touch any part of the antenna circuit (lead-in wires, spark gap, etc.) while the telegraph sending key is closed.

2. Never connect the battery to the set before both the counterpoise and aerial are connected to their respective terminals on the set box.

3. Under no circumstances should the set be tried out with the counterpoise or aerial disconnected. If the telegraph key is closed after the set is connected up but without the antenna, an emf. will be induced in the secondary winding of the coil of such high voltage that there will be great likelihood of breaking down the insulation, thus rendering the set inoperative.

4. Care must be taken to have all parts of the aerial, counterpoise and lead-in wires well insulated from the ground at all points.

As was mentioned before, the type A-3 or A-3-A antenna equipment, furnished as part of these sets, is particularly well suited for the kind of service intended. The sets may however be used with antennae of different dimensions. A higher antenna, of about the same length will give good results when a longer distance of transmission is required.

These types of antennae have the advantage of being easily hidden from enemy observation. When desired or necessary, the antenna supports can be camouflaged with paint or otherwise, to meet local conditions. In general, painting the supports will be found sufficient, but in no case should any method be used whereby any material other than the insulators provided, comes in contact with the aerial wire or lead-in wire. The insulators should not be painted as this may reduce their insulating qualities.

By tying the feet of the antenna supports with cords, to pins driven in the ground adjacent to each foot, thus hinging them at the ground, it is possible to lower or raise the entire antenna by releasing or tightening one of the end guys. This may prove convenient, as the antenna can be lowered and effectively protected during periods when the set is not in use.

As a general precaution, it is well to always keep the set in as clean and dry a condition as possible.

If it is desired to use the set for longer distances, the range may be increased by using a higher antenna. This makes the antenna more vulnerable to destruction by shell fire and hence should ordinarily be used only in rear positions or in well protected forward locations. The change in dimensions might also alter the wave length, which must be taken into consideration.

## Parts Lists

In ordering this set or parts of this set, specification must be made by names and type numbers as listed below, exactly. The designation printed in bold face type *only*, will be used in requisitioning, making property returns, purchasing, etc.

In ordering *complete* sets, it is not necessary to itemize the parts; simply specify, "2 Sets, Radio Telegraph Transmitting, Type SCR-74." If *all* the parts listed under a group heading are desired, it is not necessary to itemize the parts; simply specify, for example: "1 Equipment Type RT-3."

The Type SCR-74 Set or SCR-74-A Set is not complete unless it includes all of the items listed below, under the respective headings.

### SET, RADIO TELEGRAPH TRANSMITTING, TYPE SCR-74

**EQUIPMENT, TYPE PE-13; Power.**

- 2 Batteries, Type BB-3; Edison storage; 10 volts, 30 amp-hr.: includes powdered electrolyte in separate container.

**EQUIPMENT, TYPE RT-3; Transmitting.**

- 1 Set Box, Type BC-18; radio telegraph transmitting.
- 1 Cord, Type CD-20; extension; set box to battery.
- 1 Bag, Type BG-4; carrying; canvas.
- 2 Cords, Type CD-21; extension; set box to antenna and ground.
- 1 Screwdriver, Type TL-2.
- 1 File, Type TL-5; contact.

**EQUIPMENT, TYPE A-3; Antenna.**

- 2 Supports, Type MS-4; antenna; complete with guys.
- 1 Antenna, Type AN-2; antenna cord, 150 ft. complete with 20-ft. lead-in wire and 4 Electroose No. 4500 insulators, of which 2 in series linked to each end of antenna wire; free end of insulator provided with open wire hook.
- 1 Counterpoise, Type CP-1; two 150-ft. lengths counterpoise wire, spec. 416-I, with terminal plug on one end.

- 1 Block, Type BL-3; connecting; at one end of 20-ft. lead-in.
- 4 Stakes, Type GP-2; ground, standard.
- 3 Reels, Type RL-3; hand; for antenna and counterpoise wires.
- 1 Bag, Type BG-8; carrying; for ground stakes, antenna and accessories.
- 2 Hammers, Type HM-1; 2 lb.

### SET, RADIO TELEGRAPH TRANSMITTING, TYPE SCR-74-A

#### EQUIPMENT, TYPE PE-11; Power.

- 3 Batteries, Type BB-23; lead storage; 10 volts, 20 amp-hr.; electrolyte is not included; concentrated acid for electrolyte supplied separately in carboys; 1 in use, 2 spare.

#### EQUIPMENT, TYPE RT-3-A; Transmitting.

- 1 Set Box, Type BC-18-A; radio telegraph transmitting.
- 1 Contact, Type CN-10; moving; with vibrator spring and screws; spare.
- 1 Contact, Type CN-11; stationary.
- 1 File, Type TL-30; contact.

#### EQUIPMENT, TYPE A-3-A; Antenna.

- 2 Supports, Type MS-4-A; antenna; complete with guy rope type RP-5, insulator type IN-5, ground stake type GP-5 and guy rope fastener type FT-9.
- 1 Antenna, Type AN-5; with snap hooks on both ends.
- 1 Stake, Type GP-6; ground.
- 1 Reel, Type RL-3; hand; for antenna wire.
- 1 Bag, Type BG-15; carrying; for ground stakes, antenna and accessories.
- 1 Hammer, Type HM-1; 2-lb.
- 1 Mat, Type MT-3; ground.
- 1 Pliers, Type TL-19; combination.
- $\frac{1}{2}$  lb. Tape, Friction;  $\frac{3}{4}$ -in.



---

**Prepared in the  
Office of the Chief Signal Officer  
Training Section  
Washington**

---





*CONFIDENTIAL* For Official Use Only

# Airplane Radio Telephone Sets



*Communication*  
RADIO PAMPHLET No. 20  
Second Edition Revised to May 21, 1919

Signal Corps, U. S. Army





**CONFIDENTIAL!** For Official Use Only

# **Airplane Radio Telephone Sets**



**RADIO PAMPHLET No. 20**  
**Second Edition Revised to May 21, 1919**

---

**Signal Corps, U. S. Army**



**Washington : Government Printing Office : 1919**



**Airplane Radio Telephone Sets**

**Type SCR-68**

**Type SCR-68-A**

**Type SCR-114**

**Type SCR-116**

**Airplane Radio Receiving Sets**

**Type SCR-59**

**Type SCR-59-A**

**Type SCR-75**

**Type SCR-115**

(3)





## TABLE OF CONTENTS

	Page.
Set, Airplane Radio Telephone, Type SCR-68-A.....	7
The Transmitting Circuit.....	7
The Receiving Circuit.....	13
Set, Airplane Interphone, Type SCR-57-A.....	16
Other Parts of the Set.....	18
Fan Driven Generator.....	18
Filter Box.....	19
Radio Set Box.....	20
Installation of the Set.....	20
Calibration of Set Type SCR-68-A.....	26
Calibrating the Transmitting Circuit.....	27
Calibrating the Receiving Circuit.....	30
Operating the Set.....	31
Preflight Inspection and Tests.....	31
Operating the Set in the Air.....	32
Troubles and Remedies.....	33
Generator.....	33
Mounting; Leads; Brushes and Their Mountings; Bearings; Commutators; Field; Armature; Hunting; Excessive Voltage; Filament; Vibra- tion; Tube Mounting.....	33
Airfan.....	35
Pitch; Injury; Mounting.....	35
Filter Box.....	36
Radio Set Box.....	36
Ballast Lamp; Blocking; Paralysis; Noise in Re- ceivers; Failure to Oscillate; Faulty Tubes; Tube Sockets; Jacks and Plugs; Batteries Type BA-2; Indistinct Speech; Shocks; Vibration.....	36
Interphone Set Box.....	38
Batteries; Switches; Helmets and Telephone Transmitters.....	38
Antenna.....	39
Length; Fish; Reel; Short Circuits.....	39

Set, Airplane Interphone—Continued.	Page.
Trouble Charts.....	39
Noise in the Receivers.....	40
Indistinct Speech or No Speech when Using Inter- phone.....	40
Failure to Hear One's Self While Transmitting.....	41
Filament of Receiving Tubes too Bright.....	41
Signals too Loud in Receivers when Transmitting...	41
Failure of Receiving Tubes to Light.....	41
Failure to Receive Signals.....	41
Failure of Signal Loudness to Increase when Amplifi- cation Switch is Pushed In.....	41
Varying Strength of Signals in Receivers when Trans- mitting.....	42
Blocking—Modulator Tube.....	42
Failure to Oscillate.....	42
Set, Airplane Radio Telephone, Type SCR-68.....	42
Sets, Airplane Radio Telephone, Type SCR-114 and SCR-116	43
Set, Airplane Radio Receiving, Type SCR-59.....	43
Installing the Set.....	45
Preflight Inspection.....	45
Calibrating the Set.....	46
Tuning in the Air.....	47
Trouble.....	48
Sets, Airplane Radio Receiving, Type SCR-59-A and SCR- 115.....	48
Set, Airplane Radio Receiving, Type SCR-75.....	48
Installing the Set.....	49
Preflight Inspection.....	49
Calibrating the Set.....	49
Tuning the Set in the Air.....	51
Troubles.....	52
Parts Lists.....	52
Set, Airplane Radio Receiving, Type SCR-59.....	53
Set, Airplane Radio Receiving, Type SCR-59-A.....	53
Set, Airplane Radio Telephone, Type SCR-68.....	54
Set, Airplane Radio Telephone, Type SCR-68-A.....	55
Set, Airplane Radio Receiving, Type SCR-75.....	56
Set, Airplane Radio Telephone, Type SCR-114.....	56
Set, Airplane Radio Receiving, Type SCR-115.....	57
Set, Airplane Radio Telephone, Type SCR-116.....	58

## SET, AIRPLANE RADIO TELEPHONE, TYPE SCR-68-A

**T**HE TYPE SCR-68 and SCR-68-A sets are airplane radio telephone transmitting and receiving sets designed primarily for inter-plane communication work between airplanes in squadron formation, these sets being used by the commanders of squadrons. The other planes of the squadron are usually equipped with the type SCR-59 receiving set. The set may also be used for two-way communication with ground stations equipped with the type SCR-67 or SCR-67-A sets. The type SCR-68 and SCR-68-A sets have an approximate wave length range of 215 to 450 meters. A detailed study will be made here of the type SCR-68-A set, which is the more recent model, and the differences with the type SCR-68 will be pointed out in a later section.

The set comprises a special constant voltage generator, which furnishes the power for transmitting and for heating the receiving vacuum tube filaments; a filter box; a radio set box; an interphone set box for permitting telephone communication between the pilot and the observer; two head sets and telephone transmitters; and the required connecting cords.

### The Transmitting Circuit

A complete circuit diagram of the set is given in Fig. 1. The set box is equipped with a multi-pole double throw "Transmit-Receive" switch, which connects either the transmitting or receiving circuit. For the purpose of facilitating explanation, these circuits are treated separately.

A schematic diagram of the circuits in use when the switch is in the "Transmit" position is given in Fig. 2. This circuit comprises a type VT-2 three-electrode vacuum tube connected up as an oscillator to generate undamped high frequency oscillations in the antenna circuit. The plate circuit of this tube is energized by a 275-volt direct current generator, the terminal voltage of which is kept constant by means of special devices described in a later paragraph. In series with this plate circuit is a jack  $J_2$ , which permits the insertion of an ammeter for reading the plate current, an iron core choke

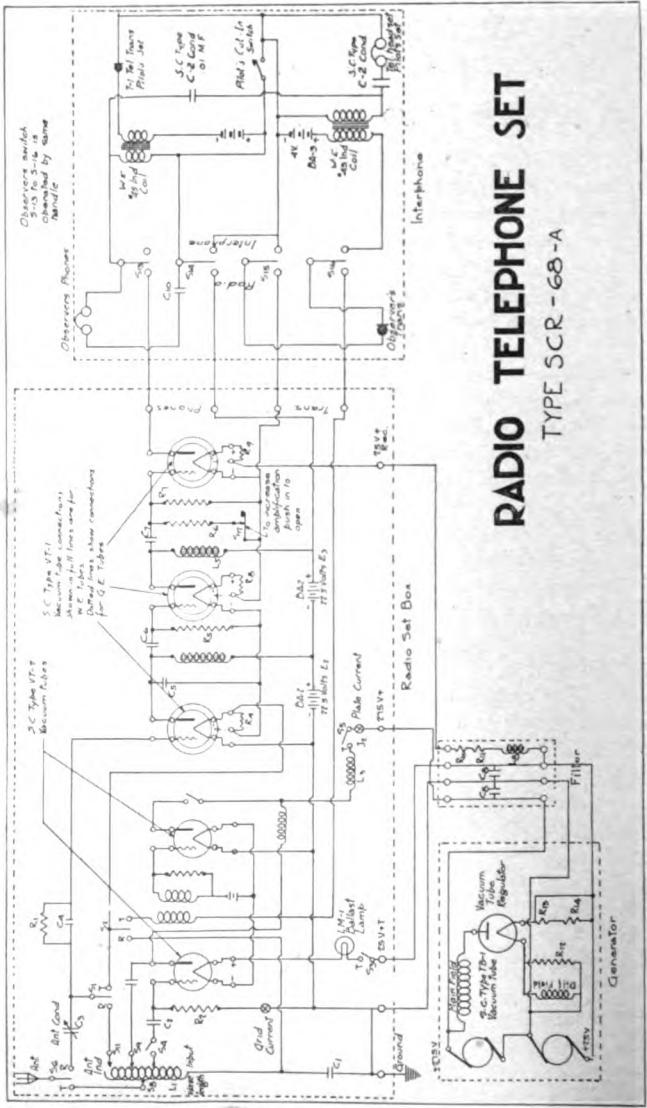

# RADIO TELEPHONE SET

TYPE SCR - 68 - A

FIG. 1.—Complete Schematic Circuit Diagram of the Radio Telephone Set Type SCR-68-A.

coil  $L_3$  which tends to keep the current from the generator constant, and a radio frequency choke coil to prevent the high frequency alternating current generated by the tube from flowing outside the radio circuits.

The filament of the oscillator tube is in series with that of a modulator tube, the function of which will be explained later, and is heated by the current from a 25-volt direct current generator,

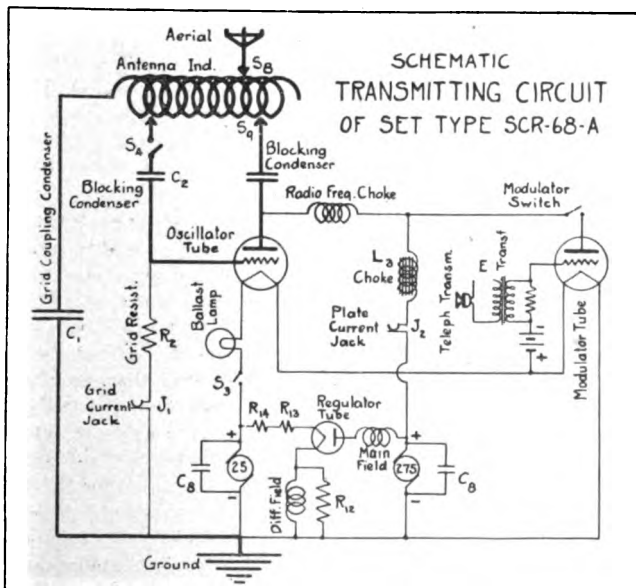

FIG. 2.—Schematic Diagram of the Transmitting Circuit of Set Type ECF-68-A.

mounted on the same shaft and having the same fields as the 275-volt generator.

The grid circuit of the oscillator tube comprises a high resistance  $R_2$  and a jack  $J_1$  which permits the insertion of a milliammeter for reading the grid current. The function of the grid resistance is to obtain a negative potential on the grid when the tube is oscillated.

The grid and plate circuits are coupled electrostatically by means of a fixed condenser  $C_1$  connected between the grid and the filament, and the condenser formed by the antenna and counterpoise in the

plate circuit. An antenna inductance, which forms the inductance of the oscillatory circuit, is connected directly between the plate and the grid. A blocking condenser is inserted in each of the plate and grid radio circuits in order to prevent any possible short circuiting of the direct current circuits. The wave length, grid and plate couplings may be changed by connecting the aerial, grid and plate wires to different points of the antenna inductance.

A second three-electrode vacuum tube (the modulator) is connected with its plate circuit in parallel with that of the oscillator tube, that is, between the negative terminal of the 275-volt generator armature and a point between the iron core choke coil and the radio frequency choke. The grid of this modulator tube is connected to the filament through a 20-volt dry battery, type BA-2, and the secondary of an "input" transformer. This gives the grid of the modulator tube a constant negative potential. The primary of the input transformer is connected in series with a telephone transmitter type T-3 described below, and a source of continuous potential which is the voltage drop across the filament of one receiving tube and two resistances of the receiving tube filament circuit.

With the circuits as described above and shown in Fig. 2, it may be seen that the constant current of the 275-volt generator divides between the plate circuits of the oscillator and modulator tubes. The amplitude of the alternating current generated by the oscillator tube in the antenna circuit, and therefore of the waves radiated by the latter, is directly proportional to the amount of direct current flowing in the plate circuit of that tube. On the other hand, the potential of the grid of the modulator tube controls the amount of current which may flow through the modulator tube. And since, due to the iron core choke coil  $L_3$ , the sum of the plate currents in the two tubes is constant, any variation in the amount of current allowed to flow through the modulator tube is accompanied by a corresponding variation (in opposite direction) of the current supplied to the plate circuit of the oscillator tube, and therefore, in the amplitude of the oscillations generated by the latter tube.

The principle underlying the transmission of speech by means of this set is therefore the following. When no speech is impressed on the telephone transmitter, the potential of the modulator tube grid remains constant, and there is no variation in the plate currents of the two tubes. The oscillations in the antenna circuit are then of constant amplitude, as shown in Fig. 3. When one talks into the

telephone transmitter, a pulsating current is made to flow in the primary of the input transformer, resulting from the action of the transmitter, which impresses on the grid of the modulator tube an alternating or varying potential following the modulations of the voice. These variations of potential produce corresponding variations in the current allowed to flow in the plate circuit of the modulator tube, and therefore in the plate current of the oscillator tube, and finally, in the amplitude of the oscillations in the antenna circuit. The result is that the waves radiated by the set, instead of being of constant amplitude, have an envelope reproducing the pulsations of current in the telephone transmitter circuit. In

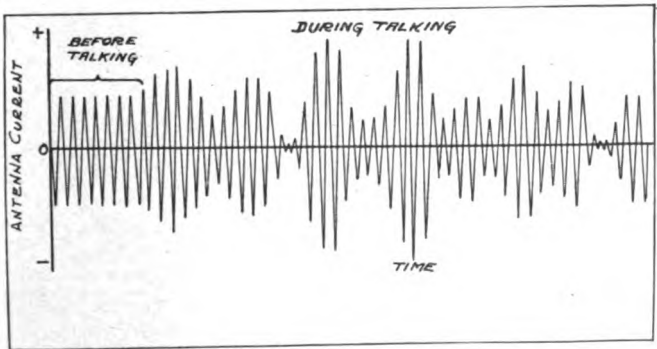

FIG. 3.—Effect of Voice Modulation upon the Amplitude of the Waves in the Antenna Circuit.

other words, the waves are modulated to the speech. For a more thorough explanation of modulation and voice transmission by radio, see Radio Pamphlets Nos. 1 and 40.

Some essential requirements must be fulfilled for giving a satisfactory operation of the set, and with the conditions encountered in airplane work these requirements necessitate the use of special regulating devices. The generator furnishing the power to the plate and filament circuits is a fan driven generator mounted on the strut of the landing gear of the airplane. It is enclosed in a streamline case, and driven by a special regulating airfan, the purpose of which is to keep the speed of the generator constant for varying airplane and wind speeds. This airfan, type FA-7, is made of metal and its two blades may be rotated around their longitudinal



axis so that the pitch of the airfan will automatically change when the speed of the airfan through the air changes. The twist of the airfan blades is counterbalanced by a set of springs and weights<sup>s</sup> inside the airfan hub. The operation of this airfan maintains a constant generator speed of about 4000 r. p. m. for airplane speeds of from 50 to 200 m. p. h.

An additional means of keeping the generator voltage constant is provided in the peculiar method of exciting the generator. It is self-excited and has a main and differential field winding, the fluxes of which are opposed. The main field winding is connected in series with a special two-electrode type TB-1 vacuum tube, the filament circuit of which comprises the differential winding. This is shown in Fig. 2. The operation of this device is then as follows.

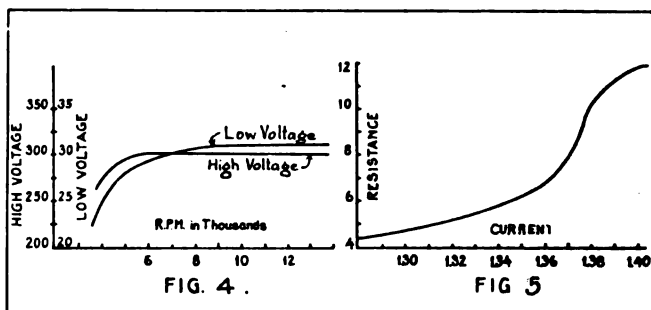

FIGS. 4 and 5.

If the generator speed should tend to increase, the generated voltage would increase, which consequently would increase the current in the main field winding and in the regulator tube filament in series with it. It would also increase the plate voltage on the tubes, and therefore the plate current. The latter current, flowing through the differential field winding, would increase the flux in the latter and counteract that of the main field, and thus prevent any further rise of the generator voltage. In case the generator should be driven at a speed below normal, the effect would be exactly opposite, and the generator voltage would be thus kept constant despite the small variations in speed which are not entirely corrected by the regulating airfan. The combined effect of the several regulating devices is shown in Fig. 4.

In order to reduce the pulsations in the output current of the two armatures of the generator resulting from commutation, a condenser  $C_8$  is shunted across each. These condensers are located in the filter box, and serve as a by-pass for the commutation pulses. Without this precaution, these pulsations, especially those on the 275-volt armature, would produce a steady hum in the telephone receivers, due to a modulation of the wave resulting from them.

An additional precaution in maintaining constant the current in the filament circuit is taken by the use of a "ballast lamp." This lamp, which is located in the radio set box, is connected in series with the filament circuit. It has an iron filament and is filled with hydrogen. The resistance of this lamp is a function of

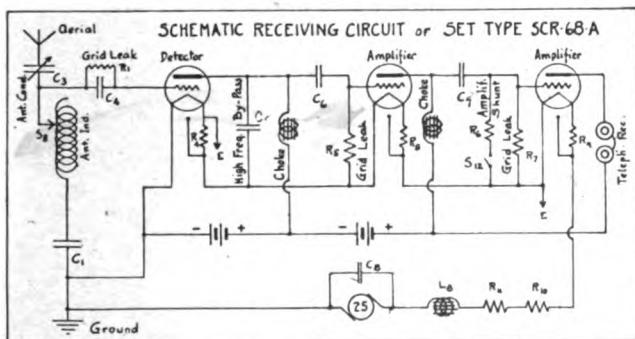

FIG. 6.—Schematic Diagram of the Receiving Circuit of Set Type SCR-68-A.

the current flowing through it, as shown by the characteristic curve of Fig. 5. The operation of this lamp may be understood when it is noted that an increase of filament current would increase the ballast lamp filament resistance, which would therefore tend to prevent the current from increasing (and vice versa), thus aiding to keep the current constant.

### The Receiving Circuit

The type SCR-68-A set has a receiving circuit which is connected for operation when the switch on the radio set box is closed in the "Receive" position. It may be used for the purpose of receiving a conversation sent out by another set using the transmitting circuit described above or a similar one. A schematic diagram of this receiving circuit is given in Fig. 6. It may be seen that the circuit com-

prises a type VT-1 three-electrode vacuum tube used as a detector, and two similar tubes used as audio frequency amplifiers, the coupling between successive tubes being by means of iron core choke coils. The antenna circuit comprises a variable air condenser  $C_2$ , used for tuning, an antenna inductance, a large blocking condenser  $C_1$ , and the antenna-counterpoise condenser. The antenna inductance and blocking condenser are connected between the grid and filament of the detector tube, there being also a grid condenser and leak resistance in series with the grid. The plate circuit of the detector tube is energized by a type BA-2 dry battery, in series with

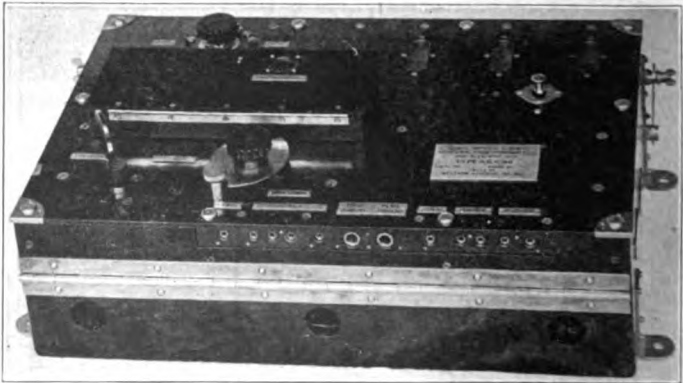

FIG. 7.—Operating Panel of Set Box Type BC-11 Used in Set Type SCR-68, Showing Jacks Along the Bottom Edge.

which is an iron core choke coil. Shunting the battery and choke is a condenser  $C_3$ , which by-passes the high frequency oscillations, while the audio frequency pulsations which are the envelope of the incoming waves produce pulsations in the plate current of the detector tube. In flowing through the choke coil, these pulsations induce a high counter-emf. across the latter, which is impressed upon the grid of the first amplifier tube through the condenser  $C_4$ .

The potential variations of the grid of the first amplifier tube are thus similar to those of the grid of the detector tube, but are of greater amplitude. The resulting variations in the plate current of the first amplifier tube are therefore amplifications of those of the plate current of the detector tube. The amplifier tube operates at a

plate voltage of about 40 volts, obtained by means of two type BA-2 dry batteries in series. Connected between the grid and filament of the first amplifier tube is a high resistance  $R_s$  through which the charges on the grid may leak off to the filament, thus preventing the accumulation of a charge on the grid as it is being transferred from the detector tube to the amplifier tube.

The first amplifier tube is coupled to the second amplifier tube in the same way the detector tube is coupled to the first amplifier. The plate circuit of the second amplifier tube, however, instead

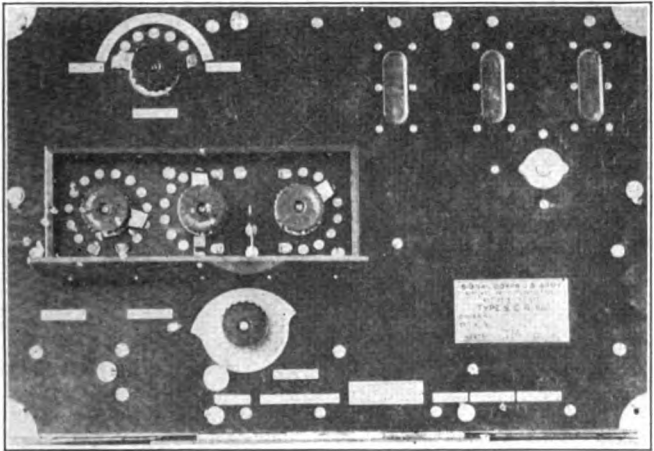

FIG. 8.—Operating Panel of Set Box Type BC-11 Used in Set Type SCR-68, Showing the "Wave Length," "Coupling" and "Input" Switches in the Small Covered Panel.

of comprising a choke coil, comprises the telephone head sets of the observer and pilot, which are connected to it through the circuits of the interphone set box in a manner described in a later paragraph. A resistance  $R_6$  is shunted between the grid and filament of the last amplifier tube and may be connected by means of a push button switch when it is desired to reduce the amount of amplification.

The filaments of the three receiving vacuum tubes are connected in series and are energized by the 25-volt armature of the generator. In series with each filament is a small resistance of about one ohm,

which, for certain types of tubes, is short circuited automatically, as indicated in Fig. 1. The filament circuit also comprises an iron core choke coil  $L_s$  located in the filter box and the function of which is to assist in maintaining the filament current constant.

#### Set, Airplane Interphone, Type SCR-57-A

The telephone head set and transmitter of the radio operator may be connected directly to the radio set box of the type SCR-68-A

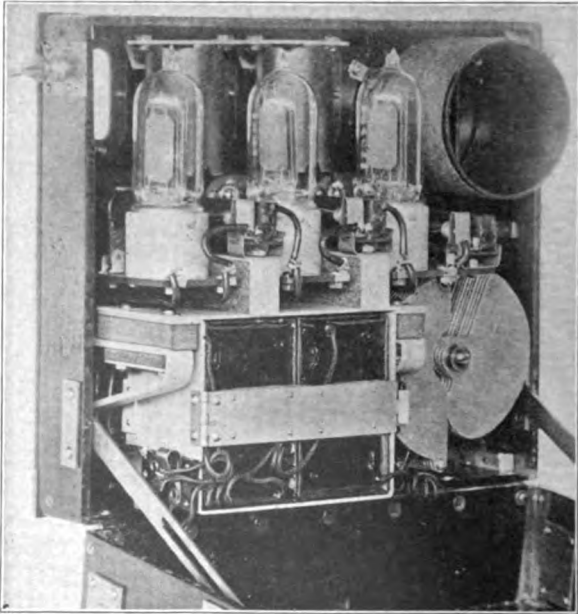

Fig. 9.—Mounting of Apparatus in Set Box Type BC-11 Used in Set Type SCR-68.

set. However, it is of advantage that both the observer and the pilot should be able to receive signals and to converse with each other. This is done by means of the interphone set type SCR-57-A, which differs from the type SCR-57 in some points as explained at the end of this paragraph. A circuit diagram of the set is shown in Fig. 1 and two photographs in Fig. 10.

With the four-pole double throw switch closed to the right in the "Interphone" position, the pilot and observer are entirely discon-

nected from the radio set, and are connected to each other by an ordinary telephone circuit. They may talk back and forth without any additional operation. A special feature of the set is the "side tone" circuit, which comprises a condenser the purpose of which is to shunt some of the telephone current from the transmitter circuit back into the telephone receiver circuit of the person talking. This circuit is used in order to enable the operator to hear his own voice and know how loud he is talking and whether the circuit is in working condition. Without this provision, he would not hear himself talk on account of the sound proof helmet he wears.

With the switch closed to the left in the "Radio" position, the observer's telephone receivers are directly connected to the radio receiving circuit, and his telephone transmitter is directly connected to the transmitter terminals at the radio set box. The observer's telephone transmitter is however disconnected from the interphone circuit so that the observer cannot talk to the pilot. The pilot's

circuits are disconnected, but by closing the "cut-in switch," he can receive radio signals and talk to the observer.

The operation of the set is then as follows. When the observer and pilot want to talk back and forth to each other, the observer closes the interphone-radio switch to "Interphone." When the observer desires to receive or send radio signals, this switch is closed to "Radio." If, now, the pilot desires to talk to the observer, he must first close his cut-in switch, and if he does not hear any incom-

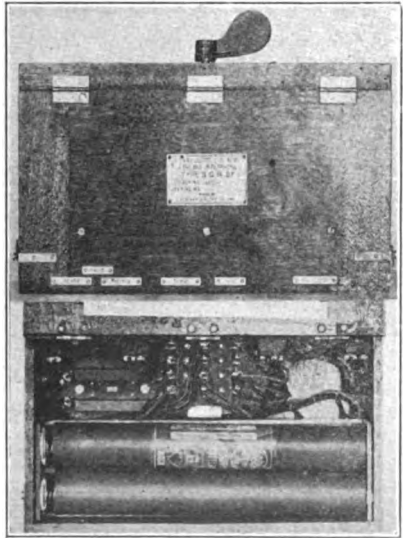

FIG. 10.—Set Box Type BC-10 Used in the Interphone Set Type SCR-57, Lower View Showing the Mounting of Batteries and Radio-Interphone Switch Within the Box.

ing radio conversation, he may speak to the observer without interrupting him in the reception of a message. If he hears an incoming radio conversation, he should wait for the end of the message. If the observer desires to answer the pilot, he must close the inter-phone radio switch to "Interphone." This, however, disconnects him from the radio set so he should not leave the switch in this position longer than necessary or he may miss some incoming radio signals.

### Other Parts of The Set

*Fan Driven Generator.*—The characteristics of the fan driven generator supplying the current for heating the filaments of the transmitting and receiving vacuum tubes and for supplying power

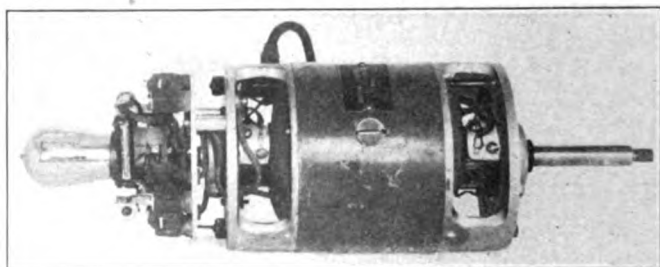

FIG. 11.—Generator Type GN-1 with the Housing and Airfan Removed.

to the plate circuits of the transmitting vacuum tubes were partly described in the discussion of the transmitting circuit. The generator is a self-excited unit having one main field, one differential field, and two armatures wound on the same core. It is enclosed in a streamline case, including also the regulator tube, the function of which was explained in a previous paragraph. See Fig. 11. Due to the regulating action of the airfan type FA-7 and of the regulator tube, the generator will work satisfactory between speeds of 4000 to 14000 r. p. m. The regulation will be entirely satisfactory provided the brushes are correctly adjusted. This adjustment is made in the following manner:

The high voltage brushes which are at the front end of the generator are locked exactly on the no-load electrical neutral point, and the low voltage brushes which are at the rear end of the generator are moved enough forward of the no-load electrical neutral point to obtain the flat voltage characteristic curve shown in Fig. 4.

As may be seen from the circuit diagram of Fig. 1, three resistances labeled  $R_{12}$ ,  $R_{13}$ , and  $R_{14}$ , are mounted inside the generator casing. They are respectively of 100, 1.5 and 1.5 ohms resistance. They are mounted around the regulator tube socket in a triangle. The 100-ohm resistance is connected across the main field winding and helps to prevent hunting. The other two resistance units are not connected in any circuit when the generator leaves the factory. They are to be used for voltage adjustment as explained in the following paragraph.

It was explained above that the voltage regulation is dependent on the current through the filament of the regulator tube. This current is determined by the voltage generated by the low voltage armature and by the resistance of the filament circuit, which includes the main field winding. If this resistance decreases for any reason, the voltage required for supplying sufficient filament current to produce regulation will be less and it will be attained at a lower generator speed. Therefore, both high and low voltages will have values below those required by the set. This occurs at high altitudes and during cold weather, the field windings being kept cooler, and having therefore less resistance.

To compensate for this effect, one or both of the 1.5-ohm units may be connected in series with the main field winding to obtain the correct resistance. Connecting one of the units increases the low voltage by about two volts and the high voltage by about twenty volts.

While the generator may be safely used on airplanes producing a wind speed of from 50 to 200 miles per hour if equipped with a type FA-7 regulating airfan, it should not be used outside the limits of from 60 to 160 miles per hour when using the airfan type FA-3.

*Filter Box.*—The filter box contains two condensers, labelled  $C_8$ , Fig. 1, one choke coil  $L_8$ , and two resistances  $R_{10}$  and  $R_{11}$ . It is a wooden box with a bakelite panel and binding posts, weighing 6 lb. and measuring  $8\frac{3}{8}$  in. x  $3\frac{7}{8}$  in. x 6 in., Fig. 12. The function of these units has been previously discussed.

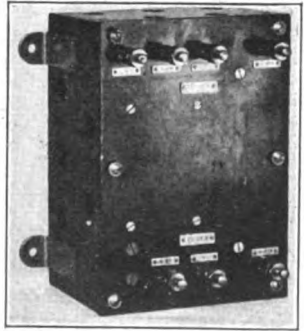

FIG. 12.—Filter Type FL-1 Used in Set Type SCR-68.



**Radio Set Box.**—The radio set box contains the circuits shown in Fig. 1, and is illustrated by the photographs given herewith. It weighs about 17 lb. and measures  $16\frac{1}{2}$  in. x  $4\frac{3}{4}$  in. x 11 in.

#### Installation of the Set.

The plan of installation of the type SCR-68 or SCR-68-A sets as given here is only of a very general character, since definite and

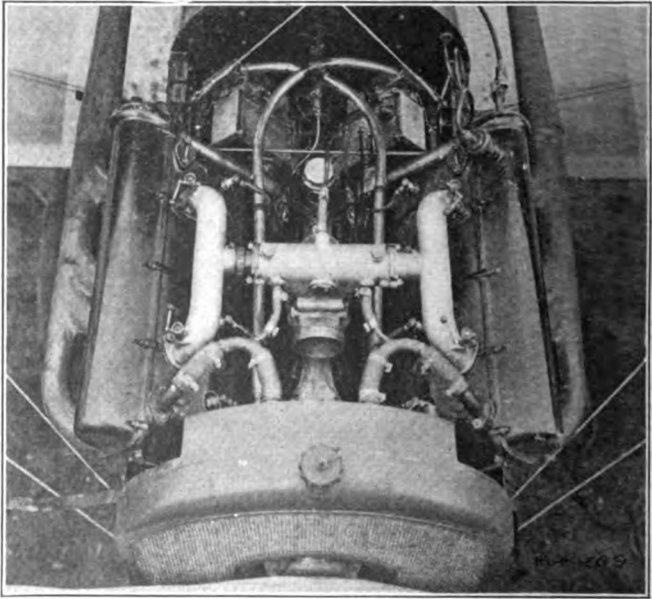

FIG. 13.—Engine Ignition Circuits Encased in Copper Tubing and Magnetos Also Encased as a Shield Against Interference with the Radio Set.

special instructions will have to be given for each kind of airplane on which the set is to be used. Before attempting to install any radio apparatus on an airplane, a thorough knowledge of the contents of Radio Pamphlet No. 30 should be had.

As a special precaution against interference, no wires should be near and parallel to those of the switch operated by the pilot in controlling the ignition system, for the magneto is a source of particular

annoyance to the radio set. As a further remedy against magneto interference, it is well to shield the entire magneto system. This may be done by means of metallic covers for all the high-tension wires and the magnetos. The best practice is that of using solid metallic tubing for enclosing the high tension ignition wires and

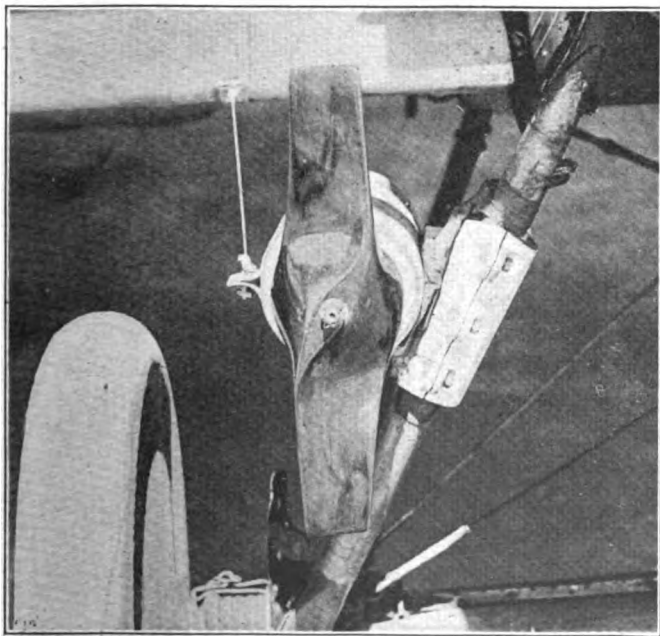
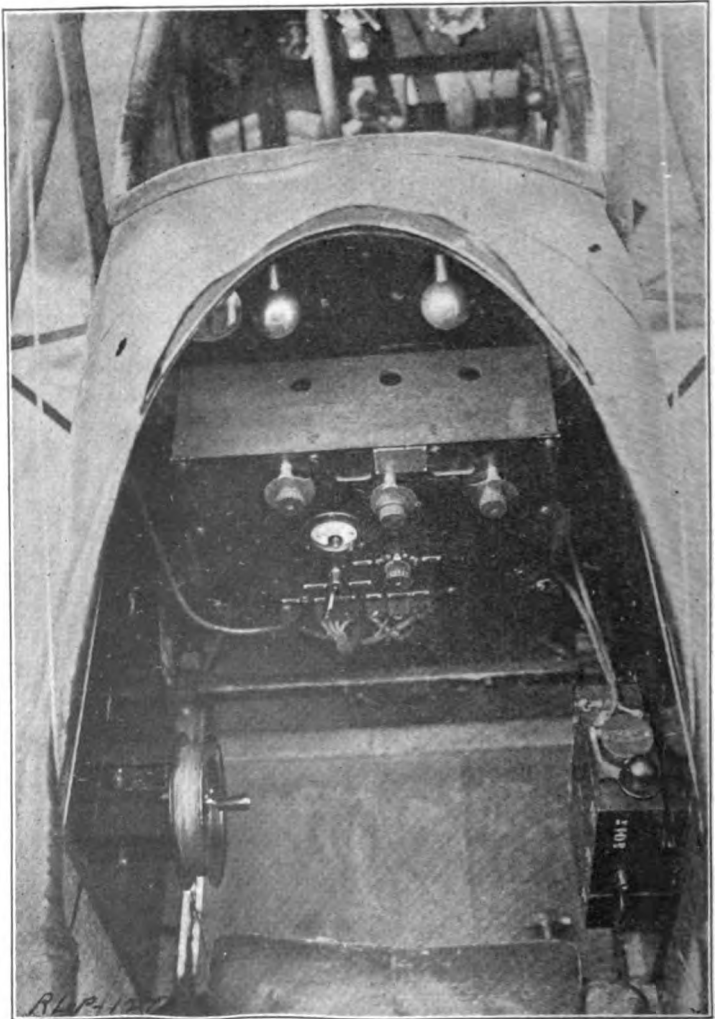

FIG. 14.—Method of Mounting the Generator of Set Type SCR-68 on the Landing Gear Strut.

then connecting the tubing and the magneto covers to the frame of the airplane motor. An installation of this kind is shown in Fig. 13.

The generator should be mounted in the slip stream, a good location being slightly above the middle of the right hand vertical strut of the landing gear, Fig. 14. When this position is not available, due to a lighting or heating generator occupying this strut, as is the case with the De Håviland airplane, the left hand strut must be



**FIG. 15.—General View of the Mounting of Set Type SCR-80 in the Observer's Cockpit. The Mounting of this Set is Practically Identical with that of the Set Type SCR-68-A.**

used. The generator base is bolted to a mounting made of iron, aluminum or wood (Mountings Type FT-7 or FT-8) which is clamped to the strut.

The airfan driving the generator may be the wooden fan type FA-3 or the regulating fan type FA-7. The fan type FA-3 is held in place by a nut screwed on the end of the generator shaft which presses against the aluminum hub of the fan, forcing it against a collar on the shaft and thus preventing the fan from rotating independently of the shaft. To replace fan type FA-3 by a type FA-7, remove the fan and generator front casing; then put on the casing supplied with the airfan type FA-7, using the screws taken out of the old casing. The nut which held the wooden fan is not to be used, as the type FA-7 fan is itself screwed on the shaft and then clamped in place.

A variable speed fan should be twisted about its longitudinal axis before each flight, to determine that the governor is functioning properly. The fan must be tightly fastened on the shaft or it may vibrate loose. A light oil should frequently be used to lubricate the bearings and gears of the fan and generator shaft. To properly oil the type FA-7 airfan, remove it from the shaft and oil the cone bearing and ball bearing of each blade as well as the gears at the bottom of the shaft bore.

The filter box is usually screwed to the fuselage floor, under the forward seat, or placed in the cockpit under the dash. In the De Haviland it is necessary to mount the filter box on the left side of the cockpit.

The radio set box should be mounted where its operating panel will be in easy reach of the operator so that he may readily use the various switches mounted thereon. It should be supported so that vibration will be reduced to a minimum, and whenever possible, so that the panel may be readily swung open from bottom hinges without interference.

When possible the interphone set box should be located near the radio set box and placed so that the switch is within easy reach of the operator, and with the jacks in a position which will allow the plugs to be readily inserted. The box may be mounted on the side of the cockpit without unbalancing the airplane.

The pilot's interphone extension cord, type CD-6, should be run along the longitudinal member supporting the seat, and the pilot should have the interphone jack within easy reach so that the trans-

mitter and receiver plugs may be inserted conveniently. The pilot's cut-in switch should be installed in a readily accessible position. The cord type CD-62 is provided with the SCR-68-A set to care for the necessity in certain installations to mount the interphone box and the transmitter and receiver jacks in different locations and some distance apart.

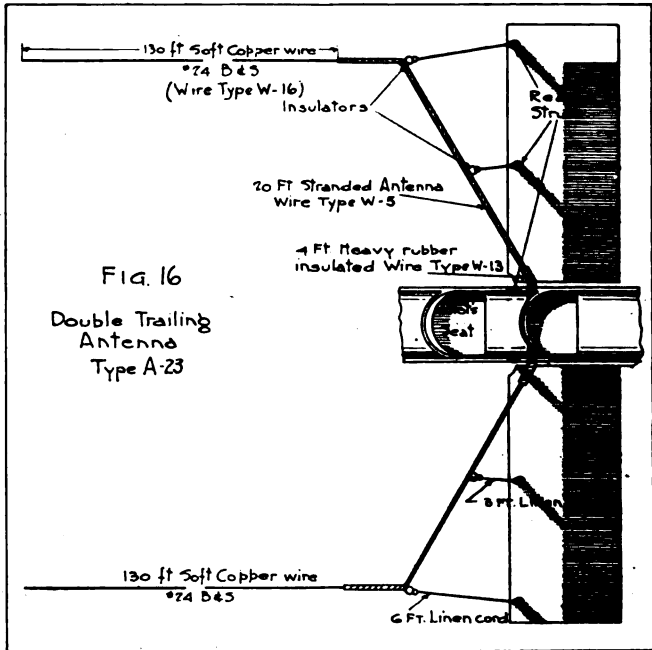

FIG. 16.

If a trailing antenna is to be used, the antenna reel should be mounted on the left hand inside of the fuselage on a wooden mounting fastened between the upper longeron and the seat support. The fairlead should be installed in the floor so that the wire will be guided directly in line with the reel.

The single trailing antenna type A-21 which is used for straight-away flying comprises a 4-ft. length of cord made fast to the reel at one end and tied at the other end to a 290-ft. length of antenna wire,

which at its free end is spliced to a 10-ft. length of hemp center phosphor bronze wire having a lead fish weight on the end.

For airplanes flying in squadron formation, it is necessary to use a double trailing antenna so that there will be less restriction of the movements of the machine. This antenna is illustrated in Fig. 16. The counterpoise, as in the case of a single wire trailing antenna, consists of the metal parts and wires of the airplane itself. ■

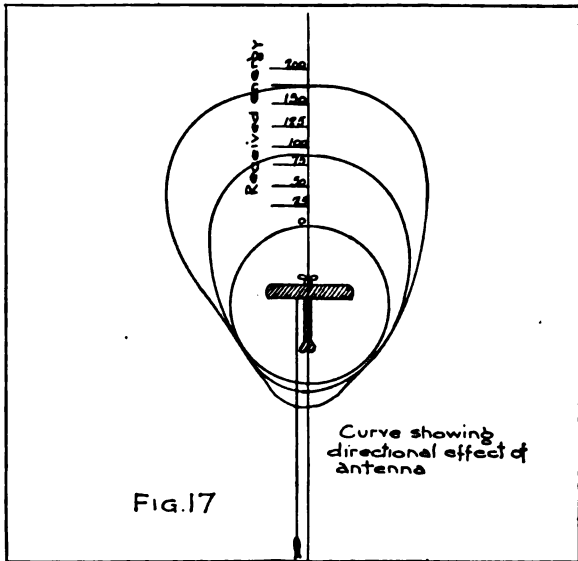

FIG. 17.

Both of these antennae have a general directive effect about as shown on Fig. 17. Transmission and reception is best when the airplane is flying toward the station with which communication is being carried on.

All the stay wires of the airplane should be carefully bonded and electrically connected to the motor and other important metal parts of the airplane to form the counterpoise. This is a very important part of the installation work, and the thoroughness with which it is done not only improves the operation of the set but insures against dangerous sparks between metal parts resulting from the high voltage.

The various units of the type SCR-68 set having been installed as explained above, they should be interconnected by means of the extension cords furnished with the set and in the manner shown in the cording diagram of Fig. 18.

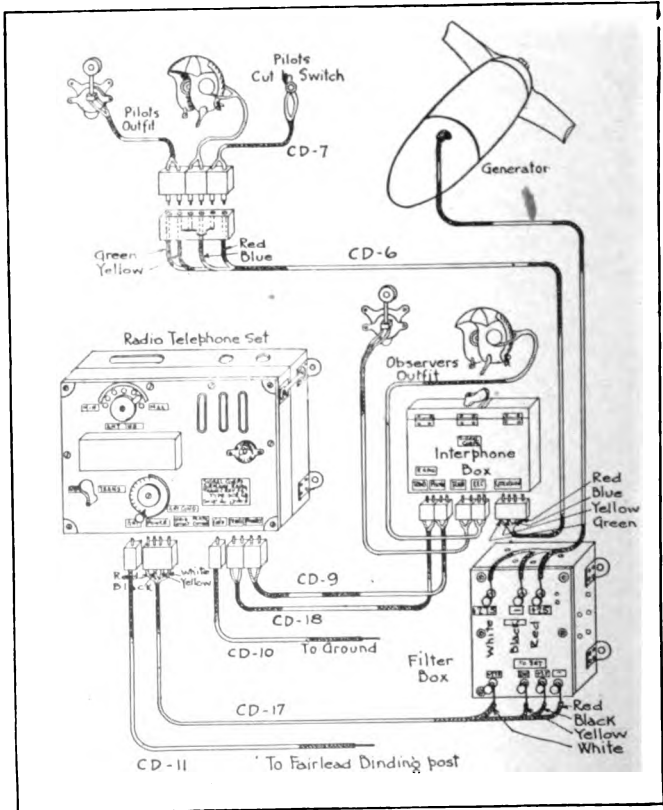

FIG. 18.—Cording Diagram of Sets Type SCR-68 and SCR-68-A.

### Calibration of Set Type SCR-68-A

The set having been properly installed and connected as explained in previous paragraphs, it is necessary to tune it for transmitting and receiving at a given wave length. While the operation

of tuning may be done in the air during flight, it is better practice to calibrate the set on the ground and record the settings of the various switches for a number of different wave lengths within the range of the set. It is then possible, by referring to this record chart, to rapidly tune the set to any desired wave length. This calibration must be repeated every time the set is installed in a different airplane, or whenever a new antenna is used having different characteristics. The method of calibrating the set on the ground is as follows:

The calibration of the set on the ground is made with a phantom antenna adjusted to have the same effective resistance and capacitance as the actual antenna to be used with the set. The first thing to do is then to determine the constants of the actual antenna to be used. These may be readily measured, but this process is not described here. The antennae generally used are the type A-21 or type A-23. The former is a 300-ft. single wire trailing antenna, while the latter is a double trailing antenna, as shown in Fig. 16. The constants of these two antennae are given in the curves of Fig. 19 for different wave lengths. The natural wave length of the single wire trailing antenna is given in Fig. 20 for various lengths of wire.

A phantom antenna well suited for this purpose of calibration is the type A-50. The following meters will also be required:

- 1 Voltmeter Type I-5, range 0-50 volts.
- 1 Voltmeter Type I-6, range 0-500 volts.
- 1 Ammeter Type I-7, range 0-150 mililamp.
- 1 Ammeter Type I-9, hot wire, 0-0.5 amp.
- 1 Wavemeter Type SCR-60-C

The method of calibrating the set is then given in the following paragraph, the various operations being performed in the order given.

#### Calibrating the Transmitting Circuit.—

1. Remove the airfan from the generator and couple the generator shaft to a motor which will drive it at any desired speed between 4000 and 6000 r. p. m. Also remove the streamline casing of the generator.

2. With the "Transmit-Receive" switch of the radio set box on "Receive" to protect the operator from high voltage on the antenna and in the transmitting circuit, drive the generator at several speeds between 4000 and 6000 r. p. m. and measure the voltage at the



brushes. This should be between 275 and 300 volts on the high voltage side, and from 25 to 29 volts on the low side. If the voltage is much above 310 volts on the high side, inspect the connections and brushes. If these are in good condition, change the regulator tube and repeat the test.

3. Disconnect the real antenna by removing from the radio set box the "Antenna" and "Ground" plugs.

4. Substitute for the real antenna, the phantom antenna type A-50, after the latter has been properly set to have the same constants as the real antenna, as given in the curves of Fig. 19. The settings should be those corresponding to the average wave length of the set, that is, about 400 meters. In order to be connected to the "Ground" and "Antenna" jacks of the radio set box, the wires coming from the phantom antenna terminals should be equipped with plugs type PL-12.

5. Insert the telephone transmitter and receiver plugs in the proper jacks of the interphone set box.

6. Throw the "Interphone-Radio" switch of the interphone set box to the position "Radio."

7. Throw the "Transmit-Receive" switch of the radio set box to "Transmit."

8. Turn the "Input" and "Coupling" dial switches in the small covered panel of the radio set box all the way to the left and right, respectively, which corresponds to their maximum settings. The settings of the "Wave Length" switch are made for adjusting the wave length, the longer waves being obtained when the switch is turned to the right. In order to calibrate the set over the entire range, the various steps given below should be repeated for each position of the wave length switch.

9. Connect the milliammeter to the "Plate Current" jack of the radio set box.

10. Open the modulator switch. This is the small knife switch between the "Input" and "Coupling" dial switches.

11. Throw the "Transmit-Receive" switch on the radio set box to the "Transmit" position.

12. Observing the oscillator plate current on the milliammeter, adjust the coupling switch so that the reading will be as near as possible to 40 milliamp. This current should be maintained between 30 and 50 milliamp. It should be noted that increasing the coupling (turning the coupling switch to the right) decreases the plate current.

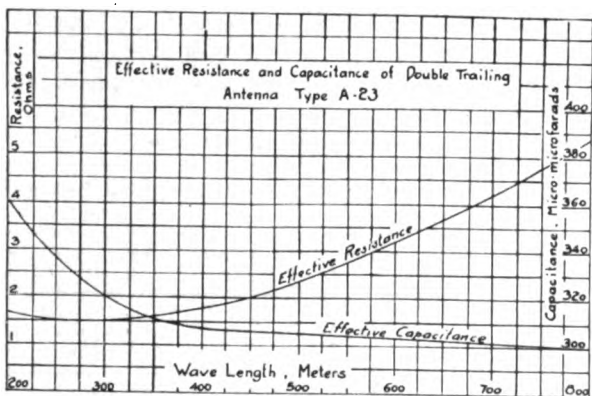

FIG. 19

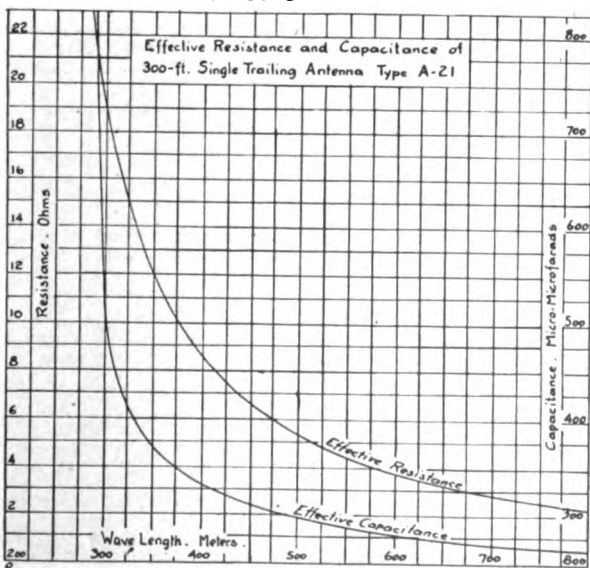

FIG. 19.

13. Set the "Transmit-Receive" switch to "Receive."

14. Close the modulator switch.

15. Set the "Transmit-Receive" switch to "Receive." The plate current should be between 60 and 80 milliamp., generally about 70. If greater than 80 milliamp., the modulator tube is defective and should be replaced.

16. Connect the milliammeter to the grid current jack. Adjust the "Input" switch so that the grid current, as read on the milliammeter, will be between 2 and 6 milliamp., and so that the radia-

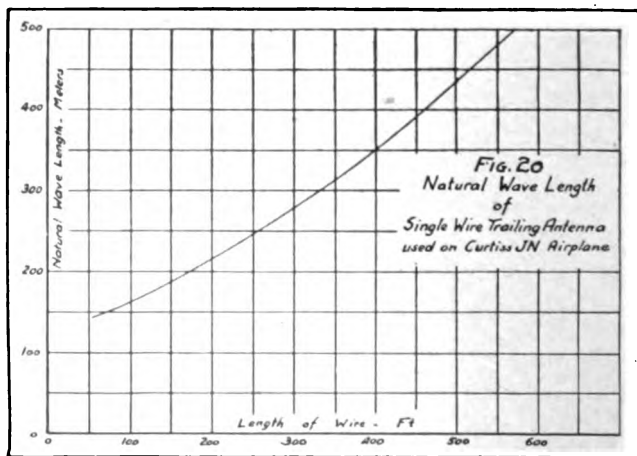

FIG. 20.

tion is a maximum as indicated by the hot wire ammeter on the phantom antenna.

17. Measure the emitted wave length by means of the wavemeter, placing the latter near the upper left hand corner of the radio set box.

18. Record the wave length, and the settings of the input, coupling and wave length switches.

19. Repeat the procedure for all positions of the wave length switch.

#### Calibrating the Receiving Circuit.—

1. Follow steps 1, 2, 3, 4, 5 and 6 above.

2. Set the "Antenna Condenser" (the handle to the right of the transmit-receive switch) approximately to its middle position.

3. Place the wavemeter at some distance from the radio set box, and set its buzzer into action.

4. For each position of the "Antenna Inductance" switch, adjust the wavemeter until the maximum signals are received in the telephone receivers connected to the radio set through the interphone set box.

5. Record the wave length giving maximum signals for each setting of the antenna receiving inductance. This calibration is only approximate, as will be seen from the method of operating the set in the air.

### Operating the Set

**Preflight Inspection and Tests.**—Before each flight, the set should be thoroughly inspected and tested to insure proper operation during the flight. This should be done in the following manner:

1. Test the generator as explained in paragraphs 1 and 2, page 27.
2. Replace the airfan on the generator shaft, tightening it securely.
3. Ascertain that the following conditions are met:

No loose or broken connection.

No worn insulation.

Plugs inserted in their proper jacks.

Good condition of the airfan.

Secure mounting of airfan, generator, radio set box, interphone set box, filter box.

Required number of vacuum tubes in the set box.

Vacuum tubes free from imperfections.

Batteries connected with the proper polarity.

Proper insulation of antenna, and proper length of antenna wire as gauged by the eye.

Fish weight attached to antenna, if A-21 is used.

Receive-Transmit switch on "Receive."

4. Set the various switches in accordance with the calibration chart obtained as explained above, so that the set will be tuned to transmit and receive at the desired wave length.

5. Test the interphone box by talking to the pilot through the telephone transmitter with the switch on "Interphone." Then replace the interphone switch to the "Radio" position.

6. The set being then ready and the switches on "Radio" and "Receive," the operator should hear a certain amount of magneto noise in the receivers, while the pilot is testing out the airplane engine. Also, when the engine is brought to full speed, the generator

will be driven by the wind of the propeller, and the receiving tube filaments of the radio set box should glow a dull red.

**Operating the Set in the Air.**—No additional adjustments are required for transmitting if the set has been properly tuned on the ground. If a type A-21 antenna is used, it should be unreeled when the airplane has reached an altitude of about 500 meters. When receiving, some slight readjustments may be made by means of the "Antenna Condenser" handle. Until the first signals are heard, the amplification push button switch on the radio set box should be pushed in. If then the incoming signals are too strong, it should be pulled out. If the receiving circuit has not been calibrated on the ground, tuning may be done by varying the antenna condenser for each position of the antenna inductance switch, with the amplification push button pushed in until the signals are heard loudest. The operation then consists merely in throwing the switch on the interphone set box to "Radio," and the switch on the radio set box to "Transmit" or "Receive," as desired. When not transmitting or talking to the pilot, the observer should always have these switches on "Radio" and "Receive," in order to be sure of not missing any radio signals which may happen to come in.

Receiving and transmitting with the type SCR-68-A set presents no special difficulties when simple rules are remembered. A list of these, emphasizing the principal points of operation, is given below:

- (1) Do not forget to inspect the set before each flight.
- (2) Do not forget to plug in the telephone transmitter and telephone receiver plugs.
- (3) Do not forget to throw the "Receive-Transmit" switch on "Transmit" and the "Interphone-Radio" switch on "Radio" while talking.
- (4) Do not talk rapidly.
- (5) Do not have the telephone transmitter away from the mouth while transmitting.
- (6) Do not "cup" the hands over the telephone transmitter.
- (7) Do not shout into the telephone transmitter.
- (8) Do not forget to leave the "Receive-Transmit" on "Receive" when not using the set.
- (9) Do not become impatient if you do not hear incoming signals immediately.

(10) Do not expect satisfactory operation over more than five miles range.

(11) Do not forget to put the "Interphone-Radio" switch on "Radio" after talking over the interphone.

(12) Do not touch any uninsulated parts of the set while the switch is on "Transmit."

(13) Do not tinker with the set.

(14) Do not forget to note any cause as to failure of the set to operate.

(15) Do not fail to study the instructions thoroughly.

### Troubles and Remedies

In the following outline of troubles encountered with type SCR-68-A sets, no endeavor is made to arrange them in the order of their importance, the reason being that it is easily ascertained to just what extent such troubles may affect the operation and what can be done in case of emergency.

#### Generator.—

*Mounting.*—Trouble may be experienced with the generator mounting if it is not firmly fastened to the strut, thus allowing considerable vibration which may cause the generator base to become loosened from the mounting and possibly to break the base.

*Leads.*—If the lead from the generator to the filter box has been run along the innerside of the strut, the insulation may become oil-soaked and deteriorate to such an extent as to cause a short circuit. To avoid this the lead should always be fastened on the outside of the strut—the side farthest from the engine.

*Brushes and Their Mountings.*—It is very important to inspect the condition of the brushes and their mountings. In the type GN-2 generator there are two kinds of brushes used, one a composition of carbon and copper for the low voltage side and the other, a high resistance carbon for the high voltage side. These should obviously not be interchanged. In the type GN-1 generator only one type of brush is used, thus obviating any trouble due to interchange of brushes. Sometimes the brush holders of the type GN-2 generator become quite hot and then unsoldered, in which event it is necessary to re-solder them. Furthermore, the pig-tails on the brushes may also become loose and thus necessitate the renewal of the brushes. Trouble from these sources has been eliminated in the design and

construction of the type GN-1 generator. In case the brush pressure becomes too low on any type of generator, it is advisable to insert new brushes, as this is an indication that the brushes have become worn down.

**Bearings.**—The generator usually runs at a high speed, requiring that the bearings be in good condition and well oiled at all times.

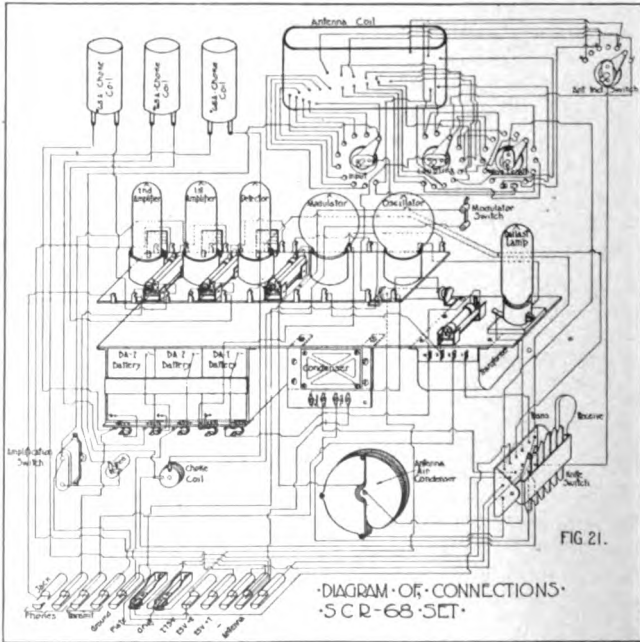

FIG. 21.—Actual Wiring Connections Within Set Box Type BC-11 Used in Set Type SCR-68.

**Commutators.**—Dirty, scratched and burned commutators, and also low brush pressure will cause very much noise when transmitting, which “comes in” as interference, and may even make it impossible to understand what is being said. These same conditions may also produce noise in the telephone receivers of the transmitting set itself.

*Field.*—Due to overheating, the terminals of the differential field of the generator may become unsoldered on the regulator tube mounting, causing very high voltage with the subsequent burning out of the regulator tube. In warm weather the resistance of the differential field is greater than in cold weather and consequently the voltage regulation may be somewhat higher, but this will probably not cause any trouble.

*Armature.*—It may happen that the generator armature rubs slightly against the pole faces which is an indication that the bearings have become worn.

*Hunting.*—Some of the first type GN-2 generators manufactured have a copper shield on the differential pole which may cause hunting, but this can be remedied by the removal of the shield. The 100 ohm resistance in parallel with the main field is used to prevent hunting; therefore, an open circuit in the shunt resistance would be a source of hunting.

*Excessive Voltage.*—In the operation of the set the plate voltage should not attain a value much over 310 volts. If this occurs, it is probably caused by the regulator tube, or by the generator brushes being incorrectly set.

*Filament.*—Due to imperfections in the construction of some of the tubes, the filament and plate sometimes short circuit. Incorrect adjustment of the generator brushes may produce an excessive voltage across the filament and result in its burning out.

*Vibration.*—Vibration of a tube may result in the filament making an intermittent contact with the plate thus producing an effect in the transmitting circuit similar to that caused by generator hunting.

*Tube Mounting.*—Wear by vibration and deterioration of the sponge rubber upon which the tube mounting is held, may cause too much play in the mounting and thus loosen the tube leads.

*Airfan.*—

*Pitch.*—The airfan is a very important part of the generator. If the pitch of the airfan is too small, the generator and regulator tube are overloaded and if too large the generator may at times run too slowly to produce the proper voltage. Fixed blade airfans must not be used on airplanes traveling at higher speeds than that for which the airfans are designed, because the airfan may break and the result may be serious injury to the airplane and its occupants.

*Injury.*—When the airplane “lands” or “takes off,” the rush of air created by its propeller may cause pebbles to be thrown against



the generator airfan. A type FA-3 fan may become marred and at times damaged seriously enough to prevent its being used.

*Mounting.*—The airfan should be securely fastened to the shaft of the generator. Since no key is provided to keep the airfan from turning on the shaft, the transmission of power from it to the shaft depends entirely upon friction, and therefore, if only loosely installed, slipping will take place and little or no voltage be delivered from the generator.

*Filter Box.*—This part of the set will give very little or no trouble, the only probable source being the danger of connections becoming loose and short circuiting each other. These should therefore be securely made.

*Radio Set Box.*—The type SCR-68 set has many possible sources of trouble but only those that may be commonly experienced are enumerated here.

*Ballast Lamp.*—While operating the set, if it is noticed that the filaments of the receiving tubes are not lighted, and it is known that power is being delivered to the set, the probable cause of trouble is a broken or burned out filament in the ballast lamp.

*Blocking.*—Blocking is the failure of the modulator tube to properly modulate. It manifests itself by a noise in the telephone receivers and an intermittent or complete cessation of the transmitted speech. When intermittent, it acts just as though the "Receive-Transmit" switch were thrown alternately from "Receive" to "Transmit," thus causing the receiving set to obtain only part of the incoming message. If the operator is experiencing a very severe case of blocking he will be unable to hear himself in the telephone receivers while talking and unable to cause his message to be received. The oscillator and modulator tubes should be interchanged periodically after about ten hours of use, for any tube will eventually develop blocking if used continuously in the modulator circuit. Blocking is a result of the characteristic of the modulator, of too high plate voltage or too low filament current. The interchanging of the modulator and oscillator tubes may remedy this trouble or it may be necessary to discard the tube and replace it.

*Paralysis.*—Paralysis is the stoppage of plate current due to an abnormal accumulation of negative charge on the grid. It manifests itself by an intermittent or complete cessation of incoming sound when receiving, and sometimes can be remedied by the

interchanging of receiving tubes. Or it may be necessary to disconnect the tube and replace it. Paralysis of the oscillator tube can be detected by putting an ammeter in the antenna circuit and observing the intermittent or complete absence of antenna current. Lowering the grid current or throwing the "Receive-Transmit" switch to "Receive" may remedy paralysis of the oscillator.

*Noise in Receivers.*—Noise in the telephone receivers may be due to various causes such as poor or worn out dry batteries in the receiving circuit, poor grid leak resistances, loose connections, poor tube contacts, noisy tubes or trouble on the low voltage side of the generator.

*Failure to Oscillate.*—Failure to obtain a grid current or of the set to oscillate may be caused either by a burned out tube or an open circuit in the antenna or counterpoise. This, however, does not happen very frequently if the tubes are inspected before each flight, and also the connections to antenna and counterpoise. Paralysis of a tube will prevent it from oscillating to a greater or less extent. The paragraph of this section entitled "Paralysis" as relating to the oscillation tube, should be referred to.

*Faulty Tubes.*—Faulty regulator, transmitting and receiving tubes or ballast lamp will cause the most frequent trouble and the only method of avoiding this is to ascertain by inspection and tests that no such tubes or lamps are in use.

*Tube Sockets.*—The tube sockets sometimes cause difficulties either by being too tight or too loose. In the latter case any vibration of the set will tend to injure the tubes, whereas tight fitting sockets only prevent the tubes from being readily inserted and removed.

*Jacks and Plugs.*—Unless properly adjusted the plugs may give some trouble by becoming loose, but this can be avoided by proper maintenance of plugs and jacks.

*Batteries Type BA-2.*—The type BA-2 batteries which are used in this set must be carefully inspected and tested because if their voltage falls below 17 volts they will not give satisfactory operation and may fail completely at any moment. The ammeter should not be used to test these batteries as it results in practically short circuiting them and thus materially decreasing their life. It has sometimes been found that the terminals of the batteries are incorrectly marked. Therefore, whenever these batteries are installed, a test should be made to ascertain their correct polarity.

*Indistinct Speech.*—Indistinct transmission of speech may be produced by the operator having the telephone transmitter too far from his lips, by his speaking inarticulately or in too weak or too strong a voice. The paragraphs of this section entitled "Blocking" and that part of "Paralysis" relating to the oscillator tube should be referred to.

*Shocks.*—Frequent shocks may be experienced by the operator making adjustments unless the "Receive-Transmit" switch is on "Receive." A particularly severe shock may be obtained from the antenna which should of course not be touched while transmitting.

*Vibration.*—Vibration of the airplane may cause the screws of the set to become loose and the mortised joints to open. It is therefore advisable to inspect the set rather closely for this trouble, particularly after a set has been in operation some time.

#### **Interphone Set Box.—**

*Batteries.*—The equipment of the interphone set box is important, if communication between pilot and observer is to be maintained. The type BA-3 batteries used with the type SCR-57 set should be placed in the interphone set box in the correct position, so that they may make proper contact. Their voltage should be frequently checked and they should be replaced when it is less than 3.5 volts. The 6-volt storage battery, type BB-7, used with the type SCR-59 set should be recharged when its voltage is less than 5 volts.

*Switches.*—In operating the "Interphone-Radio" switch, it should be thrown to its extreme positions for otherwise poor communication will result. The pilot's cut-in switch should be frequently inspected. If the observer continually leaves the switch on "Interphone," some pilots may complain of the additional noise in their receivers. To prevent this, always leave the switch on "Radio" except when talking to the pilot.

*Helmets and Telephone Transmitters.*—Each pilot and observer should have his own helmet which should be most carefully adjusted to fit the individual wearer and not loaned to others. The telephone receivers should come directly over the ear canals and exert sufficient pressure to exclude most of the extraneous noises. The telephone transmitter should be so adjusted that its wearer can use it without causing him to bend his head when transmitting.

**Antenna.**—

*Length.*—After the antenna has been used, it becomes frayed and consequently weakens so that sections of it are apt to be broken off during flight. The antenna must at all times be kept of proper length.

*Fish.*—Little trouble will be experienced from the loss of the fish weight if it is attached to phosphor bronze wire and the splice is made securely and so that it will not catch in the fairlead.

*Reel.*—In the use of the single trailing antenna, the reeling up of the last few feet should be done slowly so that the fish will not whip around with danger of damage to the fuselage. The vibration of the airplane may cause the antenna to unreel, due generally to the spring which holds the pawl being too weak, or the pawl and ratchet being worn. The wearing of the pawl and ratchet can be greatly minimized by releasing the catch while reeling in.

*Short Circuits.*—Great care should be taken that the antenna and counterpoise do not become short circuited, for if this happens with the type SCR-68 set while the Transmit-Receive switch is on "Transit," it may result in the burning out of coil  $L_2$  in Fig. 1 or 2. In case a fire is started, pull out all the plugs and use the Pyrene extinguisher and do it quick. If necessary, the pilot should be notified to prepare to land.

### Trouble Charts

The following chart has been prepared to assist in tracing various troubles which occur with this set. The first column indicates how the trouble manifests itself to the operator, while the other columns show what part of the set probably causes the trouble. It is then merely a process of elimination of possible troubles in order to determine which particular one is the cause. The more familiar one is with the set, the easier this is to do.

Noise in the Receivers.	Detector circuit....	Connections.....	{ Loose Poor spring contacts in tube socket
		Detector tube.....	{ Loose or broken supports Faulty tube
		Loose contact at type BA-2 batteries	
		Grid leak.....	{ Faulty grid leak resistance Broken down grid condenser
	Amplifier circuit....	Connections.....	{ Loose Poor spring contacts in tube sockets
		Loose contact at type BA-2 batteries	
		Faulty grid leak resistances, especially first amplifier	
	Generator.....	Amplifier tubes....	{ Noisy tubes Loose or broken supports Faulty tubes
		Sparking commutators	{ Incorrect adjustment of brushes Incorrect type of brushes used
		Shorted commutator bars Chattering of brushes	{ Insufficient brush pressure
Filter box.....	Connections.....	{ Loose, especially at terminals.	
	Shorted or open condensers Connectors.....	{ Loose, especially at terminals	
Telephone receiver circuit	Loose contacts in interphone radio switch		
	Poor plug contacts Telephone cord....	{ Poor cord Loose connections	
Indistinct Speech or No Speech When Using Interphone.	Interphone batteries.	{ Low voltage Poor contacts Incorrect position	
	Switches.....	{ Poor contacts in Transmit-Receive switch Poor contacts in Interphone-Radio switch Failure of pilots cut-in switch	
	Leads and connections	{ Loose plug connections Poor cords	
	Poor telephone transmitter Poor telephone receivers Poor fitting helmet	{ Loose wiring connections	

Failure to Hear One's Self While Transmitting	Tubes.....	Plate circuit..... Lack of grid current Poor contacts in tube socket Burned out filament Faulty tube filament	Open circuit Spring contact in base of tube socket loose Open grid circuit Faulty telephone transformer Faulty telephone transmitter Broken receiving tube Not enough resistance in receiving tube circuit
Filament of Receiving Tubes too Bright			Open circuit in differential field of generator Poor regulator tube High voltage brush contact broken Propeller pitch too low
Signals too Loud in Receivers When Transmitting			Improper adjustment of set
Failure of Receiving Tubes to Light	Connections..... Tubes..... Generator.....	Poor tube socket contacts Open in filter box Open in filament circuit Open in filament Burned out filament Regulator tube..... Open circuits.....	Break in filament Filament and plate shorted Main field Armature
Failure to Receive Signals	Grid leak resistances Tubes..... Antenna and counterpoise Condensers..... Connections..... Telephone receivers Interphone..... Dry batteries.....	Open Shorted High resistance Burned or broken filaments Broken tubes Faulty tubes Open circuit in antenna or ground Grounded antenna Poor connections Shorted antenna condenser Shorted input condenser Shorted or open grid condensers Open circuits Loose switch contacts Loose Poor tube socket contacts Open circuit Shorted Loose diaphragms Improper adjustment of helmet Poor switch contact Incorrect placing of cord connection to radio set Low voltage Incorrect connections	
Failure of Signal Loudness to Increase When Amplification Switch is Pushed in			Second amplifier tube faulty Amplification switch not functioning properly Shunt resistance has open circuit Incoming waves too great in amplitude Incorrect connections of shunt resistance and amplification switch

Varying Strength of Signal in Receivers when Transmitting	Generator.....	Hunting.....	{ Open in 100-ohm resistance { Poor tube { Loose filament support { No filament support
	Regulator tube.....	Filament of tube moving with respect to plate	
Blocking—Modulator Tube	Faulty tube.....	Characteristic abnormal	{ Open plate circuit { Poor tube { Open differential field { Incorrect setting of brushes
		Loose connections	
	Regulator tube.....	Generator.....	
	High plate voltage..		
	Low filament current	Faulty regulator tube	
High resistance ballast lamp			
Generator.....			
Low voltage type BA-2 battery			
*Failure to Oscillate	Low plate voltage..	Regulator tube.....	{ Short circuited tube { Poor tube { Open circuit { Poor brushes
		Generator.....	
	Improper adjustment of set.....	Low plate current.	{ Low plate current. { No grid current. { Open in filament circuit
		No grid current.	
	Failure of oscillator tube to light.....	Burned out filament	{ Burned out filament { Ballast lamp broken { Open circuit
		Ballast lamp broken	
	Antenna circuit....	Leaky insulation	{ Leaky insulation { Grounded antenna { Faulty regulator tube { High resistance ballast lamp
Grounded antenna			
Low filament current in oscillation tube.....	Faulty regulator tube	{ Poor brush contact { Incorrect brushes { Incorrect brush adjustment { Poor brushes	
	High resistance ballast lamp		
Generator.....			

### SET, AIRPLANE RADIO TELEPHONE, TYPE SCR-68

The type SCR-68 set is an earlier model of the airplane radio telephone and is now superseded by the type SCR-68-A described in the previous pages. The method of operation is identically the same as given above for the type SCR-68-A. The main differences from the type SCR-68-A set are the following:

A wooden airfan, type FA-3, is provided instead of the regulating airfan, type FA-7. The set may therefore not be used on airplanes having a speed of less than 60 or more than 160 miles per hour.

\*Existence of this condition can only be determined by a radio frequency ammeter in the antenna circuit or a milliammeter in the grid circuit.

The plate blocking condenser shown in Figs. 1 and 2 is not provided in the set box of the type SCR-68 set. It was added in the newer set in order to prevent the possibility of short circuiting the 275-volt generator armature by accidentally grounding the antenna. This protects the set and the operator as well.

The interphone set used with the type SCR-68 set is the type SCR-57, now superseded by the type SCR-57-A. The latter was described as a part of the type SCR-68-A set. The older type is not provided with the side tone circuit and therefore the observer or pilot does not hear his own voice when speaking in the telephone transmitter when the switch on the interphone set box is on "Interphone." This has the disadvantage that the person talking does not know how loud he is speaking.

The telephone transmitter used with the type SCR-68 set is the type T-1, of which the type T-3 used with the type SCR-68-A set is an improvement. These differ but little, the former having an aluminum face plate perforated with numerous pin holes, while the latter has an insulating face plate having only three pin holes.

These differences do not affect materially the performance and operation of the sets, and what has been said about the type SCR-68-A set heretofore, as to method of operation, etc., applies also to the older type SCR-68 sets, a number of which are in use.

### **SETS, AIRPLANE RADIO TELEPHONE, TYPE SCR-114 AND SCR-116**

The type SCR-114 set is essentially the same as the type SCR-68-A, with the main difference that no interphone set is provided. The type SCR-116 set is the same as the type SCR-68-A, except that the five-station interphone set, type SCR-89, is used instead of the two-station type SCR-57-A set.

### **SET, AIRPLANE RADIO RECEIVING, TYPE SCR-59**

The type SCR-59 set is an airplane set for receiving damped or modulated wave radio signals. It is primarily intended for the reception of signals sent by a radio telephone set. The circuit is essentially the same as the receiving circuit of the type SCR-68-A set, except that the vacuum tube filaments are in parallel and derive their energy from a 4-voltage storage battery instead of a fan driven generator.



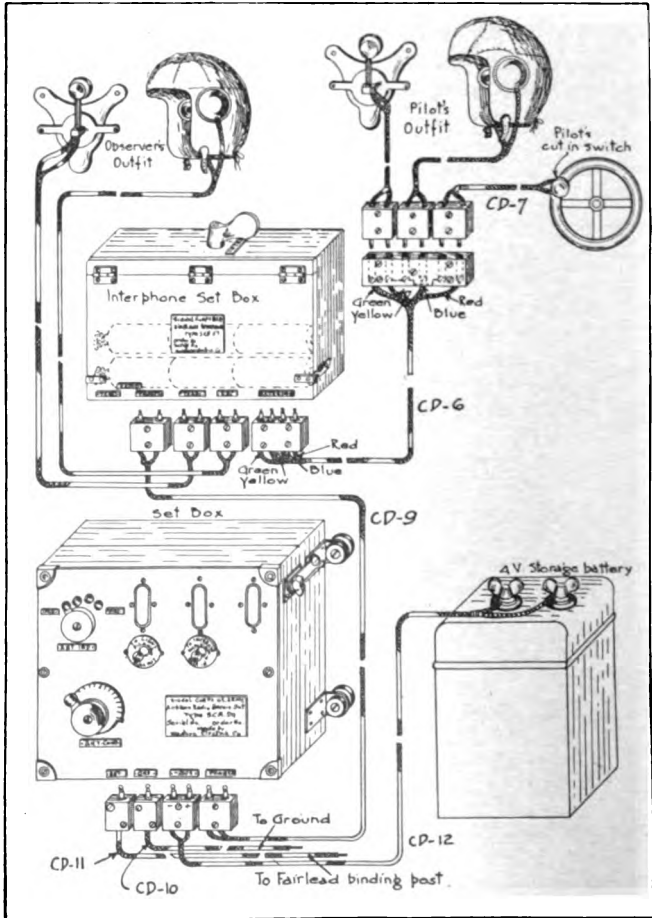

FIG. 22.—Cording Diagram of Sets Type SCR-50, SCR-50-A and SCR-75.

The theory of the circuit being the same as for the SCR-68-A set is therefore not repeated here. The method of using the set is very nearly the same as for the type SCR-68-A and is briefly summarized below.

**Installing the Set.**—In the installation of the set on an airplane, the general principles given above for the type SCR-68 set should be followed. There is no generator or filter box to install with this set. The various units of the set should be interconnected by means of the extension cords furnished, as shown in Fig. 22.

**Preflight Inspection.**—Before each flight, a careful inspection of the set should be made to insure satisfactory operation. Inspect the insulation of the connecting wires and check that all connections

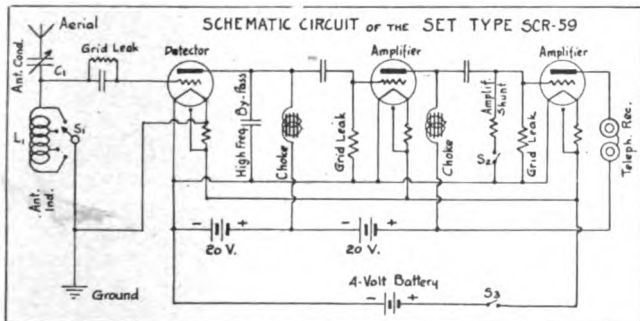

FIG. 23.—Schematic Circuit Diagram of Set Type SCR-59.

are correct and tight. Check that the interphone set is in operating condition by throwing the interphone-radio switch to "Interphone" and talking to the pilot through the telephone transmitter. Check the storage battery voltage and polarity.

See that the radio set box contains three type VT-1 vacuum tubes in good condition, and two type BA-2 dry batteries properly connected and of a voltage greater than 17.5 volts each.

See that the filament of *all three* vacuum tubes are glowing when the filament push button switch (left hand push button on the radio set box) is pulled out.

The final test showing that the set is in operating condition is made while the pilot is testing out the airplane engine on the ground. The radio operator should throw the interphone switch to "Radio," pull out the filament switch and push in the amplification switch.

He should then hear the magneto hum in his telephone receivers for all positions of the antenna inductance and condenser handles.

**Calibrating the Set.**—If the wave length to be received is known in advance, the set may be tuned on the ground in the following manner:

1. Remove the "Ground" and "Antenna" plugs from the radio set box and connect in their place the two terminals of a phantom antenna having the same constants as the real antenna. See page 28.

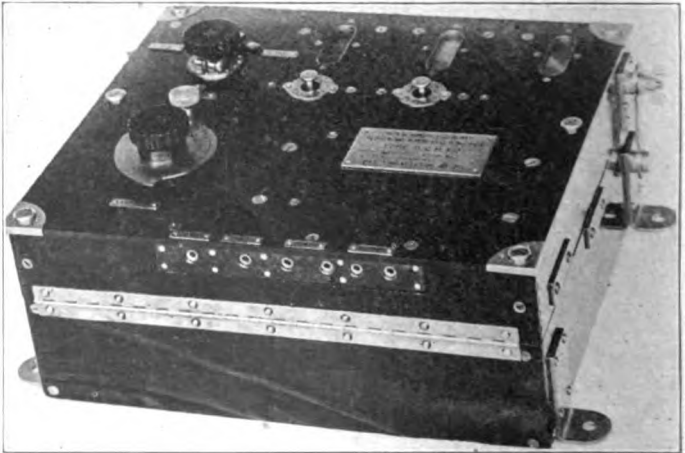

FIG. 24.—Operating Panel of Set Box Type BC-12 used in Set Type SCR-59.

2. Place a wave meter, type SCR-60-C, near the set box and let it emit some known wave length, excited by means of the buzzer.

3. Throw the interphone switch to "Radio," pull out the filament switch on the radio set box to light the filaments, and push in the amplification switch.

4. Set the "Antenna Inductance" switch of the radio set box in each of its various positions successively, varying the "Antenna Condenser" over its entire range for each of these positions until maximum response is heard in the telephone receiver. If the note is too strong for accurate tuning, pull out the amplification switch to reduce the amplification.

5. Record the setting of the inductance and condenser handles and the wave length. Repeat the operation for a number of wave lengths within the range of the set, in order to obtain a complete record chart.

6. Cut off the filament current by pushing in the filament switch.

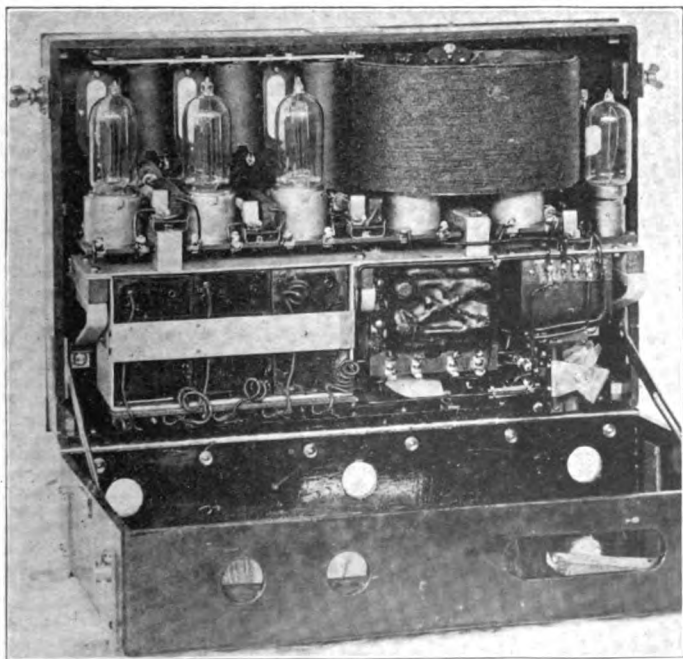

FIG. 25.—Mounting of Apparatus on the Panel of Set Box Type BC-12.

7. Remove the phantom antenna and re-connect the real antenna and ground.

8. The set is now tuned and only minor adjustments of the antenna condenser will be required in the air to perfect the tuning.

**Tuning in the Air.**—If the set has been previously tuned on the ground, proceed as follows. If the set has not been tuned on the ground, proceed as per paragraph 9 below.

1. Reel out the antenna when the airplane has reached a sufficient height.

2. Throw the interphone switch to "Radio."

3. Pull out the filament switch.

4. Push in the amplification switch.

5. Set the antenna inductance and condenser in accord with the calibration chart for the wave length to be received.

6. Upon receiving the signals, adjust slightly the condenser to see if the tuning is improved.

7. If the amplification is too great, reduce it by pulling out the amplification switch.

8. Do not forget after having used the interphone set, to replace the switch to "Radio" in order to be always in a position to receive any signals which may come in.

9. If the set has not been tuned on the ground, proceed as above, but replacing paragraphs 2, 3, 4, 5, 6, and 7 by paragraphs 3 and 4 of the instructions for calibrating the set on the ground.

**Trouble.**—All that has been said for the type SCR-68-A set concerning trouble when receiving may be applied to this set.

### **SETS, AIRPLANE RADIO RECEIVING, TYPE SCR-59-A AND SCR-115**

The type SCR-59-A set differs from the type SCR-59 in that the type SCR-57-A interphone set is used instead of the type SCR-57, and that the single wire trailing antenna is replaced by a double trailing antenna.

The type SCR-115 set comprises no interphone set, but is otherwise the same as the type SCR-59-A set.

### **SET, AIRPLANE RADIO RECEIVING, TYPE SCR-75**

The type SCR-75 set is an airplane set for the reception of damped or modulated wave signals, and especially suited for the reception of radio telephone signals. The only difference of the circuit of this set from that of the type SCR-59 set is that the detector tube, instead of being directly connected to the antenna circuit, is coupled to the latter through a secondary tuned circuit. This secondary circuit may be cut out by means of a switch, the circuit of the set being then identical with that of the type SCR-59. The purpose of this double tuning is to afford greater selectivity by sharper tuning. The type SCR-75 set should therefore be used when it is

impossible with the type SCR-59 set to eliminate interference from neighboring sets.

The theory of the set is not materially different from that of the sets described previously in this pamphlet, and may easily be understood from the circuit diagram.

**Installing the Set.**—The method of installing the set on an airplane is the same as for installing a type SCR-59 set. The cording diagram, Fig. 22 for the type SCR-59 set also applies to the type SCR-75 set.

**Preflight Inspection.**—All that has been said under this heading for the type SCR-59 set may be applied to the type SCR-75 set.

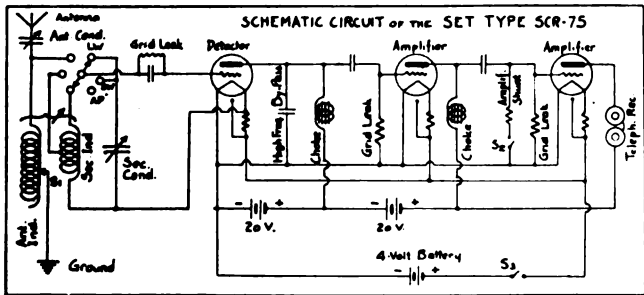

FIG. 26.—Schematic Circuit Diagram of Set Type SCR-75.

**Calibrating the Set.**—The calibration of the set on the ground after it has been installed on the airplane comprises the calibration of the primary or antenna circuit, and that of the secondary circuit. While the calibration of the primary circuit must be repeated whenever a new antenna is used having different constants, the calibration of the secondary is made once for all. The method is as follows:

1. Remove the ground and antenna plugs from the radio set box and connect in their place the two terminals of a phantom antenna having the same constants as the real antenna.
2. Place a wavemeter, type SCR-60-C, near the set box and let it emit a known wave length, excited by means of the buzzer.
3. Throw the interphone switch to "Radio," pull out the filament switch on the radio set box, and push in the amplification switch.

4. Set the three-position switch in the upper left hand corner of the radio set box operating panel in the position marked "AP" (aperiodic). This disconnects the secondary tuned circuit and permits the calibration of the primary (antenna) circuit.

5. For each position of the "Antenna Inductance" switch, vary the "Antenna Condenser" over its entire range, until maximum response is obtained in the telephone. If the amplification is too high and prevents accurate tuning, reduce it by pulling out the amplification switch.

6. Record the wave length, and settings of the antenna condenser and antenna inductance switches and repeat the operation for

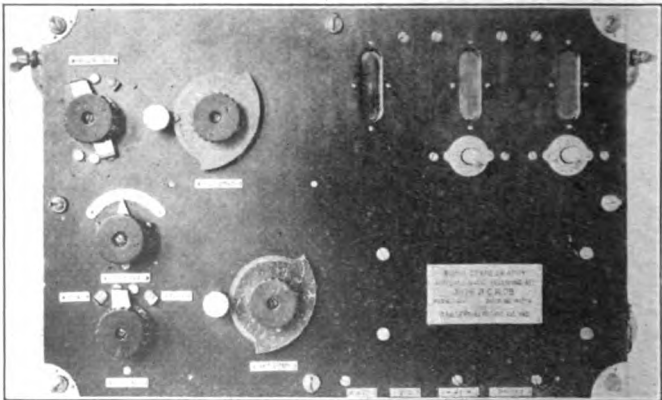

FIG. 27.—Operating Panel of Set Box Type BC-20 used in Set Type SCR-75.

various values of wave length, in order to obtain a calibration chart covering the entire range of the set. This will complete the calibration of the primary circuit.

7. Set the "Coupling" handle in the zero position and push in the amplification switch.

8. The wavemeter being placed near the radio set box and emitting a known wave length, tune the set by placing the three-position switch in the position "SW" and "LW" successively, varying the "Secondary Condenser" over its entire range for each position of the three-position switch, until maximum response is obtained in the telephone receivers. If the amplification is too great and pre-

vents accurate tuning, reduce it by pulling out the amplification switch.

9. Record the wave length and settings of the "LW-SW" and "Secondary Condenser" switches and repeat the operation for different wave lengths to cover the entire range of the set.

10. The calibration being complete, push in the filament switch.

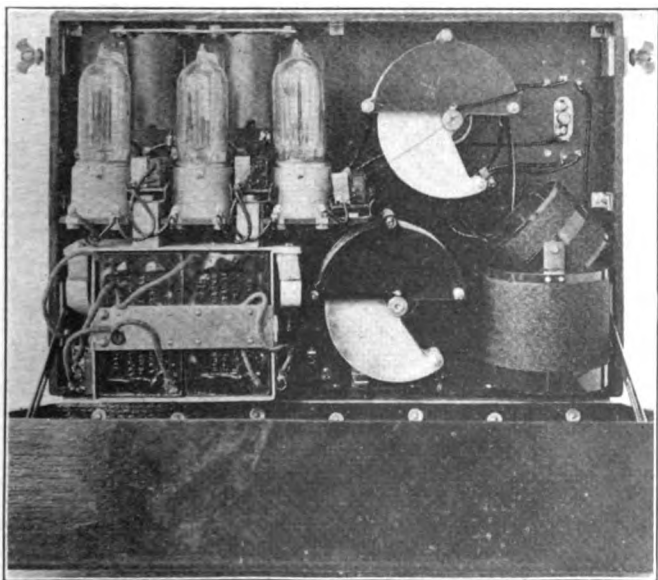

FIG. 28.—Mounting of Apparatus on the Panel of Set Box Type BC-20.

11. Disconnect the phantom antenna and re-connect the real antenna and ground.

**Tuning the Set in the Air.—**

1. Reel out the antenna when the airplane has reached a sufficient height.

2. Push in the amplification switch.

3. Pull out the filament switch.

4. Throw the interphone switch to "Radio."



5. If the wave length to be received is unknown, proceed as per paragraphs 10 to 14 below. If the wave length is known in advance, proceed as follows:

6. Set the "Coupling" switch to "90."

5. Set the "LW-SW" switch, the "Antenna Condenser," "Secondary Condenser" and "Antenna Inductance" switches in accord with the calibration chart.

8. If the signals come in too loud or if too much interference is experienced, reduce the coupling and pull out the amplification switch.

9. Try slight readjustments of the two condensers to see if the tuning can be improved.

If the set has not been calibrated on the ground or if the wave length to be received is unknown, proceed as follows:

10. Set the three-position switch to "AP."

11. For each position of the antenna inductance switch, vary the antenna condenser over its entire range until the signals are heard loudest.

12. Reduce the coupling by turning the coupling handle toward the right until the incoming signals are barely heard.

13. For each of the LW and SW positions of the three-position switch, vary the secondary condenser over its entire range until the signals are heard loudest.

14. If the signals are too loud or if there is too much interference, reduce the coupling and pull out the amplification switch.

**Troubles.**—Most of the troubles experienced with this set are of the same nature as for the type SCR-59 set, to which reference is here made. An additional source of trouble may be the breaking off, due to wear, of the flexible wires connecting the secondary inductance coil.

### PARTS LISTS.

In ordering any of these sets or parts of these sets, specification must be made by names and type numbers as listed below, exactly. The designation printed in bold face type *only*, will be used in requisitioning, making property returns, etc.

In ordering complete sets, it is not necessary to itemize the parts; simply specify, for example, "Set, Airplane Radio Receiving, Type SCR-59." If all the parts listed under a group heading are desired, it is not necessary to itemize the parts; simply specify, for example, "1 Equipment Type PE-14."

Any of the sets is not complete unless it includes all of the items listed in the component parts table, below.

**SET, AIRPLANE RADIO RECEIVING, TYPE SCR-59.**

- 1 Equipment Type PE-14**
  - 3 Batteries Type BB-4**
- 1 Equipment Type RC-2**
  - 1 Set Box Type BC-12**
  - 1 Cord Type CD-10; for connecting BC-12 to ground**
  - 1 Cord Type CD-11; for connecting BC-12 to fairlead**
  - 1 Cord Type CD-12; for connecting BC-12 to battery**
  - 8 Tubes Type VT-1; 3 in use, 5 spare**
  - 8 Batteries Type BA-2; 2 in use, 6 spare**
  - 1 Set Box Type BC-10**
  - 2 Head Sets Type HS-1**
  - 2 Transmitters Type T-1**
  - 1 Cord Type CD-9; for connecting BC-12 to BC-10**
  - 1 Cord Type CD-6; for connecting BC-10 to pilot's jack**
  - 1 Cord Type CD-7; for connecting BC-10 to pilot's cut-in switch**
  - 20 Batteries Type BA-3; 2 in use, 18 spare**
- 1 Equipment Type A-21**
  - 1 Reel Type RL-2**
  - 2 Drums Type DR-2**
  - 3000 ft. Wire Type W-5**
  - 10 Weights Type WT-1; 1 in use, 9 spare**
  - 2 Fairleads Type F-1; Type F-2 when Type F-1 is not available;**
    - 1 in use, 1 spare**
  - 20 ft. Twine Type TW-2; approx. 2 ft. in use**

**SET, AIRPLANE RADIO RECEIVING, TYPE SCR-59-A**

- 1 Equipment Type PE-14**
  - 3 Batteries Type BB-4**
- 1 Equipment Type RC-2-A**
  - 1 Set Box Type BC-12**
  - 1 Cord Type CD-10; for connecting BC-12 to ground**
  - 1 Cord Type CD-11; for connecting BC-12 to antenna**
  - 1 Cord Type CD-12; for connecting BC-12 to battery**
  - 8 Tubes Type VT-1; 3 in use, 5 spare**
  - 8 Batteries Type BA-2; 2 in use, 6 spare**
  - 1 Set Box Type BC-10-A**
  - 2 Head Sets Type HS-2**
  - 2 Transmitters Type T-3**

**1 Equipment Type BC-2-A—Continued.**

- 1 Cord Type CD-6; for connecting BC-10-A to pilot's jack
- 1 Cord Type CD-62; for connecting BC-10-A to observer's jack
- 1 Cord Type CD-7; for connecting cut-in switch to pilot's jack
- 1 Cord Type CD-9; for connecting BC-12 to BC-10-A
- 20 Batteries Type BA-3; 2 in use, 18 spare

**1 Equipment Type A-23**

- 1 Antenna Type AN-6
- 780 ft. Wire Type W-16; in six 130-ft. lengths, wound on 6 spools, spare
- 4 Insulators Type IN-8
- 40 ft. Cord Type BP-6; in two 20-ft lengths
- 1/4 lb. Tape Type TL-83

**SET, AIRPLANE RADIO TELEPHONE, TYPE SCR-68****1 Equipment Type PE-1**

- 2 Airfans Type FA-3; 1 in use, 1 spare
- 1 Generator Type GN-1 or Type GN-2
- 5 Tubes Type TB-1; 1 in use, 4 spare
- 1 Cord Type CD-19
- 1 Filter Type FL-1

**1 Equipment Type RE-1**

- 1 Set Box Type BC-11
- 8 Tubes Type VT-2; 2 in use, 6 spare
- 8 Tubes Type VT-1; 3 in use, 5 spare
- 3 Lamps Type LM-1; 1 in use, 2 spare
- 12 Batteries Type BA-2; 3 in use, 9 spare
- 1 Cord Type CD-10
- 1 Cord Type CD-11
- 1 Cord Type CD-17
- 1 Cord Type CD-9
- 1 Cord Type CD-18
- 1 Set Box Type BC-10
- 2 Head Sets Type HS-1
- 2 Transmitters Type T-1
- 1 Cord Type CD-6
- 1 Cord Type CD-7
- 20 Batteries Type BA-3; 2 in use, 18 spare

**1 Equipment Type A-21****1 Reel Type RL-2****2 Drums Type DR-2****3000 ft. Wire Type W-5****10 Weights Type WT-1; 1 in use, 9 spare****2 Fairleads Type F-1; Type F-2 when Type F-1 is not available  
1 in use, 1 spare****20 ft. Twine Type TW-2; approx. 2 ft. in use****SET, AIRPLANE RADIO TELEPHONE, TYPE SCR-68-A****1 Equipment Type PE-1-A****2 Airfans Type FA-7; if not available, Airfan Type FA-3****1 Generator Type GN-1-A or Type GN-2-A****5 Tubes Type TB-1****1 Cord Type CD-19****1 Filter Type FL-1-A****1 Equipment Type RE-1-A****1 Set Box Type BC-11-A****8 Tubes Type VT-2; 2 in use, 6 spare****8 Tubes Type VT-1; 3 in use, 5 spare****3 Lamps Type LM-1; 1 in use, 2 spare****12 Batteries Type BA-2; 3 in use, 9 spare****1 Cord Type CD-10****1 Cord Type CD-11****1 Cord Type CD-17****1 Cord Type CD-9****1 Cord Type CD-13****1 Set Box Type BC-10-A****2 Head Sets Type HS-2****2 Transmitters Type T-3****1 Cord Type CD-6****1 Cord Type CD-62****1 Cord Type CD-7****20 Batteries Type BA-3; 2 in use, 18 spare****1 Equipment Type A-23****1 Antenna Type AN-6****780 ft. Wire Type W-16; in six 130-ft. lengths, wound on 6 spools,  
spare****4 Insulators Type IN-8****40 ft. Cord Type BP-6; in two 20-ft. lengths****1/4 lb. Tape Type TL-83**

**SET, AIRPLANE RADIO RECEIVING, TYPE SCR-75**

- 1 Equipment Type PE-14**
  - 3 Batteries Type BB-4**
- 1 Equipment Type RC-4**
  - 1 Set Box Type BC-20**
  - 1 Cord Type CD-10**
  - 1 Cord Type CD-11**
  - 1 Cord Type CD-12**
  - 8 Tubes Type VT-1; 3 in use, 5 spare**
  - 8 Batteries Type BA-2; 2 in use, 6 spare**
  - 1 Cord Type CD-9**
  - 1 Set Box Type BC-10**
  - 2 Head Sets Type HS-1**
  - 2 Transmitters Type T-1**
  - 1 Cord Type CD-6**
  - 1 Cord Type CD-7**
  - 20 Batteries Type BA-3; 2 in use, 18 spare**
- 1 Equipment Type A-23**
  - 1 Antenna Type AN-6**
  - 780 ft. Wire Type W-16; in six 130-ft. lengths, wound on 6 spools; spare**
  - 4 Insulators Type IN-8**
  - 40 ft. Cord Type RP-6; in two 20-ft. lengths**
  - 1/4 lb. Tape Type TL-83**

**SET, AIRPLANE RADIO TELEPHONE, TYPE SCR-114**

- 1 Equipment Type PE-1-A**
  - 2 Airfans Type FA-7; if not available, Airfan Type FA-3**
  - 1 Generator Type GN-1-A or Type GN-2-A**
  - 5 Tubes Type TB-1**
  - 1 Cord Type CD-19**
  - 1 Filter Type FL-1-A**
- 1 Equipment Type RE-11**
  - 1 Set Box Type BC-11-A**
  - 8 Tubes Type VT-1**
  - 8 Tubes Type VT-2**
  - 3 Lamps Type LM-1**
  - 12 Batteries Type BA-2**
  - 1 Cord Type CD-10**

**1 Equipment Type RE-11—Continued.**

- 1 Cord Type CD-11
- 1 Cord Type CD-17
- 1 Head Set Type HS-2
- 1 Transmitter Type T-3

**1 Equipment Type A-23**

- 1 Antenna Type AN-6
- 780 ft. Wire Type W-16; in six 130-ft. lengths, wound on 6 spools; spare
- 4 Insulators Type IN-8
- 40 ft. Cord Type RP-6; in two 20-ft. lengths
- 1/4 lb. Tape Type TL-83

**SET, AIRPLANE RADIO RECEIVING, TYPE SCR-115****1 Equipment Type PE-20**

- 2 Airfans Type FA-7; if not available, Airfans Type FA-3
- 1 Generator Type GN-1-A or Type GN-2-A
- 5 Tubes Type TB-1
- 1 Cord Type CD-19
- 1 Filter Type FL-1-A
- 3 Batteries Type BB-7

**1 Equipment Type RC-9**

- 1 Set Box Type BC-12
- 1 Cord Type CD-10
- 1 Cord Type CD-11
- 1 Cord Type CD-12
- 8 Tubes Type VT-1
- 8 Batteries Type BA-2
- 1 Head Set Type HS-2

**1 Equipment Type A-23**

- 1 Antenna Type AN-6
- 780 ft. Wire Type W-16; in six 130-ft. lengths, wound on 6 spools, spare
- 4 Insulators Type IN-8
- 40 ft. Cord Type RP-6; in two 20-ft. lengths
- 1-4 lb. Tape Type TL-83

**SET, AIRPLANE RADIO TELEPHONE, TYPE SCR-116**

- 1 Equipment Type PE-20**
  - 2 Airfans Type FA-7; if not available, Airfans Type FA-3**
  - 1 Generator Type GN-1-A, or Type GN-2-A**
  - 5 Tubes Type TB-1**
  - 1 Cord Type CD-19**
  - 1 Filter Type FL-1-A**
  - 3 Batteries Type BB-7**
- 1 Equipment Type RE-14**
  - 1 Set Box Type BC-11-A**
  - 8 Tubes Type VT-1**
  - 8 Tubes Type VT-2**
  - 3 Lamps Type LM-1**
  - 12 Batteries Type BA-2**
  - 1 Cord Type CD-10**
  - 1 Cord Type CD-17**
  - 1 Interphone Circuit Type BC-56**
  - 5 Transmitters Type T-3**
  - 5 Head Sets Type HS-2**
  - 1 Cord Type CD-9**
  - 1 Cord Type CD-18**
  - 1 Cord Type CD-11**
- 1 Equipment Type A-23**
  - 1 Antenna Type AN-6**
  - 780 ft. Wire Type W-16; in six 130-ft. lengths, wound on 6 spools, spare**
  - 4 Insulators Type IN-8**
  - 40 ft. Cord Type RP-6; in two 20-ft. lengths**
  - 1-4 lb. Tape Type TL-83**
- 1 Equipment Type A-24**
  - 1 Reel Type RL-2**
  - 2 Drums Type DR-2**
  - 3,000 ft. Wire Type W-5**
  - 50 Weights Type WT-5**
  - 2 Fairleads Type F-5**
  - 20 ft. Cord Type RP-6**











---

**Prepared in the  
Office of the Chief Signal Officer  
Training Section  
Washington**

---

*EPA*

**CONFIDENTIAL!** For Official Use Only

# Airplane Radio Telegraph Transmitting Sets

Type SCR-65

Type SCR-65-A



*Communication*  
RADIO PAMPHLET No. 5

Second Edition, Revised to November 16, 1918

Signal Corps, U. S. Army



Washington : Government Printing Office : 1918



**AIRPLANE RADIO TELEGRAPH TRANS-  
MITTING SETS**

**Types SCR-65 and SCR-65-A.**



**T**HE GENERAL use for which the radio telegraph transmitting sets, types SCR-65 and SCR-65-A are intended is that of sending messages from airplanes to the ground. The type SCR-65 set is modeled after the Sterling type transmitting set, which is used almost exclusively by the British in artillery fire-control work. The type SCR-65-A set differs from the type SCR-65 only in minor details. Both have proved very efficient and well suited to conditions of actual warfare on account of their simplicity and ruggedness. They are tuned spark-coil transmitting sets, producing damped waves. When used with

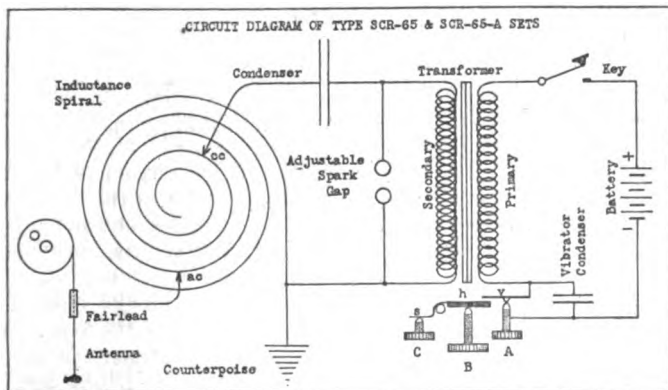

FIG. 1.—Schematic Wiring Diagram of the Type SCR-65 Set.

the usual airplane trailing antenna, 150 to 250 ft. in length, and with the bonded wire stays of the machine as a counterpoise, the wave length is from 100 to 300 meters, depending upon the adjustments.

The essential parts of either set are the spiral tuning inductance, the induction coil, spark gap and sending condenser. The induction (or spark) coil, sending condenser and spark gap are mounted in a box measuring  $7\frac{1}{8} \times 6\frac{1}{2} \times 3\frac{1}{2}$  in. over all. The flat spiral of 12 turns of  $\frac{1}{4}$ -in. brass strip and four binding



posts, marked "Antenna," "Counterpoise," "Key," and "Battery," are mounted on a hard rubber panel set in the top of the set box. Hard rubber markers are placed at a number of different points around the spiral to indicate the position of connection for the condenser clip for various wave lengths of the closed oscillatory circuit.

Fig. 1 shows the diagram of connections for either the type SCR-65 or type SCR-65-A set. It will be noticed that the tuning inductance of the closed oscillatory circuit is the same coil as the tuning inductance of the open oscillatory circuit, thus giving conductive and inductive coupling between the two circuits. Selectivity between sets is obtained by differing the transmitted wave length and also by differing the spark tone according to predetermined schedules. The change in tone is accomplished by the adjustment of the vibrator on the induction coil.

The vibrator, as shown in Fig. 1, consists of a hammer *h*, which is held against the screw B by the tension of the spring *s*. This iron hammer is mounted opposite one end of the transformer core and at a distance from it which may be varied by means of the screw B. The vibrator spring blade *v* projects out into the gap between the hammer *h* and the core and normally rests against the contact point of the screw A. The principle of operation of this vibrator is as follows:

As the telegraph sending key is closed, the current from the battery flows in the primary circuit, comprising the screw A, spring blade *v*, and primary coil of the transformer. A magnetic field builds up in the latter, increasing until it is strong enough to overcome the tension of the hammer spring *s*, at which time the hammer *h* is attracted toward the core. After leaving the screw B on which it was resting, the hammer strikes the end of blade *v*, which, upon being lifted off the tip of screw A, breaks the primary circuit, thus stopping the current flow in it, and the hammer falls back, due to the tension of spring *s*. This, however, permits the blade *v* to reestablish contact with A, closing the primary circuit, and the operation repeats itself.

It will be seen from the above discussion that the strength of the magnetic field, and therefore the intensity of the primary

current, required to lift the hammer from its position, depends on the spring tension adjustment (screw C) and on the hammer stroke adjustment (screw B). Also, as the hammer is moved by means of the screw B, it is necessary to adjust the vibrator contact screw A in order to keep the blade *v* in proper position. The method of making these adjustments is explained in a later paragraph.

In order to reduce the sparking at the vibrator and make the break quicker a 0.6 mfd. condenser is shunted across the contact points.

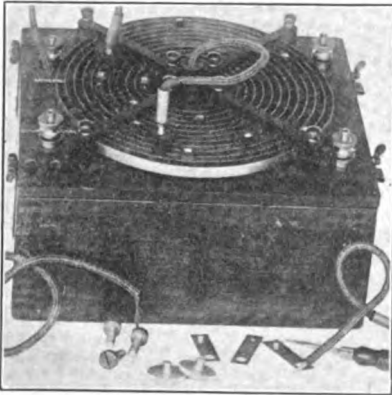

FIG. 2.—Inductance Spiral on Set Box Type BC-15 of the Type SCB-65 Set.

The spark gap consists of two zinc electrodes, one of which is mounted on a finely threaded brass screw with a knurled hard rubber handle by means of which the length of the gap may be readily adjusted. The stems of the two electrodes are provided with cooling flanges which cool the electrodes by increasing the area of contact with the surrounding air. This, together with the metal of the electrode sparking surface, results in a fairly good quenching action of the gap.

The sending condenser is made up of 15 sheets of brass placed alternately between 16 sheets of mica and inclosed in a fiber case. The capacity is approximately 0.009 mfd.

### Method of Operation.

The set is adjusted on the ground before being installed in the airplane. A phantom antenna is used for this purpose, having the same inductance, capacitance, and resistance as the particular airplane antenna to be used in the flight. The 10-volt storage battery and a telegraph sending key (or a switch) are connected to the "Battery" and "Key" terminals of the set box, while

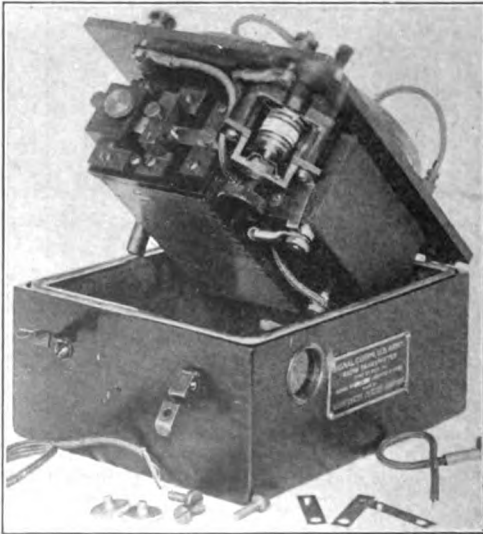

FIG. 3.—Induction Coil, Spark Gap, and Condenser Mounting in Type BC-15 Set Box of the SCR-65 Set.

the phantom antenna is connected to the "Counterpoise" and "Antenna" terminals. A hot wire ammeter should be included in the phantom antenna circuit. The method of adjusting the set is then as follows:

1. Place the closed circuit clip, *cc* (the clip coming out of the center of the panel) on the spiral inductance next to the marker corresponding to the wave length at which it is desired to transmit. This will make the constants of the closed oscillatory cir-

cuit of such values as to give it the natural wave length marked on the spiral inductance. As may be seen on the circuit diagram, Fig. 1, the closed oscillatory circuit comprises the spark gap, the fixed sending condenser, and that part of the inductance spiral connected in the circuit by the closed circuit clip *cc*.

2. Open the box by lifting the operating panel and loosen the spark gap clamping screw.

3. Turning the movable spark gap electrode, bring the two electrodes together so they will just touch, and note the position of the movable electrode adjusting screw knob. Then open the spark gap by turning this screw back three-quarters turn to one turn, and tighten the clamping screw.

4. Place the antenna clip *ac* (the clip coming from the "Antenna" binding post) on the inductance spiral one turn away from the closed circuit clip. This will couple the antenna circuit to the closed oscillatory circuit.

5. Adjust the vibrator, proceeding as follows:

(a) Loosen the vibrator clamping screws just enough to allow adjusting.

(b) Loosen the hammer stroke adjusting screw B, and tighten the hammer spring adjusting screw C so that the hammer stands well away from the vibrator spring *v*.

(c) Make sure that the vibrator contact points A are clean, and directly in line, one above the other.

(d) Adjust the vibrator contact screw A until it just makes contact with the vibrator spring, and then tighten it up another one-quarter or one-half turn.

(e) Tighten screw B until the hammer almost touches the contact spring.

(f) Loosen screw C until contact with the hammer tension spring is barely made. This will decrease the current in the primary winding.

(g) Close the telegraph key, and if required make such slight readjustments of A, B and C (in the order mentioned) as will produce a clear tone with minimum sparking at the vibrator. Adjustments of B and C should always be made in opposite directions, so that the tension of the hammer spring will remain about the same. Also make a slight adjustment of the spark gap, so that white sparks will occur, these taking place between various points on the electrode surface.

(h) Set all clamping screws.

6. Close the set box.

7. Tune the antenna circuit by moving the antenna clip *ac*, along the inductance spiral while the telegraph key is closed, until a point is found giving maximum current on the antenna hot wire ammeter. At this point, the clip is securely fastened.

8. The vibrator should now be readjusted slightly so that the set will produce fairly good radiation with the least sparking at the vibrator contact points.

9. Disconnect the phantom antenna and install the set on the airplane.

### Installation of the Set.

The method of installing the set on an airplane varies with the type of machine. The fittings required are furnished by the Bureau of Aircraft Production. The principles underlying the installation of the type SCR-65 or SCR-65-A sets are the following:

The set box and storage battery should be mounted near each other, so that the connecting leads may be as short as possible, in order to reduce to a minimum the energy losses in those wires. Also, the set box should be of easy access, as it is almost always necessary to remove it from the plane for tuning and inspection. In fact, a frequent practice is to have a number of sets all ready and tuned on the ground, so that when an airplane comes down to the ground with a defective set, another may be substituted immediately. To effect this, a sliding wooden tray is often used, on which the set box is mounted together with its battery. It is then simply necessary to make the connections to the "Counterpoise" and "Key" binding posts of the set box.

In service, the vibrator contacts soon become pitted due to sparking, and then give a ragged spark and greatly lower the efficiency of the set. The contacts must therefore be watched closely and kept smooth by the use of a very fine, flat file or replaced with the spare contacts provided. The antenna, counterpoise, battery and key leads should be attached securely to their respective binding posts so that the vibration of the airplane will not loosen them and make the set inoperative at possibly a critical moment. It should be noted that the key is not

mounted on the box containing the set. The keys used are of a special airplane type (type J-7), and are mounted on small batens located at the sides of the cockpits, Fig. 4, one on either side of the pilot's cockpit and one on the right of the observer. These are all connected in parallel.

The zinc spark electrodes should be removed at regular intervals and cleaned and trued up. When the electrodes are in place, the faces should be exactly opposite and parallel. A zinc oxide deposit is formed around them and should be removed frequently. It is very essential that this set be thoroughly inspected before being used in the air.

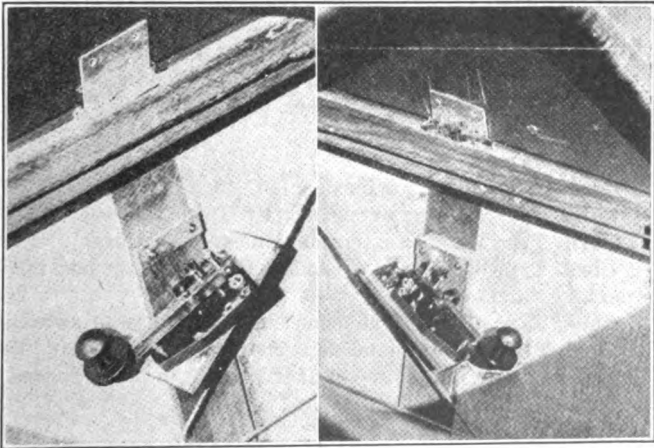

FIG. 4.—Mounting of Sending Keys on Either Side of Pilot.

### PARTS LISTS.

In ordering this set or parts of this set specification must be made by names and type numbers as listed below, exactly. The designation printed in bold face type *only*, will be used in requisitioning, making property returns, purchasing, etc.

In ordering *complete* sets, it is not necessary to itemize the parts; simply specify, "2 Sets, Airplane Radio Telegraph Transmitting, Type SCR-65." If *all* the parts listed under a group heading are desired, it is not necessary to itemize the parts; simply specify, for example, "1 Equipment, Type RT-1."

These sets are not complete unless they include all of the items listed below under the respective set names.

## **SET, AIRPLANE RADIO TELEGRAPH TRANSMITTING, TYPE SCR-65.**

**EQUIPMENT, TYPE PE-21; Power.**

**2 Batteries, Type BB-11; lead storage; Liberty; 8 volts; discharge rate 3 amp. for 3 hours; 1 in use, 1 spare.**

**EQUIPMENT, TYPE RT-1; Transmitting.**

**1 Set Box, Type BC-15; airplane radio telegraph transmitting.**

**1 Stone, Type TL-3; carborundum, No. 53 medium India.**

**1 Screwdriver, Type TL-4; steel wire; 5 in. long.**

**3 Contacts, Type CN-3; upper; vibrator; spare.**

**3 Contacts, Type CN-4; lower; vibrator; spare.**

**2 Electrodes, Type CN-5; spark gap, spare.**

**1 Switch, Type SW-9; battery.**

**2 Keys, Type J-7.**

**1 Cord, Type CD-27; extension; BC-15 to ground.**

**1 Cord, Type CD-28; extension; BC-15 to fairlead.**

**1 Cord, Type CD-29; extension; BC-15 to battery.**

**1 Cord, Type CD-30; extension; battery and set box to observer's key and switch.**

**1 Cord, Type CD-31; extension; observer's key to switch.**

**1 Cord, Type CD-32; extension; observer's key to pilot's key.**

**6 Lamps, Type LM-3; for blinker keys; 2 in use, 4 spares.**

**EQUIPMENT, TYPE A-21; Antenna.**

**1 Reel, Type RL-2; antenna.**

**2 Drums, Type DR-2; antenna reel.**

**3,000 ft. Wire, Type W-5; probable maximum length of antenna, 300 ft.**

**10 Weights, Type WT-1; antenna; 1 in use, 9 spares.**

**2 Fairleads, Type F-1; type F-2 when type F-1 is not available; 1 in use, 1 spare.**

**20 ft. Cord, Type RP-6; approximately 2 ft. in use.**

## SET, AIRPLANE RADIO TELEGRAPH TRANSMITTING. TYPE SCR-65-A.

**EQUIPMENT, TYPE PE-21; Power.**

**2 Batteries, Type BB-11;** lead storage; Liberty; 8 volts; discharge rate, 3 amp. for 3 hours; 1 in use, 1 spare.

**EQUIPMENT, TYPE RT-1-A; Transmitting.**

**1 Set Box, Type BC-15-A;** airplane radio telegraph transmitting; weight, 6 lb. 12 oz.

**1 Stone, Type TL-3;** carborundum; medium India; No. 53.

**1 Screwdriver, Type TL-4;** steel wire; 5 in. long.

**1 Screwdriver, Type TL-22;** for spark coil clamping screws; similar to Stanley No. 55; 1½-in. blade, ⅜ in. diameter; ¼-in. tip; 4 in. over all.

**3 Contacts, Type CN-3;** assemblies; spare.

**3 Contacts, Type CN-4;** assemblies; spare.

**2 Electrodes, Type CN-5;** spark gap; spare.

**1 Switch, Type SW-14;** battery.

**2 Keys, Type J-7;** with winker light sockets.

**6 Lamps, Type LM-3;** for keys; 2 in use, 4 spares.

**30 ft. Cord, Type W-8;** lamp; No. 16 B. & S. gauge, special braid, N. E. C.; wound on 8-in. coil; total weight, 1 lb. 6 oz.

**15 ft. Cable, Type W-9;** high tension; Packard; No. 30 B. & S. gauge, 40-strand; outside diameter of cable, ¾ in.; wound on 8-in. coil; total weight, 3 lb.

**1 Lead, Type CD-2;** spiral inductance; 11½ in. long; spare.

**1 Lead, Type CD-3;** spiral inductance; 6½ in. long; spare.

**EQUIPMENT, TYPE A-21; Antenna.**

**1 Reel, Type RL-2;** antenna.

**2 Drums, Type DR-2;** antenna reel.

**3,000 ft. Wire, Type W-5;** Antenna; probable length of antenna, 300 ft.

**10 Weights, Type WT-1;** antenna; 1 in use, 9 spare.

**2 Fairleads, Type F-1;** type F-2 when type F-1 is not available; 1 in use, 1 spare.

**20 ft. Cord, Type RP-6;** approximately 2 ft. in use.









---

**Prepared in the  
Office of the Chief Signal Officer  
Training Section  
Washington**

---

*3700*  
**CONFIDENTIAL!** For Official Use Only

**Two-Way T. P. S. Set**  
**Type SCR-76-A**



**RADIO PAMPHLET No. 19**

April 20, 1919

—  
**Signal Corps, U. S. Army**





## Two-Way T. P. S. Set. Type SCR-76-A.

**T**HE TYPE SCR-76-A SET is a transmitting and receiving set for ground telegraph work (t. p. s. or earth induction), and is therefore to be used at stations where two-way communication is necessary. It is practically an assembly of the type SCR-71 t. p. s. buzzer and the type SCR-72 amplifier (with some important changes in design) into a single unit to facilitate the installation and use of the two when both are required at one location. The set comprises an adjustable frequency power buzzer, a telegraph key for sending, and a two-stage vacuum tube low frequency amplifier for receiving. The power required to operate the buzzer and to light the filaments of the vacuum tubes is derived from a 10-volt storage battery. Provision is made for operating the buzzer from a 20-volt battery should extreme conditions demand a higher output than is possible with the use of a 10-volt battery.

### Principles and Description.

The principle of operation of the type SCR-76-A set is illustrated in the wiring diagram given herewith, Fig. 1. In general it consists of generating by induction, high potential current of audio frequency, which is caused to flow through the ground between two ground terminals separated by about 500 ft. In flowing through the ground the lines of current spread out in all directions, so that some of them may be intercepted at considerable distances by a suitable receiving device similarly connected to the ground and sensitive enough to respond to the extremely small currents thus received by conduction through the earth. Then by breaking up the pulsating emf. impressed on the ground into dots and dashes, it is possible to read the signals at the receiving station.

In the two-way t. p. s. set, the same ground connections and the same 10-volt storage battery are used for both sending and receiving, this being accomplished by means of a double pole double throw "Transmit-Receive" switch mounted on the panel of the set.

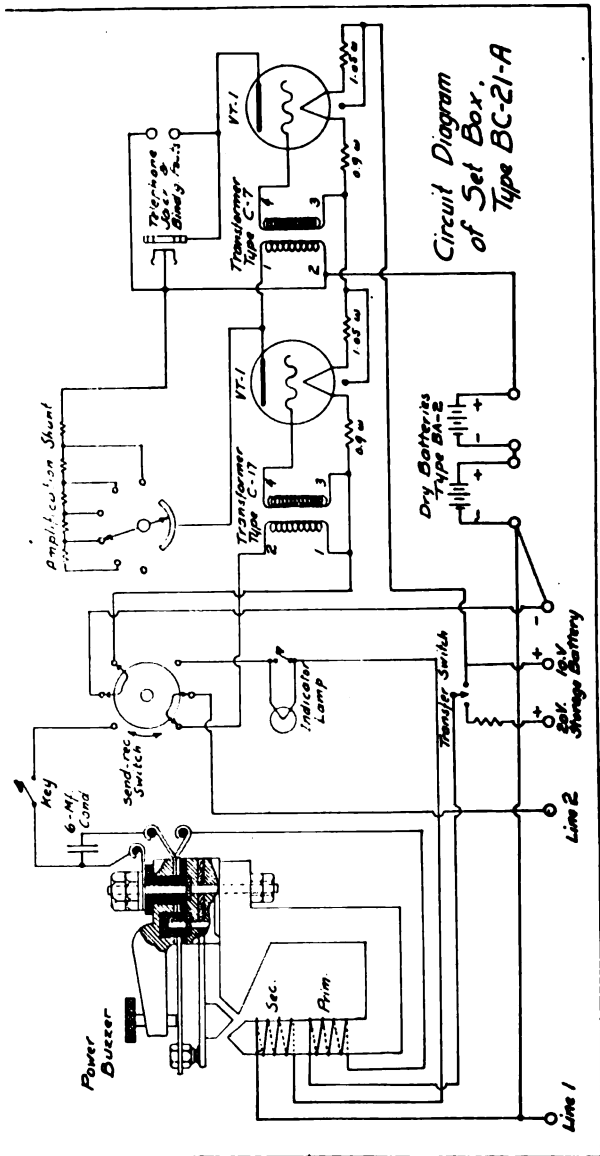

FIG. 1.—Schematic Circuit Diagram of Set Box Type BC-21-A Which Forms a Part of Set Type SCR-76-A.

With the switch in the "Transmit" position, the local circuit from the storage battery through the sending key and the primary of the power buzzer is completed and the base line wires are connected directly to the secondary or high potential winding. When the sending key is closed, the vibrator interrupter makes and breaks the current through the primary winding at a frequency which is controlled by means of small weights screwed to the vibrating armature. Six different frequencies are possible, as listed under a later paragraph (par. 9 of "Method of Operating"). The pulsating primary current resulting from the action of the buzzer induces an alternating emf. of high potential in the secondary winding.

The power buzzer is a double winding, closed magnetic circuit, buzzer interrupter, of practically the same construction as the SCR-71 t. p. s. buzzer. As in the SCR-71 buzzer, a condenser is connected across the vibrator contact points to reduce the spark and improve operation. For every change of frequency, the screw on top of the buzzer should be adjusted to give a good clear note, and then locked in position. The adjustment should be made as tight as possible and still give a clear note, as the current into the ground will then be a maximum.

The proper setting of the vibrator adjustment may be obtained by depressing the "Line Lamp" switch on the face of the panel and holding down the key with the "Send-Receive" switch in the "Send" position. The vibrator screw should then be adjusted until the line lamp glows at maximum brilliancy.

When it is desirable to operate the buzzer at 20 volts input, an additional 10-volt storage battery is required. This second battery is connected in series with the first battery without disconnecting the leads used for 10-volt operation (these are necessary for lighting the filaments for receiving), and the positive terminal is connected to the third (rear) binding post on the right side of the set. The transfer switch, located inside the set box on the back of the box is thrown to the right.

**CAUTION.**—Under no condition should 20 volts be applied to two forward battery binding posts, since this would result in burning out the tube filaments when the "Send-Receive" switch is turned to "Receive."

For good operation of the buzzer, the vibrator contact points must be clean, and the surfaces even and parallel. After some time, these contact points may become pitted and require cleaning and truing



up. It is best not to use the file furnished with the set, but to remove the contacts from the vibrator and rub them gently on a piece of emery cloth laid on a flat surface. Only in exceptional cases will it be found necessary to use the file or to replace the contact points with the spare ones furnished with the set.

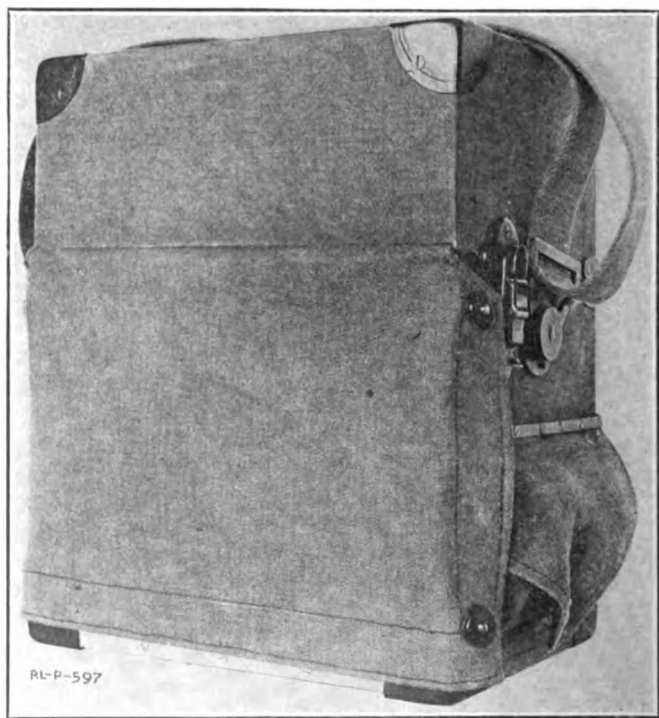

FIG. 2.—Set Box Type BC-21-A as it Appears Closed Up Ready for Transportation.

With the switch closed in the "Receive" position, the base and 10-volt battery are connected to the amplifier. This is a low frequency, two-stage amplifier, using two type VT-1 three-electrode vacuum tubes connected for cascade amplification by means of two iron core transformers. Jacks and binding posts for connecting telephone receivers are provided in the plate circuit of the last tube. The fila-

ments of the two tubes are connected in series to the 10-volt storage battery. Four fixed resistances having a total value of 3.9 ohms are in series with the filament circuit. These resistances are so con-

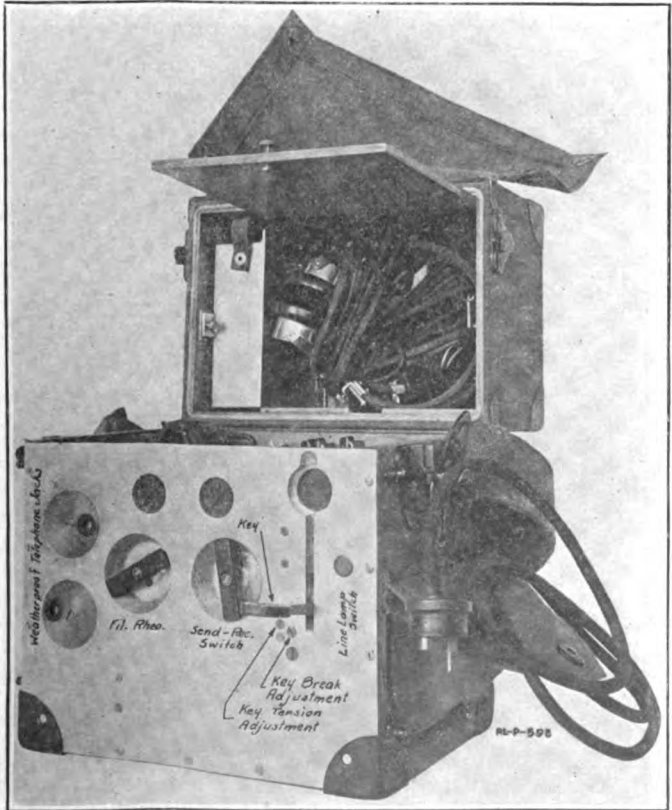

FIG. 3.—Set Box Type BC-21-A Opened to Show Upper Compartment for the Head Sets. This is Normally Closed While Operating and the Panel Exposed by Fastening the Canvas Flap Up.

nected as to allow the substitution of VT-11 or VT-21 tubes for the VT-1 tubes normally furnished with the set, without changing the internal connections of the set. There is no variable resistance in

series with the filament circuit. Variation of amplification is obtained by shunting the primary of the second transformer with a resistance. A switch marked "Amplification" is provided on the face of the panel for this purpose. A plate potential of about 45

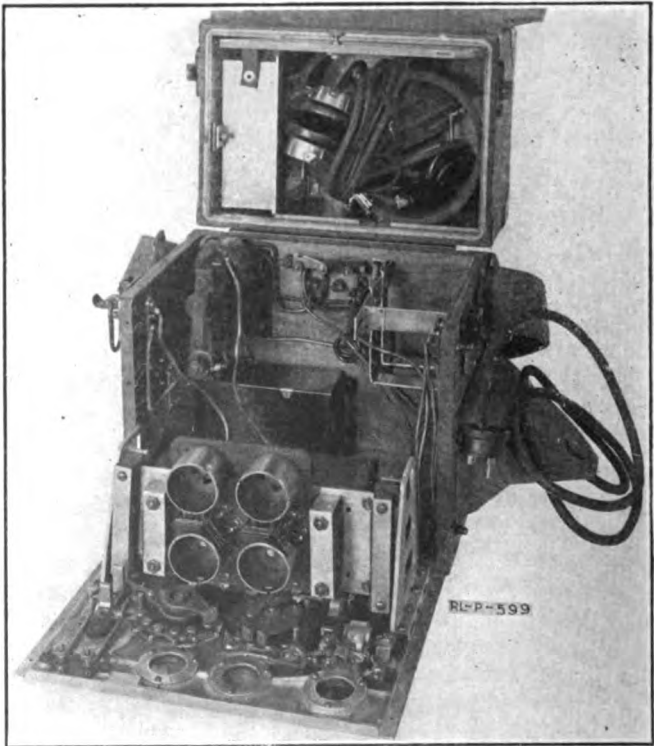

FIG. 4.—Panel of Set Box Type BC 21-A Opened Forward to Show Mounting of Various Apparatus. Note Transfer Switch or Strap on the Back (Top Center) of the Box.

volts is obtained for both tubes by means of two type BA-2 dry batteries connected in series. When the battery voltage has run down to 34 volts (17 volts each) the batteries should be replaced.

When it is necessary to replace the dry batteries of the amplifier circuit, particular care must be taken to see that they are connected

in with the correct polarity. This is essential for the operation of the vacuum tubes. It is also necessary that both vacuum tubes be in good condition, since the amplifier can not operate on one tube only, with the other one broken, burned out, or out of the circuit. If the amplifier does not work properly, this may be due to a poor

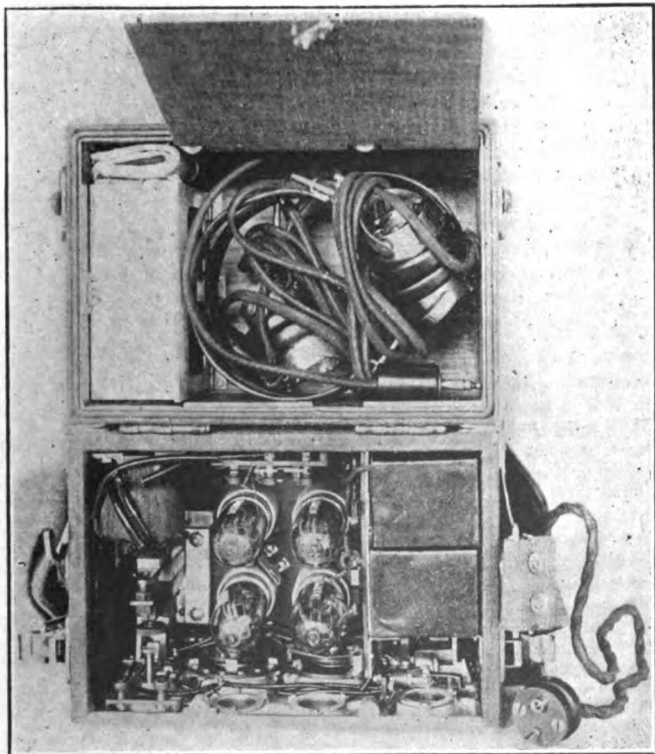

FIG. 5.—Looking Down on the Top of Set Box Type BC-21-A with Top Compartment Opened.

telephone connection, or to a wrong connection of either the storage or the dry batteries, or to the failure of one of the tubes.

When the set is not in use, the transmit-receive switch should be in the "Off" position, as this will avoid any possibility of unnecessarily running down the storage battery.

**Mounting of the Set.**—The set is mounted in a rugged canvas covered wooden case, having the overall dimensions of  $12\frac{1}{2}$  in. x  $10\frac{1}{2}$  in. x  $7\frac{1}{2}$  in. This case is provided with one lid which closes against a rubber gasket and is held tightly by two strong toggle latches. The panel is protected by a canvas cover which buckles over the face of the set. This construction makes the set fairly waterproof, especially if care is taken to keep the rubber gaskets clean and free from dirt or mud before clamping the lid shut.

The lid carries two Headsets, Type P-11, two Batteries, Type BA-2, and a tool roll containing tools, vibrator weights, and spare parts for the buzzer. The two spare vacuum tubes are carried on the same tube base mounting that carries the operating tubes. Two spare line lamps are carried in sockets located below the transfer switch. The battery cord for standard 10-volt operation of the set is permanently connected to the battery binding posts and is carried in the pocket on the outside of the set. This cord is provided with a standard plug for making battery connection.

**Opening a Station.**—To open a station, the base line, approximately 500 ft. long, is established in accord with the rules laid down below, and connected to the line binding posts on the left hand end of the set. The battery cord is removed from the pocket and connected to the battery. The canvas cover over the panel is then unbuckled and catches released so that the lid may be thrown back. The telephones are then removed from the lid and inserted in the telephone jack. The lid should now be closed to protect the set. This operation is of especial importance, particularly during bad weather. By moving the switch to "Receive" and setting the "Amplification" switch to "Max," the set is ready for receiving signals. If it is desired to send a message, the switch is thrown to "Send" and the key is revolved down in the operating position. Should the buzzer require adjusting, it will be necessary to open the lid. This is also necessary in the case of changing tubes or "B" batteries, but under all other conditions the lid should remain closed.

**How to Lay Out the Base Lines.**—When laying out the base lines of various stations communicating with each other, it is very important to follow the general rule of arranging them so that the imaginary straight line joining the centers of the base lines of the stations will make equal angles with the two base lines, the angles considered being taken on the same side of that imaginary line and between the base lines. The best position is that in which the two base lines are parallel to each other and the line joining their centers makes right angles with them. This arrangement is indicated in the first drawing of Fig. 6. The other two drawings show the applica-

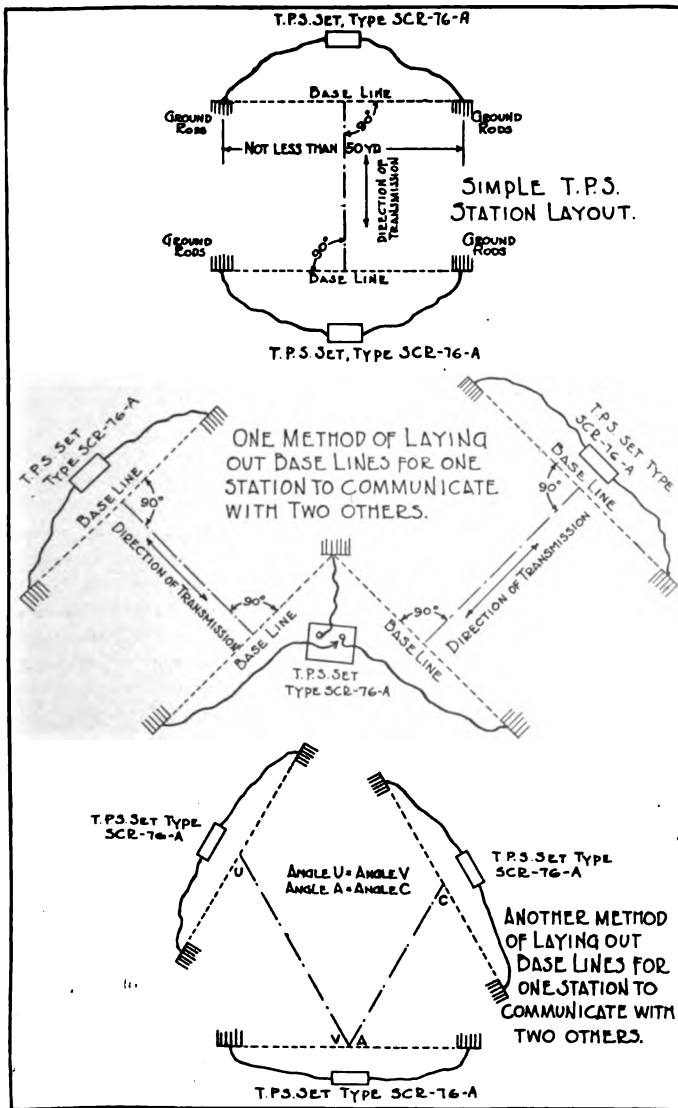

FIG. 6.—Methods of Laying Out a Simple T. P. S. Station, and One Station to Communicate with Two Others.

tion of the above rule by two different methods to the case of one station communicating with two others.

If one station is to communicate with a number of different stations, best results are obtained by providing at that one station a number of base lines, laid out radially around the station in positions at right angles, respectively, to the lines joining that base line to each of the other station base lines. A selector switch then enables the connection of the central station to any desired base line.

The installation of such a central station may be made in a number of different ways. Two methods are illustrated in Fig. 7, making use of Switch Type SW-16. By the method shown in the upper drawing, any one of the four outer ground terminals may be used with the local ground to make four different base lines, these covering closely almost any direction. By the method shown in the lower drawing, the two switches will usually be placed to make A and A, or B and B, etc., the ends of the base line in use. However, the terminals D and B on opposite switches might be used as the pair of ground terminals if they were laid out the proper distance apart. This gives an idea of the various combinations possible.

The first method is preferable, it being easier to install and operate. There are only five grounds to establish, and one-half of the selector switch only is used. In the second method, both sides of the switch are used and there are eight grounds to establish.

When a station having a single line is to communicate with a central station having the choice of a number of base lines, the single station will establish its base perpendicularly to the line joining the two stations. The central station then selects the one of its bases which is nearest perpendicular to the line joining the two stations.

The best method for laying out the base lines is to use a compass, by means of which the direction of the bases of the various stations can be determined accurately. A number of types of compasses are in use, which makes it impossible to give definite rules as to their use in this connection.

Another important consideration is the method of grounding the far ends of the base line wires. Twelve ground rods are furnished with the set. At least four rods should be driven into the ground in a straight line at each end of the base, and at a distance apart of not less than 2 ft. They should be driven at least 1 ft. into the ground. It is well to moisten the ground around the rods after they have been driven in.

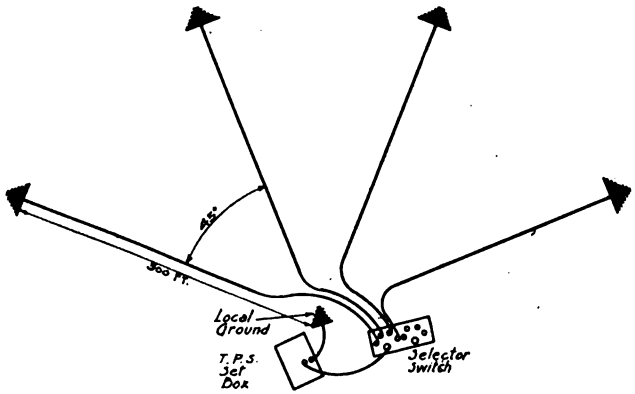

*VARIOUS METHODS OF USING T.P.S. SELECTOR SWITCH*

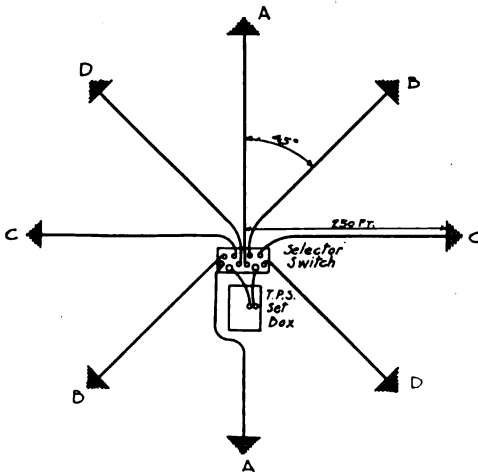

FIG. 7.—Methods of Laying Out Central T.P.S. Station.



Special care should be taken to use only line wires having perfect insulation for connecting the ground rods to the set box. These line wires may be buried in the ground if desired in order to protect them somewhat from shell fire. This, however, may increase the difficulties in case it is necessary to repair the wire after it has been cut by a shell. Inspect the line wires frequently to see that they are in good condition. If splices have to be made, insulate them carefully. Never use lead covered cable for these wires.

In order to make ground connections of low resistance, it is often useful to bury tin cans, shell cartridges, pieces of pipe, etc., in addition to the ground rods, or in place of them in cases of emergency. All these metallic masses should be carefully interconnected and connected to the line.

For more complete details on the theory of ground telegraphy and the methods of laying out ground stations, see Radio Pamphlet No. 10. For details of the listening-in service and the means of coping with interference, see Radio Pamphlet No. 18.

### **Method of Setting Up and Operating.**

**Installation of the Grounds.**—After the direction of the base line has been determined, a ground connection is made at each end of the base, the grounds being separated by a distance of approximately 500 ft.

1. The base line wire is run out from the set box by means of the breast reel, on which is wound 500 ft. of wire. One end of the wire is connected to the set box, as explained below. At the other end drive four to six ground stakes as deep as possible into the ground, in a straight line coinciding with the line of the base, and with at least 2 ft. separation between adjacent stakes. All the stakes are connected together by means of a wire which is then spliced to the line wire.

2. Near the set box, drive another group of four to six stakes into the ground and interconnect them similarly. This ground is connected to the other line wire from the set box. If possible, moisten the ground around each ground connection by pouring some water over the ground stakes after they have been driven in.

**Connecting up the Set.**—While the base line is being established, the set box can be connected up in the following manner:

3. Connect the free ends of the base line wires to the two binding posts on the left hand side of the set box.

4. Open the canvas pocket on the right hand side of the box and connect the 10-volt storage battery to the terminals in that pocket, using the battery plug or ordinary connection wires. If under exceptional circumstances it is desired to increase the range, 20 volts may be used for energizing the buzzer. In this case, connect one 10-volt battery between the "0" and "10 V" binding posts, with the positive pole of the battery to the "10 V" binding post, and connect another 10-volt battery to the "10 V" and "20 V" binding posts, with the positive pole of the battery to the "20 V" binding post.

5. Unbutton the front curtain covering the operating panel of the box and open the cover of the box to remove the telephone receivers. At the same time, check up that the two vacuum tubes in use are in good shape. These are the two tubes which are mounted directly in back of the operating panel of the box. Also check up that the two dry batteries are connected up with the proper polarity.

6. See that the line lamp is in good condition. This is the small lamp mounted in back of the opening in the front panel, which is ordinarily covered by the telegraph key when the latter is folded flush with the panel.

7. Three small binding posts are mounted inside the box, on the rear wall, above the spare line bulbs, and a strap fastened to the center post may be made to connect across either pair. If 20 volts are to be used for energizing the buzzer, connect the metal strap between the two right hand binding posts. If a 10-volt battery only is to be used, connect the strap between the two left hand binding posts.

**Adjustments for Transmitting.**—8. Place the right hand switch of the operating panel in the "Send" position.

9. Open the top of the box and by means of the special wrench to be found in this cover, fasten the desired weight to the power buzzer armature, according to the frequency at which it is desired to transmit. The following frequencies may be obtained by attaching the weight indicated:

	Cycles per second.
Large weight out.....	630
Large weight in.....	700
2 small weights out.....	830
1 small weight out.....	980
1 small weight in.....	1150
No weights.....	1380

10. Unlock the buzzer adjusting screw. Straighten out the telegraph sending key and depress it so that the buzzer will vibrate. Hold the key down and adjust the buzzer adjusting screw until a good clear note is obtained, then lock the screw in this position. As the current input into the ground is greater, the tighter the adjustment, the screw should be turned in as far as possible and retain a clear tone. If the tone is ragged, it is very difficult to eliminate interference at the receiving station.

11. Close the top cover. The set is now in operating condition for transmitting.

12. In order to test whether the base line wires are in good condition, and whether the proper current is flowing into the ground, depress the small black push button at the right of the key, and observe that the small line bulb is glowing. If it fails to light or glow, the base line must be broken or the buzzer is poorly adjusted.

13. The gap and tension of the sending key may be adjusted by means of the two screws located on the panel at the left of the stem of the key, the upper screw being the gap adjustment, the lower screw being the tension adjustment.

**Adjustments for Receiving.** 14.—Place the right hand switch of the operating panel in the "Receive" position.

15. Observe that both vacuum tubes are glowing by looking through the mica covered openings in the operating panel.

16. Open the cover of the box, check up the polarity of the dry batteries, and close the cover again.

17. Insert the telephone receiver plug into one of the jacks.

18. In order to vary the intensity of the received signals, such as for minimizing interference, operate the "Amplification" switch of the panel (left hand switch marked "Filament Rheostat" in Fig. 3).

19. While waiting for signals, check up frequently that the filaments of both vacuum tubes are glowing, as an assurance that the set is in operating condition and that nothing is being missed.

### **Precautions.**

When the set is not in use, the transmit-receive switch must be placed in the "Off" position, so that there will be no possibility of running down batteries unnecessarily.

Always keep the set box dry and waterproof. Keep the rubber gaskets on the cover clean so that they will keep moisture out of the box. In case of rain, cover the operating panel of the set with the canvas curtain furnished for this purpose.

Do not operate the set on run down batteries. Check up the voltage of the storage battery (10 volts) and of each dry battery separately (20 volts) by means of the voltmeter furnished with the set. The lower limit of working voltage for the dry batteries is 17.5 volts per battery.

It is impossible to operate the set for receiving messages with only one vacuum tube inserted, or with one tube broken or burned out. Two good tubes in place are essential. At least two spare tubes should be kept on hand at all times. This will be a sufficient supply to take care of the requirements between times of getting new supplies from the depot.

Take note that the contact points on the buzzer vibrator are clean and not pitted or burned. If they require cleaning or truing up, remove them by means of the wrench, and gently rub them against some emery cloth on a plane surface. Do not use the file unless absolutely necessary. Replace the contacts carefully, with their surfaces in plane contact. Be sure to place the upper contact on the upper armature and the lower one on the lower armature. Do not interchange them.

Keep the connection leads as dry as possible. Frequently inspect the base line wires, as they may be broken by shell fire and this makes communication impossible.

While sending, another check on the condition of the line wires is obtained by means of the small line lamp, as explained in the operating instructions. Care should be taken that this lamp does not remain in the circuit while sending messages, and that the push button springs back in position when not used, short circuiting the lamp filament.

It is important to check up the connection of the three binding posts on the back wall inside the set box, and see that the position of the connection strap is correct for the storage batteries being used with the set.

### **Comparison of SCR-76-A with SCR-71 and SCR-72 Combination.**

The advantages of the SCR-76-A set over the former practice of utilizing the SCR-71 buzzer and SCR-72 amplifier are given as follows:

1. The set is more convenient to set up, as there is no switch to connect, thereby avoiding the numerous short interconnecting wires. Generally, all connections are easier to make.

# WIRING DIAGRAM or SET BOX, TYPE BC-21-A

*Note - Wires marked 3 are No. 16 B&S, solid square conductor. Other wires are No. 16 stranded. Coil X is a 0.3-ohm resistance mounted in rear of box. Conductors having like designations to be connected.*

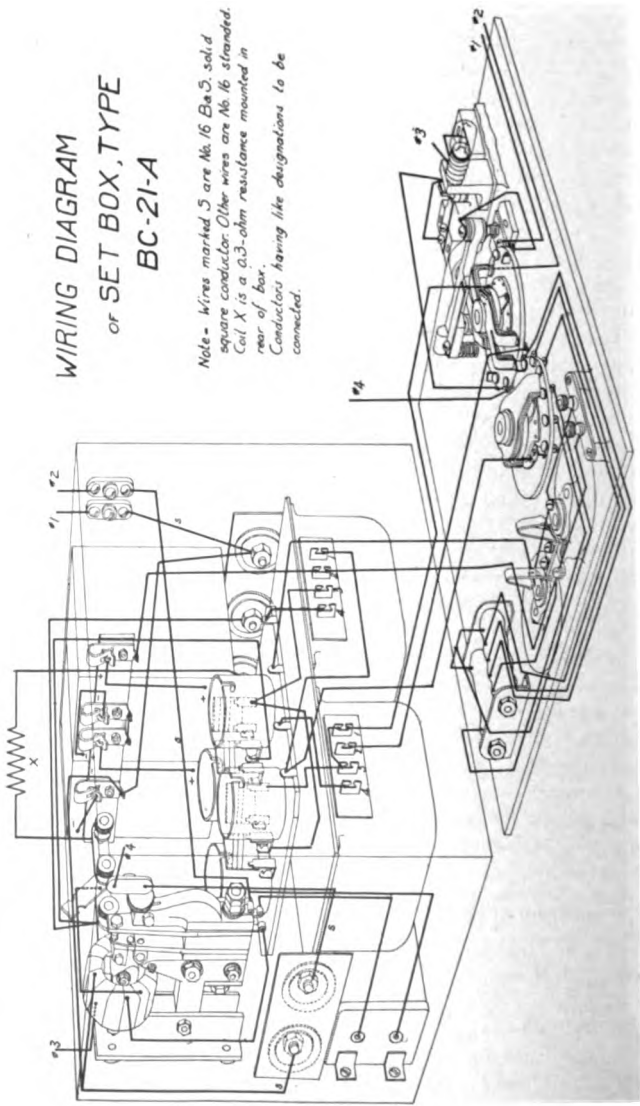

2. The radio apparatus is easier to transport, as it is contained in a single box which is not an excessive load for one man. The total weight of the two sets SCR-71 and SCR-72 is somewhat greater than that of the SCR-76-A.

3. A great advantage is that there is only one storage battery required for the set, the 4-volt filament battery of the former set being entirely eliminated.

4. Space for spare vacuum tubes and dry batteries is provided within the set, while they had to be carried in separate boxes with the old sets.

The following disadvantages may be pointed out:

1. If the set is used at stations where one-way communication only is required, the SCR-76-A set provides superfluous material and equipment.

2. The amplifier of the SCR-76-A set cannot be used for radio frequency amplification purposes. If it is desired to use it in connection with radio signals, it must be connected in the audio frequency circuits of the receiving set.

### PARTS LIST.

In ordering this set or parts of this set, specification must be made by names and type numbers as listed below, exactly. The designation printed in bold face type *only* will be used in requisitioning, making property returns, etc.

In ordering *complete* sets it is not necessary to itemize the parts; simply specify, "1 Set, Two-Way T.P.S., Type SCR-76-A." If all the parts listed under a group heading are desired, it is not necessary to itemize the parts; simply specify, for example, "1 Equipment Type RE-3-A."

The type SCR-76-A set is not complete unless it includes all of the items listed below.

#### **Set, Two-Way T.P.S Type SCR-76-A.**

**Equipment Type PE-11:** power:

**3 Batteries, Type BB-23;** storage; lead; 10-volt, 20 amp-hr.; acid for electrolyte to be supplied separately in carboys; 1 in use, 2 spare.

(Or, as an alternative, not for overseas use, **Equipment Type PE-13;** power, comprising **2 Batteries, Type BB-3;** storage; Edison; 10-volt, 8-cell, 25-amp-hr.; with electrolyte in separate containers; 1 in use, 1 spare.)

<b>Equipment Type GD-3-A; ground:</b>	<b>★</b>
1 Bag Type BG-8; carrying.....	(1)
12 Stakes Type GP-6; ground.....	(2)
2 Drums Type DE-8; for breast reel.....	(3)
1 Reel Type RL-6; breast.....	(4)
1000 ft. Wire Type W-4; two 500-ft. lengths, each wound on drum.....	(5)
60 ft. Wire Type W-5; two 30-ft. lengths, each wound in 3-in. coil.....	(6)
1 Hammer Type HM-1.....	(7)
<b>Equipment Type BE-3-A; t.p.s.</b>	
1 Set Box Type BC-21-A; two-way t.p.s.....	(8)
1 Cord Type CD-61; extension; set box to battery.....	(9)
1 Tool Roll Type BG-20.....	(Not shown.)
1 Weight Type WT-2; large; for vibrator.....	(10)
2 Weights Type WT-3; small; for vibrator.....	(11)
2 Contacts Type CN-1; upper; for vibrator; spare.....	(12)
2 Contacts Type CN-2; lower; for vibrator; spare.....	(13)
1 Wrench Type TL-6; for changing vibrator weights....	(14)
1 Gage Type TL-7; air gap; for vibrator.....	(15)
1 File Type TL-5; for vibrator contacts.....	(16)
2 Head Sets Type P-11; telephone.....	(17)
4 Batteries Type BA-2; dry; 2 in use, 2 spare.....	(18)
4 Tubes Type VT-1; vacuum; receiving; 2 in use, 2 spare.	(19)
3 Lamps Type LM-6; current indicating; 1 in use, 2 spare	(20)
1 Bag Type BG-13; carrying.....	(21)
1 Switch Type SW-18; selector.....	(Not shown.)
1 Compass Type I-1; "cebynite" or equivalent.....	(22)
½ lb. Tape friction; ¼ in.....	(23)
1 Pliers Type TL-19; pair combination.....	(24)
1 Voltmeter Type I-10; 0-10/0-50 volts; with lead (Not shown.)	
1 Screwdriver Type TL-2.....	(25)
1 Sheet Emery Cloth, No. 4-0; approx. 11 in. x 8 in.....	(26)

\* Figures in parenthesis in the right hand column refer to the corresponding parts in the illustration on the opposite page.

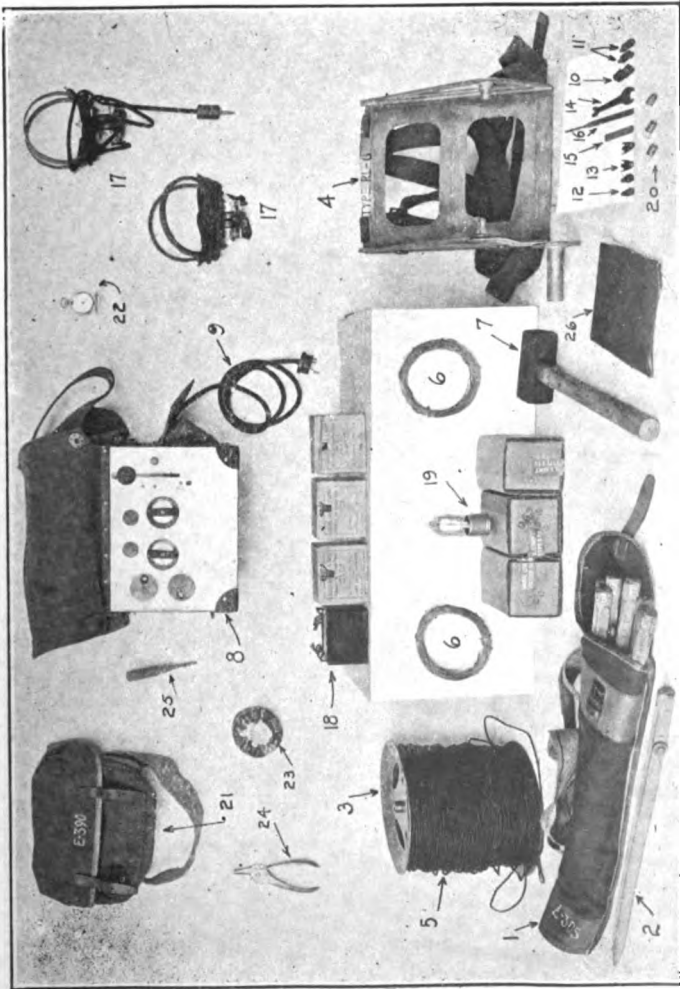







---

**Prepared in the  
Office of the Chief Signal Officer  
Training Section  
Washington**

---

*CR*  
FOR OFFICIAL USE ONLY

# TWO-WAY T.P.S. SET

Type SCR-76

(Confidential)

*Communication*  
Radio Pamphlet  
No. 15

Signal Corps, U. S. Army

8-10-18

THE UNIVERSITY OF CHICAGO  
LIBRARY

**Two-Way T.P.S. Set**  
**Type SCR-76**



## TWO-WAY T. P. S. SET, TYPE SCR-76

The type SCR-76 set is a transmitting and receiving set for ground telegraph work (T. P. S. or earth induction), and is therefore to be used at stations where two-way communication is necessary. It is practically an assembly of the type SCR-71 T. P. S. buzzer and the type SCR-72 amplifier (with some important changes in design) into a single unit to facilitate the installation and use of the two when both are required at one location. The set comprises an adjustable frequency power buzzer, a telegraph key for sending, and a two-stage vacuum tube low frequency amplifier for receiving. The power required to operate the buzzer and to light the filaments of the vacuum tubes is derived from a 10-volt storage battery.

### Principles of Operation

The principle of operation of the SCR-76 set is illustrated in the wiring diagram given herewith, Fig. 1. In general it consists of generating by induction, high potential current of audio frequency, which is caused to flow through the ground between two ground terminals separated by about 500 ft. In flowing through the ground, the lines of current spread out in all directions so that some of them may be intercepted at considerable distances by a suitable receiving device similarly connected to the ground and sensitive enough to respond to the extremely small currents thus received by conduction through the earth. Then by breaking up the pulsating emf. impressed on the ground into dots and dashes, it is possible to read the signals at the receiving station.

In the two-way T. P. S. set, the same ground connections and the same 10-volt storage battery are used for both sending and receiving, this being accomplished by means of a double pole double throw "Transmit-Receive" switch mounted on the panel of the set. With the switch in the "Transmit" position, the local circuit from the storage battery through the sending key and the primary of the power buzzer is completed and the base line wires are connected directly to the secondary or high potential winding. When the sending key is closed, the vibrator interrupter makes and breaks the current through the primary winding at a frequency which is controlled by means of small



weights screwed to the vibrating armature. The following frequencies are possible :

- Large weight out . . . . . 630 cycles per second.
- Large weight in . . . . . 700 cycles per second.
- Two small weights out . . . 830 cycles per second.
- One small weight out . . . 980 cycles per second.
- One small weight in . . . 1150 cycles per second.
- No weights . . . . . 1380 cycles per second.

The pulsating primary current resulting from the action of the buzzer, induces an alternating emf. of high potential in the secondary winding.

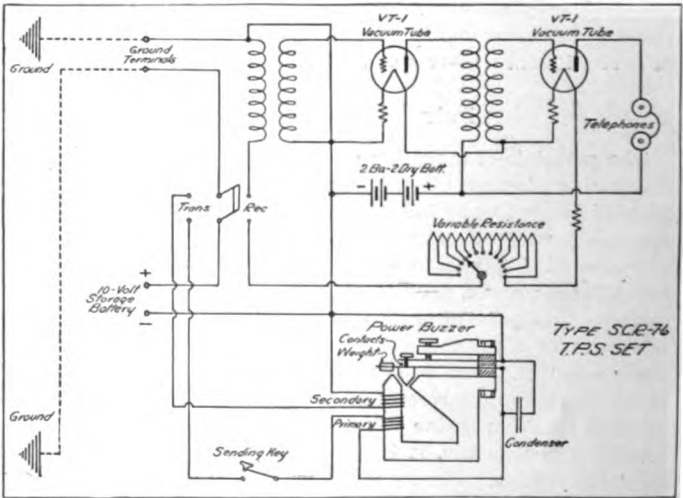

Fig. 1—Schematic Circuit Diagram of Two-Way T.P.S. Set.

The power buzzer is a double winding, closed magnetic circuit, buzzer interrupter, of practically the same construction as the SCR-71 T.P.S. buzzer. As in the SCR-71 buzzer, a condenser is connected across the vibrator contact points to reduce the spark and improve operation. For every change of frequency, the screw on top of the buzzer should be adjusted to give a good clear note, and then locked in position. The adjustment should be made as tight as possible and still give a clear note, as the current input into the ground will then be a maximum.

For good operation of the buzzer, the vibrator contact points must be clean, and the surfaces even and parallel. After

some time, these contact points may become pitted and require cleaning and truing up. It is best not to use the file furnished with the set, but to remove the contacts from the vibrator,

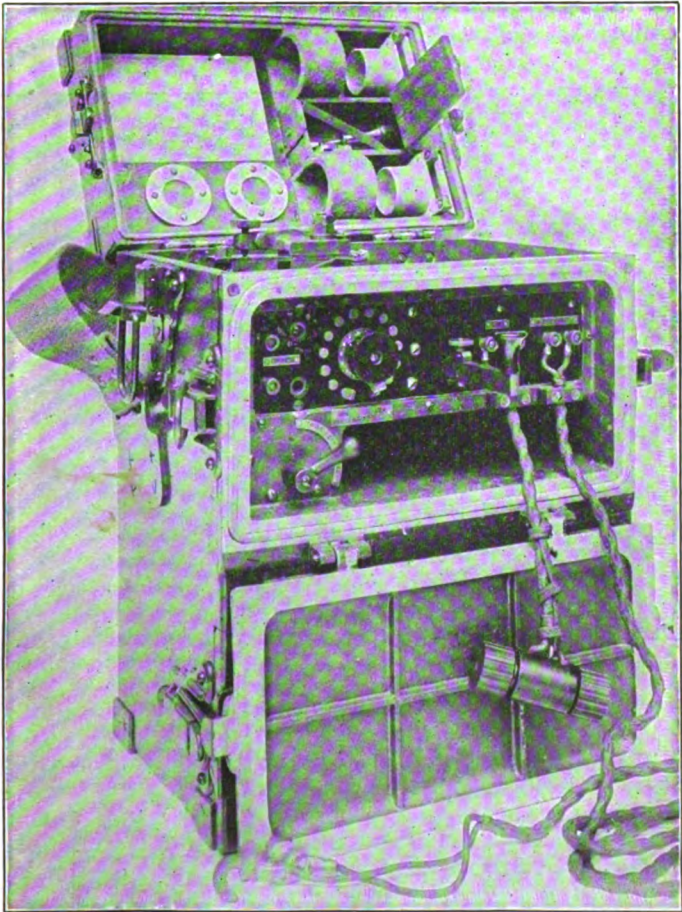

Fig. 2—Buzzer in Top Compartment and the Operating Panel on the Side.

and rub them gently on a piece of emery cloth laid on a flat surface. Only in exceptional cases will it be found necessary

to use the file or to replace the contact points with the spare ones furnished with the set.

With the switch closed in the "Receive" position, the base and 10-volt battery are connected to the amplifier. This is a low frequency, two stage amplifier, using two type VT-1 three-electrode vacuum tubes connected for cascade amplification by

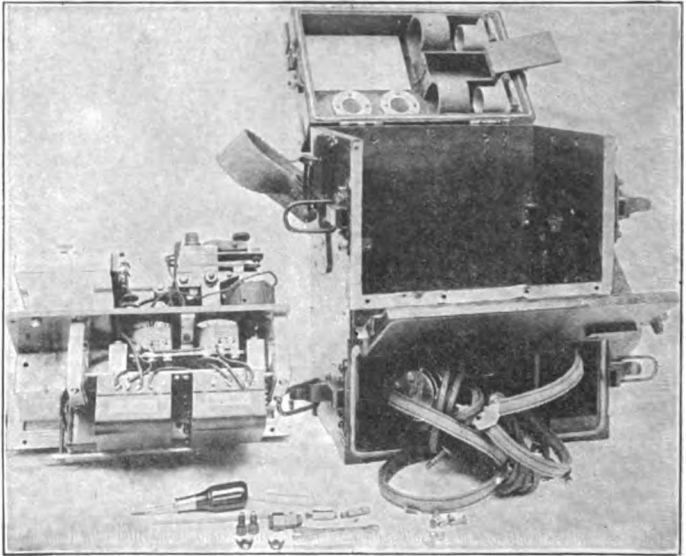

Fig. 3—Radio Apparatus Removed from Set Box.

means of two iron core transformers. Jacks and binding posts for connecting telephone receivers are provided in the plate circuit of the last tube. The filaments of the two tubes are connected in series to the 10-volt storage battery. Three fixed resistances having a total value of 3.9 ohms, and a 6-ohm resistance variable in 12 steps, are in series with the filament circuit. The variable resistance is operated by means of a dial switch on the operating panel of the set, and is cut entirely out of the circuit on the last point to the right, this being the position for maximum amplification. To reduce the degree of amplification, the rheostat is turned to the left to insert resistance in the filament circuit. This decreases the filament temperature and reduces the electron emission in the tubes,

and hence the degree of amplification. A plate potential of about 45 volts is obtained for both tubes by means of two type BA-2 dry batteries connected in series. When the battery voltage has run down to 34 volts, (17 volts each) the batteries should be replaced.

When it is necessary to replace the dry batteries of the amplifier circuit, particular care must be taken to see that they are connected in with the correct polarity. This is essential for the operation of the vacuum tubes. It is also necessary that both vacuum tubes be in good condition, since the amplifier cannot operate on one tube only, with the other one broken, burned out, or out of the circuit. If the amplifier does not work properly, this may be due to a poor telephone connection, or to a wrong connection of either the storage or the dry batteries, or to the failure of one of the tubes.

When the set is not in use, the Transmit-Receive switch should be in the "Off" position as this will avoid any possibility of unnecessarily running down the storage battery.

### **Mounting of the Set**

The set is mounted in a rugged wooden case having the overall dimensions,  $15\frac{1}{4}$  in. x  $12\frac{3}{4}$  in. x  $8\frac{1}{2}$  in. This case is provided with three doors or covers, one at the top and two on the front side, which close against rubber gaskets and are held tightly by strong toggle latches, Fig. 2 and Fig. 3. This construction makes the set fairly waterproof, especially if care is taken to keep the rubber gaskets clean and free from dust or mud before clamping the doors shut.

The upper cover gives access to the power buzzer, the tubes in use, and the dry batteries in use. Two spare vacuum tubes, spare parts for the buzzer, the vibrator weights and tools are mounted in the top of the cover. This cover should be open only while adjusting the buzzer or replacing tubes or batteries. It should be kept closed during operation, particularly in rainy weather.

The upper side-cover is of metal and hinges downward. It encloses the operating panel of the set. On this are mounted the telegraph sending key, the filament rheostat, the "Transmit-Receive" switch, two telephone jacks and two emergency telephone binding posts, two binding posts for the line wires, and two binding posts for connecting the 10-volt storage battery.

The telegraph sending key may be folded back against the panel so that it will not protrude beyond the face of the box and thus will allow the cover to close.

Two twisted pair cords are also permanently attached to panel binding posts. One of these is provided with lugs for making connection to an Edison storage battery, and the other is connected to a special double terminal block by means of which connection to the two base line wires is effected. When not in use, these two cords are folded in the pocket provided underneath the operating panel which may be clearly seen in Fig. 2. If a French made storage battery is used instead of an Edison battery, the connection lugs are to be replaced by special terminals provided for the purpose, and normally kept in the top cover box compartment of the set. A rubber curtain is provided with the set to protect the operating panel while using the set in rainy weather.

The bottom compartment of the box, which is normally closed by a wooden cover hinging upward, contains two P-11 telephone head sets and two spare BA-2 dry batteries, Fig. 3.

It may be necessary to take the set apart for repair or inspection. This may be done by opening the top cover and the metal side door and unscrewing the six screws which fasten the panel frame work to the set box. The entire set will then come out of the box as a unit.

### Opening a Station

To open a station, the base line, approximately 500 ft. long, is established in accord with the rules laid down below. The set box is then laid horizontally on its back, the bottom door opened, the telephone head receivers removed, and the door carefully clamped shut. This is done in order to keep the set clean and waterproof. The box is then set upright and the metal side door opened. The battery wires are connected to the 10-volt storage battery terminals, due regard being given to the polarity. The two base line wires are connected to the special connector. In order to remove any mechanical strain from the electrical connections on the connector, the line wires are tied together with a piece of cord about 8 in. from their free ends and the cord is tied to the small metal ring at the center of the connector. All these inter-connections between set parts are shown in Fig. 4.

The telephones are plugged in the telephone jack, or connected to the telephone binding posts. By moving the switch to "Re-

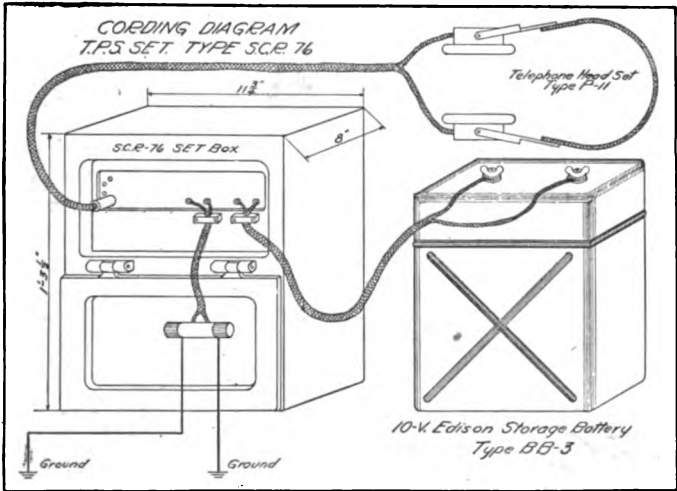

Fig. 4—Cording Diagram of T.P.S. Set, Type SCR-76.

celve" and setting the filament rheostat to the desired value (generally to "Maximum"), the set is ready for receiving signals. If it is desired to send a message, the switch is thrown to "Transmit", the telegraph key straightened out and the buzzer adjusted to give a clear note of the desired frequency. This is done, after opening the top cover, by placing the proper weight on the vibrator armature and adjusting the set screw of the buzzer. The cover is then closed and the set is ready for operation.

### How to Lay Out the Base Lines

When laying out the base lines of various stations communicating with each other, it is very important to follow the general rule of arranging them so that the imaginary straight line joining the centers of the base lines of the stations will make equal angles with the two base lines, the angles considered being taken on the same side of that imaginary line and between the base lines. The best position is that in which the two base lines are parallel to each other and the line joining their centers makes right angles with them. This arrangement is indicated in the first drawing of Fig. 5. The other two drawings show the application of the above rule by two different methods to the case of one station communicating with two others.

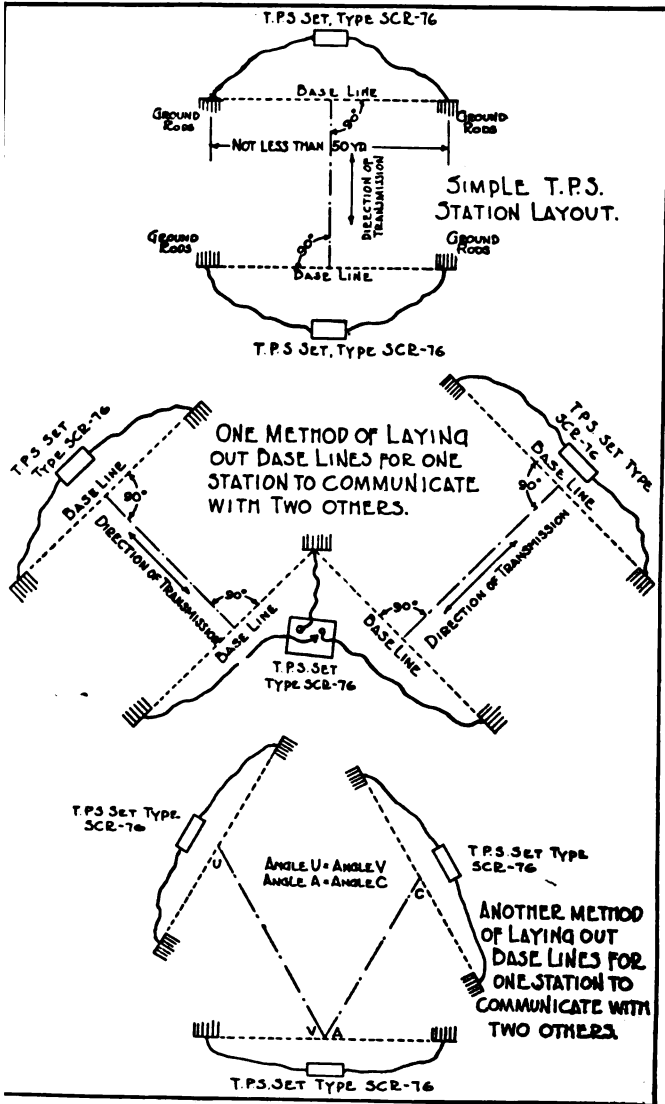

Fig. 5—Methods of Laying Out Simple T.P.S. Station, and One Station to Communicate with Two Others.

If one station is to communicate with a number of different stations, best results are obtained by providing at that one station a number of base lines, laid out radially around the station in positions at right angles, respectively, to the lines joining that base line to each of the other station base lines. A selector switch then enables the connection of the central station to any desired base line.

The installation of such a central station may be made in a number of different ways. Two methods are illustrated in Fig. 6. By the method shown in the upper drawing, any one of the four outer ground terminals may be used with the local ground to make four different base lines, these covering closely almost any direction. By the method shown in the lower drawing, the two switches will usually be placed to make A and A, or B and B, etc., the ends of the base line in use. However the terminals D and B on opposite switches might be used as the pair of ground terminals if they were laid out the proper distance apart. This gives an idea of the various combinations possible.

The first method is preferable, it being easier to install and operate. There are only five grounds to establish, and one half of the selector switch only is used. In the second method, both sides of the switch are used and there are eight grounds to establish.

When a station having a single base line is to communicate with a central station having the choice of a number of base lines, the single station will establish its base perpendicularly to the line joining the two stations. The central station then selects the one of its bases which is nearest perpendicular to the line joining the two stations.

The best method for laying out the base lines is to use a compass, by means of which the direction of the bases of the various stations can be determined accurately. A number of types of compasses are in use, which makes it impossible to give definite rules as to their use in this connection.

Another important consideration is the method of grounding the far ends of the base line wires. Twelve ground rods are furnished with the set. At least four rods should be driven into the ground in a straight line at each end of the base, and at a distance apart of not less than 2 ft. They should be driven at least 1 ft. into the ground. It is well to moisten the ground around the rods after they have been driven in.



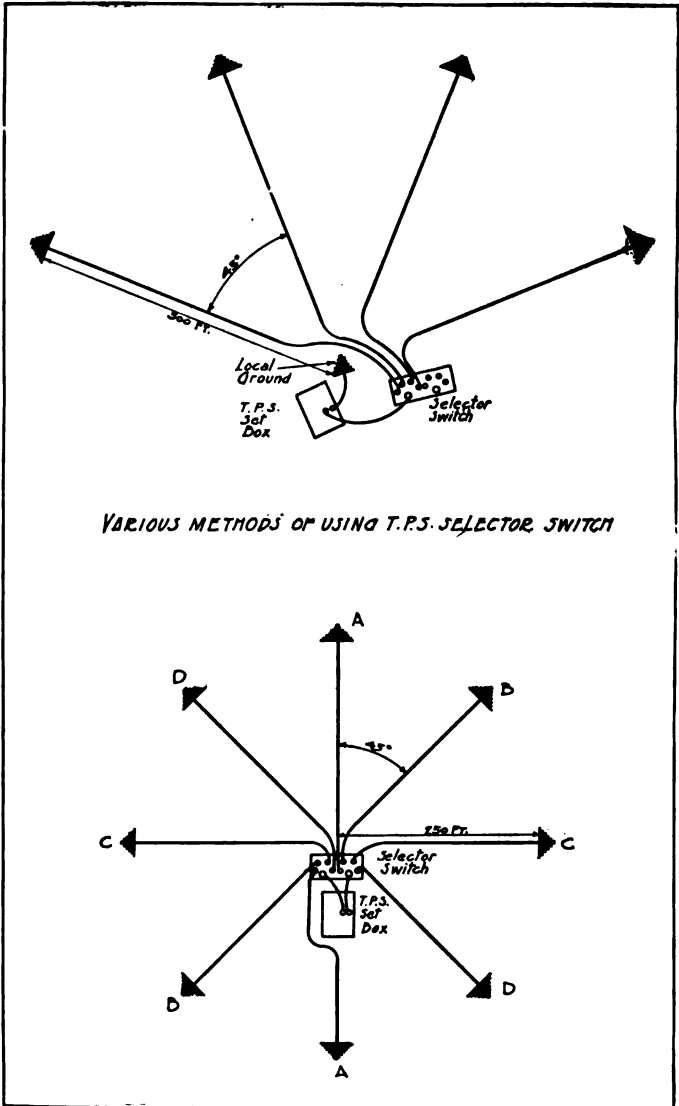
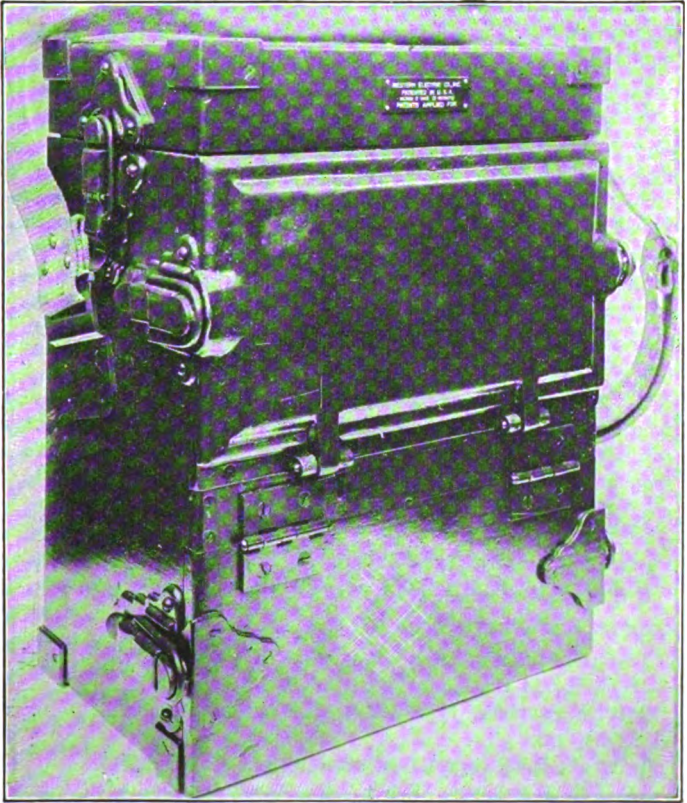

Fig. 6—Methods of Laying Out Central T.P.S. Stations.

For more complete details on the theory of ground telegraphy, and the methods of laying out ground stations, see Radio



**Fig. 7—Type SCR-76 Set Box Closed Up and Waterproof.**

Pamphlet No. 10. For details of the listening-in service and the means of coping with interference, see Radio Pamphlet No. 18.

### **Comparison of SCR-76 with SCR-71 and SCR-72 Combination**

The advantages of the SCR-76 set over the former practice of utilizing the SCR-71 buzzer and SCR-72 amplifier are given as follows:

1. The set is more convenient to set up, as there is no switch to connect, thereby avoiding the numerous short interconnecting wires. Generally, all connections are easier to make.

2. The radio apparatus is easier to transport, as it is contained in a single box which is not an excessive load for one man. The total weight of the two sets SCR-71 and SCR-72 is somewhat greater than that of the SCR-76 box.

3. A great advantage is that there is only one storage battery required for the set, the 4-volt filament battery of the former set being entirely eliminated.

4. Space for spare vacuum tubes and dry batteries is provided within the set, while they had to be carried in separate boxes with the old set.

The following disadvantages may be pointed out:

1. If the set is used at stations where one-way communication only is required, the SCR-76 set provides superfluous material and equipment.

2. The amplifier of the SCR-76 set cannot be used for radio frequency amplification purposes. If it is desired to use it in connection with radio signals, it must be connected in the audio frequency circuits of the receiving set.

### **Parts List of the Two-Way T.P.S. Set, Type SCR-76**

#### **POWER EQUIPMENT, TYPE PE-13.**

2 Storage Batteries, type BB-3. (1 in use, 1 spare).

#### **GROUND EQUIPMENT, TYPE GD-3.**

12 Ground Rods, type GP-4; size 22½ in. x ⅝ in.; weight 5 lb. 14 oz.

2 Wire Carriers, type DR-3; for breast reel; size 9 in. x 9½ in.

1 Breast Reel, type RL-6; size 10 in. x 12 in. x 2 in.

1,000 ft. Wire, type W-4, in two 500-ft. lengths, each wound on wire carrier, type DR-3; net weight 20 lb.; modified B & S No. 16 gage.

1 Carrying Bag, type BG-3 for wire, ground stakes, etc.

60 ft. Wire, type W-5; 16 strands of No. 30 B & S soft copper, braided, in two 30-ft. lengths, each wound in 3-in. coll.

#### **T. P. S. EQUIPMENT, TYPE RE-3.**

1 T.P.S. Set Box, type BC-21; size 15½ in. x 11¾ in. x 8 in.; weight 32 lb.

1 Large Weight for vibrator, type WT-2.

- 2 Small Weights for vibrator, type WT-3.
- 2 Spare Upper Contacts for vibrator, type CN-1.
- 2 Spare Lower Contacts for vibrator, type CN-2.
- 1 Wrench for changing vibrator weights, type TI-6.
- 1 Air Gap Gauge for vibrator, type TL-7.
- 1 Contact File for vibrator, type TL-5.
- 2 Telephone Head Sets, type P-11; total weight 2 lb. 4 oz.
- 4 Dry Batteries, type BA-2 (2 in use, 2 spare); weight 3 lb. 8 oz.
- 4 Vacuum Tubes, type VT-1 (2 in use, 2 spare).
- 1 Selector switch, type SW-16.
- 1 Compass, type I-1.
- 1 Roll Friction Tape,  $\frac{3}{4}$ -in., Spec. 569-B.
- 1 Pair Pliers, type TL-19; Universal.
- 1 Voltmeter, type I-2; with leads; 8 to 24 volts, d.c.
- 1 Screwdriver, type TI-2.
- 1 Sheet Emery Cloth, 11 in. x 8 in.
- 1 Carrying Bag, type BG-13; size  $9\frac{1}{2}$  in. x  $7\frac{1}{2}$  in. x 1 in.

#### CARRYING UNITS.

All of the above parts are included in five carrying units, as follows:

1. Set Box, type BC-21,  $15\frac{1}{2}$  in. x  $11\frac{3}{4}$  in. x 8 in.; weight 39 lb., including telephone head sets, dry batteries, vacuum tubes, etc.
2. Carrying Bag, containing 12 ground rods, 2 spools of wire and 2 coils of wire.
3. Storage Battery, type BB-3, 10 volts; 11 in. x  $10\frac{1}{2}$  in. x 7 in.; weight 45 lb.
4. Carrying Bag, containing compass, voltmeter, tape, screwdriver, pliers, emery cloth, selector switch, also breast reel if desired.
5. Breast Reel, type RL-6, 10 in. x 12 in. x 2 in., when not included in unit 4 above.





\_\_\_\_\_ 21 \_\_\_\_\_

Prepared in the  
Office of the Chief Signal  
Training and Instruction Division  
Washington

\_\_\_\_\_

1922  
1922

FOR OFFICIAL USE ONLY

**RADIO TELEGRAPH  
TRANSMITTING SET**

Type SCR-69

*(Confidential)*

**Radio Pamphlet  
No. 14**

**Signal Corps, U. S. Army**

Second Edition, Revised to  
10-30-18



\_\_\_\_\_ 501

**Prepared in the  
Office of the Chief Signal  
Training and Instruction Dir.  
Washington**

\_\_\_\_\_

12.2  
192

FOR OFFICIAL USE ONLY

**RADIO TELEGRAPH  
TRANSMITTING SET**

Type SCR-69

*(Confidential)*

**Radio Pamphlet  
No. 14**

**Signal Corps, U. S. Army**

Second Edition, Revised to  
10-30-18



**Radio Telegraph Transmitting Set  
Type SCR-69**



**T**HE RADIO telegraph transmitting set, type SCR-69, is an undamped wave set which is intended primarily for use as an instruction unit. It is designed to serve somewhat the same purpose as the French E-3 or E-10 sets and is issued only to organizations in training. Light weight, high efficiency and sharp tuning are its special characteristics. Three kinds of undamped wave sending may be used with the one set, making it possible to communicate with a receiving station, whether the latter is equipped with a heterodyne or an ordinary rectifying detector set. This feature makes it more or less universal in character and particularly

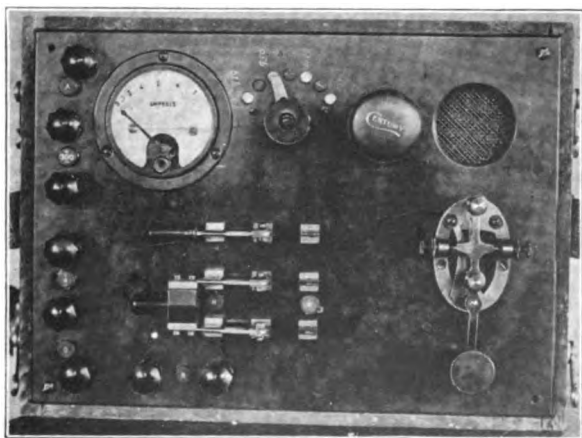

**Operating Panel of Type SCR-69 Transmitting Set**

suited to use under training conditions where several types of receiving sets may be employed. In case the batteries of a heterodyne or autodyne receiving unit working with this transmitting set should fail, it would still be possible to use this same set by sending buzzer-modulated waves and receiving by ordinary crystal detection.

As the operating characteristics of this set have not been satisfactory, only a comparatively small number of sets will be manufactured, and it is anticipated that these will be displaced in the near future by the type SCR-79 set, described in Radio Pamphlet No. 17.

## Description of the Set

The type SCR-69 set consists essentially of a three-electrode vacuum tube, type VT-12, having its grid and plate circuits inductively coupled together and to the antenna. The three coupling coils (antenna, plate and grid coils) are mounted on the same axis. The antenna and grid coils are about 7 in. in diameter and the plate coil is about 3 in. in diameter, and these coils are so wound that the capacitance between the turns is reduced to a low value. The wave length of the set may be changed by means of the four taps on the antenna coil, whereby four different wave lengths ranging between the limits of about 600 meters and 1500 meters with a type A-6 antenna, can be secured. A definite specification as to the type of antenna to be used with this set has

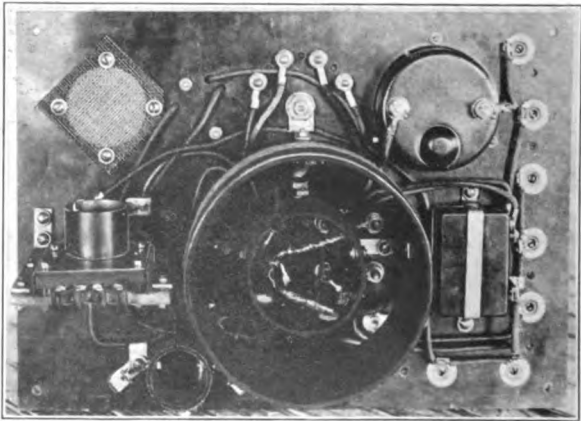

**Mounting of Apparatus on Under Side of Panel**

not been made. Its operation with the type A-6 antenna is somewhat improved by opening the "V" to a greater angle than the standard 60 deg., in order to increase the capacitance of the antenna. The greatest capacitance is obtained when the angle is 180 deg. The three masts should then be erected in a straight

line with the station it is desired to signal, the lead-in wires being connected as usual at the center.

The vacuum tube plate current is supplied by a dynamotor running on a 10-volt storage battery to supply 325 volts potential between the plate and the filament. The high voltage side of this dynamotor is shunted by a condenser which serves the double purpose of smoothing out the small variations in the 325-volt direct current supply, and of providing a path for the high frequency oscillations generated by the tube which would otherwise be choked out by the impedance of the dynamotor windings. A negative grid potential of about 20 volts is supplied by a BA-2 dry battery which is contained inside the case. The filament is heated by a 4-volt storage battery which forms part of the auxiliary apparatus accompanying the set. The filament circuit includes an adjustable rheostat which should be set to limit the filament current to 1.36 amp. This corresponds with the VT-12 tubes to a reddish yellow glow and with the VT-2 tubes, should these happen to be used in

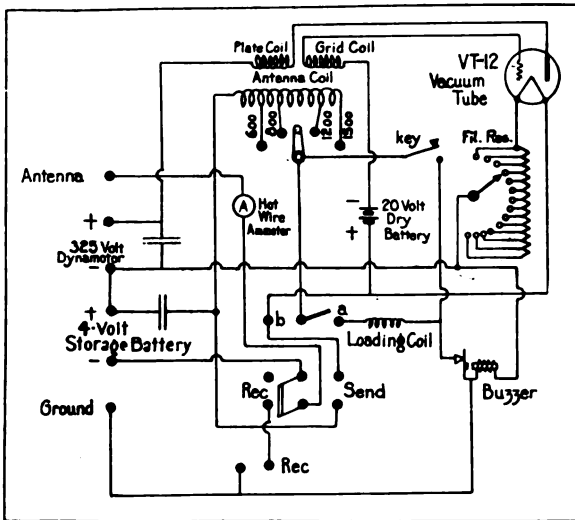

Fig. 1—Wiring Diagram of the Type SCR-69 Set

emergency, to a dull red glow. The rheostat is not shown in the cut of the panel, but it forms part of the panel equipment on the sets now under construction.



A sending key and hot wire ammeter are inserted in the antenna circuit. The latter indicates whether or not the vacuum tube is oscillating. A double pole double throw switch mounted on the panel provides a connection such that the antenna and ground of the sending set may be readily connected to any receiving set which may be connected to the "Receiving" terminals on the panel of SCR-69.

## Method of Operation

The set being properly connected up to the antenna, ground, dynamotor and batteries, and the d. p. d. t. switch closed to the right (sending position), there are three methods of radiating the oscillations generated by the tube which correspond to the three positions of the single pole double throw switch marked ab, Fig. 1, and mounted on the panel of the set. The character of waves radiated, corresponding to each of the three positions of this switch, is as follows:

### Compensated Wave Sending

**S. P. D. T. Switch Closed to the Right.**—Closing the switch to the right places the small loading coil in parallel with the sending key. The equivalent circuit is shown in Fig. 2, first diagram, for simplicity. With these connections, the oscillations generated by the tube are radiated continuously from the antenna, and are of a wave length  $\lambda_1$ , determined by the size of the antenna and the tap used on the antenna coil. When the key is now closed, in sending signals, the small loading coil is short circuited, thus reducing the inductance of the antenna and shortening the wave length to a value  $\lambda_2$ . This condition is shown in Fig. 3, first series of waves. The small loading coil, which has about ten turns of wire and a diameter of about 2 in., is so calculated that the difference between the wave lengths radiated with the key open and with the key closed is from 5 to 10 meters. As these waves are undamped, they are received by the heterodyne method which affords very sharp tuning and thereby makes it entirely possible to tune the receiving set to the shorter signal wave  $\lambda_2$ , and cut out the interference from the longer wave  $\lambda_1$ , corresponding to the key open. It is also possible to receive both waves simultaneously if so desired. With this adjustment, two notes are heard in the receiver, a high pitched note for the spaces and intervals and a low pitched note for the dots and dashes. This method of sending is called the "compensated wave" or "detuning" method.

## Cut-In Sending

**S. P. D. T. Switch Open.**—The equivalent circuit for this connection is shown in the second diagram of Fig. 2. In this case, the key is placed directly in the antenna circuit so that it opens and closes that circuit. The result is that the oscillations generated by the tube are radiated from the antenna only when the key is

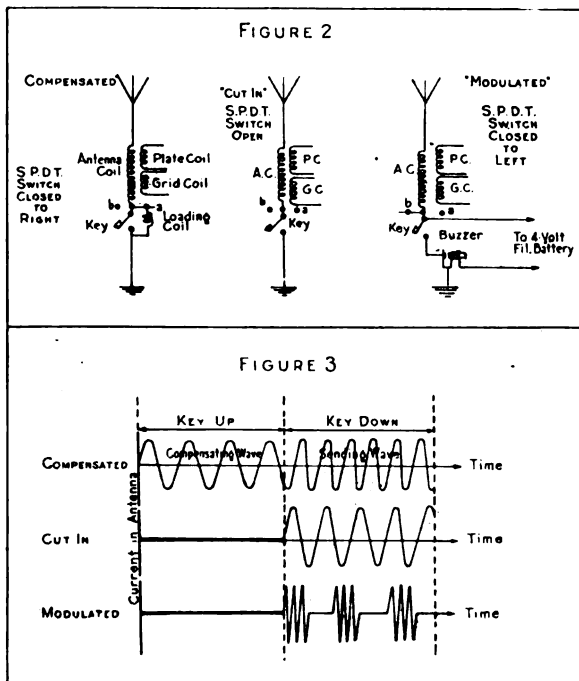

Fig. 2 and 3—Schematic Representation of Different Sending Connections and Waves Radiated

closed, no energy leaving the antenna when the key is open. A dot or dash will then be sent out as a train of undamped waves (Fig. 3, second series of waves), while a space will correspond to no energy sent out. As for the compensated method, reception of these signals must be made by the heterodyne method, the only difference in the signals heard at the receiving station being that no note will be obtained for spaces or intervals. This method of sending is called the "cut-in" method.

## Modulated Sending

**S. P. D. T. Switch Closed to Left.**—The equivalent circuit for this position of the switch is shown in the third diagram of Fig. 2. In this case, the antenna circuit is opened when the key is up, and no energy is radiated. When the key is down, energy is radiated in a manner similar to that of the cut-in method, except that the closing of the key not only completes the antenna circuit, but also a circuit through a small buzzer, the vibrator of which opens and closes the antenna circuit. The undamped wave thus sent out is interrupted at regular intervals by the buzzer vibrator and a dot or dash is consequently made up of a series of short trains of undamped oscillations (Fig. 3, third series of waves). While the frequency of the oscillations is above audibility, the wave train or group frequency is equal to the buzzer vibrator frequency and therefore within the range of audibility. These waves can therefore be received by an ordinary receiving set and rectifying detector, just as damped wave signals. This method of sending is called the "modulated" method.

## Choice of the Method of Sending

Each of the above sending methods has its respective advantages and disadvantages which determine and limit its use. The compensated method is the best of the three, in that the constants of the various circuits are changed very little by the closing of the key and there is therefore no danger of the tube being stopped from oscillating. The ammeter in the antenna circuit should give a practically constant reading whether the key is closed or open. This method has the disadvantage that it requires a certain amount of skill on the part of the operator, as no sound is produced by the transmitter and he must therefore make his dots and dashes purely by touch and not at all by ear. At the receiving end, it is not always possible to completely tune out the compensating waves, that is, the waves corresponding to the spaces, and the signals may be somewhat harder to read and cause an untrained operator some trouble. In tuning a set to receive waves sent out by the compensated method, it is important that the sending and not the compensating wave should be tuned in, as the former is made up of the signalling dots and dashes, while the latter is made up of the spaces between the dots and dashes.

The cut-in method gives no radiation of electric waves when the key is up. When the key is closed, the antenna circuit is suddenly coupled to the tube circuit. This is generally sufficient to produce an initial change in the potential of the grid of the tube

and thus start it oscillating. However, due to various conditions, it sometimes happens that the resulting change is not sufficient, and oscillations may not take place when the key is closed. This method is therefore not as reliable as the compensated method, but it may be more easily read at the receiving station, as it produces only one note in the receiver. It has the same disadvantage for the sending operator as the compensated method—no sound to aid the hand.

The modulated method of sending has the same defects and advantages as the cut-in method. It has the additional advantage that the buzzer emits a sound which may assist the operator in sending. However, due to the breaking up of the waves, less energy is radiated by the antenna. The modulated method is the only one of the three by which signals can be received by means of an ordinary crystal detector such as is supplied with the SCR-54 receiving set.

Particular care should be taken that the antenna and lead-in wire are completely insulated from the counterpoise and the ground, as a leak from antenna to ground, due to contact with a tree or shrubbery, or even leakage due to rain or damp weather, will not only cut down the radiation considerably, but may also prevent the tube from oscillating. Care should be taken that the counterpoise wire is heavily insulated from ground. A poorly insulated or partially grounded counterpoise will increase the antenna resistance and may prevent the tube from oscillating. The resistance of the antenna and lead-in wires should be kept as low as possible.

## Parts List

In ordering this set or parts of this set, specification must be made by names and type numbers as listed below, exactly. The designation printed in bold-face type *only* will be used in requisitioning, making property returns, purchasing, etc.

In ordering *complete* sets, it is not necessary to itemize the parts; simply specify, "2 Sets, Radio Telegraph Transmitting, Type SCR-69." If *all* the parts listed under a group heading are desired, it is not necessary to itemize the parts; simply specify, for example, "1 Equipment, Type PE-8."

The Type SCR-69 set is not complete unless it includes all of the items listed below:

**SET, RADIO TELEGRAPH TRANSMITTING, TYPE SCR-69  
EQUIPMENT, TYPE PE-8; Power**

**2 Batteries, Type BB-1; Edison storage; 7 cells, 10 volts,  
37.5 amp-hr.: 1 in use, 1 spare.**

**2 Batteries, Type BB-2;** Edison storage; 3 cells, 4 volts, 75 amp-hr.; 1 in use, 1 spare.

**1 Dynamotor, Type DM-1;** Westinghouse; 10-300 volts, 50 watts.

**EQUIPMENT, TYPE RT-6;** Transmitting.

**1 Set Box, Type BC-34;** Radio telegraph transmitting; complete with carrying strap.

**5 Tubes, Type VT-12;** vacuum; 1 in use, 4 spare.

**EQUIPMENT, TYPE A-6;** Antenna; (old type SCR-53 set).

**3 Mast Sections, Type MS-1;** without tubes.

**12 Mast Sections, Type MS-2;** with tubes.

**3 Caps, Mast, Type MP-5.**

**3 Insulators, Type IN-1;** hard rubber, with hooks.

**9 Reels, Type RL-3;** hand.

**1 Antenna, Type AN-5;** two lengths of braided antenna cord 150 ft. long, and one length of lead-in wire 40 ft. long, all carried on three hand reels.

**9 Guys, Type GY-3;** No. 5 sash cord, each 36 ft. long, with metal tent slide and hook; a set of three guys to be carried on each of three hand reels.

**1 Counterpoise, Type CP-4;** two lengths of wire 150 ft. long, and one lead-in wire 40 ft. long, all joined together at their intersection; to be carried on three hand reels.

**3 Hammers, Type HM-1.**

**9 Stakes, Type GP-2;** guy.

**3 Cords, No. 5 Sash; Pieces, 3 ft. Long**

**1 Chest, Type BC-35;** carrying; used for packing antenna equipment for transportation.











*EWB*

**CONFIDENTIAL!** For Official Use Only

# Ground Radio Telephone Sets

*SCR-67*

*SCR-67-a*



*Communication*

**RADIO PAMPHLET No. 22**

April 20, 1919

**Signal Corps, U. S. Army**





**SETS, RADIO TELEPHONE, TYPE**  
**SCR-67 AND SCR-67-A.**

115457-19—1



**T**HE TYPE SCR-67 SET is a two-way radio telephone set for use on the ground in communicating with a similar set, or with the airplane radio telephone sets type SCR-59, SCR-68 and other or similar sets. The type SCR-67-A set is an improvement of the type SCR-67 set, and differs from the latter in minor details only, which do not affect the method of operation, or the explanation of the theory of the circuits. The circuits given here are those of the type SCR-67-A set, and the points in which the circuits of the type SCR-67 set differ are noted in the text and indicated in the drawings, the type SCR-67 constants and other variations being indicated in parentheses and dotted lines in Fig. 2, except for the wiring of the three-position power switch.

The average working range of either set when used with one of the airplane sets mentioned above, is 2 to 3 miles. This range depends to a considerable extent on the adjustments of the set, the type antenna used, and on the quality and distinctness of the operator's voice. When communicating with a ground set, the range may be as great as 5 to 7 miles.

The range of wave lengths is from 250 to 450 meters when transmitting, and from 200 to 700 or 800 meters when receiving and making use of a suitable antenna. Some antenna constructions are given in a later paragraph.

### **Theory Underlying the Operation of the Set.**

The complete theory of radio telephony is not taken up in this pamphlet. For this, reference is made to Radio Pamphlets No. 1 (2nd Edition), 20 (2nd Edition) and 40. The principle of transmission involves the generation of undamped oscillations of a frequency greater than that of audible vibrations in the antenna circuit, and the varying of the amplitude of these oscillations proportionally to the voice modulations to be transmitted. These modulated high frequency oscillations, when rectified in the receiving circuit, produce in the telephone receivers a current of amplitude varying proportionally to the voice modulations at the transmitting station, and therefore reproduce the speech. The process will be better understood after the description of the circuits has been given.

Operating Panel of Set Box Type BC-13 used in Set Type SCR-67 Showing Covered Panel Lid Partly Open.



A complete circuit diagram of the type SCR-67-A set is given in Fig. 1. By operating the three-position switch, marked on the panel, "Off, 12-V On, Power On," the set may be used either for receiving alone, or for receiving and transmitting. For the latter position of the switch, the transmitting circuit is connected by depressing a control push button, while the receiving circuit is connected when the push button is released. These two circuits are analyzed separately in the following paragraphs.

**Theory of the Transmitting Circuit.**—The circuit in use when transmitting is shown schematically in Fig. 2. The same letters and names are used as in Fig. 1, so that reference may be made to both diagrams if desired.

Undamped oscillations are generated by a type VT-2 three-electrode vacuum tube. The filament of this tube is heated by the current of a 12-volt storage battery. In series with the latter is a rheostat for regulating the current, and an ammeter. The negative side of the circuit is connected to ground.

A constant positive potential of about 350 volts is applied to the plate of the tube by means of a type DM-2 dynamotor, the low voltage side of which is run by the same 12-volt battery that furnishes the filament heating current. In series with the plate circuit is a short circuiting jack in which a plug connected to a milliammeter may be inserted to read the space current in the tube. The function of the choke coils marked B and D, and that of resistances  $R_1$ ,  $R_2$ , and  $R_3$  will be explained later. A filter circuit, comprising two coils and two condensers F is connected across the 350-volt terminals of the dynamotor for the purpose of minimizing the pulsations of current resulting from commutation.

A constant negative potential is impressed upon the grid of the oscillator tube, which is the voltage drop across a 100-ohm resistance connected between the filament and the grid. In series with this resistance is a 20,000-ohm resistance and a choke coil marked A. The latter prevents any high frequency oscillations from flowing through this grid circuit. The 20,000-ohm resistance is shunted by a condenser, and it provides the proper negative potential when the tube is oscillating. A short circuiting jack is also in series with the circuit. This permits the insertion of a plug for connecting in a milliammeter.

In the type SCR-67 set, resistance  $R_1$  is 130 ohms instead of 100 ohms, and 10,000 ohms are used instead of 20,000 for the high resistance. The choke coil A and condenser C are also omitted.



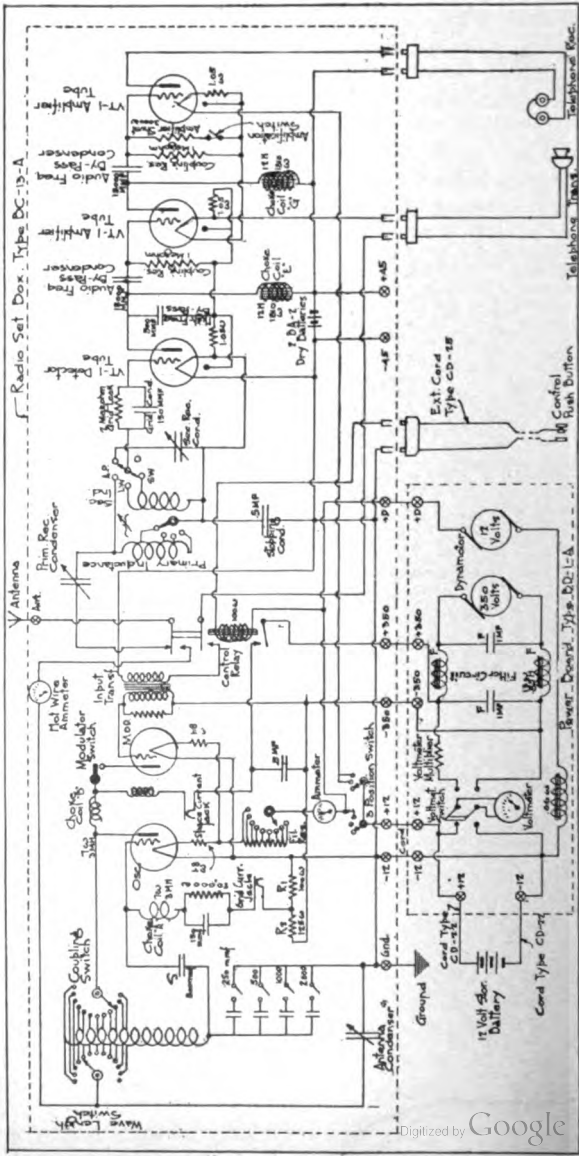

Fig. 1.—Complete Schematic Circuit Diagram of Set, Radio Telephone, Type SCR-67-A.

The grid and plate circuits just described are coupled so that the tube will generate oscillations. The oscillatory circuit comprises a grid coupling condenser, the antenna, and the transmitting inductance coil. The grid coupling is effected through a fixed condenser S in series with any one or all of four fixed condensers in parallel, which may be connected as required by closing the small knife switches in the covered panel. This condenser S also serves as a stopping condenser in preventing the 350-volt d. c. plate poten-

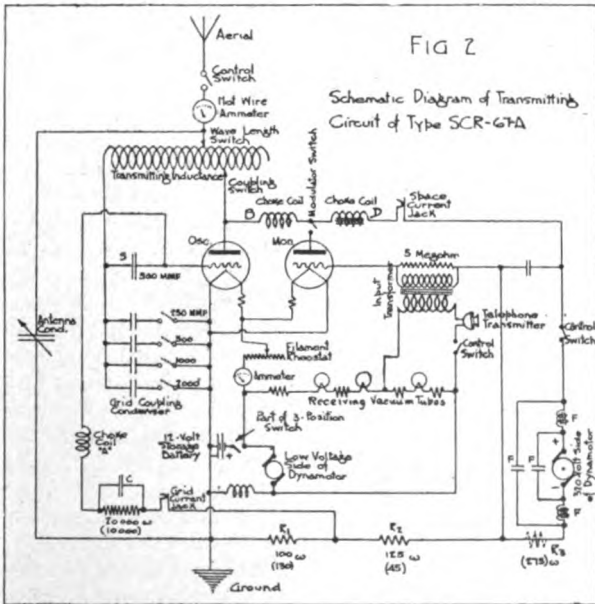

FIG. 2.—Schematic Diagram of the Transmitting Circuit of Set Type SCR-67-A.

tial from being applied to the grid through the transmitting inductance. The plate coupling is made through the antenna and the transmitting inductance. The latter is connected at one end between the condenser S and the four parallel grid coupling condensers. At the other end of the coil are twelve taps, connected to two 12-point dial switches, marked "Coupling" and "Wave Length," to which the plate and aerial are connected respectively. The operation of the plate dial switch alters the plate coupling.

while that of the aerial dial switch changes the transmitted wave length. A variable air condenser, marked "antenna condenser" in Fig. 2, shunts the antenna, and gives a continuous variation of wave length between any two consecutive taps of the wave length switch.

It may thus be seen from the above description how the direct current generated by the dynamotor is transformed by the oscillator tube into a high frequency undamped alternating current in the antenna circuit, which continually radiates energy into space. The amplitude of these oscillations is proportional to the amount of current furnished by the dynamotor and flowing in the oscillator tube from the plate to the filament. A method of varying the amplitude of the oscillations is to vary the amount of direct current furnished to the tube. This is done in the type SCR-67 and SCR-67-A sets by means of a second three-electrode tube, called the modulator tube. The plate circuit of this tube shunts the plate circuit of the oscillator tube, as may best be seen from Fig. 2. The current generated in the 350-volt armature of the dynamotor will thus divide between the oscillator and the modulator tube in inverse proportion to their impedances.

In order to modulate the amplitude of the oscillations generated by the tube, the impedance of the modulator tube is varied by impressing upon the grid of this tube a potential the frequency and amplitude of which are determined by the strength and pitch of the voice. This is accomplished by connecting the secondary winding of a transformer, called the "input transformer," between the grid and the negative side of the filament of the modulator tube. The grid circuit also comprises resistances  $R_1$  and  $R_2$ , which give to the grid a negative potential derived from the drop across these two resistances due to the current flowing through them. This grid potential is of such value as to make the tube operate on the point of its characteristic curve which is most suitable for modulation.

The primary circuit of the input transformer comprises a telephone transmitter. The current flowing in that circuit is obtained by connecting the circuit across the filament of one of the receiving tubes and two 1-ohm resistances. In case of the type SCR-67 set, the filament of the first amplifier tube is used, while for the type SCR-67-A set, the detector tube is used instead.

The entire transmitting circuit having now been described, its theory of operation may be explained as follows.

The circuit will be ready for operation when the main switch, push button control switches, modulator switch and the required grid coupling condenser switches are closed. The three-position switch will complete the filament heating circuit and the low voltage dynamotor circuit. The three control switches are closed by pressing the control push-button.

By suitable adjustment of the wave length switch, plate coupling, grid coupling, and antenna condenser, the oscillator tube is made to generate undamped oscillations. This adjustment is made, in accordance with the rules given in a later paragraph, for the greatest antenna current with as small a space and grid current as possible.

By closing the modulator switch, the plate circuit of the modulator tube is connected in parallel with that of the oscillator tube, so that the current from the dynamotor, instead of all flowing through the oscillator tube, will divide between the oscillator and modulator tubes. By talking into the telephone transmitter, an alternating emf. is induced in the secondary of the input transformer, and therefore on the grid of the modulator tube. This emf. is proportional to the voice modulations, and the impedance of the modulator tube is varied accordingly. The result is that a correspondingly greater or lesser part of the total constant current generated by the dynamotor will be shunted off the oscillator tube, by the modulator tube, and the amplitude of the oscillations is thus modulated. It is evident that the operation of this scheme will be satisfactory only if the current fed by the dynamotor is kept constant. This is insured by the presence of an iron core choke coil "D" in the plate circuit of the two tubes. A 0.5-megohm resistance is shunted around the input transformer secondary for improving its operation. The actual method of operating the transmitting circuit is explained under a separate heading.

**Theory of the Receiving Circuit.**—The circuits in use when receiving are shown schematically in Fig. 3. Reference may also be made to Fig. 1, where the same letters and designations are used. The primary (antenna) circuit comprises the aerial, a variable air condenser, an inductance coil variable in four steps, a large stopping condenser and the ground. The stopping condenser does not stop the incoming high frequency oscillations, but prevents a short circuit in the filament circuit of the tubes. Inductively coupled to this circuit is the secondary oscillatory circuit, comprising a variable air condenser and an inductance coil variable in two steps, the entire coil being used when receiving long waves, and only half the

coil being used for short waves. The secondary circuit may be entirely disconnected when the dial switch is placed in the aperiodic position, "AP." In this case, the detector tube is directly connected to the antenna circuit. This position cuts out the secondary tuned circuit and is used when searching for signals of unknown wave length.

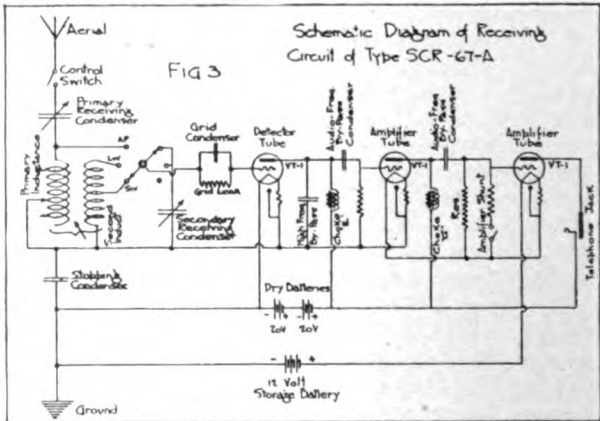
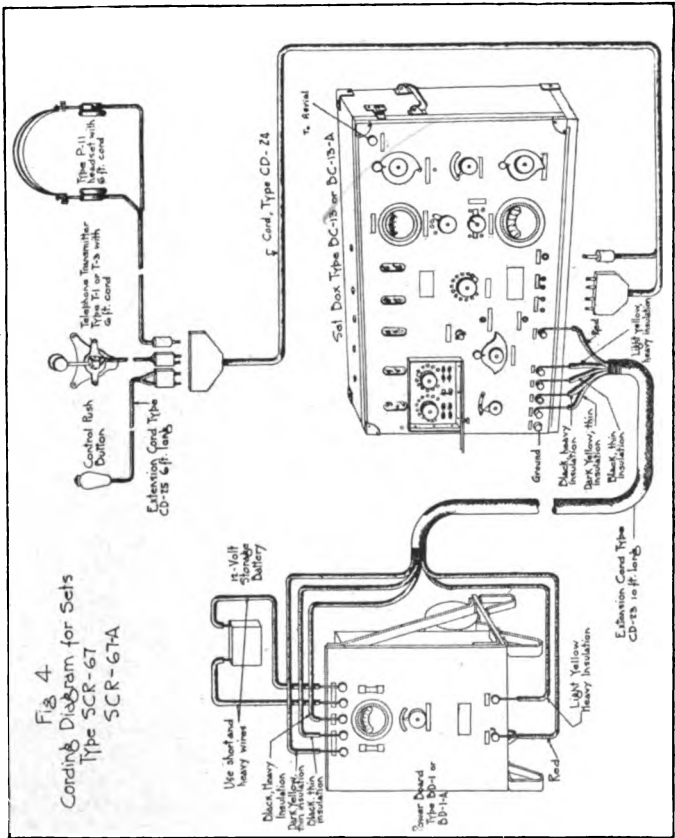

FIG. 3.—Schematic Diagram of the Receiving Circuit of Set Type SCR-67-A.

The detector tube is a type VT-1 three-electrode tube, having its filament and grid connected across the receiving inductance. A grid condenser shunted by a 2-megohm leak resistance is connected in series with the grid. The filament of this tube is in series with the filaments of the amplifier tubes, and is heated by the current from the 12-volt storage battery. The plate current of the detector tube is furnished by a 40-volt battery, made up of two type BA-2 dry batteries in series. In the case of the type SCR-67 set, one 20-volt BA-2 battery only is used for the detector tube. The high frequency currents are by-passed from the plate to the filament by a fixed condenser, while the audio frequency currents, in flowing through the choke coil E, induce in the latter a high alternating emf. This emf. is transferred through the grid stopping condenser to the grid of the first amplifier tube, correspondingly varying the plate current of that tube. The latter variations are therefore amplified repetitions of the detector tube plate current audio frequency variations. The charges induced on the grid of the first amplifier tube leak off to the filament through a 1-megohm resistance.



A similar scheme is used for coupling the first and second amplifier tubes. Both amplifiers work at a plate voltage of about 40 volts derived from the same battery that is used for the detector tube. In the type SCR-67 set, this plate potential is obtained by means of a second type BA-2 battery in series with the one used for the detector tube. Telephone receivers are plugged in the plate circuit of the last tube, and the degree of amplification may be reduced by closing the "Amplifier" switch, which connects a low resistance across the input circuit of the last amplifier tube, thus reducing the intensity of the sound in the telephones.

**Summary of Differences between the Type SCR-67 and SCR-67-A Sets.**—The main differences between the type SCR-67 and SCR-67-A sets are the following. The choke coil A and condenser C, Fig. 2, do not exist in the type SCR-67 set. The grid resistance is 10,000 ohms in the type SCR-67 set, and 20,000 ohms in the type SCR-67-A set. Resistances  $R_1$  and  $R_2$  are 130 and 45 ohms respectively in the

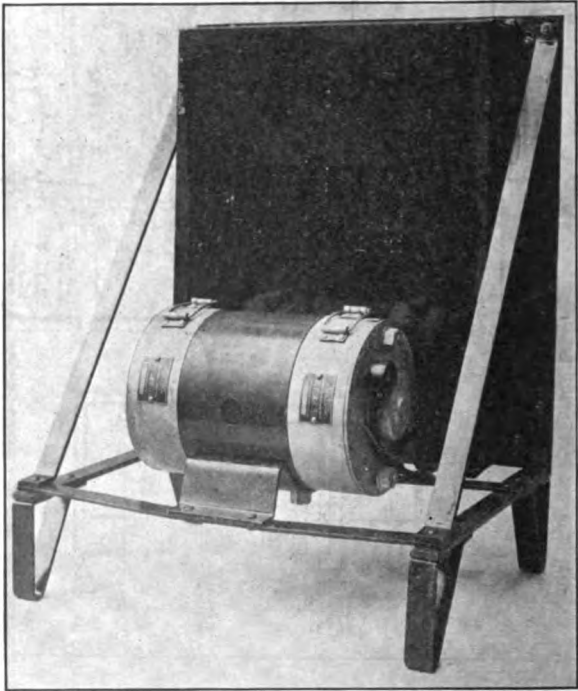

Rear of Powerboard Showing Dynamotor Type DM-2.

SCR-67, and 100 and 125 ohms in SCR-67-A. Resistance  $R_3$  exists in the type SCR-67 set only. The connections of the three-position switch are quite different. When in the middle position, all five tubes light with SCR-67, while the receiving tubes only are on in the SCR-67-A set. These differences may be noted in Figs. 5 and 6 at the end of the pamphlet.

### Component Parts of the Set.

The apparatus making up the set comprises the radio set box, type BC-13 or BC-13-A which contains the radio circuits and operating switches; the power board, in back of which is mounted the dynamotor and dynamotor filter circuit, and which also has a voltmeter for reading the storage battery voltage and the voltage generated by the dynamotor; the 12-volt storage battery; the telephone head set and transmitter; the control push button; and the connecting cords. The set box measures  $23\frac{1}{2}$  in. x  $15\frac{1}{2}$  in. x  $6\frac{1}{2}$  in. overall. The powerboard measures  $17\frac{3}{4}$  in. x  $13\frac{1}{4}$  in. x  $10\frac{1}{4}$  in. The various parts of the set are interconnected as shown in the cording diagram, Fig. 4. Heavy wire should be used to connect the storage battery to the powerboard, in order to reduce the resistance losses. This is an important point which affects the radiation to an appreciable extent.

### Method of Operation.

Various types of antennae may be used with the ground telephone sets. Two factors which are of great importance in setting up the antenna are its resistance and natural wave length. The resistance should be as low as possible, preferably less than 20 ohms. The natural wave length must be smaller than the smallest wave length to be used for transmitting. The following types of antenna construction are suggested.

(a) An umbrella type antenna, 40 ft. high, with six 50-ft. aerial wires and six 90-ft. insulated counterpoise wires. The aeriels are held in proper position by means of guy ropes 75 ft. long. The natural wave length is 256 meters.

(b) A "V" antenna, 24 ft. high, 100 ft. long on each side, using two 100-ft. insulated counterpoise wires or two buried ground mats. The natural wave length is about 250 meters.

(c) An inverted "L" antenna, 20 ft. high, 100 ft. long, with an insulated counterpoise wire 100 ft. long. This has a natural wave length of 200 meters.

(d) An inverted "L" antenna 20 ft. high, 150 ft. long, with an insulated counterpoise wire 150 ft. long. This antenna has a natural wave length of 325 meters, and is recommended for use when working at wave lengths greater than this value.

**Transmitting.**—The set having been fully connected up as per cording diagram, Fig. 4, and using a suitable antenna, the method of operation is as follows.



It is well to calibrate the set in advance for a number of wave lengths, with the set connected to the antenna to be used. The method of calibrating the transmitting circuit, or of operating the latter when not previously calibrated is given below.

1. Open the radio set box, and see that two type VT-2 tubes and three type VT-1 tubes are inserted in their proper sockets. The VT-2 tubes are at the left, the VT-1 tubes at the right of the box, as one faces the operating panel.

2. By means of a voltmeter, check the voltage and polarity of the dry batteries. The voltmeter should read not less than 36 volts, and should in general read 40 to 45 volts.

3. Close the set box and throw the voltmeter switch on the power board to "12" volts and check the storage battery voltage. This should be at least 12 volts, and may be 14 volts without damage to the apparatus. A voltage of 13 or 14 volts will, in fact, improve the operation of the set, but the latter limit should never be exceeded. After checking the voltage, throw the switch to "Off."

4. Place a type SCR-60-C or SCR-61 wavemeter near the left hand end of the radio set box and set it to the desired wave length. If the type SCR-61 wavemeter is used, insert type P-11 telephone receivers in the wavemeter jack, start the buzzer and adjust the crystal detector. Keep the buzzer running while adjusting the radio set. If the type SCR-60-C wavemeter is used, operate similarly, or better, simply read the galvanometer, without using the buzzer or telephone receivers.

5. Turn the filament current switch of the radio set box all the way to the left, to the position "Minimum."

6. Insert the milliammeter plugs in the jacks marked "Grid Current" and "Space Current." Two type I-7 ammeters may be used, with an extension cord type CD-57.

7. Open the modulator switch. This is the small vertical knife switch in the center of the covered panel.

8. Throw the three-position power switch all the way to the right, in the position marked "Power On." This should light the filaments of all five vacuum tubes, should give a reading on the filament current ammeter, and should start the dynamotor.

9. Adjust the filament current so that the filament current ammeter will indicate 2.6 to 2.7 amp.

10. Press the control push button. This will connect the control relay, Fig. 1, across the 12-volt storage battery, which in turn will close the three contacts, corresponding to the control switches of Fig. 2. The space current should be about 50 milliamp. if the oscillator tube is working properly.

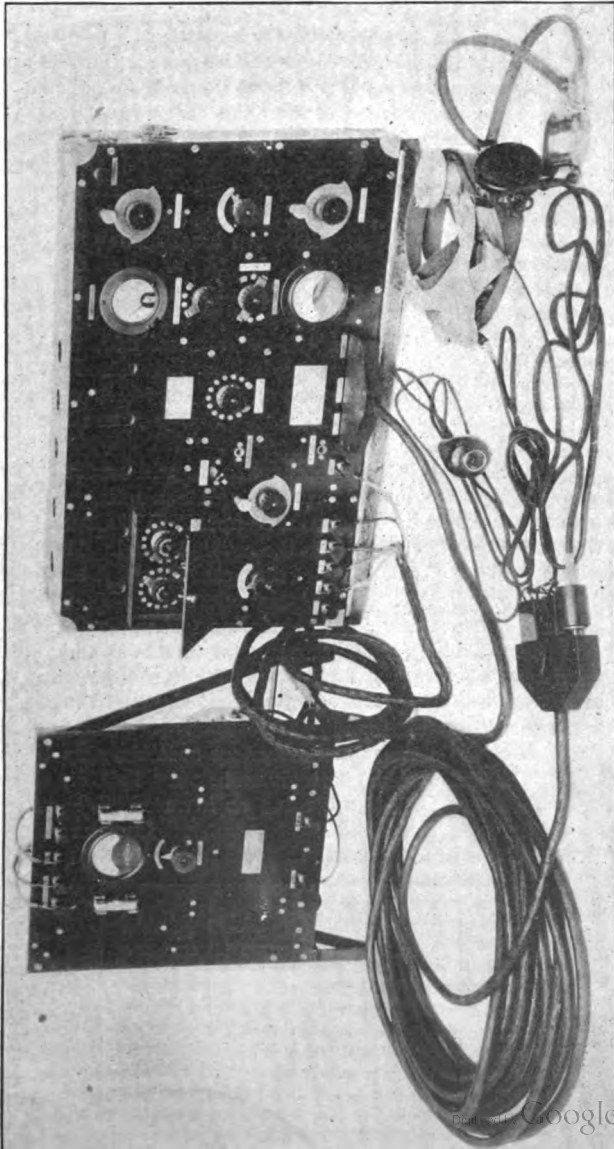

t Box and Powerboard, Showing Extension Cords Used When It Is Desired to Remove the Dynamotor from Close Proximity of the Set  
Box to Reduce the Noise.

11. Connect the 750 or the 1000 micro-mfd. grid coupling condenser, by closing the corresponding knife switch in the covered panel, and set the 12-point "Coupling" dial switch so that the tube will oscillate, as indicated by a reading on the antenna ammeter.

12. Adjust then, in rotation and in the order mentioned, the "Wave Length" switch, antenna transmitting condenser ("Cond. Trans."), and "Coupling" switch until maximum response is obtained on the wavemeter. Also try various combinations of the four grid condenser switches, so that the grid current will be between 2 and 7 milliamp. The greater the wave length, the greater the grid condenser to be used.

13. Readjust the wave length switch and antenna condenser to perfect the tuning.

14. Readjust several times, in the order mentioned, the plate "Coupling" dial switch, grid coupling knife switches, and antenna transmitting condenser to secure that adjustment which will give, at the desired wave length, greatest radiation and smallest grid and space current possible.

15. If the grid current is too high, increase the grid condenser. If the space current is too high, increase the plate coupling. With a suitable antenna, the radiation should be from .3 to .6 amp.

16. Close the modulator switch in the covered panel. The space current will be 60 to 70 milliamp. In no case should it exceed 80 milliamp.

17. The set is now ready for transmitting. Remove the wavemeter and the grid and plate milliammeters. When talking, speak in an even tone of voice, not too high nor loud, and with the lips close to the transmitter. It is essential that the push button be kept closed while transmitting.

18. An idea of the settings of the various switches may be obtained from the calibration chart given below. This chart was obtained with a type SCR-67 set, using an inverted "L" antenna having a natural wave length of about 200 meters. Such an antenna is not very well suited for use with this set.

Wave length	Antenna switch point	Coupling switch point	Antenna transmitting condenser	Grid coupling condenser
235	1	12	100	500
250	2	12	100	750
300	5	12	70	1000
350	8	11	80	1000
400	11	11	26	1000
450	12	10	100	1000

**Caution.**—Do not touch the modulator and grid condenser switches with bare hands while the power is on.

**Receiving.**—The receiving circuit may be calibrated, after the set has been connected to the antenna, by means of a wavemeter which is set to a number of wave lengths, the set being tuned in as explained below, and the settings of the various switches recorded. If not calibrated in advance, or if the wave length to be received is unknown, the procedure is as follows.

1. Follow the instructions given in paragraphs 1, 2, 3 and 5 of the previous section.

2. Close the three-position power switch of the radio set box in the middle position, marked "12 Volts." This should light the filaments of the three receiving tubes. The circuits in use are shown in Fig. 3. The antenna control switch, Fig. 2, is closed and it is not necessary to close the push button. If it is desired to transmit and receive, set the three-position switch to "Power On." When transmitting, press the push button; when receiving, release the push button. In case of the type SCR-67 set, all five vacuum tubes will light simultaneously when the power switch is in the 12-Volt or Power On position.

3. Set the three-point dial switch located above the filament current ammeter in the position "AP."

4. Adjust the receiving "Primary Inductance" and the "Primary Receiving Condenser" until the signals are heard loudest.

5. Set the three-point dial switch to "LW" or "SW", and adjust the secondary receiving condenser for loudest signals, using maximum coupling if required.

6. If the signals are too loud, set the "Amplifier" key to "Minimum." If they are not loud enough, set it to "Maximum." Also, reduce the coupling for protection against interference.

### Possible Sources of Trouble.

Frequently, the set does not operate satisfactorily on account of incomplete adjustment of the transmitting circuit. In making adjustments, each setting affects all the others, and it is therefore necessary to go over all adjustments in the same order, until proper conditions are obtained. Once the set is adjusted, it will therefore save time to record the settings and corresponding wave length. These settings will of course change if the antenna is changed.

With a set properly adjusted, the results are still dependent on the voice of the operator. The speech should be clear, rather slow and in an even, moderate tone, and with the lips close to the telephone transmitter.

Mounting of Apparatus on the Back of the Panel of Set Box Type BC-13.

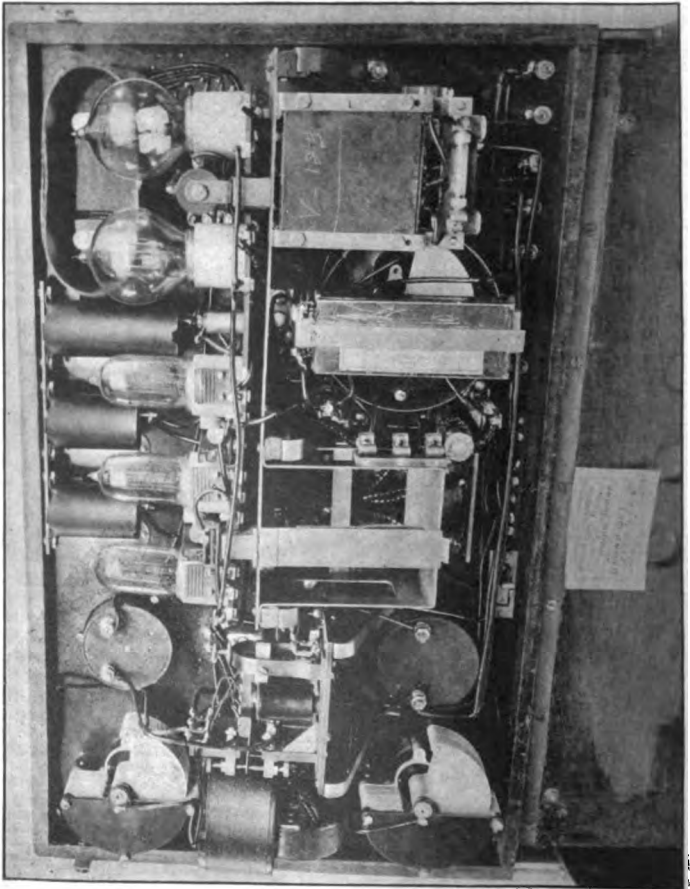

In general, it may be said that the set is operating properly when, with the switch on "Power On" and the control push button closed, and the amplification switch on "Minimum", the operator hears himself distinctly in the telephone receiver while talking in the transmitter in a low tone of voice. The explanation of this test is that the modulated oscillations of the transmitting circuit induce currents in the receiving inductance. The test is therefore a check on the working condition of the circuits, but may not be considered as a conclusive proof that the circuits are perfectly adjusted.

Some of the troubles which may be encountered in operating the set are mentioned below. The wiring diagrams of Fig. 5 and 6 may be helpful when tracing the circuits in the set box.

#### *Noise in Receiver.*

- (a) Worn out dry batteries. Voltage should not be less than 17.5 volts per battery.
- (b) Noisy leak resistances.
- (c) Loose connections in plate, filament or grid circuits. Inspect soldered connections, especially of long wires which may vibrate loose. Inspect connection clips of grid leak and telephone jack.
- (d) Poor contact between vacuum tube and spring contacts in socket.
- (e) Broken down grid leak condenser. Remove condenser and test for click using telephones.
- (f) Noisy detector vacuum tube.
- (g) Sparking at dynamotor commutator, due to poor brushes or dirty commutator.

#### *Failure to Receive.*

- (a) Tap on the detector tube. If a loud ringing noise is heard, the trouble is probably in the antenna primary and secondary circuits. If no noise is heard, the trouble is probably between the detector and telephones.
- (b) Failure of filaments to light; due to broken filament in one of the receiver tubes (VT-1) or open in filament circuit. May also be due to broken down antenna stopping condenser.
- (c) Blocking of detector tube; due to too high resistance grid leak or open in grid circuit. Examine grid leak connecting clips.
- (d) Receiving condenser short circuited, due to buckled plates; or antenna stopping condenser broken down.

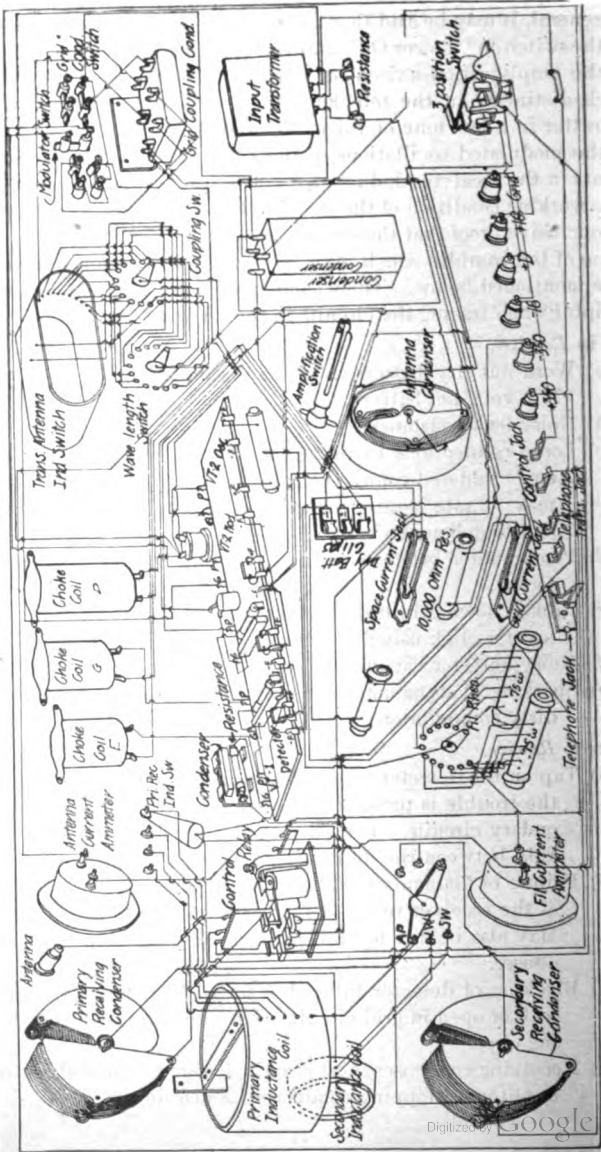

FIG. 5.—Actual Wiring Connections Within the Set Box Type BC-13, Which Forms Part of the Set Type SCR-67.

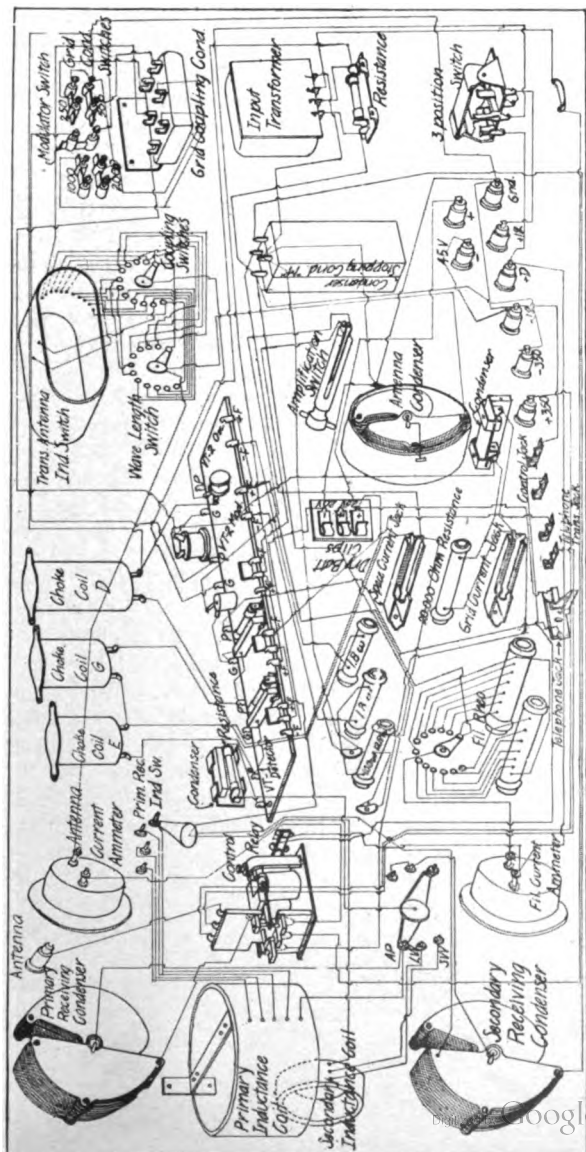

FIG. 6.—Actual Wiring Connections Within the Set Box Type BC-13-A, Which Forms Part of the Set Type SCR-67-A.



*Failure of Amplifier.*

- (a) Amplifier resistances may be burned out, or short circuited, or the connections may be broken.
- (b) Condenser terminals grounded to metal frame.
- (c) Loose connections. Condenser terminal connections broken off.

*Failure to Oscillate.*

- (a) Failure to have any space current with modulator switch open may be due to a failure to impress the plate voltage on the tube. Test d.c. plate circuit for an open by shunting the plate and filament terminals of the tube socket with a buzzer or receiver. Test dynamotor voltage on power board. The milliammeter circuit may be open. Inspect space current jack and plug. The contacts on the control relay may not operate properly. Too small a space current may be due to too small a filament current.
- (b) Failure to have any grid current may be due to a burned out grid resistance. Test the latter by clicking through with the telephones. It may also be due to a burn out or open in the  $R_2$  and  $R_3$  resistance (Fig. 2), to an imperfect grid current jack, or burned out ammeter.
- (c) Oscillator tube filament may not light due to an open in the filament circuit.
- (d) No reading on antenna ammeter may be due to an open in the antenna circuit. Ammeter may be burned out, or antenna inductance coil may be open. Test by buzzer. Antenna condenser may be shorted. Antenna switches may be faulty.
- (e) Test grid coupling condenser by buzzer.
- (f) Circuit may not be adjusted properly.
- (g) Antenna insulator may leak, or antenna may be grounded.

*Over-heating of Oscillator Tube.*

- (a) Too much plate voltage.
- (b) Improper adjustment of circuit.
- (c) Lack of grid current or excessive grid current due to improper adjustment of circuit.
- (d) Faulty tube.

*Failure to Modulate.*

- (a) Receiving tube filaments may not light.
- (b) Control relay contacts may not work.
- (c) Open in modulator plate circuit. Modulator knife switch should be closed. If the latter is open, space current ammeter should read 40 to 50 milliamp. When closed, space current should be 60 to 70 milliamp.
- (d) Iron core choke coil may be short circuited.
- (e) Faulty or burned out input transformer.
- (f) Short circuit on input transformer secondary.
- (g) Open circuit between transformer and grid of modulator tube.
- (h) Faulty telephone transmitter.
- (i) Faulty tube.
- (j) Blocking of modulator may be due to too high or too low a space current, or to improper resistances in plate circuit. A tendency of the tube to block will be evidenced by a high and unsteady reading on the space current ammeter when blowing or whistling on the telephone transmitter. Blocking of the modulator is also evidenced by the fact that when the operator talks into the transmitter while sending, he hears his speech interruptedly. A remedy, if the tube is not faulty, is to interchange the oscillator and modulator tubes.

**PARTS LIST.**

In ordering this set or parts of this set specification must be made by names and type numbers as listed below, exactly. The designation printed in bold face type *only*, will be used in requisitioning, making property returns, etc.

In ordering complete sets, it is not necessary to itemize the parts; simply specify "Set, Radio Telephone, Type SCR-67." If all the parts listed under a group heading are desired, it is not necessary to itemize the parts; simply specify, for example, "1 Equipment Type PE-2."

The set is not complete unless it includes all of the items listed in the component parts table below.

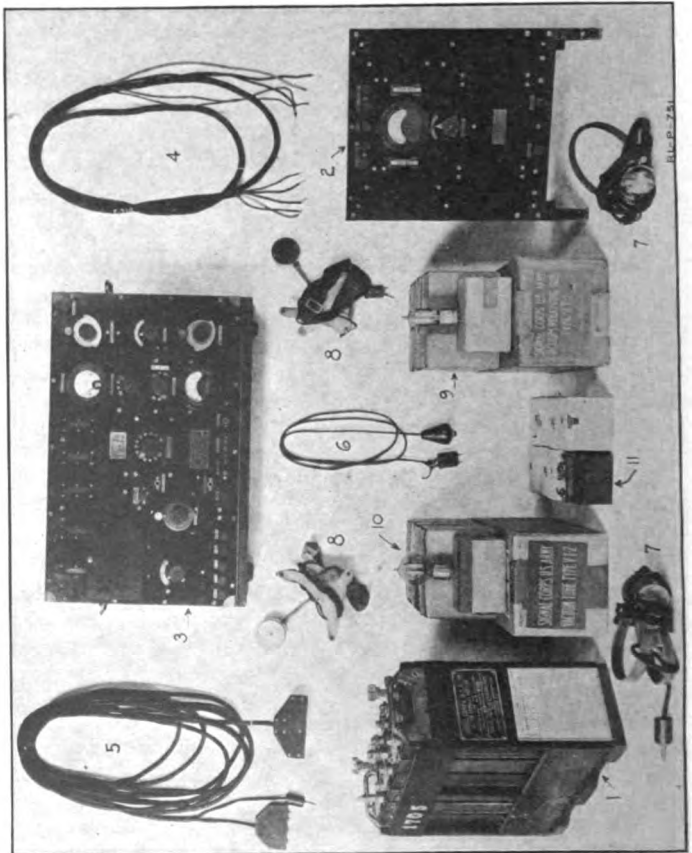

ILLUSTRATION

**Set, Radio Telephone, Type SCR-67.**

- 1 Equipment Type PE-2; power.**
  - 4 Batteries Type BB-5; 2 in use, 2 spare.**
  - 1 Powerboard Type BD-1.**
  - 1 Cord Type CD-22.**
- 1 Equipment Type RE-2; radio.**
  - 1 Set Box Type BC-13.**
  - 1 Cord Type CD-23; powerboard to set box.**
  - 1 Cord Type CD-24.**
  - 1 Cord Type CD-25.**
  - 2 Head Sets Type P-11; 1 in use, 1 spare.**
  - 2 Transmitters Type T-1; 1 in use, 1 spare**
  - 16 Tubes Type VT-1; 3 in use, 13 spare.**
  - 16 Tubes Type VT-2; 2 in use, 14 spare.**
  - 8 Batteries Type BA-2; 2 in use, 6 spare**
- 1 Equipment Type A-9; antenna.**
  - 6 Insulators Type IN-5.**
  - 6 Insulators Type IN-7.**
  - 6 Couplers Type FT-2.**
  - 3 Mats Type MT-3.**
  - 750 ft. Wire Type W-1.**
  - 2 Reels Type RL-3.**
  - 300 ft. Wire Type W-6.**
  - 6 Mast Sections Type MS-5**
  - 2 Bags Type BG-14.**
  - 12 Stakes Type GP-3.**
  - 1 Bag Type BG-8.**
  - 50 ft. Wire Type W-4.**
  - 1 Hammer Type HM-1.**
  - ½ lb. Marlin Type RP-2.**
  - 300 ft. Cord Type RP-3.**

**Set, Radio Telephone, Type SCR-67-A.**

<b>1 Equipment Type PE-2-A; power.....</b>	<b>*</b>
<b>6 Batteries Type BB-5 or Type BB-14.....</b>	<b>(1)</b>
<b>1 Powerboard Type BD-1-A.....</b>	<b>(2)</b>
<b>1 Cord Type CD-48.</b>	
<b>2 Cords Type CD-38; 1 in use, 1 spare.</b>	
<b>1 Equipment Type RE-2-A; radio.</b>	
<b>1 Set Box Type BC-13-A.....</b>	<b>(3)</b>
<b>1 Cord Type CD-23; powerboard to set box.....</b>	<b>(4)</b>
<b>1 Cord Type CD-25; set box to operator's cut-in switch.</b>	<b>(5)</b>
<b>1 Cord Type CD-24; set box to operator's jack.....</b>	<b>(6)</b>
<b>2 Head Sets Type P-11; 1 in use, 1 spare.....</b>	<b>(7)</b>
<b>2 Transmitters Type T-3; 1 in use, 1 spare.....</b>	<b>(8)</b>
<b>16 Tubes Type VT-1; 3 in use, 13 spare.....</b>	<b>(9)</b>
<b>16 Tubes Type VT-2; 2 in use, 14 spare.....</b>	<b>(10)</b>
<b>8 Batteries Type BA-2; 2 in use, 6 spare.....</b>	<b>(11)</b>
<b>1 Equipment Type A-9; antenna.</b>	
<b>6 Insulators Type IN-5.</b>	
<b>6 Insulators Type IN-7.</b>	
<b>6 Couplers Type FT-2.</b>	
<b>3 Mats Type MT-3.</b>	
<b>750 ft. Wire Type W-1.</b>	
<b>2 Reels Type RL-3.</b>	
<b>300 ft. Wire Type W-6.</b>	
<b>6 Mast Sections Type MS-5.</b>	
<b>2 Bags Type BG-14.</b>	
<b>12 Stakes Type GP-3.</b>	
<b>1 Bag Type BG-8.</b>	
<b>50 ft. Wire Type W-4.</b>	
<b>1 Hammer Type HM-1.</b>	
<b>½ lb. Marlin Type RP-2.</b>	
<b>300 ft. Cord Type RP-3.</b>	

\*Numbers in parenthesis at the right refer to the corresponding part in the illustration on the adjacent page.











---

**Prepared in the  
Office of the Chief Signal Officer  
Training Section  
Washington**

---

FOR OFFICIAL USE ONLY

**AIRPLANE  
RADIO TELEGRAPH  
TRANSMITTING SET**

**Type SCR-73**

*( Confidential )*

**Radio Pamphlet  
No. 13**

**Signal Corps, U. S. Army**  
6-30-18



**AIRPLANE RADIO TELEGRAPH  
TRANSMITTING SET**

**Type SCR-73**



# AIRPLANE RADIO TELEGRAPH

## TRANSMITTING SET

### Type SCR-73

The airplane radio telegraph transmitting set, type SCR-73, is designed for use on fire control airplanes. It is a damped wave transmitting set supplied with power from a self-excited inductor type alternator which is driven by a special constant speed airfan, or sometimes for training purposes by a fixed blade wooden airfan. The alternator, the rotary spark gap employed, the potential transformer, the condenser and oscillation transformer are all self-contained in the streamline casing of the alternator, which is generally mounted on the under side of the fuselage where it will be in the air stream of the propeller. The only apparatus mounted inside the fuselage are the three sending keys, the field and battery switch, the dry battery in its holder, the variometer and the antenna reel. The complete list of the component parts of this transmitting set is given at the end of this pamphlet.

In general, the set is a simple, rotary gap, indirectly excited spark set provided with nine taps on the inductance coil of the closed oscillating circuit to give as many different wave lengths, and with five different toothed discs for the rotary spark gap to give five different signal tones. These two variations make possible 45 different combinations of wave length and tone whereby it is practical to operate a large number of fire control airplanes in a comparatively small area without their interfering with each other's work. Adjustment of the wave lengths and tones of the closed oscillating circuit can be made only from the ground before the airplane starts out to work, as the set is not accessible to the pilot or observer. The principal adjustment of the open or antenna oscillating circuit is also made on the ground. The only adjustment the observer has to make in the air is that accomplished by a variometer mounted in the fuselage which brings the open oscillating circuit into resonance with the closed circuit, as indicated by the maximum current reading on a hot wire ammeter in the variometer box. The set is thus very simple to operate and quite dependable as there is no battery to run down or other auxiliary apparatus

to get out of order. The hot wire ammeter affords the operator knowledge of whether or not his signals are radiated.

The high power of the set—200 watts—was made necessary by the practice of the French of using powerful sets, since our forces will be working in the same section of the front as the French, and interference from their powerful sets would make a less powerful set on our airplanes impractical. The possibility of ultimately using a fixed antenna on the airplane, which would require a greater energy input than the trailing antenna for equivalent radiation, also had a bearing on the high power of the set.

### Description of the Apparatus

As already mentioned, practically all of the apparatus of this sending set is mounted in the streamline casing of the generator. It is mounted from front to rear in the generator housing as follows: airfan, generator, rotary spark gap, condenser and potential transformer, and oscillation transformer. This general arrangement is quite clearly shown in Fig. 1.

**Generator.**—The special inductor type alternator is rated as a 4500-rpm., 116 to 126-volt on open circuit, 900-cycle, 200-watt generator. The stator is made up with four direct current poles. Four slots are cut into each of these poles and the high frequency alternating current windings placed in them. The rotor is made with 12 teeth and acts as the inductor. In the slots between teeth, the direct current winding for exciting the field is wound. The commutator on one end of the rotor delivers the direct current to the field coils, one side of this circuit being carried to a distributing block to facilitate connecting in a field switch and a dry battery which is used as an auxiliary means of exciting the field. This battery is only a temporary provision which will be supplied with the set until such time as experience has shown that the field will always build up without the momentary impulse from the battery. In rotating, the 12 teeth pass the alternating current windings and vary the flux through 12 cycles for each revolution. The frequency of the generator at the normal speed of 4500-rpm. is thus seen to be 900 cycles per second.

**Airfan.**—The generator is driven by a 20-in. two-blade airfan at a practically constant speed for wide variations of air

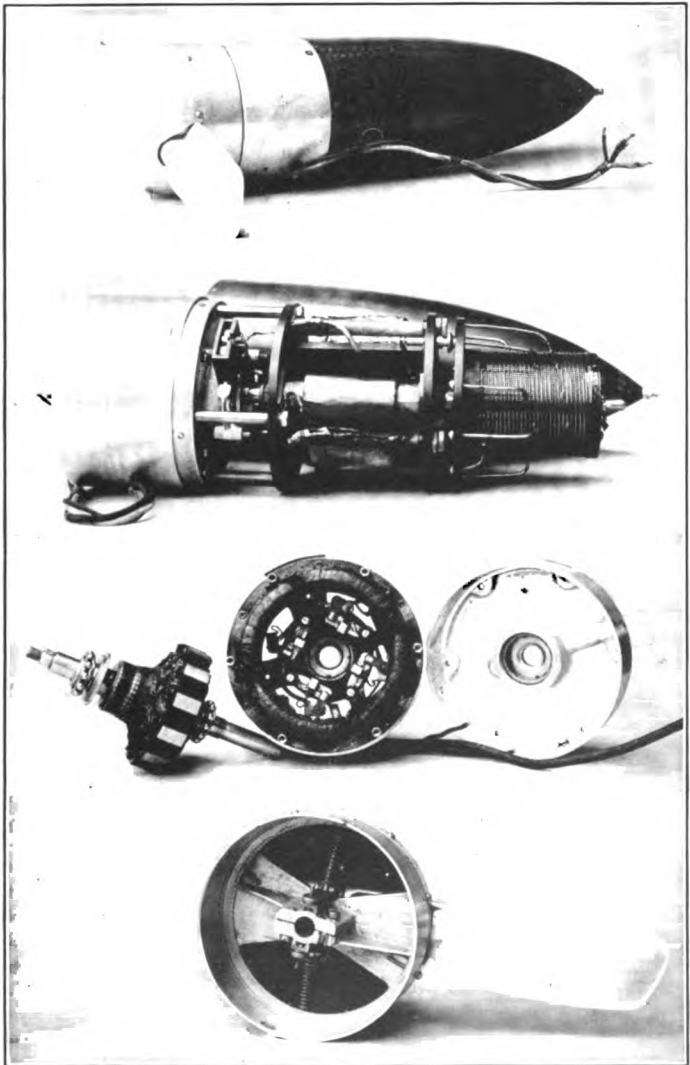

**Fig. 1—Top to Bottom: Type SCR-73 Set Assembled. Casing Removed Showing Radio Apparatus. Rotor and Stator of Alternator. Airfan and Governor.**



velocity. This is accomplished by means of a centrifugal governor mounted at the center of the fan inside the housing, which changes the pitch of the blades to compensate for the different air speeds. This arrangement will maintain the speed of the generator within plus or minus 4 percent. of 4500 rpm. with an air speed variation from 50 to 175 miles per hour. Since the set will operate satisfactorily with the power output corresponding to a speed as low as 4000 rpm. or as high as 5200 rpm., this governor control is well within the working limits.

The change in the pitch of the blades is effected by means of two weights, one attached to each blade arm, the positions of which are controlled by centrifugal force. The centrifugal force of the weights is counteracted by compression springs, so that when the spring reaction and the weight on the arms are properly adjusted, the position of equilibrium between these two opposing forces will be such as to maintain the speed of 4500 rpm., within the wind velocities mentioned above. The rotation of the blades about their own axes, as the governor changes the pitch, is made on ball bearings at each side of the housing.

**Rotary Spark Gap.**—The rotary spark gap which determines the tone of the signals sent and to a slight degree quenches the spark, consists of a rotary brass disc forming one electrode of the gap, and a piece of tungsten forming the other or fixed electrode of the gap. The brass disc is mounted on an insulating hub which is keyed to the shaft of the alternator. The stationary tungsten electrode is mounted in an insulating block and held by an adjustable bracket which is clamped to the hub of the alternator. Five interchangeable discs are furnished with the set. These have respectively 6, 8, 12, 17 and 24 teeth and give the corresponding tones of 450, 600, 900, mixed tone, and 1,800 sparks per second. In installing any one of these discs, two adjustments are necessary; namely, the angular and radial adjustments of the stationary electrode. The first adjustment determines when the spark will occur with reference to the cycle of the generator voltage, and the second adjustment determines the length of gap between the stationary electrode and the rotating teeth as they pass. The angular adjustment is made by shifting the stationary electrode holder one way or the other so that a mark on the electrode will be opposite one of the two marks on the generator hub designated by the figures "24"

and "6" stamped on the end-bell shoulder. For the 24-tooth disc, the stationary electrode is set opposite the "24" mark, and for the 6, 8, 12 and 17-tooth discs, the holder is set opposite figure "6." The angular adjustments thus specified, produce a good note and give a power output of about 200 watts maximum.

In making the radial adjustment, the clamping screw is first loosened and then the adjusting screw turned to bring the stationary electrode to a position which will leave a gap of about  $1/64$  in. in length. While this adjustment is being made, the disc should be rotated very slowly by hand. In case it is not true, the adjustment should be made so that at the minimum gap, the teeth will clear the stationary electrode by  $1/64$  in. After the angular and radial adjustments are completed, the stationary electrode holder should be carefully locked in place by tightening the locking screw.

The streamline casing is made of molded canvas and bakelite and is attached to the generator by means of a bayonet joint and catch in the steel reinforcing band. In order to dissipate the heat and carry off the gases produced by the spark, special ventilating holes are provided in this housing. When the generator is mounted properly, the position of the streamline is such that one of the ventilating holes is at the side behind the mounting bracket of the generator, where the air current tends to force the air into the housing. The other ventilating hole is at the side of the casing, where it is in the free path of the air current. In this position it causes a suction tending to pull the air out of the housing. These two holes thus cause a stream of air to flow through the housing which assists slightly in quenching the spark at the spark-gap. A spring catch engaging with a hole in the steel band, determines the proper angular position of the casing.

**Power Transformer and Condenser.**—The power transformer for stepping up the voltage supplied by the alternator, and the condenser in the closed oscillatory circuit, are mounted beside each other in the generator streamline and are held in place by two bakelite insulating discs which are clamped together by means of fiber rods. The transformer is of the closed core type having its primary coil wound on one leg and its secondary coil on the other leg of the core. The condenser is one employing mica as a dielectric and having a capacity of .004 mfd. It is mounted in an open frame of aluminum and is coated with a special compound which protects it from moisture.

**Oscillation Transformer.**—The oscillation transformer consists of a solid bare copper wire wound in grooves around a hollow bakelite cylinder fastened to a bakelite disc which is mounted on a short shaft held in the insulating frame of the set. Part of the turns of this coil serve as the primary and the remainder as the secondary, the two coils being inductively coupled and their common point grounded. Nine primary taps to the coil are brought out to contact buttons on the disc at the front end of the coil and each button is marked with the wave length of the

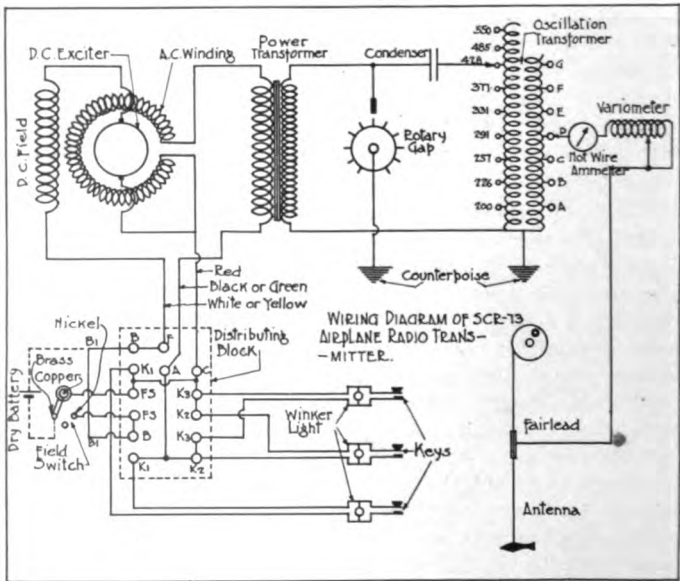

Fig. 2—Schematic Wiring Diagram of Type SCR-73 Set.

closed oscillatory circuit corresponding to it. Connection is made with these various contact buttons by means of a spring contactor having a socket in the end which fits over the button, making connection and at the same time holding the inductance cylinder in that position. To change the connection, this spring contact is pulled toward the fan and the whole inductance cylinder revolved until the contact button desired comes opposite the spring contact.

The seven secondary taps on the oscillation transformer are

brought out to contact buttons on a disc at the back end of the cylinder and connection is made to the various buttons by means of a simple lever switch which pivots about the axis of the cylinder. The secondary turns of the transformer are included in the open oscillatory circuit, or antenna circuit, and by changing the number of turns by means of the several taps marked, A, B, C, etc., it is possible to change the amount of power transferred from the primary to the secondary windings and hence the amount radiated, between the limits of normal and  $1/16$  normal output. The minimum power is obtained when the switch is in contact with tap A. The output current is delivered from this coil to the antenna through a special coil spring and socket connector in the point of the casing which bears on a metal post in the center of the disc at the back end of the oscillation transformer cylinder. This flexible connection facilitates taking the casing off to make the wave length and tone adjustments without disturbing the connection from the casing to the variometer.

**The Variometer.**—The variometer is installed along with a hot wire ammeter in a wooden box which is mounted in the airplane fuselage between the two cockpits where it can be reached by the observer for making adjustments. It has an inductance, variable between the limits of .035 and .40 millihenrys. It consists of a cylindrical coil of solid copper wire wound on a hollow cylinder of light insulating material. The inductance is varied by means of a trolley mounted within the coil which moves parallel to the axis of the coil, and makes contact with the bare turns of wire as it passes. It can thus be made to cut out or in one turn of wire at a time as it is moved along. This trolley is moved by means of a handle on the cover of the box which rotates a pinion engaging with a ratchet on which the sliding trolley is fastened. The free end of the coil is connected in the circuit so that a break in the trolley contact would insert the full coil in the circuit and not interrupt operating. A brass disc moving with the trolley inside the coil, serves to insulate or short circuit the magnetic lines of force and thus prevent losses in the short circuited coils. It serves also to make the changes in inductance more gradual. The eddy current losses in this disc are negligible.

The purpose of the variometer, as already explained in the opening paragraph of this pamphlet, is to tune the antenna circuit to the wave length of the closed oscillatory circuit. It

is so designed that it covers the entire range of wave lengths without any change of connections. Rotating the handle clockwise increases the wave length, and counter-clockwise, decreases it.

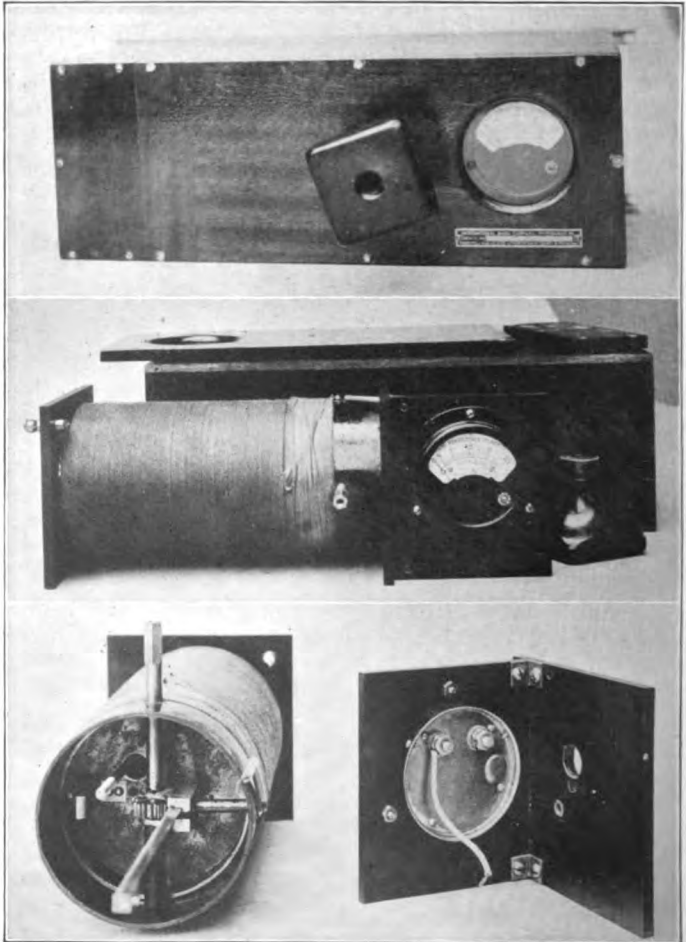

Fig. 3—Type VA-1 Variometer Assembled and Disassembled to Show the Coil, and Pinion and Ratchet-Actuated Sliding Contact

In connection with this tuning process, it is very important to note that the following lengths of antenna wire are to be used in order to get the desired wave length. The third column of the table below indicates the button of the oscillation transformer secondary to which connection should be made to secure the maximum radiation of current, for each wave length adjustment.

Length of Antenna in feet	Wave Length in Meters	Power Tap for Maximum Radiation
100	200	D
150	226	D
150	257	E
200	291	E
200	331	E
200	377	F
200	426	F
200	485	G
200	550	G

*Caution.*—No higher power tap than C should be used with the type F-1 and type F-2 fairleads, because the high voltage may cause a dangerous spark.

The hot wire ammeter mounted in the variometer box is covered with a glass window so that the meter case which is at a high potential, cannot be touched by the operator. The meter is designed to read from 0 to 2.5 amp. and it gives a steady reading despite the vibration of the airplane.

**Sending Keys and Winker Lamps.**—The three sending keys are the special flameproof type embodying a heavy construction and having an adjustable gap. A bayonet type socket for a winker lamp is mounted on the base of each key and a spun metal cap provided to protect it. The lamps used are special 130-volt Mazda type and they are connected in parallel with the key. A lamp is then on when the key is open and off when the key is closed. It thus serves simultaneously, the purposes of giving an indication by the brilliancy of the filament as to the voltage being delivered by the generator, of notifying either pilot or observer when the other is sending signals so that he will not use his key and interrupt, and perhaps of assisting the operator in properly sending code by providing him with a visual indication of the spacing of dots and dashes.

## Interconnection of the Parts of the Set

Fig. 4 shows quite clearly the electrical interconnection which must be made between the several parts of the type SCR-73 set when installed on an airplane. The three sending keys, the toggle-joint field switch and the dry cells are mounted in the fuselage and connected to a terminal block, Fig. 5, which is mounted on the floor or wall just inside the fuselage above the point where the control cable from the generator

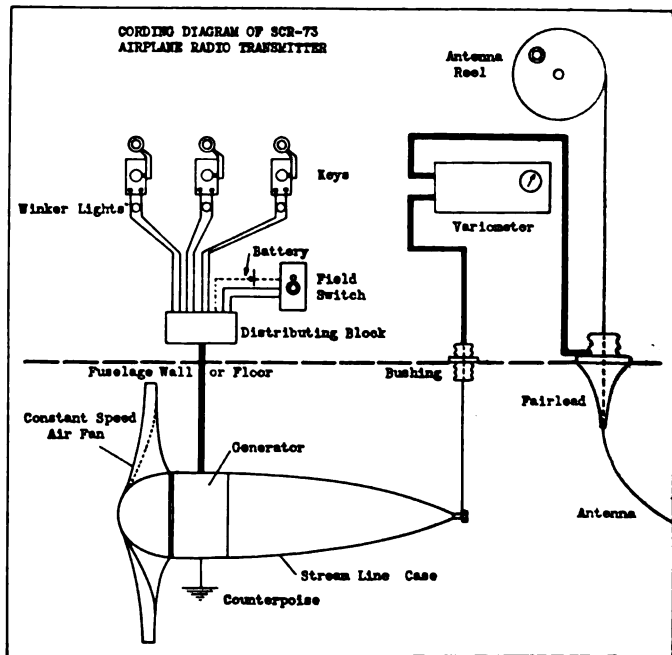

Fig. 4—Interconnection Between Parts of Type SCR-73 Set.

enters. This distributing block has six terminals on one side for the connection of the keys and switch just mentioned, and four main terminals on the opposite side for connecting up the armature and field leads from the alternator. The three keys are connected in parallel. The high frequency, high voltage outgoing radio current is lead from the spring contactor at the point of the generator streamline casing.

through a special bushing in the wall or bottom of the fuselage and thence to the variometer. From here it is carried over another cable to the fairlead mounted in the floor of the fuselage which makes electrical connection with the trailing antenna. The ground or counterpoise connection for the radio circuit is made through the frame of the generator and the metal brackets which clamp the generator in position. It is important that the high tension lead from the variometer to the fairlead be kept at least 1 in. away from any metal to avoid possibility of a spark with its attendant dangers.

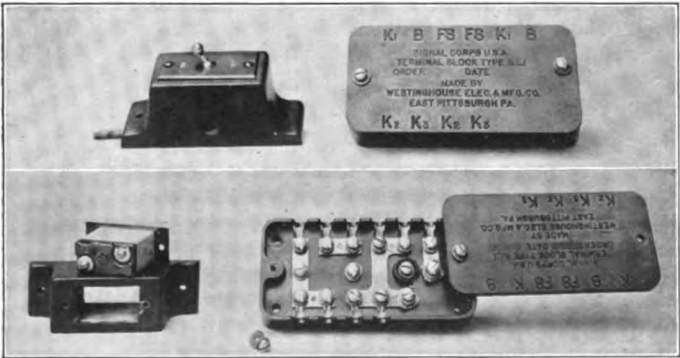

Fig. 5—Type SW-3 Toggle-Joint Field Switch and Type BL-1 Distributing Block.

The leads from the generator are supplied in three different colors for the purpose of distinguishing connections. A black or green lead is connected to the ac. armature, white or yellow to the field, and red is the common return.

### Method of Operating the Set

In the ordinary use of the type SCR-73 set, a certain wave length and tone will be assigned to each airplane before it makes a flight. The usual practice will probably be to assign one note to each squadron or flight, and different wave lengths to each airplane of this squadron. Hence in preparation for a flight for fire control work, the first step in connection with making ready the radio apparatus is to remove the streamline casing and put on the rotary disc with the proper number of teeth for the tone assigned to the squadron. The angular



and radial adjustments are then made as explained in the paragraph describing the rotary spark gap. The wave length adjustment is made, as indicated in the paragraph describing the oscillation transformer, by rotating the entire transformer to bring the contact button which is marked the wave length desired, in connection with the stationary spring contact. The oscillation transformer secondary, regulating the power supplied to the antenna, is then adjusted for maximum output according to the table of antenna lengths and wave lengths on page 11, but more often for an output lower than this maximum. With the type F-1 or F-2 fairleads, the power tap should not be adjusted for a higher output than that furnished by the contact button marked C. The voltage on taps higher than C is so great that with these fairleads, a spark might be caused, producing a fire hazard.

With the three adjustments of tone, wave length and power output made, the streamline casing may be replaced, and the set is then ready to be tried out at the same time the airplane motor is tested previous to making a flight. While the motor is running at high speed, the generator fan will be driven by the wind of the propellor at a speed suitable for testing. The test comprises merely the closing of the field switch and noting that the winker lamps are lighted, indicating that the generator is working properly, and of depressing a sending key and noting a reading on the hot wire ammeter in the variometer box, substituting for the regular antenna, a type A-51 phantom antenna, one of which is included in the standard equipment of a squadron radio officer. A small motor for driving the generator without running the airplane engine is also provided in this list of equipment for use if needed. A final adjustment of the set is made in the air during flight.

After the airplane has attained a safe altitude, the observer lets out the antenna wire, the length of which has been previously made according to the table on page 11, by unlocking the reel and allowing it to unwind the full length. The field switch is then closed in the "on" position. If the winker lamps do not glow, this is an indication that the generator field has not built up. In that event, the field switch is closed momentarily in the "battery" position and then returned to the "on" position. The winker lamps will then glow and give evidence that the apparatus is connected correctly and is in operating condition. It is

PRECAUTION

Particular care must be taken not to use a higher power tap than C with an F-1 or F-2 fairlead. Taps higher than C produce voltages which may cause serious sparks, endangering the lives of the pilot and observer. When it is necessary in long range work to use higher power than the output from Tap C, a fairlead designed for higher voltages must be used and the insulation of the lead from variometer to fairlead generally increased. Fairleads bearing the type number F-4 or F-5 are being designed for this purpose.

C on the oscillation transformer should be used.

The antenna wire should be of the proper length so that it will always be fully unreeled when in use, in order that the reel will be insulated from the antenna by the 2 ft. of braided twine which attaches the antenna wire to the reel.

Care should be taken that the frame of the generator is well grounded to the metal parts of the airplane forming the counterpoise. To this end, the bracket in which the generator is clamped should be kept free of oil and dirt, or any insulating material.

## Parts List of Type SCR-73 Airplane Radio Telegraph Transmitting Set

### POWER EQUIPMENT, TYPE PE-3

- 2 Regulating Airfans, type FA-4 (1 in use, 1 spare)
  - 1 Wind Driven Generator, type GN-4 (including one set of spare brushes)
  - 1 Field Switch, type SW-3 or SW-12\*
  - \*1 Dry Battery Case, type CS-3
  - \*6 Dry Batteries, type BA-3 (1 in use, 5 spares)
- \*(To be used only on first sets until experience gives definite assurance that the building up of the generator field is positive)

### TRANSMITTING EQUIPMENT, TYPE RT-4

- 1 Power Transformer, type TF-1
- 1 Transmitting Condenser, type CA-3
- 1 Stationary Electrode and Support, type ET-6
- 1 Spark Gap Electrode, 24 teeth, type ET-1
- 1 Spark Gap Electrode, 17 teeth, type ET-2
- 1 Spark Gap Electrode, 12 teeth, type ET-3
- 1 Spark Gap Electrode, 8 teeth, type ET-4
- 1 Spark Gap Electrode, 6 teeth, type ET-5
- 1 Oscillation Transformer, type ID-3
- 2 Spring Contacts and Terminals, type TM-4 (1 in use, 1 spare)
- 1 Streamline Casing, type CS-1
- 1 Variometer, type VA-1
- 1 Insulating Bushing, type BU-1
- 1 Distributing Block, type BL-1
- 3 Keys, type J-7
- 9 Winker Lamps, type LM-2 (3 in use, 6 spares)
- 1 Set of Connecting Leads

### ANTENNA EQUIPMENT, TYPE A-21

- 1 Antenna Reel, type RL-2
- 2 Antenna Reel Drums, type DR-2
- 3000 ft. Antenna Wire; 16-strand, No. 30 B&S gauge, soft copper, braided; (probable maximum length of antenna, 300 ft.)
- 10 Antenna Weights, type WT-1 (1 in use, 9 spares)
- 2 Fairleads, type F-1; type F-2 when type F-1 is not available. (1 in use, 1 spare)
- 20 ft. Braided Twine; breaking strength 70 to 80 lb.; treated with insulating compound. (Approximately 2 ft. in use.)



---

**Prepared in the  
Office of the Chief Signal Officer  
Training Section  
Washington**

---

*E. N. R.*

**CONFIDENTIAL!** For Official Use Only

**U. W. Airplane Radio Telegraph  
Set Type SCR-80**

*Communication*  
**RADIO PAMPHLET No. 23**  
April 14, 1919

Signal Corps, U. S. Army





**U.W. AIRPLANE RADIO TELEGRAPH SET**  
**TYPE SCR-80**

113948-10--1





**T**HE TYPE SCR-80 SET is a transmitting and receiving undamped wave airplane radio telegraph set, having a wave length range of from 550 to 750 meters. It may be used with a single wire trailing antenna about 300 ft. long, or with a two-wire antenna, such as the type A-23, which gives the same range of wave lengths.

This set is primarily intended for long range fire control work in conjunction with the type SCR-79 ground set. However, it may

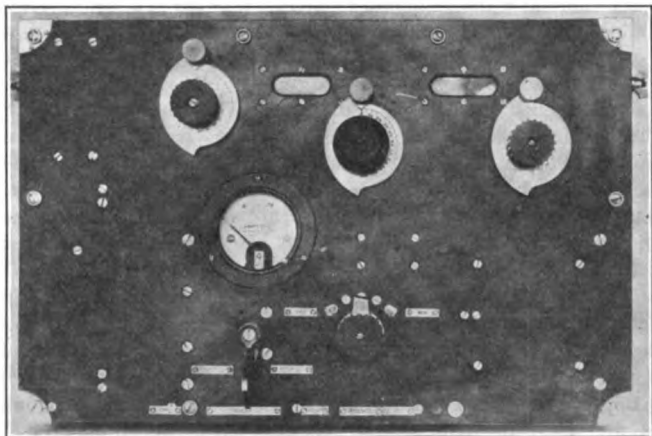

Operating Panel of Set Box Type BC-52 Used in Set Type SCR-80, as it Appears Set Vertically in Front of the Observer.

be used for intercommunication with other airplanes similarly equipped. When communicating with a type SCR-79 set, the type SCR-80 set has a range of about 20 miles. This distance will vary with the type of antenna used and may be as great as 40 miles. This is an exceptionally long range for an airplane set.

An advantage of this set is that it is practically interchangeable with the type SCR-68 set, as it uses the same double voltage, fan driven generator, the same filter box and interphone box. The set box itself may be mounted on a bracket differing but little from that

used for the set box of the type SCR-68 set. The principal difference in the installation is that one or more telegraph sending keys are used on the set box instead of telephone transmitters.

The set is rugged and compact and is very simple to operate, there being only one adjustment of the transmitting circuit and two adjustments of the receiving circuit.

### General Description and Principle of Operation.

A complete schematic circuit diagram of the set is given in Fig. 1, which illustrates the principle of operation of the set. A five-pole, double-throw "Transmit-Receive" switch is provided on the set box, which effects all the necessary changes in the connections of the set box when transmitting or receiving.

**Switch in "Transmit" Position.**—With the switch in the "Transmit" position, the circuits in use are equivalent to those shown in Fig. 2. The two type VT-2 three-electrode vacuum tubes used for the generation of the oscillations are connected with their filaments in series, and the filament heating circuit, which comprises also a ballast lamp, is connected across the 25-volt terminals of the fan driven generator.

The ballast lamp has a filament the resistance of which varies with the current flowing through it, and it functions to minimize the variations of the filament current resulting from the slight variations of generator potential. These potential variations are due to slight changes in the speed of the generator and to the action of commutation. They are reduced and smoothed out by the condenser  $F_1$ , which is located in the filter box, and acts jointly with the ballast lamp to deliver a constant current to the transmitting tube filaments.

The grids and plates of the two tubes are connected in parallel, so that the arrangement is equivalent to one single tube of larger size. A continuous positive potential of 275 volts, generated by the 275-volt armature of the fan driven generator, is applied to the plates when the telegraph key is closed. This location of the key in the plate circuit insures a very positive action of the tubes, since there is thus no plate current when the key is open, which prevents any accumulation of negative charge on the grid, and hence any lag in the starting of the oscillations when the key is closed is avoided. In order to smooth out small variations of plate potential, such as

those resulting from commutation, a condenser  $F_2$  is connected across the 275-volt terminals of the generator. This condenser, like the condenser  $F_1$ , is located in the filter box.

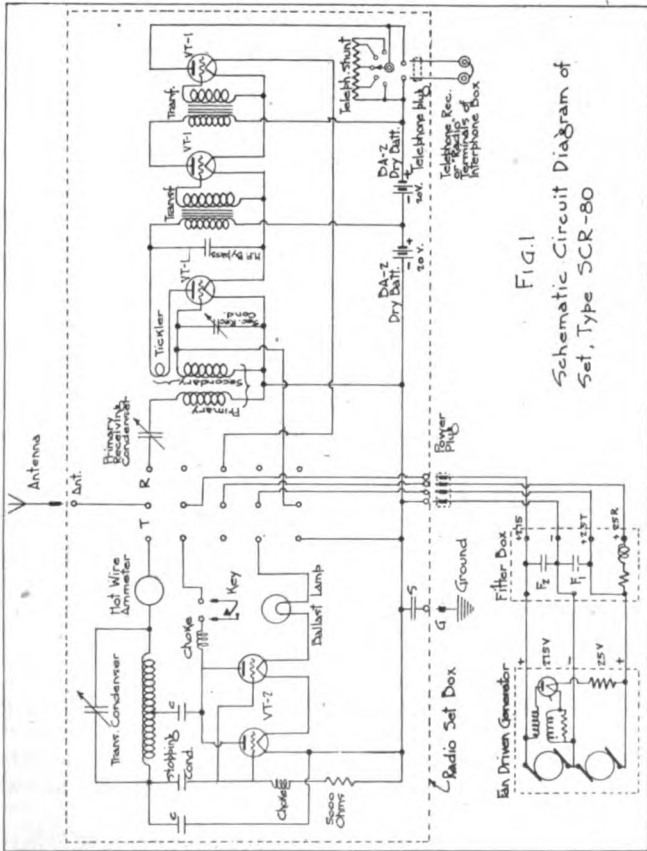
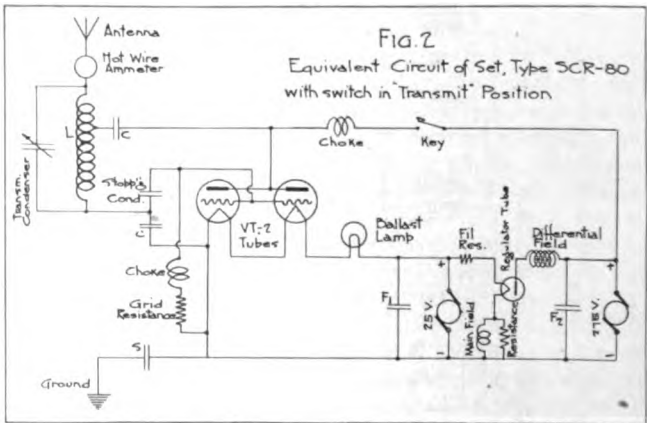

FIG. 1  
Schematic Circuit Diagram of  
Set, Type SCR-80

A continuous negative potential is impressed upon the grid, which is derived from the potential drop resulting from the grid current flowing through a 5000-ohm grid resistance connected

between the grid and the filament. A choke coil is inserted in each of these d.c. grid and plate potential circuits in order to prevent the high frequency oscillations generated by the tubes from entering these circuits.

The plate and grid circuits just described are coupled electrostatically through the medium of two fixed mica condensers marked C, Fig. 2. The oscillatory circuit in which undamped oscillations are generated comprises the inductance coil L, the radiating antenna-ground condenser and the variable "Transmitting Condenser" in parallel with it. A hot wire ammeter in series with



the antenna indicates the radiation, and provides a method of checking that the vacuum tubes are in an oscillating condition. It should be noted that the condenser S in the ground wire prevents any possible outside short circuit of the generator. As may be seen from the above, the only adjustment provided in the circuit is that of the transmitting condenser. This is sufficient to cover the entire wave length range of the set.

**Switch in "Receive" Position.**—Since the signals to be received by the set are undamped wave signals, the heterodyne method is used for their reception. With the switch in the "Receive" position, the circuits in use are equivalent to those of Fig. 3. The incoming signals first energize the primary circuit, which comprises

the antenna, primary tuning condenser, primary inductance, stepping condenser S, and ground (counterpoise). Inductively coupled to the primary inductance is the secondary oscillatory circuit, comprising a secondary inductance coil and a variable secondary condenser. No provision is made to vary the coupling of the primary and secondary coils since this is not necessary for satisfactory operation, and reduces the number of adjustments. A peculiar feature of the secondary condenser is the micrometer adjustment which makes possible a fine adjustment of the secondary

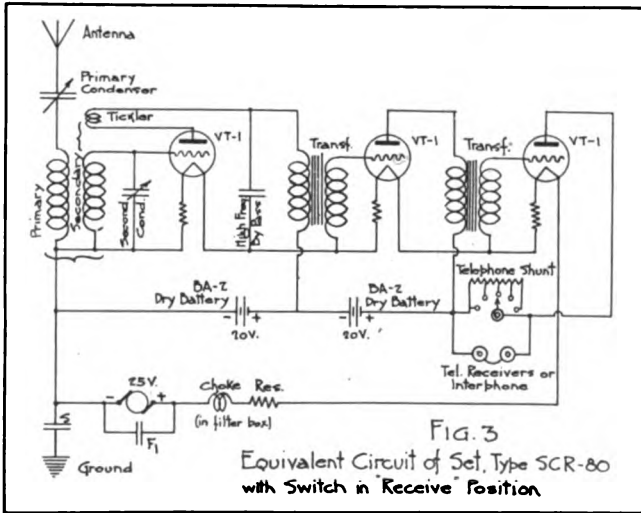

circuit. This is made necessary by the use of the heterodyne method of reception. The secondary condenser is operated by means of an insulating handle which rotates all the movable plates but one. This one plate is operated separately by means of a smaller handle mounted on the same shaft.

The secondary oscillatory circuit is connected between the grid and the negative side of the filament of a type VT-1 vacuum tube used as a detector. The plate current for this tube is furnished by a 20-volt, type BA-2 dry battery. The plate circuit comprises a tickler coil, permanently coupled to the secondary inductance, and

the primary winding of an iron core transformer which couples the detector tube circuit to the first amplifier tube. Shunting this transformer winding and dry battery is a fixed mica condenser which

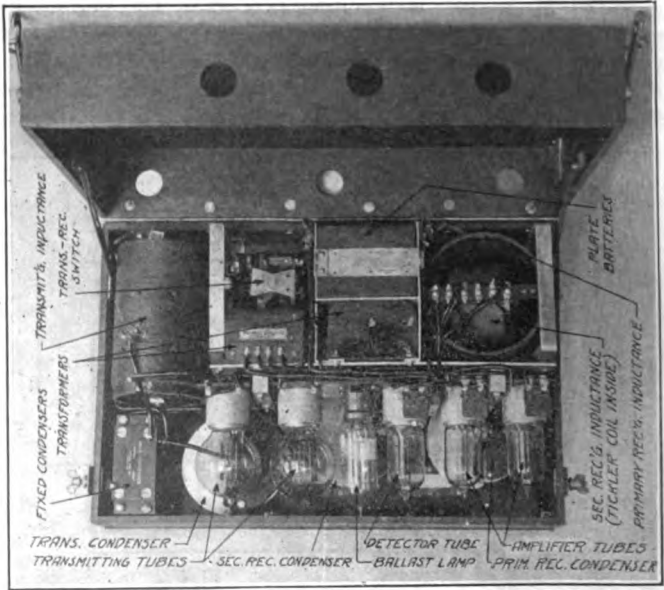

View of Set Box Type BC-52 Interior, as it Opens Before the Observer When the Set Box is Mounted in the Airplane Cockpit.

serves as a by-pass for the locally generated high frequency oscillations.

The remainder of the receiving circuit is a two-stage cascade amplifier using type VT-1 vacuum tubes, with a plate potential of 40 volts on each one of these tubes, and iron core transformers coupling them. Telephone receivers are inserted in the plate circuit of the last tube. These are shunted by a resistance variable in five steps, which is used to vary the proportion of the signal current flowing through the receivers and thus permits the elimination of weak interfering sounds.

All three filaments are connected in series, the heating current being furnished by the 25-volt side of the fan driven generator. In series with the latter is a choke coil and resistance, which are located in the filter box and which serve to reduce the commutation pulses which were not by-passed by the condenser  $F_1$ . This condenser shunts the generator terminals and smooths out the commutation pulses of the generator. In series with each filament is a 1-ohm resistance the voltage drop across which supplies to the grid of each tube the proper negative potential.

It will be noted, Fig. 1, that the secondary receiving condenser is short circuited when the switch is in the "Transmit" position.

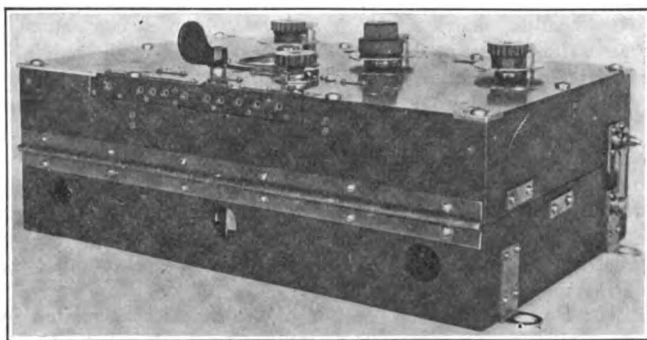

Bottom View of Set Box Type BC-52 Showing Connecting Jacks and Elevation of Operating Handles.

This arrangement is made in order to prevent excessive currents from being induced in the secondary receiving inductance coil by the oscillations taking place in the transmitting inductance while sending.

**Description of Generator.**—The fan driven generator, type GN-1-A or GN-2-A, used with this set is the same as that used with the type SCR-68-A airplane radio telephone set. It has two armature windings, giving 25 and 275 volts, respectively, when the generator is run at rated speed. Since it is very important for the satisfactory operation of the set that the terminal voltage of the generator remain constant, a regulating fan, type FA-7, is used. This fan has a variable pitch which adjusts itself automatically for vary-



ing wind velocities, so that it will rotate at a constant speed within wide limits of wind (or airplane) velocities. When no regulating fan is available, a type FA-3 wooden airfan may be used, which, however, is likely to give less satisfactory operation under conditions of varying wind velocity. In addition to the regulating action of the variable pitch airfan, the voltage output of the generator is also controlled through the use of a main and a differential field winding, the fluxes of which are opposed in effect. There is also a special two-electrode regulating tube inserted in series with the differential field. The complete connections are illustrated in Fig. 1. The action of this device may be explained as follows:

When the generator is driven at a higher speed than normal, the generated voltage has a tendency to increase, which consequently increases the current in the main field winding and in the regulator tube filament in series with it. It also increases the plate voltage on this tube, and therefore the plate current. The latter current, flowing through the differential field winding, increases the flux in the latter, which counteracts that of the main field, and thus prevents any further rise of the generator voltage. In case the generator is driven at a speed below normal, the phenomena occur in exactly the opposite manner. By means of this arrangement, the output voltages of the generator are maintained fairly constant under the conditions encountered in practice.

**Filter Box.**—With the operation of the generator regulated by means of the variable pitch airfan, the regulator tube, and differential field, there remains the pulsating terminal voltage of the generator resulting from commutation to be eliminated. The result of such a pulsating current is a steady hum in the telephone receivers. This noise is minimized by the use of a filter box, which is of the same type as that used with the type SCR-68-A set. It consists of two condensers, shunting the 25-volt and 275-volt terminals of the generator, and a reactance coil and resistance connected in series in the filament circuit of the receiving tubes.

**Interphone.**—While the type SCR-80 set is essentially a radio telegraph set, it is of great importance in connection with its use that the pilot and observer should be able to talk to each other during the flight. Also, while the observer is the only one to use the sending key, it is of advantage that both the pilot and observer receive the incoming signals, so that the pilot will not talk to the observer while the latter is receiving a message. This double function is accomplished by the interphone which is connected to the radio

set box in place of the telephone receiver, as shown in Figs. 1 and 4. The set used is the Set, Airplane Interphone, Type SCR-57-A, for which a circuit diagram is shown in Fig. 5. This set is also used on airplane radio telephone sets, such as the type SCR-68-A. It has two radio telephone transmitter terminals, which are not used when the interphone set is used with the telegraph set type SCR-80.

The method of functioning of the interphone may readily be understood from the circuit diagram. When the four-pole double-throw switch is closed in the position "Interphone," the contacts marked "I" in the diagram are closed. The pilot and observer are

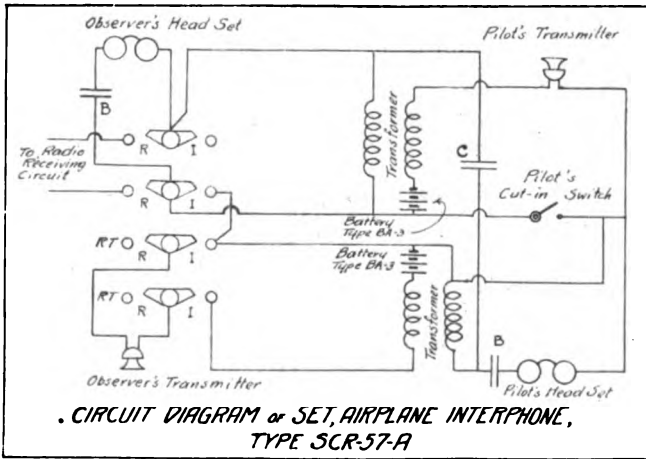

Fig. 5.—Circuit Diagram of the Interphone Set Used With Set Type SCR-80.

then entirely disconnected from the radio set, and are connected to each other by an ordinary telephone circuit. They may talk back and forth without any additional operation. A special feature of the set is the "side tone" circuit, which comprises the condenser C, and the purpose of which is to shunt some of the telephone current from the transmitter circuit back into the telephone receiver circuit of the person talking, so that he may hear his own voice and know how loud he is talking and whether or not the circuit is working.

When the switch on the interphone set box is closed to "Radio," the observer's telephone receivers are directly connected to the radio telegraph receiving circuit, and the observer receives incoming

radio signals in the ordinary manner. The observer's telephone transmitter is entirely disconnected, so that he can not talk to the pilot. The pilot's circuits are disconnected, but by closing his cut-in switch he can receive the radio signals and talk to the observer. The operation is then as follows:

When the observer and pilot want to talk back and forth to each other, the observer closes the interphone-radio switch to "Interphone." When the observer desires to receive radio signals, this switch is closed to "Radio." If, now, the pilot desires to talk to the observer, he must first close his cut-in switch, and if he does not hear any radio signals, he may speak to the observer without interrupting him in the reception of a radio message. If he hears incoming radio signals, he should wait for the end of the message. If the observer desires to answer the pilot, he must close the interphone-radio switch to "Interphone." This, however, disconnects him from the radio set, so he should not leave the switch in this position longer than is necessary or he may miss some incoming radio signals.

### Method of Installing the Set.

All of the apparatus described above is grouped in a number of units, as indicated schematically by the dotted lines, Fig. 1. These units comprise the fan driven generator, generally mounted on the right hand strut in the landing gear; the filter box, which may be installed on the floor inside the fuselage; the radio set box, preferably mounted as for the SCR-68 in front of the observer; and the interphone set box, which is conveniently mounted on the right hand side of the observer's cockpit. The antenna reel can then be mounted on his left hand side. When one telegraph key is used, it is mounted on the right hand side of the observer. When two keys are used, such as in the De Haviland DH-4 two-seated machine, one is mounted in front and the other in back of the observer. These suggestions for the installation of the set are, of course, of a general character, and the actual location of the apparatus will differ in the various types of airplanes. The usual precautions of good insulation, neat wiring, balancing of the load, etc., must be observed.

The interconnection of the various units should be made with the extension cords provided and in accord with the cording diagram given in Fig. 4. Care should be taken to see that all connections and plugs are tight, since a loose connection or broken cord will prevent satisfactory operation of the set.

Fig. 4. Wiring Diagram for Set Type SCR-80

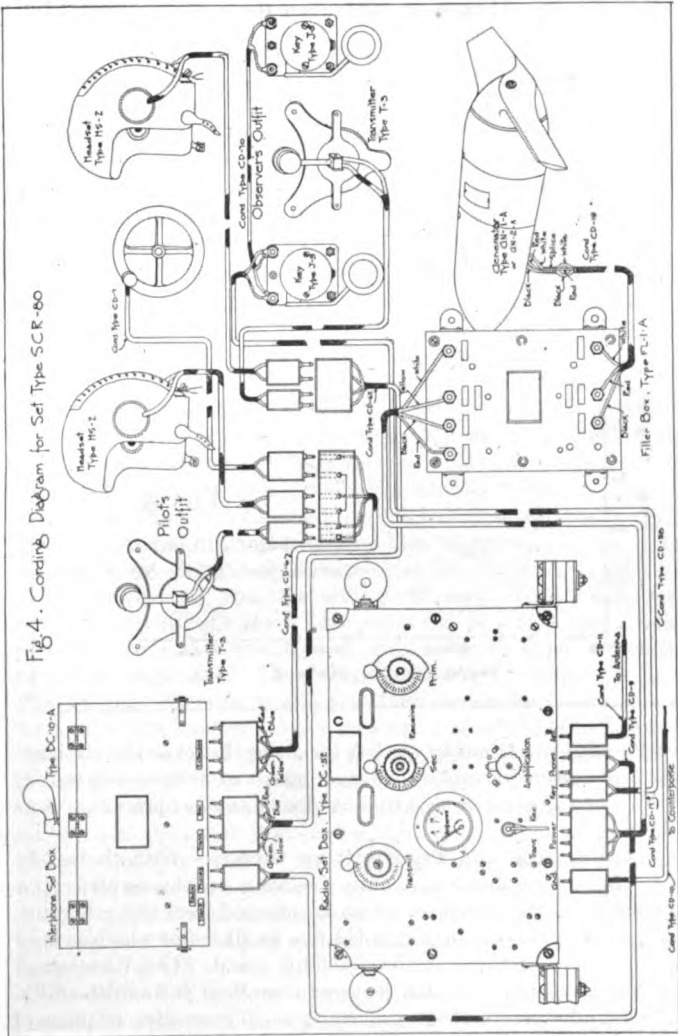

### Method of Calibrating the Set.

In general, an airplane will always use an antenna of the same length, so that it will be found of advantage to calibrate the transmitting circuit of the set for this antenna. This is done in order that the setting of the transmitting condenser will be known for any value of wave length it is desired to use. It is also well to calibrate the secondary receiving circuit of the set, so that it may be adjusted in advance to receive any predetermined wave length. The calibration of this latter circuit will not change, even if the set is used with an antenna having different characteristics. The calibration

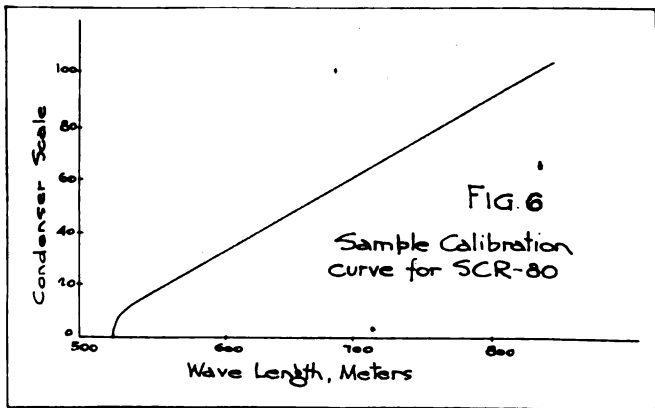

may be made in a laboratory before installing the set on the airplane. This is of especial advantage when a number of sets are to be tested. For calibrating a set on an airplane, the method of procedure is as follows.

(a) **Calibrating the Transmitting Circuit.**—With the set in good working condition and fully installed on the airplane and connected up, the generator airfan is removed from the generator. The generator shaft is then coupled to a small motor which is used to drive the generator at the standard speed. The “Antenna” and “Ground” plugs are first removed from their jacks in the radio set box, and a phantom antenna, type A-50, connected in place of the real antenna. The phantom antenna is set to correspond to

the constants of the real antenna. If no phantom antenna is available, a condenser may be used having the same capacitance (about 300 micro-mfd.) as the real antenna. This is, however, not as good practice, since the calibration will not be quite so accurate. In all cases, whether the phantom antenna, type A-50, or an improvised phantom antenna is used, the connecting wires should be equipped with plugs, type PL-12, so they will fit the "Antenna" and "Ground" jacks of the radio set box.

The "Transmit-Receive" switch is thrown to the "Transmit" position, and the set excited by running the generator at its rated speed. The telegraph sending key is closed and the wave length emitted by the set is measured by means of a type SCR-95 wavemeter for a number of positions of the transmitting condenser covering its entire range. A curve is then plotted, similar to that shown in Fig. 6, from which the transmitting condenser setting may be found for any value of wave length within the limits of the set. Maximum coupling between the type SCR-95 wavemeter and the type SCR-80 set radio circuits may be obtained, if required, by placing the side of the wavemeter box marked "Plane of Coil" in front of the lower left hand side of the operating panel of the type SCR-80 radio set. Complete instructions regarding the use of this wavemeter are given in Radio Pamphlet No. 21, second edition.

(b) **Calibrating the Receiving Circuit.**—To calibrate the receiving circuit, the set is first connected to a phantom antenna and the generator is driven by a small motor, as explained in the preceding paragraph. The "Transmit-Receive" switch is then closed to the "Receive" position, and the wavemeter is successively made to emit a number of wave lengths covering the entire range of the set. For each wave length, the secondary receiving condenser is adjusted to give maximum response in the telephone receivers. This calibration is made with the primary receiving condenser set on "0" and then with that condenser set at "100," and a curve is plotted similar to that of Fig. 6, giving the secondary condenser setting for receiving any desired wave length within the range of the set. The points will, in most cases, be on either side of the calibration curve, which should therefore be an average curve for the readings obtained.

The calibration of the receiving circuit, as explained above, will have to be made only once, as the set is put into use the first time.

The calibration of the transmitting circuit will have to be repeated every time a new antenna is used having different electrical constants.

### Method of Operating the Set.

The following tests should be made on the ground prior to each flight, for the purpose of ascertaining that the set is in good working condition.

1. Remove the airfan from the generator shaft, and couple the generator to a motor, which will be used to run it at rated speed.

2. Remove the "Power" plug from the corresponding jack in the radio set box, and start the generator.

3. By means of a voltmeter, check the voltage between the "Power" plug terminals. The voltmeter readings should be 25 and 275 volts, respectively.

4. By means of a voltmeter, check the voltage of the type BA-2 dry batteries in the set box. This should not be less than 18 volts. Note that the batteries are connected with the correct polarity.

5. Connect a phantom antenna in place of the real antenna and ground, insert the "Power" plug into its jack in the radio set box, and close the "Transmit-Receive" switch in the "Transmit" position.

6. The two type VT-2 transmitting tube filaments should now glow a dull red, and the hot wire ammeter on the operating panel should read from about 0.9 to 0.6 amp. when the transmitting condenser is turned from the "0" to the "100" position.

7. Close the "Transmit-Receive" switch to "Receive," and the interphone switch to "Radio." The three type VT-1 tube filaments should now glow a dull red, and the characteristic commutation hum should be heard in the telephone receivers, for all positions of the primary and secondary receiving condensers.

8. Turn the telephone shunt switch over its entire range, and note that there occurs a gradual change in the intensity of the commutation hum.

9. Check the oscillating condition of the detector tube for various positions of the receiving condensers. This is done by opening the set box, and touching the grid terminal (upper terminal of the secondary condenser) with a wet finger, when a click should be heard in the telephone receivers.

10. The generator is now stopped, and the airfan replaced and locked tight to the shaft, so that it will not work loose or vibrate during the flight. The airfan blades should be twisted around once or twice, to see that they rotate properly. Oil the bearings slightly if required.

11. The set having been found in good working condition, the phantom antenna is removed, and the real antenna and ground are plugged in. The transmitting condenser is then set to the proper position, as given by the calibration curve of the transmitting circuit, for the wave length at which it is desired to transmit. The secondary receiving condenser is also set at the predetermined wave length to receive the signals from the ground set. This latter setting is only approximate and will have to be adjusted while in flight, as explained below.

12. The set is now ready for the flight. After the airplane has reached a sufficient height, the antenna is reeled out, if such a type be used, and the "Transmit-Receive" switch is closed in the "Transmit" position. Upon closing the telegraph sending key, the hot wire ammeter should read from 0.9 to 0.6 amp. It is well to check up that the waves emitted are of the desired length. This may be done by closing the key and using the type SCR-95 wavemeter, which can be readily taken up in the airplane on account of its small size. On account of the rather large current passing through the key, it is best to have a large opening of the key, in order to prevent possible arcing between the key contact points.

13. For receiving, the "Transmit-Receive" switch is closed in the "Receive" position, and the interphone switch placed in the "Radio" position. The secondary receiving condenser having been set on the ground at approximately the correct position for the signals to be received, it is not disturbed at first. The primary receiving condenser setting is varied over its range until a position is found at which the signals are heard. If the signals are not received after the entire range of the primary condenser has been tried, the setting of the secondary condenser should be altered slightly either way, and the operation repeated. It is well when flying within 5 to 10 miles of the sending station to set the telephone shunt switch on the middle tap. For finer adjustment of the set, the secondary condenser micrometer adjustment may be used, especially when receiving weak signals, such as when flying at a great distance.



### Possible Sources of Trouble.

Among the possible sources of trouble with this set, the following may be mentioned:

**Switch on "Receive."**—Failure to receive signals with the set properly tuned may be due to a failure of the detector tube to oscillate. The test for oscillating condition is given in Par. 9 above.

If signals are not received and the commutation hum is not heard, the dry battery may be run down, or the filament of one of the three receiving tubes may be broken.

A crackling noise in the telephone receivers may be due to poor brushes on the generator, poor setting of the brushes, sparking at the commutator, or to poor dry batteries, or loose connections in the telephone cords or in the circuit. It may also be due to magneto interference. This last may be prevented effectively by shielding the magneto and magneto wires leading to the spark plugs of the airplane motor. A fairly satisfactory solution was found which involved the use of metallic covers for all the high tension wires and the magnetos. The most common practice made use of flexible copper clad cables for this purpose, but after considerable experimenting it was found that solid metallic tubing was preferable, it being possible to completely screen out the disturbances with this form of shielding.

**Switch on "Transmit."**—If the hot wire ammeter does not indicate any current, it may be due to a faulty transmitting condenser. This would usually be noticed in the preflight test on the ground. It may be the result of buckled and short circuited condenser plates.

A broken filament of improper plate voltage such as might result from a faulty regulator tube in the generator, will prevent operation of the set.

Generator trouble will frequently be found to be in the wiring and mounting of the regulator tube, in the brushes or commutators, or in the differential field circuit. An open in the latter will generally cause the burning out of the regulator tube filament or the three-electrode tube filaments or even the high voltage generator armature.

A frequent source of trouble will be due to loose connections at the filter box terminals. Breaking of the connection wires at those terminals usually results from the wires being run too tightly.

**PARTS LIST.**

In ordering this set or parts of this set, specification must be made by names and type numbers as listed below, exactly. The designations written in bold face type *only*, will be used in requisitioning, making property returns, etc.

In ordering *complete* sets, it is not necessary to itemize the parts; simply specify, "2 Sets, U. W. Airplane Radio Telegraph, Type SCR-80." If *all* the parts listed under a group heading are desired, it is not necessary to itemize the parts; simply specify, for example, "1 Equipment, Type PE-1-A."

The type SCR-80 set is not complete unless it includes all of the items listed below.

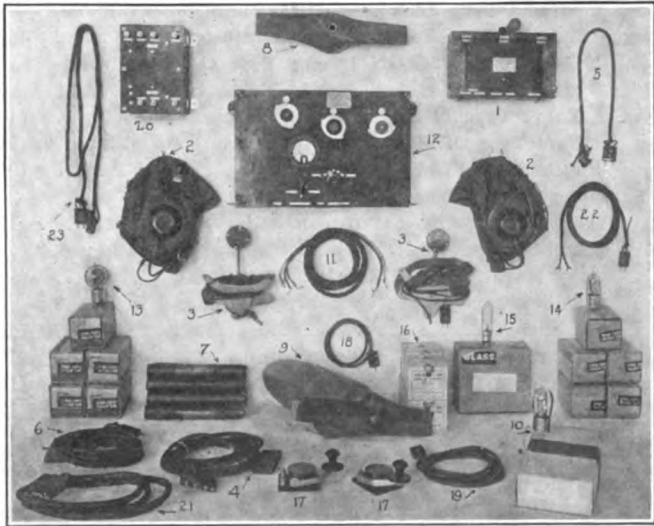

## Set, U. W. Airplane Radio Telegraph, Type SCR-80.

<b>1 Set, Airplane Interphone, Type SCR-57-A:</b>	★
1 Set Box Type BC-10-A.....	(1)
2 Head Sets Type HS-2.....	(2)
2 Transmitters Type T-3.....	(3)
1 Cord Type CD-6; extension; 12 ft.; set box to pilot's jack.....	(4)
1 Cord Type CD-7; extension; push-button switch to pilot's jack.....	(5)
1 Cord Type CD-62; extension; 4 ft.; set box to observer's jack.....	(6)
20 Batteries Type BA-3; dry; 2 in use, 18 spare.....	(7)
<b>1 Equipment Type PE-1-A; power:</b>	
2 Airfans Type FA-7; regulating; or if not available, Airfan Type FA-3, wooden; 1 in use, 1 spare.....	(8†)
1 Generator Type GN-1-A or Type GN-2-A; wind-driven.....	(9)
5 Tubes Type TB-1; regulator; 1 in use, 4 spare.....	(10)
1 Cord Type CD-19; extension; generator to filter....	(11)
1 Filter Type FL-1-A.....	(20)
<b>1 Equipment Type RE-9; radio:</b>	
1 Set Box Type BC-52; airplane radio telegraph.....	(12)
6 Tubes Type VT-2; vacuum; transmitting; 2 in use, 4 spare.....	(13)
6 Tubes Type VT-1; vacuum; receiving; 3 in use, 3 spare.....	(14)
3 Lamps Type LM-1; ballast; 1 in use, 2 spare.....	(15)
8 Batteries Type BA-2; dry; 2 in use, 6 spare.....	(16)
2 Keys Type J-5; flame proof.....	(17)
1 Cord Type CD-10; extension; BC-52 to ground.....	(18)
1 Cord Type CD-11; extension; BC-52 to antenna.....	(19)
1 Cord Type CD-70; extension; for connecting keys in parallel.....	(not shown)
1 Cord Type CD-17; extension; BC-52 to filter.....	(21)
1 Cord Type CD-58; extension; BC-52 to flame proof key.....	(22)
1 Cord Type CD-9; extension; set box type BC-52 to set box type BC-10-A.....	(23)

★The figures in parentheses in the right hand column refer to the corresponding part in the illustration on page 19.

†The airfan shown is the type FA-3, not regulating.

1 **Equipment Type A-23**; antenna:

1 **Antenna Type AN-6**.

780 ft. **Wire Type W-16**; in six lengths of 130 ft. each; wound on six spools; for use on AN-6; spare.

4 **Insulators Type IN-8**; phenol fiber rod; 4 in. long.

$\frac{1}{2}$  lb. **Tape Type TL-83**.

40 ft. **Cord Type BP-6**; impregnated linen; in two lengths of 20 ft. each.

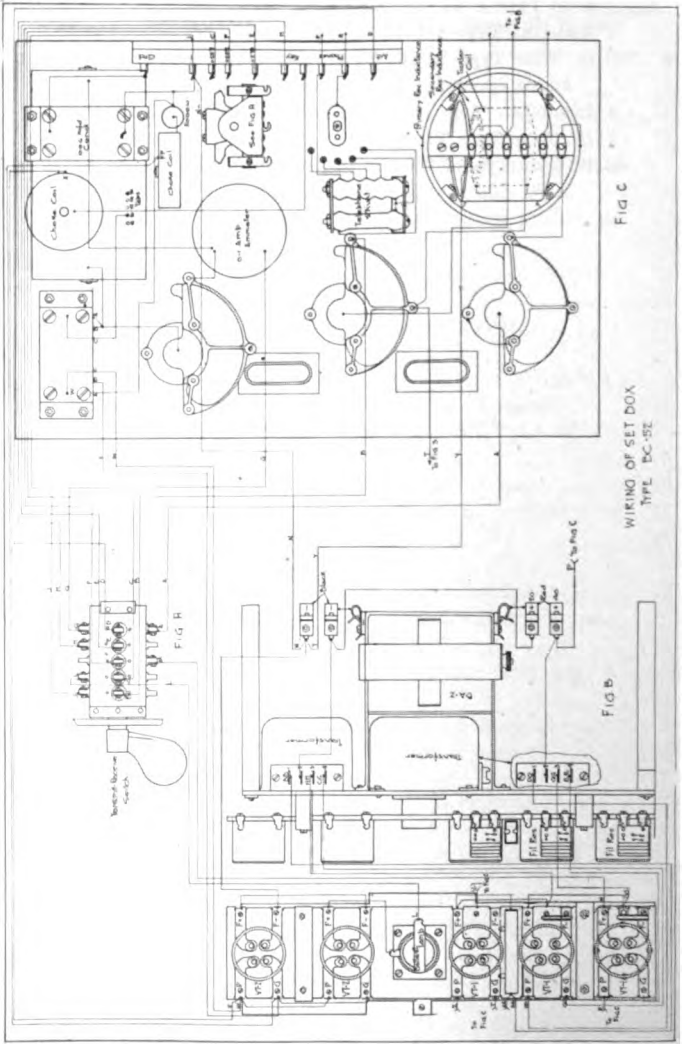

FIG. C

WIRING OF SET BOX TYPE DC-52

FIG. B











---

**Prepared in the  
Office of the Chief Signal Officer  
Training Section  
Washington**

---

FOR OFFICIAL USE ONLY

**AIRPLANE  
RADIO TELEGRAPH  
TRANSMITTING SET**

Type SCR-73

*( Confidential )*

**Radio Pamphlet  
No. 13**

**Signal Corps, U. S. Army**  
6-30-18



**AIRPLANE RADIO TELEGRAPH  
TRANSMITTING SET**

**Type SCR-73**



# AIRPLANE RADIO TELEGRAPH

## TRANSMITTING SET

### Type SCR-73

The airplane radio telegraph transmitting set, type SCR-73, is designed for use on fire control airplanes. It is a damped wave transmitting set supplied with power from a self-excited inductor type alternator which is driven by a special constant speed airfan, or sometimes for training purposes by a fixed blade wooden airfan. The alternator, the rotary spark gap employed, the potential transformer, the condenser and oscillation transformer are all self-contained in the streamline casing of the alternator, which is generally mounted on the under side of the fuselage where it will be in the air stream of the propeller. The only apparatus mounted inside the fuselage are the three sending keys, the field and battery switch, the dry battery in its holder, the variometer and the antenna reel. The complete list of the component parts of this transmitting set is given at the end of this pamphlet.

In general, the set is a simple, rotary gap, indirectly excited spark set provided with nine taps on the inductance coil of the closed oscillating circuit to give as many different wave lengths, and with five different toothed discs for the rotary spark gap to give five different signal tones. These two variations make possible 45 different combinations of wave length and tone whereby it is practical to operate a large number of fire control airplanes in a comparatively small area without their interfering with each other's work. Adjustment of the wave lengths and tones of the closed oscillating circuit can be made only from the ground before the airplane starts out to work, as the set is not accessible to the pilot or observer. The principal adjustment of the open or antenna oscillating circuit is also made on the ground. The only adjustment the observer has to make in the air is that accomplished by a variometer mounted in the fuselage which brings the open oscillating circuit into resonance with the closed circuit, as indicated by the maximum current reading on a hot wire ammeter in the variometer box. The set is thus very simple to operate and quite dependable as there is no battery to run down or other auxiliary apparatus

to get out of order. The hot wire ammeter affords the operator knowledge of whether or not his signals are radiated.

The high power of the set—200 watts—was made necessary by the practice of the French of using powerful sets, since our forces will be working in the same section of the front as the French, and interference from their powerful sets would make a less powerful set on our airplanes impractical. The possibility of ultimately using a fixed antenna on the airplane, which would require a greater energy input than the trailing antenna for equivalent radiation, also had a bearing on the high power of the set.

### Description of the Apparatus

As already mentioned, practically all of the apparatus of this sending set is mounted in the streamline casing of the generator. It is mounted from front to rear in the generator housing as follows: airfan, generator, rotary spark gap, condenser and potential transformer, and oscillation transformer. This general arrangement is quite clearly shown in Fig. 1.

**Generator.**—The special inductor type alternator is rated as a 4500-rpm., 116 to 126-volt on open circuit, 900-cycle, 200-watt generator. The stator is made up with four direct current poles. Four slots are cut into each of these poles and the high frequency alternating current windings placed in them. The rotor is made with 12 teeth and acts as the inductor. In the slots between teeth, the direct current winding for exciting the field is wound. The commutator on one end of the rotor delivers the direct current to the field coils, one side of this circuit being carried to a distributing block to facilitate connecting in a field switch and a dry battery which is used as an auxiliary means of exciting the field. This battery is only a temporary provision which will be supplied with the set until such time as experience has shown that the field will always build up without the momentary impulse from the battery. In rotating, the 12 teeth pass the alternating current windings and vary the flux through 12 cycles for each revolution. The frequency of the generator at the normal speed of 4500-rpm. is thus seen to be 900 cycles per second.

**Airfan.**—The generator is driven by a 20-in. two-blade airfan at a practically constant speed for wide variations of air

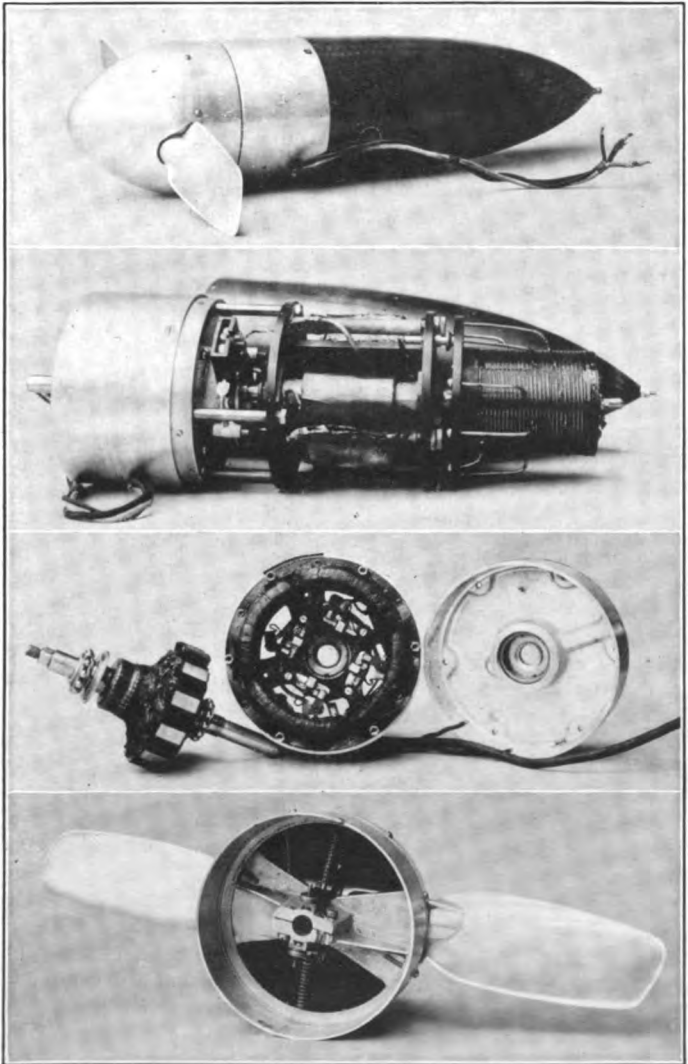

**Fig. 1—Top to Bottom: Type SCR-73 Set Assembled. Casing Removed Showing Radio Apparatus. Rotor and Stator of Alternator. Airfan and Governor.**



velocity. This is accomplished by means of a centrifugal governor mounted at the center of the fan inside the housing, which changes the pitch of the blades to compensate for the different air speeds. This arrangement will maintain the speed of the generator within plus or minus 4 percent. of 4500 rpm. with an air speed variation from 50 to 175 miles per hour. Since the set will operate satisfactorily with the power output corresponding to a speed as low as 4000 rpm. or as high as 5200 rpm., this governor control is well within the working limits.

The change in the pitch of the blades is effected by means of two weights, one attached to each blade arm, the positions of which are controlled by centrifugal force. The centrifugal force of the weights is counteracted by compression springs, so that when the spring reaction and the weight on the arms are properly adjusted, the position of equilibrium between these two opposing forces will be such as to maintain the speed of 4500 rpm., within the wind velocities mentioned above. The rotation of the blades about their own axes, as the governor changes the pitch, is made on ball bearings at each side of the housing.

**Rotary Spark Gap.**—The rotary spark gap which determines the tone of the signals sent and to a slight degree quenches the spark, consists of a rotary brass disc forming one electrode of the gap, and a piece of tungsten forming the other or fixed electrode of the gap. The brass disc is mounted on an insulating hub which is keyed to the shaft of the alternator. The stationary tungsten electrode is mounted in an insulating block and held by an adjustable bracket which is clamped to the hub of the alternator. Five interchangeable discs are furnished with the set. These have respectively 6, 8, 12, 17 and 24 teeth and give the corresponding tones of 450, 600, 900, mixed tone, and 1,800 sparks per second. In installing any one of these discs, two adjustments are necessary; namely, the angular and radial adjustments of the stationary electrode. The first adjustment determines when the spark will occur with reference to the cycle of the generator voltage, and the second adjustment determines the length of gap between the stationary electrode and the rotating teeth as they pass. The angular adjustment is made by shifting the stationary electrode holder one way or the other so that a mark on the electrode will be opposite one of the two marks on the generator hub designated by the figures "24"

and "6" stamped on the end-bell shoulder. For the 24-tooth disc, the stationary electrode is set opposite the "24" mark, and for the 6, 8, 12 and 17-tooth discs, the holder is set opposite figure "6." The angular adjustments thus specified, produce a good note and give a power output of about 200 watts maximum.

In making the radial adjustment, the clamping screw is first loosened and then the adjusting screw turned to bring the stationary electrode to a position which will leave a gap of about  $1/64$  in. in length. While this adjustment is being made, the disc should be rotated very slowly by hand. In case it is not true, the adjustment should be made so that at the minimum gap, the teeth will clear the stationary electrode by  $1/64$  in. After the angular and radial adjustments are completed, the stationary electrode holder should be carefully locked in place by tightening the locking screw.

The streamline casing is made of molded canvas and bakelite and is attached to the generator by means of a bayonet joint and catch in the steel reinforcing band. In order to dissipate the heat and carry off the gases produced by the spark, special ventilating holes are provided in this housing. When the generator is mounted properly, the position of the streamline is such that one of the ventilating holes is at the side behind the mounting bracket of the generator, where the air current tends to force the air into the housing. The other ventilating hole is at the side of the casing, where it is in the free path of the air current. In this position it causes a suction tending to pull the air out of the housing. These two holes thus cause a stream of air to flow through the housing which assists slightly in quenching the spark at the spark-gap. A spring catch engaging with a hole in the steel band, determines the proper angular position of the casing.

**Power Transformer and Condenser.**—The power transformer for stepping up the voltage supplied by the alternator, and the condenser in the closed oscillatory circuit, are mounted beside each other in the generator streamline and are held in place by two bakelite insulating discs which are clamped together by means of fiber rods. The transformer is of the closed core type having its primary coil wound on one leg and its secondary coil on the other leg of the core. The condenser is one employing mica as a dielectric and having a capacity of .004 mfd. It is mounted in an open frame of aluminum and is coated with a special compound which protects it from moisture.

**Oscillation Transformer.**—The oscillation transformer consists of a solid bare copper wire wound in grooves around a hollow bakelite cylinder fastened to a bakelite disc which is mounted on a short shaft held in the insulating frame of the set. Part of the turns of this coil serve as the primary and the remainder as the secondary, the two coils being inductively coupled and their common point grounded. Nine primary taps to the coil are brought out to contact buttons on the disc at the front end of the coil and each button is marked with the wave length of the

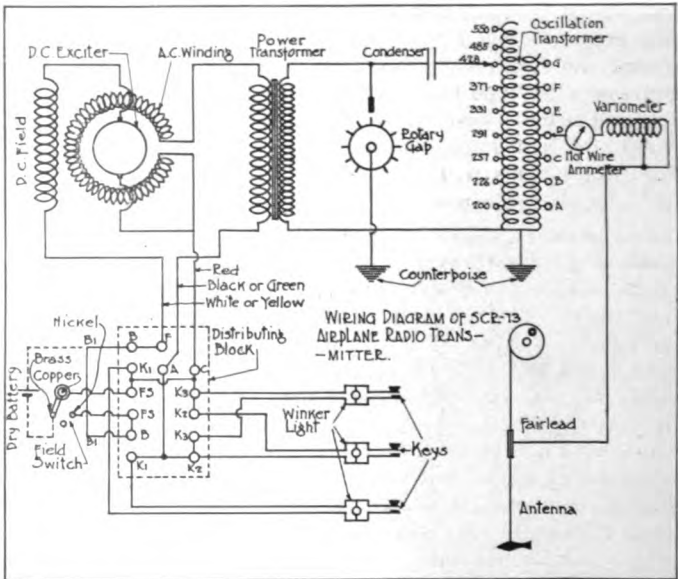

Fig. 2.—Schematic Wiring Diagram of Type SCR-73 Set.

closed oscillatory circuit corresponding to it. Connection is made with these various contact buttons by means of a spring contactor having a socket in the end which fits over the button, making connection and at the same time holding the inductance cylinder in that position. To change the connection, this spring contact is pulled toward the fan and the whole inductance cylinder revolved until the contact button desired comes opposite the spring contact.

The seven secondary taps on the oscillation transformer are

brought out to contact buttons on a disc at the back end of the cylinder and connection is made to the various buttons by means of a simple lever switch which pivots about the axis of the cylinder. The secondary turns of the transformer are included in the open oscillatory circuit, or antenna circuit, and by changing the number of turns by means of the several taps marked, A, B, C, etc., it is possible to change the amount of power transferred from the primary to the secondary windings and hence the amount radiated, between the limits of normal and 1/16 normal output. The minimum power is obtained when the switch is in contact with tap A. The output current is delivered from this coil to the antenna through a special coil spring and socket connector in the point of the casing which bears on a metal post in the center of the disc at the back end of the oscillation transformer cylinder. This flexible connection facilitates taking the casing off to make the wave length and tone adjustments without disturbing the connection from the casing to the variometer.

**The Variometer.**—The variometer is installed along with a hot wire ammeter in a wooden box which is mounted in the airplane fuselage between the two cockpits where it can be reached by the observer for making adjustments. It has an inductance, variable between the limits of .035 and .40 millihenrys. It consists of a cylindrical coil of solid copper wire wound on a hollow cylinder of light insulating material. The inductance is varied by means of a trolley mounted within the coil which moves parallel to the axis of the coil, and makes contact with the bare turns of wire as it passes. It can thus be made to cut out or in one turn of wire at a time as it is moved along. This trolley is moved by means of a handle on the cover of the box which rotates a pinion engaging with a ratchet on which the sliding trolley is fastened. The free end of the coil is connected in the circuit so that a break in the trolley contact would insert the full coil in the circuit and not interrupt operating. A brass disc moving with the trolley inside the coil, serves to insulate or short circuit the magnetic lines of force and thus prevent losses in the short circuited coils. It serves also to make the changes in inductance more gradual. The eddy current losses in this disc are negligible.

The purpose of the variometer, as already explained in the opening paragraph of this pamphlet, is to tune the antenna circuit to the wave length of the closed oscillatory circuit. It

is so designed that it covers the entire range of wave lengths without any change of connections. Rotating the handle clockwise increases the wave length, and counter-clockwise, decreases it.

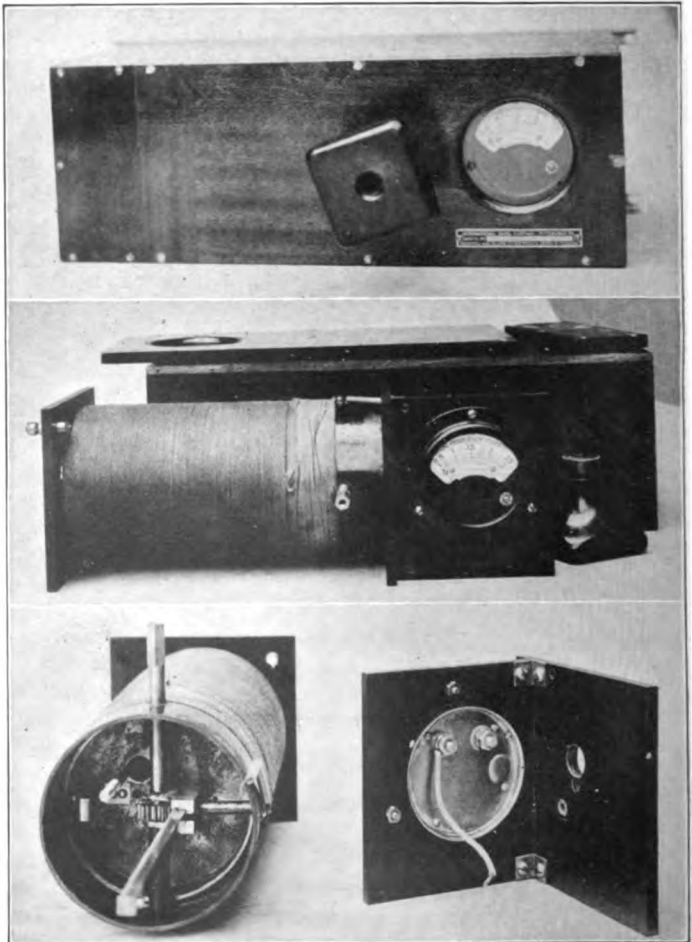

Fig. 3—Type VA-1 Variometer Assembled and Disassembled to Show the Coil, and Pinion and Ratchet-Actuated Sliding Contact.

In connection with this tuning process, it is very important to note that the following lengths of antenna wire are to be used in order to get the desired wave length. The third column of the table below indicates the button of the oscillation transformer secondary to which connection should be made to secure the maximum radiation of current, for each wave length adjustment.

Length of Antenna in feet	Wave Length in Meters	Power Tap for Maximum Radiation
100	200	D
150	226	D
150	257	E
200	291	E
200	331	E
200	377	F
200	426	F
200	485	G
200	550	G

*Caution.*—No higher power tap than C should be used with the type F-1 and type F-2 fairleads, because the high voltage may cause a dangerous spark.

The hot wire ammeter mounted in the variometer box is covered with a glass window so that the meter case which is at a high potential, cannot be touched by the operator. The meter is designed to read from 0 to 2.5 amp. and it gives a steady reading despite the vibration of the airplane.

**Sending Keys and Winker Lamps.**—The three sending keys are the special flameproof type embodying a heavy construction and having an adjustable gap. A bayonet type socket for a winker lamp is mounted on the base of each key and a spun metal cap provided to protect it. The lamps used are special 130-volt Mazda type and they are connected in parallel with the key. A lamp is then on when the key is open and off when the key is closed. It thus serves simultaneously, the purposes of giving an indication by the brilliancy of the filament as to the voltage being delivered by the generator, of notifying either pilot or observer when the other is sending signals so that he will not use his key and interrupt, and perhaps of assisting the operator in properly sending code by providing him with a visual indication of the spacing of dots and dashes.

## Interconnection of the Parts of the Set

Fig. 4 shows quite clearly the electrical interconnection which must be made between the several parts of the type SCR-73 set when installed on an airplane. The three sending keys, the toggle-joint field switch and the dry cells are mounted in the fuselage and connected to a terminal block, Fig. 5, which is mounted on the floor or wall just inside the fuselage above the point where the control cable from the generator

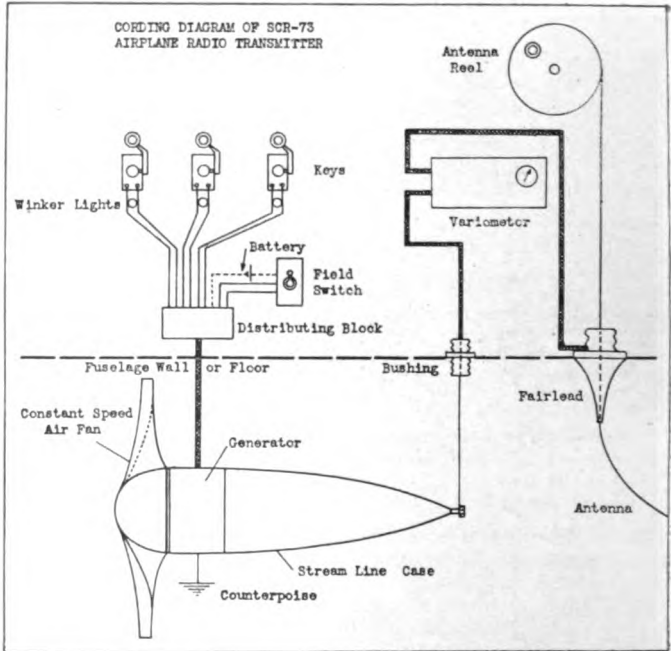

Fig. 4—Interconnection Between Parts of Type SCR-73 Set.

enters. This distributing block has six terminals on one side for the connection of the keys and switch just mentioned, and four main terminals on the opposite side for connecting up the armature and field leads from the alternator. The three keys are connected in parallel. The high frequency, high voltage outgoing radio current is lead from the spring contactor at the point of the generator streamline casing.

through a special bushing in the wall or bottom of the fuselage and thence to the variometer. From here it is carried over another cable to the fairlead mounted in the floor of the fuselage which makes electrical connection with the trailing antenna. The ground or counterpoise connection for the radio circuit is made through the frame of the generator and the metal brackets which clamp the generator in position. It is important that the high tension lead from the variometer to the fairlead be kept at least 1 in. away from any metal to avoid possibility of a spark with its attendant dangers.

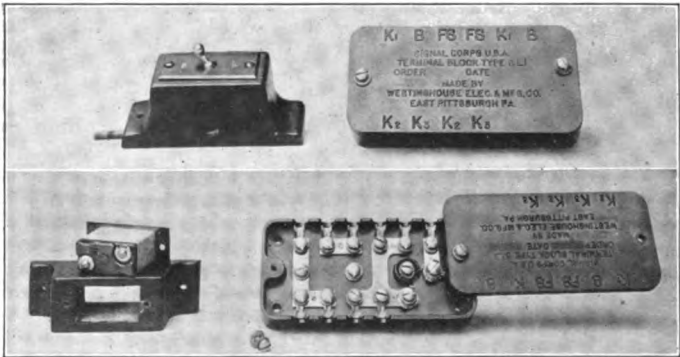

Fig. 5—Type SW-3 Toggle-Joint Field Switch and Type BL-1 Distributing Block.

The leads from the generator are supplied in three different colors for the purpose of distinguishing connections. A black or green lead is connected to the ac. armature, white or yellow to the field, and red is the common return.

### Method of Operating the Set

In the ordinary use of the type SCR-73 set, a certain wave length and tone will be assigned to each airplane before it makes a flight. The usual practice will probably be to assign one note to each squadron or flight, and different wave lengths to each airplane of this squadron. Hence in preparation for a flight for fire control work, the first step in connection with making ready the radio apparatus is to remove the streamline casing and put on the rotary disc with the proper number of teeth for the tone assigned to the squadron. The angular



and radial adjustments are then made as explained in the paragraph describing the rotary spark gap. The wave length adjustment is made, as indicated in the paragraph describing the oscillation transformer, by rotating the entire transformer to bring the contact button which is marked the wave length desired, in connection with the stationary spring contact. The oscillation transformer secondary, regulating the power supplied to the antenna, is then adjusted for maximum output according to the table of antenna lengths and wave lengths on page 11, but more often for an output lower than this maximum. With the type F-1 or F-2 fairleads, the power tap should not be adjusted for a higher output than that furnished by the contact button marked C. The voltage on taps higher than C is so great that with these fairleads, a spark might be caused, producing a fire hazard.

With the three adjustments of tone, wave length and power output made, the streamline casing may be replaced, and the set is then ready to be tried out at the same time the airplane motor is tested previous to making a flight. While the motor is running at high speed, the generator fan will be driven by the wind of the propellor at a speed suitable for testing. The test comprises merely the closing of the field switch and noting that the winker lamps are lighted, indicating that the generator is working properly, and of depressing a sending key and noting a reading on the hot wire ammeter in the variometer box, substituting for the regular antenna, a type A-51 phantom antenna, one of which is included in the standard equipment of a squadron radio officer. A small motor for driving the generator without running the airplane engine is also provided in this list of equipment for use if needed. A final adjustment of the set is made in the air during flight.

After the airplane has attained a safe altitude, the observer lets out the antenna wire, the length of which has been previously made according to the table on page 11, by unlocking the reel and allowing it to unwind the full length. The field switch is then closed in the "on" position. If the winker lamps do not glow, this is an indication that the generator field has not built up. In that event, the field switch is closed momentarily in the "battery" position and then returned to the "on" position. The winker lamps will then glow and give evidence that the apparatus is connected correctly and is in operating condition. It is

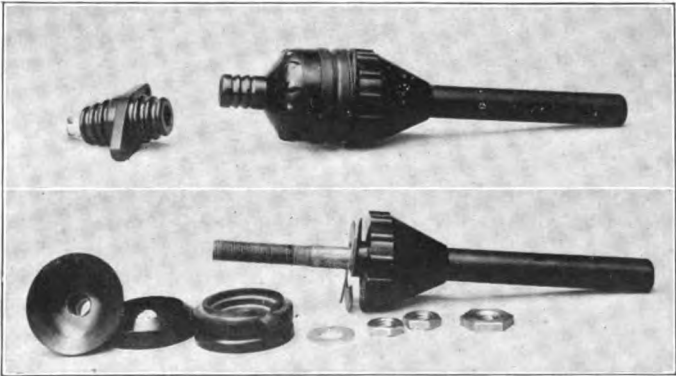

Fig. 6—Type F-1 Fairlead and Type BU-1 Insulating Bushing at Left of the Upper Insert.

then only necessary to press the key and turn the variometer handle until the hot wire ammeter indicates the maximum radiation. When the maximum reading is observed, the antenna circuit is in tune and the set is ready to operate. The operator should glance at the ammeter from time to time and note that radiation is taking place as the key is operated.

### Care and Precautions

In using the SCR-73 set, it is extremely important to remember that the airfans must not be used with a wind velocity greater than that indicated on the tag attached to the fan. Before each flight the blades should be twisted about their longitudinal axes, to make sure that the governor is acting properly. Notice should be taken that the fan is tight on the generator shaft so that there will be no chance of it vibrating loose. The ball bearings of the fan blade and the generator shaft should be oiled frequently with a light non-gunning oil.

With the type F-1 and F-2 fairleads, no higher power tap than C on the oscillation transformer should be used.

The antenna wire should be of the proper length so that it will always be fully unreeled when in use, in order that the reel will be insulated from the antenna by the 2 ft. of braided twine which attaches the antenna wire to the reel.

Care should be taken that the frame of the generator is well grounded to the metal parts of the airplane forming the counterpoise. To this end, the bracket in which the generator is clamped should be kept free of oil and dirt, or any insulating material.

## Parts List of Type SCR-73 Airplane Radio Telegraph Transmitting Set

### POWER EQUIPMENT, TYPE PE-3

- 2 Regulating Airfans, type FA-4 (1 in use, 1 spare)
  - 1 Wind Driven Generator, type GN-4 (including one set of spare brushes)
  - 1 Field Switch, type SW-3 or SW-12\*
  - \*1 Dry Battery Case, type CS-3
  - \*6 Dry Batteries, type BA-3 (1 in use, 5 spares)
- \*(To be used only on first sets until experience gives definite assurance that the building up of the generator field is positive)

### TRANSMITTING EQUIPMENT, TYPE RT-4

- 1 Power Transformer, type TF-1
- 1 Transmitting Condenser, type CA-3
- 1 Stationary Electrode and Support, type ET-6
- 1 Spark Gap Electrode, 24 teeth, type ET-1
- 1 Spark Gap Electrode, 17 teeth, type ET-2
- 1 Spark Gap Electrode, 12 teeth, type ET-3
- 1 Spark Gap Electrode, 8 teeth, type ET-4
- 1 Spark Gap Electrode, 6 teeth, type ET-5
- 1 Oscillation Transformer, type ID-3
- 2 Spring Contacts and Terminals, type TM-4 (1 in use, 1 spare)
- 1 Streamline Casing, type CS-1
- 1 Variometer, type VA-1
- 1 Insulating Bushing, type BU-1
- 1 Distributing Block, type BL-1
- 3 Keys, type J-7
- 9 Winker Lamps, type LM-2 (3 in use, 6 spares)
- 1 Set of Connecting Leads

### ANTENNA EQUIPMENT, TYPE A-21

- 1 Antenna Reel, type RL-2
- 2 Antenna Reel Drums, type DR-2
- 3000 ft. Antenna Wire; 16-strand, No. 30 B&S gauge, soft copper, braided; (probable maximum length of antenna, 300 ft.)
- 10 Antenna Weights, type WT-1 (1 in use, 9 spares)
- 2 Fairleads, type F-1; type F-2 when type F-1 is not available. (1 in use, 1 spare)
- 20 ft. Braided Twine; breaking strength 70 to 80 lb.; treated with insulating compound. (Approximately 2 ft. in use.)



---

Prepared in the  
Office of the Chief Signal Officer  
Training Section  
Washington

---

FOR OFFICIAL USE ONLY

# GROUND TELEGRAPHY OR T.P.S.

Transmitting Set, Type SCR-71  
Receiving Sets, Type SCR-72  
and SCR-72-B

(Confidential)

*Communication*  
Radio Pamphlet

No. 10

Signal Corps, U. S. Army

Second Edition, Revised to  
10-31-18



**Ground Telegraphy or T. P. S.  
Description and Use of Transmitting Set,  
Type SCR-71 and Receiving Sets,  
Type SCR-72 and Type SCR-72-B**





**G**ROUND TELEGRAPHY or T. P. S. (from the French "télégraphie par sol") is a means of communication which requires no wire connection between the sending and receiving stations, but it is different from radio telegraphy, in that it involves the use of pulsating or alternating currents of comparatively low frequency (600 to 1800 cycles per second) instead of oscillations of high frequency, of the order of 100,000 to 2 or 3 million cycles per second. Also, the transfer of electrical energy from the transmitting to the receiving apparatus take place by induction and conduction through the ground, instead of through the air as with radio.

The principles on which the theory of this means of communication are based, are quite simple. They are illustrated in Fig. 1. A generator A (alternator or buzzer) producing an audio frequency, high voltage alternating or pulsating current is connected to the ground by means of two wires, AB and AC, which are grounded at points B and C. These two grounds are 50 yd. to 200 yd. apart. The circuit followed by the current generated at A is then made up by the two wires AB and AC, and by the conducting ground between B and C. Since the ground is a fair conductor of electricity, the electric current will not be concentrated on the straight line BC, but it will follow a great number of paths through the ground, called lines of current flow, and represented schematically in Fig. 1 by the dotted lines. These lines of current flow may, under suitable geological conditions of the ground, spread out as far as 2 or 3 miles away from the sending circuit ABC.

If now at a certain distance from the sending circuit ABC, a metal wire is grounded at two points D and E, the current from A will not flow through the ground between points D and E along the corresponding line of current flow. Instead, will flow through the wire DFE, which is a low resistance path shunting the line of current flow DE in the ground. A suitable instrument F inserted in series with the wire DE, may therefore be employed to utilize this current in

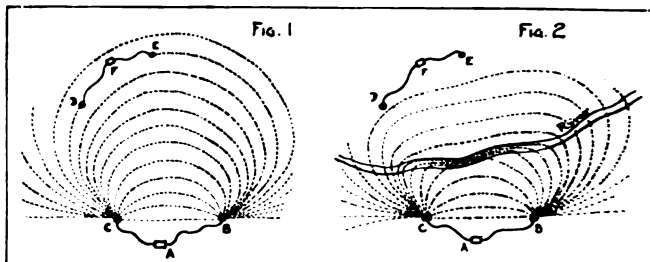

signaling work. The current in the circuit DFE is extremely small due to the rather high resistance of the ground and to the fact that the current generated by A spreads over such a considerable area that the wire DE picks up only a very small portion of the total current flowing through the ground in the various paths between B and C. The instrument F must therefore be very sensitive. It is usually a telephone receiver.

In most cases, the current in the wire DE is even too faint to produce a sound in a telephone receiver directly inserted in series with the wire. This has made it necessary to use amplifying devices, which amplify the currents received.

When the generator A is made to generate pulsating or alternating current of audio frequency, the corresponding current flowing in the circuit DFE will produce a sound in the telephone receiver F, and by opening and closing the sending circuit ABC by means of a telegraph key, it is possible to transmit telegraph signals which will be heard at F.

### Natural Conditions Affecting T. P. S. Communication

Since the conductivity of the ground is one of the most important factors affecting the transmission of T.P.S. signals, the distance over which communication is possible with a certain set of transmitting and receiving apparatus will depend greatly on the geological conditions of the surrounding region. Thus, a strata of non-conducting ground below the transmitting circuit BC will prevent the current from passing to any depth into the ground and will force it to spread out horizontally to quite considerable distances. A very dry ground, being of high resistance, will permit only a very weak current to flow, and hence will correspondingly reduce the distance over which communication is possible. A very wet

ground is too good a conductor and permits practically all the current to flow directly between B and C without spreading out to a sufficient extent. The best ground is neither too dry or too wet. The presence of a river or sizable brook between the receiving and sending stations greatly reduces the strength of the current received at the receiving station, and correspondingly decreases the intensity of the signals. This is illustrated in Fig. 2, where a stream is shown to flow between the two stations. Most of the lines of current flow, upon striking the stream, follow it since it is of much better conductivity than the ground. The amount of current available at F is considerably reduced.

## **T. P. S. Apparatus Used by the Signal Corps**

In the following pages, a description will be given of the transmitting and receiving apparatus used by the Signal Corps, and also a discussion of the best relative positions of the stations, their installation, maintenance, etc.

The transmitting apparatus consists of the type SCR-71 T.P.S. transmitting set. The receiving apparatus is the type SCR-72 or SCR-72-B T.P.S. receiving set. At certain stations, two-way communication is required, in which case the above-mentioned apparatus may be used although the work may be facilitated by using a two-way T.P.S. set, type SCR-76, which is a combination in one unit of the transmitting and receiving apparatus. The latter set is fully described in Radio Pamphlet No. 15, and is therefore simply mentioned here. A later model of this set is the type SCR-76-A set, which is described in Radio Pamphlet No. 27.

### **T. P. S. Transmitting Set, Type SCR-71**

The T.P.S. transmitting set, type SCR-71, consists of a power buzzer, used for generating a high-voltage, audio frequency, pulsating current; a storage battery used for energizing the buzzer; and the necessary ground equipment, consisting of ground stakes, field wire, etc. A complete parts list is given at the end of this pamphlet. The method of laying out the station is in many respects similar to that used for laying out a receiving station, and is explained below under a separate heading.

The power buzzer, a circuit diagram and photograph of which are given in Figs. 3 and 4, is practically a copy of the French T.P.S. buzzer. The principle of operation is the

same as that of an induction coll. Two windings, the primary and secondary, are wound on a common laminated iron core. The primary winding is energized by a 10-volt storage battery. A telegraph sending key and an interrupter vibrator of special design are in series with this primary circuit. When the sending key is depressed, the primary circuit is closed, and the magnetic field created by the primary coil sets the vibrator interrupter in motion. A pulsating current is thus made to flow in the primary circuit.

The two terminals of the secondary winding of the buzzer are connected to the ground, through the line wires and

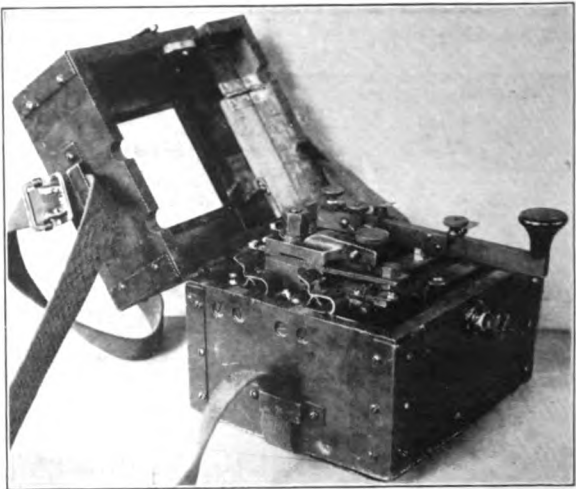

Fig. 3—Set Box, Type BC-16 of the Type SCR-71 Set

ground rods, at two points not less than 50 yd. apart. By this means, the high pulsating emf. induced in the secondary winding by the current in the primary circuit, causes a pulsating current of the same frequency to flow in the secondary (ground) circuit. The current thus flowing into the earth is of about .4 amp. when the ground resistance measured between the grounded ends of the line wires is not over 50 ohms.

The frequency of the pulsating current depends on the adjustment of the vibrator, and can be varied between the approximate limits of 650 and 1700 cycles per second. This

adjustment is obtained by means of a set of small weights which can be fastened singly or in pairs to the vibrator armature by means of a special wrench furnished with the buzzer. The different combinations possible are given below, but the actual frequency obtained may vary quite materially from that given in the table.

Large weight, all the way out.....	650	cycles	per	second
Large weight, all the way in.....	750	"	"	"
Two small weights, all the way out...	800	"	"	"
One small weight, all the way out....	1000	"	"	"
One small weight, all the way in....	1250	"	"	"
No weight .....	1750	"	"	"

The magnetic circuit of the power buzzer is completely metallic, except for a "V" shaped air gap between the iron core of the two windings and an iron armature attached to

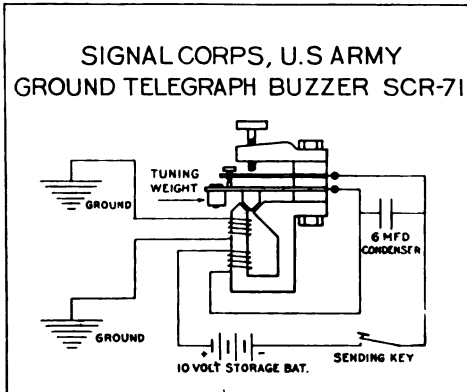

Fig. 4—Schematic Wiring Diagram of the Type SCR-71 Set

the vibrator. The best operation of the buzzer is obtained when the air gap on either side of the projecting "V" is uniform. This adjustment of the air gap is made by loosening the nut and bolt through the yoke of the vibrator and shifting the armature pieces slightly, locking them when in the proper position.

The vibrator contacts are shunted by a condenser for the purpose of reducing the sparking. Good operation is obtained by means of an adjusting screw, which is mounted on top of the vibrator and is used to vary the stroke of the vibrating armature. This screw is locked in position by a small nut

on the side of the frame holding the adjusting screw, which must be loosened before the adjusting screw can be turned and should be tightened up again after the adjustment has been made. Proper adjustment of the buzzer is made when the adjusting screw is screwed down as tight as is possible and maintain a good clear note of the vibrator. This adjustment must be made every time the weights are changed on the vibrator, or whenever the note of the buzzer is unsatisfactory.

For good operation of the buzzer, the vibrator contacts must be clean, and their surfaces even and parallel. After a time these contact points may become pitted and require cleaning and truing up. It is best not to use the file furnished with the set, but to remove the contacts from the vibrator, and rub them gently on a piece of fine emery cloth laid on a flat surface. Only in exceptional cases, will it be found necessary to use the file or to replace the contact points with the spare ones furnished with the set and kept in the cover of the buzzer box.

#### **Method of Operation**

The method of operating the type SCR-71 transmitting set is as follows. By means of the special wrench, place the desired vibrator weight on the buzzer armature in the proper position. Connect the base line wires and storage battery wires to their proper terminals on the type BC-16 set box. Adjust the vibrator by means of the large thumb-screw which is on top of the buzzer frame, first loosening the clamping screw on the frame of the buzzer. The telegraph sending key is then closed and the large buzzer adjusting screw adjusted until a clear steady note is obtained. The adjusting screw is then clamped in place again, and the set is ready to operate by sending code with the key in the usual way.

#### **T. P. S. Receiving Set, Type SCR-72**

The T.P.S. receiving set, type SCR-72, is a low frequency amplifier, consisting of a vacuum tube amplifier with the necessary storage batteries and telephone receivers, and a ground equipment similar to that of the SCR-71 transmitting set. A complete parts list is given at the end of this pamphlet.

The amplifier consists of two type VT-1 three-electrode vacuum tubes connected for cascade amplification, and making possible the use of either one or two stages of amplifica-

tion. As shown on the circuit diagrams, Fig. 6, the T.P.S. current to be amplified is made to flow through the primary winding of an iron core input transformer, by connecting the two grounded receiving line wires to the binding posts of the amplifier box marked "T.P.S." The secondary of this input transformer is connected between the filament and the grid of the first vacuum tube. The plate circuit of this tube comprises a 22-volt, type BA-2 dry battery connected in series with the primary of an iron core transformer which couples the plate circuit of the first tube to the grid circuit of the second tube. The secondary winding of this coupling transformer is connected between the grid and the filament of the second tube, while a type BA-2 dry battery furnishes the plate current.

The filaments of the two vacuum tubes are connected in parallel across a 4-volt storage battery. In series with each filament is a small resistance which limits the filament current to the proper value. Certain vacuum tubes require a greater filament voltage than others. In these tubes, the positive terminal of the filament is permanently connected to the metal base of the tube, and connection is installed in the amplifier from the metal socket to the positive side of the filament resistance whereby the resistance is thus automatically short-circuited when a tube of this type is inserted.

Telephone jacks are provided in the plate circuit of the last tube, across the plate of the first tube, and across part of the secondary of the input transformer. This gives three different sound intensities for the corresponding jacks, the signals having a maximum strength when the telephones are plugged in the jacks of the last vacuum tube.

This amplifier is not limited in its use to the reception of T.P.S. signals. It may also be used to amplify damped or modulated radio signals after they have been detected (rectified). For this purpose, the entire primary winding of the input transformer is used, the corresponding terminals on the amplifier box being marked "Radio." These terminals are connected to the telephone terminals or plug of the radio receiving set used in the reception of the radio signals it is desired to amplify. This inserts the amplifier in the audio frequency circuit of the radio receiving set. The telephone receivers are then plugged into the particular jack of the amplifier box giving the desired degree of amplification.



When using the amplifier, it is well to insulate the box from the ground, and to protect it from mechanical vibration. This is best done by setting the box on some cushioning substance. The amplifier being all connected up and ready for operation, and with the telephones connected for maximum amplification, a test which will show whether or not the amplifier is in proper working order is to gently tap the first vacuum tube with the finger. A loud ringing noise should be

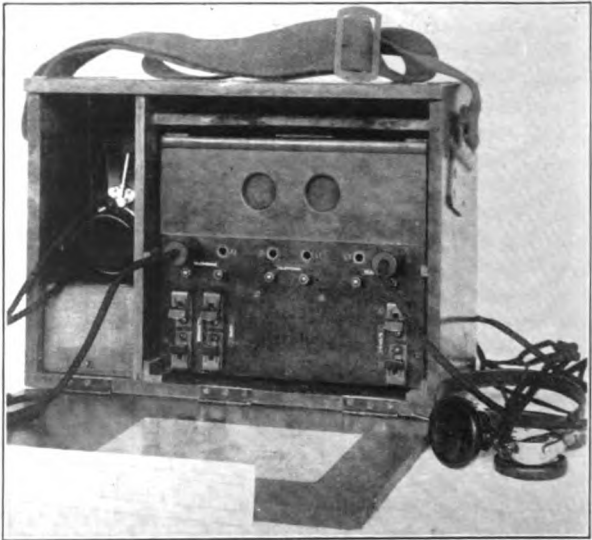

Fig. 5—Set Box, Type BC-17 of the Type SCR-72 Set

heard in the telephone receiver. If the amplifier does not work, the battery connections should be checked up. It is essential that the dry batteries be connected with the proper polarity, as marked on the box and in the circuit diagram.

Very often, the loudness of the signal is considerably increased when the tubes are interchanged. If some spare tubes are available, the different combinations should be tried until a pair is found giving satisfactory results. Sometimes, singing is observed in the amplifier. This is due to internally generated oscillations taking place in the amplifier circuits, accompanied by rapid interruptions of the plate current. It

seriously interferes with the reception of the signals and may be prevented or stopped by grounding the negative terminal of the storage battery supplying the filament current. A sizzling noise in the telephones may be due to poor connection of the battery leads, or poor contacts in the vacuum tube sockets.

It is important to use storage batteries of a voltage not higher than 4 volts, as the higher voltage would greatly shorten the life of the tubes. Also, if the filaments are burned too bright, the tubes may not amplify properly, as this would shift the position of the characteristic curve of the tubes with reference to the axes. The 22.5-volt dry batteries supplying the plate current may be used satisfactorily until their terminal voltage runs down to about 17.5 volts.

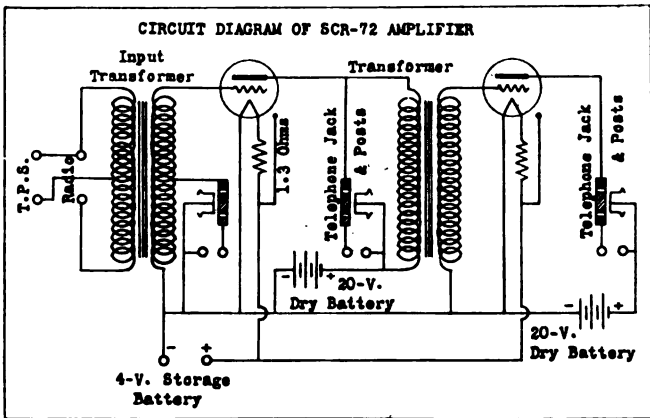

The amplifier box may be opened on top for the purpose of changing vacuum tubes and dry batteries. The box should be kept closed at other times and in as dry condition as possible. Two glass windows in the front panel permit one to observe the glow of the filaments of the vacuum tubes, while in operation. While no signals are being received but the set is in operation ready to receive anything that comes in, it is well to look at the tubes frequently to make sure that the filaments are glowing. When the set is not in use the filaments (4-volt) battery should be disconnected from the set. Disconnect at the battery rather than at the set box.

The amplifier box is enclosed in a carrying box, which also contains two telephone head sets, message books and spare dry batteries. This carrying box is provided with a carrying strap and weighs about 27 lb. with the full equipment. Spare vacuum tubes must be carried separately.

With this amplifier, should one tube be burned out and there be none available for replacement, it is still possible to use the first amplification stage if the good tube is placed in the left-hand socket and the telephones plugged into the central jacks. This is not true with the SCR-72-B set.

### **Method of Operation**

The method of operating the type SCR-72 set for receiving T.P.S. signals is as follows. The base line wires are connected to the "T.P.S." binding posts and the 4-volt storage battery to the proper terminals of the type BC-17 set box, due regard being given to polarity. Both vacuum tube filaments should then glow. The telephone receivers are plugged into the telephone jacks corresponding to the degree of amplification desired. The set is now ready for receiving signals.

If signals are not received, it may be because one of the tubes is burned out or because one of the type BA-2 dry batteries is connected with the wrong polarity. Both tubes and dry batteries may be changed by removing the amplifier box from the carrying chest, and opening the cover on top of the box.

### **T. P. S. Receiving Set, Type SCR-72-A**

The type SCR-72-A receiving set, which is electrically the same as the type SCR-72-B set described below, has been entirely superseded by the latter, and is therefore only mentioned here. Only a few models of this set are in existence.

### **T. P. S. Receiving Set, Type SCR-72-B**

The type SCR-72-B receiving set uses an improved type of amplifier which is illustrated by the photographs and circuit diagram given herewith, Figs. 7, 8 and 9. Like the amplifier of the SCR-72 set, it is a two-stage, audio frequency, cascade amplifier, using two type VT-1 vacuum tubes, and working on the same principle as the set described above. The differences from the SCR-72 are the following:

Both tubes work at a plate voltage of 40 volts, supplied by two type BA-2 dry batteries in series. One double telephone

jack is provided in the plate circuit of the last tube only and the degree of amplification is adjusted by a rheostat in the filament circuit which varies the temperature of the filaments and therefore the electron emission and plate current.

Unlike the type SCR-72 amplifier, the type SCR-72-B set will not operate at all unless both vacuum tubes are in operative condition. This is due to the fact that only one telephone jack is provided and this is inserted in the plate circuit of the last tube.

When the type SCR-72-B set is not in use, the filament battery should be disconnected. This is done by turning the



Fig. 7—Set Box, Type BC-44 of the Type SCR-72-B Set

“Filament Current” switch to the “Off” position (extreme left), and it is not necessary to disconnect the battery leads.

As for the SCR-72 amplifier, singing may be stopped by grounding the negative side of the storage battery. Should type BA-2 batteries be not available at any time, any other 40-volt d. c. supply may be readily used in place of them by connecting to the binding posts marked “B-Battery.” Care should be taken never to short circuit these posts as this would short circuit the plate batteries.

The amplifier box is a great improvement over the SCR-72 amplifier box, no carrying chest being required. The box is

waterproof, the cover closing on rubber gaskets. Two telephone head sets are carried in a compartment of the amplifier box. The operating panel is hinged at one side, and may be lifted after unscrewing the two thumbscrews in the upper corners of the panel. This is done when it is desired to change vacuum tubes or dry batteries. The spare tubes and dry batteries are supported in holders at the bottom of

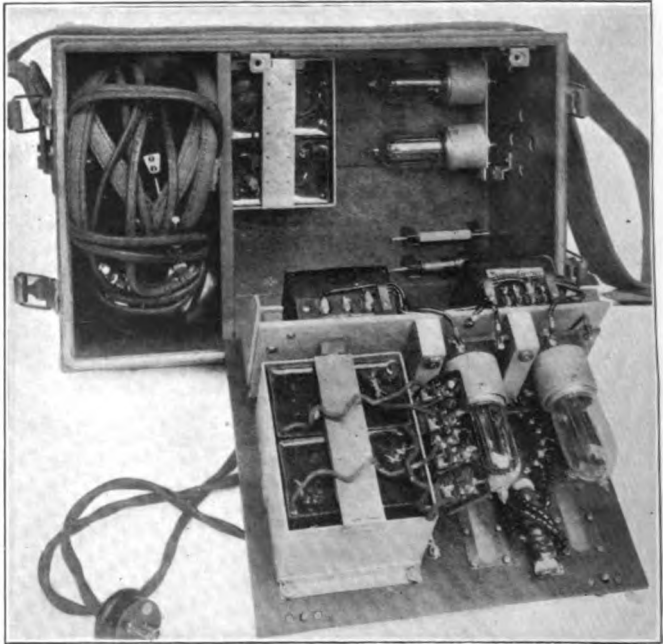

**Fig. 8—Mounting of Apparatus and Spare Tubes and Batteries  
in the Type BC-44 Set Box**

the box as seen in Fig. 7. Care should be taken that the leads on the spare dry batteries do not come in contact with each other either directly or by touching the metal holder.

#### **Method of Operation**

The proper method of operating the type SCR-72-B set for receiving T.P.S. signals is as follows. The base line wires are connected to the "Ground Telegraph" binding posts, the battery plug is plugged in the 4-volt storage battery, the tele-

phone receivers are connected to the telephone jack or telephone binding posts, and the "Filament Current" dial switch is turned toward the right until the vacuum tube filaments are observed to glow with a dull red color. If signals are received very faintly, this switch should be turned somewhat more toward the right. This should be avoided if possible, however, as the brighter the filaments are burned, the shorter

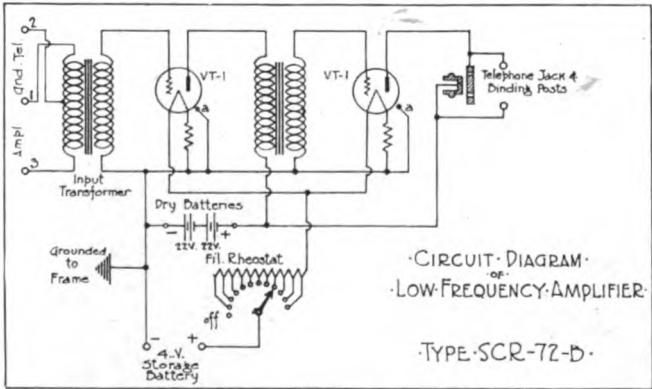

Fig. 9—Schematic Wiring Diagram of the Type SCR-72-B Set

the life of the vacuum tubes. Failure to receive signals may be due to a vacuum tube burned out, or to one of the dry batteries connected with the wrong polarity.

## Laying out Stations and Establishing Grounds

In using ground telegraph sending and receiving sets, special attention should be directed to the position of the ground rods of the sending and receiving stations relative to each other. The power buzzer is connected to the two sets of ground rods placed not less than 50 yd. apart. A straight line joining these earth connections is called the "sending base line." The receiving instrument or amplifier is similarly connected to ground rods, and the line connecting them is called the "receiving base line." These two base lines must be laid out in such a manner that a straight line joining the centers of the bases will make equal angles with each of them, the angles considered being on the same side of that line. The best position is that whereby the bases are exactly parallel and opposite each other. This condition is shown in Fig. 10, top drawing.

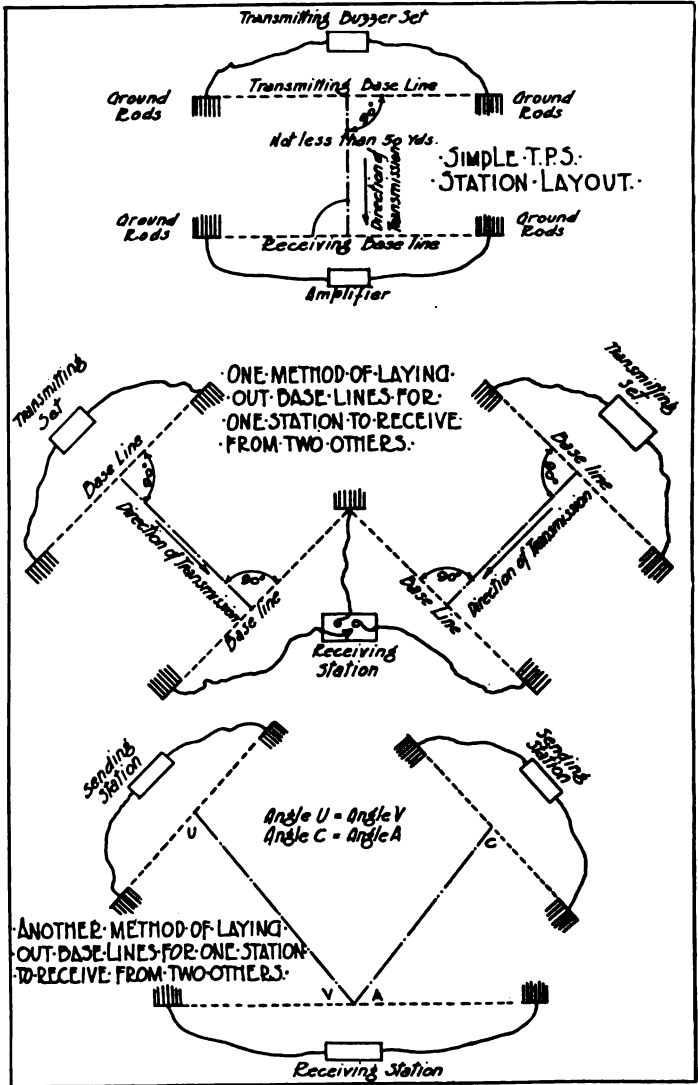

Fig. 10—Methods of Laying Out Simple T. P. S. Station, and One Station to Communicate with Two Others

When two power buzzers communicate with the same receiving station from different directions, it is desirable that separate bases for the reception of signals from each sending station should be provided, as shown in Fig. 10, middle drawing. If it is impossible to provide two bases, the single receiving base should be aligned with respect to the two sending stations, as shown in Fig. 10, bottom drawing, so that a straight line joining the centers of the bases will make equal angles with the two bases joined. This follows the general law first stated, as applied to each combination of receiving and sending stations. The correct relative positions of receiving and sending base lines may be established by the use of a compass which should always be utilized to insure proper orientation. Usually the angle between the base line and the line connecting the centers of the receiving and sending bases must be greater than 60 deg. to enable communication. Special attention should be paid to securing a good earth connection at the ends of both the sending and receiving base lines.

Due to the nature of this system of communication, it is very easy for the enemy to pick up messages sent, and all communications should therefore be in code.

In place of the ground rods furnished with the set, or in addition to them, various metallic bodies, like cartridge cases, etc., may be buried in the ground and connected to the wire. This provides a lower ground resistance and increases the range of the signals. In cases of very weak signals at the receiving station, or if very great range is desired, the sending buzzer may be operated on 20 volts without injury to the apparatus. This should however be avoided.

The wires used to connect the t. p. s. apparatus (sending or receiving) to the two ground plates should always have a perfectly good insulation. They may then be laid on the ground, or even be buried, which is quite frequent practice at the sending stations which are generally in or near the first line trenches. In no case should bare wire or lead covered cable be used for making up the sending station, as signals could not be sent out to any distance. The weakness of the bare wire is obvious. With lead covered cable, the metal sheath will short circuit the current leaving the ground plates of the sending station, instead of letting it spread out through the ground to the receiving station. At the receiving station the wires are seldom buried underground, as there is



less danger of having them cut by shell fire, the receiving station being generally at some distance from the front line. It should be noted that lead covered wire is not objectionable at the receiving station. However, when a station is used for two-way communication, ordinary insulated wire should be used. Other wire than that supplied with the equipment should be used only in case of emergency.

## Parts Lists

In ordering this set or parts of this set specification must be made by names and type numbers as listed below, exactly. The designations printed in **bold face type only**, will be used in requisitioning sets or parts, making property returns, etc.

In ordering *complete* sets, it is not necessary to itemize the parts; simply specify, "2 Sets, T.P.S. Transmitting, Type SCR-71." If *all* parts listed under a group heading are desired, it is not necessary to itemize the parts; simply specify, for example, "1 Equipment, Type RT-2."

The sets are not complete unless they include all items listed under their respective headings.

### SET, T.P.S. TRANSMITTING, TYPE SCR-71

#### EQUIPMENT, (A) TYPE PE-13\* or (B) TYPE PE-11; Power

- (A)\* 2 Batteries, Type BB-3; Edison storage; 10 volts. 30 amp-hr.; includes electrolyte in separate container; 1 in use, 1 spare, or
- (B) 3 Batteries, Type BB-23; lead storage; 10 volts, 20 amp-hr.; electrolyte is not included; concentrated acid for electrolyte supplied separately in carboys; 1 in use, 2 spares.

#### EQUIPMENT, TYPE RT-2; Transmitting

- 1 Set Box, Type BC-16; t. p. s. transmitting; 7¼ in. x 6½ in. x 6½ in.
- 1 Strap, Type ST-4; carrying, for BC-16.
- 1 Weight, Type WT-2; large, for vibrator in BC-16.
- 2 Weights, Type WT-3; small, for vibrator in BC-16.
- 2 Contacts, Type CN-1; upper; spares for use in BC-16.
- 2 Contacts, Type CN-2; lower; spares for use in BC-16.
- 1 Wrench, Type TL-6; for changing vibrator weights in BC-16.
- 1 Gauge, Type TL-7; air gap; for BC-16.
- 1 File, Type TL-5; contact; for BC-16.
- 1 Lead, Type CD-22; battery; two-conductor.

**EQUIPMENT, TYPE GD-3; Ground**

- 12 Stakes, Type GP-4; ground; 18 $\frac{3}{8}$  in. x  $\frac{5}{8}$  in.; weight 5 lb. 14 oz.
- 1 Reel, Type RL-6; breast; 9 in. x 11 in. x 4 $\frac{1}{2}$  in.
- 2 Drums, Type DR-3; 8 in. x 8 $\frac{1}{2}$  in.; for type RL-6 reel.
- 1 Bag, Type BG-3; carrying; for ground stakes.
- 1000 ft. Wire, Type W-4; No. 16 B. & S. gauge, modified, N. E. C. lamp cord; two 500-ft. lengths, each wound on type DR-3 drum; net weight, 20 lb.
- 60 ft. Wire, Type W-5; 16 strands, No. 30 B. & S. gauge, soft copper, braided; in two 30-ft. lengths, each wound in a 3-in. coil.

\* Not to be shipped overseas.

**SET, T.P.S. RECEIVING, TYPE SCR-72****EQUIPMENT, TYPE PE-12; Power**

- 2 Batteries, Type BB-2; Edison storage; 4 volts, 90 amp-hr.; with powdered electrolyte in separate container.

**EQUIPMENT, TYPE RC-3; Receiving**

- 1 Set Box, Type BC-17; t. p. s. receiving.
- 1 Case, Type CS-2; carrying; for T.P.S. receiving set.
- 2 Head Sets, Type P-11; telephone.
- 1 Lead, Type CD-22; battery; two-conductor.
- 4 Batteries, Type BA-2; dry; 2 in use, 2 spares.
- 4 Tubes, Type VT-1; vacuum; 2 in use, 2 spares.

**EQUIPMENT, TYPE GD-3; Ground**

- 12 Stakes, Type GP-4; ground; 18 $\frac{3}{8}$ x $\frac{5}{8}$  in., weight, 5 lb. 14 oz.
- 1 Reel, Type RL-6; breast; 9x11x4 $\frac{1}{2}$  in.
- 2 Drums, Type DR-3; 8x8 $\frac{1}{2}$  in.; for type RL-6 reel.
- 1 Bag, Type BG-3; carrying; for ground stakes.
- 1000 ft. Wire, Type W-4; modified No. 16 B. & S. gauge, N. E. C. lamp cord; two 500-ft. lengths each wound on type DR-3 drum; net weight 20 lb.
- 60 ft. Wire, Type W-5; 16 strands, No. 30 B. & S. gauge, soft copper, braided; in two 30-ft. lengths, each wound in 3-in. coil.

**SET, T.P.S. RECEIVING, TYPE SCR-72-B****EQUIPMENT, TYPE PE-10; Power**

- 3 Batteries, Type BB-14; storage; lead; 4 volts; 100-amp-hr. at 10-amp. discharge rate; acid for electrolyte supplied separately in carboys; 1 in use, 2 spare.

**EQUIPMENT, TYPE RC-3-B; Receiving.**

- 1 Amplifier, Type BC-44; low frequency; 14 $\frac{5}{8}$  in. x 9 $\frac{1}{8}$  in. x 7 $\frac{3}{4}$  in.; weight 15 lb. 5 oz.
- 2 Cords, Type CD-40; extension; 6 ft., 2-conductor, No. 16 B. & S. gauge lamp cord, type W-8, with battery plug on one end and spade clips on other end; amplifier to battery; 1 in use, 1 spare.
- 1 Cord, Type CD-56; extension; 4 ft. long, 2-conductor, wire type W-15; with telephone plug type PL-5 on one end and spade clips on other end; for connecting amplifier to a radio receiving set box for amplifying radio signals.
- 2 Head Sets, Type P-11; telephone.
- 4 Batteries, Type BA-2; dry; 2 in use, 2 spare.
- 4 Tubes, Type VT-1; vacuum; 2 in use, 2 spare.
- 1 Bag, Type BG-13; carrying; 10 in. x 7 $\frac{1}{4}$  in. x 3 in.
- 1 Compass, Type I-1; "Cebynite" or equivalent; luminous dial.
- $\frac{1}{4}$  lb. Tape, Friction;  $\frac{3}{4}$ -in.
- 1 Pliers, Type TL-19; universal, 6-in., similar to Fairbanks' combination pliers No. 70.
- 1 Voltmeter, Type 1-10; d.c.; 0 to 10 and 0 to 50 volts; with lead.
- 1 Screwdriver, Type TL-2; 4 in. long; Stanley No. 21 or equivalent.
- 1 Emery Cloth, Sheet; No. 4-0; about 11 in. x 8 in.
- 1 Pamphlet, Instruction.

**EQUIPMENT, TYPE GD-3-A; Ground**

- 1 Bag, Type BG-8; carrying, for ground stakes; 21 in. x 4 $\frac{1}{4}$  in.
- 12 Stakes, Type GP-6; ground; 18 in. long,  $\frac{1}{2}$  in. diameter with wing nut binding post near top.
- 1 Reel, Type RL-6; breast; 9 in. x 11 in. x 4 $\frac{1}{2}$  in.
- 2 Drums, Type DR-3; for breast reel; 8 in. x 8 $\frac{1}{2}$  in.
- 1000 ft. Wire, Type W-4; No. 16 B. & S. gauge, modified N. E. C. lamp cord; two 500-ft. lengths, each wound on drum type DR-3; net weight, 20 lb.
- 60 ft. Wire, Type W-5; 16 strands, No. 30 B. & S. gauge, soft copper, braided; in two 30-ft. lengths, each wound in 3-in. coils.
- 1 Hammer, Type HM-1.

**Carrying Units**

All of the parts of the type SCR-72-B set may be grouped in nine carrying units, as follows:

- 1 to 3.—3 Batteries, Type BB-14.
  - 4.—1 Amplifier, Type BC-44; containing:
    - 1 Cord, Type CD-40.
    - 1 Cord, Type CD-56.
    - 2 Head Sets, Type P-11.
    - 4 Batteries, Type BA-2.
    - 4 Tubes, Type VT-1.
  - 5.—1 Bag, Type BG-13, containing:
    - 1 Cord, Type CD-40.
    - 1 Compass, Type I-1.
    - 1 Tape, Friction, Rolls.
    - 1 Pliers, Type TL-19.
    - 1 Voltmeter, Type I-10; with leads.
    - 1 Screwdriver, Type TL-2.
    - 1 Emery Cloth, Sheet.
    - 1 Pamphlet, Field.
    - 2 Wire, Type W-5; coils.
  - 6.—1 Bag, Type BG-8, containing:
    - 12 Stakes, Type GP-6.
  - 7.—1 Reel, Type RL-6.
  - 8 and 9.—2 Drums, Type DR-3, on each of which is wound 500 ft. of lamp cord, Type W-4.
-











---

**Prepared in the  
Office of the Chief Signal Officer  
Training Section  
Washington**

---

*CONFIDENTIAL! For Official Use Only*

# **The Radio Mechanic and the Airplane**



**RADIO PAMPHLET No. 30**

**Second Edition, Revised to November 26, 1918**

---

**Signal Corps, U. S. Army**



**Washington : Government Printing Office : 1919**



## **THE RADIO MECHANIC AND THE AIRPLANE.**

**General Survey of Types of Machines—Brief Treatise on the Mechanics of the Airplane—Special Precautions in the Installation of Radio Apparatus—Airplane Nomenclature and Dictionary.**

1



**I**N ORDER that a radio mechanic may undertake the work of installing radio apparatus on airplanes, it is essential that he have some knowledge of the mechanics of the airplane. It is the purpose of this pamphlet to give the reader a general idea of the various types of machines in use and their respective purposes, and to point out in a very brief way the principal features in the mechanics of the airplane with which a radio mechanic should be thoroughly familiar in order to go about his task of installing radio apparatus with assurance that his work will result in no bad effect in the operation of the airplane, and at the same time will produce satisfactory operation of the radio apparatus.

The various types of airplanes now in use in Europe may be classified into four general groups; namely, pursuit, fighting, reconnaissance, and bombing planes. The principal characteristics of these types may be summed up as follows:

*Pursuit Planes.*—These are small, heavily armed, one motor, one seater, mono-, bi- or triplane machines, with a mounting of one, two or three machine guns, and even in some cases a cannon. They are capable of speeds from 180 to 250 kilometers per hour (110 to 155 m. p. h.) and more, and will climb to a height of 1,000 meters in about two minutes. The maximum elevation or ceiling of their climbing ability is about 6,000 meters and more. They are called upon for an endurance of from two to three hours flight at a time. They are often spoken of as scout machines.

*Fighting Planes.*—These are medium or large sized, heavily armed two or three seater or more biplanes, mounting two to six or more machine guns and often a cannon. Occasionally a monoplane or biplane is used as a fighter. Many of them are armored. They are driven by two or more motors and equipped with radio apparatus. High speed and good climbing ability are characteristics of this type.

*Reconnaissance Planes.*—These are medium and large sized biplanes equipped chiefly for reconnoitering purposes. They are armed for defense only and are equipped with radio and photographic apparatus and carry a crew of two or three men. They develop a medium speed and climbing rate, but have long endurance.

*Bombing Planes.*—These machines are large biplanes and triplanes, with capacity for carrying heavy bombing loads. They are equipped with high-powered motors, but due to the heavy load which they carry they are naturally slow machines and of rather poor ceiling, although these characteristics improve as the bombs are dropped. They are usually equipped with radio apparatus and electrical night-flying apparatus. They have an endurance of at least four hours.

As an example of the bombing class of airplane may be mentioned the English Handley Page machine, the wings of which have a spread of 98 ft. It is driven by two 275-h.p. Rolls-Royce engines and will carry its load of bombs and crew of three men at a speed of 80 m.p.h. and at an altitude of 6,000 ft. These great planes naturally climb slowly, taking 42 minutes to make an elevation of 10,000 ft. The Italians have the large Caproni biplanes and triplanes, driven by three Isotta Fraschini motors of 300 h.p. and more each. The biplanes have a wing spread slightly less than the Handley Page machines and the triplanes a greater spread. They carry a great load of bombs and a crew of five men, including two gunners in some cases. The French have the Caudron, the Letard, and the De Havilland, which are all twin engined, three seaters, with large wing spreads.

In general appearance, the chief points to be noted in connection with this type of machines are: first, the great wing spread; second, the single fuselage (with the exception of the Caproni, which has two fuselages), with the two engine housings, one on either side of the fuselage; and third, the balanced ailerons, rudders, and elevators.

In the reconnaissance class of airplanes may be included the Sopwith two seater, the Morane two seater tractor, the Voisin, Farman Freres, the Armstrong-Whitworth-Beardmore, Maurice Farman, Martinsyde, and others. These types of machines are generally equipped with a single engine mounted in the fuselage and are usually arranged for carrying two passengers. They are used for observation work, photographing, for fire control work with artillery, and for general reconnaissance purposes.

Fighting in the air is the most spectacular use to which the military airplanes are put. Speed and climbing ability are the principal characteristics. These features are absolutely essential, as they are weapons of offense and defense second only to the guns which the machine carries. The tendency in design for this type of plane at the present time is toward very light

weight in ratio to the horsepower of the engines employed. Such machines are very difficult to land on account of the high speed necessary to create sufficient lift.

Examples of the fighting type machine are the single seater Sopwith "Pup," so called because of its small size; the Sopwith "Camel," thus named because it carries two machine guns instead of one; the Morane "Parasol," Nieuport, Bristol "Bullet," the 190 h.p. Bristol Fighter, the Vickers, the Spad, which was a great favorite of the famous Guynemer, the F. E. 8, F. E. 2d, built by the Royal Aircraft factory, the Morane Monocoque, De Haviland, and scores of others. The British aviators alone use at least 15 or more different types of fighting planes.

The smallest machine flown to-day is the Sopwith "Kitten." This tiny plane has a wing spread of but 19 feet. It is driven by a 30-h.p. engine at a speed of 90 m.p.h. Next in size is the Sopwith "Pup," which has a spread of 26 ft. 6 in., and then the Sopwith "Camel," having a wing spread of 28 ft. and driven by a 130-h.p. Clerget engine. This latter fighter can make 97.5 m.p.h. at an altitude of 10,000 ft., and can gain this altitude in 17 minutes. The De Haviland 4 is one of the most efficient larger fighters. It has a spread of about 42 ft. and is driven by a 375-h.p. Rolls-Royce engine. It will climb 10,000 ft. in 9 minutes, to 15,000 in 16.5 minutes, and maintain a speed of 136 m.p.h. at an altitude of 6,000 ft., 133.5 m.p.h. at 10,000 ft. and 126 m.p.h. at 15,000 ft.

Among the bombing machines used by the enemy are the Friedrichshafen, driven by two 225-h.p. Benz engines, and the Gothas. In the reconnaissance class are the Aviatik two seater, the Albatross two seater, the Gothas, and other types. In the fighting class, the Germans are using the Fokker single seater monoplane, the Halberstader biplane, the Albatross single seater biplane, the Aviatik single seater, the Friedrichshafen fighter, with its whale-type fuselage, the Albatros Scouts 1 and 2, Roland and Ago, etc. The last mentioned machine has back tapered wings and but one metal strut where other machines carry two. The reason for the peculiar construction of this machine is that it enables the gunner to direct the fire of his machine gun on either side of the pilot, forward as well as backward.

In our own country, machines of the bombing, reconnaissance, and fighting types are being built and equipped with the Liberty motor. They compare most favorably with the British and



French machines. Several different types of training planes are in use at the American training schools. The Curtiss JN-4-D has a wing spread of 43 ft. and is equipped with a 90-h.p. Curtiss motor and arranged with a dual control so that either of the two passengers may operate the plane. This plane will make 72 m.p.h. and climb at the rate of 300 ft. per minute. The Curtiss JN-4-H machine is practically a duplicate, except that it is equipped with a 150-h.p. engine and consequently is somewhat faster than the JN-4-D. The Curtiss S-3 triplane, having but a single seat, a 100-h.p. motor, and smaller wings, will climb at the rate of 900 ft. per minute. The Standard J-1 airplane is a rather slow machine, which is equipped with a Hall-Scott 100-h.p. motor. It has a wing spread of some 38 ft. The Thomas Morse S-4-B single seater, having a 26 ft. 7 in. spread, is also a training plane.

*Airplane Types and Ratings.*

Type.	Motor.	Number of cylinders.	Horse-power.	Weight (empty with water).	Gross weight.	Maximum speed at 6,500 ft. elevation.	Continuous flight ability.
				<i>Pounds</i>	<i>Pounds</i>	<i>M. p. h.</i>	<i>Miles.</i>
JN-4-D.....	Curtiss.....	8	92	1,430	1,920	75	172.5
JN-4-H.....	Curtiss.....	8	150	1,595	2,145	90	225
Thomas-Morse.....	Le Rhone.....	9	89				
De Haviland 4.....	U. S.-12-A.....	12	360	2,391	3,582	120	312
Handley-Page.....	U. S.-21-A.....	2-12	300	8,270	13,700	93	

### The Mechanics of the Airplane.

The flight of an airplane is secured by driving through the air a surface or surfaces inclined to the direction of motion. Such inclination is called the angle of incidence. In this way, the surface, that is, the lifting planes, secure an upward pressure from the air by virtue of the angle of the plane as it cuts through the air. And when the speed is sufficient, this lift becomes greater than the weight of the airplane, which must then rise. It is well to bear in mind that the lift is always trying to collapse the planes upward.

The resistance of the air to the passage of the airplane is termed the "head resistance," and is also commonly called the "drift." This is overcome by the action of the propeller, which

thrusts the airplane through the air. The head resistance is always tending to collapse the plane backward. Thus it is seen that there are four forces always acting on the airplane: the lift, which is opposed to the weight, and the thrust, which is opposed to the drift. The lift is useful, while the drift is detrimental. The proportion of lift to drift is known as the lift-drift ratio, and it is of paramount importance, for upon it depends the efficiency of the airplane. In rigging an airplane greatest care must therefore be taken to preserve the lift-drift ratio, and the radio mechanic should keep this in mind.

The angle of incidence is the inclination of the lifting surfaces to the direction of motion, most commonly, to the horizontal. If the angle of incidence is increased over the angle specified in the original design, then both the lift and the drift are increased also, and the drift is increased in greater proportion than the lift. On the other hand, if the angle of incidence is decreased over the correct amount, the lift and drift are decreased, and the lift is decreased in greater proportion than the drift. Hence it is seen, that any process which will alter the angle of incidence in either direction will act to impair the efficiency of the machine.

The whole weight of the airplane is balanced upon or slightly forward of the center of the lift. If the center of weight is too far forward, then the machine will be nose heavy. If it is too far behind the center of lift, then the airplane is tail heavy. By the stability of the airplane is meant its tendency to remain upon an even keel and to keep its course; that is, not to fly one wing down, tail down, or to try to turn off its course.

The directional stability of an airplane is its natural tendency to hold its course. If this does not exist, the airplane is continually trying to turn to the right or the left, and the pilot may be unable to control it. For an airplane to have directional stability, it is necessary for it to have, in effect, more keel surface behind its turning axis than in front of it. By keel surface is meant everything in view when looking at the airplane from the side—the side of the fuselage, landing gear, wires, struts, etc. Directional stability is sometimes called "weathercock" stability. Everyone knows what would happen in the case of the weathercock if there was too much keel surface in front of its turning axis, which is the point upon which it is pivoted. It would turn around and point the wrong way. That is exactly

the manner in which the keel surfaces affect the airplane. Directional stability will be badly affected if there is more drift, i. e., resistance on one side of the airplane than on the other side. Consequently, in installing apparatus on airplanes this matter of balancing the amount of head resistance on the two sides and in front of and behind the center of lift of a machine must be constantly borne in mind.

One reason why an airplane may be directionally bad in its flying, is that the plane surfaces may be distorted. It must be understood that the planes are "cambered" (curved), so that they will pass through the air with the least possible resistance. If the leading edge, bars, or trailing edge should become bent or warped slightly, the curvature is changed with the result that the amount of drift on one side of the plane outbalances that on the other side, giving the machine a tendency to turn off its course.

### Stress and Strain.

In order to be able to intelligently install radio apparatus on an airplane without impairing the strength or operating characteristics of the airplane, it is necessary to have a correct idea of the work every wire and every part of the airplane does. The work any part of the machine does is called stress. If it is subjected to undue strain, the material becomes distorted and this distortion is called strain. The simple stress of compression is a force which produces a crushing strain. Examples of airplane members under compression are the interplane and fuselage struts. The simple stress of tension is one which results in the strain of elongation. For example, all the wires of an airplane are under tension—a force tending to pull them in two. When a piece of material is bent, it is subjected to a compound stress, composed of both tension and compression.

Suppose, for instance, that a straight piece of wood is bent to form a circle. Before being bent, a line at either edge and one through the center, longitudinally, are all of the same length, Fig. 1. After the wood is bent into a circle, the center line is still of the same length as it was before, but it will be noted that the top line, now being on the outside of the circle, must be longer than the center line. This could only be brought about through a strain of elongation or stretching of the fiber of the wood at the outer rim, which is then under tension. Hence it is seen that the portion of the wood between the center line and

the outer edge of the circle is in tension, and that the greatest tension is at the outer edge of the wood because the greatest elongation takes place there.

It will also be noticed that the line at the inside of the circle, which before being bent was of the same length as the center line, must now be shorter because it is nearest to the center of the circle, and the three circles are concentric. This could only be brought about by the strain of crushing, which is a state of compression. Hence, it is seen that the wood between the center line and the inside circle is in compression, and the greatest compression is nearest the inside edge because the fiber at

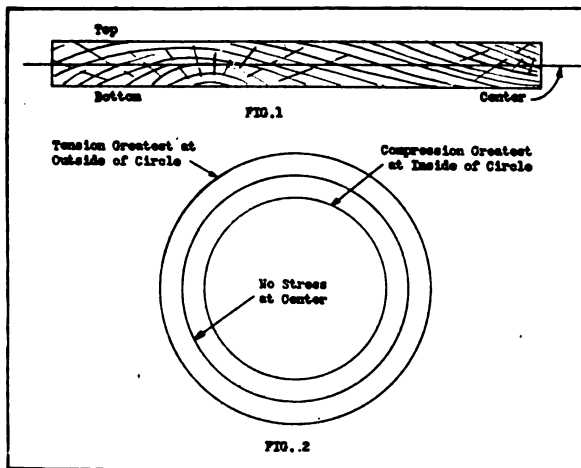

this innermost edge has been crushed together the greatest amount. The circles of Fig. 2 represent the three lines of the straight stick in Fig. 1.

From the above paragraphs it will be seen that the wood nearest the center line of the piece does the least work, and this is the reason that it is possible to hollow out the center of spars and struts without weakening them unduly. In this way it is possible to reduce the weight of the wood in an airplane by 25 to 33 per cent without sacrificing much of the strength.

A shearing stress is one such that the forces tend to slide one part of the piece over the other. An example of this may be found in ordinary machine bolts used to connect any two members of

an airplane together. The two members tending to pull apart or to push toward each other place a stress on the bolt tending to cut it in two, or shear it off.

The stress of torsion is one involving a tendency to twist the fiber of a rod or stick. A twisting stress may be a combination of compression, tension, and shear. An example of torsion is found in the propeller shaft or crank shaft of the engine where the forces at the opposite ends of the shaft are in opposite directions, thus tending to twist the shaft off.

### Character of Wood Under Stress.

For its weight, wood takes the stress of compression better than other materials. For instance, a walking stick weighing about  $\frac{1}{2}$  lb. will probably stand up to a compression stress of a ton or more before crushing, provided it is kept perfectly straight. If the same stick is put under a bending load,

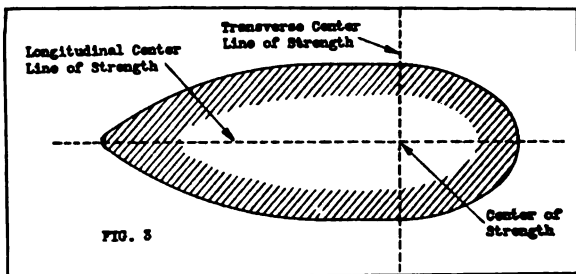

It will probably collapse under a stress of not much more than 50 lb. These two conditions show a very great difference in strength, and since weight is of greatest importance in an airplane, the wood must be kept as far as possible in a state of direct compression, that is, in direct line with the direction of stress upon it. This involves the careful observance of the following conditions:

1. All the spars and struts of an airplane must be perfectly straight. Fig. 3 shows a section through an interplane strut. If a strut is to be prevented from bending, then the compression upon it must be equally disposed around the center of strength. If it is not straight, there will be more compression on one side of the center of strength than on the other side and this will be a step toward the condition of having a compression

on one side and a tension on the other side. In this case the strut will be forced to take a bending stress for which it is not designed. Even if it should not break, it would become somewhat shorter and thus throw all the wire bracing attached to the top and bottom of it out of adjustment and greatly lessen the flight efficiency of the airplane, to say nothing of the resulting undue and dangerous stress placed upon other wires (see Fig. 4). This simply emphasizes the importance of not placing or bracing any radio apparatus on an airplane in a manner which will cause a bending moment in any direction in any wood member.

2. All struts and spars must be symmetrical. By that is meant that the cross-sectional dimensions must be correct

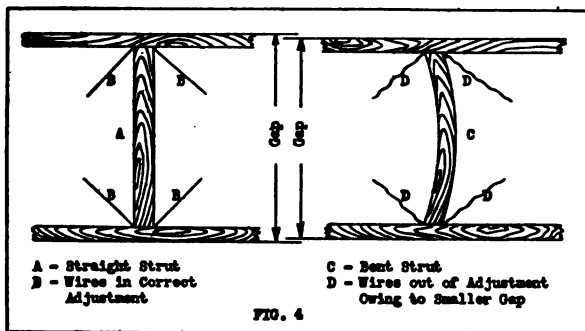

throughout the full length, otherwise there will be bulging places on the outside with the result that the stress will not be uniformly disposed around the center of strength, and a bending stress will be produced.

3. Struts, spars, etc., must not be damaged. It should be remembered from what has been stated about bending stresses that the outside fibers of the wood are doing by far the most work. If a strut or spar is bruised or scored, it suffers in strength much more than one might think, and if a bending stress occurs, the piece is most likely to break at that point during a flight.

4. The wood must have a good clear grain with no cross grain, knots or shakes. Such blemishes mean that the wood is weaker in some places than in others and that if there is a tendency to bend, the piece will be likely to break at the weak points.

5. All struts, spars, and other wood members must be properly bedded into their sockets or fittings. They must make a good pushing or gentle tapping fit. They must never be so tight as to require driving in with a heavy hammer. Also, they must bed well down all over the cross-sectional area, otherwise the center of compression will be shifted to one side of the cross-sectional area with the result that the force will not be evenly disposed around the center of strength and this will produce a bending stress. The bottom of the strut or spar should be covered with some sort of paint, bedded into the socket or fitting, and then withdrawn to see if the paint has stuck all over the bottom of the fitting. This last is a test to see that the strut or member is in bearing at all points on its cross-sectional area.

6. The atmosphere is sometimes much damper than at other times, and this causes the wood to expand and contract appreciably. This would not matter but for the fact that it does not expand and contract uniformly, but becomes unsymmetrical, that is, distorted. This effect of the elements should be minimized as much as possible by thoroughly varnishing the wood to keep the moisture out of it.

*Boring Holes in Wood.*—It is a strict rule in airplane construction that no spar shall be used that has an unnecessary hole in it. Before boring a hole in any member, its position should be passed upon by whoever is in charge of the shop. The hole should be of such size that the bolts can be pushed in, or, at any rate, not more than gently tapped into place. Bolts must not be hammered in as this may split the spar. On the other hand, a bolt must not be loose in the hole as in this case it may work sideways and split the spar, or at least throw the wires leading from the lug or socket underneath the bolt head, out of adjustment. Whenever it is possible, a clamp should be used to attach anything to a strut or other wooden member in preference to boring a hole, as the former does not weaken the member.

*Washers.*—A washer should be placed under every bolt head and also underneath the nut. The size of this washer should be very large as compared with that normally used in ordinary construction work. The purpose of this large washer is to disperse the stress over a large area of wood, otherwise the washer might be pulled into the wood and weaken it, possibly throwing the wires attached to the bolt or fitting out of adjustment.

*Locking Nuts.*—If split pins are used for the purpose of locking nuts in place, they should be used in such a way that the

nut can not possibly unscrew. If the nut is locked by means of burring the bolt, this burring should not be done by means of a heavy hammer in an attempt to spread out the head of the bolt, as that might damage the woodwork inside the plane and possibly bend the bolt inside the strut or member, causing it to split. A small light hammer should be used for the purpose, gently tapping around the edge of the bolt until it is burred over.

*Tension of Wire Bracings.*—The tension to which wires must be adjusted is of greatest importance. All the wires on an airplane should be of the same tension, otherwise the airplane will likely become distorted and fly badly. As a rule the wires are tensioned too much. The tension should be sufficient to keep the framework rigid. Anything more than that changes the factor of safety, throws various parts of the framework into undue compression, pulls the fittings into the wood, and may in the end distort the whole framework of the airplane. Experience is about the only instructor of what tension to employ and to assist in securing the same tension on all wires. This comes by cultivating a touch for proper tensioning of the wires.

In some cases, wires occur in the airplane which have no opposition wires, as the overhang in the Curtiss machines. In such cases it is essential to be extremely careful not to tighten the wires beyond taking up the slack. These wires must be a little slack, or otherwise they will distort the top spar downward. That will change the camber of the plane and result in changing both the lift and drift of that part of the airplane. Such a condition will cause the machine to lose its directional stability and also to fly one wing down.

In view of the above considerations, the radio mechanic must be very cautious in adjusting the tension of bracing wires whenever he may have occasion to do any work on a plane which requires the temporary removal of any wires, or when he finds it necessary to place additional wires on the plane to support radio apparatus. The general rule to be followed, except in emergency, is that the radio mechanic should not touch any bracing wires or other vital parts of the airplane, this being left to the airplane mechanics.

*Wire Loops.*—Wires are often bent to form a loop at the end. These loops even when perfectly made have a tendency to elongate and throw the wire tension out of adjustment. Great care should be taken to minimize this as much as possible (Fig. 5). The rules which should be observed are as follows:



1. The size of the loop should be as small as possible within reason. By this is meant that it should not be so small as to create the possibility of the wire breaking.

2. The shape of the loop should be symmetrical.

3. The loop should have good shoulders in order to prevent the ferrule from slipping up, but at the same time the shoulders should have no angular points.

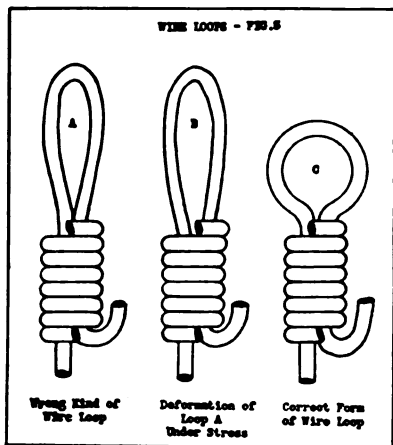

FIG. 5.—Wrong and Right Wire Loops.

4. When the loop is finished it should be undamaged, that is, not badly scored from the tools used in making it, as is often the case.

### Produce No Bending Stresses.

It should be remembered that nearly all the wood of an airplane is designed to take the stress of direct compression, and it can not be safely bent. In blocking up an airplane from the ground to do any work upon it, the blocking must be used in such a way as to come underneath the interplane strut and the fuselage strut. Padding should always be placed on the surfaces upon which the airplane is to rest. When pulling a machine along the ground for any purpose, always pull it from the landing gear if possible. If necessary to pull it from some other point, grasp the interplane struts as low down as possible.

In handling parts of an airplane, never lay anything covered with fabric on a concrete floor, as any slight movement will cause the fabric to scrape over the concrete with resultant damage. Struts, spars, etc., should never be left about the floor, as they are likely to become damaged, and it has already been explained how important it is to protect the outside fiber of the wood. It should be remembered also that wood becomes easily distorted; this applies particularly to interplane struts. The best method of caring for them while they are off the plane is to stand them up in as nearly vertical position as possible.

**Apparatus on Airplanes.**

In order to give the radio mechanic an idea of the large amount of apparatus which must be installed on an airplane, and hence the competition which exists for space within the fuselage, the several different instruments and apparatus are listed in part in the table below. The small pursuit airplanes are usually equipped with very little auxiliary apparatus and few instruments, and with no radio apparatus. The apparatus on the bombing and reconnaissance type planes follow:

**APPARATUS ON BOMBING TYPE AIRPLANES.**

*In Pilot's Cockpit.*

- Air speed indicator.
- Aneroid.
- Clock.
- Compass.
- Drift indicator.
- Flare dropping device.
- Radio sending key.
- Incline indicator.
- Lateral indicator.
- Map case or roll.
- Electric light fixtures.
- Oil pressure gauge.
- Tachometer.
- Fire extinguisher.
- Telephone.

*In Bomber's Cockpit.*

- Air speed indicator.
- Aneroid.
- Bomb dropping device.
- Clock.
- Compass.
- Drift indicator.
- Radio apparatus.
- Radio sending key.
- Incline indicator.
- Lateral indicator.
- Map case or roll.
- Electric light fixtures.
- High altitude sighting device.
- Camera.
- Fire extinguisher.
- Telephone.

## APPARATUS ON RECONNAISSANCE TYPE AIRPLANES.

*In Pilot's Cockpit.*

Air speed indicator.  
 Aneroid.  
 Tachometer.  
 Clock.  
 Compass.  
 Gasoline gauge.  
 Map case or roll.  
 Oil pressure gauge.  
 Radio sending key.  
 Fire extinguisher.  
 Interphone.

*In Observer's Cockpit.*

Air speed indicator.  
 Aneroid.  
 Camera.  
 Clock.  
 Compass.  
 Gasoline gauge.  
 Map case or roll.  
 Radio apparatus.  
 Radio sending key.  
 Fire extinguisher.  
 Interphone.

**Installation of Radio Apparatus on Airplanes.**

The mounting of any auxiliary apparatus on airplanes involves many considerations of great importance. The responsibility therefore rests heavily upon radio mechanics and radio personnel generally to make absolutely certain that all of these considerations are given mature thought before proceeding to mount any radio apparatus which may in the slightest degree alter the structural make-up, control or balance of an airplane. The following general precautions must be observed, and in addition it will usually be strongly advisable to consult an aeronautic expert before making any change in the airplane.

*Fire Hazard.*—The liability of an airplane catching fire is perhaps the most serious danger encountered, and for this reason an open spark should be guarded against, above all things. Under normal conditions, with the motor running at its best and all gas connections good, there is nevertheless a small amount of unburned combustible gas passing back from the motor section into the cockpit at all times. A small leak in the piping, tank, or carbureter, or a missing cylinder will add to the amount of gas and consequently to the hazard. Under such conditions an open spark from any source would be disastrous. For this reason, vibrator contacts and spark gaps are completely inclosed or at least covered with fine mesh metal gauze. Connections should always be well made, and soldered and taped. All wiring should be firmly secured in a position entirely clear of moving parts such as control wires, wheel supports and foot bar.



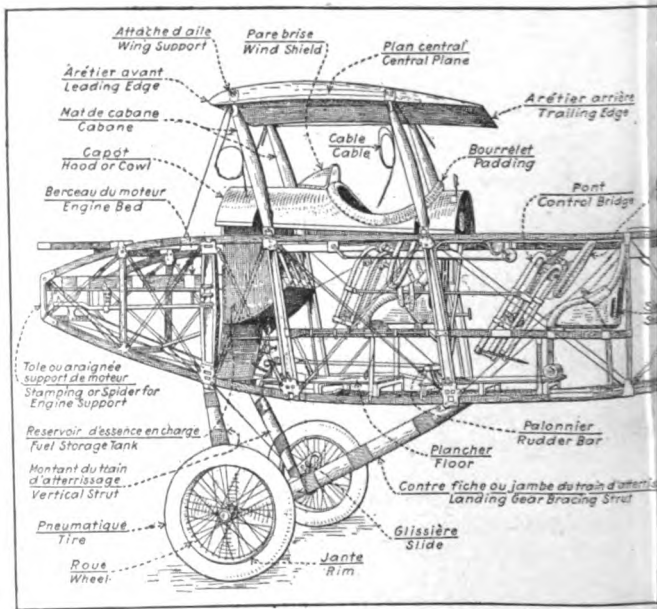
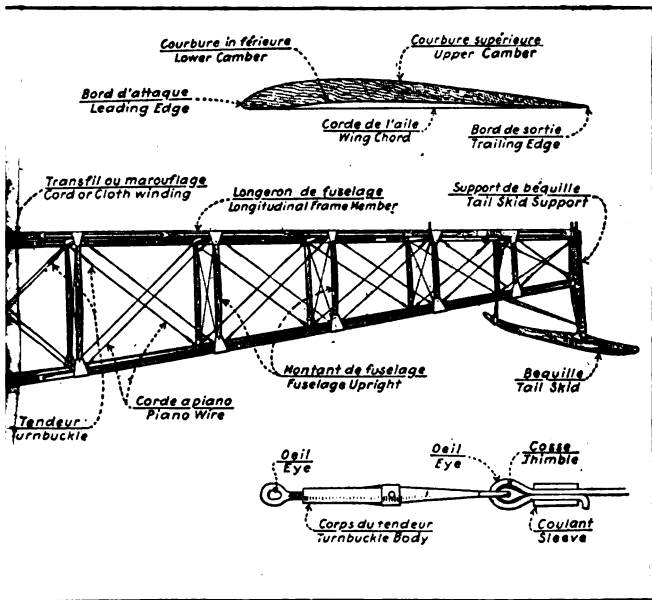

FIG. 6.—Skeleton View of Tractor Biplane



Various Parts Named in French and English



The antenna and counterpoise leads should be heavily insulated from the metal stays and framework of the machine generally, and run in as direct a route as possible. There should not be any uninsulated portion of a circuit where it can possibly come in contact with the pilot, the observer, or the plane. The more powerful the radio set, the greater must be the precautions against leakage. Airplane wings and control surfaces are covered with linen, which is coated with 8 or 10 layers of acetone base material, forming a highly inflammable substance easily ignited by a spark. A fire once started on the wing surface, is fanned by an 80 to 120 mile per hour breeze, and will completely envelop the machine in a few seconds.

*Ruggedness of Construction.*—Except for the fire hazard, the loss of control of airplanes is the most serious danger. All fittings must be made sufficiently rugged to absolutely prevent failure or breakage during flight. A piece of metal or wood weighing an ounce may easily strike the operator or pilot a disabling blow, if it breaks away at flying speed, and, at the very least, a broken fitting renders a set inoperative and makes the flight useless. Radio wires, fittings, etc., must not touch the control wires, foot bar, wheel, or wheel supports when they are in any position. Aside from the danger of wearing away insulation and causing dangerous sparks, there is a further danger of jamming the controls and bringing the machine to earth. After the installation of any radio apparatus is completed, the controls should be operated to the extreme of their movements in all directions, in order to make certain that it is impossible for any part of the apparatus to touch any moving part of the airplane. Wiring in the vicinity of the pulleys must be especially guarded against, as a jammed pulley probably will be fatal to the plane. When apparatus is directly exposed to the wind pressure, as is the case when a generator is mounted on the wing, it should be doubly safeguarded so that no parts can possibly fly off. Control wires have been cut in this manner.

*Avoiding Injury to the Airplane.*—Airplanes have a smaller factor of safety than practically any other piece of machinery, in order to make them faster and more easily controlled. This should be kept constantly in mind when mounting auxiliary apparatus. No struts, longerons, or other woodwork should ever be weakened by drilling. It is always preferable to clamp or lash around the wood whenever possible. When something must be fastened otherwise, wood screws should be used, the



safe rule being that the screws should not enter the wood more than one-sixth its thickness. Only a sufficient number of screws should be used to hold the fittings rigidly in place. All parts of a fitting should be fastened together before mounting on the plane, and dependence should never be placed on the woodwork of the airplane for holding two pieces of auxiliary equipment together when they could be held by exterior fastenings. In lashing or clamping apparatus in place, it is very important that the tension on the fittings should not distort the members or disturb the alignment of the plane. Storage batteries should be carried where there will be no possibility for any electrolyte to spill over or come in contact with metal parts or canvas of the machine or with the skin of the observer or pilot. In cutting the covering fabric to install fittings, the edges cut should be secured or bound, in order not to weaken the fabric to any great extent.

*Ease of Operation.*—In locating apparatus on an airplane, it should be borne in mind that the operator is usually strapped in his seat and his movements are limited. Any apparatus requiring adjustment during flight should therefore be within easy reach of the operator and made as accessible for manipulation as possible. Accessibility, however, should be sacrificed for the precautions outlined in the three previous paragraphs. The sending key and control switches and adjusting handles should be mounted so as to be worked conveniently from the operator's seat. Good sending from an airplane on a rough day is difficult under the best arrangement of apparatus, and is almost impossible if the key is so mounted that the operator is placed in a constrained position while sending. A rest should be provided for the sending arm, or the key should be so placed as to allow the operator to rest his arm upon his knee while sending.

*Interchangeability of Auxiliary Apparatus.*—A very important consideration in the mounting of auxiliary apparatus on airplanes is that it shall be quickly and easily taken off and replaced in case of trouble. It should always be possible for a plane to arrive at the hangar with a defective set or exhausted storage battery, have the defective apparatus taken out of the machine and replaced with new equipment, and the machine get away again within five minutes or less.

*Location of Apparatus.*—In addition to the influence of accessibility and ease of operation upon the location of auxiliary apparatus, there are other considerations which have a bearing

in determining the location of this apparatus on a machine. It should be remembered that an airplane is designed for a fine balance in all directions. For this reason, no great weight should be placed anywhere without consulting the aeronautical expert. In general, however, weight can be borne forward more easily than aft and with less liability of disaster, as a heavy aft weight brings about grave danger of a tail spin. Also, the right-hand side of the plane is better for balancing additional weights than the left side, for up to a certain amount the side torque of the propeller will counteract the weight.

On fighting planes, where speed is a prime requisite, all auxiliary apparatus must be mounted inside of the fuselage. It should be remembered that approximately six or eight times as much weight can be carried inside the fuselage as can be carried when the additional surface is exposed to the air currents outside. In this connection, it is interesting to note that the resistance of a fan when revolving is approximately twice as great as it is when locked still. The apparatus can be mounted at exterior positions upon training machines or on those used for observation purposes, since speed is not so important in this work, and more space is sometimes acquired inside the fuselage by this means. Specific detailed instructions as to the location and method of mounting radio apparatus on the airplane will be supplied with each set, and these directions must be followed faithfully. One very important precaution is that of avoiding the installation of any wires, even though insulated, along the metal cowl or other metal part of an airplane, as this would result in considerable loss in radiation.

*Compass Location Relative to Radio Sending Apparatus.*—It is very important that the radio sending apparatus on airplanes should be installed at such a point that it will not affect the operation of the compass; otherwise, this instrument will be entirely useless. In some airplanes, the observer is placed in the forward seat with a cockpit for the pilot behind him, while in other machines this order is reversed; but in either case, if the sending set is installed in the fuselage somewhere behind the rear cockpit, it will probably have no effect upon the compass, whether the latter is installed in front of the rear seat or in front of the front seat. In any event, the sending set must be far enough away from the compass so that it will have no effect upon it. If it does affect the compass, it will make that instrument useless while messages are being sent. Or in some instances, it has been found that the sending apparatus had a

permanent effect upon the compass and put it entirely out of true orientation.

The test to determine whether or not the wireless apparatus has any detrimental effect upon the compass is to place the nose of the airplane toward each of the cardinal directions and then operate the wireless instrument and observe whether it has any effect on the compass in any of these positions. It may frequently happen that in one position the wireless set will have no effect upon the compass, while in another it will affect it seriously.

### Airplane Nomenclature and Dictionary.

- Aerial*.—Pertaining to the air, or in radio work, the wires which radiate the electric oscillations.
- Aerobatics*.—The art, or almost science, of performing acrobatically in the air, including looping, tail sliding, nose diving, and so forth, all of which are necessary to fighting pilots.
- Acrodonetics*.—An invented word, to describe the science of soaring flight.
- Aerodrome*.—An open space arranged for the starting and alighting of airplanes, and with accommodation for machines and repair work.
- Aerodynamics*.—The science of dynamics as applied to the action of the air, especially in relation to mechanical flying.
- Aerofoil*.—Literally an "air leaf." A lifting surface of an airplane, which is commonly called a "plane," though it is not a plane surface.
- Aero-hydroplane*.—A hydroplane boat with wings and empennage fitted so that it flies; more generally called a flying-boat.
- Aeronaut*.—One who navigates the air, commonly designating an airship pilot (or any of his crew), to distinguish him from an aviator.
- Aeronautics*.—The science of aerial navigation of all kinds.
- Aeronef*.—French for aircraft.
- Aeroplane*.—See Airplane.
- Aerostat*.—Any lighter-than-air craft, not necessarily navigable, and thus including spherical and kite-balloons.
- Aerostatics*.—The science of aerostats.
- Aerostation*.—The general art of handling aerostats.
- Aileron*.—The flap at the rear of an airplane wing-tip, used for lateral control; i. e., rotation about the fore and aft axis.
- Air bottle*.—Container for compressed air used for starting big engines.
- Air-cooled (engine)*.—Cooled by air, as opposed to water.
- Aircraft*.—Any kind of machine which will convey people into the air.
- Airman*.—One who comprehends the handling of aircraft. The difference between an aviator and an airman is the difference between a sailor and a seaman. A man may be a good sailor and yet a poor seaman.
- Airmanship*.—The art of handling aircraft. A parallel quality to seamanship.
- Airplane*.—Commonly, any heavier-than-air craft, with fixed wings and driven mechanically, as opposed to an "airship," which is lighter than air.

- Airscrew.**—Any screw propeller which moves an aircraft, whether a "pusher" propelling from behind, a "tractor" pulling in front, or a side screw as used on airships; generally called "propeller" on pusher planes and "screw" on tractors.
- Airship.**—Specifically a dirigible aerostat, as opposed to an airplane.
- Air-speed meter.**—An instrument designed to measure the velocity of an aircraft with reference to the air through which it is moving.
- Albatros.**—A famous make of German airplane.
- Albatross.**—A large seabird, notable for its soaring ability.
- Altimeter.**—An instrument for indicating the height of an airplane above the surface of the earth.
- Amerissage.**—French for an alighting on the sea.
- Anemometer.**—An instrument with which to measure air speed, with reference to the earth or some fixed body.
- Aneroid.**—A barometer arranged to indicate barometric pressure (and height above starting level) on a dial.
- Angle of entry, attack, incidence.**—The angle to the horizontal of a line drawn from front to back of an airplane's wings when flying.
- Angle iron.**—A bent piece of iron or steel used for reinforcing angles of a structure, or a strip of iron or steel of, or approximately of, L section.
- Anti-drift (wires).**—Wires to stay the wings or spars horizontally backward, against strains likely to force them forward, as in a sudden stoppage on landing, or in a tail slide.
- Anti-friction metal.**—A soft metal used for engine bearings which melts at low temperatures and so prevents the freezing up of bearings in case of defective lubrication.
- Anti-lift (wires).**—Wires or cables which take the weight of the wings when on the ground (landing wires).
- Aspect ratio.**—The ratio between the span and chord of an aerofoil, or of a complete pair of airplane wings.
- Atterrissage.**—French for a "landing."
- Aviatic.**—Pertaining to aviation.
- Aviatic.**—A famous make of German airplane.
- Avion.**—The French term for an airplane of war, as distinct from commercial or instructional or pleasure airplanes. (*e. g.* *Avion de chasse*, a "chaser" or "destroyer." *Avion de bombardement*, a bombing machine. *Avion canon*, a machine carrying a gun bigger than a machine gun. *Avion de combat*, a fighting machine.)
- Aviation.**—The whole art of flying, as opposed to aerostation.
- Aviator.**—One who flies.
- Babbit metal.**—An anti-friction alloy.
- Backplate.**—The sheet-steel plate in the front of a fuselage or nacelle, to which a rotary or radial engine is attached.
- Back-wash.**—The air disturbance behind an aircraft in motion.
- Balanced (rudder or elevator).**—A rudder or other control plane which has a portion of its surface in front of its axis to facilitate the work of moving it and to make it more effective.
- Balance (to).**—To maintain a state of equilibrium.
- Ballonet.**—An air bag inside an aerostat, to maintain gas pressure, or the separate gas bags of an airship.
- Balancing plane.**—See Aileron and Elevator.

**Balloon.**—Practically any flexible receptacle for gas.

**Banking.**—Inclining an airplane so that the wings assume an angle, or bank, to a transverse horizontal line.

**Barograph.**—A barometer designed to register its readings on a chart; otherwise, to make a "graph."

**Bat boat.**—Specifically a Sopwith flying boat, in which the tail booms and empennage are not integral with the hydroplane, as in other flying boats.

**Bay.**—The portion of a biplane or multiplane wing composed of two contiguous pairs of struts and the wing structure and bracing between them.

**Beam.**—Any structure designed to sustain weight when supported at points and not along its whole length. Also a ray of light.

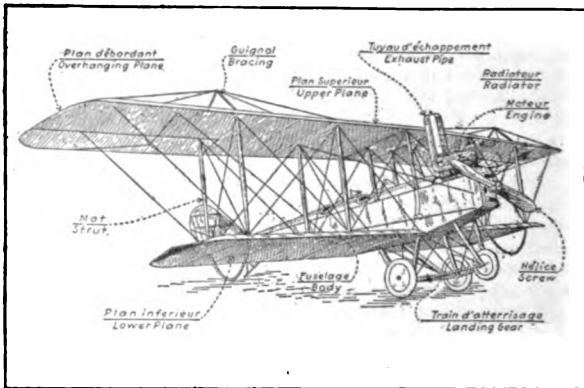

FIG. 7.—Front View of Tractor Airplane.

**Bell crank.**—Any lever of approximately L shape, with which to transmit motion round a corner.

**Bevel gear.**—A pair of cog wheels designed with the teeth on the bevel, or at an angle, to transmit power round a corner.

**Bifurcate.**—To form into a two-membered fork.

**Biplane.**—An airplane with two pairs of wings, one above the other.

**Blades.**—The paddle-shaped portions of air screws, outside the boss.

**Blower.**—A mechanical fan with which to blow up balloons.

**Body.**—The portion of an airplane which incloses the pilot, passengers (if any), and generally the engine of an aircraft. (Also called fuselage and nacelle.)

**Bonnet.**—The metal covering or cowl over the engine and the end of the fuselage or nacelle, as the case may be.

**Box kite.**—Properly a box-shaped kite, but generally applied to the early types of "pusher" biplanes with front elevators.

**Bracing.**—Tension members, generally of wire, in a girder structure (load wires, landing wires, drift wires, etc.).

**Bushing.**—A circular metal lining. Generally the detachable portion of a bearing.

**Cabane.**—The trestle-shaped or pyramidal structure of tubes above the fuselage of a monoplane, which hold the landing wires. A similar structure is also used in most German biplanes for the attachment of the upper wings, and in some British and French biplanes also.

**Cable.**—A series of wires, or other material calculated to endure tension, twisted or woven into strands for increased strength.

**Cabre.**—A flying attitude in which the angle of attack is greater than normal; tail down; down by the stern—tail low.

**Camber.**—The convexity or rise of a curve of an aerofoll from its cord, usually expressed as the ratio of the maximum departure of the curve from the cord as a fraction thereof. "Top camber" refers to the top surface of an aerofoll, and "bottom camber" to the bottom surface. "Mean camber" is the mean of these two.

**Canard.**—Literally a duck, French slang for a rumor, but aviatically an airplane with the elevator in front and without a tail, and thus having a duck-like appearance when in the air.

**Canvas.**—A fabric made of coarse cotton thread, a term frequently employed erroneously for the fine linen fabric of airplanes.

**Capacity:**

**Lifting.**—The maximum flying load of an aircraft.

**Carrying.**—Excess of the lifting capacity over the dead load of an aircraft, which latter includes structure, power plant, and essential accessories.

**Car.**—Aeronautically, the basket of a balloon, or the nacelle of an airship.

**Carlingue (Carling).**—French for that portion of a "pusher" biplane which includes the engine-bearers, tank-seating, and the attachments for the seats for the crew, and control mechanism.

**Castle nut.**—A nut with notches cut in its top surface to permit of the insertion of a split-pin into the bolt on which the nut is screwed.

**Cavitation.**—The action of a screw (air or water) in sucking fluid in behind it, or rather in causing a vacuum behind it, owing to its section being incorrect for its work.

**Cellule.**—A useful French term for the whole or part of the box-girder structure which is formed by the wings of a biplane or multiplane; e. g., the right cellule would be the whole of the upper and lower right wings considered as a unit. The right outer cellule would be the box structure comprising the front and rear outside struts, the front and rear struts next toward the fuselage, and everything in between them.

**Center of gravity.**—The theoretical line along which the weight of the aircraft (or any other body) operates.

**Center of lift.**—(See Center of pressure.)

**Center of pressure.**—The theoretical vertical line along which an airplane is supported by the air.

**Center of resistance (or of drift).**—The theoretical line along which the resistance of the air to the forward progress of the aircraft is centralized.

*Center of side pressure.*—The theoretical line along which the pressure of the air is centralized if the aircraft tries to move sideways (as in turning).

*Center of thrust.*—The theoretical line along which the air-screw operates.

*Chassis.*—Landing gear, or undercarriage of an airplane.

*Cord.*—The distance from the entering edge to the trailing edge of an aerofoll, measured in a straight line.

*Cockpit.*—The portion of a fuselage designed to accommodate the pilot and passenger or passengers.

*Colonnette bolt.*—A long bolt, or column, connecting the top of a cylinder direct to the crank case or sometimes to the crank-shaft bearings.

*Control.*—Generally the lever or wheel which controls the motions of the aircraft laterally and longitudinally. Also applied to the control surfaces.

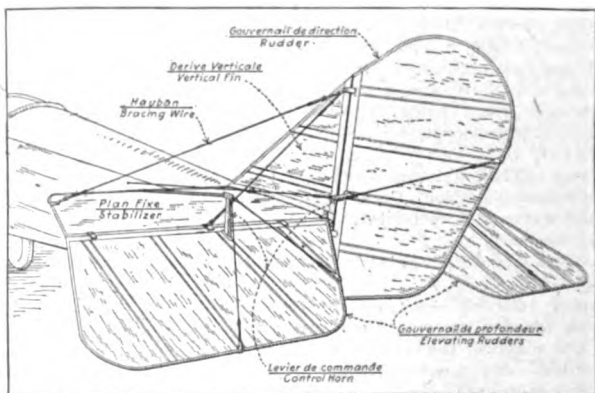

FIG. 8.—Control Members of an Airplane.

*Cowl.*—The metal covering or bonnet over the engine and the end of the fuselage or nacelle.

*Dashboard.*—The board in front of an aircraft pilot, on which the navigating instruments are fitted.

*Dic-casting.*—A casting made in a metal die instead of in sand.

*Dihedral angle.*—An open angle upward—as in airplane wings, the right and left wings form a dihedral angle owing to the outer tips being higher than the butts of the wings where they join the fuselage.

*Direct-driven.*—A term generally used on an air screw to indicate that it is fixed direct to the engine crank-shaft, instead of being driven by gear.

*Dirigible.*—A form of balloon, the outer envelope of which is of elongated form, provided with a propelling system, car, rudders, and stabilizing surfaces.

*Disk-wheels.*—Landing wheels in which the spokes are covered by disks of fabric or metal to reduce head-resistance.

*Disk area of a propeller.*—The total area of the disk swept by the propeller.

**Diving rudder.**—See Elevator.

**Dope.**—A special acetyl-cellulose varnish used to shrink and harden fabric used on airplanes.

**Double-surfaced.**—Aerofolls or control surfaces in which (as is now almost universal) a framework or skeleton is covered on both sides by fabric, the two surfaces not touching one another.

**Drag.**—The total resistance to motion through the air of an aircraft.

**Drift.**—An erroneous expression for "head resistance."

**Drift-wires.**—Wires or cables designed to prevent wings from folding backward under the strain of head resistance, an erroneous but handy substitute for "head resistance wires."

**Dual control.**—An arrangement of control mechanism by which either the passenger or pilot (or both) can direct the movements of an airplane.

**Dual ignition.**—An arrangement of magnetos by which two spark plugs are fired in one cylinder simultaneously. Or an arrangement by which an engine is started by a storage battery system of ignition and subsequently run on a magneto.

**Elevator.**—A hinged surface for controlling the longitudinal attitude of an aircraft—i. e., its rotation about the lateral axis.

**Empennage.**—Literally the feathering (of an arrow). In an aircraft, the fixed tail (or stabilizer) with the elevator, plus the vertical fin and rudder considered as a complete unit.

**Engine.**—The machine which by expansion of gas in its cylinders imparts motion to the aircraft. (Specifically a hydrocarbon engine, as no steam engines are used for the purpose.)

**Engine bearers.**—The heavy members of the fuselage or nacelle which carry the engine, or its back-plate.

**Entering edge.**—The front edge of the wing or aerofoll, which enters the air first.

**Envelope.**—The fabric, or skin bag, which contains the gas of an aerostat or airship.

**Extension.**—That portion of the upper wings of a biplane or multiplane which extends beyond the span of the lower wings.

**Fabric.**—The woven material, generally fine linen, which forms the covering of the wings, body, and control surfaces of an airplane. Or the material, generally cotton, of which an airship envelope is made.

**Factor of safety.**—The figure representing the strength of any portion of an aircraft in proportion to the stress it is called upon to bear; e. g., a factor of safety of 6 implies that the part is six times as strong as the greatest stress which will be put upon it when in use.

**Fairing.**—A light casing or addition to any part of an aircraft placed and shaped so as to give the part a better stream line shape.

**Fan.**—Either the cooling fan used on certain air-cooled engines or the blower of an airship, but never the propeller.

**Fin.**—Small planes on aircraft to promote stability; for example, vertical tail fins, horizontal tail fins, skid fins, etc.

**Flatten out (to).**—To raise the nose of an airplane after a nose-dive and to make it return to its proper flat flying path.

**Flight.**—The action of flying a heavier-than-air craft, but can not be correctly applied to the navigation of an airship—which floats.

**Float.**—A water-tight box, or pontoon, used to sustain seaplanes when on the water.



- Flying-boat.**—A hydroplane with which wings, empennage, and air screw have been combined. Originated in America by Mr. Glenn Curtiss.
- Flying machine.**—Virtually an airplane, as opposed to an airship, though the term applies to ornithopters, orthopters, and helicopters.
- Foot-bar.**—The pivoted horizontal bar which operates the rudder of an airplane.
- Fokker.**—The name of a famous German airplane.
- Frame.**—Any arrangement of solid material which acts as a skeleton on which to build up other material.
- Fuselage.**—The shuttle-shaped body of a tractor airplane, in which the engine is placed in front, the pilot (and passengers, if any) behind it, and the empennage at the after end. (From the French *fusel*, a shuttle.)
- Gap.**—The distance between the projections on the vertical axis of the entering edges of the upper and lower wing of a biplane.
- Gas-bag.**—The fabric envelope used to contain gas in any aerostat or airship.
- Gills.**—The flat plates fitted to the water tubes of radiators other than those of honeycomb pattern.
- Girder.**—Any structure built of compression struts and tension bracing designed to carry a big load in proportion to its own weight.
- Glide.**—To descend on an airplane under proper control after the engine has been stopped (*volplane*).
- Glider.**—A small airplane without an engine, designed to be launched from a high place and to descend under control to lower ground. Used largely for experiments in the past.
- Gliding angle.**—The flattest angle (i. e., the most acute angle to the horizontal) at which an airplane will descend after the engine has been stopped, and without getting out of control.
- Gondola.**—The German term for the car or nacelle of an airship.
- Gun-bus.**—A slang term for a gun-carrying airplane; specially applied to the Vickers' "pusher" biplane, the first machine to be built specially to carry a machine gun.
- Guy.**—A rope, chain, wire, or rod attached to an object to guide or steady it, such as guys to wing, tail, or landing gear.
- Hangar.**—French for any kind of shed. Used specifically in English for an airplane shed.
- Head resistance.**—The resistance offered by the air to the movement ahead of an aircraft. This is actually caused to a greater extent by the suction behind the parts of the aircraft than by the direct resistance in front.
- Hells.**—Strictly any kind of screw. Aeronautically an air screw.
- Hoik (to).**—A slang term indicating the action of jerking an airplane rapidly onto an upward path.
- Hydro-airplane.**—An airplane designed to start from and alight on water. Officially called a "seaplane" and inaccurately called by the daily press a "waterplane."
- Hydrogen.**—The lightest gas which can be produced commercially. Largely used for the purpose of floating airships.
- Hydroplane.**—A motor boat with a bottom designed so that it slides, or "planes," along the surface of the water. Not a flying machine of any sort.

**Ignition.**—Primarily the action of firing the gas charge in the cylinder of an engine. Generally the whole system of mechanism which produces ignition.

**Incidence (angle of).**—The angle at which the cord of an aerofoil or wing is inclined when flying in relation to a horizontal line.

**Incidence bracing.**—The wires between the front and rear struts of a biplane or multiplane, by which the incidence of the wings is varied or adjusted.

**Inclinometer.**—An instrument for measuring the angle made by any axis of an aircraft with the horizontal.

**Interplane struts.**—The vertical, or slightly inclined struts, generally in pairs front and rear, in biplanes and multiplanes, connecting the spars of a lower wing to the corresponding spars of the wing above.

**Instrument-board.**—(See Dashboard.) Generally contains a revolution indicator, an air speed indicator, a clock, a compass, the ignition switches, and an angle of climb indicator.

**Joy stick.**—A slang word for the control lever.

**Kat-hedral.**—Kata-bedral, a jesting word coined to express downward drooping wings, as opposed to a dihedral angle.

**Kite-balloon.**—The German "drachen-ballon." A sausage-shaped balloon used as an elevated observation post in war. The tail, or lower end of the balloon, is designed so that the whole affair operates in the manner of a kite and does not sway up and down or revolve, as does a spherical captive balloon.

**Laminations.**—A series of strips of solid material placed together to build up a stronger and thicker member. (e. g., the leaves of a spring of a motor car.) Air screws are built up of laminations, or laminae, of wood glued together.

**Landing-carriage.**—The struts and wheels below the wings, on which an airplane rests when normally on the ground. (See Chassis.)

**Landing-gear.**—(See Landing-carriage.)

**Leading-edge.**—(See Entering-edge.)

**Limiting height.**—The extreme height to which an aircraft will rise, without altering its design, or its engine, or some other inherent characteristic. Familiarly known as the "ceiling" or "roof" of that particular machine.

**Loop (to).**—Looping the loop consists in lifting the nose of an airplane, either when flying level or after a preliminary dive, and keeping the elevator up so that the machine finally passes the upward vertical path and falls over backwards. If skillfully done, centrifugal force maintains the pressure of the wings on the air, and the machine performs a perfect loop instead of a back-somersault.

**Longerons.**—The longitudinal members, generally of wood, in the fuselage or nacelle of an aircraft. Also used by the French for the main spars of the wings.

**Long-horn.**—A familiar name for the old type Maurice Farman biplane, which had an elevator in front (as well as behind), carried on two long, curved, wooden booms.

**Magneto.**—An electric generator producing the spark which fires the gas charge and gives power to the engine.

**Mast.**—A single strut or tube, used in some monoplanes instead of a cabane.

- Monocoque.**—Literally, a "single-hull." Applied to fuselage of the type originated by the Deperdussin firm in which the fuselage is built up on a former or mold from alternate layers of thin wood strips and fabric cemented together, thus forming a shell without internal longerons or bracing. Erroneously applied to fuselages which are overlaid with a fabric or wood streamline fairing built up on hoops outside the longerons.
- Monoplane.**—An airplane which has only one pair of wings on the same level, or plane.
- Monosoupape.**—Literally, "single valve." Applied to the type of Gnome engine which has a single valve in the cylinder-head for the air inlet and the exhaust of the explosion, the gasoline being taken in from the crank-case through ports in the lower part of the cylinders.
- Motor.**—A common expression for an internal combustion engine.
- Multiplane.**—Strictly, any airplane with more than one pair of wings, but generally applied to any with more wings than a biplane or triplane.
- Nacelle.**—Literally, "a cradle." Applied to the bodies of "pusher" airplanes and to the cars of airships.
- Negative (angle).**—The angle to the true horizontal made by an aerofoil, either wing or tail plane, which is flying with its leading edge lower than its trailing edge.
- Non-rigid.**—An airship without a rigid frame or keel, and dependent on the gas pressure in the envelope for the maintenance of its shape, the car, or nacelle, suspended direct from the envelope.
- Non-diver.**—The action of diving an airplane vertically nose first toward the ground.
- Obturator ring.**—A thin ring of special flexible metal used on Gnome pistons to give extra gas-tightness, and acting like the "sucker" of a pump.
- Outrigger.**—A term frequently applied to the tail booms of a "pusher" airplane, but originally used only for the booms carrying the front elevators of box-kites of the early Farman types.
- Parasol.**—A type of monoplane in which the wings are raised above the fuselage to about the position of the upper wings of a biplane, thus covering the pilot's head, and leaving a perfectly clear view below.
- Petrol.**—Petroleum spirit used as fuel for internal-combustion engines. Known in America as "gasoline," in France as "essence," and in most other countries as "benzin."
- Pilot.**—An aviator or aeronaut who pilots an aircraft, as distinct from the passenger, observer, gunner, or other occupant. Also any person who has qualified to act as a pilot.
- Piston.**—The pot-shaped plunger which, by sliding up and down in the cylinder, conveys the expansion of the exploding gas via the connecting-rod to the crank shaft.
- Piston ring.**—An expanding spring ring placed round a piston to make it gas-tight in the cylinder.
- Pitot tube.**—An arrangement of tubes, with one end facing the direction of flight, invented by M. Pitot, to indicate the speed of air currents. Now used to indicate the speed of airplanes through the air.

**Plane.**—Strictly, a perfectly flat surface, but colloquially and erroneously applied to any aerofoll, or surface of an airplane, and sometimes to the whole machine (as in "seaplane," "war plane," "battle plane," etc.).

**Positive angle.**—The angle made with the horizontal by an aerofoll or surface, which has its leading edge above its trailing edge.

**Post.**—*Stern post*, the last vertical strut in a fuselage. *Rudder post*, the vertical tube or strut to which the rudder is hinged.

**Power plant.**—The engine, plus all its accessories, such as tanks, radiators, instruments, control levers, and switches, and possibly including the airscrew.

**Propeller.**—Strictly, anything that propels, correctly applied to a "pusher" airscrew as distinguished from a "tractor." Commonly used for any airscrew.

**Pusher.**—Specifically an airscrew placed in back of an airplane and pushing it along instead of drawing it along. Loosely applied to any airplane moved by a pusher screw.

**Pylon.**—Literally, any kind of post, but generally a built-up post, of uprights and cross-bracing. Used to mark the course on an aerodrome; also, pyramids of tubes used on some monoplanes, instead of masts or cabanes, for supporting the landing wires above and the warp-wires below the fuselage.

**Quadruplane.**—An airplane with four pairs of wings, one above another.

**Race of a propeller.**—The air stream delivered by the propeller.

**Radial engine.**—An engine with the cylinders fixed radially around the crank-case, and with three or more connecting-rods on each crank pin. The cylinders remain still and the crank shaft revolves, as in ordinary engines, and unlike rotary engines.

**Radiator.**—A metal receptacle for hot water from the engine, arranged to permit the percolation of air so as to cool the water.

**Radius rod.**—A rod fixed at one end to one part of an aircraft and attached at the other end to another moving part, so as to insure the latter always maintaining the same distance from the former.

**Ratchet.**—A row of teeth, each tooth being vertical on one side and sloped on the other, so that a spring-held catch, or pawl, can slip up the sloping side. It is then held by the vertical side against return until it is lifted at the will of the person in control.

**Revolution indicator.**—A mechanism which indicates on a dial in front of the pilot the number of revolutions made per minute by the engine.

**Rib.**—The fore and aft members of an aerofoll or wing which support the fabric and maintain it in the proper curve.

**Rigid.**—An airship having an external skeleton so that it does not depend on gas pressure to maintain its shape.

**Rotary engine.**—An engine in which the cylinders are arranged radially around the crank-case, which rotates with the cylinders around a stationary crank-shaft, the airscrew being fixed to a beak-shaft fitted to the front of the crank-case.

**Rudder.**—The movable vertical control surface which directs the course of an aircraft over a horizontal plane.

**Sausage-balloon.**—(See Kite-balloon.)

**Scout.**—Literally, a maker of military reconnaissances, and so applied to small fast single-seat airplanes, though this type of machine is now used almost entirely for fighting, and reconnaissances are almost always made on two-seaters, carrying a pilot and an observer. The title of "scout" was first applied to the small Bristol biplane.

**Seaplane.**—The official term, entirely erroneous in origin, for a hydro-airplane.

**Section (wing).**—(See Camber.)

**Semi-rigid.**—An airship with a non-rigid envelope, but stiffened by a keel or a long spar, along the greater part of its length, the nacelle or nacelles being suspended from the keel or spar, instead of direct from the envelope.

**Self-starter.**—A mechanism, generally an electric motor driven by a storage battery, but sometimes a small auxiliary petrol engine, which is geared to the main engine of an aircraft to make it possible for the crew to start the main engine without manual labor.

**Shock absorber.**—Any contrivance designed to diminish the shock of landing an aircraft. Generally the spring contrivance between the wheel-axes and landing carriage of an airplane, which is usually either rubber cord or an oil-pneumatic device.

**Side-area.**—The projected area of an aircraft when viewed in side elevation.

**Side slipping.**—Sliding toward the center of a turn. It is due to excessive banking for the turn made and is the opposite of skidding.

**Single-surface.**—Any surface of an aircraft which consists of fabric exposed on both sides to the air, without an intermediate frame or skeleton. This is irrespective of the number of layers of fabric which compose the single surface.

**Skidding.**—Sliding sideways in flight away from the center of the turn. It is usually caused by insufficient banking in a turn, and is the opposite of side slipping.

**Skids.**—Long wooden or metal runners designed to prevent nosing of a land machine when landing, or to prevent dropping into holes or ditches in rough ground. Generally designed to function should the wheels collapse or fail to act.

**Skin-friction.**—The friction of the air over the skin, or surface, of car body passing through it, as distinct from direct resistance in front or suction behind.

**Slip.**—This term applies to propeller action and is the difference between the actual velocity of advance of an aircraft and the speed calculated from the known pitch of the propeller and its number of revolutions.

**Socket.**—Any fitting into which a compression member of a girder fits, generally applied to strut sockets. (See Interplane struts.)

**Soaring.**—The sustaining of an aerofoll by an upward current of air, without mechanical means. Man-carrying gliders have been known to soar for several minutes at a time in winds blowing up a hill-side. The word is frequently applied erroneously to an airplane climbing steeply by means of its own power plant.

**Span.**—The measurement of an airplane from the extreme tip of the right wing to the extreme tip of the left wing. Also the extreme measurement, across the machine, of any other horizontal surface, such as the tail, or elevator.

**Spar.**—The main members of an airplane wing, running from the butt of the wing, where it joins the fuselage or cabane, outward to the wing-tip. Generally made of wood, frequently hollow. Sometimes made of steel tube. The word spar may also be correctly applied to any main compression member of considerable length.

**Spark plug.**—A plug screwed into a cylinder, and so constructed that an electric spark generated by the magneto takes place between two points inside the cylinder and ignites the gas charge.

**Spread.**—The maximum distance laterally from tip to tip of an airplane wing. (See Span.)

**Stabilizer.**—A term for the fixed horizontal tailplane of an aircraft, which governs its longitudinal stability, or pitching tendency. Sometimes erroneously applied to the elevator.

**Stabilizer.**—See Fins (mechanical). Any automatic device designed to secure stability in flight.

**Stability.**—The tendency of an aircraft to return to its normal flying position if deflected therefrom by an air current, or by the operation of the controls. *Automatic stability* is procured by mechanical means, such as a gyroscope. *Inherent stability* is procured by the inherent design of the machine combining the effects of its own surfaces on the air with the action of gravity. *Longitudinal stability* refers to the stability of the aircraft fore and aft, or its pitching up and down in a vertical plane. *Lateral stability* refers to the movements sideways, i. e., the twisting around its own longitudinal axis, analogous to the rolling of a ship. *Directional stability* refers to movements on a horizontal plane, analogous to the direction of a motor car on a road.

**Stagger.**—The amount of advance of the entering edge of the upper wing of a biplane over that of the lower; it is considered positive when the upper surface is forward.

**Stall (to).**—To allow an airplane to slow down below its proper flying speed so that it falls, either by nose-diving or by rolling over sideways, and side-slipping.

**Stay.**—A wire, rope, or the like, used as a tie piece to hold parts together, or to contribute stiffness; for example, the stays of the wing and body trussing.

**Step.**—A notch in the bottom of a hydroplane which assists it to plane, or skim over the surface of the water.

**Strainer (wire).**—(See Turnbuckle.)

**Streamline.**—The natural flow of air streams. A streamline shape is one given to a body so that in passing through the air it causes the minimum amount of disturbance to the air streams which pass over it or around it, thus minimizing the head resistance.

**Stringer.**—A longitudinal member placed to stiffen a structure; e. g., stringers are used between the hoops of a mock-monocoque fuselage to stiffen the fairing outside the main longerons.

**Strut.**—Strictly, any compression member in a girder structure. In airplanes, generally applied to the interplane struts of biplanes or multiplanes, which strut the upper apart from the lower wings, each front strut running from a point on top of the lower front spar to a corresponding point on the bottom of the upper front spar, and having behind it on the bottom rear spar a companion rear strut to the top rear spar.

- Swept-back wings.**—Wings designed so that when viewed in plan the tips are behind a straight line drawn at right angles to the center line of the airplane from a point at the butt-end of the leading edge. Commonly used on many German machines until the end of 1916; (e. g., all "Taube" type monoplanes had swept-back wings).
- Tachometer.**—A device for indicating the speed (r. p. m.) of the engine or propeller. Usually operates on centrifugal principle, but sometimes is a magnetic device.
- Tailboom.**—Any one of the protecting tubes or wooden members, which carry the tail of a "pusher" airplane.
- Tail.**—Loosely, the whole empennage, but more correctly only the fixed horizontal tail-plane or stabilizer.
- Tail-slide.**—The result of forcing the nose of an airplane as nearly as possible vertically upward, so that in falling it does so tail first, instead of nose-diving or side-slipping.
- Tappet.**—The plunger which operates a valve of an engine, more commonly called the "lift rod."
- Taube.**—German, literally a dove or pigeon, hence applied to all airplanes with wings swept back and narrowing to an upward-curved tip, in the style originated by the Austrian inventor, Herr Igo Etrich.
- Thrust deduction.**—Due to the influence of the propellers, there is a reduction of pressure under the stern of the vessel which appreciably reduces the total propulsive effect of the propeller. This reduction is termed "thrust deduction."
- Tinclip.**—A slang term applied by aircraft workers to all sheet or strip metal clips, irrespective of material.
- Torque.**—The force which reacts against the air screw, and endeavors to turn the airplane around on the shaft of the air screw, instead of turning the air screw around on its own axis.
- Tractor.**—Specifically, an air screw placed in front of an airplane and drawing it along by traction instead of pushing it. Loosely applied to any airplane moved by a tractor screw.
- Trailing edge.**—The rear edge, when flying, of any aerofoll or surface of an airplane.
- Triplane.**—An airplane with three pairs of wings, one above another.
- Turnbuckle.**—A metal barrel threaded internally right handed at one end and left handed at the other, so that by turning it one way it draws both bolts together internally, or vice versa, drives them out simultaneously. For this reason it is used largely in screwing up the tension of airplane wires or cables by inserting a turnbuckle into the line of the wire or cable.
- Twin-engined.**—An airplane with two engines placed usually side by side in separate nacelles or fuselages.
- U-bolt.**—A two-legged bolt of U section, used frequently in attaching wires to woodwork.
- Undercarriage.**—(See Chassis, Landing carriage, Landing gear.)
- Useful load.**—A term applied to the load which an airplane can carry after being equipped with all necessary fittings for flying, and with water in the radiators. Useful load includes pilot, passenger, fuel, bombs, guns, ammunition, cameras, wireless apparatus, etc.
- Volplane.**—French for a glide. Literally, planed flight, as opposed to mechanically driven flight.
- Wake.**—(See Back-wash.)

- Warping.**—The twisting of an airplane wing by raising or lowering the rear spar to control the machine laterally. Now practically superseded by the use of ailerons.
- Warplane.**—Press term for an airplane of war, or avion.
- Water-cooled (engine).**—An engine kept at correct working temperature by water cooling instead of air cooling.
- Water-jacket.**—The casing outside the cylinder of an engine which contains the cooling water.
- Web.**—Specifically the vertical part of an airplane rib. More generally any thin vertical member of any girder.
- Whirling table.**—A species of "round-about," consisting of a long girder arm revolving horizontally on a central pivot, the extreme end being fitted with mechanism for observing experiments with parts of aircraft, such as aerofolls, engines, and air screws.
- Wind screen.**—A small screen fitted in front of the pilot or passenger to protect him from the air pressure.
- Wing.**—Any one of the aerofolls of an airplane which supports the weight of the machine, as distinct from the control or stabilizing surfaces, whether aerofolls or not.
- Wing loading.**—The weight carried per unit area of supporting surface.
- Wing-tip.**—The extreme outer end of the wing of an airplane.
- Yaw.**—To swing off the course about the vertical axis owing to gusts or lack of directional stability. *Angle of.*—The temporary angular deviation of the fore and aft axis from the course.



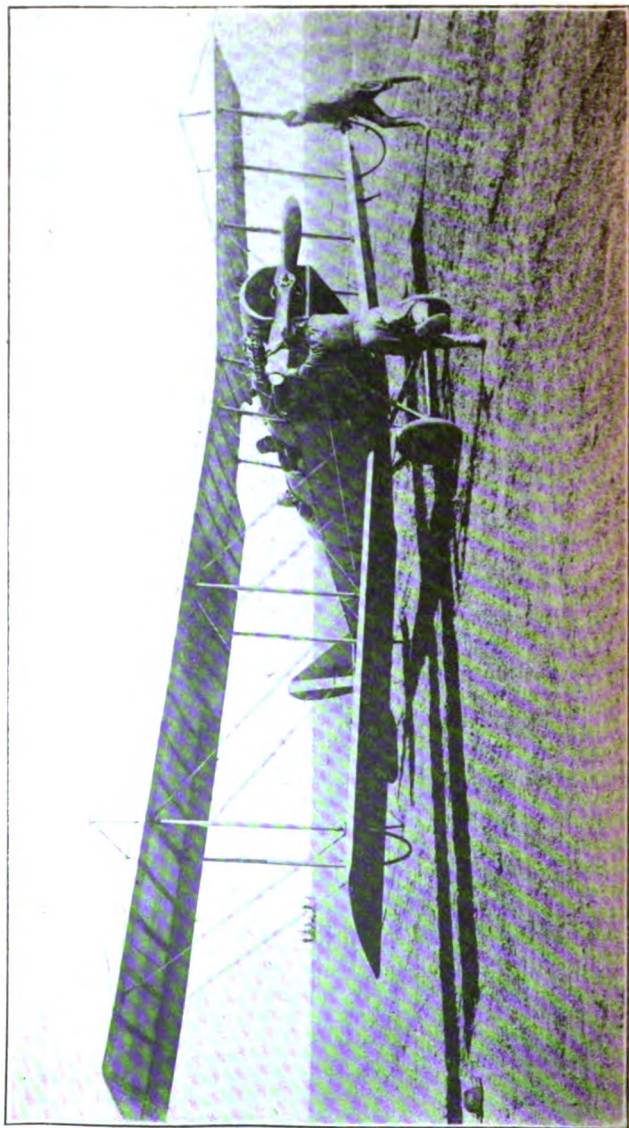

FIG. 9.—Cranking the Engine of a Curtiss JN-4-H Airplane.



---

Prepared in the  
Office of the Chief Signal Officer  
Training Section  
Washington

---

*SRR.*

CONFIDENTIAL

# TRENCH LINE CONSTRUCTION

*Wire Communication Pamphlet*

~~TRAINING PAMPHLET~~

~~NO. 6~~

*M-6.*

Signal Corps, United States Army



WAR PLANS DIVISION

July, 1918

---

War Department  
Document No. 828  
*Office of the Adjutant General.*

---

**Prepared in the  
Office of the Chief Signal Officer  
Training and Instruction Division  
Washington**

---

CONFIDENTIAL

# TRENCH LINE CONSTRUCTION

~~TRAINING PAMPHLET~~

~~No. 6 A~~

*Wire Communication Pamphlet  
No. 6.*

Signal Corps, United States Army



WAR PLANS DIVISION  
July, 1918

War Department  
Document No. 828  
*Office of the Adjutant General.*

War Department  
Document No. 828  
*Office of the Adjutant General.*

WAR DEPARTMENT,  
WASHINGTON, *July 15, 1918.*

The following pamphlet, entitled "Trench Line Construction—  
Training Pamphlet No. 6-A," is published for the information of  
all concerned.

(062.1 A.G.O.)

BY ORDER OF THE SECRETARY OF WAR:

PEYTON C. MARCH,  
*General, Chief of Staff.*

OFFICIAL:

H. P. McCAIN,  
*The Adjutant General.*





## TABLE OF CONTENTS

---

	Page
CHAPTER I.—GENERAL FORWARD LINE CONSTRUCTION.....	7
CHAPTER II.—WIRE TRENCH AND LINE CONSTRUCTION.....	11
Type A Construction.....	11
Type B Construction.....	11
Type C Construction.....	12
Type D Construction.....	12
Type E Construction.....	13
Method of Constructing Wire Trenches.....	13
Methods of Carrying Trench Lines Across a Road.....	19
CHAPTER III.—LINE CONSTRUCTION IN COMMUNICATING AND FIRE TRENCHES.....	23
Methods of Supporting Lines.....	25
1. Wire Staples.....	25
2. Insulators Attached to Boards.....	26
3. Wood Stakes with Insulators on the End.....	26
4. Posts with Slots or Insulators.....	27
5. Looped Wire Supports.....	27
6. Tying to Brush Revetment.....	27
Transpositions.....	28
Emergency Circuits.....	28
CHAPTER IV.—TAGGING TRENCH LINES.....	30
Scheme No. 1.....	30
Scheme No. 2.....	32



## CHAPTER I.

### GENERAL FORWARD LINE COMMUNICATION.

In the great maze of communications which must be promptly and efficiently handled in military operations, the telephone affords, from many points of view, perhaps the most satisfactory communication system. It has the great advantage over the telegraph, buzzerphone, visual signaling and radio that it gives direct communication which requires no translation for interpretation, that it makes possible the transmission of much more complete and explicit information in the same or less time, and that the telephone instrument itself is very rugged and dependable. Likewise the telegraph and buzzerphone systems have great advantages over the visual signaling systems and the telephone because of their greater secrecy. However, despite their convenience and worth, the telephone and other wire systems have one serious disadvantage or deficiency. They require the use of wire lines between stations, and in the forward areas, these can be installed and maintained only with the greatest difficulty owing to the destructive shell fire of the enemy. But even with this handicap, the telephone and telegraph are of such great value that no efforts are spared in an endeavor to maintain the systems operative.

The area from the front line back a distance of about 6,000 yds. is shelled with such intensity that no practical method of adequately protecting the open wire lines has been developed. About the only way that the circuits can be entirely protected from shell fire is by making use of lead covered cable and burying it to a depth of 15 ft. or more. The expense of this construction is prohibitive for a system of the extent required within the 6,000 yd. zone. So a composite system of cable and open wire trench lines has been shown by experience to be about the most satisfactory wire network layout, although this is by no means free from interruption.

In each divisional sector, one main artery of wire lines is installed from rear to front, starting at division headquarters and following the "axis of communication" in as straight a line as

possible to a point approximately 1,200 yds. back of the front line. This main artery is made up of one or more lead covered cables buried to a depth of 6 ft. to 12 ft., depending on the character of the soil and proximity to points likely to draw heavy shelling from the enemy, 8 ft. being the depth most commonly used. Cables providing 40 or 50 pairs of wire are usually installed in this main cable run and are brought through terminal or test boxes installed in small dugout manholes about every 2,000 ft. The lateral circuits spreading out in both directions over the entire divisional area are lead out from these terminal boxes and they are carried in one of the three following ways:

1. **By Overhead Wire Distribution.**—This is of course the easiest way of carrying the lateral leads, but this method can be employed only where the shelling is very light, as may be the case in the zone of division headquarters.

2. **By Small Underground Cable Distribution.**—From the viewpoint of permanency and safety from shelling, this is the most satisfactory method of distribution but it cannot commonly be used because of the great amount of labor involved in its installation. It is generally used only to connect the forward end of the main cable run with the forward end of similar cables in the adjoining divisional sector. Small underground cables are also sometimes used as lateral leads to very important points where it is imperative that telephone communication be maintained without interruption even under heavy shell fire.

3. **By Trench Line Distribution.**—The most common method of lateral distribution employed is that of installing open wire lines below the ground level in trenches. While this method of construction does not prevent the wires from being broken by shell fire, it does afford some protection to the wires and greatly facilitates repairs because of the protection it gives the men employed in this work.

In general two kinds of trenches are employed for running wire circuits. These are, first, small trenches constructed primarily for this purpose and known as "wire trenches;" and second, trenches that are constructed primarily for other purposes, such as communicating and fire trenches.

Which of these two general classes of trenches is to be employed must be determined by the local conditions. In this connection it should be remembered that the stringing of wire in trenches used for other purposes is a makeshift and should be done only

where unavoidable. Wires in trenches used for other purposes are subject to the shell fire aimed at the troops in them. Moreover, the troops themselves in passing through the trenches do as much if not more damage to the wires than the shell fire. In this connection, all officers should impress upon their men the great importance of the wires in the trenches and caution them frequently to be very careful not to damage the lines in any way. In the extreme forward area where only few circuits are necessary, and where the ground is exposed or so badly cup up with traffic that the construction of another trench for wire purposes would be a source of hindrance to the movement of traffic, it is considered necessary or advisable to use the second class of trenches.

The general rule as to who shall be responsible for the construction and maintenance of lines is that each detachment will handle those lines from its own headquarters inclusive, forward to but exclusive of the next headquarters. However, in repairing a broken line, men from both stations should start out to locate and repair the break in order that the interruption to communications may be as short as possible. In these matters, the fullest measure of cooperation should exist and no one should wait for someone else to do a job when he can do it more quickly.

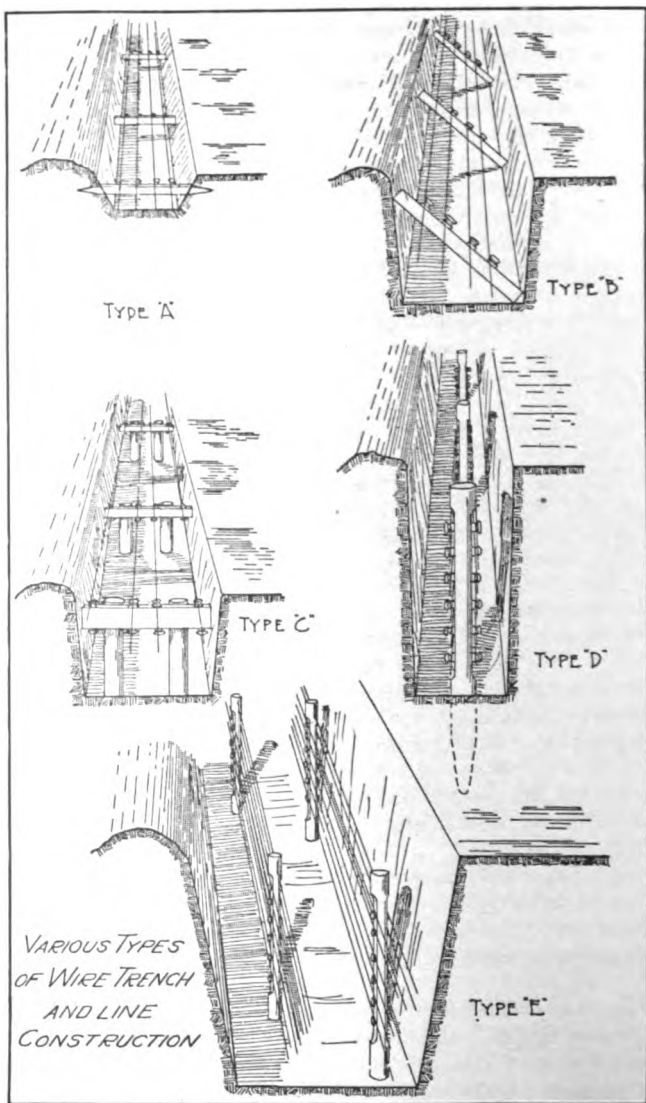

## CHAPTER II.

### WIRE TRENCH AND TRENCH LINE CONSTRUCTION.

Wire Trenches are used not only for lateral leads from the main underground cable but also for installing connecting lines between any points in the zone of heavy shelling where it is not necessary or expedient to use communicating or fire trenches, nor justifiable to use underground cable. They vary in depth and width according to the number of lines the trench is to carry and the amount of protection desired. They range from 10 in. wide x 10 in. deep to 36 in. wide x 30 in. deep. They afford considerable protection from shell fire, except a direct hit in or very close to the trench, and also avoid damage to lines, due to trench traffic.

The construction employed for wire trenches in general may be divided into five types, any of which can be modified to suit local conditions. They are as follows:

**Type A Construction.**—This construction provides a shallow and narrow trench about 10 in. wide and 10 in. deep, which is used for carrying one or two twisted pairs. Inside the trench, at intervals of 15 or 20 ft., cross sticks are placed horizontally, projecting into the sides and about midway between the top and bottom of the trench. The wires may be fastened to these cross sticks by tying with wire or string. It is preferable, however, to place insulators on top of the sticks and tie the wires to them.

This type A trench is used where one to three circuits are required, as for example between the batteries of artillery and from a battery to its battalion. It can be constructed quite rapidly. A detail of two men should dig 35 yds. per day in good ground. The cross sticks, with the insulators nailed onto them, can be prepared under shelter in advance of the need. The objection to this type of trench is that it fills quickly with leaves, sticks and soil and is very hard to clean out on account of the difficulty of lifting the wires out of the trench.

**Type B Construction.**—The type B construction provides a trench about 10 in. wide and 18 in. deep in which a wooden arm 20 in. long is laid diagonally in the trench. The wires are fastened to insulators nailed to one side of the arm. These supporting arms



are spaced about 20 ft. apart. With this method of construction the arms holding the wire may be raised up at the upper end and the trench readily cleaned when necessary. This type of trench is used when it is desired to have one or two more circuits than the type A will permit. As it will accommodate four or five twisted pair lines.

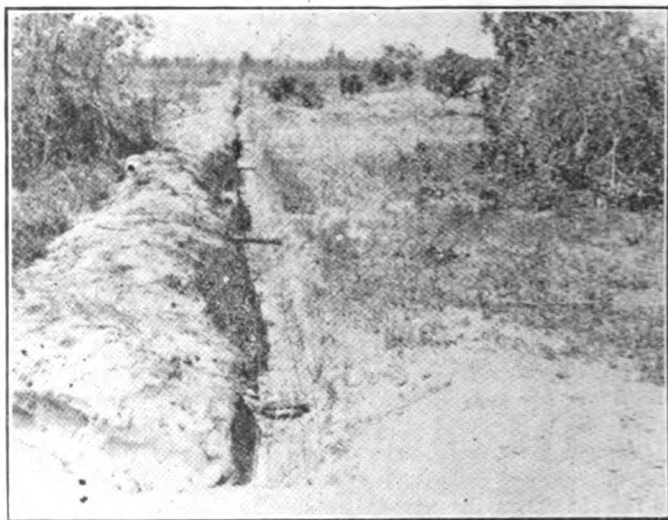

Type A Wire Trench and Line Construction

**Type C Construction.**—With this type of construction, the trench is made about 20 in. wide and about 20 in. deep. At intervals of 15 to 20 ft., two posts are driven into the bottom of the trench and a cross arm long enough to carry five or six twisted pairs is supported on them. The wires are fastened to insulators which are attached to the cross arm. This method of construction is used where it is practical to put in a more permanent installation than that of type B. A detail of two men can dig about 25 yds. of this type of trench per day in good ground.

**Type D Construction.**—When more than six circuits are required, it is necessary to construct a trench about 30 in. deep x 12 in. wide at the bottom and 18 in. wide at the top. In this trench, posts

about 4 in. in diameter and 4 ft. long are driven in the bottom of the trench to a depth of 18 in. and spaced about 25 ft. apart. These posts are gained on two opposite sides from a point 5 in. below the top to a point 20 in. lower. Seven insulators are then nailed on each of the flat sides of the posts and staggered on opposite sides so that the nails will be evenly spaced and not as likely to split the pole. As many as 14 twisted pairs can be carried

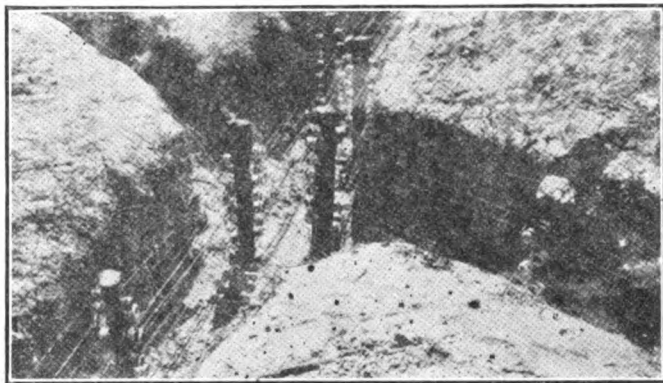

A Type B Trench and Two Type D Trenches Joining In a Type E Trench

in this type of wire trench. A detail of two men can prepare about 100 posts per day and a detail of two men can dig about 25 yds. of this type of trench per day in good ground.

**Type E Construction.**—While the type D construction can carry as high as 14 twisted pairs, it is better practice when the number required exceeds 10, to construct a type E wire trench which is similar to the former but wider. This trench is made 3 ft. wide at the top, 2 ft. wide at the bottom and 30 in. deep. Two parallel lines of the type D trench wiring can be installed if desired. This wire trench will serve to carry from 10 to 20 twisted pairs and it has a maximum capacity of 28 pairs. A detail of two men can dig about 15 yds. of this trench per day in good ground.

#### METHOD OF CONSTRUCTING WIRE TRENCHES

The routing of the wire trenches should be carefully determined through reconnaissance of the ground and study of the map of the

sector, so that they will be as easily constructed and as well protected as possible. This study is usually made by an officer, assisted by the non-commissioned officer who will be in charge of the construction work. The route selected should be as straight as is consistent with the necessity to avoid obstructions and

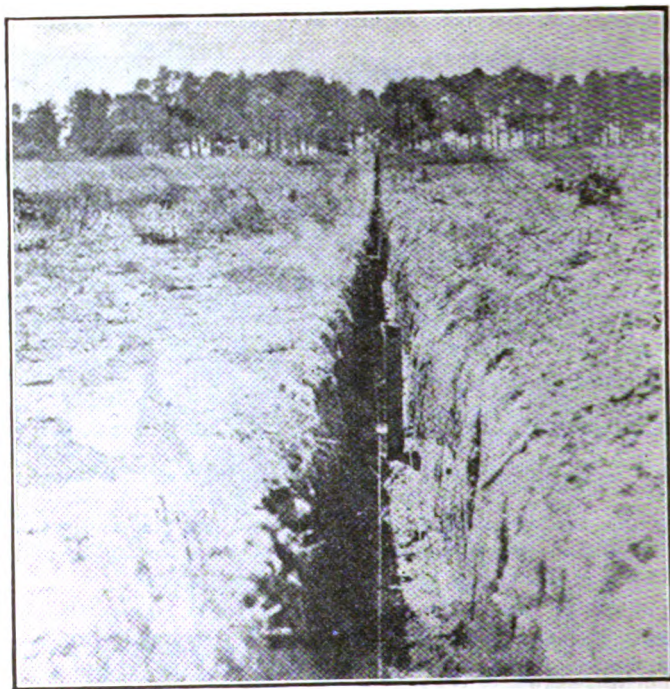

**Type D Wire Trench and Line Construction, Showing Installation of First Lines at Bottom**

points where there is likely to be heavy shelling. The best route is not necessarily the shortest one. For example, the circuits which run to units in the same general direction should not immediately branch out to their various destinations, but instead, should be kept together in a trunk line as far as possible. In fact, the saving of material and labor resulting, will often warrant

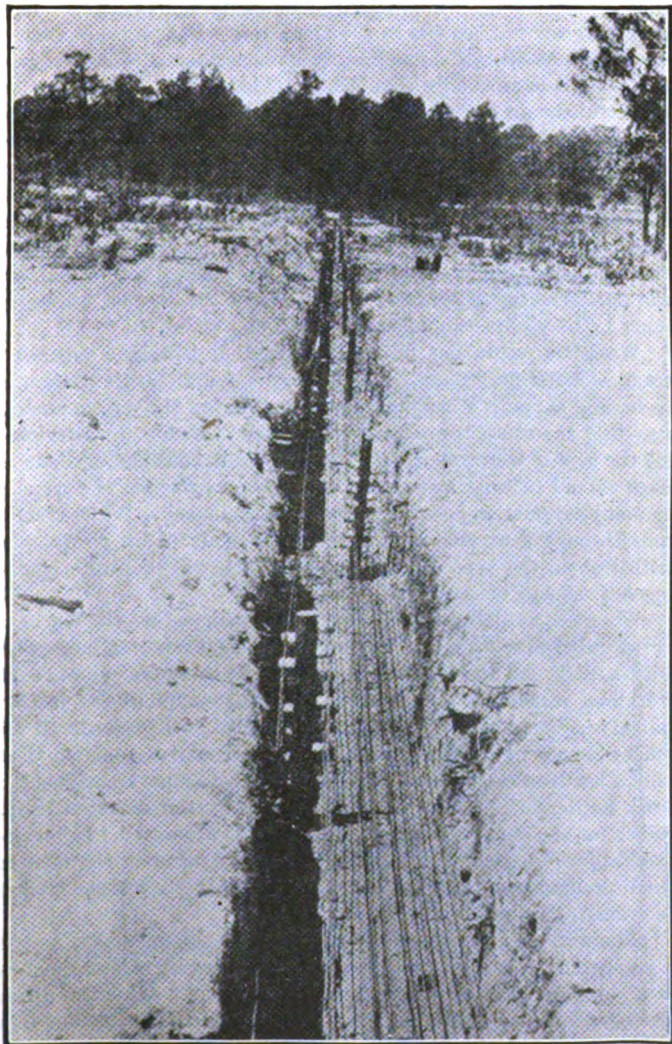

**Type E Wire Trench and Line Construction, Showing Staggered Post Location**

the installation of a switchboard at the point of separation. This may save several circuits in the trunk line. The trenches should never be constructed immediately at the sides of roads. Junctions of roads especially should be avoided. The relation of the profile of the ground to the problem of transporting the necessary line material should be considered in choosing the route. Whenever possible, the trench lines should run through woods in order to obscure them from aerial observation. Ordinarily, it is unnecessary to conceal wire trenches as there are so many trenches running through the shelled area that those used for communication purposes are not likely to attract any unusual attention from the enemy aerial observer. Both ends of the trench, however, must be carefully camouflaged.

When the route has been determined, it is staked out with small wooden pegs placed about 10 yds. apart. If the trench is to be dug at night it should be outlined during the day in such a way that the route can be readily followed at night. In determining the type of wire trench to be constructed the need for additional lines should be anticipated and the general principle of carrying as many circuits as possible in one route followed. If the trench runs through a wooded area, where it is likely to fill up quickly with leaves, the type of construction which will facilitate cleaning out, should be used.

When the actual construction of the trench begins, the workers are divided into groups of two men each and one man equipped with a pick and the other with a shovel. A liberal number of workmen should be asked for in order to complete the job as quickly as possible. When the number of men exceeds 50 an officer should be present. If there is a scarcity of tools so that only a few men can be used at a time and these must consequently work harder in order to complete the job by the specified time, reliefs for the men on frequent shifts will be necessary. In localities subject to shelling, the work is done by dividing the men in small groups and separating the groups along the line of the trench in order to minimize losses.

Where the visibility of the freshly dug soil is great, as for example with clay, the ditch should be obscured by using branches or a camouflage of canvas made up in advance. After the ditch has been finished, walking along the edge should be avoided in order to prevent the dirt from sliding back into the trench. In soft crumbly ground, the dirt can be kept from sliding by sloping

TRENCH LINE CONSTRUCTION.

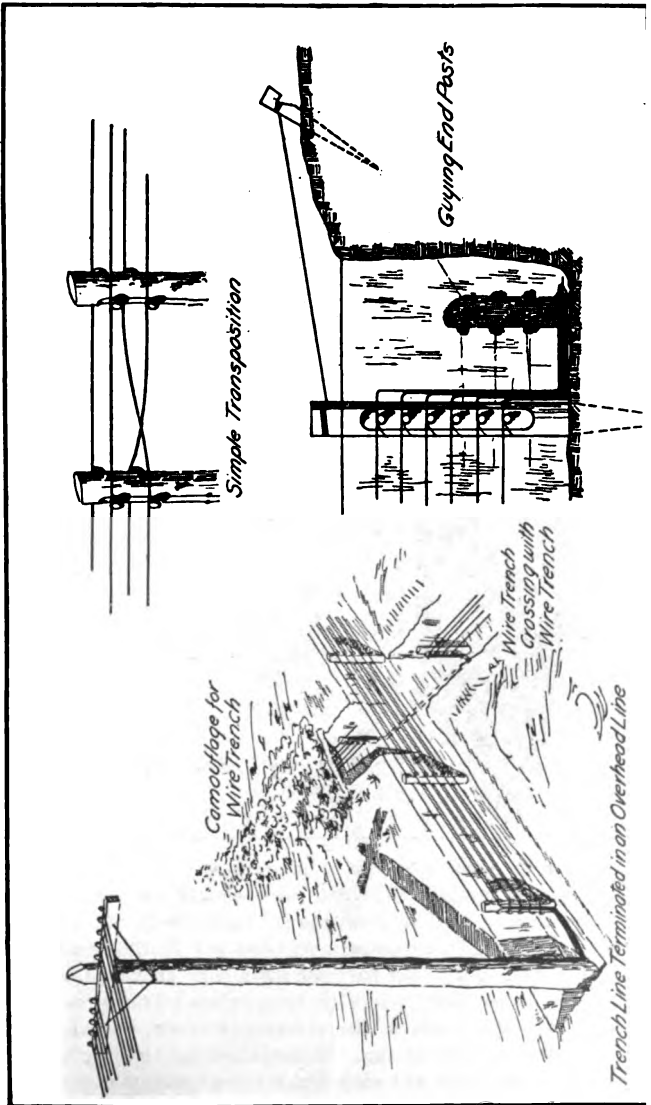

the sides toward the top, and if necessary by timbering or revetting the weak spots. The work will generally be completed more quickly if it is laid out in tasks divided equally between the groups of men detailed. No more work should be started than can be completed with the men available. The speed of construction of the trench depends upon the care with which the route is selected, upon the organization and discipline of the digging squad and upon their devotion to duty.

The required trench posts should be prepared as described and distributed along the trench. At turns in the trench or when a

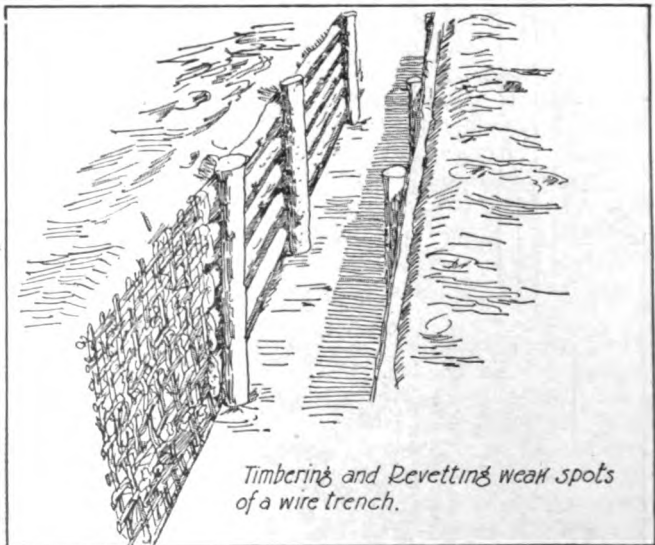

crossing with other trenches is made, etc., the posts must be placed closer together. The end posts should be slightly higher than the trench so that they can be guyed from the outside if necessary. When the posts have been set in the ground, the bottom wire should be the first one installed. It should be placed about 6 in. above the bottom of the trench. The wires are fastened to the insulators in the ordinary manner, but allowing a rather liberal amount of sag. If stretched too tightly, they will loosen the posts and will also break more quickly from concussion if a shell should burst near them.

Trench lines are terminated either by running the trench directly into a terminal station, by connecting to an overhead system or to an underground cable outlet box. Care must be taken to camouflage a wire trench for 100 yds. before its termination, in order to prevent airplane photographs from plainly showing the location of a unit's headquarters, the important test points, etc. When a trench line is terminated in an overhead system, the wires should leave the trench tied together in cable form. In this manner they are run up the side of the pole and distributed.

Trench lines can be terminated in the main buried cable only by being brought into the nearest test box of the cable. In so terminating, the wire trench should not be brought directly up to the box, even though carefully camouflaged. It is much safer to run the wires into a short length of buried lead cable and then into the main cable test box.

#### METHODS OF CARRYING TRENCH LINES ACROSS A ROAD

When it is necessary to cross a road with a wire trench, the best procedure is to dig a trench across the road and put the lines in a wooden, clay, or iron conduit, filling in above it. If practicable, but half the road should be dug up at a time in order not to interfere with traffic. The conduit need be buried only deep enough to protect it from road traffic and no other effort need be made to provide protection from shell fire. If no conduit is available, single pair lead covered cable may be used for crossing underneath the road, splicing it to a twisted pair on each side of the road. It is not desirable, however, to do this. If the wires are new and the insulation in good condition, the lines can be tied together at close intervals and laid directly in the trench and protected by sand bags. When this is done, it will usually be necessary to dig a small well at either side of the road and fill it with stones to provide drainage for water seeping through the surface of the road, and which might lie in the bottom of the trench and rapidly destroy the insulation. In order to assure proper drainage the bottom of the trench under the center of the road should be 3 or 4 in. higher than the bottom of the trench at the sides of the road. If the conditions of the ground and the traffic make it impractical to go under the road, the wires may be bound together in cable form and carried overhead on poles. In attaching the wires to these poles, marlin should be used and



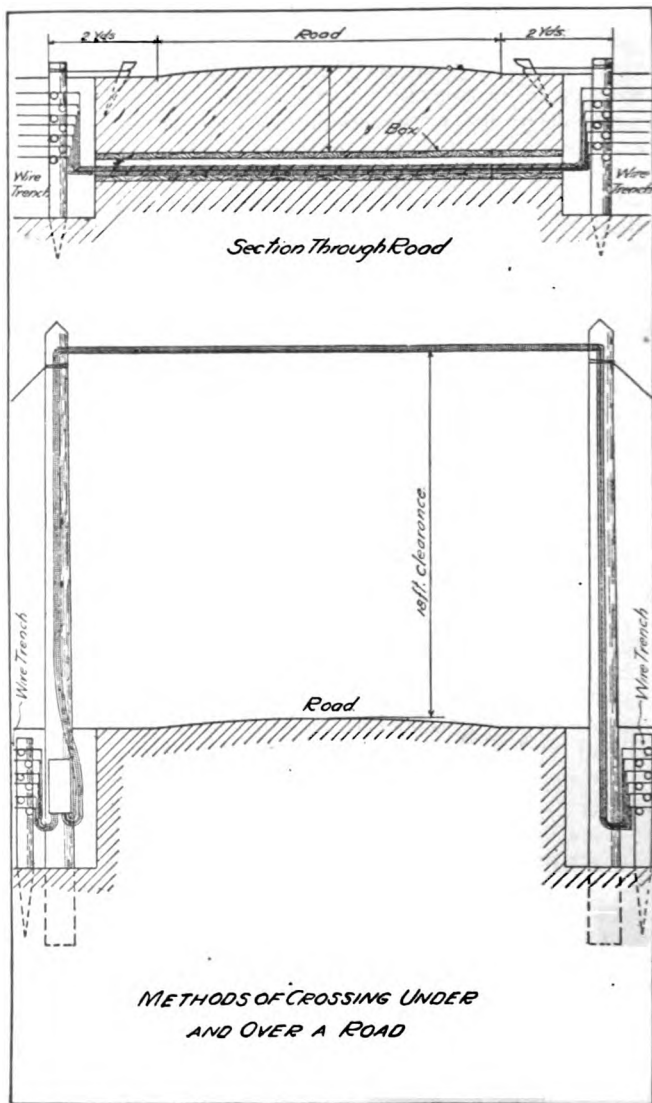

the wire itself should not be noosed or hitched around the pole. On one side of the road all the wires should be brought into a terminal box and properly tagged. French law requires a road clearance of 15 ft. for lanes and side roads and 18 ft. on main roads.

#### DRAINAGE OF WIRE TRENCHES

In constructing any type of wire trench, provision must be made for proper drainage. This can be accomplished by digging ditches or saps leading off from the trench at the low places. If the ground should be of such nature that proper drainage is not possible, some other route must be sought, for the wires in the trench will be made useless if the trench fills with water.

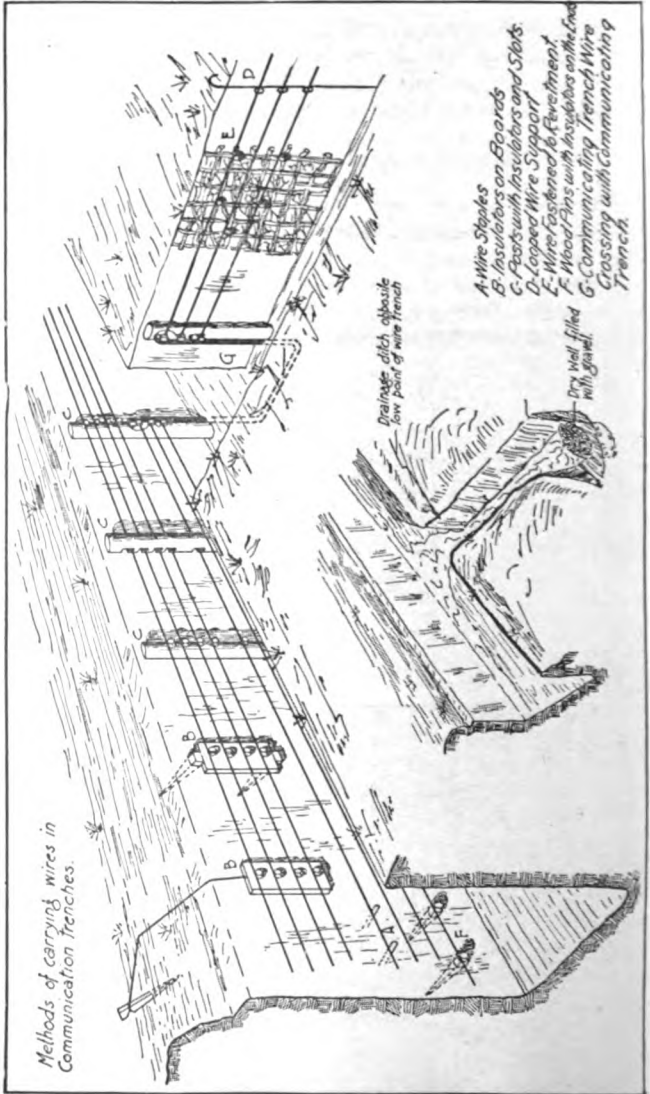

### CHAPTER III.

## LINE CONSTRUCTION IN COMMUNICATING AND FIRE TRENCHES.

Communicating and fire trenches are not dug for the use of the Signal Corps, but because of the crowded condition of the front line territory and the danger and difficulty of constructing trenches, the Signal Corps has been given permission to use these trenches for a limited number of lines—not to exceed six circuits. This number is sufficient to enable all telephone and buzzerphone communications to be taken care of. Owing to the amount of traffic, fire and communicating trenches are not satisfactory for permanent use and should be used only for temporary lines except in the extreme front where no other method is practical. From the regiment forward, the use of communicating and fire trenches for telephone and buzzerphone lines is not only permissible but generally necessary. The six circuits allowed are quickly installed and easily maintained, the personnel performing the work under shelter.

The trenches in which wires are strung should be carefully chosen. For example, trenches which may soon be abandoned or which go through an area under constant shell fire should be avoided if possible. It can be ascertained which trenches are to be kept open at all hazards and these trenches selected, provided they are well constructed. Evacuation, support and traffic trenches should be avoided if possible. Strong points and machine gun emplacements also should be avoided as they are targets for shelling. Before beginning the installation of a new line, the shortest and best route is determined upon by an officer. The length should be estimated and the proper amount of material obtained in advance. The route should then be marked off on the map and this turned over to the officer or non-commissioned officer given charge of the construction work.

As a general rule, the lines must be kept on the side of the trench nearest the enemy and as near the wall as possible. The near side of the trench presents little advantage in the way of protection from shell fire, but this practice should not be adhered to when other conditions make it more desirable to use the other side.

This is true especially in narrow fire trenches where the increased protection would be more than outweighed by the danger of breakage resulting from the men working and firing on this side of the trench. Under such conditions it is better practice to place the wires upon the rear wall of the trench.

In cases where it is absolutely necessary to run more than six circuits in a communicating trench, it usually will be found necessary to wire both sides of the trench. When this is the case it is best to place all wires belonging to the infantry on one side of the trench and those belonging to the artillery upon the opposite side

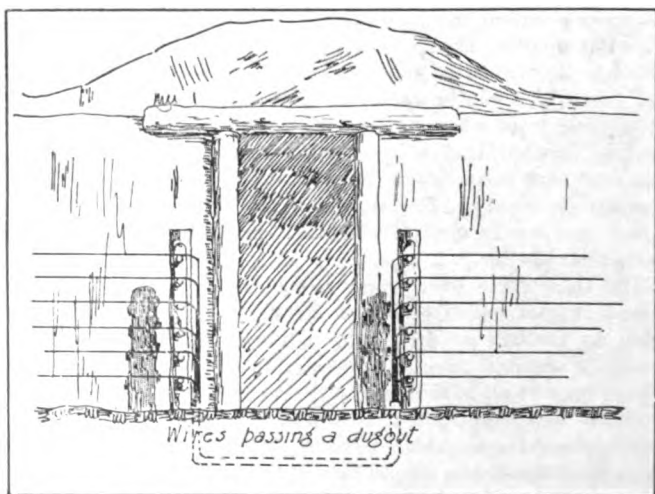

When passing the doors of dugouts or shelters in the side of the trench, the wires should be laid under the door and not run above it. Where the sill is well made of timber, the wires may be laid underneath it and protected by sand bags. Where there is no such sill, the wires should be buried to a depth of 5 or 6 in. Where the lines cross other trenches they should be carried underground, in iron pipe if this is available; otherwise, they should be laid in a small cross ditch and protected by sand bags.

Trench lines should not be fastened too close to the top of the trenches for they are likely to be damaged by the sides caving

in during wet weather. If fastened too low, they are likely to come in contact with water in the bottom of the trench, and to be cut and broken by trench traffic. Wires placed at heights between 10 and 30 in. from the duck boards or bottom of the trench are in the best position and least subject to interruption from these causes.

#### METHODS OF SUPPORTING TRENCH LINES

After the route of a trench line has been selected, the next question to be decided is the method of construction to be used to obtain the desired results. The results desired are:

1. Good transmission.
2. Best possible protection from traffic and shelling.
3. Easiest and quickest installation.
4. Smallest possible expenditure of material.

There are several approved methods of supporting lines in trenches, as shown in the following paragraphs. In attaching wires to the insulators or other supports, the greatest care should be taken not to injure the insulation. Wherever the insulation becomes broken or defective, a leak to ground will probably develop. Such leaks greatly aid the listening-in work of the enemy.

**Wire Staples.**—Wires may be fastened to the side of a trench by staples made of stiff wire and about 12 in. long. These staples are placed over the wire and driven into the earth as far as possible so that the wire is drawn closely to the side of the trench and held firmly in place. A small pad of burlap, tar paper, felt or any insulating material should be placed over the wire where the head of the staple presses against it in order to reinforce the insulation at that point. The staples may be spaced anywhere from 6 to 10 ft. apart, but should be close enough to each other to hold the wire closely to the wall of the trench at all points.

The advantages of this system of supporting the wires are ease in preparing the staples, ease and quickness of installation and the closeness with which the wire is held against the side of the trench, protecting it from traffic. In trenches having very solid walls, a small groove may be cut in the side wall deep enough to take the wires, thus affording them further protection. Care must be taken to make this groove shallow, for any considerable undercutting in the side of the trench soon results in a cave-in.

The disadvantage of this system is that the staples form a very good ground connection in case the insulation on the wire becomes faulty. With a heavily insulated wire, however, and reasonable care in construction and inspection, this disadvantage is largely overcome and does not outweigh the advantages.

**Insulators on Boards Fastened to the Side of the Trench.**—Another method of supporting wires in a trench is to fasten boards, on which the desired number of insulators have been mounted, to the side of the trench by means of rods or staples long enough to get a firm grip in the soil. The wires are then tied on these insulators in the usual way.

This is an excellent method, providing the ground is of a firm clay-like nature, which permits the boards to be held firmly in place. It has the disadvantage of holding the wires at a distance of 2 or 3 in. from the side of the trench, thus making it somewhat exposed to injury. The advantages of this system are the ease and quickness of construction and maintenance. With old wire or with wire having an inferior grade of insulation, this method is more desirable than the use of staples, since the latter brings the wires in direct contact with the earth. In communicating trenches which are not kept in good condition, or where the sides are likely to slide or cave in, the same type of small board may be used, but instead of being pinned to the side of the trench it can be hung by a wire brought up over the edge of the trench and attached to a stake driven at a point sufficiently far from the edge of the trench to be beyond the line of ordinary cave-in. With this construction it is possible to avoid breaks in wires resulting from cave-ins. However, it is unsatisfactory from all other viewpoints as the wires are extremely loose and may be easily torn away from the side of the trench.

**Small Wooden Stakes with Insulators Attached to the End.**—A third method of supporting trench lines is to drive wooden stakes or pegs, 6 to 8 in. long and 1 or 2 in. in diameter, into the trench wall and nail insulators to the exposed ends. These pegs should be driven in until practically flush with the wall of the trench before the insulators are attached. This construction provides more protection than the staple method, yet holds the wires fairly close to the side of the trench. The pegs should be placed close enough so that the wire will follow closely the line of the trench wall, special care being taken to secure the wires snugly in any corners or turns of the trench.

**Posts with Slots or Insulators.**—Posts about 6 ft. in length and 3 to 4 in. in diameter, may be used to support wires in communicating trenches. These posts should be driven as firmly as possible into the ground and set close to the side of the trench. They may be countersunk into the trench wall to one-half their thickness where this is practical. The wires are attached to the posts by means of insulators or by merely cutting narrow slots in the side of the post into which the wire is laid. This gives a strong construction and requires but a small amount of upkeep. It has the disadvantage of requiring considerable time and labor for its installation. It has the additional disadvantage that it holds the wires far enough from the side of the trench to subject them to more breakage by traffic. In a straight trench these poles should be spaced a distance of 25 ft. apart. In a winding trench, they should be placed much closer, it being necessary for one to be at every corner or change of direction. In large communicating trenches where the placing of wire posts does not take up too much of the space available for traffic, and where the number of circuits required is large, this method is very satisfactory. For narrow communicating trenches or for fire trenches, it is not a satisfactory construction unless careful countersinking of the posts is resorted to.

**Looped Wire Supports.**—Where the walls of a trench are in good condition, wires may be supported on the sides by means of looped wire supports. These are made of No. 9 or heavier galvanized iron wire. The necessary number of loops in them is made by twisting the wire about a hammer handle or some round form. The loops thus made should be spaced about  $2\frac{1}{2}$  in. apart on the wire. After the loops are completed, one end of the support wire is attached to a stake driven in the bottom of the trench and the other end is carried up out of the trench and attached to a stake driven into the solid ground a foot or two from the edge of the trench. The wire support should be drawn as tightly as possible so that it will lie closely to the side of the trench, with the loops parallel to the wall. In attaching the line wires, they are not run through the loops but are simply pressed down into them and the loops closed with a pair of pliers, merely tight enough to hold the wires in place. They can then be easily removed when necessary.

**Wire Fastened to Brush Revetment.**—In trenches which are well revetted satisfactory results may be obtained by tying the



wires to the revetment or attaching them to insulators placed on the revetment posts. This is a quick method of installation, the consumption of material is small and the system is easily kept in working order. The wire must be brought carefully into the corners of the trench and tied as closely as possible against the revetment.

#### TRANSPOSITIONS IN TRENCH LINES

It is required that twisted pair be used within 3,000 yds. of the enemy's front line in order to minimize the possibility of the enemy picking up information with his listening-in service. A minimum of 5,000 yds. is better. Even back of this area twisted pairs should still be used in trenches although it may occasionally be necessary to run a circuit of single conductor wire. When this is done, it will be necessary to overcome the self-induction that occurs when long wire lines are run parallel to each other by transposing the wires of the several circuits. While in permanent overhead construction with a large number of circuits, it is necessary that an elaborate transposition scheme be worked out for all the wires considered as a whole, in trench line construction where the circuits are few in number, it will be found that transposition of the wires of each circuit with reference to the others every 1,000 ft. or 1,500 ft., will reduce the induction and resulting cross-talk to an inconsequential amount.

#### EMERGENCY CIRCUITS

Signalmen should be familiar with emergency ways of establishing telephone communication when the regular lines are put out of commission. If the telephone system has been well laid out, it will always be possible to establish communication between any two important points by a roundabout route using lateral lines to switchboards of other similar units and working through them. The different possibilities or combinations of paths around fictitious points of trouble should be sought out in anticipation of the need.

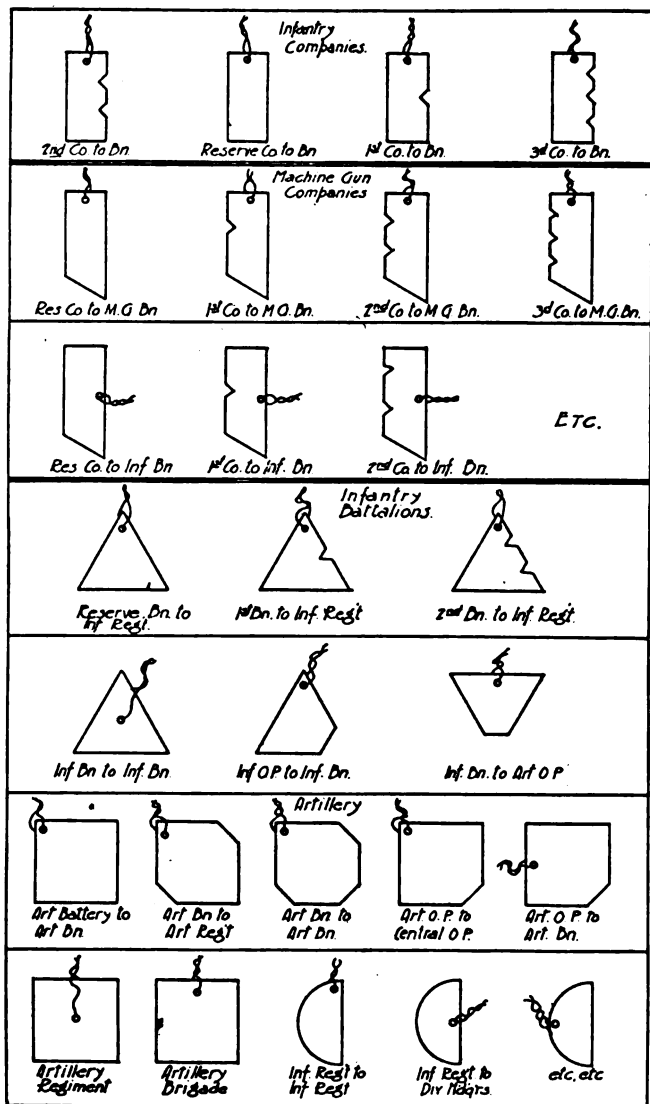

Scheme No. 1 for Tagging Trench Lines

## CHAPTER IV.

### TAGGING TRENCH LINES.

All circuits in the divisional area should be marked to show their use. Marking of lines is accomplished by means of small tags made of thin wood or fibre and having various shapes. They should be attached to each circuit at frequent intervals. These tags should clearly indicate the origin and destination of the circuit to which they are attached. This information can be supplied by varying the shape of the tag, the location of the tying wire or string on the tag, and by making one or more notches along the edges of the tag. Using these three variants, it is possible to give the desired designation in such form that the linemen have no trouble in locating or identifying a circuit, even on the darkest night, simply by feeling of the tag.

All tags must be kept up to date and correspond to the most recent assignment of circuits. A line completed but unassigned should be so marked, and no line should be left untagged. In trench wiring the tags should not be more than 50 yds. apart, even on direct routes. Where test boxes or junction boxes occur, lines should be tagged on both sides of the boxes and near enough to them so that the linemen will have no difficulty in tracing lines. Tags should be placed both inside and outside of all stations. Tags should be securely tied or wired to the circuit, but if wire is used in doing this, it should not be drawn tight enough to injure the insulation of the line. Circuits should be tagged whenever they enter or leave the ground and at the junction of a trench route with an overhead route. This applies to a short road crossing as well as to a long buried route.

No standard scheme of tagging trench lines has yet been adopted by the American Expeditionary Forces. At present it is the duty of the division signal officer to work out the code of tags for use within his division. The two following schemes are given simply as suggestions, they being based on codes which have been used satisfactorily.

**Scheme 1.**—In this system, the tags correspond in shape where possible to the shape of the identification panel of the various units connected. Lines between units use the tag of the

TRENCH LINE CONSTRUCTION.

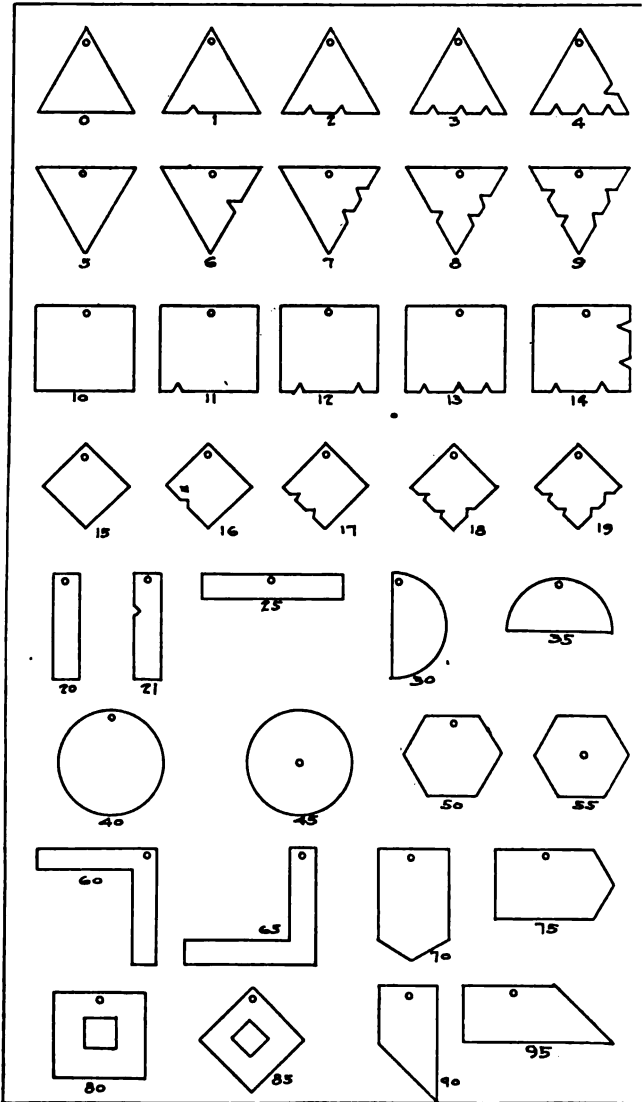

higher unit. On lines between the artillery and the infantry the tag of the infantry is used; between the machine gun battalions and the infantry or artillery the tags of the machine gun battalions are used.

**Scheme 2.**—This system of tags makes use of the three variants employed in the first system, but instead of the tags indicating the lines directly, they are used to make a series of numbers from one to one hundred, or more if necessary, and these numbers are assigned to the various units within the division. There is a different shaped tag for each group of ten numbers, the first five numbers being indicated by one to five notches made on the tag when it is tied at one corner and the other five numbers by one to five notches when the tag is tied at the center of one side. This avoids the necessity to make a large number of notches, which would complicate the work of the linemen in finding a particular circuit by touch. The corresponding units within different regiments, which are not adjoining, may have the same numbers assigned to them if it is certain that there is no possibility of conflict. For example, the first battalion of the first regiment may be assigned numbers from one to ten, while the first battalion of the fourth regiment may be assigned these same numbers.

FOR OFFICIAL USE ONLY

# TRENCH LINE CONSTRUCTION

*(Confidential)*

---

**Training Pamphlet  
No. 6**

---

**Signal Corps, U. S. A.**  
7-15-18



*CONFIDENTIAL! For Official Use Only*

# Tank Radio Telegraph Set



**RADIO PAMPHLET No. 24**

**April 20, 1919**

---

**Signal Corps, U. S. Army**



Washington : Government Printing Office : 1919





## U. W. Radio Telegraph Set Type, SCR-78-A.

For Use in the 6-Ton Signal Tanks.

---

**T**HE TYPE SCR-78 SET is designed primarily for use on the special 6-ton signal tanks. It may, however, be used on the 30-ton fighting tanks by making a few alterations. It is an undamped wave telegraph set employing four transmitting tubes, type VT-2, and three receiving tubes, type VT-1. Its wave length range both in transmitting and receiving is nominally 600 to 1000 meters, but due to generous design it is actually about 500 to 1100 meters. Its power is about 15 watts.

The tactical use will probably include three lines of communication as follows:

- (a) Between tank and division headquarters or an intermediate field station.
- (b) Between tank and infantry contact airplanes.
- (c) Between tank and tank.

The radio set employed at division headquarters or the intermediate field station for communication with signal tanks will be the type SCR-79 which is very similar to the type SCR-78 and has the same wave length range, 500 to 1100 meters. The radio set employed by the infantry contact airplanes is an undamped wave set, type SCR-80, having a wave length range of 550 to 750 meters.

The maximum distances through which two-way communication can be expected over the above mentioned lines when the tank is in motion are listed below.

- (a) Between tank and D. H. Q. or a field station, 6 miles.
- (b) Between tank and infantry contact airplanes, 2 to 4 miles.
- (c) Between tank and tank, 3 miles.

The limiting factor in communication with signal tanks is the reception within the tank. The noise encountered when the tank is in motion is very great, and this condition necessitates a rather strong signal. A much greater range of communication is possible if the tank is not in motion, and with the engine either idling very slowly or entirely stopped.

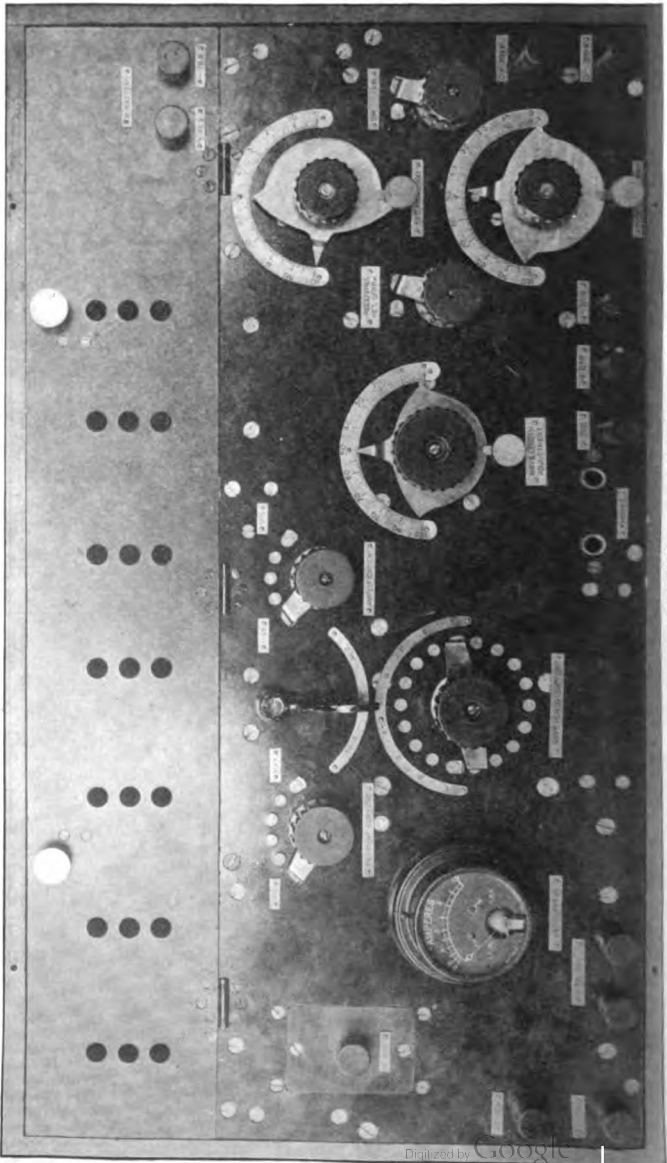

Characteristics diagram of set, form 1, type 865, 1000 series for use in the 1000 series.

Two types of tank antennae are furnished with the set, either one of which may be used as desired.

### Theory of Operation.

A complete circuit diagram of the set is given in Fig. 1. A multi-pole double throw "Transmit-Receive" switch is provided on the set box, which effects all the necessary changes in the connections of the set box when transmitting or receiving.

**Switch in "Transmit" Position.**—With the switch in the "Transmit" position, the circuits in use are equivalent to those shown in the simplified diagram, Fig. 2. The four type VT-2 three-electrode vacuum tubes used for the generation of oscillations are connected in parallel—that is, the plate, grid, and filament terminals are connected respectively together, as shown in Fig. 1. This is equivalent to using one single large tube, as shown in Fig. 2. The filaments are heated by the current from a 12-volt storage battery, made up of three type BB-17 4-volt units in series, described in a separate paragraph below. In series with this battery is a 6-point rheostat by means of which the filament current, and therefore the filament temperature, may be adjusted.

A continuous potential of about 350 volts is applied between the plate and the negative side of the filaments by a type DM-1 dynamotor, the low voltage side (motor side) of which is energized by the same 12-volt battery as used for heating the filaments. In series with the plate circuit is a choke coil which prevents the high frequency oscillations from damaging the dynamotor armature, and also prevents the antenna from being short circuited by the dynamotor. A telegraph sending key is also in series with the circuit, and it may thus be seen that the plate current, and therefore the oscillations generated by the tube, are entirely stopped when the key is open. The dynamotor does not run when the "Transmit-Receive" switch is thrown to "Receive."

A 2500-ohm resistance is connected between the grid and the filament of the transmitting tubes, in order to establish a negative potential on the grid when the tubes are oscillating. A choke coil in series with this resistance stops all high frequency oscillations in that circuit.

The d. c. grid and plate circuits just described are electrostatically and electromagnetically coupled for oscillation generation by means of the antenna, a 9-point condenser, and the transmitting inductance.

Simultaneous changes of wave length and coupling are effected by means of the three switches marked  $WS_1$ ,  $WS_2$ , and  $WS_3$  in Fig. 2. which are all operated by a single "Wave Length Switch" handle.

Condensers  $S_1$  and  $S_2$  are stopping condensers. They prevent the 350-volt d.c. plate potential from reaching the grid through the transmitting inductance.

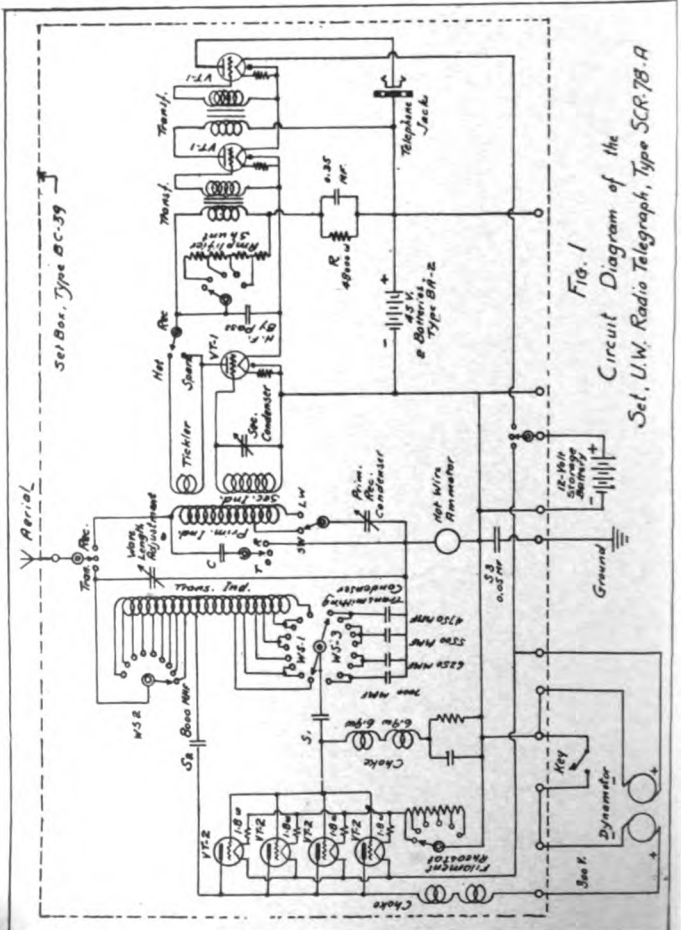

In order to make the variation of wave length continuous between two successive positions of the wave length switch, a wave length adjusting air condenser is shunted across the antenna.

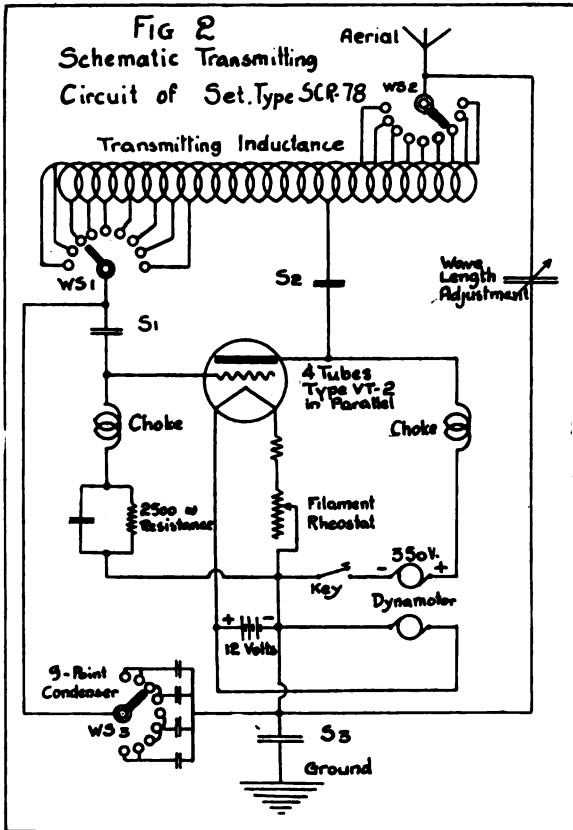

A hot wire ammeter is inserted in series with the ground wire, and indicates antenna current. The stopping condenser  $S_3$  prevents short circuits of the dynamotor high voltage armature.

**Switch in "Receive" Position.**—With the switch in the "Receive" position, the circuit in use is equivalent to that shown in Fig. 3. This circuit comprises a primary (antenna) circuit, a secondary

tuned detector circuit, and a two-stage vacuum tube cascade amplifier. The filaments of the three tubes are in series with the 12-volt storage battery. A 1-ohm resistance is in series with each filament, to maintain the grid at the proper potential.

The primary circuit comprises the aerial in series with the primary inductance, primary variable condenser, a stopping condenser  $S_2$ , and the ground. The primary condenser and coil are shunted by a fixed condenser  $C$ , which simplifies the construction of the set by permitting the use of a smaller primary inductance coil. A tap is connected to the primary inductance coil, which permits a rough adjustment of the set to long or short waves. The final primary adjustment is made by means of the variable primary condenser. The stopping condenser  $S_3$  is large, and does not interfere with the high frequency oscillations of the system.

The primary and secondary circuits are coupled inductively, and the coupling is fixed. The secondary inductance coil, which is shunted by a variable air condenser, is connected on one side to the grid, and on the other to the filament of a type VT-1 three-electrode vacuum tube used as a detector. The plate circuit of this tube comprises a 40-volt dry battery, made up of two type BA-2 batteries in series, a high non-inductive resistance and the primary winding of an iron core transformer which couples the detector circuit to the first amplifier tube. A switch in the plate circuit of the detector tube permits of inserting a tickler coil in this circuit, for the reception of undamped waves by the self-heterodyne (autodyne) method. This tickler coil is permanently coupled to the secondary inductance coil, and the tube will oscillate without any further adjustment. When receiving damped waves, the tickler coil is cut out of the plate circuit by means of the switch. The purpose of the high resistance  $R$  is to reduce the plate potential to 20 volts on the detector tube. This resistance is shunted by a condenser which by-passes the audio frequency currents, while another condenser shunts the entire plate circuit to by-pass the locally generated high frequency oscillations.

The other type VT-1 vacuum tubes are connected for untuned cascade amplification, using iron core transformers. The full 40 volts of the dry battery are impressed on the plates of these tubes. Telephone jacks are provided in the plate circuit of the last tube. The degree of amplification may be varied by means of a variable resistance shunting the primary winding of the transformer of the first amplifier tube. The use of reduced amplification will frequently eliminate weak interfering signals.

### Description of Parts.

**Set Box.**—The set box, type BC-39, contains all the controls and radio circuits for both transmitting and receiving. The box is made of wood with a removable cover, its overall dimensions including cover being: length, 23 in.; height, 13 in.; depth,  $10\frac{1}{4}$  in. The panel is a sheet of micarta, upon which are mounted all the parts, the control handles projecting above the face of the panel. The vacuum tubes are all mounted on flexible sponge rubber supports to minimize jarring. They may be replaced by opening the door which extends completely across the top of the panel.

**Set Box Mountings.**—The set box mountings consist of four cylindrical sponge rubber pads and two spring anchor bands, the latter being essentially spiral steel springs with a hook at each end.

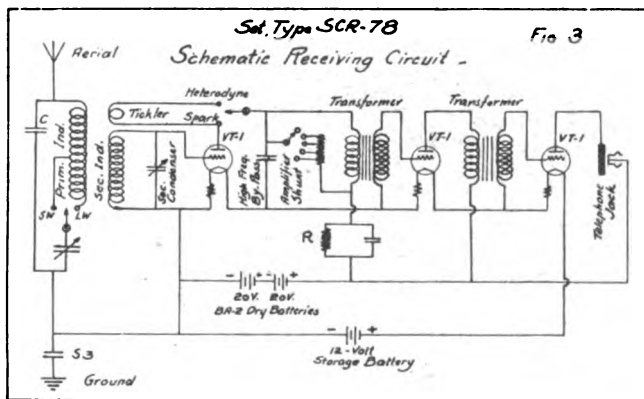

The pads protect the set box from any undue jarring and are screwed to the wooden shelf which supports the set box. The set box rests upon these pads and is held down by the two spring anchor bands which hook into the carrying strap handles and into the screw eyes fastened to the supporting shelf at each end of the set box.

**Head Sets.**—The telephone head sets are the standard Signal Corps telephone head sets, type P-11.

**Keys.**—The key is very similar to the standard Western Union key. It is not equipped with a short-circuiting switch and the contacts are  $\frac{1}{4}$  in. diameter coil silver. Two keys are furnished,



one mounted in the cover of the set box, the other to be carried in the accessory box.

**Storage Batteries.**—The type BB-17 storage batteries are of the lead-acid type, 4-volt, 160-amp-hr. capacity at a discharge rate of 12 amp. The cell containers are of hard rubber while the battery boxes are of wood. The overall dimensions of each battery are: length,  $12\frac{3}{8}$  in.; width,  $8\frac{1}{4}$  in.; height,  $10\frac{5}{8}$  in. The cover is hinged and has recesses in two corners for two external binding posts, so that connections may be made without opening the cover. The cover is flat topped to allow stacking of batteries. A remov-

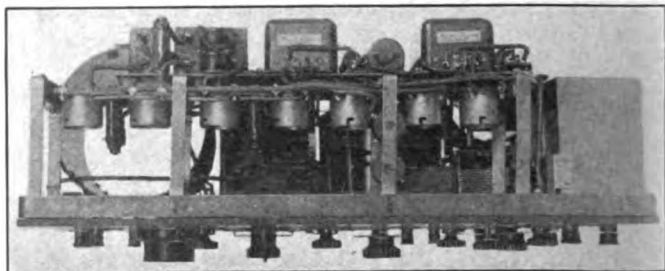

Top view of the panel of set box type BC-39 when removed from the box.

able carrying strap is provided which snaps into the handles at either end of the battery.

**Dynamotor.**—The dynamotor, type DM-1, is rated as a 50-watt, 10 to 300-volt machine. It is run, however, from the 12-volt storage battery and delivers about 160 milliamp. to the plate circuits of the four transmitting tubes at a potential of 350 volts. It is mounted in an aluminum carrying case which has a hinged cover and carrying strap. Binding posts are mounted on a micarta panel for attaching the connecting cords to the 12-volt and the 350-volt sides of the dynamotor. The panel also carries a two-pole, single throw switch which closes the 12-volt circuit, and a fuse block which is arranged for a small piece of 20-amp. fuse wire in the 12-volt circuit to protect the machine in case of a short circuit on the 350-volt line. A spool containing 10 ft. of fuse wire is mounted in the cover of the aluminum box.

**Wavemeter.**—The type SCR-95 wavemeter used with the set is similar to the French type T-1 wavemeter and has a wave length range of 500 to 1100 meters. The condenser in the oscillating cir-

cuit is a fixed mica condenser, the tuning of the meter being accomplished by means of a variable inductance. The position of the fixed coil of this inductance is indicated upon the panel of the meter. The wave length is indicated by the graduation on the movable circular dial which is raised slightly above the surface of the panel. The resonance point when transmitting is indicated by a miniature lamp which projects above the panel and which is in series with the condenser and variable inductance. A buzzer is provided for exciting the wavemeter when it is desired to tune the receiving circuit to a particular wave length. The wavemeter box is of wood

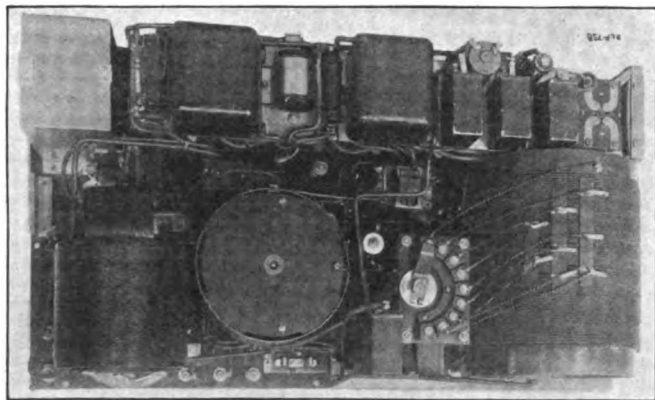

Rear view of panel of set box type BC-39 showing mounting of apparatus.

and its overall dimensions are: length,  $5\frac{3}{8}$  in.; width,  $4\frac{7}{8}$  in.; depth,  $4\frac{1}{2}$  in. This wavemeter is fully described in Radio Pamphlet No. 21, second edition.

**Mast Antenna.**—This type A-8 antenna is for use with signal tanks only. It is a tapered steel rod in five sections, the total length being 16 ft. The first or lower section is a piece of straight steel tubing having an outside diameter of 1 in and a length of 4 ft. The remaining sections are each 3 ft. long and vary in diameter from  $\frac{5}{8}$  in. at the bottom of the first to  $\frac{1}{8}$  in. at the top of the fourth. The sections fit together like a fishing rod and make thorough electrical contact.

**Umbrella Antenna.**—This type A-7 antenna is of steel and is in two sections, each 3 ft. long and 1 in. in diameter. When erected it has four light steel arms projecting from the top at right angles to

each other, and parallel to the earth. The four steel arms can be collapsed within the top section.

**Mast Clamp.**—The type FT-12 mast clamp is made almost wholly of iron and steel and when installed in the turret of the small signal tank is located in the forward right hand corner of the observer's conning tower. It is supported from three insulators which are bolted to the roof of the turret. As its name indicates, it is used to hold the mast antenna or the umbrella antenna rigidly in a vertical position. The part of the clamp which makes contact with the mast, that is, the part below the insulators, is in two halves, one half fixed to the insulators and the other half hinged to the first. The movable half swings through an arc of about  $100^{\circ}$  and is locked in place by the motion of a single handle. Electrical contact with the mast antenna or the umbrella antenna is made through the clamp, a binding post being provided on the bottom of the stationary portion of the clamp, to which the antenna wire from the set box is connected.

**Rain Shield.**—The type M-10 rain shield is a funnel shaped piece of hard rubber which is slipped over the lower section of either tank antenna in such a position that when the antenna is erected it shields the opening in the roof of the turret, through which the antenna projects, from rain. Its maximum diameter is 4 in.

**Voltmeter.**—The type I-10 voltmeter is a direct current instrument with two ranges, 0 to 10 volts and 0 to 50 volts. The 10-volt range is used for storage battery testing and the 50-volt range is used for testing the type BA-2 dry batteries. The meter box is of wood covered with black leather. The negative contact is a pointed brass prong projecting from one end of the box, and the positive contact is a small pointed brass rod set in a red handle on the end of an 18-in. extension cord which is connected to a binding post at the end of the box opposite the negative terminal. In order to use the 10-volt range it is necessary to press a small push button at the back of the box.

**Operator's Light.**—The operator's light is a portable desk lamp which fastens to the set box shelf with a spring clamp. It has a cylindrical shade, the axis of which is parallel to the front edge of the shelf and about 6 in. from it. The shade is capable of rotation so that the light may be thrown either on the set box or on the operator's writing desk. The socket is equipped with a key switch. The lamp used is a 12-volt, 0.35-amp. lamp with a candelabra

base. The source of energy is the storage battery, a 3-ft. connecting cord being furnished, the spade terminals of which are connected to the battery binding posts on the set box.

**Accessory Box.**—The type BC-33 accessory box is built of fiberoid and shaped much like a suitcase, its external dimensions being: length, 18 in.; width,  $12\frac{1}{2}$  in.; thickness, 6 in. It is used to store and carry spare parts and small pieces of apparatus like vacuum tubes, dry batteries, the voltmeter and wavemeter. The cover is hinged and fastened shut with suitcase snaps. The box is equipped with a carrying strap.

**Charging Set.**—The 6-ton signal tanks are provided with a battery charging outfit, which consists of a 12-volt generator and its control apparatus. This outfit is fully described on page 18.

#### **Installation of Set Type SCR-78-A in the 6-Ton Signal Tank.**

All of the radio apparatus except the storage batteries is mounted on a shelf or platform which extends around the four sides of the turret, the operator standing in the opening with his outfit conveniently grouped about him. The set box is placed at the right hand side of the shelf which extends across the front of the turret, as shown in Fig. 4. The face of the panel should be about even with the edge of the shelf and the right hand end of the set box should be about  $2\frac{1}{2}$  in. from the corresponding wall of the turret. The four sponge rubber pads which support the set box at the corners are to be set in holes in the wooden shelf, diameter 2 in., depth  $\frac{1}{2}$  in., and screwed in place by the 1-in. No. 6 wood screws and washers furnished for this purpose. The holes in the wood shelf are not provided and must be bored therein at the time of installation. One of the No. 10 screw eyes is to be fastened to the shelf at each end of the set box and about  $1\frac{1}{2}$  in. therefrom, to catch the hooks of the spring anchor bands which hook into the carrying strap handles and hold the set box in place. The wooden shelf can be easily removed by taking out a few machine screws, so that the holes for the rubber pads can readily be bored and pads screwed in place. There is room behind the set box for the cover when the set is in use.

Either the key mounted in the set box cover or the one carried in the accessory box is fastened with screws to the small folding wooden shelf in front of the radio operator. Its location should be near the left or outer edge of the shelf, so that the operator may more easily use a message pad, which would then be placed to the right of the key.



fastened to the three bolts which protrude from the insulators. Great care should be taken to properly tighten all of the nuts, so that the clamp will be held perfectly rigid.

To erect the mast antenna, first swing the mast clamp open, get all five sections in a vertical position under the clamp and resting on the floor of tank. Then push the top or smallest section through the hole in the roof above the clamp. Push the lower end of this smallest section into the top end of the next largest section and raise this upward. Repeat the process until all sections are together. Push the mast up until the lower end is about even with the bottom of the clamp, then close and lock the clamp. Care should be taken to see that all joints are free from grease, mud and dirt and that the bottom 1 ft. of the mast and the surfaces of the clamp which grip it are clean and bright. Emery cloth is provided for removing rust from the clamp and the lower end of the mast. These precautions must be taken to insure good electrical contact all the way from the tip of the mast down to the antenna binding post on the set box.

The umbrella antenna is erected in much the same manner as the other. The top section is held in a vertical position beneath the mast clamp and the four arms are pulled out in a bunch and the brass plug, to which they are pivoted, locked in place by a 20° turn. The top section is raised partly through the hole and the lower section attached and the whole shoved up until the lower end is about even with the bottom of the mast clamp, when the mast clamp is locked. The same precautions regarding electrical contact are to be observed as in the case of the mast antenna. The operator should note whether all the arms fall into their proper position, as it is possible for them to fall the wrong way.

The rubber rain shield is slipped over the bottom section of either tank antenna and located at such a distance from the lower end that when the antenna is erected, the rain shield will not be closer than  $\frac{1}{2}$  in. nor farther than 1 in. from the steel ring around the mast hole. The minimum distance is so specified because of the high voltage between the mast and the tank. The maximum distance is put at 1 in., so that rain will not drive in beneath the shield.

The operator's light fixture is not equipped with leads, the connecting cord being furnished separately. The connecting cord, type CD-46, is 2 ft. 6 in. long, and is connected to the socket in the same manner as a regular lamp socket. The spade clips are

attached to the same binding posts on the set box as the battery cords, marked “-12 V” and “+12 V.” The spring clamp is attached to the front shelf, which supports the set box, so that the fixture projects straight out from the edge of this shelf. The shade may then be rotated, so that the light may be thrown either on the key shelf or on the set box panel.

The accessory box is to be carried on the front shelf to the left of the set box.

The installation of the charging set is included in the assembly of the tank proper, and will therefore not be taken up here.

**Connecting up the Set.**—All of the two-conductor extension cords are made up with one red cord and one black cord, the red being plus and the black minus. The spade clips are also stamped + and -. No cord should be connected up without throwing the transmit-receive switch to “Off.” The installation of connecting cords is a rather important matter and care should be taken to see that all contacts are clean and tight and that all cords are placed out of the way of driver, operator, and observer, and that any excess length of cord is properly taken up by doubling it back and taping up the overlapped part. Fig. 4 gives approximately the proper position of the various cords, except that the binding posts are not shown exactly as they are on the actual set box. It will be noted that each set of batteries has attached to it an extension cord type CD-51 which has on the opposite end a Hubbel wall receptacle. These receptacles should be screwed to the lower side of the set box shelf about centrally located with respect to the set box and perhaps 2 in. or 3 in. apart. The cords should be fastened to the lower side of the shelf by means of the cleats provided. The connections from the batteries to the set box and charging panel are completed by cords, type CD-52, which have a polarity plug on one end and spade clips on the other, and which should be fastened down by means of the cleats as shown in Fig. 4. It is intended that these cords, type CD-51 and CD-52, shall be left in the tank even though the set is removed. The ground connection is made to the bolt directly beneath the right hand edge of the front shelf.

### **Method of Operating the Set.**

Having connected up the set as explained above, and erected the antenna it is desired to use, the set may be operated according to the following rules.

**Transmitting Signals.**—1. Turn the "Filament Current" switch to "Minimum," and then close the "Transmit-Receive" switch to "Transmit." The four VT-2 tubes (at the left hand side of the box) should glow a dull red, and the dynamotor should start running.

2. Lock the telegraph sending key so that it will be permanently closed, and turn the filament current switch toward the "Maximum" position until the ammeter reading reaches a maximum value. Then, turn the filament current switch back a little, so that the ammeter reading will fall off slightly.

3. To adjust the set for a given wave length, set the wavemeter switch to "C," and adjust the resistance so that the wavemeter indicator lamp will glow a dull red. Set the wavemeter to the desired wave length, and hold the wavemeter box directly beneath the left hand end of the radio set box, with the face of the panel in a vertical position.

4. Adjust the "Wave Length" switch and "Wave Length Adjustment" to the point where the wavemeter lamp will glow brightest.

5. Unlock the telegraph key, and start sending. When not using the set, place the transmit-receive switch in the "Off" position.

**Receiving Signals.**—1. Close the transmit-receive switch in the "Receive" position, and turn the "Amplification" switch to "Maximum." The three receiving tube filaments (at the right hand side of the box) should now glow a dull red.

2. Set the receiving switch to "Heterodyne" or "Spark" according to whether undamped or damped wave signals are to be received. Signals sent out by a type SCR-78, SCR-79, or SCR-80 set are undamped wave signals, and should be received on "Heterodyne."

3. If the wave length to be received is below 800 meters, set the switch marked "S.W.—L.W." to "S.W." If it is above 800 meters, set it to "L.W."

4. Set the primary condenser in various positions successively, varying the secondary condenser over its entire range for each one of these positions, until the signals are heard with the greatest intensity.

5. If required, reduce the amplification by means of the "Amplification" switch.

6. If the wave length to be received is known in advance, set the wavemeter to that wave length, and excite it by means of the buzzer by placing the wavemeter switch on "B." Set the "Receiving" switch of the radio set box on "Spark," and tune the set as explained



in paragraph 4 above. After tuning, stop the buzzer, and set the switch to "Heterodyne."

### Battery Charging Outfit.

Two 12-volt storage batteries are furnished with the set and installed in the tank, as shown in Fig. 4, one being used to energize the radio set, the other being a spare, and usually under charge while the first is in use. A battery charging outfit is therefore provided in the tank for this purpose. This comprises a 12-volt, d.c. generator and its control apparatus, which are furnished by the Tank Corps and not included in the parts list for the type SCR-78-A set.

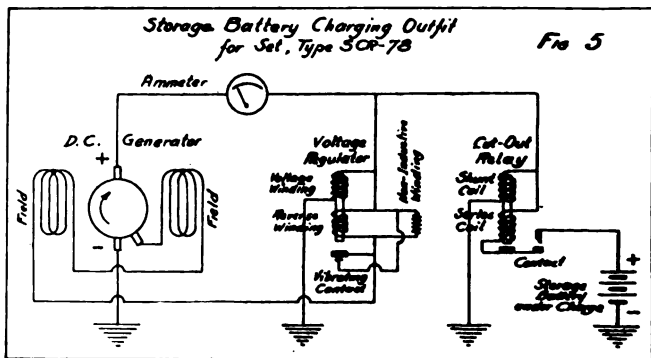

**Generator.**—The generator is mounted on the tank motor and is driven by a chain belt from the magneto shaft. It is a 12-volt, two-pole generator, with the negative terminal grounded. The armature is carried on ball and roller bearings, a ball bearing being provided on the drive end and a roller bearing on the commutator end of the armature shaft.

Regulation of the generator voltage at different engine speeds and varying battery conditions is obtained by the use of a third brush used in connection with a vibrating type voltage regulator, described below with the control apparatus. The third brush method of regulation permits of a rather high charging rate at slow operating speeds when the storage battery is partially discharged, but prevents an excessive charging rate on nearly discharged batteries when the

engine is running at high speed. The output of the generator may be varied by changing the position of the third brush on the commutator. Shifting it in the direction of rotation of the armature produces an increase in the charging rate. A decrease of the charging rate is then obtained by shifting the brush in the reverse direction. The maximum safe charging rate is about 14 amp.

After changing the position of the brush, it should be noted that it is seating properly on the commutator, since improper seating will affect the generator output materially. As the negative terminal of the generator is grounded to the frame, only one armature terminal is provided, the other being connected to the grounded main brush. One of the field leads is connected to the third brush, while the other is brought out to a terminal on top of the generator and connected to the voltage regulator through the field terminal on the side of the control box. The generator is provided with two oilers, and should be oiled about every two weeks.

**Control Apparatus.**—The control apparatus comprises an automatic voltage regulator, an automatic cut-out relay, and an ammeter, Fig. 5. These are mounted in a waterproof iron box, with only the ammeter face exposed to view. The box is bolted to the right side of the turret. Connection from the generator to this box is made by running a wire from the field terminal of the generator to the "Field" binding post of the box, and another wire from the main brush terminal of the generator to the "Armature" binding post of the box.

**Voltage Regulator.**—The function of the voltage regulator is to keep the generator voltage at a constant value. The regulator consists of a coil having three windings wound around a common soft iron core. These windings consist of a voltage winding, a reverse winding, and a non-inductive winding. The voltage winding is made up of a large number of turns of fine copper wire, and is connected across the main generator brushes. The reverse winding is connected in series with the generator field, and the current in this winding flows in the reverse direction to that of the voltage winding. The non-inductive winding has no magnetic effect on the core, and simply acts as a resistance. It is connected in parallel with the reverse winding.

The entire coil is mounted on a frame, which also supports a movable armature, which is attracted toward the iron core of the coil, when the latter is magnetized. Upon being attracted, two contact points are separated by the motion of the armature. These contacts

are connected in parallel with the reverse winding and non-inductive winding. The operation of the regulator is then as follows. When the generator is in operation, a certain current flows in the voltage winding, proportional to the generator voltage. This current will set up a magnetic field in the iron core, and tend to attract the movable armature. If the generator voltage rises beyond a certain limit, the current in the voltage coil will be great enough to overcome the tension of the armature spring, and the armature will be attracted toward the core, opening the contacts, which while closed, shunted the reverse winding and carried the greater part of the generator field current. As they break contact, however, a large part of the field current flows through the reverse winding. This has two effects. By introducing the resistance of the reverse winding in the field cir-

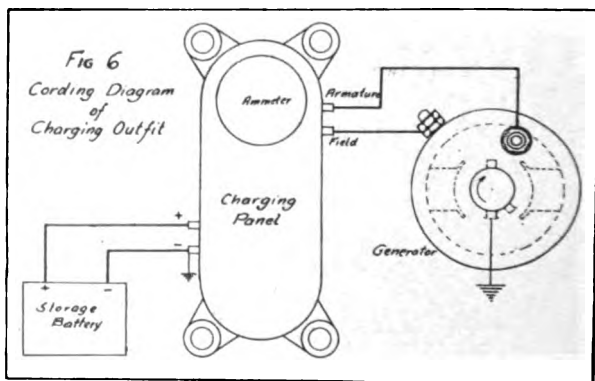

cuit, it reduces the generator field current, and therefore the generator voltage. Also, it decreases the magnetic field in the regulator, since the field due to the voltage winding is counteracted by that of the reverse winding. The decrease in generator voltage resulting from this decrease in the generator field current produces a decrease in the current through the voltage winding of the regulator and thus further reduces the attraction on the vibrator contact armature. The armature will therefore fall back in place and again close the contacts. The generator voltage then rises again, and the operation repeats itself. The contacts vibrate at a very high speed, and the currents do not build up to their final value. The strength of the current and therefore the generator voltage depending on the speed

of vibration, it will be possible to regulate the voltage by adjusting the tension spring of the vibrator. It is thus possible to hold the voltage anywhere between 13.5 and 15 volts.

**Cut-out Relay.**—The function of the cut-out relay is to provide a safeguard against discharging the storage battery through the generator when the engine is running at a very low speed, or is stopped entirely. The necessity of such a safeguard may be readily appreciated, since the storage battery is connected directly across the generator terminals. Should the generator be stopped, there being no longer any emf. to counterbalance that of the battery, the latter would discharge through the generator windings. This would also occur when the generator was driven at a speed low enough to make the generator emf. less than the battery emf. The cut-out relay therefore opens the circuit whenever the generator voltage becomes less than a certain predetermined value. Its operation is explained below.

The cut-out relay consists of a set of contacts which are held open by spring tension, and may be closed by an electromagnet when the magnetic field in the latter is strong enough. This electromagnet has a double winding, consisting of a voltage or shunt coil connected across the generator terminals, and a current or series coil, in series with the load. The armature contacts are also in series with the load, so that no current flows in the series coil and battery circuit as long as the contacts are open.

When the generator is started, the generator voltage builds up, and a current flows in the shunt coil of the cut-out relay, setting up a magnetic field in the core. When the generator voltage reaches a value of between 13 and 15 volts, this field is strong enough to overcome the tension of the spring, and attract the armature. This closes the contacts and completes the circuit between the generator and the battery. The current now flows through the series coil, which is so wound as to produce a magnetic field in the same direction as that due to the shunt coil. This strengthens the pull on the armature and holds the contacts closed. When the generator slows down and its voltage drops below that of the battery, the current flows from the battery to the generator in the reverse direction. This current flows also through the series coil of the relay, while the current in the shunt coil has not changed in direction. The magnetic fields of the two coils thus oppose each other, and the resultant field is no longer sufficient to hold the armature against the spring tension. The armature then falls back, opening the contacts, and

preventing any further discharge of the storage battery. The relay should cut out when the discharge current is between 0 and 1 amp.

In order to adjust the relay to cut out at the proper value of discharge current, two factors are to be considered—the air gap between the armature and the core, and the spring tension. The air gap has practically no effect on the cut-out point, which is almost entirely governed by the spring tension. The point of cutting in, however, is governed by both the air gap and spring tension.

Care should always be taken to keep the contacts clean and lined up properly. If required, they may be cleaned by means of some emery cloth.

**Connecting up the Control Box.**—The connection from the generator to the control box has been explained in the paragraph covering the generator. The storage battery terminals of the control box are connected to a type CD-52 extension cord, the polarity plug of which fits into the charging socket, as shown in Fig. 4. Care should be taken to connect up the cord with the proper polarity. The general scheme of connection of the generator, charging panel and storage battery are shown in Fig. 6.

### PARTS LIST.

In ordering this set or parts of this set specification must be made by names and type numbers as listed below, exactly. The designation printed in bold face type *only*, will be used in requisitioning, making property returns, etc.

In ordering complete sets, it is not necessary to itemize the parts; simply specify "Set, U. W. Radio Telegraph, Type SCR-78-A." If all the parts listed under a group heading are desired, it is not necessary to itemize the parts; simply specify, for example, "Equipment Type PE 22."

The set is not complete unless it includes all of the items listed in the component parts table below.

#### **Set, U. W. Radio Telegraph, Type SCR-78-A.**

1 **Equipment Type PE-22**; power.

1 **Box Type BC-25**; or **Type BC-25-A**.

1 **Dynamotor Type DM-1**.

12 **Batteries Type BB-17**; 6 in use, 6 spare.

**1 Equipment Type RE-6-A; radio.**

- 1 Set Box Type BC-39; radio telegraph.**
- 1 Box Type BC-33; accessories.**
- 1 Set Box Type BC-40; wavemeter.**
- 3 Batteries Type BA-4; for set box type BC-40; 1 in use, 2 spare.**
- 4 Batteries Type BA-2; for set box type BC-39; 2 in use, 2 spare.**
- 4 Lamps Type LM-4; for set box type BC-40; 1 in use, 3 spare.**
- 4 Lamps Type LM-5; for operator's light; 1 in use, 3 spare.**
- 2 Head Sets Type P-11.**
- 2 Keys Type J-12.**
- 1 Screwdriver Type TL-21.**
- 1 Pliers Type TL-19.**
- 1 Voltmeter Type I-10.**
- 1 Fixture Type FT-10.**
- 6 Tubes Type VT-1; 3 in use, 3 spare.**
- 7 Tubes Type VT-2; 4 in use, 3 spare.**
- 2 Cords Type CD-41; set box type BC-39 to 12-volt side of dynamotor; 1 in use, 1 spare.**
- 3 Cords Type CD-42; set box type BC-39 to 300-volt side of dynamotor, and to transmitting key; 2 in use, 1 spare.**
- 2 Cords Type CD-44; set box type BC-39 to antenna; 1 in use, 1 spare.**
- 2 Cords Type CD-45; set box type BC-39 to ground; 1 in use, 1 spare.**
- 2 Cords Type CD-46; for operator's light; 1 in use, 1 spare.**
- 3 Cords Type CD-51; from storage batteries; 2 in use, 1 spare.**
- 3 Cords Type CD-52; from charging panel to set box type BC-39; 1 in use, 2 spare.**
- 4 Bands Type FT-11; 2 in use, 2 spare.**
- 6 Pads Type M-9; 4 in use, 2 spare.**
- 4 Screweyes; 2 in use, 2 spare.**
- 2 lb. Wire Type W-7.**
- 4 Rain Shields Type M-10; 1 in use, 3 spare.**
- 6 Screws and Washers; 4 in use, 2 spare.**
- 5 sheets Emery Cloth.**
- $\frac{1}{2}$  lb. Tape Type TL-83.**

- 1 **Equipment Type A-7; umbrella antenna.**
  - 3 **Mast Sections Type MS-6; 1 in use, 2 spare.**
  - 3 **Mast Sections Type MS-7; 1 in use, 2 spare.**
- 1 **Equipment Type A-8, mast antenna.**
  - 7 **Mast Sections Type MS-8; 1 in use, 6 spare.**
  - 7 **Mast Sections Type MS-9; 1 in use, 6 spare.**
  - 7 **Mast Sections Type MS-10; 1 in use, 6 spare.**
  - 7 **Mast Sections Type MS-11; 1 in use, 6 spare.**
  - 7 **Mast Sections Type MS-12; 1 in use, 6 spare.**
  - 1 **Clamp Type FT-12.**
  - 1 **Bag Type BG-16.**







---

**Prepared in the  
Office of the Chief Signal Officer  
Training Section  
Washington**

---

*ENR*  
FOR OFFICIAL USE ONLY

# LAYING CABLE IN THE FORWARD AREA

(Confidential)

~~Training Pamphlet~~

~~No. 3~~

*Wire Communication Pamphlet  
No. 4*

Signal Corps, U. S. Army

7-27-18

*24*



## **Laying Cable in the Forward Area**

## Table of Contents

	<b>Page</b>
Installing Underground Cable.....	3
Assignment of Pairs.....	4
Two-Man Method.....	5
One-Man Method.....	6
Splicing Lead-Covered Paper Insulated Cable.....	7
Planning the Splice.....	8
Stripping and Bolling Out.....	8
Wrapping the Splice.....	11
Splicing Ferrin Cable.....	12
Determining the Nature of Cable Trouble.....	12
Short.....	13
Ground.....	14
Cross.....	14
Split Pairs.....	15
Open Pair.....	15
Locating Cable Troubles.....	16
Varley Loop Test.....	16
Murray Loop Test.....	17
Locating Ground with One Bad Wire of Known Length and Two Good Wires of Unknown Length.....	17
Locating Ground with All Wires Bad.....	19
Locating an Open.....	20
Locating a Split Pair.....	21
Locating a Short.....	22
Precautions in Handling Cable.....	22

## LAYING CABLE IN THE FORWARD AREA

**I**N a large part of the wire communication systems from the front positions back over a distance of three to five miles, extensive use is made of underground cable consisting of a number of pairs of wires insulated with paper and covered with a lead sheath, which can be used for telephone, telegraph, buzzerphone, etc., work. The route to be followed for such cable runs, and the size of cable (number of pairs of wire) to be laid is determined by the corps or division signal officer. As a rule, not less than 20 pairs are laid in one trench.

### Installing Underground Cable

Trenches for laying the cable are dug to a depth of from 6 ft. to 15 ft., depending on the location and importance of the run, and 24 in. to 36 in. wide. The smaller sizes of cable are received wound on reels in 1000-ft. lengths. When the cable is laid, the reels are jacked up on a shaft to rotate easily and the cable pulled from them. On long runs the cable is usually laid in 1000-ft. lengths between splicing points.

Before the cable is laid a layer of sand or screening at least 3 in. deep should be put in the bottom of the trench to facilitate drainage. The cable should be laid with some slack, so that it will more readily withstand heavy vibration caused by shell fire. In burying the cable, if possible, it is best to cover it with brush and then fill in with soil. This will act as a cushion and give considerable protection against the destructive shells. In laying and covering the cables, utmost care should be exercised to avoid injury to the lead sheath. Particular precaution should be taken to avoid kinking the cable, as this is very likely to make a crack in the lead into which moisture will creep and cause cross talk or short circuits. Care must also be taken to protect the cables from all electrical injury. Where aerial lines join an underground cable a lightning arrester should be installed on the last pole. Telephone stations connected directly to underground cable without any intervening aerial wire or cable do not need to have any lightning protection.

At least every 3000 ft. in a cable run, manholes or testing stations should be installed, the approximate dimensions of the manholes being 6 ft. long x  $3\frac{1}{2}$  ft. wide x whatever depth is needed to give the necessary head room and install the roof protection. The long way of the manhole should be parallel to the line of the cable run. The construction of these manholes will of course be governed by the conditions met with, but where possible the ceiling should be 2 ft. below the surface of the surrounding ground and covered with corrugated sheet iron, at least two layers of sand in bags, 6 in. of reinforced concrete blocks, and at least 3 ft. of earth on top, and the fresh soil covered with a brush camouflage. Steps from the surface should be installed to lead into the manhole at one end, the long sides being kept clear for racking the cable in an orderly manner to facilitate splicing, testing, etc. A manhole is used as a test station, as a point from which to take off branch cables to aerial lines, as a place to cross-connect and reroute pairs, to lead off twisted pair lines, etc. In case of injury to the cable, or a breakdown between two manholes, twisted pair sometimes may be temporarily run between the two manholes until repairs can be made. To facilitate repair in this manner it is therefore desirable to have manholes as frequently as practicable with the cost in mind.

Greatest care must be taken when working with paper insulated cable to prevent moisture from getting into it. The presence of the slightest dampness seriously impairs the transmission of communications through the cable, making it necessary to promptly locate the leak, open up the sheath, boil out the cable with paraffin and close up the opening with a standard splice. The longer the delay in removing a bad place in a cable, the farther the moisture creeps in, it sometimes being necessary to cut out several feet and splice in a new section of cable. The method of locating such faults is taken up in a later section.

### Assignment of Pairs

In all the lead-covered cables used for Signal Corps purposes the wire conductors are twisted in pairs, so that in a cable having 20 pairs of wires there are 20 separate, direct telephone or telegraph two-wire circuits. In all cases the two wires are wrapped in different colored paper, usually one red,

blue or brown, and one white. The colored wire is usually called the "line," and the white wire of the pair, the "mate."

Whenever two men are available for testing purposes, a cable can be tested out satisfactorily for assignment to proper terminals in a very few minutes. Sometimes only one man is available, however, and a method is necessary whereby he can make the test alone. Each of these methods is described.

**Two-Man Method.**—One end of the cable is led into a terminal box placed at the proper location. The wires are brought out and each pair is connected to terminals provided for the purpose inside the box. In all cases the line wire (colored) is connected to the upper terminal and the mate (white) to the lower terminal of a pair. The terminals are numbered successively.

The helper remains at the terminal box which has been connected up and numbered as outlined above, and the splicer goes to the other end, at which is located the terminal box to be connected up to the other end of the cable.

The splicer selects a pair of wires and connects to one of them one side of a circuit consisting of a dry battery and an ordinary watch case telephone receiver, Fig. 1. The other side of this circuit is grounded by connecting it to the lead sheath of the cable. The helper has a simple circuit containing nothing but a telephone receiver, one side of which is connected to the lead sheath. With the wire from the other side, he taps the terminals of the first terminal box, in which the pairs are numbered, until he hears a click in the receiver. This tells him that he is on the other end of the wire to which the splicer has connected his circuit. The helper uses his receiver as a transmitter and tells the splicer the number of the pair and whether the wire he is on is line or mate. The splicer then marks the pair and selects another one. The same procedure is gone through with until the entire cable is tested and the wires properly tagged.

After having obtained the click on the first wire, it is best for the splicer to leave this connection secure and use another flexible lead connected to the same circuit to make the further tests. This is advisable, as it maintains connection on one circuit over which splicer and helper can always get into communication in case they are unable to pick each other up at any time.



**One-Man Method.**—Assume that pairs No. 1, No. 2 and No. 3, Fig. 2, represent three pairs of wires in a cable. One man can test out the cable without assistance by using the following method. All the wires are connected at one end of

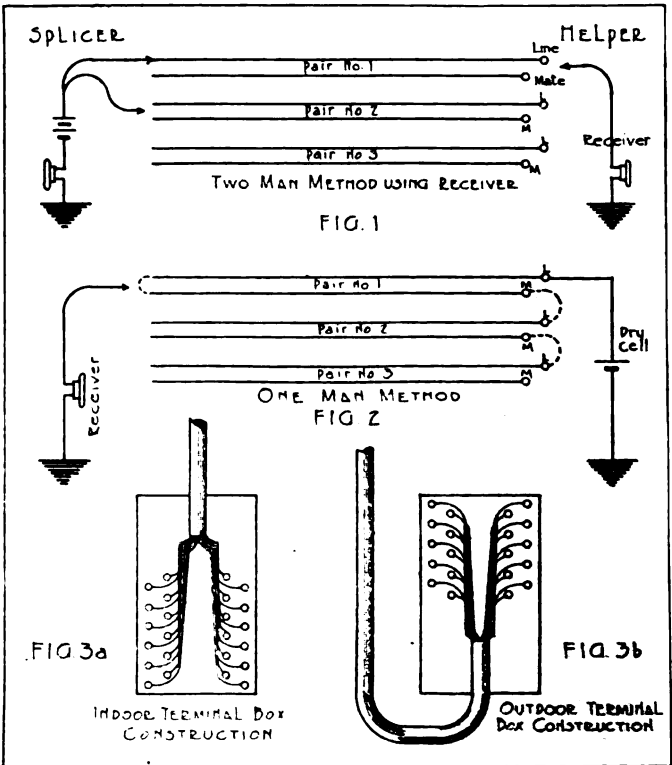

the cable to the terminals in the terminal box. Then the pairs are cross-connected down the panel as indicated by the dotted lines at the right, Fig. 2, connecting the mate of pair No. 1 to the line of pair No. 2, the mate of pair No. 2 to the line of pair No. 3, etc. The line of pair No. 1 is connected to ground (lead sheath) through a dry cell. After all these connections are made firm the tester goes to the other end of the cable section and connects a head set to ground on one side and to a piece of wire on the other. About 2 in. of

the paper insulation is skinned off at the ends of the wires. The ends are then touched with the free receiver connection until a wire is found which causes a click in the receiver. This will identify that wire as the line wire of pair No. 1, since this is the only circuit through the battery at the far end. This wire is twisted lightly with its mate (just enough to make an electrical contact) and is marked "Pair No. 1" with some sort of tag. The two ends of pair No. 1 are thus connected as shown by the dotted line at the left of Fig. 2. Next, the tester begins touching the other wire ends with the receiver contact wire until another click is obtained. This wire must be the line wire of pair No. 2, as will be seen by tracing out the circuit, Fig. 2. This wire is connected to its mate and tagged "No. 2." The test is repeated until all the pairs of the cable are identified. The wires are then permanently connected in the terminal box in their proper order. To clear the lines, the temporary connections between pairs which were made at the beginning of the test are removed from the first terminal box.

From the above it is seen that the main object in testing out cables newly installed is to identify the various pairs so that they may be given the same numbers at all terminals, as this greatly expedites assignment of pairs and location of trouble.

On installations inside of buildings the cable may be brought into a terminal box at the top or bottom, whichever gives the most direct route, Fig. 3-a. At all outside terminal boxes or at boxes installed in dugouts, the cable must be brought into the bottom of the terminal box so that the water running down the cable will drip off below the box and not get into the exposed wiring, Fig. 3-b.

### Splicing of Lead Covered Paper Insulated Cable.

Cables and communicating systems installed near the front are constructed with no great aim toward permanency. The life of any cable system in the area subjected to heavy shelling is not long, and the standard construction methods are therefore abandoned in favor of a temporary construction which serves the purpose just as well. The following instructions cover the method of making splices on the small, for-

ward cables and they should not be used to govern work on the more permanent cable systems farther back.

#### Materials Required.

Paper sleeves  
Paraffin  
Rolls of muslin strip  
Rubber tape  
Friction tape  
Insulating compound  
Wooden splice box  
Nails (1½ doz. 10-penny)  
Gasoline

#### Tools Required.

Pliers  
Cable knife  
Hammer, claw  
Paraffin kettle  
Dipper  
Gasoline furnace  
Compound kettle  
Blow torch

**Planning the Splice.**—The lead sheath should not be opened until ready to work on the wires and all the necessary material is at hand. The longer a cable is open to the atmosphere, the more likely it is to absorb moisture with resulting bad operation. The length of time a cable is open should be made the minimum possible, and it should never be left open overnight without being thoroughly wrapped with muslin and rubber tape and boiled out next morning when re-opened. Whenever a piece of cable is cut off a reel, both ends thus exposed must be sealed immediately with solder to keep out the moisture.

**Stripping and Boiling Out.**—The first step in making a splice is to dismantle the splice box, taking off the top and removable end. Each end of the box has a hole bored in it which will just admit the cable with a fairly snug fit. The splice box is placed on one cable end and the free end of the box on the other, both being slipped back out of the way, Fig. 4. The inside dimensions of the splice box are 3 in. x 3 in. x 13 in., and it should be made out of 1-in. boards, preferably pine.

The two cable ends are brought up together so that they overlap about 4 in., Fig. 8. About 6 in. of sheath is measured off on each cable and a ring made around each at these points by cutting a slight notch around the sheath with a cable knife. The sheath is then cut lengthwise from the ring to the end by driving the corner of the cable knife along the cable with a hammer, while holding the knife as nearly tangent to the cable as possible and still make it cut. This

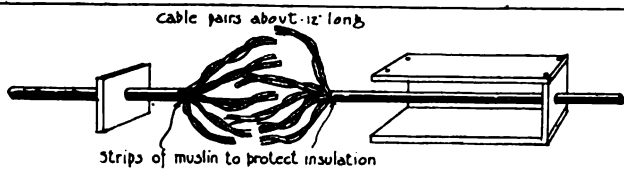

FIG. 4

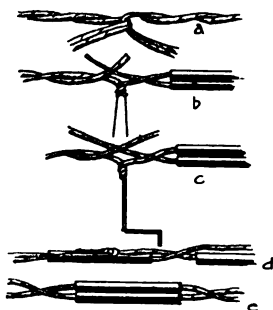

FIG. 5

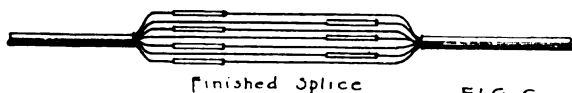

FIG. 6

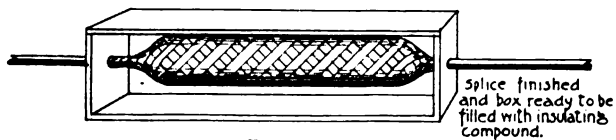

FIG. 7

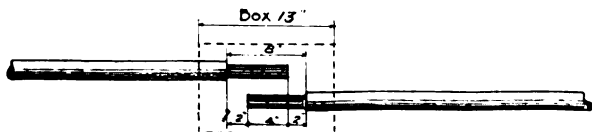

FIG. 8

will avoid cutting the paper insulation. After the sheath is thus cut open it is pulled back each way around the cable with the claws of the hammer and broken off at the ring. When completed the splice should be something less than 13 inches long over-all, so that it will be easily enclosed by the 13-in. splice box.

When the sheath is removed, the cable core should be served at the edges of the sheath with several wrappings of muslin. The paper wrapping is then removed from the core and hot paraffin poured over the muslin and open wire to assist in keeping the moisture out while the joint is open. The muslin will prevent the sheath from injuring the insulation of the wires when they are bent back preparatory to splicing. The paraffin should always be poured from the sheath toward the center of the splice. This tends to drive any moisture toward the center of the opening rather than back into the sheath. The temperature of paraffin should be above that of boiling water (212 deg. F.), but not hot enough to scorch the paper insulation. If the temperature is not higher than that of boiling water, the moisture will not be driven out. A common and effective test is to expectorate in the paraffin. If a considerable sputtering results, the paraffin is hot enough. If the paraffin is allowed to become too hot, it will catch fire on the surface very readily, so that this may be used as an indication of overheating. This "boiling out" of cable is absolutely essential and must be carefully done and never omitted. If not done properly, a faulty splice will develop.

After boiling out, the wires of each pair are twisted together tightly, so that no "split pairs" will result. This is very important. The conductors are now bent back over the sheath out of the way. Starting with the far layer of pairs, a pair of wires from each cable end which have approximately the corresponding positions in the cables are brought together, Fig. 5-a. The ends of the two wires of one pair are untwisted and a paper sleeve slipped over each wire of that pair and pushed back out of the way. The two line wires are brought together, allowing some slack, and given two or three twists, Fig. 5-b. The mates are then brought together in the same manner. The ends of both are cut off about 2 in. from the twist and the insulating paper removed up to the wist. The bare ends of the two line wires are now bent into

a crank handle, Fig. 5-c, and the two ends wound up until there is about 1 in. of tight twist, having at least 10 half-turns. The ends are cut off below the twist and the twisted portion bent over against and parallel to the insulated portion, Fig. 5-d. The operation is repeated with mate ends. The paper sleeves are then slipped up over the bare twists and the two wires of each pair given a few twists about each other to hold them together and keep the paper sleeves in place, Fig. 5-e.

In bringing successive pairs together for splicing, the locations of the twists should be staggered to distribute along the splice the bulkiness of the paper sleeves, Fig. 6. Before using the paper sleeves they must always be thoroughly boiled out in hot paraffin and then allowed to drain and cool.

The above "crank-handle method" of splicing can be used satisfactorily only on the smaller sizes of wire, such as Nos. 19 and 22 gauge, which are the sizes most commonly employed. Where larger than No. 16 gauge wire is encountered, it will be necessary to use copper sleeves and solder instead of a twisted connection.

**Wrapping the Splice.**—After the wires are all spliced, muslin strips are wrapped closely around the splice. The splice is then thoroughly saturated with hot paraffin to remove any possible moisture present before closing up the joint. The paraffin is then carefully cleaned off the lead sheath and two reversed layers of rubber tape tightly wrapped around the muslin and extended onto the sheath for a distance of  $1\frac{1}{2}$  in. at each end of the splice. Over the rubber tape two layers of friction tape are wound and extended onto the sheath for a length of  $\frac{1}{2}$  in. beyond the rubber tape. The tape must be wrapped particularly tight at both ends to insure a water-tight joint. Care must be taken that the taping is not extended over the sheath for too great a length, as this would cause the splice to buckle in the splice box when this was closed.

The box is now assembled around the splice and the unattached end nailed in place, Fig. 7. The box is then filled with very hot insulating compound and the top nailed on. The box must not be disturbed while the compound is cooling, or the seal which it provides will be broken. The effect of this hot compound is not only to seal the joint when it sets, but also, by virtue of its temperature, to actually vulcanize the rubber tape, friction tape and muslin into a unit water-proof covering.

## Splicing Ferrin Cable

Where less than a 10-pair cable is needed, it is now quite general practice with the American Expeditionary Forces to make use of Ferrin cable, commonly called "loom" cable. This consists of a tar, cloth and rubber casing enclosing rubber covered wire twisted in pairs. The manner of splicing is quite different from that employed with lead covered cable. The covering at the two ends of the cable is cut open along the cable as short a distance back from the end as possible and give sufficient length of wire to make the splice (approximately 6 in. on each end). About 2 in. of insulation is scraped off on each wire and the proper wires twisted together, using the Western Union joint and taking special precaution to make the length of each wire between cable sheath ends uniform. This is important in order that any strain on the cable will be borne equally by all wires, as the opened sheath will not take up the strain. If practicable, each joint should be soldered, but if solder is not available, a layer of tinfoil or paper should be placed over the bare joint before it is wrapped with the rubber tape. This will prevent oxidation of the copper due to the action of the rubber, which would take place if there were no protection. The joint is then heated with a candle or other flame and moulded slightly with the fingers to partially vulcanize the rubber and seal the insulation.

After all the wires are treated in this manner, the split ends of the sheath are put back in place, cutting them to fit together as snugly as possible around the core. A double layer of friction tape is wrapped over the sheath, after which two reverse layers of rubber tape are applied. This taping is heated to vulcanize and form it into a unit insulation and then served with two or three layers of friction tape for protection.

## Determining the Nature of Cable Trouble

In splicing cable, any one of the following troubles may occur: short, ground, cross, split pairs or open pairs. All these faults except split pairs are sometimes found in the cable upon receipt from the manufacturer, but this is rare as the cable is tested before being shipped. The methods of testing given in the following paragraphs are intended pri-

marily for use at the time the cable is installed before pairs are assigned and in use. Determining the nature of these faults after the cable is in use is simplified, as it is usually known just which pair the trouble is in.

**Short.**—This trouble in a pair of wires means that, due to faulty insulation, the two wires are short circuited and therefore cannot be used as a pair for communication purposes, Fig. 9. The illustration is of course exaggerated inasmuch as a shorted pair can result from a very small defect in the insulation.

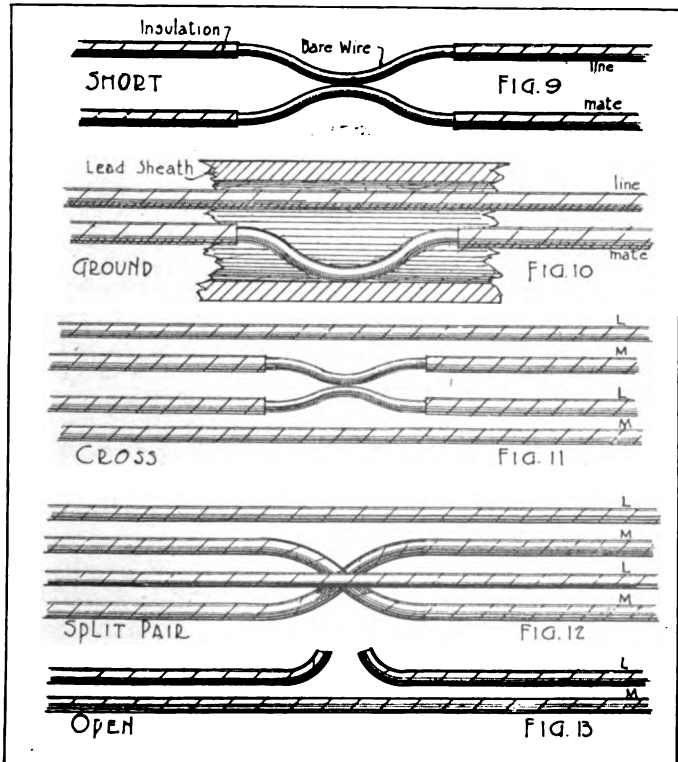

To test out a cable for shorts, a circuit consisting of an ordinary watch case telephone receiver and a dry cell is connected successively across the wires of each pair of the



cable. If a click is heard in the receiver upon touching the two ends of any pair, when it is known that that pair is open at the opposite end of the cable, this signifies that there is a short-circuit between the two wires. In long cable runs it is possible that there will be enough static capacity to cause a click even though the pair is not shorted. It is therefore best to tap the test circuit connection to the wires of the pair several times, and if a click is heard after the first or second tap, it is a certain indication that a short exists. This same precaution against static clicks must be observed in connection with testing out for the troubles described in the following paragraphs.

**Ground.**—A ground in a pair of wires in such a condition as is shown in an exaggerated way in Fig. 10. In this case one of the wires is grounded on the lead sheath of the cable or on some other grounded object inside the cable, and while the pair can be used for conversation, the transmission usually will be poor and there likely will be a scratching, sizzling noise in the receiver. In case both wires of a pair are grounded, there exists the equivalent of a shorted pair, and this pair cannot be used for communication purposes.

To test out for a ground in any of the pairs of a cable the same circuit referred to above is used, one side being connected to the ground or cable sheath and the other side to all of the wire ends in the cable successively. If a click is heard when connection is made to any wire, it signifies that this wire is grounded, thereby completing the circuit through the test circuit receiver.

**Cross.**—When pairs are crossed, conversation can be had over either pair, but both cannot be used at the same time, as both conversations will be heard over both pairs. A ring on either pair will probably cause the signals of both at the exchange to drop. Both pairs will be noisy. An illustration of crossed pairs is shown in Fig. 11.

To test a cable for crossed pairs, using the receiver and dry cell circuit, one side of the test circuit is connected successively to each of the wire ends of the entire cable, and for each such connection the other side of the test circuit is touched to all other wire ends. As seen from Fig. 11, if a cross exists in the cable, one combination of interconnection between pairs will form a circuit and a click will be heard in the receiver. This will identify the pairs in trouble, since if

all were perfect such a connection would give no click whatever.

**Split Pairs.**—This fault is caused by the splicer being careless in splicing the pairs together. A split pair practically never occurs in the cable traceable to any other cause than the work of the splicer. A split pair exists when the two wires of one pair are connected to one wire each of two opposite pairs. This fault defeats the purpose of the transpositions in the cable, which are made about every 3 in., and results in cross talk. Fig. 12 illustrates a split pair in a cable.

To test out for this trouble, two men are necessary. The helper goes to the far end of the cable section and cross-connects the two wires of each pair. At the opposite end of the section the splicer connects one side of a test circuit, consisting of a receiver and a dry cell, to the line wire of each pair successively, and for each such connection, touches the other side of the test circuit to all the other wire ends in the cable. If a split pair exists, one wire other than the mate of the line wire to which the first side of the test circuit is connected will be found which will give a click in the receiver. There will probably be two such combinations of connections, since if one pair is split, it will necessitate the splitting of another pair in order to make the pairs come out even.

**Open Pair.**—An open pair exists when one wire of a pair is broken, Fig. 13. Such a pair cannot be used for communication purposes. It can be used only as a one-wire grounded line for emergency purposes.

The test for open pair is to use the same receiver and dry cell circuit, and connect all terminals together at one end of the cable section. One receiver lead is then held on any terminal at the opposite end of the section and the other side of the test circuit touched to all other terminals. Any wire which does not give a click indicates an open circuit in that wire.

**General.**—In making the tests as described above, a tone machine or buzzer, or a magneto may be employed effectively. When using the tone machine, a buzz will be heard by the tester when the trouble is located, except when there is an open. With the magneto, a bell may be used, or a receiver, to designate the circuits in trouble. When a cable section has

been installed and connections made in both terminals, it should be tested out for all the faults indicated above.

### Locating Cable Troubles

After having determined the nature of the trouble in a pair of wires by using any one or all of the foregoing methods, it then becomes necessary to locate the exact point of the trouble, so that it can be removed. An accurate method of locating trouble is to use a Wheatstone bridge, which will determine quite closely the distance out on a cable at which the trouble exists, in terms of the resistance of the intervening wire.

**Varley Loop Test.**—The Varley loop test is a very accurate method of locating a cross or a ground, provided there is a good wire running parallel to the defective one. A Wheatstone bridge and galvanometer are required. Connections are made as shown in Fig. 14.  $R$ ,  $R_1$  and  $R_2$  are variable known

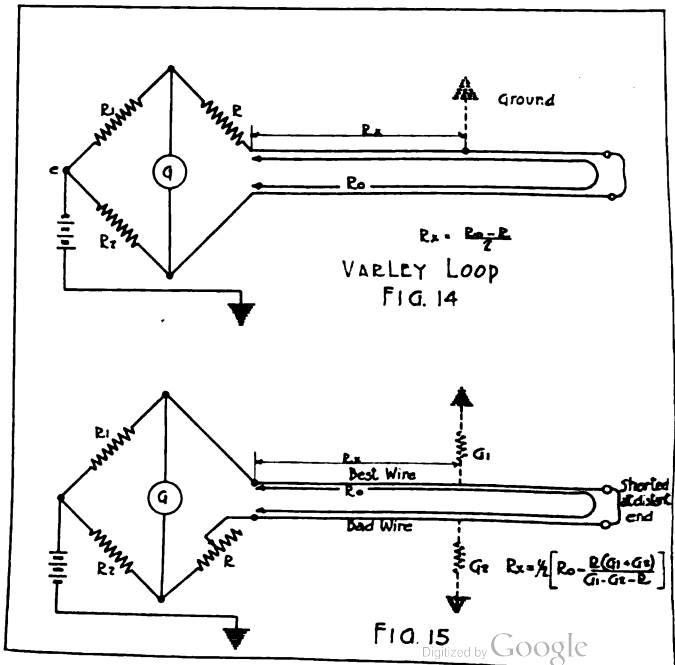

resistances. When  $R_1$  is made equal to  $R_2$ , and  $R$  is adjusted until no deflection of the galvanometer takes place, then the following equation is true:

$$R_x = \frac{R_0 - R}{2},$$

where  $R_x$  is the resistance out to the ground.  $R_0$  is the resistance of a complete loop consisting of the good wire and the grounded wire, and  $R$  is the resistance of the bridge arm.  $R_0$  can be obtained from standard wire tables if the size or resistance of the wire and distance between sections are known. The distance to the ground may then be computed by dividing the resistance  $R_x$  by the resistance per foot as obtained from the tables.

**Murray Loop Test.**—The Murray loop test is used when only two bridge resistance arms and a galvanometer are available. Connections are made as in Fig. 16 and when  $R_1$  and  $R_2$  are so adjusted that no deflection of the galvanometer is noted, the following equation may be solved to determine the resistance of the bad wire out to the fault, from which the distance to the fault can be computed as outlined in the Varley loop test:

$$R_x = \frac{R_1 R_0}{R_1 + R_2}$$

**Faulty Wire of Known Length and Two Good Wires of Unknown Length.**—The above described loop methods, the **Murray and Varley**, are the ones most frequently used. Some other loop methods and various modifications of these tests have been worked out to meet specific requirements. One of the most important follows. This method has a wide application, because either good aerial cable sheath or any good cable wires, or both, may be used for the good wires, the only requisite being that they terminate at the same point as the faulty wire. The length of the two good wires does not need to be known.

First, connections are made as for the Murray loop test, Fig. 18. The two arms  $R_1$  and  $R_2$  of the bridge are so arranged that they can be varied until a balance is secured. In the types of testing sets having a variable rheostat, the rheostat should be used for one of the arms. Where the resistance of the faulty wire to the grounded point is called

$R_x$ , the total resistance of the faulty wire is called  $r$ , and the resistance of one of the other wires joined to it to complete the loop is called  $n$ , then

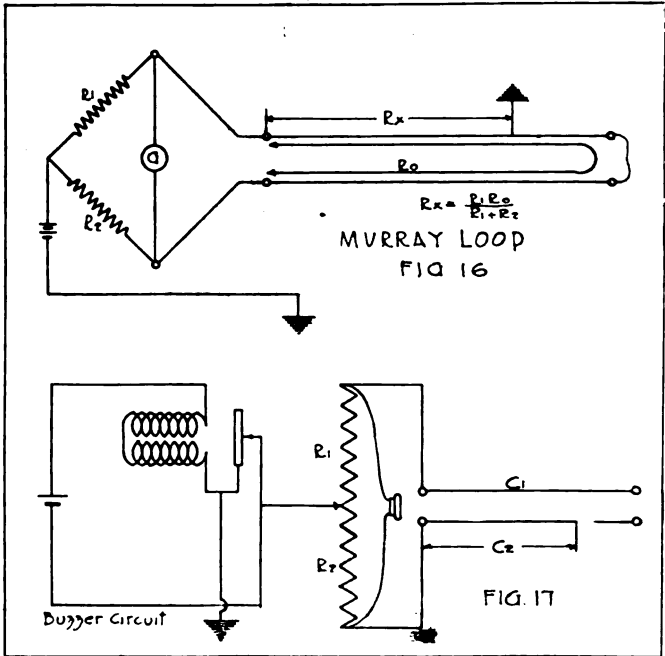

$$\frac{R_1}{R_2} = \frac{r - R_x + n}{R_x} \text{ and } n = \frac{R_1 R_x + R_2 R_x - R_2 r}{R_2}$$

Now, connecting as shown in Fig. 19, and adjusting for a new balance, calling the new readings  $R'_1$  and  $R'_2$

$$\frac{R'_1}{R'_2} = \frac{n}{r} \text{ and } n = \frac{R'_1 r}{R'_2}$$

Equating the two values of  $n$  and clearing,

$$R_x = \frac{R_2 (R'_1 + R'_2) r}{R'_2 (R_1 + R_2)}$$

In the types of bridges in which the  $R_1$  to  $R_2$  ratio is made by sliding a contact along a uniform resistance,  $R_1 + R_2$  is always equal to  $R'_1 + R'_2$ , and the above reduces to

$$R_x = \frac{R_2}{R'_2} r$$

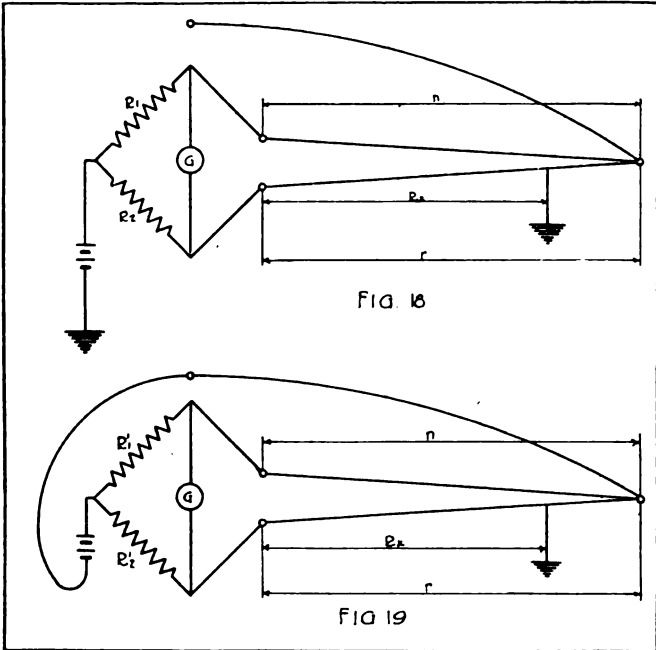

Since the length of  $L$  of the faulty wire is known, then the equation may be written

$$d = \frac{R_2}{R'_2} L,$$

where  $d$  is the distance to the fault.

**Locating Ground with All Wires Bad.**—In the Varley loop and most other methods of locating grounds, it is necessary to have one good wire throughout the length of the cable. It may happen that at a certain point every wire of a cable is defective, due usually to moisture. In this case the more

common Wheatstone bridge methods cannot be used. If a megger, galvanometer or voltmeter is available for determining the insulation resistance to ground of two wires, the following method may be employed to locate the trouble, Fig. 15.

$R$ ,  $R_1$  and  $R_2$  are the bridge arms,  $G_1$  is the insulation resistance to ground of the best wire,  $G_2$  is the insulation resistance to ground of a bad wire,  $R_0$  is the full loop resistance as estimated from wire tables, and  $R_x$  is the resistance of a single conductor out to the fault. The wires for determining the insulation resistances  $G_1$  and  $G_2$  should be selected so that  $G_2$  will always be less than  $G_1$ .

When the two wires are shorted at the far end as shown and a balance secured on the bridge, the following equation is true:

$$R_x = \frac{1}{2} \left[ R_0 - \frac{R(G_1 + G_2)}{G_1 - G_2 - R} \right]$$

The distance out to the fault can then be computed by dividing the resistance  $R_x$  by the resistance per foot of the wire.

**Locating an Open.**—To locate an open circuit in a wire, a simple capacitance test can be used effectively. The far terminals of the pair are left open. A buzzer circuit is used and connected between a known variable resistance arm and ground, Fig. 17. A telephone receiver is connected across the total resistance. Calling  $C_1$  the capacitance of the good wire and  $C_2$  the capacitance of the faulty wire out to the break, the resistances  $R_1$  and  $R_2$  are adjusted until the buzz in the receiver is a minimum. Under this condition the following ratio is true:

$$\frac{R_1}{R_2} = \frac{C_1}{C_2}$$

In uniform wires and cables the capacitance is directly proportional to the length, so that in the above equation,

$$\frac{R_1}{R_2} = \frac{C_1}{C_2} = \frac{D_1}{D_2}$$

where  $D_1$  is the length of the good wire and  $D_2$  the length of the bad wire out to the open.

$D_1$  is known, so

$$D_2 = \frac{D_1 R_2}{R_1}$$

**Locating a Split Pair.**—When a split pair is found, it is usually corrected by changing the connections of wires at the terminal box. This makeshift defeats the object of the transpositions and the two pairs involved may be noisy and produce cross talk. It is sometimes not worth while to attempt to locate a split, particularly if the cable is a long one with many splices. This serves to emphasize to the splicer

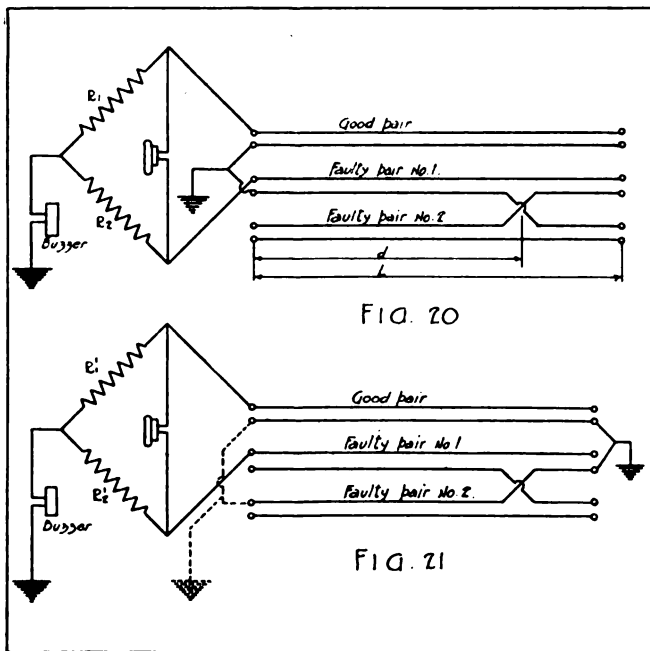

the importance of connecting the pairs properly at every joint he makes, otherwise there will result two practically useless pairs in the cable, which must remain permanently so. If there is a shortage of pairs, it may save considerable time when a long run of cable is involved to test out to locate the split in a pair rather than to open up joints until it is found.

A Wheatstone bridge may be used in this test, provided one good cable pair is available. The connections are first made as shown in Fig. 20, a telephone receiver being used in place of the galvanometer and a buzzer in place of the bat-



tery. The resistance  $R_2$  is adjusted until no sound is heard in the receiver. The ground connections are then changed, as shown in Fig. 21. These ground connections may be made either at the far end of the cable, as shown by the full lines, or at the near end of the cable, as shown by the dotted lines. The value of  $R'_2$  for a balance is found as before.

Now, where  $d$  represents the distance to the cross and  $L$  the length of a pair of wires,

$$d = \frac{LR_2(R'_2 - R'_1)}{2R_2R'_2 - R_1R'_2 - R'_1R_2}$$

(For the purpose of this pamphlet, it is not considered necessary to enter into the rather lengthy proof of the above formula.)

**Locating a Short.**—The location of a short circuit is a simple Wheatstone bridge test, whereby the resistance of the wire out to the short and return is measured and divided by two in figuring the equivalent distance.

### Precautions in Handling Cable

Circular No. 78, A.E.F., dated July 6, 1918, contains the following instructions relative to handling cable:

Results obtained over the lead cable and Ferrin cable systems in use by the Signal Corps "will depend largely upon the manner in which the cable is handled prior to installation. For this reason the following instructions will be observed:

- "(a) Reels containing cable will be so located in yards or warehouses as to minimize the possibility of damage to the cable.
- "(b) Reels containing cable will be relagged after a section of the cable is removed.
- "(c) Cable on lagged and unlagged reels will be securely lashed and fastened to the reel in such a manner as to prevent movement of the cable on the reel while being transported.
- "(d) All paper cable on reels and sections of reels during installation will be securely sealed by means of a floated solder seal.
- "(e) Paper insulated cable will not be used as jumper cable by forming it in the shape usually prescribed for switchboard cable, thereby exposing the paper insulation."







---

**Prepared in the  
Office of the Chief Signal Officer  
Training and Instruction Division  
Washington**

---

FOR OFFICIAL USE ONLY

# Listening-In Stations

*Confidential*

Radio Pamphlet  
No. 18

Signal Corps, U. S. Army  
10-29-18



**L**ISTENING STATIONS are established for the purpose of overhearing telephone conversations and T.P.S. communications of the enemy. Such stations also enable the policing of our own telephone and T.P.S. systems, as they disclose what sort of information the enemy is likely to obtain with his listening stations.

As the possibility of overhearing enemy communications depends upon the proximity of the listening stations to the enemy lines of communication, these stations are generally established rather close to the front line trenches at a point where the enemy lines are not far distant. It has been found that T.P.S. messages, which are transmitted through the earth, and telephone conversations taking place on single-wire ground return circuits are easiest to pick up. Conversation over a two-wire telephone system, well insulated from the ground, is practically impossible to overhear, provided well insulated twisted pair is used. If, however, the insulation of such a circuit fails at some point and one of the wires becomes leaky or grounded, it is quite probable that the conversation will be overheard. Hence, a listening station may be used to indicate to some extent the condition of our own telephone system.

It may happen, for several weeks at a time, that a station in a quiet sector will not hear any signals from the enemy lines, except the testing calls. This should not lead the station personnel to allow its continual vigilance to relax, but they should attend to the usual routine work in strict military fashion. At any moment messages of considerable importance may be overheard, or at any moment our own lines may become damaged to such an extent as to make it possible for the enemy to overhear important messages.

In a sector where there is unusual enemy activity such as prevails before an offensive, it is practically certain that messages of importance will be picked up, due to the greater telephone traffic in the advanced enemy trench lines and to the various artillery units, T.P.S. sets, etc., being advanced nearer to the first line trenches.

The personnel of a listening station should consist of at least three men, each of whom is an experienced radio operator and is thoroughly conversant with the German language,



and, if possible, with the French. One man must be on listening duty all the time, night and day. The duty of the others, when not listening, is to maintain the apparatus in good working condition, repair breaks in the line wires, etc.

The usefulness and success of a listening station depends in a large measure upon the character and knowledge of the non-commissioned officer in direct charge of the work. He should be thoroughly familiar with the operation of the apparatus and the principles guiding the proper installation of the entire system of a listening station, and of the simple electrical theory involved. The officer in charge should himself have had training along these lines, and should be in a position to perfect the instruction of the men under him.

### Theory of the Listening-In Systems

Before explaining the principles of the various listening-in systems, it is necessary to give an idea of the mode of propagation of electric currents through the ground in the case of T.P.S. or of single-wire (ground return) telephone communication; also of the various auxiliary phenomena which make it possible to overhear a conversation on an entirely metallic and insulated telephone circuit.

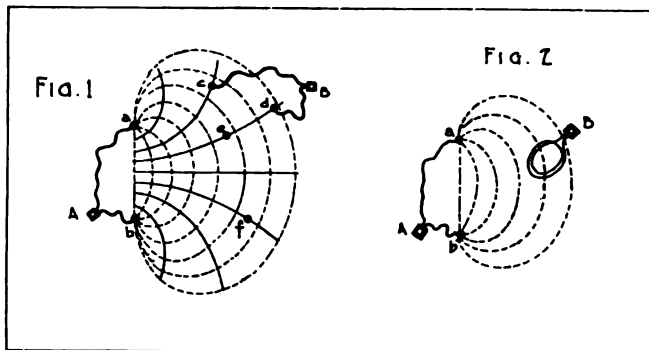

Let A, Fig. 1, represent a T.P.S. sending buzzer, or a telephone transmitter on a grounded telephone circuit, Aa and Ab being the two line wires, grounded at the points a and b. The electric current flows, for instance, in the line wire from A to a, then through the ground from a to b, and then, through the second line wire, from b to A. The ground being a fairly good conductor of electricity, the electric current while flowing

through the ground from a to b will not only follow the straight line ab, but will spread through the ground and follow a large number of lines, some of which may extend out two or three miles. The general shape of these lines of current flow may therefore be considered as an electric conductor along which the flow of electric current produces a continuous drop of potential in the direction of the current flow. Equipotential lines can therefore be drawn, as shown by the light solid lines of Fig. 1. Each one of these lines joins the points on the lines of current flow having the same potential.

If, then, two points d and e of the same equipotential line are connected by means of a metallic wire, no current will flow through the wire, since its two extremities are at the same potential. If, however, the two ground connections are made at points c and d not situated on the same equipotential line, a current will flow in the wire cd, and if a telephone receiver B is inserted in this wire, the T.P.S. signals or the telephone conversation sent out from A will be overheard at B. The currents in the wire cBd may be too small to be heard in an ordinary telephone, in which case an amplifier may be inserted in the circuit. Also, if the ground connections are made at c and f, so as to establish a greater difference of potential at the extremities of the line wires of the listening station, the signals at B will be correspondingly louder.

This explanation, which involves only the phenomena of current conduction through the ground, is not complete. There is also an inductive action of the transmitting circuit upon the receiving circuit. This may be explained by the fact that each one of these two circuits is a closed loop, the line wires being short-circuited by the conducting ground. The interrupted buzzer currents or the voice-modulated currents in the transmitting circuit will then induce an emf. in the closed receiving circuits and thus produce a current in it, which may be heard in the telephone receiver, generally after amplification.

These two effects, current conduction through the ground and induction, are distinctly separate phenomena. In the case of grounded transmitting and receiving circuits, the two phenomena add their effects in producing sounds in the telephone receiver. It may be seen, however, that the grounding of the receiving circuit is not essential. A closed loop made entirely of insulated metal wire may be used, Fig. 2. This loop is generally of quite considerable dimensions, 200 to 300 meters in length and 50 to 100 meters in width, and of sev-

eral turns, generally three or four. When using this method the signals are usually weaker than with a grounded receiving circuit, since only the induction phenomenon is made use of. This is partly compensated by the larger number of turns of the loop, which increases the strength of the inductive effect.

The respective advantages and uses and the actual method of installation of insulated loops and ground line wire receiving circuits will be studied below. It is usually more difficult to overhear telephone conversations than T.P.S., for the currents involved are considerably weaker. Telephone conversations are seldom overheard at a distance exceeding 2 kilometers.

The problem of overhearing conversations taking place over entirely insulated metallic circuits is somewhat different from the previous one, where the grounded line was considered. If the circuit over which conversation is taking place is insulated over its entire length, the only way the telephone currents can act upon some outside circuit is by induction. This inductive effect of the telephone circuit upon the listening circuit can be enormously reduced if the two wires of the telephone line are run parallel and very close together, or if twisted pair is used, since the electromagnetic field of one wire will almost entirely neutralize that of the other. The action of such a circuit being entirely inductive, an insulated loop circuit such as that of Fig. 2 may be used for listening in.

However, in a circuit such as that of Fig. 1, the receiving set B with two ground line wires was shown to be, in fact, a closed loop circuit. It may therefore be used instead of an insulated loop, and it will then not only be acted upon by direct induction, as in the case of the insulated loop, but it will also pick up conductively the currents induced in the ground, if any, by the insulated telephone circuit. Thus, as before, the grounded listening-in circuit may, under certain circumstances, have the advantage over the insulated loop circuit.

### **Methods of Installation of Listening Stations**

The station itself is installed in a deep and dry dugout located about 500 to 1500 yards back of the first lines. Great care is always observed in handling the amplifier and the auxiliary apparatus, to insulate it from the ground and to protect it from mechanical vibrations. This may best be done by mounting it on a table or shelf, resting the amplifier set box on rubber pads.

The wires connecting the apparatus in the dugout to the forward ground connections outside or to the wires making up the listening-in loop must be of heavily insulated wire, such as field wire furnished with T.P.S. sets, which is made of phosphor bronze and is mechanically strong.

In the case of grounded circuits, the grounds are made as far forward as possible, often in no-man's land. These ground connections are best made by burying some metal netting (ground mats) about 1 ft. deep in the bottom of a trench. If no mats are available, or if the installation has to be made very hurriedly, four or five T.P.S. ground rods may be driven in the ground at least 1 ft. deep, at a distance from each other of not less than 2 ft., and connected together. Such a ground is about as effective as a ground mat.

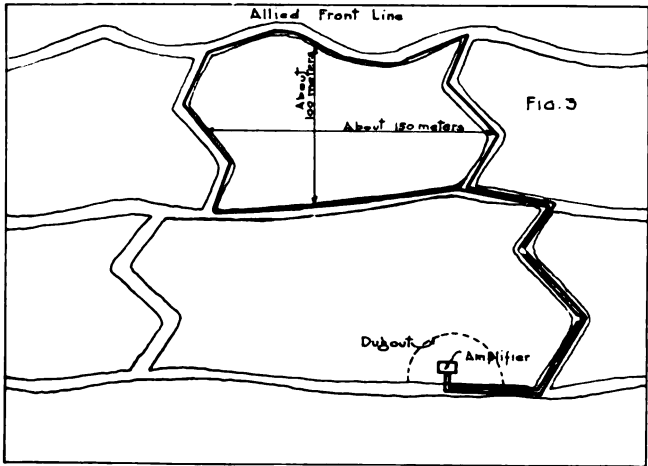

The wires connecting these grounds to the amplifier are run very close together whenever possible, either on the ground or tied by means of cords to short wooden poles, in order that the moisture on the earth's surface may not damage the insulation. No porcelain insulators are required. These wires should be run in a trench separate from that provided for the telephone and telegraph lines, so that the latter will not produce too great interference by induction.

In case a loop circuit is used, the loop is made up of the same kind of wire, also preferably tied to short wooden poles. The wire is run around a block of earth included between two

lateral trenches and two communicating trenches, the latter being preferably not used for heavy traffic, Fig. 3. The loop should be of large size, and of at least three turns. A wire is tapped off at every turn and led into the amplifier dugout.

### Testing Out Line Wires and Loop

An essential condition is that the insulation of the wire be in perfect condition at all times. A method for testing out this insulation is given below.

**Testing the Insulation of the Ground Line Wires.**—A good ground connection is first established in the amplifier dug-out, or at close proximity to the station, and the ground line wire under test is connected to this local ground through a voltmeter and a 40-volt battery. The dry batteries of the amplifier may be used for this purpose, see Fig. 4. If the line

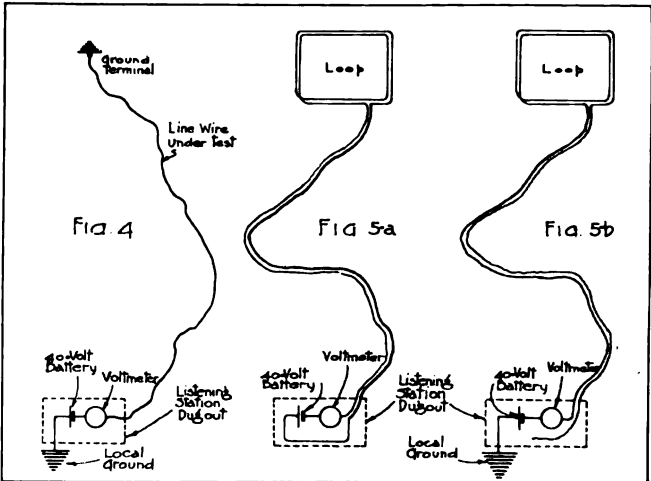

is in good condition, the voltmeter reading should be only slightly less than the direct voltage across the battery—10 per cent less perhaps. If it is more than 25 per cent below the battery voltage, the line should be examined for breaks and for poor ground connection.

**Testing a Loop Circuit.**—In case of a loop circuit, two tests, one for insulation and one for continuity of the circuit, are available. Connecting the two terminals of the incoming line wires to the voltmeter and 40-volt battery, Fig. 5-a, the volt-

meter reading should be almost exactly the same as the direct voltage across the battery terminals. If no reading is obtained on the voltmeter, the line or the loop must be broken at some point.

The other test consists of insulating the end of one of the incoming wires and grounding the other one to the local ground through the battery and voltmeter, Fig. 5-b. No reading should be obtained on the voltmeter if the insulation is in good condition.

To repair a break in the wire, peel back the insulation from the broken ends, thus exposing the copper or phosphor bronze wires. Scrape these clean and twist them together tightly. Cover the splice with rubber tape, wound around tightly, and cover finally with a layer of friction tape for protection.

### Methods of Dealing With Interference

The general care of the amplifier and usual precautions to be observed when using it will not be taken up here. Any two-stage or more amplifiers may be used. Full instructions regarding the amplifiers of the types SCR-72, SCR-72-B, SCR-76 and SCR-76-A sets are given in Radio Pamphlets Nos. 10, 15 and 27.

In listening work the messages and signals to be received are generally quite faint, and it is therefore important that foreign noises be eliminated as much as possible. Such noises are produced in the amplifier by foreign currents entering the ground line wires, or inducing currents in the receiving circuits. Such currents may be due to leaky transmission lines in the neighborhood of the station, currents from motors, generators, friendly T.P.S. stations, etc., also "strays," or currents induced in the ground under certain atmospheric conditions. A number of schemes have been devised which serve to eliminate these noises to greater or less degree.

Generally speaking, the loop system is less affected by stray currents than the grounded circuit. At the same time, it is often less effective than the grounded line systems, because the loop cannot be installed as near the enemy lines. Also, the loop requires more wire, and is generally more difficult to maintain in good condition.

The methods of eliminating interference are, however, similar for the two systems, and some are given below. Before using any of these methods it is necessary to ascertain whether the interfering currents are due to a single source in a well-

defined direction, such as currents from a certain T.P.S. station, or from a single motor, generator, etc., or whether the currents come from several directions, such as a number of motors or T.P.S. stations installed over a sector of front, or a long distribution line running parallel to the listening base line. The following methods have been used extensively by the French Army:

(a) In case the interference is produced by currents of various frequencies, or of a frequency distinctly different from that of the T.P.S. buzzer or voice currents it is desired to receive, the amplifier input terminals may be shunted by an oscillatory circuit, Fig. 6, tuned to the frequency of the cur-

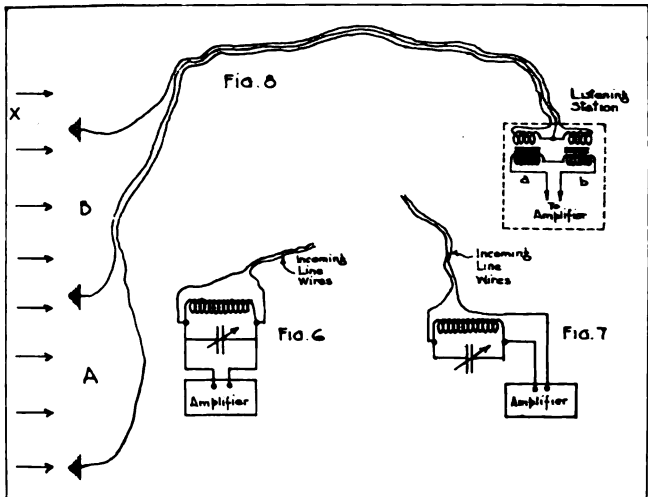

rents it is desired to receive. This circuit having higher impedance for that frequency than any other frequency, will allow most of the current to flow into the amplifier. For currents of any other frequency it will shunt most of the current, and therefore weaken the interfering noises in the amplifier.

(b) In case of an interfering current of a well defined frequency, such as that of a long a. c. transmission line, an oscillatory circuit tuned to that frequency may be placed in series with the amplifier, Fig. 7. The interfering noises will thus be reduced, the oscillatory circuit having highest impedance for that frequency.

(c) In case of a non-directional disturbance, such as that produced by a long transmission line, the arrangement of Fig. 8 is made. It consists of a "balanced" circuit comprising two identical listening-in circuits, disposed symmetrically with respect to the disturbing current. Each of the circuits A and B is connected to the primary winding a and b, respectively, of a small iron core transformer. The two secondary windings are so connected that the emf.'s induced in them by the equal interfering currents flowing in the two primaries will counter-balance each other. No noise is then produced in the amplifier until some conversation or signals occur at a point x which affects one of the two listening circuits more than the other, thus producing an unbalance of fluxes in the two transformers and, therefore, a current in the amplifier.

Another method which has been devised by the Signal Corps, United States Army, is outlined below.

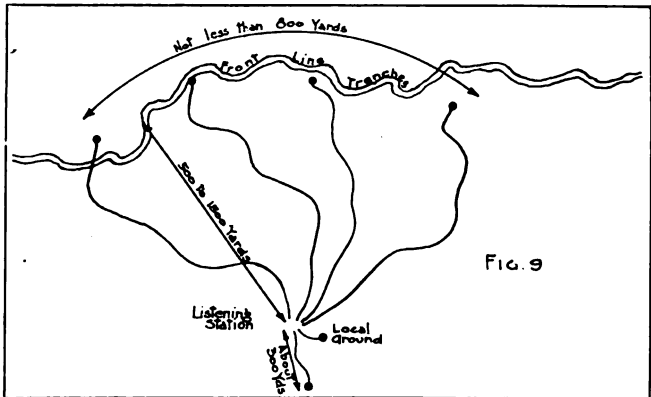

A number of grounds are installed along the first line trenches, or in no man's land as near the enemy lines as possible, Fig. 9, and each is connected to the listening station in a dugout by means of heavily insulated wire, as explained above. A local ground is also installed at the station itself and one in back of the station, about 300 yd. away. The distance between the extreme grounds should not be less than 800 yd.

In the station dugout the incoming line wires are then properly tagged and all connected to three dial switches, as shown in Fig. 10. Two methods are used to operate this



station, according to whether the interference is directional or non-directional.

**Non-Directional Interference.**—Two of the dial switches are connected to the amplifier input terminals through the medium of two 10,000-ohm rheostats. A .5-mfd. condenser is also connected across the amplifier terminals. The dial switches are then adjusted until two ground line wires are found for which

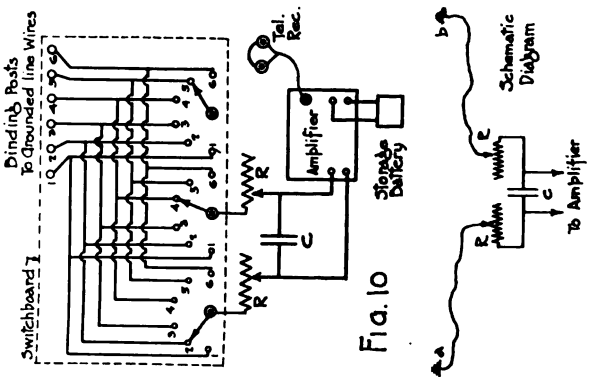
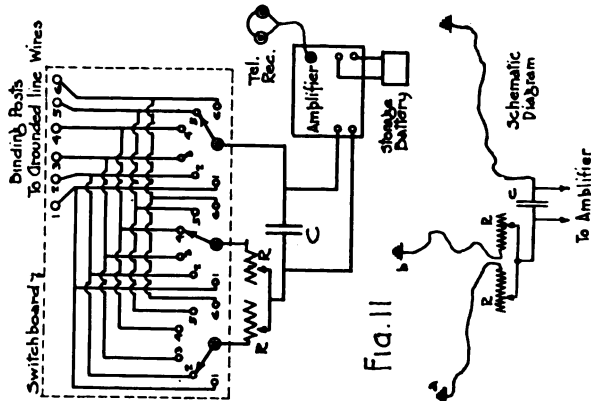

the disturbing noises are a minimum. For this position (see schematic diagram, Fig. 10) the two grounds a and b are, among those available, the nearest to an equipotential line of the electrostatic field created by the interfering current. The use of these two grounds will then minimize the disturbance while receiving. The purpose of the resistances RR is to absorb interfering currents of a frequency of less than about 600 cycles per second. They are adjusted for each setting of the dial switches until a combination of grounds and resistances is obtained which gives the minimum interference and readable signals. The condenser C acts as a short circuit for high frequency disturbances, such as radio signals, which are sometimes heard without this precaution.

**Directional Interference.**—The connections to be made in case of directional interference such as coming from a buzzer, or machine in some definite direction, are shown in Fig. 11. The rheostats and dial switches are adjusted until the disturbance is a minimum. The connections are then as shown in the schematic diagram, Fig. 11. The resistances and condenser serve the same purpose as above, and the disturbing currents, affecting both ground lines a and b, will neutralize their effects in those circuits.

### Equipment Available

Attention is invited to the fact that none of the apparatus referred to in connection with the problems of interference is available in the U. S. A. as standard Signal Corps equipment, except the amplifier, ground rods, ground mats and line wires. In other words, the special equipment needed for listening-in work must be devised from materials at hand, if needed. The resistance and condenser units needed, as indicated in Fig. 10 and Fig. 11, may perhaps be secured by requisitioning telephone line testing resistances and standard condensers described in S. C. Manual No. 3, Chapter 4, or by securing a replacement condenser of about the right capacitance, designed for some radio set and maintained in stock in the supply depot. An audibility meter might serve as the variable resistance. The conditions referred to in this paragraph apply to training work in the United States, but it is understood that suitable equipment is available in France for the use of the Field Signal Battalions attached to Army headquarters.

The listening-in stations are maintained by Army and Corps Field Signal Battalions and such special apparatus is issued to them as is needed. The Division Battalions should be informed in this work but need not try to secure suitable equipment for actually undertaking the work.

---



Prepared in the  
Office of the Chief Signal Officer  
Training Section  
Washington

*Come down in this order. Leaf in one of them  
Pal 0110 3 and so on. May or June of year. m n n t*











AUG 26 1955

