

WIRELESS TELEGRAPHY

BY

GUSTAV EICHHORN, Ph.D.,

FORMERLY MANAGER OF THE LARGE BALTIC EXPERIMENTAL STATIONS FOR
PROFESSOR BRAUN, SIEMENS AND HALSKE.

With 79 Illustrations.



LONDON:
CHARLES GRIFFIN AND COMPANY, LIMITED,
EXETER STREET, STRAND.

1906.

[*All Rights Reserved.*]

WIRELESS TELEGRAPHY

CHARLES GRIFFIN & CO., LTD., PUBLISHERS.

SECOND EDITION. Revised. Fully Illustrated. 24s. net.

CENTRAL ELECTRICAL STATIONS.

Their Design, Organisation, and Management.

By CHAS. WORDINGHAM, A.K.C., M.Inst.C.E., M.I.Mech.E., etc.

"One of the most valuable contributions to central station literature we have had for some time."—*Electricity*.

In Large 8vo. Handsome Cloth. Profusely Illustrated. 12s. 6d. net.

ELECTRICITY CONTROL.

A Treatise on Electric Switchgear, and Systems of Transmission.

By LEONARD ANDREWS, Assoc.M.Inst.C.E., M.I.E.E.

"The author's style is clear and forcible. . . . The illustrations are excellently reproduced . . . obviously a book which should form part of the library of every electrical engineer."—*Technica*.

In Large 8vo. Handsome Cloth. Profusely Illustrated.

ELECTRICITY METERS.

By HENRY G. SOLOMON, A.M.I.E.E.

Deals in a lucid and exhaustive manner with all types of meters for measuring continuous and single- and polyphase currents; and with meters for special purposes, such as battery, switchboard, tramcar meters, etc.

SECOND EDITION. Revised and Enlarged. Fully Illustrated. 21s. net.

ELECTRIC SMELTING AND REFINING.

A Practical Manual of the Extraction and Treatment of Metals by Electrical Methods.

Being the "ELEKTRO-METALLURGIE" of DR W. BORCHERS.

Translated by WALTER G. McMILLAN, F.I.C., F.C.S.

"Must of necessity be acquired by everyone interested in the subject."—*Nature*.

SECOND EDITION. Revised, Enlarged, and Partly Rewritten. 10s. 6d.

ELECTRO-METALLURGY: A Treatise On.

Embracing the application of Electrolysis to the Plating, Depositing, Smelting, and Refining of Various Metals.

By WALTER G. McMILLAN, F.I.C., F.C.S.

"One of the best and most complete manuals hitherto published on electro-metallurgy."—*Electrical Review*.

SEVENTEENTH EDITION. Revised and Enlarged. Pocket Size. Leather. 8s. 6d.

A POCKET-BOOK OF

ELECTRICAL RULES AND TABLES.

By JOHN MUNRO, C.E., and ANDREW JAMIESON, M.Inst.C.E., F.R.S.E.

"Worthy of the highest recommendation we can give it."—*Electrician*.

In FIVE VOLUMES. Handsome Cloth. Fully Illustrated.

A TEXT-BOOK OF PHYSICS.

By J. H. POYNTING, Sc.D., F.R.S.
Professor of Physics, Birmingham
University.

And J. J. THOMSON, M.A., F.R.S.,
Prof. of Experimental Physics in Cambridge
University.

INTRODUCTORY VOLUME, fully Illustrated. THIRD EDITION, Revised. Price, 10s. 6d.

PROPERTIES OF MATTER.

"The style is clear and convincing, and the information up-to-date, including as it does all the recent research on the subject."—*Cambridge Review*.

VOLUME II. THIRD EDITION, Revised. Fully Illustrated. 8s. 6d.

SOUND.

"The work . . . may be recommended to anyone desirous of possessing an EASY, UP-TO-DATE STANDARD TREATISE ON Acoustics."—*Literature*.

VOLUME III. SECOND EDITION, Revised. Fully Illustrated. 15s.

HEAT.

"Well up to date, and extremely clear and exact throughout, and is as complete as it would be possible to make such a text-book."—*Nature*.

Remaining Volumes in Preparation—Light: Magnetism and Electricity.

LONDON: CHAS. GRIFFIN & CO., LTD., EXETER ST., STRAND.

Dedicated
TO
PROFESSOR M. WIEN, Ph.D.
WITH
EXPRESSION
OF HIGHEST ESTEEM.

11920144

108645
JUL 23 1907

TK
5707
E32
TQW
E12

P R E F A C E .

ANY reader expecting this book to consist of a compilation of the so-called "systems" of Wireless Telegraphy will be deceived. I fail to see that such a compilation would be of use to anyone, believing rather that a simple and comprehensive unfolding of the fundamental principles and working methods of modern telegraphy by means of electric waves is the more appropriate. On these grounds I may claim the right to term my work objective. Besides, I can draw on the abundant store of personal practical experience I was able to gather as manager of the important experimental stations on the Baltic Sea (Sassnitz-Gross-Moellen) for Professor Braun, Siemens & Halske. Hence I hope to create interest in wider circles for this rapidly growing branch of science and technology, as well as to perform some service to those more closely concerned with the subject, by combining theory and practice.

It is for me a welcome duty to offer my thanks in this place to Dr L. Mandelstam, for his advice and skilful co-operation in the most recent attempts to develop a selective system of wireless telegraphy. I am also greatly obliged to the Gesellschaft für drahtlose Telegraphie "Telefunken," of Berlin, for the use of blocks and photographs, and also wish to express my thankfulness to Mr M. G. Fox, for his kind assistance in revising the English style of the manuscript.

G. EICHHORN.

ZURICH, *January* 1906.

CONTENTS.

	PAGE
CHAPTER I.	
INTRODUCTION,	1
CHAPTER II.	
THE ETHER AND ELECTRICAL OSCILLATIONS,	3
CHAPTER III.	
COUPLED SYSTEMS,	14
CHAPTER IV.	
THE RECEIVER,	20
CHAPTER V.	
THEORETICAL RESULTS FURNISHED BY THE SENDER,	23
CHAPTER VI.	
THEORETICAL RESULTS AND CALCULATIONS IN RESPECT OF SENDER AND RECEIVER,	36
CHAPTER VII.	
BRAUN—ENERGY SYSTEMS,	51
CHAPTER VIII.	
MEASUREMENT OF WAVES,	56
CHAPTER IX.	
MANAGEMENT OF A STATION,	62

CHAPTER X.		PAGE
MODERN APPARATUS AND METHODS OF MOUNTING,		67

CHAPTER XI.		
CONCLUSION,		99
BIBLIOGRAPHY,		111
INDEX,		114

LIST OF ILLUSTRATIONS.

FIG.	PAGE
1. Circuit of Discharge of a Leyden Jar,	4
2. Curves showing Aperiodic Discharges,	8
3. Curves showing Damped Sinonical Vibrations,	8
4. Braun's Closed Oscillation Circuit,	9
5. The Hertz Oscillator,	10
6. Marconi Transmitter,	11
7. Rod Conductor for Electrical Vibrations,	12
8. Braun's Direct Coupling,	15
9. Braun's Indirect Coupling,	15
10. Secondary System with Symmetrical Attachments,	17
11. Correct Relative Position of Coupled Systems,	18
12. Incorrect Relative Position of Coupled Systems,	18
13. Symmetry Wire supplemented by Metal Plate,	18
14. Arrangement of Coherer,	20
15. Arrangement of Receiving Instrument, with Coherer, Relay, Morse, and Tapper,	21
16. Receiver with Tunable Secondary Circuit,	22
17. General Scheme for Coupled Senders,	28
18. Resonance Curves,	30
19. General Scheme for Sender and Receiver,	37
20. Amplitude Curves as Function of the Dissonance,	41
21. Spark-gaps in Series,	44
22. General Scheme of Braun's Energy System,	52
23. Braun's Energy System,	52
24. Braun's Energy System,	52
25. Energy System used at the Baltic Stations,	52
26. Secondary System with Counter Capacity,	54
27. The Ondameter,	56
28. Plan of Ondameter,	57
29. Elevation of Ondameter,	57
30. Measuring the Frequency of the Primary Condenser Circuit,	59
31. Measuring the Individual Oscillation of the Secondary System,	60
32. Slaby's Measuring Rod,	61
33. Mounting a Complete Station,	64
34. A Baltic Station,	65

FIG.	PAGE
35. Inductor with Hammer Interruptor,	69
36. Resonance Inductor,	69
37. Mercurial Turbine Interruptor,	70
38. Current Transformer (direct)	70
39. Current Transformer (two machines)	71
40. Morse Key, with Magnetic Blow-out,	71
41. Morse Key, with Automatic Minimum Current Cut-out,	71
42. Discharger (Multiplex Spark-gap),	72
43. Multiplex Discharger for Fixed Stations,	72
44. Excitation Circuit in Coupled Senders (type for use on board ship),	73
45. Excitation Circuit (for portable stations),	74
46. Method of Mounting the Sender in Portable Stations,	75
47. Leyden Jar System,	76
48. Primary Induction Circuit,	77
49. Annular Multiplex Spark-gap,	78
50. Current Generator for Light Portable Stations,	79
51. Coherer,	79
52. Coherer,	80
53. Schloemilch Detector,	81
54. Method of Mounting the Schloemilch Detector,	81
55. Receiver with Schloemilch Detector and Morse Register,	83
{ 56. Receiver with Schloemilch Detector and Telephone,	84
{ 57A. Course of High-frequency Oscillations in such a Receiver,	85
{ 57B. Showing the Battery Circuit in such a Receiver,	85
58. Marconi Detector,	88
59. Lodge-Muirhead Coherer,	89
60. Specimen of Script with a Lodge-Muirhead Coherer,	90
61. Receiving Apparatus,	91
62. Receiving Apparatus,	92
63. Light Receiving Apparatus for Portable Stations,	92
64. Receiving Apparatus for use on board Ship,	93
65. Receiving Transformer for Close Coupling,	94
66. The Mounting in the Receiver for Close Coupling,	95
67. Receiving Oscillation Circuits with Loose Coupling,	96
68. Mounting for Multiplex Telegraphy as used at the Baltic Stations,	96
69. Wireless Telegraph Station,	97
70. Wireless Telegraphy at Pilot Stations,	101
71. Wireless Telegraphy at Light-ship Stations,	103
72. German Imperial Yacht fitted with Wireless Telegraphy,	104
73. Portable Wireless Telegraphy Station (power waggon),	105
74. Portable Wireless Telegraphy (apparatus waggon),	106
75. Portable Wireless Telegraphy Station on the March,	107
76. Portable Wireless Telegraphy Station, Train unlimbered,	107
77. Demonstration Apparatus, Sender,	108
78. Demonstration Apparatus, Receiver,	108
79. Demonstration Apparatus, Complete Sender,	109

WIRELESS TELEGRAPHY.

CHAPTER I.

INTRODUCTION.

THE historical development of wireless telegraphy may be summarised briefly.

Every physicist knows that the scientific foundations were already most widely laid.

Michael Faraday's original and ingenious ideas of interpreting the action of forces at a distance broke the ice, and, transplanted into the brain of a Clerk Maxwell, generated that undying masterpiece, the electromagnetic theory of light. Rays of light, radiant heat, and rays of electrical energy, must be thoroughly identical in character, differing merely in the dimensions of their wave lengths: they must all be based upon electromagnetic oscillations in the all-penetrating universal ether, in which they spread at the same enormous velocity of 186,000 miles per second. Equally ingenious with the theory was the long-delayed proof advanced by Heinrich Hertz with his renowned investigations into the propagation of electrical energy. Besides, the laws of oscillating discharges for the generation of periodic electromagnetic vibrations were known through the labours of Helmholtz, William Thomson (Lord Kelvin), and Gustav Kirchhoff, and had been verified in all their details by that rarely-endowed experimenter Fæddersen. The experimental conditions with which they worked, however, were not adapted for action at a distance, this being first accomplished by the special form of Hertz's arrangements. The uniform subjection of all radiant phenomena to the same laws then became clearly apparent, and we learned how to guide the mechanism of the ether at pleasure and to detect the results of its action at distant stations. Signalling, by means of electrical waves, through the free universal ether was made possible, and wireless telegraphy was born. If it be

desired to speak of a "system" at all, it would be only just to talk of the Hertz system of electrical-wave telegraphy. As a matter of fact, in point of principle, there is nothing in modern wireless telegraphy that was not contained in the above-mentioned stage of development, brought to such a brilliant conclusion by the labours of Hertz.

Nevertheless, considerable time elapsed before the new revolutionary discovery found application in practice, this being impossible so long as one was restricted to the delicate appliances with which Hertz detected the propagation of electrical radiation.

In 1890 this obstacle was finally overcome, through the discovery by a French physicist, Branly, of a phenomenon which led to the production of the coherer, the soul of practical wireless telegraphy. In 1894 Lodge first employed the coherer for laboratory experiments. It was not, however, until 1895 that the use of a coherer outside the laboratory came into notice through Professor Popoff, who exhibited before the Military Academy in Cronstadt a registering device for aero-electrical discharges, wherein the electrical impulses were automatically indicated by means of a coherer in conjunction with a tapper.

The decisive turning-point was reached in 1896, by the labours of Guglielmo Marconi, who made a definite attempt to elaborate a system of wireless telegraphy by means of electric waves. True, he stood upon the secure foundation of the ingenious experiments of Hertz; but the persistence and skill with which he contrived to overcome the practical difficulties in his way, cannot be sufficiently admired. Thus Marconi was the first to actually telegraph over a distance of many miles without wires, thereby winning lasting renown.

However, the capacity of his instruments soon reached a limit. In Germany, too, the labours of Slaby-Arco led to no improvement, in point of principle; but the course of development was diverted into an entirely new channel with unexpected progress by the work of Professor Ferdinand Braun, of Strassburg.

By complete mastery of the existing material, well-designed application of scientific principles and appropriate use of technical appliances, he created the basis on which wireless telegraphy is now everywhere conducted. To the personal modesty of Professor Braun nothing is more objectionable than the fruitless conflict over the so-called "systems": and he would be the first to put an end to the envious and distracting outcry raised by the companies engaged in exploiting wireless telegraphy, and to use the name "Hertzian Electrical-Wave Telegraphy" as the worthiest title possible.

CHAPTER II.

THE ETHER AND ELECTRICAL OSCILLATIONS.

THE ETHER.

THE processes with which we have to deal in wireless telegraphy are carried on in that infinitely tenuous medium known as the ether, which penetrates all matter, and yet seems to stand in a very definite relation to it.

Almost contradictory to such a property is the extreme elasticity of the ether, by reason of which periodic vibrations are transmitted with a velocity which though finite is none the less enormous, namely, 186,000 miles per second.

One side of the physical character of the ether is revealed by its elastic tension, which is well defined both in value and direction, as may be shown by the lines of electric force. Tension curves of this kind form the electric field, and have their beginnings and ends in the bodies by which the field is excited.

Another physical property of the ether reveals itself in a kind of motion. Here we have apparently to do with a rotation or torsion of minute ether particles; and to this frictionless motion without change of position of the particles themselves the name "magnetic field" has been given.

There is still another manifestation of force by ether, namely, gravitation; but up to the present its nature has not been determined.

The electric and magnetic conditions of the ether have an invariable mutual relation, from which the laws of a periodically varying condition, the electromagnetic field, have been deduced. This forms the mechanism by means of which the rapid vibrations of light, with their delicate wave-curl, spread out in a similar manner and at the same velocity with the far slower oscillations of correspondingly greater wave length employed in wireless telegraphy.

Electric and magnetic forces are mutually perpendicular; and, as we have to deal with transverse vibrations, the electromagnetic energy is transmitted at right angles to both, this being the direction of radiation.

OSCILLATIONS.

We must now picture to ourselves the method in which electrical oscillations originate.

In the year 1847 Helmholtz first definitely expressed the conception that, under ordinary conditions, in discharging a Leyden jar (fig. 1) with a discharger (the path traversed by the spark being represented at F) we have to do with vibrations; that is to say, the electricity flowing through the wire of the discharger oscillates to and fro between the coatings like a liquid in a U-tube when its equilibrium is destroyed.

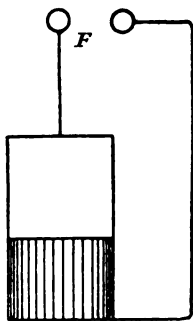

FIG. 1. — Circuit of Discharge of a Leyden Jar.

At the present time this demonstration can be fully elucidated. The difference of potential existing between the coatings of the charged jar sets the electricity in motion. A current is produced, and this continues to increase in intensity until a maximum value is reached, whilst the potentials concurrently decline to zero. The current in its onward path now charges the coatings in the opposite direction: its intensity sinks to zero,

whilst the potentials are almost wholly restored. Both the charges and potentials are now of the opposite sign to what they were at first; the series of phenomena is repeated, but in the opposite direction, being then reversed once more, and so on, until the vibrations gradually die away, in consequence of loss of energy, and thus the stage of quiescence is reached. We have a permanent transmutation of the potential and kinetic forms of energy as in the case of a swinging pendulum.

It was to be expected that the phenomena of the discharge would be determined by relations existing between the dimensions of the electrical constants of the discharge circuit, namely, capacity, self-induction, and resistance, the definition of which terms we will assume to be understood. It was not, however, until the theoretical investigations of Sir William Thomson (Lord Kelvin) in England and Professor Gustav Kirchhoff in Germany, that a clear idea was obtained

into the possible eventualities and the conditions to which they are subjected.

We will now proceed to mathematical deductions, valuing the above-mentioned constants in accordance with the conditions prevailing in the appliances used in wireless telegraphy.

In a discharging circuit in which C represents the capacity, L the self-induction, W the total resistance, and E the difference of potential between the coatings of the condenser (with a charge, Q), the discharge generates a current, i , in accordance with the equation

$$i = -\frac{E - L \frac{di}{dt}}{W}, \text{ wherein } t \text{ represents the time.}$$

Moreover, $E = \frac{Q}{C}$ and $i = -\frac{dQ}{dt}$.

By substitution we obtain the differential equation

$$\frac{d^2Q}{dt^2} + \frac{W}{L} \frac{dQ}{dt} + \frac{Q}{CL} = 0.$$

This is satisfied by $Q = Ae^{at}$

Thus we obtain for a the equation

$$a^2 + \frac{W}{L}a + \frac{1}{LC} = 0,$$

whence

$$a = \frac{W}{2L} \pm \sqrt{\frac{W^2}{4L^2} - \frac{1}{LC}}.$$

If the roots are real, we have to do with a progressively decreasing discharge. If, on the contrary, the roots are imaginary, *i.e.* if

$$\frac{1}{LC} > \frac{W^2}{4L^2},$$

or

$$W < 2\sqrt{\frac{L}{C}},$$

we obtain, by introducing trigonometrical functions,

$$Q = e^{-\frac{Wt}{2L}} \left(B_1 \cos t \sqrt{\frac{1}{LC} - \frac{W^2}{4L^2}} + B_2 \sin t \sqrt{\frac{1}{LC} - \frac{W^2}{4L^2}} \right);$$

that is to say, the discharge becomes oscillatory, with the periods

$$T = \frac{2\pi}{\sqrt{\frac{1}{LC} - \frac{W^2}{4L^2}}}$$

To determine B_1 and B_2 , which, although arbitrary, may be taken as real, we may employ for our purpose the conditions

$$\text{for } t=0: Q=Q_0 \text{ and } \frac{dQ}{dt}=0.$$

This gives

$$\begin{aligned} B_1 &= Q_0 \\ B_2 &= \frac{Q_0 W}{2L\sqrt{\frac{1}{LC} - \frac{W^2}{4L^2}}} \end{aligned}$$

Hence we have

$$Q = Q_0 e^{-\frac{Wt}{2L}} \left(\cos t \sqrt{\frac{1}{LC} - \frac{W^2}{4L^2}} + \frac{W}{2L\sqrt{\frac{1}{LC} - \frac{W^2}{4L^2}}} \sin t \sqrt{\frac{1}{LC} - \frac{W^2}{4L^2}} \right).$$

$$\text{By setting } t \sqrt{\frac{1}{LC} - \frac{W^2}{4L^2}} = 2\pi \frac{t}{T},$$

we then have

$$Q = Q_0 e^{-\frac{Wt}{2L}} \left(\cos 2\pi \frac{t}{T} + \frac{W}{2L\sqrt{\frac{1}{LC} - \frac{W^2}{4L^2}}} \sin 2\pi \frac{t}{T} \right).$$

The expression in brackets is of the form

$$a \cos x + b \sin x = c \sin (x + \phi),$$

in which ϕ represents the phase-displacement and is determined from

$$\operatorname{tg} \phi = \frac{a}{b}.$$

Since

$$c = \sqrt{a^2 + b^2}$$

then

$$Q = Q_0 e^{-\frac{Wt}{2L}} \left(\frac{1}{\sqrt{\frac{4L}{CW^2} - 1}} \sin 2\pi \frac{t}{T} + \phi \right).$$

When, as in our case, $\frac{W^2}{4L^2}$ can be neglected in comparison with $\frac{1}{LC}$ the expression for the duration of the vibration is :

$$T = 2\pi \sqrt{LC}.$$

The *damping* is found from the ratio between the values of two successive amplitudes, *i.e.* :

$$\frac{e^{-\frac{Wt}{2L}}}{e^{-\frac{W(t+T)}{2L}}} = e^{-\frac{WT}{2L}}$$

which may be written as the logarithmic decrement, *S* :

$$S = \pi W \sqrt{\frac{C}{L}}.$$

Here we may already mention—though the matter will be reverted to later—that *W* does not represent the constant ohmic resistance, but constitutes in the appliances for wireless telegraphy, as in all discharges through the path of a spark, a still unknown function of the quantity of electricity, the potential and the frequency.

Hence there is a well-marked limit, defined by $W = 2\sqrt{\frac{L}{C}}$, separating aperiodic discharges from oscillating ones.

A representation of the progress of aperiodic discharges with two different resistances, both situated above the critical limit, is given in fig. 2. During the discharge the potential gradually sinks to zero, the time consumed increasing with the resistance. The resulting current increases to a maximum, and then sinks to zero again.

The progress of an oscillatory discharge is graphically illustrated in fig. 3, which represents a damped sinoidal vibration. The potential and the intensity of the current diminish progressively, the maximum of the latter, however, coinciding with the zero points of the potential, and *vice versa*.

In both figures the abscissæ indicate periods of time, the ordinates the momentary potential. Both curves were plotted with an improved Helmholtz pendulum, made in accordance with the instructions of my esteemed instructor, Professor A. Kleiner of Zürich.

Of course, only the oscillations are applicable to wireless telegraphy, and it is evidently a point of extreme importance to keep the resistance of the path of the discharge as low as possible.

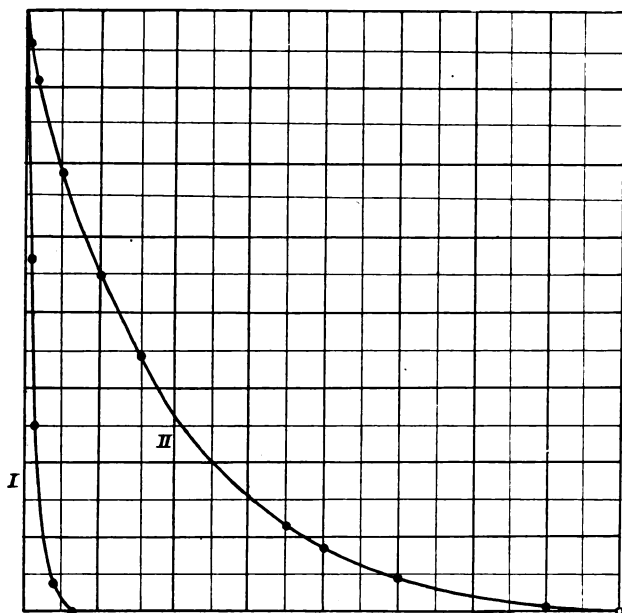

FIG. 2.—Aperiodic Discharges.

CLOSED OSCILLATION SYSTEMS.

As first employed by Professor Braun, it is now almost universally the practice to use a Thomson-Kirchhoff electrical oscillation circuit for **generating** powerful vibrations.

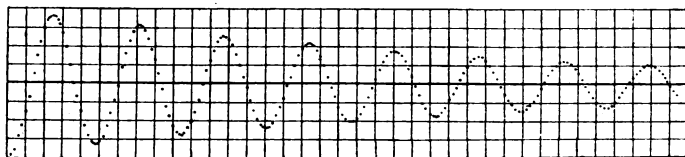

FIG. 3.—Damped Sinoidal Vibrations.

The special arrangement of this apparatus is diagrammatically illustrated in fig. 4. To represent the capacity it contains two groups of Leyden jars, $C_1 C_2$, the outer coatings of which are connected together by means of the self-induction coil, L , whilst the inner

coatings lead to the sparking terminals F_1F_2 , the poles of which are connected to the secondary poles of an induction coil.

When the primary current in J is interrupted, an induction impulse occurs, charging the one inner coating positively and the other negatively. When the discharging potential attains a value corresponding to the length of the spark-gap, the opposing electricities are compensated, the inner coatings through the spark-gap, the outer coating through the coil L . This compensation is oscillatory, and only possible along the path indicated, since the discharge cannot traverse the secondary circuit of the induction coil, owing to the very high self-induction, *i.e.* the excessive inductive resistance of the latter.

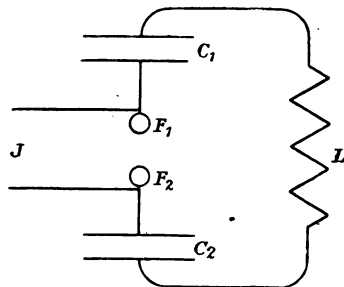

FIG. 4.—Braun's closed Oscillation Circuit.

An oscillation circuit of this kind is entirely closed during the discharge, but it consists of two symmetrical halves, in which equal quantities of electricity move simultaneously in opposite directions, so that no appreciable external effect is produced. The case is analogous to that of a tuning-fork held freely in the hand absorbing a very large amount of energy when struck; the prongs, however, vibrate simultaneously in opposite directions, and the ear is only able to detect a very faint sound, even at a short distance.

To formulate the case in electrophysical terms, it must be stated that to each current element belongs a diametrically opposed element of equal length and direction; in each the current is of equal amplitude and phase, but of opposite sign, regarded from a point at a great distance. The distance between the current elements is small in comparison with the wave length, as the whole circuit is small compared with the wave length. Therefore the partial-fields of the two current elements act against each other and the amplitude at the resulting field nearly equals the difference of the amplitudes of the partial-fields, *i.e.* they almost compensate each other. It may also be said that such a condenser circuit, the individual wave length of which is very great in comparison with the length of the discharger (L), produces practically no external lines of force. Consequently, in accordance with the axiom of Poynting, it radiates little or no energy.

These preliminary considerations may be summed up by the statement that a closed condenser is only suitable for generating electrical oscillations.

OPEN OSCILLATION SYSTEM.

From the foregoing it is evident, therefore, that other means had to be adopted in order to transmit the electrical energy to a distance. This is accomplished by the Hertz oscillator, the principle of which can be seen by reference to fig. 5.

A straight wire, $a b$ (with or without the metal plates $C_1 C_2$ for increasing the capacity), is interrupted by a spark-gap F , connected in turn with the secondary poles of an induction coil J . The discharge of such an **open system** also proceeds in oscillations, provided the

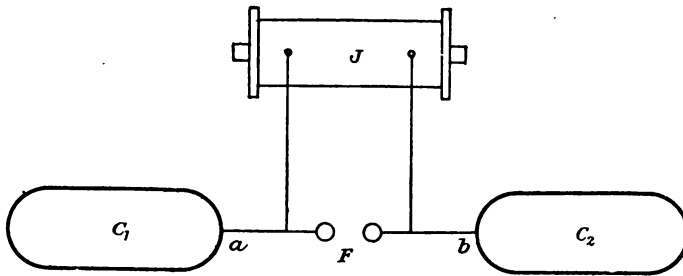

FIG. 5.—The Hertz Oscillator.

known condition for their production is fulfilled; and at each semi-oscillation the poles of the system become alternately positive and negative by the backward and forward flow of the charge. The two halves of the wire, however, take up not only potential but also an appreciable amount of current, so that lines of magnetic force are developed in planes perpendicular to the axis of the wire. The conversion of electrical energy into magnetic energy begins after the electrical lines of forces have attained their numerical maximum, and then commence to withdraw into the conductor.

Hertz pointed out the peculiar property of the external lines of force (those which have extended furthest away from the conductor of the electrical vibrations), namely, that they separate from the rest as closed lines of force, which pass off into space and return no more. The initial energy is thus diminished by that appertaining to the separated portion, *i.e.* the energy of radiation.

These Hertzian rays traverse space with the velocity of light, and transmit their energy through great distances.

The true source of radiation, however, resides, not in the vibrant conductor, but at a distance of one quarter wave length therefrom, since electrical and magnetic oscillations are mutually retarded, in point of time, by a quarter period. Hence, within the first quarter wave length, electrical and magnetic forces are alternatively of equal and opposite signs, whereby a portion of the energy returns to the oscillator. Beyond this limit, however, differences of time and locality cause the two forces to act in the same sense, so that there the point of radiation is to be found.

Both the electrical and the magnetic forces are of an oscillating nature, oscillating in the periods of the discharge, an electromagnetic wave resulting. Consequently, the wave length can be found from the known equation $\lambda = T \times V = \frac{V}{n}$; wherein λ , T , n , V express the wave length, time of vibration, number of vibrations per second, *i.e.* frequency, and velocity of transmission ($= 3 \cdot 10^{10}$ cm.) respectively.

Marconi in the course of his practical experiments devised arrangements like the one illustrated in fig. 6. This will be easily recognised as a Hertz oscillator arranged vertically, the one half consisting of a wire extending high up in the air (aerial wire or antenna), and the other half of an earth connection. Marconi himself

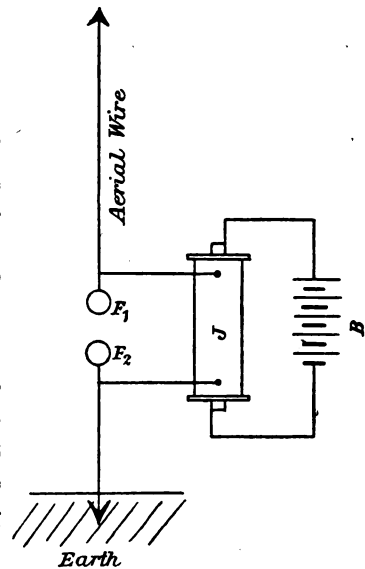

FIG. 6.—Marconi Transmitter.

failed to recognise properly the importance of his air wire, believing that he had to deal with very small waves, generated at the ball terminals and radiated from the entire length of the upright wire. He was led into this error by the Righi radiator, which he used without antennæ in his earlier experiments, and in which the dimensions of the so-called Righi balls actually determined the wave length, which amounted to not more than a few millimetres.

The complete theory of a rod conductor for electrical vibrations

(fig. 7) was enunciated by V. Bjerkness and M. Abraham, from whose results we select the following, as specially important for our purpose.

When the ratio of thickness and length of the rod is sufficiently small (rod-shaped rotation ellipsoid) we have a decided fundamental vibration, the wave length of which is equal to twice the length of the rod.

In addition there are formed approximately harmonic upper vibrations, which, however, are negligible in practice, their intensity being inappreciably small and their cessation occurring earlier than that of the fundamental vibration.

The period of this vibration depends on the dielectric constant of the surrounding medium. An antenna covered with insulating material is of greater capacity than one of naked wire, and therefore gives a somewhat greater wave length.

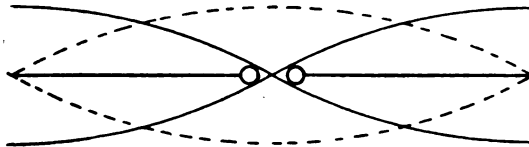

FIG. 7.—Rod Conductor for Electrical Vibrations.

Damping by radiation decreases constantly with the diminished thickness of the rods. The importance of the cage antennæ, or nets used in practice—that is to say, a system of wires laid parallel or conically—resides chiefly in the attainment of increased radiation. As will be more fully dealt with later, P. Drude has shown that, in respect to the increase in the specific periods, such a system of antennæ is equivalent to a single antenna of large diameter; hence, according to the Poynting axiom, these multiple antennæ are also equivalent, in point of radiation, to a single antenna of greater radius (compare also p. 47 *et seq.*).

The current distribution of the rod-shaped conductor (antenna) may be considered as the superposition of a wave running up to the free extremity and of another wave of equal amplitude, but opposite sign of current reflected there. A stationary wave is formed as represented by the dotted lines in fig. 7; whilst the distribution of potential is indicated by the continuous lines, and is naturally directly opposed to that of the current. Nodes of the current are invariably formed at the free ends, *i.e.* the mag-

netic force disappears at these points. The prolongation of the antennal axis represents node lines of magnetic force, and the radiation of the energy of vibration consequently occurs in a lateral direction and not axially.

The chief effect obtained by Marconi in replacing the one half of the excited oscillator by an earth connection was to increase the wave length. Earthing acts like reflection, in so far as the effective wave length is doubled and is then equal to four times the length of the aerial conductor down to the earthing point. In this first practical appliance for wireless telegraphy, the energy is both generated and radiated. A short examination of the conditions with regard to energy will soon enable us to decide on the advisability of such a method.

The energy is determined by the expression $\frac{CV^2}{2}$, in which C is the capacity and V the discharge potential. The capacity of a simple aerial wire is very small. Even if large metal surfaces were suspended therefrom, as was proposed by Lodge, the gain would be slight; and in any case a limit is quickly imposed, on practical grounds. In fact, the discharge potential alone would come into consideration; and this is determined by the length of the spark-gap. Now the resistance of the latter increases very rapidly with the length, especially when the quantities of electricity passing over are small. The damping of the vibrations by resistance is excessive, and we soon approach the critical limit of the oscillatory character of the discharges. True, Professor Braun, by introducing a subdivided spark-gap (which we shall have occasion to describe later), enabled this factor of energy to be considerably increased, so that it is now possible to transmit signals over a distance of nearly two hundred miles by simple Marconi apparatus; but, as we shall shortly see, the development of wireless telegraphy has brought us to a territory in which new demands presented themselves.

At all events, it may be concluded, from these considerations, that the best course is to utilise **the open oscillation system solely for the dispatch of energy.**

CHAPTER III.

COUPLED SYSTEMS.

THE COUPLING.

IN acoustics, when it is desired to obtain the maximum tone from a tuning-fork, it is necessary to mount the latter on a sounding box, or resonator, responding to the same note. Now, we have already compared the tuning-fork to the closed circuit of electrical oscillations: and the best analogy for the open system is the sounding box. The aerial wire and the sounding box fulfil identical functions, namely, to transmit to the environment the energy of the relatively undamped system with which it is coupled. It is, of course, necessary in electricity also to provide for the fulfilment of the condition of resonance (or, better, syntonny) between the two coupled oscillation systems, in order to increase the radiation of energy to a maximum. In this case the store of energy in the closed circuit is exhausted most quickly; this arrangement is utilised to the best advantage, when as much energy is supplied as is radiated.

With regard to the connection of the closed circuit with the open oscillator, Professor Braun distinguishes between "direct coupling" (fig. 8) and "indirect" or electromagnetic coupling (fig. 9). However, as we shall see later, there is no fundamental difference between them.

The oscillations are generated solely in the comparatively slightly damped condenser circuit of high energy capacity (primary system), which is completely closed by the spark-gap in discharging; and they are transmitted thence to the strongly damped aerial wire, *i.e.* an open, uninterrupted metallic path of low energy capacity (secondary system). We have here to deal with compulsory oscillations.

The effective wave lengths are determined by the frequency, damping, and coupling.

THE COUPLING.

A sufficient definition for the coupling is

$$\tau^2 L_1 L_2 = L_{12}^2,$$

wherein $L_1 L_2$ represent the coefficients of self-induction of the

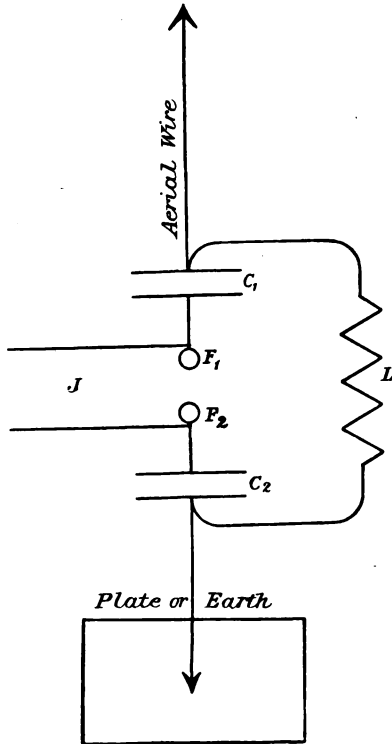

FIG. 8.—Braun's Direct Coupling.

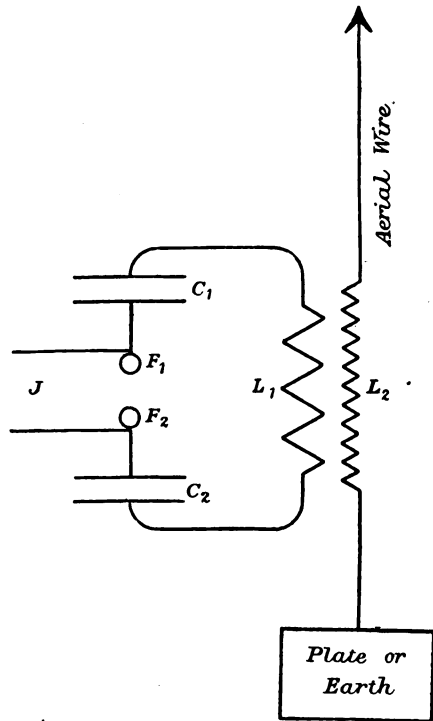

FIG. 9.—Braun's Indirect Coupling.

primary and secondary systems, L_{12} the coefficients of mutual induction, and $\tau^2 = \tau_1 \tau_2$ the coefficients of coupling. The limits for the degree of coupling are determined by $0 \leq \tau \leq 1$. A perfectly rigid coupling, $\tau = 1$, or $L_1 L_2 = L_{12}^2$, *i.e.* where all the lines of magnetic force of the primary system must traverse the current plane of the secondary system, is impossible in appliances for wireless telegraphy, owing to the high self-induction of the free aerial wire.

At the lower end of the same is a coil (the other end of which is connected to the "compensating counter-capacity" or to earth) for effecting the inductive excitation. The larger this coil, the firmer the coupling, in consequence of the higher mutual induction, and *ceteris paribus*, the shorter must the aerial wire be in order to maintain the self potential of the entire secondary system unchanged. Such shortening, however, is effected at the expense of the energy of radiation; and it is also counter to the dictates of experience, namely, that the aerial wire should be as high as possible in order that it may project above surrounding objects.

In practical wireless telegraphy, the degree of coupling therefore varies only between perfectly loose coupling ($\tau=0$) on the one hand, and fairly close coupling on the other. With respect to the effective oscillations—syntony of the individual systems being assumed—the theoretical possibilities are reduced in this manner to two eventualities. By this means the limits of practicability and the maximum results obtainable in any case can be easily surveyed. This we shall also see from the theoretical results obtained by M. Wien, discussed in Chapter V.

The coupling may also be appropriately defined in another way. If we let λ_0 represent the wave common to both systems in the uncoupled condition, and λ_1 and λ_2 the resulting deformed waves after coupling, the following equations apply, damping being neglected.

For the longer waves, $\lambda_1 = \lambda_0 \sqrt{1 + \tau}$.

For the shorter waves, $\lambda_2 = \lambda_0 \sqrt{1 - \tau}$.

For the degree of coupling τ we can deduce, with a fair amount of accuracy, a proportionality to $\frac{\lambda_1 - \lambda_2}{\lambda_0}$.

In this manner the degree of coupling can also be determined experimentally with ease, by measuring the waves present in the coupled system with the aid of the ondiameter described in Chapter VIII.

COMPENSATING THE AERIAL WIRE.

Before concluding these general considerations with regard to the transmitter of wireless telegraphy, it will be necessary to deal with the important problem of the best method of "compensating" the aerial wire.

In fig. 10 the secondary system is again illustrated diagrammatically in symmetrical arrangement. At one end of the coil is the aerial wire, and at the other a perfectly equivalent symmetry wire. At the symmetrical centre Z we have a potential node, and at a and b current nodes. These symmetrical arrangements, on which theoretical calculations are based with regard to the duration of oscillation of the entire system, can rarely be realised in practice. Moreover, the symmetry wire has proved unfavourable, in consequence of increased damping through the generation of heat in accordance with Joule's law, and through radiation. Clearly enough, however, it cannot be simply omitted, but

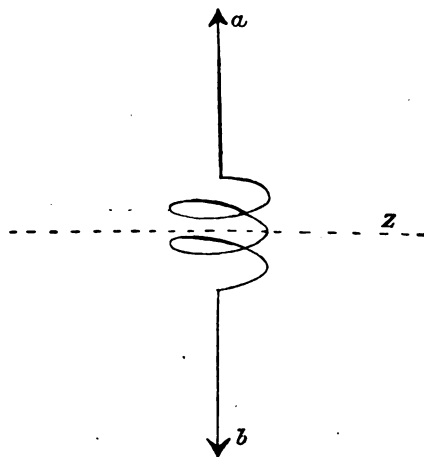

FIG. 10.—Secondary System with Symmetrical Attachments.

must be replaced by a more efficient substitute. The importance of the symmetry wire, and the best substitute for the same, namely, metallic surfaces, were first theoretically elucidated by J. Zenneck. This observer formed the conclusion that the point of attack of the inductive excitation must be at a place of electrical movement (belly of the current), in order to excite oscillations of maximum intensity. This certainly seems quite obvious.

Hence the relative position of the coupled systems must be such as is shown in fig. 11. On the other hand, fig. 12 indicates a false relative position, since in this case the primary coil is situated opposite a current node in the secondary system. If the symmetry wire be cut off in this fashion, it must be supplemented by metallic surfaces, so that the belly of the current may return to the right position.

Fig. 13 gives the arrangement then obtained; and it follows—not merely from the foregoing, but also from purely theoretical considerations advanced by P. Drude—that we have to deal with well-defined conditions demonstrating the error of assuming that “earthing” is equivalent to a compensating counter-capacity. It would be more accurate to say that, in case of need, recourse may be

had to earth connection also ; but this is quite impracticable when the soil is of badly conducting material. Earthing has also the drawback

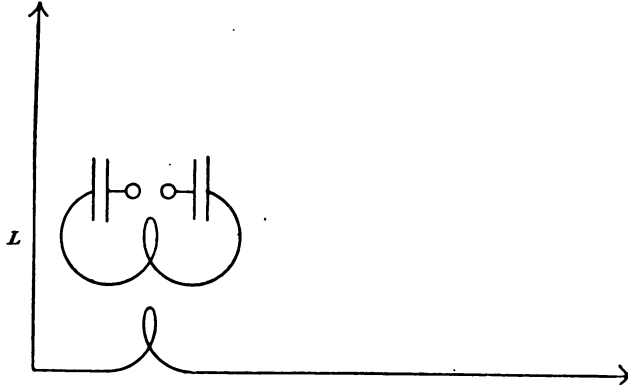

FIG. 11.—Correct Relative Position of the Coupled Systems.

of causing considerable disturbance, by introducing atmospheric discharges.

I have determined experimentally the dimensions of the com-

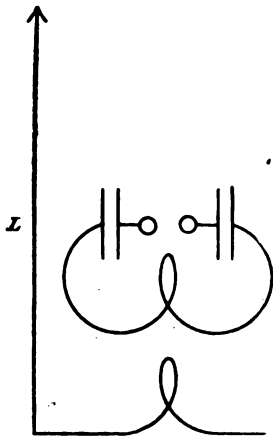

FIG. 12.—Incorrect Relative Position of the Coupled Systems.

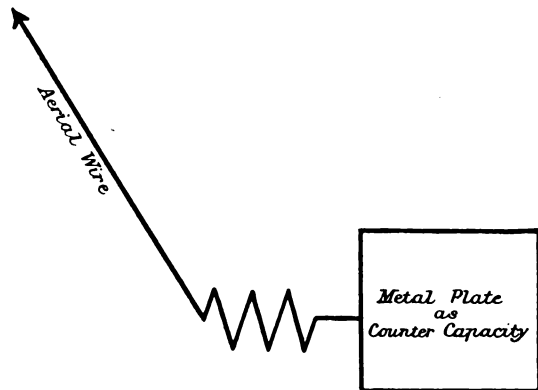

FIG. 13.—Symmetry Wire Supplemented by Metal Plate.

pensating metallic surfaces, the results coinciding almost exactly with the formula (see pp. 50, 55) deduced theoretically by Drude nearly a year later. This circumstance, and other experiments made in the same connection, lead me to consider it improbable that the

earth plays any important part in wave transmission. On account of "earth resistance" in this sense, many at present hold the idea that the metal surfaces should be as large as possible; but according to my researches, with the growing size of the compensating surfaces the theoretical size is at first very quickly and then gradually approached until we reach a corresponding maximum, which in practice shows itself to be the optimum.

If the aerial wire be grounded, it must of course be borne in mind, as already mentioned, that the vibration is thereby lowered; and besides—as L. Mandelstam theoretically deduced—the coupling becomes closer.

CHAPTER IV.

THE RECEIVER.

WE will now turn to a brief preliminary consideration of the receiving instrument and its development.

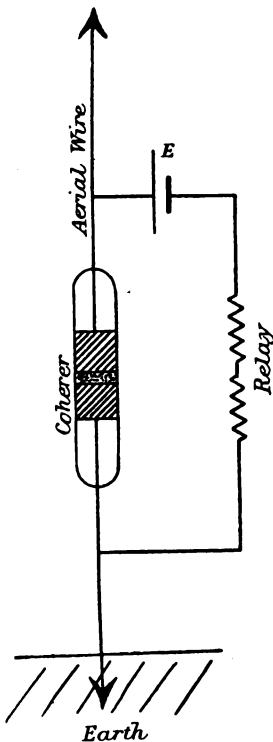

FIG. 14.—Arrangement of the Coherer.

The important component for detecting the electrical impulse is the coherer. This consists, as shown in figs. 14 and 15, of loose metallic powder or granules, packed into a small space r between the terminal surfaces of two metallic electrodes m , the whole being enclosed in a glass or ebonite tube. One electrode is connected to the aerial wire collecting the electrical impulses, the other to the earth. In its ordinary condition, the coherer forms an imperfect contact, the high resistance of which in the circuit of the element E prevents the passage of the current. As soon, however, as the electrical impulses are received, the resistance of the coherer sinks to a very low value. A current then passes, and, by means of a relay, actuates a more powerful circuit (Battery B), as shown in fig. 15. In addition to a Morse instrument, this circuit includes a tapper for the purpose of gently shaking the coherer into the non-conducting state again after each exposure to radiation, and thus making it sensitive to new impulses.

Through shorter and longer radiation we obtain in this manner the dots and dashes of the Morse alphabet, and thus wireless messages are received.

Opinions differ widely as to the actual manner in which the coherer acts, and correspondingly numerous theories have been advanced. It is hardly necessary to repeat them, beyond giving a bibliographical list in the Appendix, to which those who are interested in the matter may refer.

Of importance, however, are the properties of the coherer, which have now been definitely established and may be summarised as follows. The coherer reacts on fluctuations in potential, even when

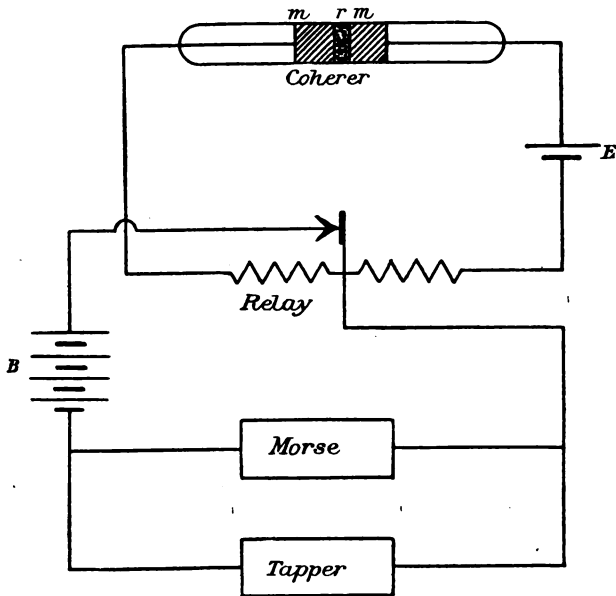

FIG. 15.—Arrangement of Receiving Instrument, with Coherer, Relay, Morse, and Tapper.

the amounts of energy are exceedingly minute and transitory. Its sensitiveness to the rapidly alternating differences of potential of the vibrations pulsating in the receiver is so enormous that the most sensitive galvanometer is inferior by comparison.

In its ordinary condition the coherer must be regarded as high resistance and low capacity; and it is just these two properties that have rendered possible the evolution of the modern receiver, which—omitting intermediate stages of development—is illustrated diagrammatically in fig. 16.

In this case, also, coupled systems are employed. A primary circuit with the capacity C and the self-induction L_1 is connected

with the attachments (aerial wire—counter-capacity). The coherer is situated in the completely closed, induced secondary circuit with the small capacity C_r and the high self-induction L_2 . The secondary system is thus developed into an independent and but slightly damped form, capable of resonance. The capacities are furnished by variable air condensers.

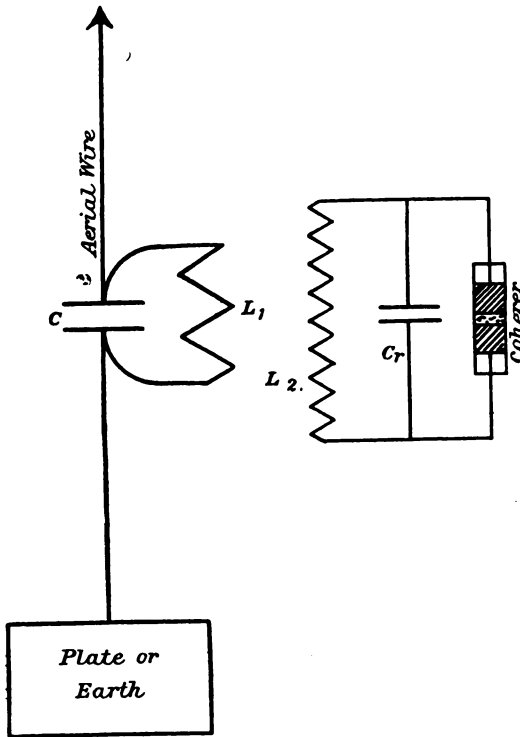

FIG. 16. — Receiver with Tunable Secondary Circuit.

the effective oscillation of the sender is not merely possible, but essential, especially in the secondary system. The capacity of the attachments for the primary circuit, and the small capacity of the coherer for the secondary circuit must be reckoned as supplementary capacities in tuning.

If the sender had anything approaching the ideal properties of such a highly developed receiver, the sphere of activity of wireless telegraphy would be capable of far wider extension than now possible.

As we shall soon see, a decisive part is played by the suitable distribution of capacity and self-induction, and of the degree of coupling between the attachments and the primary circuit, as well as between the latter and the secondary system.

Such an arrangement would be impossible if the coherer had to be regarded as a high capacity or as a conductor.

The accurate tuning of the receiver to

CHAPTER V.
THEORETICAL RESULTS FURNISHED
BY THE SENDER.

IT was stated on p. 12 that the theory of the simple Hertz oscillator, in the form used by Marconi, was elaborated by V. Bjerkness and M. Abraham. As the Marconi sender now possesses little more than historic value, the principal results already given appeared to be sufficient.

With regard to the modern coupled system we are chiefly indebted to M. Wien for his very lucid theoretical explanations, which I have the greater inducement to reproduce, inasmuch as they are the base of the recent work carried on at the Braun-Siemens Baltic experimental station by me in conjunction with L. Mandelstam, for the purpose of establishing a system of selective electric wave telegraphy, *i.e.* wireless multiplex telegraphy, which object was accomplished with a degree of perfection previously unattained.

Additional valuable work has been done, especially by P. Drude, M. Abraham, and L. Mandelstam, in respect of the thorough elucidation of the phenomena of vibrations in these coupled systems. These works we shall have occasion to refer to frequently.

Coupled vibrating elastic systems had previously been dealt with, in a general manner, by M. Wien in his publication on the reaction of a resonant system. He took, as a starting-point, the interesting acoustic experiments conducted by Warburg in 1868; also the theoretical labours of J. von Geitler on undamped coupled electrical systems (electric- or force-coupling), and the work of Galitzin and Overbeck on magnetic- or acceleration-coupling. In his publication *On the Employment of Resonance in Wireless Telegraphy*, the developed equations were applied to the special conditions of the coupled electrical system of wireless telegraphy, more particularly in connection with inductive electromagnetic-coupling.

In considering the case of resonance, Wien assumed the primary and secondary systems as each having a single degree of freedom. This is a special instance in the domain of the vibrations of systems with several degrees of freedom, the laws of which are elucidated by Lord Rayleigh in his "Theory of Sound."

The reasons why very close coupling is impossible in apparatus for practical wireless telegraphy have been already stated on p. 15; and it was on these grounds that Wien very properly neglected the square of the damping and coupling in comparison with the square of the frequency.

Hence we have as a starting-point the two simultaneous differential equations of the coupled elastic systems for damped oscillations, and they run as follows for the force coupling:—

$$\text{I. } \begin{cases} \frac{d^2x_1}{dt^2} + 2h_1 \frac{dx_1}{dt} + K_1^2 x_1 + \tau_1 K_1^2 x_2 = 0. \\ \frac{d^2x_2}{dt^2} + 2h_2 \frac{dx_2}{dt} + K_2^2 x_2 + \tau_2 K_2^2 x_1 = 0. \end{cases}$$

This furnishes the differential equation of the fourth order:

$$\text{II. } \begin{cases} \frac{d^4x}{dt^4} + \frac{d^3x}{dt^3} 2(h_1 + h_2) + \frac{d^2x}{dt^2} (K_1^2 + K_2^2 + 4h_1 h_2) \\ + \frac{dx}{dt} 2(h_2 K_1^2 + h_1 K_2^2) + K_1^2 K_2^2 (1 - \tau_1 \tau_2) = 0; \end{cases}$$

and this in turn, for $n = \delta + i\nu$, the biquadratic equation.

$$\text{III. } \begin{cases} n^4 + 2(h_1 + h_2)n^3 + (K_1^2 + K_2^2 + 4h_1 h_2)n^2 + 2(h_2 K_1^2 + h_1 K_2^2)n \\ + K_1^2 K_2^2 (1 - \tau_1 \tau_2) = 0. \end{cases}$$

$$\text{IV. } \begin{cases} \text{The roots have the form:—} \delta \pm i\nu_1 \\ \text{and } -\delta_2 \pm i\nu_2. \end{cases}$$

The same applies to acceleration-coupling, which differs from force-coupling in dimensions of the second order alone, which can be neglected for the electrical system. The two simultaneous differential equations for acceleration coupling are

$$\text{V. } \begin{cases} \frac{d^2x_1}{dt^2} + \tau_1 \frac{d^2x_2}{dt^2} + 2h_1 \frac{dx_1}{dt} + K_1^2 x_1 = 0. & \frac{d^2x_2}{dt^2} + \tau_2 \frac{d^2x_1}{dt^2} + 2h_2 \frac{dx_2}{dt} + K_2^2 x_2 = 0. \end{cases}$$

By introducing the electrical dimensions of the primary and secondary systems:

W_1 and W_2 for the resistances,
 L_1 and L_2 for the self potentials,
 C_1 and C_2 for the capacities, and
 L_{12} for the coefficient of mutual induction,
 we have the

$$\text{Number of vibrations in } 2\pi \text{ seconds} \dots K_1^2 = \frac{1}{L_1 C_1}; K_2^2 = \frac{1}{L_2 C_2}.$$

$$\text{Damping} = h \dots h_1 = \frac{W_1}{2L_1} \quad L_2 = \frac{W_2}{2L_2}.$$

$$\text{Coefficient of coupling} = \tau \dots \tau_1 = \frac{C_2}{C_1} \cdot \frac{L_{12}}{L_1}; \quad \tau_2 = \frac{C_1}{C_2} \cdot \frac{L_{12}}{L_2}.$$

Consequently for the oscillating potential V of the electro-magnetic coupled system, we have :

$$\text{VI.} \quad \begin{cases} \frac{d^2 V_1}{dt^2} + \frac{C_2}{C_1} \cdot \frac{L_{12}}{L_1} \frac{d^2 V_2}{dt^2} + \frac{W_1}{L_1} \frac{dV_1}{dt} + \frac{V_1}{L_1 C_1} = 0. \\ \frac{d^2 V_2}{dt^2} + \frac{C_1}{C_2} \cdot \frac{L_{12}}{L_2} \frac{d^2 V_1}{dt^2} + \frac{W_2}{L_2} \frac{dV_2}{dt} + \frac{V_2}{L_2 C_2} = 0. \end{cases}$$

With the individual systems in perfect syntony, the number of oscillations per 2π seconds will be: $n_1 = \frac{1}{L_1 C_1} = n_2 = \frac{1}{L_2 C_2}$.

$$\text{The coefficients of coupling: } \tau_1 = \frac{L_{12}}{L_2} \quad \tau_2 = \frac{L_{12}}{L_1}.$$

$$\tau = \sqrt{\tau_1 \tau_2}.$$

According to IV. the solution of the differential equations must be

$$\begin{aligned} V_1 &= A_1 e^{-\delta_1 t} \sin(\nu_1 t + \phi_1) + B_1 e^{-\delta_2 t} \sin(\nu_2 t + \psi_1) \\ V_2 &= A_2 e^{-\delta_1 t} \sin(\nu_1 t + \phi_2) + B_2 e^{-\delta_2 t} \sin(\nu_2 t + \psi_2). \end{aligned}$$

Hence there are formed, in general, two common but mutually independent oscillations, differing in number, ν_1 and ν_2 , and in damping, δ_1 and δ_2 .

The relations of the amplitudes A_2/A_1 , B_2/B_1 , and $\nu_1 \nu_2$, $\delta_1 \delta_2$, are determined by the constants n_1 and n_2 , h_1 and h_2 , τ_1 and τ_2 , of the individual systems. The absolute values of $A_1 B_1$ and the phase constants $\phi_1 \phi_2$, $\psi_1 \psi_2$, are arbitrary, or rather depend on the initial conditions, *i.e.* on the method of exciting the oscillations.

The relation between the amplitudes in both systems is determined by the following equation, in which the influence of the damping (δ_1^2) may be neglected with reference to the number of oscillations (ν_1^2).

$$\frac{A_2}{A_1} = \frac{\nu_1^2 \frac{L_{12}}{L_1}}{\sqrt{(\nu_1^2 - n^2)^2 + 4 \left(h_2 \nu_1 - \delta_1 \frac{n^2}{\nu_1} \right)^2}};$$

and accordingly

$$\frac{B_2}{B_1} = \frac{\nu_2^2 \frac{L_{12}}{L_1}}{\sqrt{(\nu_2^2 - n^2)^2 + 4 \left(h_2 \nu_2 - \delta_2 \frac{n^2}{\nu_2} \right)^2}}.$$

The roots of our equation of the fourth degree (III.) are (IV.):

$$\pm i \nu_1 - \delta_1 = \pm i (Q - R) - \left(\frac{h_1 + h_2}{2} - S \right)$$

$$\pm i \nu_2 - \delta_2 = \pm i (Q + R) - \left(\frac{h_1 + h_2}{2} + S \right),$$

$$\text{wherein } Q = \sqrt{\frac{a}{2} - \frac{a^2 - 4c}{8a}}; \quad R \left\{ \begin{array}{l} \\ S \end{array} \right\} = \sqrt{\frac{\sqrt{(a^2 - 4c)^2 + 8ab^2 \pm (a^2 - 4c)}}{16a}};$$

$$\text{and } a = n_1^2 + n_2^2 + \frac{(h_1 - h_2)^2}{2}; \quad b = -(h_1 - h_2)(n_1^2 - n_2^2).$$

$$a - 4c = (n_1^2 - n_2^2)^2 - (2h_1 - h_2)^2(n_1^2 + n_2^2) + 4\tau^2 n_1^2 n_2^2.$$

It is now necessary to consider that in coupled systems of wireless telegraphy we have to deal with very unequal damping of the component systems. For the case of resonance ($n_1 = n_2 = n$), we shall have

$$a = 2n^2 - \frac{(h_1 - h_2)^2}{2}, \quad b = 0, \quad a^2 - 4c = -4(h_1 - h_2)^2 n^2 + 4\tau^2 n^4.$$

$$Q = n\sqrt{1 - \frac{\tau^2}{4}}, \quad R = \sqrt{\frac{\tau^2 n^2 - (h_1 - h_2)^2}{4}}, \quad S = 0.$$

We have now to distinguish between two classes—

Class A, in which the coupling predominates;

Class B, in which the damping is the prime factor.

Class A is limited by $\tau n > h_1 - h_2$.

$$\text{Hence} \quad \delta_1 = \delta_2 - \frac{h_1 + h_2}{2}$$

$$\text{and} \quad \nu_1 = n\sqrt{1 - \frac{\tau^2}{4}} + \sqrt{\frac{\tau^2 n^2 - (h_1 - h_2)^2}{4}};$$

$$\nu_2 = n\sqrt{1 - \frac{\tau^2}{4}} - \sqrt{\frac{\tau^2 n^2 - (h_1 - h_2)^2}{4}};$$

or, since $\tau^2 n^2$ may be neglected, for reasons already given :

$$\begin{aligned} \nu_1 &= n + \frac{1}{2} \sqrt{\tau^2 n^2 - (h_1 - h_2)^2}, \\ \nu_2 &= n - \frac{1}{2} \sqrt{\tau^2 n^2 - (h_1 - h_2)^2}. \end{aligned}$$

Result: Equal damping and unequal number of oscillations.

Class B is limited by $\tau n < h_1 - h_2$.

Then $\nu_1 - \nu_2 = n$,

and

$$\begin{aligned} \delta_1 &= \frac{h_1 + h_2}{2} + \frac{1}{2} \sqrt{(h_1 - h_2)^2 - \tau^2 n^2}, \\ \delta_2 &= \frac{h_1 + h_2}{2} - \frac{1}{2} \sqrt{(h_1 - h_2)^2 - \tau^2 n^2}, \end{aligned}$$

or approximately,

$$\delta_1 = h_1 + \frac{\tau^2 n^2}{4(h_2 - h_1)}, \quad \delta_2 = h_2 - \frac{\tau^2 n^2}{4(h_2 - h_1)}.$$

Result: Equality in the number of oscillations, but unequal damping.

Before going on to discuss further the two classes, we will briefly summarise a purely general theory enunciated by L. Mandelstam for any coupled sender, the damping being assumed as slight.

For an arrangement with m closed oscillation circuits, in which c, f , and p represent the equal capacities and self-inductions respectively, we have for the fundamental oscillation,

$$n = \frac{\pi}{2\sqrt{PC}} \left(\frac{4m}{\pi} \sin \frac{\pi}{4m+2} \right);$$

wherein $C = mc$ and $P = mp$, denoting respectively the total capacity and self induction.

For $m = 10$, the bracketed fraction differs from 1 by merely a small percentage, *i.e.* with reference to the fundamental oscillation such an arrangement replaces (m being sufficiently large) an open system (aerial wire) of equal self-induction and capacity. This applies equally to the distribution of current and tension.

In the case of two coupled systems, the primary closed and the secondary open, Mandelstam established for calculating the frequency n the equation,

$$\frac{1}{L_1 n} - C_1 n = \frac{L_2}{L_1} \sqrt{\frac{E}{L}} \frac{\sin n \sqrt{LEl} \sin n \sqrt{LEl_1}}{\sin n \sqrt{LE(l+l_1)}};$$

and for calculating the current amplitudes A and B,

$$A \left(\frac{1}{C_1} - L_1 n^2 \right) - M n^2 B = 0;$$

$$A M n^2 + (L_2 n^2 - f) B = 0.$$

Here C_1 and L_1 , C_2 and L_2 , represent the capacity and self-induction of the primary and secondary systems respectively; M the coefficient of mutual induction; E and L the capacity and self-induction per unit of length; l and l_1 the lengths of the secondary attachments f a trigonometrical function dependent on n , p , c , and m .

The equation for the frequency has an infinite number of real roots corresponding to the upper oscillations. In the interval,

$$\frac{\pi}{\sqrt{LEl}} > n > 0,$$

there are two real roots, corresponding to the two main oscillations.

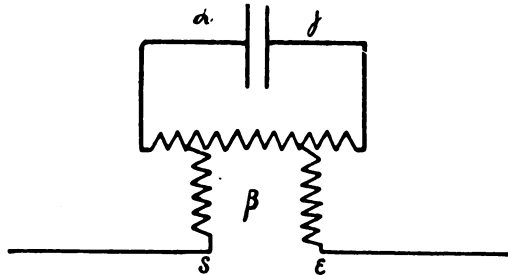

FIG. 17.—General Scheme for Coupled Senders.

These two deepest oscillations alone come under consideration in practice; and one of them is deeper, the other higher, respectively than the deepest and highest individual oscillations of the two systems.

Mandelstam also shows how the direct coupling (fig. 17) can be traced back to the inductive coupling, the unity of principle having been previously demonstrated by J. Zenneck. All the equations concerned retain their form, provided L_1 be understood to represent the self-induction $\alpha \beta \gamma$, L_2 the self-induction $\delta \beta \epsilon$, and M that of the portion of L_1 and L_2 common to both. The direct coupling possesses the advantage that, in order to obtain the same degree of coupling, the number of windings in the aerial wire can be smaller than with inductive coupling.

We will now revert to the special deductions of Wien, the results of which may be formulated as follows:—

A. *In close coupling* (but not quite fast coupling, which, as repeatedly mentioned, is practically impossible), when given absolute syntony of the component systems, one of the resulting oscillations is as much above the common specific tone as the other is below it. Both have practically the same damping, namely, equal to the arithmetical mean of the dampings of the component systems.

In consequence of the unequal frequency of the two resulting oscillations, beats occur throughout the entire oscillation, and occasionally give rise to increased amplitudes of potential. Wien also shows that if the specific tones of the component systems did not exactly correspond, the resulting frequencies would be more divergent than in case of syntony (perfect resonance). Beats are then present at the outset only, and disappear the sooner the greater the difference is in the two frequencies.

B. *In the case of loose coupling—i.e.* when damping is the prime factor—only a single oscillation is effective, the numerical value of whose frequency coincides with the common specific tone of the component systems (which should be equalised as closely as possible, in order to obtain maximum resonance). The damping is slight, since by means of perfectly loose coupling it can be reduced to the relatively small value of the damping of the primary circuit. (Theoretically there result two equal frequencies with very divergent damping; but the one damping is enormous, nearly equal to that of the open system, so that the corresponding oscillation, which is of weak energy, disappears almost immediately, and can therefore be practically disregarded.)

COMPARATIVE MEASUREMENTS IN THE SENDER. CONSEQUENCES OF THEORY.

In the measurements performed at the Baltic experimental stations the results obtained were completely in harmony with those of theory.

In the resonance curves (fig. 18), obtained with the aid of the ondameter, the description and functions of which will be found in Chapter VIII., the abscissæ correspond with the wave lengths, the ordinates with the squares of the current intensities which are registered by the Riess thermometer of the ondameter.

The curve in full lines refers to class A (close coupling).

Two waves result: $\lambda_1 = 230$ metres, and $\lambda_2 = 330$ metres.

In this case the dampings are unequal because the specific wave lengths of the component systems were unequal, measuring λ prim. 260 metres and λ sec. 280 metres respectively.

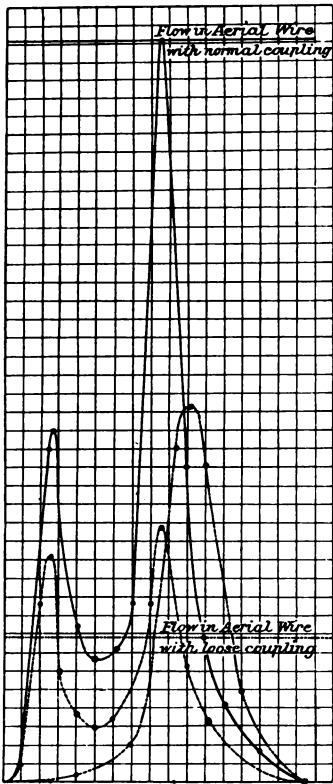

FIG. 18.—Resonance Curves.

The resulting deeper oscillation is the more slightly damped one, as indicated by the dotted curve. The latter is obtained by artificially increasing the damping in the resonance circuit, whereby the already strongly damped upper oscillation is influenced to a smaller extent than the less damped deeper oscillation.

Class B (loose coupling) is indicated by the curve $\dots\dots$ (the component systems were in syntony in this measurement). It reveals the presence of only a single effective oscillation; and at the same time a comparison of the resonance curves with the corresponding level of the flow in the aerial wire (marked by horizontal lines in the figure) confirms the fact that the damping has throughout the lowest value in loose coupling.

Turning again to the measurement in class A, and assuming

perfect syntony of the component systems, together with the following data:—

Specific wave length, $\lambda = 280$;

consequent frequency, $N = \frac{3 \times 10^{10}}{2.8 \times 10^4} = 1.07 \times 10^6$;

or per 2π seconds, $n = 2\pi \times 1.07 \times 10^6 = 6.723 \times 10^6$.

Primary self-induction, $L_1 = 3.5 \times 10^3$ centimetres;

hence primary capacity, $C_1 = \frac{1}{n^2 L_1} = 0.0063$ microfarad.

Also $L_2 = 4.5 \times 10^5$ centimetres ;
 hence $C_2 = \frac{1}{n^2 L_2} = 4.917 \times 10^{-6}$ microfarad ;
 mutual induction, $L_{12} = 1.3 \times 10^4$ centimetres.

Resistance of primary circuit estimated at 0.5 ohm at the most,
 hence $W_1 = 0.5 \times 10^9$ centimetres.

W_2 , the so-called "effective resistance," which would replace all the losses of energy, is determined from $W_2 = 2L_2 \sqrt{\gamma} = 318$ ohms = 318×10^9 centimetres, wherein γ , the log. radiation decrement, is determined, according to Abraham, by

$$\gamma = \frac{2.44}{\ln \frac{2l}{r}} = 0.33.$$

The length of the aerial wire $l = 65$ metres.

The "effective" radius r (see p. 47) = 10 cm., bearing in mind the multiplex antenna (net) used.

The dampings are

$$\begin{aligned} \text{primary } h_1 &= \frac{W_1}{2L_1} = 7.143 \times 10^4, \\ \text{secondary } h_2 &= \frac{W_2}{2L_2} = 3.53 \times 10^5. \end{aligned}$$

The degree of coupling :

$$\tau = \sqrt{\tau_1 \tau_2} = \sqrt{\frac{L_{12}}{L_2} \times \frac{L_{12}}{L_1}} = 0.3276 \text{ and } n\tau = 2.2 \times 10^6.$$

The resulting numbers of oscillations per 2π seconds should be

$$\begin{aligned} n_1 &= n + \frac{1}{2} \sqrt{\tau^2 n^2 - (h_1 - h_2)^2} = 7.814 \times 10^6, \\ n_2 &= n - \frac{1}{2} \sqrt{\tau^2 n^2 - (h_1 - h_2)^2} = 5.632 \times 10^6; \end{aligned}$$

or the frequencies

$$\begin{aligned} N_1 &= \frac{n_1}{2\pi} = 1.2435 \times 10^6, \\ N_2 &= \frac{n_2}{2\pi} = 0.89635 \times 10^6. \end{aligned}$$

The experimental results (in the absence of syntony) were $\lambda_1 = 230$ metres ; $\lambda_2 = 330$ metres.

or $\text{exp. } N_1 = 1.3 \times 10^6,$
 $\text{exp. } N_2 = 0.9 \times 10^6.$

Consequently in the case of syntony (resonance) the difference in the frequencies is a minimum.

With syntony, both the resulting oscillations would have dampings of no appreciable difference, namely,

$$= \frac{h_1 + h_2}{2} = \frac{(0.714 + 3.53)10^5}{2} = 2.122 \times 10^5,$$

or the log. decrement

$$= \frac{2.122 \times 10^5}{N} = \frac{2.122 \times 10^5}{1.07 \times 10^6} = 0.198 \text{ or } = \frac{1}{5.1}.$$

It is evident that close coupling is not very favourable for the production of well-developed resonance, since in the optimum event ($h_1 = 0$) the damping of the emitted waves could not be reduced by more than half.

Wien showed that close coupling must be utilised in quite a different direction. We know that for different points in space the maximum amplitude values of the oscillating electric and magnetic forces diminish with the distance. The values of the amplitude of potential are, however, the decisive factor, for the coherer at least.

Now, with close coupling, the amplitude ratio—disregarding the quadratic correction terms—is :

$$\frac{A_2}{A_1} = \frac{n + \sqrt{\tau^2 n^2 - (h_1 - h_2)2\tau_2}}{\tau n};$$

or, assuming τn to be large in comparison with $h_1 h_2$, approximately :

$$\frac{A_2}{A_1} = (1 + \tau) \sqrt{\frac{\tau_2}{\tau_1}} = \left(1 + \frac{L_{12}}{\sqrt{L_1 L_2}}\right) \sqrt{\frac{L_2}{L_1}} = \left(1 + \frac{L_{12}}{\sqrt{L_1 L_2}}\right) \sqrt{\frac{C_1}{C_2}};$$

and

$$\frac{B_2}{B_1} = (1 - \tau) \sqrt{\frac{\tau_2}{\tau_1}} = \left(1 - \frac{L_{12}}{\sqrt{L_1 L_2}}\right) \sqrt{\frac{L_2}{L_1}} = \left(1 - \frac{L_{12}}{\sqrt{L_1 L_2}}\right) \sqrt{\frac{C_1}{C_2}}.$$

After half a beat $\left(\frac{1}{2N\tau}\right)$ the phase of the two oscillations in the secondary system is identical; and, neglecting the damping, the maximum potential will be

$$V_2 = A_2 + B_2 = \left\{ A_1 + B_1 + \tau(A_1 - B_1) \right\} \sqrt{\frac{L_2}{L_1}};$$

that is to say, only slightly removed from $(A_1 + B_1) \sqrt{\frac{L_2}{L_1}}$,

or from $V_1 \sqrt{\frac{L_2}{L_1}} = V_1 \sqrt{\frac{C_1}{C_2}}$.

Hence, by close coupling, the amplitude of potential will be increased $\sqrt{\frac{L_2}{L_1}}$ fold that of the primary potential.

In our example, this would give

$$\sqrt{\frac{L_2}{L_1}} = \sqrt{\frac{4.5 \times 10^5}{3.5 \times 10^3}} = 11.4 \text{ times the primary potential.}$$

Owing to the damping during the half beat,

$$\frac{V_2}{V_1} = \sqrt{\frac{L_2}{L_1}} \times e^{-\frac{\delta_1}{2N\tau}} = 8.4 \text{ is more correct.}$$

We operated in the primary circuit with a spark-gap 1 cm. across, corresponding to about 30,000 volts; so that the maximum amplitude of potential of the emitted series of waves was

$$8.4 \times 30,000 = \text{about } 250,000 \text{ volts.}$$

Considerations of energy will render the matter still clearer. The energy of the primary system is

$$\begin{aligned} E &= \frac{CV^2}{2} \\ \text{i.e. for our example} &= \frac{6.3 \times 10^{-18} \times (30,000 \times 10^8)^2}{2} \\ &= 2.835 \times 10^7 \text{ ergs} = 2.835 \text{ watt sec.} \end{aligned}$$

This energy is not very great in itself, but is expended in a very short space of time. As the log. decrement $\frac{1}{5.1}$ expressed, we have 5.1 oscillations before the amplitude has receded to $\frac{1}{e}$ times its initial value. We will assume six oscillations, but will make the restriction that of the total energy during this time of $6 \times 0.93 \times 10^{-6}$ sec., only one-third is converted into useful radiation, so that we thus obtain an effect of

$$\begin{aligned} &\frac{2.835}{3 \times 6 \times 0.93 \times 10^{-6}} \dots \text{watts} = \text{about } 169 \text{ kilowatts,} \\ &\text{or about } 229 \text{ horse-power.} \end{aligned}$$

Hence by close coupling the potential energy of the primary circuit is explosively expelled by means of the secondary system. We obtain

maximum efficiency and therefore transmission through maximum distances, though at the cost of selective possibilities.

In class B, namely, with loose coupling, we have to do with only a single effective oscillation with the damping,

$$\delta_1 = h_1 + \frac{\tau^2 n^2}{4(h_2 - h_1)}.$$

Hence, by perfectly loose coupling, the damping can be reduced to the relative low value of that of the primary circuit, thus fulfilling the condition for the development of a decided resonance.

How does the matter stand, however, with reference to the maximum amplitude of the potential? The amplitude ratio is

$$\frac{A_2}{A_1} = \frac{n\tau_2}{2(h_2 - \delta_1)};$$

or, since δ_1 is small compared with h_2 ,

$$\frac{A_2}{A_1} = \frac{n\tau_2}{2h_2} = \frac{nL_{12}}{2W_2} \times \frac{L_2}{L_1}.$$

To make the relation clear we will perform another calculation with the dimensions already used.

At the border between the two classes we have $\tau n = h_2 - h_1$,

hence
$$L_{12} = \frac{(h_2 - h_1) \sqrt{L_1 L_2}}{n} = 1.52 \times 10^3.$$

Let us now consider the coupling to be loose, and take $L_{12} = 1.3 \times 10^3$.

The coupling is $\tau = 0.03$, hence about $\frac{1}{10}$ th of the close coupling of our example.

Now
$$\delta_1 = h_1 + \frac{\tau^2 n^2}{4(h_2 - h_1)} = 1.144 \times 10^5,$$

hence the decrement is
$$\frac{0.1144 \times 10^6}{1.07 \times 10^6} = \text{about } \frac{1}{10}.$$

We thus have already twice as many oscillations as with close coupling (for which the decrement was about $\frac{1}{10}$ th).

On the other hand the amplitude ratio is

$$\frac{A_2}{A_1} = \frac{n \times L_{12}}{2W_2} \times \frac{L_2}{L_1} = 1.77,$$

or only about one-fifth that with close coupling (= 8.4).

With still looser coupling,

$$\begin{aligned}\tau &= 0.33 \times 10^{-2} \text{ (i.e. } \frac{1}{100} \text{ of close coupling),} \\ L_{12} &= 1.3 \times 10^2 \\ \delta_1 &= 0.718 \times 10^5,\end{aligned}$$

hence the decrement = $0.067 = \text{about } \frac{1}{15}$.

$$\frac{A_2}{A_1} = 0.18 \left(= \text{about } \frac{8.4}{47} \right).$$

We get, therefore, thrice as many oscillations as with close coupling, but with the amplitude of potential diminished forty-seven times.

Consequently, loose coupling affords the possibility of generating feebly damped waves and thus obtaining sharper resonance, though at the cost of intensity.

CHAPTER VI.

THEORETICAL RESULTS AND CALCULATIONS.

THEORETICAL RESULTS AND CALCULATIONS IN RESPECT OF SENDER AND RECEIVER.

THE design of a modern receiver has already been explained by a sketch on p. 22, the primary circuit having high capacity and low self induction, with these conditions reversed in the secondary circuit, the idea being to increase the amplitude of potential, since the coherer reacts on maximum differences of potential.

In pursuing the matter further we will make use of the diagram fig. 19, all four systems being in unison ($R = 280$ metres).

A. *Closely-coupled Sender and Receiver.*

In this case the frequencies in the receiver will be analogous to those in the sender, thus,

$$\nu_3 = n \left(1 + \frac{T}{2} \right) = \nu_1; \quad \nu_4 = n \left(1 - \frac{T}{2} \right) = \nu_2,$$

and the dampings,

$$\delta_3 = \delta_4 = \frac{h_3 + h_4}{2};$$

or if we regard the fully closed secondary receiving system as being undamped,

$$\delta_3 = \delta_4 = \frac{h_3}{2} = \frac{h_2}{2}.$$

It is not worth while to try and ascertain the possibility of a decided resonance between closely coupled sender and receiver; for, as might be expected, this is not greater than in the simple original form of Marconi apparatus, *i.e.* it is practically non-existent.

The advantage again lies in another direction. If the damping of the effective wave were the same in the case of close coupling as

in a simple Marconi system, we should now have in the receiver—as a consequence of the 50 per cent. lower damping—an amplitude twice as great as in the simple systems. However, by means of the secondary coil with numerous windings, the amplitude of potential ($\frac{V_4}{V_3} = \sqrt{\frac{L_4}{L_3}}$) is increased at least 3-fold. Bearing in mind also the previously ascertained 8.4-fold increase of the potential amplitude in the sender, we arrive at the result that

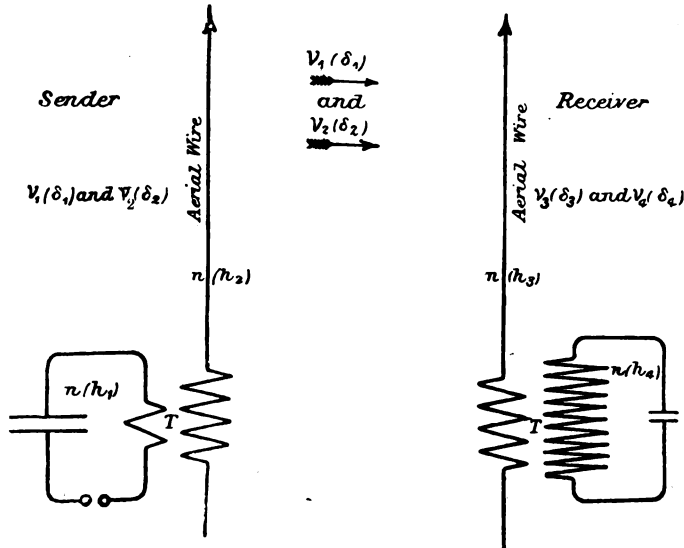

FIG. 19.—General Scheme for Sender and Receiver.

(neglecting the disturbances introduced by the increased distances, such as earth curvature, etc.), a combination of closely coupled sender and receiver enables us to telegraph over a distance $2 \times 3 \times 8.4 =$ about fifty times greater than could formerly be done with the simple Marconi systems which were effective up to about fifteen miles.

In this direction, therefore, resides the advantage of relatively close-coupled systems; and distances of 450 to 600 miles can in this way be bridged over with ordinary installations. Bearing in mind, however, the enfeebling influence of obstructions and the curvature of the earth, the range of normal installations is reduced to about 300 miles, as practical results have demonstrated. Moreover, this presupposes the existence of favourable atmospheric conditions, namely,

moist, un-ionised air. If the atmosphere is not of this character, as is usually the case after a long spell of dry weather, a further 20-30 per cent. must be deducted from the range. The conviction that a large margin of safety must be taken into calculation, coupled with the ever-increasing distances attempted, led to the necessity of supplying larger amounts of energy in the form of effective electric waves. The fulfilment of this endeavour was, however, opposed by difficulties of no slight character, arising from various scientific and technical causes. Nevertheless, this problem also has been solved by Professor Braun, by his method of increasing the effective energy, the principle of which will be described on p. 51 *et seq.*

B. *Loose-coupled Sender and Receiver.*

We have seen that in the sender there is only a single effective oscillation, with the damping $\delta_1 = h_1 + \frac{n^2 T^2}{4(h_2 - h_1)}$, *i.e.* with the damping of the primary circuit by perfectly loose coupling.

Similarly we have in the receiver,

the frequencies

$$\nu_3 = \nu_4 = n,$$

and the dampings, $\delta_3 = h_3 - \frac{n^2 T^2}{4(h_3 - h_4)}$; $\delta_4 = h_4 + \frac{n^2 T^2}{4(h_3 - h_4)}$,

wherein T represents the coefficient of coupling in the receiver.

Since $h_3 = h_2$ is great in comparison with h_4 there is again practically only a single oscillation with the damping δ_4 to be considered.

The secondary circuit of the receiver is completely closed, so that the damping h_4 is very slight; and by perfectly loose coupling, the damping δ_4 could thus be reduced to the very low value h_4 .

Unfortunately, owing to the much greater damping δ_1 of the effective sender wave, there is still no advantage in fully utilising this possibility in the receiver.

In order to find the resulting amplitude ratio, Wien reverted to a result of the Bjerkness theory for simple systems. Bjerkness finds for the maximum amplitude of the receiver

$$M = \frac{A}{2nh_1} \times \left(\frac{h_2}{h_1}\right)^{\frac{h_2}{h_1 - h_2}} = \frac{A}{2nh_2} \left(\frac{h_1}{h_2}\right)^{\frac{h_1}{h_2 - h_1}},$$

Hence the maximum amplitude remains the same, whether a strongly damped sender oscillation excites an undamped receiver, or

whether the effective wave is undamped, and the receiver has the same damping as the sender in the first case. Consequently the equations for compulsory damped oscillation under the influence of a periodic force (the periodicity of which determines the amplitude of both the coupled systems) are applicable.

For the amplitude a_2 in coupled elastic systems, Wien found

$$a_2 = \frac{-E \times \tau_2 K_1^2}{\sqrt{\{(\kappa_1^2 - n^2)(\kappa_2^2 - n^2) - 4h_1 h_2 n^2 - \tau_1 \tau_2 \kappa_1^2 \kappa_2^2\}^2 + 4n^2\{h_1(\kappa_2^2 - n^2) + h_2(\kappa_1^2 - n^2)\}^2}}$$

or for our case:

$$A_4 = \frac{A\nu^2\tau_4}{\sqrt{\{(n^2 - \nu^2)^2 - 4h_3 h_4 \nu^2 - \nu^4 \tau^2\}^2 + 4\nu^2(n^2 - \nu^2)^2(h_3 + h_4)^2}}$$

For $\nu = n$, and neglecting $\nu^2\tau^2$ in comparison with $4h_3 h_4$, the maximum amplitude is

$$M_4 = \frac{A\tau_4}{4h_3 h_4}$$

On the other hand, Bjerckness finds for the maximum, M , of his resonance curve, that is to say, for the maximum potential amplitude in the resonator of the simple systems in unison,

$$M = \frac{A \times X^2}{4\pi\gamma} \left(\frac{\delta}{\gamma}\right)^{\gamma - \delta}$$

wherein X indicates the duration of oscillation, γ and δ the log. decrements in sender and receiver.

For equal damping ($\gamma = \delta$): $M = \frac{A}{4\pi} \times \frac{X^2}{\gamma} \times \frac{1}{e}$;

or by introducing the damping h_1 instead of the decrement

$$M = \frac{A}{2nh_1} \times \frac{1}{e}$$

wherein n represents the number of oscillations in 2π seconds, and $e = 2.71828 \dots$ the basis of the natural log.

In our case, therefore, the maximum amplitude for the simple system is

$$M_0 = \frac{A}{2nh_3 e}$$

Since $h_4 = \delta_4 = \delta_1$, then

$$\frac{M_4}{M_0} = \frac{n\tau_4 e}{2\delta_1} = \frac{nL_{34} e}{2\delta_1 L_3}$$

Let us take still another calculation. L_{34} is determined by the equation given for δ_4 , neglecting the small value h_4 .

$$\tau^2 = \frac{L_{34}^2}{L_3 L_4} = \frac{4h_3 \delta_4}{n^2}.$$

Let $\delta_4 = \frac{\delta_1}{9},$

then $L_{34} = \frac{2}{3n} \sqrt{h_3 \delta_1 L_3 L_4}.$

We have the following data :

$$n = 6.7 \times 10^6, \quad (\text{p. 30})$$

$$h_3 = h_2 = 3.5 \times 10^5, \quad (\text{p. 31})$$

$$\delta_1 = 0.72 \times 10^5, \quad (\text{p. 35})$$

$$L_3 = L_2 = 4.5 \times 10^5, \quad (\text{p. 31})$$

$$L_4 = 9L_3 = 40.5 \times 10^5, \quad (\text{p. 37}).$$

Hence $L_{34} = 2.13 \times 10^4,$
and the amplitude ratio,

$$\frac{M_4}{M_0} = \frac{n L_{34} \times 2.718 \dots}{2 \delta_1 \times L_3} = 5.9.$$

The calculation shows that, given an equal amplitude of the effective waves, the amplitude in the receiver is about six times as great as in the simple system, and about twice as great as with relatively fast coupling. Nevertheless, on the other side we have seen that the low damping necessary to secure such an effect in the receiver could only be obtained through loose coupling in the sender, thus giving rise to a nearly 47-fold diminution of potential amplitude in comparison with close coupling.

The normal range of about 300 miles for the latter is therefore diminished to $\frac{300 \times 2}{47}$, or about $12\frac{1}{2}$ miles when loose-coupled sender and receiver are used.

The slighter the damping, the sharper the resonance, and therefore the smaller the dissonance can be between simultaneous effective oscillations, without the possibility of mutual disturbance.

By means of the graphical illustration reproduced in fig. 20, wherein the amplitude of the secondary system is represented as a function of the dissonance, Wien clearly demonstrated the greater sharpness of resonance in loosely-coupled systems than in the simple

system; there is a still greater contrast when the loosely-coupled systems are compared with close-coupled systems.

The ratio between the maximum amplitude of the secondary system in unison and the corresponding amplitude in case of dissonance may be termed "ratio of sensitiveness." Neglecting small dimensions, and with small dissonance $n-\nu$, Wien finds for this ratio of sensitiveness,

$$\frac{M_4}{A_4} = \sqrt{\frac{(n-\nu)^4}{h_3^2 \delta_1^2} + \frac{(n-\nu)^2}{\delta_1^2} + 1.}$$

If the value of the same be estimated at 2-4 according as the receiver is assumed to be 2-4 times as sensitive to the correct frequency as to a deviating one, it is easy to calculate the "necessary dissonance" $n-\nu$ (contained in the above expression) for which no mutual disturbance occurs. Usually the value 2 is sufficient for the "ratio of sensitiveness"; but if the simultaneous effective oscillations differ in strength, say as the result of different distances, 4 is the lowest value that should be chosen. The "necessary dissonance" fluctuates accordingly between about 5 per mille and 5 per cent. of the frequency.

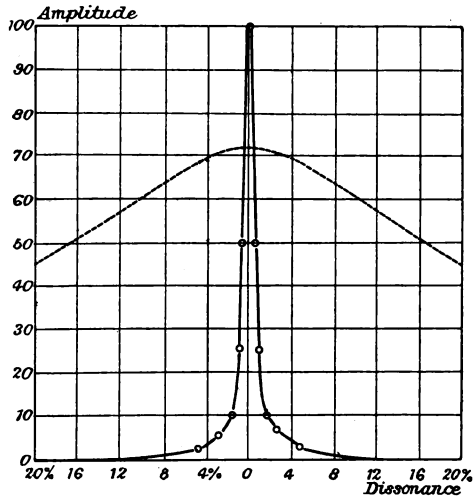

FIG. 20.—Amplitude Curves as Function of the Dissonance.

The wave lengths usual in practice, by reason of the limited height of the masts, vary between about 100 and 500 metres, or, expressed in frequencies, between 3×10^6 and 6×10^5 sec.

With a dissonance of 5 per mille it is possible, in accordance with the equation $3 \times 10^6 = 6 \times 10^5 \left(1 + \frac{5}{1000}\right)^x$, to send messages simultaneously with $x=322$ senders, without disturbance. Similarly, with a dissonance of 5 per cent., 33 senders could be used, though, as we have seen, the range is relatively shorter.

However, to obtain such a high selective capacity at the expense

of the intensity or distance seems an unnecessary detrimental luxury, so long as wireless telegraphy is restricted to its present chief sphere of application, namely, for military and naval purposes.

As the experiments at the Braun-Siemens Baltic stations have demonstrated, the employment of the above described loose-coupled receiver with a sender coupled to a degree approximating the boundary of loose coupling is sufficient, even in the case of the unfavourable "distance ratio" 1:10 and for a maximum distance of about 125 miles, to enable messages to be transmitted to a certain station simultaneously from several stations, working with effective wave lengths differing by about 10 per cent.

Such a system of *multiplex wireless telegraphy*, developed on these lines, should prove sufficient for some time. The absolute reliability of this system was demonstrated two years ago by the author before the authorities of the Imperial German Navy, after having been in regular work for two months.

The method of coupling up the circuit for this multiplex telegraphy will be described later.

The tuning of sender and receiver in loose-coupled systems is not only possible but essential, more particularly with regard to the primary circuit of the sender and the secondary circuit of the receiver. These must be tuned with almost perfect accuracy, since even the smallest discordance due to a few per mille variance from absolute syntony will immediately annul the otherwise powerful signals. Owing to the technical perfection of the apparatus, not the slightest difficulty in realising such sharp tuning is encountered in practice.

Disturbance in loose-coupled systems by close-coupled senders can be guarded against by using the latter for long distance work and long wave lengths only, whilst for short distances the messages are dispatched and received with loose-coupled systems and with waves of a much smaller size.

Notwithstanding the enormous progress made in theoretical development and the practical application of the same, no revolutionary encroachment on the existing domain of ordinary telegraphy will be possible until we are able to operate with controllably sustained electrical oscillations of sufficient frequency, instead of more or less strongly damped series of waves as at present. The seemingly feasible project of wireless telephony by means of electrical oscillations also suffers from this limitation.

SPECIAL THEORETICAL RESULTS OF PRACTICAL IMPORTANCE.

We have already seen that the value W occurring in the formulæ is not represented by the constant ohmic resistance. Even when measuring free oscillations in a completely closed circuit (by means of the Helmholtz pendulum at the Physical Institute of Zürich University, Professor A. Kleiner), Heinrich Mayer finds that the effective resistance increases approximately with the square of the frequency.

Almost simultaneously, Dolezalek, in measuring the coefficients of induction of coils, found that, in the case of alternating currents with over 300 oscillations per second, a considerable increase of resistance occurs in comparison with the values from direct current or slow alternating current. He also records a diminution of the self-induction with the duration of oscillation, whereas Mayer found a considerable increase, which Dolezalek attributes to the presence of high capacities.

Wien, in his publication on the flow of rapid alternating currents through wire coils, made a theoretical examination of the experimental results obtained by Dolezalek. In fact, theory demonstrates that the effective resistance must increase with the square of the frequency. The occurrence of eddy currents in cases of high frequency causes the lines of flow to be forced progressively inward, the mean radius of the circuit being reduced and the self potential diminished.

The practical result is that, in accordance with the proposals of Dolezalek, the use of solid wires for the induction coils has been replaced by thin insulated wires, twisted together in the form of cord. Such divided wires ought to have practically identical resistance, self induction, and mutual induction. Hence the "Deutsche Gesellschaft für drahtlose Telegraphie" (German Wireless Telegraphy Co.) makes all its conductors of cords, prepared by a special process, the several wires of which are only 0.1 mm. in diameter. This plan of dividing and twisting the wires renders corrections practically unnecessary.

The ohmic resistance of the primary circuit with the spark-gap is determined by the latter alone in all well-designed modern installations. According to a communication to me from Professor Drude, which also appears in his publication on the damping of condenser circuits with spark-gaps, the results furnished by his

measuring experiments show that the resistance W of the spark-gap is not even approximately constant, but varies considerably with L and C . Hence it is not possible, even by selecting a large L and small C , to obtain small log. decrements ($\gamma = \pi W \sqrt{\frac{C}{L}}$).

The labours of Zenneck, Braun, Drude, and Abraham, with regard to the spark-gap, the distribution of capacity and self-induction in the primary circuit, and other decisive factors, furnish the following considerations of practical importance.

The increase of the primary initial potential with the length of the spark depends chiefly on the radius of the spark-gap balls. With large balls the potential increases approximately in proportion to the length of the spark-gap, up to several centimetres. It is therefore advisable to use large ball caps for the spark-gap, in which event the maximum amplitude in the secondary system will also increase with the growing primary potential at a relatively rapid rate up to a sparking distance of several centimetres.

The modification of resistance in the spark-gap is a function of the quantity of electricity passing. With large capacities, of more than about 200 cm., the spark resistance, for a gap of about 0.5 cm., is of minimum value; these represent the most favourable conditions.

Enlarging the spark-gap increases this resistance, slowly with large capacities, more quickly when these are small. In normal installations the spark resistance should not exceed 0.1–0.2 ohm.

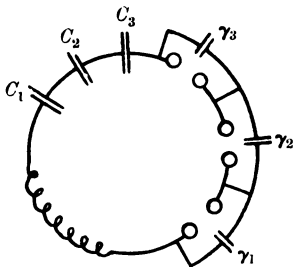

FIG. 21.—Spark-gaps in Series.

Under given conditions there is always an optimum length of spark, *i.e.* one in which the percentage of total energy absorbed by the spark is minimal. If this point be neglected, the increased spark damping in most cases causes a greater amount of loss than the gain effected by increasing the initial potential. These considerations led Professor Braun to introduce a series of spark-gaps, as illustrated in fig. 21. Instead of a simple long spark-gap, use is made of a number of small gaps arranged in series. The distribution of potential to correspond most suitably to the spark-gaps is effected by means of small supplementary condensers, γ_1 , γ_2 , γ_3 . The capacity of these so-called “potential distributors” is negligible in proportion to the total energy of the system; and its oscillations can, if necessary, be

cut out entirely by large inductive resistances. In this manner any desired potential of discharge can be economically utilised by employing the most favourable length of spark.

In the primary circuit the spark damping is the decisive factor, and must be kept as low as possible by the use of large capacities; the self-induction will then be correspondingly small. This applies also to the case of loose coupling, though on the ground of the log. decrement, one would otherwise be disposed to draw an opposite conclusion with reference to the distribution of capacity and self-induction for the attainment of minimum damping in the primary circuit, which, as mentioned before, is the main point to be considered in loose coupling.

To obtain the smallest possible decrements it is by no means unimportant to connect the wires from the inductor as closely to the spark as possible, *i.e.* at the potential nodes of the produced oscillation.

In the case of relatively close coupling, the advisability of having L as small and C as large as possible, is clearly evident for other reasons. This has already been shown by Wien, who demonstrated that the secondary potential amplitude is raised to $\sqrt{\frac{L_2}{L_1}}$ times that of the primary potential.

Drude finds generally that only a single thick primary winding should be used, dispersion being prevented as much as possible by "dead" self-induction (self-induction without inductive action).

These considerations, moreover, formed the basis on which Zenneck, some years back, carried out his first practical experiments for Professor Braun; and they led him to the construction of a (patented) sender-transformer, the primary of which had only one winding, or two windings coupled up in parallel. Unfortunately, these and many other results obtained by this painstaking and ingenious worker have been entirely neglected by his successors; otherwise some very advantageous scientific and technical arrangements of installations for wireless telegraphy would have been generally known years ago.

Zenneck had previously found, by trial, that there is always an optimum degree of coupling for installations with relatively close coupling, at which degree a maximum amplitude of potential in the secondary system is attained. Drude finds that this optimum degree of coupling should be $\tau = 0.6$, but admits that the final increase to the optimum is asymptotic, *i.e.* that relative maxima are obtained

with much lower degrees of coupling. J. Zenneck made some careful practical experiments extending the degree of coupling to $\tau=0.6$, and found a great discrepancy between his results and those derived from Drude's theoretical deductions with regard to the relation between the maximal amplitude in the secondary system and the degree of coupling. Especially, the experiments seem to point out that it is to no purpose to have the degree of coupling more than 0.30-0.35.

In theory it is assumed that the decrement of the primary circuit remains constant during an oscillation, and that it is independent of the degree of coupling. In oscillation circuits with *spark-gaps* this is certainly not the case, and hence the difference between theory and practice.

Besides, for reasons already stated, such close couplings as $\tau=0.6$ are generally impossible in installations for wireless telegraphy.

With regard to the secondary system, Drude employs for the calculation of its individual wave length a formula which we reproduce, with others of importance, on p. 54 *et seq.* However convenient such a calculation may be, it is only unconditionally applicable provided the position of the antenna approximates to the ideal case of a free wire. The condition of an absolutely free wire is only satisfied when its distance from any object in the neighbourhood is at least very great in comparison to its own length. Practically this cannot be attained, but, as done at the Baltic stations, it is advisable to hold the aerial wire as free as possible by the use of insulated ropes. Furthermore, the upper stay ropes holding the mast were attached somewhat lower down the mast than constructive security warranted; and they were insulated by insulation bolts above and below. Usually, however, practical conditions are of a much less favourable character; and it is altogether preferable to excite the secondary system independently, by mounting a spark-gap in the aerial wire and thus exciting the latter as a Hertz oscillator, the specific wave length being then determined experimentally by means of the ondiameter (see p. 60). In any case a comparison of the results with a calculation based on the Drude formula will always be interesting.

Incidentally it may be here mentioned that the wave length can also be approximately estimated. In most cases the current distribution in the aerial wire is almost sinoidal, and the belly of the current lies in the centre of the secondary coil. Therefore, for the

wave lengths λ we get the equation $\frac{\lambda}{4}$ = length of the antenna plus half the length of the windings of the secondary coil.

For a multiplex secondary system, Drude also formulated the following:—

“A multiplex antenna (cage antenna), which may be heterogeneous (partly multiplex and partly simple), ‘acts’ like a simple antenna of a single wire the radius of which is equal to the radius (when the wires are few) or the diameter (when the wires are many) of the mean sectional area (reckoned as a circle) applicable to the total length and enclosed by the antennæ wires.

“The advantage of using multiplex antennæ in the senders in wireless telegraphy resides to some extent in the diminution of the frequency, but more particularly in the increase of radiation. Both these results are best attained by the use of thick antennæ. Multiplex antennæ are therefore advisable on both grounds, since they are able to replace the heavier thick antennæ.

“The checking action of a coil towards alternating current is greater in proportion as the windings are ‘closer, and the less the radius exceeds that of the straight wire conducting the alternating current.”

In the sense employed by Drude, this “act” implies, in the first place, that the multiplex antenna is equivalent to a simple antenna of greater radius, in so far as the wave length of the sender is concerned, that is to say, it induces an augmentation of the period. According to the axiom of Poynting and the inalterable relative position of the electric and magnetic lines of force at a greater distance from the sender, it results as a further consequence that the multiplex antennæ effect an increase in the radiation. With regard to these statements of P. Drude, we should like to draw attention to the following remarks by J. Zenneck, which undoubtedly deserve the closest attention. A simple and a multiplex antenna of the same frequency, and whose dimensions of cross section are very small compared with those of length, have in a distance which is great in comparison with the wave lengths, the same field when the current amplitude in both is the same. With the same potential (spark-gap) the current amplitude is much larger in the multiplex than in the single antenna. The relations can best be shown by the following. From the theoretical considerations of Hertz may be derived the following equation for the field intensity E (in the

equatorial plane which is alone to be considered in wireless telegraphy):—

$$E_0 = A \cdot \frac{l}{\lambda} \cdot \frac{i_0}{r},$$

in which A represents a constant factor dependent on the system of measurement, l the length of the aerial wire, λ the wave lengths, i the current mean value in the antenna, r the distance from it, and the index o the amplitude.

When a simple antenna is replaced by a multiplex antenna of the same length, and of the same wire radius, the potential amplitude being given, there are two changes—

(a) the frequency and hence the ratio $\frac{l}{\lambda}$ (b) the current amplitude i_0 .

The ratio $\frac{l}{\lambda}$ has been discussed by Drude, with the result that in respect of its individual period a multiplex antenna is equivalent to a simplex antenna of a greater radius. Hence it follows that in both the ratio $\frac{l}{\lambda}$ has the same value. As is shown by the experimental measurements of Drude, this ratio for a multiplex antenna, the cross section dimensions of which are small compared with those of length, varies only slightly from that of a simple antenna of the same wire thickness.

This ratio consequently plays only a minor part in practice.

But in regard to the current amplitude a comparison of simple and multiplex antennæ of the same length and wire thickness leads to the following relation:—

I. $\frac{i_1 o}{i_2 o} = \frac{C_1}{C_2}$ when the antenna is used as a simple Marconi sender or a secondary system in a loose-coupled Braun arrangement.

II. $\frac{i_1 o}{i_2 o} = \sqrt{\frac{C_1}{C_2}}$ for antennæ used as secondary systems in close-coupled Braun arrangements.

Here C indicates the capacity per length unit; the index 1 refers to the multiplex, the index 2 to the simple antenna.

As the capacity per length unit of the multiplex antenna is

much larger¹ than that of a simple antenna, it follows that the current amplitude, and hence the amplitude of the electric field intensity E in the case of the multiplex antenna, is also considerably larger than in the case of a simple antenna. In this fact lies the real importance of a multiplex antenna, not in the alteration of the period with its accompanying minute change of the field intensity.

The superiority of multiplex antennæ over the simple forms may also be expressed in the following way. From M. Abraham's publication on wireless telegraphy it follows that the attainment of maximum potential on the upper extremity of the aerial wire is less important than maximum amplitudes of current at the lower end of the antenna. However, according to M. Wien, this current amplitude is nearly proportional to $\sqrt{C_1 C_2}$, wherein C_1 and C_2 represent the primary and secondary capacity. Hence the multiplex antennæ act more favourably in consequence of their greater capacity. For the same reason of strengthening the current in the antenna, it is therefore necessary to minimise the primary self-induction as well, a result at which we have already arrived by another path.

For the current amplitude, Abraham finds the following additional axiom:—

“If, with a given antenna of the capacity C_2 (in microfarads), directly coupled with a primary condenser circuit, it be desired to obtain the highest possible increase in the maximum amplitude of the effective waves, the primary self-induction L_1 must be selected in accordance with the equation $L_1 = 6.7 \times 10^5 C_2$.”

There consequently results an optimum for L_1 and a corresponding one for the primary capacity C_1 ; any further increase of the latter would excessively augment the radiation and thereby weaken the maximum wave amplitude occurring after half a beat. These considerations, however, are restricted to relatively close-coupled arrangements of sender and receiver. In loose coupling, the chief point to attain is the production of protracted oscillations, even at the expense of the wave amplitude.

¹ According to J. A. Fleming (*Cantor Lectures on Hertzian Wave Telegraphy*, p. 14; London, 1903) the capacity of a multiplex antenna whose component wires lie pretty close together is about \sqrt{N} times (N =number of wires) larger than the capacity of a single antenna of the same length and wire thickness; a multiplex antenna of 50 wires would show approximately 7 (resp. 2.6) times the effect of a corresponding single antenna.

Moreover, as results from Brandes' measurements, with multiple antennæ the amount of the radiation in relation to the existing energy, *i.e.* the radiation decrement, is greater than with simple antennæ; hence the use of the former ensures better utilisation of the primary energy.

For the so-called "counter capacity," already frequently mentioned, namely, a metallic surface, *S*, which forms the electrical counterpoise for the antenna of the length *l*, Drude finds the equation

$$\sqrt{S} = \frac{0.603l}{\text{brigg. log. } l/\varsigma},$$

in which ς represents the "effective" radius in the sense already described.

According to Drude, the different modes of action of the various couplings furnish valuable information on the nature of the indicators to be used in the receiver. The coherer reacts on differences of potential, and therefore is evidently the most suitable indicator when close coupling is used, the chief property of which resides in the production of maximum amplitudes of potential. With loose coupling, however, the integral effect is the main point, so that Rutherford's magnetic indicator seems more suitable in such cases than the coherer. The reason for this is that alterations in the damping make far less difference to the maximum amplitude than to the integral effect; hence when damping is mostly to be considered, the coherer suffers from a certain indifference. For loose-coupled apparatus it is preferable to use an antenna with relatively high self-induction (coils in the vicinity of the belly of the current) in order to prolong radiation.

At great distances, *r*, the action of the sender on the receiver, diminishes like the amplitude of intensity of the electric and magnetic field, and consequently like $\frac{1}{r^2}$. The radiation is proportional to the square of the resulting field intensity.

CHAPTER VII.

BRAUN—ENERGY SYSTEMS.

It has already been stated that the energy available for radiation is determined by $\frac{1}{2}CV^2$, in which expression C represents the capacity and V the discharge potential of the condenser circuit. The dimensions of the capacity *per se* are subjected to a natural limitation by the length of waves obtainable in practice because of the relatively short masts. Besides, an increase of the capacity at the expense of the self-induction soon reaches a limit. Furthermore, insuperable difficulties, both theoretical and practical, oppose the increase of the discharge potential.

The way out of this dilemma was discovered by Braun in a method of arrangement, the general principle of which is illustrated in fig. 22.

Here, n equal condensers C are connected by n equal self-inductions L in series to a circuit which is closed by the spark-gaps at the moment of discharge. The charging of the condensers, however, is effected in parallel with low potentials only, by means of the large ohmic or inductive resistances W_1, W_2, W_3 , which have nothing to do with the oscillations.

The total available energy is therefore

$$\frac{1}{2}\left(\frac{C}{n}\right)(nV^2) = \frac{1}{2}nCV^2,$$

and that, too, with an unchanged duration of oscillation, since

$$T = 2\pi\sqrt{nL\frac{C}{n}} = 2\pi\sqrt{LC},$$

as for a simple oscillation circuit.

Braun also proves that the spark discharge is equiphasal throughout, and that each spark has only the damping corresponding to the partial potential difference V.

With an n -fold energy we can thus work the n oscillation circuits with the same economy as a simple one.

The energy can be utilised in many different arrangements. Thus fig. 23 shows the method of inductive coupling, whilst an

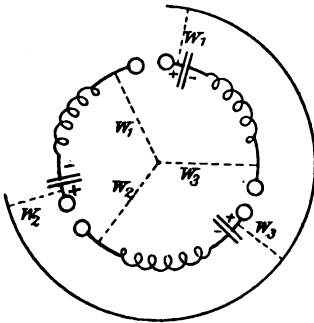

FIG. 22.—General Scheme of Braun's Energy System.

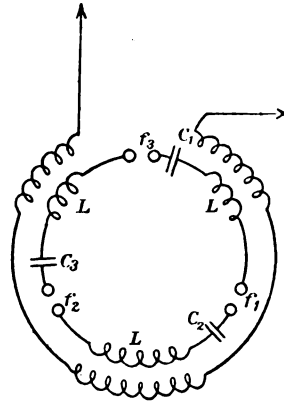

FIG. 23.—Braun's Energy System.

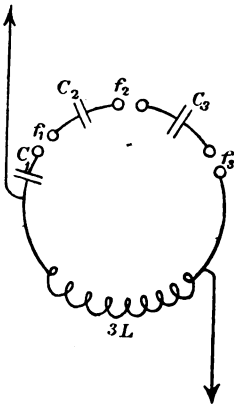

FIG. 24.—Braun's Energy System.

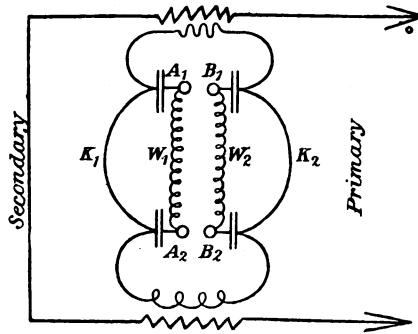

FIG. 25.—Energy System used at the Baltic Stations.

instance of direct coupling for exciting n separate aerial wires is given in fig. 24.

The form of arrangement illustrated in fig. 25 was used with great success at the Baltic stations. The condensers are connected in parallel, for charging with the large resistances W_1W_2 . The

induction-free "coupling arcs" K_1K_2 ensure that when the discharge takes place in A_1B_1 , the spark in A_2B_2 must pass simultaneously and in an equiphasal manner. The secondary systems were suitably connected in series.

PRINCIPAL FORMULÆ.

Owing to the irregular conditions it is impossible to calculate the capacity of the Leyden jars used in the primary condenser circuit; and even measurements performed by known static methods, or with the telephone bridge, give entirely useless values. Thus, measurements, made at the normal frequencies of the oscillations used in wireless telegraphy, gave variations up to 30 per cent. This is due to the losses of energy in solid dielectric glass, these losses increasing with the number of oscillations and in accordance with the manner in which the "residue" is developed. A condenser in which a residue is formed often takes several minutes to attain its maximum charge, so that it cannot act up to its full capacity in the very short time occupied by the oscillations. The difficulties arising from these and other factors in the way of accurately measuring the wave lengths generated in the primary condenser circuit, have now been removed by the use of a resonance circuit, containing an adjustable condenser with ideal properties, the capacity values of which, resulting from various adjustments, can be determined with great exactness, and if necessary reduced to "dynamic" capacity. This instrument is the "ondameter," or, better still, "frequency meter," to which reference has been made in the previous pages, and of which a description will be given in the next chapter.

The self-induction of coils in which the dimensions of the rectangular section of the annular space occupied by the wire windings are small in comparison with the mean diameter of the coil (as is the case both in the induction coil of the ondameter, and in the primary coils in the sender and receiver) can be calculated according to the well-known Stefan formula, as modified by Drude, by introducing the necessary correction on account of the rapidly alternating currents used in electrical wave telegraphy. This formula runs:

$$L = 4\pi r^2 n^2 \left[\left(1 + \frac{h^2}{32r^2} \right) \log. \text{nat.} \frac{8a}{\sqrt{h^2 + \delta^2}} - \gamma_1 + \frac{h^2}{16r^2} \gamma^2 \right] + \log. \text{nat.} \frac{g}{\delta} - \Delta,$$

wherein

n = number of windings,
 r = radius of coil,
 $h = (n - 1)g$ = height of coil,
 g = pitch of the windings,
 δ = thickness of the bare wire.

For y_1 and y_2 the values should be taken from Stefan's tables and that for Δ from Drude's tables.

The reasons for replacing thick wire in inductive coils by cords consisting of a number of separately twisted strands made of very thin wire have already been given.

The self-induction of long, narrow coils, such as are used in the

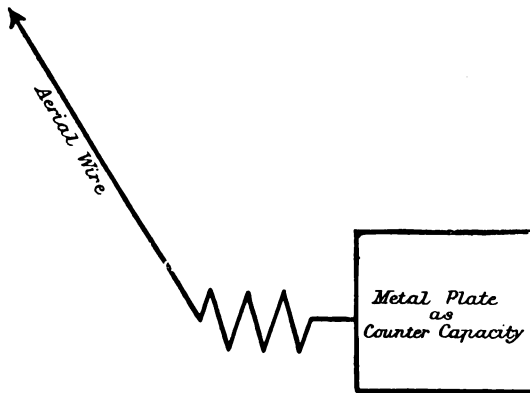

FIG. 26.—Secondary System with Counter Capacity.

secondary system of the receiver, is calculated by Drude from the formula

$$L = \frac{l^2}{h},$$

wherein

$l = 2r\pi n$,
 r = radius of coil,
 n = number of windings,
 $h = (n - 1)g$ = height of coil,
 g = pitch of windings.

For calculating the individual periods of the secondary system (the practical use of which is dependent on a formerly mentioned condition) Drude gives the relations

$$\beta = \text{brigg. log.} \frac{l}{s} \times \frac{f}{n} \sqrt{\frac{h}{2r}} \times \phi,$$

and hence the specific wave length λ according to the formula

$$tg \frac{\pi}{2} \times \frac{\lambda_0 tg 2\pi \frac{l}{\lambda}}{\lambda} = \beta,$$

wherein

$$\frac{1}{2}\lambda_0 = f l_1.$$

Here $l_1 = 2r\pi n$ represents the length of wire in the coil, l the length of the antenna, ς its "effective" radius (see p. 47 *et seq.*), n the number of windings on the coil, $h = (n-1)g$ the height of the coil, g the pitch of the windings, $2r$ the diameter of the coil. The values for f (a function of n , $\frac{h}{2r}$, $\frac{g}{\delta}$, and ϵ) and for ϕ (a function of $\frac{h}{2r}$ and $\frac{g}{\delta}$) are to be found in Drude's tables: δ represents the thickness of the wires, and ϵ the dielectric constant of the core.

For the already defined "counter-capacity," we refer to the Drude formula, given on p. 50,

$$\sqrt{S} = \frac{0.603l}{\text{brigg. log. } l/\varsigma}.$$

At the Baltic stations the "net" or "cage" of the aerial wire was mounted on rings 20 centimetres in diameter, and therefore had an effective radius $\varsigma = 0.1$ metre; furthermore, $l = 65$ metres, so that the dimensions, S , from the formula were 13.93 sq. metres, whereas the result of the empirical determination was $S = 13.7$ sq. metres.

The counter-capacity of the secondary system, diagrammatically represented in fig. 26, is now usually formed of a surface of wire gauze. With "direct" coupling, coils of suitable dimensions have to be interposed between the condenser circuit and the counter-capacity.

CHAPTER VIII.
MEASUREMENT OF WAVES.

THE ONDAMETER.

THE principle of determining the frequency by the resonance was expounded by Hertz-Bjerkness. It was first applied to the practice

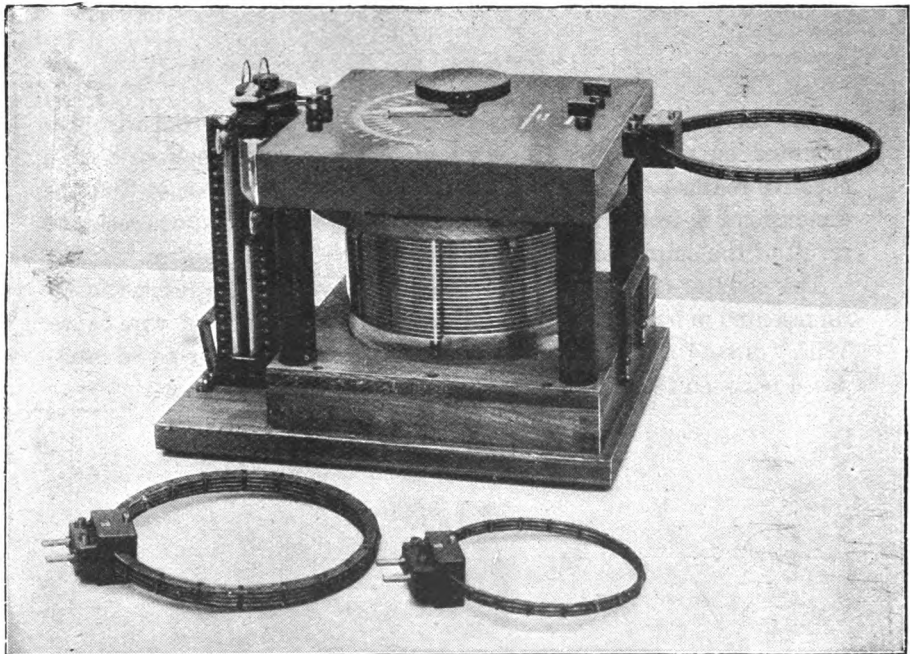

FIG. 27.—Ondameter.

of wireless telegraphy by J. Zenneck, and though Zenneck's apparatus was very cleverly developed, in a technical sense, by J. Dönitz, the

name under which it is generally known, viz., "Dönitz's ondiameter," is hardly justified.

This ondiameter (or, more properly, "frequency meter"), fig. 27,

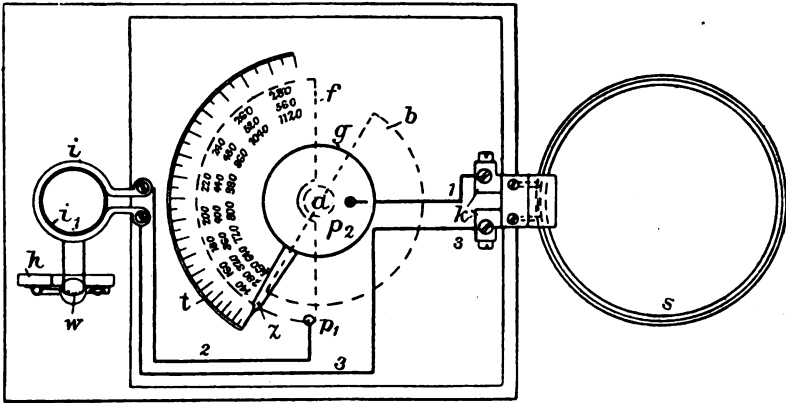

FIG. 28.—Plan of Ondiameter.

consists of a closed oscillation circuit, in which the dimensions of the capacity are made to vary within wide limits. When subjected to the action of an oscillating system, it is excited to oscillate in

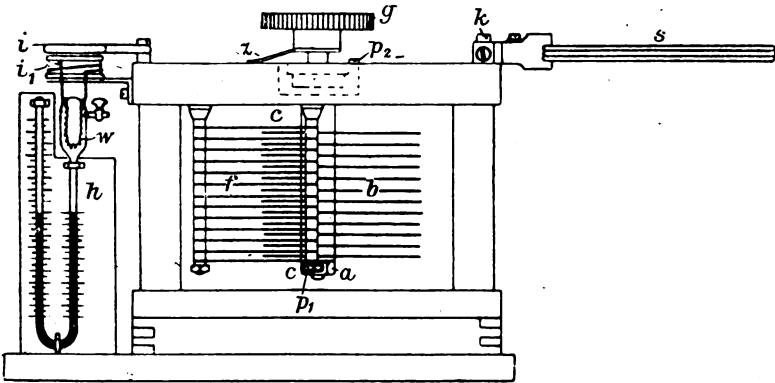

FIG. 29.—Ondiameter Elevation.

sympathy. The resulting currents (which are read off on a Riess thermometer, the indications of which are proportional to the squares of the current intensities) reach a decided maximum as soon as perfect resonance is attained. Hence the same wave length is then

present in both systems, and can be read off on the scale of the ondiameter.

Figs. 28 and 29 represent a plan and elevation respectively of the instrument. So that a variable capacity may be available, the condenser is composed of two sets of parallel semicircular plates, one of which, f , is fixed, and the other, b , can rotate on the axis a . Both sets are mutually insulated, the component members of each set, however, being in metallic connection and connected with the poles p_1 and p_2 .

By turning the knob g the movable plates are caused to enter the intermediate spaces between the fixed plates, whereby the effective surface, and therefore the capacity, is gradually increased. The condenser is immersed in a bath of vaseline oil, c (boiled in order to expel air bubbles), for the purpose of securing more complete insulation, and to increase the limits of capacity, owing to the greater dielectrical constant of vaseline oil in comparison with air.

The self-induction coils s are connected to the terminals k by a plug contact, and the thermometer (hot-wire instrument) h is also included in the oscillation circuit. This latter connection, however, is inductive (not direct), a primary winding i in the condenser circuit inducing the secondary windings i_1 , the ends of which are connected to the hot wire w .

The inductive excitation of the thermometer is for the purpose of enabling the extent of the indications to be regulated by altering the distance between the primary and secondary windings. The instrument is fitted with three different self-induction coils, which are interchangeable and of such dimensions that the resulting three limits of measurement follow each other in close order, so that all wave lengths between about 100 and 1000 metres can be measured.

To the knob g is connected the pointer z , which moves over the scale t . This scale is inscribed, in three rows, with the wave lengths corresponding to the three coils and the momentary adjustment of the condenser.

To use the instrument, say for measuring the frequency of the *primary condenser circuit* of the sender, it is operated in the manner illustrated in fig. 30. The coil L_1 of the exciting condenser circuit is placed above the coil L_2 of the ondiameter W , so that the latter is traversed by lines of magnetic force from the former. By gradually

altering the capacity C_v , the flow becomes progressively stronger, as is shown by the rise in the thermometer T ; and finally the adjustment of the condenser reaches the stage at which the intensity of the current attains a maximum, whereupon any further adjustment of the condenser results in a fall in the thermometer. At this maximum (*i.e.* the attainment of resonance), the effective wave length is denoted by the position of the pointer on the scale.

A point to be kept in mind in these measurements is that the distance a between the planes L_1 and L_2 must be sufficient to preclude any reaction of the resonator circuit on the exciting oscillation circuit by the induced current. In other words, the coupling must

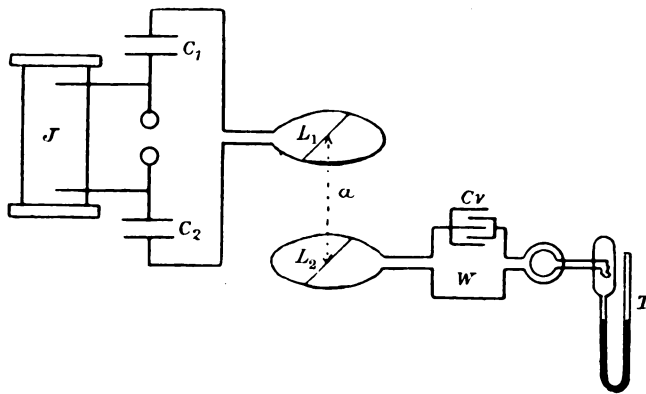

FIG. 30.—Measuring the frequency of the Primary Condenser Circuit, with the aid of the Ondameter.

not be too close, otherwise—as we have seen in the theoretical section—a deformation of the oscillation will occur. The optimum degree of coupling is about $a=3$ cm. If the distance be increased, *i.e.* the coupling made looser, the position of resonance of course remains the same, but the indications of the thermometer will be naturally of smaller amplitude, so that the adjustment for resonance cannot be made with the same sharpness. If there are several oscillations present (as we have seen to be the case with close-coupled systems), the different amplitudes of the thermometer indications enable a conclusion to be formed of the various amplitudes of the effective waves.

Moreover, the flow may develop in very different ways. Sometimes the level of the liquid in the thermometer will remain almost

stationary for a considerable time, until it shoots up quickly, the state of resonance being reached; and it will fall with equal rapidity when that condition is exceeded. At other times the thermometer indications rise slowly until the maximum is attained, and then sink gradually.

Hence the sharpness of the resonance can be determined in the case of different oscillations, and conclusions drawn as to their different dampings (p. 30).

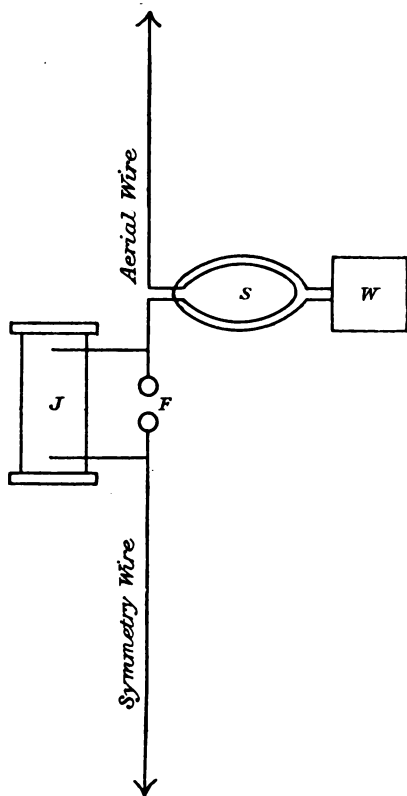

FIG. 31.—Measuring the individual Oscillation of the Secondary System with the Ondameter.

The measurement of the individual oscillation of the *open secondary system* is performed with the ondameter in the manner illustrated in fig. 31. By introducing a spark-gap, F, the secondary system is excited as a Hertz oscillator, and induces the coil of the ondameter W by a loop S. The ondameter is then set for resonance in the manner just described.

Before this latter measurement is performed, the aerial wire must be brought into the position in which it will actually be used; for the capacity of the wire depends on its relative position to the earth and other adjacent objects, so that a change in position will also cause an alteration of the specific periods.

Finally, the ondameter also enables the effective oscillations in the *complete coupled sender* to be determined (namely, a single oscillation with loose coupling, and two oscillations with close coupling), inasmuch as an inductive action is exerted on the ondameter by means of a loop in the aerial wire (which in this case is no longer fitted with a spark-gap).

A simpler ondameter, though insufficient for accurate determina-

tions, is the measuring rod (fig. 32) of Professor Slaby. Here again the principle of resonance is applied, barium-platinum cyanide being

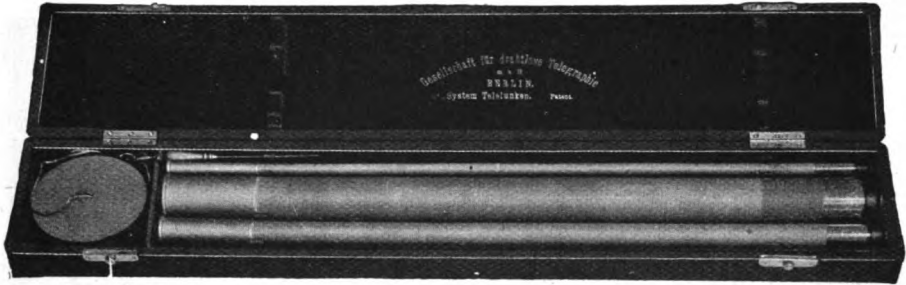

FIG. 32.—Slaby's Measuring Rod.

employed as the indicator. On approaching the free end to a point of high potential variation in the system under examination, the cyanide is excited.

CHAPTER IX.

MANAGEMENT OF A STATION.

THE construction of a station for wireless telegraphy proceeds by the following chief stages. In the first place, the aerial wire or aerial wire system is set up in an approximately vertical position, by mounting it, in a properly insulated manner, on high masts, or, in the case of movable stations, attaching it to kites or balloons. Then the necessary dimensions of the "counter-capacity" are determined either by calculation or experiment. In the latter event a symmetry wire, exactly equivalent to the aerial wire, is stretched out as a counterpoise, the effect of flow being next determined in the aerial wire by means of a Riess thermometer, mounted in the vicinity of the belly of the current. The symmetry wire is afterwards replaced by successively increased metal surfaces, until approximately the same current effect is produced.

The next step is the determination of the specific period of the secondary system, and of the primary condenser circuit, separately, by the aid of the ondiameter and the most accurate mutual adjustment possible.

A decision has now to be made in favour of either loose or relatively close coupling, according as it is possible or necessary to obtain sharp tuning (at the expense of intensity, *i.e.* range) or an extensive range, *i.e.* intensity (at the cost of tuning properties at the receiver).

In order to fully utilise the specific advantages of the different couplings the construction of the aerial wire system must be modified in accordance with the class of coupling employed. For loose coupling, types allowing of gradual radiation must be chosen, *i.e.* aerial conductors with maximum conductivity and high self-induction, which is partly distributed uniformly in the aerial conductor

and partly concentrated in coils in the vicinity of the current maximum.

For close coupling, on the other hand, highly radiating aerial wires of low self-induction are to be used, that is to say, they should be set up in the shape of a cone or harp, with a number of separate wires mounted in parallel.

The aerial wire of the sender is also used in connection with the receiver, by the aid of a switch. The optimum of the degree of coupling, and also the adjustment of the receiver to the effective wave length, can be determined with great accuracy by calculation or experiment. This point will be discussed later.

For the sake of completeness it should be mentioned here that, according to Drude, very close coupling ($\tau^2 > 0.6$) in the sender—which however, is generally impossible—is attended with a more strongly damped upper free oscillation and a more slightly damped lower one. If this be employed with a loose-coupled receiver, the frequency of the latter must be smaller, in the proportion $1 : \sqrt{2}$, than that of the two syntonised sender oscillation systems taken separately. With this very close coupling the damping of the lower free oscillation possesses only half the value it has with ordinary cases of close coupling, *i.e.* is only equal to half the arithmetical mean of the dampings of the two individual systems of the sender.

According to Wien, the same reduction in damping can also be attained at the boundary of the aforesaid two great classes, *i.e.* when the coupling is exactly equal to the difference in the damping of the component systems. In such event, *ceteris paribus*, the period of oscillation of the component system must be adjusted to that of the lower free oscillation, by doubling it. To attain this object, the self-induction of the secondary system must be doubled, thereby reducing the damping to one-half. The further necessary doubling of the capacity in the primary circuit results also in the doubling of the energy of oscillation. Since there is only a single effective oscillation present, there are consequently no disturbing undulations, as happens with close coupling; and this circumstance is naturally an additional advantage. Such an arrangement, however, merely represents a compromise; and the only possible way to secure *accurate syntonny* is, as we have already seen, to employ *loose coupling in both sender and receiver*.

The arrangement of a complete installation will be more clearly seen by a reference to the sketch, fig. 33. This shows the installations at the Baltic stations, and is more easily examined than a

sketch of up-to-date installations, which are in a state of greater technical perfection, giving rise to more complicated details.

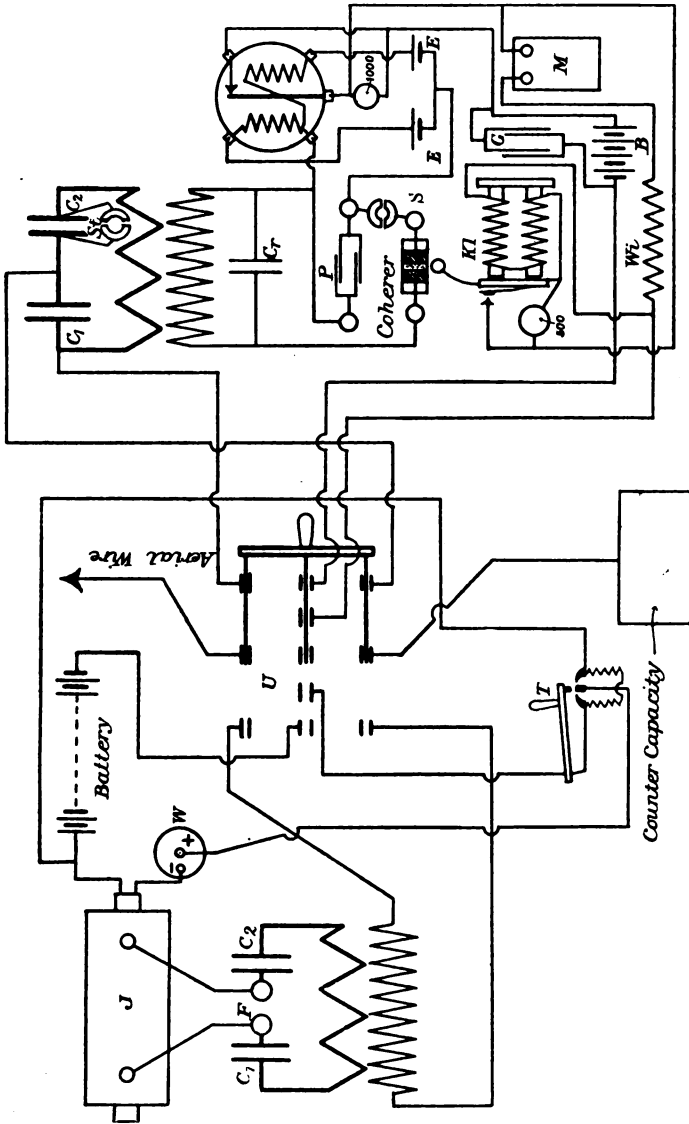

FIG. 88.—Mounting a Complete Station.

On the left of the figure is the sender, and on the right the receiver. In the middle, between them, is the switch, U , by means of which the attachments (aerial wire, counter-capacity) can be connected with

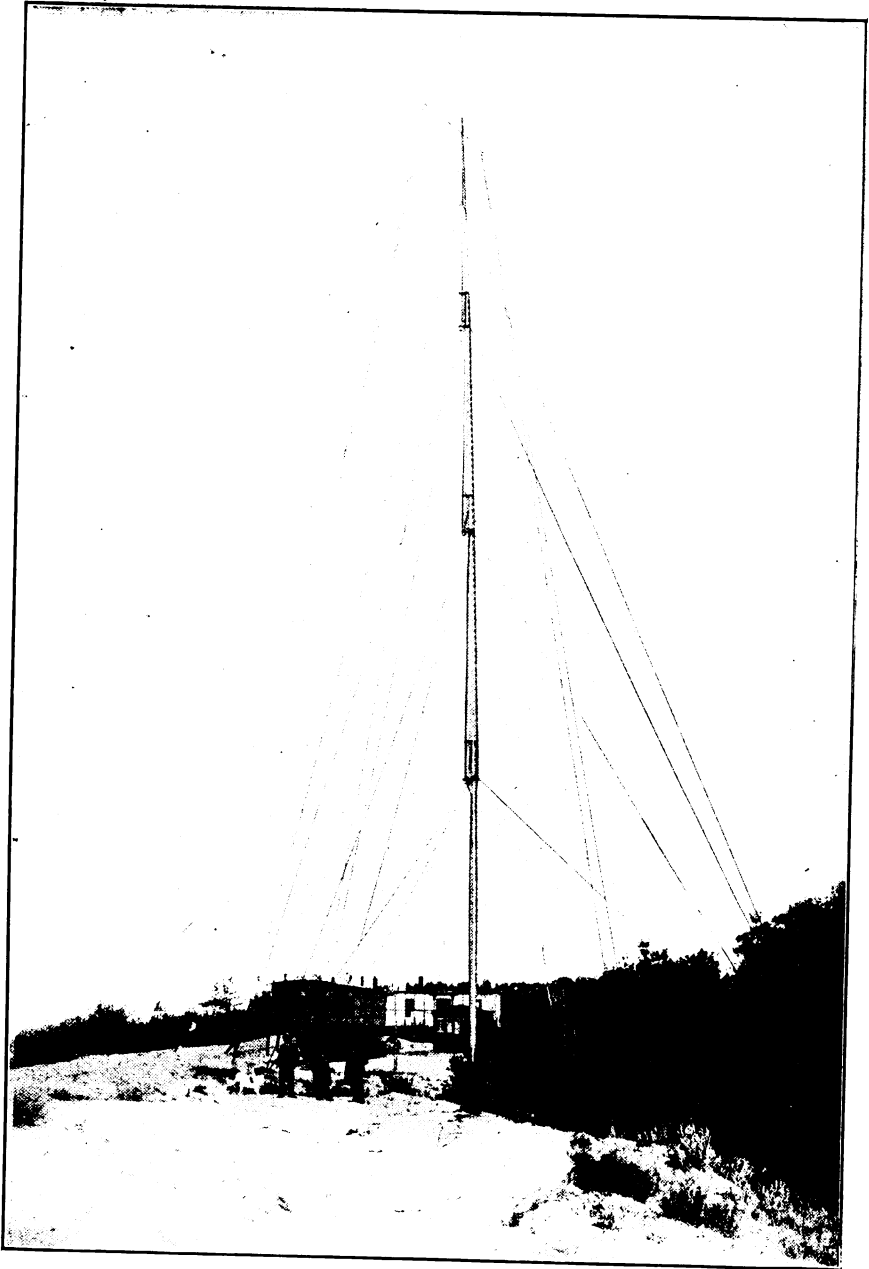

FIG. 34.—A Baltic Station.

the sender and receiver in turn. The lever of this switch consists of three horizontal metal bars, fastened together by the insulated vertical traverse, fitted with a handle.

When the switch is turned to the left, the aerial wire above and the counter-capacity below are connected with the secondary coil of the sender. At the same time the middle bar closes the circuit from the battery or electric power station. This circuit contains the primary coil of the inductor J, the interruptor W (Wehnelt, turbine or hammer commutator), and the signalling Morse key T, in parallel arrangement is the so-called magnetic blow-out, *i.e.* a transverse magnetic field for the purpose of dispersing the sparks at the breaking contact.

With the secondary terminals of the inductor is connected the primary oscillation circuit with spark-gap.

To receive messages, the switch is turned over to the right, *i.e.* to the position shown in the drawing. In this position the outer bars connect the attachments with the primary oscillation circuit of the receiver, whilst the middle bar closes the circuit of the local battery, B, which also includes the Morse register M and tapper KI.

The primary receiver circuit contains the two relatively large adjustable air condensers C_1C_2 , of which the former may be short-circuited by a plug contact whenever necessary, so as to adjust at once the primary circuit to a different wave length. This possibility of easy adjustment is of special use, when several waves are simultaneously effective. In the secondary circuit is a small adjustable air condenser, Cr. On the other hand, the terminals of the secondary coil are connected to the coherer by means of a small mica condenser P, which does not obstruct the oscillations, but must be attached to prevent short-circuiting of the relay current of the two parallel coupled dry cells E. To protect the relay, its circuit is opened by means of the plug contact S, when signals are sent off. To prevent any unfavourable influences on the coherer there were provided a small condenser, G, parallel to the battery, a 1000-ohms resistance coil parallel to the relay contact, and one of 500 ohms parallel to the tapper contact; otherwise at each of these latter points, sparks, exciting the coherer, would be formed in consequence of the breaking current. The resistance coil Wi was for the purpose of dividing the current for the Morse register and tapper according to requirements, and thereby regulate the force of the blow struck by the latter.

A photographic view of the outside of one of the Baltic stations is shown in fig. 34.

CHAPTER X.

MODERN APPARATUS AND METHODS OF MOUNTING.

AN important factor in the sender is the provision of a suitable source of electricity for charging the condenser circuit.

For short ranges, ordinary inductors with a vibrating interruptor would be sufficient, a type of which is illustrated in fig. 35, supplying primary energy up to 350 watts, at a maximum of 110 volts. These are provided with a condenser of suitable dimensions for preventing interruption sparks.

Where greater power is required, the so-called resonance inductors (fig. 36) are now exclusively used, this type being the outcome of our experience with the spark-gap, because of its irregularities. The spark-gap enables the condenser circuit to be charged up to a certain potential, *i.e.* it stores up the energy of the circuit until a certain discharge potential is reached. At this point we have a sudden fall in potential, whereby the oscillations are set up, and when they have ceased the spark-gap must at once become again non-conducting, in order that the cycle may recommence. The pauses between the single discharge complexes are enormously great in comparison with the duration of the latter themselves; but this is necessarily the case, since otherwise there would be the possibility of the spark-gap not returning to its non-conducting state. In such event there would be a permanent equalisation of the charges through the spark-gap to a lower potential, a luminous arc would be formed, and the spark become "inactive." With the resonance inductor this phenomenon is impossible. In it the generated electricity flows to and fro in slow oscillations until the maximum amplitude corresponding to the discharge potential is reached, and the spark-gap is suddenly traversed.

The self-induction of the secondary winding of the inductor (which in this case is made of the thickest wire possible, in order to diminish the ohmic resistance), and the capacity of the Leyden jars with which it is joined, cause a decided slow oscillation of definite periodicity, about 50 per second, as now generally employed in power stations. When such an inductor, secondarily laden with a capacity, is connected with a normal alternating current of 50 periods, the primary alternating current and the secondary induced current are in resonance. An important point to be kept in mind in this connection is the degree of coupling between the inductor and the source of current. With "close" coupling there would be just as many discharge complexes as primary alternations, *i.e.* 100 sparks for 50 periods. Consequently, this would not correspond with the function already described, which is to be performed by the resonance inductors. This is only feasible with close coupling, both between the two alternating currents of the inductor and also between the latter and the source of current, this being an alternating current machine containing a certain amount of self-induction in its armature. A check coil is mounted between the machine and the primary winding of the inductor; and the optimum degree of coupling is obtained by the suitable adjustment of these two self-inductions to the primaries of the inductor.

Now we obtain the aforesaid phenomenon, namely, that the energy of several successive alternations in the work of magnetising the inductor is accumulated to a maximum corresponding to the spark-gap, whereupon a discharging spark passes. Hence there are fewer sparks than primary alternations in the inductor. The same primary energy is now distributed among fewer discharges, but these are of a more powerful character.

To obtain the desired speed in telegraphing, it is of course impossible to go below a certain limit, about 30 sparks per second.

With a primary energy of from 350 watts to 1.5 kilowatts, use may be made of either the well-known mercury turbine interruptor (a photograph of which is shown in fig. 37, representing a type fitted with Cardanic suspension for naval stations); or else current transformers are used. The latter are either direct transformers—single machines (fig. 38), or mounted in sets of two machines—a continuous current motor and an alternating current generator (fig. 39).

The transformer is mounted in such a manner that automatic blocking occurs between the transformer and the receiving instru-

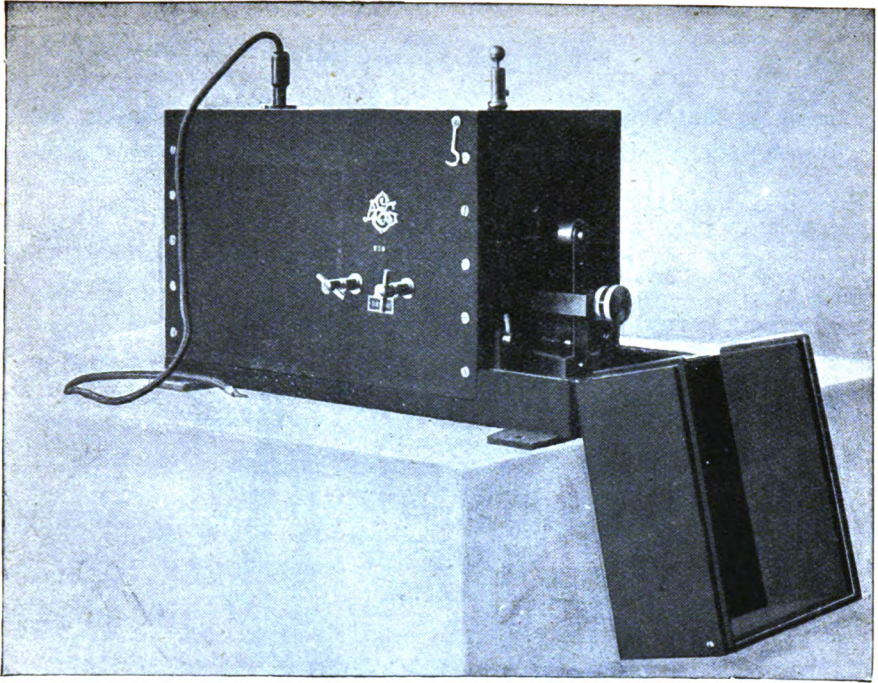

FIG. 35.—Inductor with Hammer Interrupter.

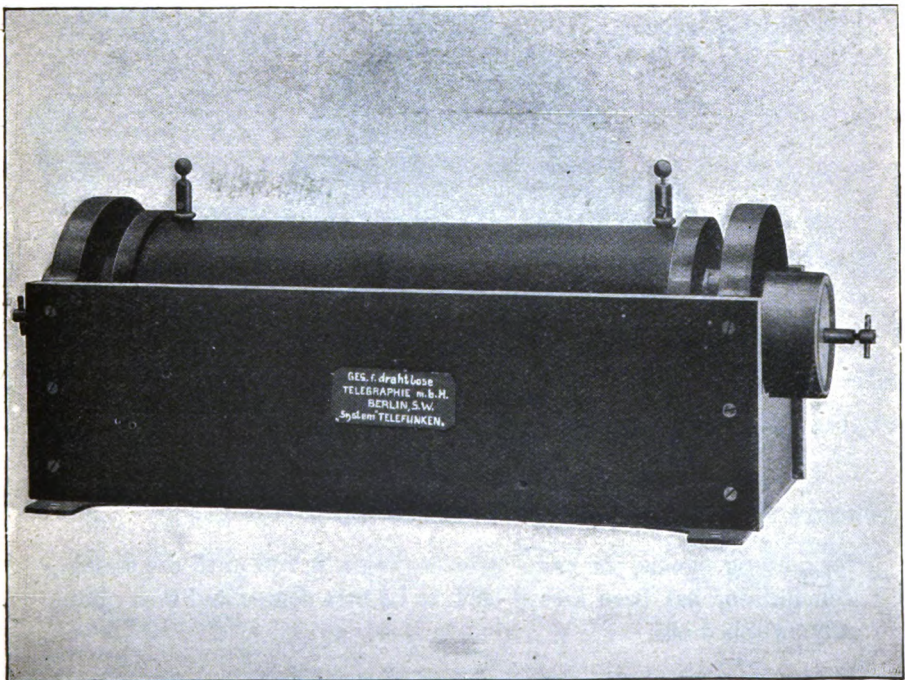

FIG. 36.—Resonance Inductor.

ment, so that when the receiver is set for receiving signals, the transformer is switched out. Conversely, when the apparatus is set

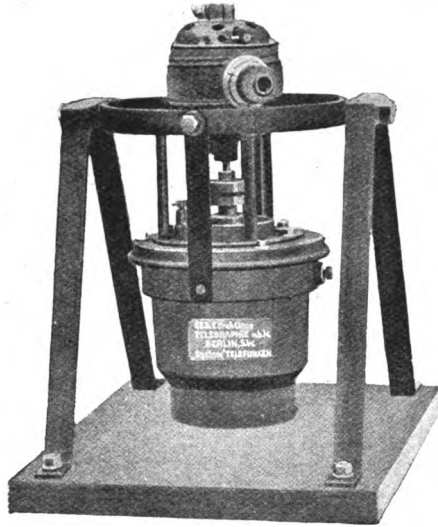

FIG. 37.—Mercurial Turbine Interruptor, with Cardanic Suspension, for Naval Stations.

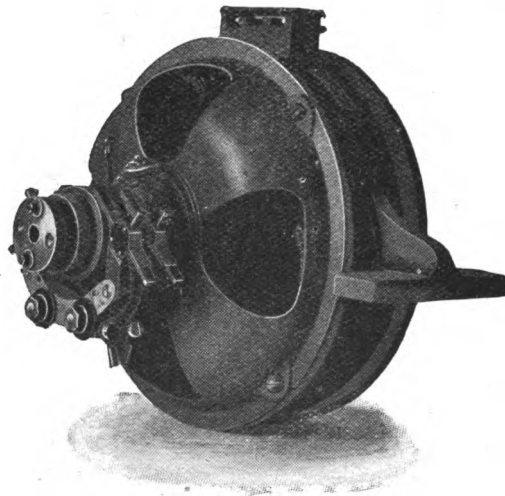

FIG. 38.—Current Transformer.

for sending signals, the motor does not begin to run until the starting commutator has been turned back to its first degree and then gradually switched out.

The Morse keys are either equipped with electromagnetic spark extinguishers, as in fig. 40, or else are constructed as automatic minimum current cut-outs (fig. 41).

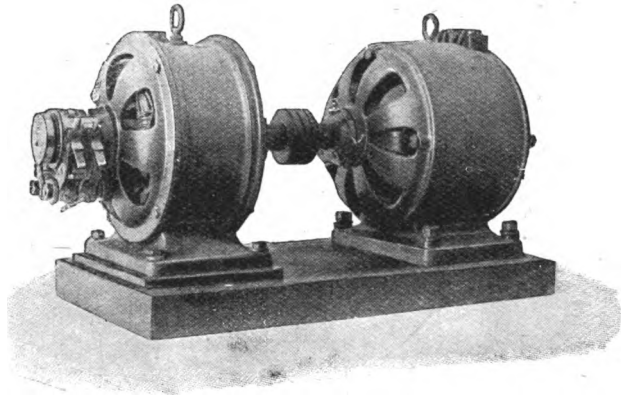

FIG. 39.—Current Transformer.

In large stations worked with current intensities of more than 40 amperes, several platinum contacts are connected in parallel.

The only spark-gaps now employed by the "Telefunken" Wire-

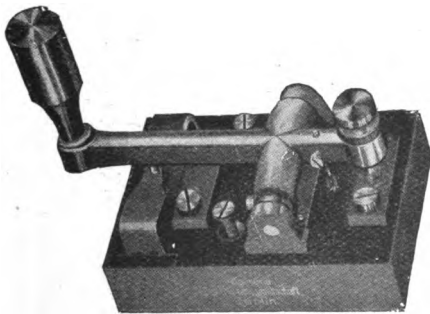

FIG. 40.—Morse Key, with Magnetic Blow-out.

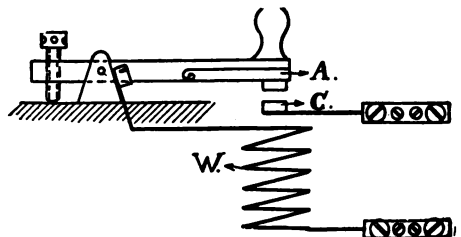

FIG. 41.—Morse Key, with Automatic Minimum Current Cut-out.

less Telegraphy Co. are of the "multiplex" type, with potential dividers (see p. 44). Fig. 42 illustrates one of these dischargers, as employed for portable stations in the German military airship corps.

In fixed stations, the dischargers (fig. 43) are covered with felt, for sound-deadening purposes; but ventilation takes place at each discharge.

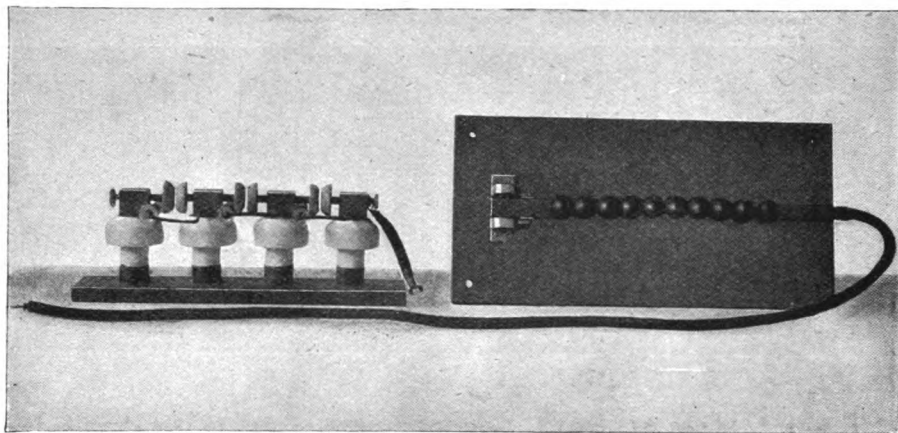

FIG. 42.—Discharger (Multiplex Spark-gap).

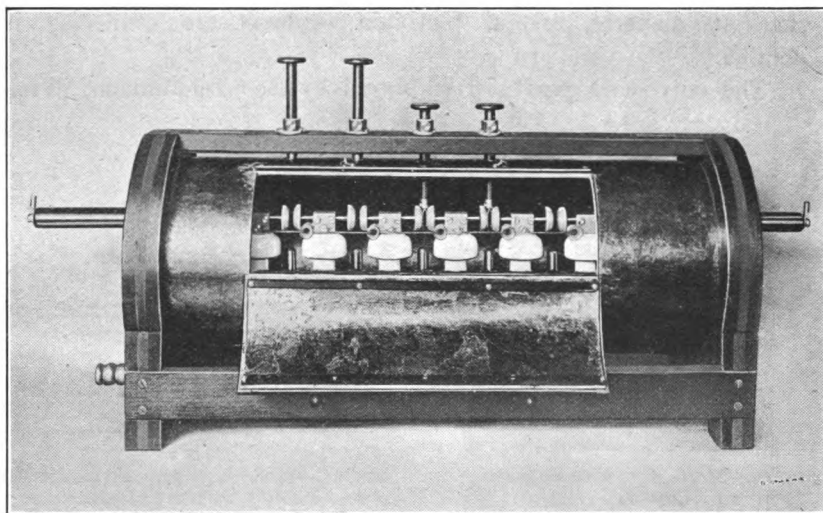

FIG. 43.—Multiplex Discharger for Fixed Stations.

The *excitation circuits* for coupled senders consist of (α) one “multiplex” discharger—usually with three spark-gaps; (β) a Leyden

jar battery, and (γ) a self-induction coil generally variable. Fig. 44 shows a normal form of construction for use on shipboard. In this instrument the wave can be varied from 120 metres up to 1000 metres in length. Fig. 45 illustrates an excitation

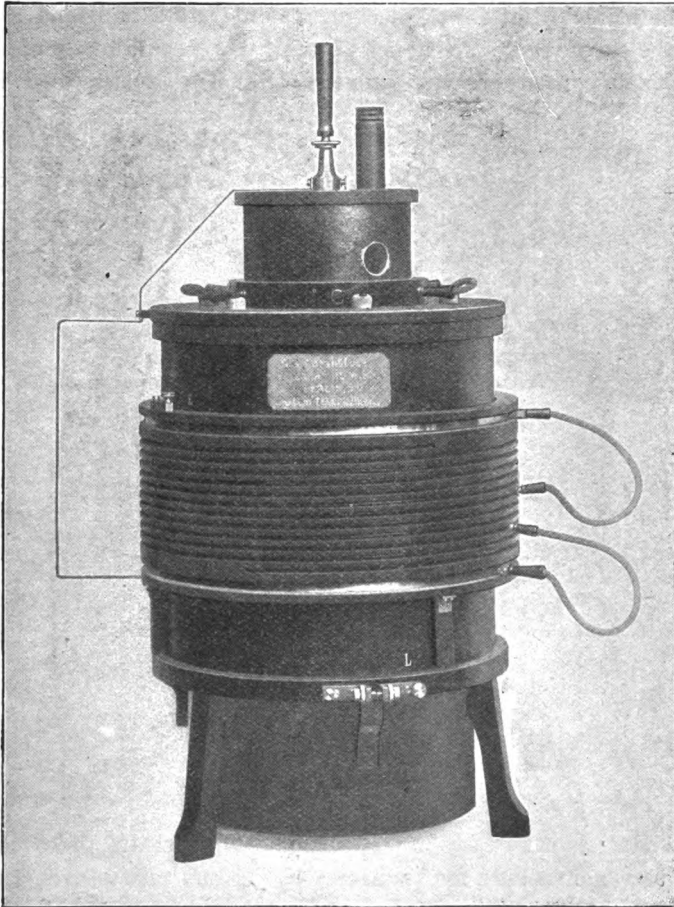

FIG. 44.—Excitation Circuit in Coupled Senders (type for use on board ship).

circuit for the portable stations mentioned above; and in this apparatus two different waves may be excited, by changing the plugs at P_1 , P_2 . The mounting is "direct," as represented in the diagram, fig. 46.

For various practical reasons, no provision is made in these

portable stations—in which single aerial conductors, 200 metres in length, are suspended from balloons or kites—for constantly varying the waves, but only for producing two definite waves, one of which corresponds to the normal oscillation, the other to the first upper octave.

The employment of an “electrical counterpoise” (instead of earthing), the theoretical importance of which has been already explained, and which consists of wire gauze, is specially advantageous in this

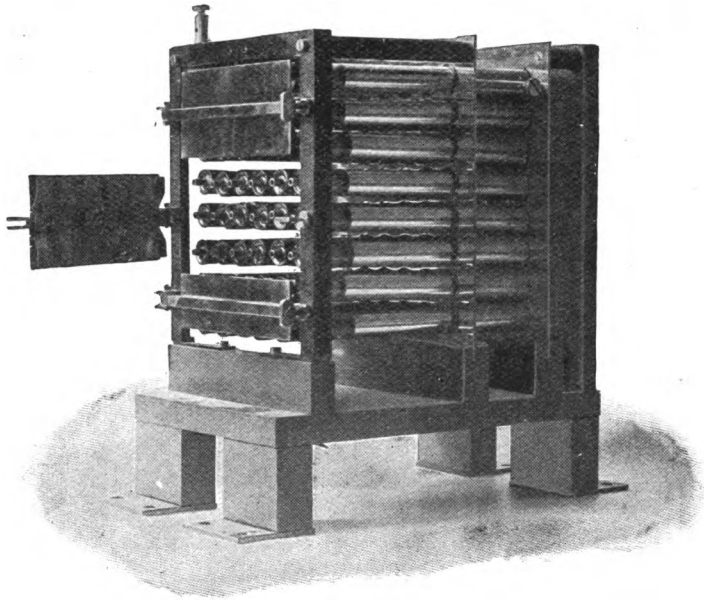

FIG. 45.—Excitation Circuit (for portable stations).

case. It obviates the difficulties encountered in these movable stations when seeking for “suitable earth,” and also prevents, within the limits of possibility, the atmospheric disturbances so detrimental to the receiver, and otherwise rendered inevitable by the great height of the aerial wire. The excitation circuit consists of the constant capacity C , to which the high potential is supplied, the “multiplex” spark-gap F , and an induction coil L . Only part of this latter is placed in the circuit for exciting the short wave, by inserting a plug at P_1 , whilst for exciting the long wave all the windings are placed in the circuit by plugging at P_2 . On the one hand, the excitation

circuit is connected to the aerial wire, and on the other to the coils S_1S_2 , the self-induction of which, in conjunction with the capacity of the wire gauze, effects the counterpoise of the aerial wire. S_1 is employed in the case of the normal vibration, and S_2 with its octave. When exciting the long wave, the "coupling" to the excitation circuit amounts to 15 per cent., but to only 10 per cent. when

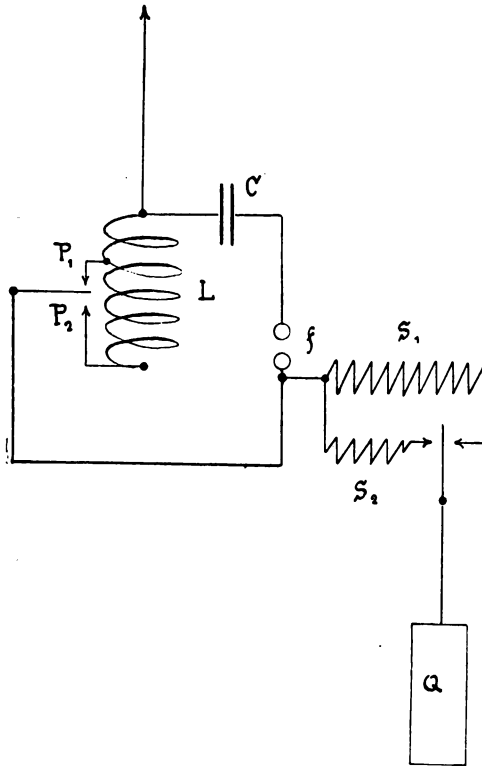

FIG. 46.—Method of Mounting the Sender in Portable Stations.

the short wave is being excited. The dimensions of the coils S_1 and S_2 correspond to those of the wire gauze and the waves emitted.

Of the next three photographs, fig. 47 shows the construction of a Leyden jar system, with (fig. 48) the appurtenant induction circuit and (fig. 49) a specially constructed "annular multiplex spark-gap," with annular electrodes. These apparatus are employed by the Telefunken Company in its 1000-kilometre stations.

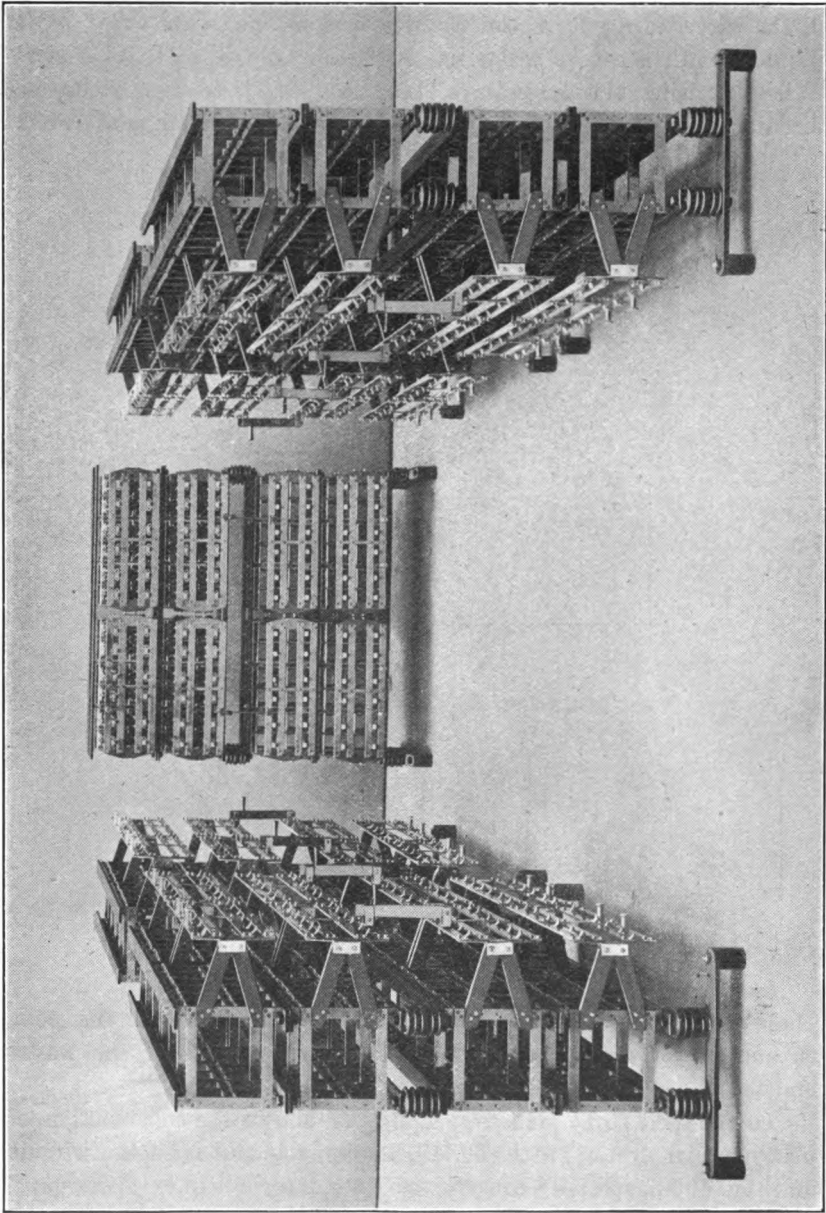

FIG. 47.—Leyden Jar System.

Finally, we may mention the newest and most interesting type (fig. 50) of current generator, as used in the lightly constructed portable stations of the Telefunken Company, with a range of 25 kilometres on land. A small continuous-current dynamo, with a capacity of about 100 watts, is mounted on a bicycle frame. Motion is transmitted from the fly-wheel to the dynamo by a cord and aluminium

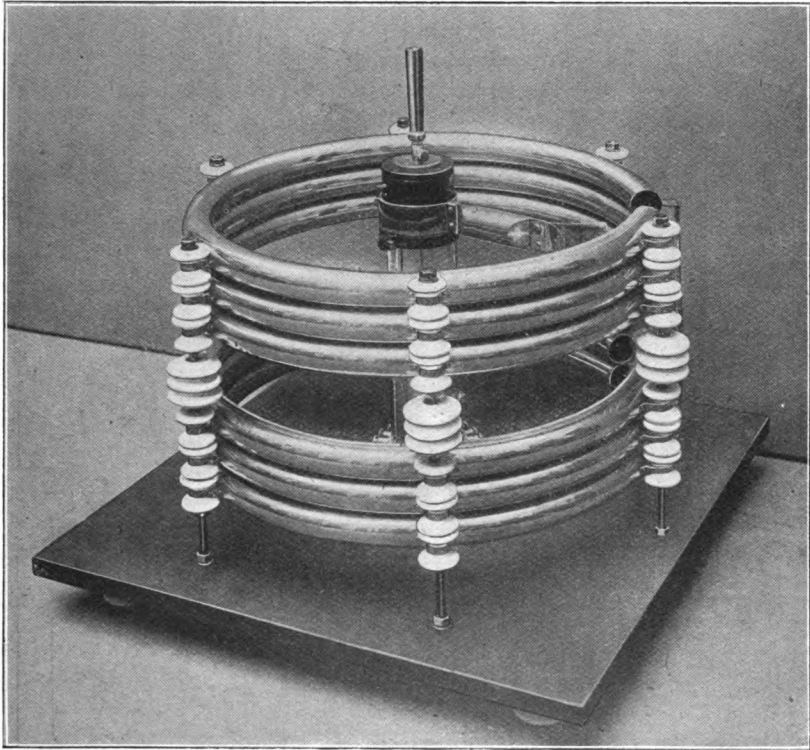

FIG. 48.—Primary Induction Circuit.

pulley of suitable design. The gearing is of such proportions that with normal pedalling a spark 4 mm. long is obtained in the inductor.

In these light portable stations, the mast for carrying the aerial conductor is made of telescopic steel tube. The complete station, with sender and cycle frame dynamo, weighs only about 4 cwts., and can be easily carried by two to three horses or eleven men.

As already mentioned, one and the same aerial wire or wire system is generally employed to serve both sender and receiver. When

signals are being sent, the receiving apparatus is separated from the aerial conductor by a main switch, while conversely the sender is disconnected when the instrument is set for receiving. In modern installations these operations are performed with a single handle; and to enable these to be done, a "spark-gap" switch is arranged in the aerial conductor. In "sending," sparks traverse this gap and connect the

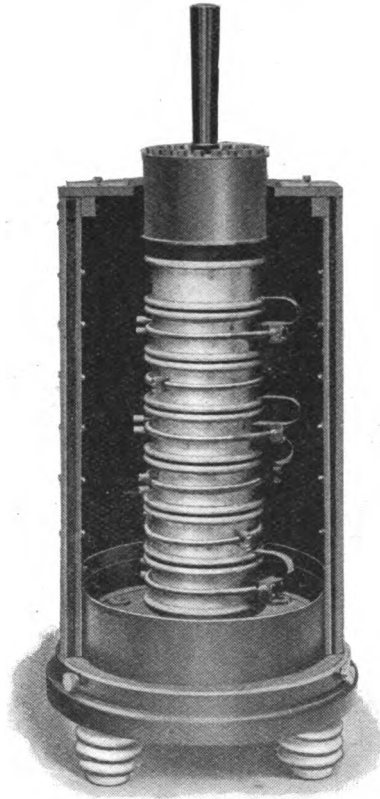

FIG. 49.—"Annular Multiplex Spark-gap."

aerial conductor with the sender; but in "receiving," no sparks pass, and the sender is automatically disconnected from the aerial conductor.

COHERER AND OTHER DETECTORS FOR ELECTRIC WAVES.

In connection with the receiver, we will now consider its main component, the coherer, taking the so-called steel coherer (fig. 51) first.

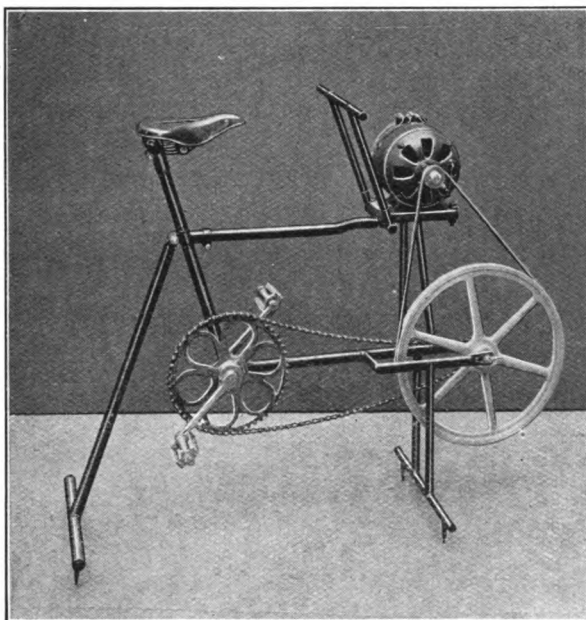

FIG. 50.—Current Generator for Light Portable Stations.

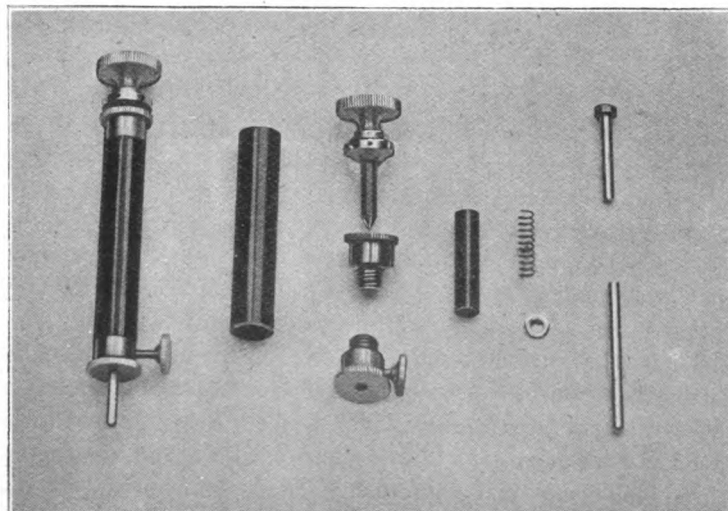

FIG. 51.—Coherer.

This consists of two steel electrodes, adjustably mounted by means of a screw and held in a tube of hard rubber. In the very small space between the highly polished inner surfaces of the electrodes are placed about thirty to forty steel granules. The smaller the number of granules, the greater the sensitiveness of the coherer; so that by increasing or diminishing their number, and by adjusting the electrodes, any desired degree of sensitiveness can be obtained. A further refinement in this connection consists in mounting the one

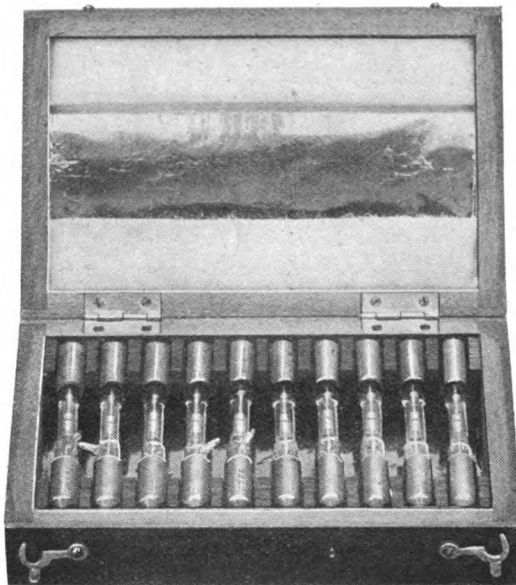

FIG. 52.—Coherer.

electrode of the coherer between the poles of a small open annular magnet, which can be adjusted by gearing, so that the coherer may be magnetised to either polarity or entirely demagnetised, thereby modifying the coherence of the granules and the sensitiveness of the coherer.

In another form of coherer (fig. 52), there are two silver electrodes in a glass vacuum tube, the terminal surfaces being ground so as to leave a small wedge-shaped intermediate space for the reception of a mixture of silver and nickel granules. The instrument can be turned so as to bring the granules into a larger or smaller space, thus regulating the sensitiveness.

A large number of appliances have been devised for replacing the coherer, which occasionally exhibits very tricky antics ; and a few of the most recent of these " detectors " will now be briefly described.

The first claim to our notice is undoubtedly possessed by the Schloemilch detector, the external appearance of which is shown in fig. 53.

The inventor of this detector connects an ordinary polarisation cell, with platinum electrodes immersed in dilute acid, to a source of current having an E.M.F. slightly exceeding that of the cell. Consequently a current passes, and the electrolyte is decomposed with slight liberation of gas. If now the cell is exposed to electric waves, an immediate strengthening of the current is evidenced by a more violent disengagement of gas. Schloemilch found that the action is greatly strengthened when the surface of the positive electrode is extremely small, whilst that of the negative electrode may be of any suitable size. At present the positive electrodes have a diameter of only 0.001 mm. and a length of 0.01 mm. On reversing the electrodes the aforesaid phenomenon disappears almost completely, a proof that the gas liberated at the smaller electrode plays an important part.

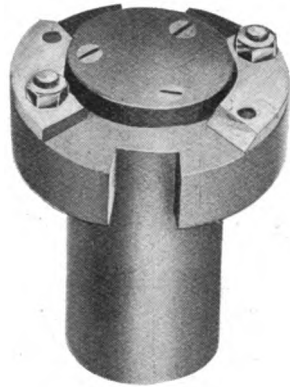

FIG. 53.—Schloemilch Detector.

The strength of the current, and consequently the liberation of gas on which the sensitiveness of the cell depends, can be regulated by a resistance. The more intense the electric irradiation, the more powerful the reaction of the cell. The nature of the phenomenon has not yet been accurately determined, but it seems to be a species of depolarisation. The cell can now be connected in the usual manner with a relay, in order to actuate the working circuit with a Morse register. No tapper is used, the cell always automatically resuming its normal condition after the action is over.

Moreover, the cell can also be connected with a telephone, which renders audible the fluctuations produced in the current by the effective electric waves. In this latter connection the Schloemilch detector is of inestimable service, the more so in that it is insensitive to vibration. The illustration (fig. 54) shows the simplest method of

mounting, the cell lying direct in the aerial wire. The connecting in parallel of a very large condenser C is to minimise the damping influence of the cell, notwithstanding the high ohmic resistance, since this condenser affords an undamped bye-pass for the oscillations. At

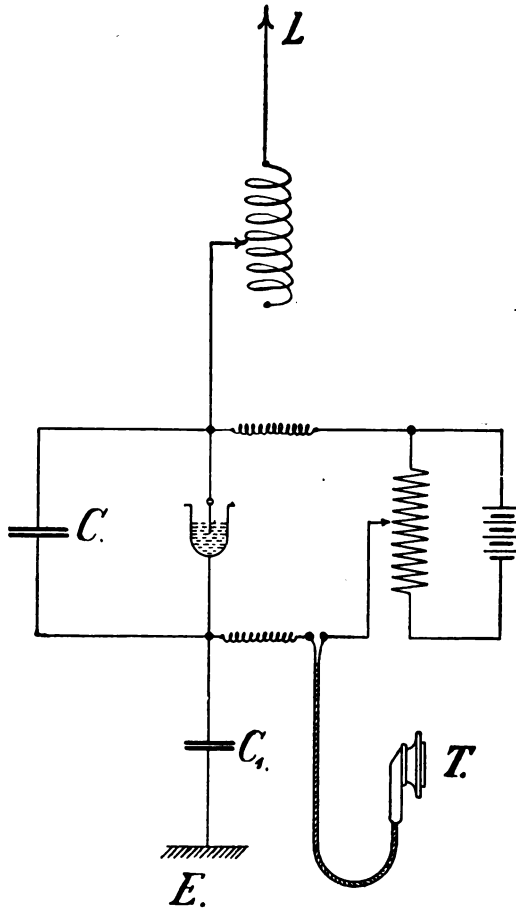

FIG. 54.—Method of Mounting the Schloemilch Detector.

the same time, of the total energy oscillating in the receiving wire, only a small amount per oscillation, corresponding to the low potential generated at the high capacity condenser, is absorbed by the cell. Far more accurate syntony is, however, obtained by inductive mounting. This can be arranged by simply turning a switch lever, so that the cell is included in an inductively excited, closed

secondary oscillation system. A condenser mounted in parallel with the cell diminishes its damping influence on the secondary system.

Figs. 55 and 56 show the latest types of the apparatus, which is actually the simplest and most reliable receiver for wireless telegraphy. For this reason a more detailed description of the mounting and working of this electrolytic detector should be of interest.

Fig. 57 shows the course of the high-frequency oscillations.

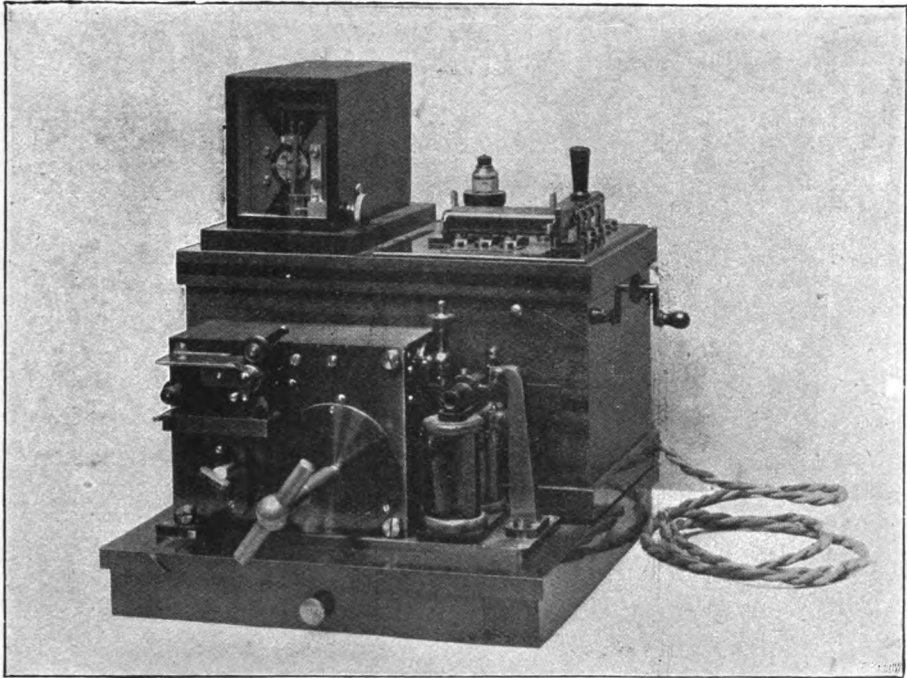

FIG. 55.—Receiver with Schloemilch Detector and Morse Register.

After connection of the aerial wire and the laying in of the main switch through the spring contact 1, 2, the high-frequency currents reach a condenser (3, 4) of a larger capacity, which serves for barring the battery circuit of many receiving apparatus switched parallel and interchangeable, as also for preventing short-circuiting of the cells by the discharging coil (20, 19), which will be explained later on. The oscillations then pass the syntonising coil 5, 6, and the variable condenser 7, 8. The first serves to lengthen the aerial wire when necessary, whilst, on the other hand, the variable condenser

serves to shorten the specific oscillation of the aerial wire. The terminals 7, 8 are usually connected by a short circuit piece. From point 9 the leads for the high-frequency oscillations branch out. They pass, on the one hand, through the switch 10, 11, across the detector 12, 13, through the switch 14, 15, and on through the earth-switch 16, 17, to the earth-terminal 18, and from there

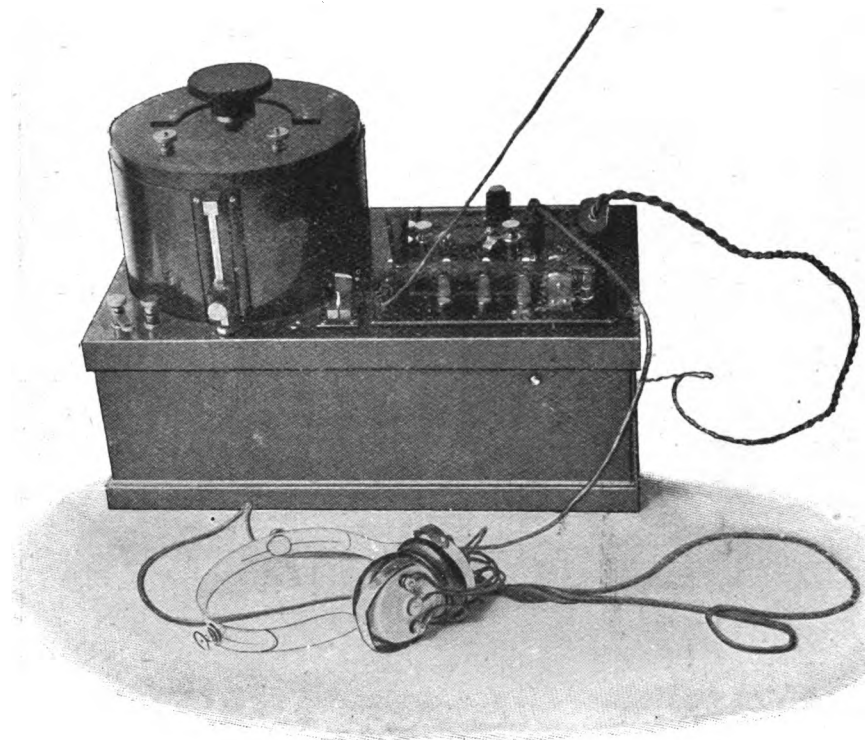

FIG. 56. —Receiver with Schloemilch Detector and Telephone.

to the earth. On the other hand, a branch leads over to the plug-contact 21 towards the variable condenser 22 to point 23, and from thence through the switch-terminal 15 back to the other pole of the detector. With the plug-contact 9, 21, the variable parallel condenser 22, 23, which serves for syntonising, can be completely switched off in case of need.

To let atmospheric charges flow direct to the earth, a choking-coil 20, 19, is applied at the point where the conductor is joined up

with the apparatus, and this coil is connected with the earth by the switch 16, 17, and the terminal 18.

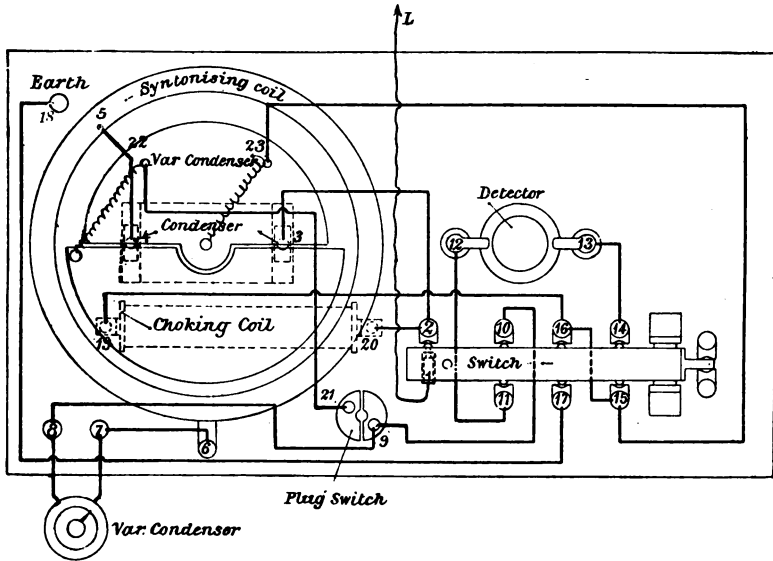

FIG. 57A.—Course of the High-frequency Oscillations.

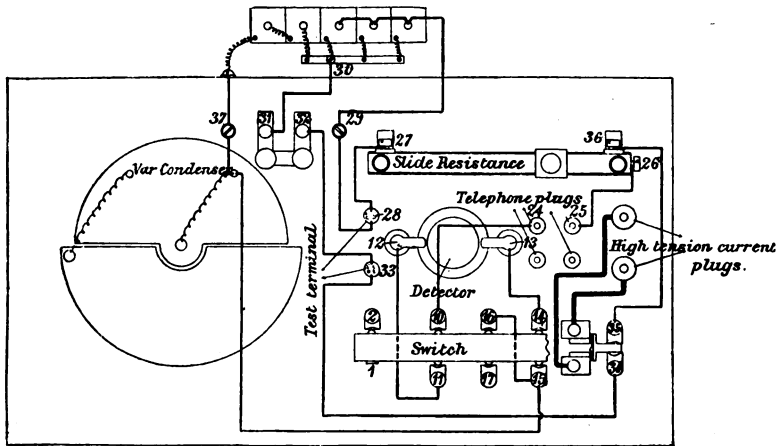

FIG. 57B.—Showing the Battery Circuit.

The battery consists of three dry cells, connected in parallel, which are permanently closed by the slide-resistance 27, 36, and two cells connected in series, which are placed in a row with this

combination. The tension of the first set can be varied, through the resistance within the limits of 0 to 1.5 volt, and one of these values can be added to those of the series of cells at will.

Starting from the parallel cells 29, 30, the current passes through the switch 31, 32, to the negative test-terminal 33. The switch 31, 32, is intended for interrupting the permanent circuit when the apparatus is not being used in order to prevent unnecessary exhaustion of the cells (for instance, in transport, during which time the switch lever must be closed by way of precaution). After the current has passed the switch 34, 35, it arrives through the slide-resistance 36, 27, at the positive test-terminal 28, and then passes back to the end terminal 29.

The real principal circuit, in which the telephone and the detector are situated, must next be considered.

Starting from the latter, the current passes from its terminal 12, through the brown leads to the switch 11, 10, then through the black wire to the telephone 24, 25. The connection contacts of the latter are so arranged that either one or two telephones may be used, the connection in the latter case being either parallel or in series.

The contact 25 is further connected with the regulating-slide 26, which forms a part of the regulating resistance, and the current reaches the positive pole of the cells connected in parallel through the point 27, the test-terminal 28, and the terminal 29. It then passes through both cells in series to the point 37, through 23, the switch 15, 14, and so back to the negative terminal of the detector 13.

The working of the apparatus is simple in the extreme. The accessible terminal 31, 32, of the battery current is first closed after removing the cover, and the detector is then fixed in such a way that the pole signs marked on the latter coincide with those of the contact pieces on the apparatus.

For the telephone, four symmetrically arranged plug-switches are provided, which are laid between the detector and the strong current plug-connection, of which the two placed nearest the observer are directly connected with the leads, whilst the other two can be switched to these either parallel or in series. The parallel and series mounting can be performed in a simple way by means of the spring-contact, which is quite visible on the under-side of the cover. The object of the spring-contact is to enable the

telephones to be connected up in such a way (with regard to their several ohmic resistances, as also to the current fluctuations which become weaker in long-range telegraphy) that the maximum strength of sound is obtained from them.

To enable the detector to be adjusted to its maximum sensitiveness, the telephone is held to the ear and the position of the regulating slide is altered, till the faint rushing noise, produced by the over-displacement of the regulating slide, disappears abruptly. The correct adjustment of the slide with new apparatus will be found close to the limit of the lowest voltage range, as in calculating the dimensions of the apparatus allowance is made for variations in the voltage of the cells, the occurrence of which will necessitate adjusting the slide.

After the adjustment has been effected the working of the detector is tested by touching the metallic casing of a coherer-tester with a detector-terminal and by listening in the telephone for the emission of sounds.

Syntonising in receiving.—This is quickly done, as no further material (coils and so forth) is necessary, and the whole of the syntonising material (with the exception, perhaps, of an earth condenser) is attached to the apparatus, simply by joining the plug-connection of the hard-rubber-lever to the aerial wire and the earth-terminal E with the earth.

To enable the apparatus, which is in connection with the aerial conductor, to be attuned to the wave-length of the counter station, a previously determined sign of the Morse alphabet is repeatedly sent from the latter with mean intensity, and the slide of the syntonising coil is shifted till a maximum strength of sound in the telephone has been obtained. With simple aerial wires of mean capacity it is advisable to adjust the parallel condenser beforehand to a capacity which corresponds to about 40° on the scale. If the self-induction of the syntonising-coil and the parallel condenser be now more or less modified, the most advantageous combination will be found in a short time. When the apparatus has been tuned in this way, the adjustment of the voltage-regulating slide is again altered slightly, as the detector voltage can only be adjusted accurately when syntonisation is being effected.

Another very useful detector, though only applicable in conjunction with a telephone, is that newly introduced by Marconi. In this

instrument the known phenomenon of magnetic hysteresis is utilised, the arrangement being that shown in fig. 58.

An endless cord *S* of thin soft iron wires is led in front of the poles of a magnet *M*, and there traverses a coil of insulated copper wire, connected on the one hand with the aerial wire *L* and on the other with the earth (*E*). On this coil is wound an insulated secondary coil, in which the telephone, *T*, is included. Normally the iron is prevented by hysteresis from immediately following the rapidly alternating magnetisation; but when the primary coil is traversed by electrical waves the residual magnetism is suddenly dispersed for the moment. Hereupon the current impulse induced in the secondary coil excites the telephone and renders the wireless Morse signal audible. This complex device, provided as it is with moving parts, gives only the same effect as the simple Schloemilch cell.

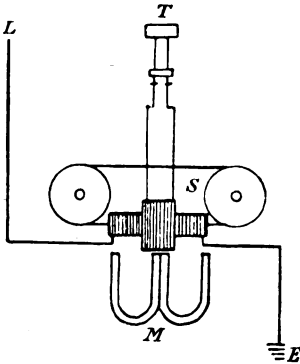

FIG. 58.—Marconi Detector.

An extremely sensitive wave recorder is Rutherford's magnetic indicator. Part of the wire composing the resonator is coiled round a magnetised steel needle. The electric oscillations influence the magnetisation of the needle and thereby cause the deflection of a second magnetic needle suspended close by, and whose movements can be observed with the aid of a mirror and telescope (as in a galvanometer).

It has been mentioned already that this indicator is preferably used in loose-coupled systems, in which the integral effect is the main point.

An interesting new type of indicator is the Lodge-Muirhead coherer, which is described as follows in the catalogue of the Lodge-Muirhead Wireless and General Telegraphy Syndicate, Limited.

"The illustration (fig. 59*) shows the form of coherer, which requires no tapper, but is kept perpetually sensitive by the rotation of a small steel disc just separated from a column of mercury by a film of mineral oil. The impulse of electric oscillations breaks down the oil film and establishes momentary cohesion between the steel disc and the mercury. No effective contact occurs between the wheel and the mercury, notwithstanding the immersion, because

* Block kindly lent by *The Electrician*.

of the film of oil; but the slightest difference of potential applied to the two, even less than one volt, is sufficient to break the film down and complete a circuit, which, however, the rotation of the wheel instantaneously breaks again. The spark is so sudden that for its purposes the wheel is for the instant virtually stationary, and yet the decohesion is so rapid that signals can be received in very quick succession.

“The definiteness of the surfaces and of the intervening layer makes the instrument remarkably trustworthy, and the thinness of the insulating film makes it very sensitive. In fact, a single cell of a battery cannot be employed as a detector, because it is of too high a voltage for the film to stand. A fraction of a volt is employed by means of a potentiometer device—usually from 0.3 to 0.5 of a volt—and it is adjusted to suit circumstances.

“The battery acts through the coherer direct on a low-resistance recorder, without any relay, and the record on the strip shows every character of the arriving pulses, and exhibits any defect in the signalling. Provided that every joint and contact, except the one intended to be filmed, is thoroughly good, the coherer is so definite that defects may in general be sought for at the sending end. The signals are picked up and recorded precisely as they are emitted, as has been tested by intercalating a siphon recorder in a much diluted tapping circuit at the sending end, so as to get a record with which to make comparison. The traces obtained at the two ends are identical to a surprising degree.

“The mercury level has an adjustment which is easily made. One precaution is to keep the rim of the wheel clear of dust, which is done by a cork or leather pad pressed lightly against it by a spring.

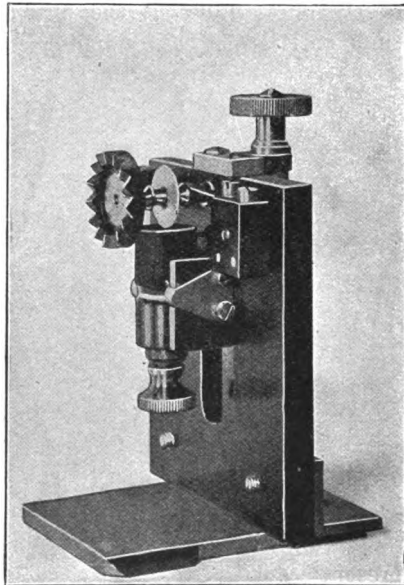

FIG. 59.—Lodge-Muirhead Coherer.

“The instrument is not at all sensitive to tremor, and requires no particular delicacy of adjustment. The wheel has to be positive, the mercury negative.

“A telephone in circuit, through a transformer or otherwise, affords an easy method of discriminating the signals by ear. The speed of the wheel gives another convenient adjustment to suit various circumstances.”

In fig. 60 we have a specimen of script kindly furnished by Professor A. Tobler of Zürich.

“If the rapidity of the sparks at the transmitting station is insufficiently great, the signal becomes a broken or wavy line, and not a steady deflection; but if the rapidity be increased this waviness disappears and the recorder needle is simply held over, giving a

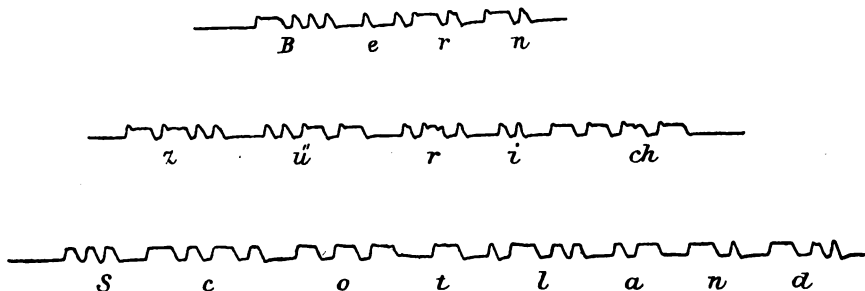

FIG. 60.—Specimen of Script with a Lodge-Muirhead Coherer.

steady long deflection to represent a dash, and a momentary one to represent a dot.”

Mention may also be made of the Neugeschwender or Schäfer plate, as the prototype of an “anti-coherer,” *i.e.* a wave indicator in which the transitory resistance is increased instead of being diminished as it is in the coherer.

A glass plate is coated with a deposit of silver, which has been scored with a diamond graver, the plate being afterwards varnished.

The resulting gap is, however, imperfect, being bridged over by extremely fine metallic threads. These bridges are probably temporarily destroyed by the heat of minute sparks, the resistance being thereby increased. As soon as the action stops, the metallic vapours are re-condensed and the original value of the resistance is restored.

Finally, we will just refer to the Fessenden detector, in which the

heating effect of the electrical waves induces fluctuations of resistance in bolometer wires.

The foregoing description of detectors makes no claim to completeness, and is merely intended to throw light upon the best known principles of detecting electrical waves.

RECEIVING APPARATUS.

A complete receiving apparatus, with steel coherer but without oscillation circuit, is illustrated in fig. 61.

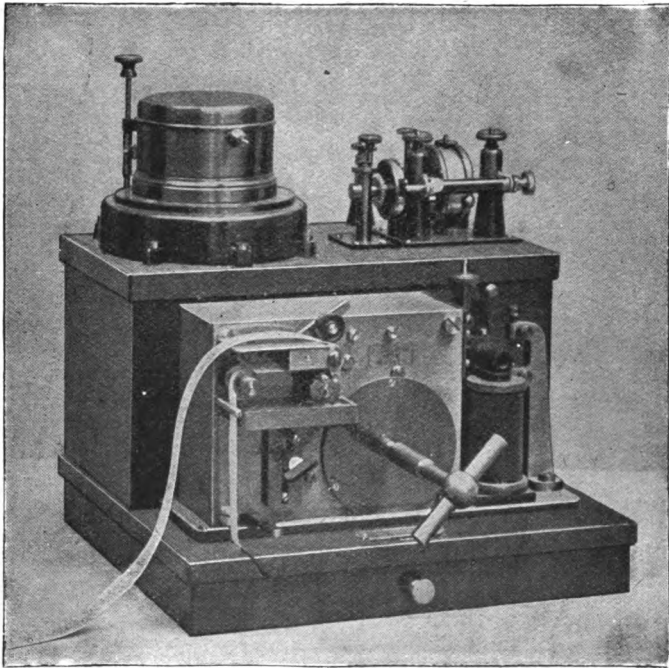

FIG. 61.—Receiving Apparatus.

The relay is mounted on the left side of the hinged cover of a wooden box, the coherer, tapper, and magnetic regulator being mounted on the right side. An ordinary Morse register is visible in front.

The box contains the cells and the supplementary coils and mica condensers aforesaid.

A modern type, with silver-nickel coherer, is shown in fig. 62.

Fig. 63 represents a very light and compact pattern, specially designed for portable stations.

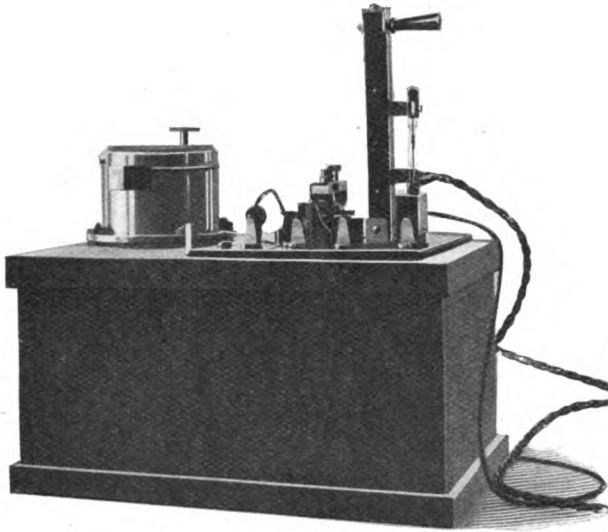

FIG. 62.—Receiving Apparatus.



FIG. 63.—Light Receiving Apparatus for Portable Stations.

The polarised relays always used are specially guarded against the mechanical vibrations of the tapper. For ships' use, the whole receiving apparatus—including Morse register—is fitted with easy springs to absorb any vibration from the engines. Such an arrangement is shown in fig. 64.

The tapper is made for a high frequency, and is of the smallest possible dimensions.

A main switch on the receiving apparatus serves to change

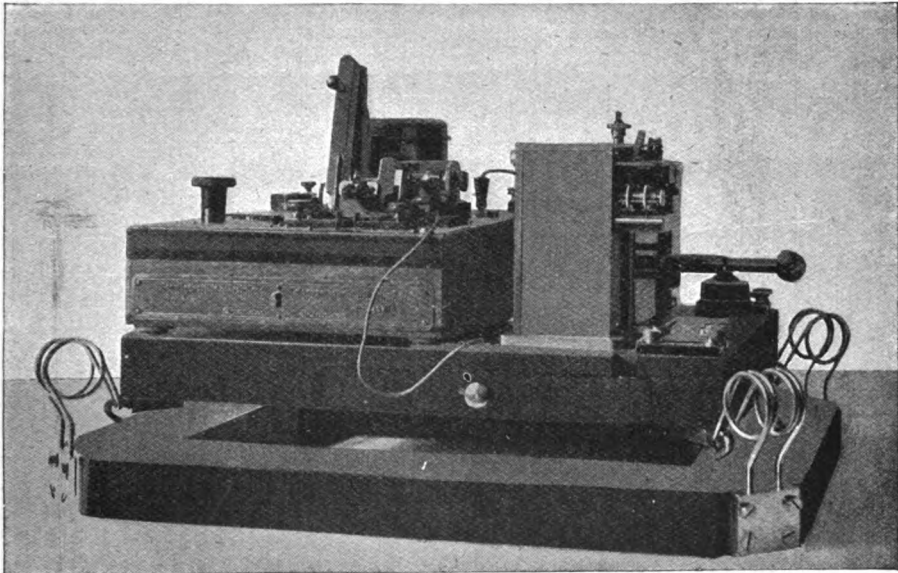

FIG. 64.—Receiving Apparatus for use on board Ship.

from receiver to transmitter, cutting out all local circuits at the receiving station, or blocking the primary current in the transmitter.

As mentioned, sparking at the relay or the tapper is entirely avoided by using various ohmic resistances or polarisation batteries.

RECEIVING OSCILLATION CIRCUITS.

For oscillation circuits or receiving transformers various types have been devised, according as close or loose coupling is resorted to in the receiver. With close coupling, the transformers (fig. 65) consist of a single coil, so arranged that any number of the windings may be brought into use by means of adjusting slides.

The mounting adopted with close coupling—in which, as already stated, accurate syntonising is impossible—is represented in fig. 66. In this, *F* is the granular coherer, *K* a constant condenser, the capacity of which is very great in proportion to that of the coherer—

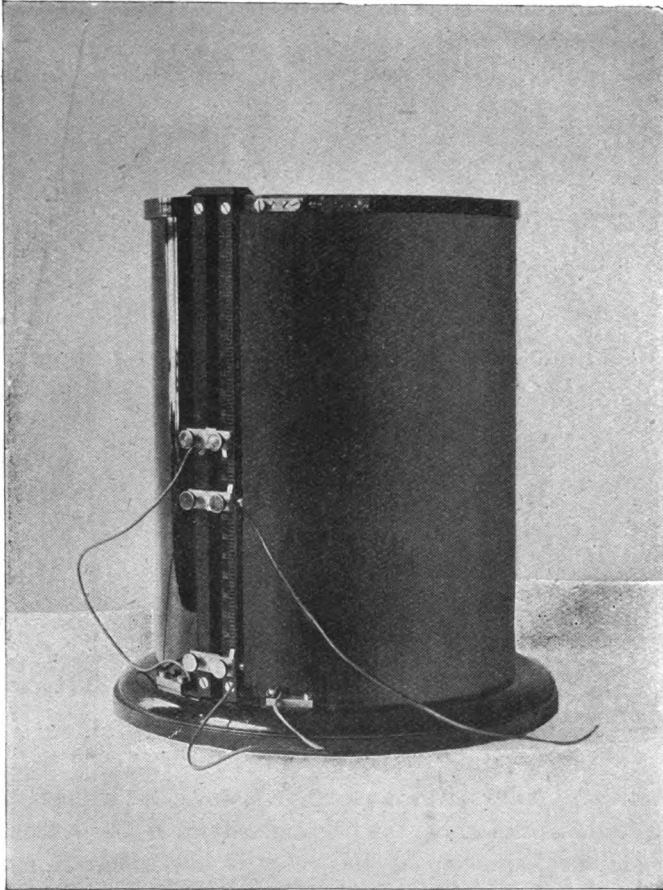

FIG. 65.—Receiving Transformer for Close Coupling.

which the Baltic station experiments first demonstrated to be very small—and can therefore be disregarded with reference to the frequency of the system. *J* is an induction coil with three variable contacts, *a*, *b*, and *c*. The tuning of the coherer circuit is effected by changing the position of the slide *b*. By means of the slide *c*

the other windings are short-circuited and prevented from oscillating with the rest. The conductor *bc* is earthed by means of a variable condenser C, and the aerial wire connected to the slide *a*. The aerial wire can be tuned, both by changing the number of windings between *a* and *b*, and by means of the condenser C. Consequently the larger the number of windings *ab* for a given wave-length, and the correspondingly smaller the condenser C, the closer will be the coupling and the more imperfect the tuning.

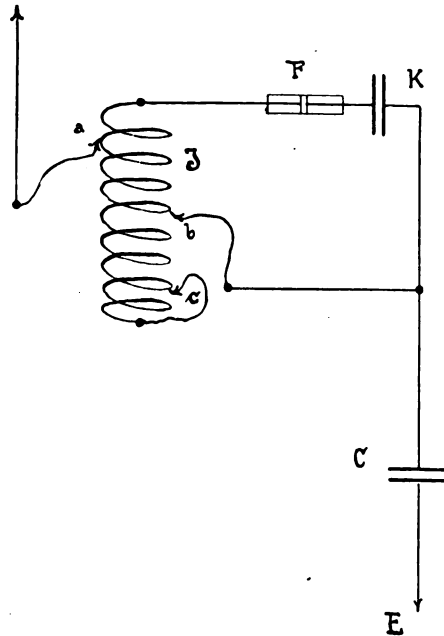

FIG. 66.—The Mounting in the Receiver for Close Coupling.

The mounting of the loose-coupled oscillation circuits in the receiver—which system is the only applicable one for securing accurate tuning—has been already described on p. 22. The construction is illustrated in fig. 67. Any desired degree of loose coupling can be obtained by adjusting the outer primary coil. The secondary coil is inside, and is surmounted by the variable air condenser of the secondary circuit. The number of effective windings, and therefore the self-induction of the secondary coil, can be varied by means of a slide.

The mounting adopted at the Baltic stations for obtaining

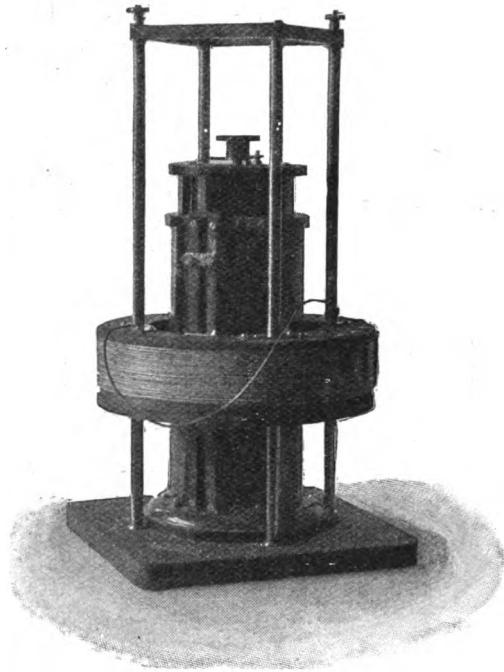

FIG. 67.—Receiving Oscillation Circuits with Loose Coupling.

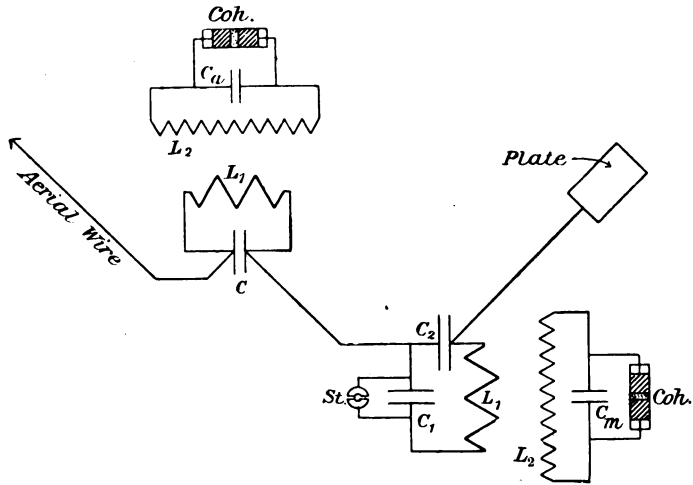

FIG. 68.—Mounting for Multiplex Telegraphy as used at the Baltic Stations.

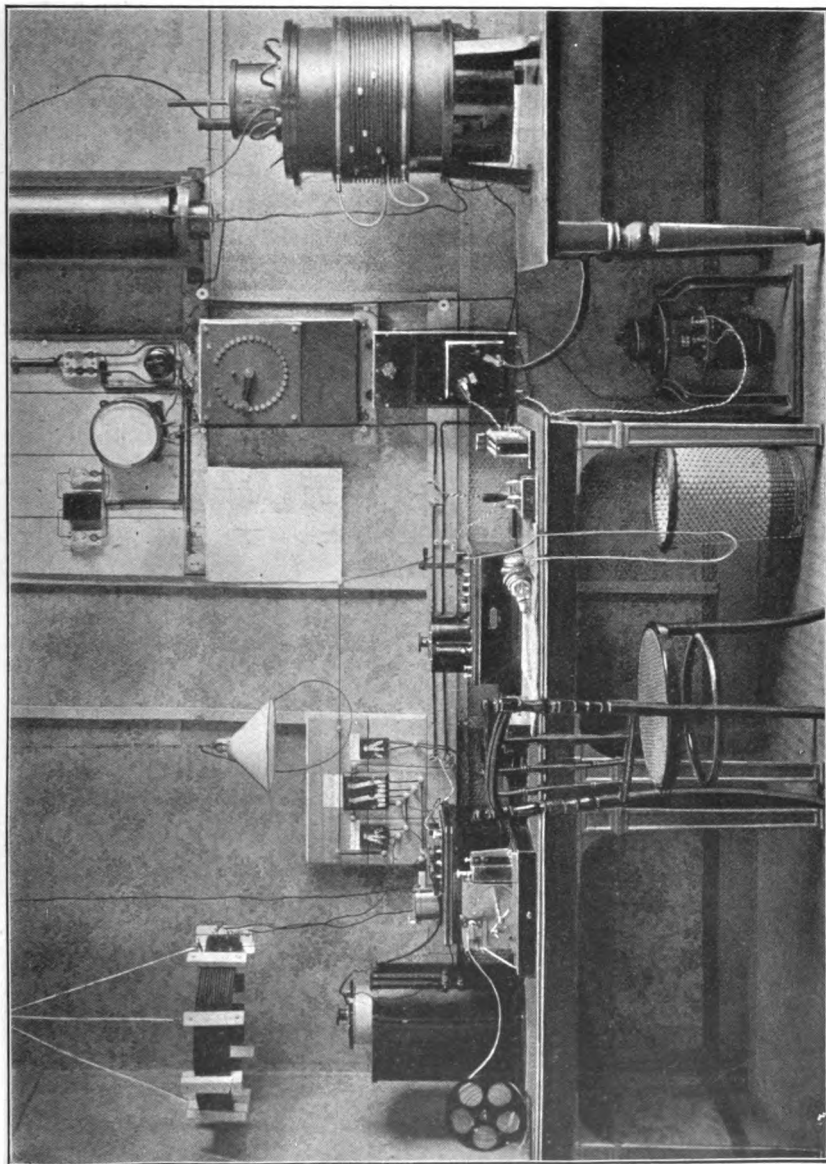

FIG. 69. — Wireless Telegraph Station.

absolutely reliable *multiplex wireless telegraphy*, is made clear by fig. 68. The oscillation circuits were excited by the same aerial wire. The attachments were coupled direct, but relatively loosely, with the primary circuits, and the latter excited the secondary circuits, the coupling between the two being very loose. The difference between the two effective wave lengths amounted to only about 10 per cent. in the case of a highly unfavourable distance ratio of 10 : 100 miles.

This method of mounting is unquestionably not the best. Theoretically, the use of only one aerial wire entails joining of same with the various oscillation circuits by different degrees of coupling, in which case losses of energy are inevitable. The best plan—though unfortunately not the simplest in practice—is of course the use of several distinct antennæ for the different oscillation circuits.

Fig. 69 represents the interior of a fully equipped wireless telegraphy station. To the right are the sending apparatus, whilst the receivers are mounted at the left of the long table. From the descriptions already given the reader should feel himself quite at home in this up-to-date telegraph station.

CHAPTER XI.

CONCLUSION.

By strenuous labour in both the scientific and the technical branches, wireless telegraphy has been raised within a single decade, from the smallest beginnings to an indispensable means of communication. This will constitute a lasting memorial of our progressive age, a visible sign of the intelligence and high endeavour, love of work, and capacity of appreciating the deeds of our leading spirits. It also shows how unremitting labour for securing ideal benefits to mankind is not only an ennobling moral influence, but also may lead to practical results outstripping the wildest dreams of imagination. Who would have thought it possible to waft messages across the ocean without any visible means of transmission! Of course progress has been accompanied by a clamour for more, the requirements advanced showing how far we are still from the ideal goal, which appeared so near when the real principles involved were first clearly recognised.

We have seen that at present the work has to be carried on with oscillatory discharge complexes, which even in the most favourable conditions (perfectly loose coupling) produce only relatively slightly damped wave series. The pauses between the sets of discharges are infinitely long in proportion to the time they themselves occupy, the situation being comparable to that of a sea, perfectly quiet all day long except for a single minute's disturbance by waves. In reality, we excite merely a series of short electrical tone impulses which, on account of the wide interval between them, cannot even be regarded as a chain of impulses.

What a difference there would be in the practical utility of electric oscillations were we able to generate and maintain, at will, persistent electric tones of sufficient frequency! Our most modern

alternating generators are cumbrous devices for producing very slow oscillations (about fifty per second), whereas, for wireless telegraphy, a mean frequency of about a million per second is required. Here is a worthy and profitable subject for inventive skill, and one whose solution might lead to perfectly incalculable results.

As was quite natural, the value of wave telegraphy was at first appreciated only in comparison with the range of distance covered; and though this progressively increased, it was not until the introduction of the Braun coupled systems that any imposing dimensions were attained. We have seen that the energy can be brought to exert itself instantly by the use of close coupling, so that vibrations of an explosive character are produced, but that while these can penetrate to great distances, they excite any receiver, whether syntonised or not. As we have seen, it has also become possible to render any amount of energy effective in the form of electrical waves, so that at present stations with a range of 600 miles represent merely ordinary types.

It has already been pointed out that an excess of energy has always to be allowed for in practical wireless telegraphy, because the transmission of the energy varies greatly with the weather. Bright sunshine lessens the action considerably; and a still more unfavourable effect on the transmission of signals is produced by protracted spells of dry weather, during which the air becomes ionised. On the other hand, when the ionisation has been destroyed by rain, the original efficiency is at once restored. A soft, damp state of the atmosphere is best for the operations of wireless telegraphy, though the ordinary man would be inclined to think the opposite. For these reasons modern stations are always arranged to develop three times the maximum efficiency required for their range.

The explosive emission of energy resulting from close coupling must naturally be attended with great drawbacks when several stations are working simultaneously at short distances apart.

Recently, however, more delicate methods of operating have come into use by the introduction of loose coupling. We have seen how the reduction of the damping through resistance is attained at all points of the oscillation track, especially in the primary sender circuit by subdividing the spark-gap and constructing it of the most suitable length. In the receiver, the secondary system especially has been elaborated into an independent and almost undamped oscillator, to secure the clearest resonance with an effective sender oscillation.

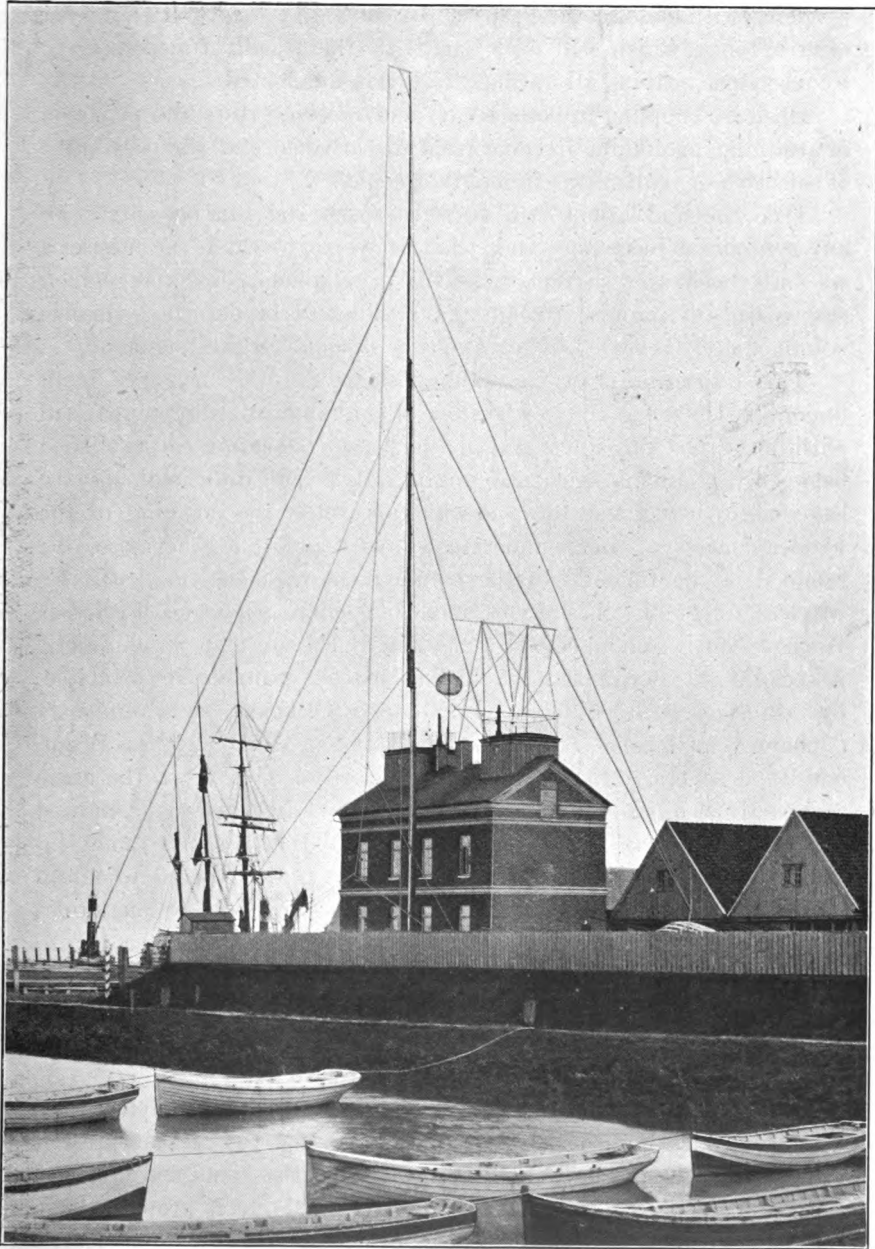

FIG. 70.—Wireless Telegraphy at Pilot Stations.

Thus, with loose coupling, space is traversed by weak but elongated electric tones, which will only excite the identically tuned receiver by resonance, leaving all untuned receivers unaffected.

On loose coupling in both sender and receiver rests the principle of attaining maximum freedom from disturbance and the possibility of selective or multiplex wireless telegraphy.

True, the oscillations still traverse space and can be caught by any syntonised receptacle, and, what is worse, to catch the messages we only need the extremely sensitive telephone detectors, which react with any impulse, though the attainment of perfect resonance is immediately revealed by a maximum of sound in the telephone.

This impossibility of maintaining secrecy in the messages is an undoubted defect of the new system of communication in comparison with telegraphy through wires, in which the connection is established between certain mathematical points only. The drawback may be lessened by using a secret code which prevents the meaning of the wireless message being understood by others. Furthermore, the removal of the difficulty by the employment of a system of *directed* wireless telegraphy has been under consideration; and Professor Braun recently announced at a meeting of the German Shipbuilders' Association at Berlin, that he had solved the problem, in principle, by using several differently-phased oscillations simultaneously ("phasenverschobene Schwingungen"). For this purpose Braun employed several antennæ in which oscillations partly of the same and partly of different phases were excited. Furthermore, he showed an easy method of producing several oscillations of the same frequency but of a different phase. In this way it is possible to obtain different actions in different directions, *i.e.* a "directed" wireless telegraphy. Nevertheless, the practical results do not seem, so far, to have reached the level of theoretical requirements.

Despite these limitations, the practical utility of wireless telegraphy is undeniable, and increasing in importance. To illustrate this more clearly, we may review its chief spheres of activity.

The first proofs of the usefulness of wireless telegraphy were afforded by its application at pilot stations (fig. 70), and at present almost all such stations, and fire- and life-boat stations, are equipped with the apparatus (fig. 71). Many lives and much property have been saved by this means. The enormous superiority of electric waves to optical signals is nowhere more apparent than in bad and especially foggy weather, since the small waves of light are

shattered against the comparatively large globules of fog, whereas the latter are, as it were, carried onwards by the gigantic electric waves being unable to check their advance.

The new method of communication is also increasing in usefulness for the commercial purposes of the mercantile marine. The advantages are self-evident, since important news can be transmitted between ships and shore, for hours, and even days, after leaving or

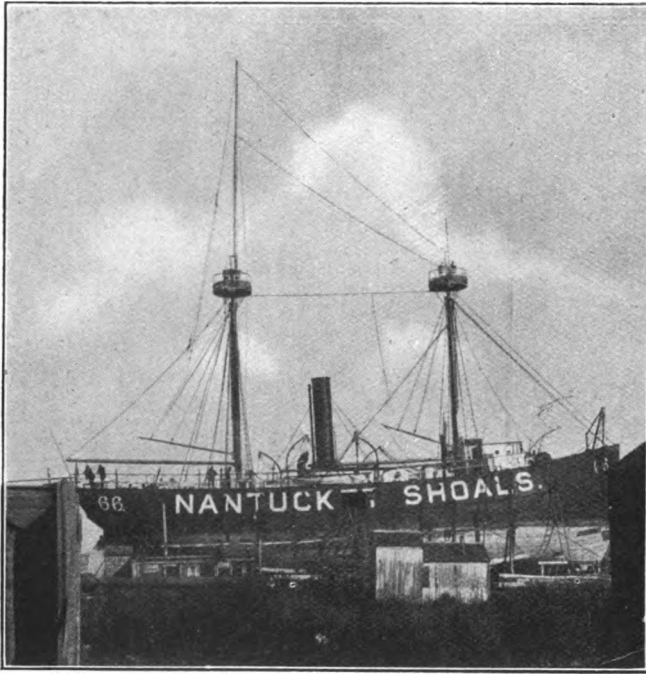

FIG. 71.—Wireless Telegraphy at Light-ship Stations.

before entering port; and in case of accident or sea-damage, aid can be rendered promptly. Hence the number of coast stations are being constantly increased on every sea, and nearly all the large liners are now fitted with wireless telegraphic apparatus. This can be used at a low, fixed rate; and in some cases wireless messages of general importance are published on board in newspaper form.

Special importance, and rightly so, is attached to wireless telegraphy in military circles. Probably no large man-of-war is without the necessary apparatus for wireless signalling, now that

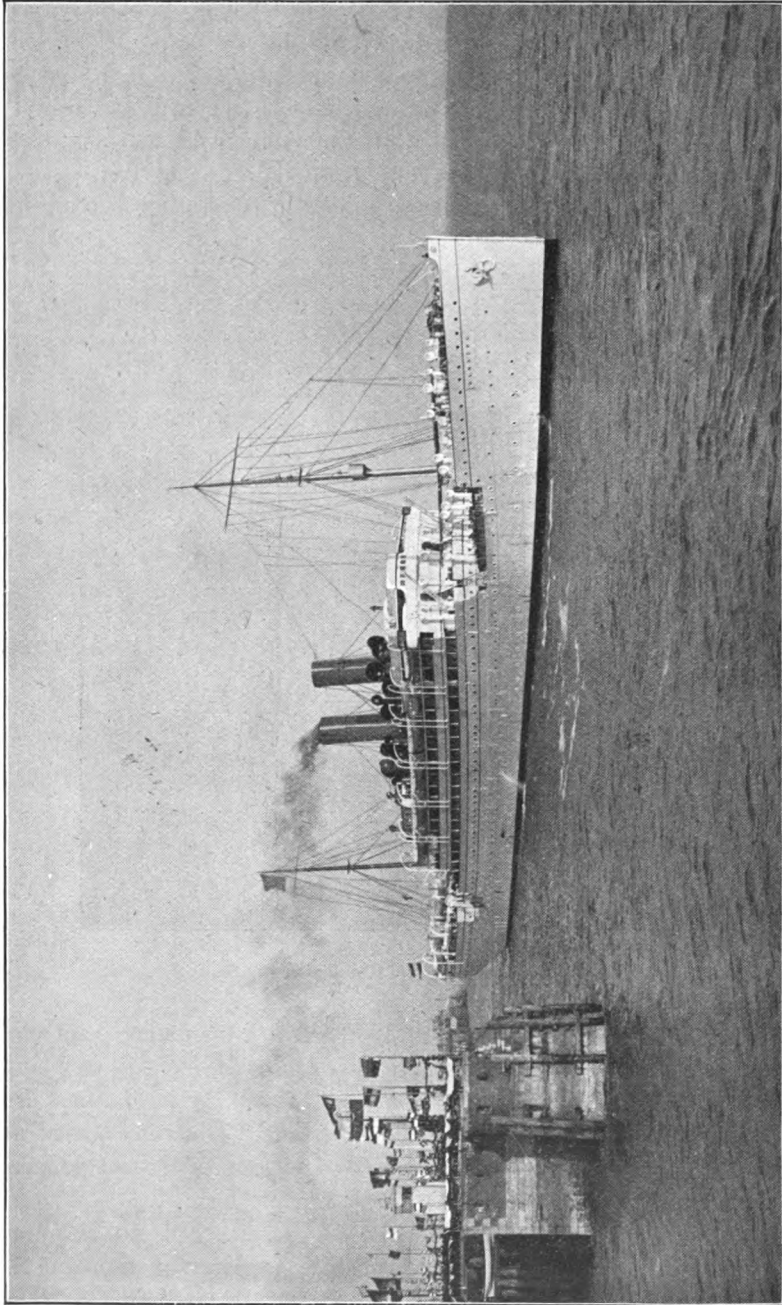

FIG. 72.—Yacht of the German Emperor with Wireless Telegraphy Installation.

technical skill has overcome the special difficulties arising from the presence of large masses of iron and restricted accommodation.

Fig. 72 shows the German Imperial yacht *Hohenzollern* with wireless telegraphy installation.

Incalculable advantage is secured by the possibility of thus transmitting orders from a flagship to the rest of the squadron, the individual members of which again are in close mutual touch by the same means. The centralisation of authority and increased

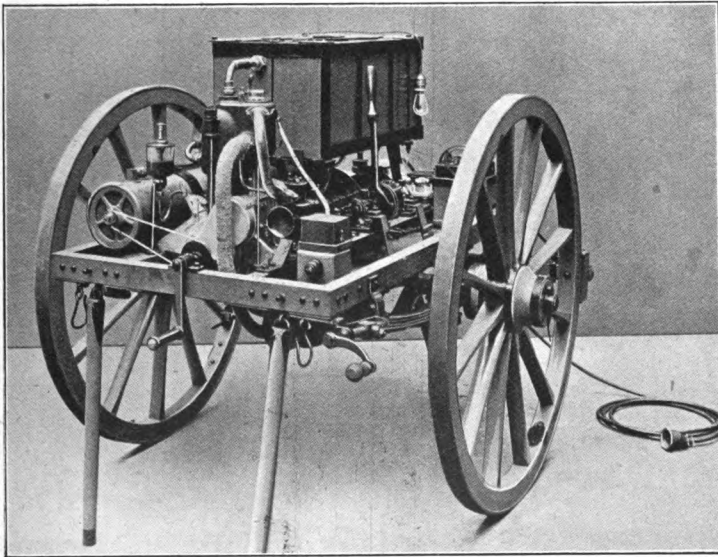

FIG. 73.—Portable Wireless Telegraphy Station (waggon containing the source of power).

facility for making reports and reconnoitring are also accompanied by a great saving in fuel and an increased sphere of operations, whilst the establishment of communication with the shore forts secures the inestimable advantage of co-operation between land and sea forces.

A special application of wireless telegraphy to military purposes has been carried out in the German army. The chief problem was to obtain apparatus sufficiently portable to accompany marching troops, especially cavalry, even off the high roads. This difficult task was accomplished by the Telefunken Company by mounting all the station apparatus, including the current generators, on light army transport vehicles capable of going over any road or country, the

air conductors being elevated by means of kites or balloons instead of masts.

Fig. 73 shows the waggon conveying the source of power, namely, a benzine motor with condenser and all accessories, together with a dynamo generating a current of 120 volts at 20 ampères = about 2.5 kilowatts.

Fig. 74 shows the second waggon carrying the apparatus. The

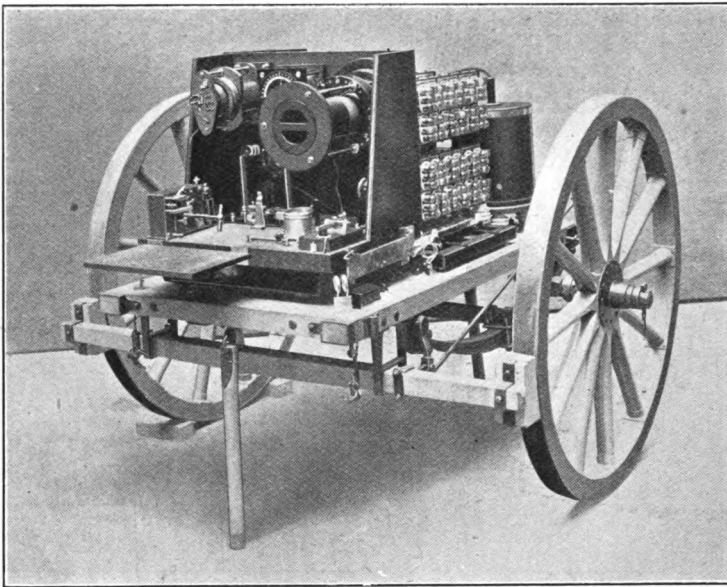

FIG. 74.—Portable Wireless Telegraphy Station (waggon conveying the apparatus).

corps consists of an officer, a non-com. and five privates, in addition to the drivers ; and is shown on the march in fig. 75.

Fig. 76 represents the unlimbering of a train and the setting up of apparatus for work, an operation taking only a very few minutes from the time of arriving on the ground.

These portable stations have answered admirably in numerous manœuvres, following the most rapid cavalry movements, and enabling full communication to be established between commanding officers over distances equal to several days' march.

In order to direct the attention of students in high schools and universities to the importance of research in wireless telegraphy, the

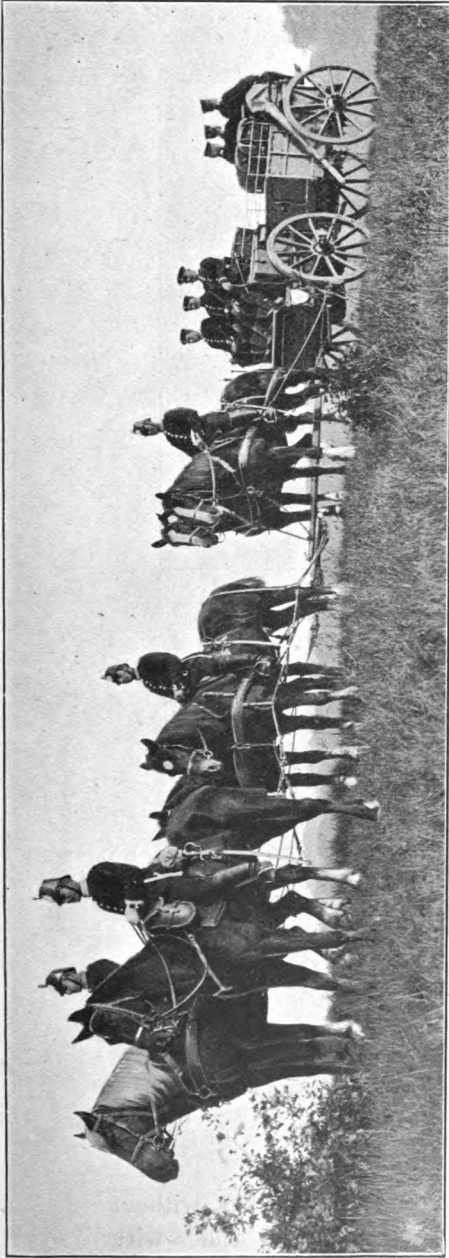

FIG. 75.—Portable Wireless Telegraphy Station on the March.

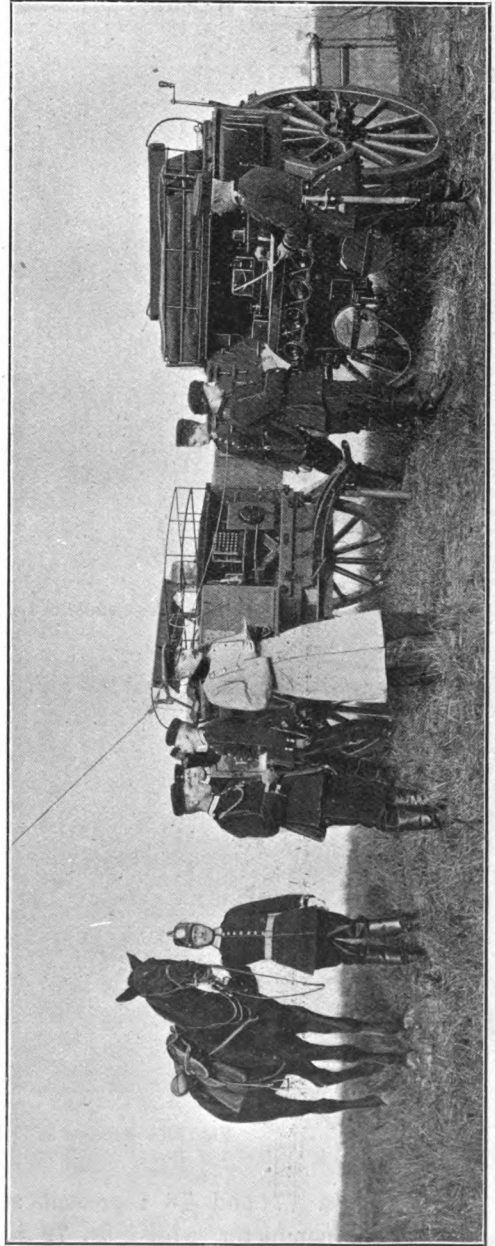

FIG. 76.—Portable Wireless Telegraphy Station—Train Unlimbered.

Telefunken Company has constructed models illustrating the *modus operandi* of the full-size apparatus.

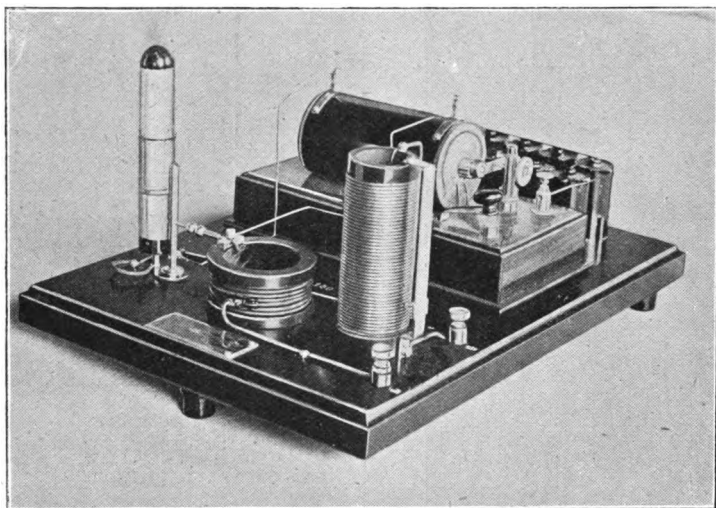

FIG. 77.—Sender of Demonstration Apparatus.

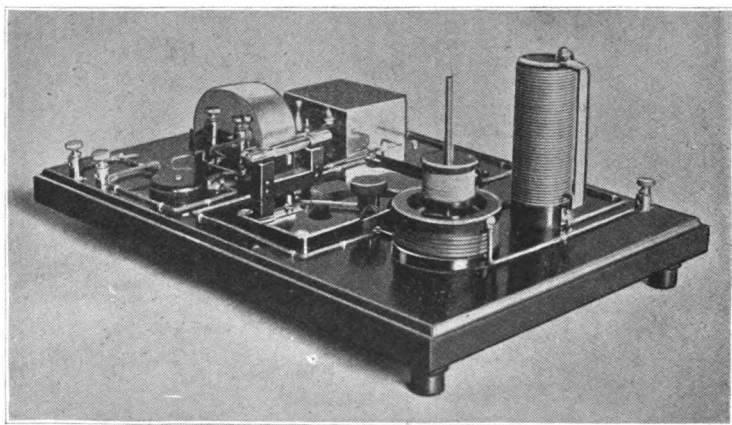

FIG. 78.—Receiver of Demonstration Apparatus.

Figs. 77 and 78 represent sender and receiver, but without aerial conductor, whilst fig. 79 illustrates a complete sender with slow-radiating aerial fitting, the latter consisting of a vertical

copper wire, with terminal capacities attached top and bottom

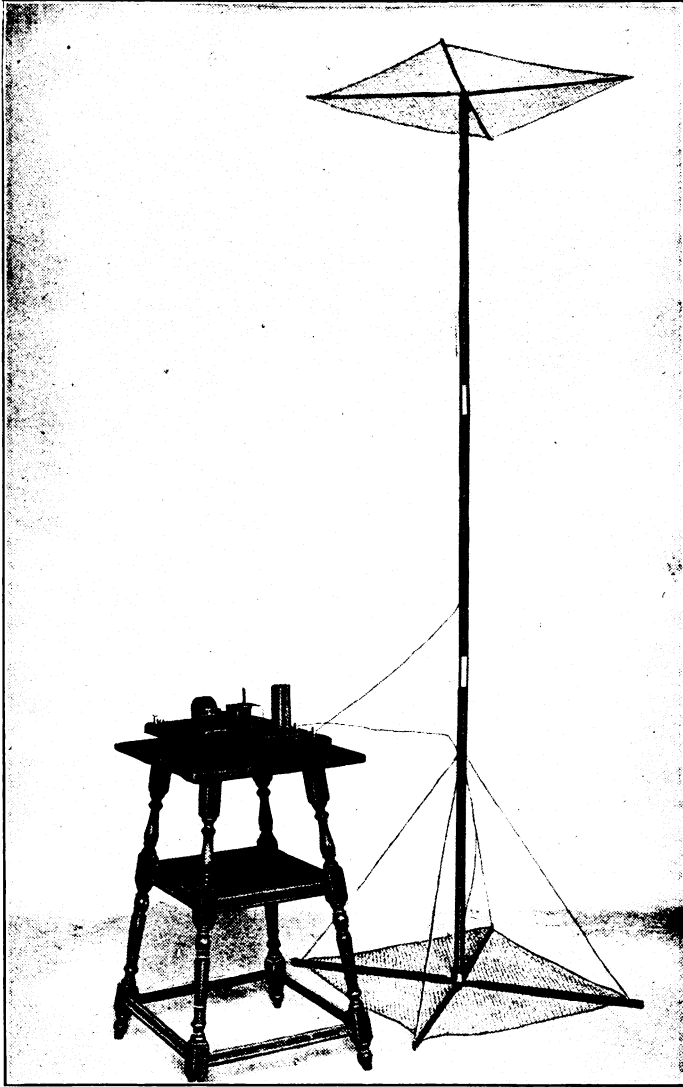

FIG. 79.—Complete Sender of Demonstration Apparatus for Wireless Telegraphy.

(aerial-wire—counter-capacity). In the centre of the aerial conductor is mounted a coil for coupling purposes, and also a variable

self-induction (large bare wire coil) to regulate the wave length of the aerial conductor.

By the use of loose coupling in sender and receiver, these models can be employed to demonstrate not only the transmission of wireless messages, but also the selective or multiplex wireless telegraphy with three different wave lengths.

The foregoing review of the successive development of wireless telegraphy will have clearly illustrated the enormous advance that has been made in a comparatively short time. For a while it seemed threatened with grave danger. In consequence of fantastic reports the general public was led to overestimate the new means of communication to such an extent that the days of the cable were looked upon as over. Naturally a reaction set in, and hot enthusiasm was replaced by its antithesis. Nevertheless, the strenuous labour of professionals, and the recognition that wireless telegraphy has its natural limitations, have rescued it from discredit and directed public opinion into a healthy channel of active interest. Wireless telegraphy is destined to supplement and not displace the cable, and its aid will be the more valuable since the cost of installation and maintenance is lower than that of cable work. In fact, for a range of 600 miles the prime cost of a wireless installation is at most only one-tenth, and the cost of maintenance one-third that of a cable system. The special field of wireless telegraphy is that in which communication is to be established as quickly as possible, either temporarily or between movable points.

The last stages of development have (to use an expression of Hertz) placed us in the position of no longer being compelled to make *in electricis* music with wooden clappers, for we now have a whole range of tones at our disposal for the purpose.

We are still far from the goal, achieved in acoustics, of uniting great intensity with the highest resonance possibilities, and for the present have to be content with the choice between the two.

Such higher aims can only be realised by close co-operation of science and technology, which is in no field so essential as in wireless telegraphy.

BIBLIOGRAPHY.

GENERAL.

- Abraham, M.**, *Ann. der Physik*, Bd. 66, p. 435, 1898.
„ *Physikal. Zs.*, No. 7, 1904.
- Braun, F.**, *Drahtlose Telegraphie durch Wasser u. Luft*, Leipzig, 1901.
„ *Ann. d. Physik*, Bd. 8, p. 165, 1902.
„ *Umschau* (Frankfurt), Nos. 17, 18, 1902.
„ *Physikal. Zs.*, Bd. 3, 1902.
„ „ Bd. 3, 1903.
„ „ Bd. 4, 1904.
„ *Über drahtlose Telegraphie und neuere physikal. Forschungen.*
Rektoratsrede, 1905.
- Bjerkness, V.**, *Ann. der Physik*, Bd. 55, p. 121, 1895.
- Dönitz, J.**, *Elektrotechn. Zeitschrift*, p. 920, 1903. (Der Wellenmesser—
The Ondameter.)
- Drude, P.**, *Ann. d. Physik*, Bd. 53, p. 721, 1894.
„ „ „ Bd. 61, p. 631, 1897.
„ „ „ Bd. 9, p. 293, 1902.
„ „ „ Bd. 9, p. 611, 1902.
„ „ „ Bd. 11, p. 957, 1903.
„ „ „ Bd. 13, p. 512, 1904.
„ „ „ Bd. 15, p. 709, 1904.
„ „ „ Bd. 16, p. 116, 1905.
„ *Physikal. Zs.*, No. 23, p. 745, 1905.
- Eichhorn, G.**, *Dissertation*, Zürich, 1901.
„ *Die drahtlose Telegraphie*, Veit & Co., Leipzig, 1904.
- Fedderson, Pogg. Annalen**, Bd. 103, 108, 112, 113, 116.
- Fleming, J. A.**, *Cantor Lectures on Hertzian Wave Telegraphy*, London,
1903.
„ *Proc. Roy. Soc. London*, 71, p. 347.
- Helmholtz, H.**, *Die Erhaltung der Kraft*.

- Hertz, H., *Annalen der Physik*, Bd. 31, p. 421, 1887.
 „ „ „ Bd. 34, p. 155, 1888.
 „ „ „ Bd. 36, pp. 1, 769, 1889.
 „ „ „ Bd. 45, p. 553, 1892.
 „ Lodge, *The Work of Hertz*, London, 1897.
- Kelvin, Lord. See Thomson, Sir William.
- Kirchhoff, *Pogg. Annalen*, Bd. 121, p. 554, 1864.
- Lecher, *Physikal. Zs.*, No. 11, 1903.
- Lodge, Sir O., *Electrician*, 12th Nov. 1897.
 „ *Modern Views of Electricity*, London, 1892.
 „ *Nature*, 41, p. 368, 1890.
 „ *The Work of Hertz and some of his Successors*, London, 1897.
- Lomsché, C., *Dissertation*, Zürich, 1903.
- Mandelstam, L., *Physikal. Zs.*, No. 9, 1904.
- Marconi, *Electrician*, 24th and 31st May and 18th July 1902.
 „ Fahie, *History of Wireless Telegraphy*, London, 1899.
 „ *Proc. Roy. Soc. London*, 70, p. 341, 1902.
 „ Righi u. Dessau, *Die Telegr. ohne Draht*, Braunschweig, 1903.
- Mayer, H., *Dissertation*, Zürich, 1904.
- Oberbeck, A., *Ann. der Physik*, Bd. 55, p. 623, 1895.
- Poincaré, *Annuaire du Bureau des Longitudes*, 1902.
- Righi, *Die Optik der elektrischen Schwingungen*, Leipzig, 1898.
- Righi u. Dessau, *Die Telegraphie ohne Draht*, Braunschweig, 1903.
- Seiler, U., *Ann. d. Physik*, Bd. 61, p. 30, 1897.
 „ *Schwingungen in Rückstand bildenden Kondensatoren*, Zürich, 1902.
- Simon u. Reich, *Physikal. Zs.*, Nos. 13 and 26B, 1903.
- Slaby, *Die Funkentelegraphie*, Berlin, 1901.
 „ *Elektrotechn. Zeitschrift*, Bd. 23, 1902.
 „ „ „ IV. Quartal, 1904 and 1905.
- Sundell u. Tallqvist, *Ann. d. Physik*, Bd. 4, p. 72, 1901.
- Thomson, Sir W., *Philosoph. Mag.*, vol. 5, p. 393, 1853.
- Wien, M., *Ann. d. Physik*, Bd. 61, p. 151, 1897.
 „ „ „ Bd. 4, p. 425, 1901.
 „ „ „ Bd. 8, p. 686, 1902.
 „ „ „ Bd. 14, p. 1, 1904.
 „ „ „ Bd. 14, p. 626, 1904.
 „ *Phys. Zs.*, Bd. 4, p. 76, 1902.
- Zenneck, J., *Ann. d. Physik*, Bd. 11, pp. 1121, 1135, 1903.
 „ *Physikal. Zs.*, No. 24, 1903.
 „ „ No. 19, 1904.
 „ „ No. 4, 1905.
 „ „ No. 7, 1905.

ON WAVE DETECTORS.

- Aschkinass**, *Verhandl. d. Phys. Ges. Berlin*, Bd. 13, p. 103, 1894.
 „ *Ann. d. Phys.*, Bd. 66, p. 284, 1898.
- Branly**, *Les radio-conducteurs: Rapport au Congrès internat. de Phys.*, Paris, 1900.
 „ *Comp. rend.*, vol. 118, p. 348, 1894.
 „ *La Lum. Electr.*, vol. 51, p. 526, 1894.
- Eccles**, *Electrician*, vol. 47, pp. 682, 715, 1900.
- Ferrié**, *L'Éclair. Electr.*, vol. 24, p. 499, 1901.
- Fessenden**, *Elektrotechn. Zs.*, Bd. 24, p. 589, 1903.
 „ *Electrical World and Engineer*, 19th Sept. 1903.
- Guthe u. Trowbridge**, *Phys. Rev.*, Bd. 11, p. 22, 1900.
- Van Gulik**, *Ann. d. Phys.*, Bd. 66, p. 136, 1898.
- Madelung, E.**, *Ann. d. Physik.*, No. 10, p. 861, 1905 (über die Wirkungsweise des Rutherford-Marconi Detectors).
- Marconi**, *Electrician*, 20th and 27th June 1902.
- Neugeschwender**, *Ann. d. Phys.*, Bd. 67, p. 430, 1899.
 „ „ „ Bd. 68, p. 92, 1899.
 „ *Physikal. Zs.*, Bd. 2, p. 550, 1901.
- Reich, M.**, *Phys. Zs.*, No. 12, 1904 (Einige Beobachtungen am Schloemilch Detektor).
- Robinson, P. E.**, *Ann. d. Phys.*, Bd. 11, p. 754, 1903.
- Rutherford**, *Proc. Roy. Soc.*, vol. 60, p. 184, 1897 (magnetic detector).
 „ *Phil. Trans.*, 89, p. 1, 1897.
- Schloemilch, W.**, *Elektrotechn. Zs.*, p. 959, 1903 (Der Schloemilch Detektor).

INDEX.

- ABRAHAM**, 12, 23, 31, 44, 49.
Aerial wire, 12, 14, 17, 22, 46, 47, 55, 60, 62, 63, 66, 106, 109.
Air condensers, 22.
Air, ionisation of the, 100.
Alternating currents, 43, 68.
Amplitude, 32, 33, 34, 36, 37, 38, 39, 40, 41, 44, 47, 48, 49, 59.
 curves, 41.
Antennæ. *See* Aerial wire.
 multiplex, 47.
 ratio of, to simple, 48.
Aperiodic discharges, 7.
Arco, 2.
Atmospheric discharges and earthing, 18, 84.

BJERKNES, 12, 38, 39, 56.
Brandes, 50.
Branly, 2.
Braun, 2, 8, 9, 13, 14, 38, 44, 45, 51, 100, 102.
 direct and indirect coupling, 15.
 energy systems, 46.
 Siemens' Baltic station, 23, 29, 42, 46, 52, 55, 63, 66, 94.

CAGE antenna, 12, 47, 48, 49, 55.
Capacity, 5-8, 53.
 of single aerial wire, 13.
Close coupling, 15, 24, 29, 33, 34, 42, 63, 93.
Closed oscillation systems, 8-10.
 condenser, 10.
Closely-coupled sender and receiver, 36.
Code, use in wireless telegraphy, 102.
Coherer, 2, 20, 21, 22, 36, 78.
 action of, 20.
 forms and descriptions of, 78 *et seq.*
 properties of, 21.
Commercial purposes, use of wireless telegraphy for, 105.
Commutator, mercurial turbine, 68.
Comparative measurements in the sender, 29.
Compensating the aerial wire, 16.
 by metallic surfaces, 17, 18.
Conclusion, 99.

Condenser circuit, charging, 67.
Condensers, 4-10, 83.
 capacity of, 5-8.
 insulation of, 58.
Construction of a wireless telegraphy station, 62.
Cost, 110.
Counter capacity, 13-19, 50, 62, 74.
Coupling, 14, 45, 46. *See* Loose coupling, *also* Close coupling.
 degree of, in practical wireless telegraphy, 16, 22.
Current for wireless telegraphy, 66, 107.
 amplitude, 49.
 generators, 77.
 transformers, 68.
Cut-outs, automatic minimum current, 71.

DAMPING, 7, 12, 13, 17, 25, 26, 27, 29, 33, 36, 37, 39, 40.
Detectors for electric waves, 81, 87. *See also* Coherer.
Determination of effective oscillations in coupled sender, 60.
Directed messages, 102.
Discharges, aperiodic and oscillatory, 7.
Dissonance, 41.
Distance, range of, 37.
Dolezalek, 43.
Dönitz, 57.
Drude, 12, 17, 18, 23, 43, 44, 45, 46, 47, 48, 50, 53, 54, 55, 63.

EARTHING, 13-19, 74.
Electrical energy, rays of, 1.
 counterpoise, 74.
Electro-magnetic energy, 3, 4.
 waves, 1, 11.
Energy, conversion of electric, 10.
 source of, in modern apparatus, 67, 77.
 systems, 50.
 transmutation, 4.
Ether, 1, 3-13.
 elasticity of, 3.
 particles, torsion of, 3.
Excess of energy necessary in wireless telegraphy, 100.

- Excitation circuit for portable stations, 73.
for coupled senders, 72.
- FARADAY, 1.
Fedderson, 1.
Fessenden detector, 90.
Fleming, 49.
Frequencies, 31, 36, 41, 43, 53, 85.
Frequency meter. *See* Ondameter.
Frequency necessary in wireless telegraphy, 100.
- GALITZIN, 23.
Geitler's experiments, 23.
Generator for portable stations, 77.
German army, use of wireless telegraphy in, 71, 105.
Gravitation, 3.
- HAMMER interruptor, 69.
Heat, theory of, 1.
Helmholtz, 1, 4, 7, 43.
Hertz, 1, 10, 11, 23, 46, 47, 49, 56, 60, 110.
oscillator, 10.
Hertzian electrical wave telegraphy, 2.
rays, 10, 11.
- INDUCTORS, 67.
Intensities, 7, 35, 50, 57.
Ionisation of the air, 100.
- JOULE, 17.
- KELVIN, Lord, 1, 4, 8.
Kirchhoff, 1, 4, 8.
Kleiner, 7, 43.
- LEYDEN jar, 4-10, 53, 68.
phenomena of discharge, 4.
system, construction of, 75.
Light, theory of, 1.
waves, 3, 103.
Lodge, 2, 13, 88, 90.
Loose coupling, 29, 34, 35, 42, 95, 99, 102, 110.
Loose-coupled sender and receiver, 38.
Loss of energy in dielectric, 53.
- MAGNETIC indicator, Rutherford's, 88.
Management of a station, 62.
Mandelstam, 18, 23, 27, 28.
Marconi, 2, 11, 13, 23, 36, 37, 48, 87, 88.
apparatus, 36.
transmission of signals by, 13.
detector, 88.
transmitter, 11, 23.
Mast for aerial conductor in portable stations, 77.
Maxwell, 1.
Mayer, 43.
- Measuring frequency of primary condenser circuit, 58.
oscillation of open secondary circuit, 60.
Mercurial turbine interruptor, 70.
Messages, directed, 102.
Military purposes, use of wireless telegraphy for, 105.
Models of complete installations, 103.
Modern apparatus, 67.
Morse alphabet, 20, 21.
keys, 71.
Muirhead, 88.
Multiplex antennæ, 47.
ratio of, to simple, 48.
secondary system, Drude on, 47.
spark-gaps, 44, 71, 75.
wireless telegraphy, 23, 42, 98.
- Naval purposes, use of wireless telegraphy for, 105.
Neugeschwender plate, 90.
- ONDAMETER, 53, 56-61.
method of using, 56.
Open oscillation system, 10-13.
Oscillations, 4, 28-38, 41-46, 49, 53, 60, 66-68, 102.
Oscillatory discharges, 7.
Overbeck, 23.
- PILOT station, use of wireless telegraphy for, 103.
Popoff, 2.
Portable wireless telegraphy stations, 105
et seq.
Potential, difference of, 4, 5-8.
energy, 33.
amplitude, 36, 37, 40.
Poynting, 9, 12, 47.
- RADIATION, 11, 14.
Range, 37, 38, 41, 42, 100.
Rayleigh, 24.
Receiver, 20-22, 108.
closely-coupled, 36.
evolution of the modern, 21.
loose-coupled, 38.
tuning, 22.
theoretical results and calculations, 36.
with Schloemilch detector and Morse register, 83 *et seq.*
Receiving apparatus, modern, 91 *et seq.*
oscillation circuits, 93.
Resistance, 5-8, 43, 45, 48, 52.
of coherer, 20.
of spark-gap and primary circuit, 43.
Resonance, 14, 29, 30, 35, 36, 39, 40, 57, 62, 105.
determining frequency by, 56.
inductors, 67.
Righi radiator, 11.

- Rod conductor for electrical vibrations, 11.
 ratio of thickness and length, 12.
- Rutherford, 50, 88.
 magnetic indicator, 88.
- SCHÄFER plate detector, 90.
- Schloemilch detector, 81 *et seq.*
- Script from Lodge-Muirhead detector, 90.
- Secrecy of messages, importance of, 102.
- Selective electric wave telegraphy, 23.
- Self-induction, 5-8, 51.
 of aerial wire, 109.
 of coils, 53.
 of primary and secondary system, 15.
- Sender, closely-coupled, 36.
 loose-coupled, 38.
- Slaby, 2.
 measuring rod, 61.
- Source of energy, 67.
- Spark-gap, 14, 33, 43-46, 67, 71, 100.
 annular multiplex, 75.
 Braun's subdivided, 13.
- Station. *See* Wireless telegraphy.
- Stefan formula, 53, 54.
- Symmetry wires, 17, 62.
- Syntonising in receiving, 87.
- Syntony, 14, 31, 32, 42, 63, 82.
- TAPPER for coherer, 20.
- Telephone, 86, 87, 90.
- Theoretical results furnished by sender,
 23-35.
 and calculations, 37.
- Thomson, Sir W. *See* Kelvin.
- Tobler, 90.
- Torsion curves, 3.
- Transformers, 68, 70, 71, 93, 94.
- Tuning of sender and receiver, 42.
- USEFULNESS of wireless telegraphy, 102.
- VELOCITY of light rays, 1.
 of vibrations, 3.
- Vibrations. *See* Oscillations, *also* Waves.
 generating powerful, 8.
 in ether, 3.
- WARBURG, 23.
- Wave-lengths, 11, 12, 55.
 determination of effective, 15.
 used in practice, 41.
- Waves, kind and speed, 1.
 velocity of, in ether, 1, 3.
 damped siniconal vibrations, 8.
- Weather, effect of, on wireless telegraphy,
 38, 100.
- Weight of complete portable stations, 77.
- Wien, 16, 23, 24, 29, 32, 38, 40, 41, 43,
 45, 49, 63.
- Wireless telegraphy—
 development, 1, 2, 110.
 in German army, 105.
 mean frequency used in, 100.
 messages, reception of, 20.
 secrecy of, 102.
 speed in, 68.
 sphere of application, 42, 102.
 station, construction of, 62.
 management of, 62.
 supplementary to telegraphy by wires,
 110.
- Wires for induction coils, 43, 45.
- ZENNECK, 17, 28, 44, 45, 46, 47, 56.

A SELECTION FROM
CHARLES GRIFFIN & CO.'S PUBLICATIONS
OF
SCIENTIFIC AND TECHNICAL WORKS.

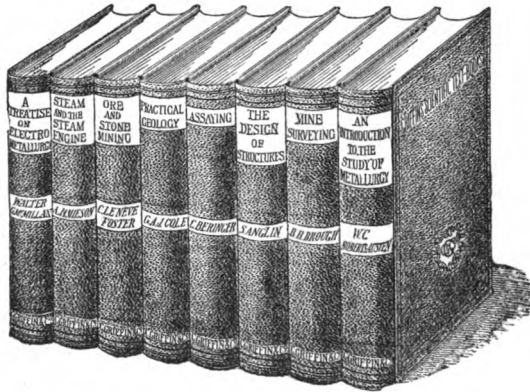

MESSRS. CHARLES GRIFFIN & COMPANY'S PUBLICATIONS may be obtained through any Bookseller in the United Kingdom, or will be sent Post-free on receipt of a remittance to cover published price. To prevent delay, Orders should be accompanied by a Cheque or Postal Order crossed "UNION OF LONDON AND SMITH'S BANK, Chancery Lane Branch."

. For *INDEX*, see next page.



✉ COMPLETE TECHNICAL, MEDICAL, and GENERAL CATALOGUES forwarded Post-free on Application.

LONDON:
EXETER STREET, STRAND.

1/11/06.
M.T. 64.

	PAGE
ADAMS (W. P.), Motor Mechanism, . . .	33
AITKEN, (T.), Road Making, . . .	79
ALFORD (J.), Mining Law, . . .	57
ALLINGHAM (W.), Meteorology, . . .	41
ANDREWS (L.), Electricity Control, . . .	48
ANGLIN (S.), Design of Structures, . . .	26
ARCHBUTT & DEELEY, Lubrication, . . .	32
ATHERTON (Wm.), Design of Beams, . . .	27
BARKER (D. WILSON-), Navigation, . . .	41
— Seamanship, . . .	40
BAUER (M.), Precious Stones, . . .	68
BERINGER (J. J. & C.), Assaying, . . .	66
BICHEL & LARSEN, Explosives, . . .	58
BILES (Prof.), Marine Steam Turbine, . . .	29
BJÖRLING, Peat, . . .	75
BLACKMORE (E.), Mercantile Marine, . . .	40
BLOUNT (B.) and BLOXAM (A. G.), Chemistry for Engineers, . . .	46
— Chemistry for Manufacturers, . . .	71
BLYTH (A. Wynter), Foods and Poisons, . . .	72
BORCHERS (Dr.), Electric Smelting, . . .	67
BROUGH (B. H.), Mine-Surveying, . . .	57
BRUCE (Robt.), Food Supply, . . .	54
BUCK (R. C.), Algebra, . . .	42
— Trigonometry, . . .	42
BURNS (D.), Colliery Electricity, . . .	58
BUTTERFIELD (W. J. A.), Gas, . . .	77
CAIN & THORPE, Synthetic Dyestuffs, . . .	82
CARTER (H. R.), Long Fibre Spinning, . . .	83
CASTELL-EVANS, Chemical Tables, . . .	79
CLAYWORKER'S HANDBOOK, . . .	75
COLE (Prof. G. A. J.), Practical Geology, . . .	53
— Open Air Studies in Geology, . . .	85
COLE (W. H.), Light Railways, . . .	30
COLLINS, (H. F.), Lead and Silver, . . .	64
COX (S. H.), Prospecting for Minerals, . . .	55
CRIMP (W. S.), Sewage Disposal Works, . . .	76
CUNNINGHAM (B.), Dock Engineering, . . .	27
DAVEY (H.), Pumping Machinery, . . .	37
DIXON (C.), Bird-Life, . . .	85
DONKIN (Bryan), Gas and Oil Engines, . . .	28
— Efficiency of Steam Boilers, . . .	28
DOWSING (H. J.), Electrical Prices, . . .	49
DUERR (Geo.), Bleaching, &c., . . .	84
DUPRE & HAKE, Manual of Chemistry, . . .	70
EICHHORN, Wireless Telegraphy, . . .	49
FARNSWORTH, Cons. Steel Work, . . .	26
FIDLER (Prof.), Bridge-Construction, . . .	26
FIELD (E. R.), Mining Report Book, . . .	57
FOSTER (Sir C. Le Neve), Mining, . . .	56
— Elementary Mining, . . .	56
— & HALDANE, Mine Air, . . .	57
GAIRNS (J. F.), Loco. Compounding, . . .	30
GINSBURG (Dr.), Legal Duties of Shipmasters, . . .	43
GOLDING (H. A.), Bonus Tables, . . .	31
GROSSMANN (J.), Chem. Engineering, . . .	46
GURDEN (R.), Traverse Tables, . . .	31
GUTTMANN (O.), Blasting, . . .	58
HANNAN (W. I.), Textile Fibres, . . .	83
HARBORD (F. W.), Steel, . . .	65
HARRISON (J. W.), Sanitation, . . .	79
HICKS (J. A.), Mineral Oil Testing, . . .	61
HODGSON (R. B.), Emery Grinding, . . .	33
HUGHES (H. W.), Coal Mining, . . .	56
HURST (Chas.), Valves, . . .	31
— Hints on Engine Design, . . .	31
HURST (G. H.), Painters' Colours, . . .	80
— Laboratory Guide to Paints, . . .	80
— Garment Dyeing and Cleaning . . .	84
JAMIESON (Prof.), MANUALS, . . .	34
JOHNSON (J. C. F.), Getting Gold, . . .	58
JUDE (A.), Steam Turbine, . . .	28
JULIAN (H. F.) and SMART (E.), Cyaniding Gold and Silver Ores, . . .	59
KASSNER (T.), Gold Seeking, . . .	59
KERR (G. L.), Practical Coal-Mining, . . .	58
— Elementary Coal-Mining, . . .	58
KNECHT & RAWSON, Dyeing, . . .	82
LAFAR, Technical Mycology, . . .	74

	PAGE
LAMBERT, Glue, Gelatine, &c., . . .	81
LAWN (J. G.), Mine Accounts, . . .	57
LEEDS (F. H.), Acetylene, . . .	77
LIVERSIDGE, Engine-Room Practice, . . .	29
MACKENZIE (T.), Mechanics, . . .	42
MACLEOD (W. A.) and WALKER (C.), Metallurgical Chemistry, . . .	60
M'MILLAN (W. G.), Electro-Metallurgy, . . .	67
— & BORCHERS, Electric Smelting, . . .	67
M'WILLIAM, Foundry Practice, . . .	68
MIDDLETON (R. E.), Water Supply, . . .	77
MILL (Dr. R. H.), New Lands, . . .	54
MILLAR (W. J.), Latitude & Longitude, . . .	43
MITCHELL (C. A.), Flesh Foods, . . .	74
— & HEPWORTH (T. C.), Inks, . . .	81
MORGAN (J. J.), Metallurgical Tables, . . .	66
MUNRO & JAMIESON'S Electrical Pocket-Book, . . .	48
MUNRO (R. D.), Steam-Boilers, . . .	32
— Kitchen Boiler Explosions, . . .	32
NAYLOR (W.), Trades' Waste, . . .	76
NICHOLSON (W.), Smoke Abatement, . . .	76
NORTH (S.), Oil Fuel, . . .	29
OPPENHEIMER (C.), Ferments, . . .	74
— Toxines and Antitoxines, . . .	74
OSMOND & STEAD, Micro. Analysis, . . .	69
PARK, (J.), Cyanide Process, . . .	59
— Mining Geology, . . .	55
PEARCE (W. J.), Painting, . . .	80
PETTIGREW (W. F.), Loco. Eng., . . .	30
PHILLIPS & BAUERMAN, Metallurgy, . . .	60
POYNTING (Prof.), Mean Density, . . .	50
— & THOMSON, Physics, . . .	50
PRAEGER (R. L.), Open Air Botany, . . .	85
RANKINE'S Works, . . .	35, 36
RAWSON, GARDNER, & LAYCOCK, Dictionary of Dyestuffs, . . .	82
REDGRAVE (G. R.), Cements, . . .	76
REDWOOD (Dr. Boverton), Petroleum, . . .	61
— & THOMSON, Handbook, . . .	61
REED (Sir E. J.), Stability of Ships, . . .	38
REID (Geo., M. D.), Sanitation, . . .	78
REIMER, Shaft Sinking, . . .	58
RICHMOND (H. D.), Dairy Chemistry, . . .	73
— Dairy Analysis, . . .	75
RILEY (W.), Bacteriology of Brewing, . . .	73
ROBERTS - AUSTEN, Metallurgy, . . .	3
ROBINSON (Prof.), Hydraulics, . . .	37
ROSE (T. K.), Gold, Metallurgy of, . . .	63
ROTHWELL, (C. F. S.), Textile Printing, . . .	83
SCHWACKHÖFER and BROWNE, Fuel and Water, . . .	47
SCHWARTZ (Dr. von), Fire Risks, . . .	77
SEATON (A. E.), Marine Engineering, . . .	44
— & ROUNTHWAITE, Marine Engineers' Pocket-Book, . . .	44
SEELEY (Prof.), Physical Geology, . . .	52
SEXTON (Prof.), Metallurgy, . . .	66
— Quantitative & Qualitative Analysis, . . .	70
SHELTON (W. V.), Mechanic's Guide, . . .	36
SINDALL, Paper Technology, . . .	81
SMITH, (J.), Shipmaster's Medical Help, . . .	43
SMITH (Prof. R. H.), Calculus, . . .	45
— Measurement Conversions, . . .	45
SOLOMON (H. G.), Electricity Meters, . . .	49
STRICKLAND (F.), Petrol Motors, . . .	33
SUPLEE (H. H.), Mech. Pocket Book, . . .	45
SYKES (Dr. W. J.), Brewing, . . .	75
TRAILL (T. W.), Boilers, . . .	29
TURNER (Thos.), Iron, Metallurgy of, . . .	65
— Ironfounding, . . .	68
WALTON (T.), Know Your Own Ship, . . .	44
— Present-Day Shipbuilding, . . .	38
— Steel Ships, . . .	38
WEBER (Dr. C. O.), India Rubber, . . .	81
WELLS (S. H.), Engineering Drawing, . . .	27
WIGLEY (T. B.), Jeweller's Art, . . .	68
WILLOUGHBY (Dr. E. F.), Milk, . . .	73
WOOD (Francis), Sanitary Engineering, . . .	78
WORDINGHAM, Electrical Stations, . . .	48
WRIGHT (Dr. A.), Oils and Fats, . . .	71

Griffin's Standard Publications

	PAGE
Applied Mechanics,	RANKINE, BROWNE, JAMIESON, 35, 46, 34
Civil Engineering,	PROF. RANKINE, 35
Design of Structures,	S. ANGLIN, 26
Bridge-Construction,	PROF. FIDLER, 26
Design of Beams,	W. H. ATHERTON, 27
Dock Engineering,	B. CUNNINGHAM, 27
Engineering Drawing,	S. H. WELLS, 27
Constructional Steelwork,	A. W. FARNSWORTH, 26
Central Electrical Stations,	C. H. WORDINGHAM, 48
Electricity Control,	L. ANDREWS, 48
" Meters,	H. G. SOLOMON, 49
Light Railways,	W. H. COLE, 30
Sewage Disposal Works,	SANTO CRIMP, 76
Sanitary Engineering,	F. WOOD, 78
Traverse Tables,	R. L. GURDEN, 31
Locomotive Engineering,	W. F. PETTIGREW, 30
Locomotive Compounding,	J. F. GAIRNS, 30
Valves and Valve-Gearing,	CHAS. HURST, 31
Hints on Design,	CHAS. HURST, 31
Marine Engineering,	A. E. SEATON, 44
The Steam Turbine,	ALEXANDER JUDE, 28
Marine Steam Turbine,	PROF. BILES, 29
Engine-Room Practice,	J. G. LIVERSIDGE, 29
Pocket-Book,	SEATON AND ROUNTHWAITE, 44
Present Day Shipbuilding,	T. WALTON, 38
Design of Ships,	PROF. HARVARD BILES, 38
Steel Vessels,	T. WALTON, 38
Stability of Ships,	SIR E. J. REED, 38
Nautical Series,	Ed. by CAPT. BLACKMORE, 39
The Steam-Engine,	RANKINE, JAMIESON, . . 35, 34
Gas, Oil, and Air-Engines,	BRYAN DONKIN, 28
Boilers: Land and Marine,	T. W. TRAILL, 29
" Steam,	R. D. MUNRO, 32
" Kitchen,	R. D. MUNRO, 32
" Heat Efficiency of,	BRYAN DONKIN, 28
Oil Fuel,	SIDNEY H. NORTH, 29
Machinery and Millwork,	PROF. RANKINE, 35
Pumping Machinery,	H. DAVEY, 37
Hydraulic Machinery,	PROF. ROBINSON, 37
Grinding Machinery,	R. B. HODGSON, 33
Lubrication and Lubricants,	ARCHBUTT & DEELEY, 32
Rules and Tables,	RANKINE AND JAMIESON, 36
Bonus Tables,	H. A. GOLDING, 31
Electrical Pocket-Book,	MUNRO AND JAMIESON, 48
The Calculus for Engineers,	PROF. ROBT. H. SMITH, 45
Measurement Conversions,	PROF. ROBT. H. SMITH, 45
Chemistry for Engineers,	BLOUNT & BLOXAM, 46

LONDON: CHARLES GRIFFIN & CO., LIMITED, EXETER STREET, STRAND.

FOURTH EDITION, *Revised, with Numerous Diagrams, Examples, and Tables, and a Chapter on Foundations. In Large 8vo. Cloth. 16s.*

THE DESIGN OF STRUCTURES:

**A Practical Treatise on the Building of Bridges,
Roofs, &c.**

BY S. ANGLIN, C. E.,

Master of Engineering, Royal University of Ireland, late Whitworth Scholar, &c.

"We can unhesitatingly recommend this work not only to the Student, as the **BEST** TEXT-BOOK on the subject, but also to the professional engineer as an **EXCEEDINGLY** VALUABLE book of reference."—*Mechanical World.*

THIRD EDITION, *Thoroughly Revised. Royal 8vo. With numerous Illustrations and 13 Lithographic Plates. Handsome Cloth. Price 30s.*

A PRACTICAL TREATISE ON BRIDGE-CONSTRUCTION:

**Being a Text-Book on the Construction of Bridges in
Iron and Steel.**

FOR THE USE OF STUDENTS, DRAUGHTSMEN, AND ENGINEERS.

BY T. CLAXTON FIDLER, M. INST. C. E.,

Prof. of Engineering, University College, Dundee.

"The new edition of Mr. Fidler's work will again occupy the same **CONSPICUOUS** POSITION among professional text-books and treatises as has been accorded to its predecessors. **SOUND, SIMPLE, AND FULL.**"—*The Engineer.*

*In Medium 8vo. Handsome Cloth. Pp. i-xv + 248, with over
100 Illustrations. Price 10s. 6d. net.*

CONSTRUCTIONAL STEELWORK:

**Being Notes on the Practical Aspect and the Principles of
Design, together with an Account of the Present
Methods and Tools of Manufacture.**

BY A. W. FARNSWORTH,

Associate Member of the Institute of Mechanical Engineers.

"A worthy volume, which will be found of much assistance. . . . A book of particular value."—*Practical Engineer.*

"Will be found of value to all Architects and Engineers engaged in steelwork construction."—*Building News.*

LONDON: CHARLES GRIFFIN & CO., LIMITED, EXETER STREET, STRAND.

In Large 8vo. Handsome Cloth, Gilt, Uniform with *Stability of Ships and Steel Ships* (p. 38). With 34 Folding Plates and 468 Illustrations in the Text. 30s. net.

The Principles and Practice of DOCK ENGINEERING.

By BRYSSON CUNNINGHAM, B.E., Assoc. M. INST. C.E.,
Of the Engineers' Department, Mersey Docks and Harbour Board.

GENERAL CONTENTS.

Historical and Discursive.—Dock Design.—Constructive Appliances.—Materials.—Dock and Quay Walls.—Entrance Passages and Locks.—Jetties, Wharves, and Piers.—Dock Gates and Caissons.—Transit Sheds and Warehouses.—Dock Bridges.—Graving and Repairing Docks.—Working Equipment of Docks.—INDEX.

"We have never seen a more profusely-illustrated treatise. It is a most important standard work, and should be in the hands of all dock and harbour engineers."—*Steamship*.

"Will be of the greatest service to the expert as a book of reference."—*Engineer*.

FOURTH EDITION. In Two Parts, Published Separately.

A TEXT-BOOK OF

Engineering Drawing and Design.

VOL. I.—PRACTICAL GEOMETRY, PLANE, AND SOLID. 4s. 6d.

VOL. II.—MACHINE AND ENGINE DRAWING AND DESIGN. 4s. 6d.

BY

SIDNEY H. WELLS, W.H.Sc., A.M.I.C.E., A.M.I.MECH.F.,
Principal of the Battersea Polytechnic Institute, &c.

With many Illustrations, specially prepared for the Work, and numerous Examples, for the Use of Students in Technical Schools and Colleges.

"A CAPITAL TEXT-BOOK, arranged on an EXCELLENT SYSTEM, calculated to give an intelligent grasp of the subject, and not the mere faculty of mechanical copying. . . . Mr. Wells shows how to make COMPLETE WORKING-DRAWINGS, discussing fully each step in the design."—*Electrical Review*

In Large Crown 8vo. Handsome Cloth. With 201 Illustrations. 6s. net.

AN INTRODUCTION TO

THE DESIGN OF BEAMS, GIRDERS, AND COLUMNS

IN MACHINES AND STRUCTURES.

With Examples in Graphic Statics.

By WILLIAM H. ATHERTON, M.Sc., M.I.MECH.E.

"A very useful source of information. . . . A work which we commend very highly . . . the whole being illustrated by a large collection of very well chosen examples."—*Nature*.

"There should be a strong demand for this concise treatise."—*Page's Weekly*.

LONDON: CHARLES GRIFFIN & CO., LIMITED, EXETER STREET, STRAND.

JUST PUBLISHED. In Handsome Cloth. With 252 Illustrations. 15s. net.

THE THEORY OF THE STEAM TURBINE.

A Treatise on the Principles of Construction of the Steam Turbine,
with Historical Notes on its Development.

BY ALEXANDER JUDE.

CONTENTS.—Fundamental.—Historical Notes on Turbines.—The Velocity of Steam.—Types of Steam Turbines.—Practical Turbines.—The Efficiency of Turbines Type I.—Trajectory of the Steam.—Efficiency of Turbines, Types II., III. and IV.—Turbine Vanes.—Disc and Vane Friction in Turbines.—Specific Heat of Superheated Steam.—Strength of Rotating Discs.—Governing Steam Turbines.—Steam Consumption of Turbines.—The Whirling of Shafts.—Speed of Turbines.—INDEX.

Works by BRYAN DONKIN, M.Inst.C.E., M.Inst.Mech.E., &c.

NOW READY. FOURTH EDITION, Revised and Enlarged. With additional Illustrations. Large 8vo, Handsome Cloth. 25s. net.

A TREATISE ON GAS, OIL, AND AIR ENGINES.

BY BRYAN DONKIN, M.INST.C.E., M.INST.MECH.E.

CONTENTS.—PART I.—Gas Engines: General Description of Action and Parts.—Heat Cycles and Classification of Gas Engines.—History of the Gas Engine.—The Atkinson, Griffin, and Stockport Engines.—The Otto Gas Engine.—Modern British Gas Engines.—Modern French Gas Engines.—German Gas Engines.—Gas Production for Motive Power.—Utilisation of Blast-furnace and Coke-oven Gases for Power.—The Theory of the Gas Engine.—Chemical Composition of Gas in an Engine Cylinder.—Utilisation of Heat in a Gas Engine.—Explosion and Combustion in a Gas Engine.—PART II.—Petroleum Engines: The Discovery, Utilisation, and Properties of Oil.—Method of Treating Oil.—Carburators.—Early Oil Engines.—Practical Application of Gas and Oil Engines.—PART III.—Air Engines.—APPENDICES.—INDEX.

"The best book now published on Gas, Oil, and Air Engines."—*Engineer*.

"A thoroughly reliable and exhaustive treatise."—*Engineering*.

In Quarto, Handsome Cloth. With Numerous Plates. 25s.

THE HEAT EFFICIENCY OF STEAM BOILERS (LAND, MARINE, AND LOCOMOTIVE).

With many Tests and Experiments on different Types of Boilers, as to the Heating Value of Fuels, &c., with Analyses of Gases and Amount of Evaporation, and Suggestions for the Testing of Boilers.

BY BRYAN DONKIN, M.INST.C.E.

GENERAL CONTENTS.—Classification of Different Types of Boilers.—425 Experiments on English and Foreign Boilers with their Heat Efficiencies shown in Fifty Tables.—Fire Grates of Various Types.—Mechanical Stokers.—Combustion of Fuel in Boilers.—Transmission of Heat through Boiler Plates, and their Temperature.—Feed Water Heaters, Superheaters, Feed Pumps, &c.—Smoke and its Prevention.—Instruments used in Testing Boilers.—Marine and Locomotive Boilers.—Fuel Testing Stations.—Discussion of the Trials and Conclusions.—On the Choice of a Boiler, and Testing of Land, Marine, and Locomotive Boilers.—Appendices.—Bibliography.—INDEX.

*With Plates illustrating Progress made during recent years,
and the best Modern Practice.*

"Probably the MOST EXHAUSTIVE resumé that has ever been collected. A PRACTICAL BOOK by a thoroughly practical man."—*Iron and Coal Trades Review*.

LONDON: CHARLES GRIFFIN & CO., LIMITED, EXETER STREET, STRAND.

JUST PUBLISHED. In Large Crown 8vo. Handsome Cloth. With
131 Illustrations.

LECTURES ON THE MARINE STEAM TURBINE.

BY PROF. J. HARVARD BILES, M. INST. N. A.,
Professor of Naval Architecture in the University of Glasgow.

FOURTH EDITION, Revised. Pocket-Size, Leather, 12s. 6d.

BOILERS, MARINE AND LAND: THEIR CONSTRUCTION AND STRENGTH.

A HANDBOOK OF RULES, FORMULÆ, TABLES, &C., RELATIVE TO MATERIAL,
SCANTLINGS, AND PRESSURES, SAFETY VALVES, SPRINGS,
FITTINGS AND MOUNTINGS, &C.
FOR THE USE OF ENGINEERS, SURVEYORS, BOILER-MAKERS,
AND STEAM USERS.

BY T. W. TRAILL, M. INST. O. E., F. E. R. N.,
Late Engineer Surveyor-in-Chief to the Board of Trade.

"THE MOST VALUABLE WORK on Boilers published in England."—*Shipping World*.
"Contains an ENORMOUS QUANTITY OF INFORMATION arranged in a very convenient form. . . .
A MOST USEFUL VOLUME . . . supplying information to be had nowhere else."—*The Engineer*.

FIFTH EDITION. Large Crown 8vo. With numerous
Illustrations. 6s. net.

ENGINE-ROOM PRACTICE:

A Handbook for Engineers and Officers in the Royal Navy
and Mercantile Marine, Including the Management
of the Main and Auxiliary Engines on
Board Ship.

BY JOHN G. LIVERSIDGE, R. N., A. M. I. C. E.

Contents.—General Description of Marine Machinery.—The Conditions of Service and Duties of Engineers of the Royal Navy.—Entry and Conditions of Service of Engineers of the Leading S.S. Companies.—Raising Steam—Duties of a Steaming Watch on Engines and Boilers.—Shutting off Steam.—Harbour Duties and Watches.—Adjustments and Repairs of Engines.—Preservation and Repairs of "Tank" Boilers.—The Hull and its Fittings.—Cleaning and Painting Machinery.—Reciprocating Pumps, Feed Heaters, and Automatic Feed-Water Regulators.—Evaporators.—Steam Boats.—Electric Light Machinery.—Hydraulic Machinery.—Air-Compressing Pumps.—Refrigerating Machines.—Machinery of Destroyers.—The Management of Water-Tube Boilers.—Regulations for Entry of Assistant Engineers, R. N.—Questions given in Examinations for Promotion of Engineers, R. N.—Regulations respecting Board of Trade Examinations for Engineers, &c.
"THIS VERY USEFUL BOOK. . . . ILLUSTRATIONS ARE OF GREAT IMPORTANCE IN A WORK of this kind, and it is satisfactory to find that SPECIAL ATTENTION has been given in this respect."—*Engineers' Gazette*.

In Large Crown 8vo, Cloth. Fully Illustrated. 5s. net.

OIL FUEL: ITS SUPPLY, COMPOSITION, AND APPLICATION.

BY SIDNEY H. NORTH,
LATE EDITOR OF THE "PETROLEUM REVIEW."

CONTENTS.—The Sources of Supply.—Economic Aspect of Liquid Fuel.—Chemical Composition of Fuel Oils.—Conditions of Combustion in Oil Fuel Furnaces.—Early Methods and Experiments.—Modern Burners and Methods.—Oil Fuel for Marine Purposes.—For Naval Purposes.—On Locomotives.—For Metallurgical and other Purposes.—Appendices.—INDEX.
"Everyone interested in this important question will welcome Mr. North's excellent text-book."—*Nature*.

LONDON: CHARLES GRIFFIN & CO., LIMITED, EXETER STREET, STRAND.

SECOND EDITION, Revised. With numerous Plates reduced from Working Drawings and 280 Illustrations in the Text. 21s.

A MANUAL OF LOCOMOTIVE ENGINEERING:

A Practical Text-Book for the Use of Engine Builders,
Designers and Draughtsmen, Railway
Engineers, and Students.

By WILLIAM FRANK PETTIGREW, M.INST.C.E.

With a Section on American and Continental Engines.

By ALBERT F. RAVENSHEAR, B.Sc.,

Of His Majesty's Patent Office.

Contents.—Historical Introduction, 1763-1863.—Modern Locomotives: Simple.—Modern Locomotives: Compound.—Primary Consideration in Locomotive Design.—Cylinders, Steam Chests, and Stuffing Boxes.—Pistons, Piston Rods, Crossheads, and Slide Bars.—Connecting and Coupling Rods.—Wheels and Axles, Axle Boxes, Hornblocks, and Bearing Springs.—Balancing.—Valve Gear.—Slide Valves and Valve Gear Details.—Framing, Bogies and Axle Trucks, Radial Axle Boxes.—Boilers.—Smokebox, Blast Pipe, Firebox Fittings.—Boiler Mountings.—Tenders.—Railway Brakes.—Lubrication.—Consumption of Fuel, Evaporation and Engine Efficiency.—American Locomotives.—Continental Locomotives.—Repairs, Running, Inspection, and Renewals.—Three Appendices.—Index.

"The work CONTAINS ALL THAT CAN BE LEARNT from a book upon such a subject. It will at once rank as THE STANDARD WORK UPON THIS IMPORTANT SUBJECT."—*Railway Magazine*.

At Press. In Large 8vo. Fully Illustrated.

LOCOMOTIVE COMPOUNDING AND SUPERHEATING.

By J. F. GAIRNS.

CONTENTS.—Introductory.—Compounding and Superheating for Locomotives.—A Classification of Compound Systems for Locomotives.—The History and Development of the Compound Locomotive.—Two-Cylinder Non-Automatic Systems.—Two-Cylinder Automatic Systems.—Other Two-Cylinder Systems.—Three-Cylinder Systems.—Four-Cylinder Tandem Systems.—Four-Cylinder Two-Crank Systems (other than Tandem).—Four-Cylinder Balanced Systems.—Four-Cylinder Divided and Balanced Systems.—Articulated Compound Engines.—Triple-Expansion Locomotives.—Compound Rack Locomotives.—Concluding Remarks Concerning Compound Locomotives.—The Use of Superheated Steam for Locomotives.—INDEX.

In Large 8vo. Handsome Cloth. With Plates and Illustrations. 16s.

LIGHT RAILWAYS AT HOME AND ABROAD.

By WILLIAM HENRY COLE, M.INST.C.E.,

Late Deputy-Manager, North-Western Railway, India.

Contents.—Discussion of the Term "Light Railways."—English Railways, Rates, and Farmers.—Light Railways in Belgium, France, Italy, other European Countries, America and the Colonies, India, Ireland.—Road Transport as an alternative.—The Light Railways Act, 1896.—The Question of Gauge.—Construction and Working.—Locomotives and Rolling-Stock.—Light Railways in England, Scotland, and Wales.—Appendices and Index.

"Will remain, for some time yet a STANDARD WORK in everything relating to Light Railways."—*Engineer*.

"The whole subject is EXHAUSTIVELY and PRACTICALLY considered. The work can be cordially recommended as INDISPENSABLE to those whose duty it is to become acquainted with one of the prime necessities of the immediate future."—*Railway Official Gazette*.

LONDON: CHARLES GRIFFIN & CO., LIMITED, EXETER STREET, STRAND.

FOURTH EDITION, Thoroughly Revised and Greatly Enlarged.
With Numerous Illustrations. Price 10s. 6d.

VALVES AND VALVE-GEARING:

A PRACTICAL TEXT-BOOK FOR THE USE OF
ENGINEERS, DRAUGHTSMEN, AND STUDENTS.

By CHARLES HURST, Practical Draughtsman.

PART I.—Steam Engine Valves.

PART II.—Gas Engine Valves and
Gears.

PART III.—Air Compressor Valves and
Gearing.

PART IV.—Pump Valves.

"MR. HURST'S VALVES AND VALVE-GEARING will prove a very valuable aid, and tend to the production of Engines of SCIENTIFIC DESIGN and ECONOMICAL WORKING. . . . Will be largely sought after by Students and Designers."—*Marine Engineer*.

"As a practical treatise on the subject, the book stands without a rival."—*Mechanical World*.

Hints on Steam Engine Design and Construction. By CHARLES HURST, "Author of Valves and Valve Gearing." SECOND EDITION, Revised. In Paper Boards, 8vo., Cloth Back. Illustrated. Price 1s. 6d. net.

CONTENTS.—I. Steam Pipes.—II. Valves.—III. Cylinders.—IV. Air Pumps and Condensers.—V. Motion Work.—VI. Crank Shafts and Pedestals.—VII. Valve Gear.—VIII. Lubrication.—IX. Miscellaneous Details.—INDEX.

"A handy volume which every practical young engineer should possess."—*The Model Engineer*.

SIXTH EDITION. Folio, strongly half-bound, 21s.

TRAVERSE TABLES:

Computed to Four Places of Decimals for every Minute of Angle
up to 100 of Distance.

For the Use of Surveyors and Engineers.

By RICHARD LLOYD GURDEN,

Authorised Surveyor for the Governments of New South Wales and Victoria.

* * *Published with the Concurrence of the Surveyors-General for New South Wales and Victoria.*

"Those who have experience in exact SURVEY-WORK will best know how to appreciate the enormous amount of labour represented by this valuable book. The computations enable the user to ascertain the sines and cosines for a distance of twelve miles to within half an inch, and this BY REFERENCE TO BUT ONE TABLE, in place of the usual Fifteen minute computations required. This alone is evidence of the assistance which the Tables ensure to every user, and as every Surveyor in active practice has felt the want of such assistance FEW KNOWING OF THEIR PUBLICATION WILL REMAIN WITHOUT THEM."

—*Engineer*.

Strongly Bound in Super Royal 8vo. Cloth Boards. 7s. 6d. net.

BONUS TABLES:

For Calculating Wages on the Bonus or Premium Systems.

For Engineering, Technical and Allied Trades.

By HENRY A. GOLDING, A.M.I.N.S.T.M.E.,

Technical Assistant to Messrs. Bryan Donkin and Clench, Ltd., and Assistant Lecturer in Mechanical Engineering at the Northampton Institute, London, E.C.

"Cannot fail to prove practically serviceable to those for whom they have been designed."—*Scotsman*.

LONDON: CHARLES GRIFFIN & CO., LIMITED, EXETER STREET, STRAND.

JUST READY. SECOND EDITION. Large 8vo, Handsome Cloth. With Illustrations, Tables, &c.

Lubrication & Lubricants:

A TREATISE ON THE
THEORY AND PRACTICE OF LUBRICATION

AND ON THE
NATURE, PROPERTIES, AND TESTING OF LUBRICANTS.

By LEONARD ARCHBUTT, F.I.C., F.C.S.,
Chemist to the Midland Railway Company,

AND

R. MOUNTFORD DEELEY, M.I.MECH.E., F.G.S.,
Chief Locomotive Superintendent, Midland Railway Company.

CONTENTS.—I. Friction of Solids.—II. Liquid Friction or Viscosity, and Plastic Friction.—III. Superficial Tension.—IV. The Theory of Lubrication.—V. Lubricants, their Sources, Preparation, and Properties.—VI. Physical Properties and Methods of Examination of Lubricants.—VII. Chemical Properties and Methods of Examination of Lubricants.—VIII. The Systematic Testing of Lubricants by Physical and Chemical Methods.—IX. The Mechanical Testing of Lubricants.—X. The Design and Lubrication of Bearings.—XI. The Lubrication of Machinery.—INDEX.

"Destined to become a CLASSIC on the subject."—*Industries and Iron.*

"Contains practically ALL THAT IS KNOWN on the subject. Deserves the careful attention of all Engineers."—*Railway Official Gazette.*

FOURTH EDITION. *Very fully Illustrated. Cloth, 4s. 6d.*

STEAM - BOILERS: THEIR DEFECTS, MANAGEMENT, AND CONSTRUCTION.

By R. D. MUNRO,

Chief Engineer of the Scottish Boiler Insurance and Engine Inspection Company

GENERAL CONTENTS.—I. EXPLOSIONS caused (1) by Overheating of Plates—(2) By Defective and Overloaded Safety Valves—(3) By Corrosion, Internal or External—(4) By Defective Design and Construction (Unsupported Flue Tubes; Unstrengthened Manholes; Defective Staying; Strength of Rivetted Joints; Factor of Safety)—II. CONSTRUCTION OF VERTICAL BOILERS; Shells—Crown Plates and Uptake Tubes—Man-Holes, Mud-Holes, and Fire-Holes—Fireboxes—Mountings—Management—Cleaning—Table of Bursting Pressures of Steel Boilers—Table of Rivetted Joints—Specifications and Drawings of Lancashire Boiler for Working Pressures (a) 80 lbs.; (b) 200 lbs. per square inch respectively.

"A valuable companion for workmen and engineers engaged about Steam Boilers, ought to be carefully studied, and ALWAYS AT HAND."—*Coll. Guardian.*

"The book is VERY USEFUL, especially to steam users, artisans, and young Engineers."—*Engineer.*

BY THE SAME AUTHOR.

KITCHEN BOILER EXPLOSIONS: Why they Occur, and How to Prevent their Occurrence. A Practical Handbook based on Actual Experiment. With Diagram and Coloured Plate. Price 3s.

LONDON: CHARLES GRIFFIN & CO., LIMITED, EXETER STREET, STRAND.

In Crown 8vo, Cloth. Fully Illustrated. 5s. net.

EMERY GRINDING MACHINERY.

A Text-Book of Workshop Practices in General Tool Grinding, and the Design, Construction, and Application of the Machines Employed.

By R. B. HODGSON, A.M. INST. MECH. E.

INTRODUCTION.—Tool Grinding.—Emery Wheels.—Mounting Emery Wheels.—Emery Rings and Cylinders.—Conditions to Ensure Efficient Working.—Leading Types of Machines.—Concave and Convex Grinding.—Cup and Cone Machines.—Multiple Grinding.—“Guest” Universal and Cutter Grinding Machines.—Ward Universal Cutter Grinder.—Press.—Tool Grinding.—Lathe Centre Grinder.—Polishing.—INDEX.

“Eminently practical . . . cannot fail to attract the notice of the users of this class of machinery, and to meet with careful perusal.”—*Chem. Trade Journal*.

IN THREE PARTS. Crown 8vo, Handsome Cloth. Very Fully Illustrated.

MOTOR-CAR MECHANISM AND MANAGEMENT.

By W. POYNTER ADAMS, M. INST. E. E.

IN THREE PARTS.

Part I.—The Petrol Car. Part II.—The Electrical Car.

Part III.—The Steam Car.

PART I.—THE PETROL CAR. 5s. net.

Contents.—SECTION I.—THE MECHANISM OF THE PETROL CAR.—The Engine.—The Engine Accessories.—Electrical Ignition and Accessories.—Multiple Cylinder Engines.—The Petrol.—The Chassis and Driving Gear.—SECTION II.—THE MANAGEMENT OF THE PETROL CAR.—The Engine.—The Engine Accessories.—Electrical Ignition.—The Chassis and Driving Gear.—General Management.—GLOSSARY.—INDEX.

“Should be carefully studied by those who have anything to do with motors.”—*Automobile and Carriage Builders' Journal*.

AT PRESS. In Large 8vo. Handsome Cloth. Very Fully Illustrated.

A MANUAL OF PETROL MOTORS AND MOTOR-CARS.

Comprising the Designing, Construction, and Working of Petrol Motors.

By F. STRICKLAND.

GENERAL CONTENTS.—PART I.: ENGINES.—Historical.—Power Required.—General Arrangement of Engines.—Ignition.—Carburettors.—Cylinders, Pistons, Valves, &c.—Crank Shafts, Crank Chambers, Cams, Runners, Guides, &c.—Pumps.—Flywheels.—Pipe Arrangements.—Silencers.—Engine Control, Balancing.—Motor Cycle Engines.—Marine Motors.—Two-Cycle Motors.—Paraffin Carburettors.—Gas Producers. PART II.: CARS.—General Arrangements.—Clutches.—Transmission.—Differential Gears.—Universal Joints.—Axles.—Springs.—Radius Rods.—Brakes.—Wheels.—Frames.—Steering Gear.—Radiator.—Steps, Mudguards, Bonnets, &c.—Lubrication.—Ball Bearings.—Bodies.—Factors of Safety.—Calculations of Stresses.—Special Change Speed Gears.—Special Cars.—Commercial Vehicles.—Racing Cars.—INDEX.

LONDON: CHARLES GRIFFIN & CO., LIMITED, EXETER STREET, STRAND.

WORKS BY

ANDREW JAMIESON, M.INST.C.E., M.I.E.E., F.R.S.E.,

Formerly Professor of Electrical Engineering, The Glas. and W. of Scot. Tech. Coll.

PROFESSOR JAMIESON'S ADVANCED TEXT-BOOKS.

*In Large Crown 8vo. Fully Illustrated.***STEAM AND STEAM-ENGINES, INCLUDING TURBINES**AND BOILERS. For the Use of Engineers and for Students preparing for Examinations. With 800 pp., over 400 Illustrations, 11 Plates, many B. of E., C. and G., Questions and Answers, and all Inst. C.E. Exams. on *Theory of Heat Engines*. FIFTEENTH EDITION, Revised. 10s. 6d."The BEST Book yet published for the use of Students."—*Engineer*.**APPLIED MECHANICS & MECHANICAL ENGINEERING.***Including All the Inst. C.E. Exams.* in (1) Applied Mechanics; (2) Strength and Elasticity of Materials; (3a) Theory of Structures; (ii) Theory of Machines; Hydraulics. Also B. of E.; C. and G. Questions.

Vol. I.—Comprising 568 pages, 300 Illustrations, and Questions. Part I., The Principle of Work and its Applications; Part II.: Friction, Lubrication of Bearings, &c.; Different kinds of Gearing and their Applications to Workshop Tools, &c. FIFTH EDITION. 8s. 6d.

"FULLY MAINTAINS the reputation of the Author."—*Pract. Engineer*.

Vol. II.—Comprising Parts III. to VI., with over 800 pages, 371 Illustrations; Motion and Energy, Theory of Structures or Graphic Statics; Strength and Elasticity of Materials; Hydraulics and Hydraulic Machinery. FIFTH EDITION. 12s. 6d.

"WELL AND LUCIDLY WRITTEN."—*The Engineer*.

** Each of the above volumes is complete in itself, and sold separately.

PROFESSOR JAMIESON'S INTRODUCTORY MANUALS

*Crown 8vo. With Illustrations and Examination Papers.***STEAM AND THE STEAM-ENGINE (Elementary**

Manual of). For First-Year Students, forming an Introduction to the Author's larger Work. ELEVENTH EDITION, Revised and Enlarged. 3/6.

"Should be in the hands of EVERY engineering apprentice."—*Practical Engineer*.**MAGNETISM AND ELECTRICITY (Practical Elementary**

Manual of). For First-Year Students. With Stud Inst.C.E. and B. of E. Exam. Questions. SEVENTH EDITION, Revised and Enlarged. 3/6.

"A THOROUGHLY TRUSTWORTHY Text-book. PRACTICAL and clear."—*Nature*.**APPLIED MECHANICS (Elementary Manual of).**

For First-Year Students. With B. of E., C. and G.; and Stud. Inst. C.E. Questions. SEVENTH EDITION, Revised and Greatly Enlarged. 3/6.

"The work has VERY HIGH QUALITIES, which may be condensed into the one word 'CLEAR.'"—*Science and Art*.**A POCKET-BOOK of ELECTRICAL RULES and TABLES.**

For the Use of Electricians and Engineers. By JOHN MUNRO, C.E., and Prof. JAMIESON. Pocket Size. Leather, 8s. 6d. EIGHTEENTH EDITION. [See p. 48.]

LONDON: CHARLES GRIFFIN & CO., LIMITED, EXETER STREET, STRAND.

WORKS BY
W. J. MACQUORN RANKINE, LL.D., F.R.S.,

Late Regius Professor of Civil Engineering in the University of Glasgow.

THOROUGHLY REVISED BY

W. J. MILLAR, C.E.,

Late Secretary to the Institute of Engineers and Shipbuilders in Scotland.

A MANUAL OF APPLIED MECHANICS :

Comprising the Principles of Statics and Cinematics, and Theory of Structures, Mechanism, and Machines. With Numerous Diagrams. Crown 8vo, cloth. SEVENTEENTH EDITION. 12s. 6d.

A MANUAL OF CIVIL ENGINEERING :

Comprising Engineering Surveys, Earthwork, Foundations, Masonry, Carpentry, Metal Work, Roads, Railways, Canals, Rivers, Waterworks, Harbours, &c. With Numerous Tables and Illustrations. Crown 8vo, cloth. TWENTY-SECOND EDITION. 16s.

A MANUAL OF MACHINERY AND MILLWORK :

Comprising the Geometry, Motions, Work, Strength, Construction, and Objects of Machines, &c. Illustrated with nearly 300 Woodcuts. Crown 8vo, cloth. SEVENTH EDITION. 12s. 6d.

**A MANUAL OF THE STEAM-ENGINE AND OTHER
PRIME MOVERS :**

With a Section on GAS, OIL, and AIR ENGINES, by BRYAN DONKIN, M.Inst.C.E. With Folding Plates and Numerous Illustrations. Crown 8vo, cloth. SIXTEENTH EDITION. 12s. 6d.

LONDON: CHARLES GRIFFIN & CO., LIMITED, EXETER STREET, STRAND.

PROF. RANKINE'S WORKS—(*Continued*).

USEFUL RULES AND TABLES :

For Architects, Builders, Engineers, Founders, Mechanics, Shipbuilders, Surveyors, &c. With APPENDIX for the use of ELECTRICAL ENGINEERS By Professor JAMIESON, F.R.S.E. SEVENTH EDITION. 10s. 6d.

A MECHANICAL TEXT-BOOK :

A Practical and Simple Introduction to the Study of Mechanics. By Professor RANKINE and E. F. BAMBER, C.E. With Numerous Illustrations. Crown 8vo, cloth. FIFTH EDITION. 9s.

. *The "MECHANICAL TEXT-BOOK" was designed by Professor RANKINE as an INTRODUCTION to the above Series of Manuals.*

MISCELLANEOUS SCIENTIFIC PAPERS.

Royal 8vo. Cloth, 31s. 6d.

Part I. Papers relating to Temperature, Elasticity, and Expansion of Vapours, Liquids, and Solids. Part II. Papers on Energy and its Transformations. Part III. Papers on Wave-Forms, Propulsion of Vessels, &c.

With Memoir by Professor TAIT, M.A. Edited by W. J. MILLAR, C.E. With fine Portrait on Steel, Plates, and Diagrams.

"No more enduring Memorial of Professor Rankine could be devised than the publication of these papers in an accessible form. . . . The Collection is most valuable on account of the nature of his discoveries, and the beauty and completeness of his analysis. . . . The Volume exceeds in importance any work in the same department published in our time."—*Architect*.

By W. VINCENT SHELTON (Foreman to the Imperial Ottoman Gun Factories, Constantinople) :

THE MECHANIC'S GUIDE : A Hand-Book for Engineers and Artizans. With Copious Tables and Valuable Recipes for Practical Use. Illustrated. *Second Edition*. Crown 8vo. Cloth, 7/6.

LONDON : CHARLES GRIFFIN & CO., LIMITED, EXETER STREET, STRAND.

THIRD EDITION, *Thoroughly Revised and Enlarged. With 60 Plates and Numerous Illustrations. Handsome Cloth. 34s.*

HYDRAULIC POWER

AND

HYDRAULIC MACHINERY.

BY

HENRY ROBINSON, M. INST. C.E., F.G.S.

FELLOW OF KING'S COLLEGE, LONDON; PROF. EMERITUS OF CIVIL ENGINEERING,
KING'S COLLEGE, ETC., ETC.

CONTENTS—Discharge through Orifices.—Flow of Water through Pipes.—Accumulators.—Presses and Lifts.—Hoists.—Rams.—Hydraulic Engines.—Pumping Engines.—Capstans.—Traversers.—Jacks.—Weighing Machines.—Riveters and Shop Tools.—Punching, Shearing, and Flanging Machines.—Cranes.—Coal Discharging Machines.—Drills and Cutters.—Pile Drivers, Excavators, &c.—Hydraulic Machinery applied to Bridges, Dock Gates, Wheels and Turbines.—Shields.—Various Systems and Power Installations—Meters, &c.—INDEX.

"The standard work on the application of water power."—*Cassier's Magazine.*

Second Edition, Greatly Enlarged. With Frontispiece, several Plates, and over 250 Illustrations. 21s. net.

THE PRINCIPLES AND CONSTRUCTION OF PUMPING MACHINERY

(STEAM AND WATER PRESSURE).

With Practical Illustrations of ENGINES and PUMPS applied to MINING,
TOWN WATER SUPPLY, DRAINAGE of Lands, &c., also Economy
and Efficiency Trials of Pumping Machinery.

BY HENRY DAVEY,

Member of the Institution of Civil Engineers, Member of the Institution of
Mechanical Engineers, F.G.S., &c.

CONTENTS—Early History of Pumping Engines—Steam Pumping Engines—Pumps and Pump Valves—General Principles of Non-Rotative Pumping Engines—The Cornish Engine, Simple and Compound—Types of Mining Engines—Pit Work—Shaft Sinking—Hydraulic Transmission of Power in Mines—Electric Transmission of Power—Valve Gears of Pumping Engines—Water Pressure Pumping Engines—Water Works Engines—Pumping Engine Economy and Trials of Pumping Machinery—Centrifugal and other Low-Lift Pumps—Hydraulic Rams, Pumping Mains, &c.—INDEX.

"By the 'one English Engineer who probably knows more about Pumping Machinery than ANY OTHER' . . . A VOLUME RECORDING THE RESULTS OF LONG EXPERIENCE AND STUDY."—*The Engineer.*

"Undoubtedly THE BEST AND MOST PRACTICAL TREATISE ON Pumping Machinery THAT HAS YET BEEN PUBLISHED."—*Mining Journal.*

LONDON: CHARLES GRIFFIN & CO., LIMITED, EXETER STREET, STRAND

Royal 8vo, Handsome Cloth. With numerous Illustrations and Tables. 25s.

THE STABILITY OF SHIPS.

BY

SIR EDWARD J. REED, K.C.B., F.R.S., M.P.,

KNIGHT OF THE IMPERIAL ORDERS OF ST. STANILAUS OF RUSSIA; FRANCIS JOSEPH OF AUSTRIA; MEVDJIDIE OF TURKEY; AND RISING SUN OF JAPAN; VICE-PRESIDENT OF THE INSTITUTION OF NAVAL ARCHITECTS.

"SIR EDWARD REED'S 'STABILITY OF SHIPS' IS INVALUABLE. THE NAVAL ARCHITECT WILL FIND BROUGHT TOGETHER AND READY TO HIS HAND, A MASS OF INFORMATION WHICH HE WOULD OTHERWISE HAVE TO SEEK IN AN ALMOST ENDLESS VARIETY OF PUBLICATIONS, AND SOME OF WHICH HE WOULD POSSIBLY NOT BE ABLE TO OBTAIN AT ALL ELSEWHERE."—*Steamship*.

THE DESIGN AND CONSTRUCTION OF SHIPS. By JOHN HARVARD BILES, M.INST.N.A., Professor of Naval Architecture in the University of Glasgow. [In Preparation.]

THIRD EDITION. Illustrated with Plates, Numerous Diagrams, and Figures in the Text. 18s. net.

STEEL SHIPS: THEIR CONSTRUCTION AND MAINTENANCE.

A Manual for Shipbuilders, Ship Superintendents, Students, and Marine Engineers.

By THOMAS WALTON, NAVAL ARCHITECT,

AUTHOR OF "KNOW YOUR OWN SHIP."

CONTENTS.—I. Manufacture of Cast Iron, Wrought Iron, and Steel.—Composition of Iron and Steel, Quality, Strength, Tests, &c. II. Classification of Steel Ships. III. Considerations in making choice of Type of Vessel.—Framing of Ships. IV. Strains experienced by Ships.—Methods of Computing and Comparing Strengths of Ships. V. Construction of Ships.—Alternative Modes of Construction.—Types of Vessels.—Turret, Self Trimming, and Trunk Steamers, &c.—Rivets and Rivetting, Workmanship. VI. Pumping Arrangements. VII. Maintenance.—Prevention of Deterioration in the Hulls of Ships.—Cement, Paint, &c.—INDEX.

"So thorough and well written is every chapter in the book that it is difficult to select any of them as being worthy of exceptional praise. Altogether, the work is excellent, and will prove of great value to those for whom it is intended."—*The Engineer*.

AT PRESS. In Handsome Cloth. Very fully Illustrated.

PRESENT-DAY SHIPBUILDING.

For Shipyard Students, Ships' Officers, and Engineers.

By THOS. WALTON,

Author of "Know Your Own Ship."

GENERAL CONTENTS.—Classification.—Materials used in Shipbuilding.—Alternative Modes of Construction.—Details of Construction.—Framing, Plating, Rivetting, Stem Frames, Twin-Screw Arrangements, Water Ballast Arrangements, Loading and Discharging Gear, &c.—Types of Vessels, including Atlantic Liners, Cargo Steamers, Oil carrying Steamers, Turret and other Self Trimming Steamers, &c.—INDEX.

LONDON: CHARLES GRIFFIN & CO., LIMITED, EXETER STREET, STRAND.

GRIFFIN'S NAUTICAL SERIES.

EDITED BY EDW. BLACKMORE,

Master Mariner, First Class Trinity House Certificate, Assoc. Inst. N.A.;

AND WRITTEN, MAINLY, by SAILORS for SAILORS.

"THIS ADMIRABLE SERIES."—*Fairplay*. "A VERY USEFUL SERIES."—*Nature*.

"EVERY SHIP should have the WHOLE SERIES as a REFERENCE LIBRARY. HANDSOMELY BOUND, CLEARLY PRINTED and ILLUSTRATED."—*Liverpool Journ. of Commerce*.

The British Mercantile Marine: An Historical Sketch of its Rise and Development. By the EDITOR, CAPT. BLACKMORE. 8s. 6d.

"Captain Blackmore's SPLENDID BOOK . . . contains paragraphs on every point of interest to the Merchant Marine. The 243 pages of this book are THE MOST VALUABLE to the sea captain that have EVER been COMPILED."—*Merchant Service Review*.

Elementary Seamanship. By D. WILSON-BARKER, Master Mariner, F.R.S.E., F.R.G.S. With numerous Plates, two in Colours, and Frontispiece. FOURTH EDITION, Thoroughly Revised. With additional Illustrations. 6s.

"THIS ADMIRABLE MANUAL, by CAPT. WILSON BARKER, of the 'Worcester,' seems to us PERFECTLY DESIGNED."—*Athenæum*.

Know Your Own Ship: A Simple Explanation of the Stability, Construction, Tonnage, and Freeboard of Ships. By THOS. WALTON, Naval Architect. With numerous Illustrations and additional Chapters on Buoyancy, Trim, and Calculations. NINTH EDITION. 7s. 6d.

"MR. WALTON'S book will be found VERY USEFUL."—*The Engineer*.

Navigation: Theoretical and Practical. By D. WILSON-BARKER and WILLIAM ALLINGHAM. SECOND EDITION, Revised. 3s. 6d.

"PRECISELY the kind of work required for the New Certificates of competency. Candidates will find it INVALUABLE."—*Dundee Advertiser*.

Marine Meteorology: For Officers of the Merchant Navy. By WILLIAM ALLINGHAM, First Class Honours, Navigation, Science and Art Department. With Illustrations, Maps, and Diagrams, and facsimile reproduction of log page. 7s. 6d.

"Quite the BEST PUBLICATION on this subject."—*Shipping Gazette*.

Latitude and Longitude: How to find them. By W. J. MILLAR, C.E. SECOND EDITION, Revised. 2s.

"Cannot but prove an acquisition to those studying Navigation."—*Marine Engineer*.

Practical Mechanics: Applied to the requirements of the Sailor. By THOS. MACKENZIE, Master Mariner, F.R.A.S. SECOND EDITION, Revised. 8s. 6d.

"WELL WORTH the money . . . EXCEEDINGLY HELPFUL."—*Shipping World*.

Trigonometry: For the Young Sailor, &c. By RICH. C. BUCK, of the Thames Nautical Training College, H.M.S. "Worcester." THIRD EDITION, Revised. Price 3s. 6d.

"THIS EMINENTLY PRACTICAL and reliable volume."—*Schoolmaster*.

Practical Algebra. By RICH. C. BUCK. Companion Volume to the above, for Sailors and others. SECOND EDITION, Revised. Price 3s. 6d.

"IT IS JUST THE BOOK for the young sailor mindful of progress."—*Nautical Magazine*.

The Legal Duties of Shipmasters. By BENEDICT WM. GINSBURG, M.A., LL.D., of the Inner Temple and Northern Circuit: Barrister-at-Law. SECOND EDITION, Thoroughly Revised and Enlarged. Price 4s. 6d.

"INVALUABLE to masters. . . . We can fully recommend it."—*Shipping Gazette*.

A Medical and Surgical Help for Shipmasters. Including First Aid at Sea. By WM. JOHNSON SMITH, F.R.C.S., Principal Medical Officer, Seamen's Hospital, Greenwich. THIRD EDITION, Thoroughly Revised. 6s.

"SOUND, JUDICIOUS, REALLY HELPFUL."—*The Lancet*.

LONDON: CHARLES GRIFFIN & CO., LIMITED, EXETER STREET, STRAND.

GRIFFIN'S NAUTICAL SERIES.*Introductory Volume. Price 3s. 6d.*

T H E

British Mercantile Marine.

By EDWARD BLACKMORE,

MASTER MARINER; ASSOCIATE OF THE INSTITUTION OF NAVAL ARCHITECTS;
MEMBER OF THE INSTITUTION OF ENGINEERS AND SHIPBUILDERS
IN SCOTLAND; EDITOR OF GRIFFIN'S "NAUTICAL SERIES."

GENERAL CONTENTS.—**HISTORICAL:** From Early Times to 1486—Progress under Henry VIII.—To Death of Mary—During Elizabeth's Reign—Up to the Reign of William III.—The 18th and 19th Centuries—Institution of Examinations—Rise and Progress of Steam Propulsion—Development of Free Trade—Shipping Legislation, 1862 to 1875—"Locksley Hall" Case—Shipmasters' Societies—Loading of Ships—Shipping Legislation, 1884 to 1894—Statistics of Shipping. **THE PERSONNEL:** Shipowners—Officers—Mariners—Duties and Present Position. **EDUCATION:** A Seaman's Education: what it should be—Present Means of Education—Hints. **DISCIPLINE AND DUTY—**Postscript—The Serious Decrease in the Number of British Seamen, a Matter demanding the Attention of the Nation.

"INTERESTING and INSTRUCTIVE . . . may be read WITH PROFIT and ENJOYMENT."—*Glasgow Herald.*

"EVERY BRANCH of the subject is dealt with in a way which shows that the writer 'knows the ropes' familiarly."—*Scotsman.*

"This ADMIRABLE book . . . TEEMS with useful information—Should be in the hands of every Sailor."—*Western Morning News.*

FOURTH EDITION, *Thoroughly Revised. With Additional Illustrations. Price 6s.*

A MANUAL OF

ELEMENTARY SEAMANSHIP.

BY

D. WILSON-BARKER, MASTER MARINER; F.R.S.E., F.R.G.S., &c., &c.
YOUNGER BROTHER OF THE TRINITY HOUSE.

With Frontispiece, Numerous Plates (Two in Colours), and Illustrations in the Text.

GENERAL CONTENTS.—The Building of a Ship; Parts of Hull, Masts, &c.—Ropes, Knots, Splicing, &c.—Gear, Lead and Log, &c.—Rigging, Anchors—Sailmaking—The Sails, &c.—Handling of Boats under Sail—Signals and Signalling—Rule of the Road—Keeping and Relieving Watch—Points of Etiquette—Glossary of Sea Terms and Phrases—Index.

. The volume contains the NEW RULES OF THE ROAD.

"THIS ADMIRABLE MANUAL, by CAPT. WILSON-BARKER of the 'Worcester,' seems to us PERFECTLY DESIGNED, and holds its place excellently in 'GRIFFIN'S NAUTICAL SERIES.' . . . Although intended for those who are to become Officers of the Merchant Navy, it will be found useful by ALL YACHTSMEN."—*Athenæum.*

. For complete List of GRIFFIN'S NAUTICAL SERIES, see p. 39.

LONDON: CHARLES GRIFFIN & CO., LIMITED, EXETER STREET, STRAND.

GRIFFIN'S NAUTICAL SERIES.SECOND EDITION, *Revised and Illustrated.* Price 3s. 6d.**NAVIGATION:
PRACTICAL AND THEORETICAL.**

By DAVID WILSON-BARKER, R.N.R., F.R.S.E., &c., &c.,

AND

WILLIAM ALLINGHAM,

FIRST-CLASS HONOURS, NAVIGATION, SCIENCE AND ART DEPARTMENT.

With Numerous Illustrations and Examination Questions.

GENERAL CONTENTS.—Definitions—Latitude and Longitude—Instruments of Navigation—Correction of Courses—Plane Sailing—Traverse Sailing—Day's Work—Parallel Sailing—Middle Latitude Sailing—Mercator's Chart—Mercator Sailing—Current Sailing—Position by Bearings—Great Circle Sailing—The Tides—Questions—Appendix: Compass Error—Numerous Useful Hints. &c.—Index.

"PRECISELY the kind of work required for the New Certificates of competency in grades from Second Mate to extra Master. . . . Candidates will find it INVALUABLE."—*Dundee Advertiser*.

"A CAPITAL LITTLE BOOK . . . specially adapted to the New Examinations. The Authors are CAPT. WILSON-BARKER (Captain-Superintendent of the Nautical College, H.M.S. 'Worcester,' who has had great experience in the highest problems of Navigation), and MR. ALLINGHAM, a well-known writer on the Science of Navigation and Nautical Astronomy."—*Shipping World*.

*Handsome Cloth. Fully Illustrated. Price 7s. 6d.***MARINE METEOROLOGY,**
FOR OFFICERS OF THE MERCHANT NAVY.

By WILLIAM ALLINGHAM,

Joint Author of "Navigation, Theoretical and Practical."

With numerous Plates, Maps, Diagrams, and Illustrations, and a facsimile Reproduction of a Page from an actual Meteorological Log-Book.

SUMMARY OF CONTENTS.

INTRODUCTORY.—Instruments Used at Sea for Meteorological Purposes.—Meteorological Log-Books.—Atmospheric Pressure.—Air Temperatures.—Sea Temperatures.—Winds.—Wind Force Scales.—History of the Law of Storms.—Hurricanes, Seasons, and Storm Tracks.—Solution of the Cyclone Problem.—Ocean Currents.—Icebergs.—Synchronous Charts.—Dew, Mists, Fogs, and Haze.—Clouds.—Rain, Snow, and Hall.—Mirage, Rainbows, Coronas, Halos, and Meteors.—Lightning, Comets, and Auroras.—QUESTIONS.—APPENDIX.—INDEX.

"Quite the BEST publication, AND certainly the MOST INTERESTING, on this subject ever presented to Nautical men."—*Shipping Gazette*.

* * For Complete List of GRIFFIN'S NAUTICAL SERIES, see p. 39.

LONDON: CHARLES GRIFFIN & CO., LIMITED, EXETER STREET, STRAND.

GRIFFIN'S NAUTICAL SERIES.

SECOND EDITION, REVISED. With Numerous Illustrations. Price 3s. 6d.

Practical Mechanics :

Applied to the Requirements of the Sailor.

BY THOS. MACKENZIE,

Master Mariner, F.R.A.S.

GENERAL CONTENTS.—Resolution and Composition of Forces—Work done by Machines and Living Agents—The Mechanical Powers: The Lever; Derricks as Bent Levers—The Wheel and Axle: Windlass; Ship's Capstan; Crab Winch—Tackles: the "Old Man"—The Inclined Plane; the Screw—The Centre of Gravity of a Ship and Cargo—Relative Strength of Rope: Steel Wire, Manilla, Hemp, Coir—Derricks and Shears—Calculation of the Cross-breaking Strain of Fir Spar—Centre of Effort of Sails—Hydrostatics: the Diving-bell; Stability of Floating Bodies; the Ship's Pump, &c.

"THIS EXCELLENT BOOK . . . contains a LARGE AMOUNT of information."
—*Nature*.

"WELL WORTH the money . . . will be found EXCEEDINGLY HELPFUL."
—*Shipping World*.

"NO SHIPS' OFFICERS' BOOKCASE will henceforth be complete without CAPTAIN MACKENZIE'S 'PRACTICAL MECHANICS.' Notwithstanding my many years' experience at sea, it has told me *how much more there is to acquire*."
(Letter to the Publishers from a Master Mariner).

"I must express my thanks to you for the labour and care you have taken in 'PRACTICAL MECHANICS.' . . . IT IS A LIFE'S EXPERIENCE. . . . What an amount we frequently see wasted by rigging purchases without reason and accidents to spars, &c., &c.! 'PRACTICAL MECHANICS' WOULD SAVE ALL THIS."
(Letter to the Author from another Master Mariner).

WORKS BY RICHARD C. BUCK,

of the Thames Nautical Training College, H.M.S. 'Worcester.'

A Manual of Trigonometry :*With Diagrams, Examples, and Exercises. Price 3s. 6d.*

THIRD EDITION, Revised and Corrected.

* * Mr. Buck's Text-Book has been SPECIALLY PREPARED with a view to the New Examinations of the Board of Trade, in which Trigonometry is an obligatory subject.

"THIS EMINENTLY PRACTICAL AND RELIABLE VOLUME."
—*Schoolmaster*.

A Manual of Algebra.*Designed to meet the Requirements of Sailors and others.*

SECOND EDITION, Revised. Price 3s. 6d.

* * These elementary works on ALGEBRA and TRIGONOMETRY are written specially for those who will have little opportunity of consulting a Teacher. They are books for "SELF-HELP." All but the simplest explanations have, therefore, been avoided, and ANSWERS to the Exercises are given. Any person may readily, by careful study, become master of their contents, and thus lay the foundation for a further mathematical course, if desired. It is hoped that to the younger Officers of our Mercantile Marine they will be found decidedly serviceable. The Examples and Exercises are taken from the Examination Papers set for the Cadets of the "Worcester."

"Clearly arranged, and well got up. . . . A first-rate Elementary Algebra."
—*Nautical Magazine*.

* * For complete List of GRIFFIN'S NAUTICAL SERIES, see p. 29.

LONDON: CHARLES GRIFFIN & CO., LIMITED, EXETER STREET, STRAND.

GRIFFIN'S NAUTICAL SERIES.

SECOND EDITION, Thoroughly Revised and Extended. In Crown 8vo.
Handsome Cloth. Price 4s. 6d.

THE LEGAL DUTIES OF SHIPMASTERS.

BY

BENEDICT WM. GINSBURG, M.A., LL.D. (CANTAB.),
Of the Inner Temple and Northern Circuit; Barrister-at-Law.

General Contents.—The Qualification for the Position of Shipmaster—The Contract with the Shipowner—The Master's Duty in respect of the Crew: Engagement; Apprentices; Discipline; Provisions, Accommodation, and Medical Comforts; Payment of Wages and Discharge—The Master's Duty in respect of the Passengers—The Master's Financial Responsibilities—The Master's Duty in respect of the Cargo—The Master's Duty in Case of Casualty—The Master's Duty to certain Public Authorities—The Master's Duty in relation to Pilots, Signals, Flags, and Light Dues—The Master's Duty upon Arrival at the Port of Discharge—Appendices relative to certain Legal Matters: Board of Trade Certificates, Dietary Scales, Stowage of Grain Cargoes, Load Line Regulations, Life-saving Appliances, Carriage of Cattle at Sea, &c., &c.—Copious Index.

"No intelligent Master should fail to add this to his list of necessary books. A few lines of it may save a LAWYER'S FEE, BESIDES ENDLESS WORRY."—*Liverpool Journal of Commerce.*

"SENSIBLE, plainly written, IN CLEAR and NON-TECHNICAL LANGUAGE, and will be found of MUCH SERVICE by the Shipmaster."—*British Trade Review.*

SECOND EDITION, Revised. With Diagrams. Price 2s.

**Latitude and Longitude:
How to Find them.**

BY W. J. MILLAR, C.E.,

Late Secretary to the Inst. of Engineers and Shipbuilders in Scotland.

"CONCISELY and CLEARLY WRITTEN . . . cannot but prove an acquisition to those studying Navigation."—*Marine Engineer.*

"Young Seamen will find it HANDY and USEFUL, SIMPLE and CLEAR."—*The Engineer.*

FIRST AID AT SEA.

THIRD EDITION, Revised. With Coloured Plates and Numerous Illustrations, and comprising the latest Regulations Respecting the Carriage of Medical Stores on Board Ship. Price 6s.

**A MEDICAL AND SURGICAL HELP
FOR SHIPMASTERS AND OFFICERS
IN THE MERCHANT NAVY.**

BY WM. JOHNSON SMITH, F.R.O.S.,

Principal Medical Officer, Seamen's Hospital, Greenwich.

* * The attention of all interested in our Merchant Navy is requested to this exceedingly useful and valuable work. It is needless to say that it is the outcome of many years PRACTICAL EXPERIENCE amongst Seamen.

"SOUND, JUDICIOUS, REALLY HELPFUL."—*The Lancet.*

* * For Complete List of GRIFFIN'S NAUTICAL SERIES, see p. 39.

LONDON: CHARLES GRIFFIN & CO., LIMITED, EXETER STREET, STRAND.

GRIFFIN'S NAUTICAL SERIES.

NINTH EDITION. *Revised, with Chapters on Trim, Buoyancy, and Calculations. Numerous Illustrations. Handsome Cloth, Crown 8vo. Price 7s. 6d.*

KNOW YOUR OWN SHIP.

BY THOMAS WALTON, NAVAL ARCHITECT.

Specially arranged to suit the requirements of Ships' Officers, Shipowners, Superintendents, Draughtsmen, Engineers, and Others,

This work explains, in a simple manner, such important subjects as:—Displacement.—Deadweight.—Tonnage.—Freeboard.—Moments.—Buoyancy.—Strain.—Structure.—Stability.—Rolling.—Ballasting.—Loading.—Shifting Cargoes.—Admission of Water.—Sail Area.—&c.

The little book will be found EXCEEDINGLY HANDY by most officers and officials connected with shipping. . . . Mr. Walton's work will obtain LASTING SUCCESS, because of its unique fitness for those for whom it has been written."—*Shipping World.*

BY THE SAME AUTHOR.

Steel Ships: Their Construction and Maintenance.

(See page 38.)

FIFTEENTH EDITION, *Thoroughly Revised, Greatly Enlarged, and Reset Throughout. Large 8vo, Cloth. pp. i-xxiv+708. With 280 Illustrations, reduced from Working Drawings, and 8 Plates. 21s. net.*

**A MANUAL OF
MARINE ENGINEERING:**

COMPRISING THE DESIGNING, CONSTRUCTION, AND WORKING OF MARINE MACHINERY.

By A. E. SEATON, M.I.C.E., M.I.Mech.E., M.I.N.A.

GENERAL CONTENTS.—PART I.—Principles of Marine Propulsion. PART II.—Principles of Steam Engineering. PART III.—Details of Marine Engines: Design and Calculations for Cylinders, Pistons, Valves, Expansion Valves, &c. PART IV.—Propellers. PART V.—Boilers. PART VI.—Miscellaneous.

"The Student, Draughtsman, and Engineer will find this work the MOST VALUABLE HANDBOOK of Reference on the Marine Engine now in existence."—*Marine Engineer.*

NINTH EDITION, Thoroughly Revised. Pocket-Size, Leather. 8s. 6d.

**A POCKET-BOOK OF
MARINE ENGINEERING RULES AND TABLES,**

FOR THE USE OF

Marine Engineers, Naval Architects, Designers, Draughtsmen, Superintendents and Others.

By A. E. SEATON, M.I.C.E., M.I.Mech.E., M.I.N.A.,

AND

H. M. ROUNTHWAITE, M.I.Mech.E., M.I.N.A.

"The best book of its kind, and the information is both up-to-date and reliable."—*Engineer.*

LONDON: CHARLES GRIFFIN & CO., LIMITED, EXETER STREET, STRAND.

WORKS BY PROF. ROBERT H. SMITH, Assoc.M.I.C.E.,
M.I.M.E., M.I.E.L.E., M.I.Min.E., Whit. Sch., M.Ord. Melji.

THE CALCULUS FOR ENGINEERS AND PHYSICISTS,

Applied to Technical Problems.

WITH EXTENSIVE

CLASSIFIED REFERENCE LIST OF INTEGRALS.

By PROF. ROBERT H. SMITH.

ASSISTED BY

R. F. MUIRHEAD, M.A., B.Sc.,

Formerly Clark Fellow of Glasgow University, and Lecturer on Mathematics at
Mason College.

In Crown 8vo, extra, with Diagrams and Folding-Plate. 8s. 6d.

"PROF. R. H. SMITH'S book will be serviceable in rendering a hard road AS EASY AS PRACTICABLE for the non-mathematical Student and Engineer."—*Athenæum*.

"Interesting diagrams, with practical illustrations of actual occurrence, are to be found here in abundance. THE VERY COMPLETE CLASSIFIED REFERENCE TABLE will prove very useful in saving the time of those who want an integral in a hurry."—*The Engineer*.

MEASUREMENT CONVERSIONS

(English and French):

43 GRAPHIC TABLES OR DIAGRAMS, ON 28 PLATES.

Showing at a glance the MUTUAL CONVERSION of MEASUREMENTS
in DIFFERENT UNITS

Of Lengths, Areas, Volumes, Weights, Stresses, Densities, Quantities
of Work, Horse Powers, Temperatures, &c.

For the use of Engineers, Surveyors, Architects, and Contractors.

In 4to, Boards. 7s. 6d.

* * * Prof. SMITH'S CONVERSION-TABLES form the most unique and comprehensive collection ever placed before the profession. By their use much time and labour will be saved, and the chances of error in calculation diminished. It is believed that henceforth no Engineer's Office will be considered complete without them.

Pocket Size, Leather Limp, with Gilt Edges and Rounded Corners, printed on Special Thin Paper, with Illustrations, pp. i-xii + 834. Price 18s. net.

(THE NEW "NYSTROM")

THE MECHANICAL ENGINEER'S REFERENCE BOOK

*A Handbook of Tables, Formulæ and Methods for Engineers,
Students and Draughtsmen.*

By HENRY HARRISON SUPLEE, B.Sc., M.E.

"We feel sure it will be of great service to mechanical engineers."—*Engineering*.

LONDON: CHARLES GRIFFIN & CO., LIMITED, EXETER STREET, STRAND.

SECOND EDITION. In Large 8vo. Handsome Cloth. 16s.

CHEMISTRY FOR ENGINEERS.

BY
BERTRAM BLOUNT, AND A. G. BLOXAM,
F.I.C., F.C.S., A.I.C.E. F.I.C., F.C.S.

GENERAL CONTENTS.—Introduction—Chemistry of the Chief Materials of Construction—Sources of Energy—Chemistry of Steam-raising—Chemistry of Lubrication and Lubricants—Metallurgical Processes used in the Winning and Manufacture of Metals.

"The authors have succeeded beyond all expectation, and have produced a work which should give FRESH POWER to the Engineer and Manufacturer."—*The Times*.

By the same Authors, "CHEMISTRY FOR MANUFACTURERS," see p. 71.

In Handsome Cloth. With about 50 Illustrations. 3s. 6d. net.

THE ELEMENTS OF CHEMICAL ENGINEERING.

By J. GROSSMANN, M.A., PH.D., F.I.C.

WITH A PREFACE BY

SIR WILLIAM RAMSAY, K.C.B., F.R.S.

CONTENTS.—The Beaker and its Technical Equivalents.—Distilling Flasks, Liebig's Condensers.—Fractionating Tubes and their Technical Equivalents.—The Air-Bath and its Technical Equivalents.—The Blowpipe and Crucible and their Technical Equivalents.—The Steam Boiler and other Sources of Power.—General Remarks on the Application of Heat in Chemical Engineering.—The Funnel and its Technical Equivalents.—The Mortar and its Technical Equivalents.—Measuring Instruments and their Technical Equivalents.—Materials Used in Chemical Engineering and their Mode of Application.—Technical Research and the Designing of Plant.—Conclusion.—Chemicals and Materials.—INDEX.

"Excellent. . . . Every student of chemistry attending a technical course should obtain a copy."—*Chemical News*.

WORKS BY WALTER R. BROWNE, M.A., M.INST.C.E.

THE STUDENT'S MECHANICS:

An Introduction to the Study of Force and Motion.

With Diagrams. Crown 8vo. Cloth, 4s. 6d.

"Clear in style and practical in method, 'THE STUDENT'S MECHANICS' is cordially to be recommended from all points of view."—*Athenaeum*.

FOUNDATIONS OF MECHANICS.

Papers reprinted from the *Engineer*. In Crown 8vo, 1s.

Demy 8vo, with Numerous Illustrations, 9s.

FUEL AND WATER:

A Manual for Users of Steam and Water.

By PROF. FRANZ SCHWACKHÖFER OF VIENNA, AND
WALTER R. BROWNE, M.A., C.E.

GENERAL CONTENTS.—Heat and Combustion—Fuel, Varieties of—Firing Arrangements: Furnace, Flues, Chimney—The Boiler, Choice of—Varieties—Feed-water Heaters—Steam Pipes—Water: Composition, Purification—Prevention of Scale, &c., &c.

"The Section on Heat is one of the best and most lucid ever written."—*Engineer*.

LONDON: CHARLES GRIFFIN & CO., LIMITED, EXETER STREET, STRAND.

GRIFFIN'S LOCAL GOVERNMENT HANDBOOKS.WORKS SUITABLE FOR MUNICIPAL AND COUNTY ENGINEERS,
ANALYSTS, AND OTHERS.See also Davies' *Hygiene*, p. 99, and MacLeod's *Calculations*, p. 110.

Gas Manufacture (The Chemistry of). A Handbook on the Production, Purification, and Testing of Illuminating Gas, and the Assay of Bye-Products. By W. J. A. BUTTERFIELD, M.A., F.I.C., F.C.S. With Illustrations. FOURTH EDITION, Revised. Vol. I., 7s. 6d. net. Vol. II., *in preparation*. [See page 77.]

Water Supply: A Practical Treatise on the Selection of Sources and the Distribution of Water. By REGINALD E. MIDDLETON, M.Inst.C.E., M.Inst.Mech.E., F.S.I. With Numerous Plates and Diagrams. Crown 8vo. 8s. 6d. net. [See page 77.]

Central Electrical Stations: Their Design, Organisation, and Management. By C. H. WORDINGHAM, A.K.C., M.I.C.E. SECOND EDITION. 24s. net. [See p. 43.]

Electricity Control. By LEONARD ANDREWS, A.M.Inst.C.E., M.I.E.E. 12s. 6d. net. [See page 48.]

Electricity Meters. By HENRY G. SOLOMON, A.M.Inst.E.E. 16s. [See page 49.]

Trades' Waste: Its Treatment and Utilisation, with Special Reference to the Prevention of Rivers' Pollution. By W. NAYLOR, F.C.S., A.M.Inst.C.E. With Numerous Plates, Diagrams, and Illustrations. 21s. net. [See page 76.]

Calcareous Cements: Their Nature, Preparation, and Uses. With some Remarks upon Cement Testing. By GILBERT REDGRAVE, Assoc.Inst.C.E., and CHAS. SPACKMAN, F.C.S. With Illustrations, Analytical Data, and Appendices on Costs, &c. 15s. net. [See page 76.]

Road Making and Maintenance: A Practical Treatise for Engineers, Surveyors, and others. With an Historical Sketch of Ancient and Modern Practice. By THOMAS AITKEN, Assoc.M.Inst.C.E., M. Assoc. Municipal and County Engrs.; M. San. Inst. SECOND EDITION, Revised. Fully Illustrated. [See page 79.]

Light Railways at Home and Abroad. By WILLIAM HENRY COLE, M.Inst.C.E., late Deputy Manager, North-Western Railway, India. Large 8vo, Handsome Cloth, Plates and illustrations. 16s. [See page 30.]

Practical Sanitation: A Handbook for Sanitary Inspectors and others interested in Sanitation. By GEO. REID, M.D., D.P.H., Medical Officer, Staffordshire County Council. With Appendix on Sanitary Law, by Herbert Manley, M.A., M.B., D.P.H. THIRTEENTH EDITION, Thoroughly Revised. 6s. [See page 78.]

Sanitary Engineering: A Practical Manual of Town Drainage and Sewage and Refuse Disposal. By FRANCIS WOOD, A.M.Inst.C.E., F.G.S. SECOND EDITION, Revised. Fully Illustrated. 8s. 6d. net. [See page 75.]

Dairy Chemistry: A Practical Handbook for Dairy Managers, Chemists, and Analysts. By H. DROOP RICHMOND, F.I.C., Chemist to the Aylesbury Dairy Company. With Tables, Illustrations, &c. Handsome Cloth, 16s. [See page 73.]

Dairy Analysis: The Laboratory Book of. By H. DROOP RICHMOND, F.I.C. Fully Illustrated, Cloth. 2s. 6d. net. [See page 73.]

Milk: Its Production and Uses. With Chapters on Dairy Farming, The Diseases of Cattle, and on the Hygiene and Control of Supplies. By EDWARD F. WILLOUGHBY, M.D. (Lond.), D.P.H. (Lond. and Camb.), Inspector of Farms and General Scientific Adviser to Welford & Sons, Ltd. 6s. net. [See page 73.]

Flesh Foods: With Methods for their Chemical, Microscopical, and Bacteriological Examination. A Handbook for Medical Men, Inspectors, Analysts, and others. By C. AINSWORTH MITCHELL, B.A., F.I.C., Mem. Council Soc. of Public Analysts. With numerous Illustrations and a coloured Plate. 10s. 6d. [See page 74.]

Foods: Their Composition and Analysis. By A. WYNTER BLYTH, M.E.C.S., F.C.S., Public Analyst for the County of Devon, and M. W. BLYTH, B.A., B.Sc. With Tables, Folding Plate, and Frontispiece. FIFTH EDITION, Thoroughly Revised. 21s. [See page 72.]

"AN ADMIRABLE DIGEST of the most recent state of knowledge."—*Chemical News*.

LONDON: CHARLES GRIFFIN & CO., LIMITED, EXETER STREET, STRAND.

ELECTRICAL ENGINEERING.

SECOND EDITION, Revised. In Large 8vo. Handsome Cloth. Profusely Illustrated with Plates, Diagrams, and Figures. 24s. net.

CENTRAL ELECTRICAL STATIONS:**Their Design, Organisation, and Management.**

By CHAS. H. WORDINGHAM, A.K.C., M. INST. C.E., M. INST. MECH. E.,
Late Memb. of Council Inst. E. E., and Electrical Engineer to the City of Manchester ;
Electrical Engineer-in-Chief to the Admiralty.

ABRIDGED CONTENTS.

Introductory.—Central Station Work as a Profession.—As an Investment.—The Establishment of a Central Station.—Systems of Supply.—Site.—Architecture.—Plant.—Boilers.—Systems of Draught and Waste Heat Economy.—Coal Handling, Weighing, and Storing.—The Transmission of Steam.—Generators.—Condensing Appliances.—Switching Gear, Instruments, and Connections.—Distributing Mains.—Insulation, Resistance, and Cost.—Distributing Networks.—Service Mains and Feeders.—Testing Mains.—Meters and Appliances.—Standardising and Testing Laboratory.—Secondary Batteries.—Street Lighting.—Cost.—General Organisation.—Mains Department.—Installation Department.—Standardising Department.—Drawing Office.—Clerical Department.—The Consumer.—Routine and Main Laying.—INDEX.

"One of the MOST VALUABLE CONTRIBUTIONS to Central Station literature we have had for some time."—*Electricity*.

In Large 8vo. Handsome Cloth. Profusely Illustrated. 12s. 6d. net.

ELECTRICITY CONTROL.

A Treatise on Electric Switchgear and Systems of Electric Transmission.

By LEONARD ANDREWS,

Associate Member of the Institution of Civil Engineers, Member of the Institution of Electrical Engineers, &c.

General Principles of Switchgear Design.—Constructional Details.—Circuit Breakers or Arc Interrupting Devices.—Automatically Operated Circuit-Breakers.—Alternating Reverse Current Devices.—Arrangement of 'Bus Bars, and Apparatus for Parallel Running.—General Arrangement of Controlling Apparatus for High Tension Systems.—General Arrangement of Controlling Apparatus for Low Tension Systems.—Examples of Complete Installations.—Long Distance Transmission Schemes.

"Not often does the specialist have presented to him so satisfactory a book as this. . . . We recommend it without hesitation to Central Station Engineers, and, in fact, to anyone interested in the subject."—*Power*.

EIGHTEENTH EDITION. Leather, Pocket Size. 8s. 6d.

A POCKET-BOOK

OF

ELECTRICAL RULES & TABLES

FOR THE USE OF ELECTRICIANS AND ENGINEERS.

By JOHN MUNRO, C.E., & PROF. JAMIESON, M. INST. C.E., F. R. S. E.

GENERAL CONTENTS.

Units of Measurement.—Measures.—Testing.—Conductors.—Dielectrics.—Submarine Cables.—Telegraphy.—Electro-Chemistry.—Electro-Metallurgy.—Batteries.—Dynamos and Motors.—Transformers.—Electric Lighting.—Miscellaneous.—Logarithms.—Appendices.

"WONDERFULLY PERFECT. . . . Worthy of the highest commendation we can give it."—*Electrician*.

LONDON: CHARLES GRIFFIN & CO., LIMITED, EXETER STREET, STRAND.

In Large 8vo. Profusely Illustrated. 8s. 6d. net.

WIRELESS TELEGRAPHY.

By GUSTAVE EICHHORN, PH.D.

CONTENTS.—Oscillations.—Closed Oscillation Systems.—Open Oscillation Systems.—Coupled Systems.—The Coupling Compensating the Aerial Wire.—The Receiver.—Comparative Measurement in the Sender.—Theoretical Results and Calculations in respect of Sender and Receiver.—Closely-Coupled Sender and Receiver.—Loose-Coupled Sender and Receiver.—Principal Formulæ.—The Ondameter.—Working a Wireless Telegraph Station.—Modern Apparatus and Methods of Working.—Conclusion.—Bibliography.—INDEX.

"Well written . . . and combines with a good deal of description a careful investigation of the fundamental theoretical phenomena."—*Nature*.

Large 8vo, Handsome Cloth, with 334 Pages and 307 Illustrations.
16s. net.

ELECTRICITY METERS.

By HENRY G. SOLOMON, A.M.Inst.E.E.

CONTENTS.—Introductory.—General Principles of Continuous-Current Meters.—Continuous-Current Quantity Meters.—Continuous-Energy Motor Meters.—Different Types.—Special Purposes, *i.e.*, Battery Meters, Switchboard Meters, Tramcar Meters.—General Principles of Single- and Polyphase Induction Meters.—Single-phase Induction Meters.—Polyphase Meters.—Tariff Systems.—Prepayment Meters.—Tariff and Hour Meters.—Some Mechanical Features in Meter Design.—Testing Meters.—INDEX.

"An earnest and successful attempt to deal comprehensively with modern methods of measuring current or power in electrical installations."—*Engineering*.

"Trustworthy information. . . . We can confidently recommend the book to every electrical engineer."—*Electricity*.

SECOND EDITION, Cloth, 8s. 6d. Leather, for the Pocket, 8s. 6d.

GRIFFIN'S ELECTRICAL PRICE-BOOK: For Electrical, Civil, Marine, and Borough Engineers, Local Authorities, Architects, Railway Contractors, &c., &c. Edited by H. J. DOWSING.

"The ELECTRICAL PRICE-BOOK REMOVES ALL MYSTERY about the cost of Electrical Power. By its aid the EXPENSE that will be entailed by utilising electricity on a large or small scale can be discovered."—*Architect*.

ELECTRIC SMELTING AND REFINING. By Dr. W. BORCHERS and W. G. McMILLAN. SECOND EDITION, Revised and Enlarged. 21s. net. [See page 67.]

ELECTRO - METALLURGY, A Treatise on. By WALTER G. McMILLAN, F.I.C., F.C.S. SECOND EDITION, Revised and in Part Re-Written. 10s. 6d. [See page 67.]

ELECTRICAL PRACTICE IN COLLIERIES. By D. BURNS, M.E., M.Inst.M.E. SECOND EDITION, Revised and greatly Enlarged. 7s. 6d. net. [See page 58.]

LONDON: CHARLES GRIFFIN & CO., LIMITED, EXETER STREET, STRAND.

By PROFESSORS J. H. POYNTING & J. J. THOMSON.

In Five Volumes. Large 8vo. Sold Separately.

A TEXT-BOOK OF PHYSICS.

BY

J. H. POYNTING,

Sc.D., F.R.S.,

Late Fellow of Trinity College, Cambridge;
Professor of Physics, Birmingham
University.

AND

J. J. THOMSON,

M.A., F.R.S.,

Fellow of Trinity College, Cambridge; Prof.
of Experimental Physics in the University
of Cambridge.

INTRODUCTORY VOLUME. THIRD EDITION, Revised. Fully Illustrated.
10s. 6d.

PROPERTIES OF MATTER.

CONTENTS.—Gravitation.—The Acceleration of Gravity.—Elasticity.—Stresses and Strains.—Torsion.—Bending of Rods.—Spiral Springs.—Collision.—Compressibility of Liquids.—Pressures and Volumes of Gases.—Thermal Effects Accompanying Strain.—Capillarity.—Surface Tension.—Laplace's Theory of Capillarity.—Diffusion of Liquids.—Diffusion of Gases.—Viscosity of Liquids.—INDEX.

"Students of physics cannot fail to derive benefit from the book."—*Knowledge*.

"We regard this book as quite indispensable not merely to teachers but to physicists of every grade above the lowest."—*University Correspondent*.

VOLUME II. FOURTH EDITION. Fully Illustrated. Price 8s. 6d

SOUND.

CONTENTS.—The Nature of Sound and its chief Characteristics.—The Velocity of Sound in Air and other Media.—Reflection and Refraction of Sound.—Frequency and Pitch of Notes.—Resonance and Forced Oscillations.—Analysis of Vibrations.—The Transverse Vibrations of Stretched Strings or Wires.—Pipes and other Air Cavities.—Rods.—Plates.—Membranes.—Vibrations maintained by Heat.—Sensitive Flames and Jets.—Musical Band.—The Superposition of Waves.—INDEX.

"The work . . . may be recommended to anyone desirous of possessing an **UP-TO-DATE STANDARD TREATISE ON ACOUSTICS**."—*Literature*.

"Very clearly written. . . . The names of the authors are a guarantee of the **SCIENTIFIC ACCURACY AND UP-TO DATE CHARACTER** of the work."—*Educational Times*.

VOLUME III. SECOND EDITION, Revised. Fully Illustrated. Price 15s.

HEAT.

CONTENTS.—Temperature.—Expansion of Solids.—Liquids.—Gases.—Circulation and Convection.—Quantity of Heat; Specific Heat.—Conductivity.—Forms of Energy; Conservation; Mechanical Equivalent of Heat.—The Kinetic Theory.—Change of State; Liquid Vapour.—Critical Points.—Solids and Liquids.—Atmospheric Conditions.—Radiation.—Theory of Exchanges.—Radiation and Temperature.—Thermodynamics.—Isothermal and Adiabatic Changes.—Thermodynamics of Changes of State, and Solutions.—Thermodynamics of Radiation.—INDEX.

"Well up-to-date, and extremely clear and exact throughout. . . . As clear as it would be possible to make such a text-book."—*Nature*.

Remaining Volumes in Preparation—

LIGHT; MAGNETISM AND ELECTRICITY.

THE MEAN DENSITY OF THE EARTH: An Essay to which the Adams Prize was adjudged in 1893 in the University of Cambridge. By J. H. POYNTING, Sc.D., F.R.S., Late Fellow of Trinity College, Cambridge; Professor of Physics, Birmingham University. In Large 8vo, with Bibliography, Illustrations in the Text, and Seven Lithographed Plates. 12s. 6d.

"Cannot fail to be of **GREAT AND GENERAL INTEREST**."—*Athenæum*.

LONDON: CHARLES GRIFFIN & CO., LIMITED, EXETER STREET, STRAND.

Griffin's Geological, Prospecting, Mining, and Metallurgica Publications.

	PAGE
Geology, Stratigraphical,	R. ETHERIDGE, F.R.S., 52
„ Physical,	PROF. H. G. SEELEY, 52
„ Practical Aids,	PROF. GRENVILLE COLE, 53
„ Open Air Studies,	„ 85
Mining Geology,	JAMES PARK, F.G.S., 55
Prospecting for Minerals,	S. HERBERT COX, A.R.S.M., 55
Food Supply,	ROBT. BRUCE, 54
New Lands,	H. R. MILL, D.Sc., F.R.S.E., 54
Ore and Stone Mining,	SIR O. LE NEVE FOSTER, 56
Elements of Mining,	„ 56
Coal Mining,	H. W. HUGHES, F.G.S., 56
Practical Coal Mining,	G. L. KERR, M.Inst.M.E., 58
Elementary „	„ 58
Electrical Coal Mining,	D. BURNS, 58
Mine-Surveying,	BENNETT H. BROUGH, A.R.S.M., 57
Mine Air, Investigation of,	FOSTER AND HALDANE, 57
Mining Law,	C. J. ALFORD, 57
Blasting and Explosives,	O. GUTTMANN, A.M.I.C.E., 58
Testing Explosives,	BICHEL AND LARSEN, 58
Mine Accounts,	PROF. J. G. LAWN, 57
Mining Engineers' Pkt.-Bk.,	E. R. FIELD, M.Inst.M.M., 57
Petroleum,	SIR BOVERTON REDWOOD, 61
A Handbook on Petroleum,	THOMSON AND REDWOOD, 61
Oil Fuel,	SIDNEY H. NORTH, 29
Metallurgical Analysis,	MACLEOD AND WALKER, 60
Microscopic Analysis,	F. OSMOND & J. E. STEAD, F.R.S., 60
Metallurgy (General),	PHILLIPS AND BAUERMAN, 60
„ (Elementary),	PROF. HUMBOLDT SEXTON, 66
Getting Gold,	J. C. F. JOHNSON, F.G.S., 59
Gold Seeking in South Africa,	THEO KASSNER, 59
Cyanide Process,	JAMES PARK, F.G.S., 59
Cyaniding,	JULIAN AND SMART, 59
Electric Smelting,	BORCHERS AND M ^c MILLAN, 67
Electro-Metallurgy,	W. G. M ^c MILLAN, F.I.C., 67
Assaying,	J. J. & C. BERINGER, 66
Metallurgical Analysis,	J. J. MORGAN, F.C.S., 66
Metallurgy (Introduction to),	SIR W. ROBERTS-AUSTEN, K.O.B., 63
Gold, Metallurgy of,	DR. KIRKE ROSE, A.R.S.M., 63
Lead and Silver, „	H. F. COLLINS, A.R.S.M., 64
Iron, Metallurgy of,	THOS. TURNER, A.R.S.M., 65
Steel, „	F. W. HARBORD, 65
Iron-Founding,	PROF. TURNER, 68
Precious Stones,	DR. MAX BAUER, 68

LONDON: CHARLES GRIFFIN & CO., LIMITED, EXETER STREET, STRAND.

Demy 8vo, Handsome cloth, 18s.

Physical Geology and Palæontology, ON THE BASIS OF PHILLIPS.

BY

HARRY GOVIER SEELEY, F.R.S.,
PROFESSOR OF GEOGRAPHY IN KING'S COLLEGE, LONDON.

With Frontispiece in Chromo-Lithography, and Illustrations.

"It is impossible to praise too highly the research which PROFESSOR SEELEY'S 'PHYSICAL GEOLOGY' evidences. IT IS FAR MORE THAN A TEXT-BOOK—it is a DIRECTORY to the Student in prosecuting his researches."—*Presidential Address to the Geological Society, 1885, by Rev. Prof. Bonney, D.Sc., LL.D., F.R.S.*

"PROFESSOR SEELEY maintains in his 'PHYSICAL GEOLOGY' the high reputation he already deservedly bears as a Teacher."—*Dr. Henry Woodward, F.R.S., in the "Geological Magazine."*

"PROFESSOR SEELEY'S work includes one of the most satisfactory Treatises on Lithology in the English language."—*American Journal of Engineering.*

Demy 8vo, Handsome cloth, 34s.

Stratigraphical Geology & Palæontology, ON THE BASIS OF PHILLIPS.

BY

ROBERT ETHERIDGE, F.R.S.,
OF THE NATURAL HIST. DEPARTMENT, BRITISH MUSEUM, LATE PALÆONTOLOGIST TO THE
GEOLOGICAL SURVEY OF GREAT BRITAIN, PAST PRESIDENT OF THE
GEOLOGICAL SOCIETY, ETC.

With Map, Numerous Tables, and Thirty-six Plates.

"No such compendium of geological knowledge has ever been brought together before."—*Westminster Review.*

"If PROF. SEELEY'S volume was remarkable for its originality and the breadth of its views, MR. ETHERIDGE fully justifies the assertion made in his preface that his book differs in construction and detail from any known manual. . . . Must take HIGH RANK AMONG WORKS OF REFERENCE."—*Athenæum.*

OPEN-AIR STUDIES IN GEOLOGY:

An Introduction to Geology Out-of-doors.

By PROFESSOR GRENVILLE COLE, M.R.I.A., F.G.S.

For details, see Griffin's Introductory Science Series, p. 85.

LONDON: CHARLES GRIFFIN & CO., LIMITED, EXETER STREET, STRAND.

Crown 8vo. Handsome Cloth. 2s. 6d.

**RESEARCHES ON THE PAST AND PRESENT HISTORY
OF
THE EARTH'S ATMOSPHERE.**

Including the latest Discoveries and their Practical Applications.

BY DR. THOMAS LAMB PHIPSON.

PART I.—THE EARTH'S ATMOSPHERE IN REMOTE GEOLOGICAL PERIODS.

PART II.—THE ATMOSPHERE OF OUR PRESENT PERIOD.

APPENDICES ; INDEX.

* * Dr. Phipson's work presents, amidst much which is of interest to the Scientist and the General Reader alike, a short *résumé* of his discovery of the origin of Atmospheric Oxygen, the existence of which he attributes wholly to the action of Solar Radiation upon vegetable life. The book will be found replete with much that is new, curious, and interesting, both in connection with Weather Lore, and with Scientific Meteorology.—*Publisher's Note.*

"The book should prove of interest to general readers, as well as to meteorologists and other students of science."—*Nature.*

By **GRENVILLE A. J. COLE, M.R.I.A., F.G.S.,**

Professor of Geology in the Royal College of Science for Ireland, and Examiner in the University of London.

See also the two following pages (54, 55), and page 85.

**AIDS IN
PRACTICAL GEOLOGY:**

WITH A SECTION ON PALÆONTOLOGY.

BY PROFESSOR GRENVILLE COLE, M.R.I.A., F.G.S.

FIFTH EDITION, Thoroughly Revised. With Frontispiece and Illustrations. Cloth. 10s. 6d.

GENERAL CONTENTS.—

PART I.—SAMPLING OF THE EARTH'S CRUST.

PART II.—EXAMINATION OF MINERALS.

PART III.—EXAMINATION OF ROCKS.

PART IV.—EXAMINATION OF FOSSILS.

"Prof. Cole treats of the examination of minerals and rocks in a way that has never been attempted before . . . DESERVING OF THE HIGHEST PRAISE. Here indeed are 'Aids' INNUMERABLE and INVALUABLE. All the directions are given with the utmost clearness and precision."—*Athenæum.*

"That the work deserves its title, that it is full of 'AIDS,' and in the highest degree 'PRACTICAL,' will be the verdict of all who use it."—*Nature.*

"This EXCELLENT MANUAL . . . will be a VERY GREAT HELP. . . . The section on the Examination of Fossils is probably the BEST of its kind yet published. . . . FULL of well-digested information from the newest sources and from personal research."—*Annals of Nat. History.*

LONDON: CHARLES GRIFFIN & CO., LIMITED, EXETER STREET, STRAND

GRIFFIN'S "NEW LAND" SERIES.

*Practical Hand-Books for the Use of Prospectors, Explorers,
Settlers, Colonists, and all Interested in the opening
up and Development of New Lands.*

EDITED BY GRENVILLE A. J. COLE, M.R.I.A., F.G.S.,
Professor of Geology in the Royal College of Science for Ireland, and Examiner in
the University of London.

In Crown 8vo. Handsome Cloth. 5s.

With Numerous Maps Specially Drawn and Executed for this Work.

NEW LANDS:

THEIR RESOURCES AND PROSPECTIVE ADVANTAGES.

BY HUGH ROBERT MILL, D.Sc., LL.D., F.R.S.E.,

INTRODUCTORY.—The Development of New Lands.—The Dominion of
Canada.—Canada, Eastern Provinces.—Canada, Western Provinces and
Territories.—Newfoundland.—The United States.—Latin America, Mexico.—
Latin America, Temperate Brazil and Chili.—Latin America, Argentina.—
The Falkland Islands.—Victoria.—New South Wales.—Queensland.—South
Australia.—Tasmania.—Western Australia.—New Zealand.—The Resources
of South Africa.—Southern Rhodesia.—INDEX.

"PAINSTAKING . . . COMPLETE . . . of great PRACTICAL ASSISTANCE."—*The Field.*

"A want admirably supplied. . . . Has the advantage of being written by a pro-
fessed Geographer."—*Geographical Journal.*

With many Engravings and Photographs. Handsome Cloth, 4s. 6d.

FOOD SUPPLY.

BY ROBERT BRUCE,

Agricultural Superintendent to the Royal Dublin Society.

With Appendix on Preserved Foods by C. A. MITCHELL, B.A., F.L.C.

GENERAL CONTENTS.—Climate and Soil—Drainage and Rotation of
Crops—Seeds and Crops—Vegetables and Fruits—Cattle and Cattle-
Breeding—Sheep and Sheep Rearing—Pigs—Poultry—Horses—The Dairy
—The Farmer's Implements—The Settler's Home.

"BRISTLES WITH INFORMATION."—*Farmers' Gazette.*

"The work is one which will appeal to those intending to become farmers at home
or in the Colonies, and who desire to obtain a general idea of the true principles of
farming in ALL ITS BRANCHES."—*Journal of the Royal Colonial Inst.*

"A most READABLE and VALUABLE book, and merits an EXTENSIVE SALE."—*Scottish
Farmer.*

"Will prove of service in ANY PART OF THE WORLD."—*Nature.*

LONDON: CHARLES GRIFFIN & CO., LIMITED, EXETER STREET, STRAND.

GRIFFIN'S "NEW LAND" SERIES.

FOURTH EDITION, Revised. With Illustrations. Handsome Cloth, 6s.

PROSPECTING FOR MINERALS.*A Practical Handbook for Prospectors, Explorers, Settlers, and all interested in the Opening up and Development of New Lands.*By S. HERBERT COX, Assoc.R.S.M., M.Inst.M.M., F.G.S.,
Professor of Mining at the Royal School of Mines.

GENERAL CONTENTS.—Introduction and Hints on Geology—The Determination of Minerals: Use of the Blow-pipe, &c.—Rock-forming Minerals and Non-Metallic Minerals of Commercial Value: Rock Salt, Borax, Marbles, Lithographic Stone, Quartz and Opal, &c., &c.—Precious Stones and Gems—Stratified Deposits: Coal and Ores—Mineral Veins and Lodes—Irregular Deposits—Dynamics of Lodes: Faults, &c.—Alluvial Deposits—Noble Metals: Gold, Platinum, Silver, &c.—Lead—Mercury—Copper—Tin—Zinc—Iron—Nickel, &c.—Sulphur, Antimony, Arsenic, &c.—Combustible Minerals—Petroleum—General Hints on Prospecting—Glossary—Index.

"This ADMIRABLE LITTLE WORK . . . written with SCIENTIFIC ACCURACY in a CLEAR and LUCID style. . . . An IMPORTANT ADDITION to technical literature . . . —*Mining Journal*.

IN PREPARATION.

BUILDING CONSTRUCTION IN WOOD, STONE, AND CONCRETE. By JAMES LYON, M.A., Professor of Engineering in the Royal College of Science for Ireland; sometime Superintendent of the Engineering Department in the University of Cambridge; and J. TAYLOR, A.R.C.S.I.

** Other Volumes, dealing with subjects of PRIMARY IMPORTANCE in the EXAMINATION and UTILISATION of Lands which have not as yet been fully developed, are in preparation.

Crown 8vo. Handsome Cloth. Illustrated. 6s.

MINING GEOLOGY.**A TEXT-BOOK FOR MINING STUDENTS AND MINERS.**

By PROF. JAMES PARK, F.G.S., M.Inst.M.M.,

Professor of Mining and Director of the Otago University School of Mines; late Director Thames School of Mines, and Geological Surveyor and Mining Geologist to the Government of New Zealand.

GENERAL CONTENTS.—Introduction.—Classification of Mineral Deposits.—Ore Veins, their Filling, Age, and Structure.—The Dynamics of Lodes and Beds.—Ore Deposits Genetically Considered—Ores and Minerals Considered Economically.—Mine Sampling and Ore Valuation.—The Examination and Valuation of Mines.—INDEX.

"A work which should find a place in the library of every mining engineer."—*Mining World*.

LONDON: CHARLES GRIFFIN & CO., LIMITED, EXETER STREET, STRAND

SIXTH EDITION. With Frontispiece and 716 Illustrations. Price 34s.

ORE & STONE MINING.

By SIR C. LE NEVE FOSTER, D.Sc., F.R.S.,
LATE PROFESSOR OF MINING, ROYAL COLLEGE OF SCIENCE.

REVISED, AND BROUGHT UP-TO-DATE

By BENNETT H. BROUGH, F.G.S., Assoc.R.S.M.

GENERAL CONTENTS.

INTRODUCTION. Mode of Occurrence of Minerals.—Prospecting.—Boring.—Breaking Ground.—Supporting Excavations.—Exploitation.—Haulage or Transport.—Hoisting or Winding.—Drainage.—Ventilation.—Lighting.—Descent and Ascent.—Dressing—Principles of Employment of Mining Labour.—Legislation affecting Mines and Quarries.—Condition of the Miner.—Accidents.—Index.

"We have seldom had the pleasure to review a work so thorough and complete as the present one. Both in manner and in matter it is FAR SUPERIOR TO ANYTHING ON ITS SPECIAL SUBJECT HITHERTO PUBLISHED IN ENGLAND."—*Athenæum*.

"Not only is this work the acknowledged text-book on metal mining in Great Britain and the Colonies, but that it is so regarded in the United States of America is evidenced by the fact that it is the book on that subject recommended to the students in most of the mining schools of that country."—*The Times*.

In Crown 8vo. Handsome Cloth. With nearly 300 Illustrations, many of them being full page reproductions of views of great interest. Price 7s. 6d. net.

THE ELEMENTS OF MINING AND QUARRYING.

An Introductory Text-Book for Mining Students.

By SIR C. LE NEVE FOSTER, D.Sc., F.R.S.,

Professor of Mining at the Royal College of Science, London, with which is incorporated the Royal School of Mines; lately one of H.M. Inspectors of Mines.

GENERAL CONTENTS.—INTRODUCTION.—Occurrence of Minerals.—Prospecting.—Boring.—Breaking Ground.—Supporting Excavations.—Exploitation.—Haulage or Transport.—Hoisting or Winding.—Drainage.—Ventilation.—Lighting.—Descent and Ascent.—Dressing, &c.—INDEX.

"A remarkably clear survey of the whole field of mining operations."—*Engineer*.

"Rarely does it fall to the lot of a reviewer to have to accord such unqualified praise as this book deserves. . . . The profession generally have every reason to be grateful to Sir C. Le Neve Foster for having enriched educational literature with so admirable an elementary Text-book."—*Mining Journal*.

FIFTH EDITION, *Revised and Greatly Enlarged.* With 4 Plates and 670 Illustrations. Price 24s. net.

A TEXT-BOOK OF COAL-MINING:

*FOR THE USE OF COLLIERY MANAGERS AND OTHERS
ENGAGED IN COAL-MINING.*

By HERBERT WILLIAM HUGHES, F.G.S.,

Assoc. Royal School of Mines, General Manager of Sandwell Park Colliery.

GENERAL CONTENTS.

Geology.—Search for Coal.—Breaking Ground.—Sinking.—Preliminary Operations.—Methods of Working.—Haulage.—Winding.—Pumping.—Ventilation.—Lighting.—Works at Surface.—Preparation of Coal for Market.—INDEX.

"Quite THE BEST BOOK of its kind . . . as PRACTICAL in aim as a book can be . The illustrations are EXCELLENT."—*Athenæum*.

"We cordially recommend the work."—*Colliery Guardian*.

"Will soon come to be regarded as the STANDARD WORK of its kind."—*Birmingham Daily Gazette*.

LONDON: CHARLES GRIFFIN & CO., LIMITED, EXETER STREET, STRAND.

TWELFTH EDITION, Revised. With Numerous Diagrams.
Cloth, 7s. 6d.

A TREATISE ON MINE-SURVEYING:

*For the use of Managers of Mines and Collieries, Students
at the Royal School of Mines, &c.*

BY BENNETT H. BROUGH, F.G.S., ASSOC.R.S.M.,
Formerly Instructor of Mine-Surveying, Royal School of Mines.

"ITS CLEARNESS OF STYLE, LUCIDITY OF DESCRIPTION, and FULNESS OF DETAIL have long ago won for it a place unique in the literature of this branch of mining engineering, and the present edition fully maintains the high standard of its predecessors. To the student, and to the mining engineer alike, ITS VALUE is inestimable. The illustrations are excellent."—*The Mining Journal*.

In Large Crown 8vo. Fully Illustrated. 6s. net.

THE INVESTIGATION OF MINE AIR:

*An Account by Several Authors of the Nature, Significance, and Practical
Methods of Measurement of the Impurities met with in the
Air of Collieries and Metalliferous Mines.*

EDITED BY

SIR CLEMENT LE NEVE FOSTER, D.Sc., F.R.S.,
AND J. S. HALDANE, M.D., F.R.S.

"We know of nothing essential that has been omitted. The book is liberally supplied with illustrations of apparatus."—*Colliery Guardian*.

In Crown 8vo, Handsome Cloth. 8s. 6d. net.

MINING LAW OF THE BRITISH EMPIRE.

BY CHARLES J. ALFORD, F.G.S., M.Inst.M.M.

CONTENTS.—The Principles of Mining Law.—The Mining Law of Great Britain.—British India.—Ceylon.—Burma.—The Malay Peninsula.—British North Borneo.—Egypt.—Cyprus.—The Dominion of Canada.—British Guiana.—The Gold Coast Colony and Ashanti.—Cape of Good Hope.—Natal.—Orange River Colony.—Transvaal Colony.—Rhodesia.—The Commonwealth of Australia.—New Zealand, &c.—INDEX.

"Should be specially useful to all those engaged in the direction of mining enterprises."—*Financial Times*.

"Cannot fail to be useful . . . we cordially recommend the book."—*Mining World*

In Large 8vo. FOURTH EDITION. Price 10s. 6d.

Mine Accounts and Mining Book-Keeping.

For Students, Managers, Secretaries, and others.

With Examples taken from Actual Practice of Leading Companies.

BY JAMES GUNSON LAWN, A.R.S.M., A.M.Inst.C.E., F.G.S.,
Professor of Mining at the South African School of Mines.

EDITED BY SIR C. LE NEVE FOSTER, D.Sc., F.R.S.

"It seems IMPOSSIBLE to suggest how Mr. LAWN's book could be made more COMPLETE or more VALUABLE, careful, and exhaustive."—*Accountants' Magazine*.

THE MINING ENGINEERS' REPORT BOOK AND DIRECTORS'

AND SHAREHOLDERS' GUIDE TO MINING REPORTS. By
EDWIN R. FIELD, M.Inst.M.M. With Notes on the Valuation of
Mining Property and Tabulating Reports, Useful Tables, &c., and
provided with detachable blank pages for MS. Notes. Pocket Size,
Strongly Bound in Leather. 3s. 6d.

"An ADMIRABLY compiled book which Mining Engineers and Managers will find
EXTREMELY USEFUL."—*Mining Journal*.

LONDON: CHARLES GRIFFIN & CO., LIMITED, EXETER STREET, STRAND.

SECOND EDITION. *In Crown 8vo. Handsome Cloth. With 30 New Illustrations. 7s. 6d net.*

ELECTRICAL PRACTICE IN COLLIERIES.

By D. BURNS, M.E., M.INST.M.E.,

Certificated Colliery Manager, and Lecturer on Mining and Geology to the Glasgow and West of Scotland Technical College.

Units of Measurement, Conductors, &c.—The Theory of the Dynamo.—The Dynamo, Details of Construction and Working.—Motors.—Lighting Installations in Collieries.—Pumping by Electricity.—Electrical Haulage.—Coal Cutting.—Miscellaneous Applications of Electricity in Mines.—Coal Mines Regulation Act (Electricity).—INDEX.

"A clear and concise introduction to electrical practice in collieries."—*Mining Journal*.

FOURTH EDITION, Thoroughly Revised and Greatly Enlarged. Re-set throughout. Large Crown 8vo. Handsome Cloth. 12s. 6d.

PRACTICAL COAL-MINING:

A MANUAL FOR MANAGERS, UNDER-MANAGERS, COLLIERY ENGINEERS, AND OTHERS.

With Worked-out Problems on Haulage, Pumping, Ventilation, &c.

By GEORGE L. KERR, M.E., M.INST.M.E.

"AN ESSENTIALLY PRACTICAL WORK, and can be confidently recommended. No department of Coal-Mining has been overlooked."—*Engineers' Gazette*.

ELEMENTARY COAL-MINING: For the Use of Students, Miners, and others preparing for Examinations. By GEORGE L. KERR, M.E., M.INST.M.E., Author of "Practical Coal-Mining." In Crown 8vo. Handsome Cloth. With 200 Illustrations. 3s. 6d.

"An abundance of information conveyed in a popular and attractive form. . . Will be of great use to all who are in any way interested in coal mining."—*Scottish Critic*.

BLASTING: and the Use of Explosives. A Handbook for Engineers and others Engaged in Mining, Tunnelling, Quarrying, &c. By OSCAR GUTTMANN, M.Inst.C.E., Mem. Soc. of Civil Engs. and Architects of Vienna and Budapest, Cor. Mem. Imp. Roy. Geol. Inst. of Austria, &c. SECOND EDITION, Revised. In Large 8vo, with Illustrations and Folding-Plates. 10s. 6d.

"Should prove a *vade-mecum* to Mining Engineers and all engaged in practical work."—*Iron and Coal Trades Review*.

TESTING EXPLOSIVES. By C. E. BICHEL and AXEL LARSEN. CONTENTS.—Historical—Testing Stations—Power Gauges—Products of Combustion—Heat of Decomposition—Rate of Detonation—Rate and Duration of Flame—After Flame Rates—Transmission of Explosion—Efficiency, &c. In Medium 8vo. Fully Illustrated. 6s. net.

"Its pages bristle with suggestions and actual experimental results to an extent seldom found in a volume of five times its size."—*Arms and Explosives*

SHAFT SINKING IN DIFFICULT CASES. By J. REIMER. Translated from the German by J. W. BROUGH, A.M.Inst.C.E. With 18 Figures in the Text, and 19 Plates. Large 8vo. AT PRESS.

LONDON: CHARLES GRIFFIN & CO., LIMITED, EXETER STREET, STRAND.

In Medium 8vo. With Numerous Plates, Maps, and Illustrations.
21s. net.

CYANIDING GOLD & SILVER ORES.

A Practical Treatise on the Cyanide Process; its Application,
Methods of Working, Design and Construction of
Plant, and Costs.

By H. FORBES JULIAN,

Mining and Metallurgical Engineer; Specialist in Gold; Late Technical Adviser of the
Deutsche Gold und Silber Scheide Anstalt, Frankfort-on-Maine.

AND EDGAR SMART, A.M.I.C.E.,

Civil and Metallurgical Engineer.

"A handsome volume of 400 pages which will be a valuable book of reference for all
associated with the process."—*Mining Journal*.

"The authors are to be congratulated upon the production of what should prove to be
a standard work."—*Page's Magazine*.

In Large Crown 8vo. With 13 Plates and many Illustrations in the Text.
Handsome Cloth. 7s. 6d.

THE CYANIDE PROCESS OF GOLD EXTRACTION.

A Text-Book for the Use of Metallurgists and Students at
Schools of Mines, &c.

By JAMES PARK, F.G.S., M.INST.M.M.,

Professor of Mining and Director of the Otago University School of Mines; late Director
Thames School of Mines, and Geological Surveyor and Mining Geologist
to the Government of New Zealand.

FOURTH ENGLISH EDITION. Thoroughly Revised and Greatly Enlarged.
With additional details concerning the Siemens-Halske and other
recent processes.

"Deserves to be ranked as amongst the BEST OF EXISTING TREATISES."—*Mining Journal*.

THIRD EDITION, Revised. *With Plates and Illustrations. Cloth, 3s. 6d.*

GETTING GOLD:

A GOLD-MINING HANDBOOK FOR PRACTICAL MEN.

By J. O. F. JOHNSON, F.G.S., A.I.M.E.,

Life Member Australasian Mine-Managers' Association.

GENERAL CONTENTS.—Introductory: Prospecting (Alluvial and General)—
Lode or Reef Prospecting—Genesisiology of Gold—Auriferous Lodes—Drifts—
Gold Extraction—Lixiviation—Calcination—Motor Power and its Transmission—
Company Formation—Mining Appliances and Methods—Australasian
Mining Regulations.

"PRACTICAL from beginning to end . . . deals thoroughly with the Prospecting,
Sinking, Crushing, and Extraction of gold."—*Brit. Australasian*.

In Crown 8vo. Illustrated. Fancy Cloth Boards. 4s. 6d.

GOLD SEEKING IN SOUTH AFRICA:

A Handbook of Hints for intending Explorers, Prospectors,
and Settlers.

By THEO KASSNER,

Mine Manager, Author of the Geological Sketch Map of the De Kaap Gold Fields.

With a Chapter on the Agricultural Prospects of South Africa.

As fascinating as anything ever penned by Jules Verne."—*African Commerce*.

LONDON: CHARLES GRIFFIN & CO., LIMITED, EXETER STREET, STRAND.

Large 8vo. Handsome Cloth. With Illustrations.
12s. 6d. net.

METALLURGICAL ANALYSIS & ASSAYING:

A THREE YEARS' COURSE
FOR STUDENTS OF SCHOOLS OF MINES.

By W. A. MACLEOD, B.A., B.Sc., A.O.S.M. (N.Z.),

Formerly Assist.-Director, Thames School of Mines (N.Z.), and Lecturer in Chemistry, University of Tasmania; Director of Queensland Government School of Mines, Charters Towers;

AND CHAS. WALKER, F.C.S.,

Formerly Assist.-Demonstrator in Chemistry, Sydney University; Lecturer in Chemistry and Metallurgy, Charters Towers School of Mines

PART I.—Qualitative Analysis and Preparation and Properties of Gases.
PART II.—Qualitative and Quantitative Analysis. PART III.—Assaying, Technical Analysis (Gas, Water, Fuels, Oils, &c.).

"The publication of this volume tends to prove that the teaching of metallurgical analysis and assaying in Australia rests in competent hands."—*Nature*.

In Crown 8vo, Beautifully Illustrated with nearly 100
Microphotographs of Steel, &c. 7s. 6d. net.

MICROSCOPIC ANALYSIS OF METALS.

By FLORIS OSMOND & J. E. STEAD, F.R.S., F.I.C.

CONTENTS.—Metallography considered as a method of Assay.—Micrographic Analysis of Carbon Steels.—Preparation of Specimens.—Polishing.—Constituents of Steel; Ferrite; Cementite; Pearlite; Sorbite; Martensite; Hardenite; Troostite; Austenite.—Identification of Constituents.—Detailed Examination of Carbon Steels.—Conclusions, Theoretical and Practical.—Apparatus employed.—APPENDIX.

"There has been no work previously published in English calculated to be so useful to the student in metallographic research."—*Iron and Steel Trades' Journal*.

THIRD EDITION. With Folding Plates and Many Illustrations. 36s.

ELEMENTS OF METALLURGY.

A PRACTICAL TREATISE ON THE ART OF EXTRACTING METALS
FROM THEIR ORES.

By J. ARTHUR PHILLIPS, M.INST.O.E., F.C.S., F.G.S., &c.

AND H. BAUERMAN, V.P.G.S.

GENERAL CONTENTS.—Refractory Materials.—Fire-Clays.—Fuels, &c.—Aluminium.—Copper.—Tin.—Antimony.—Arsenic.—Zinc.—Mercury.—Bismuth.—Lead.—Iron.—Cobalt.—Nickel.—Silver.—Gold.—Platinum.

"Of the THIRD EDITION, we are still able to say that, as a Text-book of Metallurgy, it is THE BEST with which we are acquainted."—*Engineer*.

"A work which is equally valuable to the Student as a Text-book, and to the practical Smelter as a Standard Work of Reference. . . . The Illustrations are admirable examples of Wood Engraving."—*Chemical News*.

LONDON: CHARLES GRIFFIN & CO., LIMITED, EXETER STREET, STRAND

SECOND EDITION, Revised, Enlarged, and Re-set Throughout on Larger Page.
With Valuable Bibliography, New Maps, Illustrations, etc. 45s. net.

IN TWO VOLUMES.
A TREATISE ON
PETROLEUM.

By SIR BOVERTON REDWOOD,

D.Sc., F.B.S.E., Assoc. Inst. C.E., F.I.C.,

Hon. Mem. Am. Phil. Soc.; Hon. Mem. Imp. Russ. Tech. Soc.; Adviser on Petroleum to the Admiralty and Home Office; Consulting Adviser to the Corporation of London under the Petroleum Acts; Adviser on Petroleum Transport to the Thames Conservancy.

CONTENTS.—SECTION I.: Historical Account of the Petroleum Industry.—SECTION II.: Geological and Geographical Distribution of Petroleum and Natural Gas.—SECTION III.: The Chemical and Physical Properties of Petroleum and Natural Gas.—SECTION IV.: The Origin of Petroleum and Natural Gas.—SECTION V.: The Production of Petroleum, Natural Gas, and Ozokerite.—SECTION VI.: The Refining of Petroleum.—SECTION VII.: The Shale Oil and Allied Industries.—SECTION VIII.: The Transport, Storage, and Distribution of Petroleum.—SECTION IX.: The Testing of Crude Petroleum, Petroleum and Shale Oil Products, Ozokerite, and Asphalt.—SECTION X.: The Uses of Petroleum and its Products.—SECTION XI.: Statutory, Municipal, and other Regulations relating to the Testing, Storage, Transport, and Use of Petroleum and its Products.—APPENDICES.—BIBLIOGRAPHY.—INDEX.

SECOND EDITION, Revised. With Illustrations. Price 8s. 6d. net.

A HANDBOOK ON PETROLEUM.

FOR INSPECTORS UNDER THE PETROLEUM ACTS,

And for those engaged in the Storage, Transport, Distribution, and Industrial Use of Petroleum and its Products, and of Calcium Carbide. With suggestions on the Construction and Use of Mineral Oil Lamps.

By CAPTAIN J. H. THOMSON,

H.M. Chief Inspector of Explosives,

AND SIR BOVERTON REDWOOD,

Author of "A Treatise on Petroleum."

CONTENTS.—I. Introductory.—II. Sources of Supply.—III. Production.—IV. Chemical Products, Shale Oil, and Coal Tar.—V. Flash Point and Fire Test.—VI. Testings.—VII. Existing Legislation relating to Petroleum.—VIII.—IX.—Precautions Necessary.—X. Petroleum Oil Lamps.—XI. Carbide of Calcium and Acetylene.—Appendices.—INDEX.

"A volume that will enrich the world's petroleum literature, and render a service to the British branch of the industry. . . . Reliable, indispensable, a brilliant contribution."—*Petroleum.*

In Crown 8vo. Fully Illustrated. 2s. 6d. net.

THE LABORATORY BOOK OF MINERAL OIL TESTING.

By J. A. HICKS,

Chemist to Sir Boverton Redwood.

CONTENTS.—Specific Gravity.—Flashing Point.—Tests.—Viscosity.—Colour.—Apparatus.—Detection of Petroleum Vapour.—Capillary Test.—Melting Point of Paraffin Scale and Wax.—Oil in Scale.—Estimation of Sulphur, of Water.—Calorific Value.—Tables.—INDEX.

OIL FUEL. By SIDNEY H. NORTH. (See page 29.)

THE PETROLEUM LAMP: Its Choice and Use. A Guide to the Safe Employment of the Paraffin Lamp. By CAPT. J. H. THOMSON and SIR BOVERTON REDWOOD. Illustrated. 1s. net.

"A work which will meet every purpose for which it has been written."—*Petroleum.*

LONDON: CHARLES GRIFFIN & CO., LIMITED, EXETER STREET, STRAND.

Griffin's Metallurgical Series.

STANDARD WORKS OF REFERENCE

FOR

Metallurgists, Mine-Owners, Assayers, Manufacturers,
and all interested in the development of
the Metallurgical Industries.

EDITED BY

Sir W. ROBERTS-AUSTEN, K.C.B., D.C.L., F.R.S.

In Large 8vo, Handsome Cloth. With Illustrations.

INTRODUCTION to the STUDY of METALLURGY.

By the EDITOR. FIFTH EDITION. 18s. (See p. 63.)

GOLD (The Metallurgy of). By THOS. KIRKE ROSE,

D.Sc., Assoc. R.S.M., F.C.S., Chemist and Assayer of the Royal Mint. FIFTH EDITION. 21s. (See p. 63.)

LEAD AND SILVER (The Metallurgy of). By H. F.

COLLINS, Assoc. R.S.M., M.Inst.M.M. Part I., Lead, 16s; Part II., Silver, 16s. (See p. 64.)

IRON (The Metallurgy of). By T. TURNER, A.R.S.M.,

F.I.C., F.C.S. THIRD EDITION, Revised. 16s. (See p. 65.)

STEEL (The Metallurgy of). By F. W. HARBORD,

Assoc. R.S.M., F.I.C., with a Section on Mechanical Treatment by J. W. HALL, A.M.Inst.C.E. SECOND EDITION. 25s. net. (See p. 65.)

Will be Published at Short Intervals.

METALLURGICAL MACHINERY: the Application of

Engineering to Metallurgical Problems. By HENRY CHARLES JENKINS, Wh.Sc., Assoc. R.S.M., Assoc. M.Inst.C.E., of the Royal College of Science. (See p. 64.)

COPPER (The Metallurgy of). By THOS. C. CLOUD, Assoc.

R.S.M.

ALLOYS. By EDWARD T. LAW, Assoc. R.S.M.

* * Other Volumes in Preparation.

LONDON: CHARLES GRIFFIN & CO., LIMITED, EXETER STREET, STRAND.

GRIFFIN'S METALLURGICAL SERIES.

FIFTH EDITION, thoroughly Revised and considerably Enlarged. Large 8vo, with numerous Illustrations and Micro-Photographic Plates of different varieties of Steel. 18s.

An Introduction to the Study of

METALLURGY.

BY

Sir W. ROBERTS-AUSTEN, K.C.B., D.C.L., F.R.S., A.R.S.M.,
Late Chemist and Assayer of the Royal Mint, and Professor of Metallurgy
in the Royal College of Science.

GENERAL CONTENTS.—The Relation of Metallurgy to Chemistry.—Physical Properties of Metals.—Alloys. The Thermal Treatment of Metals.—Fuel and Thermal Measurements.—Materials and Products of Metallurgical Processes.—Furnaces.—Means of Supplying Air to Furnaces.—Thermo-Chemistry.—Typical Metallurgical Processes.—The Micro-Structure of Metals and Alloys.—Economic Considerations.

‘No English text-book at all approaches this in the COMPLETENESS with which the most modern views on the subject are dealt with. Professor Austen's volume will be INVALUABLE, not only to the student, but also to those whose knowledge of the art is far advanced.’—*Chemical News*.

FIFTH EDITION, Revised, Considerably Enlarged, and in part Re-written.
With Frontispiece and numerous Illustrations. 21s.

THE METALLURGY OF GOLD.

BY

T. KIRKE ROSE, D.Sc.Lond., Assoc.R.S.M.,
Chemist and Assayer of the Royal Mint.

GENERAL CONTENTS.—The Properties of Gold and its Alloys.—Chemistry of the Compounds of Gold.—Mode of Occurrence and Distribution of Gold.—Shallow Placer Deposits.—Deep Placer Deposits.—Quartz Crushing in the Stamp Battery.—Amalgamation in the Stamp Battery.—Other Forms of Crushing and Amalgamating Machinery.—Concentration in Gold Mills.—Dry Crushing.—Re-grinding.—Roasting.—Chlorination: The Plattner Process, The Barrel Process, The Vat-Solution Process.—The Cyanide Process.—Chemistry of the Cyanide Process.—Refining and Parting of Gold Bullion.—Assay of Gold Ores.—Assay of Gold Bullion.—Statistics of Gold Production.—Bibliography.—INDEX.

‘A COMPREHENSIVE PRACTICAL TREATISE on this important subject.’—*The Times*.

‘The MOST COMPLETE description of the CHLORINATION PROCESS which has yet been published.’—*Mining Journal*.

‘Adapted for all who are interested in the Gold Mining Industry, being free from technicalities as far as possible, but is more particularly of value to those engaged in the industry.’—*Cape Times*.

LONDON: CHARLES GRIFFIN & CO., LIMITED, EXETER STREET, STRAND.

GRIFFIN'S METALLURGICAL SERIES.

EDITED BY SIR W. ROBERTS-AUSTEN, K.C.B., F.R.S., D.C.L.

In Large 8vo. Handsome Cloth. With Illustrations.

In Two Volumes, Each Complete in Itself and Sold Separately.

THE METALLURGY OF LEAD AND SILVER.

BY H. F. COLLINS, Assoc.R.S.M., M.Inst.M.M.

Part I.—LEAD:

A Complete and Exhaustive Treatise on the Manufacture of Lead, with Sections on Smelting and Desilverisation, and Chapters on the Assay and Analysis of the Materials involved. Price 16s.

SUMMARY OF CONTENTS.—Sampling and Assaying Lead and Silver.—Properties and Compounds of Lead.—Lead Ores.—Lead Smelting.—Reverberatories.—Lead Smelting in Hearths.—The Roasting of Lead Ores.—Blast Furnace Smelting; Principles, Practice, and Examples; Products.—Flue Dust, its Composition, Collection and Treatment.—Costs and Losses, Purchase of Ores.—Treatment of Zinc, Lead Sulphides, Desilverisation, Softening and Refining.—The Pattinson Process.—The Parkes Process.—Cupellation and Refining, &c., &c.

"A THOROUGHLY SOUND and useful digest. May with EVERY CONFIDENCE be recommended."—*Mining Journal*.

Part II.—SILVER.

Comprising Details regarding the Sources and Treatment of Silver Ores, together with Descriptions of Plant, Machinery, and Processes of Manufacture, Refining of Bullion, Cost of Working, &c. Price 16s.

SUMMARY OF CONTENTS.—Properties of Silver and its Principal Compounds.—Silver Ores.—The Patio Process.—The Kazo, Fondon, Kröhnke, and Tina Processes.—The Pan Process.—Roast Amalgamation.—Treatment of Tailings and Concentration.—Retorting, Melting, and Assaying.—Chloridising-Roasting.—The Augustin, Claudet, and Ziervogel Processes.—The Hypo-Sulphite Leaching Process.—Refining.—Matte Smelting.—Pyritic Smelting.—Matte Smelting in Reverberatories.—Silver-Copper Smelting and Refining.—INDEX.

"The author has focussed a LARGE AMOUNT OF VALUABLE INFORMATION into a convenient form. . . . The author has evidently considerable practical experience, and describes the various processes clearly and well."—*Mining Journal*.

*IN PREPARATION.***METALLURGICAL MACHINERY:****The Application of Engineering to Metallurgical Problems.**

BY HENRY CHARLES JENKINS,

Wh.Sc., Assoc. R.S.M., Assoc. M.Inst. C.E.

LONDON: CHARLES GRIFFIN & CO., LIMITED, EXETER STREET, STRAND.

GRIFFIN'S METALLURGICAL SERIES.

SECOND EDITION, Revised. With Numerous Illustrations. Large 8vo.
Handsome Cloth. 25s. net.

With Additional Chapter on The Electric Smelting of Steel.

THE METALLURGY OF STEEL.

By F. W. HARBORD, Assoc.R.S.M., F.I.C.,
Consulting Metallurgist and Analytical Chemist to the Indian Government,
Royal Indian Engineering College, Coopers Hill.

With 37 Plates, 280 Illustrations in the Text, and nearly 100 Micro-
Sections of Steel, and a Section on

THE MECHANICAL TREATMENT OF STEEL.

By J. W. HALL, A.M. INST. C.E.

ABRIDGED CONTENTS.—The Plant, Machinery, Methods and Chemistry of the Bessemer and of the Open Hearth Processes (Acid and Basic).—The Mechanical Treatment of Steel comprising Mill Practice, Plant and Machinery.—The Influence of Metalloids, Heat Treatment, Special Steels, Microstructure, Testing, and Specifications.

"A work which we venture to commend as an invaluable compendium of information upon the metallurgy of steel."—*Iron and Coal Trades' Review*.

The *Engineer* says, at the conclusion of a review of this book:—"We cannot conclude without earnestly recommending all who may be interested as makers or users of steel, which practically means the whole of the engineering profession, to make themselves acquainted with it as speedily as possible, and this may be the more easily done as the published price, considering the size of the book, is extremely moderate."

THIRD EDITION, Revised. SHORTLY.

THE METALLURGY OF IRON.

By THOMAS TURNER, Assoc.R.S.M., F.I.C.,
Professor of Metallurgy in the University of Birmingham.

IN LARGE 8VO, HANDSOME CLOTH, WITH NUMEROUS ILLUSTRATIONS
(MANY FROM PHOTOGRAPHS).

General Contents.—Early History of Iron.—Modern History of Iron.—The Age of Steel.—Chief Iron Ores.—Preparation of Iron Ores.—The Blast Furnace.—The Air used in the Blast Furnace.—Reactions of the Blast Furnace.—The Fuel used in the Blast Furnace.—Slags and Fluxes of Iron Smelting.—Properties of Cast Iron.—Foundry Practice.—Wrought Iron.—Indirect Production of Wrought Iron.—The Puddling Process.—Further Treatment of Wrought Iron.—Corrosion of Iron and Steel.

"A MOST VALUABLE SUMMARY of knowledge relating to every method and stage in the manufacture of cast and wrought iron . . . rich in chemical details. . . . EXHAUSTIVE and THOROUGHLY UP-TO-DATE."—*Bulletin of the American Iron and Steel Association*.

"This is a DELIGHTFUL BOOK, giving, as it does, reliable information on a subject becoming every day more elaborate."—*Colliery Guardian*.

"A THOROUGHLY USEFUL BOOK, which brings the subject UP TO DATE. OF GREAT VALUE to those engaged in the iron industry."—*Mining Journal*.

** For Professor Turner's *Lectures on Iron-Founding*, see page 68.

LONDON: CHARLES GRIFFIN & CO., LIMITED, EXETER STREET, STRAND

A TEXT-BOOK OF ASSAYING:

For the use of Students, Mine Managers, Assayers, &c.

By J. J. BERINGER, F.I.C., F.C.S.,

Public Analyst for, and Lecturer to the Mining Association of, Cornwall.

AND C. BERINGER, F.C.S.,

Late Chief Assayer to the Rio Tinto Copper Company, London,

With numerous Tables and Illustrations. Crown 8vo. Cloth, 10s. 6d.

TENTH EDITION.

GENERAL CONTENTS. — PART I. — INTRODUCTORY; MANIPULATION: Sampling; Drying; Calculation of Results—Laboratory-books and Reports. METHODS: Dry Gravimetric; Wet Gravimetric—Volumetric Assays: Titrometric, Colorimetric, Gasometric—Weighing and Measuring—Reagents—Formulae, Equations, &c.—Specific Gravity.

PART II.—METALS: Detection and Assay of Silver, Gold, Platinum, Mercury, Copper, Lead, Thallium, Bismuth, Antimony, Iron, Nickel, Cobalt, Zinc, Cadmium, Tin, Tungsten, Titanium, Manganese, Chromium, &c.—Earths, Alkalies.

PART III.—NON-METALS: Oxygen and Oxides; The Halogens—Sulphur and Sulphates—Arsenic, Phosphorus, Nitrogen—Silicon, Carbon, Boron—Useful Tables.

"A REALLY MERITORIOUS work, that may be safely depended upon either for systematic instruction or for reference."—*Nature*.

"This work is one of the BEST of its kind."—*Engineer*.

FOURTH EDITION, *Revised. Handsome Cloth. With Numerous Illustrations. 6s.*

A TEXT-BOOK OF ELEMENTARY METALLURGY.

Including the Author's PRACTICAL LABORATORY COURSE.

By A. HUMBOLDT SEXTON, F.I.C., F.C.S.,

Professor of Metallurgy in the Glasgow and West of Scotland Technical College.

GENERAL CONTENTS.—Introduction.—Properties of the Metals.—Combustion.—Fuels.—Refractory Materials.—Furnaces.—Occurrence of the Metals in Nature.—Preparation of the Ore for the Smelter.—Metallurgical Processes.—Iron.—Steel.—Copper.—Lead.—Zinc and Tin.—Silver.—Gold.—Mercury.—Alloys.—Applications of ELECTRICITY to Metallurgy.—LABORATORY COURSE.

"Just the kind of work for Students COMMENCING the study of Metallurgy, or for ENGINEERING Students."—*Practical Engineer*.

"EXCELLENTLY got-up and WELL-ARRANGED."—*Chemical Trade Journal*.

In Large 8vo. Handsome Cloth. Price 4s.

TABLES FOR QUANTITATIVE METALLURGICAL ANALYSIS.

FOR LABORATORY USE.

ON THE PRINCIPLE OF "GROUP" SEPARATIONS.

By J. JAMES MORGAN, F.C.S., M.S.C.I.

"The Author may be CONGRATULATED on the way his work has been carried out."—*The Engineer*.

"Will COMMEND ITSELF highly in Laboratory Practice. Its CLEARNESS and PRECISION mark the book out as a highly useful one."—*Mining Journal*.

LONDON: CHARLES GRIFFIN & CO., LIMITED, EXETER STREET, STRAND.

SECOND EDITION, Revised, Enlarged, and in part Re-written.
With Additional Sections on MODERN THEORIES OF ELECTROLYSIS
COSTS, &c. Price 10s. 6d.

A TREATISE ON ELECTRO-METALLURGY:

Embracing the Application of Electrolysis to the Plating, Depositing,
Smelting, and Refining of various Metals, and to the Repro-
duction of Printing Surfaces and Art-Work, &c.

BY

WALTER G. M^cMILLAN, F.I.C., F.C.S.,

Secretary to the Institution of Electrical Engineers; late Lecturer in Metallurgy
at Mason College, Birmingham.

With numerous Illustrations. Large Crown 8vo. Cloth

"This excellent treatise, . . . one of the BEST and MOST COMPLETE
manuals hitherto published on Electro-Metallurgy."—*Electrical Review*.

"This work will be a STANDARD."—*Jeweller*.

"Any metallurgical process which REDUCES the COST of production
must of necessity prove of great commercial importance. . . . We
recommend this manual to ALL who are interested in the PRACTICAL
APPLICATION of electrolytic processes."—*Nature*.

SECOND EDITION, Thoroughly Revised and Enlarged. In large 8vo.
With Numerous Illustrations and Three Folding-Plates. 21s. net.

ELECTRIC SMELTING & REFINING:

A Practical Manual of the Extraction and Treatment
of Metals by Electrical Methods.

Being the "ELEKTRO-METALLURGIE" of DR. W. BORCHERS.

Translated from the Latest German Edition by WALTER G. M^cMILLAN,
F.I.C., F.C.S.

CONTENTS.

PART I.—ALKALIES AND ALKALINE EARTH METALS: Magnesium,
Lithium, Beryllium, Sodium, Potassium, Calcium, Strontium, Barium,
the Carbides of the Alkaline Earth Metals.

PART II.—THE EARTH METALS: Aluminium, Cerium, Lanthanum,
Didymium.

PART III.—THE HEAVY METALS: Copper, Silver, Gold, Zinc and Cad-
mium, Mercury, Tin, Lead, Bismuth, Antimony, Chromium, Molybdenum,
Tungsten, Uranium, Manganese, Iron, Nickel, and Cobalt, the Platinum
Group.

"COMPREHENSIVE and AUTHORITATIVE . . . not only FULL of VALUABLE INFOR-
MATION, but gives evidence of a THOROUGH INSIGHT into the technical VALUE and
POSSIBILITIES of all the methods discussed."—*The Electrician*.

"DR. BORCHERS' WELL-KNOWN WORK . . . must OF NECESSITY BE ACQUIRED by
every one interested in the subject. EXCELLENTLY put into English with additional
matter by Mr. M^cMILLAN."—*Nature*.

"Will be of GREAT SERVICE to the practical man and the Student."—*Electric Smelting*

LONDON: CHARLES GRIFFIN & CO., LIMITED, EXETER STREET, STRAND.

In Large 4to, Library Style. Beautifully Illustrated with 20 Plates, many in Colours, and 94 Figures in the Text. £2, 2s. net.

PRECIOUS STONES:

Their Properties, Occurrences, and Uses.

A Treatise for Dealers, Manufacturers, Jewellers, and for all Collectors and others interested in Gems.

BY DR. MAX BAUER,

Professor in the University of Marburg,

TRANSLATED BY L. J. SPENCER, M.A. (CANTAB.), F.G.S.

"The plates are remarkable for their beauty, delicacy, and truthfulness. A glance at them alone is a lesson on precious stones, whilst the perusal of the work itself should add a new interest to any casket of jewels or cabinet of gems, or even to a jewellers' window."—*Athenæum*.

In Large Crown 8vo. With Numerous Illustrations. 8s. 6d.

The Art of the Goldsmith and Jeweller

A Manual on the Manipulation of Gold and the Manufacture of Personal Ornaments.

BY THOS. B. WIGLEY,

Headmaster of the Jewellers and Silversmiths' Assoc. Tech. School, Birmingham.

ASSISTED BY J. H. STANSBIE, B.Sc. (LOND.), F.I.C.,

Lecturer at the Birmingham Municipal Technical School.

GENERAL CONTENTS.—Introduction.—The Ancient Goldsmith's Art.—Metallurgy of Gold.—Prices, &c.—Alloys.—Melting, Rolling, and Slitting Gold.—The workshop and Tools.—Wire Drawing.—Rings.—Chains and Insignia.—Antique Jewellery and its Revival.—Etruscan Work.—PRECIOUS STONES.—Cutting.—Polishing and Finishing.—Chasing, Embossing, and Repoussé Work.—Colouring and Finishing.—Enamelling.—Engraving.—Moulding and Casting Ornaments, &c.—Fluxes, &c.—Recovery of the Precious Metals.—Refining and Assaying.—Gilding and Electro Deposition.—Hall-Marking.—Miscellaneous.—Appendix.

Extra Crown 8vo. With 48 Illustrations. " 3s. 6d. net.

LECTURES ON IRON-FOUNDING.

BY THOMAS TURNER, M.Sc., A.R.S.M., F.I.C.,

Professor of Metallurgy in the University of Birmingham!

CONTENTS.—Varieties of Iron and Steel.—Application of Cast Iron.—History.—Production.—Iron Ores.—Composition.—The Blast Furnace.—Materials.—Reactions.—Grading Pig Iron.—Carbon, Silicon, Sulphur, Phosphorus, Manganese, Aluminium, Arsenic, Copper, and Titanium.—The Foundry.—General Arrangement.—Re-melting Cast Iron.—The Cupola.—Fuel Used.—Changes due to Re-melting.—Moulds and Moulding.—Foundry Ladles.—Pouring and Pouring Temperature.—Common Troubles.—Influence of Shape and Size on Strength of Castings.—Tests.

"Ironfounders will find much information in the book."—*Iron Trade Circular (Ryland's)*.

In Medium 8vo. Handsome Cloth. Fully Illustrated.

GENERAL FOUNDRY PRACTICE:

A Practical Handbook for Iron, Steel and Brass Founders, Metallurgists, and Students of Metallurgy.

BY A. C. McWILLIAM, A.R.S.M., AND PERCY LONGMUIR.

LONDON: CHARLES GRIFFIN & CO., LIMITED, EXETER STREET, STRAND.

Griffin's Chemical and Technological Publications.

	PAGE
Inorganic Chemistry, . . .	PROFS. DUPRÉ AND HAKE, 70
Quantitative Analysis, . . .	PROF. HUMBOLDT SEXTON, 70
Qualitative . . .	" " 70
Chemistry for Engineers, . . .	BLOUNT AND BLOXAM, . 46
" " " " Manufacturers, . . .	" " 71
Foods and Poisons, . . .	A. WYNTER BLYTH, . 72
Tables for Chemists, . . .	PROF. CASTELL-EVANS, . 79
Dairy Chemistry, . . .	H. D. RICHMOND, . 73
Dairy Analysis, 73
Milk, . . .	E. F. WILLOUGHBY, . 73
Flesh Foods, . . .	C. A. MITCHELL, . 74
Practical Sanitation, . . .	DR. G. REID, . . . 78
Sanitary Engineering, . . .	F. WOOD, . . . 78
Technical Mycology, . . .	LAFAR AND SALTER, . 74
Ferments, . . .	C. OPPENHEIMER, . 75
Toxines and Antitoxines, 74
Brewing, . . .	DR. " W. J. " SYKES, . 75
Bacteriology of Brewing, . . .	W. A. RILEY, . . . 75
Sewage Disposal, . . .	SANTO CRIMP, . . . 76
Trades' Waste, . . .	W. NAYLOR, . . . 76
Smoke Abatement, . . .	WM. NICHOLSON, . . . 76
Paper Technology, . . .	R. W. SINDALL, . . . 81
Cements, . . .	G. R. REDGRAVE, . . 76
Water Supply, . . .	R. E. MIDDLETON, . . 77
Road Making, . . .	THOS. AITKEN, . . . 79
Gas Manufacture, . . .	W. ATKINSON BUTTERFIELD, 77
Acetylene, . . .	LEEDS AND BUTTERFIELD, 77
Fire Risks, . . .	DR. SCHWARTZ, . . . 77
Petroleum, . . .	SIR BOVERTON REDWOOD, 61
—(Handbook), . . .	THOMSON AND REDWOOD, 61
Ink Manufacture, . . .	MITCHELL AND HEPWORTH, 81
Glue, Gelatine, &c., . . .	THOS. LAMBERT, . . . 81
Oils, Soaps, Candles, . . .	WRIGHT & MITCHELL, 71
Lubrication & Lubricants, . . .	ARCHBUTT AND DEELE, 32
India Rubber, . . .	DR. CARL O. WEBER, . 81
Painters' Colours, Oils, &c., . . .	G. H. HURST, . . . 80
Painters' Laboratory Guide, . . .	" " . . . 80
Painting and Decorating, . . .	W. J. PEARCE, . . . 80
Dyeing, . . .	KNECHT AND RAWSON, . 82
Dictionary of Dyes, . . .	RAWSON AND GARDNER, 82
The Synthetic Dyestuffs, . . .	CAIN AND THORPE, . . 82
Spinning, . . .	H. R. CARTER, . . . 83
Textile Printing, . . .	SEYMOUR ROTHWELL, . 83
Textile Fibres of Commerce, . . .	W. I. HANNAN, . . . 83
Dyeing and Cleaning, . . .	G. H. HURST, . . . 84
Bleaching, Calico-Printing, . . .	GEO. DUERR, . . . 84

LONDON : CHARLES GRIFFIN & CO., LIMITED, EXETER STREET, STRAND.

THIRD EDITION, Revised, Enlarged, and Re-issued. Price 6s. net.

A SHORT MANUAL OF INORGANIC CHEMISTRY.

BY

A. DUPRÉ, Ph.D., F.R.S.,

AND

WILSON HAKE, Ph D., F.I.C., F.C.S.,
Of the Westminster Hospital Medical School.

"A well-written, clear and accurate Elementary Manual of Inorganic Chemistry. . . . We agree heartily with the system adopted by Drs. Dupré and Hake. WILL MAKE EXPERIMENTAL WORK TREBLY INTERESTING BECAUSE INTELLIGIBLE."—*Saturday Review*.

"There is no question that, given the PERFECT GROUNDING of the Student in his Science, the remainder comes afterwards to him in a manner much more simple and easily acquired. The work is AN EXAMPLE OF THE ADVANTAGES OF THE SYSTEMATIC TREATMENT of a Science over the fragmentary style so generally followed. BY A LONG WAY THE BEST of the small Manuals for Students."—*Analyst*.

LABORATORY HANDBOOKS BY A. HUMBOLDT SEXTON,

Professor of Metallurgy in the Glasgow and West of Scotland Technical College

OUTLINES OF QUANTITATIVE ANALYSIS.

FOR THE USE OF STUDENTS.

With Illustrations. FOURTH EDITION. Crown 8vo, Cloth, 3s.

"A COMPACT LABORATORY GUIDE for beginners was wanted, and the want has been WELL SUPPLIED. . . . A good and useful book."—*Lancet*.

OUTLINES OF QUALITATIVE ANALYSIS.

FOR THE USE OF STUDENTS.

With Illustrations. FOURTH EDITION, Revised. Crown 8vo, Cloth, 3s. 6d.

"The work of a thoroughly practical chemist."—*British Medical Journal*.

"Compiled with great care, and will supply a want."—*Journal of Education*.

ELEMENTARY METALLURGY:

Including the Author's Practical Laboratory Course. With many Illustrations. [See p. 66.]

FOURTH EDITION, Revised. Crown 8vo. Cloth. 6s.

"Just the kind of work for students commencing the study of metallurgy."—*Practical Engineer*.

LONDON: CHARLES GRIFFIN & CO., LIMITED, EXETER STREET, STRAND.

"The authors have succeeded beyond all expectations, and have produced a work which should give **RASH POWERS** to the Engineer and Manufacturer."—*The Times*.

In Two Vols., Large 8vo. With Illustrations. Sold Separately.

CHEMISTRY FOR ENGINEERS AND MANUFACTURERS.

A PRACTICAL TEXT-BOOK.

BY

BERTRAM BLOUNT, F.I.C., & A. G. BLOXAM, F.I.C.

VOLUME I. Price 10s. 6d.

CHEMISTRY OF ENGINEERING, BUILDING, AND
METALLURGY.

General Contents.—INTRODUCTION—Chemistry of the Chief Materials of Construction—Sources of Energy—Chemistry of Steam-raising—Chemistry of Lubrication and Lubricants—Metallurgical Processes used in the Winning and Manufacture of Metals.

VOLUME II. Price 16s.

SECOND EDITION, Thoroughly Revised. Illustrated. 16s.

THE CHEMISTRY OF MANUFACTURING
PROCESSES.

General Contents.—Sulphuric Acid Manufacture—Alkali, &c.—Destructive Distillation—Artificial Manure—Petroleum—Lime and Cement—Clay and Glass—Sugar and Starch—Brewing and Distilling—Oils, Resins, and Varnishes—Soap and Candles—Textiles and Bleaching—Colouring Matters, Dyeing, and Printing—Paper and Pasteboard—Pigments and Paints—Leather, Glue, and Size—Explosives and Matches—Minor Manufactures.

"Certainly a good and useful book, constituting a PRACTICAL GUIDE for students by affording a clear conception of the numerous processes as a whole."—*Chemical Trade Journal*.

SECOND EDITION. In Large 8vo. Handsome Cloth. With 800 pages and 154 Illustrations. 25s. net.

OILS, FATS, BUTTERS, AND WAXES :

THEIR PREPARATION AND PROPERTIES, AND MANUFACTURE THERE-
FROM OF CANDLES, SOAPS, AND OTHER PRODUCTS.

By C. R. ALDER WRIGHT, D.Sc., F.R.S.,

Late Lecturer on Chemistry, St. Mary's Hospital Medical School; Examiner in "Soap" to the City and Guilds of London Institute.

Thoroughly Revised, Enlarged, and in Part Rewritten

By C. AINSWORTH MITCHELL, B.A., F.I.C., F.C.S.

"Will be found ABSOLUTELY INDISPENSABLE."—*The Analyst*.

"Will rank as the STANDARD ENGLISH AUTHORITY ON OILS and FATS for many years to come."—*Industries and Iron*.

LONDON: CHARLES GRIFFIN & CO., LIMITED, EXETER STREET, STRAND.

FIFTH EDITION, Thoroughly Revised, Greatly Enlarged and Re-written.
With additional Tables, Plates, and Illustrations. 21s.

FOODS:

THEIR COMPOSITION AND ANALYSIS.

By A. WYNTER BLYTH, M.R.C.S., F.I.C., F.C.S.,
Barrister-at-Law, Public Analyst for the County of Devon, and
Medical Officer of Health for St. Marylebone.

AND M. WYNTER BLYTH, B.A., B.Sc., F.C.S.

GENERAL CONTENTS. — History of Adulteration. — Legislation. — Apparatus. — "Ash." — Sugar. — Confectionery. — Honey. — Treacle. — Jams and Preserved Fruits. — Starches. — Wheaten-Flour. — Bread. — Oats. — Barley. — Rye. — Rice. — Maize. — Millet. — Potatoes. — Peas. — Lentils. — Beans. — Milk. — Cream. — Butter. — Oleo-Margarine. — Cheese. — Lard. — Tea. — Coffee. — Cocoa and Chocolate. — Alcohol. — Brandy. — Rum. — Whisky. — Gin. — Arrack. — Liqueurs. — Absinthe. — Yeast. — Beer. — Wine. — Vinegar. — Lemon and Lime Juice. — Mustard. — Pepper. — Sweet and Bitter Almonds. — Annatto. — Olive Oil. — Water Analysis. — Appendix: Adulteration Acts, &c.

"Simply INDISPENSABLE in the Analyst's laboratory."—*The Lancet*.

"A new edition of Mr. Wynter Blyth's Standard work, ENRICHED WITH ALL THE RECENT DISCOVERIES AND IMPROVEMENTS, will be accepted as a boon."—*Chemical News*.

FOURTH EDITION, Thoroughly Revised. In Large 8vo, Cloth, with
Tables and Illustrations.

POISONS:

THEIR EFFECTS AND DETECTION.

By A. WYNTER BLYTH, M.R.C.S., F.I.C., F.C.S.,
Barrister-at-Law, Public Analyst for the County of Devon, and
Medical Officer of Health for St. Marylebone.

GENERAL CONTENTS.

I.—Historical Introduction. II.—Classification—Statistics—Connection between Toxic Action and Chemical Composition—Life Tests—General Method of Procedure—The Spectroscope—Examination of Blood and Blood Stains. III.—Poisonous Gases. IV.—Acids and Alkalies. V.—More or less Volatile Poisonous Substances. VI.—Alkaloids and Poisonous Vegetable Principles. VII.—Poisons derived from Living or Dead Animal Substances. VIII.—The Oxalic Acid Group. IX.—Inorganic Poisons. *Appendix: Treatment, by Antidotes or otherwise, of Cases of Poisoning.*

"Undoubtedly THE MOST COMPLETE WORK on Toxicology in our language."—*The Analyst (on the Third Edition)*.

"AS A PRACTICAL GUIDE, we know NO BETTER work."—*The Lancet (on the Third Edition)*.

*. In the THIRD EDITION, Enlarged and partly Re-written, NEW ANALYTICAL METHODS have been introduced, and the CADAVERIC ALKALOIDS, or PROMAINES, bodies playing so great a part in Food-poisoning and in the Manifestations of Disease, have received special attention.

LONDON: CHARLES GRIFFIN & CO., LIMITED, EXETER STREET, STRAND.

With Numerous Tables, and 22 Illustrations. 16s.

DAIRY CHEMISTRY
FOR DAIRY MANAGERS, CHEMISTS, AND ANALYSTS
 A Practical Handbook for Dairy Chemists and others
 having Control of Dairies.

By H. DROOP RICHMOND, F.I.C.,
 CHEMIST TO THE AYLESBURY DAIRY COMPANY.

Contents.—I. Introductory.—The Constituents of Milk. II. The Analysis of Milk. III. Normal Milk: its Adulterations and Alterations, and their Detection. IV. The Chemical Control of the Dairy. V. Biological and Sanitary Matters. VI. Butter. VII. Other Milk Products. VIII. The Milk of Mammals other than the Cow.—Appendices.—Tables.—Index.

“ . . . In our opinion the book is the BEST CONTRIBUTION ON THE SUBJECT THAT HAS YET APPEARED in the English language.”—*Lancet*.

Fully Illustrated. With Photographs of Various Breeds of Cattle, &c.
 6s. net.

MILK: ITS PRODUCTION & USES.

With Chapters on Dairy Farming, The Diseases of Cattle, and on the Hygiene and Control of Supplies.

By EDWARD F. WILLOUGHBY,
 M.D. (Lond.), D.P.H. (Lond. and Camb.),

Late Inspector of Farms and General Scientific Adviser to Welford and Sons, Ltd.

“ A good investment to those in the least interested in dairying. Excellently bound; printed on good paper, and well illustrated, running to 259 pages, the purchaser gets at the price of a novel a work which will stand good as a work of reference for some years to come.”—*Agricult. Gazette*.

“ We cordially recommend it to everyone who has anything at all to do with milk.”—*Dairy World*.

In Crown 8vo, Fully Illustrated. 2s. 6d. net.

THE LABORATORY BOOK OF
DAIRY ANALYSIS.

By H. DROOP RICHMOND, F.I.C.,
 Analyst to the Aylesbury Dairy Co., Ltd.

CONTENTS.—Composition of Milk and its Products.—Analysis of Milk.—Analysis of Liquid Products.—Application of Analysis to the Solution of Problems.—The Analysis of Butter.—Analysis of Cheese.—Tables for Calculation.—Standard Solutions.—INDEX.

“ Without doubt the best contribution to the literature of its subject that has ever been written.”—*Medical Times*.

In Large 8vo. Handsome Cloth.

AGRICULTURAL CHEMISTRY AND ANALYSIS:
 A PRACTICAL HANDBOOK FOR THE USE OF AGRICULTURAL STUDENTS.

By J. M. H. MUNRO, D.Sc., F.I.C., F.C.S.,
 Professor of Chemistry, Downton College of Agriculture.

[In Preparation.]

LONDON: CHARLES GRIFFIN & CO., LIMITED, EXETER STREET, STRAND.

Crown 8vo, Handsome Cloth. Fully Illustrated. 10s. 6d.

FLESH FOODS:

With Methods for their Chemical, Microscopical, and Bacteriological Examination.

A Practical Handbook for Medical Men, Analysts, Inspectors and others.

By C. AINSWORTH MITCHELL, B.A., F.I.C., F.C.S.,
Member of Council, Society of Public Analysts.

With Numerous Tables, Illustrations, and a Coloured Plate.

CONTENTS.—Structure and Chemical Composition of Muscular Fibre.—of Connective Tissue, and Blood.—The Flesh of Different Animals.—The Examination of Flesh.—Methods of Examining Animal Fat.—The Preservation of Flesh.—Composition and Analysis of Sausages.—Proteids of Flesh.—Meat Extracts and Flesh Peptones.—The Cooking of Flesh.—Poisonous Flesh.—The Animal Parasites of Flesh.—The Bacteriological Examination of Flesh.—The Extraction and Separation of Ptomaines.—INDEX.

"A compilation which will be most useful for the class for whom it is intended."—*Athenaeum*.

"A book which NO ONE whose duties involve considerations of food supply CAN AFFORD TO BE WITHOUT."—*Municipal Journal*.

In Large 8vo. Handsome Cloth. With numerous Illustrations.

Each Volume Complete in Itself, and Sold Separately.

TECHNICAL MYCOLOGY:

The Utilisation of Micro-organisms in the Arts and Manufactures.

By DR. FRANZ LAFAR,

Prof. of Fermentation-Physiology and Bacteriology in the Technical High School, Vienna.

With an Introduction by DR. EMIL CHR. HANSEN, Principal of the Carlsberg Laboratory, Copenhagen.

TRANSLATED BY CHARLES T. C. SALTER.

Vol. I.—SCHIZOMYCETIC FERMENTATION. 15s.

Vol. II., Part I.—EUMYCETIC FERMENTATION. 7s. 6d.

"The first work of the kind which can lay claim to completeness in the treatment of a fascinating subject. The plan is admirable, the classification simple, the style is good, and the tendency of the whole volume is to convey sure information to the reader."—*Lancet*.

Crown 8vo, Handsome Cloth. With Diagrams. 7s. 6d. net.

[Companion Volume to "FERMENTS," by the same Author.]

TOXINES AND ANTITOXINES.

By CARL OPPENHEIMER, PH.D., M.D.,

Of the Physiological Institute at Erlangen.

TRANSLATED FROM THE GERMAN BY

C. AINSWORTH MITCHELL, B.A., F.I.C., F.C.S.

With Notes, and Additions by the Author, since the publication of the German Edition.

"For wealth of detail, we have no small work on Toxines which equals the one under review."—*Medical Times*.

LONDON: CHARLES GRIFFIN & CO., LIMITED, EXETER STREET, STRAND

In Crown 8vo, Handsome Cloth. Price 7s. 6d. net.

F E R M E N T S
A N D T H E I R A C T I O N S .
A Text-book on the Chemistry and Physics of Fermentative Changes.

By CARL OPPENHEIMER, PH. D., M. D.,
Of the Physiological Institute at Erlangen.

TRANSLATED FROM THE GERMAN BY

C. AINSWORTH MITCHELL, B. A., F. I. C., F. C. S.

ABRIDGED CONTENTS.—Introduction.—Definition.—Chemical Nature of Ferments.—Influence of External Factors.—Mode of Action.—Physiological Action.—Secretion.—Importance of Ferments to Vital Action.—Proteolytic Ferments.—Trypsin.—Bacteriolytic and Hæmolytic Ferments.—Vegetable Ferments.—Coagulating Ferments.—Saccharifying Ferments.—Diastases.—Polysaccharides.—Enzymes.—Ferments which decompose Glucosides.—Hydrolytic Ferments.—Lactic Acid Fermentation.—Alcoholic Fermentation.—Biology of Alcoholic Fermentation.—Oxydases.—Oxidising Fermentation.—Bibliography.—INDEX.

“Such a veritable *multum in parvo* has never yet appeared. The author has set himself the task of writing a work on Ferments that should embrace human erudition on the subject”—*Brewers' Journal*.

THIRD EDITION. In Handsome Cloth. Fully Illustrated.
PRINCIPLES AND PRACTICE OF BREWING.
FOR THE USE OF STUDENTS AND PRACTICAL MEN.

By WALTER J. SYKES.

REVISED BY ARTHUR R. LING, F. I. C., F. C. S.,
Editor of the Journal of the Institute of Brewing.

In Crown 8vo. Handsome Cloth.

A PRACTICAL LABORATORY HANDBOOK ON
THE BACTERIOLOGY OF BREWING.

By WALTER A. RILEY, F. C. S.

ABRIDGED CONTENTS.—Laboratory Handbook and Apparatus.—Sterilisation.—Nutritive Liquids.—Microscope, Reagents, &c.—Methods of Analysis.—Practical Methods, including the use of “*Brettanomyces*,” Cider and Wine Fermentations.—Determining Races of Yeasts, &c.—Practical Notes on Yeast.

IN ACTIVE PREPARATION. In Crown 8vo. Handsome Cloth. Fully Illustrated.

P E A T : Its Use and Manufacture.

By PHILIP R. BJÖRLING, Consulting Hydraulic Engineer,
AND FREDERIC T. GISSING.

ABRIDGED CONTENTS.—Introduction.—The Formation of Peat.—Area and Depth of Bogs in Principal Countries.—Manufacture of Peat Fuel, &c.—Peat, Dredged Peat, and Manufactured Peat.—Machinery employed in the Manufacture of Peat Fuel.—Peat Moss Litter, and the Machinery employed in its Manufacture.—Peat Charcoal and its Manufacture.—Cost of making Peat Fuel and Charcoal.—Other Productions derived from Peat, such as Tar, Manure, Candles, Dyes, Paper, &c.—BIBLIOGRAPHY.—INDEX.

In Crown 8vo. Handsome Cloth. With 30 Illustrations. 6s. net.

THE CLAYWORKER'S HANDBOOK.
An Epitome of the Materials and Methods employed in Brickmaking and Pottery.

By THE AUTHOR OF “THE CHEMISTRY OF CLAYWORKING,” &c.

GENERAL CONTENTS.—Materials used in Clayworking: Clays, Engobes, Glazes, Colours, Water, Fuel, Oils, and Lubricants.—The Preparation of the Clay, Mining and Quarrying, Weathering, Washing, Grinding, Tempering, and Pugging.—Machinery: Boilers, Engines, General Machinery, Sieves, Mixing Machinery, Presses, &c.—Dryers and Drying.—Engobing and Glazing.—Setting or Charring, Transport.—Kilns.—Firing.—Discharging, Sorting, and Packing.—Defects and Waste.—Tests, Analysis and Control.—BIBLIOGRAPHY.—TABLES.—INDEX.

LONDON: CHARLES GRIFFIN & CO., LIMITED, EXETER STREET, STRAND.

SECOND EDITION, REVISED AND ENLARGED.
With Tables, Illustrations in the Text, and 37 Lithographic Plates. Medium
8vo. Handsome Cloth. 30s.

SEWAGE DISPOSAL WORKS:

A Guide to the Construction of Works for the Prevention of the
Pollution by Sewage of Rivers and Estuaries.

By W. SANTO CRIMP, M. INST. C. E., F. G. S.,
Late Assistant-Engineer, London County Council.

"Probably the MOST COMPLETE AND BEST TREATISE on the subject which has appeared
in our language."—*Edinburgh Medical Journal*.

*Beautifully Illustrated, with Numerous Plates, Diagrams, and
Figures in the Text. 21s. net.*

TRADES' WASTE:

ITS TREATMENT AND UTILISATION.

A Handbook for Borough Engineers, Surveyors, Architects, and Analysts.

By W. NAYLOR, F. O. S., A. M. INST. C. E.,
Chief Inspector of Rivers, Ribble Joint Committee.

CONTENTS.—I. Introduction.—II. Chemical Engineering.—III.—Wool De-greasing
and Grease Recovery.—IV. Textile Industries: Calico Bleaching and Dyeing.—V. Dyeing
and Calico-Printing.—VI. Tanning and Fellmongery.—VII. Brewery and Distillery
Waste.—VIII. Paper Mill Refuse.—IX. General Trades' Waste.—INDEX.

"There is probably no person in England to-day better fitted to deal rationally with
such a subject."—*British Sanitarian*.

In Handsome Cloth. With 59 Illustrations. 6s. net.

SMOKE ABATEMENT.

A Manual for the Use of Manufacturers, Inspectors, Medical Officers of
Health, Engineers, and Others.

By WILLIAM NICHOLSON,
Chief Smoke Inspector to the Sheffield Corporation.

CONTENTS.—Introduction.—General Legislation against the Smoke Nuisance.—
Local Legislation.—Foreign Laws.—Smoke Abatement.—Smoke from Boilers, Furnaces,
and Kilns.—Private Dwelling-House Smoke.—Chimneys and their Construction.—
Smoke Preventers and Fuel Savers.—Waste Gases from Metallurgical Furnaces.—
Summary and Conclusions.—INDEX.

"We welcome such an adequate statement on an important subject."—*British
Medical Journal*.

SECOND EDITION. In Medium 8vo. Thoroughly Revised and Re-Written.
15s. net.

CALCAREOUS CEMENTS:

THEIR NATURE, PREPARATION, AND USES.

With some Remarks upon Cement Testing.

By GILBERT R. REDGRAVE, ASSOC. INST. C. E.,
Assistant Secretary for Technology, Board of Education, South Kensington,

AND CHARLES SPACKMAN, F. C. S.

"We can thoroughly recommend it as a first-class investment."—*Practical Engineer*.

LONDON: CHARLES GRIFFIN & CO., LIMITED, EXETER STREET, STRAND.

With Four Folding Plates and Numerous Illustrations. Large 8vo.
8s. 6d. net.

WATER SUPPLY:

A Practical Treatise on the Selection of Sources and the Distribution of Water.

By REGINALD F. MIDDLETON, M. INST. C. E., M. INST. MECH. E., F. S. I.

ABRIDGED CONTENTS.—Introductory.—Requirements as to Quality.—Requirements as to Quantity.—Storage Reservoirs.—Purification.—Service Reservoirs.—The Flow of Water through Pipes.—Distributing Systems.—Pumping Machines.—Special Requirements.

"As a companion for the student, and a constant reference for the technical man, we anticipate it will take an important position on the bookshelf."—*Practical Engineer*.

In Large Crown 8vo. Fully Illustrated. In Two Volumes.

VOLUME I. FOURTH EDITION. Price 7s. 6d. net.

„ II. THIRD EDITION. READY SHORTLY.

THE CHEMISTRY OF

GAS MANUFACTURE:

A Hand-Book on the Production, Purification, and Testing of Illuminating Gas, and the Assay of the Bye-Products of Gas Manufacture.

By W. J. ATKINSON BUTTERFIELD, M. A., F. I. C., F. C. S.,
Formerly Head Chemist, Gas Works, Beckton, London, E.

"The BEST WORK of its kind which we have ever had the pleasure of reviewing."—*Journal of Gas Lighting*.

With Diagrams and Illustrations. 5s. net.

ACETYLENE:

THE PRINCIPLES OF ITS GENERATION AND USE.

By F. H. LEEDS, F. I. C., F. C. S.,

Member of the Society of Public Analysts and of the Acetylene Association;

AND W. J. ATKINSON BUTTERFIELD, M. A., F. I. C., F. C. S.,
Consulting Chemist, Author of "The Chemistry of Gas Manufacture."

"Brimful of information."—*Chem. Trade Journal*.

"We can thoroughly recommend the book to the manufacturer as a reliable work of reference, to the user as supplying valuable hints on apparatus and methods of procedure, and to the student as a safe and certain guide."—*Acetylene*.

Large 8vo. Handsome Cloth. Price 16s. net.

FIRE AND EXPLOSION RISKS:

A Handbook of the Detection, Investigation, and Prevention of Fires and Explosions.

By DR. VON SCHWARTZ.

Translated from the Revised German Edition

By C. T. C. SALTER.

ABRIDGED GENERAL CONTENTS.—Fires and Explosions of a General Character—Dangers arising from Sources of Light and Heat.—Dangerous Gases.—Risks Attending Special Industries.—Materials Employed.—Agricultural Products.—Fats, Oils, and Resins.—Mineral Oils and Tar.—Alcohol, &c.—Metals, Oxides, Acids, &c.—Lightning Ignition Appliances, Fireworks.

"The work affords a wealth of information on the chemistry of fire and kindred topics."—*Fire and Water*.

"A complete and useful survey of a subject of wide interest and vital importance."—*Oil and Colourman's Journal*.

LONDON: CHARLES GRIFFIN & CO., LIMITED, EXETER STREET, STRAND.

THIRTEENTH EDITION, Revised and Enlarged. Price 6s.

PRACTICAL SANITATION: **A HAND-BOOK FOR SANITARY INSPECTORS AND OTHERS** **INTERESTED IN SANITATION.**

By **GEORGE REID, M.D., D.P.H.,**
Fellow, Mem. Council, and Examiner, Sanitary Institute of Great Britain,
and Medical Officer to the Staffordshire County Council.

With an Appendix on Sanitary Law.

By **HERBERT MANLEY, M.A., M.B., D.P.H.,**
Medical Officer of Health for the County Borough of West Bromwich.

GENERAL CONTENTS.—Introduction.—Water Supply: Drinking Water, Pollution of Water.—Ventilation and Warming.—Principles of Sewage Removal.—Details of Drainage; Refuse Removal and Disposal.—Sanitary and Insanitary Work and Appliances.—Details of Plumbers' Work.—House Construction.—Infection and Disinfection.—Food, Inspection of; Characteristics of Good Meat; Meat, Milk, Fish, &c., unfit for Human Food.—Appendix: Sanitary Law; Model Bye-Laws, &c.

“A VERY USEFUL HANDBOOK, with a very useful Appendix. We recommend it not only to SANITARY INSPECTORS, but to HOUSEHOLDERS and ALL interested in Sanitary Matters.”—*Sanitary Record.*

In Handsome Cloth. With 53 Illustrations. 3s. 6d. net.

LESSONS ON SANITATION.

By **JOHN WM. HARRISON, M.R.SAN.I.,**

Mem. Incor. Assoc. Mun. and County Engineers; Surveyor, Wombwell, Yorks.

CONTENTS.—Water Supply.—Ventilation.—Drainage.—Sanitary Building Construction.—Infectious Diseases.—Food Inspection.—Duties of an Inspector of Nuisances and Common Lodging-Houses.—Infectious Diseases Acts.—Factory and Workshop Acts.—Housing of the Working-Class Act.—Shop Hours Acts.—Sale of Food and Drugs Acts.—The Margarine Acts.—Sale of Horseflesh, &c., Rivers Pollution.—Canal Boats Act.—Diseases of Animals.—Dairies, Cowsheds and Milkshops Order.—Model Bye-Laws.—Miscellaneous.—INDEX.

“Accurate, reliable, and compiled with conciseness and care.”—*Sanitary Record.*

SECOND EDITION, Revised. In Crown 8vo. Handsome Cloth. Profusely Illustrated. 8s. 6d. net.

SANITARY ENGINEERING:

A Practical Manual of Town Drainage and Sewage and Refuse Disposal.

For Sanitary Authorities, Engineers, Inspectors, Architects,
Contractors, and Students.

By **FRANCIS WOOD, A.M.INST.C.E., F.G.S.,**

Borough Engineer and Surveyor, Fulham; late Borough Engineer, Bacup, Lancs.

GENERAL CONTENTS.

Introduction.—Hydraulics.—Velocity of Water in Pipes.—Earth Pressures and Retaining Walls.—Powers.—House Drainage.—Land Drainage.—Sewers.—Separate System.—Sewage Pumping.—Sewer Ventilation.—Drainage Areas.—Sewers, Manholes, &c.—Trade Refuse.—Sewage Disposal Works.—Bacterial Treatment.—Sludge Disposal.—Construction and Cleansing of Sewers.—Refuse Disposal.—Chimneys and Foundations.

“The volume bristles with information which will be greedily read by those in need of assistance. The book is one that ought to be on the bookshelves of EVERY PRACTICAL ENGINEER.”—*Sanitary Journal.*
“A VERITABLE POCKET COMPENDIUM of Sanitary Engineering. . . . A work which may, in many respects, be considered as COMPLETE . . . COMMENDABLY CAUTIOUS . . . INTERESTING . . . SUGGESTIVE.”—*Public Health Engineer.*

LONDON: CHARLES GRIFFIN & CO., LIMITED, EXETER STREET, STRAND.

VOL. I. NOW READY. IN HALF MOROCCO, 24s. NET.

In Two Volumes, each complete in itself.

PHYSICO-CHEMICAL TABLES

FOR THE USE OF ANALYSTS, PHYSICISTS, CHEMICAL
MANUFACTURERS AND SCIENTIFIC CHEMISTS.

Volume I.—Chemical Engineering, Physical Chemistry.

Volume II.—Chemical Physics, Pure and Analytical Chemistry.

By JOHN CASTELL-EVANS, F.I.C., F.C.S., ^[Shortly]

Superintendent of the Chemical Laboratories, and Lecturer on Inorganic Chemistry and Metallurgy at the Finsbury Technical College.

The Tables may almost claim to be exhaustive, and embody and collate all the most recent data established by experimentalists at home and abroad. The volumes will be found invaluable to all engaged in research and experimental investigation in Chemistry and Physics.

The Work comprehends as far as possible ALL RULES AND TABLES required by the Analyst, Brewer, Distiller, Acid- and Alkali-Manufacturer, &c., &c.; and also the principal data in THERMO-CHEMISTRY, ELECTRO-CHEMISTRY, and the various branches of CHEMICAL PHYSICS. Every possible care has been taken to ensure perfect accuracy, and to include the results of the most recent investigations.

SECOND EDITION. *In Large 8vo. Handsome Cloth. Beautifully Illustrated. With Plates and Figures in the Text.*

Road Making and Maintenance :

**A PRACTICAL TREATISE FOR ENGINEERS,
SURVEYORS, AND OTHERS.**

WITH AN HISTORICAL SKETCH OF ANCIENT AND MODERN PRACTICE.

By THOS. AITKEN, Assoc.M.Inst.C.E.,

Member of the Association of Municipal and County Engineers; Member of the Sanitary Inst.; Surveyor to the County Council of Fife, Oupar Division.

WITH NUMEROUS PLATES, DIAGRAMS, AND ILLUSTRATIONS.

CONTENTS.—Historical Sketch.—Resistance of Traction.—Laying out New Roads.—Earthworks, Drainage, and Retaining Walls.—Road Materials, or Metal.—Quarrying.—Stone Breaking and Haulage.—Road-Rolling and Scarifying.—The Construction of New, and the Maintenance of existing Roads.—Carriage Ways and Foot Ways.

"The Literary style is EXCELLENT. . . . A COMPREHENSIVE and EXCELLENT Modern Book, an UP-TO-DATE work. . . . Should be on the reference shelf of every Municipal and County Engineer or Surveyor in the United Kingdom, and of every Colonial Engineer."—*The Surveyor*.

LONDON: CHARLES GRIFFIN & CO., LIMITED, EXETER STREET, STRAND.

FOURTH EDITION, Revised and Enlarged. With Illustrations. 12s. 6d.

Painters' Colours, Oils, & Varnishes:

A PRACTICAL MANUAL.

BY GEORGE H. HURST, F.C.S.,

Member of the Society of Chemical Industry; Lecturer on the Technology of Painters' Colours, Oils, and Varnishes, the Municipal Technical School, Manchester.

GENERAL CONTENTS.—Introductory—THE COMPOSITION, MANUFACTURE, ASSAY, and ANALYSIS OF PIGMENTS, White, Red, Yellow and Orange, Green, Blue, Brown, and Black—LAKES—Colour and Paint Machinery—Paint Vehicles (Oils, Turpentine, &c., &c.)—Driers—VARNISHES.

"A THOROUGHLY PRACTICAL book, . . . the ONLY English work that satisfactorily treats of the manufacture of oils, colours, and pigments."—*Chemical Trades' Journal*.

* * FOR Mr. HURST'S GARMENT DYEING AND CLEANING, see p. 84.

In Crown 8vo. Handsome Cloth. With Illustrations. 5s.

THE PAINTER'S LABORATORY GUIDE.

A Student's Handbook of Paints, Colours, and Varnishes.

BY GEORGE H. HURST, F.C.S., M.S.C.I.

ABSTRACT OF CONTENTS.—Preparation of Pigment Colours.—Chemical Principles Involved.—Oils and Varnishes.—Properties of Oils and Varnishes.—Tests and Experiments.—Plants, Methods, and Machinery of the Paint and Varnish Manufactures.

This Work has been designed by the Author for the Laboratory of the Technical School, and of the Paint and Colour Works, and for all interested or engaged in these industries.

"This excellent handbook, . . . the model of what a handbook should be."—*Oils, Colours, and Drysalteries*.

SECOND EDITION, Revised. In Crown 8vo. extra. With Numerous Illustrations and Plates (some in Colours), including Original Designs. 12s. 6d.

Painting and Decorating:

*A Complete Practical Manual for House
Painters and Decorators.*

BY WALTER JOHN PEARCE,

LECTURER AT THE MANCHESTER TECHNICAL SCHOOL FOR HOUSE-PAINTING AND DECORATING.

GENERAL CONTENTS.

Introduction—Workshop and Stores—Plant and Appliances—Brushes and Tools—Materials: Pigments, Driers, Painters' Oils—Wall Hangings—Paper Hanging—Colour Mixing—Distempering—Plain Painting—Staining—Varnish and Varnishing—Imitative Painting—Graining—Marbling—Gilding—Sign-Writing and Lettering—Decoration: General Principles—Decoration in Distemper—Painted Decoration—Relievo Decoration—Colour—Measuring and Estimating—Coach-Painting—Ship-Painting.

"A THOROUGHLY USEFUL BOOK . . . GOOD, SOUND, PRACTICAL INFORMATION in a CLEAR and CONCISE FORM."—*Plumber and Decorator*.

"A THOROUGHLY GOOD and RELIABLE TEXT-BOOK. . . . So FULL and COMPLETE that it would be difficult to imagine how anything further could be added about the Painter's craft."—*Builders' Journal*.

LONDON: CHARLES GRIFFIN & CO., LIMITED, EXETER STREET, STRAND.

SECOND EDITION. In Large 8vo. Handsome Cloth. With 4 Plates and Several Illustrations. 16s. net.

THE CHEMISTRY OF INDIA RUBBER.

A Treatise on the Nature of India Rubber, its Chemical and Physical Examination, and the Determination and Valuation of India Rubber Substitutes.

Including the Outlines of a Theory on Vulcanisation.

By CARL OTTO WEBER, PH.D.

"Replete with scientific and also with technical interest. . . . The section on physical properties is a complete *résumé* of every thing known on the subject."—*India-rubber Journal*.

In Large Crown 8vo. Fully Illustrated. 5s. net.

GLUE, GELATINE,

AND THEIR ALLIED PRODUCTS,

A Practical Handbook for the Manufacturer, Agriculturist, and Student of Technology.

By THOMAS LAMBERT,

Analytical and Technical Chemist.

CONTENTS.—Historical.—GLUE.—GELATINE.—Size and Isinglass.—Treatment of Effluents produced in Glue and Gelatine Making.—Liquid and other Glues, Cements, &c.—Uses of Glue and Gelatine.—Residual Products.—Analysis of Raw and Finished Products.—APPENDIX.—INDEX.

"A sufficient account of modern methods of working, chiefly from a practical standpoint. A book . . . of real value."—*Chemical News*.

In Medium 8vo, Handsome Cloth. Fully Illustrated. 12s. 6d. net.

PAPER TECHNOLOGY:

AN ELEMENTARY MANUAL ON THE MANUFACTURE, PHYSICAL QUALITIES, AND CHEMICAL CONSTITUENTS OF PAPER AND OF PAPERMAKING FIBRES.

With Selected Tables for Stationers, Publishers, and Others.

By R. W. SINDALL, F.C.S.

CONTENTS.—Introduction.—Technical Difficulties relating to Paper.—The Manufacture of Rag Paper, Hand-made, Machine-made; Esparto Papers; Chemical Wood Pulp; Mechanical Wood Pulp; Wood Pulp Papers; Art Papers; Hemp, Jute, and other Papers.—The Physical Qualities of Paper: Weight, Thickness, Strength, Elasticity, &c.—The Chemical Constituents of Paper: Clay, Pearl Hardening, Gelatine, Casein, Rosin, Alum, Starch, Pigments, Aniline Dyes, &c.—Chemical Analysis of Paper.—Microscopical Analysis.—Conditions Affecting Quality.—"C.B.S. Units."—Vegetable Fibres used in Paper-making.—Chemical and Physical Characteristics of Fibres.—Cellulose.—Statistics relating to Paper.—Tables.—Bibliography.—INDEX.

In Large 8vo. Handsome Cloth. With Plates and Illustrations. 7s. 6d. net.

THE MANUFACTURE OF INK.

A Handbook of the Production and Properties of Printing, Writing, and Copying Inks.

By C. A. MITCHELL, B.A., F.I.C., F.C.S., & T. C. HEPWORTH.

GENERAL CONTENTS.—Historical.—Inks and their Manufacture.—Writing Inks.—Carbon and Carbonaceous Inks.—Tannin Materials for Ink.—Nature of Inks.—Manufacture of Iron Gall Ink.—Logwood, Vanadium, and Aniline Black Inks.—Coloured Inks.—Examination of Writing Inks.—Printing Inks.—Early Methods of Manufacture.—Manufacture of Varnish Inks.—Preparation and Incorporation of the Pigment.—Coloured Printing Inks.—Copying Inks.—Marking Inks.—Natural Vegetable Inks.—Safety Inks and Papers.—Sympathetic Inks.—Ink Powders and Tablets.—Appendices.—Patent Specifications, &c.

"Thoroughly well arranged . . . and of a genuinely practical order."—*British Printer*.

LONDON: CHARLES GRIFFIN & CO., LIMITED, EXETER STREET, STRAND.

THE TEXTILE INDUSTRIES.

SECOND EDITION, *Thoroughly Revised Throughout. In Two Large Volumes. Handsome Cloth.*

A MANUAL OF DYEING:
FOR THE USE OF PRACTICAL DYERS, MANUFACTURERS, STUDENTS,
AND ALL INTERESTED IN THE ART OF DYEING.

BY

E. KNECHT, Ph.D., F.I.C.,

Head of the Chemistry and Dyeing Department of
the Technical School, Manchester; Editor of "The
Journal of the Society of Dyers and Colourists;"

CHR. RAWSON, F.I.C., F.C.S.,

Late Head of the Chemistry and Dyeing Department
of the Technical College, Bradford; Member
Council of the Society of Dyers and Colourists;

And RICHARD LOEWENTHAL, Ph.D.

GENERAL CONTENTS.—Chemical Technology of the Textile Fabrics—
Water—Washing and Bleaching—Acids, Alkalies, Mordants—Natural
Colouring Matters—Artificial Organic Colouring Matters—Mineral Colours
—Machinery used in Dyeing—Tinctorial Properties of Colouring Matters—
Analysis and Valuation of Materials used in Dyeing, &c., &c.

"This authoritative and exhaustive work . . . the MOST COMPLETE we have yet seen
on the subject."—*Textile Manufacturer.*

In Large 8vo, Handsome Cloth. Pp. i-xv + 405. 16s. net.

THE SYNTHETIC DYESTUFFS,

AND

THE INTERMEDIATE PRODUCTS FROM WHICH THEY ARE DERIVED.

By JOHN CANNELL CAIN, D.Sc. (MANCHESTER AND TUBINGEN),
Technical Chemist,

AND JOCELYN FIELD THORPE, Ph.D. (HEIDELBERG),
Lecturer on Colouring Matters in the Victoria University of Manchester.

Part I. Theoretical. Part II. Practical. Part III. Analytical.

"We have no hesitation in describing this treatise as one of the most valuable books
that has appeared. . . . Will give an impetus to the study of Organic Chemistry
generally."—*Chemical Trade Journal.*

*Companion Volume to Knecht & Rawson's "Dyeing." In Large 8vo.
Handsome Cloth, Library Style. 16s. net.*

A DICTIONARY OF

DYES, MORDANTS, & OTHER COMPOUNDS
USED IN DYEING AND CALICO PRINTING.

*With Formulae, Properties, and Applications of the various substances described,
and concise directions for their Commercial Valuation,
and for the Detection of Adulterants.*

By CHRISTOPHER RAWSON, F.I.C., F.C.S.,
Consulting Chemist to the Behar Indigo Planters' Association; Co-Author of "A Manual
of Dyeing;"

WALTER M. GARDNER, F.C.S.,

Head of the Department of Chemistry and Dyeing, Bradford Municipal Technical College;
Editor of the "Journ. Soc. Dyers and Colourists;"

AND W. F. LAYCOCK, Ph.D., F.C.S.,

Analytical and Consulting Chemist.

"Turn to the book as one may on any subject, or any substance in connection with the
trade, and a reference is sure to be found. The authors have apparently left nothing out."
—*Textile Mercury.*

LONDON: CHARLES GRIFFIN & CO., LIMITED, EXETER STREET, STRAND.

Large 8vo. Profusely Illustrated with Plates and Figures in the Text.
16s. net.

THE SPINNING AND TWISTING OF LONG VEGETABLE FIBRES

(FLAX, HEMP, JUTE, TOW, & RAMIE).

A Practical Manual of the most Modern Methods as applied to the Hackling, Carding, Preparing, Spinning, and Twisting of the Long Vegetable Fibres of Commerce.

By HERBERT R. CARTER, Belfast and Lille.

GENERAL CONTENTS.—Long Vegetable Fibres of Commerce.—Rise and Growth of the Spinning Industry.—Raw Fibre Markets.—Purchasing Raw Material.—Storing and Preliminary Operations.—Hackling.—Sorting.—Preparing.—Tow Carding and Mixing.—Tow Combing.—Gill Spinning.—The Roving Frame.—Dry and Demi-sec Spinning.—Wet Spinning.—Spinning Waste.—Yarn Reeling.—Manufacture of Threads, Twines, and Cords.—Rope Making.—The Mechanical Department.—Modern Mill Construction.—Steam and Water Power.—Power Transmission.

"Meets the requirements of the Mill Manager or Advanced Student in a manner perhaps more than satisfactory. . . . We must highly commend the work as representing up-to-date practice."—*Nature*.

In Large 8vo, Handsome Cloth, with Numerous Illustrations. 9s. net.

TEXTILE FIBRES OF COMMERCE.

A HANDBOOK OF

The Occurrence, Distribution, Preparation, and Industrial
Uses of the Animal, Vegetable, and Mineral
Products used in Spinning and Weaving.

By WILLIAM I. HANNAN,

Lecturer on Botany at the Ashton Municipal Technical School, Lecturer on Cotton Spinning at the Chorley Science and Art School, &c.

With Numerous Photo Engravings from Nature.

"USEFUL INFORMATION. . . . ADMIRABLE ILLUSTRATIONS. . . . The information is not easily attainable, and in its present convenient form will be valuable."—*Textile Recorder*.

In Large 8vo, with Illustrations and Printed Patterns. Price 21s.

TEXTILE PRINTING:

A PRACTICAL MANUAL.

Including the Processes Used in the Printing of
COTTON, WOOLLEN, SILK, and HALF-
SILK FABRICS.

By C. F. SEYMOUR ROTHWELL, F.C.S.,

Mem. Soc. of Chemical Industries; late Lecturer at the Municipal Technical School, Manchester.

GENERAL CONTENTS.—Introduction.—The Machinery Used in Textile Printing.—Thickeners and Mordants.—The Printing of Cotton Goods.—The Steam Style.—Colours Produced Directly on the Fibre.—Dyed Styles.—Padding Style.—Resist and Discharge Styles.—The Printing of Compound Colourings, &c.—The Printing of Woollen Goods.—The Printing of Silk Goods.—Practical Recipes for Printing.—Useful Tables.—Patterns.

"BY FAR THE BEST AND MOST PRACTICAL BOOK ON TEXTILE PRINTING which has yet been brought out, and will long remain the standard work on the subject. It is essentially practical in character."—*Textile Mercury*.

"THE MOST PRACTICAL MANUAL OF TEXTILE PRINTING which has yet appeared. We have no hesitation in recommending it."—*The Textile Manufacturer*.

LONDON: CHARLES GRIFFIN & CO., LIMITED, EXETER STREET, STRAND.

Large 8vo. Handsome Cloth. 12s. 6d.

BLEACHING & CALICO-PRINTING.

A Short Manual for Students and
Practical Men.

BY GEORGE DUERR,

Director of the Bleaching, Dyeing, and Printing Department at the Acrrington and Bacup
Technical Schools; Chemist and Colourist at the Irwell Print Works.

ASSISTED BY WILLIAM TURNBULL

(of Turnbull & Stockdale, Limited).

With Illustrations and upwards of One Hundred Dyed and Printed Patterns
designed specially to show various Stages of the Processes described.

GENERAL CONTENTS.—COTTON, Composition of; BLEACHING, New Processes; PRINTING, Hand-Block; Flat-Press Work; Machine Printing—MORDANTS—STYLES OF CALICO-PRINTING: The Dyed or Madder Style, Resist Padded Style, Discharge and Extract Style, Chromed or Raised Colours, Insoluble Colours, &c.—Thickeners—Natural Organic Colouring Matters—Tannin Matters—Oils, Soaps, Solvents—Organic Acids—Salts—Mineral Colours—Coal Tar Colours—Dyeing—Water, Softening of—Theory of Colours—Weights and Measures, &c.

"When a READY WAY out of a difficulty is wanted, it is IN BOOKS LIKE THIS that it is found."—*Textile Recorder*.

"MR. DUERR'S WORK will be found MOST USEFUL. . . . The information given is of GREAT VALUE. . . . The Recipes are THOROUGHLY PRACTICAL."—*Textile Manufacturer*.

SECOND EDITION. Revised and Enlarged. With Numerous
Illustrations. 4s. 6d.

GARMENT DYEING AND CLEANING.

A Practical Book for Practical Men.

BY GEORGE H. HURST, F.C.S.,

Member of the Society of Chemical Industry.

GENERAL CONTENTS.—Technology of the Textile Fibres—Garment Cleaning—Dyeing of Textile Fabrics—Bleaching—Finishing of Dyed and Cleaned Fabrics—Scouring and Dyeing of Skin Rugs and Mats—Cleaning and Dyeing of Feathers—Glove Cleaning and Dyeing—Straw Bleaching and Dyeing—Glossary of Drugs and Chemicals—Useful Tables.

"An UP-TO-DATE hand book has long been wanted, and Mr. Hurst has done nothing more complete than this. An important work, the more so that several of the branches of the craft here treated upon are almost entirely without English Manuals for the guidance of workers. The price brings it within the reach of all."—*Dyer and Calico-Printer*.

"Mr. Hurst's WORK DECIDEDLY FILLS A WANT . . . ought to be in the hands of EVERY GARMENT DYER and cleaner in the Kingdom"—*Textile Mercury*.

LONDON: CHARLES GRIFFIN & CO., LIMITED, EXETER STREET, STRAND.

"Boys COULD NOT HAVE A MORE ALLURING INTRODUCTION to scientific pursuits than these charming-looking volumes."—Letter to the Publishers from the Headmaster of one of our great Public Schools.

Handsome Cloth, 7s. 6d. Gilt, for Presentation, 8s. 6d.

OPEN-AIR STUDIES IN BOTANY:

SKETCHES OF BRITISH WILD FLOWERS IN THEIR HOMES.

By R. LLOYD PRAEGER, B.A., M.R.I.A.

Illustrated by Drawings from Nature by S. Rosamond Praeger,
and Photographs by R. Welch.

GENERAL CONTENTS.—A Daisy-Starred Pasture—Under the Hawthorns—By the River—Along the Shingle—A Fragrant Hedgerow—A Connemara Bog—Where the Samphire grows—A Flowery Meadow—Among the Corn (a Study in Weeds)—In the Home of the Alpines—A City Rubbish-Heap—Glossary.

"A FRESH AND STIMULATING book . . . should take a high place . . . The illustrations are drawn with much skill."—*The Times*.

"BEAUTIFULLY ILLUSTRATED. . . One of the MOST ACCURATE as well as INTERESTING books of the kind we have seen."—*Athenæum*.

"Bedolent with the scent of woodland and meadow."—*The Standard*.

With 12 Full-Page Illustrations from Photographs. Cloth.
Second Edition, Revised. 8s. 6d.

OPEN-AIR STUDIES IN GEOLOGY:

An Introduction to Geology Out-of-doors.

By GRENVILLE A. J. COLE, F.G.S., M.R.I.A.,

Professor of Geology in the Royal College of Science for Ireland,
and Examiner in the University of London.

GENERAL CONTENTS.—The Materials of the Earth—A Mountain Hollow—Down the Valley—Along the Shore—Across the Plains—Dead Volcanoes—A Granite Highland—The Annals of the Earth—The Surrey Hills—The Folds of the Mountains.

"The FASCINATING 'OPEN-AIR STUDIES' of PROF. COLE give the subject a GLOW OF ANIMATION . . . cannot fail to arouse keen interest in geology."—*Geological Magazine*.

"A CHARMING BOOK, beautifully illustrated."—*Athenæum*.

Beautifully Illustrated. With a Frontispiece in Colours, and Numerous
Specially Drawn Plates by Charles Whympers. 7s. 6d.

OPEN-AIR STUDIES IN BIRD-LIFE:

SKETCHES OF BRITISH BIRDS IN THEIR HAUNTS.

By CHARLES DIXON.

The Spacious Air.—The Open Fields and Downs.—In the Hedgerows.—On Open Heath and Moor.—On the Mountains.—Amongst the Evergreens.—Copses and Woodland.—By Stream and Pool.—The Sandy Wastes and Mud-flats.—Sea-laved Rocks.—Birds of the Cities.—INDEX.

"Enriched with excellent illustrations. A welcome addition to all libraries."—*Westminster Review*.

LONDON: CHARLES GRIFFIN & CO., LIMITED, EXETER STREET, STRAND.

Twenty-third Annual Issue. Handsome cloth, 7s. 6d.

(To Subscribers, 6s.)

THE OFFICIAL YEAR-BOOK

OF THE

SCIENTIFIC AND LEARNED SOCIETIES OF GREAT BRITAIN AND IRELAND.

COMPILED FROM OFFICIAL SOURCES.

Comprising (together with other Official Information) LISTS of the PAPERS read during the Session 1905-1906 before all the LEADING SOCIETIES throughout the Kingdom engaged in the following Departments of Research:—

- | | |
|--|---|
| § 1. Science Generally: <i>i.e.</i> , Societies occupying themselves with several Branches of Science, or with Science and Literature jointly. | § 6. Economic Science and Statistics. |
| § 2. Mathematics and Physics. | § 7. Mechanical Science, Engineering, and Architecture. |
| § 3. Chemistry and Photography. | § 8. Naval and Military Science. |
| § 4. Geology, Geography, and Mineralogy. | § 9. Agriculture and Horticulture. |
| § 5. Biology, including Microscopy and Anthropology. | § 10. Law. |
| | § 11. Literature. |
| | § 12. Psychology. |
| | § 13. Archæology. |
| | § 14. MEDICINE. |

“FILLS A VERY REAL WANT.”—*Engineering*.

“INDISPENSABLE to any one who may wish to keep himself abreast of the scientific work of the day.”—*Edinburgh Medical Journal*.

“THE YEAR-BOOK OF SOCIETIES is a Record which ought to be of the greatest use for the progress of Science.”—*Lord Playfair, F.R.S., K.C.B., M.P., Past-President of the British Association*.

“It goes almost without saying that a Handbook of this subject will be in time one of the most generally useful works for the library or the desk.”—*The Times*.

“British Societies are now well represented in the ‘Year-Book of the Scientific and Learned Societies of Great Britain and Ireland.’”—(Art. “Societies” in New Edition of “Encyclopædia Britannica,” vol. xxii.)

Copies of the FIRST ISSUE, giving an Account of the History, Organization, and Conditions of Membership of the various Societies, and forming the groundwork of the Series, may still be had, price 7/6. *Also Copies of the Issues following.*

THE YEAR-BOOK OF SOCIETIES forms a complete INDEX TO THE SCIENTIFIC WORK of the sessional year in the various Departments. It is used as a HANDBOOK in all our great SCIENTIFIC CENTRES, MUSEUMS, and LIBRARIES throughout the Kingdom, and has become an INDISPENSABLE BOOK OF REFERENCE to every one engaged in Scientific Work.

READY IN OCTOBER EACH YEAR.

LONDON: CHARLES GRIFFIN & CO., LIMITED, EXETER STREET, STRAND.

89042757773



b89042757773a