

WIRELESS TIME SIGNALS

RADIO-TELEGRAPHIC TIME AND
WEATHER SIGNALS TRANSMITTED
FROM THE EIFFEL TOWER,
AND THEIR RECEPTION

*Issued by the Paris Bureau of Longitudes. Authorised
Translation, with Additional Tables and Data*

WITH 1 FOLDING PLATE AND 30 ILLUSTRATIONS



London:
E. & F. N. SPON, LIMITED, 57 HAYMARKET
New York:
SPON & CHAMBERLAIN, 123 LIBERTY STREET

1915

WIRELESS TIME SIGNALS

WORKS ON

WIRELESS TELEGRAPHY

Plans and Specifications for Wireless Telegraph

Sets. By A. FREDERICK COLLINS. Part I. Complete and detailed instructions for making an Experimental Set, also a One to Five Mile Set. 37 illustrations, viii + 47 pp., crown 8vo. (S. & C. SERIES, No. 41.) 1s. 6d. net.

Plans and Specifications for Wireless Telegraph

Sets. By A. FREDERICK COLLINS. Part II. Complete and detailed data for constructing a Five to Ten Mile Set, also a Ten to Twenty Mile Set. 62 illustrations, viii + 72 pp., crown 8vo. (S. & C. Series, No. 42.) 1s. 6d. net.

Wireless Telegraphy for Intending Operators.

By C. K. P. EDEN, B.Sc., etc. A Simple Treatise upon the Theory and Working of Commercial Wireless Telegraphy. 16 illustrations, 80 pp., crown 8vo. (S. & C. SERIES, No. 43.) 1s. 6d. net.

Making Wireless Outfits.

A Concise and Simple Explanation of the Construction and Use of an Inexpensive Wireless Equipment for Sending and Receiving up to 100 miles, giving full details and illustrations. By NEWTON HARRISON, E.E., Instructor of Electrical Engineering, Newark Technical Schools. 27 illustrations, 61 pp., crown 8vo. (S. & C. SERIES, No. 11.) 1s. 6d. net.

Wireless Telephone Construction.

By NEWTON HARRISON, E.E. 43 illustrations, 74 pp., crown 8vo. (S. & C. SERIES, No. 12.) 1s. 6d. net.

Practical and Experimental Wireless Telegraphy.

A Handbook for Operators, Students and Amateurs. By W. J. SHAW, Member of the Wireless Society of London. 42 illustrations, 102 pp., crown 8vo. 3s. 6d. net. (Post free, 3s. 10d.)

General Principles—Detectors—The Aerial Apparatus—Tuning the Circuit—Useful Formulæ and Notes—How to Make—General Hints—Index.

E. & F. N. SPON, LTD., 57 HAYMARKET, S.W.

CONTENTS

PREFACE	PAGE ix
-------------------	------------

CHAPTER I.—INSTALLATION OF RECEIVING APPARATUS

Aerials	I
Earth	6
Receiving Apparatus	7

CHAPTER II.—ORDINARY TIME SIGNALS

Organisation of the Service	31
Despatch of Ordinary Time Signals	34
Reception of Ordinary Time Signals	40
Corrections	41

CHAPTER III.—SCIENTIFIC TIME SIGNALS

Despatch of Signals	62
Reception of Signals	66
Improvement of Time transmitted	67
Determination of Longitudes	68

365086

CHAPTER IV.—HOW TO MAKE AND CALCULATE THE COMPARISONS MADE WITH SCIENTIFIC TIME SIGNALS

	PAGE
Arrangement of Receiving Apparatus	74
Carrying out Comparisons	75
General Remarks	84
Calculation of the Times of the 1st and 300th Scientific Time Signals	86
Use of Special Scientific Signals	91
Table giving in Seconds the Value of a Number or Intervals of Scientific Time Signals	98

APPENDIX A.—TIME SIGNALS AND WEATHER REPORTS AT PRESENT TRANSMITTED DAILY FROM THE EIFFEL TOWER STATION

Ordinary Morning Time Signals	107
Ordinary Night Time Signals	108
Scientific Time Signals	108
General Weather Report	109
Paris Weather Report	112

APPENDIX B.—ADDITIONAL NOTES BY TRANSLATORS

Weather Reports—Augmented	114
Rhythmic Signals	115
Coincidences—Reduced Method	115
Weather Reports—English	118

CONTENTS

vii

	PAGE
Time Table for Amateurs	119
Norddeich Time Signals	120
International Time Scheme	121

APPENDIX C. — TABLES AND FRENCH- ENGLISH VOCABULARY

Call Letters (International)	121
Time Signals (Proposed International Stations, etc.)	121
Morse Code (International)	123
Vocabulary—French	124

APPENDIX D. — CHANGES IN BRITISH WEATHER REPORTS

Conversion Table—Mercury Inches to Millibars	127
" " Millibars to Mercury Inches	128
" " Miles per Hour to Metres per Second	129
" " Barometric Readings — Inches to Millimetres	130
 INDEX	 131

PLATE I. <i>to face</i>	83
-----------------------------------	----

TRANSLATORS' PREFACE

THE supreme importance of the Wireless Time Signals sent out from the Eiffel Tower has suggested this English translation of the official handbook—*Réception des Signaux Radiotélégraphiques par la Tour Eiffel*.

The book—already well known to many acquainted with the French language—is of such practical value to navigators, geodesians, explorers, and horologists in general, that an English translation is almost indispensable to the great and ever-widening circle of all those interested in “Wireless.”

The work will appeal particularly to amateurs as giving a most lucid and simple exposition of the principles of radio-telegraphy, with practical installations suitable for their use, free from technicalities, and the section devoted to the methods and apparatus used at the Eiffel Tower will be found of especial interest.

The translators have added to the original work some Appendices (B, C, and D) containing other information, tables, etc., and a short vocabulary, which they trust will facilitate the use of the book.

E. K. S. AND C. S.

MALTON.

WIRELESS TIME SIGNALS

CHAPTER I

THE INSTALLATION OF THE RECEIVING APPARATUS

THE elements required for the reception of radio-telegraphic signals are three in number, viz. *the aerial, the earth connection, and the receiving apparatus proper.*

Aerials (Antennae).—The function of the aerial, in conjunction with the earth connection, is to collect part of the energy radiated in the transmission of signals so that it may act on the receiver proper, which transforms it in such a way that the radio-telegraphic signals are rendered perceptible to the senses.

The efficiency of an aerial depends upon its height, its linear dimensions, the number of, and the distance between the wires of which it is made, and consequently upon its electrical properties (capacity

and self-induction) being such that its *natural wavelength* is as nearly as possible equal to the wavelength used in transmitting the signals.

Actually the energy radiated by the Eiffel Tower Station in transmitting signals is great enough to permit of the use of receiving aerials of reduced height and dimensions throughout the whole of France and in the French possessions in North Africa.

Installation of a Single-Wire Aerial.—The simplest form of aerial which can be installed is a wire of insulated cable, or a bare conductor of

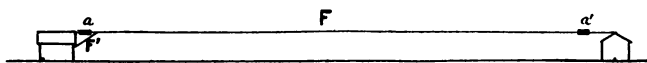

FIG. 1.

copper, bronze, or even galvanised iron, which is stretched between two high buildings or any other supports, and well insulated from these by means of insulators a , a' (fig. 1) of porcelain, glass, ebonite, etc., or even more simply by blocks of dry wood soaked in oil or melted paraffin-wax. The wire may be of any diameter so long as it is strong enough not to snap through wind or frost.

One end of the wire F is extended to the receiving apparatus by means of another conductor F' , which is soldered to F if the two cannot be made in one piece; the receiving apparatus being advantageously fixed in a room on the ground floor so that its earth wire may be as short as possible.

This second conductor F' must also be most carefully insulated throughout its whole length right up to the receiving apparatus.

To pass into the room containing the latter, the conductor should be extended by a rubber-covered cable soldered to it, or it may be merely wrapped with pitch-tape or rubber-cloth at the part where it passes through the window-casing, in which a hole of suitable size has been made. It is not essential that the two terminals a and a' (fig. 1) should be the same height above ground. Should they be at different heights, it is better that the insulated

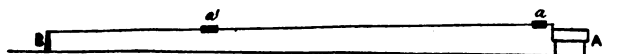

FIG. 2.

end terminal a' should be the lower, and the relative heights of a and a' above ground not less than $a'\frac{1}{2}$.

When only a single support is used for the aerial, it is generally easy to fasten the free end a' (fig. 2) to a tree or post B by means of a stay $a'B$, fastened securely to a' , and adjusted so that a' is the requisite height above ground, as mentioned above.

The direction of the wire is of minor importance. There is, however, a slight advantage in aligning it in a vertical plane towards the transmitting station, the end joined to the receiver being turned towards Paris.

When the distance permits, an aerial telegraph

or telephone wire¹ may be used as an aerial by merely connecting the receiver with it when it is not being utilised for its ordinary purpose, and if it is not subject to induction from other neighbouring lines in use. In this case it is necessary to use a receiving apparatus which permits of adjustments corresponding to the use of aerials of great length.²

Multiple-Wire Aerials.—When height and length are restricted if the reception is insufficient, it can be improved by using several wires of equal length fixed in the way already given for single-wire aerials, and joined at the one end to each other, and at the other end to the receiving apparatus. There is some advantage in aligning each wire differently so as to separate them as much as possible and also increase the area enclosed by the whole aerial.

¹ As a rule the self-induction and resistance of telegraphic and telephonic apparatus are such that it acts as if the line were insulated on both sides.

² When the distance from the Eiffel Tower is short enough, all that is required is a small aerial placed parallel to the telephone or telegraph wire without direct contact. In Paris or its immediate vicinity, a short antenna suspended inside a room suffices, the earth wire being fixed to the gas- or water-pipe. It is even possible to dispense with the antenna in certain cases, the observer replacing it by his own body placed in contact (by a hand) with the *aerial* terminal of the receiver. It is equally possible with certain types of receiver to replace the aerial by a second earth connection. For example, the receiver may be joined to a water conduit on the one hand, and a gas-pipe on the other. It is, however, advisable to have at least one of these earth wires of considerable length from the apparatus to the ground.

Fig. 3 shows a type of diverging twin-wire aerial. When the distance from the Tower is great, or even when the contour of the ground round about the receiving station interferes greatly with the propagation of waves, it becomes necessary to erect an aerial similar to those in general use at radio-telegraphic stations. The description of these aerials is outside the scope of this work, but may

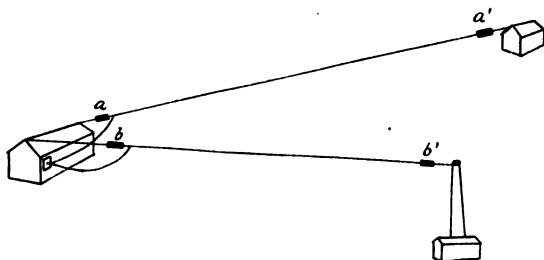

FIG. 3.

be found in special publications on Wireless Telegraphy.

Selection of a Site.—The space round the aerial should be as free and open as possible. It is best for the aerial to be fixed on supports on ground free from other buildings or trees. In particular it is advantageous that there should be no building or trees just beneath the aerial or in its immediate vicinity. If this condition cannot be fulfilled, the height of the aerial must be increased by means of masts.

For instance, when the space surrounding the aerial is very open and the site is a large plateau

or a very large valley skirted by gently undulating ground on the Paris side, a single-wire aerial, 8 to 12 metres high and about 100 metres long, is quite sufficient to receive the *daily* time signals of the Eiffel Tower throughout the whole of France with a receiver of moderate quality.

In all cases the aerial should be far enough from aerial telephone, telegraph, or power lines, so that there need be no fear of these setting up induction phenomena which would confuse the reception of radio-telegraphic signals because of the medley of sounds produced in the telephones of the receiver.

It is impossible to give, in advance, definite instructions as to the distance to be observed, because the effects of induction vary greatly according to circumstances. Usually 100 metres is a sufficient distance.

Following the hints here given, it is easy to conceive the arrangements to be adopted in the various cases which may present themselves. The essential precautions to be taken are as follow: *Insulate the wire or wires well, let them be of sufficient length, and fix them as high as possible above ground or above conductors connected with earth.*

Earth Connection.—It is important to arrange a good earth system to be connected with the receiver. Underground metal conduits for gas and water will do very well if they are in damp ground and if the pipes are not made up of sections with leather or rubber or even oxidized joints. It is wise to solder

a wire to the earth-lead in order to effect the connection with the receiver, as a slight blow may give a bad contact because of oxidation.

Should no metal mains be available, a good earth connection may be obtained by burying in the ground a metal plate $\frac{1}{2}$ to 1 square metre in area, fixed deep enough to be always in contact with damp soil and connected with the receiver by a metal wire soldered to it. When it is inconvenient to excavate deeply enough to reach damp soil, the area of the metal plate must be increased, which may be readily done by making it of several sections soldered together. Long strips of very large mesh galvanised iron netting may be successfully used if buried in only slightly damp ground. The greater the dimensions of the buried strips, the better the earth connection. At least 50 square metres of strips should be used. In all cases earthing should be made as close as possible to the room in which the receiver is, so that the wire joining the latter to earth may be very short.

Receiving Apparatus.—The receiving apparatus, which is joined on the one hand to the aerial, and on the other to the earth connection, comprises all the instruments necessary to render perceptible to the senses the electrical oscillations set up in the aerial by the Hertzian waves produced in transmitting signals. A very large majority of receivers are of such a nature that these oscillations are finally reproduced as sounds in a telephone. This is the

only type of receiver which concerns us, and our attention is confined to the simplest kinds, which are also those most generally in use for the purpose discussed in this work.

Principle.—The following is the general principle of radio-telegraphic reception :—An aerial A (fig. 4) earthed at its lower end and subjected to the action of Hertzian waves emanating from a transmission station, becomes the seat of electrical oscillations, *i.e.* alternating currents of very high frequency. These reach their maximum intensity, all other factors being equal, when the electrical properties of the aerial (capacity and self-induction) are such that its natural wave-length is equal to that of the waves to be received. When an aerial consists of a single wire, its natural wave-length is at least equal to four times the length of the wire. When the aerial is made of several wires of equal dimensions, its natural wave-length is much more than four times the length of one wire, and becomes still greater if the number of wires is increased and they are fixed widely apart. In this way the waves obtained can be double or treble the length of those got from a single wire. As it is not usually possible to instal an aerial of wires above 100 metres long, and as the waves transmitted from the Eiffel Tower have a length of about 2000 metres, it is evidently not practicable to give the aerial a wave-length equal to that of the Eiffel Tower by increasing the number and length of the wires. It is easy, however,

to attain this equality by putting a suitably constructed self-induction coil B in series with the aerial (fig. 5). Thus the total self-induction of the aerial is increased and can be easily adjusted, or "tuned," to such a value that the natural wave-length (which is a function of this self-induction) may be equal to

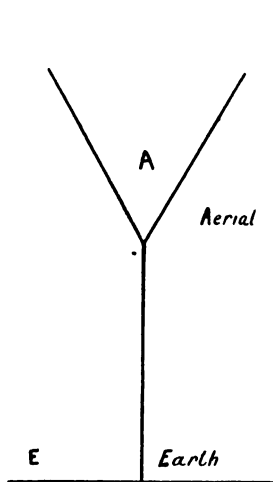

FIG. 4.

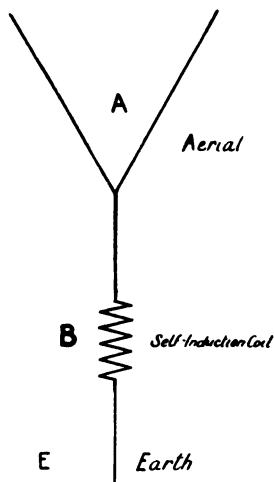

FIG. 5.

that transmitted by the Eiffel Tower. The conditions to secure the desired maximum intensity for the electrical oscillations generated in the aerial are now fulfilled.

Let us now consider the type and arrangement of the instruments necessary for the reproduction of these oscillations as sounds in the telephone. The oscillations are too rapid and their intensity

too feeble to be indicated by the apparatus ordinarily used in electricity. Special instruments called *wave-detectors* must be employed.

There are a great many types of detectors in existence, but we will here confine ourselves to a description of those most generally used: *electrolytic* and *crystal detectors*.

Electrolytic Detectors.—The principle of the

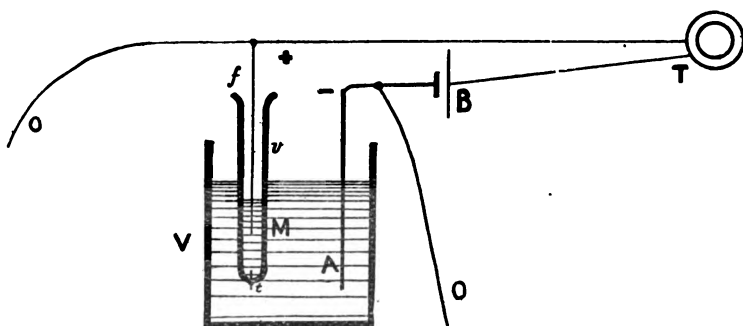

FIG. 6.

construction of an electrolytic detector is as follows:—In the bottom of a glass tube v closed at one end (fig. 6) a platinum wire t is fused and cut off flush with the glass on the outside. This platinum wire should be $\cdot 01$ or $\cdot 02$ millimetre diameter. A little mercury is poured into the tube v so as to place a copper wire f in communication with t . The tube v is plunged into a jar V containing acidulated water (accumulator acid): a platinum wire A of any diameter is also placed in the jar. The wires f and A are joined to a circuit comprising a battery B of

suitable strength and a telephonic earpiece T. The current from B passing through the acidulated water between A and t decomposes it, and a bubble of oxygen forms on the point t . The current then ceases and no sound is heard in the telephone. If this arrangement is subjected to the action of Hertzian waves or electrical oscillations coming from a circuit OO, the bubble of oxygen on t breaks away, and the current from B once more passes through the liquid. Thus all the time the apparatus is subjected to the waves a sound is heard in the telephone. This sound is caused by the passage through the telephone of currents of short duration, produced by the series of wave-groups, each of these being the effect of one transmitting spark. Immediately the waves cease to act the bubble is again formed on t , and no sound is heard in the telephone. If, then, this arrangement is subjected to a series of long and short Hertzian waves, these are reproduced in the telephone as sounds of long and short duration. This detector requires no other adjustment beyond that of the E.M.F. of the battery B, which should be between 2.5 and 3 volts according to the construction of the apparatus, this adjustment being made once and for all. When the voltage is too high, the bubble will not remain on the point t , but breaks away as soon as it is formed, and a continuous buzzing is heard in the telephone.

Crystal Detectors.—Crystal detectors are in principle formed by the contact of two crystalline

masses, or of a metal and a crystalline mass. There are a great many varieties, which may be divided into two classes, the first being those which require the use of the battery ; but detectors of this type are seldom used. The theory of these is analogous to

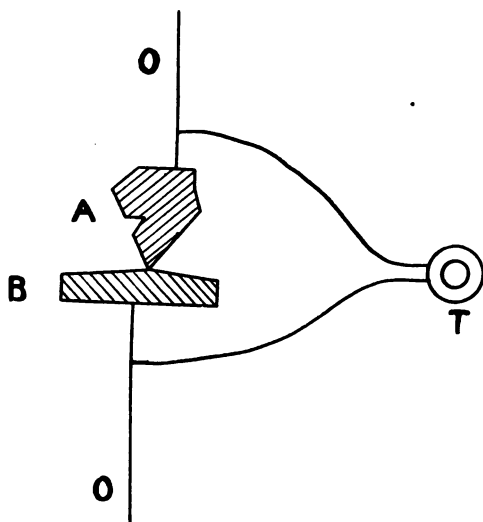

FIG. 7.

that of the electrolytic detector ; an electrolysis of the solids in contact is produced, as occurs in acidulated water. The theory generally accepted for the second class of detectors is the following :— The contact of two selected bodies A and B (fig. 7) exhibits the phenomenon of unilateral conductivity ; that is to say, a positive current, for example, can pass through the contact A to B, encountering but

feeble resistance, whilst it meets a far greater resistance in the reverse direction B to A. In other words, the contact AB allows positive currents to pass from A to B, but will not permit negative currents to pass in that direction. When the contact is subjected to electrical oscillations (Hertzian waves), *i.e.* to alternating currents of high frequency, changing direction many times per second, which reach it through a circuit OO, the positive alternations pass through the contact, whilst the negative are checked. If a telephone T be joined up to the terminals of the contact AB, its high self-induction resists the passage of oscillations coming from OO. Even if they could pass through it, the telephone disc would not vibrate, the frequency of the oscillations being too high. But as the positive alternations pass through the contact AB, the negative alternations, which are merely a very rapid succession of similarly-directed currents, can pass through the telephone and work it. The series of oscillations coming through OO, which are each produced by weakened wave-groups corresponding in number to the transmission sparks which generate them, will be therefore reproduced in the telephone as sounds having the same duration and absolutely like those of the transmission sparks, each of them producing a vibration of the disc of the telephone.

Crystal detectors may be constructed in a great variety of ways. Those most commonly used are made with the following contacts :—

Carborundum	.	.	Metal, <i>e.g.</i> a copper or platinum plate.
Zincite	.	.	Chalcopyrites, bornite, etc.
Iron or copper pyrites	.	.	Metal (a firm point of copper or steel lightly pressing on it).
Galena	.	.	Copper wire or very fine platinum, etc., etc.

The inconvenience of these detectors is that it is frequently necessary to readjust the point of contact of the two bodies in order to find which points of the crystal most satisfactorily exhibit unilateral conductivity. But they are certainly very sensitive, and as they are easily made, they are frequently used.

The following is an example of an easily-constructed detector:—A piece of galena *G* with large crystals¹ is gripped in a copper clamp *M*, having good contact with it. This clamp is fixed in a metal binding-post *C* connected with a terminal *B* on a stand *L*. Another binding-post *C'* connected with a terminal *B'* carries another clamp *N* bearing a copper wire *f*, as fine as possible. The terminals *B*, *B'*, are joined up on the one hand with the telephone *T*, and on the other with the circuit *OO*, through which the electrical oscillations are conveyed. By suitably adjusting the pressure of *f* on the crystal *G* and finding on the surface of the latter the best points of contact, it is easy to make a very sensitive

¹ The sensitiveness of detectors constructed like this varies according to the type of the crystal.

detector. The apparatus when adjusted must be most carefully protected from shocks or even vibrations as the contact is extremely easily deranged and the sensitiveness of the detector destroyed. In this way a detector may be easily made with an ordinary sewing needle and a crystal of pyrites. There is no need to deal with the process of manufacture of detectors, for it is usually an advantage to obtain these instruments from special makers.

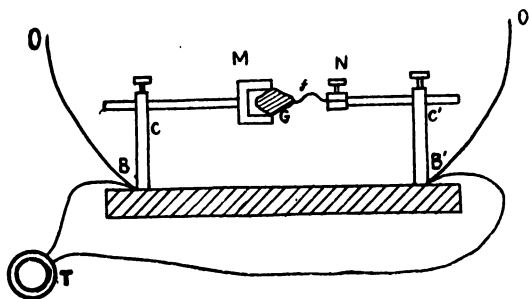

FIG. 8.

Fitting up the Receiver. — We have now to consider what is the best way to connect the detector with the aerial and the earth system so that the electrical oscillations gathered by the aerial have a maximum effect on the detector, *i.e.* are reproduced by the loudest possible sounds in the telephone.

(a) *Simplified Receiver.*¹—The simplest method is to connect the two poles of the detector with the terminals of the inductance which it is necessary to

¹ At short distances from the Eiffel Tower the receiver may be still further simplified and the inductance S dispensed with.

place in the aerial circuit to tune it to the waves to be received, as already indicated (fig. 5). With an electrolytic detector the arrangement is as shown in fig. 9. S is the tuning inductance of the aerial, D the detector, T the telephone earpiece, P the battery (two cells), the positive pole of which is placed on the same side as the point or needle of

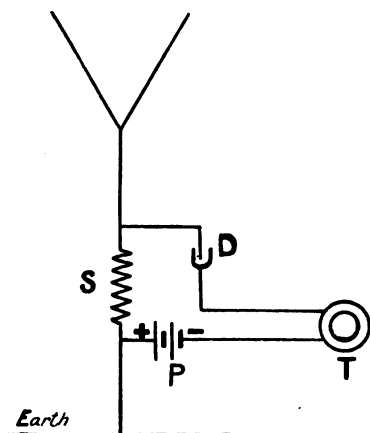

FIG. 9.

the detector. The waves or electrical oscillations existing in the aerial produce an alternating potential difference between the terminals of the inductance S, which acts upon the detector D. Under this action D becomes a conductor, as has already been shown, and allows the current of the battery P to pass through it, which simultaneously produces a sound in the telephone. The absence of an induction coil for regulating the potential difference

THE RECEIVING APPARATUS 17

to which D is subjected by means of the battery causes a continuous buzzing in the telephone, but as a rule this does not greatly interfere with the reception of the signals.

The detector being in good order and the battery

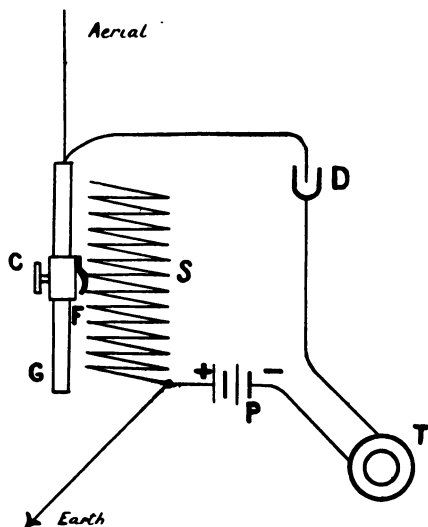

FIG. 10.

of suitable strength, the only adjustment to be made is that of the inductance S to obtain the maximum intensity of the oscillations produced in the aerial by the transmitted waves. In order that this tuning may be conveniently effected, the inductance may be made of insulated wire, coiled in closely wound spirals on a cylinder or prism. The turns are then stripped bare in such a way that a slider FC (fig. 10),

rubbing on these spirals and sliding the whole length of a metal rod *G*, can be placed in contact with any one of the turns. The number of turns used in the aerial circuit can thus be varied at will, and tuning becomes a simple matter. Fig. 10 shows the complete arrangement when an electro-

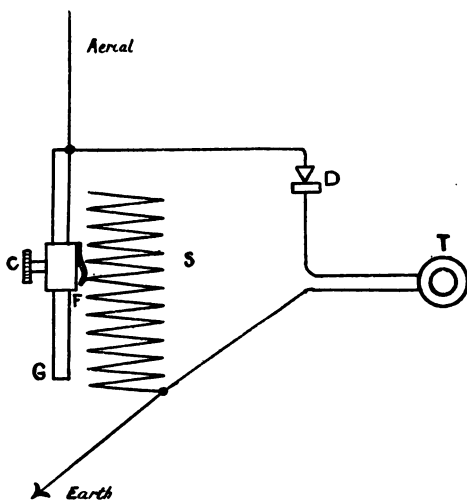

FIG. 11.

lytic detector is used, and figs. 11 and 12 in the case of a crystal detector.

In both cases, assuming the detector to be in good order, there is only one adjustment to be made in order to receive the signals, and that is to move the slider until the signals are heard with the greatest possible clearness. In certain types of apparatus the inductance *S* is in two parts, one

fixed, the other variable, and the former may be short-circuited by means of a commutator when it is desired to receive short waves, *i.e.* when it is not necessary to connect the aerial with a strong inductance to tune it to the waves to be received.

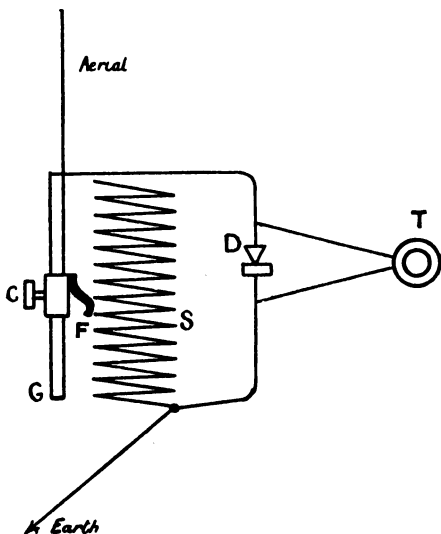

FIG. 12.

When the receiver is intended to pick up waves from one transmission only, always of the same strength, it is easy to make a certain number of inductances *S* without slider or tuner, and, by experiment (modifying where necessary), find one which gives the best results. These inductances may be very readily made by coiling any kind of wire, silk-covered or bell-wire, etc., of a diameter of from 0.3

to 1·0 millimetre round a cylinder or block of insulating material (*e.g.* wood or cardboard boxes) of about 10 to 30 cm. thickness. The coils should be closely wound, though this is not absolutely essential. The number of turns varies according to the length of the aerial, the diameter of the inductance, and the diameter of the wire: it must be found by experiment.

Instead of coiling the wire in spirals placed side by side, it may be coiled in gradually diminishing spirals tied together, so that it has the appearance of a truncated cone. It is even possible to tune by deforming this cone.

In the case of electrolytic detectors it is best to use high-resistance telephones, 3000 to 10,000 ohms. The telephones used with a crystal detector may be of any resistance whatever.

(*b*) *More Complete Receivers.*—The arrangement just described is the simplest, but it is far from being the best, as much as regards its production as its purity of resonance; that is to say, as regards protection against disturbances of all kinds, such as simultaneous extraneous transmissions and natural electrical phenomena.

From a technical point of view the following arrangement (fig. 13) has a certain superiority and may be used with success:—On a cylinder of insulating material of, say, 25 cm. diameter, a certain number of spirals of insulated wire are closely wound, 150 turns of bell-wire will do.

These turns S are stripped as before. Two sliders C, C' , moving along an insulating rod G , are furnished with scrubbers f, f' , which can be placed in contact with any turn whatever. The slider f is joined to the aerial, and f' to earth.

When an electrolytic detector is used, its anode

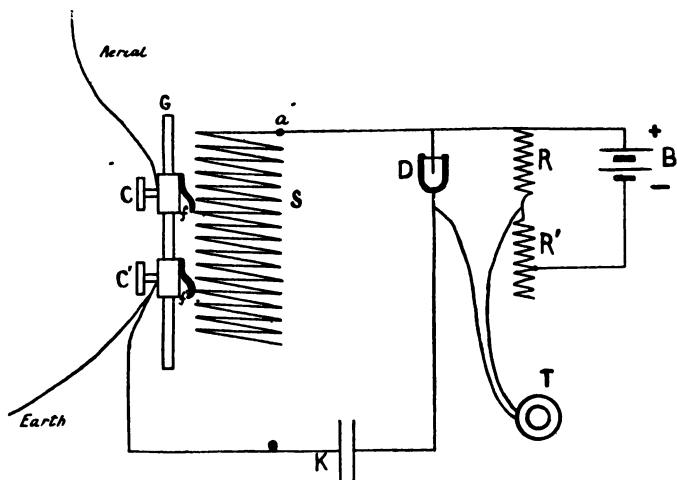

FIG. 13.

is joined to one terminal a of the coil, the cathode being connected with one armature of a condenser K , the other armature of which is joined to f' , *i.e.* to earth. This condenser may be made of any type of Leyden jar, or even in the following way:—One armature is made of three or four sheets of tinfoil about 10 cm. square, the other armature consisting of two or three similar sheets.

The dielectric interposed between these plates is made of strong paper soaked in oil or paraffin-wax, of slightly larger size than the sheets of tinfoil. The whole is gripped between two strips of wood joined at the edges outside the condenser by several screws. The two electrodes of the electrolytic detector are joined to the terminals of a fixed resistance R (say 1000 ohms), one or more telephonic earpieces being joined up with the connections. The fixed resistance R is placed in circuit with a variable resistance R' and a battery B of 3 or 4 volts. The resistance R' may be either of continuous variation or of intermittent variation of 100 in 100 ohms from 100 to 1000 ohms. In this way it is possible to vary the voltage at the terminals of R , *i.e.* also at the terminals of the detector, from 1.5 up to 3 volts, if the battery has an E.M.F. of 3 volts. This arrangement, called a *potentiometer*, permits of the adjustment of the difference of potential at the detector terminals to a value best suited to its working: R may also be 100 ohms, and R' vary 10 in 10 ohms from 0 up to 100 ohms in order to simplify the construction of the potentiometer, but in that case the low resistance would cause the battery B to polarise rapidly, and two accumulators must be used instead. To make use of this apparatus the following adjustments must be carried out.

Adjustment of the Detector.—In finding the value of the variable resistance of the potentiometer

which best suits the detector, the correct one is easily recognised as the detector does not cause a continuous buzzing in the telephone, whilst this buzzing is produced when the next higher value is used.

Adjustment of the Number of Turns in the Aerial Inductance, i.e. the number of turns between the two sliders.—This is for the purpose of finding the amount of self-induction which must be introduced into the aerial circuit to tune it to the length of the waves to be received.

To carry out this adjustment, give the earth slider any position, then move the aerial slider until the signals are heard with the greatest possible clearness. If nothing is observed in all positions of the aerial slider, give the earth slider a new position and again experiment with the aerial slider, and so on until a perceptible sound is obtained.

Adjustment of the Resonance Circuit of the Detector, i.e. the number of turns in circuit with the condenser K and the detector D (fig. 13).—This circuit, on which the oscillations set up in the aerial act by induction, should also be tuned to the wave-length of these oscillations.

This tuning is effected by finding the self-induction which suits the circuit, *i.e.* the number of turns to be introduced. These turns are between the slider f' and the terminal a . To do this, keep the distance between the two sliders the same as found previously and move them gradually to the

position which corresponds to the maximum intensity of sound heard in the telephone.

In practice these two adjustments are made simultaneously. The slider f' is placed at the

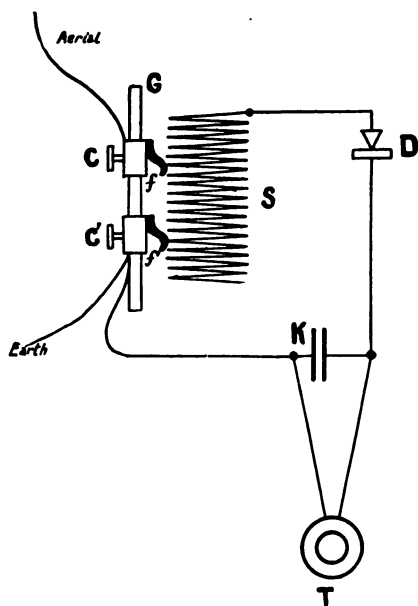

FIG. 14.

bottom of the coil, and the best position for f found ; f' is moved again, and f once more adjusted, and so on. The adjustment finally selected is that which gives the greatest distinctness of sound in the telephone.

When a *crystal detector* is used, the analogous grouping adopted is as indicated in fig. 14.

There is no battery in the circuit, and the telephone T is joined to the terminals of the condenser K. The adjustment of the detector consists in finding by experiment the best point of contact of the metal with the crystal. The tuning by means of the sliders is carried out exactly as already described.

(c) *Complete Receiver.*—The arrangement shown in figs. 13 and 14, although better than that of figs. 10 and 11, still does not give adequate protection against the various disturbances. It is impossible to give here an account of all the arrangements capable of being used for obtaining still better results, since it would be necessary to describe all the receivers at the fully-equipped wireless stations. By way of example, it will be sufficient to describe one of those installed for the reception of greater wave-lengths than the natural wave-length of the receiving aerial, and which is particularly adapted to receive the Eiffel Tower signals. The aerial circuit is entirely separated from the detector circuit (fig. 15). The former consists of an inductance F, which is tuned by a slider C, as described above, and a second coil P equally adjustable and also fixed on a hollow cylinder of insulating material, say ebonite. Inside this coil P is another S, also wound on a cylinder of insulating material, and which for convenience is shown in the sketch alongside P.

This coil S is also made of closely wound spirals

and can be moved inside P so as to increase or diminish the induction produced in it by P. Its terminals are joined to the condenser K and the

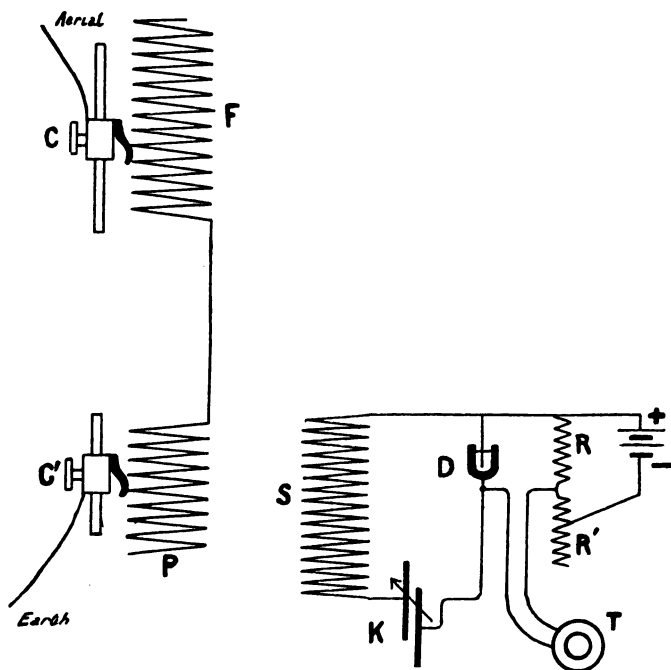

FIG. 15.

detector D. The condenser is generally variable ; that is to say, its capacity can be altered by sliding one armature over the other. When an electrolytic detector (fig. 15) is used, the potentiometer and the telephones are grouped as in fig. 13. But if a

crystal detector is used (fig. 16), the apparatus is connected up as in fig. 14.

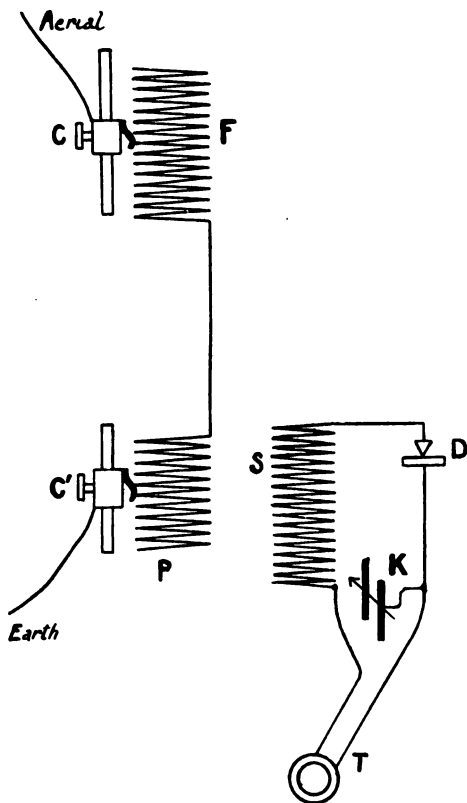

FIG. 16.

The necessary adjustments are :—

Adjustment of the Detector.—As above.

Adjustment of the Aerial.—Find the inductance

which must be added to the aerial circuit to tune it to the wave-length of the signals to be received. This inductance may be varied by moving either P or F, or both. First place the slider C' on P in a position corresponding to, say, 20 turns, for instance. Push S to the bottom of P to give K an average value. Then find by experiment the best position of the slider C on the coil F, *i.e.* which gives the loudest sound in the telephone.

Adjusting the Resonance Circuit of the Detector.—

The detector is inserted in a circuit comprising a capacity K and an inductance S, and it is necessary to tune this circuit also to the wave-length to be received. This tuning can be effected either by altering the inductance, *i.e.* the number of turns of S, or the capacity K. Suppose the number of turns is constant, then the condenser K must be adjusted. The tuning of the aerial having been carried out as stated, vary K's capacity to find once more the value giving the best reception. Separate S and P a little, and again find by experiment the best position of C and the best value of K.

When the observer is troubled by any disturbances whatever, he should not hesitate to reduce the sound of the signals he wishes to receive if by so doing he also reduces the sounds of the disturbances. In this case S and P should be further separated and new values of C and K found by experiment until the disturbances are weakened, the signals yet

being perceptible. P also may be shortened, *i.e.* the number of turns in circuit diminished by the slider, and a new adjustment of C made. With sufficient practice tuning may be rapidly effected. If the results are still not satisfactory and disturbances are still evident, replace the coil S by another, either longer or shorter, and again tune.

Verification of Receivers.—Whatever type of receiver is used, it is frequently necessary to ascertain that the detectors are in good order, these instruments being very quickly deranged or worn out, especially when they are subjected to powerful waves or violent natural electrical disturbances. Their condition can be ascertained by listening to a familiar transmission, the intensity of which is known by experience.

When an electrolytic detector is not working well, rubbing the point of the platinum wire which is fused into the glass with very fine emery paper is usually effective. It is advisable to verify the voltage and internal resistance of the battery periodically.

The contacts and sliders should always be kept in good condition and free from oxidation. Make sure also that the frequent handling of the sliders¹ does not wear away the spirals of the coil, nor short-circuit them.

In case of casual bad working, when the aerial

¹ Whenever possible, it is preferable to replace the sliders by plug commutators.

has been tested and the earthing and receiver connections examined, make certain that the detector, battery, telephone, and connections are in good order. The other parts need not be examined until these have been tested. First tighten up all the contacts, all communicating screws—be sure that the connecting wire is not detached or broken,—then examine the sliders and the condition of the coil as well as that of the condenser.

CHAPTER II

ORDINARY TIME SIGNALS

Organisation of the Service.—In 1909 the *Bureau des Longitudes*, on behalf of the authorities interested, took the initiative in bringing about arrangements whereby the military radio-telegraphic station at the Eiffel Tower could be organised for the transmission of time signals twice daily. These signals were primarily intended to enable ships equipped with suitable wireless receivers to set their chronometers to the time of the prime meridian.

It is well known how important it is to navigators, especially when approaching shore or in danger, to have the exact time of the prime meridian, the difference between this and the local time giving the longitude, *i.e.* their exact *meridional position*. Many of the shipwrecks on the coast are due to errors of *position*.

The time signals directly supply the time of the prime meridian. If they are sufficiently exact; they also enable the rate of chronometer at sea to be determined, a knowledge of which is indispensable when out of range of the signals.

Railway companies, clockmakers, etc., immediately desired to have the benefit of these signals, and at present there are a great many radio-telegraphic receiving installations intended solely for the reception of the Eiffel Tower time signals.

It was hardly possible to leave to the military staff of the Eiffel Tower the responsibility of attending to the astronomical clocks necessary to give out at any moment a sufficiently exact time, even if these clocks could be frequently regulated by astronomical observations. It was therefore decided to fix them at the Paris Observatory, and to connect the latter with the radio-telegraphic station by two underground lines. Telephonic apparatus is connected with one of these lines to enable the staffs of the two establishments to communicate with each other. Another line enables the transmitting radio-telegraphic apparatus to be controlled by the instruments fixed at the Observatory, which are two special clocks which can be set to time as often as required and which are used alternately. They are provided with electrical contacts which enable them to close the transmission circuit by means of relays connected to them by the underground line, *i.e.* to produce a radio-telegraphic signal exactly at the selected time (fig. 17).

In addition, by means of an ordinary key shunted across the electrical contact of the clocks the astronomer on duty is enabled to transmit the

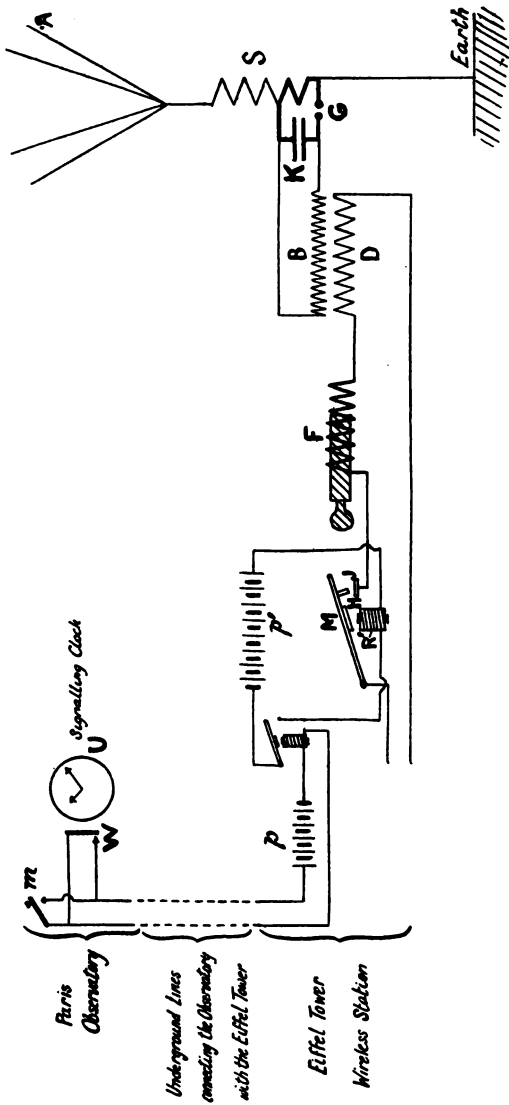

FIG. 17.

preparatory signals with which we are hereafter concerned.

Despatch of Ordinary Time Signals.—The wave-length at present in use at the Eiffel Tower

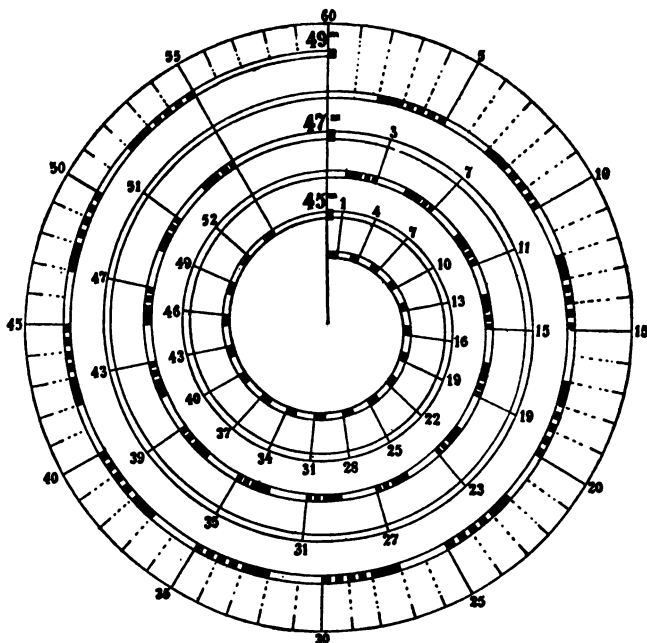

FIG. 18.—Eiffel Tower Time Signals.

for transmitting time signals is about 2000 metres. The power is 50 kilowatts—rare, low frequency spark. At present the time is transmitted every night at 11.45 p.m., 11.47 p.m., and 11.49 p.m., Greenwich mean time, in the following manner:—Some minutes before 11.45 p.m. the Eiffel Tower

These signals cease at about 11h. 48m. 55s. p.m. At exactly 11.49 p.m. the Observatory clock once more closes the transmission circuit, and a *dot* is again produced ; **this is the third time signal.**

The nature of the warning signals transmitted before each of the three time signals prevents any confusion.

Time signals are also transmitted every day at 10.45 a.m., 10h. 47m., and 10h. 49m., in the same way as just described. These signals are followed by the despatch of a weather report from the Central Meteorological Office (Bureau Central Met.). (See Appendix A, p. 107.)

The *International Time Conference*¹ (Conférence Internationale de l'Heure), which met in Paris from 15th to 23rd October 1912, on the initiative of the Bureau des Longitudes, decided that, commencing with 1st July 1913, all the stations transmitting time signals should send out the same signals and conform to the scheme shown in fig. 19.

The total duration of the signals is reduced to three minutes : they will commence at 57m. and finish exactly at the hour.

They will consist of, first, warning signals, a series of letters X (— -- —) from 57m. 0s. to 57m. 50s. ; then the *time signals proper* of dashes and dots. The Conference also determined the

¹ The reports and transactions of the *International Time Conference* are published under the auspices of the *Bureau des Longitudes* at the Librairie Gauthier-Villars, Paris.

duration of the component elements of these last signals as follows :—

Dash = 1 second.

Dot = $\frac{1}{4}$ second.

Interval between two consecutive signals = 1 second.

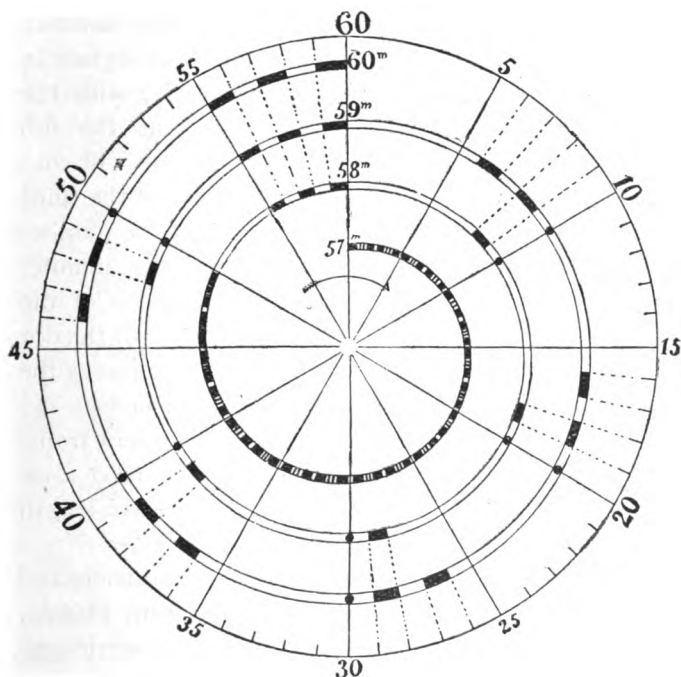

FIG. 19.—Proposed International Time Signals.

m.	s.	m.	s.	
57	0 to 57	50		Warning Signals.
57	55 to 58	0		
58	8 to 59	0		} Time Signals.
59	6 to 60	0		

In order to avoid errors of duration and spacing, the Conference advised that the signals be made automatically and not by hand. As the diagram shows, at the end of each minute from the 55th to the 60th second three dashes will be sent, the completion of the last taking place at the full minute. In addition, during the last two minutes there will be groups of identical signals in each, finishing exactly every 10 seconds, with the exception, of course, of the signals at the full minute. The groups of the second minute will consist of a consecutive dash and dot ; those of the third minute of two dashes and a dot, so that the number of signals in each group will mark the minute. According to the above-mentioned definition of the dot and interval, it results that in the case of the dot it is the commencement which must be taken as the signal of the completion of the full 10 seconds.

These new ordinary signals are at present transmitted daily from the Eiffel Tower at 10.0 a.m. (10h.) and 12.0 midnight (24h.). The wave-length used will be about 2500 metres.

The radio-telegraphic stations at Norddeich and Arlington, which at present send out time signals, will transmit time signals of this uniform wave-length at the following times (Greenwich mean time):—

- Norddeich-Wilhelmshaven (Germany),
12.0 noon (12h.) and 10 p.m. (22h.)
- Arlington (United States of America),
3.0 a.m. (3h.) and 5.0 p.m. (17h.)

Other time stations will in turn be established, so that in every quarter of the globe it will be possible to receive at least one daily and one nightly time signal. The emissions will be effected at an exact hour (Greenwich time) and at different times except for stations which cannot be heard simultaneously by the same observer. The stations already decided on for time signalling in the near future are the following :—

- San Fernando de Noronha (Brazil),
2.0 a.m. (2h.), and (16h.) 4.0 p.m.
- Manilla (Philippines),
4.0 a.m. (4h.) (by way of experiment).
- Mogadiscio (Italian Somaliland),
4.0 a.m. (4h.).
- Timbuctoo (Soudan),
6.0 p.m. (6h.).
- Massowah (Eritrea),
6.0 p.m. (18h.).
- San Francisco (United States),
8.0 p.m. (20h.).

All the radio-telegraphic time-signalling stations should use, as far as possible, a musical emission, the note being chosen so as to facilitate the observation of the signals in the midst of disturbances of any kind which may occur.

The Eiffel Tower in particular will give out a musical emission of about 100 kilowatts.

The practical unification of time and the con-

sideration of all problems dealing with *time* will be entrusted to an *International Time Commission* (Commission Internationale de l'Heure), having as its executive the *International Time Office* (Bureau International de l'Heure), which will be situated in Paris and will make use of the Eiffel Tower radio-telegraphic station for the transmission of *scientific time signals* to enable this unification of time to be brought about.¹

Reception of Ordinary Time Signals.—In order to receive the time signals thus transmitted and



FIG. 20.

compare them with a time-measuring instrument, clock, or chronometer, the observer must arrange a receiving apparatus as described in Chapter I., so as to hear at the same time the beats of his time-keeper and count them. The operation consists in *placing* the signals with respect to the beats which include them. The beats may be graphically represented (fig. 20) by equidistant strokes, which are numbered . . . 53s., 54s. . . . 60s., 1s., 2s., 3s. . . . if the instrument beats the second, and a dot, for instance, by the mark *s*, equal in size to about one-

¹ The decisions of the *Conférence Internationale de l'Heure* can only come into force after being approved by the governments represented at this Conference. Details of these scientific signals are given in Chapter III.

quarter the interval between the numbered strokes. To obtain the correction to be made to the time recorded by his instrument, the observer first of all must note the number of the second which immediately precedes s , say 1 second, and estimate the interval of time which separates this second from s , say 0·2 second. He must then read the minute and the hour corresponding to the signal s , say 10h. 44m. If the signal s is that of 10h. 45m., the correction for the watch or clock will be

$$(10h. 45m.) - (10h. 44m. 1\cdot2s.) = +58\cdot8 \text{ seconds.}$$

In other words, he must add 58·8 seconds to the time recorded by his instrument. The computation of this fraction of a second cannot be made with great accuracy, for there is the difficulty of mentally isolating the commencement of the dot, then of placing it with reference to the seconds' beats which include it, with only the rhythmic succession of beats as a guide.

It is easy enough, however, even for anyone with little practice, to estimate it to at least half a second ; for an expert and somewhat gifted observer the error is rarely more than 0·2 second. To *place* the beginning or end of a dash proceed in a similar fashion.

Corrections.—To get the total error, it is advisable to add the error of the time signal itself to the error of estimation just indicated. To calculate its average value, the various causes which may

influence it must be examined. The time calculated by means of the rate of the time-keeping clocks, and by which the *signal-sending* clock is regulated, is affected by an error as great as the number of clocks used in the extrapolation is small, and their quality mediocre, and generally this error increases with the time which elapses after the last adjustment. When this time exceeds fifteen days, as is not uncommon in Paris in the winter months, the error may be as much as 1 second. To reduce it to a minimum, there is only one thing to be done, and that is to diminish the time of extrapolation as much as possible by utilising the readings obtained in other observatories. It will be seen later how the use of *scientific time signals* will enable several observatories to co-operate without difficulty in determining the time. Under these conditions the time of extrapolation of the rate of the time-keeping clocks will never be more than a few days, and the error of the time calculated will always be very small, 0·1 second at most.

With the present arrangement (fig. 17) for sending time signals from the Eiffel Tower, in order to regulate the clock sending the signals according to this *extrapolée* time, the following must be taken into account :—

1. The difference between the moment when the clock beats the given time for sending the time signal, and the time when the electric contact W is closed (fig. 17).

2. The delay, with reference to the closing of the contact W , and the production of the spark in the spark-gap G , *i.e.* of the emission of Hertzian waves.
3. The time which elapses between the moment when the waves are launched into space, and that when the corresponding sound is perceived by the observer in his telephone receiver.

When the despatch of the signals is made automatically, notice must also be taken of the error caused by the automatic transmitter, the contacts of which may close either too soon or too late with respect to the clock. This error must be periodically determined. The difference between the moment of closing of the contact W and the corresponding beat of the clock U is apparently not determinable with much accuracy, owing to the arrangement of the system which produces the contact; it may be obtained approximately by measuring the duration of the contact with the end of which the beat appreciably coincides.

The retardation in the production of the spark with respect to the closing of the contact W or of the automatic transmitter contact is due to the mechanical and electrical inertia of the intervening instruments. It consists of the retardation in the attraction of the relay plate, the retardation in the closing of the key M , and the time necessary for the current of the feeding circuit to produce at the

armatures of the condenser K a potential difference sufficient to cause the spark pass at G.

Finally, the retardation in the perception of the waves in the telephone is analysed in the following manner : (1) Time necessary for the propagation of waves between the points of emission and reception (negligible in practice) ; (2) interval separating the moment the waves strike the aerial from the moment the corresponding sound is heard in the telephone by the observer. There is no occasion to carry this analysis further, the process hereafter given permits of the easy measurement of the total retardation from the moment the contact W of the clock transmitting the signals is closed, up to that when the sound is perceived in the telephone receiver.

This process is based on the use of the *method of coincidences* which is already utilised for the accurate comparison of two time-measuring instruments.

Principle of the Method of Coincidences.—The following is the principle of this method:—Let A and B be the two time-measuring instruments to be compared. Draw an indefinite straight line Ot to represent the axis of time, starting from an origin O corresponding to the moment taken for the initial period. On this line mark off lengths proportional to the times of the successive beats of A and B. The diagram shown in fig. 21 is obtained. The numbered marks above Ot represent the beats of A, those below it of B. The intervals between

the beats of A are supposed to be equal to each other, as also are those of B, the latter being shorter than the former by $\frac{1}{80}$ of a second. By listening either directly or by the intermediary of telephones to the collective beats of the two series, the beat of B which follows that of A is heard to approach it gradually, then almost coincide with it, pass it, and gradually diverge from it more and more. Note the times h_A and h_B of the beats of A and B which most nearly coincide. If the period ϵ which separates these is small, neglect it and take as a comparison $h_A - h_B$ either for the time h_A of A or

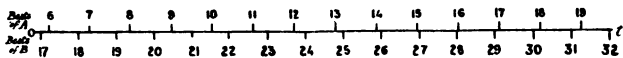

FIG. 21.

for that of h_B of B. Graphically, the method of procedure is as follows:—Trace the beats of A, commencing with, say, No. 8, up to the one which coincides best with a beat of B; No. 16 of A is seen to follow No. 28 of B very closely, whilst 15, which came before 27 of B, is more markedly separated from it; and for comparison with the time 16 *beats* of A or 28 *beats* of B (16–28), beats are taken, neglecting the hours and minutes. The operation, as will be seen, is the same as reading a vernier, only, as there is no obligation to take a fixed beat of B as the zero of the vernier, by preference that of the coincidence is taken. The approximation obtained by this method is calculated

exactly like that of a vernier. If this comprises n divisions equal exactly to $(n-1)$ divisions of the scale, each of them is equal to $\left(1 - \frac{1}{n}\right)$ scale divisions, and the error in reading is at most equal to half the excess of a scale division over a vernier division or $\frac{1}{2n}$ *scale division*. Graphically, the maximum error in comparison by coincidence is at $\frac{1}{4\theta}$ *beat* of A.

In a general way, if the interval of the beats of B, which most nearly approaches the interval T_A of the beats of A, has a value $T_A\left(1 \pm \frac{1}{n}\right)$, n being any number whatever, the separation e of the two beats which most nearly coincide is at most equal to $\frac{T_A}{2n}$.

In practice the accuracy attainable by the method of coincidences is as rapidly limited as that of the vernier. When n is rather large the observation of the coincidence becomes difficult and in part illusory, if the sound of the beats has a duration which is not negligible. This duration is graphically represented in a greater or less thickness of the marks which represent the beats. As a result, several consecutive divisions of A and B apparently coincide. This is the principal but not the only cause which affects the accuracy of the estimation of the coincidence. If the beats of one series are

louder than those of the other, the latter are obscured in the region of the coincidence. The sonorousness of the beats, their difference of pitch and tone are equally unfavourable for the close estimation of coincidences.

Determination of the Retardation of a Time Signal with regard to the Corresponding Contact of the Signalling Clock.—To apply this method to the determination of the retardation of the

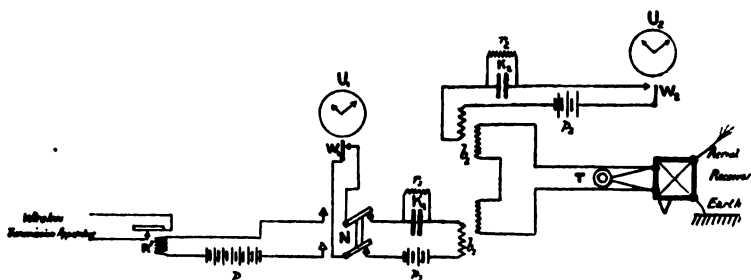

FIG. 22.

signal perceived in the telephone with relation to the closing of the contact W , the operation is as follows :—For the clock U , or for the automatic transmitter which does not lend itself to the transmission of rhythmic signals, substitute an auxiliary clock U_1 (fig. 22) whose period can be regulated. This is provided with an electrical contact W_1 , similar to that W of the first clock, but closing at each beat for a short and adjustable period. The other portions of the apparatus require no modification. By conveniently adjusting the duration of the contact,

a wireless transmission spark is obtained at each complete oscillation of the new clock. This series of unique sparks is heard in the telephone T of a wireless receiver V placed close to the clocks. A second auxiliary clock U_2 , like the preceding one, but regulated to give a period differing from it by $\frac{1}{100}$ to $\frac{1}{1000}$ of a second, is likewise fitted up. The contact W_2 of U_2 is connected with a battery p_2 , a condenser K_2 (telephone type) of 2 mfd., shunted by a resistance r_2 of 30,000 ohms, and finally to the primary b_2 of a small telephonic induction coil which is movable inside the secondary. This latter is put in series with the secondary of a similar coil b_1 and both secondaries joined up to the terminals of the telephone T of the wireless receiver V above mentioned.

Each time the contact W_2 closes, the condenser K_2 is suddenly charged; the current from this charge generates an induced current in the secondary of b_2 and produces in turn a sound in the telephone T. When W_2 is opened, no sound is heard in the telephone. The condenser being discharged through the resistance r_2 again becomes charged with another closing of the contact, and again a sound is perceived. Each complete oscillation of U_2 is therefore distinguished by a clear and unique sound in the telephone T. Considering the electrical elements in the circuit, the interval which separates the moment of perception of a sound in the telephone from that of closing the contact is negligible.

Finally, a circuit similar to the above is established in connection with the induction coil b_1 . A double commutator N enables contact W_1 of U_1 to be connected either to this second circuit or to the wireless transmitting apparatus. All the apparatus being thus arranged, commence by placing commutator N across the left-hand contacts. The clock U_1 produces a series of radio-telegraphic dots which, acting on the receiving aerial, are perceived in the telephone T at the same time as the beats of U_2 . Move the primary b_2 more or less into the secondary so as to equalise the intensity of these latter beats with the radio-telegraphic beats of U_1 and observe their coincidences. Take a sufficient number of them to obtain, with as much accuracy as desired, their time a in time of U_1 for instance, and immediately after having written down the time h of the clock U_1 of the last, move the commutator to the right-hand contacts. The closings of the contact W_1 of the clock U_1 then produce in the telephone C through the intermediary of b_1 beats similar to those of U_2 . Their period is evidently equal to that of the radio-telegraphic beats previously observed; the interval of their coincidences with the beats of U_2 is therefore still a . But the first coincidence, instead of happening at a time $h+a$ of U_2 as would have been the case if the commutator N had not been moved, now happens at a different time h' . This time h' is less than $h+a$, that is, that the coincidence comes earlier if U_1 beats more quickly than U_2 ;

on the other hand, it happens later if U_1 beats more slowly than U_2 . To make this clear, let us suppose that the period T_1 of U_1 is shorter than that T_2 of U_2 , and state

$$T_1 = T_2 \left(1 - \frac{1}{n} \right)$$

The gain $h+a-h'$ evidently represents the number of times the retardation required (ρ) contains $T_2 - T_1$ and we get

$$\rho = (h+a-h')(T_2 - T_1) = (h+a-h') \frac{T_1}{n-1}$$

If we have

$$T_1 = T_2 \left(1 + \frac{1}{n} \right)$$

the retardation ρ is expressed by

$$\rho = (h' - h - a)(T_1 - T_2) = (h' - h - a) \frac{T_1}{n+1}$$

This test has been carried out at the Eiffel Tower and enables us to state that with the key used at present the retardation is from $\frac{8}{1000}$ to $\frac{10}{1000}$ second.

It is easy to take this into account when setting the signalling clock to time by putting it forward a fraction of a second equal to ρ .

To sum up, the preceding considerations show that the errors which affect the time obtained by means of a time signal are reduced to the two following:—The error in the transmitted signal coming from the extrapolation in the rate of the clock, and the error in estimating the fraction of

a second between the full second which precedes the signal and the signal itself, which error is made by the observer. Except in quite special cases, this latter error is rarely less than $\frac{1}{10}$ second. In general, the exactness of the legal time obtained by transmission of time signals cannot be reckoned to nearer than $\frac{1}{10}$ second: that is the limit for an expert observer.

For an inexperienced observer this limit becomes about $\frac{1}{2}$ second at least.

Transferring the Record of a Printing Chronograph, such as is obtained by Astronomical Observations, to that of a Time-keeping Clock.—Previous remarks have been based on the assumption that astronomical observations directly supplied the reading of one of the time-keeping clocks; that is to say, the correction of the time recorded by the clock at the moment of any beat, ordinary or electrical, if the clock is provided with contacts. This is what takes place, ignoring the personal equation of the observer when the observations are made by the method of the eye and the ear. It is not nearly the same when a printing chronograph is used, as is to-day the case in the majority of observatories: the correction, then, to be deduced from the observations of the transits thus noted is that of the chronograph, leaving out the personal equation of the observer, and the time which elapses between the closing of the electric-recorder circuit corresponding to an observation and

the printing of the time. But unlike an ordinary clock with or without contact, the printing chronograph does not lend itself to direct comparisons, and it is necessary, in order to utilise the record it gives, to transfer this reading to that of a time-keeping clock, preferably a synchronised clock whose difference of reading from the chronograph should be constant.

It will be of interest to indicate a process by which, firstly, the true correction of the printing chronograph can be obtained, then this correction passed on to any one of the time-keeping clocks. To make this clear, let us suppose we are using a Gautier printing chronograph. It will be easy, if another type is used, to modify the processes in question so as to render them applicable. We will suppose, moreover, that this chronograph is associated, as is the case at the Paris Observatory, with an automatic recording micrometer, so as to consider the personal equation of the observer negligible. The working of the apparatus is then as follows :—The movable wire of the micrometer is kept constantly pointed to the star, and each time it passes a fixed position an automatic contact is produced which closes the electric-recorder circuit.

This circuit being put into action, attracts a plate forming one arm of a lever ; the other arm is formed of spring bands carrying at their ends points which strike a sharp blow on a roll of paper and press it against three wheels making a turn in one second,

one minute, and one hour respectively. Each of these wheels bears characters in relief which print on the parts of the roll where the points press, so that the hundredth of a second, the second, and the minute of the chronograph are obtained for each transit of the micrometer wire, and therefore of the passing of a fixed position by the star.

The wheel bearing hundredths of a second is subjected to the synchronising action of a special clock, which is itself synchronised by means of relays with a time-keeping clock. Its rotary speed is regulated to a little more than one turn per second ; but an arrangement controlled by a second recorder worked by the electric current traversing the contact of the special clock, stops the wheel at each revolution so as to reduce its speed by one turn. It will be understood without going into further details, that the reading determined with the times of transit thus registered, calls for some correction before it can be considered with the true reading of the chronograph.

Firstly, between the moment when the transit of a certain known position by the micrometer wire produces an electric contact, and that when the point presses the roll on to the "hundredths" wheel and prints a figure on it, a certain period of time elapses. This retardation which is due to the electrical and mechanical inertias of the electric recorder and its plate, includes the time necessary for the point to get into motion and the duration of

its displacement from the position of rest until it touches the wheel.

To measure this interval of time, a process analogous to that described on p. 49 is employed.

For this replace the electrical contact of the recording micrometer by that of a clock P_1 ; but as the strength of current necessary to work the electro-writer E is rather great and might deteriorate the clock contacts, it is as well to interpose a relay R (fig. 23).¹ Also glue a piece of thin tin-foil to the roll of paper α . A primary commutator, C_1 enables the contact of the relay R to be connected at will either to the electric-writer E and its battery ρ , or to a second circuit comprising a commutator C_2 , a battery ρ_1 , a condenser K_1 provided with a resistance, and finally the primary of a small induction coil B_1 . The condenser has a value of 2 mfd., for example, and the resistance joined across its armatures—about 25,000 ohms. The primary of the coil B_1 with its core can be moved inside the secondary so that the induction can be varied at will.

The body of the chronograph, and in particular the "hundredths" wheel r , as well as the tin-foil α , are all joined to the free terminals of the commutator C_2 .

A second clock P_2 whose period is regulated so as to differ by about $\frac{1}{100}$ of a second from that of P_1

¹ Clock and relay may consist of the synchronising clock and recorder of the chronograph if this recorder has a contact such that it can be used as a relay.

is provided with an electrical contact put in circuit with a battery p_2 , a condenser K_2 and its resistance, and finally with the primary of a second induction

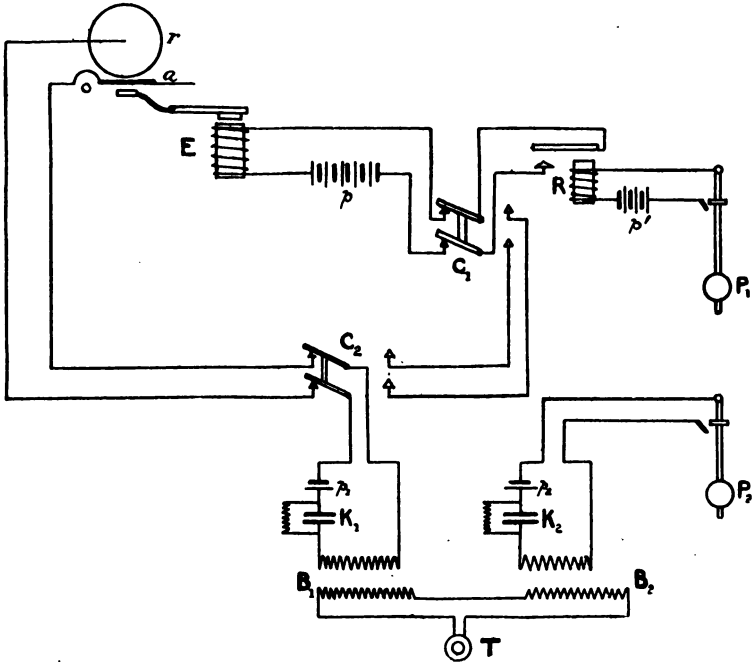

FIG. 23.

coil B_2 . The secondaries of the two coils are joined in series with a telephone T.

The two commutators being pressed down to the right, observe by means of the telephone T the coincidences of the beats of the relay R and those of the clock P_2 ; measure their intervals and note

the time recorded by P_2 at the moment of the last coincidence observed.

At this moment move the two commutators to the left and note the time recorded by P_2 at the moment of the first coincidence observed (in turn) between the beats of P_2 and those of the contacts of the foil a with r . It is then easy to deduce, as indicated in a previous example (p. 50), the interval of time which separates the moment of a contact of

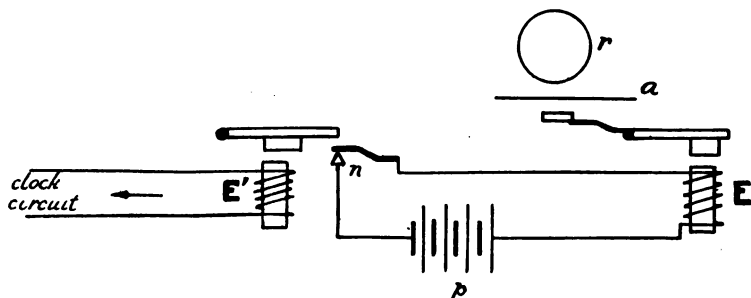

FIG. 24.

the relay R from the moment of the consecutive contact of a with r . This interval is evidently the same as that which exists when the electric-writer is controlled either by the recording micrometer or by a contact made by hand with a weight. If it is possible to arrange in front of the plate of the electric regulator E' of the chronograph an adjustable electrical contact placed in circuit (fig. 24) with the electric-writer E and its plate, each beat will be written on the paper roll, and it is easy to reckon the regularity of the synchronisation of the

“hundredths” wheel since the “hundredths” figure marked on the roll should then always be the same. It is equally easy to verify the regularity of the speed of the “hundredths” wheel by controlling the electric-writer, directly or through relays, by a clock whose period differs by $\frac{1}{100}$ of a second, for instance, from that of the clock acting on the electric-regulator. If the speed is constant, the “hundredths” figures marked successively on the roll will differ from each other by one unit.

If this is not the case, the speed is irregular: the differences, however, indicate how much this irregularity is, and so it is possible to calculate it. Arrangements could equally be fitted up without much difficulty, enabling the beat of a round second of the electric-regulator, which immediately follows a *prick* of the electric-writer, to be inscribed on the roll. It would serve no useful purpose to describe these arrangements here.

The *true reading of the chronograph*, *i.e.* that which is obtained if the point strikes the “hundredths” wheel at the very moment the contacts of the recording micrometer are made, being known, it remains to determine that of the synchronising time-keeping clock or of any timekeeper whatever.

For this it is sufficient to arrange again opposite the plate of the electric-regulator a contact *n* (fig. 25) whose position can be adjusted so that it closes at the moment the synchronising action occurs, *i.e.* when the plate is at the end of its motion, by

supposing that this moment corresponds exactly to the full second of the chronograph, and arrange as shown in figure 25.

P_1 is a time-keeping clock, beating the same time as that which controls the electric-synchroniser of the chronograph and with which the latter is to be

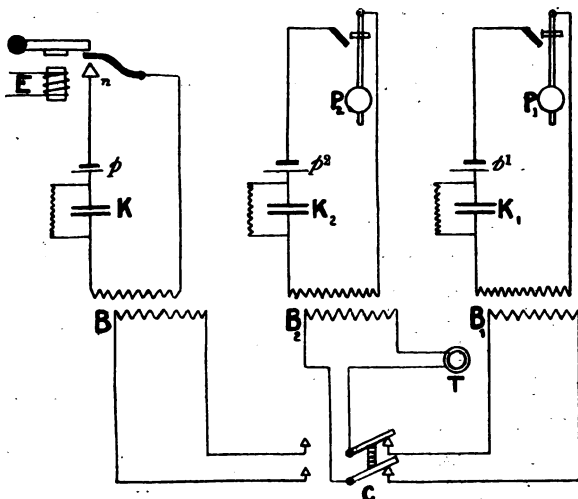

FIG. 25.

compared. P_2 is a clock whose period differs from that of the former by $\frac{1}{100}$ of a second, for instance. The electrical contacts of the three instruments are put in circuit (each on its side) with a condenser provided with a discharging resistance, a battery, and the primary of an induction coil.

A commutator C permits of the successive comparison of the auxiliary clock P_2 with the contact n

of the chronograph and the clock P_1 by the method of coincidences. Then from these successive comparisons with the auxiliary clock, that of the electrical beats of P_1 and the chronograph is deduced.

If the electrical contact of the clock P_1 has to close other contacts, either to directly synchronise other clocks or to control relays, the arrangements are rather more complicated, but easy to conceive. There is no occasion to indicate them here. They have been carried out at the Paris Observatory.

To compare several clocks with each other, the operation is precisely as just described, the contact of the chronograph being replaced by that of the clock to be compared with P_1 .

When the timekeepers (clocks or chronometers) have no electrical contact, the electrical beats are replaced by the natural ones. Very accurate results can then be obtained as follows:—The timekeepers being supposed to beat sidereal time, take as an intermediary for comparison a third time recorder C regulated to mean time, for example. Fix a microphone on each of the three instruments. These microphones m_1, m_2, m_3 (fig. 26) are put in separate circuits of batteries p_1, p_2, p_3 , and the primaries of small induction coils b_1, b_2, b_3 . The diagram shows how the connections are made.

A telephone T is connected on one side to one of the terminals of the secondary b_3 , and on the other to one of the arms of the double-pole commutator

N whose other arm is in communication with the second terminal of the secondary of b_3 .

The commutator N being put in contact with the right-hand terminals, the operator simultaneously perceives in the telephone T the beats of C and of B, the divergence of these being variable since C

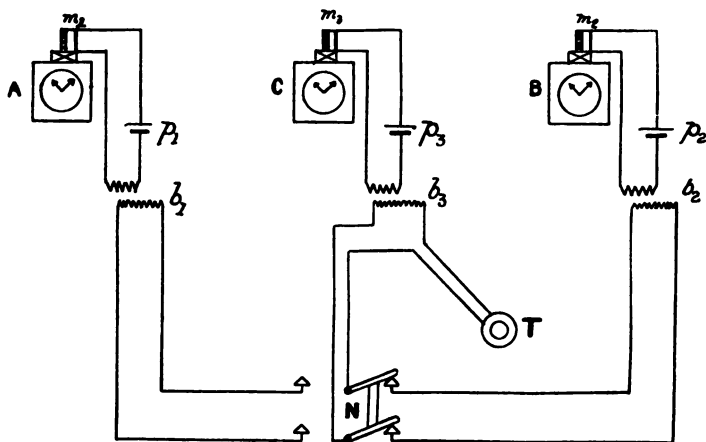

FIG. 26.

is in mean time and B in sidereal time. He then observes equidistant coincidences of which the interval in time of C is a . ($a = 365 \cdot 25$ seconds if both instruments beat the seconds, and are well regulated.) Immediately after, having noted the time on C of the latter, he turns the commutator N so as to make contact with the left-hand terminals corresponding to A. He ascertains that the following coincidence, which, between B and C, occurred at

the time $h+a$ of C, happens at a time $h' < h+a$. This gain $h+a-h'$ evidently represents the number of times the required divergence between A and B contains the difference $T_m - T_s$ of the periods of C and of A or B, and we have

$$\epsilon = (h+a-h')(T_m - T_s).$$

This assumes that the period of A and B are exactly the same. It is easy to ascertain this by observing several coincidences between C and A. The same interval should be found as between C and B.

To sum up, the preceding remarks show that it is practically possible to determine to nearly $\frac{2}{1000}$ or $\frac{3}{1000}$ of a second (with the restriction made regarding the chronograph) the total retardation of errors caused by the various instruments interposed between the meridian telescope and the telephone receiver of the time signals, admitting that the exact rate of the clocks is known and that the signals are given almost immediately after the astronomical observations are made.

CHAPTER III

SCIENTIFIC TIME SIGNALS

AS we have said in the preceding chapter, the ordinary time signals enable an expert observer, under most favourable circumstances, to take the time to nearly 0·1 second. This degree of accuracy, which even the transmitted time itself does not always attain, amply fulfils the requirements of navigation, railways, watchmakers, and, in the majority of cases, of practical life. For certain scientific purposes, however, it is necessary to reduce as much as possible the errors of estimation in receiving.

Several methods may be devised for the purpose of sending and receiving time with very great accuracy; we will, however, confine ourselves to the description of that at present used at the Eiffel Tower.

Despatch of Signals. — A clock U_1 provided with a contact W_1 which is closed at each oscillation of the pendulum (fig. 27), and whose period can be regulated so that the interval between two beats is about $(1 - \frac{1}{80})$ seconds, sidereal time, is installed in the radio-telegraphic station itself in order that its action can be supervised from an electrical point of

view. It is connected with a battery ρ_1 and the relay R' which controls the wireless transmission apparatus, as is indicated by fig. 27. In the course of a preliminary trial some minutes before the emission of the signals, this apparatus is suitably regulated so that at each oscillation of the pendulum a single spark is produced in the spark-gap. At a moment arranged beforehand, so that the observer is not taken unawares, but which may be

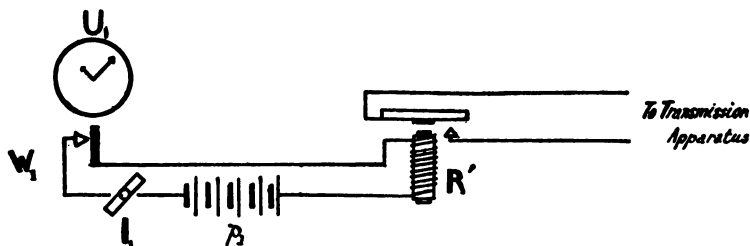

FIG. 27.

at any moment whatever, the interruptor I is closed so as to put the apparatus in action. It then produces a series of radio-telegraphic signals formed of single dots, spaced between each other by $(1 - \frac{1}{80})$ second. 180 beats are thus transmitted, the 60th and 120th beats being suppressed so as to establish a basis for calculation.

This series is heard at the Paris Observatory with a wireless receiver (fig. 28) at the same time as the beats of the master-clock A_2 , on which is fixed, for example, a microphone m_1 which is in circuit with a battery ρ_1 and the primary of a small induction

coil b_1 whose secondary is connected to the terminals of the wireless receiver telephones.

When the clock is provided with an electrical contact, the microphone is replaced by this contact placed in circuit with a battery p' , a condenser K , and its resistance r , and the primary of the induction coil, the secondary of this being connected with the telephone of the wireless receiver (fig. 29).

The astronomer perceives, during the series of 180 radio-telegraphic signals, three coincidences of

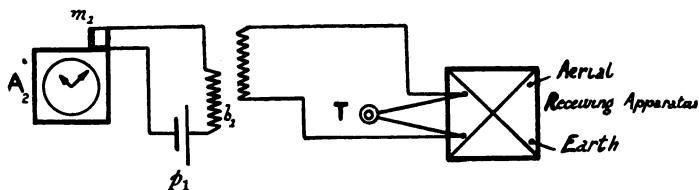

FIG. 28.

the signals with the beats of the clock A_2 . He carefully notes the times of the clock A_2 at these coincidences and at the two interruptions caused by the suppression of the 60th and 120th signals. Given these, it is easy for him to calculate—

1. The interval in times of A_2 between two consecutive coincidences.
2. The exact value in time of A_2 of the interval between two consecutive signals.
3. The exact times according to A_2 of the 1st and 180th beats, to which he adds the correction for the clock to get the sidereal times of these beats, which he finally converts into legal time.

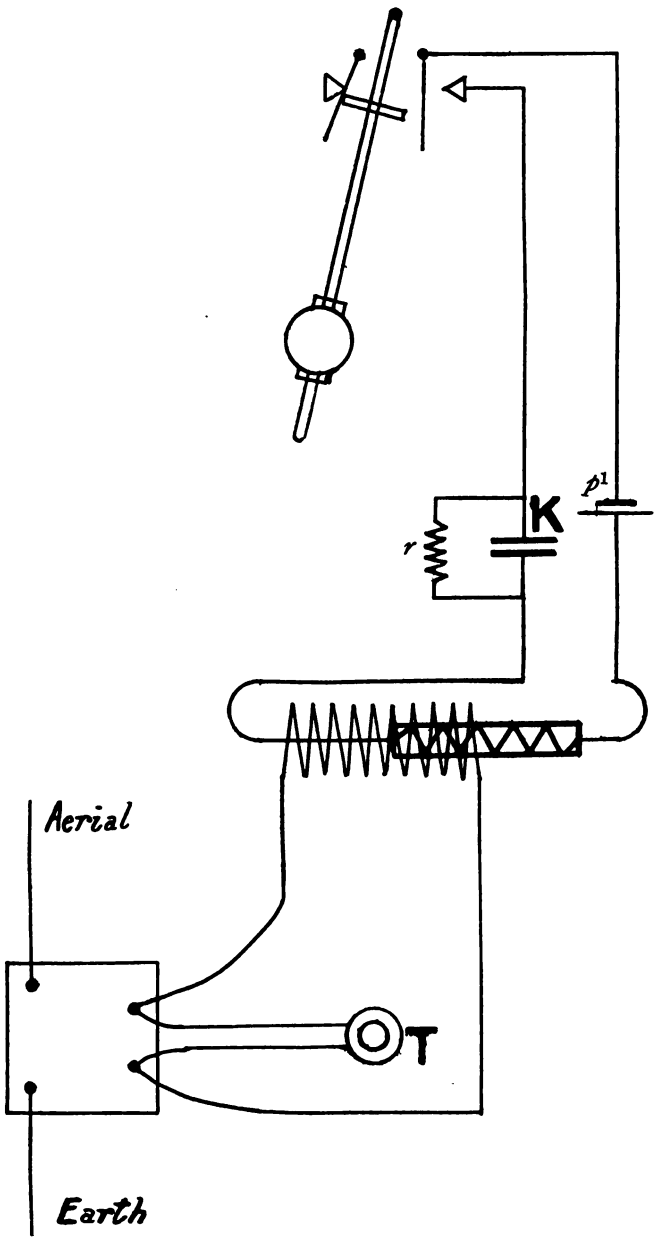

FIG. 29.

These calculations can be carried out in a very few minutes.

In practice the 180 beats we are now dealing with are sent shortly before the ordinary time signals, and it is during the despatch of the latter that the calculation of the 1st and 180th beats is made. These times are in turn telegraphed as soon as the ordinary time signals are completed. If the time calculated for the 1st and 180th beats are, for example, 11h. 35m. 12s·32 p.m. and 11h. 38m. 7s·78 p.m., the following groups, repeated three times, are telegraphed—

351232, 380778.

Reception of the Signals.—The signals thus transmitted can be perceived by all observers located within the radius of action of the transmitting station. At present at least, they would, however, appear to have no utility except for scientific or astronomical observatories, or for geodesians and explorers.

Each observer connects his wireless receiver with his time-measuring instrument, as has been indicated in fig. 29, for example. He then operates as has been explained in the case of the astronomer at the Paris Observatory and calculates the times, in legal time, of the first and last radio-telegraphic beats according to indications of his time recorder and its relation to legal time. He then listens to the figures telegraphed after the time signals, which

give the times of these same beats as determined by the Paris Observatory. The comparison of these times with those he has himself calculated should give two sets of figures which should agree to 0.01 or 0.02 of a second nearly, if on the one hand he has judged the coincidences well, and if on the other there is no error in his calculation. Their average is the divergence of the legal times determined at Paris from those determined by the observer. Considering all points, the accuracy obtained by this method of sending and receiving the time is within $\frac{1}{80}$ of a second; when the observations are made by a practised hand under favourable conditions, the accuracy is within $\frac{1}{100}$ of a second.

The *Conférence Internationale de l'Heure* has decided to maintain, for the present at any rate, the scientific time signals as just described, increasing their duration, however, from three to five minutes. Further on (in Chap. IV. p. 74), detailed explanations will be found of the way to carry out these comparisons to avoid all error, and also an example of calculating the times of the first and second beats, with numerical tables to shorten the process.

Improvement of the Transmitted Time.—This second method of transmission and reception of legal time permits of the use of the time observations and the time-measuring instruments of various observatories for correcting the time determined at the Paris Observatory and sent out from the Eiffel

Tower. All that is necessary is that these observatories telegraph to Paris, by wire, as soon as possible, the times of the first and second beats which they have calculated according to their observations and clocks. When the condition of the sky has prevented the Paris Observatory from determining the rate of its master-clock, it uses the information telegraphed from the affiliated observatories.

It is anticipated that the organisation of this new service will enable the error in the time sent out by the two methods just discussed to be kept between the limits of ± 0.1 second.

Determination of Longitude.—The longitude of a point A on the earth being equal to the difference between the local time at that point and the time of the prime meridian, its determination comprises—

- (1) That of the local time at A and at a point on prime meridian, or, more generally, at a second point B, the longitude of which is known exactly.
- (2) The simultaneous comparison of these local times.

The first problem belongs to the domain of astronomy and need not be discussed here. As for the second, it is only a particular case of the general problem of transmission and reception of the time, and, as such, is solved by the use of one of the methods of sending and receiving by wireless which we have already discussed. However, as the point A, of which the longitude is required, is not

necessarily, for the moment at least, within the radius of action of a radio-telegraphic station which despatches the time of the prime meridian, and as, on the other hand, the time sent is always an *extrapolée* time, we must examine the modifications necessary to make the methods already described applicable to the determination of longitude. We must here distinguish between several cases according to the degree of accuracy desired.

The time-signalling radio-telegraphic stations having been established principally to fulfil the requirements of *navigation*, the accuracy with which the first method of sending out isolated signals enables the time of the prime meridian to be obtained at sea is amply sufficient, especially if the time has been corrected so that there is no need to fear great variations from one despatch to the next, variations which partly interfere with the use of the radio-telegraphic signals for determining the going of chronometers at sea. The nature of the signals, alone, has been the object of special criticism; they have been objected to as short and isolated, and therefore easily confused with the natural electrical disturbances so frequent in summer.

The *Conférence Internationale de l'Heure* is endeavouring to find a uniform system of signals which will be beyond such criticism. The one adopted (see p. 37) appears to be of a kind which gives every satisfaction to navigators. In the case of *explorers*, who determine the *position* solely to guide them-

selves, it is scarcely necessary to know the time of the prime meridian with the same accuracy required by *navigators*. But when it is a question of determining the position of special localities, they should endeavour to obtain this time with at least as much accuracy as that with which they determine the local time. That is to say, it is advisable to compare this standard watch with the rhythmic signals which precede the time signals, when they are within the radius of action of a station such as the Eiffel Tower, so as to leave no error but that of the transmitted time. If they deem it useful, they would even have the possibility, on their return, of eliminating the greater part of this error of extrapolation in the rate of the timekeepers of the Paris Observatory by a request at this establishment for the readings of the master-clock and those obtained from other observatories: a simple interpolation between the readings at the time the signals were despatched will give them the condition of the clock at this moment, and, by comparison with that used in calculating the first and second beats, the necessary correction to the longitude can be made.

But it will most frequently happen that the explorer will be in the radius of action of a radio-telegraphic station which has not the means of determining the time so as to send time signals corresponding with the absolute time of the prime meridian. In such a case the following method of procedure may be employed:—The transmitting

station sends out signals analogous to the time signals at times fixed approximately in advance and at the most convenient hour of the day, being careful to send out very distinct warning signals before each one. At the same time that the explorer makes his observations at the point A of which he requires to determine the longitude to get the relation of his watch to local time, a second observer does the same at a point B, if possible of known longitude and situated within the radius of action of the station; then both, being supplied with the necessary receiving stations, note the times on their respective watches of the time signals, which here fulfil the function of *instantaneous signals*.

They have thus all the data necessary for the determination of the longitude of A with reference to B.

If the longitude of B is unknown, and this point is within the radius of action of another transmitting station at the same time as a point C of known longitude, the observers carry out the same operations between B and C with the second station so as to obtain the difference in longitude of B and C, and finally the longitude of A. In extremely accurate determinations of difference of longitude, such as those effected by *astronomers* and *geodesians*, either to fix the boundary of a large tract of country or to obtain the deviations from the vertical in the sense east to west at the summits of a geodesic system, it is absolutely necessary to

have recourse to the second method of sending time so that the method of coincidences may be applied for the comparison of the time recorders at the two stations.

The accuracy of the comparisons made by this method, with the help of wireless telegraphy, depends on the spacing and number of the coincidences. It is therefore advisable that the interval of the radio-telegraphic beats should differ by as small a fraction of a second as possible from the instruments to be compared, without, however, going beyond the limit at which it begins to be difficult to judge the coincidences. The microphone arrangement described on p. 63 does not permit this difference to be below $\frac{1}{140}$ of a second, whilst, with the arrangement using the charging currents from a condenser induced by an electric contact controlled by the time recorder, it is easily possible to go to $\frac{1}{1000}$ of a second, supposing that the isochronisation of the closings of the contact can be realised with this degree of accuracy, and that the rate of the timekeeper is sufficiently constant for the interval of coincidences separated by a period of 1000 seconds to remain the same.

In point of fact, the research of such an accuracy, besides wasting time, would be altogether superfluous, seeing that astronomical observations give the local time at most to about 0.01 second. It may then be admitted that in determining longitudes there is no purpose in seeking to make the

comparison to any better than $\frac{1}{100}$ to $\frac{1}{140}$ of a second, and that the microphone arrangement should always be quite sufficient.

But already, for this degree of accuracy, the scientific time signals spaced $(1 - \frac{1}{80})$ second, of which, moreover, the time of emission may not be convenient, will hardly be sufficient, and it will often be necessary to have *special signals* sent. Experiment has shown that all the accuracy requisite can be obtained with three series of radio-telegraphic beats of interval about $(1 \pm \frac{1}{100})$ second, each comprising 300 signals, the 60th, 120th, 180th, and 240th being suppressed to serve as data.

The series are separated from each other by silences of a duration equal to 60 intervals between two beats (p. 90). The generalisation of the use of musical notes in wireless telegraphy will frequently prevent the use of single-dot signals. Nevertheless, the method may be applied, although with rather less accuracy, if the dots are replaced by dashes of about 0.5 second duration, taking the coincidences at the commencement of the dashes.

CHAPTER IV

HOW TO MAKE AND CALCULATE COMPARISONS BY MEANS OF THE SCIENTIFIC TIME SIGNALS.

Arrangement of Receiving Apparatus: Preparation of Comparative Tables.—Comparisons by the method of coincidences, to be made with certainty and accuracy, call for great attention on the part of the observer, and a very clear perception of the beats to be compared. That is to say, at a station for receiving scientific signals, the room containing the apparatus should be shut off from all noise, and the observer must not be disturbed whilst receiving.

The apparatus should be conveniently arranged in order on a table in such a manner that the observer seated at this table has all the adjustments within reach of his hand. If the instrument to be compared is a clock, the dial should be illuminated and the table arranged so that the observer can easily read the seconds whilst seated. If it is a chronometer it can be fixed on the table itself with all accessories to render the beats, natural or electric, audible in the telephone, and should be near the observer so that he can note the

seconds without hesitation at any moment. For example, it may be set at one side, and the wireless receiving apparatus at the other, the middle of the table being clear for the comparative tables. The wires should be clearly arranged in such a manner that all connections can be tested in case of defective working. To write down the comparisons, the observer should make use of tables previously compiled, on the lines of those found further on (pp. 87, 88).

Carrying out Comparisons.—The observer is concerned with noting the times h of the beats of his clock or chronometer, and the number n of the scientific signals which most nearly coincide with it. The process which naturally occurs to the mind is to watch the seconds-hand of the time-keeper and to count the scientific signals mentally: this method is based on that in use for comparing two timekeepers placed side by side. In the latter case it is easy enough to avoid errors in counting the beats of the instrument under the eye of the observer, because there is always an opportunity, at any rate before the coincidence, of making sure that the count is correct, and of verifying the difference between the times after having written them down; but it is very different when the beats to be counted come from an instrument whose dial is not visible. Errors are to be particularly feared if the observer were obliged to continue counting the scientific signals whilst he writes down the time

h of the beat and the number n of the coinciding signals, as would be the case when he has no other data for reckoning the signals but the first and last.

With one interruption every sixty signals, he may stop counting after each coincidence to write down the factors h and n which relate to it, and need not recommence counting until the following interruption. It is necessary, however, that the coincidence and the interruption should not follow each other too closely.

But when there is no possibility of verifying the counting shortly before the coincidence, nor of checking the difference between h and n immediately afterwards, much practice in comparison by coincidences is necessary, and up to a certain point special arrangements are required, even if it is merely in order to retain and note without error at the moment the time h of the beat and the number n of the coinciding signal. On the other hand, the coincidences are only correctly judged if the faculty of hearing alone is called into service; the beat of the timekeeper, whose duration is negligible compared with the duration of the movement of the seconds-hand, corresponds to a certain phase of that movement which is neither the start nor the stop, so that the impression of the eye is far less accurate than that of the ear. The superimposition of the first on the second has the effect of making the latter less clear. The observer must avoid following the seconds-hand of the time-

keeper with the eye, but must count its beats mentally if he desires to obtain the maximum accuracy possible by this method.

In this way the habit is cultivated of suppressing the direct counting of the scientific signals, and the operation of comparison is divided into two parts so as not to have to note both h and n at the same time.

The observer begins by determining h . To do this he mentally counts the beats of the timekeeper: if he desires to verify his counting, he should do so at least 10 seconds before the coincidence so as not to have to watch the seconds-hand, and to be able to concentrate all his attention on the beats and the signals which come near each other. When the coincidence has occurred, he writes down the time he was counting at the moment it took place: this is the time h . He then goes on with the second part of the operation, the determination of the number n of the corresponding scientific signal. He does this indirectly by counting the number N of the intervals between the scientific signals from the coincidence to the next interruption. Let n' be the number of the signal corresponding to this interruption, then

$$n = n' - (n' - n) = n' - N$$

n' being known and N observed, by difference n will be obtained.

To reckon N the timekeeper is used. Let us

imagine for a moment that the second of the timekeeper, commencing with the coincidence, is equal to one interval of the scientific signals : the coincidence between the beats and the scientific signals will be continuous. Let h' be the time recorded by the timekeeper under these conditions at the moment of interruption, then

$$N = h' - h \text{ (in seconds).}$$

It is then sufficient to read h' . Now it is very easy for the observer to imagine that a sort of abrupt change in the period of the timekeeper is introduced ; all he need do is suppress the beats of the latter in the telephone. He then hears only the scientific signals with which he presumes the beats of the modified timekeeper are blending. Only, so that this illusion may be maintained when he looks at the seconds-hand, he must not wait too long after a coincidence to make this suppression, especially if the instrument beats half-seconds, since the divergence of the movement of the hand with respect to the scientific signals goes on increasing. The observer having written down the time h and suppressed the beats of the timekeeper, next takes the time on the dial of the seconds-hand as if he heard its beats still blending with the scientific signals, and he continues to count mentally on these latter. The time he counts at the moment of interruption will be h' . Such is the process which the observer will find most convenient for enabling

him to give his whole attention to noting the coincidences, and at the same time avoid all errors in counting. It now remains to describe it in detail. So that the description may be easily followed, we shall have recourse to the diagrammatic representation which has already been utilised in explaining the method of coincidences.

A few minutes before the commencement of the despatch of the scientific signals, the observer carefully tests all his connections and closes the circuit of the microphone battery or of the timekeeper contact ; then taking the telephone headpiece he satisfies himself that the beats can be heard well enough ; he adjusts the microphone as required to improve the sound if he is dealing with natural beats, and modifies the resistance, or tunes the inductance so as to lessen their intensity suitably and suppress the resonance. He then seats himself at his table, arranges his papers, fills in his headings of the comparative tables, and listens.

As soon as he hears the preliminary signals (see Appendix A, p. 107) of the Eiffel Tower, he proceeds to adjust the receiver as described in Chapter I. ; and when he has obtained the maximum intensity of the radio-telegraphic signals, by eliminating as far as possible all disturbing signals which may be going on simultaneously, he arranges matters so that the intensity of the radio-telegraphic signals and the beats of the timekeeper are to him as equal as possible. This done, he reads the seconds

on the timekeeper, and then, without looking at it again, he commences counting on the beats which he hears in the telephone.

When the scientific signals proper commence, he notes mentally, if possible, the beat which follows the first signal so as not to miss the first interruption which occurs about 59 seconds later, and immediately afterwards he devotes his attention to the beat which immediately precedes each signal. Here it is necessary to distinguish between two cases—the comparison of a seconds-pendulum and of a chronometer beating the half-second. In the second case, if the beat which precedes each signal is a beat on a completed second, the first coincidence will take place on a completed second: it will take place on the half-second should the contrary hypothesis hold, and the observer has then to count, not only on the seconds, but also on the half-seconds of the chronometer; as required, he must also look at the seconds so that if necessary he can vary his counting half a second.

The counting being thus effected in all cases on the beat which immediately precedes each scientific signal, and which is caught up progressively by him, the observer concentrates his whole attention on this beat, regulating his intensity once and for all if it is not quite equal to that of the signal. The nearer the beat and the signal to each other, the better he will be able to gauge this. He waits until the signal has slightly overtaken the beat to notice

which was best in coincidence. Let this beat be 31'0 seconds. He writes it down in the first column of his comparative tables, the one headed

Reading $\left\{ \begin{array}{l} \text{of the clock} \\ \text{of the chronometer} \end{array} \right\}$ at the moment of coincidence

(see pp. 87, 88); then, if he has time before the first interruption, he writes down the minute (7m.) and the hour (10h.) which he reads on the dial. This time of coincidence, 10h. 7m. 31s'0, is that previously denoted by h .

Taking up the process again at the second of the beat which is now slightly behind the signal, he continues counting, not only on the beats of the timekeeper, but also on the scientific signals so as to get the number N of intervals of these signals included between the first coincidence and the interruption which follows it (this, of course, on condition that there is no other coincidence before the first interruption, in which case it would be necessary to again take up the counting on the beat which again precedes the signal in order to observe the second coincidence). The sound of the signal in the telephone being much clearer than that of the beat when the latter is a natural beat transmitted by a microphone, it is easy enough to take no notice of the latter so as to count only on the first, especially if one does not look at the dial. However, it is more convenient, especially for amateurs, to suppress the beats of the timekeeper in the

telephone so as to leave the signals only. This suppression is about indispensable when, in place of natural beats, those produced in the telephone artificially by the closing of an electric contact are heard, these being identical with the signals. To effect this, it is sufficient to break the primary circuit of the microphone or the contact, or to move the inductor if the coil is a movable one. The observer having counted, for example, 40s.0 at the moment a signal is missing, writes this number down in the second column headed

Reading $\left\{ \begin{array}{l} \text{of the clock} \\ \text{of the chronometer} \end{array} \right\}$ at the moment of interruption

on the line below that of 10h. 7m. 31s., and immediately connects up again the primary and secondary circuits in their condition so as to hear again the beats of the timekeeper in the telephone. If he has time before the second coincidence, he completes the entry of the second of interruption by adding the minute (7m.) and the hour (10h.), and draws a line below columns 1 and 2 to show that the time of the interruption relates to the first coincidence (which shows, moreover, on the chronometer tables, the identity of the zero decimals of the recorded times). This time, 10h. 7m. 40s., is that denoted above by h' .

The observer continues thus noting the times of the coincidences and interruptions until the end of the series, which is here supposed to comprise 300

TIME

*Resumption of the
Pendulum beats*

2^s 3^s 4^s

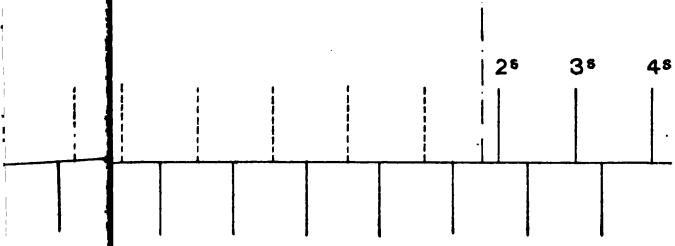

(time

1^s 2^s 3^s 4^s

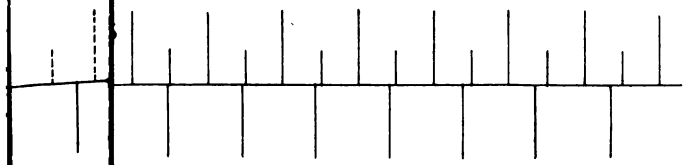

(time to be noted)

E & F N Spon, Ltd London

signals, less the 60th, 120th, 180th, and 240th (see Appendix). As regards the chronometer, the first coincidence observed being produced at a full second, the second must occur at a half-second: the observer on resumption must count on the beat preceding the signal—that is to say, on the half-second, as has been said above. At the 300th signal he notes the time as if he were dealing with an interruption, and writes it in the second column, with the comment, *final signal*.

The graphic chart (Plate I.) enables one to comprehend at a glance the various operations which have just been described for the determination of the times h and h' either for a seconds clock or a half-seconds chronometer. Above the axis of time the lines represent the seconds beats of the clock and the half-seconds of the chronometer: those corresponding to the full second are all equal, those of the half-second are half the former. Below the axis the lines represent the scientific signals with regular intervals of about $(1 - \frac{1}{80})$ of a second. The numbering is made on the beats and the signals on which the observer has to count. The dotted lines indicate missing beats or signals (suppressed beats or interrupted signals); the mixed lines signify times to be noted or operations to be conducted to suppress or recover the beats in the telephone. It will be seen that in assuming, as we have in the chart, that the two timekeepers, clock and chronometer, are indicating the same time, the

operations for obtaining the times h and h' of a coincidence and an interruption are identical when the interruption follows a coincidence at a full second; the half-second beats may be ruled out. But while with the pendulum one has ample time to take up the beats again and count after the interruption at 40.0 seconds, since one knows that the following coincidence will not occur till about the 20th second of the following minute, with the chronometer one must make haste as the coincidence will be at about 55.5 seconds of the same minute. It will also be noticed that after this second coincidence the beats are not to be suppressed, the third coincidence taking place before the second interruption.

Sundry Remarks.—(1) It may happen that when one signal is slightly behind the beat, the following one may be in front; in other words, the signal overtakes the beat without coinciding with it. This is what generally happens with artificial beats if the electric contact is open. In this case take the nearest beat to the signal as the coincidence. If two consecutive beats seem to be equidistant, the first from the preceding signal and the second from the following one, write down the times of both (bracketed) in the first column, and take the mean as the time h .

(2) If the times of the first and fifth coincidences with the beats of the chronometer were missed, inverted commas are substituted. In like manner

with the chronometer it was not possible to note the time of the third interruption, which came only two seconds after a coincidence. It is easy to fill this in by reference to the others which come later on. A single time of an interruption, if it is exact, and provided one knows its order, is sufficient to fix all the others. Consequently, if the observation of an interruption would cause the observer to miss a coincidence, he need have no hesitation in passing it by when he has several fixed times of interruption.

(3) The same interruption may be referred to the coincidence which precedes or which follows; but the time written down is not the same in both cases. Thus in the chronometer comparative tables the time of the first interruption which in relation to the first coincidence noted 10h. 7m. 31s. is fixed at 10h. 7m. 40s.0, would be 10h. 7m. 39s.5 when referred to the second coincidence. This is easily accounted for by recalling the way in which this time, 10h. 7m. 40s.0, was obtained, or still more simply by consulting the chart. 10h. 7m. 40s.0 is not the exact time of the chronometer, but merely a time such that the number of seconds (9) of its difference from 10h. 7m. 31s.0, the time of the coincidence to which it belongs, represents in intervals of scientific signals the time which elapsed between the first coincidence observed and the first interruption. Similarly the difference, 10h. 7m. 55s.5 - 10h. 7m. 39s.5 = 16 seconds, signifies that between the first

interruption and the second coincidence observed a time elapsed equal to 16 intervals of scientific signals.

(4) In the column headed *Remarks* all circumstances are noted which may affect the accuracy of the coincidences observed: defective transmission (doubled or missed), difficult reception (atmospheric or foreign transmissions), feeble reception, noises, etc. At the end of the series the observer makes a general note of his opinion on the whole of the coincidences noted, in which he takes into consideration not only the effects of the preceding influences, but also of his more or less effective arrangements.

Calculation of the 1st and 300th Scientific Signals.—It is now a matter of calculating the times of the clock and chronometer corresponding to the 1st and 300th signals, by the aid of the numbers in the first and second columns of the appended comparative tables, in order that, by adding thereto the *extrapolée* condition of the timekeepers, the forecasted times of these signals may be compared with those of the Paris Observatory, or, conversely, by deducting them from the transmitted times to obtain the condition of the timekeepers.

CALCULATING COMPARISONS 87

COMPARISONS WITH THE SCIENTIFIC TIME SIGNALS SENT OUT BY THE EIFFEL TOWER STATION

Observatory: X.
Name of Observer: O_X.
Date: 27th January 1913.
Clock: P_X.

Reading of the Clock.		Remarks.	Numbers of Signals.	Times Calculated for First and Last Signal.	Calculations.
At the Moment of the Coincidence.	At the Moment of the Interruption.				
h. m. s. <i>10. 7.31</i> Correction for N = -50 : -49.015 (Table)	h. m. s. <i>10. 7.40</i>		1	h. m. s. 10. 6.41.085	
			51		Intervals between coincidences
			60		50s.
					49
					50
					50
<i>8.31</i>	<i>8.39</i>	Atmospherics.	102		---
			120		199

					$\frac{1}{4} = 49s.75$
<i>9.10</i>	<i>9.38</i>		152		
			180		
<i>10.0</i>	<i>10.37</i>		203		50.75
			240		intervals in signals
					= 49s.75 of the clock, therefore
					1 interval
					= 1s. - $\frac{1s.}{50.75}$
10.50 Correction for N = +46 : +45.093 (Table)	11.36 (Last signal)	Good series.	264		
			300	10. 11. 35.093	
				Difference, 4.53.108	

Note.—The times in italic figures are the only ones written down by the observer during the comparison.

Commence by determining whether the intervals between the coincidences are regular. If the coincidences have been well observed, the difference in the various values will not exceed 1 second. When this is the case, take the means of these intervals as the value of the interval in seconds of the timekeeper. That amounts to dividing the difference between the times of the first and last coincidence by the number of intervals. These two coincidences therefore play a very important part, and it is essential to make sure that the times are not wrong. They are verified by the series of intervals. If one of the two times seems doubtful, it will be expedient to eliminate it. The mean interval of the two coincidences, plus one unit, gives the number of intervals of the equivalent signals. Thus 49s·75 being the mean divergence of the coincidences, the equation is obtained—

$$50\cdot75 \text{ intervals of the signals} = 49\cdot75 \text{ seconds of the clock,}$$

whence

$$1 \text{ signal interval} = \left(1\text{s.} - \frac{1\text{s.}}{50\text{s}\cdot75} \right) \text{ clock seconds.}$$

For the Chronometer.—The mean divergence of the coincidences being 24s·83, in the same way

$$(24\text{s}\cdot83 + 0\text{s}\cdot5) \text{ signal intervals} = 24\text{s}\cdot83 \text{ (chronometer)}$$

$$\begin{aligned} 1 \text{ signal interval} &= \frac{24\text{s}\cdot83}{24\text{s}\cdot83 + 0\text{s}\cdot5} = \frac{49\text{s}\cdot66}{49\text{s}\cdot66 + 1} \\ &= 1\text{s.} - \frac{1\text{s.}}{50\text{s}\cdot66} \text{ (chronometer).} \end{aligned}$$

These calculations may be made on the same sheets as the comparisons. Next fill in in the fourth column the numbers of the signals which correspond to the coincidences and interruptions observed. This may be quickly done by following paragraph No. 3 on p. 85.

Thus it will be seen that the first coincidence observed corresponds to the 51st signal, and by deducting $N=50$ signal intervals from the time 10h. 7m. 31s.0 of this first coincidence, the time of the first signal is obtained. The tables at the end of this work will give at once the products of N from the values in seconds of the interval for N comprised between 0 and 300, and for values of the interval varying from 1s. $-\frac{1}{4}$ s. to 1s. $-\frac{1}{81}$ s. By this means we find

$$50 \times \left(1s. - \frac{1s.}{50s.75} \right) = 49s.015.$$

$$50 \times \left(1s. - \frac{1s.}{50s.66} \right) = 49s.013.$$

Subtracting these numbers from 10h. 7m. 31s.0, we obtain 10h. 6m. 41s.985 and 10h. 6m. 41s.987 for the respective times of the pendulum and the chronometer at the moment of the first signal, which times we write in the fifth column.

In the same way we calculate the times of the pendulum and the chronometer corresponding to the 300th or last signal from the last coincidence observed with each.

To check the result by subtracting the first time from the second on each of the comparative tables, find the value of 299 intervals from the tables.

Use of Special Scientific Signals for the Comparison at a Distance of Timekeepers in determining Differences of Longitude.—As has been stated on p. 72, in determining differences of longitude when the maximum of accuracy is desired, it is advisable to use, for the comparison of the timekeepers at the station, scientific signals with a difference of period of less than $\frac{1}{80}$ of a second. Even $\frac{1}{100}$ of a second and less may be taken.

The operations to be carried out at each station do not differ from those made with scientific time signals; only the coincidences are further apart. The calculations are, however, made in a slightly different way with a view to obtaining a greater number of results.

The two tables given hereafter show a scheme dealing with the same series of signals; a copy of the comparative tables of two observers O_A and O_B working, one at A and the other at B respectively, with the chronometers C_A and C_B both regulated on mean time.

TABLE A

Station : A.
 Name of Observer : O .
 Date : 26th May 1911.
 Chronometer : C_A.
 Emitting Station : Eiffel Tower.

Number of Series.	Reading of the Chronometer.		Actual Reading of the Chronometer at the Moment of the Interruption.	Remarks.
	At the Moment of the Coincidence.	At the Moment of the Interruption.		
I	h. m. s. 10. 7.40'0	h. m. s. 10. 8.5'0	h. m. s. 10. 8.5'186	Some duplications.
	10. 8.47'5	10. 9.5'5	10. 9.5'634	
	10. 9.55'0	10.10.6'0	10.10.6'082	
	10.11. 2'5 3'5	10.11.6'5 10.12.6'5	10.11.6'526	
			Good series.	

Note.—The times in small characters are the only ones written by the observer during the comparisons.

TABLE B

Station : B.
 Name of Observer : O_B.
 Date : 26th May 1911.
 Chronometer : C_B.
 Emitting Station : Eiffel Tower.

Number of Series.	Reading of the Chronometer.		Actual Reading of the Chronometer at the Moment of the Interruption.	Remarks.
	At the Moment of the Coincidence.	At the Moment of the Interruption.		
I	h. m. s. 7. 1. 5'5	h. m. s. 7.1.15'5	h. m. s. I.I.15'574	Duplications.
	7. 2.13'0	7.2.16'0	7.2.16'022	
	7. 3.21'5	7.3.16'5 7.4.16'5	7.3.16'463	
	7. 4.29'0	7.4.17'0 7.5.17'0 (Last signal)	7.4.16'911	

Note.—The times in small characters are the only ones written by the observer during the comparisons.

The most exact process for deducing from these tables comparisons between C_A and C_B consists in reconstituting the comparisons taken at A and B as has been previously said, by calculating the numbers *n* of the scientific signals of the coincidences observed, then associating each of those at A with the nearest of those at B and referring the two comparisons of each group thus formed. For example : those corresponding to the scientific signals

n_A and n_B at the mean instant $\frac{n_A + n_B}{2}$ by using the respective mean values between n_A and $\frac{n_A + n_B}{2}$; $\frac{n_A + n_B}{2}$ and n_B of one interval of scientific signals in times of C_A and C_B .

However, if this interval remains perceptibly constant in the course of the series, which may be judged by the more or less regular spacing of the coincidences at the two stations, it will be sufficient to refer each of the comparisons of A and B at the moment of the nearest interruption, which does away with the need of reconstituting these comparisons, and permits of the calculation being done separately for each list of results.

It is assumed from what has just been said, that the same scientific signal is perceived at the same moment at both stations; in other words, the time of transmission between A and B is negligible. If this difference is an appreciable amount, the result is corrected accordingly.

The first thing, then, is to test whether the differences between the times of the coincidences are practically constant. Thus we obtain

From the Coincidences observed by O_A	From the Coincidences observed by O_B
m. s.	m. s.
1.7.5	1.7.5
7.5	8.5
8.0 ¹	7.5
Mean <u>1.7.67</u>	Mean <u>1.7.83</u>

¹ By taking the mean of the two times noted.

The variation of time between the differences at each station is confined to errors in observation. It may then be assumed that the interval between the scientific signals has remained constant during the whole series, and we may take as values for this interval in times of each chronometer the quotient of the mean difference with this number diminished by $\frac{1}{2}$.¹

We have thus

Value of the Interval of the two Scientific Signals.	
In Times of Chronometer C _A	In Times of Chronometer C _B
$\frac{67s \cdot 67}{67 \cdot 67 - \frac{1}{2}} = \text{Is.} + \frac{\text{Is.}}{2 \times 67 \cdot 67 - 1}$	$\frac{67s \cdot 83}{67 \cdot 83 - \frac{1}{2}} = \text{Is.} + \frac{\text{Is.}}{2 \times 67 \cdot 83 - 1}$
Log Factor of the Correction.	Log Factor of the Correction.
$\text{Log} \left[\frac{\text{Is.}}{2 \times 67 \cdot 67 - 1} \right] = 3 \cdot 872$	$\text{Log} \left[\frac{\text{Is.}}{2 \times 67 \cdot 83 - 1} \right] = 3 \cdot 871$

With these values it is easy to calculate the times of the chronometers at the moment of the interruption. Above all, we can fill in the times of interruptions omitted in the tables of comparisons.

In Table A the times of the two last interruptions, which referred to the last coincidence observed, are missing, but are evidently 10h. 11m. 6s·5 and 10h. 12m. 6s·5.

In Table B the time of the third interruption is missing. Referred to the preceding coincidence it

¹ If the period of the scientific signals was less than the second of each chronometer, it would be necessary to take as denominator the mean of the differences increased by $\frac{1}{2}$.

would be 7h. 3m. 16s. ; but it is advantageous to refer it to the following coincidence to which it is quite close: it then becomes 7h. 3m. 16s·5, and is written on the line above that of 7h. 3m. 21s·5. For the same reason the time of the fourth interruption, which is referred to the preceding coincidence, should be referred to the following one which it more nearly approaches ; and from 7h. 4m. 16s·5 it becomes 7h. 4m. 17s·0.

It is now necessary to calculate the times of the chronometers at the time of the same interruptions, commencing with that of the nearest coincidence.

To get, for example, the time of C_A at the moment of the first interruption, we make the difference, 10h. 8m. 5s·0 - 10h. 7m. 40s·0 = +25s., between the times noted for the first interruption and the first coincidence. We thus obtain the number of intervals of scientific signals which separate them. This number, multiplied by the value found previously for an interval in time of C_A gives the amount to be added to 10h. 7m. 40s·0.

It is simpler to multiply +25 by the factor of correction and to add the product to 10h. 8m. 5s·0.

The calculation is made thus :—

Log factor	. 3·872	Time noted of interruption	10h. 8m. 5s·0.
Log +25	. 1·398	Correction	. . . +0s·186.
Log correction	<u>1·270</u>	Exact time of interruption	<u>10h. 8m. 5s·186.</u>

This exact time is written in the fourth column of the table of comparisons with regard to the noted time of the interruption.

CALCULATING COMPARISONS 97

All the calculations for correction are made together as follows:—

STATION A

Differences between Times of Coincidences and Times of Interruptions.	Log Differences. $\bar{3}\cdot872.$	Log Corrections.	Corrections.
secs. + 25 + 18 + 11 + 3'5	1'398 + 1'255 + 1'041 + 0'554 +	1'270 + 1'227 + 2'913 + 2'416 +	+0s'186 +0'134 +0'082 +0'026

STATION B

Differences between Times of Coincidences and Times of Interruptions.	Log Differences. $\bar{3}\cdot871.$	Log Corrections.	Corrections.
secs. + 10 + 3 - 5 - 12	1'000 + 0'477 + 0'699 - 1'079 -	2'871 + 2'348 + 2'570 - 2'950 -	+0s'074 +0'022 -0'037 -0'089

Column 4 in the tables of comparison being filled in, take the differences in the times which correspond in these columns in the two tables. We thus obtain other comparisons of which we take the mean—

Comparisons $C_A - C_B$

h. m. s.
3. 6.49'612
49'612
49'619
49'615

Mean . . . 3. 6.49'614

TABLE GIVING IN SECONDS THE VALUE OF A NUMBER OF
N INTERVALS OF SCIENTIFIC SIGNALS

N.	Intervals of Scientific Signals.					Increase in the Denominator of the Fraction of the Interval.				
	Is. - $\frac{Is.}{49}$	Is. - $\frac{Is.}{49'5}$	Is. - $\frac{Is.}{50}$	Is. - $\frac{Is.}{50'5}$	Is. - $\frac{Is.}{51}$	0'1	0'2	0'3	0'4	0'5
	seconds.	seconds.	seconds.	seconds.	seconds.	10^{-3}	10^{-3}	10^{-3}	10^{-3}	10^{-3}
1	0'980	0'980	0'980	0'980	0'980	0	0	0	0	0
2	1'959	1'960	1'960	1'960	1'961	0	0	0	0	0
3	2'939	2'939	2'940	2'941	2'941	0	0	0	0	1
4	3'918	3'919	3'920	3'921	3'922	0	0	0	1	1
5	4'898	4'899	4'900	4'901	4'902	0	0	1	1	1
6	5'878	5'879	5'880	5'881	5'882	0	0	1	1	1
7	6'857	6'859	6'860	6'861	6'863	0	1	1	1	1
8	7'837	7'838	7'840	7'842	7'843	0	1	1	1	2
9	8'816	8'818	8'820	8'822	8'824	0	1	1	1	2
10	9'796	9'798	9'800	9'802	9'804	0	1	1	2	2
11	10'776	10'778	10'780	10'782	10'784	0	1	1	2	2
12	11'755	11'758	11'760	11'762	11'765	0	1	1	2	2
13	12'735	12'737	12'740	12'743	12'745	1	1	2	2	3
14	13'714	13'717	13'720	13'723	13'725	1	1	2	2	3
15	14'694	14'697	14'700	14'703	14'706	1	1	2	2	3
16	15'673	15'677	15'680	15'683	15'686	1	1	2	3	3
17	16'653	16'657	16'660	16'663	16'667	1	1	2	3	3
18	17'633	17'636	17'640	17'644	17'647	1	1	2	3	4
19	18'612	18'616	18'620	18'624	18'627	1	2	2	3	4
20	19'592	19'596	19'600	19'604	19'608	1	2	2	3	4
21	20'571	20'576	20'580	20'584	20'588	1	2	3	3	4
22	21'551	21'556	21'560	21'564	21'569	1	2	3	4	4
23	22'531	22'535	22'540	22'545	22'549	1	2	3	4	5
24	23'510	23'515	23'520	23'525	23'529	1	2	3	4	5
25	24'490	24'495	24'500	24'505	24'510	1	2	3	4	5
26	25'469	25'475	25'480	25'485	25'490	1	2	3	4	5
27	26'449	26'455	26'460	26'465	26'471	1	2	3	4	5
28	27'429	27'434	27'440	27'446	27'451	1	2	3	4	6
29	28'408	28'414	28'420	28'426	28'431	1	2	3	5	6
30	29'388	29'394	29'400	29'406	29'412	1	2	4	5	6

N.	Intervals of Scientific Signals.					Increase in the Denominator of the Fraction of the Interval.				
	Is. - 49	Is. - 49'5	Is. - 50	Is. - 50'5	Is. - 51	0'1	0'2	0'3	0'4	0'5
	m. s.	m. s.	m. s.	m. s.	m. s.	10 ⁻³	10 ⁻³	10 ⁻³	10 ⁻³	10 ⁻³
31	30'367	30'374	30'380	30'386	30'392	1	2	4	5	6
32	31'347	31'354	31'360	31'366	31'373	1	3	4	5	6
33	32'327	32'333	32'340	32'347	32'353	1	3	4	5	7
34	33'306	33'313	33'320	33'327	33'333	1	5	4	5	7
35	34'286	34'293	34'300	34'307	34'314	1	3	4	6	7
36	35'265	35'273	35'280	35'287	35'294	1	3	4	6	7
37	36'245	36'253	36'260	36'267	36'275	1	3	4	6	7
38	37'224	37'232	37'240	37'248	37'255	2	3	5	6	8
39	38'204	38'212	38'220	38'228	38'235	2	3	5	6	8
40	39'184	39'192	39'200	39'208	39'216	2	3	5	6	8
41	40'163	40'172	40'180	40'188	40'196	2	3	5	7	8
42	41'143	41'152	41'160	41'168	41'176	2	3	5	7	8
43	42'122	42'131	42'140	42'149	42'157	2	3	5	7	9
44	43'102	43'111	43'120	43'129	43'137	2	4	5	7	9
45	44'082	44'091	44'100	44'109	44'118	2	4	5	7	9
46	45'061	45'071	45'080	45'089	45'098	2	4	6	7	9
47	46'041	46'051	46'060	46'069	46'078	2	4	6	8	9
48	47'020	47'030	47'040	47'050	47'059	2	4	6	8	10
49	48'000	48'010	48'020	48'030	48'039	2	4	6	8	10
50	48'980	48'990	49'000	49'010	49'020	2	4	6	8	10
51	49'959	49'970	49'980	49'990	50'000	2	4	6	8	10
52	50'939	50'949	50'960	50'970	50'980	2	4	6	8	10
53	51'918	51'929	51'940	51'950	51'961	2	4	6	8	11
54	52'898	52'909	52'920	52'931	52'941	2	4	6	9	11
55	53'878	53'889	53'900	53'911	53'922	2	4	7	9	11
56	54'857	54'869	54'880	54'891	54'902	2	4	7	9	11
57	55'837	55'848	55'860	55'871	55'882	2	5	7	9	11
58	56'816	56'828	56'840	56'851	56'863	2	5	7	9	12
59	57'796	57'808	57'820	57'832	57'843	2	5	7	9	12
60	58'776	58'788	58'800	58'812	58'824	2	5	7	10	12
61	0 59'755	0 59'768	0 59'780	0 59'792	0 59'804	2	5	7	10	12
62	I 0'735	I 0'747	I 0'760	I 0'772	I 0'784	2	5	7	10	12
63	1'714	1'728	1'740	1'752	1'765	3	5	8	10	13
64	2'694	2'707	2'720	2'733	2'745	3	5	8	10	13
65	3'673	3'687	3'700	3'713	3'725	3	5	8	10	13

N.	Intervals of Scientific Signals.					Increase in the Denominator of the Fraction of the Interval.				
	Is. - Is. 49	Is. - Is. 49·5	Is. - Is. 50	Is. - Is. 50·5	Is. - Is. 51	0·1	0·2	0·3	0·4	0·5
	m. s.	m. s.	m. s.	m. s.	m. s.	10 ⁻³	10 ⁻³	10 ⁻³	10 ⁻³	10 ⁻³
66	I 4'653	I 4'667	I 4'680	I 4'693	I 4'706	3	5	8	11	13
67	5'633	5'646	5'660	5'673	5'686	3	5	8	11	13
68	6'612	6'626	6'640	6'653	6'667	3	5	8	11	14
69	7'592	7'606	7'620	7'634	7'647	3	6	8	11	14
70	8'571	8'586	8'600	8'614	8'627	3	6	8	11	14
71	9'551	9'566	9'580	9'594	9'608	3	6	9	11	14
72	10'531	10'545	10'560	10'574	10'588	3	6	9	12	14
73	11'510	11'525	11'540	11'554	11'569	3	6	9	12	15
74	12'490	12'505	12'520	12'535	12'549	3	6	9	12	15
75	13'469	13'485	13'500	13'515	13'529	3	6	9	12	15
76	14'449	14'465	14'480	14'495	14'510	3	6	9	12	15
77	15'429	15'444	15'460	15'475	15'490	3	6	9	12	15
78	16'408	16'424	16'440	16'455	16'471	3	6	9	12	16
79	17'388	17'404	17'420	17'436	17'451	3	6	9	13	16
80	18'367	18'384	18'400	18'416	18'431	3	6	10	13	16
81	19'347	19'364	19'380	19'396	19'412	3	6	10	13	16
82	20'327	20'343	20'360	20'376	20'392	3	7	10	13	16
83	21'306	21'323	21'340	21'356	21'373	3	7	10	13	17
84	22'286	22'303	22'320	22'337	22'353	3	7	10	13	17
85	23'265	23'283	23'300	23'317	23'333	3	7	10	14	17
86	24'245	24'263	24'280	24'297	24'314	3	7	10	14	17
87	25'224	25'242	25'260	25'277	25'294	3	7	10	14	17
88	26'204	26'222	26'240	26'257	26'275	4	7	11	14	18
89	27'184	27'202	27'220	27'238	27'255	4	7	11	14	18
90	28'163	28'182	28'200	28'218	28'235	4	7	11	14	18
91	29'143	29'162	29'180	29'198	29'216	4	7	11	15	18
92	30'122	30'141	30'160	30'178	30'196	4	7	11	15	18
93	31'102	31'121	31'140	31'158	31'176	4	7	11	15	19
94	32'082	32'101	32'120	32'139	32'157	4	8	11	15	19
95	33'061	33'081	33'100	33'119	33'137	4	8	11	15	19
96	34'041	34'061	34'080	34'099	34'118	4	8	12	15	19
97	35'020	35'040	35'060	35'079	35'098	4	8	12	16	19
98	36'000	36'020	36'040	36'059	36'078	4	8	12	16	20
99	36'980	37'000	37'020	37'040	37'059	4	8	12	16	20
100	37'959	37'980	38'000	38'020	38'039	4	8	12	16	20

CALCULATING COMPARISONS 101

N.	Intervals of Scientific Signals.					Increase in the Denominator of the Fraction of the Interval.				
	Is. - Is.	Is. - Is.	Is. - Is.	Is. - Is.	Is. - Is.	0'1	0'2	0'3	0'4	0'5
	49	49'5	50	50'5	51					
m. s.	m. s.	m. s.	m. s.	m. s.	10 ⁻³	10 ⁻³	10 ⁻³	10 ⁻³	10 ⁻³	
101	I 38'939	I 38'960	I 38'980	I 39'000	I 39'020	4	8	12	16	20
102	39'918	39'939	39'960	39'980	40'000	4	8	12	16	20
103	40'898	40'919	40'940	40'960	40'980	4	8	12	16	21
104	41'878	41'899	41'920	41'941	41'961	4	8	12	17	21
105	42'857	42'879	42'900	42'921	42'941	4	8	13	17	21
106	43'837	43'859	43'880	43'901	43'922	4	8	13	17	21
107	44'816	44'838	44'860	44'881	44'902	4	9	13	17	21
108	45'796	45'818	45'840	45'861	45'882	4	9	13	17	22
109	46'776	46'798	46'820	46'842	46'863	4	9	13	17	22
110	47'755	47'778	47'800	47'822	47'843	4	9	13	18	22
111	48'735	48'758	48'780	48'802	48'824	4	9	13	18	22
112	49'714	49'737	49'760	49'782	49'804	4	9	13	18	22
113	50'694	50'717	50'740	50'762	50'784	5	9	14	18	23
114	51'673	51'697	51'720	51'743	51'765	5	9	14	18	23
115	52'653	52'677	52'700	52'723	52'745	5	9	14	18	23
116	53'633	53'657	53'680	53'703	53'725	5	9	14	19	23
117	54'612	54'636	54'660	54'683	54'706	5	9	14	19	23
118	55'592	55'616	55'640	55'663	55'686	5	9	14	19	24
119	56'571	56'596	56'620	56'644	56'667	5	10	14	19	24
120	57'551	57'576	57'600	57'624	57'647	5	10	14	19	24
121	58'531	58'556	58'580	58'604	58'627	5	10	15	19	24
122	59'510	59'535	59'560	59'584	59'608	5	10	15	20	24
123	2 0'490	2 0'515	2 0'540	2 0'564	2 0'588	5	10	15	20	25
124	1'469	1'495	1'520	1'545	1'569	5	10	15	20	25
125	2'449	2'475	2'500	2'525	2'549	5	10	15	20	25
126	3'429	3'455	3'480	3'505	3'529	5	10	15	20	25
127	4'408	4'434	4'460	4'485	4'510	5	10	15	20	25
128	5'388	5'414	5'440	5'465	5'490	5	10	15	20	26
129	6'367	6'394	6'420	6'446	6'471	5	10	15	21	26
130	7'347	7'374	7'400	7'426	7'451	5	10	16	21	26
131	8'327	8'354	8'380	8'406	8'431	5	10	16	21	26
132	9'306	9'333	9'360	9'386	9'412	5	11	16	21	26
133	10'286	10'313	10'340	10'366	10'392	5	11	16	21	27
134	11'265	11'293	11'320	11'347	11'373	5	11	16	21	27
135	12'245	12'273	12'300	12'327	12'353	5	11	16	22	27

N.	Intervals of Scientific Signals.					Increase in the Denominator of the Fraction of the Interval.				
	Is. - 49	Is. - 49'5	Is. - 50	Is. - 50'5	Is. - 51	0'1	0'2	0'3	0'4	0'5
	m. s.	m. s.	m. s.	m. s.	m. s.	10 ⁻³	10 ⁻³	10 ⁻³	10 ⁻³	10 ⁻³
136	2 13'224	2 13'253	2 13'280	2 13'307	2 13'333	5	11	16	22	27
137	14'204	14'232	14'260	14'287	14'314	5	11	16	22	27
138	15'184	15'212	15'240	15'267	15'294	6	11	17	22	28
139	16'163	16'192	16'220	16'248	16'275	6	11	17	22	28
140	17'142	17'172	17'200	17'228	17'255	6	11	17	22	28
141	18'123	18'152	18'180	18'208	18'235	6	11	17	23	28
142	19'102	19'131	19'160	19'188	19'216	6	11	17	23	28
143	20'082	20'111	20'140	20'168	20'196	6	11	17	23	29
144	21'061	21'091	21'120	21'149	21'176	6	12	17	23	29
145	22'041	22'071	22'100	22'129	22'157	6	12	17	23	29
146	23'020	23'051	23'080	23'109	23'137	6	12	18	23	29
147	24'000	24'030	24'060	24'089	24'118	6	12	18	24	29
148	24'980	25'010	25'040	25'069	25'098	6	12	18	24	30
149	25'959	25'990	26'020	26'050	26'078	6	12	18	24	30
150	26'939	26'970	27'000	27'030	27'059	6	12	18	24	30
151	27'918	27'949	27'980	28'010	28'039	6	12	18	24	30
152	28'898	28'929	28'960	28'990	29'020	6	12	18	24	30
153	29'878	29'909	29'940	29'970	30'000	6	12	18	24	31
154	30'857	30'889	30'920	30'950	30'980	6	12	18	25	31
155	31'837	31'869	31'900	31'931	31'961	6	12	19	25	31
156	32'816	32'848	32'880	32'911	32'941	6	12	19	25	31
157	33'796	33'828	33'860	33'891	33'922	6	13	19	25	31
158	34'776	34'808	34'840	34'871	34'902	6	13	19	25	32
159	35'755	35'788	35'820	35'851	35'882	6	13	19	25	32
160	36'735	36'768	36'800	36'832	36'863	6	13	19	26	32
161	37'714	37'747	37'780	37'812	37'843	6	13	19	26	32
162	38'694	38'728	38'760	38'792	38'824	6	13	19	26	32
163	39'673	39'707	39'740	39'772	39'804	7	13	20	26	33
164	40'653	40'687	40'720	40'752	40'784	7	13	20	26	33
165	41'633	41'667	41'700	41'733	41'765	7	13	20	26	33
166	42'612	42'646	42'680	42'713	42'745	7	13	20	27	33
167	43'592	43'626	43'660	43'693	43'725	7	13	20	27	33
168	44'571	44'606	44'640	44'673	44'706	7	13	20	27	34
169	45'551	45'586	45'620	45'653	45'686	7	14	20	27	34
170	46'531	46'566	46'600	46'634	46'667	7	14	20	27	34

CALCULATING COMPARISONS 103

N.	Intervals of Scientific Signals.					Increase in the Denominator of the Fraction of the Interval.				
	Is. - $\frac{Is.}{49}$	Is. - $\frac{Is.}{49 \cdot 5}$	Is. - $\frac{Is.}{50}$	Is. - $\frac{Is.}{50 \cdot 5}$	Is. - $\frac{Is.}{51}$	0'1	0'2	0'3	0'4	0'5
	m. s.	m. s.	m. s.	m. s.	m. s.	10^{-3}	10^{-3}	10^{-3}	10^{-3}	10^{-3}
171	2 47'510	2 47'545	2 47'580	2 47'614	2 47'647	7	14	21	27	34
172	48'490	48'525	48'560	48'594	48'627	7	14	21	28	34
173	49'469	49'505	49'540	49'574	49'608	7	14	21	28	35
174	50'449	50'485	50'520	50'554	50'588	7	14	21	28	35
175	51'429	51'465	51'500	51'535	51'569	7	14	21	28	35
176	52'408	52'444	52'480	52'515	52'549	7	14	21	28	35
177	53'388	53'424	53'460	53'495	53'529	7	14	21	28	35
178	54'367	54'404	54'440	54'475	54'510	7	14	21	28	36
179	55'347	55'384	55'420	55'455	55'490	7	14	21	29	36
180	56'327	56'364	56'400	56'436	56'471	7	14	22	29	36
181	57'306	57'343	57'380	57'416	57'451	7	14	22	29	36
182	58'286	58'323	58'360	58'396	58'431	7	15	22	29	36
183	59'265	59'303	59'340	59'376	59'412	7	15	22	29	37
184	3 0'245	3 0'283	3 0'320	3 0'356	3 0'392	7	15	22	29	37
185	1'224	1'263	1'300	1'337	1'373	7	15	22	30	37
186	2'204	2'242	2'280	2'317	2'353	7	15	22	30	37
187	3'184	3'222	3'260	3'297	3'333	7	15	22	30	37
188	4'163	4'202	4'240	4'277	4'314	8	15	23	30	38
189	5'143	5'182	5'220	5'257	5'294	8	15	23	30	38
190	6'122	6'162	6'200	6'238	6'275	8	15	23	30	38
191	7'102	7'141	7'180	7'218	7'255	8	15	23	31	38
192	8'082	8'121	8'160	8'198	8'235	8	15	23	31	38
193	9'061	9'101	9'140	9'178	9'216	8	15	23	31	39
194	10'041	10'081	10'120	10'158	10'196	8	16	23	31	39
195	11'020	11'061	11'100	11'139	11'176	8	16	23	31	39
196	12'000	12'040	12'080	12'119	12'157	8	16	24	31	39
197	12'980	13'020	13'060	13'099	13'137	8	16	24	32	39
198	13'959	14'000	14'040	14'079	14'118	8	16	24	32	40
199	14'939	14'980	15'020	15'059	15'098	8	16	24	32	40
200	15'918	15'960	16'000	16'040	16'078	8	16	24	32	40
201	16'898	16'939	16'980	17'020	17'059	8	16	24	32	40
202	17'878	17'919	17'960	18'000	18'039	8	16	24	32	40
203	18'857	18'899	18'940	18'980	19'020	8	16	24	32	41
204	19'837	19'879	19'920	19'960	20'000	8	16	24	33	41
205	20'816	20'859	20'900	20'941	20'980	8	16	25	33	41

N.	Intervals of Scientific Signals.					Increase in the Denominator of the Fraction of the Interval.				
	Is. - $\frac{Is.}{49}$	Is. - $\frac{Is.}{49.5}$	Is. - $\frac{Is.}{50}$	Is. - $\frac{Is.}{50.5}$	Is. - $\frac{Is.}{51}$	0.1	0.2	0.3	0.4	0.5
	m. s.	m. s.	m. s.	m. s.	m. s.	10^{-3}	10^{-3}	10^{-3}	10^{-3}	10^{-3}
206	3 21'796	3 21'838	3 21'880	3 21'921	3 21'961	8	16	25	33	41
207	22'776	22'818	22'860	22'901	22'941	8	17	25	33	41
208	23'755	23'798	23'840	23'881	23'922	8	17	25	33	42
209	24'735	24'778	24'820	24'861	24'902	8	17	25	33	42
210	25'714	25'758	25'800	25'842	25'882	8	17	25	34	42
211	26'694	26'737	26'780	26'822	26'863	8	17	25	34	42
212	27'673	27'717	27'760	27'802	27'843	8	17	25	34	42
213	28'653	28'697	28'740	28'782	28'824	9	17	26	34	43
214	29'633	29'677	29'720	29'762	29'804	9	17	26	34	43
215	30'612	30'657	30'700	30'743	30'784	9	17	26	34	43
216	31'592	31'636	31'680	31'723	31'765	9	17	26	35	43
217	32'571	32'616	32'660	32'703	32'745	9	17	26	35	43
218	33'551	33'596	33'640	33'683	33'725	9	17	26	35	44
219	34'531	34'576	34'620	34'663	34'706	9	18	26	35	44
220	35'510	35'556	35'600	35'644	35'686	9	18	26	35	44
221	36'490	36'535	36'580	36'624	36'667	9	18	27	35	44
222	37'469	37'515	37'560	37'604	37'647	9	18	27	36	44
223	38'449	38'495	38'540	38'584	38'627	9	18	27	36	45
224	39'429	39'475	39'520	39'564	39'608	9	18	27	36	45
225	40'408	40'455	40'500	40'545	40'588	9	18	27	36	45
226	41'388	41'434	41'480	41'525	41'569	9	18	27	36	45
227	42'367	42'414	42'460	42'505	42'549	9	18	27	36	45
228	43'347	43'394	43'440	43'485	43'529	9	18	27	36	46
229	44'327	44'374	44'420	44'465	44'510	9	18	27	37	46
230	45'306	45'354	45'400	45'446	45'490	9	18	28	37	46
231	46'286	46'333	46'380	46'426	46'471	9	18	28	37	46
232	47'265	47'313	47'360	47'406	47'451	9	19	28	37	46
233	48'245	48'293	48'340	48'386	48'431	9	19	28	37	47
234	49'224	49'273	49'320	49'366	49'412	9	19	28	37	47
235	50'204	50'253	50'300	50'347	50'392	9	19	28	38	47
236	51'184	51'232	51'280	51'327	51'373	9	19	28	38	47
237	52'163	52'212	52'260	52'307	52'353	9	19	28	38	47
238	53'143	53'192	53'245	53'287	53'333	10	19	29	38	48
239	54'122	54'172	54'220	54'267	54'314	10	19	29	38	48
240	55'102	55'152	55'200	55'248	55'294	10	19	29	38	48

N.	Intervals of Scientific Signals.					Increase in the Denominator of the Fraction of the Interval.				
	Is. - $\frac{Is.}{49}$	Is. - $\frac{Is.}{49 \cdot 5}$	Is. - $\frac{Is.}{50}$	Is. - $\frac{Is.}{50 \cdot 5}$	Is. - $\frac{Is.}{51}$	0'1	0'2	0'3	0'4	0'5
	m. s.	m. s.	m. s.	m. s.	m. s.	10^{-3}	10^{-3}	10^{-3}	10^{-3}	10^{-3}
241	3 56'082	3 56'131	3 56'180	3 56'228	3 56'275	10	19	29	39	48
242	57'061	57'111	57'160	57'208	57'255	10	19	29	39	48
243	58'041	58'091	58'140	58'188	58'235	10	19	29	39	49
244	59'020	59'071	59'120	59'168	59'216	10	20	29	39	49
245	4 0'000	4 0'051	4 0'100	4 0'149	4 0'196	10	20	29	39	49
246	0'980	1'030	1'080	1'129	1'176	10	20	30	39	49
247	1'959	2'010	2'060	2'109	2'157	10	20	30	40	49
248	2'939	2'990	3'040	3'089	3'137	10	20	30	40	50
249	3'918	3'970	4'020	4'069	4'118	10	20	30	40	50
250	4'898	4'949	5'000	5'050	5'098	10	20	30	40	50
251	5'878	5'929	5'980	6'030	6'078	10	20	30	40	50
252	6'857	6'909	6'960	7'010	7'059	10	20	30	40	50
253	7'837	7'889	7'940	7'990	8'039	10	20	30	40	51
254	8'816	8'869	8'920	8'970	9'020	10	20	30	41	51
255	9'796	9'848	9'900	9'950	10'000	10	20	31	41	51
256	10'776	10'828	10'880	10'931	10'980	10	20	31	41	51
257	11'755	11'808	11'860	11'911	11'961	10	21	31	41	51
258	12'735	12'788	12'840	12'891	12'941	10	21	31	41	52
259	13'714	13'768	13'820	13'871	13'922	10	21	31	41	52
260	14'694	14'747	14'800	14'851	14'902	10	21	31	42	52
261	15'673	15'727	15'780	15'832	15'882	10	21	31	42	52
262	16'653	16'707	16'760	16'812	16'863	10	21	31	42	52
263	17'633	17'687	17'740	17'792	17'843	11	21	32	42	53
264	18'612	18'667	18'720	18'772	18'824	11	21	32	42	53
265	19'592	19'646	19'700	19'752	19'804	11	21	32	42	53
266	20'571	20'626	20'680	20'733	20'784	11	21	32	43	53
267	21'551	21'606	21'660	21'713	21'765	11	21	32	43	53
268	22'531	22'586	22'640	22'693	22'745	11	21	32	43	54
269	23'510	23'566	23'620	23'673	23'725	11	22	32	43	54
270	24'490	24'545	24'600	24'653	24'706	11	22	32	43	54
271	25'469	25'525	25'580	25'634	25'686	11	22	33	43	54
272	26'449	26'505	26'560	26'614	26'667	11	22	33	44	54
273	27'429	27'485	27'540	27'594	27'647	11	22	33	44	55
274	28'408	28'465	28'520	28'574	28'627	11	22	33	44	55
275	29'388	29'444	29'500	29'554	29'608	11	22	33	44	55

N.	Intervals of Scientific Signals.					Increase in the Denominator of the Fraction of the Interval.				
	Is. - $\frac{Is.}{49}$	Is. - $\frac{Is.}{49 \cdot 5}$	Is. - $\frac{Is.}{50}$	Is. - $\frac{Is.}{50 \cdot 5}$	Is. - $\frac{Is.}{51}$	0'1	0'2	0'3	0'4	0'5
	m. s.	m. s.	m. s.	m. s.	m. s.	10^{-3}	10^{-3}	10^{-3}	10^{-3}	10^{-3}
276	4 30'367	4 30'424	4 30'480	4 30'535	4 30'588	11	22	33	44	55
277	31'347	31'404	31'460	31'515	31'569	11	22	33	44	55
278	32'327	32'384	32'440	32'495	32'549	11	22	33	44	56
279	33'306	33'364	33'420	33'475	33'529	11	22	33	45	56
280	34'286	34'343	34'400	34'455	34'510	11	22	34	45	56
281	35'265	35'323	35'380	35'436	35'490	11	22	34	45	56
282	36'245	36'303	36'360	36'416	36'471	11	23	34	45	56
283	37'224	37'283	37'340	37'396	37'451	11	23	34	45	57
284	38'204	38'263	38'320	38'376	38'431	11	23	34	45	57
285	39'184	39'242	39'300	39'356	39'412	11	23	34	46	57
286	40'163	40'222	40'280	40'337	40'392	11	23	34	46	57
287	41'143	41'202	41'260	41'317	41'373	11	23	34	46	57
288	42'122	42'182	42'240	42'297	42'353	12	23	35	46	58
289	43'102	43'162	43'220	43'277	43'333	12	23	35	46	58
290	44'082	44'141	44'200	44'257	44'314	12	23	35	46	58
291	45'061	45'121	45'180	45'238	45'294	12	23	35	47	58
292	46'041	46'101	46'160	46'218	46'275	12	23	35	47	58
293	47'020	47'081	47'140	47'198	47'255	12	23	35	47	59
294	48'000	48'061	48'120	48'178	48'235	12	24	35	47	59
295	48'980	49'040	49'100	49'158	49'216	12	24	35	47	59
296	49'959	50'020	50'080	50'139	50'196	12	24	36	47	59
297	50'939	51'000	51'060	51'119	51'176	12	24	36	48	59
298	51'918	51'980	52'040	52'099	52'157	12	24	36	48	60
299	52'898	52'960	53'020	53'079	53'137	12	24	36	48	60
300	53'878	53'939	54'000	54'059	54'118	12	24	36	48	60

APPENDIX A

TIME SIGNALS AND METEOROLOGICAL RADIO-TELEGRAMS AT PRESENT TRANSMITTED DAILY FROM THE EIFFEL TOWER

THE ordinary time signals are transmitted each morning at 10.45, 10.47, and 10.49, and each night at 23.45 (11.45 p.m.), 23.47, and 23.49 (legal or Greenwich time).

A series of 300 rhythmic beats permitting of the application of the method of coincidences to obtain the time with approximate accuracy is transmitted each night at 23h. 30m. (11.30 p.m.), the 60th, 120th, 180th, and 240th beats being suppressed.

A general meteorological telegram is despatched every morning just after the 10.49 time signal.

Three meteorological telegrams relating to the Paris district are transmitted daily (except Sundays and holidays) respectively at 8.0 a.m., 10.55 a.m. (just after the general weather report), and 3.0 p.m. The 8.0 a.m. and 3.0 p.m. transmissions are made with one-quarter normal power.

The following are the details of these various transmissions which are all made with the same wave-length of about 2200 metres.

Ordinary Morning Time Signals.—Some minutes before 10.45 a.m. the Eiffel Tower wireless station is connected by underground lines with the Paris Observatory, from which the wireless transmission apparatus at the Tower can then be controlled through relays.

At about 10.43 a.m. are transmitted the words:

Observatoire de Paris, Signaux Horaires (Paris Observatory, Time Signals), followed by the "wait" signal repeated four times (- — - - -).

At 10.44 a.m. a series of warning signals consisting of a succession of *dashes* is sent :

— — — — —

These cease at about 10h. 44m. 55s.

At 10h. 45m. 0s. a clock at the Observatory automatically closes the transmission circuit by means of a suitable arrangement for a time equal to about $\frac{1}{4}$ second, which produces a rather long *dot* ; this is the first time signal.

At about 10.46 a.m. a new series of warning signals is sent, consisting of *dashes* separated by *two dots* :

— - - - -

These cease at about 10h. 46m. 55s.

At 10h. 47m. 0s. the second time signal is transmitted in the same way as the first.

At about 10.48 a.m. a third series of warning signals is sent, composed this time of *dashes* separated by *four dots* :

These cease at about 10h. 48m. 55s.

At 10h. 49m. 0s. the third time signal is transmitted in the same way as the first and second.

The nature of the warning signals sent before each of the three time signals prevents all liability to confusion.

Ordinary Night Time Signals. — The ordinary night signals are transmitted in the same manner as the morning signals at 23h. 45m. (11.45 p.m.), 23.47, and 23.49.

Scientific Time Signals. — Each night at about 23h. 29m. (11.29 p.m.) the call (— - — - —) is sent for 45 seconds ; then after 15 seconds rest—that is to say, at about 23h. 30m. (11.30 p.m.)—a series of 300 radio-

telegraphic dots is sent spaced about $(1 - \frac{1}{80})$ of a second, the 60th, 120th, 180th, and 240th being suppressed to give data for calculation. This series is heard at the Paris Observatory in a wireless receiving apparatus and compared with the beat of a time-keeping clock by the method of coincidences. A very simple calculation permits of the times of the 1st and 300th beats of the series being determined to about $\frac{1}{100}$ or $\frac{1}{200}$ second by means of the times of the coincidences noted on the clock, and by adding the corresponding correction for the clock these may be converted into legal time.

These last times are transmitted immediately after the ordinary 11.49 p.m. time signal in the following manner:— If the times of the 1st and 300th beats are, for example, 23h. 30m. 13s.28 and 23h. 35m. 6s.14, the two following groups of figures are transmitted three times—

— — — — — 301328 . 350614
 — — — — — 301328 . 350614
 — — — — — 301328 . 350614 — — — — —

To know with approximate accuracy the correction to be introduced for a chronometer or precision clock with regard to the legal time of the Observatory, it is sufficient to listen to the beats through the intermediary of a microphone at the same time as the series of 300 *dots* sent out from the Eiffel Tower. Then calculate the times of the chronometer or clock at the moments of the 1st and 300th beats. By subtracting these times from the corresponding ones transmitted by the Eiffel Tower, two values for the chronometer or clock correction are obtained which should agree to about $\frac{1}{200}$ of a second.

The duration of the scientific signals is therefore about 5 minutes.

General Weather Telegram.— Immediately after

the 10.49 a.m. time signal a general meteorological telegram is sent from the Paris *Bureau Central Météorologique* (*Central Weather Office*) giving the atmospheric pressure, the direction and force of the wind, the state of the sky, and the state of the sea for the following six stations:—

Reykjavik (Iceland).
 Valentia (Ireland).
 Ouessant (Ushant) (France).
 La Corogne (Corunna) (Spain).

Horta (Azores).
 St. Pierre et Miquelon (Newfoundland).

These stations are respectively denoted in the despatch by their initial letters, R, V, O, C, H, S.

The weather information corresponding to each is condensed into a group of figures constituted as follows:—The first, second, and third figures give the barometric pressure to the 10th of a millimetre after the addition of 700 (*i.e.* if the first, second, and third figures are 586, the reading of the barometer is 758·6 millimetres). The fourth and fifth figures give the direction of the wind, the sixth its force, the seventh the state of the sky, and the eighth the state of the sea (this last indication is not given in the groups of figures corresponding to Reykjavik and to St. Pierre).

The conversion of these figures into ordinary language is given in the tables which follow.

When an observation is missing from any station the corresponding figures in the station group are replaced by the letter X (— -- —).

Each group is preceded by the characteristic letter of the station to which it refers.

In addition to these six groups some indication is given in ordinary language of the general state of the atmosphere in Europe and especially the position of the centres of high and low pressure.

EXAMPLE OF TELEGRAM

BCM BCM . R 5861637 . V 58920353 . O 52032143 .
 C 61528181 . H 68022342 . S 6802214.

Anticyclone Europe centrale beau temps général dépression Ouest Irlande allant vers Est.—F.L.

The translation of the group is as follows:—

BCM (*Bureau Central Météorologique*).

Reykjavik: Barometric pressure, 758·6 mm. (29·87 ins. approx.); wind, south, light; misty.

Valentia: Pressure, 758·9 mm. (29·87 ins.); wind, SW, light; rain; slight sea, etc.

TABLE I. (Fourth and Fifth Figures)

DIRECTION OF THE WIND

02 = NNE	10 = ESE	18 = SSW	26 = WNW
04 = NE	12 = SE	20 = SW	28 = NW
06 = ENE	14 = SSE	22 = WSW	30 = NNW
08 = E	16 = S	24 = W	32 = N

TABLE II. (Sixth Figure)

FORCE OF THE WIND

	Metres per second.
0 Calm	0 to 1
1 Almost calm	1 to 2
2 Very light. Slight breeze	2 to 4
3 Light. Gentle breeze	4 to 6
4 Moderate. Fair breeze	6 to 8
5 Rather strong. Good breeze	8 to 10
6 Strong. Fresh	10 to 12
7 Very strong. Very fresh	12 to 14
8 Violent. Windy	14 to 16
9 Hurricane	above 16

TABLE III. (Seventh Figure)

STATE OF THE SKY

0 Fine.	5 Rain.
1 Slightly cloudy.	6 Snow.
2 Cloudy.	7 Misty.
3 Very cloudy.	8 Fog.
4 Overcast.	9 Storm.

TABLE IV. (Eighth Figure)

STATE OF THE SEA

0 Calm.	5 Rough.
1 Very smooth.	6 Very rough.
2 Smooth.	7 High.
3 Slightly choppy.	8 Very high.
4 Choppy.	9 Tempestuous.

Weather Telegram for Paris and District.—

Every day three weather reports relating to the Paris district are sent out at about 8.0 a.m., 10.55 a.m., and 3.0 p.m. The 8.0 a.m. and 3.0 p.m. transmissions are made with one-quarter normal power. Each of these gives the following information, supplied by the *Bureau Central Météorologique* half an hour before the transmission:—

(1) Velocity of the wind at the top of the Eiffel Tower in metres per second together with its sense of variation.

(2) Direction of the wind:

N, NNE, NE, ENE, E, ESE, SE, SSE, S,
N, NNW, NW, WNW, W, WSW, SW, SSW, S,

and the sense of variation of its direction towards north or south.

(3) The barometric pressure at the *Bureau Central Météorologique* and its tendency.

(4) The state of the sky.

(5) The prevailing conditions.

These radio-telegrams then have the following form:
Voici renseignements météorologiques Paris (Paris weather information).

Wind x (metres per second) . . .	{	increasing.
		decreasing.
		stationary.
Direction y (as (2) above) . . .	{	stationary.
		northerly.
		southerly.
Pressure z (in millimetres) . . .	{	rising.
		falling.
		steady.
Sky	{	clear.
		cloudy.
		overcast.

Sunny, hazy, fog, light rain, heavy rain, snow.

These three telegrams are not as a rule sent out on Sundays and holidays.

APPENDIX B

BY THE TRANSLATORS

Augmented Weather Reports. — The weather reports from FL (The Eiffel Tower) have been considerably augmented, and the morning reports now comprise :—

R = Reykjavik.	CO = Corunna.
V = Valentia.	H = Azores.
O = Ushant.	S = St. Pierre.

General Report.

FL = Paris.	SH = Shields.
C = Clermont-Ferrand.	HE = Le Helder.
BI = Biarritz.	SK = Skudesness.
M = Marseilles.	ST = Stockholm.
N = Nice.	P = Prague.
A = Algiers.	T = Trieste.
SY = Stornoway.	R = Rome.

The 5.0 p.m. report is constituted as follows :—

FL = Paris.	V = Valentia.
BR = Brest.	S = Skudesness.
BI = Biarritz.	R = Rome.
N = Nice.	CO = Corunna.

It will be observed (p. 110), in the groups of figures constituting the weather reports from the various stations, that the first figure in each station's series will practically never be less than 3 or more than 7, and that the fifth figure in each series can only be 0, 1, 2, or 3. By doubling the sixth figure in each series the velocity of the wind in metres per second can be obtained.

Experimental Rhythmic Signals.—To assist in the investigation of the influence of various phenomena on the propagation of electric waves over long distances, a special series of signals is transmitted twice daily from the Eiffel Tower.

These signals, which are invariably transmitted with the same power and wave-length, are sent at 9.52 a.m. and 11.52 p.m. (23h. 53m.), and consist of six dashes, each of 5 seconds duration, with an interval of 5 seconds between each.

The signals are of special utility in comparing the intensity of the reception of signals, by day and by night, at different times of the year.

Method of Coincidences (Reduced Method).—

The method of coincidences may be explained as follows:—If two pendulums, one of slightly shorter period than the other, are set swinging together, the one soon gets ahead of the other, and it will be some little time before they are again swinging together; but when this is so, one will have lost or gained just one swing with reference to the other.

The following concrete example will enable the amateur to make an approximately accurate comparison of a clock with the Paris scientific time signals.

Suppose the figures telegraphed from **FL** for the 1st and 300th beats are respectively 300416 and 345718; *i.e.* the 1st beat occurred at 11h. 30m. 45[·]16 and the 300th at 11h. 34m. 57[·]18. Therefore the whole series of 300 beats (299 intervals) occupied 4 minutes 53[·]02 seconds, and one interval is equal to 0[·]98 of a second. If the first coincidence occurs at the 21st beat (20 intervals), the clock to be compared records 11h. 30m. 21s.

Twenty scientific signal intervals occupy $20 \times 0\cdot98$ seconds = 19[·]60 seconds, so that the Observatory time at the moment of the first coincidence is 11h. 30m. 45[·]16 + 19[·]60 seconds = 11h. 30m. 23[·]76, from which it will be seen that the clock under examination is 2[·]76 seconds slow.

Tabulated results :—

	h. m. s.
(a) Time of 1st beat	11.30. 4.16
(b) Time of 300th beat	11.34.57.18
(c) Time of 299 intervals ($b - a$)	4.53.02
(d) Time of one interval ($c \div 299$)	0.98
(e) First coincidence at 21st beat (20 intervals), clock reading	11.30.21.0
(f) Twenty intervals occupy ($d \times 20$)	19.60
(g) Observatory time at moment of first coincidence ($a + f$)	11.30.23.76
∴ clock is slow ($g - c$)	2.76

The *International Time Conference* has not yet published any finite decision regarding the proposed international stations, and it is probable that the list finally adopted will differ considerably from that originally suggested. It is certainly to be hoped that the extraordinary anomaly of an international chain without a British station will be rectified, and that the greatest maritime nation in the world will occupy its proper place in the future development of "wireless" time signals, which are of such vital importance to its navigators, geodesians, and explorers; for whilst rapid and commendable progress is being made in the establishment of an Imperial chain of stations, it is even more imperative that Great Britain should be represented in any international scheme.

Although the proposed international time signals are much simpler and clearer than those at present in use—the legal (Greenwich) time being transmitted by all at exact hours, on the same wave-length of 2500 metres, with no overlapping of two stations,—the actual signals have not met with unanimous approval, considerable difference of opinion being expressed as to the merits of the termination of whole minutes being given by a dash or by a dot; many

are agreed, that the dash termination is not so markedly distinguishable as the sharp dot of the present system.

The Council of the National Association of Goldsmiths (the representative association of horologists in this country) has submitted to the English members of the *International Time Conference* the suggestion that the termination of the final minute shall be — — - (dash, dash, dot), and that the signal at each 10th second of the 2nd and 3rd minutes shall be respectively — - (dash, dot), as at present proposed, and — - - (dash, dot, dot), so that every signal of the series would end with a sharp dot, each series being so distinctly different that no confusion could occur.

The use of the Eiffel Tower station to issue radio-telegrams of "urgent information to navigators" in case of dangerous storms is also being considered by the *International Time Conference*.

Until a few years ago each country reckoned its longitude east or west of some arbitrary prime meridian of its own; but with the rapid development of international commerce and the facilities of intercommunication, it became necessary to establish one prime meridian for all.

The meridian of Greenwich has almost universally been accepted as the primary meridian of the world, and the earth has been divided into 24 (hourly) zones, the time over each zone being that of its central meridian. For Western Europe the standard is Greenwich time. For Central Europe the time of the 15th degree of longitude east of Greenwich is taken, or one hour fast of Greenwich time. Eastern Europe adopts the time of the 30th degree of longitude east of Greenwich, or two hours in advance of Greenwich time, and so on.

Ireland characteristically retains the meridian of Dublin, 25 minutes 21 seconds behind Greenwich mean time.

Greece and Holland and one or two of the minor countries still keep their own meridian.

The distribution of "wireless" Greenwich time was initiated by the French Board of Longitude at the Eiffel Tower; and when the first *International Time Conference* assembled, the Eiffel Tower was established as the Central Bureau for the transmission of international time; hence Greenwich time *via* Paris, which is such an apparent anomaly to the average Englishman.

The Royal Observatory at Greenwich reports daily to Paris any error in the Paris signals as compared with the Greenwich clock. Other French observatories also communicate with the Paris Observatory in a similar manner to ensure the accuracy of the system.

English Weather Reports are issued by the Admiralty (Whitehall) at 9.30 a.m. and 8.30 p.m., and Cleethorpes at 10 a.m. and 10 p.m. (twice repeated). A specimen of the 10 p.m. weather report from Cleethorpes is appended—

"WEATHER REPORT

"Barometer: *highest*.—1029·4 millibars (30·4 ins.) and upwards, Azores; 1022·7 millibars (30·2 ins.) and upwards in anticyclone, extending over Spain and southern part of Bay.

"*Lowest*.—985·4 millibars (29·1 ins.) and less in a depression which is moving away from Iceland in northerly direction.

"*Forecast*.—Westerly to north-westerly winds, probable on all coasts; blowing strong in west and south-west, with rather rough seas.

"Moderate to fresh on all eastern coasts, with slight or moderate sea, squally; showery, with some rain or sleet in east or north-east coasts."

Cleethorpes also transmits official Admiralty messages every half-hour.

At 11.30 p.m. Poldhu (Cornwall) transmits press wire-

messages, containing all the news of the day, to the outgoing and incoming liners, who then print their own ocean newspapers on board, so that the passengers on these palatial boats can have their daily paper at breakfast time, as on land.

In America a very efficient and far-reaching system of wireless weather reports and time signals has been instituted, extending from Arlington to Boston, New York, Carolina, Florida, New Orleans, Nova Scotia, Bermuda, etc.

Special weather reports are also transmitted from

Australia : Hobart and Brisbane.

South Africa : Cape Town and Durban.

Holland : Scheveningen.

Wireless Time Table for Amateurs

a. m.		
8.0	Eiffel Tower .	. Paris Weather Report.
9.30	Whitehall .	. Weather Report.
10.0	Cleethorpes .	. Weather Report and Forecast. .
10.0	Eiffel Tower .	. International Time Signals.
10.45-10.49	Eiffel Tower .	. Time Signals preceded by the Rhythmic and Warning Signals about 10.40 a. m.
10.50	Eiffel Tower .	. European Weather Reports.
12.0 noon	Norddeich .	. Time Signals.
p. m.		
3.0	Eiffel Tower .	. Paris Weather Report.
5.0	Eiffel Tower .	. European Weather Report.
8.0	Eiffel Tower .	. French Press News.
8.30	Whitehall .	. Weather Report.
10.0	Cleethorpes .	. Weather Report.
10.15	Norddeich .	. German Press Messages.
11.29	Eiffel Tower .	. Scientific Time Signals.
11.30	Poldhu .	. Press Messages.
11.45	Eiffel Tower .	. Time Signals preceded by Rhythmic and Warning Signals.
11.50	Eiffel Tower .	. Times of 1st and 300th Beats— Scientific Signals.
12.0 night	Norddeich .	. Time Signals.

In addition to these the amateur can pick up a host of Continental, shipping, and other stations at all hours.

Norddeich Time Signals.—Greenwich mean time

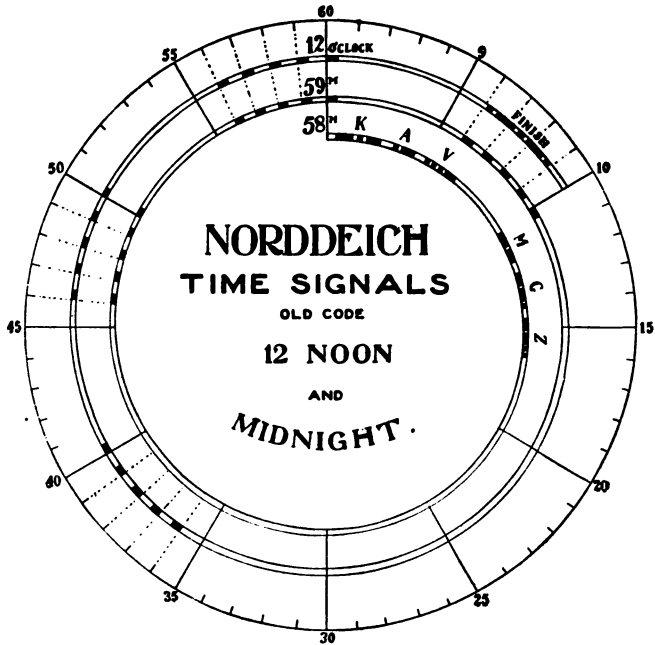

FIG. 30.

signals are transmitted from Norddeich (Germany) at 12.0 noon and 12.0 midnight (24 h.) on system illustrated above, together with a weather report.

At 10.15 p.m. Norddeich transmits press news.

APPENDIX C

INTERNATIONAL SIGNALS AND FRENCH-ENGLISH VOCABULARY

International Time Signals.—(Proposed scheme, liable to modification):—

Stations.	Call Letters.	Normal Range in Nautical Miles.	Normal Wave-Length in Metres.	Proposed Times of Operating (Greenwich Time).
Paris	FL	...	2200	10.0 a.m. and 12 p.m.
San Fernando (Brazil).	SPN	220-540	600	2.0 a.m. and 4.0 p.m.
Arlington (U.S.A.) .	NAA	1000	2500	3.0 a.m. and 5.0 p.m.
Manilla (Philippine Is.) (provisional)	WVU	4.0 a.m.
Mogadiscio (Somaliland)	ISG	1600	4000	4.0 a.m.
Timbuctoo	6.0 a.m.
Norddeich (Germany) .	KAV {	420, day 830, night }	600	12 noon and 10 p.m.
Massowah	ICX	1600	4000	6.0 p.m.
San Francisco	KPH	8.0 p.m.

International Call Letters.—Owing to the enormous growth of wireless telegraphy it has been found necessary to reserve the use of certain combinations of letters used as call signals for the countries here specified:—

Great Britain.—All combinations commencing with B, G, and M.

- British Colonies.*—Combinations CAA to CMZ.
Austro-Hungary and Bosnia.—Combinations OAA to OMZ, and UNA to UZZ.
Belgium.—ONA to OTZ.
Brazil.—EPA to EZZ.
Bulgaria.—SRA to SRZ.
Chili.—COA to CPZ.
Denmark.—OUA to OZZ.
Egypt.—SUA to SUZ.
France.—All combinations of letters commencing with F, and combinations UAA to UMZ.
Germany.—All combinations of letters commencing with A and D, and combinations KAA to KCZ.
Greece.—SVA to SZZ.
Holland.—PAA to PMZ.
Italy.—All combinations commencing with I.
Japan.—All combinations commencing with J.
Mexico.—XAA to XCZ.
Monaco.—CQA to CQZ.
Morocco.—CNA to CNZ.
Norway.—LAA to LHZ.
Portugal.—CRA to CTZ.
Roumania.—CVA to CVZ.
Russia.—All combinations commencing with R.
Spain.—EAA to EGZ.
Sweden.—SAA to SMZ.
Turkey.—TAA to TMZ.
United States of America.—All combinations of letters commencing with N and W, and combinations KIA to KZZ.
Uruguay.—CWA to CWZ.

INTERNATIONAL MORSE CODE.

The following table shows the signals employed in working Morse instruments:—

International Morse Code Signals.

LETTERS.

a - — —	n — — —
ä - — — - — —	ñ — — — - — — — —
á or Å - — — - — — — —	o — — — —
b — — — - -	ö — — — — - -
c — — - - -	p — — — — -
ç h — — — — — — —	q — — — — - — —
d — — - - -	r — — — -
e -	s - - - -
é - - — — - - -	t — —
f - - — — - -	u - - — — —
g — — — — -	ü - - — — — — —
h - - - - -	v - - - — —
i - -	w - — — — —
j - — — — — — —	x — — - - — — —
k — — — — —	y — — — — — — —
l - — — - -	z — — — — - - -
m — — — —	

FIGURES.

1 - — — — — — — —	6 — — - - - - -
2 - - — — — — — —	7 — — — — - - -
3 - - - — — — — —	8 — — — — — - -
4 - - - - — — — —	9 — — — — — — -
5 - - - - -	0 — — — — — — —

Spacing and length of signals:—

1. A dash is equal to 3 dots.
2. The space between the signals which form the same letter is equal to 1 dot.
3. The space between two letters is equal to 3 dots.
4. The space between two words is equal to 5 dots.

PUNCTUATION AND OTHER SIGNS.

Full stop	- . - . - . - . - .	(.)	-----
Comma	- , - , - , - , - ,	(,)	-----
Note of interrogation, or request for the repetition of anything transmitted which is not understood	- ? - ? - ? - ? - ? -	(?)	-----
Hyphen or dash	- - - - - - - -	(-)	-----
Bar indicating fraction	- / - / - / - / - /	(/)	-----
Parentheses (before and after the words)	- (- (- (- (- (()	-----
Inverted commas (before and after each word or each passage placed between inverted commas)	- " - " - " - " - " - "		-----
Call (preliminary of every transmission)	- C - C - C - C - C -		-----
Double dash (=) (signal separating the preamble from the address, the address from the text, and the text from the signature)	- = - = - = - = - =		-----
Understood	- U - U - U - U - U -		-----
Error	- E - E - E - E - E -		-----
Cross (end of transmission)	- X - X - X - X - X -	(+)	-----
Invitation to transmit	- T - T - T - T - T -		-----
Wait	- W - W - W - W - W -		-----
"Received" signal	- R - R - R - R - R -		-----
End of work	- O - O - O - O - O -		-----

Vocabulary.—The observer with a limited knowledge of the French language will find the following short vocabulary of assistance in reading the weather reports from Paris.

allant	=going (<i>aller</i> , to go).	nord	=North.
assez	=rather, enough.	nuage	=cloud.
averses	=showers.	nuageux	=cloudy.
baisse	=fall.	nuit	=night.
barométrique	=barometric.	ondées	=showers.
bas, basse	=low.	orage	=storm.
beau, bel, belle	=fine.	ouest	=West.
brise	=breeze.	peu	=little, slightly.
brouillard	=fog, mist.	pluie	=rain.
brumeux	=foggy, hazy.	presque	=almost.
chaud	=warm, hot.	pression	=pressure.
ciel	=sky.	quelque	=some.
couvert	=totally overcast.	soir	=evening.
croissant-e	=increasing.	soleil	=sun.
décroissant-e	=decreasing.	stationnaire	=stationary.
découvert	=clear.	sud	=South.
éclair	=lightning.	tempête	=tempest.
elevée	=rise.	temps	=weather, time, season.
est (noun)	=East.	tonnerre	=thunder.
est (verb)	=is.	très	=very.
état	=state, condition.	vent	=wind.
faible	=feeble, light.	vers	=towards.
fort-e	=strong, very.	vitesse	=velocity, speed.
frais	=fresh, cool.	Allemagne	=Germany.
froid	=cold.	Angleterre	=England.
gelée	=frost.	Autriche	=Austria.
glace	=ice.	Belgique	=Belgium.
grêle	=hail.	Écosse	=Scotland.
hausse	=rise.	Espagne	=Spain.
haut-e	=high.	États Unis	} = { United States of America.
matin	=morning.	d'Amérique	
mer	=sea.	Irlande	=Ireland.
midi	=noon.	Manche	=Channel.
modéré	=moderate.		
neige	=snow.		

APPENDIX D

CHANGES IN BRITISH WEATHER REPORTS

SEVERAL changes of meteorological measurements have recently been introduced into the daily weather reports, the most important being that of barometric pressure; absolute units taking the place of mercury inches.

The *absolute* unit of pressure now adopted is the dyne per square centimetre, but the *practical* unit is the megadyne per square centimetre; this unit is called a "bar." The centibar and millibar (the hundredth and thousandth part of the "bar") are used as the working units.

By kind permission of Dr. W. N. Shaw, Royal Meteorological Office, conversion tables of the new unit into inches, and wind velocity tables, are appended.

(It will be noted that 1000 millibars = 29.53 ins., *i.e.* practically "change" on the ordinary barometer dial.)

This system¹ of measurements of barometric pressure has been definitely adopted by the Royal Meteorological Office and Royal Meteorological Society in the daily weather reports for the British Isles; and also in America by the United States Weather Bureau, with the intention of putting the system on an international basis.

The rainfall data in the weather reports will be published in millimetres instead of inches.

(To convert millimetres to inches or *vice versa*, multiply-

¹ Full particulars of the centimetre-gramme-second system of units to meteorological measurements are given in the *Observer's Handbook*, published by the Royal Meteorological Office.

ing or dividing by .04, as the case may be, will give results accurate enough for all practical purposes.)

PRESSURE VALUES

Equivalents in Millibars of Inches of Mercury at 32° F. and Latitude 45°

Mercury Inches.	'00	'01	'02	'03	'04	'05	'06	'07	'08	'09
	Millibars.									
27'0	914'3	914'6	915'0	915'3	915'7	916'0	916'3	916'7	917'0	917'4
27'1	917'7	918'0	918'4	918'7	919'0	919'4	919'7	920'1	920'4	920'7
27'2	921'1	921'4	921'8	922'1	922'4	922'8	923'1	923'4	923'8	924'1
27'3	924'5	924'8	925'1	925'5	925'8	926'1	926'5	926'8	927'2	927'5
27'4	927'9	928'2	928'5	928'9	929'2	929'5	929'9	930'2	930'6	930'9
27'5	931'2	931'6	931'9	932'3	932'6	932'9	933'3	933'6	933'9	934'3
27'6	934'6	935'0	935'3	935'6	936'0	936'3	936'7	937'0	937'3	937'7
27'7	938'0	938'3	938'7	939'0	939'4	939'7	940'0	940'4	940'7	941'1
27'8	941'4	941'7	942'1	942'4	942'8	943'1	943'4	943'8	944'1	944'4
27'9	944'8	945'1	945'5	945'8	946'1	946'5	946'8	947'2	947'5	947'8
28'0	948'2	948'5	948'8	949'2	949'5	949'9	950'2	950'5	950'9	951'2
28'1	951'6	951'9	952'2	952'6	952'9	953'2	953'6	953'9	954'3	954'6
28'2	954'9	955'3	955'6	956'0	956'3	956'6	957'0	957'3	957'7	958'0
28'3	958'3	958'7	959'0	959'3	959'7	960'0	960'4	960'7	961'0	961'4
28'4	961'7	962'1	962'4	962'7	963'1	963'4	963'7	964'1	964'4	964'8
28'5	965'1	965'4	965'8	966'1	966'5	966'8	967'1	967'5	967'8	968'1
28'6	968'5	968'8	969'2	969'5	969'8	970'2	970'5	970'9	971'2	971'5
28'7	971'9	972'2	972'6	972'9	973'2	973'6	973'9	974'2	974'6	974'9
28'8	975'3	975'6	975'9	976'3	976'6	977'0	977'3	977'6	978'0	978'3
28'9	978'6	979'0	979'3	979'7	980'0	980'3	980'7	981'0	981'4	981'7
29'0	982'0	982'4	982'7	983'0	983'4	983'7	984'1	984'4	984'7	985'1
29'1	985'4	985'8	986'1	986'4	986'8	987'1	987'5	987'8	988'1	988'5
29'2	988'8	989'1	989'5	989'8	990'2	990'5	990'8	991'2	991'5	991'9
29'3	992'2	992'5	992'9	993'2	993'5	993'9	994'2	994'6	994'9	995'2
29'4	995'6	995'9	996'3	996'6	996'9	997'3	997'6	997'9	998'3	998'6
29'5	999'0	999'3	999'6	1000'0	1000'3	1000'7	1001'0	1001'3	1001'7	1002'0
29'6	1002'4	1002'7	1003'0	1003'4	1003'7	1004'0	1004'3	1004'7	1005'1	1005'4
29'7	1005'7	1006'1	1006'4	1006'8	1007'1	1007'4	1007'8	1008'1	1008'4	1008'8
29'8	1009'1	1009'5	1009'8	1010'1	1010'5	1010'8	1011'2	1011'5	1011'8	1012'2
29'9	1012'5	1012'8	1013'2	1013'5	1013'9	1014'2	1014'5	1014'9	1015'2	1015'6
30'0	1015'9	1016'2	1016'6	1016'9	1017'3	1017'6	1017'9	1018'3	1018'6	1018'9
30'1	1019'3	1019'6	1020'0	1020'3	1020'6	1021'0	1021'3	1021'7	1022'0	1022'3
30'2	1022'7	1023'0	1023'3	1023'7	1024'0	1024'4	1024'7	1025'0	1025'4	1025'7
30'3	1026'1	1026'4	1026'7	1027'1	1027'4	1027'7	1028'1	1028'4	1028'8	1029'1
30'4	1029'4	1029'8	1030'1	1030'5	1030'8	1031'1	1031'5	1031'8	1032'2	1032'5
30'5	1032'8	1033'2	1033'5	1033'8	1034'2	1034'5	1034'9	1035'2	1035'5	1035'9
30'6	1036'2	1036'6	1036'9	1037'2	1037'6	1037'9	1038'2	1038'6	1038'9	1039'3
30'7	1039'6	1039'9	1040'3	1040'6	1041'0	1041'3	1041'6	1042'0	1042'3	1042'6
30'8	1043'0	1043'3	1043'7	1044'0	1044'3	1044'7	1045'0	1045'4	1045'7	1046'0
30'9	1046'4	1046'7	1047'1	1047'4	1047'7	1048'1	1048'4	1048'7	1049'1	1049'4

Equivalents in Mercury Inches at 32° and Latitude 45°
of Millibars

Millibars.	0	1	2	3	4	5	6	7	8	9
	Mercury Inches.									
910	26'87	26'90	26'93	26'96	26'99	27'02	27'05	27'08	27'11	27'14
920	27'17	27'20	27'23	27'26	27'29	27'32	27'35	27'38	27'41	27'44
930	27'46	27'49	27'52	27'55	27'58	27'61	27'64	27'67	27'70	27'73
940	27'76	27'79	27'82	27'85	27'88	27'91	27'94	27'97	28'00	28'03
950	28'05	28'08	28'11	28'14	28'17	28'20	28'23	28'26	28'29	28'32
960	28'35	28'38	28'41	28'44	28'47	28'50	28'53	28'56	28'59	28'62
970	28'65	28'67	28'70	28'73	28'76	28'79	28'82	28'85	28'88	28'91
980	28'94	28'97	29'00	29'03	29'06	29'09	29'12	29'15	29'18	29'21
990	29'24	29'26	29'29	29'32	29'35	29'38	29'41	29'44	29'47	29'50
1000	29'53	29'56	29'59	29'62	29'65	29'68	29'71	29'74	29'77	29'80
1010	29'83	29'86	29'89	29'92	29'94	29'97	30'00	30'03	30'06	30'09
1020	30'12	30'15	30'18	30'21	30'24	30'27	30'30	30'33	30'36	30'39
1030	30'42	30'45	30'48	30'51	30'53	30'56	30'59	30'62	30'65	30'68
1040	30'71	30'74	30'77	30'80	30'83	30'86	30'89	30'92	30'95	30'98
1050	31'01	31'04	31'07	31'10	31'13	31'16	31'18	31'21	31'24	31'27

Differences for tenths of a millibar:—

mb.	'1	'2	'3	'4	'5	'6	'7	'8	'9
in.	'003	'006	'009	'012	'015	'018	'021	'024	'027

WIND VELOCITY

Equivalents of Miles-per-Hour in Metres-per-Second

Miles per Hour.	0	1	2	3	4	5	6	7	8	9
	Metres per Second.									
0	0'0	0'4	0'9	1'3	1'8	2'2	2'7	3'1	3'6	4'0
10	4'5	4'9	5'4	5'8	6'3	6'7	7'2	7'6	8'0	8'5
20	8'9	9'4	9'8	10'3	10'7	11'2	11'6	12'1	12'5	13'0
30	13'4	13'9	14'3	14'8	15'2	15'6	16'1	16'5	17'0	17'4
40	17'9	18'3	18'8	19'2	19'7	20'1	20'6	21'0	21'5	21'9
50	22'4	22'8	23'2	23'7	24'1	24'6	25'0	25'5	25'9	26'4
60	26'8	27'3	27'7	28'2	28'6	29'1	29'5	30'0	30'4	30'8
70	31'3	31'7	32'2	32'6	33'1	33'5	34'0	34'4	34'9	35'3
80	35'8	36'2	36'7	37'1	37'6	38'0	38'4	38'9	39'3	39'8
90	40'2	40'7	41'1	41'6	42'0	42'5	42'9	43'4	43'8	44'3

Equivalents of Metres-per-Second in Miles-per-Hour

Metres per Second.	0	1	2	3	4	5	6	7	8	9
	Miles per Hour.									
0	0'0	2'2	4'5	6'7	9'0	11'2	13'4	15'7	17'9	20'1
10	22'4	24'6	26'8	29'1	31'3	33'6	35'8	38'0	40'3	42'5
20	44'7	47'0	49'2	51'5	53'7	55'9	58'2	60'4	62'6	64'9
30	67'1	69'4	71'6	73'8	76'1	78'3	80'5	82'8	85'0	87'2
40	89'5	91'7	94'0	96'2	98'4	100'7	102'9	105'1	107'4	109'6

Table for converting Barometric Readings in Inches into Millimetres

Inches and Tenths.	Hundredths of an Inch.									
	0	1	2	3	4	5	6	7	8	9
	Mm.	Mm.	Mm.	Mm.	Mm.	Mm.	Mm.	Mm.	Mm.	Mm.
27°0	685·8	686·0	686·3	686·6	686·8	687·1	687·3	687·6	687·8	688·1
1	688·3	688·6	688·8	689·1	689·3	689·6	689·9	690·1	690·4	690·6
2	690·9	691·1	691·4	691·6	691·9	692·1	692·4	692·7	692·9	693·2
3	693·4	693·7	693·9	694·2	694·4	694·7	694·9	695·2	695·4	695·7
4	696·0	696·2	696·5	696·7	697·0	697·2	697·5	697·7	697·9	698·2
5	698·5	698·7	699·0	699·3	699·5	699·8	700·1	700·3	700·5	700·8
6	701·0	701·3	701·5	701·8	702·0	702·3	702·6	702·8	703·1	703·3
7	703·6	703·8	704·1	704·3	704·6	704·8	705·1	705·4	705·6	705·9
8	706·1	706·4	706·6	706·9	707·1	707·4	707·6	707·9	708·1	708·4
9	708·7	708·9	709·2	709·4	709·7	709·9	710·2	710·4	710·7	710·9
28°0	711·2	711·4	711·7	712·0	712·2	712·5	712·7	713·0	713·2	713·5
1	713·7	714·0	714·2	714·5	714·7	715·0	715·3	715·5	715·8	716·0
2	716·3	716·5	716·8	717·1	717·3	717·5	717·8	718·0	718·3	718·6
3	718·8	719·1	719·3	719·6	719·8	720·1	720·3	720·6	720·8	721·1
4	721·4	721·6	721·9	722·1	722·4	722·6	722·9	723·1	723·4	723·6
5	723·9	724·1	724·4	724·7	724·9	725·2	725·4	725·7	725·9	726·2
6	726·4	726·7	726·9	727·2	727·4	727·7	728·0	728·2	728·5	728·7
7	729·0	729·2	729·5	729·7	729·9	730·2	730·5	730·7	731·0	731·3
8	731·5	731·8	732·0	732·3	732·5	732·8	733·0	733·3	733·5	733·8
9	734·1	734·3	734·6	734·8	735·1	735·3	735·6	735·8	736·1	736·3
29°0	736·6	736·8	737·1	737·4	737·6	737·9	738·1	738·4	738·6	738·9
1	739·1	739·4	739·6	739·9	740·1	740·4	740·7	740·9	741·2	741·4
2	741·7	741·9	742·2	742·4	742·7	742·9	743·2	743·4	743·7	744·0
3	744·2	744·5	744·7	745·0	745·2	745·5	745·7	745·9	746·2	746·5
4	746·8	747·0	747·3	747·5	747·7	748·1	748·3	748·5	748·8	749·0
5	749·3	749·5	749·8	750·1	750·3	750·6	750·8	751·1	751·3	751·6
6	751·8	752·1	752·3	752·6	752·8	753·1	753·4	753·6	753·9	754·1
7	754·4	754·6	754·8	755·1	755·4	755·6	755·9	756·1	756·4	756·7
8	756·9	757·2	757·4	757·7	757·9	758·2	758·4	758·7	758·9	759·2
9	759·5	759·7	760·0	760·2	760·5	760·7	761·0	761·2	761·5	761·7
30°0	762·0	762·2	762·5	762·8	763·0	763·3	763·5	763·8	764·0	764·3
1	764·5	764·8	765·0	765·3	765·5	765·8	766·1	766·3	766·6	766·8
2	767·1	767·3	767·6	767·8	768·1	768·3	768·6	768·8	769·1	769·4
3	769·6	769·9	770·1	770·4	770·6	770·9	771·1	771·4	771·6	771·9
4	772·2	772·4	772·7	772·9	773·2	773·4	773·7	773·9	774·2	774·4
5	774·7	774·9	775·2	775·5	775·7	776·0	776·2	776·5	776·7	777·0
6	777·2	777·5	777·7	778·0	778·2	778·5	778·8	779·0	779·3	779·5
7	779·8	780·0	780·3	780·5	780·8	781·0	781·3	781·5	781·8	782·1
8	782·3	782·6	782·8	783·1	783·3	783·6	783·8	784·1	784·3	784·6
9	784·9	785·1	785·4	785·6	785·9	786·2	786·4	786·7	786·9	787·1
31°0	787·4	787·6	787·9	788·2	788·4	788·7	788·9	789·2	789·4	789·7
1	789·9	790·2	790·4	790·7	790·9	791·2	791·5	791·7	792·0	792·2
2	792·5	792·7	793·0	793·2	793·5	793·7	794·0	794·2	794·5	794·8
3	795·1	795·3	795·5	795·8	796·0	796·3	796·5	796·8	797·0	797·3
4	797·6	797·8	798·1	798·3	798·6	798·8	799·1	799·3	799·6	799·8

INDEX

- Accuracy, degree of, 51, 61, 72, 73, 91.
- Aerial, I.
— circuit, 25.
— direction of, 3.
— inductance, 23.
— multiple, 4.
— simple, 2, 3.
- Atmospherics, 28.
- Barometric pressure, 110.
- Battery, 11.
- Beats, chronometer, 40, 45, and Plate I.
— clock, 40, 45, and Plate I.
- Coincidences, principle of, 44.
— reduced method, 115.
- Comparisons, calculation of, 75.
- Condenser, variable, 26, 27.
- Detector, adjustments, 22.
— circuit, 23, 28.
— crystal, 11, 12.
— crystals, 14.
— electrolytic, 10.
— galena, 15.
- Earth connections, 6.
- Eiffel Tower, power, 34, 39.
— — wave-length, 34, 38.
- Greenwich time, 118.
- Imperial chain, 116.
- Inductance, 4.
— coils, 19, 20.
- Insulation, 6.
- International call letters, 121.
— signal stations, 121.
— time chain, 39.
— — conference, 36.
— — signals, 117.
— — — modification of, 117.
- Intervals of scientific signals, tables, 98-106.
- Longitude, determination of, 68.
— differences of, 91.
- Meridian zones, 117.
- Microphone, 59.
- Millibars, 126.
— conversion tables, 127, 128.
- Millimetre table, 130.
- Morse code, 123.
- Norddeich time signals, 120.
- Oscillations, electrical, 15.
- Plug commutators, 29.
- Potentiometer, 22.
- Printing chronograph, 51.
- Rainfall data, 126.
- Receiver, adjustment of, 28.
— arrangement of, 74.
— double slide, 21.
— fitting up, 15.
— general principles of, 8.
— loose-coupled, 25, 26, 27.
— simplified, 16.
— single slide, 17, 18, 19.
— tuning, 23.
— verification of, 29.

- Receiving apparatus, 7.
 Rhythmic signals, 115.
- Scientific time signals, 62.
 — — calculations of, 86.
 — — chronometer comparisons, 88,
 89, 92, 93, 95.
 — — clock comparisons, 59, 87.
 — — receiving, 66, 76.
 — — remarks on, 84.
- Sea, state of, tables, 111.
 Service, organisation of, 31.
 Short wave reception, 19.
 Site, selection of, 5.
 Sky, state of, 112.
 Star transits, 52, 53.
- Telephones, 20.
 Time signals, corrections, 42.
 — — daily, 108.
 — — despatch of, 62, 107.
 — — importance of, 31.
- Time signals, international, 37.
 — — ordinary, 34.
 — — reception of, 40.
 — — retardation, 47.
- Transmitted time, improvements in,
 67.
 — — 1st and 300th beats, 66.
- Unilateral conductivity, 12.
- Vocabulary, 125.
- Weather reports, additional, 114.
 — — changes in, 126.
 — — telegrams, examples of, 111,
 118.
 — — general, 109.
 — — Paris, 113.
- Wind direction tables, 111.
 — velocity, 129.
- Wireless time table, 119.
 — without antennæ, 4.

INDEX TO ILLUSTRATIONS

- Aerial, single wire, 2, 3.
— twin wire, 5.
— receiver, principles of, 9.
— — with inductance, 9.
Automatic transmission apparatus, 47.
Clock and chronometer beats (graphic diagram), 40, 45, and Plate I.
Detector, crystal, 12.
— galena, 15.
Electrolytic detector, 10.
International time signals (graphic diagram), 37.
Ordinary time signals (graphic diagram), 34.
Printing chronograph apparatus, 55, 56.
Scientific signal despatch, 65.
Signal despatch apparatus, 63.
— receiver apparatus, 64.
Simple receiver, 16.
— — single slide, 17, 18, 19.
— — double slide, 21, 24.
— loose-coupled, 26, 27.
Synchronised time, 58.
— — telephonic apparatus, 60.
Transmission apparatus (Paris Observatory and Eiffel Tower), 33.

**PRINTED IN GREAT BRITAIN BY
NEILL AND CO., LTD.,
EDINBURGH**

A SHORT LIST OF SCIENTIFIC BOOKS

PUBLISHED BY

E. & F. N. SPON, LTD

57, Haymarket, London, S.W.

Telephone—3450 Central.

Telegrams—Fenspon, Charles, London.

	PAGE		PAGE
AGRICULTURE	2	MANUFACTURES	22
ARCHITECTURE.. .. .	2	MARINE ENGINEERING	26
ARTILLERY	4	MATERIALS	28
AVIATION	4	MATHEMATICS	28
BRIDGES AND ROOFS	5	MECHANICAL ENGINEERING	29
BUILDING	2	METALLURGY	32
CEMENT AND CONCRETE	7	METRIC TABLES	33
CIVIL ENGINEERING	8	MINERALOGY AND MINING	34
CURVE TABLES	11	MISCELLANEOUS	47
DICTIONARIES	11	MODEL MAKING	35
DOMESTIC ECONOMY	12	MOTOR BODY BUILDING	4
DRAWING	12	MUNICIPAL ENGINEERING	39
EARTHWORK	13	NAVAL ARCHITECTURE	26
ELECTRICAL ENGINEERING	13	ORGANIZATION	36
FOREIGN EXCHANGE	18	PHYSICS	36
GAS AND OIL ENGINES	19	PRICE BOOKS	37
GAS LIGHTING	20	RAILWAY ENGINEERING	38
HISTORICAL: BIOGRAPHICAL	20	SANITATION	39
HOROLOGY	21	STRUCTURAL DESIGN	5
HYDRAULICS; PUMPS	21	SURVEYING AND LEVELLING	9, 10
INDUSTRIAL CHEMISTRY.. .. .	22	TELEGRAPH CODES	41
INSTITUTIONS	48	USEFUL TABLES	46
INTEREST TABLES	25	WARMING: VENTILATION	41
IRRIGATION	25	WATER SUPPLY	42
LOGARITHM TABLES	26	WORKSHOP PRACTICE	43

All books are bound in cloth unless otherwise stated.

SOLE ENGLISH AGENTS for the Books of—

MYRON C. CLARK, NEW YORK
SPON & CHAMBERLAIN, NEW YORK

Established 1830.

AGRICULTURE

- Hemp.** A Practical Treatise on the Culture for Seed and Fibre. By **S. S. Boyce.** 13 illus., 112 pp., crown 8vo. (*New York, 1900.*) 2s. 6d. net.
- Farm Drainage.** By **H. F. French.** 100 illus., 284 pp., crown 8vo. (*New York, 1912.*) 4s. 6d. net.
- Talks on Manures.** By **J. Harris.** New edition, 366 pp., crown 8vo. (*New York, 1902.*) 6s. 6d. net.
- Coffee, its Culture and Commerce in all Countries.** By **C. G. W. Lock.** 11 plates, 274 pp., crown 8vo. (1888.) 12s. 6d.
- Sugar, a Handbook for Planters and Refiners.** By the late **J. A. R. Newlands** and **B. E. R. Newlands.** 236 illus., 876 pp., 8vo. (1909.) £1. 5s. net.
- Hops, their Cultivation, Commerce and Uses.** By **P. L. Simmonds.** 143 pp., crown 8vo. (1877.) 4s. 6d.
- Estate Fences, their Choice, Construction and Cost.** By **A. Vernon.** Re-issue, 150 illus., 420 pp., 8vo. (1909.) 8s. 6d. net.

ARCHITECTURE AND BUILDING

- The Hydropathic Establishment and its Baths.** By **R. O. Allsop.** 8 plates, 107 pp., demy 8vo. (1891.) 5s.
- The Turkish Bath, its Design and Construction.** By **R. O. Allsop.** 27 illus., 152 pp., demy 8vo. (1890.) 6s.
- The Builder's Clerk.** By **T. Bales.** Second edition, 92 pp., fcap. 8vo. (1904.) 1s. 6d.
- Glossary of Technical Terms used in Architecture and the Building Trades.** By **G. J. Burns.** 136 pp., crown 8vo. (1895.) 3s. 6d.
- Chimney Design and Theory.** By **W. W. Christie.** Second edition, 54 illus., 200 pp., crown 8vo. (*New York, 1902.*) 12s. 6d. net.
- Approximate Estimates.** By **T. E. Coleman.** Fourth edition, 407 pp., 32mo. (1914.) 5s. net.

- Stable Sanitation and Construction.** By T. E. Coleman. 183 illus., 226 pp., crown 8vo. (1897.) 3s. net.
- House Plans and Building Construction for General Contractors and House Builders.** By M. M. Dustman. 511 illus., 239 pp., oblong folio. (*New York, 1912.*) 8s. 6d. net.
- Building Construction Drawing.** By Richard B. Eaton. In Two Parts. Imperial 8vo, limp. (1914.)
Part I. 26 plates, 59 pp. 1s. 6d. net.
Part II. 26 plates, 64 pp. 1s. 6d. net.
Parts I and II in one volume. 3s. net.
- Architectural Examples in Brick, Stone, Wood and Iron.** By W. Fullerton. Third edition, 245 plates, 254 pp., demy 4to. (1914.) 15s. net.
- Building Supervision.** By Geo. W. Grey. x + 146 pp., crown 8vo. (1913.) 2s. 6d. net.
- The Clerk of Works' Vade Mecum.** By G. G. Hoskins. Eighth edition. (1914.) 1s. 6d. net.
- A Handbook of Formulæ, Tables, and Memoranda for Architectural Surveyors.** By J. T. Hurst. Fifteenth edition, new impression, 112 illus., viii + 512 pp., royal 32mo, roan. (1914.) 5s. net.
- Paint and Colour Mixing.** By A. S. Jennings. Fourth edition, 14 col. plates, 190 pp., 8vo. (1910.) 5s. net.
- Quantity Surveying.** By J. Leaning. Fifth edition, new impression, 936 pp., 8vo. (1912.) £1 5s. net.
- Builders' Quantities.** By H. M. Lewis. 6 illus., 44 pp., crown 8vo. (S. & C. SERIES, No. 40.) (1911.) 1s. 6d. net.
- Obstruction to Light.** A Graphic Method of determining Problems of Ancient Lights. By H. B. Molesworth. 9 folding plates, 4to. (1902.) 6s. net.
- Suburban Houses.** A series of practical plans. By J. H. Pearson. 46 plates and 12 pp. text, crown 4to. (1905.) 5s. net.
- Solid Bitumens, their Physical and Chemical Properties.** By S. F. Peckham. 23 illus., 324 pp., 8vo. (*New York, 1909.*) £1 1s.
- Roman Architecture, Sculpture and Ornament.** By G. B. Piranesi. 200 plates, reproduced in facsimile from the original. 2 vols., imperial folio, in wrappers. (1900.) £2 2s. net.

- The Seven Periods of English Architecture**, defined and illustrated. By **E. Sharpe**. Third edition, 20 steel plates, royal 8vo. (1888.) 12s. 6d.
- Our Factories, Workshops and Warehouses**, their Sanitary and Fire-Resisting Arrangements. By **B. H. Thwaite**. 183 illus., 282 pp., crown 8vo. (1882.) 9s.
- Elementary Principles of Carpentry**. By **T. Tredgold** and **J. T. Hurst**. Eleventh edition, 48 plates, 517 pp., crown 8vo. (1914.) 7s. 6d. net.
- Motor Body Building** in all its branches. By **C. W. Terry**. With additional matter by **Arthur Hall**. Medium 8vo, 256 pp., 15 illus., 50 plates. (1914.) 10s. 6d. net. Postage, inland, 5d.; abroad, 10d.
- Practical Stair Building and Handrailing**. By **W. H. Wood**. 32 plates, 91 pp., crown 4to. (1894.) 10s. 6d.
- Spons' Architects' and Builders' Pocket Price-Book**. Edited by **Clyde Young**. Revised by **Stanford M. Brooks**. 16mo, green leather cloth (size 6½ in. by 3¾ in. by ½ in. thick). 2s. 6d. net. *Revised and issued annually.*
- Spons' Practical Builders' Pocket Book**. Edited by **Clyde Young** and **Stanford M. Brooks**. 74 illus., viii + 456 pp., 16mo, maroon leather cloth (1915). 5s. net.

ARTILLERY

- Guns and Gun Making Material**. By **G. Ede**. xii + 74 pp., crown 8vo. (1889.) 6s.
- Treatise on Application of Wire to Construction of Ordnance**. By **J. A. Longridge**. 180 pp., 8vo. (1884.) £1 5s.

AVIATION

- The Atmosphere**, its Characteristics and Dynamics. By **F. J. B. Cordeiro**. 35 illus., 129 pp., small 4to. (*New York, 1910.*) 10s. 6d. net.
- Theory and Practice of Model Aeroplaning**. By **V. E. Johnson**. 61 illus., xvi + 148 pp., crown 8vo. (1910.) 3s. 6d. net.

- Natural Stability and the Parachute Principle in Aeroplanes.** By **W. Le Maitre.** 34 illus., 48 pp., crown 8vo. (S. & C. SERIES, No. 39.) (1911.) 1s. 6d. net.
- How to Build a 20-ft. Bi-plane Glider.** By **A. P. Morgan.** 31 illus., 60 pp., crown 8vo. (S. & C. SERIES, No. 14.) (New York, 1909.) 1s. 6d. net.
- Flight-Velocity.** By **A. Samuelson.** 4 plates, 42 pp., 8vo, sewed. (1906.) 2s. net.
- Resistance of Air and the Question of Flying.** By **A. Samuelson.** 23 illus., 36 pp., 8vo, sewed. (1905.) 2s. net.
- The Laws of Avanzini.** Laws of Planes moving at an angle in air and water. By Lieut.-Col. **R. de Villamil.** 2 folding plates, 3 illus., 23 pp., super royal 8vo, sewed. (1912.) 2s. net.
- Aeroplanes in Gusts, Soaring Flight and Aeroplane Stability.** By **S. L. Walkden.** Second Edition. 4 plates, 47 illus., xvi + 188 pp., 8vo. (1913.) 12s. 6d. net.

BRIDGES, ARCHES, ROOFS, AND STRUCTURAL DESIGN

- Strains in Ironwork.** By **Henry Adams.** Fourth edition, 8 plates, 65 pp., crown 8vo. (1904.) 5s.
- Designing Ironwork.** By **Henry Adams.** Second series. 8vo, sewed.
- Part I. A Steel Box Girder. (1894.) 9d. net.
- ,, II. Built-up Steel Stanchions. (1901.) 1s. 3d. net.
- ,, III. Cisterns and Tanks. (1902.) 1s. net.
- ,, IV. A Fireproof Floor. (1903.) 1s. net.
- Columns and Struts.** Theory and Design. By **Wm. Alexander.** 101 illus., xii + 265 pp., demy 8vo. (1912.) 10s. 6d. net.
- A Practical Treatise on Segmental and Elliptical Oblique or Skew Arches.** By **G. J. Bell.** Second edition, 17 plates, 125 pp., royal 8vo. (1906.) £1 1s. net.
- Economics of Construction in relation to Framed Structures.** By **R. H. Bow.** Third thousand, 16 plates, 88 pp., 8vo. (1873.) 5s.
- Theory of Voussoir Arches.** By **Prof. W. Cain.** Third edition, 201 pp., 18mo, boards. (New York, 1905.) 2s. net.

- Theory of Arches and Suspension Bridges.** By **J. Melan** and **D. B. Steinman**, C.E., Ph.D. Demy 8vo, 303 pp., 118 illus. (*New York, 1913.*) 15s. net. Postage, inland, 5d.; abroad, 10d.
- New Formulæ for the Loads and Deflections of Solid Beams and Girders.** By **W. Donaldson**. Second edition, 11 illus., viii + 56 pp., 8vo. (*1872.*) 4s. 6d.
- Plate Girder Railway Bridges.** By **M. Fitzmaurice**. 4 plates, 104 pp., 8vo. (*1895.*) 6s.
- Pocket Book of Calculations in Stresses.** By **E. M. George**. 66 illus., 140 pp., royal 32mo, half roan. (*1895.*) 3s. 6d.
- Tables for Roof Framing.** By **G. D. Inskip**. Second edition, 451 pp., 8vo, leather. (*New York, 1905.*) 12s. 6d. net.
- Stresses in Girder and Roof Frames**, for both dead and live loads, by simple Multiplication, etc. By **F. R. Johnson**. 28 plates, 215 pp., crown 8vo. (*1894.*) 6s.
- A Graphical Method for Swing Bridges.** By **B. F. La Rue**. 4 plates, 104 pp., 18mo, boards. (*New York, 1904.*) 2s. net.
- Notes on Cylinder Bridge Piers and the Well System of Foundations.** By **J. Newman**. 144 pp., 8vo. (*1893.*) 6s.
- Calculation of Columns.** By **T. Nielsen**. 4 plates, 36 pp., 8vo. (*1911.*) 4s. 6d. net.
- A New Method of Graphic Statics** applied in the Construction of Wrought Iron Girders. By **E. Olander**. 16 plates, small folio. (*1887.*) 10s. 6d.
- Steel Bar and Plate Tables.** Giving Weight of a Lineal Foot of all sizes of L and T Bars, Flat Bars, Plates, Square and Round Bars. By **E. Read**. On large folding card. 1s. net.
- Reference Book for Statical Calculations.** By **F. Ruff**. With diagrams, 140 pp., crown 8vo. (*1906.*) 5s. net.
- Suspension Bridges and Cantilevers.** By **D. B. Steinmann**. vii + 185 pp., 18mo, boards. (VAN NOSTRAND SERIES, No. 127.) (*New York, 1911.*) 2s. net.
- The Anatomy of Bridgework.** By **W. H. Thorpe**. 103 illus., 190 pp., crown 8vo. (*1914.*) 6s. net.

CEMENT AND CONCRETE

- Portland Cement**, its Manufacture, Testing and Use. By **D. B. Butler**. Third edition, 135 illus., including 17 plates, xii + 450 pp., 8vo. (1913.) 16s. net.
- Theory of Steel-Concrete Arches and of Vaulted Structures**. By **W. Cain**. Fifth ed., 27 illus., 212 pp., 18r no, boards. (New York, 1909.) 2s. net.
- Reinforced Concrete Construction. Elementary Course**. By **M. T. Cantell**. 65 illus., 135 pp., crown 8vo. (1911.) 4s. 6d. net.
- Reinforced Concrete Construction. Advanced Course**. By **M. T. Cantell**. 242 illus., xvi + 240 pp., super royal 8vo. (1912.) 12s. 6d. net.
- Graphical Reinforced Concrete Design**. A series of Diagrams on sheets (measuring $17\frac{1}{2}$ in. by $22\frac{1}{2}$ in.) for Designing and Checking. With 48-page pamphlet. By **J. A. Davenport**. Complete in roll. (1911.) 5s. net.
- Cement Users' and Buyers' Guide**. By **Calcare**. 115 pp., 32mo, cloth. (1901.) 1s. 6d. net.
- Diagrams for Designing Reinforced Concrete Structures**. By **G. F. Dodge**. 31 illus., 104 pp., oblong folio. (New York, 1910.) 17s. net.
- Cements, Mortars, and Concretes**; their Physical properties. By **M. S. Falk**. 78 illus., 176 pp., 8vo. (New York, 1904.) 10s. 6d. net.
- Concrete Construction, Methods and Cost**. By **H. P. Gillette** and **C. S. Hill**. 310 illus., 690 pp., 8vo. (New York, 1908.) £1 1s. net.

Works by A. A. HOUGHTON.

- Practical Silo Construction**. 18 illus., 69 pp., cr. 8vo. (S. & C. SERIES, No. 27.) (New York, 1911.) 1s. 6d. net.
- Moulding Concrete Chimneys, Slate and Roof Tiles**. 15 illus., 61 pp., cr. 8vo. (S. & C. SERIES, No. 28.) (New York, 1911.) 1s. 6d. net.
- Moulding and Curing Ornamental Concrete**. 5 illus., 58 pp., cr. 8vo. (S. & C. SERIES, No. 29.) (New York, 1911.) 1s. 6d. net.

Concrete Wall Forms. 16 illus., 62 pp., cr. 8vo. (S. & C. SERIES, No. 30.) (*New York, 1912.*) 1s. 6d. net.

Concrete Monuments, Mausoleums and Burial Vaults. 18 illus., 65 pp., cr. 8vo. (S. & C. SERIES, No. 31.) (*New York, 1911.*) 1s. 6d. net.

Concrete Floors and Sidewalks. 8 illus., 63 pp., cr. 8vo. (S. & C. SERIES, No. 32.) (*New York, 1911.*) 1s. 6d. net.

Moulding Concrete Baths, Tubs, Aquariums and Natatoriums. 16 illus., 64 pp., cr. 8vo. (S. & C. SERIES, No. 33.) (*New York, 1911.*) 1s. 6d. net.

Concrete Bridges, Culverts, and Sewers. 14 illus., 58 pp., cr. 8vo. (S. & C. SERIES, No. 34.) (*New York, 1912.*) 1s. 6d. net.

Constructing Concrete Porches. 18 illus., 62 pp., cr. 8vo. (S. & C. SERIES, No. 35.) 1s. 6d. net.

Moulding Concrete Flower-Pots, Boxes, Jardinières, etc. 8 illus., 52 pp., cr. 8vo. (S. & C. SERIES, No. 36.) (*New York, 1912.*) 1s. 6d. net.

Moulding Concrete Fountains and Lawn Ornaments. 14 illus., 56 pp., crown 8vo. (S. & C. SERIES, No. 37.) (*New York, 1912.*) 1s. 6d. net.

Concrete and Reinforced Concrete. By H. A. Reid. 715 illus., 884 pp., royal 8vo. (*New York, 1907.*) 11s. net

Specification for Concrete Flags. Issued by the Institution of Municipal and County Engineers. Folio, sewed. (1911.) 2s. 6d. net.

CIVIL ENGINEERING

Canals, Surveying.

(See also *Irrigation and Water Supply.*)

Practical Hints to Young Engineers Employed on Indian Railways. By A. W. C. Addis. 14 illus., 154 pp., 12mo. (1910.) 3s. 6d. net.

Levelling, Barometric, Trigonometric and Spirit. By I. O. Baker. Third edition, 15 illus., 145 pp., 18mo, boards. (*New York, 1910.*) 2s. net.

River and Canal Engineering. By E. S. Bellasis. 72 illus., x + 220 pp., 8vo. (1913.) 8s. 6d. net.

- Punjab Rivers and Works.** By E. S. Bellasis. Second edition, 47 illus., viii + 64 pp., folio. (1912.) 8s. net.
- Notes on Instruments** best suited for Engineering Field Work in India and the Colonies. By W. G. Bligh. 65 illus., 218 pp., 8vo. (1914.) 5s. 6d.
- The Civil Engineers' Cost Book.** By Major T. E. Coleman, R.E. xii + 289 pp., Pocket size ($6\frac{1}{2} \times 3\frac{3}{8}$ in.), leather cloth. (1912.) 5s. net.
- Retaining Walls in Theory and Practice.** By T. E. Coleman. 104 illus., 160 pp., crown 8vo. (1914.) 5s. net.
- On Curved Masonry Dams.** By W. B. Coventry. 8vo, sewed. (1894.) 2s.
- A Practical Method of Determining the Profile of a Masonry Dam.** By W. B. Coventry. 8vo, sewed. (1894.) 2s. 6d.
- The Stresses on Masonry Dams** (oblique sections). By W. B. Coventry. 8vo, sewed. (1894.) 2s.
- Handbook of Cost Data for Contractors and Engineers.** By H. P. Gillette. 1,854 pp., crown 8vo, leather, gilt edges. Second ed. (New York, 1914.) £1 1s. net.
- High Masonry Dams.** By E. S. Gould. 2nd. edit. With illus., 88 pp., 18mo, boards. (New York, 1905.) 2s. net.
- Railway Tunnelling in Heavy Ground.** By C. Gripper. 3 plates, 66 pp., royal 8vo. (1879.) 7s. 6d.
- Levelling and its General Application.** By Thomas Holloway. Revised by H. T. Tallack. 8vo, 71 illus., 149 pp. Third ed. (1914.) 2s. 6d. net. Postage, inland, 4d.; abroad, 6d.
- Waterways and Water Transport.** By J. S. Jeans. 55 illus., 520 pp., 8vo. (1890.) 9s. net.
- Table of Barometrical Heights to 20,000 Feet.** By Lieut.-Col. W. H. Mackesy. 1 plate, 24 pp., royal 32mo. 3s.
- Aid Book to Engineering Enterprise.** By E. Matheson. Third edition, illustrated, 916 pp., medium 8vo, buckram. (1898.) £1 4s.
- A Treatise on Surveying.** By R. E. Middleton and O. Chadwick. Third edition, royal 8vo. (1911.)
 Part I. 11 plates, 162 illus., 285 pp. 10s. 6d.
 „ II. 152 illus. and 2 plates, 340 pp. 10s. 6d.

- A Pocket Book of Useful Formulæ and Memoranda**, for Civil and Mechanical Engineers. By Sir **G. L. Molesworth** and **H. B. Molesworth**. With an Electrical Supplement by **W. H. Molesworth**. Twenty-seventh edition, 800 illus., viii + 936 pp., oblong 32mo, leather. (1913.) 5s. net.
- The Pocket Books of Sir G. L. Molesworth and J. T. Hurst**, printed on India paper and bound in one vol. Royal 32mo, russia, gilt edges. 10s. 6d. net.
- Metallic Structures : Corrosion and Fouling and their Prevention**. By **J. Newman**. 38 Illus., xii + 374 pp., crown 8vo. (1896.) 9s.
- Scamping Tricks and Odd Knowledge** occasionally practised upon Public Works. By **J. Newman**. New imp., 129 pp., crown 8vo. (1908.) 2s. net.
- Compensation Discharge in the Rivers and Streams of the West Riding** (Yorkshire, England). By **M. M. Paterson**. 55 pp., 8vo. (1896.) 2s. net.
- Co-ordinate Geometry** applied to Land Surveying. By **W. Pilkington**. 5 illus., 44 pp., 12mo. (1909.) 1s. 6d. net.
- Pioneering**. By **F. Shelford**. 14 Illus., 88 pp., crown 8vo. (1909.) 3s. net.
- Topographical Surveying**. By **G. J. Specht**. 4th edition, 2 plates and 28 illus., 210 pp., 18mo, boards. Fourth ed. (*New York, 1910.*) 2s. net.
- Spons' Dictionary of Engineering**, Civil, Mechanical, Military and Naval. 10,000 illus., 4,300 pp., super royal 8vo. (1874; Supplement issued in 1881.) Complete, in 4 vols. £3 3s. net.
- Surveying and Levelling Instruments**. Theoretically and practically described. By **W. F. Stanley**. Revised by **H. T. Tallack**. For Construction, Qualities, Selection, Preservation, Adjustments and Uses ; with other apparatus and appliances used by Civil Engineers and Surveyors in the field. Fourth ed. 433 illus., 606 pp. (1914.) 7s. 6d. net. Postage, inland, 5d. ; abroad, 10d.
- Surveyor's Handbook**. By **T. U. Taylor**. 116 illus., 310 pp., crown 8vo, leather, gilt edges. (*New York, 1908.*) 8s. 6d. net.
- Logarithmic Land Measurement**. By **J. Wallace**. 32 pp., royal 8vo. (1910.) 5s. net.

- The Drainage of Fens and Low Lands** by Gravitation and Steam Power. By W. H. Wheeler. 8 plates, 175 pp., 8vo. (1888.) 12s. 6d.
- Stadia Surveying**, the theory of Stadia Measurements. By A. Winslow. Ninth ed, 148 pp., 18mo, boards. (*New York, 1913.*) 2s. net.
- Handbook on Tacheometrical Surveying.** By C. Xydis. 55 illus., 3 plates, 63 pp., 8vo. (1909.) 6s. net.

CURVE TABLES

- Grace's Tables for Curves**, with hints to young engineers. 8 figures, 43 pp., oblong 8vo. (1908.) 5s. net.
- Data relating to Railway Curves and Super-elevations**, shown graphically. By J. H. Haiste. On folding card for pocket use. 6d. net.
- Tables for setting-out Railway Curves.** By C. P. Hogg. A series of cards in neat cloth case. 4s. 6d.
- Tables for setting out Curves** for Railways, Roads, Canals, etc. By A. Kennedy and R. W. Hackwood. 32mo. 2s. net.
- Spiral Tables.** By J. G. Sullivan. 47 pp., 12mo, leather. (*New York.*) 6s. 6d. net.
- Tables for Setting out Curves** from 101 to 5,000 feet radius. By H. A. Cutler and F. J. Edge. Royal 32mo. 2s. net.
- Tables of Parabolic Curves** for the use of Railway Engineers, and others. By G. T. Allen. Fcap. 16mo. 4s.
- Transition Curves.** By W. G. Fox. Second edition, 80 pp., 18mo, boards. (*New York.*) 2s. net.

DICTIONARIES

- Technological Dictionary in the English, Spanish, German and French Languages.** By D. Carlos Huelin Y Arsu. Crown 8vo.
- Vol. I. ENGLISH-SPANISH-GERMAN-FRENCH. 609 pp. (1906.) 10s. 6d. net.
- Vol. II. GERMAN-ENGLISH-FRENCH-SPANISH. 720 pp. (1908.) 10s. 6d. net.
- Vol. III. FRENCH-GERMAN-SPANISH-ENGLISH. *In preparation.*
- Vol. IV. SPANISH-FRENCH-ENGLISH-GERMAN. 750 pp. (1910.) 10s. 6d. net.

- Dictionary of English and Spanish Technical and Commercial Terms.** By W. Jackson. 164 pp., fcap. 8vo. (1911.) 2s. 6d. net.
- English-French and French-English Dictionary of the Motor-Car, Cycle and Boat.** By F. Lucas. 171 pp., crown 8vo. (1905.) 2s. net.
- Spanish-English Dictionary of Mining Terms.** By F. Lucas. 78 pp., 8vo. (1905.) 5s. net.
- English-Russian and Russian-English Engineering Dictionary.** By L. Meycliar. 100 pp., 16mo. (1909.) 2s. 6d. net.

DOMESTIC ECONOMY

- Food Adulteration and its Detection.** By J. P. Battershall. 12 plates, 328 pp., demy 8vo. (*New York, 1887.*) 15s.
- The Cooking Range, its Failings and Remedies.** By F. Dye. 52 pp., fcap. 8vo, sewed. (1888.) 6d.
- Spices and How to Know Them.** By W. M. Gibbs. With 47 plates, including 14 in colours, 179 pp., 8vo. (*New York, 1909.*) 15s. net.
- The Kitchen Boiler and Water Pipes.** By H. Grimshaw. 8vo, sewed. (1887.) 1s. net.
- Spons' Household Manual.** 250 illus., 1,043 pp., demy 8vo. (1902.) 7s. 6d.
- Ditto ditto half-bound French morocco. 9s.

DRAWING

- The Ornamental Penman's, Engraver's and Sign Writer's Pocket Book of Alphabets.** By B. Alexander. New Impression. Oblong 12mo, sewed. 6d. net.
- Slide Valve Diagrams : a French Method for their Construction.** By L. Bankson. 18mo, boards. (*New York, 1892.*) 2s. net.
- A System of Easy Lettering.** By J. H. Cromwell. Twelfth edition, 39 plates, oblong 8vo. (*New York, 1912.*) 2s. 6d. net.
- Key to the Theory and Methods of Linear Perspective.** By C. W. Dymond, F.S.A. 6 plates, 32 pp., crown 8vo. (S. & C. SERIES, No. 20.) (1910.) 1s. 6d. net.

- Plane Geometrical Drawing.** By R. C. Fawdry. Illustrated, 185 pp., crown 8vo. (1901.) 3s. net.
- Hints on Architectural Draughtsmanship.** By G. W. T. Hallatt. Fourth ed., 80 pp., 18mo. (1906.) 1s. 6d. net.
- A First Course of Mechanical Drawing (Tracing).** By G. Halliday. Oblong 4to, sewed. 2s.
- A Text-Book of Graphic Statics.** By C. W. Malcolm. 155 illus., 316 pp., 8vo. (*New York, 1909.*) 12s. 6d. net.
- Drawings for Medium-sized Repetition Work.** By R. D. Spinney. 47 illus., 130 pp., 8vo. (1909.) 3s. 6d. net.
- Mathematical Drawing Instruments.** By W. F. Stanley. Seventh ed., 265 illus., 370 pp., cr. 8vo. (1900.) 5s.

EARTHWORK

- Tables for Computing the Contents of Earthwork in the Cuttings and Embankments of Railways.** By W. Macgregor. 1 plate, 59 pp., royal 8vo. 6s.
- Tables for facilitating the Calculation of Earthworks.** By D. Cunningham. 120 pp., royal 8vo. 10s. 6d.
- Grace's Earthwork Tables.** 36 double-page tables, 4to. 12s. 6d. net.
- Earthwork Slips and Subsidences on Public Works.** By J. Newman. 240 pp., crown 8vo. (1890.) 7s. 6d.

ELECTRICAL ENGINEERING

- Journal of the Institution of Electrical Engineers.** Edited by P. F. Rowell, Secretary. Issued in quarto parts. The number of parts will be from 12 to 16 annually. Annual Subscription, 46s. post free, payable in advance. Single copies, 3s. 9d. post free.
- Practical Electric Bell Fitting.** By F. C. Allsop. Tenth edition, 186 illus., including 8 folding plates, 185 pp., cr. 8vo. (1914.) 2s. 6d. net.
- Telephones : their Construction and Fitting.** By F. C. Allsop. Eighth edition, new imp., 184 illus., 222 pp., cr. 8vo. (1914.) 2s. 6d. net.

- Electric Bell Construction.** By F. C. Allsop. New imp., 177 illus., xii + 131 pp., cr. 8vo. (1914.) 2s. 6d. net.
- Induction Coils and Coil Making.** By F. C. Allsop. Second edition, new imp., 125 illus., xii + 172 pp., cr. 8vo. (1914.) 2s. 6d. net.
- Auto-Transformer Design.** By A. H. Avery. 25 illus., 60 pp., 8vo. (1909.) 2s. 6d. net.
- Principles of Electric Power (Continuous Current) for Mechanical Engineers.** By A. H. Bate. 63 illus., 204 pp., crown 8vo. (1914.) (FINSBURY TECHNICAL MANUAL.) 4s. 6d. net.
- Practical Construction of Electric Tramways.** By W. R. Bowker. 93 illus., 119 pp., 8vo. (1914.) 6s. net.
- Dynamo Lighting for Motor Cars.** By M. A. Codd. Second edition, 140 illus., vi + 107 pp., 8vo. (1914.) 2s. 6d. net.
- Design and Construction of Induction Coils.** By A. F. Collins. 155 illus., 272 pp., demy 8vo. (New York, 1909.) 12s. 6d. net.
- Plans and Specification for Wireless Telegraph Sets.** By A. F. Collins. Crown 8vo. (S. & C. SERIES, Nos. 41 and 42). (New York, 1912.) 1s. 6d. each net.
- PART I. An Experimental Set and a One to Five Miles Set. 37 illus., viii + 45 pp.
- PART II. A Five to Ten Mile Set and a Ten to Twenty Mile Set. 63 illus., viii + 72 pp.
- Switchboard Measuring Instruments for Continuous and Polyphase Currents.** By J. C. Connan. 117 illus., 150 pp., 8vo. (1914.) 3s. 6d. net.
- Electric Cables, their Construction and Cost.** By D. Coyle and F. J. O. Howe. With many diagrams and 216 tables, 466 pp., crown 8vo, leather. (1909.) 15s. net.
- Management of Electrical Machinery.** By F. B. Crocker and S. S. Wheeler. Eighth edition, 131 illus., 223 pp., crown 8vo. (New York, 1909.) 4s. 6d. net.
- Electric Lighting: A Practical Exposition of the Art.** By F. B. Crocker. Royal 8vo. (New York.)
- Vol. I. **The Generating Plant.** Sixth edition, 213 illus., 470 pp. (1904.) 12s. 6d. net.
- Vol. II. *New edition in preparation.*

- The Care and Management of Ignition Accumulators.**
By **H. H. U. Cross.** 12 illus., 74 pp., crown 8vo. (S. & C. SERIES, No. 19.) (1910.) 1s. 6d. net.
- Elements of Telephony.** By **A. Crotch.** 51 illus., 90 pp., crown 8vo. (S. & C. SERIES, No. 21.) (1911.) 1s. 6d. net.
- Elementary Telegraphy and Telephony.** By **Arthur Crotch.** New impression, 238 illus., viii + 223 pp., 8vo. (FINSBURY TECHNICAL MANUAL.) (1912.) 4s. 6d. net.
- Electricity and Magnetism in Telephone Maintenance.**
By **G. W. Cummings.** 45 illus., 137 pp., 8vo. *New York, 1908.*) 6s. 6d. net.
- Grouping of Electric Cells.** By **W. F. Dunton.** 4 illus., 50 pp., fcap. 8vo. (1914.) 1s. 6d. net.
- Wireless Telegraphy for Intending Operators.** By **C. K. P. Eden.** 16 illus., 80 pp., cr. 8vo. (S. & C. SERIES, No. 24.) (1913.) 1s. 6d. net.
- Magnets and Electric Currents.** By **J. A. Fleming, M.A., D.Sc., F.R.S.** An elementary treatise for the use of Electrical Artisans and Science Teachers. Cr. 8vo, 136 illus., 408 pp. Third ed. (1914.) 3s. 6d. net. Postage, inland, 4d.; abroad 8d.
- Notes on Design of Small Dynamo.** By **George Halliday.** Second edition, 8 plates, 8vo. (1895.) 2s. 6d.
- Practical Alternating Currents and Power Transmission.**
By **N. Harrison.** 172 illus., 375 pp., crown 8vo. (*New York, 1906.*) 10s. 6d. net.
- Practical and Experimental Wireless Telegraphy.** A Handbook for Operators, Students and Amateurs. By **W. J. Shaw**, Member of the Wireless Society of London. 42 illus., 102 pp., cr. 8vo. (1914.) 3s. 6d. net. Post free, 3s. 10d.
- Making Wireless Outfits.** By **N. Harrison.** 27 illus., 61 pp., crown 8vo. (S. & C. SERIES, No. 11.) Second ed. (*New York, 1914.*) 1s. 6d. net.
- Wireless Telephone Construction.** By **N. Harrison.** 43 illus., 73 pp., crown 8vo. (S. & C. SERIES, No. 12.) (*New York, 1912.*) 1s. 6d. net.
- Testing Telegraph Cables.** By **Colonel V. Hoskier.** Third edition, 11 illus., viii + 75 pp., crown 8vo. (1889.) 4s. 6d.

- Long Distance Electric Power Transmission.** By R. W. Hutchinson. 136 illus., 345 pp., crown 8vo. (*New York, 1907.*) 12s. 6d. net.
- Theory and Practice of Electric Wiring.** By W. S. Ibbetson. 119 illus., 366 pp., crown 8vo. (*1914.*) 3s. 6d. net.
- Practical Electrical Engineering for Elementary Students.** By W. S. Ibbetson. 61 illus., 155 pp., crown 8vo. (*1914.*) 2s. 6d. net.
- Form of Model General Conditions,** recommended for use in connection with Contracts for Electrical Works. Issued by the **Institution of Electrical Engineers.** F'cap, 19 pp. Revised April, 1914. 6d. net. Postage, 1d.
- Telegraphy for Beginners.** By W. H. Jones. 19 illus., 58 pp., crown 8vo. Second ed. (*New York, 1913.*) 2s. net.
- A Handbook of Electrical Testing.** By H. R. Kempe. Seventh ed., 285 illus., 706 pp., 8vo. (*1908.*) 18s. net.
- Electromagnets, their Design and Construction.** By A. N. Mansfield. 36 illus., 155 pp., 18mo, boards. Second ed. (*New York, 1908.*) 2s. net.
- Telephone Construction, Methods and Cost.** By C. Mayer. With Appendices on the cost of materials and labour by J. C. Slippy. 103 illus., 284 pp., crown 8vo. (*New York, 1908.*) 12s. 6d. net.
- Practical Electricians: a Universal Handybook on Every Day Electrical Matters.** Ninth ed., 126 illus., 135 pp., 8vo. (S. & C. SERIES, No. 13.) (*New York, 1909.*) 1s. 6d. net.
- Wiring Houses for the Electric Light.** By N. H. Schneider. 40 illus., 85 pp., crown 8vo. (S. & C. SERIES, No. 25.) (*New York, 1911.*) 1s. 6d. net.
- Induction Coils.** By N. H. Schneider. 79 illus., 285 pp., crown 8vo. Second ed. (*New York, 1909.*) 4s. 6d. net.
- How to Install Electric Bells, Annunciators and Alarms.** By N. H. Schneider. 59 illus., 63 pp., crown 8vo. (S. & C. SERIES, No. 2.) *New edition in preparation.*
- Modern Primary Batteries, their construction, use and maintenance.** By N. H. Schneider. 54 illus., 94 pp., crown 8vo. (S. & C. SERIES, No. 1.) (*New York, 1905.*) 1s. 6d. net.

- Practical Engineers' Handbook on the Care and Management of Electric Power Plants.** By N. H. Schneider. 203 illus., 274 pp., crown 8vo. (*New York, 1906.*) 5s. net.
- Electrical Circuits and Diagrams**, illustrated and explained. By N. H. Schneider. 8vo. (S. & C. SERIES, Nos. 3 and 4.) (*New York.*)
- No. 3, Part 1. Second edition. 217 illus., 72 pp. (*New York, 1914.*) 1s. 6d. net.
- No. 4, Part 2. 73 pp. Second ed. (*1911.*) 1s. 6d. net.
- Electrical Instruments and Testing.** By N. H. Schneider and J. Hargrave. Fourth edition, 133 illus., xxiv + 256 pp., cr. 8vo. (*New York, 1913.*) 4s. 6d. net.
- Experimenting with Induction Coils.** By N. H. Schneider. 26 illus., 73 pp., crown 8vo. (S. & C. SERIES, No. 5.) (*New York, 1911.*) 1s. 6d. net.
- Study of Electricity for Beginners.** By N. H. Schneider. 54 illus., 88 pp., crown 8vo. (S. & C. SERIES, No. 6.) (*New York, 1910.*) 1s. 6d. net.
- Wiring Houses for the Electric Light : Low Voltage Battery Systems.** 44 illus., 86 pp., crown 8vo. (S. & C. SERIES, No 25.) (*New York, 1911.*) 1s. 6d. net.
- Low Voltage Electric Lighting with the Storage Battery.** By N. H. Schneider. 23 illus., 85 pp., crown 8vo. (S. & C. SERIES, No. 26.) (*New York, 1911.*) 1s. 6d. net.
- Dry Batteries : how to Make and Use them.** By a Dry Battery Expert. With additional notes by N. H. Schneider. 30 illus., 59 pp., crown 8vo. (S. & C. SERIES, No. 7.) (*New York, 1910.*) 1s. 6d. net.
- The Diseases of Electrical Machinery.** By E. Schulz. Edited, with a Preface, by Prof. S. P. Thompson. 42 illus., 84 pp., cr. 8vo. (*1904.*) 2s. net.
- Electricity Simplified.** By T. O. Sloane. Thirteenth edition, 29 illus., 158 pp., crown 8vo. (*New York, 1905.*) 4s. 6d. net.
- How to become a Successful Electrician.** By T. O. Sloane. Fifteenth edition, 4 illus., 202 pp., crown 8vo. (*New York, 1906.*) 4s. 6d. net.
- Electricity : its Theory, Sources and Applications.** By J. T. Sprague. Third edition, 109 illus., 658 pp., crown 8vo. (*1892.*) 7s. 6d. net.

- Telegraphic Connections.** By C. Thom and W. H. Jones. 20 plates, 59 pp., oblong 8vo. (*New York, 1892.*) 3s. 6d. net.
- Dynamo Electric Machinery.** By Prof. S. P. Thompson. Seventh edition, demy 8vo. (FINSBURY TECHNICAL MANUAL.)
- Vol. I. CONTINUOUS-CURRENT MACHINERY. With 4 coloured and 30 folding plates, 573 illus., 984 pp. (1904.) £1 10s. net.
- Vol. II. ALTERNATING CURRENT MACHINERY. 15 coloured and 24 folding plates, 546 illus., 900 pp. (1905.) £1 10s. net.
- Design of Dynamos (Continuous Currents).** By Prof. S. P. Thompson. 4 coloured and 8 folding plates, 243 pp., demy 8vo. (1903.) 12s. net.
- Schedule for Dynamo Design,** issued with the above. 6d. each, 4s. per doz., or 18s. per 100, net.
- Curves of Magnetic Data for Various Materials.** A reprint on transparent paper for office use of Plate I from Dynamo Electric Machinery, and measuring 25 in. by 16 in. 7d. net.
- Electrical Tables and Memoranda.** By Prof. S. P. Thompson. Second ed., 15 illus. viii. + 136 pp., oblong 64mo (waistcoat-pocket size), leather. (1913.) 1s. net.
- Do., do., in celluloid case. 1s. 6d. net.
- Elements of Electro-Plating.** By J. T. Sprague. Cr. 8vo, 72 pp., 2 illus. (1914.) (S. & C. Series, No. 44.) 1s. 6d. net. Postage 2d.
- The Electromagnet.** By C. R. Underhill. 67 illus., 159 pp., crown 8vo. (*New York, 1903.*) 6s. 6d. net.
- Practical Guide to the Testing of Insulated Wires and Cables.** By H. L. Webb. Fifth edition, 38 illus., 118 pp., crown 8vo. (*New York, 1902.*) 4s. 6d. net.
- Wiring Rules.** With Extracts from the Board of Trade Regulations and the Home Office Regulations for Factories and Workshops. Issued by **The Institution of Electrical Engineers.** Sixth edition, 42 pp., 8vo, sewed. (1911.) 6d. net.

FOREIGN EXCHANGE

English Prices with Russian Equivalents (at Fourteen Rates of Exchange). English prices per lb., with equivalents in roubles and kopecks per pood. By A. Adlassewich. 182 pp., fcap. 32mo. 1s. net.

English Prices with German Equivalents (at Seven Rates of Exchange). English Prices per lb., with equivalents in marks per kilogramme. By **St. Koczorowski**. 95 pp., fcap. 32mo. 1s. net.

English Prices with Spanish Equivalents. At Seven Rates of Exchange. English prices per lb., with equivalents in pesetas per kilogramme. By **S. Lambert**. 95 pp., 32mo. 1s. net.

English Prices with French Equivalents (at Seven Rates of Exchange). English prices per lb. to francs per kilogramme. By **H. P. McCartney**. 97 pp., 32mo. 1s. net.

Principles of Foreign Exchange. By **E. Matheson**. Fourth edition, 54 pp., 8vo, sewed. (1905.) 3d. net.

GAS AND OIL ENGINES

The Theory of the Gas Engine. By **D. Clerk**. Edited by **F. E. Idell**. Third edition, 19 illus., 180 pp., 18mo, boards. (New York, 1903.) 2s. net.

Electrical Ignition for Internal Combustion Engines. By **M. A. Codd**. 109 illus., 163 pp., crown 8vo. (1911.) 3s. net.

Design and Construction of Oil Engines, with full directions for Erecting, Testing, Installing, Running and Repairing, including descriptions of American and English Kerosene Oil Engines, with an appendix on Marine Oil Engines. By **A. H. Goldingham, M.E., M.Am.S.M.E.** Fourth edition, 137 illus., 299 pp. (New York, 1914.) 8s. 6d. net. Postage, inland, 5d.; abroad, 10d.

Gas Engine in Principle and Practice. By **A. H. Goldingham**. New impression, 107 illus., 195 pp., 8vo. (New York, 1912.) 6s. 6d. net.

Practical Handbook on the Care and Management of Gas Engines. By **G. Lieckfeld**. Third edition, square 16mo. (New York, 1906.) 3s. 6d.

Elements of Gas Engine Design. By **S. A. Moss**. 197 pp., 18mo, boards. Second ed. (New York, 1907.) 2s. net.

Gas and Petroleum Engines. A Manual for Students and Engineers. By **Prof. W. Robinson**. (FINSBURY TECHNICAL MANUAL.) Third edition in preparation.

GAS LIGHTING

- Transactions of the Institution of Gas Engineers.** Edited by Walter T. Dunn, *Secretary*. Published annually. 8vo. 10s. 6d. net.
- Gas Analyst's Manual.** By J. Abady. 102 illus., 576 pp., demy 8vo. (1902.) 18s. net.
- Gas Works: their Arrangement, Construction, Plant and Machinery.** By F. Colyer. 31 folding plates, 134 pp., 8vo. (1884.) 8s. 6d. net.
- Lighting by Acetylene.** By F. Dye. 75 illus., 200 pp., crown 8vo. (1902.) 6s. net.
- A Comparison of the English and French Methods of Ascertaining the Illuminating Power of Coal Gas.** By A. J. Van Eijndhoven. Illustrated, crown 8vo. (1897.) 4s.
- Gas Lighting and Gas Fitting.** By W. P. Gerhard. Third edition, 190 pp., 18mo, boards. (*New York, 1904.*) 2s. net.
- A Treatise on the Comparative Commercial Values of Gas Coals and Cannels.** By D. A. Graham. 3 plates, 100 pp., 8vo. (1882.) 4s. 6d.
- The Gas Engineer's Laboratory Handbook.** By J. Hornby. Third edition, revised, 70 illus., 330 pp., crown 8vo. (1911.) 6s. net.
- Electric Gas Lighting.** By N. H. Schneider. 57 illus., 101 pp., crown 8vo. (S. & C. SERIES, No. 8.) (*New York, 1901.*) 1s. 6d. net.

HISTORICAL AND BIOGRAPHICAL

- Extracts from the Private Letters of the late Sir William Fothergill Cooke, 1836-9, relating to the Invention and Development of the Electric Telegraph; also a Memoir by Latimer Clark.** Edited by F. H. Webb, Sec.Inst.E.E. 8vo. (1895.) 3s.
- A Chronology of Inland Navigation in Great Britain.** By H. R. De Salis. Crown 8vo. (1897.) 4s. 6d.
- A History of Electric Telegraphy to the year 1837.** By J. J. Fahie. 35 illus., 542 pp., crown 8vo. (1889.) 2s. net.
- Life as an Engineer: its Lights, Shades, and Prospects.** By J. W. C. Haldane. New edition, 23 plates, 390 pp., crown 8vo. (1910.) 5s. net.

- A Cornish Giant.** Richard Trevethick, the father of the Locomotive Engine. By E. K. Harper. 12 illus., including 2 plates, 60 pp., 8vo. sewed. (1913.) 1s. net.
- Philipp Reis,** Inventor of the Telephone: a Biographical Sketch. By Prof. S. P. Thompson. 8vo, cloth. (1883.) 7s. 6d.
- The Development of the Mercurial Air Pump.** By Prof. S. P. Thompson. 43 illus., 37 pp., royal 8vo, sewed. (1888.) 1s. 6d.

HOROLOGY

- Watch and Clock Maker's Handbook,** Dictionary and Guide. By F. J. Britten. Eleventh edition, 450 illus., 492 pp., crown 8vo. (1907.) 5s. net.
- Prize Essay on the Balance Spring** and its Isochronal Adjustments. By M. Immisch. 7 illus., 50 pp., crown 8vo. (1872.) 2s. 6d.

HYDRAULICS AND HYDRAULIC MACHINERY

(See also *Irrigation and Water Supply*.)

- Hydraulics with Working Tables.** By E. S. Bellasis. Second edition, 160 illus., xii+311 pp., 8vo. (1911.) 12s. net.
- Pumps: Historically, Theoretically and Practically Considered.** By P. R. Björling. Second edition, 156 illus., 234 pp., crown 8vo. (1895.) 7s. 6d.
- Pump Details.** By P. R. Björling. 278 illus., 211 pp., crown 8vo. (1892.) 7s. 6d.
- Pumps and Pump Motors: A Manual for the use of Hydraulic Engineers.** By P. R. Björling. Two vols., 261 plates, 369 pp., royal 4to. (1895.) £1 10s. net.
- Practical Handbook on Pump Construction.** By P. R. Björling. Second ed., new imp., 9 plates, viii+86 pp., cr. 8vo. (1912.) 3s. 6d. net.
- Water or Hydraulic Motors.** By P. R. Björling. 206 illus., 287 pp., crown 8vo. (1903.) 9s.
- Hydraulic Machinery, with an Introduction to Hydraulics.** By R. G. Blaine. Third edition, 307 illus., 468 pp., 8vo. (FINSBURY TECHNICAL MANUAL.) (1913.) 10s. 6d. net.

- Practical Hydraulics.** By T. Box. Fifteenth edition, 8 plates, 88 pp., crown 8vo. (1909.) 5s. net.
- Pumping and Water Power.** By F. A. Bradley. 51 illus., vii + 118 pp., demy 8vo. (1912.) 4s. 6d. net.
- Hydraulic, Steam, and Hand Power Lifting and Pressing Machinery.** By F. Colyer. Second edition, 88 plates, 211 pp., imperial 8vo. (1892.) 10s. 6d. net.
- Pumps and Pumping Machinery.** By F. Colyer.
Vol. I. Second edition, 53 plates, 212 pp., 8vo. (1892.) 10s. 6d. net.
Vol. II. Second edition, 48 plates, 169 pp., 8vo (1900.) 10s. 6d. net.
- Construction of Horizontal and Vertical Water-wheels.** By W. Cullen. Second edition, 12 plates, 4to. (1871.) 5s.
- Donaldson's Poncelet Turbine and Water Pressure Engine and Pump.** By W. Donaldson. 2 plates, viii + 32 pp., demy 4to. (1883.) 5s.
- Principles of Construction and Efficiency of Water-wheels.** By W. Donaldson. 13 illus., 94 pp., 8vo. (1876.) 5s.
- Practical Hydrostatics and Hydrostatic Formulæ.** By E. S. Gould. 27 illus., 114 pp., 18mo, boards. (New York, 1903.) 2s. net.
- Hydraulic and Other Tables for purposes of Sewerage and Water Supply.** By T. Hennell. Third edition, 70 pp., crown 8vo. (1908.) 4s. 6d. net.
- Tables for Calculating the Discharge of Water in Pipes for Water and Power Supplies.** Indexed at side for ready reference. By A. E. Silk. 63 pp., crown 8vo. (1914.) 3s. 6d. net.
- Simple Hydraulic Formulæ.** By T. W. Stone. 9 plates, 98 pp., crown 8vo. (1881.) 4s.
- A B C of Hydrodynamics.** By Lieut.-Col. R. de Villamil. 48 illus., xi + 135 pp., demy 8vo. (1912.) 6s. net.
- Motion of Liquids.** By Lieut.-Col. R. De Villamil, R. Eng. (Ret.). 8vo, xiv + 210 pp., 86 illus., 30 tables. (1914.) 7s. 6d. net; Postage, inland, 4d.; abroad, 8d.

INDUSTRIAL CHEMISTRY AND MANUFACTURES

Transactions of the American Institute of Chemical Engineers. Issued annually. 30s. net. per volume.

- Perfumes and their Preparation.** By G. W. Askinson. Translated by I. Fuest. Fourth ed., 32 illus., 512 pp., 8vo. (*New York, 1914.*) 21s. net.
- Brewing Calculations, Gauging and Tabulation.** By C. H. Bater. 340 pp., 64mo, roan, gilt edges. (*1914.*) 1s. 6d. net.
- A Pocket Book for Chemists, Chemical Manufacturers, Metallurgists, Dyers, Distillers, etc.** By T. Bayley. Seventh edition, new impression, 550 pp., royal 32mo, roan, gilt edges. (*1912.*) 5s. net.
- Practical Receipts for the Manufacturer, the Mechanic, and for Home use.** By Dr. H. R. Berkeley and W. M. Walker. New impression, 250 pp., demy 8vo. (*1912.*) 5s. net.
- A Treatise on the Manufacture of Soap and Candles, Lubricants and Glycerine.** By W. L. Carpenter and H. Leask. Second edition, 104 illus., 456 pp., crown 8vo. (*1895.*) 12s. 6d.
- A Text Book of Paper Making.** By C. F. Cross and E. J. Bevan. Third edition, 97 illus., 411 pp., crown 8vo. (*1907.*) 12s. 6d. net.
- C.B.S. Standard Units and Standard Paper Tests.** By C. F. Cross, E. J. Bevan, C. Beadle and R. W. Sindall. 25 pp., crown 4to. (*1903.*) 2s. 6d. net.
- Pyrometry.** By C. R. Darling. 60 illus., 200 pp., crown 8vo. (*1911.*) 5s. net.
- Soda Fountain Requisites.** A Practical Receipt Book for Druggists, Chemists, etc. By G. H. Dubelle. Fourth ed.; 157 pp., crown 8vo. (*New York, 1911.*) 4s. 6d. net.
- Spices and How to Know Them.** By W. M. Gibbs. 47 plates, including 14 in colours, 176 pp., 8vo. (*New York, 1909.*) 15s. net.
- The Chemistry of Fire and Fire Prevention.** By H. and H. Ingle. 45 illus., 290 pp., crown 8vo. (*1900.*) 9s.
- Ice-making Machines.** By M. Ledoux and others. Sixth edition, 190 pp., 18mo, boards. (*New York, 1906.*) 2s. net.
- Brewing with Raw Grain.** By T. W. Lovibond. 75 pp., crown 8vo. (*1883.*) 5s.
- The Chemistry, Properties, and Tests of Precious Stones.** By J. Mastin. 114 pp., fcap. 16mo, limp leather, gilt top. (*1911.*) 2s. 6d. net.

- Sugar, a Handbook for Planters and Refiners.** By the late J. A. R. Newlands and B. E. R. Newlands. 236 illus., 876 pp., 8vo. (1909.) £1 5s. net.
- Principles of Leather Manufacture.** By Prof. H. R. Procter. *Second edition in preparation.*
- Leather Industries Laboratory Handbook of Analytical and Experimental Methods.** By H. R. Procter. Second edition, 4 plates, 46 illus., 450 pp., 8vo. (1908.) 18s. net.
- Leather Chemists' Pocket Book.** A short compendium of Analytical Methods. By Prof. H. R. Procter. Assisted by Dr. E. Stiasny and H. Brumwell. 4 illus., xiv + 223 pp., 16mo, leather. (1912.) 5s. net.
- Theoretical and Practical Ammonia Refrigeration.** By I. I. Redwood. Third edition, 15 illus., 146 pp., square 16mo. (New York, 1914.) 4s. 6d. net.
- Breweries and Maltings.** By G. Scammell and F. Colyer. Second edition, 20 plates, 178 pp., 8vo. (1880.) 6s. net.
- Factory Glazes for Ceramic Engineers.** By H. Rumbellow. Folio. Series A, Leadless Sanitary Glazes. (1908.) £2 2s. net.
- Spons' Encyclopædia of the Industrial Arts, Manufactures and Commercial Products.** 2 vols. 1,500 illus., 2,100 pp., super royal 8vo. (1882.) £2 2s. net.
- Tables for the Quantitative Estimation of the Sugars.** By E. Wein and W. Frew. Crown 8vo. (1896.) 6s.
- The Puering, Bating and Drenching of Skins.** By J. T. Wood. 33 illus., xv + 300 pp., 8vo. (1912.) 12s. 6d. net.
- Workshop Receipts.** For the use of Manufacturers, Mechanics and Scientific Amateurs. NEW AND THOROUGHLY REVISED EDITION, crown 8vo. (1909.) 3s. each net.
- Vol. I. ACETYLENE LIGHTING to DRYING. 223 illus., 532 pp.
- Vol. II. DYEING to JAPANING. 259 illus., 540 pp.
- Vol. III. JOINTING PIPES to PUMPS. 256 illus., 528 pp.
- Vol. IV. RAINWATER SEPARATORS to WIRE ROPE SPLICING. 321 illus., 540 pp.
- Practical Handbook on the Distillation of Alcohol from Farm Products.** By F. B. Wright. Second edition, 60 illus., 271 pp., crown 8vo. (New York, 1907.) 4s. 6d. net.

INTEREST TABLES

The Wide Range Dividend and Interest Calculator, showing at a glance the Percentage on any sum from One Pound to Ten Thousand Pounds, at any Interest, from 1 per cent. to $12\frac{1}{2}$ per cent., proceeding by $\frac{1}{4}$ per cent. By A. Stevens. 100 pp., super royal 8vo. 6s. net.

Quarter morocco, cloth sides, 7s. 6d. net.

The Wide Range Income Tax Calculator, showing at a glance the Tax on any sum from One Shilling to Ten Thousand Pounds, at the Rate of 9d., 1s., and 1s. 2d. in the Pound. By A. Stevens. On folding card, imperial 8vo. 1s. net.

IRRIGATION

Irrigation Works. By E. S. Bellasis. 37 illus., viii + 174 pp., 8vo. (1913.) 8s. net.

Punjab Rivers and Works. By E. S. Bellasis. Second edition, 47 illus., 65 pp., folio. (1912.) 8s. net.

Irrigation Pocket Book. By R. B. Buckley. Second ed., 80 illus., viii + 475 pp., cr. 8vo, leather, gilt edges. (1914.) 15s. net.

The Design of Channels for Irrigation and Drainage. By R. B. Buckley. 22 diagrams, 56 pp., crown 8vo. (1911.) 2s. net.

The Irrigation Works of India. By R. B. Buckley. Second edition, with coloured maps and plans. 336 pp., 4to, cloth. (1905.) £2 2s. net.

Irrigated India. By Hon. Alfred Deakin. With Map, 322 pp., 8vo. (1893.) 8s. 6d.

Indian Storage Reservoirs, with Earthen Dams. By W. L. Strange. Second ed., 16 plates, 59 illus., xxiv + 442 pp., 8vo. (1913.) 21s. net.

The Irrigation of Mesopotamia. By Sir W. Willcocks. 2 vols., 46 plates, 136 pp. (Text super royal 8vo, plates folio.) (1911.) £1 net.

Egyptian Irrigation. By Sir W. Willcocks and J. I. Craig. In 2 Vols. Third edition, 81 plates, 183 illus., 900 pp., sup. roy. 8vo. (1913.) 42s. net.

The Nile Reservoir Dam at Assuân, and After. By Sir W. Willcocks. Second edition, 13 plates, 35 pp., super royal 8vo. (1903.) 3s. net.

The Assuân Reservoir and Lake Moeris. By Sir W. Willcocks. With text in English, French and Arabic. 5 plates, 116 pp., super royal 8vo. (1904.) 3s. net.

The Nile in 1904. By Sir W. Willcocks. 30 plates, 200 pp., super royal 8vo. (1904.) 5s. net.

LOGARITHM TABLES

Aldum's Pocket Folding Mathematical Tables. Four-figure Logarithms, and Anti-logarithms, Natural Sines, Tangents, Cotangents, Cosines, Chords and Radians for all angles from 1 to 90 degrees. And Decimalizer Table for Weights and Money. On folding card. 4d. net. 20 copies, 6s. net.

Tables of Seven-figure Logarithms of the Natural Numbers from 1 to 108,000. By C. Babbage. Stereotype edition, 224 pp., medium 8vo. 5s. net.

Four-Place Tables of Logarithms and Trigonometric Functions. By E. V. Huntington. Ninth thousand, 34 pp., square 8vo, limp buckram, with cut lateral index. (New York, 1911.) 3s. net.

Short Logarithmic and other Tables. By W. C. Unwin. Fourth edition, small 4to. 3s.

Logarithmic Land Measurement. By J. Wallace. 32 pp., royal 8vo. (1910.) 5s. net.

A B C Five-figure Logarithms with Tables, for Chemists. By C. J. Woodward. Crown 8vo. 2s. 6d. net.

A B C Five-figure Logarithms for general use, with lateral index for ready reference. By C. J. Woodward. Second edition, with cut lateral Index, 116 pp., 12mo, limp leather. 3s. net.

MARINE ENGINEERING AND NAVAL ARCHITECTURE

Marine Propellers. By S. W. Barnaby. Fifth edition, 5 plates, 56 illus., 185 pp., demy 8vo. (1908.) 10s. 6d. net.

The Suction Caused by Ships and the Olympic-Hawke Collision. By E. S. Bellasis. 1 chart and 5 illus. in text, 26 pp., 8vo, sewed. (1912.) 1s. net.

Yachting Hints, Tables and Memoranda. By A. C. Franklin. Waistcoat pocket size, 103 pp., 64mo, roan, gilt edges. 1s. net.

- Steamship Coefficients, Speeds and Powers.** By C. F. A. Fyfe. 31 plates, 280 pp., fcap. 8vo, leather. (1907.) 10s. 6d. net.
- How to Build a Speed Launch.** By E. W. Graef. 14 plates, 32 pp., quarto. (New York, 1903.) 4s. 6d. net.
- Steamships and Their Machinery, from first to last.** By J. W. C. Haldane. 120 illus., 532 pp., 8vo. (1893.) 15s.
- Tables for Constructing Ships' Lines.** By A. Hogg. Third edition, 3 plates, 20 pp., 8vo, sewed. (1911.) 3s. net.
- Tabulated Weights of Angle, Tee, Bulb, Round, Square, and Flat Iron and Steel for the use of Naval Architects, Shipbuilders, etc.** By C. H. Jordan. Sixth edition, 640 pp., royal 32mo, leather, gilt edges. (1909.) 7s. 6d. net.
- Particulars of Dry Docks, Wet Docks, Wharves, etc., on the River Thames.** Compiled by C. H. Jordan. Second edition, 7 coloured charts, 103 pp., oblong 8vo. (1904.) 2s. 6d. net.
- Marine Transport of Petroleum.** By H. Little. 66 illus., 263 pp., crown 8vo. (1890.) 10s. 6d.
- Questions and Answers for Marine Engineers, with a Practical Treatise on Breakdowns at Sea.** By T. Lucas. 12 folding plates, 515 pp., gilt edges, crown 8vo. (New York, 1902.) 8s. net.
- How to Build a Motor Launch.** By C. D. Mower. 49 illus., 42 pp., 4to. (New York, 1904.) 4s. 6d. net.
- Reed's Engineers' Handbook to the Board of Trade Examinations for certificates of Competency as First and Second Class Engineers.** Nineteenth edition, 37 plates, 358 illus., 696 pp., 8vo. 14s. net.
- Key to Reed's Handbook.** 7s. 6d. net.
- Reed's Marine Boilers.** Third edition, 79 illus., 258 pp., crown 8vo. (1905.) 4s. 6d. net.
- Reed's Useful Hints to Sea-going Engineers.** Fourth edition, 8 plates, 50 illus., 312 pp., crown 8vo. (1903.) 3s. 6d. net.
- How to Build a Three-horse Power Launch Engine.** By E. W. Roberts. 14 plates, 66 pp., folio. (New York, 1901.) 10s. 6d. net.

MATERIALS

- Practical Treatise on the Strength of Materials.** By T. Box. Fourth edition, 27 plates, 536 pp., 8vo. (1902.) 12s. 6d. net.
- Solid Bitumens.** By S. F. Peckham. 23 illus., 324 pp., 8vo. (New York, 1909.) £1 1s. net.
- Lubricants, Oils and Greases.** By I. I. Redwood. 3 plates, ix + 54 pp., 8vo. (1898.) 6s. 6d. net.
- Practical Treatise on Mineral Oils and their By-Products.** By I. I. Redwood. 76 illus., 336 pp., 8vo. (1914.) 10s. 6d. net.
- Silico-Calcareous Sandstones, or Building Stones from Quartz, Sand and Lime.** By E. Stoffler. 5 plates, 8vo, sewed. (1901.) 4s. net.
- Proceedings of the Fifth Congress, International Association for Testing Materials.** English edition. 189 illus., 549 pp., 8vo. (1910.) 18s. net.
- Proceedings of the Sixth Congress.** (1913.) 30s. net.

MATHEMATICS

- Imaginary Quantities.** By M. Argand. Translated by Prof. Hardy. 18mo, boards. (New York.) 1881. 2s. net.
- Text-book of Practical Solid Geometry.** By E. H. de V. Atkinson. Revised by Major B. R. Ward, R.E. Second edition, 17 plates, 134 pp., 8vo. (1913.) 7s. 6d.
- Quick and Easy Methods of Calculating, and the Theory and Use of the Slide Rule.** By R. G. Blaine. Fourth edition, 6 illus., xii + 152 pp., 16mo. (1912.) 2s. 6d. net.
- Symbolic Algebra, or the Algebra of Algebraic Numbers.** By W. Cain. 12 illus., 131 pp., 18mo, boards. (New York, 1884.) 2s. net.
- Nautical Astronomy.** By J. H. Colvin. 127 pp., crown 8vo. (1901.) 2s. 6d. net.
- Chemical Problems.** By J. C. Foye. Fourth edition, 141 pp., 18mo, boards. (New York, 1898.) 2s. net.
- Primer of the Calculus.** By E. S. Gould. Fifth ed., 24 illus., 122 pp., 18mo, boards. (New York, 1912.) 2s. net.
- Elementary Treatise on the Calculus for Engineering Students.** By J. Graham. Fourth edition, 116 illus., xii + 355 pp., cr. 8vo. (1914.) 5s. net.

- Manual of the Slide Rule.** By **F. A. Halsey.** Second edition, 31 illus., 84 pp., 18mo, boards. (*New York, 1901.*) 2s. net.
- Reform in Chemical and Physical Calculations.** By **C. J. T. Hanssen.** 4to. (1897.) 6s. 6d. net.
- Algebra Self-Taught.** By **P. Higgs.** Third edition, 104 pp., crown 8vo. (1903.) 2s. 6d.
- A Text-book on Graphic Statics.** By **C. W. Malcolm.** 155 illus., 316 pp., 8vo. (*New York, 1909.*) 12s. 6d. net.
- Galvanic Circuit Investigated Mathematically.** By **G. S. Ohm.** Translated by **William Francis.** 269 pp., 18mo, boards. Second ed. (*New York, 1905.*) 2s. net.
- Elementary Practical Mathematics.** By **M. T. Ormsby.** Second edition, 128 illus., xii + 410 pp., medium 8vo. (1911.) 5s. net.
- Elements of Graphic Statics.** By **K. Von Ott.** Translated by **G. S. Clarke.** 95 illus., 128 pp., crown 8vo. (1901.) 5s.
- Figure of the Earth.** By **F. C. Roberts.** 2 illus., 95 pp., 18mo, boards. (*New York, 1885.*) 2s. net.
- Arithmetic of Electricity.** By **T. O'C. Sloane.** Twentieth ed., 5 illus., 162 pp., crown 8vo. (*New York, 1909.*) 4s. 6d. net.
- Graphic Method for Solving certain Questions in Arithmetic or Algebra.** By **G. L. Vose.** Second edition, 28 illus., 62 pp., 18mo, boards. (*New York, 1902.*) 2s. net.
- Problems in Electricity.** A Graduated Collection comprising all branches of Electrical Science. By **R. Weber.** Translated from the French by **E. A. O'Keefe.** 34 illus., 366 pp., crown 8vo. Third ed. (1902.) 7s. 6d. net.

MECHANICAL ENGINEERING

Steam Engines and Boilers, etc.

- Engineers' Sketch Book of Mechanical Movements.** By **T. W. Barber.** Fifth edition, 3,000 illus., 355 pp., 8vo. (1906.) 10s. 6d. net.
- The Repair and Maintenance of Machinery.** By **T. W. Barber.** 417 illus., 476 pp., 8vo. (1895.) 10s. 6d.
- The Science of Burning Liquid Fuel.** By **William Newton Best.** 100 illus., 159 pp. 8vo. (1913.) 9s. net.
- Practical Treatise on Mill Gearing.** By **T. Box.** Fifth edition, 11 plates, 128 pp., crown 8vo. (1892.) 7s. 6d.

- The Mechanical Engineer's Price Book.** Edited by **Geoffrey Brooks**, A.M.I.Mech.E. 182 pp., pocket size ($6\frac{1}{2}$ by $3\frac{1}{2}$ by $\frac{1}{8}$ inch). Leather cloth with rounded corners. Second ed. (1914.) 4s. net. Postage 3d.
- Safety Valves.** By **R. H. Buell**. Third edition, 20 illus., 100 pp., 18mo, boards. (New York, 1898.) 2s. net.
- Machine Design.** By Prof. **W. L. Cathcart**.
Part I. FASTENINGS. 123 illus., 291 pp., demy 8vo. (New York, 1903.) 12s. 6d. net.
- Chimney Design and Theory.** By **W. W. Christie**. Second edition, 54 illus., 192 pp., crown 8vo. (New York, 1902.) 12s. 6d. net.
- Furnace Draft: its Production by Mechanical Methods.** By **W. W. Christie**. 5 illus., 80 pp., 18mo, boards. Second edition. (New York, 1906.) 2s. net.
- The Stokers' Catechism.** By **W. J. Connor**. 63 pp., limp. (1914.) 1s. net.
- Treatise on the use of Belting for the Transmission of Power.** By **J. H. Cooper**. Fifth edition, 94 illus., 399 pp., demy 8vo. (New York, 1901.) 12s. 6d. net.
- The Steam Engine considered as a Thermo-dynamic Machine.** By **J. H. Cotterill**. Third edition, 39 diagrams, 444 pp., 8vo. (1896.) 15s.
- Fireman's Guide, a Handbook on the Care of Boilers.** By **K. P. Dahlstrom**. Eleventh edition, fcap. 8vo. (S. & C. SERIES, No. 16.) (New York, 1906.) 1s. 6d. net.
- Heat for Engineers.** By **C. R. Darling**. Second edition, 110 illus., 430 pp., 8vo. (FINSBURY TECHNICAL MANUAL.) (1912.) 12s. 6d. net.
- Belt Driving.** By **G. Halliday**. 3 folding plates, 100 pp., 8vo. (1894.) 3s. 6d.
- Worm and Spiral Gearing.** By **F. A. Halsey**. 13 plates, 85 pp., 18mo, boards. Second ed. (New York, 1911.) 2s. net.
- Commercial Efficiency of Steam Boilers.** By **A. Hanssen**. Large 8vo, sewed. (1898.) 6d.
- Corliss Engine.** By **J. T. Henthorn**. Third edition, 23 illus., 95 pp., crown 8vo. (S. & C. SERIES, No. 23.) (New York, 1910.) 1s. 6d. net.
- Liquid Fuel for Mechanical and Industrial Purposes.** By **E. A. Brayley Hodgotts**. 106 illus., 129 pp., 8vo. (1890.) 5s.

Elementary Text-book on Steam Engines and Boilers.

By **J. H. Kinealy**. Fourth edition, 106 illus., 259 pp., 8vo.
(*New York, 1903.*) 8s. 6d. net.

Centrifugal Fans. By **J. H. Kinealy**. 33 illus., 206 pp., fcap.
8vo, leather. (*New York, 1905.*) 12s. 6d. net.

Mechanical Draft. By **J. H. Kinealy**. 27 original tables
and 13 plates, 142 pp., crown 8vo. (*New York, 1906.*)
8s. 6d. net.

The A B C of the Steam Engine, with a description of the
Automatic Governor. By **J. P. Lisk**. 6 plates, 8vo.
(S. & C. SERIES, No. 17.) (*New York, 1910.*) 1s. 6d. net.

Valve Setting Record Book. By **P. A. Low**. 8vo, boards.
1s. 6d.

The Lay-out of Corliss Valve Gears. By **S. A. Moss**.
Second edition, 3 plates, 108 pp., 18mo, boards. (*New
York, 1906.*) 2s. net.

Steam Boilers, their Management and Working. By **J.
Peattie**. Fifth edition, 35 illus., 230 pp., crown 8vo.
(*1906.*) 4s. 6d. net.

Treatise on the Richards Steam Engine Indicator. By
C. T. Porter. Sixth edition, 3 plates and 73 diagrams,
285 pp., 8vo. (*1902.*) 9s.

Practical Treatise on the Steam Engine. By **A. Rigg**.
Second edition, 103 plates, 378 pp., demy 4to. (*1894.*)
£1 5s.

Power and its Transmission. A Practical Handbook for
the Factory and Works Manager. By **T. A. Smith**.
76 pp., fcap. 8vo. (*1910.*) 2s. net.

Slide Valve Simply Explained. By **W. J. Tennant**. Re-
vised by **J. H. Kinealy**. 41 illus., 83 pp., crown 8vo. (*New
York, 1899.*) 2s. net.

Shaft Governors. By **W. Trinks** and **C. Hoosum**. 27 illus.,
97 pp., 18mo, boards. (*New York, 1906.*) 2s. net.

Treatise on the Design and Construction of Mill Buildings.
By **H. G. Tyrrell**. 652 illus., 490 pp., 8vo. (*New York,
1911.*) 17s. net.

Slide and Piston Valve Geared Steam Engines. By **W. H.
Uhland**. 47 plates and 314 illus., 155 pp. Two vols.,
folio, half morocco. (*1882.*) £1 16s.

- How to run Engines and Boilers.** By E. P. Watson. Sixth ed., 31 illus., 160 pp., 8vo. (*New York, 1913.*) 4s. 6d. net.
- Position Diagram of Cylinder with Meyer Cut-off.** By W. H. Weightman. On card. (*New York.*) 1s. net.
- Practical Method of Designing Slide Valve Gearing.** By E. J. Welch. 69 illus., 283 pp., crown 8vo. (*1890.*) 6s.
- Elements of Mechanics.** By T. W. Wright. Eighth edition, 215 illus., 382 pp., 8vo. (*New York, 1909.*) 10s. 6d. net.

METALLURGY

Iron and Steel Manufacture

- Life of Railway Axles.** By T. Andrews. 8vo, sewed (*1895.*) 1s.
- Microscopic Internal Flaws in Steel Rails and Propeller Shafts.** By T. Andrews. 8vo, sewed. (*1896.*) 1s.
- Microscopic Internal Flaws, Inducing Fracture in Steel.** By T. Andrews. 8vo, sewed. (*1896.*) 2s.
- Practical Alloying.** A compendium of Alloys and Processes for Brassfounders, Metal Workers, and Engineers. By John F. Buchanan. 41 illus., 205 pp., 8vo. (*New York, 1911.*) 10s. 6d. net.
- Brassfounders' Alloys.** By J. F. Buchanan. 23 illus., viii + 129 pp., crown 8vo. (*1905.*) 4s. 6d. net.
- The Moulder's Dictionary** (Foundry Nomenclature). By J. F. Buchanan. New impression, 26 illus., viii + 225 pp., crown 8vo. (*1912.*) 3s. net.
- American Standard Specifications for Steel.** By A. L. Colby. Second edition, revised, 103 pp., crown 8vo. (*New York, 1902.*) 5s. net.
- Galvanized Iron : its Manufacture and Uses.** By J. Davies. 139 pp., 8vo. (*1914.*) 5s. net.
- Management of Steel.** By G. Ede. Seventh edition, 216 pp., crown 8vo. (*1903.*) 5s.
- The Frodair Handbook for Ironfounders.** 160 pp., 12mo. (*1910.*) 2s. net.
- Manufacture of Iron and Steel.** By H. R. Hearson. 21 illus., xii + 103 pp., 8vo. (*1912.*) 4s. 6d. net.
- Cupola Furnace.** By E. Kirk. Third edition, 106 illus., 484 pp., 8vo. (*New York, 1910.*) 15s. net.

Practical Notes on Pipe Founding. By J. W. Macfarlane. 15 plates, 148 pp., 8vo. (1888.) 12s. 6d.

Atlas of Designs concerning Blast Furnace Practice. By M. A. Pavloff. 127 plates, 14 in. by 10½ in. oblong, sewed. (1902.) £1 is. net.

Album of Drawings relating to the Manufacture of Open Hearth Steel. By M. A. Pavloff.

Part I. OPEN HEARTH FURNACES. 52 plates, 14 in. by 10½ in. oblong folio, in portfolio. (1904.) 12s. net.

Metallography Applied to Siderurgic Products. By H. Savoia. Translated by R. G. Corbet. 94 illus., 180 pp., crown 8vo. (1910.) 4s. 6d. net.

Modern Foundry Practice. By J. Sharp. Second edition, new impression, 272 illus., 759 pp., 8vo. (1911.) £1 is. net.

Roll Turning for Sections in Steel and Iron. By A. Spencer. Second edition, 78 plates, 4to. (1894.) £1 10s.

METRIC TABLES

French Measure and English Equivalents. By J. Brook. Second edition, 80 pp., fcap. 32mo, roan. 1s. net.

A Dictionary of Metric and other useful Measures. By L. Clark. 113 pp., 8vo. (1891.) 6s.

English Weights, with their Equivalents in kilogrammes. By F. W. A. Logan. 96 pp., fcap. 32mo, roan. 1s. net.

Metric Weights with English Equivalents. By H. P. McCartney. 84 pp., fcap. 32mo, roan. 1s. net.

Metric Tables. By Sir G. L. Molesworth. Fourth edition, 95 pp., royal 32mo. (1909.) 2s. net.

Metric-English and English-Metric Lengths. By G. A. Rossetti. xii + 80 pp., ob. 32mo. 1s. net. Giving equivalents in millimetres (to five significant figures) of all English lengths from $\frac{1}{8}$ th of an inch to 10 ft., advancing by 64ths of an inch; and equivalents to the nearest 64th of an inch of all Metric lengths from 1 to 3,200 millimetres advancing by millimetres.

Tables for Setting out Curves from 200 metres to 4,000 metres by tangential angles. By H. Williamson. 4 illus., 60 pp., 18mo. 2s. net.

MINERALOGY AND MINING

- Rock Blasting.** By G. G. Andre. 12 plates and 56 illus. in text, 202 pp., 8vo. (1878.) 5s.
- Practical Treatise on Hydraulic Mining in California.** By A. J. Bowie, Junr. Eleventh ed., 73 illus., 313 pp., royal 8vo. (*New York, 1910.*) £1 1s. net.
- Tables for the Determination of Common Rocks.** By O. Bowles. 64 pp., 18mo, boards. (*New York, 1910.*) 2s. net.
- Fire Assaying.** By E. W. Buskett. 69 illus., 105 pp., crown 8vo. (*New York, 1907.*) 4s. 6d. net.
- Tin :** Describing the Chief Methods of Mining, Dressing, etc. By A. G. Charleton. 15 plates, 83 pp., crown 8vo. (1884.) 12s. 6d.
- Gold Mining and Milling in Western Australia, with Notes upon Telluride Treatment, Costs and Mining Practice in other Fields.** By A. G. Charleton. 82 illus. and numerous plans and tables, 648 pp., super royal 8vo. (1903.) 12s. 6d. net.
- Miners' Geology and Prospectors' Guide.** By G. A. Corder. 29 plates, 224 pp., crown 8vo. (1914.) 5s. net.
- Blasting of Rock in Mines, Quarries, Tunnels, etc.** By A. W. and Z. W. Daw. Second edition, 90 illus., 316 pp., demy 8vo. (1909.) 15s. net.
- Gold Dredging.** By C. T. Earl. 17 maps, 78 illus., xvi + 208 pp., 8vo. (1913.) 20s. net.
- Handbook of Mineralogy ;** determination and description of Minerals found in the United States. By J. C. Foye. 180 pp., 18mo, boards. Fifth ed. (*New York, 1907.*) 2s. net.
- Our Coal Resources at the End of the Nineteenth Century.** By Prof. E. Hull. 157 pp., demy 8vo. (1897.) 6s.
- Hydraulic Gold Miners' Manual.** By T. S. G. Kirkpatrick. Second edition, 12 illus., 46 pp., crown 8vo. (1897.) 4s.
- Economic Mining.** By C. G. W. Lock. 175 illus., 680 pp., 8vo. (1895.) 10s. 6d. net.
- Gold Milling :** Principles and Practice. By C. G. W. Lock. 200 illus., 850 pp., demy 8vo. (1901.) £1 1s. net.
- Mining and Ore-Dressing Machinery.** By C. G. W. Lock. 639 illus., 466 pp., super royal 4to. (1890.) £1 5s.

- Miners' Pocket Book.** By C. G. W. Lock. Fifth edition, 233 illus., 624 pp., fcap. 8vo, leather, gilt edges. (1908.) 10s. 6d. net.
- Chemistry, Properties and Tests of Precious Stones.** By J. Mastin. 114 pp., fcap. 16mo, limp leather, gilt top. (1911.) 2s. 6d. net.
- Tests for Ores, Minerals and Metals of Commercial Value.** By R. L. McMechen. 152 pp., 12mo. (*New York, 1907.*) 5s. 6d. net.
- Practical Handbook for the Working Miner and Prospector, and the Mining Investor.** By J. A. Miller. 34 illus., 234 pp., crown 8vo. (1897.) 7s. 6d.
- Theory and Practice of Centrifugal Ventilating Machines.** By D. Murgue. 7 illus., 81 pp., 8vo. (1883.) 5s.
- Examples of Coal Mining Plant.** By J. Povey-Harper. Second edition, 40 plates, 26 in. by 20 in. (1895.) £4 4s. net.
- Examples of Coal Mining Plant, Second Series.** By J. Povey-Harper. 10 plates, 26 in. by 20 in. (1902.) £1 12s. 6d. net.

MODELS AND MODEL MAKING

- How to Build a Model Yacht.** By H. Fisher. 45 illus., 50 pp., 4to. (*New York, 1902.*) 4s. 6d. net.
- Model Engines and Small Boats.** By N. M. Hopkins. 50 illus., viii+74 pp., crown 8vo. (*New York, 1898.*) 5s. 6d. net.
- Theory and Practice of Model Aeroplaning.** By V. E. Johnson. 61 illus., xvi + 148 pp., crown 8vo. (1910.) 3s. 6d. net.
- The Model Vaudeville Theatre.** By N. H. Schneider. 34 illus., 90 pp., crown 8vo. (S. & C. SERIES, No. 15.) (*New York, 1910.*) 1s. 6d. net.
- Electric Toy-Making.** By T. O. Sloane. Twentieth ed., 70 illus., 183 pp., crown 8vo. (*New York, 1914.*) 4s. 6d. net.
- Model Steam Engine Design.** By R. M. De Vignier. 34 illus., 94 pp., crown 8vo, limp. (S. & C. SERIES, No. 9.) (*New York, 1907.*) 1s. 6d. net.
- Small Engines and Boilers.** By E. P. Watson. 33 illus., viii + 108 pp., crown 8vo. (*New York, 1899.*) 5s. 6d. net.

ORGANIZATION

Accounts, Contracts and Management

- Organization of Gold Mining Business**, with Specimens of the Departmental Report Books and the Account Books. By **Nicol Brown**. Second edition, 220 pp., fcap. folio. (1903.) £1 5s. net.
- Cost Keeping and Management Engineering**. A Treatise for those engaged in Engineering Construction. By **H. P. Gillette** and **R. T. Dana**. 184 illus., 346 pp., 8vo. (*New York, 1909.*) 15s. net. .
- Handbook on Railway Stores Management**. By **W. O. Kempthorne**. 268 pp., demy 8vo. (1907.) 10s. 6d. net.
- Depreciation of Factories, Municipal, and Industrial Undertakings, and their Valuation**. By **E. Matheson**. Fourth edition, 230 pp., 8vo. (1910.) 10s. 6d. net.
- Aid Book to Engineering Enterprise**. By **E. Matheson**. Third edition, 916 pp., 8vo, buckram. (1898.) £1 4s.
- Office Management**. A handbook for Architects and Civil Engineers. By **W. Kaye Parry**. *New Edition in preparation.*
- Commercial Organization of Engineering Factories**. By **H. Spencer**. 92 illus., 221 pp., 8vo. (1914.) 10s. 6d. net.

PHYSICS

Colour, Heat and Experimental Science

- The Entropy Diagram and its Applications**. By **M. J. Boulvin**. 38 illus., 82 pp., demy 8vo. (1914.) 5s.
- Physical Problems and their Solution**. By **A. Bourgougnon**. 224 pp., 18mo, boards. Second ed. (*New York, 1904.*) 2s. net.
- Heat for Engineers**. By **C. R. Darling**. Second edition, 110 illus., 430 pp., 8vo. (FINSBURY TECHNICAL MANUAL.) (1912.) 12s. 6d. net.
- Beaumé and Specific Gravity Tables for liquids lighter than water**. By **Nat H. Freeman**. 27 pp., cr. 8vo. (1914.) 2s. 6d. net. Post free, 2s. 8d.
- Engineering Thermodynamics**. By **C. F. Hirschfeld**. 22 illus., 157 pp., 18mo, boards. Second ed. (*New York, 1910.*) 2s. net.

- The Dynamics of Surfaces:** An introduction to the study of Biological Surface Phenomena. By **Prof. Dr. Med. Leonor Michaelis**. Privatdozent in the University of Berlin. Translated by W. H. Perkins, M.Sc. Demy 8vo, 118 pp., 8 illus. (1914.) 4s. net. Postage, inland, 3d.; abroad, 6d.
- Experimental Science:** Elementary, Practical and Experimental Physics. By **G. M. Hopkins**. Twenty-third edition, 920 illus., 1,100 pp., 8vo. (*New York, 1902.*) £1 1s. net.
- Reform in Chemical and Physical Calculations.** By **C. J. T. Hanssen**. Demy 4to. (1897.) 6s. 6d. net.
- The Gyroscope, an Experimental Study.** By **V. E. Johnson**. 34 illus., 40 pp., cr. 8vo. (S. & C. SERIES, No. 22.) (1911.) 1s. 6d. net.
- The Gyroscope.** By **F. J. B. Cordeiro**, Author of "The Atmosphere," etc., etc. 19 illus., viii + 105 pp., cr. 8vo. (*New York, 1913.*) 6s. 6d. net.
- Introduction to the Study of Colour Phenomena.** By **J. W. Lovibond**. 10 coloured plates, 48 pp., 8vo. (1905.) 5s. net.
- The Energy Chart.** Practical application to reciprocating steam-engines. By **Captain H. R. Sankey**. 157 illus., 170 pp., 8vo. (1907.) 7s. 6d. net.

PRICE BOOKS

- The Mechanical Engineers' Price Book.** By **G. Brooks**. 200 pp., pocket size (6½ in. by 3¾ in. by ½ in. thick), leather cloth, with rounded corners. 4s. net.
- Approximate Estimates.** By **T. E. Coleman**. Fourth edition, 481 pp., oblong 32mo, leather. (1914.) 5s. net.
- The Civil Engineers' Cost Book.** By **Major T. E. Coleman**. xii + 289 pp., pocket size (6½ in. by 3¾ in.), leather cloth. (1912.) 5s. net.
- Railway Stores Price Book.** By **W. O. Kempthorne**. 490 pp., demy 8vo. (1909.) 10s. 6d. net.
- Spons' Architects' and Builders' Pocket Price-Book.** Edited by **Clyde Young**. Revised by **Stanford M. Brooks**. Forty-first ed., viii + 308 pp., green leather cloth. Published annually. (Size 6½ in. by 3¾ in. by ½ in. thick.) 2s. 6d. net.
- Handbook of Cost Data for Contractors and Engineers.** By **H. P. Gillette**. 1,854 pp., crown 8vo, leather, gilt edges. Second ed. (*New York, 1914.*) £1 1s. net.

RAILWAY ENGINEERING AND MANAGEMENT

- Practical Hints to Young Engineers Employed on Indian Railways.** By A. W. C. Addis. 14 illus., 154 pp., 12mo. (1910.) 3s. 6d. net.
- Up-to-date Air Brake Catechism.** By R. H. Blackall. Twenty-fifth edition, 5 coloured plates, 96 illus., 305 pp., crown 8vo. (*New York, 1913.*) 8s. 6d. net.
- Prevention of Railroad Accidents, or Safety in Railroading.** By Geo. Bradshaw. 64 illus., 173 pp., square crown 8vo. (*New York, 1912.*) 2s. 6d. net.
- Simple and Automatic Vacuum Brakes.** By C. Briggs, G.N.R. 11 plates, 8vo. (1892.) 4s.
- Notes on Permanent-way Material, Plate-laying, and Points and Crossings.** By W. H. Cole. Sixth edition, revised, 44 illus. in 39 plates, 203 pp., crown 8vo. (1912.) 7s. 6d. net.
- Railway Engineers' Field Book.** By Major G. R. Hearn, R.E., Assoc. Inst. Civil Engrs., and A. G. Watson, C.E. 12mo, leather, 230 pp., 33 illus. (1914.) 21s. net. Postage, inland, 3d.; abroad, 6d.
- Statistical Tables of the Working of Railways in various countries up to the year 1904.** By J. D. Diacomidis. Second edition, 84 pp., small folio, sewed. (1906.) 16s. net.
- Locomotive Breakdowns, Emergencies and their Remedies.** By Geo. L. Fowler, M.E., and W. W. Wood. Seventh ed., 92 illus., 266 pp., 12mo. (*New York, 1911.*) 4s. 6d. net.
- Permanent-way Diagrams.** By F. H. Frere. Mounted on linen in cloth covers. (1908.) 3s. net.
- Formulæ for Railway Crossings and Switches.** By J. Glover. 9 illus., 28 pp., royal 32mo. (1896.) 2s. 6d.
- Setting out of Tube Railways.** By G. M. Halden. 9 plates, 46 illus., 68 pp., crown 4to. (1914.) 10s. 6d. net.
- Railway Engineering, Mechanical and Electrical.** By J. W. C. Haldane. New edition, 141 illus., xx + 583 pp., 8vo. (1908.) 15s.
- The Construction of the Modern Locomotive.** By G. Hughes. 300 illus., 261 pp., 8vo. (1894.) 9s.

- Practical Hints for Light Railways at Home and Abroad.**
By F. R. Johnson. 6 plates, 31 pp., crown 8vo. (1896.)
2s. 6d.
- Handbook on Railway Stores Management.** By W. O. Kempthorne. 268 pp., demy 8vo. (1907.) 10s. 6d. net.
- Railway Stores Price Book.** By W. O. Kempthorne. 490 pp., demy 8vo. (1909.) 10s. 6d. net.
- Railroad Location Surveys and Estimates.** By F. Lavis. 68 illus, 270 pp., 8vo. (New York, 1906.) 12s. 6d. net.
- Pioneering.** By F. Shelford. 14 illus., 88 pp., crown 8vo. (1909.) 3s. net.
- Handbook on Railway Surveying for Students and Junior Engineers.** By B. Stewart. 55 illus., 98 pp., crown 8vo. (1914.) 2s. 6d. net.
- Modern British Locomotives.** By A. T. Taylor. 100 diagrams of principal dimensions, 118 pp., oblong 8vo. Second ed. (1914.) 4s. 6d. net.
- Locomotive Slide Valve Setting.** By C. E. Tully. Illustrated, 18mo. 1s. net.
- The Railway Goods Station.** By F. W. West. 23 illus., xv + 192 pp., crown 8vo. (1912.) 4s. 6d. net.
- The Walschaert Locomotive Valve Gear.** By W. W. Wood. 4 plates and set of movable cardboard working models of the valves, 193 pp., crown 8vo. Third ed. (New York, 1913.) 6s. 6d. net.
- The Westinghouse E.T. Air-Brake Instruction Pocket Book.** By W. W. Wood. 48 illus., including many coloured plates, 242 pp., crown 8vo. (New York, 1909.) 8s. 6d. net.

SANITATION, PUBLIC HEALTH AND MUNICIPAL ENGINEERING

- Engineering Work in Public Buildings.** By R. O. Allsop. 77 illus., ix + 158 pp., demy 4to. (1912.) 12s. 6d. net.
- Public Abattoirs, their Planning, Design and Equipment.** By R. S. Ayling. 33 plates, 100 pp., demy 4to. (1908.) 8s. 6d. net.
- Sewage Purification.** By E. Bailey-Denton. 8 plates, 44 pp., 8vo. (1896.) 5s.

- Water Supply and Sewerage of Country Mansions and Estates.** By E. Bailey-Denton. 76 pp., crown 8vo. (1901.) 2s. 6d. net.
- Sewerage and Sewage Purification.** By M. N. Baker. Second edition, 144 pp., 18mo, boards. (*New York, 1905.*) 2s. net.
- Bacteriology of Surface Waters in the Tropics.** By W. W. Clemesha. viii + 161 pp., 8vo. (*Calcutta, 1912.*) 7s. 6d. net.
- Housing and Town-Planning Conference, 1913.** Being a Report of a Conference held by the **Institution of Municipal and County Engineers** at Great Yarmouth. Edited by T. Cole. 42 folding plates, 227 pp., 8vo. 10s. 6d. net.
- Housing and Town Planning Conference, 1911.** Report of Conference held by the **Institution of Municipal and County Engineers** at West Bromwich. Edited by T. Cole, Secretary. 30 plates, 240 pp., 8vo. 10s. 6d. net
- Sanitary House Drainage, its Principles and Practice.** By T. E. Coleman. 98 illus., 206 pp., crown 8vo. (1896.) 3s. 6d. net.
- Stable Sanitation and Construction.** By T. E. Coleman. 183 illus., 226 pp., crown 8vo. (1897.) 3s. net.
- Discharge of Pipes and Culverts.** By P. M. Crosthwaite. Large folding sheet in case. 2s. 6d. net.
- A Complete and Practical Treatise on Plumbing and Sanitation.** By G. B. Davis and F. Dye. 2 vols., 637 illus. and 21 folding plates, 830 pp., 4to, cloth. (1899.) £1 10s. net.
- Standard Practical Plumbing.** By P. J. Davies.
Vol. I. Fourth edition, 768 illus., 355 pp., royal 8vo. (1905.) 7s. 6d. net.
Vol. II. Second edition, 953 illus., 805 pp. (1905.) 10s. 6d. net.
Vol. III. 313 illus., 204 pp. (1905.) 5s. net.
- Conservancy, or Dry Sanitation versus Water Carriage.** By J. Donkin. 7 plates, 33 pp., 8vo, sewed. (1906.) 1s. net.
- Sewage Disposal Works.** By W. C. Easdale. 160 illus., 264 pp., 8vo. (1910.) 10s. 6d. net.

- House Drainage and Sanitary Plumbing.** By **W. P. Gerhard.** Eleventh ed., 6 illus., 231 pp., 18mo, boards. (*New York, 1905.*) 2s. net.
- The Treatment of Septic Sewage.** By **G. W. Rafter.** 137 pp., 18mo, boards. Second ed. (*New York, 1907.*) 2s. net.
- Reports and Investigations on Sewer Air and Sewer Ventilation.** By **R. H. Reeves.** 8vo, sewed. (*1894.*) 1s.
- Sewage Drainage Systems.** By **Isaac Shone.** 27 folding plates, 47 illus., 440 pp., 8vo. (*1914.*) 25s. net.
- Drainage and Drainage Ventilation Methods.** By **Isaac Shone, C.E.** 7 folding plates, 36 pp., 8vo, leather. (*1913.*) 6s. net.
- The Law and Practice of Paving Private Street Works.** By **W. Spinks.** Fourth edition, 256 pp., 8vo. (*1904.*) 12s. 6d. net.

STRUCTURAL DESIGN

(See Bridges and Roofs)

TELEGRAPH CODES

- New Business Code.** 320 pp., narrow 8vo. (Size $4\frac{3}{4}$ in. by $7\frac{3}{4}$ in. and $\frac{1}{2}$ in. thick, and weight 10 oz.) (*New York, 1909.*) £1 1s. net.
- Miners' and Smelters' Code** (formerly issued as the **Master Telegraph Code**). 448 pp., 8vo, limp leather, weight 14 oz. (*New York, 1899.*) £2 10s. net.
- General Telegraph Code.** Compiled by the **Business Code Co.** 1,023 pp., small 4to, with cut side index for ready reference. (*New York, 1912.*) 63s. net. Postage, inland, 6d.; abroad, 1s. 4d.
- Billionaire Phrase Code,** containing over two million sentences coded in single words. 56 pp., 8vo, leather. (*New York, 1908.*) 6s. 6d. net.

WARMING AND VENTILATION

- Heat for Engineers.** By **C. R. Darling.** Second edition, 110 illus., 430 pp., 8vo. (**FINSBURY TECHNICAL MANUAL.**) (*1912.*) 12s. 6d. net.

- Hot Water Supply.** By F. Dye. Fifth edition, new impression, 48 illus., viii + 86 pp., 8vo. (1912.) 3s. net.
- A Practical Treatise upon Steam Heating.** By F. Dye. 129 illus., 246 pp., 8vo. (1901.) 10s. net.
- Practical Treatise on Warming Buildings by Hot Water.** By F. Dye. 192 illus., 319 pp., 8vo. (1905.) 8s. 6d. net.
- Charts for Low Pressure Steam Heating.** By J. H. Kinealy. Small folio. (*New York.*) 4s. 6d.
- Formulæ and Tables for Heating.** By J. H. Kinealy. 18 illus., 53 pp., 8vo. (*New York, 1899.*) 3s. 6d.
- Centrifugal Fans.** By J. H. Kinealy. 33 illus., 206 pp., fcap. 8vo, leather. (*New York, 1905.*) 12s. 6d. net.
- Mechanical Draft.** By J. H. Kinealy. 27 original tables and 13 plates, 142 pp., crown 8vo. (*New York, 1906.*) 8s. 6d. net.
- Theory and Practice of Centrifugal Ventilating Machines.** By D. Murgue. 7 illus., 81 pp., 8vo. (1883.) 5s.
- Mechanics of Ventilation.** By G. W. Rafter. Third ed., 143 pp., 18mo, boards. (*New York, 1912.*) 2s. net.
- Principles of Heating.** By W. G. Snow. New edition, 59 illus., xii + 224 pp., 8vo. (*New York, 1912.*) 9s. net.
- Furnace Heating.** By W. G. Snow. Fourth edition, 52 illus., 216 pp., 8vo. (*New York, 1909.*) 6s. 6d. net.
- Ventilation of Buildings.** By W. G. Snow and T. Nolan. 83 pp., 18mo, boards. (*New York, 1906.*) 2s. net.
- Heating Engineers' Quantities.** By W. L. White and G. M. White. 4 plates, 33 pp., folio. (1910.) 10s. 6d. net.

WATER SUPPLY

(See also Hydraulics)

- Potable Water and Methods of Testing Impurities.** By M. N. Baker. 97 pp., 18mo, boards. Second ed. (*New York, 1905.*) 2s. net.
- Manual of Hydrology.** By N. Beardmore. New impression, 18 plates, 384 pp., 8vo. (1914.) 10s. 6d. net.
- Boiler Waters, Scale, Corrosion and Fouling.** By W. W. Christie. 77 illus., 235 pp., 8vo. (*New York, 1907.*) 12s. 6d. net.

- Bacteriology of Surface Waters in the Tropics.** By W. W. Clemesha. 12 tables, viii + 161 pp., 8vo. (*Calcutta, 1912.*) 7s. 6d. net.
- Water Softening and Purification.** By H. Collet. Second edition, 6 illus., 170 pp., crown 8vo. (1908.) 5s. net.
- Treatise on Water Supply, Drainage and Sanitary Appliances of Residences.** By F. Colyer. 100 pp., crown 8vo. (1899.) 1s. 6d. net.
- Purification of Public Water Supplies.** By J. W. Hill. 314 pp., 8vo. (*New York, 1898.*) 10s. 6d.
- Well Boring for Water, Brine and Oil.** By C. Isler. Second edition, 105 illus., 296 pp., 8vo. (1911.) 10s. 6d. net.
- Method of Measuring Liquids Flowing through Pipes by means of Meters of Small Calibre.** By Prof. G. Lange. 1 plate, 16 pp., 8vo, sewed. (1907.) 6d. net.
- On Artificial Underground Water.** By G. Richert. 16 illus., 33 pp., 8vo, sewed. (1900.) 1s. 6d. net.
- Notes on Water Supply in new Countries.** By F. W. Stone. 18 plates, 42 pp., crown 8vo. (1888.) 5s.
- The Principles of Waterworks Engineering.** By J. H. T. Tudsbery and A. W. Brightmore. Third edition, 13 folding plates, 130 illus., 447 pp., demy 8vo. (1905.) £1 1s. net.

WORKSHOP PRACTICE

For Art Workers and Mechanics

- Alphabet of Screw Cutting.** By L. Arnaudon: Fifth edition, 92 pp., cr. 8vo., sewed. (1913.) 4s. net.
- A Handbook for Apprenticed Machinists.** By O. J. Beale. Third ed., 89 illus., 141 pp., 16mo. (*New York, 1901.*) 2s. 6d. net.
- Practice of Hand Turning.** By F. Campin. Third edition, 99 illus., 307 pp., crown 8vo. (1883.) 3s. 6d.
- Artistic Leather Work.** By E. Ellin Carter. 6 plates and 21 illus., xii + 51 pp., crown 8vo. (1912.) 2s. 6d. net.
- Calculation of Change Wheels for Screw Cutting on Lathes.** By D. de Vries. 46 illus., 83 pp., 8vo. (1914.) 3s. net.
- Milling Machines and Milling Practice.** By D. de Vries. 536 illus., 464 pp., medium 8vo. (1910.) 14s. net.

- French-Polishers' Manual.** By a **French-Polisher.** New impression, 31 pp., royal 32mo, sewed. (1912.) 6d. net.
- Art of Copper-Smithing.** By **J. Fuller.** Fourth edition, 483 illus., 319 pp., royal 8vo. (New York, 1911.) 12s. 6d. net.
- Saw Filing and Management of Saws.** By **R. Grimshaw.** Third ed., 81 illus., 16mo. (New York, 1912.) 4s. 6d. net.
- Cycle Building and Repairing.** By **P. Henry.** 55 illus., 96 pp., cr. 8vo. (S. & C. SERIES, NO. 43.) 1s. 6d. net.
- Paint and Colour Mixing.** By **A. S. Jennings.** Fourth edition, 14 coloured plates, 190 pp., 8vo. (1910.) 5s. net.
- The Mechanician :** a Treatise on the Construction and Manipulation of Tools. By **C. Knight.** Fifth edition, 96 plates, 397 pp., 4to. (1897.) 18s.
- Turner's and Fitter's Pocket Book.** By **J. La Nicca.** 18mo, sewed. 6d.
- Tables for Engineers and Mechanics,** giving the values of the different trains of wheels required to produce Screws of any pitch. By **Lord Lindsay.** Second edition, royal 8vo, oblong. 2s.
- Screw-cutting Tables.** By **W. A. Martin.** Seventh edition. New imp., oblong 8vo. 1s. net.
- Metal Plate Work,** its Patterns and their Geometry, for the use of Tin, Iron and Zinc Plate Workers. By **C. T. Millis.** Fourth Ed., New imp., 280 illus., xvi + 456 pp., cr. 8vo. (1912.) 9s.
- The Practical Handbook of Smithing and Forging.** Engineers' and General Smiths' Work. By **T. Moore.** New impression, 401 illus., 248 pp., crown 8vo. (1912.) 5s. net.
- Modern Machine Shop Construction,** equipment and management. By **O. E. Perrigo.** 208 illus., 343 pp., crown 4to. (New York, 1906.) £1 1s. net.
- Turner's Handbook on Screw-cutting,** Coning, etc. By **W. Price.** New impression, 56 pp., fcap. 8vo. (1912.) 6d. net.
- Introduction to Eccentric Spiral Turning.** By **H. C. Robinson.** 12 plates, 23 illus., 48 pp., 8vo. (1906.) 4s. 6d. net.

- Manual of Instruction in Hard Soldering.** By H. Rowell. Sixth edition, 7 illus., 66 pp., crown 8vo. (*New York, 1910.*) 3s. net.
- Forging, Stamping, and General Smithing.** By B. Saunders. 728 illus., ix + 428 pp., demy 8vo. (*1912.*) £1 1s. net.
- Pocket Book on Boilermaking, Shipbuilding, and the Steel and Iron Trades in General.** By M. J. Sexton. Sixth edition, new impression, 85 illus., 319 pp., royal 32mo, roan, gilt edges. (*1912.*) 5s. net.
- Power and its Transmission.** A Practical Handbook for the Factory and Works Manager. By T. A. Smith. 76 pp., fcap. 8vo. (*1910.*) 2s. net.
- Spons' Mechanics' Own Book :** A Manual for Handicraftsmen and Amateurs. Sixth edition, New impression, 1,430 illus., 720 pp., demy 8vo. (*1914.*) 6s.
Ditto ditto half French morocco, 7s. 6d.
- Spons' Workshop Receipts for Manufacturers, Mechanics and Scientific Amateurs.** New and thoroughly revised edition, crown 8vo. (*1909.*) 3s. each net.
- Vol. I. ACETYLENE LIGHTING to DRYING. 223 illus., 532 pp.
- Vol. II. DYEING to JAPANING. 259 illus., 540 pp.
- Vol. III. JOINTING PIPES to PUMPS. 257 illus., 528 pp.
- Vol. IV. RAINWATER SEPARATORS to WIRE ROPES. 321 illus., 540 pp.
- Gauges at a Glance.** By T. Taylor. Second edition, post 8vo, oblong, with tape converter. (*1900.*) 5s. net.
- Simple Soldering, both Hard and Soft.** By E. Thatcher. 52 illus., 76 pp., crown 8vo. (S. & C. Series, No. 18.) (*New York, 1910.*) 1s. 6d. net.
- The Modern Machinist.** By J. T. Usher. Fifth edition, 257 illus., 322 pp., 8vo. (*New York, 1904.*) 10s. 6d. net.
- Practical Wood Carving.** By C. J. Woodsend. 108 illus., 86 pp., 8vo. Second ed. (*New York, 1908.*) 4s. 6d. net.
- American Tool Making and Interchangeable Manufacturing.** By J. W. Woodworth. Second Ed. 600 illus., 535 pp., 8vo. (*New York, 1911.*) 18s. net.

USEFUL TABLES

See also CURVE TABLES, EARTHWORK, FOREIGN EXCHANGE, INTEREST TABLES, LOGARITHMS, AND METRIC TABLES.

Weights and Measurements of Sheet Lead. By J. Alexander. 32mo, roan. 1s. 6d. net.

Barlow's Tables of Squares, Cubes, Square Roots, Cube Roots and Reciprocals, of all Integer Numbers from 1 to 10,000. 200 pp., crown 8vo, leather cloth. 4s. net.

Tables of Squares. Of every foot, inch and $\frac{1}{16}$ of an inch from $\frac{1}{16}$ of an inch to 50 feet. By E. E. Buchanan. Eleventh edition, 102 pp., 16mo. 4s. 6d. net.

Land Area Tables. By W. Codd. For use with Amsler's Planimeter. On sheet in envelope with explanatory pamphlet, 1s. 6d. net. Or separately: tables on sheet 1s. net. Pamphlet, 6d. net.

Calculating Scale. A Substitute for the Slide Rule. By W. Knowles. Crown 8vo, leather. 1s. net.

Planimeter Areas. Multipliers for various scales. By H. B. Molesworth. Folding sheet in cloth case. 1s. net.

Tables of Seamless Copper Tubes. By I. O'Toole. 69 pp., oblong fcap. 8vo. 3s. 6d. net.

Steel Bar and Plate Tables. Giving Weight per Lineal Foot of all sizes of L and T Bars, Flat Bars, Plates, Square, and Round Bars. By E. Read. On large folding card. 1s. net.

Rownson's Iron Merchants' Tables and Memoranda. Weight and Measures. 86 pp., 32mo, leather. 3s. 6d.

Spons' Tables and Memoranda for Engineers. By J. T. Hurst, C.E. Twelfth edition, 278 pp., 64mo, roan, gilt edges. (1913.) 1s. net.

Ditto ditto in celluloid case, 1s. 6d. net.

Optical Tables and Data, for the use of Opticians. By Prof. S. P. Thompson. Second edition, 130 pp., oblong 8vo. (1907.) 6s. net.

Traverse Table, showing Latitudes and Departure for each Quarter degree of the Quadrant, and for distances from 1 to 100, etc. 18mo, boards. 2s. net.

- The Wide Range Dividend and Interest Calculator**, showing at a glance the percentage on any sum from £1 to £10,000, at any Interest from 1% to 12½%, proceeding by ½%; also Table of Income Tax deductions on any sum from £1 to £10,000, at 9d., 1s., and 1s. 2d. in the £. By **Alfred Stevens**. 100 pp., super royal 8vo. 5s. net. Quarter Morocco, cloth sides. 7s. 6d. net.
- The Wide Range Income Tax Calculator**, showing at a glance the tax on any sum from One Shilling to Ten Thousand Pounds at the Rates of 9d., 1s., and 1s. 2d. in the £. By **Alfred Stevens**. 8 pp., printed on stiff card, royal 8vo. 1s. net.
- Fifty-four Hours' Wages Calculator**. By **H. N. Whitelaw**. Second edition, 79 pp., 8vo. 2s. 6d. net.
- Wheel Gearing**. Tables of Pitch Line Diameters, etc. By **A. Wildgoose** and **A. J. Orr**. 175 pp., fcap. 32mo. 2s. net.

MISCELLANEOUS

- The Atmosphere: Its Characteristics and Dynamics**. By **F. J. B. Cordeiro**. 35 illus., 129 pp., crown 4to. (*New York, 1910.*) 10s. 6d. net.
- Popular Engineering**. By **F. Dye**. 704 illus., 477 pp., crown 4to. (*1895.*) 5s. net.
- The Phonograph**, and how to construct it. By **W. Gillett**. 6 folding plates, 87 pp., crown 8vo. (*1892.*) 5s.
- Engineering Law**. By **A. Haring**. Demy 8vo, cloth. (*New York.*)
Vol. I. THE LAW OF CONTRACT. 518 pp. (*1911.*) 17s. net.
- Particulars of Dry Docks, Wet Docks, Wharves, etc., on the River Thames**. By **C. H. Jordan**. Second edition, 7 coloured charts, 103 pp., oblong 8vo. (*1904.*) 2s. 6d. net.
- New Theories in Astronomy**. By **W. Stirling**. 335 pp., demy 8vo. (*1906.*) 8s. 6d. net.
- Inventions, How to Protect, Sell and Buy Them**. By **F. Wright**. 118 pp., crown 8vo. (S. & C. SERIES, No. 10.) (*New York, 1908.*) 1s. 6d. net.

The Journal of the Iron and Steel Institute.

Edited by G. C. LLOYD, *Secretary.*

Published Half-yearly, 8vo. 16s. net.

Carnegie Scholarship Memoirs.

Published Annually, 8vo. 10s. net.

The Journal of the Institution of Electrical Engineers.

Edited by P. F. ROWELL, *Secretary.*

Issued in quarto parts. The number of parts are from 12 to 16 annually. Annual Subscription, 46s., payable in advance. Single numbers, 3s. 9d. post free.

The Proceedings of the Institution of Municipal and County Engineers.

Edited by THOMAS COLE, Assoc.M.Inst.C.E. *Secretary.*

Issued in monthly parts (fortnightly during April, May, June and July). Price 1s. 9d., post free, each part.

Transactions of the Institution of Gas Engineers.

Edited by WALTER T. DUNN, *Secretary.*

Published Annually, 8vo. 10s. 6d. net

Proceedings of the International Association for Testing Materials.

(English Edition.)

Proceedings of 5th Congress, 18s. net. Proceedings of 6th Congress, 30s. net.

Transactions of the American Institute of Chemical Engineers.

Published Annually, 8vo. 30s. net.

.W.

e.

ret.

et.

l

om
le

al

ie

t

UNIVERSITY OF CALIFORNIA LIBRARY
BERKELEY

Return to desk from which borrowed.
This book is DUE on the last date stamped below.

JAN 26 1948

11 May '59 LA

REC'D LD

APR 27 1959

LD 21-100m-9,'47(A5702s16)476

YB 75318

**RETURN TO the circulation desk of any
University of California Library**

or to the

**NORTHERN REGIONAL LIBRARY FACILITY
Bldg. 400, Richmond Field Station
University of California
Richmond, CA 94804-4698**

ALL BOOKS MAY BE RECALLED AFTER 7 DAYS

- 2-month loans may be renewed by calling
(510) 642-6753
- 1-year loans may be recharged by bringing
books to NRLF
- Renewals and recharges may be made
4 days prior to due date

DUE AS STAMPED BELOW

FEB 19 2005

DD20 6M 9-03

