

SEVENTY-FIVE CENTS

an *ALLIED* publication

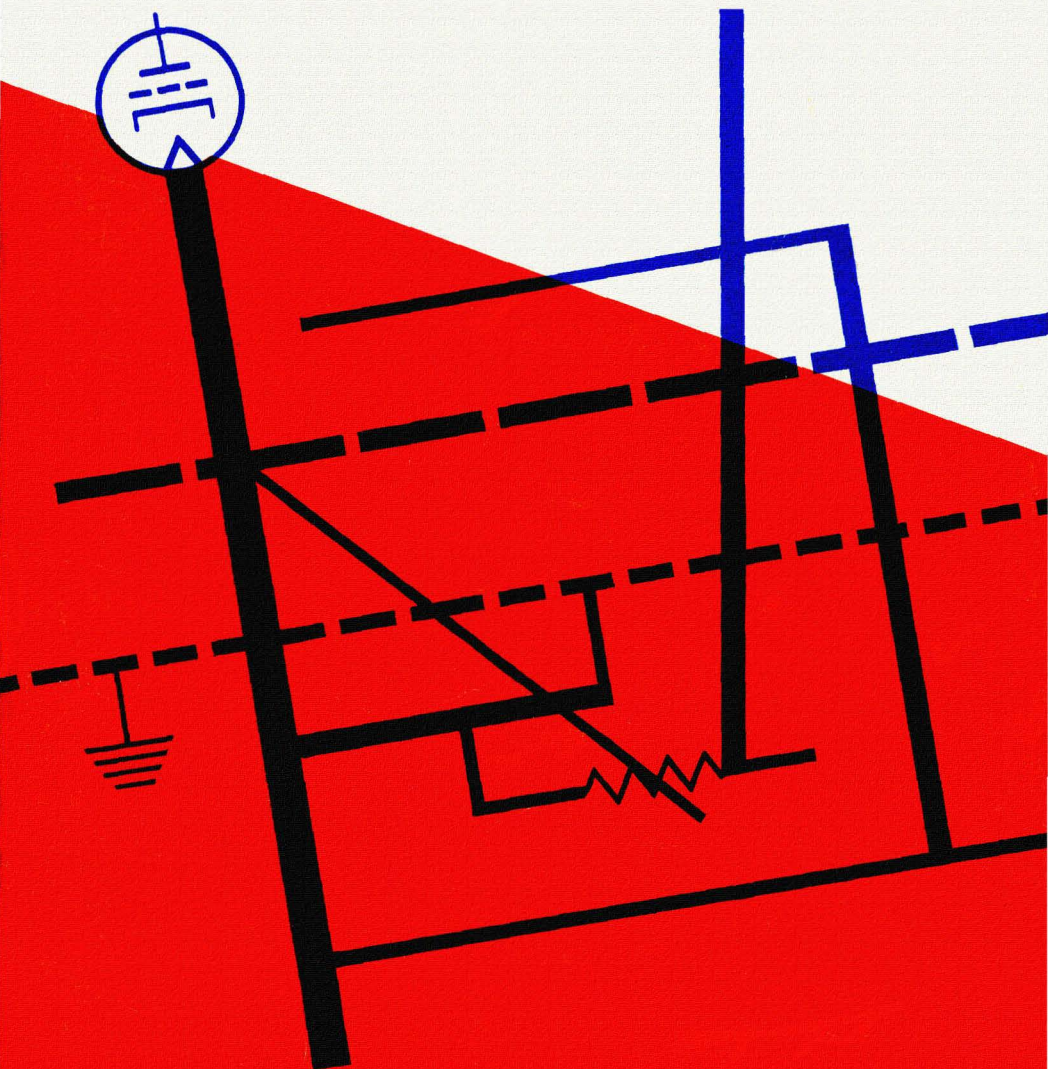

understanding
**schematic
diagrams**



UNDERSTANDING SCHEMATIC DIAGRAMS

**Written Under the Direction of
the Publications Division
Allied Radio Corporation**

Edited by

**Julian M. Sienkiewicz
WA2CQL/KMD4313**

**Editor of
Radio-TV Experimenter
Elementary Electronics
Electronics Hobbyist**



ALLIED RADIO
CHICAGO, ILLINOIS 60680

FIRST EDITION

SIXTH PRINTING—SEPTEMBER, 1970

UNDERSTANDING SCHEMATIC DIAGRAMS

Copyright © 1967 by Allied Radio Corporation, Chicago, Ill. 60680 Printed in the United States of America.

Reproduction or use, without express permission, of editorial or pictorial content, in any manner, is prohibited. No patent liability is assumed with respect to the use of the information contained herein.

Library of Congress Catalog Card Number: 67-24759

Preface

It is unfortunate that the average beginner or service technician considers the schematic somewhat complicated. In truth, the schematic is a short cut to learning the essential details about a circuit. As shown in the book, the schematic is, in fact, the easiest method of conveying information about the circuit. Thus, the understanding of the schematic is an ideal beginning in the study of electronics.

Learning how to read a schematic is not too difficult, because the schematic can be broken down into easily understandable symbols. The schematic has aptly been described as "the roadmap of electronics," and just as a roadmap is easy to read, once the symbols are understood, so can the mysteries of the schematic be divulged.

This book approaches the subject from the beginning. You will learn about the various components—resistors, capacitors, coils, etc.—that make up the circuit, and the symbols for these components. Then you will learn how these components are joined together, just as the towns and cities on a roadmap are linked by highways. Finally, with this background you are able to read a complete schematic.

No knowledge of electronics is required to understand this book. It includes the necessary elementary electronics for the beginner's benefit. The book will also be useful as a brush-up for the service technician who may not be familiar with all the latest symbols.

ALLIED RADIO CORP.

Contents

CHAPTER 1

GETTING STARTED	7
Why Schematics? — Symbol Differences — Other Types of Diagrams — Fundamentals	

CHAPTER 2

FUNDAMENTAL COMPONENTS	24
Resistors — Capacitors — Coils — Transformers — Summary	

CHAPTER 3

TUBES AND SEMICONDUCTORS	46
Vacuum Tubes — Semiconductor Diodes — Transistors — Other Semiconductors	

CHAPTER 4

OTHER COMPONENTS	59
Antennas—Pick-Up Devices—Magnetic Heads—Speakers— Earphones and Headphones—Batteries—Vibrators—Protective Devices—Lamps—Crystals—Motor and Generators— Meters	

CHAPTER 5

CONNECTING DEVICES	78
Wires—Ground Points—Test Points—Switches—Code Keys —Connectors—Jack and Plugs—Relays	

CHAPTER 6

PUTTING IT ALL TOGETHER	92
Other Information on Schematics—Single Amplifier Stage — Short-Wave Receiver — Transistor AM Radio — Differences in Schematics	

CHAPTER 1

GETTING STARTED

The understanding of schematic diagrams is probably the most important single item for anyone connected with the science of electronics. Nobody who has even the slightest interest in the subject can escape the schematic diagram. From the casual hobbyist to the advanced engineer—if it is electronics, there is a schematic diagram somewhere. Since schematic diagrams are so important to electronics, it follows then that obtaining a sound understanding of schematics* is the only logical place to start.

WHY SCHEMATICS?

Why is the schematic such an important item in electronics? To the novice, the schematic may seem to be only a way to confuse the subject. After all, the symbols used to represent the components do seem unfamiliar at first. Couldn't the schematic just be dispensed with and thereby eliminate a lot of confusion? The answer is no! Through the years, experience has proven that nothing can show as much information in such a small space as the schematic. In fact, the schematic is universally understood. Even if you cannot understand a word of the language a manual is printed in, the symbols will be so close to those given in this book that you will be able to understand the schematic.

A schematic shows all of the electrical connections and circuit components in a piece of electronic equipment. It also tells you the electrical value or the type used for each component in the unit. Just to list the components and to explain the connections in words would take many pages. In fact, for a typical television receiver the explanation would probably fill more pages than this book contains. A schematic of a television receiver will fit on two pages, as shown in Fig. 1-1. If a draw-

*The word schematic is an adjective; however, it is commonly used in both the singular and plural form as a noun.

Understanding Schematic Diagrams

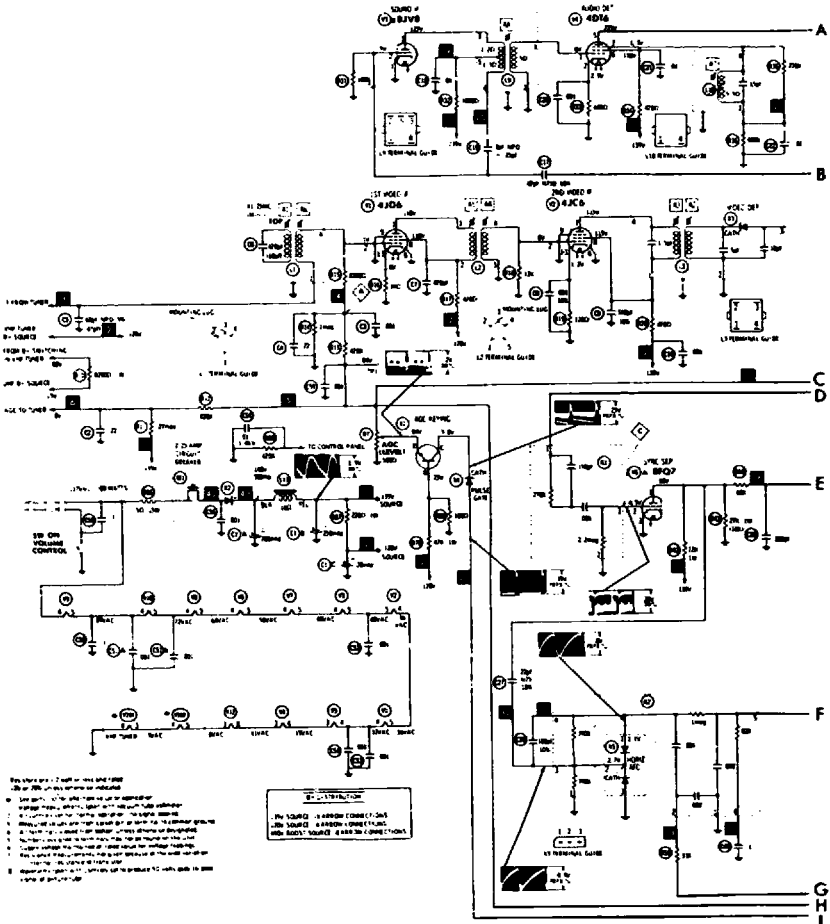
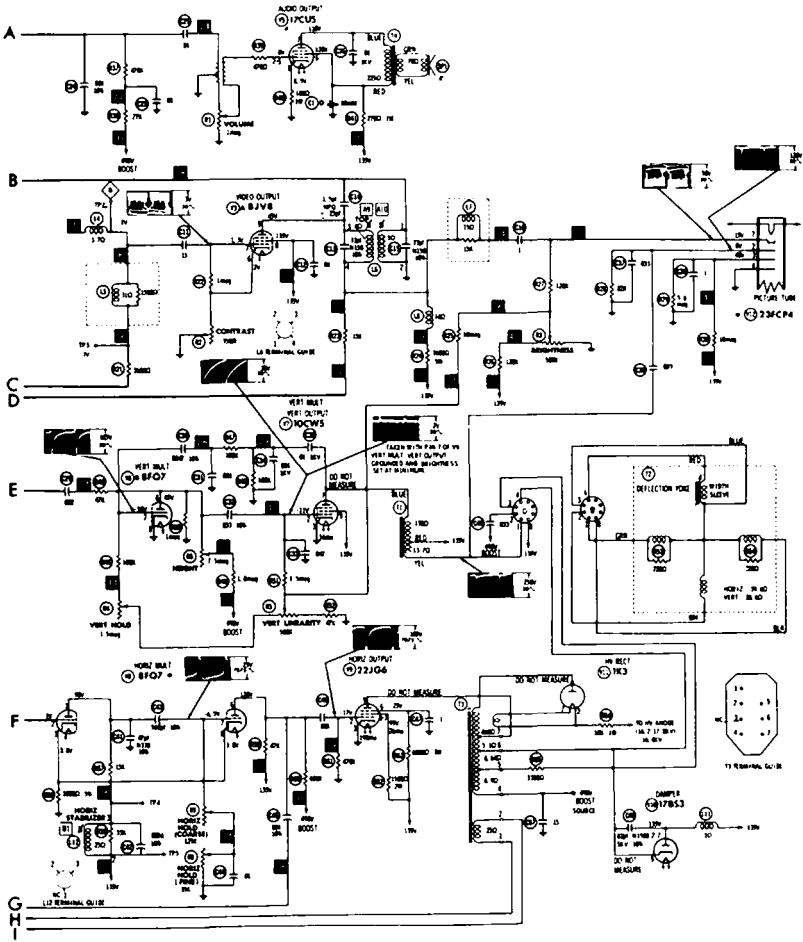

Fig. 1-1. Schematic of a

ing were made showing the actual components, it would take far longer to prepare, require more space, and still not be as useful.

The schematic in Fig. 1-1 contains much more information than just the components, values, and their connections. It is often all the television service technician needs to locate a trouble in the receiver. To the uninitiated, the schematic in Fig. 1-1 seems quite confusing, but to anyone experienced in electronics it is as easy to “read” as a newspaper. By the time you have finished this book, you, too, will be able to read this diagram and understand much of the information it conveys.

Getting Started



typical television receiver.

Of course, understanding it thoroughly requires a knowledge of the theory and operation of television. This is beyond the scope of this book, but after it has been read and understood, you will have the sound basis needed for further study.

The symbols used to represent the various components have been carefully selected. There is a relationship between the function or construction of the various components and the symbols chosen. These relationships will be explained. Once this correlation between components and symbols becomes apparent, you will have attained not only considerable knowledge of electronics, but also an understanding of schematics.

SYMBOL DIFFERENCES

It would be convenient if everyone used identical symbols on his schematics. Unfortunately, this is not the case. In recent years, there has been much progress in the standardization of symbols. The American Standards Association (ASA) and the military services have published standards for symbols. Fortunately they are identical. Other organizations have also adopted standards. Recently, the Electronic Industries Association, a voluntary association of electronics manufacturers, surveyed the member companies and published a list of suggested symbols based on a composite of those used by the various member companies. Since this is a voluntary organization, members are not compelled to comply with the published symbols. In most cases a choice of symbols was given in this report.

Actually there is nothing to prevent any company—or person for that matter—from adopting any symbol he chooses to represent a given component. However, the desire to make schematics as understandable as possible has led to a general agreement on standard symbols. There are a few differences in ones chosen by various companies for components, but the areas of agreement far outnumber the areas of disagreement.

Symbols are much like traffic signs. As we travel across the country, we will notice that most of the traffic signs look about the same, although there are differences. Sometimes these differences are only minor. For example, one sign may use bolder letters, a different style of letter, or a different color from the one to which we are accustomed. It is the same with schematic symbols. Most of the differences involve heavier or lighter lines, a slightly different shape, or similar minor items, as shown in Fig. 1-2.

In general, the weight of a line makes no difference. Arrowheads are often used in schematic symbols; usually they can be solid or open without changing the meaning. The symbol can be laid on its side, upside down, or in any other position without changing its meaning. In fact, it can even be the mirror image of the symbol—that is, exactly opposite, as shown by the first two symbols in Fig. 1-2C—and not change the meaning. (In each part of Fig. 1-2, the symbols represent the same item.)

Most of the differences in schematics stem from the means used to prepare the drawing. Originally they were drawn with pencil or pen and ink, and the information was hand lettered on the schematic. This system is very time consuming. Many differences would creep into schematics prepared in this way,

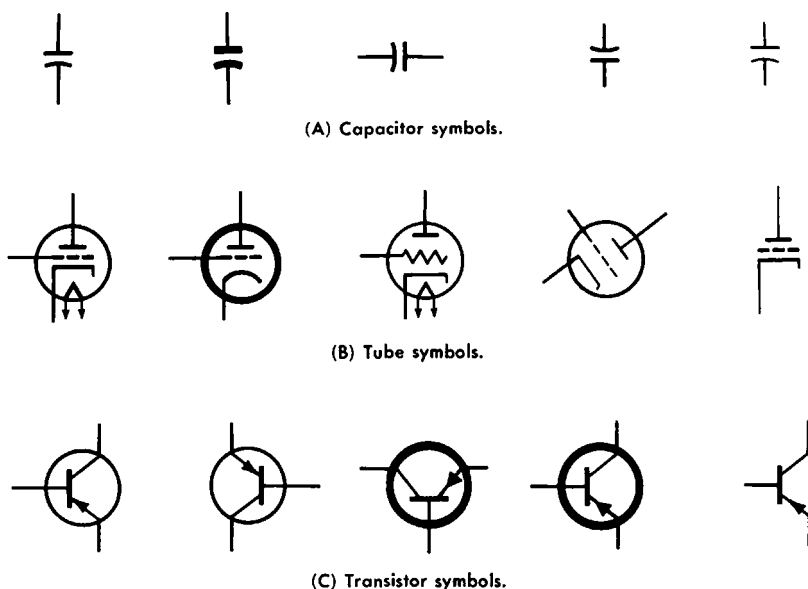

Fig. 1-2. Symbol differences.

since each draftsman might show a symbol in a slightly different manner.

In an effort to speed up the drafting process and at the same time to "standardize" the symbols, most companies went to a system in which all the symbols were preprinted. Usually the symbol is printed on a clear acetate sheet which is cut out and placed on the sheet of paper on which the schematic is "drawn." Symbols of this nature are available for all types of components and special ones can be made up by using combinations of other symbols. The acetate may have a wax backing for affixing it to the paper. In another method, rubbing the acetate sheet removes the printing from the back of the sheet. The sheet is placed in the correct spot, and then the printing is transferred to the paper on which the drawing is desired.

The latest development in the art of schematic drafting is pictured in Fig. 1-3. This unit, called the *Diagrammer*, is manufactured by the same company which makes the *Linotype* machines for typesetting. In much the same way as the typesetter punched the keys on a keyboard to produce the type for this book, the operator of the unit in Fig. 1-3 can "type" a schematic on this electromechanical-optical system. The symbol is selected on the keyboard at the left, which contains 256 keys, and positioned on the screen in the center by using the keys

Understanding Schematic Diagrams

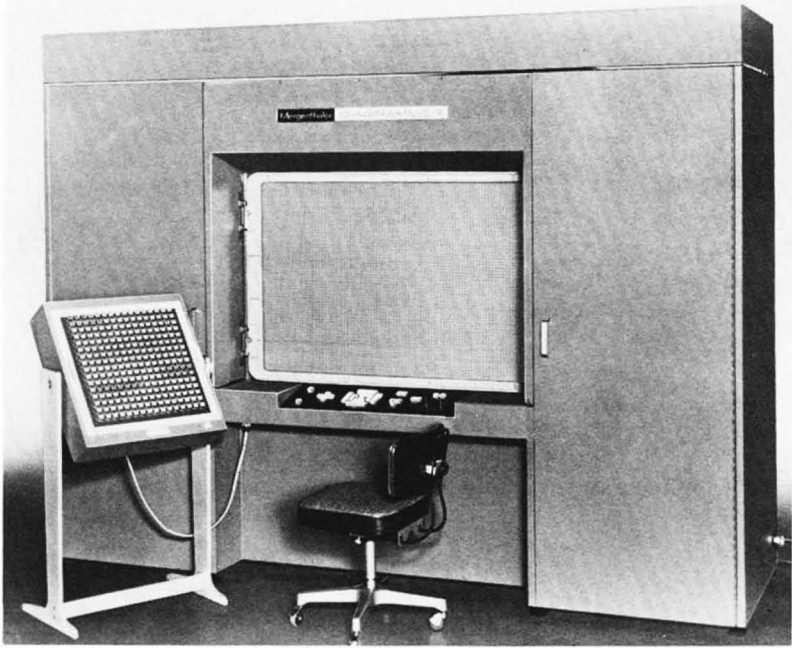

Fig. 1-3. A machine for "typesetting" schematics.

below the screen. When properly positioned the symbol is exposed on photographic film. This process is repeated until an entire schematic, including all symbols, words, values, lines, etc., is produced. The individual keys or the entire keyboard can be changed as desired. The individual symbols used for the exposure are stored on glass slides in a magazine within the machine.

OTHER TYPES OF DIAGRAMS

The schematic is not the only type of diagram used in electronics. As stated before, it is the most useful because it conveys more information than any other type of diagram, but even the schematic does have limitations. There are things that cannot be shown by a schematic, or that can be shown much more efficiently by other diagrams. In this section, some of the other types of diagrams will be examined and their advantages and disadvantages discussed.

Block Diagram

The block diagram (Fig. 1-4) is about the simplest of all diagrams used in electronics. It gives only limited information,

Fig. 1-4. Block diagram of the TV receiver in Fig. 1-1.

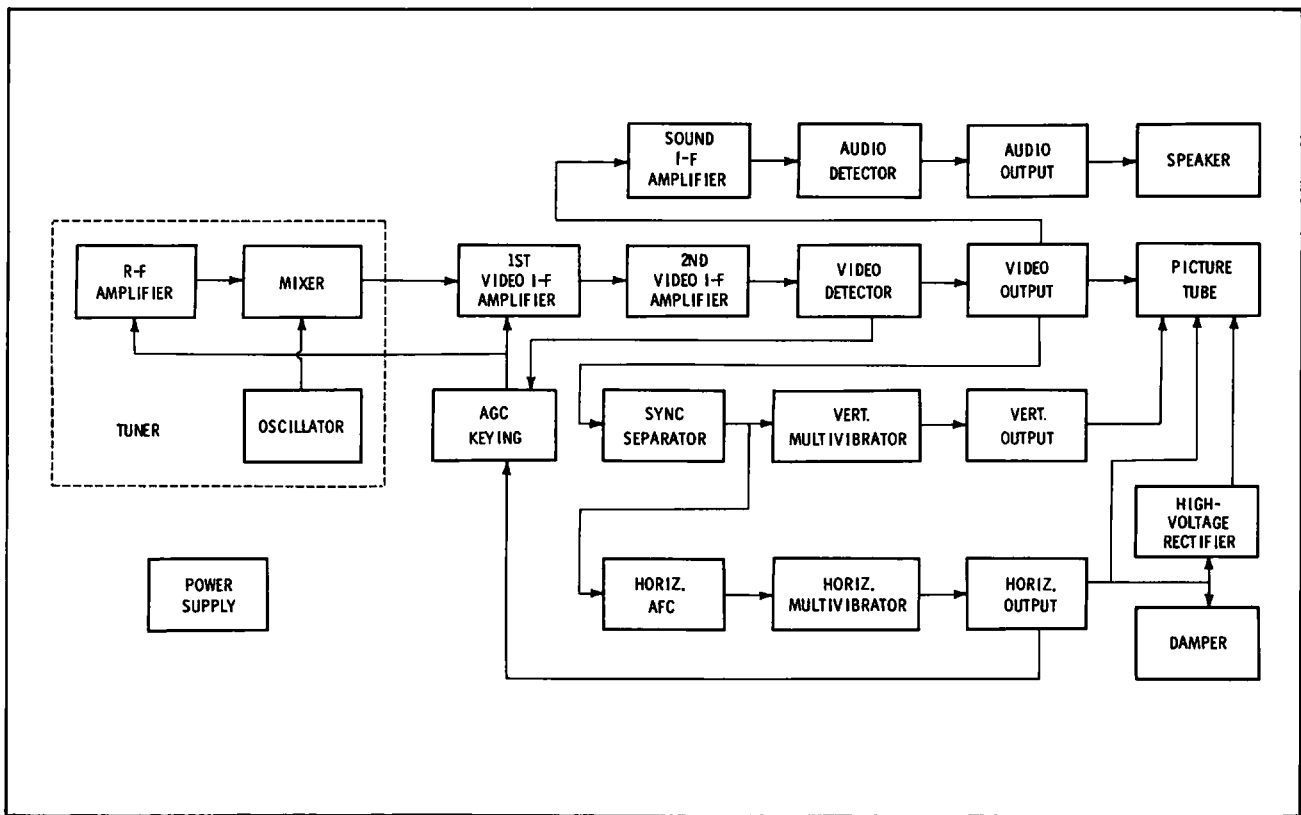

but in some applications it serves a valuable purpose. As shown in Fig. 1-4, the block diagram consists of a series of "boxes" connected by lines with arrows. (This is a block diagram of the television set in Fig. 1-1.) If all that is needed is a brief look at the overall operation of a unit, the block diagram is the best means of showing the desired information. Usually a separate "box" is used to show each tube or transistor and its associated components (called a stage). The box is labeled by the function performed by this stage. The lines and arrows show how the various stages fit together to provide the desired results. Some boxes may not be a tube or transistor, but some other component or group of components which performs a specific function in the overall operation.

After you are familiar with schematics, you will be able to look at one and mentally break it down with a block diagram. In fact, this is the only way that a schematic can actually be understood. However, if a knowledge of the individual component is not important and all that is needed is a general idea of what is happening in the unit, the block diagram will suffice. It is particularly useful for complicated pieces of equipment. For example, an entire broadcasting station might be shown in a block diagram, with each block representing a unit of equipment such as a tape player, turntable, or amplifier—each of which might contain many stages.

Chassis Layouts

The schematic cannot show the placement of parts. Usually you can assume that a part associated with a given tube or other large component will be physically located close to the larger, easier-to-find component, but this assumption is not always true.

Sometimes it is even difficult to locate a given tube or other component. If several tubes of the same type are used, it is difficult to determine which one performs which function. The chassis-layout diagram of Fig. 1-5 is useful in this case. It shows the location of each tube and some of the other components on the top of the chassis for the television set of Figs. 1-1 and 1-4. By looking at this diagram you can easily locate each tube associated with the blocks in the diagram of Fig. 1-4. Sometimes a photograph with the various items labeled will be used in place of the drawing of Fig. 1-5.

Underneath the chassis (Fig. 1-6), the problem of locating the components is even greater. Two systems are used to aid in locating a given component. In the first, each component in the photograph of Fig. 1-6 is identified and pointed out with

an arrow, as shown in Fig. 1-7. This is the method most commonly used in service literature.

In the photographs of Figs. 1-6 and 1-7, most of the components are apparent, but it is impossible to tell just how they are connected. Of course, in service literature the actual physical points of connection are not needed—they can be seen by

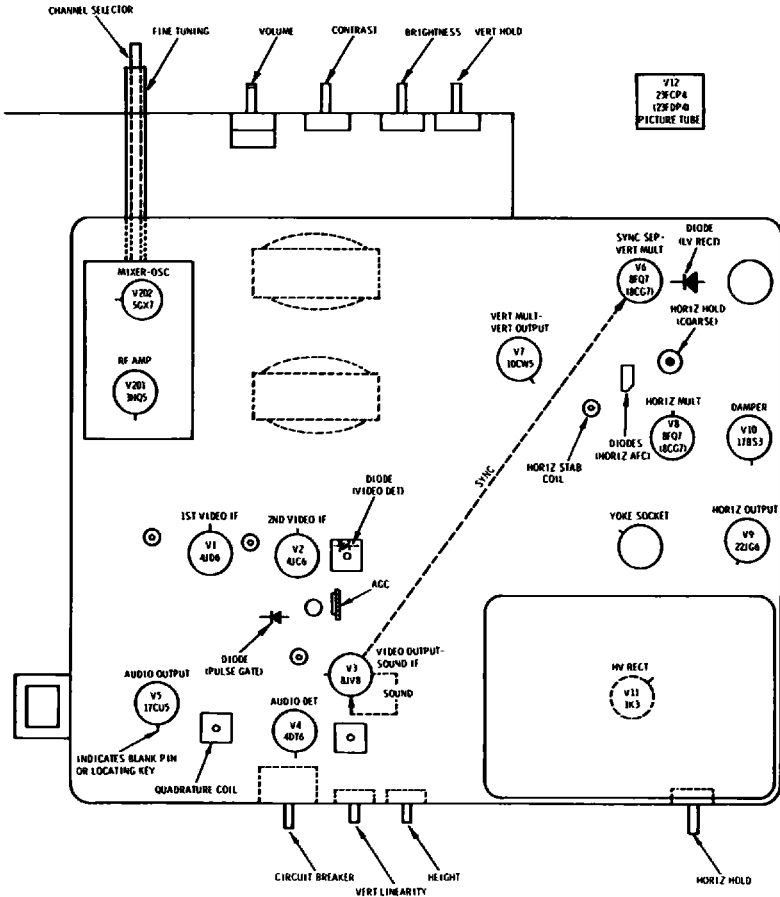

Fig. 1-5. Chassis-layout diagram of the TV receiver in Fig. 1-1.

looking at the unit. The schematic provides the information on how they are connected in the circuit, and it is far more useful than the photograph for tracing the actual circuit. The purpose of the photograph in Fig. 1-7 is to aid in locating a specific point where measurements can be made in checking the equipment or to locate a component that is suspected of being bad.

Understanding Schematic Diagrams

Fig. 1-7 is adequate—and, in fact, the most desirable way—for these purposes.

In the construction of kits, it is essential that not only the location of the components, but the connections as well, be shown. The *pictorial diagram* shown in Fig. 1-8 is commonly used in the construction manuals for kits. Here, each compo-

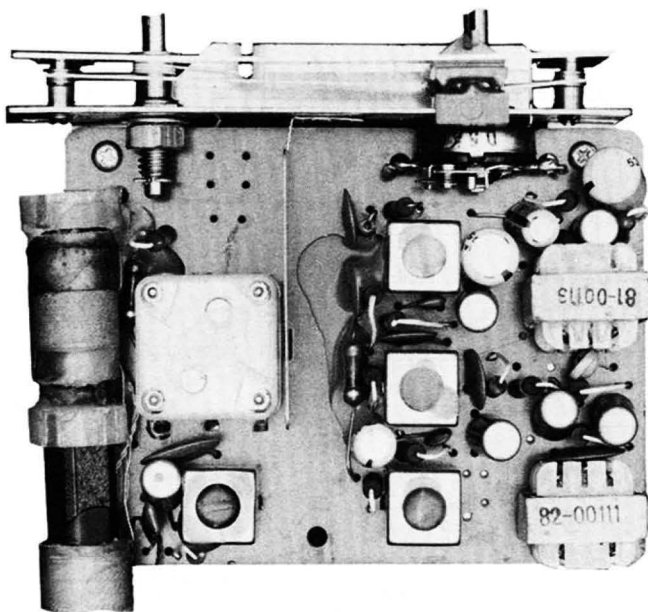

Fig. 1-6. A radio chassis.

nent is identified, its location shown, and the points where it is connected given. It may be necessary to “move” a few components slightly to prevent one from being on top of the other in Fig. 1-8, but this does not affect its usefulness.

Mechanical Diagrams

There is one item that cannot be shown by a schematic or a chassis diagram. Often, some form of mechanical action takes place in a piece of electronic equipment. For instance, a record changer or antenna rotator is entirely mechanical. Likewise, the system of pulleys and the drive cord used to pull the pointer across a radio dial is mechanical. These actions are shown by drawings of the units. Fig. 1-9 is a drawing showing a typical dial-cord stringing. This one is fairly simple and could probably be determined without the aid of the draw-

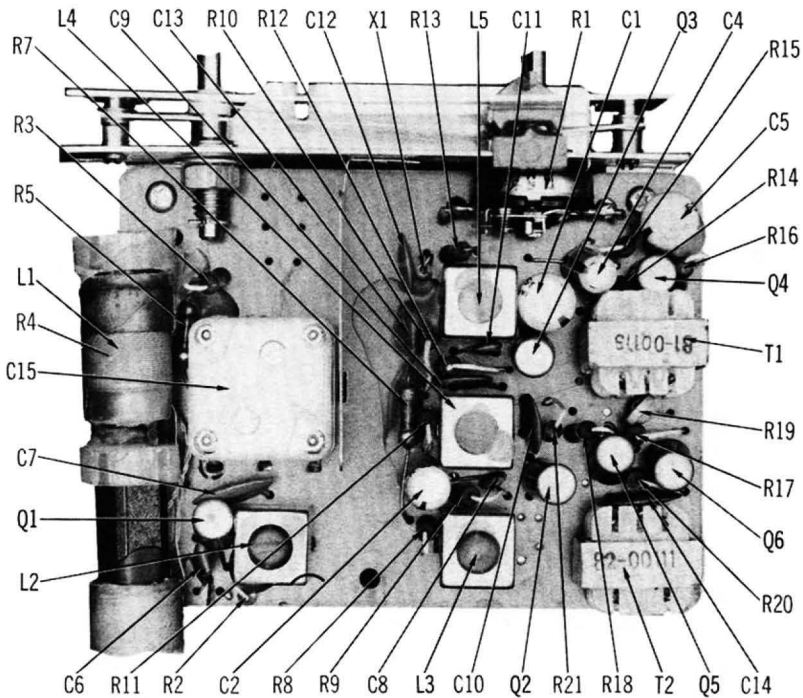

Fig. 1-7. The radio chassis in Fig. 1-6 with the components identified.

ing, but others are quite complicated and have more than one cord. Without a drawing, it might take hours to determine how the cord should be strung, and even then you would not be sure that you had it right.

The mechanical parts of a record player or tape recorder are usually drawn as shown in Fig. 1-10. Each part is shown separated but still in the same general relationship with the other parts it is associated with. This type of drawing is often called an *exploded view* because each item is "exploded" from its normal position so that you can see it more clearly, but still it is in the same relationship so its operation can be determined. The numbers are used for identification. By referring to the parts list, you can find the part number and the name of each component, should you need a replacement part.

FUNDAMENTALS

Before studying the individual components and the symbols used to represent them on schematics, it is first necessary to

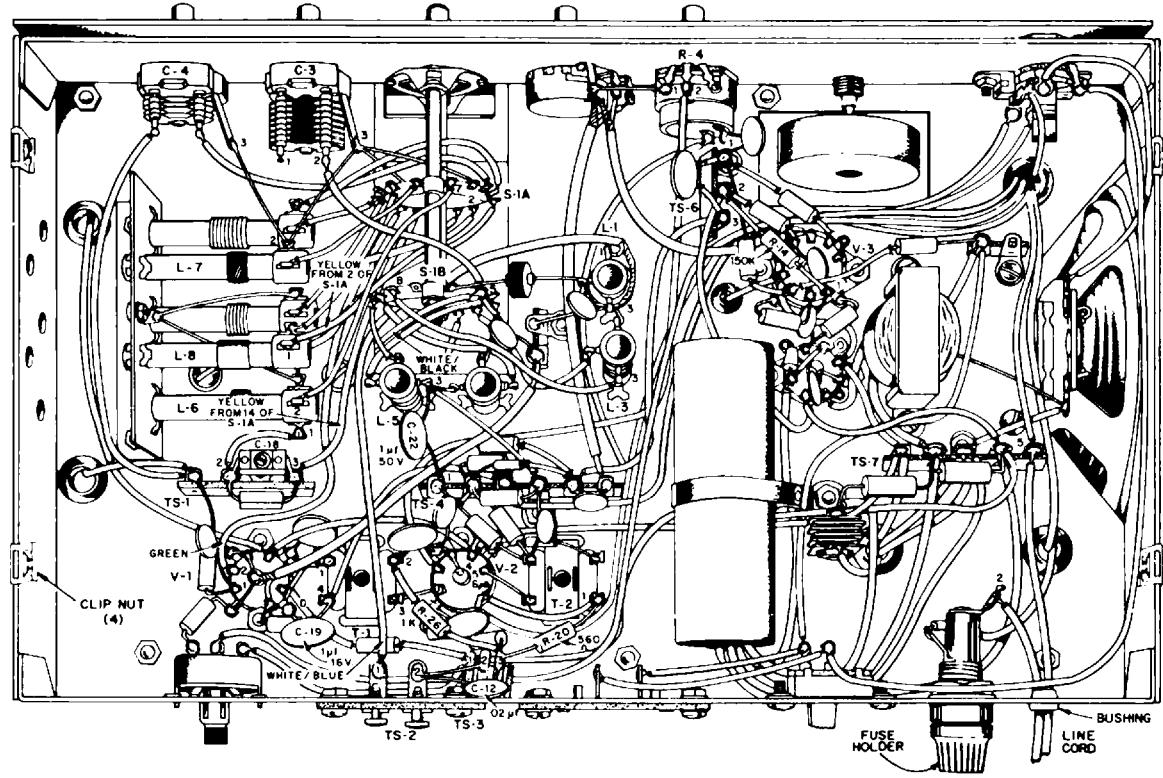

Fig. 1-8. Pictorial diagram of the Knight-Kit ® Star Roamer receiver.

understand a few of the principles and terms employed in electronics. It is not the author's intention to make this book a course in electronics. However, as an introduction to the uninitiated and as a review for others, a brief summary of the fundamentals is given in the following.

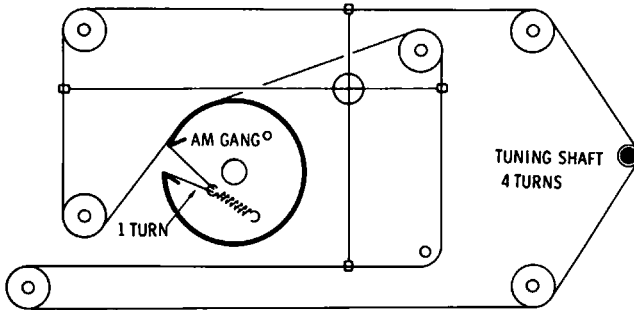

Fig. 1-9. A typical dial-cord stringing diagram.

All matter is made up of about a hundred fundamental materials called *elements*. (Actually, there are 104 known elements, but several are man-made and do not occur in nature.) Examples of elements are common materials such as gold, copper, and oxygen, rarer materials such as helium, tantalum, and xenon, and man-made elements such as californium, einsteinium, and nobelium. All material on earth is made up of these elements or combinations of them. The elements, in turn, are made up of *atoms*, which are minute particles so small that one cannot be seen under even the most powerful microscope.

These atoms are also composed of even smaller particles, and the composition of the atoms for each element is different from that for every other element. Fig. 1-11 shows a representation of a simple element (helium). The center of an atom is called the nucleus. In Fig. 1-11 it is represented by the shaded circle with the plus sign and consists of a cluster of positively charged particles called *protons*. Circling the nucleus in orbits similar to the way the planets orbit about the sun are negatively charged particles called *electrons* (represented by the circles with the minus signs in Fig. 1-11). There are several other particles within an atom, but the electron and proton are sufficient for our purposes.

In the normal condition, the electrical charge of the electrons and the protons is such that it holds the atom together. Under certain conditions, however, an electron can be made to move from its orbit to a similar orbit around the nucleus of a neigh-

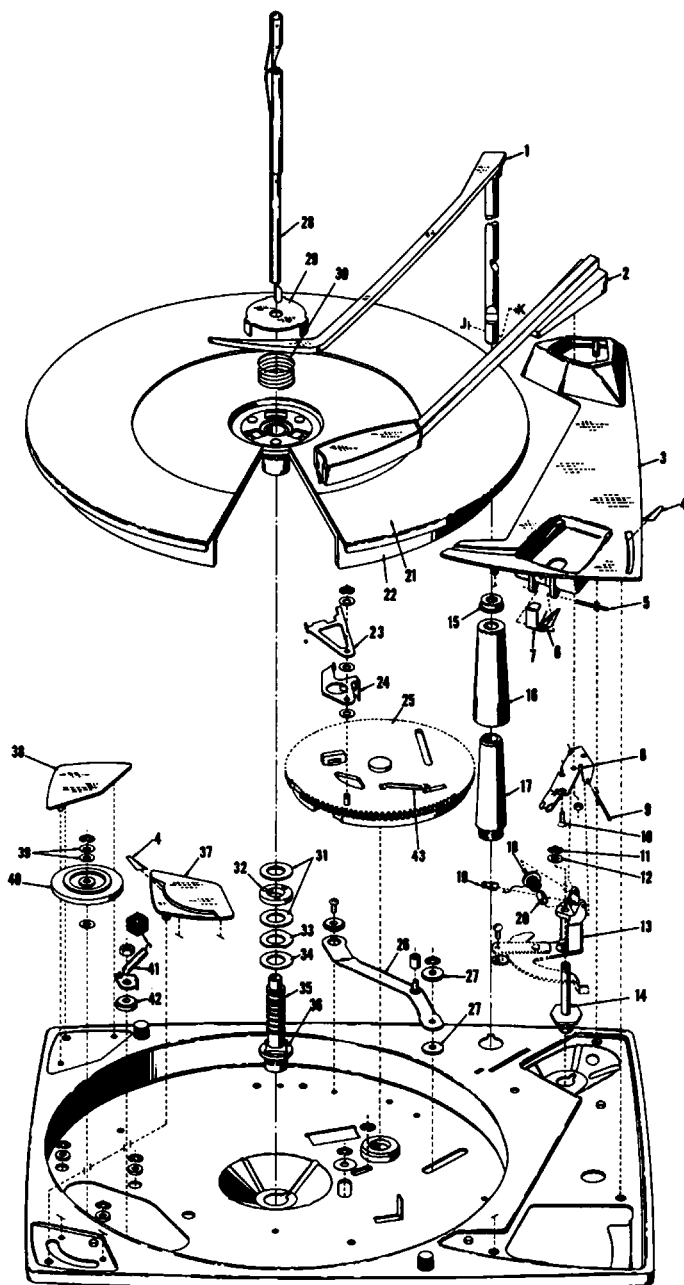
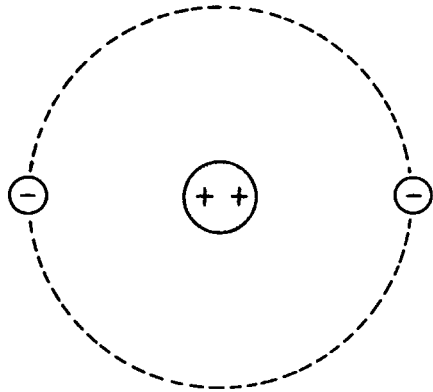

Fig. 1-10. "Exploded" view of a record changer.

boring atom. When the electron moves into orbit around the neighboring atom, it “bumps” an electron from this atom into orbit around another atom, etc. Thus, once started, a chain reaction is set up, and, in effect, electrons move from one point to the other. The control of this electron movement, called *electron flow*, is the basis for all of electronics.

Fig. 1-11. Diagram of a helium atom.



In some substances, the electrons are held very tightly in orbit, making it difficult for them to be dislodged and move to the next atom. These substances are called *insulators*. For other elements, great numbers of electrons are easily dislodged and the electrons move freely from one atom to the next. These elements are called *conductors*.

Before electrons can move (flow) in a particular direction, there must be some force which causes them to do so. If a body has a surplus of electrons, it is said to be negatively charged. If a deficiency of electrons is present in a body, it is said to have a positive charge. If a suitable path (conductor) is placed between these two bodies, electrons will try to move from the negatively charged to the positively charged material. The movement of electrons through the conductor is called *current*. It is measured in amperes, which is the rate at which the electrons flow. The greater the difference between the two points—that is, the greater the difference in the number of electrons present in the two materials—the greater the current will be through the conductor. This difference between the two points is the force which causes electrons to flow and is called *electromotive force* (abbreviated *emf*), or more commonly, *voltage*. It is measured in units called volts. Voltage can be supplied to a circuit by a battery, the AC power lines, or one of several other methods.

Understanding Schematic Diagrams

The voltage applied to a circuit can be in many different forms. The battery mentioned previously is the simplest form. A battery will present a constant voltage—negative at one point and positive at the other. Therefore, electrons will flow from the negative terminal, through the circuit, to the positive terminal. The current will be constant and always in one direction. Graphically, such an electron flow is represented in Fig. 1-12A and is called *direct current* (abbreviated DC).

If the applied voltage is caused to change periodically—that is, to vary first positive and then negative—the resulting current is first in one direction and then in the other. This is

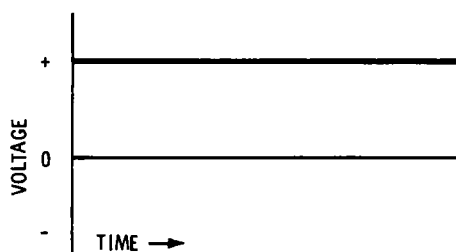

(A) Direct current.

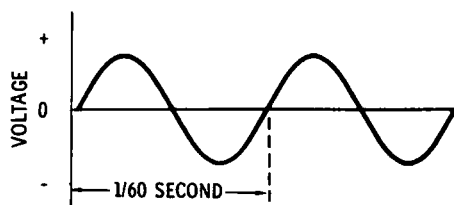

(B) Alternating current.

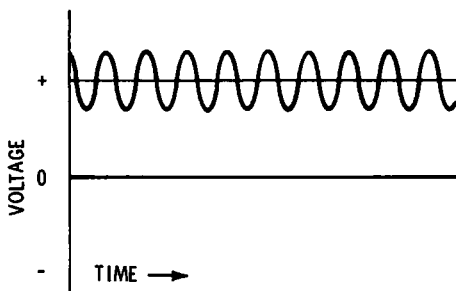

(C) Pulsating direct current.

Fig. 1-12. Voltage plotted against time.

called *alternating current* and is shown graphically in Fig. 1-12B. The most common example of this type of current is the power supplied by the power lines to our homes. This current reverses itself 60 times each second. Hence, it is termed 60-cycle-per-second (cps) AC. More recently, the term "hertz" is being used for cycles per second. Therefore a 60-hertz (abbreviated Hz) current is a 60-cps current.

Another type of current is shown graphically in Fig. 1-12C. It is one of the most common encountered in electronics. The fact that the line does not extend below the center line representing zero volts shows that it is direct current. However, it is not constant and varies around a point above the line. Essentially it is a combination of the two previous examples, with the alternating current riding "piggyback" on the direct current. Such a current is called a *pulsating direct current*.

The foregoing points should be remembered. Once you have mastered them, you should have no trouble understanding the remainder of this book.

CHAPTER 2

FUNDAMENTAL COMPONENTS

Certain circuit components are found in nearly every type of electronic equipment, regardless of its purpose. The components discussed in this chapter—resistors, capacitors, coils, and transformers—are used in virtually every electronic device found in the home and industry.

RESISTORS

The resistor is probably the most common of all circuit components. Several are used in practically every piece of electronic equipment, whether it is a radio, television receiver, or signal generator.

A resistor performs exactly the function in an electronic circuit that its name implies. It *resists*, or opposes, the flow of electrons through a circuit. In any component, even a piece of wire, there is a certain amount of resistance, or “electrical friction,” as the electrons attempt to move from one atom to the next. However, electrons flow more easily in certain materials than in others. A resistor is made of a material through which it is rather difficult for electrons to flow. In other words, a resistor introduces a high amount of electrical friction in the circuit.

There are two types of values (ratings) specified for resistors. The electrical value—that is, how much resistance the resistor will introduce in the circuit—is one. This value is given in *ohms*, the unit of resistance measurement. If the resistor has a value of 10 ohms, it will introduce 10 units of opposition to the flow of electrons through it.

At first thought it might appear that an opposition to electron flow such as that presented by a resistor would not be desirable, but such is not the case. The opposition presented by the resistor will reduce the amount of current in the circuit. At the same time, a voltage will be developed across the resistor. That is, as the electrons flow through the circuit, a voltage will appear across the resistor. The amount of this

voltage depends on the amount of resistance (ohms) and the amount of current (amperes) through the circuit. The formula for determining the amount of this voltage is known as Ohm's law, which states that $E = I \times R$, where E is the voltage (in volts), I is the current (in amperes), and R is the resistance (in ohms).

The second value by which resistors are rated is *wattage*. Wattage is a measure of how much current there can be through the resistor before it will be damaged. Wattage is measured in *watts*, and in general, the larger the physical size of the resistor, the higher the wattage it will handle. Regardless of the wattage, the resistance (in ohms) does not change. Thus, any resistor can be replaced with one having a higher wattage without affecting the operation. A resistor should *never* be replaced with one having a lower wattage.

Quite often the word "ohm" is abbreviated Ω . This symbol is the Greek letter *omega*. Also, it is quite common to use the letter K for 1000 in electronics terminology. Thus a 1K (or 1K Ω) resistor is a one thousand-ohm resistor. Likewise, the letter M or the prefix *meg* is used for one million. Thus, 1M, 1M Ω , 1 meg, or 1 megohm are all ways of designating a resistor having one million units of electrical resistance. Watts are usually designated by the letter W .

Fixed Resistor

A fixed resistor means one that is constant in value. The ohmic value cannot be changed or will not change under normal usage conditions. Its value depends on the composition and amount of material used in the manufacture of the resistor.

The most common fixed resistors are made entirely of carbon (A in Fig. 2-1) or a metal, carbon, or other composition deposited on glass, ceramic, or other material (B in Fig. 2-1). Other fixed resistors are made of a length of wire having a high resistance (such as *Nichrome*) wound around a form made of porcelain. Two examples of this type of resistor are pictured at C and D in Fig. 2-1.

Most carbon resistors have a color code printed on them to designate their value. Notice the bands around the resistor at A in Fig. 2-1. These colored bands are the code for the value. Table 2-1 gives the code used. The first band represents the first digit in the resistor value, and the second band, the second digit. The third band is the multiplier. That is, the first two digits are multiplied by the value shown in the multiplier column to obtain the value of the resistor.

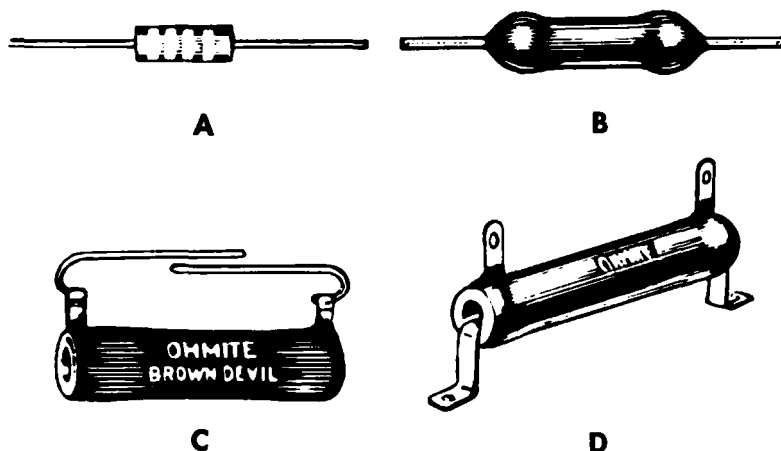

Fig. 2-1. Fixed resistors.

A fourth band is often added to specify the tolerance of the resistor, or within what percentage of the value given by the color code the actual resistor value falls. It is impossible to make each resistor an exact value, so certain standard values have been adopted, and if a resistor falls within a certain percentage of this value, it is coded with that value. When no fourth band is included, the resistor is within 20% of the value specified. The tolerances specified by the fourth band are also given in Table 2-1. Thus, a resistor with a red, violet, orange, and silver band indicates that it is a 27,000-ohm resistor and that its actual value will be within $\pm 10\%$ of the rated value. That is, it can be between 24,300 and 29,700 ohms and in most cases still be capable of meeting the circuit requirements. In actual practice, only the silver, gold, or no band is usually encountered for the tolerance. Resistors having other tolerances normally will not be carbon units, and the value and tolerance are normally printed on the sides of other types of resistors.

The symbol at A in Fig. 2-2 is almost universally employed to represent a fixed resistor on schematics. Recall that the function of a resistor is to present an opposition to electron flow. The zigzag line of the symbol presents a mental picture of opposition similar to that of a maze.

The symbol at B in Fig. 2-2 is for a special type of fixed resistor called a tapped resistor. In certain applications, it is desirable to "tap in" at a point along the resistance element, and on wirewound resistors a connection can be made at any

Table 2-1. Resistor color code

Color	Digits	Multiplier	Tolerance
Black	0	1	20%
Brown	1	10	±1%
Red	2	100	±2%
Orange	3	1000	±3%
Yellow	4	10,000	GMV*
Green	5	100,000	±5%
Blue	6	1,000,000	±6%
Violet	7	10,000,000	±12½%
Gray	8	.01	±30%
White	9	.1	±10%
Gold	—	.1	±5%
Silver	—	.01	±10%
No Color	—	—	±20%

*Guaranteed Minimum Value—That is, —0% + 100% tolerance

point along the wire. Thus, only a portion of the total resistance will be present between the tap and either end. Two taps are shown in the symbol at B in Fig. 2-2; however, any desired configuration can be made. Sometimes the dot at the point of connection will be omitted, as shown by the symbol at C.

Variable Resistors

It is often desirable to have a means of varying the value of a resistor. For example, the volume control of a radio or television set is a variable resistor. Other variable resistors are used in lighting and power circuits. Fig. 2-3 shows some of the many types in use. Most consist of a circular resistance element (either wire or carbon) with connections to one or both ends. A movable arm is placed in contact with the resistance and mechanically attached to the shaft, which protrudes from the unit. Moving this shaft changes the position of the movable arm on the resistance element. By connecting one of the termi-

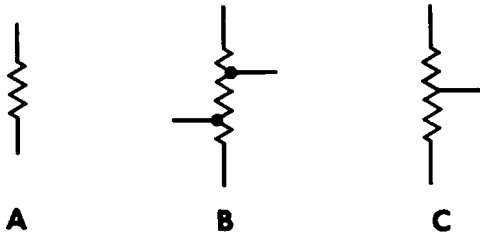
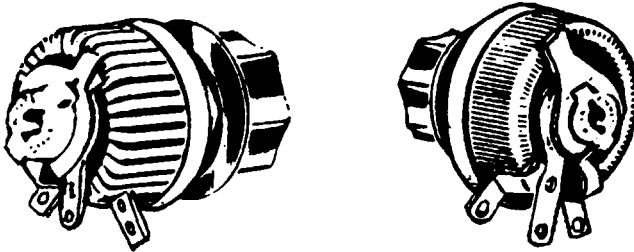
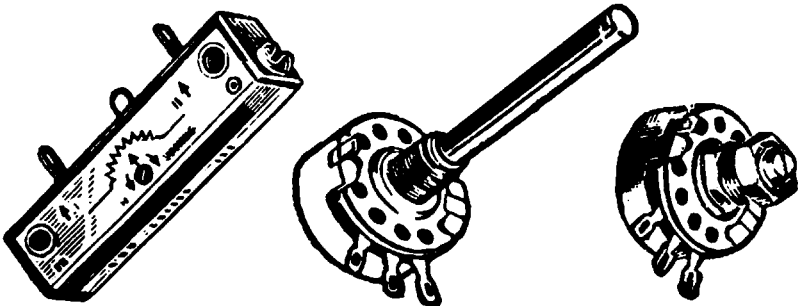

Fig. 2-2. Fixed resistor symbols.



(A) Rheostats.



(B) Potentiometers.

Fig. 2-3. Variable resistors.

nals to this movable arm, a point is obtained which can be adjusted to any desired value of resistance between the two ends.

When terminals are attached to both ends of the resistance element, the resistor is called a *potentiometer*; when a terminal is attached to only one end, it is called a *rheostat*. The most common symbols for potentiometers and rheostats are given at A and B in Fig. 2-4. Notice that it is the normal resistor symbol, with the arrow denoting the sliding contact. Sometimes a circle is added to the movable contact, as shown at C and D.

The only difference between the potentiometer and rheostat symbols is that in B and D, no provision is made for a connection to the bottom end of the resistance element. The reason is that a rheostat has a connection at only one end, as stated previously; however, this same symbol can denote a potentiom-

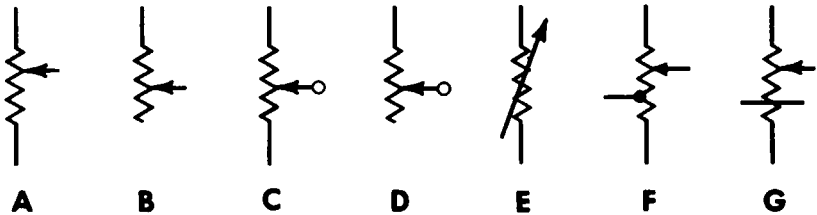

Fig. 2-4. Variable resistor symbols.

eter with one terminal unused. Another symbol which is frequently encountered for a variable resistor is given at E in Fig. 2-4. Here the arrow through the resistor symbol denotes that it is variable. Use of this symbol should be avoided, however, because no provision is made for the third connection to a potentiometer.

The symbols at F and G in Fig. 2-4 are for two special types of variable resistors. The one at F is for a potentiometer with a tap on the resistance element. Such units are often used in tone controls and other circuits. The symbol at G is for a potentiometer in which the movable arm cannot move to the end of the resistance element. Thus, there will always be a certain amount of resistance between the movable arm and the bottom of the control. The stop is symbolized by the line drawn across the resistance element.

Special Resistors

Occasionally there is a need for a resistor with special characteristics which cause its resistance to vary because conditions in the circuit or the area surrounding it change. Many of these units are actually semiconductors (to be discussed later); however, they are included here because they function in the circuit like a resistor.

The temperature of a resistor may rise because of heat from the surrounding components or from the electrons flowing through it. As this happens, the actual resistance of the unit will increase. By varying the composition, special resistors can be produced whose resistance can be made to increase or decrease by certain specified amounts, or to remain constant regardless of the direction of temperature change

Understanding Schematic Diagrams

(within limits, of course). Thus, a special resistor which decreases in resistance can compensate for a normal resistor which increases in resistance. Such resistors are called *temperature-compensating resistors*, *thermal resistors*, or *Thermistors*.

The symbols used to designate temperature-compensating resistors are given in Fig. 2-5. Notice that they are made up with the regular resistor symbol plus the letter *T* (for temperature). The arrow in the symbol at B and the line through the symbol at C designate that the resistance of the unit varies.

When its resistance decreases as the temperature increases, the unit is said to have a *negative temperature coefficient*, ab-



Fig. 2-5. Temperature compensating resistor symbols.

breviated NTC. When the resistance increases as the temperature does, the unit is said to have a *positive temperature coefficient* (PTC). The abbreviation signifying the type of temperature compensation is usually placed beside the symbol.

There are other resistors which will vary in value when the current through them or the voltage across them changes. In others, the amount of light striking the resistor changes the resistance value. Usually the same symbols shown in Fig. 2-5 will be used for such resistors, except that the letters *I* (for current), *V* (voltage), *VDR* (voltage-dependent resistor), *L* (light), or *LDR* (light-dependent resistor) will be substituted

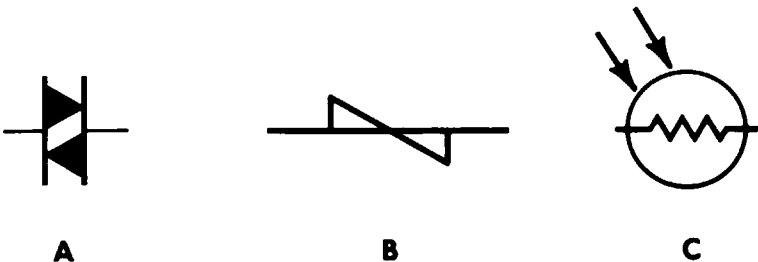

Fig. 2-6. Special resistor symbols.

for the T in Fig. 2-5. The Greek letter *lambda* (λ) may also be used for light-dependent resistors. (*Lambda* is the Greek letter “L”, which stands for light.)

Two additional symbols used for voltage-dependent resistors are given at A and B in Fig. 2-6. Two arrows, as shown at C, may be used with the resistor symbol to designate a light-dependent unit. The circles around the symbol for the resistance elements in some of the symbols in Fig. 2-5 and 2-6 may be omitted, but usually a circle or rectangle is included.

CAPACITORS

Like the resistor, several capacitors are found in nearly every electronic circuit. Another name for the capacitor is *condenser*; however, the latter term is seldom used today except for the “condenser” used in automotive electrical systems and condenser microphones. Formerly, “condenser” was the accepted term for this unit, but since a capacitor doesn’t “condense” anything, the term “capacitor” is preferred by most of the industry.

The elementary capacitor consists of two metal plates with connections to them, separated by an insulating material as shown in Fig. 2-7. Here the insulating material is the air be-

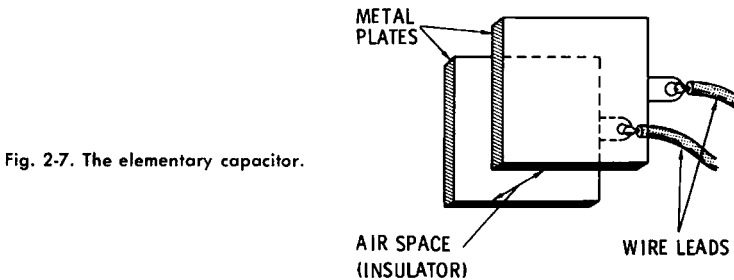

Fig. 2-7. The elementary capacitor.

tween the two plates. A capacitor has the ability to store and release electrons as dictated by the external circuit. This storage and release of electrons is called the charge and discharge of the capacitor.

Electrons cannot flow through the insulating material between the two plates. As far as direct current is concerned, a capacitor acts as an open circuit. However, when an AC voltage is applied to one of the plates, this plate will alternately store and discharge electrons in step with the applied voltage. (During the negative half-cycle, electrons will be stored, and during

the positive half-cycle, they will be discharged.) Furthermore, when an excess of electrons is stored on one plate, electrons will be driven away from the other plate and through the circuit connected to it. Also, when there is a deficiency of electrons on one plate (during the positive half-cycle), electrons will be attracted to the opposite plate. Thus, while no electrons actually flow *through* the capacitor, the effect is the same as if they do whenever an alternating current is connected to one plate and the other plate is connected to some circuit or ground.

The foregoing are the three important properties of capacitors: (1) storing electrons, (2) blocking direct current, and (3) "coupling" alternating current.

The electrical property of capacitors which enables them to store electrons is called capacitance. The unit of measurement for capacitance is the *farad*. For most applications the farad is too large a unit, so the *microfarad*, which is one millionth of a farad, and *picofarad*, equal to one millionth of a microfarad, are more common. Microfarad is abbreviated mf, mfd, μF , μf , or μfd , and picofarad is abbreviated pf, pF, or pfd (μ is the greek letter *mu* and is commonly used in electronics terminology to signify one millionth). The term "picofarad" is relatively new in the United States; formerly the term "micro-microfarad" (mmf, mmfd, $\mu\mu\text{f}$, $\mu\mu\text{F}$, or $\mu\mu\text{fd}$) was used, but is losing favor to the newer term. Thus:

$$1 \text{ pF} = 1 \mu\mu\text{F} = .000001 \mu\text{Fd} = .000000000001 \text{ farad}$$

Fixed Capacitors

The capacitor in Fig. 2-7 is not practical because it is too large physically for use in most applications. As the area of

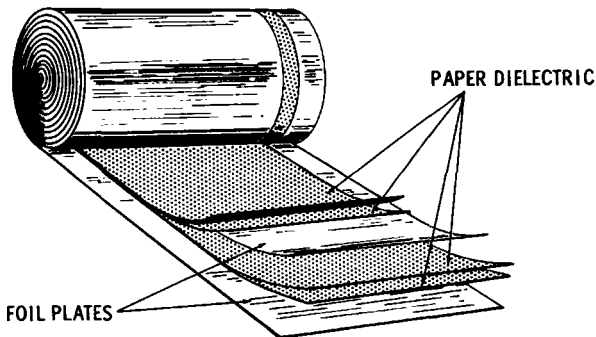

Fig. 2-8. Basic construction of a tubular capacitor.

the plates is increased, there will be a greater capacity for electron storage and hence a greater capacitance. To make a practical capacitor a different type of insulation (called the dielectric) must be used to concentrate a large plate area within a small space. The tubular capacitor (Fig. 2-8) is one of the most common types. Here an insulating material, which may be paper as shown in Fig. 2-8, or Mylar or some other material, is placed between the metal foil plates, which are the conductors. The entire structure is rolled up as shown, and connection

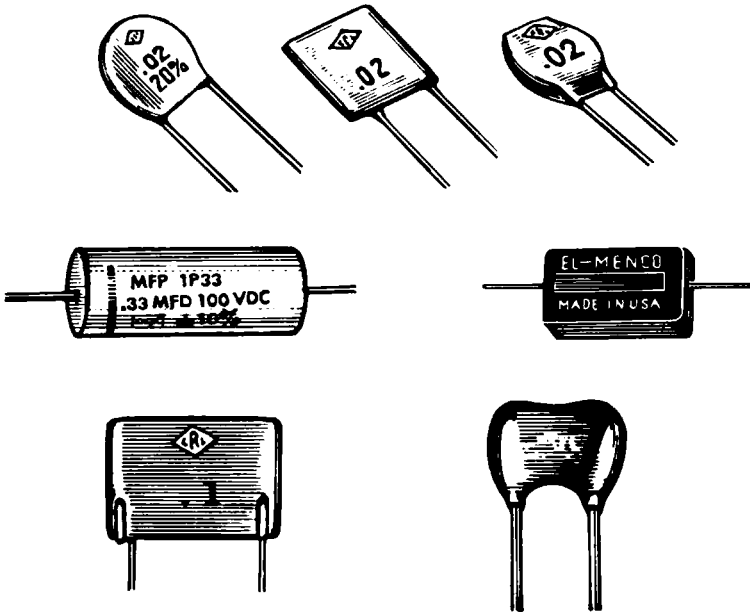

Fig. 2-9. Typical fixed capacitors.

made to the ends of the foil. In other types of construction, mica, ceramic, glass, and other insulation may be used. In any type, the construction is essentially the same—layers of conductors separated by an insulating material. Fig. 2-9 shows the appearance of several types of capacitors.

Once their construction is understood, it is easy to see why the symbols shown in Fig. 2-10 were chosen to represent them. The two horizontal bars (or the bar and arc) represent the two conducting plates; the vertical lines are the leads connected to them; and the space between represents the dielectric. Usually one of the lines is curved, as shown at A.

Understanding Schematic Diagrams

A color code similar to that used for resistors is employed for capacitors. Quite often, however, the value of the capacitor will be stamped on the unit. Also, like resistors, temperature-compensating capacitors are available. Such capacitors can de-



Fig. 2-10. Fixed capacitor symbols.

crease or increase in value with a rise in temperature; units are available for several different rates of variation. Capacitors whose values do not vary with temperature are called NPO capacitors.

Another important rating of capacitors is the working DC voltage. If this voltage is exceeded, the electrons will “jump” across the dielectric causing a very hot arc to occur. When this happens, the capacitor is usually destroyed. Hence, it is important that this voltage not be exceeded. Many capacitors have the working DC voltage stamped on them.

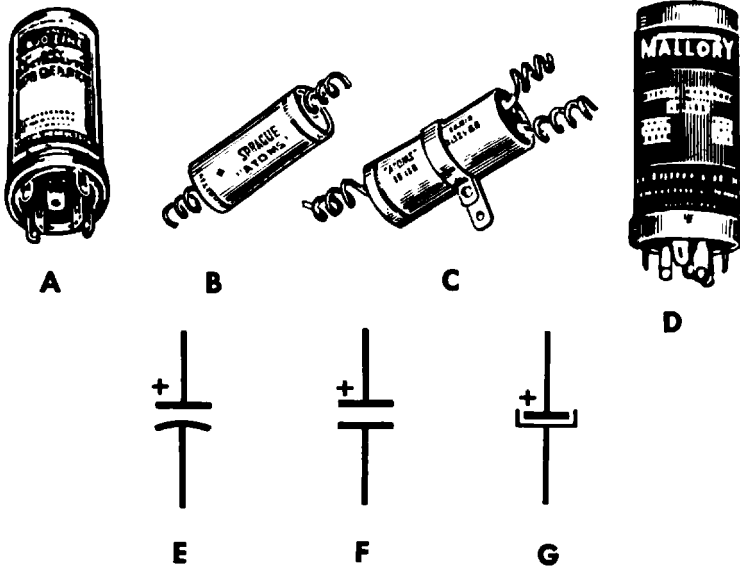

Fig. 2-11. Electrolytic capacitors and symbols.

Electrolytic Capacitors

In another type of capacitor, one of the plates is made up of a moist substance called an *electrolyte*; capacitors employing this construction are called *electrolytic capacitors* (Fig. 2-11). The electrolyte causes an oxide film to form on the aluminum plate. This film acts as the dielectric between the metal plate and the electrolyte. High values of capacitance can be obtained using this principle.

An electrolytic capacitor must be connected in the correct polarity. That is, the positive terminal must go to the most positive voltage point, and the negative terminal to the most

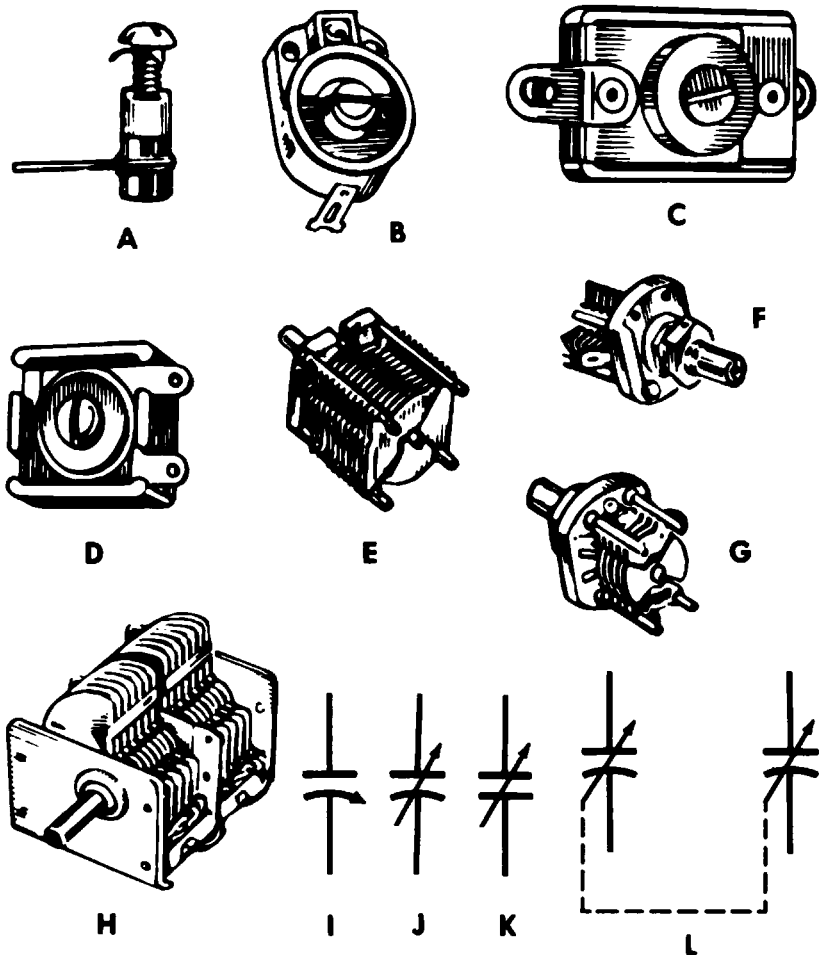

Fig. 2-12. Variable capacitors and symbols.

Understanding Schematic Diagrams

negative (or least positive) point. Plus signs are added to the basic capacitor symbols at E and F in Fig. 2-11 to distinguish these symbols as being for electrolytic capacitors. A minus sign may also be included (by the other plate) in the symbols at E and F. Another symbol for this type of unit is shown at G.

Variable Capacitors

Capacitors can also be constructed so their value can be adjusted by turning a shaft. The tuning control on most radios is a variable capacitor whose capacitance is varied as the tuning knob is rotated. In general, there are two types of adjustable capacitors. Those at A, B, C, and D in Fig. 2-12 are usually called trimmer capacitors. They have a dielectric of mica, ceramic, or similar material and are adjusted by a screwdriver-type adjustment. Those at E, F, G, and H in Fig. 2-12 normally have an air dielectric and are usually adjusted by a knob attached to the shaft. In general, the capacity of this type is greater than that of trimmer capacitors.

As stated, the capacitors at E, F, G, and H usually have air as the dielectric. The two sets of plates are meshed together; that is, one set moves inside the other, but they do not touch. As the shaft is rotated, one set of plates will move in or out and vary the area of the meshed plates, hence, the capacitance between the two. The symbols at I, J, and K in Fig. 2-12 designate either type of variable capacitor. They are identical to the fixed-capacitor symbols except for the arrow, which denotes they are variable.

The unit at H in Fig. 2-12 is actually two separate capacitors, with both being adjusted by the same shaft. Such a capacitor is used to tune two sections of a radio. The symbol at L is normally used to show this. Two capacitor symbols are included, and the dashed line between the arrows denotes that both capacitors are mechanically connected and tuned simultaneously.

COILS

The coil, or inductor as it is sometimes called, can be one of the simplest of all electronic components, but it can also be one of the most complex. In its simplest form, it is just what the name implies—a length of wire wound in the form of a coil. However, to be useful it is usually more complex. A useful coil must be wound in a certain way and have a certain size of wire.

When electrons flow through any conductor, magnetic lines of force are set up in the area around the conductor. As long as the current is steady, the magnetic field will be stationary, but if the current varies, so will the magnetic field. When the current stops, the magnetic field collapses.

If a magnetic field cuts across a conductor, an electric current will be set up in this conductor also. Thus, in a coil, the turns are placed close enough that the magnetic field set up by the current through one turn of the coil will cause a current to be set up in the adjacent turns, and vice versa. This is repeated for each turn of the coil.

The overall effect is that when a current increases, decreases, or changes direction through a coil, the coil will tend to oppose the changes and "smooth out" the variations in the current. For a steady current (direct current), the coil will present no opposition except the resistance of the wire itself.

The electrical property of the coil which tends to oppose any change in the current through it is called *inductance*, and the basic unit of measurement for it is called the *henry* (abbreviated H, h, or hy). Like the farad, the henry is too large a unit for many applications, so the millihenry (mH or mh), equal to one-thousandth of a henry, and the microhenry (μH or μh) are more common units of measure.

Air-Core Coils

If the wire is heavy enough, the loops of coil can be formed and held in place by the stiffness of the wire itself. Usually, however, the turns of wire will be wound around a plastic,

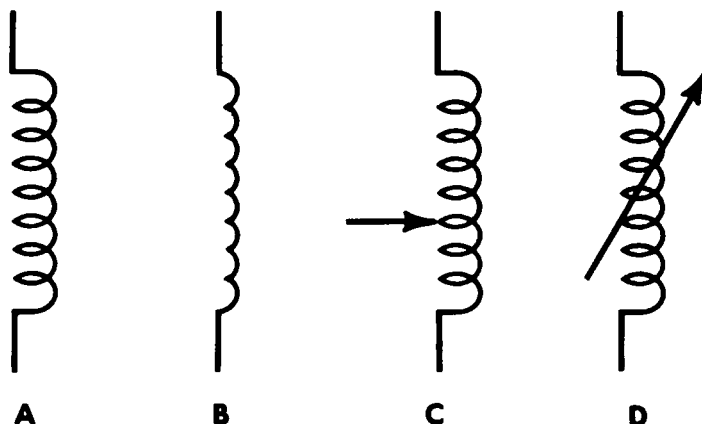

Fig. 2-13. Air-core coil symbols.

paper, or similar nonmetallic form for support. The entire coil may then be coated with plastic for protection. As long as no metallic substances are used for the form (called the core), the coil is considered an air-core coil.

Fig. 2-13 shows some symbols used for air-core coils. Each symbol has loops which represent the turns of wire in the coil. In other instances, the shape of the loops may vary slightly. While not common, it is possible to make an air-core coil adjustable, as shown by the addition of the arrow to the symbols at C and D. The symbol at C represents a system in which a sliding contact comes in contact with the loops of the coil. The one at D is usually employed to show that the loops of the coil can be stretched or compressed to change the inductance of the unit. This method is commonly used in adjusting high-frequency circuits.

Powdered-Iron Core Coils

Only a limited number of magnetic lines of force will find their way to the other turns of an air-core coil. Often a core made by molding ferrite or powdered iron to the desired shape is used instead of the air or other nonmetallic substance pre-

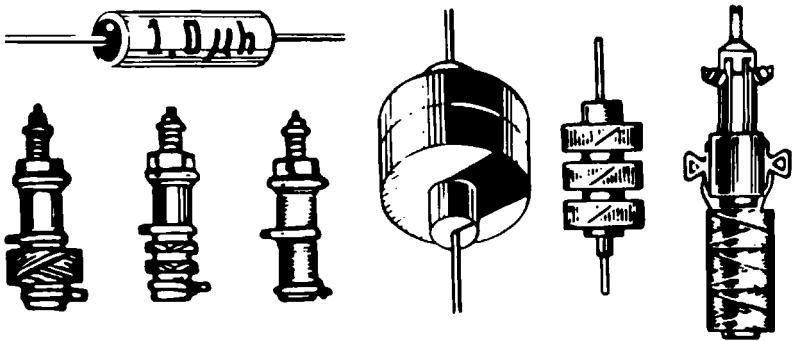

Fig. 2-14. Ferrite-core coils.

viously described. When brought near or inserted within the loops of the coil, a core of this type offers a convenient path for the magnetic lines of force. Thus, more lines of force will cut the other conductors in the coil, increasing the inductance. Coils of this type are available in many shapes and sizes, as shown by a few representative samples in Fig. 2-14.

The symbol for powdered-iron or ferrite-core coils is similar to the one for the air-core symbol except for the dashed lines

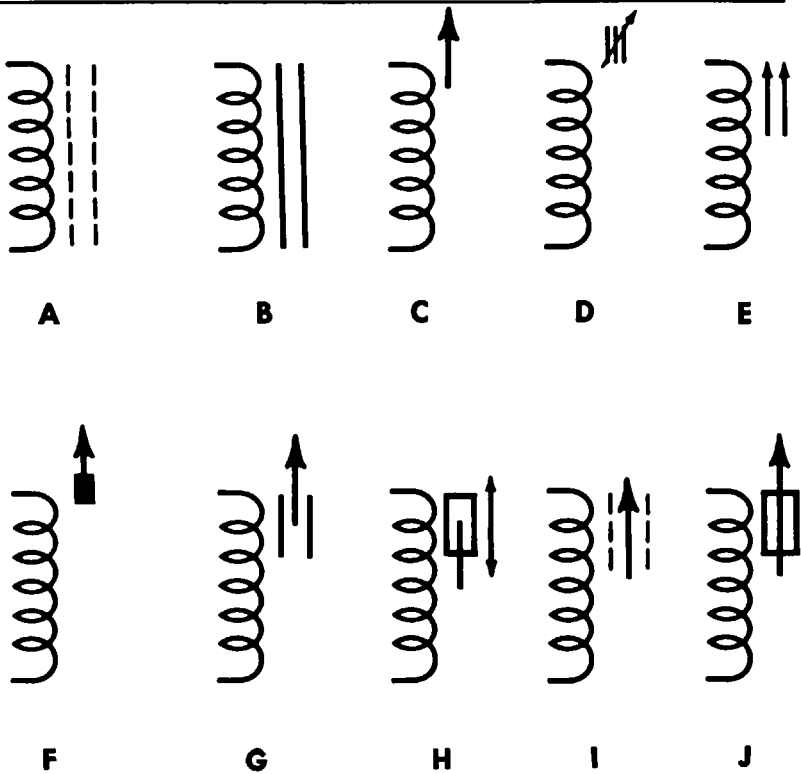

Fig. 2-15. Powdered-iron core coil symbols.

which represent the core, as shown at A in Fig. 2-15. Sometimes the core will be represented by solid lines, as shown at B. Quite often the core is adjustable in this type of coil. Many ways are used to show this variability. All, however, use an arrow in the same manner. The dashed line representing the core may also be included, but quite often it is omitted and only the symbol representing adjustability is added to the basic coil symbol.

Iron-Core Coils

The third method of coil construction uses an iron core. This type of coil is normally called a choke; its primary purpose is to “choke,” or smooth out, variations in the current through it. The construction of a typical iron-core choke is shown in Fig. 2-16. The core is usually constructed of a series of thin sheets of steel called laminations and stacked one on top of another, visible in the center of the unit. The wire of the coil is wound around the core and separated from it by insulation

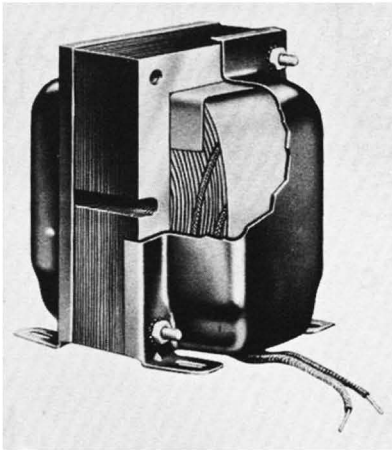

Fig. 2-16. Iron-core choke construction.

(usually paper). In the unit of Fig. 2-16, the entire assembly is then enclosed within a metal shell, but in some units no shell is used. The metal in this core provides even more coupling between windings, and iron-core chokes are characterized by high inductance, usually in the henry range. Fig. 2-17 shows the symbols used for iron-core chokes. They are the same as for an air-core coil except for the two or three solid lines, which represent the core. Usually such

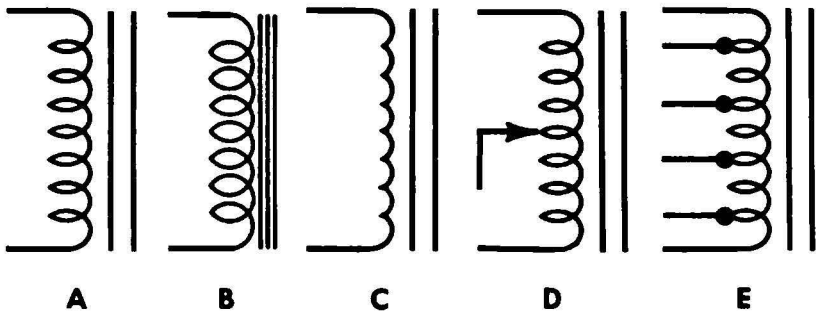

Fig. 2-17. Iron-core choke symbols.

chokes are not variable. If so, however, an arrow is added as shown at D. This represents a sliding contact which moves along the winding of a coil. At other times, several taps are connected to the winding, and a switch is used to select the desired amount of inductance. The symbol for this is given at E.

TRANSFORMERS

Essentially, a transformer consists of two or more coils (called windings), positioned close enough that the lines of force of the magnetic field set up by current in one coil will cut across the windings of the other coil, setting up a current in the second coil. The winding connected to the source of current is called the primary, and the other winding (or windings) is called the secondary.

When a varying current is connected to the primary winding, the resulting current set up in the secondary winding will vary in step with the current in the primary winding. Thus, a transformer can be used for coupling in much the same way as a capacitor.

If a capacitor is connected across the primary winding, it will "tune" the winding so that only one frequency, or a small group of frequencies, will be coupled to the secondary winding. Likewise, adding a capacitor across the secondary winding causes it to accept only certain frequencies. By proper choice of the inductance of the transformer windings and capacitance of the capacitors, only the desired frequency—i.e., those of a particular radio station—will be passed; all others will be rejected.

If the number of turns in the two windings is the same, the voltage across the secondary will be nearly equal to that across the primary. If the secondary has more turns than the primary, the voltage across the secondary will be greater than that across the primary, but the current will be less. If the secondary has fewer turns, the secondary voltage will be less, but the current will be greater.

Thus, the two main purposes of transformers are coupling between circuits and stepping voltages up or down.

Air-Core Transformers

Transformers, like coils, may have an air, ferrite, or iron core. Fig. 2-18 shows symbols used to depict air-core transformers. Notice that they are the same as for air-core coils except that two windings are shown. Usually the winding on

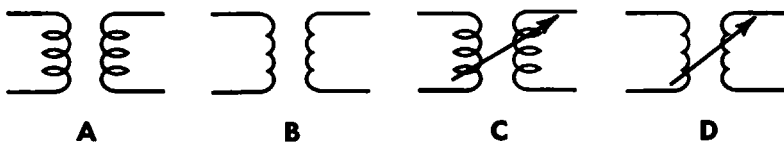

Fig. 2-18. Air-core transformer symbols.

Understanding Schematic Diagrams

the left is the primary and the one on the right is the secondary, but there are exceptions to this general rule. An air-core transformer is normally not adjustable, since the only way to make it variable is to move one winding closer to or farther from the other. When made variable, however, it is usually represented by an arrow through both windings, as shown at C and D in Fig. 2-18.

Powdered-Iron Core Transformers

There are many different sizes and shapes of transformers using powdered-iron or ferrite cores. Fig. 2-19 shows the appearance of a few of them. Notice that some are enclosed in

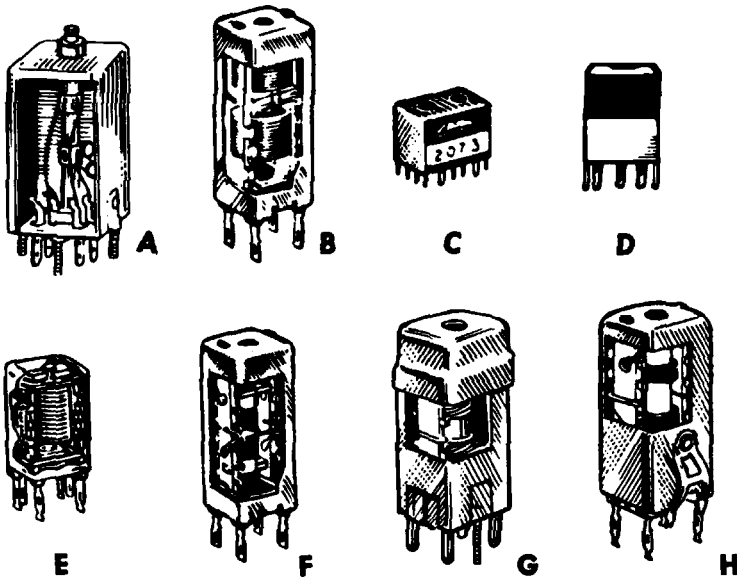

Fig. 2-19. Powdered-iron core transformers.

metal enclosures called "cans." This metal can serves to keep signals from other unwanted sources from interfering with the desired signals. Usually such units, called permeability-tuned transformers, are adjustable, enabling the desired frequencies to be "tuned in."

Just as for powdered-iron core coils, there are many ways to show powdered-iron core transformers on schematics. The first two symbols in Fig. 2-20 are for untuned coils. The remaining symbols show some of the many ways used to show variable transformers. Notice that on some of the symbols, only one

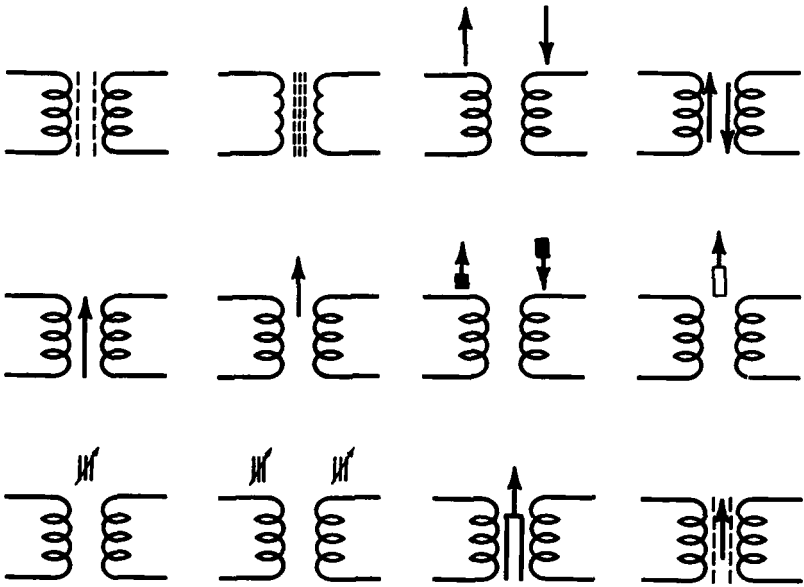

Fig. 2-20. Powdered-iron core transformer symbols.

tuning adjustment is shown. Here, one adjustment affects both windings simultaneously. As for coils, the core material may not be shown in the adjustable symbols. Various types of loops may be used to designate the coils for any of the drawings given; the shape of the loop and whether it is open or closed makes no difference.

Iron-Core Transformers

Fig. 2-21 gives a representative sampling of the many types of iron-core transformers. Notice that as with chokes, some are encased in metal cases; others are not. Unlike other transformers, iron-core transformers often have more than one secondary. For example, a typical power transformer may have one secondary which delivers approximately 300 volts for the B+ supply. Another secondary may supply 6.3 volts and still another 5 volts for the tube filaments (explained in the next chapter).

The symbol at A in Fig. 2-22 is for this power transformer. The winding marked A is the 5-volt secondary, the one labeled B is the 300-volt one, and C is the 6.3-volt winding. Notice that windings at A and C have fewer loops than the primary, denoting a step-down function, and winding B has more loops, representing a step-up winding. The number of loops shown is not

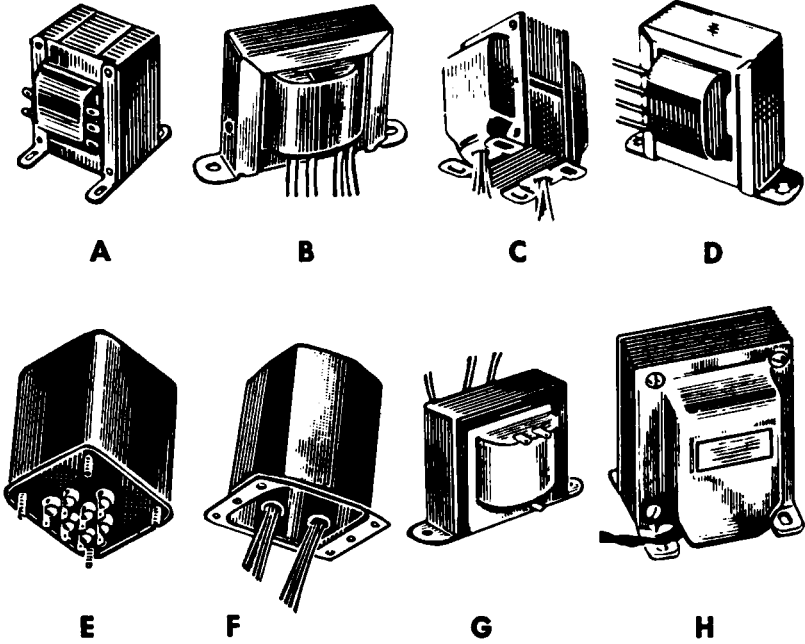

Fig. 2-21. Typical iron-core transformers.

actually proportional to the voltage; it merely indicates a step-up or step-down transformer.

The symbol at B in Fig. 2-22 is for a two-winding step-down transformer, and the one at C is for a transformer that has equal windings. Here the voltage across the secondary is the

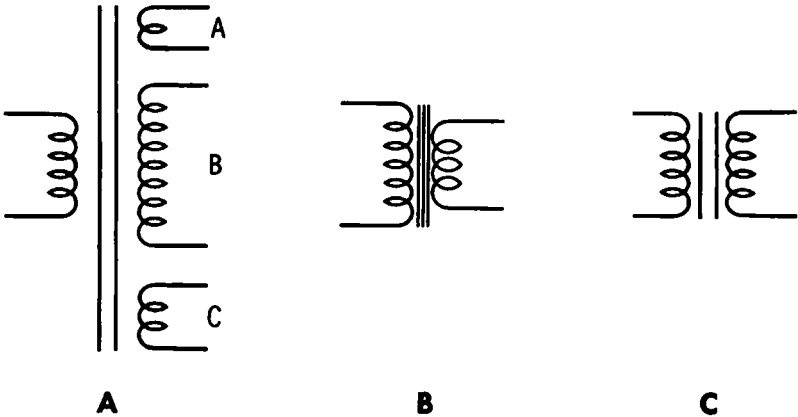

Fig. 2-22. Iron-core transformer symbols.

same as that across the primary. (This type is called an isolation transformer.)

All iron-core transformers will follow the general patterns given in Fig. 2-22. The two or three lines represent the core, and the windings, as drawn, represent the actual windings of the transformers. Normally such transformers are not variable, but if so the variability is represented by an arrow as was done for iron-core chokes.

SUMMARY

In this chapter, the three properties most important in electronic circuits—resistance, capacitance, and inductance—and the components associated with these properties—resistor, capacitor, and coil—have been examined. Any piece of electronic equipment will usually contain several of each of the fundamental components explained in this chapter. In the following chapters, additional components will be examined; when used with the three components of this chapter, they accomplish the desired results for all the various types of electronic equipment.

CHAPTER 3

TUBES AND SEMICONDUCTORS

The entire foundation of electronics is based on the control of a tiny, negatively charged particle called the *electron*. It has been shown (Chapter 1) how this electron will flow from a negative to a positive voltage source as long as there is a complete conductive path between the two points. It has also been shown how resistors, capacitors, and coils will affect this electron flow, called electron current.

Before this electron flow can serve much of a useful purpose, however, some means must be provided to control it. We must be able to turn it on, shut it off, increase, decrease, or change its frequency. These functions are provided by the tubes, transistors, diodes, and other devices to be explained in this chapter.

VACUUM TUBES

Ever since Dr. Lee de Forest invented his *audion* tube early in the 20th Century, the vacuum tube has been the heart of nearly every piece of electronic equipment. In recent years the transistor has replaced it in many applications, but the vacuum tube has not been obsoleted by this amazing device, as was once forecast. There are applications where each is better suited, and each is destined to be used for years to come. In the future, the vacuum tube may indeed be replaced by semiconductor devices, but it will be many years before a complete changeover takes place.

The Diode

The simplest vacuum tube is called a *diode*. Fig. 3-1 shows its basic construction. It consists of a glass case (called an envelope), a base through which pins are inserted for connection to the individual parts, and the individual parts themselves (called elements) inside the tube. All the air has been removed from the inside of the tube envelope leaving the elements in a vacuum.

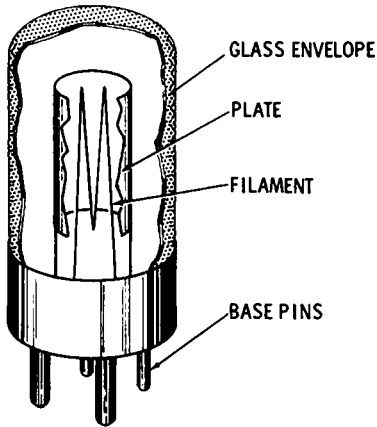

Fig. 3-1. Construction of a diode tube.

At the center of Fig. 3-1 is an element labeled the *filament*. It is a length of special-resistance wire which becomes hot when electrons flow through it. The filament has a coating which, when heated, causes electrons to be expelled from the filament into the vacuum space. In other tubes another element, called the cathode and shaped like a sleeve, is placed around the filament. Here, the only function of the filament is to heat the cathode, which, in turn, expels electrons into the surrounding vacuum when hot. (In this latter application, the filament is often called the heater.)

Another element called the plate is shown in the tube of Fig. 3-1. If this element is connected to a source of positive voltage, the electrons which were expelled from the filament (or cathode) will be attracted to it. Recall that electrons flow from negative to positive as long as there is a conductor connected between the two points. In a vacuum, the conductor is not necessary and the electrons will flow across the vacuum of the tube *as long as the plate is more positive than the filament (or cathode)*.

This introduces us to the most important function of the diode tube—rectification. If an AC voltage is connected to the plate, electrons will flow from the filament to the plate during the positive half-cycles of the applied alternating current. During the negative half-cycles, no electrons will flow. Thus, the alternating current is changed to pulsating direct current at the cathode. This pulsating current is smoothed out by an electrolytic capacitor, giving us a relatively steady direct current.

Fig. 3-2 shows the symbols for a diode tube. The one at A is for a tube having only a filament and plate, and the one at B is for a tube which also contains a cathode. The circle represents

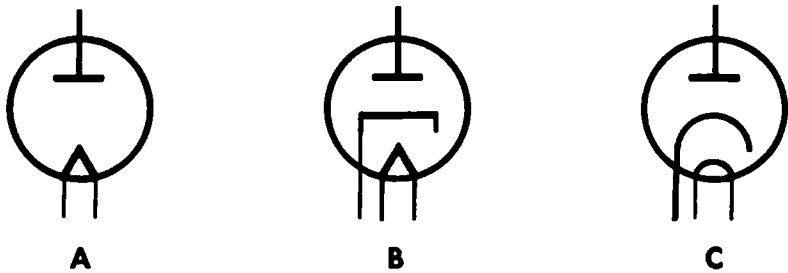

Fig. 3-2. Diode tube symbols.

the glass envelope; the pointed element at the bottom is the filament. The element that looks like an inverted T at the top is the plate. The additional element is the cathode.

Most manufacturers follow essentially the same symbols shown in Fig. 3-2. Some of the lines may be heavier or lighter, or longer or shorter; the connections which extend from the element may go in a different direction, but it makes no difference. About the only significant difference is that the cathode or filament may be rounded by some manufacturers, as shown at C. Sometimes the heater will not be shown as part of the symbol, but will be shown separately in the power-supply section since its only function is to heat the cathode.

The Triode

Fig. 3-3 shows the construction of a triode tube. Notice that it is essentially the same as the diode shown previously except for an added element called the grid. (A cathode, explained previously, is also shown in Fig. 3-3).

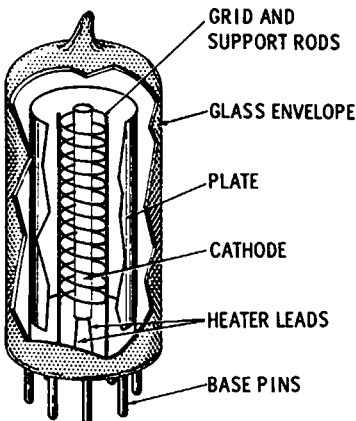

Fig. 3-3. Construction of a triode tube.

The diode tube, as explained previously, can change alternating current to direct current, but it cannot increase the strength of a signal. It will actually introduce a slight loss in the circuit.

The triode overcomes this disadvantage. Notice in Fig. 3-3 that the grid is made of a fine-mesh wire supported by two supports whose only purpose is to hold the grid wires in place. Fig. 3-4 shows the symbol for the triode tube. The grid is represented by the dashed lines between the cathode and plate. Thus, all electrons trying to flow between the cathode and plate must flow through the holes in the grid. If this grid is made negative enough, it will repel all the electrons, forcing them back to the cathode. As it is made less negative, some electrons

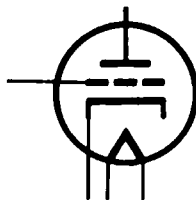

Fig. 3-4. Triode tube symbol.

will flow through it and on to the plate. When made still less negative (more positive), more electrons will flow on to the plate. Only a small change is required in the grid voltage to produce a large change in the electron current which travels from the cathode to the plate. If a small AC voltage representing the signal (for example, the music, speech, etc., of a radio program) is applied to the grid, the signal at the plate will vary with the one at the grid, but will be much larger. This is amplification—the primary function of a triode tube. Because of its function in controlling the number of electrons flowing through the tube, the grid is usually called the control grid.

Other Tubes

The triode can be used to amplify practically any signal, but in many applications additional elements are desired. The symbol at A in Fig. 3-5 is for a *tetrode* tube. As you might guess from looking at the symbol, it contains another element, similar in construction to the control grid, added between the grid and the plate. This grid is called the *screen grid*, and sometimes the tetrode tube is called a *screen-grid* tube. As mentioned previously, any two conductors will have a certain amount of capacitance between them. The screen grid is placed in the

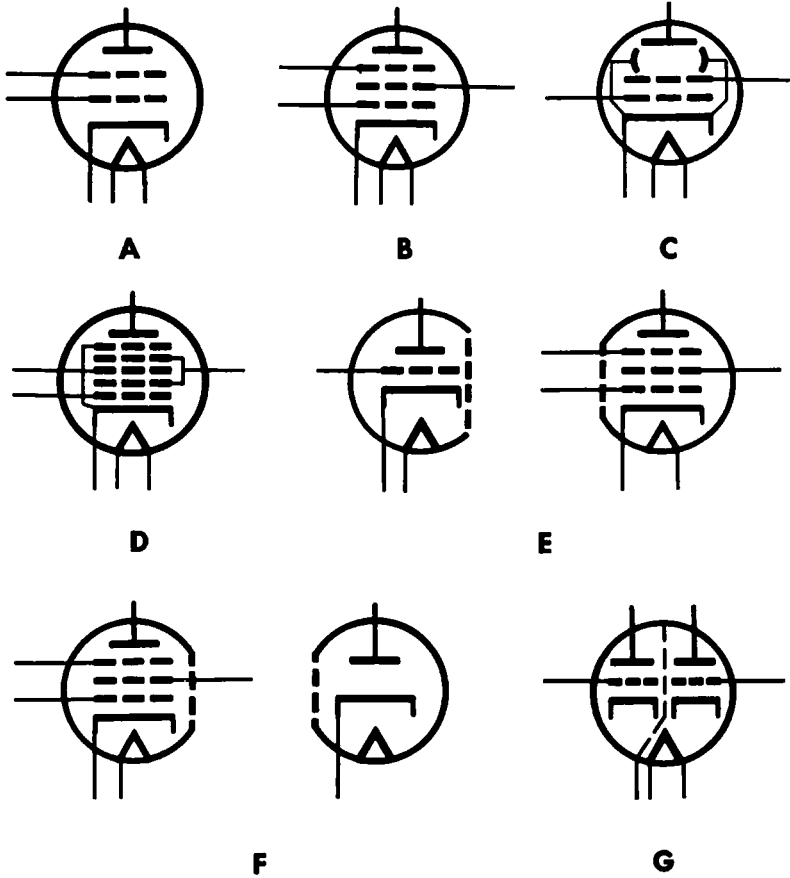

Fig. 3-5. Other vacuum tube symbols.

tube to minimize capacitance between the control grid and plate. Usually a capacitor is connected between the screen grid and ground to remove any signal voltage on this element and keep it at a neutral position. Thus, it acts as a shield between the control grid and plate. Much higher gain (amplification) can be obtained from a tetrode tube than from a triode.

The tetrode offers considerable advantage over the triode in many applications, but another problem is often encountered, called *secondary emission*. It occurs when the electrons from the cathode strike the plate with such force that they bounce off and also knock off some electrons already on the plate. These electrons will be attracted by the positive voltage on the screen and collect on it, causing the screen to receive more than

its share of electrons and reduce the amount delivered to the plate, where needed. This effect can be overcome by adding an additional grid between the screen grid and plate. This grid, called a *suppressor grid*, is connected to the cathode or ground. Since the plate is connected to a positive voltage and the suppressor grid is much more negative than it, the suppressor will repel any secondary-emission electrons back to the plate before they can reach the screen.

A tube containing a cathode, control grid, screen grid, suppressor grid, and plate is called a *pentode*. The symbol for the pentode is shown at B in Fig. 3-5. It is the same as for the tetrode except for the added dashed line representing the suppressor grid.

There are many other types of tubes, each designed to perform a needed function. The symbol at C in Fig. 3-5 is for a *beam-power* tube. This tube has a control grid and screen grid plus a special set of elements which guide the electron stream into a beam and direct all electrons to the plate. This type of tube can be made to handle considerably more power and is usually employed in the output stages of an amplifier. The small curved elements near the plate but connected to the cathode in the symbol at C are the beam-forming elements. Sometimes they will be omitted from the symbol and the tetrode symbol used; others may use the pentode symbol to represent this tube.

The symbol at D in Fig. 3-5 has *five* grids between the cathode and plate. Called a *pentagrid converter*, such a tube performs the combined function of oscillator and mixer in an AM radio. There are several other types of vacuum tubes, but most will be represented by symbols similar to those given in this chapter. Usually the center element is shown at the bottom (the heater). Then each succeeding element is shown in its respective place within the envelope as you travel outward to the plate—the outside element—at the top of the symbol.

It is also possible to construct two or more tubes within a single glass envelope. When this is done, a common heater is used, but the remaining elements of the tube may be entirely separate or shared by both tube functions. The same symbols may be used to represent a dual-section tube, as these are called. Usually, however, a portion of the circle will be dotted, as shown at E and F in Fig. 3-5, to signify that there is more to the tube. The two sections can be drawn within a single symbol, as shown at G, or they can be separated and placed wherever that particular section of the tube falls in the circuits as at E and F. Any desired combination can be manufac-

Understanding Schematic Diagrams

tured in this way. A triode pentode is shown at E, a pentode diode at F, and a dual triode at G. Notice the dashed line through the center of the tube at symbol G. It represents a shield placed inside the tube to prevent interaction between the two sections.

Gas-Filled Tubes

Certain tubes do not have a vacuum inside, but instead are filled with an inert gas. Some tubes of this type do not require a heated cathode; hence they are called *cold-cathode* or *ionical-*

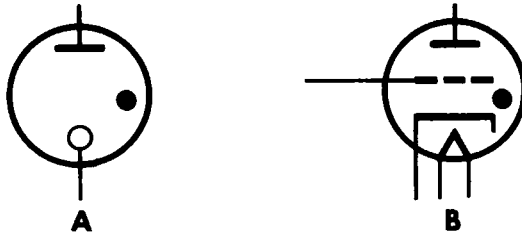

Fig. 3-6. Gas-filled tube symbols.

ly heated cathode tubes. The symbol for this type of tube is given at A in Fig. 3-6. Here the round circle at the bottom represents the cold cathode. The small black dot inside the envelope signifies it is a gas-filled tube. The symbol at B is for a gas-filled triode tube, called a *thyatron*. It is used in certain control applications.

SEMICONDUCTOR DIODES

Semiconductors, or *solid-state* devices as they are sometimes called, can perform virtually every function that a vacuum tube can, and some they can perform better. Furthermore, the life expectancy of a semiconductor is usually greater than that for a comparable tube.

Materials such as selenium, germanium, and silicon, when properly treated, have the property of allowing electrons to flow in one direction through them, but not in the opposite direction. Although the individual elements, corresponding to the plate and cathode of a vacuum tube, actually touch each other instead of being separated by a vacuum or gas, electrons will flow in one direction but not the other. Furthermore, no heater is required and, in general, they occupy a much smaller space.

The oldest form of semiconductor device used in entertainment equipment is the selenium rectifier. It performs exactly

Fig. 3-7. A typical selenium power rectifier.

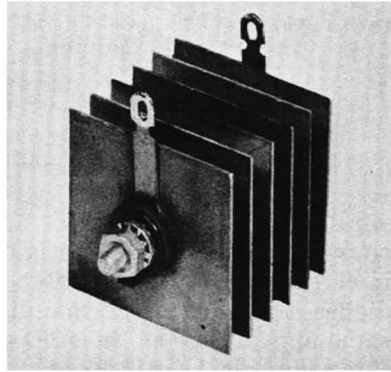

the same function as the diode rectifier tube—that of converting the input alternating current to a pulsating direct current which, in turn, is smoothed out by electrolytic capacitors. Fig. 3-7 shows the appearance of such a rectifier. Selenium rectifiers have been largely replaced by ones made of silicon, however. With the latter, much higher currents can be handled with much smaller units. Fig. 3-8 shows the appearance of several types of silicon rectifiers. The symbol for the power rectifier may be solid black as shown at A, or unshaded as

Fig. 3-8. Typical silicon power rectifiers.

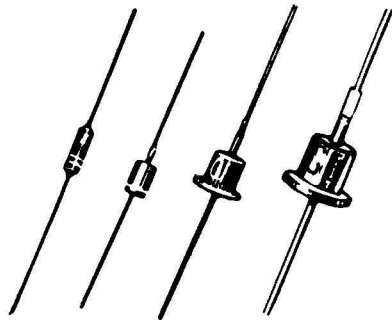

shown at B, in Fig. 3-9. The bar on the symbol corresponds to the cathode of a vacuum tube and is called the cathode in the rectifier also. The arrowhead of the symbol corresponds to the plate of the vacuum tube; here it is called an anode. Electrons flow toward the arrowhead (anode) when it is positive with respect to the cathode.

The semiconductors described in the preceding paragraph are called power rectifiers because they are designed to pass the large amounts of current present in the power supplies and

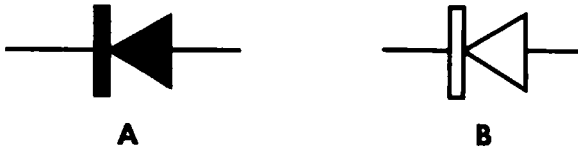

Fig. 3-9. Semiconductor power rectifier and signal diode symbols.

similar applications. There are other diodes, called *signal diodes*, which perform essentially the same function but are used in signal circuits. Thus, only small currents are present. Signal diodes are made of germanium or silicon and have about the same appearance as the silicon power rectifier in Fig. 3-8. The same symbols (Fig. 3-9) are used to represent the signal diode as the power rectifier.

TRANSISTORS

The transistor performs essentially the same functions as a vacuum tube. Transistors are available in many sizes and shapes. Some are no larger than a pinhead; others are rather large and generate a considerable amount of heat. Fig. 3-10

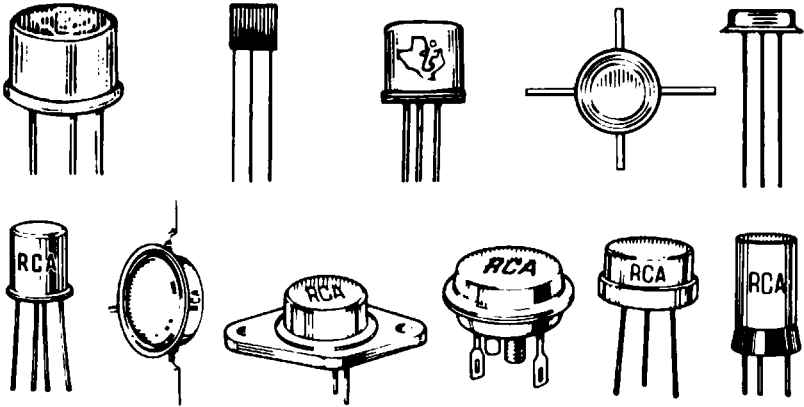

Fig. 3-10. Typical transistors.

shows several types of transistors. The study of solid-state physics essential for an understanding of transistor operation is beyond the scope of this book. Only the essentials considered necessary will be given here.

The pure semiconductor material such as silicon or germanium must be treated before it is useful in semiconductor devices. This treating consists of adding small amounts of impurities to the material to alter its electrical properties. Two types of material are created. One contains an excess of electrons and is called *N-type material*; the other has a deficiency of electrons and is called *P-type material*. Fig. 3-11 shows the basic construction of one type of transistor. Notice that it consists of three layers arranged in a "sandwich." Here an N, a P, and then another N layer are shown. This is an NPN transistor. The layers can be reversed, giving us a P, an N, and then another P-type layer and it is called a PNP transistor. Of course, the manufacturing process is far more complicated than implied here—you can't just cut off three pieces, put them together, connect the proper voltages, and have a transistor.

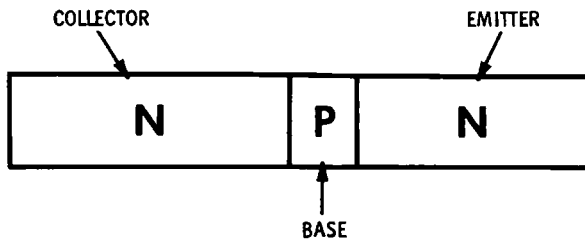

Fig. 3-11. Elementary transistor construction.

The names of the three elements are also given in Fig. 3-11. The emitter is roughly the equivalent of the cathode in a vacuum tube, the base roughly corresponds to the control grid, and the collector to the plate of a vacuum tube.

In a transistor, however, the voltages applied to the various elements vary for the two types. The base of an NPN transistor must be more positive than the emitter, and the collector must still be more positive. For a PNP transistor the emitter is the most positive element, the base is negative with respect to the emitter, and the collector is still more negative. Likewise, the current through the two types is in opposite directions. In an NPN transistor, electrons flow from emitter to base to collector, much the same as in vacuum tubes. However, in a PNP transistor, electrons flow from collector to base to emitter.

The symbol for an NPN transistor is given at A in Fig. 3-12; the symbol for a PNP transistor is given at B. A variation of

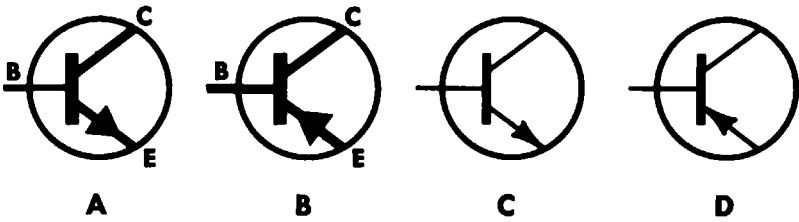

Fig. 3-12. Transistor symbols.

the NPN symbol is given at C and of the PNP transistor at D. Notice that the NPN and PNP symbols are identical except for the direction the arrow points. This element, which represents the emitter, points toward the circle representing the envelope for the NPN transistor, and toward the bar through the center which represents the base for the PNP transistor. The remaining diagonal line extending from the base to the envelope represents the collector. The arrow on the emitter symbol always points in the direction opposite to the electron flow. This is called the direction of *hole* flow in transistor terminology.

The letters with the symbols at A and B in Fig. 3-12 indicate the base (B or b), collector (C or c), and emitter (E or e) of the transistor. These letters may or may not be included as part of the symbol on schematics.

The emitter may be placed at the top or the bottom of the symbol. In practice, it is placed wherever it is convenient for the layout of the remainder of the circuit. In fact, the entire symbol may be reversed, with the base pointing to the right, or it may be at the top or bottom of the symbol. The circle representing the case may be omitted, but it is usually included.

OTHER SEMICONDUCTORS

There are many other types of semiconductor devices in use. More and more types are being developed as solid-state technology advances and new needs are developed. Some of the newer functions that semiconductors perform cannot be duplicated by comparable tube circuits. No effort will be made to explain the operation of these devices here; however, the symbols for many devices are given in Fig. 3-13. As with other semiconductors, the symbols may or may not be enclosed in circles. Circles are shown in Fig. 3-13 because this is the preferred method. Unfortunately, many of the devices have multiple names and some devices share symbols. Several names will be given for some of the elements.

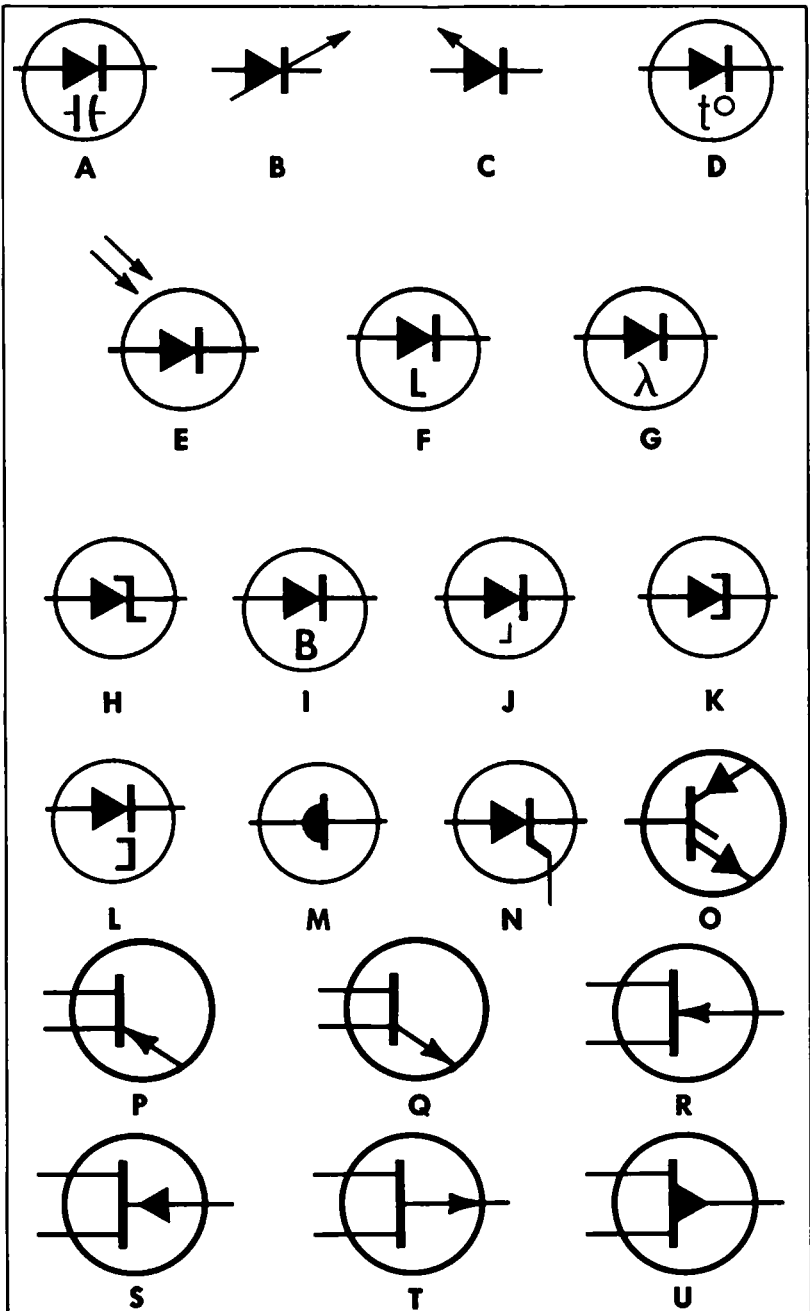

Fig. 3-13. Other semiconductor symbols.

The symbols at A, B, and C in Fig. 3-13 are for a capacitive diode, also called a *Varicap*, varactor, reactance diode, or parametric diode. This device acts much like a capacitor, and its capacitance varies according to the voltage applied to it. The device at D is a temperature diode, and the ones at E, F, and G are for light-dependent diodes or solar cells.

The symbols at H, I, and J in Fig. 3-13 are for zener diodes, also known as breakdown diodes, backward diodes, voltage-regulator diodes, and voltage-reference diodes. This is a device used in maintaining a constant voltage at a needed point in the equipment. The symbols at K, L, and M are for tunnel diodes.

Silicon-controlled rectifiers (scr's), which have wide use in motor control and light-dimming circuits, are represented by the symbol at N. The symbol at O is for a PNPN switch, also called a Shockley diode or four-layer diode.

A unijunction transistor, double-base diode, or filamentary transistor is symbolized by P and Q. P is for an N-type and Q is for the P-type unit. The symbols at R, S, T, and U are for field-effect transistors, with R and S showing the N-type base, and T and U the P-type base.

CHAPTER 4

OTHER COMPONENTS

With the proper combinations of resistors, capacitors, and coils, and with tubes or some type of semiconductor device to amplify and control the electron flow, we can build practically anything—but it would be worthless. Before it can serve a useful purpose, some means must be provided to connect the proper signal to the equipment and/or to use the results obtained. Without an antenna, microphone, phono pickup, or some other type of input and a speaker, earphone, recording head, or other output, the signal cannot be useful. Also, other items are essential for the proper operation of most pieces of equipment. These devices are discussed in this chapter.

ANTENNAS

Any type of receiver or transmitter, whether it is an AM radio, television set, CB radio, or radar set, must have an antenna. If the antenna is part of the set, it usually is included on the schematic; however, if it is a separate unit, often only the point where it is to be connected is included.

The symbol at A in Fig. 4-1 is the general antenna symbol, which can be used to represent any type of antenna. Quite often, however, a symbol which more nearly pictures the antenna in use is employed. For example, the monopole or whip antenna such as shown on the CB transceiver in Fig. 4-2 is usually represented by one of the symbols at B, C, or D in Fig. 4-1. These symbols more nearly show the construction of the unit. Antennas of this type are also used on other radios and on television receivers.

Some television receivers may use two telescopic units; this will be represented by using two of the symbols shown for the monopole—usually set at an angle as shown at E in Fig. 4-1. Such an antenna is called a *dipole*. At other times a dipole which is not adjustable may be shown. The symbol at F is for a dipole antenna, which is nothing more than two lengths of tubing or transmission line extending in opposite directions, as

Understanding Schematic Diagrams

shown by the symbol. The symbol at G is for a special type of dipole called a folded dipole. A uhf antenna may be depicted by symbols such as those at H and I, which represent the physical shape of many uhf television antennas. At other times, one of the other symbols may be used for a uhf antenna.

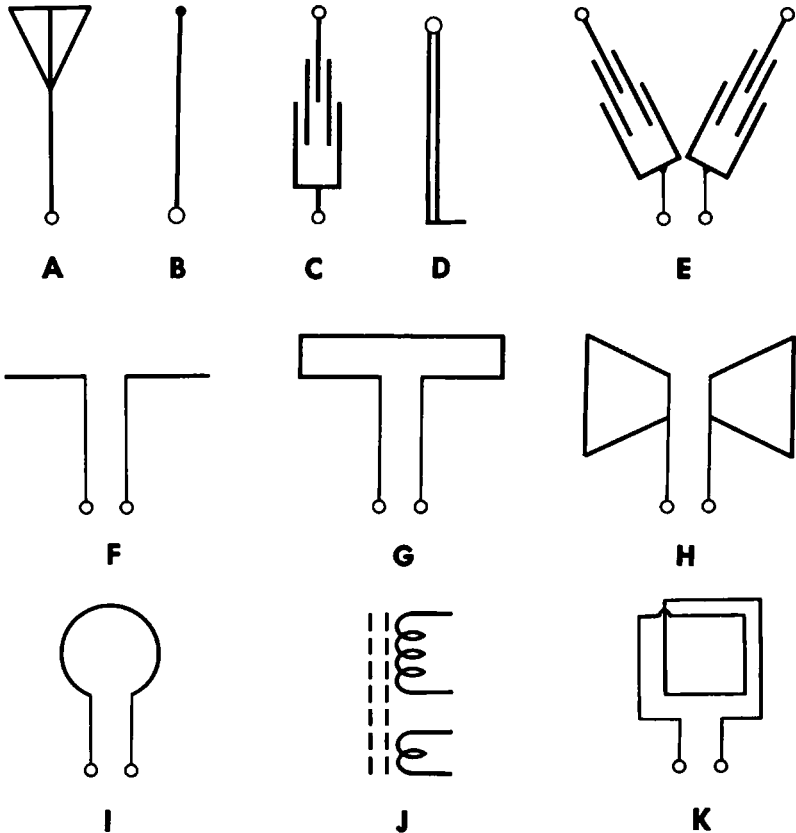

Fig. 4-1. Antenna symbols.

The antenna in most transistor radios and many other table radios is actually a ferrite rod with one or two coils wound around it. Therefore, the symbol used to represent this unit is like that used for ferrite coils, as shown at J in Fig. 4-1. (The other symbols shown in Chapter 2 for ferrite coils or transformers may also be used). At other times the antenna may be a length of wire fastened to the back panel of the set in the form of a loop. The symbol at K is for this type of antenna.

Fig. 4-2. The Knight-Kit [®] C-555 Citizens Band transceiver.



PICK-UP DEVICES

Before the sound from a phonograph can be amplified by an amplifier, the variations in the record groove must first be converted into an electrical signal. This is done by the phono cartridge or pickup. The symbol at A in Fig. 4-3 is a general type used to represent any type of cartridge. Usually, however, a symbol similar to that at B will be employed. The symbol at

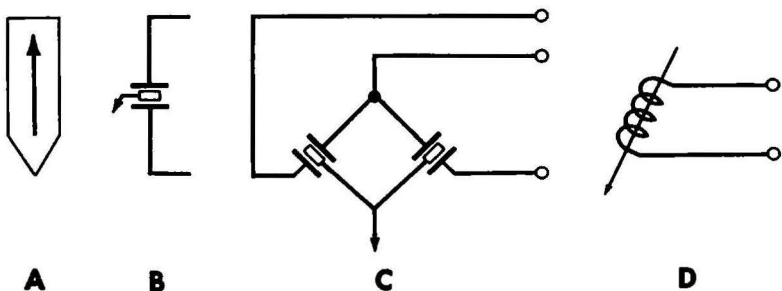

Fig. 4-3. Phono pickup symbols.

Understanding Schematic Diagrams

C is a stereo version of the one at B. The symbols at B and C are used to indicate piezoelectric-type pickups. A symbol sometimes used for magnetic phono pickups is given at D. Other symbols are also used, but in general, all will be more or less a picture of the actual pickup.



Fig. 4-4. Typical microphone.

The microphone (Fig. 4-4) is another type of pickup device. It converts the sound waves from voices or music into an electrical signal which can then be amplified and converted to another form, or whatever is desired. The most common symbols used to represent a microphone are shown at A and B in Fig. 4-5. A special type of microphone, called an *ultrasonic*

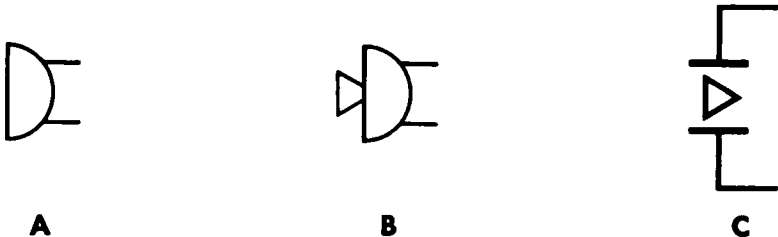

Fig. 4-5. Microphone symbols.

microphone or transducer, is represented by the symbol at C. This type of microphone receives ultrasonic sound waves such as those used by the remote controls of many television receivers. Small transceivers such as the one in Fig. 4-2 and intercoms often use the speaker as the microphone. In this case, the speaker symbol (given later) will be used.

MAGNETIC HEADS

In tape recorders, small devices called heads are used to record the magnetic pattern on the tape, to extract the information recorded on the tape for playback, and to erase the tape.

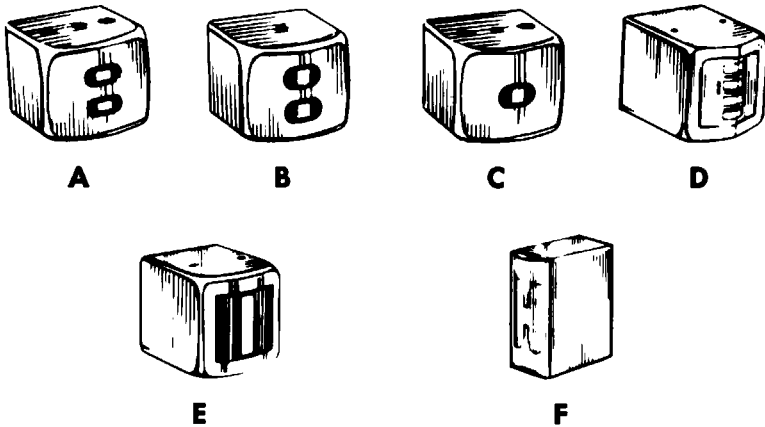

Fig. 4-6. Typical magnetic heads.

Since tape heads (Fig. 4-6) are essentially a coil and a suitable magnetic material which acts as the core, the conventional coil symbols shown in an earlier chapter are used by some to represent magnetic heads. The ones in Fig. 4-7 are more proper, however. All are identical except for the letter inside the

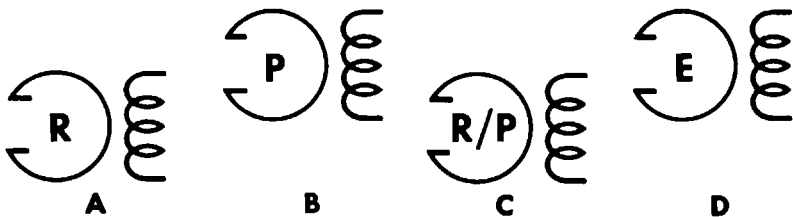

Fig. 4-7. Magnetic head symbols.

curved section which represents the magnetic material. The R stands for record, P for playback, and R/P is for a single head used for both recording and playback. The symbol with the E in it is for an erase head.

SPEAKERS

Just as the phono pickup and the microphone convert mechanical vibrations into an electrical signal, the speaker converts an electrical signal into mechanical vibrations known as sound. Fig. 4-8 shows the basic construction of a speaker. It consists of a permanent magnet with a small coil, called the voice coil, placed in the magnetic field of the permanent magnet. The voice coil is physically connected to the cone through

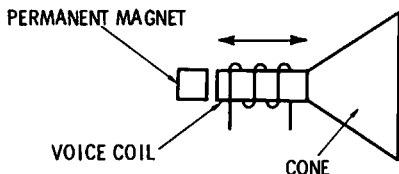

Fig. 4-8. Elementary construction of a speaker.

a device called the spider. The audio signal flows through the voice coil. As you will recall from Chapter 2, a magnetic field is set up around any wire through which there is a current. This magnetic field will cause the voice coil to be attracted or repelled by the magnetic field of the permanent magnet. The only way the voice coil can move is back and forth in the direction of the arrow in Fig. 4-8. This movement also causes the cone to vibrate at the same rate because the two are physically connected. The vibrating cone causes the surrounding air to vibrate at the same rate. This air vibration is what we hear as sound.

There are many symbols used to designate speakers on schematics. It almost seems that each manufacturer tries to come up with something a little different. Fig. 4-9 shows some of the ones in use. Almost all show a coil and some type of representation of the cone.

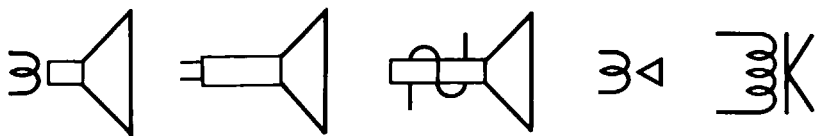

Fig. 4-9. Speaker symbols.

EARPHONES AND HEADPHONES

Earphones and headphones accomplish the same purpose as a speaker, but are designed for private listening. In general, the same type of construction is used; that is, a coil in a magnetic field without a cone is used. Fig. 4-10 shows some of the many types. The first two are similar except the first one is a dual unit for listening with both ears, whereas the second one has only one earpiece. The third unit is a combination headphone and microphone. The microphone is mounted on the long arm extending from the lower right toward the center of the drawing. A unit of this type can be used to talk and listen to someone at a remote location and is usually called a *headset*. The unit on the right in Fig. 4-10 is an earphone designed to fit inside the ear. This is the type used with most portable transistor radios.

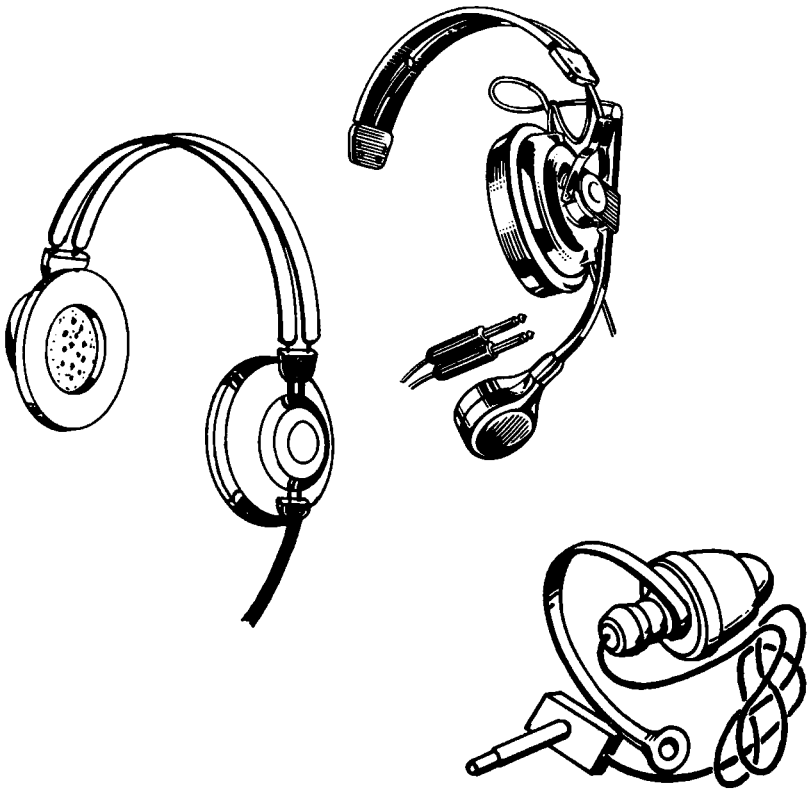

Fig. 4-10. Headphones and earphones.

Understanding Schematic Diagrams

The symbol at A in Fig. 4-11 is for a single earphone or headset, and the one at B is for a double one. Some units employing two earpieces are designed for stereo listening, with the left channel connected to the left earpiece and the right channel to the right earpiece. In this case an *L* and an *R* are

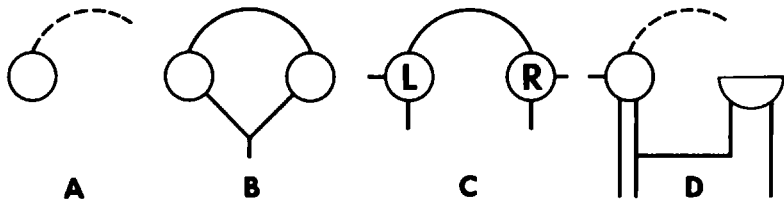

Fig. 4-11. Headphone and earphone symbols.

usually placed inside the small circle representing the earpiece, and separate connections are made to the individual earpieces, as shown at C. The symbol at D is for the combination earphone and microphone. The same symbol is used to represent a telephone handset, except the dashed line representing the band across the top of the head is omitted.

BATTERIES

Batteries are used to power all types of portable electronic equipment from hearing aids to television receivers and even larger equipment. In order to meet the requirements for such a large range of items, many different sizes and types of batteries have been developed. Some are designed to deliver high current intermittently, others very small current continuously; they range from slightly over one to several hundred volts output.

To meet these varied requirements necessitates several different kinds of batteries. There are five basic types of batteries used in electronic equipment. Essentially all batteries consist of two dissimilar materials in a solution, but the materials and the construction vary. One of the five types is the familiar automobile battery which supplies power for mobile equipment. It will not be discussed here since it is not normally considered a part of electronic equipment.

Carbon-Zinc Battery

The most familiar battery to most people—the flashlight “battery”—really is not a battery. The proper term for this

unit is *cell*. A battery is made up of two or more cells, but in popular usage all are called batteries.

The carbon-zinc cell consists of an outside covering of zinc which acts as the negative electrode for the battery. The other electrode is actually manganese dioxide and other materials in a moist acid solution, but usually the carbon rod is thought to be the positive electrode. This carbon rod with a metal cap

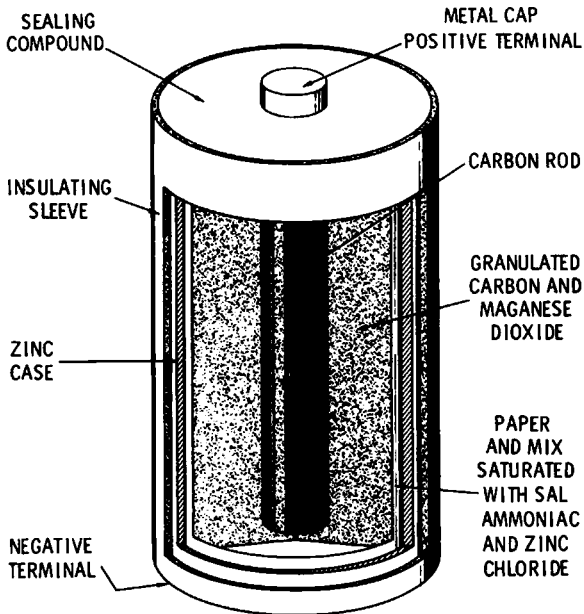

Fig. 4-12. Construction of carbon-zinc cell.

is inserted in the manganese dioxide in order to get a good electrical contact. Carbon is a good conductor, so it allows electrons to move from the cap to the manganese dioxide freely, but it does not actually enter into the chemical action of the cell. Fig. 4-12 shows the construction of a typical carbon-zinc cell.

Each carbon-zinc cell delivers 1.5 volts when fully charged, regardless of its physical size. To obtain different voltages, the individual cells are connected within the battery. For example, four cells can be connected to deliver 6 volts, and six cells for 9 volts. The carbon-zinc cell is characterized by its low cost. It has a short life, compared to other types, but it no doubt will be the most popular type of battery for many years.

Mercury Battery

The mercury battery has been used for several years where an accurate voltage and small size are needed. It also can be operated under extreme temperature conditions where other batteries are not usable.

The negative electrode of a mercury battery is again zinc, but for this type of battery it is normally made from a highly purified powder. The positive electrode is a pressed structure of mercuric oxide, with graphite added for conduction. The

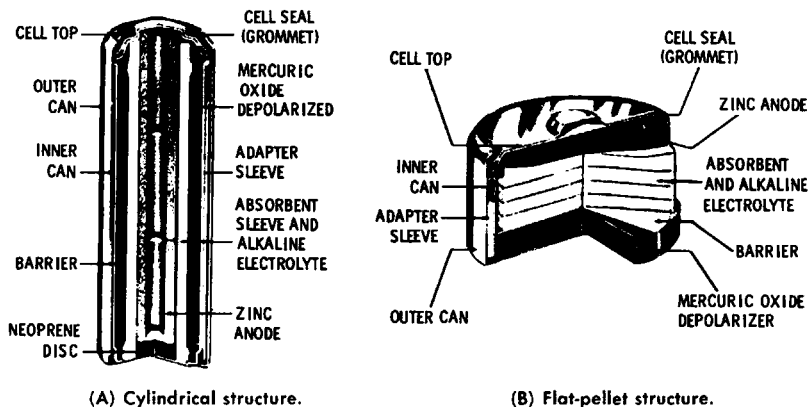

Fig. 4-13. Construction of mercury cells.

electrolyte is a solution of potassium hydroxide placed in an absorbent cellulose or gel material between the two electrodes. The mercury cell is available in a long cylindrical structure or a flat pellet. Fig. 4-13 shows the construction of both types. The individual cells can be packaged in any number of sizes and shapes of containers to obtain the desired voltage.

The mercury cell is best suited for applications where a relatively low current and a stable voltage are needed. The voltage per cell of a standard mercury cell is 1.35 volts \pm .007 volt. It is often used as a secondary-voltage standard. If such extreme accuracy is not desired, a small percentage of manganese dioxide may be added to the mercuric oxide. The voltage of this cell will be 1.4 volts, but the tolerance is \pm .05 volt. The latter battery is less expensive, so where an exact voltage is not required it is usually more suitable. For a given size, a mercury battery will deliver three to six times the energy of a zinc-battery, or the same energy can be delivered by a battery only one-third to one-fourth the size.

Nickel Cadmium

The nickel-cadmium battery is the first truly rechargeable dry cell. It is the type usually employed in cordless devices such as shavers; the battery can be recharged over and over again. Nickel-cadmium batteries can deliver a very high current and will hold their charge for long periods of time.

In a typical cell, both plates are made of a specially prepared nickel material. The positive plate is then impregnated with a nickel-salt solution, and the negative plate with a cadmium-salt solution.

A separator, commonly an absorbent material saturated with a potassium-hydroxide solution, is placed between the positive and negative plates. The entire structure is then rolled into a cylindrical form or arranged in layers, and the proper connections and container added.

Each cell delivers 1.2 volts. Cells are available in standard flashlight size (AA, C, and D) as well as other sizes. Disc-shaped types are also available. The individual cells can be packaged within the battery to make up the desired voltage.

Alkaline Battery

The mercury and nickel-cadmium batteries described in the foregoing are actually alkaline batteries because they use an alkaline solution as the electrolyte, instead of the acid of the carbon-zinc type. The term "alkaline battery," however, is normally applied to ones using alkaline-manganese cells. Es-

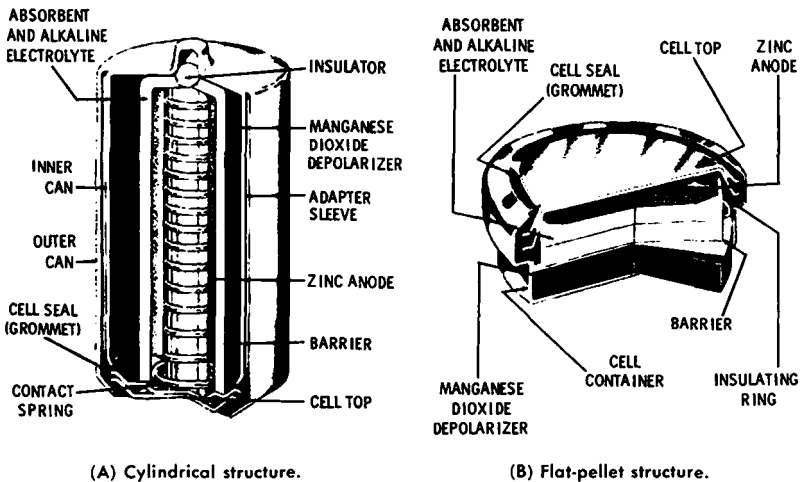

Fig. 4-14. Construction of alkaline-manganese cells.

Understanding Schematic Diagrams

essentially this cell is the same as the carbon-zinc cell, since both use the same active materials, but it uses an alkaline electrolytic and the physical arrangement of the cells is different. Fig. 4-14 shows the construction of both the cylindrical and pellet-type cells. For the cylindrical unit, the zinc electrode (negative) is in the center, next is a layer of an absorbent material saturated with the electrolyte, and then the manganese-dioxide positive electrode. Since this is the reverse of the carbon-zinc cell, the adapter sleeve and two cans are used to reverse the arrangement so the positive terminal will be at the center. This allows the cell to be substituted for a carbon-zinc cell. In arrangements designed specifically for this type of cell, the reversing procedure is not necessary.

Alkaline cells are capable of delivering a rather high current for a rather long time. Each cell delivers 1.5 volts. Alkaline cells are finding wide use in portable radio and television receivers and tape recorders as well as other small appliances.

While all alkaline cells are rechargeable, until recently the recharging process has been rather restrictive. Newer cells, designed specifically to be recharged, are now available. When properly used and charged, they provide a practical battery at much lower cost. The rechargeable batteries are available in the standard AA, C, and D sizes.

Symbols

The symbol at A in Fig. 4-15 is for a single cell. The long bar represents the positive electrode, and the short one the negative electrode. The plus and minus signs may both be

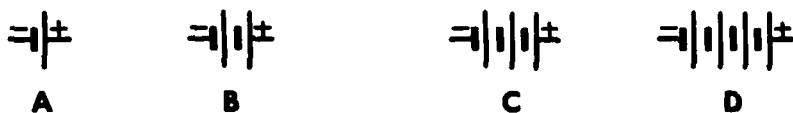

Fig. 4-15. Battery symbols.

included, but at times one or both of the signs are omitted. A two-cell battery may be represented by the symbol at B, and a three-cell one by the symbol at C. Usually, however, a "standard" symbol corresponding to approximately four cells (D) is used for all batteries, and a note is placed beside the symbol to show the voltage.

VIBRATORS

The vibrator was formerly a part of all automobile radios. It converted the low voltage from the car battery (6 or 12

volts) to the higher voltage needed to operate the tubes. Today all automobile radios use transistors which operate directly off the battery, but the vibrator is still found in a few specialized applications. Fig. 4-16 shows the general appearance and a representative symbol for a vibrator.

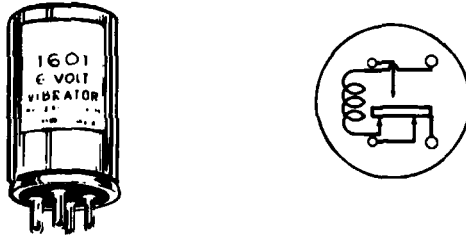

Fig. 4-16. The vibrator and its symbol.

Inside the metal “can” of the vibrator is a vibrating reed and some contacts. When the car-battery voltage is applied, the reed vibrates, opening and closing the contacts. This opening and closing of contacts interrupts the voltage and produces a pulsating direct current. To a transformer a pulsating direct current is the same as an alternating current, so the pulsating direct current is applied to the primary windings of a transformer, where the voltage is stepped up and rectified at the secondary, much the same as was described previously. There are many combinations of connections in vibrators. The schematic symbols are a large circle representing the can, and smaller circles representing the pins where connections are made to the external circuit. Inside the can, a schematic representation of the connections is included. In Fig. 4-16 the coil is for an electromagnet which causes the reed represented by the vertical bar to vibrate. The arrowheads are the contacts.

PROTECTIVE DEVICES

Just as devices are necessary to protect the house wiring, should an overload occur, they are also necessary in electronic equipment. Without a fuse or circuit breaker, valuable equipment could be destroyed, should some defect cause an excessive current through the circuit. Fig. 4-17 shows some of the many types of fuses used. They are designed to fit into fuse holders like those in Fig. 4-18. A fuse is nothing more than a special wire encased in glass or ceramic, with metal ends. This wire is selected so that it will allow the rated amount of current



Fig. 4-17. Typical fuses.

through it, but no more. If the current exceeds the rated amount, the wire will open up (burn out) and must be replaced (after the cause of the overload is found). Thus, instead of valuable equipment being destroyed, only a fuse costing no more than twenty-five cents need be replaced.

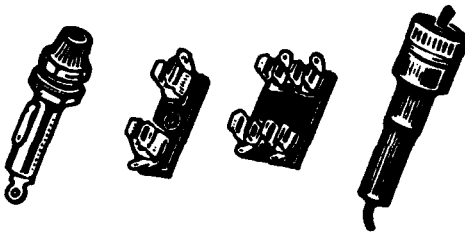

Fig. 4-18. Typical fuse holders.

Fig. 4-19 shows the symbol used for fuses (at A). At times a length of wire or a special type of resistor is added to the circuit to perform the function of a fuse. In such cases, the fuse symbol may be used to designate it, and a note added to explain its construction, or the resistor symbol may be used. A dot is sometimes placed on the symbol, as shown in the symbol at B in Fig. 4-19, to denote a chemical fuse—a special type which uses a chemical instead of the wire previously described.

Circuit breakers may be used instead of fuses to open a circuit in case of an overload. Unlike a fuse, the circuit breaker is not destroyed when it opens and may be reset to operate again. Fig. 4-20 shows two typical units. When the current through the circuit breaker exceeds the rated amount, the heat produced by the current, or the magnetic action produced by a coil in the circuit breaker, causes it to open the circuit.



Fig. 4-19. Fuse symbols.

Fig. 4-20. Typical circuit breakers.

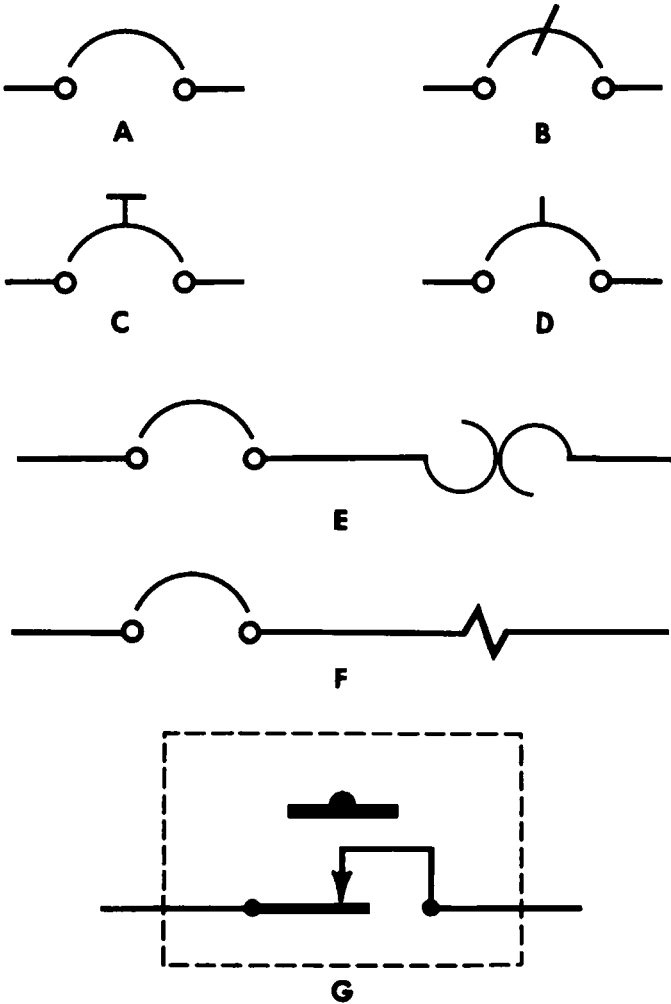
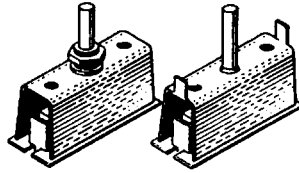

Fig. 4-21. Circuit breaker symbols.

Understanding Schematic Diagrams

The basic circuit-breaker symbol is shown at A in Fig. 4-21. Sometimes an additional mark is included to show the type of action the circuit breaker employs. For example, the symbol at B is for a switch-type circuit breaker, the one at C is for a push-pull type, and the one at D is for a push type. The fact that it is a thermal or magnetic type may also be indicated by the symbol. The two portions of a circle added to the symbol at E signify a thermal-type circuit breaker, and the symbol at F is for a magnetic type. Another symbol sometimes used is given at G in Fig. 4-21.

LAMPS

Small lights may be used as indicators or to illuminate the dial of electronic equipment. The most common type of lamp is the incandescent, similar to an ordinary home light bulb except smaller. Such lamps are available in various sizes and with several bases for connection into mating sockets.

The symbols at A and B in Fig. 4-22 are most common for this type of lamp. The circle represents the bulb and the portion within the filament.

Other lamps give off a faint glow. For example, a neon lamp will give a red glow and is often used as an indicator. Argon lamps have a pale blue-violet glow. Such lamps are properly

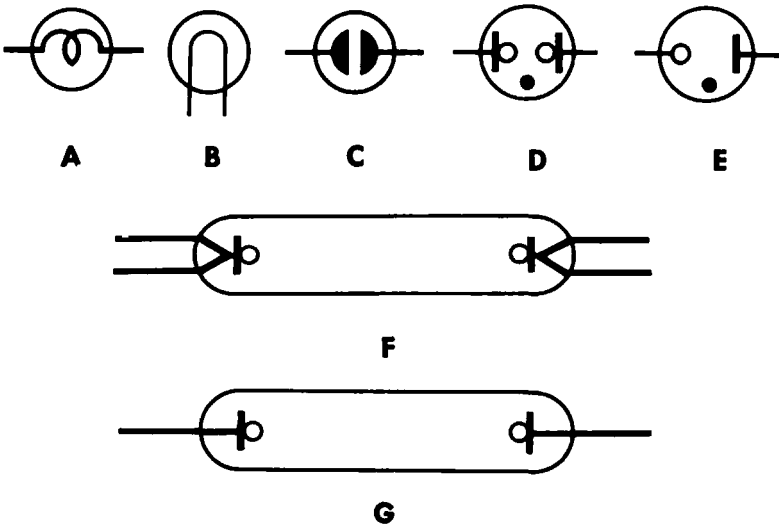

Fig. 4-22. Lamp symbols.

called *glow-discharge* lamps, although neon lamp is a more commonly used term. The symbol at C in Fig. 4-22 is a general glow-discharge symbol, while the one at D is for an AC type and the one at E for a DC type. (The dots in symbols D and E indicate a gas-filled device.) While not normally encountered in electronic equipment, the symbols at F and G are for fluorescent lamps. The one at F is for a lamp having four terminals, and the one at G for a two-terminal lamp.

CRYSTALS

Some materials such as quartz have the unique property of generating a voltage when pressure is applied to them, and of bending and twisting when a voltage is applied to them. If cut at the proper angle and to the correct dimensions, and if electrical connections are made to a metal plate (called the holder), the crystal can be made to oscillate (vibrate) at what

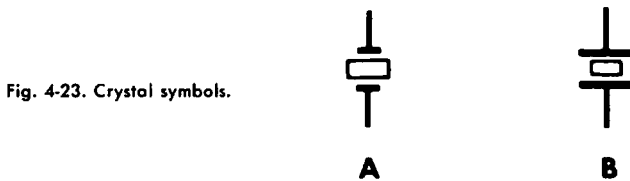

Fig. 4-23. Crystal symbols.

is known as its resonant frequency. This resonant frequency will not change for that particular crystal, but if another slab of the crystal has a slightly different size or angle of cut, it will have a different resonant frequency.

Once the crystal has started oscillating, only a very small force is required to keep it oscillating at the same frequency. These oscillations can be used to keep an oscillator exactly on frequency. The symbols used for a crystal are given in Fig. 4-23. The bars at the top and bottom represent the holder, and the rectangular element represents the crystal itself.

MOTORS AND GENERATORS

While not electronic, motors are sometimes included in electronic equipment. For example, a motor drives the turntable of a record player or the reels of a tape recorder. Usually, a motor or generator will be represented by a circle with the letters MOT or GEN inside, as shown at A and B in Fig. 4-24. Sometimes only the letter M or G is used. At other times the symbols at C or D may be used. The one at D is for a phono

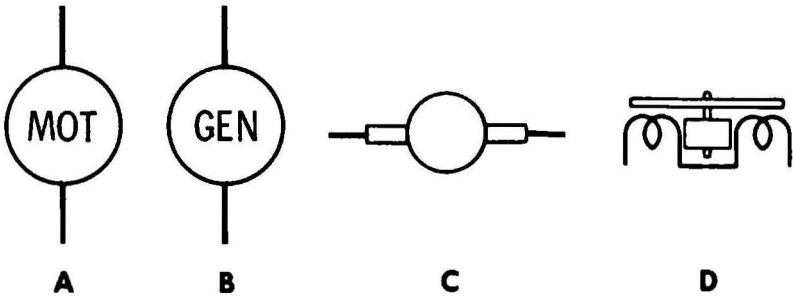

Fig. 4-24. Motor and generator symbols.

motor. Often, the actual connections of the motor will be shown, with coils representing the windings and a circle the shaft.

METERS

Meters are used to give an indication for many measurements. A ham or short-wave receiver may include an S meter to give an indication of the strength of the received signal. While we call the unit in Fig. 4-25 a vacuum-tube voltmeter, actually only the portion on the left with the dial is the meter.

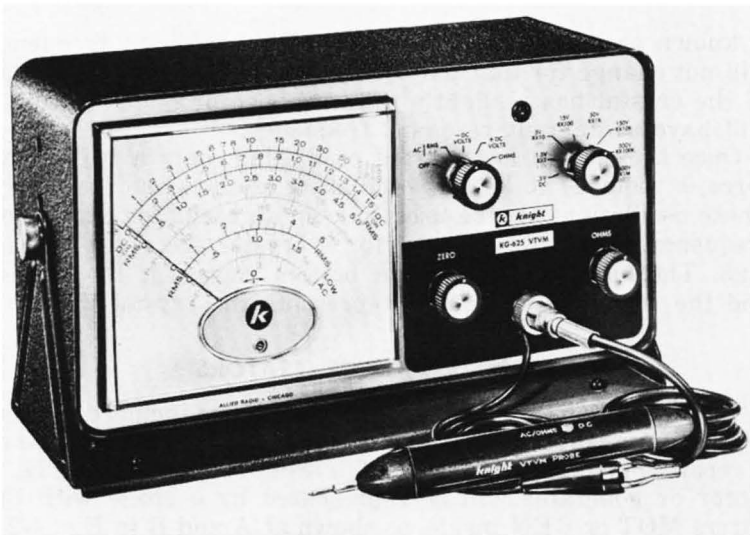

Fig. 4-25. The Knight-Kit ® Model KG-625 VTVM.

The remainder of the unit contains the circuitry and controls necessary to get the proper indication on the meter.

The symbol for a meter is simply a circle with an arrow inside representing the pointer, as shown at A and B in Fig. 4-26. Sometimes the letter *M* is placed in a circle as shown at C in Fig. 4-26. Since a meter must be connected in the proper polarity for use, the + and - signs are also included.

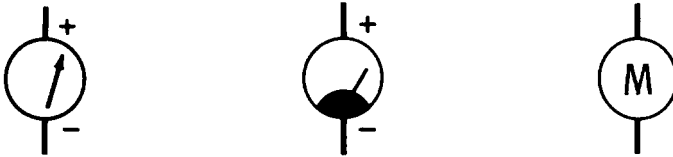

Fig. 4-26. Meter symbols.

Meters can be used to indicate many values; therefore, an abbreviation is normally placed beside the meter symbol to indicate the type of meter. Some of the more common abbreviations are given in Table 4-1.

Table 4-1. Meter Abbreviations

Abbreviation	Meaning	Abbreviation	Meaning
A	ammeter	PH	phasemeter
AH	ampere-hour	PF	power factor
DB	decibel meter	REC	recording
DM	demand meter	T or t°	temperature
F	frequency meter	V	voltmeter
G	galvanometer	VA	volt-ammeter
I	indicating	VI	volume-indicating
MA	milliammeter	VU	volume units
NM	noise meter	W	wattmeter
OHM	ohmmeter	μA	microammeter

CHAPTER 5

CONNECTING DEVICES

Up to now only individual components have been described, but to be useful they must be connected. The connection may be only a wire or even the leads of the component itself, or a switch, relay, or something else that "completes the circuit."

WIRES

Of course, the simplest method of connection is by a plain wire. As you no doubt know by now, a straight line is used to denote a wire. But what happens when it is necessary to cross two wires? There are three systems in use, as shown in Fig. 5-1. In each case the line on the left is connected and the one on the right is not. The three methods can lead to confusion if you are not careful. Notice that the symbol for a nonconnected point in A is the same as for a connected point in B. The system at C is preferred since it uses a dot to show a connection, and a half-circle (called a jumper) to show that the two points are not connected.

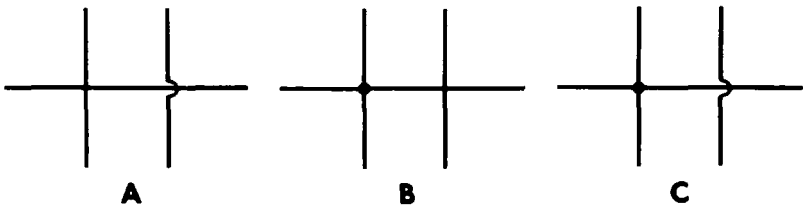

Fig. 5-1. Methods of showing wires connected and not connected.

Any wire will act as an antenna; therefore if a wire is routed close to another through which any AC signal is flowing, a certain amount of this signal will be picked up. In fact, a length of wire can even pick up hum or a radio signal from outside sources. To minimize such interference, a wire which has a braided metallic covering over the insulation is used. Two leads (conductors) are shown in Fig. 5-2, but any

number (including a single conductor) can be enclosed in the shield. The shield will be designated by adding a solid or dashed circle around the lead, as shown at A and B in Fig. 5-3. It can also be shown by two dashed lines above and below the

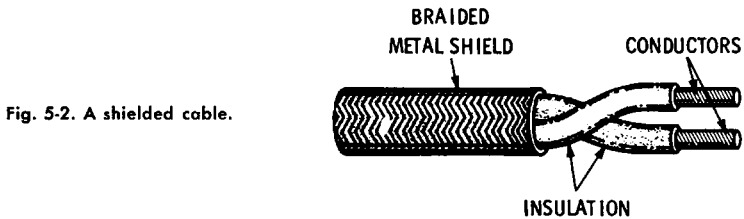

Fig. 5-2. A shielded cable.

lead, as shown at C. This shield is then connected to ground to drain off any extraneous signals. If two or more leads are included in a shielded cable, it is shown as at D in Fig. 5-3. For a shielded cable, a ground symbol will be added to the circle.

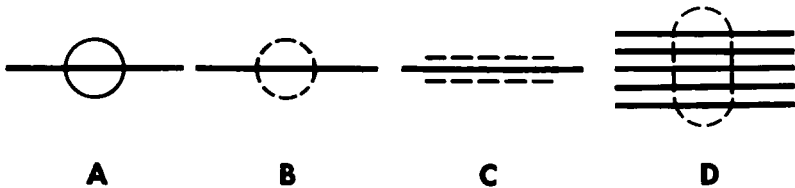

Fig. 5-3. Shielded lead symbols.

For an unshielded cable, the symbol at A will be used and no ground symbol included.

GROUND POINTS

In any piece of electronic equipment, there is a common point called ground. This term is a carryover from the early days of radio, when this point was actually connected to earth (ground). It serves as the common return point for all circuits. Usually the chassis of the equipment is the ground, but



Fig. 5-4. Ground and other common point symbols.

Understanding Schematic Diagrams

in AC/DC equipment, this point will be isolated from the chassis to prevent dangerous shock.

The symbol at A in Fig. 5-4 is the most common symbol used for ground. Often more than one symbol will be needed on a schematic to show other common points. For example, in AC/DC equipment the symbol at B is usually employed to denote the chassis. Other symbols used to designate ground or common points are given at C and D.

TEST POINTS

Sometimes convenient places for checking the operation of a circuit are connected to some type of terminal and labeled. Such a point will usually be indicated by one of the methods shown in Fig. 5-5.

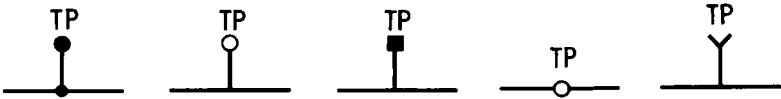

Fig. 5-5. Test point symbols.

SWITCHES

Switches are usually classified by two methods. The first is by the number of circuits they control, and the second is by the type of physical construction. Perhaps the simplest switch is the knife switch pictured at A in Fig. 5-6. This is called

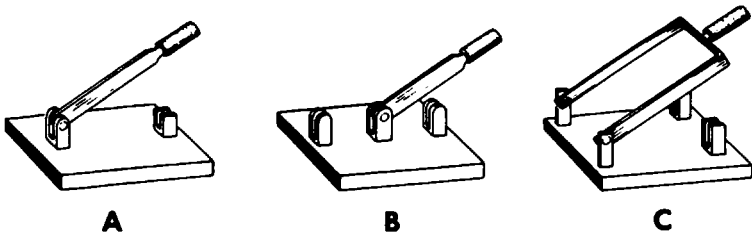

Fig. 5-6. Knife switches.

a single-pole, single throw (abbreviated SPST) switch; it can open or close one circuit. The switch at B is a single-pole, double-throw (SPDT) switch. That is, two connections can be made; the point connected to terminal 1 can be switched to point 2 or 3.

The switch at C in Fig. 5-6 is for a double-pole, single-throw (DPST) switch. In other words, two circuits can be opened and

closed at once. (The center portion with the knob is an insulator and does not make any electrical connection between the two knives.) If two additional terminals were added to the other side of the switch at C (as in B), it would become a double-pole, double-throw (DPDT) switch.

All switches perform essentially the same function as the ones in Fig. 5-6. They were selected because the action is easier to see in this example.

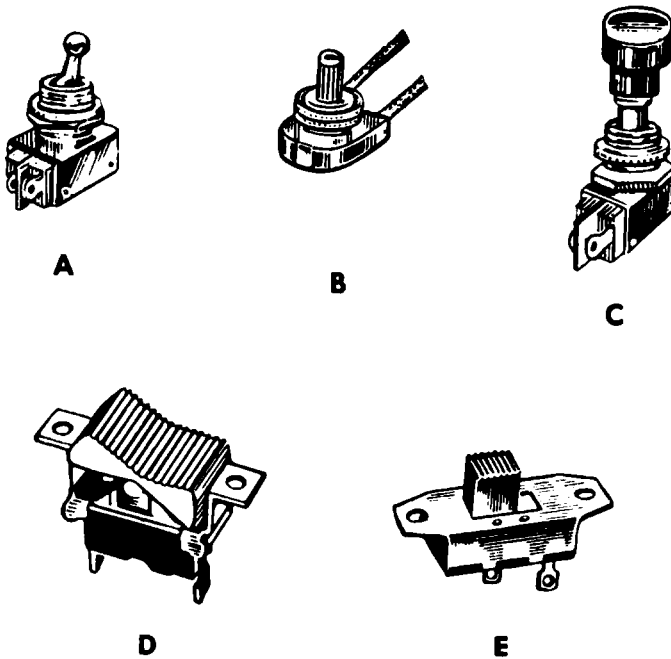

Fig. 5-7. Switch types.

Five other types of simple switches are illustrated in Fig. 5-7. The one at A is called a toggle switch, while the one at B is a rotary switch which is operated by rotating the knob at the top. Switch C in Fig. 5-7 is a push-button switch, and the one at D employs a rocker action. The switch at E is a slide switch.

The switches in Figs. 5-6 and 5-7 can all be represented by the same symbol. The one at A in Fig. 5-8 is the most common for a single-pole, single-throw switch, but the one at B is also quite popular. The two are the same except for the arrowhead

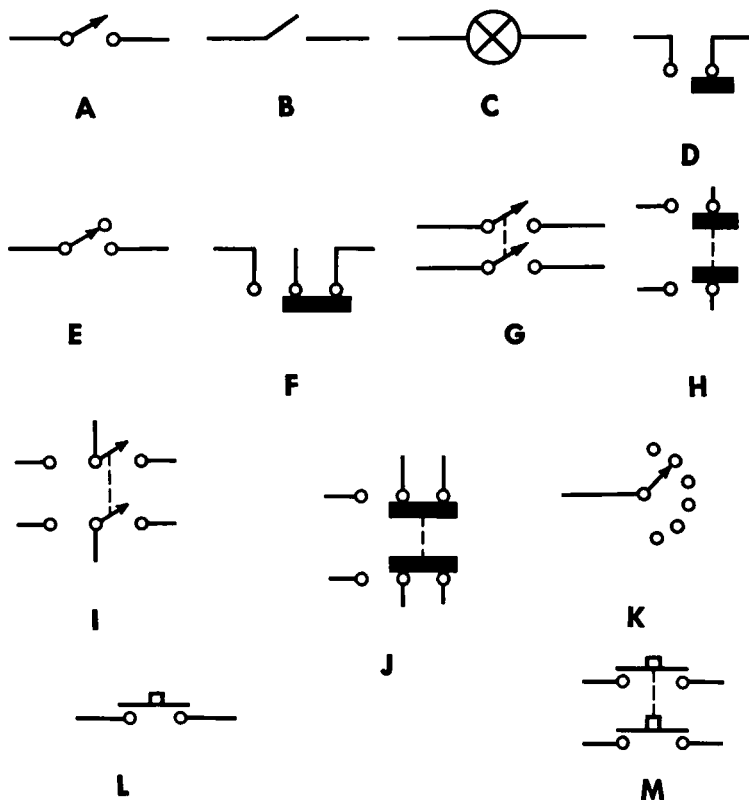

Fig. 5-8. Switch symbols.

on the slanted portion, which represents the portion of the switch that moves, and the omission of the circles representing the contacts. Another symbol for a single-pole, single-throw switch is given at C. The symbol at D is normally used for a slide switch like that shown at E in Fig. 5-7, but it can be used for other types.

To show other types of switches, the symbols are modified to show the configuration of the unit. For example, the symbol at E in Fig. 5-8 is for a single-pole, double-throw switch. This same symbol may be used for a single-pole, single-throw switch but, of course, no connections can be made to the added terminal because, in reality, it does not exist. The slide-switch version of this symbol is given at F.

A double-pole, single-throw switch is shown at G and H, while a double-pole, double-throw switch is shown at I and J. In these symbols the dashed lines between the two sections

signify that there is a mechanical connection between the two switch arms and that both will move simultaneously, but there is no electrical connection.

Switches can be constructed to fit any need. For example, a rotary switch can be made to have any number of positions. The symbol at K in Fig. 5-8 is for a single-pole, six-position switch. Rotating the shaft will cause the switch arm to move to each of the positions, one after the other. Very often an explanatory note or switch label near the rotary switch symbol on the schematic will indicate the intended switch setting function. For example, a function switch on an amplifier schematic might be labeled "Mono," "Stereo," and "Stereo Reverse."

Another method of showing a push-button switch is given at L (SPST) and M (DPST) in Fig. 5-8. Other combinations can be made up using this type of symbol.

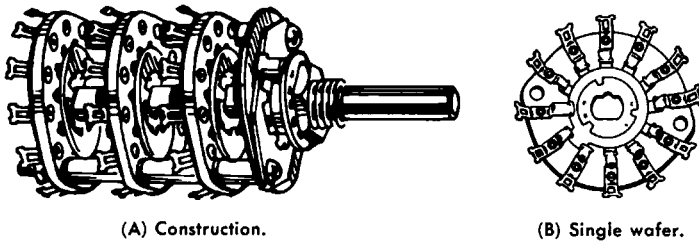

Fig. 5-9. The wafer switch.

The wafer switch (Fig. 5-9) is very popular when it is desired to control several circuits with different types of switches by a single knob. The individual sections or "wafers" can be added to the framework as desired. Three sections are shown in Fig. 5-9A. Construction of a typical individual section is pictured in Fig. 5-9B. In this section, the contact at the right of the mounting hole is longer than the others. It contacts the metal ring in the center at all times. Notice that an extension at the outer edge of the center ring is contacting the two contacts next to this long contact. Thus, these two contacts are connected to the longer one through the ring in this position. As the shaft is rotated, other contacts will be connected to the longer contact through the center ring. By varying the number and shape of extensions on the ring, any number of connections can be made. The ring can be broken so one side of the switch will make connections to one circuit and the other side to another circuit.

Understanding Schematic Diagrams

While 12 positions are shown in the wafer of Fig. 5-9B, this does not necessarily mean it can be rotated to 12 positions. Often it can only be set to two or three positions, and the various connections are made by different extensions on the shorting ring and/or longer contacts at these points.

The symbols used to show a wafer switch usually resemble those in Fig. 5-10. The center portion representing the shorting ring is drawn the same as it is actually constructed. The

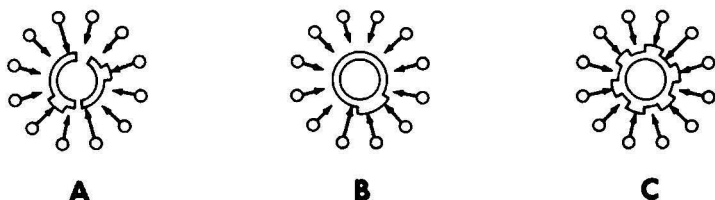
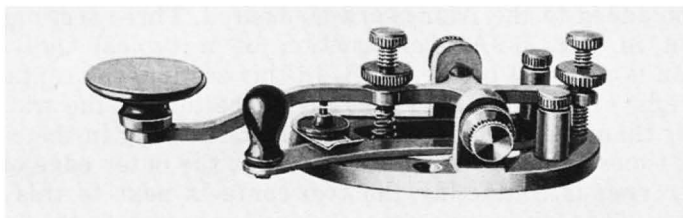

Fig. 5-10. Typical wafer-switch symbols.

arrowheads represent the contacts. The ones for the long contacts are shown longer so they will touch the narrow section of the ring, while the others are only long enough to touch the wider section of the ring. The symbol at B is for the section pictured in Fig. 5-9B.

CODE KEYS

The code-sending key used by amateurs and other radio operators (Fig. 5-11A) or in telegraph systems is really a special type of switch. Closing the key connects two contacts



(A) Appearance.



(B) Symbol.

Fig. 5-11. Telegraph or code key.

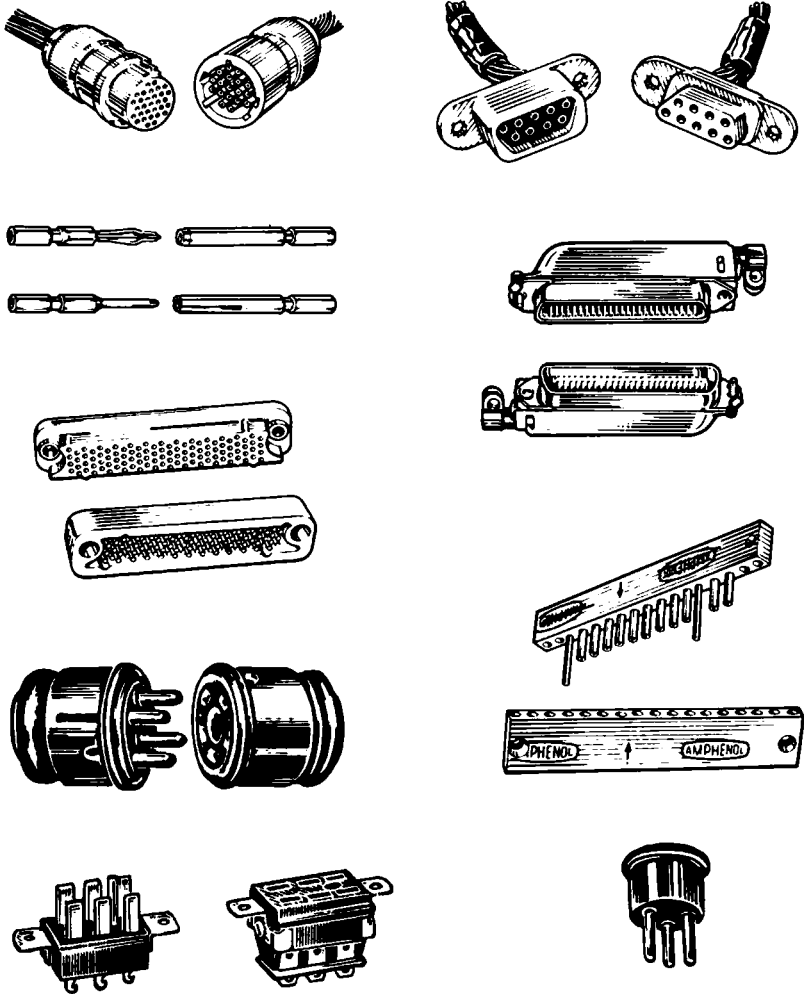

Fig. 5-12. Typical connectors.

in a circuit of the transmitter, and a dot or dash (depending on how long the contacts are closed) is transmitted. The symbol for the key resembles that of a switch, as shown in Fig. 5-11B.

CONNECTORS

It is often necessary for different points to be connected, but with provision for them to be disconnected and reconnected.

Understanding Schematic Diagrams

For example, the familiar AC wall socket and the matching plug are types of connectors. In electronics, connectors are needed for connection between separate chassis where it would be impractical to solder each wire between the two in place. In each case a socket and matching plug are used. Connectors may be used to connect one lead or over a hundred, depending on the application. Fig. 5-12 shows just a few of the thousands of types available.

The basic symbol for a connector is shown at A in Fig. 5-13. The portion on the left is the socket or hole section (called the female section), and the portion on the right is the plug or protruding section (called the male section). At other times, circles, squares, or rectangles which represent the actual shape of the plug and the socket opening are used. Examples are shown at B, C, and D in Fig. 5-13; again the open section

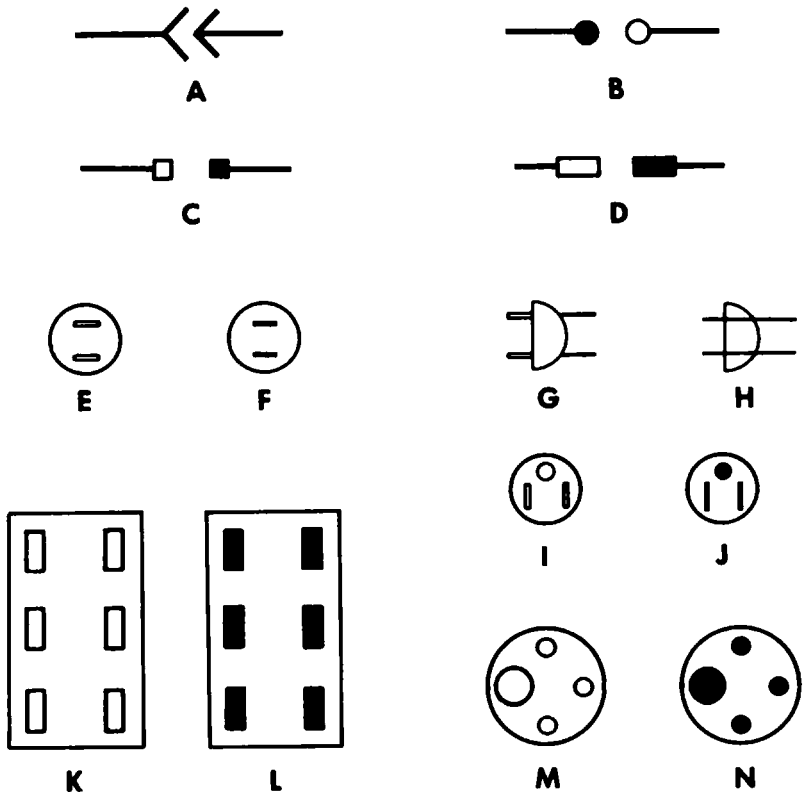

Fig. 5-13. Connector symbols.

represents the female portion, and the solid section the male section.

The symbols at A, B, C, and D may be used to depict a connector used to attach two leads together, or to show the individual connections of a connector having multiple contacts. In connectors where more than one connection is made, the symbols for individual connections may be located at convenient points on the schematic and labeled. Then a drawing somewhere on the schematic will show the physical layout of the connector.

The actual physical construction of the connector may be shown in the schematic symbol. For example, the symbol at E in Fig. 5-13 is usually employed to represent the female AC outlet (wall receptacle) while those at F, G, and H are used for its matching male plug.

Other examples of representative plugs and sockets are given at I, J, K, L, M, and N. In each case, the arrangement is the same as that of the actual connector. The socket and plug at K and L are for the one at the lower left in Fig. 5-12. As more pins are added to the connector, it is difficult to represent the connector by a symbol like those at E through N in Fig. 5-13. For example, it would be impossible to run 50 lines into the symbol for a plug having 50 contacts. For this reason, the individual connections symbols (A through D) are usually employed in such cases.

JACKS AND PLUGS

A jack and plug are really types of connectors, but they are special types. In addition to connecting two points, they can also be used to connect or disconnect other circuits. Typical plugs are shown in Fig. 5-14A and jacks in Fig. 5-14B. The end of the plug (called the tip) is insulated from the remainder of the plug (called the sleeve). At times, another separate piece called the ring may be included directly behind

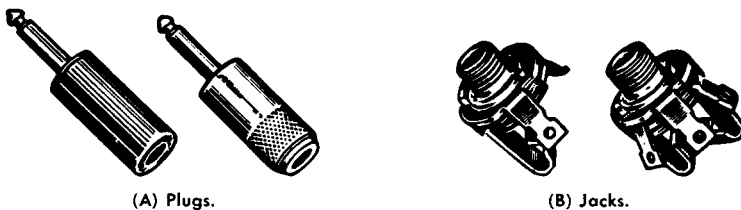

Fig. 5-14. Plugs and jacks.

Understanding Schematic Diagrams

the tip and insulated from both the tip and the sleeve. Connections are made through a cable inserted through the hole in the end of the plug.

The symbol at A in Fig. 5-15 is for a two-conductor plug, and the one at B is for a three-conductor plug. The tip, ring, and sleeve are identified in the drawings, but are not actually

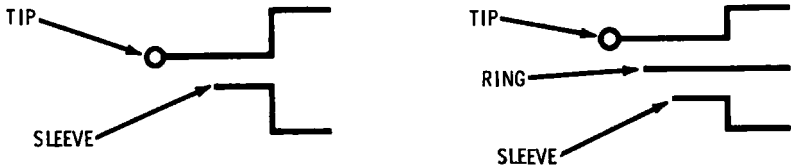

Fig. 5-15. Plug symbols.

part of the symbol. At other times, a more “pictorial” representation of the plug will be used for the symbol, but it will resemble the symbols in Fig. 5-15.

The symbols for jacks are given in Fig. 5-16. The one at A is for a simple jack for use with the two-conductor plug. To understand its operation, envision the plug as being inserted where the arrow (not part of the symbol) is shown. The “V”-shaped portion mates with the tip of the plug, and the re-

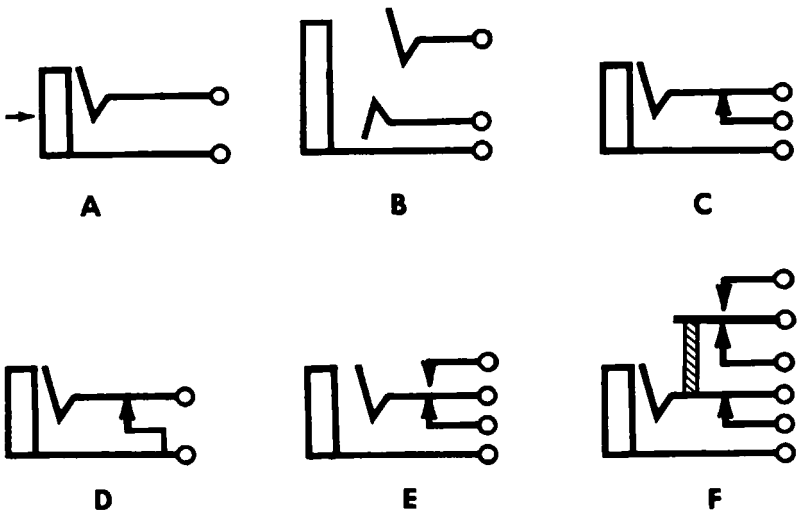

Fig. 5-16. Jack symbols.

remainder makes contact with the sleeve. The symbol at B is for a three-conductor plug. The portions which mate with the tip and sleeve are in the same location, and the added portion (center terminal) makes contact with the sleeve. Notice that it is placed between the tip and the sleeve.

As mentioned previously, additional connections can be made or broken when the jack is inserted into the plug. For example, in the symbol at C, when the plug is inserted, the tip connection will move up, breaking the connection between the top and the arrowhead below it. The tip and sleeve are connected as shown in the symbol at D, but when the jack is inserted this connection is broken. At E, the connection with the bottom arrow is broken and connection at the top is made when the jack is inserted.

A more elaborate jack is shown at F in Fig. 5-16. Here, when the jack is inserted, a connection is broken between the tip and the arrowhead below it. In addition, the connection is broken between the center and bottom of the three upper terminals, and is made between the center and upper terminals. The bar portion with the slanted lines through it represents a physical but not an electrical connection. It is an insulator which moves the top contact, but there is no electrical connection between the two points. Many other combinations are possible, but each can be analyzed in the same way as the ones presented here.

Another type of jack and plug is pictured in Fig. 5-17A. These are the familiar phono plug and jack used for connec-

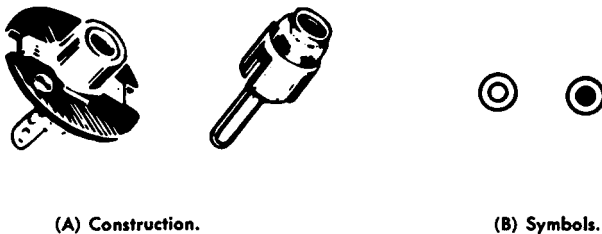

Fig. 5-17. Phono jack and plug.

tions to the back of many tuners, amplifiers, etc. The most common symbols for these units are given in Fig. 5-17B. Again the solid dot represents the plug, and the open circle the jack. The outer circle represents the outside of the jack and plug, which are normally connected to ground.

RELAYS

A relay is an electrical switch operated by current through a coil. Relays are available for operation on alternating or direct current and in sizes capable of handling only a very minute current to large heavy-current devices. Some have only a single switch action, while others, like jacks, can perform several switching actions at once.

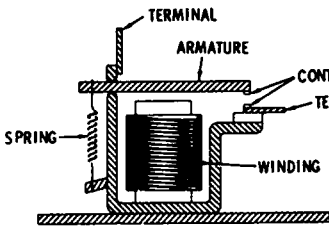

Fig. 5-18. Elementary construction of a relay.

Refer to Fig. 5-18, which shows the basic construction of a relay, to understand its operation. A coil winding with a metallic core near the center forms an electromagnet. When the current through this coil reaches sufficient magnitude, the electromagnet pulls the armature (which pivots at the left) toward it. (This is called energizing the relay.) The two contacts at the right close. Thus, there is a complete path from the two points marked "terminal," and a circuit connected to these two points is completed. When the current through the coil stops or is reduced, the electromagnet no longer attracts the armature, and the spring at the left returns the armature to its original position. If a contact is placed above the armature so that the contacts are normally closed, the circuit will be opened when the electromagnet attracts the armature down-

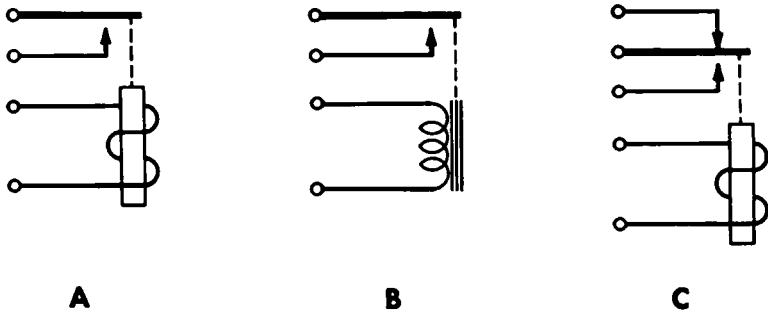

Fig. 5-19. Relay symbols.

ward. Many different possibilities can be performed with a relay. As with jacks, an insulated spacer can be used to operate still another set of contacts with no electrical connection between the two sets. At other times, more than one armature may be used.

The symbol for a simple relay like that in Fig. 5-18 is given at A in Fig. 5-19. The vertical rectangular section with the spiral around it represents the coil and its core. The heavy flat bar above represents the armature, and the arrowhead the other contact. The dashed line from the core to the armature represents the magnetic attraction. A different way of showing the same relay is given at B. Here the regular iron-core coil symbol is used for the electromagnet. The relay at C shows an arrangement where the armature is normally connected to the upper contact, but when sufficient current flows through the coil the bar moves down, disconnecting the circuit with the upper contact and connecting the circuit with the lower contact. Thus it is a single-pole, double-throw switch.

Many other possible arrangements can be made. For any relay, study the connections as they are shown. Then visualize what happens to each contact when the armature(s) moves to the other position. The symbol for a relay is almost always drawn in the unenergized position. If not, a note should be placed near the coil symbol to indicate "relay shown in energized position."

CHAPTER 6

PUTTING IT ALL TOGETHER

In the preceding chapters, practically all components used in electronic equipment have been described. Their operation and construction, and the symbols used to represent them on schematics, have been explained. The foregoing chapters not only can serve as a good background to understanding schematics, but to a basic understanding of electronics itself.

OTHER INFORMATION ON SCHEMATICS

A schematic is much more than a bunch of symbols. There is a great wealth of other information included in it. While the amount of this additional information will vary with different manufacturers, the schematic in Fig. 6-1 is fairly representative of the type supplied by the industry. This is a schematic of the Knight-Kit ® Model C-555 Citizens-Band transceiver that was pictured in Fig. 4-2.

Component Identification

Without some means of identifying each individual component, a schematic would be very difficult to use. Most pieces of equipment contain several resistors, capacitors, coils, etc.; therefore, some means must be provided to identify each specific component. Notice that each component in Fig. 6-1 has a letter and a number beside it (e.g., at the upper left is a coil marked L-6).

These letter-and-number combinations are used to identify each component on the schematic. A different letter is used to identify the various components of the same type, and a number indicates which one of this specific type of component. While all companies do not agree on what letter to assign to each specific type of component, just as they do not agree on the same symbols, there is much in common in the choices. The most common identification letters used for the various types of components are given in Table 6-1. Where more than one letter is fairly popular, the alternates are included. These

Table 6-1. Identification Letters

Component	Letters	Component	Letters
Antenna	L, I Ant.	Phono Cartridge	P, PU
Battery	B, BT, M	Plug	P, PL
Capacitor	C	Power rectifier	CR, X, SR, M
Circuit breaker	F, CB	Relay	K, RE, RL
Coil	L	Resistor	R
Crystal	XTAL, X, Q, M, Y	Socket	S, X
Diode	CR, X, D, XD	Speaker	S, SP, SPK, LS
Fuse	F	Switch	S, SW
Jack	J	Transformer	T
Lamp	I, B, M, NE	Transistor	TR, Q, X
Meter	M	Tube	V
Microphone	M, MIC	Vibrator	V, VB, M

identification letters are keyed to the parts list and to any photographs or drawings of the chassis.

In addition to the identification number, the electrical value of most components will be indicated beside the component. The notes on the schematic of Fig. 6-1 state that the capacitor values are in microfarads unless specified. This eliminates the need of repeating μF after each capacitor value. For example, C-1 (upper left in schematic) is labeled .0015; it is not necessary to add the mfd or μF . However, C2 is labeled 47 $\mu\mu\text{F}$, since this value is in micromicrofarads.

Likewise, the notes state that: (1) resistor values are in ohms, (2) K = 1000 ohms, and (3) all resistors are 1/4-watt units with a $\pm 10\%$ tolerance unless otherwise specified. Thus, the 33 below R-3 means this resistor is a 33-ohm, 1/4-watt, 10% resistor, and the 5.6K below R-2 means this is a 5600-ohm (5.6×1000), 1/4-watt, 10% unit. All resistors in the schematic of Fig. 6-1 are 1/4-watt $\pm 10\%$, but if some had a higher wattage or different tolerance, it would be labeled on the schematic.

Notes such as the foregoing eliminate the need for such information to be repeated for each component. This makes the schematic easier to read because, if repeated each time, the schematic could get rather cluttered. Not every company will use the same standards, so any notes on the schematic should be read before attempting to understand it.

Voltages

The voltages measured at various points in the circuit are also given in Fig. 6-1. Usually the voltage at each tube pin or transistor element is included. No voltage is shown at the

Understanding Schematic Diagrams

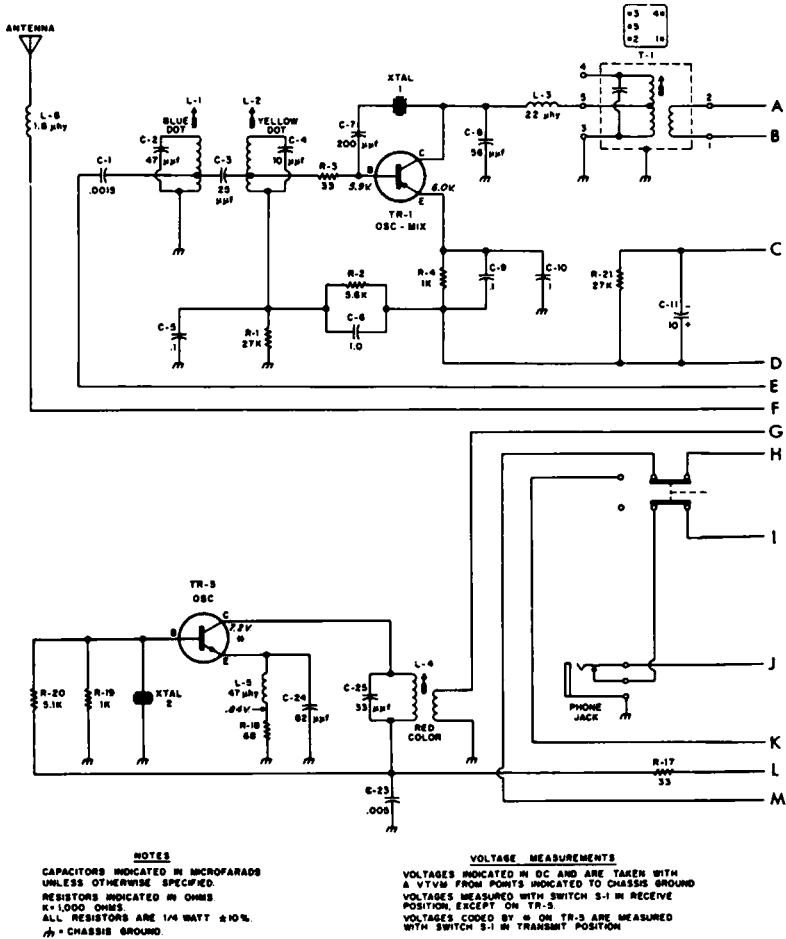
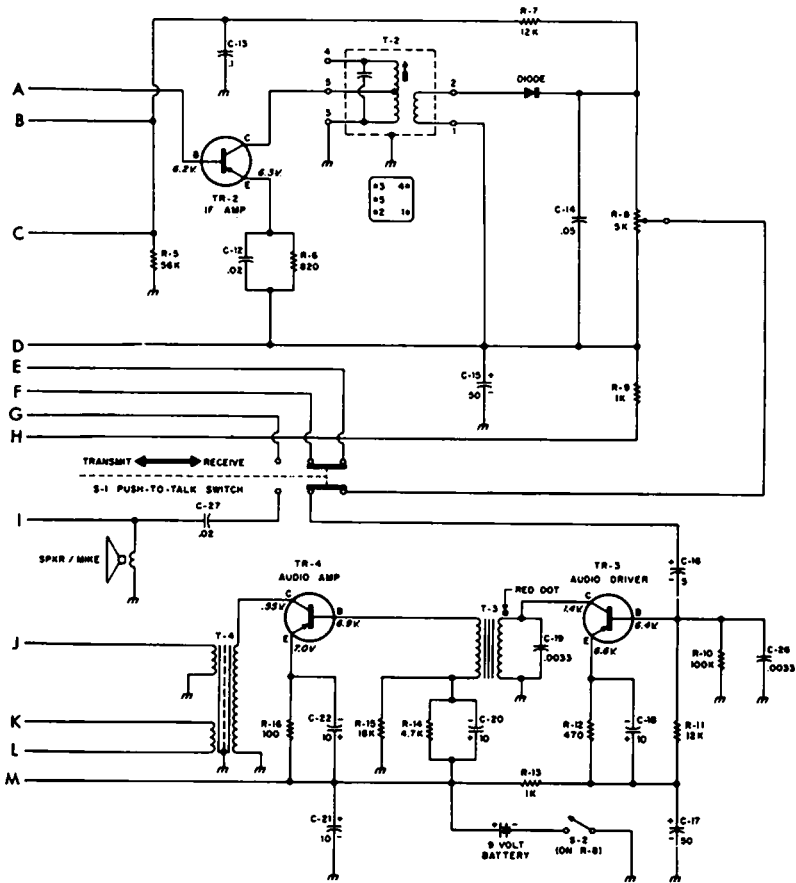

Fig. 6-1. Schematic of the Knight-Kit

collectors of TR-1 and TR-2 in Fig. 6-1 because it is so close to zero that it is not measurable. Also, the voltage at the junction of L-5 and R-18 is given instead of the emitter voltage on TR-2 because this is the recommended place to measure this voltage.

The notes at the bottom of the schematic state the conditions under which the voltage measurements were taken and the type of meter used. Quite often the position of controls or switches will make a significant difference in the voltage measured. If the controls and switches are not in the same



® Model C-555 Citizens Band transceiver.

position when you make these measurements, you may think a fault in the circuit is causing the difference, when it is just a different control or switch setting.

If the same voltage is measured by a VTVM and a VOM, the two readings may vary, so the type of meter is also specified.

Identification Notes

There are also aids in locating specific points in the circuit on the schematic of Fig. 6-1. Coil L-1 is coded with a blue dot, and L-2 with a yellow dot; this is noted on the schematic to

aid you in locating these components. The small drawings by transformers T-1 and T-2 show the location of the various terminals on the transformers. The numbers shown at the points on the schematic may not actually be stamped on the transformer. With these drawings, however, location of the proper terminals is easy. Sometimes leads will extend from a transformer instead of its having terminals. Each of the leads will be a different color, and the colors are usually specified on the schematic.

SINGLE AMPLIFIER STAGE

When viewed as a whole, a schematic can seem rather confusing, especially if it is for an elaborate piece of equipment such as a ham radio receiver or a television set. When broken down into individual stages, however, schematics are not difficult to understand, once the meaning of the various symbols and a little of the operation of the various components are understood.

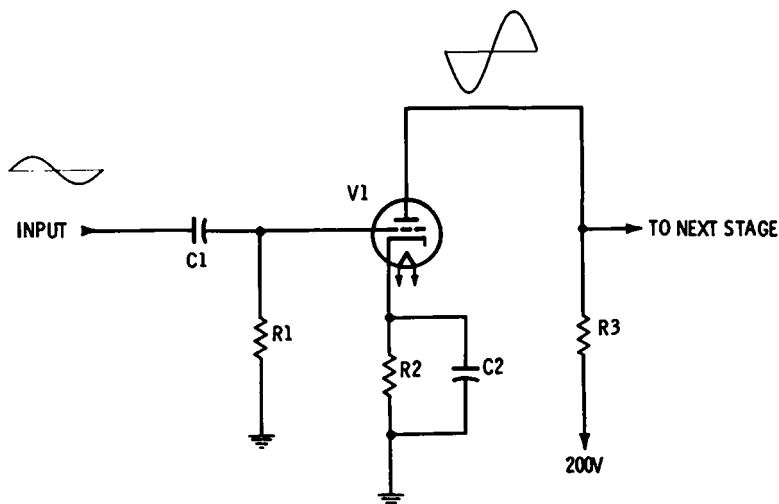

Fig. 6-2. The basic amplifier circuit.

The basic tube-type amplifier stage is given in Fig. 6-2. Let's look at the actions which take place within this stage.

Assume an AC signal, represented by the sine wave above the input, is connected to this stage. (This signal can be from

another amplifier, a microphone, antenna, or any other source.) You will recall that when a voltage is placed on one plate of a capacitor, electrons do not actually flow through the capacitor, but the effect is the same as if they did. Thus, during the positive half-cycle of this AC signal, there will be a deficiency of electrons on the right plate of C1. Since a positive charge will attract electrons, they rush to the left-hand plate of this capacitor. The only place these electrons can come from is the ground below R1, so electrons flow up through R1 and to the left, to the right-hand plate of C1. The amount of electron flow depends on how positive the voltage of the applied sine wave is.

The electrons flowing up through R1 cause a small voltage drop across this resistor. This voltage will be negative at the ground and positive at the top of the resistor. (Anytime electrons flow through a resistor, the polarity of the resulting voltage across the resistor will always be negative at the end where the electrons enter and positive where they exit.)

This voltage across the resistor will also appear at the grid of tube V1 because the two points are connected. The plate of the tube is connected to a 200-volt positive voltage (through R3), and the cathode is connected to ground (through R2); therefore, the plate is positive with respect to the cathode, and electrons will be flowing from the cathode to the plate. The addition of the small positive voltage to the grid of V1 will cause more electrons to reach the plate because the more positive the grid (within limits, of course), the more electrons are allowed to flow from cathode to plate.

At the plate, these electrons must flow down through R3 to the 200-volt power source, where they return to ground, completing the circuit. As mentioned in Chapter 3, a small change in the grid voltage will produce a large change in the amount of electrons flowing from cathode to plate in the tube. Therefore, the electron flow through R3 will cause a large voltage drop across R3, which is negative at the top. This voltage must be subtracted from that of the power supply to obtain the actual voltage present at the top of R3 (and plate of V1). Thus, a negative-going voltage is produced at the plate which is identical to that supplied to the grid except it is much greater in amplitude. This is amplification. The amplified signal will then be coupled to the next stage.

The actual voltage at the plate of V1 will be positive (because of the power-supply voltage), with the negative-going AC voltage riding "piggyback" on top of it. Thus, it will be a pulsating DC voltage like that of Fig. 6-3 instead of a steady

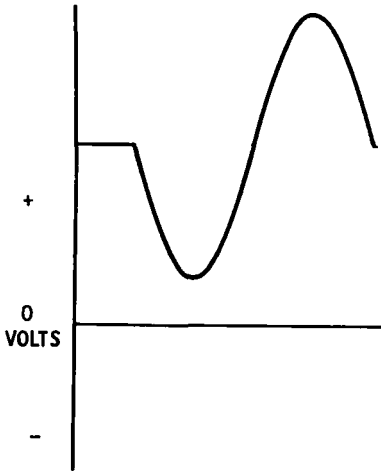

Fig. 6-3. Pulsating DC plate waveform.

direct current, but this makes no difference. The important points are that it is less positive than before the positive-going voltage was applied to the grid, and this change in the plate voltage is the same as that applied to the grid except it is greater in amplitude.

During the next half-cycle of the input sine wave, the process is repeated, except in reverse. When the negative-going half-cycle of the applied voltage appears at the left plate of C1, electrons are driven away from the right plate and down through R1, producing a voltage whose polarity is negative at the top. This negative voltage at the grid allows fewer electrons to flow from cathode to plate in the tube. With a reduced amount of electrons flowing out of the plate through R3, the voltage drop across this resistor will be reduced, making the plate voltage more positive.

While there are many types of circuits used in electronics, the foregoing gives a good understanding of what happens to individual stages. Coils or transformers may be used in place of the resistors, the coils and transformers may be "tuned" so that only the wanted frequencies are allowed to pass, some may handle small signals and others large, but essentially all amplifiers operate in the manner described.

Still other stages may be used to generate a signal. Called oscillators, these stages are essentially amplifiers in which a portion of the output is coupled back to the input of the stage for a signal.

SHORT-WAVE RECEIVER

The schematic for the Knight-Kit *Star Roamer* receiver of Fig. 6-4 is given in Fig. 6-5. By tracing the signal through this complete receiver, you can see what happens at each stage in it. In Fig. 6-5 the gray line with arrows has been added to show the path the signal takes through the receiver. This gray line is not actually part of the schematic.

The signal picked up by the antenna is connected through the lead-in wire to the antenna terminals at the upper left in the schematic. From here it travels down to terminal 11 of wafer switch S-1B and through the switch to terminal 6. At terminal 6 the signal exits and flows through L-11 and L-1. (Actually, L-1 is a transformer; the signal is coupled from the primary to the secondary of L-1). From L-1 the signal travels upward to terminal 12 of S-1B and out through terminal 5 of this switch.

Coil L-1 is for Band 1 (200 to 400 kilohertz) ; L-2, L-3, L-4, and L-5 are switched in the circuit as selector switch S-1B is moved to the other bands. S-1B is shown in its extreme



Fig. 6-4. The Knight-Kit ® *Star Roamer* short-wave receiver.

counterclockwise position in Fig. 6-5. As it is moved to Band 2 (550 to 1800 kHz), the ring is rotated one position clockwise. In this position the antenna is disconnected and the loopstick (L-2) is substituted. This band is the standard a-m broadcast band, and it is common practice to use a loopstick antenna

Understanding Schematic Diagrams

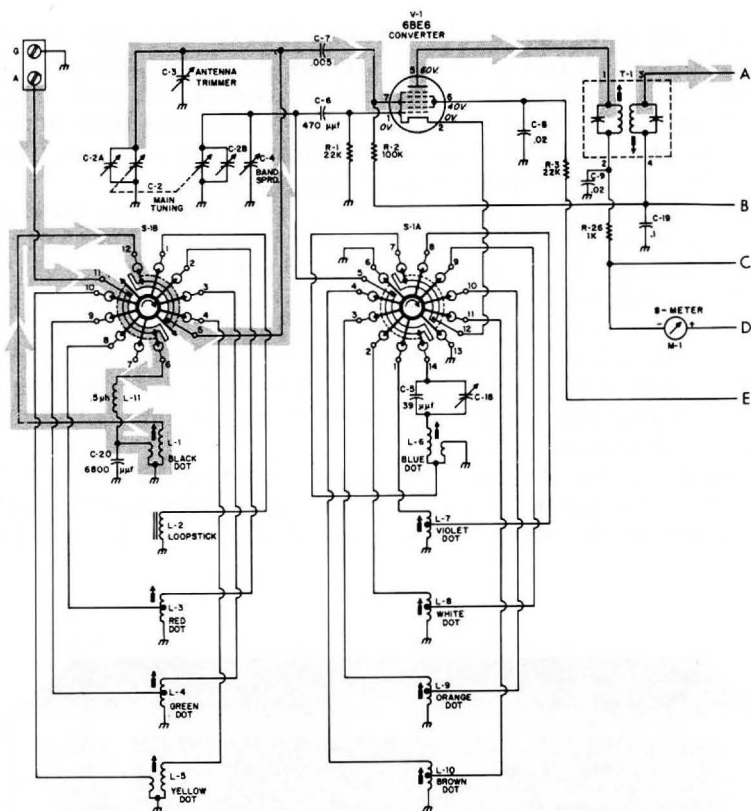

Fig. 6-5. Schematic of the Knight-

for the broadcast band in multiband receivers. This way, no external antenna is needed to receive these stations.

From switch S-1B, the signal travels upward to V-1. Capacitor C-2A, in conjunction with the coil selected by S-1B, tunes the circuit so that only the signals from the desired station are allowed to pass. C-2 is the tuning capacitor and is adjusted by the tuning knob on the front of the receiver in Fig. 6-4. The signal from this desired station is then connected to a grid (pin 7) of the 6BE6 converter tube.

The converter is a special pentagrid tube which actually has two functions in the receiver. The coils connected to switch S-1A and C-2B, along with the grid connected to pin 1, the cathode, and the lower grid connected to pin 6 in the tube, form the oscillator. Here a signal is generated whose frequency

Putting It All Together

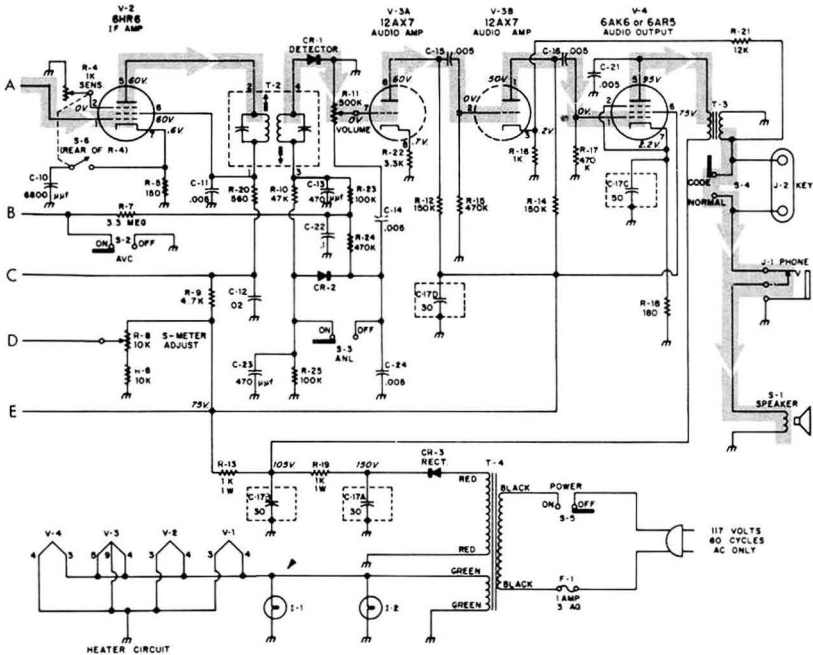

NOTES

RESISTORS INDICATED IN OHMS.
 K=1,000 OHMS
 MEG=1,000,000 OHMS
 CAPACITORS INDICATED IN MICROFARADS UNLESS OTHERWISE SPECIFIED.
 ⌋ = CHASSIS GROUND

VOLTAGE MEASUREMENTS

ALL VOLTAGES SHOWN $\pm 20\%$
 VOLTAGES MEASURED FROM POINTS INDICATED TO CHASSIS WITH A 20,000 Ω /VOLT METER
 S-1 SHOWN IN MAXIMUM CCW (BAND 1) POSITION.
 NO SIGNAL INPUT.

Kit ® Star Roamer receiver.

will always be 455 kilohertz different from the one from the station. This 455-kc difference is done automatically since both sections of the tuning capacitor are set simultaneously.

Thus, two signals are present in this tube—the one from the antenna and the one from the oscillator. These two signals are “mixed” in the tube, producing two additional signals, one equal to the sum of the two signal frequencies and the other to the difference between the two frequencies.

The difference frequency is the one of interest here. Transformer T-1 is tuned to accept the 455-kc difference frequency and reject all others. This frequency is called the *intermediate frequency* (abbreviated IF), since it is between the higher frequencies of the station and the lower audio frequencies. The advantage of using the intermediate frequency is that once set, no further adjustment of the circuit is needed. Also, it is

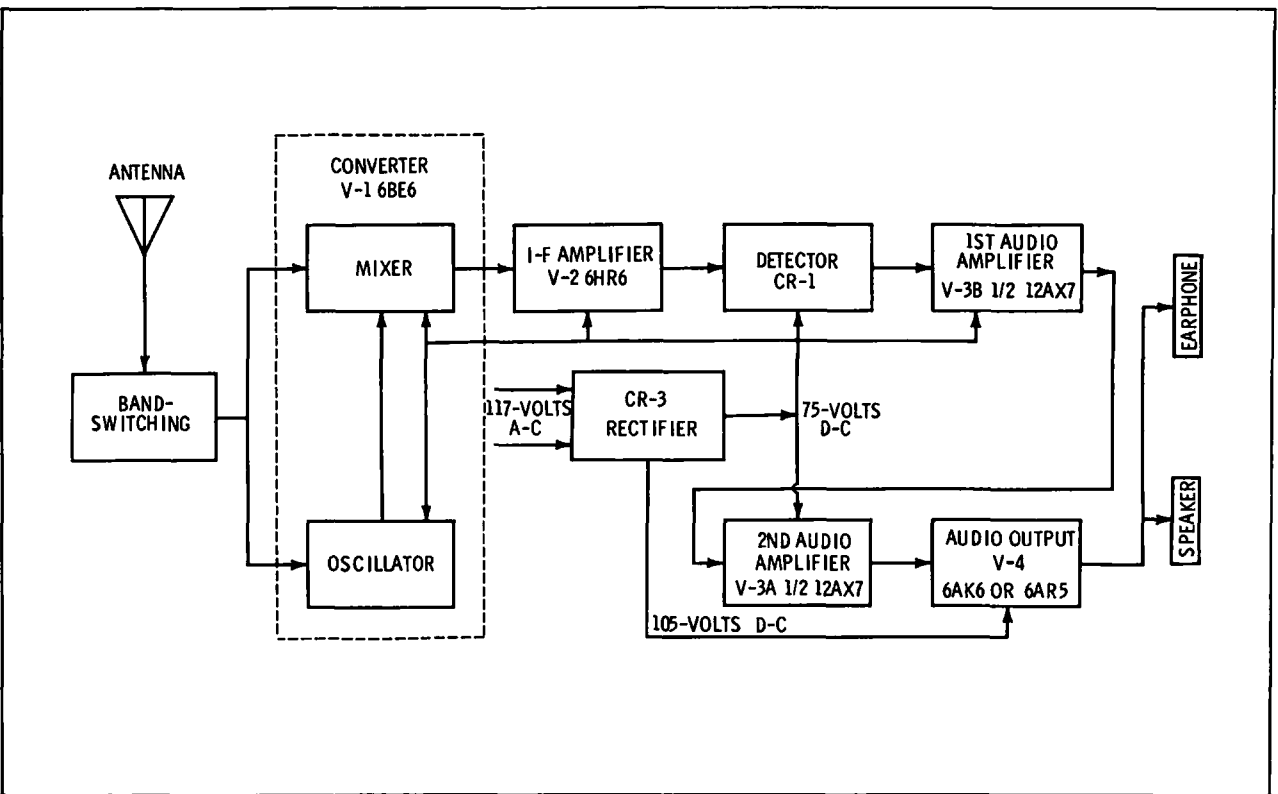

Fig. 6-6. Block diagram of the Knight-Kit® Star Roomer receiver.

easier to design an amplifier for one specific frequency than for many frequencies.

In Fig. 6-5, the signal from the primary of T-1 is coupled to the secondary of this transformer. Here it is connected to V-2, a 6HR6 IF amplifier tube. The IF signal is amplified by V-2 and coupled through T-2 to CR-1, the detector.

An amplitude-modulated (AM) signal, which this receiver is designed for, will vary in amplitude in step with the audio being transmitted. The detector, a signal diode, responds only to the overall changes in the amplitude; the individual variations for each cycle of the IF signal do not affect the circuit. Thus, at the output of CR-1, a low-frequency signal which corresponds to the speech or music originally used to modulate the signal is produced. This is called the audio signal and is coupled to R-11, the volume control.

A portion of the audio signal is picked off by the movable arm of this potentiometer and coupled to V-3A, which is one-half of a 12AX7 tube. Here the audio signal is amplified and coupled to V-3B, the other half of the 12AX7 tube, which further amplifies the audio signal.

After V-3B, the signal is coupled via C-16 to V-4, a 6AK6 or 6AR5 audio-output tube. This final stage further amplifies the audio signal to obtain the high power needed at the output.

T-3 is the audio-output transformer for coupling the audio signal to the speaker. If S-4 is moved to the closed (normal) position, the audio signal flows through this switch and jack J-1 to the speaker. Here the audio signal is converted to sound waves, as explained in Chapter 4. Notice that if a plug is inserted in jack J-1, the line to the speaker will be open. Instead, the signal will be coupled, via the jack and plug, to the earphones.

This completes the signal path through the receiver. Power for tube operation is obtained from the power supply at the lower right. The 117-volt AC power line is connected to transformer T-4 when on-off switch S-5 is closed. Fuse F-1 protects the circuit in case of overload.

Power rectifier CR-3 is used to convert the AC voltage at the secondary of T-4 (red leads) to the direct current needed for operation of the tubes. C-17A and B are electrolytic filter capacitors which smooth out the pulsating direct current.

The other secondary of T-4 (green leads) supplies the 6.3 volts AC needed for dial lights I-1 and I-2 and the tube filaments. Notice that the filaments are drawn separately from the tubes. This is fairly common practice.

Actually, in the foregoing explanation we have been breaking the schematic down into "blocks." By examining each stage separately, we can form a mental block diagram of the entire receiver (Fig. 6-6). This is the only way a schematic can really be understood. It must first be broken down into individual stages whose function can be understood, and then these blocks are put together to get the complete picture.

TRANSISTOR AM RADIO

The same procedure outlined previously can be used to understand the schematic for any type of equipment. Fig. 6-7 is the schematic of a typical six-transistor AM radio. Here L1 is the loopstick antenna, which picks up the radio signal; C19 is the tuning capacitor which with L1 selects the desired signal and rejects the others.

This signal is then coupled via C10 to the base of converter transistor X1. As explained for the circuit in Fig. 6-5, the incoming signal and the local-oscillator signal (X1 plus L2 and its associated components form the oscillator) are combined to produce the IF signal. Two stages of IF amplification are provided by X2 and X3. X7 is the detector, where the audio signal is obtained at its output and coupled to volume control R1. A portion of the audio is coupled via electrolytic capacitor C3 to driver transistor X4. The term "driver" is another name for audio amplifier, so this stage amplifies the audio signal and it is coupled, via transformer T1, to both X5 and X6. The latter two transistors are connected in what is known as a *push-pull* audio-output circuit. X5 actually amplifies one half-cycle of the signal and X6 the other half-cycle. The two are combined at T2 and coupled to the speaker.

Power for operation of this radio is supplied by the 9-volt battery shown at the lower left. Notice the two points labeled -9-volt source and -8.3-volt source. Instead of running leads from the power supply to each point where these voltages are connected, this point is marked on the power supply. Then, at the various points where this voltage is to be used, an arrow labeled -8.3V or -9V is used. This is a common procedure employed to simplify schematics. Especially where several different voltages are obtained in the power supply, the many different leads can be very confusing.

DIFFERENCES IN SCHEMATICS

Not all schematics will look exactly like those shown in this book. As already pointed out, there will be differences in the

Fig. 6-7. Schematic of a typical 6-transistor AM receiver.

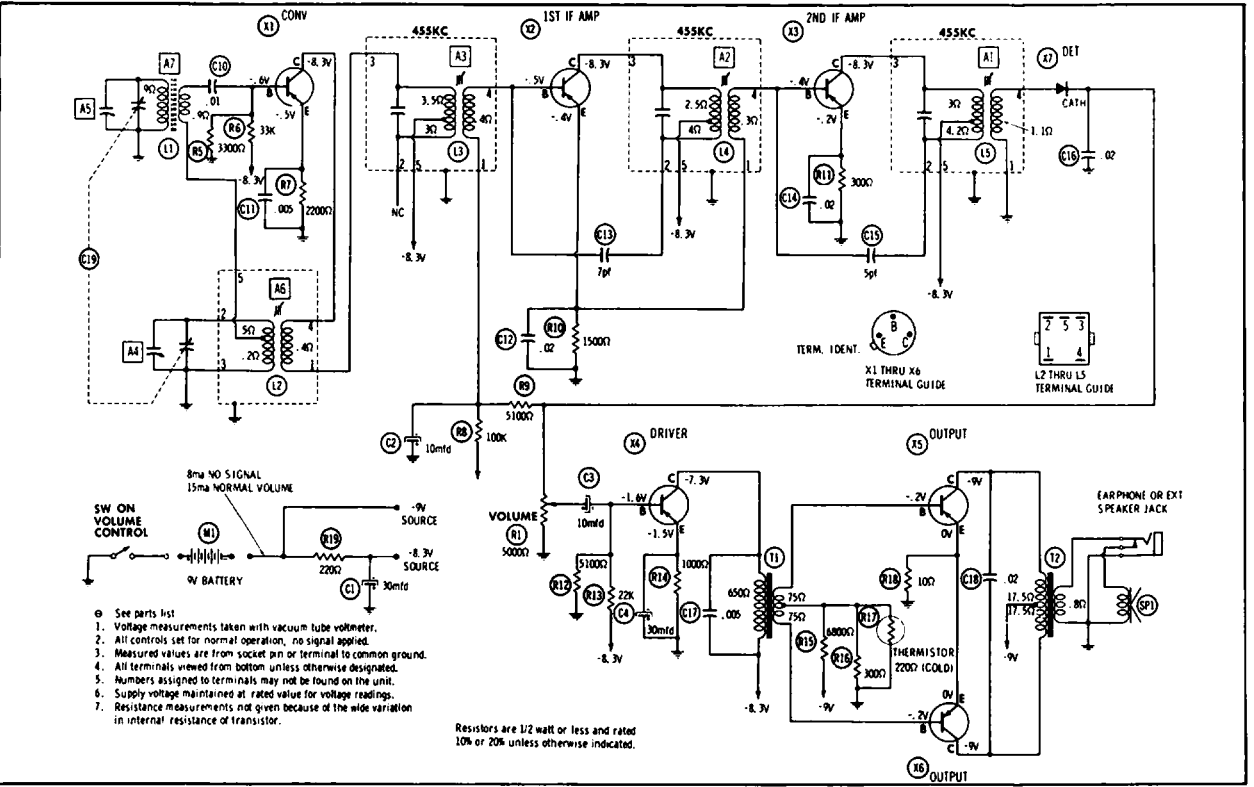

- 0. See parts list
- 1. Voltage measurements taken with vacuum tube voltmeter.
- 2. All controls set for normal operation, no signal applied.
- 3. Measured values are from socket pin or terminal to common ground.
- 4. All terminals viewed from bottom unless otherwise designated.
- 5. Numbers assigned to terminals may not be found on the unit.
- 6. Supply voltage maintained at rated value for voltage readings.
- 7. Resistance measurements not given because of the wide variation in internal resistance of transistor.

Resistors are 1/2 watt or less and rated 10% or 20% unless otherwise indicated.



Putting It All Together

Understanding Schematic Diagrams

weight of the lines and even in the actual shape of the symbols used to represent the various components. Where major differences exist, most of those encountered have been given in this book. Should you encounter an unfamiliar symbol, look at it carefully to see if it doesn't resemble one given in this book, or a combination of symbols.

Complete schematics are usually arranged in the manner shown in this book. That is, normally the signal flows from left to right and top to bottom across the schematic. If in doubt, remember that normally the input to a tube is to the grid, and the output is from the plate. The input to a transistor is normally to the base, and the output is from the collector, although quite often in a transistor the input or output can be at the emitter.

The information presented in this book will serve as a good foundation for a further study in electronics. The information about the construction and operation of the various components will be of great help in any further study. Only the basic information is given here. Much more—in fact, many books—have been written about each component and each function.

Any further study in electronics, however, will involve schematics. By mastering the information in this book—learning each symbol and a little about each component—you will have avoided the biggest pitfall most beginners encounter. This pitfall is that many fail to recognize the importance of the schematic and the understanding of it; instead, they attempt to get ahead of themselves, when all they can read is the words of the text. They cannot “read” the schematic, which often says more than anything else in an electronic circuit.

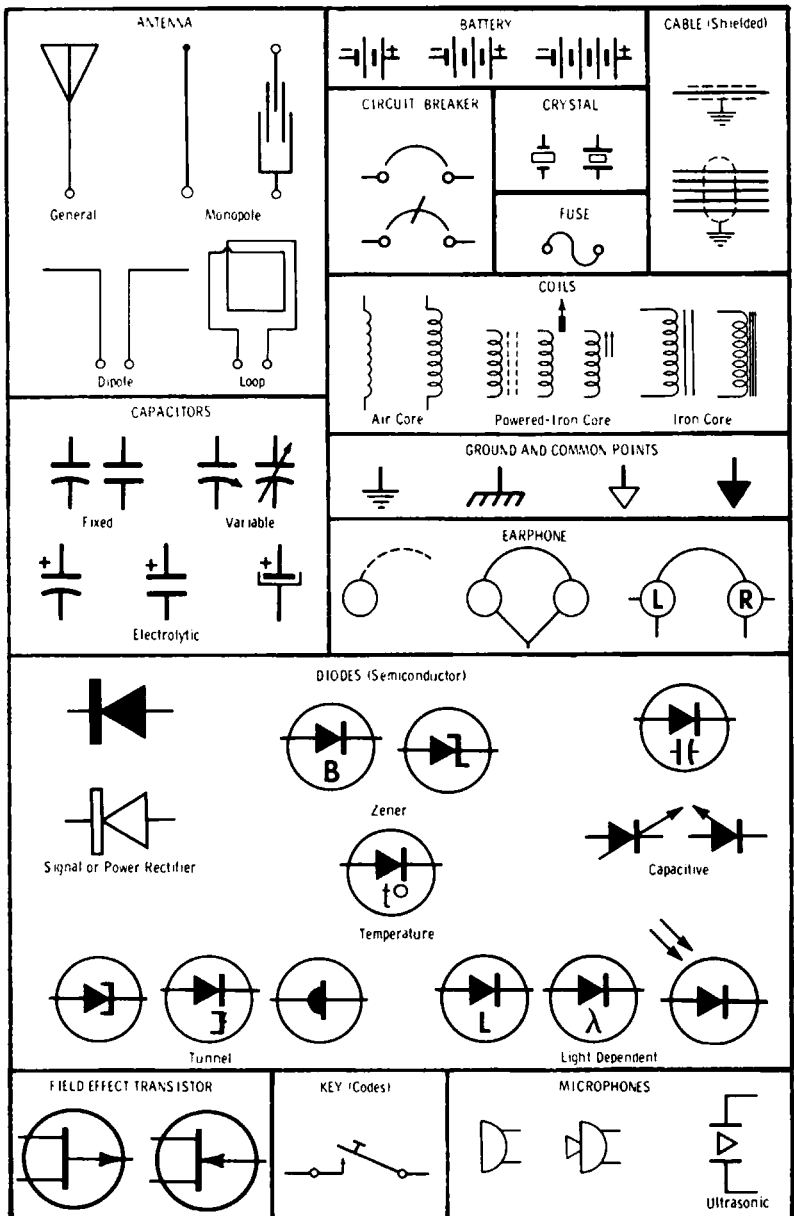

Understanding Schematic Diagrams

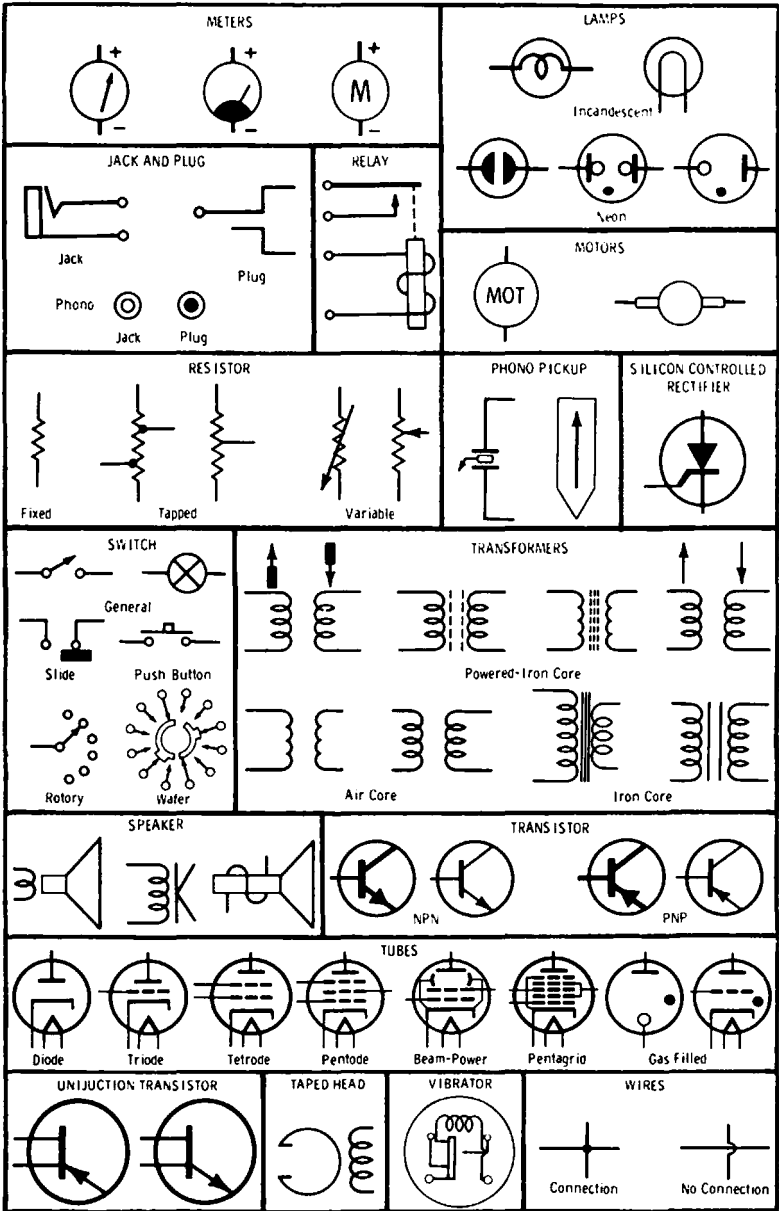

Index

A

Air-core transformer, 41-42
 Alkaline battery, 69-70
 Alternating current, 23
 Amplifier, single-stage, 95-98
 AM Radio, transistor, 104-105
 Antenna, 59-60
 Argon lamp, 74
 Atom, composition of, 19
 Audio amplifier, 103
 Audio output, 103

B

Backward diode, 58
 Band switch, 99-100
 Base, 55
 Battery, 66-70
 Beam-power tube, 51
 Block diagram, 12-14
 Breakdown diode, 58

C

Cable, 78-79
 Capacitor, 31-36
 electrolytic, 35-36
 fixed, 32-34
 operation of, 31-32
 temperature compensating, 34
 variable, 36
 Carbon resistor, 25-27
 Carbon-zinc battery, 66-67
 Cathode, vacuum tube, 47
 Cell, carbon-zinc, 66-67
 Chassis layout diagrams, 14-16
 Choke, 39-40
 Circuit, basic amplifier, 95-97
 Circuit breaker, 72-74
 Code key, 84-85
 Coils, 36-40
 air-core, 37-38
 iron-core, 39-40
 powdered-iron core, 38-39
 Collector, 55
 Color code, capacitor, 34
 resistor, 25-27

Component identification, 92-93
 Condenser, 31
 Conductors, 21
 Connections, 78
 Connector, 85-87
 Converter, 100-102
 Crystals, 75
 Current, 21-23

D

Detector, 103
 Diagram, chassis layout, 14-16
 mechanical, 16-17
 pictorial, 16
Diagrammer, 11-12
 Dial cord stringing, 16-17
 Diode, semiconductor, 52-54
 symbols, 57-58
 tube, 46-48
 Dipole, 59
 Direct current, 22
 pulsating, 22-23
 Double-base diode, 58
 Drafting, 10-12

E

Earphone, 65-66
 Electrolytic capacitor, 35-36
 Electromotive force, 21
 Electron flow, 21
 Electronics fundamentals, 17, 19,
 21-23
 Electrons, 19-20
 Emitter, 55
 Exploded view, 17, 20

F

Farad, 32
 Ferrite-core coils, 38-39
 Field-effect transistor, 58
 Filament, vacuum tube, 47
 Filamentary transistor, 58
 Flow, electron, 21
 Fluorescent lamp, 75
 Force, electromotive, 21

Four-layer diode, 58
Fundamentals, electronic, 17, 19,
21-23
Fuses, 71-72

G

Gas-filled tubes, 52
Generator, 75-76
Glow-discharge lamp, 75
Grid, vacuum tube, 49
Grounds, 79-80

H

Head magnetic, 63-64
Headphone, 65-66
Henry, 37
Hertz, 23

I

IF amplifier, 103
Inductance, 37
Insulators, 21
Intermediate frequency, 101-103
Iron-core transformer, 43-45

J

Jacks, 87-89

K

Key, code, 84-85
Knife switch, 80-81

L

Lamps, 74-75
Light-dependent diode, 58

M

Magnetic head, 63-64
Mechanical diagram, 16-17
Megohm, 25
Mercury battery, 68
Meters, 76-77
Microfarad, 32
Microhenry, 37
Micromicrofarad, 32
Microphone, 62-63

Millihenry, 37
Motor, 75-76

N

Neon lamp, 74-75
Nickel-cadmium battery, 69
Nichrome, 25
Nucleus, of atom, 19

O

Ohms, 24
Ohms law, 25

P

Parametric diode, 58
Parts placement, 14-16
Permeability-tuned transformer, 42
Pentagrid converter, 51
Phono, jack, 89
pickup, 61-62
Photograph, chassis, 14-16
Picofarad, 32
Pictorial diagram, 16
Plate, vacuum tube, 47
Plugs, 86-89
PNPN switch, 58
Potentiometer, 28-29
Power rectifier, 103
Proton, 19
Pulsating direct current, 23

R

Reactance diode, 58
Receiver, short-wave, 99-104
Rectification, 47
Rectifier, silicon controlled, 58
Relays, 90-91
Rheostats, 28-29,
Resistance, of resistor, 24
Resistors, 24-31
Rotary switch, 83

S

Schematic differences, 105-106
Schematic, information on, 92-95
Screen-grid tube, 49
Secondary emission, 50
Selenium rectifier, 52-54
Semiconductor diode, 52-54

Shielded cable, 78-79
Shockley diode, 58
Short-wave receiver, 99-104
Signal diodes, 54
Silicon controlled rectifiers, 58
Silicon rectifier, 53
Sockets, 86-87
Solar cell, 58
Solid-state device, 52
Speaker, 64
Standards, 10
Suppressor grid, 51
Switches, 80-84
Symbol, antenna, 60
 battery, 70
 cable, 78-79
 capacitors 33-36
 circuit breaker, 73-74
 coils, 38-40
 connections, 78
 connectors, 86-87
 crystal, 75
 differences, 10-12
 earphone, 65-66
 fuse, 71
 generator, 75-76
 ground, 79-80
 head, magnetic, 63-64
 headphone, 65-66
 how chosen, 9
 key, code, 84
 microphone, 62
 motor, 75-76
 phono pickup, 61-62
 plug, 88, 89
 relay, 90-91
 resistors, 26-31
 semiconductor diode, 53-54
 semiconductors, 57-58
 speaker, 64
 switch, 82, 84
 test points, 80
 transformers, 41-45
 transistor, 55-56
 tubes, 48, 49, 50, 52
 vibrator, 70-71
 wires, 78-79

T

Tape recorder head, 63-64
Telegraph key, 84-85

Television receiver, schematic of, 8-9
Temperature compensating capacitor, 34
Temperature compensating resistor, 29-30
Temperature diode, 58
Test points, 80
Tetrode tube, 49
Thermal resistor, 30
Thermistor, 30
Thyratron, 52
Tolerance, resistor, 26
Transistor AM Radio, 104-105
Transistors, 54-56
Transformers, 41-45
Trimmer capacitor, 36
Triode tube, 48-49
Tubes, 46-52
Tunnel diode, 58

U

Unijunction transistor, 58
Ultrasonic transducer, 62

V

Vacuum tubes, 46-52
Varactor, 58
Variable capacitor, 36
Variable resistors, 27-29
Varicap, 58
Vibrator, 70-71
Voltage, 21
 reference diode, 58
 regulator diode, 58
Voltages, schematic, 93

W

Wattage, resistor, 25
Wires, 78-79
Wirewound resistor, 26-27
Working voltage, capacitor, 34

Z

Zener diode, 58