

**FUNDAMENTALS OF**

**S**ingle  
**S**ide  
**B**and

**COLLINS RADIO COMPANY**

**FUNDAMENTALS OF**

**Single**

**Side**

**Band**



**597 0331 00**

**2nd EDITION, 1 SEPTEMBER 1959**

**PRINTED IN THE UNITED STATES OF AMERICA**

**© COLLINS RADIO COMPANY**

**1957, 1958, 1959**

**CEDAR RAPIDS, IOWA U.S.A.**



**Collins Designed AN/URC-32 Fixed Station  
SSB Communications System Provides  
Transmission and Reception in the 2 to  
30 Mc Range, with 500 Watts PEP**

# Collins SSB AMATEUR EQUIPMENT PRICE SCHEDULE

Effective May 13, 1960

TYPE/DESCRIPTION	PART NUMBER	AMATEUR NET PRICE	TYPE/DESCRIPTION	PART NUMBER	AMATEUR NET PRICE
<b>TRANSMITTERS</b>			<b>MECHANICAL FILTERS</b>		
30S-1 Linear Amplifier	522 1286 00	\$1556.00	F455J-05 Mechanical Filter (75A-4)	526 9154 00	80.00
32S-1 Transmitter	522 1169 00	666.00	F455J-15 Mechanical Filter (75A-4)	526 9155 00	60.00
32S-2 Transmitter	522 1488 00	746.00	F455J-21 Mechanical Filter (75A-4)	526 9156 00	60.00
<b>RECEIVERS</b>			F455J-31 Mechanical Filter (75A-4)	526 9089 00	60.00
75S-1 Receiver	522 1168 00	520.00	F455J-60 Mechanical Filter (75A-4)	526 9091 00	60.00
75S-2 Receiver	522 1489 00	600.00	F455K-15 Mechanical Filter (75S)	526 9168 00	60.00
75S-1 Receiver with F455Q-5 Filter and BFO Crystal	522 1168 011	600.00	F455Q- 5 Mechanical Filter (75S)	526 9367 00	52.00
75S-2 Receiver with F455Q-5 Filter and BFO Crystal	522 1489 011	680.00	<b>NOISE BLANKER</b>		
<b>TRANSCEIVERS</b>			136B-2 Noise Blanker (136B-2)	522 1661 00	124.00
KWM-2 Transceiver	522 1611 00	1150.00	<b>CABLE TROUGH</b>		
KWM-2A Transceiver	522 1792 00	1250.00	Cable Trough (KWM-2)	097 6192 00	8.00
<b>MOUNTS</b>			Cable Trough (S-Line)	097 6193 00	10.00
351D-1 Mobile Mount (KWM-1)	522 0873 00	100.00	<b>ANTENNA COUPLER</b>		
351D-2 Mobile Mount (KWM-2)	522 1726 00	120.00	180S-1 Antenna Coupler	522 0651 00	600.00
351E-1 Table Mount (32S/75S)	522 1479 003	15.00	<b>WATTMETERS</b>		
351E-2 Table Mount (516F-2, 312B-4)	522 1480 003	15.00	302C-3 Directional Wattmeter	522 1696 00	130.00
351E-3 Table Mount (312B-3)	522 1481 003	15.00	B312-1 Directional Coupler	543 8118 004	85.00
351E-4 Table Mount (KWM-2)	522 1482 003	15.00	<b>PHONE PATCH</b>		
<b>POWER SUPPLIES</b>			189A-2 Phone Patch	522 0872 00	67.00
PM-2 Portable Power Supply & Carrying Case (KWM-2, KWM-2A)	097 6103 00	250.00	<b>CABLES</b>		
PM-2 Power Supply Only	097 6102 00	150.00	440E-1 Cable (516E-1 to KWM-2)	522 2051 00	17.00
516E-1 12V DC Power Supply (KWM-1/2)	522 0846 005	270.00	440F-1 Cable (Extension Cable 516F-2)	522 2114 00	17.00
516E-1 12 V DC Power Supply (S-Line)	522 0846 015	300.00	<b>CRYSTALS</b>		
516E-1 with Positive Ground (KWM-1/2)	522 0846 025	325.00	Crystals for KWM-1, KWM-2, 32S, 75S		4.50
516F-2 AC Power Supply (32S/KWM-2)	522 1170 00	115.00	BFO Crystals for 75S		16.00
<b>SPEAKERS</b>			100 KC Crystals for KWM-1, KWM-2, 75S		16.00
312B-2 Speaker Console (KWM-1)	522 0850 00	Special	<b>PRINTED MATERIAL</b>		
312B-3 Speaker (S-Line)	522 1166 00	29.00	Fundamentals of SSB	597 0331 00	5.00
312B-4 Speaker Console (S-Line, KWM-2)	522 1167 00	195.00	All Instruction Books		2.00
312B-5 PTO Console (KWM-2)	522 1668 00	350.00	All Schematics		.50
399C-1 PTO Speaker (KWM-2)	522 1597 00	230.00	<i>Prices and Specifications subject to change without notice.</i>		
<b>MICROPHONES</b>			PRINTED IN U. S. A		
SM-1 Fixed Station Microphone	097 5944 00	32.00	World Radio History		
SM-2 Fixed Station Microphone	097 5946 00	45.00			
MM-1 Mobile Hand Microphone	097 5945 00	25.00			
MM-2 Mobile Boom Microphone with Earphone	097 6027 00	39.00			
MM-3 Mobile Boom Microphone	097 6026 00	27.00			



# FUNDAMENTALS OF SINGLE SIDEBAND

For the ham who wants to study the theory and practical aspects of single sideband communication, the Collins Radio Company has published "Fundamentals of Single Sideband." This 13 - chapter book covers the following areas:

- Introduction to Single Sideband
- Single Sideband Exciters
- Single Sideband Receivers
- Stabilized Master Oscillators
- Frequency Standards
- Principles of Servomechanisms
- RF Linear Power Amplifier
- Test Equipment and Techniques
- High Frequency Antennas
- Antenna Feed Systems
- Radio Wave Propagation
- Kineplex<sup>®</sup> Data Transmission
- Single Sideband for the Radio Amateur

Available at your nearest distributor—Price \$5.00



COLLINS

**SSB**

AMATEUR  
EQUIPMENT  
PRICE  
SCHEDULE

# TABLE OF CONTENTS

Chapter		Page
<b>1</b>	<b>INTRODUCTION TO SINGLE SIDEBAND . . . . .</b>	<b>1-1</b>
	1. Need for Single Sideband . . . . .	1-1
	2. What Single Sideband Means . . . . .	1-1
	3. Historical Development of Single-Sideband Communication Systems . . . . .	1-1
	4. Basic Functional Units of a Single-Sideband Transmitting System . . . . .	1-2
	5. Basic Functional Units of a Single-Sideband Receiving System . . . . .	1-5
	6. Comparison of SSB with AM. . . . .	1-5
	a. Power Comparison of SSB and AM. . . . .	1-5
	b. Antenna Voltage Comparison of SSB and AM. . . . .	1-6
	c. Advantage of SSB with Selective Fading Conditions. . . . .	1-8
	d. Comparison of SSB with AM. under Limiting Propagating Conditions . . . . .	1-8
	e. Comparison of Airborne High-Frequency Systems. . . . .	1-10
	f. Summary . . . . .	1-11
	7. Comparison of SSB with FM . . . . .	1-11
	8. Nature of Single-Sideband Signals . . . . .	1-11
	a. Introduction . . . . .	1-11
	b. The SSB Generator . . . . .	1-12
	c. Generating the Single-Tone SSB Waveform . . . . .	1-12
	d. Generating the SSB Waveform of a Single Tone with Carrier . . . . .	1-13
	e. Generating the Two-Tone SSB Waveform. . . . .	1-14
	f. Generating the Square Waveform . . . . .	1-15
	g. Generating the Voice Waveform. . . . .	1-16
	9. Mechanical Filters . . . . .	1-17
<b>2</b>	<b>SINGLE-SIDEBAND EXCITERS . . . . .</b>	<b>2-1</b>
	1. Single-Sideband Exciter Considerations . . . . .	2-1
	a. Filter System . . . . .	2-1
	b. Phase Shift System . . . . .	2-1
	2. The Single-Sideband Generator . . . . .	2-2
	a. Input Signal Processing . . . . .	2-2
	b. Modulators for Single Sideband . . . . .	2-5
	c. Suppressing the Carrier . . . . .	2-7
	d. Sideband Selection . . . . .	2-7
	3. Translation to the Operating Frequency . . . . .	2-10
	a. Spurious Mixer Products . . . . .	2-10
	b. Oscillator Requirements . . . . .	2-14
	4. Amplification . . . . .	2-15
	a. Tuned Circuits . . . . .	2-15
	b. Linear Amplification . . . . .	2-15
	5. Summary . . . . .	2-16
<b>3</b>	<b>SINGLE-SIDEBAND RECEIVERS . . . . .</b>	<b>3-1</b>
	1. Single-Sideband Receiver Considerations . . . . .	3-1
	2. R-F Section. . . . .	3-2
	a. Noise Sources. . . . .	3-2
	b. R-F Selectivity . . . . .	3-5
	c. Mixers . . . . .	3-5
	3. I-F Section . . . . .	3-6

## TABLE OF CONTENTS (CONT)

Chapter	Page
a. Selectivity . . . . .	3-6
b. Amplification . . . . .	3-7
c. Automatic Gain Control . . . . .	3-7
4. Audio Section . . . . .	3-9
a. The Product Demodulator . . . . .	3-9
<b>4 STABILIZED MASTER OSCILLATORS . . . . .</b>	<b>4-1</b>
1. Technical Requirements. . . . .	4-1
2. AFC vs Absolute Frequency Control . . . . .	4-1
3. Development of Frequency Control . . . . .	4-1
4. Frequency Synthesizers. . . . .	4-2
a. Harmonic Generators . . . . .	4-2
b. Harmonic Frequency Selectors . . . . .	4-3
5. The Stabilized Master Oscillator. . . . .	4-3
a. Frequency Discriminator . . . . .	4-4
b. Reactance Control . . . . .	4-4
c. Basic SMO Operation . . . . .	4-6
d. Multiple Frequency SMO Operation. . . . .	4-8
<b>5 FREQUENCY STANDARDS . . . . .</b>	<b>5-1</b>
1. Introduction. . . . .	5-1
2. Deterioration of Generated Frequency . . . . .	5-2
a. Effect of Doppler Shift . . . . .	5-2
b. Effect of Propagation Characteristics . . . . .	5-3
c. Effects of Equipment Circuitry . . . . .	5-3
3. Measurement Techniques . . . . .	5-3
a. Time Comparison . . . . .	5-3
b. Frequency Intercomparison . . . . .	5-5
c. Phase Intercomparison. . . . .	5-5
4. Quartz Resonator Theory . . . . .	5-7
a. Construction and Operation . . . . .	5-7
b. Characteristics . . . . .	5-8
c. Construction of Precision Resonators . . . . .	5-10
5. Oscillator Theory. . . . .	5-10
a. General Theory . . . . .	5-10
b. Typical Oscillator Circuits . . . . .	5-11
c. Precision Crystal-Controlled Oscillators . . . . .	5-13
6. Oven Theory . . . . .	5-15
a. General Theory . . . . .	5-15
b. Typical Precision Oven . . . . .	5-15
7. Frequency Divider Theory. . . . .	5-16
8. System Considerations . . . . .	5-17
<b>6 PRINCIPLES OF SERVOMECHANISMS . . . . .</b>	<b>6-1</b>
1. Definitions . . . . .	6-1
2. A Typical Position Servo System. . . . .	6-1
3. Servo Stability Requirements . . . . .	6-3
4. Components and Circuits . . . . .	6-6

## TABLE OF CONTENTS (CONT)

Chapter		Page
<b>7</b>	<b>R-F LINEAR POWER AMPLIFIER</b>	<b>7-1</b>
	1. Introduction	7-1
	2. Power Amplifier Classification	7-1
	3. R-F Power Amplifier Tubes	7-2
	4. Basic Linear Power Amplifier Circuits	7-4
	a. General	7-4
	b. Grid Driven Triode Power Amplifier	7-4
	c. Cathode Driven Triode Power Amplifier	7-4
	d. Grid Driven Tetrode Power Amplifier	7-5
	5. Power Amplifier Output Networks	7-5
	a. Tank Circuit Considerations	7-5
	b. Circuit Losses	7-6
	c. Tank Coil and Capacitor Requirements	7-6
	6. Neutralization	7-7
	a. Effects of Plate-to-Grid Capacitance	7-7
	b. Neutralizing Circuits	7-7
	c. Testing for Proper Neutralization	7-8
	7. R-F Feedback Circuits	7-8
	a. Introduction	7-8
	b. Feedback Around One Stage	7-8
	c. Feedback Around Two Stages	7-9
	8. Automatic Load Control	7-10
	9. Linear Power Amplifier Tuning	7-11
	a. Introduction	7-11
	b. Phase Comparison Tuning	7-11
	c. Loading Comparator Circuit	7-12
	d. Antenna Tuning and Loading	7-13
	10. Power Supplies for Power Amplifiers	7-14
	11. Control Circuits	7-14
	12. Tube Operating Conditions for R-F Linear Power Amplifiers	7-15
	a. General	7-15
	b. Class A R-F Linear Amplifiers	7-15
	c. Class AB R-F Linear Amplifiers	7-15
	d. Estimating Tube Operating Conditions	7-16
	13. Distortion	7-17
	a. Causes of R-F Linear Power Amplifier Distortion	7-17
	b. Distortion Reduction	7-18
	c. Linearity Tracer	7-19
<b>8</b>	<b>TEST EQUIPMENT AND TECHNIQUES</b>	<b>8-1</b>
	1. General	8-1
	2. Frequency Measurement	8-1
	3. Signal Level	8-2
	4. Undesired Power Output	8-5
	5. Panoramic Spectrum Analyzer 478R-1	8-8
	6. Angle Modulation Measurements	8-12
	7. Compression Measurement	8-12
	8. Intermodulation Measurements with Built-In Monitor	8-13
	9. Linearity Measurement with Noise Loading	8-13
	10. Delay Distortion	8-14
	11. Field Test Set for Intermodulation Distortion Measurements	8-14
	12. Summary	8-19

## TABLE OF CONTENTS (CONT)

Chapter		Page
<b>9</b>	<b>HIGH-FREQUENCY ANTENNAS</b>	<b>9-1</b>
1.	Introduction.	9-1
2.	Antenna Fundamentals	9-1
	a. Radiation Characteristics of a Linear Conductor	9-1
	b. Polarization	9-3
	c. Reciprocity.	9-3
	d. Image Antennas	9-3
	e. Mutual Impedance	9-3
	f. Antenna Directivity	9-4
3.	Typical High-Frequency Antennas	9-6
	a. The Practical Half-Wave Dipole.	9-6
	b. Electrically Short Antennas	9-9
	c. Long Wire Antenna	9-10
	d. Phased Dipole Arrays with Parasitic Elements.	9-11
	e. The Folded Dipole	9-12
	f. Reflector Type Antennas (Billboard)	9-12
4.	Logarithmically Periodic Antennas	9-14
	a. Principles of Operation	9-14
	b. Unidirectional HF Rotable Antennas	9-16
	c. Point to Point Unidirectional Antenna	9-17
	d. Horizontally Polarized Omnidirectional Antennas	9-18
<b>10</b>	<b>ANTENNA FEED SYSTEMS</b>	<b>10-1</b>
1.	Introduction.	10-1
2.	Types of R-F Lines	10-1
3.	Transmission Line Properties	10-1
4.	Typical R-F Transmission Lines	10-2
	a. Two-Wire Balanced Lines--Air Dielectric	10-2
	b. Four-Wire Balanced Lines--Air Dielectric	10-3
	c. Two-Wire Balanced Lines--Solid Dielectric.	10-3
	d. Air Dielectric Coaxial Lines	10-4
	e. Solid Dielectric Coaxial Lines	10-4
	f. Two Conductor Shielded Cables	10-5
	g. Single Wire Line	10-5
5.	Transmission Line Sections as Circuit Elements	10-5
	a. Line Sections as Parallel Resonant Circuits.	10-5
	b. Line Sections as Series Resonant Circuits	10-7
	c. Line Sections as Low-Loss Reactances	10-7
	d. Line Sections as Impedance Transformers	10-8
	e. Line Sections as Balancing Devices	10-9
6.	Methods of Coupling to the Antenna	10-12
	a. Direct Feeding	10-12
	b. Resonant Line Feeding	10-12
	c. Nonresonant Line Feeding.	10-13
	d. Typical Antenna Feeds	10-16
7.	Measurements	10-16

## TABLE OF CONTENTS (CONT)

Chapter		Page
<b>11</b>	<b>RADIO WAVE PROPAGATION</b>	<b>11-1</b>
	1. Introduction	11-1
	2. Formation of the Ionosphere	11-1
	3. Ionospheric Absorption	11-1
	4. Structure of the Ionosphere	11-2
	5. Natural Phenomena Which Affect Ionic Layers	11-5
	a. Sunspots	11-5
	b. Sudden Ionospheric Disturbances	11-5
	c. Magnetic Storms	11-5
	d. Sporadic E Layer	11-5
	6. Sky Wave Transmission	11-5
	a. Sky Wave Reflection	11-5
	b. Sky Wave Absorption	11-7
	c. Sky Wave Field Intensity	11-8
	d. Lowest Useful High Frequency	11-11
	e. Maximum Usable Frequency	11-11
	f. Lowest Effective Power	11-11
	7. Ground Wave Propagation	11-11
	8. Charts and Graphs	11-13
	9. Sample Propagation Analysis	11-63
	a. Introduction	11-63
	b. Sky Wave Propagation Analysis	11-63
	c. Ground Wave Propagation Analysis	11-67
	d. Final Analysis	11-68
<b>12</b>	<b>KINEPLEX DATA TRANSMISSION</b>	<b>12-1</b>
	1. Introduction	12-1
	2. Codes Used for Data Transmission	12-1
	3. Telegraph Signaling	12-2
	4. Frequency Shift Keying	12-2
	5. Predicted Wave Signaling	12-2
	6. Kineplex	12-3
<b>13</b>	<b>SINGLE SIDEBAND FOR THE RADIO AMATEUR</b>	<b>13-1</b>
	1. Introduction	13-1
	2. 75S-1 Receiver	13-3
	a. R-F Circuits	13-3
	b. Frequency-Conversion Data	13-4
	c. I-F Circuits	13-7
	d. A-F Circuits	13-7
	e. Oscillator Circuits	13-7
	f. Power Supply	13-7
	3. 32S-1 Transmitter	13-7
	a. Frequency-Conversion Data	13-8
	b. A-F Circuits	13-8
	c. Balanced Modulator and Low-Frequency I-F Circuits	13-10
	d. Balanced Mixers	13-10
	e. R-F Circuits	13-10
	f. Control Circuits	13-10
	g. Oscillators	13-10
	h. Sync Operation	13-13
	i. Transceiver Operation with the 75S-1 Receiver	13-13

## TABLE OF CONTENTS (CONT)

Chapter	Page
4. KWM-1 Transceiver . . . . .	13-13
a. Receive-Transmit Common Circuits . . . . .	13-14
b. Receive Circuits . . . . .	13-14
c. Transmit Circuits . . . . .	13-14
d. Control Circuits . . . . .	13-14
e. Oscillator Circuits . . . . .	13-18
5. KWM-2 Transceiver . . . . .	13-18
a. Frequency-Conversion Data . . . . .	13-18
b. Transmitter Circuits . . . . .	13-22
c. Receiver Circuits . . . . .	13-22
6. 30S-1 Linear Amplifier . . . . .	13-28
a. R-F Circuit Description . . . . .	13-31
b. Power Supply . . . . .	13-31
7. 312B-4 Station Control . . . . .	13-31
8. Noise Blankers . . . . .	13-31
9. Directional Wattmeters . . . . .	13-36
a. R-F Circuit . . . . .	13-37
b. D-C Circuit . . . . .	13-37
c. Frequency Linearity . . . . .	13-37
d. Real Power . . . . .	13-37
10. Power Supplies . . . . .	13-37
a. 516E-1 12-Volt D-C Power Supply . . . . .	13-37
b. 516E-2 28-Volt D-C Power Supply . . . . .	13-38
c. 516F-2 A-C Power Supply . . . . .	13-38

## LIST OF ILLUSTRATIONS

Figure		Page
1-1	Location of SSB Signal in R-F Spectrum . . . . .	1-1
1-2	Functional Units of an SSB Transmitting System . . . . .	1-3
1-3	Generation of the Twin-Channel Sideband Signal. . . . .	1-4
1-4	Generation of Two Channel SSB Signal . . . . .	1-4
1-5	Functional Units of an SSB Receiving System. . . . .	1-5
1-6	SSB and AM. Comparison with Equal Signal-to-Noise Ratio. . . . .	1-7
1-7	Deterioration of an AM. Signal with Selective Fading . . . . .	1-9
1-8	Relative Advantage of SSB over AM. with Limiting Propagating Conditions. . . . .	1-10
1-9	AN/ARC-38 and AN/ARC-58 Comparison . . . . .	1-10
1-10	SSB Performance Compared with FM . . . . .	1-11
1-11	Filter-Type SSB Generator. . . . .	1-12
1-12	Single-Tone, Balanced Modulator Output . . . . .	1-13
1-13	Single-Tone Balanced Modulator Output After Filtering Out the LSB . . . . .	1-13
1-14	Single-Tone SSB Signal with Carrier--Carrier Equal in Amplitude to Tone. . . . .	1-13
1-15	Single-Tone SSB Signal with Carrier--Carrier 10 DB Below Tone. . . . .	1-13
1-16	Two-Tone SSB Signal--Tones of Equal Amplitude . . . . .	1-14
1-17	Two-Tone SSB Signal with Small Reinserted Pilot Carrier . . . . .	1-14
1-18	Power Measurements from Two-Tone SSB Test Signal . . . . .	1-14
1-19	Square Wave SSB Signal--All Frequency Components Present . . . . .	1-15
1-20	SSB Envelope Developed from 300 CPS, Clipped Sine-Wave (Harmonics above 9th Attenuated)	1-15
1-21	Voice Signal at Audio Frequency--a Sound . . . . .	1-16
1-22	SSB Voice Signal--a Sound . . . . .	1-16
1-23	Power Distribution in Speech Frequencies--Low and High Frequencies Removed. . . . .	1-16
1-24	Elements of a Mechanical Filter . . . . .	1-18
1-25	Electrical Analogy of a Mechanical Filter. . . . .	1-18
1-26	Mechanical Filter Characteristic Curve . . . . .	1-19
1-27	Size Comparison Between a Mechanical Filter and a Miniature Tube . . . . .	1-19
2-1	Typical Single-Sideband Exciter, Functional Diagram. . . . .	2-1
2-2	Basic Single-Sideband Generator, Block Diagram . . . . .	2-2
2-3	Peak-to-Average Level Variations of Speech. . . . .	2-3
2-4	Compressor Circuit . . . . .	2-3
2-5	Clipper Circuit . . . . .	2-4
2-6	Basic Ring Modulator Circuits . . . . .	2-6
2-7	Basic Shunt Modulator Circuits . . . . .	2-6
2-8	Basic Series Modulator Circuits . . . . .	2-6
2-9	Vacuum Tube Balanced Modulators . . . . .	2-8
2-10	Ring Modulator Carrier Current Paths. . . . .	2-9
2-11	Selectivity Considerations in Frequency Translators . . . . .	2-13
3-1	Typical Single-Sideband Receiver, Functional Diagram . . . . .	3-1
3-2	Noise Sources in R-F Section of Single-Sideband Receiver . . . . .	3-3
3-3	Generalized Selectivity Curve. . . . .	3-4
3-4	Typical Receiver Mixer Spurious Response . . . . .	3-5
3-5	Receiver Mixer Crossover Response . . . . .	3-5
3-6	Selectivity Comparison . . . . .	3-7
3-7	AGC Circuit . . . . .	3-8
3-8	Product Demodulator. . . . .	3-8
4-1	Multiple Crystal Frequency Synthesizer . . . . .	4-2
4-2	Single Crystal Frequency Synthesizer . . . . .	4-2
4-3	Harmonic Generator . . . . .	4-3
4-4	Harmonic Frequency Selector. . . . .	4-4
4-5	Simple Stabilized Master Oscillator with Frequency Discriminator . . . . .	4-5
4-6	Frequency Discriminator . . . . .	4-5



**LIST OF ILLUSTRATIONS (CONT)**

Figure		Page
4-7	Variable Inductor Response Curve . . . . .	4-6
4-8	Discriminator Frequency Response Curve . . . . .	4-6
4-9	Simple Stabilized Master Oscillator with Phase Discriminator . . . . .	4-7
4-10	Block Diagram of Basic Stabilized Master Oscillator . . . . .	4-7
5-1	Multiple-Crystal Frequency Synthesizer . . . . .	5-2
5-2	Single-Crystal Frequency Synthesizer . . . . .	5-2
5-3	Typical Long-Term Stability . . . . .	5-2
5-4	Typical Short-Term Stability . . . . .	5-2
5-5	Doppler Frequency Shift in Aircraft . . . . .	5-3
5-6	Time Comparison System, Aural Indication . . . . .	5-4
5-7	Time Comparison System, Visual Indication, Chronoscope . . . . .	5-4
5-8	Frequency Intercomparison System Using Frequency Counter . . . . .	5-5
5-9	Frequency Intercomparison System Using Power Line Frequency Recorder . . . . .	5-5
5-10	Phase Intercomparison System . . . . .	5-5
5-11	Quartz Crystal Showing Types of Cuts . . . . .	5-6
5-12	Modes of Vibration . . . . .	5-7
5-13	Quartz Resonator Equivalent Circuit . . . . .	5-8
5-14	Impedance Versus Frequency Curve . . . . .	5-8
5-15	Frequency Versus Temperature Characteristics . . . . .	5-9
5-15.1	Quartz Resonators, Aging Rate versus Temperature . . . . .	5-10
5-16	Precision Quartz Resonator, Construction and Mode of Vibration of 5th Overtone AT Cut . . . . .	5-10
5-17	Equivalent Circuit of a Crystal-Controlled Oscillator . . . . .	5-11
5-18	Calculation of Resonator Power Dissipation . . . . .	5-11
5-19	Basic Crystal Oscillator Operating the Resonator at Series Resonance . . . . .	5-12
5-20	Basic Pierce Oscillator . . . . .	5-12
5-21	Meacham Oscillator . . . . .	5-13
5-22	Precision Pierce Oscillator . . . . .	5-14
5-23	Oven Operation Equivalent Electrical Circuit . . . . .	5-15
5-24	Typical Oven Construction . . . . .	5-16
5-25	Oven Control Oscillator . . . . .	5-16
5-26	8U-1 Frequency Divider, Block Diagram . . . . .	5-17
5-27	Typical Secondary Frequency Standard, Covers Removed . . . . .	5-18
5-28	Collins Radio Company Primary Frequency Standard . . . . .	5-19
6-1	Position Follow-Up Servomechanism . . . . .	6-1
6-2	Voltage Regulator . . . . .	6-2
6-3	Idealized Torque versus Voltage Curve . . . . .	6-2
6-4	Servo Loop Block Diagram . . . . .	6-3
6-5	Response of Motor and Amplifier to Step Input . . . . .	6-4
6-6	Response of Follow-Up Servo to Step Input . . . . .	6-4
6-7	Effect of Rate Generator on Response Time . . . . .	6-5
6-8	Lead Network . . . . .	6-5
6-9	Effect of Lead Network on Response Time . . . . .	6-5
6-10	Motor-Generator Schematic Diagram . . . . .	6-6
6-11	Electromechanical Chopper Circuit . . . . .	6-7
6-12	Synchro Error Circuit . . . . .	6-7
7-1	Class A Tube Operation . . . . .	7-1
7-2	Class B Tube Operation . . . . .	7-2
7-3	Class C Tube Operation . . . . .	7-3
7-4	Grid Driven, Plate Neutralized Triode Power Amplifier . . . . .	7-4
7-5	Cathode Driven Triode Power Amplifier . . . . .	7-4
7-6	Grid Driven Tetrode Power Amplifier . . . . .	7-5
7-7	Tuning Controls for Pi-L Output Network . . . . .	7-6
7-8	Circuit Losses in Pi-L Network . . . . .	7-6

## LIST OF ILLUSTRATIONS (CONT)

Figure		Page
7-9	Conventional Grid-Neutralized Amplifier . . . . .	7-7
7-10	Modified Grid-Neutralized Amplifier . . . . .	7-8
7-11	One-Stage Feedback with Neutralization . . . . .	7-8
7-12	Two-Stage Feedback with Neutralization . . . . .	7-9
7-13	Vector Relationship of Voltages for Two-Stage Feedback. . . . .	7-10
7-14	Automatic Load Control Circuit . . . . .	7-10
7-15	Automatic Load Control Performance Curve . . . . .	7-11
7-16	Phase Discriminator for PA Tuning. . . . .	7-11
7-17	Coarse Discriminator for PA Tuning . . . . .	7-12
7-18	Discriminator Output Curves for PA Tuning . . . . .	7-12
7-19	Loading Comparator for PA Loading . . . . .	7-13
7-20	Output Network Tuning and Loading Controls. . . . .	7-13
7-21	Optimum Static Plate Current for Linear Operation . . . . .	7-16
7-22	Graphical Determination of Tube Operating Conditions. . . . .	7-16
7-23	Efficiency and Plate Dissipation for Class AB Operation. . . . .	7-17
7-24	Typical PA Tube Transfer Characteristic Curve . . . . .	7-17
7-25	Spectrum Distribution of Products Generated in PA Stage . . . . .	7-18
7-26	Odd-Order Intermodulation Products Causing SSB Distortion . . . . .	7-18
7-27	Linearity Tracer, Block Diagram . . . . .	7-19
7-28	Envelope Detector, Schematic Diagram . . . . .	7-19
7-29	Typical Linearity Traces . . . . .	7-19
8-1	Directional Wattmeter, SWR Chart . . . . .	8-4
8-2	Receiver/Signal Generator Substitution, Block Diagram . . . . .	8-5
8-3	Idealized Panoramic Spectrum Analyzer Pattern . . . . .	8-8
8-4	Practical Panoramic Spectrum Analyzer Pattern . . . . .	8-8
8-5	Panoramic Spectrum Analyzer 478R-1, Block Diagram . . . . .	8-9
8-6	Two-Tone Generator, Source Isolation. . . . .	8-10
8-7	Intermodulation Products in a Noise Loaded System . . . . .	8-13
8-8	Audio Two-Tone Test Generator, Block Diagram . . . . .	8-15
8-9	Audio Distortion Analysis Filter, Block Diagram . . . . .	8-16
8-10	R-F to Audio Converter, Block Diagram . . . . .	8-17
8-11	Test of Intermodulation in Transmitter. . . . .	8-18
8-12	Test of Intermodulation in Receiver. . . . .	8-18
8-13	Test of Intermodulation in Audio Amplifier . . . . .	8-18
8-14	System Test for Intermodulation Distortion . . . . .	8-18
8-15	Transmitter Monitor, Block Diagram . . . . .	8-18
8-16	Test of Two-Tone Audio Generator . . . . .	8-19
8-17	Test of Intermodulation in R-F to Audio Converter. . . . .	8-19
9-1	Sinusoidal Voltage and Current Distribution on Resonant Wires . . . . .	9-2
9-2	Lumped Circuit Analogy for Half-Wave Radiators . . . . .	9-2
9-3	Image Antennas . . . . .	9-3
9-4	Polar Diagram of Radiation Patterns of an Isotropic Radiator, Elementary Dipole, and Half-Wave Dipole, in Free Space . . . . .	9-4
9-5	Image Antenna and Ground Effect . . . . .	9-5
9-6	Angles of Ground Reflection Factor Maxima and Minima for Antenna Heights up to Two Wave Lengths. . . . .	9-5
9-7	Variation of the Radiation Resistance of a Theoretical Half-Wave Dipole with Height above a Perfectly Conducting Earth . . . . .	9-6
9-8	Vertical Radiation Pattern of a Vertical Dipole at the Surface of an Earth of Finite Conductivity . . . . .	9-6
9-9	Vertical Radiation of a Vertical Dipole a Quarter Wave Length Above an Earth of Finite Conductivity . . . . .	9-6

## LIST OF ILLUSTRATIONS (CONT)

Figure		Page
9-10	Vertical Radiation Pattern of a Vertical Dipole a Half Wave Length above an Earth of Finite Conductivity . . . . .	9-7
9-11	Vertical Radiation (in the plane perpendicular to the axis of the dipole) of a Horizontal Dipole a Quarter Wave Length above an Earth of Finite Conductivity. . . . .	9-7
9-12	Vertical Radiation Pattern (in the plane perpendicular to the axis of the dipole) of a Horizontal Dipole a Half Wave Length above an Earth of Finite Conductivity . . . . .	9-7
9-13	Common Methods of Exciting High-Frequency Antennas . . . . .	9-7
9-14	Radiation Patterns of Center-Fed Vertical Dipoles. . . . .	9-8
9-15	Experimental Patterns of Wire Antennas with Different Feed Points . . . . .	9-8
9-16	Top-Loaded Antennas . . . . .	9-9
9-17	Current Distribution for Short Vertical Antennas . . . . .	9-9
9-18	(a) Theoretical Current Distribution and (b) Radiation Pattern of a Two-Wave Length End-Fed Antenna . . . . .	9-10
9-19	Radiation Pattern for Terminated Long Wire Antenna . . . . .	9-10
9-20	V Antenna . . . . .	9-11
9-21	Rhombic Antenna . . . . .	9-11
9-22	Three Element Parasitic Array . . . . .	9-11
9-23	Half-Wave Folded Dipole . . . . .	9-12
9-24	Impedance Step-Up Ratio . . . . .	9-13
9-25	Billboard Antenna. . . . .	9-13
9-26	High-Frequency, Broad-Band, Billboard Antenna . . . . .	9-13
9-27	Steerable Beam Antenna . . . . .	9-13
9-28	Log Periodic Antenna Showing Design Parameters . . . . .	9-14
9-29	Effect of Angle $\psi$ on Pattern Characteristics for Antenna with $\alpha = 60^\circ$ $\tau = .6$ . . . . .	9-15
9-30	Effect of Angle $\alpha$ on Pattern Characteristics for Antenna with $\psi = 30^\circ$ . . . . .	9-15
9-31	Collins Unidirectional Antenna 237A-2 . . . . .	9-16
9-32	Logarithmically Periodic Antenna for Use in Point to Point Communications . . . . .	9-17
9-33	Horizontally Polarized Omnidirectional Antenna . . . . .	9-18
10-1	Approximate Representation of a Two-Wire Transmission Line by Means of Lumped Constants . . . . .	10-1
10-2	Effect of SWR on Line Loss . . . . .	10-2
10-3	Cross Section of Two-Wire Balanced Line. . . . .	10-3
10-4	Characteristic Impedances for Typical Values of Conductor Size and Spacing (Two-Wire Balanced Lines) . . . . .	10-3
10-5	Cross Section of Four-Wire Balanced Lines . . . . .	10-4
10-6	Characteristic Impedances of Four-Wire Balanced Line with Typical Values of Conductor Size and Spacing. . . . .	10-4
10-7	Cross Section of Air Dielectric Coaxial Line. . . . .	10-5
10-8	Cross Section of Solid Dielectric Coaxial Line . . . . .	10-5
10-9	Lumped Circuit Analogy for Quarter-Wave Section of Transmission Line Terminated in a Short Circuit . . . . .	10-6
10-10	Lumped Circuit Analogy of Transmission Line Sections of Various Lengths . . . . .	10-6
10-11	Quarter-Wave Open Transmission Line Section and its Equivalent Circuit . . . . .	10-7
10-12	Effect of Shorted Stub on SWR Between Stub and Generator . . . . .	10-7
10-13	Universal Reactance Curves for Open or Shorted Lines Less than a Quarter-Wave in Length. . . . .	10-8
10-14	Line Sections as Reactive Elements. . . . .	10-8
10-15	Quarter-Wave Line Section as Transformer . . . . .	10-8
10-16	Bazooka Type Balun . . . . .	10-9
10-17	Double Bazooka Type Balun . . . . .	10-9
10-18	Parallel-Conductor Type Balun with 1:1 Impedance Transfer . . . . .	10-10
10-19	Simple Balun Impedance Transformer . . . . .	10-10
10-20	Half-Wave Balun with 4:1 Impedance Transfer . . . . .	10-11

## LIST OF ILLUSTRATIONS (CONT)

Figure		Page
10-21	Broad Band Coil Balun with 1:1 Impedance Transfer . . . . .	10-11
10-22	Coupling the Directly Fed Antenna Through a Pi Network . . . . .	10-12
10-23	Current and Voltage Feed in Antennas Operated at One, Two, and Three Times Fundamental Frequency. . . . .	10-12
10-24	Coupling Networks for Resonant Feedlines . . . . .	10-13
10-25	Coupling to Nonresonant Balanced and Unbalanced Lines . . . . .	10-13
10-26	Typical Coupling to Center-Fed Half-Wave Dipoles. . . . .	10-14
10-27	Typical Applications of Matching Stubs. The curves shown apply only if the characteristic impedance of the line and the stub are the same and the load is resistive. When applicable, modify lengths of A and B by the appropriate velocity factor. Where coaxial lines are used, the same principles apply. . . . .	10-15
10-28	Typical Applications of Practical Transmission Lines . . . . .	10-16
10-29	Relationship of SWR to Incident and Reflected Power . . . . .	10-18
10-30	VSWR Correction Curves for Attenuation on Transmission Line . . . . .	10-19
10-31	Attenuation Data for Common Types of Transmission Lines. . . . .	10-20
11-1	Formation of an Ionized Layer by a Single-Frequency Ultraviolet Wave . . . . .	11-2
11-2	Typical Ionospheric Record . . . . .	11-3
11-3	Geomagnetic Co-ordinates as Related to East, West, Intermediate, and Auroral Zone . . . . .	11-4
11-4	Distance Limitations for Single Reflection Transmission (A) and Modes of Transmission (B). . . . .	11-6
11-5	Refraction of a Radio Wave . . . . .	11-6
11-6	Ray Path for a Curved Earth and a Curved Ionosphere . . . . .	11-7
11-7	Geometric Length of 1-Hop E Layer Sky Wave Propagation Path; Length Equals 190 Km . . . . .	11-10
11-8	World Map Showing Zones Covered by Predicted Charts, and Auroral Zones . . . . .	11-15
11-9	Great Circle Chart Centered on Equator; Solid Lines Represent Great Circles; Numbered Dot-Dash Lines Indicate Distances in Thousands of Kilometers . . . . .	11-16
11-10	Median $F_2$ -Zero-MUF, in Mc, W Zone, Predicted for April 1957. . . . .	11-17
11-11	Median $F_2$ -4000-MUF, in Mc, W Zone, Predicted for April 1957. . . . .	11-18
11-12	Median E-2000-MUF, in Mc, Predicted for April 1957 . . . . .	11-19
11-13	Median $fE_s$ , in Mc, Predicted for April 1957. . . . .	11-20
11-14	Gains of Spaced Diversity Receiving Antennas for Rapidly Fading Signals . . . . .	11-21
11-15	Rapid Variation of Sky Wave Field Intensity . . . . .	11-22
11-16	Slow Variation of Sky Wave Intensity . . . . .	11-23
11-17	Slow Variation of Atmospheric Noise . . . . .	11-24
11-18	Radiation Angle Versus Great Circle Distance Curves . . . . .	11-25
11-19	Nomogram for Transforming E-2000 MUF to Equivalent MUF's and Optimum Working Frequencies Due to Combined Effect of E Layer and $F_1$ Layer at Other Transmission Distances . . . . .	11-26
11-20	E Layer MUF and Penetration Nomogram. . . . .	11-27
11-21	Nomogram from Transforming $F_2$ ZERO MUF and $F_2$ 4001 MUF to Equivalent MUF's at Intermediate Transmission Distances; Conversion Scale for Obtaining Optimum Working Frequencies . . . . .	11-28
11-22	Absorption Index Chart (Excluding Auroral Absorption) for April . . . . .	11-29
11-23	Auroral Absorption Chart . . . . .	11-30
11-24	$K_d$ Nomogram, Transmission Path Entirely in the Day Region . . . . .	11-31
11-25	K or $K_d$ Correction Factors . . . . .	11-32
11-26	Table of Service Gains, Sky Wave Communications, Fading Signal . . . . .	11-33
11-27	Median Incident Sky Wave Intensity, 0 to 200 km, 1-hop- $F_2$ . . . . .	11-34
11-28	Median Incident Sky Wave Field Intensity, 0 to 200 km, 2-hop- $F_2$ . . . . .	11-35
11-29	Median Incident Sky Wave Intensity, 0 to 200 km, 1-hop-E . . . . .	11-36
11-30	Median Incident Sky Wave Field Intensity, 400 km, 1-hop- $F_2$ . . . . .	11-37
11-31	Median Incident Sky Wave Field Intensity, 400 km, 2-hop- $F_2$ . . . . .	11-38

**LIST OF ILLUSTRATIONS (CONT)**

Figure	Page
11-32 Median Incident Sky Wave Field Intensity, 400 km, 1-hop-E . . . . .	11-39
11-33 Median Incident Sky Wave Field Intensity, 800 km, 1-hop-F <sub>2</sub> . . . . .	11-40
11-34 Median Incident Sky Wave Field Intensity, 800 km, 2-hop-F <sub>2</sub> . . . . .	11-41
11-35 Median Incident Sky Wave Field Intensity, 800 km, 1-hop-E . . . . .	11-42
11-36 Noise Distribution Chart for March, April, and May . . . . .	11-43
11-37 Minimum Required Incident Field Intensities, Noise Grade 2.5, Summer . . . . .	11-44
11-38 Minimum Required Incident Field Intensities, Noise Grade 2.5, Winter. . . . .	11-45
11-39 Minimum Required Incident Field Intensities, Noise Grade 2.5, Equinox . . . . .	11-46
11-40 Minimum Required Incident Field Intensities and Discriminator Gain, 15-foot Whip Antenna . . . . .	11-47
11-41 Minimum Required Incident Field Intensities and Discrimination Gain, 1/4-Wave Grounded Vertical Antenna . . . . .	11-48
11-42 Minimum Required Incident Field Intensities and Discrimination Gain, 1/2-Wave Grounded Vertical Antenna, Transmission Line Fed from Base of Antenna . . . . .	11-49
11-43 Gain Curves, 15-foot Whip Antenna Erected Above Poor Ground . . . . .	11-50
11-44 Gain Curves, 1/4-Wave Vertical Antenna Erected Above Poor Ground . . . . .	11-51
11-45 Gain Curves, 1/2-Wave Vertical Antenna Erected Above Poor Ground . . . . .	11-52
11-46 World Map Showing Various Types of Terrain . . . . .	11-53
11-47 Ground-Wave Field Intensity Versus Distance Curves for Various Frequencies in Mc, for Vertical Polarization, 1-2,000 miles--Poor Ground. . . . .	11-54
11-48 Ground-Wave Field Intensity Versus Distance Curves for Various Frequencies in Mc, for Vertical Polarization, 1-2,000 miles--Good Ground. . . . .	11-55
11-49 Ground-Wave Field Intensity Versus Distance Curves for Various Frequencies in Mc, for Vertical Polarization, 1-2,000 miles--Sea Water. . . . .	11-56
11-50 Minimum Required Field Intensity in the Presence of Set Noise, and Discrimination Gains in the Presence of Atmospheric Noise, for Various Antennas . . . . .	11-57
11-51 Service Gains, Ground-Wave Communication, Nonfading Signal . . . . .	11-58
11-52 Inverse Distance Field Intensity Expressed as an Antenna Gain in Respect to 186.3 Millivolts per Meter at 1 mile, Grounded Vertical Antenna . . . . .	11-59
11-53 Inverse Distance Field Intensity Expressed as an Antenna Gain in Respect to 186.3 Millivolts per Meter at 1 Mile, 15-foot Vertical Whip Antenna . . . . .	11-60
11-54 Inverse Distance Field Intensity Expressed as an Antenna Gain in Respect to 186.3 Millivolts per Meter at 1 Mile, Half-Wave Vertical Antenna Erected Above Perfect Earth at a Height of $h/\lambda$ . . . . .	11-61
11-55 Line of Sight Distance for Elevated Antennas (For Smooth Spherical Earth with an Effective Radius of 4/3 the Actual Values), Antenna Heights from 0 to 5,000 . . . . .	11-62
11-56 Overlay on World Map . . . . .	11-63
11-57 Overlay on Great Circle Chart . . . . .	11-65
11-58 Overlay on F <sub>2</sub> Zero MUF, W Zone Chart . . . . .	11-65
11-59 Tabulated Sky Wave Propagation Analysis. . . . .	11-69/11-70
11-60 Tabulated Ground Wave Propagation Analysis . . . . .	11-71/11-72
12-1 Basic Telegraph Circuit . . . . .	12-2
12-2 Predicted Wave Detection . . . . .	12-2
12-3 Phase Modulation Vector Diagrams . . . . .	12-3
12-4 Keyed Filter Pair, Quench-Drive-Ring Sequence . . . . .	12-4
12-5 Energy Versus Frequency Distribution of Transmitted Pulses and Infinite Q Resonator Responses. . . . .	12-5
12-6 Timing Pulse Relation . . . . .	12-7
12-7 Channel Allocation at 100 WPM . . . . .	12-8
12-8 Kineplex (Frequency Division) Block Diagram . . . . .	12-9



**LIST OF ILLUSTRATIONS (CONT)**

Figure	Page
13-1 75S-1 Receiver . . . . .	13-3
13-2 75S-1 Block Diagram . . . . .	13-4
13-3 75S-1 Schematic Diagram . . . . .	13-5/6
13-4 32S-1 Transmitter . . . . .	13-8
13-5 32S-1 Block Diagram . . . . .	13-9
13-6 32S-1 Schematic Diagram . . . . .	13-11/12
13-7 KWM-1 Transceiver . . . . .	13-13
13-8 KWM-1 Block Diagram . . . . .	13-15
13-9 KWM-1 Vacuum-Tube Control Circuits . . . . .	13-16
13-10 KWM-1 Relay and Switch Control Circuits . . . . .	13-17
13-11 KWM-1 Antenna Switching Circuit . . . . .	13-18
13-12 KWM-1 Schematic Diagram . . . . .	13-19/20
13-13 KWM-2 Transceiver . . . . .	13-21
13-14 KWM-2 Block Diagram . . . . .	13-23/24
13-15 KWM-2 Schematic Diagram . . . . .	13-25/26
13-16 30S-1 Linear Amplifier . . . . .	13-28
13-17 30S-1 Block Diagram . . . . .	13-28
13-18 30S-1 Schematic Diagram . . . . .	13/29/30
13-19 312B-4 Station Control . . . . .	13-31
13-20 312B-4 Schematic Diagram . . . . .	13-32
13-21 136A-1 Noise Blanker Installed in 75S-1 . . . . .	13-33
13-22 136B-1 Noise Blanker Installed in KWM-1 . . . . .	13-33
13-23 136A-1 Block Diagram . . . . .	13-34
13-24 136A-1 Schematic Diagram . . . . .	13-35
13-25 302C-1 Directional Wattmeter . . . . .	13-36
13-26 302C-1 Directional Wattmeter, Simplified Schematic Diagram . . . . .	13-36
13-27 516E-1 12-Volt D-C Power Supply. . . . .	13-37
13-28 516E-2 28-Volt D-C Power Supply. . . . .	13-38
13-29 616F-2 A-C Power Supply (Removed from Case) . . . . .	13-38
13-30 516E-1 Schematic Diagram . . . . .	13-39
13-31 516E-2 Schematic Diagram . . . . .	13-40
13-32 516F-2 Schematic Diagram . . . . .	13-41

## LIST OF TABLES

Table		Page
2-1	Calculated Frequency Products Contained in the Plate Current of a 12AU7 Triode Mixer . . . . .	2-11
2-2	Spurious Response Chart . . . . .	2-12
2-3	Typical Oscillator Long-Term Frequency Error . . . . .	2-14
2-4	Typical Oscillator Short-Term Frequency Error . . . . .	2-15
3-1	Equivalent Tube Noise Resistance . . . . .	3-3
5-1	Frequency Range of Quartz Resonators. . . . .	5-9
8-1	Comparative Meter Readings 1 to 16 Equal Tones Amplifier Output Held Constant on VU Meter . . . . .	8-2
8-2	Comparative Meter Readings 16 to 1 Equal Tones Amplifier Output Set to +3 VU With 16 Equal Tones . . . . .	8-3
8-3	Single-Sideband Distortion Products. . . . .	8-7
12-1	Kineplex Phase Relationships . . . . .	12-4
12-2	Timing Frequencies and Pulse Widths . . . . .	12-6

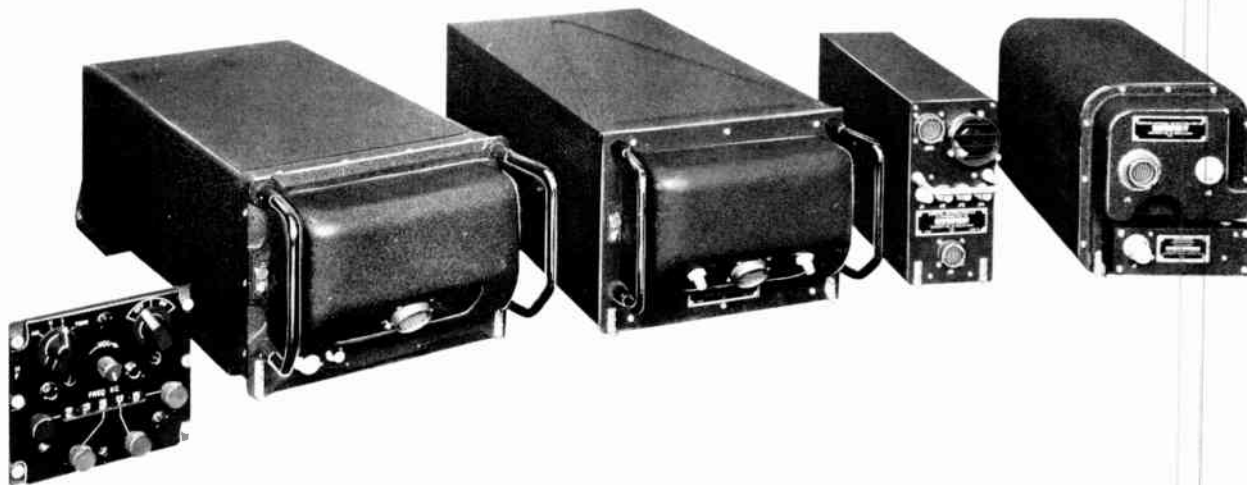

Collins Designed Radio Set AN/ARC-58, Single Sideband High-Frequency Communications System, Providing 28,000 Directly Selectable Frequency Channels and 1000 Watts PEP

## CHAPTER 1

### INTRODUCTION TO SINGLE SIDEBAND

#### 1. NEED FOR SINGLE SIDEBAND

The need for single-sideband communication systems has arisen because present day radio communications require faster, more reliable, spectrum conservative systems. The quantity of commercial and military traffic is presently so great in the high-frequency (2 to 30 mc) spectrum that it has become necessary to restrict the use of this spectrum to those services which cannot be accommodated by other means. Land-lines, microwave links, and uhf scatter propagation are employed to relieve the load from the high-frequency spectrum. In many instances, these provide a better and more reliable service.

There are, however, many communication services which need the propagation characteristics obtainable only in the high-frequency range. Among these are ship-to-shore communications, air-to-ground communications, and the many military and naval systems which require independence, mobility, and flexibility. Since high-frequency spectrum space is limited, it is essential that the best possible use be made of the space available. This means that communication systems must use a minimum bandwidth, that the guard bands between channels to allow for frequency drift and poor selectivity be minimized, and that spurious radiation be kept to a very low value to avoid interference between services. In addition to this, a more reliable signal is desirable if not essential. Single-sideband communication systems in their present state of development provide these assets.

#### 2. WHAT SINGLE SIDEBAND MEANS

A single-sideband (SSB) signal is an audio signal converted to a radio frequency, with or without inversion. For instance, an intelligible voice signal contains audio frequencies over the range of 300 to 3000 cycles per second (cps). If this audio signal is converted to a radio frequency by mixing it with a 15 mc r-f frequency, the resultant sum frequencies cover the range of 15,000,300 to 15,003,000 cps. Such a signal is an SSB signal without inversion and is referred to as an upper sideband, because it occupies the spectrum space above the r-f conversion frequency. Note that the 15 mc carrier is not included in the range of the SSB signal. The above example does not indicate the presence of a difference frequency. However, when the voice signal is mixed with the r-f frequency, a difference frequency does develop which covers the

range from 14,999,700 to 14,997,000 cps. This signal is also an SSB signal but is an SSB signal with inversion. This SSB signal is referred to as a lower sideband signal because it occupies the spectrum space below the r-f conversion frequency. Figure 1-1 illustrates the position of the SSB signal in the r-f spectrum

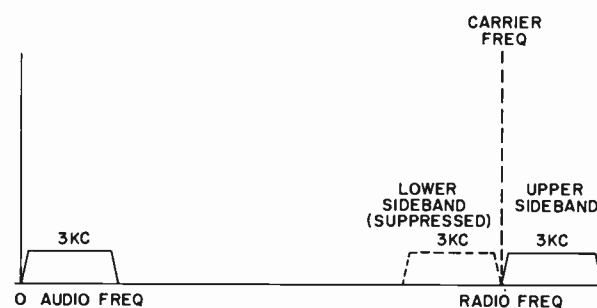

Figure 1-1. Location of SSB Signal in R-F Spectrum

From the above description of the SSB signal, it is apparent that only one sideband signal need be transmitted to convey the intelligence. Since two sideband signals are obtained from the mixing process, it is also necessary to remove one sideband before transmission. To receive the SSB signal, it is necessary to convert the SSB signal back to the original audio signal. This requires identical transmitter and receiver conversion frequencies. In the past, a low-power, pilot carrier was transmitted for automatic frequency control (afc) purposes to provide this end. However, with present day frequency stabilities (1 cps at 10 mc in ground and 10 cps at 10 mc in mobile equipment) the need for afc and pilot carriers is eliminated.

Several methods of sideband communication are in use or under development. The "single-sideband" method as the term is used throughout this book refers to the method which is, perhaps, more accurately termed "single-sideband, suppressed carrier." In this method, only one sideband is transmitted and the carrier is suppressed to the point of non-existence. To demodulate the single-sideband signal requires conversion of the signal with a locally-generated signal close to the proper frequency but



with no phase relationship required. In the "single-sideband, pilot carrier" system only one sideband is transmitted, but a low-level carrier of sufficient amplitude for reception is also transmitted. To demodulate this signal, the pilot carrier is separated from the sideband in the receiver, then amplified and used as the conversion frequency to demodulate the sideband signal. In another method, the pilot carrier is used for automatic frequency control of the receiver. In the "double-sideband" (DSB) system, both the upper and lower sidebands of the signal are transmitted with the carrier suppressed to the point of nonexistence. To demodulate the double sideband requires insertion of a locally-generated carrier of both the proper frequency and the proper phase. This system depends upon an automatic frequency and phase control, derived from the double-sideband signal, for control of the locally-generated carrier. In the "single-sideband, controlled carrier" system only one sideband is transmitted, but a carrier which varies inversely with the signal level is also transmitted. This allows an appreciable average carrier level for automatic-frequency-control without reducing the sideband power below the full transmitter rating.

### 3. HISTORICAL DEVELOPMENT OF SINGLE-SIDEBAND COMMUNICATION SYSTEMS

Although SSB transmission has only received publicity in the last few years, the knowledge of the sideband and the development and use of SSB techniques have progressed over the last 40 years. The acoustical phenomenon of combining two waves to produce sum and difference waves carried over into electric-wave modulation. The presence of the upper and lower sidebands in addition to the carrier frequency were tacitly assumed to exist but were not concretely visualized in the earliest modulated transmissions. Recognition that one sideband contained all the signal elements necessary to reproduce the original signal came in 1915. It was then, that at the Navy Radio Station at Arlington, Va., that an antenna was tuned to pass one sideband well, even though the other was attenuated.

From 1915 until 1923, the physical reality of sidebands was vigorously argued with the opponents contending that sidebands were mathematical fiction. However, the first trans-Atlantic radiotelephone demonstration in 1923 provided a concrete answer. This system employed an SSB signal with a pilot carrier. Single sideband was used in this system because of the limited power capacity of the equipment and the narrow resonance bands of efficient antennas at the low frequency (57 kc) used. By 1927 trans-Atlantic SSB radiotelephony was open for public service.

The first overseas system was followed by short-wave systems, 3 to 30 mc, which transmitted double sideband and carrier because SSB development did not

permit practical SSB transmission in this frequency range. However, SSB techniques were employed in various telephony applications and in various multiplexing systems. It has not been until recently that equipment developments have permitted the advantages of SSB communication to be fully exploited. These developments have been in the fields of frequency stability, filter selectivity, and low-distortion linear power amplifiers. These developments have led to military and commercial acceptance of SSB communication systems. There are presently available several radio amateur and commercial SSB radio sets, fixed-station SSB exciters up to 45 kw linear power amplifiers, and airborne transceivers capable of reliable communications with unlimited range. Some of these equipments, especially the military equipments, are provided with automatic frequency selection and automatic tuning to further enhance their value as reliable, easily operated systems.

### 4. BASIC FUNCTIONAL UNITS OF A SINGLE-SIDEBAND TRANSMITTING SYSTEM

Some of the basic functional units of an SSB system have been previously mentioned. Figure 1-2 shows these units in their functional relationship for an SSB transmitter.

The audio amplifier is of conventional design. Audio filtering is not required because the highly selective filtering which takes place in the SSB generator attenuates the unnecessary frequencies below 300 cps and above 3000 cps. It should be noted that a voice signal is used only as a convenience for explanation. The input signal may be any desired intelligence signal and may cover all or any part of the frequency range between 100 and 6000 cps. The upper limit of the input audio signal is determined by the channel bandwidth and the upper cutoff frequency of the filter in the SSB generator. The lower limit of the input audio signal is determined by the lower cutoff frequency of the filter in the SSB generator.

The SSB generator produces the SSB signal at an i-f frequency. The most familiar way to produce the SSB signal is to generate a double-sideband (DSB) signal and then pass this signal through a highly selective filter to reject one of the sidebands. The SSB signal is generated at a fixed i-f frequency because highly selective circuits are required. The highly selective filter requirements for the filter method of SSB generation are met by either crystal or mechanical filters. Both of these filters have been improved in performance and reduced in size and cost to make their application practical.

The generated SSB signal at a fixed i-f frequency then goes through mixers and amplifiers where it is

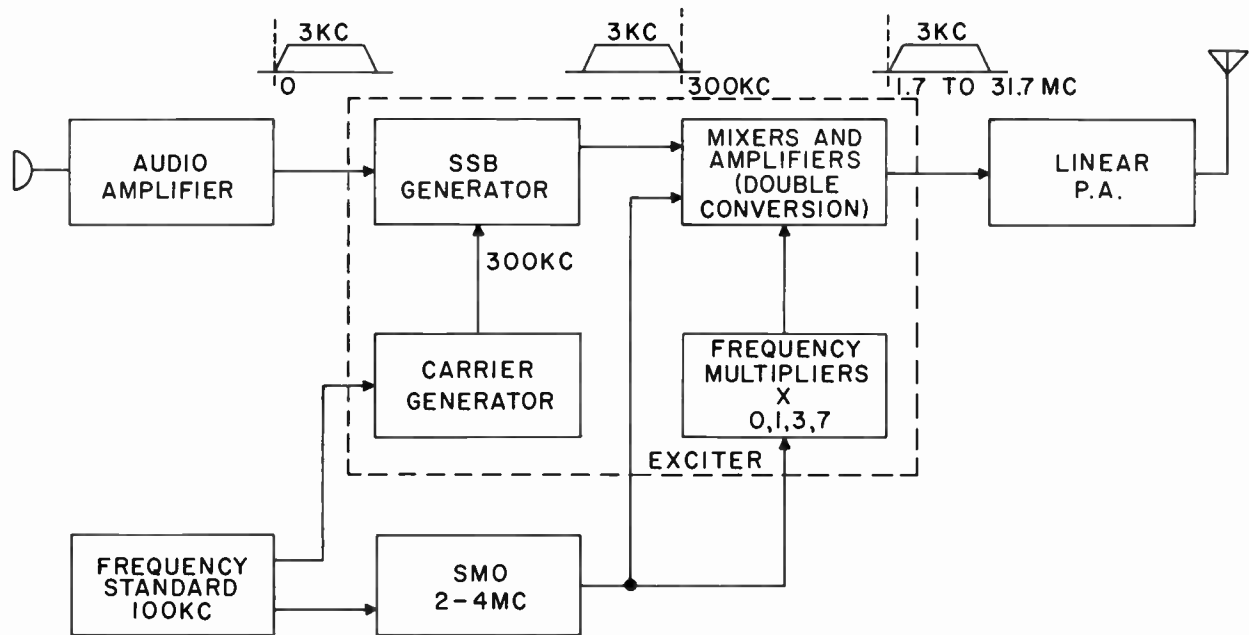

## NOTE:

SIGNAL INVERSION, DUE TO SUBTRACTIVE MIXING IN FIRST STAGE OF SSB EXCITER, MAKES IT NECESSARY TO USE THE LOWER SIDEBAND OUTPUT, FROM THE SSB GENERATOR, TO PRODUCE THE FINAL UPPER SIDEBAND SIGNAL.

Figure 1-2. Functional Units of an SSB Transmitting System

converted up in frequency to the transmitted r-f frequency. Two stage conversion is shown with the second conversion frequency being a multiple of the first conversion frequency. The frequency conversions required to produce the r-f frequency produce sum and difference frequencies as well as higher order mixing products inherent in mixing circuits. However, the undesired difference frequency or the undesired sum frequency, along with the higher order mixing products, is attenuated by interstage tuned circuits.

The SSB exciter drives a linear power amplifier to produce the high power r-f signal. A linear power amplifier is required for SSB transmission, because it is essential that the plate output r-f signal be a replica of the grid input signal. Any nonlinear operation of the power amplifier will result in intermodulation (mixing) between the frequencies of the input signal. This will produce not only undesirable distortion within the desired channel but will also produce intermodulation outputs in adjacent channels. Distortion in the linear power amplifier is kept low by the design choice of power amplifier tubes, their

operating conditions, and use of r-f feedback circuits. The low distortion obtainable in modern linear power amplifiers is not essential to the SSB system nor is it essential for good voice transmission, but it is essential to minimize the guard band between channels and thereby permit full utilization of the spectrum space.

Because an SSB system without a pilot carrier demands an extremely stable frequency system, the frequency standard and stabilized master oscillator (smo) are extremely important. The standard frequency is obtained from a crystal oscillator with the crystal housed in an oven. Since the stability of the crystal frequency depends directly upon the stability of the oven temperature, stable thermal control of the oven is necessary. This thermal control of the oven is obtained by using heat-sensitive semiconductors in a bridge network. Any variation in the oven temperature, then, is indicated and corrected by an unbalance in the control bridge. This system will limit changes in oven temperature to 0.001°C. Such oven stability will provide a standard frequency which will vary no

more than 1 cps in 10 mc per day when used in fixed-station equipment and no more than 10 cps in 10 mc per day when used in mobile station equipment.

The carrier generator provides the i-f carrier used to produce the fixed i-f SSB signal, and the smo provides the necessary conversion frequencies to produce the r-f SSB signal. The frequencies developed in these units are derived from or phase locked to the single standard frequency so that the stability of the standard frequency prevails throughout the SSB system. Choice of the fixed i-f frequency and the conversion frequencies to obtain the r-f frequency is an extremely important design consideration. Optimum operating frequencies of the various circuits must be considered as well as the control of undesirable mixing products. The frequency scheme shown is the result of extensive study and experimental verification. It produces minimum spurious output in the high-frequency range (2 to 32 mc). The use of harmonically related conversion frequencies in the mixer permits the frequency range to be covered with a single 2 to 4 mc oscillator, a very practical range for obtaining high oscillator stability. Use of the 300 kc fixed i-f frequency is the optimum operating frequency for the mechanical filter required in the SSB generator.

The foregoing discussion may give the erroneous impression that only single channel communication is

possible with an SSB system. Quite the opposite is true. To add additional channels to the SSB system requires only additional circuits in the SSB generator. One method is to use the upper sideband of one signal and the lower sideband of the other signal. Figure 1-3 shows the circuit for producing these two channels and the location of each channel with respect to the carrier frequency. It should be noted that with this method a twin sideband is transmitted, and that the signal in the lower sideband is inverted. Another method of adding channels is shown in figure 1-4. Different fixed i-f frequencies, one raised 4 kc from the original, are injected into separate SSB generators, and the upper sideband is filtered from each output. This produces two channels both using the upper sideband. It should be realized that as additional channels are added to the system, less transmitter power output is available for each channel.

The SSB transmitter is designed for linear operation from the audio input amplifier through the output power amplifier. That is, the transmitter faithfully transmits the original input intelligence with negligible distortion. This distortion-free system is ideally suited for the transmission of multiplex and Kineplex signals, because the original pulses are transmitted without distortion of their wave shape.

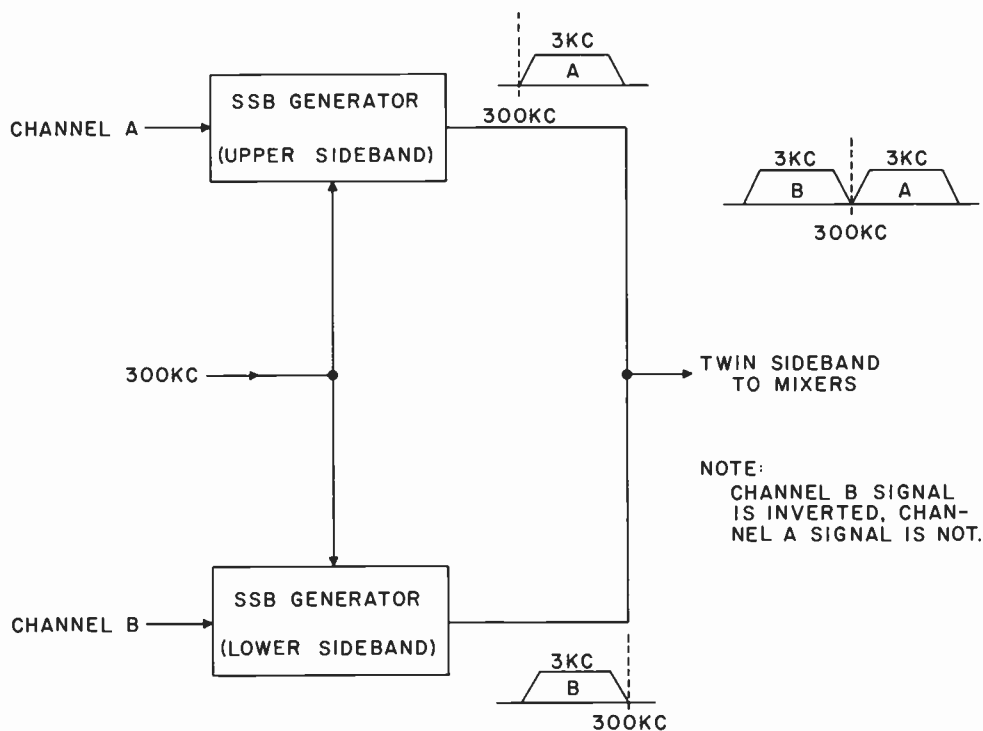

Figure 1-3. Generation of the Twin-Channel Sideband Signal

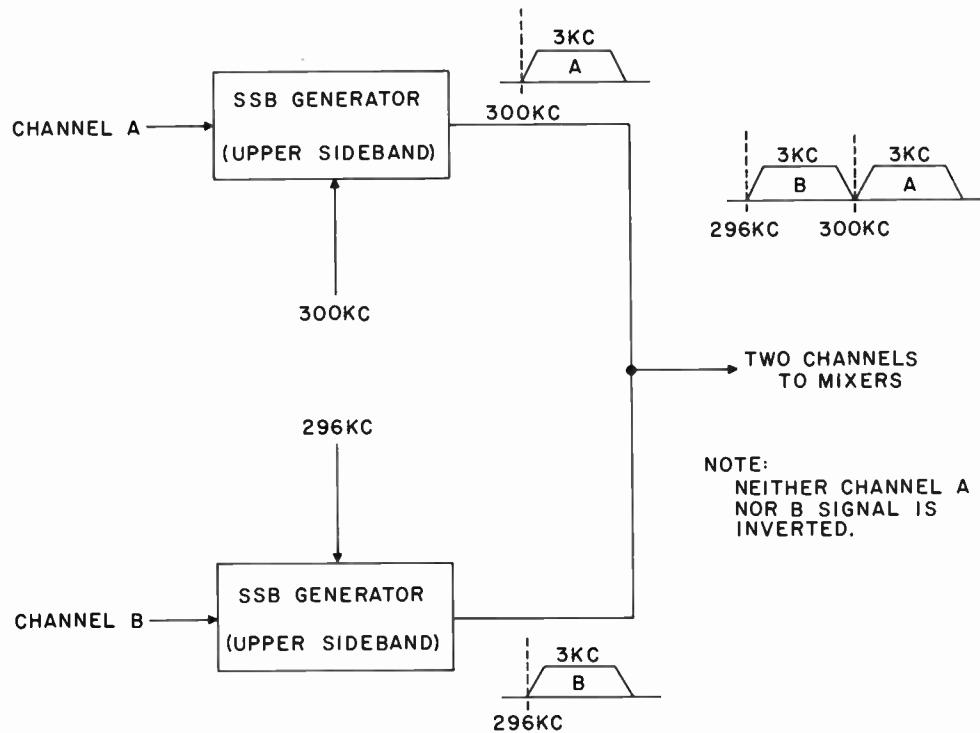

Figure 1-4. Generation of Two Channel SSB Signal

## 5. BASIC FUNCTIONAL UNITS OF A SINGLE-SIDEBAND RECEIVING SYSTEM

To receive the SSB signal requires a heterodyning system which will convert the radio-frequency signal back down to its original position in the audio spectrum. The basic functional units of such a receiver are shown in figure 1-5. It can be seen that the SSB receiver is almost identical to a conventional heterodyne receiver except for the detection circuit. The r-f signal is amplified and converted down in frequency to a fixed i-f frequency. Then a final fixed i-f injection frequency is required to bring the signal down to its original position in the audio spectrum.

Many of the units of an SSB receiver are identical with units of the SSB transmitter as can be seen by comparing figure 1-2 with figure 1-5. The frequency standard, carrier generator, and smc are identical. The double conversion mixer and amplifier unit of the receiver can be made identical to the double conversion mixer and amplifier unit of the transmitter. This similarity of functions permits the construction of transceivers with much of the circuitry used for both receiving and transmitting by merely adding switching to reverse the direction of signal flow. By using dual purpose units and adding switching to reverse the direction of the signal, equipment size,

weight, cost, and power consumption are substantially reduced.

## 6. COMPARISON OF SSB WITH AM.

### a. POWER COMPARISON OF SSB AND AM.

There is no single manner which can be used to evaluate the relative performance of AM systems and SSB systems. Perhaps the most straightforward manner to make such a comparison is to determine the transmitter power necessary to produce a given signal-to-noise (s/n) ratio at the receiver for the two systems, under ideal propagating conditions. Signal-to-noise ratio is considered a fair comparison, because it is the s/n ratio which determines the intelligibility of the received signal. Figure 1-6 shows such a comparison between an AM system and an SSB system where 100 percent, single-tone modulation is assumed.

Figure 1-6A shows the power spectrum for an AM transmitter rated at 1 unit of carrier power. With 100 percent sine-wave modulation, such a transmitter will actually be producing 1.5 units of r-f power. There is .25 unit of power in each of the two sidebands and 1 unit of power in the carrier. This AM transmitter is compared with an SSB transmitter rated at

.5 unit of peak-envelope-power (PEP). Peak-envelope-power is defined as the rms power developed at the crest of the modulation envelope. The SSB transmitter rated at .5 unit of peak-envelope-power will produce the same s/n ratio in the output of the receiver as the AM. transmitter rated at 1 unit of carrier power.

The voltage vectors related to the AM. and SSB power spectrums are shown in figure 1-6B. The AM. voltage vectors show the upper and lower sideband voltages of .5 unit rotating in opposite directions around a carrier voltage of 1 unit. For AM. modulation, the resultant of the two sideband voltage vectors must always be directly in phase or directly out of phase with the carrier so that the resultant directly adds to or subtracts from the carrier. The resultant shown when the upper and lower sideband voltage are instantaneously in phase produces a peak-envelope-voltage (PEV) equal to twice the carrier voltage with 100 percent modulation. The .5 unit of voltage shown in each sideband vector produces the .25 unit of power shown in A, .25 unit of power being proportional to the square of .5 unit of voltage. The SSB voltage vector is a single vector of .7 unit of voltage at the upper sideband frequency. The .7 unit of voltage produces the .5 unit of power shown in A.

The r-f envelopes developed by the voltage vectors are shown in figure 1-6C. The r-f envelope of the AM. signal is shown to have a PEP of 2 units, the sum of the two sideband voltages plus the carrier voltage. This results in a PEP of 4 units of power. The PEP

of the SSB signal is .7 unit of voltage with a resultant PEP of .5 unit of power.

When the r-f signal is demodulated in the AM. receiver, as shown in figure 1-6D, an audio voltage develops which is equivalent to the sum of the upper and the lower sideband voltages, in this case 1 unit of voltage. This voltage represents the output from the conventional, diode detector used in AM. receivers. Such detection is called coherent detection because the voltages of the two sidebands are added in the detector. When the r-f signal is demodulated in the SSB receiver, an audio voltage of .7 unit develops which is equivalent to the transmitter upper sideband signal. This signal is demodulated by heterodyning the r-f signal with the proper frequency to move the SSB signal down in the spectrum to its original audio position.

If a broadband noise level is chosen as .1 unit of voltage per 6 kc bandwidth, the AM. bandwidth, the same noise level is equal to .07 unit of voltage per 3 kc bandwidth, the SSB bandwidth. This is shown in figure 1-6E. These values represent the same noise power level per kc of bandwidth; that is,  $.1^2/6$  equals  $.07^2/3$ . With this chosen noise level, the s/n ratio for the AM. system is  $20 \log s/n$  in terms of voltage, or 20 db. The s/n ratio for the SSB system is also 20 db, the same as for the AM. system. The  $1/2$  power unit of rated PEP for the SSB transmitter, therefore, produces the same signal intelligibility as the 1 power unit rated carrier power for the AM.

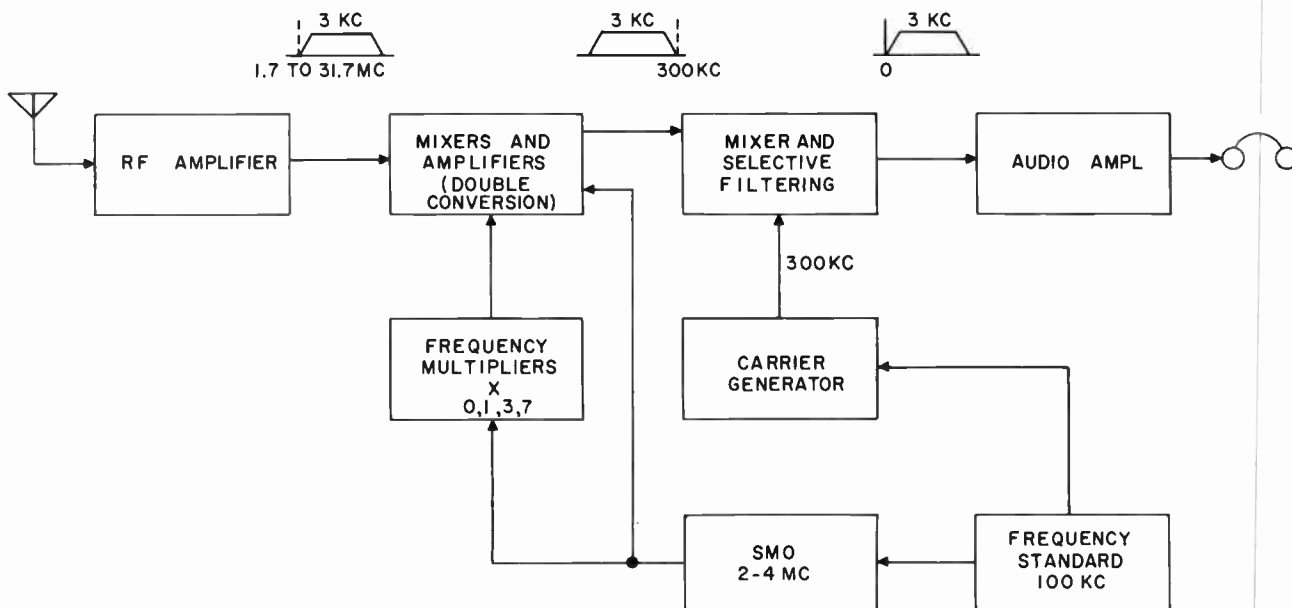

Figure 1-5. Functional Units of an SSB Receiving System



	AM SINGLE TONE, SINE-WAVE MODULATION	SSB SINGLE TONE, SINE-WAVE MODULATION
RATED POWER	<p>RATED CARRIER POWER = 1</p> <p>LSB C USB</p>	<p>RATED PEP POWER = .5</p> <p>C USB</p>
VOLTAGE VECTORS 100% MODULATION	<p>LSB .5 .5 USB</p> <p>C</p> <p>PEV = 2</p>	<p>C USB</p> <p>PEV = .7</p>
RF ENVELOPE	<p>PEV = 2 PEP = 4</p>	<p>PEV = .7 PEP = .5</p>
RCVR AUDIO SIGNAL VOLTAGE	<p>USB + LSB = 1</p>	<p>.7</p>
NOISE VOLTAGE [ARBITRARY NOISE POWER PER KC OF BW EQUAL IN AM AND SSB; I.E., $(.1)^2/6 = (.07)^2/3$ ]	<p>VOLTAGE = .1 PER 6KC BANDWIDTH</p>	<p>VOLTAGE = .07 PER 3KC BANDWIDTH</p>
S/N RATIO	$20 \text{ LOG } \frac{1}{.1} = 20 \text{ DB}$	$20 \text{ LOG } \frac{.7}{.07} = 20 \text{ DB}$

Figure 1-6. SSB and AM. Comparison with Equal Signal-to-Noise Ratio

transmitter. This conclusion can be restated as follows:

Under ideal propagating conditions but in the presence of broadband noise, an SSB and AM. system perform equally (same s/n ratio) if the total sideband power of the two transmitters is equal. This means that an SSB transmitter will perform as well as an AM. transmitter of twice the carrier power rating under ideal propagating conditions.

### **b. ANTENNA VOLTAGE COMPARISON OF SSB AND AM.**

Of special importance in airborne and mobile installations where electrically small antennas are required, is the peak antenna voltage. In these installations, it is often the corona breakdown point of the antenna which is the limiting factor in equipment power. Figure 1-6C shows the r-f envelopes of an SSB transmitter and an AM. transmitter of equal performance under ideal conditions. The peak-envelope-voltage produced by these two transmitters is shown to be in the ratio 2 for the AM. transmitter to .7 for the SSB transmitter. This indicates that for equal performance under ideal conditions, the peak antenna voltage of the SSB system is approximately 1/3 that of the AM. system.

A comparison between the SSB power and the AM. power which can be radiated from an antenna of given dimensions is even more significant. If an antenna is chosen which will radiate 400 watts of peak-envelope-power, the AM. transmitter which may be used with this antenna must be rated at no more than 100 watts. This is true because the PEP of the AM. signal is four times the carrier power. An SSB transmitter rated at 400 watts of PEP, all of which is sideband power, may be used with this same antenna. Compared with the 50 watts of sideband power obtained from the AM. transmitter with a 100-watt carrier rating.

### **c. ADVANTAGE OF SSB WITH SELECTIVE FADING CONDITIONS**

The power comparison between SSB and AM. given in the previous paragraph is based on ideal propagation conditions. However, with long distance transmission, AM. is subject to selective fading which causes severe distortion and a weaker received signal. At times this can make the received signal unintelligible. An AM. transmission is subject to deterioration under these poor propagation conditions, because all three components of the transmitted signal, the upper sideband, lower sideband, and carrier must be received exactly as transmitted to realize fidelity and the theoretical power from the signal. Figure

1-7 shows the deterioration of an AM. signal with different types of selective fading.

The loss of one of the two transmitted sidebands results only in a loss of signal voltage from the demodulator. Even though some distortion results, such a loss is not basically detrimental to the signal, because one sideband contains the same intelligence as the other. However, since the AM. receiver operates on the broad bandwidth necessary to receive both sidebands, the noise level remains constant even though only one sideband is received. This is equivalent to a 6 db deterioration in s/n ratio out of the receiver. Although the loss of one of the two sidebands may be an extreme case, a proportional deterioration in s/n ratio results from the reduction in the level of one or both sidebands.

The most serious result of selective fading, and the most common, occurs when the carrier level is attenuated more than the sidebands. When this occurs, the carrier voltage at the receiver is less than the sum of the two sideband voltages. When the carrier is attenuated more than the sidebands, the r-f envelope does not retain its original shape, and distortion is extremely severe upon demodulation. This distortion results upon demodulation because a carrier voltage at least as strong as the sum of the two sideband voltages is required to properly demodulate the signal. The distortion resulting from a weak carrier can be overcome by use of the exalted carrier technique whereby the carrier is amplified separately and then reinserted before demodulation. In using the exalted carrier, the carrier must be reinserted close to the original phase of the AM. carrier.

Selective fading can also result in a shift between the relative phase position of the carrier and the sidebands. An AM. modulation is vectorally represented by two counter-rotating sideband vectors which rotate with respect to the carrier vector. The resultant of the sideband vectors is always directly in phase or directly out of phase with the carrier vector. In an extreme case, the carrier may be shifted 90° from its original position. When this occurs, the resultant of the sideband vectors is ±90° out of phase with the carrier vector. This results in converting the original AM. signal to a phase modulated signal. The envelope of the phase modulated signal bears no resemblance to the original AM. envelope and the conventional AM. detector will not produce an intelligible signal. Any shift in the carrier phase from its original phase relationship with respect to the sidebands will produce some phase modulation with a consequential loss of intelligibility in the audio signal. Such a carrier phase shift may be caused by poor propagating conditions. Such a carrier phase shift will also result from using the exalted carrier technique if the reinserted carrier is not close to its original phase, as previously mentioned.

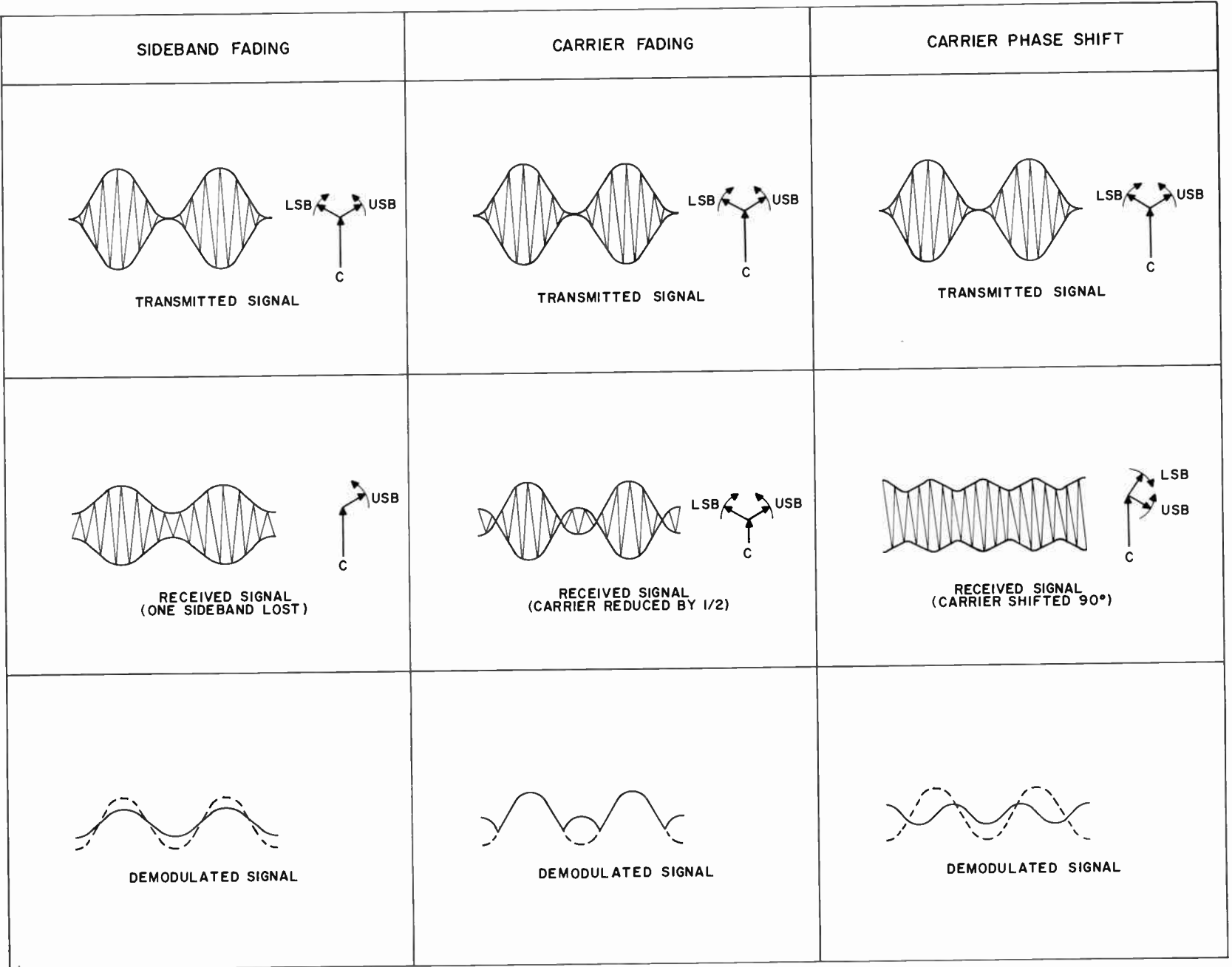

Figure 1-7. Deterioration of an AM. Signal with Selective Fading



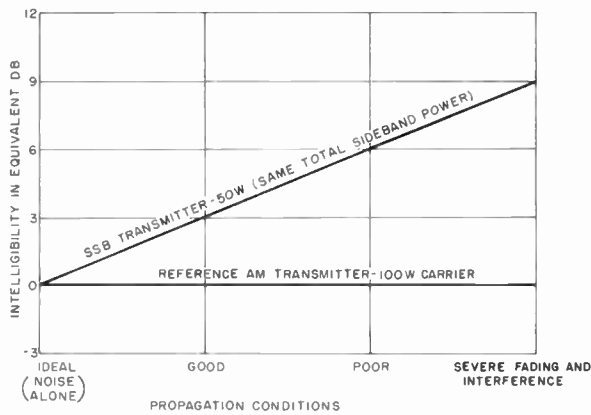

Figure 1-8. Relative Advantage of SSB over AM with Limiting Propagating Conditions

An SSB signal is not subject to deterioration due to selective fading which varies either the amplitude or the phase relationship between the carrier and the two sidebands in the AM transmission. Since only one sideband is transmitted in SSB, the received signal level does not depend upon the resultant amplitude of two sideband signals as it does in AM. Since the receiver signal does not depend upon a carrier level in SSB, no distortion can result from loss of carrier power. Since the receiver signal does not depend upon the phase relationship between the sideband signal and the carrier, no distortion can result from phase shift. Selective fading within the one sideband of the SSB system only changes the amplitude and the frequency response of the signal. It very rarely produces enough distortion to cause the received signal or voice to be unintelligible.

#### d. COMPARISON OF SSB WITH AM UNDER LIMITING PROPAGATING CONDITIONS

One of the main advantages of SSB transmission over AM transmission is obtained under limiting propagating conditions over a long-range path where communications are limited by the combination of noise, severe selective fading, and narrow-band interference. Figure 1-8 illustrates the results of an intelligibility study performed by rating the intelligibility of information received when operating the two systems under varying conditions of propagation.<sup>1</sup> The two transmitters compared have the same total sideband power. That is, a 100 watt AM transmitter puts 1/4 of its rated carrier power in each of two

sidebands, while a 50 watt SSB transmitter puts its full rated output in one sideband. This study shows that as propagation conditions worsen, and interference and fading become prevalent, the received SSB signal will provide up to a 9 db advantage over the AM signal. The result of this study indicates that the SSB system will give from 0 to 9 db improvement under various conditions of propagation when total sideband power in SSB is equal to AM. It has been found that 3 of the possible 9 db advantage will be realized on the average contact. In other words, in normal use, an SSB transmitter rated at 100 watts (PEP) will give equal performance with an AM transmitter rated at 400 watts carrier power. It should be pointed out that in this comparison the receiver bandwidth is just enough to accept the transmitted intelligence in each case and no speech processing is considered for SSB transmission.

#### e. COMPARISON OF AIRBORNE HIGH-FREQUENCY SYSTEMS

Figure 1-9 shows a comparison in weight, volume, input power, effective output power, and peak antenna voltage between Radio Set AN/ARC-38 and Radio Set AN/ARC-58. These sets are both airborne transceivers operating in the 2 to 30 mc, high-frequency range. The AM set, AN/ARC-38, is rated at 100 watts r-f output, and the SSB set, AN/ARC-58, is rated at 1000 watts r-f output.

The effective output power of the SSB transceiver is shown to be 16 db higher than the AM transceiver. This 16 db is equivalent to a power advantage of 40 to 1, which is an enormous advancement in the communication ability of an airborne system. In addition to the power advantage of the SSB system of significance in airborne equipment is the more efficient use of the antenna with the SSB system.

#### f. SUMMARY

For long-range communications in the low-, medium-, and high-frequency ranges, SSB is well suited because of its spectrum and power economy and because it is less susceptible to the effects of selective fading and interference than is AM. The principal advantages of SSB result from the elimination of the high-energy AM carrier and from improved performance under unfavorable propagating conditions. On the average contact, an SSB transmitter will give equal performance to an AM transmitter of four times the power rating. The advantage of SSB over AM is most outstanding under unfavorable propagating conditions. For equal performance, the

<sup>1</sup> J. F. Honey, "Performance of AM and SSB Communications," Tele-Tech, September 1953.

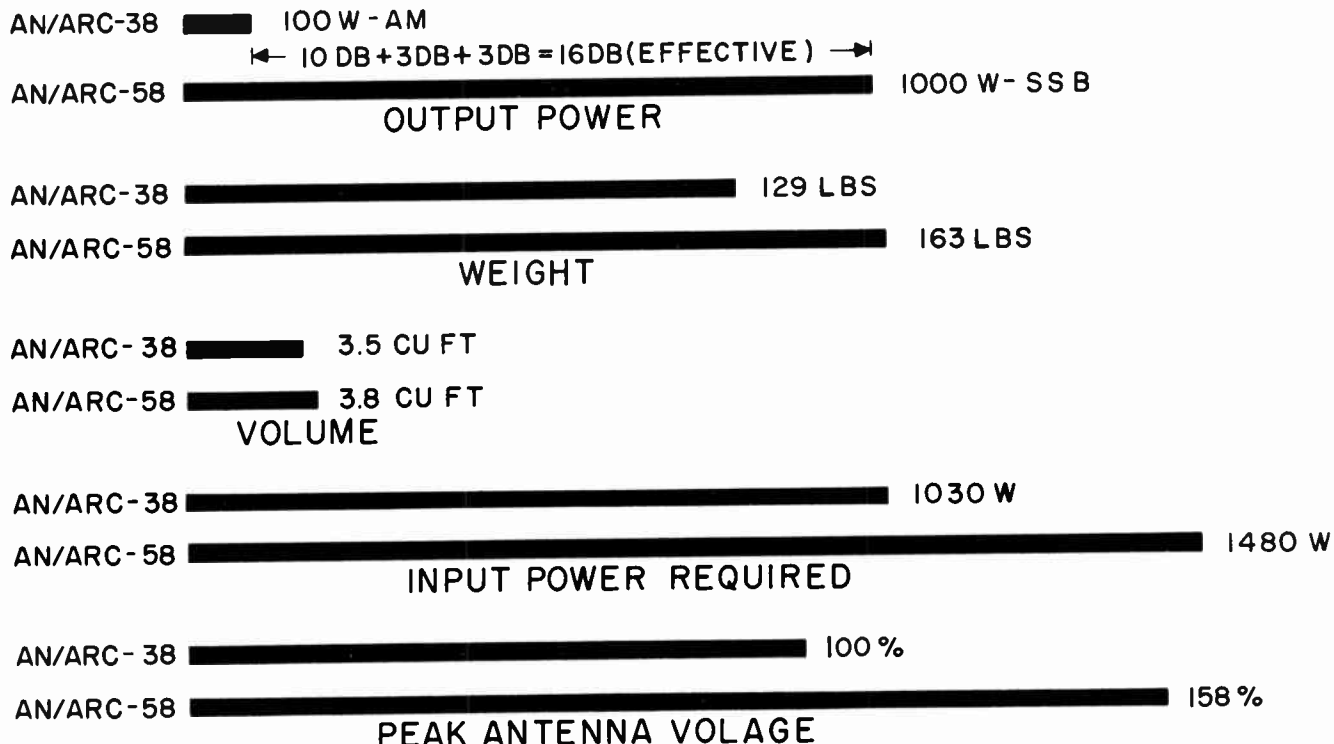

Figure 1-9. AN/ARC-38 and AN/ARC-58 Comparison

size, weight, power input, and peak antenna voltage of the SSB transmitter is significantly less than the AM transmitter.

### 7. COMPARISON OF SSB WITH FM

Although much experimental work has been done to evaluate the performance of SSB systems with AM systems, very little work has been done to evaluate the performance of SSB systems with FM systems. However, figure 1-10 shows the predicted result of one such study based on a mobile FM system as compared to a mobile SSB system of equal physical size.<sup>1</sup> The two systems compared also used the same output tubes to their full capacity so that the final r-f amplifiers dissipated the same power during normal speech loading. The study is complicated by evaluating the effects of speech processing, such as clipping and pre-emphasis, with its resultant distortion. Such speech processing is essential in the FM system but has little benefit in the SSB system.

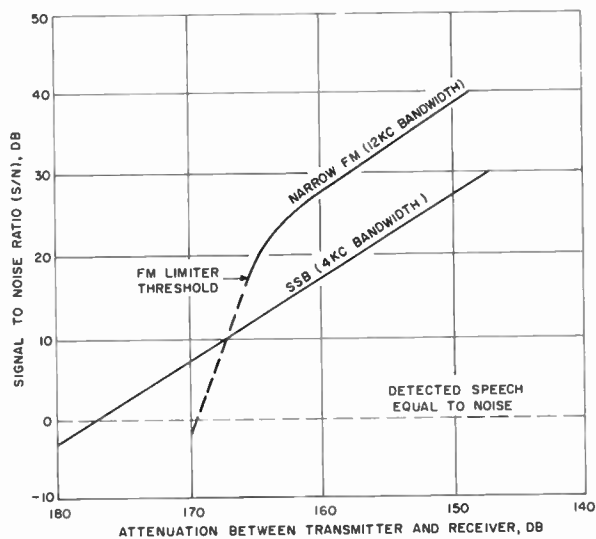

Figure 1-10. SSB Performance Compared with FM

<sup>1</sup> H. Magnuski and W. Firestone, "Comparison of SSB and FM for VHF Mobile Service," Proceedings of the IRE, December 1956.

Figure 1-10 shows the signal-to-noise ratio in decibels on the y-axis and the attenuation between transmitter and receiver in decibels on the x-axis. This graph indicates that with between 150 to 160 db of attenuation between the transmitter and receiver, a strong signal, the narrow-band FM system provides a better s/n ratio than the SSB system. Under weak signal condition, from 168 and higher db of attenuation between transmitter and receiver, the s/n ratio of the FM system falls off rapidly, and the SSB system provides the best s/n ratio. This fall-off in the FM s/n ratio results when the signal level drops below the level required for operation of the limiter in the FM receiver.

The conclusions which can be drawn from figure 1-10 are as follows: (1) For strong signals, the FM system will provide a better s/n ratio than the SSB system. However, this is not an important advantage because when the s/n is high, a still better s/n ratio will not improve intelligibility significantly. (2) For weak signals, the SSB system will provide an intelligible signal where the FM system will not. (3) The SSB system provides three times the savings in spectrum space as the narrow-band FM system.

## 8. NATURE OF SINGLE-SIDEBAND SIGNALS

### a. INTRODUCTION

As defined in paragraph 2, chapter 2, a single-sideband signal is an audio signal converted to a radio frequency, with or without inversion. To facilitate

illustrating the manner and the results of this conversion, it is necessary to use pure sine-wave tones, rather than the very complex waveforms of the human voice. For this reason single tones or combinations of two or three tones are generally used in the following discussion.

### b. THE SSB GENERATOR

The most familiar SSB generator consists of a balanced modulator followed by an extremely selective mechanical filter as shown in figure 1-11. The balanced modulator produces basically two output frequencies: (1) An upper sideband frequency equal to the injected i-f frequency plus the input audio frequency. (2) A lower sideband frequency equal to the injected i-f frequency minus the input audio frequency. Theoretically, the injected i-f frequency is balanced out in the modulator so that it does not appear in the output.

It should be especially noted that the generation of undesirable products occur in any mixing operation as well as the generation of the desired products. The equipment must be so designed to minimize the generation of undesirable products and to attenuate those undesirable products which are generated. This is accomplished by designing good linear operating characteristics into the equipment to minimize the generation of undesirable frequencies and by choosing injection frequencies which will facilitate suppression of undesirable frequencies.

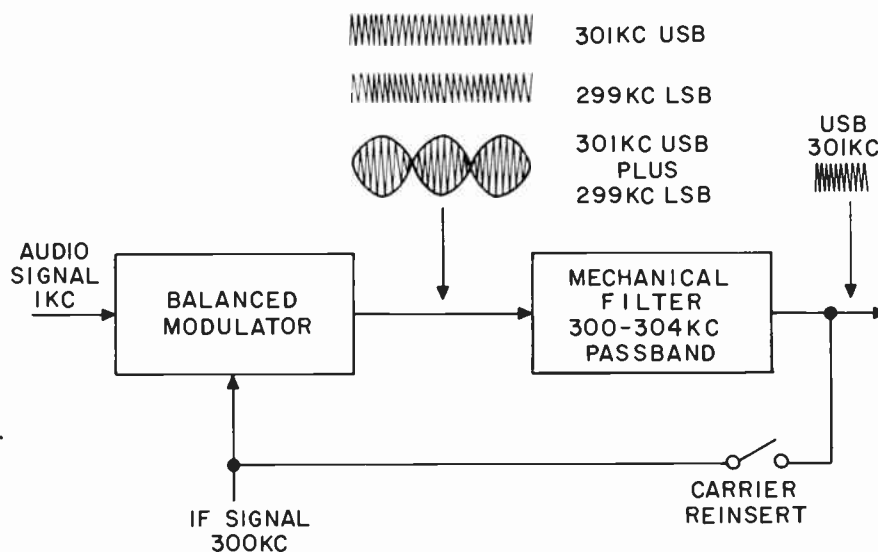

Figure 1-11. Filter-Type SSB Generator

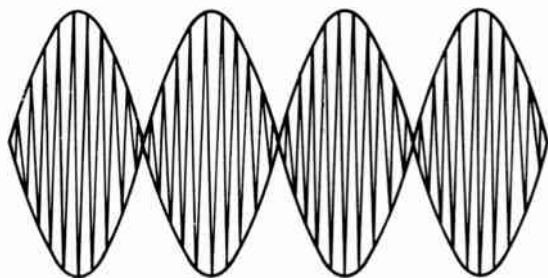

Figure 1-12. Single-Tone, Balanced Modulator Output

It should also be noted that the i-f carrier injected into the balanced modulator is only theoretically canceled from the output. Practical design considerations determine the extent to which the carrier can be balanced out. Present balanced modulators, using controlled carrier leak to balance out uncontrolled carrier leak, result in carrier suppression of from 30 db to 40 db below the PEP of the sidebands. Further suppression of the carrier by the SSB filter results in an additional 20 db of carrier suppression. Total carrier suppression of from 50 db to 60 db can, therefore, reasonably be expected from the transmitter system.

#### c. GENERATING THE SINGLE-TONE SSB WAVEFORM

The most fundamental SSB waveform is generated from the single audio tone. This tone is processed through the SSB generator to produce a single i-f frequency. As pointed out in paragraph 4, chapter 1, the SSB signal is actually generated at an i-f frequency and is subsequently converted up in frequency to the transmitted r-f frequency. It is the generation of the SSB signal at the i-f frequency with which we are concerned.

Figures 1-12 and 1-13 show the waveforms obtained in a filter-type SSB generator. The audio tone injected into the balanced modulator is 1 kc and the i-f frequency injected is 300 kc. The output from the balanced modulator contains the 299 kc lower sideband and 301 kc upper sideband frequencies. These two sideband frequencies, being of equal amplitude, produce the characteristic half sine-wave envelope shown in figure 1-12. The repetition rate of this envelope with a 1-kc tone is 2 kc, the difference between the two frequencies represented by the envelope. This i-f signal, which contains both the upper sideband and lower sideband signal, is called a double-sideband signal (DSB).

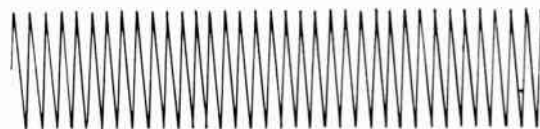

Figure 1-13. Single-Tone Balanced Modulator Output After Filtering Out the LSB

By passing the DSB signal through a highly selective filter with a 300 kc to 303 kc passband, the upper sideband signal is passed while the lower sideband signal is attenuated. The 301 kc signal which remains is the upper sideband signal and appears as shown in figure 1-13. Note that the SSB signal remaining is a pure sine wave when a single-tone audio signal is used for modulation. This SSB signal is displaced up in the spectrum from its original audio frequency by an amount equal to the carrier frequency, in this case 300 kc. This SSB signal can be demodulated at the receiver only by converting it back down in the frequency spectrum. This is done by mixing it with an independent 300 kc i-f signal at the receiver.

#### d. GENERATING THE SSB WAVEFORM OF A SINGLE TONE WITH CARRIER

From the single-tone SSB signal without carrier, it is a simple step to generate the single-tone SSB signal with carrier. This is done by reinserting the carrier after the filtering operation, as shown in figure 1-11. When the carrier reinserted is of the same amplitude as the SSB signal, the waveform shown in figure 1-14 results. Note that this waveform is similar to the double-sideband signal obtained directly out of the balanced modulator, as shown in

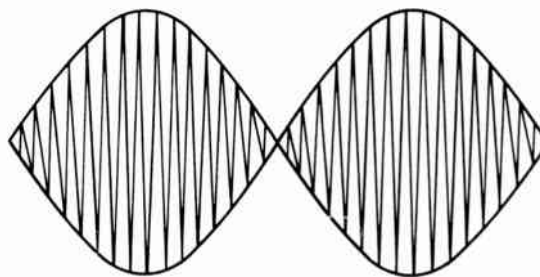

Figure 1-14. Single-Tone SSB Signal with Carrier--Carrier Equal in Amplitude to Tone



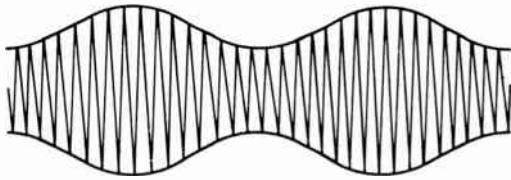

Figure 1-15. Single-Tone SSB Signal with Carrier--  
Carrier 10 DB Below Tone

figure 1-12. However, the frequency components of the two waveforms are not the same. The frequency components of the SSB signal with carrier are 301 kc and 300 kc when a 1-kc audio signal is used. The SSB signal with full carrier can be demodulated with a conventional diode detector used in AM. receivers without serious distortion or loss of intelligibility.

If the reinserted carrier is such that the carrier level is less than the level of the single-tone SSB signal, the waveform shown in figure 1-15 results. To successfully demodulate this signal, the carrier must be separated, amplified, exalted, and reinserted in the receiver, or locally supplied. The separate carrier amplification should be sufficient to raise the reinserted carrier to a level greater than the level of the sideband signal. The waveform shown in figure 1-15 represents the waveform used in the SSB with pilot carrier systems. The exalted carrier technique is used to demodulate such a signal.

#### e. GENERATING THE TWO-TONE SSB WAVEFORM

The two-tone SSB waveform is generated by combining two audio tones and then injecting this two-tone signal into the balanced modulator. One sideband is then suppressed by the filter, leaving the SSB waveform shown in figure 1-16. This two-tone SSB signal is seen to be similar to the single-tone DSB signal as well as the SSB signal with full carrier. However,

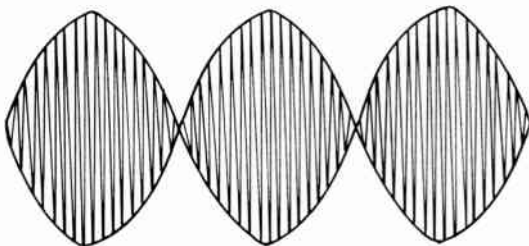

Figure 1-16. Two-Tone SSB Signal--  
Tones of Equal Amplitude

the two-tone SSB signal contains a different two frequencies than either of the other two. In the two-tone SSB signal shown in figure 1-16, 1 kc and 2 kc audio signals of equal amplitude are injected into the balanced modulator. After filtering, this results in a two-tone SSB signal containing frequencies of 301 kc and 302 kc. If a pilot carrier is reinserted with the two-tone test signal, the pilot carrier will be indicated by the appearance of a sine-wave ripple on the two-tone waveform. This waveform is shown in figure 1-17.

The generation of this two-tone envelope can be shown clearly with vectors representing the two audio frequencies, as shown in figure 1-18. When the two vectors are exactly opposite in phase, the envelope value is zero. When the two vectors are exactly in phase, the envelope value is maximum. This generates the half sine-wave shape of the two-tone SSB envelope which has a repetition rate equal to the difference between the two audio tones.

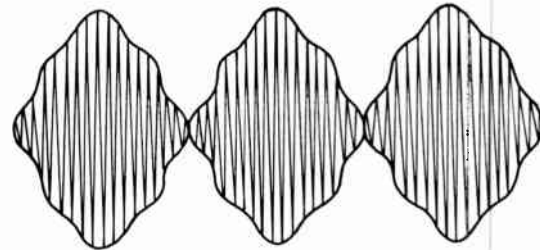
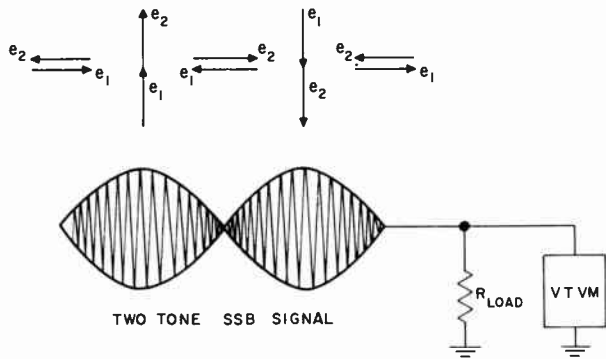

Figure 1-17. Two-Tone SSB Signal with Small  
Reinserted Pilot Carrier

The two-tone SSB envelope is of special importance because it is from this envelope that power output from an SSB system is usually determined. An SSB transmitter is rated in peak-envelope-power output with the power measured with a two equal-tone test signal. With such a test signal, the actual watts dissipated in the load are one-half the peak-envelope-power. This is shown in figure 1-18. When the half sine-wave signal is fed into a load, a peak-reading, rms-calibrated vtm across the load indicates the rms value of the peak-envelope-voltage. This voltmeter reading is equal to the in-phase sum of  $e_1 + e_2$ , where  $e_1$  and  $e_2$  are the rms voltages of the two tones. Since in the two-tone test signal  $e_1$  equals  $e_2$ , the PEP equals  $(2e_1)^2/R$  or  $(2e_2)^2/R$ . The average power dissipated in the load must equal the sum of the power represented by each tone,  $e_1^2/R + e_2^2/R$ ,  $4e_1^2/R$  or  $4e_2^2/R$ . Therefore, with a two equal-tone SSB test signal, the average power dissipated in the load is equal



$$V_{vtvm} = (e_1 + e_2),$$

with  $e_1$  and  $e_2$  in phase and rms values

$$PEP = V_{vtvm}^2 / R_{load} = 4e_1^2 / R \text{ or } 4e_2^2 / R,$$

where  $e_1 = e_2$

$$P_{average} = e_1^2 / R + e_2^2 / R = 2e_1^2 / R \text{ or } 2e_2^2 / R$$

Therefore: (1)  $PEP = V_{vtvm}^2 / R$   
 (2)  $P_{average} = 1/2 PEP$   
 (3)  $P_{tone1} \text{ or } P_{tone2} = 1/4 PEP$

Figure 1-18. Power Measurements from Two-Tone SSB Test Signal

to 1/2 of the PEP, and the power in each tone is equal to 1/4 of the PEP. Peak-envelope-power can be determined from the relationship " $PEP = V_{vtvm}^2 / R$ ;" the average power can be determined from the relationship " $P_{average} = 1/2 V_{vtvm}^2 / R$ ." This is true only where the vtvm used is a peak-reading, rms-calibrated voltmeter. Similar measurements can be made using an a-c ammeter in series with the load instead of the vtvm across the load.

The above analysis can be carried further to show that with a three equal-tone SSB test signal, the power in each tone is 1/9 of the PEP, and the average power dissipated in the load is 1/3 the PEP. These relationships are true only if there is no distortion of the SSB envelope, but since distortion is usually small, its effects are usually neglected.

**f. GENERATING THE SQUARE WAVEFORM**

Transmitting an audio square wave at a radio frequency imposes severe requirements on any transmitting system. This is true because the square wave is composed of an infinite number of odd-order harmonics of the fundamental frequency of the square wave. Therefore, to transmit such a signal without distortion requires an infinite bandwidth, an infinite

spectrum. This, of course, is impossible because tuned circuits will not pass an infinite bandwidth. The idealized SSB square wave, where all frequency components are present, shown in figure 1-19, indicates that the SSB signal requires infinite amplitude as well as infinite bandwidth. This occurs because the harmonically related SSB components will add vectorally to infinity when the modulating signal switches from maximum positive to maximum negative and vice versa. This infinite amplitude is not present in an AM envelope, because the AM envelope contains both sidebands with the frequency components in one sideband counter-rotating vectorally from the frequency components in the other sideband. The result is, then, when the resultant amplitude of one sideband is plus infinity; the resultant amplitude of the other sideband is minus infinity, which produces a net amplitude of zero.

The significance of the SSB square wave lies in its relationship with conventional clipping techniques used to limit the modulation level. Figure 1-20 shows the SSB envelope which results from severely clipping a 300 cps sine wave. The clipping level is such that the modulating signal is essentially a square wave. In generating the SSB envelope from the modulating signal, all harmonics above the ninth are removed by the highly selective SSB filter. Figure 1-19 shows that speech clipping, as used in AM., is of no practical value in an SSB transmitter because the SSB envelope is so different from the audio envelope. In an SSB transmitter, automatic load control, rather than clipping, is used to prevent overdriving the power amplifier by holding down the modulation level. It is possible to use a significant amount of clipping in an

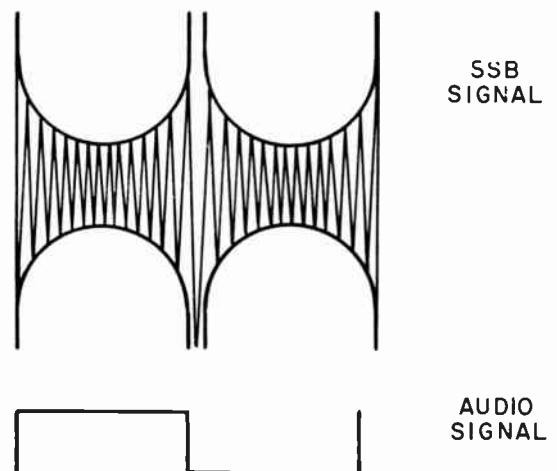

Figure 1-19. Square Wave SSB Signal--All Frequency Components Present

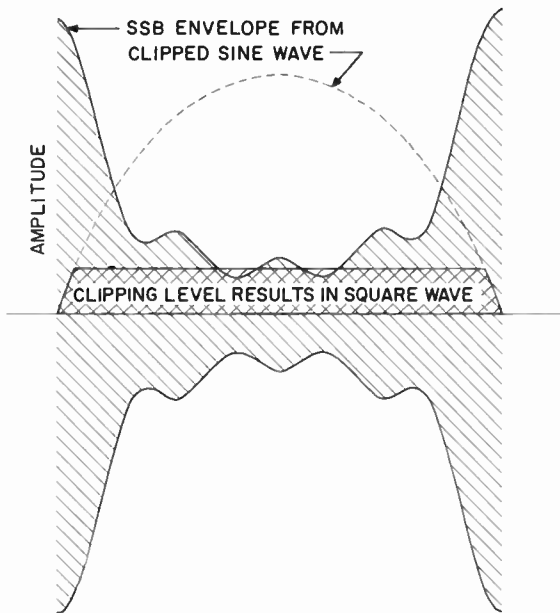

Figure 1-20. SSB Envelope Developed from 300 CPS, Clipped Sine-Wave (Harmonics above 9th Attenuated)

SSB transmitter if the clipping is performed on the i-f SSB signal rather than on the audio signal. If clipping were performed at this time, additional filtering would be required to remove the harmonic products caused by the clipping. However, clipping at this stage is satisfactory, because the harmonic products produced are not in the passband of the filter and only small intermodulation products are generated in the passband.

### g. GENERATING THE VOICE WAVEFORM

The human voice produces a complex waveform which can be represented by numerous frequency components of various amplitudes and various instantaneous phase relationships. No human voice is exactly like another voice, but statistical averages concerning the frequencies and amplitudes in the human voice can be determined. The average power level of speech is relatively low when compared to the peak power level. An audio frequency waveform of an  $\bar{a}$  sound is shown in figure 1-21. This same  $\bar{a}$  sound, raised in frequency, is shown in figure 1-22 as it appears as an SSB signal. From the "Christmas-tree" shape of these waveforms, it is evident that the peak power, which is related to the peak voltage of a waveform is considerably higher than the average power.

Over-all transmission efficiency depends upon the average power transmitted, while transmitter power is limited to the peak power capability of the transmitter. Therefore, for voice transmission, it behooves the transmitter designer to use speech-processing circuits which will increase the average power in the voice signal without increasing the peak power. This can be done in three different ways: (1) by clipping the power peaks, (2) by emphasizing the low-power, high-frequency components of the speech signal and attenuating the high-power, low-frequency components of the speech signal, and (3) by using automatic-gain-control circuits to keep the signal level near the maximum capability of the transmitter.

Figure 1-23 shows a power vs frequency distribution curve for the average human voice, after filtering below 200 cps and above 3000 cps. This curve shows that the high-power components of speech are concentrated in the low frequencies. Fortunately, it is the low-frequency components of speech which contribute little to intelligibility since these frequencies are concentrated in the vowel sounds. The low frequencies, therefore may be attenuated without undue loss

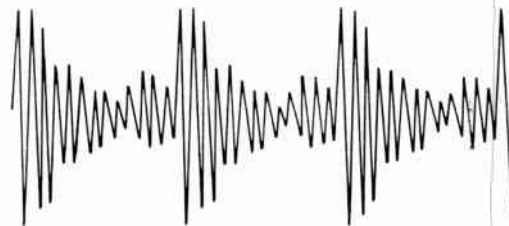

Figure 1-21. Voice Signal at Audio Frequency-- $\bar{a}$  Sound

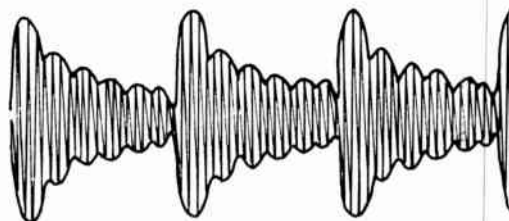

Figure 1-22. SSB Voice Signal-- $\bar{a}$  Sound



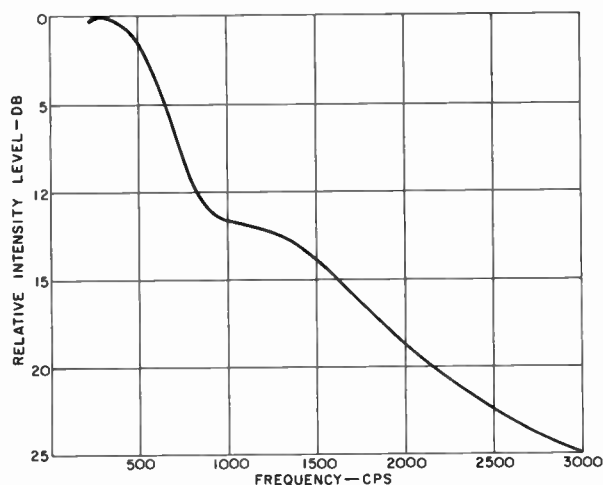

Figure 1-23. Power Distribution in Speech Frequencies--Low and High Frequencies Removed

of intelligibility of the speech. The low-power, high-frequency components present in a voice signal can be pre-emphasized to increase the average power of the signal. Since it is the high-frequency components which are predominate in the consonant sounds, some emphasis of the high frequencies will improve intelligibility. However, to emphasize the high frequencies sufficiently to raise the average power level significantly would require compatible de-emphasis at the receiver to prevent loss of fidelity.

Clipping power peaks results in flattening the waveform at the clipping level, and with severe clipping the voice signal becomes a series of square waves. Since an SSB square wave envelope requires infinite amplitude as well as infinite bandwidth, clipping the audio signal must be done with discretion. In the SSB transmitter, automatic load control is used to control the average power level input, rather than clipping, to prevent overdriving the power amplifier. Clipping then is used only to remove the occasional power peaks.

Speech-processing methods are being reinvestigated in relationship to SSB transmission to determine the most suitable method or combination of methods. Several circuits are presently used in SSB transmitters which effect some speech processing, although the primary purpose of most of these circuits is to process the input signal to prevent overdriving the power amplifier. These circuits include the following: (1) Automatic-load-control to maintain signal peaks at the maximum rating of the power amplifier. (2) Speech compression, along with some clipping, to

maintain a constant signal level to the single-sideband generator. (3) Highly-selective filters used in filter-type SSB exciters attenuate some of the high-power, low-frequency components of the voice signal. There are also several speech processing circuits under investigation which, if effective and practical, will be used to improve the efficiency of voice transmission. These circuits include (1) increased audio clipping with additional filtering to remove the harmonics generated, (2) reduction of the power level of frequencies below 1000 cps by shaping the audio amplifier characteristics for low-frequency roll-off, and (3) use of speech clipping at an i-f level where the generated harmonics can be more easily filtered. See paragraph 2-2a for input signal processing circuits used in an SSB exciter.

## 9. MECHANICAL FILTERS

Both SSB transmitters and SSB receivers require very selective bandpass filters in the region of 100 kc to 500 kc. In receivers, a high order of adjacent channel rejection is required if channels are to be closely spaced to conserve spectrum space. In SSB transmitters, the signal bandwidth must be limited sharply in order to pass the desired sideband and reject the other sideband. The filter used, therefore, must have very steep skirt characteristics and a flat bandpass characteristic. These filter requirements are met by LC filters, crystal filters, and mechanical filters. Until recently, crystal filters used in commercial SSB equipment were in the 100-kc range. These filters have excellent selectivity and stability characteristics, but their large size makes them subject to shock or vibration deterioration and their cost is quite high. Newer crystal filters are being developed which have extended frequency range and are smaller. These newer crystal filters are more acceptable for use in SSB equipment. LC filters have been used at i-f frequencies in the region of 20 kc. However, generation of the SSB signal at this frequency requires an additional mixing stage to obtain a transmitting frequency in the high-frequency range. For this reason, LC filters are not widely used. The recent advancements in the development of the mechanical filter have led to their acceptance in SSB equipment. These filters have excellent rejection characteristics, are extremely rugged, and are small enough to be compatible with miniaturization of equipment. Also to the advantage of the mechanical filter is a Q in the order of 10,000 which is about 100 times the Q obtainable with electrical elements.

Although the commercial use of mechanical filters is relatively new, the basic principles upon which they are based is well established. The mechanical filter is a mechanically resonant device which receives electrical energy, converts it into mechanical



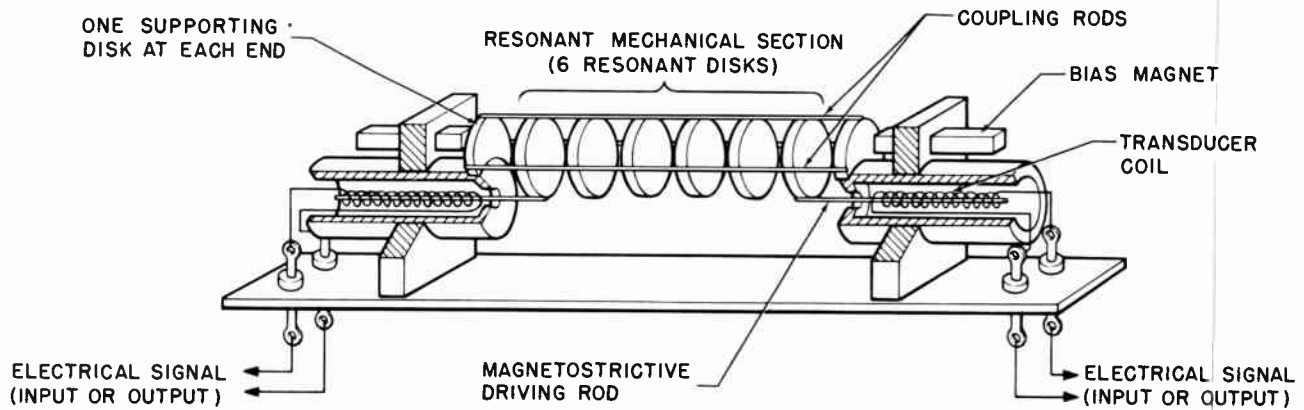

Figure 1-24. Elements of a Mechanical Filter

vibration, then converts the mechanical energy back into electrical energy at the output. The mechanical filter consists of basically four elements: (1) an input transducer which converts the electrical input into mechanical oscillations, (2) metal disks which are mechanically resonant, (3) coupling rods which couple the metal disks, and (4) an output transducer which converts the mechanical oscillations back into electrical oscillations. Figure 1-24 shows the elements of the mechanical filter, and figure 1-25 shows the electrical analogy of the mechanical filter. In the electrical analogy the series resonant circuits  $L_1 C_1$  represent the metal disks, the coupling capacitors  $C_2$  represent the coupling rods, and the input and output resistances  $R$  represent the matching mechanical loads.

The transducer, which converts electrical energy into mechanical energy and vice versa, may be either a magnetostrictive device or an electrostrictive

device. The magnetostrictive transducer is based on the principle that certain materials elongate or shorten when in the presence of a magnetic field. Therefore, if an electrical signal is sent through a coil which contains the magnetostrictive material as the core, the electrical oscillation will be converted into mechanical oscillation. The mechanical oscillation can then be used to drive the mechanical elements of the filter. The electrostrictive transducer is based on the principle that certain materials, such as piezoelectric crystals, will compress when subjected to an electric current. In practice, the magnetostrictive transducer is more commonly used. The transducer not only converts electrical energy into mechanical energy and vice versa; it also provides proper termination for the mechanical network. Both of these functions must be considered in transducer design.

From the electrical equivalent circuit, it is seen that the center frequency of the mechanical filter is

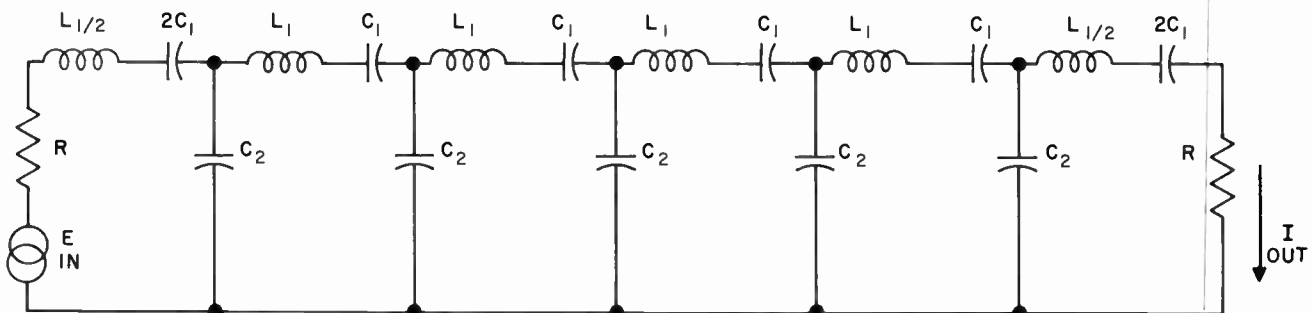

Figure 1-25. Electrical Analogy of a Mechanical Filter

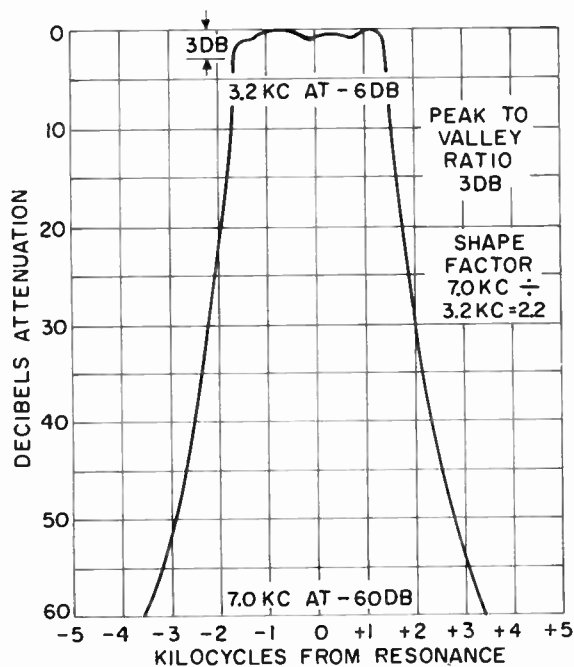

Figure 1-26. Mechanical Filter Characteristic Curve

determined by the metal disks which represent the series resonant circuit  $L_1C_1$ . In practice, filters between 50 kc and 600 kc can be manufactured. This by no means indicates mechanical filter limitations, but is merely the area of design concentration in a relatively new field. Since each disk represents a series resonant circuit, it follows that increasing the number of disks will increase skirt selectivity of the filter. Skirt selectivity is specified as shape factor which is the ratio (bandpass 60 db below peak)/(bandpass 6 db below peak). Practical manufacturing presently limits the number of disks to eight or nine in a mechanical filter. A six-disk filter has a shape factor of approximately 2.2, a seven-disk filter a shape factor of approximately 1.85, a nine-disk filter shape factor of approximately 1.5. The future development of mechanical filters promises even a faster rate of cutoff.

In the equivalent circuit, the coupling capacitors  $C_2$  represent the rods which couple the disks. By varying the mechanical coupling between the disks, that is, making the coupling rods larger or smaller, the bandwidth of the filter is varied. Because the bandwidth varies approximately as the total area of the coupling wires, the bandwidth can be increased by either using larger or more coupling rods. Mechanical filters with bandwidths as narrow as 0.5 kc and

as wide as 35 kc are practical in the 100 kc to 500 kc range.

Although an ideal filter would have a flat "nose" or passband, practical limitations prevent the ideal from being obtained. The term "ripple amplitude" or "peak-to-valley ratio" is used to specify the nose characteristic of the filter. The peak-to-valley ratio is the ratio of maximum to minimum output level across the useful frequency range of the filter (figure 1-26). A peak-to-valley ratio of 3 db can be obtained on a production basis by automatic control of materials and assembly. Mechanical filters with a peak-to-valley ratio of 1 db can be produced with accurate adjustment of filter elements.

Spurious responses occur in mechanical filters due to mechanical resonances other than the desired resonance. By proper design, spurious resonances can be kept far enough from the passband to permit other tuned circuits in the system to attenuate the spurious responses.

Other mechanical filter characteristics of importance include insertion loss, transmission loss, transfer impedance, input impedance, and output impedance. Since the input and output transducers of the mechanical filter are inductive, parallel external capacitors must be used to resonate the input and output impedances at the filter frequency. With such capacitors added, the input and output impedances are largely resistive and range between 1000 ohms to 50,000 ohms. The insertion loss is measured with both the source and load impedance matched to the input and output impedance of the filter. The value of insertion loss ranges between 2 db and 16 db, depending upon the type of transducer. The transmission loss is an indication of the filter loss with

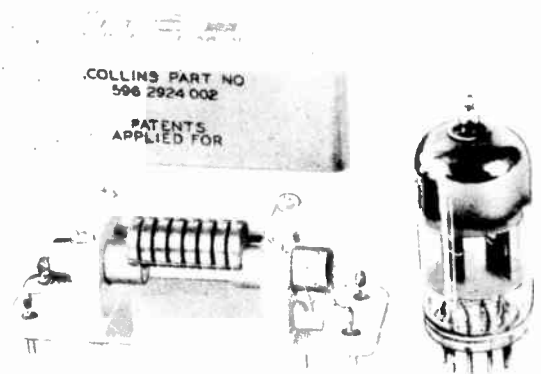

Figure 1-27. Size Comparison Between a Mechanical Filter and a Miniature Tube

source and load impedances mismatched. The transmission loss is of importance when using a mechanical filter in pentode i-f amplifiers where both source and load impedance are much greater than the filter impedances. The transfer impedance is useful to determine the over-all gain of a pentode amplifier stage which utilizes a mechanical filter. The transfer impedance of the filter multiplied by the transconductance of the pentode gives the gain of the amplifier stage.

The physical size of the mechanical filter makes it especially useful for modular and miniaturized construction. Figure 1-27 shows a mechanical filter compared with a miniature tube. The mechanical filter is about 1 inch square by 3 inches long. More

recent development has resulted in a smaller tubular filter which is about 1/2 inch in diameter by 1-3/4 inches long.

Mechanical filter types other than the disk type are presently being used. These include the plate type which is a series of flat plates assembled in a ladder arrangement. Another type which has recently been developed is the neck-and-slug type. This filter consists of a long cylinder which is turned down to form the necks which couple the remaining slugs. All mechanical filters are similar in that they employ mechanical resonance. Mechanical filters differ in that they employ various modes of mechanical oscillation to achieve their purpose. They may also use different types of transducers.



Collins 618T Single Sideband Transceiver Provides Communication on All Aeronautical Bands in the 2 to 30 Mc Range with 400 Watts PEP

## CHAPTER 2

### SINGLE-SIDEBAND EXCITERS

#### 1. SINGLE-SIDEBAND EXCITER CONSIDERATIONS

The single-sideband exciter must translate the incoming audio frequency signal to a band of frequencies in the r-f range. A single-sideband exciter is, in fact, a complete transmitter in itself. It must generate a radio-frequency sideband from an audio input signal, translate this r-f sideband to the final output frequency, and provide sufficient amplification to drive the r-f power amplifier. A functional diagram of a typical single-sideband exciter is shown in figure 2-1.

To generate the r-f sideband of frequencies, the single-sideband exciter uses low-level modulation and obtains the desired output level through the use of linear amplifiers. Low-level modulation is used since the carrier and unwanted sideband must be suppressed. The best suppression is obtained at a fixed low frequency since the problems involved in building a high-level balanced modulator, capable of working over a wide frequency range, appears to be insurmountable.

The most desirable performance characteristics of a single-sideband exciter would be the ability to generate the desired sideband, completely suppress the undesired sideband, and suppress the carrier. Practical design permits suppressing the undesired sideband and carrier frequencies by more than 40 db.

Careful consideration must be given to the amount of frequency spectrum space occupied by the generated signal. The band of side frequencies is normally held

to 4 kc in single-sideband exciters for communication purposes.

The two basic systems for generating single-sideband signals are the filter system, shown in figure 2-2A, and the phase shift system, shown in figure 2-2B.

#### a. FILTER SYSTEM

The filter system uses a band-pass filter having sufficient selectivity to pass one sideband and reject the other. Filters having such characteristics are normally constructed for relatively low frequencies, below 500 kc, but recent developments in crystal filter research has produced workable filters at 5 megacycles. The carrier generator output is combined with the audio output of a speech amplifier in a balanced modulator. The upper and lower sidebands appear in the output, but the carrier is suppressed. One of the sidebands is passed by the filter and the other rejected, so that a single-sideband signal is applied to the mixer. The signal is mixed with the output of a high-frequency r-f oscillator to produce the desired output frequency. The problem of undesired mixer products arising in the frequency conversions of single-sideband signals becomes important. Either balanced modulators or sufficient selectivity must be used to attenuate these frequencies in the output and minimize the possibility of unwanted radiations.

#### b. PHASE SHIFT SYSTEM

The principle involved in the generation of a single-sideband signal by the phase shift method,

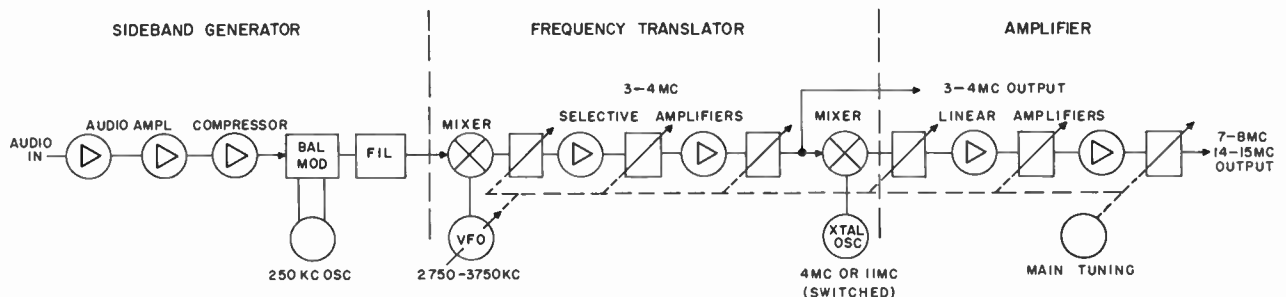

Figure 2-1. Typical Single-Sideband Exciter, Functional Diagram

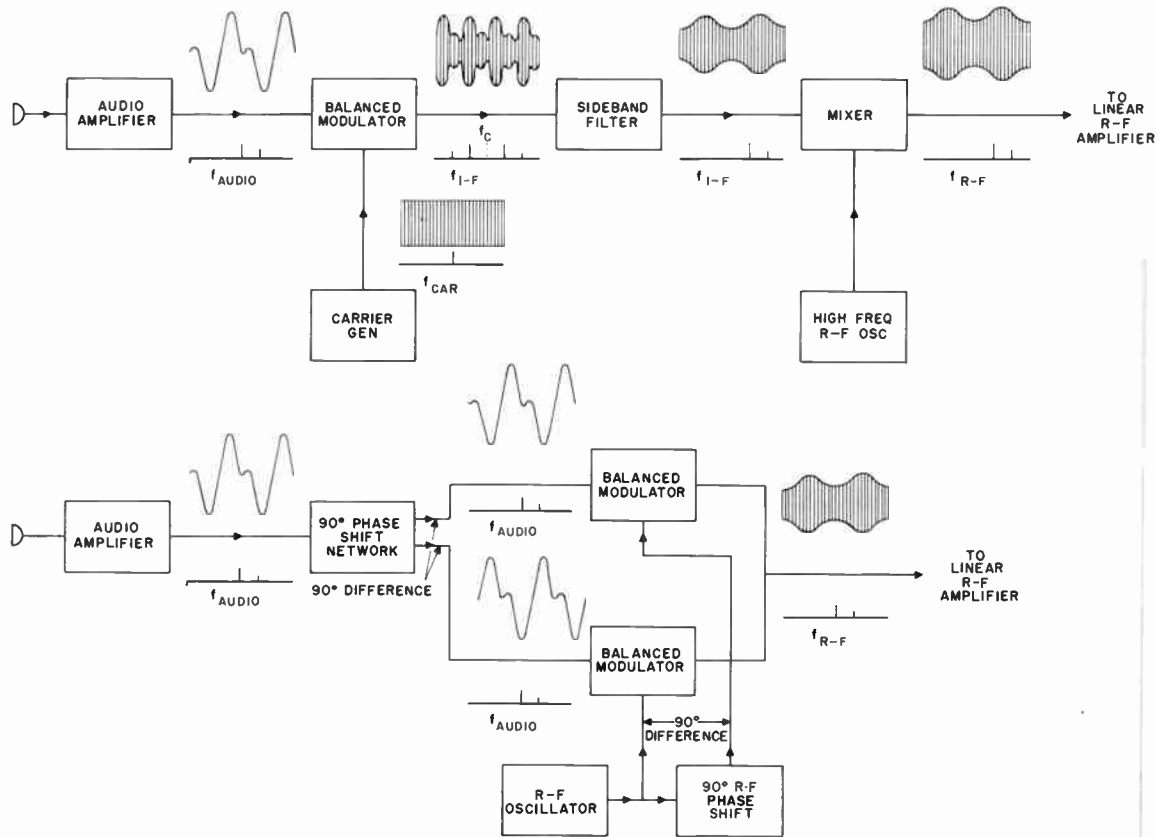

Figure 2-2. Basic Single-Sideband Generator, Block Diagram

shown in figure 2-2B, is centered about two separate simultaneous modulation processes and the combination of the modulation products. The audio signal is split into two components that are identical except for a phase difference of 90 degrees. The output of the r-f oscillator (which may be at the operating frequency if desired) is also split into two separate components having a 90-degree phase difference. One r-f and one audio component are combined in each of two separate balanced modulators. The carrier is suppressed in the modulators, and the relative phases of the sidebands are such that one sideband is balanced out while the other sideband is accentuated in the combined output. If the output from the balanced modulator is of sufficient amplitude, such a single-sideband exciter can work directly into the antenna, or the power level can be increased in a following linear amplifier.

## 2. THE SINGLE-SIDEBAND GENERATOR

The sideband generator processes the input audio signal, generates the r-f sideband in a modulator,

selects the desired sideband while suppressing the unwanted sideband, and suppresses the carrier. The circuits which perform these functions are shown in the single-sideband generator portion of figure 2-1. The audio input wave must be amplified, amplitude limited, and shaped before being applied to the modulator circuits. Sideband generation is accomplished by using this audio input signal to vary the amplitude of a carrier wave in a modulator. The desired sideband is selected from the modulator output using frequency discrimination or phase discrimination. The carrier wave is suppressed by using balanced modulators or rejection filters.

### a. INPUT SIGNAL PROCESSING

Processing of the audio input signal is an important part of single-sideband generating. If the input signal is a tone, or group of tones, of constant amplitude, such as the signal from a data gathering device, only a limited degree of processing will be required. However, if the input audio signal is a voice signal,



rather elaborate input processing circuits must be designed to obtain optimum results.

The amount of amplification required depends upon the output capability of the source of the audio signal and the input signal requirements of the modulator. Modulators require an audio signal in the range of .1 to 1 volt at impedances of 200 ohms for diode modulators or several hundred-thousand ohms for vacuum tube modulators. The output of a microphone may be from 100 to 1000 times less than the .1 to 1 volt range. Telephone line levels will also be considerably less than the required level. To obtain efficient utilization of the transmitter power amplifier, the applied driving signal should be as close to maximum without exceeding the overload level. To avoid driving the power amplifier into overload, it is necessary to adjust gain to the point where maximum output is obtained with the maximum input signal.

When the input signal is made up of extreme variations, such as a peak level to average level of 4:1, the average transmitted power level will only be 1/4 the maximum output the transmitter is capable of furnishing. This analogy is illustrated in figure 2-3. An effort must be made to compress the dynamic range of the human voice to make it more compatible with the electrical characteristics of a communications system. The two methods most commonly used to reduce these amplitude variations are compression and clipping circuits.

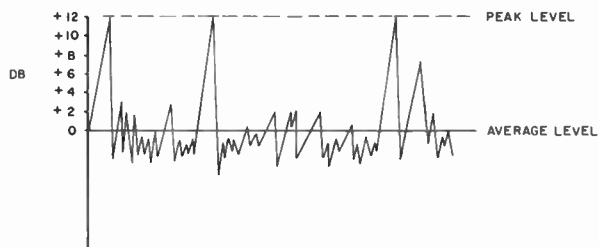

Figure 2-3. Peak-to-Average Level Variations of Speech

(1) COMPRESSOR CIRCUIT

A compressor is an automatic variable gain amplifier whose output bears some consistent relation to its input; for example, a one db rise in output for a two db rise in input. This circuit has very low steady state distortion. Common compressors use some type of feedback loop that samples the output of the amplifier and regulates the gain of the stage. The time constants of this type circuit are necessarily slow to prevent oscillation, motorboating, and distortion. The attack time, the time necessary to reach steady state condition after a sudden rise in input level, will be several milliseconds. The release time, the

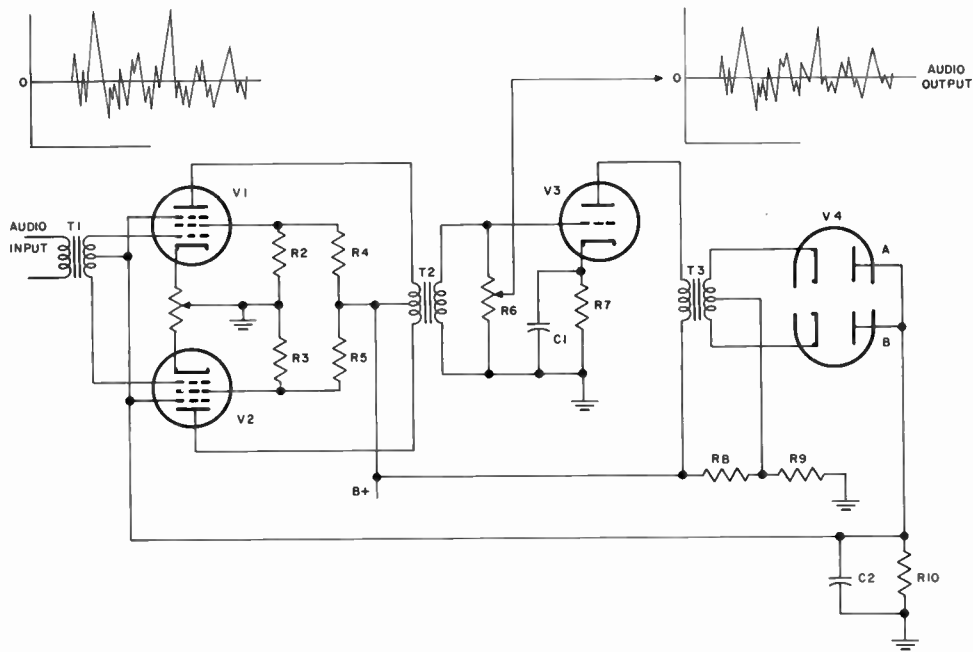

Figure 2-4. Compressor Circuit



time necessary to reach a steady state condition after a sudden drop in input level, will be several seconds. Compression of about 10 db is usually considered as an acceptable maximum value.

Operation of the compressor circuit, illustrated in figure 2-4, is such that the d-c bias voltage applied to the control and suppressor grids of the push-pull stage is in direct proportion to the amplitude of the signal passing through the circuit. If a large amplitude signal is impressed on the control grids of V1 and V2, such as a large amplitude low frequency, the signal is amplified and appears across transformer T3. As the audio signal swings positive at the top of the secondary of the transformer, tube V4B conducts, since the bottom of the secondary is negative with respect to ground, and the resultant current flow creates a bias voltage drop across resistor R10. The negative voltage on the control and suppressor grids of V1 and V2 reduces the gain of the tubes to limit the excursion of the audio signal. Conversely, as the audio signal swings negative at the top of the secondary of transformer T3, tube V4A conducts. Since the plates of the rectifiers are in parallel, the bias voltage is produced on both positive and negative going portions of the audio signal.

## (2) CLIPPER CIRCUIT

The clipper circuit, illustrated in figure 2-5, prevents the amplitude of a signal from exceeding a preset level. Its time constants are practically instantaneous, and it functions on each cycle of a wave. Distortion is very high, which results in loss of individuality in speaking and broadening of the spectrum occupied by the speech. Low-pass filters are usually used in conjunction with clippers to limit the spectrum and reduce distortion. The advantages of clipping is simplicity of circuit design and its ability to prevent overmodulation. The ability to prevent overmodulation results from its extremely fast attack on a wave after it exceeds the threshold. A well-designed clipper has no overshoot and an extremely fast release. A weak signal following one cycle after a wave that is heavily clipped will not be limited. This means that a weak consonant that follows a loud vowel in human speech will be given full amplification, although the preceding vowel was severely clipped. This amplifying of weak sounds in relation to soft sounds is referred to as consonant amplification.

The clipper circuit, illustrated in figure 2-5, serves as an instantaneous voltage amplitude limiter at a predetermined point on the positive and negative going portions of the audio signal. As the cathode of V1A swings positive, the tube will conduct until the potential on the cathode reaches the potential of the plate. The current flow through resistor R3 causes a voltage drop across R3 which is alternately reinforcing and bucking the plate voltage in exact

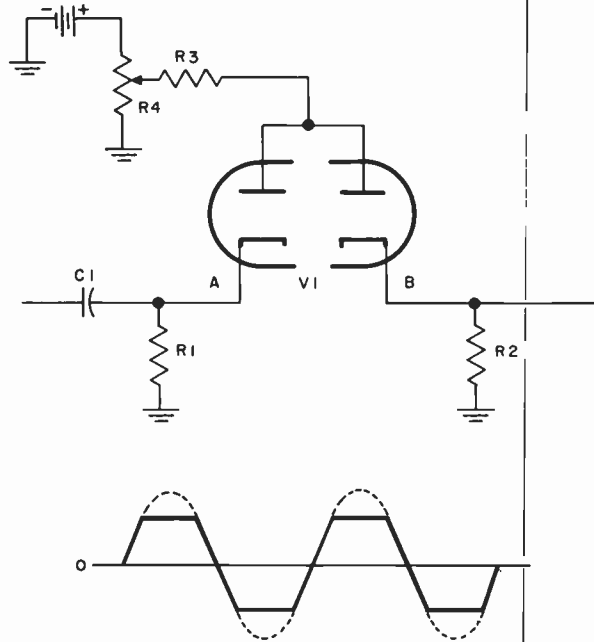

Figure 2-5. Clipper Circuit

response to the applied audio signal. This action causes the current through V1B to vary as the plate voltage varies and the signal in the output, across resistor R2, will be the same as the signal at the input, across resistor R1. When tube V1A is cut off, due to the cathode becoming more positive than the plate, there is no change of the plate voltage applied to V1B, and the current through the tube is held at a constant point. When the signal starts negative, the current variations through V1B will follow the current variations through V1A until the current through V1A becomes sufficiently great to cause the negative voltage drop across resistor R3 to equal the applied d-c plate potential. At this point the plate of V1B is no longer positive with respect to the cathode, and V1B ceases to conduct. The net result of this action is the clipping (or limiting) of the positive and negative peaks of an audio signal at a value predetermined by the setting of potentiometer R4.

## (3) FREQUENCY RESPONSE SHAPING

The energy contained in a voice signal is confined principally to frequencies below 1000 cycles per second. Most of this energy is used to produce the vowel sounds which contribute little to intelligibility. The energy used to produce the consonant sounds is largely high frequency in content and is very important in intelligibility. An improvement in intelligibility will result if the frequency response of the audio input signal circuits is modified to amplify the high frequencies more than the low frequencies.

## B. MODULATORS FOR SINGLE SIDEBAND

The r-f sideband is obtained by combining the audio signal obtained from the processing circuits and an r-f carrier wave in an amplitude modulator. There are many types of modulators, but they can be grouped into two main functional divisions: (1) those in which the modulation is dependent on the polarity of the modulating signal, and (2) those where the modulation is dependent on the instantaneous waveform of the modulating signal. For practical reasons, it is more convenient to group modulator circuits in the following three categories, based on the circuit components: (1) rectifier modulators (2) multielectrode vacuum tube modulators, and (3) nonlinear reactance modulators. Each group has its advantages and disadvantages, and these control the extent of their use. Because one of the characteristics of a modulator is frequency changing or frequency translating, this type of modulator is used in the frequency changing portion of a single-sideband exciter.

### (1) RECTIFIER MODULATORS

Rectifier modulators have several advantages which make them particularly useful for single-sideband generation. Their great advantage is high stability in comparison with vacuum tube modulators. They require no heating elements, and therefore no power is required and no heat has to be dissipated. They can be made quite compact, have long life, and require little maintenance. Rectifier modulators may be one of three general types, ring, series, or shunt. These type names refer to the manner in which the diodes are connected in the circuit. In all circuits, the rectifiers are made to work like switches by using a large r-f switching signal which greatly exceeds the audio signal level. These modulators are almost invariably connected as balanced modulators so that, as nearly as possible, there is no output of the r-f switching voltage in the modulator output terminals

The basic circuits of the ring, shunt, and series modulators are shown in figures 2-6A, 2-7A, and 2-8A. It must be assumed that the rectifiers are capable of switching at zero voltage from an infinite back resistance to a zero forward resistance and back again. The basic signal circuits may then be represented by the equivalent circuits shown in figures 2-6B, 2-7B, and 2-8B. These equivalent signal circuits are shown for any half-cycle of the carrier voltage, with switches shown in place of the rectifiers. Practical rectifiers are not ideal, but will have a finite forward and backward resistance. If it is assumed that the carrier frequency is several times that of the input signal, the resulting output waveforms are as shown in figures 2-6C, 2-7C, and 2-8C.

The output of these modulators consists of a series of pulses whose polarity and repetition frequency are determined by the switching or carrier

voltage, and whose amplitude is controlled by the input audio signal. A spectrum analysis of these output signals reveals the presence of an upper sideband and a lower sideband displaced about the switching or carrier frequency. A similar set of sidebands is placed about the second harmonic of the carrier frequency and some other undesired products higher in frequency.

The ring modulator has the highest efficiency, being capable of twice as much output voltage as the shunt or series modulator. Where carrier balance is important, a split ring modulator may be used in which it is possible to balance independently the two sets of diodes. The shunt modulator has the unique ability of being able to handle input and output terminations of the unbalanced, one-side-grounded type.

Rectifier balanced modulators are capable of a high performance; however, if they are to retain this performance for long periods of time, they must be carefully made of good quality, accurately matched components. Initial carrier balance exceeding 40 db may be readily obtained, but it is difficult to retain this degree of carrier suppression if the environmental conditions are severe. The level of third order intermodulation products can be held to 50 db below the desired sideband output signal.

### (2) MULTIELECTRODE VACUUM TUBE MODULATORS

Multielectrode vacuum tube modulators are flexible and used in a wide variety of applications in addition to generating sidebands. They are capable of giving conversion gain rather than loss as the case in rectifier modulators. However, they are quite unstable as to gain and impedance which makes them undesirable in balanced modulators. Since they employ vacuum tubes they require power, dissipate heat, and have relatively short life compared with rectifier modulators. Vacuum tube modulators, employing modulating functions dependent on the instantaneous amplitude of the modulating signals, are basically one of two types: a product modulator, or a square law modulator.

In a product modulator the output signal is proportional to the two input signals. In single-sideband application the input signals would be the carrier signal and the modulating signal. An example of such a product modulator is a double grid vacuum tube. The carrier voltage is applied to one grid, and the modulating signal applied to the other. Modulation takes place due to the combined action of the grids on the plate current. It is important to realize that non-linearity is not necessary, and modulation will take place even if each grid has a linear mutual characteristic.

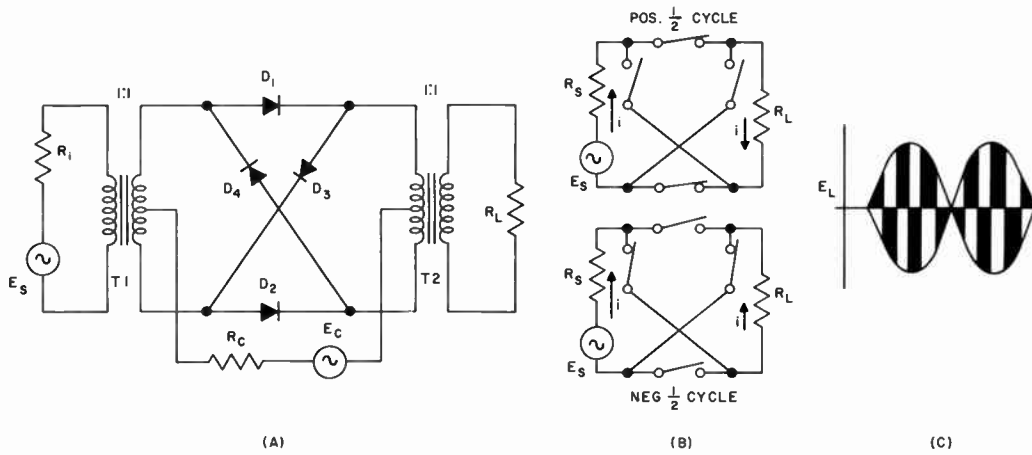

Figure 2-6. Basic Ring Modulator Circuits

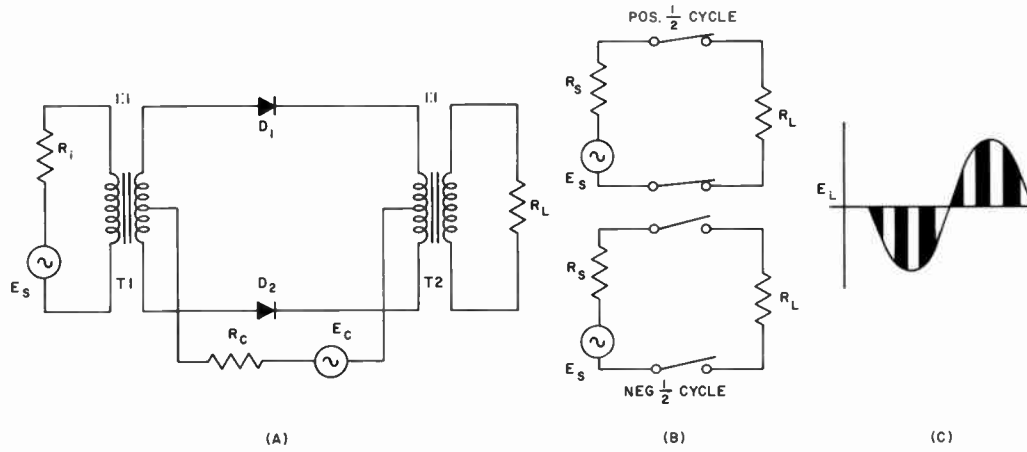

Figure 2-7. Basic Shunt Modulator Circuits

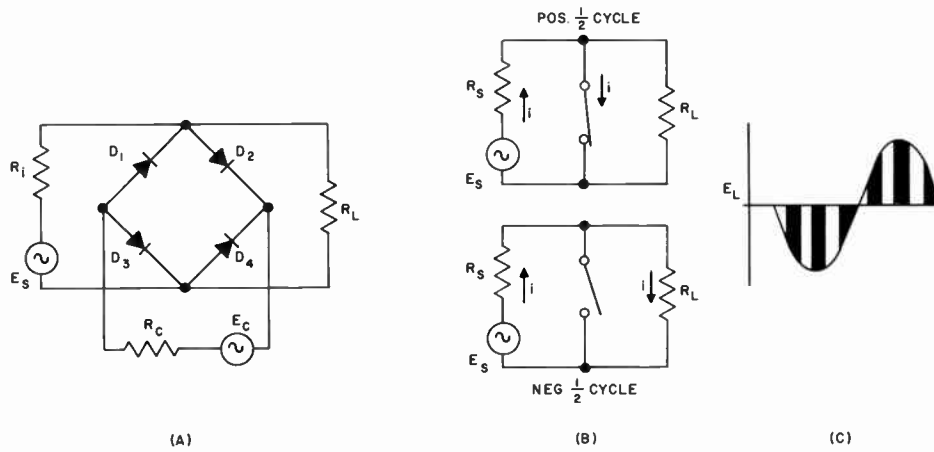

Figure 2-8. Basic Series Modulator Circuits

In contrast to the product modulator is a square law modulator in which modulation takes place directly because of a nonlinearity. An example of a square law modulator is a triode vacuum tube in which the shape of the plate current versus grid voltage curve has at least second order curvature or square law. This characteristic is possessed by all vacuum tubes and is the cause of distortion in amplifiers. If the curvature is purely square law, it can be shown that the output signal will contain only the desired sum or difference frequency and no other products except the second harmonics of the input signals. Product modulators and square law modulators are particularly useful in frequency changers because they generate a minimum of unwanted products.

Vacuum tube modulators in which the modulating function is dependent on the polarity of the modulating signal are large signal devices that have high efficiency but also generate considerable amounts of spurious signals. An example of such a modulator is a plate modulated triode operated class C. The modulating signal is used to vary the plate voltage applied to the class C amplifier. The resulting output is a series of pulses recurring at the carrier frequency rate and with amplitude proportional to the modulating signal. The tuned output circuit is necessary to suppress the harmonics of the signal. The double grid vacuum tube can also be used as a switching type modulator by increasing the amplitude of the signal applied to one of the grids. This signal can be large enough to drive the plate current of the tube to cutoff in one direction and saturation in the other, resulting in an output signal somewhat similar in waveform to that of a rectifier modulator.

Modulators using nonlinear reactances, instead of rectifiers or vacuum tubes, have not seen much use in high-frequency equipments due to the lack of materials usable at high frequencies. With suitable components such as titanate capacitors and ferrite-core inductors now available, it is probable that such modulators will be used more frequently in the future.

### c. SUPPRESSING THE CARRIER

The carrier frequency can be suppressed or nearly eliminated by the use of a balanced modulator. The basic principle in any balanced modulator is to introduce the carrier in such a way that current at the carrier frequency in the output circuit cancels out.

#### (1) VACUUM TUBE BALANCED MODULATORS

The requirements stated above are satisfied by introducing the audio in push-pull and the r-f drive in parallel, and connecting the output of the tubes in push-pull, as shown in figure 2-9A. Balanced modulators can also be connected with the r-f drive and audio inputs in push-pull and the output in parallel (figure 2-9B)

with equal effectiveness. The choice of a balanced modulator circuit is generally determined by constructional considerations and the method of modulation preferred by the builder. Screen-grid modulation is shown in the examples in figure 2-9, but control grid or plate modulation could be used with the same result. In balanced modulator vacuum tube circuits, there will be no output with no audio signal because the circuits are balanced. The signal from one tube is balanced or canceled in the output circuit by the signal from the other tube. The circuits are thus balanced for any value of parallel audio signal. When push-pull audio is applied, the modulating voltages are of opposite polarity, and one tube will conduct more than the other. Since any modulation process is the same as mixing, sum and difference frequencies (sidebands) will be generated. The modulator is not balanced for the sidebands, and they will appear in the output. The amount of carrier suppression obtained is dependent upon the matching of the two tubes and their associated circuits. Normally, two tubes of the same characteristics can be adjusted to give at least 30 db of carrier suppression without further filtering. Balance is difficult to maintain since tube characteristics change with age and supply voltage variations. Since in suppressed carrier single-sideband transmission it is desirable to suppress the carrier at least 40 db, the selective filter following the balanced modulator is used for further carrier suppression.

#### (2) DIODE BALANCED MODULATORS

The operation of diode balanced modulators was discussed in paragraph 2.b. (1) and figures 2-6, 2-7, and 2-8. The equivalent circuits illustrated in figures 2-6B, 2-7B, and 2-8B do not present the carrier balancing action of the modulators. This action may be analyzed from the basic circuits shown in figures 2-6A, 2-7A, and 2-8A. Using the ring modulator as an example, the carrier currents may be as shown in figures 2-10A and 2-10B. Assume that the carrier generator voltage is such that D1 and D2 conduct. The current flow will be through  $R_C$ , T1, D1 and D2, T2, and back to the generator. The current through the two windings of the output transformer T2 are out of phase and will cancel. On the next carrier half-cycle, D3 and D4 conduct, and the phases of all currents are changed by 180 degrees. The output currents are again out of phase. Therefore, no carrier voltage appears across the output load,  $R_L$ . Carrier currents may be similarly traced in the shunt and series circuits to show the balancing action of the carrier currents.

#### d. SIDEBAND SELECTION

It is a property of all modulators that the output consists of a pair of sidebands symmetrically disposed on either side of the carrier frequency. Since the objective is to transmit only a single sideband, a

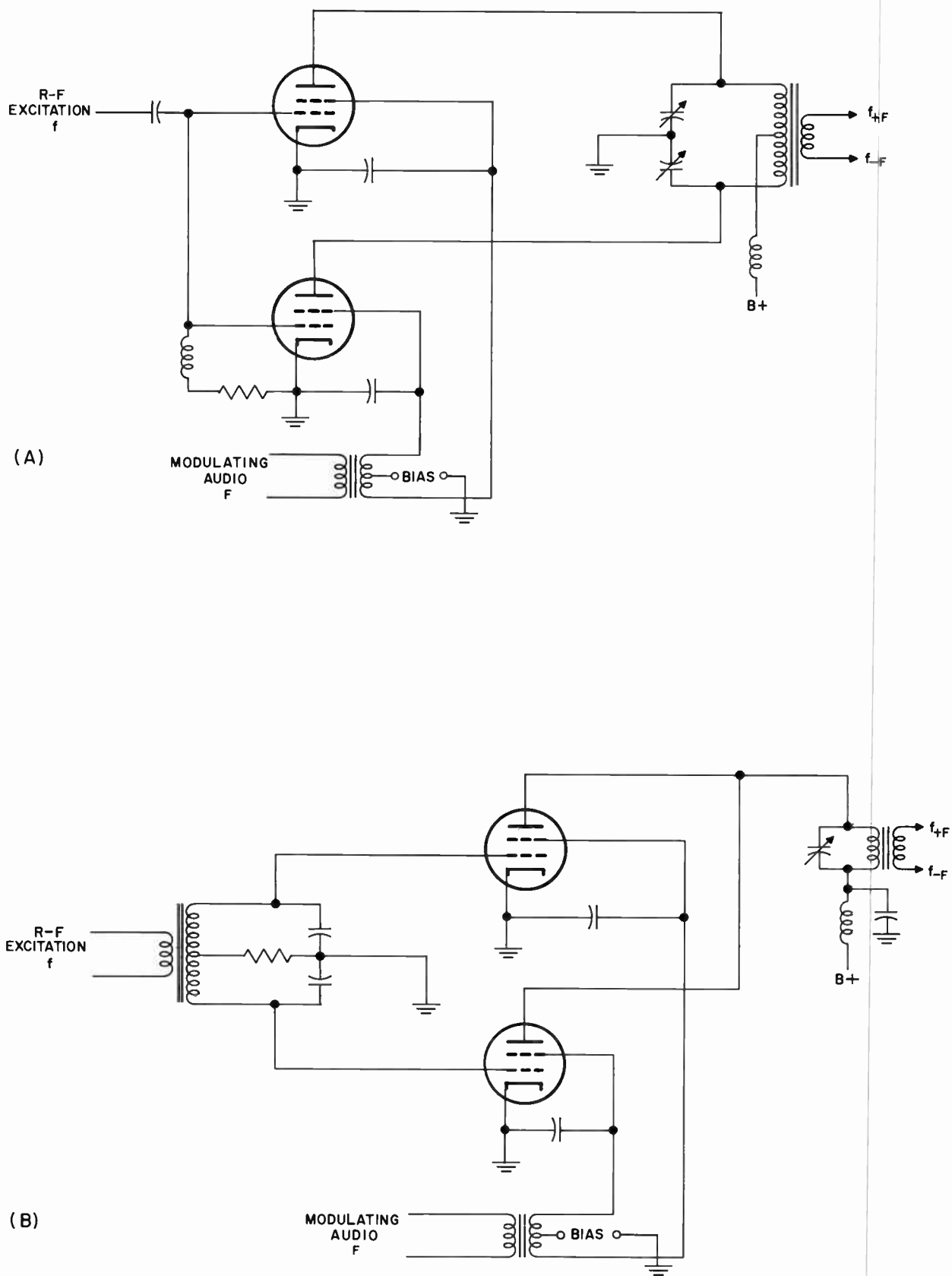

Figure 2-9. Vacuum Tube Balanced Modulators



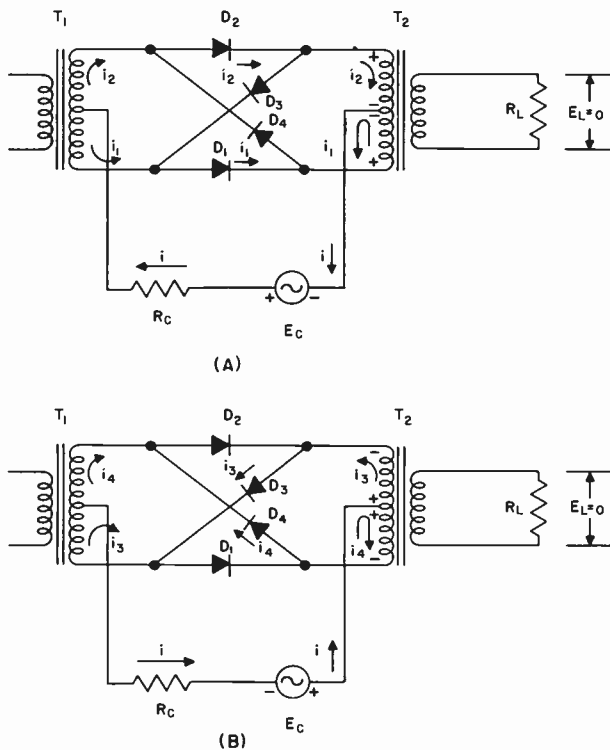

Figure 2-10. Ring Modulator Carrier Current Paths

means must be found to select the desired sideband and suppress the undesired sideband. This may be accomplished through the use of one of two techniques: the technique of frequency discrimination (filtering) or the technique of phase discrimination (phase shift).

#### (1) FILTER SYSTEM OF SIDEBAND SELECTION

The frequency discrimination method uses a frequency selective filter to select the desired sideband. This is possible because the modulating wave is usually confined to a restricted band of frequencies, and this frequency band is separated from the carrier by an appreciable amount. The rapid increase of attenuation required of a sideband selecting filter in order that it may adequately suppress the unwanted sideband is a decisive factor in filter design. Components having a high rate of change of impedance with frequency, or high  $Q$ , must be used. The requirement is a certain amount of attenuation in a given number of cycles. For a given frequency of filter operation and a certain degree of sideband suppression, the quality or  $Q$  factor of the components making up the sideband filter is determined. This means that for low-frequency sideband selection a lower  $Q$  element may be used, conversely for high-frequency sideband selection high  $Q$  elements are required. Inductors and capacitors have low  $Q$  factors and can be successfully used for sideband filters only at relatively low

frequencies, up to about 50 kilocycles per second. Small metal plates and quartz crystal plates on the other hand have extremely high  $Q$  factors and can be used to build sideband filters capable of operating at higher frequencies. Mechanical filters or metal plate filters have been built to operate up to 600 kilocycles, and crystal filters have been made to work at frequencies as high as 5 megacycles.

Removing the unwanted sideband through the use of a selective filter has the advantage of simplicity and good stability. The suppression unwanted sideband is determined by the attenuation of the sideband selecting filter. The stability of sideband suppression is determined by the stability of the elements used in constructing the sideband filter. This stability can be quite high because it is possible to use materials that have very low temperature coefficient of expansion.

#### (2) PHASE SHIFT METHOD OF SIDEBAND SELECTION

In the phase shift method, two balanced modulators are used, and the exciting signals to these modulators are arranged to have phase relationships such that when the outputs of these two modulators are combined, the desired sideband components are reinforced and the unwanted components are canceled out. Into modulator number 1 the modulating signal and the carrier signal are fed directly. Into modulator number 2 these signals are fed after first being passed through networks which shift the relative phase of these signals  $90^\circ$ . In other words, the modulating signal fed into modulator number 2 is shifted  $90^\circ$  with respect to the phase of the audio signal fed into modulator number 1. Similarly the phase of the carrier voltage fed into modulator number 2 is shifted  $90^\circ$  relative to the phase of the carrier voltage fed to modulator number 1. If these phase relationships are maintained over the desired modulating signal frequency range, the action is to suppress completely one set of sidebands and to reinforce the opposite set in the output of the combining circuit. If balanced modulators are used, the carrier signal will not appear in the output. Practically speaking, it is very difficult to design a phase shifting network that will perform according to the above restriction for the modulating signal phase shift network. However, if a separate phase shifting network is inserted in each modulating signal input circuit, it is possible to maintain a phase difference of  $90^\circ$  between the two network outputs over the required signal frequency range. The action of this circuit with these networks is identical with that in which a  $90^\circ$  phase shift is used in one branch alone.

The phase shift method of single-sideband generation does not require a rapid change of discrimination in a narrow frequency interval; therefore, it can be used to generate a single-sideband signal which can have extremely low-frequency components.



Since no selective filter is required, it is possible to generate the single sideband at the operating frequency with no frequency conversion being required. The degree of suppression of the undesired sideband is dependent on the accuracy with which the undesired sideband components are canceled. To obtain complete cancellation, it is necessary to maintain accurately the phase shifts and amplitudes of the signals applied to the combining network. These requirements place a very stiff specification on the phase shift and amplitude control properties of the circuit. The circuit is also somewhat more complex since two modulators are required.

### 3. TRANSLATION TO THE OPERATING FREQUENCY

The single-sideband signal is translated to the operating frequency by the use of one or more frequency changers. These frequency changers perform their function through the modulation process which is identical with that used to generate the sideband signal. The sideband signal is used to modulate a high-frequency carrier whose frequency is such that the upper or lower sideband is on the desired operating frequency. As a result of this modulation process, the sideband signal will be shifted to a new frequency that is either the sum of the carrier and sideband frequencies or the difference between the carrier and sideband frequencies. It is important to realize that if the lower sideband of the translation modulation process is selected, an inversion of the sideband signal occurs. That is to say, an upper sideband signal will be converted into a lower sideband signal. Another important consideration is the frequency accuracy and stability of the carrier used in the modulation process since any error in the carrier frequency is passed on to sideband signal in exact proportion. The translation system consists of two major components: the modulator (commonly called a mixer) and the carrier (commonly called oscillator signal).

All modulators previously described can be used for frequency changing. Vacuum tube modulators are used almost exclusively in this service, because these circuits have considerable gain and generate a minimum of spurious products. It is these spurious products which exert the most influence on the design of the frequency translation system.

#### a. SPURIOUS MIXER PRODUCTS

In order to show how undesired frequencies may be generated in a mixer stage, consider the case where signal and oscillator voltages are applied to the same grid of a mixer tube. In order that the desired sum or difference frequency be generated, it is necessary that the plate current versus grid voltage characteristic have some nonlinearity or curvature. The components of the plate current will be the d-c,

signal, oscillator, signal second harmonic, oscillator second harmonic, and the sum and differences of the signal and oscillator. It is necessary to eliminate all the products except the desired sum or difference product by filtering. To obtain the desired sum or difference product, we would desire a tube in which the characteristic curve had only second order curvature. Unfortunately, all practical tubes have characteristic curves having higher order curvature. This higher order curvature contributes additional unwanted frequency components into the output current. Sometimes the frequency of these unwanted components is far removed from the desired output frequency, and they are easily filtered out, but often these frequencies are very nearly equal in frequency to the desired signal frequency, and they will fall within the passband of the filter used in the mixer output circuit. The amplitude or strength of these undesired mixer products varies from tube type to tube type and tube to tube and with a given tube will change when the operating point is varied. Consequently, it is not surprising that tube designers have not been particularly successful in designing tubes having the desired second order curvature to the exclusion of any higher order curvature. The circuit designer, therefore, must select his mixer tubes by means of a series of experiments in which the amplitudes of these undesired mixer products are measured. The result of such an experimental determination of mixer product amplitudes is shown in table 2-1.

It can be seen that there are several undesired products that are greater in amplitude than the desired signal and a considerable number that are weaker than the desired signal. Furthermore, it can be seen that as the order of the mixer product involved increases, its amplitude decreases. The presence of undesired mixer products in the output of the frequency translation system may be minimized through intelligent selection of the signal and oscillator frequencies. The problem of frequency selection is relatively simple where the operating frequencies are fixed. Where the operating frequency must be varied, the problem becomes more complex; and if continuous operation over wide frequency ranges is required, the problem is exceedingly complicated. In an attempt to simplify the problem, circuit designers have resorted to charts in which the frequency of the spurious mixer products is plotted with respect to the signal and oscillator frequencies. Such a chart is shown in table 2-2.

The following example illustrates the spurious product problem. In this example, it is desired to produce a single-sideband transmitter capable of operating on the amateur 20, 40, and 80 meter bands. These bands are 3.5 to 4.0 megacycles, 7.0 to 7.3 megacycles, 14.0 to 14.35 megacycles. Assume that the single-sideband signal has been generated at 250 kilocycles carrier frequency. The lowest frequency band 3.5 to 4.0 megacycles can be covered by mixing

TABLE 2-1. CALCULATED FREQUENCY PRODUCTS CONTAINED IN THE PLATE CURRENT OF A 12AU7 TRIODE MIXER

CALCULATED FREQUENCY PRODUCTS CONTAINED IN THE PLATE CURRENT OF A 12AU7 TRIODE MIXER

$$e_{osc} = P \cos pt = 2V_{rms} \quad e_{sig} = Q \cos qt = .2V_{rms}$$

$$E_b = 250V \quad E_k = 10V \quad E_{bb} = 415V \quad R_L = 10K$$

TABLE DERIVED FROM POWER SERIES EXPANSION

WHERE  $e_{in} = P \cos pt + Q \cos qt$

ZERO DB REFERENCE IS MAGNITUDE OF  $(p \pm q)$

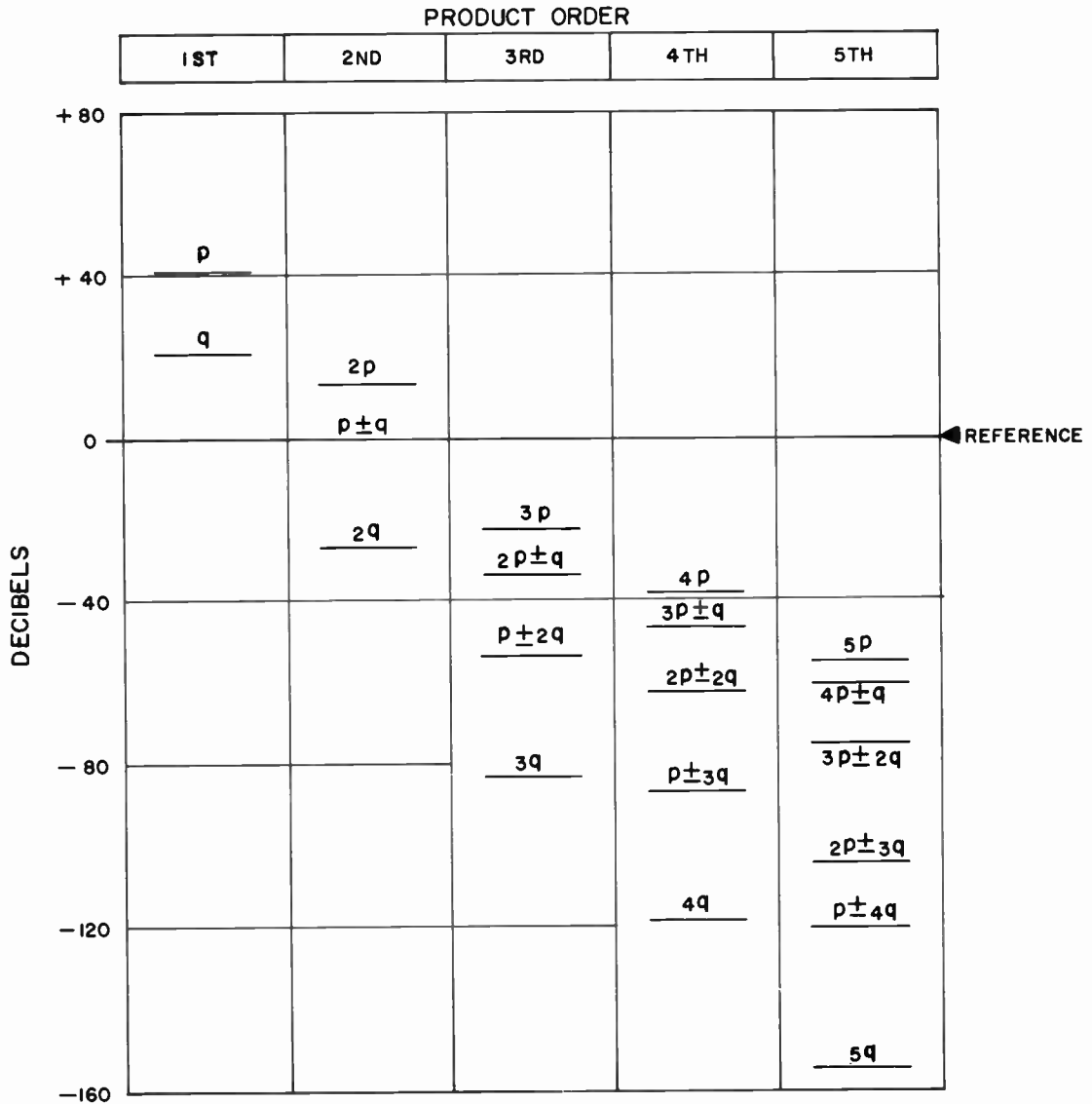

COEFFICIENTS OF POWER SERIES FROM REPORT BY  
DR. V.W. BOLIE DUAL TRIODE MIXERS 7/23/53

$$a_1 = 3.47 \times 10^{-4}, \quad a_2 = 1.47 \times 10^{-5}, \quad a_3 = 2.2 \times 10^{-7}, \quad a_4 = 3.7 \times 10^{-8}, \quad a_5 = 5.7 \times 10^{-9}$$

TABLE 2-2. SPURIOUS RESPONSE CHART

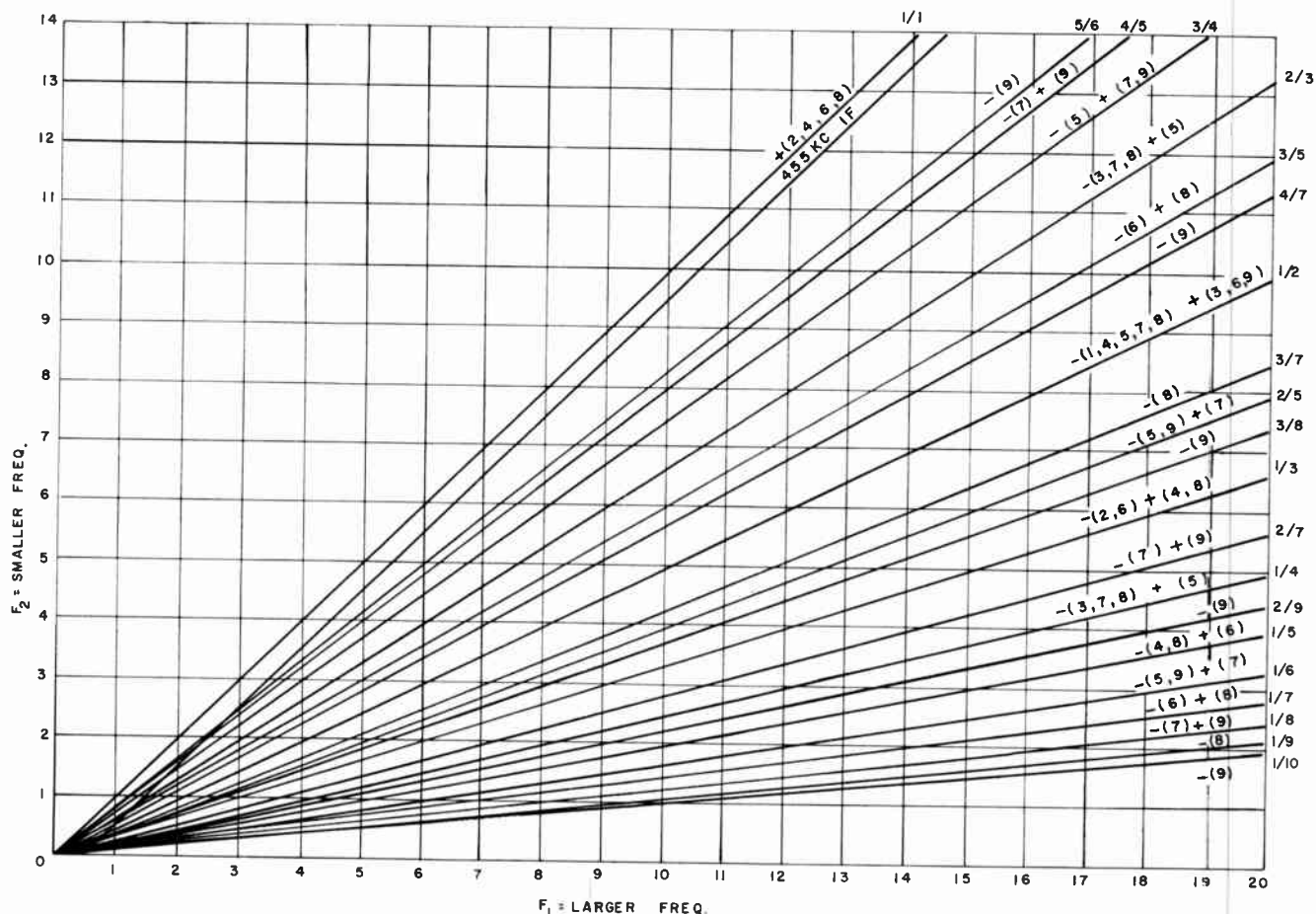

		$F_2 \sim F_1$								
ORDER		1	2	3	4	5	6	7	8	9
1/1			•20 •02		•13 •31		•24 •42		•35 •53	
1/2	10			•12 •40	31	32	•33 •51	52	53	•54 •72
1/3		20			•22 •40		42	51	•53 •71	
1/4			30			•32 •50		52	71	
1/5				40			•42 •60		62	
1/6					50			•52 •70		72
1/7						60			•62 •80	
1/8							70			•72 •90
1/9								80		
1/10									90	
2/3			21			•23 •41		43	53	

		$F_2 \sim F_1$								
ORDER		1	2	3	4	5	6	7	8	9
2/5					41			•43 •61		63
2/7								61		•63 •81
2/9										81
3/4						32		•34 •52		54
3/5							42		•44 •62	
3/7									62	
3/8										72
4/5								43		•45 •63
4/7										63
5/6										54

• INDICATES SUM MIXING  
OTHER - DIFF MIXING

this single-sideband signal with the output of a variable frequency oscillator tunable from 3.25 megacycles to 3.75 megacycles. Due to the large difference between the signal and oscillator frequencies, there are no difficulties with undesired mixer products. However, the oscillator signal is only 250 kilocycles removed from the output frequency and must be filtered by means of a band-pass filter or else balanced out through the use of a balanced modulator. As it is quite difficult to build a modulator which can retain balance over a wide frequency range, it is necessary to resort to a combination of both methods to obtain suppression of this spurious frequency of at least 60 db. As the operating frequency increases, it becomes difficult to suppress this product, and some other method must be found. This is because the selectivity required in the tuned circuits is so high as to be impracticable. A solution to the problem is to use a second conversion following the first. In this mixer,

the 3.5 to 4.0 megacycle output of the first conversion is mixed with the output of a crystal oscillator at 3.3 megacycles. This crystal frequency is chosen rather than 3.5 megacycles because with a 7.0 megacycle output frequency, there is a crossover of the second harmonic of the 3.5 megacycle signal with the desired output. A closer look at the frequencies involved, however, reveal that even with this crystal frequency, the second harmonic of the crystal at 6.6 megacycle is only 400 kilocycles removed from the low-frequency desired output, and the 7.4 megacycle second harmonic of the input signal is only 400 kilocycles on the other side of the desired output frequency. Selectivity of a very high order would be required to reduce these spurious signals satisfactorily. Some relief can be obtained by extending the range of the variable frequency oscillator used in the first mixer so that the output frequency from the first conversion runs from 3.0 to 4.0 megacycles. Now, a crystal oscillator

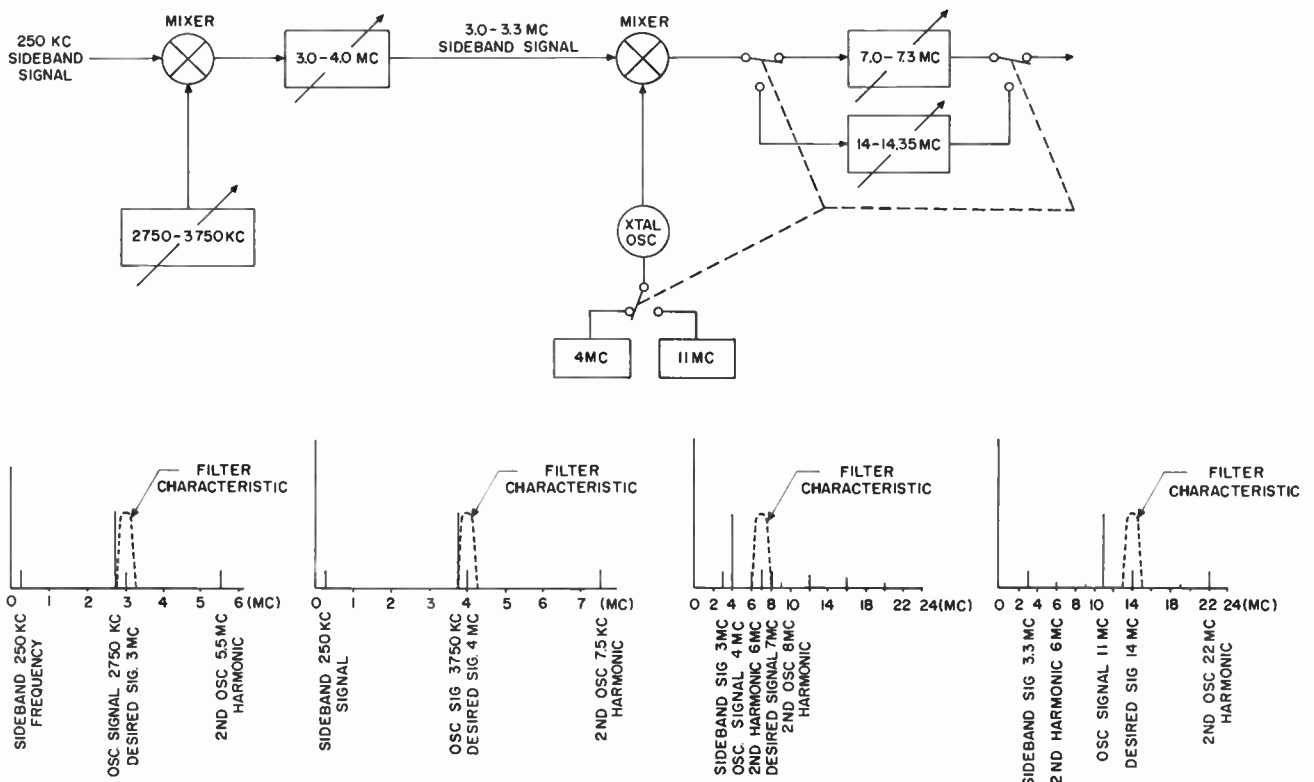

Figure 2-11. Selectivity Considerations in Frequency Translators



frequency at the second mixer of 4 megacycles can be used. With this frequency the range of the first converter system of 3.0 to 3.3 megacycles can be used to cover the 7.0 to 7.3 megacycle band. With this frequency scheme, the second harmonic of the crystal oscillator is at least 700 kilocycles removed from the desired operating range, and the second harmonic of the signal frequency ranges from 100 to 700 kilocycles below the desired output frequency range. These can be filtered adequately with relatively simple filters. According to the spurious frequency chart, a seventh order crossover occurs at the low end of the band when the third harmonic of 3 megacycles mixes with the fourth harmonic of 4 megacycles to yield a frequency equal to the output frequency. However, the level of a seventh order spurious signal is sufficiently low that it may be neglected, providing sufficient attention is paid to the selection of the mixer tube and its operating point. In considering frequencies to be used to cover the 14 to 14.35 megacycle band, one notes that if the difference product is selected, a clear region exists in the spurious chart between the 1/5 line and the 1/6 line. However, if such a scheme were adopted, the dial scale for this band would be reversed with respect to the two lower frequency bands, a distinctly unattractive feature. Fortunately, it is possible to use the sum product if a crystal frequency of 11 megacycles is used. The ninth order crossover occurring near the low end of the range is of no consequence since it is of negligible amplitude.

#### b. OSCILLATOR REQUIREMENTS

It must be realized that the frequency stability of the output signal is dependent on the frequency stability of the carrier frequency and the oscillator outputs used in the frequency changers. The total frequency error is the sum of the error in all three of these oscillators. This oscillator frequency error has two aspects. First, there is the accuracy of the calibration of the frequency involved. The second aspect of the frequency error is that of stability or a

drift. If the equipment is to be operated and continuously monitored by skilled operators, it is possible to get by with rather large errors in both calibration and drift. In some cases, it is possible to use equipment in which the calibration error is relatively large, but the frequency drift is quite small. In this case, it may be possible to carry out effective communication with such an equipment, providing an operator is available to make the initial tuning adjustment. In some cases where it is desired to operate the equipment on many channels by remote control and with relatively unskilled operators, it is necessary to provide equipment with a high degree of performance both with respect to calibration and drift. Authorities tend to disagree as to the allowable frequency error which can be tolerated in a single-sideband communication system used for voice communication. As the error increases, the naturalness of the reproduced speech suffers first. If the error is such as to place the reinserted carrier on the high side of the original carrier frequency, the voice becomes lower pitched. If the error is such as to place the reinserted carrier on the low frequency side, the voice becomes higher pitched. As the error is increased, a point is reached where intelligibility is degraded. The frequency error at which this occurs is approximately 100 cycles per second. When the single-sideband transmitter is used to transmit narrow-band telegraph or teletype signals, it is sometimes necessary to maintain accuracy considerably higher than that required for voice transmission.

The stability that can be obtained from oscillators is an important factor in the design of a frequency translation system. Typical oscillator frequency errors are shown in tabular form in tables 2-3 and 2-4. In table 2-3, the frequency error is the long-term frequency error. Calibration, drift, and aging all contribute to the long-term frequency error. The errors listed in table 2-3 are typical for a term of several months. The short-term frequency errors are shown in table 2-4. The short-term frequency

TABLE 2-3. TYPICAL OSCILLATOR LONG-TERM FREQUENCY ERROR

OSCILLATOR TYPE	ERROR %	ERROR CPS		
		3 mc	10 mc	30 mc
Variable Frequency Oscillator	.05	1500	5000	15,000
Crystal Oscillator	.005	150	500	1500
Temperature Controlled Crystal Oscillator	.001	30	100	300
Precision Standard Oscillator	.0001	3	10	30

TABLE 2-4. TYPICAL OSCILLATOR SHORT-TERM FREQUENCY ERROR

OSCILLATOR TYPE	ERROR PPM	ERROR CPS		
		3 mc	10 mc	30 mc
Variable Frequency Oscillator	20	60	200	600
Crystal Oscillator and Temperature Controlled Crystal Oscillator	1	3	10	30
Precision Standard Oscillator	.01	.03	.1	.3

error is principally that of frequency drift, although in some cases aging is rapid enough to have some effect. From the data shown in these tables, it can be seen that single-sideband equipments using variable frequency oscillators would require manual operation and frequent attention. For an equipment to meet the stability and accuracy requirements for quick frequency selection by remote control by unskilled operators, it is necessary to use the form of oscillator known as a stabilized master oscillator, in which a variable frequency oscillator is stabilized by comparing its frequency with that of a frequency derived from a reference standard oscillator. Oscillators of this type are described in a later chapter.

#### 4. AMPLIFICATION

In order that the single-sideband exciter have useful output, it is necessary to provide amplification of the sideband signal. Since the output power will be used to drive the power amplifiers of the system, the power output of the exciter is determined by system considerations. The driving power required is usually quite small since it is customary to use high gain tetrode tubes in most linear amplifiers. As a result, the power output of the single-sideband exciter may be limited to a fraction of a watt. This power level can be readily obtained through the use of receiving type tubes.

Pentode receiving tubes designed for use as r-f or i-f amplifiers in receivers may be used for low-level voltage amplifier stages. Low grid-to-plate capacitance is a necessary requirement for linear r-f amplifiers, since positive feedback through this path increases distortion. High mutual conductance is a useful characteristic because the required gain is then obtained with a minimum of stages. Receiving-type power pentodes may be used to obtain moderate power output, although most types suffer from having relatively large grid-to-plate capacitance. Tubes designed for video power amplifier use are best suited for use in linear r-f power amplifiers.

#### a. TUNED CIRCUITS

Tuned circuits used in a single-sideband linear amplifier perform a dual function. A tuned circuit provides a suitable load impedance for the amplifier stage, so that the amplifier may provide sufficient voltage amplification. Secondly, this tuned circuit acts as part of a selective filter which acts to suppress unwanted mixer products generated in the frequency translation system. To obtain sufficient selectivity, it is quite often necessary to use double-tuned and even triple-tuned circuits in order that the required selectivity be obtained.

#### b. LINEAR AMPLIFICATION

It is necessary to use linear amplifiers in a single-sideband transmitter in which low level modulation is used. The single-sideband system is an amplitude modulated system and once the modulation is performed, the amplitude relationships of the sideband components must be faithfully maintained. The principal distortion component encountered in tuned linear amplifiers is the third order intermodulation product. This product is so called because its generation depends on the third order curvature of the input-output amplifier characteristic. Unlike audio linear amplifiers which must handle a wide frequency range, tuned radio-frequency linear amplifiers seldom have difficulty with products generated due to second order curvature, such as sums and difference frequencies and harmonics. These frequencies usually fall far outside the tuned passband and are suppressed accordingly. On the other hand, the third order intermodulation products are always close to the desired frequency band, and many of the products actually fall within the desired passband. These intermodulation products are generated whenever there are two tones, or frequencies, within the amplifier passband whose frequencies are sufficiently close together that the second harmonic of one will mix with the other to yield a third frequency within the tuned amplifier passband. The amplitude of these spurious products can



be controlled by limiting the input signal amplitude so that operation of the tube is always over a linear part of its input-output characteristic. It is readily possible to obtain sizable voltage and power amplification using receiving type tubes and still limit the amplitude of the third order intermodulation product to a level more than 50 db below the desired.

An important consideration in transmitters using linear power amplifiers is that the amplifier be driven with sufficient signal and yet not be overdriven to cause excessive intermodulation distortion. There are many factors which tend to cause the output of a single-sideband exciter to vary. The gain of the amplifier stages changes from one frequency channel to another due to the impedance of the tuned circuits, used as the load impedances in these stages, varying with frequency. Tube gain characteristics change from tube to tube and from time to time as the tubes age. Changes in temperature and other environmental factors can also cause changes in amplifier gain. An effective way to cope with these variations is to

sample the driving voltage of the power output amplifier with a rectifier, and to use the resulting d-c to control the gain of one or more amplifier stages in the exciter. This control voltage may be used to control the gain of amplifier stages using remote cutoff characteristic tubes similar to those used in receiver r-f amplifiers on which automatic gain control is used.

## 5. SUMMARY

The single-sideband exciter consists of three major sections: a single-sideband generator, a frequency translator, and a voltage power amplifier. In the sideband generator the audio input signal is processed by the use of amplification, amplitude limiting, and frequency energy distribution. The processed signal is then converted into an r-f sideband in a modulator. The desired signal or sideband is selected and the unwanted sideband suppressed, using the technique of frequency discrimination or phase discrimination. The desired sideband is then translated to the desired range of operating frequency by means of a frequency translation system. The desired output level is obtained through the use of linear amplifiers.

## CHAPTER 3

# SINGLE-SIDEBAND RECEIVERS

### 1. SINGLE-SIDEBAND RECEIVER CONSIDERATIONS

The operation of a single-sideband receiver is, in a limited sense, the reverse of the process carried out in a single-sideband exciter. The received single-sideband radio-frequency signal is amplified, translated to a low i-f frequency, and converted into a useful audio-frequency signal. The reception of a high-frequency single-sideband signal is essentially the same as receiving a high-frequency AM signal. Receivers are invariably of the superheterodyne type to provide high sensitivity and selectivity. The absence of a carrier in the received SSB signal accounts for the principal difference between single-sideband and AM receivers. In order to recover the intelligence from the single-sideband signal, it is necessary first to restore the carrier. This local carrier must have the same relationship with the sideband components as the initial carrier used in the exciter modulator. To achieve this, it is a stringent requirement of single-sideband receivers that the oscillator which produces the reinserted carrier have extremely good frequency accuracy and stability. The total frequency error of the system must be less than 100 cycles per second, or the intelligibility of the received signal will be degraded.

The single-sideband receiver must be able to select a desired signal from among the many signals which populate the high-frequency band. Good selectivity

becomes an essential requirement when signals of considerable variance in amplitude are spaced close together in the frequency spectrum. The sensitivity of the receiver must be sufficient to recover signals which are of very low amplitude, almost lost in the noise which is constantly present in the antenna. These requirements determine the design of the front end, or r-f section, of the receiver.

Double conversion superheterodyne circuits are used in present day receivers. The principal advantages of such circuits are the extra image rejection obtained and the decided improvement in frequency stability. This can be achieved by using a crystal oscillator in the high-frequency conversion and injecting the tunable oscillator at a lower frequency conversion where its error has less effect.

In a conventional receiver, the audio intelligence is recovered from the radio-frequency signal by means of an envelope detector. This detector may be a simple diode rectifier. This same diode detector, provided with a local carrier, can also be used to recover the audio signal from a single-sideband suppressed carrier signal; however, the amplitude of the local carrier must be quite high in order that the intermodulation distortion be kept low. Better performance, particularly with respect to distortion, may be obtained by using product demodulators to recover the audio signal.

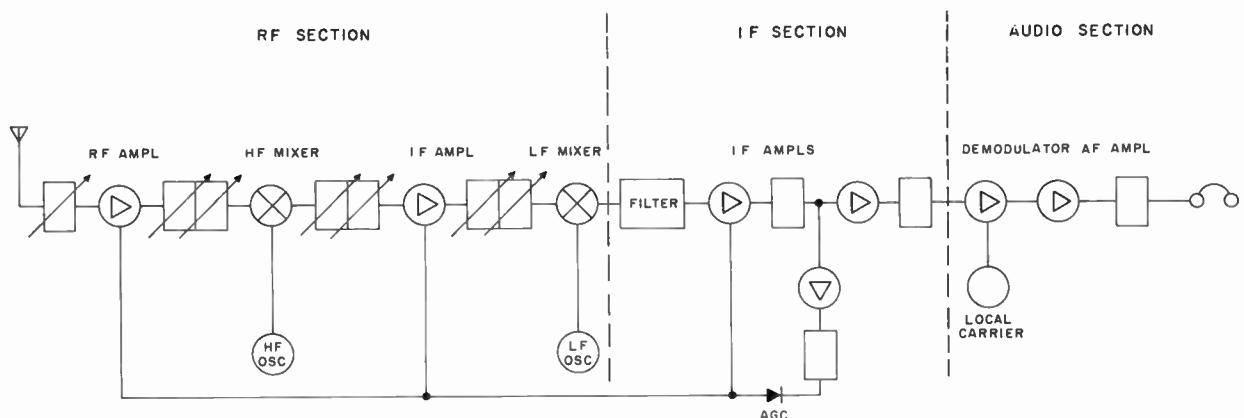

Figure 3-1. Typical Single-Sideband Receiver, Functional Diagram

The characteristics of the automatic gain control system of a single-sideband receiver must be somewhat different from those of a receiver designed for conventional AM signals. The conventional AVC system provides the automatic gain control by rectifying the carrier signal, since this carrier is relatively constant and does not vary in amplitude rapidly. This AVC system can have a relatively long time constant. In a receiver for single-sideband suppressed carrier signals, the AGC rectifier must be of a quick acting type because the signal amplitude is changing very rapidly and frequently disappears altogether.

Single-sideband receivers have three main sections: a radio-frequency section, an intermediate-frequency section, and an audio-frequency section. These sections of a typical single-sideband receiver are shown in figure 3-1. The principal requirement of the r-f section is to select the desired signal in the antenna and translate this signal to a lower r-f frequency (intermediate frequency) with a minimum of distortion and generation of spurious signals. The intermediate-frequency section provides selectivity and amplification. The audio section recovers the audio-frequency intelligence and provides the necessary audio-frequency amplification.

## 2. R-F SECTION

The r-f section consists of an r-f amplifier and one or more mixers which translate the signal to the intermediate frequency. The use of an r-f amplifier as the first stage of a receiver provides increased sensitivity and reduction in spurious responses. Increased sensitivity results from the lower inherent noise of amplifiers compared with mixers. Spurious signals are reduced because increased r-f filtering can be used without degrading the signal-to-noise ratio. The amplification provided by the r-f amplifier offsets the losses inherent in the passive filter circuits.

The sensitivity of a receiver is usually defined as the minimum signal with which a 10 db signal-plus-noise-to-noise ratio may be obtained. This definition has a practical basis because it recognizes the fact that ultimately the noise level is the limiting factor in readability, and that a signal 10 db stronger than the noise level is acceptable for voice communication. Maximum receiver sensitivity is not determined by the gain of the receiver but by the magnitude of the receiver noise. The three sources of noise which contribute to the noise level of a receiver are the antenna to which the receiver is connected, the input resistance of the receiver, and the grid circuit of the first tube used in the receiver. If the gain of the first amplifier is low, it is possible that the noise of the second tube in the receiver can also have some effect on the receiver over-all noise level.

### a. NOISE SOURCES

A noise voltage will be present across the terminals of any conductor due to the random motion of electrons. This random electron motion is known as thermal agitation noise and is proportional to resistance of the conductor and its absolute temperature. All noise currents and voltages are random fluctuations and occupy an infinite frequency band. The actual magnitude of noise voltage which affects a device is proportional to the bandwidth of the device. The noise voltage can be calculated with the following equation.

$$E_n = \sqrt{4 KTBR}$$

where  $E_n$  = rms noise voltage  
 $K$  = Boltzmann's Constant,  $1.38 \times 10^{-23}$   
 $T$  = absolute temperature  
 $B$  = bandwidth in cps  
 $R$  = resistance in ohms

If the antenna to which the receiver is connected could be placed in a large shielded enclosure, there would exist at the terminals of this antenna a noise voltage equal to the thermal agitation noise of a resistor which is equal to the radiation resistance of the antenna. Even if a receiver could be built with no internal sources of noise, noise would still be introduced into the receiver from the antenna, and weak signals would have to compete with this noise.

Additional noise signals originating in atmospheric disturbances, the sun and other stellar sources, and in electrical machinery increase the noise threshold below which even a perfect receiver could not detect signals. In the h-f band from 2-30 mc, this threshold is usually much higher than that set by receiver internal noise sources. However, the external noise threshold is subject to many variations, and it is possible that under certain favorable combinations of conditions, the receiver noise could be a factor at frequencies in the upper half of the band. For this reason, the noise generated in the receiver circuits is an important consideration.

The internal noise generated in a receiver is conveniently described by a number called the noise figure. The noise figure is expressed as the ratio in decibels between the noise level of the receiver to the noise level of a so-called perfect receiver, in which all the noise is assumed to be generated in the antenna by thermal agitation. A perfect receiver in which the input circuit is designed to match the antenna resistance has a noise figure of 3 db.

The sources of noise in a receiver are the input circuit resistance, the first tube grid circuit, and the second tube grid circuit if the first tube gain is low.

These noise sources are shown in schematic form in figure 3-2. For convenience, the tube noise is usually expressed as being equivalent to the noise generated in a resistance of the proper value, referred to as the equivalent noise resistance of the tube. A tube having a low value of equivalent noise resistance is a low noise tube. Equivalent noise resistances of a number of tubes are listed in table 3-1. From the figures shown, it can be seen that triodes have lower noise than pentodes, and amplifiers have lower noise than mixers. Tube noise, although important, is not a decisive factor in tube selection. Pentode tubes offer advantages over triodes as amplifiers, since they have very low grid-to-plate capacitance and give large gain without neutralization. Pentagrid mixers require less oscillator power, have excellent isolation between signal and oscillator circuits, and give high conversion gain.

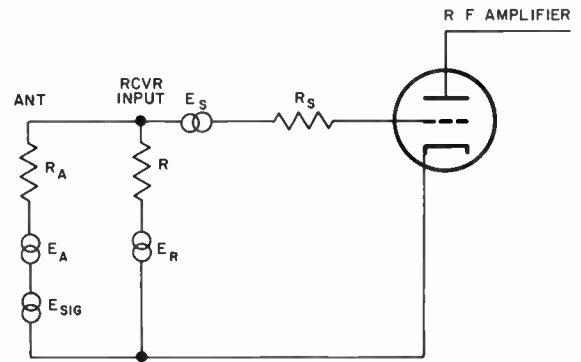

Figure 3-2. Noise Sources in R-F Section of Single-Sideband Receiver

TABLE 3-1. EQUIVALENT TUBE NOISE RESISTANCE

Type	Application	gm or gc	Calculated Req
2C51	Triode Amplifier	5500	455
6AC7		11200	220
6AH6		11000	230
6AN4		10000	250
6BK75		6100	410
6BQ7A		6400	390
6BZ7		6800	370
6J4		11000	230
6J6		5300	470
6T4		7000	360
6U8		8500	295
12AT7		6600	380
12AU7		2200	1140
12AX7		1600	1560
12BH7		3100	810
5687		10000	250
5842		24000	105
6386		4000	625
6AG5	Pentode Amplifier	5000	1650
6AH6		9000	720
6AK5		5100	1880
6AK6		2300	8800
6AU6		5200	2660
6BA6		4400	3520
6BC5		5700	1350
6BD6		2350	13800
6BH6		4600	2360
6BJ6		3800	3860
6BZ6		6100	1460
6CB6		6200	1440
6U8		5200	2280

TABLE 3-1. EQUIVALENT TUBE NOISE RESISTANCE (Cont)

Type	Application	gm or gc	Calculated Req
2C51	Triode Mixer	1375	2900
6AN4		2500	1600
6J4		2750	1450
6J6		1575	2540
6T4		1750	2290
12AT7		1650	2430
12AU7		550	7280
12BH7		775	5170
5687		2500	1600
6386		1000	4000
6AG5	Pentode Mixer	1250	6600
6AK5		1280	7520
6BA6		1100	14080
6BC5		1425	5400
6BZ6		1525	5840
6U8		1300	9120
6X8		2100	7780
6BA7	Pentagrid Converter	950	61700
6BE6		475	174000
6SA7		450	240000
6SB7Y		950	61700

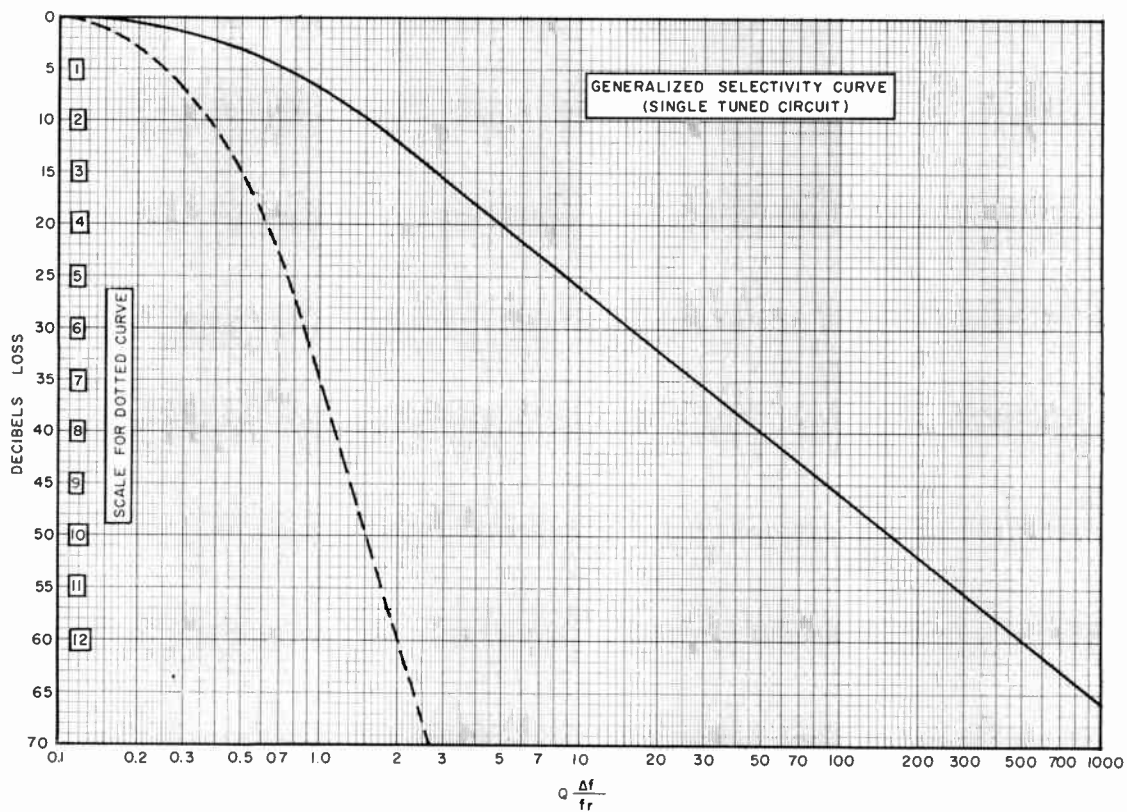

Figure 3-3. Generalized Selectivity Curve



**b. R-F SELECTIVITY**

For minimum spurious responses, it would be best to provide all the selectivity ahead of the amplifiers in the receiver. This is impractical for several reasons. First, the h-f band spans a range of frequencies in which filters having the required selectivity would be large and difficult to tune. Furthermore, they would have such high insertion loss that the noise figure would be seriously degraded. In some applications where the noise figure can be sacrificed and pre-selection is a necessity, r-f filters are used. Usually a single-tuned circuit is used between the antenna and the r-f amplifier grid. The selectivity required to suppress adequately the various spurious signals is provided by a tuned filter between the r-f amplifier and the mixer. The tuned filter may consist of several parallel-tuned LC circuits interconnected by mutual inductance or capacitance. The number of tuned elements required depends on the Q factor, frequency, and attenuation required. A universal selectivity curve relating these factors is a convenient tool and is shown in figure 3-3.

**c. MIXERS**

The r-f signal is translated in frequency from the operating frequency to the intermediate frequency by means of modulation in circuits commonly called mixers. This process has been previously described in detail in chapter 2. The problems encountered in using mixers in receivers is slightly different from those encountered in exciters. Referring to figure 3-4, it can be seen that to translate a desired signal of 1500 kc to an intermediate frequency of 500 kc, a local oscillator having a frequency of 2000 kc can be used. Going further into the example, it can be seen that there are several other signals that can enter the i-f amplifier through the mixer. Some of these signals are listed in figure 3-4. The response at 2500 kc is called the image response and is usually the most troublesome. The higher order responses are attenuated in the mixer tube. Careful selection of a tube and the operating point is necessary to obtain the maximum possible suppression of these responses.

Careful selection of frequencies used in the i-f amplifier is necessary to avoid spurious responses. These responses occur whenever the spurious response frequency coincides with the desired frequency. This type of response is referred to as a crossover, tweet, or birdie, and is illustrated in figure 3-5. A signal of 1001 kc when mixed with an oscillator signal of 1500 kc yields a desired signal of 499 kc. Due to the non-linearity of the mixer, another product is generated which has frequency equal to the difference between the second harmonic of the signal and the oscillator frequencies. Both these signals are passed by the i-f filter because they are only 3 kc apart. These signals will be demodulated by the audio section to yield an audio

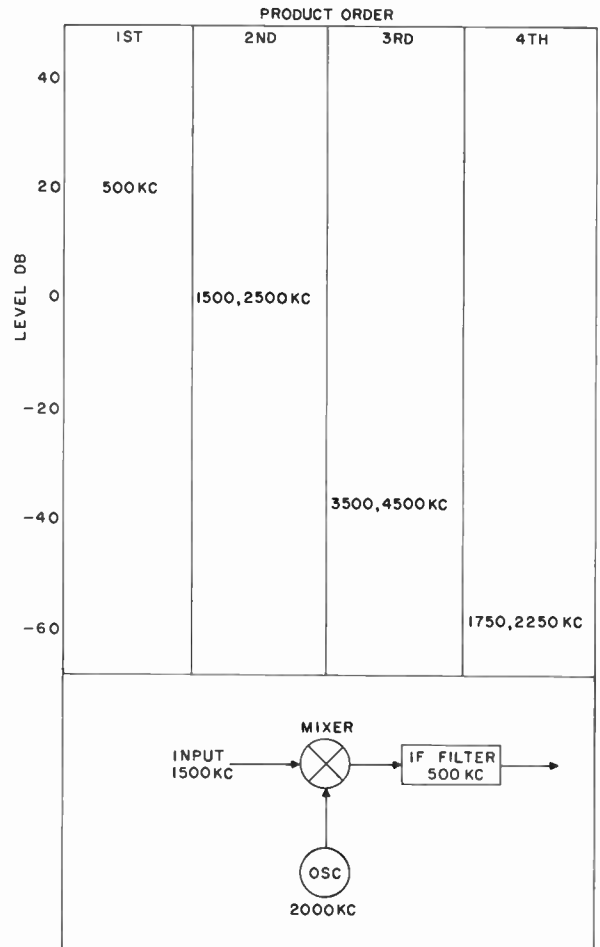

Figure 3-4. Typical Receiver Mixer Spurious Response

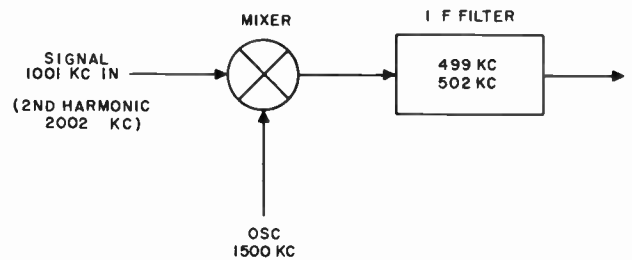

Figure 3-5. Receiver Mixer Crossover Response

output (or tweet) of 3 kc in addition to the usual desired output. Spurious responses are minimized if the intermediate frequency is kept as low as possible consistent with good image rejection.



As the range over which the receiver must operate is increased, it becomes increasingly difficult to find frequency schemes which are reasonably free of spurious responses. In order to keep these responses attenuated when covering the h-f band (2-30 mc), it is necessary to resort to double conversion or the use of two intermediate-frequency sections. Single conversion is then used on the low frequencies, and the second conversion is brought into use at high frequencies.

The use of double conversion makes possible an improvement of frequency stability through the use of a crystal-controlled high-frequency oscillator. Tuning is accomplished by providing a variable first intermediate frequency ganged to the tunable low-frequency oscillator. As shown in table 2-3, the frequency stability of crystal oscillators are many times better than that obtainable from tunable oscillators. Furthermore, the tuning rate remains the same on the high-frequency bands as it is on the low-frequency bands. On the low-frequency band, the r-f amplifier feeds directly into the tunable i-f circuit, retaining the favorable ratio of signal to i-f frequencies.

For the best sensitivity, it is desirable to have as much gain as possible ahead of the mixers. This would insure that the signal level would be strong enough to override completely the noise from the mixer. From the standpoint of strong signals, it is desirable to have low amplification until the selectivity of the receiver is effective. This would keep the level of strong adjacent channel signals from becoming high enough to overload the initial stages of the receiver. These requirements for no amplification ahead of the selective filter for strong signal reception, and high gain in the r-f amplifier for weak signal reception, conflict, and a compromise is necessary.

When a receiver is tuned to a weak signal and a strong signal is present outside the passband of the i-f selective filter, a type of interference known as cross modulation can exist. The selectivity of the r-f section circuits is not so good as the i-f selective filter, and there is a region near the operating frequency in which strong signals are accepted by the r-f section. Due to the sharp selectivity of the i-f circuits, these signals are not passed by the i-f amplifier and, therefore, do not produce automatic gain control voltage. As a result, these large interfering adjacent channel signals are amplified along with the weak desired signal by the r-f amplifier. When these interfering signal voltages are large enough to drive the amplifier and mixer tubes into nonlinear operation, they cause modulation of the desired signal. To minimize the generation of cross-modulation interference, it is necessary to very carefully select the tubes used in the r-f section. The application of automatic gain control bias is helpful since as the desired signal level increases, the gain of the r-f amplifier can be decreased, reducing the amplification of the interfering signals as well as the desired

signal. It is necessary that the tube used in the r-f amplifier retain its linearity with the application of variable bias. It is interesting to note that cross modulation is not as troublesome in single-sideband reception. As an example, if both the undesired adjacent channel signal and the desired signal are conventional AM signals with full carrier, the modulation of the undesired signal is readily transferred to the desired signal through the process of cross modulation. Effectively the modulation on the undesired signal is modulated onto the carrier of the desired signal. This undesired modulation is passed through the receiver as readily as the desired modulation, and considerable interference results. In the case of single-sideband suppressed carrier reception, there is no carrier present to be modulated, and therefore, the modulation is applied to each of the sideband signal components. As the single-sideband signal consists of a number of relatively weak components, this undesired modulation is spread. Furthermore, when the single-sideband signal is demodulated, the interfering signal is merely recovered as noise and is not as troublesome.

### 3. I-F SECTION

The intermediate-frequency section contains the frequency selective filter elements and the principal amplifier stages.

#### a. SELECTIVITY

Consideration must be given to the bandwidth of the receiver as well as the transmitter if the advantages offered by single-sideband communications are to be realized. Optimum receiver selectivity occurs when the noise bandwidth (6 db point) is wide enough to pass the required intelligence, and the skirt bandwidth (60 db point) is narrow enough to reject an unwanted signal in the adjacent communication channel. Extremely steep skirts on the selectivity curves are required to obtain this optimum passband. Ideally, the ratio of the 60 db to 6 db bandwidths should be 1. See curve 3 in figure 3-6. This figure shows the selectivity obtainable from a Collins Mechanical Filter and also from three pairs of double-tune, slightly overcoupled i-f transformers (coil Q's of 150). These curves are superimposed for comparison and show how nearly the mechanical filter selectivity curve approaches the ideal selectivity curve.

Selectivity performance has generally been made by comparing the shape factor, which is the ratio of the 60 db to the 6 db bandwidths. This basis of evaluation has developed from the problem of avoiding adjacent channel interference. While it is customary to define receiver performance in terms of shape factor, it is not always adequate. It can be shown that better shape factors are easier to obtain in wide-band systems than in narrow-band systems. The shape

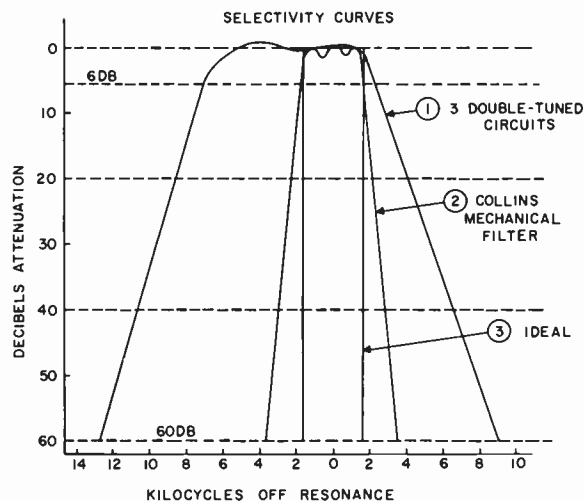

Figure 3-6. Selectivity Comparison

factor is a good comparison if the selectivity curves being compared have the same nose bandwidth. A better method of specifying the performance of a selective system is to define the selectivity in terms of the nose bandwidth and the decibel attenuation per kilocycle on the slopes of the selective curve.

A receiver having an i-f selectivity as in curves 2 or 3 will have a 3 db advantage over a receiver having a selectivity curve as in 1 when receiving an SSB signal whose bandwidth is 3 kc. This is due to both the receiver bandwidth and the input noise power being cut in half. In addition, interference is reduced because the receiver passband is narrow, thus permitting a large percentage of clear signals.

It is desirable to place the selective filter in the circuit ahead of the amplifier stages so that strong adjacent channel signals are attenuated before they can drive amplifier tubes into the overload region. These filters are very similar to the filters used in sideband generators for selecting the desired sideband while rejecting the undesired sideband. Electro-mechanical elements, piezo elements, and inductance capacitance elements can be used in these filters. In one respect, the requirements for these filters are different from those of sideband selecting filters used in the exciter. In order for the receiver to have good rejection to strong adjacent channel signals, it is necessary for the filter used in the receiver to have the ability to reject signals outside the passband to a much higher degree. Attenuation of 60 db or more is necessary for this purpose, and greater rejection is required under some conditions when receiving extremely weak signals. Since single-sideband transmission occupies one-half the bandwidth of a conventional AM. signal, the i-f filter need be only one-half the bandwidth.

## b. AMPLIFICATION

The amplifier portion of the intermediate-frequency section consists of the necessary amplifiers to build up the signal to a level suitable for the demodulator. This amplifier consists of cascaded class A linear amplifier stages using remote cutoff pentode tubes. Tuned circuits may be used to provide the load resistance for these stages. The selectivity of these tuned circuits is helpful in improving the over-all receiver selectivity, especially at frequencies which are down on the skirt of the selectivity curve. Some types of filters have spurious responses outside the passband which can be suppressed in this manner.

## c. AUTOMATIC GAIN CONTROL

A factor to be carefully considered in single-sideband receiver design is the use of automatic gain control. The basic function of the automatic gain control is to keep the signal output of the amplifier constant and thus hold constant audio output for changing signal levels. This automatic gain control is also applied to amplifiers in the r-f section. However, it is important to delay the application of avc voltage to the r-f amplifier until a suitable signal-to-noise ratio is reached. Conventional AM. systems are generally not usable since they operate on the level of the carrier. This carrier is suppressed in single sideband. Automatic gain control systems must be used which obtain their information directly from the modulation envelope. Refer to figure 3-7. This can be done with conventional diode rectifiers and additional amplification. This may be a d-c amplifier or an a-c amplifier using the i-f frequency. Special care must be taken to isolate the agc system from the reinserted carrier since it is a large signal of the same frequency as the i-f signals. This problem can be avoided by developing the agc voltage from the audio signal. In either case, the time constant of the system is very important. The control must be rapid enough to prevent strong signals from coming through too loud at first and yet be slow enough not to follow the syllabic variation of normal speech. One solution to this time constant problem is to use a fast charge, slow discharge type of circuit. Circuits having a charge time of 50 milliseconds and discharge time of 5 seconds have proven successful. Consideration should also be given to dual time constant circuits having a ratio of 100 to 1. Such a circuit allows the rapid signal changes to develop a control voltage across one RC network and the slow signal variation to develop a control voltage across another RC circuit. These two voltages can then be applied in series or to different stages to give the desired control characteristics. Such a dual time constant circuit is similar to a rapid agc system used in conjunction with a manual gain control.

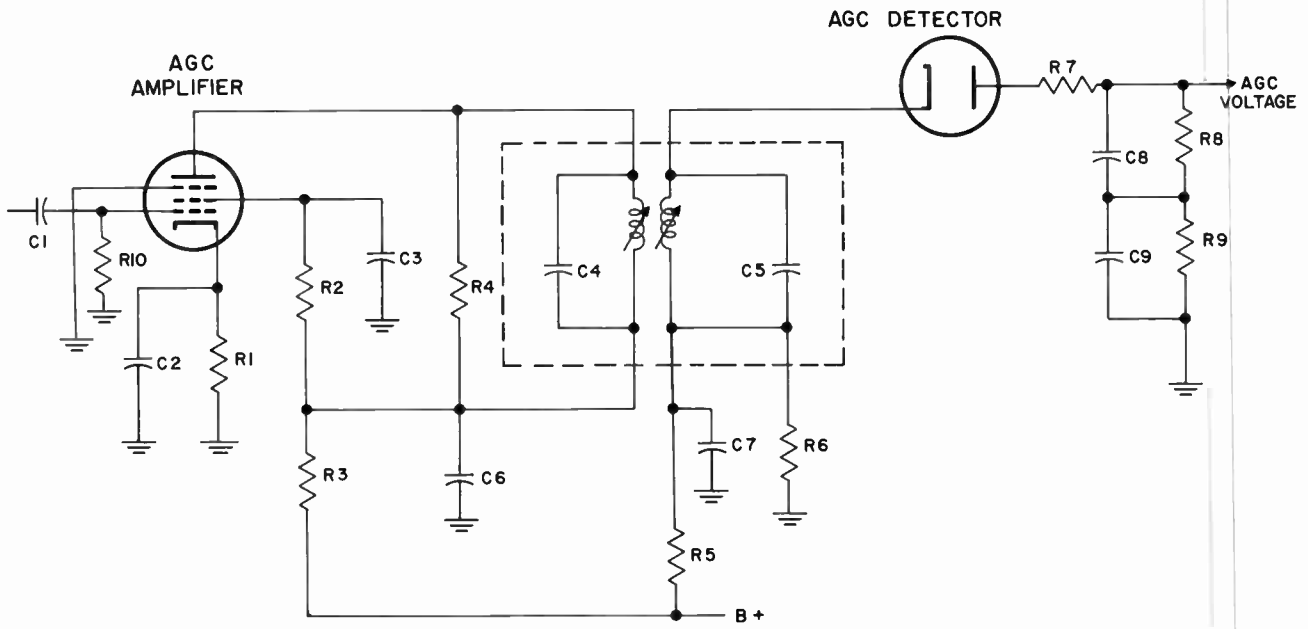

Figure 3-7. AGC Circuit

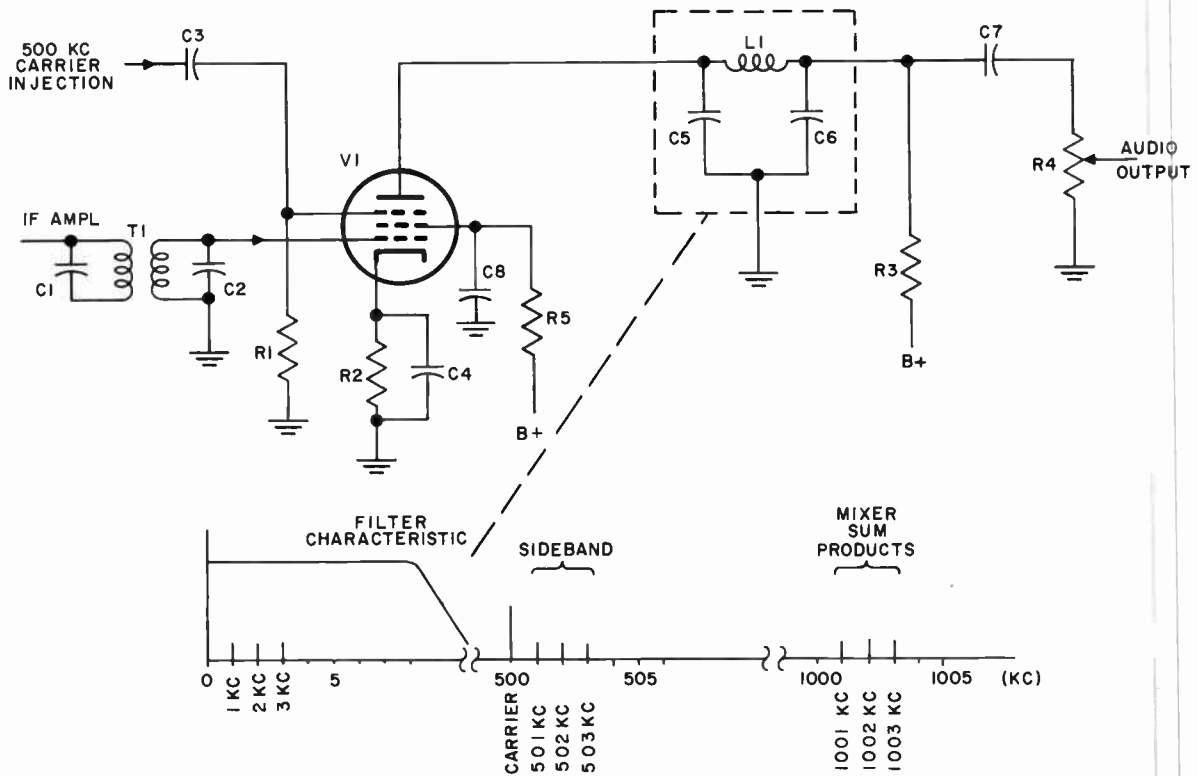

Figure 3-8. Product Demodulator

## 4. AUDIO SECTION

The information carried by the single-sideband signal is recovered and amplified to a level suitable for the audio output circuits. The circuits used to recover this audio intelligence perform the same function as the modulator in the exciter, and therefore, the same circuits can be used. The single-sideband is first combined with a local carrier. The local carrier must have a proper frequency relationship with the sideband components for faithful reproduction of the original audio signal. In the demodulator, the single-sideband signal is used to modulate the local carrier. The demodulator output consists of an audio signal and several r-f outputs. These signals are easily filtered by passing the output of the modulator through an audio low-pass filter. It is necessary to maintain the proper frequency relationship between the sideband signal and the local carrier. If the received signal is an upper sideband, the carrier frequency is below this sideband; and if the received signal is a lower sideband, the carrier frequency is above the sideband signal. If a receiver must be used to receive either upper or lower sidebands, it is necessary to provide a means of changing the relative position of the carrier with respect to the sideband. One way of accomplishing this is to use two sideband filters in the i-f section and a single carrier at the demodulator. The desired sideband is then selected by switching in the proper filter. A single filter can be used for dual sideband reception by providing a means of shifting the local carrier from one side of the i-f filter passband to the other and then retuning the oscillators in the r-f section.

### a. THE PRODUCT DEMODULATOR

Product demodulator circuits are preferred in single-sideband reception, because they minimize intermodulation distortion products present in the audio output signal and do not require large local carrier voltages. Figure 3-8 shows a typical product demodulator. The sideband signal from the i-f amplifier is applied to the control grid of the dual control pentode tube, V1, through transformer T1. The carrier is applied to the other control grid. The desired audio output signal is recovered across resistance R4 in the demodulator plate circuit. Since the plate current of the demodulator is controlled by both grids acting simultaneously, the plate current will contain frequencies equal to the sum and difference between the sideband and carrier frequency. There will also be components of plate current having a frequency equal to the carrier frequency and the sideband frequency. These components are suppressed by means of a low-pass filter (L1, C5, and C6), and the desired audio signal is passed to the audio amplifier. The frequency spectrum presentation in figure 3-8 shows the principal components which will be present in the demodulator plate current. In this example, it is assumed that the sideband signal consists of three components having frequencies of 501, 502, and 503 kc. The carrier frequency is 500 kc. The plate current components consist of three audio-frequency components of 1, 2, and 3 kc as well as the carrier and original sideband frequencies. By constructing a low-pass filter in the plate circuit, consisting of L1, C5, and C6, it is possible to filter out all frequencies except the difference frequencies. By this method the audio frequency has been recovered from the i-f sideband signal.





## CHAPTER 4

# STABILIZED MASTER OSCILLATORS

### 1. TECHNICAL REQUIREMENTS

The frequency accuracy requirements for single-sideband communications are very precise when compared with most other communications systems. A frequency error in carrier reinsertion of 20 cps or less will give good voice reproduction. Errors of only 50 cps result in noticeable distortion, and intelligibility is impaired when the frequency error is 150 cps or greater.

There are significant frequency errors introduced by the propagation medium and by Doppler shifts due to relative motion between transmitter and receiver in aircraft communications. In h-f skywave transmission, the Doppler shifts caused by the motion of the ionosphere introduce frequency shifts of several cycles per second. Doppler shift due to relative motion amounts to one part in  $10^6$  for every 670 miles per hour difference in velocity between the transmitting and receiving station. At a carrier frequency of 20 megacycles, communicating from a jet aircraft to ground, the frequency shift will be approximately 20 cps. Inasmuch as this represents approximately half of the desired maximum frequency error, the errors introduced by the transmitting and receiving equipment must be comparatively small. This dictates a design goal in the vicinity of  $\pm 1/2$  part in  $10^6$  in both ground and aircraft installations.

Present day trends demand that communications be established on prearranged frequencies without searching a portion of the spectrum in order to obtain netting, and therefore, the figure of  $\pm 0.1$  part in  $10^6$  presents the required absolute accuracy rather than short term stability. Most military and some commercial applications demand that operation be obtained on any one of the seven thousand SSB voice channels in the h-f band. A channel frequency generator having an absolute accuracy of  $\pm 0.1$  part in  $10^6$  ( $\pm 0.00001\%$ ) and providing either continuous coverage or channelized coverage in steps no greater than 4 kc is required in many SSB systems.

### 2. AFC VS ABSOLUTE FREQUENCY CONTROL

To meet the stringent frequency control requirements, early h-f single-sideband systems utilized various methods of automatic control of the reinserted carrier at the receiver. Either a pilot tone or carrier was transmitted along with the sideband components, and the receiver frequency was synchronized with the

transmitter frequency. No stabilization of the transmitter frequency was used other than that obtained by using crystal-controlled oscillators.

The first single-sideband radiotelephony system did not use automatic frequency control and was able to accomplish its purpose because the operating frequency of about 60 kc was low enough that oscillators were then available with sufficient stability. Although oscillators have long been available with sufficient frequency stability and accuracy for use in high-frequency single-sideband equipment, these oscillators were bulky, fragile, and limited in frequency channels. They were used principally as laboratory frequency standards. Improvements in the crystal art, development of circuit technique, and new components have made available the means to obtain h-f receivers and transmitters capable of multichannel operation with sufficient frequency accuracy and stability for independent operation of the receiver.

The advantages obtained through the use of independent absolute frequency control are considerable. The bandwidth required for a communication channel is minimized since there need be no allotment for the synchronizing signal and the frequency tolerance. The relationship between transmitter and receiver carriers is absolute and indestructible and is immune to any type or degree of interference, resulting in maximum fidelity of the received signal. Even in the extreme cases where Doppler effects introduce sufficient frequency shift to upset the system making some form of automatic frequency correction necessary, the use of absolute frequency control assures that the bandwidth and, therefore, the interference susceptibility of the afc circuit will be minimized.

### 3. DEVELOPMENT OF FREQUENCY CONTROL

It is of some interest to trace the development of frequency control circuits and the technical and economic forces that caused their evolution. In the early days of radio the tunable LC oscillator provided a simple and serviceable answer to the problem of generating channel frequencies. The lower frequency end of the spectrum and amplitude modulation were in use and the spectrum was not unduly crowded.

Later crowding of the spectrum was alleviated by closer channel spacing and expansion into the higher frequency regions. The increased frequency accuracy required was provided by crystal oscillators, and a

multiplicity of channels was provided by a like number of crystals. In World War II the logistics of delivering the right crystal to the right place at the right time became untenable.

It became apparent to those involved in multichannel equipment that the simple MOPA circuit would no longer provide desired flexibility. A choice of one of hundreds of channels was required at the flick of a switch, guard bands were narrowed, vhf bands were pressed into more extensive service, and under these forces, the multiple crystal synthesizer soon evolved. The principle was simple: the output frequencies of several crystal oscillators were mixed together to produce the desired output frequencies. Each oscillator was provided with a means of selecting one of ten or more crystals so that a large number of channel frequencies may be synthesized. This principle is illustrated in figure 4-1.

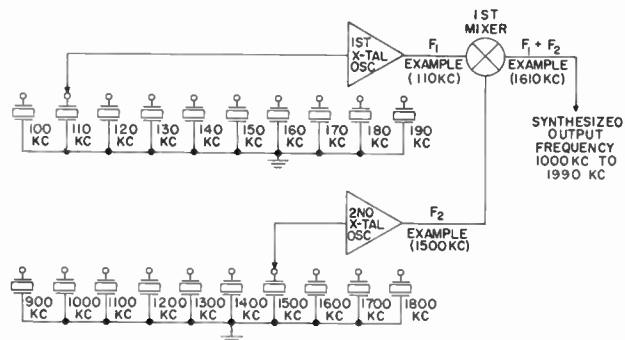

Figure 4-1. Multiple Crystal Frequency Synthesizer

It would be technically and economically unfeasible to maintain all the crystals in a multiple crystal synthesizer to the required accuracy. It would be more practical to place all the stability requirements in one or, at the most, several highly stable oscillators. From this challenge has emerged several operationally satisfactory types of single crystal synthesizers.

#### 4. FREQUENCY SYNTHESIZERS

The frequency synthesizer is basically a circuit in which harmonics and subharmonics of a single standard oscillator are combined to provide a multiplicity of output signals which are all harmonically related to a subharmonic of the standard oscillator. A simple block diagram of such a synthesizer is shown in figure 4-2. A great advantage of this circuit is that the accuracy and stability of the output signal is essentially equal to that of the standard oscillator. The problems involved in building a single frequency oscillator of extreme precision are much simpler than those

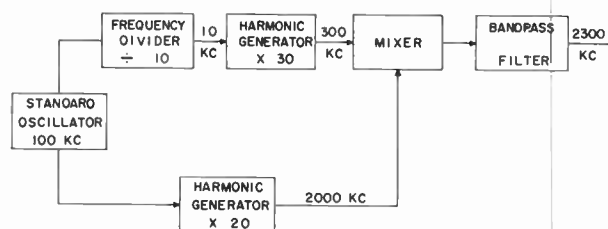

Figure 4-2. Single Crystal Frequency Synthesizer

associated with multifrequency oscillators. Furthermore, as techniques improve, the stability of the synthesizer is readily improved because it is necessary only to replace the standard oscillator to obtain improved precision. The primary difficulty encountered in the design of the frequency synthesizer is the presence of spurious signals generated in the combining mixers. Extensive filtering and extremely careful selection of operating frequencies are required for even the simplest circuits. Spurious frequency problems increase rapidly as the output frequency range increases and the channel spacing decreases.

#### a. HARMONIC GENERATORS

The generation of higher harmonics of signals from low-frequency sources is a rather difficult problem when carried to higher order harmonics. To obtain stable signals which are exact multiples of a low frequency, several schemes can be used. An ordinary class C amplifier can be used for harmonics up to the ninth. Diode clippers yielding square or rectangular waveforms provide much higher harmonics, but have limited amplitude capability. A blocking oscillator synchronized to the reference frequency generates short, sharp pulses which contain considerable harmonic energy. A particularly effective harmonic generator can be devised using a keyed oscillator (see figure 4-3). In this circuit, the low-frequency reference signal is shaped by a clipper to provide an off-on keying signal which is used to turn on and off a free-running oscillator tuned to the approximate frequency of the desired harmonic of the keying signal repetition frequency. The resulting oscillator output is a train of r-f pulses. If the keying signal is sharply defined and the oscillator starts oscillation uniformly, each pulse will begin on the same r-f phase. The output waveform will then be as shown in figure 4-3. The spectrum of this wave consists of a number of components having various amplitudes grouped around the oscillator free-running frequency. The frequency of each component is an exact integral multiple of the keying signal repetition frequency.

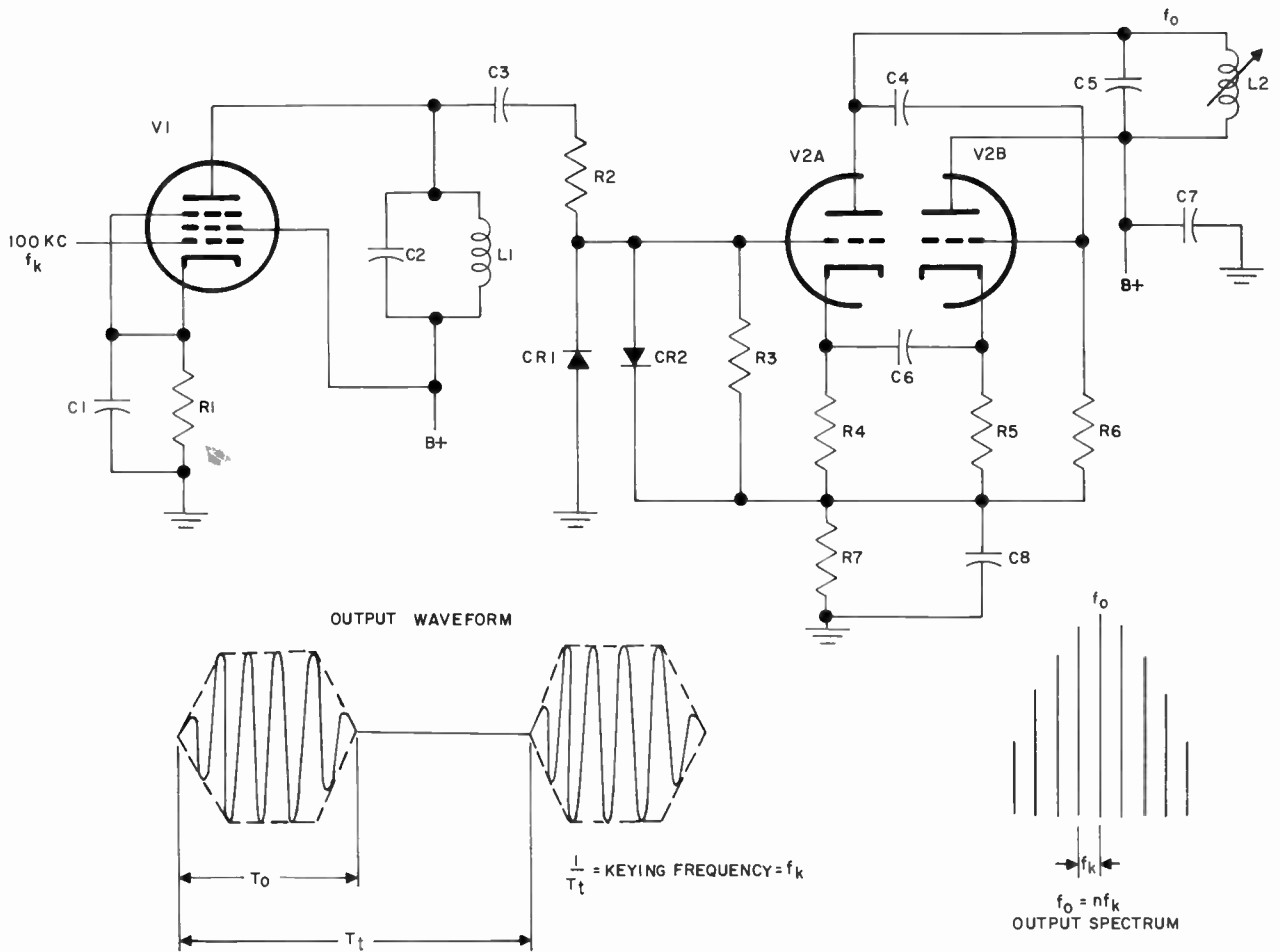

Figure 4-3. Harmonic Generator

**b. HARMONIC FREQUENCY SELECTORS**

The problem now is to select the desired harmonic while rejecting the adjacent undesired harmonic. Such a selection requires very sharp filters, as the frequency range increases and the spacing between harmonics decreases. By means of an additional mixer it is possible to relieve this situation. Such an arrangement is shown in figure 4-4. In this case it is desired to select higher order harmonics from a one kilocycle source. The one kilocycle reference signal is applied to a harmonic generator, the output of which is tuned to approximately 2.4 megacycles. A considerable number of one kilocycle harmonics will be contained within the harmonic generator output. This harmonic generator output is fed to mixer number one along with a local oscillator of 1945 kilocycles. The desired output of 455 kilocycles is selected by means of a mechanical filter having a bandwidth of

less than one kilocycle. This signal is fed to mixer number two along with the output of the same oscillator used to drive mixer number one, and the desired product of 2.400 megacycles is selected in the output filter. To select the adjacent one kilocycle harmonic of the reference signal, the local oscillator is moved to a frequency one kilocycle higher. The desired output is then 2.401 megacycles. The stability of the output signal is dependent entirely upon the stability of the one kilocycle reference signal. The local oscillator frequency accuracy need only be such as to keep the desired 455 kilocycle signal within the passband of the mechanical filter.

**5. THE STABILIZED MASTER OSCILLATOR**

It is possible to retain the advantage of the frequency synthesizer and avoid many of the spurious frequency

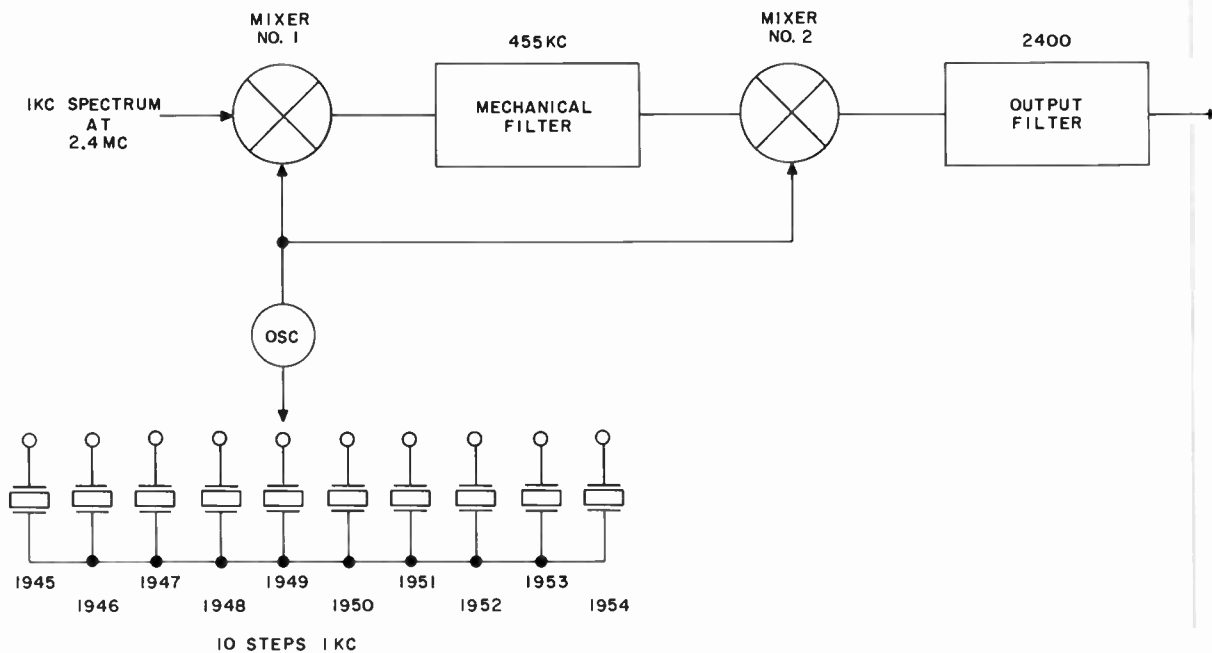

Figure 4-4. Harmonic Frequency Selector

problems by using the synthesizer to provide a reference signal to control the frequency of a variable frequency master oscillator. Such a circuit has come to be known as a stabilized master oscillator (frequently referred to by its initials smo). The basic elements of a stabilized master oscillator circuit are the master oscillator, reactance control, and discriminator (see figure 4-5). The frequency of the master oscillator is determined by the inductance and capacitance of elements L1 and C1. The frequency of oscillation may be manually changed by varying the capacitance of C1, or electronically changed by varying the permeability of the core on which L1 is wound.

#### a. FREQUENCY DISCRIMINATOR

The operation of the frequency discriminator is such to provide a d-c output signal whose amplitude and polarity is determined by the relationship between the input signal frequency and the frequency to which the discriminator is tuned. The frequency discriminator consists of a double-tuned transformer and two diode rectifiers (see figure 4-6). The transformer is used to supply signals to the two rectifiers, the outputs of which are series connected. The coupling capacitor C1 places the center tap of the secondary at the same r-f potential as the plate end of the primary winding. As a result of this connection the voltage applied to

each diode is the sum of one-half the secondary voltages plus the voltage appearing across the primary. The voltage applied to each diode is shown in the vector diagrams below the circuit diagram. The action of the discriminator depends on the fact that the phase of the voltage developed across the secondary of the discriminator transformer will vary as the frequency of the applied signal is varied above and below the transformer resonant frequency. Referring to the vector diagrams (figure 4-6) it can be seen that if the applied signal frequency is equal to the discriminator frequency, the equal voltages are applied to each discriminator diode and the d-c output of the discriminator is zero (figure 4-6B). If the applied frequency is higher than the discriminator frequency, the voltage applied to diode one exceeds that applied to diode two, and the resulting d-c output is positive (figure 4-6A). If the applied signal is lower than the discriminator frequency, the voltage applied to diode one exceeds that applied to diode two, and the resulting d-c output is negative (figure 4-6C). This direct current output is applied to a reactance control device.

#### b. REACTANCE CONTROL

The reactance control provides the means by which the direct current output of the discriminator is made to alter the inductance or capacitance of the

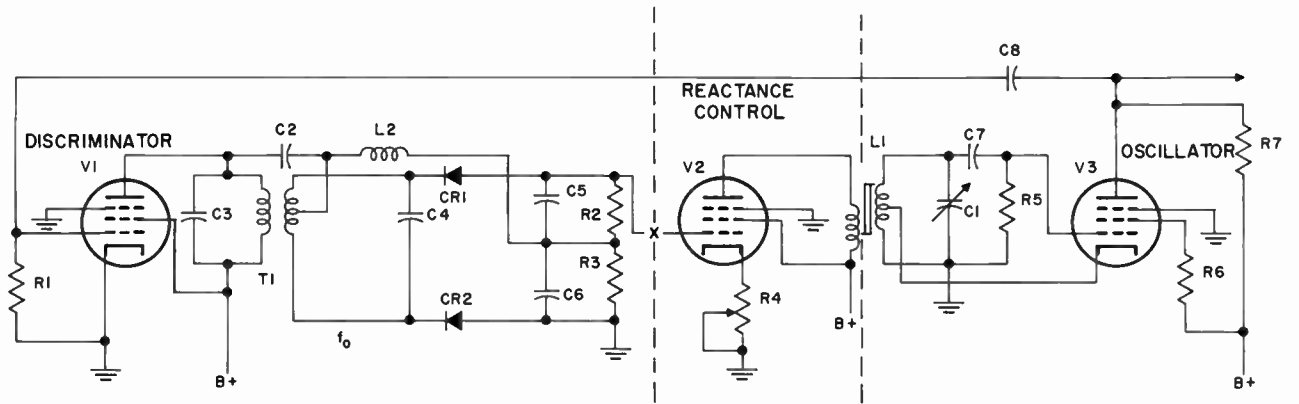

Figure 4-5. Simple Stabilized Master Oscillator with Frequency Discriminator

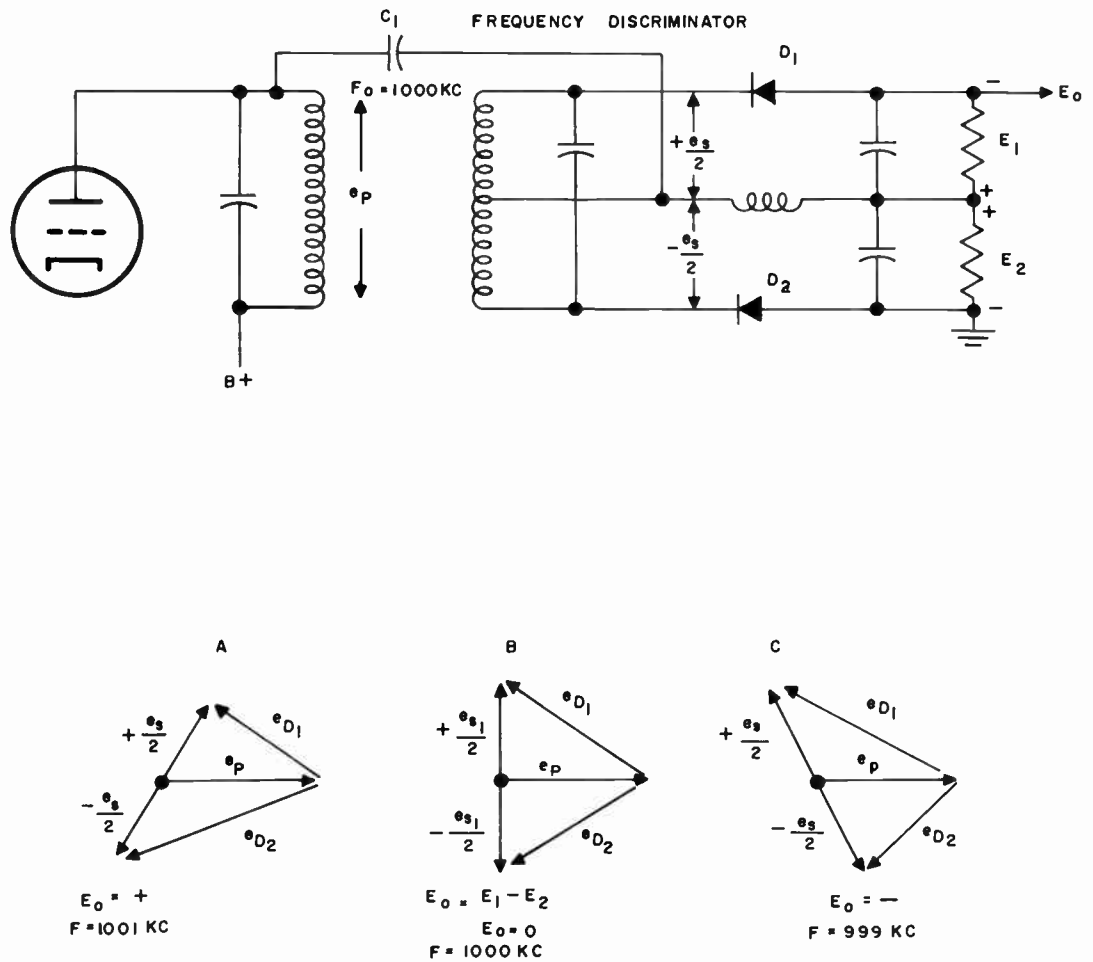

Figure 4-6. Frequency Discriminator



tuning elements of the master oscillator. Devices that have been used for this are reactance tube circuits, saturable reactors (i.e. current-sensitive inductors), voltage-sensitive capacitors, and motor-driven variable capacitors. The saturable reactor is used in the example given as its operation is easily understood. The saturable reactor consists of an inductor wound on a core material having magnetic permeability which is a nonlinear function of the magnetizing force. Such a reactor will have inductance which can be changed by varying the current in its winding or through an auxiliary control winding (see figure 4-7). The change in permeability will be the same for either polarity of magnetizing force. For this reason it is necessary to resort to fixed magnetic bias to obtain inductance change that will reverse polarity when the external magnetizing force polarity reverses. The magnetic bias may be obtained from a permanent magnet or from a bias current in the control winding as is the case in the example shown.

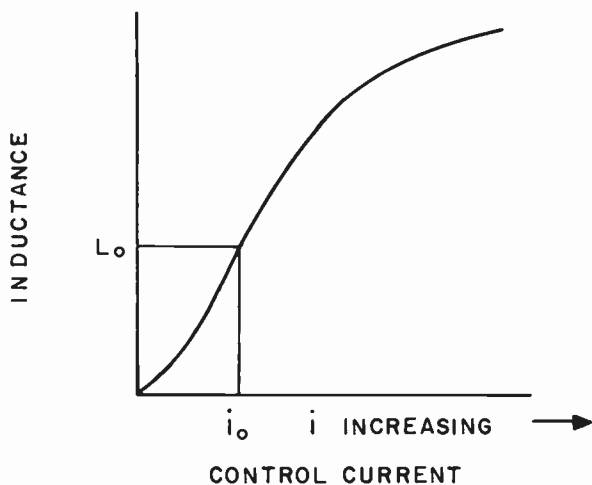

Figure 4-7. Variable Inductor Response Curve

**c. BASIC SMO OPERATION**

The manner in which the stabilized master oscillator circuit operates may be described in two conditions, open-loop and closed-loop. If the control is opened at the grid of the reactance control tube and the tuning of the oscillator varied with the discriminator tuning fixed at  $f_0$ , the output voltage of the discriminator will follow the open-loop curve shown in figure 4-8. In this curve the discriminator voltage is plotted on the vertical scale versus oscillator frequency on the horizontal scale. If the master oscillator frequency differs from the discriminator frequency when the loop is

closed, the master oscillator frequency will be pulled toward the discriminator frequency provided the proper polarity of discriminator and control device has been observed. It is important to realize that perfect correction cannot be achieved unless there is an infinite amount of amplification of the error signal from the discriminator. This can be seen by examining the discriminator output when the loop is closed. If perfect correction had somehow been achieved, the discriminator output would be zero. Obviously such cannot be the case as there must be some signal applied to the reactance control to correct the oscillator frequency error. The closed-loop frequency error will depend on the master oscillator error and on the gain of the control loop. The performance of the closed-loop is shown by the dashed curve in figure 4-8.

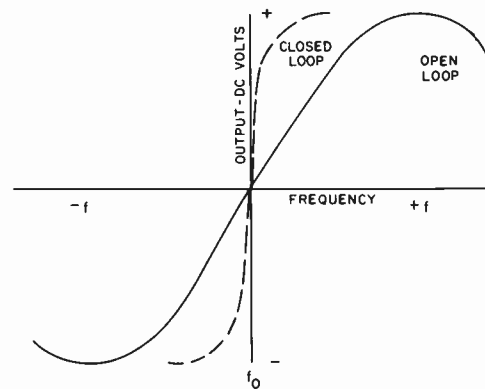

Figure 4-8. Discriminator Frequency Response Curve

In the example shown, the oscillator frequency is effectively compared with the discriminator frequency. There are two fundamental defects in this stabilizing system: (1) there is a residual frequency error and, (2) the stability obtainable from the discriminator is limited. The over-all accuracy of a system using this principle in the h-f band is approximately 50 PPM, insufficient for SSB service.

Both of these shortcomings can be eliminated by utilizing phase deviation rather than frequency deviation error signals in the control-loop. To do this, the frequency discriminator is replaced by a phase discriminator with a reference signal derived from a standard oscillator (see figure 4-9). The stabilized master oscillator is then locked in frequency synchronization with the reference oscillator, and the error signal is the phase angle between the two oscillator voltages. As the frequency of the controlled oscillator drifts away from the reference frequency,

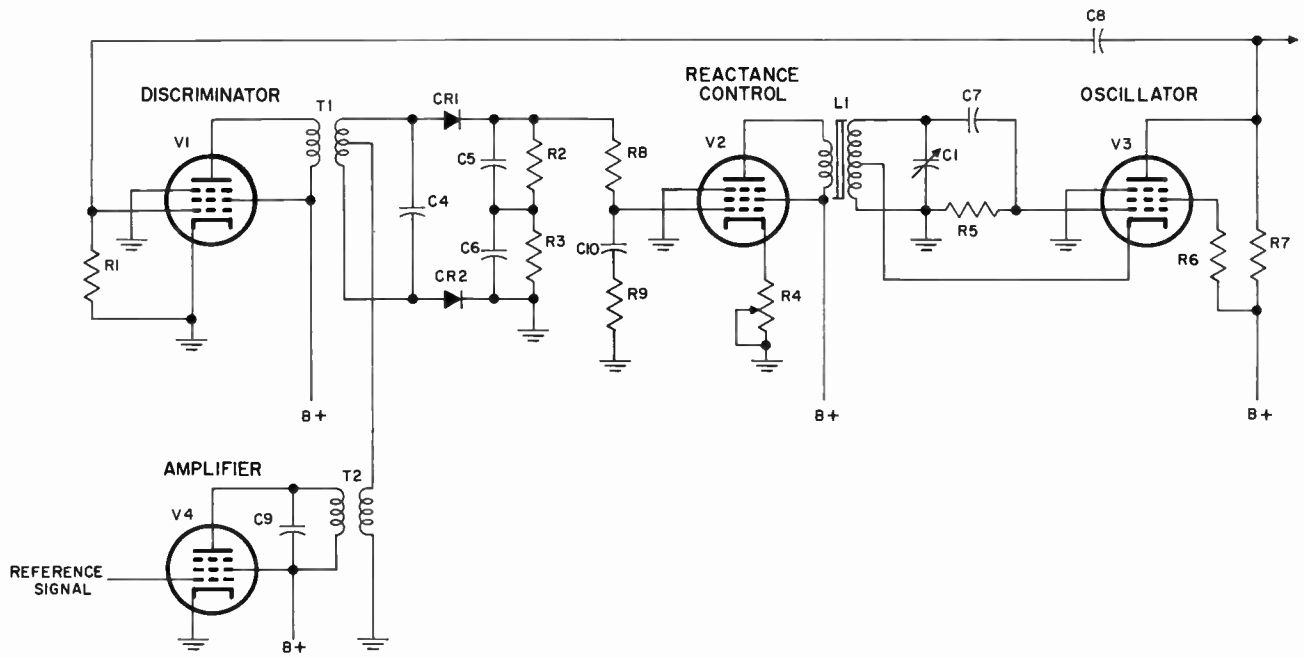

Figure 4-9. Simple Stabilized Master Oscillator with Phase Discriminator

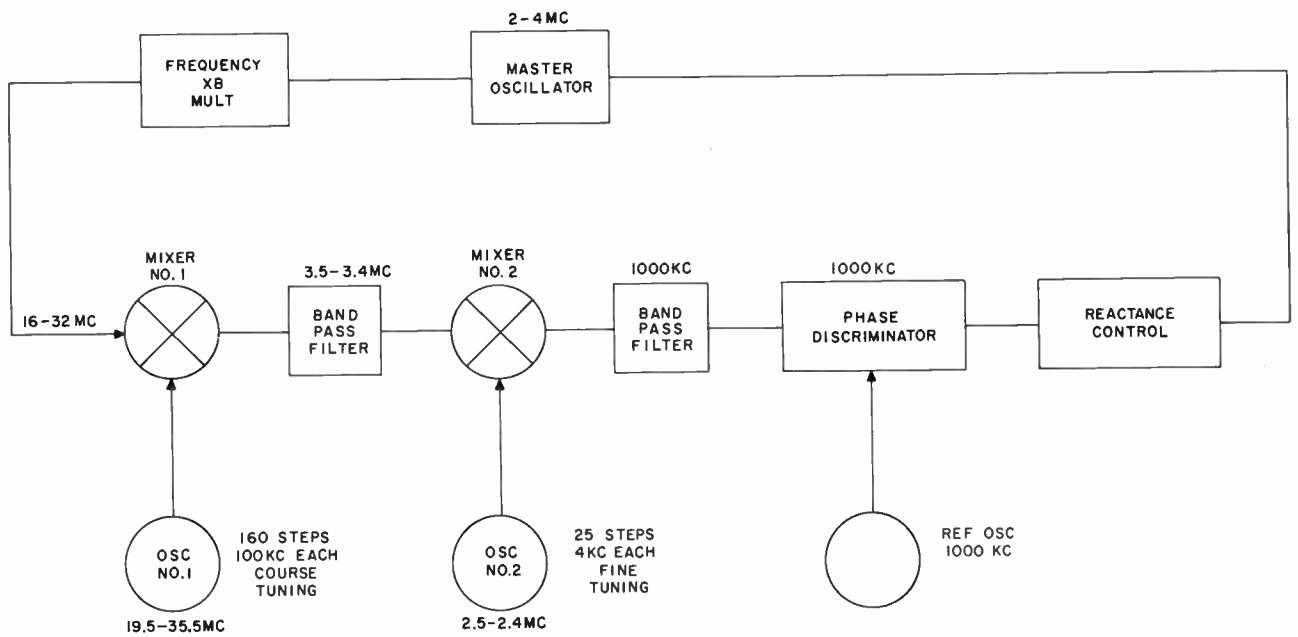

Figure 4-10. Block Diagram of Basic Stabilized Master Oscillator

the phase angle between the two voltages increases to provide the correcting voltage necessary to operate the reactance control. The stability of the system now is completely dependent on the stability of the reference oscillator. The stabilization loop is a feedback system and, as a result, careful attention must be paid to gain and phase shift if stable operation is to be obtained. If the gain at the frequency at which phase shift around the loop is  $180^\circ$  is unity, oscillation will result. The low-pass filter network in the grid of the reactance control tube provides the necessary control of gain to avoid oscillation by reducing the gain at the critical frequency.

#### d. MULTIPLE FREQUENCY SMO OPERATION

Although the stabilized master oscillator described is capable of operating on one frequency only, the circuit can be extended to operate on additional frequencies. To accomplish this, a double-mixer frequency translation system is designed to feed the discriminator (see figure 4-10). By this means, the reference frequency is translated upward in frequency to the range 16 to 32 megacycles. As long as oscillator two is fixed in frequency, the reference signal can be translated to frequencies separated 100 kilocycles between 16.0 and 32.0 megacycles, 16.0, 16.1, 16.2, etc. If the frequency of oscillator one is fixed and oscillator two is varied, the reference signal will be translated in steps of four kilocycles each over an interval of 96 kilocycles, (16,000, 16004, 16008, etc.). In this way

the reference frequency can be translated to any one of 4000 frequencies between 16 and 32 megacycles, spaced four kilocycles apart.

The master oscillator operates from two to four megacycles, this range being best suited to covering the h-f band using both fundamental and harmonics. For synchronization with the reference, the master oscillator output frequency is multiplied by eight so that the master oscillator signal frequency range corresponds to the reference frequency range. Under these conditions the master oscillator fundamental output frequency will be stabilized on 1/2 kilocycle intervals over the range two to four megacycles. More channels can be synthesized by adding another mixer stage or by increasing the number of steps used at each mixer.

The accuracy of the stabilization obtained by the system described above depends on the accuracy of the frequencies used at the translating mixers. To obtain the greatest accuracy, all of these frequencies are derived from a single source; a standard reference oscillator of extremely high accuracy and having great stability.

The use of a phase error signal in the control loop insures that the residual error of the stabilized oscillator will be measured in terms of degrees of phase angle between controlled and reference oscillators rather than cycles of frequency difference if only a frequency discriminator were used.

## CHAPTER 5 FREQUENCY STANDARDS

### 1. INTRODUCTION

Because frequency is defined in terms of cycles per second or events per unit time, frequency control and timekeeping are inseparable. Any measurement of frequency can be only as accurate as the time unit used. Thus in order to determine the accuracy of a frequency standard, its period of oscillation must be compared to a time standard of known accuracy. The best secondary time standard consists of a frequency standard which drives a cycle counter or clock. The accuracy of this time standard can be then determined by comparing it with the primary time standard which is the mean solar day, that is, the time required for the earth to complete one revolution about its axis.

Time measurement has always been based on astronomical phenomena. Days and years are determined by the relative motion of the earth with respect to the sun. However, to co-ordinate events and to make precise measurements of physical phenomena, a device that can divide the day into accurate, shorter intervals is required. The search for accurate timing devices started in prehistoric time. It followed two separate lines: first, those devices which derive time directly from astronomical observations; and second, independent mechanisms and devices for measuring time intervals. The first type started with the casual observation of the position of the sun, progressed to the sundial, and culminated in the modern Zenith tube. The second type started with devices based on restricted flow. The first of these were the noncycling types, such as the sand clocks, water clocks, time candles, and time lamps. Typically, sand clocks or hourglasses had inaccuracies of 4,000 seconds per day. These were followed by automatic recycling types using escapement mechanisms controlled by friction and inertia, such as the Verge and Foliot balance. Clocks of this type varied 1,000 seconds per day. With the discovery of resonance phenomena, that is, an oscillating system in which energy is alternately stored in the form of kinetic and potential energy, much more accurate time measurements were made possible. The first device using resonance phenomena to measure time was the pendulum clock which ultimately attained an accuracy of .002 second per day. The pendulum was followed by the hairspring and balance which attained an accuracy of .2 second per day, and the electrically activated tuning fork which attained an accuracy of .008 second per day. The quartz crystal, which followed the tuning fork as the resonator in time and frequency standards, has an

accuracy of 1 part in  $10^9$  per day or .0001 second per day and is the most widely used control element in modern time and frequency standards. Due to variations in the rotation of the earth, the short-term accuracy of the quartz crystal is better than that of the mean solar day. Seasonal variations of several milliseconds and yearly variations as great as 1.6 seconds in the mean solar day have been observed. On a long-term basis, however, the length of the mean solar day is increasing at the rate of only .00164 second per century. In order to achieve long-term accuracy, the standard must remain in constant operation; and since mechanical devices such as the quartz crystal clock will run for only a few years, they will probably not replace astronomical phenomena as a primary time standard. The most recent development is the use of devices based on atomic or molecular resonance. These have attained short-term accuracy equal to that of the quartz crystal, but their long-term accuracy is expected to be considerably better.

Technical and economic forces have led to the development of more and more accurate frequency control circuits. In the early days of radio, the tunable LC oscillator provided a simple and serviceable answer to the problem of generating channel frequencies. The lower frequency end of the spectrum and amplitude modulation were used, and the spectrum was not unduly crowded. Later crowding of the spectrum led to closer channel spacing and expansion into the higher frequency regions. This in turn required more accurate frequency control. Crystal oscillators provided the required accuracy, but many crystals were required to provide the required number of channels. During World War II, it became almost impossible to deliver the right crystal to the right place at the right time. After the war, users of communication equipment demanded a choice of hundreds of channels at the flick of a switch. In order to meet the demand for spectrum space, guard bands were narrowed, and the vhf bands were put to more extensive use. All of these forces led to the development of the multiple-crystal frequency synthesizer (figure 5-1) in which the output frequencies of several crystal oscillators were mixed together to produce the desired output frequencies, providing many more channels than the number of crystals used. Present crowding of the spectrum and increasing demand for communication channels now indicate that some method of further decreasing the spectrum space required for each channel must be found. Single sideband is a solution to this problem. The use of single

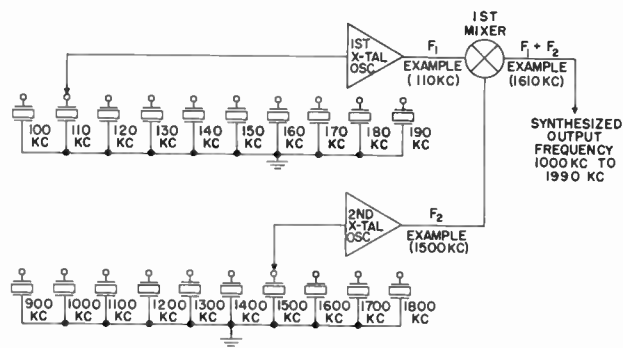

Figure 5-1. Multiple-Crystal Frequency Synthesizer

sideband, however, requires that channel frequencies be maintained within  $\pm 1/2$  part per million. Maintaining all of the crystals in a multiple-crystal synthesizer to the required accuracy is impractical; therefore, all the stability requirements must be concentrated in one or, at the most, several highly stable oscillators. The solution to this problem is the single-crystal frequency synthesizer. Figure 5-2 is a block

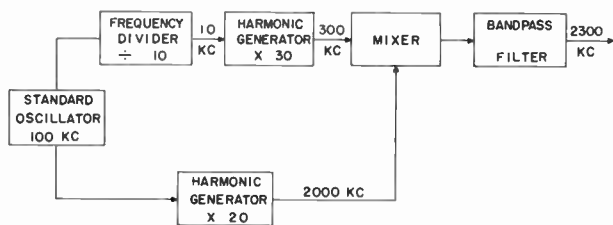

Figure 5-2. Single-Crystal Frequency Synthesizer

diagram of a typical single-crystal frequency synthesizer. Basically it is a circuit in which harmonics and subharmonics of a single standard oscillator are combined to provide a number of output signals which are all harmonically related to a subharmonic of the standard oscillator. In this system the accuracy and stability of the output signals are equal to that of the standard oscillator and as techniques improve, the stability of the synthesizer can be improved by replacing only the standard oscillator.

The best laboratory standards now available have aging rates of approximately 1 part in  $10^9$  per month and short-term variations of several parts in  $10^{11}$ . Operational standards have several orders of magnitude greater instability. Typical examples are shown

in the curves of figures 5-3 and 5-4. In figure 5-3, the dots represent errors derived from direct time comparison with WWV, and the crosses represent errors derived from time comparison with WWV after correction according to WWV's time correction bulletin.

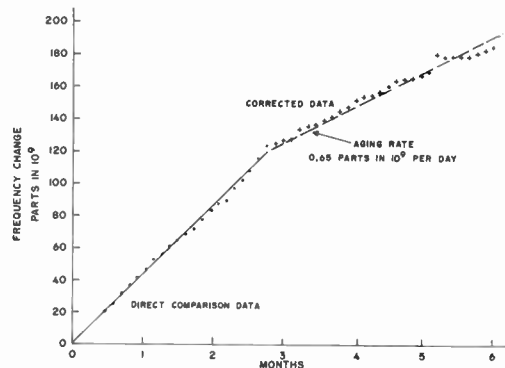

Figure 5-3. Typical Long-Term Stability

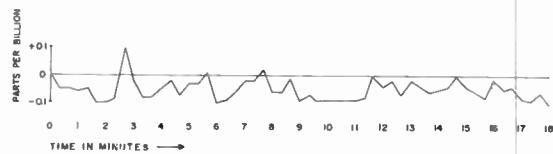

Figure 5-4. Typical Short-Term Stability

## 2. DETERIORATION OF GENERATED FREQUENCY

Although frequency standards in use today have accuracies of 1 part in  $10^8$  or better, serious errors can be introduced in the transmission and reception of the signal. These errors are caused by Doppler shift, shifts due to propagation characteristics, and shifts due to equipment circuitry.

### a. EFFECT OF DOPPLER SHIFT

Relative motion between receiving and transmitting stations causes premature or delayed reception of individual cycles of the transmitted signal. Since the speed of propagation of radio signals is equal to the speed of light or 186,000 miles per second, cycles of the transmitted signal will be received 1 millisecond earlier or later for every 186 miles of change in transmission path length. A change in transmission path length at a rate of 670 miles per hour results in



a frequency shift due to Doppler effect of 1 part in  $10^6$ . Figure 5-5 shows an aircraft approaching a radio transmitter. In the formula shown in the figure,  $v$  = velocity of the aircraft and  $C$  = speed of light. If the aircraft is approaching at a velocity of 670 miles per hour or 0.186 miles per second, then the ratio  $v/C = 0.186/186,000$  or  $1/1,000,000$ . Thus the ratio of frequency change to transmitted frequency ( $\Delta f/f$ ) is  $1/10^6$ . If the transmitter is operating on a frequency of 10 mc, then the frequency as received at the aircraft will be 10 mc plus 10 cps. If the transmitter were also in an aircraft flying toward the first aircraft at a velocity of 670 miles per hour, the frequency error would be doubled because the relative velocity would be the sum of the velocities of the two aircraft or 1,340 miles per hour. In ship to ship communication or in communication between ground vehicles, Doppler shifts of 1 part in  $10^7$  or greater are possible. Doppler shifts due to antenna sway caused by the pitch and roll of a ship are of the order of  $\pm 3$  parts in  $10^9$ . Extreme examples of Doppler shift are the case of back-pack radios in which the Doppler shift while the operator is walking is 5 parts in  $10^9$ , and the case of the IGY satellite, where signals transmitted by the satellite will suffer frequency shifts of up to 30 parts per million. Signal transit time in the case of a jet aircraft traveling 670 miles per hour and communicating with a fixed station changes at the rate of 3.5 milliseconds per hour, and in the case of battleships communicating with each other the signal transit time can change 0.2 milliseconds per hour.

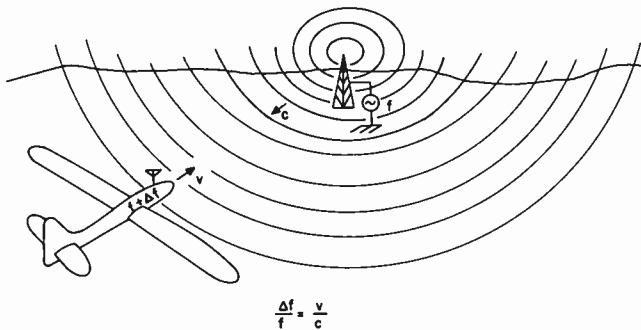

Figure 5-5. Doppler Frequency Shift in Aircraft

### b. EFFECT OF PROPAGATION CHARACTERISTICS

Low-frequency waves tend to follow the curvature of the earth, and the length of the transmission path is not seriously affected by atmospheric or ground conditions. Errors introduced by the propagation medium at low frequencies are only about  $\pm 3$  parts in  $10^9$  in frequency and  $\pm 40$  microseconds in transit time. In the high-frequency bands, however, reflections from the ionosphere are used for long-range communications.

Frequency variations of  $\pm 2$  parts in  $10^7$  and transit time variations of  $\pm 1$  or 2 milliseconds can be introduced by changes in path length due to movement of the reflection point in the ionized layer and variations of the skip distance. Errors introduced in vhf and uhf scatter propagation are not well known, but available data indicate that they may be several parts in  $10^8$  in frequency and several hundred microseconds in transit time.

### c. EFFECTS OF EQUIPMENT CIRCUITRY

Transmitter or receiver circuit elements when subjected to mechanical vibration or temperature changes can cause temporary frequency shifts by temporarily shifting the phase of the signal. Phase advancement of 360 degrees in one second adds 1 cycle per second to the frequency of a signal. Thus, a phase shift change of 1 degree per second imposed on a 100 kilocycle signal would cause a temporary frequency shift of 3 parts in  $10^8$ . Mechanical vibration of tuning elements causes phase shifts which even under laboratory conditions may cause frequency shifts as great as 1 part in  $10^8$ . Under operating conditions severe mechanical vibration and temperature changes may be encountered which, if not compensated for, would cause excessive frequency errors. Therefore, in precision work, mechanically rigid components must be used in all tuned circuits.

## 3. MEASUREMENT TECHNIQUES

### a. TIME COMPARISON

Accurate comparisons of time and frequency using radio communication are difficult because of variations in propagating mediums. Present methods are based on time measurements taken over a long period so that these variations average out. By taking time measurements from WWV over a period of 20 days, accuracies of 1 part in  $10^9$  can be attained in the 2 mc to 30 mc bands. At 16 kc, the same accuracy can be attained in approximately one day because the variations in the propagating medium have less effect on the low-frequency signal. Figures 5-6 and 5-7 are block diagrams of time comparison systems suitable for fixed station use. On shipboard errors introduced by changes in signal transit time due to relative motion between stations must be taken into account to achieve the same accuracies as are attained in fixed station use.

Figure 5-6 shows a system using an aural indication of synchronization of a clock, controlled by a local oscillator, with the time signals transmitted by WWV. The oscillator operates at 100 kc; this frequency is divided by 100, and the resulting 1000 cps signal operates the synchronous clock. The clock operates a switch which closes once each second. A receiver tuned to WWV's signal is used to detect the

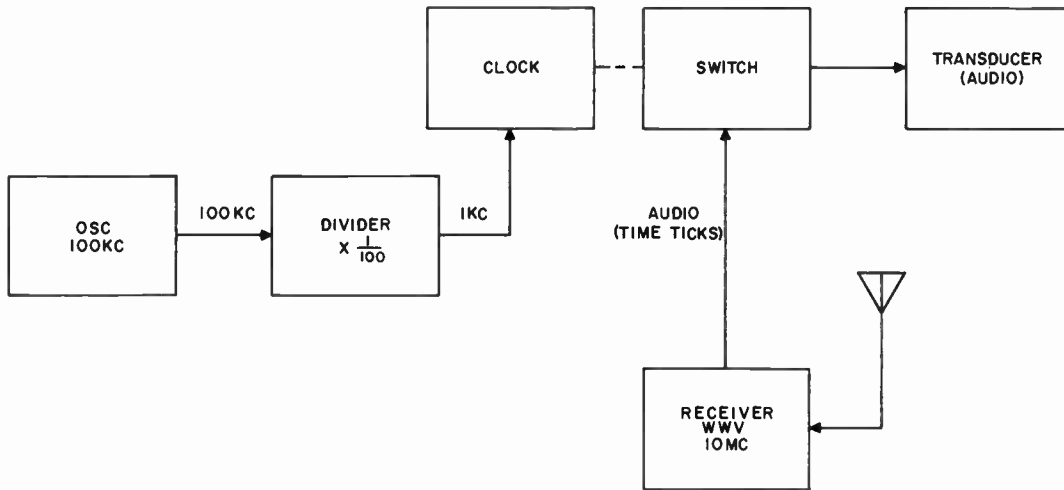

Figure 5-6. Time Comparison System, Aural Indication

time signals which are in the form of clock ticks. These clock ticks consist of 5 cycles of a 1000 cps tone, transmitted at the rate of one tick per second. The ticks are coupled to a loud-speaker through the clock operated switch which can be adjusted to close each time a tick is received. Once adjusted, the switch will continue to close in synchronism with the reception of the clock ticks as long as the frequency of the oscillator remains exactly 100 kc. If the oscillator frequency changes, the speed of the clock will also change, and the switch closures will slowly drift out of synchronization. A calibrated dial is used to adjust the synchronization of the switch daily to permit only

the last cycle of the clock tick to pass. The stability of the oscillator can be determined to an accuracy of 12 parts in  $10^8$  by calculations based on the amount of adjustment required in one day. The accuracy of measurement can be increased to 1.2 parts in  $10^9$  by basing the calculations on the amount of adjustment required in a period of 100 days.

Figure 5-7 is a block diagram of a chronoscope. The 100 kc signal from the oscillator is divided to 10 cps and applied to the vertical and horizontal plates of the cathode-ray tube through phase shifting networks to produce a circular trace on the scope screen. A 1

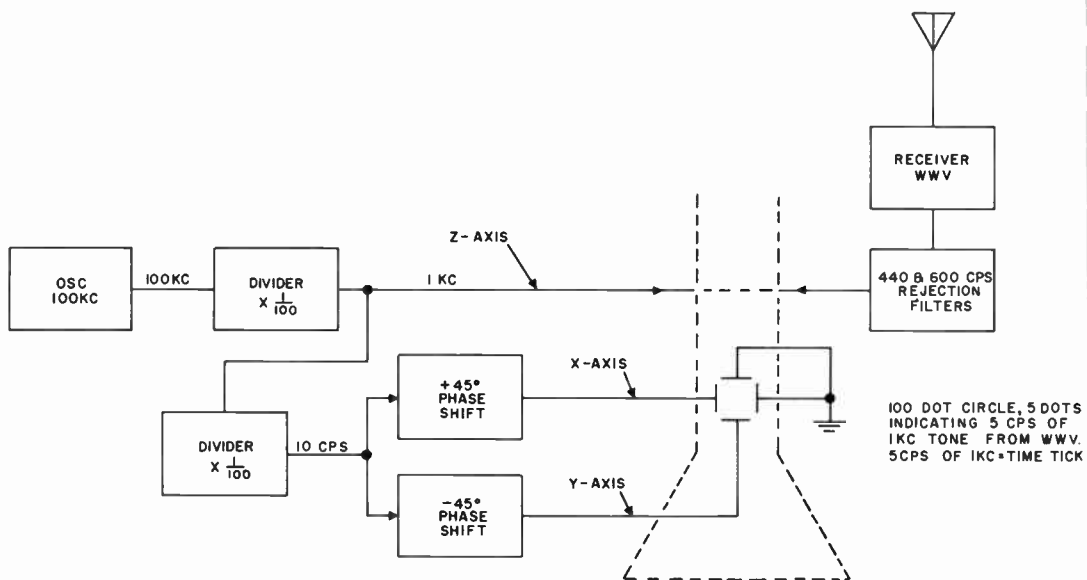

Figure 5-7. Time Comparison System, Visual Indication, Chronoscope

kc signal derived from the same oscillator is applied to the intensity control grid to break this solid circle into 100 dots. A receiver tuned to WWV supplies the clock ticks to the same control grid producing five additional dots somewhere on the 100 dot circle depending upon the relative phase of the 1 kc signal from the oscillator and the 5 cycles of 1 kc which comprise the clock tick. If the phase relationship remains constant, the 5 dot pattern on the screen will remain fixed; but if the phase changes, the pattern will move around the 100 dot circle at a rate determined by the rate of phase change. The rate of movement in turn indicates the magnitude of frequency error. With this system the frequency of the oscillator can be determined to an accuracy of 1.2 parts in  $10^8$  in one day or 1.2 parts in  $10^9$  in 10 days.

**b. FREQUENCY INTERCOMPARISON**

Short-term stabilities of oscillators can be determined by intercomparison of the frequencies of two or more oscillators. When only two oscillators are compared, only the relative stabilities of the oscillators with respect to each other can be determined. Statistical data which will indicate the short-term stability of an individual oscillator can be obtained by inter-comparing the frequencies of three or more oscillators two at a time.

Figure 5-8 illustrates a system using two oscillators operating at frequencies differing by, nominally, 1 cps. One oscillator operates at 1 mc, and the other operates at 1 mc plus 1 cps.

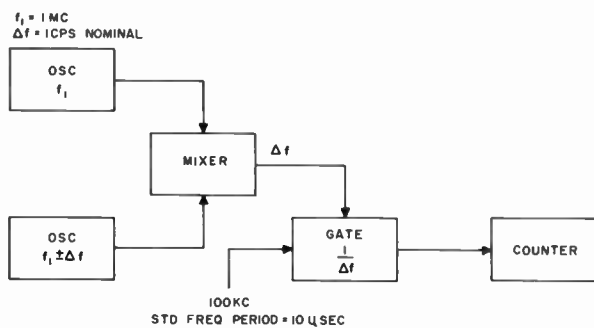

Figure 5-8. Frequency Intercomparison System Using Frequency Counter

Their outputs are mixed and the difference frequency, 1 cps, is used to control a gate circuit. A 100 kc standard frequency is applied to the gate and the number of cycles of this standard frequency which are counted at the output indicates the length of time the gate is open. This in turn is the period of the difference frequency controlling the gate. Thus if the difference frequency is exactly 1 cycle per second, the

gate will be open exactly 1 second, and the counter will count exactly 100,000 cycles. If the difference frequency is more than 1 cycle per second, the counter will count less than  $10^5$  cycles, and if the difference frequency is less than 1 cycle per second, the counter will count more than  $10^5$  cycles. This system will indicate the relative stability of one oscillator with respect to the other to 1 part in  $10^{11}$ .

Figure 5-9 illustrates a system using two oscillators adjusted to operate at frequencies differing by 0.6 cps. The frequency of each oscillator is multiplied by 100 before mixing so that the resultant beat note is 60 cps. This beat note is recorded on a power line frequency recorder to give a continuous indication of relative stability between the two oscillators with an accuracy of 5 parts in  $10^{10}$ .

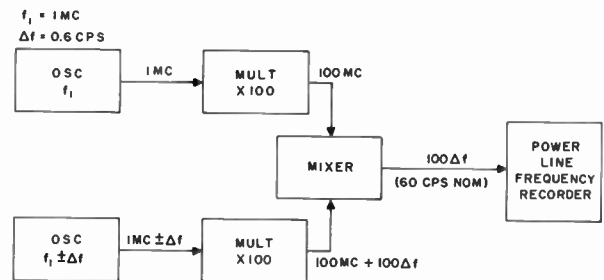

Figure 5-9. Frequency Intercomparison System Using Power Line Frequency Recorder

**c. PHASE INTERCOMPARISON**

Figure 5-10 illustrates a system wherein the relative phase of two oscillators operating at the same frequency is measured. If the relative phase as indicated by the phase comparison meter changes 360 degrees in one second, then the difference in frequency of one oscillator with respect to the other is 1 cps;

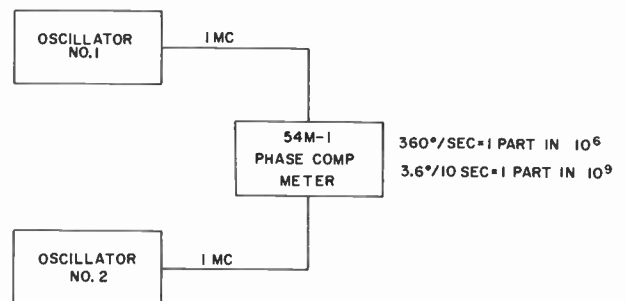

Figure 5-10. Phase Intercomparison System

QUARTZ CRYSTAL MODEL  
SHOWING COMMONLY USED  
CUTS OF QUARTZ PLATES  
IN THEIR RESPECTIVE  
ORIENTATION.

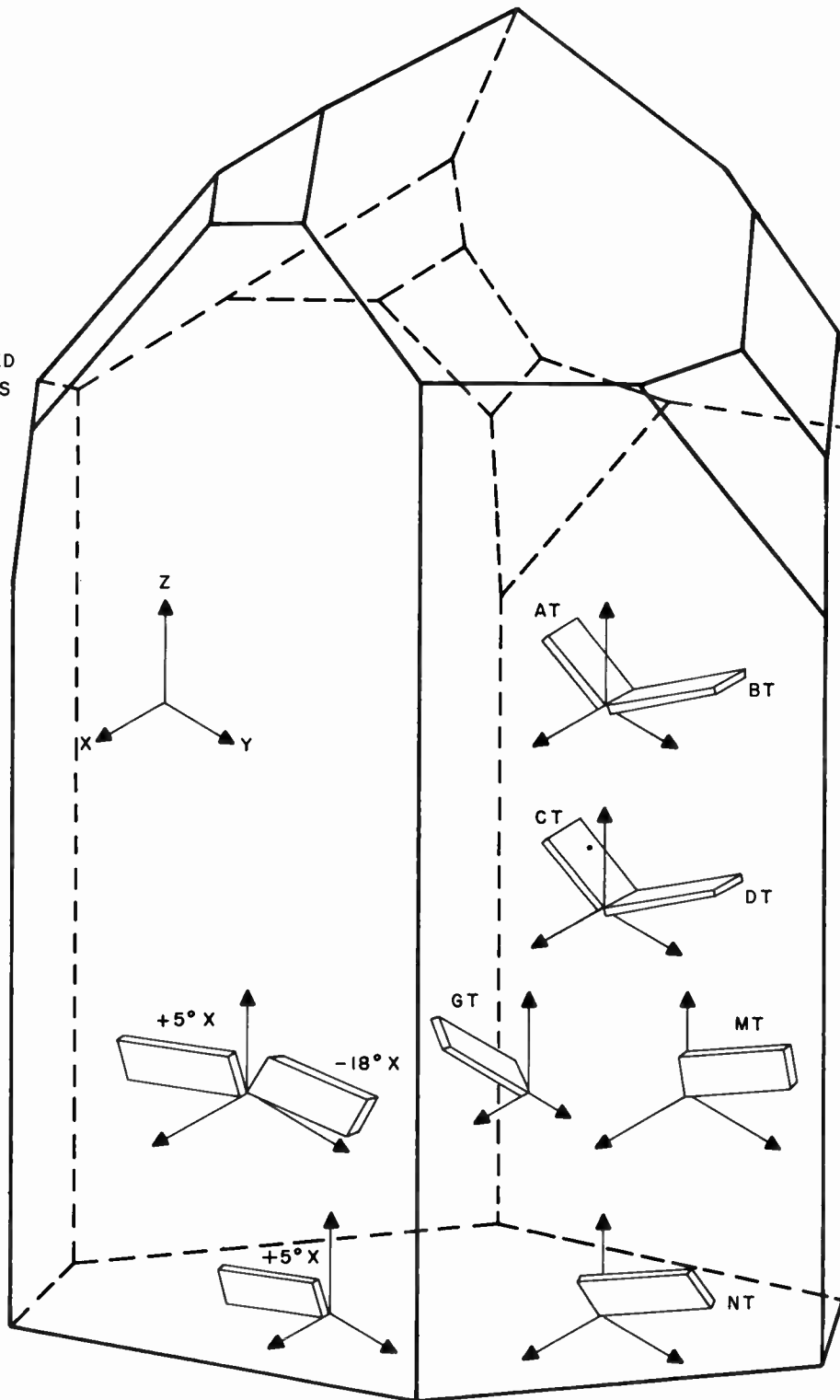

Figure 5-11. Quartz Crystal Showing Types of Cuts

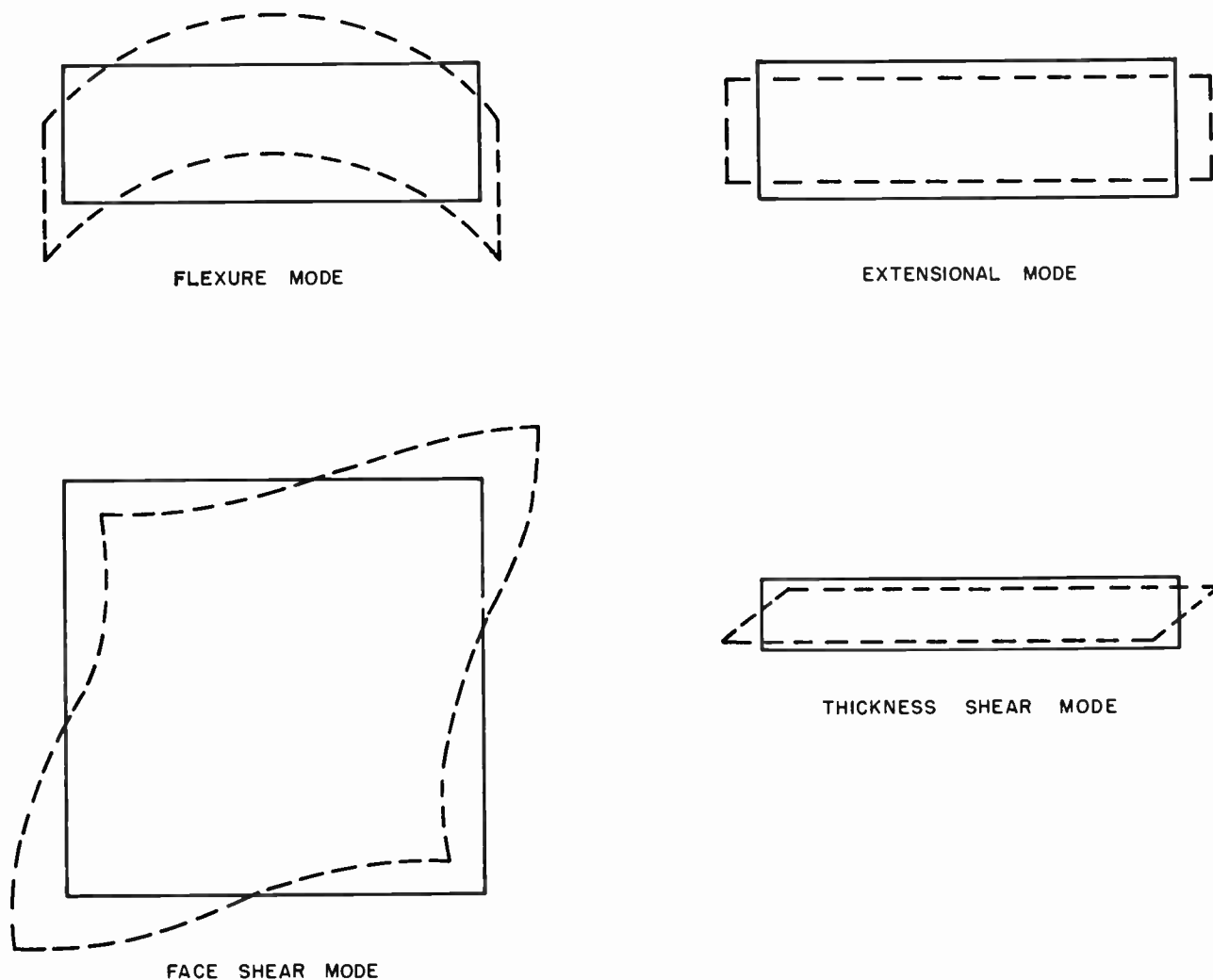

Figure 5-12. Modes of Vibration

or if the oscillators are operating on a nominal frequency of 1 mc, the difference is 1 part in  $10^6$ . If the phase changes only 3.6 degrees in 10 seconds, the difference is only 1 part in  $10^9$ . Thus, small differences in frequency can be measured and recorded. The resulting record will be an indication of the relative short-term stabilities of the oscillators.

#### 4. QUARTZ RESONATOR THEORY

##### a. CONSTRUCTION AND OPERATION

Quartz resonators are electromechanical devices having extremely high Q's and stable resonant frequencies and are used as resonant circuits in electronic oscillators and filters. Quartz is a piezo electric material, that is, mechanical deformation of the quartz causes an electric charge to appear on certain

faces, and conversely, application of voltage across the quartz causes a mechanical deformation. The quartz resonator unit generally consists of a crystal-line quartz bar or plate provided with electrodes and suitably mounted in a sealed holder. The mounting structure supports the bar or plate at nodal points in its vibrational pattern so that damping of the mechanical vibrations with resultant degradation of Q is minimized. The bar or plate is cut from the mother crystal at a carefully controlled angle with respect to the crystallographic axes and finished to close dimensional tolerances. The quartz bar or plate has a mechanical resonant frequency determined by its dimensions. This resonant frequency changes with temperature, but by properly orienting the angle at which the blank is cut from the mother crystal, this temperature coefficient can be minimized. Commonly used orientations have been given designations, such as AT, CT, and DT cuts. Figure 5-11 illustrates the



relationship between these cuts and the crystallographic axes. Proper orientation of electrodes on the quartz plate provides electric coupling to its mechanical resonance. The electrodes usually consist of a metal plating which is deposited directly on the surface of the quartz plate. Connections from these electrodes to external circuits are usually made through the mounting structure. After the blank has been cut from the mother crystal, it is reduced in thickness by successive stages of lapping until it is within etching range of the specified frequency. After thorough cleaning, the blank is etched to final frequency for pressure-mounting or to the preplating frequency if the electrodes are to be metal plated and the unit wire mounted. After the etching process, the blank is again thoroughly cleaned. After cleaning, the blank is base plated, recleaned, and wire mounted in a clean, moisture free, hermetically sealed holder designed to support the crystal unit against the effects of vibration. After mounting, the metal plated quartz plate is adjusted to the precise final frequency by additional plating. Typical metals used for plating are gold, silver, aluminum, and nickel. Silver is the metal most often used. Quartz crystal units vibrate in different modes depending upon the principal resonant frequency, the three most common modes being flexure, extensional, and shear. In high-frequency precision type units, the shear mode is used. Figure 5-12 illustrates the various modes of vibration.

**b. CHARACTERISTICS**

Two terminal plated quartz resonators may be represented by the electrical equivalent circuit shown in figure 5-13. The series arm consisting of  $R_1$ ,  $L_1$ , and  $C_1$  represents the motional impedance of the

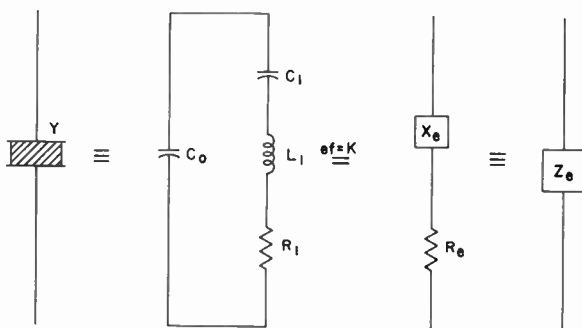

Figure 5-13. Quartz Resonator Equivalent Circuit

quartz plate while  $C_0$  represents the electrode capacitance,  $C_2$ , plus the holder capacitance,  $C_h$ . At a single frequency this can be simplified to an effective reactance,  $X_e$ , in series with an effective resistance,  $R_e$ . These impedances are a function of frequency as shown in the impedance versus frequency curve illustrated in four views in figure 5-14. The frequency  $f_s$

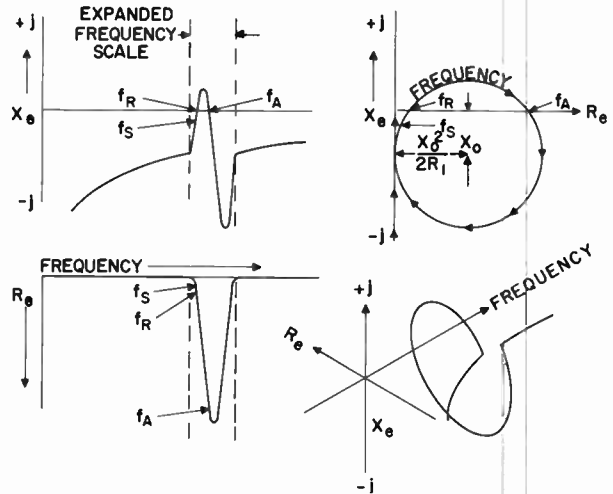

Figure 5-14. Impedance Versus Frequency Curve

is the resonant frequency of the series arm and  $f_R$  is the resonant frequency of the quartz resonator unit. The antiresonant frequency of the resonator,  $f_A$ , is only a fraction of one per cent higher than  $f_R$ . At frequencies removed from  $f_A$  by about one per cent, the resonator appears to be a capacitor having a value  $C_0$ . Resonators have a number of responses of lesser degree which are usually called unwanted responses. However, certain responses that are approximately harmonically related to the main response are called overtones and are used to control the frequency of vhf oscillators. The equivalent circuit values of a resonator can be controlled to about  $\pm 10\%$  except for the series arm resistance,  $R_1$ . The resonant frequency can be controlled to close tolerances by close dimension control in the construction of the quartz plate. The resonator performance in a particular application can be calculated if the values of the equivalent circuit are given. If a capacitance  $C_x$  is added in series with the resonator and this combination operated at its series resonant frequency  $f_x$ , the following formulae hold.

$$X_e = \frac{1}{2\pi f_x C_x}$$

$$R_e = \frac{X_0}{2R_1} - \sqrt{\frac{X_0^4}{4R_1^2} - (X_0 + X_x)^2} \quad \text{if } X_0^2 \gg R_1^2$$

$$R_e \approx \left(\frac{C_0 + C_x}{C_x}\right)^2 R_1$$

$$R_1 \approx \left(\frac{C_x}{C_0 + C_x}\right)^2 R_e$$

$$f_x \approx f_s \left[1 + \frac{C_1}{2(C_0 + C_x)}\right]$$

$$\frac{df_x}{f_x} \approx - \frac{C_1}{2(C_0 + C_x)^2} dC_x$$

The frequency range over which a quartz resonator operates best is determined by the type of cut. Each type of cut has its own optimum frequency range as determined by the physical dimensions of the resonator plate. The following table lists the different cuts and their normal frequency range.

TABLE 5-1

FREQUENCY RANGE OF QUARTZ RESONATORS

Cut	Normal Frequency Range
Fundamental AT	500 kc to 20 mc
3rd Overtone AT	10 mc to 60 mc
5th Overtone AT	30 mc to 80 mc
7th Overtone AT	60 mc to 120 mc
CT	300 kc to 800 kc
DT	200 kc to 500 kc
NT	16 kc to 100 kc
+5°X	90 kc to 300 kc
Bounded +5°X	1.2 kc to 10 kc

Temperature characteristics of quartz resonators are determined mainly by the orientation of the cut with respect to the crystallographic axes. The frequency versus temperature characteristics are shown in figure 5-15. The peaks of the parabolic shaped curves can be moved so as to appear at any desired temperature by changing the orientation of the cut slightly, and the S-shaped curve of the AT cut resonator can be tipped up or down by the same technique. It is seldom possible to adjust a quartz resonator to an exact resonant frequency at a specified temperature. Normal finishing tolerance for commercial units is about  $\pm 20$  parts in  $10^6$ . However, in precision resonators, finishing tolerances as low as 1 part in  $10^6$  have been achieved.

The resonant frequency of a resonator and the resistance of the series arm are, to some extent, a function of the amplitude of vibration or the power dissipated in the resonator. Below a current of about 100 microamperes, the frequency and resistance are essentially constant. As the current exceeds this critical value, the series arm resistance,  $R_1$ , increases; and the resonator frequency changes as the square of the current. In AT cut elements, the frequency increases about 0.1 part in  $10^6$  per milliwatt per mc. At still higher values of current, the frequency drifts considerably because of self-heating and

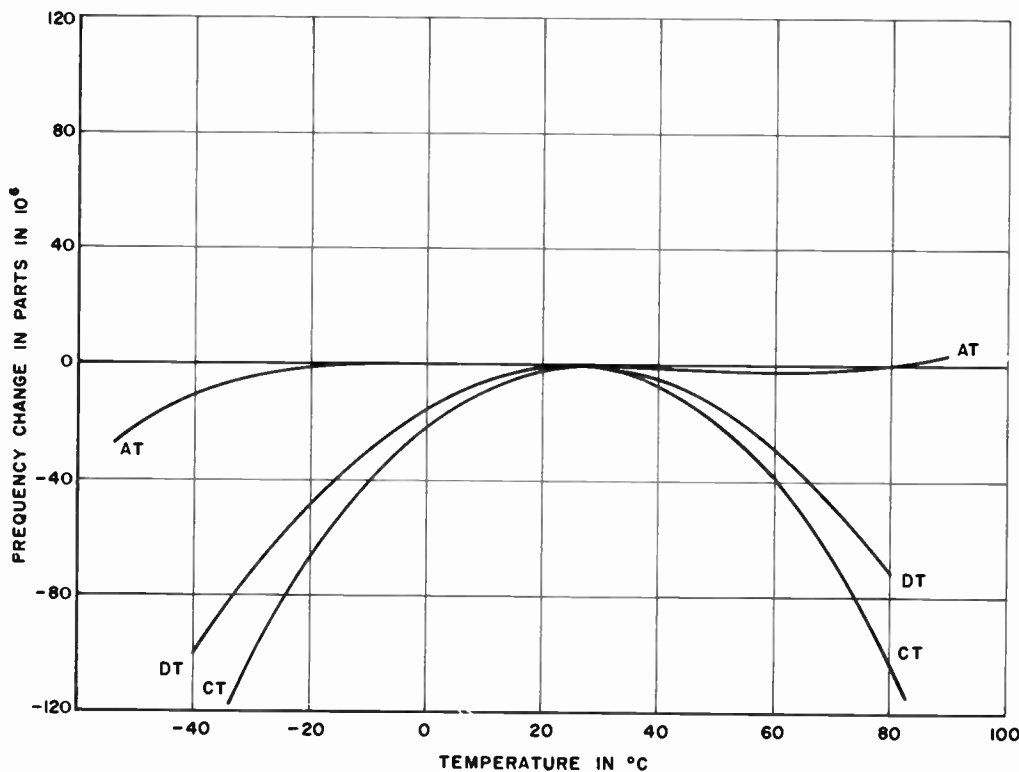

Figure 5-15. Frequency Versus Temperature Characteristics

finally the resonator fractures because of the large amplitude of vibration. Also, coupling of harmonically related modes of vibration can occur because the vibrations are not linear at the higher amplitudes. This coupling degrades the Q of the wanted response, and since these other modes usually have poor temperature coefficients, the Q depends upon both ambient temperature and resonator current. This Q degradation is known as an activity dip. In AT cuts, the unwanted responses within several per cent of the desired frequency are usually higher in frequency than the desired response. These can become prominent enough to control the frequency in oscillator applications. The resonator frequency also changes some with time due to surface contamination of the quartz and to sublimation of the plated electrodes. The actual amount of change depends on the cut, design, cleanness, and construction of the resonator unit. The rate of aging generally increases rapidly with temperature and is sometimes 100 times greater at 40°C than at 0°C. Therefore, aging is more rapid in oven controlled units. At present, the aging in commercial high-frequency AT cut crystal units is about 40 parts in 10<sup>6</sup> per year at 85°C. However, in precision, oven controlled resonators aging rates as low as 1 part in 10<sup>9</sup> per month have been achieved. Normal aging rates for precision units are 1 part in 10<sup>8</sup> per day. Recent studies on the aging rate of quartz resonators indicate that their stability is improved by very low temperature operation. Figure 5-15.1 shows that stability on the order of 1 part in 10<sup>10</sup> per day can be achieved by operating commercial grade crystals at 4°K.

**c. CONSTRUCTION OF PRECISION RESONATORS**

Figure 5-16 shows the construction and mode of vibration of a precision crystal resonator, 5th overtone AT cut. The blank is made circular with one spherical surface and one flat surface. In a crystal of this shape, all of the mechanical vibration takes place near the center of the plate and the edges remain dormant. Thus, supports can be attached to the edges of the plate without degrading Q through damping of the vibrations. The quartz plate is usually given a high polish

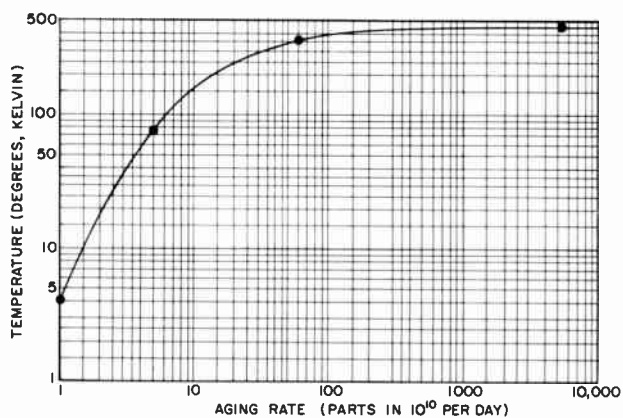

Figure 5-15.1. Quartz Resonators, Aging Rate versus Temperature

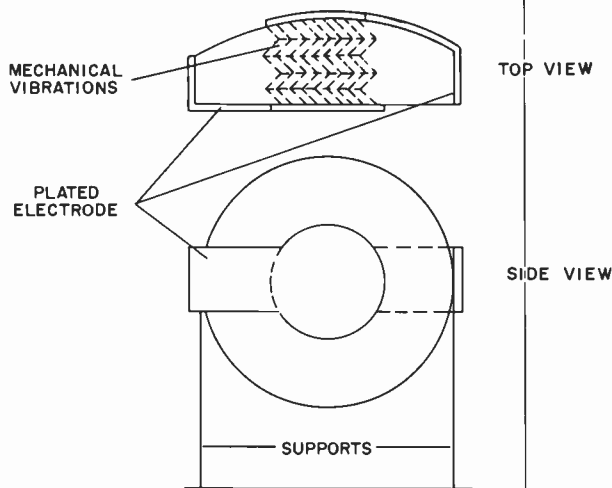

Figure 5-16. Precision Quartz Resonator, Construction and Mode of Vibration of 5th Overtone AT Cut

which may be followed by a brief etching operation before the electrodes are plated on. The plating operation is performed in a vacuum in order to minimize contamination and after plating, the unit is sealed in an evacuated glass or metal envelope. The mode of vibration used is the 5th overtone in thickness shear. Use of this mode of vibration greatly decreases the volume to effective surface ratio and at the same time reduces the effective surface area exposed to contamination since ten effective surfaces, consisting of the five interfaces resulting from 5th mode operation, are inside the crystal. Typical applications for these units are in 2.5 mc and 5 mc frequency standards. The resonant frequency of 5th overtone AT cut crystals is not affected by shock and vibration below the level that permanently damages the mounting structure.

**5. OSCILLATOR THEORY**

**a. GENERAL THEORY**

Oscillator operation can be analyzed on a feedback basis wherein the oscillator consists of an amplifier with a frequency selective device which couples energy at the desired frequency from the output back to the input. When the circuit is adjusted so that the amplifier supplies energy at the desired frequency sufficient to overcome the losses in the feedback path, the circuit oscillates and generates a signal at a frequency controlled by the resonant frequency of the feedback path. If energy is to be coupled out of the oscillator and used to drive other devices, the amplifier must supply this energy in addition to that required to overcome the losses in the feedback path.

In crystal-controlled oscillators a quartz resonator network provides the coupling from the output of the amplifier to its input. Because of its high Q, the resonator operates as a highly selective feedback network with extremely high attenuation of frequencies on either side of its resonant frequency. Thus the frequency of oscillation cannot deviate appreciably from the resonator frequency. Since the output of the feedback network is the input of the amplifier, the total phase shift around the loop must be zero. For this reason the resonator must compensate for phase shifts in the rest of the oscillator circuit and these phase shifts will affect the frequency stability of the circuit.

Another method of analysis is that based on the negative resistance theory. Figure 5-17a is an

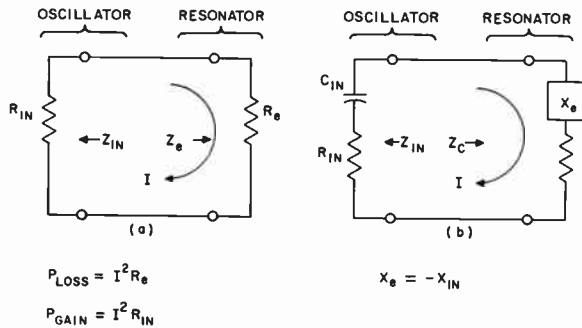

Figure 5-17. Equivalent Circuit of a Crystal-Controlled Oscillator

equivalent circuit of an oscillator operating at series resonance. The input impedance of the oscillator is a negative resistance,  $R_{in}$ , and the resonator has an effective resistance,  $R_e$ . The power loss in the resonator is  $I^2 R_e$ , and the power supplied by the oscillator is  $I^2 R_{in}$ . If the power gain is greater than the power loss, oscillations will build up; and if the power gain is less than the power loss, oscillations will die out. The negative oscillator input resistance is a function of the current  $I$  so that  $R_{in}$  will decrease as oscillations build up, until  $R_{in}$  equals  $R_e$  and a stable amplitude is reached. A more general case is illustrated in figure 5-17b in which the oscillator input impedance has a capacitive component. It is standard practice to make this input capacitance,  $C_{in}$ , 32 uuf at frequencies above 500 kc and 20 uuf at frequencies below 500 kc. The entire network oscillates at a frequency such that  $X_e = -X_{in}$ , and the equations for power loss and gain given for figure 5-17a still apply. All types of oscillators can be analyzed in this manner except that in a few special cases the reactive component of oscillator input impedance may be inductive.

Mathematical analysis consists of replacing the resonator with an imaginary test voltage generator and solving for  $Z_{in} = \frac{E_{in}}{I_{in}} = R_{in} + jX_{in}$ . Figure 5-18 illustrates a method of calculating the power dissipation in

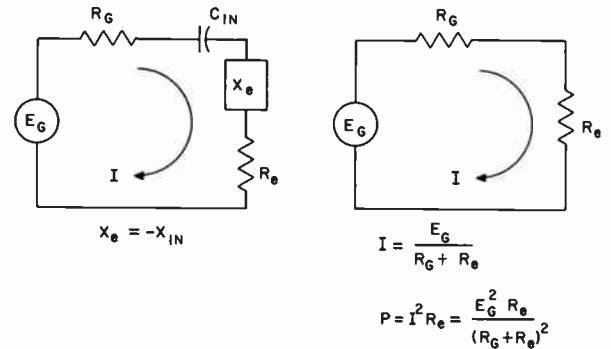

Figure 5-18. Calculation of Resonator Power Dissipation

the resonator for vacuum-tube saturation limiting. In the first equivalent circuit the oscillator is represented by a generator,  $E_G$ , with a series generator resistance,  $R_G$ . Since the resonator reactance,  $X_e$ , equals the negative reactance,  $-X_{in}$ , of the input capacitance,  $C_{in}$ , these two reactances cancel, and the equivalent circuit is reduced to the second circuit shown in figure 5-18. After the grid voltage on the oscillator tube reaches the value that saturates the tube, the generator voltage  $E_G$  remains relatively constant and independent of grid drive. Then resonator current is given by  $I = \frac{E_G}{R_G + R_e}$ , and the power dissipated in the resonator is given by  $P = I^2 R_e = \frac{E_G^2 R_e}{(R_G + R_e)^2}$ .

**b. TYPICAL OSCILLATOR CIRCUITS**

Quartz crystal resonators have two resonant frequencies. At one frequency they exhibit antiresonant characteristics, and at a slightly lower frequency they exhibit series resonant characteristics. At frequencies between these two the resonator reactance is inductive, and at frequencies outside this range the reactance is capacitive. The design of the oscillator circuit determines in which part of the reactance characteristic it will be used. In the oscillator represented by figure 5-19, the series resonant response is used. The amplifier is designed so that the total phase shift from amplifier input to output is zero. Since the total phase shift around the complete loop, including the feedback network, must be zero, the feedback network must also have zero phase shift. If the feedback network is to have zero phase shift, it

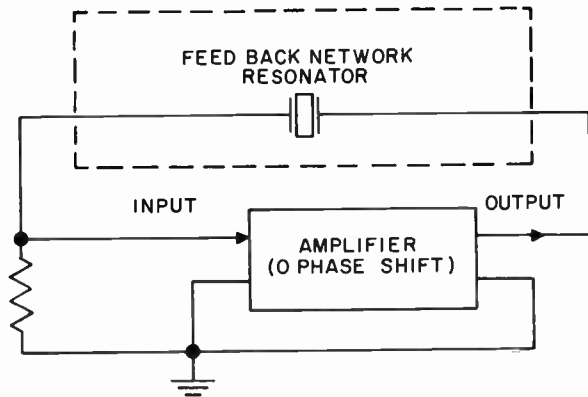

Figure 5-19. Basic Crystal Oscillator Operating the Resonator at Series Resonance

must be resistive at the frequency of oscillation. The quartz resonator which forms the feedback network is resistive at two frequencies, its antiresonant frequency and its series resonant frequency. Since the resonator is in series with the feedback path, the frequency at which it offers the least resistance to the signal is its series resonant frequency, and this will be the frequency of oscillation.

Figure 5-20 shows the basic Pierce oscillator circuit, an equivalent circuit, and a vector diagram showing the phase relationships, neglecting circuit losses. In this oscillator the feedback network operates at antiresonance, but the resonator operates at a point between its series resonant frequency and its antiresonant frequency where it is sufficiently inductive to resonate with  $C_p$  and  $C_g$  in series. The generator voltage  $-\mu E_g$  is the grid voltage multiplied by the gain of the tube. Since the circuit representing

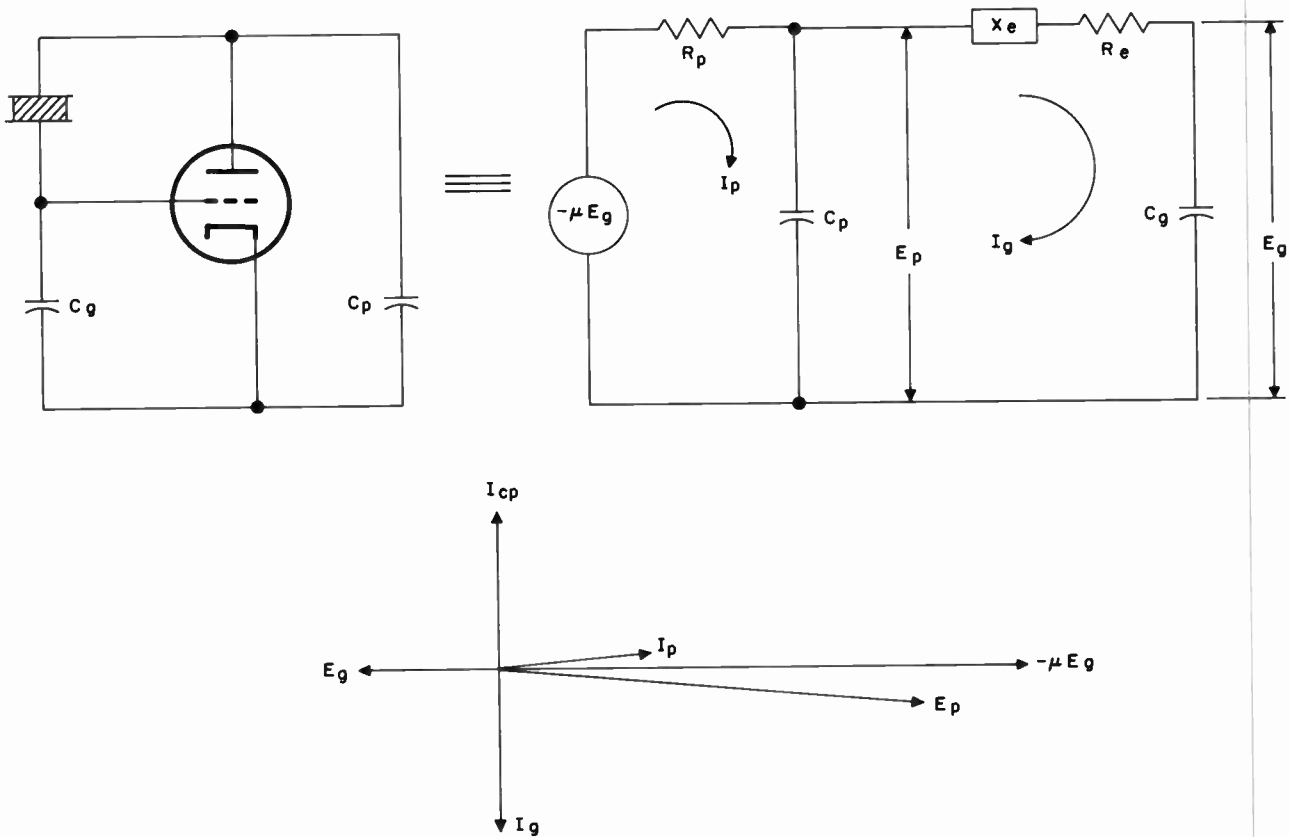

Figure 5-20. Basic Pierce Oscillator



the generator load is resonant,  $I_p$  will be in phase with  $-uE_g$ ; and since the branch consisting of  $X_e$ ,  $R_e$ , and  $C_g$  is inductive,  $I_g$  will lag  $-uE_g$  by  $90^\circ$ . The voltage,  $E_g$ , developed across  $C_g$  will lag  $I_g$  by  $90^\circ$ . Therefore,  $E_g$  will lag  $-uE_g$  by  $180^\circ$ , and since the tube introduces another  $180^\circ$  phase shift, the condition that there be zero phase shift around the loop is satisfied.

### c. PRECISION CRYSTAL-CONTROLLED OSCILLATORS

In the design of precision oscillators, several precautions must be taken to minimize instabilities. The construction of the quartz resonator itself was described in paragraph 4 of this chapter. Additional precautions to be observed in the use of quartz resonators in precision oscillators are listed below.

- (1) The components that make up the resonant circuit must be placed in a controlled environment.
- (2) The amplitude of oscillation must be controlled to avoid instabilities caused by nonlinearity in the vibration pattern of the resonator at high amplitudes.
- (3) Phase instabilities in the active amplifying portion of the oscillator must be held to a minimum.
- (4) External circuitry must be isolated from the oscillator so that reactive components are not reflected back into the resonant circuit to cause instability.

(5) The  $Q$  of the resonator should be high so that loop phase shifts can be compensated for with minimum change in resonator operating frequency. In addition, high  $Q$  makes possible low coupling between the resonator and the active amplifying portion of the oscillator, thus minimizing the effect of the active network on the resonator.

(6) Nonlinearities in the active amplifying portion of the oscillator cause harmonic distortion. Adjacent harmonics are mixed together in the same or other nonlinear portion of the circuit after having passed around the feedback network. The fundamental frequency component thus produced is usually not phase stable and causes phase instability in the oscillator. Therefore, the amplifier must be operated on the linear portion of its characteristic.

Figure 5-21 illustrates the principle of operation of the Meacham oscillator. The resonator,  $Y1$ , operates at its series resonant frequency and thus offers a low resistance and zero phase shift to the frequency of oscillation. The opposite leg of the bridge circuit is an incandescent lamp which when cold also has a low resistance. Resistors  $R1$  and  $R2$  have about the same resistance as the effective resistance of the resonator at its series resonant frequency. This condition exists when oscillations start. The coupling between the amplifier and the feedback loop is relatively tight, and there is a large amount of positive feedback. As oscillations build up, the

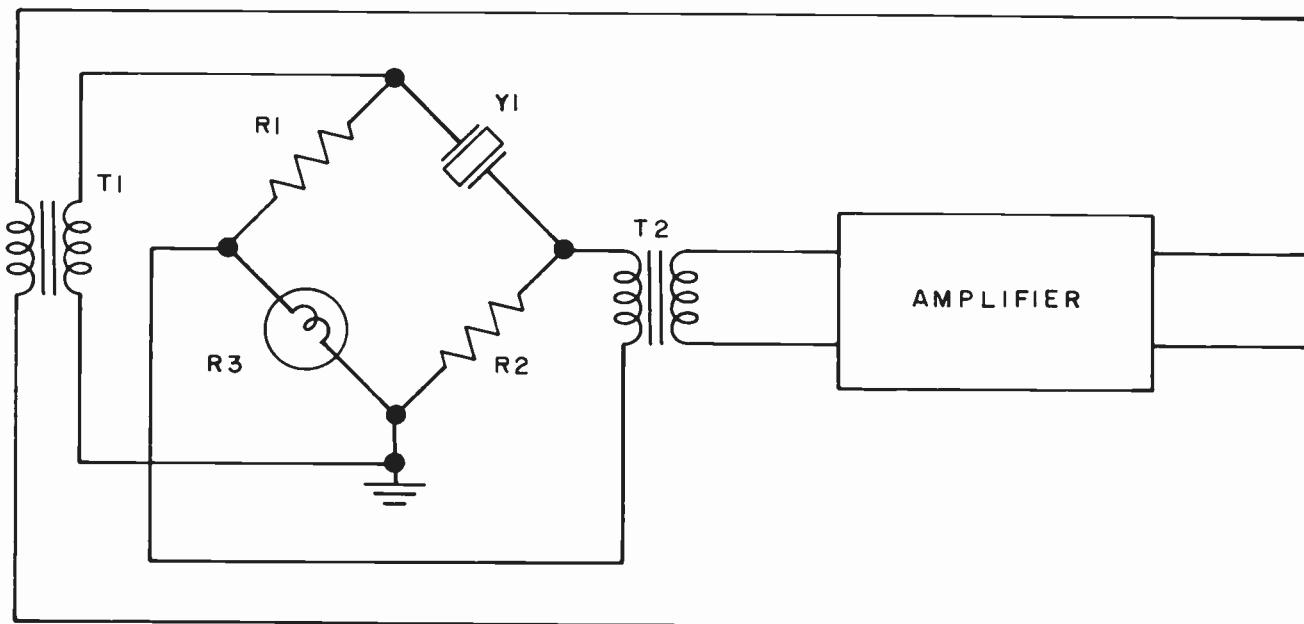

Figure 5-21. Meacham Oscillator

lamp, R3, is heated by the r-f current, and its resistance increases until it is almost equal to that of R1. As the lamp resistance increases, the bridge approaches balance; the positive feedback is reduced until the bridge is almost in balance, and the residual positive feedback is just sufficient to sustain oscillation. This oscillation is usually used only at frequencies below 1 mc because of the difficulties of obtaining transformers that do not cause phase instabilities at the higher frequencies.

Figure 5-22 is a schematic diagram of a typical Pierce oscillator used in high precision frequency standards. The 1 mc quartz resonator, V1, is a fundamental AT cut crystal, sealed in an evacuated glass envelope. Its temperature coefficient is only several parts in  $10^7$  per degree centigrade. The components that make up the resonant circuit, Y1, R1, C1, C2, and C3 are housed in an oven in which the temperature is held constant to better than  $.01^\circ\text{C}$ . Capacitor C1 and resistor R1 hold the d-c voltage impressed on the resonator, Y1, to a minimum. The resonator has a minimum Q of 1 million, thus capacitors C2 and C3 can be made large to bypass effectively the plate and grid of the tube to ground and reduce the coupling between the resonator and the active portion of the

circuit to a low value. In addition, all frequency controlling components are isolated from other circuit elements by shielding. Capacitor C4 is a precision variable capacitor which provides a small range of adjustment of the resonant frequency of the circuit. The total range of adjustment is about 4 cps at the nominal operating frequency of 1 mc. The output of the oscillator is coupled to an untuned buffer stage which isolates the oscillator from succeeding stages. Two stages of amplification follow the buffer stage and provide additional isolation. The amplitude of oscillation is controlled by negative voltage developed in the grid circuit of the last amplifier stage. Cathode bias on this tube delays development of negative voltage until the signal applied to the grid reaches a predetermined level. When this level is reached, the resultant negative voltage couples to the grid of the oscillator tube through an RC filter increasing grid bias, and thus reducing the tube gain, and limiting the amplitude of oscillation to a low level. This automatic amplitude control system holds the operating power level in the quartz resonator to less than .1 microwatt. This type of oscillator has attained short-term stability of better than 1 part in  $10^{10}$  and long-term stability of better than 1 part in  $10^9$  per day. Oscillators are now being designed to use the 5th overtone AT cut crystal. These are expected to have even better stabilities than oscillators using the fundamental AT cut crystal.

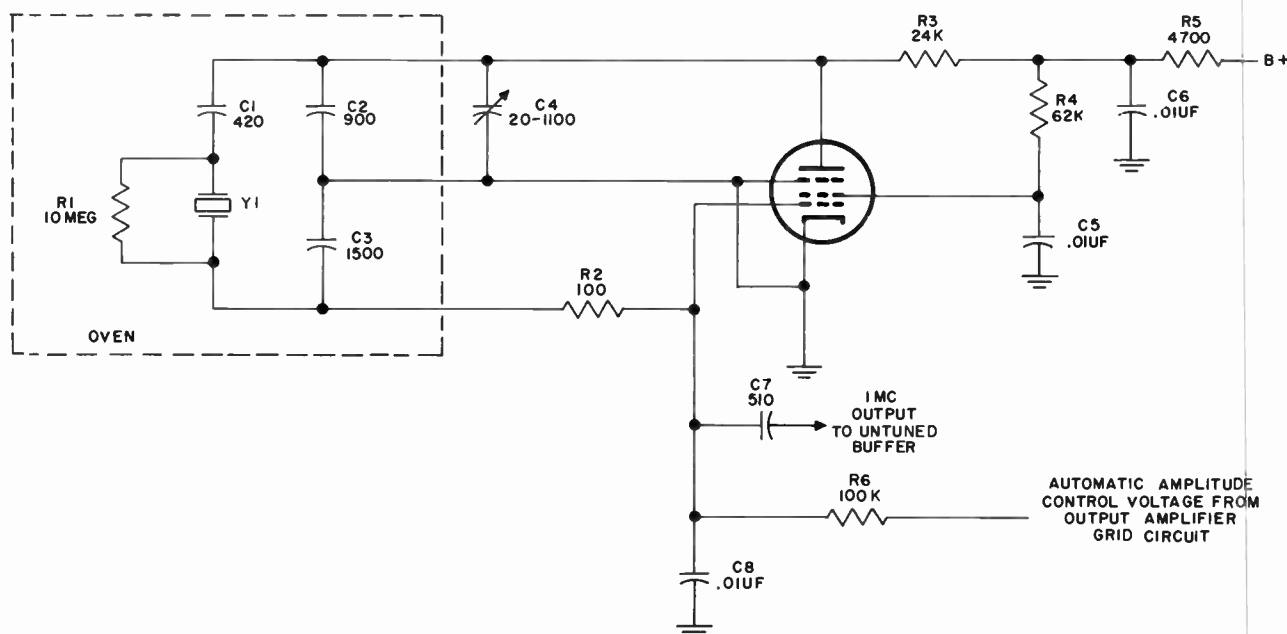

Figure 5-22. Precision Pierce Oscillator

## 6. OVEN THEORY

### a. GENERAL THEORY

Since all quartz resonators have some variation of frequency with temperature, the resonator must be kept at a constant temperature in order to achieve maximum stability. In most frequency standards, this is accomplished by placing the resonator in an oven and then maintaining the oven temperature at a level somewhat higher than the ambient temperature surrounding it. The six items listed below make up a typical oven.

- (1) The resonator or device to be temperature controlled
- (2) The oven heater
- (3) A device for controlling the power delivered to the heater
- (4) A temperature sensing element
- (5) A heat sink (ambient temperature around oven)
- (6) Thermal insulation or thermal resistance

The operation of the oven can be compared to the operation of an electrical bridge circuit as illustrated in figure 5-23. The arms of the bridge  $R_1$ ,  $R_2$ ,  $R_3$ ,

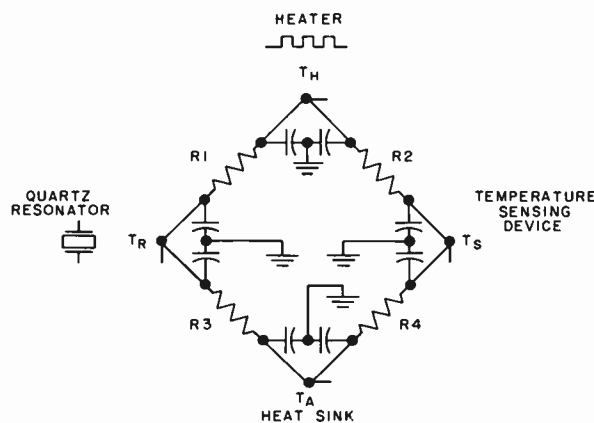

Figure 5-23. Oven Operation Equivalent Electrical Circuit

and  $R_4$  represent thermal resistance, that is, resistance to heat flow. The temperatures  $T_H$ ,  $T_R$ ,  $T_A$ , and  $T_S$  are analogous to electrical potentials at the points indicated.  $T_H$  is the heater temperature;  $T_R$  is

the resonator temperature;  $T_A$  is the temperature surrounding the oven, and  $T_S$  is the temperature of the sensing element. The heat storage or thermal capacities of the materials in the heat flow path are analogous to electrical capacitance. The temperature of the heater  $T_H$ , is regulated by the sensing element through a servo system so that the temperature  $T_S$  remains constant. To maintain the temperature  $T_R$  of the resonator constant regardless of variations in  $T_A$ ,  $T_R$  must equal  $T_S$ , that is, the bridge must be balanced or  $R_1/R_3$  must equal  $R_2/R_4$ . Conditions for balance are less critical if  $R_1$  and  $R_2$  are made very small as compared to  $R_3$  and  $R_4$ , since then  $T_H$ ,  $T_S$ , and  $T_R$  will be more nearly equal. The time lag between  $T_H$  and  $T_S$ , caused by the time constant of the thermal resistance  $R_2$  and its associated thermal capacities, causes the servo system to hunt and this in turn causes the temperature  $T_S$  to cycle. Reducing the time constant of  $R_2$  and its associated capacities to a very low value eliminates this cause of hunting. However, another cause of hunting is the operating differential of thermostats. When these are used as temperature sensing devices, the time constant of  $R_1$  and its associated capacities must be made long in order to filter out variations in  $T_R$  caused by hunting in the servo system. If proportional control is used, the time lag due to operating differential in the sensing element is eliminated, and the time constant of  $R_2$  and its associated capacities can be made very low to eliminate hunting. If the servo system is free of hunting, then the time constant of  $R_1$  and its associated capacities can be made low, and if at the same time the time constants in the  $R_3$  leg and the  $R_4$  leg are made long,  $T_S$  and  $T_R$  will be on an isothermal line with  $T_H$ . Ovens using this system can maintain temperature within  $.01^\circ\text{C}$ .

### b. TYPICAL PRECISION OVEN

Figure 5-24 illustrates the construction of a typical precision oven. In this oven, the resonator, the heater, and the temperature sensing element are all in an isothermal space. The resonator in its sealed envelope is housed in an aluminum cylinder upon which the heater is wound. Because of the high heat conductivity of aluminum and because the resonator is almost completely surrounded by aluminum, the temperature of the resonator is nearly identical to that of the aluminum enclosure. The heater is wound on this enclosure and tightly coupled to it thermally. Thus the resistance  $R_1$  in figure 5-23 and the thermal time constant between  $T_H$  and  $T_R$  are nearly zero. The heater is constructed so that it is also the temperature sensing element, making  $R_2$  in figure 5-23 and the time constant between  $T_H$  and  $T_S$  nearly zero. The resistances  $R_3$  and  $R_4$  are made very large by housing this assembly in a vacuum bottle. The vacuum bottle is enclosed in a second aluminum cylinder which makes  $T_A$  uniform on all sides of the oven.

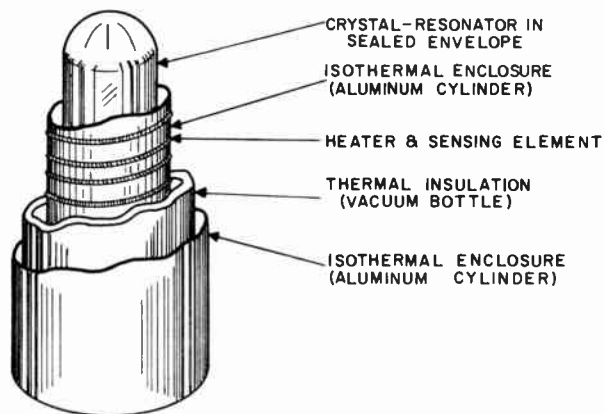

Figure 5-24. Typical Oven Construction

Since the heater, the resonator, and the temperature sensing element have been placed in an isothermal space well isolated from the ambient temperature, the only remaining requirement is to maintain the heater at a constant temperature. The circuit of figure 5-25 satisfies this requirement. The bridge circuit, HR601, performs two functions. It is the heating element for the oven and the control element for the oven oscillator. Two arms of the bridge are made of nickel wire, and the other two arms are made of Low Ohm wire. The arms are of selected lengths so that their resistances at the desired oven temperature are almost equal. When the oven temperature is low, the nickel wire has less resistance than the Low Ohm wire, and terminals 5 and 7 of the secondary winding of T601 see less resistance to ground than do terminals 4 and 6. At the same time, terminals 4 and 6 of T601

see less resistance to the feedback path than do terminals 5 and 7. As a result, the alternating current flowing through the bridge is applied as positive feedback to the first amplifier stage. Under these conditions, the circuit oscillates at an amplitude determined by the amount of bridge unbalance which in turn is controlled by the temperature. Thus, proportional control is provided, and the thermal lag inherent in thermostatic devices is eliminated. The power supplied to HR601 by the oscillator heats the oven; and as the temperature approaches the desired level, the bridge approaches balance reducing the amount of feedback until at the desired temperature, it is just sufficient to sustain oscillation. When the oven reaches this steady state condition, the oven control oscillator supplies just enough power to the heater to replace the heat lost to the surrounding medium and maintains the oven temperature constant within .01°C. If for any reason the temperature of the oven rises above the desired level, the bridge becomes unbalanced in the opposite direction and resultant negative feedback prevents oscillation.

### 7. FREQUENCY DIVIDER THEORY

In order to obtain maximum stabilities, standard signals must be generated at higher frequencies than the lowest frequency required for use in the equipment. In order to obtain the lower frequencies, frequency dividers must be used, and if the divided frequency is to have the same stability as the original, these dividers must be under control of the standard. Figure 5-26 is a block diagram of a typical divider. The equipment contains two regenerative dividers which divide their input frequencies by 10. With a 1 mc input, this circuit provides outputs at 1 mc, 100 kc, and 10 kc. The principles of operation of the two dividers are identical except for the frequencies involved; therefore, only the 1 mc to 100 kc divider will be discussed. When the 1 mc signal supplied to

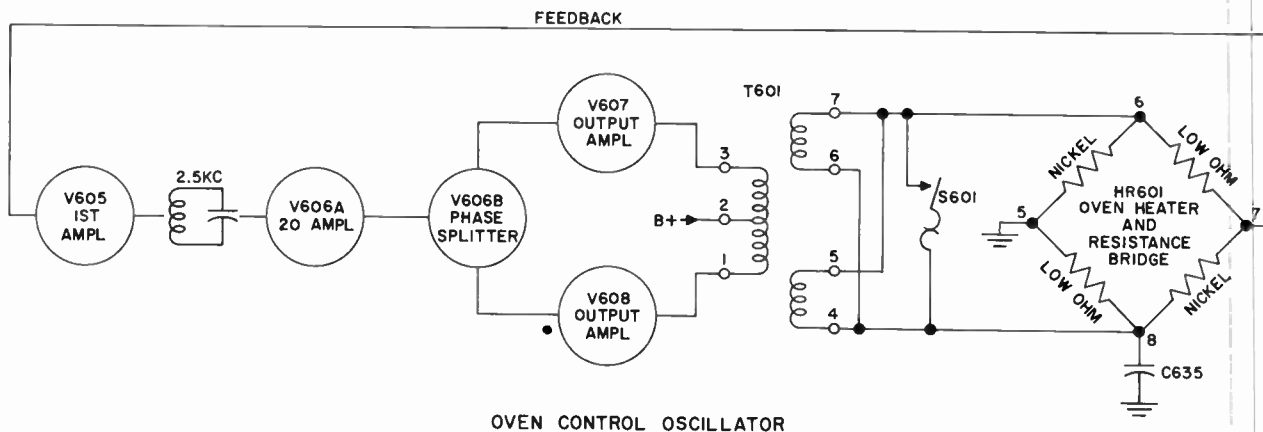

Figure 5-25. Oven Control Oscillator

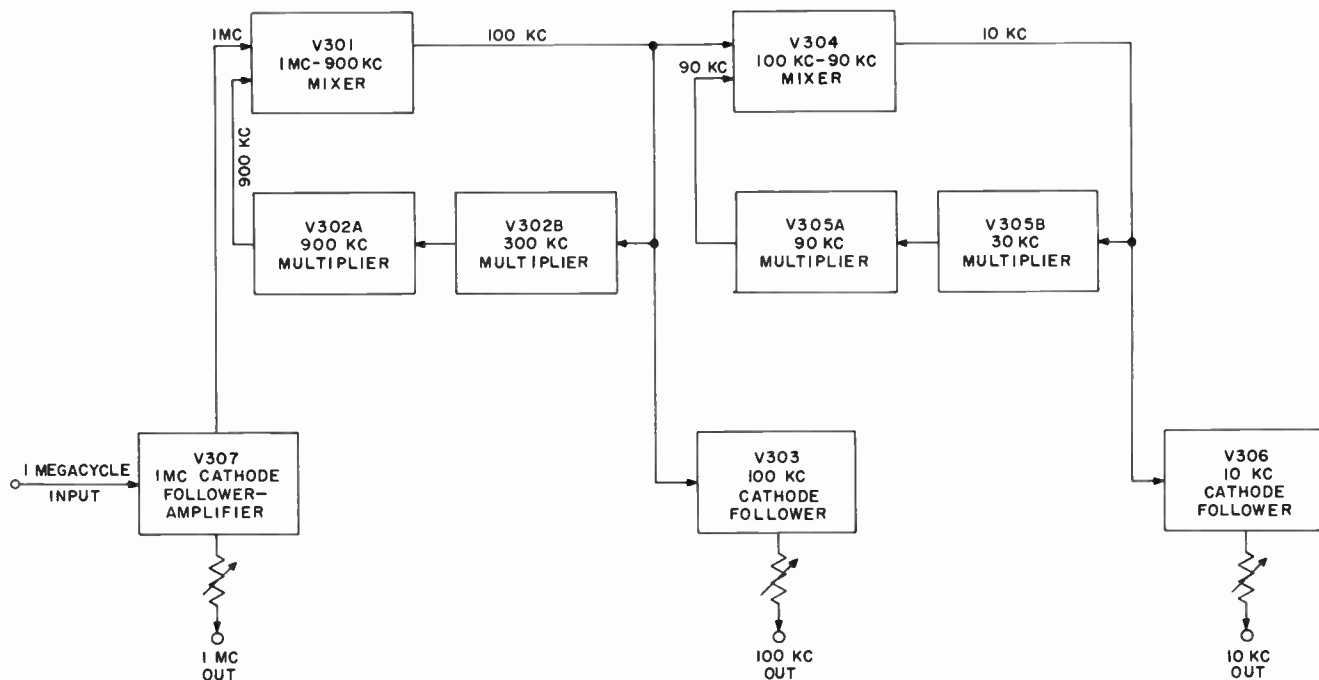

Figure 5-26. 8U-1 Frequency Divider, Block Diagram

the injection grid of mixer V301 is large enough to make the circuit sufficiently regenerative, noise energy at 900 kc appearing at the signal grid of V301 mixes with the 1 mc signal to produce sufficient 100 kc signal to drive multiplier V302B. This circuit multiplies the 100 kc signal by 3 producing a 300 kc signal which drives a second multiplier V302A. The 300 kc signal is again multiplied by 3 to produce a 900 kc signal for mixing in V301. The 100 kc signal thus produced is under complete control of the 1 mc signal. If the 1 mc injection falls below the threshold level, the loop gain of the circuit falls below the level required to maintain operation, and no output is available. The second divider circuit operates from the 100 kc signal in the same way to produce a 10 kc signal. The cathode followers used to couple the signals to external circuits provide isolation.

## 8. SYSTEM CONSIDERATIONS

In single-sideband communications, the total frequency shift in the system, both transmitting and receiving, should not exceed 50 cps. At 20 mc this requires a system stability of 2.5 parts in  $10^6$ ,

including errors introduced by the propagating medium, Doppler shifts, and errors in terminal equipment. To assure total system stability of 2.5 parts in  $10^6$  over a period of months without readjustment, stabilities of 1 part in  $10^8$  per day are required in the frequency standards. Frequency, time, and phase stability requirements in other systems, such as Kineplex\*, are even more severe. In the Kineplex system, 22 millisecond pulses are transmitted. Each pulse is a reference for the succeeding pulse. Short-term phase stability for this system must be within a few degrees over a 44 millisecond period. Frequency accuracy must be  $\pm .5$  cps to prevent deterioration of the signal. Errors of  $\pm 1$  cps cause noticeable distortion and  $\pm 3$  cps is the practical limit of permissible frequency error. Time accuracy within  $\pm 1$  millisecond would provide a signal with no noticeable deterioration, but  $\pm 5$  milliseconds is the practical limit of time error. Thus, in these systems, total system frequency stabilities of 6 parts in  $10^7$  and total system time stabilities of 1 part in  $10^8$  are required. In mobile systems, Doppler shifts, and time variations due to changing transmission path lengths must be compensated for either by automatic correction circuits or by manual readjustment of local equipment.

\* Registered in U. S. Patent Office



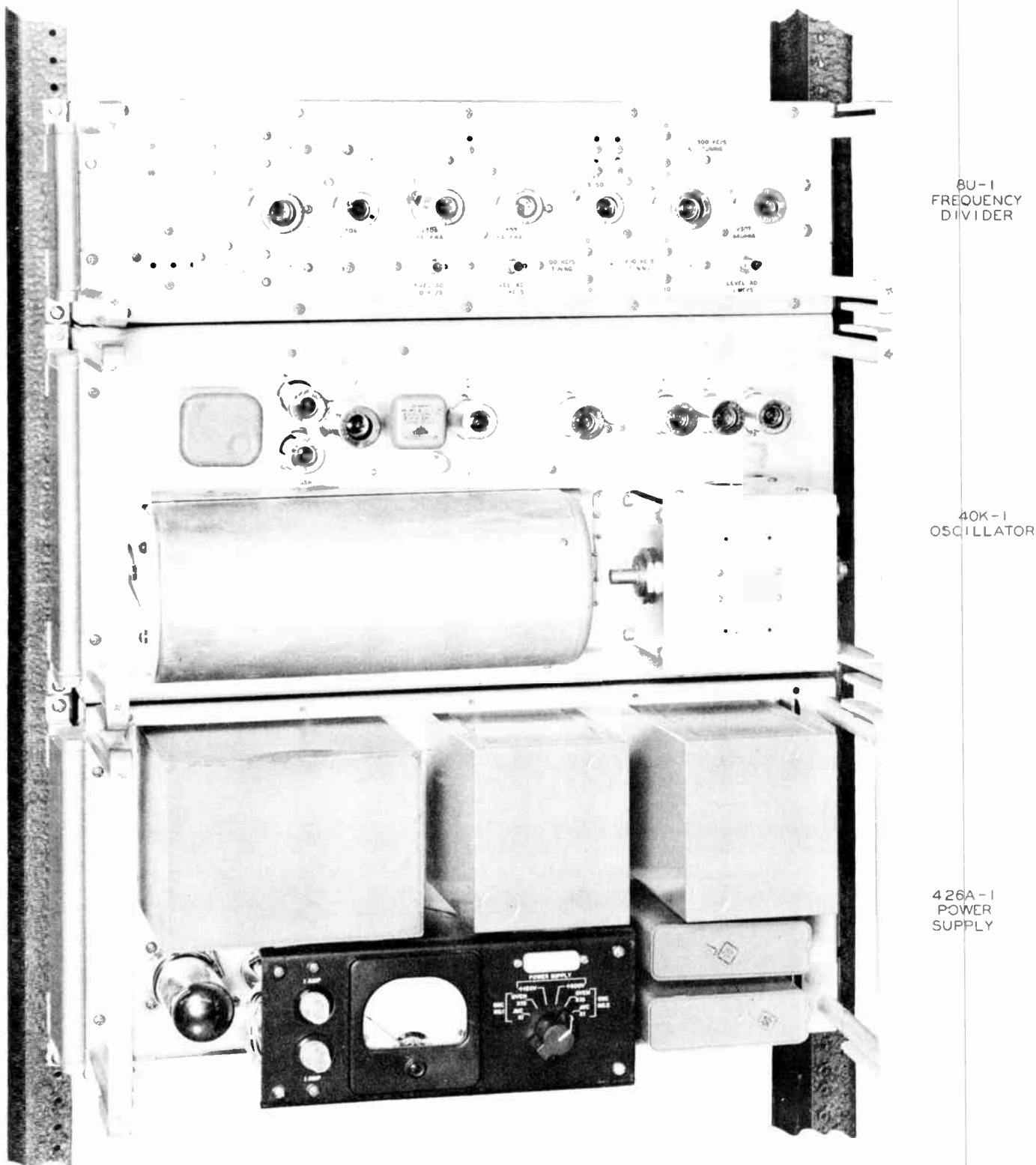

Figure 5-27. Typical Secondary Frequency Standard, Covers Removed



Figure 5-28. Collins Radio Company Primary Frequency Standard



## CHAPTER 6 PRINCIPLES OF SERVOMECHANISMS

### 1. DEFINITIONS

A servomechanism is most commonly defined as a feedback control system of which at least one element is mechanical in nature. Voltage regulators for power supplies, automatic volume control and automatic frequency control circuits used in radio equipment and thermostats used to regulate temperature in home heating equipment and in various electrical appliances are examples of feedback control systems. Power steering, gun turret positioning devices, and airplane autopilots are examples of servomechanisms.

In all feedback control systems, the quantity to be controlled is measured in some manner. This measured value is compared to a desired, or reference, value to form an error signal, and the controlling action is governed by some function of the error signal. Feedback control devices may contain electrical, mechanical, pneumatic, hydraulic, and other types of elements. Frequently, a human operator is included in the feedback loop.

### 2. A TYPICAL POSITION SERVO SYSTEM

Figure 6-1 illustrates a typical position follow-up type of servomechanism. This type of device can be used for repeating the position of a shaft at a remote point. For example, in an airborne radio transmitter, it could make the shaft of a precision oscillator follow a dial in the pilot's control box. Follow-up servos are also used to repeat the shaft position of a delicate instrument at a shaft where a large amount of torque is needed. In this case, the purpose of the servo is to provide torque amplification.

In figure 6-1 the reference input  $R$  is a shaft position. A voltage proportional to the shaft position is obtained from a linear potentiometer connected across a battery. This voltage is mixed with a voltage proportional to the controlled variable to form the error signal  $E$  which is then amplified and applied to the winding of a motor. The motor shaft is coupled through a gear train to the load, which in most cases is a friction device, although it sometimes contains a

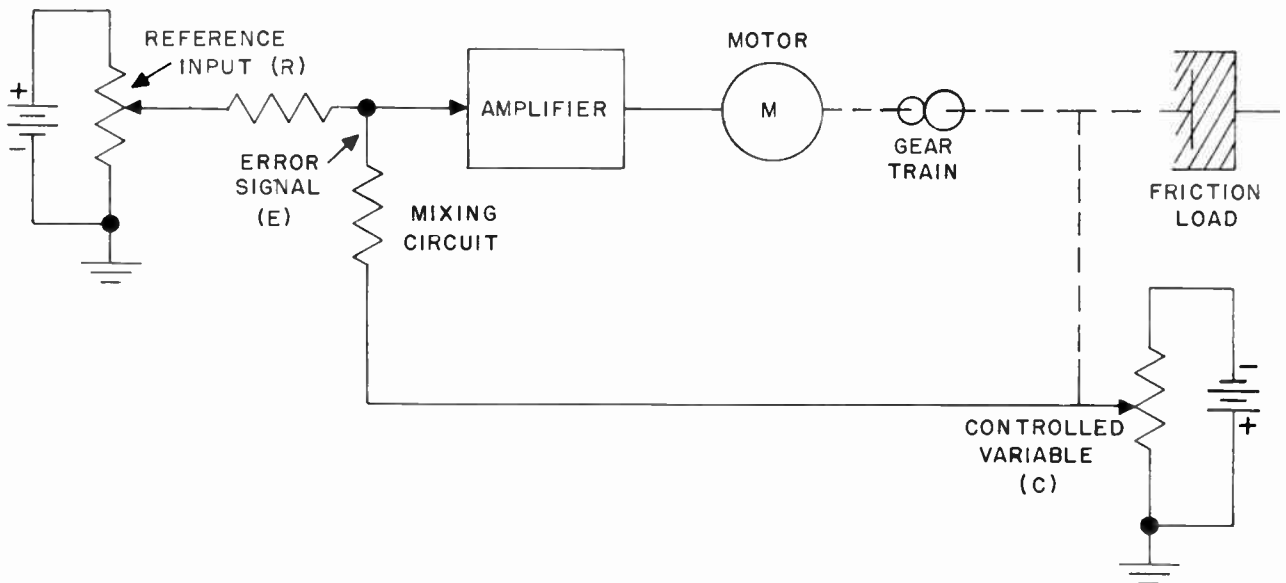

Figure 6-1. Position Follow-up Servomechanism

significant amount of inertia. Coupled to the load shaft is another potentiometer which produces a voltage  $C$ , proportional to the position of the output shaft. The mixing circuit subtracts the controlled voltage  $C$  from the reference voltage  $R$  to obtain error signal  $E$ . The amplifier drives the motor in such a way that if  $E$  is positive the motor turns in one direction, and if  $E$  is negative the motor reverses. When  $E$  is zero, the motor stops. Below the saturation level of the motor and amplifier, the motor speed is proportional to the error signal. A device of this kind is called a proportional controller.

Suppose that when power is applied to the circuit, the reference input  $R$  is greater than the controlled variable  $C$  so that  $E$  is positive. If the motor is connected so that a positive  $E$  causes the motor to turn in such a direction as to increase  $C$ , then as the motor turns,  $E$  will decrease, and the motor will slow down until  $R$  and  $C$  become equal. Then  $E$  is zero, and the motor stops. If the battery voltages feeding the reference input and the control variable potentiometers are equal, and the electrical angles of the two potentiometers are equal, this null condition will occur only when the load shaft is at the same angular position as the reference input shaft. If some external force, such as vibration, displaces the output shaft so as to increase  $C$ ,  $E$  will become negative, and the motor will apply torque to the load in a direction to decrease  $C$ . This torque is proportional to the displacement, and the result is similar to the effect of a spring. In a feedback device of the type described above, the motor will run as long as there is an error signal sufficient to overcome the load friction. Consequently, the amount of residual error in this type of servo depends only on the amount of friction in the load, and not upon the value of  $c$ .

In contrast to this type of behavior is a class of feedback control devices typified by the voltage regulator circuit of figure 6-2. In this case, the controller is a tube whose plate to cathode resistance varies in proportion to its grid voltage. The feedback signal  $C$ , obtained from a voltage divider across the regulated

output, is compared in a mixer circuit with a reference voltage obtained from a voltage reference tube. The resulting error signal  $E$  is amplified and applied to the grid of the controller. If the supply voltage suddenly drops,  $C$  will be reduced and  $E$  increased. The resulting change in the grid voltage of the controller will reduce its effective resistance and raise the output voltage. However, the output voltage can not become quite as high as it was before the supply voltage dropped, for if it did,  $E$  would return to its original value, and the resistance of the controller would become the same as it was before the decrease in the supply voltage. This condition could be corrected by replacing the controller with a motor driven rheostat and connecting the motor to the amplifier. In this case, as soon as the supply voltage dropped, the resulting error voltage would be amplified and applied to the motor causing it to drive the rheostat to reduce the resistance and increase the output voltage. The motor would continue to run until the error signal went to zero, at which time the output voltage must be up to its original value.

The accuracy with which a positioning servo can repeat the shaft position  $R$  is in most cases limited by the amount of torque required to move the friction load. Figure 6-3 shows the torque versus error signal characteristic of a typical servo with the motor stalled. The figure shows that a certain error voltage must exist to produce enough torque to move the load shaft against the starting friction. The battery feeding the controlled variable potentiometer determines how many volts of error signal  $E$  will be produced per degree displacement of the controlled variable shaft. Increasing this battery voltage will increase the stiffness of the system at the load shaft.

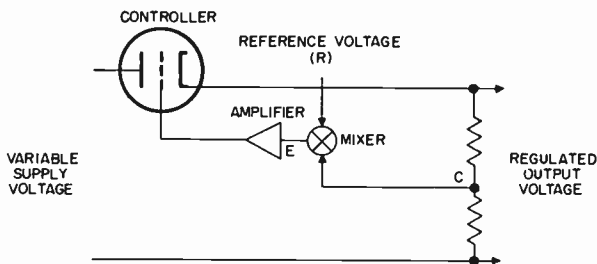

Figure 6-2. Voltage Regulator

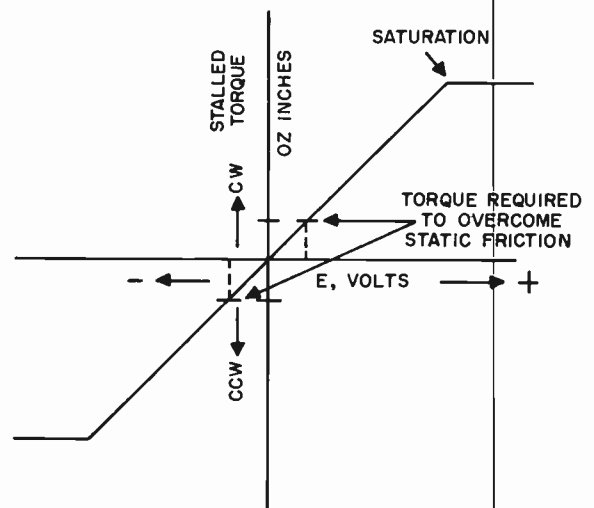

Figure 6-3. Idealized Torque versus Voltage Curve



Stiffness is defined as the reaction torque at the load shaft divided by displacement of the shaft. The greater the stiffness of the system, the smaller will be the residual error.

If the controlled variable shaft is required to follow the reference shaft when it is moving at a constant speed, the motor must turn the output shaft at the same speed as the reference input shaft. Since a certain amount of power from the motor is required to overcome the running friction of the load, there must be a fixed difference between R and C sufficient to produce an error signal capable of driving the motor at the required speed. This difference between R and C indicates that the controlled variable shaft lags behind the reference input shaft by a certain number of degrees, although both are traveling at the same speed. This type of error, called a dynamic tracking error, has a magnitude at any speed of reference input determined by the velocity constant of the servo. To obtain the velocity constant, the shaft of the controlled variable potentiometer is uncoupled from the gear train and displaced one degree from the null position, producing an error signal. The speed of the output shaft is measured, and the ratio of this speed in degrees per second to the error in degrees required to produce it is the velocity constant of the servo system. In figure 6-1, increasing either the gain of the amplifier or the voltage of the battery across the controlled variable potentiometer will increase the velocity constant as well as the stiffness of the servo, so that increasing the over-all gain of the system will decrease both the static friction error and the dynamic tracking error of the system.

### 3. SERVO STABILITY REQUIREMENTS

A servo system such as that of figure 6-1 may be represented by the block diagram shown in figure 6-4.

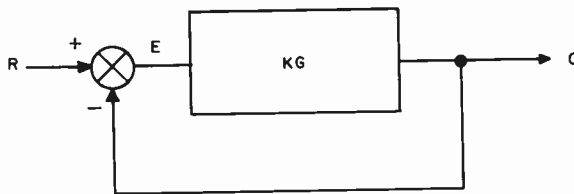

Figure 6-4. Servo Loop Block Diagram

The box labeled KG represents the amplifier, the motor, and the gear train. K is the gain constant of the system, in this case the velocity constant of the entire loop. It includes the amplifier gain, the motor velocity constant, and the gain of the reference input

and controlled variable potentiometers. The constant K is independent of the frequency of the applied signals, but G is an expression that describes the frequency response or time response of the amplifier and motor to error signals. From figure 6-4,

$$E = R - C, \text{ and} \tag{1}$$

$$C = KGE \tag{2}$$

Solving (2) for E:

$$E = \frac{C}{KG} \tag{3}$$

Substituting (3) into (1):

$$\frac{C}{KG} = R - C \tag{4}$$

$$C = RKG - CKG \tag{5}$$

$$C(1 + KG) = RKG \tag{6}$$

Hence, the effective gain of the closed loop is:

$$\frac{C}{R} = \frac{KG}{1 + KG} \tag{7}$$

Since the amplifier and motor must be built with physically realizable components, the function G represents a certain finite bandwidth. The inertia of the motor will tend to slow down its response to high-frequency error signals, and since a roll-off in frequency response is accompanied by a phase shift, there will be some frequency at which the controlled variable C will lag the error signal E by 180 degrees. At this frequency the quantity KG becomes negative, and if KG approaches -1, the denominator of equation 7 approaches 0 so that  $\frac{C}{R}$  approaches infinity. Physically, this can be interpreted to mean that an output C is obtained with no input R. This is the condition under which the loop will oscillate and is known as the Nyquist stability criterion. Because of the finite bandwidth of G, this condition for stability imposes a limitation on the value of K that may be used.

Now that the condition required for stability has been developed mathematically, the system of figure 6-1 may be examined to see what happens when a servomechanism is unstable. The higher the velocity constant, which includes amplifier gain and the voltage of the battery driving the controlled variable potentiometer, the greater will be the motor speed at any given value of error signal. Because the motor, gear train, and load possess inertia, the system in motion has kinetic energy equal to  $J\omega^2$ . In order to stop the motor, this energy must be dissipated. Because an inertia cannot be made to move instantaneously, the response of motor speed to a step of error signal

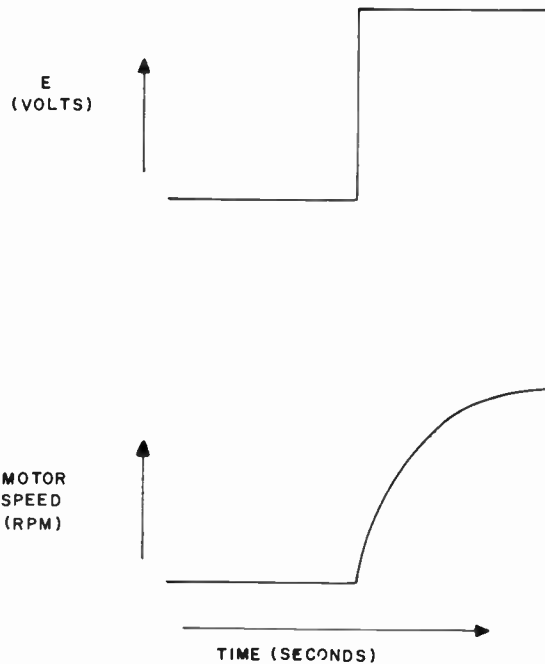

Figure 6-5. Response of Motor and Amplifier to Step Input

voltage into the amplifier is as given in figure 6-5. At the beginning of the step, a step of torque is applied to the rotor, producing acceleration. However, as the motor builds up speed the friction in the load, motor bearings, and gear train dissipates an increasing amount of energy. Eventually, the motor reaches a speed at which the amount of power supplied to the motor winding by the amplifier equals the total amount of power dissipated in the friction load, the motor and gear train bearing friction, and in the copper loss in the motor winding. At this point, the motor speed remains constant. If the system gain is low, the stiffness at the load will be quite small. As the output shaft approaches the null position, the motor torque drops off rapidly enough that the friction can dissipate all the kinetic energy in the motor. Consequently, the response of the closed loop system to a step input will be as shown in figure 6-6b. This condition of the servo loop is referred to as overdamped. If the gain is increased, increasing the stiffness, an oscillatory condition is reached in which the friction load cannot dissipate the energy stored in the inertia by the time the error signal gets to zero. In this case, the motor will overshoot the null position, and the position feedback signal will produce a reverse torque, causing the motor to overshoot in the opposite direction. This oscillation will continue with less energy imparted to the system on each oscillation, until a point is reached

where the total system energy at the null is zero. This system is underdamped and has the response to a step of  $R$  as shown in figure 6-6c. If the system gain is made sufficiently large, the stiffness is so great that the amplifier is able to add more kinetic energy to the motor in each successive cycle of oscillation than the friction load can dissipate. This condition results in divergent oscillations, as shown in figure 6-6d.

#### 4. STABILIZING METHODS

In many cases a servo may be satisfactorily damped by merely adding some sort of velocity-proportional friction device to absorb the energy stored in the inertia. Automobile shock absorbers are an example of this type of damper, and small instrument servomotors are frequently equipped with a drag cup fastened to the motor shaft and turning in a fixed magnetic field. Such dampers produce a torque proportional to velocity. Friction dampers reduce the velocity constant of a system because the motor requires more voltage to run at a given speed. However, the damping effect allows the gain to be made up in the amplifier, so that for a given velocity constant a greater stiffness may be realized, and this reduces the static error in the system.

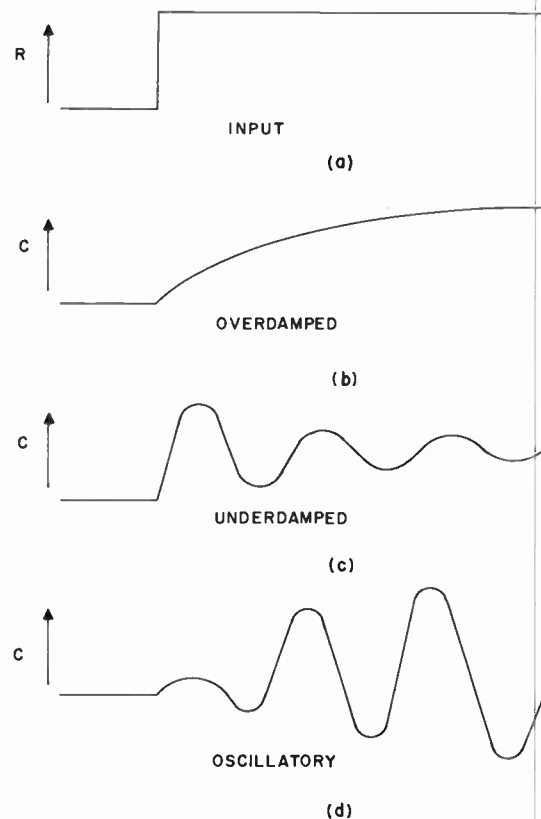

Figure 6-6. Response of Follow-Up Servo to Step Input

Another method of damping a servo is to use rate feedback, as shown in figure 6-7b. A generator is coupled directly to the motor shaft, and the output of the generator is a voltage directly proportional to the motor speed. If this voltage is fed back inversely to the amplifier, it results in a torque proportional to speed, the same as would be obtained with a friction or drag cup damper. However, since the subtracting is done at a low signal level, the amplifier is not required to supply any more power than when it is driving a motor with no load, and the motor does not have to be so large. Also, there is no requirement for dissipating the motor's energy when it is running. Figure 6-7a shows the response of motor speed to a step of error voltage, similar to figure 6-5. Let us assume for illustration that in the steady state condition .1 volt of  $E$  is required to make the motor turn at 1000 rpm. Very little torque is available to accelerate the motor initially because of the small error signal, and hence the rise time is rather large. In figure 6-7b, the generator fastened to the motor shaft puts out 1 volt per 1000 rpm. When excited with a step function  $E$  of 1.1 volts, the error signal  $\epsilon$  will at first be 1.1 volts, since the motor starts at zero speed and the generator output is initially zero. As the motor picks up speed, the generator voltage which is an exponential will subtract from the 1.1 volts initial value, and in the steady state condition, when the motor reaches

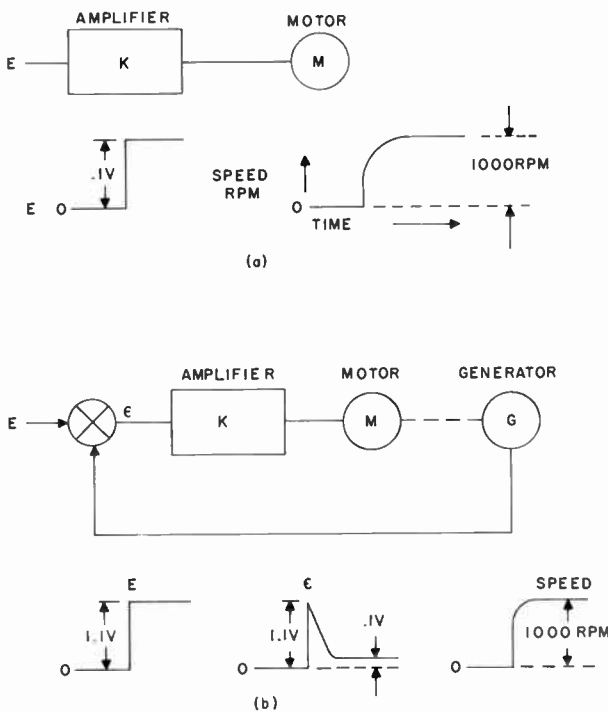

Figure 6-7. Effect of Rate Generator on Response Time

1000 rpm,  $\epsilon$  will be 1.1 volts minus the 1 volt generator output, which leaves .1 volt. The voltage going into the amplifier for the steady state condition is the same as in figure 6-7a, but the 1.1 volt spike present in the amplifier input in figure 6-7b produces eleven times more acceleration torque at the motor, reducing the rise time. Because the amplifier gain  $K$  is the same in both cases and because the rate generator output is 0 when the motor is stalled, the stalled torque for a given error signal is the same in both cases. Because of the much larger value of  $E$  required to get 1000 rpm with a rate generator, the velocity constant for this case will be 1/11 that of the motor alone. If in figure 6-7b, the amplifier gain  $K$  were multiplied by 11, the two systems would then have the same velocity constant but the system with the rate generator would have 11 times the stiffness, and the positioning accuracy would be 11 times as great.

Another method of stabilizing a servo and allowing an increase in its stiffness is to use a lead network. Figure 6-8 shows a lead network and its transient response to a step input. If 1 volt is suddenly applied

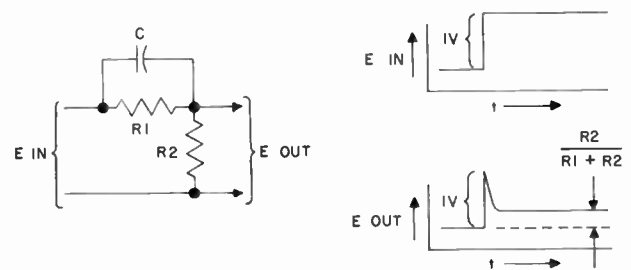

Figure 6-8. Lead Network

as  $E_{in}$ , the entire 1 volt will appear as  $E_{out}$  because the voltage across  $C$  cannot be changed instantaneously. As the capacitor charges up,  $E_{out}$  will drop exponentially and approach the value it would have if  $C$  were not present, which is  $E \frac{R_2}{R_1 + R_2}$ . This transient response is similar to that of  $\epsilon$  in figure 6-7b. Figure 6-9 shows how a lead network is used to accomplish a result similar to that obtained with a rate generator.

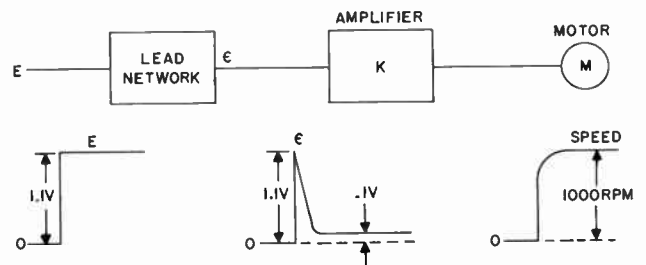

Figure 6-9. Effect of Lead Network on Response Time

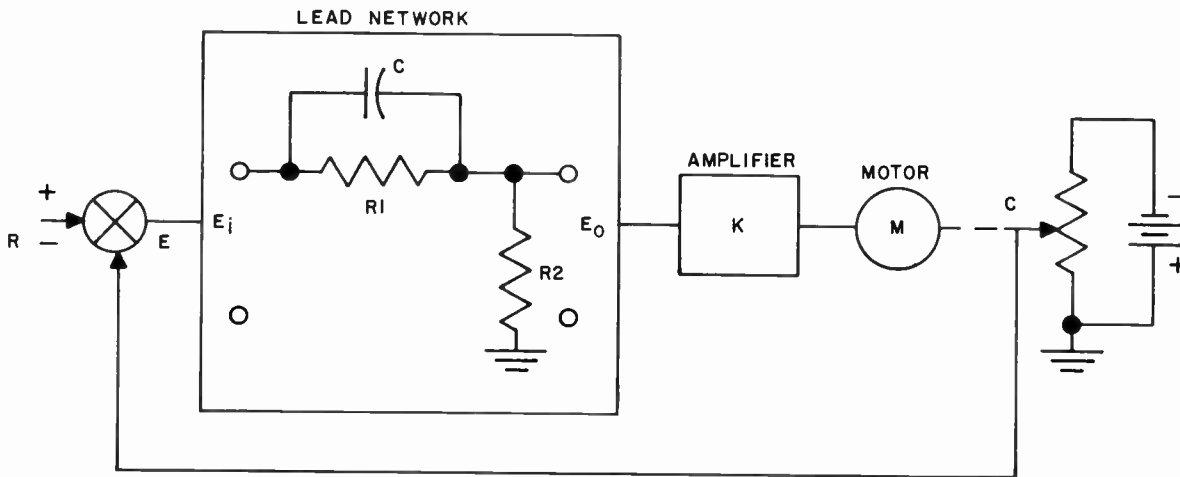

Figure 6-10. Position Follow-up Servo with Lead Network

If  $\frac{R_2}{R_1 + R_2}$  is made equal to  $1/11$ , a voltage of 1.1 volt applied at  $E$  will produce the wave form shown at  $\epsilon$  and this will produce a rapid acceleration of the motor to a speed of 1000 rpm. The capacitor in the lead network must be chosen to produce the same time constant in the signal at  $\epsilon$  as that of figure 6-7b.

The transfer function of the lead network of figure 6-8 may be derived by considering it a voltage divider with the parallel combination of  $R_1$  and  $C$  in the top leg and  $R_2$  in the bottom leg. Thus the output impedance is

$$Z_o = R_2$$

The parallel impedance of  $R_1 C$  is

$$\frac{R_1 \frac{1}{pC}}{R_1 + \frac{1}{pC}} = \frac{R_1}{1 + pR_1 C}$$

and the total series impedance of the divider is

$$Z_t = R_2 + \frac{R_1}{1 + pR_1 C} \quad \text{Hence}$$

$$\begin{aligned} \frac{E_o}{E_i} &= \frac{Z_o}{Z_t} = \frac{R_2}{R_2 + \frac{R_1}{1 + pR_1 C}} = \frac{R_2(1 + pR_1 C)}{R_1 + R_2 + pR_1 R_2 C} \\ &= \frac{R_2}{R_1 + R_2} \frac{1 + pR_1 C}{1 + p \frac{R_1 R_2}{R_1 + R_2} C} \end{aligned}$$

This expression may be rewritten as follows:

$$\frac{E_o}{E_i} = \frac{R_2}{R_1 + R_2} + \frac{R_2}{R_1 + R_2} \left( R_1 - \frac{R_1 R_2}{R_1 + R_2} \right) \frac{pC}{1 + \frac{R_1 R_2}{R_1 + R_2} pC}$$

$$\frac{E_o}{E_i} = \frac{R_2}{R_1 + R_2} + \frac{R_1^2 R_2 C}{(R_1 + R_2)^2} \frac{p}{1 + \frac{R_1 R_2}{R_1 + R_2} p}$$

$$\frac{E_o}{E_i} = K_1 + K_2 \frac{T_p}{1 + T_p p}$$

$$\text{therefore } E_o = K_1 E_i + K_2 \frac{T_p}{1 + T_p p} E_i$$

Thus, the lead network behaves like a straight feed with a gain of  $K_1$  plus a high-pass filter with a gain of  $K_2$ . The network differentiates low frequency signals. When connected in a closed position loop, as shown in figure 6-10, a lead network provides the sum of a position signal and a differentiated position signal, so that the rate of change of  $\epsilon$  is used, producing an effect similar to that of a rate generator except that  $R$  is differentiated as well as  $C$ .

## 5. COMPONENTS AND CIRCUITS

In the preceding discussion of the position follow-up servomechanism of figure 6-1, it was assumed that

the reference input and controlled variable voltages, the amplifier, and the motor were all direct-current components. In practice, 400 cycle or 60 cycle carrier systems are more commonly used for small, low power servo systems in radio communication equipment. The use of an a-c carrier system simplifies the design of the amplifier, and since an amplifier bandwidth of 40 or 50 cycles usually suffices, the d-c operating point of the individual stages is of no consequence. Because of the low-frequency requirement, the junction transistor is well suited to servo work. Where 20 watts or more of amplifier output is required, a magnetic amplifier or saturable reactor driven by a transistor preamplifier may be used. Some servo amplifiers employ high performance magnetic amplifiers for all stages.

The most commonly used type of servomotor is the two phase induction motor, and frequently a two phase induction generator is built into the same case and coupled to the motor shaft. The schematic diagram for a typical motor generator appears in figure 6-11. The reference phase of the motor must be driven with a voltage 90° out of phase with the voltage on the control phase in order to obtain torque. If the control phase voltage leads the reference phase voltage, the motor will turn in one direction, and if the control phase voltage lags the reference voltage, the motor will turn in the opposite direction. Thus if the error signal source is a 400 cps signal, a phase reversal of the error signal produces a reversal of motor rotation, as required.

In some cases where the servo amplifier output is either in phase or 180 degrees out of phase with the line voltage depending on the sense, the required quadrature relationship between control and reference winding is obtained by means of a phase shift capacitor C which produces a quadrature voltage on the reference winding. Sometimes however, it is more convenient to produce the required 90° phase shift inside the servo

amplifier, in which case the reference winding is connected directly to the 400 cps line. When its excitation winding is driven from the 400 cps line, the rate generator produces across its output terminals a voltage proportional to the speed of rotation and either in phase or out of phase with the excitation voltage, depending upon the direction of rotation.

If the purpose of the servomechanism is merely to repeat the position of a shaft or to produce an output shaft position proportional to a voltage used as a reference input, a-c line voltages may be used across reference and controlled variable potentiometers in place of the d-c voltages used in the illustration of figure 6-1. In this case, as the controlled variable voltage increases and becomes larger than the reference input, the phase of the error signal voltage reverses and reverses the direction of rotation of the two-phase servomotor. In this way a carrier servo system may be constructed in which all variables are represented by 400 cps a-c voltages.

In some transmitter tuning servos and antenna matching networks, it is desired to have the servomotor and gear train position a mechanical tuning element such as a variable capacitor to a position such that the phase shift imposed upon an r-f signal by the tuned circuit is zero. An r-f phase discriminator circuit of the type used for detection of FM signals may be used to obtain a d-c voltage proportional to the magnitude of the phase shift through the r-f circuit, and of polarity determined by whether the output leads or lags the input. If this d-c error information is to be fed into a carrier type servomechanism, it may be converted to a-c by means of an electromechanical chopper connected as in figure 6-12. The chopper consists of a vibrating reed and a pair of contacts which form a single-pole double-throw switch. The reed is excited from a magnetic coil and is driven from the 400 cps line. In most cases the action of the reed contact is not in phase with the excitation voltage fed to the coil, so that a phase shift network must be used on the coil

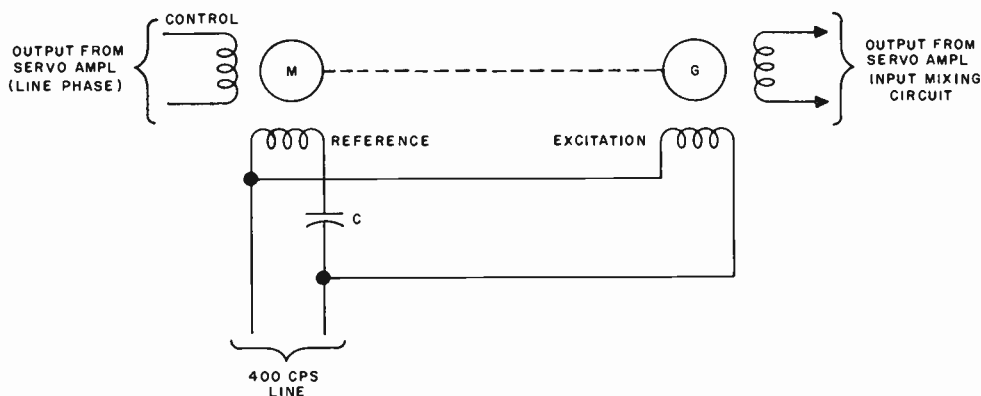

Figure 6-11. Motor-Generator Schematic Diagram



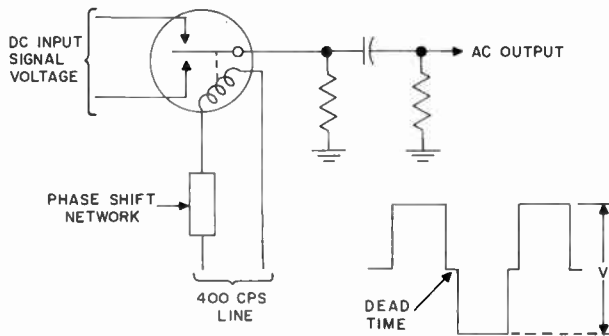

Figure 6-12. Electromechanical Chopper Circuit

to make the reed contact action either in phase with or in quadrature with the line, as required. In the chopper output wave form shown in figure 6-12, the peak to peak voltage of the square wave is the amplitude of the d-c voltage connected across the contacts.

Another type of position transmitter frequently encountered is the synchro. Figure 6-13 illustrates a typical synchro error circuit. The synchro transmitter may be thought of as being a transformer with a single primary, the rotor winding, and three secondaries, the three stator windings. The stator windings are placed with their axes  $120^\circ$  apart. The rotor winding induces an a-c voltage in each of the stator windings proportional to the cosine of the angle between the rotor winding axis and the respective stator winding axes. The stator windings of the control transformer are connected directly across the stator windings of the transmitter. Therefore, the same voltages will exist across each of the control transformer stator windings as are induced in the corresponding stator windings of the transmitter, and the

field pattern set up inside the core of the control transformer will be a replica of the field pattern in the transmitter. If the control transformer rotor winding axis is lined up with this field, the error signal voltage developed across the rotor terminals will be maximum. As the control transformer rotor is turned, the error signal voltage will decrease and become zero when the rotor axis makes an angle of  $90^\circ$  with the field pattern set up by the stator windings. Further rotation of the rotor will produce an increasing error voltage of reversed phase. Thus, if the rotor of the transmitter is actuated by the reference input shaft of a position follow-up system (figure 6-1) and the control transformer rotor is coupled to the controlled variable shaft, the voltage developed across the rotor of the control transformer may be used as an error signal  $E$  to be fed into the servo amplifier, and the rotor of the control transformer will follow the transmitter rotor.

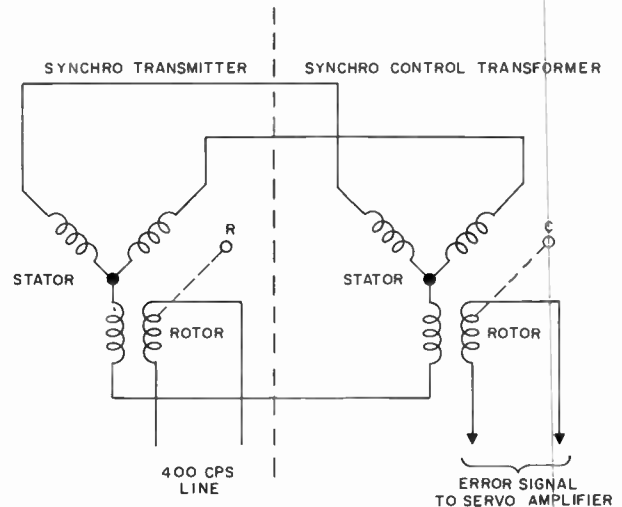
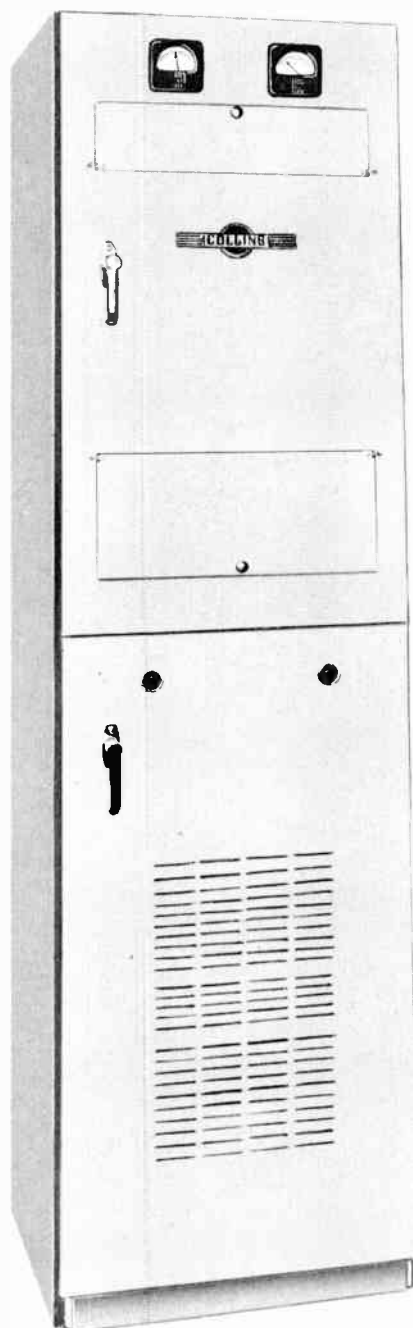

Figure 6-13. Synchro Error Circuit





Collins 204F Power Amplifier, a Three Stage Linear Amplifier with an Output of 2.5 Kw PEP

## CHAPTER 7

### R-F LINEAR POWER AMPLIFIERS

#### 1. INTRODUCTION

The r-f power amplifier of the SSB transmitter receives a low power level, radio-frequency SSB signal from the exciter. The function of the power amplifier is to raise the power level of the input signal without changing the signal. That is, the envelope of the output signal must be a replica of the envelope of the input signal. A power amplifier which will perform this function is, by definition, a linear power amplifier.

#### 2. POWER AMPLIFIER CLASSIFICATION

Radio-frequency amplifiers are classified A, B, and C according to the angle of plate current flow; that is, the number of degrees of plate current flow during a 360° r-f cycle. Class A amplifiers have a continuous plate current flow and operate over a small portion of the plate current range of the tube, as shown in figure 7-1. This class amplifier is used for amplification of small signals for low distortion.

Its efficiency in converting d-c plate power input into r-f power output is quite low, usually less than 35 per cent, but this is seldom of major importance where small signals are amplified.

Class B amplifiers have their grids biased to near plate current cutoff so that plate current flows for approximately 180° of the r-f cycle, as shown in figure 7-2. Amplifiers operated with appreciably more than 180° of plate current flow but less than 360° are called class AB amplifiers. Both class AB and class B operation is used in the high-power stages of r-f linear amplifiers to achieve higher efficiency and maximum output power with low distortion. Plate efficiency depends upon the tube used and the operating conditions selected, with efficiencies in the range of 50 to 70 per cent obtainable. The distinction between class B and class AB is somewhat arbitrary since both operate over more than 180° but less than 360°. However, the class AB amplifier draws appreciably more static plate current than the class B amplifier, which draws only a small static plate current.

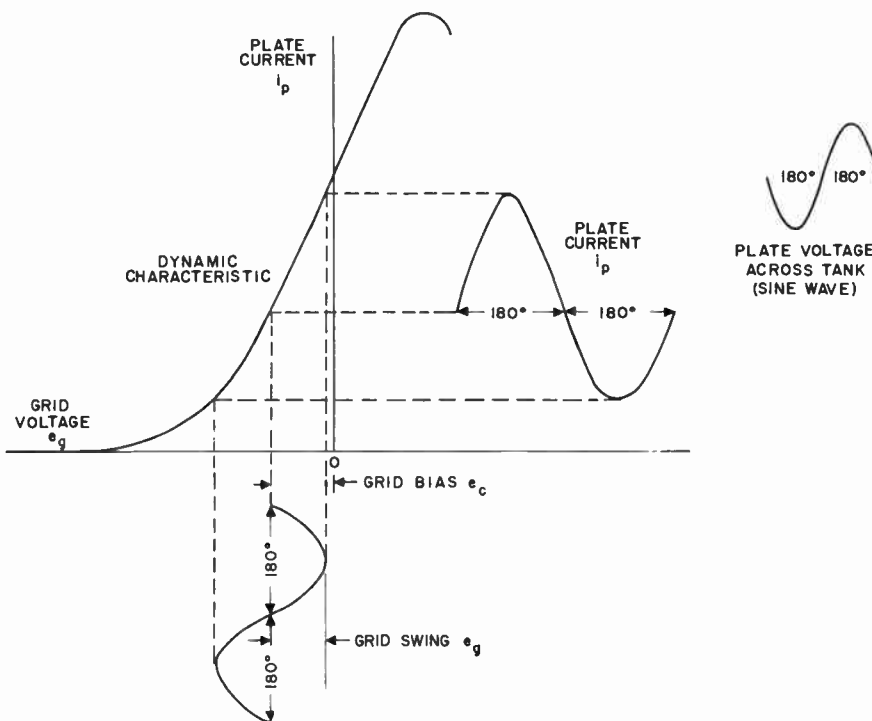

Figure 7-1. Class A Tube Operation

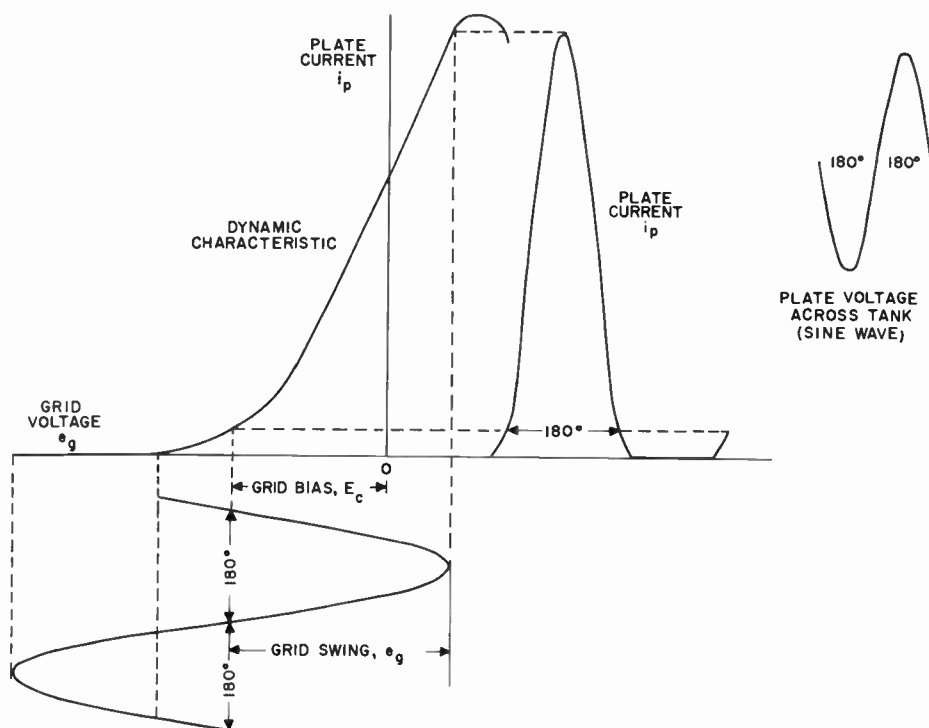

Figure 7-2. Class B Tube Operation

The class C amplifier, as shown in figure 7-3, is biased well beyond cutoff so that plate current flows less than 180° of the r-f cycle. The principal advantage of the class C amplifier is high plate efficiency, from 65 to 85 per cent, but class C amplifiers are not suited for SSB use because they are not linear amplifiers and will not respond to low-level input signals.

A subscript number is commonly added to the amplifier class designator to indicate whether or not the tube is operated in the positive grid region over part of the cycle. For example, class AB<sub>1</sub> indicates that the grid never goes positive so that no grid current is drawn. Class AB<sub>2</sub> indicates that the grid does go positive so that grid current is drawn. Because class A amplifiers are nearly always operated without grid current, and because class C amplifiers are nearly always operated with grid current, subscript designators are omitted unless they are operated to the contrary of the usual practice.

### 3. R-F POWER AMPLIFIER TUBES

Conventional grid-controlled power amplifier tubes are classified according to the number of elements they have. Until fairly recently, the triode which has a control grid in addition to the cathode and anode was the only transmitting-type tube available in the medium and high power sizes. (The cathode is sometimes called the filament because the cathode is

usually directly heated in high power tubes, and the anode is often called the plate.) Tetrodes, which have a screen grid between the control grid and plate, have recently become available. The screen grid provides an accelerating potential to the electron stream and also provides an electrostatic shield between the anode and the control grid. The two grids of most transmitting-type tetrodes provide a beaming action to the electron stream which improves the tube characteristics. This beaming action reduces the d-c screen current and increases the control of the control grid. Power pentodes up to 1 kw have an additional grid, a suppressor grid, located between the screen and the anode. In some beam power tubes this element may consist of beam forming plates which, in general, give an improved plate characteristic when the plate voltage swings below or in the region of the d-c screen voltage.

Triode power amplifier tubes have the advantage of simplicity, low cost, and availability in all sizes. In general, they require a large amount of driving power. Also, since their grid is exposed directly to the plate, there is considerable capacitive coupling from the plate to the grid within the tube. This plate-to-grid capacitance must be accurately neutralized in r-f linear power amplifiers. The amplification factor of triode tubes ranges from 4 to 5 for low mu tubes, to twenty for medium mu tubes to fifty for high



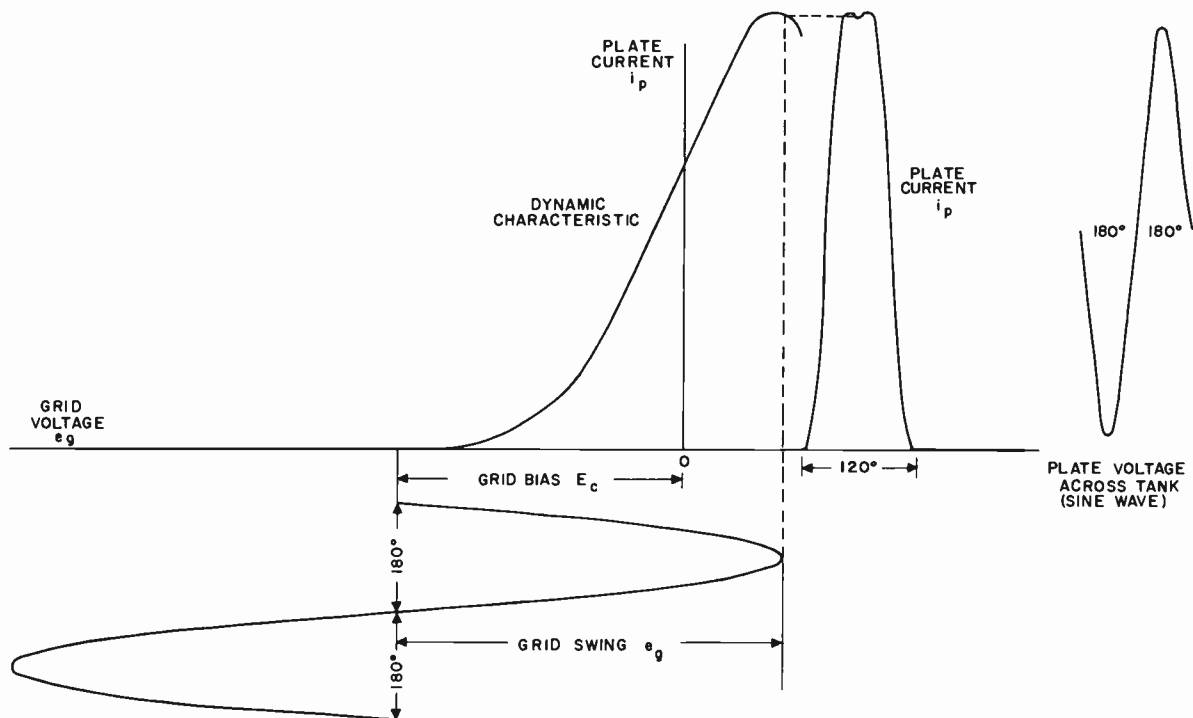

Figure 7-3. Class C Tube Operation

mu tubes. Generally only the low and medium mu triodes can be used for linear power amplifier circuits. Therefore, a large grid swing is required to obtain the power amplification available from the tube.

In tetrode power amplifier tubes, the screen grid acts as an electrostatic shield between the plate and control grid which reduces the plate-to-grid capacitance. This reduces the neutralization required to as little as one-hundredth of that required for a triode. However, since the gain of the tetrode tube is so much higher than that of the triode, neutralization of the small residual plate-to-grid capacitance of the tetrode is still required for the best, high-gain linear performance. Because of the high gain of the tetrode, the tube requires relatively low drive to obtain high power output. This advantage allows fewer stages to be used to obtain a given power output.

Pentode construction is used in most small receiving size power tubes and in some cases in power tubes up to 1 kw output. In small tubes, pentodes provide good performance with low plate voltage, and in larger tubes, pentodes give improved efficiency because the r-f plate swing can be increased some. The pentode has disadvantages in that it is more complex than the tetrode, is more expensive, and requires extra circuitry for the suppressor grid. These disadvantages have limited the development of the pentode power tubes. At the present time, the pentode has little advantage over the well designed tetrode.

For r-f linear amplifier operation, the following features are desirable in the power amplifier tubes:

- (1) High gain
- (2) Low plate-to-grid capacitance
- (3) Good efficiency
- (4) Linear characteristics which are maintained without degradation at all frequencies in the desired operating range

The needs for power amplifier tubes in the vhf and uhf ranges have spurred development of tubes suitable for operation at those frequencies. This has resulted in tubes with better performance in the h-f (3 to 30 mc) range. A typical comparison can be made between the type 813 tube and the type 4X250B tube which are in the same power class. The small compact design of the 4X250B tube results in short lead lengths, better screening, closer element spacing and much higher performance which can be maintained easily over the h-f range. The ceramic construction, rather than glass, of an increasing number of new tubes promises to result in a more rugged and longer lived tube. Ceramic sealed tubes which are now available include the RCA-6118 which is smaller than the 4X150A, the Eimac 4CX300A which has characteristics similar to the 4X250B, an all ceramic version of the

4X250B, the Eimac 4CX5000A which is capable of 10 kw of r-f output, and an RCA super-power, shielded-grid tube that will deliver 500 kw of r-f output. Tube manufacturers have additional types of power amplifier tubes under development which promise better performing tubes for the near future.

The Collins Radio Company has chosen to use high gain tubes of those types considered to be the best compromise of desired characteristics. At low signal levels, such as exist in exciters, conventional receiver-type r-f amplifier tubes are used. For delivering .1 watt output from exciters, the type 6CL6, which is a miniature 9-pin tube, is generally used. The 6CL6 is also frequently used to excite type 4X250B power amplifier tubes. The 4X250B tube is used in small, compact equipment for power levels of 1 kw by paralleling three, and for power levels of 500 watts by paralleling two. The type 4CX5000A is used for power levels of from 5 kw to 10 kw. This tube is used to obtain power levels up to 45 kw by paralleling four of them.

#### 4. BASIC LINEAR POWER AMPLIFIER CIRCUITS

##### a. GENERAL

For linear operation, r-f power amplifiers may be operated class A or class AB. The amplifiers used are quite conventional, being either grid driven or cathode driven (grounded grid) type amplifiers. However, the design considerations are extremely stringent to produce maximum linearity for a given tube in a given circuit. The tube operating point must be discreetly chosen and precisely maintained, neutralization must be as effective as possible, r-f feedback circuits are often used, and input and output impedances must be held as constant as possible. Generally class A pentode power amplifiers are employed in low-level power stages to preserve linearity in these stages while producing enough power to drive the higher level stages. Class AB<sub>1</sub> or AB<sub>2</sub>, triode or tetrode power amplifiers are employed in the high-level power stages to obtain the desired power output.

##### b. GRID DRIVEN TRIODE POWER AMPLIFIER

Figure 7-4 is a simplified schematic of a typical grid driven triode power amplifier. This amplifier, operating class AB<sub>1</sub>, produces up to 2.5 kw using the type 3X3000A-1 triode. The triode tube, having a large plate-to-grid interelectrode capacitance, always requires neutralization to prevent oscillation when used in the grid-driven circuit. The only types of triodes capable of class AB<sub>1</sub> operation are the low amplification factor types, such as the 3X3000A-1. Due to the low amplification factor, very high r-f grid excitation voltage is required, on the order of 1000 volts for the 3X3000A-1. A similar tube suitable for class AB<sub>2</sub> operation is the 3X2500A-3 which has an

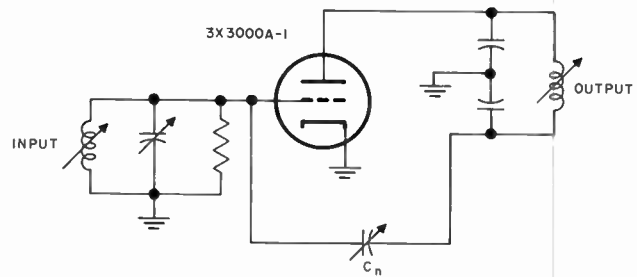

Figure 7-4. Grid Driven, Plate Neutralized Triode Power Amplifier

amplification factor of 20. This medium- $\mu$  triode requires less grid swing, but it requires grid driving power for class AB<sub>2</sub> operation. Neutralization, of course, is still required.

A swamping resistor is used in the grid circuit to maintain a constant input impedance to the stage and for stability. When the stage is operated class AB<sub>2</sub>, the grid current represents a varying load to the driving source. By adding the swamping resistor, the grid current drawn represents only a small portion of the total grid load so that the driver load impedance is relatively constant. The swamping resistor does increase the required driving power. The swamping resistor also improves stability by affording a low impedance to ground for regenerative feedback through the plate-to-grid capacitance.

##### c. CATHODE DRIVEN TRIODE POWER AMPLIFIER

Figure 7-5 is a simplified schematic of a typical cathode driven (grounded grid) triode power amplifier. This amplifier, operating class AB<sub>2</sub> produces 4 to 5 kw using the type 3X2500A triode. In the cathode driven amplifier, the control grid is at r-f ground and the signal is fed to the cathode. The main advantage

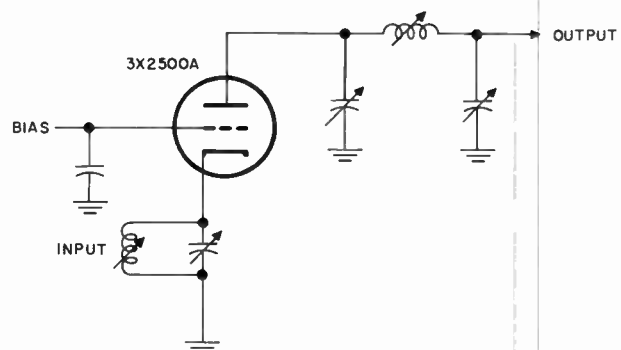

Figure 7-5. Cathode Driven Triode Power Amplifier

of operating the triode in this manner is that the control grid becomes an effective screen between the plate and the cathode making neutralization seldom necessary. The small values of plate-to-cathode capacity have very little effect on the input signal because the input circuit impedance is usually quite low. Since neutralization is not required, triodes with an amplification factor of 20, such as the 3X2500A, can be used. Another advantage of the cathode driven power amplifier is that the feedthrough power is an effective load across the input circuit, making swamping resistors unnecessary. The main disadvantages of this circuit are that a large driving power is required and that power gains of from six to ten are all that can be realized. Most of the power required for driving, however, feeds through the stage and appears in the plate circuit so that it is not lost. The cathode driven circuit is a convenient circuit to use when high power has already been developed and needs another step up.

#### d. GRID DRIVEN TETRODE POWER AMPLIFIER

Figure 7-6 is a simplified schematic of a grid driven tetrode power amplifier. This amplifier, operating class AB<sub>1</sub> produces 250 watts per tube using the type 4X250B tetrode. In general, the same design considerations exist for tetrode amplifiers as for triode amplifiers. That is, grid circuit swamping is required to hold the input impedance constant if the tetrode is driven into the grid current region, and neutralization is generally required if the tube is to operate over the entire high-frequency range. However, since the plate-to-grid capacitance is small in the tetrode, neutralization is much simpler. The tetrode amplifier, being a high gain tube, requires relatively little driving power and a relatively small grid swing for operation. This permits the paralleling of tubes with a common input network and a common output network which reduces the number of stages and simplifies tuning. In the tetrode power amplifier, the screen voltage has a very pronounced effect on the

dynamic characteristic of the tube. By lowering the screen voltage, the static current required for optimum linearity is lowered. This permits greater plate r-f voltage swing which improves efficiency. The use of lower screen voltage has the adverse effect of increasing the grid drive for class AB<sub>2</sub> operation and lowering the power output for class AB<sub>1</sub> operation. The tetrode tube can be used in the cathode driven circuit and can be so used without neutralization in the high-frequency range.

## 5. POWER AMPLIFIER OUTPUT NETWORKS

### a. TANK CIRCUIT CONSIDERATIONS

The plate tank circuit of an r-f power amplifier must perform four basic functions:

- (1) It must maintain a sine wave r-f voltage on the plate of the tube.
- (2) It must provide a low impedance path from plate to cathode for harmonic components of the plate current pulses.
- (3) It must provide part or all of the necessary attenuation of harmonics and other spurious frequencies.
- (4) It must provide part or all of the impedance matching from the tube plate to the antenna.

In addition, for many uses the output circuit should be single ended so that it will feed into a 52 ohm coaxial transmission line. A 52 ohm coaxial transmission line is desirable because it prevents stray r-f radiation near the transmitter; it is convenient for coaxial r-f switching; it is a convenient impedance for additional r-f filtering, and because it is ideal for directional wattmeter installation. For simplicity of operation, the output circuit should require a minimum of tuning controls. A direct-coupled network, such as the Pi-L network, is the most suitable network to meet these requirements.

The Q of the plate circuit, of which the tank is a part, must be sufficient to keep the r-f plate voltage close to a sine wave shape. This is often referred to as the "flywheel effect." If the plate circuit Q is insufficient, the r-f waveform may be distorted which will result in low plate efficiency. This loss of efficiency is seldom noticed unless the plate circuit Q is less than 5. A plate circuit Q of at least 10 is known to be sufficient for linear operation and is a recommended minimum.

A power amplifier operating either class AB, B, or C delivers power to the tank circuit by plate current pulses. The harmonic content of these pulses is determined primarily by the angle of plate current

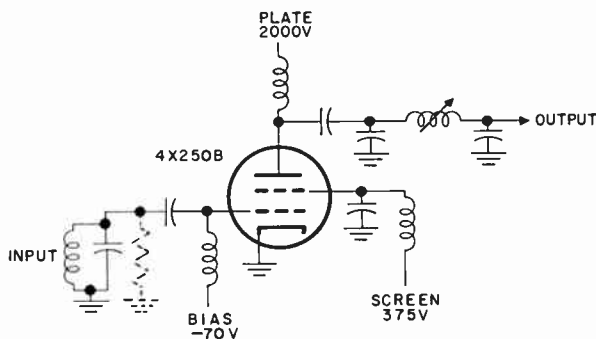

Figure 7-6. Grid Driven Tetrode Power Amplifier

flow, the harmonics being greater with a smaller angle of plate current flow. In a linear power amplifier, the second harmonic component can be as great as 6 db below the fundamental at full peak envelope power. The higher order harmonic components drop off rapidly but their magnitude varies greatly, depending upon the pulse shape. These harmonics must be attenuated in the output network so that they are 50 db, 80 db, or even further, below the fundamental component. The Pi-L network will attenuate the second harmonic to about 50 db below the fundamental, which is from 10 db to 15 db more attenuation than can be obtained from the simple Pi network. Where more attenuation is required, external filters of either the low-pass or band rejection type are added. Increasing plate circuit Q increases harmonic attenuation, but since doubling the Q results in only about 6 db more second harmonic attenuation, Q's above 20 are seldom used below 30 mc.

The Pi-L output network is ideally suited to matching a tube load to a 52-ohm coaxial transmission line. Loads with a standing wave ratio as high as 4 to 1 can be matched easily. This can be done with any value of tube load impedance, whereas the simple Pi network has difficulty matching to low load impedance when the tube plate load resistance is high.

The Pi-L network has only four variable elements, and they can be ganged to have only a tuning control and a loading control, as shown in figure 7-7. Since in the Pi-L network, C<sub>2</sub> and L<sub>2</sub> affect loading in the same direction, the extra capacity and inductance range of the elements required to extend the loading range of the circuit is relatively small. For example, the loading control varies about ±25 per cent to match a 52 ohm load with a 4:1 swr. The tuning control varies about ±10 per cent.

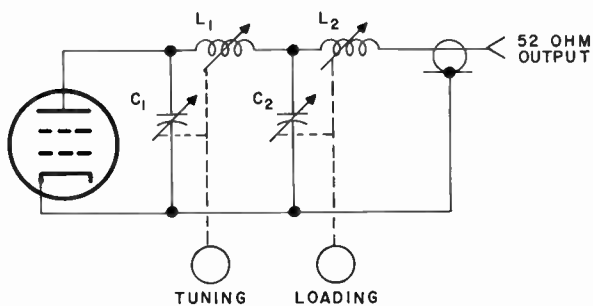

Figure 7-7. Tuning Controls for Pi-L Output Network

**b. CIRCUIT LOSSES**

Nearly all of the tank circuit loss occurs in the coils. These losses are closely related to the ratio of

plate circuit Q to coil Q, but other design considerations enter in. These circuit losses are shown in figure 7-8 for a Pi-L network, which has lower losses than other networks for 50 db of second harmonic attenuation. Resistances r<sub>1</sub> and r<sub>2</sub> represent the equivalent series resistance of the coils determined from coil Q and reactance. Resistance r<sub>q</sub> is the equivalent load resistance in series with L<sub>1</sub> and is determined from the relationship

$$r_q = \frac{R_L}{Q^2 + 1} = \frac{R_L}{(R_L/XC)^2 + 1}$$

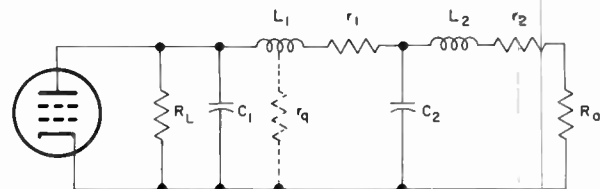

Figure 7-8. Circuit Losses in Pi-L Network

Resistance R<sub>a</sub> is the series resistive component of the load. The Pi-L network loss is given by the equation:

$$\text{Per cent loss} = \left( \frac{r_1}{r_q + r_1} + \frac{r_2}{R_a + r_2} \right) 100$$

**c. TANK COIL AND CAPACITOR REQUIREMENTS**

The frequency range and method of tuning are major factors in determining tank circuit components. Continuously variable coils and capacitors which will cover the entire frequency range without any band switching are the most desirable. However, this is not practical in Autotune transmitters because of the limited torque available to drive the tuning elements and the often short repositioning time specified. With these limitations, bandswitching is almost essential. Where instantaneous frequency change is specified, it is common to switch from one pretuned r-f unit to another and manually tuned circuits are suitable for this purpose. Servo control of the tuning elements permits incorporation of various automatic tuning or repositioning circuits and is well suited for driving continuously variable elements. A practical way to design a transmitter is to use continuously variable elements that can be operated either manually or by an accessory servo system.

The use of continuously variable elements has the following advantages:

- (1) The circuit Q can be kept more uniform across the frequency range.



- (2) The circuit losses can be kept to a minimum.
- (3) The range of variable coils and capacitors can be less.
- (4) A maximum amount of harmonic attenuation is more easily maintained across the frequency range.

Variable vacuum capacitors are widely used in transmitters with power levels of 1 kw and higher. Their added expense is often justified by the added capacity range, small size, and low series inductance, especially where voltages above 2500 volts are employed. Variable tank coils are usually constructed with a rotary coil and either a sliding or rolling contact that traverses the length of the coil as it is rotated. The unused turns are shorted out to keep high voltages from developing in them. The series self-resonant frequency of the shorted-out section must not be near the operating frequency or high circulating currents will develop and cause, appreciable power dissipation.

## 6. NEUTRALIZATION

### a. EFFECTS OF PLATE-TO-GRID CAPACITANCE

The purpose of neutralization is to balance out the effect of plate-to-grid capacitive coupling in a tuned r-f amplifier.

In a conventional tuned r-f amplifier using a tetrode tube, the effective input capacity of the tube is given by the following equation:

$$\text{Input capacitance} = C_{in} + C_{gp} (1 + A \cos \Theta)$$

where  $C_{in}$  is tube input capacitance

$C_{gp}$  is plate-to-grid capacitance

$A$  is voltage amplification from grid to plate

$\Theta$  is phase angle of plate load.

In an unneutralized, 4-1000A tetrode amplifier with a gain of 33, the input capacity of the tube with the plate circuit in resonance is increased 8.1 uuf due to the unneutralized plate-to-grid capacity. This small increase in capacitance is not particularly important in amplifiers where the gain remains constant, but if the gain does vary, serious detuning and r-f phase shift can result. The gain of a tetrode or pentode r-f amplifier operating below plate saturation does vary with loading so that if it drives a following stage into grid current, the loading increases and the gain falls off.

The input resistance of the grid is also affected by the plate-to-grid capacitance. The input resistance is given by the following equation:

$$\text{Input resistance} = \frac{1}{2\pi f C_{gp} (A \sin \Theta)}$$

This input resistance is in parallel with the grid current loading, grid tank circuit losses, and driving source impedance. When the plate circuit is tuned to the inductive side of resonance, energy is transferred from the plate to the grid circuit through the plate-to-grid capacitance (positive feedback). This introduces negative resistance in the grid circuit. When this shunt negative resistance across the grid circuit is lower than the equivalent positive resistance of the grid loading, circuit losses, and driving source impedance, the amplifier will oscillate. As the plate circuit is tuned to the capacitive side of resonance, the input resistance becomes positive and power is transferred from the grid-to-the-plate circuit. This is why the grid current in an unneutralized tetrode r-f amplifier varies from a low value to a high value as the tank circuit is varied from below to above resonance. If the amplifier is overneutralized, the effect reverses. This effect can be observed in a pentode or tetrode amplifier operating class A or  $AB_1$  by placing an r-f voltmeter across the grid circuit and tuning the plate circuit through resonance.

### b. NEUTRALIZING CIRCUITS

Most of the neutralizing circuits developed for use with triodes may be used equally successfully with tetrodes. However, those circuits which require balanced tank circuits for neutralizing purposes only, are undesirable because the trend in r-f power amplifier design is toward single-ended stages.

A conventional grid neutralized amplifier is shown in figure 7-9. Capacitor  $C_3$  balances the grid-to-filament capacity to keep the grid circuit in balance. When  $C_1 = C_2$  and  $C_n = C_{gp}$ , it is readily seen that a signal introduced into the grid circuit will not appear across the plate circuit because the coupling through  $C_n$  is equal and opposite to the coupling through  $C_{gp}$ .

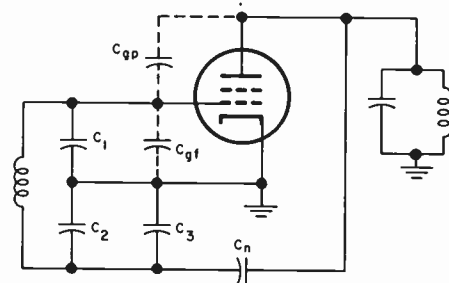

Figure 7-9. Conventional Grid-Neutralized Amplifier



The relationship for no coupling from the grid circuit to the plate circuit is given by the relationship

$$\frac{C_1}{C_2} = \frac{C_{gp}}{C_n}$$

This indicates that the grid tank circuit need not be balanced to ground. If  $C_2$  is made larger, then  $C_n$  must be made correspondingly larger. In a tetrode amplifier,  $C_{gp}$  is very small (approximately .1 uuf) so that practical values, 5 uuf, can be used for  $C_n$  when  $C_2$  is very much larger than  $C_1$ .

By placing most of the grid tuning capacitance across the grid tank coil, using the bypass capacitor  $C$  from the bottom end of the grid tank circuit to ground for  $C_2$ , and using the grid-to-filament capacity for  $C_1$ , the modified grid neutralized circuit shown in figure 7-10 results. The relationship for neutralization of this circuit is given by the relationship

$$\frac{C_n}{C} = \frac{C_{gp}}{C_{gf}}$$

This relationship assumes perfect screen and filament bypassing and negligible effect from stray inductance and capacity. This modified grid neutralizing circuit is very effective for neutralizing tetrode power amplifiers and is accomplished with single-ended tuning elements.

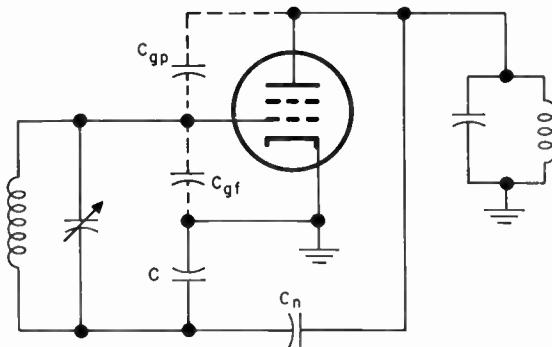

Figure 7-10. Modified Grid-Neutralized Amplifier

**c. TESTING FOR PROPER NEUTRALIZATION**

When a power amplifier stage is properly neutralized, the power output peaks at the same time the plate current dips. An indication of this simultaneous peak and dip is often the most convenient way of testing for proper neutralization. To perform such a test, the d-c cathode current, or plate current, of the

neutralized stage is used to obtain an indication of plate current dip. The power output from the same stage or the grid drive to any succeeding stage is used to obtain an indication of power output. A power amplifier is usually checked for proper neutralization near the high-frequency end of its range where neutralization is more critical.

When the drive to a neutralized stage is so low that a plate current dip is not present, the best way to test for proper neutralization is by injecting a test signal into one circuit and checking for coupling of the signal into another circuit. In the modified grid neutralized circuit shown in figure 7-10, proper neutralization balances out coupling between the input tank circuit and the output tank circuit, but it does not remove all coupling between the plate circuit and the grid-to-cathode circuit. Therefore, a test signal injected into the plate circuit will result in grid-to-cathode signal even with proper neutralization. However, a test signal injected into the plate circuit will not result in a signal in the grid coil with proper neutralization. The presence of a signal in the grid coil can be detected by using an inductive coupling loop. This circuit can also be neutralized by inductively coupling an input signal into the input circuit and adjusting the neutralizing capacitor for minimum signal on the plate circuit.

**7. R-F FEEDBACK CIRCUITS**

**a. INTRODUCTION**

An r-f feedback is a very effective means of reducing distortion in a linear power amplifier. Twelve decibels of r-f feedback produces nearly twelve decibels of distortion reduction, and this distortion reduction is realized at all signal levels. However, voltage gain per stage is reduced by the amount of feedback employed, so that with 12 db of feedback the gain is reduced to one-quarter.

**b. FEEDBACK AROUND ONE STAGE**

Figure 7-11 shows a negative feedback circuit around a one-stage r-f amplifier. The voltage

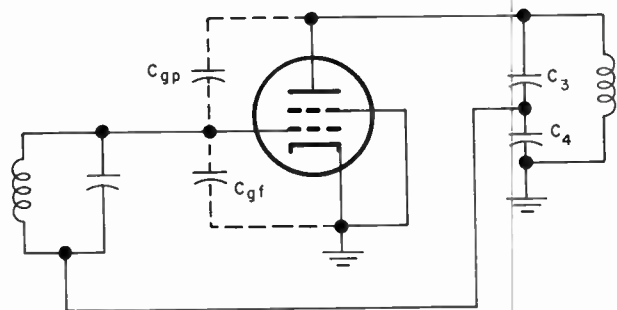

Figure 7-11. One-Stage Feedback with Neutralization

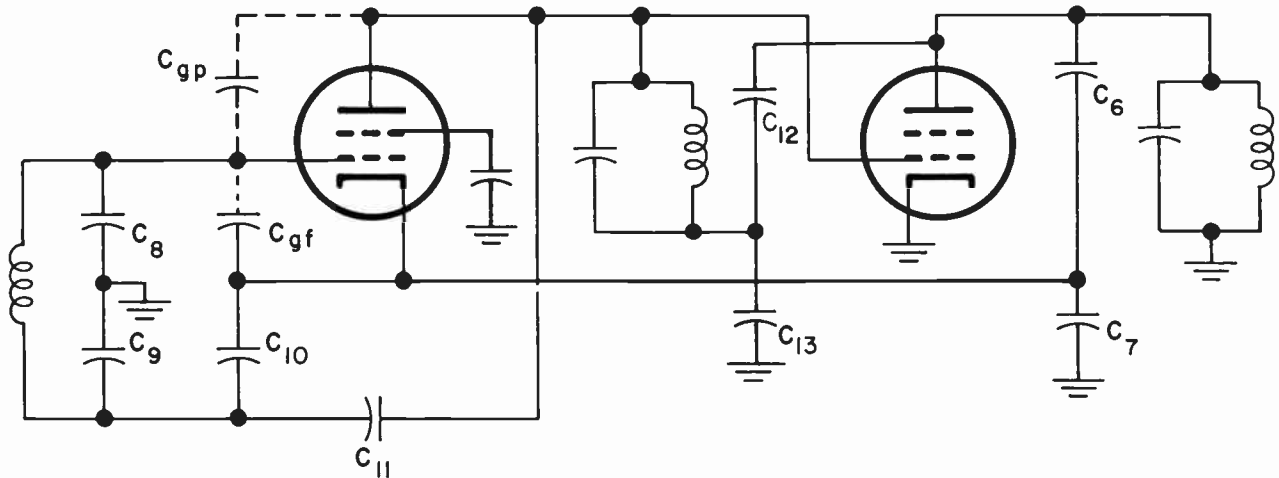

Figure 7-12. Two-Stage Feedback with Neutralization

developed across  $C_4$  is introduced in series with the voltage developed across the grid tank circuit and is in phase opposition to it. The feedback obtainable with this circuit can be varied between zero and 100 per cent by properly choosing the values of  $C_3$  and  $C_4$ . It is necessary to neutralize this feedback amplifier, the neutralization requirements being

$$\frac{C_{gp}}{C_{gf}} = \frac{C_3}{C_4}$$

To satisfy the neutralization requirement, it is usually necessary to add capacity from the plate to the grid.

Using this circuit presents a problem in coupling into the grid circuit. Inductive coupling is ideal, but the extra tank circuit complicates the tuning of the power amplifier if several cascaded amplifiers are used with feedback around each. The grid can be capacity coupled to a driver with a high source impedance, such as a tetrode or pentode. However, if this is done, feedback can not be used in the driver because it would cause the source impedance to be low.

### c. FEEDBACK AROUND TWO STAGES

Feedback around two r-f stages has the advantage that more of the tube gain can be realized while nearly as much distortion reduction can be obtained. For instance, 12 db feedback around two stages provides about the same distortion reduction as 12 db around each of two stages separately. Figure 7-12 shows a negative feedback circuit around a two stage amplifier with each stage neutralized. The small feedback voltage required is obtained from the voltage divider  $C_6$  and  $C_7$ . This feedback voltage is applied to the cathode

of the first stage. The feedback divider can be left fixed for a wide frequency range since  $C_6$  is only a few micromicrofarads. For example, if the combined tube gain is 160 and 12 db of feedback is desired, the ratio of  $C_7$  to  $C_6$  may be 400 uuf to 2.5 uuf. Either inductive input coupling or direct capacitive coupling may be used with this circuit, and any form of output coupling can be used.

It is necessary to neutralize the cathode-to-grid capacity of the first tube in the two stage feedback circuit to prevent undesirable feedback coupling to the input grid circuit. The relationship for the circuit which accomplishes this cathode-to-grid neutralization is

$$\frac{C_8}{C_9} = \frac{C_{gf}}{C_{10}}$$

To reduce the voltage across the input tank coil and minimize the power dissipated by the coil, the input circuit can be unbalanced by making  $C_9$  up to five times  $C_8$ , as long as  $C_{10}$  is increased accordingly. The cathode-to-grid capacity of the first tube can be neutralized by injecting a test signal into the cathode of the tube. The neutralizing bridge is then adjusted for minimum signal as indicated by a detector which is inductively coupled into the input coil.

Except for tubes with very small plate-to-grid capacity, it is necessary to neutralize  $C_{gp}$  in both tubes. This neutralization for the second tube is realized by choosing  $C_{12}$  and  $C_{13}$  so that the ratio  $C_{12}/C_{13}$  equals the ratio  $C_{gp}/C_{gf}$  in the second tube.

If neutralization of  $C_{gp}$  is necessary for the first tube, it is obtained by satisfying the relationship

$$\frac{C_{gp}}{C_{11}} = \frac{C_{gf}}{C_{10}} = \frac{C_8}{C_9}$$

The screen and suppressor of the first stage should be grounded to keep the tank output capacity directly across the interstage circuit. This avoids common coupling between the feedback on the cathode and the interstage circuit.

In a two stage feedback amplifier, the voltage fed back to the cathode of the first stage must be in phase with the grid input signal, measured from grid to ground. If the feedback voltage is not in phase with the grid input signal, the resultant grid-to-cathode voltage increases as shown in figure 7-13. When the output circuit is properly tuned, the resulting grid-to-cathode voltage on the first tube is minimum which

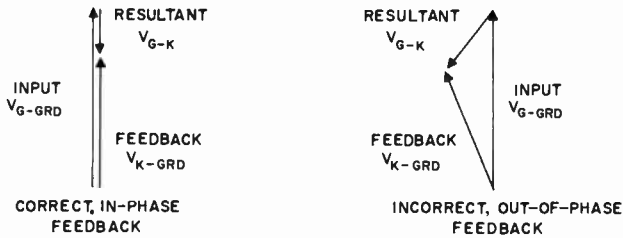

Figure 7-13. Vector Relationship of Voltages for Two-Stage Feedback

will make the voltage across the interstage tank circuit minimum also.

### 8. AUTOMATIC LOAD CONTROL

Automatic load control is a means of keeping the signal level adjusted so that the power amplifier works near its maximum power capability without being overdriven on signal peaks. In AM systems, it is common to use speech compressors and speech clipping to perform this function. However, in an SSB system these methods are not equally useful because the peaks of the SSB signal do not necessarily correspond with the peaks of the audio signal. Therefore, the most effective means of control is obtained by a circuit which receives its input from the envelope peaks in the power amplifier and uses its output to control the gain of the exciting signal. Such a circuit is an automatic load control (alc) circuit.

Figure 7-14 is a simplified schematic of an alc circuit. This circuit uses two variable gain stages of remote cutoff tubes, such as a 6BA6, operating very similarly to the i-f stages of a receiver with automatic volume control. The grid bias voltage of the variable gain amplifiers is obtained from the alc rectifier connected to the power amplifier plate circuit. The capacity voltage divider steps down the r-f voltage from the power amplifier plate to about 50 volts for the rectifier. A large delay bias is used on the rectifier so that no reduction of gain takes place until the signal level is nearly up to full power capability of the power amplifier. The output of the alc rectifier passes through RC networks to obtain the

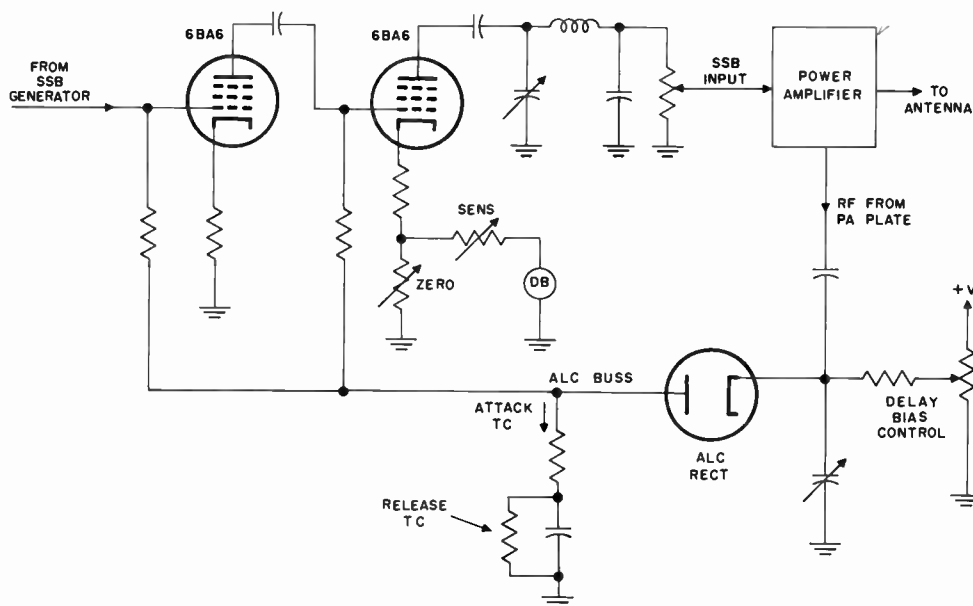

Figure 7-14. Automatic Load Control Circuit

desired attack and release times. Usually a fast attack time, about two milliseconds, is used for voice signals so that the gain is reduced rapidly to remove the overload from the power amplifier. After a signal peak passes, a release time of about one-tenth second returns the gain to normal. A meter calibrated in decibels of compression is used to adjust the gain for the desired amount of load control.

In single channel speech transmission, the alc circuit performs the function of a speech compressor. To do this a range of 12 db is usually provided with control maintained on input peaks as high as 20 db above the threshold of compression. Since the signal level should be fairly constant through the preceding SSB generator, it is unlikely that more than a 12 db range of the alc would be useful. If the signal level varies more than 12 db for the SSB generator, a speech compressor in the input audio amplifier is usually used to limit the range of the signal fed into the SSB generator.

Figure 7-15 shows the effectiveness of the alc circuit in limiting the output signal to the capabilities of the linear power amplifier. An adjustment of the delay bias will put the threshold of compression at the desired level.

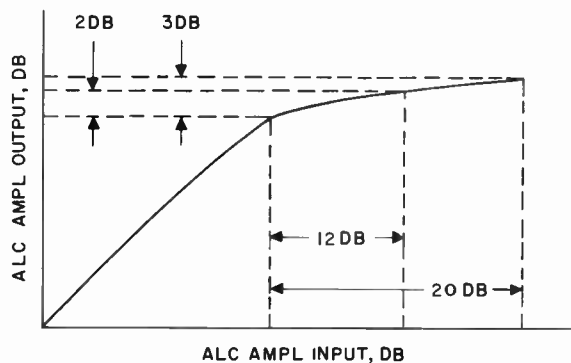

Figure 7-15. Automatic Load Control Performance Curve

## 9. LINEAR POWER AMPLIFIER TUNING

### a. INTRODUCTION

When a power amplifier is operated class C, a pronounced plate current dip and grid current peak are fairly accurate indications of proper tuning. In a linear power amplifier, the use of these indications are limited. For instance, in a class A amplifier there will be no plate current dip; therefore, the class A amplifier output circuit must be tuned for an indication of maximum input to the next stage. In

class AB amplifiers, the plate current dip is not always readily detected. This does not mean that conventional tuning procedures will not properly tune a linear amplifier, but tuning a linear amplifier with conventional procedures is much more exacting. One procedure commonly used is to increase the drive to a stage in order to obtain a good plate current dip indication.

In low Q tank circuits, the point of plate current dip is not a true indication of exact resonance because the plate current dip occurs at maximum impedance rather than when the tank circuit is pure resistive. This is especially true for Pi networks and Pi-L networks. For instance, in a network with a Q of ten, the phase angle at maximum impedance is about 17° from unity. Tuning this far from resonance in a linear amplifier with r-f feedback can be much more serious than in a class C amplifier because the phase angle of the feedback voltage is critical.

### b. PHASE COMPARISON TUNING

Use of a phase comparator circuit to compare the phase of the input signal to the phase of the output signal affords the most sensitive means of tuning a linear power amplifier stage. This circuit employs a phase discriminator, such as shown in figure 7-16, for phase comparison. A balanced, push-pull voltage is obtained through a 90° phase-shifting network to provide the voltage  $E_a + E_b$ . In the figure shown,  $E_a + E_b$  is in phase with the current in the inductive branch of the grid tank circuit. Since the current in the inductive branch is 90° out of phase with the voltage across the tank circuit, the induced voltage  $E_a + E_b$  is also 90°

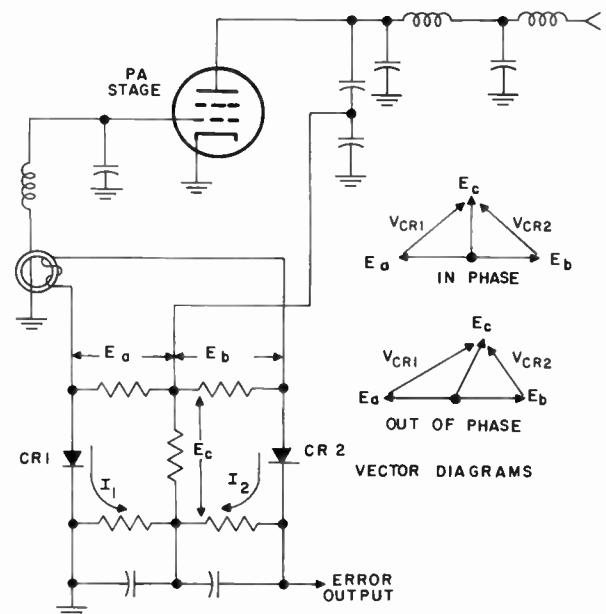

Figure 7-16. Phase Discriminator for PA Tuning

out of phase with the voltage across the tank circuit. From the output of the stage,  $E_c$  is obtained. When  $E_c$  is exactly  $90^\circ$  out of phase with  $E_a$  and  $E_b$ , the voltages across the two crystals, CR1 and CR2, are equal in magnitude. Then, the d-c currents in the diode loads are equal and flowing in opposite directions which produces zero output. When  $E_c$  is not exactly  $90^\circ$  out of phase with  $E_a$  and  $E_b$ , the voltages across the two crystals are unequal in magnitude. This will cause the d-c currents in the diode loads to be unequal which will produce an output. The error signal derived from this circuit can be used to operate a zero-center meter for manually tuning the output circuit. When tuned for zero meter indication, the output voltage is exactly  $180^\circ$  out of phase with the input voltage, the condition for true resonance.

The phase discriminator can also be used to obtain an error signal for servo tuning the stage. However, for servo tuning, coarse positioning information is necessary because the phase discriminator responds to harmonic tuning points and because there is insufficient output from the phase discriminator over much of the frequency range. This coarse positioning information can be provided with a coarse follow-up potentiometer which receives information from the exciter frequency control circuits. Such a system requires that the master potentiometer track the tuning curves of the amplifier tank circuits and that sequencing controls be used to initiate and halt coarse positioning at the proper times. Pretuning information can also be derived from the exciter r-f output signal by using a coarse discriminator circuit, such as is shown in figure 7-17. This circuit is a series RC network fed with r-f voltage from the exciter. A servo system

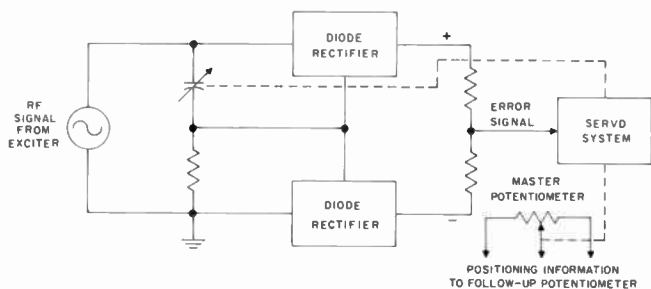

Figure 7-17. Coarse Discriminator for PA Tuning

then drives the capacitor in the RC bridge to produce zero error signal at the same time it positions a master potentiometer. A second, tuning servo then drives a follow-up potentiometer which is wound to cause the tuning servo to track the tuning curve of the amplifier tank circuit. To automatically tune the amplifier, the error signals from the phase discriminator and the course discriminator can be combined to operate a single servo. The servo system will then operate over the whole frequency range and have a precise zero error signal position, as shown in figure 7-18.

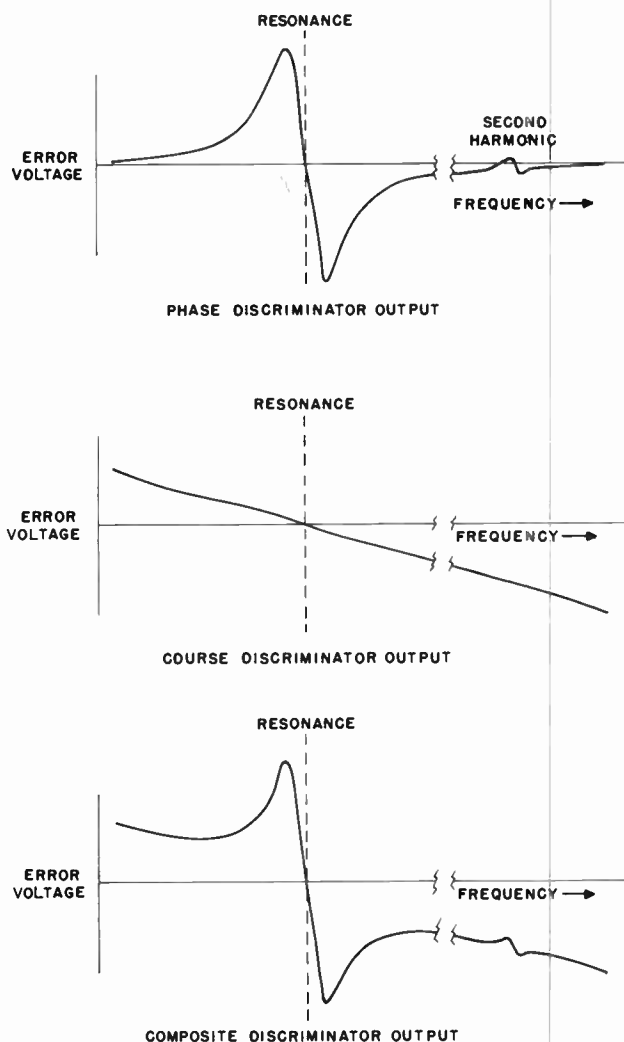

Figure 7-18. Discriminator Output Curves for PA Tuning

**c. LOADING COMPARATOR CIRCUIT**

Since the voltage gain of a tube is dependent upon the load resistance, a loading comparator circuit, as



shown in figure 7-19, can be used to determine proper loading. The loading comparator is designed so that a predetermined ratio between positively rectified grid voltage and negatively rectified plate voltage produces zero error signal output. The power amplifier is then manually or automatically loaded until the error signal output goes to zero. The clamping diode is required so that the circuit will maintain control under light load when the amplifier is driven into plate saturation. In plate saturated operation, the rectified grid voltage will continue to rise with reduced loading while the rectified plate voltage remains relatively constant. This will cause the circuit to lose its sense of direction and result in reducing the load even further. To maintain the sense of direction under this condition, the clamping diode prevents the rectified grid voltage from exceeding a voltage which is proportional to plate current. Therefore, in plate saturated operation, which is similar to class C operation, loading is determined by the ratio of plate current to r-f plate voltage. Proper compromise of the magnitude of the plate, grid, and clamping signal voltages results in a loading comparator that produces proper loading information regardless of the operating conditions, provided the plate circuit is held at resonance.

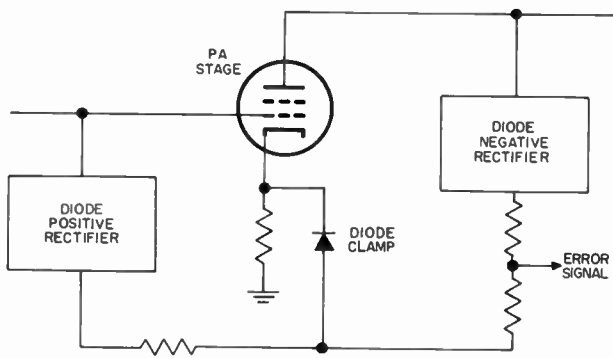

Figure 7-19. Loading Comparator for PA Loading

**d. ANTENNA TUNING AND LOADING**

The output network of a variable frequency transmitter must be capable of tuning and loading into a transmission line which presents different impedances at different frequencies. This requires output networks which will match a wide range of load impedances with the power amplifier output. In fixed-station equipment, the power amplifier usually works into a transmission line and antenna designed so that the load impedance presented to the amplifier varies over only a limited range. In this case the output network is designed to match the load impedance directly. In mobile and airborne equipment, the power amplifier

usually works into a coaxial transmission line terminated with a wide variety of antennas that present unwieldy terminating impedances. In this case an antenna coupler is used which can be located in one of two positions: (1) It can be located near or in the transmitter to provide proper coupling between the transmitter output network and a transmission line which is terminated with a mismatched antenna; (2) It can be located near the antenna to terminate the transmission line properly and provide coupling for maximum power transfer to the antenna. The first method is commonly used in mobile transmitters, and the second method is used in airborne transmitters.

Two power amplifier control functions are required to match properly the load impedances presented to the power amplifier with the power amplifier network. One is a phasing control, or tuning control, which will balance out undesirable reactance and make the load resistive or as nearly resistive as is possible. The other is a load control which will provide the proper terminating impedance. Figure 7-20 shows

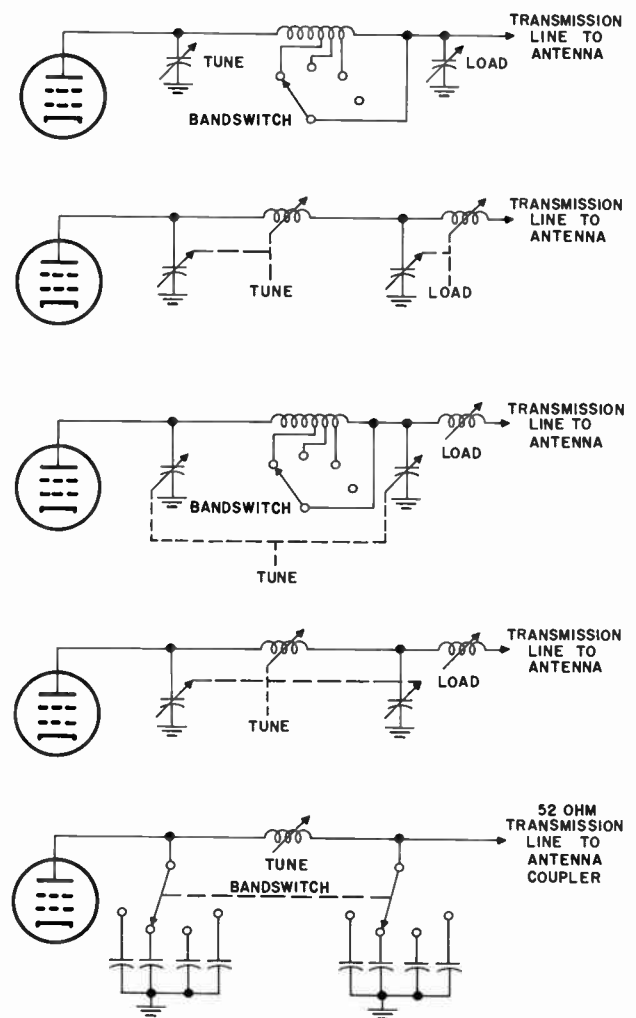

Figure 7-20. Output Network Tuning and Loading Controls

several ways that the output network components can be ganged to provide tuning and loading with two controls. The tuning control is adjusted to produce a plate current dip, which indicates maximum impedance. For more precise tuning and automatic tuning, the phase discriminator circuit is used. The loading control is adjusted to produce a pre-established value of grid voltage and plate current or, in some cases, a pre-established value of screen current and plate current. For more precise loading and automatic loading, the loading comparator circuit is used. The loading and tuning circuits must be so designed that the controls will not lose sense of direction under any circumstances. This is absolutely essential for automatic loading and tuning and is highly desirable for manual loading and tuning.

## 10. POWER SUPPLIES FOR POWER AMPLIFIERS

Fixed transmitters up to 1 kw usually use a single-phase a-c power source, and larger fixed transmitters usually use a three-phase a-c power source. Mobile equipment may operate from a 6-volt to 28-volt d-c power source using dynamotors or vibrator power supplies to obtain the required high voltages. Airborne equipment usually uses the 400-cycle a-c power source of the aircraft.

In addition to supplying the required d-c voltage and output current, the power supply must have adequate d-c regulation, good dynamic regulation, and low ripple or noise output. Most high-voltage power amplifiers have a varying load characteristic so that good d-c regulation is essential. To reduce ripple and noise, high-voltage filters are used between the rectifier circuit and the power supply load. The filter chokes place a high impedance between the rectifier and the load, making large capacitors necessary in the output side of the filter. These output capacitors supply the rapid variations in load current which are impeded by the filter choke. This is particularly necessary in high-voltage power supplies for linear power amplifier stages.

Vacuum rectifiers can be used for small, low-voltage power supplies which have relatively constant load. Gas-type rectifiers are required where better regulation is necessary. The mercury-vapor rectifier is the most common gas-type rectifier used because it has long life when properly operated. Operating a mercury-vapor rectifier above or below its rated temperature, changes the vapor pressure in the tube and reduces its peak-inverse-voltage capability, making the rectifier more susceptible to arc-back. Equipment which is subject to wide ambient-temperature variations, such as military equipment, uses inert gas rectifiers such as the 3B28 and 4B32. These tubes can be operated in ambient temperatures from  $-75^{\circ}\text{C}$  to  $+90^{\circ}\text{C}$ , which is frequently a necessary feature. The tube life of the inert gas rectifier,

however, is only about one-third the tube life of an equivalent mercury-vapor rectifier. Metallic rectifiers, such as selenium and copper oxide, are frequently used in power supplies delivering less than 100 volts for relay operation, etc.

Rectifier tube life is increased by operating the filaments  $90^{\circ}$  out of phase with the plate voltage. This minimizes the difference in voltage from each end of the filament to the plate and allows a more uniform emission over the entire filament. A  $60^{\circ}$  phase difference between the filament and the plate voltage is often used when it is more easily obtained because almost the full advantage of quadrature operation is realized. Tube ratings of some of the larger rectifier tubes are increased for quadrature operation.

Transient voltages and currents which far exceed the steady-state values occur in power supplies when the supply is energized. If these transient peaks exceed the peak-inverse-voltage rating of the tube, an arc-back may result. For this reason, rectifier tubes are often operated so that the normal peak-inverse-voltage does not exceed one-half of the rated peak-inverse-voltage. If this is not possible, a step-start circuit is used which starts the transformer with resistors in series with the primary. After a short time delay, these resistors are shorted out. Some high-voltage rectifiers are started with a resistor in series with the filter capacitor, with the resistor being shorted out after a short time delay. This prevents a transient due to the charging current required to bring the voltage up on the filter capacitor. The added resistance in the circuit prevents excessive current in the rectifier.

## 11. CONTROL CIRCUITS

Power amplifier control circuits must perform three functions; (1) they must supply circuit control, (2) they must provide equipment protection, and (3) they must provide personnel protection. In small transmitters, the control circuits may consist of nothing more than an on-off switch to supply heater power and a push-to-talk button to apply plate voltage and put the transmitter on the air. In larger equipment, push buttons are usually used to initiate a certain sequence of relay operations which complete a function in the proper manner. Many transmitters, particularly those suitable for remote control, are capable of complete energization from a single push-button control.

The filament on-off switch, or push button, initiates a sequence of functions that applies power to the filaments, starts the cooling system, and energizes time delay circuits that make the power amplifier ready for the application of plate power. When operated to the off position, the power amplifier is shut down.

Filaments of high-power amplifier tubes are energized separately, and, in the case of mercury-vapor tubes, a time delay allows warmup time. The blower is started at the beginning of the starting sequence because the life and reliability of many components is greatly dependent upon operating temperature control. Air interlocks prevent the application of power to high-power tubes before cooling air is present and a blower-off delay maintains cooling air after shutdown. In various power amplifier stages, it is essential that bias voltage be applied before plate or screen voltage is applied. This requires sequencing the application of the bias voltage and the plate voltage as well as interlocks between the two so that the loss of bias voltage will result in removing the plate voltage.

Power amplifier control circuits are sequenced and interlocked so that everything else must be on and functioning before the high-voltage plate transformer is energized. Certain power tetrodes require that screen voltage be applied simultaneously with plate voltage to prevent excessive screen dissipation. To prevent high current and high-voltage transients, plate voltage is often applied through step-start circuits which place resistors for a short time in the power supply circuit.

Medium-power and high-power tubes are nearly always protected from excessive plate current by overload relays. These relays remove the high-voltage primary power if the plate current exceeds a preset value. Many overloads that occur during normal operation will clear themselves when the high voltage is removed. For this reason, large power amplifiers are usually provided with an overload recycle circuit. This circuit brings the power amplifier back on after an overload. If the overload reoccurs, the power amplifier will again shut down. The number of recycles before shutdown can generally be preset with a recycle counting switch.

## 12. TUBE OPERATING CONDITIONS FOR R-F LINEAR POWER AMPLIFIERS

### a. GENERAL

SSB amplifiers provide linear amplification and operating conditions similar to those of audio amplifiers. There is one fundamental difference, however, between audio and r-f linear amplifiers. This is that the input and output voltages of a tuned r-f amplifier are always sine waves because the tuned circuits, if they have adequate  $Q$ , make them so. Therefore, the distortion in an r-f amplifier results in distortion of the SSB modulation envelope and not in the shape of the r-f sine wave. This can be restated that distortion in an r-f linear amplifier causes a change in gain of the amplifier when the signal level is varied. The greatest difference between an audio amplifier and an r-f

linear amplifier is in the grid driving power requirements when driving into grid current. In the audio amplifier, the driver must supply all of the instantaneous power required by the grid at the peak of the grid swing. To deliver this peak power, the audio driver must be capable of delivering average sine wave power equal to one-half of the peak power. In an r-f linear amplifier, the tank circuit averages the power of the r-f cycle due to its "flywheel" effect so that the driver need only be capable of delivering the actual average power required, and not the peak. With these reservations in mind, examination of the audio or modulator data of a tube will give a good idea of its r-f linear power amplifier operating conditions.

### b. CLASS A R-F LINEAR AMPLIFIERS

In low-level amplifiers, where the output signal voltage is less than 10 volts, small receiving type tubes, such as the 6AU6, are very satisfactory for class A service. For voltage levels above 10 volts, the 4X150A is the best choice for class A operation because it has short leads, low plate-to-grid capacitance, and high transconductance. Class A amplifier tubes should be operated in as linear a portion of the plate characteristic curves as is practical. This can be done by inspecting the plate characteristic curves of the tube. Usually the static plate current which results in near maximum plate dissipation is the best. The maximum output voltage should be kept to about one-tenth the d-c plate voltage or less to obtain signal-to-distortion ratios of 50 db or better. The d-c plate voltage regulation for class A operation is seldom of importance and cathode bias and screen dropping resistors are commonly used. Even with tubes such as the 6AU6 and the 4X150A which have short leads and low grid-to-plate capacitance, it is desirable to load the input and output circuits to 5000 ohms when operating up to 30 mc.

### c. CLASS AB R-F LINEAR AMPLIFIERS

In the power range from 2 watts to 500 watts, class AB<sub>1</sub> is normally used. This class of operation is very desirable because distortion due to grid current loading is avoided and because high power gain can be obtained. At present, tubes are not available which will give low distortion with good plate efficiency operating class AB<sub>1</sub> at power levels above 500 watts. Therefore, for higher power levels class AB<sub>2</sub> operation is used.

For class AB operating conditions with a given screen voltage and given plate load, there is one value of static plate current which will give minimum distortion. The optimum value of static plate current for minimum distortion is determined by the sharpness of cutoff of the plate current characteristic. Grid bias is then set to produce the optimum static plate current.



This optimum point is determined from the load line on a set of constant current plate current curves. Values obtained from this curve are then plotted to obtain the plate current vs grid voltage curve shown in figure 7-21. This curve is the dynamic characteristic of the tube. By projecting the most linear portion of the curve to intersect with the zero plate current line, the grid bias is determined. This point of intersection is often referred to as the projected cutoff. The static plate current which will flow with this grid bias is the proper static plate current for minimum distortion. This procedure is used in audio amplifier design and is nearly correct for r-f linear amplifier design. Perhaps a more accurate procedure for determining the proper bias for r-f amplifiers is to choose the point Q so that the slope of the curve at Q is one-half the slope of the major linear portion. This will allow the amplifier to operate class A with small signals and deliver power over both halves of the cycle. With a large signal, the tube delivers power over essentially one-half the cycle. Then the change in plate current relative to plate voltage swing over half the cycle will be half as much for small signals as it is for large signals and linear operation is obtained at all signal levels.

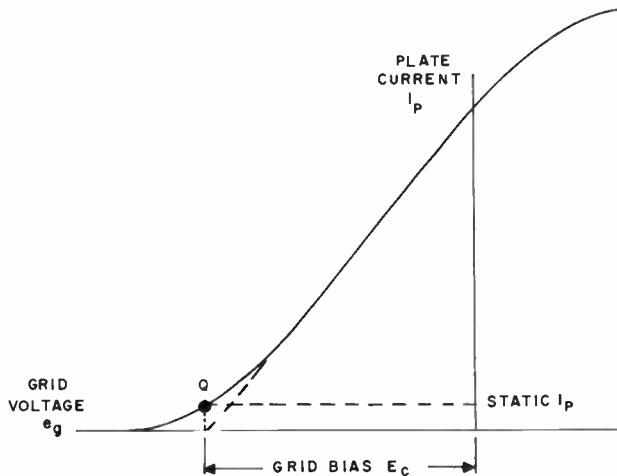

Figure 7-21. Optimum Static Plate Current for Linear Operation

The screen voltage of a tetrode tube has a very pronounced effect on the optimum static plate current, because the plate current of a tube varies approximately as the three-halves power of the screen voltage. For example, raising the screen voltage from 300 to 500 volts will double the plate current. The shape of the dynamic characteristic will stay nearly the same, however, so that the optimum static plate current for minimum distortion is also doubled. A practical

limit is reached because high static plate current causes excessive static plate dissipation.

In practice, it is found that the static plate current determined by the above method is so high that plate dissipation is near or beyond the maximum rating of the tube when using desired d-c plate voltage. For example, one of the better medium power triodes for linear amplifier service, the 3X2500A3, requires approximately .5 ampere of plate current for minimum distortion. Using a desirable plate voltage of 5000 volts, static plate dissipation is 2500 watts, which is the maximum rated plate dissipation for the tube. For this reason, it is often necessary to operate the tube below the optimum static plate current, which can be done without causing appreciable distortion. In tetrodes, the optimum static plate current is a function of screen voltage, and the high screen voltages required for class AB<sub>1</sub> operation usually require an excessive amount of plate current for minimum distortion. A choice must then be made between operating the tube at lower than optimum static plate current or using a lower screen voltage and driving the tube into the grid current region, a second principal cause of distortion.

#### d. ESTIMATING TUBE OPERATING CONDITIONS

The operating conditions of a tube operating class AB in an r-f linear power amplifier can be estimated from the load line on a set of constant plate current curves for the tube, as shown in figure 7-22.

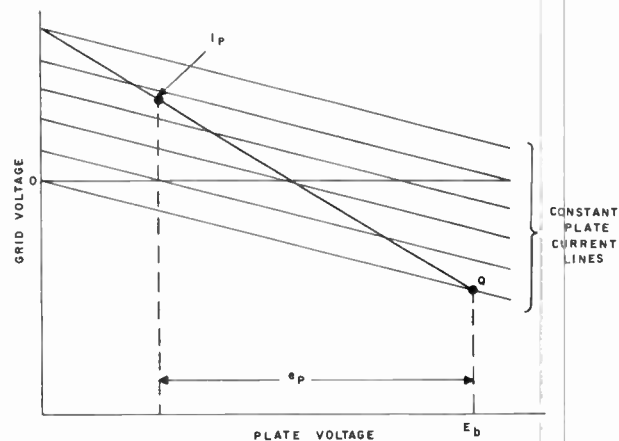

Figure 7-22. Graphical Determination of Tube Operating Conditions

From the end point of the load line, the instantaneous peak plate current,  $i_p$ , and the peak plate voltage swing,  $e_p$ , can be established. From these two values, the principal plate characteristics can be estimated

by using the following relationships for a single-frequency test signal:

$$\begin{aligned}
 \text{d-c plate current, } I_B &= \frac{i_p}{\pi} \\
 \text{plate input watts, } P_{in} &= \frac{i_p E_B}{\pi} \\
 \text{average output watts and PEP, } P_o &= \frac{i_p e_p}{4} \\
 \text{plate efficiency, } Eff &= \frac{\pi e_p}{4 E_B}
 \end{aligned}$$

For a standard two-frequency test signal the relationships are:

$$\begin{aligned}
 \text{d-c plate current, } I_B &= \frac{2i_p}{\pi^2} \\
 \text{plate input watts, } P_{in} &= \frac{2i_p E_B}{\pi^2} \\
 \text{average output watts, } P_o &= \frac{i_p e_p}{8} \\
 \text{PEP watts, } P_o &= \frac{i_p e_p}{4} \\
 \text{plate efficiency, } Eff &= \left(\frac{\pi}{4}\right)^2 \frac{e_p}{E_B}
 \end{aligned}$$

An actual tube with moderate static plate dissipation will have operating characteristics similar to those shown in figure 7-23 for the single-tone and two-tone signals. Plate dissipation and efficiency at maximum

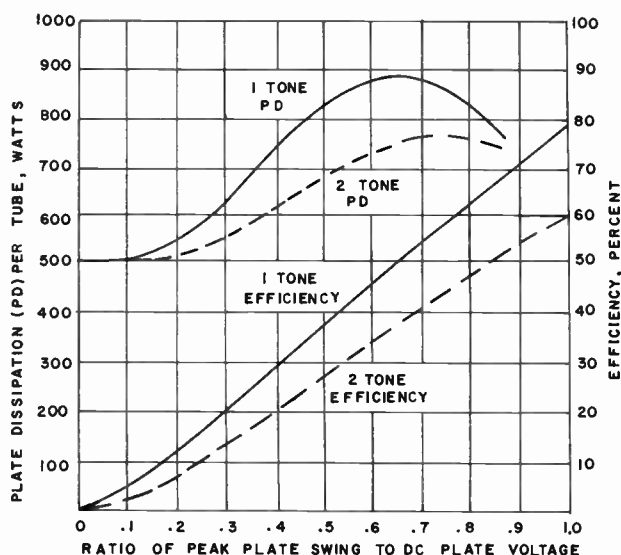

Figure 7-23. Efficiency and Plate Dissipation for Class AB Operation

signal level are affected little by even rather high values of static plate dissipation. In practice, the peak plate swing is limited to something less than the d-c plate voltage in order to avoid excessive grid drive, excessive screen current, or operation in the nonlinear plate current region. Most tubes operate with an efficiency in the region of 55 to 70 per cent at peak signal level.

### 13. DISTORTION

#### a. CAUSES OF R-F LINEAR POWER AMPLIFIER DISTORTION

The principal causes of distortion are nonlinearities of the amplifier tube plate current characteristic and grid current loading. In order to confine distortion generation to the last stage or two in a linear power amplifier, all previous stages are operated class A.

The generation of distortion products due to the nonlinear characteristics of the amplifier tube can be derived from the transfer characteristic of the tube, also called the dynamic characteristic, as shown in figure 7-24. The shape of this curve and the choice

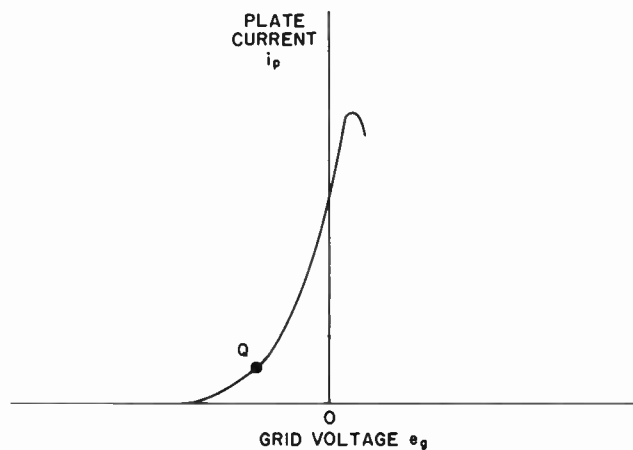

Figure 7-24. Typical PA Tube Transfer Characteristic Curve

of the zero signal operating point, Q, determine the distortion which will be produced by the tube. A power series expressing this curve, written around the zero signal operating point, contains the coefficients of each order of curvature, as shown in the following expression:

$$\begin{aligned}
 i_p &= k_0 + k_1 e_g + k_2 e_g^2 + k_3 e_g^3 + k_4 e_g^4 + k_5 e_g^5 \\
 &+ \dots + k_n e_g^n
 \end{aligned}$$



In this expression,  $i_p$  represents instantaneous plate current,  $k_1, k_2$ , etc, the coefficients of their respective terms, and  $e_g$  the input grid voltage signal. The values for the coefficients are different for every power series written around different zero signal operating points. By making the input signal,  $e_g$ , consist of two equal amplitude frequencies with a small frequency separation, the distortion products of concern in linear amplifiers can be obtained. Figure 7-25 shows the spectrum distribution of the stronger plate current components. It is seen that tuned circuits can filter out all products except those which are near the fundamental input frequencies. This removes all of the even-order intermodulation products and the harmonic products. The odd-order intermodulation products fall close to the original frequencies and

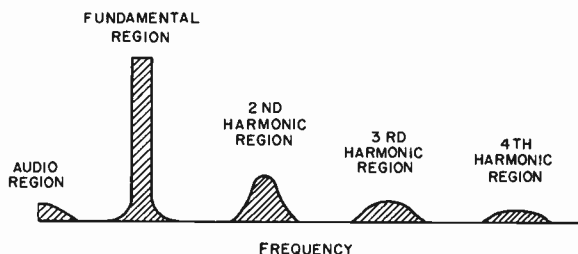

Figure 7-25. Spectrum Distribution of Products Generated in PA Stage

cannot be removed by selective circuits. Figure 7-26 shows these odd-order products which fall within the passband of selective circuits. The inside pair of intermodulation distortion products are third-order, the next fifth-order, seventh-order, etc. The first and most important means of reducing distortion, then, is to choose a tube with a good plate characteristic and choose the operating condition for low odd-order curvature (see paragraph 12c, chapter 7).

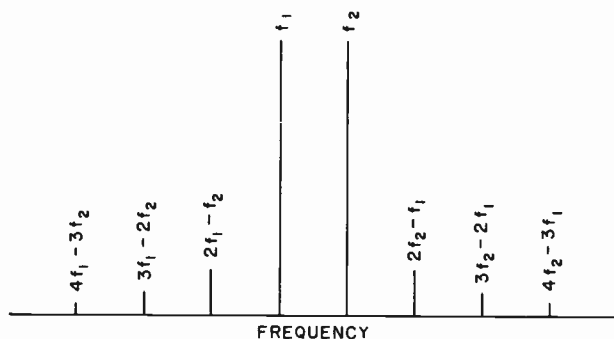

Figure 7-26. Odd-Order Intermodulation Products Causing SSB Distortion

The nonlinearity caused by grid current loading is a function of the regulation of the grid driving source. In general, this regulation with varying load is poor in linear amplifiers. It is common practice to use swamping resistors in parallel with a varying grid load so that the resistance absorbs about ten times the power that the grid of the tube requires. This provides a low, constant driving source impedance and improves linearity at the expense of increased driving power.

The instantaneous plate current of all tubes drops off and causes distortion when the instantaneous plate voltage is low. The main reason for this drop is that current taken by the grid and screen is robbed from the plate. In all but a few transmitting tetrodes, the plate can swing well below the screen voltage before plate saturation occurs. However, when the plate swings into this region, the instantaneous plate current drops considerably. If distortion requirements are not too high, the increased plate efficiency realized by using large plate swings can be realized. However, to minimize distortion, the allowable plate swing may have to be reduced.

**b. DISTORTION REDUCTION**

There is a need for reduced levels of intermodulation distortion from r-f linear power amplifiers used in SSB systems. This need exists not because the distortion noticeably reduces the intelligibility of the SSB signal, but because distortion products outside of the channel width necessary for transmission of intelligence interferes with adjacent channel transmission. The distortion of some of the early SSB power amplifiers was so great that voice channels were placed a full channel width apart to avoid adjacent channel interference. Recent power amplifier developments permit adjacent channel operation, using power amplifiers with signal-to-distortion ratios of from 35 db to 40 db. However, power amplifiers with signal-to-distortion ratios of from 45 db to 50 db would further increase the utility of single sideband.

There are two basic means of reducing distortion to levels better than is obtainable from available tubes. These are r-f feedback and envelope distortion canceling.<sup>1</sup> An r-f feedback is very effective and quite easy to obtain (see paragraph 7, chapter 7). Ten decibels of r-f feedback will produce nearly 10 db of distortion reduction which is realized at all signal levels. Envelope distortion canceling has an inherent weakness because it depends upon envelope detection for its feedback signal. This means that distortion canceling must be instantaneous to be perfect. Since some delay is inherent in the envelope detector and feedback loop, the effectiveness of this circuit depends upon how short the time delay can be made. Development work indicates that a combination of r-f feedback

<sup>1</sup> W. B. Bruene, "Distortion Reduction Means for Single-Sideband Transmitters," IRE Proceedings, Dec. 1956 7-18

and envelope distortion canceling will provide more distortion canceling than either method separately. Using 10 db of r-f feedback around all three stages of a 20-kw PEP power amplifier, and a signal synthesized from the input envelope to grid modulate the first stage, a better than 50 db signal-to-distortion ratio has been obtained for all distortion products at any signal level up to the 20-kw PEP.

**c. LINEARITY TRACER**

The linearity tracer consists of two SSB envelope detectors, the outputs of which connect to the horizontal and vertical inputs of an oscilloscope, as shown in figure 7-27. A two-tone test signal is normally used to supply an SSB modulation envelope, but

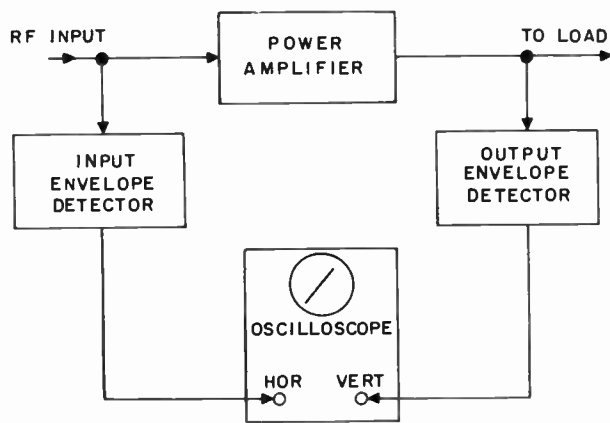

Figure 7-27. Linearity Tracer, Block Diagram

any modulating signal that provides from zero to full amplitude can be used. Even speech modulation gives a satisfactory trace. This instrument is particularly useful for monitoring the signal level and clearly shows when the amplifier is overloaded. It can also serve as a voltage indicator which can be useful for making tuning adjustments. The linearity trace will be a straight line regardless of the envelope shape if the amplifier has no distortion. Overloading, inadequate static plate current, and poor grid circuit regulation are easily detected with the linearity tracer. The instrument can be connected around any number of power amplifier stages, or it can be connected from the output of the SSB generator to the power amplifier output to indicate the over-all distortion of the entire r-f circuit.

A circuit diagram of an envelope detector is shown in figure 7-28. Any type of germanium diode may be used for the detector, but the diodes in each of the two required envelope detectors must be fairly well matched. Using matched diodes cancels the effect

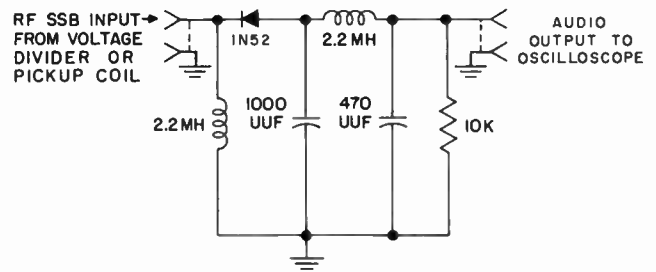

Figure 7-28. Envelope Detector, Schematic Diagram

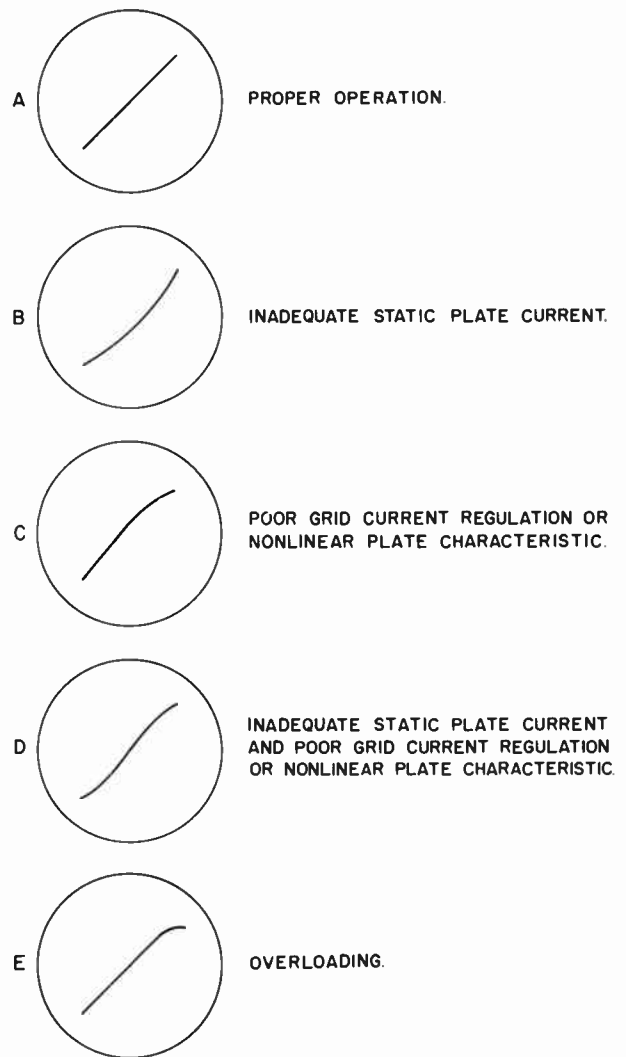

Figure 7-29. Typical Linearity Traces

on the oscilloscope of their nonlinearity at low signal levels. A diode load of from 5K to 10K minimizes the effect of diode differences. Operation of both detectors at approximately the same signal level is important so that diode differences will cancel more exactly. It is desirable to operate the envelope detectors with a minimum of 1 volt input to further minimize diode differences. It is a convenience to build the detector in a small shielded enclosure with coaxial input and output connectors. Voltage dividers can be similarly constructed so that it is easy to patch in the desired voltage stepdown from the voltage sources. A pickup coil on the end of a short coaxial cable can be used instead of voltage dividers to obtain the r-f input signal.

The frequency response and phase-shift characteristics of the oscilloscope vertical and horizontal amplifiers should be the same and should be flat to at least twenty times the frequency difference of the two test tones. Excellent high-frequency characteristics are necessary because the rectified SSB envelope contains harmonics to the limit of the envelope detector's ability to detect them. Inadequate frequency response of the vertical amplifier may cause a little foot to appear at the lower end of the trace. If the foot is small, it may be safely neglected. Another effect which may be encountered is a double trace, but this can usually be corrected with an RC network between one detector and the oscilloscope.

The best way to test the linearity tracer is to connect the inputs of the envelope detectors in parallel. A perfectly straight diagonal trace on the oscilloscope will result if everything is working properly. One of the detectors is then connected to the other source through a voltage divider which will not result in appreciable change in the setting of the oscilloscope gain controls.

Figure 7-29 shows some typical linearity traces which might be observed in linear power amplifier operation. Figure 7-29a indicates proper linear operation. Inadequate static plate current in class A amplifiers, class AB amplifiers, or mixers will result in the trace shown in figure 7-29b. This condition can be remedied by reducing the grid bias, raising the screen voltage, or lowering the signal level through mixers and class A amplifiers. The trace shown in figure 7-29c is caused by poor grid circuit regulation when grid current is drawn, or by nonlinear plate characteristics of the tube at large plate swings. This can be remedied by using more grid swamping or lowering the grid drive. The trace shown in figure 7-29d is a combination of the traces shown in b and c. The trace shown in figure 7-29e is caused by overloading the amplifier. It can be remedied by lowering the signal level.

## CHAPTER 8

### TEST EQUIPMENT AND TECHNIQUES

#### 1. GENERAL

When a transmitter is operated, three characteristics of the output signal are of prime importance. These are:

- (1) Carrier Frequency
- (2) Signal level
- (3) Undesired power output

The carrier frequency is that frequency which designates the position in the spectrum occupied by the band of frequencies required to transmit the intelligence. Desired signal level is the r-f power confined to those discreet frequencies within this band that are required to transmit the intelligence. Undesired power is the r-f power at frequencies both within this band and outside it, that are not necessary to the transmission of the intelligence and, therefore, interfere with the transmitted signal as well as with other communication channels.

#### 2. FREQUENCY MEASUREMENT

Two commonly used methods of frequency measurement are:

- (1) Frequency counter and converter
- (2) Receiver and frequency standard

A typical frequency counter for measurements up to 100 megacycles is the Hewlett-Packard 524B with the Hewlett-Packard 525A converter installed. Higher frequency measurements can be made with other converters which can be installed in place of the 525A. The frequency resolution of this instrument is variable by a switch on the front panel to as low as .1 cps, but in normal use, a resolution of  $\pm 1$  cps is sufficient. The period of the count is the reciprocal of the resolution. For example, for a resolution of 0.1 cps the count period is 10 seconds and for a resolution of 1 cps the count period is 1 second. The readout accuracy of the counter is  $\pm 1$  in the last digit so that with a resolution of 0.1 cps the accuracy of the reading displayed is  $\pm 0.1$  cps and with a resolution of 1 cps the accuracy of the reading is  $\pm 1$  cps. If the frequency to be counted is 10 mc and the resolution is 0.1 cps, then the readout accuracy is plus or minus 1 part in  $10^8$ . The over-all accuracy of the measurement depends

upon the accuracy of the time base standard. For example, if the oscillator producing the time base has an accuracy of 1 part in  $10^8$  then with a readout accuracy of 1 part in  $10^8$ , the over-all accuracy of measurement is 2 parts in  $10^8$ . The frequency counter is designed to count the frequency of a single sine wave of an amplitude of about 1 volt. It will not give a true indication of frequency in the presence of a complex wave since the digitalizing of the data obtained from the incoming signal is accomplished by counting the number of times the instantaneous voltage crosses a given absolute value. Short term errors existing during the period of the count are integrated by the counter, and the average error is included in the frequency display at the end of each count. The internal frequency standard which provides the time base for the count in the HP525A has a stability of approximately 1 part in  $10^6$  per day, but provision is made for connection of an external standard if higher accuracy is desired.

A second method of frequency measurement using a receiver and associated frequency standard is less accurate than the frequency counter method. If a receiver such as the Collins 51J is used, the internal frequency standard can be calibrated to a standard of known accuracy, and by using the bfo, the kilocycle dial can be calibrated at adjacent, integral 100 kc points on each side of the frequency at which the measurement is to be made. The accuracy of the measurement made with this receiver will be in the order of  $\pm 250$  cps.

A highly accurate adjustment between two frequency standards can be made by mixing products of the two standards into a receiver and adjusting one standard to agree with the other by observing the beat frequency on the receiver S meter. Best results are obtained when the effect of the two frequencies are equal in amplitude at the detector in the receiver. Where such comparison is made between two frequency standards, the 100 kc output of one standard can be amplified to about 100 volts and applied to the calibrator crystal socket in the receiver to obtain strong 100 kc points throughout the range of the receiver. A transmitter whose frequency standard is to be trimmed is tuned to an integral 100 kc point; the receiver is tuned to that frequency, and the beat between the two observed on the receiver S meter. The level of input to the receiver from the transmitter is adjusted for maximum swing on the S meter and then the transmitter



standard is adjusted for zero beat. When using frequency standards with stabilities of 1 part in  $10^8$  per day or better, beats having periods of approximately 20 seconds can be obtained when comparing signals at 30 mc.

Since the frequency counter will not give an accurate measurement of frequency in the presence of a complex wave, and since measurements of frequency by means of a receiver are confused in the presence of additional signals, it is necessary to disconnect modulation from the transmitter and make all frequency measurements on the reinserted carrier, or on a single tone of known frequency and stability equal to that of the equipment under test.

**3. SIGNAL LEVEL**

Most measurements of power output presume that the level of undesired power output is small compared to the accuracy required of the measurement of desired power output. Normally, the rms sum of undesired power output will be in the region of 35 to 40 db below desired power output, or about 1% of desired power. If a suitable resistive load is available to terminate the r-f output circuit, a vacuum-tube voltmeter such as the Hewlett-Packard 410B will give a reading of voltage across the load which is reasonably accurate for power computation. This meter is a

negative peak reading meter calibrated in terms of rms. It has a very high impedance a-c probe which will not change the reactive characteristics of a 50 ohm line, provided that the meter probe is connected across the line with a minimum of additional shunt capacity or series inductance. When using this method for measuring power, the accuracy of voltage measurement is important since the effect of any error is squared when computing  $P = \frac{E^2}{R}$ . The most accurate measurement available with the Hewlett-Packard 410B is made with a single tone, although experience has shown that measurement of two equal tones on the r-f output line will give a voltage indication for computing peak envelope power to an accuracy varying between 5 and 10%, the higher accuracy being obtained on the higher ranges of the meter. Table 8-1 and figure 8-1 show comparative measurements made with a vu meter which reads slightly above the average value of the applied signal, a Ballantine 310A which reads the average value, a Ballantine 320 which reads true rms, a Hewlett-Packard 410B which reads negative peaks but is calibrated in rms, and an oscilloscope which was used to obtain the peak to peak voltage of the signal. Measurements were made on a signal containing from 1 to 16 equal audio tones. In table 8-1 the output level of the amplifier was reset for each reading so that the maximum reading on the vu meter was -3.0 vu. Since beats between tones began to effect the meter readings after more than 2 tones

TABLE 8-1. COMPARATIVE METER READINGS 1 TO 16 EQUAL TONES AMPLIFIER OUTPUT HELD CONSTANT ON VU METER

Meter	VU		310A		320	410B			Scope
Reads	Average +		Average		True RMS	Neg Peak			P-P
Calibrated	VU		dbv		dbv	Volts rms			Volts
No. of Tones	Min	Max	Min	Max		Min	Avg	Max	Max
1		-3.0		-1.5	-1.5			0.85	2.6
2		-3.0		-1.7	-0.7			0.23	3.8
3		-3.0		-1.7	-0.8	1.3	1.4	1.5	4.5
4	-4.0	-3.0	-3.0	-1.7	-1.3	1.0	1.4	1.6	5.0
5	-4.0	-3.0	-2.7	-1.8	-1.2	1.1	1.4	1.8	5.5
6	-4.0	-3.0	-3.1	-1.7	-1.0	1.0	1.4	1.9	5.3
7	-4.0	-3.0	-3.0	-1.6	-0.95	1.1	1.5	2.1	6.0
8	-4.0	-3.0	-2.7	-1.8	-1.0	1.1	1.5	2.2	6.2
9	-4.0	-3.0	-3.0	-1.7	-1.0	1.1	1.5	2.3	7.0
10	-3.7	-3.0	-3.0	-1.8	-1.0	1.1	1.6	2.3	7.0
11	-3.7	-3.0	-3.0	-1.5	-1.0	1.05	1.5	2.4	7.0
12	-4.0	-3.0	-2.7	-1.8	-1.0	1.1	1.6	2.3	7.0
13	-3.9	-3.0	-2.7	-1.7	-1.0	1.1	1.6	2.2	7.0
14	-4.0	-3.0	-2.8	-1.8	-1.0	1.1	1.6	2.5	7.2
15	-4.0	-3.0	-3.0	-1.7	-1.0	1.1	1.6	2.5	7.2
16	-4.0	-3.0	-2.8	-1.7	-1.0	1.1	1.6	2.4	7.2



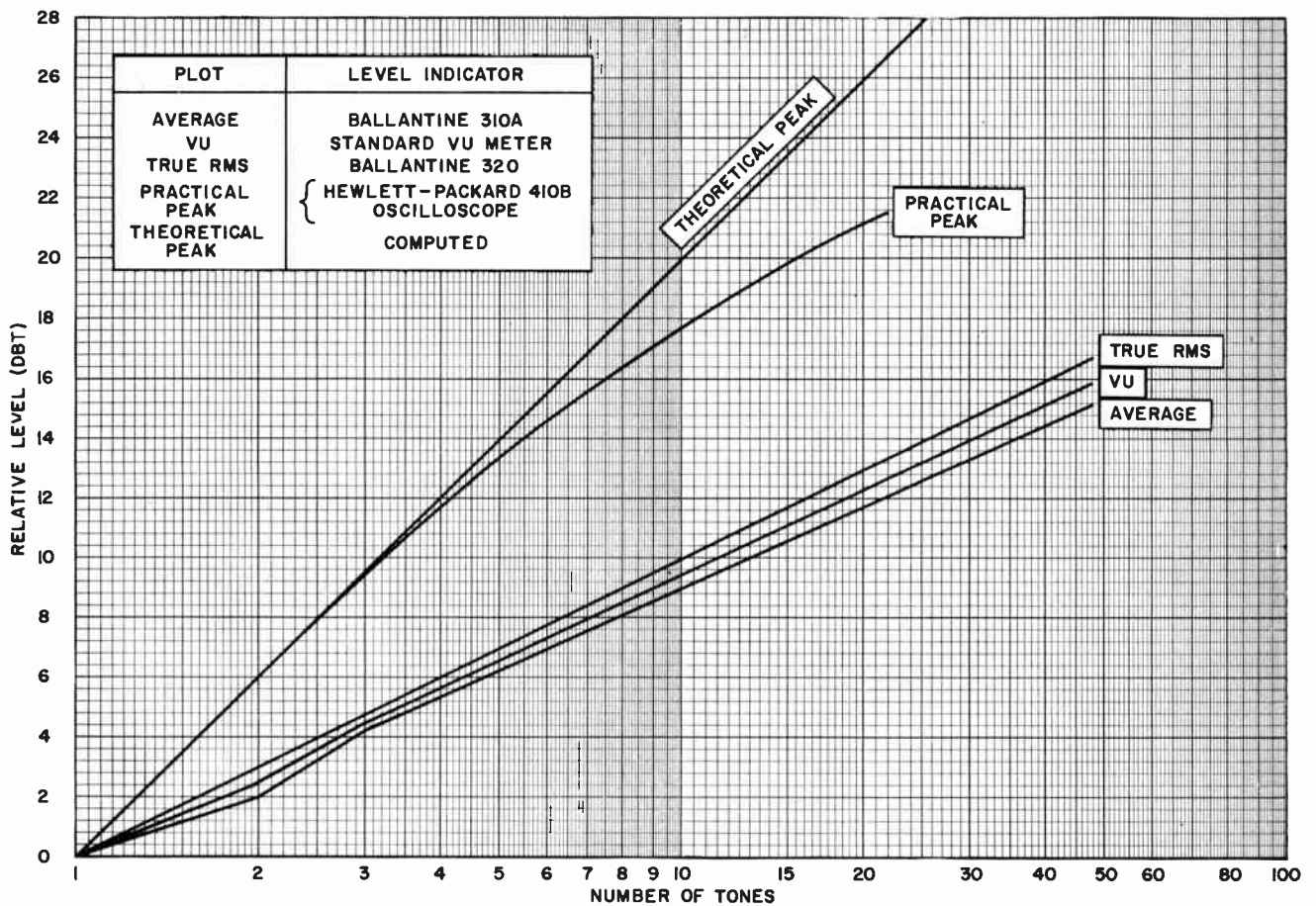

Figure 8-1. DB Level Versus Number of Equal Amplitude Tones for Various Types of Level Indicators

were combined, the minimum and maximum readings were taken each time. Where average readings are given, they are the value indicated by the meter for a major portion of the period during which each reading was taken. Similar readings were taken for figure 8-1. A signal composed of 16 tones of equal amplitude was adjusted to indicate full scale maximum on the vu meter. Then the tones were dropped one at a time and the maximum readings were taken without further level adjustment. All readings were converted to DBT (decibels with 0 db equal to the indication for a single tone on each type of indicator).

The theoretical peak was computed on the basis of a 6 db increase each time the number of tones is doubled and is indicative of theoretical peak envelope power. The true rms indication increases 3 db each time the number of tones is doubled and is indicative of true "heat" power. Statistically, the possibility of the practical peak indication approaching theoretical

peak during a given time interval may be computed. The Hewlett-Packard 410B and the oscilloscope agree within a few tenths of a decibel when read for maximum peak indication over a one minute interval, yielding the practical peak curve of figure 8-1 which is indicative of practical peak envelope power. Note the double inflection in the vu and average curves at the two-tone and three-tone points, the divergence of the vu and average curves from true rms above three tones, and the fact that the vu indication remains almost exactly midway between average and rms throughout the graph.

The Ballantine 310A is an average reading vacuum-tube voltmeter calibrated in terms of rms but does not have as high an input impedance as the Hewlett-Packard 410B probe and has a cutoff frequency of about 2 mc. However, since its sensitivity extends to less than 100 microvolts, it is useful for measuring low signal levels at i-f frequencies. Dummy loads such

as those manufactured by the Bird Electronic Corporation exhibit resistance tolerance of the order of  $\pm 0.5$  ohm and present very little reactance to the signal source. Most of these loads are good for measurements into the hundreds of megacycles. If a resistive dummy load is not available, the measurement of voltage or current will not give an accurate indication of power. In these circumstances the calorimetric method of measuring power will give a more accurate indication. The flowmeter and thermometers may be calibrated separately to high accuracies and errors in reading of the flowmeter or thermometers do not appear in a squared term in the calculation of power as do the errors in voltage or current readings. The accuracy of the temperature readings, however, is affected by the temperature at which the calorimeter is operated with respect to the ambient temperature.

Another device for measuring power, which does not require a special load and which can be used while feeding an antenna, is a directional wattmeter. Figure 10-29 is a chart showing the relationship of the standing-wave ratio to forward and reflected power. The wattmeter will measure average power integrated as affected by the time constant of the metering network, and if both forward and reflected power are measured instantaneously, the chart will hold for multiple tones. An envelope detecting voltmeter will read 45% of peak voltage when a two-tone r-f signal is applied. This presumes that the voltmeter reads the average of the r-f and the rms of the envelope. Thus  $0.707$  of  $0.637$  is  $0.45$  or 45% of peak envelope voltage. A modification of directional wattmeters to approach a measurement of peak envelope power is useful for speech and other complex single-sideband signals, since these quantities are of greater importance in single-sideband equipment than average power. With extra capacity to lengthen the time constant of the voltmeter circuit, it is possible to make the meter read approximately  $0.8$  of the peak envelope power so that it will follow speech peaks more closely.

#### 4. UNDESIRABLE POWER OUTPUT

Two types of undesired power may be present in the output of a transmitter. These are:

- (1) Spurious responses outside the passband
- (2) Intermodulation and incidental amplitude and angle modulation products in or near the passband

Spurious responses outside the passband consist mainly of harmonics of the desired output frequencies, products of frequency synthesis, and broadband noise from lower level stages amplified by the power amplifiers. The most direct method of measurement of this type of undesired response is the receiver/signal generator substitution method shown in the block diagram of figure 8-2. A portion of the transmitter output is sampled to provide approximately 1 or 2 volts r-f at desired signal frequencies through a 50 ohm attenuator to a 50 ohm load. When measurements are to be made, the transmitter is operated to provide carrier only or one sideband of modulation by a single tone of known frequency. The receiver is tuned to the transmitter output frequency and the 50 ohm attenuator is adjusted to obtain a convenient reference point on the receiver level indicator. The signal generator is then substituted for the transmitter and tuned for maximum indication on the receiver level indicator. Then the signal generator output, the 50 ohm attenuator, or both are adjusted to obtain the same indication on the receiver level indicator as was obtained with the transmitter. The reading on the signal generator level indicator, corrected to compensate for the attenuator setting, is the amplitude of the signal across the 50 ohm load which was equivalent to that obtained from the transmitter, and is the reference or zero decibel indication for measurements of spurious products. The transmitter is then reconnected to the attenuator and operated exactly as before, but the receiver is

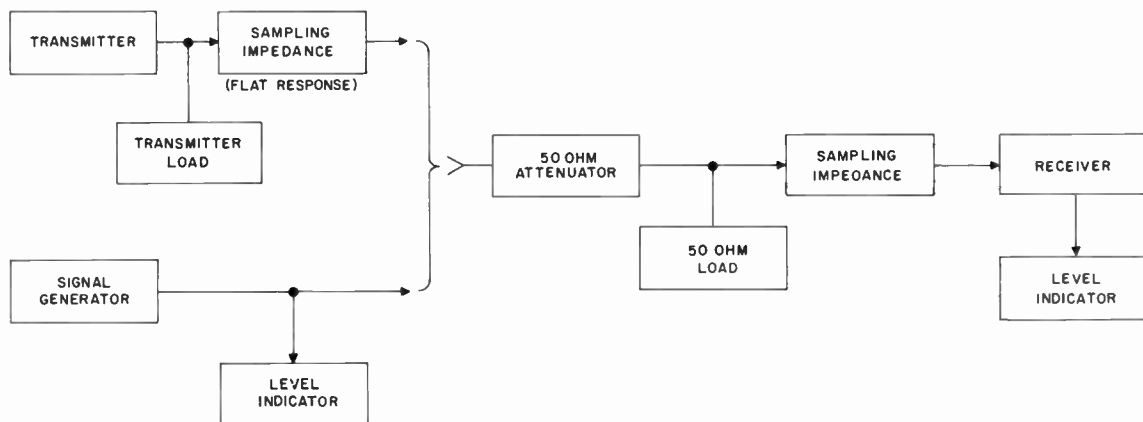

Figure 8-2. Receiver/Signal Generator Substitution, Block Diagram

tuned to a known point in its frequency range where a harmonic would appear, or a search for a spurious response is made. After the receiver is tuned for maximum level indication at a spurious response, the attenuator is adjusted to obtain a convenient reference point on the receiver level indicator. Once again the signal generator is substituted for the transmitter and tuned for maximum indication on the receiver level indicator at the frequency where the spurious response was found. The signal generator and attenuator are adjusted to obtain the same level indication at the receiver as produced by the spurious response and the voltage output of the signal generator, corrected to include the attenuator setting, provides a second reading of amplitude across the 50 ohm load. Comparison of the two readings gives the relative amplitude of the undesired response with respect to the desired signal. The accuracy of these measurements is determined by the accuracy with which the amplitude indication at the receiver level indicator is duplicated when the signal generator is substituted for the transmitter. If the receiver and signal generator are suitably isolated from any interconnecting paths such as the power line, are suitably shielded from each other, and the transmitter is shut down completely when measurements are made with the signal generator, it is possible to obtain reliable and repeatable measurements about 120 db below the desired output of the transmitter.

Since it is most practical to generate single sideband by initially generating the sideband frequencies at an intermediate frequency and subsequently heterodyning these signals to the desired r-f output frequency, products of output frequency synthesis may appear at the output of the transmitter. These products may be the actual heterodyning frequencies used to translate the intermediate frequency single-sideband signal to the r-f output frequency, or they may be mixer products of this process. Normal equipment specifications for these products are that they shall be from 70 to 80 db below the desired output of the transmitter. Low order harmonics of the output frequency are often specified 50 to 60 db below the desired output.

Since the  $Q$  of the output circuits of a reasonably efficient r-f power amplifier will be in the vicinity of 10 to 12, broadband noise generated in or amplified by the r-f power amplifier stages will not be affected appreciably by the selectivity of the output tank circuits. In a linear power amplifier with three or four stages, this noise will be due primarily to thermal and shot noise in the lower level stages. The effects of this noise may be observed on a spectrum analyzer or on a highly selective receiver. It is not normal for

this noise to interfere with communication on the channel of the transmitter causing the noise, however, if the noise is particularly severe, its broadband nature may cause it to interfere with adjacent channels several channel widths removed.

The second type of undesired power output includes those spurious responses inside or very near the passbands of frequencies including the intelligence to be transmitted. These in-band spurious products are caused by:

(1) Intermodulation distortion resulting from operation of mixers or amplifiers beyond their capabilities.

(2) Amplitude or angle modulation resulting from imperfect stabilization of the oscillator or synthesizer from which translating frequencies are derived.

In addition, the following characteristics are important to a good single-sideband signal:

(1) Suppression of opposite sideband

(2) Suppression of carrier

(3) Minimum compression of desired signal due to power amplifier loading

Two equal amplitude audio tones have become a standard test signal for distortion measurements because:

(1) One signal is insufficient to produce intermodulation.

(2) More than two signals result in so many intermodulation products that analysis is impractical.

(3) Tones of equal amplitude place more demanding requirements on the system than it is likely to encounter in normal use.

Any two tones will serve for this test but with many frequency relationships, intermodulation products and harmonics tend to merge making identification of these products impossible. A 3 to 5 frequency ratio is the simplest that will alleviate this problem. Tones having a more complex ratio may produce products with frequency relationships more suitable to certain tests, but these products will be more difficult to identify than those of the simpler ratio. The following chart shows the relationships between products produced by distortion of the upper sideband of 300 kc modulated by 3 kc and 5 kc tones.

TABLE 8-2. SINGLE-SIDEBAND DISTORTION PRODUCTS

Frequency (kc)	Order of Products							
	7	6	5	4	3	2	1	
295	-----							OSB
296								
297	IM	-----						OSB
298								
299	-----			IM				
300	-----							Car
301	-----			AIM	-----		IM	
302	-----		AIM	-----			AD	
303	AIM	-----						3 kc DT
304	-----			AIM				
305	AIM	-----						5 kc DT
306	-----		AIM	-----			AH	
307	-----			AIM	-----		IM	
308	-----		-----			AS		
309	-----			IM	-----			AH
310	-----		AIM	-----			AH	
311	IM							
312	-----		-----			AIM AH		
313	AIM							
314	-----		AIM					
315	-----			AH	-----		AH	
316	-----			AIM				

Legend:

A = Audio  
 AD = Audio Difference  
 AH = Audio Harmonic

AIM = Audio Intermodulation  
 AS = Audio Sum  
 Car = Carrier

DT = Desired Tone  
 IM = Intermodulation  
 OSB = Opposite Sideband



The idealized spectrum analyzer pattern for a two-tone single-sideband signal will consist of three discrete frequencies as illustrated in figure 8-3.

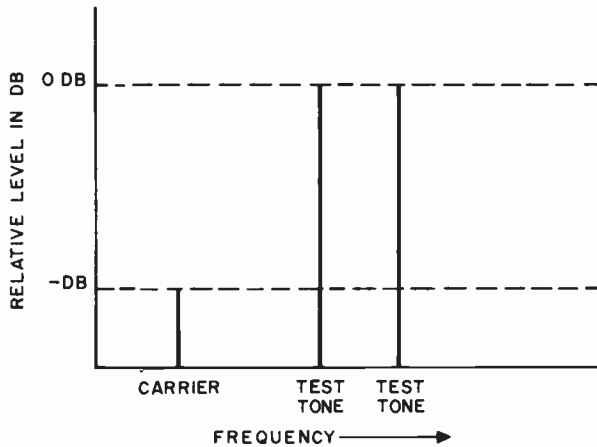

Figure 8-3. Idealized Spectrum Analyzer Pattern

These are the frequencies of each of the two audio test tones translated to the desired r-f output frequency and the carrier, which should be suppressed to the required level. The amplitudes of all undesired products and the carrier are measured in terms of decibels below either of the two equal amplitude test tones. Practical circuits always have some degree of intermodulation distortion which appears in the form of new discrete frequencies above and below the two test tones as illustrated in figure 8-4. The spacing

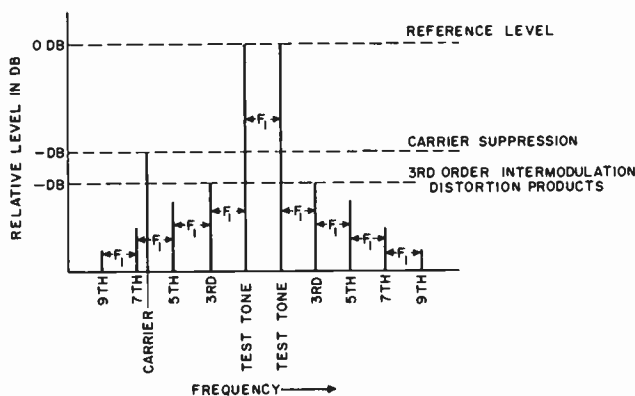

Figure 8-4. Practical Spectrum Analyzer Pattern

between each tone and the adjacent intermodulation products and the spacing between subsequent intermodulation products are equal to the spacing,  $F_1$ ,

between the two tones. The intermodulation products first adjacent to the desired tones are the third-order intermodulation distortion products; the next pair of products are the fifth-order intermodulation distortion products spaced equally outside the third-order intermodulation products; the next pair are the seventh, then the ninth and so on. The order of a distortion product is the sum of the coefficients in the frequency expression. For example, the third-order intermodulation products will be two times the frequency of one desired tone minus the frequency of the opposite tone. The fifth-order product is three times the frequency of one tone minus two times the frequency of the other. The odd-order products fall in or near the desired transmission band and are, therefore, the most objectionable because once generated they cannot be eliminated by either the transmitter or receiver. The signal to distortion ratio is the ratio of either of the two desired test tones to the largest undesired product expressed in decibels. A signal to distortion ratio of 40 db is usually acceptable for high-frequency communication systems when the equipment is tested on a two-tone basis. Unless unusual cancellation exists in the power amplifier, the third-order intermodulation products will be largest and the higher order products will be progressively smaller.

Over-all distortion resulting from several cascaded stages of amplifiers, modulators or mixers may be computed if the distortion of each stage is known. It is useful to note that each "stage" may be a "black box" actually composed of multiple stages, and one of the black boxes may be the distortion analysis equipment itself.

To obtain the over-all distortion in a system composed of several cascaded stages the following formula applies:

$$db_t = 10 \left\{ 10 - \log \left[ \log^{-1} \left( 10 - \frac{db_1}{10} \right) + \log^{-1} \left( 10 - \frac{db_2}{10} \right) + \dots + \log^{-1} \left( 10 - \frac{db_n}{10} \right) \right] \right\}$$

where  $db_t$  = Total or over-all signal to distortion ratio in db

$db_1$  = Signal to distortion ratio of 1st stage in db

$db_2$  = Signal to distortion ratio of 2nd stage in db

$db_n$  = Signal to distortion ratio of nth stage in db

$\log$  = logarithm with a base of 10

$\log^{-1}$  = antilogarithm with a base of 10



This equation yields the following typical results from two stages:

Difference between signal to distortion ratio between the two stages in db	Amount by which the overall signal to distortion ratio is degraded beyond that of the poorer stage in db
0	3.0
3	1.8
6	1.0
10	0.4

Any of the oscillators in a transmitter, receiver, or in an analyzer may have amplitude or angle modulation caused by such deficiencies as power supply ripple, alternating currents in tube heaters, mechanical vibration, or strong electric or magnetic fields in the vicinity of the oscillators or their control devices. This incidental modulation causes new sidebands to be produced by the transmitter. These may be observed on the spectrum analyzer display as responses symmetrically located on either side of all desired tones. Each distortion product will also exhibit these sidebands. When the oscillator that is used in the frequency scheme of a transmitter is modulated, the sidebands produced thereby are often unequal in amplitude because of simultaneous angle and amplitude modulation. An analysis of this phenomenon is summarized in the article entitled "Linearity Testing Techniques for Sideband Equipment" by Icenbice and Fellhauer in The Proceedings of the IRE, December, 1956. Phase modulation distorts the amplitude symmetry of the two sidebands produced by a single sine wave simultaneously angle and amplitude modulating a carrier or other desired output signal by subtracting a component from one sideband and adding it to the other.

## 5. SPECTRUM ANALYZER 478R-1

The most informative and universal method of measuring in-band spurious is by means of a spectrum analyzer such as the Collins 478R-1 Spectrum Analyzer. In this analyzer, a complete picture of the spectrum in the vicinity of the intelligence pass-band is plotted directly on an oscilloscope screen or may be recorded by means of a two-axis recorder. The problem of construction of this equipment was primarily to reduce intermodulation within the analyzer to a level appreciably below that to be measured. Although the analyzer is large and complex, the signal under test passes through only two tubes before detection by the narrow-band selective amplifier. These two tubes are both mixers, and much of the remainder of the equipment is devoted to insuring that the injection or translating frequencies applied to these mixers are sufficiently free from noise, distortion, and incidental angle modulation.

The basic circuit of the Spectrum Analyzer is that of a wave analyzer for measuring frequencies generated by signals passing through an amplifier or mixer or other system with an unknown amplitude transfer characteristic. Figure 8-5 is a block diagram of the 478R-1. Additional selectivity, variable sweep width, and other features permit accurate and simultaneous measurements of level in decibels versus frequency of distortion, hum, noise, and other spurious products in a direct plot on the analyzer screen or on a two-axis recorder. Included in the analyzer is a two-tone audio generator consisting of two audio oscillators and a filter-mixer panel. This portion of the analyzer generates a two-tone audio test signal for use as an audio input for intermodulation distortion measurements of the equipment under test.

The two-tone mixer panel satisfies several requirements for minimizing harmonic and intermodulation products in the two-tone audio test signal. One such requirement is sufficient isolation between the two audio signal generators to reduce intermodulation distortion in the output tubes of one generator because of coupling to the output of the other. This isolation is provided by pads in the output of each generator ahead of the mixing circuit. Second and higher order harmonics in the output of the generators are attenuated by plug-in low-pass filters selected to have cutoff frequencies between the fundamental frequencies and the second harmonic frequencies of their respective generators. Second-order intermodulation distortion which appears to be third-order intermodulation results from direct mixing of the second harmonic output of one audio generator with the fundamental of the other. This effect also is minimized by the low-pass filters. The difficulty of mixing the output of two signal generators so that they do not modulate each other is illustrated in figure 8-6. Both circuits A and B have the same output level but circuit A has approximately 50 db more isolation between the oscillators. The level of third-order intermodulation products is approximately 20 db higher in circuit B than in circuit A. While the attenuation of the audio output signal from oscillator no. 1 is affected primarily by the output series resistor and the 560 ohm load, the attenuation between audio oscillator no. 1 and no. 2 is affected by the output series resistor of oscillator no. 2 and the internal generator impedance of oscillator no. 2 as well as the attenuation between oscillator no. 1 and the output.

During spectrum analysis of a transmitter, products observed by the analyzer can be more readily identified by removing one or the other of the audio tones and observing the effect on the intermodulation products of interest. The ON-OFF switches in the two-tone audio generator are provided with dummy loads in the OFF position to preserve the impedance termination on the audio mixing circuit and thereby prevent a change in the amplitude of the remaining tone when

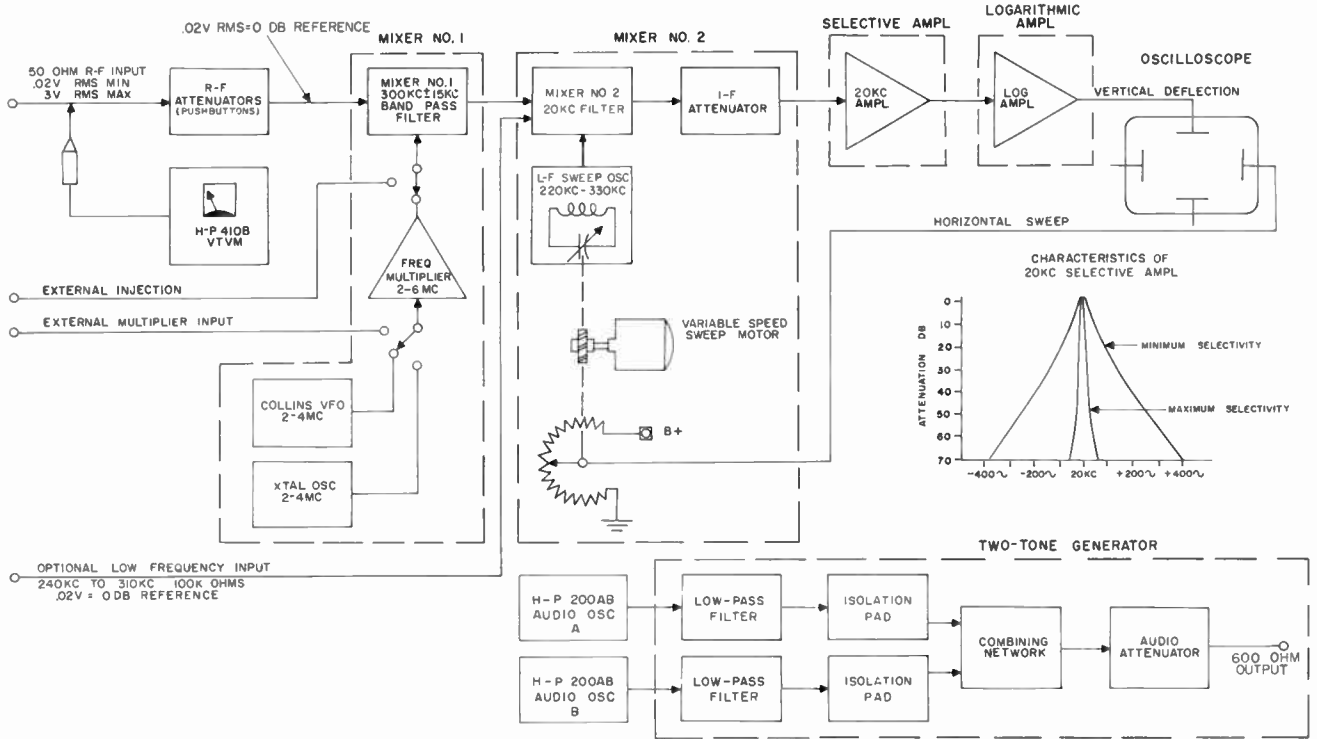

Figure 8-5. Spectrum Analyzer 478R-1, Block Diagram

one tone is switched off. The audio filters may be switched out of the circuit to allow the use of audio frequencies beyond the range of the filters, and a set of decade attenuators is provided to enable rapid and accurate testing of equipment with different amplitudes of audio input.

The dynamic range of the analyzer is 70 to 80 db, displayed on one scale to an accuracy of ±1 db. Continuous metering circuits are provided on the front panel to insure correct mixer injection level. The analyzer will accept a frequency spectrum with a center frequency from 1.7 mc to 64.3 mc and from 240 kc to 310 kc without additional coils or test equipment. The spectrum display is on a 17 in. cathode ray tube. Signal to be analyzed is fed into the precision attenuator panel where it may be monitored by the internal vacuum-tube voltmeter, Hewlett-Packard 410B. The attenuator is adjusted to the proper level and the attenuated signal is applied to mixer no. 1 which converts the signal to the 300 kc i-f. The output of mixer no. 1 passes through a 300 ±15 kc band-pass filter to mixer no. 2 where it is converted to 20 kc. Mixer no. 2 can accept directly any frequency from equipment under test between 240 kc and 310 kc. The tuning capacitor of the injection oscillator for mixer no. 2 is rotated by a variable speed motor to sweep the frequency of this oscillator through the required range.

Sweep widths of 4 kc, 8 kc, and 16 kc are available. The output of mixer no. 2 is fed through a precision attenuator with 0.1 db steps to a narrow-band 20 kc selective amplifier. The half bandwidth of the selective amplifier at 40 db below maximum response is variable from 30 to 145 cps by a control on the front panel. The output of the 20 kc selective amplifier is fed to a logarithmic amplifier. The output of this amplifier is a d-c voltage that is a logarithmic function of the input over a 70 db dynamic range. The calibrated attenuator between mixer no. 2 and the 20 kc selective amplifier provides for checking the linearity of the logarithmic amplifier and the oscilloscope to insure an accuracy of ±1 db throughout the 70 db dynamic range of the analyzer. The varying d-c output from the logarithmic amplifier is applied directly to the vertical deflection amplifier of the oscilloscope or to an external recorder. Synchronized horizontal sweep voltage is provided by a potentiometer ganged to the oscillator sweep tuning capacitor.

The signal path in the analyzer includes only three nonlinear devices ahead of the 20 kc selective amplifier after which nonlinearity causes no further intermodulation. The first nonlinear device in the signal path is the Hewlett-Packard 410B vtm probe, but the loading of this high-impedance probe on the 50 ohm circuit is so slight that negligible intermodulation

distortion results. Mixer no. 1 and mixer no. 2 consist of only one tube each and their operating characteristics have been very carefully selected to minimize intermodulation distortion. Microammeters on the mixer front panels provide continuous monitoring of injection grid current to insure that the mixers are always operated under optimum injection level conditions.

An ideal panoramic display of a constant carrier with no modulation would appear as a single line at

right angles to the frequency axis. However, in practical equipment this display is a single plot of the selectivity of the analyzer. If the selectivity of the analyzer is changed, the displayed shape of the same carrier under test will change to the new shape of the selectivity curve of the test equipment. Signals under test which have sidebands or intermodulation products to be observed by the analyzer will produce individual responses corresponding to each of these sidebands, or products, together with the desired responses themselves and each response will be

CIRCUIT A

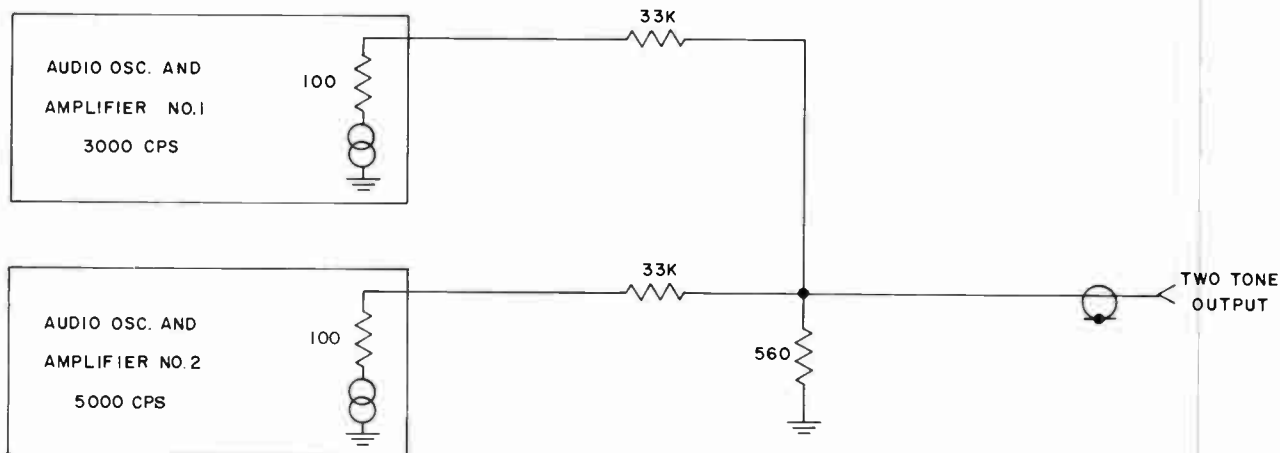

CIRCUIT B

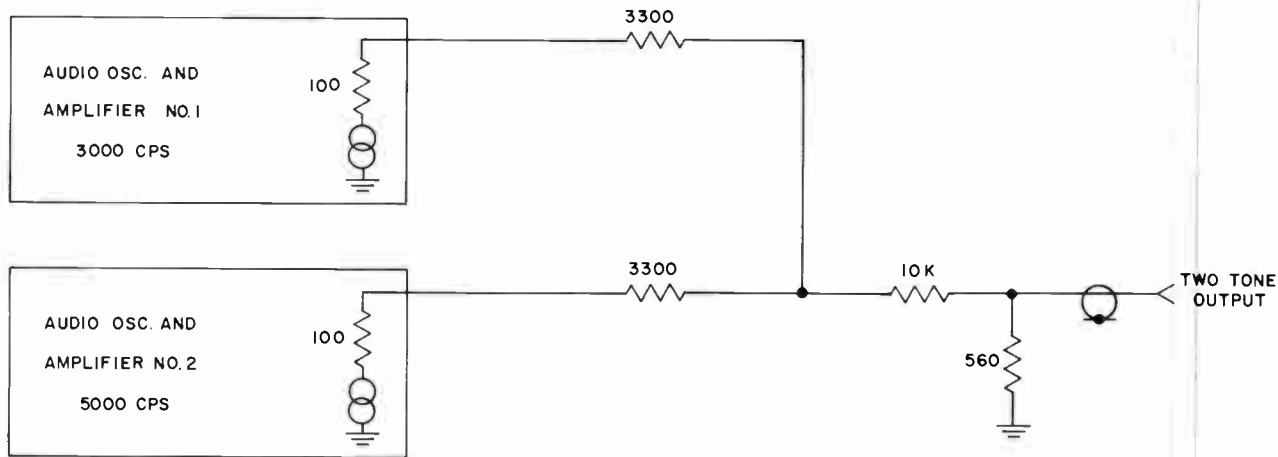

CIRCUIT	FREQ (CPS)	3RD ORDER LEVEL (DB)
A	1000	> 75
	7000	75
B	1000	52
	7000	58

GOVT NO.	COLLINE NO.
USED ON ASSEMBLY	
WEIGHT	1LB
UNLESS OTHERWISE SPECIFIED:	

Figure 8-6. Two-Tone Generator, Source Isolation

basically the shape of the analyzer selectivity curve, each with its own maximum amplitude. The maximum response from each discrete frequency is the required measurement. When these discrete frequencies or sidebands are spaced only a few cps apart, such as may be encountered with hum modulation, their corresponding responses on the analyzer screen tend to merge into each other. The responses, for example, of hum modulation will appear on the skirt of the response to the carrier for that modulation. The ability to separate such discrete frequencies is known as the resolving power of the analyzer. Maximum resolving power is attained when the equipment is operated with minimum sweep width, minimum sweep speed, and maximum selectivity. Since this mode of operation reduces the speed with which data may be obtained, provision is made for varying all three parameters so that data requiring less resolving power may be obtained more rapidly. With maximum selectivity, the speed of the sweep and the sweep width may be adjusted so that the frequency is swept through the response frequency of the analyzer so rapidly that the effective Q or selectivity of the analyzer will not allow the signal to build up to its peak amplitude before the sweep has passed this frequency. This error is always present with any reasonable amount of selectivity, but the effect will be negligible if the sweep width and sweep speed used are commensurate with the selectivity to which the analyzer is adjusted. The easiest check to insure a safe sweep speed is merely to reduce speed about one half and note whether the amplitude increases. If the peak amplitude increased more than 1 db, the original speed was too fast.

When single-sideband suppressed carrier equipment is under test, it is helpful to take the intermodulation distortion test data in steps of about 3 db. This is accomplished by inserting 3 db of attenuation in the output of the two-tone mixer by means of the audio attenuators and removing 3 db of attenuation from the r-f input to the analyzer by means of the r-f attenuators. This preserves the same amplitude of desired tones on the analyzer thus allowing observation to be concentrated on the changes in the intermodulation products. In this way, the point on the distortion versus signal curve, at which the equipment under test should be operated, can be established rapidly. The intermodulation products will increase relative to the desired output signals at an ever increasing rate, as the rated signal level of balanced modulators, mixers, or amplifier stages in the r-f equipment is approached. Near the overload point, intermodulation products commonly increase at a rate 2 or 3 db faster than the desired output signals. Beyond this point the rate of increase of the ratio of intermodulation distortion products to desired output signals becomes much more rapid. If the audio input signal level is reduced well below the normal level, the rate of increase of intermodulation distortion products' amplitude will be

reduced until at very low levels the intermodulation distortion products will change imperceptibly with respect to the desired output signals.

## 6. ANGLE MODULATION MEASUREMENTS

In order to make use of the resolution available from the selectivity of the 478R-1 Spectrum Analyzer in measurements of hum phase modulation sidebands, special precautions were taken to minimize hum phase modulation on the injection oscillators and in the signal path through the analyzer. Electronically regulated power supplies were used to reduce hum ripple on the plate voltages to less than 1 millivolt, wherever possible cathodes were operated at ground potential, and plate circuits were either shunt fed or a pair of tuned circuits were coupled to insure that the grids of the following stages were grounded with respect to hum frequencies. In critical circuits, such as in the variable frequency oscillator, where the preceding methods were not applicable, filaments were supplied with direct current, circuits and components were selected to minimize microphonic pickup, and the Sola regulating transformer was housed in a special case to reduce magnetic fields at harmonics of the 60 cps line frequency.

When angle modulation is analyzed on a spectrum basis, only a simple amplitude detecting rectifier circuit is required in addition to the analyzer selectivity. Since the selectivity of the analyzer can slope detect angle modulation, it is necessary to integrate the output of the detector rectifier because the slope detection is a function of the analyzer selectivity and will not truly represent the spectrum of the equipment under test. On the 478R-1 analyzer, an external plug-in capacitor of several microfarads may be placed across the oscilloscope deflection input terminals to perform this integration and eliminate the slope detection.

A sinusoidally modulated FM wave has a spectrum which contains not just two side frequencies as in AM, but an infinite number of side frequencies spaced equally from the carrier by intervals equal to the modulating frequency. When the angle modulation level is very low, the amplitudes of the higher order sidebands drop very rapidly. When the modulation level is high the amplitude of the carrier may be lower than some of the sidebands, and the sidebands will extend over a much larger band of frequencies. A qualitative check of the effect of low-level incidental angle modulation on a carrier may be obtained by slope detection in a receiver which has a relatively high degree of selectivity, such as the 51J or R390. The receiver is tuned to one side of the carrier signal so that the S meter indicates 1/2 or less of the maximum deflection obtained when peaked exactly on the signal. If no hum or other tone is heard in the receiver as the AVC allows the sensitivity of the



receiver to increase and the noise to rise, it may be assumed that closely spaced discreet angle modulation spectra are below the noise level.

## 7. COMPRESSION MEASUREMENT

An additional characteristic of power amplifiers known as compression is often measured as an indication of capability of the power amplifier and its power supply. Compression of the output signal may result from less than optimum d-c regulation of the power supply for the power amplifier plate, screen and bias voltages and may serve as an indication of intermodulation in the power amplifier when subjected to close spaced tones. Since the power amplifiers are normally operated in class AB<sub>1</sub>, or some other mode of class B operation with respect to plate current, the load on the power supply varies with the instantaneous amplitude of the signal envelope. Compression results when, in the presence of one signal which does not utilize full peak envelope power capability, a second signal is applied which approaches full peak envelope power. The amplitude of the first signal is compressed by an amount which is a function of the variation in the power supply output voltage as a result of the additional loading demanded by the second signal. Measurements of compression must be conducted with selective equipment which is capable of observing the amplitude of one continuous signal as a second signal is varied in amplitude. Such measurements are usually obtained with spectrum analysis equipment by observation of a continuous desired signal 10 to 20 db below peak envelope power while a second signal which demands approximate peak envelope power is switched on and off. The effect on the fixed amplitude tone is plotted in terms of decibels versus the number of decibels by which peak envelope power is approached or exceeded. The 478R-1 analyzer is particularly adaptable to this type of measurement in that its decibel scale may be expanded 10 to 1 so that each inch of oscilloscope scale equals 1 db, and the accuracy of the measurement is then  $\pm 1$  db. Such measurements may be conducted using the same tones as are used with the standard two-tone test signal and stopping the sweep motor so that the amplitude of one tone is continuously monitored while the other tone is switched on and off. Intermodulation distortion may be produced by the r-f power amplifier when operating with close spaced tones if the low-frequency a-c impedance of the power supply is too high. The screen voltage supplies for pentode power amplifiers often present stringent requirements because such amplifiers are sensitive to screen voltage changes.

## 8. INTERMODULATION MEASUREMENTS WITH BUILT-IN MONITOR

Intermodulation distortion in a transmitter may be tested by means of a monitor which uses the same frequency scheme as the transmitter, but operating in

reverse to translate the r-f output signal back to audio or some convenient fixed intermediate frequency. In this manner, spectrum analysis can be made and compared with analysis of the original audio signals applied to the transmitter. The monitor itself must be carefully designed so that its intermodulation is lower than that of the transmitter to be tested. For example, if the level of intermodulation distortion products are 40 db below desired output signals, and the intermodulation within the test equipment is 46 db below desired output, then the resulting intermodulation distortion measurement will be in error by approximately 1 db. Therefore, the result of the measurement will indicate intermodulation products 39 db below desired output rather than the actual 40 db figure. These relationships represent normal conditions but do not guarantee this result for every situation.

Measurements made by means of such a monitor, however, will not show incidental angle modulation since use of the same translating frequency sources for both the transmitter under test and the monitor will tend to cancel the effect of such incidental angle modulation. Separate translating frequencies for the test equipment must be used to measure spurious sidebands caused by incidental angle modulation.

## 9. LINEARITY MEASUREMENT WITH NOISE LOADING

Intermodulation distortion measuring equipment using two tones is very versatile for identification of linearity characteristics. However, measuring equipment using noise as the input signal has the advantage that the test signal more nearly simulates the complex signal typical of voice or multiple tone modulation.

If band limited noise is introduced into a system under test, linearity of the system may be partially described in terms of the noise outside the original band limits. If the output of a random noise generator is fed into a band-pass filter which equally passes all noise frequencies in the passband to be tested except for a small portion at the upper and lower extremes, the noise loads all but a few cycles of the transmission band to any degree of modulation desired. At the receiving end of the system, three band-pass filters with equal bandwidth and insertion loss are used for measurement purposes. One such filter is selected near the center of the transmitted noise passband, and a true rms noise voltage from this filter is used as a reference signal level. The other two filters pass the distortion sidebands just outside the intended noise passband. The output of these two filters are measured separately with the true rms voltmeter, and these levels in decibels below the reference voltage represent the intermodulation distortion generated at the low- and high-frequency ends of the loaded passband. Noise



generators for this purpose are commercially available and the band-pass filters may be selected to satisfy the requirements of the equipment under test.

As indicated in figure 8-7, a transmitter loaded with noise signals over a discreet bandwidth,  $B$ , will have all third-order intermodulation products appearing in a band equal to three times the desired bandwidth and with the same center frequency. All fifth-order

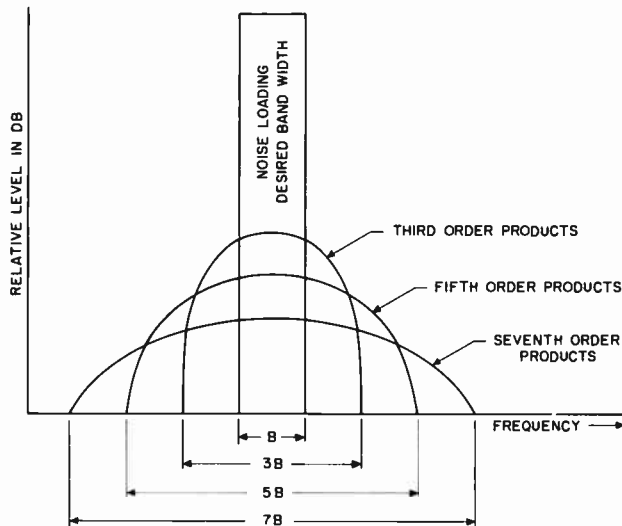

Figure 8-7. Intermodulation Products in a Noise Loaded System

intermodulation products will fall inside a bandwidth five times the width of the desired band and having the same center frequency. All seventh-order products will fall inside a band having seven times the width of the desired band and having the same center frequency and so on. Since the amplitude of the intermodulation distortion products are usually in approximate inverse proportion to the order of the product, the shape of the curves describing the amplitudes of the products may be predicted. If a two-tone test signal is employed, the discreet frequency relationships between the desired signals and the intermodulation products will be known or may be computed. When these are superimposed upon the curves of the intermodulation products for a noise loaded system (figure 8-6), an approximate plot of the entire spectrum resulting from the two-tone test signal may be predicted.

The Collins 478R-2 Baseband Spectrum Analyzer may be used in the same manner to test intermodulation distortion in a noise loaded system or in one employing multiple discreet frequencies. Only one filter is necessary at the receiving end of the system and a sweeping frequency scheme is employed to allow a

panoramic plot on an oscilloscope or on a recorder of the responses throughout and beyond the system bandwidth. This equipment permits simultaneous observation of a range of audio and video signals from 3 kc to 2 megacycles. The plot on the oscilloscope or recorder is in terms of decibels plotted on the Y axis against frequency in kilocycles on the X axis, as in the 478R-1 Spectrum Analyzer. The sweep width is variable from 0 to 70 kc, and the main tuning dial is detented to position the center frequency at 50 kc intervals over the 3 kc to 2 mc range so that the complete frequency range may be examined accurately and rapidly in 50 kc increments. This equipment is particularly suited for portable and field use when used with a portable two-axis recorder.

## 10. DELAY DISTORTION

A transmitter which has delay distortion but negligible nonlinear distortion will not cause the production of new output frequencies. The amplitude of the output components are not affected by delay distortion; therefore, the existence of delay distortion within the transmitter will not influence the results of measuring nonlinear distortion by either multisignal loading or noise loading methods if the delay distortion does not vary with time. Phase always varies with frequency in a reactive network, but phase distortion is not necessarily produced. Instruments for the direct measurement of phase of audio frequencies are commercially available. When a plot of the phase measurements against frequency is differentiated with respect to frequency, the derivative is the envelope delay. Phase delay is defined as the ratio of the phase with respect to frequency and approaches the value of the envelope delay expression, namely, the derivative of phase with respect to frequency, when the phase-frequency plot approaches a straight line. The perfect system is never available in practice, so the phase delay is never exactly equal to the envelope delay. Delay distortion measurements may be obtained by passing a modulated signal through a network and measuring the resultant modulation envelope phase shift caused by the network under test. Time delay may then be computed by using  $T_d = \Theta/360f_m$ , where  $T_d$  is the delay in seconds;  $\Theta$  is the phase shift of the modulation envelope in degrees, and  $f_m$  the frequency of modulation in cps. Systems in which delay distortion can seriously affect or completely destroy the useful characteristics of the desired signal must be tested using equipment designed for this particular purpose, the common method being the measurement of envelope phase shift.

## 11. FIELD TEST SET FOR INTERMODULATION DISTORTION MEASUREMENTS

A smaller portable spectrum analyzer would be useful for field test purposes. Such a unit could serve

as a transmitter monitor as well as an intermodulation distortion analyzer. The following measurements could be provided by this equipment:

- (1) Linearity or intermodulation distortion in a transmitter, receiver, or audio amplifier.
- (2) Carrier leak or suppression
- (3) Alignment checks
- (4) Low-level r-f voltage measurements
- (5) Transmitter monitoring

The basic technique of such a distortion analysis field test set would be to translate the r-f signal through low-distortion mixers to audio and separate the signals and distortion products with audio filters. The relative amplitudes of the intermodulation products with respect to desired signals would be obtained from attenuator readings and would be limited to about a 50 db range. When measuring intermodulation distortion in a transmitter or in a receiver, a study of relative magnitudes of the intermodulation distortion products, combined with familiarity with the frequency scheme, will usually isolate a malfunction with respect to the r-f, i-f, or audio section of the equipment under test. Such an analyzer would not indicate r-f signal levels directly in volts; however, it would indicate whether the same readings prevail that existed during a

previous test. This function would be especially useful for trimming tuned circuits that operate at levels below normal vtvm sensitivities. The monitor portion of the test unit would allow aural checks with the equipment in operation to determine if speech or multiple-tone data circuits sound normal. When the equipment is used for monitoring purposes either or both sidebands, as transmitted, would appear in the audio output without separation.

The field analyzer would consist of three basic units:

- (1) An audio two-tone test signal generator
- (2) An audio distortion analysis filter
- (3) An r-f to audio converter

For monitoring purposes, a fourth unit consisting of an audio amplifier with provisions for headphones or loudspeaker could be used.

**a. AUDIO TWO-TONE SIGNAL GENERATOR**

The audio two-tone signal generator (figure 8-8) would consist of two oscillators whose frequencies would be controlled by audio resonators such as are provided in Kineplex\* equipment. Each oscillator

\* Registered in U.S. Patent Office

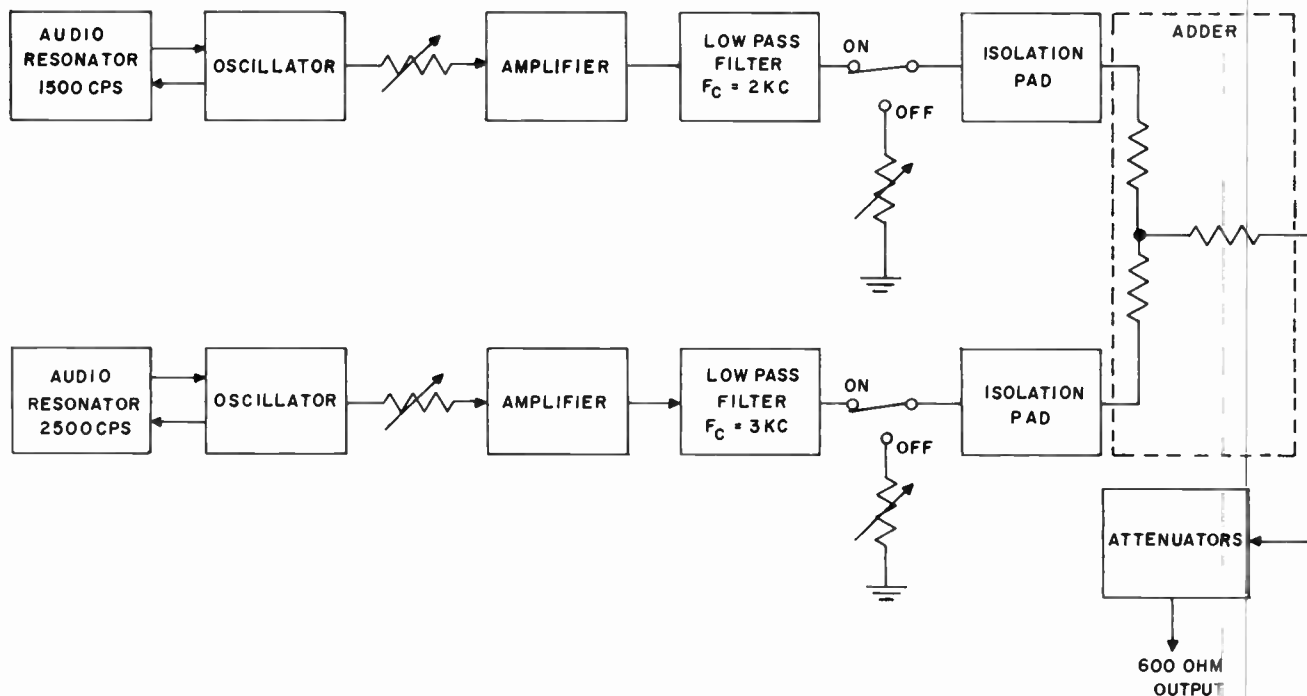

Figure 8-8. Audio Two-Tone Test Generator, Block Diagram

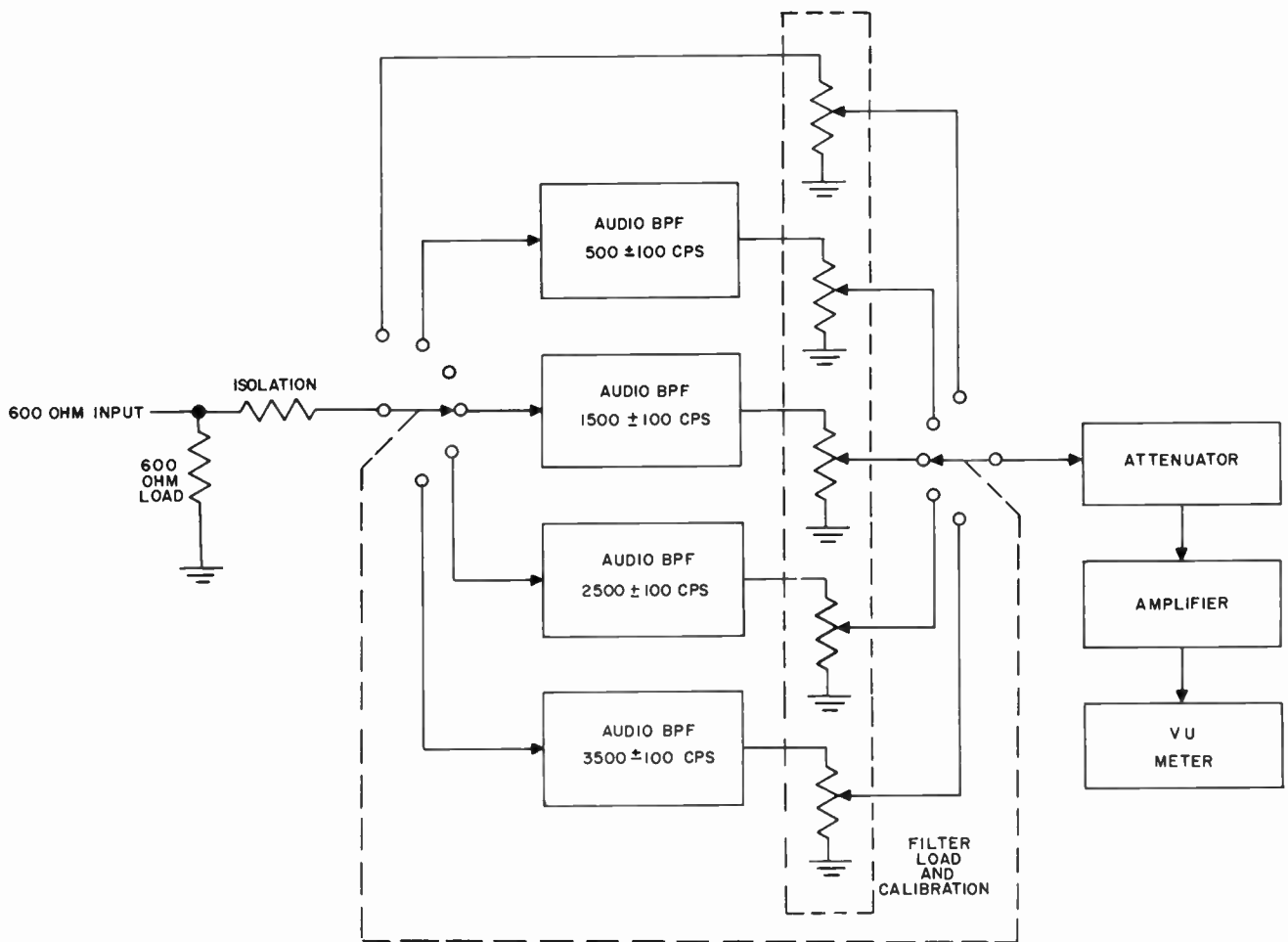

Figure 8-9. Audio Distortion Analysis Filter, Block Diagram

would be provided with a level control, its own amplifier, and a low-pass filter with the cutoff between the fundamental and second harmonic of its respective oscillator. On - off switches would be provided for each tone to enable identification of intermodulation distortion products. Isolation pads in each signal path plus the additional isolation afforded by the resistive adding network and isolation due to the presence of the low-pass filters would minimize intermodulation between the two audio amplifiers to a practical level. One and ten decibels per step attenuators in the combined output signal path would provide for intermodulation distortion measurements yielding a curve of intermodulation distortion versus audio input amplitude. The output impedance of the test generator would be 600 ohms, with an output signal level variable by means of the attenuators from approximately 3 volts per tone to 100 db below this level, approximately 30 microvolts.

#### b. DISTORTION ANALYSIS FILTER

Although audio analysis may be performed with commercial wave analyzers, the process is slow and commercial units for this purpose are expensive and impractical for field use. The audio distortion analysis filter (figure 8-9) for this field test set would have a 600 ohm input termination, suitable isolation of the internal audio band-pass filters from the 600 ohm input, and a selector switch for inserting any one of four audio band-pass filters or an unfiltered circuit in the path to the indicating meter. Each band-pass filter would be wide enough to pass only one of the discrete audio frequencies of interest, allowing for approximately 50 cps error in tuning of the vfo in the r-f to audio converter. Two of the filters normally would pass the desired two-tone test signals, and the other two filters would pass the third-order intermodulation distortion products resulting from the two

desired test tones. The unfiltered circuit would provide measurement of signal levels under normal operating conditions of the equipment monitored. Fifth-order products in a transmitter could be measured by tuning the r-f to audio converter to one side so that the desired two tones fall on the frequencies of the first and second filters. Then the third-order intermodulation distortion product would appear in the third filter and the fifth-order intermodulation product in the fourth filter. Seventh-order products could be measured by side stepping the tuning of the r-f to audio converter one additional slot so that the higher of the two desired test tones falls on the frequency of the first filter. Then the third, fifth, and seventh-order products would fall on the second, third, and fourth filters, respectively. Provision would be made for compensating for the insertion loss of the various filters individually, and a second gang on the selector switch would connect the attenuator, amplifier, and level indicating meter to the filter circuit to which the input was switched. With a 10 db per step attenuator and a level indicating meter calibrated in decibels over a 1 to 10 db range, signals could be measured with an accuracy of  $\pm 1$  db, while the dynamic range requirements on the meter amplifier would be only 10 db and, since it would pass only

one frequency at a time, its distortion requirements would be negligible.

**c. R-F TO AUDIO CONVERTER**

The r-f to audio converter (figure 8-10) would consist of three mixers. Only fixed tuned low-pass and band-pass filters would be used in the signal path of the converter to eliminate the necessity for tracking tuned circuits. The first mixer input might be switched to either a high-impedance input through a potentiometer or to a 50 ohm calibrated r-f attenuator. A limited range of input level control would be obtained thereby to allow setting input signals at optimum mixer operating levels. There would be no internal gain controls. If required, additional attenuation could be obtained before the signal is applied to the converter by means of sampling impedances in the external isolating circuits. Transmitters and other equipments under test should have suitable test points provided for monitor pickup.

The first mixer of the converter would obtain translating signals from a multiple crystal oscillator and multiplier to heterodyne the r-f input to a range of 1.7 to 4.3 mc. Since the output of the vfo need not be

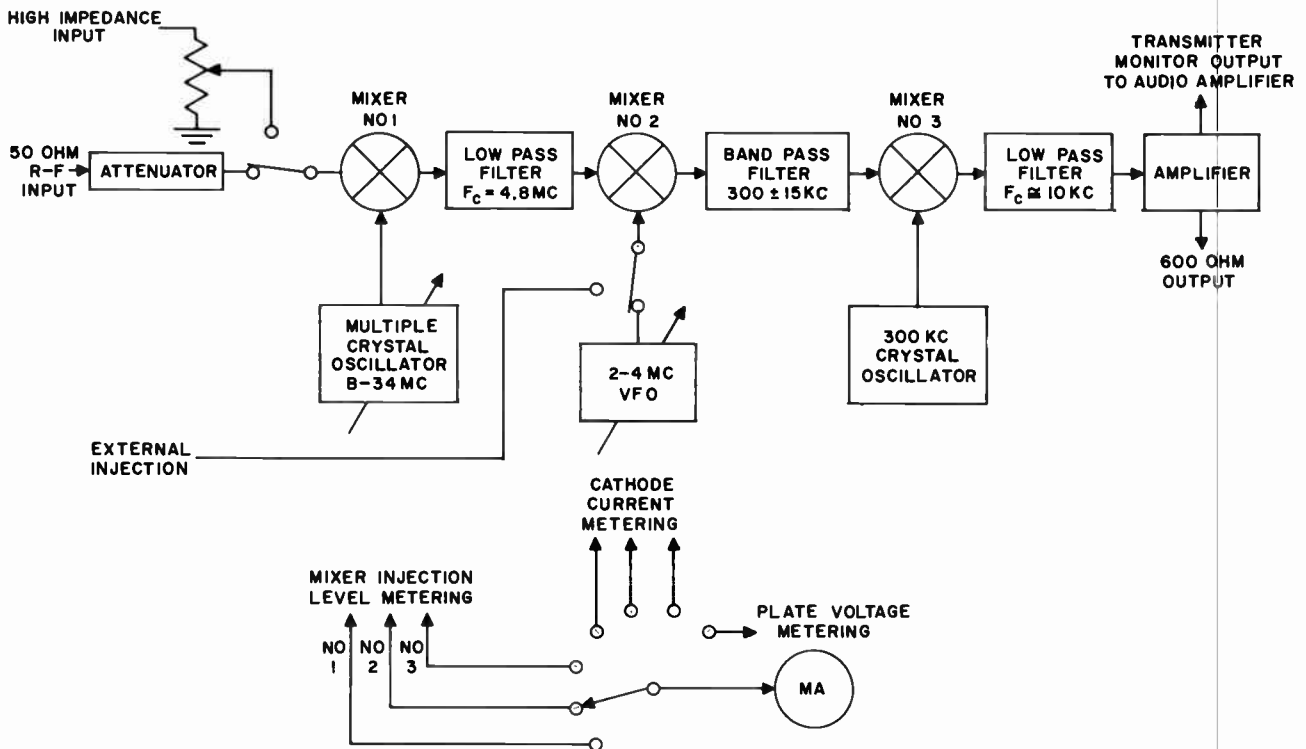

Figure 8-10. R-F to Audio Converter, Block Diagram

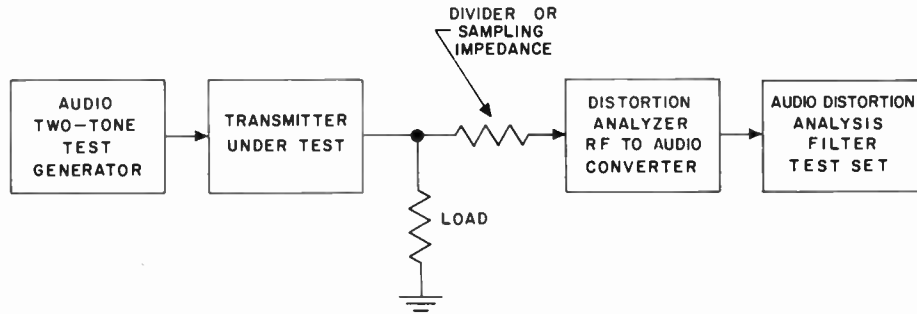

Figure 8-11. Test of Intermodulation in Transmitter

multiplied for this purpose, the stability and ease of tuning in the converter would be improved. The multiple crystal oscillator and multipliers would be provided with suitable tuned circuits for rejecting the undesired multiples where necessary. A level adjustment would be required for each range. All crystals, coils, and level controls would be selected by a range position switch. Since the output of mixer no. 1 would be filtered by a low-pass filter, signals in the range 1.7 to 4.3 mc could be applied through mixer no. 1 as an amplifier directly to mixer no. 2 without heterodyning. The second mixer would obtain a heterodyning signal from a 2 to 4 mc ten-turn variable frequency oscillator which could have a vernier control to facilitate fine tuning. If desired, the injection for mixer no. 2 could be applied externally to allow detection of signals at frequencies below 1.7 mc. The output of mixer no. 2 would be filtered by a band-pass filter approximately 30 kc wide and centered at 300 kc. Mixer no. 3 would heterodyne the signal to audio with injection obtained from a 300 kc crystal oscillator which could be provided with a trimmer for very fine tuning. The output of mixer no. 3 would be filtered to pass only the audio range after which the signal would be amplified by a low-distortion audio amplifier and made available in the form of a 600 ohm output capable of driving the audio distortion analysis filter. This 600 ohm output could be bridged with a high-impedance input audio amplifier driving headphones or a loud-speaker. If a monitor audio amplifier and speaker is used, and if the low-frequency response is adequate, the monitor would indicate the presence of hum in the transmitter. The unfiltered circuit in the distortion analysis filter could be used as an aid in rough tuning the r-f to audio converter in the absence of an audio monitor, or for measurements of the amplitudes of single signals which do not fall in the range of the filters but can be identified by audio monitoring. The latter application could implement frequency response measurements. Metering of the mixer injection

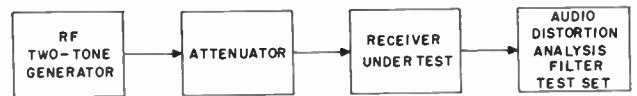

Figure 8-12. Test of Intermodulation in Receiver

levels would be provided to insure optimum mixer conversion efficiency with minimum intermodulation distortion. In addition, metering of mixer and audio amplifier cathode current and plate voltage would be provided. As in the 478R-1 Spectrum Analyzer, no preselectivity would be required and tuning of only the 2 to 4 mc vfo and selection of the proper crystal oscillator circuit for mixer no. 1 would suffice to translate the r-f signal to audio for these measurements.

The block diagrams of figures 8-11 through 8-13 demonstrate the use of the several sections of an analyzer of this type for tests of intermodulation distortion in a transmitter, a receiver or in an audio amplifier. An entire communications system could



Figure 8-13. Test of Intermodulation in Audio Amplifier



be tested or the equipment could be used as a transmitter monitor as indicated in figures 8-14 and 8-15. The analyzer would be designed so that it could be used to check itself as shown in figures 8-16 and 8-17. This system would be capable of measuring intermodulation distortion products 6 db or more higher in amplitude than the indicated measurements of these products when the analyzer is used to test itself. This condition would provide an accuracy of approximately 1 db in tests of other equipment.

## 12. SUMMARY

The demand for more communication channels in the high-frequency band and the large volume of information that must be carried on each channel has led to a search for a more effective and efficient method of communication. Technological advances in frequency control have made possible the use of single-sideband techniques which eliminate dependence upon a carrier for automatic frequency control at the receiver. However, to assure full utilization of the advantages of these techniques, test equipment must be provided which is capable of making measurements with a much higher degree of resolution than has been customary.

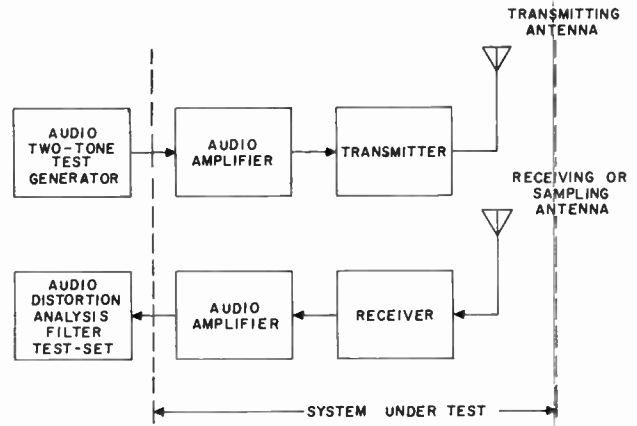

Figure 8-14. System Test for Intermodulation Distortion

Precision frequency counters provide a convenient method of measuring frequency accuracy while spectrum analysis measures the degree of linearity and frequency stability directly in terms of bandwidth requirements. Laboratory test equipment capable of the required resolution has been built and used in the development of SSB equipment. The design and construction of precision test equipment for field use is receiving added attention as the use of SSB equipment becomes more widespread.

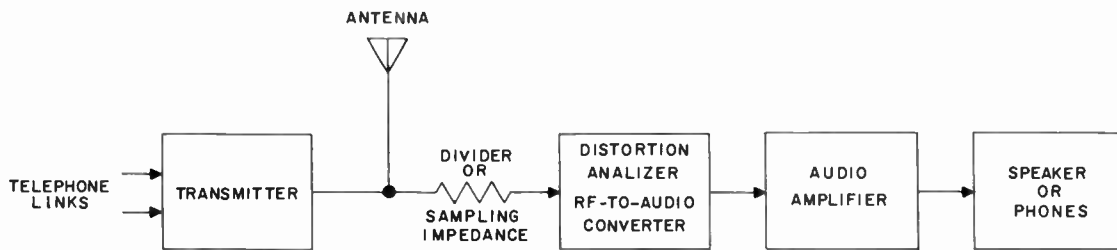

Figure 8-15. Transmitter Monitor, Block Diagram

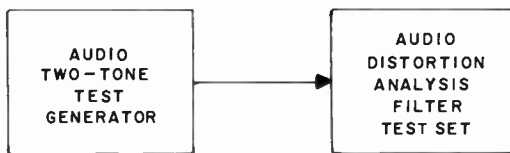

Figure 8-16. Test of Two-Tone Audio Generator



Figure 8-17. Test of Intermodulation in R-F to Audio Converter

## CHAPTER 9

# HIGH-FREQUENCY ANTENNAS

### 1. INTRODUCTION

Because of varying operational requirements, a wide variety of antenna systems are used in high-frequency communication systems. The use of single-sideband techniques does not introduce any peculiar requirements on the antenna system. The purpose of this chapter is to review basic antenna theory and to describe the characteristics of typical antennas that may be used in high-frequency communication systems.

The receiving and transmitting antennas together with the intervening medium perform the function of the transmission line in a wire communication system. At large distances the voltage that can be induced in an antenna is greater than that which can be transmitted over wires of a practical size. The attenuation of waves guided by wires increases exponentially with the length of the wire. Thus over long distances, the attenuation in wire is greater than the attenuation due to the three dimensional spreading of radio waves in space.

By the reciprocity theorem, the electrical characteristics of an antenna are the same for transmitting as they are for receiving. However, because of the different applications, certain practical differences between transmitting and receiving antennas exist. The function of a transmitting antenna is to radiate the radio-frequency energy that is generated in the transmitter and guided to the antenna by the transmission line. In this capacity the antenna acts as an impedance matching device to match the impedance of the transmission line to that of free space. In addition, the transmitting antenna should direct the most energy in desired directions and suppress the radiation in other directions where it is not wanted. For reception, however, the optimum condition is not maximum received power but rather maximum signal-to-noise ratio. Although the pattern that gives the first condition may also lead to the second, such is not necessarily the case. For example, a minor lobe in the pattern of a receiving antenna may bring in a large amount of noise if it happens to be pointed toward a noise source, and so result in a low signal-to-noise ratio. On the other hand, as a transmitting antenna, the presence of the lobe may have no ill effect other than the loss of the small amount of power that it radiates. Increasing the directivity of the transmitting antenna will always increase the signal-to-noise ratio at the receiver. Increasing the directivity of a

receiving antenna will increase the signal-to-noise ratio unless the noise is coming from the same direction as the signal. Another important factor is that in the high-frequency range the atmospheric noise picked up by a receiving antenna is usually much greater than the receiver set noise. Thus, it is possible to use a very inefficient antenna and/or loose coupling to the receiver without any apparent degradation of the signal-to-noise ratio. Since in a high-frequency communication system the same antenna is commonly used for transmission and reception, the antenna is designed for best over-all performance.

Long distance communication in the high-frequency region relies on the reflection of the radio waves from the ionosphere (see chapter 11). The result of this is that the desired direction of transmission or reception may be from several to many degrees above the horizon, depending upon the distance between the stations and the height of the reflecting layer. To obtain optimum results from any given antenna system, its design should take into account the particular propagation conditions which exist.

### 2. ANTENNA FUNDAMENTALS

#### a. RADIATION CHARACTERISTICS OF A LINEAR CONDUCTOR

To radiate electromagnetic and electrostatic energy into space, it is necessary to obtain a circuit which will not confine the useful fields to the immediate vicinity of the lumped inductance and capacitance constituting the circuit where it would be mostly absorbed. A rectilinear conductor of length comparable to a wave length and very small thickness in terms of wave length comprises a circuit with its inductance and capacitance distributed over a large area, and it will radiate a large part of the energy flowing in the conductor. Radiation from this simple antenna takes place by virtue of the expanding magnetic and electrostatic fields accompanying the charges flowing in the conductor. All of the energy traveling in the conductor however is not radiated before it reaches the end of the conductor. Some of it is reflected. These reflections from the discontinuities at the ends produce voltage and current standing waves on the conductor. If the diameter of the radiator is very small in terms of wave length, the rms voltage and current amplitude will vary substantially as a sine function. Examples

of voltage and current distribution along several resonant-length wires are shown in figure 9-1.

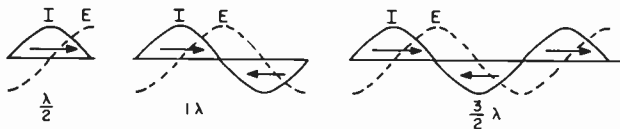

Figure 9-1. Sinusoidal Voltage and Current Distribution on Resonant Wires

The conductor is resonant when it exhibits purely resistive properties, and as in the ordinary tuned circuit, the largest amount of current will be conducted during resonance. Therefore, since the strength of the radiated electromagnetic field depends on the current flowing, it is desirable to make the conductor or antenna resonant. Resonance of the conductor occurs when its length is a half wave length or multiples thereof. A practical rectilinear conductor will resonate when it is slightly less than a half-wave in length due to end effect. End effect is due to a decrease in inductance and an increase in capacitance near the end of the conductor, which effectively lengthens the antenna. End effect increases with frequency and varies with different installations. In the high-frequency region, experience shows that the length of a half-wave radiator is in the order of 5% less than the length of a half-wave in free space. The greater the diameter of the conductor, the greater the difference between its electrical and physical length.

In actual practice, the presence of supporting insulators, feed systems, and surrounding objects such as the earth and other antenna elements have an aggregate effect upon the electrical length which may even exceed the variation in length caused by practical variations in the conductor diameter. This makes the unknown length difficult if not impossible to predict under practical conditions. Therefore, the usual procedure is to cut or adjust the radiator to a length equal to or slightly less than the correct free-space physical length, check the characteristics of the antenna experimentally, and then alter the physical length as necessary.

In order to keep the efficiency of a radiating system high, the ratio of radiated energy to the energy dissipated in the radiator must be high. This means that the antenna must have sufficient physical size in terms of wave length to exhibit appreciable radiation resistance. In the simple linear radiator, radiation resistance may be defined as the ratio of radiated power to the square of the circulating current at a maximum current point on the radiator. The term

resistance is actually fictitious but represents a resistance that would dissipate the power that disappears by radiation.

In the case where the antenna is a single half-wave element, the feed point resistance is essentially equal to the radiation resistance if the antenna is fed at the center or current loop. But when the radiating portion of the antenna consists of several elements with complex current distribution and complex mutual impedances, the feed point or input resistance is not the same as the effective radiation resistance. Feed point or input resistance refers to the resistive component of the impedance which the antenna presents to the feed line. Radiation resistance and input resistance, therefore, are not always synonymous.

The resistive and reactive components of the feed point or driving point impedance of a linear radiator are dependent upon both the length and diameter of the conductor. The manner in which these resistive and reactive components vary with change in frequency are dependent on the location of the feed point on the radiator. The feed point of an antenna looks to the transmission line much like a resistance-loaded tuned circuit, series resonant if fed at a current loop and parallel resonant if fed at a voltage loop. This analogy is illustrated for the case of the half-wave radiator in figure 9-2.

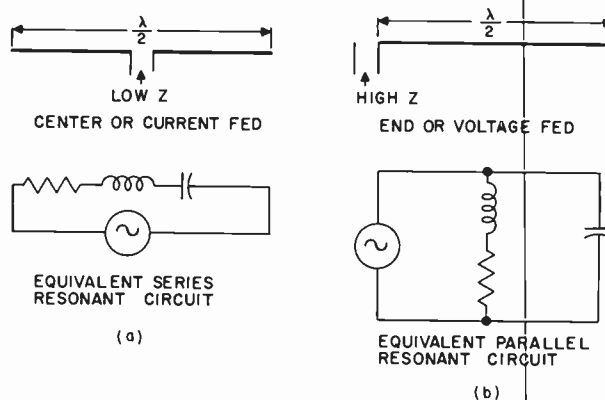

Figure 9-2. Lumped Circuit Analogy for Half-Wave Radiators

Both the feed point resistance and the feed point reactance change more slowly with frequency as the conductor diameter is increased, indicating that the effective Q is lowered as the diameter is increased. However, since the input resistance is nearly all radiation resistance rather than loss resistance, the lower Q does not represent lower efficiency. The

lower  $Q$ , therefore, is desirable because it permits use of a given radiator over a wider frequency range without resorting to means for eliminating the reactive component. Thus, the use of a large diameter conductor makes the over-all system less frequency sensitive. Radiators with sufficiently low  $Q$  to permit their input impedance to remain relatively constant over a wide frequency range are termed broad-band.

Other expedients also will provide a substantial reduction in the frequency sensitivity when broad-band characteristics are a requirement. A method commonly employed takes advantage of the opposite sign of the reactive component in a series tuned circuit with respect to that in a parallel tuned circuit when both are detuned from resonance in the same direction. If the two circuits are properly combined, their reactances cancel resulting in a relatively wide frequency range of zero reactance. A current-fed antenna (series circuit analogy figure 9-2), for example, can be made less frequency sensitive by connecting a parallel resonant circuit using lumped  $L$  and  $C$  across the feed point, the optimum  $L/C$  ratio being most easily determined by experiment. One simple antenna which owes its broad-band characteristics in part to reactance canceling effects similar to those just described is the folded dipole.

### b. POLARIZATION

The energy leaving a linear radiator is in the form of electric and magnetic fields that are perpendicular to each other and mutually perpendicular to the direction of propagation. Arbitrarily, the polarization of a radio wave is defined as the orientation of the electric field. This is convenient because the electric component is in the same plane as the linear radiator. Thus, a simple linear radiator oriented horizontally with respect to the earth will emit horizontally polarized waves. It is for this reason that antennas are often referred to as being horizontally or vertically polarized. There are, however, certain types of antennas that emit a complex or elliptical wave, but these are not commonly used in high-frequency communications.

### c. RECIPROCITY

Although the classical laws regarding reciprocity must be applied with care to practical antenna problems involving electromagnetic radiators, it may be assumed that the directional characteristics of an antenna system are the same when transmitting as when receiving. In addition, for most practical purposes, an antenna that transmits well in a given direction will also give favorable reception from the same direction despite possible ionosphere variations.

### d. IMAGE ANTENNAS

If an absolutely flat, perfectly conducting ground is assumed, the effect of the earth can be duplicated by an image antenna which is a mirror image of the actual radiator. This assumption of a mirror image is useful in determining the impedance and directional characteristics of an antenna located near a reflecting surface. The image representation is illustrated in figure 9-3. Note that while the configuration of the imaginary antenna is a mirror image of the actual radiator, the direction of current flow is not. This is because the phase of a horizontally polarized wave is reversed upon reflection from the perfect ground, while the phase of the vertically polarized wave is not. The result is that corresponding vertical components of current flow are in the same direction, while the corresponding horizontal components are in the opposite direction.

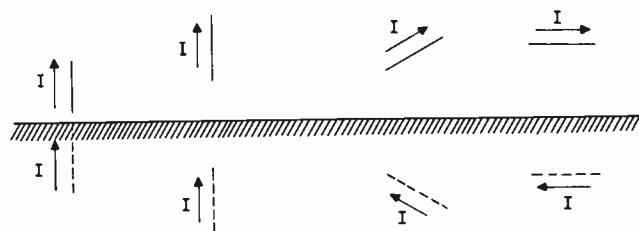

Figure 9-3. Image Antennas

### e. MUTUAL IMPEDANCE

The interaction or coupling between two or more antenna elements which are separated by not more than several wave lengths can produce a mutual impedance which is significant when compared to the self-impedance exhibited by either element alone. The magnitude and phase of the mutual impedance depends mainly upon the orientation and spacing of the conductors. The resistive component of the mutual impedance may be either positive or negative; consequently, the presence of a neighboring radiator may either raise or lower the feed point resistance of a given radiator. In addition, the reactive component of the mutual impedance may cause the resonant frequency of the given radiator to be altered, except at certain critical spacings.

The effect of a perfectly flat, perfectly conducting ground upon the impedance characteristics and current distribution of a radiator is the same as that produced by the mutual impedance exhibited by an image antenna which is substituted for the perfect earth. The effect of the actual earth and surroundings



is not easily determined in most cases, except by experiment.

#### f. ANTENNA DIRECTIVITY

When an antenna radiates more strongly in some directions than in others, it is said to possess directivity. Even the simplest, free-space, linear radiator exhibits some directional characteristics. The more the radiation is concentrated in a certain direction, the greater will be the field strength produced in that direction for a given amount of total power radiated. Thus, the use of a directional antenna produces the same result in the desired direction as an increase in transmitter power.

The increase in radiated power in a certain direction, as a result of inherent directivity, with respect to some reference antenna is termed the gain or more specifically directivity gain of the antenna. The reference antenna is commonly the hypothetical isotropic radiator which is assumed to radiate equally well in all directions. More practically, the reference antenna is the simple half-wave dipole which has a free-space directivity gain of 1.64 in power over the isotropic radiator. This means that in the direction of maximum radiation the dipole will produce the same field strength as an isotropic radiator which is radiating 1.64 times as much power. The directivity of an elementary dipole provides a free-space gain of 1.5 over the isotropic radiator. As a convenience, the power gain of an antenna system is frequently

expressed in decibels.  $(db = 10 \log_{10} \frac{P_1}{P_2})$  where  $\frac{P_1}{P_2}$

= power gain) In the case of the free-space, half-wave dipole,  $P_1/P_2 = 1.64$ , which is equivalent to 2.15 db. Power gain can be expressed with reference to any antenna if the reference is specified.

A graphical representation of the directional characteristics of a given antenna is termed its radiation pattern and illustrates the relative magnitude of radiation intensity as a function of direction. The free-space directivity or radiation patterns of the isotropic radiator, the elementary dipole and the half-wave dipole are shown in figure 9-4. The patterns show the relative magnitude of field strength for points at constant range in any plane which includes the radiator. Since field strength is based on voltage, its magnitude is proportional to the square root of radiated power. Directivity patterns are sometimes drawn to a power scale and less frequently to a db scale, but field strength plots are the most common and generally the most useful.

Figure 9-4 illustrates that more directivity is obtained from the half-wave radiator than from the

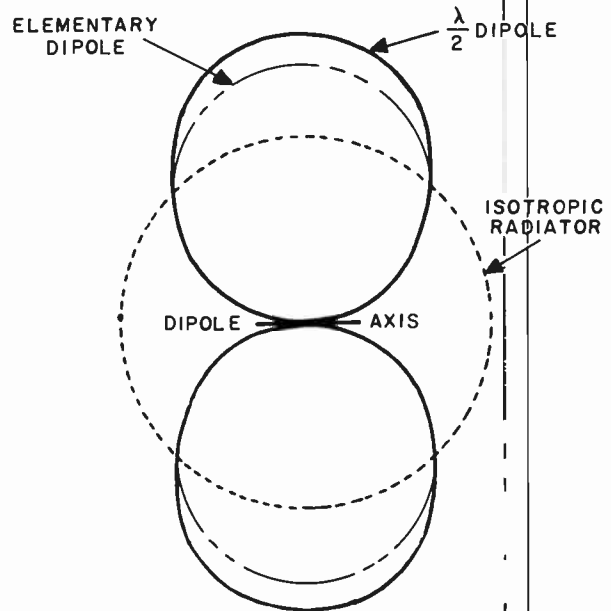

Figure 9-4. Polar Diagram of Radiation Patterns of an Isotropic Radiator, Elementary Dipole, and Half-Wave Dipole, in Free Space

elementary dipole which is much shorter than a half wave. The half-wave dipole, in fact, may be considered to be made up of a large number of elementary dipoles strung together as a chain, and the resultant radiation pattern is the summation of the fields from each elementary dipole. Stated somewhat differently, the interference, due to the radiation from different portions of the radiator arriving at a given point in space, determines its directivity. This wave interference is the basic mechanism that controls antenna directivity, whether the antenna is a simple half-wave dipole, a wire many half wave lengths long, or a complex combination of radiating elements.

In actual practice, high-frequency antennas are located in the presence of ground where their performance is considerably modified. This is particularly true with respect to the directional properties and more specifically the vertical directivity of the antennas. Waves that are radiated from the antenna at angles below the horizontal are reflected by the earth and combine with, or interfere with the direct waves that are radiated at angles above the horizontal. The resultant vertical radiation pattern is determined by this interference which depends upon the orientation of the antenna with respect to earth, the height of the antenna, the character of the ground, and the directional properties of the actual antenna. The resultant vertical directivity can be determined with good accuracy by using the "image" antenna concept previously described and more specifically illustrated in figure 9-5.



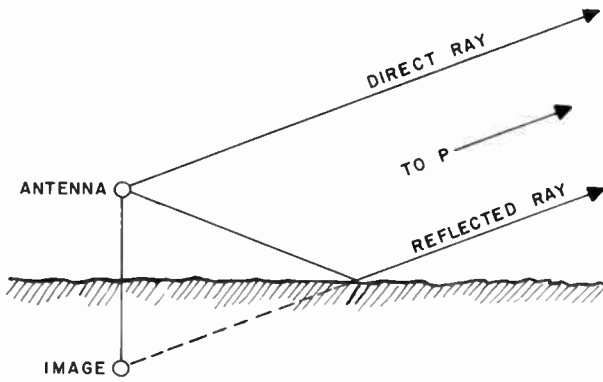
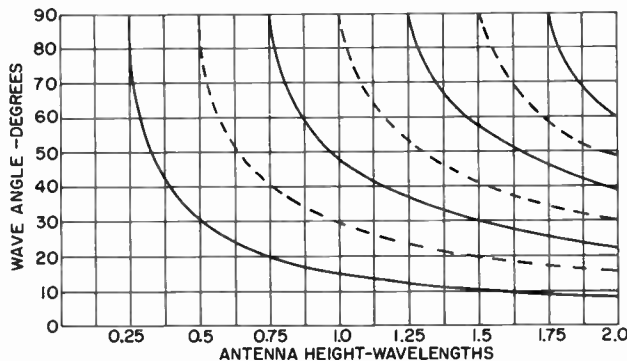

Figure 9-5. Image Antenna and Ground Effect

At some vertical angles above the horizontal, the direct and reflected waves reach the same point in space in phase, and the resultant field strength is the sum of the two. At other vertical angles the two waves arrive at a point in space out of phase, and the resultant field strength is the difference of the two. Thus, the effect of the ground increases the intensity of radiation at some angles and decreases it at others. At the particular vertical angle where the resultant field intensity is doubled (under ideal ground reflection conditions) a gain of 6 db can be realized over that when the antenna is operating in free space.

The vertical angles (wave angle) at which maxima and minima occur due to ground reflection for antenna heights up to two wave lengths are shown in figure 9-6.



SOLID LINES ARE MAXIMA, DASHED LINES MINIMA, FOR ALL HORIZONTAL ANTENNAS AND FOR VERTICAL ANTENNAS OF LENGTH EQUAL TO AN EVEN MULTIPLE OF A HALF WAVELENGTH. FOR VERTICAL ANTENNAS AN ODD MULTIPLE OF A HALF WAVE IN LENGTH THE DASHED LINES ARE MAXIMA AND THE SOLID LINES ARE MINIMA.

Figure 9-6. Angles of Ground Reflection Factor Maxima and Minima for Antenna Heights up to Two Wave Lengths

The curves are for perfect ground but give a close approximation for actual earth, provided the ground is flat.

For most practical antennas, a single cross-sectional view of the solid or three-dimensional pattern will not sufficiently describe the directional characteristics. However, it is not necessary to show the relative magnitude of radiation at all points in space to give a useful picture of the directional properties of the antenna.

The pertinent data in the case of ground wave propagation is a plot of the field strength versus compass direction at constant range. This gives the horizontal pattern at ground level. Where the sky wave is the chief mode of propagation, information on the relative field strength at various vertical angles is pertinent, and a single vertical cross section of the solid pattern taken along the direction of maximum ground level radiation often will give the necessary data. Patterns of this type are referred to as vertical patterns, depicting vertical directivity in a certain azimuth direction. Occasionally, the patterns in these two principal planes do not furnish adequate information, and additional horizontal patterns at various vertical angles may be required.

The following is a list of the terminology used to describe directive arrays with a brief definition of each term.

A driven element is one that receives power from the transmitter usually through a transmission line.

A parasitic element is one that obtains power solely through coupling to another element in the array because of its proximity to such an element.

A driven array is one in which all the elements are driven.

A parasitic array is one in which one or more of the elements are parasitic elements. At least one element in a parasitic array must be a driven element, since it is necessary to introduce power into the array.

A broadside array is one in which the principal direction of radiation is perpendicular to the axis of the array and to the plane containing the elements.

An end-fire array is one in which the principal direction of radiation coincides with the direction of the array axis.

The major lobes of the directive pattern are those in which the radiation is maximum. Lobes of lesser radiation intensity are called minor lobes.

The beam width of a directive antenna is the width, in degrees, of the major lobe between the two directions

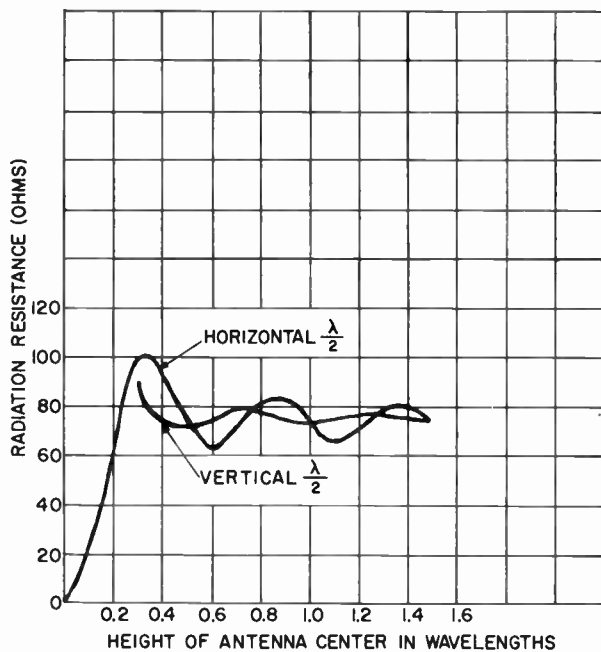

Figure 9-7. Variation of the Radiation Resistance of a Theoretical Half-Wave Dipole with Height above a Perfectly Conducting Earth

at which the relative radiated power is equal to one-half its value at the peak of the lobe. At these half-power points, the field intensity is equal to .707 times its maximum value, or 3 db down from maximum.

Front-to-back ratio means ratio of the power radiated in the forward direction to the power radiated in the opposite direction.

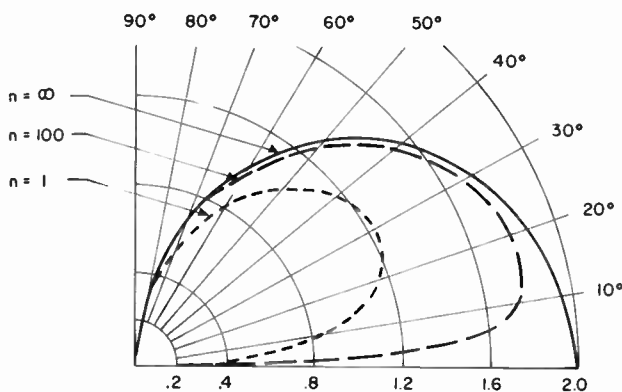

Figure 9-8. Vertical Radiation Pattern of a Vertical Dipole at the Surface of an Earth of Finite Conductivity

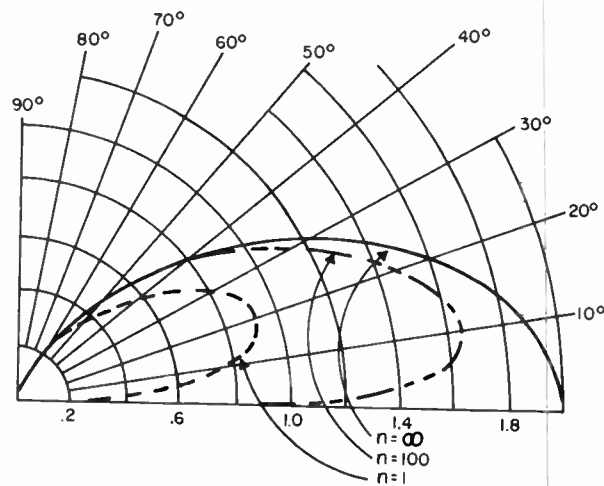

Figure 9-9. Vertical Radiation of a Vertical Dipole a Quarter Wave Length Above an Earth of Finite Conductivity

### 3. TYPICAL HIGH-FREQUENCY ANTENNAS

The types of antennas used in high-frequency communication systems are many and varied. In the following section, a few of the more common types are described to illustrate some of the basic principles of operation, construction, and performance of suitable radiating systems.

#### a. THE PRACTICAL HALF-WAVE DIPOLE

Although fundamental antenna theory is usually based on a theoretical dipole, one having infinitely thin cross section and sinusoidal current distribution, the practical half-wave dipole has a finite diameter and a current distribution that is not exactly sinusoidal. These factors affect both its directional and its impedance characteristics. However, the difference between the theoretical and actual radiation pattern of the center-fed, half-wave dipole is negligible, and for all practical purposes, the theoretical pattern can be assumed. The effect on impedance characteristics is more pronounced. The radiation resistance of the theoretical free-space, half-wave dipole is 73 ohms, while the radiation resistance of the practical half-wave dipole in free space is in the order of 65 to 70 ohms. This is due to the resonant length of the actual dipole being slightly less than a half wave.

In addition to the above effects, an actual dipole is always located above the ground, so that theoretical free-space conditions do not apply. Figure 9-7 illustrates the variations in radiation resistance of a theoretical half-wave dipole with height above a perfectly conducting ground. For a practical half-wave dipole over actual ground, the variations will be lower, but the chart shows the approximate magnitude of the

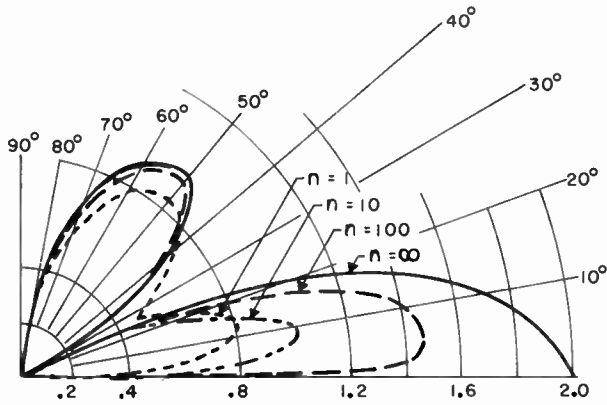

Figure 9-10. Vertical Radiation Pattern of a Vertical Dipole a Half Wave Length Above an Earth of Finite Conductivity

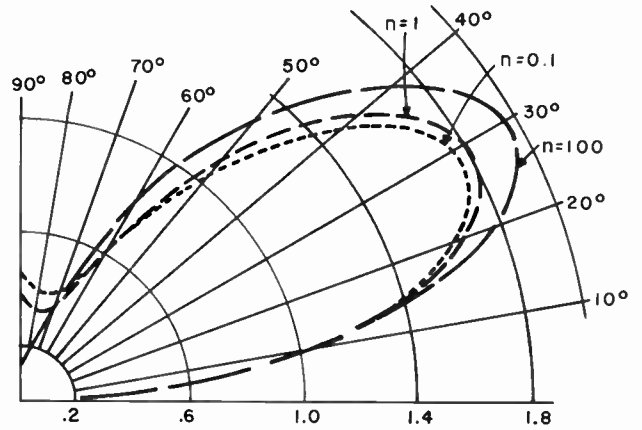

Figure 9-12. Vertical Radiation Pattern (in the plane perpendicular to the axis of the dipole) of a Horizontal Dipole a Half Wave Length Above an Earth of Finite Conductivity

change to be expected. Figures 9-8 through 9-12 illustrate the space wave vertical patterns of short vertical and horizontal dipoles above earths of various conductivities.

$$n = \frac{x}{\epsilon_r} \quad \epsilon_r = \text{Relative Dielectric Constant of Earth.}$$

$$x = \frac{18 \times 10^3 \sigma}{f_{nc}} \quad \sigma = \text{Conductivity}$$

$\epsilon_r = 15$  For these examples.  
 $n = \infty$  Represents perfect ground case.

For greater heights above the earth, the vertical pattern becomes multilobed. The approximate location of the maxima and minima of these patterns can be obtained by considering the perfect ground case shown in figure 9-6.

The most practical method of feeding a dipole antenna depends upon various considerations involved in the particular installation. Figure 9-13 shows

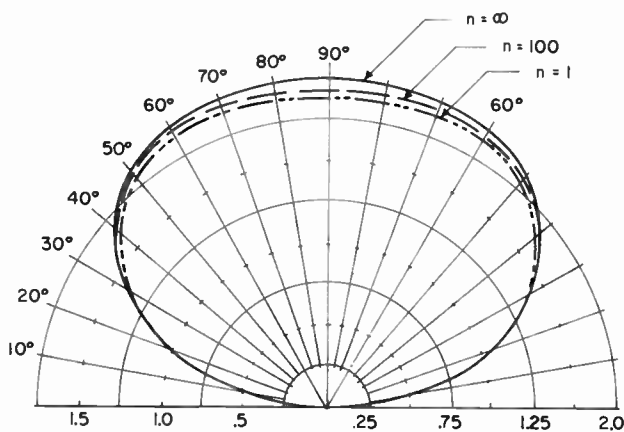

Figure 9-11. Vertical Radiation (in the plane perpendicular to the axis of the dipole) of a Horizontal Dipole a Quarter Wave Length Above an Earth of Finite Conductivity

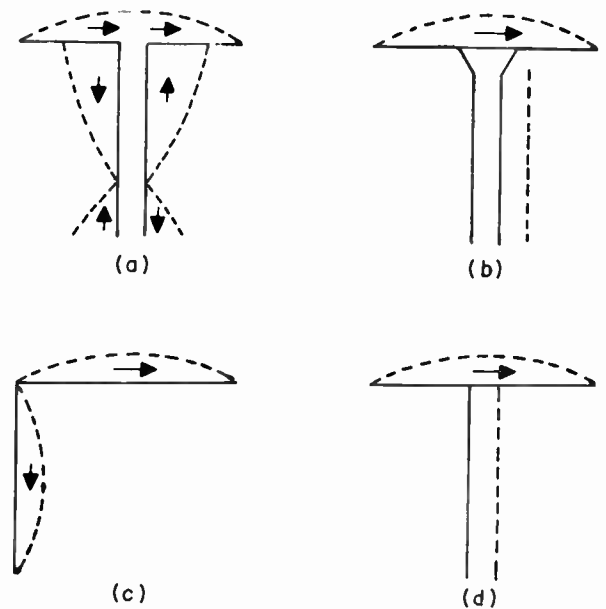
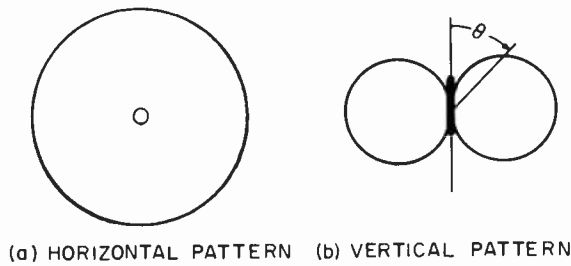

Figure 9-13. Common Methods of Exciting High-Frequency Antennas



height of the antenna above ground and upon the conductivity of the ground. These dimensions may best be determined by experiment in each case.

Although the directional properties of the elementary and half-wave dipoles have been illustrated in part previously, they are shown in figure 9-14 for convenience of comparison. The patterns shown are for free-space conditions and must be modified by the ground factor to represent actual conditions.

In the plane of polarization, the relative field intensity (radiation pattern) of the elementary or short dipole, as shown in figure 9-14(b), may be expressed by:

$$E(\Theta) = \sin \Theta$$

For the half-wave dipole of figure 9-14(c), the relative field intensity is:

$$E(\Theta) = \frac{\cos(\frac{\pi}{2} \cos \Theta)}{\sin \Theta}$$

For a dipole of any length (figures 9-14(d), (e), (f)), the relative field intensity is:

$$E(\Theta) = \frac{\cos \frac{2\pi H}{\lambda} - \cos(\frac{2\pi H}{\lambda} \cos \Theta)}{\sin \Theta}$$

where  $H = \frac{L}{2}$  and  $\lambda =$  wave length.

The directional properties of actual dipoles are also affected by location of the feed points. Experimental patterns for several different conditions are illustrated in figure 9-15.

**b. ELECTRICALLY SHORT ANTENNAS**

At the lower frequencies where wave lengths are long, it often becomes impractical to employ antennas of resonant length. Some practical antennas at these frequencies are, therefore, electrically short and are usually of the vertical ground-based type. To attain an efficiency comparable to that of a half-wave antenna, the height of the vertical radiator should be  $\frac{\lambda}{4}$ , but when this is not possible, the effective height should be that corresponding to  $\frac{\lambda}{4}$ . An antenna that is much less than  $\frac{\lambda}{4}$  in height exhibits poor impedance characteristics and becomes an inefficient radiator. As an example, the input impedance at the base of a vertical radiator of height  $\frac{\lambda}{8}$  is in the order of  $-j500$  ohms reactive and only about 8 ohms resistive. With this low radiation resistance, the ratio of power radiated to the power available from the transmitter is very small.

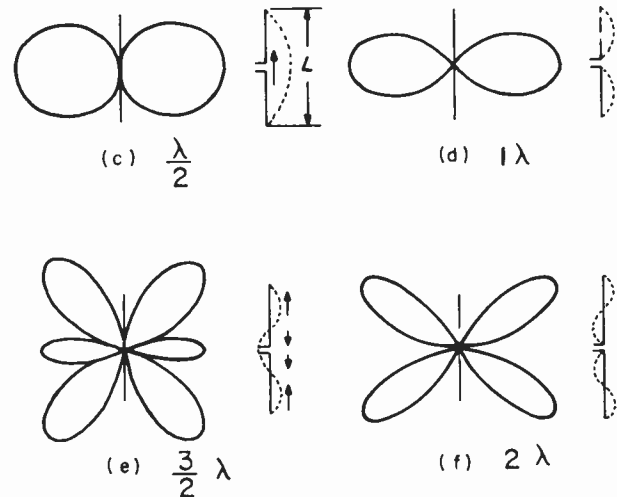

Figure 9-14. Radiation Patterns of Center-Fed Vertical Dipoles

several common methods of exciting high-frequency antennas. Figure 9-13(a) shows the balanced-line type of center feed. Because of the mismatch between the high characteristic impedance of open-wire lines and the low input resistance of a resonant dipole, this manner of excitation results in standing waves on the feed line as indicated in the figure. However, with solid dielectric, low-impedance lines, this mismatch can be almost completely eliminated. The "delta-match" or "shunt-feed" arrangement of figure 9-13(b) can result in a good impedance match and low standing waves on the feed line if the various dimensions are properly chosen. The simplest of all methods of excitation is the single-wire line "end-fed" arrangement of figure 9-13(c). In this case, the vertical "transmission line" also radiates energy; a result that may or may not be desired. By connecting the vertical wire at a lower impedance point along the horizontal antenna, as in figure 9-13(d), a better impedance match and lower standing-wave ratio on the feed line can be obtained. This results in less radiation from the vertical wire, which now carries a traveling-wave current distribution. Optimum dimensions for the types of feed shown in figure 9-13(b) and (d) are dependent on the



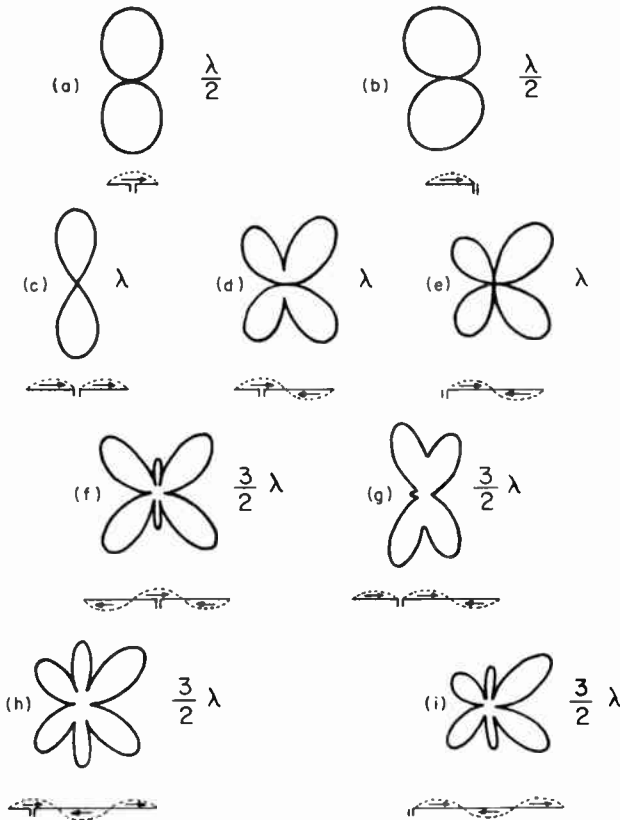

Figure 9-15. Experimental Patterns of Wire Antennas with Different Feed Points

There are several methods of improving or compensating for the poor input impedance of short antennas, but some yield more efficient operation than others. One of the more efficient methods is to increase the effective length of the antenna by top loading which consists of adding some form of capacity hat or a horizontal portion to the structure. The familiar L and T type radiators are of this class. This also has

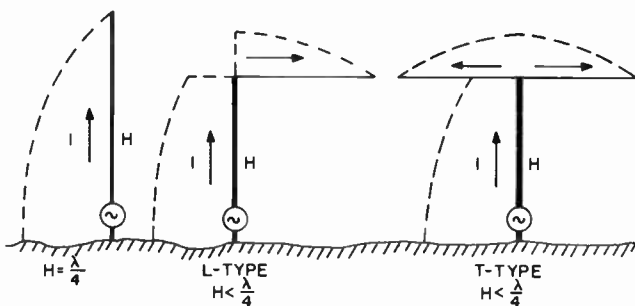

Figure 9-16. Top-Loaded Antennas

the effect of decreasing the large capacitive reactance of the short antenna (see figure 9-16).

The radiation patterns of the L and T type antennas are essentially that of a short vertical monopole. Polarization is chiefly vertical because the largest amount of current is in the vertical portion of the radiator. There is, however, a small amount of horizontally polarized energy radiated due to the currents in the horizontal members. This radiation is small not only because these horizontal currents are small, but also because the horizontal portion of the antenna is close to ground and, therefore, close to its image. For a perfectly conducting ground, the image antenna carries an equal and opposite current which tends to cancel a large part of the horizontally polarized radiated field.

The decision as to which type of top loaded antenna to employ and the amount of top loading to use is usually dictated by the facilities available rather than by optimum design.

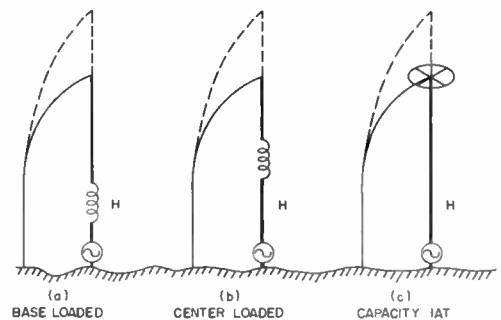

Figure 9-17. Current Distribution for Short Vertical Antennas,  $H < \frac{\lambda}{4}$

The electrical length of a radiator can be modified also by the insertion of a lumped reactance at one or more points along the radiator. In the case of the short vertical antenna, a series lumped inductance is commonly inserted to increase its effective length. This is referred to as base or center loading depending upon the placement of the loading coil. Because of the  $I^2R$  loss in the coil which is determined by the Q of the coil and the point in the radiator where the coil is inserted, this method of resonating the antenna is less efficient than that of top loading where distributed type circuit constants are employed. Losses with a given coil are greater when it is located at the base of the radiator than when it is located at the center, but to resonate the same antenna, a larger coil is required at the center than at the base. The capacity hat loading, that is, placing a disk or ring on the top of the short radiator, is more desirable, but because of the size of the hat required to resonate the antenna, it often becomes impractical. As a compromise, both the capacity hat and series inductance are often employed.



Antennas that are too long for resonance are not as often encountered as short antennas. However, if it is necessary to decrease the effective length of a long antenna, a series capacitance can be used just as the series inductance is used to increase the effective length of a short antenna. Although these methods are most often used with grounded vertical antennas, they apply equally well to suspended vertical or horizontal radiators.

**c. LONG WIRE ANTENNA**

A single long wire radiator is the simplest form of directional antenna if its directivity is compared to that of a half-wave dipole. The performance of a single long wire, however, does not begin to compare with the performance of arrays which utilize a combination of long wires. The single long wire ordinarily is employed only for reasons of available space or convenience.

Figure 9-18 shows the radiation pattern and current distribution of an end-fed,  $2\lambda$ , single wire in free space. This pattern is symmetrical with respect to the wire, with the major lobes in both forward and backward directions forming a three-dimensional cone. If the end-fed long wire is terminated in its characteristic impedance by means of a resistance

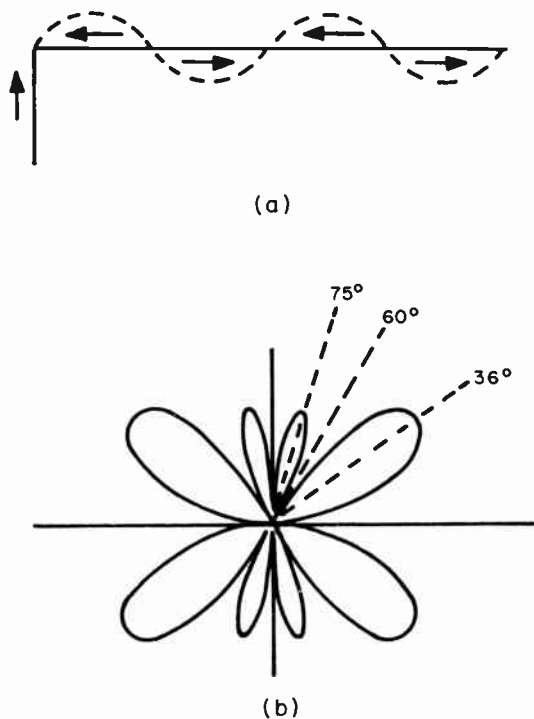

Figure 9-18. (a) Theoretical Current Distribution and (b) Radiation Pattern of a Two-Wave Length End-Fed Antenna

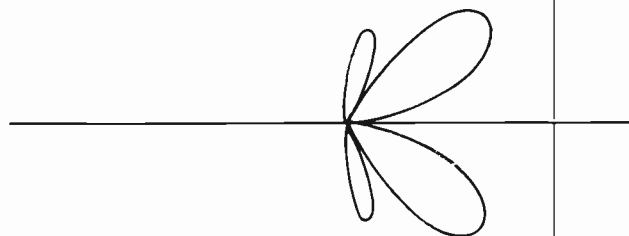

Figure 9-19. Radiation Pattern for Terminated  $2\lambda$  Long Wire Antenna

connected from the far end to ground, the current distribution along it is essentially that of a traveling wave, and the resultant free-space pattern will be that of the forward lobe only as shown in figure 9-19.

The input impedance of such a terminated long wire will remain essentially constant due to the absence of standing waves on the antenna. Standing waves are the result of reflections from the end of the wire, but since the terminating resistance absorbs the energy at the end of the line, there is none to be reflected.

An antenna many wave lengths long will exhibit the properties of a terminated antenna because all of the energy traveling away from the transmitter will be radiated before it gets to the end of the antenna; consequently, there will be none left to reflect back toward the transmitter. Such an antenna is called a traveling wave antenna as opposed to an antenna which has a wave reflected from its end causing a standing wave. The number and position of the lobes of such an antenna depend on its length.

Two long wires arranged in the form of a "V" will, where the apex angle is optimum, provide good directivity. The two wires are fed at the apex of the V by means of a balanced line, so that equal currents of opposite phase flow in corresponding parts of the two wires. The apex angle is so chosen that the main lobes of the two long wires reinforce along the bisector of the V and tend to cancel in other directions. If a pair of two-wave length wires were used, the proper apex angle would be about  $72^\circ$ . In figure 9-20, lobes 1' and 1'' add to form lobe 1 of the resultant pattern as do lobes 3' and 3'' to form lobe 3. The rest of the major and minor lobes of the individual wires tend to cancel each other, and the result is a radiation pattern that is more directive than that of a single long wire.

It is possible to obtain a unidirectional characteristic by terminating the far end of each leg with the proper resistance to ground, but it is difficult to obtain good terminations of the type required; therefore, such an arrangement is seldom employed. The rhombic

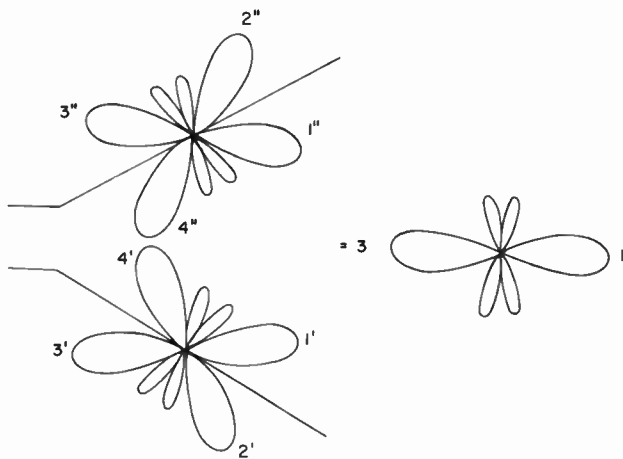

Figure 9-20. V Antenna

antenna is a much more satisfactory unidirectional antenna of the terminated type and is one of the most widely used high-frequency directional antennas in military and commercial service for point to point communication. The rhombic antenna consists of four, long wire radiating elements arranged in the shape of a rhombus, from which the antenna gets its name. The basic rhombic antenna is shown schematically in figure 9-21. The important dimensions are the leg lengths  $L$ , the tilt angle  $\phi$ , the elevation above ground, and the terminating resistance  $R$ . The

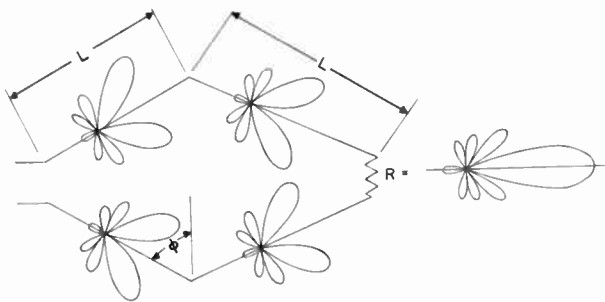

Figure 9-21. Rhombic Antenna

rhombic antenna is sometimes described, on the basis of its geometrical appearance, as two V antennas connected back to back and terminated to give a unidirectional pattern. The four long wires are arranged to produce reinforcement of the main lobes in the forward direction. This antenna is simple to construct, has high gain, is unidirectional, and most important, provides good performance over a broad frequency range. It has the disadvantage of requiring a large amount of real estate and provides

less discrimination than a broadside curtain and reflector combination having comparable gain. Typical gains of practical size rhombic antennas employed in the high-frequency region range from about 8 to 15 db above that of a half-wave dipole at the same height above ground.

**d. PHASED DIPOLE ARRAYS WITH PARASITIC ELEMENTS**

When an element  $\frac{\lambda}{2}$  in length is placed parallel and closer than about one-half wave length to a driven element, the mutual impedance is sufficient to cause a relatively large amount of current to flow in the undriven or "parasitic" element. Under these conditions the parasitic element will have appreciable effect upon the radiation pattern. By slightly detuning the parasitic element from resonance, variations in phase of the currents can be obtained with only a small effect upon the relative magnitude of current flowing in the parasitic element. The amount of current flowing in the parasitic element is chiefly a function of spacing. From a practical standpoint, however, the reduction in input resistance of the driven element with closer spacing limits the extent to which the relative current in the parasitic element may be increased.

An array consisting of one driven dipole element and one or more parasitic dipole elements is commonly known as a parasitic array or Yagi antenna (figure 9-22). It is most frequently designed to produce unidirectional pattern characteristics. A parasitic element is termed a reflector when it is behind the driven element in a unidirectional parasitic array, and a director when it is ahead of the driven element. More than one reflector is seldom employed in a simple parasitic array, but several directors are common.

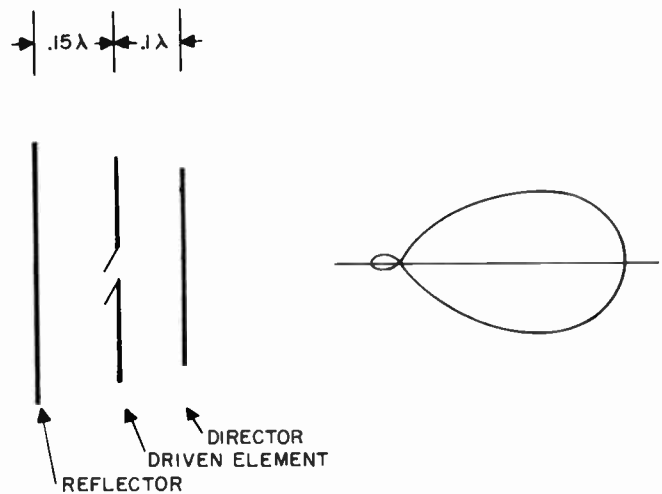

Figure 9-22. Three Element Parasitic Array

Parasitic elements are ordinarily tuned to give the desired amount and kind of reactance by control of their physical length. The parasitic element length which gives maximum gain usually does not provide maximum front to back discrimination for a particular spacing, however, adjusting the parasitic element length for maximum discrimination usually results in only a small reduction in forward gain.

One of the more popular parasitic arrays for high-frequency operation is the horizontal three element Yagi shown in figure 9-22. The director is about 5% shorter, and the reflector is about 5% longer than the resonant driven element. Although the actual directivity gain and front-to-back ratio depends on many parameters, an average gain of approximately 8 db above that of a  $\frac{\lambda}{2}$  dipole, and a front-to-back ratio of about 18 db can be expected. The azimuth half-power beam width is about 50°. Its compact construction makes mechanical rotation a simple matter, and when so employed, the array usually is constructed of self-supporting tubular elements and often is referred to as a three-element rotary beam.

In no case can a conventional parasitic array qualify as a "broad-band" antenna, because even though extremely large diameter elements may be used, a moderate change in frequency seriously upsets the reactance and phase relationships of the various elements which in turn affect the directional characteristics.

#### e. THE FOLDED DIPOLE

If a half-wave radiator is constructed of two, identical, close-spaced, parallel conductors which are shorted at the ends and the combination is fed as shown in figure 9-23(a), equal and in phase currents may be considered to flow in each conductor. With this arrangement the current at the feed point for a given power is only half that which would flow in a single element alone, which means that the input impedance is four times as high. The center impedance of the dipole as a whole is the same as the impedance of a single conductor dipole (approximately 70 ohms). A given amount of power will therefore cause a definite value of current,  $I$ . In the ordinary half-wave dipole, this current flows at the junction of the line and the antenna. In the folded dipole the same current also flows, but is equally divided between two conductors in parallel. The current in each conductor is therefore  $\frac{I}{2}$ . Consequently, the line sees a higher impedance because it is delivering the same power at only half the current. Actually, the feed point impedance is slightly less than four times that presented by one of the conductors without the other present. This is because the effective length to diameter ratio (and therefore the radiation resistance)

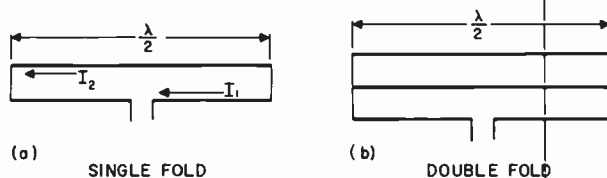

Figure 9-23. Half-Wave Folded Dipole

is lowered appreciably when the second conductor is added. The mean value of the feed point impedance in actual practice is about 250 ohms for effective heights greater than one-eighth wave length assuming horizontal polarization. The half-wave dipole formed in this way will have the same directional properties and total radiation resistance as an ordinary dipole. Figure 9-24 shows the impedance step-up ratio for the two conductor folded dipole.

The feed point impedance can be further increased by the three element arrangement shown in figure 9-23(b). For the case where the three conductors are identical and equally spaced, the effective impedance transformation is roughly nine times as compared to a single conductor alone. This raises the average input impedance in practical installations in which the effective height of the horizontal radiator exceeds one-eighth wave length to about 580 ohms.

The two element dipole method of increasing the impedance transformation is not recommended for ratios greater than 10, because the broad-band feature becomes degraded for extreme ratios. For ratios greater than 10, it is recommended that the desired transformation be obtained by increasing the number of conductors as in figure 9-23(b).

The folded dipole exhibits a flatter impedance versus frequency characteristic than a simple dipole. That is, the reactance varies rather slowly as the frequency is varied on either side of resonance, and the result is broader band operation. This flatter impedance versus frequency characteristic is due to the fact that the conductors in parallel form a single conductor of greater diameter and, in addition, the system as seen by the line is not only an antenna but also consists of two (or more) short-circuited quarter-wave transmission lines. As shown by transmission line theory, the reactance of a quarter-wave shorted section varies inversely as the reactance of the antenna with frequency. Thus, the two reactances cancel for an appreciable percentage of change in frequency.

#### f. REFLECTOR TYPE ANTENNAS (BILLBOARD)

The radiation from a single dipole element can be concentrated into a restricted solid angle by the use

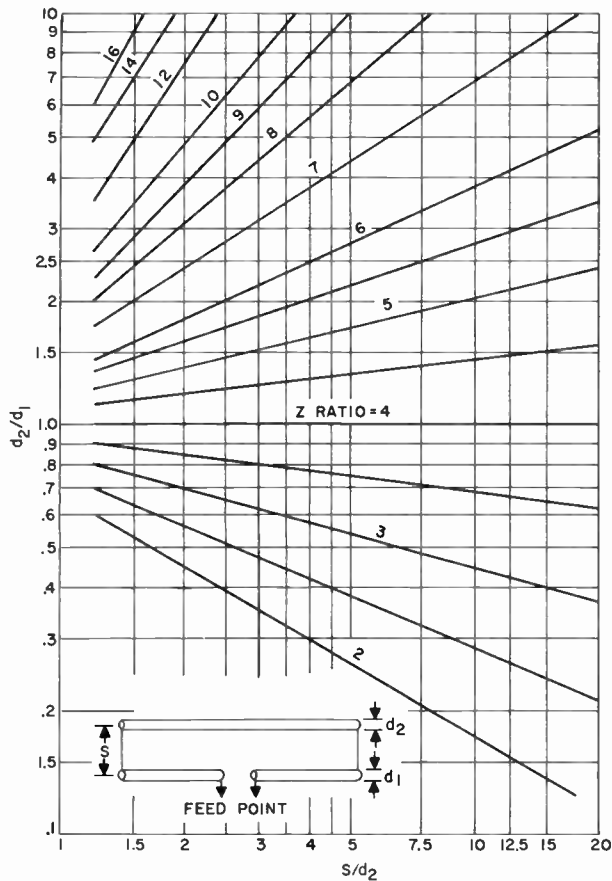

Figure 9-24. Impedance Step-Up Ratio

of a reflecting screen, producing the same beaming effect as an array of dipoles. Although the reflecting screen can take any of numerous shapes, the most desirable being determined by the particular directivity pattern desired, mechanical design considerations usually limit the shape to a flat surface for operation in the high-frequency region, and is commonly referred to as a billboard antenna. The reflecting screen normally is made up of a curtain of equally spaced wires parallel to the dipole as shown in figure 9-25. With a single half-wave dipole spaced

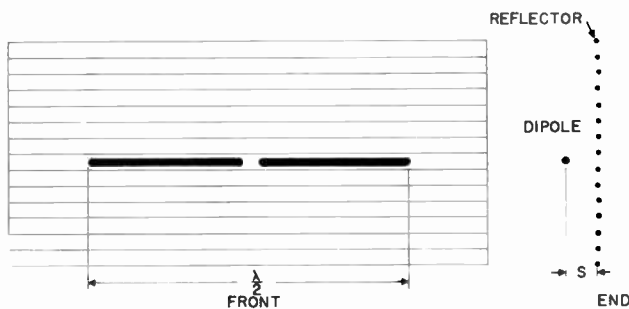

Figure 9-25. Billboard Antenna

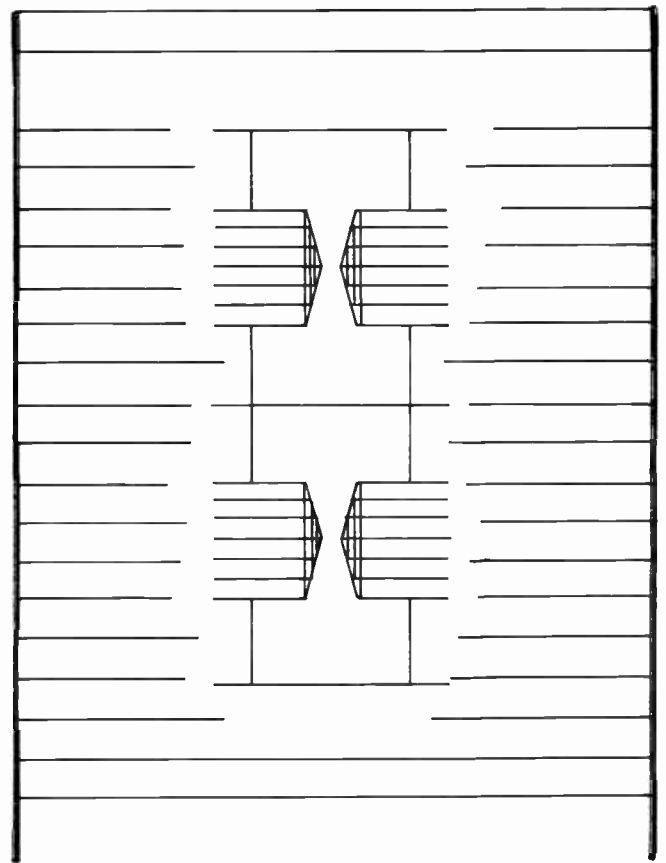

Figure 9-26. High-Frequency, Broad-Band, Billboard Antenna

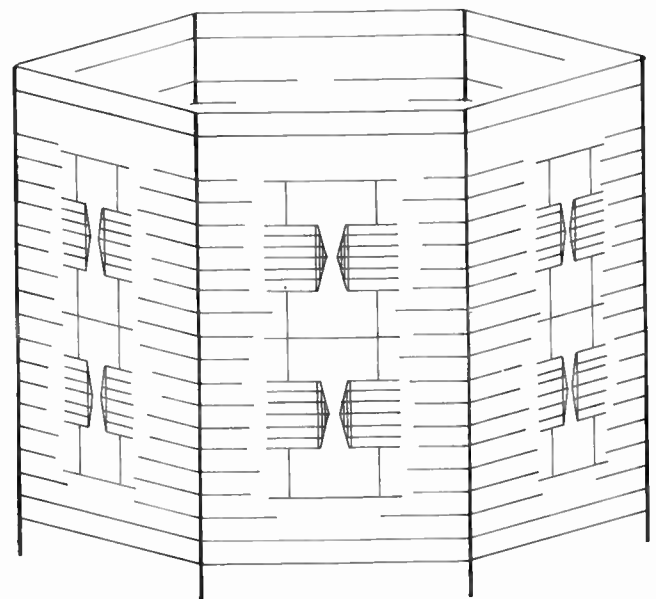

Figure 9-27. Steerable Beam Antenna



a quarter-wave from the screen, a gain of about 5.5 db over a free-space half-wave dipole can be realized. The half-power beam width in the plane of polarization is about 60° with essentially no secondary lobes. More directivity and consequently higher gain can be achieved by employing an array of dipoles in front of the screen.

Although this type of antenna usually is not considered to be broad band, a somewhat more complex structure as shown in figure 9-26 will cover a frequency range of 2:1 or greater with both patterns and input impedance remaining satisfactory. Azimuth half-power beam width varies from about 55° to 70° while the vswr remains under 2:1 over its 2:1 frequency range. The radiator consists of two vertically stacked broad-band (low Q) folded-type dipoles constructed of self-supporting tubular elements. Directivity gain depends on the mean height of the radiator above ground, but for practical heights, an average gain of about 13 db above that of a free-space half-wave dipole can be realized.

If a number of individual billboard-type antennas are arranged as shown in figure 9-27, and the proper switching is employed, an antenna system with a rotating or steerable beam is achieved. With the particular geometry shown, the azimuth beam is essentially that of a single billboard antenna. In more complex systems, however, several adjacent panels can be simultaneously and properly energized to form a more directive pattern. Directivity gains that are comparable to those of the high-frequency rhombic antenna would then be possible.

## 4. LOGARITHMICALLY PERIODIC ANTENNAS

### a. PRINCIPLES OF OPERATION

Figure 9-28 illustrates one of an infinite variety of types of log periodic antennas. The two half structures are formed by transverse wires with their extremities alternately connected by radial wires and their centers connected with wires running the length of the structures. The two structures are fed against each other at their vertices by a balanced two wire line or a coaxial line running along the center line of one structure. The angles  $\alpha$  and  $\psi$  define the extremities of the transverse wires and the orientation of the two half structures. The lengths of the transverse wires or the distances of the wires from the feed point are arranged so that they form a geometric sequence of terms. The geometric ratio,  $\tau$ , which is defined in figure 9-28 by  $R_n + 1/R_n$  determines the periodicity of the structure. If the structure was of infinite extent it can be seen that the electrical characteristics would be the same for any two frequencies related by some integral power of  $\tau$ . When these characteristics are plotted on a logarithmic frequency scale, these frequencies are equally spaced with a separation or period of logarithm  $1/\tau$ . Thus the characteristics, such as the radiation pattern and input impedance, must repeat periodically with the logarithm of the frequency; hence the name log periodic antennas. Now, if the defining parameters can be adjusted such that the variation of electrical characteristics over one period is small, then this will hold true for all periods, the result being an extremely broadband antenna. A period of frequency is defined by the frequency range

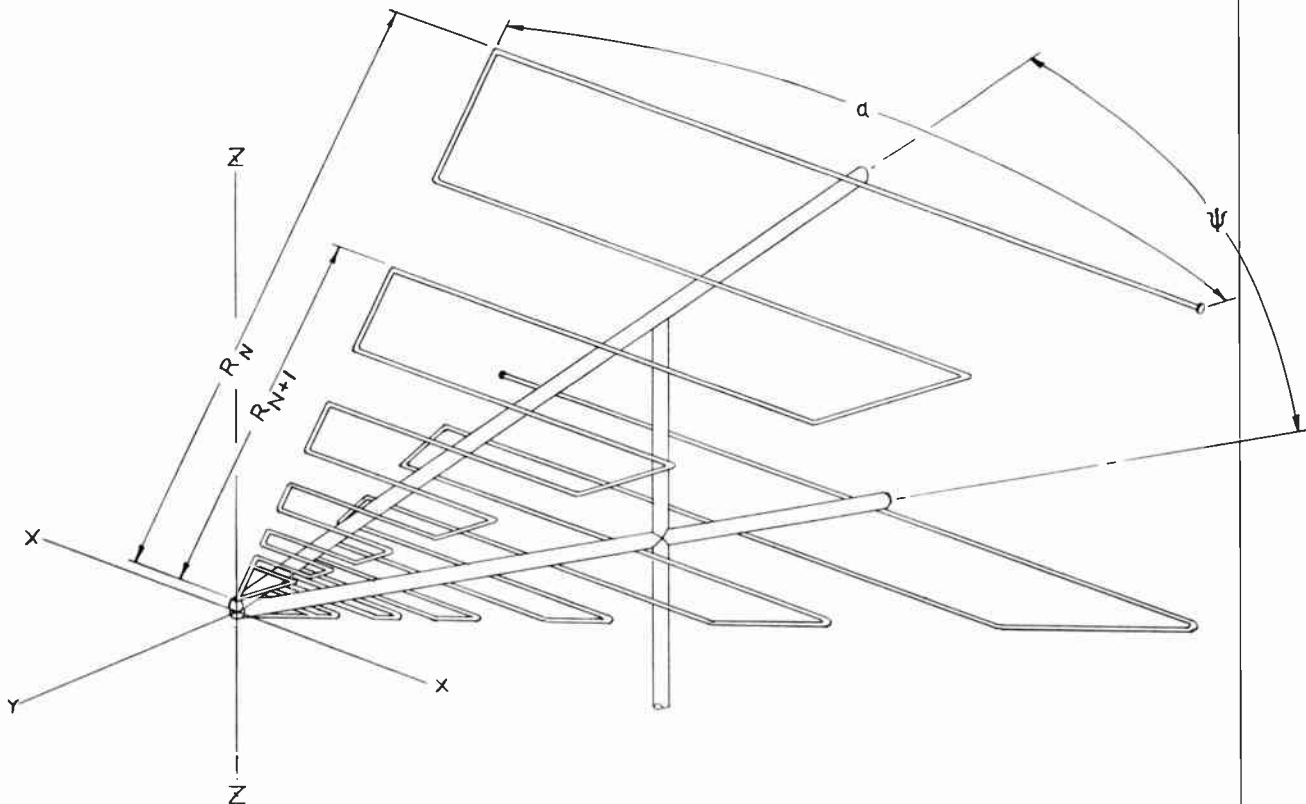

Figure 9-28. Log Periodic Antenna Showing Design Parameters



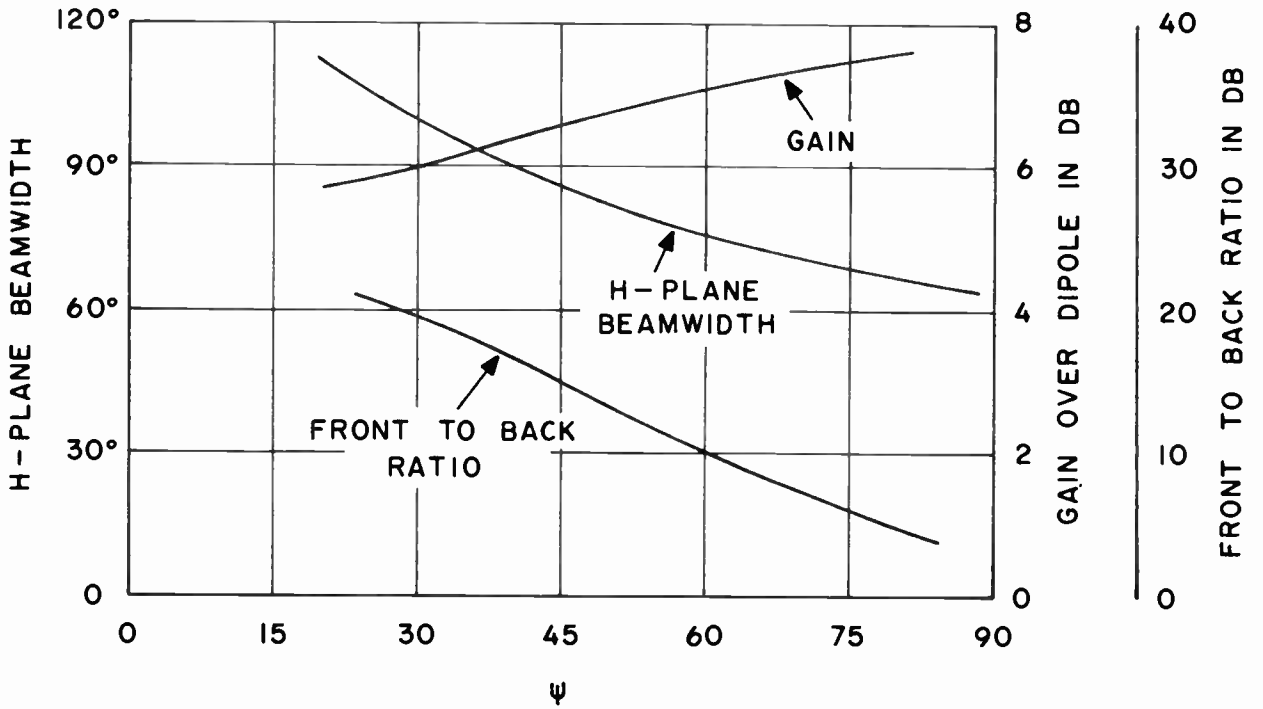

Figure 9-29. Effect of Angle  $\psi$  on Pattern Characteristics for Antenna with  $\alpha = 60^\circ$  and  $\tau = .6$

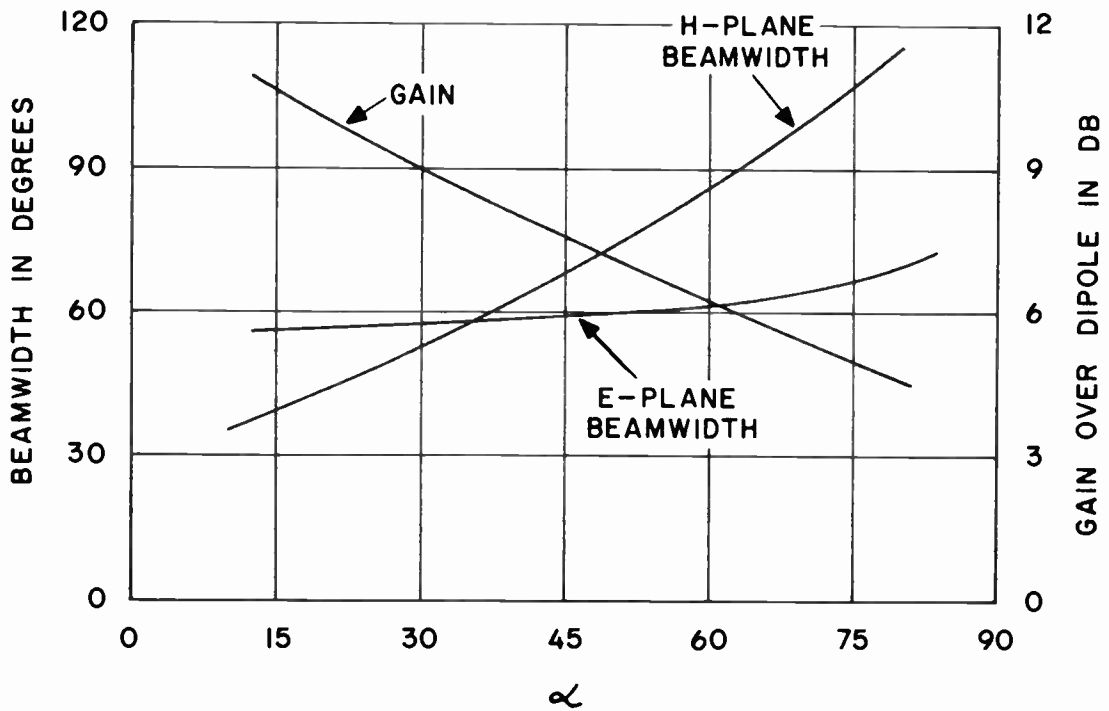

Figure 9-30. Effect of Angle  $\alpha$  on Pattern Characteristics for Antenna with  $\psi = 30^\circ$

of  $\tau f$  to  $f$ . Fortunately, it has been found that even with finite structures, there are several types of log periodic structures for which the variation is negligible. Unfortunately, since log periodic antennas are too complex to analyze by present day theoretical methods, they must be investigated by logical experimental methods. However, their repetitive nature greatly simplifies the initial experimental investigation because the characteristics need only be measured over one period of frequency. The operation over other periods may be readily predicted.

The antenna of figure 9-28 produces a unidirectional beam in the direction of the positive Y axis (that is, in the direction that the structure points) with horizontal polarization. The low frequency limit of the antenna occurs when the longest transverse element is approximately  $1/2$  wavelength long. As the frequency is increased, a smaller and smaller portion of the antenna is used to produce the beam. As one progresses from the feed point, it is found that the magnitude of the currents drops off quite rapidly after the point where a  $1/2$  wavelength long transverse element exists. The high frequency limit is obtained when the shortest transverse element is approximately  $3/8$  of a wavelength long. The pattern characteristics are very similar to that obtained when the two half structures are replaced by two three-element Yagi antennas. These types of structures have a characteristic impedance ranging from 70 to 200 ohms depending upon the values of the design parameters. Although the input impedance is not quite frequency independent, the vswr of the input impedance referred to the characteristic impedance is less than 1.5:1 or 2:1 over the bandwidth of the antenna.

Figures 9-29 and 9-30 demonstrate the dependence of some of the electrical characteristics upon the design parameters of the structure of figure 9-28. In figure 9-29, the H-plane (YZ plane) beamwidth, front to back ratio, and gain are plotted versus the angle  $\psi$  with the parameters  $\alpha = 60^\circ$  and  $\tau = .6$  held constant. For  $\psi$  equal to  $180^\circ$ , a bidirectional beam is produced. The E-plane (XY plane) beamwidth is nearly independent of the angle  $\psi$  and its value is  $63^\circ$ . Notice that if both high gain and front to back ratio are desired, a compromise value of  $\psi$  must be chosen. Figure 9-30 illustrates the variation of beamwidths and gain with the parameter  $\psi$  held constant. For these curves, the value of  $\tau$  varies from .85 to .6 as  $\alpha$  changes from  $15^\circ$  to  $75^\circ$ . Notice that the E-plane beamwidth is nearly independent of the parameter  $\alpha$ . For high gain, it can be seen that small values of  $\alpha$  are required. On the other hand, since the length of the longest transverse element is fixed for a given low frequency limit, the total length of the structure must be increased as  $\alpha$  is made smaller. Thus, a compromise between gain and size of the structure must be made.

### b. UNIDIRECTIONAL HF ROTATABLE ANTENNAS

There are many applications in high frequency communications for which log periodic antennas are very adaptable. Ground to air and ground to ground communications is an area which demands antennas

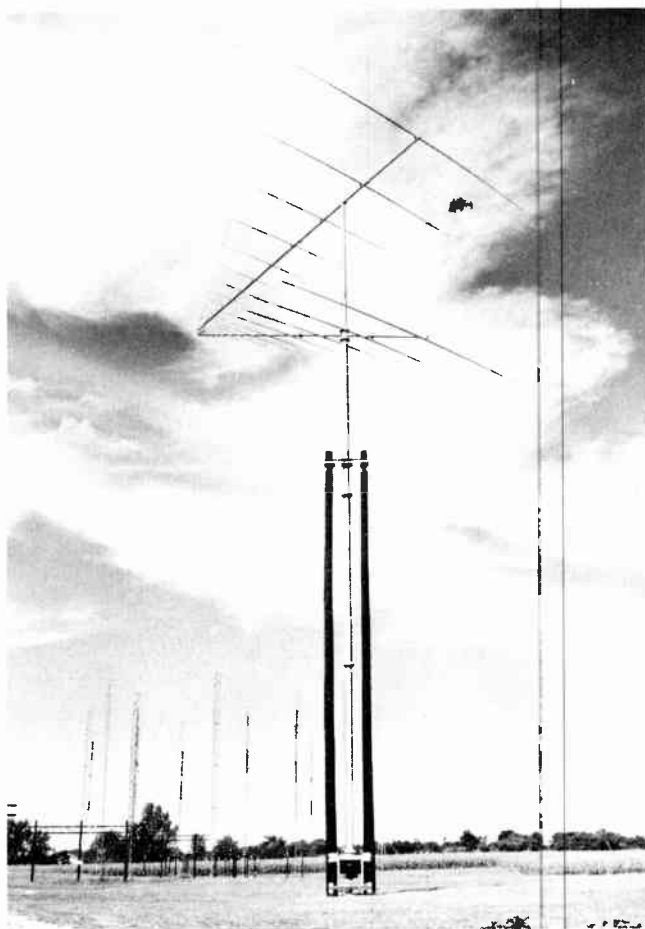

Figure 9-31. Collins Unidirectional Antenna 237A-2

with extreme bandwidths. Collins 237A-2 unidirectional antenna shown in figure 9-31 is well suited for this area of communications. The antenna, which is rotatable, covers the frequency range of 11.1 - 60 mc with a vswr less than 2:1. It provides a horizontally polarized unidirectional beam with a free space gain of 8 db over an isotropic antenna with side-lobes greater than 16 db down. It has a power handling capacity of 50 kw peak power. In addition to the 237A-2 antenna which covers the 11.1 to 60 mc range, antennas with frequency ranges of 6.5 - 60 mc and 19-60 mc have also been developed.

The nature of these antennas is such that the characteristic impedance can vary from 100 - 200 ohms depending on the design parameters. In order to match this impedance to the 50 ohm input a broadband impedance tapered line is incorporated in the antenna. The tapered line is contained inside the lower boom and then brought down the vertical supporting mast. The vertical mast which supports the antenna, as well as the lower boom which supports the elements, are also used as the outer conductor of the coaxial feed line. At the bottom of the vertical supporting mast a transition is made in the coax to permit the use of a  $3-1/8$  inch rotary coaxial joint. This provides  $360^\circ$  azimuthal coverage.

### c. POINT TO POINT UNIDIRECTIONAL ANTENNA

The HF Communications antenna problem is defined by the mode of propagation in this frequency range. From approximately 2 to 30 mc long distance communication is by means of refraction of waves directed into the earth's upper atmosphere by the ionized gases that are present there. Depending on the state of the ionosphere and the angle of incidence of the impinging wave there exists a maximum frequency at which the wave will be refracted back to earth. At frequencies greater than this maximum usable frequency (MUF) the waves penetrate the ionosphere and are useless for terrestrial communication. Since the condition of the ionosphere is a function of time of day, latitude and sun spot cycle among other things the MUF over a long path may lie almost anywhere in the H.F. spectrum sometime in a period of months or years. Consequently, if a single antenna is to be used it must be usable over the entire high frequency spectrum. An additional consideration is the desirability of directing as much of the radiated energy as possible at the so called control point of a

given path. The control point is that region or regions of the ionosphere in which the transmitted field is refracted back to earth in the direction of the receiving station. For a single hop path this region lies half way between the two stations. That part of the radiated energy that is not directed at the control point is lost as far as useful point to point communications is concerned.

Figure 9-32 shows a typical log periodic antenna which, when placed over ground, has the properties that its patterns, as well as impedance, are essentially independent of frequency. This means that the gain in a chosen direction above the horizon will be constant over any frequency range desired and can vary from 8 - 14 db over an isotropic radiator depending upon the design parameters.

It has been found that the phase center of these antennas is located a fixed number of wavelengths from their feed point. That is, the distance from the feed point to the phase center measured in wavelengths is constant. As a consequence of this phenomenon,

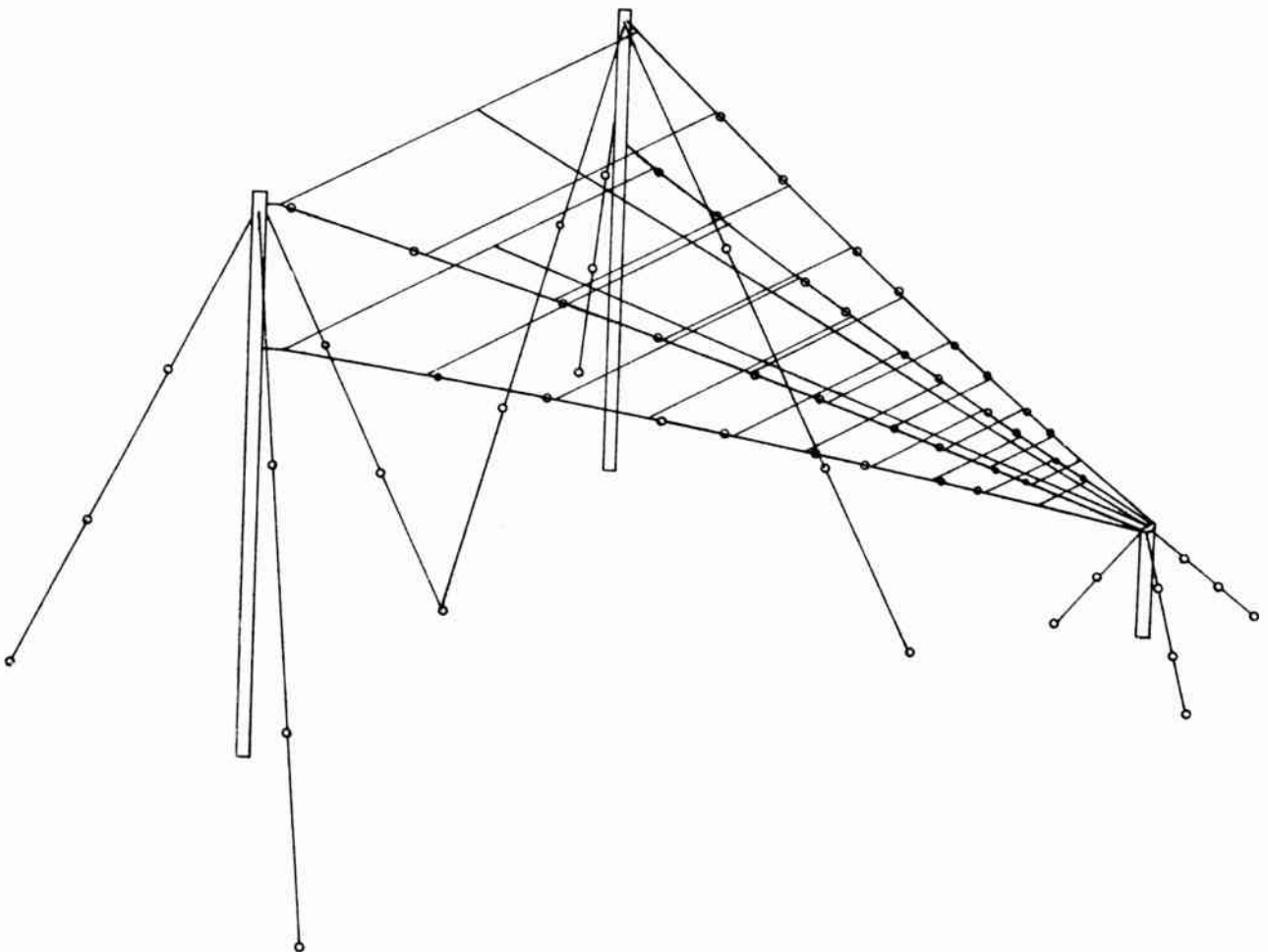

Figure 9-32. Logarithmically Periodic Antenna for Use in Point to Point Communications

when these antennas are placed at an angle with respect to ground and with their feed point at ground level, the distance from the ground to the antenna phase center measured in wavelengths is independent of frequency. The vertical plane pattern of antenna and ground system is therefore independent of frequency (to the same degree that the ground conductor and dielectric constant are independent of frequency) with the beam maximum occurring at an elevation angle determined by the angle at which the antenna is inclined to the ground. Also, an antenna of this nature produces a moderate gain (8 - 14 db over a dipole), and the maximum gain is realized over the entire frequency range. Other antennas of higher gain do not always have their main beam pointed at the desired angle and as a result, far less than maximum gain is quite often realized.

#### d. HORIZONTALLY POLARIZED OMNIDIRECTIONAL ANTENNAS

Still another type of log periodic antenna is the 237B series omnidirectional horizontally polarized antenna shown in figure 9-33. The antenna consists of two planar structures placed at right angles to each other and proportioned so as to produce an omnidirectional horizontally polarized radiation pattern. This structure is also of a repetitive nature so that its performance is essentially independent of frequency. With parameters of  $\alpha = 97.5^\circ$  and  $\tau = .6$ , a deviation of  $\pm 1\frac{1}{2}$  db from omnidirectional is experienced with a maximum deviation of  $\pm 2\frac{1}{2}$  db. The resultant cross polarization is 9 db down with minimum and maximum values of 7 db and 14 db respectively. The vswr of this antenna is less than 2:1 over the entire frequency range of the antenna. As in the case of the 237A antennas, the frequency ranges of the 237B antennas are 6.5 - 60 mc, 11.1 - 60 mc, and 19 - 60 mc.

These antennas represent a major advancement in the design of omnidirectional antennas. In the past, vertically polarized omnidirectional antennas have been designed which would operate over 3:1 or 4:1 frequency ranges with good impedance characteristics, but with radiation patterns that deteriorate at the high end of the frequency band. In addition, vertically

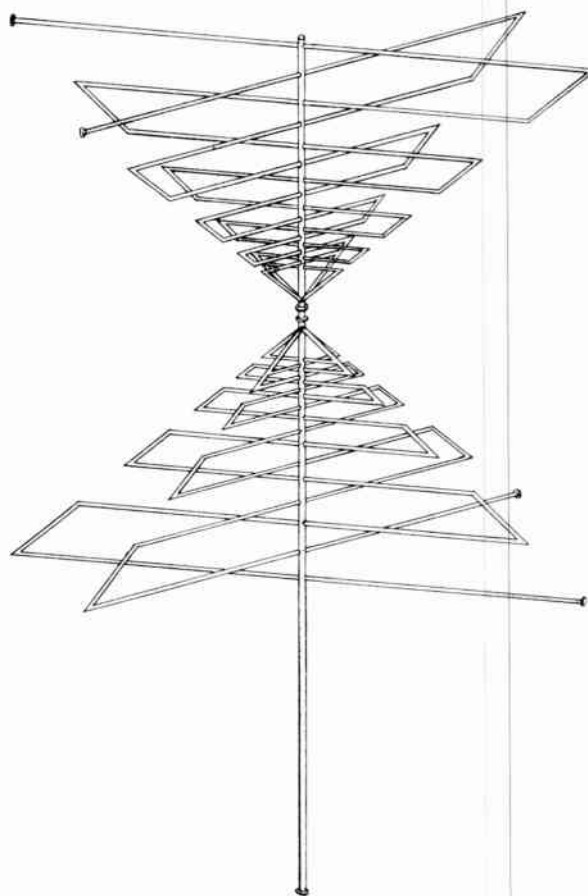
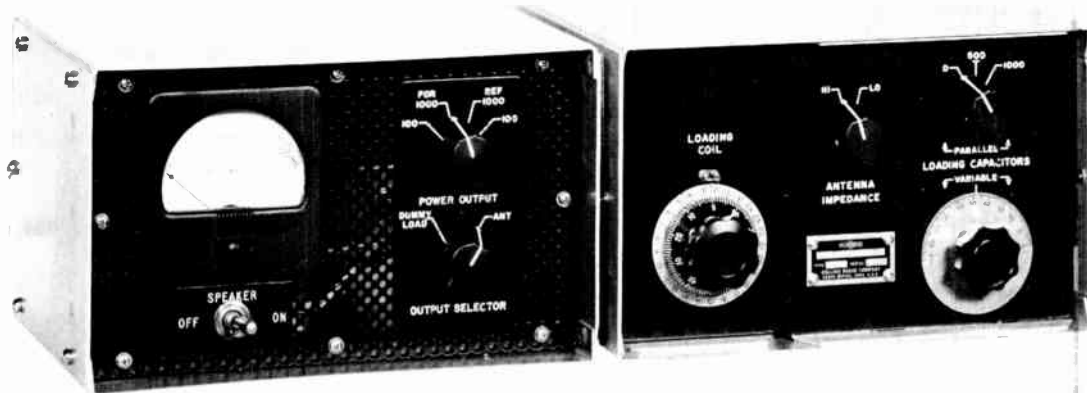

Figure 9-33. Horizontally Polarized Omnidirectional Antenna

polarized antennas are susceptible to extreme ground losses over poor earth. The 237B antennas are less susceptible to ground losses since they are horizontally polarized and their free space patterns are essentially independent of frequency.







Collins 180U-2 Fixed Station Antenna Network Matches a 50-Ohm Output to a 50-Ohm Transmission Line having a VSWR Up to 2 to 1. Power Handling Capacity is 1000 Watts over the Frequency Range of 2 - 30 Mc

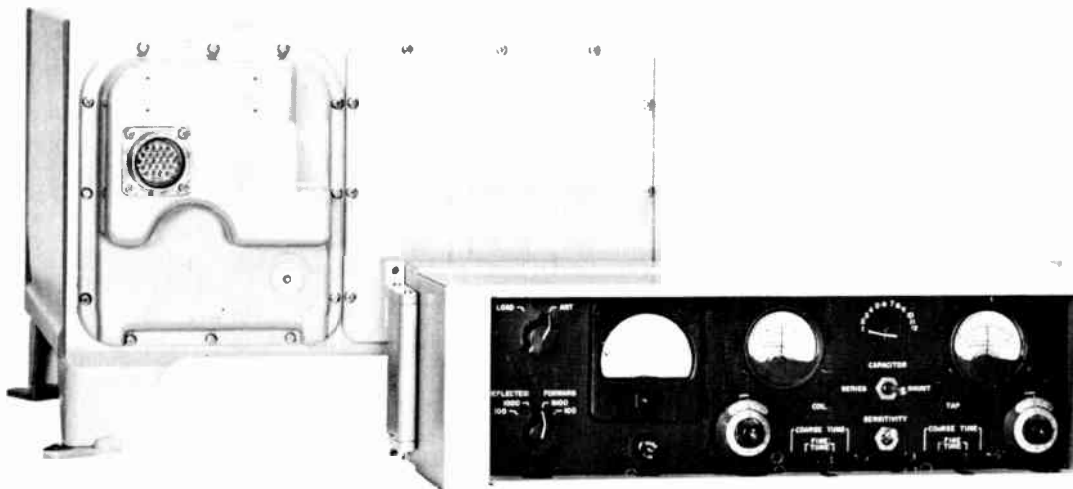

Collins Designed the AN/SRA-22 Antenna Coupler to Satisfy the Tuning Requirements of Whip and Other Antennas Normally Encountered in Shipboard Applications. The Weathertite Enclosure Mounts at the Antenna Base with a Remote Control Unit for Convenient Operation

## CHAPTER 10

### ANTENNA FEED SYSTEMS

#### 1. INTRODUCTION

The material presented in this chapter will be that concerning the network between the source and its load. As a matter of convenience, the transmitter will be considered the source, and the antenna the load; in most cases, however, the same principles apply to the receiving system. The primary subject is that of transmission lines, their physical and electrical properties, and their applications in high-frequency antenna feed systems. As with the antenna, the type of emission employed does not generally impose any particular requirements on the selection of transmission line.

Although the major part of the text is devoted to the practical aspects of feed systems, some basic transmission line theory is included as a review of the subject. Included at the end of the chapter is also a brief discussion pertaining to antenna and feedline measurements.

#### 2. TYPES OF R-F LINES

Electrically there are two basic types of uniform transmission lines for r-f operation, balanced and unbalanced. When a line operates with potentials of equal magnitude and opposite polarity from each side of the line to ground, it is balanced; when a line operates with one side at ground potential and the other side at r-f potential, it is unbalanced. Mechanically there are also two basic forms, open wire and enclosed. Open wire lines are constructed of two or more conductors, uniformly spaced and supported in air above ground; enclosed lines utilize one or more transmission circuit conductors enclosed by a metallic sheath. Lines of the enclosed type may be either balanced or unbalanced.

#### 3. TRANSMISSION LINE PROPERTIES

The electrical characteristics of a transmission line, which consist of inductance, capacitance, series resistance, and shunt conductance per unit length of line, are determined by its cross-sectional geometry and the nature of the dielectric medium. For most practical purposes, the series resistance and shunt conductance may be neglected, and the typical r-f transmission line may be represented by the equivalent circuit of figure 10-1.

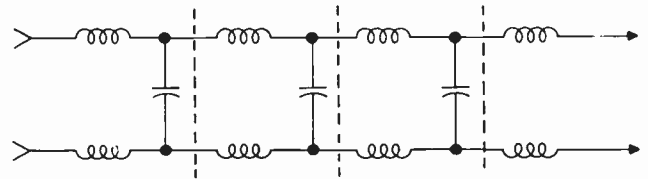

Figure 10-1. Approximate Representation of a Two-Wire Transmission Line By Means of Lumped Constants

The inductance,  $L$ , and capacitance,  $C$ , per unit length of line determine its characteristic or surge impedance,  $Z_0$ , which is equal to  $\sqrt{\frac{L}{C}}$ . The physical significance of the characteristic impedance is simply that impedance which the line offers to the flow of current (provided the line is terminated in its characteristic impedance). The characteristic impedance of typical r-f lines ranges from 50 ohms in the coaxial type to over 600 ohms in the open wire type.

When a transmission line is not terminated with a load equal to its characteristic impedance, standing waves of voltage and current will exist along the line as a result of reflection from the load end of the line. Their magnitude depends on the amount of mismatch between the characteristic impedance of the transmission line and the impedance of the termination. The standing-wave ratio,  $swr$ , is a measure of the degree of mismatch and is defined as the ratio of maximum rms voltage (or current) to the minimum rms voltage (or current) of the resultant standing waves. A line terminated in its characteristic impedance will exhibit no standing waves, and the  $swr$  will be 1:1. When a lossless (hypothetical) line is terminated in a complete short circuit or a complete open circuit, the resultant  $swr$  is infinite. Under actual conditions where lines are somewhat lossy and are affected by proximity, the  $swr$  is much less than infinite. When the load is purely resistive,

$$swr = \rho = \frac{Z_r}{Z_0} \text{ or } \frac{Z_0}{Z_r}$$

where  $Z_r$  = impedance of load

$Z_0$  = characteristic impedance of the line

$\rho$  = standing-wave ratio (by definition,  $swr \geq 1.0$ )

Swr refers to voltage or current unless power is specifically mentioned. The voltage standing-wave ratio (vswr) must be squared to convert to power relationships. The power delivered to the load is equal to the difference between the energy contained in the incident wave and the energy contained in the reflected wave, which is determined by the degree of mismatch at the load end of the line. When both incident and reflected power are known, swr can be determined from

$$\rho = \frac{\sqrt{\frac{P_i}{P_r}} + 1}{\sqrt{\frac{P_i}{P_r}} - 1}$$

where  $P_i$  = incident power

$P_r$  = reflected power

The power contained in the reflected wave, however, does not represent actual loss except as it is attenuated in traveling back to the input end of the line. Neglecting effects on the source, it is merely power which is not being coupled, resulting in inefficient operation. For most h-f antenna work, a vswr of 1.5:1 or under represents a desirable impedance match. Where an antenna is required to operate over a wide-frequency range, a vswr of 2:1 or under is usually satisfactory.

Frequently the term reflection coefficient,  $k$ , is used to designate terminal mismatch on a line and is related to the swr by

$$k = \frac{swr - 1}{swr + 1} = \frac{\rho - 1}{\rho + 1}$$

The power lost in a line is least when the line is terminated in a resistance equal to its characteristic impedance, and increases with an increase in standing-wave ratio, because the effective values of both current and voltage become greater. The increase in effective current raises the ohmic losses in the conductor, and the increase in effective voltage increases the losses in the dielectric. The effect of swr on line loss is shown in figure 10-2.

In addition, swr affects the power handling capability of a given transmission line, as limited by the

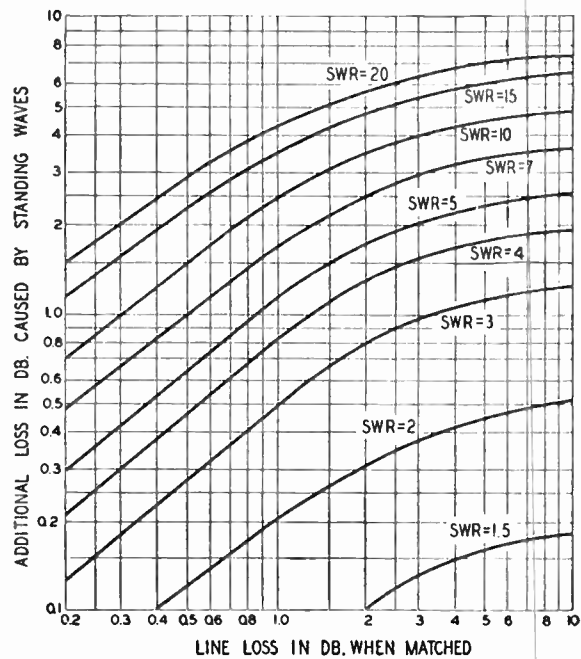

Figure 10-2. Effect of SWR on Line Loss

insulation breakdown voltage. This is of particular importance in transmission lines of the coaxial type. Most manufacturers derate their lines in direct proportion to the swr, so, in order to operate the line efficiently, it is necessary to maintain a low swr.

The velocity factor is another property of typical transmission lines. The velocity factor is the ratio of the actual propagation velocity along the line, to the propagation velocity in free space and accounts for the electrical length of a given line being somewhat longer than the physical length. Values of the velocity factor will differ for different line types and are available from manufacturers' specifications. The physical length corresponding to an electrical wave length is given by

$$L(\text{feet}) = \frac{984}{f} v$$

where  $f$  = frequency in mc

$v$  = velocity factor

#### 4. TYPICAL R-F TRANSMISSION LINES

##### a. TWO-WIRE BALANCED LINES--AIR DIELECTRIC

The two-wire balanced, air dielectric line is probably the most common type of feeder for balanced operation in the h-f range. When properly constructed and operated, the two-wire balanced line is capable of handling high power with comparatively low loss. If

the lines are not properly balanced with respect to ground or are too widely spaced, they are subject to radiation. Although the two-wire balanced line is most frequently employed where a characteristic impedance in the range of 400 to 600 ohms is required, it can also be designed for a lower characteristic impedance. Transmission lines with surge impedances in the order of 200 ohms and up can be designed by employing larger diameter conductors (tubing). Minimum spacing of lines is limited by voltage breakdown considerations, mechanical difficulties, and by the increases in losses due to proximity effects. When the effect of insulating spacers is neglected, and the lines are high enough above ground ( $h \gg b$ ), the characteristic or surge impedance of the two wire balanced line may be expressed as shown in figure 10-3.

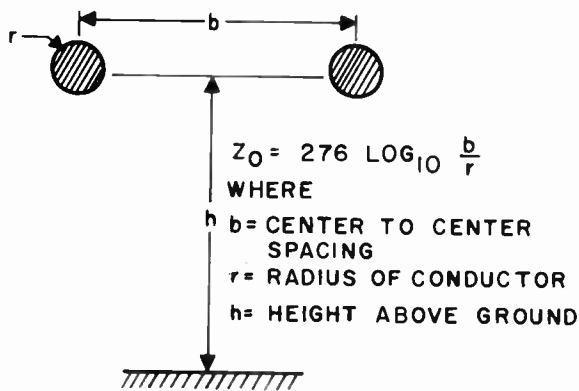

Figure 10-3. Cross Section of Two-Wire Balanced Line

Because of the effect of supporting structures, dielectric spreaders, line losses, and other factors, the velocity factor of open wire line is slightly less than unity, ranging from 0.95 to 0.98 for typical lines. Conductor size and spacing for a given characteristic impedance may be determined from the curves of figure 10-4.

**b. FOUR-WIRE BALANCED LINES--AIR DIELECTRIC**

Four-wire balanced transmission lines are commonly used where a lower characteristic impedance than that of the two-wire balanced line is required. The four-wire line can be side-connected as in figure 10-5a or cross-connected as in figure 10-5b. Both types of line exhibit a lower characteristic impedance than that of the two-wire line, but the cross-connected line shown in figure 10-5b is less subject to radiation or pickup. A popular application of the four-wire balanced line is for feeders to receiving systems in

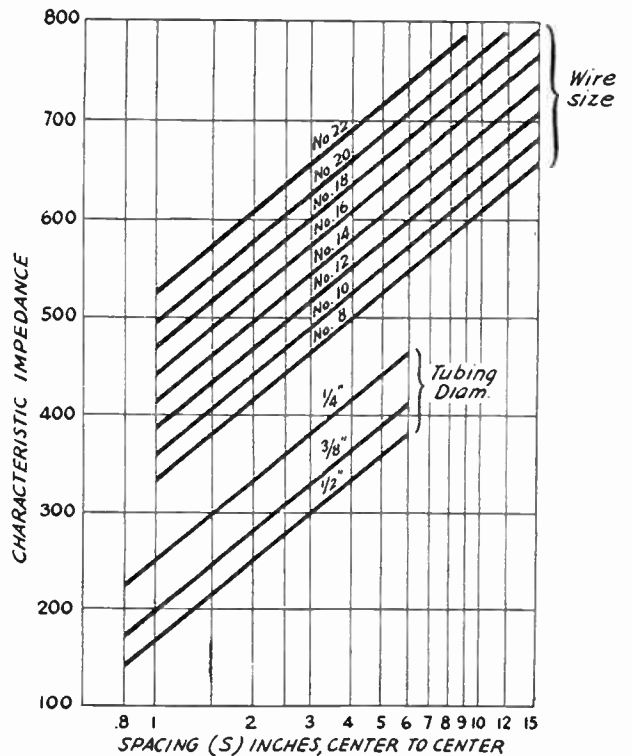

Figure 10-4. Characteristic Impedances for Typical Values of Conductor Size and Spacing (Two-Wire Balanced Lines)

which several rhombic antennas are employed for diversity reception. The characteristic impedance required here is about 200 ohms. The characteristic impedance of the feeder shown in figure 10-5b may be expressed by

$$Z_0 = 138 \log_{10} \frac{ab}{r\sqrt{a^2 + b^2}}$$

From figure 10-6, the characteristic impedance may be determined for various wire sizes and spacings for the special case where  $a = b$  and  $D$  is the diagonal dimension represented above as  $\sqrt{a^2 + b^2}$ .

**c. TWO-WIRE BALANCED LINES--SOLID DIELECTRIC**

Two-wire balanced solid dielectric lines are produced commercially in forms commonly known as molded pair, ribbon, or twin-lead. These lines are more lossy, but are flexible and fairly rugged. Because of the solid dielectric, lower characteristic impedances can be achieved than are practical with open wire, air dielectric lines. Typical size lines are 75, 100, 150, 200, and 300 ohms. The velocity factor of this type of line ranges from about 0.68 to 0.82, depending upon its construction.

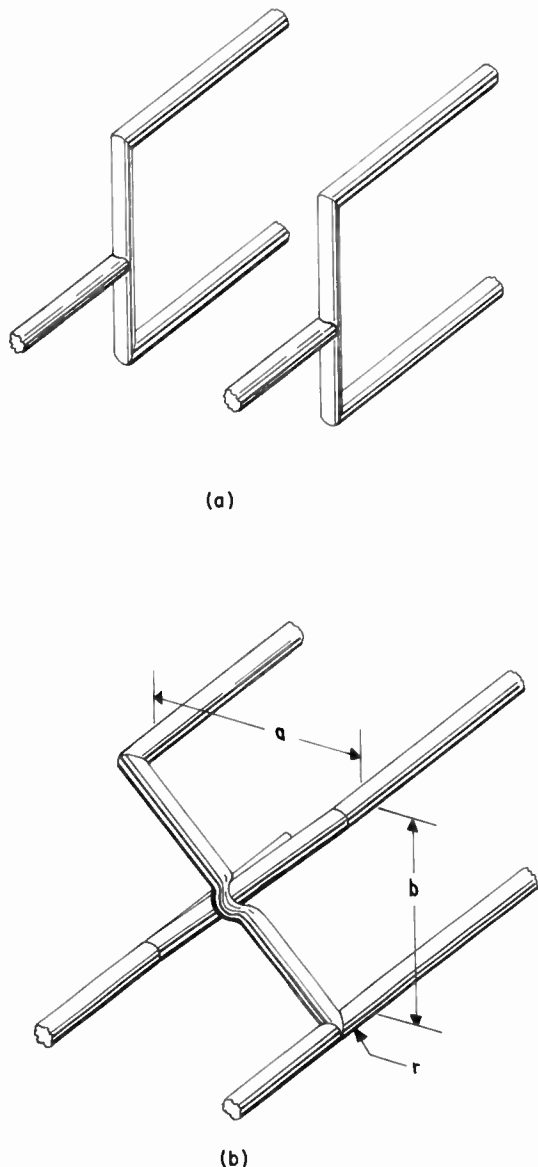

Figure 10-5. Cross Section of Four-Wire Balanced Lines

**d. AIR DIELECTRIC COAXIAL LINES**

With coaxial construction, it is possible to achieve a much lower characteristic impedance than is practical with the parallel-conductor type line. For air as the dielectric, the 50- and 70-ohm lines are the most popular. The 50-ohm coaxial line, in fact, is fast becoming a standard transmission line in modern communications systems. Since the fields are contained within the outer conductor, loss by radiation is

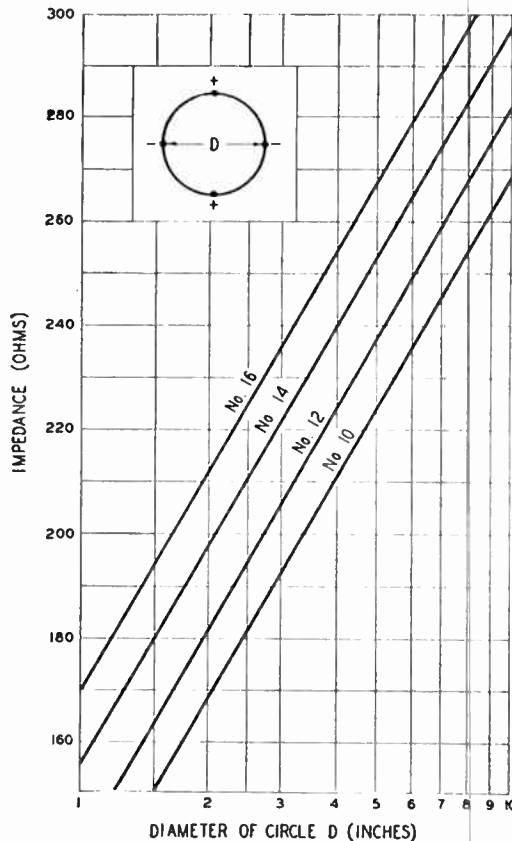

Figure 10-6. Characteristic Impedances of Four-Wire Balanced Line with Typical Values of Conductor Size and Spacing

eliminated and, by the same virtue, the line is free from pickup.

Air dielectric coaxial line is available in the rigid or the semiflexible type and in various diameters depending on the power handling requirements; some common sizes are 7/8 inch, 1-5/8 inch, 3-1/8 inches, and 6-1/8 inches (outer diameter). To prevent moisture from forming inside the line, pressurization with dry-air or nitrogen is usually required. The velocity factor ranges from 0.83 to 0.99.

The characteristic impedance of air dielectric coaxial line may be determined with sufficient accuracy from the expression shown in figure 10-7.

**e. SOLID DIELECTRIC COAXIAL LINES**

Solid dielectric coaxial lines differ from air dielectric types in that the inner and outer conductors are separated by a dielectric material, such as Polyethylene or Teflon. Such cables have the advantage of easy handling and installing, but for a given size, the attenuation is higher and the power-handling



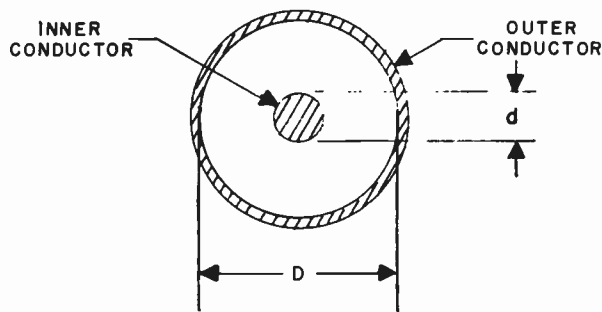

NOTE  
INNER CONDUCTOR IS SUPPORTED BY DIELECTRIC BEADS OR SPIRAL SPACERS

$$Z_0 = 138 \log_{10} \frac{D}{d}$$

WHERE  
D=INSIDE DIAMETER OF OUTER CONDUCTOR  
d=OUTSIDE DIAMETER OF INNER CONDUCTOR

Figure 10-7. Cross Section of Air Dielectric Coaxial Line

capabilities are lower than that of air dielectric types. The velocity factor for lines using Polyethylene is 0.659 and for lines using Teflon is 0.695. The characteristic impedance of solid dielectric coaxial lines may be determined from the expression of figure 10-8.

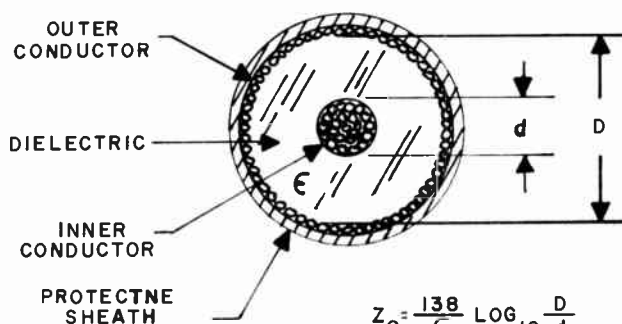

$$Z_0 = \frac{138}{\sqrt{\epsilon}} \log_{10} \frac{D}{d}$$

WHERE  
 $\epsilon$  = DIELECTRIC CONSTANT  
D= INSIDE DIAMETER OF OUTER CONDUCTOR  
d=OUTSIDE DIAMETER OF INNER CONDUCTOR

Figure 10-8. Cross Section of Solid Dielectric Coaxial Line

**f. TWO CONDUCTOR SHIELDED CABLES**

Two conductor shielded cables are commercially available for specialized applications requiring a shielded balanced line. However, this type of line is not commonly used in high-frequency antenna feed systems.

**g. SINGLE WIRE LINE**

A single wire line, well above ground and surrounding objects, exhibits a characteristic impedance of about 500 ohms when operated with ground as the return circuit. Although this type of feed is subject to radiation and is usually avoided, it provides a quick and simple method of improvising a temporary feedline.

**5. TRANSMISSION LINE SECTIONS AS CIRCUIT ELEMENTS**

The characteristics of low-loss resonant sections of transmission lines make them desirable for use as high-Q circuit elements. Their usefulness as circuit elements in the high-frequency range can be reduced to three basic applications: (a) parallel resonant circuits, (b) series-resonant circuits, and (c) low-loss reactances. The reactance of circuit elements comprised of transmission line sections varies differently with frequency than does the reactance of the ordinary inductance and capacitance type circuit. This is due to the linear configuration of the transmission line section as compared to the lumped form of the ordinary inductance and capacitance. However, the distributed inductance and capacitance of the line section do not determine directly the reactive effects of the linear circuit elements. The reactance is a result of the reflection effects which depend primarily on the relationship between L, C, line length, and line termination.

**a. LINE SECTIONS AS PARALLEL RESONANT CIRCUITS**

When a section of transmission line is terminated in an open or short circuit, high magnitude standing waves of voltage and current exist on the line. At current standing-wave nodes, the impedance appears as a pure resistance of very high value (infinite in the case of the hypothetical lossless line) and resembles the impedance of a conventional high-Q parallel resonant circuit consisting of lumped inductance and capacitance. At points substantially removed from the current node (exact resonance), the impedance characteristics of the line section no longer resemble those of the lumped constant "tank" circuit. This is due to the effect of the linear circuit.

The use of transmission line sections as parallel resonant circuits is more popular in the vhf and uhf

regions than in the h-f range, because the lines become excessively long at the lower frequencies. The quarter-wave section with its end terminated in a short circuit, as shown in figure 10-9, is the most commonly used line section for this type of circuit element, but, as can be seen from figure 10-10, other varieties of line sections will produce the same circuit. The line sections can be of the balanced or unbalanced, open wire, or coaxial type. The length of line designated for the particular circuit element is the effective electrical length, and where applicable, the velocity factor of the line must be considered.

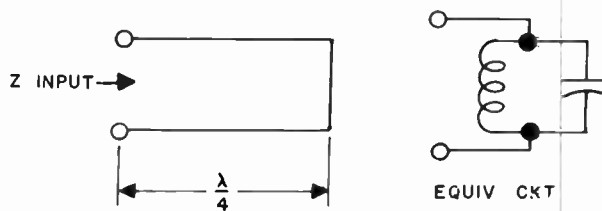

Figure 10-9. Lumped Circuit Analogy for Quarter-Wave Section of Transmission Line Terminated in a Short Circuit

LINE TERMINATION	LESS THAN $\frac{\lambda}{4}$	EXACTLY $\frac{\lambda}{8}$	EXACTLY $\frac{\lambda}{4}$	BETWEEN $\frac{\lambda}{4}$ & $\frac{\lambda}{2}$	EXACTLY $\frac{3\lambda}{8}$	EXACTLY $\frac{\lambda}{2}$
OPEN CKT		 $ X_c  = Z_0$	 $X_L = X_c$		 $ X_L  = Z_0$	 $X_L = X_c$
SHORT CKT		 $ X_L  = Z_0$	 $X_L = X_c$		 $ X_c  = Z_0$	 $X_L = X_c$
RESISTANCE GREATER THAN $Z_0$ $Z_R > Z_0$		 $ Z  = Z_0$	 $Z < Z_0, Z = \frac{Z_0^2}{Z_R}$		 $ Z  = Z_0$	 $Z > Z_0, Z = \frac{Z_0^2}{Z_R}$
RESISTANCE LESS THAN $Z_0$ $Z_R < Z_0$		 $ Z  = Z_0$	 $Z > Z_0, Z = \frac{Z_0^2}{Z_R}$		 $ Z  = Z_0$	 $Z < Z_0, Z = \frac{Z_0^2}{Z_R}$

Figure 10-10. Lumped Circuit Analogy of Transmission Line Sections of Various Lengths

For high-frequency applications where the line section length required for resonance becomes excessive, a short-circuited quarter-wave parallel resonant line can be made physically much shorter by connecting a capacitor across the open end of the line section. The degree to which a resonant quarter-wave line section is electrically lengthened or physically shortened by addition of a given lumped capacitance depends upon the characteristic impedance of the line. The higher the characteristic impedance of the line section, the greater the effect of a given lumped

capacitance. For resonance, the reactance of the capacitor must equal the inductive reactance presented by the shortened line section. As shown in figure 10-10, the effective impedance at the open end of a shorted line section less than a quarter-wave in length is inductive, and its value depends upon both its characteristic impedance and length. A practical high-frequency application for the shortened parallel resonant line section is the balanced-to-unbalanced transformer.

**b. LINE SECTIONS AS SERIES RESONANT CIRCUITS**

At voltage standing-wave nodes on a transmission line terminated in an open or short circuit, the impedance appears as a pure resistance having a very low value (zero in the case of the hypothetical lossless line) and resembles the impedance of a conventional high-Q series-resonant circuit consisting of lumped inductance and capacitance. At points on the line substantially removed from the voltage node (exact resonance), the impedance characteristics of the line section no longer resemble those of the lumped series-resonant circuit. Figure 10-10 illustrates that for series resonance, an open-circuited line may be any odd number of quarter-wave lengths long, while a short-circuited line may be any even number of quarter-wave lengths long. Although series-resonant linear circuits are not as frequently employed in antenna systems as are the parallel resonant line sections, they are quite useful for such purposes as the suppression of harmonics and as compensating reactances. When applicable, the quarter-wave line section shown in figure 10-11 is the most common.

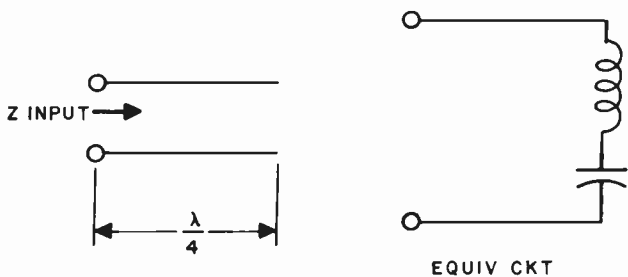

Figure 10-11. Quarter-Wave Open Transmission Line Section and its Equivalent Circuit

**c. LINE SECTIONS AS LOW-LOSS REACTANCES**

The reactance produced by linear circuit elements can have almost any magnitude and can be either capacitive or inductive, depending upon the electrical length of the line section and upon the type of termination (open or short-circuited). This is illustrated in figure 10-10 for the lossless line; losses present in actual line sections result in a small resistive component. In a well constructed line section, however, the losses are so low that this resistive component usually can be neglected. The characteristics shown in figure 10-10 are repeated for any multiple of an electrical half wave length that is added.

**(1) LINE MATCHING STUBS**

The most common use of line sections as low-loss reactive elements is for impedance matching on

antenna feedlines. In this application, they are ordinarily referred to as stubs and are employed to cancel or eliminate undesirable reactive components of impedance (figure 10-12). Although only current standing waves are shown in the figure, standing waves of both current and voltage exist, due to the mismatch at the line termination. For every wave length on the line there are four recurring points where the resistive component is equal to the characteristic impedance of the line. If a stub is placed across the line at one of these points and is adjusted so that its reactance is equal in magnitude but opposite in sign to that of the reactive component existing at that point, the line will become "flat" or matched from that point back to the generator. As shown in figure 10-12, the standing waves have been removed only between the stub and the generator. Therefore, to operate a mismatched line with the highest efficiency, the stub should be placed as close to the load as practicable. In addition, this placement will allow operation of the over-all antenna system over a broader frequency range.

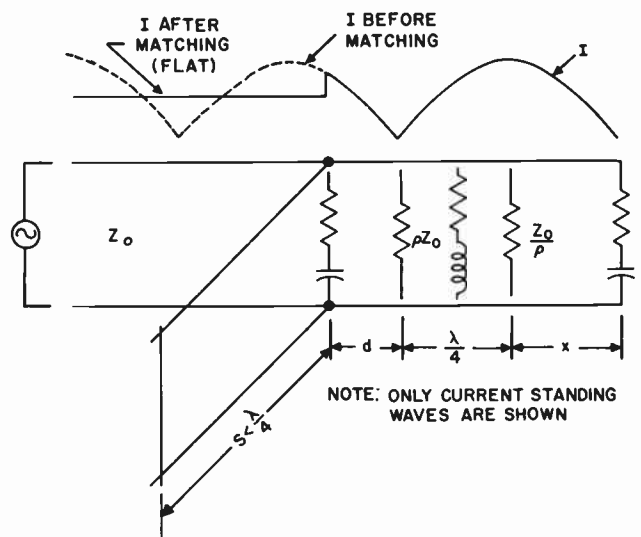

Figure 10-12. Effect of Shorted Stub on SWR Between Stub and Generator

The reactance of short-circuited or open-circuited line sections less than one quarter-wave in length may be determined from the universal reactance curves of figure 10-13, or from the equations illustrated in figure 10-14.

**(2) DOUBLE STUB MATCHING**

It often is impractical to locate a single stub at the desired point along the line; this is particularly true with coaxial lines when experimental final adjustments make it necessary to vary the point of attach-

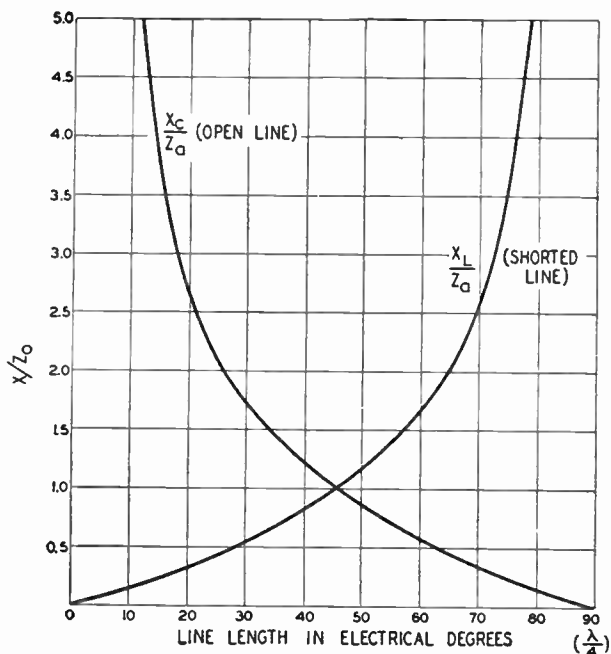

Figure 10-13. Universal Reactance Curves for Open or Shorted Lines Less than a Quarter-Wave in Length

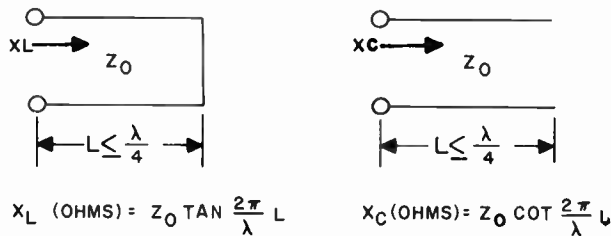

Figure 10-14. Line Sections as Reactive Elements

ment. This difficulty frequently can be overcome by employing two stubs of adjustable length with a pre-determined spacing. Common separation of the two stubs is 1/8 wave length or odd multiples of 1/8 wave length. The range of complex impedances which the double stub arrangement is capable of matching is limited, but is usually adequate for the practical antenna installation. The two stubs, together with the line, act as a combined impedance transformer and reactance-canceling circuit. The resulting effect is essentially the same as changing the location of the single stub.

**d. LINE SECTIONS AS IMPEDANCE TRANSFORMERS**

The properties of a transmission line that enable it to perform as an impedance transformer are illustrated in figures 10-10 and 10-12, where the resultant

or apparent impedance is shown to be a function of characteristic impedance and length of the line section.

An important application of this characteristic is the popular quarter-wave transformer. Referring to figure 10-12, it can be seen that at given distance,  $x$ , from the load end of the line, the apparent impedance is a resistance equal to  $\frac{Z_0}{\rho}$  where  $\rho$  is the standing-wave ratio. Then, a quarter-wave farther down the line, the apparent impedance is another resistance, but now equal to  $\rho Z_0$ , or multiplied by an amount equal to the square of the swr. Thus, a section of line a quarter-wave in length (or any odd multiple of a quarter-wave length) transforms the load at one end to an impedance at the other end by a factor of  $\rho^2$  or  $\frac{1}{\rho^2}$ , depending on the reference end. Since  $\rho$  can be defined in terms of the characteristic impedance of the line section and the impedance of the load, the relationship shown in figure 10-15 can be derived. The line section may be of either the parallel-conductor or coaxial type with the velocity factor applied where needed to make the line an electrical quarter-wave length. However, the transformer functions properly only when the load is nonreactive.

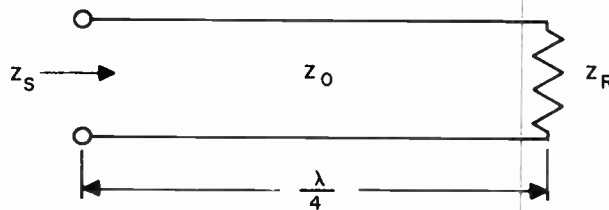

$$Z_0 = \sqrt{Z_S Z_R}$$

WHERE:

- $Z_0$  = CHARACTERISTIC IMPEDANCE OF  $\frac{\lambda}{4}$  LINE SECTION
- $Z_S$  = SENDING END IMPEDANCE
- $Z_R$  = LOAD IMPEDANCE

Figure 10-15. Quarter-Wave Line Section as Transformer

Theoretically, any value of load impedance  $Z_R$  can be transformed to any desired value of impedance  $Z_S$  by the quarter-wave line. In actual practice, the range of impedance transformation is limited by the value of  $Z_0$  which in turn depends on the physical size

of the line. Practical lines yield a range of characteristic impedances from about 50 to 600 ohms. This type of matching section is widely used in antenna feed systems. A few particular applications will be shown later in the chapter.

**e. LINE SECTIONS AS BALANCING DEVICES**

Frequently it is required to couple energy from an unbalanced system to a balanced system, or vice versa. A common example is center-feeding an elevated dipole with a coaxial transmission line. There is then a need for a device to convert the unbalanced voltage of the coaxial cable to the balanced voltage required by the antenna. If the example antenna were fed directly with the coaxial line, it would not be a strictly balanced load and the line would not operate normally. Currents would be present on the outer surface of the outer conductor of the coaxial line, causing it to radiate, and, in addition, the load presented to the source would not be strictly unbalanced. In the interest of system performance, these conditions should be avoided. A device commonly employed for this transformation is a balun, a contraction for "balanced to unbalanced."

One balun which performs the desired conversion without affecting the impedance characteristics of the system is shown in figure 10-16. Because of its physical appearance, it is sometimes referred to as a "bazooka." When the length,  $L = \frac{\lambda}{4}$ , the outer

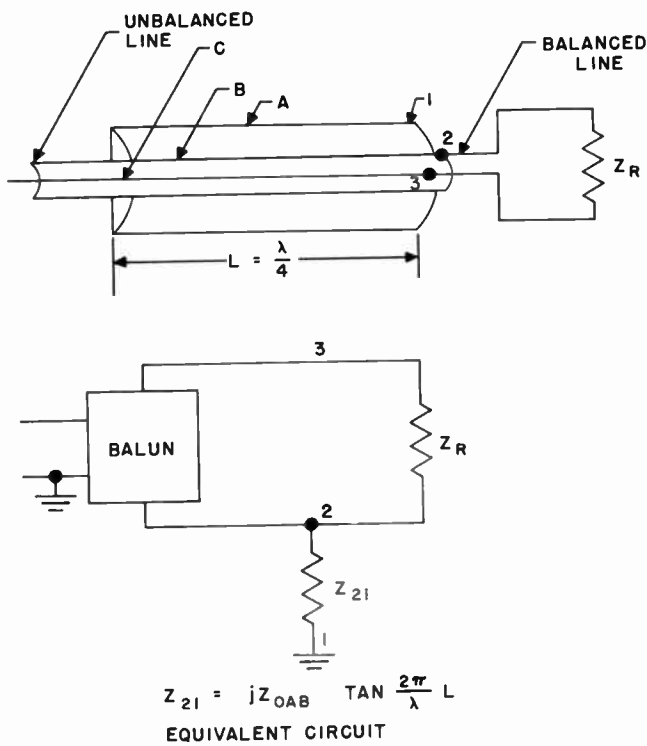

Figure 10-16. Bazooka Type Balun with 1:1 Z-Transfer

sleeve acts with the outer conductor of the enclosed section of line to form a shorted quarter-wave coaxial section, causing a high impedance to exist between points 1 and 2. The result is little or no shunt path to ground from 2 to 1, no division of current at junction 2 and, consequently, equal currents in each conductor of the dual line. The impedance to ground is then only that due to the distributed capacitance and conductance of the balanced load.

Since the currents in each of the dual conductors are equal and 180° out of phase, the voltages to ground are equal and 180° out of phase, which then results in balanced operation.

The impedance between points 2 and 1 remains high only when the length, L, is very near a quarter-wave in length. Consequently, this type of balun provides good performance over a relatively narrow band of frequencies (about 10% of the frequency of operation) Where broader band operation is required, the "double bazooka" type balun, shown in figure 10-17, may be employed. It consists of two sections of the balun in figure 10-16 joined at their open ends as illustrated. From the equivalent circuit, it can be seen that whatever the impedance between points 2 and 1 due to A and B, it will have at all frequencies an exact counterpart between 3 and 1 due to A' and B'.

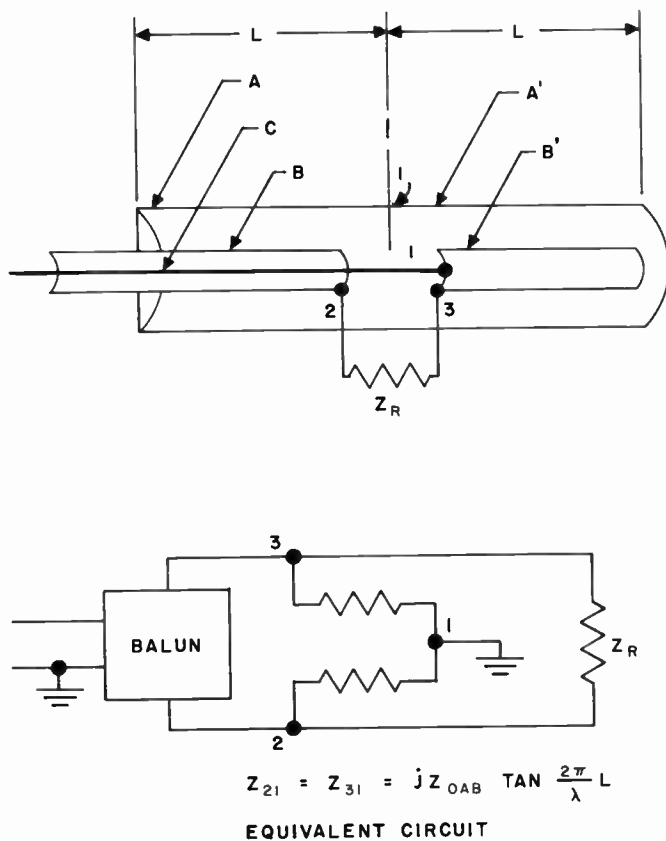

Figure 10-17. Double Bazooka Type Balun with 1:1 Z-Transfer



At the frequency at which each half of the balun is a quarter wave length, the impedance across the transmission line is only that of the dual lines. At any other frequency, the balun will shunt the dual line with an impedance of  $2Z_{21}$  or  $2Z_{31}$  as shown with the equivalent circuit.  $Z_{0ab}$  is the surge impedance of each section of the balun.

For best performance, the surge impedance,  $Z_{0ab}$ , of the coaxial sleeve should be relatively high in the order of 100 ohms. With average size coaxial line for the enclosed portion, this results in a fairly large diameter for the sleeve. For high-frequency application, the physical size and cost may not warrant its use.

A balun, the performance of which is comparable to that of the bazooka for h-f applications, and the construction of which is simpler and more economical, is shown in figure 10-18. This type balun functions

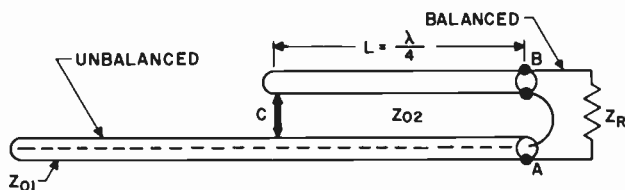

Figure 10-18. Parallel-Conductor Type Balun with 1:1 Impedance Transfer

similarly to the types just described by preventing undesirable currents from flowing along the outside of the coaxial line. Here, however, this is accomplished by a "canceling" effect rather than "choking" off the current as with the quarter-wave sleeve section. Any unbalance currents that flow from A to C due to its direct connection to the antenna (or load) will be canceled at point C by the exact counterpart of equal current flowing from B to C. Thus, there is no current flow in the outside of the coaxial feedline beyond point C.

The length,  $L$ , need not be of any particular length for this canceling effect to take place. However, when the length  $L = \frac{\lambda}{4}$ , the normal impedance characteristics of the load are not upset. It is frequently desirable to operate the balun at other than a quarter wave length in order to take advantage of the shunt reactance it presents to the load for impedance matching purposes. From the discussion on the transmission line section as a parallel-resonant circuit, it becomes apparent that the impedance characteristics of the shorted line section can be utilized here. Since the impedance characteristics of a center-fed half-wave dipole resemble those of a series-resonant circuit, the combined effect of the balun and

the dipole result in a wider frequency range of zero reactance and, thus broader band operation. Adding a lumped capacitance across the open end of the balun will permit its physical length to be shortened considerably, as was previously discussed. This is commonly done at the lower frequencies where the parallel resonant circuit properties of the quarter-wave balun are desirable but where its physical length becomes impractical.

In constructing a balun of this type (for high-frequency application) dimensions are usually not very critical. The most important consideration is to establish and maintain the two conductors parallel, which can be done suitably with dielectric spreaders. Spacing between the two conductors depends on the characteristic impedance  $Z_{02}$  desired. In most cases this impedance is not critical, varying from about 150 to 400 ohms. The impedance  $Z_{02}$  can be readily determined from the set of curves shown in figure 10-4. Generally, a higher  $Z_{02}$  is desirable for broad-band purposes. If the spacing between the conductors becomes too wide, however, a series inductance will be added due to the length of the loop connecting points A and B. The effective inductive reactance depends upon the frequency of operation (this may be a desirable or an undesirable effect).

The properties of the balun may be utilized for impedance correction in a variety of ways. Another application of this simple balun is shown in figure 10-19, where it serves also as an impedance transformer. The conversion from unbalance to balance is similar to that of the balun shown in figure 10-18, but due to the indirect loop connection at B and to the length,  $L$ , being less than a quarter-wave, the impedance transfer is no longer 1:1. The inductance,  $L$ , and capacitance,  $C$ , shown in the equivalent circuit are respectively determined by  $L_1$  and  $Z_{02}$  of the shorted section of open line, and by  $L_2$  and  $Z_{03}$  of the open section of coaxial line. These reactances may be calculated from the information given in the discussion of "Line Sections as Reactive Elements" or more conveniently from figure 10-13. The magnitude of  $X_L$  and  $X_C$  will vary with frequency, so for a given impedance transformation, this device is comparatively narrowband. It is most commonly employed

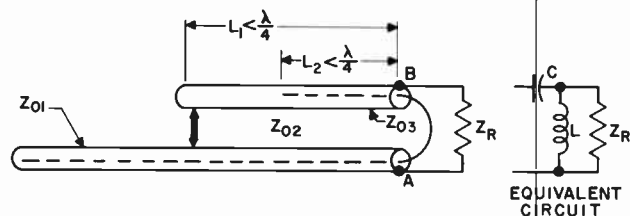

Figure 10-19. Simple Balun Impedance Transformer

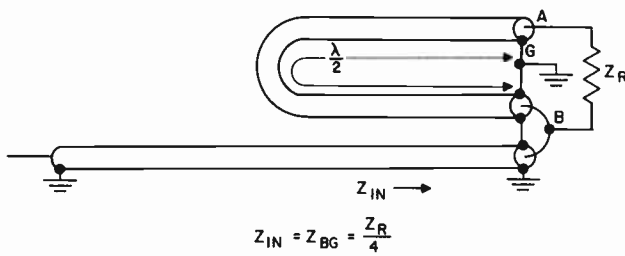

Figure 10-20. Half-Wave Balun with 4:1 Impedance Transfer

where the load impedance  $Z_R$  is several times as great as  $Z_{O1}$ .

A balun which provides a fixed impedance transformation of 4:1 is shown in figure 10-20. Advantage is taken of the fact that a half-wave section of line repeats its load but with a  $180^\circ$  phase reversal in voltage. Thus the voltages to ground from each side of the load impedance,  $Z_R$ , will be equal and  $180^\circ$  out of phase, resulting in balanced operation. The 4:1 impedance transformation may be explained as follows:  $Z_{AG} = \frac{Z_R}{2}$  due to  $Z_R$  being balanced to ground; this top half of the load impedance appears across BG due to the half-wave line repeating its load. Also appearing across BG is another value of  $\frac{Z_R}{2}$  due to the bottom half of the balanced load,  $Z_R$ . The two apparent impedances of  $\frac{Z_R}{2}$  are in parallel, thus,  $Z_{BG} = \frac{Z_R}{4}$ . Since the performance of the balun depends on the added section of line being one half-wave in length, it is a narrow-band device. This type balun finds many applications in antenna feedlines, one example of which is coupling the simple folded dipole whose input impedance is about 300 ohms, to a standard 75 ohm coaxial line.

A form of broad-band balun which is useful for application in high-frequency antenna feed systems, particularly in receiving and low-power installations, is illustrated in figure 10-21. It may be visualized as the balun shown in figure 10-18 wound into a coil. Because of the large amount of inductance and distributed capacitance formed by the coil, the length of line required for resonance is considerably reduced. The length of line actually required for a balun of this type can most easily (and practically) be determined by experiment. The coil length, diameter, number of turns, spacing between turns, location, and mounting all have an appreciable effect on the resultant distributed capacitance and inductance.

Although the coil balun of figure 10-21 appears to be a "coiled" version of the parallel-conductor

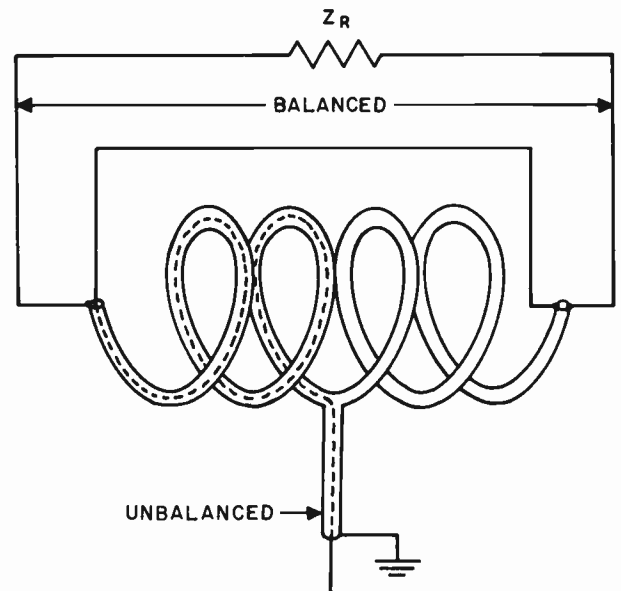

Figure 10-21. Broad Band Coil Balun with 1:1 Impedance Transfer

type of figure 10-18, its operation is somewhat more complex. For most practical purposes its operation can be compared to that of the balun shown in figure 10-17, where the linear circuit constants of the coaxial sleeve sections are replaced by the inductance and capacitance formed by the coil. A coil balun is capable of operating over a much wider range of frequencies than is the parallel-conductor type without upsetting the impedance of the system to which it is connected. This can be explained partly by its performing similarly to the balun of figure 10-17 and partly because of its lower Q.

In constructing a coil balun, assuming the designer has no previous experience with coils of this type, it is reasonable to begin with a length of a pair of lines as required for the full quarter-wave balun of figure 10-18. The coil should then be wound as illustrated to some given diameter and spacing between turns. By experiment, the two ends of the coil should be trimmed symmetrically until resonance is achieved at the desired frequency. A popular method for checking resonance is by the use of the grid-dip meter. This must be done with the balun disconnected from the load and the transmission line, and with the loop connection open. The grid-dip meter method, in fact, may be employed quite conveniently for determining the resonant frequency of baluns previously described. Generally, baluns should be designed to resonate at about the mean frequency of operation.

This chapter does not purport to describe all possible balancing devices which may be employed in

high-frequency antenna feed systems. The devices discussed here, however, are the more basic types and are representative of those commonly employed.

## 6. METHODS OF COUPLING TO THE ANTENNA

### a. DIRECT FEEDING

At the lower frequencies, particularly below the high-frequency region, the radiator is commonly brought directly in to the transmitter rather than employing a transmission line. This is done quite frequently in shipboard installations, for example, where a single wire antenna must be used over a wide range of frequencies. Since the antenna is usually not resonant at more than one frequency, an impedance matching network is necessary. In its simplest form, it consists of sufficient series reactance to compensate for the reactance presented by the antenna when it is not resonant. While this matching scheme is simple electrically, it possesses several disadvantages, chiefly the limited frequency range over which it is capable of matching. There are a number of reactive networks that are capable of providing better coupling to the transmitter, one of which is the adjustable "Pi" section shown in figure 10-22.

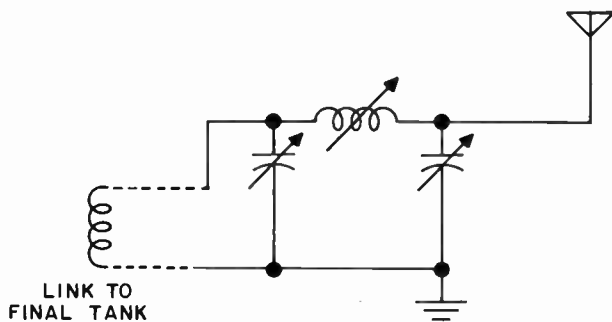

Figure 10-22. Coupling the Directly Fed Antenna Through a Pi Network

### b. RESONANT LINE FEEDING

The resonant or tuned-line method of coupling to the antenna is employed where no attempt is made to match the input impedance of the antenna to that of the feedline. The most common application for this type is in harmonically operated antennas, where, in effect, the combination of antenna and feed circuit constitute a resonant system. Consequently, the system is highly frequency sensitive, and a rather complex matching network must be employed at the transmitter unless the feedlines are cut to some critical length which will eliminate the reactive component.

Most generally, the feedline is connected either at a voltage or current loop on the antenna and, therefore, properly designated voltage feed or current feed, respectively. Several typical cases of voltage and current feed on a harmonically operated radiator are shown in figure 10-23. The transmission line is most often the open wire type because the standing-wave ratio on the feedline is usually high.

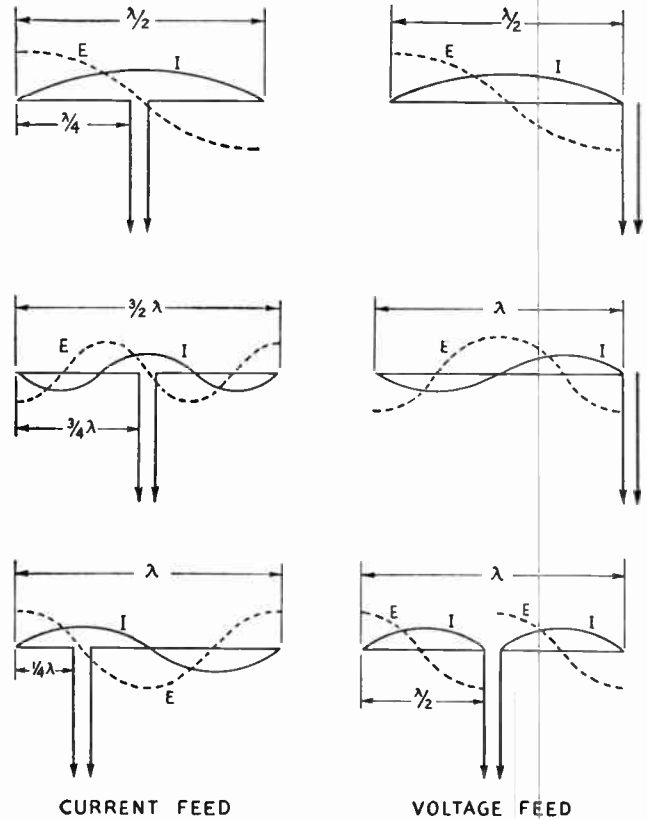

Figure 10-23. Current and Voltage Feed in Antennas Operated at One, Two, and Three Times Fundamental Frequency

Impedance conditions at the transmitter (input) end of the feedline will vary considerably with frequency, since its termination is not matched. The impedance presented to the transmitter depends on the terminating impedance and the feedline length. It is common practice to cut the line to a length where it will be a multiple of a quarter-wave at the operating frequency, so either a voltage or a current loop will occur near the input end. This is assuming that the antenna is resonant at the harmonic frequency and that it is being fed at either a voltage or current loop. The impedance at the transmitter end will then be essentially resistive, and its value will be above or below that of the line characteristic impedance

depending upon whether the loop at the input end is voltage or current, respectively.

It is usually more practical to compensate for the unmatched condition by employing an adjustable coupling network at the transmitter end of the line than by varying the line length for a given coupling coil. The coupling networks shown in figure 10-24 are frequently employed. When a voltage loop appears at the input end ( $Z_{in} > Z_0$ ), the parallel-tuned coupler of figure 10-24a is used; when a current loop appears ( $Z_{in} < Z_0$ ), the series-tuned coupler of figure 10-24b is used.

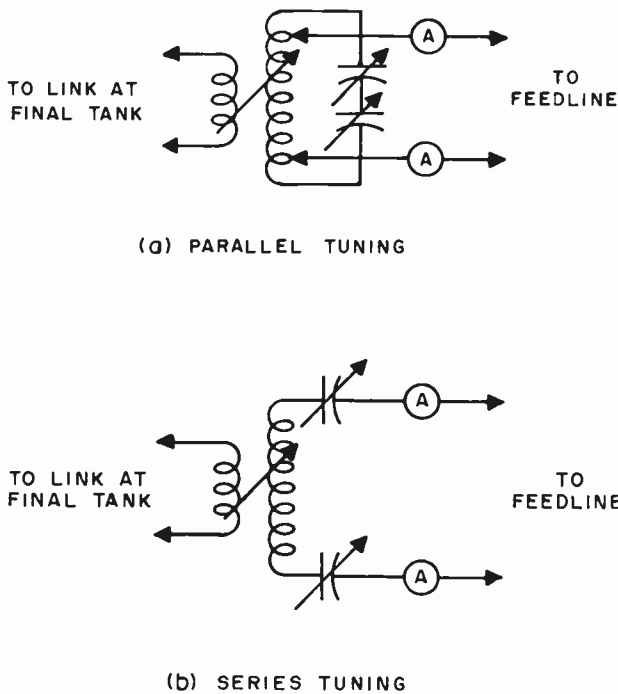

Figure 10-24. Coupling Networks for Resonant Feedlines

Since the swr is usually high when the tuned-line method of feeding is used, the line is subject to more losses and lower power limitations. Therefore, when the antenna is operated at only one frequency, there is generally no point in using this method.

**c. NONRESONANT LINE FEEDING**

Unlike the resonant line method of coupling power to the antenna, the use of the nonresonant or untuned line imposes the restriction that the line be operated with a low standing-wave ratio. Except in a few special cases, the system characteristics are such that some impedance matching and/or balancing techniques are required. This method of antenna

coupling is highly efficient and is by far the one most commonly used in modern communication systems.

It is important to note that before an attempt is made to match the antenna to the feedline, the antenna itself should be made resonant so that a resistive load will appear at the end of the line. An over-all matched system will then be less difficult to achieve, particularly in systems employing antennas with high Q. Furthermore, for a less frequency sensitive and more efficient system, the impedance matching should be performed as near to the load as practical.

In the case where the input impedance of a given antenna matches the characteristic impedance of a practical transmission line, no problem of coupling exists provided the transmitter and the radiator are both designed for the same condition of balance or unbalance. If either operates unbalanced while the other operates balanced, one of the balanced-to-unbalanced techniques (with a 1:1 impedance transfer) previously described should be incorporated in the feed system. Since this condition is not one of actual impedance correction, the position of the balun in the feedline is not important.

With untuned line feeding, where the swr on the line is low, there is no particular problem in coupling the line to the transmitter. The feedline can be matched to the final tank with various simple coupling schemes, examples of which are illustrated in figure 10-25.

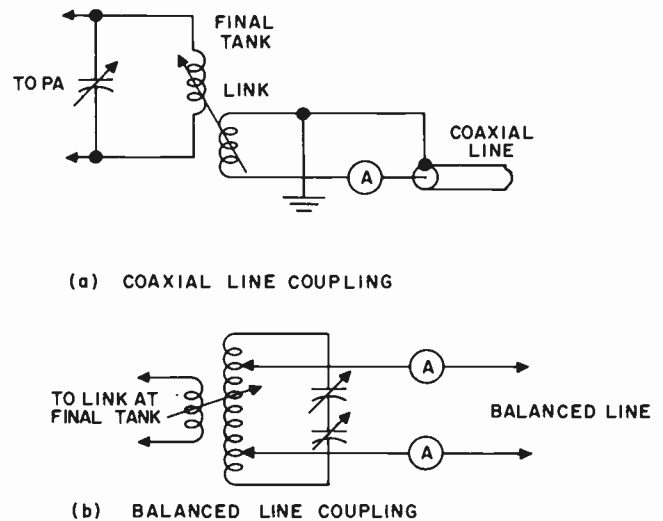

Figure 10-25. Coupling to Nonresonant Balanced and Unbalanced Lines

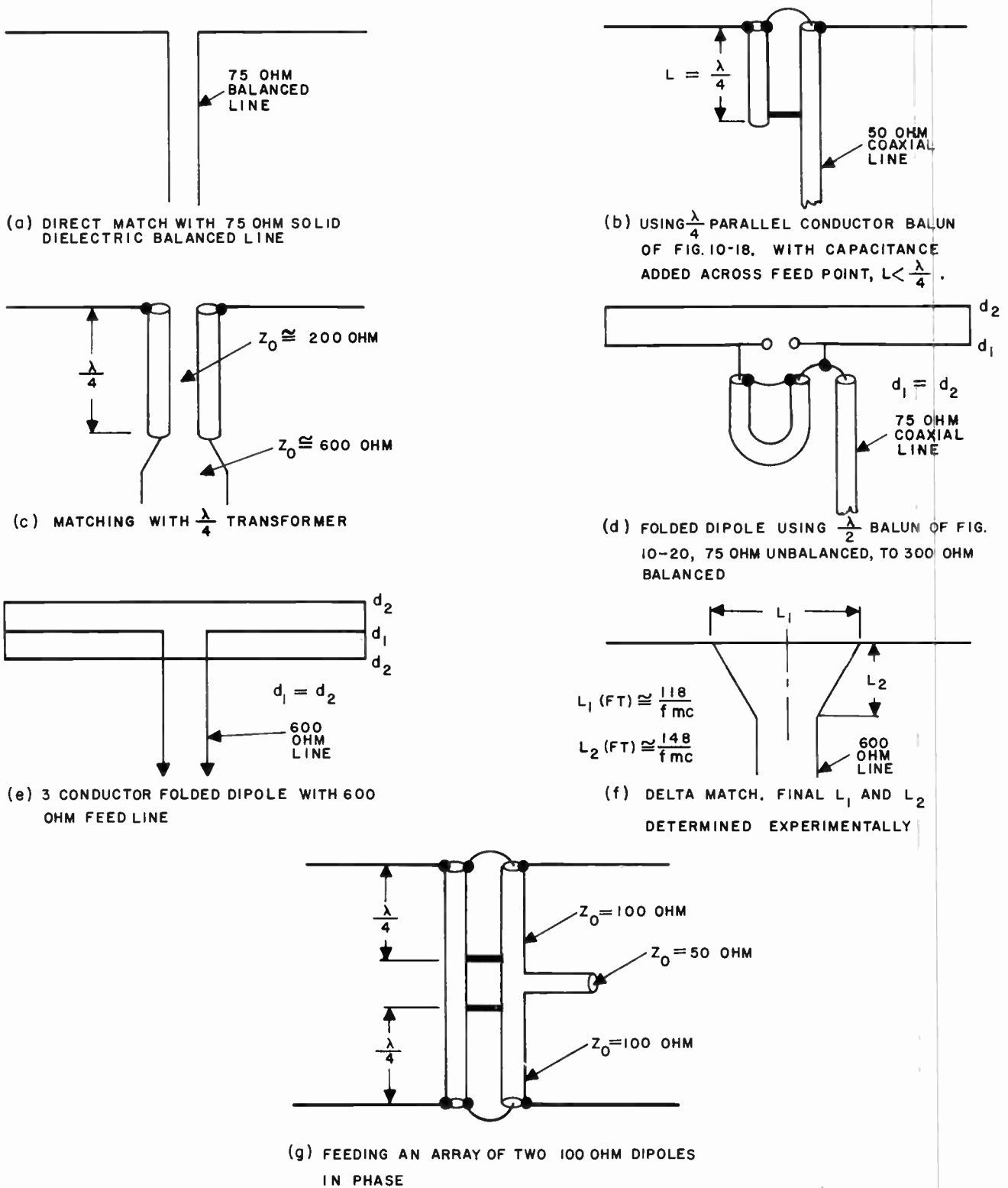
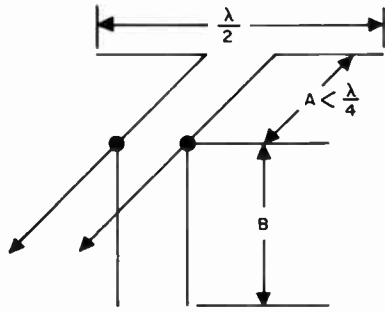
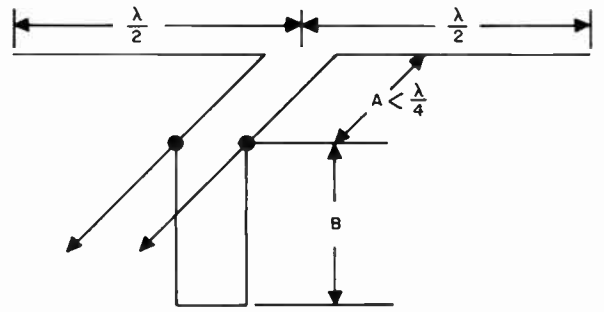

Figure 10-26. Typical Coupling to Center-Fed Half-Wave Dipoles





(a) CENTER-FED HALF-WAVE



(b) CENTER-FED FULL-WAVE

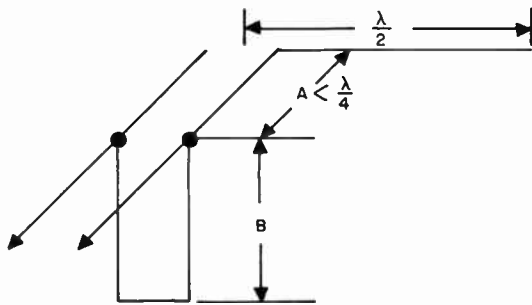

(c) END-FED HALF-WAVE

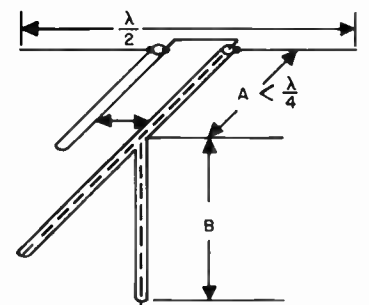

(d) CENTER-FED HALF-WAVE WITH COAXIAL LINE AND STUB

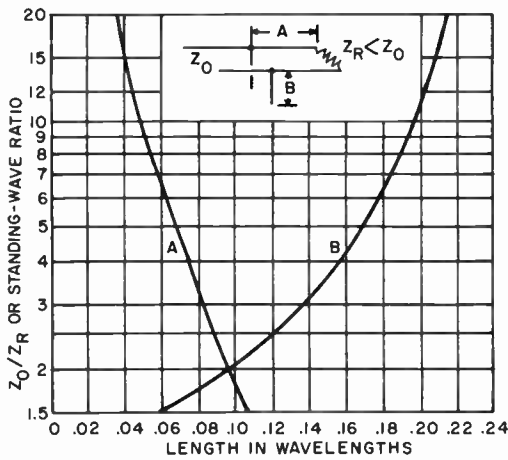

SWR FOR VARIOUS OPEN STUB LENGTHS AND POSITIONS AS A FUNCTION OF  $Z_0/Z_R$  OR STANDING WAVE RATIO.

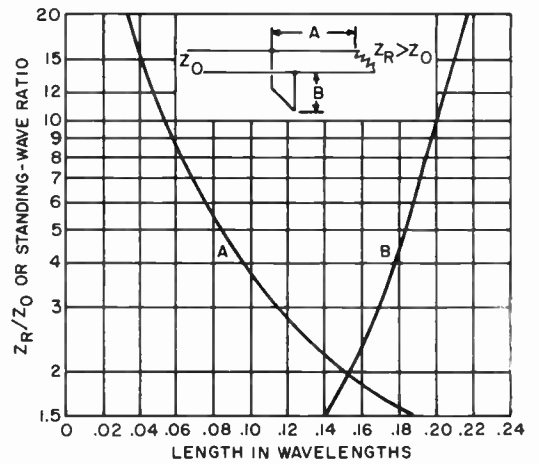

SWR FOR VARIOUS CLOSED STUB LENGTHS AND POSITIONS AS A FUNCTION OF  $Z_R/Z_0$  OR STANDING WAVE RATIO.

Figure 10-27. Typical Applications of Matching Stubs. The curves shown apply only if the characteristic impedance of the line and the stub are the same and the load is resistive. When applicable, modify lengths of A and B by the appropriate velocity factor. Where coaxial lines are used, the same principles apply. 10-15

The following illustrations (figures 10-26, 10-27, and 10-28) are typical applications of some of the antenna-to-line coupling methods and matching techniques previously described.

**7. MEASUREMENTS**

Although there are a number of measurements that can be made during the adjustment or evaluation of a complex antenna system, the following discussion will be limited to measurements of impedance and directivity. These two measurements are generally the most important and usually will adequately describe the operating characteristics of the antenna system.

Probably the most common method of measuring the actual impedance of the antenna or the impedance at some point on the transmission line is by the use of an r-f impedance or admittance bridge. The information obtained from bridge measurements often requires a great deal of data reduction before the desired information is obtained. However, when the resistive and reactive components of impedance are required,

particularly in coaxial feed systems, the bridge is an essential item.

In feed systems employing open wire lines, it becomes practical to locate the nodes and loops of the standing waves on the line and to measure their relative magnitude. When both null position and swr is known, the resistive and reactive components of a complex impedance may be determined. The swr can be obtained more directly by this method, but to determine the actual impedance, the amount of data reduction required is comparable to that when using a bridge. Since this method locates the loops and nodes of the standing waves, it is very useful when applying impedance-matching stubs. The standing waves are generally investigated with a voltage or current indicator which has adequate sensitivity and does not disturb the normal operation of the line.

When only the swr is required, a directional coupler device which responds to power in only one direction is frequently used. The incident power and the reflected power can then be measured and related to the swr by

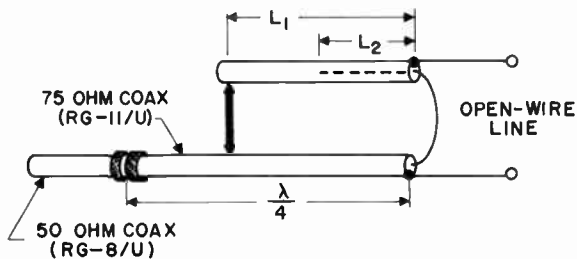

(a) BALUN AND Z TRANSFORMER FOR MATCHING 50 OHM UNBALANCED LINE TO OPEN-WIRE LINE, USING  $\frac{\lambda}{4}$  TRANSFORMER OF  $Z_0 = 75$  OHMS AND Z STEP-UP BALUN OF FIG 10-19. WHERE  $L_1$  AND  $L_2 \ll \frac{\lambda}{4}$ , CURVES OF FIG 10-13 MAY BE USED. A GIVEN OUTPUT IMPEDANCE IN THE RANGE OF ABOUT 250-550 OHMS MAY BE MATCHED WITH PROPER COMBINATION OF  $L_1$  AND  $L_2$ .

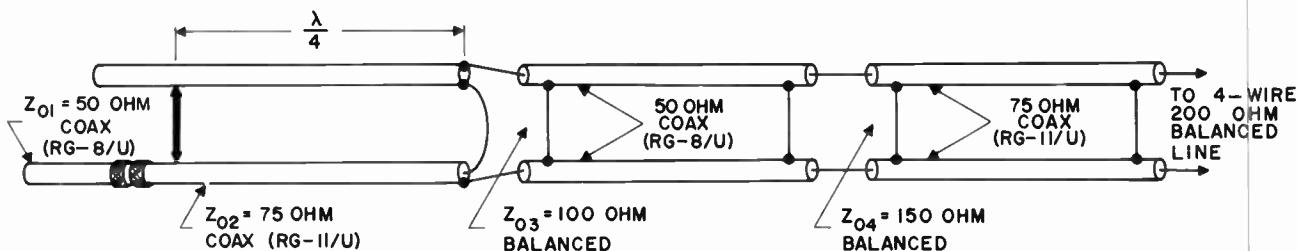

(b) BROADBAND Z TAPERED TRANSFORMER FOR MATCHING 50 OHM UNBALANCED TO 200 OHM BALANCED.

Figure 10-28. Typical Applications of Practical Transmission Lines for Impedance Matching

$$\text{swr} = \rho = \sqrt{\frac{\frac{P_i}{P_r} + 1}{\frac{P_i}{P_r} - 1}}$$

where  $P_i$  = Incident or forward power

$P_r$  = Reflected power

For convenience, this relationship is plotted in figure 10-29 for typical values of power and swr.

An important factor to consider when making swr or impedance measurements is the effect of line attenuation on the actual swr. On a lossy line, the measured swr is less than the actual swr. The degree of error introduced is dependent on the amount of line attenuation and the amount of mismatch at the point of interest. Refer to the swr correction curves of figure 10-30, and apply the correction to the apparent swr when necessary. The attenuation of some typical coaxial transmission lines is shown in figure 10-31.

The measurement of the directional properties of a high-frequency antenna usually presents a more complex problem than that of measuring its impedance. This is especially true when the antenna under test is a fixed installation.

In order that the directional characteristics of a given antenna be completely known, the relative field intensity must be measured in at least the two principal planes (azimuth and elevation). This requires that

in both planes field strength measurements be taken at sufficient increments around paths of constant range from the antenna. In most cases where the test antenna is fixed, these measurements are taken in flight with a properly equipped aircraft and experienced personnel. It is apparent that measurements requiring this technique can be involved and costly.

If the antenna under test can be rotated, pattern measurements, at least in the azimuth plane, are less difficult. With a pick-up antenna and a field strength meter located at a fixed remote point, the test antenna may be rotated through 360° in the azimuth plane and its relative field strength recorded. When its vertical directivity is required, a problem similar to that of the fixed installation exists. Because of the effect of ground on vertical directivity, vertical plane patterns derived from azimuth plane rotation would be under free-space conditions and would not be representative of the actual antenna. In a case like this, however, if the free-space vertical pattern is known, a theoretical ground factor may be applied which will modify the measured pattern. If actual ground conditions are known, the corrected pattern will be representative of the antenna under actual conditions.

In the development of high-frequency antennas large in dimension, the engineer will most often use scale model techniques. The antenna is scaled down to a size that is practical to rotate for determining pattern characteristics. The frequency is scaled up by the same factor. Scale model techniques are also applicable to investigation of impedance.

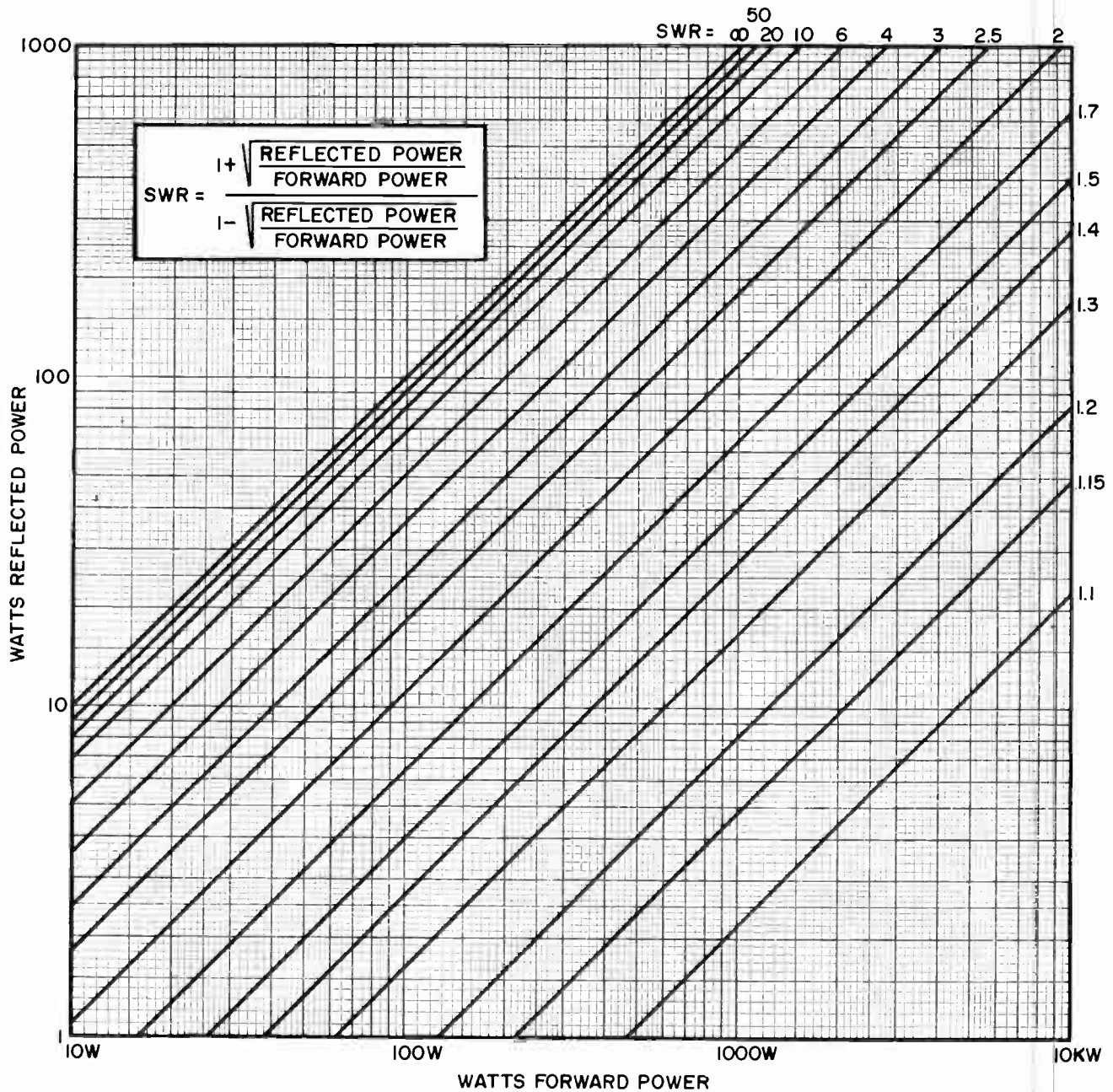
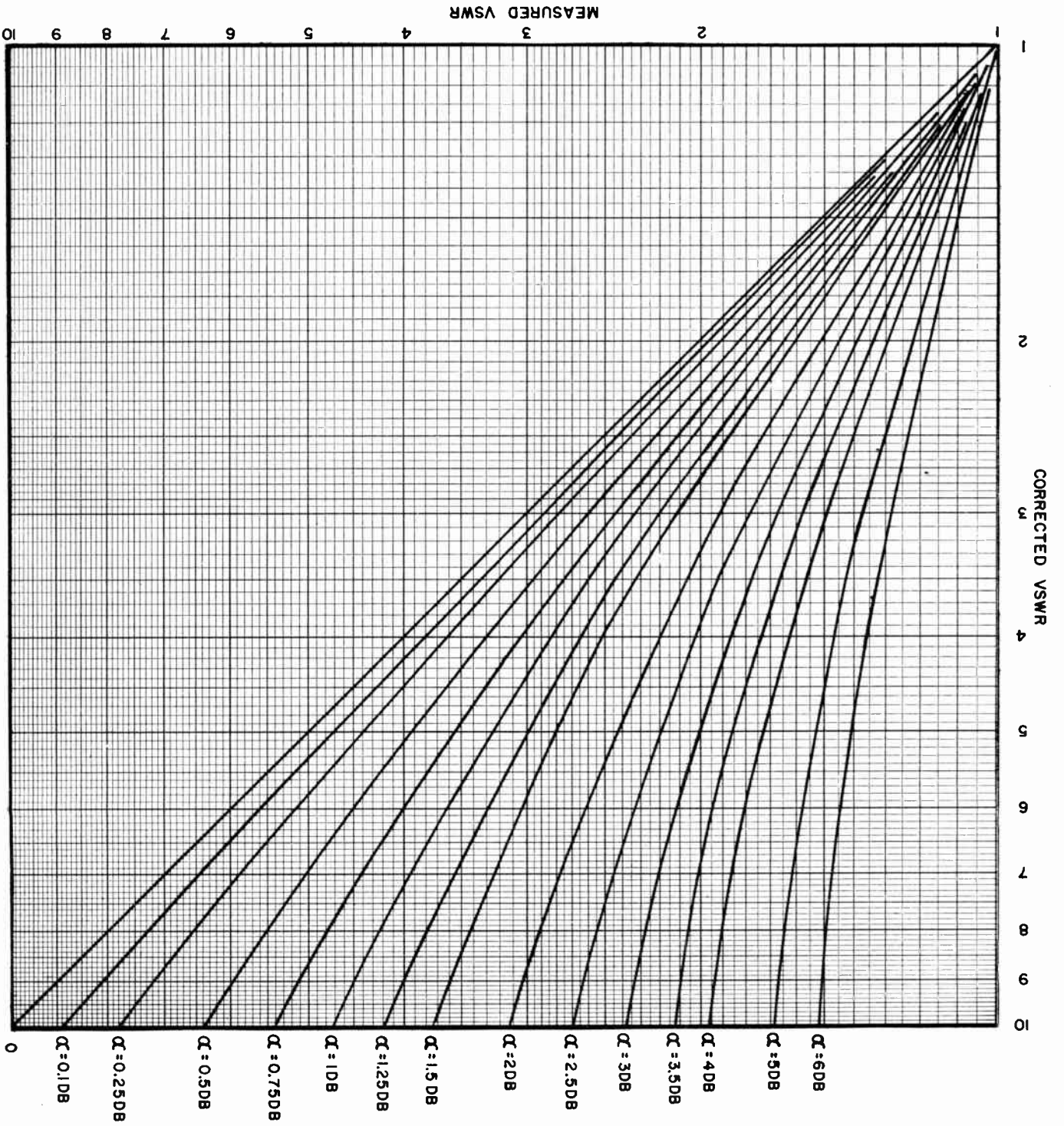

Figure 10-29. Relationship of SWR to Incident and Reflected Power



Figure 10-30. VSWR Correction Curves for Attenuation on Transmission Line





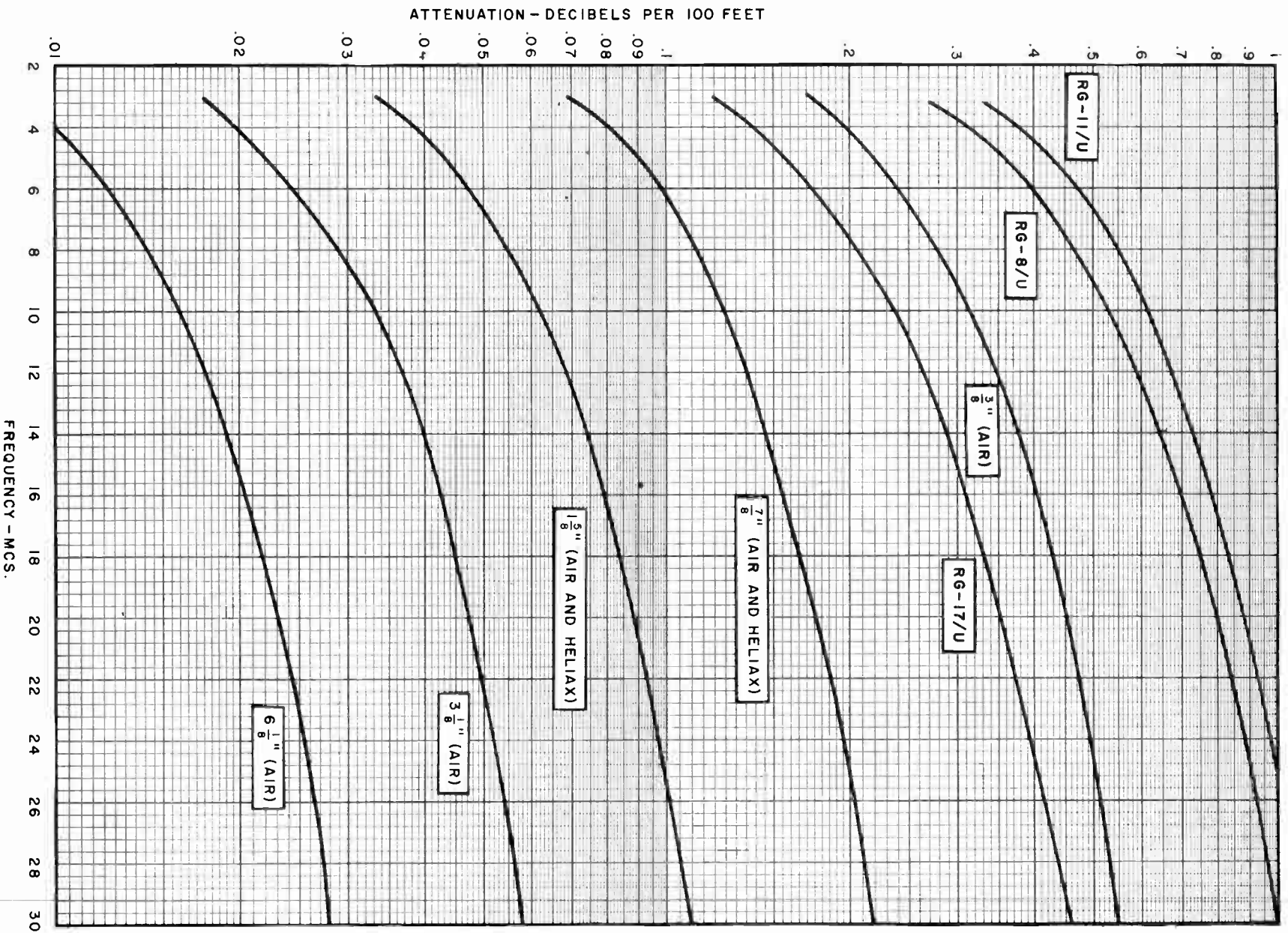

Figure 10-31. Attenuation Data for Common Types of Coaxial Transmission Lines

## CHAPTER 11

# RADIO WAVE PROPAGATION

### 1. INTRODUCTION

The science of radio wave propagation begins when the waves leave the radio transmitter antenna and ends when the waves enter the receiver antenna. A single chapter of a book cannot begin to cover a field as large as this science encompasses, and no attempt is made to do so. Sufficient information is provided in this chapter to familiarize the reader with radio wave propagation to the extent that he will be able to solve practical propagation problems. This chapter includes brief explanations of how sky wave transmission takes place, how the ionosphere is formed and its composition, ionospheric absorption of sky wave field intensity, noise limitations, and effects of different types of service. A practical problem is included to illustrate how the feasibility of a good communication link between two points is determined. This problem includes not only the feasibility of sky wave communication but also the feasibility of ground wave communication. The results of such a study provide information which can be used to improve the communication link, such as the lowest useful high frequency (LUHF) which can be employed and the lowest effective radiated power which can be used. The illustrative problem used is based on a vertically polarized wave, such as is propagated from a whip or vertical antenna, and is over a path length less than 2000 kilometers. No attempt is made here to investigate communication links greater than 2000 kilometers.

### 2. FORMATION OF THE IONOSPHERE

When an electromagnetic wave impinges on an atom, it is capable of moving an electron from an inner orbit to an outer orbit. When this occurs, the electron has absorbed energy from the wave. If the frequency of this incident wave is sufficiently high, such as in ultraviolet waves, an electron may be knocked completely out of an atom. When this occurs, a positively charged atom, called a positive ion, remains in space along with the negatively charged, free electron. The rate of ion and free-electron formation depends upon the density of the atmosphere and the intensity of the ultraviolet wave. However, as the ultraviolet wave produces positive ions and free electrons, its intensity diminishes. Therefore, the ionized region will tend to form in a layer, forming few positive ions and free electrons due to the less dense atmosphere when the ultraviolet wave is most intense, forming more positive ions and free electrons due to the more dense

atmosphere when the ultraviolet wave is of moderate intensity, and again forming few positive ions and free electrons due to the low intensity of the ultraviolet wave in the most dense atmosphere. This relationship between ultraviolet wave intensity, rate of ionization, and atmospheric density is shown in figure 11-1.

The formation of positive ions and free electrons is not, in itself, sufficient information to account for the existence of an ionic layer, because the positive ions and free electrons tend to recombine due to the inherent attraction of their unlike charges. The recombination rate is directly related to the molecular density of the atmosphere, because the more dense the atmosphere the smaller is the mean free path of the free electrons. The recombination rate is also directly related to the density of positive ions and free electrons. Therefore, as the ultraviolet waves continue to produce positive ions and free electrons, a free electron density will be reached where the recombination rate just equals the rate of formation. In this state of equilibrium, a free electron density exists for every set of given conditions, although any particular electron may be free for only a short time.

That more than one ionic layer exists is explained by the existence of different ultraviolet wave frequencies. The lower frequency ultraviolet waves tend to produce a higher altitude ionic layer, expending all of their energy at the high altitude. On the other hand, the higher frequency ultraviolet waves tend to penetrate deeper into the atmosphere before producing appreciable ionization. In addition to the ultraviolet waves from the sun, particle radiation caused by thermonuclear explosions on the sun, cosmic rays, and meteors produce ionization of the earth's atmosphere, particularly in a higher altitude layer.

### 3. IONOSPHERIC ABSORPTION

For sky wave transmission, the transmitted electromagnetic wave must travel through the ionic layers. To do so, the incident wave interchanges energy with free electrons and ions. If this interchange of energy is completely reciprocating, the wave will emerge from an ionic layer with no loss of energy. On the other hand, if an ion or free electron collides with a neutral atom or recombines with its opposite, any energy the ion or electron may have received from the incident wave is given up and lost. Energy from the sky wave which is lost in this manner is said to be

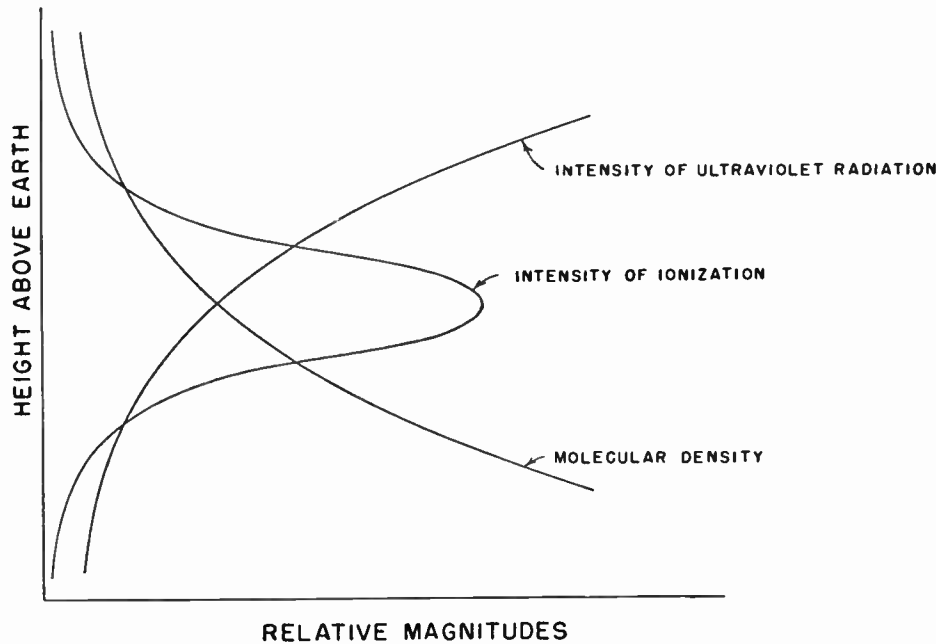

Figure 11-1. Formation of an Ionized Layer by a Single-Frequency Ultraviolet Wave

absorbed. This ionospheric absorption is greatest in the lower ionic layers because these layers exist in a denser atmosphere where the collision frequency is highest. Ionospheric absorption is discussed in greater detail in paragraph 6b. of this chapter.

#### 4. STRUCTURE OF THE IONOSPHERE

One of the most useful techniques for exploring the ionosphere is to transmit r-f pulses vertically into the atmosphere and to receive the reflected pulse. The echo time is indicative of the height of the ionospheric layer, and the received magnitude of the pulse is indicative of the thickness of the ionospheric layer. When pulses of various r-f frequencies are transmitted, a critical frequency  $f_o$  can be determined, above which the vertical sky wave will not be reflected back to the earth. This critical frequency is indicative of the extent of ionization of the layer, with a higher critical frequency indicating greater ionization. These vertical soundings indicate that there are four distinct ionic layers as shown in figure 11-2. They are as follows:

**D REGION** -- This region is not always present, but when it does exist, it exists only in the daytime and is between 50 and 90 km above the earth, being the lowest of the four layers. This region is so highly ionized, and the collision frequency is so great that little or no sky

wave reflection is obtained from it; the sky wave usually is totally absorbed.

**E LAYER** -- This layer exists only during daylight hours at a height between 90 and 140 km above the earth. This layer depends solely upon ultraviolet radiation from the sun, and it exists in an atmosphere where the ion-electron recombination rate is high. Since the E layer depends directly upon the sun, it is most dense directly under the sun. Seasonal variations occur in this layer because the sun's zenith angle varies to produce the seasons. Since the E layer exists in an atmosphere where the recombination rate is high, all of the ions and free electrons recombine shortly after sunset, and the layer disappears. Because E layer density follows the sun, points of equal latitude have the same E layer conditions at the same local time.

**F<sub>1</sub> LAYER** -- The F<sub>1</sub> layer exists at a height between 140 and 250 km above the earth during daylight hours. This layer behaves like the E layer during daylight; that is, it follows the sun. When the sun sets, the F<sub>1</sub> layer rises to merge with the next higher ionic layer, the F<sub>2</sub> layer.



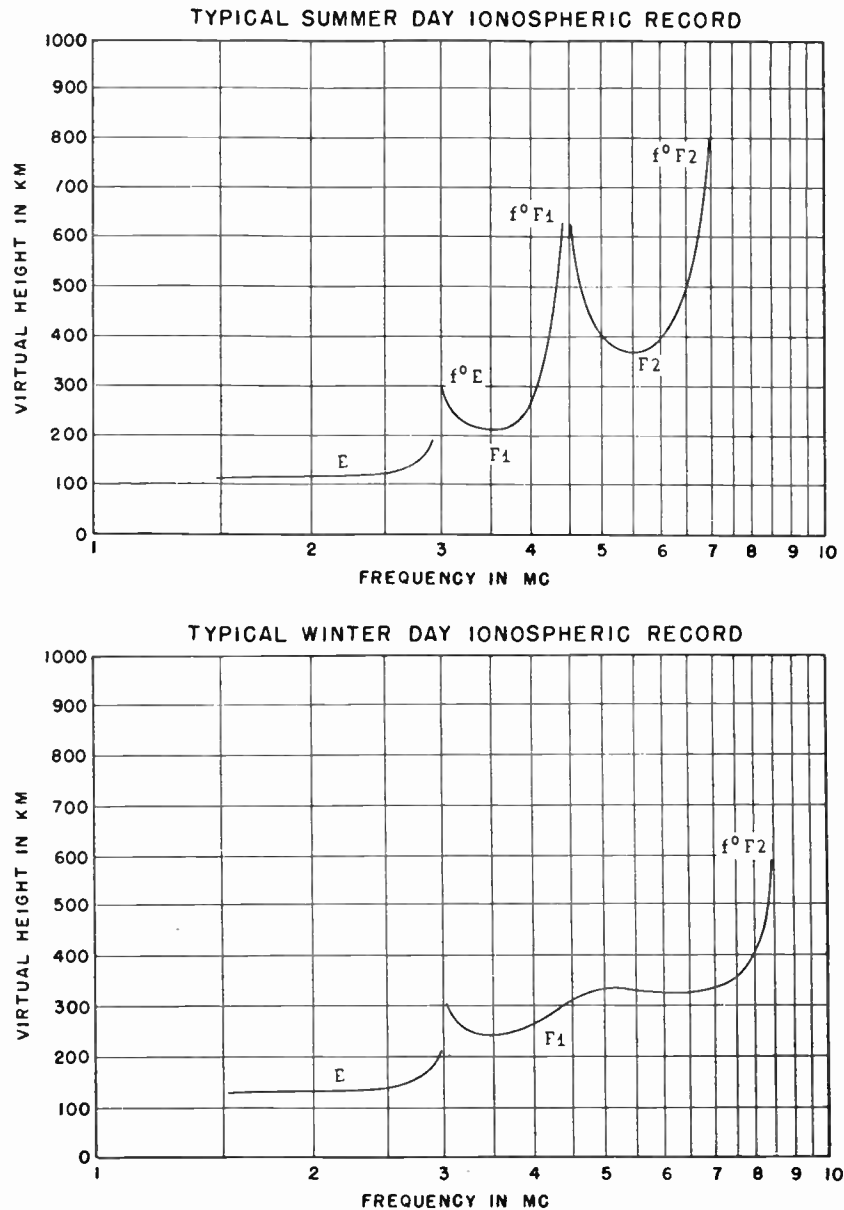
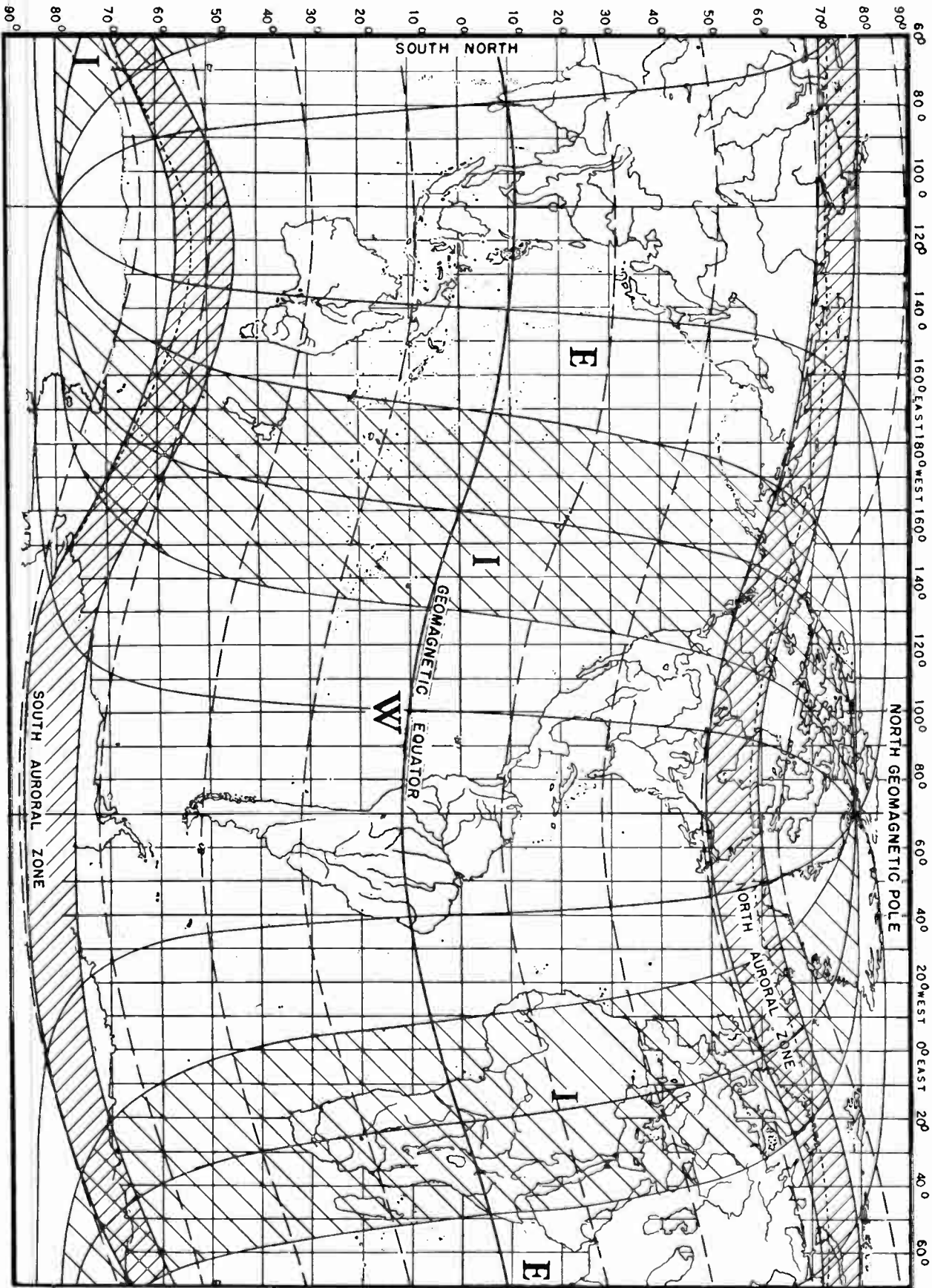

Figure 11-2. Typical Ionospheric Record

**F<sub>2</sub> LAYER** -- The F<sub>2</sub> layer is the highest and most useful ionic layer for sky wave transmission because it exists during the night as well as during the day. This layer is between 150 and 250 km above the earth during the night for all seasons of the year. During the day in the summer it is between 250 and 300 km high, and during the day in the winter it is between 150 and 300 km high. This variation in height is accounted for by the effect of solar heat on the layer which increases its height and decreases its ion density during the summer. The reduction of solar heat in the late afternoon causes the layer to descend. No complete explanation has been made for the existence of the F<sub>2</sub> layer, but it is known that it is considerably affected by particle radiation from the sun, which is evidenced by the strong

influence that the earth's magnetic field has on the distribution of the F<sub>2</sub> layer. The effect of the earth's magnetic field results in the greatest ion density, and the highest critical frequency, in a region about 20° from the magnetic poles, rather than directly under the sun as in the case of the D and E layers. Since the earth's magnetic field is not evenly distributed, longitudinal variations exist in the F<sub>2</sub> layer for points of equal latitude at the same local time. For this reason, the earth is divided into zones which represent different degrees of magnetic intensity to facilitate plotting F<sub>2</sub> layer distribution. These three zones are called the East, West, and Intermediate zones (abbreviated E, W, and I) as shown on the world map, figure 11-3. Monthly predictions of F<sub>2</sub> layer distribution are then made by the Bureau of Standards for each of the three zones.



11-4 Figure 11-3. Geomagnetic Co-ordinates as Related to East, West, Intermediate, and Auroral Zone



## 5. NATURAL PHENOMENA WHICH AFFECT IONIC LAYERS

### a. SUNSPOTS

The sun is the major, if not the only, source of energy which produces ionization of the earth's atmosphere. Therefore, any solar disturbance produces variations in the ionic layers. Sunspots are evidence of such solar disturbance which affects the ionic layers. These sunspots appear as dark patches surrounded by a hazy grey edge and are presumably vortexes of enormous gas clouds. These gaseous clouds produce vast amounts of ultraviolet energy which affects the ionization of the earth's atmosphere. Therefore, the greater the number of sunspots, the greater the ultraviolet radiations and the greater the ionization. For this reason, the number of sunspots is indicative of ion density which, in turn, is a measure of the probability of sky wave communication. Sunspot activity is measured by the Wolf sunspot number method which takes into account not only the number of actual sunspots but also the number of sunspot groups. Observations of solar activity over the past 100 years have confirmed that sunspot activity is cyclic, the cycle repeating every 11.1 years. There are variations within this cycle and variations from cycle to cycle which make it necessary to know the predicted sunspot number for a given time in order to determine the probability of sky wave communication.

### b. SUDDEN IONOSPHERIC DISTURBANCES

Occasionally daytime communication by high-frequency sky wave propagation is rendered impossible by abnormally great absorption. The onset of this condition is usually very sudden with recovery being more gradual, and the condition may last from a few minutes to several hours. This condition is known by several names, the most common being sudden ionospheric disturbance, abbreviated SID. This condition is also known as solar flare disturbance and Dellinger fade. An SID is apparently the result of a chromospheric eruption on the sun as evidenced by ionospheric absorption immediately following an eruption, by the absorption taking place in the lower ionic layers where the ion density is directly related to the sun, and by its occurrence only in the daytime. The result of an SID is a sudden increase in the ion density of the highly absorptive D region, as well as an increase in the ion density of the moderately absorptive E layer.

### c. MAGNETIC STORMS

Magnetic storms are not to be confused with sudden ionospheric disturbances, although they both have the same effect in that they reduce the probability of communication by sky wave propagation. The magnetic

storm is associated with solar activity, being more likely to occur during maximum sunspot conditions, and reoccurring in 27-day cycles, the rotation period of the sun. Magnetic storms are apparently caused by particle radiation from the sun, with the radiated particles being deflected by the earth's magnetic field. For this reason, the effects of a magnetic storm are most severe in the two geomagnetic pole regions. The origin of a magnetic storm may be the same solar eruption which produces an SID, but since particle radiation is much slower than ultraviolet radiation, the effect of the magnetic storm is not noticed until 18 to 36 hours after an SID. A magnetic storm has two phases with the first phase expanding the F<sub>2</sub> layer which reduces ion density. During this phase, the F<sub>2</sub> layer critical frequency becomes lower than normal due to the reduced ion density. The second phase is marked by a greater concentration of electrons in the highly absorptive D and E regions, especially in the geomagnetic polar regions. The increased absorption which results may prevent communication by sky wave propagation. A magnetic storm may last for several days, with its appearance being very sudden and recovery to normal very slow.

### d. SPORADIC E LAYER

A sporadic E layer, abbreviated E<sub>s</sub>, can not be accounted for by the processes which explain the normal E layer which exists at approximately the same height above the earth. Some investigators of this phenomenon believe it to be caused by particle radiation, possibly as a result of meteors entering the earth's atmosphere. The E<sub>s</sub> layer can exist during both the day and the night, but its presence during the day is difficult to detect due to the presence of the normal E layer. The distribution of this layer cannot be predicted, but it is known to vary in thickness and ion density and is frequently patchy. It is also known that the likelihood of the existence of a sporadic E layer increases with distance from the equator. Its occurrence is frequent enough in the middle latitudes to render E<sub>s</sub> sky wave propagation from 25 to 50 per cent of the time at frequencies up to 15 mc.

## 6. SKY WAVE TRANSMISSION

### a. SKY WAVE REFLECTION

When sky wave propagation is used for communication, the electromagnetic wave from the antenna is transmitted toward an ionic layer at an oblique angle. The incident wave then is apparently reflected, at the same oblique angle, from the ionic layer back toward the receiving antenna. Figure 11-4 shows sky wave propagation paths which can be used. Actually the wave is not reflected, although this term is commonly used for convenience; the wave is bent back toward the earth by refraction, just as a prism refracts light.

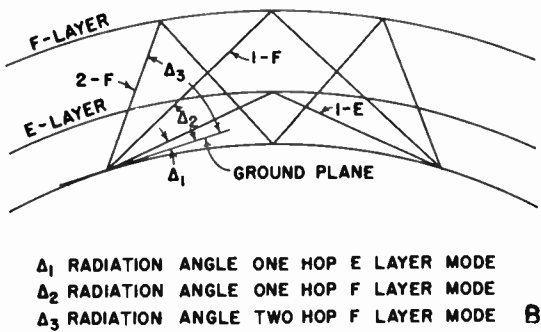
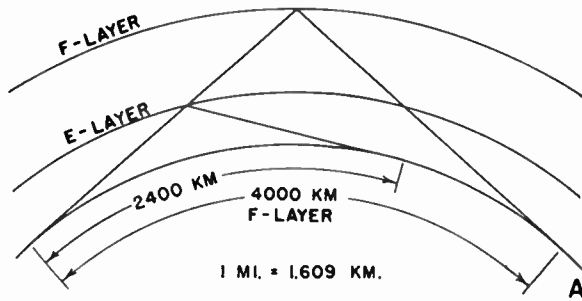

Figure 11-4. Distance Limitations for Single Reflection Transmission (A) and Modes of Transmission (B)

This bending process is a function of the refractive index of the ionic layer and behaves in accordance with Snell's law, which was originally discovered in connection with optical geometry. Roughly stated in terms of ionospheric refraction of a radio wave, this law is as follows: For a wave incident upon a densely ionized layer to be bent back toward the earth, the wave must pass from a medium with a high refractive index to a medium of low refractive index. Stated in mathematical terms, Snell's law is as follows:

$$\cos \Delta = \mu \cos \Theta \quad (1)$$

where  $\Delta$  and  $\Theta$  are the angles as shown in figure 11-5

the refractive index

$$\mu = \frac{\text{wave velocity in free space}}{\text{phase velocity in the ionized medium}}$$

The wave velocity in free space is the speed of light, and this velocity generally is assumed for a normal atmosphere. The phase velocity in the ionized medium is greater than the speed of light and increases with increased ion density. That the phase velocity in an ionized medium is greater than the speed of light does

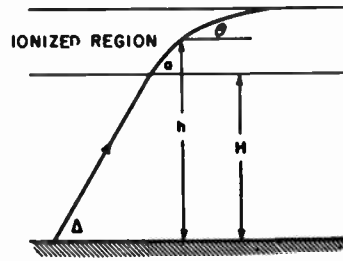

Figure 11-5. Refraction of a Radio Wave

not contradict the theory of relativity since phase velocity is defined as frequency times wave length. That the phase velocity can be greater than the speed of light then indicates an increase in wave length of a constant frequency being propagated in an ionized medium, not an increase in the velocity of propagation.

Carrying the laws of optics further, the relationship for total reflection between two media having different refractive indexes is given by the following equation:

$$\cos \Delta = \frac{\mu_{ion}}{\mu_{air}}$$

Where the refractive index of the atmosphere is taken as unity, the equation for ionospheric reflection is:

$$\cos \Delta = \mu_{ion} \quad (2)$$

If the wave is transmitted vertically,  $\Delta$  equals  $90^\circ$  and  $\cos \Delta$  equals 0. For the wave to be reflected under this condition, the refractive index of the ionosphere must then equal 0.

It can be shown that the refractive index of the ionosphere is a function of the ion density and of the frequency of the transmitted wave. This relationship is given by the following equation:

$$\mu = \sqrt{1 - 80.5N/f^2}$$

where N is the number of electrons per cubic meter

By substituting 0 for the refractive index, the condition where a vertically transmitted wave will be reflected, the critical frequency,  $f_0$ , is given by the following equation:

$$f_0 = \sqrt{80.5N}$$

A vertically transmitted frequency greater than this value will penetrate an ionosphere of density N while a

frequency less than this value will be reflected. We can then rewrite the equation for the refractive index in terms of the critical frequency as follows:

$$\mu = \sqrt{1 - \frac{f_0^2}{f^2}} \quad (3)$$

By substituting in equation (2), the following equation is obtained:

$$\cos \Delta = \sqrt{1 - f_0^2/f^2}$$

or by trigonometric transformation

$$f = f_0 \csc \Delta \quad (4)$$

The significance of the study of vertical incidence to the problems of radio propagation is apparent from the above equation. If the critical frequency,  $f_0$ , for the ionosphere over a certain point is known, the frequency,  $f$ , which will just be reflected by the ionosphere over that point can be calculated. This is the maximum usable frequency MUF for the vertical radiation angle  $\Delta$ . Frequencies above the MUF will penetrate the ionosphere; frequencies below the MUF will be reflected.

Equation (4) is derived on the assumption that both the earth and the ionosphere are parallel planes; this is not the case. However, the equation for a curved earth and curved ionosphere is of the same nature, although a little more complex. This relationship is as follows:

$$f = f_0 k \sec \phi \quad (5)$$

where  $\phi$  is the angle shown in figure 11-6

$k \sec \phi$  is referred to as the corrected secant with the value of  $k$  being determined experimentally.

From the above relationship and a vast amount of practical experience, the MUF can be determined for any distance, geographic location, sunspot number, time of day, etc. These predictions are published by the Bureau of Standards three months in advance.

**b. SKY WAVE ABSORPTION**

As stated in paragraph 3 of this chapter, a radio wave entering an ionic layer interchanges energy with the free electrons and ions. If the ions do not collide with gas molecules or other ions, all of the energy transferred to the ionosphere is reconverted back into electromagnetic energy, and the wave continues to be propagated with undiminished intensity. On the other hand, where ions and electrons engage in collisions, they dissipate the energy which they have acquired

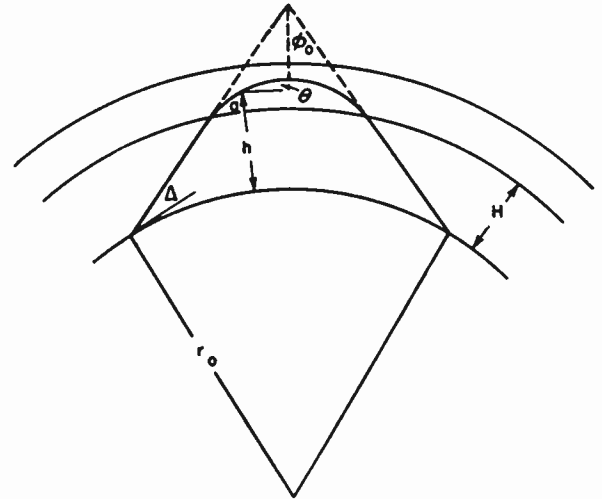

Figure 11-6. Ray Path for a Curved Earth and a Curved Ionosphere

from the wave which results in attenuation of the wave. This attenuation, or absorption, is proportional to the product of the number of ions  $N$  and the collision frequency  $f_c$ . Therefore, the attenuation is ordinarily greatest in the region where the product of ion density and the collision frequency is greatest. This absorption is great when the deviation due to refraction is small. Conversely the absorption is small when the deviation is large. For this reason, absorption due to ionic collision is called nondeviative absorption when the absorption is appreciable and deviative absorption when absorption is small.

Nondeviative absorption is very important in most radio propagation problems. It is primarily of importance in daylight transmissions because it is present predominantly in the D and E ionic regions where the ion density is great, and the collision frequency is high. Since nondeviative absorption is related to ion density in the D and E layers, the absorption is related to the number of sunspots and the season of the year. The absorption also is related to the radio wave path, the time of transmission, and the refractive index. The relationship of the transmission path, refractive index, and time of transmission is called the diurnal absorption factor  $K$ . Although a mathematical equation exists for computing  $K$ , the variables involved are so difficult to measure that using the equation for determining  $K$  is impractical, except in special cases. The diurnal absorption factor usually is obtained from absorption index charts, with a different chart being used for different months of the year. The empirical equation  $K = 0.142 + 0.858 \cos \psi$ , where  $\psi$  is the sun's zenith angle, is fairly accurate for times near sunrise and sunset. A

residual seasonal variation factor M, beyond that involved in the diurnal absorption factor, has been determined for each month of the year. The effect of the number of sunspots on absorption is called the solar activity factor S. This value is obtained from a graph relating the predicted sunspot number, SSN, with solar activity factor. From these three factors, K, M, and S, the corrected nondeviative absorption is determined by the following equation:

$$\text{Corrected K} = K \times M \times S$$

Auroral absorption  $K_a$  must also be considered when the transmission path travels through an auroral zone. The auroral zones are the zones of highest magnetic activity which are centered about 20° from the earth's magnetic poles. The auroral absorption index has been determined and plotted for these regions. Where an auroral absorption factor exists, it should be added to the corrected diurnal absorption factor to obtain the total absorption.

A third type of absorption, due to the earth's magnetic field, also contributes toward absorption of radio waves, but this absorption usually can be neglected. When an electromagnetic wave is propagated in the ionosphere, the wave is resolved into circularly polarized components which impart motion to the electrons and ions. When the propagated wave is in the direction of the earth's magnetic field, the magnetic field causes these electrons to rotate at a gyromagnetic frequency in a plane perpendicular to the direction of the wave. When the wave and field produce rotations in the same direction, the electrons rotate in larger orbits. This, in turn, produces more electron collisions with a consequential loss of energy and an increase in absorption. Similarly, if the wave and field produce rotations in opposite directions, the electrons rotate in smaller orbits which reduces absorption.

**c. SKY WAVE FIELD INTENSITY**

**(1) GENERAL**

To have effective radio communication, the received signal strength must be sufficient to overcome the effects of various noises. To determine the median sky wave field intensity at the receiving station, it is necessary to know (1) the gain of the transmitting antenna and of the receiving antenna (2) the power output of the transmitter, (3) the transmission path, (4) the total absorption, and (5) the operating frequency.

**(2) OPERATING FREQUENCY**

The operating frequency is determined first. This is done best by using "Basic Radio Propagation Predictions" which are published monthly, three months in advance of their effective date by the Central

Radio Propagation Laboratory of the Bureau of Standards. Examples of these prediction charts are included in this chapter, and their use is discussed in the example problem which follows. From these prediction charts, the maximum usable frequency (MUF) and the frequency of optimum traffic (FOT) can be determined for any propagation path for any hour of the day. Transmission at the FOT is desirable because it reduces the possibility of propagating by more than one mode (i.e., 1-hop E, 1-hop F<sub>2</sub>, 2-hop F<sub>2</sub>), and atmospheric noise is usually less.

**(3) ANTENNA GAIN**

After determining the operating frequency, the next step is to determine the gain of the transmitting antenna. This gain depends on (1) the elevation angle of the radiated energy, (2) the length of the antenna, for a simple monopole, in terms of wave length, and (3) the type of ground in the vicinity of the antenna. The gain of the antenna is referred to a standard antenna, which may be an isotropic antenna, half-wave dipole in free space, or a short vertical element over perfectly conducting ground. The short vertical element is chosen as the reference in the problem which follows, and antenna gains are in terms of decibels above or below the gain of this short vertical element. The reference antenna provides a received field intensity of 186.3 mv/m at 1 mile with a 1 kw input, measured along the ground plane. The gain of the transmitting antenna is the square of the ratio of the field intensity of the actual antenna at 1 mile with 1 kw input divided by 186.3 mv/m. This gain, expressed in equation form, is as follows:

$$\text{Gain} = \left[ \frac{\text{Field intensity in mv/m at 1 mile produced in the required direction by the actual antenna with 1 kw of input power}}{186.3 \text{ mv/m}} \right]^2$$

Several graphs are included in this chapter which show the gain of whip antennas versus frequency for various radiation angles.

The receiving antenna characteristics are defined in terms of effective area and effective height. That is, a receiving antenna in an electromagnetic field of a given power density will yield input power to the receiver equal to the product of the power density and the area of the antenna. In equation form, the expression for this relationship is as follows:

$$P = P_d \times A \tag{6}$$

where P is power in watts,  
 $P_d$  is power density in  $w/m^2$ , and  
 A is effective area, and is equivalent to  $\frac{G\lambda^2}{4\pi}$  with G being the gain of the receiving antenna at the particular radiation angle.



Similarly, for vertical antennas the input voltage is given by the following relationship:

$$V = E \times h \tag{7}$$

where V is voltage in uv,

E is field intensity in uv/m, and

h is the effective height in meters

An expression similar to equation (6) may be written in terms of input voltage, and is as follows:

$$V^2 = \frac{E^2}{377} \times \frac{g_r Z_{in} \lambda^2}{4 \pi} \tag{8}$$

where E is field intensity in uv/m,

377 ohms is the impedance of free space,

$g_r$  is the gain of the receiving antenna at a particular radiation angle in dimensionless units,

$Z_{in}$  is the input impedance in ohms of the receiver, and

$\lambda$  is the wave length in meters.

Equation (8) can be rewritten in logarithmic form as follows:

$$V_{(db)} = 20 \log E + 10 \log Z_{in} + 20 \log \lambda + G_r - 38.8$$

where V is db > 1 uv

$G_r$  is gain in db of receiving antenna

Several graphs are included in this chapter showing antenna gain versus frequency of some typical vertical antennas.

(4) FADING

Due to variations in the ionosphere, the sky wave field intensity varies from minute to minute, day to day, month to month, and year to year which causes signal fading. To increase the reliability of communication, it is necessary to increase the median level of the system output to lessen the probability that the received field intensity will go below the level required for reception. The atmospheric noise level also is subject to variations so that a further increase in output is required to increase the probability that the received signal level is sufficient to overcome the noise. Curves of slow and rapid variations of sky wave field intensity and variations of atmospheric noise are included in this chapter. Reference to these curves indicates that for a 95 per cent reliable system it is necessary to increase the median level of the system output by 7.8 db to overcome slow variations

of sky wave field intensity, 11.3 db to overcome rapid variations of sky wave field intensity, and 13 db to overcome slow variations of atmospheric noise. Therefore, for communication 95 per cent of the time, it is necessary to increase the system output by a total of (7.8 + 11.3 + 13) db, a total of 32.1 db, above the level which will provide communication 50 per cent of the time.

Polarization fading and selective fading should also be considered in evaluating the probability of communication. Polarization fading is due primarily to a plane wave front being split into randomly polarized waves by the earth's magnetic field. With a linear receiving antenna, the received field intensity is attenuated by 3 db due to polarization fading. Selective fading is due primarily to two signal sources arriving from the same transmitting antenna via different paths. This is the result of ionospheric irregularities, propagation by more than one mode, or interference between the sky wave and the ground wave. The magnitude of the two received signals may be fairly close together but out of phase, so that one signal cancels the other. The received field intensity then fluctuates as the phase relationship varies between the different, incident component waves. The effects of selective fading can be reduced by diversity reception, where two or more antennas are used and so spaced that one antenna is not correlated to the received field intensity of another antenna. A diversity gain results from such a receiving system, but such a system is impractical on shipboard. See figure 11-14 for diversity gains.

(5) ABSORPTION

The total absorption factor, discussed in paragraph 6b of this chapter, must be determined in order to obtain the median incident sky wave field intensity. Graphs of median incident field intensity of the short-element, reference antenna versus frequency for various absorption factors, various modes of propagation, and various distances are included in this chapter. Where the absorption factor is zero, these curves indicate that there is no variation of median incident field intensity with frequency, so that the K = 0 curve is a straight horizontal line. The median incident field intensity then is an inverse function of the geometric length of the sky wave path plus a 3 db depolarization loss. For the reference antenna (which produces a field intensity of 300 mv/m at 1 km) and a 200 km communication link, the losses when K = 0 are represented by the loss in field strength due to traveling the additional 199 km plus 3 db. The geometric length of the sky wave path for a 200 km communication link with 1-hop E propagation is approximately 295 km. The sky wave path length is a function of the height of the ionic layer and is determined as shown in figure 11-7 for short transmission paths. For a two-hop path, 4 db attenuation must be added due to the ground reflection. The median



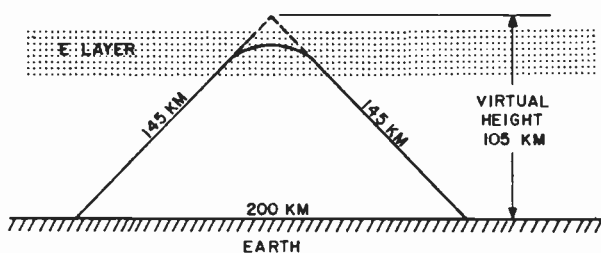

Figure 11-7. Geometric Length of 1-Hop E Layer Sky Wave Propagation Path; Length Equals 190 Km

incident sky wave field intensity curves included in this chapter are based on an E layer virtual height of 105 km and an F<sub>2</sub> layer virtual height of 320 km.

#### (6) NOISE

A satisfactory communication system exists only when the received signal level is sufficient to override the noise level at the output of the receiving system. This implies that there is a minimum required field intensity for satisfactory communication. This minimum required field intensity is dependent upon the receiving antenna, the receiver bandwidth, the quality of the service required, the type of modulation, the noise produced within the receiver, and the level of noise at the receiving location. The noise which must be overcome by the field intensity is of two types, random noise and impulse noise, and is from two sources, the atmosphere and the receiver. Random noise may be generated from distant thunderstorms, resistive components and tubes in the receiver, and from the cosmic noise of interstellar space. (Little is known of cosmic noise, but it is seldom a limiting factor for communication below 30 mc.) Although random noise is irregular, its average level can be measured, and it exhibits a characteristic average power distribution which is constant over the frequency spectrum. Impulse noise may be generated by ignition systems and local thunderstorms, and it is characterized by discrete, well-separated noise pulses having certain phase relationships.

Atmospheric noise is attributed to world-wide effects of thunderstorm activity. Atmospheric noise is highest in the equatorial regions, where thunderstorms are most frequent, and varies seasonally at the higher latitudes, being highest in the summer months. Atmospheric noise is also higher overland than oversea, because thunderstorms are more frequent overland. Thunderstorm activity also shows diurnal variations, being more frequent between 1200 and 1700 local time, which produces diurnal atmospheric noise conditions. Storms which are at a dis-

tance from the receiving station produce random noise while local storms produce impulse noise. Prediction of the impulse noise from local storms is not feasible, but prediction of the random noise from distant storms is feasible. This chapter includes world noise distribution charts from which can be obtained the noise grade for any receiving site. Minimum required incident field intensity curves for overcoming atmospheric noise are also provided. By using the curve for the proper noise grade, proper season, and proper local time, the field intensity required to overcome atmospheric noise can be determined.

Receiver system noise consists of antenna noise, thermal noise in the antenna circuit, tube noise, and thermal noise in the input circuit. If a receiver were perfect, the only noise in the receiver output would be as a result of the thermal noise in the antenna circuit and a maximum signal-to-noise ratio would result, as explained in paragraph 2a, chapter 3. A measure of the receiver system noise is a ratio of actual output noise power to the noise power that would result from the antenna thermal noise only. This ratio is called the noise figure of the receiver and may be expressed in terms of signal-to-noise ratios as follows:

$$NF = \frac{S/N \text{ of ideal receiver}}{S/N \text{ of actual receiver}}$$

where S/N is the ratio of signal power to noise power or signal voltage squared to noise voltage squared

Since the signal power is the same in both the numerator and denominator, the above equation can be reduced to the following equation:

$$NF = \frac{\text{actual noise power}}{\text{ideal noise power}}$$

or

$$\text{actual noise power} = NF \times \text{ideal noise power}$$

or

$$\text{actual noise voltage squared} = NF \times \text{ideal noise voltage squared}$$

By substituting a value given in physical parameters for the ideal noise voltage, the equation for actual noise can be expressed as follows:

$$V_n^2 = NF \times KTB$$

where  $V_n^2$  is the actual noise voltage squared  
 NF is the noise figure  
 K is Boltzmann's constant,  $1.38 \times 10^{-23}$   
 T is the absolute temperature  
 B is the bandwidth in cycles per second

Where the receiver input circuit matches the antenna resistance, a theoretical noise figure of 2 is possible. Expressed in decibels, this is equivalent to 3 db. In practice, noise figures of up to 7 db are acceptable. This chapter includes curves showing minimum required field intensities in the presence of set noise. By using the curve for the proper antenna and proper vertical angle of wave arrival, the field intensity required to overcome set noise can be determined.

Set noise and atmospheric noise are not additive since they are both random noise. Therefore, if the field intensity required to overcome set noise is greater than the field intensity required to overcome atmospheric noise, the field intensity required to overcome set noise will also overcome atmospheric noise. Conversely, if the field intensity required to overcome atmospheric noise is greater than the field intensity required to overcome set noise, the field intensity required to overcome atmospheric noise will also overcome set noise. That is, the greater of the two field intensities will overcome both atmospheric and set noise.

#### (7) SERVICE GAIN

A service gain factor is required to compensate for the generalizations made to obtain the atmospheric noise curves and the set noise curves. These curves are determined on the basis of a double sideband, speech-grade radiotelephony service, 6-kc bandwidth, 100 per cent modulation, during 90 per cent of the days. The curves are also based on a required S/N ratio of 13.8 db to obtain 90 per cent intelligibility. For types of service other than this standard, the field intensity required to overcome noise will be different. Service gain tables for both sky wave and ground wave propagation are included in this chapter. In the table of service gains for sky wave propagation, the standard double sideband radiotelephony signal indicates a service gain of 8 db. This is a result of compensating for fading signals and means that the received field intensity must be increased 8 db to compensate for rapid signal variations as shown in the rapid variation of sky wave field intensity curve, also included in this chapter.

#### d. LOWEST USEFUL HIGH FREQUENCY

The lowest useful high frequency, LUHF, (sometimes LUF for lowest useful frequency) is the lower limiting frequency which will provide satisfactory communication for a given link. The LUHF is the frequency at which the received field intensity just equals the required field intensity for reception. The received field intensity depends on the antennas, path length, and absorption, and it generally increases with frequency. The required field intensity for reception depends on noise limitations, and it decreases with frequency. Therefore, by comparing the received

median field intensity at various frequencies with the required field intensity for the same frequencies, the LUHF can be determined. To determine the LUHF, it must be kept in mind that the required field intensity must be adjusted for service gain.

#### e. MAXIMUM USABLE FREQUENCY

The maximum usable frequency, MUF, is the upper limiting frequency at which a communication circuit may be operated. The MUF, as determined from available ionospheric predictions, is actually a monthly median of the highest usable daily frequencies for a particular sky wave path at a particular hour of the day. The geographic location of reflection points, the time of day, season, and sunspot number all affect the MUF. The MUF for path lengths less than 4000 km is determined by the ionospheric conditions at the midpoint of the path. It is taken as the highest of the three maximum frequencies which will be reflected from the E layer, sporadic E layer, or  $F_2$  layer. The charts of median zero MUF and median 4000 MUF predicted for the proper month, included in this chapter, are used to determine the MUF for a given communication link.

The MUF represents the median maximum usable frequency. That is, 50 per cent of the days the actual maximum usable frequency will be less than the median MUF, and 50 per cent of the days the actual maximum usable frequency will be greater than the median MUF. For this reason, it is desirable to operate at a frequency which is slightly less than the median MUF to increase communication reliability to 90 per cent. Where  $F_2$  propagation is used, this frequency of optimum traffic, FOT, (sometimes OWF for optimum working frequency) is taken as 85 per cent of the MUF. Where E and  $F_1$  propagation is used, the FOT is taken as the MUF for E propagation, because the MUF variation from day to day is so small.

#### f. LOWEST EFFECTIVE POWER

The effective radiated power in kilowatts is the product of the antenna input power in kilowatts and the antenna gain, with respect to a short dipole reference antenna. The lowest effective power, LEP, is the minimum transmitted antenna power required to give satisfactory communication at a particular frequency. The difference between the received field intensity, determined in decibels with respect to the reference antenna radiation (300 mv/m at 1 km), and the field intensity required for reception, determines the LEP.

## 7. GROUND WAVE PROPAGATION

Ground wave propagation is propagation of r-f energy along the curved surface of the earth, without using the earth's ionosphere. Where a ground wave is transmitted beyond the line of sight, the conduc-

tivity of the earth's surface acts as a wave guide and bends the wave around the curved surface. Since fading is due primarily to ionospheric fluctuations, there is no fading associated with ground wave propagation. However, the extremely high losses associated with ground wave propagation make it impractical for most long distance transmissions. The received field intensity of a ground wave depends upon the type of terrain over the transmission path, the transmitting and receiving antennas, the power output, frequency, and antenna heights.

Only vertical polarization, such as is obtained from vertical and whip antennas, is practical for ground wave propagation. Horizontal polarization results in extremely high losses due to a short circuiting effect of the earth. Even with vertical polarization, the received field intensity of a ground wave is far below that of the direct, free-space field. The antenna height also affects ground wave propagation. However, where the antenna is considered to be at ground level, which is usually the case aboard ship, the antenna-height gain factor is neglected.

The terrain over the transmission path is an important consideration because it is the earth's

surface which bends the ground wave, and it is the earth's surface which absorbs the r-f energy. For purposes of determining the received field intensity, the terrain is divided into three categories: (1) poor soil, (2) good soil, and (3) sea water. Because of the high conductivity over sea water, ground wave propagation over sea water for fairly long distances is very practical for frequencies below 30 mc. It is generally desirable to operate at the lower end of the high-frequency band because less attenuation is suffered. Graphs are included in this chapter which show ground wave field intensity versus distance for various frequencies and various types of terrain.

For line of sight transmissions, the received field intensity is composed of a direct wave and a ground-reflected wave. If the two received waves are in the vicinity of  $180^\circ$  out of phase, the received signal level will be very low. Conversely, if the two received waves are in phase, the received signal will be almost twice as strong as the signal resulting from the direct wave. Therefore, for line of sight transmissions, the received signal level varies from near zero to twice the signal resulting from the direct wave, depending upon the transmission path length.

## 8. CHARTS AND GRAPHS

The following charts and graphs are included because they are typical of the information necessary to solve a propagation problem. However, the ones included do not make a complete set. Some of the charts and graphs are used in the example problem which follows. The charts and graphs which are included are as follows:

- Figure 11-8. World Map Showing Zones Covered by Predicted Charts, and Auroral Zones
- Figure 11-9. Great Circle Chart Centered on Equator; Solid Lines Represent Great Circles; Numbered Dot-Dash Lines Indicate Distances in Thousands of Kilometers
- Figure 11-10. Median  $F_2$ -Zero-MUF, in Mc, W Zone, Predicted for April 1957
- Figure 11-11. Median  $F_2$ -4000-MUF, in Mc, W Zone, Predicted for April 1957
- Figure 11-12. Median E-2000-MUF, in Mc, Predicted for April 1957
- Figure 11-13. Median  $fE_s$ , in Mc, Predicted for April 1957
- Figure 11-14. Gains of Spaced Diversity Receiving Antennas for Rapidly Fading Signals
- Figure 11-15. Rapid Variation of Sky Wave Field Intensity
- Figure 11-16. Slow Variation of Sky Wave Intensity
- Figure 11-17. Slow Variation of Atmospheric Noise
- Figure 11-18. Radiation Angle Versus Great Circle Distance Curves
- Figure 11-19. Nomogram for Transforming E-2000 MUF to Equivalent MUF's and Optimum Working Frequencies Due to Combined Effect of E Layer and  $F_1$  Layer at Other Transmission Distances
- Figure 11-20. E Layer MUF and Penetration Nomogram
- Figure 11-21. Nomogram from Transforming  $F_2$  ZERO MUF and  $F_2$  4001 MUF to Equivalent MUF's at Intermediate Transmission Distances; Conversion Scale for Obtaining Optimum Working Frequencies
- Figure 11-22. Absorption Index Chart (Excluding Auroral Absorption) for April
- Figure 11-23. Auroral Absorption Chart
- Figure 11-24.  $K_d$  Nomogram, Transmission Path Entirely in the Day Region
- Figure 11-25. K or  $K_d$  Correction Factors
- Figure 11-26. Table of Service Gains, Sky Wave Communications, Fading Signal
- Figure 11-27. Median Incident Sky Wave Intensity, 0 to 200 km, 1-hop- $F_2$
- Figure 11-28. Median Incident Sky Wave Field Intensity, 0 to 200 km, 2-hop- $F_2$
- Figure 11-29. Median Incident Sky Wave Intensity, 0 to 200 km, 1-hop-E
- Figure 11-30. Median Incident Sky Wave Field Intensity, 400 km, 1-hop- $F_2$
- Figure 11-31. Median Incident Sky Wave Field Intensity, 400 km, 2-hop- $F_2$

- Figure 11-32. Median Incident Sky Wave Field Intensity, 400 km, 1-hop-E
- Figure 11-33. Median Incident Sky Wave Field Intensity, 800 km, 1-hop- $F_2$
- Figure 11-34. Median Incident Sky Wave Field Intensity, 800 km, 2-hop- $F_2$
- Figure 11-35. Median Incident Sky Wave Field Intensity, 800 km, 1-hop-E
- Figure 11-36. Noise Distribution Chart for March, April, and May
- Figure 11-37. Minimum Required Incident Field Intensities, Noise Grade 2.5, Summer
- Figure 11-38. Minimum Required Incident Field Intensities, Noise Grade 2.5, Winter
- Figure 11-39. Minimum Required Incident Field Intensities, Noise Grade 2.5, Equinox
- Figure 11-40. Minimum Required Incident Field Intensities and Discrimination Gain, 15-foot Whip Antenna
- Figure 11-41. Minimum Required Incident Field Intensities and Discrimination Gain, 1/4-Wave Grounded Vertical Antenna
- Figure 11-42. Minimum Required Incident Field Intensities and Discrimination Gain, 1/2-Wave Grounded Vertical Antenna, Transmission Line Fed from Base of Antenna
- Figure 11-43. Gain Curves, 15-foot Whip Antenna Erected Above Poor Ground
- Figure 11-44. Gain Curves, 1/4-Wave Vertical Antenna Erected Above Poor Ground
- Figure 11-45. Gain Curves, 1/2-Wave Vertical Antenna Erected Above Poor Ground
- Figure 11-46. World Map Showing Various Types of Terrain
- Figure 11-47. Ground-Wave Field Intensity Versus Distance Curves for Various Frequencies in mc, for Vertical Polarization, 1-2,000 miles--Poor Ground
- Figure 11-48. Ground-Wave Field Intensity Versus Distance Curves for Various Frequencies in mc, for Vertical Polarization, 1-2,000 miles--Good Ground
- Figure 11-49. Ground-Wave Field Intensity Versus Distance Curves for Various Frequencies in mc, for Vertical Polarization, 1-2,000 miles--Sea Water
- Figure 11-50. Minimum Required Field Intensity in the Presence of Set Noise, and Discrimination Gains in the Presence of Atmospheric Noise, for Various Antennas
- Figure 11-51. Service Gains, Ground-Wave Communication, Nonfading Signal
- Figure 11-52. Inverse Distance Field Intensity Expressed as an Antenna Gain in Respect to 186.3 Millivolts per Meter at 1 mile, Grounded Vertical Antenna
- Figure 11-53. Inverse Distance Field Intensity Expressed as an Antenna Gain in Respect to 186.3 Millivolts per Meter at 1 Mile, 15-foot Vertical Whip Antenna
- Figure 11-54. Inverse Distance Field Intensity Expressed as an Antenna Gain in Respect to 186.3 Millivolts per Meter at 1 Mile, Half-Wave Vertical Antenna Erected Above Perfect Earth at a Height of  $h/\lambda$
- Figure 11-55. Line of Sight Distance for Elevated Antennas (For Smooth Spherical Earth With an Effective Radius of  $4/3$  the Actual Values), Antenna Heights from 0 to 5,000



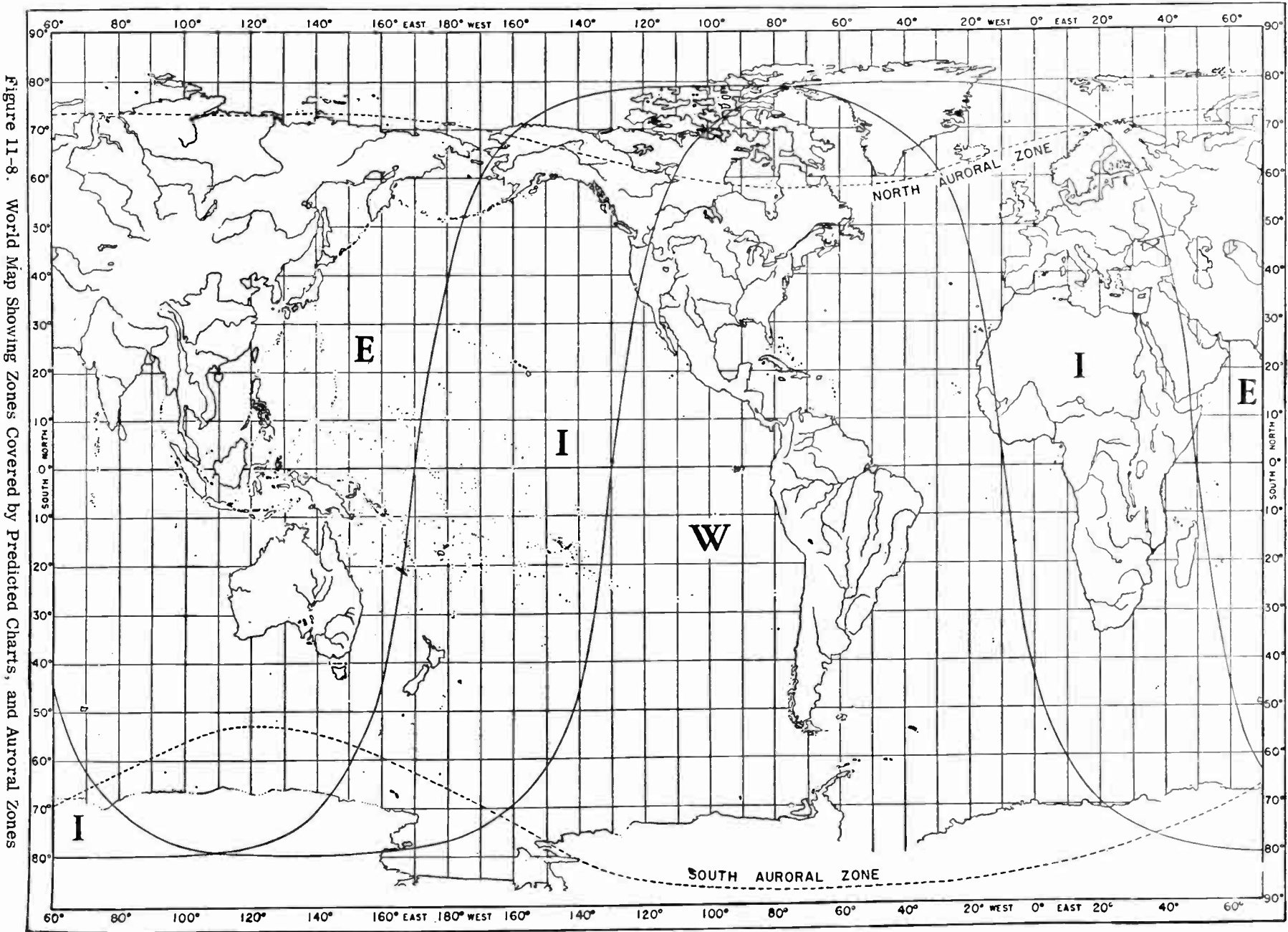

Figure 11-8. World Map Showing Zones Covered by Predicted Charts, and Auroral Zones

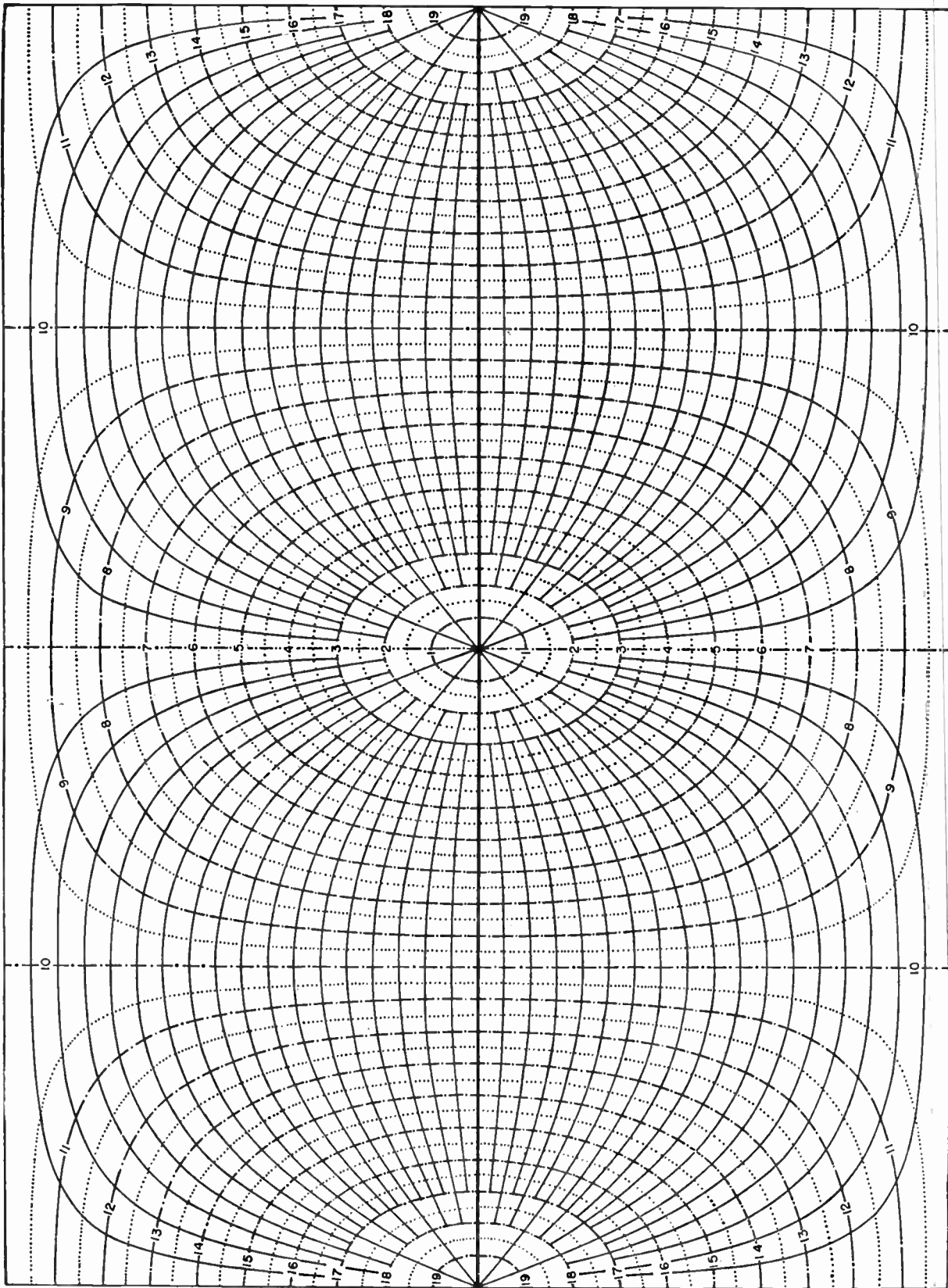

Figure 11-9. Great Circle Chart Centered on Equator; Solid Lines Represent Great Circles; Numbered Dot-Dash Lines Indicate Distances in Thousands of Kilometers

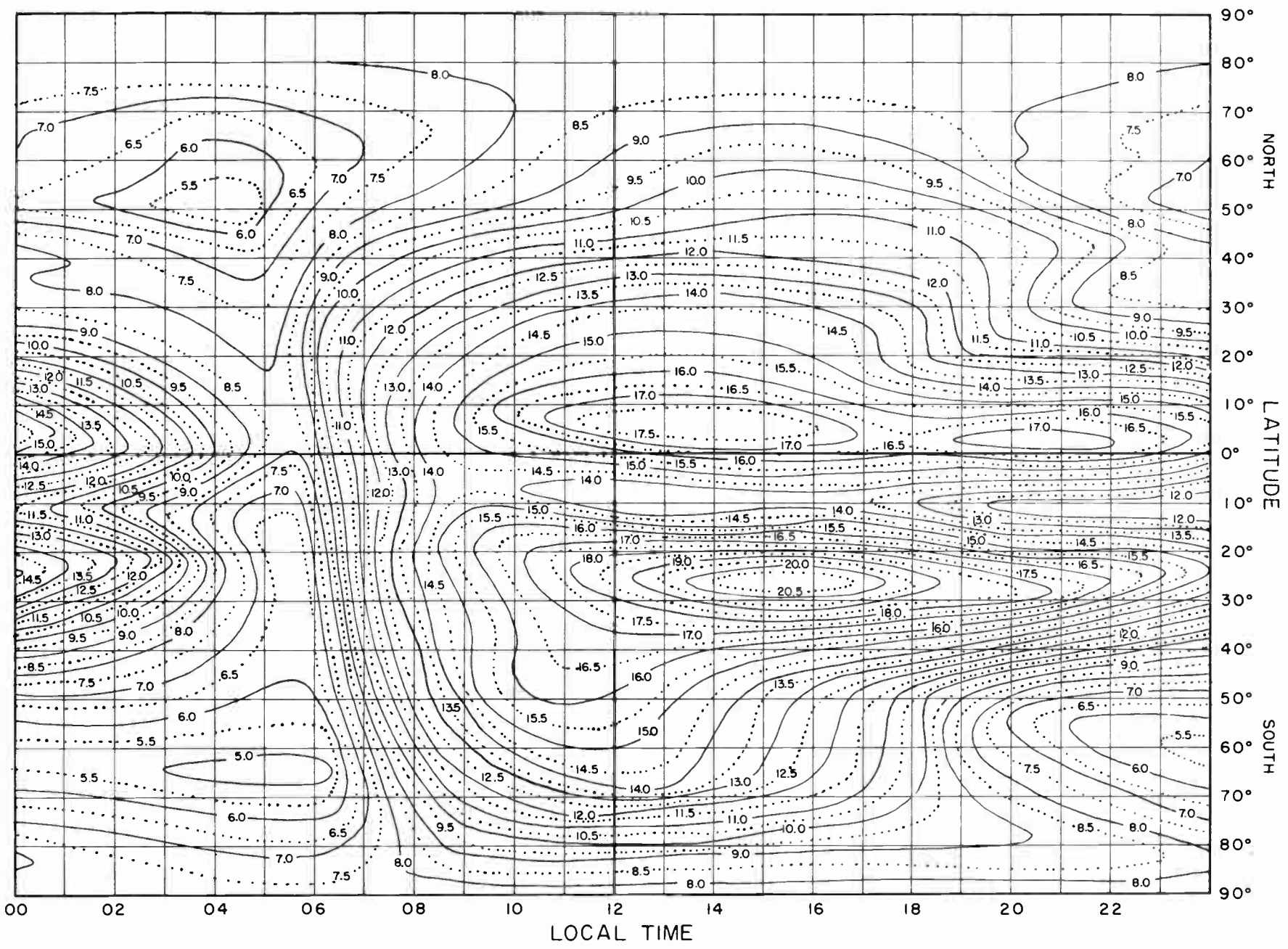
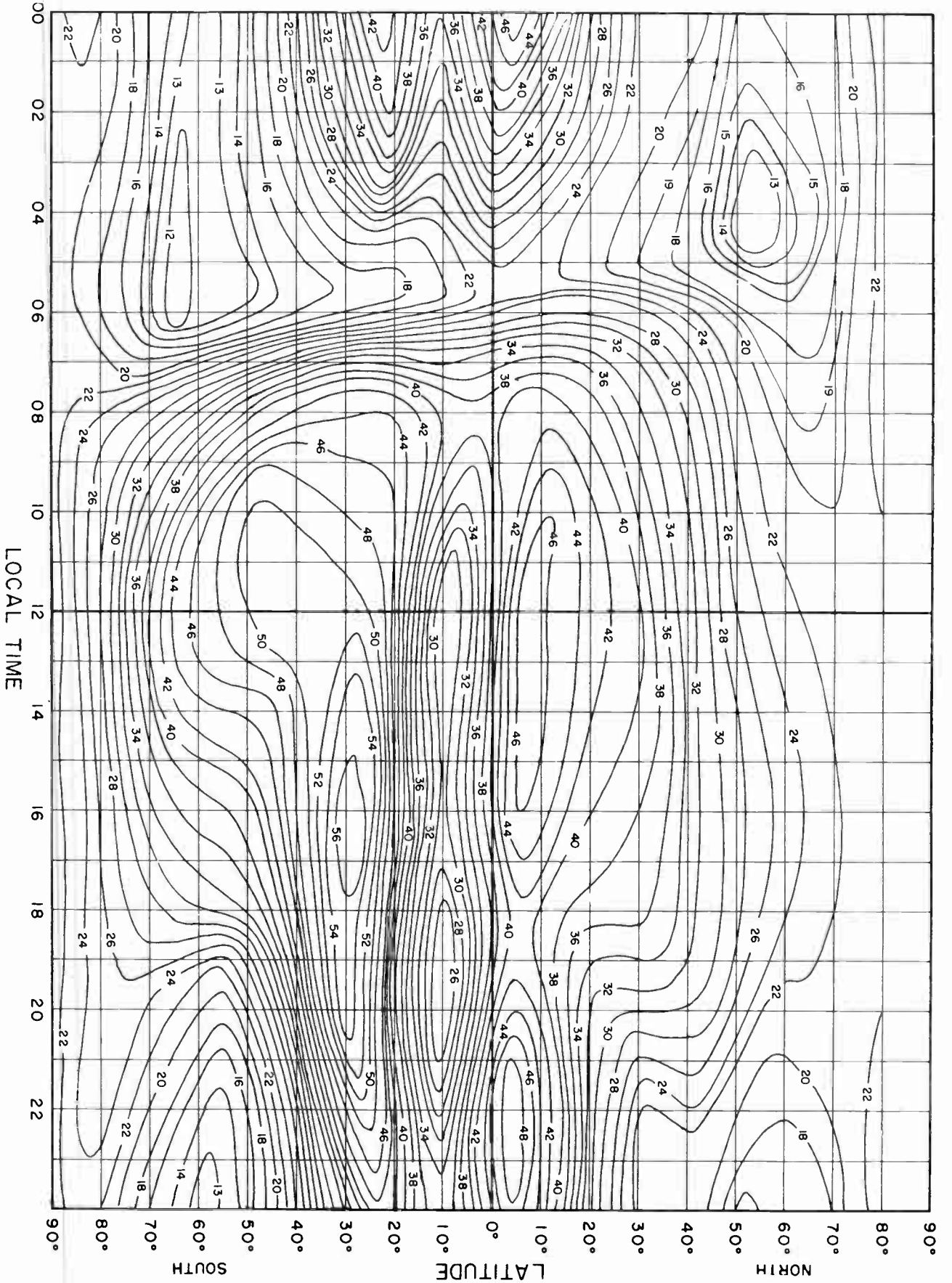

Figure 11-10. Median F<sub>2</sub>-Zero-MUF, in Mc, W Zone, Predicted for April 1957



Figure 11-11. Median  $F_2$ -4000-MUF, in Mc, W Zone, Predicted for April 1957



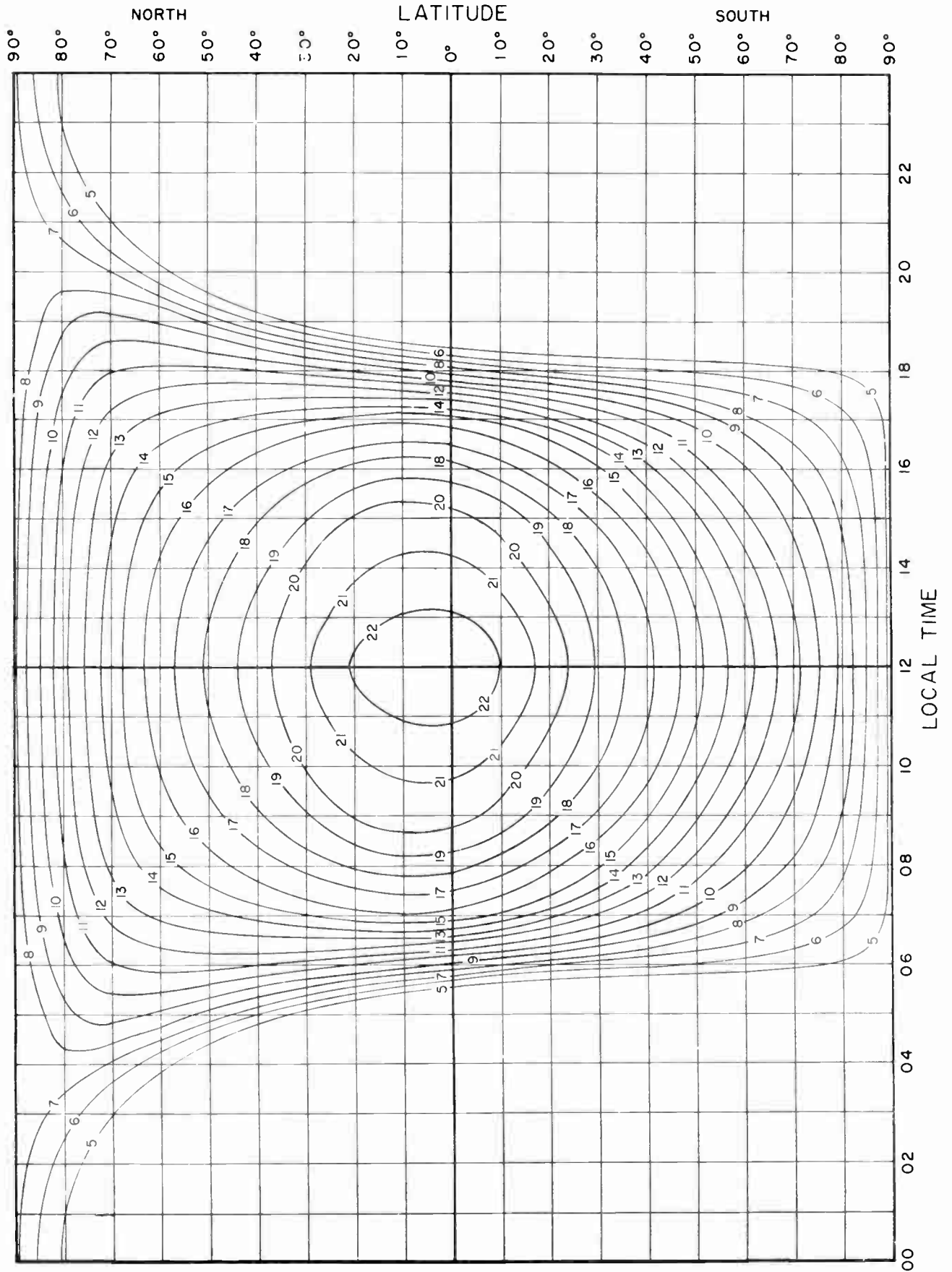

Figure 11-12. Median E-2000-MUF, in Mc, Predicted for April 1957



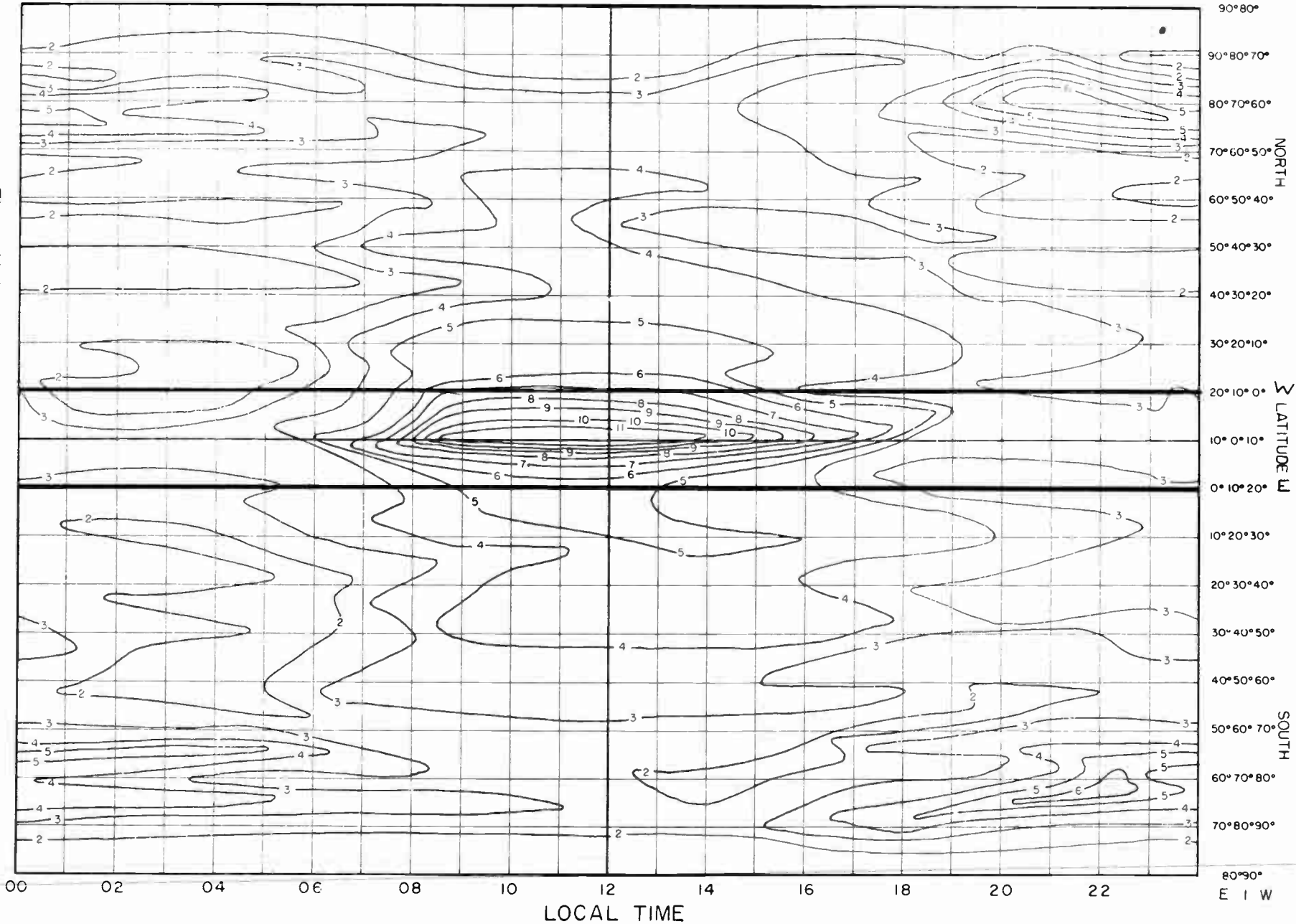

Figure 11-13. Median  $f_oF_2$  in Mc, Predicted for April 1957

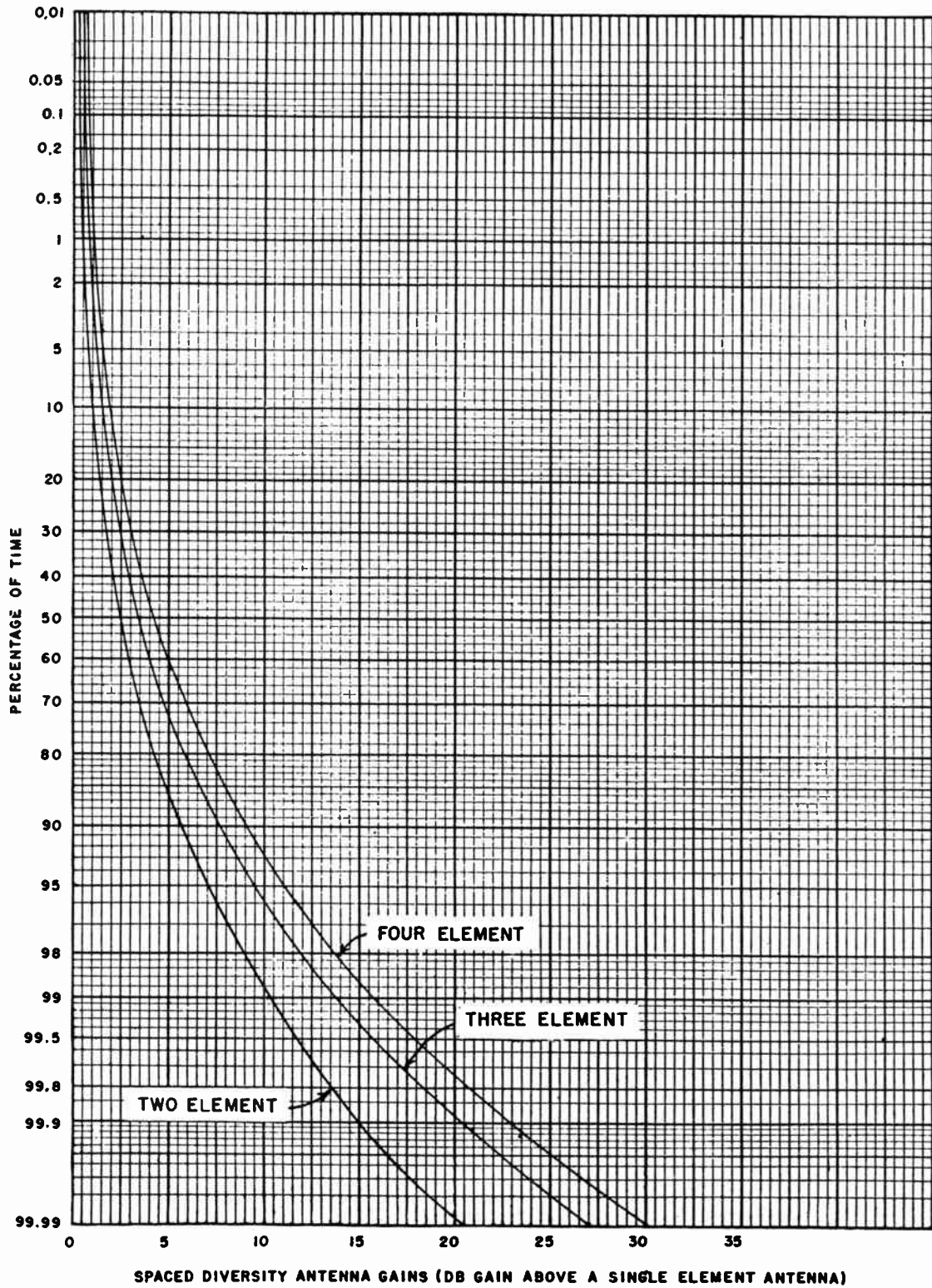

Figure 11-14. Gains of Spaced Diversity Receiving Antennas for Rapidly Fading Signals



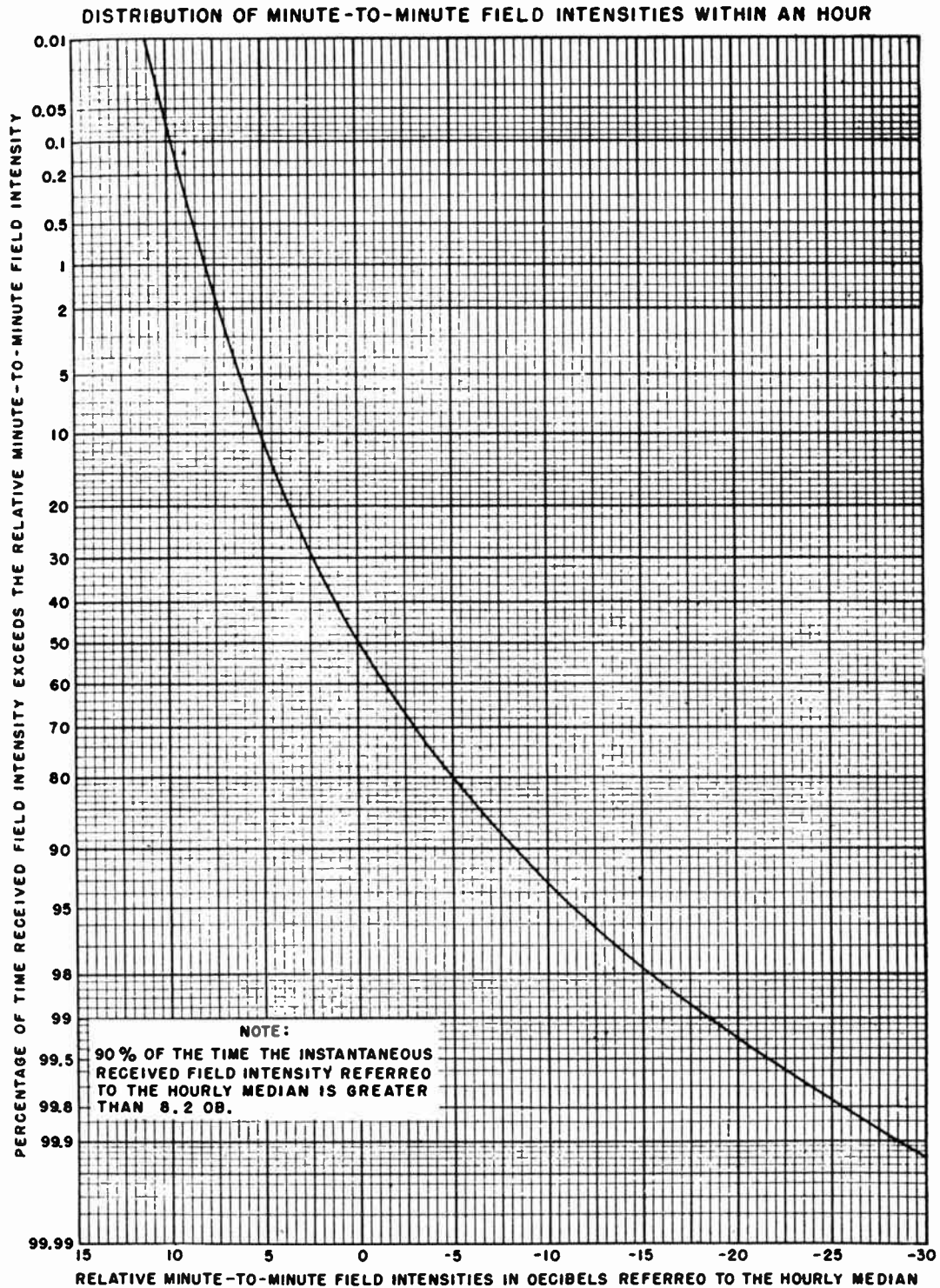

Figure 11-15. Rapid Variation of Sky Wave Field Intensity



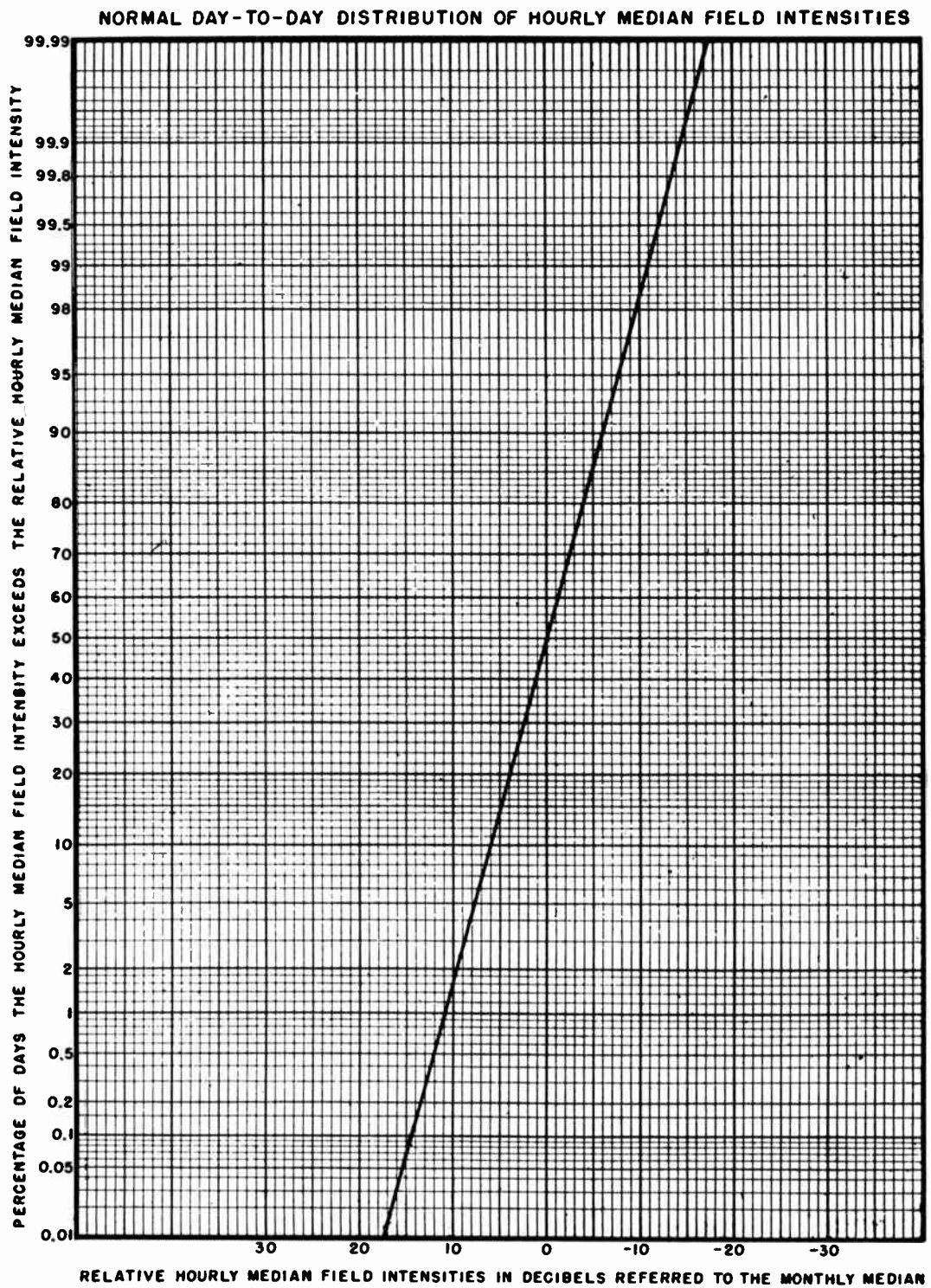
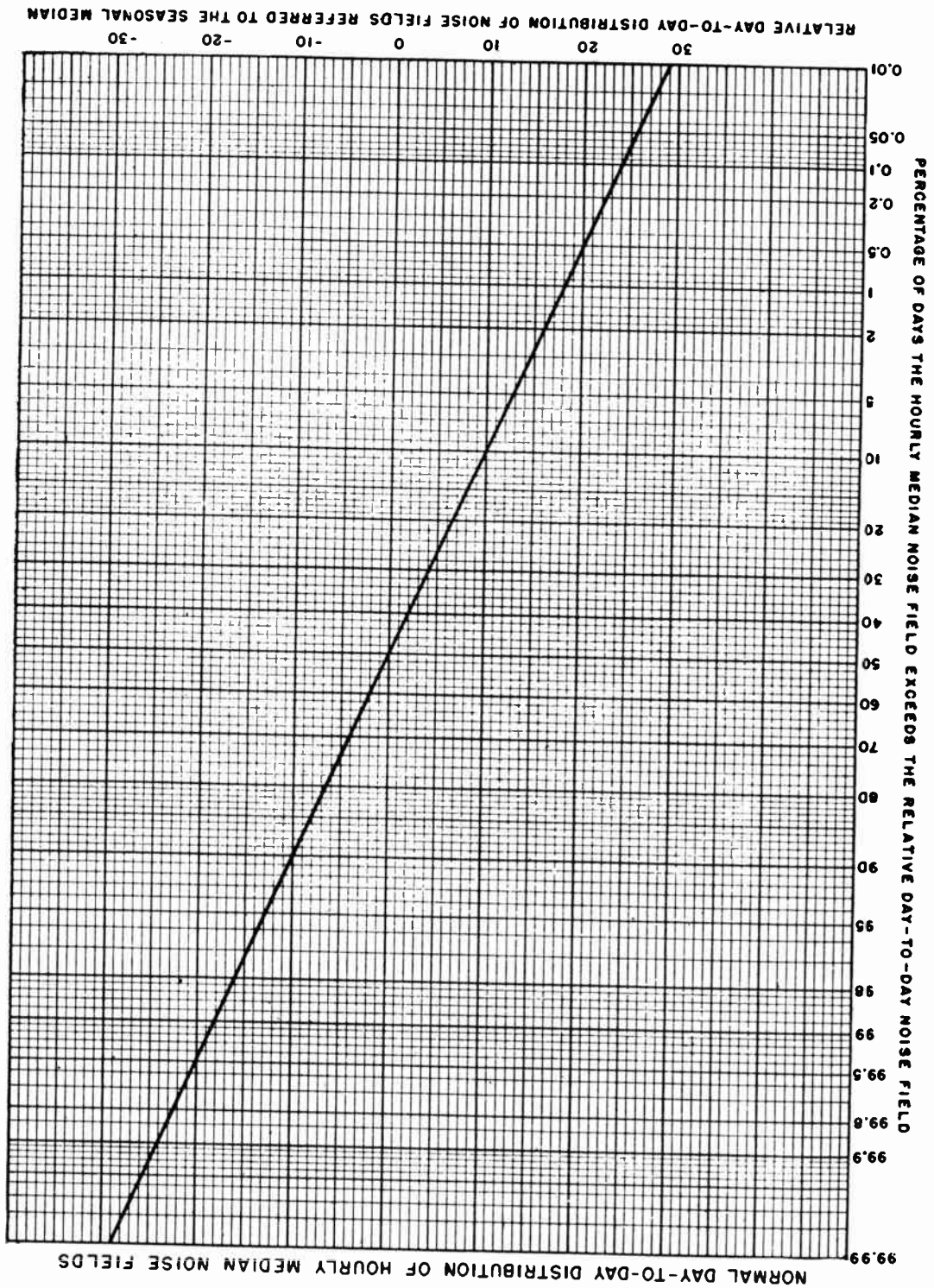

Figure 11-16. Slow Variation of Sky Wave Intensity



Figure 11-17. Slow Variation of Atmospheric Noise





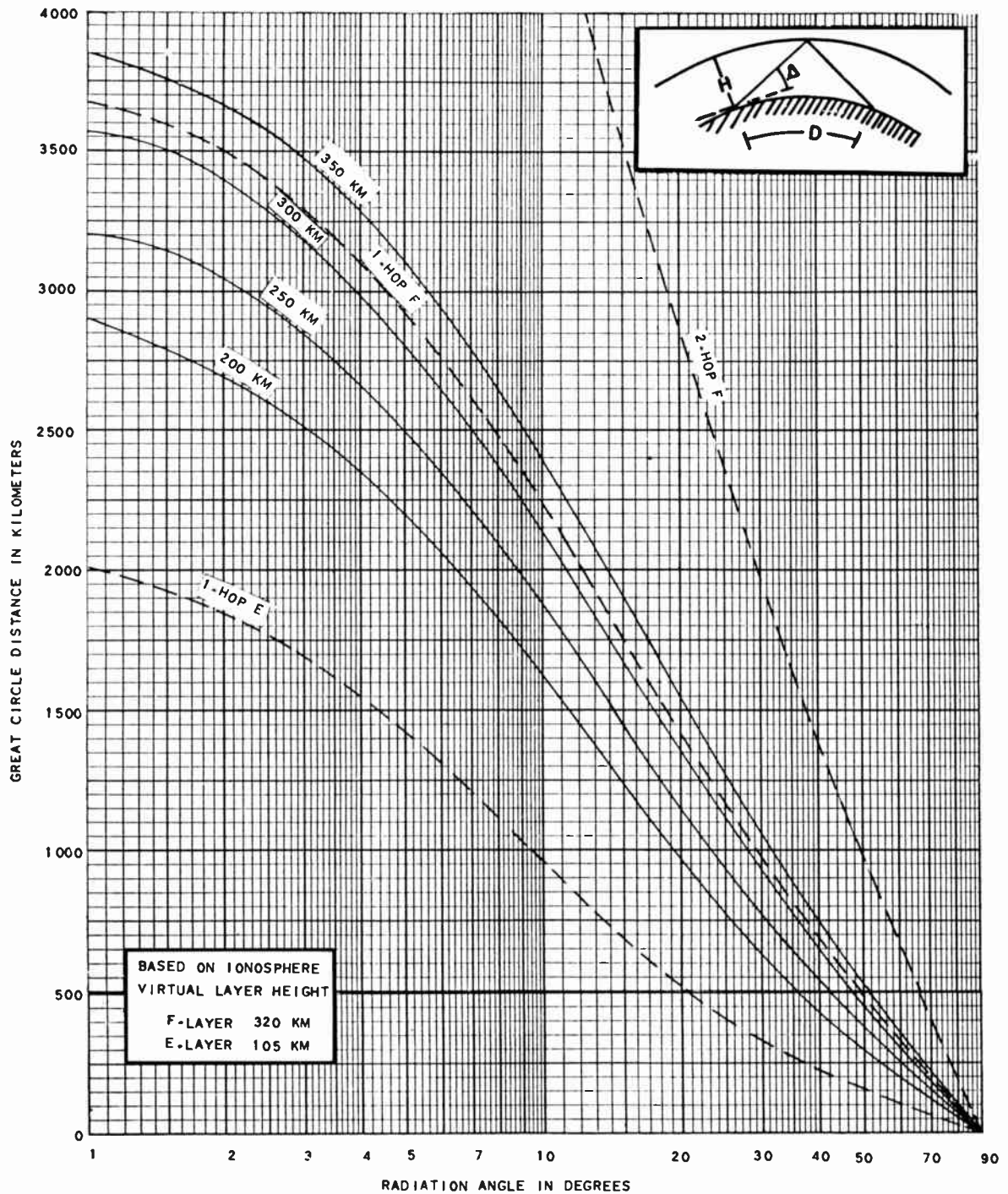

Figure 11-18. Radiation Angle Versus Great Circle Distance Curves

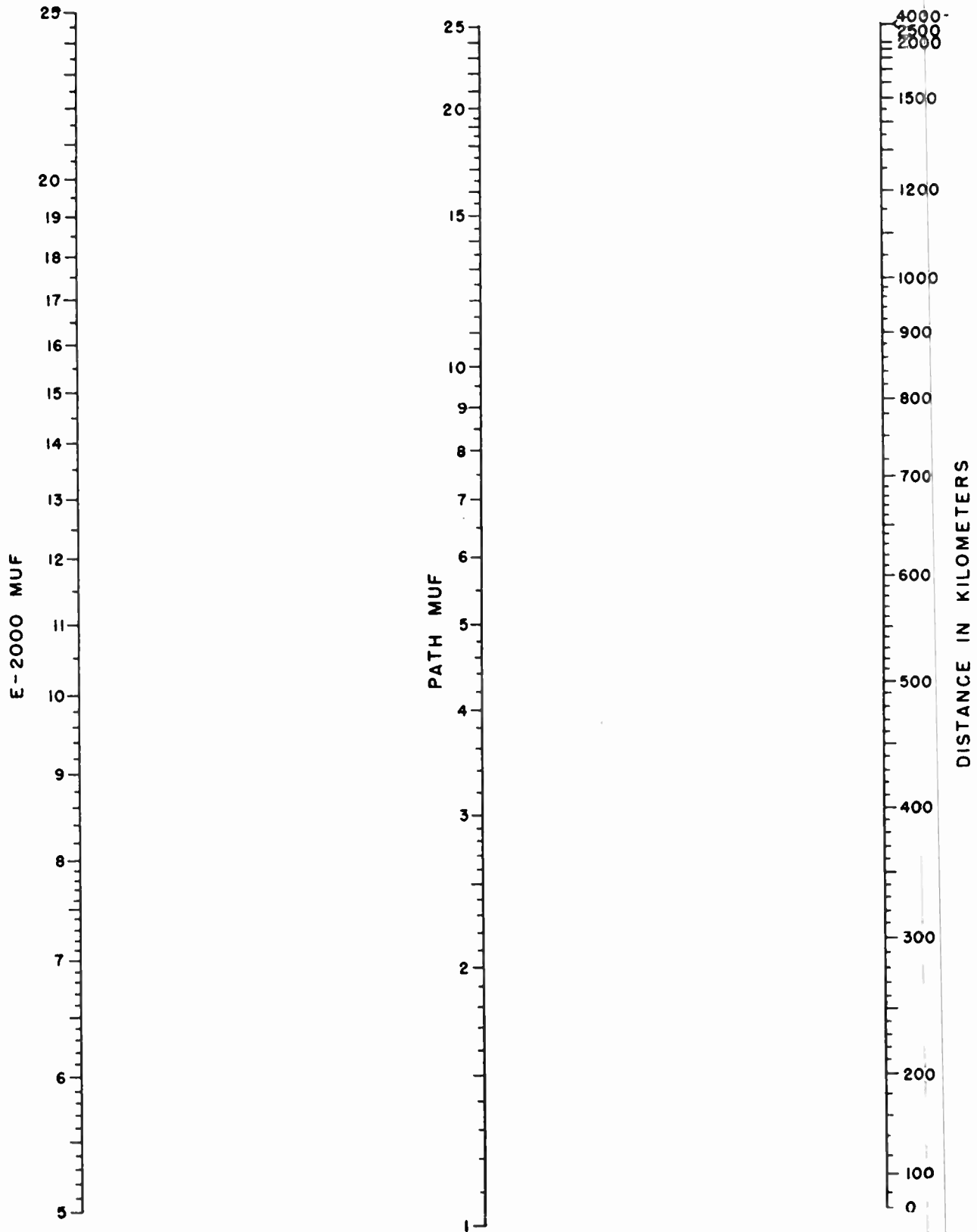

Figure 11-19. Nomogram for Transforming E-2000 MUF to Equivalent MUF's and Optimum Working Frequencies Due to Combined Effect of E Layer and F<sub>1</sub> Layer at Other Transmission Distances

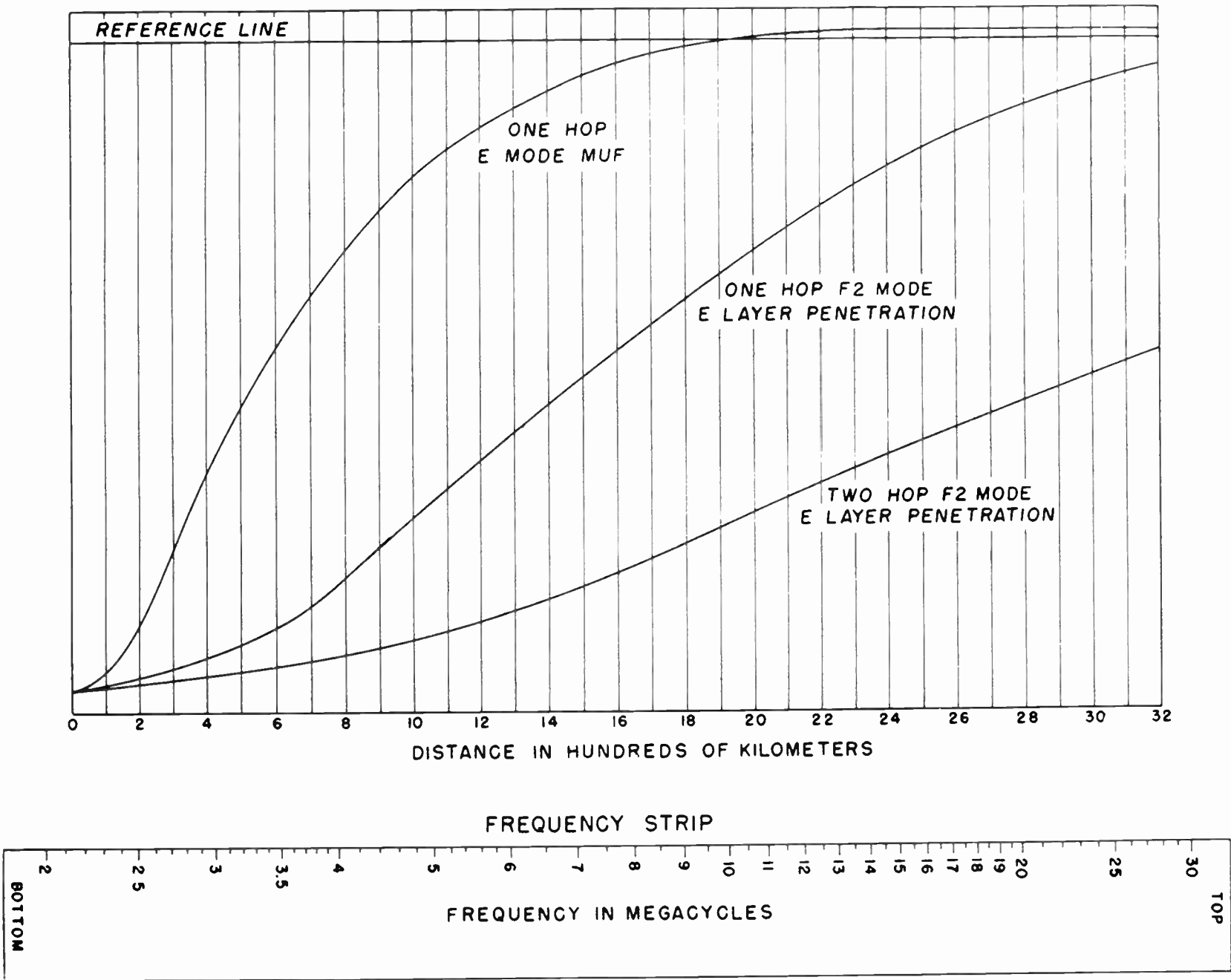

Figure 11-20. E Layer MUF and Penetration Nomogram

1 km = 0.62137 mile = 0.53961 naut. mi.  
 1 mile = 1.60935 km = 0.86836 naut. mi.  
 1 naut. mi. = 1.85325 km = 1.1516 mi.

FOR VALUES OF MUF GREATER THAN 35 Mc, MULTIPLY ALL MUF AND OWF SCALES BY 2

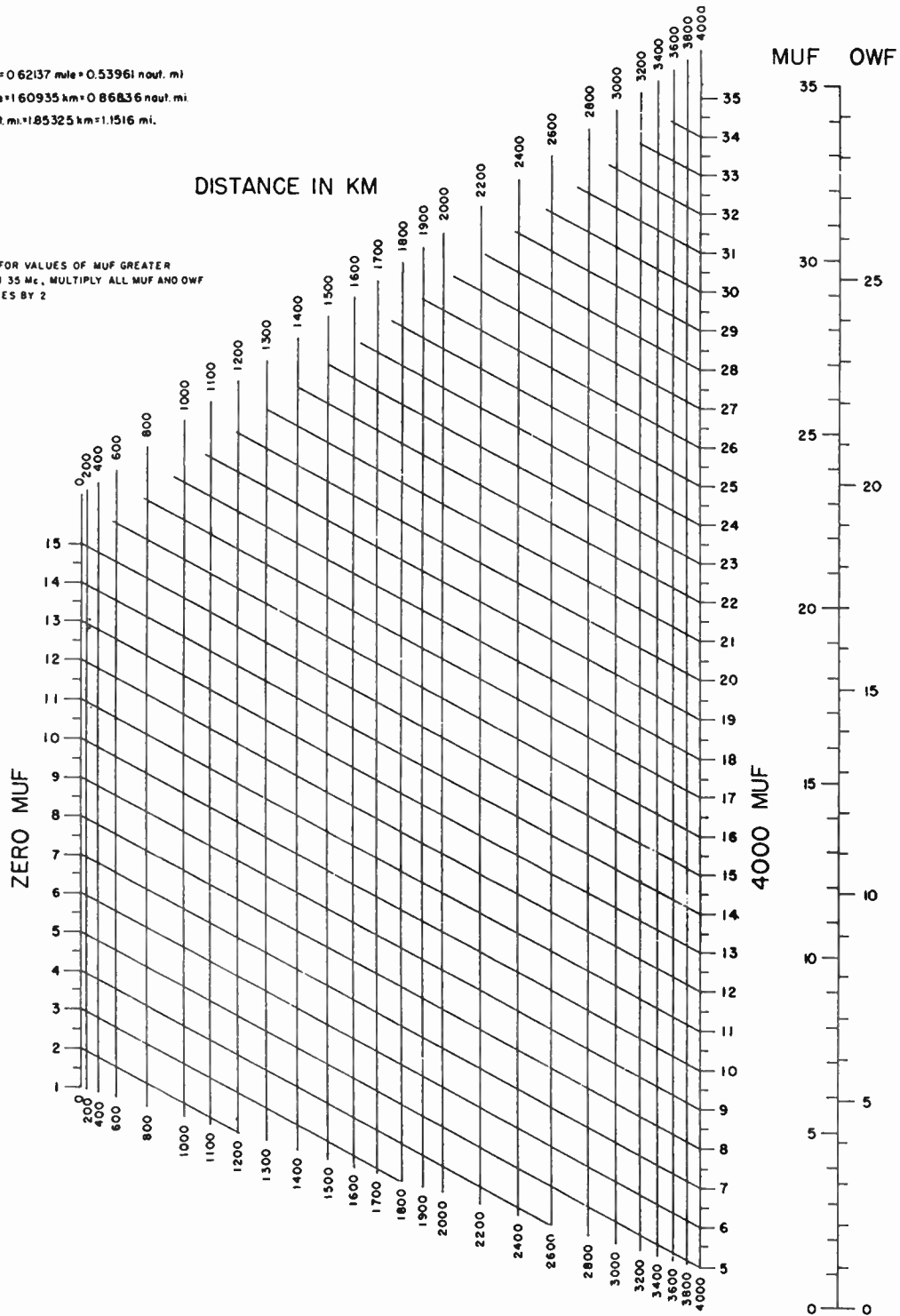

Figure 11-21. Nomogram from Transforming  $F_2$  ZERO MUF and  $F_2$  4001 MUF to Equivalent MUF's at Intermediate Transmission Distances; Conversion Scale for Obtaining Optimum Working Frequencies



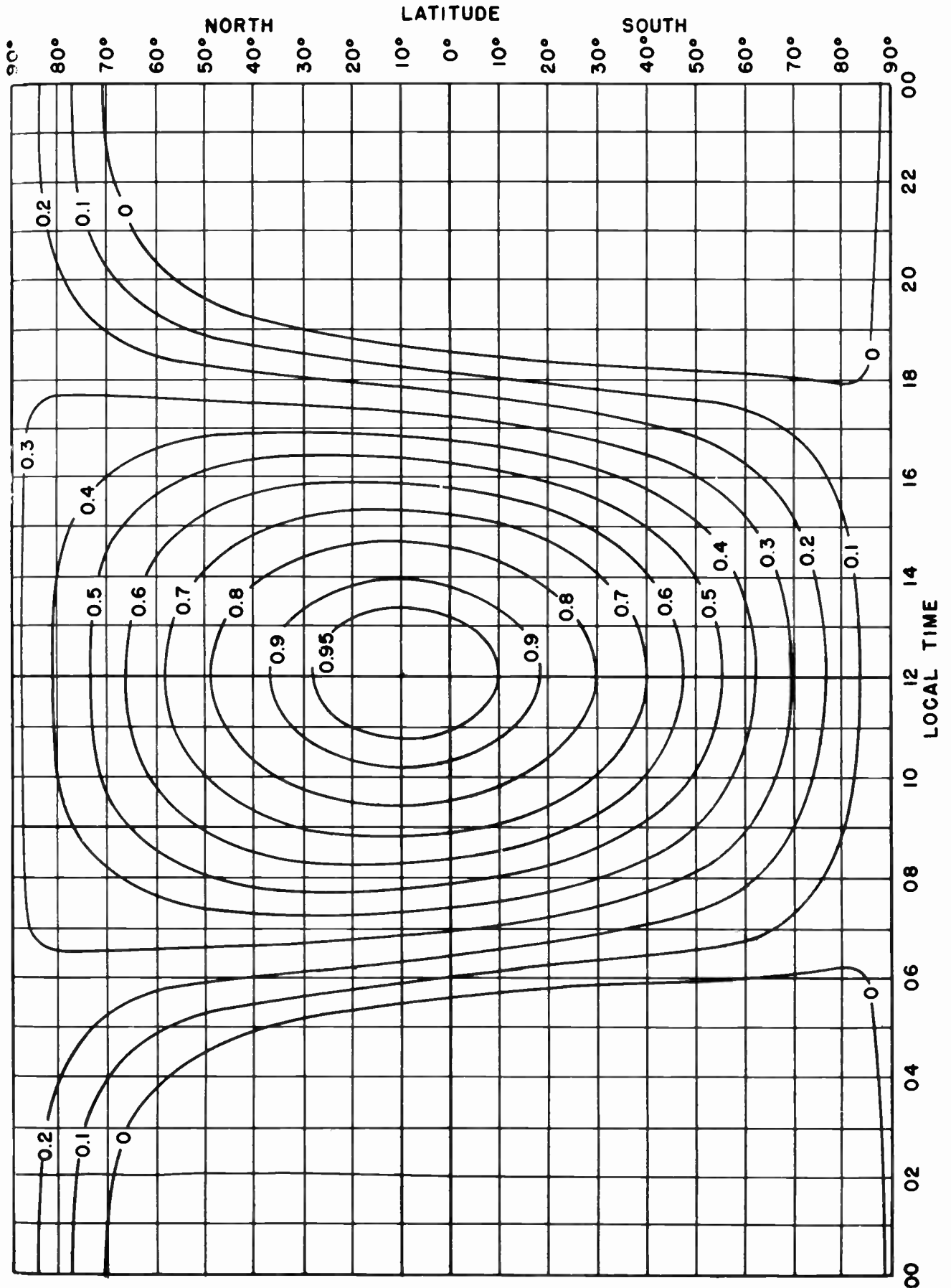

Figure 11-22. Absorption Index Chart (Excluding Auroral Absorption) for April

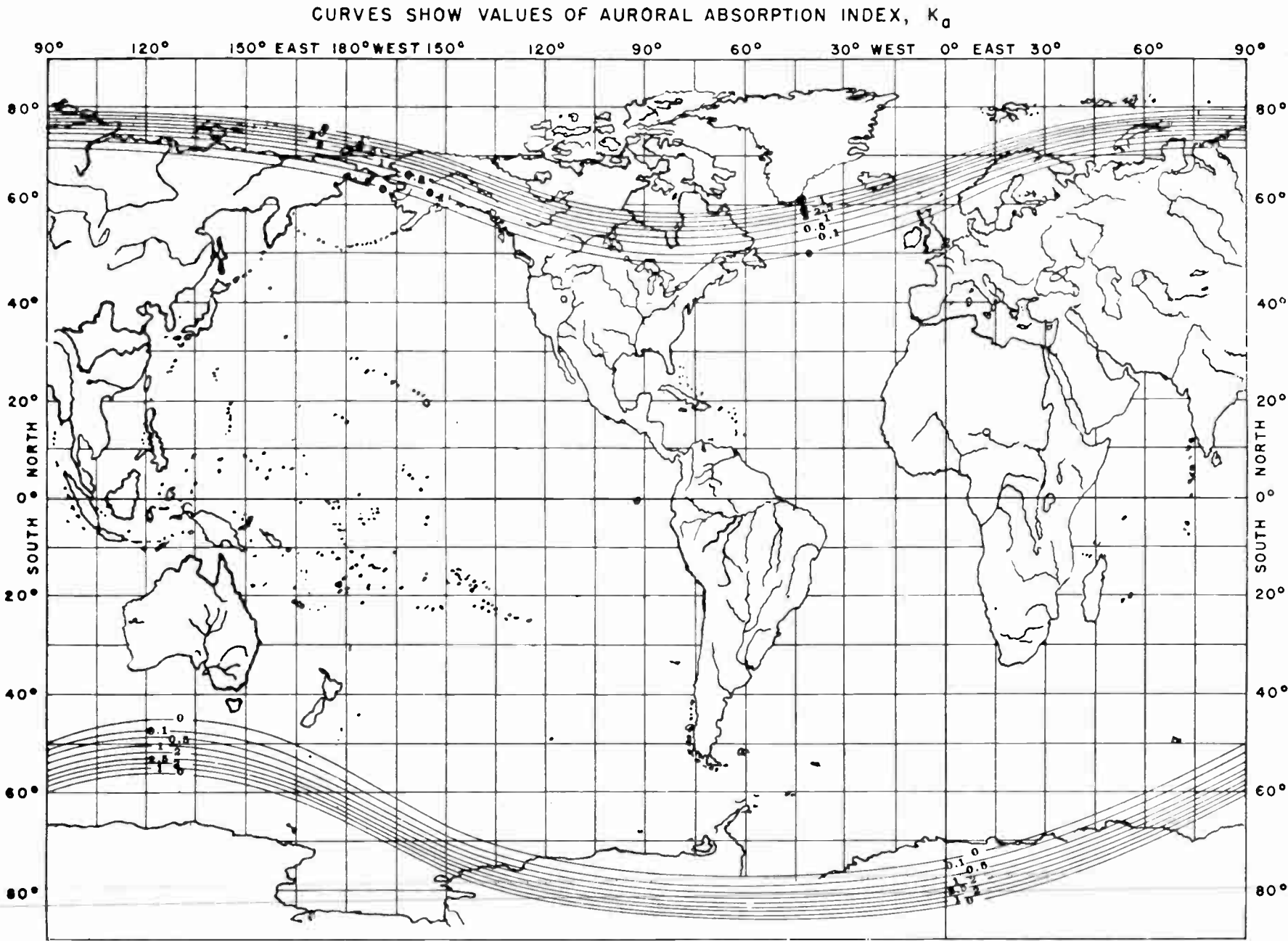

Figure 11-23. Auroral Absorption Chart

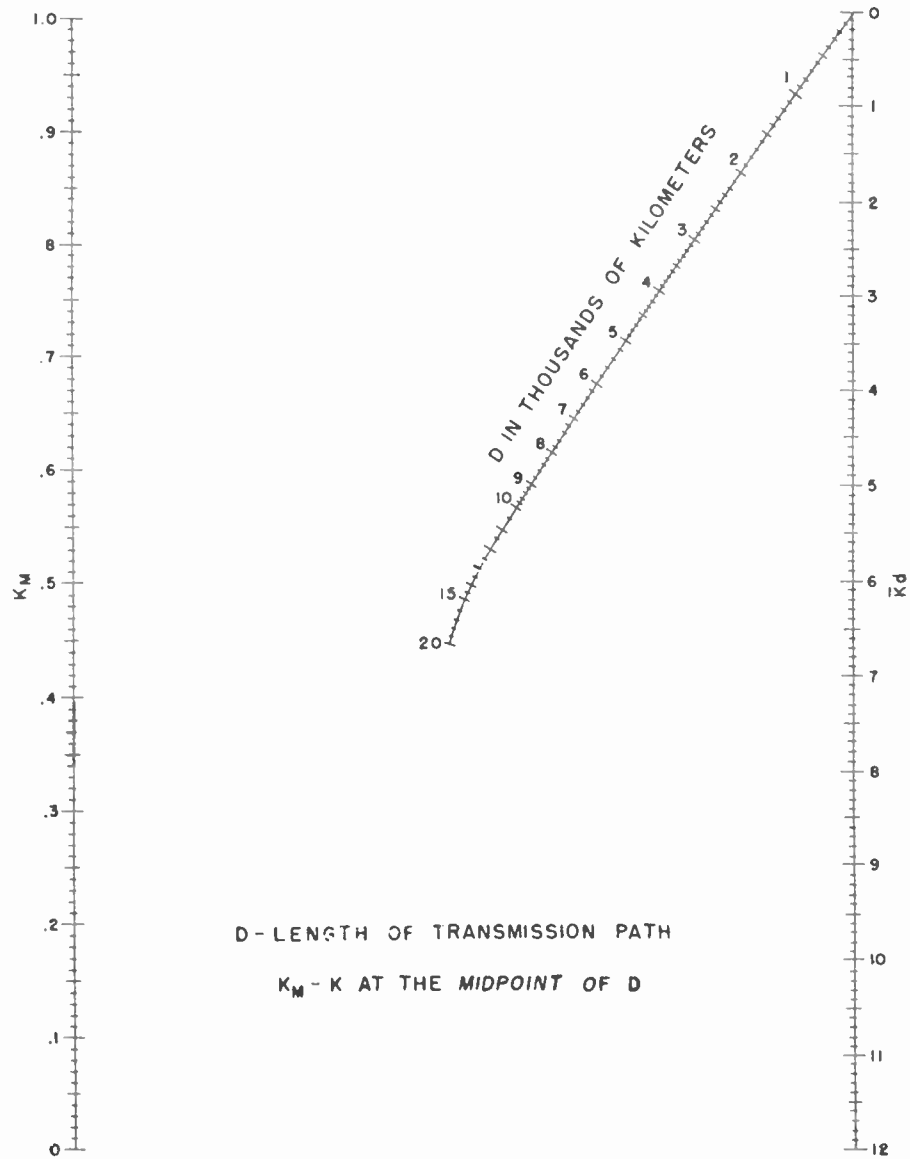
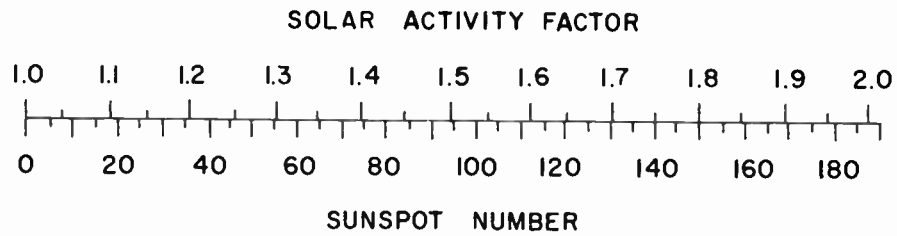

Figure 11-24.  $K_d$  Nomogram, Transmission Path Entirely in the Day Region



The solar activity factor is obtained from the predicted twelve month running average sun spot number. Predictions of this sun spot number are made three months in advance. The solar activity factor must be multiplied by the seasonal correction factor shown below to obtain the K or K<sub>d</sub> correction factor.

**SEASONAL CORRECTION FACTORS**

MONTH	BOTH TERMINALS		ONE TERMINAL N. LAT AND OTHER S. LAT
	N. LAT	S. LAT	
Jan	0.9	0.7	0.8
Feb	0.9	0.7	0.8
Mar	0.8	0.8	0.8
Apr	0.8	0.8	0.8
May	0.7	0.9	0.8
Jun	0.7	0.9	0.8
Jul	0.7	0.9	0.8
Aug	0.7	0.9	0.8
Sep	0.8	0.8	0.8
Oct	0.8	0.8	0.8
Nov	0.9	0.7	0.8
Dec	0.9	0.7	0.8

Figure 11-25. K or K<sub>d</sub> Correction Factors



Type of Service	Conditions	Bandwidth	Signal Strength in Decibels Above Reference Level
Double sideband radiotelephony	Speech grade quality at 100% modulation. 90% of the hour	6 kilocycles	8
Double sideband radiotelephony	High quality commercial service. 90% of the hour	6 kilocycles	33
Standard broadcast	High quality service	10 kilocycles	27
Single sideband radiotelephony	Speech grade quality, carrier suppressed 10 db, 90% of the hour	3 kilocycles	-1
Single sideband radiotelephony single channel	High quality, carrier suppressed 10 db, 90% of the hour	3 kilocycles	24
Single sideband radiotelephony, 2 channel	High quality, carrier suppressed 25 db, 90% of the hour	3 kilocycles	26
Manual continuous wave radiotelegraphy	15 words per minute, 90% of the hour	2 kilocycles	-9
Modulated manual continuous wave radiotelegraphy	30 words per minute, 90% of the hour	2 kilocycles	-5
Machine speed radiotelegraphy	150 words per minute, 2 element spaced diversity, 99.9% of the hour	1.5 kilocycles	3
Modulated machine speed radiotelegraphy	150 words per minute, 2 element spaced diversity, 99.9% of the hour	3 kilocycles	6
Carrier shift radioteletypewriter	150 wpm, 524 cycles shift each side of carrier, 2 element spaced diversity, 99.9% of the hour	1.7 kilocycles	5
Carrier shift duplex radioteletypewriter	150 wpm, 425 cycles shift each side of carrier, 2 channels operating simultaneously, 2 element spaced diversity, 99.9% of the hour	1.7 kilocycles	3
Interrupted carrier radioteletypewriter	150 words per minute, 2 element spaced diversity, 99.9% of the hour	3 kilocycles	8
Single sideband multitone radioteletypewriter	Single channel operation, carrier reduced 25 db, 2 element spaced diversity, 99.9% of the hour	3 kilocycles	8
Frequency modulation broadcast service	Broadcast quality	150 kilocycles	2
Facsimile	AM. subcarrier modulated, 2 element spaced diversity, 99.9% of the hour	6 kilocycles	11

Figure 11-26. Table of Service Gains, Sky Wave Communications, Fading Signal

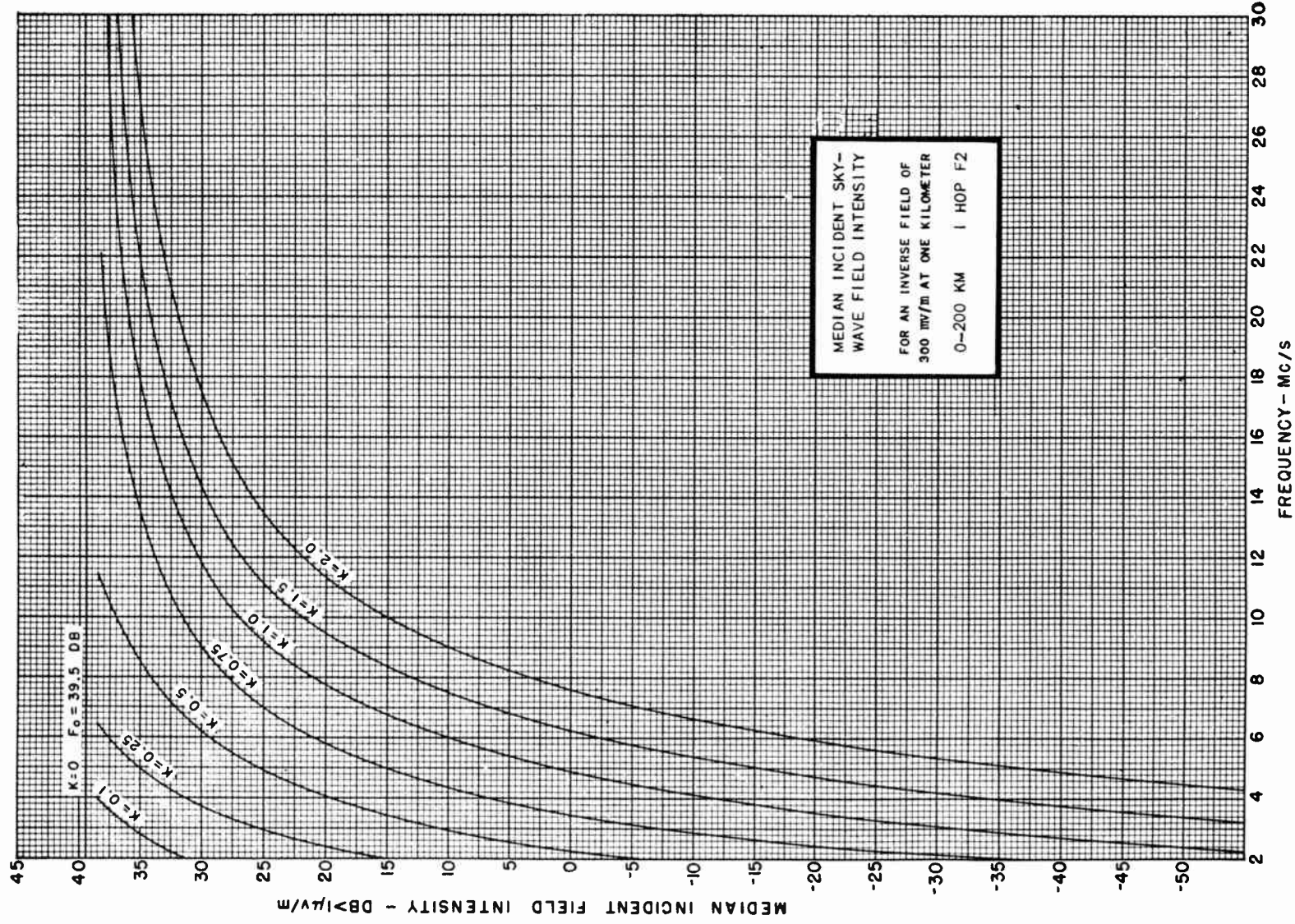

Figure 11-27. Median Incident Sky Wave Intensity, 0 to 200 km, 1-hop-F<sub>2</sub>



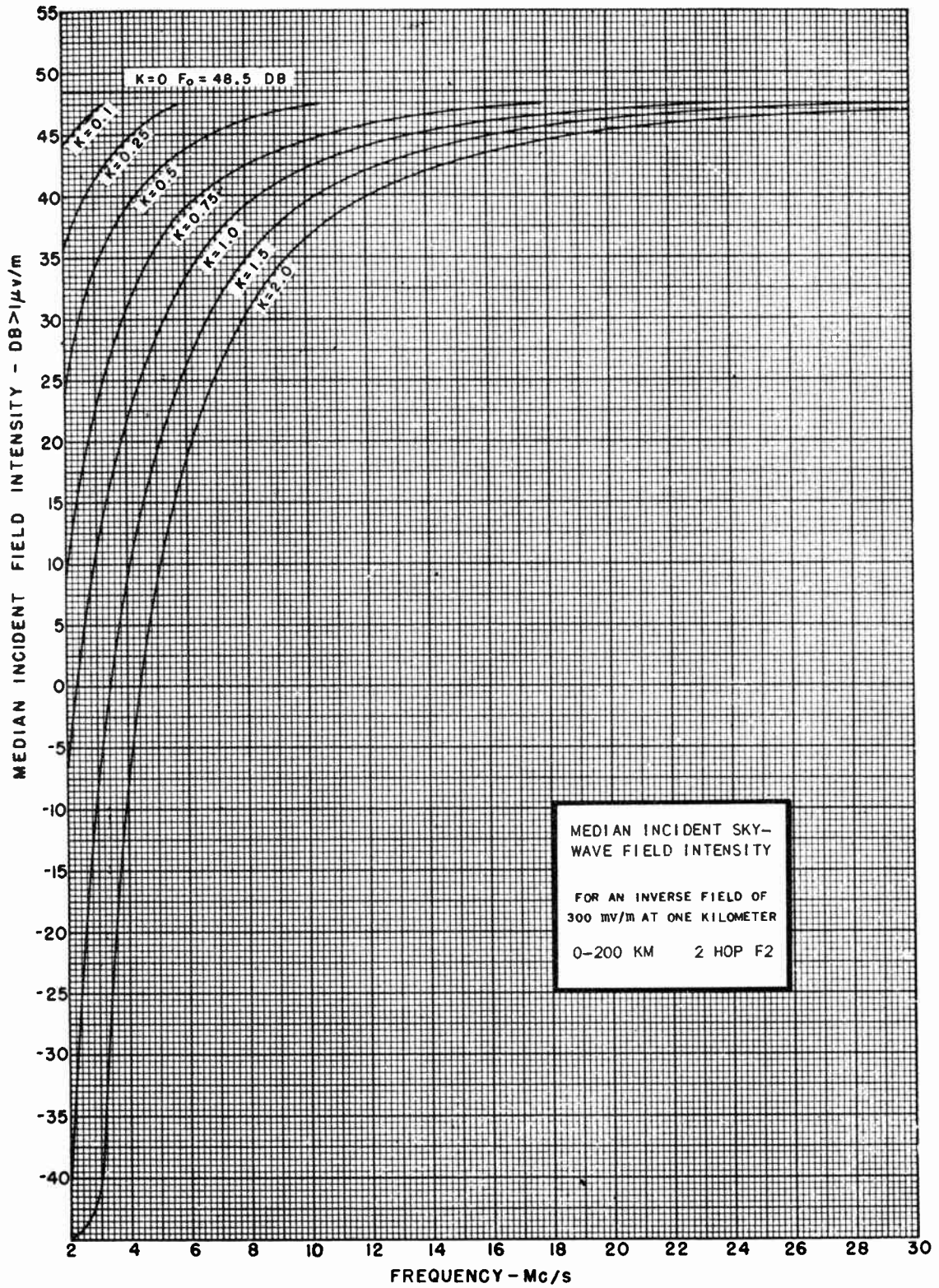

Figure 11-28. Median Incident Sky Wave Field Intensity, 0 to 200 km, 2-hop- $F_2$



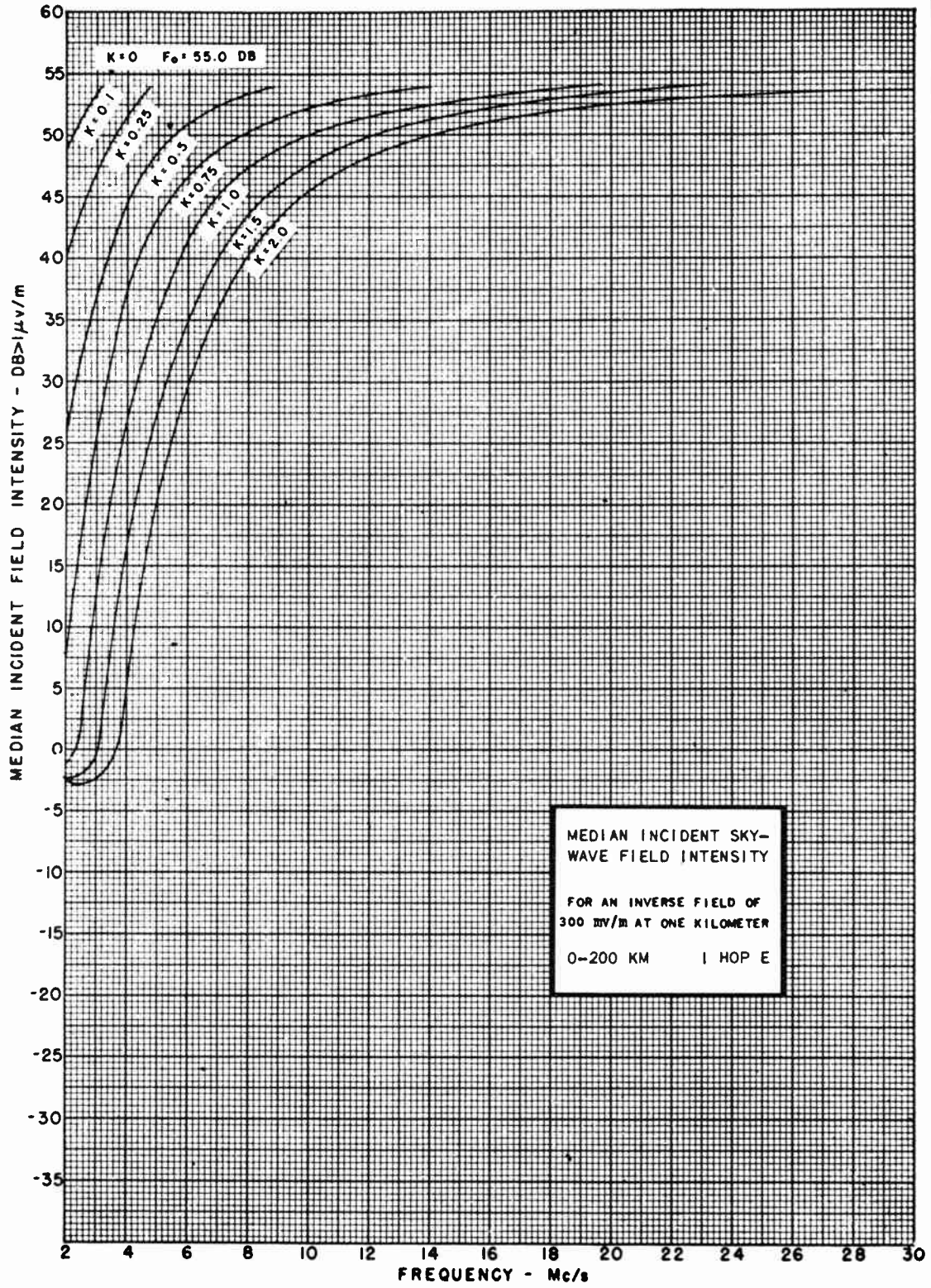

Figure 11-29. Median Incident Sky Wave Intensity, 0 to 200 km, 1-hop-E



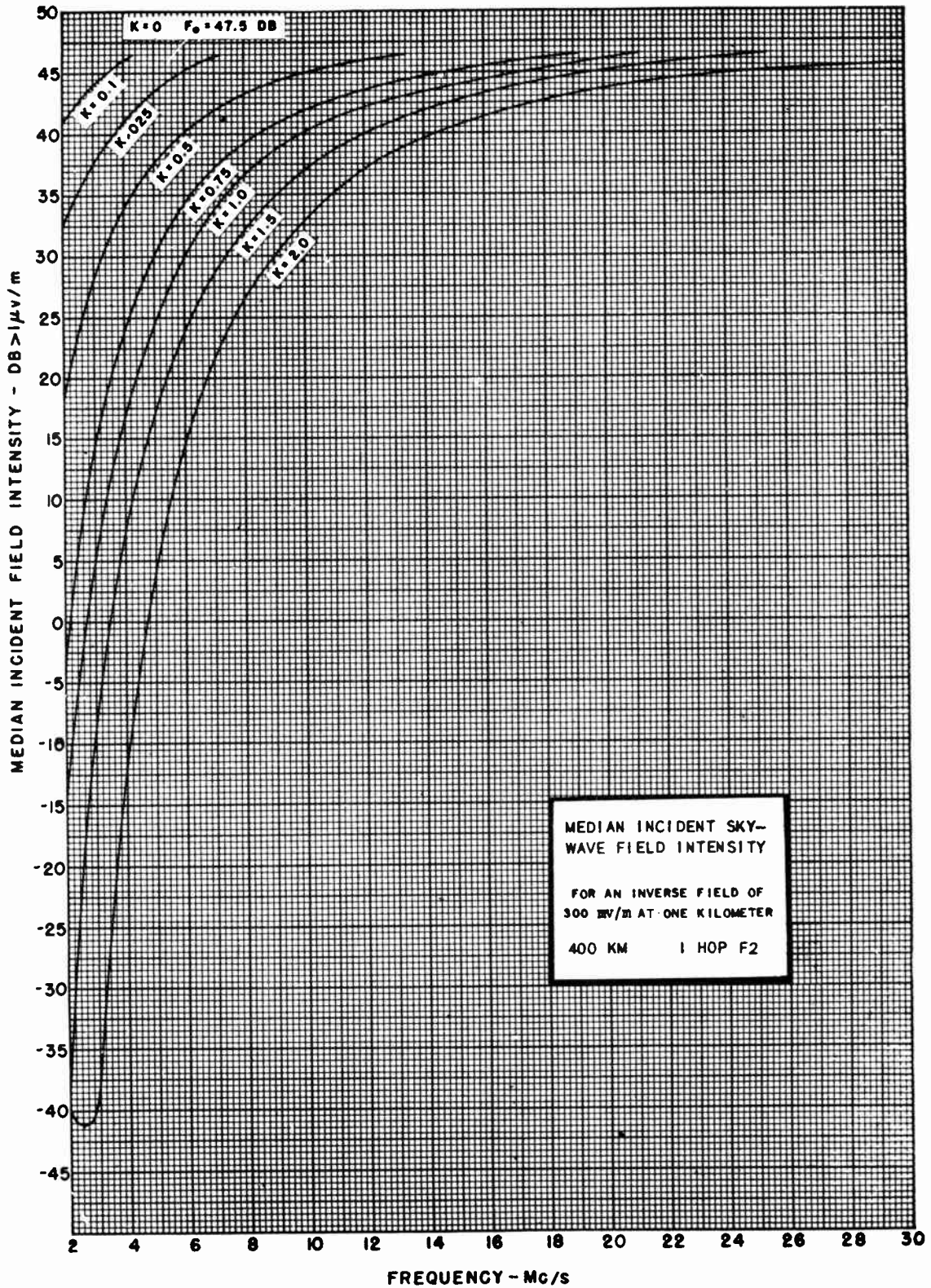

Figure 11-30. Median Incident Sky Wave Field Intensity, 400 km, 1-hop-F<sub>2</sub>



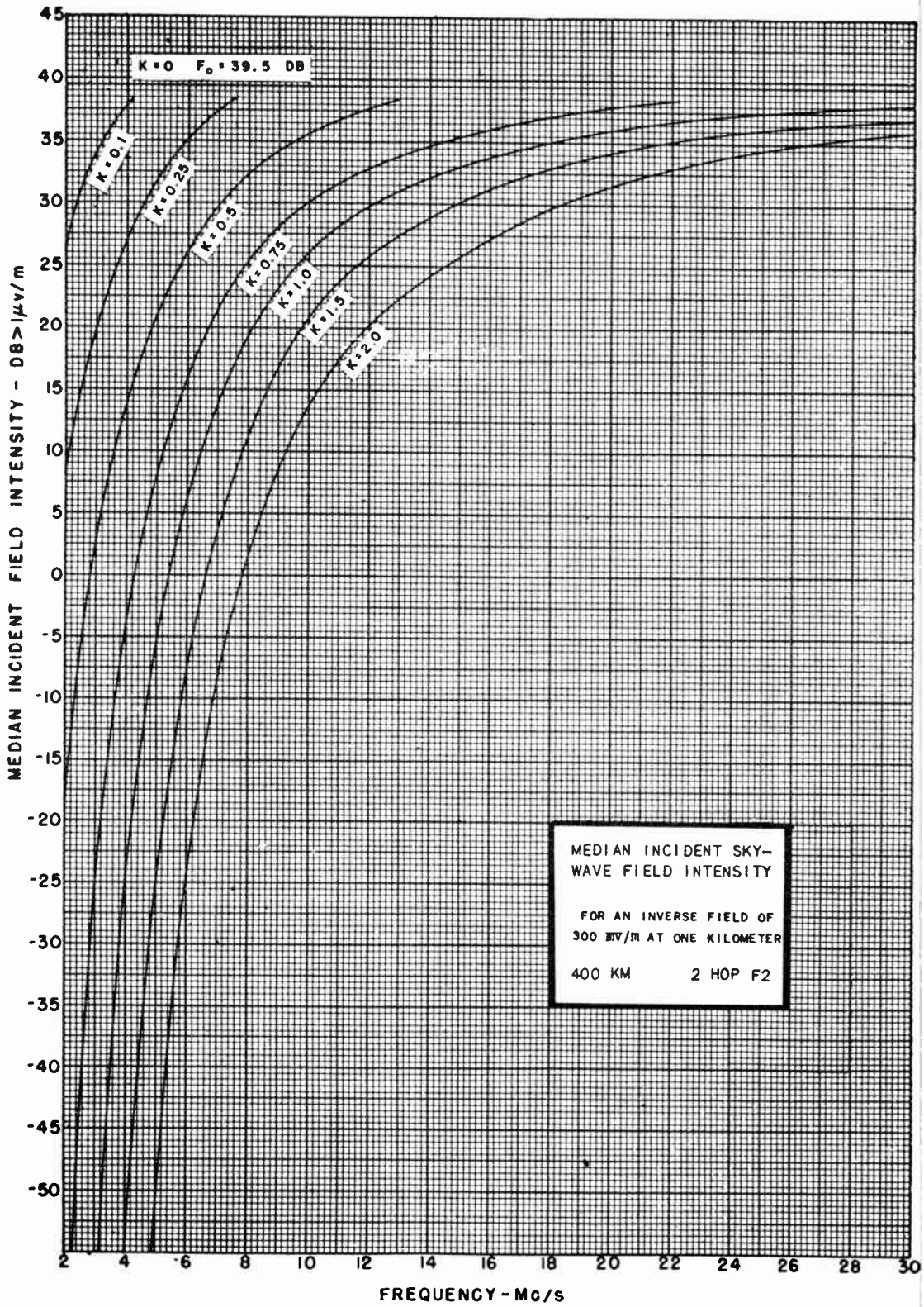

Figure 11-31. Median Incident Sky Wave Field Intensity, 400 km, 2-hop-F<sub>2</sub>



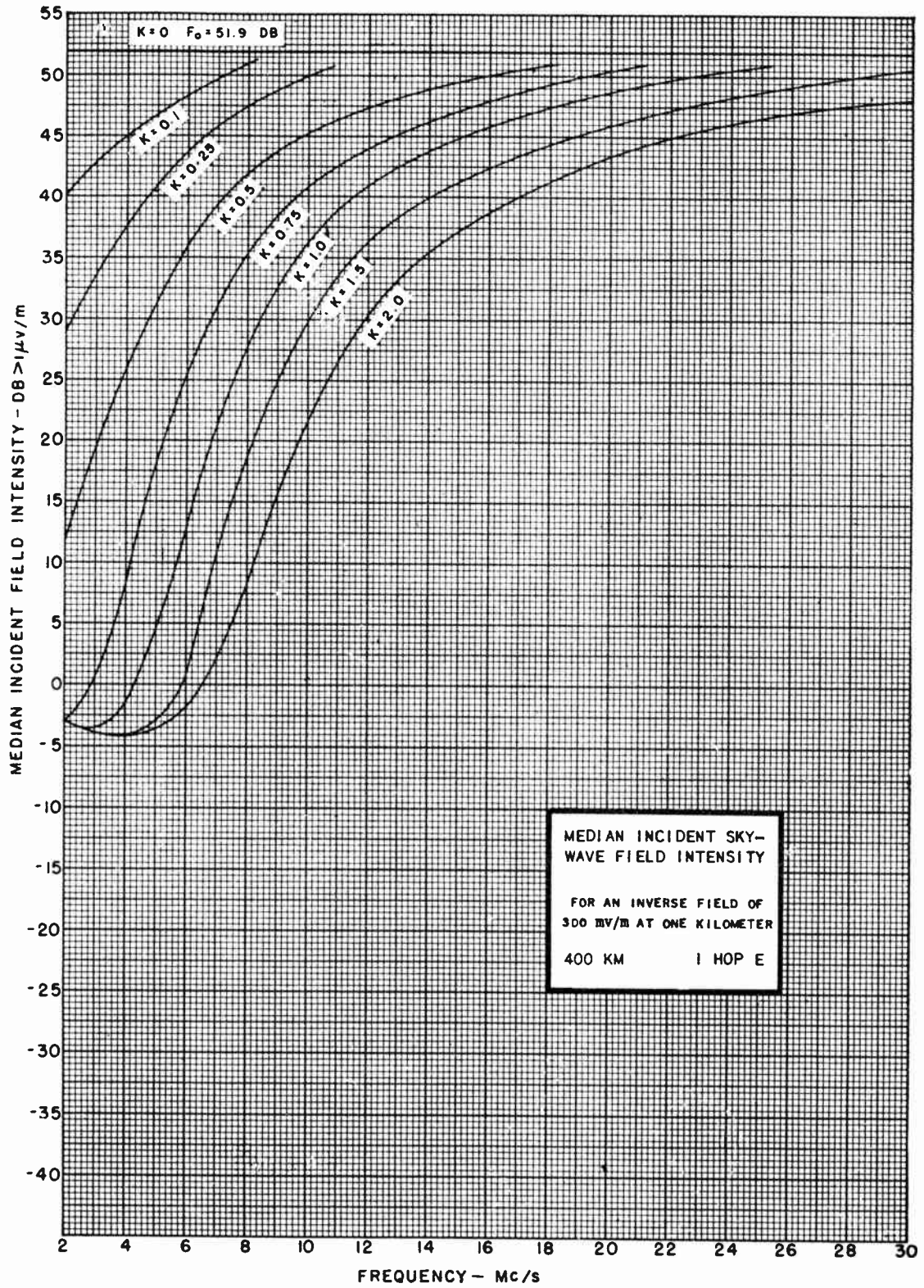

Figure 11-32. Median Incident Sky Wave Field Intensity, 400 km, 1-hop-E



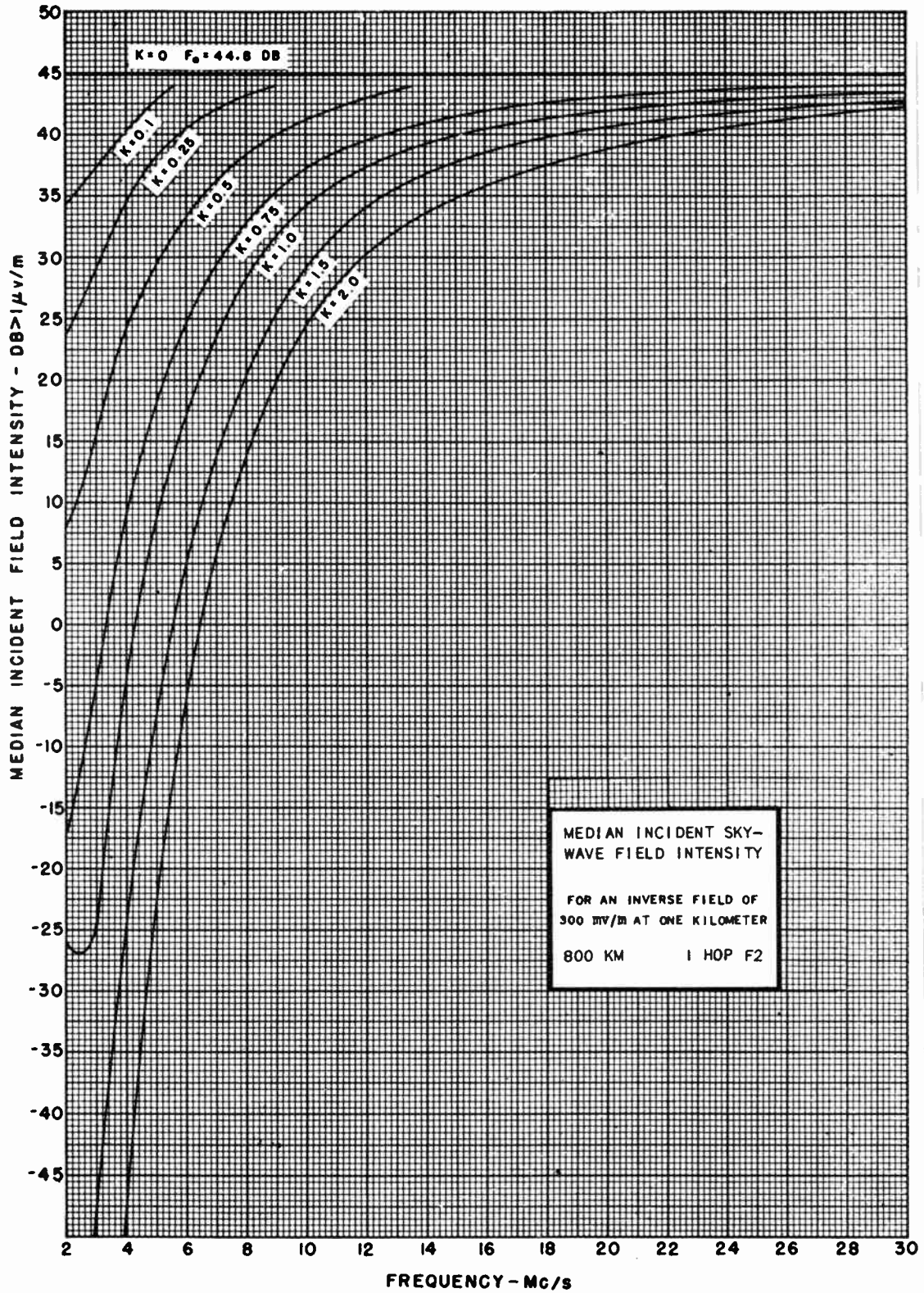

Figure 11-33. Median Incident Sky Wave Field Intensity, 800 km, 1-hop-F<sub>2</sub>



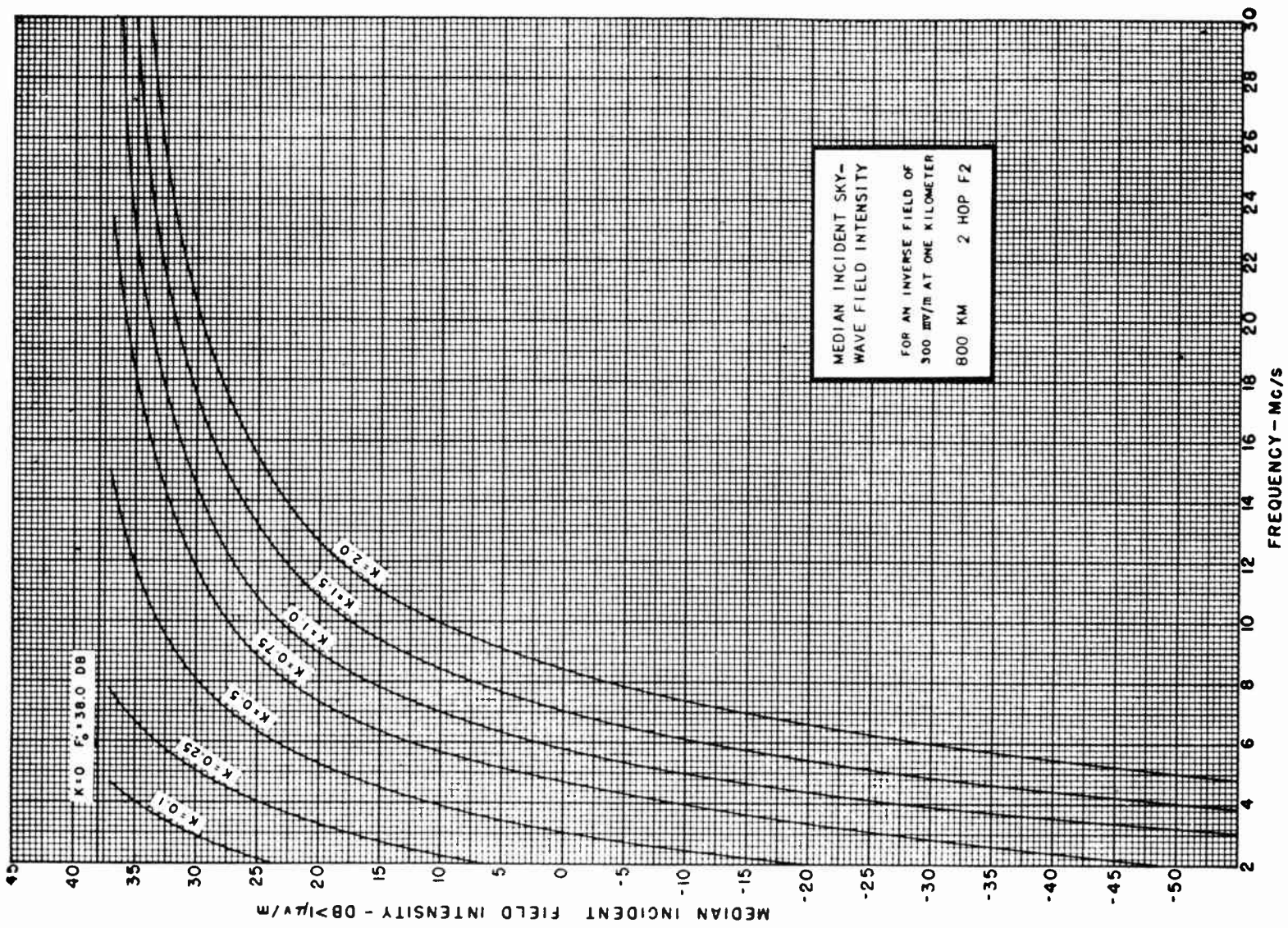
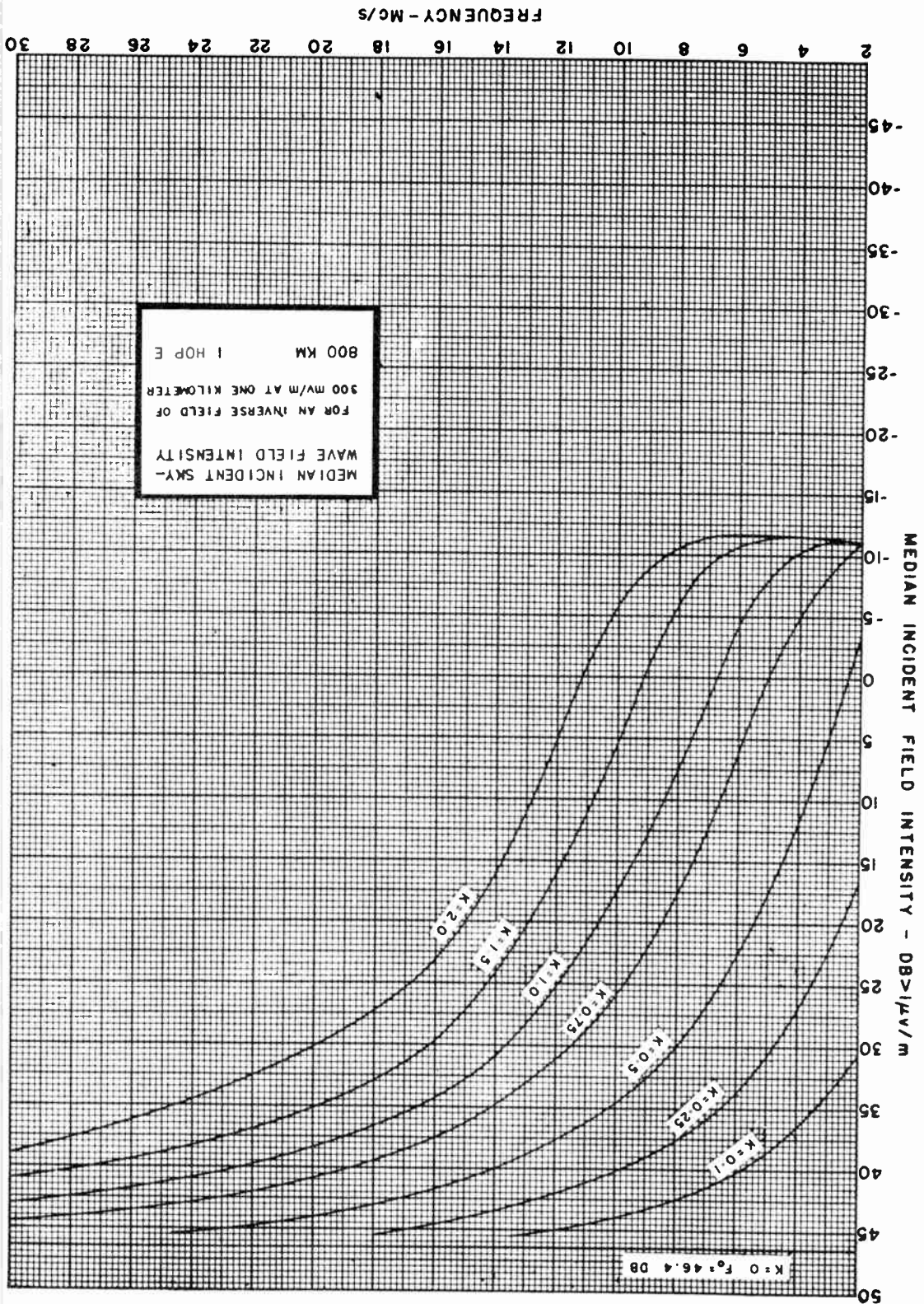

Figure 11-34. Median Incident Sky Wave Field Intensity, 800 km, 2-hop-F<sub>2</sub>



Figure 11-35. Median Incident Sky Wave Field Intensity, 800 km, 1-hop-E





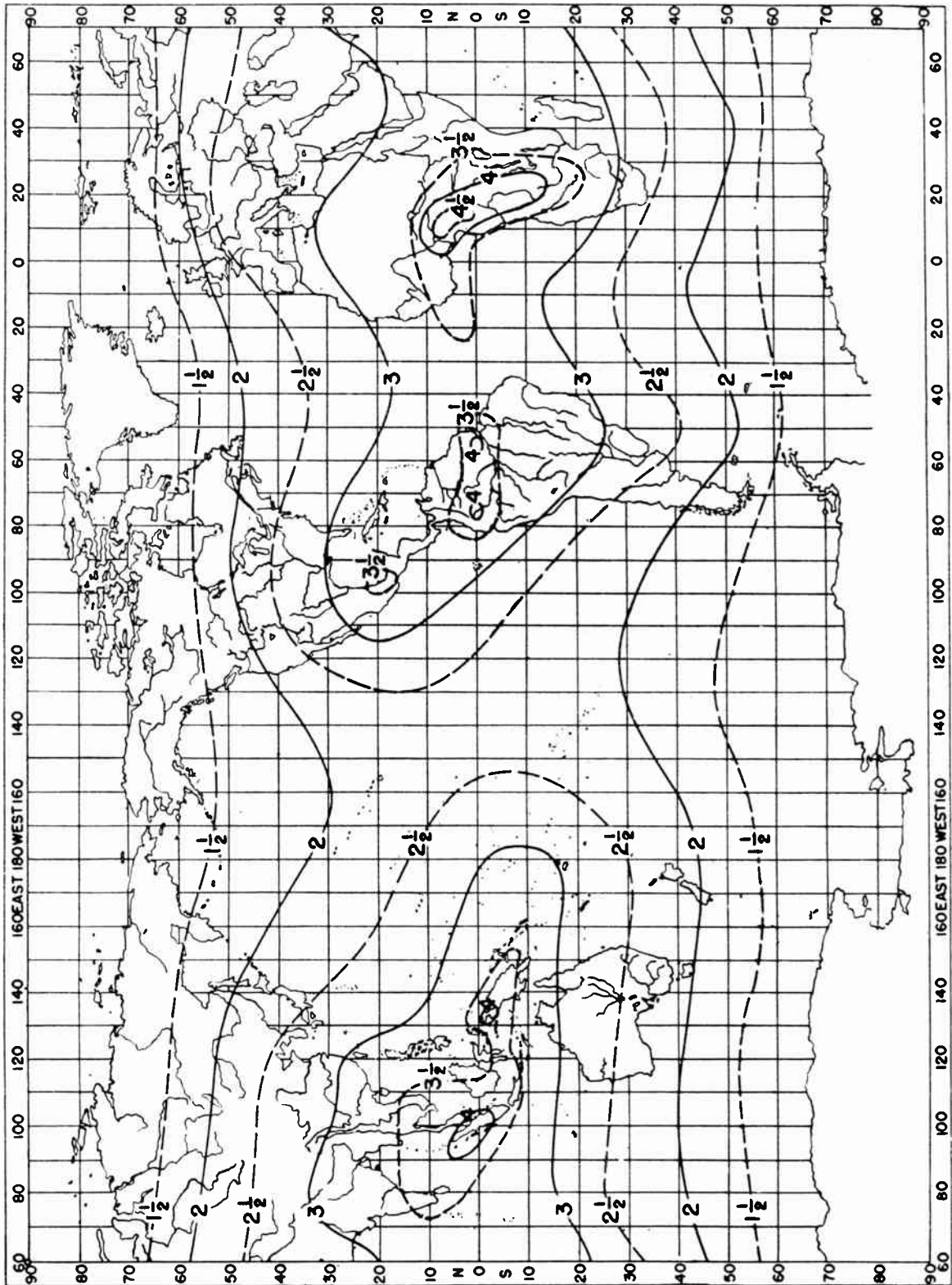
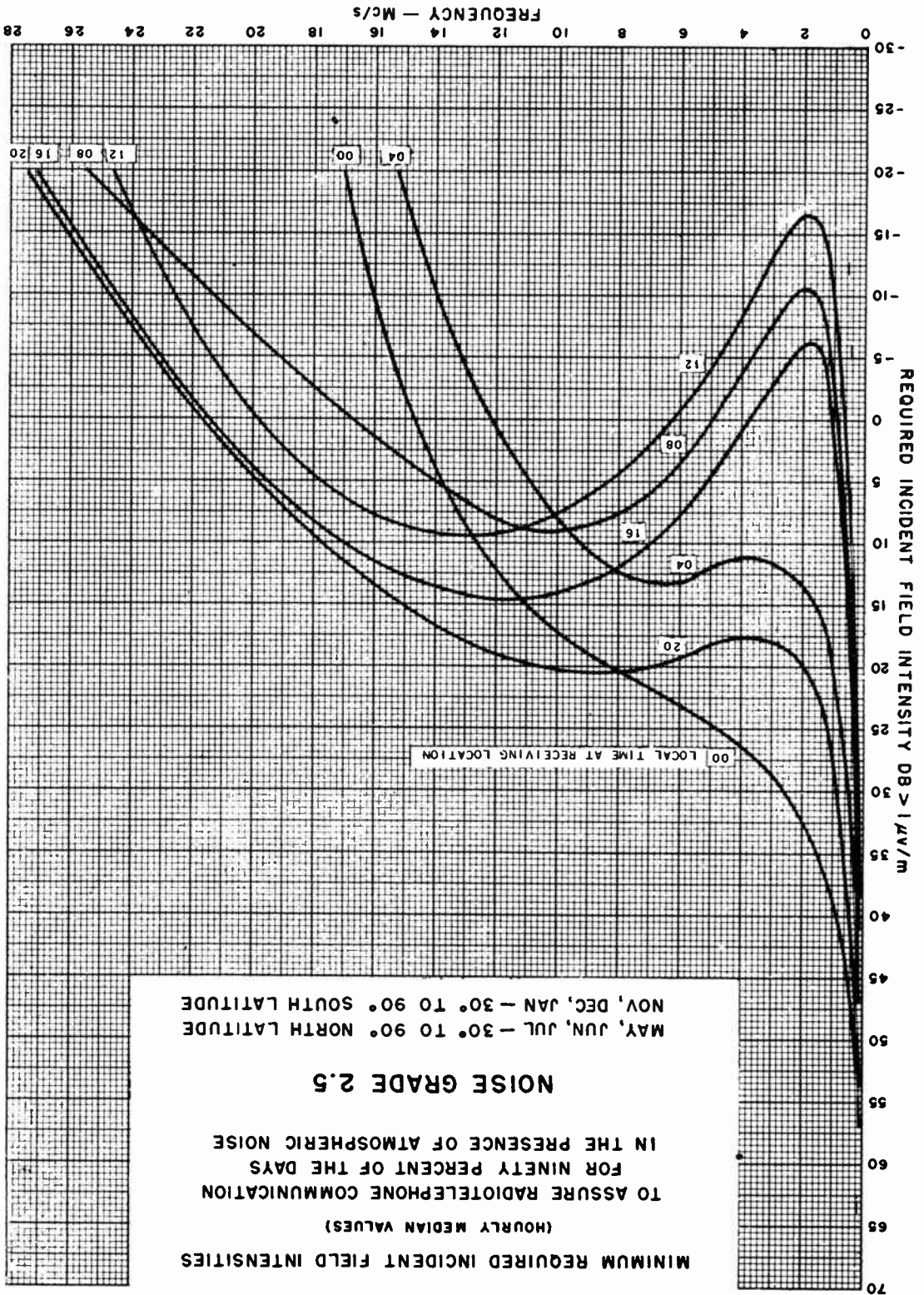

Figure 11-36. Noise Distribution Chart for March, April, and May

Figure 11-37. Minimum Required Incident Field Intensities, Noise Grade 2.5, Summer





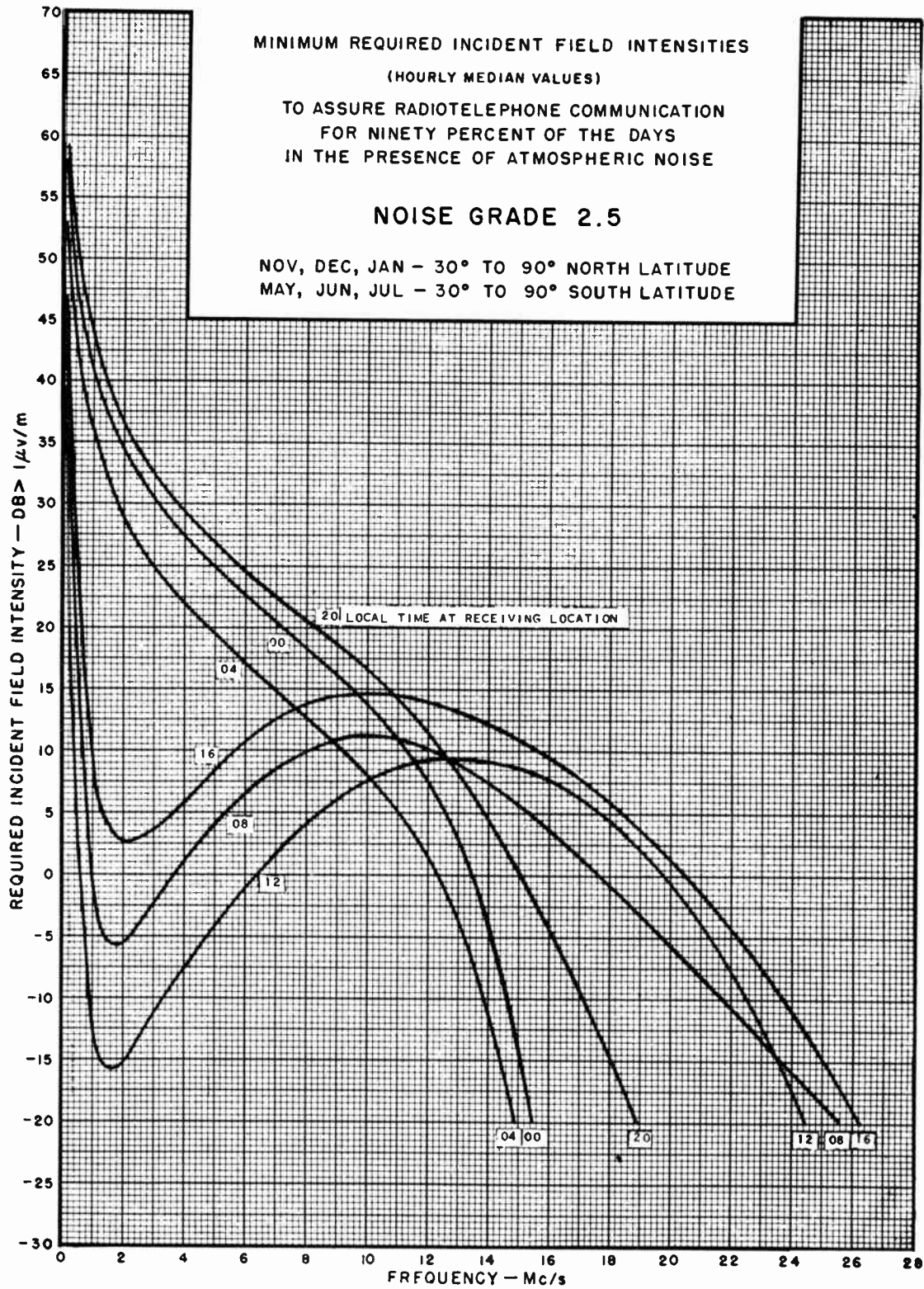
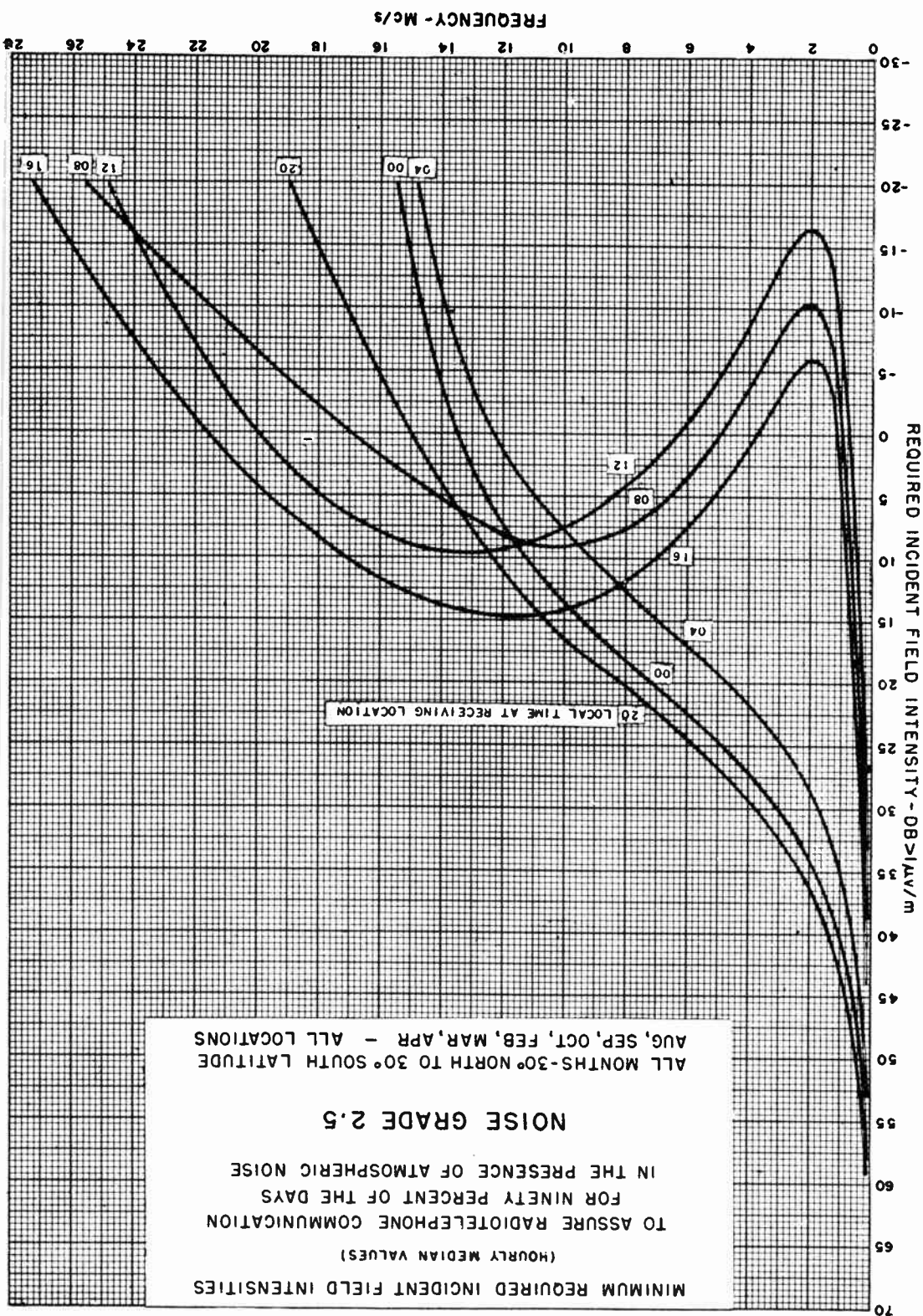

Figure 11-38. Minimum Required Incident Field Intensities, Noise Grade 2.5, Winter



Figure 11-39. Minimum Required Incident Field Intensities, Noise Grade 2.5, Equinox





MINIMUM REQUIRED INCIDENT FIELD INTENSITIES  
 (HOURLY MEDIAN VALUES)  
 TO ASSURE RADIOTELEPHONE COMMUNICATION  
 FOR NINETY PERCENT OF THE DAYS  
 IN THE PRESENCE OF SET NOISE ONLY

AND

DISCRIMINATION GAINS WHEN RECEIVING  
 IN THE PRESENCE OF ATMOSPHERIC NOISE

FOR

15' WHIP ANTENNA

CURVES ARE FOR VARIOUS VERTICAL ANGLES OF WAVE ARRIVAL  
 MEASURED FROM THE HORIZONTAL PLANE

ERECTED OVER "POOR" GROUND,  $\epsilon = 4, \sigma = 10^{-3}$  MHOS/M

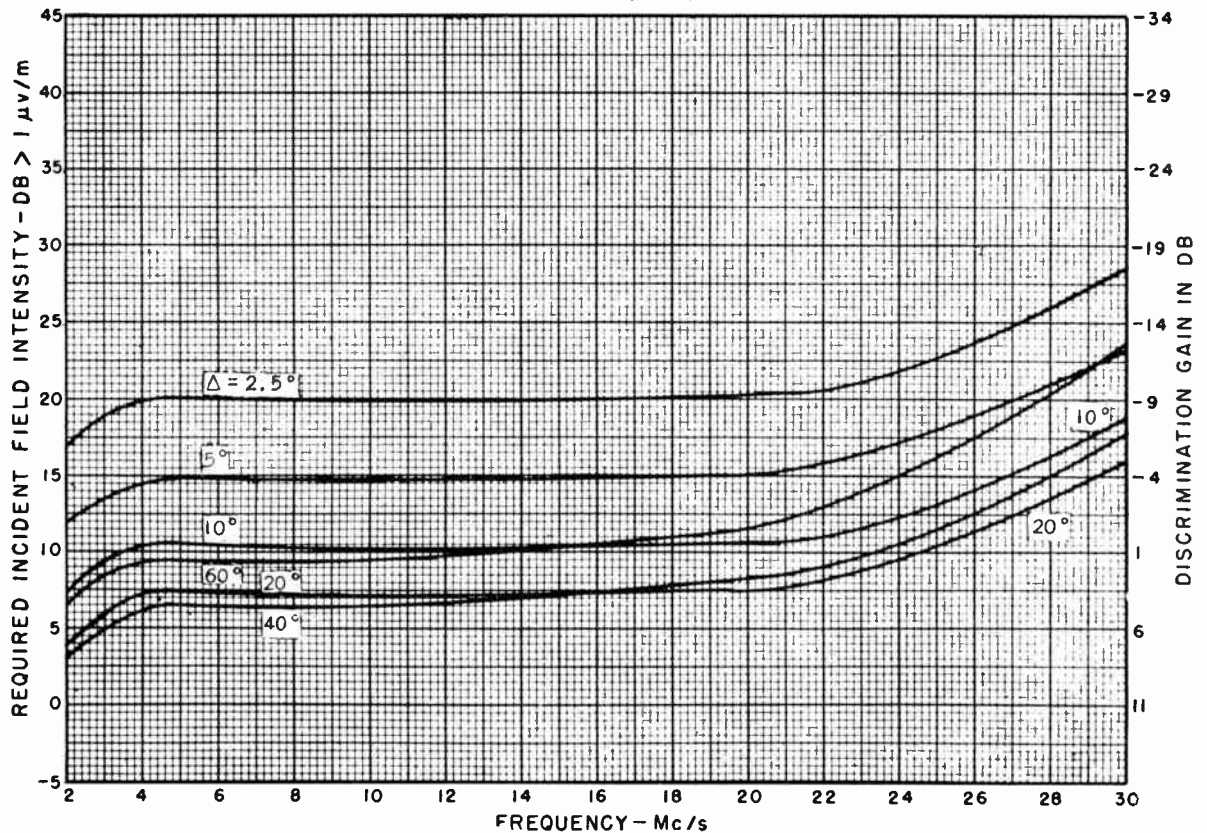

Figure 11-40. Minimum Required Incident Field Intensities and Discrimination Gain, 15-foot Whip Antenna

MINIMUM REQUIRED INCIDENT FIELD INTENSITIES  
(HOURLY MEDIAN VALUES)

TO ASSURE RADIOTELEPHONE COMMUNICATION  
FOR NINETY PERCENT OF THE DAYS  
IN THE PRESENCE OF SET NOISE ONLY

AND

DISCRIMINATION GAINS WHEN RECEIVING  
IN THE PRESENCE OF ATMOSPHERIC NOISE

FOR

$\lambda/4$  GROUNDED VERTICAL ANTENNA

CURVES ARE FOR VARIOUS VERTICAL ANGLES OF WAVE ARRIVAL  
MEASURED FROM THE HORIZONTAL PLANE

ERECTED OVER "POOR" GROUND,  $\epsilon = 4, \sigma = 10^{-3}$  MHOS/M

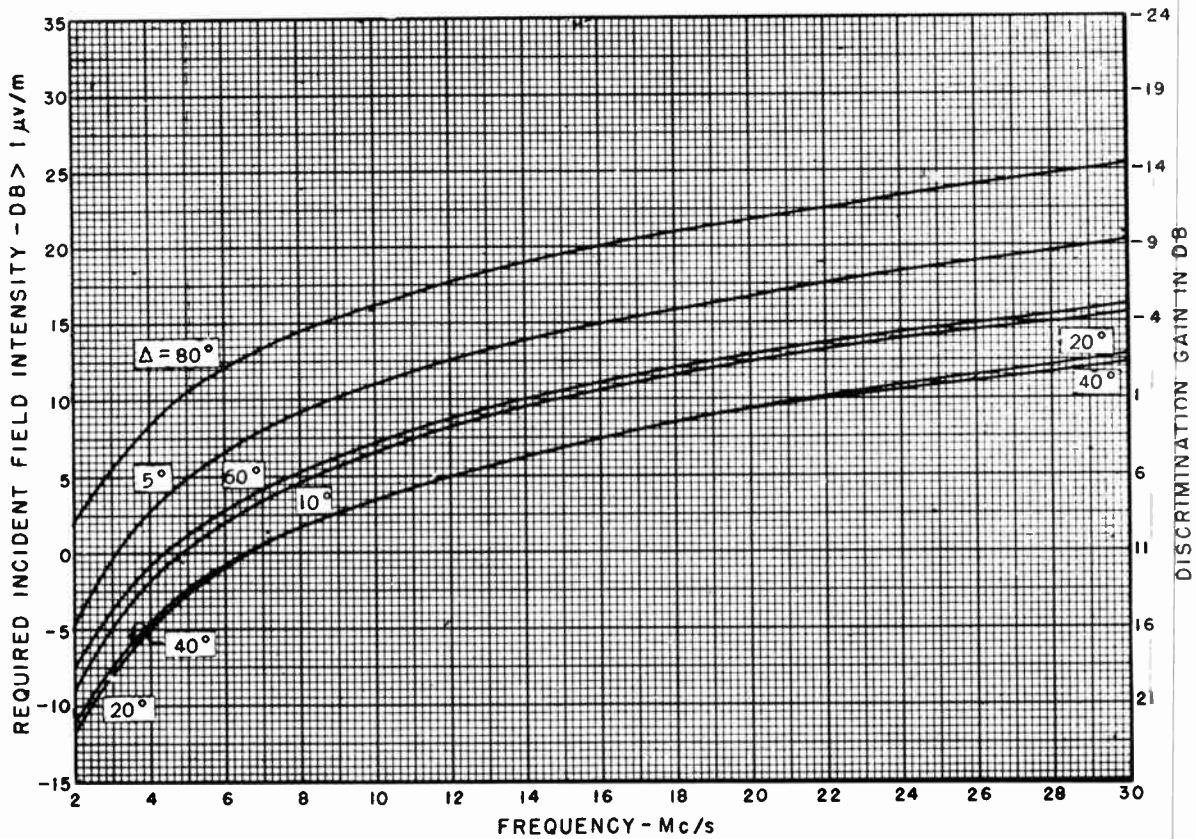

Figure 11-41. Minimum Required Incident Field Intensities and Discrimination Gain,  $\lambda/4$ -Wave Grounded Vertical Antenna



MINIMUM REQUIRED INCIDENT FIELD INTENSITIES  
 (HOURLY MEDIAN VALUES)  
 TO ASSURE RADIOTELEPHONE COMMUNICATION  
 FOR NINETY PERCENT OF THE DAYS  
 IN THE PRESENCE OF SET NOISE ONLY

AND

DISCRIMINATION GAINS WHEN RECEIVING  
 IN THE PRESENCE OF ATMOSPHERIC NOISE

FOR

**$\lambda/2$  GROUNDED VERTICAL ANTENNA**

CURVES ARE FOR VARIOUS VERTICAL ANGLES OF WAVE ARRIVAL  
 MEASURED FROM THE HORIZONTAL PLANE  
 TRANSMISSION LINE FED FROM BASE OF ANTENNA WITHOUT  
 IMPEDANCE MATCHING NETWORK  
 RADIATION RESISTANCE ASSUMED 5000 OHMS

ERECTED OVER "POOR" GROUND,  $\epsilon = 4, \sigma = 10^{-3}$  MHOS/M

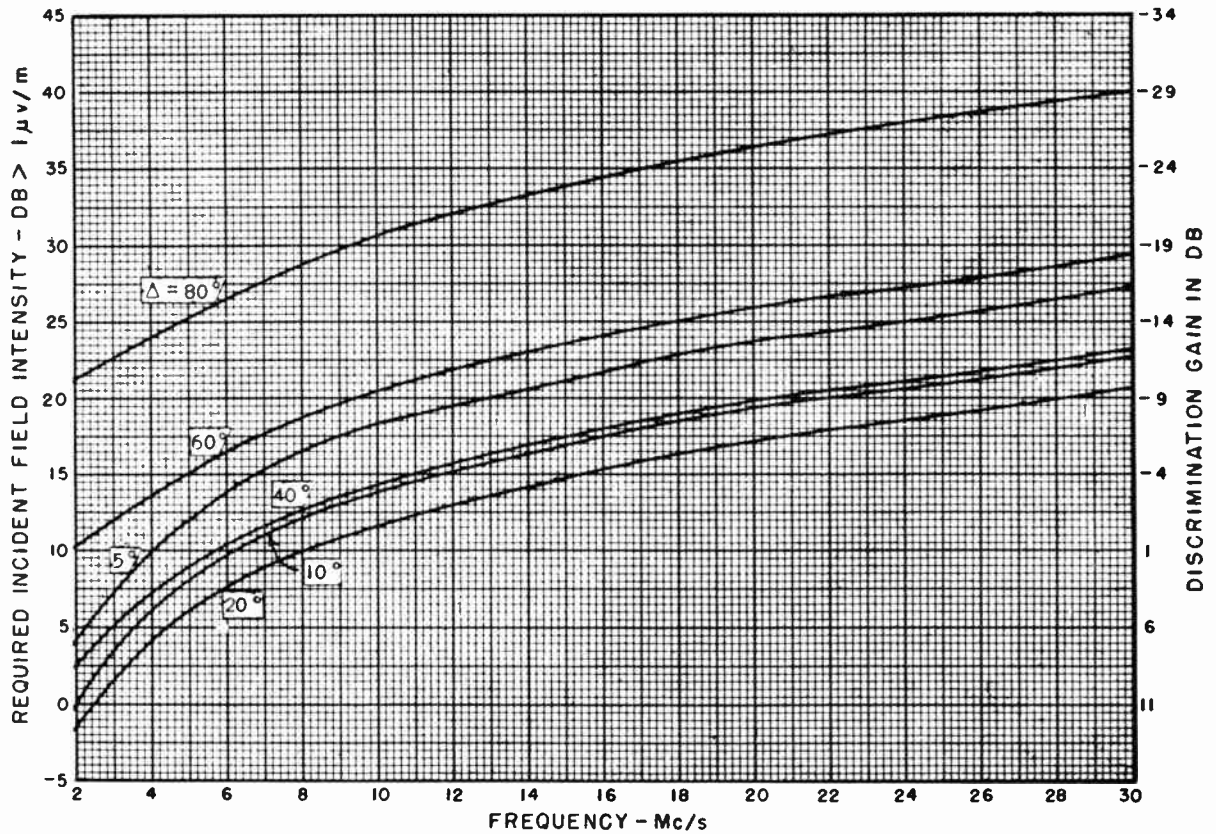

Figure 11-42. Minimum Required Incident Field Intensities and Discrimination Gain,  $\lambda/2$ -Wave Grounded Vertical Antenna, Transmission Line Fed from Base of Antenna

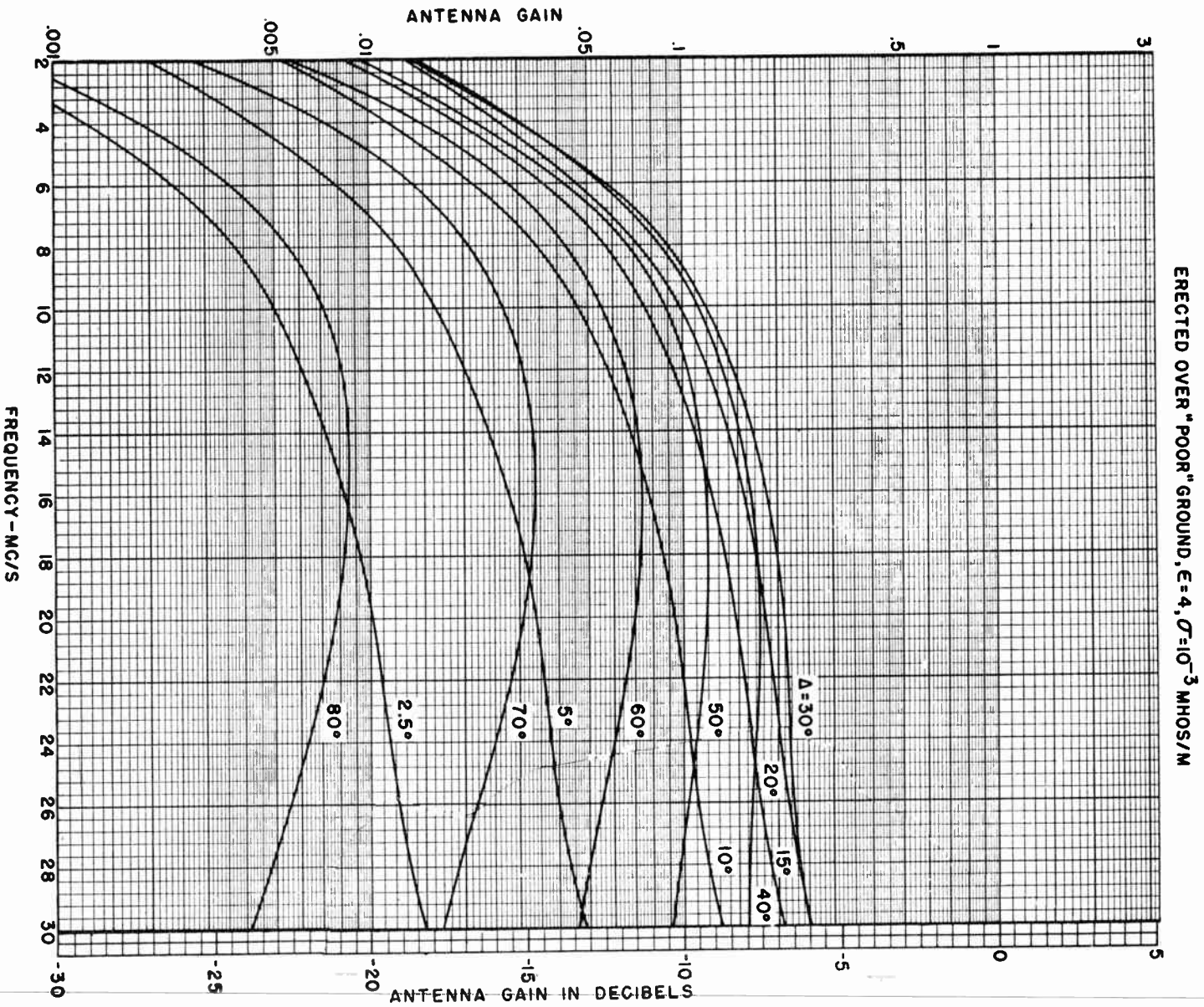

Figure 11-43. Gain Curves, 15-foot Whip Antenna Erected Above Poor Ground



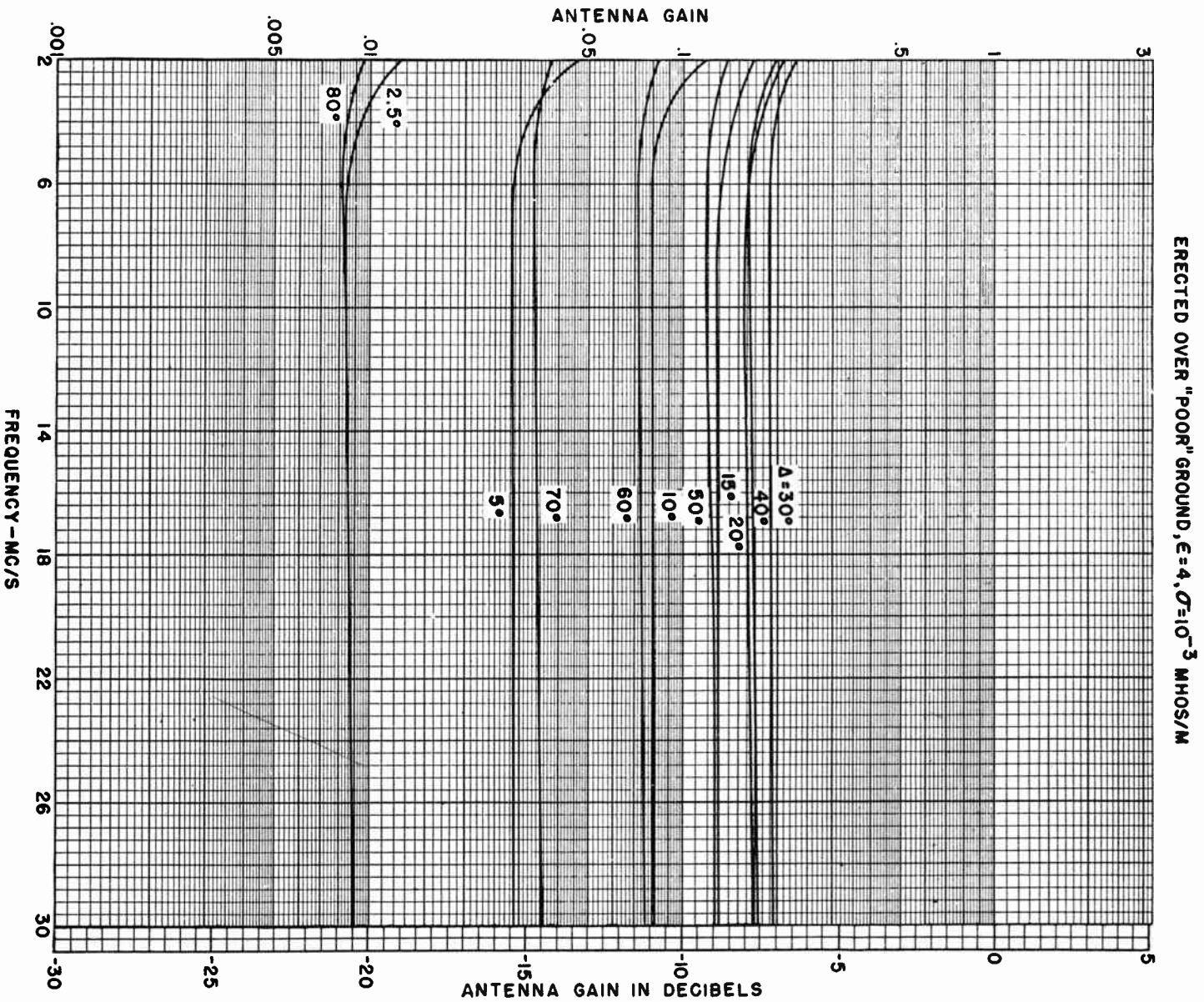

Figure 11-44. Gain Curves, 1/4-Wave Vertical Antenna Erected Above Poor Ground



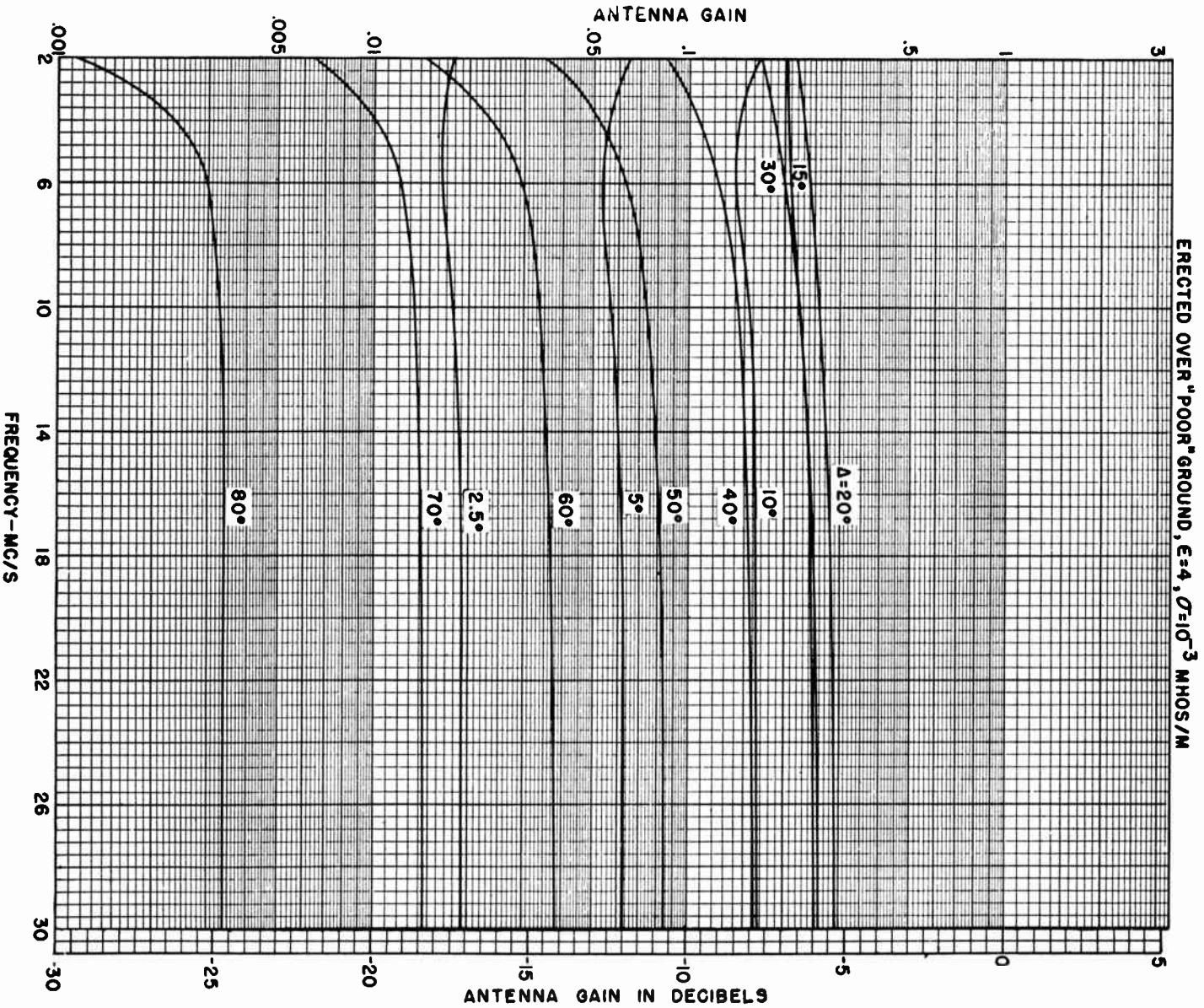

Figure 11-45. Gain Curves, 1/2-Wave Vertical Antenna Erected Above Poor Ground



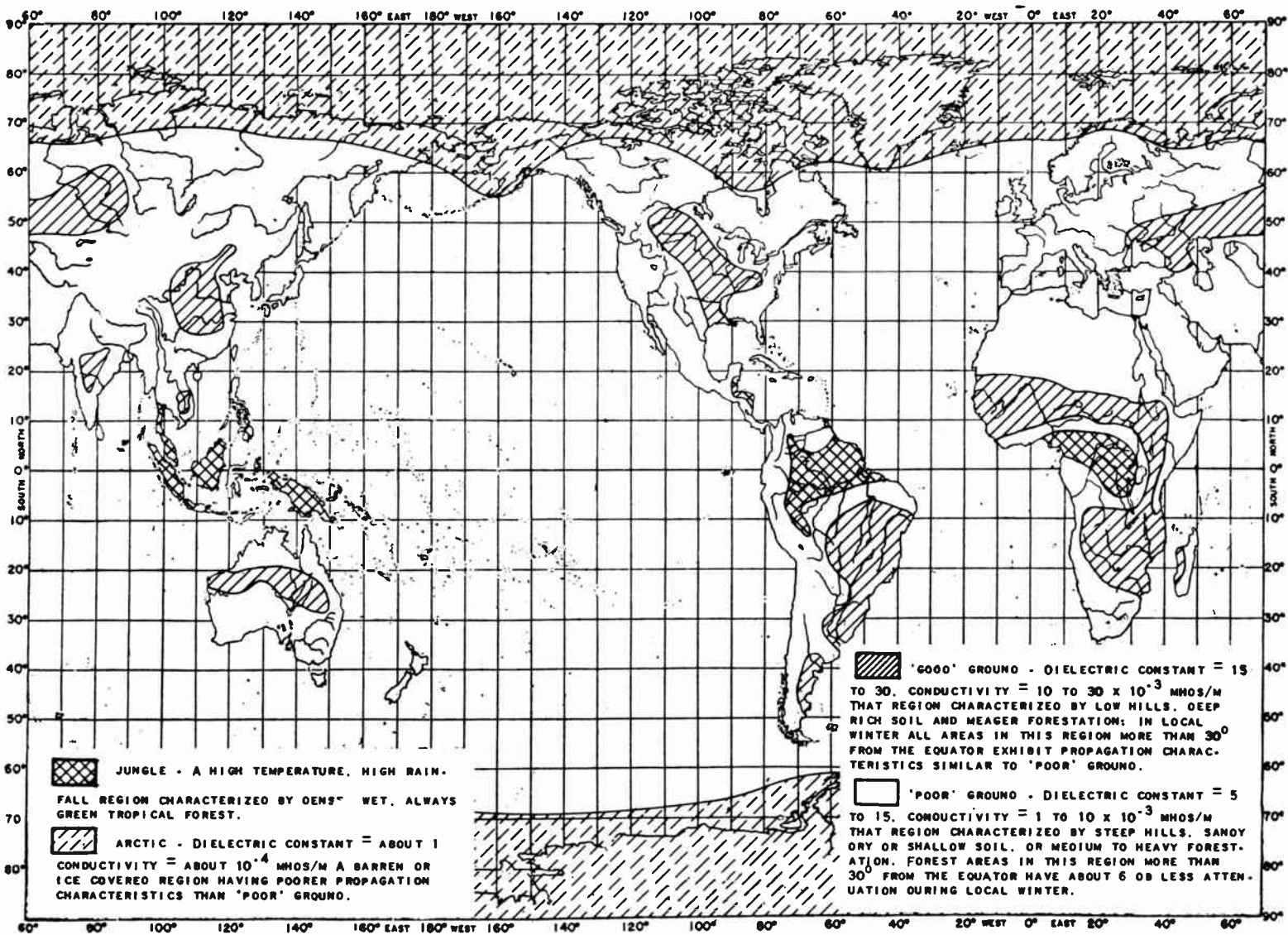

Figure 11-46. World Map Showing Various Types of Terrain

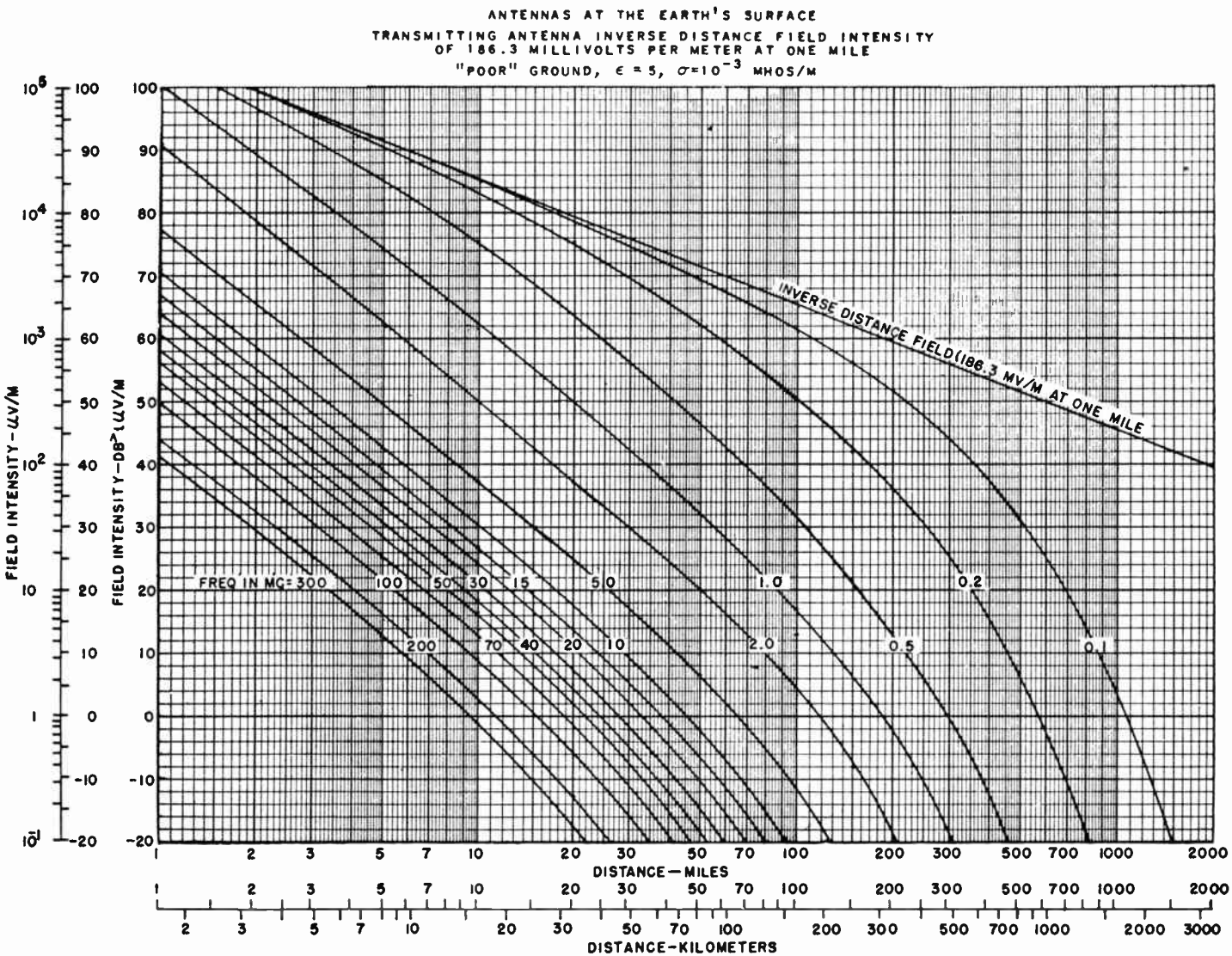

Figure 11-47. Ground-Wave Field Intensity Versus Distance Curves for Various Frequencies in mc, for Vertical Polarization, 1-2, 000 miles--Poor Ground



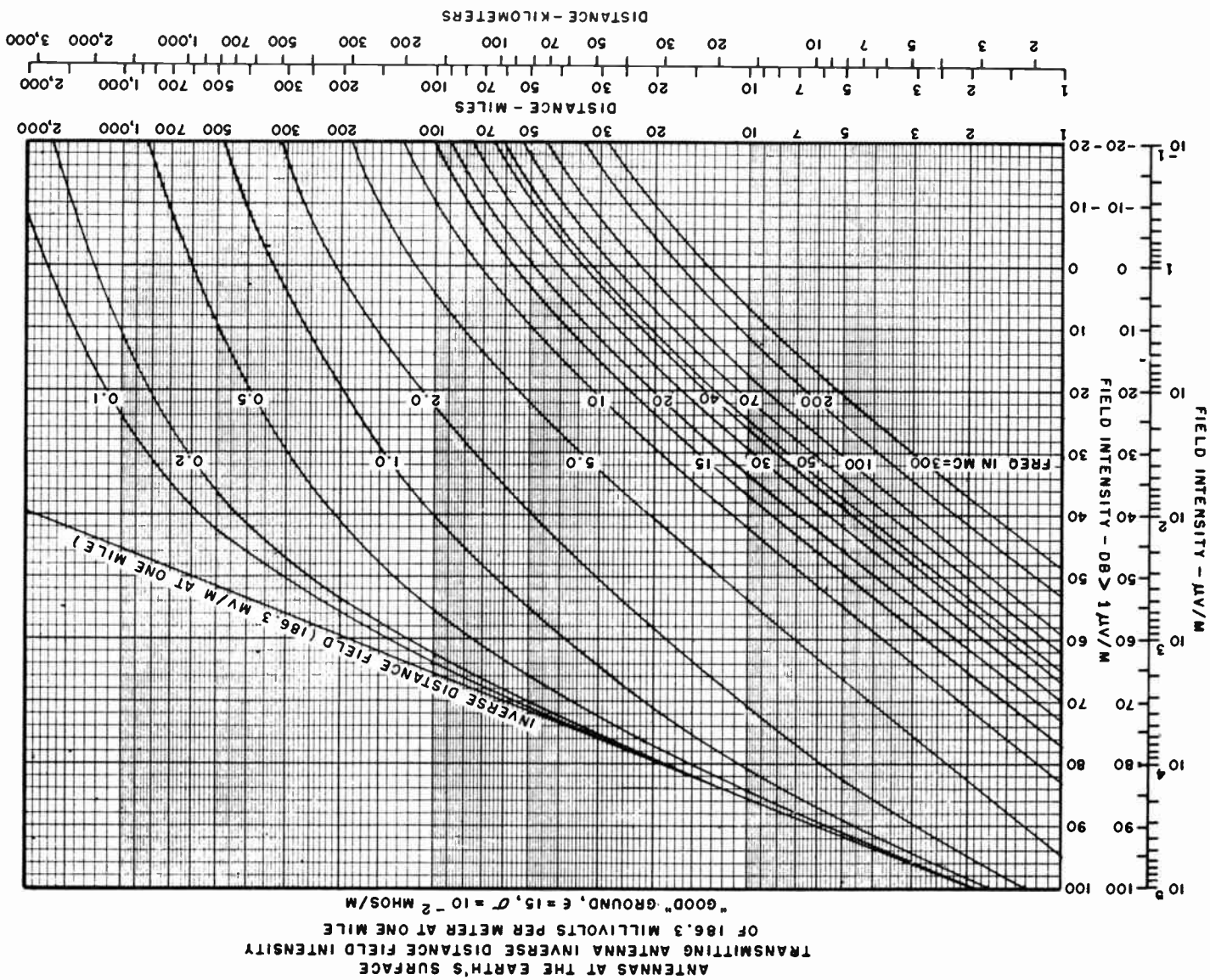

Figure 11-48. Ground-Wave Field Intensity Versus Distance Curves for Various Frequencies in mc, for Vertical Polarization, 1-2,000 miles-Good Ground

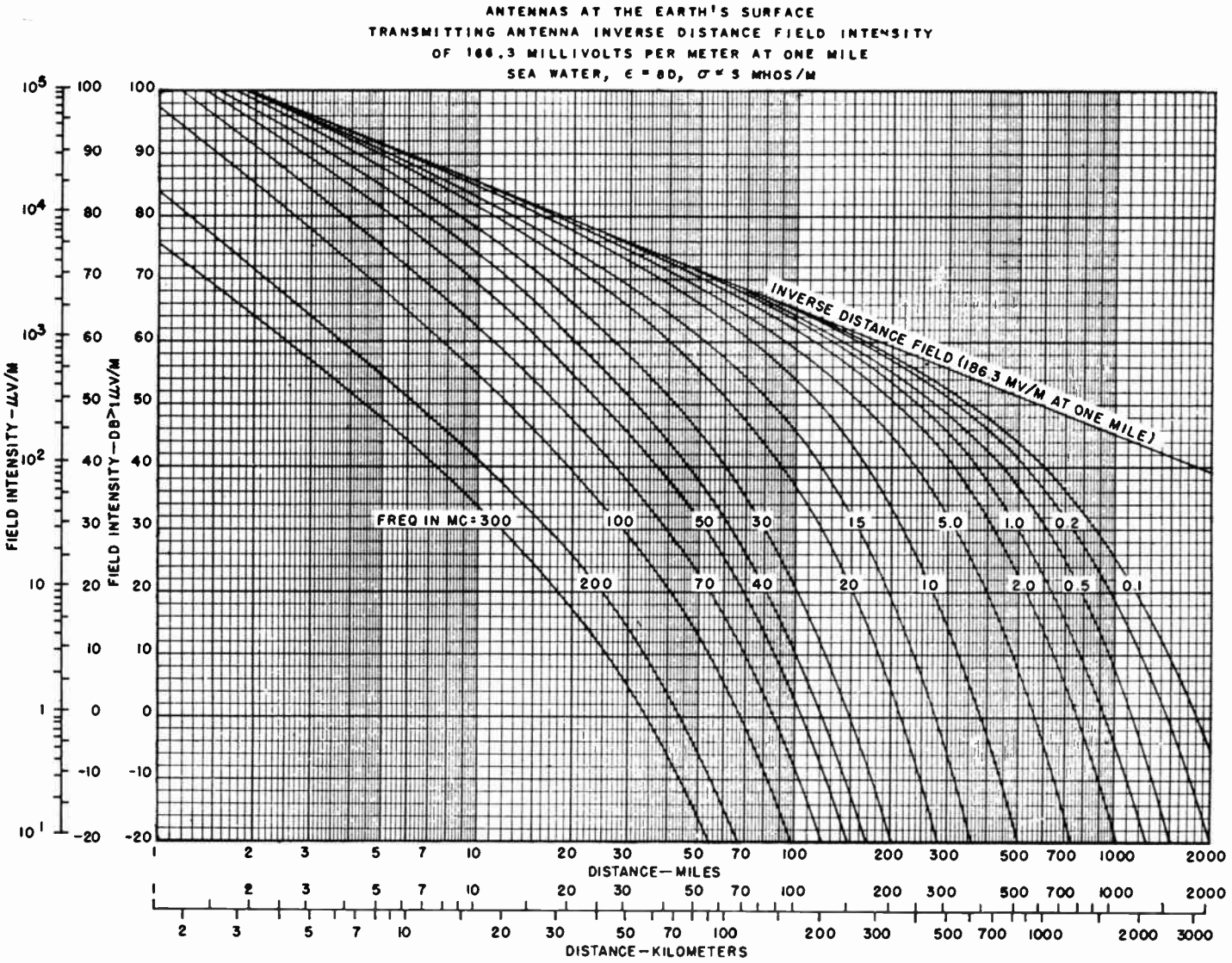

Figure 11-49. Ground-Wave Field Intensity Versus Distance Curves for Various Frequencies in mc, for Vertical Polarization, 1-2, 000 miles--Sea Water



MINIMUM REQUIRED GROUND-WAVE FIELD INTENSITY  
 (HOURLY MEDIAN VALUES)  
 TO ASSURE RADIOTELEPHONE COMMUNICATION  
 FOR NINETY PERCENT OF THE DAYS  
 IN THE PRESENCE OF SET NOISE ONLY  
 AND  
 DISCRIMINATION GAINS WHEN RECEIVING  
 IN THE PRESENCE OF ATMOSPHERIC NOISE  
 FOR  
 VARIOUS ANTENNAS

GROUND SYSTEM IS ASSUMED TO CONSIST OF COUNTERPOISE  
 OR BURIED OR SURFACE RADIAL WIRES EACH EXTENDING  
 IN LENGTH AT LEAST EQUIVALENT TO HEIGHT OF ANTENNA

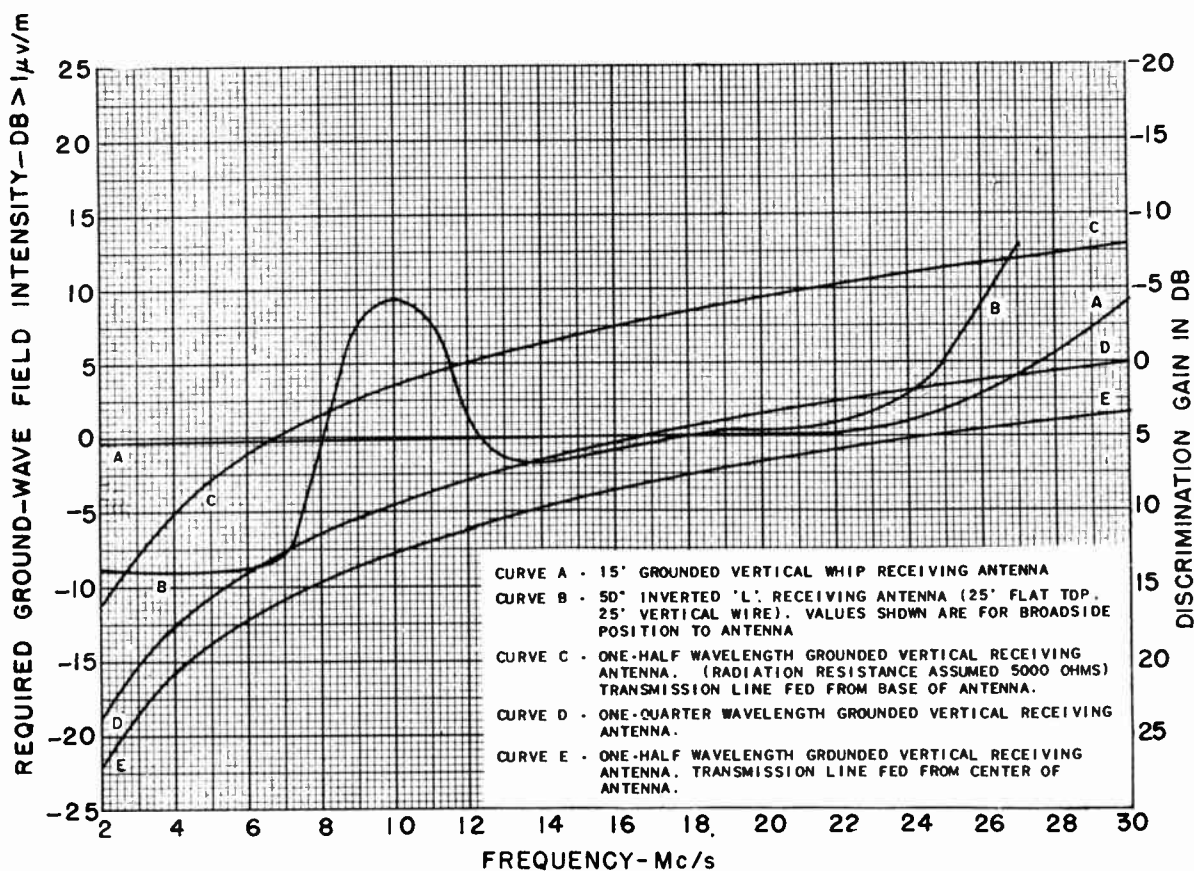

Figure 11-50. Minimum Required Field Intensity in the Presence of Set Noise, and Discrimination Gains in the Presence of Atmospheric Noise, for Various Antennas

Type of Service	Conditions	Bandwidth	Signal Strength in Decibels Above Reference Level
Double sideband radiotelephony	Speech grade quality at 100% modulation	6 kilocycles	0
Double sideband radiotelephony	High quality commercial service	6 kilocycles	25
Standard broadcast	High quality service	10 kilocycles	27
Single sideband radiotelephony	Speech grade quality, carrier suppressed 10 db	3 kilocycles	-9
Single sideband radiotelephony, single channel	High quality, carrier suppressed 10 db	3 kilocycles	16
Single sideband radiotelephony, 2-channel	High quality service	3 kilocycles	18
Manual continuous wave radiotelegraphy	15 words per minute	2 kilocycles	-17
Modulated manual continuous wave radiotelegraphy	30 words per minute	2 kilocycles	-13
Machine speed radiotelegraphy	150 words per minute	1.5 kilocycles	-11
Modulated machine speed radiotelegraphy	150 words per minute	3 kilocycles	-8
Carrier shift radioteletypewriter	150 wpm, 425 cycles shift each side of carrier	1.7 kilocycles	-9
Carrier shift duplex radioteletypewriter	150 wpm, 425 cycles shift each side of carrier, 2 channels operating simultaneously	1.7 kilocycles	-11
Interrupted carrier radioteletypewriter	150 words per minute	3 kilocycles	-6
Single sideband multitone radioteletypewriter	Single channel operation, carrier suppressed 25 db	3 kilocycles	-6
Frequency modulation broadcast service	Broadcast quality	150 kilocycles	2
Facsimile		6 kilocycles	-3

Figure 11-51. Service Gains, Ground-Wave Communication, Nonfading Signal

GROUND SYSTEM IS ASSUMED TO CONSIST OF A COUNTERPOISE  
OR OF BURIED OR SURFACE RADIAL WIRES EACH EXTENDING  
IN LENGTH AT LEAST EQUIVALENT TO THE ANTENNA HEIGHT

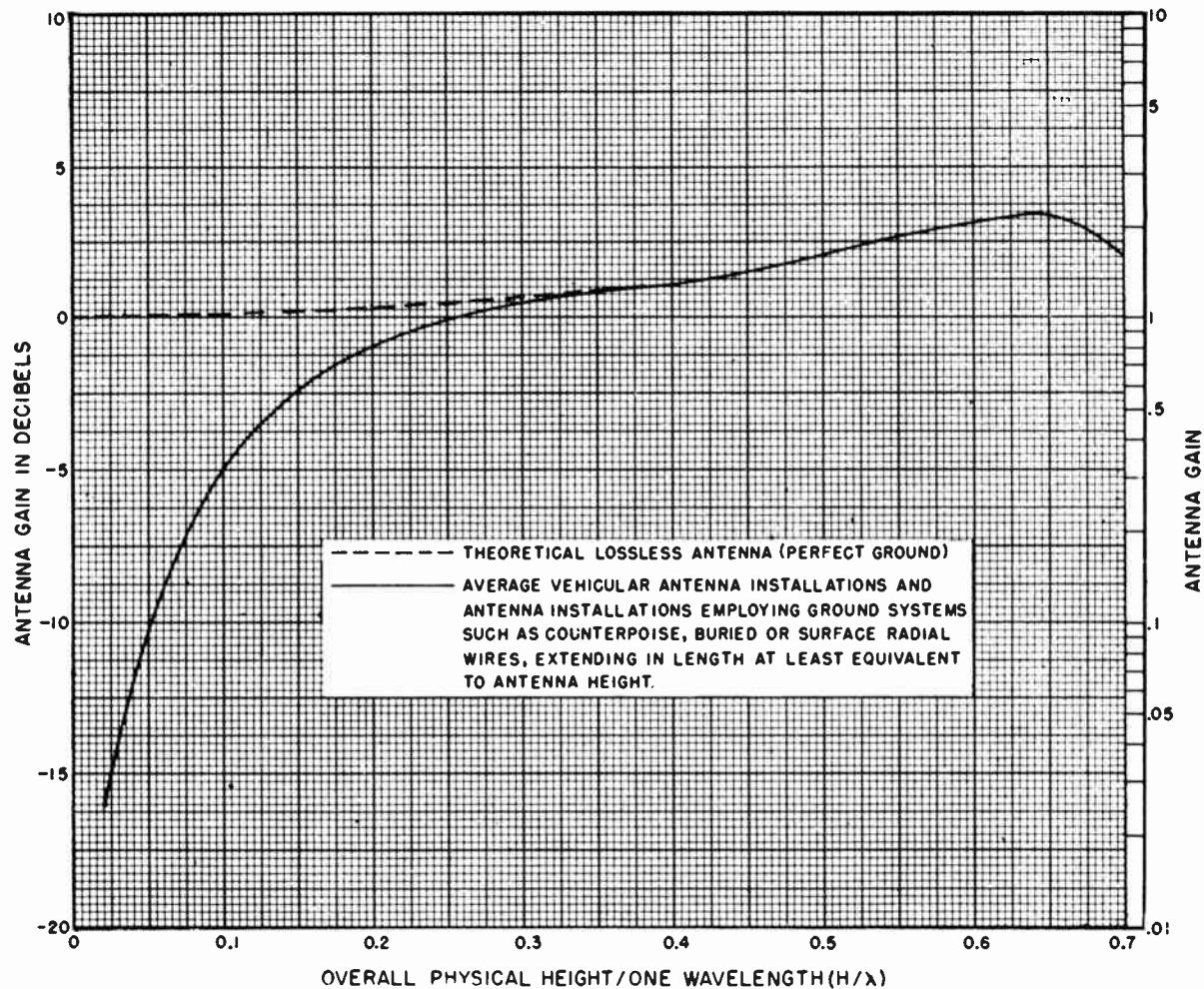

Figure 11-52. Inverse Distance Field Intensity Expressed as an Antenna Gain in Respect to 186.3 Millivolts per Meter at 1 mile, Grounded Vertical Antenna



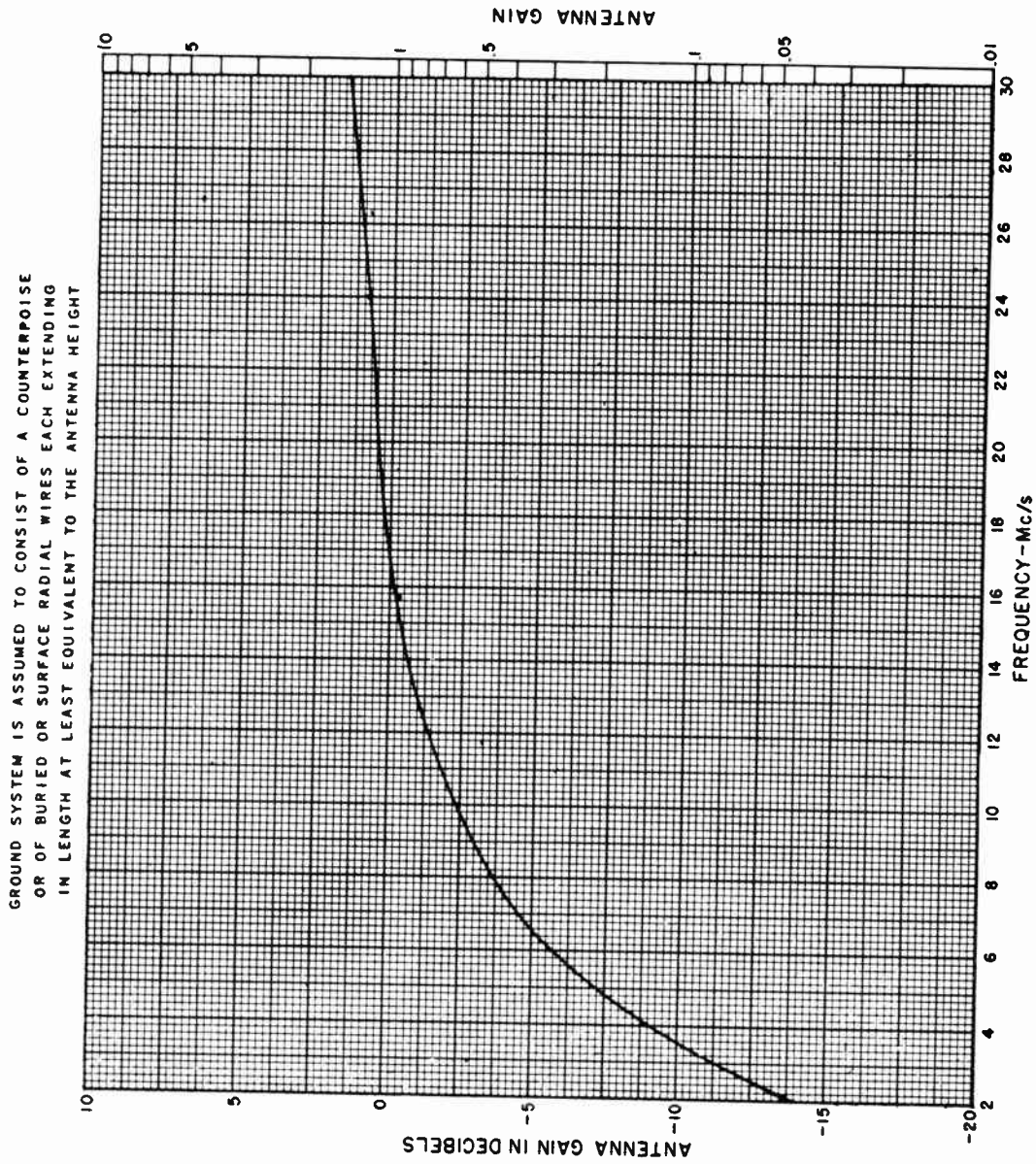

Figure 11-53. Inverse Distance Field Intensity Expressed as an Antenna Gain in Respect to 186.3 Millivolts per Meter at 1 Mile, 15-foot Vertical Whip Antenna



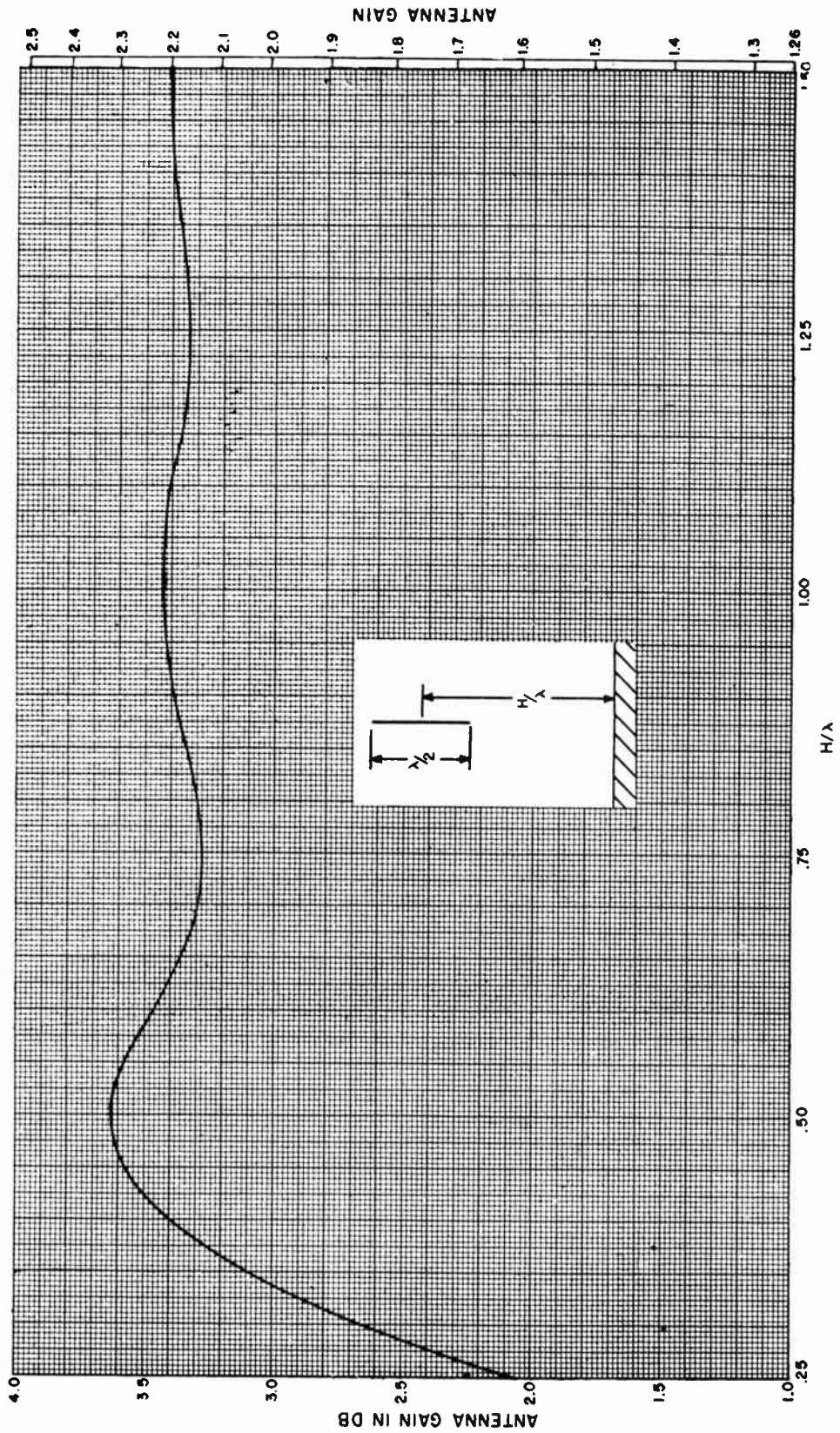

Figure 11-54. Inverse Distance Field Intensity Expressed as an Antenna Gain in Respect to 186.3 Millivolts per Meter at 1 Mile, Half-Wave Vertical Antenna Erected Above Perfect Earth at a Height of  $H/\lambda$

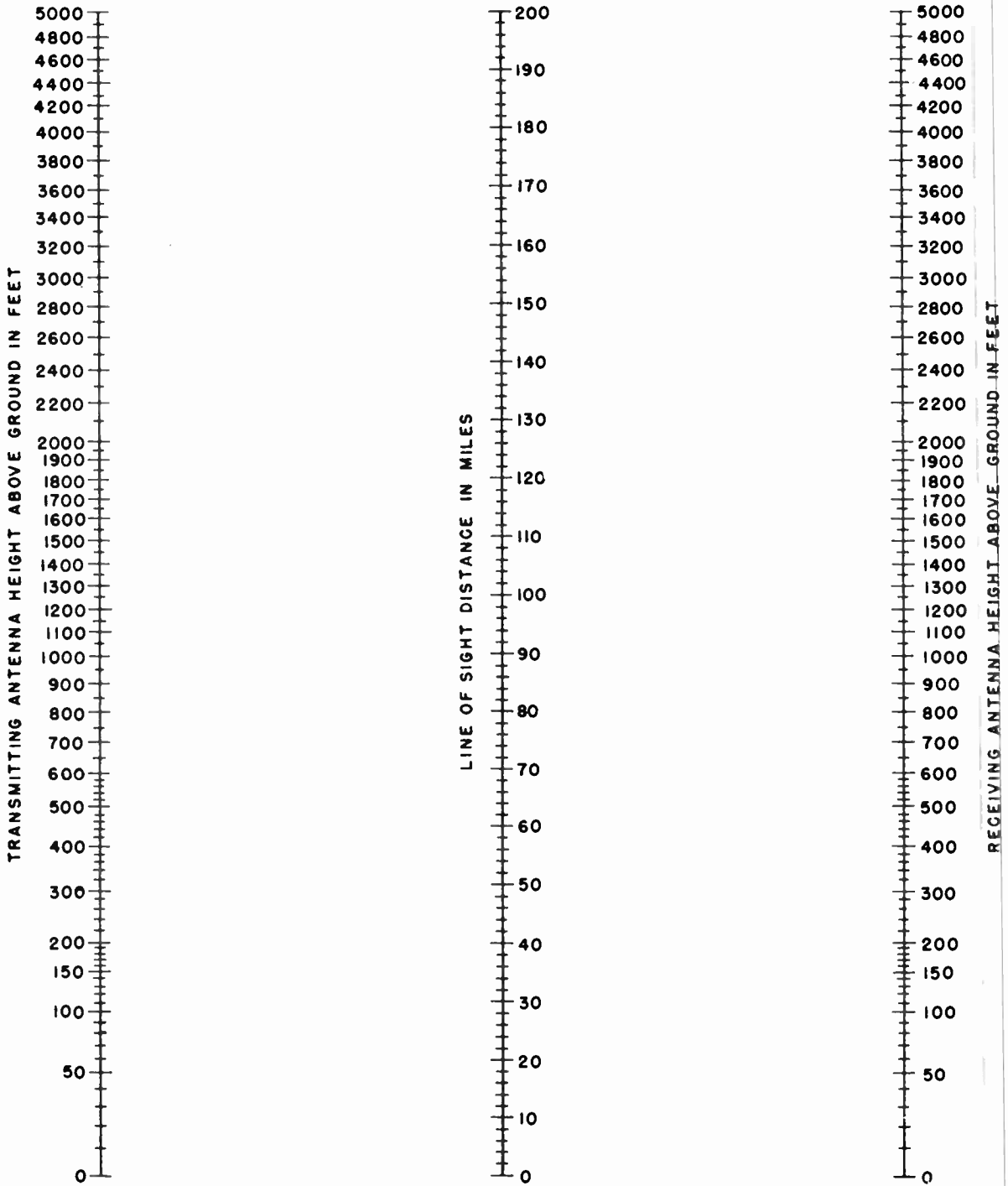

Figure 11-55. Line of Sight Distance for Elevated Antennas (For Smooth Spherical Earth With an Effective Radius of 4/3 the Actual Values), Antenna Heights from 0 to 5,000



## 9. SAMPLE PROPAGATION ANALYSIS

### a. INTRODUCTION

This paragraph illustrates the analysis and solution to a typical propagation problem to determine whether or not satisfactory communication is possible between a given transmitter and a given receiver. The solution of this problem is based on the information given in the first seven paragraphs of this chapter and the typical charts and graphs provided in paragraph 8 of this chapter. Because mathematical procedures are complex and tedious, graphical procedures are employed in a propagation analysis. In the final analysis of the problem, satisfactory communication is possible if the received field intensity is equal to or greater than the required field intensity. For a systematic solution to the problem, the information obtained and derived during the solution of the problem should be entered on a work sheet, a sample of which is provided.

### b. SKY WAVE PROPAGATION ANALYSIS

(1) The first step in determining the feasibility of satisfactory communication is to state all the known conditions under which the link will operate. For this sample problem, the known conditions are as follows:

Transmitting station location - Washington, D. C.  
 Receiving station location - Virginia Beach, Va.  
 Transmission path distance - 253 km (160 miles)  
 Month and year - April 1957  
 Daily period of operation - 0800 to 1600, local time  
 Transmitter power (KWT-6 xmtr) - 500 watts PEP  
 Antennas (transmitting and receiving) - 35-ft whips  
 Type of service - SSB, speech quality voice

(2) The next step is to determine the MUF, using the following procedure. The graphs used in this calculation are published by the Bureau of Standards for each month, three months in advance.

Step 1: Place a piece of tracing paper on the world map, figure 11-8, and draw a horizontal line coinciding with the equator. Then locate the two station locations with dots. Draw a vertical line through the Washington, D. C. station. An example of this overlay operation is shown in figure 11-56, although the transmitter and receiver locations are not Washington, D. C. and Virginia Beach.

Step 2: Place this overlay on the great circle chart, figure 11-9, and align the

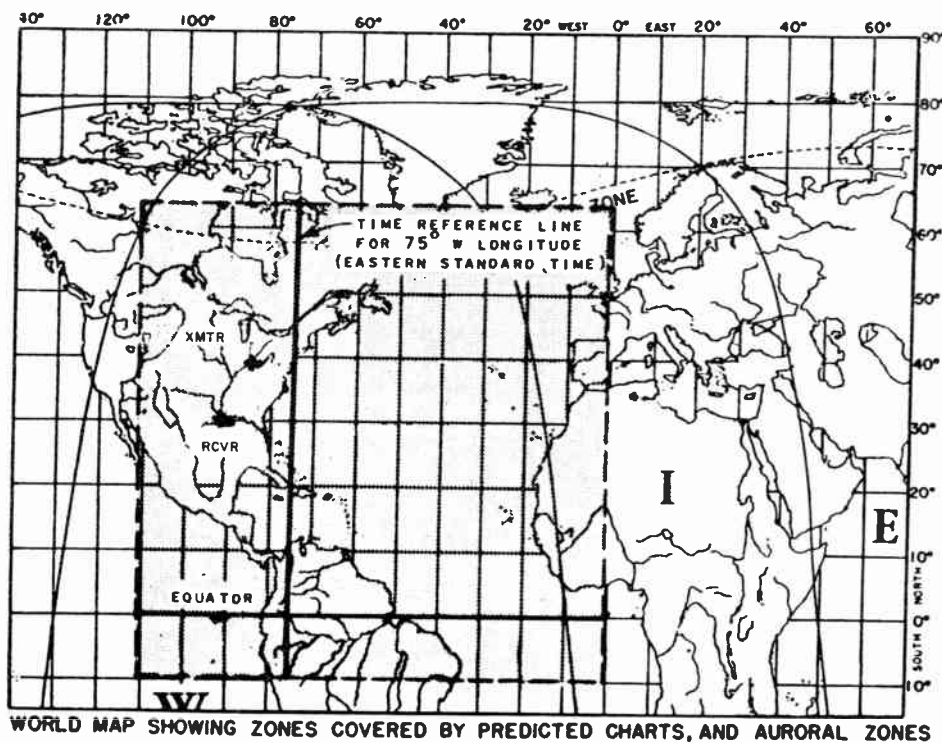

Figure 11-56. Overlay on World Map

equator line of the overlay with the equator line of the great circle chart. Then slide the overlay on the great circle chart until the two stations lie on the same great circle, and draw this transmission path. An example of this operation is shown in figure 11-57. The solid lines represent the great circles, and the dashed lines indicate distance in thousands of kilometers. On the great circle transmission path, locate the midpoint. This is the control point used in determining the MUF. The zone in which the control point lies should be noted from figure 11-8. In this case the control point lies in the W (West) zone.

- Step 3: Place the overlay on the  $F_2$ -Zero-MUF chart for the W zone, predicted for the month and year of operation, figure 11-10. Align the equator with the zero latitude line and the vertical line with the 0800 local time line. The location of the control point on this  $F_2$ -Zero-MUF contour map indicates the zero-MUF in megacycles. To obtain the  $F_2$ -Zero-MUF for the other hours of the operating period, slide the overlay horizontally, making the vertical line coincident with the hour of interest. An example of this overlay operation is shown in figure 11-58. The  $F_2$ -Zero-MUF information for two-hour increments is entered in column 2 of the work sheet, as shown in figure 11-59.
- Step 4: Place the overlay on the  $F_2$ -4000 MUF chart for the W zone, predicted for the month and year of operation, figure 11-11, and perform the same operation as in step 3. The  $F_2$ -4000-MUF information is entered in column 3 of the work sheet, as shown in figure 11-59.
- Step 5: Since the operations of step 3 and step 4 are for the specific distances of zero and 4000 km, it is necessary to interpolate between the two MUF's to obtain the MUF for the particular path length, 253 km. This interpolation is done by the nomogram of figure 11-21. The results of interpolation are entered in column 4 of the work sheet, as shown in figure 11-59. The values entered here are the MUF's for  $F_2$  propagation.
- Step 6: The E layer MUF is obtained in a manner similar to the  $F_2$  layer MUF. However, there is only one E layer chart, which

is figure 11-12, entitled Median E-2000-MUF. The E-2000-MUF is entered in column 5 of the work sheet. Again, for the particular path length involved, the actual MUF must be interpolated by using the nomogram of figure 11-19. The results of interpolation are entered in column 6 and are the MUF's for E propagation.

- Step 7: The sporadic E chart, figure 11-13, should also be analyzed in a manner similar to that for the  $F_2$  and E MUF's. The MUF values obtained from the  $E_s$  chart are multiplied by 5 to obtain the  $E_s$ -2000-MUF. Then the nomogram of figure 11-19 is used to interpolate the MUF for the particular path distance. Because of the indeterminate nature of  $E_s$ , it is not considered in this problem.

The above operations determine the MUF's for the various modes of propagation, i. e., 1-hop E, 1-hop  $F_2$ , and 1-hop  $E_s$ . For longer paths, 2-hop and 3-hop modes of propagation should also be considered. However, the short communication circuit chosen for this sample problem limits the analysis to a 1-hop sky wave and a ground wave study. This problem was chosen because (1) it is a circuit recently set up in conjunction with the U.S. Navy, and (2) the possibility of ground wave as well as sky wave communication exists because a large portion of the path is over sea water.

(3) Since there is the possibility of propagation by either or both the E layer and the  $F_2$  layer, the minimum frequency that will penetrate the E layer must be determined. If the  $F_2$  MUF is not higher than this E layer penetration frequency,  $F_2$  propagation is impossible. The E layer penetration frequency is determined from the E layer MUF and penetration nomogram, figure 11-20. To do this the frequency strip of the figure must be removed or duplicated. The frequency strip is placed vertically on the nomogram with the E-2000 MUF aligned with the reference line. Then slide the frequency strip horizontally to the point where it corresponds to the path length in kilometers. The points where the curves intersect the frequency strip now indicate (1) the 1-hop E MUF, (2) the 1-hop  $F_2$  penetration frequency, and (3) the 2-hop  $F_2$  penetration frequency, as read from the frequency strip. The value of 1-hop  $F_2$  penetration frequency, of interest in this sample problem, is entered in column 10 of the work sheet, shown in figure 11-59.

(4) The radiation angle for any particular path length and operation mode is obtained from radiation angle curves, figure 11-18. Symmetry is assumed so



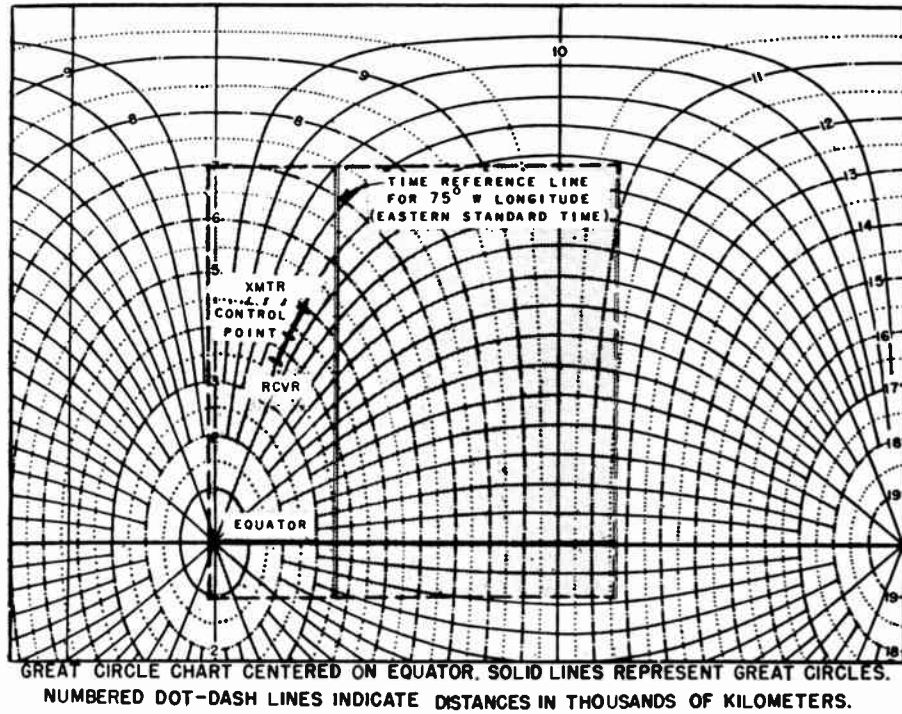

Figure 11-57. Overlay on Great Circle Chart

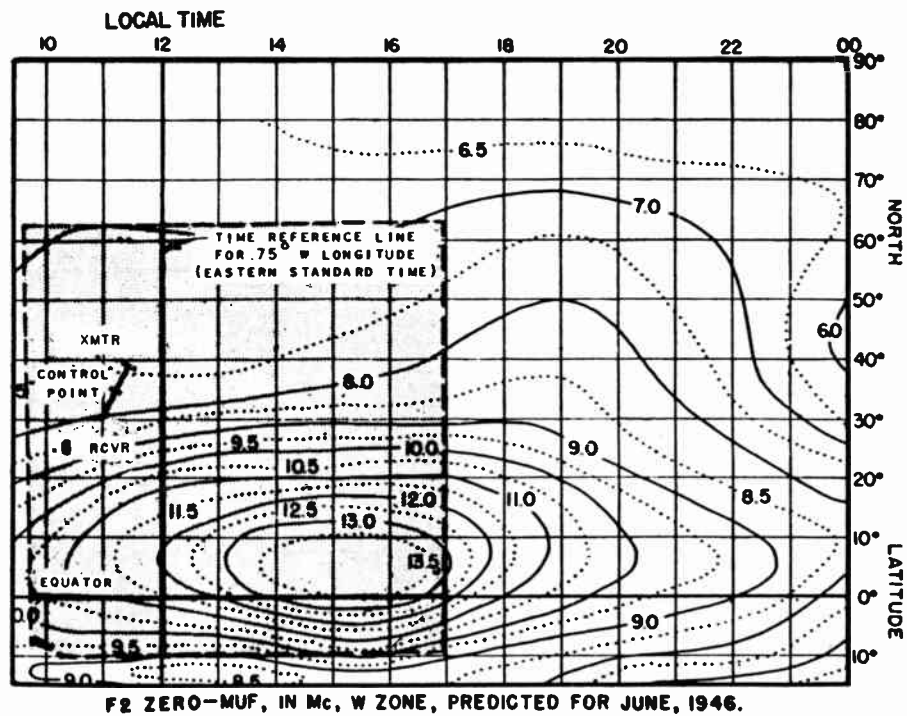

Figure 11-58. Overlay on F<sub>2</sub> Zero MUF, W Zone Chart

that the radiation angle from the transmitting antenna and the angle of reception at the receiving antenna are equal. The radiation angles for the different modes of propagation are obtained from figure 11-18 and entered in column 9 of the work sheet.

(5) Since the received median sky wave field intensity depends upon the total absorption, the absorption must be determined. Auroral absorption  $K_a$ , figure 11-23, does not enter into the total absorption because the transmission path is not in the auroral zone. The total absorption is the product,  $K \times M \times S$ . The absorption index  $K$  is obtained from the absorption index chart, figure 11-22, in the same manner as the MUF's were obtained, and it is entered in column 7 of the work sheet. Where the path length is greater than 3000 km, the absorption index  $K$  must be corrected by using the nomogram of figure 11-24. The sunspot number must be known to determine the solar activity factor  $S$ . For the month of April 1957, the sunspot number is 187 and  $S$  is found to be 2.0 from the top of figure 11-25. The seasonal correction factor  $M$  is read from the table in figure 11-25 for April and is found to be .8. The total correction factor  $M \times S$  is, therefore  $2.0 \times .8$  which equals 1.6. The corrected absorption index is entered in column 8 of the work sheet, and it is obtained by multiplying the absorption index of column 7 by the correction factor 1.6.

(6) Before the median sky wave field intensity can be determined, it is necessary to choose the operating frequency. For E layer propagation, the frequency of optimum traffic, FOT, is equal to the E layer MUF. For  $F_2$  layer propagation, the FOT is equal to 85 per cent of the  $F_2$  layer MUF. The FOT is chosen as the operating frequency and entered in column 11 of the work sheet.

(7) The received median sky wave field intensity referenced to an inverse distance field of 300 mv/m at 1 km may now be calculated from figures 11-27 through 11-35, the figures used depending upon the mode of propagation and the path length. Where the distance lies between the distances for which these graphs have been made, it is necessary to make a direct-proportion (linear) interpolation between values obtained from two graphs. The values so obtained are entered into column 12 of the work sheet.

(8) The received median field intensity obtained in the operation above is referenced to 300 mv/m at 1 km for 1 kw of radiated power from a short vertical-element antenna over perfect ground, measured in the ground plane. To calculate the actual received field intensity, it is necessary to consider the gain of the transmitting antenna and the actual transmitted power. The gain of the transmitting antenna at different radiation angles is obtained from figures 11-43 through 11-45. The gain of a 15-ft whip antenna is obtained

from figure 11-43 and is entered into column 13 of the work sheet. The value obtained is the gain over the reference antenna which is a short vertical element over perfect ground. For the 1-hop E frequencies, the 35-ft whip is less than  $1/4$  wave length. Therefore, the value obtained for the 15-ft whip is corrected by adding  $(10 \log 35/15)$  db which is +3.7 db. The value for the 35-ft whip where the radiation angle is  $37^\circ$  is entered in column 14 of the work sheet. For the 1-hop  $F_2$  frequencies, the 35-ft whip is between  $1/4$  wave length and  $1/2$  wave length. Therefore, values for the antenna gain are interpolated between the value obtained from figure 11-44 and figure 11-45 for a radiation angle of  $66^\circ$ . This value is entered in column 15 of the work sheet.

(9) The transmitter power output referenced to 1 kw is entered in column 16 of the work sheet. Since the KWT-6 transmitter used in the sample problem is rated at 500 watts PEP, the output referenced to 1 kw is -3 db. The transmitter power output must be referenced to 1 kw because the field intensity entered in column 12 is referenced to 1 kw output.

(10) The effective radiated power is equal to the algebraic sum of the transmitter output, column 16 on the work sheet, and the antenna gain, column 14 or 15. This value is entered in column 22 of the work sheet.

(11) The received field intensity of the median sky wave is the algebraic sum of the effective radiated power, column 22 on the work sheet, and the field intensity in db  $> 1$  uv/m at 1 km, column 12 on the work sheet. This value is entered in column 23 of the work sheet.

(12) Now that the received field intensity is determined, the required field intensity to overcome noise must be determined. Atmospheric noise is determined from a noise distribution chart, figure 11-36, which is drawn from noise level observations and divides the world in various noise grades ranging from 1 to 5. For this problem, the noise grade at the receiving station for April is 2.5. Since the noise level varies with operating frequency and seasons, it is necessary to refer to a curve, such as shown in figures 11-37 through 11-39, to determine the field intensity required to overcome atmospheric noise. Since the operating time is in April, the figure 11-39 is used, and the values obtained are entered in column 17 of the work sheet. The value entered here is the hourly median value of minimum required field intensity that will provide a S/N ratio of 13.8 db 90 per cent of the days for double sideband, radiotelephone communication in the presence of atmospheric noise. Because the required field intensity to overcome atmospheric noise depends upon the location of the receiving station, a separate analysis must be made for a two-way communication circuit whenever the

noise grade for the two stations is different. However, in this sample problem, the two stations are so close together that the same atmospheric noise conditions exist at both stations. Therefore, if successful transmission is possible in one direction, it is also possible in the reverse direction, in this problem.

(13) The field intensity required to overcome set noise is determined from curves such as figures 11-40 through 11-42, in a manner similar to that used for determining the antenna gain for a 35-ft whip antenna. From figure 11-40, the minimum required field intensity to overcome set noise with a 15-ft whip antenna is obtained for the 1-hop E propagation at 37°. From this value, (10 log 35/15) db is subtracted to adjust the figure for the 35-ft whip antenna. The value of (10 log 35/15) is 3.7 db. For 1-hop F<sub>2</sub> propagation at 66°, values are obtained from figures 11-41 and 11-42 for 1/4 and 1/2 wave length antennas. Then the value for the 35-ft whip antenna is logarithmically interpolated between these two values. The values obtained for field intensity to overcome set noise are entered in column 18 of the work sheet. The discrimination gain of the whip antenna is neglected.

(14) The minimum required field intensity for the system to overcome all noise is the greater of the field required to overcome atmospheric noise and the field required to overcome set noise. Therefore, the greater of column 17 and 18 is entered in column 19 on the work sheet.

(15) The required field intensity entered in column 19 is based on a median field intensity with a double sideband voice signal. To adjust this value for single-sideband voice and for a field intensity which exceeds the median 90 per cent of the time, the service gain value is used. The table of service gains for sky wave communication with a fading signal is obtained from figure 11-26. For single-sideband radiotelephony, speech grade quality, the service gain is -1 db. This service gain value, which has been adjusted for a fading signal, is entered in column 20 of the work sheet. The required field intensity for reception, column 21, is then the sum of the required field intensity to overcome noise and the service gain. That is, column 21 is equal to column 19 plus column 20. The value entered in column 21 is the required field intensity to assure satisfactory radiotelephone communication for 90 per cent of the time in the presence of atmospheric noise and set noise for single-sideband radiotelephony.

(16) If the received field intensity, column 23, is greater than or equal to the required field intensity for reception, column 21, satisfactory sky wave communication is possible. The threshold for satisfactory communication is defined as a S/N ratio of 13.8 db. In this sample problem, satisfactory 1-hop E sky wave communication is possible throughout the operation

period of 0800 to 1600 during April 1957. This fact is entered in column 24 of the work sheet. Satisfactory 1-hop F<sub>2</sub> communication is not possible.

### c. GROUND WAVE PROPAGATION ANALYSIS

(1) For the sample problem, the possibility of ground wave communication exists for the Washington, D. C. to Virginia Beach circuit because the path length is short. This possibility is made evident by an examination of the terrain over the communication path which shows that the greater portion of the path is over sea water. Also, the ability of the transmitter used to operate at frequencies as low as 2 mc increases the possibility of ground wave communication. The transmission path from Washington, D. C. to Virginia Beach, Va. consists of 0 to 50 miles over poor soil, 50 to 75 miles over sea water, 75 to 100 miles over poor soil, 100 to 160 miles over sea water. Figure 11-46 is a world map showing these various types of terrain. Since ground wave propagation over sea water is quite good, compared to propagation over poor ground which greatly attenuates the wave, the 85-mile sea water path increases the possibility of ground wave communication for this circuit.

(2) For ground wave propagation, the choice of operating frequencies is arbitrary, but generally the received field strength increases with a decrease in frequency. The received field intensity is limited only by the power capability of the transmitter and is independent of the time of day. For this sample problem, 2 mc and 4 mc frequencies are chosen for analysis and are entered in column 2 of the work sheet, figure 11-60.

(3) Figures 11-47 through 11-49 are curves which indicate the received field intensity for ground wave propagation versus distance for various types of earth. The received field intensity is referenced to 300 mv/m at 1 km radiated from a short vertical element over perfect ground with an input power of 1 kw. The received field strength over a mixed-earth transmission path is calculated as follows:

Step 1: The field strength for the first 50 miles is determined from figure 11-47 at the operating frequency for poor soil conditions.

Step 2: The field strength for the distance 50 to 75 miles is determined from figure 11-49 by entering the proper frequency curve at the same decibel level as obtained in step 1. From the distance which corresponds with the point of entry, 25 miles is added, and the resulting field strength recorded.

Step 3: The field strength for the distance 75 to 100 miles is determined from figure



11-47 by entering the proper frequency curve at the same decibel level as obtained in step 2. From the distance which corresponds with the point of entry, 25 miles is added, and the resulting field strength recorded.

Step 4: Finally, the field strength for the distance 100 to 160 miles is determined from figure 11-49 by entering the proper frequency curve at the same decibel level as obtained in step 3. From the distance which corresponds with the point of entry, 60 miles is added, and the field strength recorded. This final field strength is the received field strength for the 160 mile mixed-earth transmission path. This value is entered in column 3 of the work sheet, figure 11-60.

(4) The transmitting antenna gain for the 35-ft whip antenna at the operating frequencies is obtained from figure 11-53, which is drawn for a 15-ft whip antenna. Since the operating frequencies are low, the 35-ft whip can be considered equal to the 15-ft whip, because they both are less than  $1/8$  wave length at the frequencies involved. The antenna gain is entered in column 4 of the work sheet.

(5) Since the field intensity entered in column 3 is referenced to 1-kw input power to the antenna, the input power of the transmitter used must be referenced to 1 kw. The power input of the 500-watt PEP transmitter is -3 db. This value is entered in column 5 of the work sheet.

(6) The received ground wave field intensity can now be determined. It is the sum of the field intensity, the transmitting antenna gain, and the input power, that is, column 3, plus column 4, plus column 5. This value is entered in column 6 of the work sheet.

(7) Having completed the determination of the received ground wave field intensity, the required field intensity for reception must be determined. The required field intensity to overcome atmospheric noise is obtained in exactly the same manner as it is for sky wave propagation, and the same charts and graphs are used. See subparagraph b(12) of this paragraph for this procedure, keeping in mind that the operating frequencies for ground wave propagation are different from those used in the sky wave analysis. The values of field intensity required to overcome

atmospheric noise are entered in column 7 of the work sheet.

(8) The field intensity required to overcome set noise is determined from figure 11-50. The curve for the 15-ft grounded vertical whip antenna is used for this calculation, the 15-ft whip being considered equal to the 35-ft whip at the frequencies involved. The values of field intensity required to overcome set noise are entered in column 8 of the work sheet.

(9) The minimum required field intensity to overcome all noise is the greater of the field intensity required to overcome atmospheric noise and the field intensity to overcome set noise. This value is entered in column 9 of the work sheet. That is, column 9 is the greater of column 7 and column 8.

(10) Since the minimum required field to overcome noise is based on a double sideband radiotelephone signal, it must be adjusted by the service gain for single-sideband radiotelephony. The value of service gain for single-sideband radiotelephony for ground wave communication is -9 db, as obtained from figure 11-51. This value is entered in column 10 of the work sheet.

(11) The required field intensity for reception can now be determined. It is the algebraic sum of required field intensity to overcome noise, column 9, and the service gain, column 10. This value is entered in column 11 of the work sheet.

(12) If the received field intensity, column 6, is equal to or greater than the required field intensity for reception, column 11, satisfactory ground wave communication is possible. In this sample problem, ground wave communication is possible for an operating frequency of 2 mc. This fact is entered in column 12. Satisfactory ground wave communication is not possible for an operating frequency of 4 mc.

#### d. FINAL ANALYSIS

This study of propagating conditions between Washington, D.C. and Virginia Beach, Va. indicates that two modes of propagation may be used during an operating period between 0800 and 1600 in April 1957. Frequencies between 4.6 mc and 5.5 mc may be used for E layer, sky wave propagation, or a frequency of 2.0 mc may be used for ground wave propagation. Of the two possible modes, the strongest signal will result from E layer sky wave propagation because the received field strength is much larger than the required field strength.



- Column 1: Operation period logged in 2-hour increments
- Column 2: From figure 11-10
- Column 3: From figure 11-11
- Column 4: Interpolated between column 2 and column 3 using figure 11-21
- Column 5: From figure 11-12
- Column 6: Interpolated from column 5 using figure 11-19
- Column 7: From figure 11-22
- Column 8: Column 7 multiplied by correction factor (M x S) which is obtained from 11-25
- Column 9: From figure 11-18
- Column 10: Interpolated from column 5 using figure 11-20
- Column 11: For 1-hop E, taken as column 6; for 1-hop F<sub>2</sub>, taken as 85 per cent of column 4
- Column 12: From figures 11-27 and 11-30 for 1-hop F<sub>2</sub>, using linear interpolation between values obtained; from figures 11-29 and 11-32 for 1-hop E, using linear interpolation between values obtained
- Column 13: From figure 11-43
- Column 14: Column 13 plus (10 log 35/15) for 1-hop E
- Column 15: From figures 11-44 and 11-45 for 1-hop F<sub>2</sub> using logarithmic interpolation between values obtained
- Column 16: Transmitter power output of 500 watts referenced to 1 kw equals -3 db
- Column 17: From figures 11-36 and 11-39
- Column 18: From figure 11-40 less (10 log 35/15) for 1-hop E; from figures 11-41 and 11-42 for 1-hop F<sub>2</sub>, using logarithmic interpolation between values obtained
- Column 19: The greater of column 17 and column 18
- Column 20: From figure 11-26
- Column 21: Column 19 plus column 20
- Column 22: Column 16 plus column 14 for 1-hop E; column 16 plus column 15 for 1-hop F<sub>2</sub>
- Column 23: Column 12 plus column 22
- Column 24: "Yes" if column 23 is equal to or greater than column 21; "no" if column 23 is less than column 21

SKY WAVE PROPAGATION ANALYSIS

CIRCUIT: Washington, D.C. to Virginia Beach, Va.; 253 km (160 miles)

ANTENNAS: 35-ft whips for both transmitting and receiving

TRANSMITTER: KWT-6 with PEP output of 500 watts

TYPE OF SERVICE: SSB voice

PERIOD OF OPERATION: From 0800 to 1600, April 1957 (local time)

1	2	3	4	5	6	7	8	9	10	11	12	13	14	15	16	17	18	19	20	21	22	23	24
Local Time	F <sub>2</sub> Zero MUF (mc)	F <sub>2</sub> 4000 MUF (mc)	F <sub>2</sub> MUF 253 km, 1-hop Path (mc)	E 2000 MUF (mc)	E MUF 253 km, 1-hop Path (mc)	Absorption Index K at Control Point	Corrected K and Solar Factor (Correction factor = 1.0)	Radiation Angle, Δ (degrees)	1-hop E, 1-hop F <sub>2</sub> Penetration Freq (mc)	Operating Freq	Field Intensity for 300 mv/m at 1 km (DB > 1 uv/m)	Antenna Gain with 15-ft whip for Δ = 37° and Δ = 66° (DB)	Antenna Gain with 35-ft Whip for Δ = 37° (DB)	Antenna Gain with 35-ft Whip for Δ = 66° (DB)	Transmitter Power Output (DB > 1 kw)	Required Field Intensity to Overcome Atmospheric Noise; Noise Grade - 2.5 (DB > 1 uv/m)	Required Field Intensity to Overcome Set Noise (DB > 1 uv/m)	Required Field Intensity to Overcome Noise (DB > 1 uv/m)	Service Gain (DB)	Required Field Intensity For Reception (DB > 1 uv/m)	Effective Radiated Power (DB > 1 uv/m)	Received Field Intensity (DB > 1 uv/m)	Sky Wave Communication Possible
0800	10.6	31.0	10.8	16.8	4.6	.54	.86	37	--	4.6	37.0	-14.0	-10.3	--	-3.0	-1.0	+3.3	+3.3	-1	2.3	-13.3	23.7	Yes
1000	12.0	33.0	12.3	19.0	5.2	.80	1.28	37	--	5.2	33.0	-13.0	-9.3	--	-3.0	-1.5	+3.3	+3.3	-1	2.3	-12.3	20.7	Yes
1200	12.7	34.0	12.9	19.9	5.5	.90	1.44	37	--	5.5	32.5	-13.0	-9.3	--	-3.0	-2.5	+3.3	+3.3	-1	2.3	-12.3	20.2	Yes
1400	12.8	35.5	13.1	19.0	5.2	.80	1.28	37	--	5.2	33.0	-13.0	-9.3	--	-3.0	+1.0	+3.3	+3.3	-1	2.3	-12.3	20.7	Yes
1600	12.5	35.0	12.8	16.6	4.6	.55	.88	37	--	4.6	37.0	-14.0	-10.3	--	-3.0	+3.0	+3.3	+3.3	-1	2.3	-13.3	23.7	Yes
0800	10.6	31.0	10.8	16.8	4.6	.54	.86	66	3.7	9.2	27.0	-15.0	--	-14	-3.0	+8.0	+19.0	+19.0	-1	18.0	-17.0	10.0	No
1000	12.0	33.0	12.3	19.0	5.2	.80	1.28	66	4.2	10.5	26.0	-14.0	--	-14	-3.0	+7.5	+19.0	+19.0	-1	18.0	-17.0	9.0	No
1200	12.7	34.0	12.9	19.9	5.5	.90	1.44	66	4.4	11.0	25.0	-14.0	--	-14	-3.0	+8.0	+19.0	+19.0	-1	18.0	-17.0	8.0	No
1400	12.8	35.5	13.1	19.0	5.2	.80	1.28	66	4.2	11.1	27.0	-14.0	--	-14	-3.0	+8.0	+19.0	+19.0	-1	18.0	-17.0	10.0	No
1600	12.5	35.0	12.8	16.6	4.6	.55	.88	66	3.6	10.9	30.5	-14.0	--	-14	-3.0	+14.5	+19.0	+19.0	-1	18.0	-17.0	13.5	No

Figure 11-59. Tabulated Sky Wave Propagation Analysis



GROUND WAVE PROPAGATION ANALYSIS

CIRCUIT: Washington, D. C. to Virginia Beach, Va.; 160 miles  
 from 0-50 miles, poor soil  
 from 50-75 miles, sea water  
 from 75-100 miles, poor soil  
 from 100-160 miles, sea water

ANTENNAS: 35-ft whips for both transmitting and receiving  
 TRANSMITTER: KWT-6 with PEP output of 500 watts  
 TYPE OF SERVICE: SSB voice  
 PERIOD OF OPERATION: From 0800 to 1600, April 1957 (local time)

- Column 1: Operation period logged in 2-hour increments
- Column 2: Arbitrarily chosen
- Column 3: From figures 11-47 and 11-49
- Column 4: From figure 11-53
- Column 5: Transmitter power output of 500 watts referenced to 1 kw equals -3 db
- Column 6: Column 3, plus column 4, plus column 5
- Column 7: From figures 11-36 and 11-39
- Column 8: From figure 11-50
- Column 9: The greater of column 7 and column 8
- Column 10: From figure 11-51
- Column 11: Column 9 plus column 10
- Column 12: "Yes" if column 6 is equal to or greater than column 11; "no" if column 6 is less than column 11

Local Time	Frequency (mc)	Field Intensity (DB > 1 uv/m)	Transmitting Antenna Gain Referred to Short Vertical Element (DB)	Input Power (DB > 1 kw)	Received Field Intensity (DB > 1 uv/m)	Required Field Intensity to Overcome Atmospheric Noise (DB > 1 uv/m)	Required Field Intensity to Overcome Set Noise (DB > 1 uv/m)	Minimum Required Field Intensity to Overcome Noise (DB)	Service Gain (DB)	Required Field Intensity for Reception (DB)	Ground Wave Communication Possible
1	2	3	4	5	6	7	8	9	10	11	12
0800	4	-5	-9.0	-3.0	-17.0	-4.0	-.4	-.4	-9.0	-9.4	No
1000	4	-5	-9.0	-3.0	-17.0	-6.0	-.4	-.4	-9.0	-9.4	No
1200	4	-5	-9.0	-3.0	-17.0	-8.5	-.4	-.4	-9.0	-9.4	No
1400	4	-5	-9.0	-3.0	-17.0	-4.0	-.4	-.4	-9.0	-9.4	No
1600	4	-5	-9.0	-3.0	-17.0	+1.0	-.4	+1.0	-9.0	-8.0	No
0800	2	+8	-14.0	-3.0	-9.0	-10.0	-.4	-.4	-9.0	-9.4	Yes
1000	2	+8	-14.0	-3.0	-9.0	-13.0	-.4	-.4	-9.0	-9.4	Yes
1200	2	+8	-14.0	-3.0	-9.0	-16.5	-.4	-.4	-9.0	-9.4	Yes
1400	2	+8	-14.0	-3.0	-9.0	-11.0	-.4	-.4	-9.0	-9.4	Yes
1600	2	+8	-14.0	-3.0	-9.0	-6.0	-.4	-.4	-9.0	-9.4	Yes

Figure 11-60. Tabulated Ground Wave Propagation Analysis















## CHAPTER 12

### KINEPLEX DATA TRANSMISSION

#### 1. INTRODUCTION

The tremendous growth of industry has resulted in an increased demand for better communication. To satisfy this demand, there has been a large scale expansion of radio and wire facilities to provide additional communication channels. The paramount problem in long range radio communication is congestion of the frequency spectrum and the heavy investment attendant with expansion. The steady demand for new circuits has rapidly diminished the availability of frequency spectrum for additional channels. A major effort has been directed toward developing a new signaling and detection technique for the transmission of binary information which has much greater efficiency in regard to power and spectrum utilization when compared to standard signaling practices. The signaling and detection technique accomplishing this objective incorporates kinematic filtering and signal multiplexing and accordingly has been named "Kineplex."

Historically, it always has been more economical to spend time encoding and decoding a message in order to make it suitable for transmission by way of a simpler transmission medium. An example is the smoke signal which can be transmitted with the most primitive of apparatus. When communication between two individuals is required, speech communication has always been greatly desired because of the speed with which ideas can be transmitted and responses given back. However, telegraph type communication, in which the sender causes a receiving device to print a message, is often even more desirable because it results in a written record of the complete message.

In many cases, messages must be integrated and evaluated to learn their full significance. Where the number of such messages is relatively small, the integration and evaluation can be done manually, as on a plotting board, and voice communications can be used. However, when the volume of such messages becomes large, machine methods are required and telegraph data links, with connections to a computer, are usually required. Since such record-type communication systems can frequently require much more capacity than previously has been in existence, Kineplex was designed with far greater message carrying capacity in a given bandwidth than systems previously available.

#### 2. CODES USED FOR DATA TRANSMISSION

Coding is essential to the successful transfer of information by binary elements. The variety of codes in existence today is as varied as their methods of transmission. Each has a purposeful existence because of universal acceptance or certain desirable qualities that fulfill the demands of their users. Two important factors exist in any code, its efficiency in conveying information, and the freedom from errors introduced by the transmission medium. Actually they conflict with each other so that a given code is not necessarily the most suitable code for use in all circumstances. Similarly the methods of transmission cannot be separated from the code entirely.

Two familiar codes are the dot-dash Morse code, and the mark-space five-element teletypewriter code. The Morse code, which is important historically, suffers in efficiency and general adaptability to modern automatic transmission methods. The five-element start-stop code has proved successful in land line applications and has been generally adapted for radio-telegraph links. This highly efficient teletypewriter code is physically composed of five information elements, plus a start pulse and a stop pulse. The two conditions may be represented by a signal, or current flow, for mark and a no signal, or no current, for space. The stop pulse is made 1.42 as long as the other equal pulses so that the teletypewriter machine which is sending, and the teletypewriter machine which is receiving, will both have time to stop. This permits the two machines to start each new letter or character simultaneously. This action avoids the necessity of having both machines running at exactly the same speed and gives rise to the name "start-stop" telegraph. The addition of the start and stop elements reduces the efficiency by about 30%.

This code, which is often referred to as a 7.42 code, has a possibility of 32 permutations. A minimum of 5 bits is required to encode the entire alphabet so this allows additional functions such as, letters or figures, line feed, carriage return, etc. When reduced to equal bit lengths to utilize the benefits of synchronous predicted-wave techniques, the code is referred to as a 7.0 code. The processing of digital binary codes is essentially the same as the telegraph code since both feature two-condition on-off characteristics.

### 3. TELEGRAPH SIGNALING

The methods of sending codes are varied considerably. Some methods, while superseded by systems yielding more capacity and reliability, retain their position because of the simplicity of transmitting and receiving equipment. In its earliest form, telegraph consisted of a single wire circuit as shown in figure 12-1. At one end of the circuit, there was a battery and a key and at the other end a buzzer with a ground return. Closing of the key would cause the buzzer to operate so that with some kind of code, intelligence could be transmitted. This (on-off) circuit is still basic to all telegraphy although it does not appear in such simple form. Analogous in radio transmission was the on-off keying of a transmitter. With either method of transmission, the signals suffered deterioration. Filtering at the transmitter or receiver was limited since accurate message reproduction entailed the recovery of the coded form of the transmitted signal.

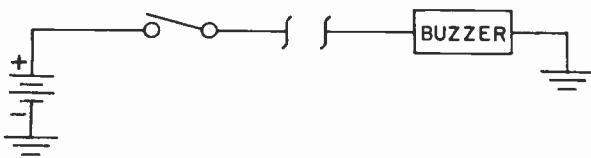

Figure 12-1. Basic Telegraph Circuit

### 4. FREQUENCY SHIFT KEYING

It soon became apparent that the function of the receive equipment was to reproduce the information content of the transmitted message and not the Fourier components of the transmitted signals. The encoding of marks and spaces on higher and lower carrier frequencies (FSK) enabled a uniform power output to be transmitted. The detector had only to decide which of two frequencies was the larger, which provides an advantage where signal distortion and a high noise level are present. The reduction of bandwidth by additional filtering substantially reduces extraneous noise at the detector.

Although frequency shift keying is widely accepted and used, there is still much to be desired in the way of reliability and efficiency of existing circuits. A classic equation shows that:

$$C = BW \log_2 \frac{S + N}{N}$$

where BW is the bandwidth in

cycles per second; S is the signal power and N the noise power.

With a signal-to-noise ratio of unity and the minimum spacing consistent with practical experience, 120 cycles, very little over a 60 wpm teletypewriter rate or 45 bits per second, could be expected while the theoretical capacity was 120 bits per second. It is to be noted that the information capacity is a much stronger function of bandwidth than the rms signal-to-noise ratio. But since increasing the bandwidth decreases the S/N ratio without an increase in radiated power, there is not a great deal to be gained in terms of information capacity by increasing the bandwidth beyond the value where the signal-to-noise ratio falls below unit. Moreover, any improvements gained by widening the transmission band are limited to conditions where favorable signal conditions prevail.

### 5. PREDICTED WAVE SIGNALING

Aware of the implications surrounding the increased bandwidth requirements, Collins Radio Company directed their attention to improved detection whereby the bandwidth can be narrowed and an increase in signal-to-noise ratio attained. To determine the optimum means of measuring the polar amplitude of a wave in the presence of wide band random noise, assume the transmission of a rectangular pulse as shown in figure 12-2A. The transmitted pulse is attenuated by the transmission path and contaminated by additive noise to give a received signal as shown in figure 12-2B. From this it is desirable to obtain a best estimate of the polar amplitude of the transmitted pulse (figure 12-2A) which carries the transmitted information. The equipment used for this measurement consists of a gate controlling the period during which the received signal-plus-noise is accumulated in an integrating device. The problem is when to open and close the gate to obtain an optimum measurement of amplitude. A wide gate, as shown in figure 12-2C, will result in the accumulation of the entire integrated value of the signal plus the accumulation of noise when there is no signal. Similarly a narrow gate, as shown in figure 12-2D, will permit the accumulation of only

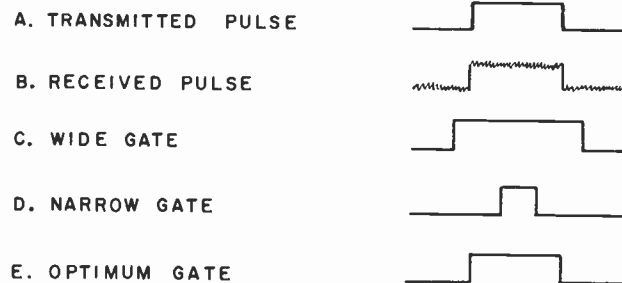

Figure 12-2. Predicted Wave Detection

a fraction of the integrated signal value and would integrate the noise over a corresponding fraction of the pulse duration. The narrow gate is a poorer choice than the wider gate because the signal contribution increases linearly with the duration of the pulse, while the noise contribution only increases by a factor of the square root (assuming the noise is to be wide band noise). This latter fact is due to the lack of coherence between the noise pulses which are being added to the integration device. The ideal condition is to open the gate at the start of a pulse and close it immediately when the pulse ends. Optimum results are obtained then by multiplying the received signal (plus noise) by a pulse of the shape of the expected signal pulse and integrating and placing the multiplying function (or weighting function) coincident in time with the expected signal pulse. It is desirable to have available locally at the receiver all the information concerning the incoming signal except the information it is designated to convey. This is called predicted wave signaling.

### 6. KINEPLEX

Using the basic principles of predicted wave signaling and incorporating FSK or phase shift keying, the Kineplex Data System through evaluation tests has proven conclusively the theoretical predictions of the benefits to be gained. The performance of the system is extended by the inclusion of near absolute frequency stability so that the bandwidth may be reduced to a minimum. Predicted wave signaling utilizes: synchronization so that the detector is given information on the time of arrival of the start and finish of each data pulse; gated very high Q integrating circuits, employing mechanical resonators, the response of which matches perfectly the energy distribution of the transmitted pulse; sampling of the detector outputs at the end of each pulse so that full integration of the received pulse may be utilized; encoding of binary information so that the theoretical minimum bandwidth for a given binary signaling rate may be approached.

An investigation of some of the unique features, such as phase shift keying of two bits of information on a single tone, the use of electromechanical resonators as high Q optimum weighting functions, the recovery of phase information from received signals, and the sequence of timing to provide synchronous gating action will advance the understanding of a basic system.

In order to avoid the complexity of timing circuits and to provide equal synchronous bit lengths, a code converter retimes nonsynchronous information, such as teletypewriter information. This standard code has a stop pulse which is longer than the other pulses by a factor of 1.42.

Since there are fractional accumulations of stop pulses (0.42 time elements) caused by the shortening

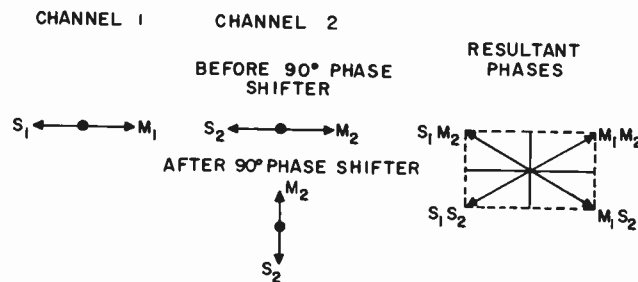

Figure 12-3. Phase Modulation Vector Diagrams

of the stop pulse, provision has been made to halt the readout of synchronous output to allow the input to catch up. This is accomplished by inserting an extra stop pulse whenever the output tends to overrun the input by a full element. While the extra stop pulse is being inserted, incoming information is read into a storage circuit. Readout information alternates between direct and stored material depending upon the time differential of the input and output. The outputs of all code converters are time synchronized. A major aspect of the Kineplex Data System is the phase modulation of two information channels upon a single tone. The resultant vector also functions as a phase reference for the succeeding element. Refer to figure 12-3. Let a mark for channel 1 be represented as an in-phase condition M1, and a space as an out-of-phase condition as S1. A second channel of information is phase shifted so that a 90° vector in reference to the first mark is assigned to the second mark, M2, and an out-of-phase condition to S2. When these two information sources are combined together, four possible phase positions are assumed by the resultant vector:

- M1 M2 — 45°
- S1 M2 — 135°
- S1 S2 — 225°
- M1 S2 — 315°

The joint action of the tone generator and keyed filter pair produces tones which are phase modulated in accordance with mark-space transitions as previously described. Each resultant becomes the phase reference for the next element.

A phase detector could easily separate the resultant vectors into components with the resultant of the preceding element as a phase reference. Assume the first element transmitted at T1, shown in table 12-1, consisted of mark information in each of the two channels. The resultant is represented at 45°. At time T2, two spaces will be transmitted from each channel. The

TABLE 12-1. KINEPLEX PHASE RELATIONSHIPS

TIME	ASSUMED SIGNALS	PHASE	STANDARD VECTOR	PREVIOUS BIT VECTOR	TRANSMITTED VECTOR
T1	M <sub>1</sub> M <sub>2</sub>	45°		→ 0°	
T2	S <sub>1</sub> S <sub>2</sub>	225°			
T3	S <sub>1</sub> M <sub>2</sub>	135°		↓ 270°	
T4	M <sub>1</sub> S <sub>2</sub>	315°			

resultant vector will be at 225°. Since the previous 45° vector is a source of reference, this 225° resultant vector is transmitted at 270° as shown. At time T3, a space is transmitted on the first channel and a mark on the second channel. The resultant when combined together is a vector at 135°. However, when the previous vector at 270° is used as a reference, the phase transmitted becomes once again 45°. In like manner each new resultant is referenced to the previous

resultant. At the receive end is present a reference vector without actually transmitting a separate phase reference. This phase comparison, element by element, so that the reference phase is maintained at the receiver integrator is a criterion of optimum predicted wave detection.

An electromechanical resonator is a device that will accept electrical energy, convert it to mechanical energy, and produce electrical energy at its output. Full utilization of these devices is made in their use as phase storage, filtering, and signal integration. Very high Q, when supplemented by a positive feedback, assumes an infinite Q. When driven by a signal (incoming), they provide a linear integration in time of the received signal thereby providing, when gated in synchronization with the incoming signal, a perfect weighting function. Their narrow bandwidth characteristics are equally acceptable as selective filters.

Two resonators with associated amplifiers are used in each keyed filter pair. A quench pulse gates a negative feedback around the resonator removing any residual information. An incoming signal is gated

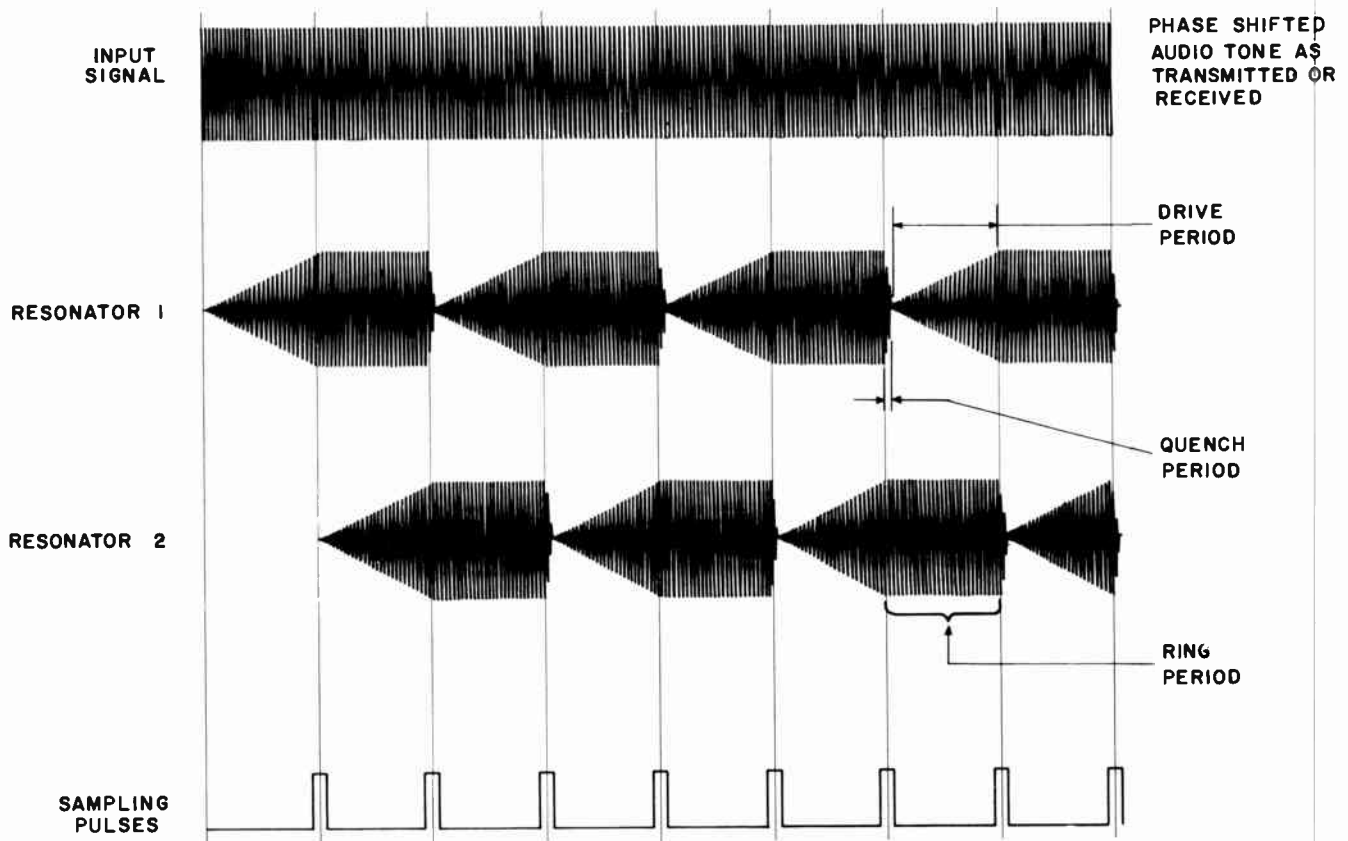

Figure 12-4. Keyed Filter Pair, Quench-Drive-Ring Sequence



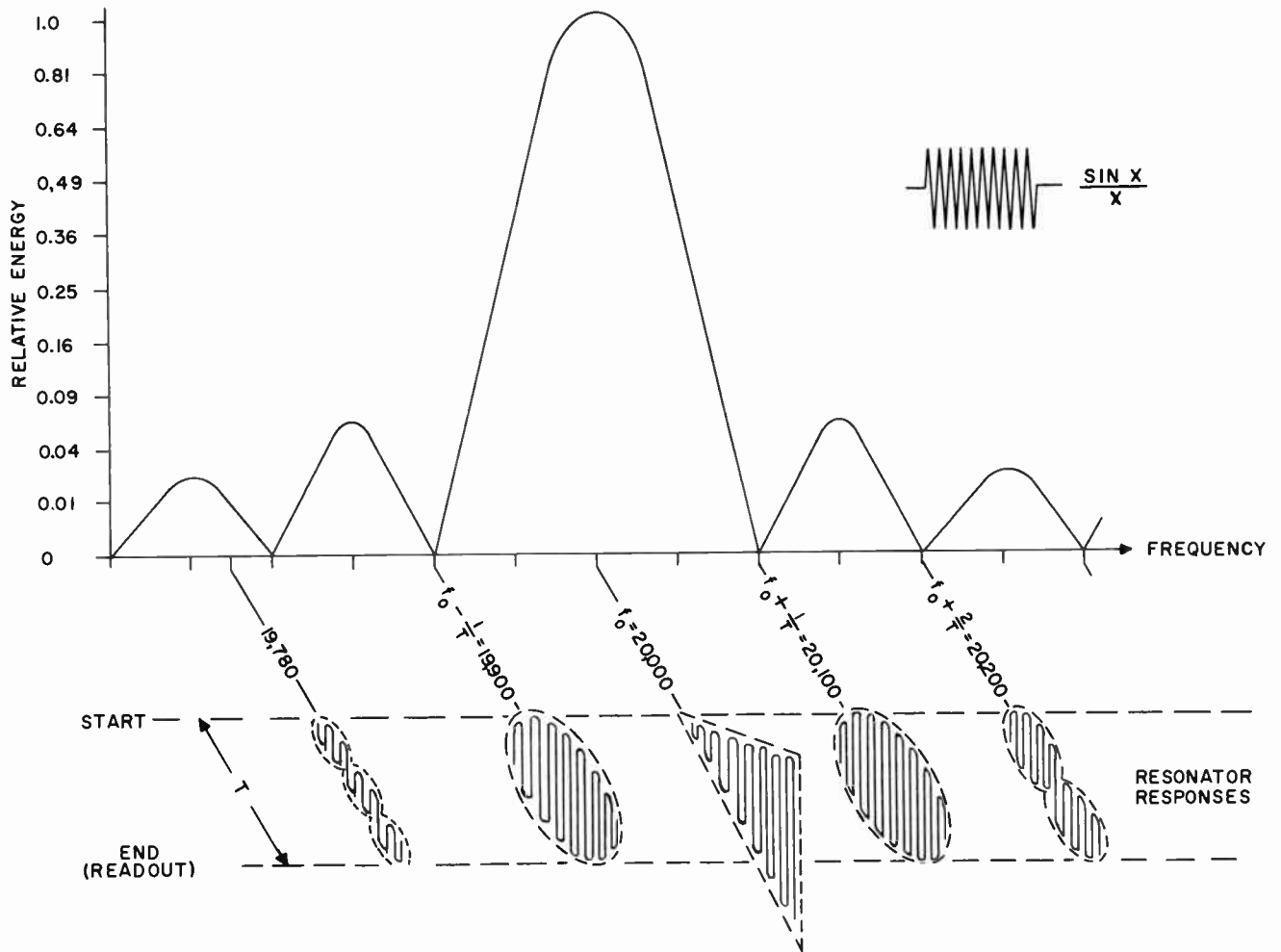

Figure 12-5. Energy Versus Frequency Distribution of Transmitted Pulses and Infinite Q Resonator Responses

into the input by drive pulses. At the end of the drive pulse, when the signal has built to a maximum, the energy is allowed to ring at the phase and frequency of the driving signal for a time equal to a quench and drive pulse. The two sections of a keyed filter pair work in alternation with one another. While one is ringing, the other is being quenched and driven, then while the first is quenched and driven, the second is ringing. Refer to figure 12-4. The resonator section that is ringing contains the frequency and phase of a driving signal that was present a time interval before. The resonator section that is being driven contains the frequency and phase information of the driving pulse that is now present. At the output of the two sections, we have information about a signal that is now being produced (or received) and equal information concerning the preceding signal. In this manner a reference is provided which is identical to that required.

A pulsed audio sine wave may be expressed by the function  $\frac{\sin X}{X}$ . Perfect integration of such a pulsed wave by a weighing function, such as that provided by a mechanical resonator, allows the recovery of the energy content of the  $\sin X/X$  function. A relationship exists between the length of the pulse  $T$  and  $1/T$  that orthogonal or null points occur at the resonant frequency plus or minus  $1/T$ . This is illustrated in figure 12-5 which is an illustration of energy versus frequency distribution of transmitted pulses and infinite Q resonator responses at 100 wpm operation. The upper portion shows the energy-frequency relationship of the transmitted pulse for a resonator whose center frequency is 20,000 cycles. The lower section shows sketches of the oscillograph waveforms of the resonator response obtained for various input frequencies. In this instance the pulse length is 10 milliseconds, and the bandwidth  $1/T$  is equal to 100 cycles. It will

be observed that the resonator amplitude builds up linearly to the sampling time at the end of the pulse. A signal 100 cycles removed from the center frequency of the resonator at 19,900 or 20,100 cycles will result in a resonator response which has a linear buildup close to start but which reaches a maximum amplitude halfway through the duration of the pulse and returns to zero at the end of the pulse period. If two resonators were available with one cut to 20,000 cycles and the other cut to 20,100 cycles, both resonators could be fed at once with both frequencies, but neither resonator would respond to the resonant frequency of the other. Similar null responses occur at every hundred-cycle increment of frequency.

As shown at 20,000 cps plus  $2/T$ , the number of loops in the response curve is equal to the value  $n$  in the expression  $n\Delta f$ , where  $\Delta f$  is the difference between the resonator frequency and the frequency of the first null point. Tone spacings or the value of  $\Delta f$  can be varied at will. In a practical system, it is possible to choose frequency spacings over a wide range merely by altering the timing signals.

In the presence of severe noise and multipath distortion, the number of information channels can be reduced. The increase in the power-per-tone attained can be discerned through the four fold increase in power-per-tone realized by reducing the number of channels by one half.

It is permissible to restrict the bandwidth emission of the transmitter by filtering to eliminate the side energy beyond approximately plus or minus  $3/T$ . The amount of energy contained in the signal beyond this third orthogonality is so small that it can be filtered out with small effect on operation. This feature is an important point in limiting intersystem interference.

The timing functions of the Kineplex Data System integrates the operations of the individual units. Refer to figure 12-6 for the relation of pulses used throughout the system. These values apply for 60 wpm

operation. The time relations of the Q and D pulses are altered at other repetition rates.

All pulses are derived by time bases which are supplied driving pulses by a standard operating at a  $16F_1$  rate, where  $F_1$  is the element repetition rate. Pulses marked with a prime are identical to their counterparts except for being  $180^\circ$  out of phase. The  $F_1$  pulses provide precise timing for the information data. The  $F_2$  pulses gate resonators alternately for signal storage during tone generation and detection. The synchronizing pulse is also gated at an  $F_2$  rate. The sampling pulse determines the sampling time of the phase-detected signal, while the  $F_2D$  pulse forms the basis of comparison signals in the synchronizing unit. A Q pulse and a D pulse occupy the same time as a code element. The Q pulses open a gate to quench or wipe out information which has been stored in a resonator before the D pulses open gates to provide resonator build up.

Note how the  $Q_1$  and  $Q_2$  and the  $D_1$  and  $D_2$  pulses alternate in time to produce the alternate quench-drive-ring sequence of the keyed filter pairs. Table 12-2 contains the repetition rates of three standard transmission rates and the associated element rate and quench and drive pulse lengths.

Figure 12-7 represents a typical frequency tone allocation of a basic system. Each of the twenty tones with frequency spacing from 605 cps to 2695 cps are allotted two channels of information. The 110 cps spacing between tones provides for readout on the second orthogonality for 60 wpm operation while at 75 wpm and 100 wpm rates, the readout occurs at the first null point. If 500 cycles protection against unfavorable delay at band extremities is allowed, a total bandwidth of 3300 cycles is employed, which permits the positioning of a synchronizing tone at 2915 cps. Actual band use suggests the use of 55 cycles for two channels which compares quite favorably with the minimum of 120 cycles per channel with frequency-shift keying.

TABLE 12-2. TIMING FREQUENCIES AND PULSE WIDTHS

TELETYPE RATE	ELEMENT RATE	$16F_1$ cps	$F_1$ cps	$F_2$ cps	QUENCH (ms)	DRIVE (ms)
60 wpm	45 bits/sec	727.27	45.45	22.72	3.8	18.2
75 wpm	55 bits/sec	888.8	55.55	27.77	8.5	9.1
100 wpm	75 bits/sec	1185.2	74.2	37.1	4.4	9.1

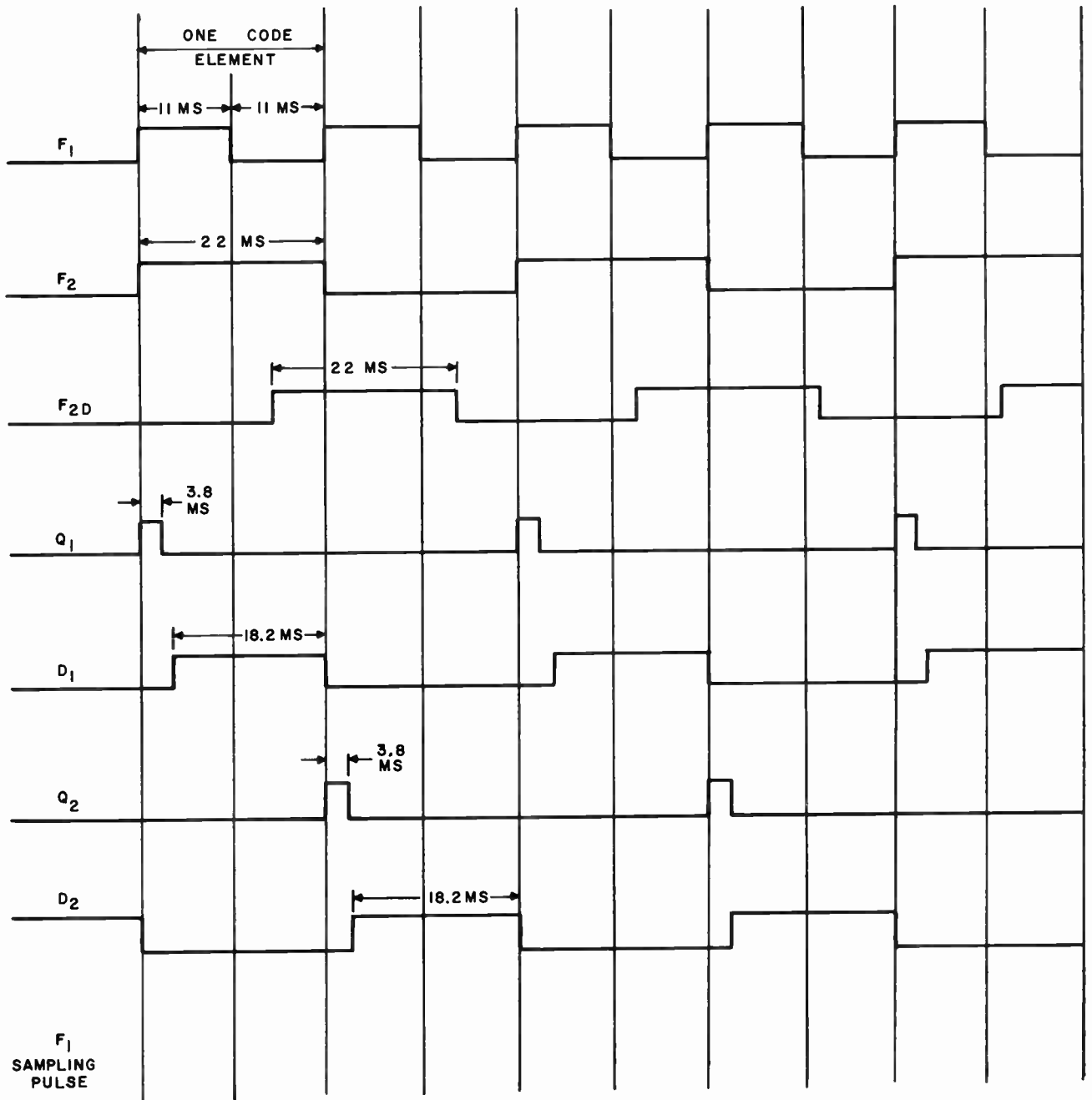

Figure 12-6. Timing Pulse Relation

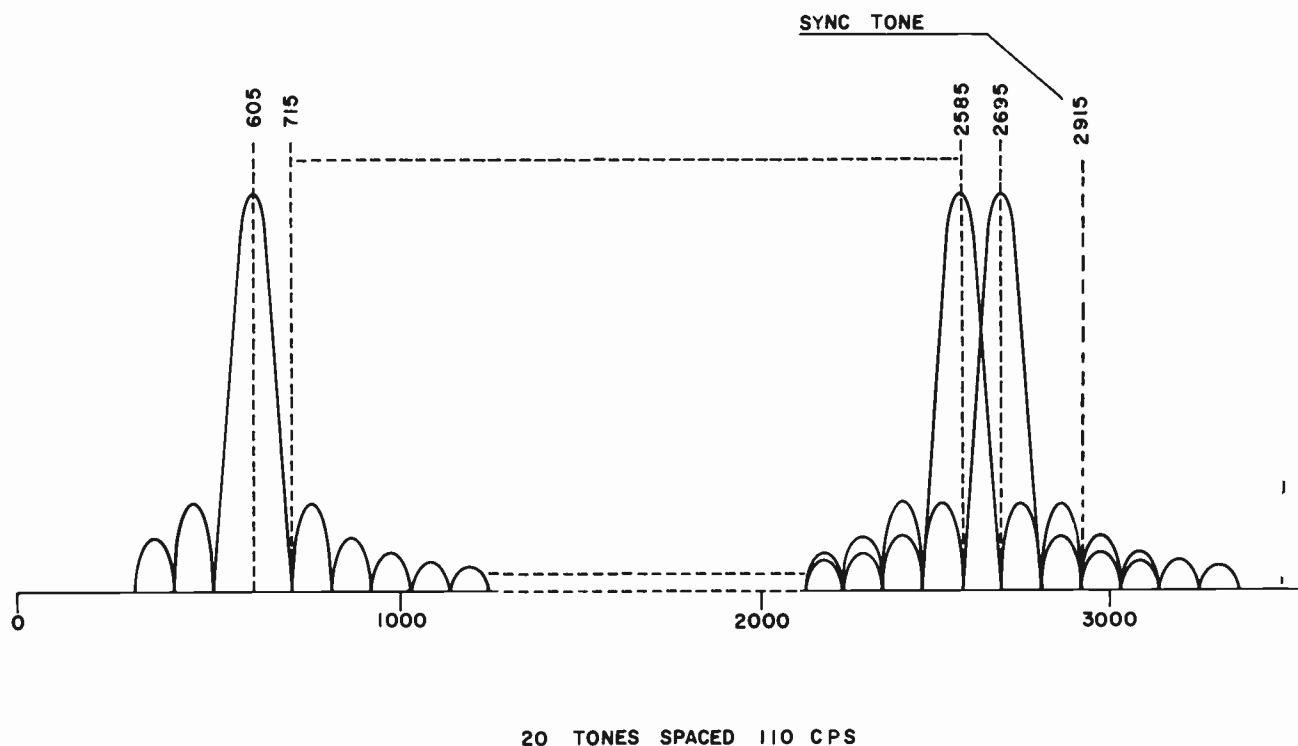

Figure 12-7. Channel Allocation at 100 WPM

With the aid of block diagram 12-8 the previous discussion of Kineplex theory will be applied to a basic system. Only two of the possible forty inputs are shown for convenience. Assume that a 60 ma d-c teletype signal is received from a transmitter-distributor or other teletypewriter device by each code converter. Since the transmitter distributors are not synchronized in any way, mark-space transitions may occur at any time on any of the channel inputs. The outputs of the code converters are gated so that all outputs occur simultaneously. Also the long stop pulse is shortened to the same length as the other pulses.

The outputs of two code converters modulate a single tone through the action of the phase shift generators and the keyed filter pairs. The output from the keyed filter pair is gated alternately to a dual-balanced modulator by an  $F_2$  timing pulse which phase modulates the tone in accordance with the signals received from the code converters. One of the balanced modulators includes a  $90^\circ$  phase-shifting network in its output so that the phase-modulated tone from both balanced modulators can be combined as shown in table 12-1 and amplified for transmission. The same output is also fed into the input of the keyed filter pair to one of the two resonators for storage as a zero phase reference. The output of the tone generator is shifted in

phase for each new element. Twenty such outputs are combined together with the synchronizing tone for transmission. Since all elements are occurring synchronously, the output is constant in amplitude thus assuring full utilization of the transmission medium.

Binary information from two sources modulating a single audio tone by phase-shifting techniques is not necessarily confined to the method described in the phase shift generator. The desired phase is recognized to be integral multiples of  $45^\circ$  of the reference phase. A  $45^\circ$  vector represents  $1/8$  of an  $F_1$  cycle so that eight increments represent any of the possible phase conditions. A selection of any of these conditions would constitute a phase-shifted vector. The retention of this vector product provides the reference point for the next vector selection. The combination is a reconstructed sine wave gated at an  $F_1$  rate containing the two channels of information.

The distributing unit in the receive section is an amplifier with a tone-operated level control which amplifies the incoming tone for application to the keyed filter pairs and synchronization unit. All other tones except the synchronizing tones are filtered at the synchronization unit input. The filtered output of a detector supplies an automatic level adjustment voltage



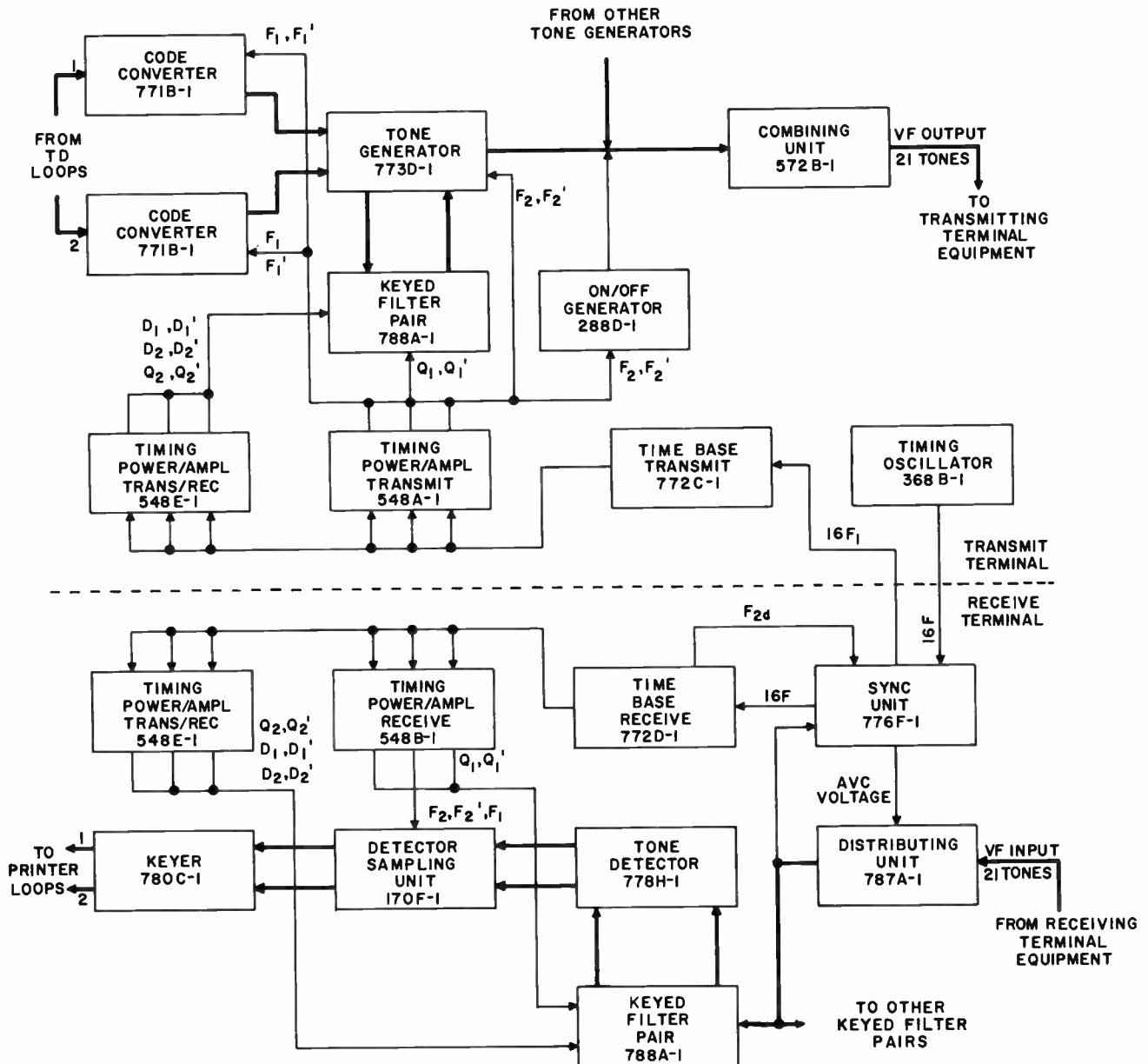

Figure 12-8. Kineplex (Frequency Division) Block Diagram

back to the distributing unit. The synchronizing tone, which is at an  $F_2$  rate, is supplied to a phase detector. An  $F_2D$  pulse, derived from the receiver time base but delayed in respect to the other pulses to compensate for the delay of the input  $F_2$  pulse in passing through the filter, is supplied to the same phase detector. The difference, if any, drives a magnetic amplifier whose windings are interconnected with a servomotor. This servo is geared to a resolver. The resolver shifts the timing frequency phase as necessary to effect synchronization with the incoming signal.

The third function of the synchronizing tone, automatic frequency control, may be accomplished with auxiliary equipment. A controlled modulator operates in conjunction with an error detector and a controlled oscillator in the following manner. An incoming signal is fed into a modulator where it is mixed with a variable-frequency signal containing translation error information from the controlled oscillator and converted into sidebands in the 250 kc frequency range. The resultant upper sideband is selected by a mechanical filter and reconverted to the audio range by

heterodyning with a fixed 250 kc signal. This resultant a-f signal is applied to the error detector, which is a frequency discriminator operating with a 2915 cps electromechanical resonator as a reference, to produce an error voltage proportional to the deviation from the incoming synchronization tone. There the error voltage thus produced is applied to the controlled oscillator to produce the variable-frequency signal containing the error information referred to above, and produces the compensatory correction for any frequency translation to insure that the received channel frequencies correspond exactly to the transmitted frequencies.

The keyed filter pairs receive all the tones from the distributing unit, each keyed filter pair accepting a tone to which its resonators are tuned. One element is used to drive one of the resonators in the keyed filter pair and then stored in that resonator during the second element, while the second element is being used to drive the second resonator. At the end of the second bit element, a phase comparison is made, and the resonator which was ringing is quenched and driven with the third element while the other resonator is allowed to ring during the third element period. This preserves the signal received during the second element for comparison at the end of the third element.

By passing signals through a direct and a 90° phase-shifted path in the tone detectors, two outputs are obtained for the two channels which were modulated on the single tone. The output is now represented by differences in voltage levels for the two conditions of mark and space.

In addition to amplifying and wave shaping, the detector sampler determines whether the signal is mark or space during a short interval at the end of each drive period.

The keyer serves to convert the voltage excursions from the detector sampler unit to definite mark and space transmissions similar in all respects to the input information at the distant end. At the same time, the power level is increased to drive teletypewriter printers or whatever kind of output device is used.

Adequate protection against phase and frequency-shift errors introduced through motion of stations in respect to one another is afforded by auxiliary equipment.

Thus far the discussion has been concerned only with frequency multiplexing. Time division multiplexing is accomplished by reducing the length of the transmitted pulses. Time division multiplexing offers the advantage of long pulses where severe delay distortion is present. However, for high speed trans-

mission pulses, as short as 1 millisecond may also be accommodated if their use is dictated. The increase in bits per second results in the increase of bandwidth or a reduction in the signal-to-noise ratio. Multiple tones may be utilized to increase the capacity for a specific application.

Either frequency diversity or space diversity may be applied to the basic Kineplex system. With frequency diversity, the added feature is accomplished with the reduction of the number of individual channels that may be transmitted. Space diversity requires only the duplication of keyed filter pairs and tone detectors in the receive section. The detector sampling unit has the additional function of combining inputs when diversity reception is used. Although the previous discussion has centered around the transmission of teletypewriter material, the inputs and outputs may be equipped with converters to process any kind of series or parallel binary data, synchronous or nonsynchronous. Such applications would include magnetic tape, punched cards, or other types of storage devices. The inputs would not be confined to one type for they may be conveniently intermixed at will.

Kineplex may be readily integrated into systems utilizing frequency division or time division multiplex. Optimum signal transfer characteristics permit a high capacity, flexible system for the transmission of binary data over open wire lines, cable facilities, carrier telephone channel circuits, multiplex channel circuits, and microwave system basebands. When equipped with appropriate conversion units, the Kineplex Data System will accept and transmit binary information for various services, such as teletypewriter, business machine, telemetering, supervisory control, and facsimile. Analog information transfer is best accomplished by conversion to digital information for transmission as binary data. This establishes a reliable communication system in the presence of noise that needs only to establish the quality of the signal rather than the quantity. With proper devices, almost any type of information could be transmitted including voice.

The basic system is readily adapted to accommodate the various input and output levels and impedances encountered in different types of transmission. Similarly power requirements are such that simple conversion units makes any available power source acceptable. Channels may be easily added or deleted from a basic system to adapt to the number of information channels required. Mobile and portable stations are as feasible as fixed stations since the over-all design incorporates minimum power and weight requisites consistent with reliability.

## CHAPTER 13

# SINGLE SIDEBAND FOR THE RADIO AMATEUR

### 1. INTRODUCTION

The whole nature of single-sideband equipment development is one of conserving the radio-frequency spectrum used by the amateur and commercial station so that there can be more channels of communication for a given number of kilocycles. In the amateur, military, and commercial fields of radio communications, there is a continuing demand for more and more channels of communication. With each passing year a larger number of people wish to talk from one point to another by means of radio. Single sideband allows more voice QSO's (contacts) per kilocycle than previous methods. Many amateur transmitters are extremely broad in characteristic, requiring much more bandwidth than is needed to carry on voice communications. An amateur who narrows his transmission and makes sure there are few spurious products from his transmitter will contribute to more efficient use of the crowded amateur bands. There is greater signal density in the sideband portion of the amateur bands than there is in the AM. portion; hence, more QSO's per kilocycle. At the same time SSB produces a much higher percentage of successful contacts than was ever true previously using AM. The use of single sideband has shown that a two-to-one reduction of bandwidth is entirely possible as compared to amplitude modulation.

To secure the desired narrow band transmission low intermodulation products, reduced harmonics, reduced spurious emissions, and the use of minimum bandwidth required for speech must all be considered. Intermodulation distortion in a transmitter results in the generation of new signal components which were not present in the original speech. These components occur both within the normal transmission band and outside. Sometimes these are spread over a wide band and are commonly referred to as splatter. Spurious emissions in a sideband transmitter are mixer products which are not adequately attenuated by tuned circuits. Minimum speech bandwidth refers to the use of narrow band circuits to reproduce a speech signal. Broadcast quality requires 15 kc. AM. stations may use 4 to 6 kc; SSB can reduce the audio bandwidth to 2 kc.

First, consider the generation of single sideband. (For additional discussion of single-sideband exciters, refer to chapter 2.) To secure a desired narrow band single-sideband transmission, start with a good method of sideband generation. This normally implies a balanced modulator plus filter, or a phasing-type generator. If a balanced modulator is used, it must be operated with adequate carrier injection and sufficient carrier balance. This must be followed by a suitable single-sideband separation filter. Either a mechanical, an LC, or a crystal filter can be used for sideband separation. However, the filter must have

certain desirable characteristics. It should provide some additional carrier attenuation so that the carrier balance of the balanced modulator is not too critical. It should supply adequate rejection of the unwanted sideband, 40 db or so, and it should also cut off at the high end of the single-sideband spectrum so that only audio frequencies up to two or three kc are permitted on the air. It can be shown that only about two kc is required for intelligible speech communications. Further, this bandwidth permits the speaker's voice to be recognized. Broadcast quality contributes nothing to communication ability, but only produces wide band interfering signals. With the filter separation method of single-sideband generation, there is no need for an audio filter.

With the phasing-type exciter, suitable results can be obtained, but audio filters are required to eliminate both the low audio frequencies and the frequencies above two or three kc. In the phasing-type exciter, it is extremely important that the high audio frequencies be attenuated properly, because normally the audio phase shift networks which are used do not hold a 90-degree relationship above approximately three kc. Thus, if audio frequencies are permitted in the phasing-type exciter above three kc, the undesired sideband will again reappear. This contributes to wide band interfering signals which are completely unnecessary.

The proper carrier level must be fed into the balanced modulator in either filter or phasing exciter. It is also important that the audio level fed into the balanced modulator does not exceed that level which will permit low distortion single-sideband generation. It is possible to drive into a distortion region with excessive audio input. This is much like overmodulation in an AM. transmitter. It is caused by driving the diodes of the balanced modulator past the linear region introducing distortion in the received signal, which detracts rather than enhances intelligibility. It should be obvious to all amateurs now that either in AM. or single sideband, a heavy hand on the gain control does not necessarily let the person on the other end of QSO hear any better. Actually the intelligibility of the channel is reduced because the signal is buried under distortion products.

Assuming that a suitable single-sideband signal has been generated, it is still a long way from this point to the antenna. In the exciter, mixers and amplifiers must be used to transform the single-sideband signal to useful drive voltage for the power amplifier. Many different types of mixers can be used to convert a low-frequency, single-sideband signal to the desired output frequency. In general, the mixers must be operated with low distortion. The injection level must be several times as strong as the highest signal level. Grid current must be avoided on the signal



grid. Operating conditions involving the bias voltage and plate voltage must be set so that low distortion operation is possible throughout the life of the equipment. The amplifier should be shielded and filtered to prevent oscillation; however, this is not enough. Even a slight amount of regeneration will contribute to increased distortion products in the exciter. Great care must be taken to ensure that the r-f voltage delivered to the final amplifier grid is an exact replica of the single-sideband signal from the SSB generator. It is possible with a reasonable amount of care to produce an exciter that has distortion products 45 to 50 db down from a two-tone test signal.

Frequency stability is accepted as a necessary part of single-sideband operation. However, frequency stability is not obtained without some design attention. It is important that a double-conversion frequency scheme be used in which a crystal oscillator provides the basic frequency stability for the higher bands. A stable vfo can then be used to secure continuous frequency coverage between the frequencies selected by the high-frequency crystals. It is easy to see that an unstable frequency-generating scheme will result in signals which drift across the band and thereby occupy more frequency spectrum than is required. Improvements in frequency stability and the tendency to use a single radio-frequency channel by both parties in the QSO also greatly increases the number of QSO's per kilocycle. The use of transceiver-type operation in which the transmitter frequency is tuned properly when the receiver is adjusted to the incoming signal ensures that both stations are operating on the same frequency.

In the power amplifier, the rules for proper operation are much like that imposed by the high-fidelity enthusiast in designing an output stage. Adequate tubes must be selected for the power amplifier to operate in the linear region. One can use the class AB<sub>1</sub> characteristics in the tube books. R-f feedback should be used to reduce the intermodulation distortion products. It is necessary to have careful neutralization; regeneration must be avoided, and automatic load control (alc) is recommended to secure a low distortion minimum bandwidth transmitter. To secure adequate neutralization, there must be careful isolation of the grid and plate circuits without common coupling paths and feedback circuits. A wide band bridge neutralization circuit is very useful because this permits a single neutralization setting over the normal range of amateur frequencies. This neutralization is necessary even with power tetrodes, because a small amount of regeneration is possible even with the shielding which is available. Careful adjustment of neutralization and periodic checks following installation of the equipment are necessary parts of the operating procedure. Normally, neutralization requires very little attention.

Regeneration is frequently present in class C stages intended for AM. transmission, but it does not contribute to undesirable characteristics normally. However, for single-sideband operation, regeneration in the power amplifier, as in the exciter, produces increased distortion products which spread the radiated signal over a wider band. Regeneration, as pointed out before, is related to proper neutralization techniques. Shielding of the circuits, particularly between the power amplifier and the exciter, is very

necessary, and adequate bypassing of leads must be used to prevent undesired coupling of energy between the power amplifier and the low-level exciter stages.

R-f feedback in a radio-frequency linear amplifier is much like audio feedback in a high-fidelity system. In r-f feedback a sample of r-f voltage is taken from the plate of the power amplifier and fed back either to the cathode of the driver stage or to the control grid of the stage which precedes the driver stage. Thus feedback is taken around either two or three stages again in much the same manner as is done in audio amplifiers. The function of r-f feedback is to reduce undesired signal components.

There are several ways in which the power amplifier and the single-sideband transmitter can be driven into nonlinear operation. In many power amplifiers, the operation is class AB<sub>1</sub>; no grid current may be drawn during any portion of the operating cycle. It is also possible to drive the tube into a condition of instantaneous plate current which is beyond its linear capability. To prevent improper operation of the power amplifier, a protective circuit called automatic load control may be used. In automatic load control, a voltage is taken from the plate of the tube, rectified, and fed back to the exciter stages in the form of a negative d-c control voltage. Like avc in a receiver, this control voltage tends to reduce the gain of the system to a level which will maintain constant output. For example, in a transmitter which has a plate voltage of about 2000 volts, a threshold of approximately 1600 volts may be set above which a rectifier in the plate circuit will conduct. Thus above 1600 volts a d-c voltage is generated which serves to control the gain of the exciter as previously mentioned. Above an instantaneous plate voltage of 1600 volts the PA tube begins to become nonlinear, and it is desirable to maintain drive level which does not exceed this point. Another method which can be used is to a-c couple a biased rectifier to the grid return resistor of the power amplifier stage. At the very moment that a minute amount of grid current is drawn an a-c voltage appears across the grid return resistor. This voltage is rectified forming a controlling d-c potential which is applied to the exciter stages to reduce the gain of the exciter. This, as before, prevents overdriving of the power amplifier stage. Operating the power amplifier in a linear region, without automatic load control, could be accomplished by reducing the r-f gain and the audio gain of the single-sideband transmitter to an extent that r-f peaks would never occur to drive the power amplifier beyond a safe level. However, this would result in a rather low level of power output from the transmitter under normal speech conditions. The use of automatic load control with its automatic protective characteristics permits a higher average level of speech; hence, a higher average power output without the danger of wide band distortion products. Automatic load control is a very simple circuit. Utilizing only a rectifier and a handful of resistors and capacitors, it performs a very important function in a single-sideband transmitter. It, in effect, reduces the peak-to-average factor in speech and yet prevents undesired wide band distortion products.



From the standpoint of total spectrum occupancy, it can be seen that transmitter harmonics are capable of interference with other services. Fortunately, the linear single-sideband amplifier has much less harmonic output than the class C amplifier used for AM. The very nature of linear amplification of single-sideband signals greatly reduces harmonic output. This is especially true at the higher harmonics in the vhf bands. For example, it normally is possible to operate a class AB<sub>1</sub> transmitter without the need of a TVI (television interference) low-pass filter, which indicates the low level of harmonic output which falls within the TV bands. Another factor which is important in single-sideband transmission is the intermittent nature of voice in terms of the power which is present at harmonic frequencies. Because there is no steady carrier present, the harmonic voltage fluctuates at the fundamental frequency output of the transmitter. This means that the net interfering effect of single-sideband harmonics is much less than that from an AM transmitter having equivalent power output.

To summarize, the transmitter should be designed and operated to minimize:

- (1) Wide band single-sideband voice components
- (2) Intermodulation distortion
- (3) Spurious products from exciter mixers and power amplifier
- (4) Unwanted sideband
- (5) Overloading and overdriving
- (6) Regeneration
- (7) Harmonics

If this is done, the transmitter will produce a clean, narrow band signal. Proper equipment design and proper equipment operation will produce a narrow band, single-sideband voice transmission.

Equally important in a single-sideband installation is the receiver. To take full advantage of the spectrum-saving features of single sideband, the receiver should embody certain design principles. Among these are (1) stability, (2) selectivity, (3) adequate sensitivity, and (4) calibration. Chapter 3 provides a discussion of the design considerations and circuits employed in Collins single-sideband receivers, including amateur models.

## 2. 75S-1 RECEIVER

The 75S-1 Receiver (figure 13-1) provides SSB, CW, and AM reception on all amateur bands between 3.5 and 29.7 mc. It is capable of coverage of the entire h-f spectrum between 3.5 and 30 mc by selection of the appropriate high-frequency beating crystals.

The standard amateur model includes crystal sockets, crystals, and band switch positions for 3.4-3.6, 3.6-3.8, 3.8-4.0, 7.0-7.2, 7.2-7.4, 14.0-14.2, 14.2-14.4, 21.0-21.2, 21.2-21.4, and 21.4-21.6 mc. Positions and crystal sockets are also



Figure 13-1. 75S-1 Receiver

provided for three 200-kc bands between 28 and 29.7 mc, with one of the sockets equipped with a crystal for 28.5 to 28.7 mc. A crystal and band switch position is also provided for 14.8 to 15.0 mc for reception of WWV and WWVH for time and frequency calibration data.

Figure 13-2 is a block diagram of 75S-1 Receiver. The 75S-1 is a double-conversion receiver with crystal-controlled, high-frequency oscillator and band-pass i-f. Separate detectors for AM and SSB are provided. Outputs from the high-frequency oscillator and the vfo are available at jacks on the chassis for controlling frequencies of companion 32S-1 Transmitter when used in transceiver service. When operating the 75S-1 with a transmitter, the function switch should be left in STDBY; this allows the receiver mute line to be externally switched; if left in OPR, the receiver mute line is grounded by the switch and the receiver cannot be muted. Figure 13-3 is a schematic diagram of the receiver.

### a. R-F CIRCUITS

One set of slug-tuned coils is used to cover the entire tuning range with appropriate capacitance switched in by band switch sections S2, S3, and S4. The r-f amplifier tube, V1, is a type 6DC6. Its output is applied to the grid of the first mixer, V2A. High-frequency injection signal is coupled from the crystal oscillator to the cathode of V2A. On any band selected, the crystal oscillator output frequency is 3.155 mc higher than the lower edge of the desired band. The difference between the crystal oscillator frequency and the desired frequency is between 3.155 mc and 2.955 mc, or the band-pass i-f frequency.

Using a triode first mixer, V2A, reduces cross modulation products. The triode mixer also has a lower noise figure than a pentode mixer. The r-f coils are peaked for the amateur bands. Receiver sensitivity is slightly reduced on the high end of each general coverage band. This can be corrected by repeaking the preselector tuned circuits to the desired frequency range.

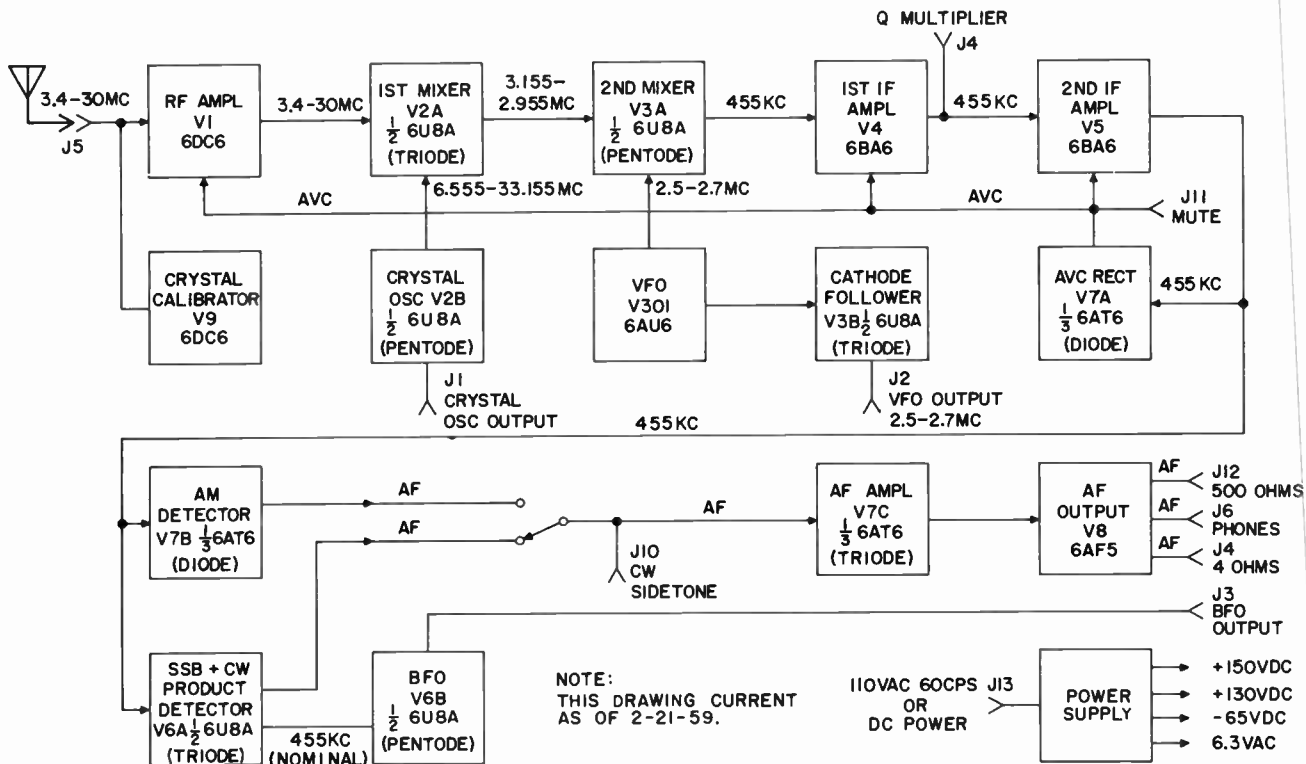

Figure 13-2. 75S-1 Block Diagram

A decided improvement in frequency stability results by using a crystal oscillator in the high-frequency conversion and injecting the tunable oscillator at a lower frequency conversion where good vfo stability is easily attained. The 70K-2 Oscillator used in the 75S-1 is a very stable vfo and essentially determines the frequency stability of the entire receiver as all other oscillators are crystal controlled.

Delayed avc is used in the 75S-1 to allow the incoming signal to build up from the noise to the delay voltage level before avc is applied. The sensitivity is one microvolt for a 15-db signal-plus-noise to noise ratio at avc threshold. The avc is fast attack, slow release for sideband and CW reception. This allows fast avc action before the end of the first syllable and a long enough hold time to prevent gain changes between words.

### b. FREQUENCY-CONVERSION DATA

To illustrate the frequency-conversion scheme used with the 75S-1, assume one wishes to listen to a lower sideband signal from a 32S-1 being transmitted at 3.9 mc. The 75S-1 is set at band 3A and the dial reads 100 (3.8 plus 100 on the dial, or 3.9 mc). This means the suppressed carrier frequency of the incoming lower sideband signal is 3.9 mc, with a voice band extending 2.4 kc lower in frequency (3.9000 down to 3.8976 mc). This is because the optimum speech range necessary for communications work is from 300 to 2400 cps (2.1 kc); however, frequencies from 0 to 2400 cps can be transmitted. By

placing the carrier 20 db down on the filter skirt of a 2.1-kc mechanical filter the undesired lower 300 cps can be attenuated.

The high-frequency-conversion oscillator V2B is crystal controlled by Y3 at 6.955 mc. Subtractive mixing in V2A inverts the incoming lower sideband signal ( $6.9550 - 3.9000 = 3.0550$  mc;  $6.9550 - 3.8976 = 3.0574$  mc) so the signal, as far as the remainder of the receiver is concerned, is upper sideband. The 3.055-mc variable i-f carrier frequency is mixed with the 70K-2 Oscillator frequency of 2.601350 mc, which gives a low-frequency i-f suppressed carrier signal of 453.650 kc. This places the suppressed carrier at the -20-db point on the low-frequency skirt of the 455-kc mechanical filter passband, FL2, and centers the desired 300- to 2400-cps portion of the signal in the 2.1-kc filter passband. To detect the audio from this i-f signal in the product detector, V6A, the bfo V6B must inject a carrier (at 453.650 kc, the i-f suppressed carrier frequency) generated by crystal Y15. The bfo signal is filtered out of the product detector output and the audio signal is fed to amplifiers V7 and V8.

To receive a 3.9-mc upper sideband signal, the suppressed carrier remains the same (3.9 mc) with the 2.4-kc speech bandwidth extending from 3.9000 mc to 3.9024 mc. Subtractive mixing in V2A inverts the incoming upper sideband signal ( $6.9550 - 3.9000$  mc = 3.0550 mc;  $6.9550 - 3.9024$  mc = 3.0526 mc) so that the signal, as far as the remainder of the receiver is concerned, is lower sideband. The









3.055-mc variable i-f carrier frequency is mixed with the 70K-2 Oscillator frequency of 2.598650 mc which gives a low-frequency, i-f suppressed carrier signal of 456.350 kc. This places the suppressed carrier at the -20-db point on the high-frequency skirt of the 455-kc mechanical filter passband, FL2, and centers the desired 300- to 2400-cps portion of the signal in the 2.1-kc filter passband. To detect the audio from this i-f signal in the product detector, V6A, the bfo V6B must inject a carrier (at 456.350 kc, the i-f suppressed carrier frequency) generated by crystal Y16. All mixing products but the desired audio are filtered out of the product detector output, and the audio signal is amplified by V7 and V8.

To keep the vfo dial frequency reading the same (100), the vfo frequency must be shifted 2.7 kc lower in frequency when receiving upper sideband. This vfo switching is done by applying a positive or negative bias to diode CR301. When the diode bias is positive, the diode impedance is lowered, C308 is effectively in parallel with L304, and the oscillator frequency for receiving upper sideband, in this example, is 2.598650 mc. When the bias is negative, diode impedance is high, C308 is effectively switched out of the circuit, and the oscillator frequency for receiving lower sideband, in this example, is 2.601350 mc.

### c. I-F CIRCUITS

The 3.155- to 2.955-mc variable i-f frequency is coupled through a band-pass network, consisting of T1 and L4, to the grid of the second mixer, V3A. This mixer is the pentode section of a type 6U8A with vfo injection signal at its cathode. Depending on the setting of EMISSION switch S2, the 455-kc second mixer output is coupled through CW filter FL1 (not supplied with receiver), AM, i-f transformers T8 and T7, or SSB filter FL2 to the first i-f amplifier, V4. The i-f amplifiers, V4 and V5, are conventionally coupled. The second i-f amplifier, V5, also operates the S-meter.

The S-meter is calibrated in S-units and db. The S-unit scale is standard up to midscale (S-9). The db scale reads relative signal strength above the avc threshold which is approximately one microvolt. Thus 40 db on the meter is 100 microvolts of signal (which also corresponds to S-9 on the S-unit scale). To read db over S-9 on the S-unit scale, subtract 40 from the corresponding db reading. For instance, a 60-db reading would be 20 db over S-9 (100 uv) or 10,000 uv of signal at the antenna. This reading then is 60 db over the db scale reference of one microvolt and 20 db over the S-9 reference of 100 uv.

### d. A-F CIRCUITS

Output from the second i-f amplifier, V5, is coupled from transformer T2 to the grid of CW/SSB product detector, V6A, and to the diodes of V7. Beat-frequency oscillator injection signal is coupled to the cathode of the product detector. Product detector output is filtered and connected to EMISSION switch section S8 where it is selected and fed to the grid of the triode section of V7. The AM, audio signal from one of the V7 diode plates is also connected to S8.

Output from the triode amplifier section of V7 is coupled to the audio output tube, V8, from which it may be fed to phones, speaker, or phone patch by plugging into J6, J8, or J12 respectively.

### e. OSCILLATOR CIRCUITS

The receiver contains four oscillators. They are crystal calibrator, crystal oscillator, vfo, and bfo. The 100-kc crystal calibrator, V9, is a type 6DC6 tube. Its output is coupled to the antenna coil, T5. The high-frequency crystal oscillator, V2B, is the pentode section of 6U8A. For high-frequency injection up to 14.955 mc, the oscillator operates on crystal fundamental frequencies. For injection frequencies higher than 14.955 mc, the oscillator doubles the crystal frequency in its plate circuit. Oscillator output is available at J1 for frequency control of companion transmitter such as the 32S-1. Unless this jack is connected to external equipment, the load resistor and plug, P1, is left plugged into J1 to provide proper oscillator plate circuit impedance. The vfo is a 70K-2 Oscillator installed as an integral unit. Its frequency range is 2.5 to 2.7 mc. Oscillator output is fed to the cathode of the second mixer and to the grid of a cathode follower, V3B. The cathode follower (triode section of a 6U8A) isolates the vfo from load variations when a companion transmitter, such as the 32S-1, is connected to it in transceiver service. The bfo is crystal controlled by one of two crystals for CW and SSB signals. If the accessory 0.5-kc CW filter is used, a matched crystal may be installed to produce an 800-cps CW note instead of the 1330-cps note obtained with Y16. EMISSION switch section S9 selects Y16 for CW and USB positions and Y15 for LSB position. Output from the bfo is connected to the product detector and to the BFO TEST jack, J3.

### f. POWER SUPPLY

The 75S-1 power supply is self-contained in the receiver and utilizes silicon diodes as rectifiers for lower voltage drop, longer life, and reduced heat. Vacuum tubes are operated at a plate voltage of 150 volts for cooler operation and longer tube life.

### 3. 32S-1 TRANSMITTER

The 32S-1 (figure 13-4) is an SSB or CW transmitter with a nominal output of 100 watts for operation on all amateur bands between 3.5 and 29.7 mc. Input power is 175 watts PEP on SSB or 160 watts on CW.

The transmitter can cover 3.5 to 30 mc except for 5.0 to 6.5 mc (the range of the second harmonic of the variable i-f). Crystal sockets, crystals, and band switch positions are provided for ten 200-kc bands, with the standard amateur model equipped as follows: 3.4-3.6, 3.6-3.8, 3.8-4.0, 7.0-7.2, 14.0-14.2, 14.2-14.4, 21.0-21.2, 21.2-21.4, and 21.4-21.6 mc. Crystal sockets and band-switch positions are also provided for three 200-kc bands between 28 and 29.7 mc. The 32S-1 is delivered with one crystal in this range (28.5 to 28.7 mc). A fourteenth position, corresponding to the WWV position on the 75S-1



Figure 13-4. 32S-1 Transmitter

Receiver, can be used for an additional 200-kc band in the 9.5- to 15.0-mc range.

Refer to figure 13-5, block diagram of the 32S-1. The 32S-1 Transmitter uses heterodyne exciter principles with crystal-controlled bfo, high-frequency oscillator, and highly stable vfo. The low-frequency i-f is 455 kc, and the high-frequency i-f is a 200-kc wide band-pass circuit. The 32S-1 may be connected in transceiver service with the companion 75S-1 Receiver. Figure 13-6 is a schematic diagram of the transmitter, and figure 13-32 is a schematic diagram of the 516F-2 A-C Power Supply. For additional discussion of single-sideband exciter circuits, refer to chapter 2.

#### a. FREQUENCY-CONVERSION DATA

To illustrate the frequency-conversion scheme used in the 32S-1, assume one wishes to transmit a lower sideband signal at 3.9 mc. The 32S-1 is set at band 3A and the dial reads 100 (3.8 plus 100 on the dial, or 3.9 mc). This means the suppressed carrier frequency of the transmitted lower sideband signal is 3.9 mc, with a speech band extending 2.4 kc lower in frequency (3.9000 mc down to 3.8976 mc). This is because the optimum speech range necessary for communications work is from 300 to 2400 cps (2.1 kc); however, frequencies from 0 to 2400 cps can be transmitted. By placing the carrier 20 db down on the filter skirt of a 2.1-kc mechanical filter, the undesired 300 cps can be attenuated.

For lower sideband output, the bfo V2B generates a carrier at 453.650 kc and injects it, along with audio from V2A, into the balanced modulator. The output of the balanced modulator is a double-sideband signal with a 453.650-kc suppressed carrier. This is fed into the 455-kc mechanical filter, FL1. The 453.650-kc suppressed carrier from the balanced modulator is placed 20 db down on the low-frequency skirt of the 2.1-kc filter, which centers the desired 300- to 2400-cps portion of the signal in the filter passband. Filter output consists of a 453.650-kc carrier suppressed approximately 50 db from the accompanying upper

sideband (which is later inverted to lower sideband by V5). This upper sideband signal is fed into the first mixer, V4A, along with a 2.601350-mc signal from the 70K-2 Oscillator. Additive mixing gives a suppressed variable i-f carrier frequency of 3.0550 mc with the upper sideband extending to 3.0574 mc (as the speech band extends to 2400 cps). The variable i-f is mixed with the output of the high-frequency crystal oscillator, V12, at 6.955 mc (using crystal Y3) in the second mixer, V5. Subtractive mixing in V5 inverts the signal to the desired lower sideband output ( $6.9550 - 3.0550 = 3.9000$  mc;  $6.9550 - 3.0574 = 3.8976$  mc). This is the lower sideband r-f output that is fed into the r-f amplifiers.

To transmit an upper sideband signal at 3.9 mc, the suppressed carrier, remains the same with the 2.4-kc speech bandwidth extending up to 3.9024 mc. For upper sideband output, the bfo V2B generates a carrier at 456.350 kc and injects it, along with audio from V2A, into the balanced modulator. The output of the balanced modulator is a double-sideband signal with a 456.350-kc suppressed carrier. This is fed into the 455-kc mechanical filter, FL1. The 456.350-kc suppressed carrier from the balanced modulator is placed 20 db down on the high-frequency skirt of the 2.1-kc filter, which centers the desired 300- to 2400-cps portion of the signal in the filter passband. Filter output consists of a 456.350-kc carrier suppressed approximately 50 db from the accompanying lower sideband (which is later inverted to upper sideband by V5). This lower sideband signal is fed into the first mixer, V4A, along with a 2.598650-mc signal from the 70K-2 Oscillator. Additive mixing gives a suppressed variable i-f carrier frequency of 3.0550 mc with the lower sideband extending down to 3.0526 mc (as the speech band extends 2400 cps). The variable i-f is mixed with the output of the high-frequency crystal oscillator V12 at 6.955 mc (using crystal Y3) in the second mixer, V5. Subtractive mixing inverts the signal to the desired upper sideband output ( $6.9550 - 3.0550 = 3.9000$  mc;  $6.9550 - 3.0526 = 3.9024$  mc). This is the upper sideband that is fed into the r-f amplifiers.

To keep the vfo dial frequency reading the same (100), the vfo frequency must be shifted 2.7 kc lower in frequency when transmitting upper sideband. This vfo switching is done by applying a positive or negative bias to diode CR301. When the diode bias is positive, the diode impedance is lowered, C308 is effectively in parallel with L304, and the oscillator frequency for transmitting upper sideband, in this example, is 2.598650 mc. When the bias is negative diode impedance is high, C308 is effectively switched out of the circuit, and the oscillator frequency for transmitting lower sideband, in this example, is 2.601350 mc.

#### b. A-F CIRCUITS

Microphone or phone patch input is connected to the grid of first audio amplifier V1A, amplified, and coupled to the grid of the second audio amplifier, V1B. Output from V1B is coupled to the grid of cathode follower V2A across MIC GAIN control. Output from the cathode follower is fed to the resistive balance

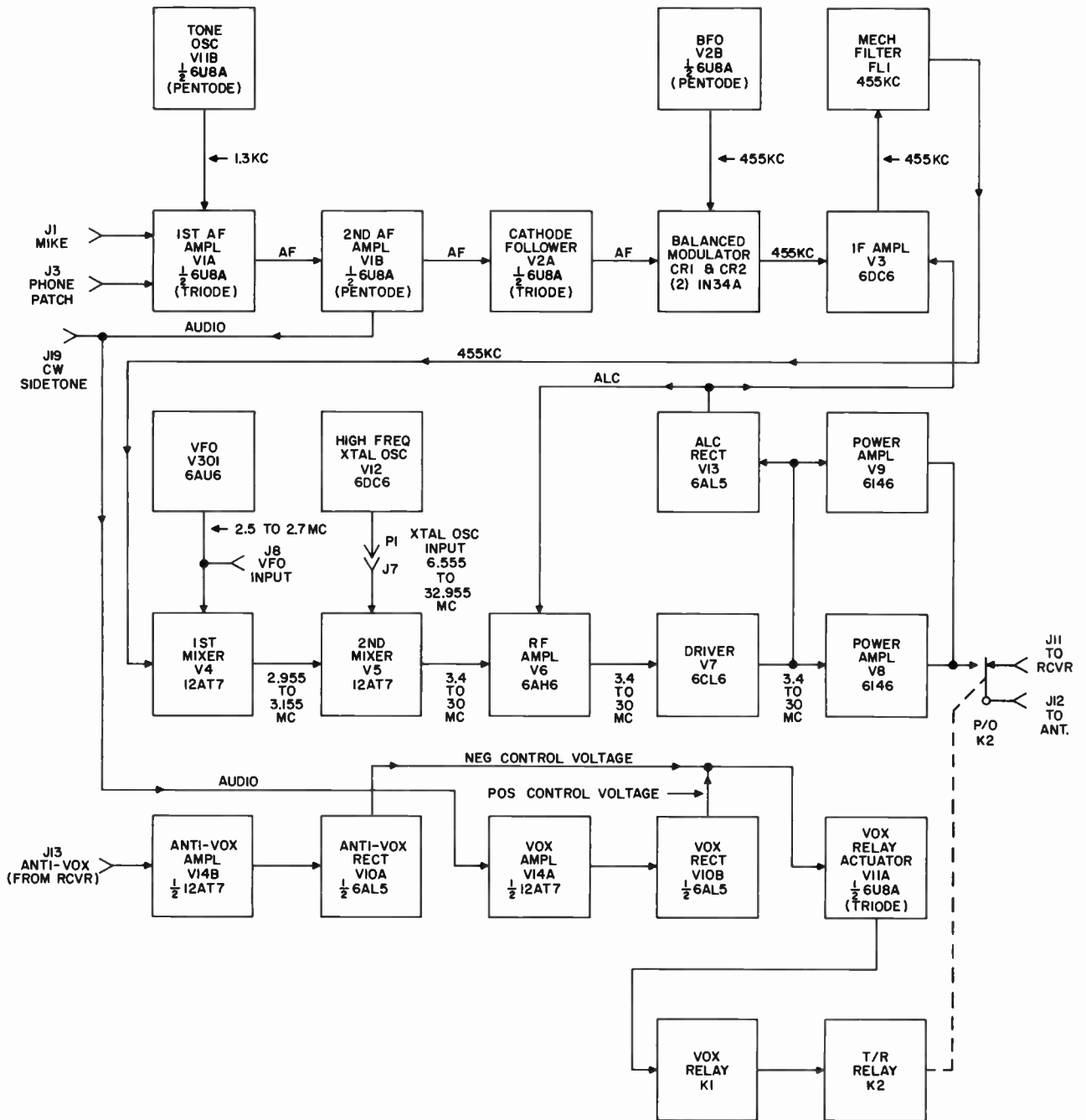

Figure 13-5. 32S-1 Block Diagram



modulator. In TUNE, LOCK KEY, and CW positions of the EMISSION switch, output from the tone oscillator, V11B, is fed to the grid of the second audio amplifier. Amplified tone oscillator signal is taken from the plate of V1B to the grid of the vox amplifier and the CW sidetone jack, J19. Because of the sharp skirt selectivity on both sides of the 2.1-kc mechanical filter, speech frequencies below 300 cps and above 2400 cps are attenuated, and the desired 300- to 2400-cps speech band is centered in the 2.1-kc filter passband. This emphasizes the optimum communications speech range (300 to 2400 cps).

### c. BALANCED MODULATOR AND LOW-FREQUENCY I-F CIRCUITS

Audio output from the cathode of V2A and bfo voltage are fed to the slider of the carrier balance potentiometer, R14. Both upper and lower sideband output from the balanced modulator are coupled through i-f transformer T2 to the grid of the i-f amplifier, V3. Output from the i-f amplifier, V3, is fed to the mechanical filter, FL1. The passband of FL1 is centered at 455 kilocycles.

This passes either upper or lower sideband, depending upon the sideband polarity selected when the EMISSION switch connects bfo crystal Y14 or Y15. The single-sideband output of FL1 is connected to the grids of the first balanced mixer in push-pull.

### d. BALANCED MIXERS

The 455-kc single-sideband signal is fed to the first balanced mixer grids in push-pull, the plates are connected in push-pull, and the vfo signal is fed to the grids in parallel. The mixer cancels the vfo signal energy and translates the 455-kc single-sideband signal to a 2.955- to 3.155-mc single-sideband carrier signal. This signal is the band-pass i-f frequency. The coupling network between the plate of the first mixer and the grid of the second balanced mixer is broadbanded to provide a uniform response to the band-pass i-f frequency. The band-pass i-f signal is fed to one of the grids of the second balanced mixer, and the high-frequency injection signal from the crystal oscillator V12 is fed to the signal input cathode and to the other grid. This arrangement cancels the high-frequency injection signal energy within the mixer and translates the band-pass i-f signal to the desired operating band. The use of triode balanced mixers reduces cross-modulation products and lowers the distortion level, although the primary purpose is to reduce oscillator feedthrough.

### e. R-F CIRCUITS

The slug-tuned circuits coupling V5 to V6, V6 to V7, and V7 to the power amplifier are ganged to the EXCITER TUNING control. The signal is amplified by the r-f amplifier, V6, and the driver, V7, to drive the power amplifier, V8 and V9. Output from the parallel power amplifiers is tuned by a pi network and applied to the antenna through contacts of transmit-receive relay K2. The pi network matches a 50-ohm load provided the load has vswr not exceeding 2:1. Negative r-f feedback from the PA plate circuit to the driver cathode circuit permits a high degree of linearity at the high power level of the PA tubes.

Both the driver and PA stages are neutralized to ensure their stability.

## f. CONTROL CIRCUITS

### (1) ALC CIRCUIT

Detected audio from the power amplifier grid circuit is rectified by V13, and the negative d-c output is fed to the alc bus. A fast-attack, slow-release, dual time constant is used to prevent overdriving on initial syllables and to hold gain constant between words. The fast time constant alc is applied to V6, and the slow time constant alc is applied to V3. If the companion 30S-1 Power Amplifier is used with the 32S-1, alc output from the 30S-1 is fed back to the alc bus. The minute amount of grid current drawn before alc acts does not degrade linearity. Rather, these few microvolts actually improve the linearity curve; only after appreciable grid current is drawn is linearity affected.

### (2) VOX ANTIVOX CIRCUITS

Output from the second audio amplifier, V1B, is fed to the grid of the vox amplifier, V14A, through the VOX GAIN control, R74. This audio input is amplified by V14A and rectified by vox rectifier V10B. When the positive output of V10B is high enough to overcome the negative bias on V11A grid, the vox relay is actuated to turn the transmitter on. Receiver output is fed from J13 through the ANTI-VOX GAIN control, R85, to the grid of antivox amplifier V14B. Output from V14B is rectified by antivox rectifier V10A to provide the negative bias necessary to keep the transmitter disabled during receive periods. The antivox circuit provides a threshold voltage to prevent loudspeaker output (picked up by the microphone circuits) from tripping the vox circuits into transmit. ANTI-VOX GAIN control R85 adjusts the value of the antivox threshold so that loudspeaker output will not produce enough positive d-c output from the vox rectifier to exceed the negative d-c output from the antivox rectifier and cause V11A to actuate vox relay K1. Speech energy into the microphone will cause the positive vox voltage to overcome the negative antivox voltage and produce the desired action of K1. Contacts of relay K1 control relay K2, the key line, PA and driver screens, receiver muting circuits, oscillator plate-voltages, and the high-voltage relay in the d-c supply.

## g. OSCILLATORS

### (1) TONE OSCILLATOR

The tone oscillator is used for tuneup and CW operation and consists of an RC phase-shift oscillator operating at approximately 1350 cps. Its output is fed to the audio amplifier and is switched by the bfo signal in the balanced modulator to provide continuous wave r-f at the grids of the first mixer. The oscillator is turned on when EMISSION switch section S8C is in TUNE, LOCK KEY, or CW position. TUNE reduces PA screen voltage to keep the PA plate dissipation within ratings during tuneup. LOCK KEY allows final tuning with full carrier.



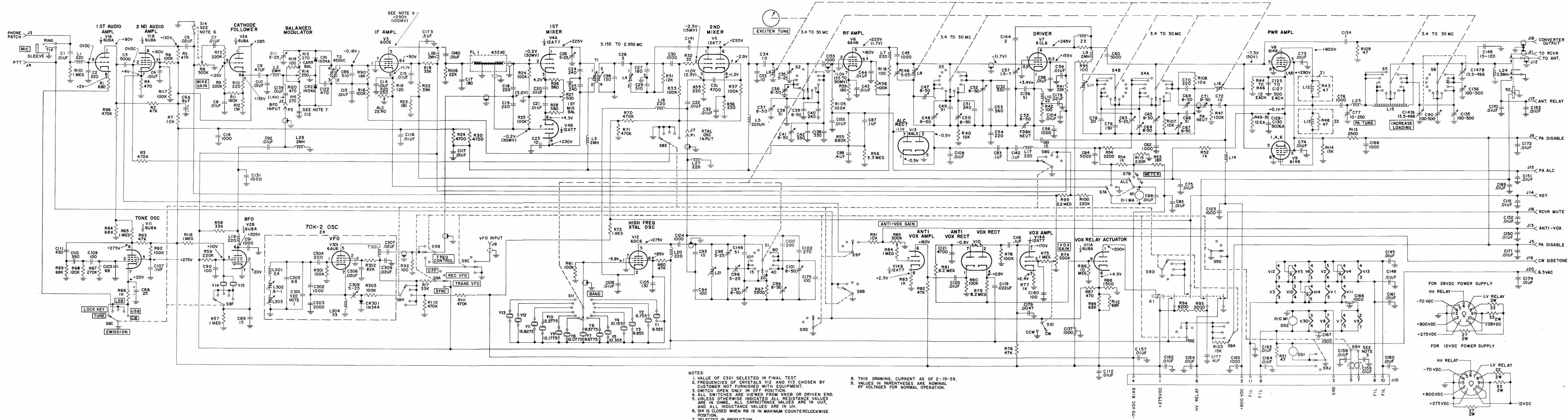

NOTES:  
 1. VALUE OF C301 SELECTED IN FINAL TEST.  
 2. FREQUENCIES OF CRYSTALS Y12 AND Y13 CHOSEN BY CUSTOMER NOT FURNISHED WITH EQUIPMENT.  
 3. SWITCH OPEN ONLY IN OFF POSITION.  
 4. ALL SWITCHES ARE VIEWED FROM KNOB OR DRIVEN END.  
 5. UNLESS OTHERWISE INDICATED ALL RESISTANCE VALUES ARE IN OHMS, ALL CAPACITANCE VALUES ARE IN UUF, AND ALL INDUCTANCE VALUES ARE IN UH.  
 6. S14 IS CLOSED WHEN RB IS IN MAXIMUM COUNTERCLOCKWISE POSITION.  
 7. SELECTED IN PRODUCTION.

8. THIS DRAWING, CURRENT AS OF 2-19-59.  
 9. VALUES IN PARENTHESES ARE NOMINAL RF VOLTAGES FOR NORMAL OPERATION.

Figure 13-6. 32S-1 Schematic Diagram



The tone oscillator is set at 1350 cps to center the tone in the mechanical filter passband and to place the second harmonic of the tone (2700 cps) out of the filter passband eliminating the possibility of tone modulation. Tone keying also permits two transceivers to work each other on the same CW frequency without leapfrogging across the band (retuning), which would be the case if the carrier were reinserted and keyed. This is because the carrier is ordinarily placed 20 db down on the 2.1-kc mechanical filter skirt, so when the receiving station tunes the CW carrier to center it in the filter passband the transceiver frequency will shift the same amount. The second station would then have to retune to center the incoming signal in the filter passband and, in doing so, would shift frequency when transmitting. Tone keying eliminates this problem.

#### (2) BEAT-FREQUENCY OSCILLATOR

The bfo is crystal controlled at either 453.650 kc or 456.350 kc, depending upon whether Y14 or Y15 is selected by EMISSION switch section S8F. These crystal frequencies are matched to the passband of the mechanical filter, FL1, so the carrier frequency is placed approximately 20 db down on the skirts of the filter response. This 20-db carrier suppression is in addition to the 30-db suppression provided by the balanced modulator.

#### (3) VARIABLE-FREQUENCY OSCILLATOR

The vfo is a Colpitts oscillator operating in the range of 2.5 to 2.7 mc. The value of the cathode choke is selected so switching a small trimmer across it shifts the oscillator frequency. This compensates for switching bfo frequency and keeps dial calibration accurate no matter which sideband is selected. Refer to paragraph 3a for additional information on why this is necessary. This vfo switching is done by applying a positive or negative bias to diode CR301. When the diode bias is positive, the diode impedance is lowered, and C308 is effectively in parallel with L304. When the bias is negative, diode impedance is high, and C308 is effectively switched out of the circuit.

#### (4) HIGH-FREQUENCY CRYSTAL OSCILLATOR

The high-frequency crystal oscillator, V12, is crystal controlled by one of 13 crystals selected by BAND switch S11. Output from the high-frequency crystal oscillator is fed to the second mixer. This frequency is always 3.155 mc higher than the lower edge of the desired transmit band. This high-frequency injection signal is crystal fundamental frequency for all desired output signals below 12 megacycles, but for operating frequencies higher than 12 megacycles, the crystal frequency is doubled in the plate circuit of the oscillator.

#### h. SYNC OPERATION

To zero the 32S-1 to the same frequency as the 75S-1 receiver, set both the transmitter and receiver to the same sideband, and set the receiver to STDBY (so the transmitter controls receiver muting). Slowly tune the transmitter vfo until the beat note sounds like

a canary chirping. When the frequency of chirps is two or three per second, the transmitter is zero beat with the receiver within two or three cycles per second. This operation involves a closed-circuit feedback loop in which the transmitter output signal is fed into the receiver. Receiver output is fed back into the transmitter speech amplifier. The feedback tone will begin to chirp as the transmitter vfo frequency approaches the receiver frequency with the number of chirps indicating the number of cycles from zero beat. At exact zero beat there would be no beat note feedback. This feedback method of frequency spotting is much more accurate than ordinary zero beating.

#### i. TRANSCEIVER OPERATION WITH THE 75S-1 RECEIVER

Since both the 32S-1 and 75S-1 use the same frequency-generating scheme it is possible to use the receiver high-frequency crystal oscillator and vfo to control the transmitter in transceiver operation. When the 32S-1 and 75S-1 are connected together in transceiver service and the **FREQ CONTROL** switch is in **REC VFO** position, the transmitter frequency is controlled by the receiver vfo. Both receiver and transmitter must have band switches set to the same position for proper r-f coil selection. Both units must be set to the same sideband, otherwise bfo injection frequencies would be incorrect. If the transmitter **FREQ CONTROL** switch is set to the **TRANS VFO** position, the two units may operate on different frequencies within the same 200 kc band. Again, both units must be set to the same band as the receiver high-frequency crystal oscillator is still controlling the transmitter.

#### 4. KWM-1 TRANSCEIVER

The KWM-1 (figure 13-7) receives or transmits (on the same frequency) SSB or CW signals in the 14- to 30-mc range. The KWM-1 transmits on upper sideband with an input of 175 watts PEP. The bands are covered in 100-kc segments with a total of ten segments available. A box that plugs into the front panel contains the ten injector oscillator crystals. For other selections than the amateur bands, extra

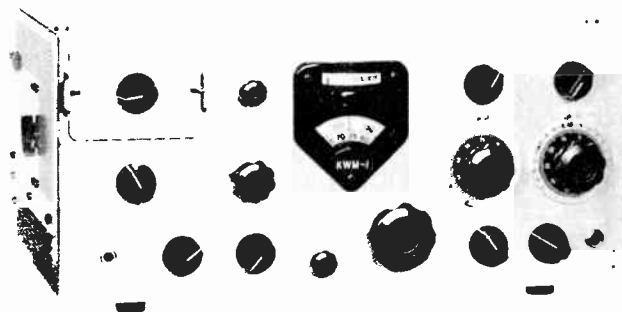

Figure 13-7. KWM-1 Transceiver



crystal boxes with the proper crystal complement are used. The front panel meter acts as an S-meter on receive and as the tuning meter on transmit. A 100-kc crystal calibrator is included for frequency reference.

Figure 13-8 is a block diagram of the KWM-1. Transmit signal paths are shown in heavy solid lines, receive signal paths in heavy dashed lines, and control circuits in light dashed lines. Figure 13-12 is the schematic diagram of KWM-1. The 516E-1 and 516E-2 D-C Power Supplies and the 516F-1 A-C Power Supply (refer to paragraph 10, power supplies) are used with the KWM-1.

#### a. RECEIVE-TRANSMIT COMMON CIRCUITS

Circuits common to both receive and transmit functions are receive-transmit amplifier V4 and its tunable grid and plate circuits. (These are gang tuned with other circuits tuned by EXCITER TUNE control on front panel.)

- (1) The 3.9- to 4.0-mc band-pass i-f transformer, T1.
- (2) Mechanical filter FL1.
- (3) High-frequency oscillator V11.
- (4) Beat-frequency oscillator V9.
- (5) Variable-frequency oscillator V22.
- (6) Control circuits.

#### b. RECEIVE CIRCUITS

##### (1) R-F CIRCUITS

Signals from the antenna are connected from J5-A1 through contacts of relays K1 and K2 to the grid of r-f amplifier V4. Grid circuit (L1, C13, and C15) and plate circuit (L3, C10, and C21) are tracked and ganged to the EXCITER TUNE control on front panel. Output from V4 and high-frequency oscillator signal from V11 are fed to the first receiver mixer, V7.

##### (2) I-F CIRCUITS

Difference frequency (3.9 to 4.0 mc) is coupled through i-f transformer T1 to the receiver second mixer, V8. The 3.9- to 4.0-mc signal is mixed with the 3.445- to 3.545-mc vfo signal in V8 to produce the 455-kc i-f signal. This i-f signal is coupled through the mechanical filter, FL1, to the grid of the receiver i-f amplifier, V13. A two-stage i-f strip, consisting of V13 and V14, amplifies the 455-kc signal and applies it to the agc rectifier, V12A, and the product detector, V15.

##### (3) A-F CIRCUITS

Beat-frequency oscillator signal is applied to the product detector which mixes the two signals to produce a demodulated audio signal. The audio signal is filtered by L17, C86, C89, C88, and C77 and

amplified by V16A and V17 for application to phone patch, speaker, and headphone circuits. Negative voltage, developed by V12A, provides automatic gain control to receiver amplifier circuits. The R. F. GAIN control, R116, is used to set the level of operating gain for all receiver r-f and i-f amplifier stages. Audio output level is controlled by A. F. GAIN control R79.

#### c. TRANSMIT CIRCUITS

##### (1) A-F CIRCUITS AND SSB GENERATION

Microphone signal is amplified by V19A and V19B and applied to cathode follower V18A. Signal level applied to the cathode follower is controlled by MIC. GAIN control R92. Output from the cathode follower is filtered (by L18, C96, and C98) and applied to the diode-ring balanced modulator (CR1 through CR4) consisting of four matched 1N67 diodes. Carrier energy is supplied from the bfo through an isolation stage, V18B, to the balanced modulator. Output of the balanced modulator (with carrier balanced out) is applied to mechanical filter FL1 which passes only the lower sideband energy to the first transmit mixer, V6.

##### (2) R-F CIRCUITS

Mixer V6 combines the 455-kc sideband signal and the 3.455- to 3.545-mc vfo signal to produce a 3.9- to 4.0-mc output. The 3.9- to 4.0-mc signal is amplified by V3 and applied to second transmit mixer V5. Tuned circuits T1 and T2 are band-pass transformers. Mixer V5 combines the 3.9- to 4.0-mc signal with the high-frequency oscillator signal and inverts the sideband to produce the desired upper sideband output frequency. This output signal is amplified by V4 and V2 and applied to the final amplifier. Both driver, V2, and final amplifier, V23 and V24, stages are neutralized by the capacity-bridge method, and negative feedback is coupled to the cathode of the driver to improve linearity. The pi-L power-output circuit consists of C42, L10, L11, C43 and C44, and L12. The pi-L network matches 50-ohm load provided the load has a vswr not exceeding 2:1. Output power is connected from L12 through contacts of K1 and connector J5-A1 to the antenna.

#### d. CONTROL CIRCUITS

Figure 13-9 shows vacuum-tube control circuits, and figure 13-10 shows relay and switching circuits.

##### (1) VOX AND ANTITRIP CIRCUITS

Vox and antitrip circuits operate as follows: A portion of the audio voltage developed across R93 (in output of V19B) is amplified by V20A and rectified by V21A. The positive d-c output of V21A is applied to the grid of V16B causing V16B to conduct current and actuate vox relay K2. Contacts of K2 switch the high-voltage plate power supply into operation (on d-c supply only; these contacts are jumpered in the a-c supply), disconnect the antenna from V4 grid, and energize relays K1 and K3. Relay K1 switches meter M1 from receiver S-meter circuits to transmitter multimeter circuits and switches antenna connections



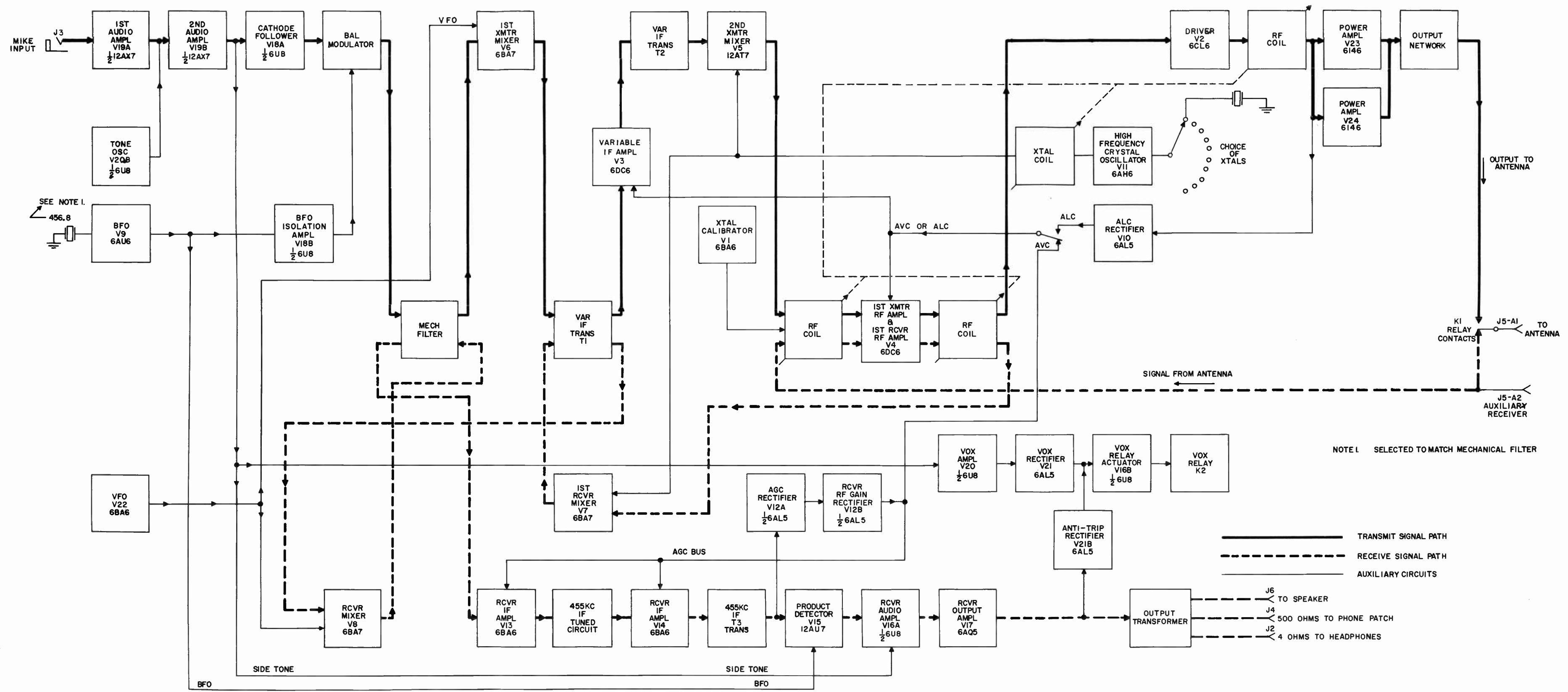

Figure 13-8. KWM-1 Block Diagram

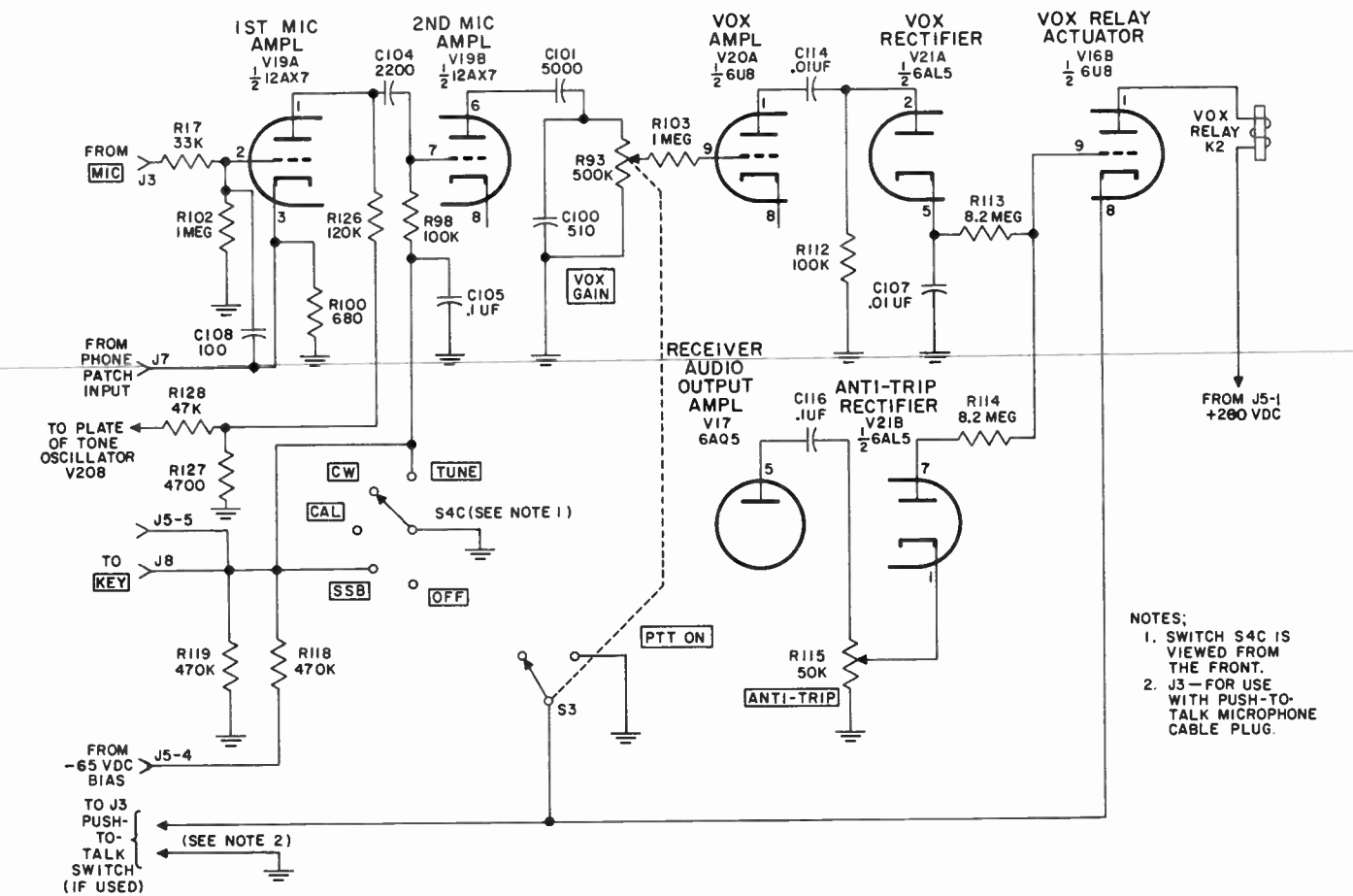

Figure 13-9. KWM-1 Vacuum-Tube Control Circuits

so that receiver input is grounded and transmitter output is connected from L12 to the antenna through J1. Relay K3 applies screen voltage to the power amplifier, and plate voltage to V18A turns on transmitter tubes (V2, V5, V6, and V18B) and turns off receiver tubes (V7, V8, V12, V13, V14, and V15).

The antitrip circuit provides a threshold voltage to prevent loud-speaker output (picked up by the microphone circuits) from tripping the KWM-1 into transmit function. Some of the receiver audio output voltage is connected through C116 and R115 to the antitrip rectifier (21). Negative d-c output voltage from V21B, connected to the grid of V16B, provides the necessary antitrip threshold. ANTITRIP control R115 adjusts the value of the antitrip threshold so that loudspeaker will not produce enough positive d-c output from the vox rectifier to exceed the negative d-c output from V21B and cause V16B to actuate K2. However, speech energy into the microphone will cause the positive vox voltage to overcome the negative antitrip voltage and produce the desired action of K2.

## (2) MANUALLY OPERATED SWITCHES

VOX GAIN control R93 is ganged mechanically to switch S3 which may be used for transmit-standby manual control if desired. When R93 is turned down through minimum, S3 closes and shorts the cathode of V16B to ground, causing the tube to conduct and actuate the switching relays. (Refer to figure 13-9.) As the EXCITER TUNE control is adjusted near 14.0 mc, 21.0 mc, or 30.0 mc, S5 connects pins 15, 16, or 17 (respectively) of J5 to ground to operate any desired combination of antenna selecting relays (see figure 13-11). Crystal selector switch S1 selects the proper crystal for high-frequency oscillator V11 to put the KWM-1 in the desired 100-kc portion of its operating range. Switch S2 selects metering function for M1 when the EMISSION SWITCH S4 is in SSB, CW, or TUNE position.

EMISSION SWITCH section S4A applies PA screen voltage through PA SCREEN switch S6 in all positions except OFF. In TUNE position, the screen voltage is reduced through a voltage divider R154 and R155. Section S4B turns on crystal calibrator V1 in

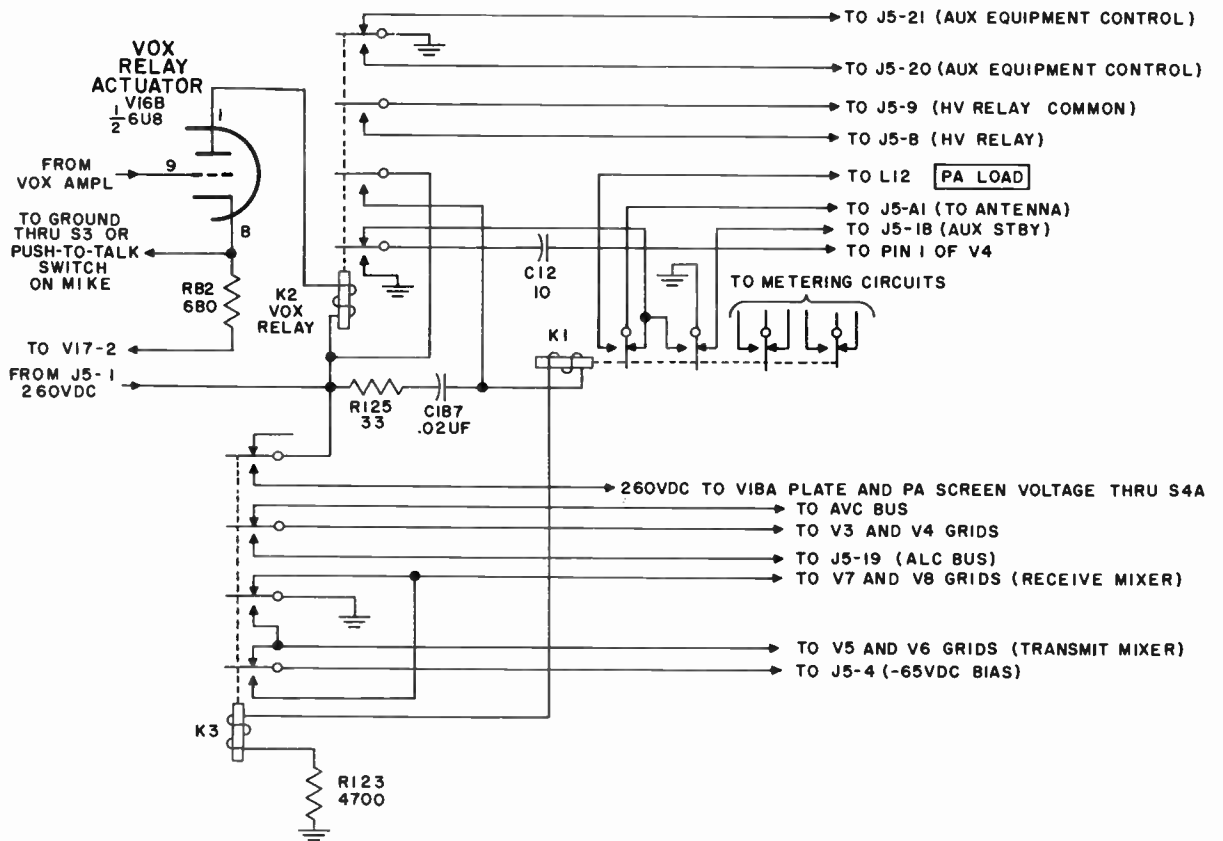

NOTE:  
S4 VIEWED FROM FRONT.

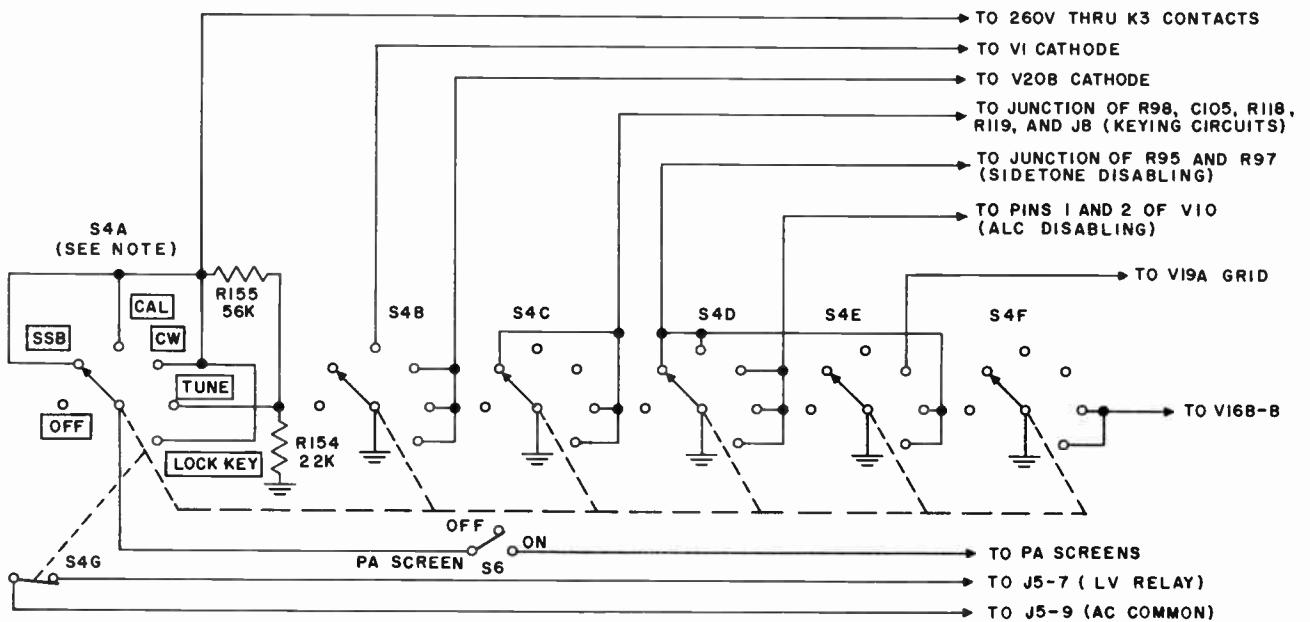

Figure 13-10. KWM-1 Relay and Switch Control Circuits

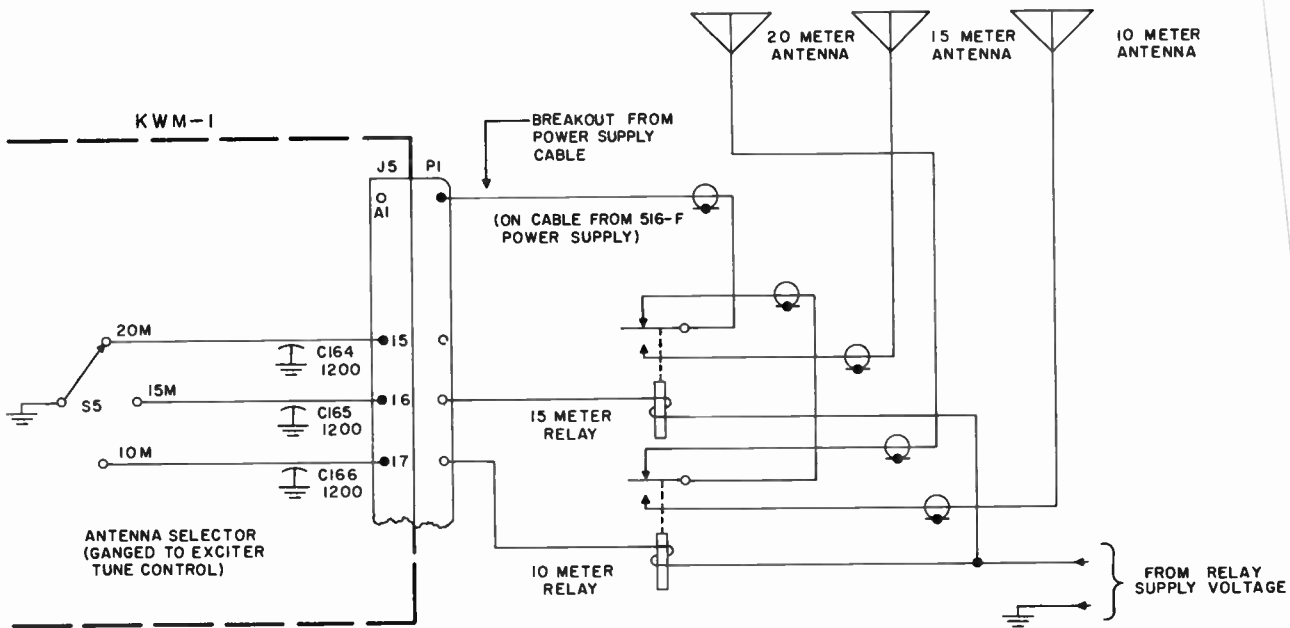

Figure 13-11. KWM-1 Antenna Switching Circuit

CAL position and turns on tone oscillator V20B in CW and TUNE positions. Section S4C removes cutoff bias from V19B when in SSB, TUNE, and LOCK KEY positions. Section S4D reduces input of V18A and V16A when in SSB and CAL positions and grounds alc voltage in CW, TUNE, and LOCK KEY positions. Switch S4G, mounted on rear of S4, turns on all low-voltage supplies in all positions except OFF.

### e. OSCILLATOR CIRCUITS

The crystal-controlled bfo provides 455-kc (nominal frequency) carrier to the balanced modulator and bfo injection to the frequency product detector. Its crystal is selected to fall at the -20-db point on the high-frequency skirt of the mechanical filter band pass. The vfo is a series-tuned type circuit. Its operating frequency of 3.445 to 3.545 mc is controlled by a permeability-tuned coil. The high-frequency oscillator, V11, is crystal controlled by one of ten crystals selected by the crystal selector switch on the front panel. These crystals may be selected to operate at any frequency in the operating range. The tone oscillator, V20B, is an RC phase shift type which supplied a 1-kc tone for tuneup and CW operation. The 100-kc crystal calibrator, V1, supplies calibration check points for calibrating the receiver dial.

## 5. KWM-2 TRANSCEIVER

Refer to figure 13-14, block diagram of the KWM-2. The KWM-2 (figure 13-13) is an SSB or CW transceiver operating in the range between 3.4 and 29.7 mc. It consists of a double-conversion receiver and a double-conversion exciter-transmitter, with an input of 175 watts PEP. The transmitter and receiver circuits use

common oscillators, common mechanical filter, and common r-f amplifier. The transmitter low-frequency i-f and the receiver low-frequency i-f is 455 kc. The high-frequency i-f for both is 2.955 to 3.155 mc. This is a band-pass i-f which accommodates the full 200-kc bandwidth. Figure 13-15 is a schematic diagram of the KWM-2. Figure 13-32 is a schematic diagram of the 516F-2 A-C Power Supply. The 516E-1 and 516E-2 D-C Power Supplies also can be used with the KWM-2. Refer to paragraph 10 for additional information on these power supplies.

### a. FREQUENCY-CONVERSION DATA

#### (1) RECEIVE

To illustrate the frequency-conversion scheme used with the KWM-2, during the receive condition, assume one wishes to listen to a lower sideband signal being transmitted at 3.9 mc. The KWM-1 band switch is set at 3.8 (band 3A) and the dial reads 100 (3.8 plus 100 on the dial, or 3.9 mc). This means the suppressed carrier frequency of the incoming lower sideband signal is 3.9 mc, with a voice band extending 2.4 kc lower in frequency (3.9000 down to 3.8976 mc). This is because the optimum speech range necessary for communications work is from 300 to 2400 cps (2.1 kc); however, frequencies from 0 to 2400 cps can be transmitted. By placing the carrier 20 db down on the filter skirt of a 2.1-kc mechanical filter, the undesired lower 300 cps can be attenuated. Higher speech frequencies above 2400 cps will also be attenuated by the opposite filter skirt so that the optimum speech range (300 to 2400 cps) is passed by the filter.



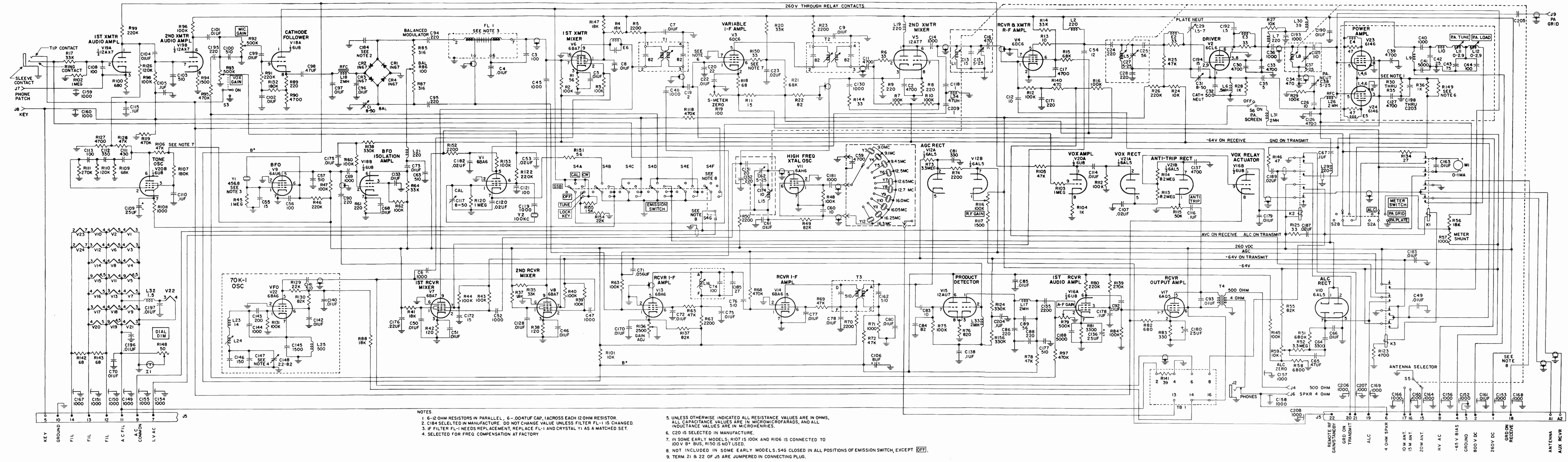

- NOTES
1. 6-12 OHM RESISTORS IN PARALLEL, .0047UF CAP, 1ACROSS EACH 12 OHM RESISTOR.
  2. C184 SELECTED IN MANUFACTURE. DO NOT CHANGE VALUE UNLESS FILTER FL-1 IS CHANGED.
  3. IF FILTER FL-1 NEEDS REPLACEMENT, REPLACE FL-1 AND CRYSTAL Y1 AS A MATCHED SET.
  4. SELECTED FOR FREQ. COMPENSATION AT FACTORY.
  5. UNLESS OTHERWISE INDICATED ALL RESISTANCE VALUES ARE IN OHMS, ALL CAPACITANCE VALUES ARE IN MICROMICROFARADS, AND ALL INDUCTANCE VALUES ARE IN MICROHENRIES.
  6. C20 IS SELECTED IN MANUFACTURE.
  7. IN SOME EARLY MODELS; R107 IS 100K AND R106 IS CONNECTED TO 100V B\* BUS, R150 IS NOT USED.
  8. NOT INCLUDED IN SOME EARLY MODELS. S4G CLOSED IN ALL POSITIONS OF EMISSION SWITCH, EXCEPT OFF.
  9. TERM. 21 & 22 OF J5 ARE JUMPERED IN CONNECTING PLUG.

Figure 13-12. KWM-1 Schematic Diagram







Figure 13-13. KWM-2 Transceiver

The high-frequency-conversion oscillator, V13A, is crystal controlled by Y3 at 6.955 mc. Subtractive mixing in V13B inverts the incoming lower sideband signal ( $6.9550 - 3.9000 = 3.0550$  mc;  $6.9550 - 3.8976 = 3.0574$  mc) so the signal, as far as the remainder of the transceiver is concerned, is upper sideband. The 3.055-mc variable i-f carrier frequency is mixed with the 70K-2 Oscillator frequency of 2.601350 mc, which gives a low-frequency i-f suppressed carrier signal of 453.650 kc. This places the suppressed carrier at the -20-db point on the low-frequency skirt of the 455-kc mechanical filter passband, FL1, and centers the desired 300- to 2400-cps portion of the signal in the 2.1-kc filter passband. To detect the audio from this i-f signal in the product detector V15B, the bfo V11A must inject a carrier (at 453.650 kc, the i-f suppressed carrier frequency) generated by crystal Y16. The bfo signal is filtered out of the product detector output and the audio signal is fed to amplifiers V16A and V16B.

To receive a 3.9-mc upper sideband signal, the suppressed carrier remains the same (3.9 mc) with the 2.4-kc speech bandwidth extending from 3.9000 mc to 3.9024 mc. Subtractive mixing in V13B inverts the incoming upper sideband signal ( $6.9550 - 3.9000$  mc = 3.0550 mc;  $6.9550 - 3.9024$  mc = 3.0526 mc) so that the signal, as far as the remainder of the transceiver is concerned, is lower sideband. The 3.055-mc variable i-f carrier frequency is mixed with the 70K-2 Oscillator frequency of 2.598650 mc which gives a low-frequency i-f suppressed carrier signal of 456.350 kc. This places the suppressed carrier at the 20-db point on the high-frequency skirt of the 455-kc mechanical filter passband, FL1, and centers the desired 300- to 2400-cps portion of the signal in the 2.1-kc filter passband. To detect the audio from this i-f signal in the product detector, V15B, the bfo V11A must inject a carrier (at 456.350 kc, the i-f suppressed carrier frequency) generated by crystal Y17. The bfo signal is filtered out of the product detector output and the audio signal is amplified by V16A and V16B.

## (2) TRANSMIT

Assume one wishes to transmit a lower sideband signal at 3.9 mc. The KWM-2 dial is set at 3.8

(band 3A) and the dial still reads 100 (3.8 plus 100 on the dial, or 3.9 mc). This means the suppressed carrier frequency of the transmitted lower sideband signal is 3.9 mc, with a speech band extending 2.4 kc lower in frequency (3.9000 mc down to 3.8976 mc). This is because the optimum speech range necessary for communications work is from 300 to 2400 cps (2.1 kc); however, frequencies from 0 to 2400 cps can be transmitted. By placing the carrier 20 db down on the filter skirt of a 2.1-kc mechanical filter, the undesired 300 cps can be attenuated. Higher speech frequencies above 2400 cps are also attenuated by the opposite filter skirt.

For lower sideband output, the bfo V11A generates a carrier at 453.650 kc and injects it, along with audio from V3A, into the balanced modulator. The output of the balanced modulator is a double-sideband signal with a 453.650-kc suppressed carrier. This is fed into the 455-kc mechanical filter FL1. The 453.650-kc suppressed carrier from the balanced modulator is placed 20 db down on the low-frequency skirt of the 2.1-kc filter, which centers the desired 300- to 2400-cps portion of the signal in the filter passband. Filter output consists of a 453.650-kc carrier suppressed approximately 50 db from the accompanying upper sideband (which is later inverted to lower sideband by V6). This upper sideband signal is fed into the first transmitter mixer, V5, along with a 2.601350-mc signal from the 70K-2 Oscillator. Additive mixing gives a suppressed variable i-f carrier frequency of 3.0550 mc with the upper sideband extending to 3.0574 mc (as the speech band extends to 2400 cps). The variable i-f is mixed with the output of the high-frequency crystal oscillator V13A at 6.955 mc (using crystal Y3) in the second transmitter mixer, V6. Subtractive mixing in V6 inverts the signal to the desired lower sideband output ( $6.9550 - 3.0550$  mc = 3.9000 mc;  $6.9550 - 3.0574$  mc = 3.8976 mc). This is the desired lower sideband r-f output that is fed into the r-f amplifiers.

To transmit an upper sideband signal at 3.9 mc, the suppressed carrier remains 3.9 mc with the 2.4-kc speech bandwidth extending up to 3.9024 mc. For upper sideband output, the bfo V11A generates a carrier at 456.350 kc and injects it, along with audio from V3A, into the balanced modulator. The output of the balanced modulator is a double-sideband signal with a 456.350-kc suppressed carrier. This is fed into the 455-kc mechanical filter, FL1. The 456.350-kc suppressed carrier from the balanced modulator is placed 20 db down on the high-frequency skirt of the 2.1-kc filter, which centers the desired 300- to 2400-cps portion of the signal in the filter passband. Filter output consists of a 456.350-kc carrier suppressed approximately 50 db from the accompanying lower sideband (which is later inverted to upper sideband by V6). This lower sideband signal is fed into the first transmitter mixer, V5, along with a 2.598650-mc signal from the 70K-2 Oscillator. Additive mixing gives a suppressed variable i-f carrier frequency of 3.0550 mc with the lower sideband extending down to 3.0526 mc (as the speech band extends 2400 cps). The variable i-f is mixed with the output of the high-frequency crystal oscillator V13A at 6.955 mc (using crystal Y3) in the second transmitter mixer, V6. Subtractive mixing inverts

the signal to the desired upper sideband output (6.9550-3.0550 mc = 3.9000 mc; 6.9550-3.0526 mc = 3.9024 mc). This is the upper sideband that is fed into the r-f amplifiers.

### (3) VFO DIAL READING

To keep the vfo dial frequency reading the same (100), the vfo frequency must be shifted 2.7 kc lower in frequency when transmitting or receiving upper sideband. This vfo switching is done by applying a positive or negative bias to diode CR301. When the diode bias is positive, the diode impedance is lowered, C308 is effectively in parallel with L304, and the oscillator frequency for upper sideband, in this example, is lowered to 2.598650 mc. When the bias is negative diode impedance is high, C308 is effectively switched out of the circuit, and the oscillator frequency for lower sideband, in this example, is 2.601350 mc.

## b. TRANSMITTER CIRCUITS

### (1) A-F CIRCUITS

Microphone or phone-patch input is connected to the grid of first audio amplifier V1A, amplified, and coupled to the grid of second audio amplifier V11B. Output from V11B is coupled to the grid of cathode follower V3A through MIC GAIN control R8. Output from the cathode follower is fed to the resistive balance point of the balanced modulator. In TUNE, LOCK, and CW positions of the EMISSION switch, output from the tone oscillator, V2B, is fed to the grid of the second audio amplifier. Amplified tone oscillator signal is taken from the plate of V11B to the grid of the vox amplifier to activate the vox circuits in CW operation. This signal also is fed to the grid of the first receiver a-f amplifier V16A for CW monitoring. Because of the sharp skirt selectivity on both sides of the 2.1-kc mechanical filter, speech frequencies below 300 cps and above 2400 cps are attenuated, and the desired 300- to 2400-cps speech band is centered in the 2.1-kc filter passband. This emphasizes the optimum communications speech range (300 to 2400 cps).

### (2) BALANCED MODULATOR AND LOW FREQUENCY I-F CIRCUITS

Audio output from the cathode of V3A and the bfo voltage are fed to the slider of the carrier balance potentiometer, R15. Both upper and lower sideband output from the balanced modulator are coupled through i-f transformer T1 to the grid of the i-f amplifier, V4A. Output from the i-f amplifier is fed to the mechanical filter, FL1. The passband of FL1 is centered at 455 kc. This passes either upper or lower sideband, depending upon the sideband polarity selected when the EMISSION switch connects the bfo crystal Y16 or Y17. The single-sideband output of FL1 is connected to the grids of the first transmitter mixer in push-pull.

### (3) BALANCED MIXERS

The 455-kc single-sideband signal is fed to the first balanced mixer grids in push-pull. The plates

of the mixer are connected in push-pull, and vfo signal is fed to the two grids in parallel. The mixer cancels the vfo signal energy and translates the 455-kc single-sideband signal to a 2.955- to 3.155-mc single-sideband signal. The coupling network between the plates of the first mixer and the grid of the second balanced mixer is broadbanded to provide a uniform response to the band-pass i-f frequency. The transmit frequency is determined within the passband by the vfo frequency. The band-pass i-f signal is fed to one of the grids of the second balanced mixer, and the high-frequency injection signal energy from the crystal oscillator V13A is fed to the signal input cathode and to the other grid. This arrangement cancels the high-frequency injection signal energy within the mixer and translates the band-pass i-f signal to the desired operating band. Balanced triode mixers are used in the KWM-2 for lower noise and less cross modulation, as well as reduced oscillator feedthrough.

### (4) R-F CIRCUITS

The slug-tuned circuits coupling V6 to V7, V7 to V8, and V8 to the power amplifier are ganged to the EXCITER TUNING control. The signal is amplified by the r-f amplifier, V7, and the driver, V8, to drive the power amplifier, V9 and V10 in class AB<sup>1</sup>. Output from the parallel power amplifiers is tuned by a pi network and fed to the antenna through contacts of transmit-receive relay K3. The pi network is designed to work into a 50-ohm load provided the load presents a vswr not exceeding 2:1. Negative r-f feedback from the PA plate circuit to the driver cathode circuit permits a high degree of linearity at the high power level of the PA tubes. Both the driver and PA stages are neutralized to ensure stability. On signal peaks, the detected envelope from the PA grids is rectified by the alc rectifier V17A. D-c output from V17A is filtered and used to control the gain of V4A and V7. This prevents overdriving the power amplifier. The minute amount of grid current drawn before alc acts does not degrade linearity. Rather, these few microvolts actually improve the linearity curve; only after appreciable grid current is drawn is linearity affected.

## c. RECEIVER CIRCUITS

### (1) R-F CIRCUITS

Signal input from the antenna is connected through relay contacts to the tuned input circuit, T3. The signal is applied from T3 to the grid of the receiver-transmitter r-f amplifier, V7. Amplified signal from V7 is applied from the tuned circuit consisting of L10 and band switch-selected capacitors to the grid of the receiver first mixer, V13B.

### (2) RECEIVER MIXERS

The input r-f signal is fed to the grid of V13B, and the high-frequency oscillator injection signal is fed to the cathode of V13B. The difference product of the first mixer is applied from the plate of the tube to the variable i-f transformer, T2. Output of T2 in the range of 2.955 to 3.155 megacycles is applied to the grid of the second receiver mixer,



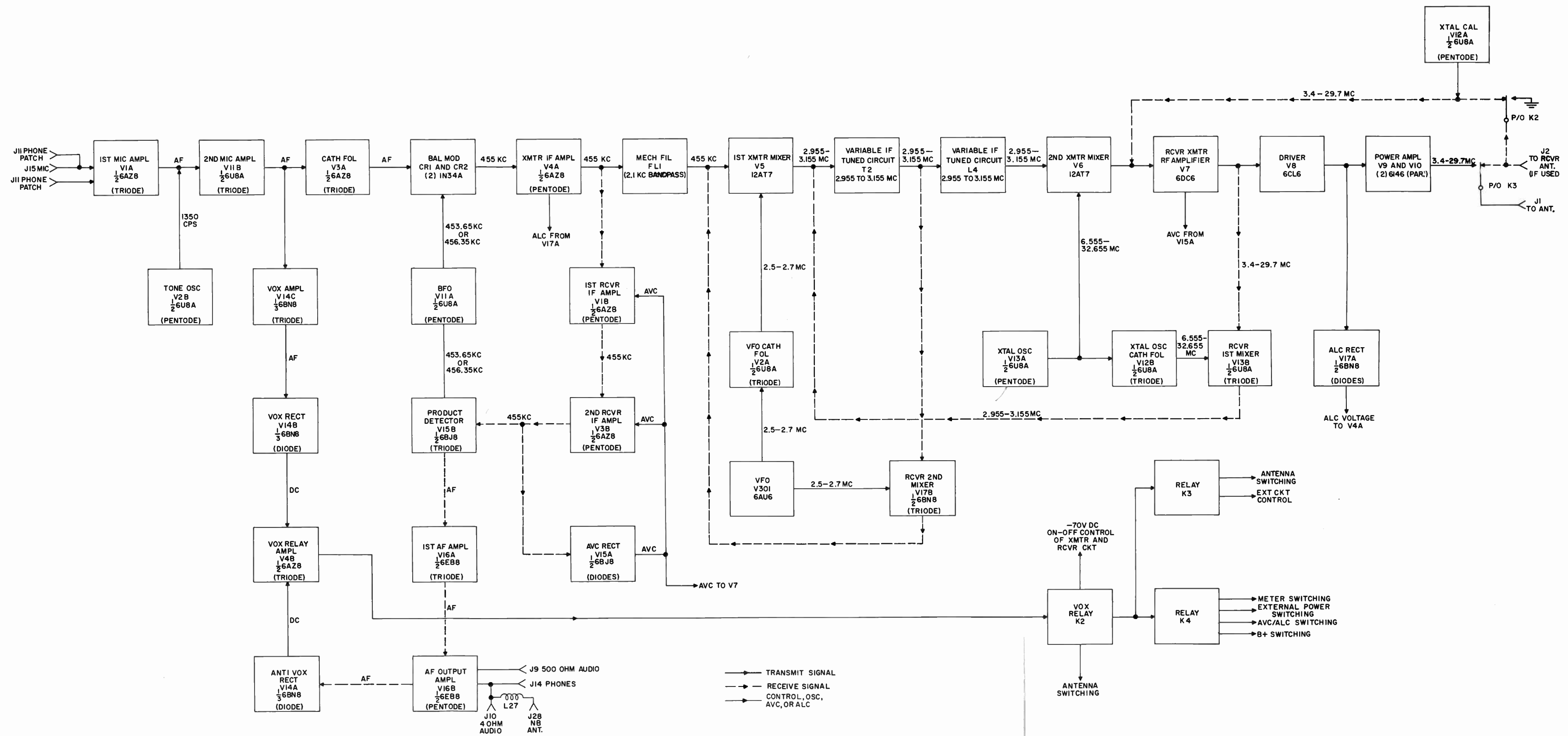
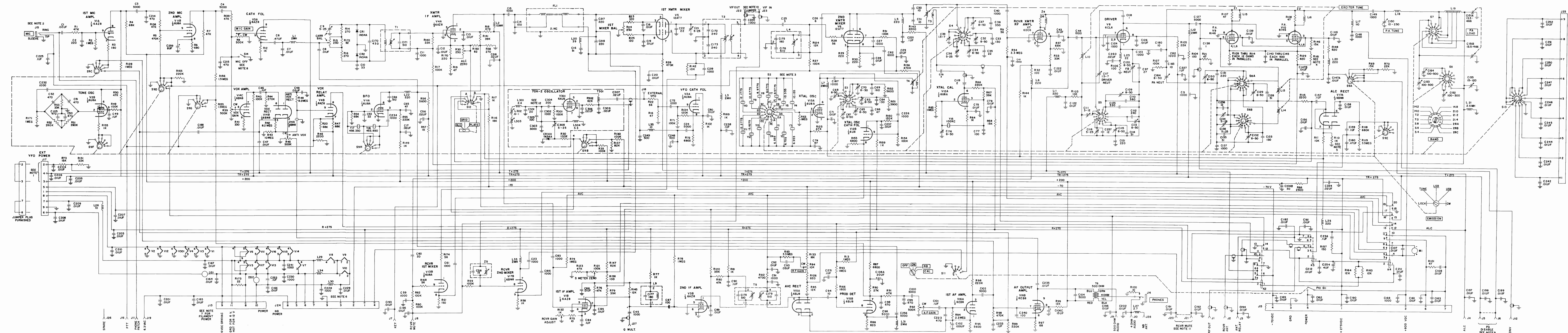

Figure 13-14. KWM-2 Block Diagram





- NOTES:
- WHEN EXTERNAL VFO IS NOT USED, JUMPER J17 PINS 1 & 2, PL-58 OR EQUIVALENTS WITH PLUG.
  - BAND SWITCHES ARE SHOWN AT 3.4 MC.
  - R41 SELECTED FOR METER CALIBRATION.
  - R41 SELECTED IN MANUFACTURE.
  - MAKE CONNECTIONS TO J26 ON CHASSIS AND PH 3 ON J24 WHEN NOISE BLANKER IS INSTALLED.
- EXTERNAL SWITCHING CIRCUITS
- AC SWITCHED
- 70 VDC
  - GROUND
  - +800 VDC
  - +275 VDC
  - 6-VOLT POWER PLUG (516F-2 OR 56F-1)
- EXTERNAL SWITCHING CIRCUITS
- AC SWITCHED
- 70 VDC
  - GROUND
  - +800 VDC
  - +275 VDC
- 12 VOLT POWER PLUG (516E-1)
- EXTERNAL SWITCHING CIRCUITS (IF DESIRED)
- SWITCHED (PWR SUPPLY)
- 70 VDC
  - GROUND
  - +800 VDC
  - +275 VDC
- 24 VOLT POWER PLUG (516E-2)
- S14 CLOSED AT MAXIMUM COW PORTION OF R8.
  - J5 AND J25 JUMPED UNLESS VHF CONVERTERS ARE USED.
  - J22 AND J23 JUMPED UNLESS NOISE BLANKER IS USED.
  - J20 AND J21 JUMPED UNLESS EXTERNAL SWITCH IS USED TO MUTE RECEIVER.
  - C501 SELECTED IN MANUFACTURE.

Figure 13-15. KWM-2 Schematic Diagram





V17B, across the parallel-tuned trap circuit, Z5. This trap circuit minimizes a spurious response which would otherwise result from harmonics of the high-frequency crystal oscillator. When signal input is applied to the grid of V17B and vfo injection signal is applied to the cathode of V17B, the 455-kc difference product is fed from V17B plate to the mechanical filter, FL1.

### (3) I-F CIRCUITS

The output from FL1 is applied to the grid of the first i-f amplifier, V1B. The i-f signal is amplified by V1B and V3B and applied through T5 to the avc rectifier, V15A, and the grid of the product detector, V15B. Beat-frequency oscillator signal is applied to the cathode of V15B and the product of mixing is the detected audio signal. Output of the avc rectifier circuit is applied to the two receiver i-f amplifiers and through contacts of relay K4 to the receiver-transmitter r-f amplifier. The avc is fast attack, slow release for sideband and CW. This allows fast avc action before the end of the first syllable and a long enough hold time to prevent gain changes between words. This avc voltage controls the gain of the receiver and prevents overloading. Delayed avc is incorporated to allow the signal to build up out of the noise before avc is applied. The avc threshold is approximately one microvolt with 100 microvolts necessary to read S-9 on the S-meter.

### (4) A-F CIRCUITS

Output from the product detector is applied through the A. F. GAIN control, R92, to the grid of the first a-f amplifier, V16A. Amplified audio output of V16A is coupled to the grid of the a-f output amplifier, V16B, which produces the power to operate speaker, headphones, or phone patch.

### (5) OSCILLATORS

The transceiver contains five oscillators. They are the tone oscillator, the beat-frequency oscillator, the variable-frequency oscillator, the high-frequency crystal oscillator, and the crystal calibrator.

#### (a) TONE OSCILLATOR

The tone oscillator operates when the EMISSION switch is in LOCK, TUNE, or CW position. It is a phase-shift oscillator operating at approximately 1350 cps. Its output is fed to the transmitter audio circuits for tuneup signal and to the balanced modulator to produce a carrier frequency 1350 cps removed from the dial reading. This signal allows carrier to be applied to the power amplifier grids for CW or tuneup. Some of the output from the tone oscillator is applied to the receiver audio circuits for sidetone monitoring in CW operation. TUNE reduces PA screen voltage to keep the PA plate dissipation within ratings for tuneup. LOCK position allows final tuneup with full carrier.

The tone oscillator is set at 1350 cps to center the tone in the mechanical filter passband and to place the second harmonic of the tone (2700 cps) out of the filter passband eliminating the possibility

of tone modulation. Tone keying also permits two transceivers (operating on the same sideband, of course) to work each other on the same frequency without leapfrogging across the band (retuning), which would be the case if the carrier were reinserted and keyed. This is because the carrier is ordinarily placed 20 db down on the 2.1-kc mechanical filter skirt, so when the receiving station tunes the CW carrier to center it in the filter passband the transmitter frequency will shift the same amount. The second station would then have to retune to center the incoming signal in the filter passband and, in doing so, would shift frequency when transmitting. Tone keying eliminates this problem.

#### (b) BEAT-FREQUENCY OSCILLATOR

The bfo is crystal controlled at either 453.650 or 456.350 kilocycles, depending upon whether Y16 or Y17 is selected by the EMISSION switch section S9H. The unused crystal is shorted out by this switch section. These crystal frequencies are matched to the passband of the mechanical filter, FL1, so that the carrier frequency is placed approximately 20 db down on the skirt of the filter response. This 20-db carrier attenuation is in addition to the 30-db suppression provided by the balanced modulator.

#### (c) VARIABLE-FREQUENCY OSCILLATOR

The vfo operates in the range of 2.5 to 2.7 mc. The value of the cathode choke is selected so that switching a small trimmer across it shifts the oscillator frequency. This compensates for switching bfo frequency and keeps dial calibration accurate no matter which sideband is selected. Refer to paragraph 5a for additional discussion on why the vfo frequency must be shifted. This bfo switching is done by applying a positive or negative bias to diode CR301. When the diode bias is positive, the diode impedance is lowered, and C308 is effectively in parallel with L304. When the bias is negative, diode impedance is high, and C308 is effectively switched out of the circuit.

#### (d) HIGH-FREQUENCY CRYSTAL OSCILLATOR

The high-frequency crystal oscillator, V13A, is crystal controlled by one of 14 crystals selected by BAND switch S2. Output from the high-frequency crystal oscillator is fed to the transmitter second mixer and to the crystal oscillator cathode follower. The cathode follower provides isolation and impedance matching between the crystal oscillator and the receiver first mixer cathode. The output frequency of this oscillator is always 3.155 mc higher than the lower edge of the desired band. This high-frequency injection signal is the crystal fundamental frequency for all desired signals below 12 megacycles, but for operating frequencies higher than 12 mc, the crystal frequency is doubled in the plate circuit of the oscillator.



Figure 13-16. 30S-1 Linear Amplifier

(e) CRYSTAL CALIBRATOR

The 100-kc crystal calibrator, V12A, is the pentode section of a type 6U8A tube. Its output is coupled to the antenna coil, T3. The calibrator may be trimmed to zero beat with WWV (or any other desired frequency standard) by adjustment of capacitor C76.

(6) VOX AND ANTIVOX CIRCUITS

Audio output voltage from the second microphone amplifier, V11B, is coupled to the VOX GAIN control, R39. A portion of this voltage is amplified by the vox amplifier, V14B, and fed to the vox rectifier which is one of the diodes of V14. The positive d-c output of the vox rectifier is applied to the grid of vox relay amplifier V4B, causing it to conduct current and actuate the vox relay, K2. Contacts of K2 switch the receiver antenna lead, the other relay coils, and the -70-volt d-c muting and bias voltage. Relays K3 and K4 switch the metering circuits from receiver to transmit, the low plate voltages from receive to transmit tubes, and the avc and alc leads.

The antivox circuit provides a threshold voltage to prevent loudspeaker output (picked up by the microphone circuits) from tripping the KWM-2 into transmit function. Some of the receiver output audio voltage is connected through C235 to the ANTI VOX gain control, R45. Signal from the slider of the potentiometer is rectified by the antivox rectifier, which is the other diode of V14. Negative d-c output voltage from the antivox rectifier, connected to the grid of V4B, provides the necessary antivox threshold. ANTI VOX control R45 adjusts the value of the antivox voltage threshold so that loudspeaker output will not produce enough positive d-c output from the vox rectifier to exceed the negative d-c output from the antivox rectifier and cause V4B to actuate K2. However, speech energy into the microphone will cause the positive vox voltage to overcome the negative antivox voltage and produce the desired action of K2.

6. 30S-1 LINEAR AMPLIFIER

The 30S-1 R-F Linear Amplifier (figure 13-16) consists of a one-stage linear amplifier and the necessary power supplies. It is capable of maximum legal input power in the amateur bands between 3.5 and 29.7 mc. It operates either CW or SSB service with any exciter (such as the KWM-1, KWM-2, or 32S-1) capable of 80 watts PEP output. In addition, the amplifier may be operated outside the amateur bands at any frequency between 3.4 and 30 mc by

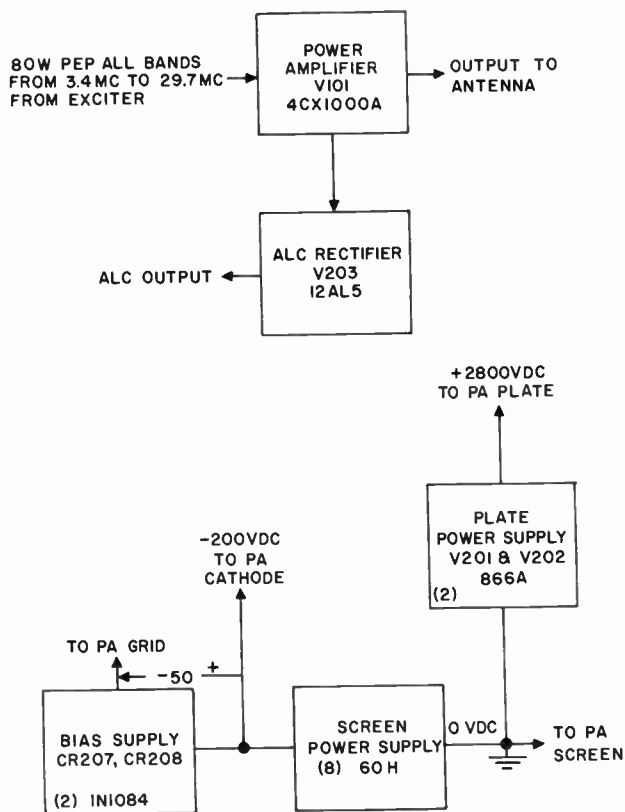
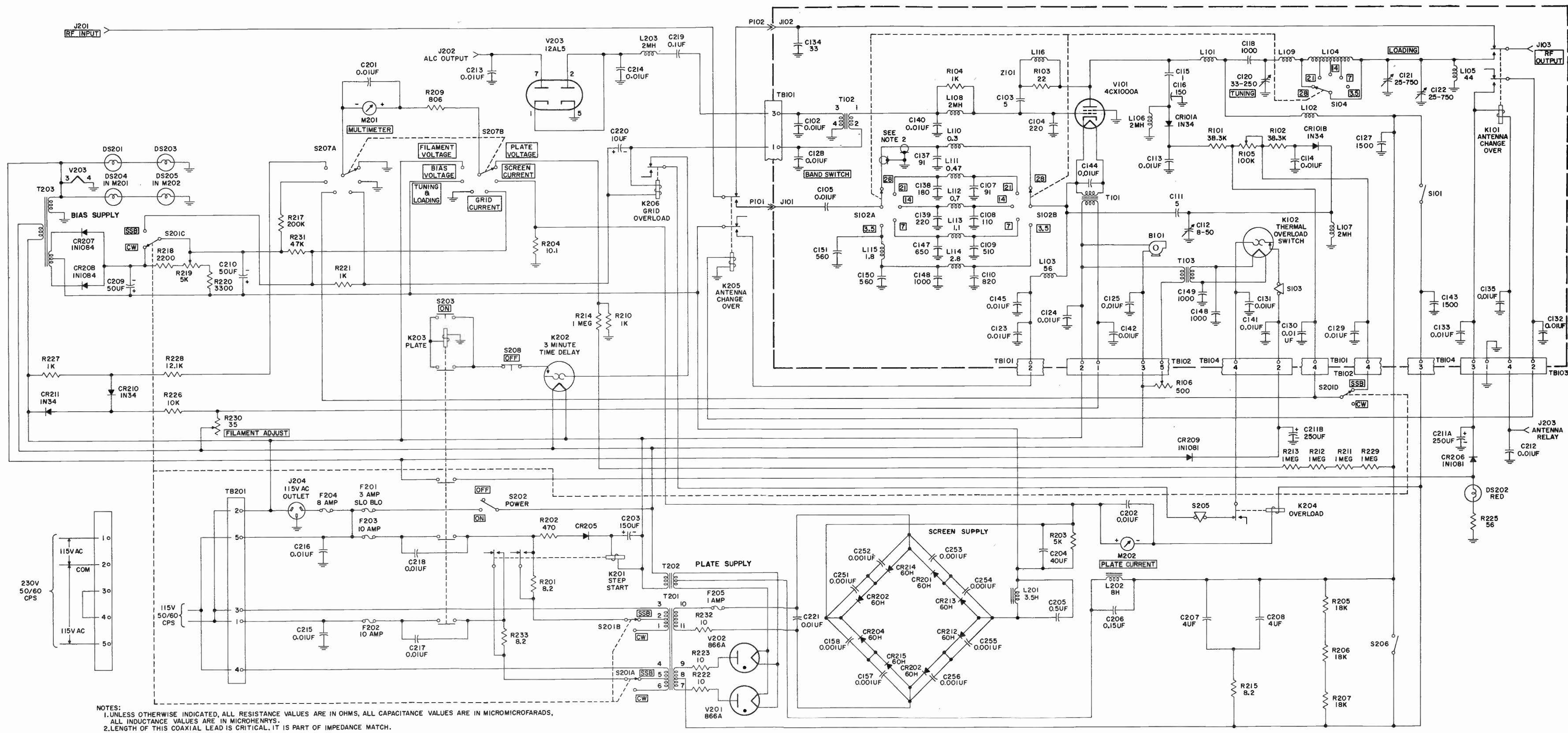

Figure 13-17. 30S-1 Block Diagram



NOTES:  
 1. UNLESS OTHERWISE INDICATED, ALL RESISTANCE VALUES ARE IN OHMS, ALL CAPACITANCE VALUES ARE IN MICROMICROFARADS, ALL INDUCTANCE VALUES ARE IN MICROHENRYS.  
 2. LENGTH OF THIS COAXIAL LEAD IS CRITICAL. IT IS PART OF IMPEDANCE MATCH.

Figure 13-18. 30S-1 Schematic Diagram





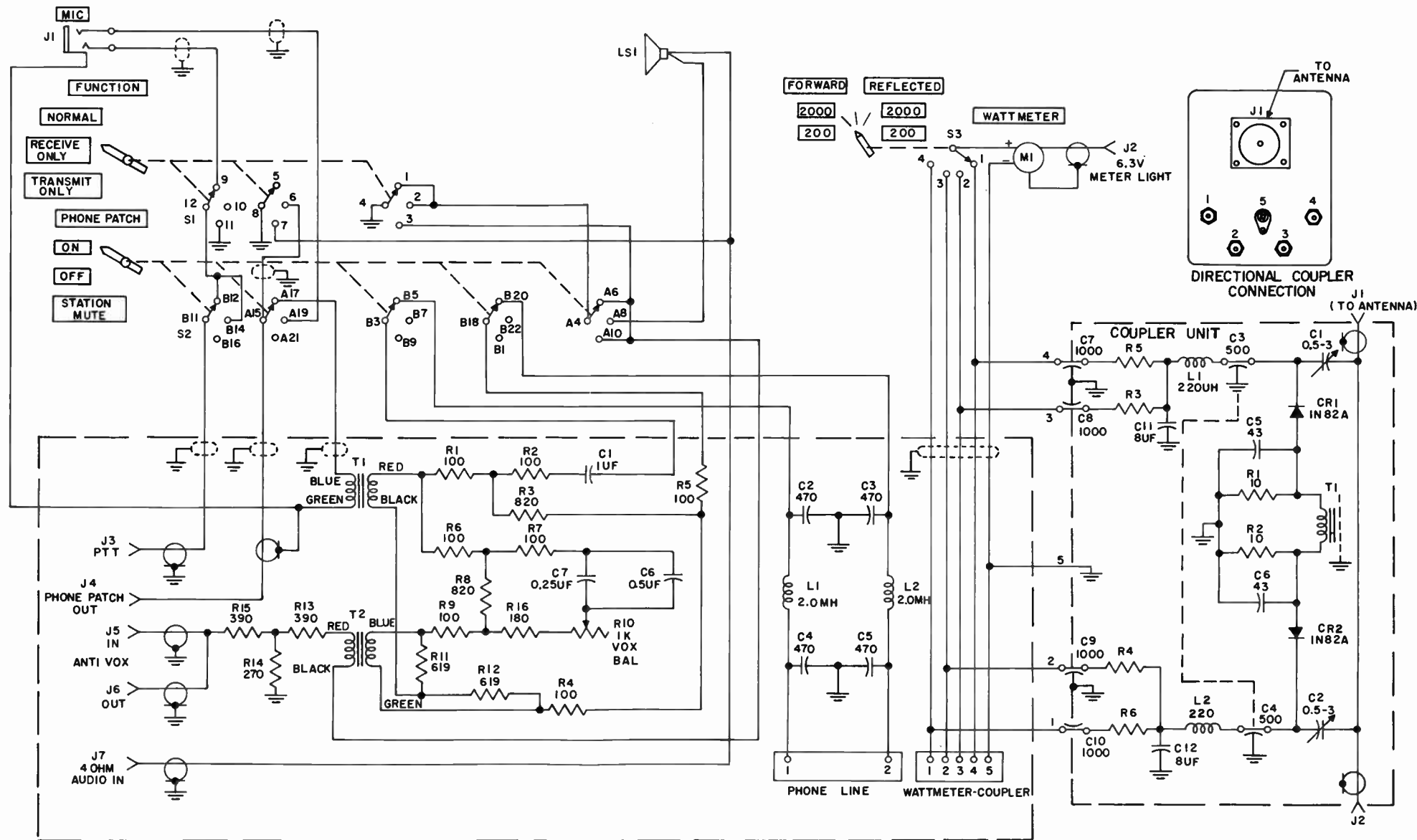

Figure 13-20. 312B-4 Schematic Diagram

retuning the input circuits. Figure 13-17 is the block diagram of the 30S-1, and figure 13-18 is the schematic diagram. Refer to chapter 7 for design considerations of linear amplifiers.

#### a. R-F CIRCUIT DESCRIPTION

The 30S-1 uses a 4CX1000A tetrode as the r-f amplifier. The cathode of the amplifier is driven, requiring some 80 watts PEP for proper operation. The screen grid is grounded directly to the chassis for better grid-plate isolation. The biased control grid is bypassed so that it is at r-f ground. A 12AL5 automatic load control rectifier monitors the grid circuit and applies a.c. to the exciter the moment the r-f amplifier draws any grid current, thus maintaining class AB<sub>1</sub> operation. The minute amount of grid current drawn before a.c. acts does not degrade linearity. Rather, these few microvolts actually improve the linearity curve; only after appreciable grid current is drawn is linearity affected. A plate overload relay, grid overload relay, and thermal overload relay are included for protection of the 4CX1000A. R-f output is coupled through a pi network into a 50-ohm load (with a maximum permissible swr of 2:1).

#### b. POWER SUPPLY

Since the power amplifier screen grid is at d-c ground potential, it is necessary to provide the cathode with negative 200 volts in order to supply screen voltage which is 200 volts higher than the cathode potential. Effective plate-cathode voltage is the sum of the screen-plate supply (2800 volts) and the cathode-screen supply (200 volts). Control grid bias is referenced to the cathode. All plate and screen current passes through the 200-volt supply, and only plate current through the 2800-volt supply. All relays are operated from d-c sources except the time-delay relay K202 and thermal overload relay K102. Switching from SSB to CW operation automatically lowers plate voltage and changes grid bias. The amplifier operates with approximately 3000 volts plate-to-cathode in SSB service and approximately 2400 volts plate-to-cathode in CW service. The power supplies may be connected to either 115-volt lines or 230-volt, 3-wire service lines. The 230-volt, 3-wire connection is preferred.

### 7. 312B-4 STATION CONTROL

The 312B-4 Station Control (figure 13-19) contains a pm (permanent magnet) speaker, a directional wattmeter, and a phone patch. The directional wattmeter indicates 0-200 or 0-2000 watts, forward or reflected. This power indication is useful in tuning and loading to produce minimum vswr. (See paragraph for a detailed discussion of directional wattmeters.) The phone patch is of the hybrid type and can be used for vox phone patch operation. The 312B-4 has a function switch for station control and can be used with any receiver transmitter combination or transceiver having power outputs up to 2000 watts PEP. The unit was designed for operation with the 32S-1, 75S-1, 30S-1 combination; the 32S-1, 75S-1; the KWM-2; or KWM-2, 30S-1 combination. Figure 13-20 is the schematic diagram.

Also available for use with the KWM-2 is the 399C-1, a unit in a case similar to the 312B-4. The 399C-1 contains a 70K-2 Oscillator identical to the one in the KWM-2 enabling the KWM-2 to transmit and receive on separate frequencies. Also included is a pm speaker and a switch for transferring oscillators. The 312B-5 combines the features of both the 312B-4 and 399C-1. It contains a 70K-2 oscillator, directional wattmeter, phone patch, and switching circuits for the KWM-2.

### 8. NOISE BLANKERS

The Collins noise blankers convert noise to bias pulses for gating the companion receivers. This minimizes receiver output noise when it is a result of radiated noise present on both the blander and receiver antennas. The 136A-1, 136B-1, 136B-2, and 136C-1 Noise Blankers are designed for the 75S-1, KWM-1, KWM-2, and 75A-4 respectively. All are similar in design but are packaged differently for each unit. The noise blander receiver operates in the 40.0-mc portion of the spectrum and works on the premise that noise pulses present in the 40.0 mc area occur simultaneously with noise pulses in the high-frequency (3-30 mc) portion, enabling the blander unit to gate noise in the receiver unit. To do this the noise blander is provided with a separate 40.0 mc antenna. Figure 13-21 shows a 136A-1 Noise Blander installed in a 75S-1, and figure 13-22 shows a 136B-1 Noise Blander installed in a KWM-1.

Figure 13-23, a block diagram of a noise blander, illustrates the blanking scheme, along with figure 13-24, schematic diagram of the 136A-1. Tube sections V1A, V2A, and V3A are connected as a three-stage, cascade, 40-mc tuned r-f amplifier. Gain of the trf amplifier is controlled by potentiometer R4 in the cathode circuit of V2A. The output of V3A is limited by the action of diode CR8 and V3A. The positive component of the signal is clamped to the cathode of V3A. The signal is detected by CR1 and filtered by C15. The combination of C15 and R5



Figure 13-19. 312B-4 Station Control

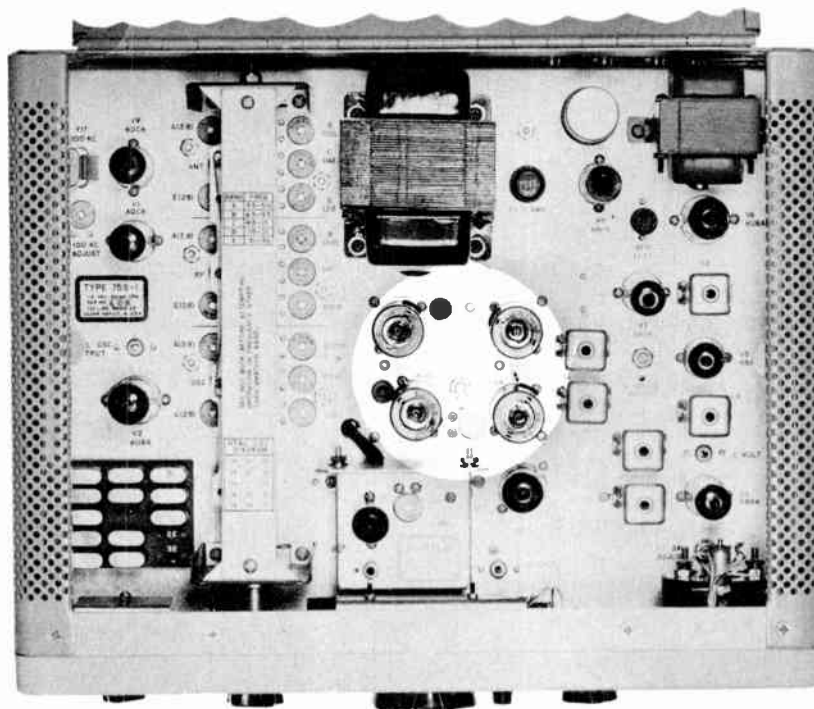

Figure 13-21. 136A-1 Noise Blanker Installed in 75S-1

determines the length of the blanking pulse. The audio component of the noise is limited by CR2 and applied to the grid of the first pulse amplifier, V3B. Positive-going output pulses from V3B are applied to the grid of V2B. Any negative portion of the waveform is clipped by CR4. Positive-going square pulses from V1B plate are applied through CR7 to the center tap of T1. The bias of CR7 keeps it cut off and at a high impedance to the low-level pulses, but high-level pulses overcome the bias and pass into the gate circuit. Gating diodes CR5 and CR6 are biased to conduction for normal, noise-free operation. However, when a high-amplitude noise burst occurs, the positive-going pulse passes through CR7 and cuts off both CR5 and CR6. This effectively disconnects the variable i-f signal for the period of blanking pulse. The length of the blanking pulse varies from a few microseconds to a maximum of 30 microseconds. Blanking pulse length is determined by the magnitude of the noise pulse appearing at the noise blanker antenna. For short-duration noise disturbances in the variable i-f, the blanking pulses are short, while greater noise bursts develop longer blanking pulses. Transformers T1 and T2 and the gating diodes are arranged in a balanced modulator configuration so that any noise which results from the gating action is canceled and prevented from entering the receiver circuits. Any discontinuity of signal resulting from the gating action is compensated by tuned-circuit restoration in the following stages of the receiver. Both sections of V4 serve to isolate the noise operated gate circuit from the receiver circuits. V4A provides only enough gain to compensate for the small

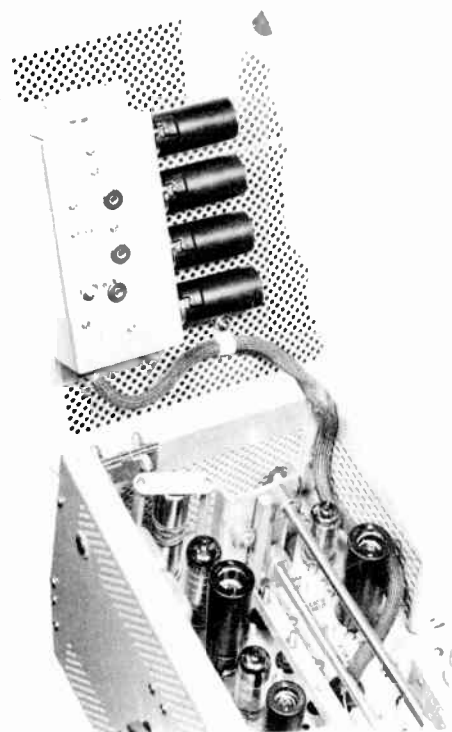

Figure 13-22. 136B-1 Noise Blanker Installed in KWM-1

loss in the gate circuit so that over-all gain through the noise blanker is approximately unity. Filament power, B+ power, and bias voltage are taken from the companion unit power supply, with the exception of the 136C-1 which has its own power supply.

The noise blanking scheme has the following three limitations which decrease blanking efficiency:

(1) Noise pulses which have no energy distribution at 40 mc will occur in the frequency spectrum of the radio receiver range. The noise blanker will

not generate a blanking pulse in this case and will permit passage of such noise pulses.

(2) A very strong signal in the passband between the first and second mixers can be modulated by blanking pulses. This modulation process will cause sidebands in the passband which result in decreased blanking efficiency.

(3) Some corona noise and static disturbances have a repetition rate in excess of one hundred thousand pulses per second. The blanking efficiency decreases as the pulse repetition rate exceeds five thousand pulses per second.

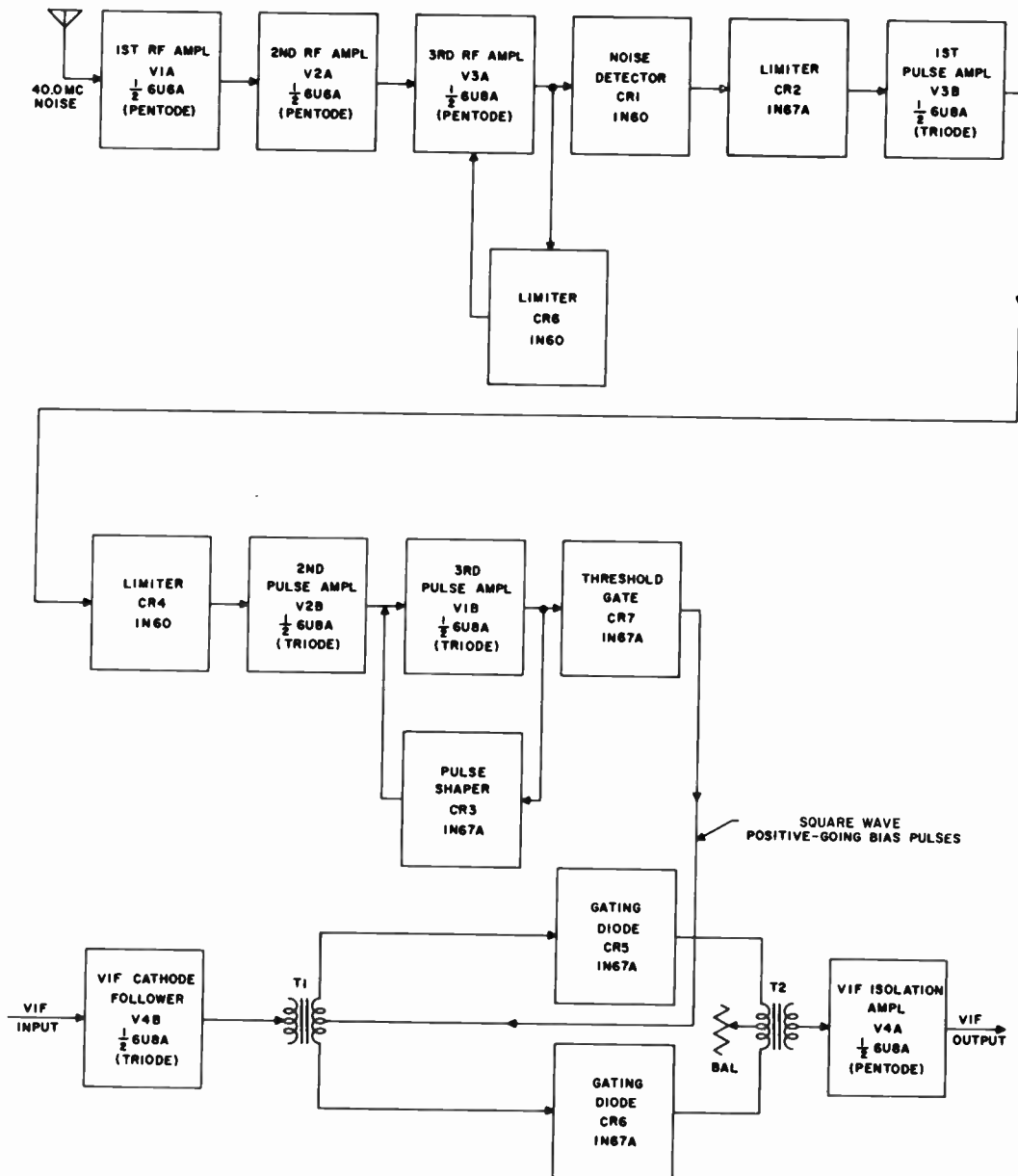

Figure 13-23. 136A-1 Block Diagram



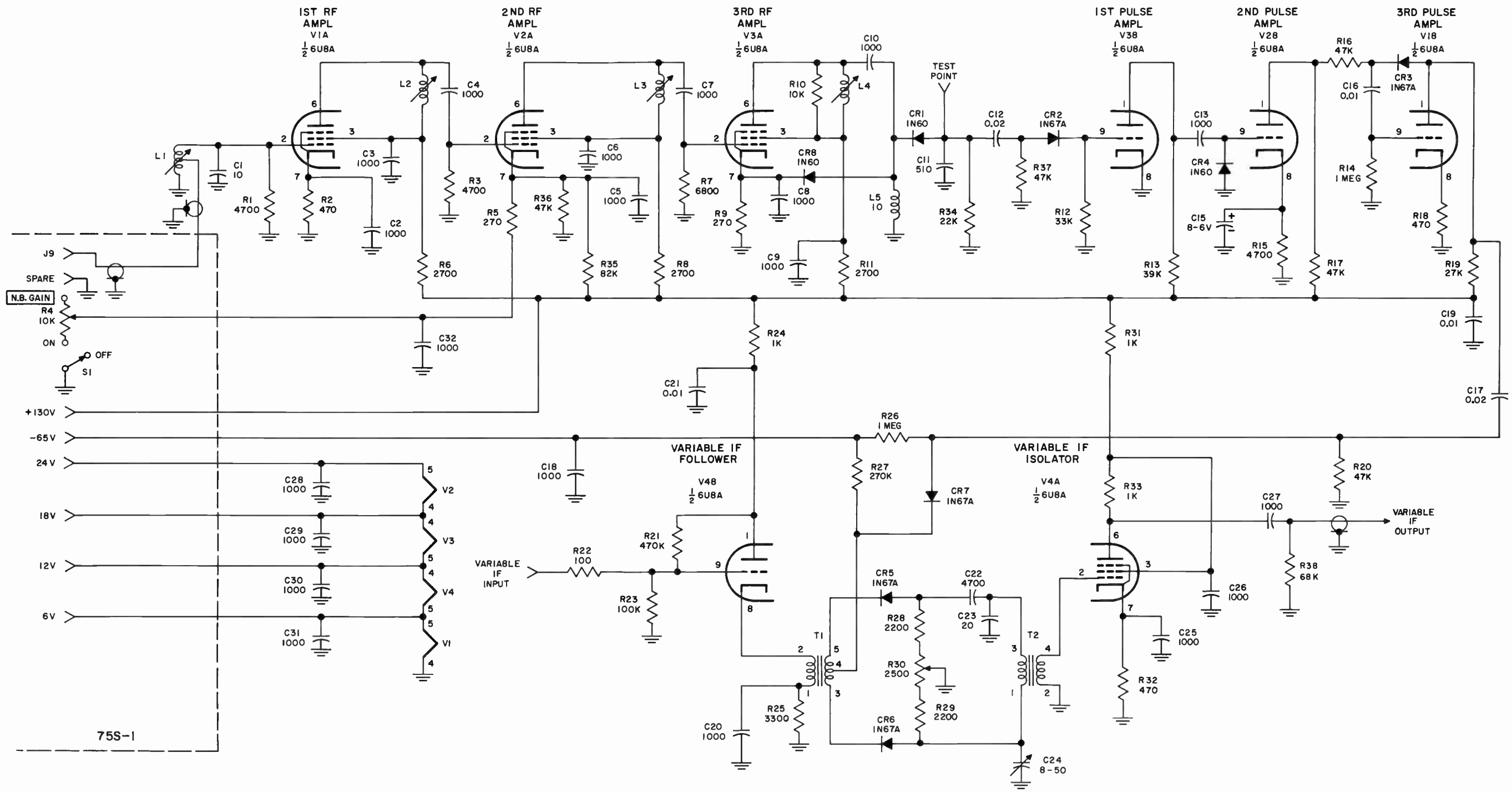

Figure 13-24. 136A-1 Schematic Diagram



Figure 13-25. 302C-1 Directional Wattmeter

**9. DIRECTIONAL WATTMETERS**

Collins directional wattmeters measure forward and reflected r-f power on 52-ohm transmission line (RG-8/U or equivalent). The instruments are accurate to  $\pm 10$  per cent (5 percent nominal) over the 3- to 30-mc frequency range. Power loss and mismatch

introduced is negligible. The forward and reflected power readings are primarily used to determine transmission line swr and transmitter power output. In addition, antenna match, antenna bandwidth (match vs frequency), attenuation in transmission lines, and other system performance characteristics can be determined from the forward and reflected power

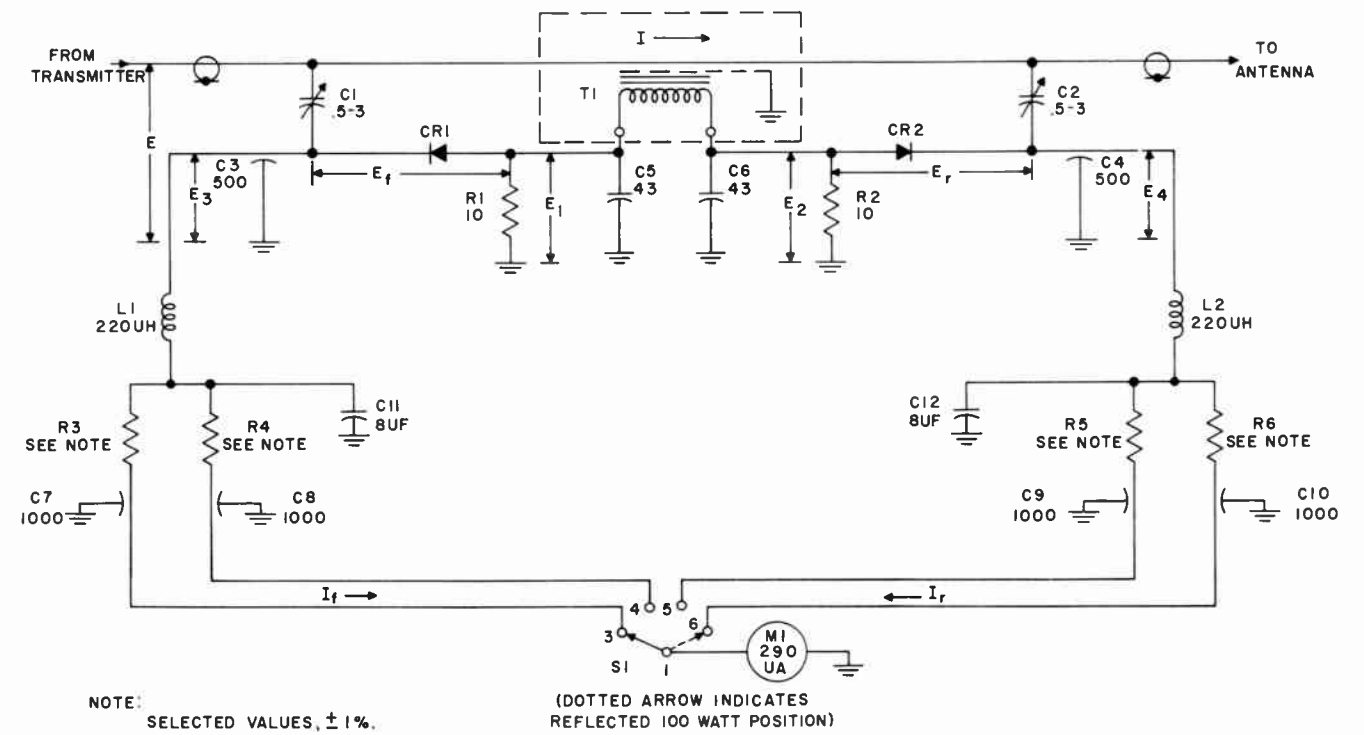

Figure 13-26. 302C-1 Directional Wattmeter, Simplified Schematic Diagram

readings. During transmission the instrument acts as a continuous monitor of transmitter performance and antenna match. Directional wattmeters are included in the 312B-2 Speaker Console for the KWM-1, the 312B-4, and 312B-5 Station Controls. They are also available separately as the 302C-1/2 Directional Wattmeter (figure 13-25) (calibrated for 100- and 1000-watt scales, 52-ohm line).

#### a. R-F CIRCUIT

Refer to figure 13-26. Transmission line current,  $I$ , flows through the line center conductor and through the center of a toroid coil. The conductor forms the primary section and the coil the secondary winding of a toroidal transformer, T1. Induced toroid current produces a voltage that divides equally across series resistors R1 and R2. This results in two equal voltages,  $E_1$  and  $E_2$ , across the resistors. Since the junction of R1 and R2 is grounded,  $E_1$  and  $E_2$  are opposite in phase and proportional to line current,  $I$ . Line voltage,  $E$ , is applied across two capacity dividers, C1-C3 and C2-C4, resulting in two equal voltages of the same phase,  $E_3$  and  $E_4$ .

When the transmission line is mismatched (terminated in an impedance other than 52 ohms),  $E_1$  and  $E_2$  represent the vector sum of two components, one proportional to the current of the forward wave, and the other proportional to the current of the reflected wave. Similarly,  $E_3$  and  $E_4$  represent the vector sum of forward- and reflected-wave voltage components. Capacitors C1 and C2 are factory adjusted so that the magnitude of the forward voltage and current components is identical; the reflected components are then equal also. The settings of C1 and C2 are correct for 52-ohm transmission line only.

The phase relationship between the various components is such that the r-f voltage across rectifier CR1 ( $E_f$ ) is equal to the arithmetic sum of the two equal forward components, while the r-f voltage across rectifier CR2 ( $E_r$ ) is equal to the arithmetic sum of the two equal reflected components.

When the transmission line is matched perfectly (terminated in a resistive load of 52 ohms),  $E_1$  is equal in magnitude to  $E_3$  and opposite in phase;  $E_f$  is the sum of  $E_1$  and  $E_3$ , or twice the value of either.  $E_2$  and  $E_4$  are equal in magnitude and of the same phase, and  $E_r$  is zero volt. These relationships are used for adjusting C1 and C2 under laboratory conditions.

#### b. D-C CIRCUIT

R-f voltages  $E_f$  and  $E_r$  are rectified and filtered by CR1, CR2, C3, and C4 to produce d-c currents,  $I_f$  and  $I_r$ , through meter M1. The meter scale is calibrated in such a way that  $I_f$  produces a scale reading proportional to forward power, while  $I_r$  produces a scale reading proportional to reflected power. Capacitors C11 and C12 cause the meter reading to approach the PEP level during SSB voice transmission. Calibrating resistors R3, R4, R5, and R6 are selected

so that  $I_f$  and  $I_r$  give accurate indications of two power levels.

#### c. FREQUENCY LINEARITY

Accuracy of the r-f wattmeter is maintained over a frequency range of 2- to 30 mc in both the inductively coupled and the capacitively coupled elements. In the inductive element, the increase with frequency of the induced voltage is canceled by the voltage drop in the toroidal coil due to the increase with frequency of the inductive reactance. In the directly coupled capacitive element, the ratio of the capacitive reactances in the voltage divider remains constant even though the reactance varies with frequency. Capacitors C5 and C6 compensate for the residual series inductance of resistors R1 and R2.

#### d. REAL POWER

Real power is the power output of the transmitter. When a line is perfectly matched, reflected power is zero and real power is equal to forward power. When the line is mismatched, the phase relationship between forward power and reflected-wave components causes the forward power to increase by an amount equal to the magnitude of the reflected power. Since the reflected power cancels a portion of the forward power at the transmitter terminals, the real power in the line is equal to the difference between forward and reflected power, or:

$$\text{Real power} = \text{forward power} - \text{reflected power}$$

## 10. POWER SUPPLIES

#### a. 516E-1 12-VOLT D-C POWER SUPPLY

Figure 13-30 is the schematic diagram of the 516E-1. The 516E-1 (figure 13-27) includes an 800-volt, 200-ma supply for the power amplifier plates and a 260-volt, 215-ma supply for other circuits. The 260-volt supply is tapped for -65 volts bias. This supply can be used with the KWM-1, KWM-2, or 32S-1. The 516E-1 is used primarily for mobile operation.

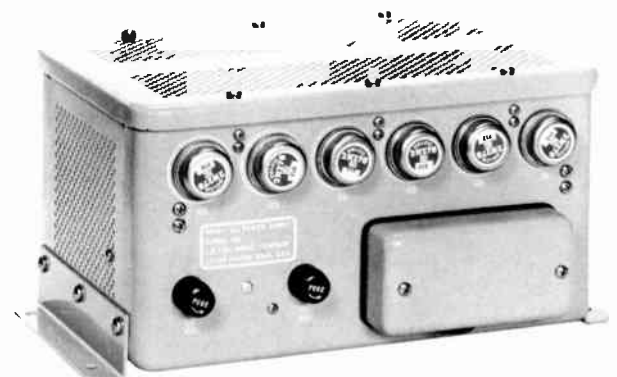

Figure 13-27. 516E-1 12-Volt D-C Power Supply

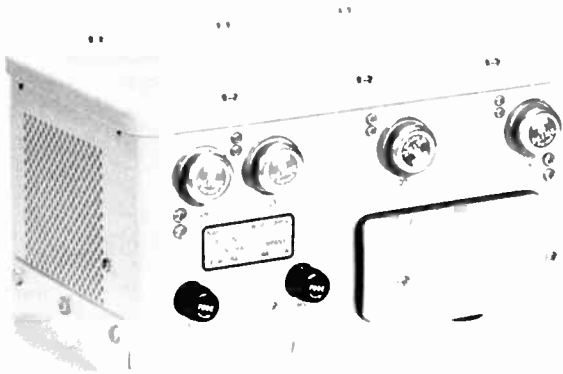

Figure 13-28. 516E-2 28-Volt D-C Power Supply

The transistors for each supply are connected in a grounded-collector multivibrator circuit which switches the d-c input power to a-c power for application to the primary winding of the power transformer. Switching rates of 600 and 800 cps are used in the two power supplies to prevent the transistor multivibrators from locking frequency with each other. Output

from the power transformer secondary is rectified in a silicon diode voltage doubler circuit. The voltage from the bias tap of the 260-volt supply is rectified by a half-wave silicon diode rectifier. Input current requirement is 25 amperes (maximum) at 12 to 14 volts d-c.

#### b. 516E-2 28-VOLT D-C POWER SUPPLY

The 516E-2 D-C Power Supply (figure 13-28) is similar in construction and layout to the 516E-1. Input voltage and current requirements are 24 to 30 volts d-c at 12.5 amperes (maximum). Figure 13-31 is the schematic diagram.

#### c. 516F-2 A-C POWER SUPPLY

The 516F-2 A-C Power Supply (figure 13-29) can be used with the KWM-2 or 32S-1. Figure 13-32 is the schematic diagram of the unit. The 516F-2 contains an 800-volt, 200-ma power supply for all plate circuits and a 260-volt, 215-ma power supply for all other plate circuits. The 260-volt supply is tapped for -65 volts bias. The input voltage requirement is 115 volts a-c, 60 cps. The 516F-1 A-C Power Supply for the KWM-1 is quite similar to the 516F-2, but uses two separate transformers for the high- and low-voltage supplies rather than a single unit. Voltage outputs are the same.



Figure 13-29. 516F-2 A-C Power Supply (Removed from Case)





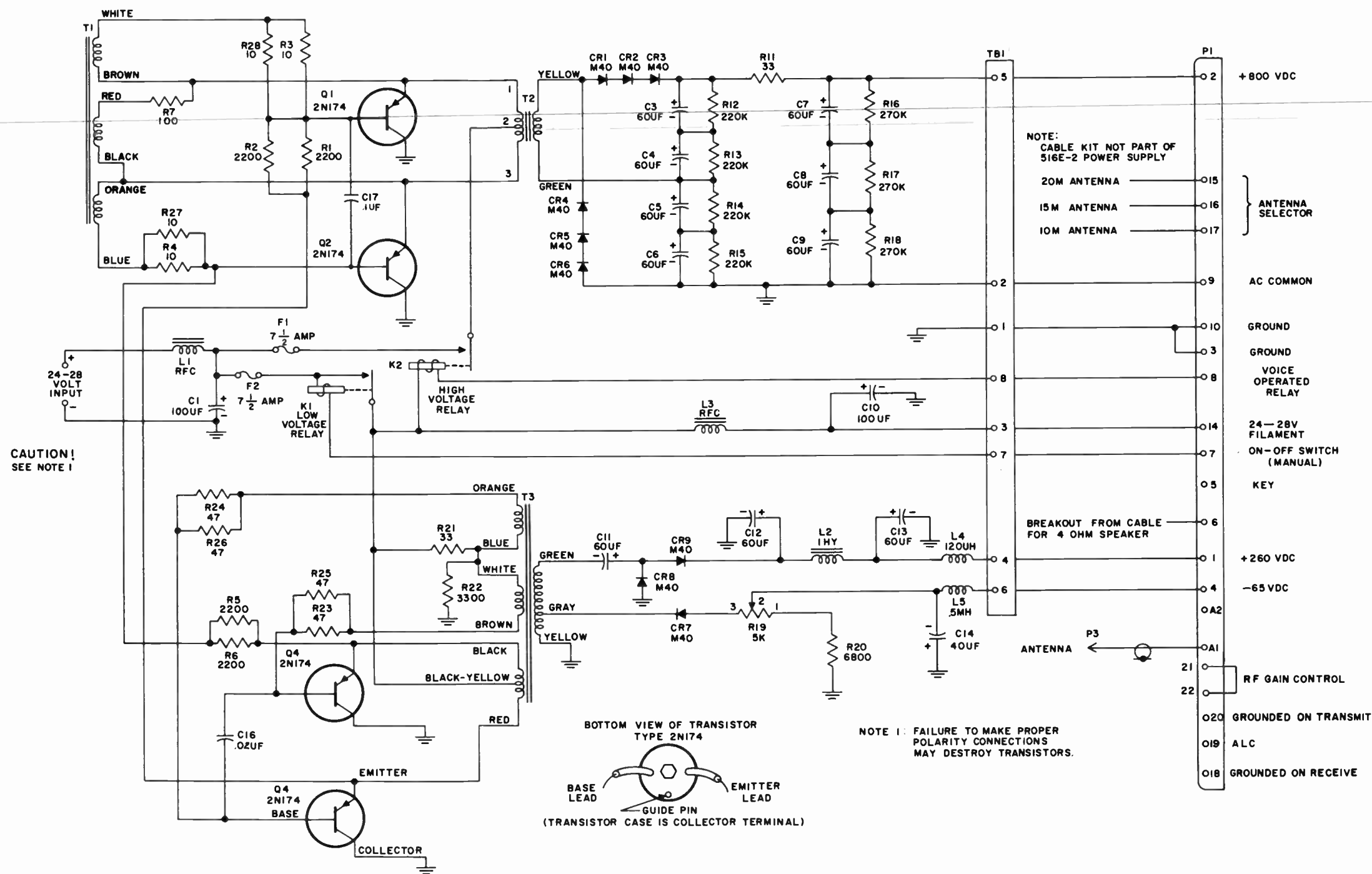

Figure 13-31. 516E-2 Schematic Diagram

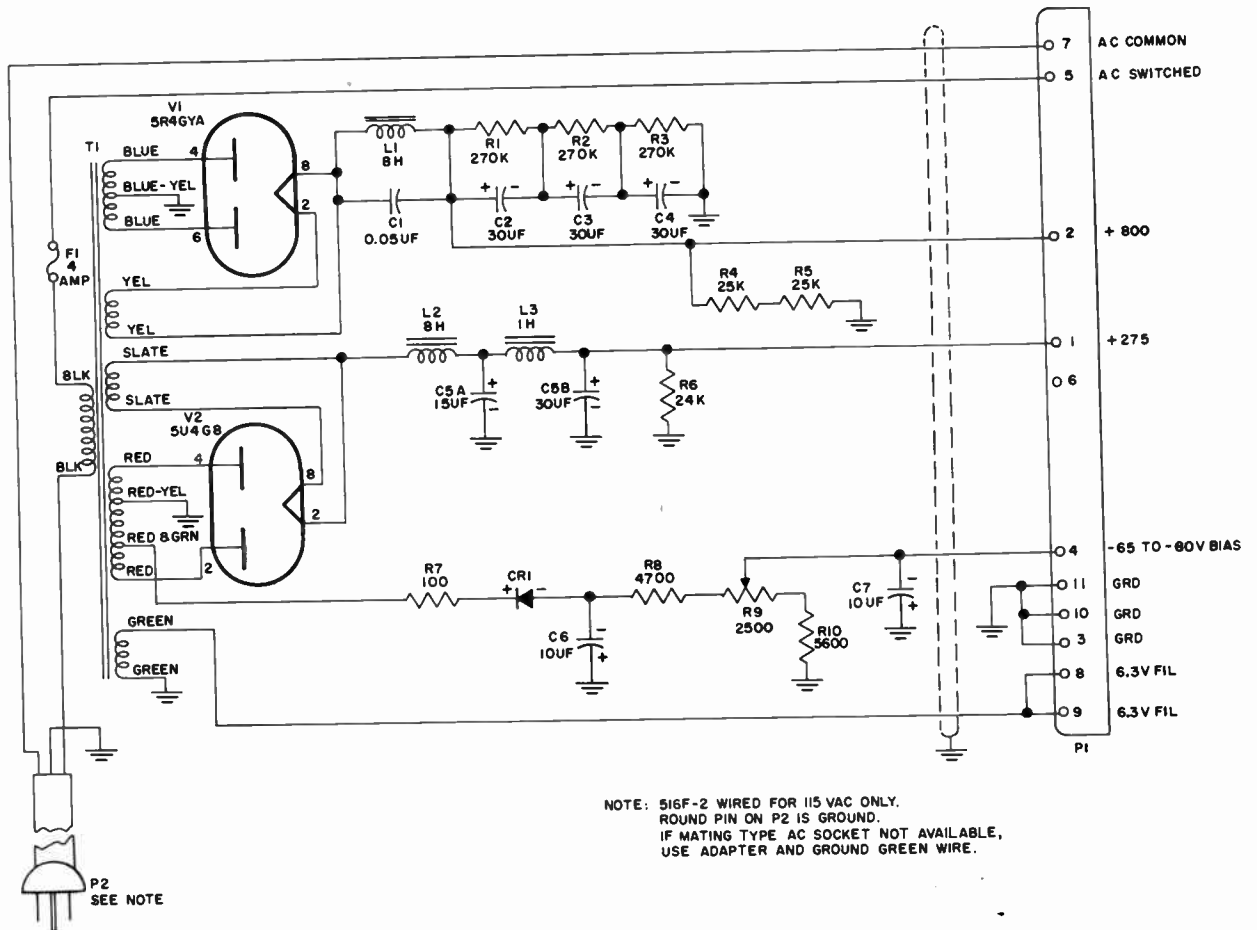

Figure 13-32. 516F-2 Schematic Diagram

