

ELEMENTS  
*of*  
RADIO

MARCUS • HORTON

# ELEMENTS OF RADIO

---

*By*

ABRAHAM MARCUS

*and*

WILLIAM MARCUS

---

*Prepared under the Editorship of*

RALPH E. HORTON

---

COMPLETE EDITION

*Prepared at the request of the War Department and  
the U. S. Office of Education in conformance with  
official pre-induction training course outline No. 201*

**PRENTICE-HALL, INC.**

**New York**

**San Francisco**

Copyright, 1943, by  
PRENTICE-HALL, INC.

*All rights reserved. No part of this book  
may be reproduced, by mimeograph or  
any other means, without permission in  
writing from the publishers.*

First Printing.....January 1943  
Second Printing.....February 1943  
Third Printing.....March 1943  
Fourth Printing.....April 1943  
Fifth Printing.....June 1943  
Sixth Printing.....August 1943  
Seventh Printing....November 1943  
Eighth Printing.....January 1944  
Ninth Printing.....February 1944  
Tenth Printing.....March 1944  
Eleventh Printing.....April 1944  
Twelfth Printing.....June 1944  
Thirteenth Printing...August 1944  
Fourteenth Printing...January 1945  
Fifteenth Printing.....May 1945  
Sixteenth Printing.....June 1945  
Seventeenth Printing....August 1945

PRINTED IN THE UNITED STATES OF AMERICA

ELEMENTS OF  
RADIO

---

Complete Edition

## Dedication

---

To the thousands of men and women who patiently and painstakingly helped answer the myriad of questions that swirled through our heads we gratefully dedicate this book.

Some of them we had the pleasure of meeting in person. Others we knew only through the anonymity of a name on a book or a signature to a magazine article. But through speech or through the printed word, each of them helped pass on our common heritage, our civilization.

We fondly hope that in some slight measure we do likewise and thus repay, in small part, the debt we owe to our teachers.

ABRAHAM MARCUS  
WILLIAM MARCUS

The establishment of pre-induction training in civilian schools is an historic event. The Pre-Induction Training Section of the Civilian Personnel Division, Headquarters, Services of Supply, has been established as the central coordinating agency of the War Department to simplify and facilitate arrangements for the appropriate training of individuals prior to their entrance into military service. The outlines herewith presented have been prepared to serve all three divisions of the Army—the Army Air Forces, the Ground Forces, and the Services of Supply. The prospect of effective collaboration between the educational and armed forces of the Nation is a healthy symbol of a vigilant democracy in action.

ROBERT P. PATTERSON  
*Under Secretary of War*

## Preface

---

A generation of Americans has grown up since the advent of radio broadcasting. We have more radio sets, per capita, than any other nation in the world. Yet, our country at war must set up an extensive training program to teach our men and women an understanding of radio. How are we to account for this?

Years of experimentation with methods of teaching radio to beginners have led the authors to the conclusion that the fault lies with our pedagogy. We require the student to learn a mass of laws and principles of electricity before teaching him radio. Some of the students may survive this ordeal, but most of them quickly lose interest or else merely memorize these abstract concepts which have no meaning or reality for them.

Our conclusions led in another direction. Most of us think in terms of our environment. Thus the student's contact with radio is, primarily, with his receiver at home. Accordingly, he should learn first how the radio receiver operates. So important is this that the first half of the book is devoted entirely to the receiver.

Of course, it would be absurd to attempt to explain to the beginner the operation of the modern superheterodyne receiver at the very beginning of the book. The simple crystal receiver is chosen as embodying all the basic principles of any receiver.

To insure a complete understanding of this simple receiver, the device of the spiral is adopted in presenting the subject matter. Thus at the first cycle an extremely elementary explanation of the radio is presented—tuning, detection, and reproduction. The next turn around covers the same ground but at a slightly higher level. And so on through the various cycles.

But at each level the complete radio receiver is presented. By this means the student's interest is maintained. Also, at each stage, set construction is presented so that the student can see

the result of the theoretical concepts of that stage in concrete form.

Having mastered an understanding of the simple crystal receiver, the student is led on to more advanced sets by being confronted with problems he must solve. Thus, the drawbacks of the crystal detector lead to the development of the vacuum-tube detector. To eliminate the nuisance of headphones requires the audio-frequency amplifier. Our search for sensitivity leads us to the radio-frequency amplifier. And so on. Note that this is how the science of radio actually developed.

Another "must" is the elimination, as far as possible, of all formulas and mathematics. Too often a formula is substituted for an explanation. We must remember that what is perfectly clear to the engineer may not be so clear to the student. Thus the first half of the book does not contain a single formula.

The second half of the book is devoted to electrical theory, transmitters, and more advanced aspects of radio. It is hoped that the student will be sufficiently enthusiastic and curious to continue beyond the first half of the book. But even if he is not, it must be remembered that the first portion is a complete unit in itself.

### *Teaching Devices*

To make the textbook a useful tool of instruction, several devices approved by most progressive teachers are included:

1. *Problems* are set up as questions at the beginning of each chapter.
2. Paragraphs are numbered and introduced by *black-face captions*.
3. A *glossary* appears at the end of each chapter.
4. A set of *questions* and *problems* accompanies each chapter.
5. A complete program of classroom *demonstrations* is provided at the end of the text.
6. Useful *tables of data* are grouped in the *Appendix*.
7. The *drawings* are large and more than usually profuse. They are definitely directed toward explanation—not for adornment.
8. A *Table of Contents* may be used as a guide to weekly planning of work.
9. A detailed index for easy reference will be found at the end of the book.



*The Time Allotment*

The book is designed for a one-year course. Experience with classes has shown that each part may serve for about one semester when one period per day, five times a week is the schedule. For more intensive work in the war course program, the period may be cut down to a few weeks.

*Methods and Equipment*

It is recommended that all principles be introduced and investigated as a problem or difficulty; that the principles be demonstrated by the teacher, and that one period or more per week be given to practical wiring, testing, soldering, and measurement by the students in the laboratory. The facilities of the school will determine the amount of individual laboratory work that can be done. But it is believed that any instructor with the ordinary equipment in physics and with the addition of the parts salvaged from one or more radio sets can carry out most of the demonstrations listed in the back of the book.

THE AUTHORS

# Table of Contents

---

## Volume I

CHAPTER	PAGE
1. HISTORY OF COMMUNICATION . . . . .	3
2. WAVE MOTION . . . . .	7
3. WAVES IN ETHER . . . . .	13
4. A SIMPLE RADIO RECEIVING SET . . . . .	19
5. THE AERIAL-GROUND SYSTEM . . . . .	27
6. THE TUNER . . . . .	31
7. THE REPRODUCER . . . . .	37
8. THE DETECTOR . . . . .	43
9. WAVE FORM . . . . .	51
10. THE ANTENNA COUPLER . . . . .	65
11. ELECTRON FLOW IN THE AERIAL-GROUND SYSTEM	73
12. ELECTRON FLOW IN THE TUNING CIRCUIT . . . .	81
13. ELECTRON FLOW IN THE CRYSTAL DETECTOR AND PHONES . . . . .	91
14. THE VACUUM-TUBE DETECTOR—THE DIODE . . .	97

CHAPTER	PAGE
15. THE VACUUM-TUBE DETECTOR—THE TRIODE . . . . .	105
16. THE REGENERATIVE DETECTOR . . . . .	121
17. THE AUDIO-FREQUENCY AMPLIFIER . . . . .	131
18. ELIMINATING THE B BATTERY . . . . .	147
19. ELIMINATING THE A BATTERY . . . . .	161
20. ELIMINATING THE C BATTERY . . . . .	169
21. THE A.C.-D.C. POWER SUPPLY . . . . .	175
22. THE DYNAMIC SPEAKER . . . . .	181
23. THE RADIO-FREQUENCY AMPLIFIER . . . . .	189
24. VOLUME CONTROL . . . . .	209
25. TONE CONTROL . . . . .	223
26. THE SUPERHETERODYNE RECEIVER . . . . .	231
27. TYPES OF VACUUM TUBES . . . . .	249
28. RADIO DIRECTION FINDERS . . . . .	281

## Volume II

INTRODUCTION TO VOLUME II . . . . .	303
29. DIRECT CURRENT AND THE NATURE OF ELECTRICITY . . . . .	305
30. MAGNETISM, MOTORS, AND MEASURING INSTRUMENTS . . . . .	339
31. ALTERNATING CURRENTS—THEORY AND MEASUREMENT . . . . .	373

## TABLE OF CONTENTS

xiii

CHAPTER	PAGE
32. INDUCTANCE, INDUCTIVE REACTANCE AND IMPEDANCE . . . . .	407
33. CAPACITANCE . . . . .	423
34. RESONANT CIRCUITS AND TUNING PRINCIPLES . . . . .	443
35. THE ELECTROMAGNETIC WAVE . . . . .	475
36. RADIO ANTENNAS FOR TRANSMITTERS . . . . .	495
37. VACUUM-TUBE CHARACTERISTICS . . . . .	519
38. VACUUM-TUBE AMPLIFIERS . . . . .	541
39. VACUUM-TUBE OSCILLATORS . . . . .	575
40. THE CONTINUOUS-WAVE (C.W.) TRANSMITTER . . . . .	585
41. THE MODULATED-WAVE TRANSMITTER . . . . .	605
42. THE CATHODE-RAY TUBE AND ITS APPLICATIONS . . . . .	625
DEMONSTRATIONS FOR VOLUME I . . . . .	647
DEMONSTRATIONS FOR VOLUME II . . . . .	659
APPENDIX . . . . .	675
INDEX . . . . .	685

# Volume I

# CHAPTER I

## History of Communication

---

**Problem:** *How has man improved his means of communication since time began?*

---

### 1. Sound Signals

Ever since man could make a sound, he has attempted to transmit messages over ever-increasing distances. A shout may have been the first “long-distance transmission.” Man soon learned that greater distances could be spanned by beating with a club on a hollow tree and, even today, a fairly efficient and effective system of drum-beat communication exists among primitive tribes.

### 2. Sight Signals

Another ancient method of message transmission involves the sense of sight. From hand-waving men progressed, thousands of years ago, to the waving of flags, the use of puffs of smoke, of fires and lanterns, of the heliograph—a device whereby sunlight is reflected by mirrors and flashed over considerable distances.

All of the above methods of communication suffer from one common fault. They are useful only over comparatively short distances, a few miles at best.

### 3. The Telegraph

Nevertheless, it was not until the nineteenth century that better means of communication were devised.

In 1832, SAMUEL F. B. MORSE invented the electric telegraph. By sending an electrical impulse along a wire, he operated an electromagnet at the end of the line. This electromagnet attracted a bar of iron, causing an audible click. By means of a code these clicks were translated into letters and words.

This was a big step forward. No longer was man bound by

the limits of sight and hearing. Wires could be strung for many miles and the electrical impulses could be sent through them at the incredible speed of nearly 186,000 miles per second! In 1866, the first message was sent from America to Europe by means of a telegraph cable beneath the Atlantic Ocean.

#### 4. The Telephone

In 1875 another stride forward was taken when ALEXANDER GRAHAM BELL invented the telephone. Now sound could be converted into electricity at the transmitting end of the line, sent through wires at the same tremendous speed as in the telegraph, and reconverted into sound at the receiving end of the line. Thus the very spoken word was sent by wire over hundreds and thousands of miles!

#### 5. Wireless Telegraph—Radio

Marvelous advances though they were, the telephone and telegraph fell short of meeting the demands which our ever-expanding civilization put upon them. Wires could not be strung everywhere. Explorers and ships at sea were cut off from communication with home and each other. The balloon, and later the airplane, required some means of communication that did not entail stringing wires from sender to receiver. In short, a wireless telegraph and a wireless telephone were clearly needed.

Like all great inventions, neither the wireless telegraph nor the wireless telephone (or radio, as we now call them both) was the product of any one man's activity. Many men from many lands each contributed their shares before the radio came into being.

Nearly a quarter of a century before the first radio wave was produced intentionally, an English scientist, JAMES CLERK MAXWELL, by means of an elaborate mathematical formula, proved the possibility of producing the radio wave. This was in 1864. His contribution was the theory of electromagnetic waves.

#### 6. Radio Communication

In 1888, HEINRICH RUDOLF HERTZ, a young German in Frankfurt, succeeded in transmitting the first radio wave across a room and picking up this wave signal on an extremely crude type of receiver.

Then followed a half-dozen years of activity during which a

large number of scientists each contributed some addition or improvement. These experiments finally led to the wireless telegraph, the first practical radio system. This was invented by GUGLIELMO MARCONI, a young Italian, in 1895. With his system, Marconi was able to send and receive messages for several miles without any intervening wires. In 1901, Marconi succeeded in spanning the Atlantic Ocean.

Here, indeed, was the way to the solution of the needs of the twentieth century—a system of communication over long distances with no need for interconnecting wires.

#### **SUMMARY**

In this chapter we have learned that man has improved his means of communication gradually. The probable steps in the progress have been successively, sound, light, electrical signals on wires, and finally signals sent and received through space by radio.

#### **QUESTIONS AND PROBLEMS**

1. What were the shortcomings of primitive means of communications?
2. What needs of daily life made wired systems of electrical communication inadequate?
3. Who first proved mathematically the possibility of producing the radio wave? When? What is the name of his theory?
4. Who first produced an elementary radio transmitter and receiver? When?
5. Who invented the first practical radio system? When? What was this system called?



## CHAPTER 2

# Wave Motion

---

**Problem:** *What is a wave?*

---

Radio communication, we are told, travels in *waves*. We must therefore try to understand what a wave is.

### 7. Water Waves

If you drop a pebble into a pond of still water, *ripples* or *waves* are created, and these travel away from the splash in ever-widening circles.



**Figure 1.** Ripples caused by throwing a stone into a still pond. These ripples travel in ever-widening circles from the point of disturbance.

If you examine these waves, you can see how they are formed and how they travel. The falling pebble, when it strikes the water, pushes some water away from its path, forming a sort of cavity or hollow in the pond. The displaced water is piled up all around the cavity and is forced above the normal level of the pond in a circular wall.

## WAVE MOTION

The weight of the water causes this circular wall to collapse, to fall—and when it falls it goes past and below the original level of the pond. This falling water, like the falling pebble, in turn

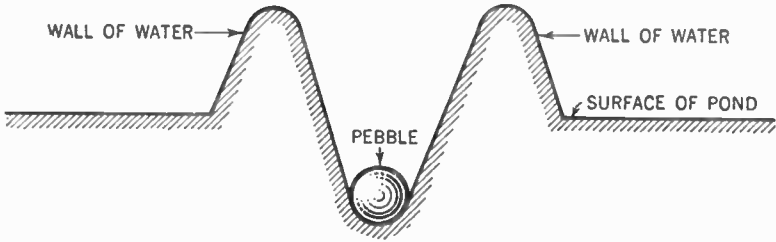

Figure 2. Sectional view of the pond showing the crater and wall of water formed by the falling pebble.

displaces some more water, causing another circular wall to be built up a little distance away from the original cavity. This rising and falling continues on and on. The building up and collapsing of the walls of water causes the wave to travel away from the original hollow made by the pebble. Because of the resistance of the water, each wall is a little lower than the one before it and when it falls it descends a little less below the surface of the pond.

Place a small piece of cork on the surface of the pond a little distance away from where you drop the pebble. As the ripples reach the cork, it bobs up and down but does not travel on with the wave. This shows how each *particle* of water moves up and down but does not travel across the pond as the wave does.

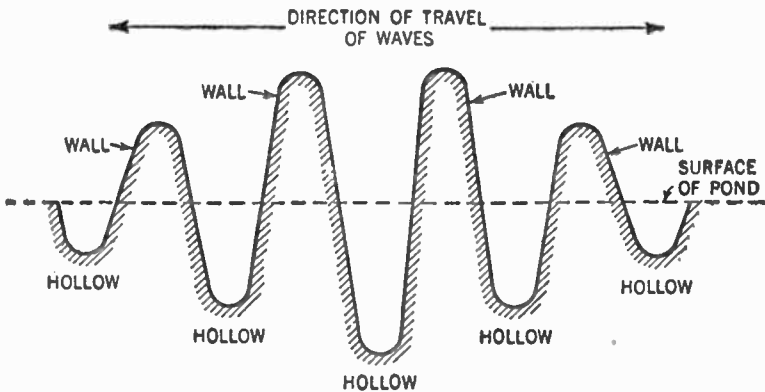

Figure 3. Sectional view of the pond showing the series of circular walls and hollows formed by the falling pebble.

### 8. What Really Travels?

You can better understand this behavior, perhaps, if you set up a row of dominoes. Tip the first one against the one alongside it. It will push its neighbor against the next one and so on. The *motion* (or wave) will pass through the whole row, but each domino will travel only a short distance.

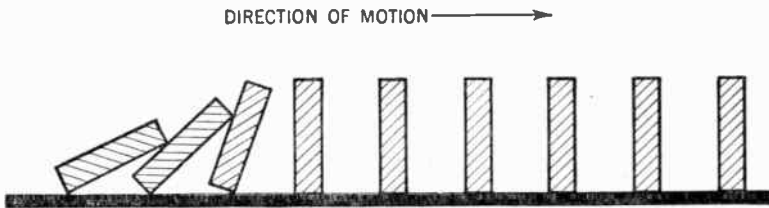

Figure 4. A row of dominoes illustrating wave motion.

It is the *energy* caused by the weight of the falling domino that travels, not the dominoes. Similarly, in the case of the water wave, the particles of water do not travel across the pond; it is the energy alone that does the traveling.

Obtain a fairly heavy rope about fifteen feet long. Fasten one end to a post. Now move the free end up and down. The rope seems to travel towards the post. But the rope itself is not traveling. You can see that because the free end is no nearer the post now than before. Each particle of rope is moving merely up and down. It is the *energy* or *wave* that is traveling through the rope from the end in your hand to the end fixed to the post.

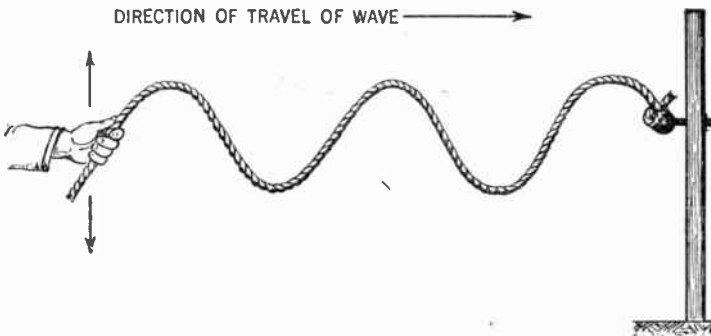

Figure 5. Illustrating wave motion with a rope.

In these examples, the water, the dominoes, and the rope are each called the *medium*. The particles of the medium move a

very short distance. *It is the energy or motion traveling through the medium from particle to particle that we call the wave.*

### 9. Wavelengths

Let us look more closely at the ripples in the pond. Recall that the pebble forms a hollow in the pond and builds up a wall of water next to that hollow; when this wall falls it makes a hollow next to it; and so on. Note that the walls and hollows alternate; that is, first there is a wall, then a hollow, then a wall, and so on. The top of the wall is called the *crest* of the wave. The bottom of the hollow is called the *trough*. The distance between one crest of a wave and the next crest (or between one trough and the next trough) is called the *wavelength*.

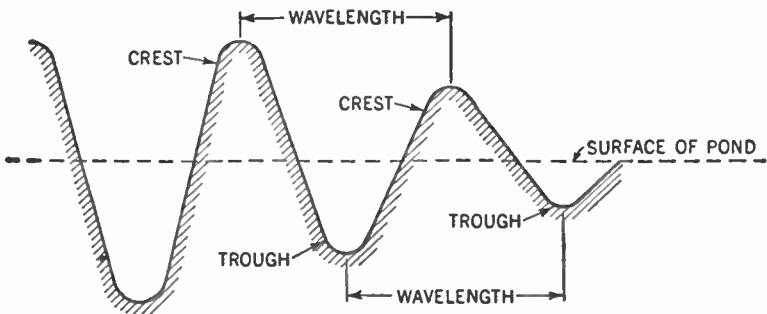

**Figure 6.** Sectional view of the pond showing what is meant by wavelength.

At the seashore, you may see waves whose wavelengths vary from a few feet up to about a half mile. You may set up a rope wave whose wavelength varies from several inches to several feet.

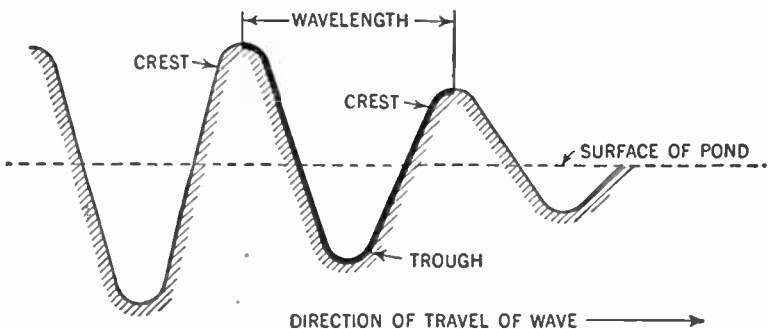

**Figure 7.** Sectional view of the pond. The heavy line shows the path of the wave going through one cycle.

The *path* that the wave travels in going one wavelength is called a *cycle*. This means the path from one crest through the trough and up to the next crest.

### 10. Frequency and Amplitude

The number of *cycles* in a given unit of *time* is called the *frequency*. Thus, an ocean wave may have a frequency of about two cycles per minute. This means that the wave will travel through two cycles in one minute.

If you examine the water ripples again, you may notice another interesting thing about them. The larger the pebble you drop, or, the more force with which you throw it, the deeper is the hollow produced and the higher the wall of water set up. The depth of the trough beneath the normal level of the pond or the height of the crest above it is called the *amplitude* of the wave.

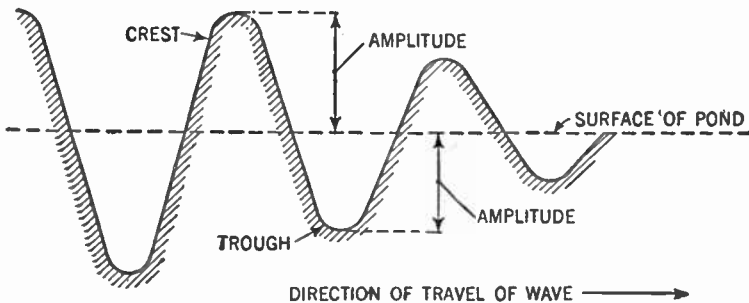

**Figure 8. Sectional view of the pond illustrating what is meant by amplitude. Notice that in this kind of wave the amplitude decreases the further the wave travels away from the point of disturbance.**

Note that the amplitude of a wave depends upon the force producing it.

Another interesting thing is the *speed* with which a wave passes through a medium. *Since the wave travels from particle to particle in the medium, the type of medium makes a difference in the speed with which a given kind of wave will pass through it.*

### SUMMARY

Now let us see what we have learned so far.

A wave is energy traveling through a medium by means of vibrations from particle to particle.

The **amplitude** (of a water wave) is the height of the crest of a wave above the surface of the medium at rest.

The **wavelength** is the distance between one crest of a wave and the next crest.

A **cycle** is the path that the wave travels in going one wavelength.

The **frequency** is the number of cycles in a given unit of time.

The **speed** with which the wave travels depends upon the nature of the **medium**.

#### QUESTIONS AND PROBLEMS

1. Describe what happens when a stone is thrown into a pond.
2. What is meant by a wave?
3. Define what is meant by wavelength. Use a diagram.
4. What is meant by a cycle? What is the relationship between cycles and frequency?
5. Upon what does the amplitude of a wave depend?
6. What determines the speed of a wave?
7. Make a diagram of a series of water waves. Label the following: wavelength, amplitude.
8. How may energy be made to travel from one place to another?

## CHAPTER 3

# Waves in Ether

---

**Problem:** *How do light, heat, and radio waves travel?*

---

### 11. Light Waves

See if you can get an electric-light bulb of the type which has a vacuum inside. These bulbs are becoming scarce because it has been found that electric-light bulbs do their work better if filled with a gas like nitrogen. You may still get the vacuum type in a large electrical supply store. Screw the bulb into the electric-light socket and turn the switch. *Light waves*, a type of energy, travel from the hot filament to our eyes. Scientists tell us that light is a wave motion.

Now: since a vacuum surrounds the hot filament, what is the medium which carries the light waves? What is the medium which carries the light waves from the sun to the earth? For scientists say that the space between the earth and sun is empty, or in other words, a vacuum.

### 12. What is "Ether?"

To get around the difficulty, scientists were forced to assume a medium. They called this medium *ether*. (Note that this ether is not the same as the gas the doctor gives you when he wants to put you to sleep.) Ether, as scientists use the word, is what remains in space when all substance or matter, as we know it, has been taken away. This so-called ether is the medium that transmits the light waves across a vacuum; hence it is called *luminiferous* (that is, light-carrying) *ether*.\*

\*The idea of an "ether" was proposed in the latter part of the seventeenth century by Sir Isaac Newton and given prominence by Christian Huygens, the Dutch physicist who discovered polarized light. There is no proof that ether does or does not exist. Some scientists prefer to ignore it. However, since "ether" is a convenient label for the idea of a medium by which all forms of radiant energy (heat, light, radio) are transmitted, it will be used in this text.

Studies have shown that the light wave travels through ether at the enormous *speed* of 186,000 miles (300,000,000 meters) per second. The *frequency* (that is, the number per second) of light waves varies from 375 million millions to 750 million millions of cycles, while their *wavelength* varies from about 15 to 30 millionths of an inch (0.000015 in. to 0.000030 in.).

### 13. Heat Waves

Now touch the outside of the "burning" electric-light bulb. It is hot. How did *heat*, another type of wave energy, get across the vacuum in the bulb? How do the heat waves sent out by the sun reach the earth?

The heat wave, like the light wave, travels through the ether. Like the light wave, its *speed* is 186,000 miles per second. The *frequency* of heat waves varies from 750,000 millions to 375 million millions of cycles per second and hence their *wavelengths* vary from about one hundredth to 30 millionths of an inch (0.01 in. to 0.000030 in.).

Waves which move in ether as a medium are known as *ether waves*. Light and heat are two forms of energy which travel by ether waves.

### 14. The Metric System

At this point it should be explained that scientists prefer the *metric system* to the *English system* for the measurement of length. Under the English system you know that

$$\begin{aligned} 12 \text{ inches} &= 1 \text{ foot} \\ 3 \text{ feet} &= 1 \text{ yard.} \\ 1760 \text{ yards} &= 1 \text{ mile} \end{aligned}$$

In the metric system the unit of length is the *meter*, which is slightly more than a yard long (39.37 inches). In this system of measurement the prefix *deka-* means ten, *hecto-* means hundred, *kilo-* means thousand, and *mega-* means million. Similarly *deci-* means a tenth (1/10), *centi-* means a hundredth (1/100), *milli-* means a thousandth (1/1000) and *micro-* means a millionth (1/1,000,000).

Thus a *kilometer* means 1000 meters, and a *millimeter* means



1/1000 meter. The following table may help to make the relationship clear:

10 millimeters (mm)	= 1 centimeter (cm)
10 centimeters	= 1 decimeter (dm)
10 decimeters	= 1 meter (m)
10 meters	= 1 dekameter (dkm)
10 dekameters	= 1 hectometer (hm)
10 hectometers	= 1 kilometer (km)

The relationship between the metric and English systems can be seen from the following table:

1 inch	= 2.54 centimeters
39.37 inches	= 1 meter
.62 mile	= 1 kilometer

The prefixes used in the metric system for length are also used to measure other values. Thus 1000 cycles becomes a *kilocycle* (kc), and 1,000,000 cycles a *megacycle* (mc). Thus, when we say that the frequency of light waves varies from 375 million millions (375,000,000,000,000) to 750 million millions (750,000,000,000,000) of cycles, we may express these numbers as from 375,000,000 megacycles (mc) to 750,000,000 megacycles.

We have taken time out to explain the metric system because you will constantly come across this system of measurement in your scientific studies. As a matter of fact, the frequency of the radio waves from the various broadcasting stations are usually listed in kilocycles (1000 cycles). Thus the frequency of station WOR, New York, is 710 kc (710,000 cycles) per second.

### 15. Other Forms of Energy

For the light and heat types of ether waves, special organs of our bodies act as *receivers*. However, other forms of energy are transmitted through the ether; we cannot detect these with any of our unaided senses. We must therefore devise special instruments that can change such forms of energy to types which our senses can perceive.

To see the effect of one such type of energy, balance a magnetic needle on a pivot and near it suspend a coil of about 25 turns of No. 18 insulated copper wire. Then pass the current from a

dry cell through the coil, and observe that the magnetic needle is sharply deflected. *Energy from the coil of wire passes to the magnetic needle.* To show that it is not the air which transmits the energy, place the whole apparatus under a bell jar and pump out the air. Once again pass the current of electricity through the coil. Again the magnetic needle is deflected. The energy is transmitted across the vacuum.

For want of a better explanation, we again fall back upon the ether and assume that it is the medium which transmits the energy. We say that when an electric current passes through a wire it sets up a *magnetic field* in the ether around that wire.

Note that this magnetic field, unlike the light and heat waves, cannot be received by our senses. Accordingly, we use the magnetic needle to detect this field, and thus to change its energy to

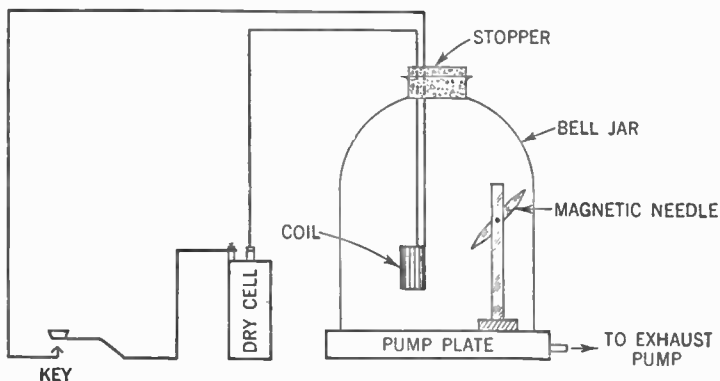

**Figure 9.** Apparatus to show that electric current, flowing through a coil of wire, will set up a magnetic field around that coil. This field is created even though the coil is surrounded by a vacuum.

a form which our senses can receive. The energy of the magnetic field is changed to the *motion* of the needle; we can see motion.

All these ether waves are "wireless" waves; they do not depend upon metallic wires to transmit their energy. Because of this fact, these waves may be used to communicate between places where it is not possible to string wires, as between an airplane and the ground. Light waves, as we well know, have been used for communications. To a lesser degree, so have heat waves and magnetic fields.

## 16. Radio Waves

Light waves travel in straight lines and cannot penetrate

opaque objects. Because of this, the curvature of the earth and such intervening objects as houses, trees, hills, and the like, limit the range of this method of communication.

As for heat waves, they are too readily absorbed by surrounding objects to permit them a large range.

The magnetic field is effective for only a very short distance. If, however, the key in Figure 9 is opened and closed very rapidly (ten thousand or more times a second), a type of ether wave new to us, a *radio* wave, is created.

This wave can travel great distances and can penetrate non-metallic objects. It travels at the speed of light, namely 186,000 miles per second, and its frequency, wave length, and amplitude are determined by the apparatus used to create it.

Radio waves vary in length from about 18 miles down to  $\frac{1}{250}$  inch. Those used in ordinary broadcasting are from 656 ft. to 1968 ft. (approximately 200 m. to 600 m.) in length.

SUMMARY

The following principles have been discussed in this chapter:

1. Certain forms of radiant energy are transmitted by means of ether waves. These forms are light, heat and radio waves.
2. The idea of a medium called "ether" has been postulated (assumed for practical reasons, although not proven).
3. Radiant energy travels through the ether with a speed of 186,000 miles or 300,000,000 meters per second.
4. The lengths of the waves are determined by the vibration frequency of the source of the waves. The ranges are:

Visible light waves .....	.00004 to .00008 cm.
Heat waves .....	.00008 to .04 cm.
Radio waves .....	.01 cm. to 30 km.

5. The length of an ether wave is found by dividing 300,000,000 meters by the number of vibrations (or cycles) per second.

GLOSSARY

**Ether:** The medium, permeating all space, which is *supposed* to carry such forms of energy as light, heat and radio waves. There is no proof that ether does or does not exist.

**Ether Wave:** A wave of energy which uses ether as a medium.

**Heat Wave:** An ether wave whose wavelength lies between .00008 cm. and .04 cm.

**Light Wave:** An ether wave whose wavelength lies between .00004 cm. and .00008 cm.

**Magnet:** A bar of iron or steel or a coil bearing an electric current that has the property of attracting to it pieces of iron, steel or other magnetic substances.

**Radio Wave:** An ether wave whose wave length lies between .01 cm. and 30 km.

#### QUESTIONS AND PROBLEMS

1. In what ways are radio, heat and light waves similar? In what ways do they differ?
2. What is the medium for radio waves?
3. At what velocity do light and radio waves travel?
4. Define and give examples of ether waves.
5. For what ether waves are our bodies receivers? For which are our bodies insensitive and in need of special receivers?
6. Why cannot the magnetic field of an electromagnet be used to send wireless messages in a practical manner?
7. Through what materials can radio waves penetrate?

## CHAPTER 4

# A Simple Radio Receiving Set

---

**Problem 1:** *What are the four essential parts of the radio receiver?*

**Problem 2:** *What is the function of each part?*

---

It will be helpful in our study of the principles of radio to learn at the start that every radio receiver, no matter how complex or involved, consists of only four essential parts. They are:

1. The *aerial-ground system*, which collects the radio waves.

2. The *tuner*, which selects the radio wave (or station) to be received and rejects all others.

3. The *reproducer*, the device which changes the energy of the radio wave to a form which our senses can perceive.

4. The *detector*, which changes the energy of the radio wave to a form whereby it can operate the reproducer.

This holds true for all receiving sets from the simplest crystal set to the most complex television receiver. Everything else in the receiver is merely a refinement of these four essentials.

### WHAT IS THE PURPOSE OF THE AERIAL-GROUND SYSTEM?

#### 17. The Aerial

Suppose we string a copper wire so that one end is up in the air and the other end is connected to the ground. Radio waves, sent out by a broadcasting station, striking this wire, will set up an *electrical pressure* or *voltage* across it. This pressure will cause

a small electrical current to flow up and down the wire. We now have the beginning of our radio receiver, the *aerial-ground system*. With it we collect the radio waves. All receivers must have an aerial-ground system. It may be external and connected to the set by wires, or it may be contained in the set itself in the form of a number of loops of wire.

To prove that this aerial-ground system is necessary to the receiver, connect up a regular broadcast receiver with an external aerial and ground. Tune in a station and then disconnect the aerial and ground. The station dies away.\*

## WHAT IS THE FUNCTION OF A TUNER?

### 18. Resonance

All radio receivers must have some method of separating the station desired from all other stations broadcasting at the same time. The apparatus which does this is called the *tuner*. Since each station sends out radio waves of a different frequency, the tuner must select the frequency desired and reject all others.

To understand how this is done you must first learn about *resonance*.

Place a number of drinking glasses of different size, shape, and thickness upon a table. Strike each with a pencil. Observe that each glass gives off a different tone. The vibrating glasses set up air waves which reach our ears and are interpreted as sound. The different tones are caused by the different frequencies of these air waves. This means that the glasses, too, are vibrating at different frequencies. The frequency at which an object will vibrate when struck depends upon its material, size, shape, and thickness. This frequency is called the *natural frequency* of the object.

### 19. Vibrations of a Pendulum

From a nail, suspend a small weight at the end of a string about a yard long. You now have a pendulum. Start the pendulum swinging gently. You will note that it swings a certain number of times per minute. That number is the natural frequency of that particular pendulum. Wait till it is swinging

\*The station may be faintly received even after the aerial and ground are disconnected. This is because the wires in the set itself act as a very inefficient sort of aerial and ground.

gently. Now, every time the pendulum reaches the end of its swing, give it a very light tap. You will soon have your pendulum swinging violently to and fro. Note that you must tap the pendulum at the exact instant it reaches the peak of its swing if you wish to increase that swing. If you tap it too soon or too late, the pendulum will slow down. The increased energy of the swing came from the tapping. Therefore, to obtain the maximum transfer of energy from the tapping to the pendulum, the *frequency of the tapping must be equal to the natural frequency of the pendulum*. We say the tapping is in *resonance* with the swing of the pendulum.

## 20. Tuning Blocks

Here is another experiment you may perform. Obtain two tuning blocks of similar frequency, say, 256 vibrations per second, which corresponds to the note we call middle C on the piano. A tuning block is a bar of steel so designed that it will vibrate at a certain frequency when struck. This bar is mounted on a hollow wooden block which amplifies the note produced.

Place these blocks about 10 feet apart. Now strike one of them vigorously. It will give off its note, middle C. Place your hand on the block you struck to stop its vibrations. You will continue to hear the note, although a good deal fainter. Bring your ear near the second block. The sound will be coming from it, although you did not strike it. Place your hand on the second block. The sound stops.

Let us see what happened. When you struck the first block it was set vibrating at its natural frequency of 256 vibrations per second. The vibrating bar set up air waves at that same frequency. These air waves struck the second block. Since the frequency of the air waves was the same as the natural frequency of this second block, the energy of the air waves was transferred to the block and it was set in vibratory motion. The second block thereupon set up air waves of its own, and it was these waves you heard when you stopped the vibrations of the first block. We say that the two blocks are in *resonance* with each other.

Repeat this experiment using two tuning blocks of different frequency, say, one at 256 or middle C and the other at 288 or D. This time you get no sound from the second block because the air waves are not vibrating at the natural frequency of the second

block and therefore there is no transfer of energy. These blocks are *not in resonance* with each other.

So you see that you have here a means of selecting only a certain frequency and rejecting all others. All you have to do is to construct your receiving block so that it is in *resonance* with the frequency you wish to receive. It will vibrate only when air waves of that frequency hit it but not at any other frequency.

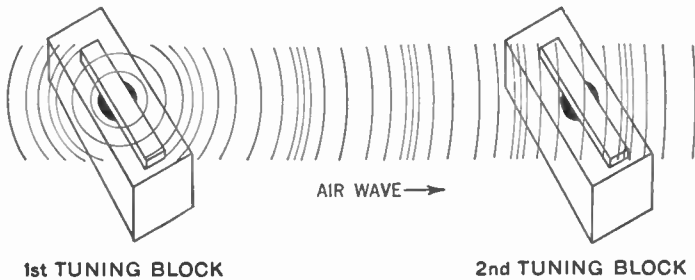

Figure 10. Set of two tuning blocks showing how air waves sent out by the first block strike the second one and set it vibrating.

## 21. Radio Tuning Means Putting a Receiver in Resonance with Certain Radio Waves

In our radio receiver we use the same principle that was shown by the tuning blocks. Assume that three stations A, B, and C are broadcasting simultaneously at frequencies of  $a$ ,  $b$ , and  $c$  respectively. If you wish to receive station A, you adjust your tuner so that the natural frequency of your receiver is the same as the frequency  $a$  of the radio wave from station A. The receiver now is in resonance with the radio wave from station A, and the energy of the radio wave is transferred to the receiver. Since stations B and C are not in resonance with the receiver, the energy of the radio waves sent out by these stations is rejected and we do not hear them.

## WHAT IS THE FUNCTION OF THE REPRODUCER?

### 22. How Do We Hear the Signals?

So far, we have been able to catch or collect the radio waves by means of the aerial-ground system and to select the station (or frequency) we desire by means of the tuner. But we still cannot hear or see the electric currents which have been set up in our



receiver. What we now need is some device which will change this electric current to a form of energy which we can hear or see. This device is called the *reproducer*.

Using copper wire, hook up a telephone transmitter, a telephone receiver, and some dry cells as shown in Figure 11.

### 23. The Telephone as a Reproducer

The electric current flows from the dry cells through the copper wire, through the telephone transmitter, then from the transmitter through the copper wire, through the telephone receiver, and then through the copper wire back again to the dry cells. We call this hookup an electrical circuit.

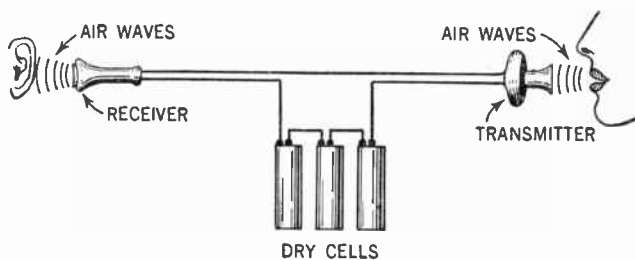

Figure 11. Hookup of a telephone transmitter, telephone receiver, and dry cells, showing how air waves, striking the transmitter, are heard as sound coming from the receiver.

When you speak into the telephone transmitter, the sound waves hitting it cause it to act like a gate, allowing more or less electric current to flow through the circuit. A fluctuating electric current is thus set flowing in the circuit. At the other end of the line, in the telephone receiver, this fluctuating electric current causes a metallic diaphragm to fluctuate in step with the current. This movement of the diaphragm causes the air next to the diaphragm to move back and forth, setting up air waves; we hear these air waves as sound. Since the air waves that hit the transmitter move the same way as the air waves set up by the diaphragm of the receiver, you hear the same sound as was spoken into the transmitter. We call the telephone receiver a *reproducer*.

Now, remember that radio waves set up an electric current in an aerial-ground system, as we discovered earlier. Hence it would seem that all you have to do to hear a radio message from a distant station is to lead this electric current through the tuner and into some type of telephone receiver.

But not so fast. There are some electric currents that cannot operate the telephone receiver. The current that the radio wave sets up in your aerial-ground system is of this type. So it is necessary to change it to current of a type that will operate the reproducer.

### WHAT IS THE FUNCTION OF THE DETECTOR?

#### 24. The Detector

There are a number of ways of accomplishing the change of current from one type to another. The simplest, perhaps, is to compel the current to pass through a certain type of mineral such as *galena*. This passage changes the aerial-ground current into a current type that will operate the telephone receiver and make it possible to hear the radio wave as sound. Such a device, which changes the electric current set up by the radio wave into a form that will operate the reproducer, is called a *detector*.

#### SUMMARY

Here, then, is your complete radio receiver. First of all is the **aerial-ground system**, which collects the radio waves. Next comes the **tuner**, which selects the station or radio wave desired and rejects all the rest. Then comes the **detector**, which changes the form of the electric current set up by the radio wave into a form that will operate the **reproducer**, which in turn produces the sound that we can hear.

#### GLOSSARY

- Aerial-Ground System:** The wire system which "picks up" radio waves and across which the radio wave produces an electrical pressure.
- Detector:** The device to change the electrical currents which are produced in a receiver by radio waves into electrical currents which can operate the reproducer.
- Natural Frequency:** The frequency at which a body will vibrate if kept free from outside interference.
- Reproducer:** A device such as a telephone receiver which changes electric currents to a form which our senses may observe.
- Resonance:** The condition of two vibrating bodies when the natural frequency of one body is equal to the frequency of the other vibrating body. In the radio receiver, when the natural frequency of the tuner is the same as the frequency of the transmitting station, the two are in resonance.
- Tuner:** The device in a radio receiver which selects a radio wave of a certain frequency and rejects all others.

### QUESTIONS AND PROBLEMS

1. What are the four essentials of all radio receivers?
2. What effect is produced when a radio wave sweeps across an aerial-ground system?
3. Explain the function of a tuner in a radio receiver.
4. In what manner does resonance of the tuner relate the receiver to the radio wave of a station?
5. Upon what factors does the natural frequency of the tone of a drinking tumbler depend?
6. Why must a reproducer be used in a radio receiver?
7. Why must a receiver have a detector?
8. What material may be used in an aerial-ground system to pick up radio waves?

## CHAPTER 5

# The Aerial-ground System

---

**Problem 1:** *How is a simple antenna set up?*

**Problem 2:** *How is the aerial connected to the ground?*

---

Before we continue our study, let us have clearly in mind what we are trying to do. The plan of this book proposes to take up the problems of radio in the following order:

1. What are the parts of a radio receiving set?
2. How are these parts connected and how do they work?
3. Why do the parts function as they do?

We have learned that the radio wave, striking the aerial, sets up an electric pressure, called an electromotive force (abbreviated E.M.F.) which causes a small electric current to flow up and down the aerial-ground system. Because this current is extremely small, it is necessary to construct your aerial-ground system as efficiently as possible and you must be sure that you do not waste this current once it is set flowing.

### 25. The Antenna

First of all there is the aerial or antenna. For ordinary broadcast reception, the simplest type of aerial consists of a single strand of wire about 75 ft. long. This wire should be of copper, of No. 12 or No. 14 gauge and may either be insulated or bare. It should be raised as high above ground as is practical and should be kept clear of all obstructions, metal especially. *Insulators* should be attached to both ends to prevent the small currents from leaking off. Insulators are substances that do not conduct electricity. Common examples are glass, porcelain, bakelite, and hard rubber. If a power line or a trolley wire runs nearby, your aerial should run at right angles to that line or wire.

## 26. The Lead-in

After the *aerial* comes the *lead-in*. This is a piece of wire similar to the aerial. It is connected at one end to the antenna and at the other end to the receiving set. If possible, the aerial and lead-in should be made of one piece of wire. But if you should have to join one piece of lead-in wire to another, or to the aerial, be sure to scrape the two pieces clean with a knife or sandpaper. Then twist one wire securely around the other. For best results this joint should be soldered. Finally, wrap friction tape around the joint to prevent the air from corroding it.

The lead-in should be kept at least 6 in. away from all walls and other surrounding objects. It is usually brought in through a window, and, to avoid the necessity of drilling a hole in the frame, the lead-in is cut and a flexible window strip is inserted. This window strip lies flat under the window frame and permits the window to be opened and closed without disturbing the installation.

From the inside end of the window strip, connect an insulated copper wire to the post on your radio set marked ANT or AERIAL. For best results, the lead-in should be about 25 ft. in length, from the aerial to your radio set.

## 27. The Ground

Finally, there is the *ground* connection.\* The best connection for a ground, if one is available, is a cold-water pipe. Next best is a radiator or any other pipe which goes to the ground. Gas pipes should *never* be used as grounds. Scrape the paint off the pipe where you plan to make the connection. Then wrap a number of turns of bare copper wire tightly around the cleaned part of the pipe.

Better yet, get a ground clamp designed for this purpose and attach it on to the pipe at the point selected. Then run a piece of insulated copper wire from your ground connection to the post marked GROUND or GND on your radio set. This wire should be about No. 18 gauge and should be as short as possible.

When we draw a diagram of our radio set we use symbols to

\*Ground is a technical term used in radio work. It refers to a part of a circuit which is directly connected either to the earth or to the metallic base of some device. In an automobile one terminal of the battery is connected to the steel frame of the car; this is a *ground*. Hence in the automobile there is only one wire leading to a lamp or other fixture, the circuit being completed by connecting it through the frame.

signify the various parts. The symbol used for the aerial and

lead-in is  and that used to signify a ground is: 

It should be understood that the aerial-ground system just described is a very simple type. In a later chapter some other types will be discussed, types better adapted to certain purposes.

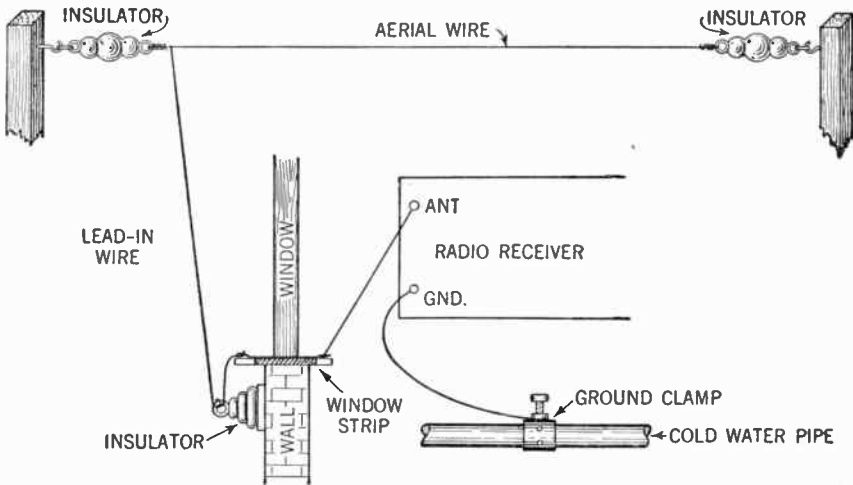

Figure 12. Diagram illustrating the installation of the aerial-ground system.

SUMMARY

1. The aerial-ground system consists of three parts: the antenna or aerial, the lead-in wires, and the ground.
2. The function of this system is to receive and capture some of the radio waves being sent out by broadcasting stations.

GLOSSARY

**Aerial or Antenna:** An elevated conductor, usually of copper, insulated from its supports and the ground and connected to the receiving set by the lead-in wire.

**Conductor:** Any substances, usually a metal wire, through which a current of electricity can flow freely.

**Ground:** A water pipe, or some such arrangement, by which the receiving set makes contact with the earth. See also footnote, p. 28.

**Insulator:** Any substance through which a current of electricity cannot flow freely.

**Lead-in:** An insulated wire connecting the aerial to the receiving set.

## SYMBOLS



Aerial and lead-in.



Ground.

## QUESTIONS AND PROBLEMS

1. Describe a simple type of aerial.
2. What is meant by an insulator? Give examples.
3. How must aerials near trolleys or power wires be set up?
4. What precautions must be taken in setting up a lead-in?
5. What is the best length for a lead-in?
6. What objects may best be used to connect our ground wires?
7. Draw the symbols for an aerial and lead-in; for a ground.
8. How should the ground connection be installed?
9. Describe the complete installation of an aerial, giving size, materials, and other details.

## CHAPTER 6

# The Tuner

---

**Problem 1:** *What are the principles of a tuning system?*

**Problem 2:** *What do we mean by inductance and capacitance?*

---

You have already learned that the tuner selects the desired radio station by adjusting the natural frequency of the receiver so that it is in *resonance* with the transmitter frequency. Let us see what determines the natural frequency of the receiver.

Examination of the tuner shows that it consists of two parts—a coil of wire to provide *inductance* and a condenser to serve as a *capacitance*. It is the electrical size or value of this combination of coil and condenser that determines the natural frequency of the receiver, even as the size and weight of a tuning block determine its natural frequency. Both inductance and capacitance (or capacity) have technical meanings, which will be explained in later chapters. For the present let us consider inductance to be the electrical disturbance in the coil caused by the influence of (or induced by) the radio waves. By capacitance, we refer to the ability (or capacity) of a condenser to hold or store electric charges.

### 28. The Inductance

The device that takes care of the *inductance* consists of a coil of wire wound around a tube usually made of cardboard or bakelite. Its electrical value depends on:

1. The number of turns or loops of wire.
2. The length of the coil of wire.
3. The diameter of the tube on which it is wound.
4. The core of the coil. This is the material inside the tube. The two most common materials for



the core are air and iron. Air-core coils are usually used for the tuner.

The unit for measurement of inductance is the *henry* (h.) or the *millihenry* (mh.). (See Chap. 32, Vol. II.) The millihenry is one one-thousandth of a henry. The symbol for inductance devices or *inductors* having cores of air or iron are:



We can vary the value of our inductance by changing one or more of the four factors listed above. It is most convenient to change the number of turns or loops of the coil. The symbol for a variable inductor is any of the following:

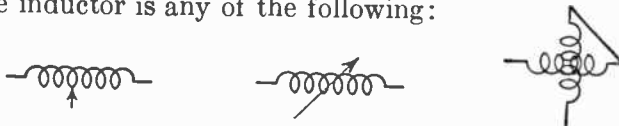

Whenever we desire to represent inductance in an electrical formula or equation we use the letter *L*.

### 29. The Capacity or Capacitance

The *capacitance* in a tuner is provided by a device called a *condenser*. This condenser is made of two or more metal plates facing each other and separated by some substance which will not conduct electricity. This substance is called a *dielectric* and usually consists of air, paper, mica, oil, or glass. The plates are usually made of brass, tinfoil, or aluminum. The electrical value of a condenser depends on:

1. The total area of the plates facing each other.
2. The material of the dielectric.
3. The thickness of the dielectric (or distance between plates).

The unit of measure of capacitance is the *farad* (f.). For radio purposes we usually use the microfarad ( $\mu\text{fd.}$ ) which is one-millionth of a farad and the *micromicrofarad* ( $\mu\mu\text{fd.}$ ), which is one one-millionth of a microfarad. (Chap. 33, Vol. II.) The symbol for the condenser is:



We can vary the value of our condenser by changing one or

more of the three factors listed above. The most convenient method is that of changing the area of the plates facing each other. This is done by making one plate, or set of plates, rotary, and the other plate, or set of plates, stationary. All the stationary plates are joined together, giving the effect of one large stationary plate. The same is done with the rotary plates. The rotary plates move in and out between the stationary plates. Thus, the more the rotary plates are moved in between the stationary plates, the greater the area of the plates facing each other and the greater the capacitance of the condenser. The symbol for a variable condenser is:

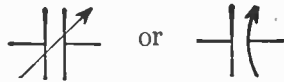

Whenever we desire to represent capacitance in an electrical formula or equation we use the letter *C*.

**30. The Tuning Circuit**

If, by means of wire, you connect a coil and condenser as shown in Figure 13, you create a tuning circuit. When you apply a voltage (electrical pressure) across this circuit, you will cause an

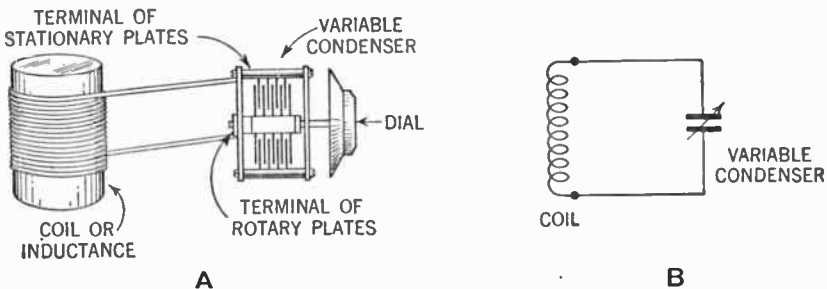

**Figure 13. Hookup showing how coil and variable condenser are connected to form the tuning circuit. Figures A and B are identical, A being the pictorial method of showing the circuit while B is the schematic method using symbols.**

electrical current to vibrate back and forth through it. We speak of such electrical vibrations as *oscillations*. These oscillations are more fully discussed in Chapter 12.

The natural frequency of the oscillations in this circuit is determined by the product of the values *L* and *C* ( $L \times C$  or  $LC$ ).

The transmitting station uses a condenser and coil hookup similar to the one we have just described to generate the radio wave it sends out. The frequency of its wave is determined by

the  $L \times C$  of the transmitting set. Should the  $L \times C$  of the transmitting station equal the  $L \times C$  of your receiver, your set will be in resonance with the transmitter. You will then receive that station only and no other.

Note that it is not necessary to have the same  $L$  and  $C$  in your receiving set as is in the transmitting station. It is enough that the product of  $L$  and  $C$  ( $L \times C$ ) of your set be equal to the  $L \times C$  of the transmitter. So if we arbitrarily give a value of 4 to the  $L$  and 4 to the  $C$  of the transmitting station, the  $L \times C$  of that station is 16. To bring your receiver in resonance with the transmitter (that is, to *tune* your set for reception) you may choose an  $L$  whose value is 2 and a  $C$  whose value is 8. Or else you may choose an  $L$  of 8 and a  $C$  of 2. Or an  $L$  of 4 and a  $C$  of 4. In other words, you may choose any value of  $L$  and  $C$  whose product is equal to 16, the same as the  $L \times C$  value of the transmitter.

Now all this is very well if you wish to build a receiver which will receive only one station. But if you wish to receive another station you must be able to vary the  $L$  or  $C$  (or both), of your receiver so that the new  $L \times C$  will be equal to the  $L \times C$  of the new station.

It has been found that it is most practical to vary the  $C$ , using a variable condenser for that purpose.

### 31. Construction of a Tuner

Now you are ready to build your tuner. Obtain a cardboard mailing tube about 2 in. in diameter and about 6 in. long. Upon this tube wind 90 turns of No. 28 gauge insulated copper wire so that the turns lie next to each other and form a single layer. This is your inductor.

Now obtain a variable condenser whose maximum value is .00035 microfarads ( $\mu\text{fd.}$ ). Such a condenser usually has from 17 to 21 plates, half rotary and half stationary. Connect one end of the coil to the rotary-plate terminal of the condenser and the other end of the coil to the stationary-plate terminal, as shown in Figure 13. You now have constructed your tuner.

### SUMMARY

1. The tuning system consists of two essential parts: a coil of wire and a condenser.
2. The coil provides a means of receiving the electrical impulses

imparted to the antenna by the radio waves. It accomplishes this by **inductance**.

3. The condenser serves as a storage place for electric charges and its ability to store them is called **capacitance** or **capacity**.

4. The mutual action of the inductance and capacitance results in the setting up of **oscillations** in the tuning circuit.

5. These oscillations may be put in **resonance** with those of a broadcasting station by making the values of  $L$  (inductance) and  $C$  (capacitance) such that the product  $L \times C$  is identical with the product  $L \times C$  of the desired station.

6. **Tuning** is achieved by using a variable condenser by which capacitance ( $C$ ) can be given any desired value.

### GLOSSARY

**Condenser:** Two sets of metal plates separated by an insulator or dielectric.

**Condenser, fixed:** A condenser whose plates are fixed so that its electrical value cannot be changed.

**Condenser, variable:** A condenser whose plates can be moved so that its electrical value can be changed at will.

**Dielectric:** An insulator placed between the plates of a condenser.

**Farad:** The unit used to measure the electrical value of a condenser.

**Henry:** The unit used to measure the electrical value of an inductor.

**Inductor:** A coil of wire wound on a form.

$L \times C$ : The product of the electrical values of the inductor and condenser of the tuning circuit which determines its natural frequency

**Micro- (prefix):**  $\frac{1}{1,000,000}$ .

**Micromicro- (prefix):**  $\frac{1}{1,000,000,000,000}$ .

**Milli- (prefix):**  $\frac{1}{1,000}$ .

**Oscillation:** The to and fro surge of an electric current in a circuit.

### SYMBOLS



Coil wound on nonmetallic core.



Coil wound on iron core.

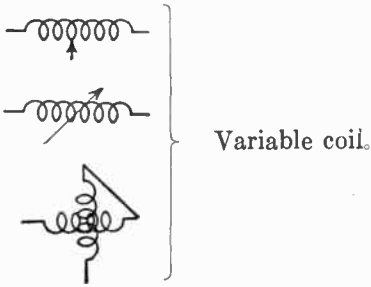

Variable coil.

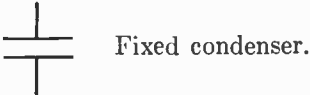

Fixed condenser.

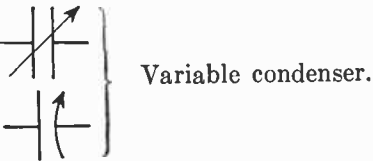

Variable condenser.

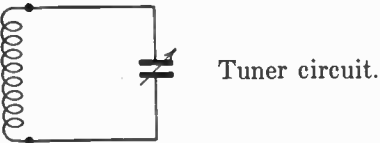

Tuner circuit.

### QUESTIONS AND PROBLEMS

1. What determines the natural frequency of the tuner of a receiver?
2. Upon what factors does the electrical value of an inductance coil depend?
3. Give the unit of inductance.
4. What is the most convenient method of varying the inductance of a coil?
5. Describe the essential parts of all condensers.
6. List several dielectric materials.
7. Upon what factors does the electrical value of a condenser depend?
8. Give the meaning of milli-, micro-, and micromicro-.
9. What is the most convenient method of varying the capacitance of a condenser of a tuner?
10. Draw a tuner circuit showing the connections of the parts.
11. What determines the natural frequency of oscillations of a tuner circuit?
12. When will a receiver be in resonance with a particular transmitter?
13. Must the physical size of a tuner at a broadcasting station be the same as that of our receiver picking up that station? Give an explanation.
14. How is the natural frequency of a tuner circuit varied in common practice?

## CHAPTER 7

# The Reproducer

---

**Problem 1:** *What are the principles of the reproducer?*

**Problem 2:** *How does a telephone receiver work?*

**Problem 3:** *What are the principles of a loudspeaker?*

---

### 32. Magnetism

To understand how the reproducer works, you must learn a few facts about magnetism and electromagnetism. Cut a circular disk of thin iron about 2 in. in diameter. Obtain a bar magnet and hold it near your iron disk. The magnet is surrounded by an invisible magnetic field of force which acts on the disk, and pulls it towards the magnet.

Obtain a piece of soft iron rod or bar stock about 1 in. in diameter and 2 in. long. Be sure it is not magnetized. Now wind upon it a coil of about 25 turns of No. 18 gauge insulated copper wire. Connect the ends of the coil to the posts of a dry cell. When the current flows through the coil the bar becomes a magnet. It has a magnetic field which will attract the iron disk just as did the bar magnet. When the current ceases to flow through the coil, the bar loses its magnetism. We call such a combination of a bar in a coil that is carrying current an *electromagnet*.

### 33. Effect of a Varying Current

Mount the bar magnet upright on a board. Remove the soft iron bar from the coil and slip the coil over the bar magnet. Above the magnet, and separated from it by about an inch, suspend your disk from a spring balance. This balance will show how much pull is being exerted on the disk.

Measure the pull which the bar magnet exerts on the disk. Connect the coil to the posts of a dry cell. The pull should increase because you now have the double pull of the bar magnet

and the electromagnet. (Should the pull decrease, reverse the connections to the dry cell.)

Now connect another dry cell *in series* with the coil. To connect this properly, disconnect the end of the coil from the outer post of the first dry cell. Connect this outer post to the center

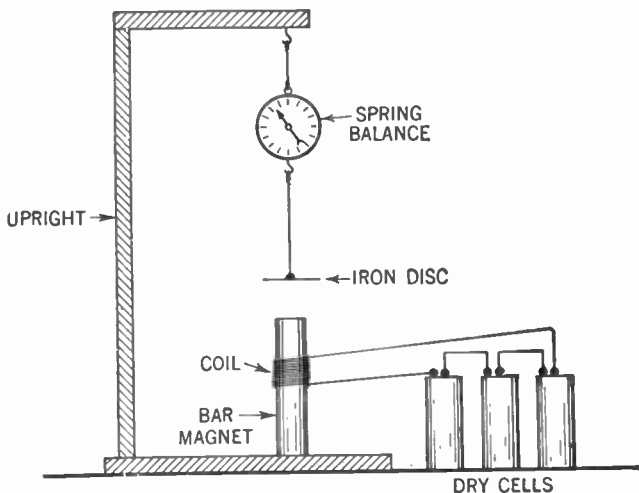

Figure 14. Apparatus used to show that a varying electric current passing through an electromagnet will exert a varying pull on an iron disk.

post of the second dry cell and connect the wire from the coil to the outer post of the second dry cell. Cells connected in this manner are *in series*.

You will observe that the pull is greater. This is to be expected because using two dry cells in series increases the current and makes the electromagnet stronger. Repeat, using three or more dry cells. As you add cells the pull becomes greater, because more current is flowing through the coil of the electromagnet. Reducing the number of dry cells reduces the current in the electromagnet coil and the pull on the disk becomes weaker. If you pass a fluctuating current through the coil the pull on the disk will fluctuate in step with the current. Note that a steady current will not cause the disk to move. It will be pulled to a certain position and then will remain stationary as long as the current is steady.

#### 34. Construction of a Telephone Receiver

Now get a telephone receiver and unscrew the cap. You will see a thin iron disk; this disk is called the diaphragm. Remove

the diaphragm and you will see a coil of wire (the electromagnet coil) which is wound over the end of a bar magnet. The ends of the wires connecting the electromagnet pass out through the far end of the telephone receiver.

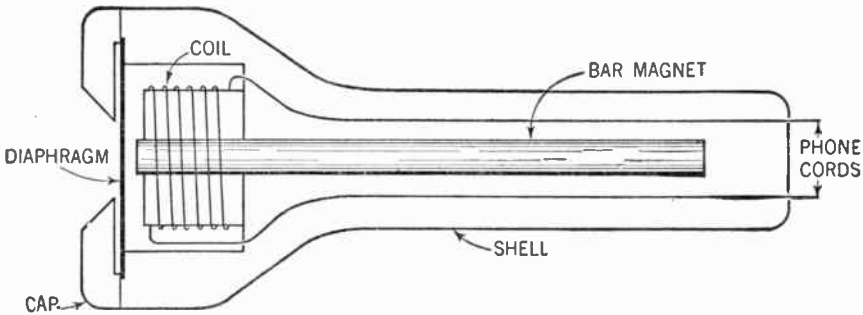

Figure 15. Construction of a telephone receiver.

The bar magnet exerts a constant pull on the diaphragm. Since the diaphragm is held fast at its rim, it can only move inward toward the magnet at its center. The springiness of the diaphragm constantly tends to pull it back. When we add the pull of the electromagnet the diaphragm bends inward much or little, depending upon the current flowing through the coil. You see then that a fluctuating current flowing through the coil causes the diaphragm to fluctuate in step with it.

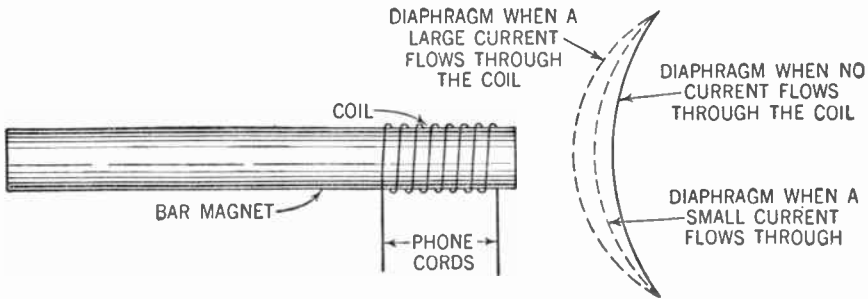

Figure 16. Diagram showing positions of diaphragm as a fluctuating current flows through the electromagnet of the phones. The bending of the diaphragm is greatly exaggerated in this drawing.

Now look back to Figure 11. You will remember that the sound waves striking the telephone transmitter cause a fluctuating current to flow through the circuit. This current fluctuates in step with the sound waves. This current is sent through the



THE REPRODUCER

electromagnet coil of the telephone receiver and the diaphragm is thus made to fluctuate in step with the original sound waves. The moving diaphragm sets the air next to it in motion, and it is these

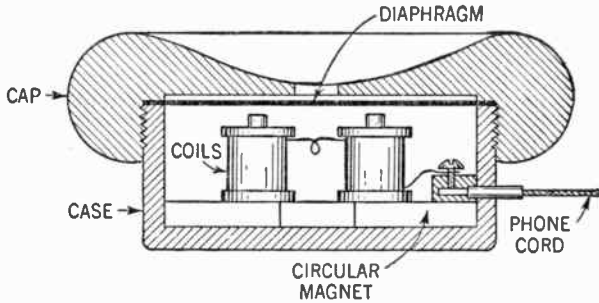

Figure 17. Diagram showing a sectional view of an earphone of the type used in radio receivers. Note how flat it is as compared to the telephone receiver. The permanent magnet here is made either circular or horseshoe shaped.

air waves which hit our ear. Thus we hear a sound which is the same as that which was spoken into the telephone transmitter.

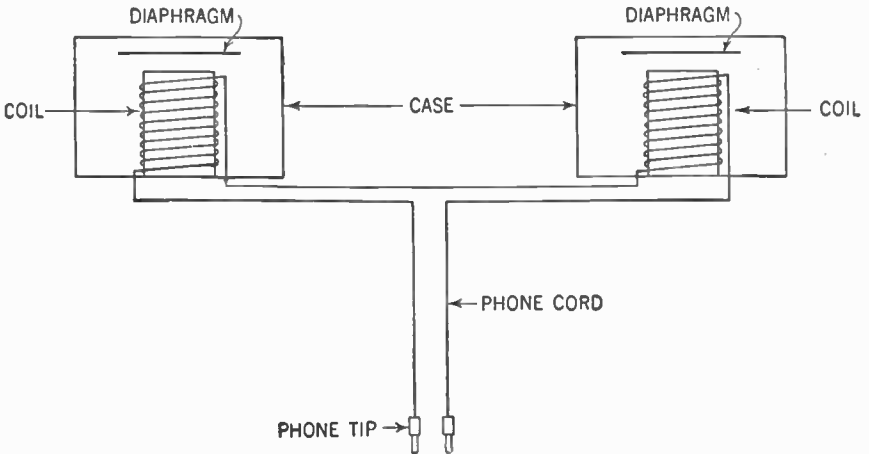

Figure 18. Diagram showing how a pair of phones are connected in series.

For the sake of convenience, the earphones used for radio reception (called simply *phones*) are made flat. This flattening is accomplished by using a circular magnet instead of the long, straight one used in the telephone receiver.

Usually two of these phones are connected together in series, one for each ear, and held in place with a metal band or spring that fits over the head.

The symbol for earphones is:



### 35. The Magnetic Loudspeaker

You have seen that the moving diaphragms of the earphones set the air next to them in motion and thus produce the sound you hear. If this sound were loud enough, you could lay the phones on the table and would not need to bother wearing them on your head.

If you were to make one of the diaphragms larger it would move a greater quantity of air and thus produce a louder sound. For practical reasons a diaphragm cannot be made very large, and so another scheme was developed. One end of a stiff wire is fastened to the center of the diaphragm. This wire now moves in and out in step with the diaphragm. To the other end of the wire a large paper cone is fastened. The fluctuating diaphragm moves

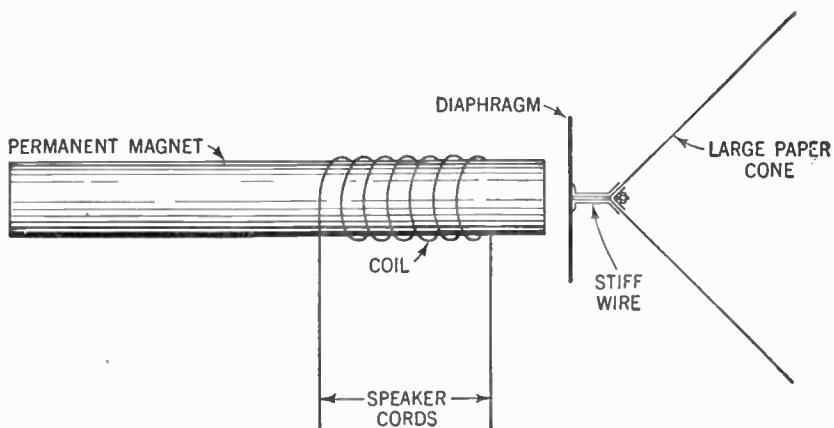

Figure 19. Diagram showing how an earphone is converted to a loudspeaker.

the wire; the wire in turn moves the paper cone. This in turn sets a large amount of air in motion, creating a loud sound. By this means we are able to do away with earphones. The device is called the *magnetic loudspeaker*.

#### SUMMARY

1. A coil of wire surrounding a core of soft iron becomes an **electromagnet** when an electric current passes through the coil.
2. The strength of the magnetic field (that is, its attractive force)

increases when the current increases and decreases when the current decreases.

3. The **telephone receiver** is an application of the electromagnet. Variations in the electric current caused by the sounds in the transmitter are reproduced in the receiver and cause fluctuating magnetic strength. A metal **diaphragm** is pulled in and out as the current is stronger or weaker. This diaphragm produces sound waves in the air.

4. **Earphones** are telephone receivers with flat electromagnets.

5. **Loudspeakers** are comparable to telephone receivers in which the diaphragm is attached to a large cone. The cone sets in motion a larger amount of air and hence gives a louder sound.

### GLOSSARY

**Diaphragm:** A thin iron disk which is set vibrating by the flow of the electric current through the coil of the earphone. This disk causes the air to vibrate, thus creating sound waves.

**Earphones or phones:** Two flat receivers, held on the head by a spring.

**Electromagnet:** A magnet made by electric current flowing through a coil of wire surrounding a core.

**Loudspeaker:** A reproducer which produces a loud, audible sound.

### SYMBOLS

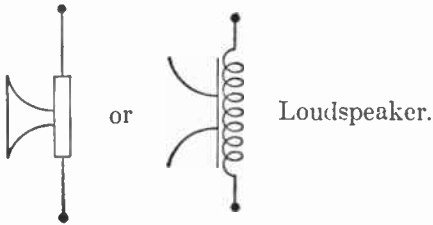

### QUESTIONS AND PROBLEMS

1. How would you construct an electromagnet?
2. How may you increase the strength of an electromagnet?
3. Under what conditions will current passing through a set of earphones fail to produce sound?
4. Describe the action of the diaphragm of an earphone under the following series of events: no current followed by an increasing current, followed by a decreasing current in the earphone.
5. In what manner are the phones of a set of earphones connected?

## CHAPTER 8

# The Detector

**Problem 1:** *What is the electron theory?*

**Problem 2:** *How is an alternating current changed to a pulsating direct current?*

**Problem 3:** *How can we make a practical detector?*

In studying the aerial and tuner you have learned that the radio wave, striking the aerial, sets up a voltage or electrical pressure in it which, in turn, causes a small current to flow in the receiver. But if you connect your phones to this circuit, you will hear nothing.

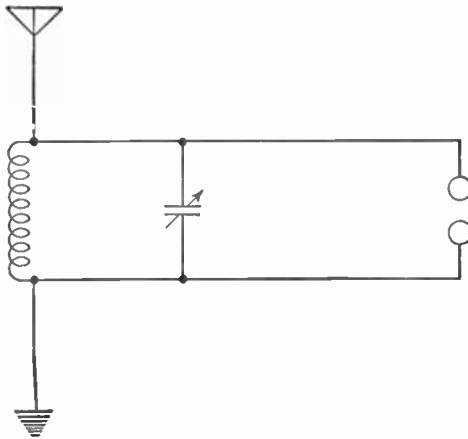

**Figure 20.** Diagram showing the aerial-ground system and the tuner connected to a set of phones. This circuit will not work.

### 36. What Is Electricity?

To understand why the electrical current flowing in the receiver fails to operate the phones, we must first consider the theory of electricity. Although scientists have succeeded in putting electricity to a great many uses, they do not know just what electricity

is. It is one of the many forms of energy and may be changed into other forms such as heat, light, and motion. From a study of the behavior of an electric current and from a study of the methods of producing electric phenomena, scientists have arrived at some theories about its nature.

### 37. Hypotheses, Theories and Laws

When a scientist tries to explain one of nature's mysteries, he carefully examines all the facts he can obtain. He makes experiments to obtain more facts and then makes a guess that tries to explain all the facts. This guess is at first called a *hypothesis*. When more evidence is found to support it, and other scientists generally accept it, the explanation is called a *theory*. After a time, someone may come along with proof which shows the theory to be true. We then call the explanation a *law*. Or someone else may come along with facts to show that the theory cannot be true. In the latter case the theory may be modified to take the new facts into account or discarded entirely in favor of a new theory which tends to explain the new facts. Some scientific theories existed a great many years before they were proven to be true or false.

So it is with the electric current. Although we do not know what it is, we have a theory which tries to explain it. It is called the *electron theory*.

### 38. What Is the Electron Theory?

According to the electron theory (Chap. 29, Vol. II.) an electric current consists of the movement of minute particles, negatively charged. These particles are called *electrons*. While some of these electrons will drift through a conductor like water flowing through a pipe, the main movement of these electrons consists in hitting their neighbors and by that means passing along the impulse of energy which we call an electric current. The action is somewhat similar to that of the dominoes of Figure 4.

This impulse of energy travels at the rate of nearly 186,000 miles per second, or nearly the same speed as light. When the electric current flows in one direction through the conductor, we say it is *direct current* (D.C.). If the current flows first in one direction and then reverses itself and flows back in the opposite direction, we say it is *alternating current* (A.C.). When an alternating cur-

rent flows in one direction, stops, and then flows in the opposite direction we say the current has gone through one *cycle*. The number of cycles per second is called the *frequency*.

### 39. Alternating Currents

The electricity used to light your house may be alternating current and have a frequency of 60 cycles per second. The current set flowing in your aerial-ground system by the action of the radio wave also is alternating current; its frequency is the same as the frequency of the radio wave. That is, it may vary from 10 kilocycles (kc.) per second to 3,000,000 megacycles (mc.) per second. Electric current whose frequency falls within that range is said to be *radio-frequency alternating current*.

Now let us go back to our radio receiver. Let us assume that a broadcasting station sends out a radio wave whose frequency is 500 kc. per second. This frequency we call *radio frequency* (R.F.). The radio wave hits our aerial and sets a current flowing in our aerial-ground system. This is an alternating current whose frequency is the same as that of the radio wave, namely, 500 kc. per second. This in turn starts an alternating current of the same frequency flowing in the tuner. It is this current which you have applied to the phones in Figure 20.

Let us see what happens in the phones. For one one-millionth of a second the current flows in one direction through the electromagnet of the phones. This causes the pull of the electromagnet to be added to that of the bar or permanent magnet. The diaphragm is therefore pulled a little closer to the magnet.

For the next one one-millionth of a second the current reverses itself and is now flowing through the electromagnet coil in the opposite direction. Now the magnetism of the electromagnet is subtracted from that of the permanent magnet and the total magnetic pull is less than before. The diaphragm starts to spring back. This process occurs every time the current reverses itself, which is once every millionth of a second.

Now one one-millionth of a second is a very small interval of time and there is no diaphragm that is so sensitive that it can follow these changes. Every time the diaphragm begins to be pulled towards the magnet, the current reverses itself and the pull is released. As a result the diaphragm stands still and you hear no sound.

#### 40. Pulsating Currents

To overcome this difficulty, someone had a brilliant idea. Suppose we put a gate in the circuit which permits an electric current to flow only in one direction and not in the other. Now let us see what happens to the radio-frequency alternating current in the circuit. For one one-millionth of a second the current will flow through the gate. During the next one one-millionth of a second the gate will block the current and there will be no flow. Then a flow in the same direction as the first. Then no flow. And so on. The effect of the gate will be to permit a series of pulses of cur-

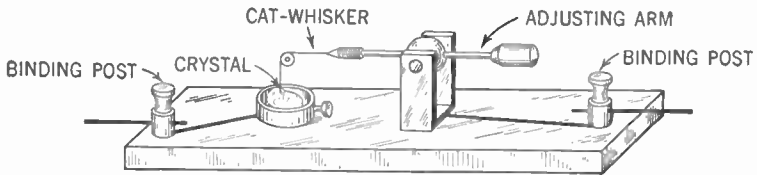

Figure 21. Diagram showing the construction of a crystal detector.

rent to flow, all going in the same direction. These pulses of current will be separated by intervals when there is no flow. Each pulse and interval will last only one one-millionth of a second.

Since the current now flows only in one direction we call it direct current. Since it is not a steady flow, but consists of a series of pulses, we call it *pulsating direct current*.

Let us see what happens when the pulsating direct current flows into our phones. For one one-millionth of a second the pull of the electromagnet is added to that of the permanent magnet and the diaphragm starts to bend in. For the next millionth of a second the electromagnet will exert no pull and the diaphragm will start to spring back. Before it can move back, however, the next pulse enters the electromagnet coil and the diaphragm is pulled a little closer. This continues and as a result of these streams of pulses the diaphragm is set vibrating and we can hear a sound.

#### 41. A Detector Is an Electrical Gate

The device used in radio which serves as a one-way gate is called a *detector*. Scientists have discovered that certain crystals like *carborundum* and the mineral *galena* have this peculiar property of permitting electric current to flow through them in one direction but not in the other. We do not know precisely how

this control is accomplished but we have theories. It would not help our understanding of modern radio receivers, however, to enter at this point into a discussion of those theories.

#### 42. Crystal Detectors

The crystal most commonly used for detectors is galena, a mineral compound consisting of lead and sulphur. Not every spot on the crystal, however, has this remarkable property of making the one-directional current. We must, therefore, use a fine wire to find the spots that will work. The symbol for the crystal detector is:



#### 43. Making Your Set Work

When you have hooked up your receiver with the crystal detector in series with the phones, you must move your fine wire (which is called a *catwhisker*) from spot to spot. When you find a spot where you hear a sound in the phones, leave the wire

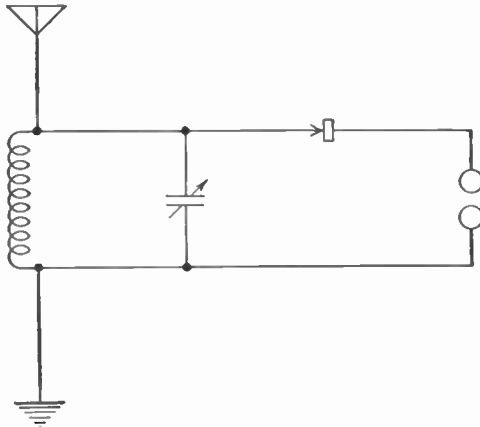

**Figure 22.** Diagram showing the complete crystal receiver. It makes no difference whether the catwhisker or crystal side of the detector is connected to the phones. This circuit will work.

at that spot. You should avoid handling the crystal as the grease from your fingers will interfere with its sensitivity. If your crystal becomes dirty, wash it in carbon tetrachloride to remove any grease.

#### SUMMARY

Your complete radio receiving set, in its simplest terms, then, must have these parts which we have discussed: an aerial and ground, a tuner



(an inductor and a condenser), a detector, and a reproducer (phones). In the diagram of Figure 22 these parts are arranged in proper relationship to each other. If you understand the symbols and connect the parts of your set according to this arrangement, you should be able to hear speech and music through the earphones.

#### GLOSSARY

**Alternating Current (A.C.):** An electric current in which the electrons periodically reverse their direction of flow.

**60-cycle Alternating Current:** An alternating current that changes direction 120 times a second or 60 cycles a second.

**Radio-frequency Alternating Current:** An alternating current that changes direction thousands and even millions of times a second.

**Catwhisker:** The thin wire with which we hunt for a sensitive spot on the crystal.

**Current, electric:** The flow of electrons through a conductor.

**Detector:** An electrical gate or valve permitting the flow of electrons in one direction but not in the other.

**Direct Current (D.C.):** An electric current in which the electrons constantly flow in one direction.

**Pulsating Direct Current:** A direct current that periodically changes in strength.

**Electron:** A minute, negatively charged particle.

**Electron Theory:** A theory which explains the nature of an electric current, as electrons moving through a conductor.

**Galena:** A mineral crystal, a compound of lead and sulphur, used as a detector in the receiving set.

**Voltage:** The electrical pressure that causes electrons to flow in a conductor.

#### SYMBOL



#### QUESTIONS AND PROBLEMS

1. Briefly describe the electron theory.
2. At what rate does an electrical current pass through a conductor?
3. Describe direct current. Compare it with alternating current.
4. Give the relationship between the frequency and the cycles of an alternating current.
5. What is the frequency of alternating current in the home? How does its frequency compare with radio-frequency alternating currents?
6. What is the response of the diaphragm of a pair of earphones when radio-frequency alternating current is sent through the phones? Account for its behavior.

7. Describe the behavior of a pulsating direct current through a conductor.
8. Describe the action of a pulsating direct current which has been obtained from a radio-frequency alternating current by means of an electrical gate or detector, as the current passes into the phones.
9. What is the electrical action of a detector? Give two crystals used as detectors.
10. How do we manipulate a crystal used as a detector, and what must we do to take proper care of it?

## CHAPTER 9

# Wave Form

- 
- Problem 1:** *How is the type of electric current shown by a graph?*
- Problem 2:** *What is meant by the "sine wave"?*
- Problem 3:** *What is a modulated radio wave?*
- Problem 4:** *In what form is the modulated carrier wave passed through the tuner, detector, and reproducer?*
- 

Did you ever visit a sick friend in a hospital? Did he, perhaps, point to the chart hung at the foot of his bed and say, "This is my temperature chart"? You examined the chart and saw on it

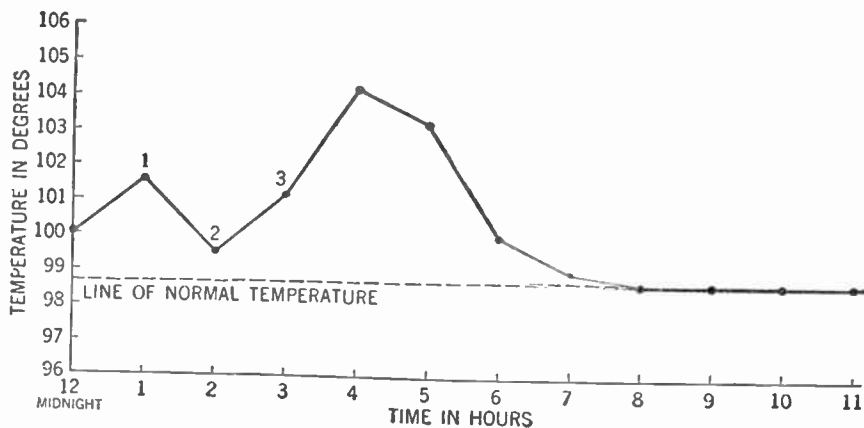

**Figure 23.** Temperature graph for your sick friend. Note that the vertical port shows the degrees of temperature while the horizontal port shows the time. By this means we can see what the temperature was at any particular time.

a wavy line going up and down several times and finally—we hope—leveling out to a horizontal line. You know, of course, that the temperature did not travel over this scenic-railway type of

path. This chart was merely a picture or diagram which showed how high your friend's temperature was at any given time of the day. We call such a chart a *graph*.

#### 44. Graphs

The word *graph* means a drawing or a picture. Many kinds of graphs are used in science, mathematics, and economics. The most common kind of graph attempts to show, by a line called a *curve*, the course of events when two different conditions are changing. In the graph, Figure 23, the two conditions are time and temperature. The hours are marked from left to right on the horizontal line in equal spaces. The degrees of temperature are marked on the vertical line with the lowest temperature at the bottom. The nurse reads the temperature of the patient each hour and makes a dot on the vertical line over the hour where the horizontal line from the observed temperature crosses it. For example, the chart shows that at 1 A.M. the patient's temperature

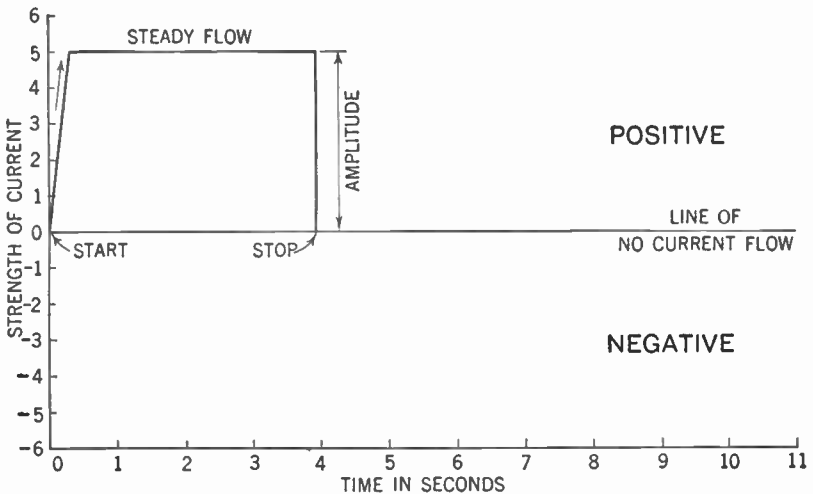

Figure 24. Graph showing curve or wave form of a steady direct current.

was  $101.8^{\circ}$  (dot 1); at 2 A.M. the temperature was  $99.5^{\circ}$  (dot 2). Thus each dot is the temperature at a certain hour. When the points or dots are connected by a continuous line, the course of the fever is pictured. This line or curve is called here the temperature curve.

**45. Graph of D.C. Flow**

We can draw such a chart or graph to show how electric current flows. First we draw a horizontal line and call it the *line of no current flow*. When electric current flows in one direction we call it *positive* and picture its path above the line of no current flow. When it reverses itself and flows in the opposite direction, we call it *negative* and picture its path below the line of no current flow. Thus, the path of a direct current is entirely above that line. If the current is a steady direct current, the picture of its flow starts at the line of no current flow and very quickly rises above it to the maximum strength of the current (see Figure 24). It then continues to flow at the same rate, and we picture it as a straight horizontal line until the instant when the current is cut off. At that point, the line drops down to zero, the line of no flow. The line we draw picturing that flow of current is called the *curve* or *wave form*.

The strength of the current at any one instant of time is shown by the distance of the curve away from the line of no current flow at that instant (amplitude).

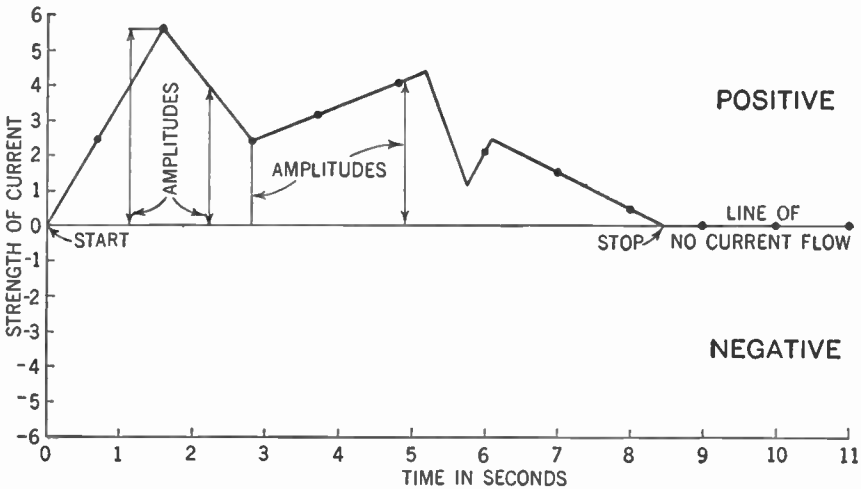

**Figure 25.** Graph showing curve or wave form of a fluctuating direct current. Note that the amplitude may assume different values at different times.

**46. Fluctuating D.C.**

A direct current may either be steady or fluctuating. If it is steady, the amplitude is constant while the current is flowing, as

shown in Figure 24. In the case of a fluctuating direct current, the amplitude is different at different intervals of time, as shown in Figure 25.

Notice that in both Figures 24 and 25 the current is direct current, that is, it flows in only one direction. You can see this from the graphs by observing that in both cases the curves lie entirely above the line of no current flow.

#### 47. The Sine Curve for A.C.

We can also picture the flow of an alternating current by means of such a graph. The current starts from zero and rises to a maximum flow in one direction. Still flowing in that direction, it starts to slow down until it again reaches the line of no current flow. Then it flows to a maximum in the opposite direction (below the line), and then slows down again until the zero line is reached. As you already know, the flow of current has gone through one cycle (see p. 45). Then it starts all over again.

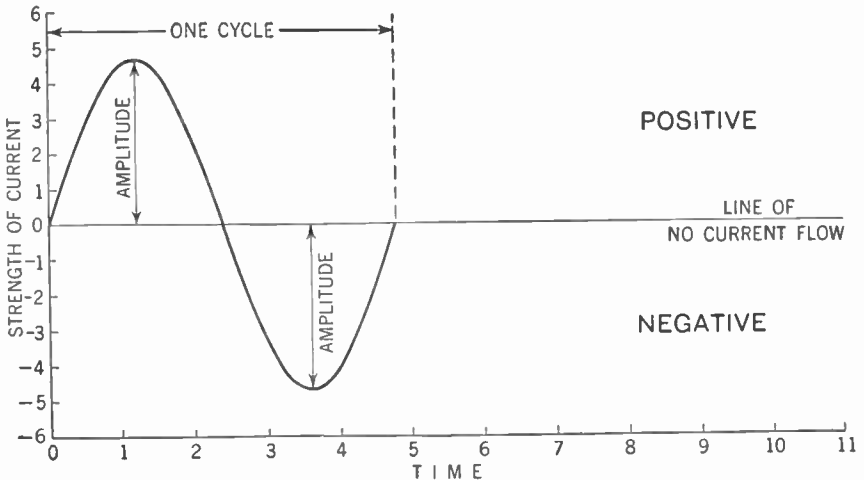

**Figure 26. Graph showing curve or wave form of an alternating current. A curve whose amplitudes rise and fall in the smooth, even and regular glide pictured here is called a sine curve.**

Note that during the first half of the cycle the amplitude increases from zero to maximum in a smooth, regular glide and then decreases to zero in that same, even way. The same thing occurs

during the second half of the cycle (the bottom loop of the curve). A curve having this form is called a *sine curve* (Figure 26).

The flow of alternating current does not always describe a smooth sine curve. The rise from zero to maximum may be irregular and varied. The decrease from maximum to zero may be the same (Figure 27).

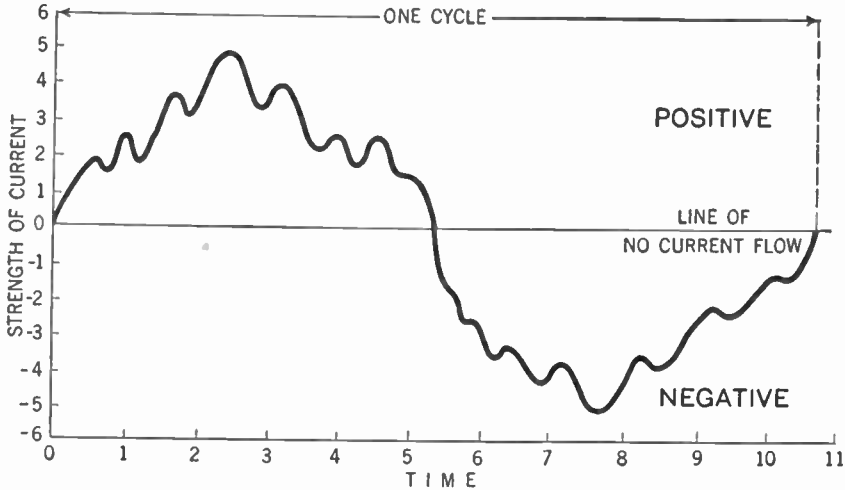

Figure 27. Graph showing curve or wave form of an alternating current. Notice that this curve is not smooth but irregular.

#### 48. Radio Wave Forms

It would help you to better understand what takes place in your receiver, perhaps, if you were to examine the wave forms of the electrical currents flowing in the various parts.

Consider the wave form of the radio wave. It is the same as that of an alternating current, that is, the wave flows first in one direction and then in the other. Its range of frequency is from 10 kc. to 3,000,000 mc. per second. In the United States, standard broadcasting stations send out radio waves whose frequencies lie between 550 kc. and 1,600 kc. per second. This range is fixed by law and each station is given a definite frequency to which it must always keep its station tuned.

The radio wave may take several different forms. For the moment, we are interested in three of them. *First*, there is the wave whose form is that of a smooth sine wave and whose maxi-

mum amplitude is constant throughout the entire wave. Such a wave is called a *continuous wave*—also known as a *carrier wave*.

*Second*, there is the wave whose form is that of a smooth sine wave but with the maximum amplitudes of successive cycles decreasing gradually. Such a wave is called a *damped wave*.

*Third*, there is the wave whose form is that of a smooth sine wave but with the maximum amplitudes of successive cycles varying irregularly. This wave form is obtained by impressing upon a continuous wave a fluctuating direct current. We call such a wave a *modulated carrier wave*. We say that the continuous or carrier wave is modulated by the fluctuating direct current. The radio waves which carry speech and music through the ether are modulated carrier waves.

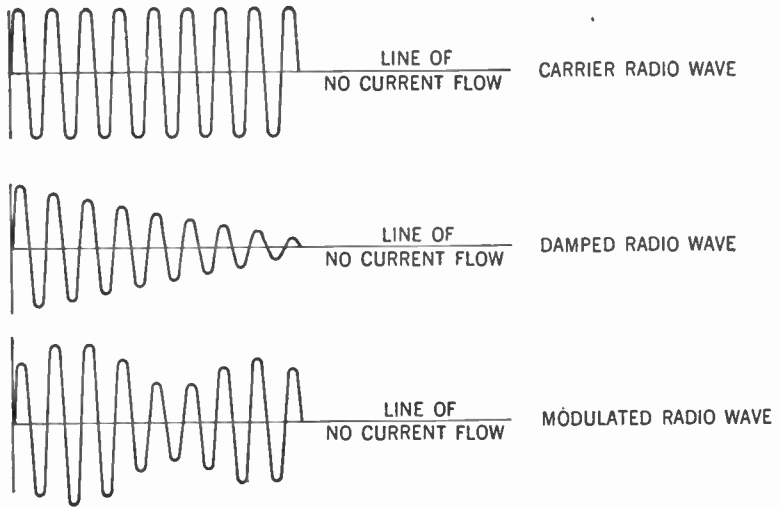

**Figure 28.** Graphs showing the wave forms of a continuous radio wave, a damped radio wave and a modulated radio wave. Note that in all three waves shown here the frequencies are the same. It is only the amplitudes that vary.

#### 49. How the Modulated Wave Is Produced

To understand the method by which a fluctuating direct current modulates the carrier wave, examine Figure 29. First of all, sound striking the microphone at the broadcasting station sets up a fluctuating direct current. Meanwhile, in another part of the transmitting set, a continuous or carrier wave has been generated. Assume the frequency of this carrier wave to be 500 kc. per second.



The fluctuating direct current is now mixed with the carrier wave. The result is the modulated radio wave whose frequency is 500 kc. per second, but whose amplitude variations correspond to the form of the fluctuating direct current.

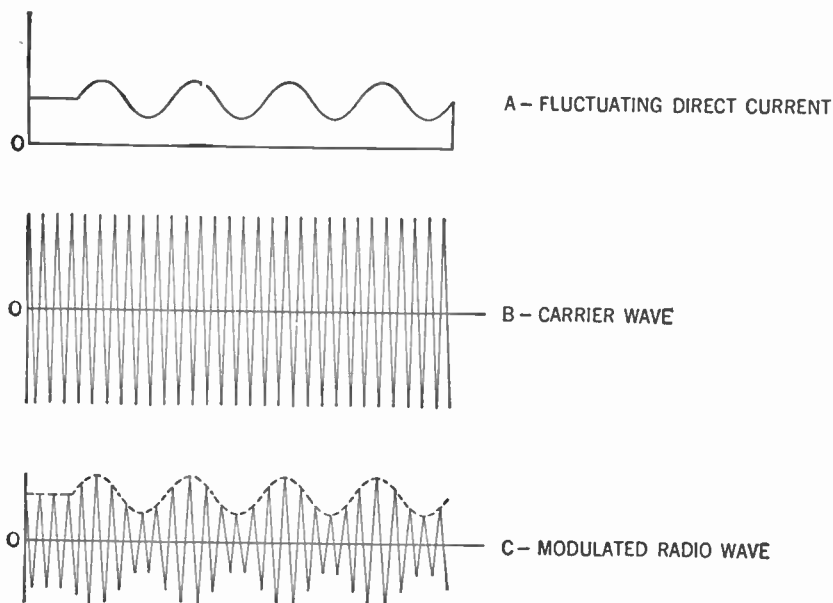

**Figure 29.** Graph showing how a fluctuating direct current from the microphone modulates the carrier wave to produce the modulated radio wave which is broadcast by the transmitting station.

In this way, we modulate the carrier wave by the electric currents set up by sound waves hitting the microphone at the transmitting station. The modulated radio wave is broadcast by the transmitter. It is the task of the radio receiver to collect this modulated radio wave and to separate the carrier wave from the electric currents impressed on it by the microphone. These impressed currents are the currents that operate our phones and through their action we reproduce the original sound waves.

## 50. Wave Form—Aerial-Ground System

You have already learned (p. 19) that when the modulated radio wave passes across the aerial of your receiving set it sets up in the aerial-ground system an electrical pressure or voltage that causes an electric current to flow in that system. The greater the pressure, the greater the flow of current. This flow of current,

therefore, conforms to the electrical pressure, which in turn conforms to the modulated radio wave. You can see, therefore, that the flow of current in the aerial-ground system will correspond to the wave form of the modulated radio wave. The current that flows in the aerial-ground system, then, is alternating current whose frequency is the same as that of the modulated radio wave. The amplitude variations of this current, too, will correspond to the amplitude variations of the modulated radio wave.

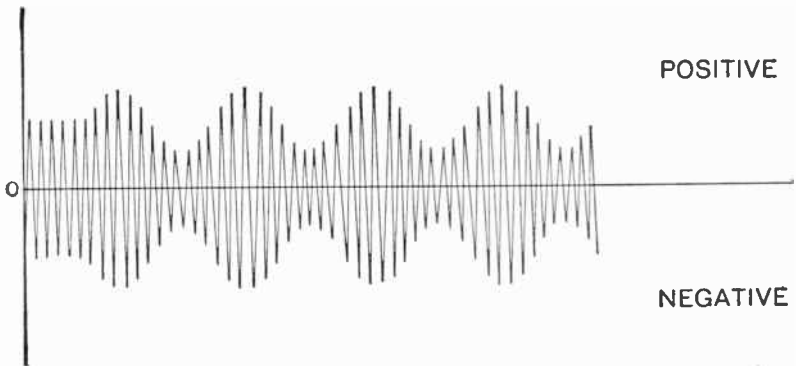

**Figure 30.** Wave form of alternating current set flowing in the aerial-ground system when the modulated radio wave shown in Figure 29-C passes across the aerial of the receiving set.

### 51. Wave Form—the Tuner

Electric current flowing in the aerial-ground system, you will recall, sets an electric current flowing in the tuning circuit of your receiver. This current takes the same wave form as that in the aerial-ground system, which in turn has taken the same wave form as that of the modulated radio wave. The current flowing in the tuner, then, is alternating current having the same frequency and amplitude variations as the current flowing in the aerial-ground system.

### 52. Wave Form—the Detector

The crystal detector, you will remember, permits electric current to flow through it only in one direction. See if you can picture what happens to an alternating current as it attempts to flow through such a crystal.

First, the positive half of the cycle approaches the crystal and finds the "gate" wide open. That is, the positive part of the cycle can pass through the crystal. When the current reverses itself, the gate is shut and no current can flow through. The current

thus flows through with all its variations as long as it is going in one direction—as long, that is, as it does not go below the line of no current flow of our graph (see Figure 31). Everything in the graph below the line of no current flow is wiped out.

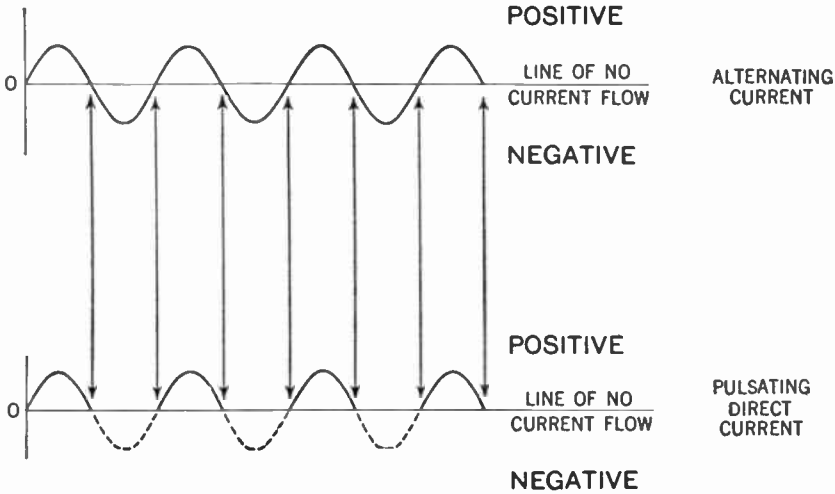

Figure 31. Graph showing how the crystal detector changes alternating current into pulsating direct current. The negative halves of the cycles which were stopped by the crystal detector are shown by the dotted lines.

Our current now consists of a series of direct-current pulses, separated by gaps of no current flow that represent the negative halves of the cycles which were stopped by the crystal. This is what is meant by a pulsating direct current.

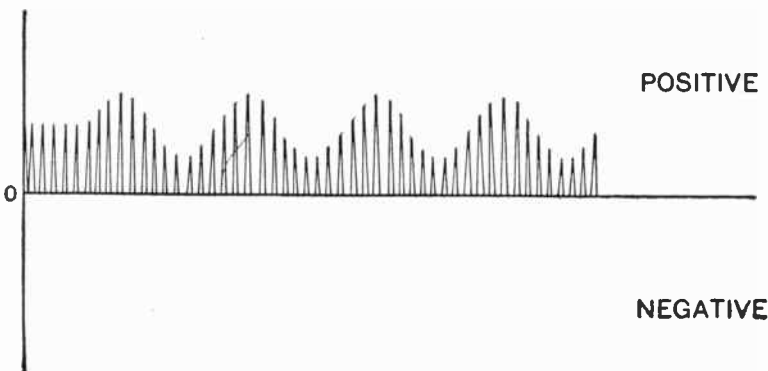

Figure 32. Graph showing flow of pulsating direct current through the crystal detector. Note the action of the detector.

We can now see what will happen to the alternating current of our tuner when it reaches the crystal detector. The current is changed from an alternating to a pulsating direct current and the bottom halves of the cycles in the curve are wiped out. This, then, is what we mean by detection. The wave-form picture is the same as that for the tuner, except that the half below the line of no current flow is eliminated (see Figure 32).

### 53. Wave Form—the Reproducer

The current flowing out of the crystal detector is now a series of direct-current pulses of varying amplitude. These variations of amplitude correspond to the curve described by the current that was set flowing by sound waves striking the microphone at the broadcasting station. If we again take our hypothetical radio station broadcasting at a frequency of 500 kc. per second, each such direct-current pulse lasts for one one-millionth of a second and is separated from its neighbor by an interval of one one-millionth of a second when no current flows.

As you already know, the diaphragms of the phones cannot respond to a pulse of such short duration, but since each pulse is flowing in the the same direction, a series or train of such pulses makes its effect felt. The result on the phones then, is the same as if a continuous, but varying, direct current, equal to the average of

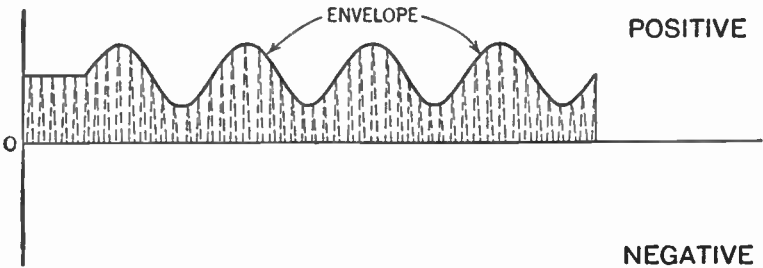

**Figure 33.** Graph showing flow of fluctuating direct current through the phones. This current flow is indicated by the envelope. Note that the envelope has the same shape as the fluctuating direct current from the microphone in Figure 29-A.

all these pulses, were to pass through the coils. This effect can be shown on the graph by joining the peaks of these pulses with a continuous line. We call such a line the *envelope* of the wave

(see Figure 33). You will notice that this envelope has the same shape as the current set up by the microphone at the broadcasting station. We have now succeeded in making the carrier wave take the form of the modulating current; and it is this modulating current, acting through our phones, that reproduces the sound originally created at the broadcasting station.

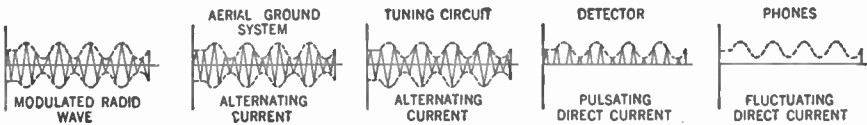
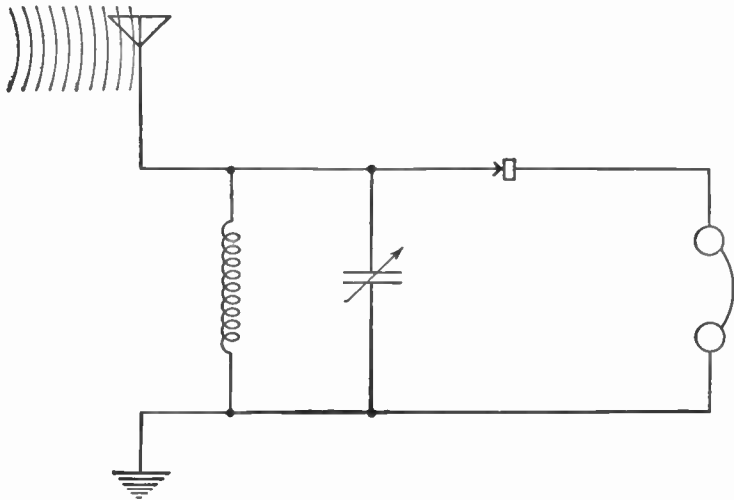

**Figure 34. Hookup of complete crystal receiver showing wave forms of electric currents flowing in the various parts.**

**SUMMARY**

1. A graph is a picture.
2. Graphs in scientific work usually show relations between two or more variable quantities.
3. The line which pictures the course of any event in a graph is called a **curve**.
4. The sine curve is the graph which shows the wave form of a simple alternating current.
5. Three forms of radio waves must be distinguished; **carrier or continuous wave, damped wave, and modulated carrier wave.**

## GLOSSARY

- Amplitude:** In a graph picturing the flow of electric current, the amplitude is the distance a point on the curve is away from the zero line (or line of no current flow) at any particular instant.
- Envelope:** The line joining the peaks of the curve lying on one side of the zero line of the graph.
- Fluctuating Direct Current:** Direct current that is constantly changing in strength or amplitude.
- Graph:** A diagram that pictures the instantaneous relationship between two varying factors, for example, temperature at a certain instant of time.
- Modulation:** The act of varying the amplitudes of a carrier wave by means of a current of lower frequency.
- Sine Curve:** A graph indicating the smooth variations of current flowing in an alternating-current circuit.
- Wave, Carrier:** A continuous wave at radio frequency (very high frequency).
- Wave, Continuous:** A wave which has an equal peak amplitude for all cycles.
- Wave, Damped:** An alternating-current sine wave whose peak amplitude gradually and continuously decreases for each cycle.
- Wave Form:** A graph showing changes of direct- and alternating-current flow.
- Wave, Modulated Carrier:** A carrier wave whose amplitude is continuously varied as the result of mixing with a current of lower frequency.

## SYMBOLS

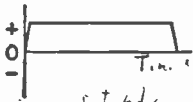

Graph showing a steady direct current.

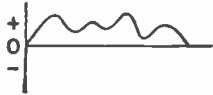

Graph showing a fluctuating direct current.



Graph showing a pulsating direct current.

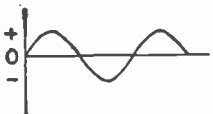

Graph of a sine curve (alternating current).

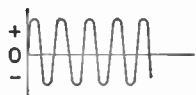

Graph of a carrier wave.

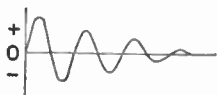

Graph of a damped wave.



Graph of a modulated carrier wave.

**QUESTIONS AND PROBLEMS**

1. What does a graph actually show?
2. Draw a graph of an alternating-current sine wave; of a steady direct current; of a pulsating direct-current.
3. What would we know if we knew the amplitude of a sine wave indicating alternating current at any one instant?
4. Draw the picture of an alternating current whose graph is not a sine curve.
5. In what particular respect are radio broadcasting stations different?
6. Give three forms that a radio wave may take and make a graph of each.
7. Describe briefly how the modulated radio wave is produced.
8. Describe the relationship between the modulated radio wave and the current in the antenna-ground system.
9. Describe the wave form of the modulated carrier after it has gone through the crystal detector. Draw a graph of it.
10. Describe what is meant by detection.
11. Why cannot phones react to the current produced in the aerial-ground system while they do respond to a detected radio-frequency current?
12. Draw the envelope of any modulated radio-frequency current graph. What does it represent?

## CHAPTER 10

# The Antenna Coupler

---

**Problem 1:** *What are the faults of a tuner having but one coil?*

**Problem 2:** *What are the principles of a transformer?*

**Problem 3:** *How do we use a transformer to correct the faults of our tuner?*

---

In continuing our study of radio, we shall follow the plan of pointing out certain faults and shortcomings of our simple sets. Then we shall explain the various methods of correcting these faults.

### 54. Faults of the Tuner

Let us study the tuner. The function of the tuning circuit is to select the wave of desired frequency and reject all others. While the tuner you built does this job fairly well, it occasionally fails to separate two stations completely, especially if these stations are quite powerful, close to your home, and not much different in frequency. You then hear a fairly loud broadcast from one station and in the background, although a good deal weaker, the *signal* or program from another station.

Theoretically, the tuning circuit should pass only one frequency. But because some resistance to the flow of current is always present in the circuit, other frequencies creep in. When this resistance becomes too great, two stations may be heard at the same time.

### 55. Why We Hear Two Stations

We can draw a picture to represent this situation. In Figure 35, we have assumed that the station desired has a frequency of 1,000 kc. Let us assume also that there is no difference in the distance or power of the stations. Along the horizontal line we have indicated successive frequencies from 960 kc. to 1,040 kc.



Along the vertical line we have indicated the loudness of the signal received. The amplitude of the curve at any point then represents the loudness with which a signal of that particular frequency will be heard when your tuner is set for 1,000 kc. If the

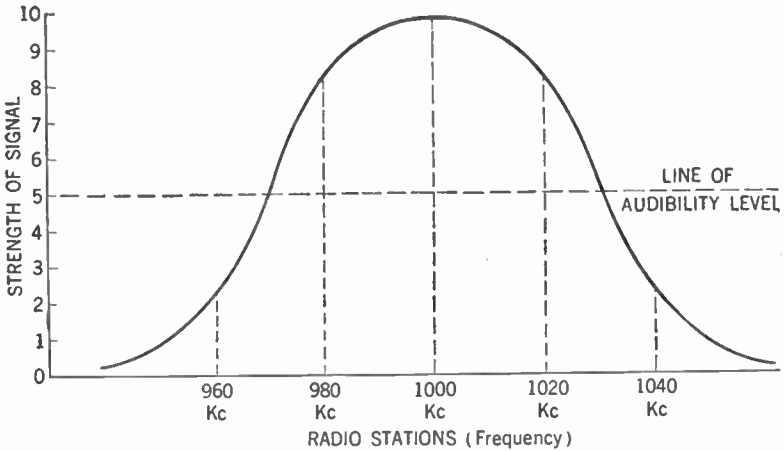

**Figure 35.** Graph or tuning curve showing what happens when a receiver tunes broadly. Note that unwanted radio stations at 980 kc. and 1020 kc. come in well above the line of audibility level. This means that three stations will be heard at the same time.

amplitude at that frequency rises above the line marked "audibility level," the signal will be heard in the earphones. If it does not reach that level, the signal will be unheard and therefore will not interfere.

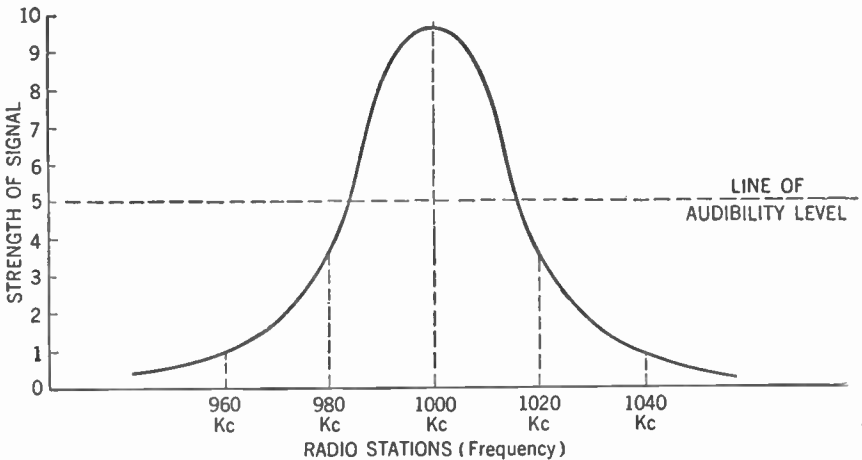

**Figure 36.** Graph or tuning curve for a sharply tuning receiver. Note that all unwanted radio stations fall below the line of audibility level.

You will notice from the graph in Figure 35 that this particular tuner will permit three stations to be heard simultaneously, the one we want at 1,000 kc. and two unwanted ones at 980 kc. and 1,020 kc. We say that such a set *tunes broadly*. We can remedy this by redesigning our tuner so it will have a tuning curve that will correspond to Figure 36.

Note that now the amplitude of every station except the one desired falls below the line of audibility level. Such a set, we say, *tunes sharply*.

### 56. Reducing Resistance in the Tuner

In practice, we accomplish the desired change by reducing the resistance of the tuning circuit.

Examine again the circuit diagram of your crystal receiver in Figure 22. You will notice that the aerial-ground system and the tuning circuit follow a common path through the tuning coil. This means that the resistance of the aerial-ground system is added to the resistance of the tuner.

It is quite possible to reduce the resistance of the tuning circuit to a very small value. But the resistance of the aerial-ground system, of necessity, is quite large. It includes the resistances of the aerial, of the lead-in wire, of the ground, and of the various connections. It is this resistance, therefore, that causes our set to tune broadly and bring in more than one station at a time. It would be ideal if we were able to transmit to the tuner the electrical currents flowing in the aerial-ground system and yet be able to keep out of the tuning circuit the aerial-ground system's resistance.

### 57. What Is a Transformer?

To see how this undesirable resistance is kept out, you must first learn what we mean by a *transformer*. You already know that when an electric current flows through a coil of wire it sets up a magnetic field around this coil. When this magnetic field cuts across a conductor it sets up an electrical pressure or voltage which in turn sets a current flowing.

We can have this magnetic field cut across a conductor in two ways. We can either have a stationary magnetic field set up by a steady direct current flowing through the coil and use a moving conductor, or we may have a moving magnetic field and a station-

ary conductor. This moving magnetic field can be produced when either a fluctuating direct current or an alternating current passes through the coil. The magnetic field is built up and collapsed in step with the variations of current in the coil.

In the transformer we have two stationary coils. We call one the *primary* and the other the *secondary*. We pass a fluctuating direct current or an alternating current through the primary coil. This current causes the magnetic field around the primary to fluctuate in step with it. This fluctuating magnetic field, cutting across the turns of the secondary coil, sets up a fluctuating electrical pressure that in turn causes an alternating current to flow in the secondary. This alternating current corresponds in form to the fluctuating direct current or the alternating current in the primary.

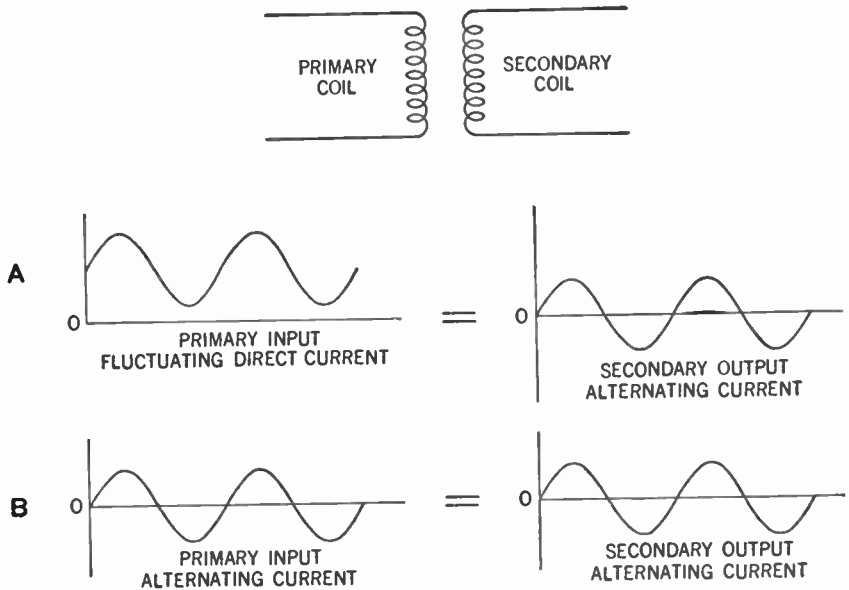

**Figure 37. Diagram showing that if a fluctuating direct current (A) or an alternating current (B) be sent into the primary of a transformer, the output from the secondary coil is always an alternating current.**

### 58. Step-up and Step-down Transformers

Here is another interesting thing about a transformer. As you know, the fluctuating magnetic field cutting across the turns or loops of wire of the secondary coil sets up an electrical pressure or voltage in those loops. If we have more loops in the secondary

coil than in the primary coil we have a greater total voltage in the secondary. If we have fewer loops in the secondary than in the primary we have a smaller total voltage in the secondary coil. Thus by varying the ratio between the number of turns of wire in the primary and secondary coils we can get a greater or smaller voltage in the secondary coil. For example, if the secondary coil has twice the number of turns that are in the primary coil, the voltage in the secondary will be twice that in the primary coil. We call such a transformer a *step-up transformer*. If, however, the secondary winding has half the number of turns that are in the primary winding, the voltage set up in the secondary winding will be half the voltage in the primary. We call such a transformer a *step-down transformer*.

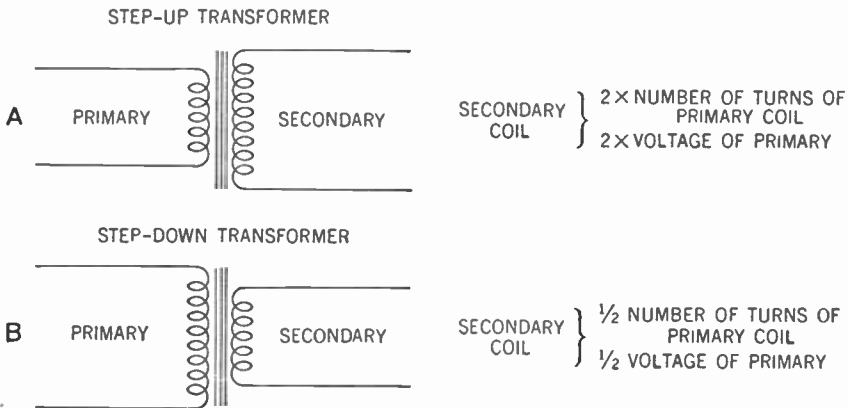

Figure 38. A—Step-up transformer. B—Step-down transformer.

### 59. The Antenna Coupler

Now see how what you have learned about a transformer fits into our radio receiver. You will recall that we were seeking a method for transferring the electric current from our aerial-ground system to the tuning circuit and, at the same time, for keeping out the aerial-ground system's resistance. The transformer is the answer. If we make the tuning coil the secondary of our transformer and hook the primary into the aerial-ground system, we have solved our problem. Now the current is passed on and the resistance of the aerial-ground system is kept out.

As a matter of fact, by making our primary winding with fewer turns than the secondary (the tuning coil), we actually get

a step-up effect and we get a greater voltage in the tuning circuit than in the aerial-ground system.

Such a transformer used at this point is called an *antenna coupler* or transformer. Through its use we obtain sharper tuning,

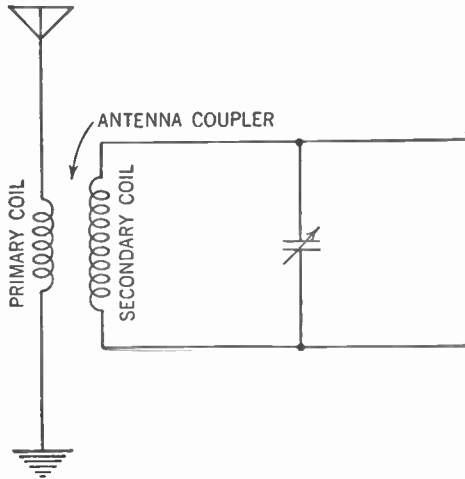

**Figure 39.** Diagram showing how an antenna coupler or transformer is connected in the radio receiver. Note that the path of the aerial-ground system no longer passes directly through the tuning circuit.

that is, we are able to keep out unwanted stations, since we have reduced the resistance of our tuning circuit.

To make such an antenna coupler, all you have to do is to wind upon the same tube that you have your tuner coil an additional

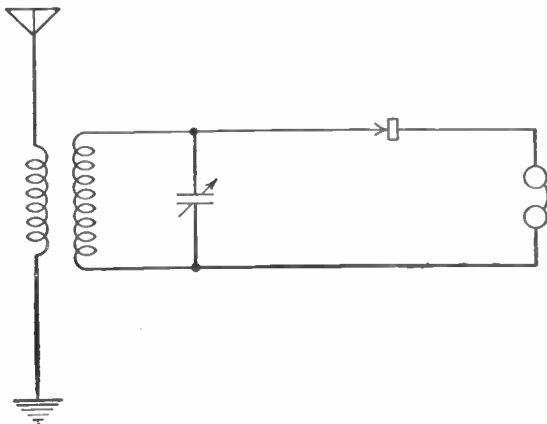

**Figure 40.** Improved crystal receiver, using an antenna coupler. This set will tune sharper than that of Figure 22.

winding of about 15 turns of wire (the primary winding). Separate the two windings about  $\frac{1}{8}$  in. Connect the lead-in from the aerial to one end of the primary winding and the ground to the other. Try reversing the aerial and ground connections to this winding to obtain best results. Your improved crystal receiver will now appear as in Figure 40.

## SUMMARY

1. One of the faults of the tuner consisting of a single coil, is that it does not sharply separate different stations.
2. This fault may be partially corrected by a transformer.
3. The transformer consists of two coils unconnected but wound upon the same core. In such a device, the magnetic field created by a current in one coil transfers the energy to the other coil. In the second coil the fluctuation in the current induced therein will follow the pattern of the current in the first coil.
4. In an iron-core transformer the voltages in the primary and secondary coils have direct ratio to the ratio of the number of turns of wire in the coils.
5. An antenna coupler is an air-core transformer having the primary in the antenna circuit and the secondary in the tuner circuit.

## GLOSSARY

**Antenna Coupler:** An air-core transformer used to couple the energy from the aerial-ground system to the tuning circuit.

**Resistance:** The opposition a substance offers to the flow of electric current through it.

**Primary:** The input coil of a transformer.

**Secondary:** The output coil of a transformer.

**Transformer:** An electrical device consisting of two separate coils, insulated from each other, used to transfer electrical energy from one circuit to another.

**Transformer, step-down:** A transformer which develops a lower voltage across the secondary than the voltage impressed across the primary.

**Transformer, step-up:** A transformer which develops a higher voltage across the secondary than the voltage impressed across the primary.

**Tuning, broad:** The simultaneous reception of several stations in a radio receiver.

**Tuning, sharp:** The ability of a radio set to receive one station only at a time.

## SYMBOLS

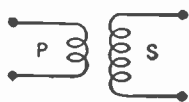

Transformer with air for a core, such as the antenna coupler.

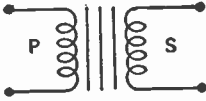

Transformer wound on an iron core.

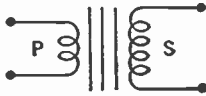

Step-up iron-core transformer.

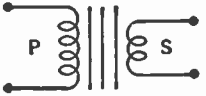

Step-down iron-core transformer.

### QUESTIONS AND PROBLEMS

1. What is the effect of resistance in a tuning circuit?
2. What response will be obtained from a receiver that tunes broadly?
3. What practical measure may we use to remove the resistance of the aerial and ground from the tuning circuit?
4. Under what circumstance will a moving magnetic field be produced about a stationary current-carrying conductor?
5. Describe the structure and operation of a transformer.
6. How may the voltage in the secondary of a transformer be made to vary from the voltage impressed across the primary?
7. Describe the type of transformer used as an antenna coupler.
8. Draw a diagram of an antenna coupler in a receiver circuit.
9. Draw a diagram of a complete crystal receiver using an antenna coupler.

## CHAPTER 11

# Electron Flow in the Aerial-ground System

**Problem 1:** *How does a dry cell produce an electromotive force?*

**Problem 2:** *What are two kinds of alternating-current generators?*

**Problem 3:** *What kind of currents are produced in the aerial-ground system by radio waves?*

You have learned in our previous study that an electric current consists of a flow of electrons through a conductor forming a circuit. Let us see if this theory can give us some new light upon what happens in a radio receiver.

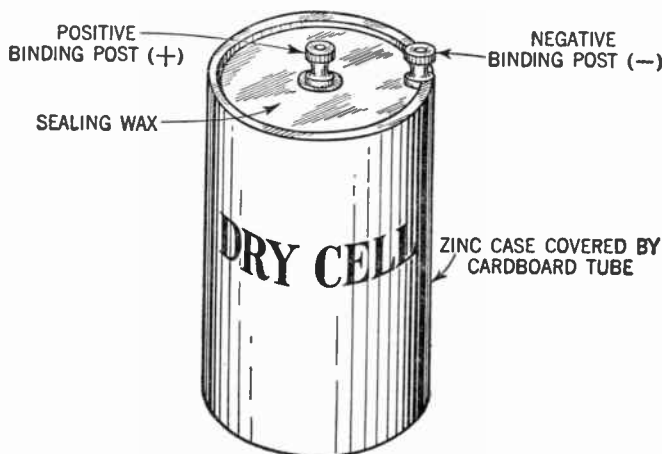

Figure 41. The dry cell.

### 60. A Dry Cell Is an Electron "Pump"

Look at a dry cell. You will notice that it is a can made of zinc, closed at one end. The other end is sealed with some insulator such as sealing wax or pitch. In the center of the sealing wax you will notice a binding post on a carbon rod. This post



## 74 ELECTRON FLOW IN THE AERIAL-GROUND SYSTEM

may be marked POSITIVE or  $+$ . At the same end of the cell, but fastened to the zinc, is a second binding post which may be marked NEGATIVE or  $-$ . The inside of the can is filled with certain chemicals.

The carbon rod in a dry cell is called the *positive pole* and the zinc is called the *negative pole*. It is customary to name the pole from which electrons leave the cell the negative pole. In general the terminals of a battery or cell are called *poles* or *electrodes*.

You may not have heard it, but a dry cell is sometimes called an electron "pump." The chemical action inside the cell builds up a pressure of electrons. This pressure exists, even when no electrons are flowing. You can understand this if you think of a water faucet. The water behind the faucet is under a pressure even when the faucet is closed and no water is flowing. When the faucet is opened the water flows out.

So it is with the electrons in the dry cell. They accumulate at the negative pole and thus produce a pressure. When a path is furnished them by connecting a conductor between the negative and positive posts of the dry cell, electrons will flow out of the negative post of the cell, through the conductor and back into the positive post of the cell.

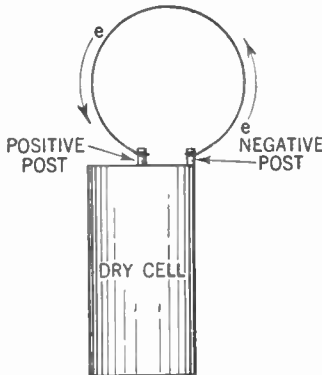

Figure 42. The dry cell is a sort of pump sending electrons streaming from the negative post to the positive post when a path is furnished.

### 61. Electromotive Force (E.M.F.)

The dry cell piles up electrons at the negative post and creates a deficiency of electrons at the positive post. When electrons are given a path to travel, they will always move from the place where

they have been piled up to a place where there is a deficiency. When electrons are in excess at a point we say that point has a *negative charge*. If given a path, then, electrons will flow from a point with a negative charge to a point with a positive charge. In other words, *electromotive force* (E.M.F.) is the tendency of electrons to move from a place where there are many electrons to a place where there are fewer electrons.

If two or more dry cells are connected in *series*, that is, with the positive post of one connected to the negative post of the other, the effect is as if two or more pumps were connected together. The E.M.F. (or voltage) of the two cells is equal to the sum of their voltages. This increased E.M.F. causes more electrons to flow through any given circuit than does one cell.

**62. Like Charges Repel; Unlike Charges Attract**

Another thing to remember about electrons is that they *repel each other*. So while electrons will be attracted to a point with a positive charge (a deficiency of electrons), they will be repelled from a point with a negative charge (an excess of electrons).

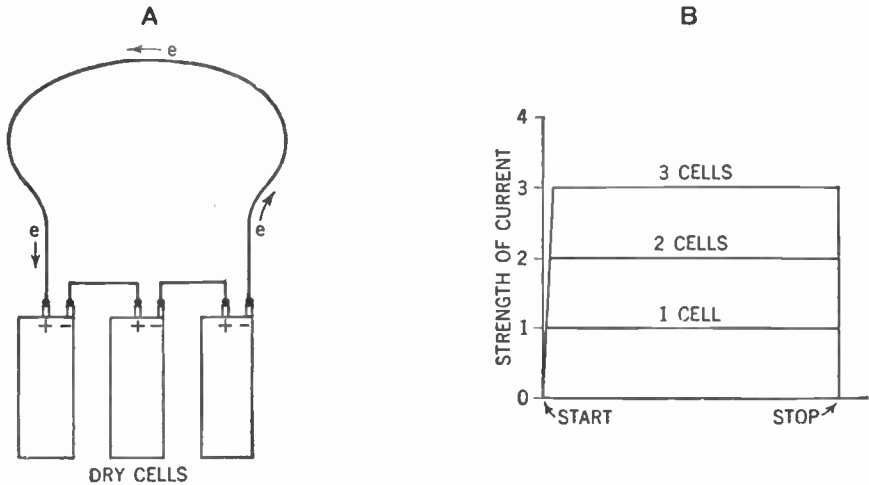

**Figure 43. A—Three dry cells connected in series. B—Graph showing flow of current from 1 dry cell, 2 dry cells, and 3 dry cells respectively.**

Since a dry cell can generate only a direct current, we have been considering the flow of electrons in one direction only. This kind of flow is called a *direct current* (D.C.). But if a pump could be devised that would cause electrons to flow first in one

## 76 ELECTRON FLOW IN THE AERIAL-GROUND SYSTEM

direction and then in the other, the current then would be called *alternating current (A.C.)*.

### 63. A.C. Generators

We have no such battery, but we have another kind of "pump" to make current flow first in one direction and then in the other. It is called an *alternating-current (A.C.) generator*. One form is the tremendous generator at the power house that supplies the current for our electric lights and electrical implements. The current is usually produced by passing conductors through magnetic fields. Each complete movement of a conductor through a magnetic field is called a cycle and in each cycle the direction of the current changes twice. The stream of electrons pumped out by most A.C. generators changes its direction of flow 120 times in a second. Hence we call the electric current from such a generator a *60-cycle alternating current*.

Another modern pump to produce alternating current is the marvelous device called the *radio tube*. At the broadcasting station one of these radio tubes sends out a stream of electrons which changes its direction of flow millions of times a second! We call such an electric current a *radio-frequency alternating current*.

### 64. A.C. Currents in the Aerial-ground System

By this time you know that the radio wave passing across your aerial causes an alternating current to flow up and down the aerial-ground system. The radio wave sets up an electrical pressure that causes the electrons to flow through the circuit. When electrons move back and forth through a circuit we say that they *oscillate*. See if you can picture how this takes place, by referring to Figure 44.

Here is the explanation. The radio wave, moving across the aerial-ground system, sets up for an instant a negative charge on the aerial and a positive charge on the ground of the system. The electrons, *which are present in the system at all times*, are set flowing *down* the aerial-ground system, as shown by the symbol:



These electrons move through the aerial wire, then through the lead-in wire, then through the primary of the antenna coupler and

## ELECTRON FLOW IN THE AERIAL-GROUND SYSTEM 77

into the ground. We show this flow on the graph in Figure 44-B.

The curve starts from point *A* on the line where the electrons are at a standstill and gradually increases its amplitude (the rate of electron flow), until at *B* the electrons are flowing at their

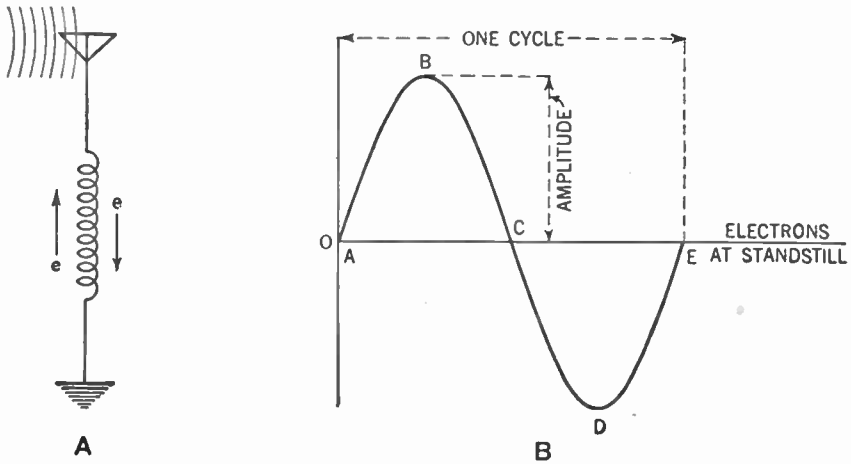

Figure 44. A—Electrons flow up and down the aerial-ground system.  
B—Graph showing one cycle of current flow in the aerial-ground system.

maximum rate. Then these electrons start to slow down, still flowing in the original direction, until they reach a standstill at point *C*.

The radio wave has now reversed the direction of its electrical pressure. There is a positive charge on the aerial and a negative charge on the ground of the aerial-ground system. The electrons now change the direction of flow and stream *up* the system from the ground.

On the graph this direction change is shown where the curve starts its bottom loop. The electrons, moving in the reversed direction, now increase their rate of flow until the rate reaches its maximum at point *D* on the curve and then slows down to a standstill at point *E*.

The electron flow has gone through one cycle. In one second there may be millions of such cycles, corresponding to the frequency of the radio waves. We cannot show more than a few in a graph, but we plan the graph so that it shows the frequency by the time intervals along the horizontal line. The amplitude of

## 78 ELECTRON FLOW IN THE AERIAL-GROUND SYSTEM

each of the graph loops, too, corresponds to the amplitude of each loop in the current generated by the radio wave, as you have learned in Chapter 9.

### SUMMARY

Try to read the following summary by supplying the right words for the blank spaces. *Do not write in the book.*

1. In the common dry cell, the outer can is made of (1) and the binding post on this electrode is marked  $+$  (2) because electrons (3) the cell at this point. Another name for an electrode is (4). The initials E.M.F. stand for (5) (6) (7), which results from the piling up of (8) and their tendency to flow through a (9) to a place where there are (10) (11) s.

2. Two devices for producing alternating currents are the (12) and the (13). When an alternating current changes direction 120 times per second it is called a (14) cycle alternating current.

3. Radio-frequency alternating currents may change directions (15) time per second.

### GLOSSARY

**Alternating Current:** A current that changes its direction of flow in a circuit because of the changing polarity of the applied voltage.

**60-cycle Alternating Current:** An alternating current that reverses its direction of flow through a circuit 120 times a second.

**Radio-frequency Alternating Current:** Alternating current that makes thousands or millions of changes in the direction of current each second.

**Cell:** A chemical device used to generate an electron pressure or voltage.

**Negative Charge:** A region where there is an excess of electrons as compared with other regions.

**Pole (or electrode):** Terminal of a cell or battery through which electrons leave or enter.

**Series Connection of Cells:** Cells connected from  $+$  to  $-$  to  $+$  to  $-$ , and so on, to supply a higher total voltage than that of any single cell.

### SYMBOLS

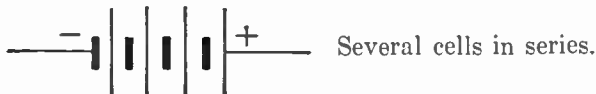

### QUESTIONS AND PROBLEMS

1. What direction will electrons always take in a circuit?
2. What is the behavior of electrons toward positive charges? Toward other negative charges?

## ELECTRON FLOW IN THE AERIAL-GROUND SYSTEM 79

3. What is the effect on the voltage of connecting several cells in series?
4. What type of current can be furnished by a dry cell?
5. Describe by a graph the changes occurring in an alternating current.
6. Give two methods of creating an alternating current on a practical basis.
7. What are the characteristics of a 60-cycle alternating current?
8. Under what conditions are electrons said to oscillate?
9. Describe the oscillations set up by radio waves in the aerial-ground system of a receiving set.

## CHAPTER 12

# Electron Flow in the Tuning Circuit

- 
- Problem 1:** *How are currents induced in conductors?*
- Problem 2:** *What is the explanation of "charging" and "discharging" a condenser?*
- Problem 3:** *What is meant by self-induction?*
- Problem 4:** *How are the oscillations of the tuning circuit produced?*
- 

We have just learned that the radio wave sets our electrons moving up and down the aerial-ground system. We now want to see the effects of this alternating current upon the other parts of our receiver.

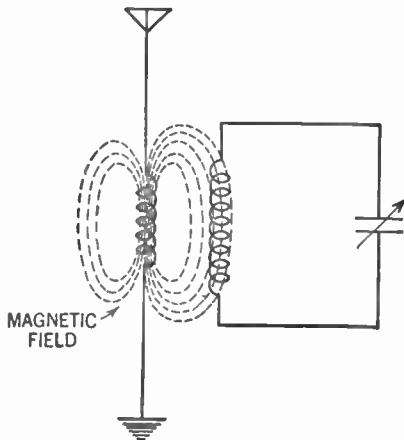

**Figure 45.** Diagram showing how a magnetic field around the primary of the antenna coupler cuts across the turns of the secondary.

### 65. Why Induction Occurs

First of all it should be recalled \* that (a) every electric current is accompanied by a magnetic field and (b) when the lines

\* At this point the main principles of the induction coil and the methods of producing an induced current should be reviewed or demonstrated. (Chap. 32, Vol. II.)

of force of a magnetic field cut through a conductor or are cut through by a moving conductor, or even when there is any fluctuation in a magnetic field near a conductor, the result is an induced alternating voltage across the conductor.

Our antenna coupler is a combination of two unconnected coils so related that any alternating or fluctuating current in either one will set up, by induction, an alternating current in the other. The relationship of electromotive force, current, and rate of change, in one such induction coil, is known as *inductance*, or in the case of two coils coupled, as *mutual inductance*. (Chap. 32, Vol. II.)

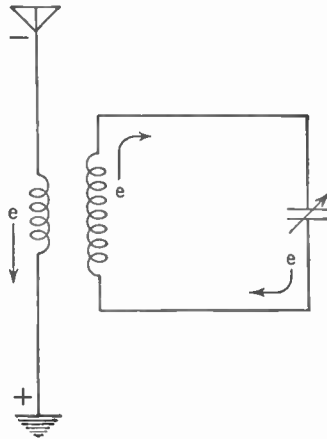

**Figure 46.** Diagram showing electrical charges and direction of electron flow in the aerial-ground system and tuning circuit during a half cycle of current flow. During the next half cycle, the charges and flow of electrons are reversed.

Here we have an explanation of how the electrical energy of the aerial-ground system is transferred to the tuning circuit through the antenna coupler. The sequence of events is: (1) The radio wave sets up an alternating current in the aerial-ground system, and especially in the primary coil of the antenna coupler. (2) This alternating current is accompanied by an alternating magnetic field. (3) The lines of force of this magnetic field cut through the conductors in the secondary coil of the antenna coupler. (4) Alternating currents in step with the radio waves are induced in the secondary coil. (5) These alternating currents, of radio frequency, are transmitted through all parts of the tuning circuit. The frequency of the current set flowing in the tuning circuit is the same as that in the aerial-ground system. The varia-



tions in amplitude of each cycle likewise follow the variations in amplitude of the current in the aerial-ground system.

Now let us examine the electron flow in the tuning circuit. You will recall that this circuit consists of a condenser and inductance connected together. We will examine each part separately, with special attention to the behavior of the electrons.

## THE CONDENSER

### 66. Charging and Discharging a Condenser

A condenser consists of two or more metal plates (or conductors) separated by a dielectric (or insulator). A conductor is a substance that permits electrons to flow through it quite easily. An insulator is a substance that does not permit electrons to flow through it readily.

Now obtain a condenser whose capacity is about 1 microfarad ( $1\ \mu\text{fd.}$ ) and connect it to a 45-volt battery for a few seconds. Dis-

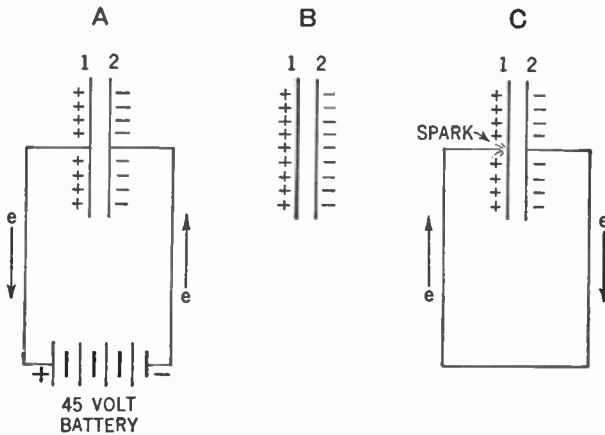

Figure 47. A—Charging a condenser.  
B—A charged condenser.  
C—Discharging a condenser.

connect the battery. By means of a piece of wire, connect one plate of the condenser to the other. You will notice a spark jump from the end of the wire to the second plate of the condenser just as you are about to touch them together.

### 67. Behavior of Electrons

This phenomenon is explained as follows: When you connected the battery to the condenser as in Figure 47-A, electrons were

pumped onto plate 2 of the condenser from the negative post of the battery; that is to say, plate 2 received a *negative charge*. This negative charge tended to repel electrons from plate 1. At the same time the positive post of the battery drew away some of the electrons from plate 1 to satisfy its deficiency. Thus, a deficiency was created on plate 1 which means that a *positive charge* was placed there. The dielectric prevented the flow of electrons through the condenser from plate 2 to plate 1. We call this process, *charging* a condenser.

When you removed the battery and wires, as in Figure 47-B, the charges remained on the plates of the condenser because there was no path over which the electrons could flow from the negative to the positive plate. Then you attached a wire to plate 2 of the condenser as in Figure 47-C. So great was the tendency of the electrons piled up on that plate to get over to plate 1 (where there was a deficiency of electrons), that they could not wait for the circuit to be closed, but actually jumped across the small gap just before you touched the end of the wire to plate 1. That was the spark you saw. This process is called *discharging* a condenser.

### 68. The Discharge Is Oscillatory

But in their surge to get to plate 1, a good many more electrons rushed across than were necessary to make up for the deficiency. As a result, plate 1 had an excess of electrons and plate 2 a deficiency of them. The charges were thus reversed. The electrons thereupon surged from plate 1 to plate 2. Again too many rushed across and again the charges were reversed. These oscillations continued to become gradually weaker and finally stopped.

You may understand this better by comparing the motion of the electrons to the behavior of a pendulum. First consider a pendulum at rest. The weight points straight down. Now raise the weight to one side. You have created a stress in this case due to the force of gravity which tends to bring the weight to its original position. Now release the weight. It rushes back to its original position but overshoots the mark and swings on to the other side. The stress thereupon pulls it down again. It rushes back toward the lowest point but again overshoots its mark. It makes many such swings, each one of less amplitude, before it finally comes to rest.

The electrons in the condenser, when discharging across a gap

or conductor, surge back and forth many times before they come to rest. All this happens in a very small part of a second. We call this swinging of electrons back and forth an *oscillatory discharge*.

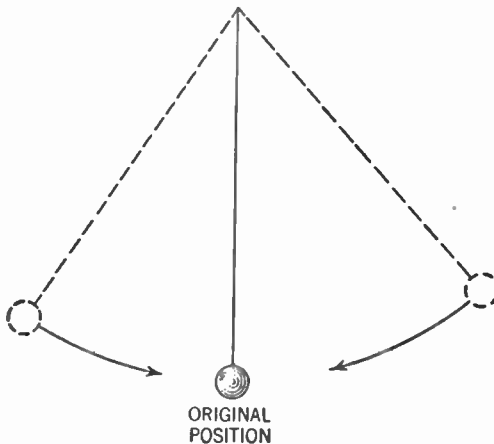

Figure 48. Diagram of pendulum illustrating electrons rushing from one plate of the condenser to the other during discharge.

charge. The capacitance of the condenser is a factor that determines the rate of oscillations.

### SELF-INDUCTION

Our study of induction up to this point has been limited to showing how an electrical current, flowing in one coil, sets up a

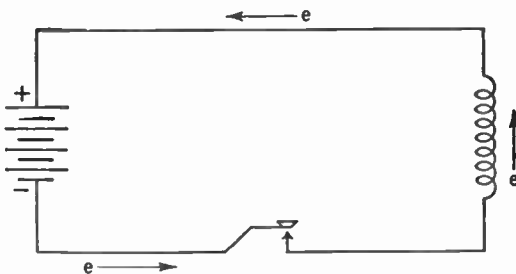

Figure 49. Hookup of coil, key, and battery to illustrate self-induction.

magnetic field that cuts across the turns of a second coil and causes a current to flow in the second coil. Now let us see what happens in the original coil.

### 69. A Back Electromotive Force

Suppose you were to hook up a coil (such as your original tuner coil of 90 turns), a battery, and a key as shown in Figure 49. At the instant the key is closed, electrons start flowing from the negative post of the battery through the circuit in a counterclockwise direction, as shown by the arrows. The current flow causes a magnetic field to be built up around the coil. This magnetic field, at the instant it is formed, cuts across the turns of the coil, and sets up an electrical pressure (E.M.F.) in the coil which will start a second stream of electrons to flowing in the coil. This second stream of electrons is only momentary and always is in a direction which *opposes* the original flow of electrons sent out by the battery. The effect, however, is to slow down the speed with which the battery can send electrons through the coil.

After the key has been closed, a steady direct current will flow through the coil. The magnetic field is now stationary. The backward flowing second stream of electrons lasted only an instant, when the magnetic field was first formed. Now the original flow of electrons from the battery will pass through unhampered.

### 70. Self-induction

As the key is opened the magnetic field collapses. Again a changing magnetic field will cut across the turns of the coil and again it will set a second momentary stream of electrons flowing through the coil. This time the second electron stream will be in the original direction of electron flow, that is, counterclockwise. This momentary pressure now acts to oppose the stopping of the electron stream from the battery and thus it tends to keep the electrons flowing through the coil for a short interval of time after the key is opened.

In summary, the motion of electrons set up in the coil by a change in the magnetic field, at the moment the key is closed or opened, will always oppose the action of the battery. The phenomenon described above is known as *self-induction*. The self-induction of a coil is included in the idea of inductance which we are gradually trying to form. Both the size and the number of turns in a coil (that is, its "electrical size") affect its properties of self-induction.

## THE TUNING CIRCUIT

## 71. Joining the Condenser and Coil

Now connect your condenser to the coil. This is the tuning circuit. Let us study the diagram of this circuit in Figure 50.

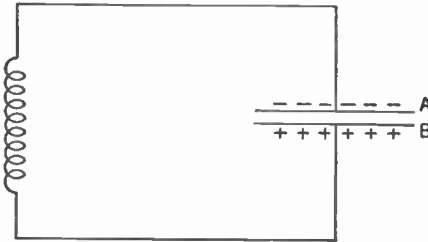

Figure 50. Tuning circuit, showing charged condenser.

Assume that a negative charge has been placed upon plate A of the condenser and a positive charge upon plate B. Now the condenser starts to discharge through the coil. The electrons surge back and forth (*oscillate*) from plate A, through the coil, onto plate B and back again, many times a second. The speed with

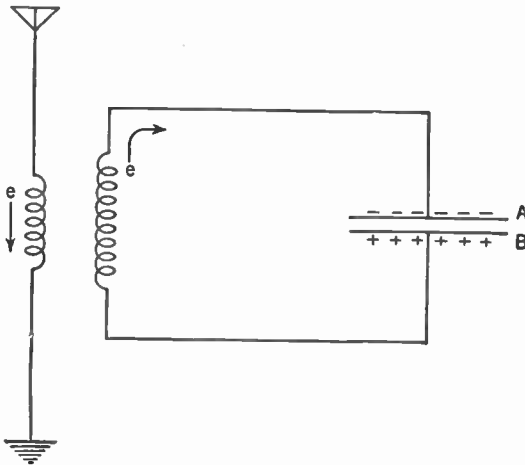

Figure 51. Diagram showing how the condenser got its charge.

which these electrons rush from one plate to the other (or oscillate in the tuning circuit) depends upon the electrical size of the condenser.

But as this alternating current flows through the coil, the self-

induction in that coil slows down this flow of electrons. So you see that it is really the electrical sizes of the condenser and coil that determine the rate at which the electrons oscillate in the tuning circuit. Another way of saying this is that the electrical sizes of the condenser and coil determine the *natural frequency* of the tuning circuit.

The question now arises, where does the condenser get its charge?

Examine Figure 51. You will notice that when electrons are flowing *down* the primary of the antenna coupler, they induce a voltage in the secondary which causes electrons to flow in the tuning circuit in a clockwise direction. This flow causes electrons to pile up on condenser plate A and a deficiency of electrons results on plate B. Then, for an instant before reversing their direction, the electrons will cease moving in the primary of the antenna coupler. Nevertheless, at this instant self-induction in the secondary of the coupler continues to pile up electrons on condenser plate A.

## 72. Reversing the Current

When the electron flow in the primary reverses itself, electrons begin to be piled up on plate B of the condenser. So you see that the flow of electrons in the primary of the antenna coupler sets a stream of electrons oscillating in the tuning circuit. The frequency of this oscillation depends upon the frequency with which the electron flow in the primary reverses itself. This frequency in turn depends upon the frequency of the radio wave.

## 73. Resonance Again

But we must not forget the other stream of electrons set flowing in the tuning circuit by the discharging of the condenser (see paragraph 71). The frequency of this second oscillation depends, as you have seen, upon the electrical values of the coil and condenser. Now if these two sets of oscillations are in step all is well and they will work together. But should they be out of step, they will interfere with each other and quickly destroy all flow of electrons. If they are in step, we say that they are in *resonance*. We therefore select the proper values of inductance and capacity to place our tuning circuit in resonance with the radio station we desire. Then oscillations caused by that station's wave are built up in our

tuning circuit. Signals from stations of different frequencies cause oscillations that are out of step and they die away.

In practice, we keep the electrical size of the inductance constant and vary the capacity of the condenser to place our tuning circuit in resonance with the radio station we wish to receive.

### SUMMARY

Read the following statements by supplying the correct terms in the blank spaces. *Do not write in the book!*

1. When a magnetic field is caused to cut through a conductor, a (1) is induced in the (2). The same effect is produced whenever a (3) and a magnetic (4) are changed relative to each other. The current induced is in one direction when the conductor passes *into* the magnetic field and in the (opposite) (same) (5) direction when the conductor passes *out* of the field.

2. When a dry cell is connected to a condenser, the plates connected to the (6) pole acquire excess electrons and the other plates have a (7) of electrons. A *spark* is caused when (8). The discharge of a condenser is said to be oscillatory because (9).

3. The magnetic field formed when a current begins to flow in a conductor sets up a momentary flow of (10) in the (same) (opposite) (11) direction to the current causing the magnetic (12). This effect is known as (13) (14).

4. The oscillations set up by the radio wave in the (15) must be in resonance with (16) in order that a given radio station may be received. The process of adjusting the set to this resonance is known as (17).

### GLOSSARY

**Condenser:** Two metal plates separated by a dielectric.

**Mutual Induction:** The method by which electrical energy from one circuit is transferred to another by means of a moving magnetic field.

**Oscillation:** The movement of electrons back and forth through a circuit.

**Self-induction:** The property of a coil whereby it tends to keep out a current coming in and, once in, to prevent it from discontinuing; in short, to oppose any current change through it.

### QUESTIONS AND PROBLEMS

1. What is the relationship between frequency of oscillation of electrons in the aerial-ground system and frequency of oscillation in the tuning circuit of a receiver?

2. Distinguish between an electrical conductor and an insulator. Give examples.

3. Give an electronic explanation (that is, in terms of electrons) of the charging of a condenser.

4. Give an electronic explanation of the discharge of a condenser.

5. Describe the chain of the events occurring when a voltage (electromotive force) is applied across a coil.

6. Describe the chain of events occurring when the voltage applied across a coil is removed.

7. In what way does the coil of a tuning circuit serve to control the rate of discharge of the condenser.

8. Give an electronic-magnetic field picture of a tuning circuit showing how the coil and condenser control the rate of oscillation of current in the tuning circuit.

9. "The receiver is in resonance with the radio wave." Electronically, what is meant by this statement?

10. Practically, how do we place our receiver in resonance with any broadcasting station? How else might we have done it?



## CHAPTER 13

# Electron Flow in the Crystal Detector and Phones

**Problem 1:** *What are parallel circuits?*

**Problem 2:** *How are the detector and phones connected to the tuning circuit?*

Up to now you have seen a stream of electrons merrily oscillating through the tuning circuit many times each second. Now for the next step. Let us see what happens in the detector and the phones.

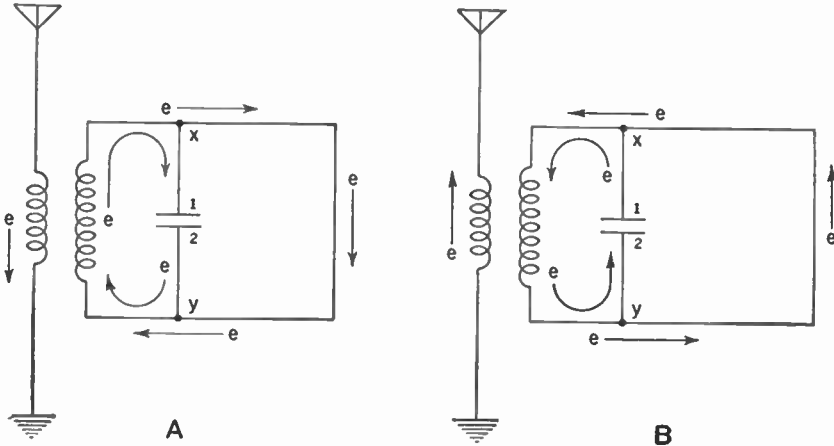

**Figure 52. Parallel circuits.**  
A—Flow of electrons during a half cycle.  
B—Flow of electrons during the next half cycle.

### 74. Parallel Circuits

Across the condenser of the tuning circuit, connect a loop of wire as in Figure 52.

When a stream of electrons flows down the primary of the

## 92 ELECTRON FLOW IN THE CRYSTAL DETECTOR

antenna coupler (Figure 52-A), another stream is set flowing in a clockwise direction through the tuning circuit and electrons are being piled up on plate 1 of the condenser. At point *X*, however, the path divides and some of the electrons are being pushed around through the loop of wire and back to the main stream at point *Y*. We say that these two paths or circuits are parallel to each other. A parallel circuit is also called a *shunt*. In parallel circuits, the electrons have two or more paths and flow at the same time through all of these paths.

When the flow of current reverses itself (Figure 52-B), the stream of electrons divides at point *Y*, some flowing onto plate 2 of the condenser while others flow through the loop of wire and rejoin the other electrons at point *X*.

In other words, electrons flow through the loop of wire (the parallel circuit) in the same direction as the flow of electrons in the tuning circuit and in step with it.

### 75. The Crystal Detector in a Parallel Circuit

Now substitute the crystal detector and the phones for the loop of wire.

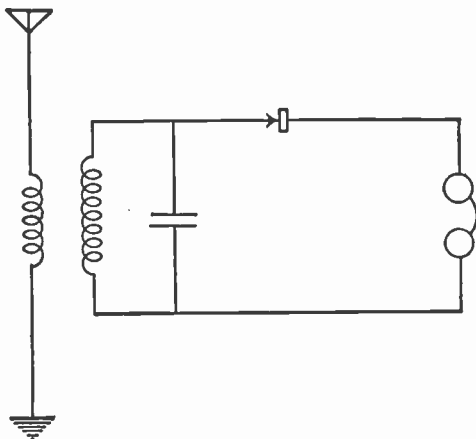

Figure 53. Diagram showing crystal detector and phones substituted for the loop of wire.

Electrons then tend to flow through the detector and phones in step with the flow of electrons in the tuning circuit.

But hold on! You will remember that the crystal detector acts like an electrical gate, permitting electrons to flow through it only in one direction. Therefore, although the electrons flow

back and forth in the tuning circuit, they can only flow through the detector and phones in one direction. This means that because of the crystal detector, the current that flows through the phones is not an alternating current, but a pulsating direct current. (See Chapter 9, Figure 32.)

**76. The Phones**

The pulses reaching the phones are a series of electron streams, each of very short duration, perhaps one one-millionth of a second or less. Also, the current is direct current, that is, the electrons always move in one direction. You already know that each such electron stream is of too short duration to move the diaphragm of the phones. But when a series or train of such electron streams push together they can cause the diaphragm to fluctuate and you can hear a sound. We will investigate how they do it.

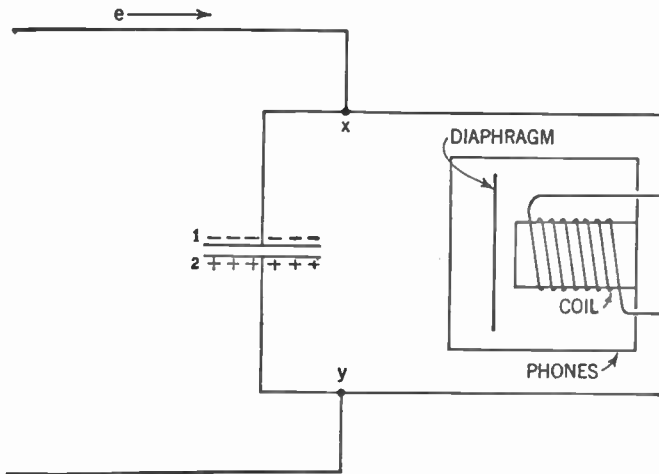

Figure 54. Diagram showing how electrons flow through the phones.

**77. Using a Fixed Condenser across the Phones**

Across the phones (parallel to the phones) connect a fixed condenser. The stream of electrons from the tuning circuit has already passed the detector and now approaches the phones, as indicated by the arrow in Figure 54.

At point X this stream divides. One part attempts to pass through the coil of the phones and the other part piles up electrons on plate 1 of the condenser. The part attempting to pass through the phones encounters considerable difficulty because the many

turns of thin wire in the coil in the phones present a good deal of resistance to the flow. Because of the very short duration of electron flow, only a few electrons find their way through. Most of the electrons, then, pile up on plate 1 of the condenser.

When the next stream comes along the same thing happens. More and more electrons continue to pile up on plate 1 of the condenser. The greater the negative charge on plate 1 the greater the positive charge that appears on plate 2 and the greater the tendency of the electrons on plate 1 to make up the deficiency on plate 2.

Since the only way the electrons on plate 1 can get to plate 2 is through the coil of the phones, they must wait until enough electrons have been piled up on plate 1 to overcome the resistance offered by the coil. When that pile-up occurs, they all rush over in one grand surge and the diaphragm is strongly attracted. It is these surges of electrons through the coil of the phones that cause the diaphragm to fluctuate and produce a sound.

You will recall that in Chapter 9 we said that the current flowing through the phones can be pictured by drawing a line through the peaks of all the direct-current pulses passing out of the detector; we called this line the envelope. Well, strictly speak-

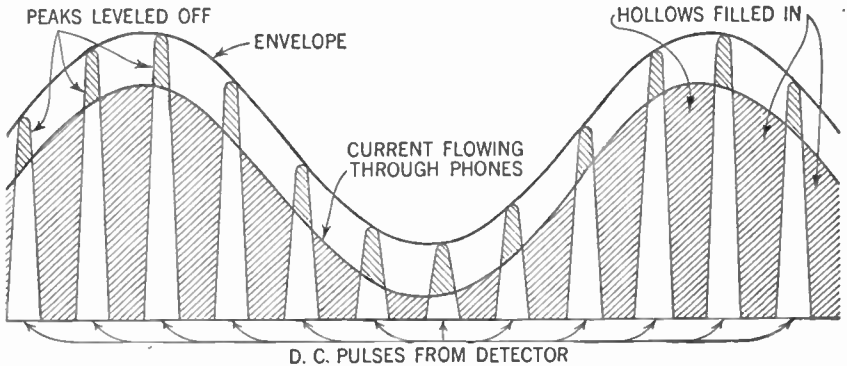

**Figure 55.** Graph showing how the condenser levels off the peaks and fills in the hollows between the pulses of direct current coming from the detector. Note that the resulting curve resembles the envelope quite closely.

ing, this is not the true picture. Actually, the effect of the condenser is to level off the peaks of these pulses and fill in the hollows. The curve now presents a continuous line whose fluctuations resemble those of the envelope. Since it is these fluctua-

tions that produce the to and fro motion of the diaphragm, the sound coming from the phones is very nearly like the sound first created at the broadcasting station.

### 78. Coils as Condensers

Let us now go back to that fixed condenser across the phones. You will have noticed that in our circuit diagrams of the crystal receiver we have omitted it. Nevertheless, it was always present. Here is why.

A condenser, you know, consists of two metallic plates separated by an insulator. In the coil of the phones we have many turns of copper wire wound next to each other and separated by an insulator. So you see that if we consider two turns of wire next to each other and separated by an insulator, we really have a very small condenser. Since there are hundreds of such small condensers in the coil, the total effect is the same as though a large condenser were connected across the phones. Thus a coil serves both as an electromagnet and a condenser at the same time.

In practice, an external condenser having a capacitance of .006  $\mu$ fd. is sometimes placed across the phones even though it is not absolutely necessary.

### SUMMARY

1. Any electrical device is connected in **parallel** in a circuit when it is one of two or more paths through which some of the current can flow. Devices are said to be in **series** when all of the current must pass through all of the devices one after another.

2. A condenser is usually connected in parallel with the phones.

3. In the graph of the current flow, the **envelope** is a fluctuating heavy line showing the peaks of the pulses that produce the sounds in the phones.

### GLOSSARY

**Parallel Circuit:** An electrical circuit in which electrons have two or more paths to follow.

**Shunt:** One of the paths in a parallel circuit.

**Series Circuit:** A circuit in which electrons have but one path.

### QUESTIONS AND PROBLEMS

1. Draw a dry cell connected to two parallel circuits.

2. Show how electrons behave in a crystal receiver in going through the crystal and phones, the latter being in parallel with the tuning circuit.

## 96 ELECTRON FLOW IN THE CRYSTAL DETECTOR

3. What is the nature of the current through the phones of a crystal receiver? Indicate it graphically.
4. Describe the action of the fixed condenser across the phones in the crystal receiver, from an electronic point of view. Why may it be omitted?
5. What is the rated value of the condenser placed across the phones?

## The Vacuum-tube Detector—The Diode

---

**Problem 1:** *What is meant by the "Edison effect"?*

**Problem 2:** *What are the principles of a Fleming valve?*

**Problem 3:** *What is the "diode" detector?*

---

### 79. Faults of the Crystal Detector

Having mastered the theory of the crystal receiver, we are now ready to go ahead. If you have constructed the receiver described here and "listened in" on it, you must be aware that the crystal detector has shortcomings. First of all, it is difficult to manipulate. Not every spot will work. You must move the cat-whisker about for some time before you touch a spot which enables you to hear radio signals in your phones.

Even after you have found the proper spot, a slight jar may dislodge the fine wire and the hunt starts over again. Perhaps dirt, grease, or oxidation from the air may spoil the sensitive spot and you have to start once again.

### 80. The Edison Effect

Oddly enough, the first hint as how to improve the detector came in 1883, long before the crystal detector was first used in a radio receiver. In that year Thomas A. Edison was experimenting with filaments for his new invention, the electric light bulb. He placed a filament in a glass bulb and then exhausted the air, creating a vacuum. By means of an electric current, he heated the filament until it glowed brightly and produced light.

He soon observed an undesirable feature about his bulbs. After a short time, a black substance was deposited on the inside of the glass, interfering with the light given out. In an attempt to stop this deposit on the glass, he inserted a metal plate. Now this plate did not help much, but one day he connected a delicate

electric meter between the plate and one end of the filament. To his amazement, the meter showed that a small electric current was flowing through the circuit.

He did not know why this current should flow and he merely jotted down this strange fact in his notebook and forgot about it.

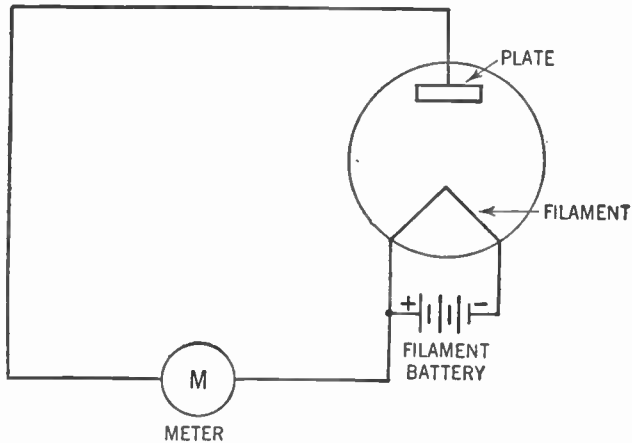

Figure 56. Diagram showing Edison's experiment.

Today, we know why this current flows. When a filament is heated to incandescence (when it becomes hot enough to give off light), it shoots off streams of electrons. This behavior is known as the "Edison Effect" or *thermionic effect* of a filament heated to incandescence.

These electrons given off by the hot filament collect on the cool plate and, if a path is furnished them, they will flow along this path toward the filament. The meter in that path shows that electrons are flowing.

### 81. The Fleming "Valve"

As we stated, this discovery of Edison's was made in 1883. At that time, the electron theory was not known. But in 1904, J. Ambrose Fleming, an Englishman, who understood the flow of the current in terms of electrons, decided to experiment a bit. To depend upon the electrons piling up on the cool plate, thought Fleming, is too slow. Suppose we were to create an actual deficiency of electrons on the plate by placing a positive charge on it, wouldn't that attract still more electrons from the filament? Flem-



ing connected a battery in the circuit from the plate to the filament, in such a way that the positive post of the battery was connected to the plate (see Figure 57). He also connected an-

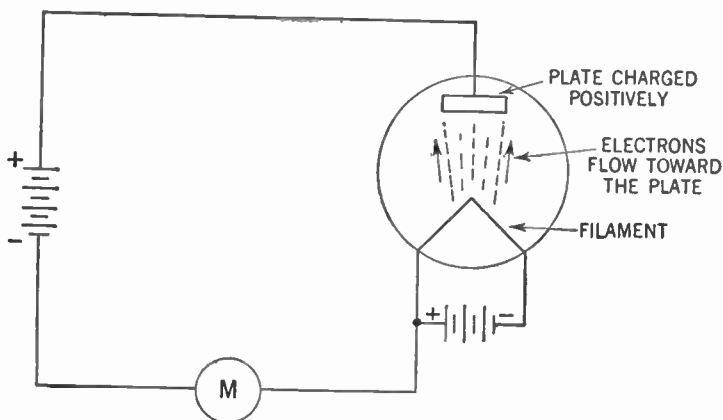

Figure 57. Fleming's experiment with a positive charge on the plate of the tube. The meter showed that an electric current was flowing through it.

other battery to the filament to heat it to incandescence. Note that this filament battery is not in the plate circuit.

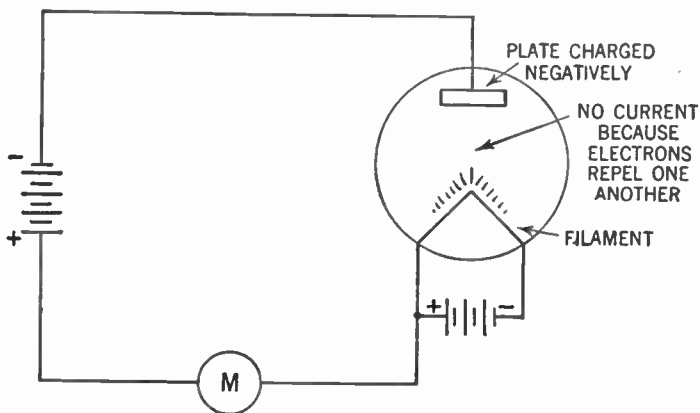

Figure 58. Fleming's experiment with a negative charge on the plate of the tube. The meter showed that no electric current was flowing through it.

By this arrangement some of the electrons of the plate were pulled away to satisfy the deficiency at the positive post of the battery. This removal resulted in a deficiency of electrons on the plate, that is, a positive charge. Fleming now connected a meter

## 100 THE VACUUM-TUBE DETECTOR—THE DIODE

in the circuit and, as he had expected, a much greater stream of electrons flowed through than before the battery was attached. He also discovered that the more powerful the battery, the greater the positive charge on the plate, the more electrons were attracted, and the greater the current flow through the meter.

Now Fleming reversed the connection to the battery and observed that the meter showed no current. The explanation is that this time the battery piled electrons onto the plate (gave it a negative charge) and electrons repel each other. Hence the stream of electrons from the filament was repelled from the plate and therefore no current flowed through the meter (see Figure 58).

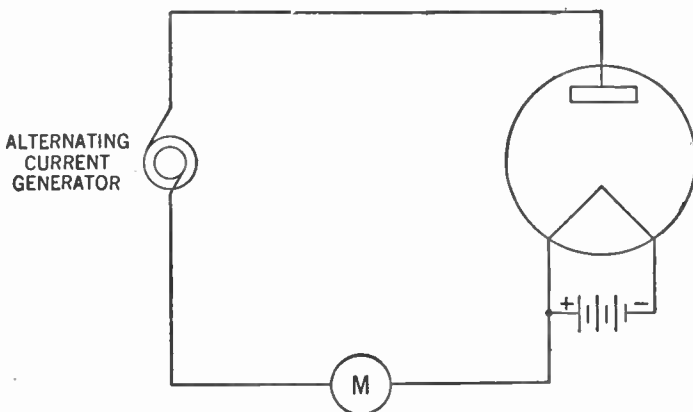

**Figure 59.** Fleming's experiment with an alternating-current generator connected to the plate of the tube. Electric current flowed through the meter only during the positive half of the alternating-current cycle.

### **82. Effects of the Fleming Valve on an Alternating Current**

By means of an alternating-current generator, Fleming now replaced the direct current of the battery with an alternating current. The symbol for the alternating current generator is:



When the proper instruments were attached and the meter reading taken, Fleming now observed that the current flowing through the meter was direct, not alternating. The explanation (see Figure 59) is as follows: During the positive half of the alternating-current cycle the plate received a positive charge.

This charge caused electrons from the heated filament to be attracted to the plate and a current flowed in the circuit as registered on the meter. During the negative half of the alternating-current cycle the plate received a negative charge. This charge repelled the electrons from the filament and the meter showed that no current was flowing. The effect of this action upon the graph of the wave form is shown in Figure 60. Only a pulsating direct current is passing through the meter.

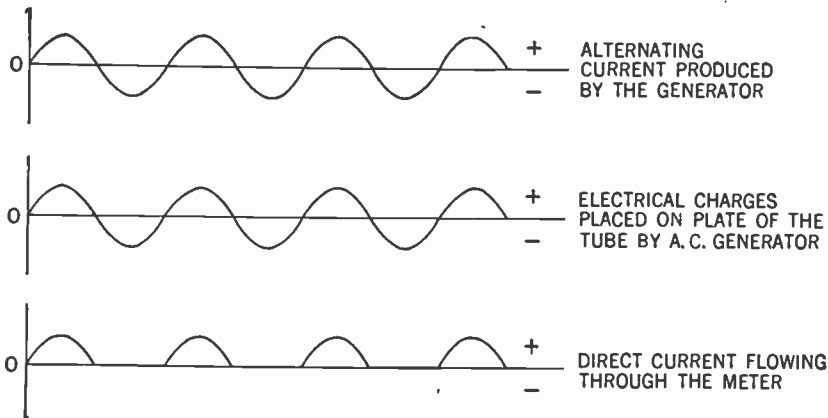

Figure 60. Graph showing the effect of connecting an alternating current generator to the plate of Fleming's tube.

Here, then, is an electrical "gate" or "valve" that will permit current to flow only in one direction. As a matter of fact, the early radio tubes were all called valves and are still called by that name in England.

Doesn't this sound familiar? Of course! The crystal detector acted in just that way.

### 83. The Fleming Valve as a Detector

Fleming went one step further. For the alternating-current generator he substituted a radio tuning circuit. Since alternating current flows out of the tuning circuit, it may be considered a sort of alternating-current generator. For the meter Fleming substituted a pair of phones and now he had the same hookup as our old receiving set with a new kind of detector to replace the crystal. (See Figure 61.)

### 84. Why the Fleming Valve Is Called a Diode

This type of detector is known as a *Fleming valve*. Because it has two electrodes, the filament and plate, it is also known as

## 102 THE VACUUM-TUBE DETECTOR—THE DIODE

a *diode* (*di*-means two; *-ode* means pole). It is easier to operate than a crystal because there is no need to hunt for a sensitive spot. Further, you can not disturb it by jarring; and no dirt, grease, or

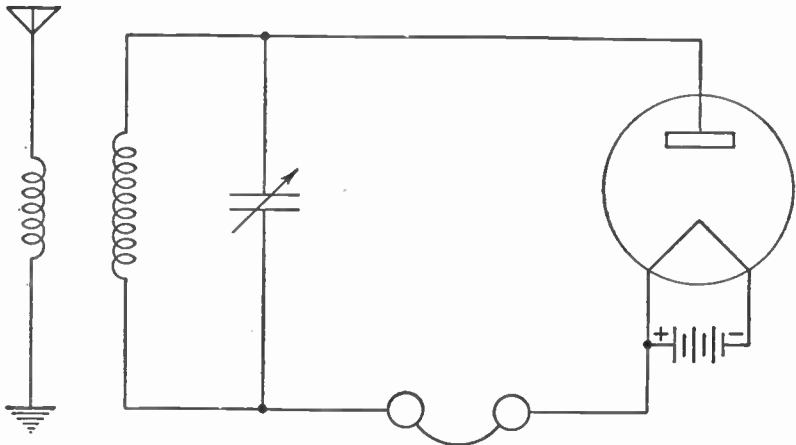

Figure 61. Radio receiving set using a Fleming valve as a detector.

air can get inside the sealed glass tube. The symbol for the diode is:



### SUMMARY

1. Thomas Edison, in 1883, discovered that in a vacuum tube an electric current passed from a hot filament through the vacuum to a plate sealed in the tube at some distance from the filament.
2. J. Ambrose Fleming in 1904 discovered that the current was increased in an Edison tube when the plate was made positive and ceased when the plate was made negative.
3. The "diode" or Fleming valve depends upon the principle that alternating currents passed through the tube are changed to direct currents because only during the positive half of an alternating-current cycle are the electrons attracted from the filament to the plate.

### GLOSSARY

- Catwhisker:** The thin wire with which we hunt for a sensitive spot on the crystal.
- Diode:** A two-electrode tube containing a plate and filament.
- Fleming Valve:** A tube ("valve") used as a detector.
- Thermionic Effect:** The throwing off of electrons by a body when it is heated to incandescence.

“Valve”: A tube with a filament and plate which will allow current through it only in one direction.

SYMBOLS

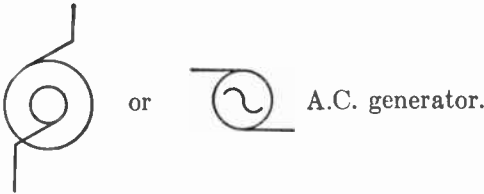

QUESTIONS AND PROBLEMS

1. Give the defects of a crystal as a detector.
2. Describe Edison's early experiment on vacuum tubes.
3. Why did a current flow from the plate to the filament in Edison's electric light bulb when the two were connected externally?
4. How did Fleming make use of the Edison effect to improve the vacuum tube?
5. What occurs in the tube containing the filament and plate when the plate is made negative?
6. Draw a graph showing the resulting effect when an alternating-current sine voltage is impressed on the plate of Fleming's valve.
7. In what way are the crystal detector and the Fleming valve alike?
8. To what electrical machine does a tuning circuit correspond?
9. What energizes the tuning circuit to make it act as the machine in question 8?
10. What is the advantage of the diode over the crystal as a detector?
11. Draw a one-tube receiver using the Fleming valve as a detector.

## CHAPTER 15

# The Vacuum-tube Detector—The Triode

---

**Problem 1:** *What did De Forest contribute to radio?*

**Problem 2:** *By what principles does the "grid" function?*

**Problem 3:** *How is the grid maintained with the proper negative charge?*

**Problem 4:** *What is the principle of volume control?*

---

Soon after Fleming's diode tube appeared, in 1907, an American inventor, Lee De Forest, undertook to carry further some ideas suggested by one of Fleming's experiments. De Forest knew that when Fleming placed a positive charge on the plate of his tube by means of a battery connected between the plate and filament (Figure 57), a much greater electric current flowed through the meter than when there was no such charge. Further, the greater the positive charge on the plate, the greater the flow through the meter. (Actually, this did not go on forever. After the positive charge reached a certain value, placing a greater positive charge on the plate had no further effect.)

### 85. "A" and "B" Batteries

The circuit traveled by the electrons—starting from the filament of the tube, going across the vacuum in a stream to the plate and back again to the filament by way of the path provided by the meter, battery, and wire—is known as the *plate circuit*. The battery used to place a positive charge on the plate is known as the *plate battery* or *B battery*. The battery used to heat the filament is known as the *filament battery* or *A battery*. (See Figure 62.)

### 86. Experiments of Lee De Forest

Now, thought De Forest, if we could only use the advantages of the B battery and substitute our phones for the meter, we would

## 106 THE VACUUM-TUBE DETECTOR—THE TRIODE

get a much louder signal in our phones. For the greater the current flowing through the phones, the greater is the magnetic pull of the coil. Greater magnetic pull means that the diaphragm is

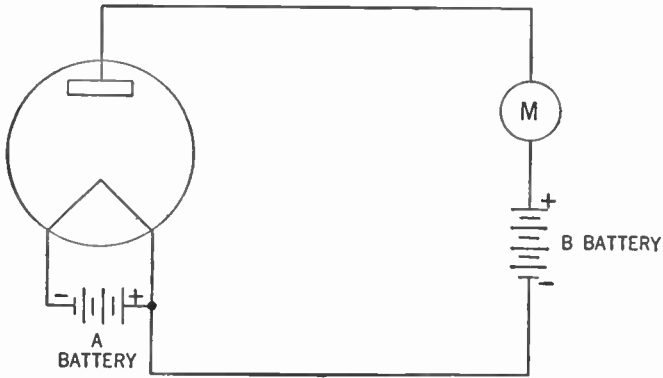

Figure 62. Diode using a B battery to place a positive charge on the plate of the tube. Current flows through the meter.

bent more; the air is set moving more violently, and a louder signal results.

At this point, however, a serious difficulty arose. The large

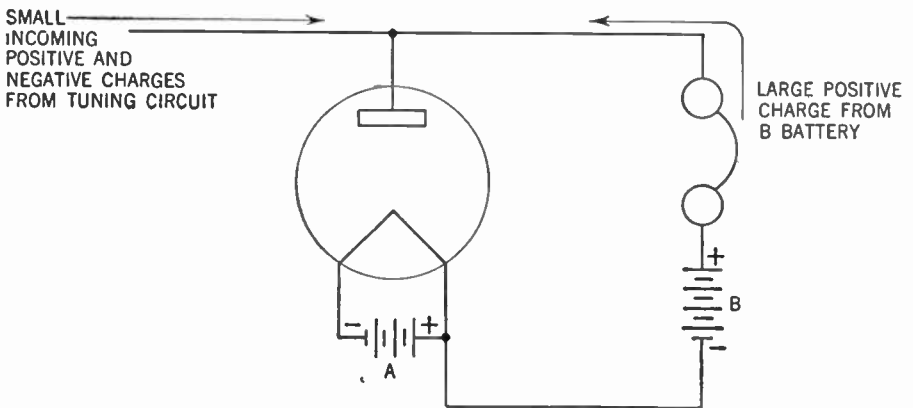

Figure 63. Diagram showing how the weak positive and negative charges placed on the plate of the diode are overwhelmed by the large positive charge placed on the same plate by the B battery.

current through the phones must be a direct current that fluctuates in step with the fluctuations of the incoming signal. De Forest quickly discovered that the small charges placed on the plate of the Fleming valve by the alternating current from the tuning cir-

circuit were undetectable in the presence of the relatively enormous positive charge placed on the plate by the B battery. Try as he would, De Forest could not utilize the advantages of a B battery in the diode tube. (See Figure 63.)

**87. Discovery of the Grid**

It was then that De Forest had a stroke of genius. Since the flow of current in the plate circuit starts with the stream of electrons shot out by the heated filament, he began to experiment with that electron stream.

Suppose, thought he, we were to place another electrode in the tube between the filament and plate. Being closer to the filament than the plate, this electrode would have a greater effect on the stream of electrons than would the plate. Thus a small positive charge on this new electrode would pull over electrons just as would a large positive charge on the plate. Also, a small negative charge on this new electrode would repel some of the stream of elec-

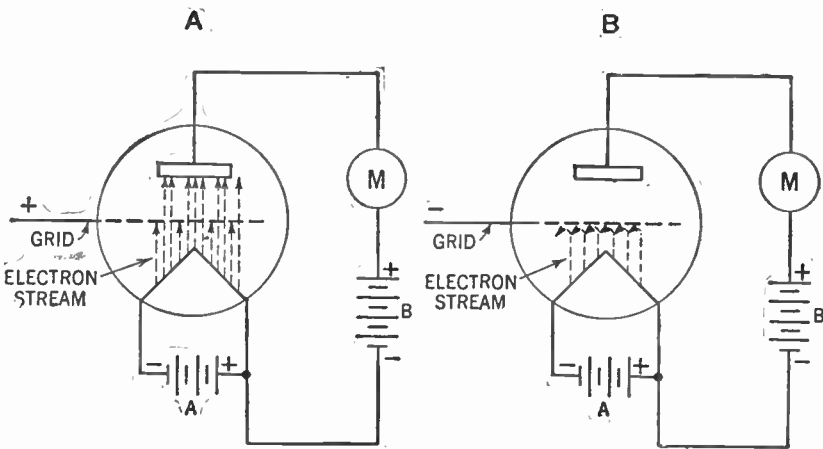

**Figure 64.** A—Diagram showing how a positive charge on the grid of De Forest's tube helps pull electrons from the heated filament to the plate. The meter shows that an electric current is flowing through it.  
 B—Diagram showing the effect of a negative charge on the grid. Since most of the electrons from the heated filament are repelled, few reach the plate. The meter shows that only a very small current is flowing through it.

trons and thus a comparatively small number of electrons would reach the plate. When few electrons reach the plate, a very small current flows in the plate circuit. Here, then, thought De Forest, is a method for controlling the flow of current in the plate circuit by means of small charges on the new electrode.



## 108 THE VACUUM-TUBE DETECTOR—THE TRIODE

But hold on! Further reasoning and experimenting convinced De Forest that when this new electrode was given a positive charge it pulled over electrons, as expected—but these electrons went to this new electrode and none found their way to the plate. After more experiments, De Forest eventually met this difficulty by making the new electrode in the form of a mesh of very fine wire, a *grid*. Since most of the grid consisted of open space, most of the electrons pulled over by a positive charge on the grid now shot through these open spaces and continued right on to the plate. The grid was the solution to his problem. (See Figure 64.)

### 88. How the Grid Works

By study of the diagram in Figure 65, we can obtain an idea of how charges on the grid affect the flow of current in the plate

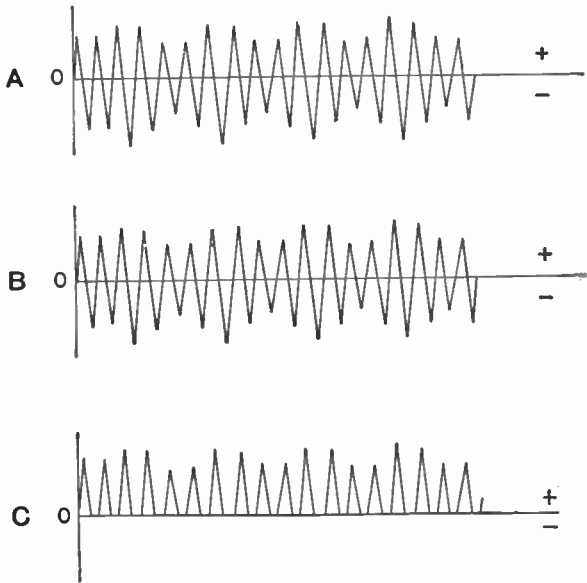

Figure 65. Graphs showing flow of electric current in various parts of the triode circuit.

A—Alternating current flowing from the tuning circuit.

B—Positive and negative charges placed on the grid of De Forest's tube by this alternating current from the tuner.

C—Fluctuating direct current flowing through the meter.

circuit. If the grid has a small negative charge it repels some of the electrons shooting off from the filament and only a few of these electrons pass through the open spaces of the grid to the positive

plate. A small current flows through the plate circuit and thus through the phones.

As the negative charge on the grid gets larger and larger, more and more electrons are repelled until none get through and therefore no current flows in the plate circuit.

As the grid gets a positive charge, it accelerates or speeds up the flow of electrons from the heated filament to the plate. The pull of the grid is now added to the pull of the plate. Most of the electron stream goes through the openwork of the grid to the plate. The more positive the grid gets, the greater the pull it exerts on the electrons; consequently, more electrons reach the plate and the plate current is greater.

### 89. How the Triode Works

Since charges on the grid control the flow of electrons from the filament, we are able to control the flow of the large plate currents by means of a small charge on the grid. And this is just what De Forest set out to do. (See Figure 66.)

He connected the small alternating-current output from the tuning circuit to the grid and studied the effects of various com-

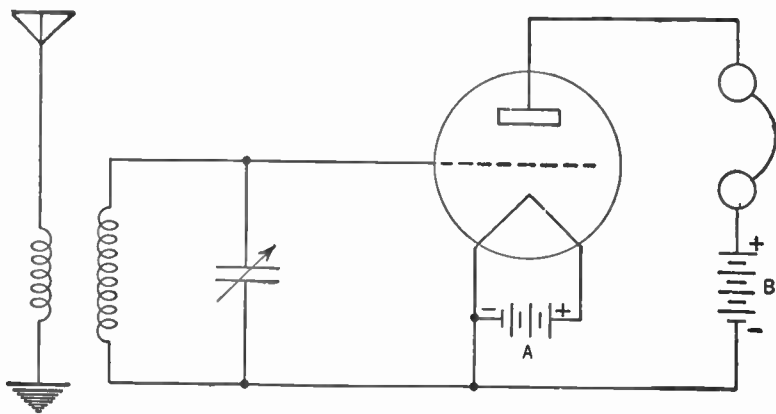

Figure 66. Diagram showing how alternating current from the tuning circuit places positive and negative charges on the grid of De Forest's tube.

binations upon the current in the plate circuit. When the positive half of the cycle of the alternating current from the tuner placed a positive charge on the grid, a large current flowed in the plate circuit. When the negative half of the cycle of the alternating current from the tuner placed a negative charge on the grid, very little

## 110 THE VACUUM-TUBE DETECTOR—THE TRIODE

current flowed in the plate circuit. These effects are shown by the graphs in Figure 65.

Now the remodeled tube, with its three parts—filament, grid, and plate—acts like an electrical gate or valve just as did the crystal detector and the diode tube. But this tube has the additional advantage that now the current that flows through the phones is not the small electrical current captured by the aerial but the very large current supplied by the B battery. Hence our signals will be much louder.

Because this new tube has three elements—the filament, the grid, and the plate—it is known as a *triode*. The symbol for the triode is:

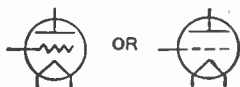

### 90. Schematic Diagrams Show Paths of Electrons

Look at the diagram in Figure 66. You will notice a number of paths or circuits through which electrons may flow. There is the *aerial-ground system or circuit*. Then there is the *tuning circuit*, consisting of the secondary of the antenna coupler and the variable condenser. Then there is the *filament circuit* consisting of the A battery and the filament. There is the *plate circuit* consisting of the filament, the stream of electrons from the filament to the plate, the plate, the phones, the B battery and the conductor leading back to the filament.

Finally there is the *grid circuit*. This path consists of the filament, the stream of electrons from the filament to the grid, the grid, the tuning circuit, and the conductor leading back to the filament. Just as current will flow through the plate circuit only when there is a positive charge on the plate, current will flow through the grid circuit only when there is a positive charge on the grid.

### 91. Electrons Pass through a Weak Negative Charge

You may have noticed a difficulty by now. In the diode, the bottom loop of the alternating-current cycle was completely cut off because the moment our plate went negative, all plate current ceased. The current flowing through the phones then fluctuated in step with the variations of the envelope and the signal was faithfully reproduced. (See Figure 67.)

But in the triode, connected as in Figure 66, the stream of electrons from the heated filament to the plate would continue to flow, even though the grid were slightly negative. In fact, this flow of electrons would continue until the grid assumed a fairly high negative charge, because of the relatively high positive charge

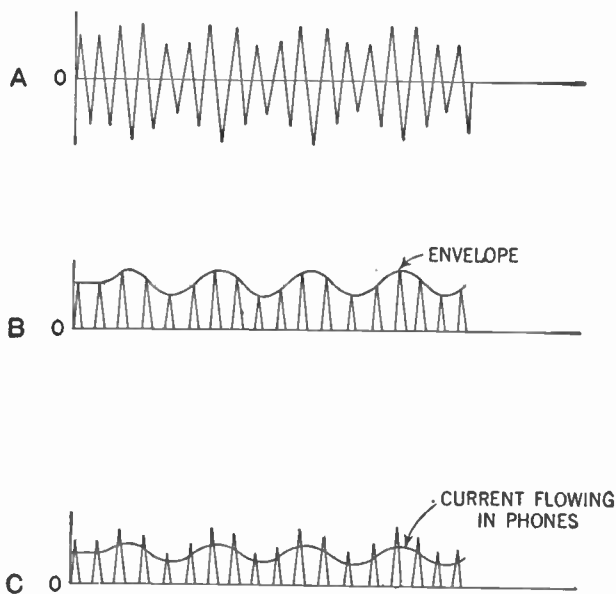

**Figure 67.** Graphs showing flow of electric current in various parts of the diode circuit.  
 A—Alternating current flowing from the tuning circuit.  
 B—Pulsating direct current flowing in the plate circuit.  
 C—Fluctuating direct current flowing through the phones.  
 Notice how closely the fluctuations here follow the fluctuations of the envelope in part B of this figure.

on the plate. Thus plate current, and current through our phones, would flow during part of each negative cycle. In Figure 68-C we see that the graph of the current flowing through the phones does not correspond to the shape of the envelope. The practical effect is that our signal in the phones is distorted.

## 92. The Use of a C Battery

Here is how this difficulty was overcome. A small negative charge was placed on the grid by means of a battery. This charge was made too small to cut off all the electrons streaming from the heated filament to the plate. Now the alternating current from the tuner was fed into the grid. (See Figure 70.)

## 112 THE VACUUM-TUBE DETECTOR—THE TRIODE

When the positive half cycle of the current from the tuner flowed into the grid, it reduced the negative charge placed there originally. This reduction meant that fewer electrons from the filament were repelled and more of them reached the plate. This greater flow of electrons in turn meant a larger plate current.

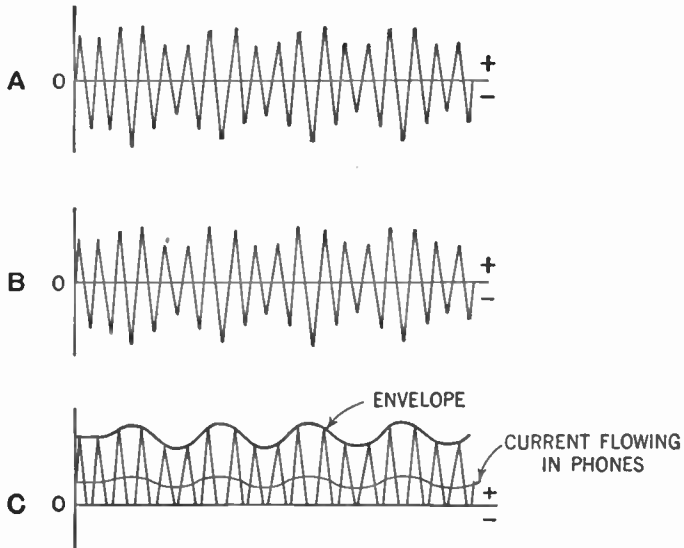

**Figure 68.** Graphs showing flow of electric current in various parts of the triode circuit.

**A—**Alternating current flowing from the tuning circuit.

**B—**Positive and negative charges placed on the grid of the triode by that alternating current from the tuner.

**C—**Fluctuating direct current flowing in the plate circuit. Notice that the current flowing in the phones is very nearly a steady direct current in no way resembling the fluctuations of the envelope. This current will cause no sound or else a distortion of the signal will be heard in the phones.

When the negative half cycle of the current from the tuner flowed into the grid, this current, by itself, could not place a negative charge on the grid great enough to cut off completely the flow of electrons to the plate. But if it were added to the negative charge we originally placed on the grid, then it would be able to stop the flow of electrons and thus to stop the flow of the plate current.

Now, you can see, practically no current will flow in the plate circuit during the negative half cycle of the current from the tuner. Just as in the case of the diode, the fluctuations in the current flowing

through our phones correspond to the shape of the envelope and, once again, our signal is faithfully reproduced. (See Figure 69.)

We place this constant negative charge on the grid by connecting a small battery in the grid circuit in such a way that the negative post of the battery is hooked up to the grid.

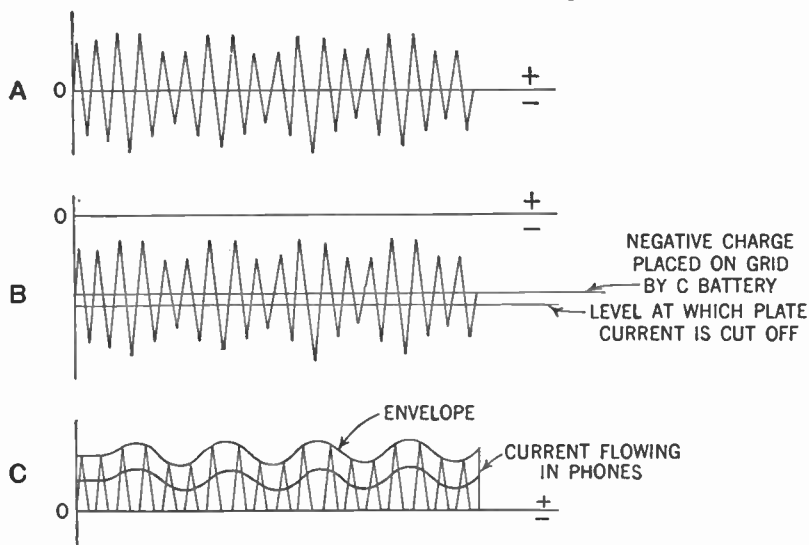

Fig. 69. Graphs showing effect of placing a steady negative charge or bias on the grid of the triode.

- A—Alternating current flowing from the tuning circuit.
- B—A steady negative charge or bias makes the grid negative. The positive half-cycle of the current from the tuner makes the charge on the grid less negative. The negative half-cycle of the current from the tuner makes the charge on the grid more negative to the point where the flow of current in the plate circuit is cut off.
- C—Fluctuating direct current flowing in the plate circuit. Notice that now the current flowing in the phones resembles the envelope.

This battery is called a *C battery*, or *grid-bias battery*. It must be of such a size that, by itself, it cannot cut off the flow of electrons from the heated filament to the plate, but when added to the negative charge of the current flowing from the tuning circuit, it can do so. The size of this battery differs for different types of tubes. Each tube manufacturer supplies data to show how large this battery should be.

### 93. The C Battery May Be Replaced by a Condenser

While the C battery is effective in placing a negative charge on the grid of the triode, it wears out in time and we are faced

## 114 THE VACUUM-TUBE DETECTOR—THE TRIODE

with the nuisance of periodically replacing it. Accordingly, another method was evolved to accomplish the same result without the use of the battery—a small fixed condenser was placed in the grid circuit as shown in Figure 71.

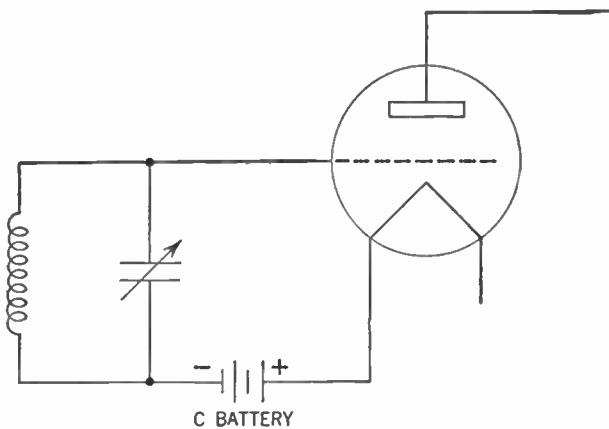

**Figure 70.** Diagram showing how a "C" battery is connected to place a negative charge or bias on the grid of the triode. The completed diagram would include the earphones, "A" and "B" batteries connected just as in Figure 66.

Here is how it works. When the negative half-cycle of the alternating current from the tuning circuit reaches plate 1 of the

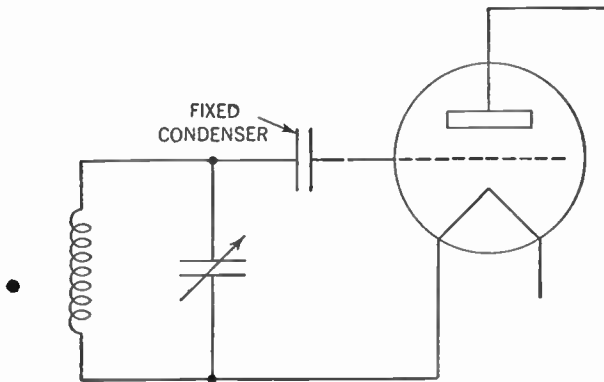

**Figure 71.** Diagram showing how a fixed condenser is connected to place a negative charge or bias on the grid of the triode.

condenser, as shown in Figure 72-A, it places a negative charge on that plate. This charge drives off some of the electrons from plate 2 of the condenser. These electrons seek to get as far away as possible from the negative charge. As a result they are driven

onto the grid of the tube. Here they remain, for the grid is cold and therefore cannot shoot off any electrons. Thus the grid gets a negative charge. But this charge is too small to stop entirely the flow of electrons from the heated filament to the plate.

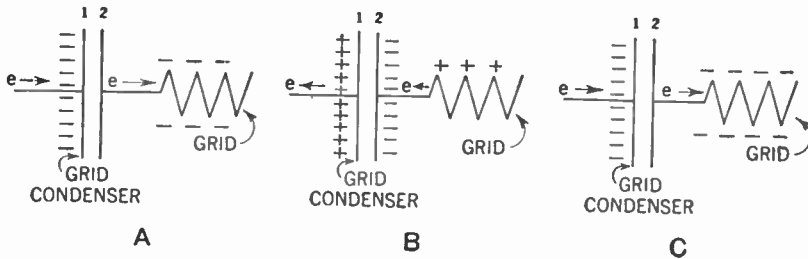

**Figure 72. The action of the grid condenser.**  
**A—A negative charge is placed on plate 1 of the condenser by current from the tuning circuit.**  
**B—A positive charge is placed on plate 1 of the condenser by current from the tuning circuit.**  
**C—Another negative charge is placed on plate 1 of the condenser by current from the tuning circuit.**

During the positive half-cycle of the alternating current from the tuner, a positive charge is placed on plate 1 of the condenser (Figure 72-B.) The electrons on the grid now are attracted back to plate 2. This movement leaves the grid with a positive charge and most of the electrons shot out by the heated filament of the tube rush to the plate of the tube. It should be noted, however, that some of these electrons strike the positively charged wires of the grid and are pulled over to plate 2 of the condenser.

During the next (negative) half-cycle, electrons are again piled up on plate 1 of the condenser (Figure 72-C). Once again electrons stream away from plate 2 to the grid. This time, however, there are more electrons on the grid. The electrons that were collected by the grid from the stream shot out by the filament during the positive half cycle have been trapped and cannot get away. So this time the grid has a larger negative charge.

As this process goes on, a larger and larger negative charge is collected by the grid. You see, we now have the same effect as when we placed a C battery in the grid circuit.

#### 94. The Function of the Grid Leak

But this process must not be permitted to go on indefinitely. Soon there will be accumulated upon the grid enough electrons to completely stop any electrons from reaching the plate of the tube.



## 116 THE VACUUM-TUBE DETECTOR—THE TRIODE

Since the electrons are trapped there, the action of the tube will be completely blocked and no signal can get through.

A method had to be worked out, therefore, to permit some of these electrons to flow off. A path was provided across the condenser so that when a positive charge was placed on plate 1, some of these trapped electrons could flow across to that plate. Provision had to be made so that not all of these trapped electrons could escape, for that would destroy the effectiveness of the condenser. Only enough of them should be permitted to leak off so that the action of the tube would not be blocked.

To provide this path, a *resistance* is connected across the condenser. A resistance is a substance that retards the flow of electrons through it. It is usually made of a special type of wire such as nichrome or of certain substances such as carbon. The greater the resistance the fewer the electrons that can flow through it. The symbol for a resistance is:



In Figure 73, you have the diagram of a receiving set using a triode as a detector. The tube used is a type called 01A. This tube requires an A or filament battery of 6 volts. The B or plate

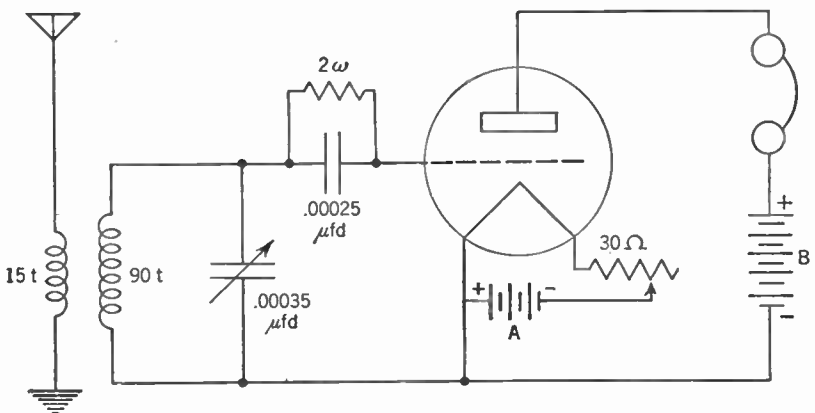

Figure 73. Diagram of the complete receiving set using the triode as a detector. The symbol  $2\omega$  over the grid leak stands for 2 megohms (2,000,000 ohms). The symbol  $30\Omega$  over the rheostat stands for 30 ohms.

battery is  $22\frac{1}{2}$  volts. The condenser used in the grid circuit is called a *grid condenser*. This condenser usually uses mica as a dielectric and its value is  $.00025 \mu\text{fd}$ .

Across this condenser is the resistance which furnishes the path

by means of which the excess electrons *leak* off the grid. Quite naturally it is called a *grid leak*. The unit for measuring resistance is the *ohm*. The value of the grid leak is 2,000,000 ohms or 2 megohms, the prefix "meg" meaning a million.

### 95. Volume Control

In the filament circuit, between the A battery and one end of the filament, you will notice a device shown by the symbol:



This is the symbol for a variable resistance or a *rheostat*. This rheostat controls the amount of current that can flow from the A battery to the filament. The resistance offered by this rheostat can be made greater or less by increasing or decreasing the length of wire through which the current must pass. This variation in length is produced by a sliding contact or by a switch moving over contact points connected to various points on the wire. Since the more current flowing through the filament, the hotter it gets, this rheostat then controls the heat of the filament. The hotter the filament, the more electrons it shoots off. The rheostat therefore controls the quantity of electrons shot off by the filament.

The more electrons hitting the plate, the greater the plate current. The greater the plate current, the greater the current through the phones and the louder the volume of the signal. So you see that this rheostat finally controls the volume of the signal.

As you have probably guessed, this rheostat is called a *volume control*. Its value is about 30 ohms.

Our receiving set, now, is quite an improvement over the one shown in Figure 22. By means of an antenna coupler we have improved its *selectivity*, that is, the ability to select the radio station desired and to reject all others. The use of the triode as a detector has increased the set's *sensitivity*. Now stations which were too weak to be heard on a crystal or diode detector set are heard in the phones.

### SUMMARY

1. Lee De Forest, an American, devised the *triode* tube.
2. The principle of the triode is that a third element called a *grid* is placed in the vacuum tube between the filament and plate.
3. The grid, when charged positively, permits electrons to flow

through it to the plate, but retards the flow of electrons when it is charged negatively.

4. By means of a C battery or by means of a condenser and grid leak the grid may be given a negative charge of the right amount.

5. This right amount of negative charge is that charge which will not prevent electrons going from the filament to the plate during the positive half of an alternating-current cycle, but will prevent them during the negative half of the alternating-current cycle.

6. The heat of the filament, and hence the volume of the signal, is controlled by a variable resistance or rheostat.

#### GLOSSARY

- A Battery:** The battery used to heat the tube's filament; also known as the **filament battery**.
- B Battery:** The battery used to place a positive charge on the plate of the tube. Also known as the **plate battery**.
- C Battery:** The battery used to place a fixed negative charge or bias on the grid of the tube. Also known as the **grid-bias battery**.
- Circuit, filament:** The path of electrons from the A battery, through the filament and back to the A battery.
- Circuit, grid:** The path of electrons from the filament to the grid of the tube, through connecting wires and electrical apparatus and back to the filament.
- Circuit, plate:** The path of electrons from the filament to the plate of the tube, through connecting wires and electrical apparatus and back to the filament.
- Grid:** An open-mesh metal screen, placed between the plate and the filament of the tube, that controls the stream of electrons going from the filament to the plate.
- Grid bias:** The fixed negative charge placed on the grid on the tube.
- Grid condenser:** A small fixed condenser placed in the grid circuit of the tube and used to hand on the electrical energy from the tuning circuit. This condenser also blocks the flow of electrons, accumulated on the grid, through the grid circuit.
- Grid leak:** A resistor placed across the grid condenser to provide a slight path or leak for the electrons accumulated on the grid of the tube.
- Meg-:** A prefix meaning 1,000,000.
- Ohm:** The unit in which we measure the resistance to the flow of electrons.
- Rheostat:** A variable resistor.
- Selectivity:** The ability of a tuner to select one radio station signal and reject all others.
- Sensitivity:** The ability of a radio receiver to respond to radio waves of very low strength.
- Triode:** A three-electrode tube containing a filament, grid, and plate.
- Volume control:** A resistance device, usually a rheostat, which controls

the volume of the radio signal coming out of the earphones or loud-speaker.

**SYMBOLS**

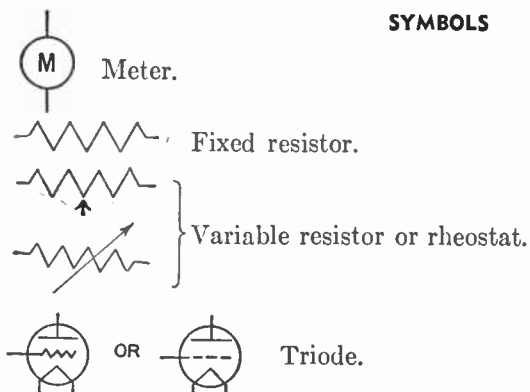

**QUESTIONS AND PROBLEMS**

1. Up to a certain saturation point, what is the effect of placing a higher positive voltage on the plate?
2. Why can't a B battery be used with a diode detector receiver?
3. How does the grid control the current flowing from the filament to the plate?
4. Impress an alternating voltage on the grid of a tube and make a graph of the current in the plate circuit.
5. Describe the construction of a triode.
6. Why should a triode be capable of giving louder signals in a receiver than a diode detector?
7. What function does the radio-frequency current serve in a triode when it is fed onto the grid?
8. What effect results from a positive voltage on the grid?
9. What purpose does the C battery serve? What is the C battery said to give the grid?
10. In what manner does the grid bias enable the triode to act as a detector?
11. How can we determine the magnitude of the grid bias used?
12. What disadvantage occurs when we use a C battery for a grid bias?
13. Explain the operation of a grid leak and grid condenser in making the triode act as a detector.
14. What is the function of a rheostat in the filament circuit? Explain how it carries out this function.
15. Draw a one-tube receiver using a triode as a detector and using a C battery as a grid bias.
16. Repeat the above, using a grid leak and grid condenser as a grid bias.

## CHAPTER 16

# The Regenerative Detector

---

- Problem 1:** *What are the principles of the regenerative system in the detector?*
- Problem 2:** *How are the faults of this system corrected?*
- Problem 3:** *How can we build a practical receiving set with a "feedback" system?*
- 

At this point in the development of the science of radio, there arose a tremendous desire for increased sensitivity in the receiving sets. The thrill of hearing a faraway radio station entranced amateur and professional alike. The hue and cry was for more "DX" (long-distance) reception.

### 96. The Feedback Circuit

This demand was satisfied by giving a new twist to the triode detector receiving set. We now call this device the *regenerative* or *feedback circuit*. Here is how it works.

When we considered the tuning circuit, you learned that there were two streams of electrons oscillating through that circuit in step with each other. One was the stream set flowing by the discharge of the tuning condenser. The other was the stream set flowing by mutual induction from the aerial-ground system.

Theoretically, the oscillations of the electrons in the tuning circuit should have continued to build up or gain in strength indefinitely. Actually, however, the resistance in the circuit limited the degree to which these oscillations could be built up. So you see there are two reasons for reducing the resistance against current flow in the tuning circuit. One, as you know, is to make our set more selective. The other is to build up the oscillations of electrons. With less resistance a greater current will flow and

therefore a weak impulse from a distant station will be built up to the point where we can hear it in our phones.

Try as we may, however, we cannot completely eliminate the resistance from our circuit. A certain minimum will always remain. This minimum can be made small enough so that it does not interfere with the selectivity of the set, but it will always remain large enough to limit the degree to which we can build up the oscillations in the tuning circuit.

An American scientist, Major E. H. Armstrong, conceived the idea of causing a third stream of electrons to flow in the tuning circuit in step with the other two. This third stream supplied the electrical energy to overcome the resistance in the circuit and now the oscillations could build up to a very high degree.

He accomplished this by causing the plate current to flow through a coil of wire called a *plate coil* or *tickler*. This plate coil was placed in close proximity to the secondary of the antenna coupler. When the plate current flowed through the plate coil, a magnetic field was created around this coil. This field cut across

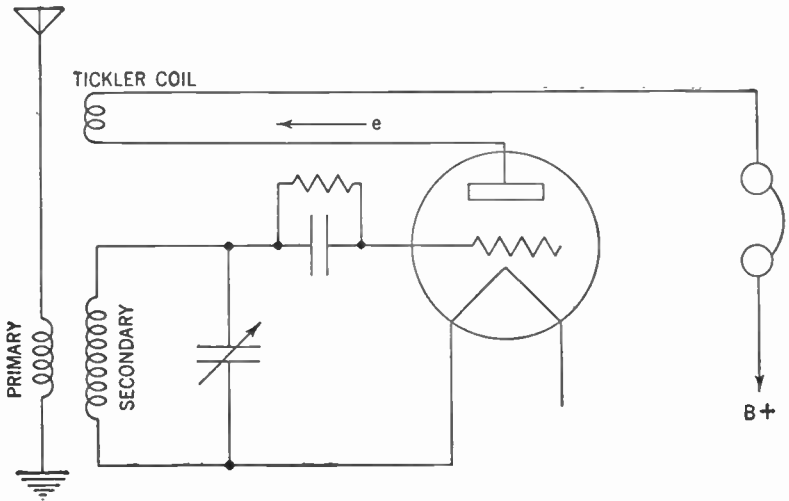

Figure 74. Diagram showing how plate current is fed back to the tuning circuit by means of the tickler coil.

the turns of the secondary of the antenna coupler and set a stream of electrons flowing in the tuning circuit just as did the primary of the antenna coupler.

So you see, current from the plate circuit has been *fed back* to

the tuning circuit. The fluctuating direct current flowing through the tickler coil sets up an alternating voltage that causes current to flow in the secondary of the antenna coupler by transformer action (Figure 37-A). Since the variations in the plate current were produced by the variations of current flowing in the tuner, the two currents are in step. This arrangement of the three coils is sometimes called a *three-circuit tuner*.

However, the oscillations of electrons in the tuning circuit were built up so well that another problem presented itself.

### 97. The Receiver Becomes a Transmitter

It was stated in Chapter 3 that if electrical pulses are sent through a circuit 10,000 times or oftener per second, a radio wave is created. Here, now, electrical pulses are being sent through the tuning circuit tens of thousands and perhaps millions of times per second. Under normal conditions the oscillations of electrons in the tuning circuit are too weak to cause any damage. But now, because the resistance of the tuning circuit has been overcome, these oscillations are built up to a point where a strong radio wave is created and our receiving set becomes a transmitting station.

This radio wave interferes with the incoming signal and causes clicks, whistles, and howls in our phones. Some of you may remember the early days of the regenerative receiver. You may remember how frequently these howls and whistles occurred. And you may remember receiving these howls and whistles from receiving sets as far away as several blocks!

When the oscillations become too strong and the receiving set becomes a transmitter, we say the set *oscillates* or *spills over*. The trick, then, is to permit the oscillations in the tuning circuit to build up to a point just before the set starts to oscillate. It is at this point that we get our loudest, undistorted signal.

### 98. Controlling the Oscillations by Moving the Tickler Coil

This limitation is usually accomplished by one of three methods. First, there is the method of controlling the efficiency of the feedback action. If we place the tickler coil further away from the secondary of the antenna coupler the electrical energy transmitted by mutual induction becomes smaller. This means that a smaller stream of electrons is set flowing in the tuning circuit. The trick is to set a stream of electrons flowing which will

just fail to overcome the resistance of the tuning circuit. It is this excess resistance that will prevent the oscillations from being built up too much.

The same effect is accomplished by changing the angle which

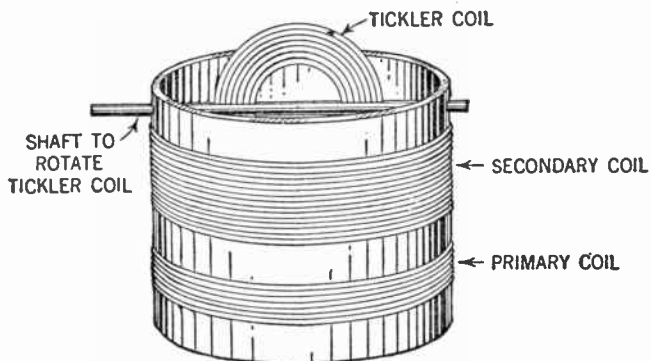

Figure 75. Three-circuit tuner showing arrangement to vary the coupling between the secondary coil and the tickler coil.

the tickler coil makes with the secondary of the antenna coupler. When the two coils are parallel you get the maximum feedback. When the two coils are at right angles, you get the minimum feedback. By making the angle adjustable, you are able to get the

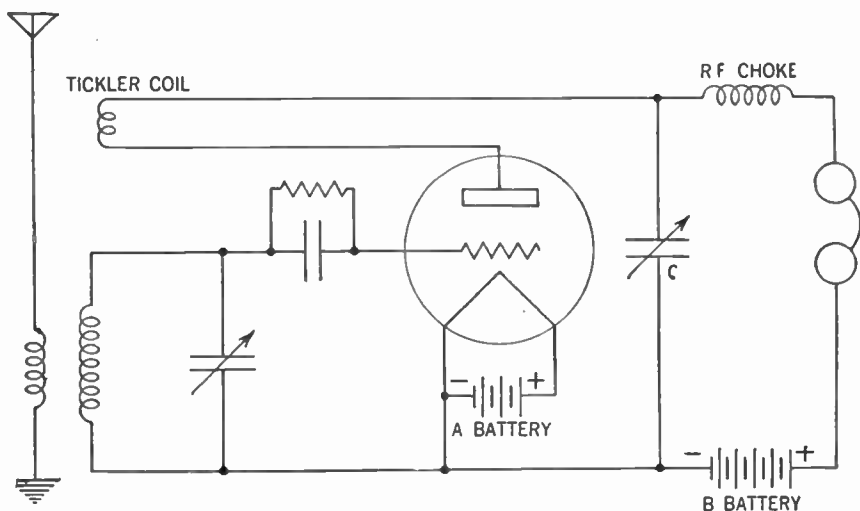

Figure 76. Three-circuit tuner using a variable condenser (C) to control the amount of feedback. The inductance marked "R. F. Choke" is a small coil of wire used to direct the plate current into the tickler coil.



desired amount of feedback. When we use this method of controlling the feedback we say that we vary the *coupling* between the two coils.

### 99. Controlling by a Variable Condenser

Another method is to utilize a *variable condenser* connected as shown in Figure 76. Now some of the electrical energy flowing in the plate circuit is used up to place a charge on this condenser. This means that there is less electrical energy left to be fed back to the tuning circuit. By varying the size of the condenser, you can vary the amount of electrical energy drained away and thus control the amount of energy to be fed back to the tuning circuit. The variable condenser used is usually the same size as the one used in the tuning circuit.

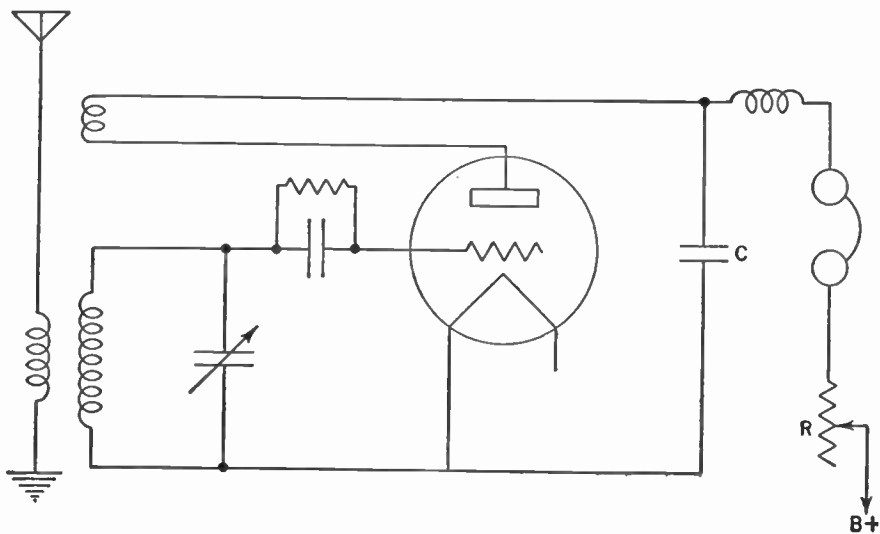

Figure 77. Three-circuit tuner using a fixed condenser (C) of about .00025 microfarad and a rheostat (R) of about 50,000 ohms to control the amount of feedback.

### 100. Using a Fixed Condenser and a Rheostat to Control the Feedback

The third method is to substitute a *fixed condenser*, whose value is usually about  $.00025 \mu\text{fd.}$ , for the variable condenser described above. We now control the amount of electrical energy fed back to the tuner by placing our old friend, the *rheostat*, in the plate circuit, as shown in Figure 77. This rheostat, usually of

about 50,000 ohms value, controls the total amount of current flowing in the plate circuit. Since a constant amount of electrical energy is drained off by the fixed condenser, the variation in the total electrical energy in the plate circuit will determine how much will be fed back to the tuner. Since, by means of the rheostat, we can vary the current in the plate circuit, we have a means for controlling the feedback current.

Another variation using the rheostat to control the amount of feedback is merely to place a 50,000-ohm rheostat across the tickler coil as in Figure 78. Now the current flowing in the plate circuit

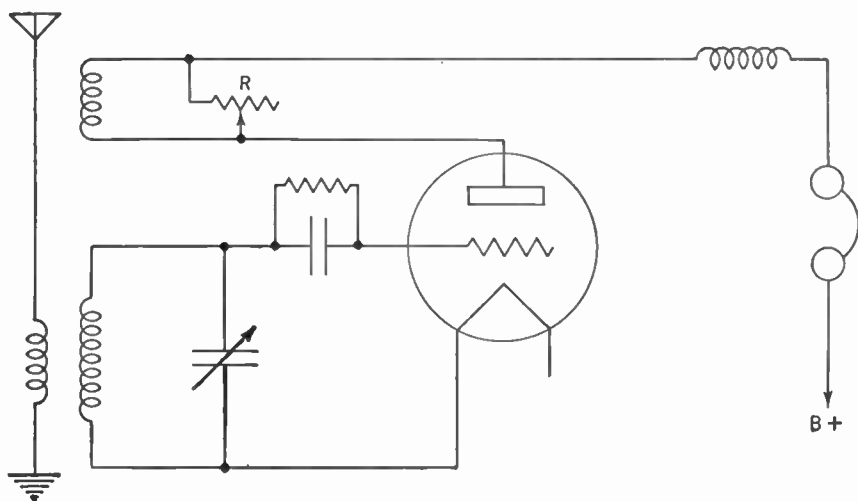

Figure 78. Three-circuit tuner using a rheostat (R) of about 50,000 ohms to vary the amount of feedback.

has two paths to follow. Part of it flows from the plate, through the rheostat and into the phones. None of this current is fed back to the tuner. The rest goes through the tickler coil and is fed back to the tuning circuit. The greater the resistance of the rheostat, the less current can flow through it and the more current flows through the tickler coil; and therefore, the more electrical energy is fed back. Thus by varying the resistance by means of the rheostat, you can vary the amount of feedback.

### 101. Building a Regenerative Receiver

These three controls of feedback—the coupling control (Figure 75), the variable condenser (Figure 76), and the rheostat (Figures 77 and 78), are called *regenerative* or *feedback controls*.

If you wish to build a regenerative set, here is how to make the coils. Obtain a cardboard mailing tube about 2 in. in diameter and about 6 in. long. At about  $\frac{1}{2}$  in. from one end drill a fine hole with a pin or needle. Thread in about a foot of No. 28 gauge double cotton-covered copper wire. This is to anchor the winding. Now wind on 15 turns of this wire, placing the turns next to each other. Anchor this end and all the ends of the other two coils the same way as above. This is your tickler coil. Look at Figure 79 to see that you have the right idea for winding the coils.

About  $\frac{1}{8}$  in. from the bottom of the tickler, start winding the secondary of the antenna coupler. Note that all three coils must be wound in the same direction. Wind on 90 turns of wire.

About  $\frac{1}{8}$  in. from the bottom of the secondary coil, wind on 15 turns for the primary of the antenna coupler.

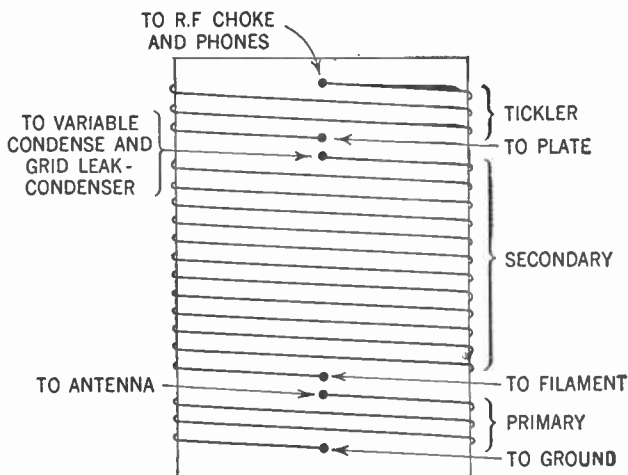

Figure 79. Diagram showing construction and connections of the three-circuit tuner.

## 102. Connecting the Parts

Now connect the top of the tickler coil to the R. F. choke and phones and the bottom of this coil to the plate of the tube. Refer to Figures 76, 77, 78, and 79. The top of the secondary of the antenna coupler goes to one end of the variable tuning condenser (usually the stationary plate terminal), and to the grid leak and grid condenser. The bottom of this coil goes to the other end of the variable tuning condenser (usually the rotary plate terminal) and the filament of the tube.

The top of the primary coil of the antenna coupler goes to the antenna, the bottom to the ground.

Here is how you operate the regenerative receiver. First tune in your station just as you would on any other set. Now rotate your regenerative control. The signal will get louder and louder until a point is reached where you will hear clicks, whistles, or howls. Now turn your regenerative control back to just before that point is reached. Your set is now tuned in for most efficient reception.

We have now traced the development of radio receivers to a point where we have made a set that is both selective and sensitive. The crystal detector has been replaced by the more stable and efficient triode. Reception is not perfect yet, but millions of radio fans all over the world, sitting up in the small hours of the night, have listened over such radio receivers to that much desired "DX" station.

#### SUMMARY

1. The **regenerative principle** was added to radio receiving sets to provide greater sensitivity in radio receivers and hence the possibility of receiving more distant stations.

2. This regenerative or **feedback principle** depends upon a third coil, connected to the plate circuit, but coupled inductively to the secondary of the tuning circuit.

3. The electron stream in the secondary of the antenna coupler set flowing by the **tickler coil** oscillates in step with the incoming impulses and builds up their strength.

4. The fault of the regenerative system is its tendency to produce whistles in the phones by oscillating like a transmitting station.

5. This tendency to oscillate may be controlled by (a) a movable tickler coil; (b) by connecting the tickler coil in series with a variable condenser; (c) by using a fixed condenser in combination with a rheostat; (d) by using a rheostat across the tickler coil.

#### GLOSSARY

**Coupling:** The degree to which electrical energy is handed on from one circuit to another.

**Grid coil:** The coil which is connected in the grid circuit of the tube. As discussed in this chapter the grid coil is the secondary of the antenna coupler.

**Grid return:** The wire connecting the end of the grid coil with the filament of the tube.

**Oscillate:** The condition under which the electrons flowing in the tuning circuit of the receiver cause it to become a transmitter of radio waves.

**Plate coil or Tickler:** The coil which is connected in the plate circuit of the tube.

**Regeneration:** The action whereby electrical energy in the plate circuit is fed back to the grid circuit to be amplified again and thus produce a louder signal in the earphones or loudspeaker.

**Regenerative control:** The device by which the amount of electrical energy fed back to the grid circuit is controlled, thus preventing the receiver from oscillating.

**Three-circuit tuner:** A tuner coupled to the plate circuit as well as to the aerial-ground system.

SYMBOLS

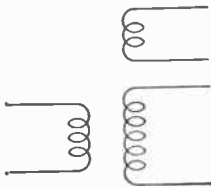

The three-circuit tuner.

QUESTIONS AND PROBLEMS

1. What factor acts to reduce and finally squelch the oscillations of electrons in a tuning circuit?
2. Where does the tickler obtain the energy to feed back to the tuned circuit?
3. Explain how direct current flowing in the tickler produces additional energy in the tuning circuit where alternating current is flowing.
4. Under what circumstance will a receiver act as a transmitter?
5. Describe three methods of regeneration control.
6. Draw a diagram of the coil used for a regenerative receiver, indicating the points for connecting of the coils.
7. What is the purpose of a regenerative control?
8. How do you tune a regenerative receiver for a station?

## CHAPTER 17

# The Audio-frequency Amplifier

---

- Problem 1:** *Why is an amplifier necessary in that part of the circuit in which the earphones are connected?*
- Problem 2:** *What are the principles of the audio-frequency amplifier?*
- Problem 3:** *What are the practical applications of audio-frequency amplifiers?*
- 

Although our radio set has been developed to the point where it can bring in weak or distant stations and separate out the unwanted ones, it still has a serious drawback. We still have to use earphones. Not only is it a nuisance to wear them but, moreover, only the person who has them on his head can hear the radio program.

### 103. The Audio-frequency (A.F.) Amplifier

To meet this objection the audio-frequency amplifier was developed.

You already know how we can attach a large paper cone to the diaphragm of the earphone and thus get a louder sound. But in order to move this large cone we must have more electrical power than ordinarily comes out of the detector. It becomes necessary to amplify or build up the electrical current flowing out of the detector before it can properly operate the loud speaker.

The triode furnishes us with the means for this building up. You know that a small current, placing electrical charges on the grid of the tube, will cause a much larger plate current to flow. This plate current closely follows the fluctuations and variations of the current being fed into the grid, and thus we get out of the tube a much greater current than was put into it, while all the fluctuations are retained in their proper proportions. The signal

coming out of the tube will accordingly be the same as the signal fed into it except that it will be much louder. Of course, you know that the B battery supplies the extra power.

All we have to do, therefore, is to feed the plate current from our detector tube into the grid of another tube. The plate current flowing from this second tube will then be our amplified signal.

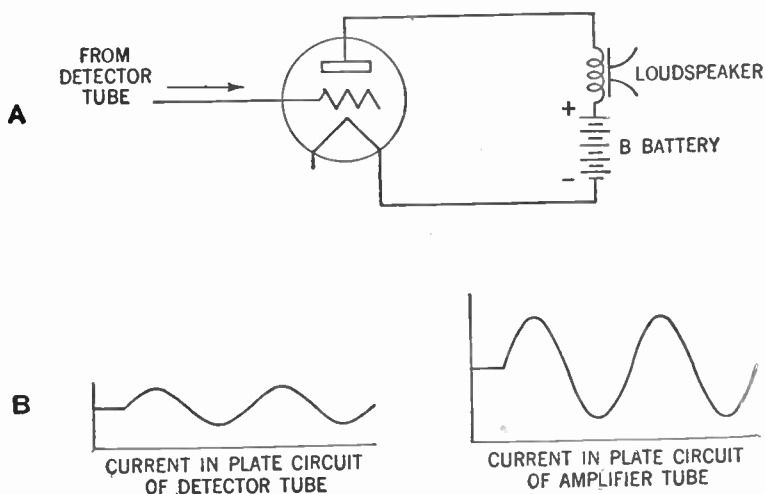

**Figure 80.** A—Audio amplifier showing how signal from the detector tube is fed to the grid of the audio-amplifier tube.  
B—Graph showing relationship between current flowing in the plate circuit of the detector tube and current in plate circuit of amplifier tube.

This second tube is called the *amplifier tube*. Theoretically, all we need is one such amplifier tube to give us the additional power required to operate the loudspeaker. In practice, however, we find that there are certain factors which limit the amplification possible with one tube. We therefore usually repeat the whole process, using a second amplifier tube to build the signal up still more to a point where the current will be strong enough to operate the loudspeaker. Each time we amplify the signal by the use of an additional triode we say we add one *stage of amplification*. Usually, two stages of amplification are required.

The electrical current flowing in the aerial-ground system and the tuning circuit is radio-frequency current. That is, it alternates millions of times per second. When this current comes out of the detector, it consists of a series of pulses. These pulses, too, occur millions of times per second, that is, at radio frequency. But when

you examine Figure 55, you see that the current flowing through the phones is fluctuating at a much slower rate. A series or train of the fast pulses or fluctuations have combined to make one slow fluctuation or pulse.

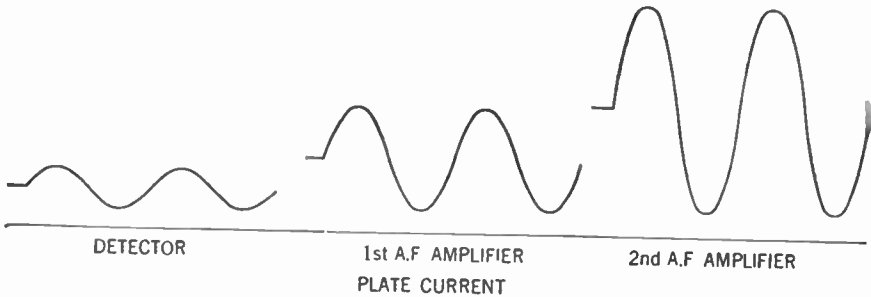

Figure 81. Graphs showing plate current in the detector, the first audio amplifier, and the second audio amplifier.

It is this slow fluctuation which moves the diaphragm and thus produces the sound we hear. We therefore say that this slow fluctuation is at *audio frequency*. The range of audio frequency is from about 30 to 15,000 cycles per second.

Inasmuch as we are now amplifying our signal after it passes out of our detector (after it is changed from radio frequency to audio frequency), we call the amplifier tubes *audio-frequency amplifiers*.

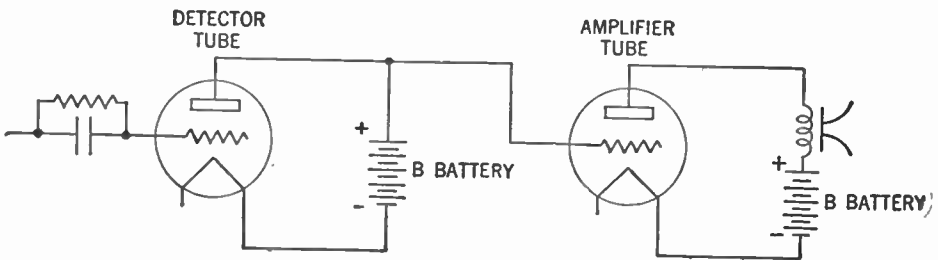

Figure 82. Diagram showing plate of detector tube connected to the grid of the amplifier tube.

### 104. Methods of Coupling

The next thing to consider is how to feed the current flowing in the plate circuit of the detector tube into the amplifier tube. This is called *coupling*. Look at Figure 82. You will see that the grid of the amplifier tube is connected to the plate of the detector tube.



A difficulty will immediately be noticed. The large B battery of the detector tube, connected directly to the grid of the amplifier tube, will place a large positive charge on that grid and thus the fluctuations of plate current will be blanketed out and no

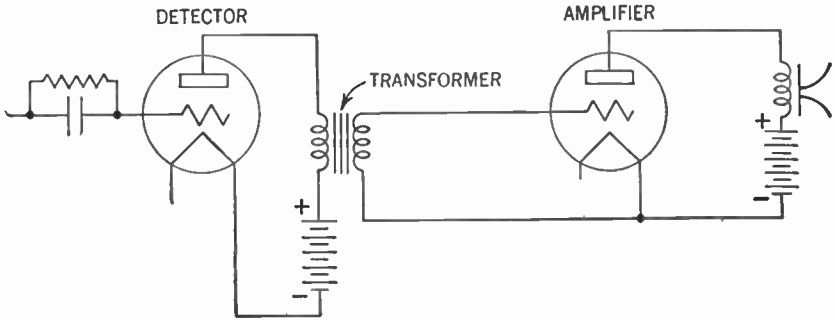

**Figure 83.** Diagram showing how the detector is coupled to the A. F. amplifier by means of a transformer.

signal will pass. A method must be devised that will pass on the fluctuations of plate current and yet be able to keep out the large positive charge of the B battery.

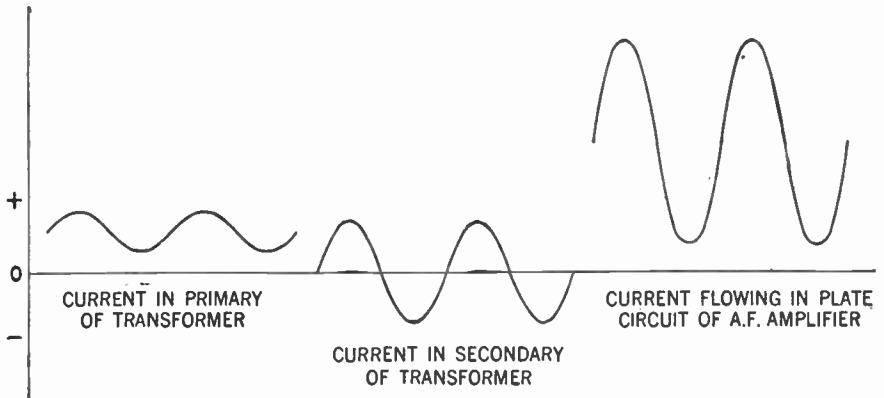

**Figure 84.** Graphs showing current flowing in primary and secondary of the transformer and in the plate circuit of the A. F. amplifier. Note that the shape of all three curves is the same although the amplitudes vary.

### 105. We Use a Transformer

Here, again, we call upon our old friend the transformer. We connect the primary in the plate circuit of the detector tube and the secondary in the grid circuit of the amplifier tube. (See Figure 83.)

Now the fluctuating plate current in the primary will set up an alternating voltage or electrical pressure in the secondary. This voltage will fluctuate in step with the fluctuations of plate current (Figure 37-A).

This fluctuating voltage will place fluctuating positive and negative charges on the grid of the amplifier tube and this, in turn, will control the plate current flowing in the plate circuit of the amplifier. This plate current in the amplifier tube will have the same form as the plate current in the detector tube, but will have a greater amplitude, indicating greater power.

Because these currents are audio-frequency currents, we are able to utilize the greater efficiency of an iron-core transformer. The symbol for such a transformer is:

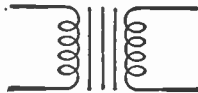

In addition, we are able to utilize the advantages of a step-up transformer. This gives us an additional amplification of the signal. In practice, it has been found that the maximum step-up permissible is about 1 to 5, that is, the secondary has about five times as many turns as the primary. Any greater step-up results in distortion and other losses.

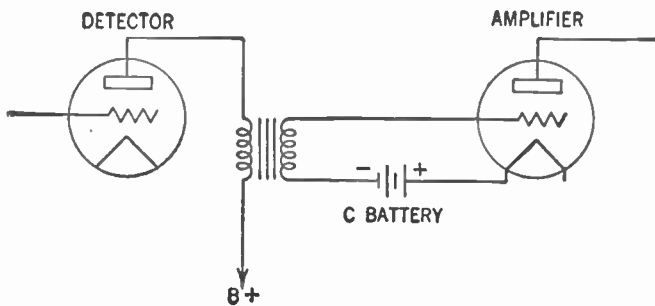

Figure 85. Diagram showing how a C battery is connected in the grid circuit of the amplifier tube.

### 106. Avoiding Distortion by Grid Bias

We must keep in mind that the amplifier must not only magnify the signal, but must reproduce it in its original form. In other words, there must be a minimum of distortion. One serious

objection to our amplifier, as shown in Figure 83, is that when the grid of our amplifier tube becomes positively charged, it will attract some of the electrons streaming from the heated filament and a current will flow in the grid circuit of the tube. This will produce distortion.

To overcome this defect, a C battery is placed in the grid circuit. This battery places a negative *charge* or *bias* on the grid of the amplifier tube and thus prevents the flow of grid current.

This grid bias keeps the grid negative at all times and the negative and positive charges placed on the grid by the alternating voltage across the secondary of the coupling transformer makes the grid more or less negative. (See Chapters 37 and 38 in Vol. II.)

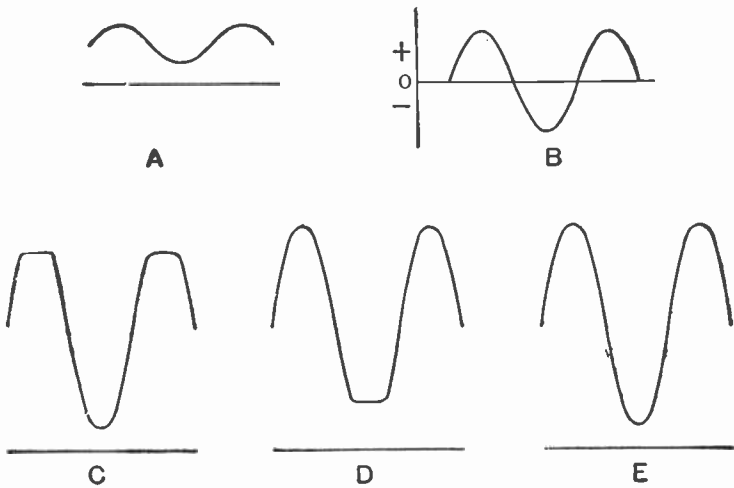

Figure 86. Graphs showing effects of grid bias.

- A—Graph of current flowing in primary of transformer.
- B—Graph of current flowing in secondary of transformer.
- C—Graph of current flowing in plate circuit of amplifier tube when grid bias is too low. A large positive charge on the grid drives it positive and it attracts electrons which would normally flow to the plate. A grid current flows and this causes distortion.
- D—Graph of plate current when grid bias is too high. A large negative charge drives the grid so far negative that all the electrons are repelled and no plate current flows. This, too, causes distortion.
- E—Graph of current flowing in the plate circuit of amplifier tube when grid bias is just right. Note that the wave form corresponds to that of Figure A.

Another precaution must be taken. In the amplifier tube, unlike the detector tube, the negative charges placed on the grid by the transformer must be prevented from driving the grid so far

negative as to cut off the flow of plate current. Such a situation would lop off part of the bottom loop of our curve and distortion would arise (Figure 86-D).

### 107. Standard Tubes and Grid Bias

Manufacturers of tubes furnish charts showing the proper value of grid bias to be used with their tubes. Thus, if we use an R.C.A. type 01A tube as an amplifier with a plate battery of 135 volts, the C battery, or bias, must be  $-9$  volts.

You may see from the above data that we can use B batteries of much greater voltage than are used in the detector circuit. Thus greater plate current, with enough power to operate the loud speaker, will be possible.

### 108. How to Couple the Audio-frequency Transformer

This method of coupling one tube to another is called *transformer coupling*. The transformer used is called an *audio-frequency transformer*. The primary winding has two terminals marked P and B +. The P terminal is connected to the plate of the detector tube, while the B + goes to the positive terminal of

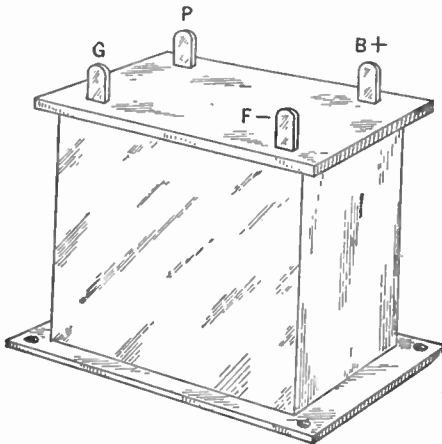

Figure 87. The Audio-frequency Transformer.

the B battery. The secondary winding also has two terminals marked G and F -. The G terminal is connected to the grid of the amplifier tube while the F - goes to the negative post of the C battery.

There is another method used to couple one tube with another

A fixed condenser is inserted between the plate of the detector tube and the grid of the amplifier tube (Figure 88).

### 109. Use of a Coupling Condenser

Now the stream of electrons flowing in the plate circuit of the detector tube divides at point *x*. Some flow to the positive post of the B battery, while others pile up on plate 1 of the condenser.

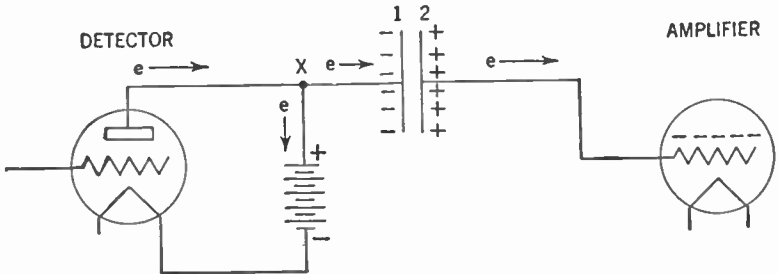

Figure 88. Diagram showing how a fixed condenser is used to couple the amplifier tube to the detector.

Thus a negative charge is placed on this plate. This negative charge drives electrons away from plate 2 of the condenser, leaving a positive charge there. The electrons thus driven away pile up on the grid of the amplifier tube, making that grid negative. Fluctuations in the plate current of the detector tube thus cause a fluctuating negative charge to be placed upon the grid of the amplifier tube. This in turn causes a fluctuating current to flow in the plate circuit of the amplifier tube.

This fixed condenser is called a *coupling condenser*. It has mica for its dielectric and its value is usually about  $.006 \mu\text{fd}$ .

### 110. Why We Need a Resistor in the Plate Circuit

But we have the B battery in the plate circuit of the detector tube to contend with. Because of its large size, the positive post has a very large deficiency of electrons. Thus, unless some means is found to prevent it, all the electrons flowing in the plate circuit of the detector tube will be attracted to it and none will be left to place a negative charge on the condenser.

To meet this difficulty a resistor (Figure 89) is placed between the positive post of the B battery and point *x*.

This resistor (*R*) retards the flow of electrons to the positive post of the B battery and thus forces some of the electrons flowing

in the plate circuit to flow to plate 1 of the condenser. This resistor is called a *plate resistor* and is usually about 100,000 ohms.

As in the case of transformer coupling, a C battery is placed in the grid circuit of the amplifier tube to prevent the flow of grid current which would cause distortion.

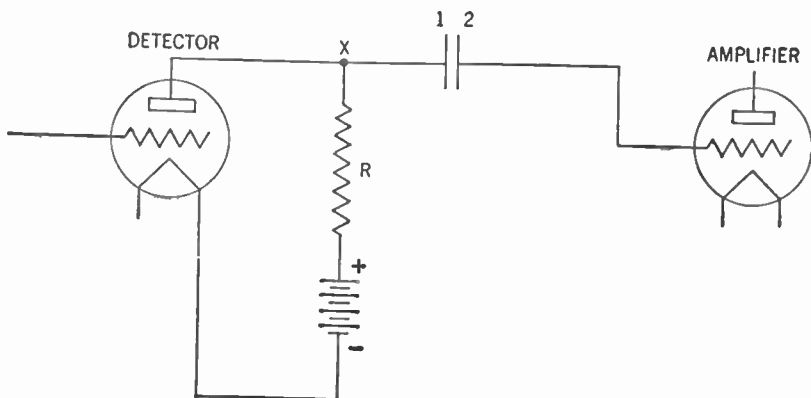

Figure 89. Diagram showing how plate resistor (R) is placed in the circuit.

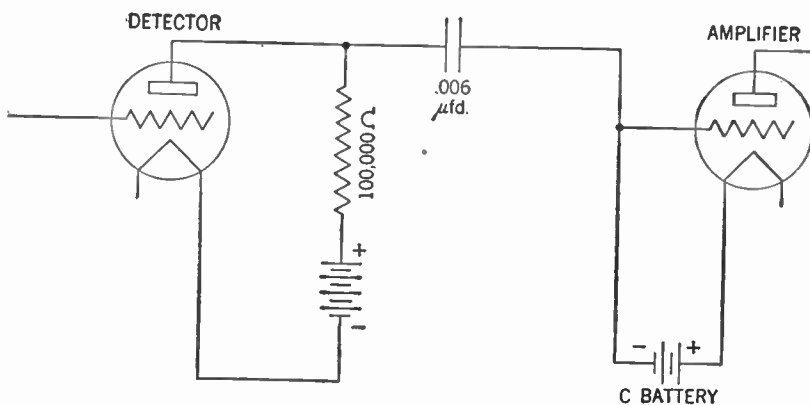

Figure 90. Diagram showing how the C battery is connected in the grid circuit of the amplifier tube.

### 111. A Grid Resistor also Is Needed

But there is still another difficulty to overcome. We are dealing with loud signals, which means that the stream of electrons may be very large. Thus it becomes possible that the stream of electrons set flowing from plate 2 of the condenser may make the

grid of the amplifier so negative as to completely cut off the flow of electrons from the heated filament to the plate.

To meet this difficulty a path is provided for these electrons to leak off slowly from the grid to the filament. A resistor is placed in the grid circuit between the C battery and the grid.

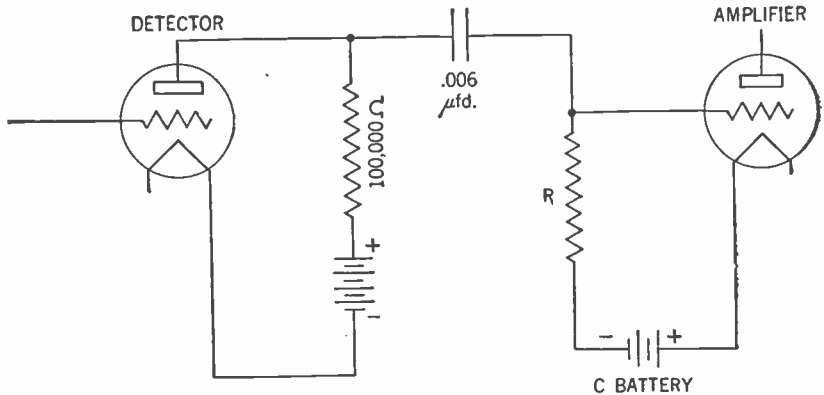

Figure 91. Diagram showing how grid resistor (R) is placed in the circuit.

This resistor is called the *grid resistor*. Its value usually is about 2,000,000 ohms (2 megohms).

This method of coupling is called *resistance coupling*. As in the case of the transformer-coupled amplifier stage described above, this amplification is at audio frequency and it is therefore described as a stage of *resistance-coupled audio-frequency amplification*.

## 112. Transformer vs. Resistance Coupling

Each of the two methods of coupling has certain advantages and disadvantages. The transformer method of coupling has the advantage that, stage for stage, it will give a greater amplification than does the resistance method of coupling. Two stages of transformer-coupled audio-frequency amplification are about equal to three stages of resistance-coupled audio-frequency amplification. The need of fewer stages with the transformers than with the resistors is due to the amplification resulting from the use of step-up transformers.

Further, we need a less powerful B battery with transformer coupling than is needed with resistance coupling to obtain the

same plate current. This difference is due to the fact that the large resistor used for a plate resistor in the resistance-coupled audio-frequency amplifier cuts down the amount of positive charge that the B battery can place on the plate of the tube.

Still another advantage is the simplicity of the transformer-coupled stage. Only one part is needed for the coupling, the audio-frequency transformer.

The resistance-coupled amplifier has the advantage in that it reproduces the signal more faithfully. The audio-frequency transformer usually introduces a certain amount of distortion. Another advantage is that resistance coupling is cheaper and lighter than the audio-frequency transformer.

### 113. The Audio-frequency Amplifier Unit

In considering the radio receiving set as a whole, the several stages of audio-frequency amplification are usually treated together as a separate unit. In fact, in some modern receivers this unit is built separately and apart from the rest of the set. As previously stated, this unit may consist of two stages of transformer-coupled or three stages of resistance-coupled amplification.

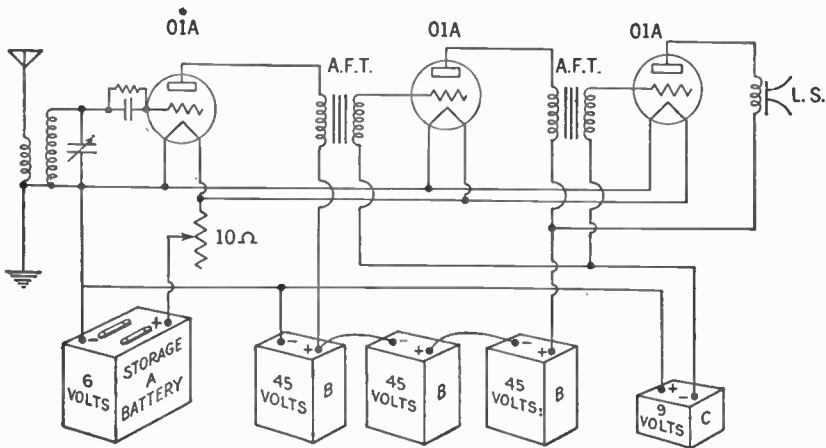

Figure 92. Diagram showing detector and two stages of transformer-coupled audio-frequency amplification.

Often the two systems are combined, with one or two stages of resistance-coupled amplification followed by a stage of transformer-coupled amplification.

It is impractical to use more than two stages of transformer-



coupled or three stages of resistance-coupled amplification. If we do, we may encounter serious distortion of the signal. Besides, for normal use, more amplification is not necessary.

In Figure 92, we have a detector followed by two stages of transformer-coupled amplification.

The tubes used are triodes of a type known as 01A. Instead of using separate A batteries for each tube, the filaments of the tubes are hooked together in parallel and connected to a single battery supplying 6 volts. The rheostat used as a volume control now limits the amount of current flowing in the filaments of all three tubes. For this purpose we use a rheostat of 10 ohms.

To obtain the B battery of 135 volts, we connect three 45-volt batteries in *series*. That is, we connect the positive terminal of one to the negative terminal of another. To obtain the 45 volts needed for the detector tube, we make our connections between the negative terminal of the first battery and the positive terminal of this same battery. If, however, we connect between the negative terminal of the first battery and the positive terminal of the third battery we obtain the 135 volts needed for our amplifier tubes.

The C-battery connections of the two amplifier tubes are likewise connected and we now can use a single C battery of 9 volts.

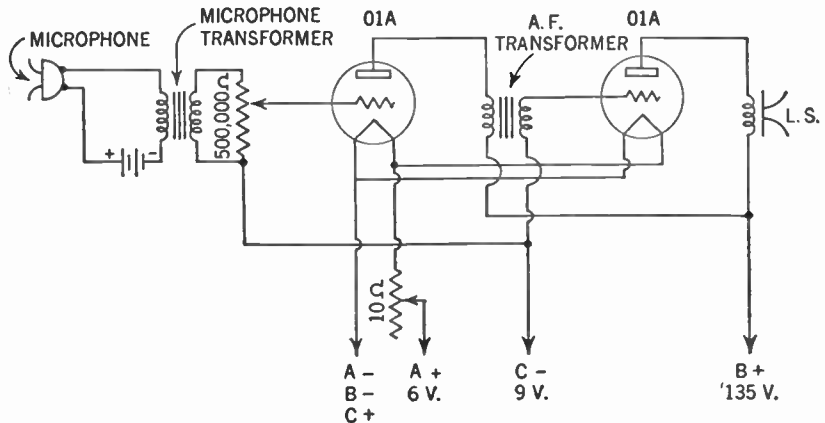

Figure 93. Diagram showing circuit of the public-address system.

#### 114. The Public-address System

We can use the audio-frequency amplifier for other purposes than amplifying a radio signal. Suppose you were to feed an

alternating voltage set up by a microphone into the grid of your amplifier tube. You would now have the public-address system used by speakers in addressing large audiences.

The microphone is similar to the telephone transmitter of Figure 11. Speaking into the microphone varies its resistance and thus causes the direct current flowing through the primary of the transformer to vary. The direct current varies in step with the variations of the sound waves created by the speaker.

This fluctuating direct current flowing through the primary of the transformer sets up a varying, alternating voltage across the secondary. This alternating voltage places varying charges upon the grid of the amplifier tube and this variation in turn causes a large, fluctuating direct current to flow in the plate circuit of the tube. After another stage of amplification the current is strong enough to operate the powerful loudspeaker.

The transformer used in a microphone circuit is similar to the audio-frequency transformer used in the radio receiver. However, in connection with it note, in Figure 93, a device that looks like a rheostat across the secondary. This is known as a *potentiometer*. Its use is to limit the amount of charge placed on the grid of the tube and thus control the volume of the amplifier. Its value in this case is about 500,000 ohms. The symbol for a

potentiometer is: 

### 115. The Electrical Phonograph

Still another use for the audio-frequency amplifier is the electrical phonograph. Use is made of the peculiar properties of crystals of a chemical compound known as Rochelle salts. When one of these crystals is squeezed it generates a minute alternating electrical voltage. This voltage varies with the variations in pressure upon the crystal. This phenomenon is known as the *piezo-electrical effect*.

Such a crystal is mounted so that the vibrations of a phonograph needle, traveling in the grooves of a phonograph record, place a varying pressure upon it. In the crystal an alternating voltage is generated that varies in step with this pressure. This voltage is fed to the grid of the amplifier tube, placing a varying electrical charge upon it. This charge in turn causes a fluctuating direct current to flow in the plate circuit of the tube. After an-

other stage of amplification the current is strong enough to operate the loudspeaker. (See Figure 94.)

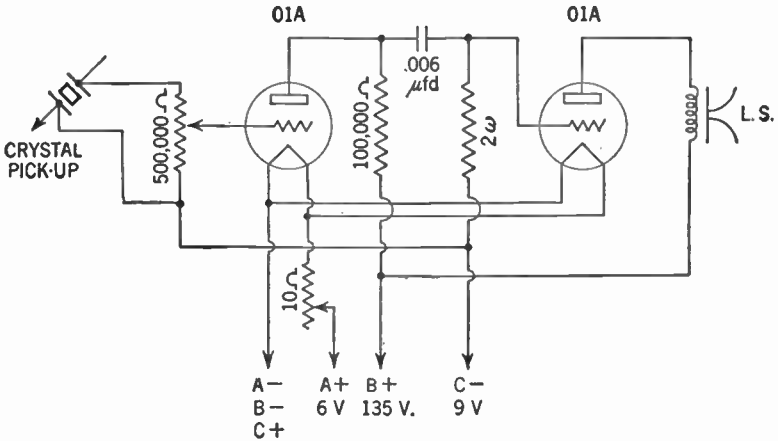

Figure 94. Diagram showing circuit of the electrical phonograph.

The crystal and its mounting is known as a *crystal phonograph pickup*. The symbol for such a pickup is:



Note that no transformer is necessary here to couple the crystal pickup with the tube. The reason is that the voltage generated is alternating voltage and it can be applied directly to the grid of the tube. A 500,000-ohm potentiometer acts as a volume control, just as in the case of the public-address system.

This suggests some uses to which the audio-frequency amplifier can be put. It can be used anywhere that a very small electrical voltage is to be amplified. It has been used successfully with photo-electric cells, in electrocardiograph machines, and the like. Each day brings forth new uses for this wonderful device.

#### SUMMARY

1. The purpose of the **audio-frequency amplifier** is to increase the intensity (loudness) of the signals so that a loudspeaker may be used instead of earphones.

2. The principle of the audio-frequency amplifier is to connect the plate circuit of a tube to the grid of another tube. The plate current in the second tube will then be an amplified reproduction of the signal in the detector tube.

3. By connecting a third tube in the same manner to the plate circuit of the first amplifying tube a second stage of amplification may be made.
4. Distortion in the amplifying system is prevented by carefully balanced values of grid bias, plate resistors, and capacity.
5. Audio-frequency amplifiers are used for public-address systems, to increase the loudness of phonograph records, for amplifying signals of photo-electric cells, and for many other purposes.

GLOSSARY

- Amplifier, audio-frequency:** A circuit to amplify the electric currents flowing out of the detector, thereby enabling us to use a loudspeaker.
- Amplification, stage of:** The tube and its accompanying electrical devices serving as an amplifier.
- Audio frequency (A.F.):** A frequency in the range between 30 and 15,000 cycles per second.
- Audio-frequency transformer:** An iron-core transformer used to transfer electrical energy at audio frequencies from one tube to another.
- Coupling condenser:** A fixed condenser used in a resistance-coupled amplifier to transfer electrical energy from one tube to another.
- Grid resistor:** A resistor connected in the grid circuit of a tube.
- Microphone:** A device used to change sound waves to a fluctuating electrical current.
- Phonograph pickup:** A device used to change variations in a phonograph-record sound-track to a fluctuating electric current.
- Piezoelectric effect:** The effect whereby pressure on certain types of crystals produces an electric current.
- Plate resistor:** A resistor connected in the plate circuit of a tube.
- Potentiometer:** A resistance device enabling us to tap off portions of the entire voltage placed across it.
- Resistance coupling:** Coupling between the plate circuit of one tube and the grid circuit of the next by means of resistors and a coupling condenser.
- Transformer coupling:** Coupling between the plate circuit of one tube and the grid circuit of the next by means of a transformer.

SYMBOLS

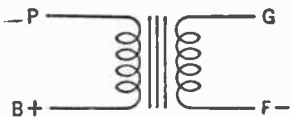

Audio-frequency transformer.



Potentiometer.



Crystal pickup.

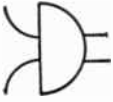

Microphone.

### QUESTIONS AND PROBLEMS

1. What purpose does an audio-frequency amplifier serve?
2. What part of the tube enables us to use the tube as an amplifier?  
How does it perform this function?
3. What is the range of audio frequencies?
4. What is meant by "coupling the energy from the plate circuit of the detector to a stage of audio-frequency amplification"?
5. What are the methods for coupling energy from the detector to an audio amplifier?
6. What is the maximum voltage step-up tolerated in an audio-frequency transformer?
7. How does the C battery in a stage of audio-frequency amplification differ from the function of that in a detector?
8. From what source does an amplifier gain the energy required to operate a loudspeaker that needs a great power input?
9. What advantage does transformer coupling have over resistance coupling?
10. What is the function of the coupling condenser?
11. What is the function of the plate resistor?
12. What is the ratio of the number of stages of the transformer-coupled audio-frequency amplification to the number of stages of resistance-coupled audio-frequency amplification?
13. What advantages have resistance-coupled audio-frequency stages over transformer-coupled stages?
14. Why can we not use many stages of audio-frequency amplification?
15. How may a few stages of audio-frequency amplification be used as a public-address system?
16. Explain how a few stages of audio-frequency amplification may be used to make a phonograph player.
17. What is the piezoelectrical effect?
18. Draw a circuit containing a regenerative detector and two stages of audio-frequency amplification, having one stage transformer-coupled to the detector and in turn resistance-coupled to another stage of audio-frequency amplification.

## CHAPTER 18

# Eliminating the B Battery

---

- Problem 1:** *What are the faults of A and B batteries?*
- Problem 2:** *How is the common alternating current converted into a steady direct current?*
- Problem 3:** *How is the common alternating current made to deliver higher voltage for the plate and lower voltage for the filament?*
- Problem 4:** *What are the essential parts of a B eliminator and how does it work?*
- 

### 116. Some Faults of Batteries

Having eliminated the nuisance of the headphones, the next problem to be tackled is that of getting rid of the various batteries required. These batteries have several serious drawbacks. They have a limited life, even though the radio receiver be used infrequently. This means periodic replacements which are not only troublesome but costly. Besides, as the batteries start to wear out, the voltage delivered starts to fall off. This deterioration means uneven performance.

Furthermore, the batteries are quite bulky, especially those of the high-voltage type used as plate batteries for the amplifier tubes.

To heat the filaments of the tubes, a storage battery is usually used. This battery must be recharged periodically as the current is used up. Besides this nuisance the storage battery is heavy, bulky, and contains an acid which may be spilled easily with disastrous results to clothing, rugs, and woodwork.

Since the use of house current for lighting purposes is fairly universal, it was only natural to seek a means of using this house current to replace the batteries.

## 117. The Diode as a Rectifier

The first battery to be eliminated was the plate or B battery. The house current most widely used in our country is alternating current with a voltage or electrical pressure of 110 volts. This alternating current usually has a frequency of 60 cycles per second.

Such an alternating current cannot be applied directly to the plate of the tube because this plate must always have a steady positive charge. Any fluctuations of the positive charge on the plate due to variations in the plate battery voltage would result in distortion of the signal. It becomes necessary, therefore, to change the alternating current of the house line to a steady direct current before it can be fed to the plate of the tube.

You will recall that the diode tube changes alternating current into pulsating direct current. So we feed the alternating current of the house line into a diode tube as in Figure 95.

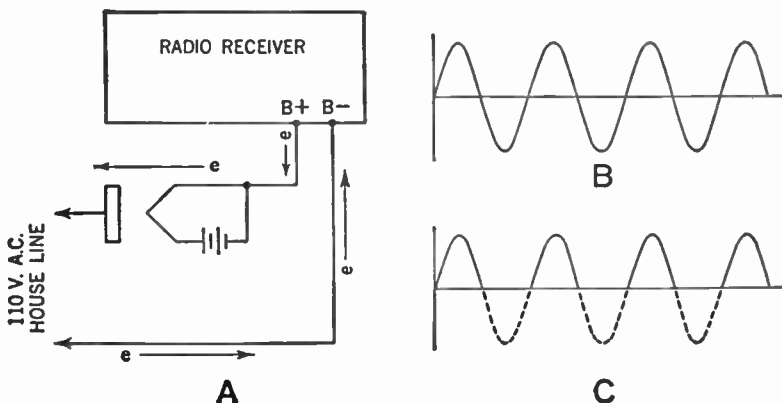

Figure 95. A—The diode as a rectifier tube. For the sake of simplicity the circle around the symbol for the diode is omitted. B—Wave form showing alternating current flowing in house line before rectification. C—Wave form showing the alternating current after it has been rectified by the rectifier tube. The bottom half of the loop has been cut off and the current now becomes a pulsating direct current.

When the plate of the diode has a positive charge on it, current will flow from the house line to the plate circuits of the radio receiver. When a negative charge is placed on the plate of the diode, no current will flow. A diode used as indicated here is called a *rectifier tube*. We say that we have *rectified* the alternating current.

118. The Filter System

But it is not enough to change the house current from alternating current to *pulsating* direct current. We must change it to a *steady* direct current. To do this we must pass the pulsating direct current through a *filter*.

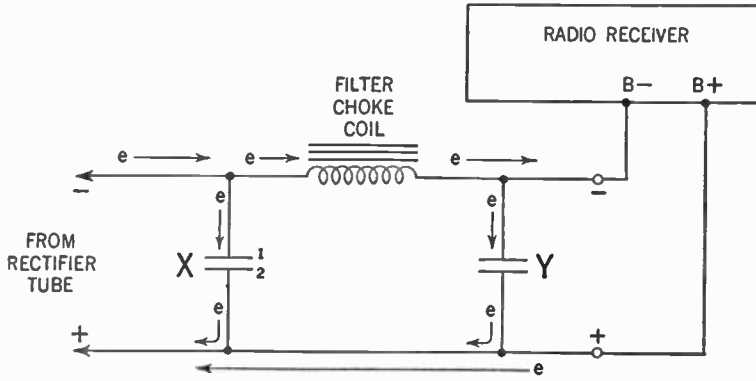

Figure 96. Hookup showing the filter system.

In Figure 96, you will notice that the pulsating direct current from the rectifier tube is fed into a network consisting of two condensers (X and Y) and an iron-core inductance. This inductance contains many turns of wire and is called a *filter choke coil*. An inductance of 30 henries is usually used.

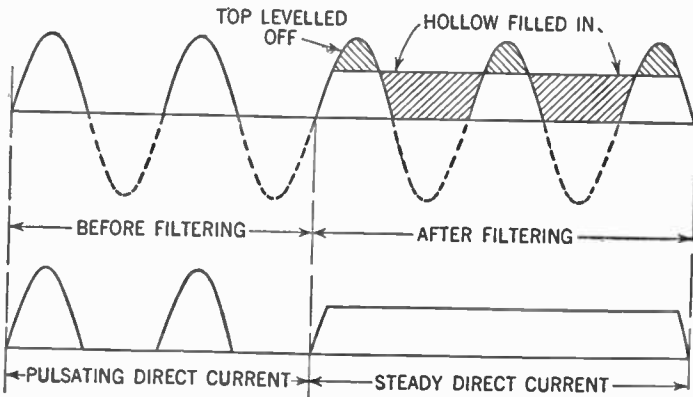

Figure 97. Wave form showing how the filter system changes pulsating direct current to steady direct current.

As the electrons rush up to the choke coil, they encounter a very great resistance resulting from the many turns of wire and the self-inductance of the coil. As a result, they are forced to pile



up on plate 1 of condenser X. Here they accumulate until enough of them are piled up to overcome the resistance offered by the coil. Thus condenser X acts as a sort of reservoir or storage tank for the electrons. On the other side of the choke coil, condenser Y also acts as a storage tank for these electrons.

A result of the action of the choke coil and condensers is shown in the graph of the wave form in Figure 96—the peaks of the pulsating direct current from the rectifier tube are leveled off and the hollows are filled in. The result in the receiving set is a steady direct current which is fed to the plates of the tubes.

The action of the filter is to hold back the pulsating electron flow until a steady average flow is reached and maintained. When this steady flow results, we say we have *filtered* the current flowing from the rectifier tube.

### 119. The Power Transformer

The voltage of the current flowing out of the filter is about the same as the voltage of the house current, namely, 110 volts. As this does not place a very high charge on the plate, someone thought of using a step-up transformer to increase the house-current voltage to about 300 volts. Thus about 300 volts of steady direct current flow out of the filter, and we are able to place a higher positive charge on the plates of the tubes in the receiver; a greater plate current flows and a louder sound comes out of the loudspeaker.

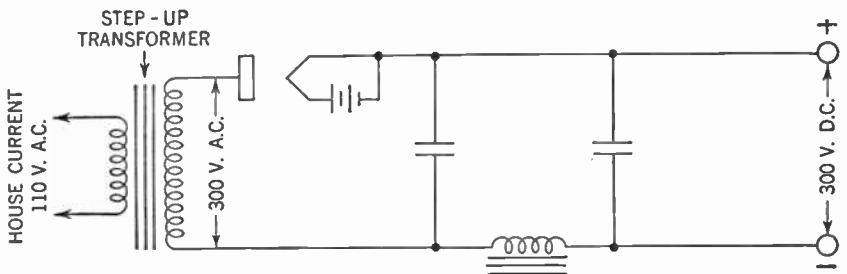

Figure 98. B battery eliminator using a step-up transformer.

In practice, the primary of the step-up transformer is connected to the 110-volt alternating current of the house line. The secondary is connected to the rectifier tube and filter (see Figure 98).

The step-up transformer used here is called a *power transformer*.

### 120. A Step-down Transformer for the Rectifier

To eliminate the necessity for using a filament battery for the rectifier tube, a step-down transformer is used to step down the

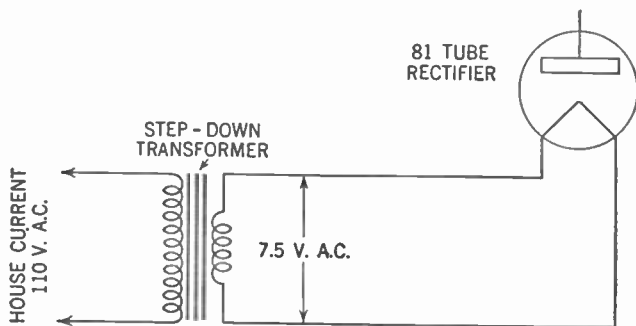

Figure 99. Step-down transformer used to heat the filament of the rectifier tube.

110-volt house alternating current to a value that the rectifier tube requires. If we use a type 81 rectifier tube, the transformer steps down the 110-volt alternating current to  $7\frac{1}{2}$ -volt alternating

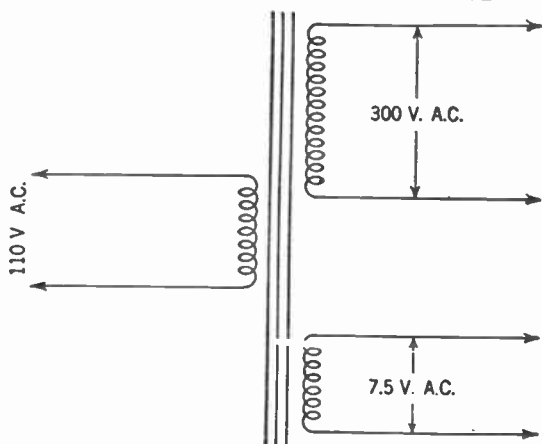

Figure 100. Transformer with two secondaries to step up the voltage for the plate supply and to step down the voltage for the filament of the rectifier tube.

current. Using alternating current on the filament of the rectifier tube does not cause any interference with the signal.

The primary of the step-down transformer is connected to the

110-volt alternating-current line and the secondary is connected across the filament of the rectifier tube in place of the filament battery. The step-down transformer used here is called a *filament transformer*. The wiring diagram is shown in Figure 99.

For convenience, the two secondaries, the step-up to the plate of the rectifier tube and the step-down to the filament, may by suitable winding, be made to operate from the same primary (see Figure 100).

Still another improvement was made to utilize the half cycle of alternating current blocked out by the action of the rectifier tube (Figure 95). By connecting up two rectifier tubes as shown in Figure 101, this half cycle could be put to use.

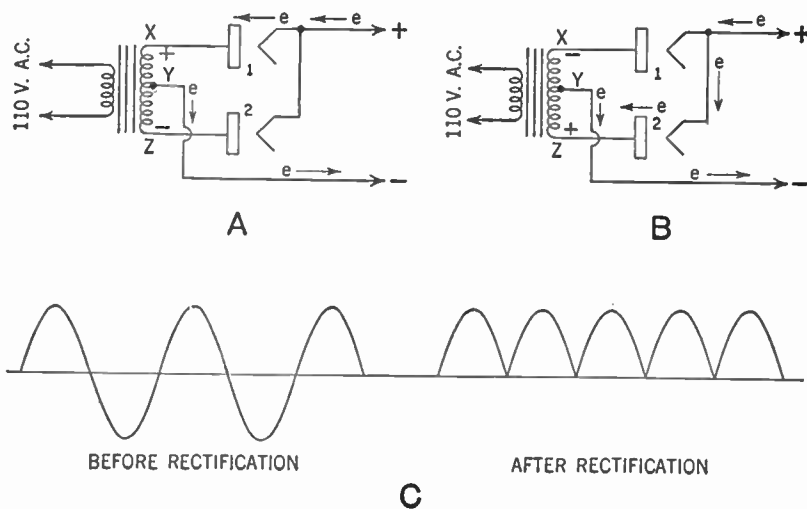

**Figure 101. Full-wave rectification using two rectifier tubes.**  
**A—**Electron flow during one half cycle.  
**B—**Electron flow during the next half cycle.  
**C—**Wave form showing full-wave rectification.

## 121. Full-wave Rectification

In Figure 101-A, when point X of the secondary of the power transformer has a positive charge on it, point Z has a negative charge. This means that the plate of rectifier tube 1 is positive and the plate of rectifier tube 2 is negative. Electrons then stream from the filament of tube 1 to the plate and through the secondary to point Y, the electrical mid-point of the secondary. Since Z is negative it repels these electrons and they are forced to stream

through the wire connecting Y to the filter circuit. Tube 2 does not operate.

During the next half cycle (Figure 101-B) the charges on the secondary are reversed. Now tube 1 does not operate, while electrons from tube 2 stream to point Y and to the filter circuit.

This method of rectification, using both halves of the alternating-current cycle, is called *full-wave rectification*. The method previously described, using only one half of the cycle, is called *half-wave rectification*.

Full-wave rectification is easier to filter because the hollows between the direct-current pulses are smaller (Figure 101-C).

A logical development was to combine the two rectifier tubes into one, using two plates and one filament. In this double tube the filament is constantly emitting electrons, which are attracted first to one plate and then to the other as the charges on these plates are alternately positive and negative.

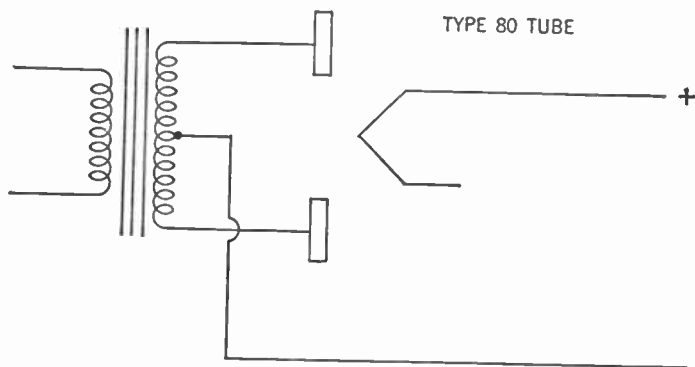

Figure 102. Type 80 rectifier tube with one filament and two plates. This tube is used for full-wave rectification.

An example of a full-wave rectifier tube is the type 80.

## 122. A Potentiometer Is a Form of Voltage Divider

After full-wave rectification was perfected, one more thing remained to be done. The steady direct current flowing out of the filter circuit was at an electrical pressure of about 300 volts. This voltage is suitable for the plates of the amplifier tubes, but it is too high for the plate of a detector tube, where a maximum of 100 volts is needed. A means had to be devised to enable us to tap off a lower voltage for the detector tube. This object was

accomplished by connecting a potentiometer across the output terminals of the filter circuit.

Here is how the potentiometer works. Assume that the electrical pressure at the output terminals of the filter circuit is 300 volts. This statement means that the electrons piled up on the

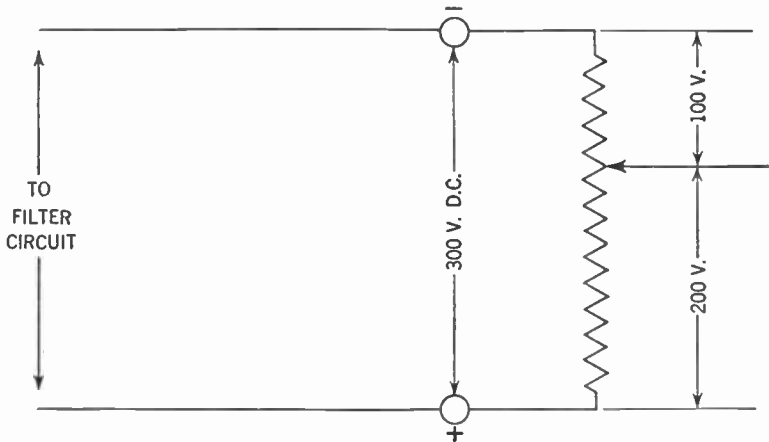

**Figure 103.** Diagram showing how a potentiometer is hooked up as a voltage divider.

negative terminal are seeking to get to the positive terminal with a force which is equal to this electrical pressure of 300 volts. Electricians call this a *drop* of 300 volts. Now we connect a resistor from the negative terminal to the positive terminal. The electrons use up the 300-volt pressure in traveling the entire length of the resistor to the positive terminal. But the drop, or fall in pressure (technically, the drop in potential) is proportional at any point to the fraction of the resistor which has been overcome at that point.

Suppose we take a point one third of the way down the resistor. At this point the electrons have used up one third the pressure and the pressure of the electrons at that point seeking to reach the positive terminal is 200 volts. At a point two thirds of the way down the resistor, two thirds of the original total voltage (or pressure) has been used and the pressure between that point and the positive terminal is only 100 volts. So by moving the slider of the potentiometer from point to point on the resistor we can get any desired voltage out of the filter circuit. The potentiometer, hooked up in this circuit, is called a *voltage divider*.

The size of the voltage divider varies with the number of tubes used in the receiver. Generally the resistance is about 15,000 to 25,000 ohms. The resistance wire must also be heavy enough to stand the current that flows through it without burning out. The amount of current a resistor can safely pass at a given voltage is expressed by its rating in *watts*. A *watt* is a unit of electrical power measured by the product of the current and the voltage (pressure). Hence with a given voltage, as the current increases the rated number of watts must increase. It follows that the more current needed for the plate currents in the radio receiver, the heavier this resistor must be. In the present case, with an assumed pressure of 300 volts, the resistor must be rated at about 25 watts.

### 123. The Dropping Resistor

There is another way by which we can get the lower voltage needed for the plate of the detector tube. Instead of connecting the positive output terminal directly to the B terminal of the audio-frequency transformer in the plate circuit of the detector tube, we insert a resistor of about 5,000 ohms between the two

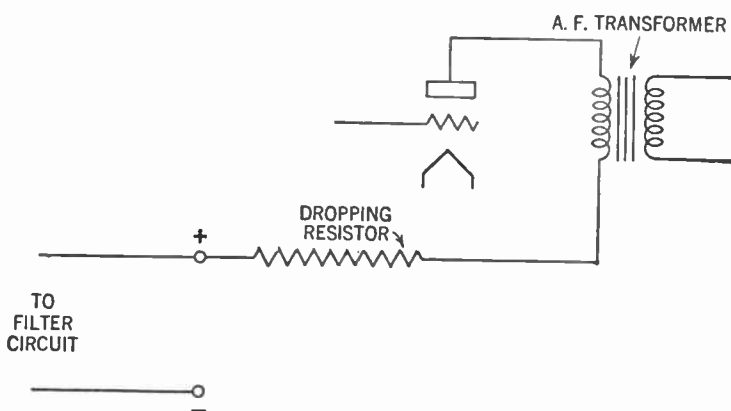
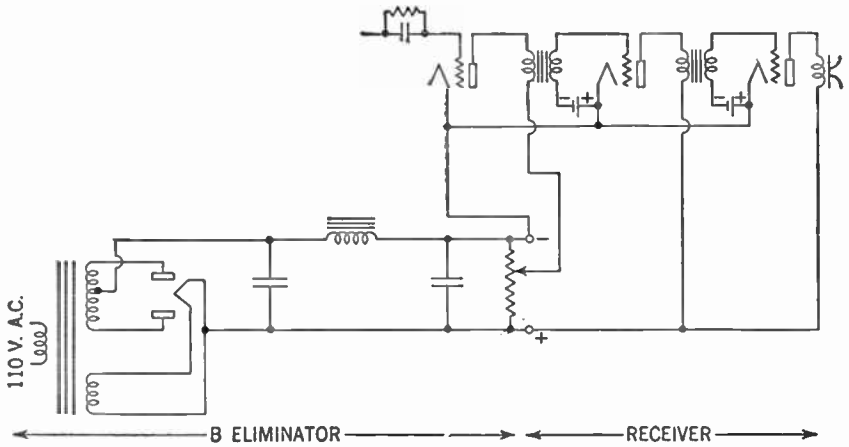

Figure 104. Circuit showing use of a dropping resistor to obtain the lower B voltage required for the plate of the detector tube.

points (see Figure 104). This plan involves the same principle of drop or fall in potential, because some of the electrical pressure is used up in forcing current through this resistor. As a result, a smaller positive charge is placed on the plate of the detector tube. This resistor is called a *dropping resistor*.

Here, now, in Figure 105, is the plan for our completed *B-battery eliminator*.



**Figure 105. Completed B eliminator, showing how it is connected to the radio receiver. See if you can name each port and state its function. Where is the aerial-ground system connected?**

#### 124. How the B Eliminator Works

The primary of the power transformer is connected to the house line which supplies 110-volt alternating current. The step-up secondary increases this voltage to 300 volts. The ends of this secondary are connected to the plates of the type 80 rectifier tube.

The step-down secondary reduces the voltage to 5 volts. The ends of this secondary are connected to the filament of the rectifier tube. The negative line of the B-battery eliminator comes from the mid-point or *center tap* of the step-up secondary and is connected to one end of the filter input. The positive line comes from the filament of the rectifier tube and goes to the other end of the filter input. At this point the current is pulsating direct current at about 300 volts.

When this current passes through the filter it comes out as a steady direct current at about 300 volts. It makes no difference whether the choke coil is in the positive or negative line. In circuit diagrams it is usually shown in the positive line.

Across the negative and positive terminals of the B-battery eliminator the electrical pressure is 300 volts. The negative terminal is connected to the filaments of the tubes in the radio re-

ceiver, just as is the negative post of the B batteries when there is no eliminator. Similarly, the positive terminal of the eliminator is connected to the B+ terminal of the second audio-frequency transformer and the loudspeaker.

Across the terminals of the eliminator, a potentiometer is connected. The sliding tap is adjusted to a point where the electrical pressure or voltage is of the desired value, about 100 volts. A connection is made from this sliding tap to the B+ terminal of the first audio-frequency transformer.

### 125. Electrolytic Condensers

The condensers used in the filter circuit are very large, about 8  $\mu$ fd. each. For this purpose we generally use condensers whose plates are made of tinfoil and whose dielectric is waxed paper. Recently, we have been using *electrolytic condensers*. These condensers have plates of aluminum and an aluminum oxide dielectric. In using these electrolytic condensers, care must be taken that the terminal marked POSITIVE or + is connected to the positive line and the terminal marked NEGATIVE or — is connected to the negative line of the filter circuit. Failure to observe this precaution may destroy the condenser.

The condensers used in the filter circuit are called *filter condensers*. Care must be taken that the dielectric is strong enough to withstand the electrical pressure—in this instance, at least 300 volts. This rating is usually marked on the side of the condenser.

### SUMMARY

1. Batteries became such a nuisance in radio sets that means were sought to eliminate them.
2. The ordinary current delivered to the home is alternating current of 60 cycles at a pressure of 110 volts.
3. By passing the alternating current through a diode tube the current is rectified to pulsating direct current.
4. By the use of coils having high resistance, called choke coils, together with condensers, the pulsating current is changed to steady current. This system of chokes and condensers is called a **filter system**.
5. **Full-wave rectifying tubes** (type 80) are made with one filament and two plates. This design makes use of the half cycle of alternating current that is blocked off during rectification by a single diode.
6. **Potentiometers** are variable resistors by the use of which a high voltage may be reduced to any desired voltage through the principle that *drop* in pressure is proportional to resistance overcome.



7. The B-battery eliminator consists of a type 80 tube with resistors and filters so connected that all the functions of the dry-cell B battery are performed by energy from house alternating current.

#### GLOSSARY

**B-battery Eliminator:** A device used to eliminate the need for B batteries by supplying plate voltage from the house mains.

**Dropping Resistor:** A resistor connected in a circuit which uses up a part of the electrical pressure, thus leaving less voltage for the remainder of the circuit.

**Electrolytic Condenser:** A fixed condenser of high capacity with aluminum plates and a dielectric of aluminum oxide.

**Filament Transformer:** A step-down transformer used to supply filament current from the house mains.

**Filter:** An electrical network used to smooth out, or eliminate variations from, a pulsating direct current, thus changing it to a steady direct current.

**Filter Choke:** A coil of many turns wound on an iron core, used in a filter.

**Filter Condenser:** A fixed condenser of high capacity, used in a filter.

**Full-wave Rectification:** Rectification which uses both halves of the alternating-current cycle.

**Half-wave Rectification:** Rectification which uses only one half of the alternating-current cycle.

**Power Transformer:** A transformer used to step up the 110-volt alternating current from the house mains to a higher voltage. It may have several step-down secondaries, which are used to supply current to heat the filaments of the tubes.

**Rectified Current:** An alternating current that has been changed to direct current by a rectifier tube or other rectifier device.

**Rectifier Tube:** A tube whose sole function is that of changing alternating current to direct current.

**Voltage Divider:** A resistor, placed across the output of the filter system, from which we may obtain various voltages by tapping off at points along its length.

**Watt:** The unit for measuring electrical power.

#### SYMBOLS



Filter choke.

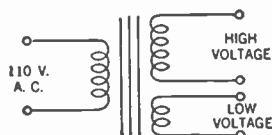

Power transformer.

## EXERCISES

1. Why is it normally desirable to eliminate batteries from a receiver?
2. What is the voltage and the number of cycles of the most common house current?
3. Why cannot normal alternating current be used in the radio receiver?
4. Show how a diode can act as a rectifier. Graph the resulting voltage.
5. What type of voltage emerges from a diode rectifier?
6. By what means is a rectified alternating current changed so that it can be used in our receiver?
7. Explain the operation of an electrical filter system.
8. Explain the operation of a half-wave rectifier.
9. Explain the operation of a full-wave rectifier.
10. Why is it easier to filter the output of a full-wave rectifier than it is that of a half-wave rectifier?
11. How may we secure various voltage levels from our power supply? Explain in detail.
12. What rating of a resistor expresses the amount of current that the resistor can safely pass without burning out?
13. Draw the circuit for a complete full-wave B-battery eliminator or power supply.
14. What care must be taken in using electrolytic condensers in the filter system of B-battery eliminators?
15. In using condensers, what must we consider in addition to the capacity rating?

## CHAPTER 19

# Eliminating the A Battery

---

**Problem:** *What device made it possible to use alternating current to heat the filament without distortion of the radio signals in the plate circuit?*

---

### 126. Attempts to Use Alternating Current for the Filament

The next battery to be eliminated was the A or filament battery. It is simple enough to use a step-down filament transformer to reduce the voltage from the 110-volt alternating current to 6-volt alternating current. But alternating current is unsatisfactory for heating the filament of the radio tube even at this reduced voltage.

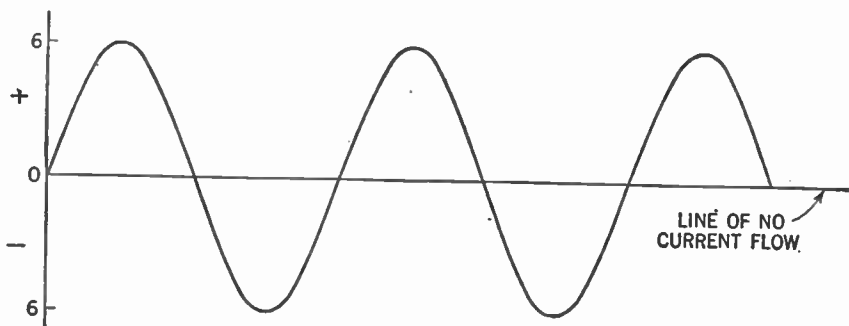

**Figure 106.** Wave form of alternating current used to heat the filament of the tube.

The reason is that any fluctuations in the stream of electrons shot out by the heated filament causes a hum or distortion of the signal. The plate current is the current produced by the stream of electrons from the filament to the plate. Examine the wave-form picture of the alternating current used to heat the filament in Figure 106.

When the alternating-current cycle reaches its peak (whether the positive or negative peak makes no difference here), the electrons are streaming through the filament at their maximum rate and the filament is being heated to maximum temperature. The electrons being emitted by the heated filament are shooting out at the maximum rate. When the alternating-current cycle reaches the line of no current flow, however, the filament starts to cool off and the number of electrons emitted starts to drop off. The result is a fluctuation in the number of the electrons reaching the plate, with resulting distortion of the signal.

### **127. First Experiments with Ribbons**

One method that has been used to combat this undesirable condition was to make the mass of the filament greater. Instead of using a thin wire, a ribbon type of filament was used. Because of its greater mass, the temperature in such a filament does not fluctuate as much as in the thinner ones during the changes in the alternating-current cycle.

But the ribbon filament was not wholly successful for two reasons: (1) some fluctuations still remained, (2) to heat this massive filament required great amounts of electric current.

### **128. Attempts to Use Rectifiers**

Another method used to overcome the difficulty was to convert the 6-volt alternating current to direct current, using a rectifier consisting of plates of copper and copper oxide. The action of this rectifier is similar to that of the crystal detector.

Still another method of rectifying the alternating current was to use a chemical rectifier. Plates of lead and aluminum were suspended in a solution of borax. This chemical rectifier passes current only in one direction.

The diode tube also was used as a rectifier, following the method described in the previous chapter.

All these methods of rectification were not very practical. They required special apparatus for the rectification and filter systems. The chemical rectifier had the additional drawback of being spilled easily.

### **129. Further Attempts to Use Alternating Current for Heating**

The use of alternating current directly on the filament of the radio tube was tried in a number of ways, but one difficulty always

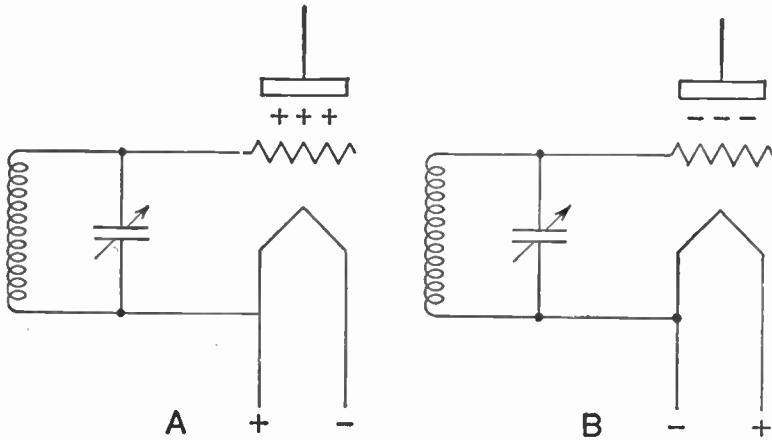

Figure 107. Circuits showing how alternating current flowing through the filament places an alternating charge on the grid of the tube.

remained. The grid of the tube, as you know, must be connected to the filament as shown in Figure 107. So if alternating current is sent through the filament, then during one half of the cycle a positive charge is placed on the grid as in Figure 107-A. During

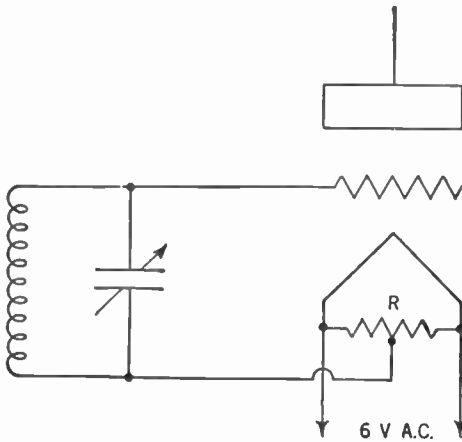

Figure 108. Circuit showing the use of a 20- to 40-ohm center-tapped resistor (R) to reduce hum.

the next half of the cycle a negative charge is placed on the grid (Figure 107-B). Thus an alternating charge is placed on the grid by the alternating current flowing in the filament. This charge

interferes with the flow of electrons to the plate and distortion results.

To help correct this fault a resistor of 20 to 40 ohms was connected across the filament. At the electrical center of this resistor, a tap was placed. To this tap was connected the wire going to the grid circuit (see Figure 108). It can be seen that whichever side of the filament is positive or negative, the center tap, being half-way between them, is always at the same electrical pressure. Thus a constant charge is placed on the grid and there are no unwanted fluctuations in the plate current.

This scheme, together with the use of the heavy ribbon-type filament, gave fairly good results.

### 130. The Cathode Sleeve

But a better method, permitting the use of alternating current on the filament, was subsequently worked out. Around the filament, but not touching it, was slipped a sleeve of metal. Now the filament was used as a stove to heat this sleeve. As the sleeve became hot, it emitted the stream of electrons which reached the plate.

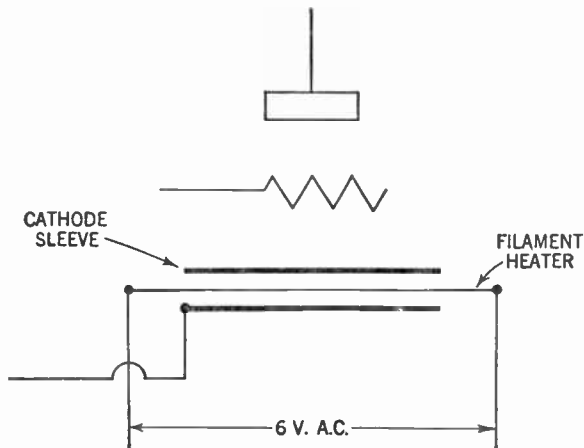



Figure 109. Diagram of tube with a cathode sleeve used as an emitter of electrons.

This sleeve is now the surface which gives off the electrons and is therefore called the *cathode*. Because it is quite massive, the temperature of the cathode does not change with the alternating-current cycle of the current flowing through the filament. Thus

the stream of electrons it emits is steady. The symbol for the cathode is: 

The wire going to the grid, called the *grid return*, is connected to the cathode instead of to the filament. The filament is thus removed from the circuit bearing the radio signals. Hence the

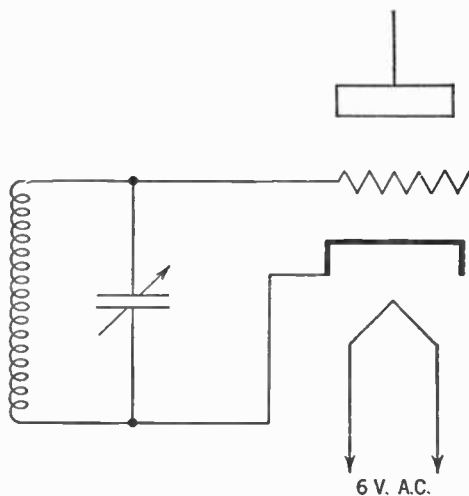

Figure 110. Circuit showing how the cathode is connected to the grid return.

current used to heat the filament may be either alternating or direct current without causing distortion of signals.

In modern tubes the cathode is usually coated with special chemicals that make it a more efficient emitter of electrons. We shall discuss this matter more fully later.

### 131. The Complete A-battery Eliminator

The use of the cathode simplifies things a great deal. The only extra piece of apparatus for this new type of tube is the step-down filament transformer. An example of a tube using this cathode is the type 27.

We have now eliminated the need for the A or filament battery. A typical hookup using the cathode-type tube is shown in Figure 111. In studying this wiring diagram you should notice that the B— terminal of the B-battery eliminator is now connected to the cathode instead of the filament. Notice, also, that a third secondary winding has been added to the power transformer. This

is a step-down secondary giving the  $2\frac{1}{2}$  volts needed for the filament of the type 27 tube.

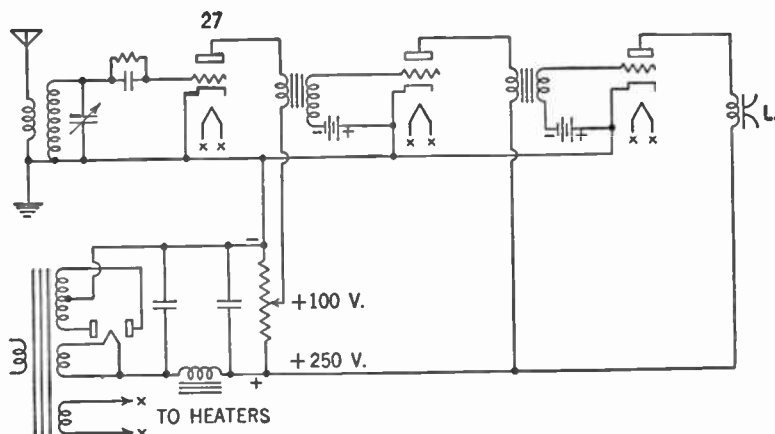

Figure 111. Radio circuit showing the use of a B-battery eliminator and cathode-type tubes.

#### SUMMARY

1. The alternating current is unsatisfactory for heating the filaments of radio tubes because of the uneven flow of electrons to the plate.
2. Various means of correcting the faults of the alternating current as a substitute for the A battery were tried before a successful method was found.
3. The device which was successful is the **cathode sleeve**. The principle in this is that the filament bearing the alternating current does not touch the cathode but merely heats it because it is close to it. The cathode therefore emits the electrons used in the plate circuit to carry the radio signals.
4. The type 27 tube has this cathode sleeve and needs to be operated at  $2\frac{1}{2}$  volts alternating current furnished by a step-down transformer.



#### GLOSSARY

- A-battery Eliminator:** A device used to serve the purpose of the A battery by supplying the current needed to heat the filament of the tube from the house mains.
- Cathode:** A metal sleeve surrounding the filament in a tube and coated with chemicals that shoot off electrons when heated by the filament.



## SYMBOLS

 Cathode in a tube.

 OR  A triode employing a cathode.

## QUESTIONS AND PROBLEMS

1. What action results when alternating current is fed to the filaments of a tube?
2. What early attempt was made to overcome the effect of the alternating current in question 1?
3. List several methods other than that in question 2 to overcome the effect considered in question 1.
4. Explain how the use of a center-tapped filament resistor helps to stabilize grid voltage when an alternating current is fed to the filament.
5. What are the advantages of the type 27 tube?
6. If we are using tubes with cathodes, in what circuit is alternating current used?
7. Describe the chief features of the A-battery eliminator; make a diagram.

## CHAPTER 20

# Eliminating the C Battery

---

**Problem:** *How is the grid bias maintained without a C battery?*

---

### 132. Keeping the Grid Negatively Charged

Having succeeded in eliminating the A and B batteries, radio engineers next tried to get rid of the C battery. It proved to be a simple matter to do away with this battery. Let us recall the function of the C battery.

Figure 112 shows the C battery connected in the grid circuit

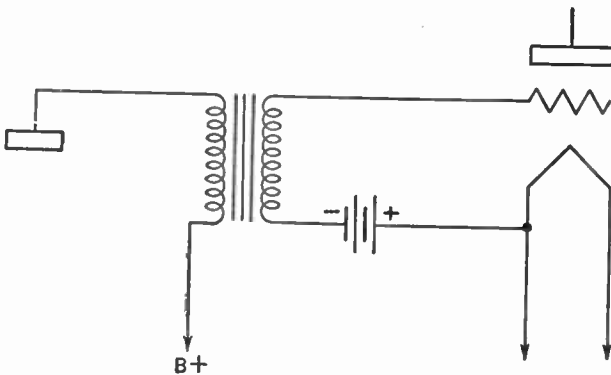

**Figure 112.** Circuit showing a C battery connected in the grid circuit of an amplifying tube. Why is this battery called a grid-bias battery?

of the triode. Since the C battery (or grid-bias battery) is connected with the negative post to the grid return and the positive post to the filament, the grid is more negative than the filament. So all we have to do is to work out a system that makes the grid slightly more negative than the filament and our C battery is eliminated.

**133. Using a Voltage Divider**

Turn back to Figure 105. The most negative point of the B eliminator is the negative terminal. Note that the filaments of the radio tubes are connected to that point. Now consider a point on the voltage divider a little distance away from the negative terminal and toward the positive terminal. As you now know, this point is a little more positive than the negative terminal.

Now, connect the filament to this new point and connect the grid return to the negative terminal. The grid in this hookup is slightly more negative than the filament and we have eliminated the necessity for a C battery.

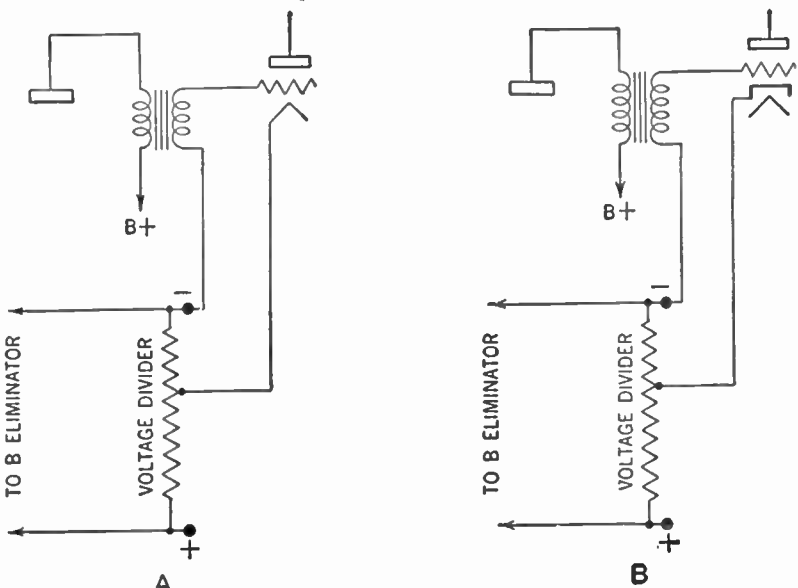

**Figure 113.** A—Circuit showing how a filament-type tube is connected to obtain the grid bias from the voltage divider.  
 B—Circuit showing how a cathode-type tube is connected to obtain the grid bias from the voltage divider.

Figure 113-B shows how a cathode-type tube is hooked up to eliminate the C battery.

**134. Another C Battery Eliminator**

There are other methods used to eliminate the C battery. For example, it has already been stated that the most negative point of the B eliminator is the negative terminal. This means that the greatest excess of electrons has accumulated there. Hence when

the grid return is connected to this terminal the grid, too, is negative.

The cathode, however, is not connected directly to the negative terminal of the B eliminator, but through a resistance of about 2,000 ohms, as in Figure 114. To understand this hookup, compare the pathways of electrons from the B-battery eliminator to

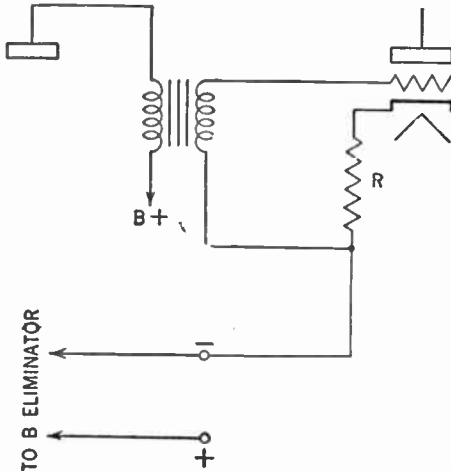

Figure 114. Circuit showing how a bias resistor (R) is used to obtain grid bias.

the grid and to the cathode respectively. As the cathode shoots off electrons, other electrons are drawn up from the large supply on the negative terminal of the B eliminator. But some of the electrical pressure is lost in pushing these electrons through the 2,000-ohm resistor. In this hookup, then, the cathode is slightly less negative than the negative terminal of the B eliminator.

The grid of the tube, connected to this negative terminal without the resistor between it and the terminal, is therefore slightly more negative than the cathode. So now again there is no need for the C battery.

The resistor we connected to the cathode of the tube is called a *bias resistor*. Different types of tubes use different bias resistors. The 2,000-ohm resistor mentioned here is suitable for the type 27 tube.

### 135. Preventing Distortion with a By-pass Condenser

If you examine Figure 115, you will notice that this bias resistor is in the plate circuit. The electrons stream up from the

negative terminal of the B eliminator, through the bias resistor to the cathode, across to the plate and through the winding of the loudspeaker and back to the positive terminal of the B eliminator. Since a fluctuating direct current is flowing in that plate circuit, this means that the difference in electrical pressure between the cathode and the grid will also fluctuate.

This condition is not desirable, for it reduces the amplification. To overcome this effect, a large condenser of about 1  $\mu$ fd. is connected across the bias resistor. This condenser, called a *by-pass condenser*, smoothes out the fluctuations on the same principle as the filter condensers in the filter circuit of the B eliminator.

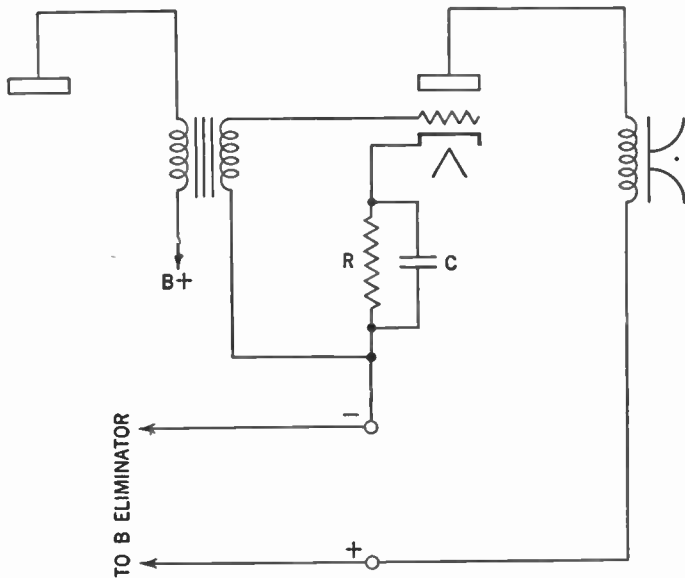

Figure 115. Circuit showing bias resistor (R) and by-pass condenser (C).

### 136. The Complete No-battery Receiver

Having succeeded in eliminating all batteries, we are now ready to present our no-battery radio receiving set. This is shown in Figure 116.

In this diagram, the wires connecting the filaments of the tubes to the step-down secondary, which gives the 2½ volts of alternating current needed to heat these filaments, are omitted for the

sake of simplicity. In wiring this set, however, a certain precaution must be taken. These wires, carrying alternating current, have a fluctuating magnetic field around them. If this field cuts across any other conductor near them, currents will be induced which will interfere with the reception of the signal.

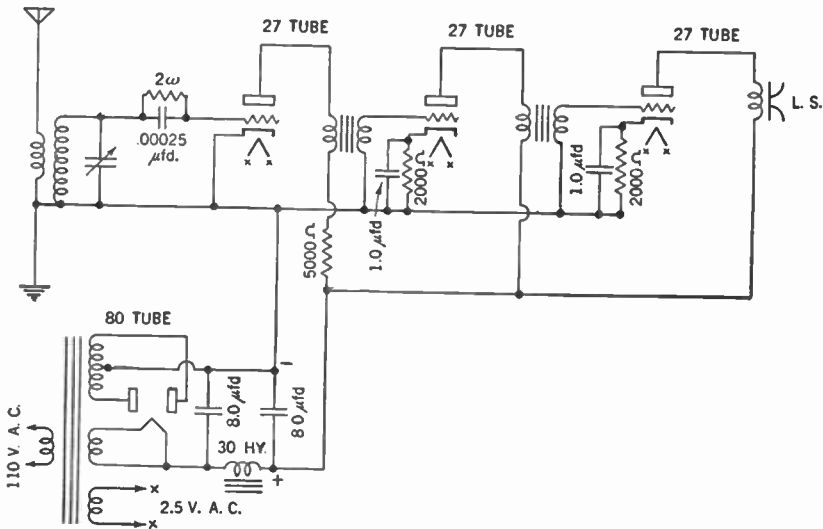

Figure 116. Diagram showing the circuit of an all-electric receiving set.

To overcome this unwanted effect, the wires carrying alternating current to the filaments are twisted around each other in such a way that the magnetic fields of these wires neutralize one another.

#### SUMMARY

1. To have the grid of a tube function properly it must have a small negative charge at all times.
2. The C battery which supplies a negative charge to the grid may be eliminated by properly connecting the grid to the B-battery eliminator.
3. Two methods of connecting the grid so as to obtain the suitable negative charge are: (a) to use a voltage divider; (b) to use a resistor in parallel with a by-pass condenser on the supply line to the cathode.
4. Wires bearing alternating current to the filament should be twisted together to neutralize the magnetic fields produced in single wires by the current.

## GLOSSARY

- By-pass Condenser:** A fixed condenser placed across the cathode-bias resistor which serves to smooth out the current variations in that resistor and thereby supply the grid with a constant negative charge.
- Cathode-bias Resistor:** A resistor between the B— terminal and the cathode of the tube, which gives the grid a negative bias.
- C-battery Eliminator:** A device used to eliminate the need for the C battery by obtaining the necessary current from the B-battery eliminator.

## QUESTIONS AND PROBLEMS

1. What is the purpose of a negative bias on the grid?
2. In what way can we obtain negative grid bias from the B-battery eliminator?
3. Explain the method of obtaining a negative grid bias by means of a cathode-bias resistor.
4. What is the purpose of the by-pass condenser across the cathode-bias resistor?
5. Why are the wires leading to the filament of a cathode-type tube usually twisted together?
6. Make a diagram of a receiver using an A-, B-, and C-battery eliminator, and an amplifier coupled by resistance coupling to the detector.

## CHAPTER 21

# The A.C.-D.C. Power Supply

---

**Problem:** *How are radio receivers adapted to operate on either alternating- or direct-current power supply?*

---

The battery eliminators described in the previous chapters all assume the use of 110-volt alternating current. In a number of localities, however, the house mains supply 110-volt direct current. Since a transformer will not operate on steady direct current, it becomes obvious that the A- and B-battery eliminators previously described will not work in these direct-current localities.

There are other reasons for not using the power transformer, even in alternating-current localities. The innovation of the midget receiving set has placed a premium upon small, light receivers that can be built cheaply. Since the power transformer is bulky, heavy, and expensive, its elimination was desired by the receiving-set manufacturers. Let us see how the problem was solved.

### 137. Current for the Filament and Amplifier

The answer is in our half-wave rectifier system (Figure 98). If we eliminate the step-up transformer and feed the 110-volt alternating current directly to the plate of the rectifier tube and filter system, we can change the house current to a steady direct current. True, we can only get about 110 volts output, but with the invention of the new and more efficient tubes, this voltage suffices for ordinary purposes.

Using this scheme and applying 110-volt direct current so that the positive lead goes to the plate of the rectifier tube, we get the same result as with the alternating current. So here we have a B-battery eliminator that works equally well on alternating or direct current and uses no power transformer.



### 138. Reducing the Voltage by Resistors Instead of Transformers

Now for the filament current. When the house mains supply 110-volt alternating current, we can get the small voltage required to heat the filaments by one of two methods. We can use a step-down transformer as described in Chapter 19. Or else we can force the 110-volt alternating current to go through a resistor before it goes through the filaments. When current goes through this resistor, its electrical pressure is reduced to (that is, *drops* to) the small amount necessary to force it through the filaments.

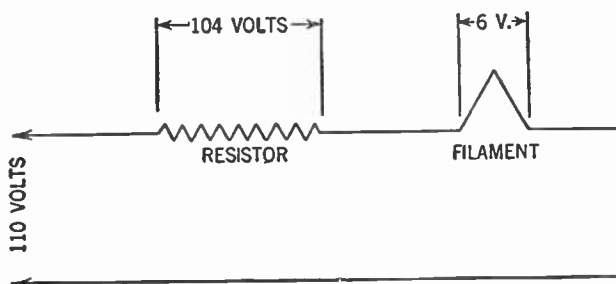

Figure 117. Diagram showing how a resistor is used to cut down the 110-volt house current to a value suitable for use on the filament of the tube.

This second method is not as desirable as the step-down transformer method, because it wastes most of the current going through the resistor. But in a direct-current locality only the resistor method of obtaining the filament current can be used. We therefore are compelled to use this method if the receiving set is to be operated in both types of localities.

### 139. Connect Filaments in Series

An increase in efficiency is gained if we connect our filaments in series. Assume that the rectifier tube requires 5 volts to force the current through its filament, while the detector tube, the first audio-frequency amplifier tube, and the second audio-frequency amplifier tube each require 6 volts.

When any electrical conductors are connected in series the resistance of the circuit is the sum of the resistances of all the parts. Hence 23 volts are required for the filaments of the tubes and only 87 volts are wasted in the resistance. (23 volts + 87 volts = 110 volts.)

Modern tubes are being manufactured that require even greater

voltage for their filaments and when they are used there is still smaller waste. As a matter of fact, some tubes use 110 volts on their filaments. These tubes are connected in parallel across the 110-volt line and no resistor is needed.

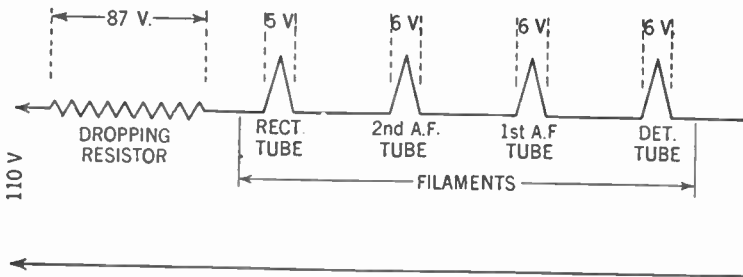

Figure 118. Diagram showing how the dropping resistor and the filaments of the rectifier, detector and first and second audio-frequency amplifier tubes are connected in series across the 110-volt house line.

#### 140. Line-cord Resistor

The resistor used in these circuits is called a *dropping resistor*. Its value obviously must vary with the type and number of tubes used. One variety of dropping resistor is the *line-cord resistor*. This resembles a common two-wire extension cord attached to a plug of the type used in the ordinary type of electrical outlet. But in addition to the two wires of this electric cord and attached to one of the terminals of the plug is a wire resistor of the proper size. The voltage drop in these resistors is made to provide for the correct voltage in the filament.

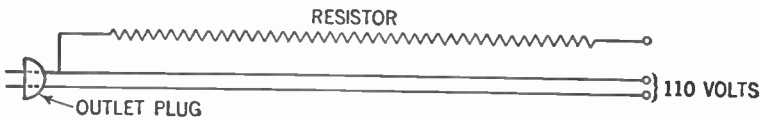

Figure 119. Diagram showing a line cord with a built-in resistor. The electric cord and resistor are covered with an asbestos and cotton casing and the assembly looks very much like the electric cord used to connect an electric iron.

This arrangement furnishes a convenient method for attaching the set to the house current and gives the additional advantage of having the resistor outside the set. Since the dropping resistor heats up somewhat because of the resistance to the current passing through it, it is advantageous to have it outside the set. Needless to say, you must not shorten or cut this cord or else you will reduce the value of the dropping resistor.

### 141. Other Features of A.C.-D.C. Sets

The C battery is eliminated as described in Chapter 20. Since the grid bias must be negative and not variable, the proper bias can be obtained by using proper resistors with any direct-current power supply.

It is possible, then, to wire a receiving set so that the plug supplying the electrical energy for all purposes may be used in any outlet for the house current regardless of whether the supply is alternating or direct current. Figure 120 shows the complete A.C.-D.C. power supply.

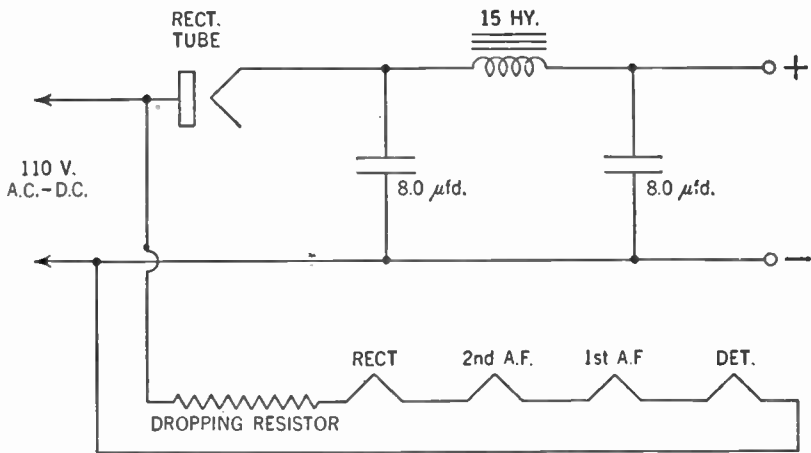

Figure 120. Diagram showing the circuit of the complete A.C.-D.C. power supply.

### 142. Better Rectifier Tubes

Practically any radio tube can be used as a rectifier. Some tubes, however, like the type 25Z5, are more efficient for this purpose.

### 143. One Precaution

If a receiving set fails to work in a direct-current locality when the set is plugged into the electrical outlet, remove the plug from the outlet, reverse it, and plug it in again. The chances are that you have plugged it in so that the negative line is connected to the plate of the rectifier tube. Reversing the plug will remedy this.

## SUMMARY

1. B-battery eliminators made to operate by the use of step-up and step-down transformers cannot be used on direct-current house mains.

2. The principle involved in the modern A.C.-D.C. receivers is to use resistors instead of transformers to produce lower voltages and to use smaller tubes of new types.

3. A.C.-D.C. sets operate by plugging in to any outlet carrying commercial current. The extension cord usually contains a line-cord resistor to provide the correct voltage for the filaments.

4. On direct-current circuits it is sometimes necessary to turn a plug around in the outlet fixture so that the direct current may enter the right wire.

## GLOSSARY

**A.C.-D.C. Power Supply:** A battery eliminator that operates from 110-volt alternating or direct current.

**Line-cord Resistor:** A resistor in the power line which uses up most of the 110 volts, leaving a small portion for the filaments.

## SYMBOLS



Line-cord resistor.

## QUESTIONS AND PROBLEMS

1. Why must we use a special power supply where direct current is furnished?

2. What is the approximate voltage output of an A.C.-D.C. power supply into which we feed 110-volt alternating or direct current?

3. How are filament voltages obtained in an A.C.-D.C. power supply?

4. What name is given to a resistor in the power cord of an A.C.-D.C. receiver?

5. What danger is there in cutting the power cord of an A.C.-D.C. receiver to make it shorter and less cumbersome?

6. If a receiver with an A.C.-D.C. power supply fails to operate in a direct-current district, after being tested, what would you examine in hunting for a possible cause?

## CHAPTER 22

# The Dynamic Speaker

---

**Problem:** *How has the loudspeaker been improved so as to give greater volume without distortion?*

---

### 144. Faults of the Paper Cone Speaker

Turn back to Figure 19. Although we have greatly improved our radio receiver since we built the crystal detector set, our loudspeaker has remained a paper cone fastened to the diaphragm of the earphone. Now let us give it some attention.

The loudspeaker, as shown, has one very bad fault. Our amplified signal is carried by a large current. This current from the plate circuit of the last amplifier tube passes through the coil of the speaker. When the resulting strong pull is exerted on the diaphragm, it is bent back until it touches the end of the permanent magnet. The effect is that the speaker rattles on loud signals.

### 145. The Permanent-magnet Dynamic Speaker

An ingenious device was evolved to overcome this defect. A speaker coil, called a *voice coil*, was wound on a small tube of bakelite. This tube was mounted so that it could slide back and forth on the permanent magnet. To this tube, the paper cone was attached. Also attached to this tube, to keep it in place, was a thin, springy sheet of bakelite called a *spider*.

The permanent magnet appearing in Figure 121 has a magnetic field around it. The fluctuating plate current, flowing through the voice coil, sets up a second, fluctuating magnetic field around the coil. These two magnetic fields, reacting with each other, move the voice coil up and down the permanent magnet. The greater the current flowing through the voice coil, the more this coil is moved down the permanent magnet.

The thin, springy spider permits the voice coil to move, but

forces it to come back once the pull ceases. The paper cone, connected to the voice coil, moves with it.

Now, large plate currents can move the paper cone quite vigorously without the danger of a diaphragm striking the end of the magnet and thus causing rattling.

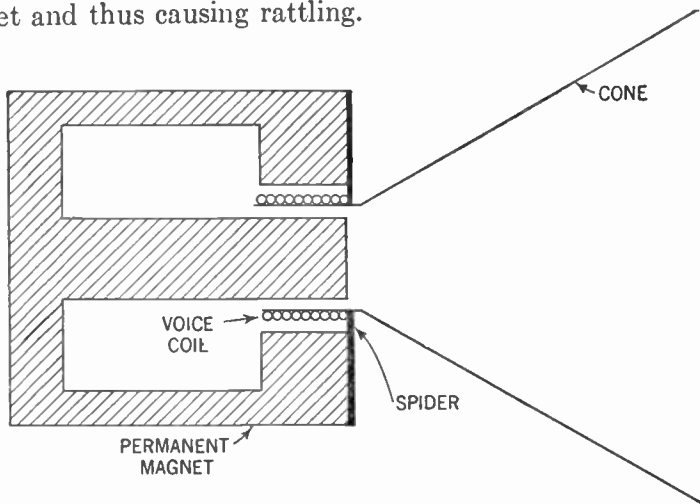

Figure 121. Diagram of a permanent-magnet dynamic speaker.

Of necessity, the voice coil, and the tube upon which it is wound, must be very light. The coil consists of a few turns of fine copper wire and the tube is made of very thin bakelite.

This type of speaker is called a *dynamic speaker*. Since it has a permanent magnet, we call it a *permanent-magnet dynamic speaker*. The symbol for this type of speaker is:



#### 146. The Output Transformer

There are two reasons why the voice coil cannot be connected directly in the plate circuit of the last amplifier tube. First of all, since the wire of the coil is very fine, the heavy plate current would burn it out. Secondly, it has been found that the most efficient transfer of power takes place when the resistance of the voice coil equals the resistance of the amplifier tube (Chap. 38, Vol. II).

The tube resistance is quite high, about 9,000 ohms for the type 27 tube. But since the voice coil must be kept light, it is wound with a few turns of wire and its resistance usually is from 2 to 30 ohms.

Here our old friend the step-down transformer comes to the rescue. The primary, which is connected in the plate circuit, has a great many turns and its resistance equals the tube resistance, thus insuring the maximum transfer of power. The secondary has few turns and its resistance is made to equal the resistance of the voice coil, thus again insuring the maximum power transfer.

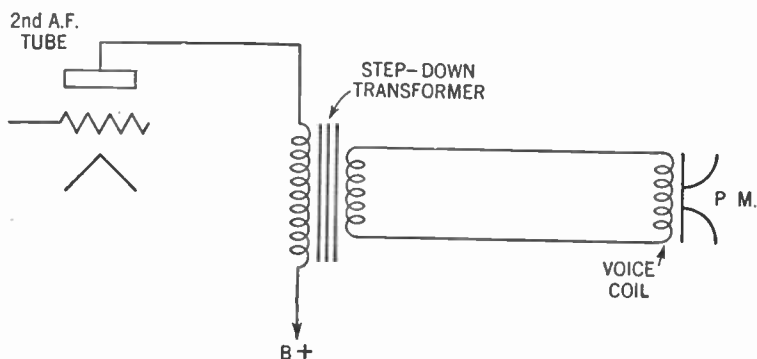

**Figure 122.** Diagram showing how a step-down transformer (output transformer) is used to couple the voice coil of the permanent-magnet dynamic speaker to the plate circuit of the second audio-frequency tube.

In Figure 122 you can see that in this hookup the heavy plate current does not flow through the voice coil and thus the danger of burning it up is removed.

The step-down transformer, used in connection with the dynamic speaker, is called an *output transformer*. Since different tubes have different resistances and the voice coils of different speakers, too, may have different resistances, an output transformer of different design must be used to match each new combination of amplifier-tube and voice-coil resistance.

### 147. Electromagnetic Dynamic Speaker

The permanent-magnet dynamic speaker still has several drawbacks. The permanent magnet deteriorates in time and the speaker gradually gets weaker. This fault may be partly remedied by the use of such alloys as Alnico, which make better, longer-lasting permanent magnets.

A more serious fault in the permanent-magnet speaker is the fact that where very loud sound is desired, as for auditorium or outdoor use, the permanent magnet cannot create a magnetic field great enough to move the paper cone properly.

To overcome these difficulties, a variation of the dynamic speaker is made which has an electromagnet replacing the permanent magnet. This electromagnet, called the *field coil*, is connected to a source of steady direct current. Since the field coil consists of a great many turns of wire, we now have a constant, powerful magnet which sets up a strong magnetic field as long as the current flowing through it is steady and constant. This field coil is wound around a soft-iron rod upon which the voice coil slides.

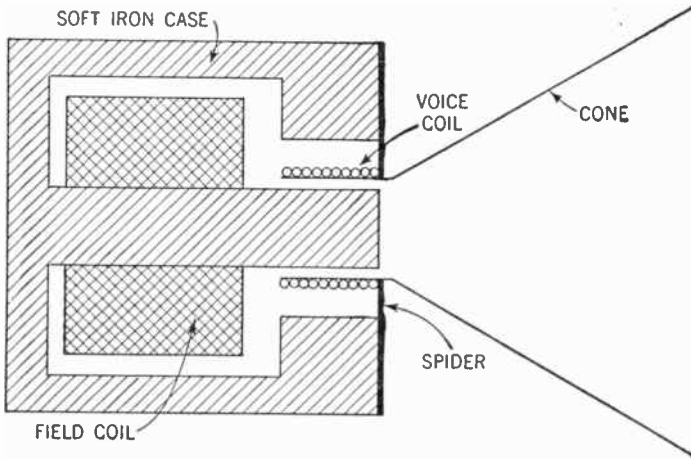
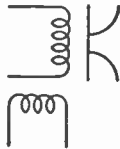

Figure 123. Diagram of an electromagnetic dynamic speaker. The field coil replaces the permanent magnet of the P. M. dynamic speaker.

This type of dynamic speaker is called an *electromagnetic dynamic speaker*. As in the case of the permanent-magnet dynamic speaker, electrical energy is transferred from the plate circuit of the last amplifier tube to the voice coil by means of an output transformer. The symbol for the electromagnetic dynamic

speaker is:



#### 148. Supplying Current for the Field Coil

There are several means for obtaining the steady direct current needed for the field coil of this speaker. We may use a separate storage battery of 6 or 12 volts for this purpose. The field coil must be designed to operate on this low voltage. The use of



storage batteries is a nuisance, but this method is used for special purposes, such as operating a loudspeaker in a moving automobile.

#### 149. Separate Filter System for the Speaker

Another method without a battery is to use a separate rectifier and filter circuit for the speaker. The systems described in Chapter 18 and Chapter 21 can be used. For these systems we must design the field coil to operate on the higher voltages obtained. This method of obtaining a field-coil current supply is used chiefly for auditorium or outdoor purposes where very loud sound is desired.

#### 150. Using Power from the B Eliminator for the Speaker

The method that is most commonly used for supplying current to the field coil without the use of batteries, is to pass the steady direct current flowing out of the B eliminator through the field coil before it is passed on to the radio receiver.

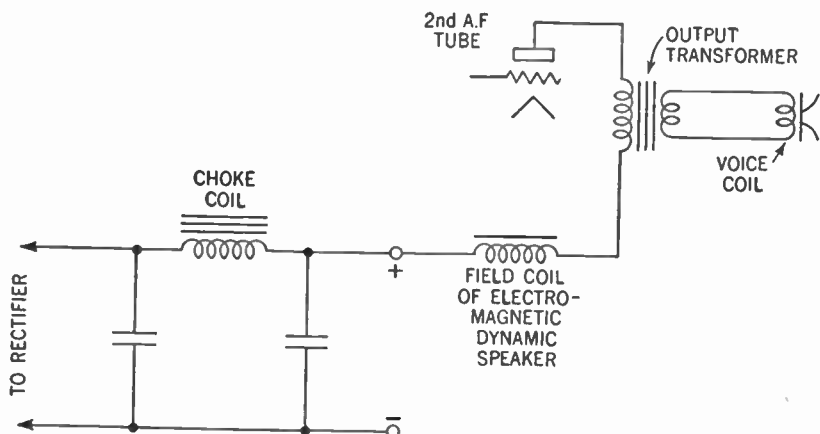

Figure 124. Diagram showing how current is obtained from the power supply to operate the field coil of the electromagnetic dynamic speaker.

Not only does this system eliminate the need for a separate storage battery or power supply for the speaker, but the field coil acts as a second choke coil and thus helps further to filter the plate current supplied to the radio receiver.

The electromagnetic dynamic speaker is widely used in sets that remain permanently near a source of house current. In portable receivers, however, to avoid the necessity for using a separate

battery to energize the field coil, permanent-magnet dynamic speakers are usually used.

### SUMMARY

Complete the meaning of the following statements by supplying the missing words. *Do not write in the book!*

1. The loudspeaker is an adaptation of that part of a telephone system called the (1) . The part which transmits the energy to the air is called the (2) , and sound reaches the ears by means of sound (3) through the (4) .

2. The first type of loudspeaker used a (5) cone attached to the (6) by means of a (7) . The louder sound was produced because the (8) (9) set more air in motion than did a metal diaphragm alone.

3. There are two types of dynamic speakers called the (10) (11) and the (12) (13) .

4. When magnetism is produced in the speaker by electricity the current must be (14) (D.C. or A.C.) .

5. The chief principle of a dynamic speaker is that a moving coil called a (15) responds to varying magnetic (16) set up by the (17) current from the second (18) (19) amplifying tube.

6. To provide current for the field coil of an electrodynamic speaker the best method is to (20; explain) .

### GLOSSARY

**Dynamic Speaker:** A type of loudspeaker that depends for its operation upon the reaction between a fixed magnetic field and the fluctuating magnetic field produced around the voice coil.

**Electromagnetic Dynamic Speaker:** A dynamic speaker that uses an electromagnet to produce the fixed magnetic field.

**Field Coil:** The electromagnet of an electromagnetic dynamic speaker.

**Output Transformer:** A step-down transformer that couples the electrical energy from the plate circuit of the last audio-frequency amplifier tube to the voice coil.

**Permanent Magnet:** A magnet that retains its magnetism after the magnetizing force which produced it is removed.

**Permanent-magnet Dynamic Speaker:** A dynamic speaker that uses a permanent magnet to produce the fixed magnetic field.

**Spider:** A piece of elastic material that constantly tends to return the voice coil to its normal position.

**Voice Coil:** The small coil of the dynamic speaker through which electrical energy from the plate circuit of the last audio-frequency amplifier tube is fed, setting up a fluctuating magnetic field that reacts with the fixed magnetic field to drive a cone, thus producing sound.

SYMBOLS

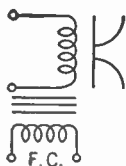

Electromagnetic dynamic speaker.



P.M. Permanent-magnet dynamic speaker.

QUESTIONS AND PROBLEMS

1. What was one defect of the diaphragm type of loudspeaker?
2. What current provides the energy for the voice coil of a loudspeaker?
3. What causes the voice coil of a loudspeaker to move?
4. Describe the structure of a permanent-magnet dynamic speaker.
5. Why cannot the voice coil be connected directly in the plate circuit of the last amplifier tube?
6. By what means is the voice coil of a loudspeaker coupled to the last amplifier tube?
7. What are some faults of a permanent-magnet dynamic speaker?
8. How is the field coil of an electromagnetic speaker energized (that is, given energy)? Describe two methods.

3 Items # 151  
# 154

## CHAPTER 23

# The Radio-frequency Amplifier

---

- Problem 1:** *What is the purpose of the radio-frequency amplifier?*
- Problem 2:** *What are the parts of a tuned radio-frequency amplifier?*
- Problem 3:** *How are the faults of a tuned radio-frequency amplifier corrected?*
- Problem 4:** *How are radio- and audio-frequency amplifying systems connected in a five-tube receiving set?*
- 

When future historians record the achievements of the first half of the twentieth century, the most outstanding accomplishment, perhaps, will be the conquest of time and space. The invention of the airplane destroyed distance. Oceans were spanned and continents crossed in a matter of a few hours.

But fast though the airplane is, it cannot compare with the speed of radio, which can flash the spoken word seven times around the world in one second!

### 151. More Power Needed

To utilize fully the magical powers of radio, the receiver must be made much more sensitive than the set we have just finished describing. True, the audio amplifier could build up the signal from a whisper in the earphones to a volume loud enough to fill a large auditorium; but in order to function, it had to receive this signal from the detector. The radio-frequency current in the aerial-ground system must be powerful enough to operate the detector.

Now a very powerful transmitting station, operating a few miles from the receiver, can set currents flowing in the aerial-ground system large enough to give satisfactory results. But weak stations, many miles away, are unable to emit a wave with suffi-

cient energy to build up a signal that can be passed on to the audio amplifier.

The problem therefore is to devise a system that will build up the signal before it reaches the detector.

### 152. The Radio-frequency Amplifier

When radio development encountered this problem, the three-element radio tube once again was called on to act as an amplifier. In this case the current flowing into the amplifier alternates at a frequency of hundreds of thousands or even millions of cycles per second. It alternates, that is, at radio frequency. For this reason the amplifier is called a *radio-frequency amplifier* to distinguish it from the audio-frequency amplifier in whose circuit the current was alternating at audio frequency, that is, between 30 cycles and 15,000 cycles per second.

The radio-frequency amplifier works in the same way as does the audio-frequency amplifier. A small alternating voltage places an alternating charge upon the grid of the radio tube. This grid charge in turn controls the large plate current supplied by the B battery (see Chapter 17).

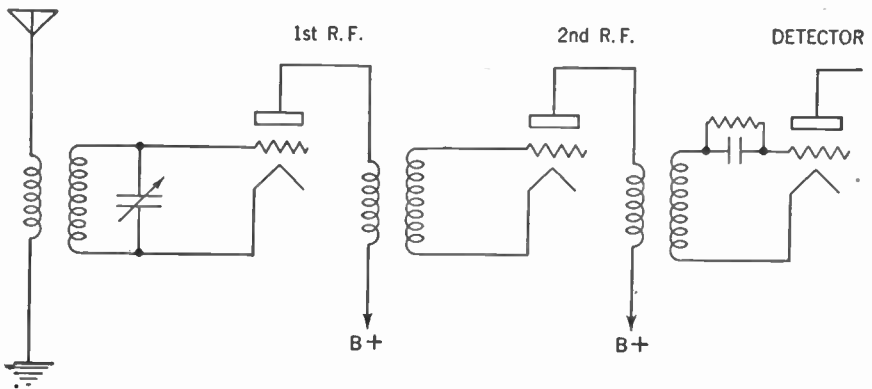

Figure 125. Diagram showing the circuit of two transformer-coupled radio-frequency amplifier stages. The "C" batteries are omitted here for the sake of simplicity.

The methods for coupling one radio-frequency amplifier tube to another are likewise the same methods used in the audio-frequency amplifier: either transformer or resistance coupling. But resistance coupling in radio-frequency amplifiers is seldom used and we need not discuss it here.

The method of coupling most commonly used is transformer

coupling. The transformer used for radio-frequency amplification differs from the audio transformer in that it is usually an air-core transformer and has fewer turns. Like the audio transformer, it has a step-up winding that makes for a greater gain in signal strength.

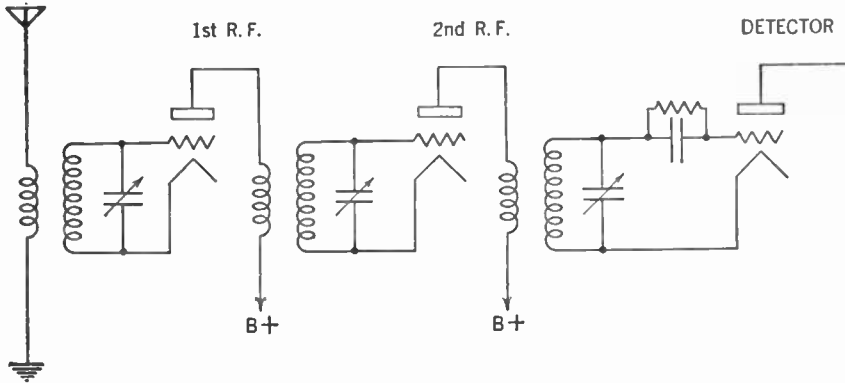

Figure 126. Diagram showing the circuit of two tuned radio-frequency amplifier stages.

### 153. The Tuned Radio-frequency Transformer

If you examine Figure 125, you will see that the radio-frequency transformer resembles the antenna coupler. The only difference is that the secondary winding of the antenna coupler is in a tuning

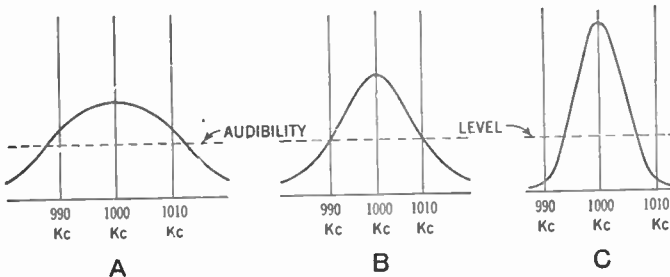

Figure 127. A—Tuning curve with one tuned circuit. Notice that stations at 990 kc. and 1,010 kc. are heard when the set is tuned to 1,000 kc.  
 B—Tuning curve with two tuned circuits. Note that the two unwanted stations are just at the audibility level.  
 C—Tuning curve with three tuned circuits. The two unwanted stations cannot be heard.

or “tuned” circuit, while the secondary of the radio-frequency transformer is not. However, it was soon discovered that certain advantages could be gained if the secondary of the transformer

was made a part of a tuned circuit by connecting it with a variable condenser similar to the one used to tune the secondary of the antenna coupler.

You already have learned how the tuning circuit permits the signal from the station of the desired frequency to flow through it and tends to stop all others. However, some unwanted frequencies do manage to get through the tuner. If the signal is forced to pass through a series of such tuning circuits, however, the chances for the unwanted frequencies to leak through become proportionately less. In this way our set becomes more selective.

#### **154. Advantages of the Tuned Radio-frequency Amplification**

A radio-frequency transformer whose secondary is tuned by means of a variable condenser is called a *tuned radio-frequency transformer*. The tuned radio-frequency transformer is practically the same as the antenna coupler, while the variable condenser used for tuning is similar in size to that used in the tuning circuit. The secondaries of the transformers are all tuned to the same frequency as the secondary of the antenna coupler. A stage of radio-frequency amplification using a tuned radio-frequency transformer with a variable condenser is called a stage of *tuned radio-frequency amplification*.

When we use two stages of tuned radio-frequency amplification (Figure 126), we have three tuned circuits. Thus our set is much more selective than if we had only one tuned circuit (Figure 127).

Tuned radio-frequency amplification has another advantage over an untuned stage. Since the natural frequency of the tuned circuits is the same as the frequency of the incoming signal, the oscillations of the electrons in the tuned circuits are permitted to build up and this building up results in a louder signal. Of course, one disadvantage of the tuned stage is that it requires an additional variable condenser and an additional dial or knob accordingly must be manipulated.

#### **155. Eliminating the Effect of Stray Magnetic Fields**

One of the difficulties encountered in the manufacture of the radio-frequency amplifier is the fact that the magnetic field around one radio-frequency transformer may be large enough to cut across the coils of another such transformer. This action sets an unwanted current flowing in the second transformer and oscillations

and distortion of the signal results. This evil is remedied in several ways.

Of course, we may space these transformers far enough apart to prevent this unwanted effect. But this plan is not practical, especially since we do not want our receiving set to be too large.

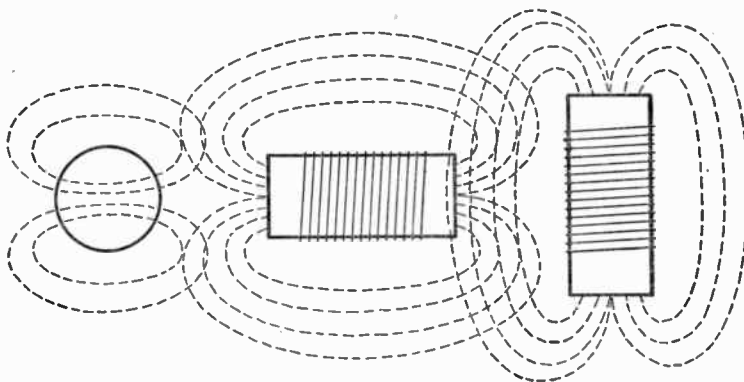

Figure 128. Tuned radio-frequency transformers mounted at right angles to each other. The dotted lines about each coil represent its magnetic field. Note that the transfer of electrical energy from one coil to the others is at minimum efficiency.

### 156. Setting the Transformers at Right Angles to Each Other

Another solution is to mount our transformers so that the windings, and hence the magnetic fields, are at right angles to each other. In such an arrangement, the transfer of energy from one

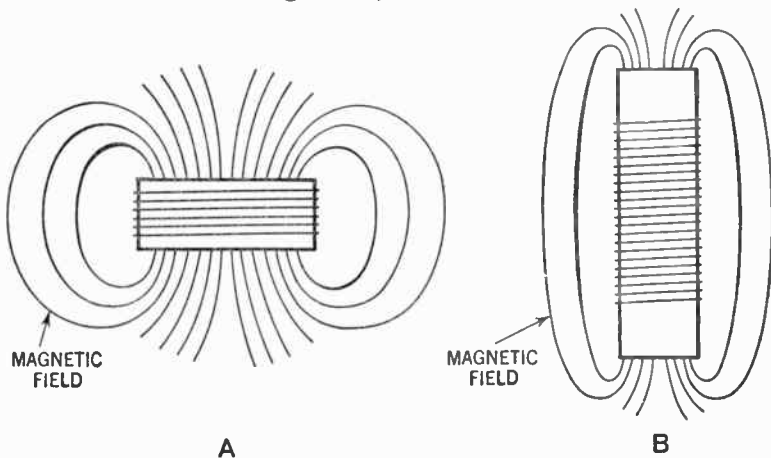

Figure 129. A—Magnetic field around a short coil of large diameter. Note how the field spreads out.  
 B—Magnetic field around a long coil of small diameter. Note that the magnetic field remains close to the coil.



transformer to another is at a minimum. (See the discussion of coupling in the regenerative receiver in Paragraph 98.)

### 157. Coils with Smaller Diameters

Still another solution is to design our transformer so that its magnetic field is kept close to it. A short coil of large diameter has a wider magnetic field around it than a long coil of smaller diameter.

We now make our transformers an inch or less in diameter and use more turns of wire.

### 158. Shielding

Another solution is to surround the transformer with a metal shield or case. This shield absorbs the magnetic field and very little of it gets through.

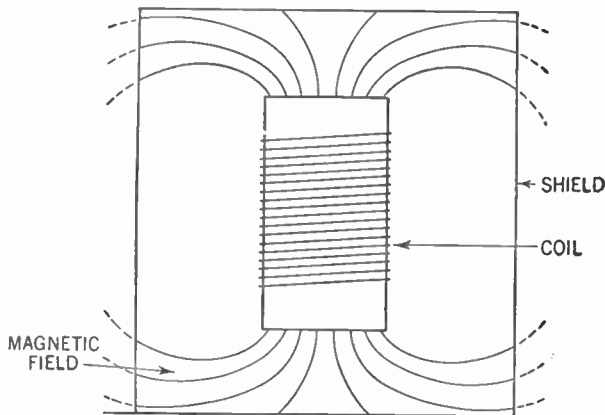

Figure 130. Coil shielded by a metallic can. Note that very little of the magnetic field penetrates the shield.

This method is called *shielding* and modern radio receivers use this device together with the narrower coil. The symbol signifying a shielded coil consists of a dotted line placed around this coil. The metals most commonly used for shielding are aluminum and copper.

Shielding is often used also to protect the radio-frequency amplifier tube from the effects of stray magnetic fields. Less frequently, the entire radio-frequency amplifier stage, consisting of the transformer, the variable condenser, the radio tube, and the wiring, is enclosed in a shielding case. Such complete shielding is

rarely necessary. It usually suffices to shield the radio-frequency transformer and tube.

All metal used for shielding must be connected to the ground of the receiver.

Audio-frequency amplifiers are less subject to the effects of these stray magnetic fields. Nevertheless, the audio transformers are usually shielded and mounted so that the windings of one transformer are at right angles to the windings of the other.

### 159. The Elimination of the Feedback

In designing radio-frequency amplifiers, means must be taken to avoid feedback. In the regenerative detector circuit we deliberately caused some of the plate current to be fed back to the grid circuit (see Chapter 16). This feedback was carefully controlled and made the set more sensitive.

In the radio-frequency amplifier, however, such feedback is undesirable for it results in oscillation and other distortions of the signal. Such feedback may come from several sources and all of it must be eliminated.

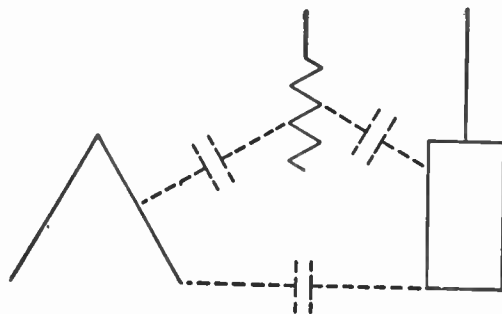

Figure 131. Diagram showing the capacity effect existing between the electrodes of the triode. The result is the same as if small condensers were connected between the electrodes.

The chief source of feedback lies in the tube itself. Any two conductors, separated by a dielectric, will form a condenser. The electrodes of the tube are such conductors. The dielectric is the vacuum between them.

### 160. How Capacitance Is Produced in Tubes

Thus a capacitance exists between the filament and the grid, the grid and the plate, and the filament and the plate. Because of the small area of the conductors, these condensers have small capaci-

tance. But small though it is, the capacitance provided by the combination of the grid and the plate causes considerable trouble. By means of this small capacity effect, the output circuit (the plate circuit) and the input circuit (the grid circuit) are linked and feedback occurs.

Examine the circuit of the stage of radio-frequency amplification shown in Figure 132.

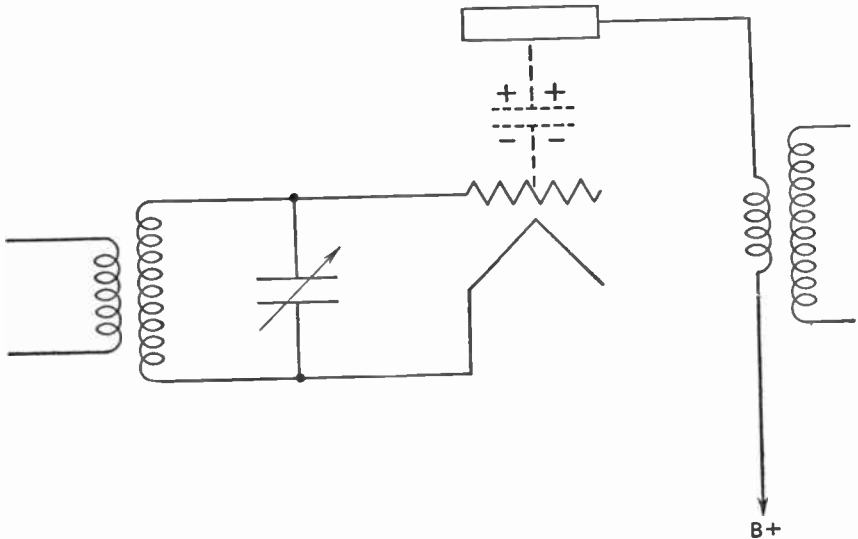

**Figure 132.** How the charge on the plate causes on opposite charge to be placed on the grid of the tube.

The B battery places a positive charge on the plate of the tube. Fluctuations of the plate current, resulting from the signal, will cause this positive charge on the plate to fluctuate.

Now consider the plate and grid as two conductors forming a condenser. The plate of the tube, being charged positively, causes a certain number of electrons to gather on the grid. The grid, that is, gets a negative charge. The more positively charged the plate, the more electrons are pulled over to the opposite electrode of the condenser, the grid.

The more highly positive the plate, then, the more electrons flow through the secondary of the radio-frequency transformer to the grid. As the plate loses some of its positive charge, some electrons are forced to flow from the grid back through the secondary of the radio-frequency transformer.

Thus the fluctuating charge on the plate of the tube sets up a corresponding oscillation of the electrons in the grid circuit. This oscillation causes distortion and must be eliminated.

**161. Correcting the Influence of the Capacitance within the Tube**

There are several methods of correcting for this tube capacitance. One is to connect a 500-1,000-ohm resistor in the grid circuit.

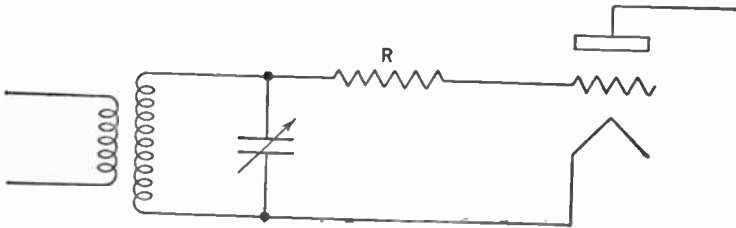

Figure 133. The "losser" method of preventing oscillations in the radio-frequency amplifier. The resistance R dissipates the unwanted flow of electrons.

This resistor uses up the electrical pressure of the electrons set oscillating in the grid circuit described above, and the distortion is therefore eliminated. This method of eliminating feedback is called the *losser method*. It suffers from the disadvantage that

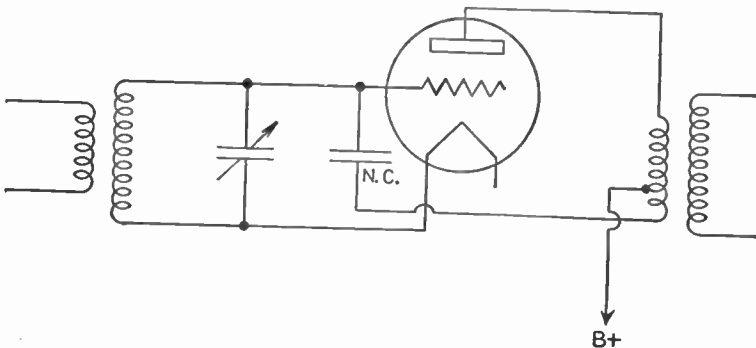

Figure 134. How a neutralizing condenser (N.C.) is employed to eliminate the feedback due to the internal capacitance between the grid and plate of the tube.

it dissipates not only the unwanted flow of electrons caused by feedback, but also some of the desired signal voltage. The result is a loss of amplification.

Another method for preventing feedback is the *neutralization method*. A small condenser, as shown in Figure 134, is connected across the grid and plate of the tube in such a way as to neutralize the plate-to-grid capacitance. This eliminates the feedback without a resulting loss of amplification. This small fixed condenser is called the *neutralizing condenser*.

One end of the neutralizing condenser is connected to the grid of the tube while the other end is connected to the bottom of the primary of the radio-frequency transformer. The B+ is brought to a tap on this primary near the bottom of the coil.

This neutralizing condenser acts as a storage tank and electrons which without it would have been sent oscillating in the grid circuit are instead stored on its negative plate. The action is as though a flow of electrons equal to the feedback, but opposite in direction, were taking place. The opposing streams of electrons cancel out and there is no feedback.

Feedback due to capacitance within the tube is eliminated in modern sets by using tubes of the screen-grid class. We will discuss this more fully in the chapter dealing with types of tubes.

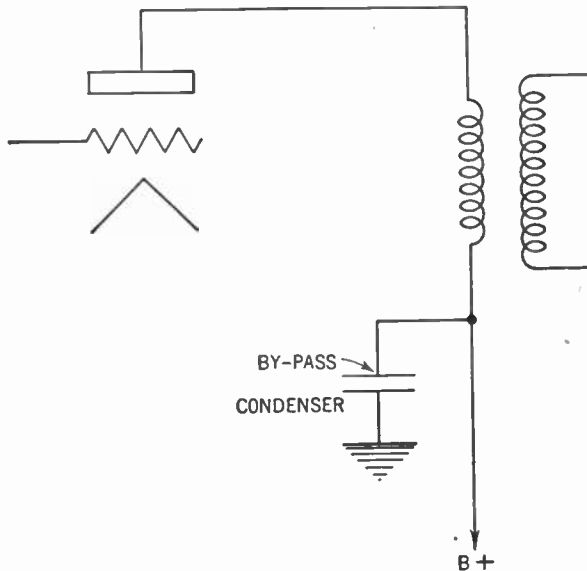

**Figure 135.** How a fixed condenser is used to by-pass any radio-frequency current leaking across the B supply.

### 162. Correcting Leakage by a By-pass Condenser

A loss of amplification may be encountered in the radio-frequency amplifier, owing to the radio-frequency voltage drop

across the B battery or the B eliminator. This difficulty is remedied by providing a separate path for any radio-frequency current which finds itself in the plate circuit.

A fixed condenser whose value is about  $.006 \mu\text{fd.}$  is connected from the B+ terminal of the primary of the radio-frequency transformer to the ground. Then any radio-frequency current leaking across the B battery flows through the condenser to the ground (which is an easy path for radio-frequency current), rather than through the primary of the radio-frequency transformer (which presents a high resistance to radio-frequency currents). We call such a fixed condenser a *by-pass condenser*.

### 163. A Radio-frequency Choke Coil

We use a slightly different device to prevent any radio-frequency current that finds itself in the plate circuit of the detector tube from going into the audio-frequency amplifier, where it may cause some distortion.

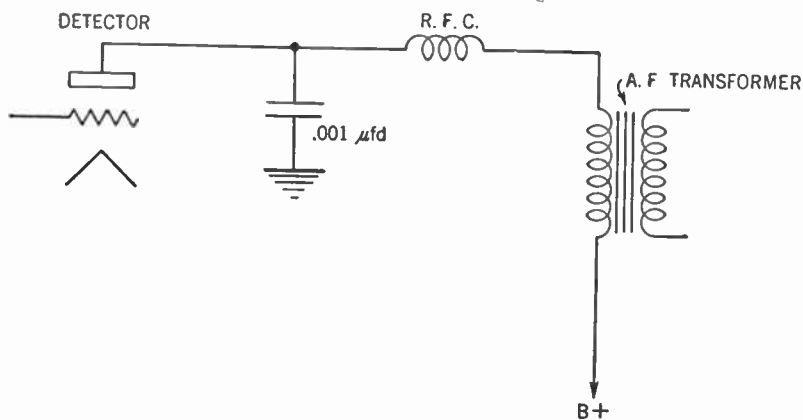

**Figure 136.** How a radio-frequency choke coil (R. F. C.) and by-pass condenser are used to keep stray radio-frequency currents from leaking into the audio-frequency amplifier.

Between the plate and the primary of the first audio transformer we connect a small inductance whose value is about  $2\frac{1}{2}$  millihenries. We call this inductance a *radio-frequency choke coil*. This choke coil offers a high resistance to the radio-frequency current, but not to the fluctuating direct current. To permit the radio-frequency current to escape we connect a small fixed con-

denser of about .001  $\mu$ fd. from a point between the plate and the choke coil to the ground.

As in the case of audio-frequency amplification, a negative bias is placed on the grid of the radio-frequency amplifier tube to prevent distortion. Here, too, care must be taken not to make this negative bias too great, else detection will take place. (See Paragraph 106.)

#### 164. Ganging of Variable Condensers

It is customary to use two stages of tuned radio-frequency amplification before the detector of the receiving set. Using fewer than two stages means not enough amplification, while using more makes it extremely difficult to control oscillations. If you examine Figure 126 you will see that such a receiver, using two stages of tuned radio-frequency amplification, has three variable condensers which must be manipulated to bring in the desired station. Since all three tuned circuits are very nearly alike, the variable condensers, too, will be meshed or unmeshed to about the same degree for receiving any given station.

It becomes logical, therefore, to connect all three variable condensers so that they may be operated simultaneously by turning one dial. This process of connecting the variable condensers is called *ganging*.

Early methods of ganging the variable condensers consisted of hooking them up with gears or a belt. This soon gave way to the simpler method of mounting all three variable condensers on one shaft. We now speak of a *three-gang variable condenser*.

#### 165. Use of Trimmers with Variable Condensers

It is quite obvious that all three tuning circuits must be identical if the set is to function properly with ganged condensers. It is impossible, however, to make two coils or two variable condensers that are absolutely identical. Small variations are bound to creep in.

To overcome these slight discrepancies, a very small condenser, called a *trimmer*, is connected across each variable condenser of the tuning circuits. This trimmer usually consists of two metal plates, about  $\frac{1}{2}$  in. square, that are separated by a sheet of mica. Turning a screw separates the plates or brings them closer together,

thus varying the capacitance of the trimmer. This small condenser is usually mounted at the side of the variable condenser.

These trimmers are adjusted to compensate for the discrepancies in the various tuning circuits. Their action is to vary slightly the

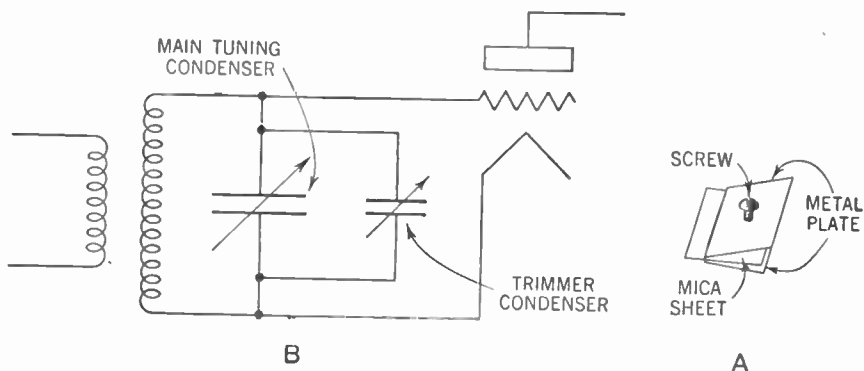

Figure 137. A—Trimmer condenser used to align the radio-frequency amplifier stages.  
B—Circuit showing how the trimmer is connected across the main tuning condenser.

amount of capacitance in the tuning circuit to make the natural frequency of that circuit equal to that of all the other tuning circuits. Once adjusted, the trimmers are left in those positions. This process of matching up the various tuning circuits of a radio receiver is called *aligning the set*.

### 166. Use of Trimmers on Aerials

While on the subject of the trimmer condenser, it should be noted here that in modern practice one of these trimmers, called the *aerial trimmer*, is usually connected in series with the aerial-ground system (see Figure 138). The effect of this small condenser is to lengthen or shorten the aerial electrically.

This change in the aerial is desirable because each set will work most efficiently with an aerial of a certain length. Of course, you may go up on the roof and snip off some of the wire from the aerial, but it is much simpler to adjust the aerial trimmer until the signals are at their loudest. Once set, the trimmer is left alone until a new aerial is put up.

### 167. Radio Amplification Compared to Audio Amplification

In comparing our two types of amplification we must remember that they complement each other. We cannot use too many



stages of either radio-frequency or audio-frequency amplification without running into oscillations, noises, or distortion of signals. Our modern receiving set therefore usually consists of two stages of radio-frequency amplification, the detector, and two or three stages of audio-frequency amplification.

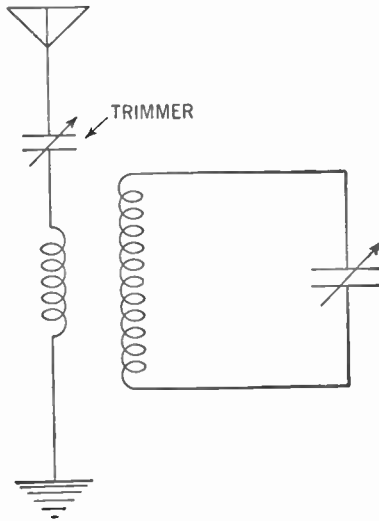

**Figure 138.** Use of trimmer condenser to adjust the aerial to the radio receiver.

A stage of tuned radio-frequency amplification has certain advantages over a stage of audio-frequency amplification. First of all, the sensitivity of the set is increased by radio-frequency amplification. In addition, the selectivity of the receiver is improved. Further, stage for stage, radio-frequency amplification gives greater gain than audio-frequency amplification.

On the other hand, the power output of the audio-frequency amplifier is greater than that of the radio-frequency amplifier. Under normal conditions, the radio-frequency amplifier and detector cannot operate a loudspeaker. Currents large enough for this purpose do not flow in their plate circuits.

Another feature of the audio-frequency amplifier is that it is normally more stable than the radio-frequency amplifier. If the set is properly designed we have no oscillations in the audio-frequency stages and need not neutralize the internal capacitance of the tube.

Since the audio-frequency stage does not require any controls

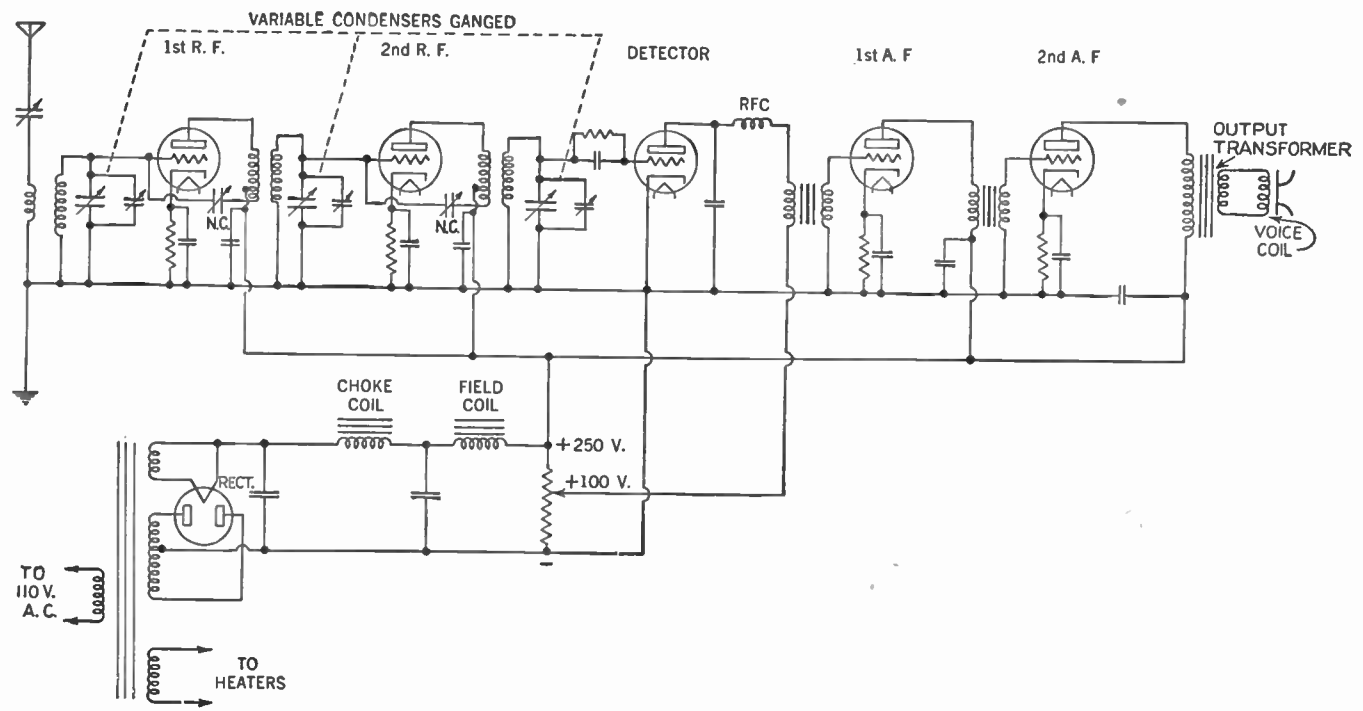

Figure 139. Circuit for a complete tuned radio-frequency receiver.

that need be manipulated, we are not troubled with such things as ganging or alignment of circuits.

### 168. The Five-tube Set

Figure 139 shows the circuit of a five-tube receiver with two stages of neutralized tuned radio-frequency amplification, a detector, and two stages of transformer-coupled audio-frequency amplification. This set is known as a *tuned radio-frequency (T.R.F.) receiver*.

The dotted lines connecting the three variable condensers show that they are ganged together. For the sake of simplicity the diagram does not show the connections of the filaments of the tubes, or the dotted lines indicating shielding around the antenna coupler, the radio-frequency transformers, and the radio-frequency and detector tubes.

#### SUMMARY

1. It has been found necessary to amplify the radio-frequency signals before transforming them into audio frequencies in order to obtain reception from distant radio stations.

2. The system developed to produce amplification of the radio-frequency currents is called the **tuned radio-frequency amplifier**.

3. The tuned radio-frequency amplifier employs a transformer whose secondary is tuned by means of a variable condenser, similar to that of the antenna coupler.

4. Two stages of tuned radio-frequency amplification, together with the tuner connected to the aerial-ground system, provide three tuned circuits. This arrangement gives great sensitivity as well as selectivity.

5. To avoid feedback from the radio-frequency amplifying system, several precautions must be taken, namely: use of narrow coils; setting coils at right angles to one another; shielding coils and tubes by metal covers; correcting influence of capacitance in tubes by resistors, condensers, or choke coils.

6. Modern five-tube sets have two stages of tuned radio-frequency amplification, two stages of audio-frequency amplification, ganged condensers, and shielded tubes and transformers.

#### GLOSSARY

**Aerial Trimmer:** A small variable condenser in the aerial circuit used to adjust the length of the aerial electrically.

**Alignment:** The process of adjusting the tuned circuits of a T.R.F. receiver so that all of them have the same natural frequency.

**By-pass Condenser:** A fixed condenser that shunts to the ground any unwanted radio-frequency currents, thereby preventing distortion of the signal.

**Feedback:** The transfer of electrical energy from the plate circuit of a tube to a preceding grid circuit. This is usually undesirable and produces distortion of the signal. (But see Regeneration, Par. 96.)

**Ganged Condensers:** Variable condensers, so hooked up that they turn simultaneously from a common shaft.

**Neutralization:** The elimination of the feedback due to the inter-electrode capacitance between the plate and grid of the tube.

**Neutralizing Condenser:** A small condenser connected in such a way as to neutralize the capacitance between the plate and grid of a tube.

**Radio Frequency:** The frequency of the radio wave. Those in the broadcast band range between 550 kc. and 1,600 kc. per second.

**Radio-frequency Amplifier:** An amplifier that amplifies the radio-frequency current from the tuning circuit before feeding it into the detector.

**Radio-frequency Choke Coil (R.F.C.):** A coil of many turns offering a high resistance to radio-frequency currents, but not to low-frequency currents.

**Radio-frequency Transformer:** A step-up transformer, usually wound with an air core, used to couple radio-frequency electrical energy from one circuit to another.

**Shielding:** The act of surrounding a current-carrying device by a metal container to keep magnetic fields in or out.

**Trimmer:** A small variable condenser connected across the large tuning condenser used to adjust the latter (see *Alignment*, above).

**Tuned Radio-frequency (T.R.F.) Receiver:** A receiver using one or more tuned radio-frequency amplifier stages, a detector, and one or more audio-frequency amplifier stages.

**Tuned Radio-frequency Transformer:** A radio-frequency transformer whose secondary is tuned by a variable condenser.

## SYMBOLS

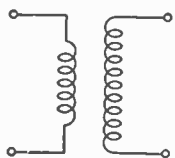

Radio-frequency transformer.

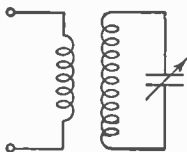

Tuned radio-frequency transformer.



Radio-frequency choke coil.

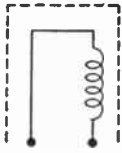

Shielded coil.

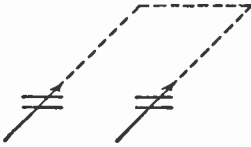

Ganged condensers.

### QUESTIONS AND PROBLEMS

1. What is the chief fault of a receiver using a regenerative detector and two stages of audio amplification?
2. How may we overcome the weakness discussed in question 1?
3. What is meant by a radio-frequency amplifier?
4. How do we couple radio-frequency amplifiers to each other and to the detector?
5. In what way does a radio-frequency transformer differ from an audio-frequency transformer?
6. Why do we gain more selectivity by using several stages of tuned radio-frequency amplification?
7. Draw a sketch of a circuit from the aerial and ground system to the detector, using two stages of tuned radio-frequency amplification.
8. List several advantages of tuned radio-frequency stages over untuned radio-frequency amplifier stages.
9. How do we prevent the stray magnetic fields developed by our radio-frequency transformers from producing unwanted voltages in other parts of our receivers? Mention three devices used.
10. To what do we usually connect a shield?
11. What is the source of feedback or regeneration in a radio-frequency amplifier stage, and what does such feedback cause?
12. Explain the condenser action or capacity effect between the plate and grid of the triode radio-frequency amplifier stage.
13. Explain the losser method of oscillation control of a radio-frequency triode amplifier.
14. Explain the neutralization method of oscillation control of a radio-frequency triode amplifier.
15. What is the most modern method of oscillation control of radio-frequency amplifiers?
16. How do we prevent unwanted radio-frequency currents from getting into the B battery or B eliminator?
17. Describe the behavior of a R.F.C. (radio-frequency choke coil).
18. What is the purpose of ganging condensers?
19. Why do condensers in tuned radio-frequency amplifiers have trimmers on them?

20. What is meant by "aligning the receiver"?
21. What is the purpose of an aerial trimmer?
22. How many radio-frequency amplifier stages are usually used in a modern tuned radio-frequency receiver?
23. Compare radio-frequency amplification with audio-frequency amplification.
24. Draw a schematic diagram of a T.R.F. (tuned radio-frequency) receiver.

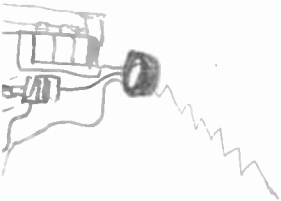

## Volume Control

- 
- Problem 1:** *How is volume controlled in battery sets?*
- Problem 2:** *What problems arise in controlling the volume in nonbattery sets?*
- Problem 3:** *What devices are used to control the volume automatically?*
- Problem 4:** *How are modern sets wired for automatic volume control?*
- 

Every radio receiving set must have some method for controlling volume or loudness of the sounds from the speaker. Otherwise, nearby powerful stations would blast through the loudspeaker

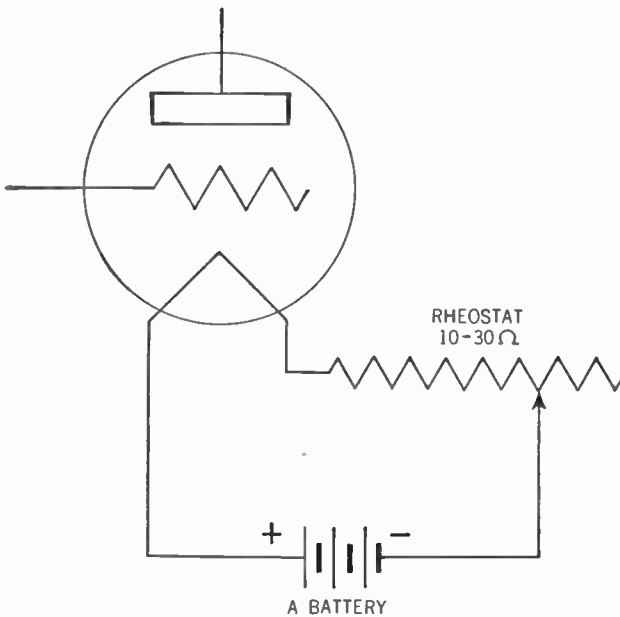

Figure 140. Rheostat in the filament circuit used to control volume.

with uncomfortable loudness and less powerful stations would be heard very faintly.

### 169. Volume Control in Battery Sets

Volume control for battery-operated sets is a relatively simple matter. The most common device is a rheostat of from 10 to 30 ohms connected in series with the A battery and the filament of the radio tube, as in Figure 140.

This rheostat controls the temperature of the filament and in this way controls the quantity of electrons emitted by the filament and therefore the plate current flowing in the plate circuit. This current in turn controls the loudness of the signal coming out of the loudspeaker.

Another method that is less frequently used is to connect a rheostat of about 250,000 ohms in the plate circuit of the tube (see Figure 141). This rheostat controls the positive charge placed on the plate by the B battery and in this way controls the plate current and thus the loudness of the sound.

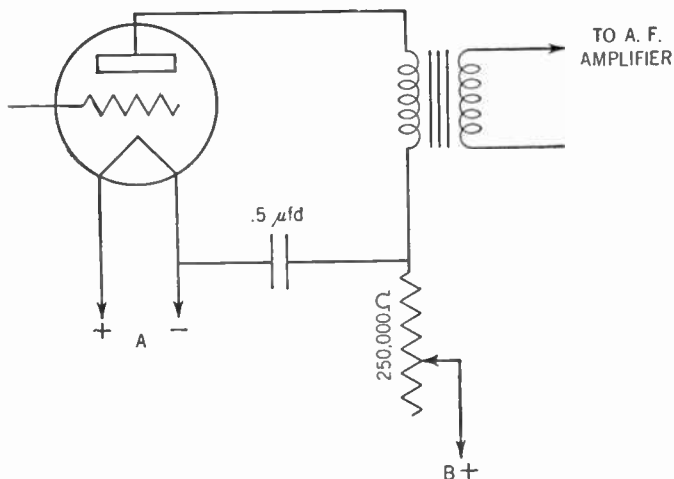

**Figure 141.** Circuit showing how a rheostat in the plate circuit is used to control volume. This device is unsatisfactory.

This rheostat must be by-passed by a fixed condenser of about  $.5 \mu\text{fd.}$  to filter off any radio-frequency currents that may leak through. This method is rarely used, as it has a tendency to detune the set unless the value of the rheostat is kept very high and



then it does not permit a large positive charge to be placed on the plate.

### 170. Volume Control on House-current Sets

In the nonbattery set, it is desirable to keep the filament current constant. This rules out the rheostat in the filament circuit. Other methods of volume control were developed.

One method is to connect a 25,000-ohm potentiometer across the primary of the antenna coupler and to connect the aerial to the sliding arm, as in Figure 142.

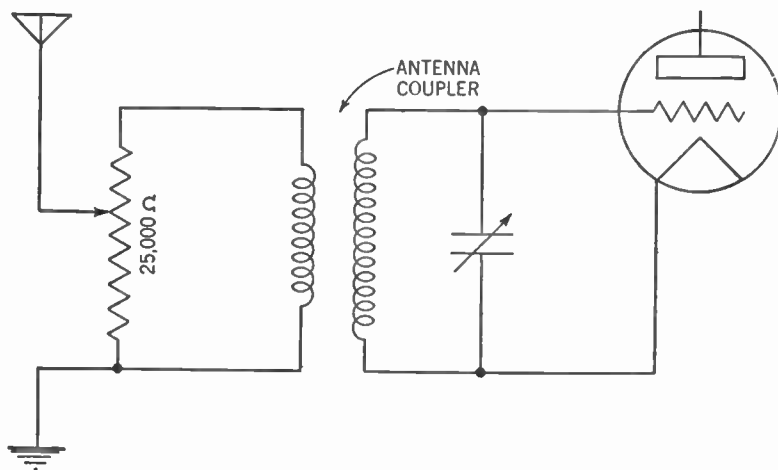

Figure 142. Circuit showing how a potentiometer across the primary of the antenna coupler is used as a volume control.

This hookup controls the amount of current fed into the tuner and thus controls the sound ultimately coming from the loudspeaker. This method suffers from the disadvantage that although it cuts down the amount of electrical energy picked up by the aerial and therefore the amount of outside static or outside electrical interference, it does not reduce the amount of electrical interference created inside the set itself. These latter interferences come through and are amplified within the set. The result is that the set is quite noisy.

Another method, shown in Figure 143, is to connect a 5,000-ohm rheostat across the primary of the transformer in the plate circuit of the second radio-frequency tube.

This method has the advantage that it cuts down the electrical interference in the radio-frequency stages within the set at the

same time as it cuts down the signal strength by dissipating a part of the plate current of the second radio-frequency stage.

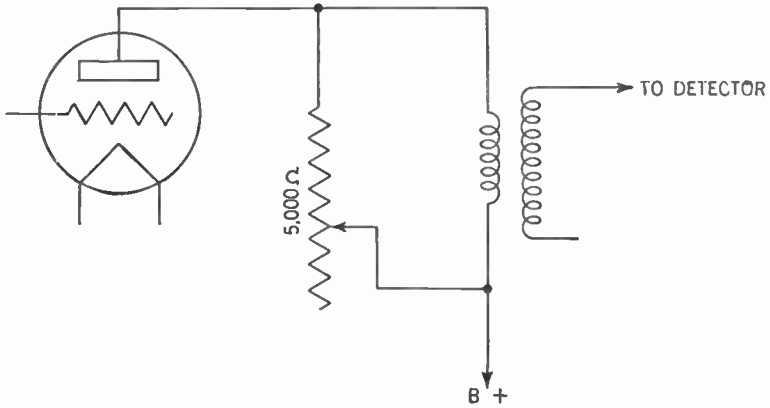

**Figure 143.** Circuit showing how a rheostat connected across the primary of the last radio-frequency transformer is used as a volume control.

Still another method of volume control, shown in Figure 144, is to connect a 500,000-ohm potentiometer across the secondary of the first audio-frequency transformer. The grid of the first audio-

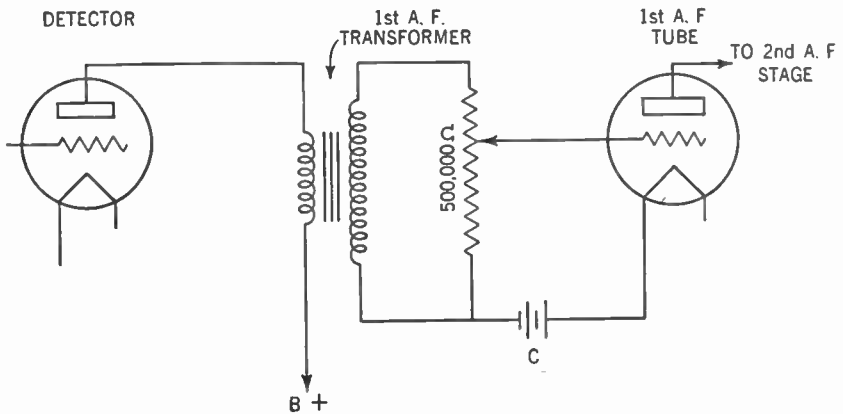

**Figure 144.** Circuit showing how a potentiometer is connected across the secondary of the first audio-frequency transformer to act as a volume control.

frequency tube is connected to the sliding arm. The potentiometer then controls the charge placed on the grid of the tube.

Sometimes the method shown in Figure 144 is combined with that shown in Figure 143. The 500,000-ohm potentiometer and

5,000-ohm rheostat are mounted on the same shaft so that, although they are insulated from each other, they are rotated together by the same control knob.

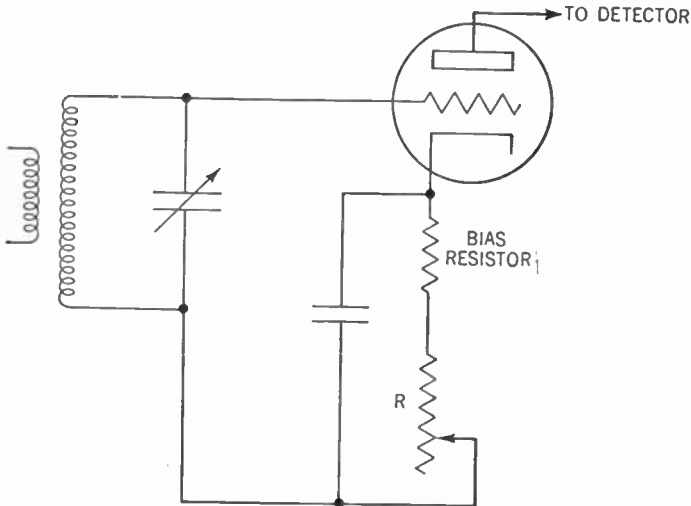

Figure 145. Circuit showing how a rheostat (R) is placed in series with the bias resistor to act as a volume control.

**171. Control of Volume when a Cathode-type Tube Is Used**

The use of a cathode and a grid bias resistor furnishes us with a simple and effective means of controlling the volume. Hooked up in series with the bias resistor is a rheostat, as in Figure 145.

By varying the rheostat, the resistance used to place a negative

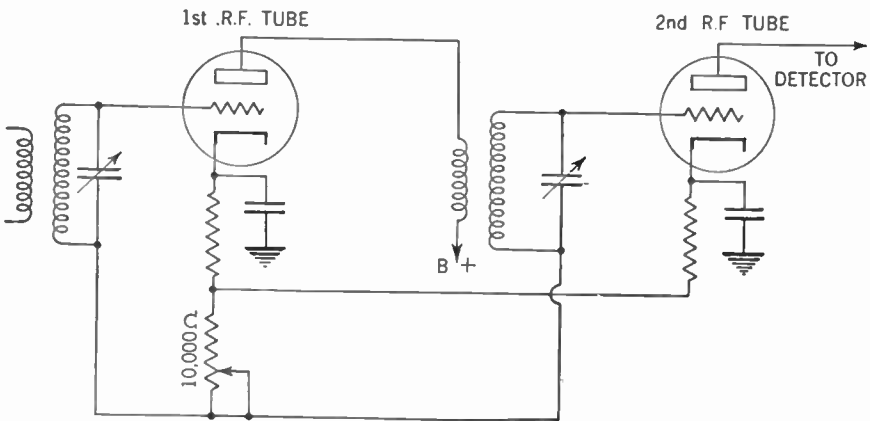

Figure 146. Circuit showing how the rheostat used as a volume control varies the grid bias of both radio-frequency tubes.

charge on the grid of the amplifier tube is made larger or smaller. (This resistance now consists of the bias resistor plus the resistance of the rheostat.) This variation in turn makes the grid more negative or less negative. The more negative the grid, the smaller the number of electrons flowing to the plate and the less the amplification. (See Chapters 15 and 20.)

This rheostat may be connected to the bias resistors of one or more tubes and thus control the amount of amplification supplied by these tubes. The value of this rheostat varies from about 5,000 to 50,000 ohms, depending upon the number of tubes controlled. The more tubes so controlled, the lower the value of the rheostat.

### 172. The Need for Automatic Volume Control

While on the subject of the volume of the sound coming out of the radio receiver, let us consider two problems which must be solved for the greater enjoyment of radio reception.

*First:* Having tuned in a fairly weak station, you have turned the volume control up to give a loud sound. Now you tune in another station. As you turn the dial you happen to pass a powerful station. Since the volume control is turned up to "loud," the new station comes in with an earsplitting blast.

*Second:* This is the more serious problem. You will soon become acquainted with the nuisance of *fading*. The signal will rise and fall, grow louder and softer. We say the signal "fades in" and "fades out."

Just why a radio wave behaves in this manner is not fully known, although we have theories that tend to explain it. We think it is due to the shifting of a layer of electrified air particles, called the "Heaviside layer," far above the surface of the earth. It is not our purpose at this point to discuss this phenomenon, except to recognize that it exists and tends to spoil our enjoyment of the radio program (Chap. 35, Vol. II).

If we had a method of automatically turning our volume control to "loud" when the signal became weaker and to "soft" when the signal became stronger, both of these problems would be solved. This task is accomplished by the *automatic volume control* (abbreviated A.V.C.).

### 173. Automatic Volume Control by Regulation of Grid Bias

How automatic volume control operates is fairly easy to under-

stand. A portion of the signal current is taken off (usually before it reaches the detector), and rectified to direct current. Thus the greater the signal strength, the larger the resulting direct current; the smaller the signal strength, the less the direct current. This direct current is then fed to the grid returns of the amplifying tubes where a negative bias is placed on the grids.

Since greater signal strength yields larger direct current, the grids become more negative. This negative charge on the grids cuts down the amplification of the tubes. Contrariwise, the smaller the signal strength, the less the direct current and the less negative the grids. The effect of less negative grids is to increase the amplification of the tubes.

The net effect is that the greater the signal strength, the less the tubes will amplify it, and the less the signal strength, the more the tubes will amplify it. This arrangement tends to keep the

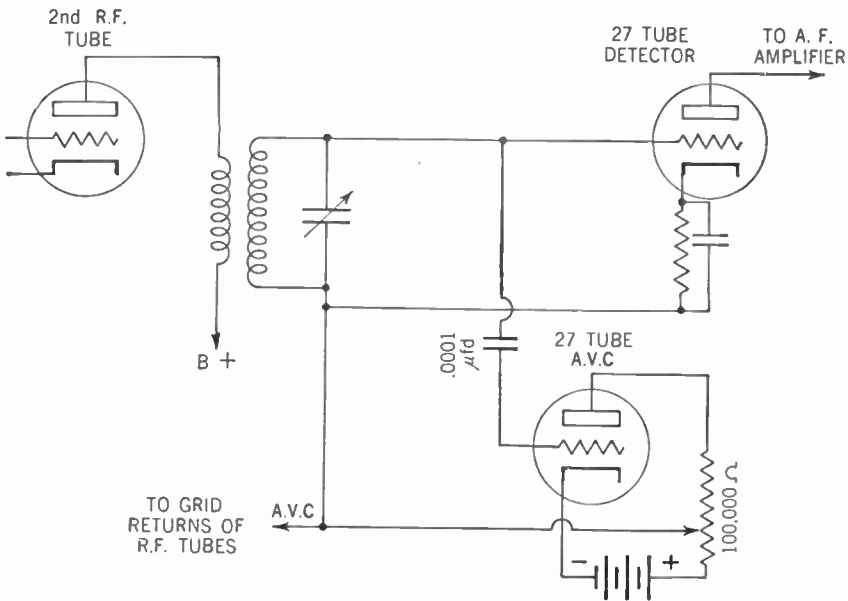

Figure 147. Circuit showing hookup using a 27 tube to obtain the automatic-volume-control voltage. Note that the detector is of the grid-bias type.

volume of sound coming out of the loudspeaker at a constant level and helps to eliminate blasting and fading.

One method of obtaining automatic volume control is shown in Figure 147. Note that the detector tube is connected up as a

grid-bias detector, using a bias resistor in the cathode circuit. The grid of the automatic-volume-control tube is connected to the grid of the detector tube through a .0001- $\mu$ fd. condenser. Thus a small part of the signal voltage is tapped off. The greater the signal, the more positive the charge placed on the grid of the detector. Likewise, a greater positive charge is placed on the upper plate of the .0001- $\mu$ fd. condenser. Accordingly more electrons are drawn from the grid of the automatic-volume-control tube to the lower plate of the condenser and therefore a greater positive charge is placed on the grid of the automatic-volume-control tube.

This charge causes more electrons to stream across from the cathode of the automatic-volume-control tube to its plate. Hence more electrons will flow through the plate circuit and through the sliding arm of the 100,000-ohm potentiometer to the grid returns of the amplifier tubes.

This electron surge in turn places a greater grid bias or negative charge on the grids of these amplifier tubes. The flow of electrons to the plates of these tubes is cut down and less amplification results.

The louder the signal, therefore, the less the amplification. The smaller the signal, the less negative bias on the grids of the radio-frequency tubes and the greater the amplification.

#### 174. Details of the Automatic-volume-control System

By means of a voltage divider across the B eliminator, as described in Chapter 18, we can get the voltage to replace the plate battery as well as that needed to place a negative bias on the grid of the automatic-volume-control tube (Figure 148). A 2-megohm resistor is used as a grid leak and the cathode and plate are by-passed by .1- $\mu$ fd. condensers to the ground to eliminate any radio-frequency current that may have leaked through.

The 250,000-ohm resistor and the .5- $\mu$ fd. condenser in the automatic-volume-control line are used to filter out unwanted fluctuations just as the choke coil and filter condensers do in the B eliminator. The arrangement of these devices is shown by the wiring diagram in Figure 148.

The potentiometer of 100,000 ohms limits the automatic-volume-control voltage. The loudest station is tuned in and the potentiometer is adjusted manually until a comfortable volume is reached. It is left in this position and no signal will come through

with a greater volume. Blasting is eliminated. Should the signal strength drop, however, the amplification of the radio-frequency tubes is increased to bring the volume up.

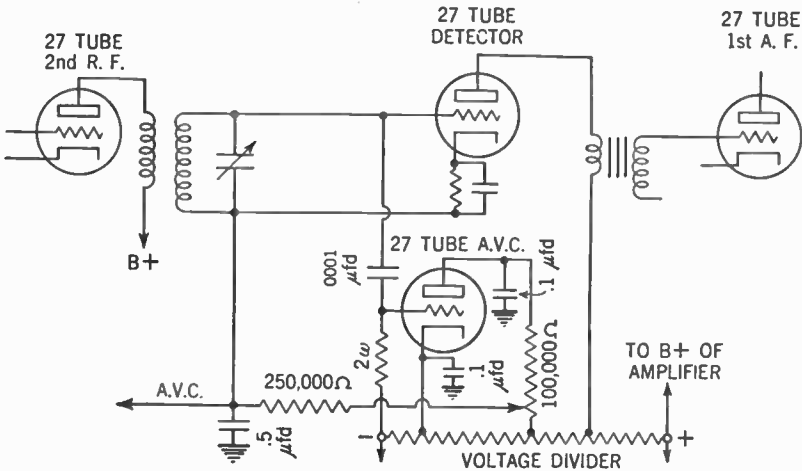

Figure 148. Complete automatic-volume-control circuit showing the by-pass condensers and filter resistances.

### 175. Replacing the Triode by a Diode for the Detector

Since the action of the automatic-volume-control tube is to rectify the signal current and feed it to the grid returns of the radio-frequency amplifier tubes, it becomes obvious that a diode may be used for this purpose instead of the triode shown in Figure 148. A logical step for improvement is to employ a circuit using a diode tube both as a detector and as an automatic-volume-control tube. The advantage of a diode detector over a triode is that the diode does not distort the signal. The disadvantage of the diode detector is that it adds no amplification. This defect, however, is overcome through the great amplification possible from the radio-frequency stages.

Figure 149 shows this circuit.

As in the case of the ordinary diode detector (see Chapter 14), the signal is impressed on the plate of the diode. When the plate is negative, no electrons are attracted from the cathode. When the plate is positive, electrons are attracted and are set flowing around the plate circuit from the plate to points 1, 2, 3, 4, 5, and back to the cathode. The more positive the plate, the greater the plate current.

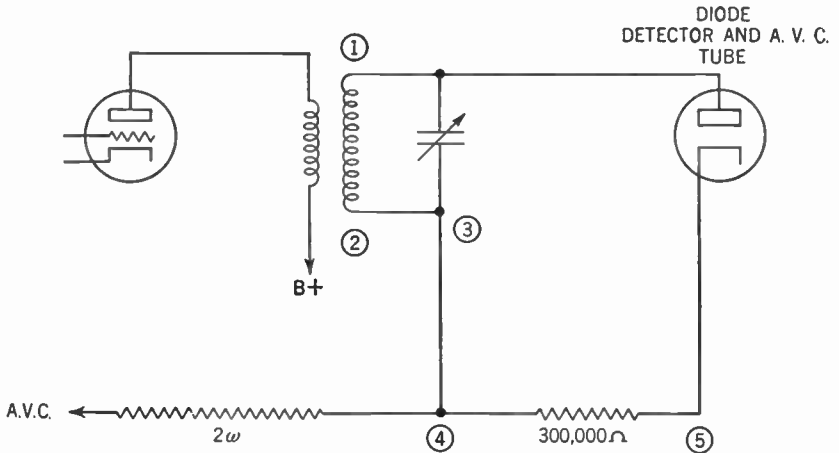

Figure 149. Circuit showing how the diode acts as a detector and automatic-volume-control tube.

At point 4, the electron stream divides. A portion flows through the 2-megohm resistor and thus furnishes the automatic-volume-control voltage which is applied to the grid returns of the radio-frequency amplifiers.

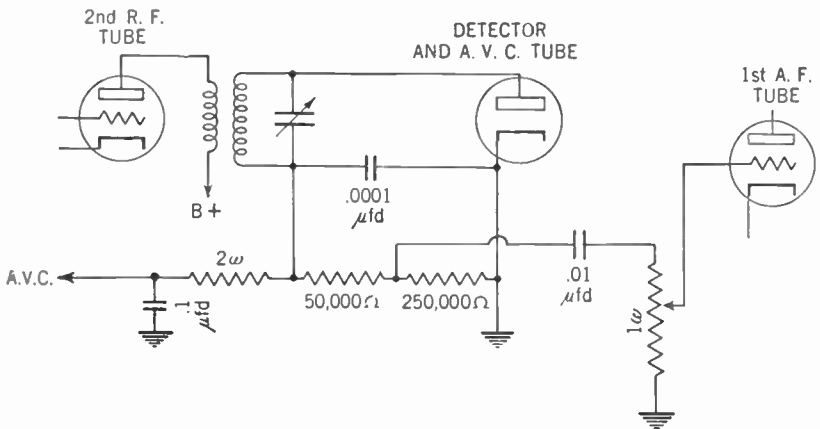

Figure 150. Circuit showing complete automatic-volume-control circuit.

### 176. The Complete Automatic-volume-control System

Since the 300,000-ohm resistor furnishes an easier path for the flow of electrons than does the 2-megohm resistor, the greater part of the electron stream flows toward point 5. This part is fed into the audio amplifier as shown in Figure 150.



The 300,000-ohm resistor consists of two resistors in series, one of 50,000 ohms and the other 250,000 ohms. The major electron stream flows through the 50,000-ohm resistor to the junction of these two resistors. Here the 250,000-ohm resistor holds back the electrons and forces them to go to the plate of the .01  $\mu$ fd. coupling condenser that couples the diode detector with the grid of the first audio-frequency amplifier tube. You recognize, of course, that this system really is the same as a stage of resistance-coupled audio-frequency amplification (see Chapter 17). The 1-megohm potentiometer controls the strength of the electrical charges placed on the grid of the first audio-frequency amplifier tube and thus acts as a manual volume control.

The .0001- $\mu$ fd. condenser by-passes to the ground the unwanted radio-frequency currents that may have leaked into the diode plate circuit. The 2-megohm resistor and .1- $\mu$ fd. condenser in the automatic-volume-control line are there to smooth out the automatic-volume-control voltage and to remove any audio-frequency currents that may be present.

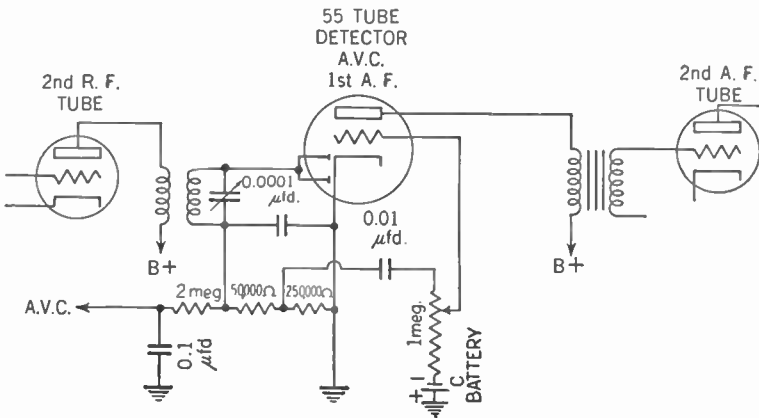

Figure 151. Circuit showing how the type 55 tube is used as a detector, automatic volume control, and first audio-frequency amplifier.

### 177. Combining Two Tubes in One

Tube manufacturers soon came out with a tube that combined the diode and triode in one envelope (glass bulb). Such a tube is the type 55. This tube has a single cathode, one surface of which emits electrons to the diode plate, while the other surface sends electrons to the grid and plate of the triode. Actually, there are two diode plates in this tube, but for our purpose we connect them

together and treat them as one plate. The advantage of such a tube is that in one envelope we have the diode detector, the automatic-volume-control tube and the first audio-frequency amplifying tube. Figure 151 shows how it is connected.

Other automatic-volume-control circuits have been developed, but the principle upon which they work is the same as that described here.

#### SUMMARY

1. The loudness of the signals coming from the speaker is known as volume.

2. In battery sets, volume is easily controlled by a rheostat that regulates the current in the filament and hence the temperature and the number of electrons emitted.

3. In nonbattery sets the filament current needs to be kept constant, so that the rheostat control in the filament circuit is not practical.

4. Control of volume by a potentiometer across the primary of the antenna coupler is less satisfactory than the use of a rheostat across the primary of the transformer in the plate circuit of the second radio-frequency tube.

5. Another method, sometimes combined with the last method mentioned in item 4, is to use a high resistance (500,000-ohm) potentiometer across the secondary of the first audio transformer.

6. A cathode-type tube with a grid-bias resistor and a rheostat is a good practical method for manual volume control.

7. Automatic volume control is achieved by devices which give a greater negative grid bias when greater currents come through, and conversely. This negative bias in turn controls directly the amplification in the radio-frequency amplifiers.

8. Modern tubes of the 55 type combine the triode and diode in one envelope.

#### GLOSSARY

**Automatic Volume Control (A.V.C.):** An automatic control of volume in the radio receiver which operates by making the receiver more sensitive to weak radio signals and less sensitive to powerful radio signals.

**Fading:** An undesired weakening of the radio signal.

**Heaviside Layer:** A layer of electrified air, consisting of charged particles called ions, from sixty to two hundred miles above the surface of the earth, which acts as a reflector for radio waves. Changes in this layer are believed to be the chief cause of fading. The layer is also known as the Kennelly-Heaviside layer or ionosphere.

**Manual Volume Control:** A control of volume, usually a variable resistor, which can be manipulated by the person operating the radio receiver.

### QUESTIONS AND PROBLEMS

1. How is the volume of a battery receiver usually controlled?
2. What are the methods of manual volume control used in modern A.C. or A.C.-D.C. power-supply receivers?
3. Why is it desirable to have automatic volume control in a receiver?
4. What is one possible cause of fading?
5. How is automatic volume control accomplished in a receiver?
6. Draw the diagram of a diode detector with automatic volume control.

## CHAPTER 25

# Tone Control

---

- Problem 1:** *How is the tone of sound waves related to the frequency?*
- Problem 2:** *What factors in radio receiving sets affect tone?*
- Problem 3:** *How do methods of tone control separate high-pitched tones from low-pitched tones?*
- 

In the last chapter you learned how the volume of sound coming out of the loudspeaker may be controlled. In this chapter you will learn how we control the tone of the radio receiving set.

### 178. What Is Meant by "Tone"?

As you know, sound is caused by air waves; these strike our eardrums and produce the sensation we call "hearing." To describe a sound we say not merely that it is loud or soft, but we also describe its tone. The tone depends upon the frequency of the sound wave. The human ear can detect frequencies from about 30 cycles to 15,000 cycles per second.

Those sound waves whose frequencies are low are described as *deep, bass* or *low-pitched sounds*. Those whose frequencies approach 15,000 cycles per second are called *shrill, treble, or high-pitched sounds*. Those whose frequencies fall in between are called *middle-register sounds*.

Music and speech, generally, are not composed of sounds having only one frequency. High-frequency and low-frequency sound waves usually are merged to produce a distinctive combination. If the result of mixing these sound waves of different frequencies is a sound whose predominant tone is that of the middle register, we say the sound has a *normal* tone.

If the sound has a preponderance of high-frequency sound

waves, we say the tone is *high-pitched*. Women's voices generally fall into this category.

If the sound has a preponderance of low-frequency sound waves, we say the tone is *low-pitched*. Men's voices generally fall into this category.

The tone of the sound coming out of the loudspeaker of the radio receiver then may be normal, high-pitched, or low-pitched, depending upon the combination of high-frequency and low-frequency sound waves present.

### 179. What Determines the Tone of a Radio Receiver?

Since tone is an audio-frequency phenomenon, we must look for the answer in the audio-frequency part of the set, that is, in the events after the electron impulses have reached the plate of the detector tube. Investigation shows that the audio-frequency amplifier usually does not amplify all the frequencies at the same rate. Thus the high frequencies may be amplified more than the low frequencies, or vice versa. Or some intermediate frequencies may be amplified more or less than those at either end of the audio scale.

Furthermore, the loudspeaker does not respond to all frequencies in like degree. The early speakers of the metallic-horn type failed to bring out the deep notes. The result was an unpleasant "tinny" sound.

Good practice in designing a radio set is to match the loudspeaker to the audio-frequency amplifier so that one compensates for the variations of the other. The result is a fairly uniform reproduction of sound at all frequencies.

### 180. The Problem of Control

It also is desirable to be able to control the tone of a radio set. Speech is clearer when it is somewhat higher pitched. On the other hand, many people prefer their music somewhat lower pitched. Some people do not enjoy listening to a soprano voice because of the preponderance of high-frequency tones.

The ideal method for controlling the tone of a radio receiver would be by means of controls which would regulate the amplification of the high-frequency notes and low-frequency notes separately. Such a method does exist, but it is quite complicated. It is used almost exclusively for public-address systems and studio

purposes. The ordinary radio receiver uses a much simpler method which closely approximates the ideal method in results.

There is a peculiarity about human hearing. Take a sound of normal tone. The high frequencies and low frequencies are present in certain proportions. If now we amplify the low frequencies, we get a bass, low-pitched sound which has the same normal amount of the high-frequencies, but more of the low frequencies.

Take the same sound of normal tone described above. Now remove some of the high frequencies. Although we have not added any new low frequencies, nevertheless we get the effect of a bass, low-pitched sound. This is called *false bass*.

Similarly, if we remove some of the low frequencies from the normal tone, we get the effect of a high-pitched, treble tone. This is a *false treble*.

### 181. How to Separate High Pitch from Low Pitch

Our next problem is to devise a method of removing some of either the high or the low frequencies.

The electric currents flowing in the audio-frequency amplifier

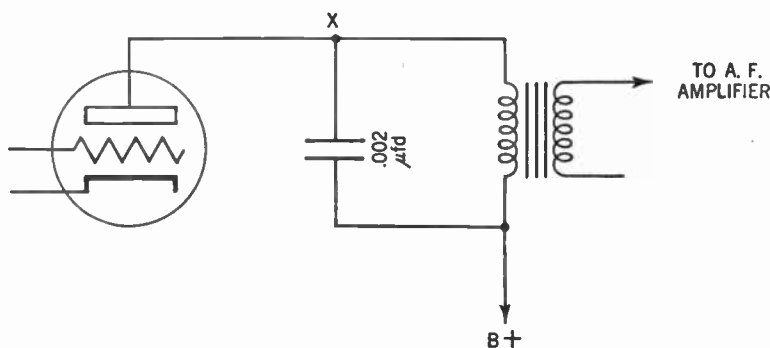

Figure 152. Circuit showing how a condenser is used to filter out some of the high-frequency current.

fluctuate within the audio range, that is, between 30 cycles and 15,000 cycles per second. These currents cause the diaphragm or cone of the loudspeaker to vibrate in step with them. Thus a current fluctuating at about 100 cycles per second will cause a deep note to come forth from the loudspeaker, while a current fluctuating at about 10,000 cycles per second will produce a high-

pitched note. Remember that when we speak here of high frequency, we mean high audio frequency and not radio frequency.

To remove some of the high-frequency current, we place a fixed condenser across the path of the audio-frequency current.

It may be shown that a condenser furnishes a path of lower impedance than that of the plate circuit to currents of high frequencies but not for currents of low frequencies. Hence the fluctuating current flowing in the plate circuit of the detector tube divides at point X (Figure 152). Some of the high-frequency current passes through the  $.002\text{-}\mu\text{fd.}$  condenser and goes on to the positive terminal of the B eliminator. The main part of the plate current, however, containing all the low frequencies, passes through the primary of the first audio-frequency transformer and is amplified. Since some of the high frequencies are missing from the sound emitted by the loudspeaker, our radio set now has a bass tone.

We can vary the amount of high-frequency current by-passed by the condenser by connecting a 500,000-ohm rheostat in series

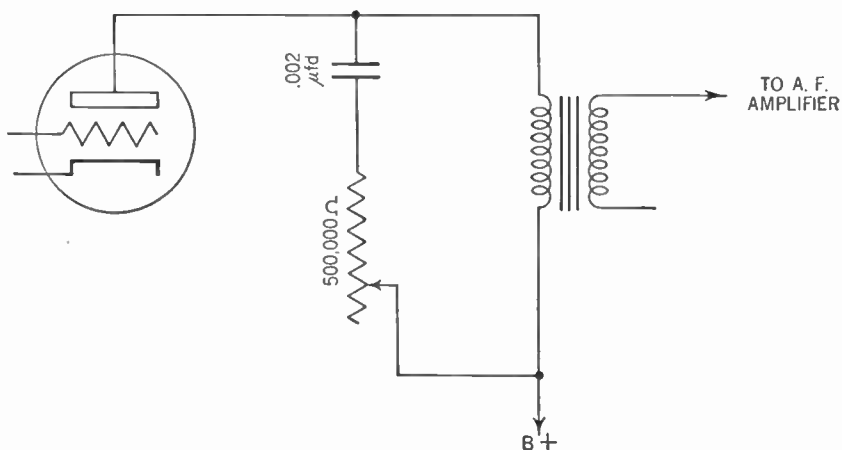

**Figure 153.** Circuit showing how a rheostat is connected in series with the condenser to control the amount of high-frequency current filtered out.

with it, as in Figure 153. The more the resistance in the circuit the less the amount of high-frequency current that will be by-passed and therefore the more treble the tone.

The combination of fixed condenser and rheostat is called a *tone control*. It may be placed anywhere in the audio circuit, across the primary of the audio transformer (as shown) or across

the secondary. It may be applied to any of the audio-frequency stages.

### 182. Tone Control by Supplying an Alternate Path to the Ground

Another type of tone control is shown in Figure 154.

This tone control consists of two arms. In one arm, A, is a  $.1\text{-}\mu\text{fd.}$  condenser. In the other, B, a  $.1\text{-}\mu\text{fd.}$  condenser is connected

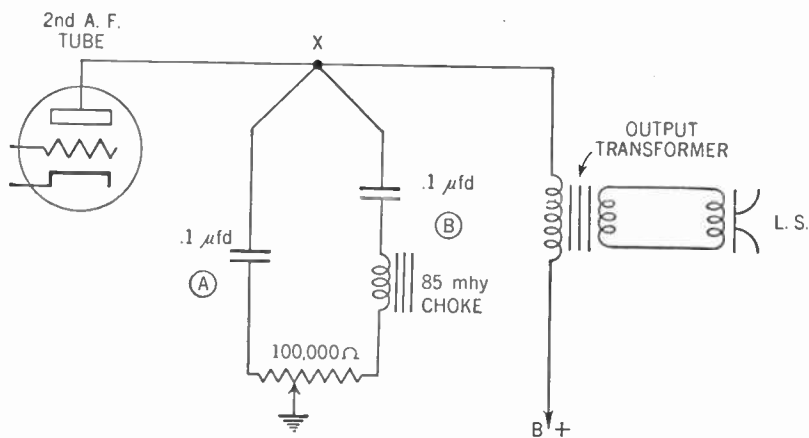

Figure 154. Circuit showing a "treble-bass" tone control.

in series with a choke coil of about 85 millihenries. One end of each arm is connected to the plate of the final audio-frequency tube. Across the other ends a 100,000-ohm potentiometer is connected with the sliding arm going to the ground.

The action of the choke coil is opposite to that of the condenser. It offers a higher impedance to currents of higher frequencies. Hence it conducts more readily the parts of the current with low frequencies.

First consider the circuit with the sliding arm of the potentiometer all the way to the left. None of the resistance is in arm A; it is all in arm B. Current flowing in the plate circuit of the audio-frequency tube divides at point X as described in Figure 152. Some of the high-frequency current is lost through the condenser. The main part of the current passes through the output transformer and our set now has a bass tone.

When the slider arm is all the way over to the right, the entire 100,000 ohms is in arm A. This prevents the loss of the high-frequency currents. As a result, the diverted current flowing from



point X must now pass through arm B. Since the choke coil offers a high impedance to the high-frequency current, it is only low-frequency currents that pass through and go on to the ground. Since we have lost some of the low frequencies, our tone now is treble.

Varying the sliding arm of the potentiometer varies the amount of high or low frequencies lost and thus the tone of the set is controlled.

### 183. Tone May Be Controlled by Using Two Speakers

There is still another method of tone control that is sometimes used. Some sets have two speakers. One is a speaker which reproduces the low frequencies better than the high frequencies. The other reproduces the high frequencies better. Both of these speakers are connected to the output transformer by a potentiometer which controls the amount of current flowing through each (Figure 155).

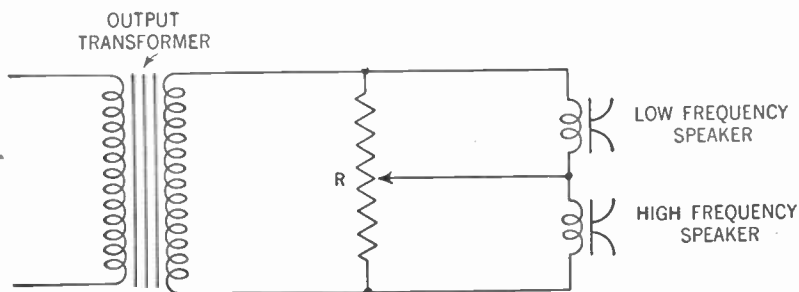

**Figure 155.** Circuit showing how tone control may be obtained through the use of higher-frequency and lower-frequency loudspeakers. The potentiometer (R) determines which speaker shall obtain the great current.

Thus if more current flows through the high-frequency speaker and less through the low-frequency speaker, the high frequencies are louder and the tone is treble. If the conditions are reversed the tone is bass. The potentiometer, then, acts as a tone control.

Different manufacturers of radio sets may use different types of devices for tone control but upon analysis of the circuits you will see that they usually are variations of the ones described here.

## SUMMARY

1. Sounds having regular frequencies are called musical tones.
2. The frequency of a tone is related to its pitch: low pitch means low frequency and high pitch means high frequency.
3. The tones coming from a speaker are influenced both by the arrangement of the parts of the audio-frequency system and also by the kind of loudspeaker.
4. The principles of tone control that are made use of within the receiver are: (1) condensers offer a path of less impedance to high-frequency currents than to low-frequency currents. (2) Choke coils offer more impedance to high-frequency currents and less impedance to low-frequency currents.
5. The most successful tone control makes use of a divided circuit leading to the ground, in one arm of which is a condenser and in the other arm a choke coil. A slide arm on the potentiometer controls the tone by permitting more or less high-frequency current to pass through.
6. Two speakers having different qualities—one good for high pitch, the other for low pitch—may be hooked to one receiver. The tone can be controlled by varying the amounts of current in the two speakers.

## GLOSSARY

- Tone:** The sound resulting from the mixture of air waves of different frequencies.
- Bass Tone:** The tone resulting when low frequencies are predominant. Also called *low-pitched tone*.
- Middle-register Tone:** The tone resulting when high and low frequencies are present in about equal proportions. Also called *normal tone*.
- Treble Tone:** The tone resulting when high frequencies are predominant. Also known as *high-pitched* or *soprano tone*.
- Tone Control:** An electrical circuit used to emphasize high- or low-frequency notes in a combination of sound frequencies. It usually consists of a fixed condenser and rheostat.

## QUESTIONS AND PROBLEMS

1. Upon what does the tone of a sound depend?
2. What is the frequency range of human hearing?
3. What is meant by a bass tone? A middle-register tone?
4. What conditions in a receiver cause distortion or inaccurate reproduction of tone?
5. What should be the pitch of the tone of speech over the radio amplifier to make it clearer?
6. What must be the function of a tone control?
7. What peculiarities of hearing enable us to use a practical tone control?
8. What is a false bass?

9. What is a false treble?
10. Draw a sketch of a practical tone-control circuit.
11. In what part of a receiver circuit do we usually place a tone control?
12. What is the purpose of using two speakers in a receiver? How do they function?

## CHAPTER 26

# The Superheterodyne Receiver

---

- Problem 1:** *Why is not the tuned radio-frequency amplifier satisfactory?*
- Problem 2:** *What is the principle of beats?*
- Problem 3:** *How is the principle of beat currents applied to obtain sharp tuning over a wide range of frequencies?*
- Problem 4:** *What are the essential principles of the superheterodyne receiver?*
- 

It is interesting to note how one great invention or discovery leads to other inventions or discoveries. Many examples of this are found in the history of radio.

After the invention of the system of tuned radio-frequency amplification, radio engineers began looking for means to correct the flaws and drawbacks of this circuit. This search led to the next improvement.

### **184. Faults of Tuned Radio-frequency Amplifiers**

The drawbacks of the circuit were found to be in the inability to have a wide range of reception and at the same time sharp tuning.

To obtain maximum sensitivity and selectivity, the tuning circuit should have a natural frequency exactly equal to the frequency of the broadcasting station. But our tuning circuit is made so that we may tune in all frequencies lying in the broadcasting range, that is, from 550 to 1,600 kilocycles. To obtain this broad coverage a compromise is made in the design of our tuned radio-frequency transformer and some of the selectivity and sensitivity is sacrificed.

The ideal way would be to have a separate set of tuned radio-

frequency transformers for each frequency received. This, of course, is impractical for home receivers.

### 185. The General Principle of a Superheterodyne

The invention of the superheterodyne receiver resulted from the experiments seeking to approach this ideal condition. In the system to which the name superheterodyne is given we have, instead of a separate set of tuned radio-frequency transformers for each frequency received, one set of tuned radio-frequency transformers that are tuned to one predetermined frequency. After selecting the radio station we desire, we change the frequency of the currents flowing in our receiver to that certain predetermined frequency and then feed it into our tuned radio-frequency amplifier.

In this manner we have the advantage of using tuned radio-frequency transformers that operate at only one frequency without the drawback of needing a separate set for each frequency. Our set is more selective and sensitive than the tuned radio-frequency set described in Chapter 23.

### 186. What Is Meant by "Beats"?

In order to understand how the frequency of the incoming signal is changed to that for which the radio-frequency transformers are tuned, you must first learn about the phenomenon of *beats*.

Strike middle C on the piano. The sound you hear has a frequency of 256 cycles per second. Now strike the note before it, B on the piano. This note has a frequency of 240 cycles per second. Now strike both keys together. The sound you hear is neither B nor C but a mixture of the two. If you listen closely you will notice that this new sound rises and falls in loudness or intensity. If you can time this rise and fall of sound you will notice that it occurs 16 times per second, the exact difference between the frequencies of B and C.

We call this rise and fall the *beat note*. Its frequency (that is, the number of beats) is equal to the difference between the frequencies of the notes producing it.

The production of beat notes occurs not only in the case of sound waves, but whenever any kind of waves of different frequencies clash or beat against each other. Thus, under certain

conditions, light waves may produce beats. Also, radio waves of different frequencies may be mixed, resulting in beats whose frequency equals the difference between those of the two original waves.

Now we can explain how we are able to change the frequency of the incoming signal to that for which the radio-frequency transformers are tuned. The problem is to mix with the incoming signal another radio-frequency current whose frequency is such that the difference between the two is equal to the predetermined and desired frequency.

### 187. Forming Best Frequencies in the Receiver

Assume we have set our radio-frequency transformers so that their natural frequency is 175 kc. Let us suppose that we are receiving the signal from a station whose frequency is 1,000 kc. All we need do is to generate a radio-frequency current whose frequency is 1,175 kc. We mix this radio-frequency current with the incoming signal (1,000 kc.) and a *beat current* results whose frequency is 175 kc. ( $1,175 \text{ kc.} - 1,000 \text{ kc.} = 175 \text{ kc.}$ ) This 175-kc. beat current is fed into the radio-frequency transformers and amplification occurs at maximum efficiency. The idea is shown in diagram form in Figure 156.

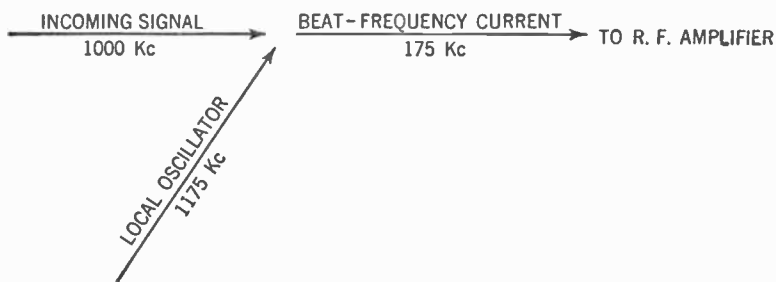

Figure 156. Diagram showing how the incoming signal mixes with the current produced by the local oscillator to produce the beat-frequency current.

The device used to generate the radio-frequency current which beats against the incoming signal is called the *local oscillator*.

To make this process clearer let us consider another example using the same tuning system having a natural frequency of 175 kc. Assume the incoming signal has a frequency of 800 kc. The local oscillator must now produce a radio-frequency current whose

frequency is 975 kc. The beat-current frequency, again, is 175 kc., the frequency at which the radio-frequency transformers are set.

To produce a beat-frequency current of 175 kc., the local oscillator produces a radio-frequency current whose frequency is 175 kc. above that of the incoming signal. Since frequencies in the broadcast band lie between 550 kc. and 1,600 kc., the local oscillator for our set must be capable of producing radio-frequency currents whose frequencies are between 725 kc. ( $550 + 175$ ) and 1,775 kc. ( $1,600 + 175$ ). Further, we must connect together the control that selects the incoming signal with the control that regulates the local oscillator in such a way that the difference in frequency is always 175 kc.

*Heterodyning* is another name for the production of beats. It is from this word that we get the name of our new type radio set, the *superheterodyne receiver*.

### 188. Beat Production Occurs in the First Detector

As in the case of the tuned radio-frequency receiver, the incoming signal is selected by the tuning circuit consisting of the antenna coupler with a variable condenser across the secondary. The radio wave, a modulated carrier wave, causes a correspondingly modu-

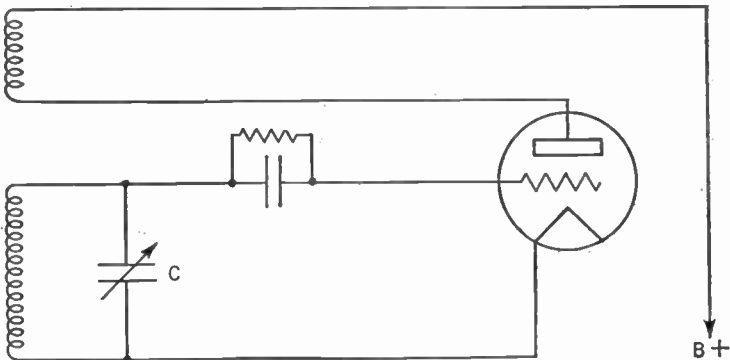

Figure 157. Circuit of the local oscillator. Note how it resembles the regenerative detector.

lated radio-frequency current to flow in the tuning circuit. This radio-frequency current is fed into the grid of an ordinary grid-leak-condenser detector. Without the local oscillator present, the modulated radio-frequency current would pass through this de-

detector. The radio-frequency part or component would be eliminated and the modulating component (the audio-frequency component) would appear at the output of the detector tube.

This is another way of explaining detection and you now can see why the detector tube is sometimes called the *demodulator tube*.

But in the superheterodyne system, before detection occurs, the steady or unmodulated radio-frequency current from the local oscillator is mixed with the incoming signal. As a result, coming out of the plate of the detector tube is a new radio-frequency cur-

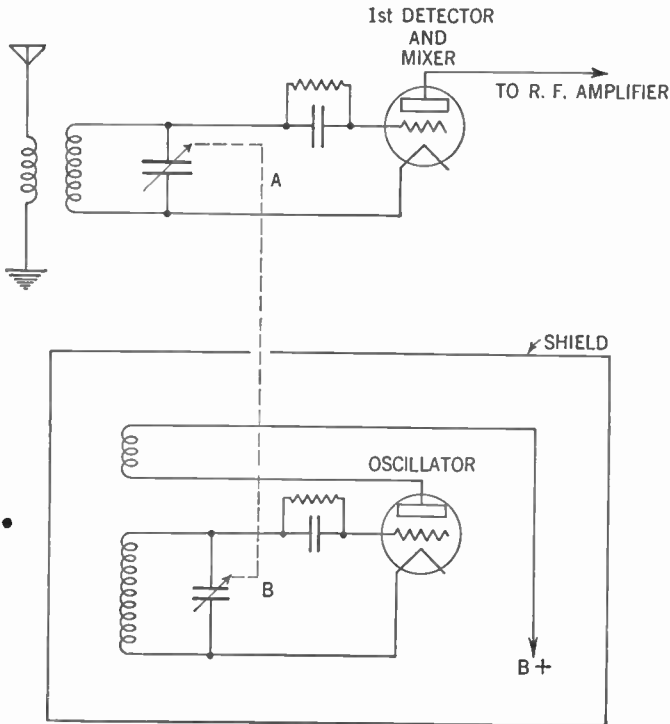

**Figure 158.** Condensers A and B are connected and turn together. (This gonging is shown by the dotted lines running from one variable condenser to the other.) Thus the natural frequencies of both tuned circuits are always a certain number of kilocycles apart (the beat frequency). Note that the local oscillator is shielded from the rest of the set.

rent whose frequency is the beat frequency and whose amplitudes are modulated in the same way as was the incoming signal. This new radio-frequency current is then fed into the radio-frequency amplifiers that are tuned to the same frequency.



Since the mixing of the two radio-frequency currents takes place in the detector tube, this tube is also called the *mixer tube*. It is called the *first detector tube* to distinguish it from the *second detector tube* which follows the radio-frequency amplifier tubes.

### 189. The Principle of the Local Oscillator

For the local oscillator we have to go back to the regenerative receiver (Chapter 16). Turn back to Figure 74. Current flowing in the plate circuit of the triode is fed back to the tuned circuit by means of a plate coil. This feed-back overcomes the resistance

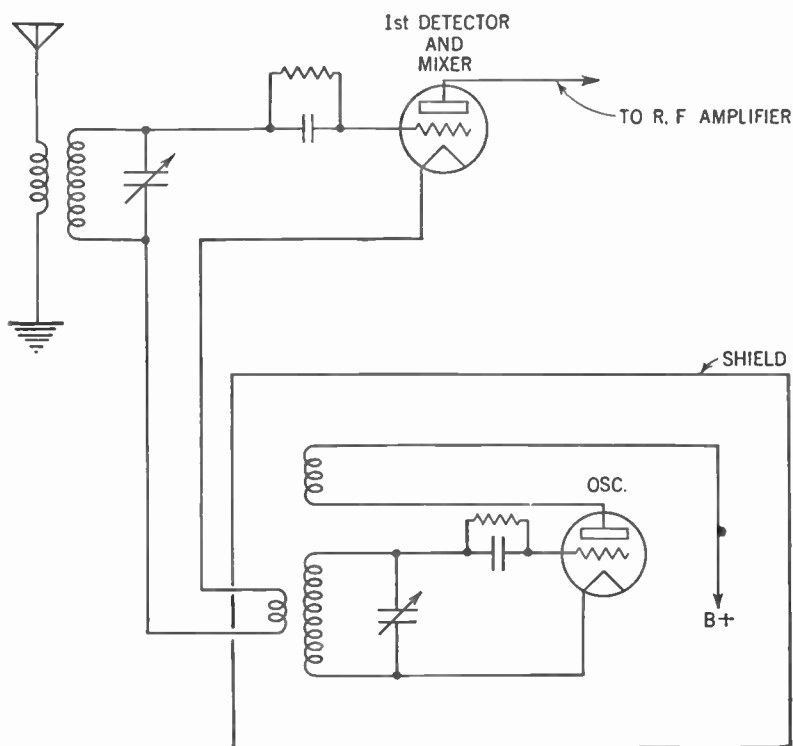

**Figure 159.** Circuit showing how current from the local oscillator is inductively coupled to the first detector and mixer circuit. The dotted lines showing that both variable condensers are connected to each other are omitted from this diagram for the sake of clarity.

of the tuned circuit and the radio-frequency current flowing in that circuit (the oscillations of the electrons) is built up (see Figure 157).

The frequency of this radio-frequency current is determined by

the electrical values of the inductance and variable condenser in the tuned circuit ( $L \times C$ ). Changing the setting of the variable condenser will change the frequency of the current produced.

Here, then, is our local oscillator. By connecting the variable condenser of this oscillator with the variable condenser of the first detector circuit so that they turn together, and selecting the proper component parts ( $L$  and  $C$ ), we are able to produce a radio-frequency current which at all times will be 175 kc. above the frequency of the incoming signal (see Figure 158).

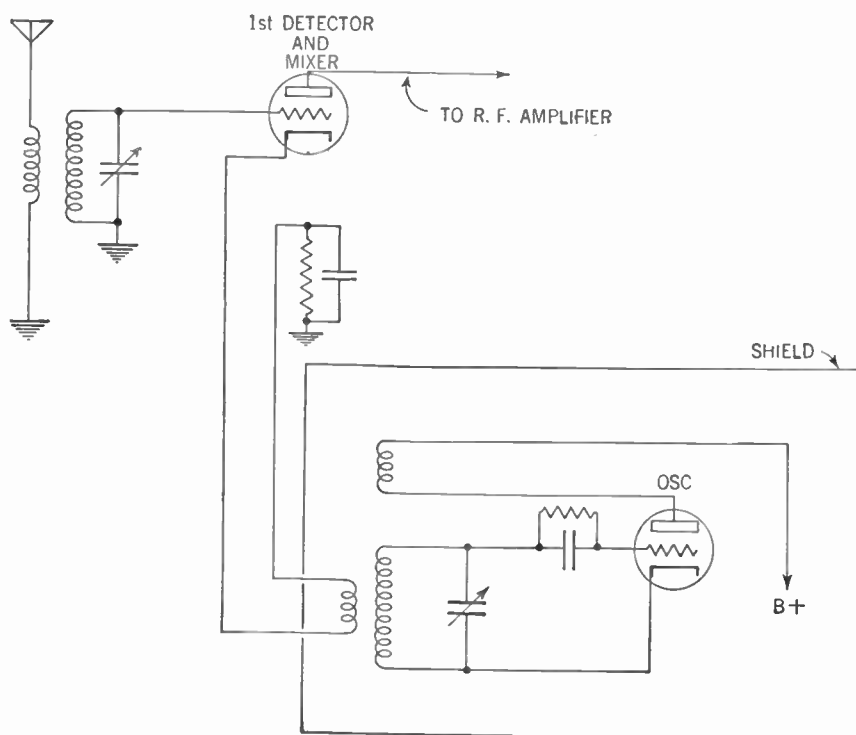

Figure 160. Circuit showing how current from the local oscillator is inductively coupled to the cathode of the first detector and mixer tube.

Note that 175 kc. is only taken as an example. Actually we can make this difference any frequency we wish, provided we have set our radio-frequency transformers to tune to that frequency.

### 190. Coupling the Oscillator to the First Detector

Several methods are used in feeding the radio-frequency current generated by the local oscillator into the mixing tube.

One such method is to make the circuits *inductive-coupled*. A coil of wire is placed near the tuned circuit of the oscillator. The radio-frequency current generated by the oscillator is passed on to this coil of wire by induction. The ends of the coil are connected in the grid circuit of the first detector and mixer tube as shown in Figure 159.

In this manner the radio-frequency current of the oscillator is mixed with the radio-frequency current flowing in the first detector and mixer circuit. The beat-frequency current results.

A variation of this method of coupling is to connect the ends of the coil in the cathode circuit of the detector and mixer tube

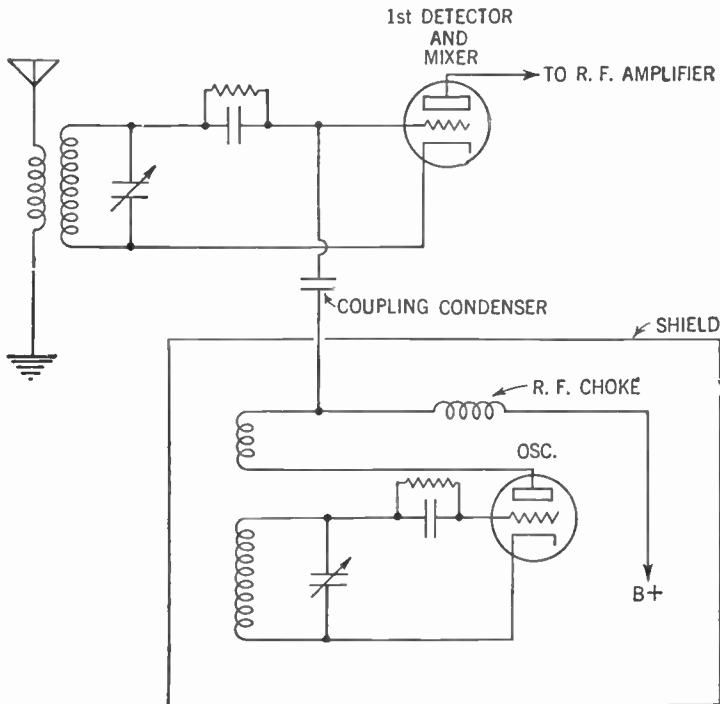

Figure 161. Circuit showing how a small fixed condenser is used to couple the current from the local oscillator to the grid of the first detector and mixer tube.

as in Figure 160. When this method is used, it is customary to have the first detector hooked up as a resistor-biased detector.

Another method is to make the circuits *capacity-coupled*. This time a small fixed condenser transfers the radio-frequency current from the oscillator to the grid of the first detector and mixer tube

as shown in Figure 161. The radio-frequency choke in the plate circuit of the oscillator tube forces the radio-frequency current through the coupling condenser to the grid of the first detector tube.

With the invention of new types of tubes, a third method of coupling was invented. In this method the two circuits are coupled through the electrodes within the tube itself. We will discuss this electron coupling further in the chapter dealing with types of tubes (see Paragraph 215).

### 191. The Intermediate-frequency Amplifier

Coming out of the first detector and mixer tube is the beat-frequency current (175 kc. in our example). This is a radio-frequency current, since it lies well above the audio range of about 15 kc. per second. But it is lower than the broadcast frequencies which lie between 550 kc. and 1,600 kc. per second. We therefore call this beat frequency the *intermediate frequency* (abbreviated to I.F.). The tuned radio-frequency transformers which are set

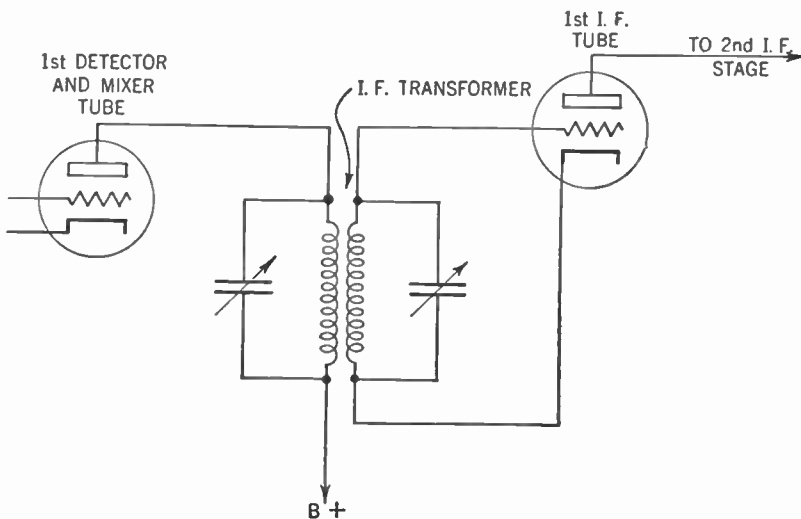

Figure 162. Circuit of the intermediate-frequency transformer.

for this beat frequency are called intermediate-frequency transformers and the amplifier is called an *intermediate-frequency amplifier*.

The intermediate-frequency transformers differ from the regular radio-frequency transformers in a number of ways. Since they

are tuned to a lower frequency, they have a greater number of turns of wire. Also, since they are to respond to only one frequency, the variable condenser is eliminated. Instead, we use a trimmer condenser adjusted to align the various tuned circuits.

Another difference is that the primary of the intermediate-frequency transformer, too, is usually tuned by means of a trimmer condenser. This arrangement, of course, increases the selectivity of the set. While it is quite possible to tune the primary of the ordinary radio-frequency transformer, the difficulty of ganging the extra variable condensers needed presents quite a problem and therefore this primary is not tuned. A diagram of the intermediate-frequency transformer used for an amplifier is shown in Figure 162.

As previously stated, the use of an intermediate-frequency transformer tuned to a fixed frequency means much greater sensitivity and selectivity. So sensitive is the superheterodyne set that it is quite possible to use a small loop aerial built inside the cabinet of the set itself instead of a long wire up on the roof.

The increase in selectivity may be shown by the tuning curves in Figure 163.

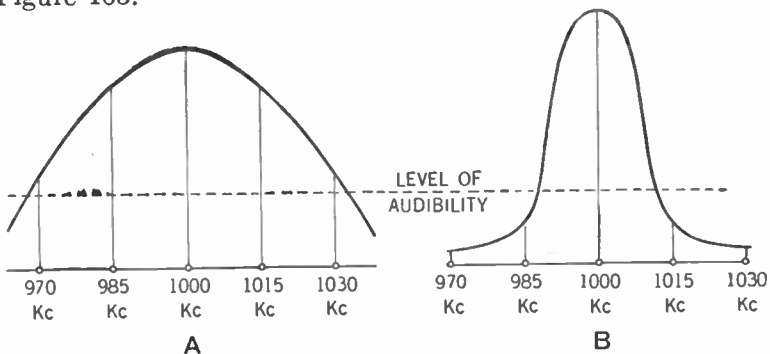

**Figure 163.** A—Tuning curve for the tuned radio-frequency receiver tuned to 1,000 kc. Note that stations whose frequencies are 970 kc. and 1,030 kc. lie above the level of audibility. This condition means that they may be heard faintly in the background of the desired station.  
 B—Tuning curve for the superheterodyne receiver tuned to 1,000 kc. Note that the unwanted stations fall below the level of audibility.

In Figure 163-A the curve indicates that when you tune in the 1,000-kc. station, the two stations whose frequencies lie 30 kc. on either side can be heard slightly. This tuning curve is typical for the tuned radio-frequency receiver.

Figure 163-B represents the tuning curve of the superheterodyne receiver. Here you will notice that stations 30 kc. away from the desired station (1,000 kc.) lie well below the level of audibility.

### 192. Can a Receiver Be Too Selective?

So selective is the superheterodyne that another problem may be presented. The set may be too selective! Here is what happens.

At the radio station, audio-frequency currents whose frequencies run up to 15 kc. per second are mixed with the steady radio-frequency carrier current generated by the transmitting set to produce the modulated radio-frequency current. Assume our broadcasting station has a carrier wave whose frequency is 1,000 kc. per second. The resulting beat current then would be 1,000 kc. minus 15 kc. or 985 kc. per second.

In discussing the production of beats we have omitted to tell you that when waves of two frequencies are mixed, not only is the beat frequency the *difference* between these two frequencies, but a beat frequency is also produced which is the *sum* of these two frequencies.

When we considered the beat-frequency current produced by mixing the incoming signal with the radio-frequency current generated by the local oscillator, we omitted the beat produced by adding the two frequencies because it lay well outside the range of our receiver. You will recall that we assumed an incoming signal whose frequency was 1,000 kc. per second. One beat frequency produced was 175 kc. The other beat frequency which we did not consider was 1,000 kc. plus 1,175 kc. or 2,175 kc. Since our intermediate-frequency transformers were tuned to 175 kc. the second beat could not be amplified.

But at the transmitting station the mixing of the 15-kc.-per-second audio current with the 1,000-kc.-per-second carrier current produces beat currents that have two different frequencies, one of 985 kc. and the other of 1,015 kc. per second. The radio station, therefore, broadcasts a wave whose frequency lies between 985 kc. and 1,015 kc. per second. The difference between the two frequencies (30 kc.) is called the *band width*.

Now if you will refer to Figure 163-B you will notice from the tuning curve for the superheterodyne receiver that when it is

tuned to 1,000 kc. the extremes of the 30-kc. band width lie below the level of audibility. This means that some of the high notes will not be heard. We call this *cutting the side bands*.

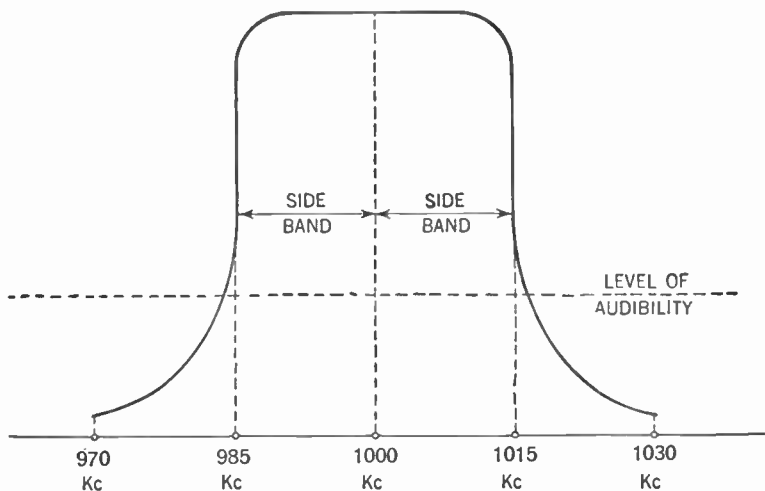

**Figure 164. Ideal tuning curve for the superheterodyne receiver. Note that the side bands are fully received, while the unwanted stations are well below the level of audibility.**

In other words, so great is the selectivity and so narrow is the tuning curve that the beat frequencies of 985 kc. and 1,015 kc. lie below the level of audibility. Thus the tone of the set will be too bass.

To remedy this defect we are compelled to reduce the selectivity of the set. The ideal condition would be to have the 985 kc. and 1,015 kc. on the tuning curve a little above the level of audibility as shown in Figure 164.

This broadening is accomplished by adjusting the trimmer condensers so that the set is slightly out of alignment. This adjustment broadens the tuning curve so as not to cut the side bands. While it is possible to judge this condition by ear, best results are accomplished by the use of special electrical instruments.

Except for the differences already noted, the intermediate-frequency amplifier is similar to the radio-frequency amplifier discussed in Chapter 23.

### 193. The Second Detector and Audio-frequency Amplification

The second detector following the intermediate-frequency amplifier is similar to the one used in the tuned radio-frequency set described in Chapter 23. A diode detector is customarily used, since the amount of amplification of the intermediate-frequency amplifier is great enough to overcome the loss of amplification that results from using a diode instead of a triode detector.

The automatic-volume-control system, the manual volume control, the tone control, and the audio amplifier are the same as those used in the tuned radio-frequency receiver.

### 194. Using a Radio-frequency Stage in Front of the First Detector

Sometimes a stage of ordinary radio-frequency amplification is placed in front of the first detector. While it is not necessary to increase the sensitivity or selectivity of the superheterodyne receiver (which is sensitive and selective enough without it), this radio-frequency stage serves two useful functions.

First of all, it serves to reduce the volume of any unwanted signals from powerful radio stations that may be in the vicinity of the receiver. If this stage were not present, this unwanted powerful signal would be impressed on the first detector and might cause some interference. While the radio-frequency stage may not completely eliminate this interfering station, it can reduce its signal strength to the point where the tuned circuit of the first detector can eliminate it completely.

### 195. Image Frequencies

But even more important is the fact that this radio-frequency stage eliminates what are called *image frequencies*. To get the idea of image frequency, assume that we are tuning to the 1,000-kc. station. Our oscillator produces a radio-frequency current whose frequency is 1,175 kc. A beat-frequency current of 175 kc. results, the same frequency to which our intermediate-frequency transformers are tuned.

Suppose, at the same time, there is a station whose frequency is 1,350 kc. This new signal will beat against the 1,175-kc. current produced by the oscillator and once again a beat frequency of



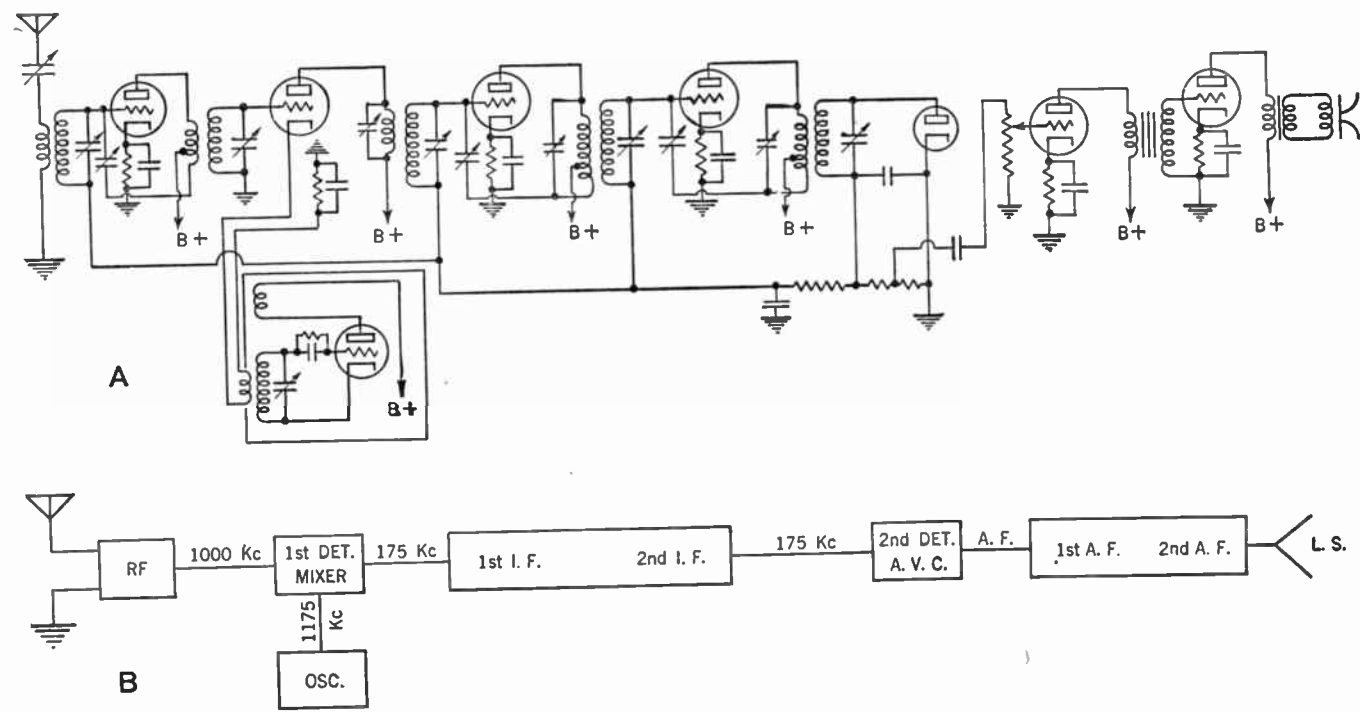

Figure 165. A—Circuit of the complete superheterodyne receiver.  
 B—Block diagram showing arrangement of the component parts.

175 kc. will result. This means that for every frequency produced by the oscillator there are *two* frequencies that will produce the desired beat frequency, one 175 kc. *above* the oscillator frequency and one 175 kc. *below* the oscillator frequency. Thus two stations may be passed on to the intermediate-frequency amplifier at the same time.

This second and unwanted frequency (1,350 kc.) is called the *image frequency*.

The stage of radio-frequency amplification eliminates the image frequency by tuning it out before it reaches the first detector.

Figure 165 shows the complete superheterodyne receiver.

### SUMMARY

1. The tuned radio-frequency receiver cannot be tuned sharply and at the same time remain able to receive stations that have a wide range of frequencies.

2. The superheterodyne receiver provides a means of sharp tuning over a wide range by means of the principle of **beat notes**.

3. Beat is a phenomenon of the alternate reinforcement and neutralization of each other by waves of two frequencies. The number of beats produced by this reaction of two sets of waves is equal to the difference between their vibration frequencies.

4. The **first detector** in a superheterodyne receiver is a tube in which the radio waves from the aerial are mixed with the waves from a local oscillator.

5. The local oscillator is tuned so that the beat note produced by its wave mixed with an incoming radio wave will always be the fixed natural frequency of the intermediate-frequency amplifier.

6. The current from the first detector tube is a beat-frequency current that is of 1750 frequency, but lower than the broadcast frequencies.

7. The radio-frequency amplifiers are set for this beat frequency and such an amplifying system is called an **intermediate-frequency amplifier**.

8. The superheterodyne receiver is very sensitive and tunes so sharply that if it is to respond to the **side bands** trimmer condensers must be used to keep the set a trifle out of **alignment**.

### GLOSSARY

**Band Width:** The range of frequencies of the radio wave sent out by a transmitting station.

**Beats:** The result of combining two waves of similar nature but of different frequencies. Thus we must combine two sound waves or

two alternating currents of different frequencies. The result, in the case of the sound waves, will be a new sound wave whose amplitudes vary at a frequency equal to either the difference between the two frequencies or the sum of the two frequencies. In the case of the alternating currents, the amplitudes of the resulting current will vary in the same manner.

**Capacitive Coupling:** A method of coupling electrical energy from one circuit to another through a condenser.

**Heterodyning:** The production of beat notes or currents by mixing two waves or two alternating currents of different frequencies.

**Image Frequency:** A frequency that is as much above the oscillator frequency as the desired station frequency is below that of the oscillator. Thus the signals from two different stations may be fed into the intermediate-frequency amplifier at the same time.

**Inductive Coupling:** A method of coupling electrical energy from one circuit to another by mutual induction.

**Intermediate Frequency:** The frequency that lies between the radio frequency of the received signal and audio frequency. It results from heterodyning two different radio frequencies.

**Intermediate-frequency (I.F.) Transformer:** A transformer tuned so that its natural frequency falls within the intermediate-frequency range.

**Local Oscillator:** A generator of radio-frequency currents in a superheterodyne receiver.

**Mixer Tube:** A tube in the superheterodyne receiver in which the incoming signal current is mixed with the radio-frequency current from the local oscillator to produce the intermediate-frequency current.

**Side Band:** The band of frequencies on either side of the fundamental carrier frequency, simultaneously transmitted with it by the broadcast station.

**Superheterodyne Receiver:** A radio receiver using the heterodyne principle.

#### SYMBOLS

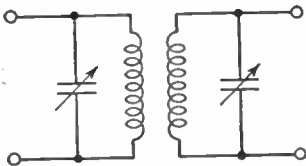

Intermediate-frequency transformer.

#### QUESTIONS AND PROBLEMS

1. List some of the weaknesses of a tuned radio-frequency receiver.
2. What is meant by a beat note?
3. What is the function of the local oscillator in the superheterodyne receiver?

4. Describe what occurs in the first detector of a superheterodyne receiver.
5. Describe the operation of the local oscillator.
6. How is the local oscillator coupled to the first detector?
7. What advantage lies in the use of intermediate-frequency transformers in the superheterodyne receiver?
8. What is meant by intermediate-frequency?
9. To what frequency are intermediate-frequency transformers tuned?
10. What are the advantages of a superheterodyne receiver over other types of receivers studied?
11. What happens to the beat frequency in a superheterodyne receiver which is the sum of the two mixed frequencies?
12. What is meant by band width?
13. What is meant by "cutting the side bands"?
14. How is the cutting of side bands in the superheterodyne eliminated?
15. What type of detector is commonly used in a superheterodyne receiver?
16. Why is a radio-frequency amplifier stage placed before the mixer in a superheterodyne receiver?
17. What is image frequency?
18. Draw a complete superheterodyne receiver, with automatic volume control.

## CHAPTER 27

# Types of Vacuum Tubes

---

- Problem 1:** *To review the functions of the diode and triode.*
- Problem 2:** *What are some methods of adapting single radio tubes to many purposes?*
- Problem 3:** *What are some trade numbers of certain special tubes?*
- 

As you have learned, it is possible to have radio without vacuum tubes. Nevertheless, the radio tube has changed what was a scientific toy into one of the world's greatest industries. The vacuum tube has greatly influenced our present civilization.

### 196. General Principles of Vacuum Tubes

The basic principles of the vacuum tube are nevertheless extremely simple. Let us study the vacuum tube more attentively. Surrounded by a vacuum, the heated filament or cathode emits a stream of electrons which form a one-way path to a positively charged plate or anode. The more the cathode is heated, the more electrons it sends out. The more positive the charge on the plate, the more of these electrons it attracts. (It should be remembered that these two statements hold true between certain limits. If you heat the filament too much it will burn up. After a certain limit is reached, placing a higher positive charge on the plate will attract no more electrons.) (Chap. 37, Vol. II.)

In some tubes, the cathode is the filament itself. This filament may be a thin wire, as in type 01A tubes. Or else it may be a heavy metal ribbon coated with certain chemicals to permit it to shoot off more electrons, as in the type 26 tubes.

In tubes of other types, the filament is merely an electric stove or heater, heating up the relatively heavy metal tube or sleeve that fits over it. This tube or sleeve is the cathode, which when

heated sufficiently emits the electrons that find their way to the plate. The type 27 tube is an example of this class.

Tubes having thin filaments usually are heated by direct current. Alternating current is generally used to heat the heavy ribbon filaments. The separate-heater types of tubes may be heated either by direct or alternating current.

### 197. Special Voltages

In practice, the tube manufacturers design the filaments and heaters of their tubes to operate at certain voltages. Thus the filament of the 01A tube operates at the 5 volts obtained from a storage battery. For use in portable receiving sets, the 1H5-G type of tube has a filament which operates from the 1½ volts furnished by a single dry cell.

Other types of tubes require different voltages. The type 45 uses 2½ volts on its filament. The heater of the 117Z6 tube uses 110 volts. There are many other types of tubes using other voltages. But the voltage at which the filament or heater of the tube operates does not determine the character or nature of the tube.

### 198. The Diode

Simplest of all vacuum tubes is the two-element tube or *diode*. These two elements consist of an emitter of electrons (either a filament or separately heated cathode), and a plate. These two elements are sealed inside a glass bulb from which all air has been evacuated.

As described in Chapter 14, the diode makes for an excellent detector. It is also used as a rectifier, changing alternating current into direct current to be used by the B eliminator (Chapter 18 and by the automatic volume-control circuit, Chapter 24).

The I-V and 12Z3 types of tubes are typical diodes. Sometimes two diodes are sealed into one envelope to make a *full-wave rectifier*. Examples of this type of tube are the 80, 5Z3 and 6H6 tubes.

### 199. The Triode

When Dr. DeForest placed a third element, the grid, between the cathode and plate of the diode, he introduced the magical word *amplification*. As already explained in Chapter 15, a small voltage placed upon the grid of the tube controls the stream of electrons

rushing from the cathode to the plate. This electron stream in turn controls the comparatively large plate current. Since this large plate current varies in step with the small voltage placed upon the grid, amplification results.

The amplifying quality of a tube is called the *amplification factor*, which appears in electrical formulas as the Greek letter  $\mu$  ( $\mu$ ). Here is what it means.

In Figure 166, we have a triode with a meter in the plate circuit.

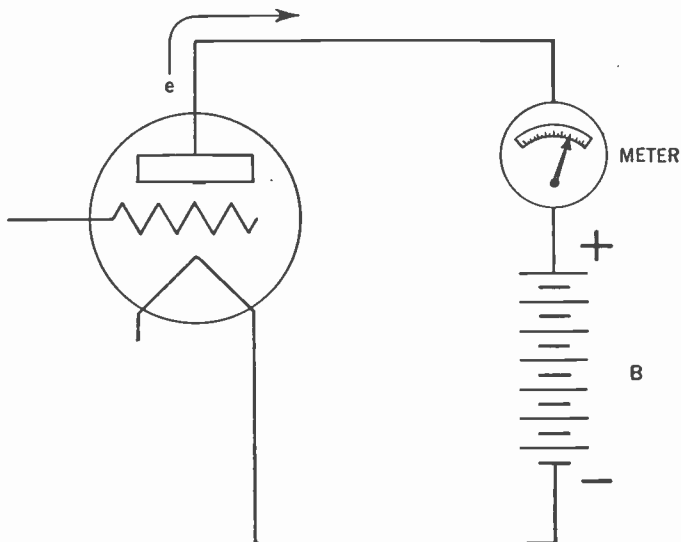

Figure 166. Meter connected in the plate circuit of the triode to show the flow of electrons.

Electrons flowing from the filament are attracted to the positively charged plate and flow on through the meter, which registers their flow. Assume that you now increase the B battery by 35 volts. The greater positive charge on the plate attracts more electrons and the meter now shows that more are flowing through it.

At this point a negative charge is placed on the grid. This will cut down the flow of electrons to the plate and fewer electrons will flow through the meter. Assume that when you have placed a negative charge of 5 volts on the grid, the meter will show the same number of electrons flowing through it as before the plate charge was raised by 35 volts. This means that 5 volts applied to the grid will have the same effect as 35 volts (of opposite charge) applied to the plate of the tube.

The amplification factor or  $\mu$  ( $\mu$ ) of this tube is therefore 35 divided by 5, namely 7.

### 200. What Determines The Amplification Factor of a Triode?

The amplification factor of a triode is determined by the mechanical construction of the tube. The nearer the grid is to the cathode, the greater is its effect on the stream of electrons flowing to the plate and the greater is the  $\mu$  or amplification factor of the tube. Also, the finer the mesh of the grid, the greater the effect of a charge upon the grid and again the greater the  $\mu$ . If the open spaces in the grid are wide, the electrons are able to rush to the plate without being very much affected by the grid charge. This condition accordingly makes for a smaller amplification factor.

In the triode, we are unable to use a grid of very fine mesh because the consequently larger area of the grid would greatly increase the internal grid-to-plate capacitance. This would increase the feedback and cause the receiver to oscillate, resulting in distortion (see Chapter 23). It is partly because of this fact that triodes have a relatively small amplification factor. The type 27 tube has a  $\mu$  of 9 and type 01A a  $\mu$  of 8.

There is another factor that limits the  $\mu$  of the triode. The electrons shot off by the cathode have a negative charge. Thus they tend to repel each other and many more are shot out than actually reach the plate. Of these electrons that do not reach the plate, a large number accumulate and fill the space around the cathode inside the envelope of the tube. This accumulation charges the space around the cathode, and is therefore called the *space charge*.

Any new electrons shot off by the cathode must fight their way through this space charge to reach the plate. It is estimated that about 85 per cent of the positive charge on the plate of the tube is used to overcome the repelling effect of the space charge, leaving about 15 per cent for amplification purposes.

The space charge, surrounding the grid, also interferes with its action and thus further reduces the  $\mu$  of the tube.

### 201. Amplification Outside the Tubes

In addition to the amplification furnished by the tube, there is the amplification due to the step-up action of the transformer. Figure 167 shows what is meant by a *stage of amplification*.



We may calculate the amplification of this stage by dividing the output voltage by the input voltage. Thus, if the output voltage is 50 volts and the input voltage is 5 volts, the amplification furnished by this stage is 50 divided by 5, or 10.

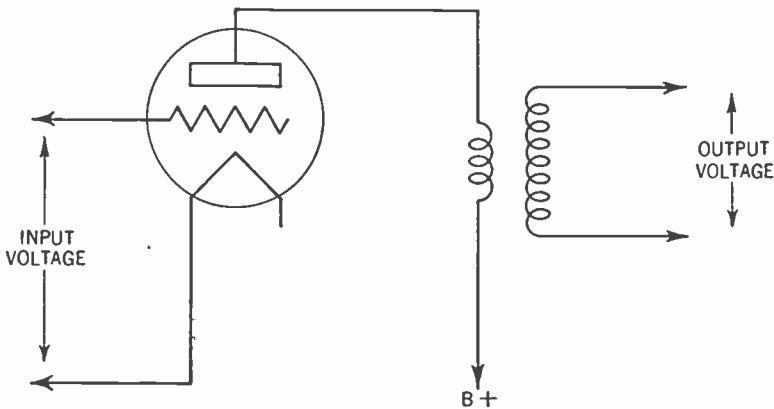

Figure 167. Diagram showing what is meant by a stage of amplification.

### 202. The Power Tube

We must remember that the radio tube is a voltage-operated device; that is, the varying voltage which is fed into the grid controls the current flowing in the plate circuit of the tube. It becomes the function, then, of each stage of amplification to amplify the variations of voltage fed into the grid. Each stage has this function, except the final audio-frequency stage, whose function it is to supply the fluctuating current or power that operates the loudspeaker.

Electrons, shot out by the cathode and attracted to the plate, circulate through the voice coil of the loudspeaker which is either in the plate circuit or else coupled to the plate circuit by means of an output transformer (see Chapter 22). The frequency of sound coming from the speaker depends upon the frequency of variations in the electron stream. The volume or loudness of this sound depends upon the amplitude of these variations. Thus, to operate our speaker at a loud level, we need a dense stream of electrons flowing in the plate circuit. Therefore, the cathode must be capable of emitting a large quantity of electrons and the tube must be able to pass them on to the plate.

It is for this reason that the last stage of audio-frequency am-

plification is called the *power stage* and the tube that operates this stage is called the *power tube*.

If the power tube is of the filament type, this filament is usually made quite heavy and rugged and is coated with chemicals that increase the electronic emission. A power tube may also contain a large number of filaments connected together to give the same effect as one heavy filament. Tubes such as the type 45 and the type 2A3 are examples.

Where the tubes have separately heated cathodes, these cathodes are large and are able to emit a large number of electrons. The 6AC5-G is such a tube.

When the electrons strike the plate, they are traveling with considerable speed and the force of the impact heats up the plate. It is for this reason that the plate of the power tube must be larger and more rugged than for the other types of tubes. It is usually coated with graphite to give it a black surface so that it may radiate away its heat more effectively.

### 203. Power Tubes Have a Small Amplification Factor

While the grid of the power tube must control the flow of electrons from the cathode to the plate, it must not block off too many of these electrons that are needed so badly in the plate circuit. For this reason, the grid of the power tube has an open mesh and is not placed so close to the cathode as in the case of other types of amplifier tubes.

This construction in turn reduces the amplification factor of the power tube. Thus the  $\mu$  of the type 2A3 tube is only 4.2 and that of the type 45 tube 3.5. Power tubes of the triode class generally have a low amplification factor.

Since the grid of the power tube is of open mesh and relatively far from the cathode, changes in the grid voltage do not affect the flow of electrons in the plate circuit as much as if the grid were of finer mesh and closer to the cathode. In order to create a certain variation in the plate current, therefore, any change in the charge on the grid of the power tube needs to be greater than the change needed by another type of amplifier tube. We say that power tubes of the triode class have low *power sensitivity*.

Because this greater *grid-voltage variation* or *swing* is necessary to operate the power tube, it is important that most of the amplification of the signal should occur before the current is fed

into the power tube. For this reason it is customary to have a stage of audio-frequency amplification between the detector and power stage.

**204. Two Power Tubes in Parallel**

Sometimes the power required for the loudspeaker is too great for a single tube to handle. In such cases we can connect two identical power tubes in *parallel*. The grid of one tube is connected to the grid of the other, the plate to the other plate, and the cathode to the other cathode (Figure 168).

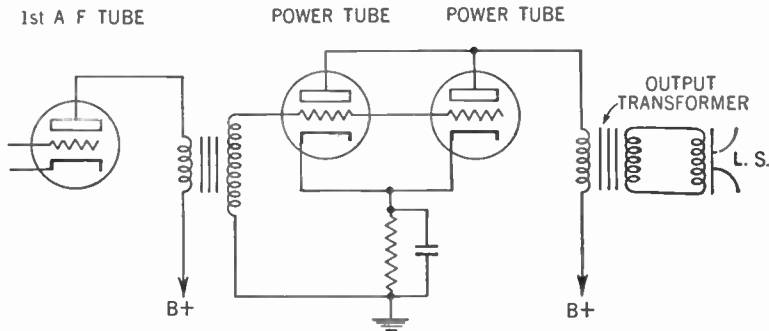

**Figure 168. Circuit showing how two power tubes are connected in parallel to handle greater power.**

The voltage placed upon the grids of two tubes in parallel is the same as that on the grid of one tube. But because two cathodes are emitting electrons, the current set flowing in the plate circuit of the tubes is twice as large. Thus from two tubes we can get nearly twice the power output that a single tube can deliver to operate the loudspeaker. It is quite obvious that three or more tubes may be connected in parallel. It is not practical, however, to use more than two tubes for ordinary purposes.

**205. The Push-pull System for Power Tubes**

Another method of multiplying the output of the power tube is to connect two of them in *push-pull*. Figure 169 shows this circuit.

You will notice that the secondary winding of the input transformer is center-tapped. Each end of this winding goes to the grid of one of the power tubes. The center tap is connected to the grid-bias resistor which in turn is connected to both cathodes.

Thus a negative bias is placed on the grids of the tubes (see Chapter 20).

The primary or the output transformer also is center-tapped. Each end of that winding goes to one of the plates while the B+ terminal is connected to the center tap. Here is how this hookup works.

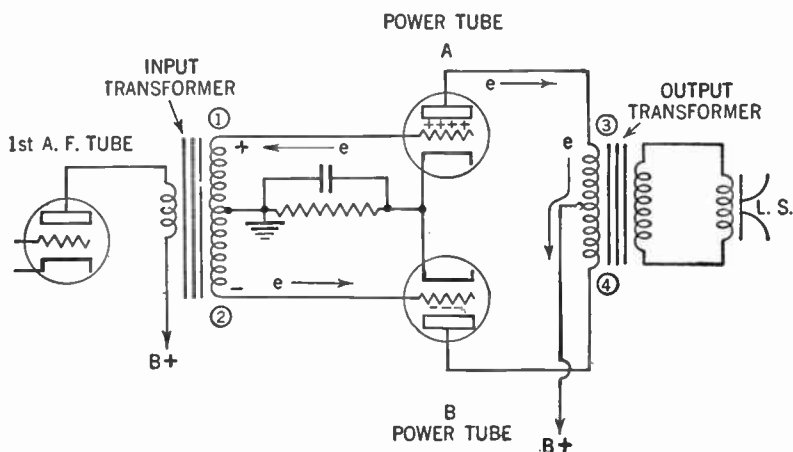

Figure 169. Circuit showing how two power tubes are connected in push-pull.

The fluctuating current in the plate circuit of the first audio-frequency tube sets up an alternating voltage across the secondary of the input transformer. Assume an instant when point 1 of the secondary is positive; point 2 then is negative. In this situation a positive charge is placed upon the grid of tube A and a negative charge upon the grid of tube B.

In tube A, the electrons shot out by the cathode are sped on to the plate and flow to point 3 of the primary of the output transformer. They then flow through the coils of the primary to the center tap and out to the positive post of the B supply.

As the current flows through the upper half of the primary of the output transformer, a magnetic field is built up. This field, cutting across the secondary of the output transformer, sets up an electrical pressure that sends current flowing through the voice coil of the loudspeaker (see Chapter 22).

Now let us see what is happening in tube B. The negative charge on the grid cuts off the flow of electrons to the plate. Thus the plate current is reduced and the current flowing through the

lower half of the primary of the output transformer falls off. This falling-off causes the magnetic field to collapse.

But a collapsing magnetic field, cutting across a conductor, sets up an electrical pressure across that conductor just as an expanding magnetic field does. Thus a second electrical pressure is set up across the secondary of the output transformer and, as a result, a much greater current flows through the voice coil of the loud-speaker.

Note that while the current flowing in one tube is increasing, the current in the other tube is diminishing. Also notice that we need twice the grid voltage that is needed to operate a single tube in order to operate a pair of tubes in push-pull. Power tubes connected in push-pull produce very little distortion of the signal.

### 206. The Tetrode

It was stated, earlier in this chapter, that the triode has a low amplification factor because:

1. We cannot use a fine-mesh grid since this causes too great a grid-to-plate capacitance and thus too much feedback.
2. The space charge within the tube wastes about 85 per cent of the positive charge on the plate.

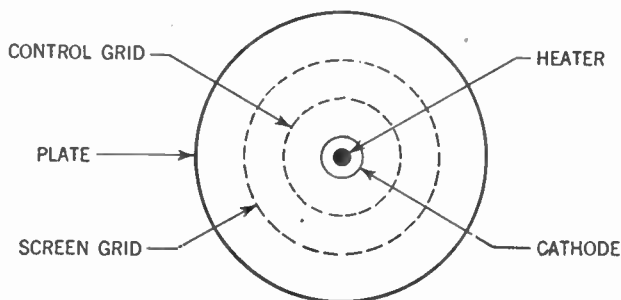

**Figure 170.** Looking down on the top of a screen-grid tube showing the arrangement of the electrodes.

To overcome these difficulties, in some tubes a second grid is placed between the original grid, now called the *control grid*, and the plate. This new grid is called the *screen grid*.

The screen grid is connected to the B+ terminal, but a dropping resistor reduces the positive charge on it to a value consid-

erably less than that on the plate. Thus if a positive charge of 250 volts is placed on the plate, 100 is placed on the screen grid.

### 207. Action of the Screen Grid in the Tetrode

This new grid acts as a screen between the plates of the condenser formed inside the tube by the control grid and plate, and thus reduces the internal capacitance of the tube. Thus the amount of feedback is cut down to almost zero and the evil of oscillation is eliminated.

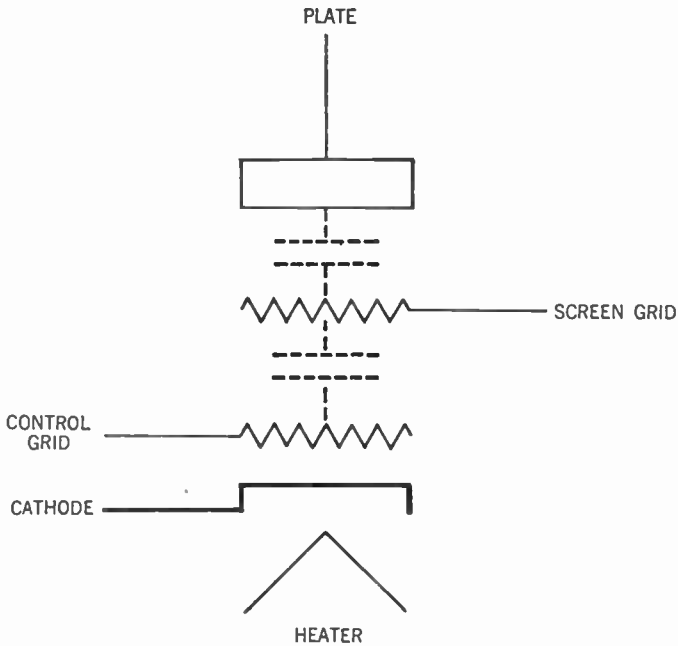

Figure 171. Arrangement of electrodes within the screen-grid tube showing the internal capacitance between the grids and the plate.

So while the 01A tube has a grid-to-plate capacitance of  $8 \mu\mu$  fd., the type 24A screen-grid tube has a grid-to-plate capacitance of about  $.007 \mu\mu$ fd.

As a result, we can now use a closely meshed control grid and this structure gives us a much greater amplification factor.

Another result of introducing the positively charged screen

grid is the dissipation of the space charge. The electron cloud which otherwise fills the inside of the tube is attracted to the screen grid. Some of the electrons hit the wires of this grid and go off to the positive post of the B supply. But most of them go through the openings and travel on to the plate, which has a higher positive charge. This electron stream gives a greater plate current and a much greater amplification factor for the tube, because now any new electrons emitted by the cathode need not dissipate themselves battling the repellent effect of the space charge.

We can fully appreciate the effect of the screen grid when we compare the amplification factor of 8 for a triode such as the type 01A with that of 400 for the type 24A screen-grid tube. While losses in the circuit may cut the real *mu* down to 40 or 50, nevertheless you can readily see the advantage of the screen-grid tube.

**208. The Screen Grid Is the Fourth Electrode**

Because the screen grid forms the fourth electrode in the tube, we call this new type of tube a *tetrode*, meaning four electrodes. In the type 24A tube the control grid is connected to a cap on the top of the tube. Another screen is usually placed around the out-

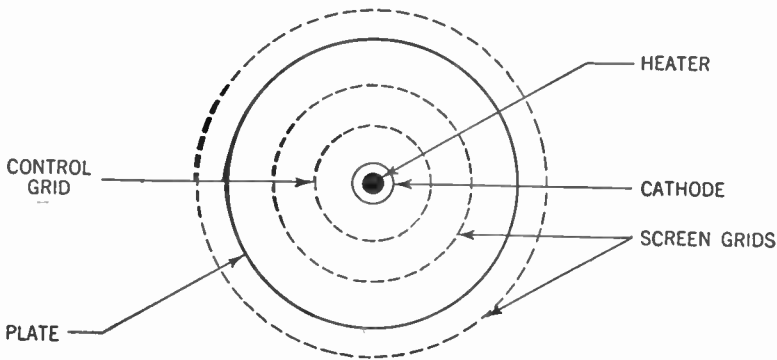

**Figure 172. Looking down on the screen-grid tube. Note the screen grid around the outside of the plate.**

side of the plate and is connected to the inner screen grid. This screen tends to shield the entire tube from external disturbances.

Because of the low grid-to-plate capacitance of the tetrode, there is no danger of oscillations being set up as the result of feedback. This condition makes it unnecessary to neutralize the radio-

frequency and intermediate-frequency stages of amplification. Figure 173 shows the circuit of a typical radio-frequency stage using the tetrode. Note that the screen grid is by-passed to ground by a .001- $\mu$ fd. condenser to eliminate any stray radio-frequency currents.

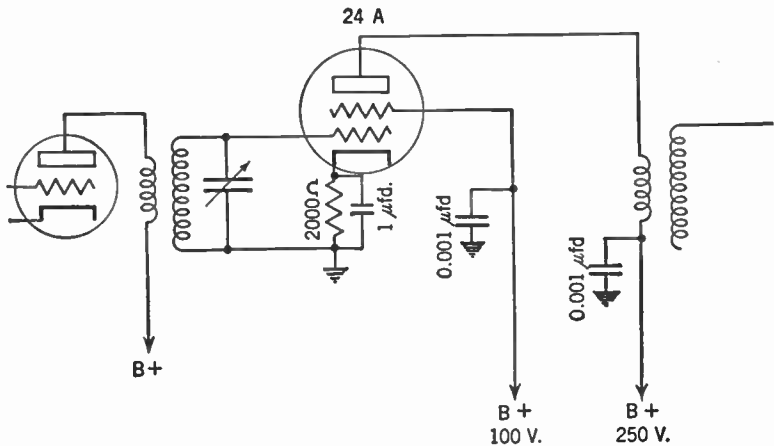

Figure 173. Circuit of a stage of radio-frequency amplification using the 24A type of screen-grid tube.

Since the positive charge on the screen grid dissipates the space charge on the tube, changing this positive charge will affect the space charge in the tube and thus the amplification factor. Because of this, the automatic volume-control voltage may be fed into the screen grid and thus control the amplification of the receiver. In practice, however, automatic volume control is usually maintained by means of variations of the grid bias as explained in Chapter 24.

### 209. Other Uses of the Tetrode

The tetrode may be used as an audio-frequency amplifier although our study of the power tube shows why the screen-grid tube is not suitable as an output tube.

The screen-grid tube may be also used as a detector as shown in Figure 174.

Figure 174-A shows the tetrode hooked up as a grid-leak-condenser detector while Figure 174-B shows the circuit of a grid-bias detector. The 50,000-ohm potentiometer controls the positive charge placed on the screen grid and thus acts as a volume control by varying the amplification factor of the tube.



210. Variable- $\mu$  Tubes

The control grid of the screen-grid tube has a very fine mesh. This means that as the electrons stream through the spaces between the wires, they are forced to pass quite close to those wires

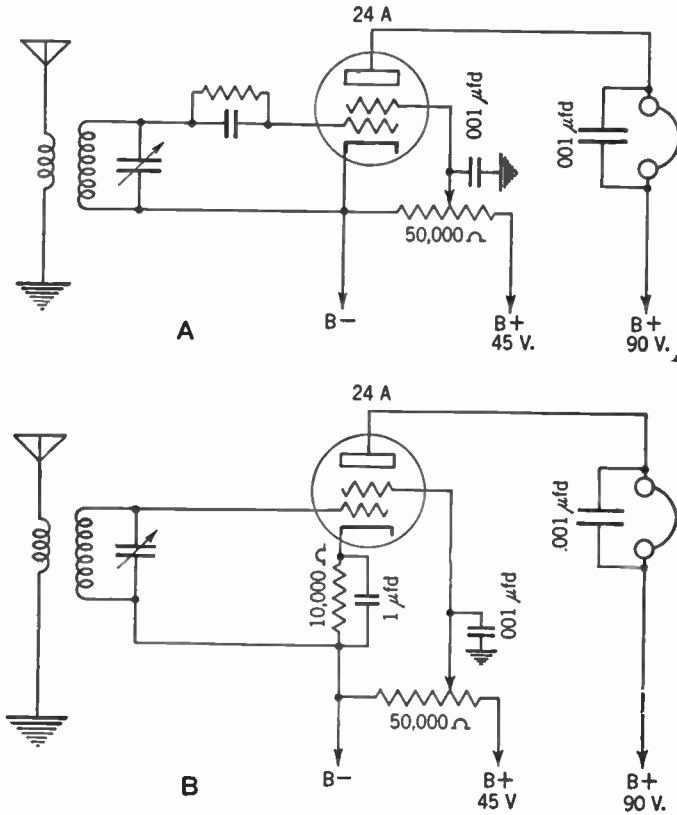

Figure 174. A—Circuit of a tetrad used as a grid-leak-condenser detector.  
B—Circuit of a tetrad used as a grid-bias detector.

A very small charge upon the wires of the grid, then, has a great effect on the electron stream flowing to the plate of the tube. The screen-grid tube is ideal for the purpose of delivering a large voltage from a small one.

The very construction that makes this tube so suitable for handling small voltages prevents it from handling high voltages. It does not require a great negative charge on the control grid to stop entirely the flow of electrons to the plate. Thus, if a large alternating voltage should be fed into the grid, the positive half

of the cycle would go through well enough, but most of the negative half cycle would be blocked out and detection or rectification would result.

If the screen-grid tube is used as a radio-frequency amplifier in a set which is located near a powerful station, the strong signal from that station will cause the automatic volume-control system to send a large negative bias to the control grid of the tetrode. This bias plus the negative half cycle of the incoming signal will cut off the flow of electrons to the plate and the radio-frequency tube will act as a grid-bias detector (see Chapter 15). This phenomenon causes a form of distortion called *cross modulation*.

This interference does not occur if the wires of the control grid are widely spaced. Charges on the grid have little effect on the electrons as they stream through the wide open spaces. But, of course, the amplification factor of the tube is much less.

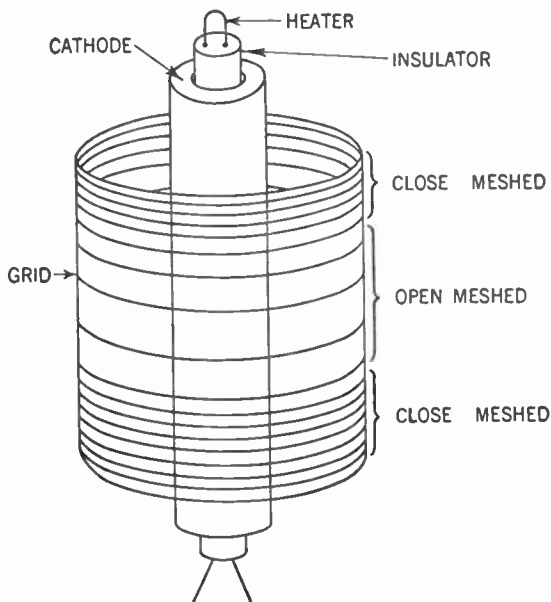

**Figure 175.** Diagram showing the construction of the control grid of a variable- $\mu$  tube.

The ideal condition, then, would be to hook up one tube with a close-meshed control grid and one with an open-meshed control grid in such a way that weak signals would travel through the close-meshed tube where they would be greatly amplified and the

strong signals, that did not need so much amplification, would travel through the open-meshed tube where they could not cause distortion.

This ideal was achieved in one tube by constructing a control grid that is close-meshed at the ends and open-meshed in the center.

When a weak signal comes in, the automatic volume-control sends little negative bias to the control grid of the radio-frequency tube and this tube then acts as a conventional screen-grid amplifier. When a loud signal comes in the negative bias of the tube is increased. This increased bias means that the electrons cannot get through the fine mesh at both ends of the control grid. But in the center, where the mesh is open, the electrons can get through and the tube now acts as a low- $\mu$  amplifier.

Such a tube is called a *variable- $\mu$  tube* or *supercontrol radio-frequency amplifier*. One example of such a tube is the type 35.

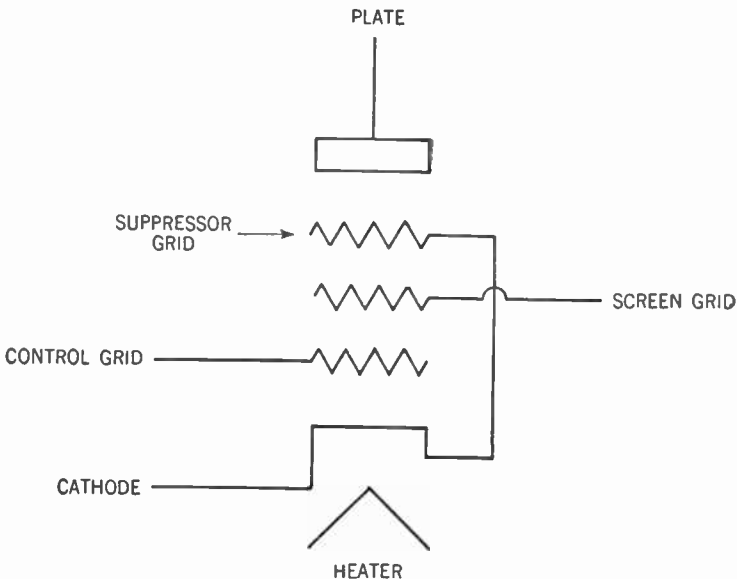

Figure 176. Arrangement of electrodes in the pentode tube.

### 211. The Radio-frequency Pentode

Although the screen-grid tube makes an excellent radio-frequency amplifier, it suffers from one defect. Because the space charge has been overcome and also because of the added pull of the positive charge on the screen grid, electrons leaving the cathode

attain a speed as great as 20,000 miles per second and strike the plate with great force.

The force of impact is great enough to knock some electrons off the plate. This phenomenon is called *secondary emission*. These electrons fly about in space and either are pulled back by the positive charge of the plate or else are attracted to the positively charged screen grid nearby. The electrons lost to the screen grid reduce the supply left for the plate circuit of the tube and amplification falls off.

To remedy this defect a third grid is placed between the screen grid and the plate. This new grid is connected to the filament or cathode of the tube.

Since it is connected to the cathode, this new grid has no charge on it and therefore will have no effect upon electrons passing through it on their way to the plate. But as compared to the positive charge on the plate, this new grid is negative. Therefore any electrons knocked off from the plate by secondary emission will be turned back by this grid to the plate where they belong. Because of this fact, the new grid is called the *suppressor grid*.

Because they have five electrodes (cathode, three grids, and a plate), tubes of this type are called *pentodes*. They make excellent radio-frequency and intermediate-frequency amplifiers because they have the sensitivity and high amplification factor of the screen-grid tubes plus the ability to suppress secondary emission. They are also known as *radio-frequency pentodes*.

The 34 tube is of this type. The suppressor grid is connected internally to the center of the filament. Sometimes the suppressor grid is led out to one of the base connections. We then must connect it to the cathode externally. The type 58 tube is an example.

## 212. The Power Pentode

Like the screen-grid tube, the radio-frequency pentode is not suited for use as a power tube. Let us see if we can design a good power tube.

First of all, it must be capable of handling a good deal of power. Hence the cathode must be a very strong emitter of electrons. These electrons must find their way to the plate quite readily. Hence we must have an open-meshed grid. The plate must be large and rugged to withstand the bombardment of electrons.

So far we have described our old friend, the triode power tube.

Now, let us see if we can step up its amplification factor. We cannot make the grid more fine-meshed because doing so would cut down the flow of needed electrons and thus reduce our power. But we can eliminate the space charge that uses up about 85 per cent of the positive charge on the plate. So between the control grid and the plate we place a positively charged screen grid and the amplification factor shoots up.

But not so fast. We are dealing here with heavy streams of electrons. Without the restraining effect of the space charge, the electrons hit the plate with tremendous impact, knocking off clouds of electrons. A large number of these electrons are attracted to the positively charged screen grid and down goes our amplification factor.

Well, let us put in a suppressor grid between the screen grid and the plate. Connect this suppressor grid to the cathode, and the electrons knocked off by the impact are forced back to the plate and up goes the amplification factor.

This tube is called a *power pentode* and one example is the type 47. Compare its amplification factor of 150 with that of the triode type 45, whose amplification factor is 3.5. Because a small grid voltage can control a large amount of power in its plate circuit, the power pentode may work directly from the detector without any need for an intervening stage of audio-frequency amplification.

Like the triode power tube, the power pentode can be connected in parallel and in push-pull circuits to get greater power output.

Although they are both pentodes, the radio-frequency pentode and the power pentode are not interchangeable. In reality, they are tubes of two different types.

### 213. The Beam Power Tube

Although it has only four electrodes, the *beam power tube* is in reality a variation of the power pentode. Here is how it works.

Electrons, shot off from the cathode, pass between the wires of the control grid and the positively charged screen grid. This screen grid has a higher positive charge than the plate. This charge acts as a brake, slowing down the electrons in their flight to the plate. Deflector plates, connected to the cathode and therefore having the same zero charge, concentrate these electrons into

a cloud or beam, moving slowly towards the plate. Any electrons knocked off by secondary emission are repelled back to the plate by this beam of electrons. Thus it can be seen that the space

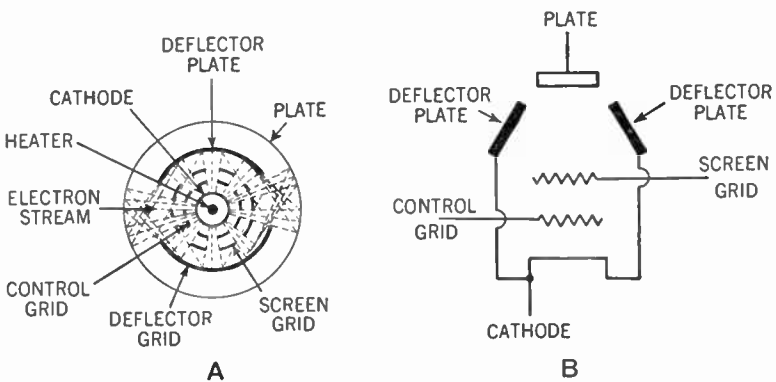

**Figure 177.** A—Looking down on beam power tube, showing electron streams threading their ways through the grids.  
B—Arrangement of electrodes in the beam power tube.

charge created by the beam of electrons acts just as the suppressor grid acts to overcome the effects of secondary emissions. Examine the diagram in Figure 177.

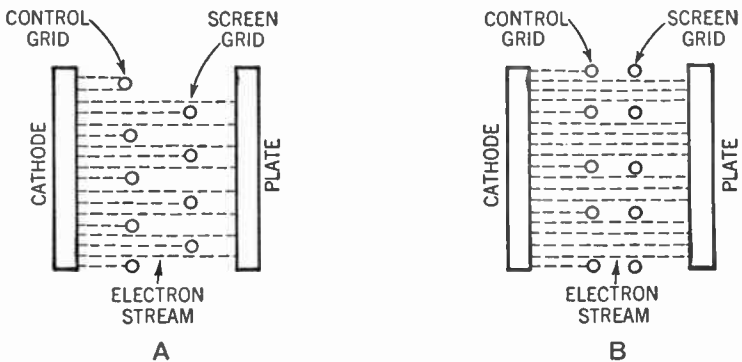

**Figure 178.** A—Arrangement of control grid and screen grid in most tubes. Note that comparatively few electrons get through to the plate.  
B—Arrangement of control grid and screen grid in beam power tube. More electrons get through to the plate.

Another innovation of the beam power tube is the special construction of the grids. In other types of tubes the control grid and screen grid appear as shown in Figure 178-A.

Note that a considerable portion of the electrons hit the screen grid and thus are lost to the plate. If a meter were connected in

the screen-grid circuit it would show a considerable flow of electrons from the screen grid to the B+ terminal.

Figure 178-B shows the construction of the beam power tube. Note that the wires of the control grid shade the wires of the screen grid in such a way that very few of the electrons hit the

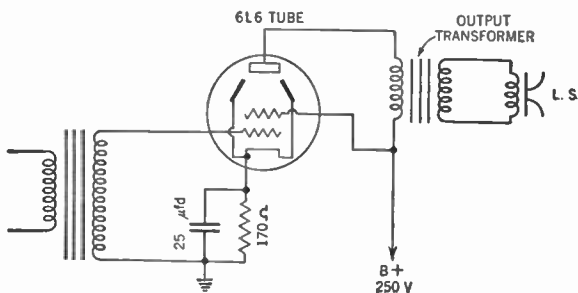

Figure 179. Circuit of beam power tube used as a power tube.

screen grid. A meter connected in the screen-grid circuit of a beam power tube accordingly would show a very small flow of current.

More electrons therefore strike the plate of a beam power tube and the efficiency of the tube is raised. Figure 179 shows how the

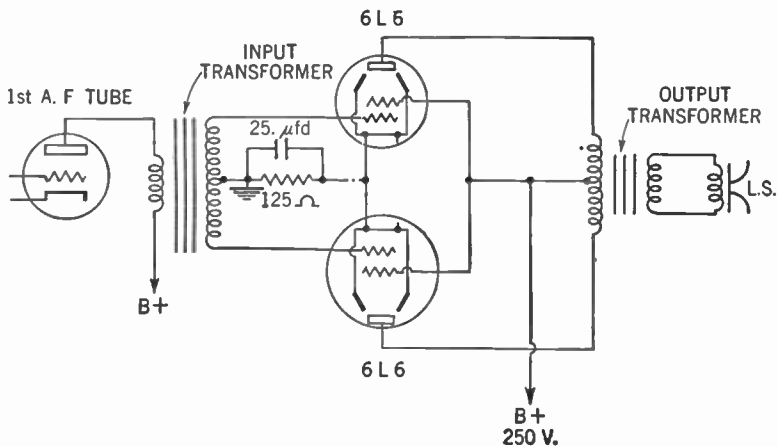

Figure 180. Circuit showing how two 6L6 tubes are hooked up in push-pull.

6L6 tube, a typical beam power tube, is connected in a circuit. Note that the positive charge on the plate is less than that upon the screen grid, since some of the electrical pressure is lost while forcing its way through the primary of the output transformer.

Some idea of the efficiency of such a beam power tube as the 6L6 can be gained by comparing it with a triode such as the type 45. With a charge of 50 volts applied to the grid, the type 45 tube delivers 1.6 watts of electrical power to the loudspeaker.

The 6L6 tube delivers 6.5 watts of electrical power and needs only 14 volts on the grid.

As in the case of other power tubes, the beam power tube can be connected in parallel and in push-pull to deliver greater power.

#### 214. Multielectrode Tubes

Tubes containing more than five electrodes are generally called *multielectrode tubes*. Although they may appear quite complicated at first glance, their operation is quite simple if we keep in

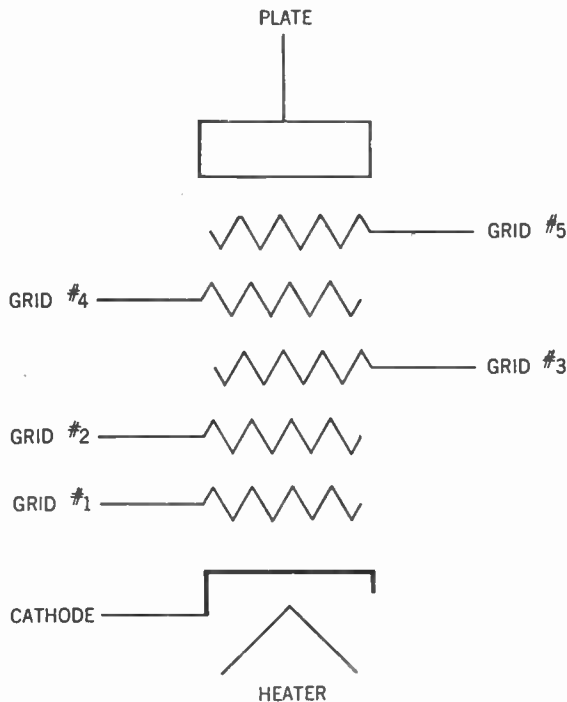

Figure 181. Diagram showing the arrangement of electrodes in the pentagrid converter tube.

mind the basic principle of the vacuum tube, that is, that electrons are shot out by the heated cathode and find their way to the positively charged plate.

In their travels the electrons pass between the wires or meshes



of a number of grids. These grids either attract or repel the electrons, either speed them up or retard them. The effects that these grids exert upon the traveling electrons depend upon the charges placed upon the grids. A positively charged grid will attract the electrons, a negatively charged grid will repel them. A varying charge upon the grid will produce a varying effect on the electrons. And that is all there is to it.

**215. The Pentagrid Converter**

Let us take a look at the type 6A8 tube. This tube has a cathode (and separate heater), a plate, and five grids as shown in Figure 181. The grids are numbered from 1 to 5 counting from the cathode toward the plate.

This tube is often used as both the mixer (first detector) tube and oscillator tube in a superheterodyne receiver (see Chapter 26).

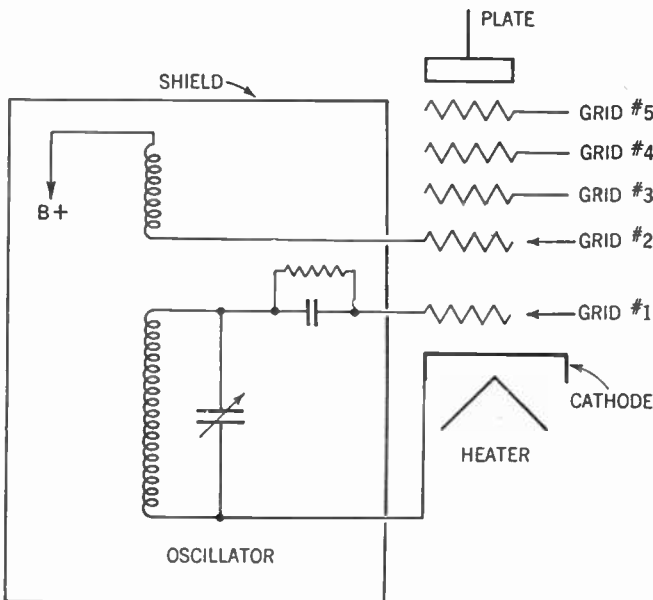

**Figure 182. Circuit showing how cathode, grid #1 and grid #2 of the pentagrid converter are used as a triode for the oscillator section of the superheterodyne receiver.**

When used for this purpose it is called a *pentagrid (five grids) converter*. Here is how it works.

First consider the cathode and grids 1 and 2 of the tube. If we place a positive charge upon grid 2 and call it the anode or

plate, and call grid 1 the control grid, you can readily recognize our old friend the triode. Now let us hook up this triode as an oscillator as described in Chapter 26.

The electrons are shot out from the cathode in a steady stream. In the oscillator circuit, however, the electrons are dashing back and forth at a tremendous rate, at a frequency of 1,175 kc. per second if we use the example in Chapter 26. Grid 1 will therefore

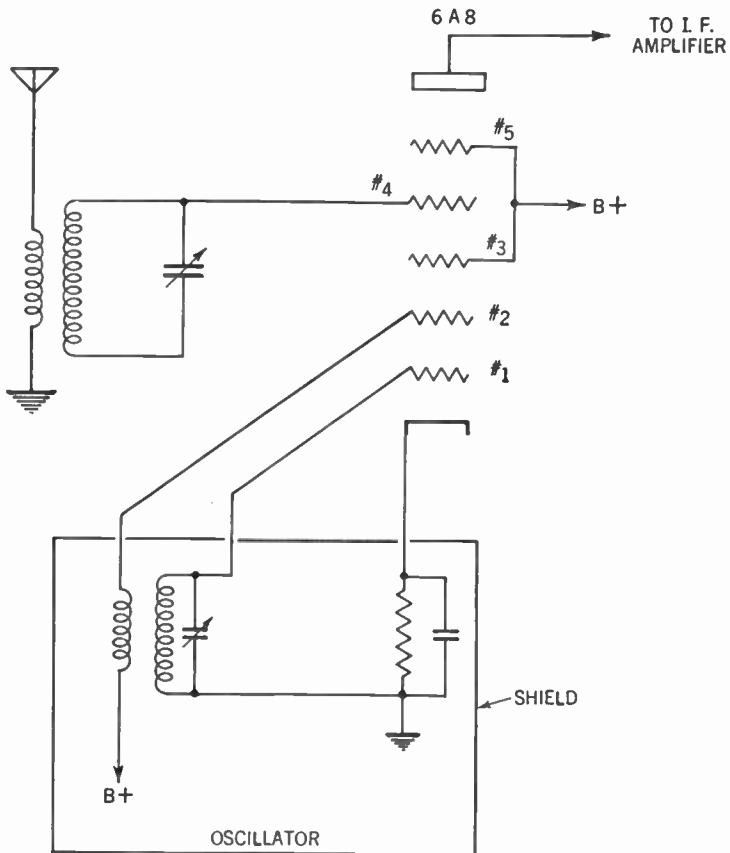

**Figure 183.** Complete circuit showing the pentagrid converter as the first detector, mixer, and oscillator tube in the superheterodyne receiver.

have a charge on it that will vary 1,175,000 times per second. This variation will cause the steady electron stream from the cathode to vary or fluctuate in step. This fluctuating stream will be attracted to the positively charged grid 2, but since this is a

grid and not a solid plate, the electrons will shoot through the meshes on their way toward the real plate of the tube.

Thus we may really consider the combination of cathode, grid 1, and grid 2 as a composite cathode, sending out a stream of electrons that are not steady, but fluctuate at the rate indicated by the oscillator, that is, 1,175 kc. per second.

We may now consider the entire tube as a screen-grid tube. The cathode and grids 1 and 2 are the composite cathode, grid 4 is the control grid, and grids 3 and 5 are tied together and connected to the B+ terminal to furnish the screen grid and to shield grid 4 from the oscillator circuit.

The incoming signal, the modulated radio-frequency voltage (1,000 kc. in our example), is fed into the control grid 4. Thus a charge that fluctuates 1,000,000 times per second is placed on this grid 4.

Streaming through this grid is a flow of electrons that already are fluctuating at the rate of 1,175 kc. per second. Beats result, and out of grid 4 comes a stream of electrons that fluctuate at the rate of 1,175 kc. minus 1,000 kc. per second, or 175 kc. per second—the exact frequency to which the intermediate-frequency transformers are tuned.

Figure 183 shows the complete circuit for the pentagrid converter.

### 216. Electronic Coupling

You will recall that when we discussed coupling the oscillator to the mixing circuit in Chapter 26 we said that in addition to the inductive and capacity methods there was a third method whereby the two circuits were coupled through the electrodes within the tube. This third method is sometimes called *electronic coupling* for obvious reasons.

### 217. Multiunit Tubes

It is quite possible to place two or more complete tubes in one envelope. Such tubes are called *multiunit tubes*. All the tubes in the envelope may even share the same cathode, but they differ from the multielectrode tube in one important way. Whereas in the multielectrode tube there is one stream of electrons that is acted on by all the electrodes, in the multiunit tube the stream of electrons flowing from the cathode divides into two or more parts and each part flows through its own unit of electrodes.

These tubes are constructed so that the electron stream of one unit is not affected by the electrodes making up any other unit, but proceeds to flow from the cathode through its various grids (if any) to its own plate.

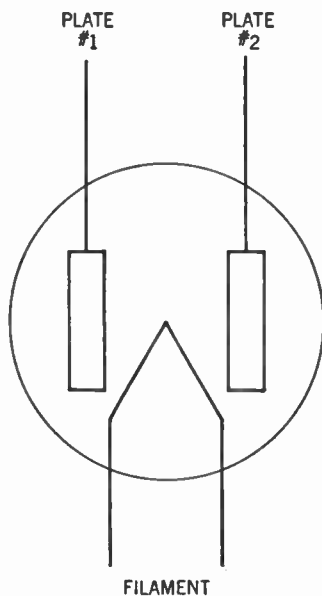

**Figure 184. Diagram of a duo-diode tube. The type 80 is an example.**

One of the simplest of these multiunit tubes is the type 80 shown in Figure 184, which is used as a full-wave rectifier. Here the electrons shot out by the filament follow two paths, one to plate 1, the other to plate 2.

Figure 185 shows the diagram for the 1H5-G tube, which has a diode and triode in one envelope.

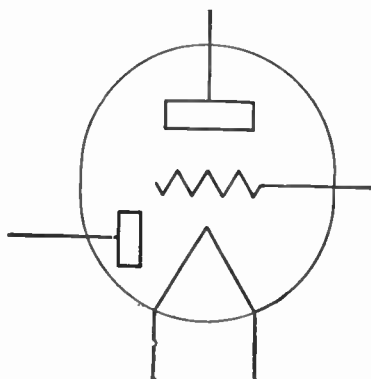

**Figure 185. The 1H5-G tube. One diode—one triode.**

Figure 186 shows a diode and a pentode in the same envelope. This tube is of type 1S5.

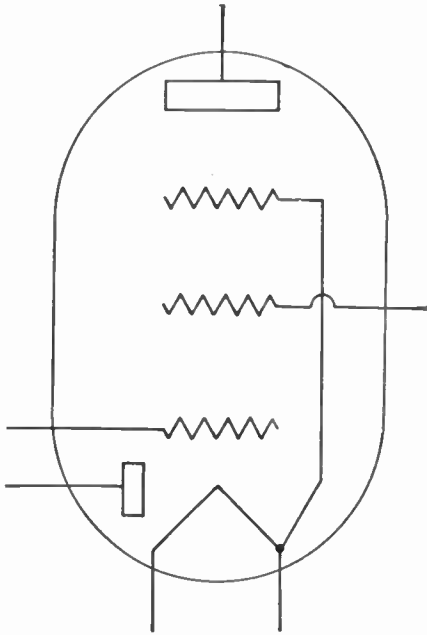

Figure 186. The 1S5 tube. One diode—one pentode.

In Figure 187 we see the 6C8-G tube, which has two triodes in one envelope.

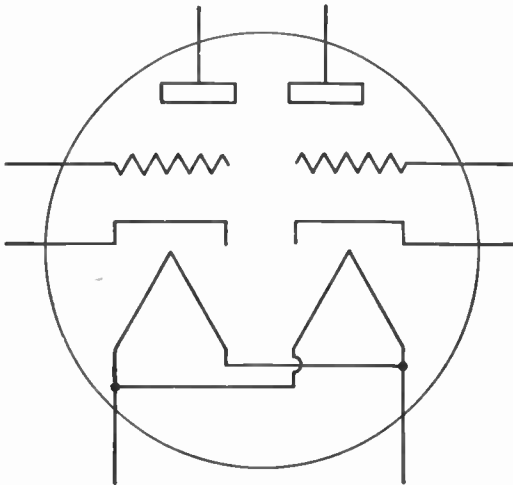

Figure 187. The 6C8-G tube (two triodes).

## TYPES OF VACUUM TUBES

In Figure 188 we see the type 6F7 tube, which has one triode and one pentode in the same envelope.

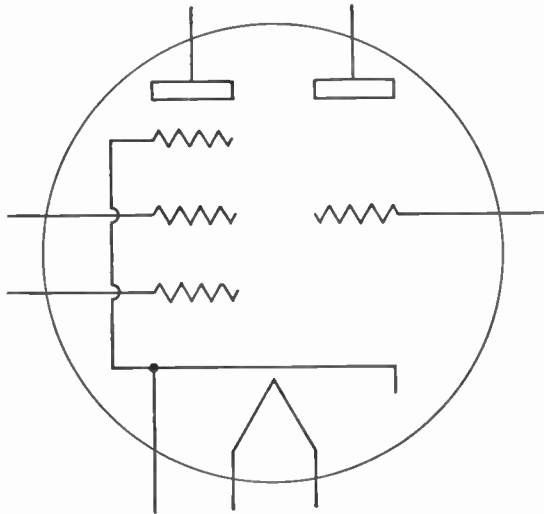

Figure 188. The 6F7 tube (one pentode—one triode).

The type 1E7-G tube (Figure 189) has two pentodes in the same envelope.

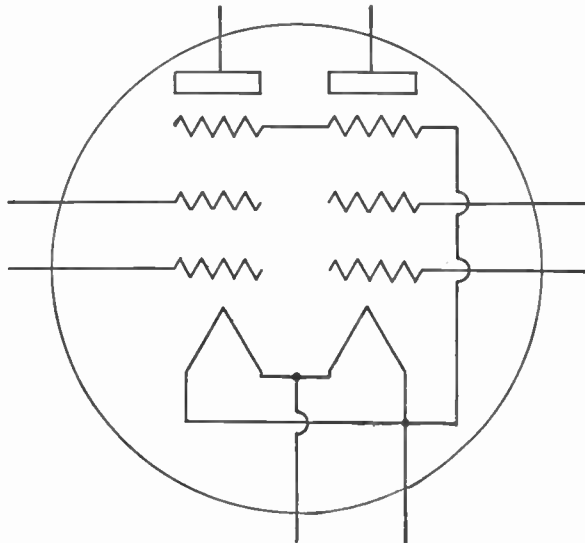

Figure 189. The 1E7-G tube (two pentodes).

The electron stream may be divided into three parts and thus make possible three distinct tubes in one envelope.

The 2A6 tube is an example, having two diodes and a triode.

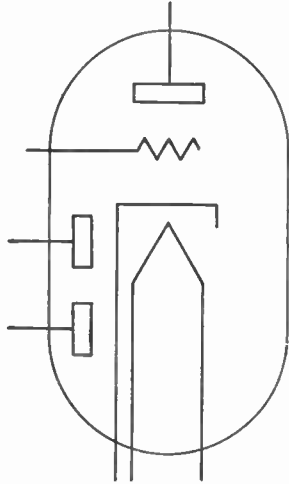

Figure 190. The 2A6 tube (two diodes—one triode).

Another such tube is the 2B7, which has two diodes and one pentode in the same envelope (Figure 191).

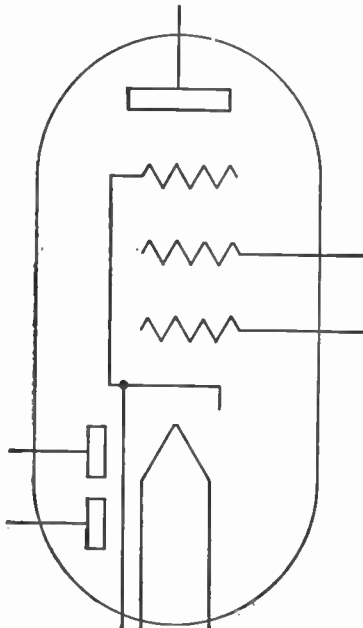
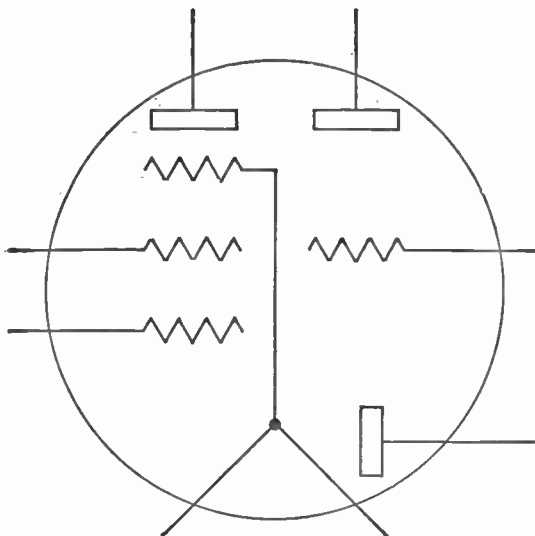

Figure 191. The 2B7 tube (two diodes—one pentode).

The 1D8-GT tube (Figure 192) contains a diode, a triode, and a pentode in one envelope.



**Figure 192. The 1D8-GT tube (one diode—one triode—one pentode).**

Of course, many other combinations can be designed, and will. But regardless of how complex they seem to be, the basic principle is a simple one. A heated cathode emits a stream of electrons which threads its way through intervening grids to a positively charged plate.

#### SUMMARY

1. The fundamental principle operating in all vacuum tubes is that electrons emitted by a filament or cathode find their way to a positively charged plate.
2. Tubes with only a filament and plate are diodes; tubes with filament, grid, and plate only are triodes.
3. Tubes having more than five elements, called multielectrode tubes, are made by adding additional grids with various charges and mesh design.
4. When two or more complete tubes are enclosed in one envelope, the tube is called a multiunit tube.
5. In multielectrode tubes only one stream of electrons passes, while in multiunit tubes there may be several different streams of electrons, each one on its way to its own plate.
6. Students of radio must learn the numbers and uses of important commercial tubes.



## GLOSSARY

- Amplification Factor ( $\mu$ ):** The ratio between a change in the grid voltage and a corresponding change in plate voltage needed to bring the plate current back to its original value.
- Beam Power Tube:** A pentode wherein the suppressor grid is often replaced by a slow-moving beam of electrons.
- Control Grid:** The grid of a tube upon which the signal voltage is impressed.
- Cross Modulation:** A condition in which a strong local signal comes in with sufficient strength to force the first radio-frequency tube to act as a detector, thus producing distortion.
- Electronic Coupling:** A method of coupling electrical energy from one circuit to another through the stream of electrons in a tube.
- Grid Swing:** The amount of grid voltage variation needed to operate the tube.
- Multielectrode Tube:** A tube with many electrodes, mainly grids, each of which acts on the single stream of electrons flowing from the cathode to the plate.
- Multiunit Tube:** A tube combining several independently acting tubes in one envelope. The electron stream divides into several parts, each part being acted upon by one set of electrodes.
- Pentagrid Converter:** A tube containing five grids in addition to the plate and cathode. This tube is used in the superheterodyne receiver to perform the functions of first detector, local oscillator and mixer tubes at one and the same time.
- Pentode:** A five-element tube containing a cathode, plate, control grid, screen grid, and suppressor grid.
- Power Tube:** A tube designed to handle more current than the ordinary amplifying tube. This tube is used in the last stage of the audio-frequency amplifier.
- Power sensitivity:** A measure of the extent to which small changes in grid voltage control large changes of power in the plate circuit of a tube.
- Push-pull:** A method of connecting two tubes to supply great power to a loudspeaker with little distortion.
- Screen Grid:** A grid of a tube placed between the control grid and the plate to reduce the space charge and plate-to-grid capacitance.
- Secondary Emission:** The cloud of electrons knocked out of the plate by the impact of the electron stream sent out by the cathode.
- Space Charge:** A cloud of electrons filling the space between the cathode and plate of a tube.
- Supercontrol Radio-frequency Amplifier Tube:** A variable- $\mu$  tube.
- Suppressor Grid:** A grid placed in a tube between the screen grid and the plate to reduce the effect of secondary emission.
- Tetrode:** A four-element tube containing a cathode, plate, control grid, and screen grid.

**Variable- $\mu$  Tube:** A tube with a specially wound grid producing a change in the amplification factor with signals of different strength.

## SYMBOLS

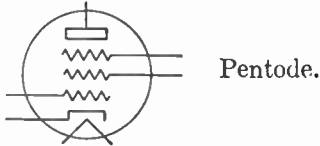
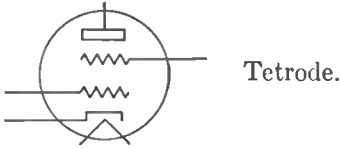

## QUESTIONS AND PROBLEMS

1. Thin-filament tubes are usually heated by what type of current?
2. Describe the structure of a diode.
3. For what may a diode be used?
4. What is meant by the amplification factor of a tube?
5. The introduction of what tube element made amplification by a tube possible?
6. Describe the structure of a triode.
7. What determines the  $\mu$  of a tube?
8. Why do triodes have relatively low amplification factors?
9. How does a power tube differ from other tubes?
10. What is generally true of the  $\mu$  of power triodes?
11. Why must we have an audio-frequency voltage amplifier between detector and power tube of a receiver?
12. Draw the diagram of two power tubes in parallel.
13. Explain the operation of a push-pull power stage.
14. Compare the qualities and characteristics of a power stage consisting of two tubes in parallel and of a push-pull power stage.
15. Describe the structure of a tetrode.
16. What effect does the introduction of a screen grid have on the tube's functioning?
17. Compare the values of grid-plate capacitance in a triode and a tetrode.
18. What gives the tetrode a higher  $\mu$  than a triode?
19. How does the use of a tetrode eliminate the need for neutralization in the radio-frequency amplifier stage?
20. What is cross modulation? How is it eliminated?
21. What is secondary emission of a tube? How is it overcome?
22. Draw a schematic diagram of a pentode.
23. What are the requirements of a good power amplifier tube?
24. Explain the operation of a beam power tube.

25. What are multielectrode tubes?
26. Explain the operation of a pentagrid converter as a first detector and oscillator.
27. How does a multiunit tube differ from a multielectrode tube?
28. What is the basic principle of all tubes regardless of complexity?

## Radio Direction Finders

---

- Problem 1:** *In what position relative to a radio wave does an aerial get maximum reception?*
- Problem 2:** *How does a loop aerial serve to determine the direction of a transmitting station?*
- Problem 3:** *How do airplane pilots guide their flight by radio signals?*
- 

For most of us, the radio receiver means entertainment and enjoyment at home. Radio networks crisscross our country and there is hardly a locality outside the range of at least one powerful transmitting station.

### **218.4 Importance of Direction Finders**

Under such conditions, the directional quality of the aerial, that is, the ability to receive better from one direction than from another, means little. The aerial is usually strung in the most convenient location to give it a position fairly high and reasonably clear of obstructions.

But ships at sea, airplanes in the sky, and armies in the field find it highly important to obtain accurate information about their location. It is here that the directional quality of the aerial serves a useful purpose.

### **219. Direction Finders Depend on Difference in Electrical Pressure**

Whenever a radio wave passes across an aerial, it sets up an electrical pressure that causes electrons to flow in the aerial-ground system.

Now an electrical pressure by itself will not cause electrons to flow. There must be a *difference* between electrical pressures at two points. The electrons flow from the point of *high pressure* to

the point of *low pressure*. If the pressure were *equal* throughout, there would be no flow of electrons, no matter how high this pressure might be.

During one half cycle, therefore, the radio wave places a negative charge (high electron pressure) on the top or antenna of the aerial-ground system and a positive charge (low pressure) on the bottom or ground of the system. The electrons then flow *down* the aerial-ground system from the high-pressure point to the low-pressure point (Figure 193-A).

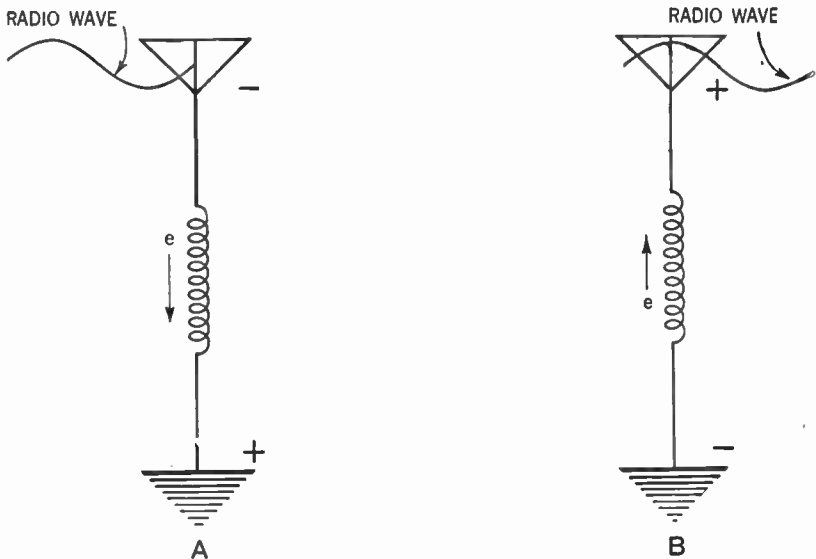

**Figure 193.** A—Charges placed on the aerial-ground system and flow of electrons as one half cycle of the radio wave passes the aerial.  
B—Charges and flow of electrons as the next half cycle of the radio wave passes the aerial.

On the next half cycle, the charges or pressures are reversed and the electrons stream *up* the aerial-ground system. (Figure 193-B.)

## 220. Reception from a Single-wire Aerial

We are now ready to learn why our simple, straight-wire aerial described in Chapter 5 can receive better from one direction than from another. Consider Figure 194-A.

All parts of the aerial are at the same distance away from the

transmitting station. The radio wave therefore strikes all parts simultaneously. Thus the electrical pressure in all parts of the aerial is the same and there is little or no flow of electrons.

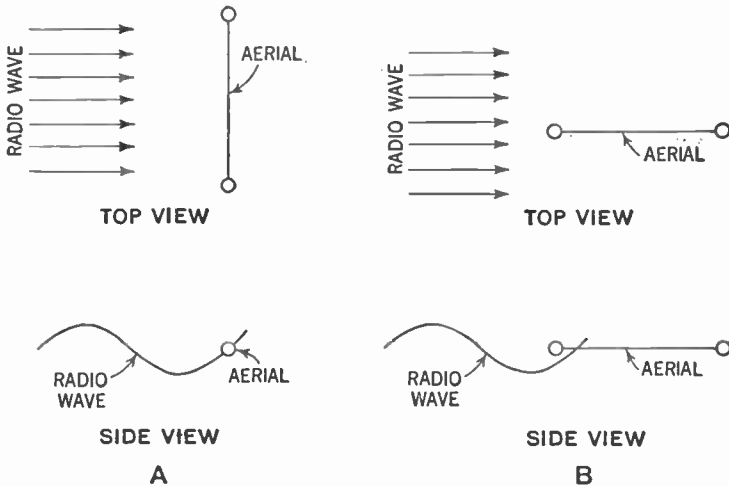

**Figure 194.** A—Diagram showing aerial broadside to the radio wave. Note that all parts of the aerial are struck simultaneously.  
 B—Diagram showing aerial pointing toward the oncoming radio wave. Note that one end of the aerial is struck first.

In Figure 194-B, however, the front of the aerial is nearer the transmitter than is the rear. The radio wave therefore strikes

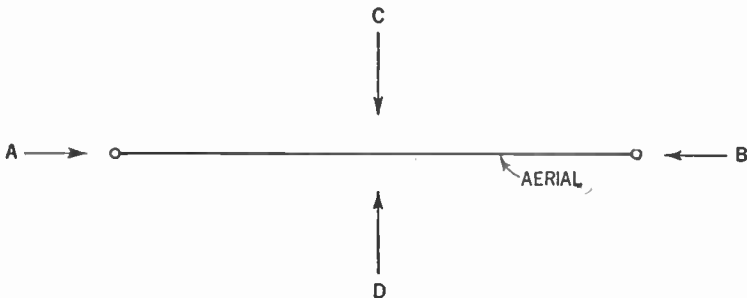

**Figure 195.** Diagram showing why signals from directions A and B will be heard louder than signals from directions C and D. The radio waves coming from A and B set up a difference of electrical pressures in the aerial.

this front part first and at that instant there is a difference of electrical pressure between the front and rear of the aerial and a flow of electrons results.

From the above, we can see that we will get louder reception if the aerial of the receiver points into the radio wave coming from the transmitter.

If you desire to get maximum reception from a certain station, you should erect your aerial so that it points toward that station. If you wish to discover the direction of a transmitting station, all you need do is to swing your aerial around to the position where the signal comes in loudest. The aerial will then be in the line of direction of the transmitter.

If you examine Figure 195 you will notice that maximum reception will come from either of the opposite directions A and B. It is for this reason that you will be unable to find the direction of the station, but merely the line along which it lies. In other words, you can not tell whether it is at A or B, but merely that it lies along a line from A to B.

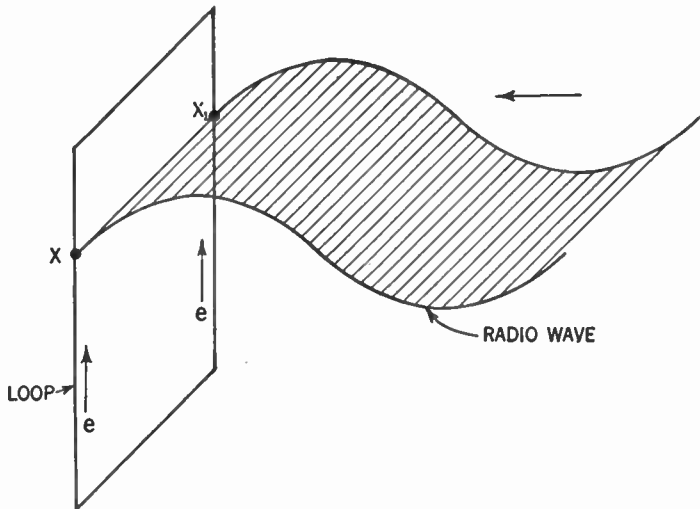

**Figure 196. Loop with flat side facing the oncoming radio wave. Since the flows of electrons in the two vertical ports are equal in strength and opposite in direction, they cancel each other out.**

### 221. The Small Loop Aerial

Of course, swinging a 100-foot aerial is not a convenient thing to do, especially aboard an airplane. A simpler method must be devised.

The extreme sensitivity of the superheterodyne receiver is utilized for this purpose. You will recall that a small loop antenna

is sufficient to operate this set. Since it is easy to rotate this small loop, our problem is solved.

Imagine a loop of wire in space, so placed that the flat side of the loop faces the oncoming radio wave (Figure 196).

The horizontal arms of the loop act like our straight-line aerial in its least efficient position and little or no flow of electrons occurs in them because there is little or no difference in electrical pressure between points in them. In the vertical arms, however, there is a flow of electrons because the wave strikes different points on these arms at different times and thus creates a difference of pressure.

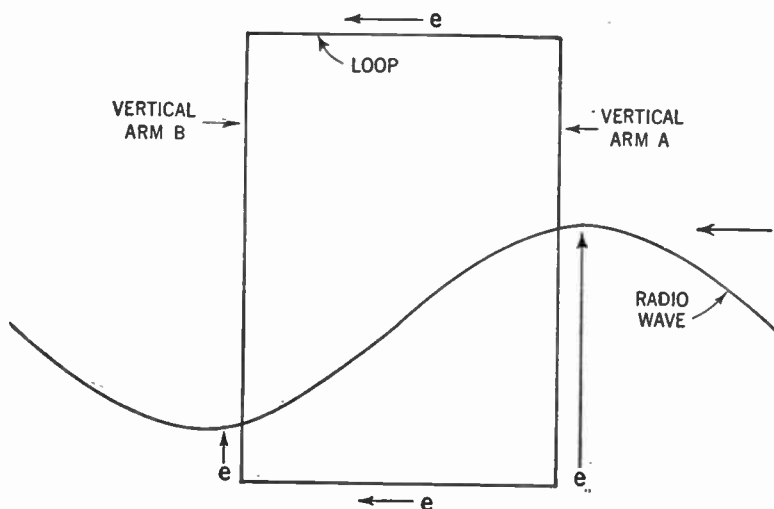

**Figure 197.** Loop with edge facing the oncoming radio wave. Since the horizontal arms are struck simultaneously, the electron streams set flowing in them cancel each other out. But a greater electrical pressure exists in vertical arm A than in vertical arm B. Electrons will therefore circulate through the loop from arm A to arm B.

But corresponding points on each vertical arm are struck simultaneously and therefore the electrons are set flowing in these arms in the same direction at the same time (*up* in Figure 196) and with equal pressure. Since the electron streams in each of the vertical arms are equal and flow toward each other, these streams cancel themselves out, hence we have no electron flow into the receiver, and therefore nothing can be heard.

Now rotate the loop 90 degrees, so that the edge of the loop faces the oncoming radio wave (Figure 197).



Since the radio wave passes corresponding points on the horizontal arms at the same time (the points nearest the transmitter), the electron streams set flowing in these arms are equal and opposite to each other. They therefore cancel out.

But vertical arm A is nearer to the transmitter than is vertical arm B. The electrical pressure in arm A is therefore greater than that in arm B, and although the electron streams are in opposite direction, the greater pressure in arm A overcomes that in arm B and electrons are set flowing through the loop in a counterclockwise direction. If we now connect a receiver to the loop, these electrons will stream into it and we will be able to hear the signal.

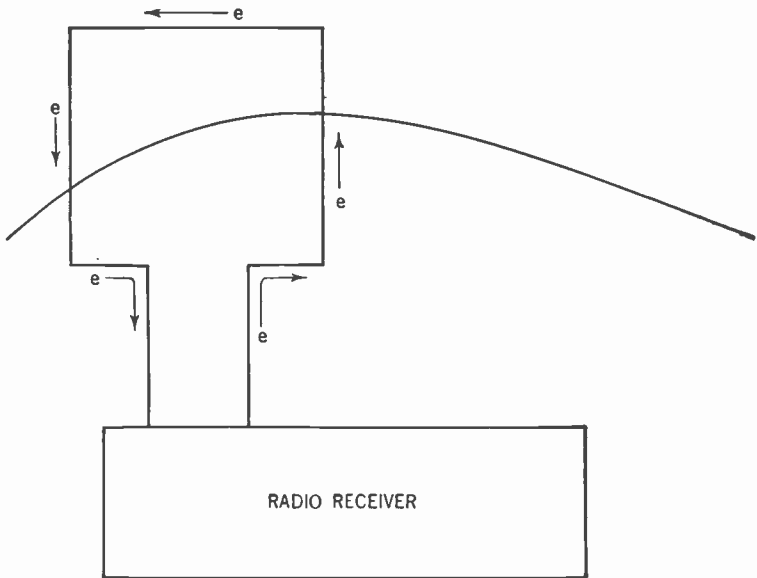

Figure 198. The flow of electrons in the loop is sent into the radio receiver and the signal is heard.

All we need do, therefore, is to rotate the loop antenna until the signal is heard at its *loudest* and the edges of the loop will be along the line of direction of the transmitting station.

## 222. Direction Is Best Determined from the Weakest Signal

In practice we reverse this procedure. We turn the loop until its flat side faces the oncoming radio wave. We then hear the signal at its *weakest*; there is little or no sound. The reason for doing this is that it is easier to distinguish between a weak signal

and no signal than it is to distinguish between the loudest signal and that which is nearly as loud. Hence weak signals help us to determine more accurately than do strong signals when we have located the direction of the transmitter. The position of the loop that gives us the weakest or zero signal is called the *null position*.

The loop antenna is tuned to the frequency of the radio wave by means of a variable condenser, just like the tuning circuit of the receiver. Since it is essential that an exact balance be established in the arms of the loop before this balance is upset by the incoming signal, a balancing variable condenser is connected across the loop. The action of this balancing condenser is similar to that of the trimmer condensers used in aligning the receiving set. After the loop is tuned and balanced it is connected across the input of the first radio-frequency amplifier tube and the signal is amplified just as in the case of an ordinary receiver (see Figure 199).

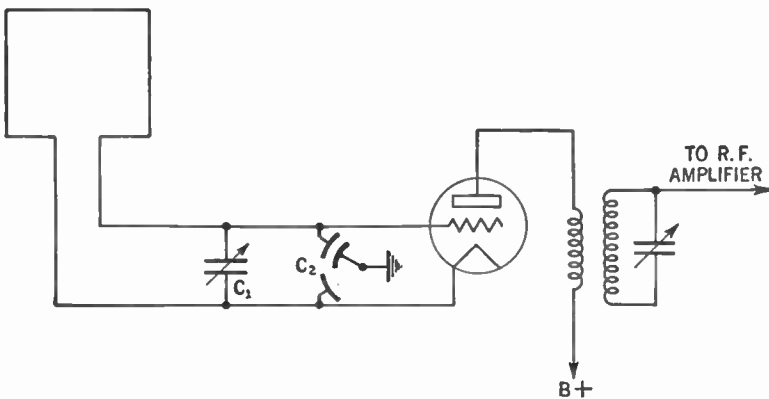

Figure 199. Diagram showing how the loop is coupled to the radio receiver. Variable condenser  $C_1$  tunes the loop to the incoming signal.  $C_2$  is a balancing condenser.

### 223. What Is "Sense of Direction"?

But so far we have covered only half the story. By rotating the loop antenna we can determine the line of direction along which the transmitter is located. We can tell that it is located on a line running, for example, from east to west. But we can not tell whether it is east or west of us. We say that we have the *line of direction*, but not the *sense of direction*.

Of course, this distinction does not matter when a receiver on the shore is locating a transmitter on a ship at sea. But two ships at sea or two airplanes in the sky cannot tell on which side of them

the transmitter is located. Further, they have no indication as to how far from them the transmitter may be.

#### 224. Locating the Position of a Ship by Radio

These difficulties may be overcome in a number of ways. Assume that a ship at sea wishes to find its exact location. It sends out a radio signal which is received simultaneously by two receiving stations located on the shore. Each of these stations determines the line of direction from it to the ship. This line is marked on a map. By telephone, one of the stations informs the other of its findings. It then becomes a simple operation for the operator at the second station to draw both lines of direction on a map. Where the two lines cross, there is the location of the ship. This location is then radioed to the waiting ship.

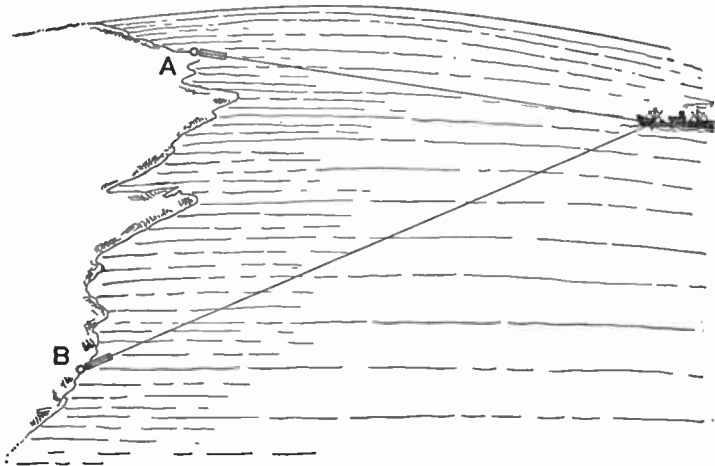

Figure 200. Diagram showing how two receiving stations on land combine to find the location of a ship at sea.

Another method is the reverse of this procedure. Along the shore there are located, at certain designated points, transmitting stations which automatically and continuously send out radio waves. To identify these stations, each one sends out a different signal. Thus one may continuously send out three dots. Another may send out two dots.

A ship at sea, wishing to know its location, finds the line of direction between it and one of the automatic sending stations. This is called *taking a bearing*. Knowing the location of the trans-

mitter, the navigator plots this line of direction on a map. He then takes a bearing on another such station and plots its line of direction on the same map. Where these two lines cross is the location of the ship.

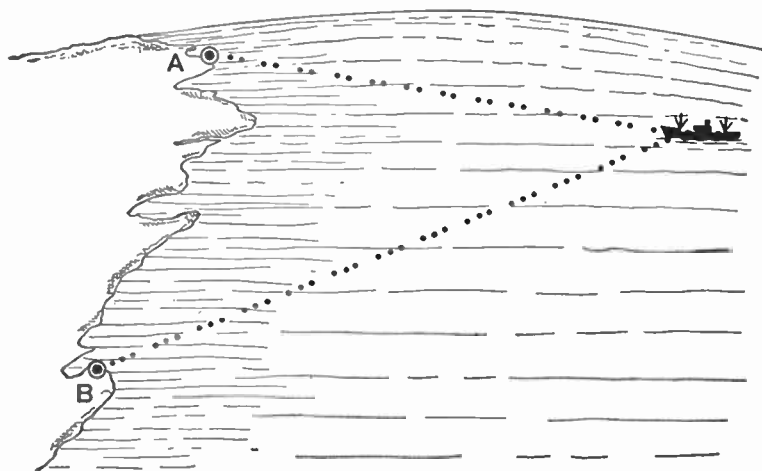

Figure 201. Diagram showing how a ship at sea can obtain its location from two automatic transmitting stations located on land.

### 225. The Problem of a Pilot in a Bomber

Note that the above methods require two stations whose positions are fixed and whose locations are known. But a Navy bomber, seeking its way back to its aircraft carrier, can get its bearing from only one station, the carrier. Further, this station is not fixed; it moves as the carrier twists and turns to avoid the enemy. A new method of direction-finding had to be developed to meet these conditions. This new method had to give not only the line of direction but the sense of direction as well, so that the airplane could fly directly to the mother ship. And direction had to be found quickly and without any need for plotting lines upon a map. Let us see how this new method was developed.

### 226. Method of Finding Direction in a Plane by Radio

Assume that you have erected a single vertical wire as an antenna, with the bottom end connected to a radio receiver. Further assume that this vertical antenna is surrounded by a circle of transmitters, each of equal power and located an equal distance from the antenna. Signals then will be received from all direc-

tions with equal strength. We say that a vertical antenna is *non-directional*.

We can show this nondirectional quality of a vertical antenna graphically by drawing a circle about the antenna as a center, as in Figure 202.

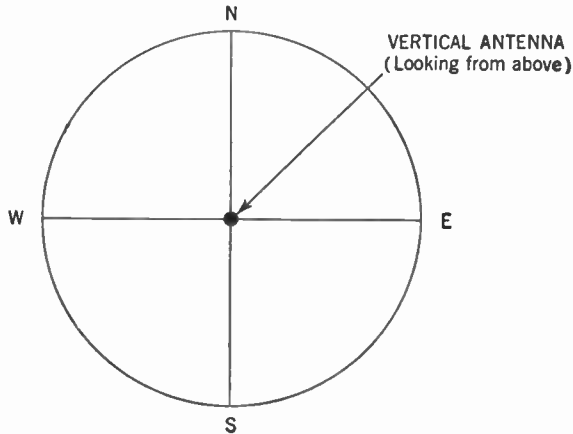

Figure 202. The pattern of the directional characteristics of a vertical antenna.

The lines running from the center to the circumference of the circle indicate the relative ability to receive signals from these directions to which they point. The nondirectional quality of the

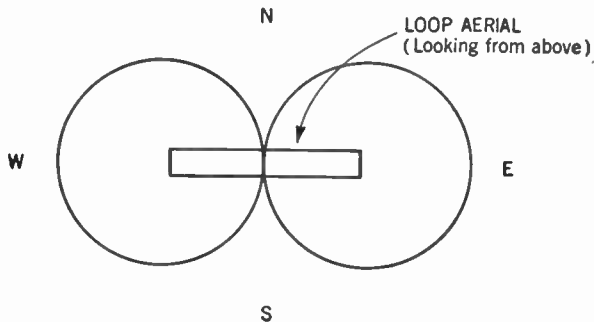

Figure 203. The pattern of the directional characteristics of a loop aerial.

vertical antennas can be seen from the fact that all these lines are of equal length.

We call the circle the *pattern* of the directional characteristics of the vertical antenna.

Now let us put a loop aerial in place of the vertical antenna.

Stations perpendicular to the face of the loop (N and S in Figure 203), will not be heard, while stations facing the edges of the loop (E and W in our diagram) will come in strongest. The pattern of the directional characteristics of the loop antenna becomes a figure 8 as shown in Figure 203.

Here is another way of looking at it. Since we have seen that the radio wave has little or no effect on the horizontal arms of the loop, we may consider the loop aerial to be two vertical antennas a little distance apart. The pattern about each such vertical antenna is a circle and the two circles combine to give us a figure 8.

From the pattern of the loop aerial we can now see the advantage of taking a null bearing upon the transmitting station. Assume that the edge of the loop has been pointed at the transmitting station (Figure 204-A).

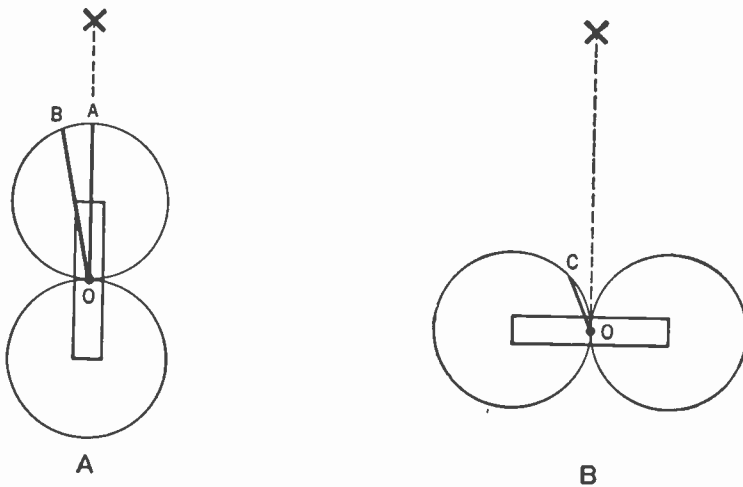

Figure 204. Diagram showing why it is better to take a null bearing rather than to turn the loop to maximum signal strength.

The line OA in the direction of X represents the strength of the signal received. If an error of, say, five degrees is made, the line OB would indicate the strength of signal. You can see that OA and OB differ little in length and why it is hard to discern the error.

But assume you have turned the face of the loop towards X. If this face is exactly perpendicular to the radio wave coming from X, no signal will be received. But an error of 5 degrees

will give us line OC, which will bring the signal in loud enough for us to discern the deviation (Figure 204-B).

So we have our loop aerial with its figure 8 pattern. Now, through the center of the loop erect a vertical antenna. The combined pattern of the two aerials will then appear as shown in Figure 205.

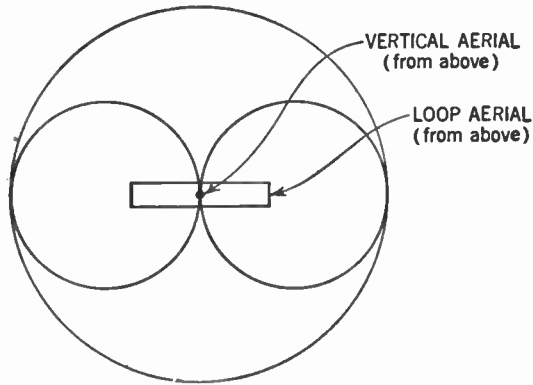

**Figure 205. Combined pattern of the directional characteristics of the loop and vertical aerials.**

Now, by means of a transformer arrangement, the electrons set flowing in the vertical aerial start a second stream of electrons flowing in one of the vertical arms of the loop. This flow unbal-

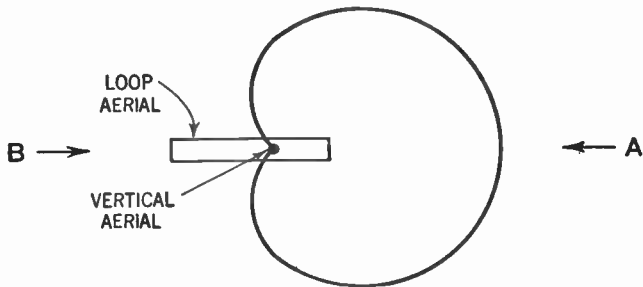

**Figure 206. Combined pattern of the directional characteristics of the loop and vertical aerials when the current flowing in the vertical aerial is inductively coupled to one of the vertical arms of the loop aerial. The pattern is cardioid or heart-shaped.**

ances the pattern of the loop and the new pattern is shown in Figure 206.

You will notice that our new aerial can receive better from one direction, A, than from the other. We can now obtain the sense

of direction, that is, we can tell from which side the signal is coming.

The vertical antenna is called the *sense aerial*. To operate our direction finder, we open the switch and take a null bearing with the loop to determine the line of direction. Then we close the

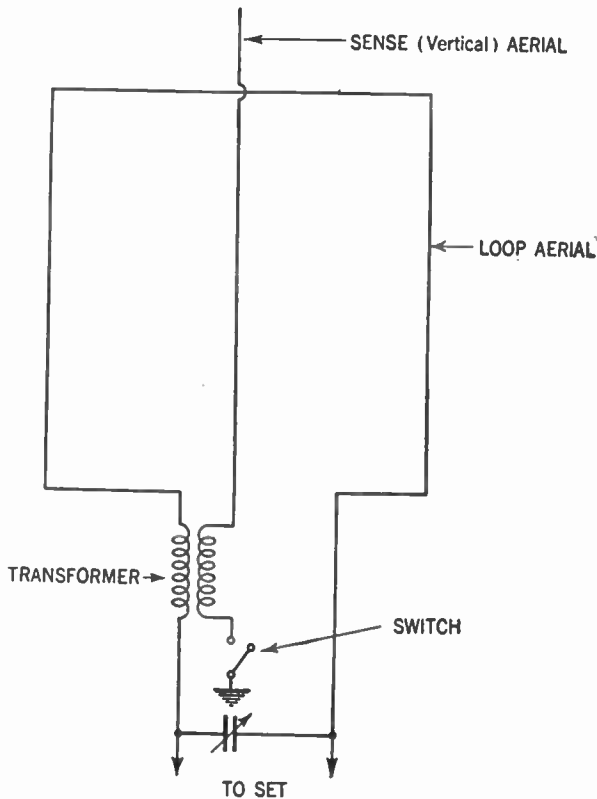

Figure 207. Circuit showing how the sense (vertical) aerial is coupled to the loop aerial.

switch, connecting the sense aerial into the circuit. We now turn the loop until the signal comes in at its loudest. A pointer, connected to the loop, indicates the direction from which the signal is coming (Figure 207).

### 227. A Bombing Plane Returning to a Carrier

If the airplane navigator wishes to reach his carrier, he first finds the direction of the boat. He then fixes his loop aerial so that it is at right angles to the axis of the airplane and then the



plane is turned until the loop is in the null position with respect to the radio wave from the carrier. As long as the plane is flying along the radio wave the loop remains in the null position and he will hear no signal. The electron stream in one vertical arm of the loop balances out the stream of the other.

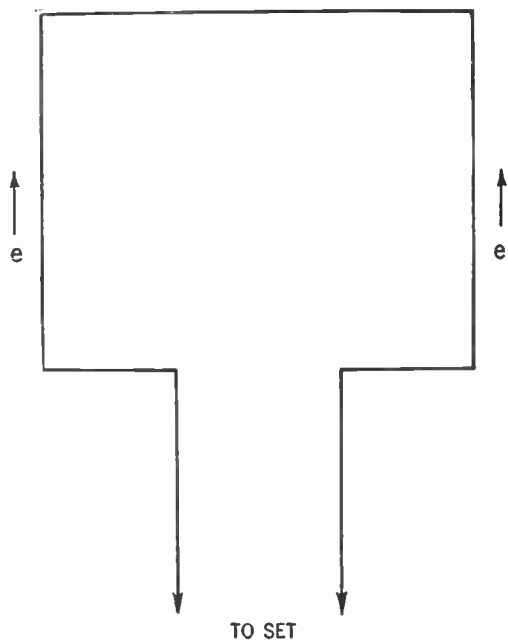

**Figure 208.** Diagram showing how the electron streams in the vertical arms of the loop aerial cancel out each other when the navigator turns the face of the loop toward the oncoming radio wave. There is no flow of current into the radio set.

Should the plane deviate from its course toward one direction, the balance is upset and the electrons stream through the loop in, say, a clockwise direction. Should he deviate in the other direction, the balance is upset again and the electrons stream in a counterclockwise direction.

### 228. The Radio Compass

If an electric meter is connected to the airplane's loop aerial, it shows no current flowing through it when the plane is on the course. The needle then rests in the center of the meter. When the flight deviates to the right, the electrons flow through the

meter in one direction and the needle swings to the right. When it deviates to the left, the needle swings to the left.

This hookup is called a *radio compass* or *homing device*.

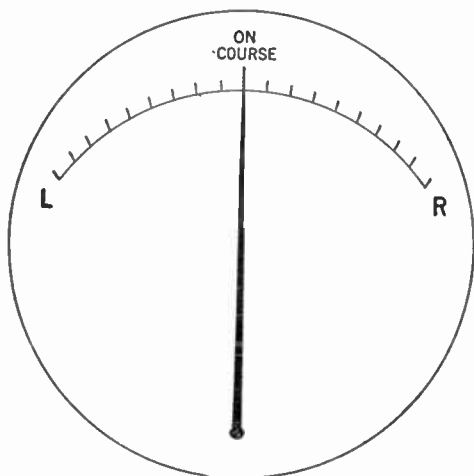

Figure 209. Dial of the radio compass. As long as the face of the loop aerial is towards the oncoming radio wave no current flows and the needle is at the zero or "on course" position in the middle of the dial. As the airplane turns to the right or left, current is set flowing and the needle swings to the right or left, indicating the deviation from the course.

## 229. Corrections for Errors

There are a number of sources of error in the direction finder. One of these is unbalance in the loop circuit. This error is eliminated through the use of the balancing condenser described above and by calibrating the loop to compensate for deviations.

Another source of error is the presence of stray electric fields set up by atmospheric disturbances. This source may be eliminated by shielding the loop with a nonmagnetic metal similar to the shielding of the radio-frequency transformers.

Large metallic objects, wires, and other conductors near the loop may cause trouble. The obvious remedy is to place the loop where it cannot be affected by these materials.

Ignition wires in an airplane set up magnetic fields which might interfere with the operation of the direction finder. The remedy is to enclose these wires in iron pipes, which absorb the magnetic field.

Still another source of trouble is called *night error*. In all our discussions we considered radio waves as though they traveled

parallel to the surface of the earth. This view is not strictly true.

### 230. The Sky Wave and the Heaviside Layer

In addition to sending out a radio wave that travels parallel to the earth, the radio transmitter sends out a wave that goes up into the sky. It might be thought that this *sky wave* travels out into space; but it does not do so. Why? The theory is that high up above the earth is a layer of electrified particles of air which acts like a mirror to reflect the sky wave back to the earth (Chap. 35, Vol. II).

This layer of electrified particles is called the *Heaviside-Kennelly layer* and shifts from a height of about sixty miles in the daytime to about two hundred miles above the surface of the earth at night. It is believed that the particles of air are electrified by the ultraviolet rays of the sun and by the cosmic rays from the stars.

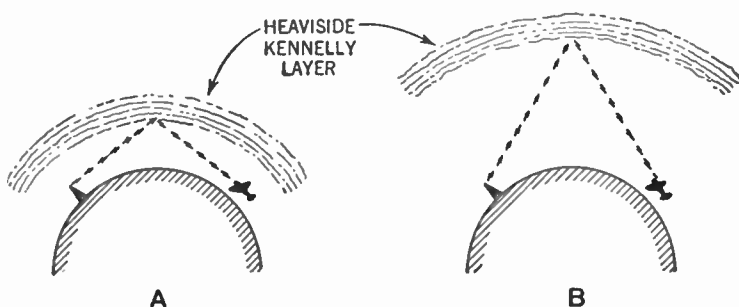

**Figure 210.** A—During the daytime the Heaviside-Kennelly layer is comparatively close to the surface of the earth. The reflected radio wave is traveling nearly parallel to the surface of the earth when it strikes the loop aerial of the airplane.  
 B—At night the layer lifts. Now the radio wave is almost perpendicular to the surface of the earth as it strikes the loop aerial of the airplane.

Because of the comparatively low altitude of this layer in the daytime the radio wave is reflected back to the earth at such an angle that it is very nearly parallel to the earth when it strikes our loop aerial and the error is therefore quite small. (Figure 210-A.)

But at night the Heaviside-Kennelly layer rises. The reflecting radio wave comes back to earth almost vertically. (Figure 210-B.) This change in direction upsets the balance in the horizontal arms

of the loop because the radio wave now hits the top arm before it strikes the lower, thus setting up a difference in electrical pressure which causes electrons to flow around the loop.

This error is overcome by use of the *Adcock loop aerial*. This is a small aerial in the form of a letter H as shown in Figure 211.

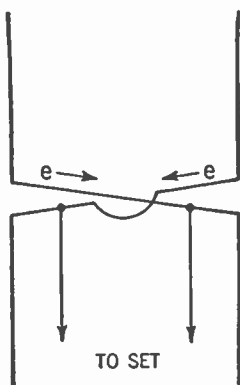

Figure 211. The Adcock loop aerial.

Since the two horizontal arms are very close to each other, the vertically approaching radio wave strikes them both almost simultaneously. Thus the electrical pressures in both these arms are very nearly equal and the electron streams are balanced out. When the vertical radio wave is eliminated the loop direction finder responds to the horizontal wave and functions as usual.

### 231. The A-N Radio Beacon

Airplanes flying over the networks of our commercial airlines make use of the radio beacon to keep them true to their course. Here is how it works.

At regular intervals along the course, usually about 125 miles apart, radio beacons are located. Each of these beacons is a radio station that sends out a narrow radio beam of signals. This radio beam really consists of two beams a degree or two apart. To set up this pair of radio beams two transmitting aeriels are employed. First one aerial sends out a radio wave that consists of a dot and a dash (the letter A in the International Code) and then the other aerial sends out a dash and a dot (the letter N). These aeriels are set up to send out their signals automatically and alternately.

Thus the pilot of an airplane flying in the A zone (Figure 212), would continually receive the letter A in his receiver and the letter N if he were in the N zone. But in the space between the two zones he would receive the A and the N equally well.

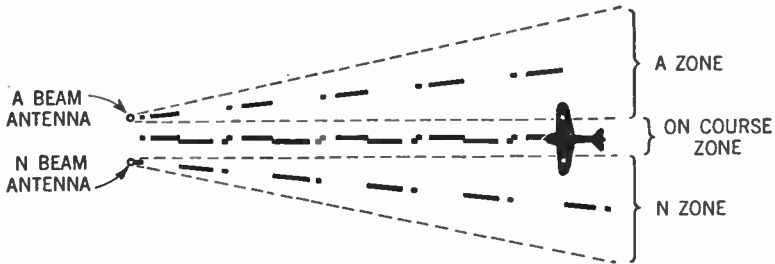

**Figure 212.** Diagram showing how the A beam and N beam overlap at the center to provide a zone where the airplane navigator hears neither A (. —) nor N (— .), but a continuous buzz.

Examination of Figure 212 shows that the pauses between the dots and dashes of the A signals are filled by the dots and dashes of the N signals. Thus, in the overlapping zone the airplane pilot will receive not dots and dashes, but a continuous buzz. This will show him that he is "on the beam," that is, on the course between the two zones.

Should he deviate from his course, he will enter either the A or N zone. He will then hear either the letter A or N. All he need do then is to turn about till he hears the continuous buzz again and he will be on the course once more.

To prevent interference, each radio beacon has its own frequency, lying between 200 kc. and 400 kc. Thus, when the pilot passes one such beacon, all he need do is tune his receiver to the frequency of the next beacon and continue on his course.

#### SUMMARY

1. A single-wire aerial receives incoming radio waves best when it is in line with the direction of the station.
2. The aerial determines the line of direction because of difference in electrical pressure at the ends of the aerial when pointed toward a broadcasting station.
3. The loop aerial, in conjunction with the superheterodyne receiver may be used to determine direction better than a single long aerial.
4. In a loop aerial set with the flat side facing the line of the radio wave, reception is weakest. When the face is at right angles to the direction of the radio wave, reception is best.

5. The null position of a loop aerial is the position when the flat side faces the direction of the radio beam.

6. **Sense of direction** means, in addition to the sense of line of direction, knowledge of the actual point of the compass from which the radio wave comes.

7. Airplane pilots use a radio compass to find their location or the location of their carrier.

8. In cross-country flying radio beacons are used to guide pilots from one station to another.

GLOSSARY

**Directional:** As applied to an aerial, the ability to receive signals better from some directions than from others.

**Line of Direction:** The line showing the directions from which signals are received at their best.

**Night Error:** Error in direction determination due to movements of the Heaviside-Kennelly layer, especially at night.

**Nondirectional:** As applied to an aerial, the ability to receive signals equally well from all directions.

**Null Position:** The position of a loop aerial for minimum signal pickup.

**Pattern:** As pertaining to an aerial, the geometric figure used to show the directional qualities of an aerial. Important patterns include the circle, the figure 8, the figure 8 and circle, and the cardioid or heart-shape.

**Radio Compass or Homing Device:** A hookup and meter that indicates automatically and instantly when a plane or ship is off the line of direction.

**Sense Aerial:** A small vertical aerial used in conjunction with a loop aerial to give the operator a sense of direction.

**Sense of Direction:** The direction, along the line of direction, from which a signal comes to the aerial of the receiver.

**Sky Wave:** The portion of the radio wave which is directed up to the sky. It is this sky wave that is reflected back by the Heaviside-Kennelly layer and causes the night error.

SYMBOLS

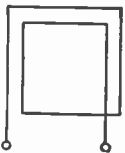

Loop aerial.

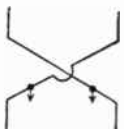

Adcock aerial.

## QUESTIONS AND PROBLEMS

1. When will electrons flow in a circuit?
- 2. With the simple horizontal aerial, when do we get louder reception from any particular station?
3. Explain the radio-wave pickup of a loop in various positions.
- 4. Why do we tune with a loop for the weakest signal?
5. Of what circuit is the loop a part?
6. When tuned to a station and adjusted to the null point, what does the loop tell us about the station position?
7. How does a ship obtain its position from shore stations?
8. Why cannot an airplane locate an aircraft carrier at sea in the same manner as ships taking bearings from land stations?
9. Differentiate between "line of direction" and "sense of direction."
- 10. What is the reception characteristic of a vertical antenna?
11. Draw the pattern of the directional characteristics of a vertical antenna.
- 12. Draw the pattern of the directional characteristics of a loop antenna.
13. Draw the pattern of the directional characteristics of a combination of loop and vertical antenna.
- 14. How do we take a bearing with a combination loop and vertical antenna?
15. What is a radio compass or homing device?
16. List several sources of error in direction finding and their remedies.
17. What is night error and what is one means of overcoming it?
- 18. Explain the operation of the A-N radio beacon.

# Volume II



# Introduction to Volume II

## TO THE STUDENT

We have completed the first part of our book. It is hoped that you have been able to obtain an understanding of the radio receiver.

But above and beyond this, the authors hope that you now have a realization of how much you do *not* know about radio and a desire to go on to obtain more knowledge on this subject so vital to our twentieth-century civilization. If we have succeeded in stirring up this desire within you, good!

You will have noticed that we have studiously avoided the use of mathematical formulas. The reason for this is twofold. First of all, we believe that mathematics, for the beginner in radio, merely tends to confuse that which is fairly clear and simple. Too often the student will be sidetracked from the radio principle involved while wrestling with some complex mathematical formula.

Secondly, we have found that a mathematical formula often may be substituted for the understanding of the basic principles. The temptation is great to present or accept the formula in lieu of a clear explanation. We who write textbooks sometimes forget that what is perfectly clear to us may not be so to the beginner.

Not that we deny the value of mathematics. But mathematics is a tool to be used when the underlying principles are pretty well understood, when measurement is needed, or when a student proposes to enter the technical radio field as a profession.

You will find, therefore, in the second part of this book, frequent use of this tool. Where it is used, the mathematics involved consists of simple algebra, with a few principles of trigonometry. Where we need mathematical explanations, we will try to explain fully and to present as far as possible all mathematical steps.

In the second part of this book we will try to explain further the nature of electricity and the radio wave. On this higher plane,

we will meet our old friends *capacitance*, *inductance*, and *resonance*. We will explore more fully the operation of the aerial and the characteristics of vacuum tubes. We shall try to learn something about the radio telegraph and telephone transmitter. And, finally, we shall investigate the cathode-ray tube, a device that holds out to us a promise of wonderful things to come.

2 5 1 5  
3 3

## CHAPTER 29

# Direct Current and the Nature of Electricity

---

- Problem 1:** *What is the modern explanation of the electric current?*
- Problem 2:** *What is Ohm's Law and how is it used to measure the properties of an electric current?*
- Problem 3:** *What are the principles of joining resistors and of measuring their combined resistance?*
- Problem 4:** *How are electric currents produced by chemical action?*
- 

### 232. Origin of the Word "Electricity"

Man discovered electricity many centuries ago. The ancient Greeks knew that when a piece of amber was rubbed on some fur or cloth it acquired the property of attracting to it small pieces of paper, dust particles, and other light substances. Indeed, it is from the Greek word *elektron*, meaning amber, that we obtain the word electricity.

### 233. Rubbing Glass with Silk

In 1600 A.D., William Gilbert, an English scientist, discovered that many other substances, when rubbed together, possessed the same mysterious property of attracting light pieces of paper and dust particles. These substances, after being rubbed together, are said to be *electrified*, or to have been given a charge of electricity.

Let us experiment a bit. Rub a small glass rod with a piece of silk cloth. Suspend the rod from a silk thread so that it may swing freely. Now rub another such glass rod with another piece of silk. Suspend this rod too. Bring the two suspended rods near each other. They will repel one another.

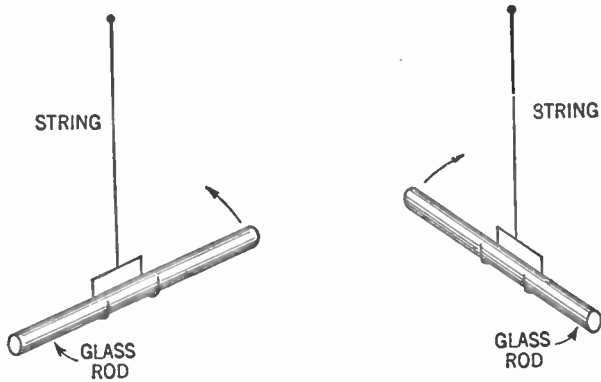

Figure 213. How two glass rods that have been rubbed with a silk cloth repel each other.

### 234. Two Kinds of Charges

Now rub a hard rubber rod on a piece of flannel, suspend it and bring it near one of the glass rods. The hard rubber rod and the glass rod will attract each other.

Benjamin Franklin explained this phenomenon as follows: When the glass rod was rubbed by the silk, said Franklin, it received an electric charge which he designated as *positive*. When the hard rubber rod was rubbed by the flannel, it received a *negative* charge. Experiments showed that *like charges repel and unlike charges attract*. That is why the positively charged glass rod repelled the positively charged glass rod, but attracted the negatively charged rubber rod.

### 235. The Electroscope

So far we have dealt with stationary or *static* electricity. The electric charge put upon the glass or rubber rods remained where placed; that is to say, it was *static*, it *stayed*.

William Gilbert also invented the device known as the *electroscope*. This instrument consists of a metal rod mounted upright in a block of sulphur, rubber, or similar nonmetallic material. At the bottom of the metal rod are attached two strips of gold leaf (Figure 214). The metal rod and its mounting are placed in a glass bottle with the upper end of the rod protruding.

Now rub the glass rod on the silk. Touch the charged glass rod to the metal rod of the electroscope. The two strips of gold leaf move apart, and when the glass rod is removed from contact

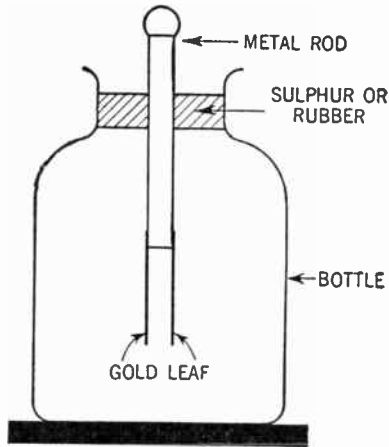

Figure 214. The gold-leaf electroscope.

with the metal the gold leaves stay apart. When the metal rod is touched with your finger or a wire the leaves fall together again. Moreover, if the experiment is repeated, but this time using a

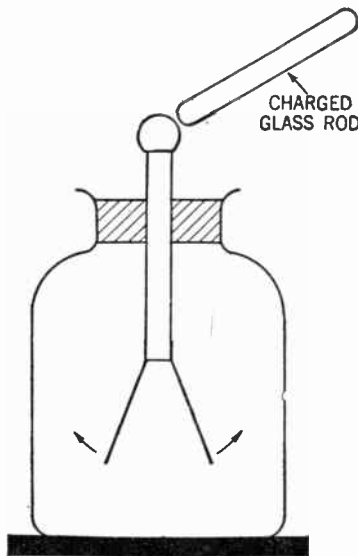

Figure 215. The effect of a charged rod on the gold-leaf electroscope.

charged rubber rod, the behavior of the gold leaves is the same as with the charged glass rod.

The explanation of these happenings as made by Franklin was the following: The electric charges brought to the metal rod

## 308 DIRECT CURRENT AND THE NATURE OF ELECTRICITY

flowed down this rod to the gold leaf. Since both pieces of gold leaf had similar charges, they repelled each other and swung apart. When the finger was touched to the metal rod, the charges on the electroscope flowed up the rod, into the finger, and out of the instrument. The leaves, chargeless, fell together because of their weight.

### 236. Conductors and Insulators

Some new terms now have to be learned. First of all, we have discovered that certain substances permit an electric charge to flow through them. We call such substances *conductors*. Metals are the most common examples of such conductors.

There are other substances, such as glass, hard rubber, and sulphur, that do not permit an electric charge to flow through them. An electric charge, placed upon any of their surfaces, stays put. We call such substances *insulators* or *nonconductors*.

### 237. An Electric Current

The concepts (ideas) of stationary charges and moving charges also have been given names. We call the stationary electric charge *static electricity*, while electricity in motion is called *current electricity* or an *electric current*.

### 238. Electricity First Thought to Be a Fluid

Early scientists observed that if a negatively charged body was connected to a positively charged body by means of a metallic wire, an electric current flowed through the wire. They made an attempt at explaining this phenomenon by declaring that electricity was a sort of fluid such as water. To them, positive electricity was one type of such fluid and negative electricity another type. When they had access to a wire, both fluids flowed through it like water through a pipe.

Benjamin Franklin suggested that there was only one fluid which flowed from the positive (+) to the negative (-). Although both the two-fluid and the one-fluid concepts have been proved wrong, electricians of today continue to speak of an electric current as flowing from positive to negative.

## THE ELECTRON THEORY

### 239. Molecules

Modern scientists have a different concept of the phenomenon of electricity. To understand this idea you must think about small particles. Suppose you take a glass of water. Pour off half of it. Divide it again. Assume you have continued this process of division until you are down to the very last particle. This particle is still water and has all the properties of the glassful you started with. The smallest particle of a compound which has all the properties of the compound is called a *molecule*.

### 240. Atoms

Close examination shows that this molecule of water consists of a number of smaller particles. It has been found that the molecule of water can be decomposed by the electric current and that each molecule consists of two particles of the gas *hydrogen* and one particle of the gas *oxygen*. Chemists call a substance that can be decomposed into two or more simple substances a *compound*; water is such a compound. A substance which cannot be decomposed into more simple substances is called an *element*; oxygen and hydrogen are elements. The smallest particle of an element is called an *atom*.

Atoms are the building blocks of all matter. The atoms of any one element are alike, but they differ from the atoms of other elements. There are ninety-two known elements and the atoms of each element are of a distinct and different kind. Just as bricks may be combined to form a great many different types of buildings, so these relatively few types of atoms, when combined in different arrangements, constitute the multitude of different substances known to man.

### 241. Electrons and Protons

For a great many years the atom was considered to be the very smallest particle of matter. But recent investigation has shown us that every atom consists of still smaller particles. This knowledge leads to the *electron theory*.

According to this theory, all atoms (and therefore all matter)

## 310 DIRECT CURRENT AND THE NATURE OF ELECTRICITY

are composed of two principal types of particles. One is a particle with a *positive electrical charge*, called a *proton*, and the other is a particle with a *negative electrical charge*, called an *electron*. The atom is pictured as having a *nucleus* (that is, a core or central part) consisting of a number of protons and other type particles packed together. Revolving around this nucleus are the electrons.

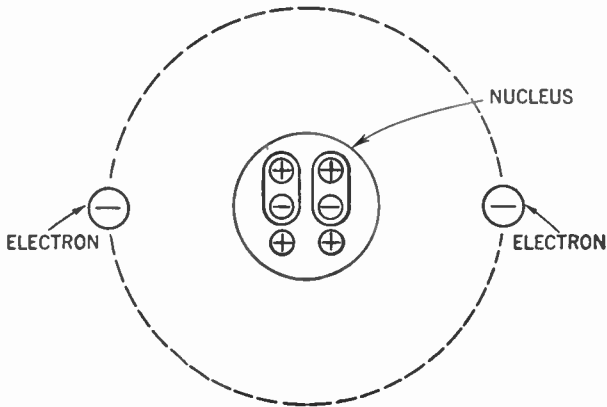

**Figure 216.** Imaginary drawing of an atom of the element helium, showing two electrons revolving around the nucleus. The nucleus is pictured as having two particles called neutrons (consisting of one proton and one electron) together with two free protons. The nucleus thus has a positive charge of two is just balanced by the two electrons having negative charges. Hence the atom is neutral.

Different kinds of atoms have different combinations of protons and electrons. The protons are always to be found in the nucleus. The electrons are pictured as revolving around the nucleus in orbits or paths in a manner resembling the movement of the earth around the sun.

### 242. How Atoms Become Charged

In the uncharged or neutral atom, the total number of free protons in the nucleus equals the number of electrons revolving about the nucleus. But if we should remove one or more electrons from the outer orbit, the number of protons would be greater than the number of electrons and the atom then would have a *positive electrical charge*. Conversely, should we add one or more electrons to the outer part of the atom, the number of electrons would exceed the number of protons and the atom then would have a *negative electrical charge*.



## DIRECT CURRENT AND THE NATURE OF ELECTRICITY 311

It should be understood that scientists are not agreed about the nature of the nucleus. They also hold a great variety of opinions about this electron theory. But we need not go into this disagreement. The idea of an electron as a minute negatively charged particle is very generally accepted. This idea suffices to explain the phenomena of electricity for our purposes.

### 243. The Charge on a Glass Rod

Now we are ready to understand what happened when we rubbed the glass rod with the silk cloth. The act of rubbing tore away a number of electrons from the atoms that went to make up the glass rod. Thus the glass rod became positively charged.

Where did these electrons go? They went onto the silk and we should expect, therefore, that the silk cloth would have a negative charge. Our expectation is correct.

### 244. A Charged Rubber Rod Has an Excess of Electrons

When we rubbed the flannel cloth over the hard rubber rod, however, electrons were torn away from the cloth by the rubber. The rubber rod, therefore, having an excess of electrons, became negatively charged, and the flannel cloth, with a deficiency of electrons, became positively charged.

### 245. Differences in Atomic Structure

What determines whether a substance may lose electrons (as in the case of the glass rod) or acquire new electrons (as in the case of the hard rubber rod)? No explanation has been made that is entirely satisfactory. But the difference appears to depend upon the arrangement of protons and electrons in the substance.

Since the protons of the nucleus are in the center of the atom and are closely bound together, it is an extremely difficult matter to get at them. But a number of electrons revolve around the nucleus. These electrons are more easily disturbed and some of these are assumed to have been pulled away.

The electrons that revolve around the nucleus are called *planetary electrons*. They are believed, according to the most prominent theory, to be arranged in a definite pattern of concentric circles or ellipses. You may visualize these concentric shells or orbits if you think of the layers of an onion.

The first shell of electrons next to the nucleus is able to con-

## 312 DIRECT CURRENT AND THE NATURE OF ELECTRICITY

tain two such planetary electrons, and no more than two. Where more than two such electrons are present in the atom, they form more rings outside of the first one. The second ring may contain any number of electrons up to eight. The third also may contain no more than eight. The fourth and fifth may hold up to eighteen, the sixth, thirty-two, and so on until a total of ninety-two electrons are arranged outside of the nucleus.

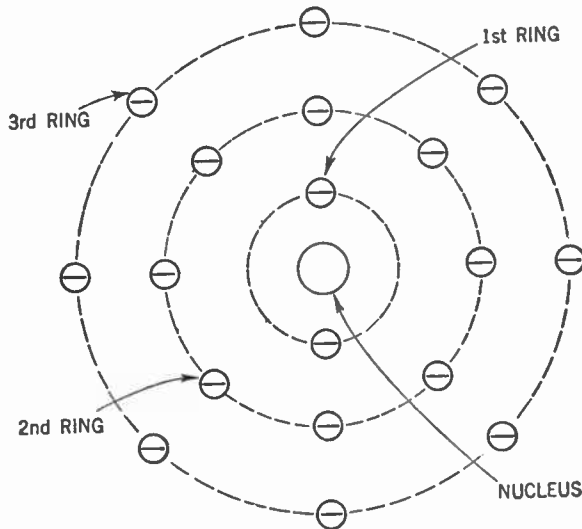

Figure 217. Picture of an atom of argon, showing the nucleus surrounded by the first three completed rings of planetary electrons. This is an inactive or inert element because since its outer ring is complete it has no tendency to lose or gain electrons.

### 246. Lending and Borrowing Electrons

It has been found that when the outermost ring of an atom has less than half the number of electrons needed to complete it, there is a tendency to lose electrons. Atoms of *metals* are in this condition and for this reason atoms of metals are called *lenders of electrons*.

But if an atom has more than half the number of planetary electrons needed to complete its outermost ring, it becomes a *borrower of electrons*. Atoms of *nonmetals* are usually in this condition. If an atom has just half the number of electrons needed to complete its outer ring, it may either be a lender or borrower of electrons. We say such an atom is *amphoteric*.

**247. Explaining the Current**

Now we shall be able to delve a little deeper into the subject of the electric current. The electrons in the outermost ring of the atom of a metal are loosely held. Using this theory, one of the explanations of the electric current being conducted through a metal is as follows: If we add an electron to an atom at one end of a piece of metal, this atom will pass one of its own electrons to its neighbor. The passing-on continues at an extremely rapid rate (nearly 186,000 miles per second), until the other end of the piece of metal is reached.

You may visualize this process by considering a tube completely filled with balls. As you force another ball into one end of the tube, a ball is discharged from the other end.

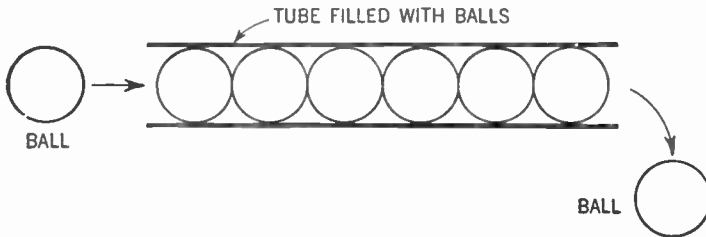

**Figure 218.** Diagram to illustrate motion of electrons through a conductor.

The handing-on of electrons takes place when the substance being considered is a conductor of electricity. But in the case of a borrower of electrons (insulator), adding an electron to one end will not start a flow of electrons. The additional electron will be snapped up by the first atom it encounters. This atom will then have a negative charge since it has one more electron than the total number of protons. This is one explanation of why conductors carry electric currents and why insulators do not pass an electric current. It is believed that insulators merely retain the electrical charge on their surfaces. This explanation of conductors and insulators should be looked upon as a workable theory but not as a complete explanation.

## THE THREE FACTORS OF AN ELECTRIC CURRENT

## 248. Electromotive Force

We have stated that if an electron were placed at one end of a conductor, it would cause a flow of electric current to the other end. This statement is not strictly true because an electrical pressure is needed to move the electric current from one end of the conductor to the other.

To get an idea of "pressure," let us consider a simple analogy. Assume we have a U-shaped tube with a valve or stopcock at the center (Figure 219). Assume the valve is closed. We now

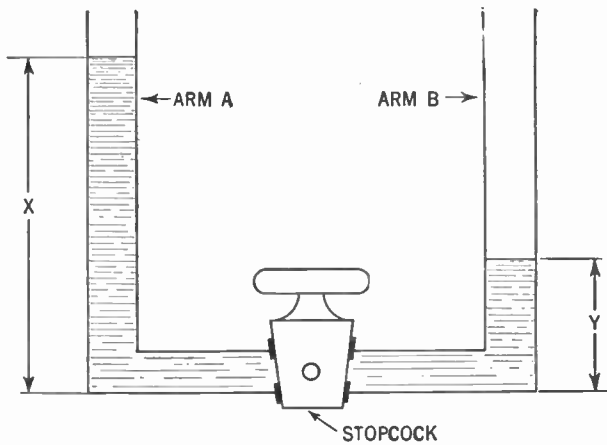

Figure 219. Diagram illustrating the fact that it is the *difference of pressure* which causes a fluid to flow through a tube.

pour water into arm *A* to a height represented by *x*. Pour water into arm *B* to a height represented by *y*. If the valve is now opened the water will flow from arm *A* to arm *B* until *x* and *y* are equal.

What caused the water to flow? It was not *pressure* in arm *A*, because when *x* and *y* are of equal length no water flows even though the water in arm *A* still exerts a pressure.

It was the *difference of pressure* between the two arms that caused the water to flow. This flow continued until the pressures in both arms were equal.

So it is with electrons. If at one end of a conductor electrons are piled up and at the other end electrons are few in number or

are being taken away, the excess electrons will flow toward the point of deficiency.

In Figure 219, the water in arm *A* can do no work until the valve is opened. Nevertheless, it represents a *potential* source of energy, that is, energy due to position. But the actual work is

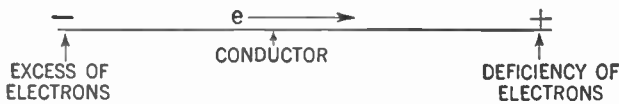

**Figure 220.** Diagram illustrating that it is the *difference* of electrical pressure which causes electrons to move through a conductor.

not done by the potential energy of the water in arm *A*, but by the *difference of potential energy* between the water in *A* and *B*.

Similarly, in Figure 220, it is not simply the potential energy caused by piling up electrons at one end of the conductor that causes the electric current to flow. It is the *difference* between the amounts of potential energy at the two ends of the conductor that does the work. We say that an electric current flows through a conductor because of the difference of potential energy at the ends of the conductor. The force that moves the electrons from one point to another is known as the *potential difference* or *electromotive force* (abbreviated to *E.M.F.*).

### 249. Resistance

But experiment shows that another factor besides potential difference affects the amount of current. Let us see how. Suppose we suspend two metallic balls in air several inches apart. Place a negative charge on one and a positive charge on the other.

Here we have a potential difference and yet no current flows. The reason is that the air between the two balls offers too great a resistance to the flow of current. If you connect the two balls by a piece of metal, however, the electric current will flow from the negatively charged ball to the other one. The resistance of the metal strip is low enough so that the potential difference may send the electric current flowing through it.

But it is not necessary to connect the two balls with a metal strip to cause the electrons to flow from one to the other. All we need do is to increase the charges. When the potential difference

## 316 DIRECT CURRENT AND THE NATURE OF ELECTRICITY

gets great enough, the electrons will jump across through the air in the form of an electric spark.

We conclude therefore, that, *for electric current to flow, the potential difference must be great enough to overcome the resistance of the path.*

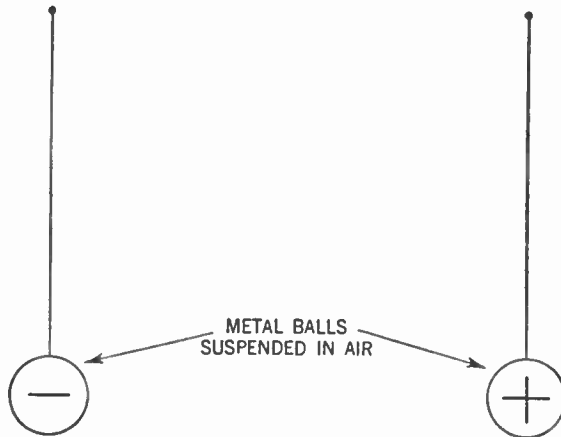

**Figure 221.** Figure showing two oppositely charged balls suspended for apart in air. Although there is a potential difference between them, no current flows because the resistance of the path between them is too great.

Different substances offer different resistances to the flow of electric current. Metals, generally, offer little resistance and are good *conductors*. Silver is the best conductor known, while copper is almost as good. Other substances such as glass, rubber, sulphur, and the like, offer a very high resistance and are known as *insulators*. But all substances will permit the passage of some electric current, provided the potential difference is high enough.

### 250. Current Depends on Both Electromotive Force and Resistance

Refer back to Figure 219. We measure the flow of water from one arm to the other in terms of quantity per unit of time. We say so many gallons flow past a certain point in a minute.

Similarly, we measure the flow of electricity by the number of electrons that flow past a point on a conductor in one second.

What determines the amount of water per unit of time that flows through the valve in Figure 219? Obviously it is the difference between the amounts of potential energy in the water in.

the two arms of the tube and the size of the opening in the valve (that is, the resistance the valve offers to the flow of water).

In the case of the electric current, the quantity of electricity per second (the number of electrons per second) which flows in a conductor depends upon the potential difference and the resistance of the conductor. *The greater the potential difference, the larger the quantity of electricity that will flow in a second. The greater the resistance, the smaller the quantity of electricity per second.*

## UNITS OF MEASUREMENT

### 251. Quantity of Electrical Charge

We have seen that when we add an electron to a neutral atom we give it a negative charge. Now the charge of one electron is small indeed. We therefore use the *coulomb* as a unit for measuring the quantity of electrical charge. A coulomb is equal to the combined charge of 6,280,000,000,000,000 electrons.

### 252. How to Write Large Numbers

The number mentioned above is an awkward one to handle. Engineers use a sort of shorthand to express such large numbers. For example, multiply 10 by 10. You get 100. Since 100 is formed by *two* tens multiplied together, the engineers express 100 as  $10^2$ . Similarly, 1,000 is formed by *three* tens multiplied together. It may therefore be expressed as  $10^3$ . Thus a coulomb is equal to the combined electrical charge of 6.28 times  $10^{18}$  electrons. That is, 6.28 multiplied by 18 tens which have been multiplied together. The symbol  $\times$  means "multiplied by." The coulomb therefore is equal to  $6.28 \times 10^{18}$  electrons.

In the number  $10^{18}$ , the small figure 18 is called the *exponent*. If we wish to express the number 1,000 by means of the exponent system, we write  $10^3$ . If we wish to indicate  $\frac{1}{1000}$ , we may write  $\frac{1}{10^3}$ . Another method is to write  $10^{-3}$ . The figure  $-3$  is called the *negative exponent*. Thus 10 may be expressed  $10^1$  and  $\frac{1}{10}$  as  $10^{-1}$ . Similarly 100 may be expressed  $10^2$  and  $\frac{1}{100}$  as  $10^{-2}$ .

### 253. Electric Current (*I*)

When we talk of electric current we mean electrons in motion. When the electrons flow in one direction only the current is called a direct current (D.C.). In the discussion in this chapter we are speaking only of direct currents. It is important to know the number of electrons that flow past a given point on a conductor in a certain length of time. If a coulomb ( $6.28 \times 10^{18}$  electrons)

## 318 DIRECT CURRENT AND THE NATURE OF ELECTRICITY

flows past a given point in one second, we call this amount one *ampere* of electrical current. Hence the unit of electric current is the ampere.

### 254. Measuring Current by Its Chemical Effects

Aside from the fact that the electrons are too small to be seen, we would find it impossible to count them as they flowed by. Accordingly we have devised another method to measure the current. It has been found that when an electric current passes through a solution of a silver salt from one electrode to another, silver is deposited out of the solution and upon the electrode which has an excess of electrons (the negative electrode). The amount of silver so deposited is in proportion to the strength of the electrical current. The more current, the more silver is deposited. Careful measurements show that *1 ampere of current will cause 0.001118 gram of silver to be deposited in one second.*

In an electrical formula the capital letter *I* stands for the current.

### 255. Factors Causing Resistance (*R*)

The resistance which a substance offers to the flow of electric current depends upon a number of factors. First of all, there is the nature of the substance itself. We have seen that different substances offer different amounts of resistance to the flow of current.

Resistance is also affected by the length of the substance. The longer an object is, the greater its resistance. Another factor is the cross-section area of the substance. This is the area of the end exposed if we slice through the substance at right angles to its length. The greater this cross-sectional area, the less the resistance to current flow. In other words, for a given kind of material the resistance varies directly as its length and inversely as its cross-sectional area.

Resistance is also affected by the temperature of the substance. Metals, generally, offer higher resistance at higher temperatures. Certain nonmetallic substances, on the other hand, offer lower resistance at higher temperatures.



**256. An Ohm Is the Unit of Resistance**

The unit of resistance is the *ohm*. *It is the resistance to the flow of electric current offered by a uniform column of mercury, 106.3 cm. long, having a cross-section area of 1 sq. mm. at 0°C.*

The symbol for the ohm is the Greek letter *omega* ( $\Omega$ ). In an electrical formula, the capital letter *R* stands for resistance.

**257. The Volt Is the Unit of Electromotive Force (E.M.F.)**

Another unit of measurement is the unit of electrical pressure (that is, *electromotive force* or *potential difference*). This unit is called the *volt*. The volt is defined as *that electromotive force that is necessary to cause 1 ampere of current to flow through a resistance of 1 ohm*. In an electrical formula the capital letter *E* or the initials E.M.F. may stand for electromotive force.

**258. A Watt Is the Unit of Electrical Power (W)**

Power is the rate at which energy is expended. Thus the electrical pressure (expressed in volts) times the number of electrons flowing per second (expressed in amperes) equals the electrical power. The unit of electrical power is the *watt*, which is designated by the capital letter *W*. Thus:

$$\text{watts} = \text{volts} \times \text{amperes} \quad \text{or} \quad W = E \times I$$

Here is an example of how this formula is used. Assume that an electric-light bulb used on the 110-volt house line is found to pass .9 amp. of current. How much power is it consuming? Substituting the given values in our formula we get:

$$W = 110 \times .9 = 99 \text{ watts}$$

We say this bulb is a 100-watt (99-watt) bulb.

**OHM'S LAW**

The relationship between the electromotive force, current, and resistance was discovered by a German scientist, Georg Simon Ohm, at the beginning of the nineteenth century. The unit of resistance was named in his honor.

## 320 DIRECT CURRENT AND THE NATURE OF ELECTRICITY

This relationship can be expressed by means of the following formula:

$$\text{current} = \frac{\text{E.M.F.}}{\text{resistance}} \quad \text{or} \quad I = \frac{E}{R}$$

This statement means that the greater the E.M.F., the greater the current and the greater the resistance, the smaller the current.<sup>2</sup>

### 259. Practice in Using Ohm's Law

Let us see how we use this formula.

*Example 1.* Turn to Figure 117, Vol. I, and you will notice that we are attempting to light the filament of a type 01A tube from the 110-volt house line. Since the filament of this tube requires about 5 volts, we are forced to get rid of the excess pressure of 105 volts in the dropping resistor. The tube manufacturer tells us that the type 01A tube requires a current of .25 amp. to heat the filament. The problem is to determine the proper resistance of the dropping resistor so that 105 volts will be used up in passing through it.

Since .25 amp. of current must flow through the tube filament, it must also flow through the dropping resistor. We therefore know that the electromotive force (or drop in potential) across this resistor is 105 volts and the current is .25 amp. Substituting these values in our formula we get:

$$.25 = \frac{105}{\text{resistance (ohms)}} \quad (1)$$

Multiplying both sides of this equation by the resistance we get:

$$.25 \times \text{resistance} = 105 \quad (2)$$

Dividing both sides of equation (2) by .25, we get:

$$\text{resistance} = \frac{105}{.25} = 420 \text{ ohms} \quad (3)$$

*Example 2.* Consider another example. Look at Figure 116, Vol. I. The bias resistor used in the cathode of the last type 27 tube is 2,000 ohms. The tube manufacturer tells us that when 180 volts are used on the plate of the tube, a current of .0045 amp. flows from the cathode to the plate. What is the voltage across

<sup>2</sup> Mathematically stated, the current varies directly as the electromotive force and inversely as the resistance.

the bias resistor which is used to place a negative charge on the grid of the tube?

Our formula is originally:

$$I = \frac{E}{R} \tag{1}$$

But we may convert this so as to express  $E$  in terms of  $I$  and  $R$ . Multiplying both sides by  $R$ , we get:

$$I \times R = \frac{E \times R}{R} \tag{2}$$

Or canceling the  $R$ 's in the fraction we get:

$$I \times R = E$$

Substituting our known values for current in the resistor and resistance of the resistor we get:

$$E = .0045 \times 2,000 = 9 \text{ volts} \tag{3}$$

Since the bottom of the resistor which goes to the grid return is more negative than the top, a bias of  $-9$  volts is thus placed upon the grid of the tube.

**260. Transposing a Formula**

By means of Ohm's Law, we have been able to express current in terms of electromotive force and resistance ( $I = \frac{E}{R}$ ), and E.M.F. in terms of current and resistance ( $E = I \times R$ ). We can also express resistance in terms of electromotive force and current.

Take the formula  $E = I \times R$ . Dividing both sides by  $I$ , we get  $R = \frac{E}{I}$ .

**HEATING EFFECT OF THE ELECTRIC CURRENT**

As the electromotive force or potential difference forces current to flow through a conductor, the resistance encountered causes the conductor to become heated. In every conductor some of the energy desired for useful work is lost by being transformed into heat. It is the electrical power (watts) that creates the heating effect, or we might more correctly say, the electrical energy is being transformed into heat energy. The formula for determining the

## 322 DIRECT CURRENT AND THE NATURE OF ELECTRICITY

electric power in terms of electromotive force and current, we have just learned, is:

$$W = E \times I \quad (1)$$

$W$  represents power in watts. To express the heating effect in terms of the resistance of the conductor, we substitute for  $E$  in equation (1) its equivalent  $E = I \times R$ . We now get:

$$W = (I \times R) \times I = I^2 \times R \quad (2)$$

Thus, if we know  $I$  and  $R$  we are able to determine the power  $W$ . Let us try an example. In the drawing of Figure 117, Vol. I, we know that  $I$  equals .25 amp. and  $R$  equals 420 ohms. Substituting in our formula we get:

$$W = (.25)^2 \times 420 = .0625 \times 420 = 26.25 \text{ watts}$$

Moreover, we can check this answer by our original formula for power:

$$W = E \times I$$

Since the voltage drop was 105 and the amperes .25, then  $105 \times .25 = 26.25$  watts.

In practice it is usual to have a safety margin of about 100%, else our resistor may burn up. We therefore specify that the dropping resistor have a resistance of 420 ohms and be capable of passing 50 watts of electrical power.

We have expressed our power formula in terms of E.M.F. (voltage) and current ( $W = E \times I$ ), and in terms of current and resistance ( $W = I^2 \times R$ ). We may also express it in terms of voltage and resistance. In our original power formula,  $W = E \times I$ , substitute the equivalent for  $I$  (that is,  $\frac{E}{R}$ ). Thus we get:

$$W = E \times \frac{E}{R} = \frac{E^2}{R}$$

We make use of the heating effect of the electric current in electric heaters, toasters, and other appliances. Another use of this heat effect of an electric current is in fuses.

### 261. Fuses

When we connect delicate instruments in an electrical circuit,

there exists a danger that too much current may pass through them and burn them up. We therefore connect in series with them a link of metal which has the property of melting when too much current flows through it. Thus the link (or *fuse*, as it is called) melts before the instruments are damaged. This melting breaks the circuit and the flow of current ceases.

Fuses are rated by the number of amperes of current that may flow through them before they will melt. Thus we have 10-amp. fuses, 30-amp. fuses, and so on. Care should be taken that

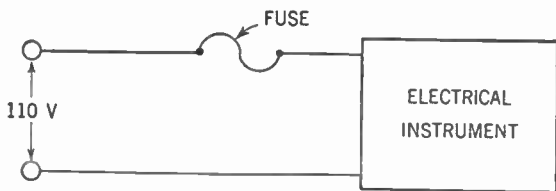

**Figure 222.** Diagram showing how a fuse is used to protect electrical instruments or appliances.

the fuses used in any circuit be rated low enough to melt or “blow” before the electrical instruments are damaged. Thus, in a house wired to stand a maximum current of 15 amp., it would be best to use 10-amp. fuses so that a 15-amp. current could never pass.

**262. Electrical Circuits**

An electrical circuit may be described as the path or paths followed by electrons from the source of *high potential* (negative post) to the source of *low potential* (positive post). There are several types of circuits.

**263. Series Circuits**

In the *series circuit* the electrons can follow only one path from the negative to positive (see Figure 223). The electromotive force (110 volts) forces the electrons through this circuit. Since there is only one path, the number of electrons per second (which determine the number of amperes) in each part of the circuit is the same.

But some of the electrical pressure is used up in pushing the electrons through each part of the circuit. The electrical pressure (voltage) gets less and less (that is, drops) as we approach

## 324 DIRECT CURRENT AND THE NATURE OF ELECTRICITY

the low potential (positive) end of the circuit until we reach the positive terminal. At that point the electrical pressure is zero.

The electrical pressure lost in pushing the electrons through each portion of the circuit is called the *voltage drop* in that portion. The sum of all the voltage drops in a series circuit is equal

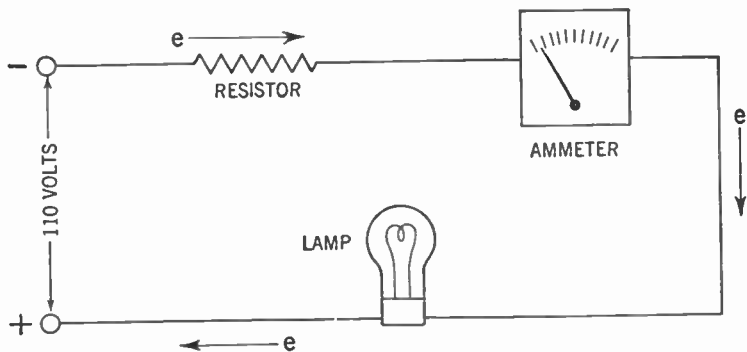

**Figure 223.** The series circuit. Electrons can follow only one path from negative to positive.

to the original electromotive force (110 volts, in this instance). Thus we may have, for example, a voltage drop of 20 volts across the resistor, 2 volts across the ammeter, and 88 volts across the lamp. As you can see, the total is 110 volts.

**RULE:** *The resistance of a series circuit is the sum of all of the resistances in the circuit.*

Thus the resistor may have a resistance of 10 ohms, the ammeter a resistance of 1 ohm, and the lamp a resistance of 44 ohms. The total is 55 ohms. Applying Ohm's Law to get the current:

$$I = \frac{E}{R} = \frac{110}{55} = 2 \text{ amp.}$$

Thus we have 2 amp. of current flowing through all parts of the circuit.

### 264. Parallel Circuits

In a *parallel circuit* the electrons can follow two or more paths simultaneously. In the circuit of Figure 224, the electron stream divides at X. Part flows through the resistor and back to the posi-

tive terminal. Another part flows through the lamp, joins the main electron stream at Y and flows to the positive terminal.

It is evident that the electromotive force (110 volts) across the resistor is the same as that across the lamp (disregarding the

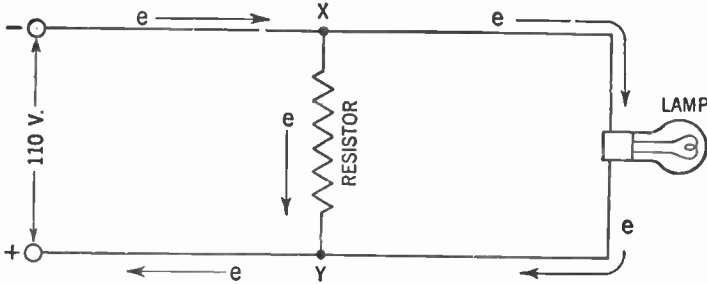

Figure 224. The parallel circuit. Here the electrons have more than one path to follow.

slight resistance of the wires connecting the resistor to the lamp. Thus the voltage drop across the resistor and the lamp are equal.

But the currents flowing through both parts of the circuit are not necessarily equal. If the electron stream encounters more resistance in the lamp, fewer electrons will flow through that path than through the resistor.

Resistors in parallel do not add their resistances to obtain the total. Instead the total resistance for several resistors in parallel is determined by the following formula:

$$\frac{1}{\text{total resistance}} = \frac{1}{R_1} + \frac{1}{R_2} + \frac{1}{R_3} +, \text{ etc.}$$

Another way of stating this formula is:

$$\text{total resistance} = \frac{1}{\frac{1}{R_1} + \frac{1}{R_2} + \frac{1}{R_3} +, \text{ etc.}}$$

In Figure 224,  $R_1$  would be the resistance of the resistor and  $R_2$  that of the lamp. If we assume the resistance of the resistor to be 10 ohms and that of the lamp to be 20 ohms, substituting these values in our formula we get:

$$\frac{1}{\text{total resistance}} = \frac{1}{10} + \frac{1}{20} \tag{1}$$

This reduces to:

$$\frac{1}{\text{total resistance}} = \frac{2}{20} + \frac{1}{20} = \frac{3}{20} \quad (2)$$

Cross multiplying, we get:

$$1 \times 20 = 3 \times \text{total resistance} \quad (3)$$

This in turn gives us:

$$\text{total resistance} = \frac{20}{3} = 6.66 \text{ ohms.} \quad (4)$$

By Ohm's Law we may find the total current  $I$ :

$$I = \frac{E}{R} = \frac{110}{6.66} = 16.5 \text{ amp.}$$

This 16.5 amp. is the total current flowing in the circuit. But since the resistance of the lamp is twice that of the resistor, only half as much current flows through the lamp as through the resistor. This is based on the principle that the current varies inversely as the resistance. Thus 11 amp. flow through the resistor and 5.5 amp. flow through the lamp. To verify these figures we may use Ohm's Law to find the current in each branch of the circuit separately. In the lamp where  $R = 20$  ohms, the formula

reads 
$$I = \frac{E}{R} = \frac{110}{20} = 5.5 \text{ amp.}$$

In the resistor where  $R = 10$  ohms we have:

$$I = \frac{E}{R} = \frac{110}{10} = 11 \text{ amp.}$$

### 265. Combined Series and Parallel Circuits

In addition to having circuits where the resistors are in series or parallel, we may have circuits having some devices connected in series and others in parallel. Such a circuit appears in Figure 225. Here  $R_1$  is in series with the combination of  $R_2$  and  $R_3$ . But  $R_2$  and  $R_3$  are connected in parallel to each other. To find the total resistance first find the total resistance of  $R_2$  and  $R_3$  by use of the formula:

$$\frac{1}{\text{total } R} = \frac{1}{R_2} + \frac{1}{R_3}.$$



Then the complete circuit is treated as a series circuit where  $R_1$  is in series with the computed resistance of  $R_2$  and  $R_3$  in parallel.

Another arrangement is one where two sets of resistors in paral-

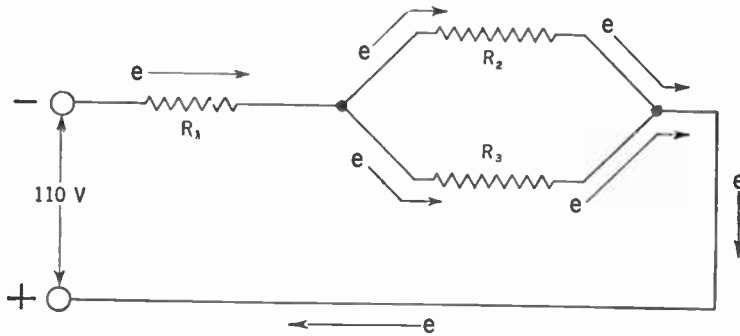

**Figure 225. The series-parallel circuit.**

l are in series with each other (Figure 226). Here we first find the equivalent resistance of  $R_1$  and  $R_2$  in parallel. We then find the equivalent resistance of  $R_3$  and  $R_4$  in parallel. We then treat

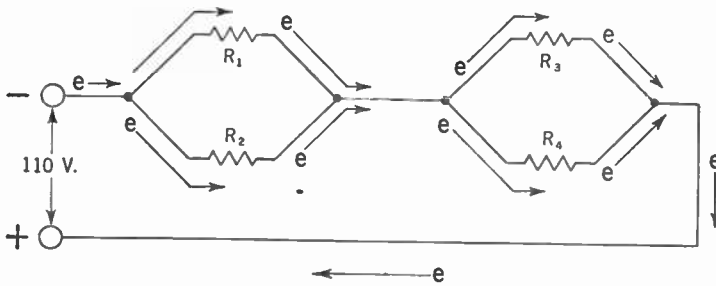

**Figure 226. Another arrangement of the series-parallel circuit.**

these two equivalent resistances as though they were in series with each other and by adding them together we get the total resistance of the circuit.

## THE BATTERY

### 266. Primary Cells

We have seen that when electrons are piled up, an electrical pressure or potential is created. These electrons will tend to flow to a point of lower electrical pressure or potential provided a path be furnished them. What causes these electrons to pile up?

### 328 DIRECT CURRENT AND THE NATURE OF ELECTRICITY

You already know that stroking a hard rubber rod with a piece of flannel tears some electrons off the cloth and deposits them upon the rod. But this method is not a convenient means of piling up electrons. Besides, once the excess electrons have flowed off, we must rub the rod once again with the flannel. What is needed is a more efficient method for piling up excess electrons and a means whereby new electrons are continuously added to replace those which flow away.

Early in the nineteenth century, an Italian scientist, Alessandro Volta, discovered that if two dissimilar substances, such as zinc and carbon, were placed in an acid solution, the chemical action would tear away electrons from the carbon rod while at the same time other electrons would accumulate on the zinc. Also, if a conductor was joined to the ends of the carbon and zinc outside of the liquid, a current flowed continuously in the wire. Here we

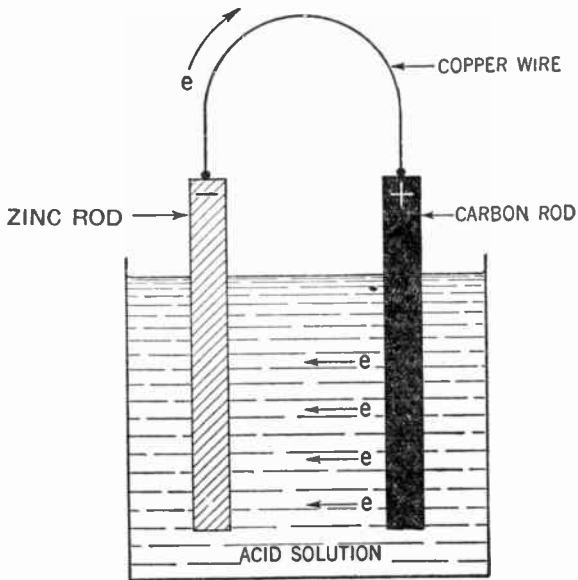

Figure 227. The Voltaic cell.

have a case where chemical energy is converted to electrical energy. Such a device is called a *Voltaic Cell*, in honor of its inventor.

Since the carbon rod loses electrons, it becomes charged *positively*. We call this rod the *anode*. Electrons, piling up on the zinc rod, give it a *negative* charge. We call this rod the *cathode*.

If a copper wire is used to connect the two rods, electrons flow through the wire from the zinc rod (high potential) to the carbon rod (low potential).

As long as the rods are in the acid solution (this solution is called the *electrolyte*), the electrons continue to be pulled off the carbon rod and to be accumulated on the zinc rod. Thus we have a continuous source of electrical potential. In time the acid will completely dissolve the zinc rod, which must be replaced.

The potential difference (electromotive force) between the carbon and zinc rods remains the same, regardless of the size of these rods. It is the material and not the size of these rods which determines the potential difference. Of course, a cell made with a larger zinc cathode will last longer and the larger the area of the rods the more current may be obtained from the cell. However, the electromotive force of such a cell is always 1.5 volts.

Other materials may be used for the anode and cathode (we call these the *electrodes*), and different electrolytes may be employed. In each case the electromotive force will depend upon the materials used.

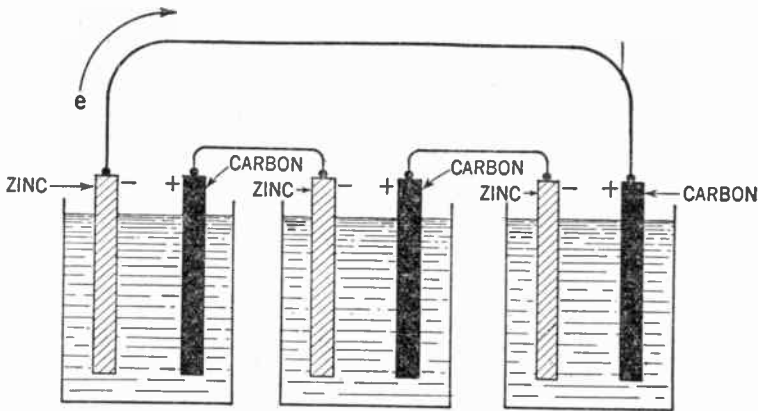

Figure 228. Three Voltaic cells in series. Note that in series connections the + pole of one cell is always joined to the - pole of the next cell.

### 267. Batteries of Cells

If two or more such cells are connected together we call them a *battery*. If several similar cells are connected in *series*, that is, with the zinc of one connected to the carbon of another (Figure

### 330 DIRECT CURRENT AND THE NATURE OF ELECTRICITY

228), the electromotive force of each one is added to the others and the total electromotive force is the sum of all of them. Thus the total electromotive force which will cause electrons to flow through the wire in the diagram shown in Figure 228 is  $1.5 \times 3 = 4.5$  volts.

If three cells such as those above are connected in *parallel*, that is, with all the zincs connected together and all the carbons joined (Figure 229), the battery acts as one cell with electrodes having three times the area of a single cell. The electromotive

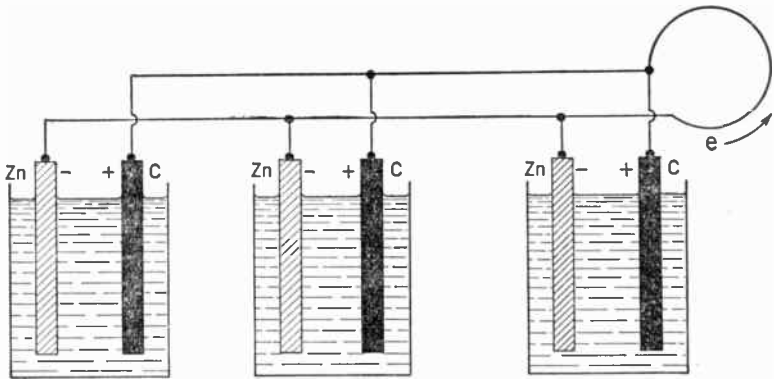

Figure 229. Three voltaic cells in parallel.

force of this battery is that of a single cell (1.5 volts). The current which can be obtained is nearly three times as great as that which we can get from the single cell.

#### 268. The Dry Cell

Because of the nuisance of spilling the electrolyte, the *dry cell* was developed. The anode is a carbon rod, the cathode is a cylindrical zinc shell or can closed at the bottom. The electrolyte is a paste made of ammonium chloride mixed with other chemicals (Figure 230). Hence this cell is "dry" only in the sense that the liquids are prevented from spilling out.

The electrolyte is poured into the zinc shell. In the center of it is set the carbon rod. Sealing wax is poured over the electrolyte to prevent it from spilling. The whole is enclosed in a cardboard case for protection and binding posts are fastened to the carbon and zinc to provide for connections. The dry cell will continue to

furnish current until either the electrolyte or the zinc is consumed, although at decreasing efficiency.

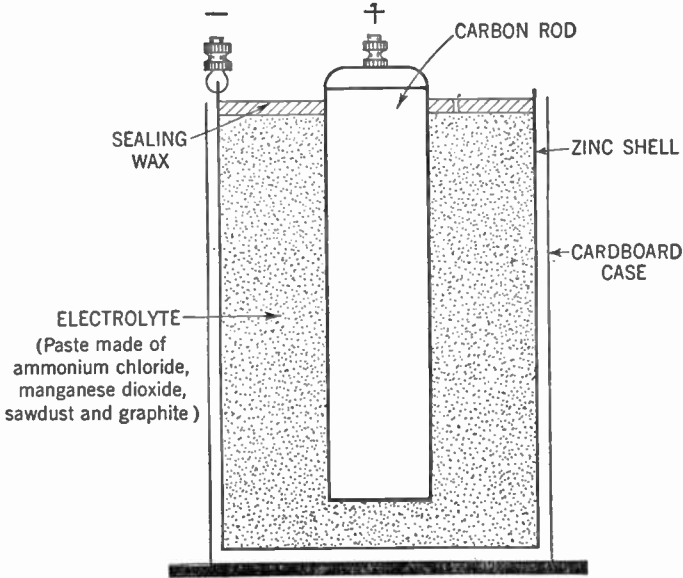

**Figure 230. Cross-section view of the dry cell.**

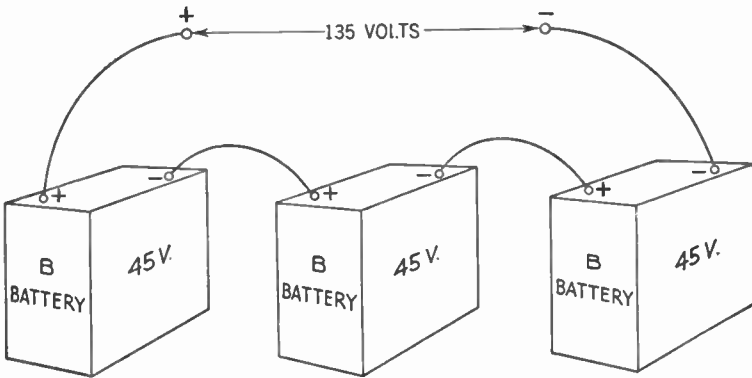

**Figure 231. Circuit showing three B batteries connected in series.**

**269. B Batteries**

For radio use, a number of dry cells may be connected in series and the whole sealed into a single block by means of wax or pitch. These blocks are known as "B" batteries. The most commonly used types are blocks of 15 cells (22.5 volts) and 30 cells (45 volts).

### 332 DIRECT CURRENT AND THE NATURE OF ELECTRICITY

Should we wish to obtain a higher electromotive force, we may connect several such B batteries in series (Figure 231).

In the cells described above, current may be furnished until one of the electrodes is eaten away by the chemical action. We call such cells *primary cells*.

#### 270. Storage Cells

There is another kind of cell wherein the chemical action does not destroy any of the electrodes but in which electrons are released by certain chemical charges. If two lead plates are immersed in sulphuric acid and a current is sent into them, the plate

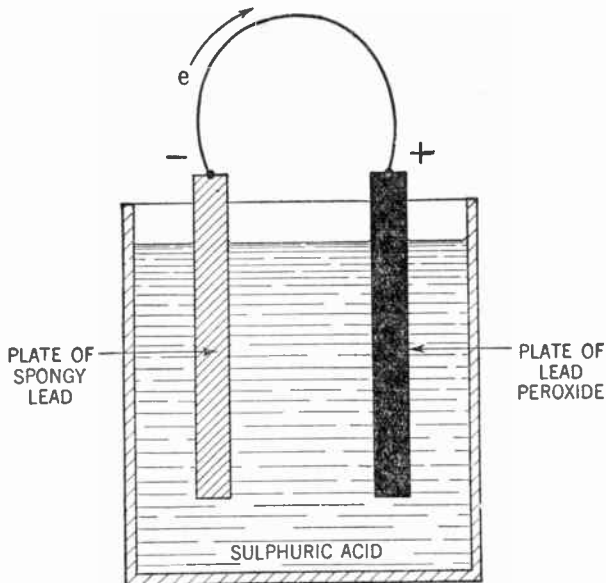

Figure 232. The lead-acid storage cell.

connected to the positive source of current will turn to brown lead peroxide and the plate attached to the negative source will become gray, spongy lead.

Now remove the source of current, and connect between the two poles an ordinary electric bell (or a voltmeter). The bell rings, showing there is a current. In fact, electrons are flowing from the spongy lead plate to the plate of lead peroxide (Figure 232).

As the current continues to flow, the two plates are changed

gradually to lead sulphate. When this happens, the current ceases to flow. If current is fed into the cell again, the plates will turn back to lead peroxide and spongy lead, and the whole process may be repeated.

This device is called a *storage cell*. The electrical energy fed into the storage cell is changed into chemical energy which is stored in the cell. When the cell is called upon to deliver current, the chemical energy is changed back to electrical energy.

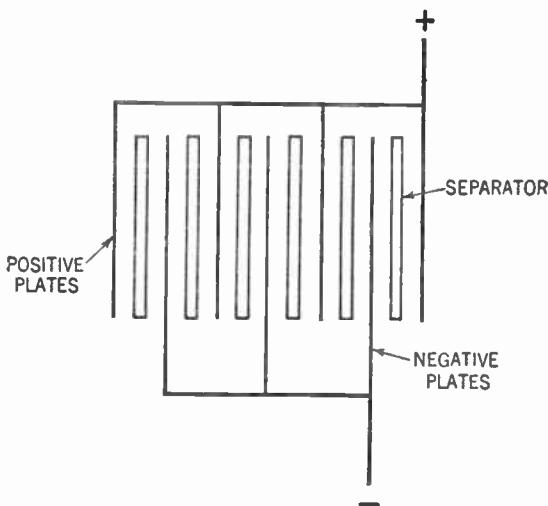

**Figure 233.** The lead-acid storage cell showing how the plates are hooked up.

A storage cell of this kind has an electromotive force of about 2 volts. Here, too, the voltage does not depend upon the size of the plates. But the amount of electrical energy which can be stored (and the amount which may be delivered) does depend upon the area of the plates. The greater the area, the greater the amount of electrical energy which may be stored.

In practice a cell may consist of a number of plates (electrodes) which are sandwiched together with insulators of wood or other material (called separators) separating the positive and negative plates. All the negative plates are connected together and the same is true for the positive plates (Figure 233).

The whole combination of plates and separators is submerged in the sulphuric acid electrolyte. In the chemical action involved the electrolyte changes in density, that is, in weight per unit

### 334 DIRECT CURRENT AND THE NATURE OF ELECTRICITY

volume. As the cell has electrical energy fed into it the density of the sulphuric acid increases. As electrical energy is taken from the cell, the density decreases. By means of a *hydrometer*, an instrument used to measure the density of a liquid, we can tell how much electrical energy is left in the cell.

When electrical energy is being stored in the cell we say we are *charging* the cell. When we draw electrical energy from the cell we say we are *discharging* the cell.

Three such cells are usually connected in series to form a battery whose electromotive force is around 6.0 volts. The whole battery is encased in a hard rubber or similar case and is known as a *lead-acid storage battery* (Figure 234).

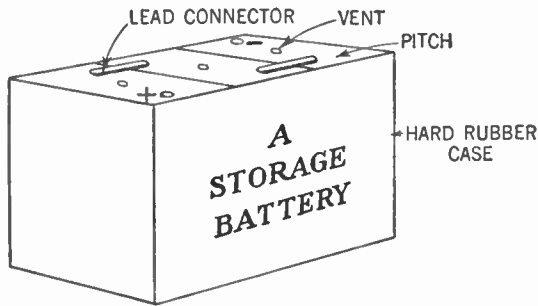

Figure 234. The lead-acid storage battery containing three cells connected in series.

The storage battery is used where a great deal of current is desired. Primary cells would quickly wear out and would have to be discarded, but the storage battery may be recharged and used over and over. Early radio sets used storage batteries called "A" batteries to supply the current needed to heat the filaments.

#### 271. The Edison Storage Battery

Another type of storage cell is the *Edison cell*. In this type, electrodes of iron oxide and nickel hydrate are used. The electrolyte is a caustic potash (potassium hydroxide) solution. This cell is more rugged than the lead-acid storage cell, but its relatively high cost prevented it from being used by the average radio enthusiast.



# DIRECT CURRENT AND THE NATURE OF ELECTRICITY 335

## SUMMARY

Complete the sentences by supplying the correct words. Do not write in the book.

1. When glass is rubbed with  $w(1)$  the charge on the glass is said to be  $(+)$ . When hard rubber is rubbed with  $F(3)$  the charge on the rubber is called  $(-)$ . A detector of electric charges is called an  $E(5)$  *electroscope*.

2. The rule for attraction and repulsion of charges is that like charges (6) each other and unlike charges (7) each other.

3. The modern electron theory explains a negative charge as being (a, an) (excess, deficiency) (8) of electrons and a positive charge as (a, an) (excess, deficiency) (9) of electrons.

4. An electric current in common usage is said to flow from the (10)  $+$  pole to the  $(-)$  (11) pole, but actually electrons flow from a point that has a  $(-)$  (12) charge to a point that has a (13)  $+$  charge.

5. The measure of electromotive force is the  $v(14)$ ; the measure of the current is the  $a(15)$ , and the unit of resistance is the (16)  $\Omega$ .

6. Ohm's Law, stated in terms of current, resistance, and electromotive force, is (17)

7. Electric energy (or power) is measured in  $w(18)$ . The formula for electric power (a) in terms of current and resistance is  $W = I^2 R$  (19); (b) in terms of volts and amperes is  $W = EI(20)$ .

8. When resistors are joined in series their combined resistance is their  $\Sigma(21)$ ; but when resistors are joined in parallel the formula for the combined resistance is (22)

9. The rating of a resistor in watts should be  $2(23)$  times the maximum load that it can be subjected to in any given circuit. This is because there is danger that  $P_{max}(24)$  *will be exceeded*.

10. A fuse is a device which makes use of the  $J(25)$  effect of the electric current. When the number 10 is stamped on a fuse it means that the (voltage, current, resistance)  $I(26)$  cannot exceed ten (27) in the circuit in which it is connected in series.

11. A dry cell has a voltage of about  $1.5(28)$  volts. When connected in series, a set of three dry cells would have a combined voltage of (29)  $4.5$  volts, but when connected in parallel, their combined voltage would be  $1.5(30)$  volts.

12. In series connections of cells, the positive pole of one cell is connected to the  $(+)(31)$  pole of the next cell.

13. A common storage cell has plates made of  $Zn(32)$  and the electrolyte is  $H_2SO_4(33)$  acid. A six-volt battery would consist of (how many?)  $6(34)$  storage cells connected in  $Series(35)$ .

14. In the early radio sets combinations of dry cells were used for the  $1(36)$  battery, while a *storage cell* was used for the (37)  $6$ . Today, batteries are still used in  $portable(38)$  radio sets and in places where  $AC(39)$  is not available.

## 336 DIRECT CURRENT AND THE NATURE OF ELECTRICITY

### GLOSSARY

- Ampere:** The unit of electrical current, represented by the passage of 1 coulomb of electron charge past a point in the circuit in 1 second.
- Anode:** The positive pole of a cell or battery.
- Atom:** The smallest particle of an element, from which all matter is built.
- Battery:** A connected group of cells.
- Cathode:** The negative pole of a cell or battery.
- Conductor:** A material which permits a fairly easy flow of electrons through itself.
- Coulomb:** The amount of negative charge possessed by  $6.28 \times 10^{18}$  electrons.
- Current Electricity:** Electrons moving through a conductor.
- Electrified:** Given a charge of electricity.
- Electron Theory:** The explanation of all matter from the point of view of what is considered fundamental electrical particles.
- Electron:** A negative electrical particle.
- Electrolyte:** The solution used in a cell—an acid, salt, or base.
- Electroscope:** A device to test for the presence of a charged body.
- Fuse:** A wire of fairly high resistance and low melting point used to protect a circuit from too great a current flow.
- Hydrometer:** A device to test the state of charge or discharge of a lead-acid storage cell.
- Insulator:** A material which does not permit a fairly easy flow of electrons through itself.
- Molecule:** The smallest particle of a chemical compound which has all the properties of the substance.
- Ohm:** The unit of resistance, standardized as the resistance of a uniform column of mercury, 106.3 cm. long with cross-section area of 1 sq. mm. at 0° C.
- Parallel Circuit:** An electrical circuit giving two or more paths from — to +.
- Primary Cell:** An electrical cell which may not be recharged.
- Proton:** A positive electrical particle.
- Series Circuit:** An electrical circuit giving a single path from — to +.
- Static Electricity:** A stationary electrical charge.
- Storage Cell:** A cell which may be recharged.
- Volt:** The unit of potential difference, standardized as that electromotive force necessary to cause 1 amp. to flow through a resistance of 1 ohm.
- Voltaic Cell:** A device to change chemical energy into electrical energy over an extended period of time.
- Watt:** The unit of electrical power or rate of expending electrical energy.

**QUESTIONS AND PROBLEMS**

1. How may an insulator be electrified? Explain how this electrification occurs.
2. Distinguish between an insulator and a conductor.
3. Explain the flow of an electric current as an electronic phenomenon.
4. Briefly explain the electron theory of matter.
5. Explain the electrical state of affairs in a neutral atom; in a negatively charged atom; in a positively charged atom.
6. Explain how an electroscope may show the presence of a charged body.
7. What factors determine the rate of flow of electrons through any particular electrical circuit? Explain each.
8. Express Ohm's Law in words. Express the same law mathematically.
9. Express the following as single numbers:  $8 \times 10^4$ ,  $\frac{8}{10^4}$ ,  $2 \times 10^{-5}$ ,  $2.8 \times 10^3$ .
10. Explain what is meant by a coulomb; by an ampere. Give another definition of the ampere.
11. Upon what factors does the resistance of any conductor depend?
12. What is the unit of resistance? How is it defined?
13. What is the unit of electrical pressure? How is it defined?
14. In what units is electrical power measured? What is its significance? How is it calculated?
15. In purchasing a resistor, how should its description be given precisely?
16. In what manner is electrical energy dissipated in a resistor?
17. How may a circuit be insured against too great a current flow through it? How does the result come about?
18. Differentiate between a series and a parallel circuit as to current and voltage drop.
19. Explain what is meant by voltage drop. How is voltage drop calculated?
20. How may the total resistance of a series circuit containing several resistances be calculated?
21. How may the total resistance of a parallel circuit of several resistors be calculated?
22. How do we consider series-parallel circuits in calculating the total resistance?
23. Describe the operation of a voltaic cell.
24. Upon what factors does the voltage of a cell depend?
25. How may a greater voltage than that of a single cell be obtained from a group of cells? A greater current?
26. What is a B battery?
27. Explain the charging and discharging of a lead-acid storage cell. How can the state of charge or discharge be determined?

## CHAPTER 30

# Magnetism, Motors, and Measuring Instruments

---

**Problem 1:** *What is the theory of magnetism?*

**Problem 2:** *How is magnetism related to electricity?*

**Problem 3:** *How is magnetism used in an electric motor?*

**Problem 4:** *What are the principles of the voltmeter, ammeter, ohmmeter and watt meter?*

---

### 272. A Bit of History

The story of magnetism is a fascinating one. About 100 B.C., a poet named Nicander wrote a poem about a shepherd who, one day while he was tending his flock, was startled to find the iron nails of his shoes attracted to a mysterious rock upon which he stood. The name of this shepherd was Magnes and it is from that name that we get the word *magnetism*.

The mysterious stone, called the *lodestone*, which has the property of attracting to it pieces of iron, intrigued the minds of men. Perhaps the best-known legend is that of the History of the Third Calender as related in the "Arabian Nights." According to this tale, when a ship passed near a certain mysterious mountain, all the nails and other iron articles were forcibly pulled out and attracted to the mountain.

Early scientists thought that the electrical charge created by rubbing amber on cloth was the same thing as the magnetism by which the lodestone attracted iron. Today we know it is not so.

### 273. The Gravitational Field and the Dielectric Field

The earth moves around the sun. Why does not the earth move away from the sun and follow an independent path?

The reason, we say, is that the pull of gravity exists between the earth and the sun and that this pull holds them together.

## 340 MAGNETISM, MOTORS, AND MEASURING INSTRUMENTS

This pull or force acts between the two bodies even though there is no material bond (such as a chain or cable) connecting them. The force acts through space. We say that there is a gravitational *field of force* attracting the earth to the sun.

You will recall that a hard rubber rod takes a negative charge and that a glass rod takes a positive charge, and that when these two rods were charged and suspended near each other they attracted each other. We say that between the two oppositely charged bodies a *dielectric field of force* existed which pulled them together. This field of force is also known as the *electrostatic field* and as the *electric field*.

### 274. Lines of Force

We visualize this field around an electric charge by a number of lines radiating out from the charge in all directions. We call these *lines of force*. In one sense they are imaginary lines; but see Paragraph 279.

In discussion or in drawings, the number of such lines of force indicates the intensity of the field. We also use arrowheads to show the *direction* of the field. The direction of a force is the direction in which a small object moves or tends to move when

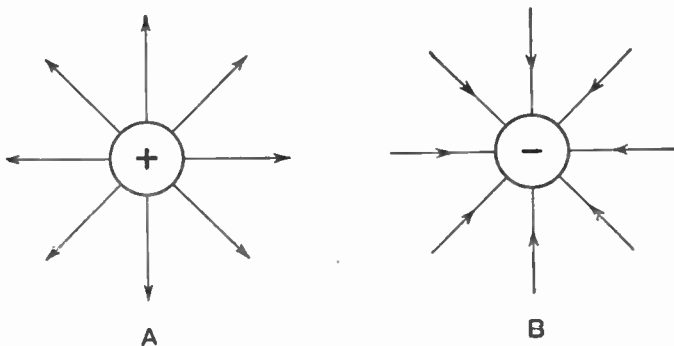
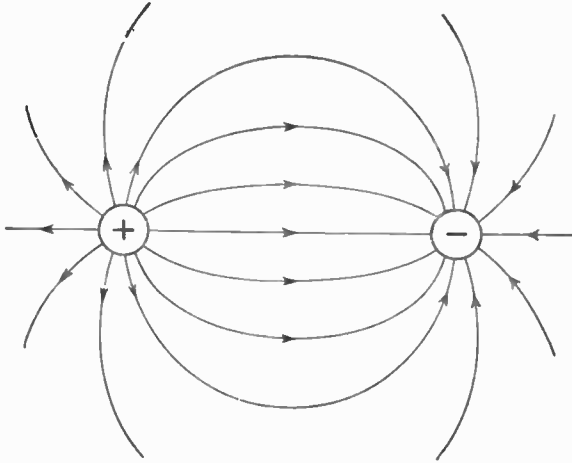

Figure 235. A—Lines of force around a positive charge.  
B—Lines of force around a negative charge.

acted on by the force, just as a cork floating in a stream shows which way the stream is flowing.

In testing the direction of a dielectric field, our scientists have agreed to use a small positive charge as a test. You can see, therefore, that this test charge will be repelled from another posi-

tive charge and attracted to a negative charge. The arrowheads on the lines of force thus point away from a positive charge and in towards a negative charge.



**Figure 236. Lines of force between two opposite charges.**

If we have two opposite charges acting upon each other, the dielectric field may be represented by lines of force connecting these charges with the arrowheads pointing from the positive charge toward the negative charge.

Figure 237 shows the field between two like charges.

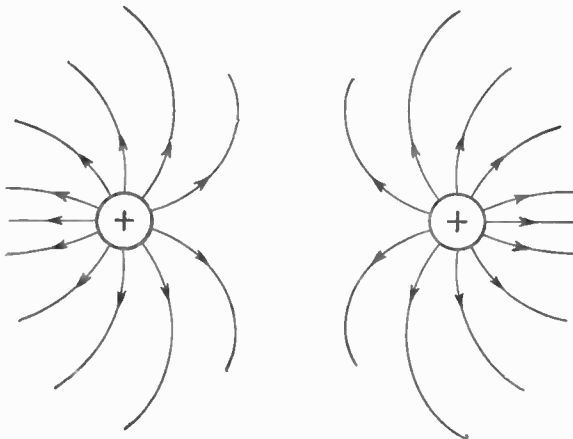

**Figure 237. Lines of force between two similar charges.**

### 275. Magnetic Fields and Magnetic Substances

Now let us turn back to our lodestone. Since it can attract a piece of iron through space, there must be a field of force between it and the iron. We call this the *magnetic field of force* or simply the *magnetic field*. Where did it come from?

Our scientists have a theory. Since an electron has an electrical charge, there is a dielectric field around it. They believe that if we can move this dielectric field, or if the electron can move this dielectric field, or if the electron moves through this field, a new field of force is created. This is the magnetic field.

Now since electrons in all materials are in constant motion revolving around the nuclei, there must be magnetic forces present inside the atoms of all substances. Why then do not all substances attract each other? Why does the lodestone attract only a few substances like iron and nickel?

The reason is that in most substances the magnetic field established by one electron revolving in one direction is canceled by the magnetic field set up by another electron revolving in another direction. Thus there is no *external* magnetic field. We say that such substances are *nonmagnetic*.

There are, however, a few substances the majority of whose electrons revolve in one direction. Since there is no cancellation of the magnetic fields set up by some of these electrons, these substances have an external magnetic field and can be attracted to the lodestone. Such substances are iron, nickel, and a few others. We say that they are *magnetic* substances. The lodestone is an iron compound. Substances that are able to attract pieces of iron or nickel are called *magnets*.

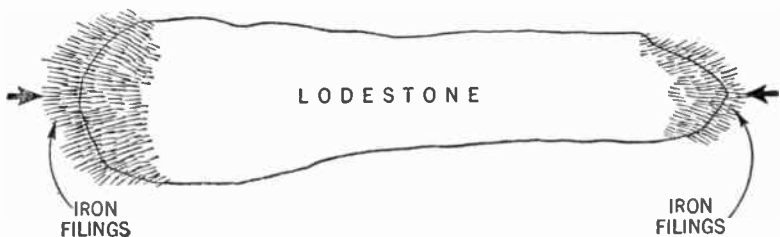

Figure 238. Iron filings clinging to the poles of a magnet.

### 276. The Poles of a Magnet

If we sprinkle iron filings over a magnet the filings adhere to it. But the greatest number of filings is found clustered at two

opposite points of the magnet. It seems as though all the magnetism is concentrated at these points. We call these points the *poles* of the magnet.

It has been found that the earth is a huge magnet. The magnetic poles of the earth are found to be located very close to its geographic poles.

If we suspend a magnet so that it can swing freely, it will always assume a position so that one of its poles points to the North Pole of the earth and the other to the earth's South Pole.

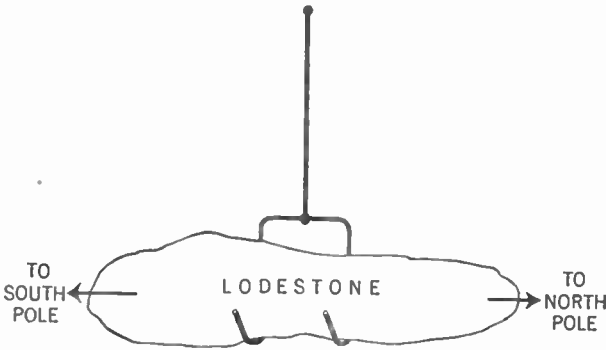

**Figure 239.** Figure showing how a freely swinging magnet turns so that its poles face the North and South Poles.

The pole of the magnet which points to the North Pole is called the *north-seeking pole* or simply the *north pole*. The opposite pole of the magnet is called the *south-seeking pole* or the *south pole*.

### **277. The Magnetic Compass**

The ancient Chinese are credited with first utilizing as an aid to navigation the fact that a freely suspended magnet will always assume this north-south position. Such a suspended magnet is called a *magnetic compass*.

Experimenters soon discovered a number of interesting facts about magnets. It was found that if the north pole of one magnet is brought near the north pole of another, the poles repel each other. The same thing occurs if two south poles are brought near each other. On the other hand, if the north pole of one magnet is placed near the south pole of another, the poles are attracted. Thus *like magnetic poles repel each other and unlike magnetic poles attract each other*.



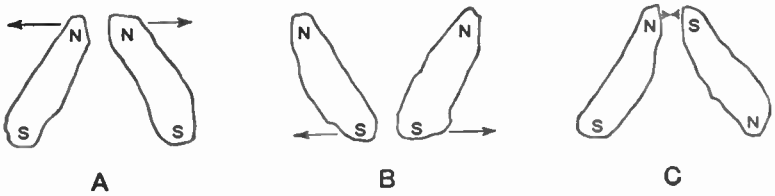

Figure 240. A—Two north poles repel each other.  
 B—Two south poles repel each other.  
 C—A north and south pole attract each other.

Another fact of interest was the discovery that a north or south magnetic pole could not exist by itself. For every magnetic pole there is an opposite pole that has equal strength. If a magnet is broken in half we get two magnets, each with its own north and south poles.



Figure 241. A—Poles on a magnet.  
 B—Arrangement of poles on a magnet broken in half. Note that each piece has two poles.

### 278. Magnetizing a Piece of Iron

It was also found that if a magnetic substance which is unmagnetized at the beginning, like iron, is stroked with a magnet (such as lodestone), the iron becomes a magnet too, with a north and south magnetic pole.

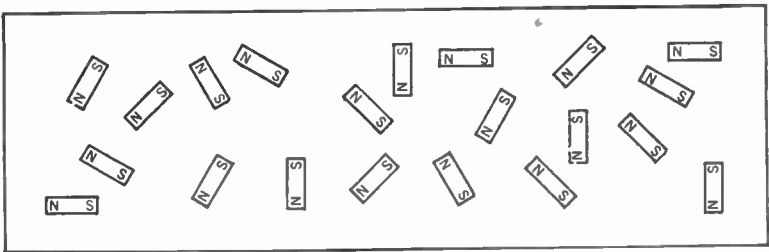

Figure 242. Helter-skelter arrangements of particles of a piece of unmagnetized iron.

Let us see how scientists explain these facts. The electrons of an atom, you will recall, move through the dielectric field within the atom and set up a magnetic field. Thus each atom becomes

**MAGNETISM, MOTORS, AND MEASURING INSTRUMENTS 345**

a small magnet. In an ordinary substance these small magnets are arranged helter-skelter and the magnetic fields neutralize each other, with the result that there is no external magnetic field.

But if the south pole of a lodestone, for example, is moved across a magnetic substance such as iron, say, in a left-to-right direction, all the north poles of the little magnets in the iron are attracted to the south pole of the lodestone and are left all facing to the right after the lodestone has passed.

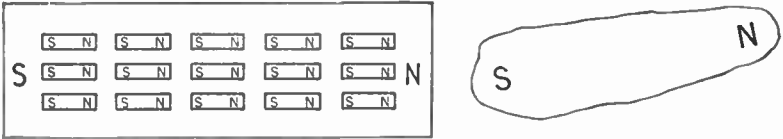

**Figure 243.** Orderly arrangement of particles of a piece of magnetized iron.

Thus the left end of the iron has all south poles and acts like a large south pole. The right end becomes a large north pole. The magnetic fields about the atoms of the iron no longer neutralize but aid each other. The iron now has an external magnetic field. We say it has been *magnetized* and is now a magnet.

We can now see why a single magnetic pole cannot exist by itself. No matter how often we break a magnet, there will always be a number of atoms lined up to give us a north and south pole.

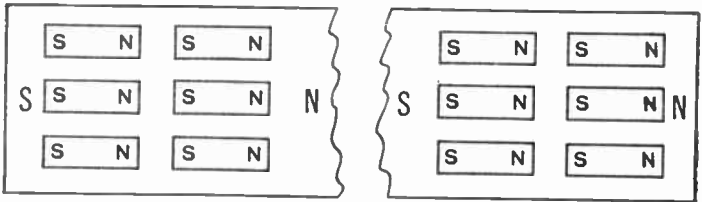

**Figure 244.** Why we get two magnets, each with a complete set of poles, when we break a magnet in half.

**279. The Pattern of a Magnetic Field**

It was also found that the magnetic force can act through any substance that is not magnetic. Thus a magnet may attract iron filings through a piece of paper.

Place a magnet on a wooden table and cover it with a piece of cardboard. Sprinkle on iron filings and tap the cardboard gently.

### 346 MAGNETISM, MOTORS, AND MEASURING INSTRUMENTS

The iron filings arrange themselves in the pattern shown in Figure 245.

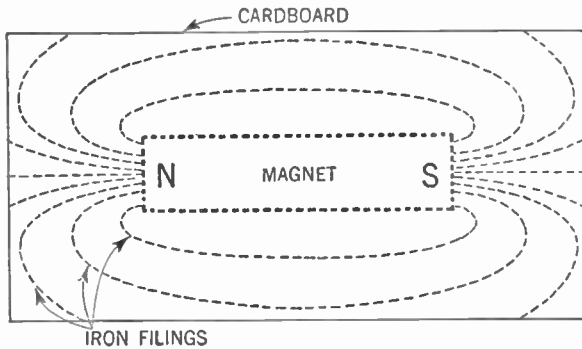

**Figure 245.** How to get a pattern of the lines of force around a magnet by the use of iron filings.

The iron filings follow the magnetic lines of force, and thus we get a picture of what we call the *magnetic field* around a magnet. These lines of force pass through the inside of the magnet from atom to atom and through the space around the magnet in ever-widening loops. The lines of force outside the magnet can attract magnetic substances such as iron filings but those lines

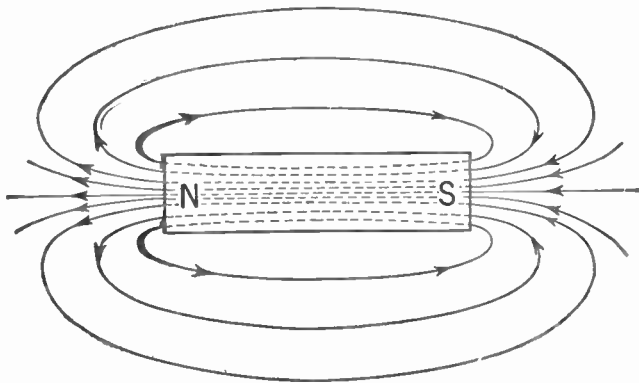

**Figure 246.** Pattern of lines of force around a magnet showing the direction of the field.

flowing through the magnet have no external effects. Thus the space directly above the magnet is clear of iron filings.

The *direction* of the magnetic field is said to be from the north pole to the south pole. The field around a magnet is then rep-

resented by Figure 246, the arrowheads indicating the direction of the field.

Note that the lines of force are more numerous around the poles of the magnet.

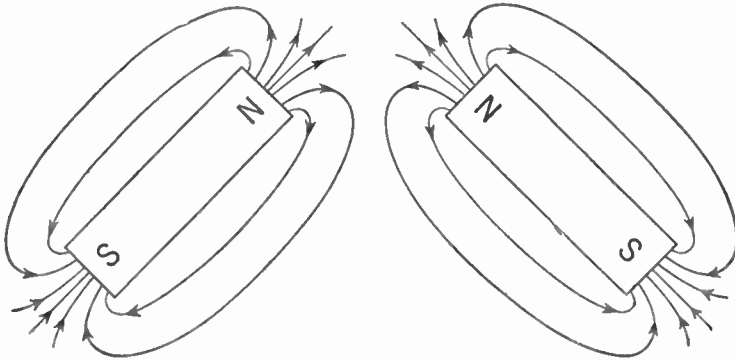

**Figure 247. Why two like poles repel each other. Notice that the fields are in opposition.**

We are now able to see why like magnetic poles repel each other and unlike poles attract. When two like poles are brought near each other, the magnetic field about them is as shown in Figure 247.

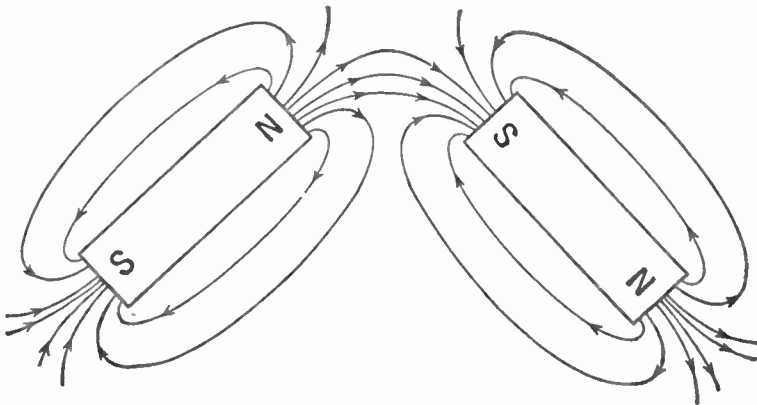

**Figure 248. Why two unlike poles attract each other. The fields aid each other. Some lines of force go from one magnet to the other.**

The two magnetic fields oppose each other and the poles are pushed apart.

If, however, two unlike poles are brought near each other, the magnetic fields about them is as shown in Figure 248. The two

magnetic fields aid each other and the poles are attracted.

### 280. Permanent and Temporary Magnets

Some substances, like steel, retain their magnetism after the magnetic field used to magnetize them has been removed. We call such magnets *permanent magnets*.

Other substances, like soft iron, remain magnets only when they are in the field of another magnet. After these fields are removed, the atoms of the soft iron go back to their helter-skelter positions and the soft iron loses its magnetism. We call such magnets *temporary magnets*.

Since it is the orderly arrangement of the atoms that makes a permanent magnet, we would expect the magnetism to be destroyed if this order were upset. Such is the case. Jarring or heating a permanent magnet disarranges the atoms and the magnetism is lost.

### 281. Units of Measurement of Magnetism

We have seen that the *magnetic line of force* is a closed loop or path running from the north pole to the south pole. The space through which these lines of force act is called the *magnetic field*.

The *magnetic flux* ( $\phi$ ) is equal to the sum total of the magnetic lines existing in the magnetic circuit and corresponds to current in the electric circuit. The unit of flux is the *maxwell*.

The *magnetomotive force* (M.M.F.), tends to drive the flux through the magnetic circuit and corresponds to the electromotive force of the electric circuit. The unit of magnetomotive force is the *gilbert*.

*Reluctance* ( $\mathcal{R}$ ) is the resistance a substance offers to the passage of magnetic flux and corresponds to resistance in the electric circuit. The unit of reluctance is the *oersted*.

We can state an analogy of Ohm's Law for magnetic circuits:

$$\text{Flux} = \frac{\text{Magnetomotive Force}}{\text{Reluctance}}$$

*Permeance* ( $\rho$ ) is the opposite of reluctance. It may be defined as the property of a substance which permits the passage of the magnetic flux. Substituting permeance as the reciprocal of reluctance in the above formula, we now get:

$$\text{Flux} = \text{Magnetomotive Force} \times \text{Permeance}$$

*Permeability* ( $\mu$ ) is the ratio of the flux existing in a certain

material to the flux which would exist if that material were replaced by air, the magnetomotive force acting upon this portion of the magnetic circuit remaining unchanged. The permeability of air is taken as unity (that is, 1) and all other substances except iron, steel, nickel, and a few others may be considered as having a permeability of unity. Iron and steel may have a permeability of from about 50 to more than 5,000.

**282. Electromagnetism**

In 1819 Hans Christian Oersted, a Danish physicist, brought a small compass near a wire that was carrying an electric current. This compass consisted of a small, magnetized needle pivoted at the center so that it was free to rotate. As he brought the compass near the wire, Oersted noticed that the needle was deflected. This discovery started a chain of events that has helped shape our industrial civilization.

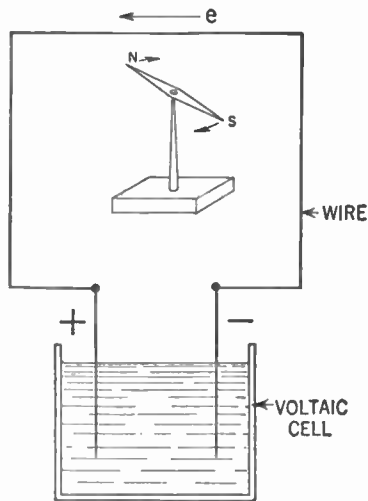

**Figure 249. Showing how the magnetic field around a conductor carrying an electric current deflects the compass needle.**

Let us see what caused the compass needle to be deflected. As was previously stated, scientists believe that when an electron moves through a dielectric field of force, it sets up a magnetic field.

Since a current flowing through a wire consists of a great many electrons in motion, we may expect to find a magnetic field around the wire. It is this magnetic field, reacting against the magnetic field of the compass needle, which causes the needle to deflect.

## 350 MAGNETISM, MOTORS, AND MEASURING INSTRUMENTS

Thus we see that the wire carrying the electric current acted like a temporary magnet. The magnetic lines of force, in the form of concentric circles around the wire, lie in planes perpendicular to the wire. The magnetic field exists only so long as the current flows. When the current is started through the wire, we may think of the magnetic field as coming into being and sweeping outward from the wire. When the flow of current ceases, the field collapses toward the wire and disappears. It was soon discovered that if the wire is formed into a coil, each turn adds its magnetic field to the other turns' fields and the result is a stronger magnet. We call such a magnet an *electromagnet*.

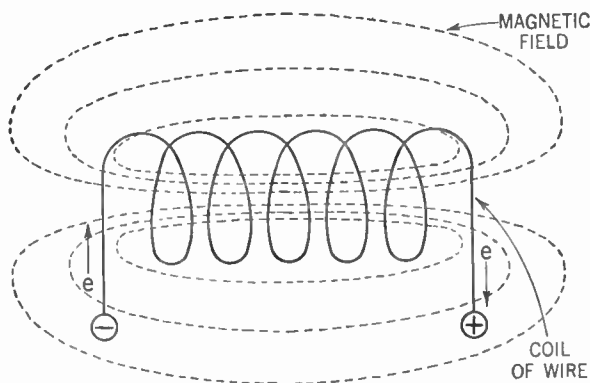

Figure 250. The magnetic field around an electromagnet.

### 283. Ampere Turns

Scientists evolved a formula to show the relationship between the magnetomotive force, the electric current flowing through the coil, and the number of turns or loops in the coil. It is

$$\text{M.M.F.} = 1.257 \times I \times N$$

where M.M.F. is the magnetomotive force expressed in gilberts,  $I$  is the electric current in amperes, and  $N$  is the number of turns in the coil.

From this formula we may see that the strength of an electromagnet depends upon the  $I \times N$  or *ampere-turns*. Thus an electromagnet of 100 turns with 1 amp. of current flowing through it is as strong as one of 10 turns with 10 amp. of current flowing through it. The number of ampere-turns is the same in each case, namely 100.

**284. Which End of an Electromagnet Is North?**

Of course, we can determine which end of a coil is a north pole and which end is a south pole by bringing the north pole of a compass needle near each end in turn. The north pole of the electromagnet repels the north pole of the compass needle while the south pole of the electromagnet attracts the north pole of the needle.

**285. The Left-hand Rule**

We have another method for determining the polarity of the electromagnet. If the coil is grasped in the left hand so that the fingers follow around the coil in the direction in which the electrons are flowing, the thumb will extend toward the north pole.

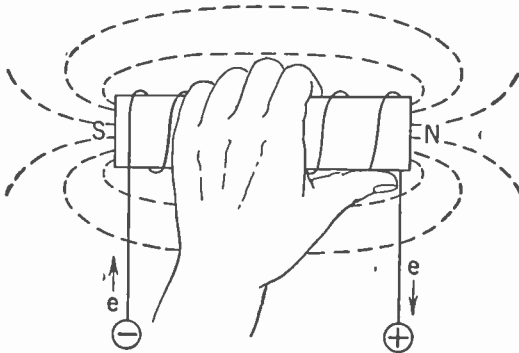

Figure 251. Method for determining the polarity of an electromagnet.

**286. Practical Electromagnets**

In the construction of an electromagnet it is customary to wind the coil upon a soft iron core. Since the permeability of the iron is greater than that of air, this tends to concentrate the lines of force in the core. Thus there is a greater concentration of these lines at the poles of the electromagnet with increased attracting power.

The electromagnet is one of our most important tools. Samuel Morse used it when he invented the telegraph. Using a switch or key he was able to control the flow of electric current through the coil. When the key was closed, the coil became an electromagnet that attracted a piece of iron and made it click against another piece of metal. When the key was opened the coil lost its magnetism and a spring pulled the piece of iron back. By means of a code of long and short intervals between clicks (dashes and



## 352 MAGNETISM, MOTORS, AND MEASURING INSTRUMENTS

dots) Morse was able to communicate with points many miles away over wires.

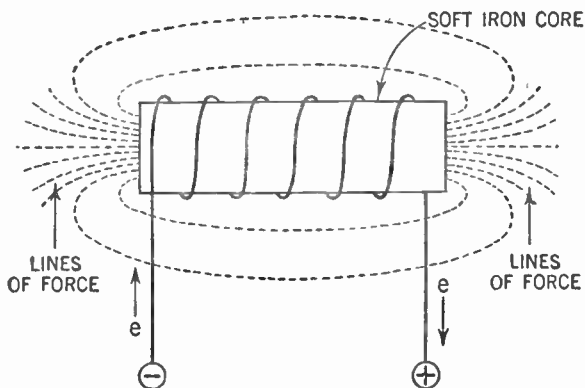

**Figure 252.** Diagram showing how lines of force of an electromagnet are concentrated at the poles by use of a soft iron core.

In our earphones we use the electromagnet to move the diaphragm to set up sound waves. In the electrodynamic speaker we employ an electromagnet with thousands of turns to give us the powerful field we need.

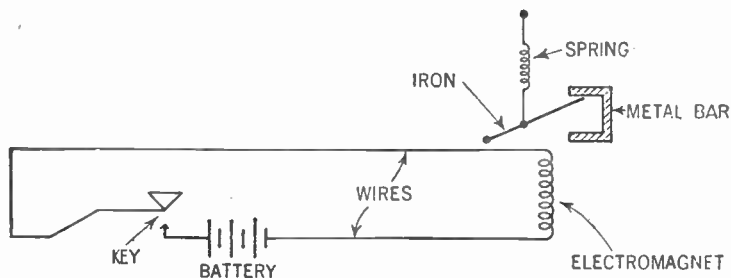

**Figure 253.** How the electromagnet is used in the telegraph.

In industry, tremendous electromagnets are built with a great many turns and carrying many amperes of current. These magnets are capable of lifting tons of iron at a time.

### 287. The Electric Motor

Perhaps the most important use to which the electromagnet has been put is in the electric motor. You will recall that when Oersted brought a compass needle near a current-carrying wire the needle was deflected. The wire was connected across a voltaic cell. Now, if Oersted had reversed the connections of the cell to

the wire so that the electrons streamed through in the opposite direction, the direction of the magnetic field would have been reversed and the needle deflected in the opposite direction.

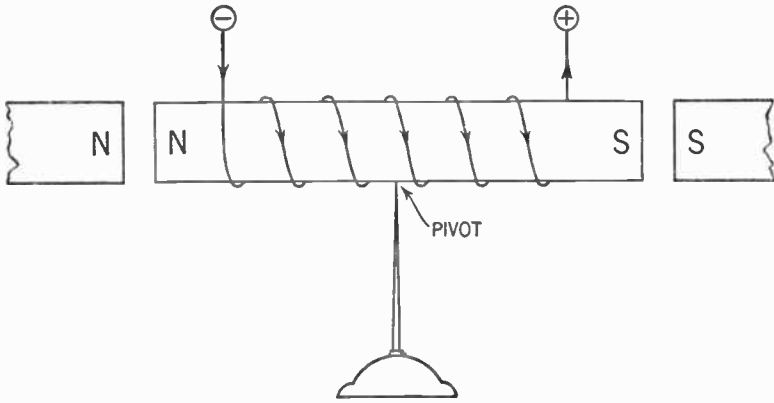

Figure 254. The electromagnet pivoted so that it may rotate between two fixed poles.

Now suppose you pivot an electromagnet so that it can rotate freely. Opposite one end of the electromagnet rigidly fix the north pole of a permanent magnet and opposite the other end fix the south pole of another permanent magnet (Figure 254).

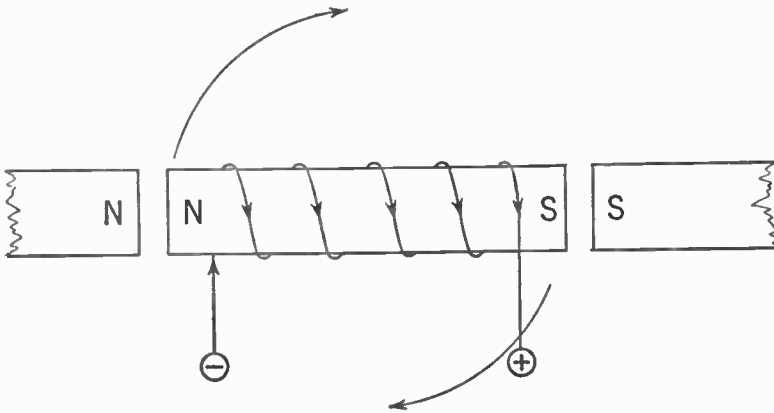

Figure 255. Looking down on the top of the electromagnet. Since like poles repel, the electromagnet is rotated in a clockwise direction.

Now pass an electric current through the coil of the electromagnet in such a way that the pole of the electromagnet facing the north pole of the permanent magnet becomes a north pole, and the pole facing the south pole of the permanent magnet be-

### 354 MAGNETISM, MOTORS, AND MEASURING INSTRUMENTS

comes a south pole. If you were looking down upon this device it would appear as in Figure 255.

The two north poles repel each other, as do the two south poles. The electromagnet revolves in a clockwise direction around its pivot, aided by the attraction between the north and south poles.

When the electromagnet has made a half-turn it will come to rest with the north poles facing the south poles and attracting each other.

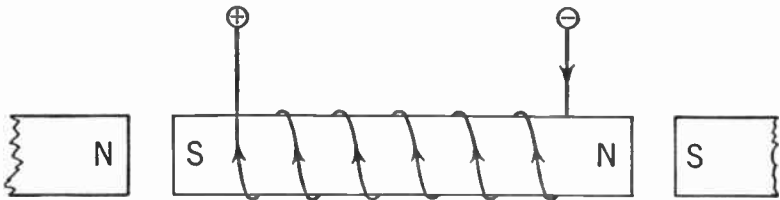

Figure 256. The electromagnet, having rotated a half turn, now comes to rest with unlike poles facing each other.

Suppose that at just this instant you reverse the direction of the flow of current through the electromagnet. Its poles will become reversed and once more it will be spun around in a clockwise direction.

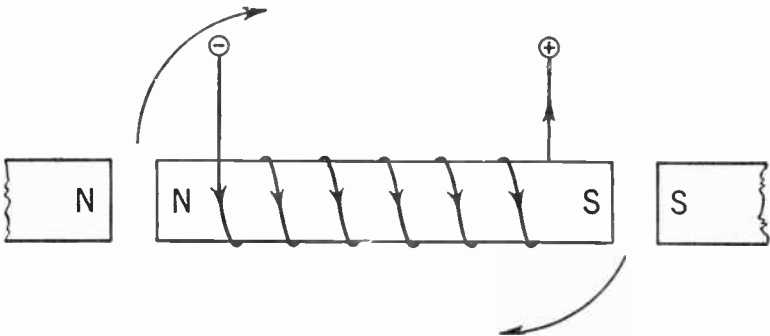

Figure 257. Now the direction of current flowing into the electromagnet is reversed. This reverses the poles of the electromagnet and, since now like poles are facing each other, the electromagnet is again rotated in a clockwise direction.

If this process could be continued, the electromagnet would continue to rotate. All we would need do, then, would be to attach a pulley to the electromagnet and we would have an electric motor.

The electromagnet and its soft iron core is called the *armature*. The permanent magnets are called the *field magnets*.

An ingenious device is used to reverse the direction of current through the coil of the armature at the proper time. Attached to the armature is a shaft. On this shaft and insulated from it is a metal band that had been split and slightly separated in the middle.

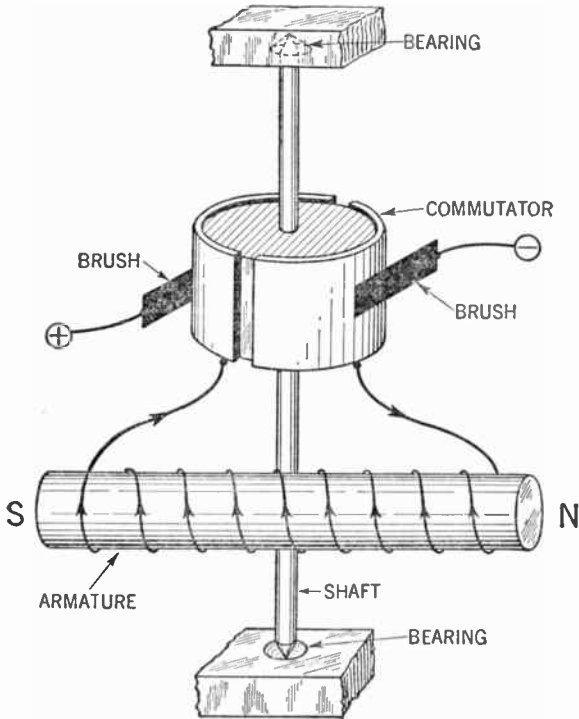

Figure 258. Figure showing the commutator and armature arrangement of the electric motor.

To each half of the metal band or ring one end of the wire of the electromagnet is attached. Pressing against each half of the ring is a springy strip of metal called a *brush*. These brushes are attached to a source of electric current and it is their function to transmit this current to the split ring and thus to the armature. The split-ring device is called the *commutator*.

This commutator rotates with the armature. When it is in one position the electrons flow in through the negative brush to one half of the commutator, to the coil of the electromagnet, to the other half of the commutator and out by means of the positive brush.

But as the armature makes a half turn, so does each half of

### 356 MAGNETISM, MOTORS, AND MEASURING INSTRUMENTS

the commutator, which thereupon comes in contact with the opposite brush. The electrons now flow into the opposite half of the commutator and thus through the coil in the opposite direction. This reverses the poles of the armature and it continues to rotate.

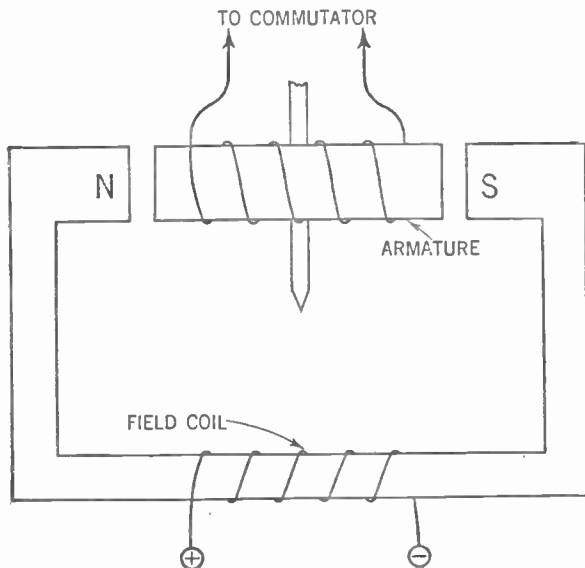

Figure 259. Diagram showing how an electromagnet is used to supply the field of a motor.

We can improve our motor by substituting another electromagnet for the field magnets. This new electromagnet is called the *field coil*. We may use either the same or another source of electric current to operate this field coil.

In our diagrams we usually represent the field electromagnet as

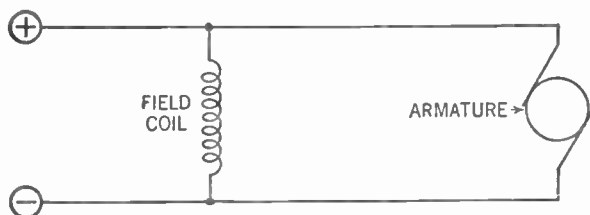
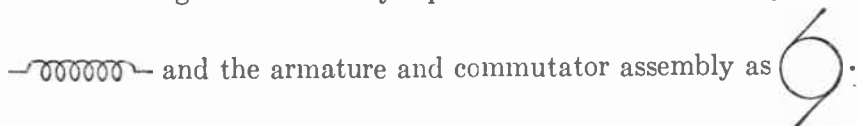

Figure 260. Hookup of a parallel or shunt motor.

### 288. Shunt-wound Motors

Of course, we may use the same source of current to operate both the armature and the field. We then have a choice of con-

## MAGNETISM, MOTORS, AND MEASURING INSTRUMENTS 357

nections. We may connect the field and armature in parallel as in Figure 260.

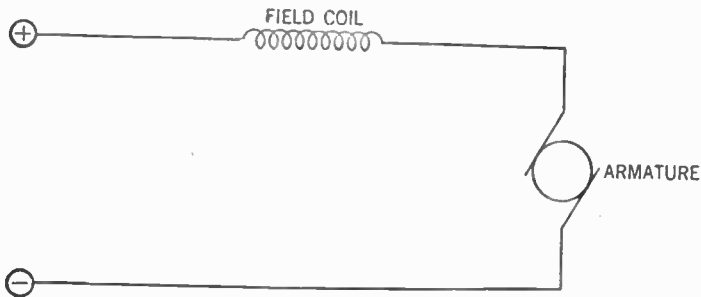

Figure 261. Hookup of a series motor.

Such a motor is called a *parallel* or *shunt* motor. Shunt motors have difficulty in starting if they are attached to a heavy load, but once started they run at a fairly constant speed regardless of load variations.

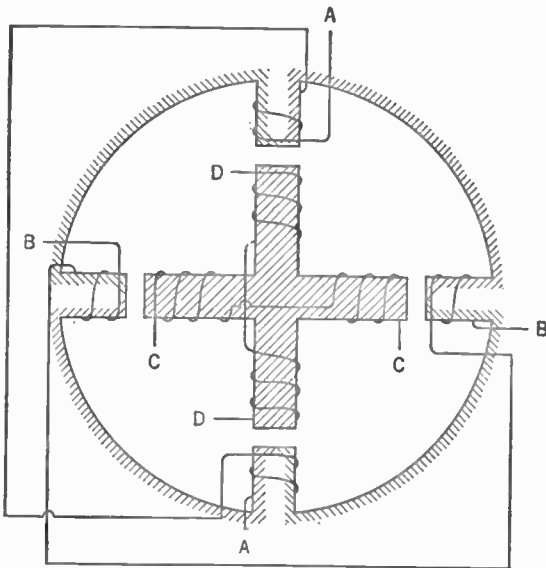

Figure 262. A four-pole motor with two sets of field and armature windings.

### 289. Series-wound Motors

Another method of connecting our motor is to have the field and armature in series.

Such a motor is called a *series* motor. A series motor can start

## 358 MAGNETISM, MOTORS, AND MEASURING INSTRUMENTS

with a large load but its speed falls off rapidly as the load is increased.

So far we have considered motors whose armatures had but two poles. We may build motors with more than one armature winding. These motors have four, six, eight, or more poles, having two poles for each additional armature winding.

### 290. Four-pole Motors

Figure 262 shows the diagram of a four-pole motor. The armature has two windings. The commutator now has four segments and each winding of the armature is connected to opposite segments. The field, too, has two windings.

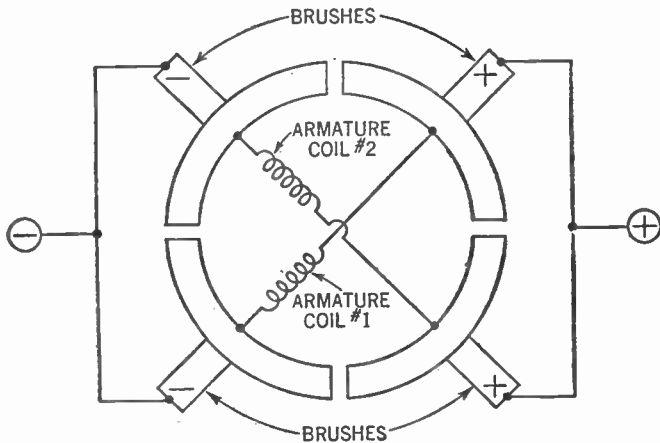

Figure 263. Diagram showing commutator connections for four-pole motor.

There are four brushes, one for each commutator segment. The two positive brushes are connected together and so are the two negative ones.

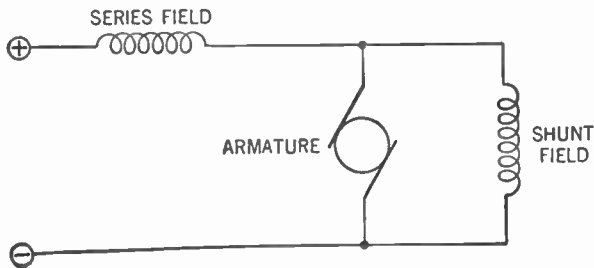

Figure 264. Hookup of a compound motor showing the arrangement of fields.

You see that you really have two motors wound together. This gives greater power.

With this motor you are able to connect one field in shunt with the armature and the other in series. Such a motor is called a *compound* motor and has some of the desirable features of both the series and shunt motors.

The speed of the motor may be controlled by changing the current (and thus the magnetic flux) produced by the field coils. This change is made by connecting a rheostat in series with the field coil.

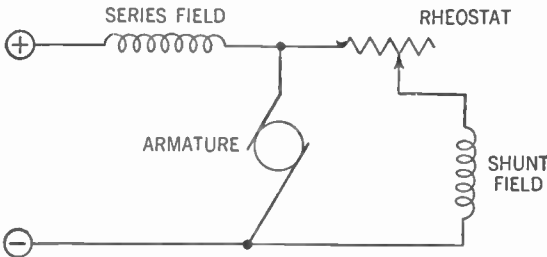

Figure 265. Hookup showing how a rheostat (R) is used to vary the speed of the compound motor.

## ELECTRICAL MEASURING INSTRUMENTS

### 291. The Galvanometer

We could not get very far in our study of electricity if we did not have instruments capable of measuring the electric current, the electromotive force, resistance, and so on, of our electrical circuits. One of the simplest and most widely used of such instruments is the *moving-coil galvanometer*.

Turn back to Figure 254, which is a diagram of a simple electric motor. Rotation of the armature is obtained by sending a current through the coil. The armature makes a half turn and stops with the north and south poles facing and attracting each other.

The strength of the field of the armature depends upon the number of its ampere-turns (see Paragraph 283). Since the number of turns is constant, the greater the current (that is, the more amperes) the stronger the field of the armature.

Suppose we have a spring pulling the armature back to its original position, that is, with the like poles facing each other.



## 360 MAGNETISM, MOTORS, AND MEASURING INSTRUMENTS

The pull of such spring opposes the repelling effect of the similar poles. The greater the repelling effect, the more the armature turns; the smaller the repelling effect, the more the spring pulls the armature back to its original position.

This repelling effect depends upon the interaction between the field of the permanent magnets and the field of the armature. Since the field of the permanent magnets is of constant strength, the stronger the field of the armature, the greater the repelling effect; and the weaker the field of the armature, the less the repelling effect.

But we have seen that the strength of the armature field depends upon the amount of current flowing through it. Therefore, the greater the flow of current through the armature coil, the greater the repelling effect and the more the armature will turn.

Here, then, is a device for measuring the flow of current. If a current of 1 amp. will cause the armature to make a quarter turn, a current of 2 amp. will cause the armature to make a half

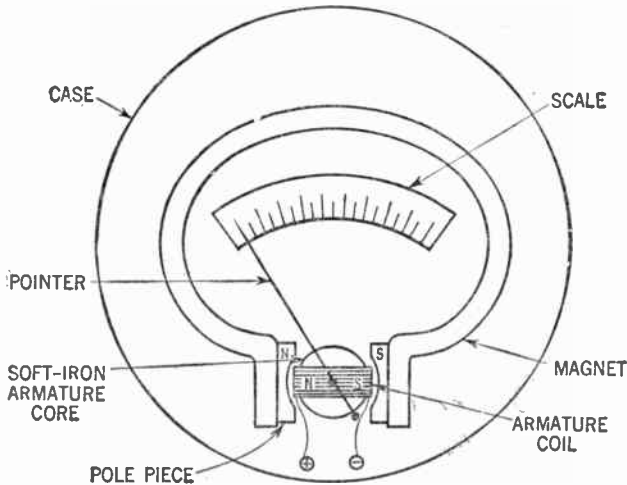

**Figure 266.** Diagram of the moving-coil or Weston galvanometer.

turn. All we need do is to fasten a pointer on the armature and by means of a scale we may determine the degree of rotation of the armature and thus the strength of the current.

### 292. The Moving-coil Type of Galvanometer

Figure 266 shows such an instrument, which is called a *Weston movement* after its inventor. The armature core is a soft iron ball

upon which is wound the armature coil, a number of turns of very fine wire. The complete armature is delicately pivoted upon jewel bearings and its rotation is retarded by a small spiral spring (not shown in this diagram). A light aluminum pointer is fastened to the core and moves with it.

Instead of two separate magnets, a horseshoe-shaped permanent magnet supplies the field. Attached to the poles of this magnet are two soft iron pole pieces which concentrate the magnetic field. Wires are brought from the armature coil to two binding posts and the whole instrument is enclosed in a glass-faced case to protect it from dust and air currents.

The maximum rotation of the armature is about a quarter turn in a clockwise direction. Care should be taken to send the current into it so that it does rotate in this clockwise direction, else the pointer may be twisted. For this reason the binding posts are marked plus (+) and minus (-) respectively. The plus binding post must be connected to the positive side of the electrical circuit and the minus binding post to the negative side.

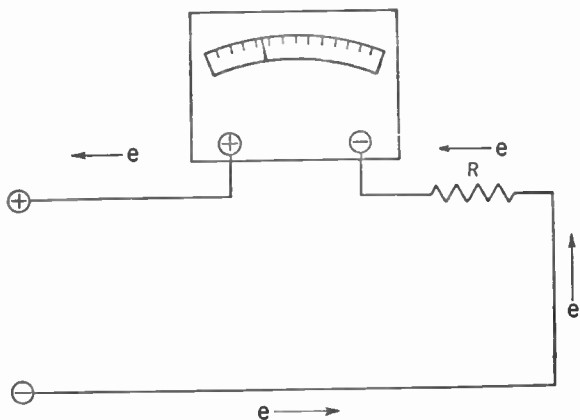

**Figure 267. Circuit showing how the galvanometer is used to measure the electric current flowing through a resistor (R).**

Since the armature coil consists of very fine wire, care must be taken not to send too much current through it, or it will burn up. The amount of current the usual type of galvanometer can safely stand is no more than a few milliamperes (a milliampere being one one-thousandth of an ampere). The symbol for the

galvanometer is: 

## 293. The Ammeter

Of course, there are many occasions when we desire to measure currents greater than the few milliamperes the galvanometer will safely carry. Under these conditions we connect a heavy copper bar, called a *shunt*, in parallel with the galvanometer.

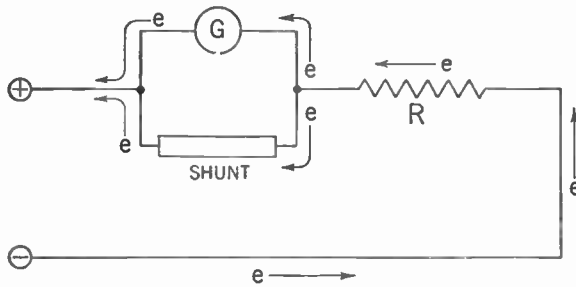

Figure 268. Circuit showing how an ohmmeter (galvanometer plus shunt) is used to measure the current flowing through the resistor (R).

From our study of parallel circuits we know that the electric current will divide when it reaches the junction of the galvanometer and the shunt. Part of the current will flow through the galvanometer and part will flow through the shunt. We also know that the greater portion of the current will flow through the path that offers lower resistance. If, then, the resistance of the galvanometer is 99 times as great as that of the shunt,  $\frac{99}{100}$  of the current will flow through the shunt and  $\frac{1}{100}$  will flow through the galvanometer.

Assume that if a current of 5 milliamperes (5 ma.) were to pass through the galvanometer, the pointer would reach the end of the scale (called full-scale deflection). Also assume that the resistance of the armature coil is 99 ohms.

Now connect a shunt whose resistance is 1 ohm in parallel with the galvanometer. The whole is then connected into the circuit as shown in Figure 268.

Assume that there is a full-scale deflection of the pointer of the galvanometer. How much current is flowing in the electrical circuit?

We know that 5 ma. must be flowing through the galvanometer because that is the amount of current which will give us a full-scale deflection. But we also know that 99 times as much current must be flowing through the shunt because the resistance of the

galvanometer is 99 times as great as is the resistance of the shunt. Therefore 99 times 5 ma. must be flowing through the shunt. This gives us 495 ma. which when added to the 5 ma. in the galvanometer gives us 500 ma. of current flowing in the complete circuit. The galvanometer scale is calibrated to read 500 ma. at full scale.

The galvanometer together with its shunt is called an *ammeter*.

The symbol for an ammeter is: 

Since we use it to measure the current which flows through a circuit, we must connect our ammeter in *series* in the circuit.

The shunt, as you can see, must be carefully calibrated (prepared as to electrical size and marked accordingly) to match the galvanometer, for unless the ratio between the resistance of the galvanometer and the resistance of the shunt have a precise ratio to one another, the readings on the galvanometer scale will be meaningless.

#### 294. Types of Ammeters

Some ammeters are built with shunts that are permanently connected inside the case of the instrument. We call these *internal-shunt ammeters*. Others have the shunt attached on the outside. These are *external-shunt ammeters*.

Ammeters come in a number of different ranges. The greater the current to be measured, the greater must be the ratio between the resistance of the galvanometer and the resistance of the shunt. Since the resistance of the galvanometer is fixed, therefore, the greater the current to be measured, the lower must be the resistance of the shunt.

Care must be taken not to use a low-range ammeter to measure high currents. The amount of current passing through the coil of the galvanometer may be great enough to burn it out. An ammeter must be used whose range is greater than the largest current we may encounter in the circuit to be tested.

#### 295. The Voltmeter

When we seek to measure the electromotive force of a circuit we wish to know the entire fall in potential between two points. Hence we must connect our galvanometer from the high potential (negative) side of the circuit to the low potential (positive) side.

### 364 MAGNETISM, MOTORS, AND MEASURING INSTRUMENTS

The instrument is therefore always connected in *parallel* with the circuit to be measured.

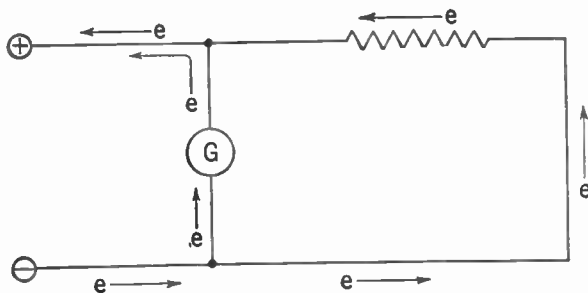

Figure 269. Circuit showing how a galvanometer is hooked up to measure the voltage of the line.

In this position there is danger that too much current may flow through the fine wire of the armature coil and burn it up. Of course, we may put a shunt across the galvanometer, but since the resistance of the shunt is very low the bulk of the current in the electrical circuit would flow through the shunt, leaving very little current to flow through the galvanometer and the rest of the circuit.

The difficulty is solved by placing a large resistor in series with the galvanometer. This resistor limits the amount of current that can flow through the galvanometer and thus serves to protect the coil from burning out and to force almost all the current to flow through the rest of the circuit. A certain amount of current is side-tracked through the galvanometer, but if the resistor in series with it is large enough, this amount is negligible.

We call a galvanometer with its *limiting resistor* (also called *multiplier*) a *voltmeter*. Although current is flowing through our voltmeter, the amount of current will depend upon the electromotive force in the circuit and will be in proportion to it. Our scale is now calibrated to read in volts. The symbol for a voltmeter is:



Here, too, we must take certain precautions. We must be sure that the current flows through the voltmeter in the right direction. Thus the binding post marked minus (—) must go to the high-potential (negative) side of the circuit and the post marked plus (+) to the low-potential side.

### 296. Practical Uses of Voltmeters

Voltmeters come in different ranges, each designed to measure a certain maximum electromotive force. The higher the voltage to be measured the greater must be the resistance of the limiting resistor. If we connect a voltmeter with a low range across a high-potential circuit, too much current may be forced through the armature coil and it will be destroyed.

We may use the voltmeter to measure the difference of potential across a part of a circuit; that is, between any two points in a circuit. In Figure 270 it is desired to measure the potential difference between the two ends of resistor  $R$ . This difference is called the *potential drop* across the resistor. There is a difference of potential because some of the electrical pressure is used up in forcing electrons through the resistor.

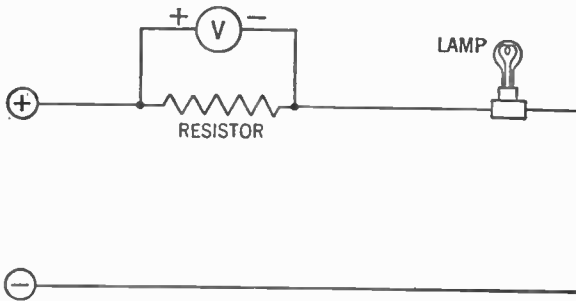

Figure 270. Circuit showing how the voltmeter is used to measure the potential drop across the resistor.

We connect the voltmeter so that the binding post marked minus goes to the high potential (—) side of the resistor. The other post goes to the low potential (+) side. The reading of the voltmeter in volts is the fall of potential or potential drop across the resistor.

### 297. How to Measure Resistance

We have a number of methods for finding the resistance of a resistor or other electrical device. Connect an ammeter in series with it to find how much current is flowing through it and connect a voltmeter across it to find its voltage drop. Connect a battery or other source of electricity together with a push button in the circuit. Press the button and take a simultaneous reading of the ammeter and the voltmeter.

### 366 MAGNETISM, MOTORS, AND MEASURING INSTRUMENTS

Assume the ammeter reads 5 amp. and the voltmeter reads 50 volts. From Ohm's Law we get:

$$R = \frac{E}{I} = \frac{50}{5} = 10 \text{ ohms}$$

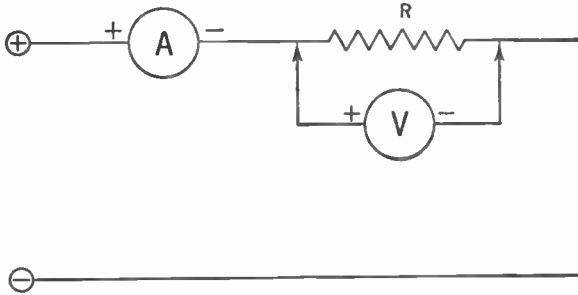

Figure 271. The voltmeter-ammeter method of finding the resistance of R.

### 298. The Ohmmeter

There is another method used to find the resistance of a resistor. Assume we have a galvanometer that gives us a full-scale deflection when 5 ma. (.005 amp.) of current passes through it. Let us connect it in series with a 3-volt battery and a 600-ohm resistor.

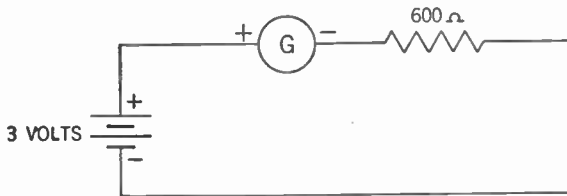

Figure 272. Circuit showing a 600-ohm resistor connected in series with a 3-volt battery and a galvanometer.

By means of Ohm's Law we can determine the amount of current flowing in this circuit. (We are ignoring the resistance of the galvanometer.) Thus:

$$I = \frac{E}{R} = \frac{3}{600} = .005 \text{ amp.}$$

In this case we get a full-scale deflection of the galvanometer.

Now assume we place another 600-ohm resistor in series with the first. Then the total resistance is 1,200 ohms. From Ohm's

## MAGNETISM, MOTORS, AND MEASURING INSTRUMENTS 367

Law you can see that only 2.5 ma. of current will flow in the circuit, half as much as before.

$$I = \frac{E}{R} = \frac{3}{1,200} = .0025 \text{ amp.}$$

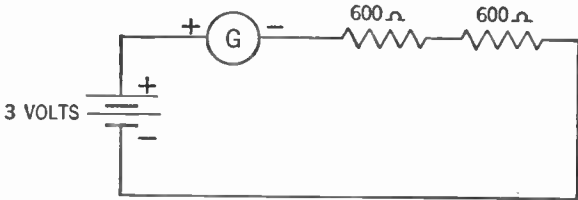

Figure 273. Circuit showing two 600-ohm resistors connected in series with a 3-volt battery and a galvanometer.

We now get a half-scale deflection of the galvanometer. By substituting different resistors for the second 600-ohm resistor in this circuit we get different deflections of the pointer of the galvanometer. On the scale we mark the location of the pointer with a series of known resistances.

We now have a device for finding the value of an unknown resistor. Figure 274 shows this circuit.

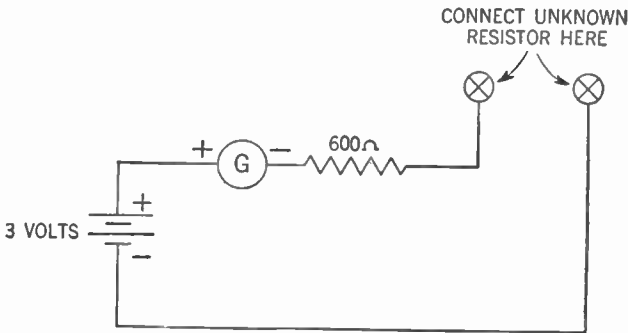

Figure 274. Circuit of the ohmmeter.

To determine the resistance of any device, all we need do is connect our unknown resistor to the two binding posts marked X. The pointer will be deflected according to the value of the unknown resistor. If the scale of the galvanometer is suitably calibrated we can tell the resistance of the unknown resistor by reading the deflection on the scale.

Such an instrument is called an *ohmmeter*.



299. The Wattmeter

There are several methods by which we may determine the electrical power (watts) consumed by an electrical circuit. Since we know that

$$\text{Watts} = \text{Volts} \times \text{Amperes}$$

we may connect a voltmeter in parallel with the circuit and an ammeter in series with it. Take the readings in volts and amperes.

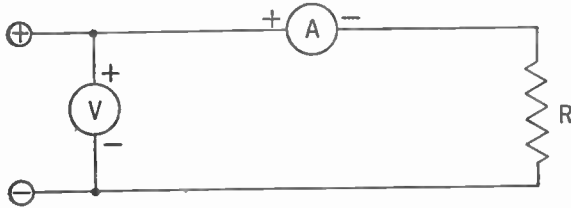

Figure 275. Circuit for calculating the power (watts) consumed by this hookup. Is this the same as the ohmmeter-voltmeter method of determining resistance?

If we multiply the number of volts by the number of amperes we get the number of watts.

There is another method for measuring the watts. In the galvanometer (Figure 266) we have the field of the armature re-

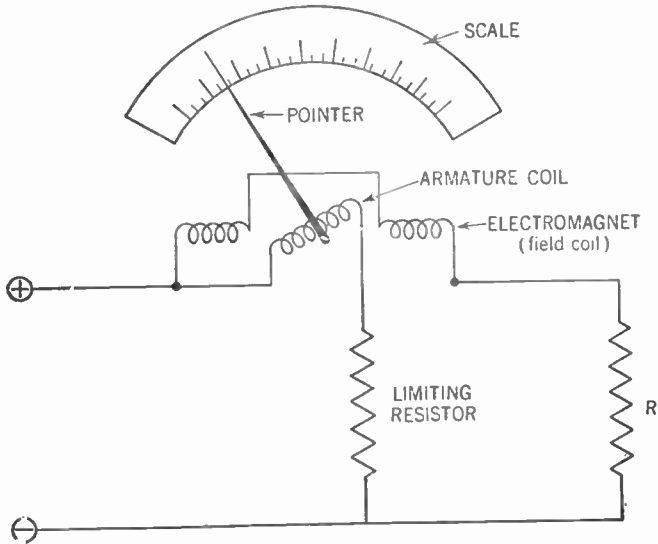

Figure 276. Circuit of wattmeter connected to measure power consumed by resistor (R).

acting against the field of the permanent magnet to give us the deflection of the pointer. You will recall that the field of the permanent magnet is constant and it is the variations of the armature field that gives us the variations of deflection.

Suppose we were to substitute an electromagnet for the permanent magnet and connect this electromagnet in series with the circuit. The amount of current flowing in the circuit would then determine the strength of the field of this electromagnet.

Now connect the coil of the armature (through a limiting resistor) in parallel with the circuit just as we connect a voltmeter. The electromotive force of the circuit will then determine the strength of the field of the armature.

Since the deflection is the result of the two magnetic fields acting on one another, the movement of the pointer will measure the product of the current flowing in the circuit and its electromotive force.

But the product of the current and electromotive force is equal to the number of watts of electrical power. Hence by proper calibration of the scale the deflection of the pointer can be made to indicate the number of watts consumed by the electrical circuit.

### SUMMARY

1. The magnetic field about a magnet consists of lines of magnetic force that run from the north pole to the south pole.

2. The pole of a freely suspended magnet that points to the north pole of the earth is called the north pole of the magnet. Such a freely suspended magnet is a **compass**.

3. A modern explanation of magnetism is: (a) an electron is surrounded by a dielectric field of force; and (b) when this field is moved relative to the electron a new field called the **magnetic field of force** is created.

4. A law of magnets is that **unlike poles attract, and like poles repel** each other.

5. **Electromagnets** are produced when an electric current is passed through a coil. The strength of the electromagnet is increased by a soft iron core.

6. The **direction** of the north pole of an electromagnet is the direction of the thumb of the left hand when the fingers of the hand grasp the coil in the direction of electron flow.

7. An electric motor consists of a movable electromagnet called an **armature** suspended between the poles of another magnet called the **field**. Motion is produced by the attraction and repulsion of the poles of the armature by the poles of the field. In order to keep the armature

## 370 MAGNETISM, MOTORS, AND MEASURING INSTRUMENTS

from coming to a stop, a device called a **commutator** causes the direction of the current in each coil of the armature to change automatically. The result is that as a pole of the armature approaches a field pole it is attracted, but the same armature pole is repelled at the instant it passes the field pole.

8. A **galvanometer**, a **voltmeter**, and an **ammeter** each consist of a movable coil of wire suspended by a spring in a permanent magnetic field. The turning of the coil is caused by the reaction of the magnetic field produced around it with the magnetic field of the permanent magnet. The amount of reaction and turning is proportional to the current in the coil.

9. **Voltmeters** must be connected **parallel** to the circuit to be measured and **ammeters** must be connected in **series** with the circuit to be measured.

10. The pointer in an **ohmmeter** moves in inverse proportion to the resistance coupled in series with it.

### GLOSSARY

**Ammeter:** A galvanometer with a very low resistance across the coil designed to measure current in amperes.

**Dielectric Field of Force:** The energy field surrounding a charged particle (also known as electrostatic or electric field).

**Electromagnet:** A magnet created by passing a current through a coil.

**Galvanometer:** A device similar to a motor, designed to measure very small currents or voltages.

**Gilbert:** The unit of magnetomotive force.

**Lodestone:** A natural magnet.

**Left-hand Rule:** The rule for determining the polarity of an electromagnet.

**Magnetic Field of Force:** The energy field surrounding a magnet.

**Magnetic Poles:** Points of concentration of the magnetic strength of a magnet.

**Magnetic Lines of Force:** The imaginary lines in the field of force along which the force makes itself felt.

**Magnetic Flux:** The sum total of the magnetic lines of force.

**Maxwell:** The unit of magnetic flux.

**Magnetomotive Force:** The force creating magnetic flux.

**Motor:** A magnetic device that changes electrical energy into the energy of rotary motion.

**Multiplier:** A limiting resistor in series with a galvanometer coil, used to convert the latter into a voltmeter.

**N-seeking Pole:** The pole of a freely swinging magnet pointing toward the earth's north magnetic pole.

**Oersted:** The unit of reluctance (not in current use).

**Ohmmeter:** A galvanometer adapted to give direct readings of the resistance of a resistor.

**Permanent Magnet:** A magnet retaining most of its magnetism after any magnetizing force is removed.

**Permeability:** The ratio of the flux existing in a certain material to the flux which would exist if that material were replaced by air, the magnetomotive force acting upon this portion of the magnetic circuit remaining unchanged.

**Permeance:** The reciprocal of reluctance.

**Reluctance:** The resistance to passage of magnetic flux.

**S-seeking Pole:** The pole of a freely swinging magnet which points towards the earth's magnetic south pole.

**Shunt:** A low-value resistor hooked up in parallel with a galvanometer when it is to be used as an ammeter.

**Temporary Magnet:** A magnet that loses most of its magnetism after any magnetizing force is removed.

**Voltmeter:** A galvanometer with a high series resistor used to measure voltage.

**Wattmeter:** A modified galvanometer used to measure directly the power consumed in a circuit.

### QUESTIONS AND PROBLEMS

1. How does an electron make its influence felt on another electron?
2. How does a magnet make its influence felt on another nearby magnet?
3. What is one theory for the making of a magnet?
4. How would a freely swinging horizontal magnet align itself? Why?
5. Like magnetic poles (?) ; unlike magnetic poles (?) .  
Explain why.
6. How is the magnetizing of a piece of steel by rubbing it with a lodestone explained?
7. Draw a sketch of the lines of force inside and outside a bar magnet.
8. What is the conventional direction of the lines of force outside a bar magnet? Inside the bar magnet?
9. What is a temporary magnet? A permanent magnet?
10. What is meant by magnetic flux and how is it measured?
11. What is meant by magnetomotive force and in what unit is it measured?
12. What is meant by magnetic reluctance?
13. State the analogue of Ohm's Law for magnetic flux.
14. What contribution did Oersted make to the study of electromagnetism?
15. What effect occurs when a current is impressed through an electrical conductor? What occurs when the current is cut off?
16. What is the mathematical formula for computing the magnetomotive force?
17. State the rule for determining the polarity of an electromagnet.

## 372 MAGNETISM, MOTORS, AND MEASURING INSTRUMENTS

18. How may the strength of an electromagnet made of wire wound on a cardboard form be increased? Explain why.
19. Where and in what manner are electromagnets used practically?
20. Draw a diagram of a motor and explain its operation, indicating all functional parts.
21. Compare the characteristics of a series wound motor, a shunt wound motor, and a compound wound motor.
22. Explain the construction and operation of a moving-coil galvanometer.
23. Explain how a shunt in an ammeter enables us to place the instrument in a circuit of high current.
24. How is an ammeter connected in a circuit to measure the current flowing?
25. When measuring difference of potential across an electrical device, how is the galvanometer connected and how is it protected from burning out?
26. Explain the purpose and operation of an ohmmeter.
27. Explain the principles involved in the operation of a wattmeter.

## Alternating Currents—Theory and Measurement

---

- Problem 1:** *How are induced currents set up in a conductor?*
- Problem 2:** *What is Lenz's Law for induced currents?*
- Problem 3:** *How are alternating currents generated?*
- Problem 4:** *How are alternating currents represented by graphs?*
- Problem 5:** *How do we measure the electromotive force, the current, and the impedance of alternating currents?*
- Problem 6:** *What are the principles of operation of alternating-current meters?*
- 

### 300. Induced Electromotive Force

You will recall that Oersted discovered that when an electric current passes through a conductor, a magnetic field is created around that conductor. In 1831, Michael Faraday, an English scientist, discovered that when a magnetic field cuts across a conductor, an electric current is set flowing in that conductor.

It appears not only that a moving dielectric field of force produces a magnetic field, but also that a moving magnetic field of force produces a dielectric field. This dielectric field of force causes the electrons of the conductor to flow in a stream, which is another way of saying that an electric current is set flowing through that conductor.

It is not enough for the conductor to be *in* the magnetic field. In order that an electric current be set flowing, the conductor must be moving *through* that magnetic field.

### 301. Experiments with Induced Currents

Obtain a sensitive galvanometer whose zero point appears in the center of the scale. When current flows through the instrument in one direction the pointer is deflected one way; when the

### 374 ALTERNATING CURRENTS—THEORY AND MEASUREMENT

current is flowing through in the opposite direction, the pointer is deflected the other way.

Connect the ends of the galvanometer to a coil of about 50 turns of wire wound in the shape of a cylinder about 2 in. in

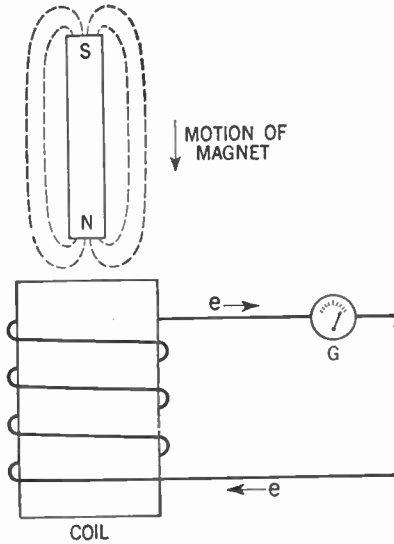

**Figure 277.** The magnet is plunged into the coil of wire. An electric current is induced in the coil.

diameter. Now plunge the north end of a permanent magnet into the center of the coil. Observe that the pointer is deflected to the right, showing that an electric current was set flowing for a moment in the coil and galvanometer.

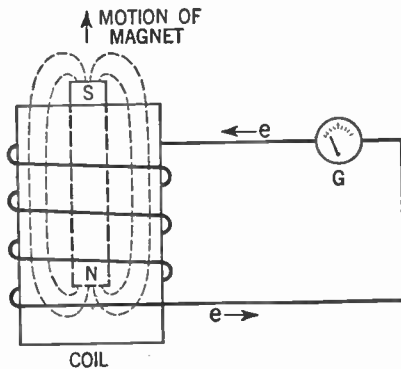

**Figure 278.** The magnet is pulled out of the coil. Once again an electric current is induced in the coil.

When the magnet comes to rest inside the coil the pointer swings back to zero, showing that the current has ceased flowing. Now remove the magnet from the coil. As you do so, the pointer swings to the left, showing that once more an electric current is set flowing, but this time in the opposite direction.

The same effect may be obtained if the magnet is held stationary and the coil moved. We call an electric current created in this manner as *induced current*.

**302: Direction of the Induced Current**

Experimentation has evolved a rule to determine in which direction an induced current will flow. Examine Figure 279. Here we have a conductor moving across a magnetic field set up between two poles of a horseshoe magnet.

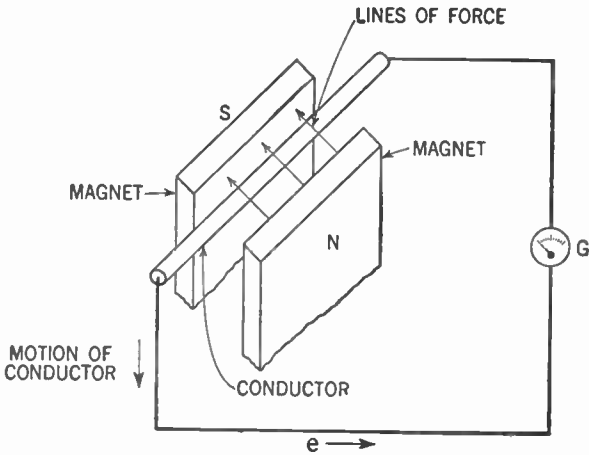

**Figure 279. Diagram of a conductor cutting across lines of force between poles of a magnet.**

**303. Left-hand Rule for Induced Currents**

Assume the conductor is moving down between the poles of the magnet. Extend the thumb, forefinger, and middle finger of the left hand so that they are at right angles to each other. Let the thumb point in the direction in which the conductor is moving (down). Now let the forefinger point in the direction of the lines of force (from the north to the south pole). The middle finger will then indicate the direction in which electrons will be set flowing by the induced electromotive force (toward the observer).



**304. Lenz's Law**

There is another important principle in connection with induced currents. Turn back to Figure 277. As the north pole of the magnet enters the coil, a current will be induced in this coil. You know already that when a current flows through a conductor it sets up a magnetic field around this conductor. Thus the coil becomes an electromagnet. The induced current in this coil is set flowing in such a direction that the end of the coil facing the north pole of the magnet becomes a north pole too. Since like poles repel, this arrangement of magnets tends to prevent the insertion of the north pole of the magnet into the coil. Work must be done to overcome the force of repulsion.

When you try to remove the magnet from the coil, the induced current is reversed. The top of the coil becomes a south pole and, by attraction to the north pole of the magnet, tends to prevent you from removing it. Thus, once again, work must be done, this time to overcome the force of attraction. You see, you must perform work to create the induced electric current. Of course, the same holds true if the magnet is stationary and the coil is moved.

These results may be summarized in a statement known as Lenz's Law: *An induced current set up by the relative motion of a conductor and a magnetic field always flows in such a direction that it forms a magnetic field that opposes the motion.*

**305. Strength of the Induced Electromotive Force**

We have seen that the induced electromotive force is set up only when lines of force are cut. From this it follows that the faster the lines of force are cut, the greater the induced electromotive force. Moreover, the stronger the magnetic field, the more lines of force there are. Hence, both the strength of the magnetic field and the rate of relative motion of conductor and magnetic field affect the electromotive force.

If we have two conductors cutting the lines of force, twice as many of the lines will be cut as if there had been only one conductor. Thus, by increasing the number of turns of the coil cutting across the magnetic field, we increase the electromotive force induced in the coil.

We may summarize by stating that *the strength of the induced*

*electromotive force depends upon the number of lines of force cut per second.* Experimentation has shown that 100,000,000 ( $10^8$ ) lines of force must be cut per second to produce an induced electromotive force of one volt. Hence, we see that the induced electromotive force may be increased by (1) increasing the number of turns of wire (2) increasing the speed of the relative motion (3) increasing the strength of the magnetic field.

### **306. Generating Alternating Electromotive Force**

In discussing the electromotive force generated by the chemical energy of the voltaic cell, we dealt with a continuous-current phenomenon; the voltaic current was always uniform and in the same direction. We referred to current of this nature as *direct current* (D.C.).

But in the case of induced electromotive force generated as shown in Figures 277 and 278, the current starts from zero (magnet outside the coil and at rest) and builds up in one direction (as the magnet enters the coil). The electromotive force dies down to zero again (magnet at rest inside the coil), then builds up in the opposite direction (as the magnet is being removed from the coil), and dies down to zero again (magnet at rest outside the coil).

We call this type of current *alternating current* (A.C.). Alternating current may be defined as *current which continually changes in magnitude and periodically reverses in direction.*

### **307. The Generator**

It is not practical to generate an alternating electromotive force by moving a magnet in and out of a coil of wire. The same result may be accomplished more easily by rotating a coil of wire between the poles of a powerful magnet. Such a device is called a *generator*.

Mount a single loop of wire so that it may be mechanically rotated on a shaft between the north and south-poles of a powerful magnet (Figure 280).

The two ends of the loop are connected respectively to two brass or copper rings, A and B, called *collector rings*, which are insulated from each other and from the shaft on which they are fastened. Thus, these collector rings rotate with the loop of wire. Two stationary brushes ( $A_1$  and  $B_1$ ) make a wiping contact with these

## 378 ALTERNATING CURRENTS—THEORY AND MEASUREMENT

rotating collector rings and lead the current that has been generated to the external circuit. These brushes are usually made of copper or carbon. This arrangement of loop, magnetic field, collector rings, and brushes constitutes a simple generator.

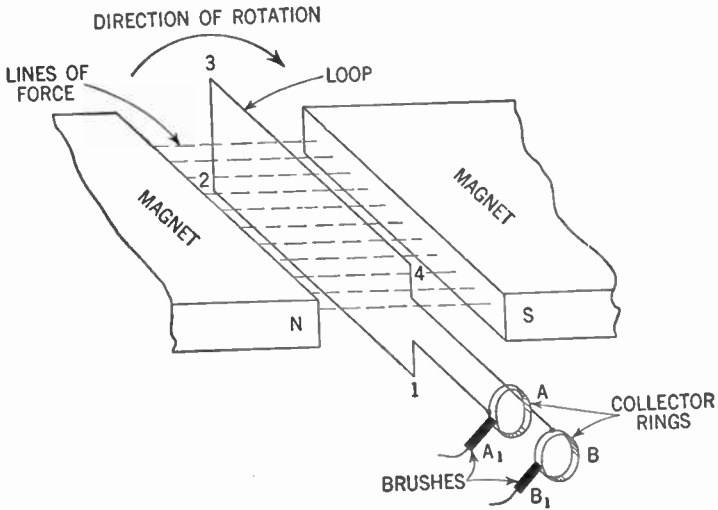

**Figure 280.** A simple alternating-current generator. It consists of a single loop of wire rotating in the magnetic field between two poles of a magnet.

### 308. How the Current Changes in One Complete Revolution

Let us assume that the loop starts from the vertical position as shown in Figure 280 and rotates at a uniform speed in a clockwise direction.

At this initial position no lines of force are being cut because the conductors 1-2 and 3-4 are moving parallel to the lines of force and not across them.

As the loop moves away from the vertical position, the conductors begin to cut across the lines of force at an increasing rate and therefore the induced electromotive force becomes larger and larger.

At the horizontal position (Figure 281) the loop has the maximum electromotive force induced in it, because a small rotation from this position causes the conductors 1-2 and 3-4 to cut across the maximum number of lines of force per second since the conductors are moving at right angles to the field.

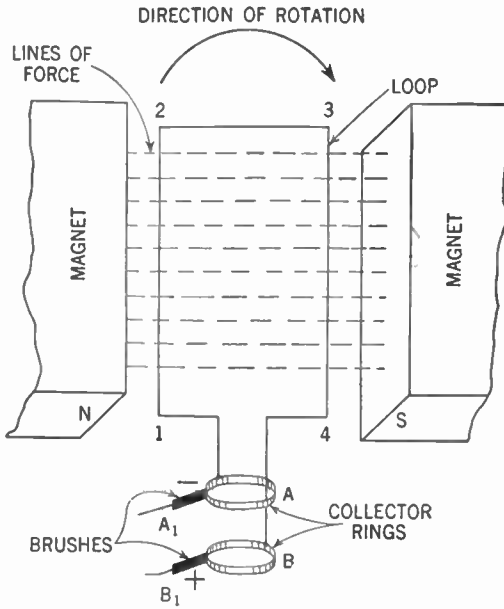

Figure 281. The loop after a quarter turn.

As the loop continues on to the vertical position of Figure 282, the electromotive force is still in the same direction but diminishes in value until at the vertical position it is again zero.

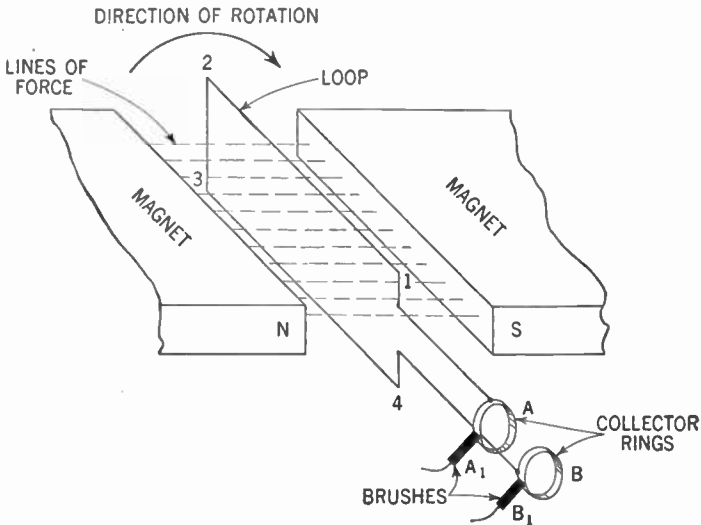

Figure 282. The loop after a half turn.

## 380 ALTERNATING CURRENTS—THEORY AND MEASUREMENT

The loop now has made one half turn, during which the induced electromotive force increased to a maximum and then gradually fell off to zero. Since now the conductors 1-2 and 3-4 are in reversed positions, the induced electromotive force changes in direction in both conductors. The electromotive force, however, again increases in strength and becomes maximum when the loop is horizontal (Figure 283).

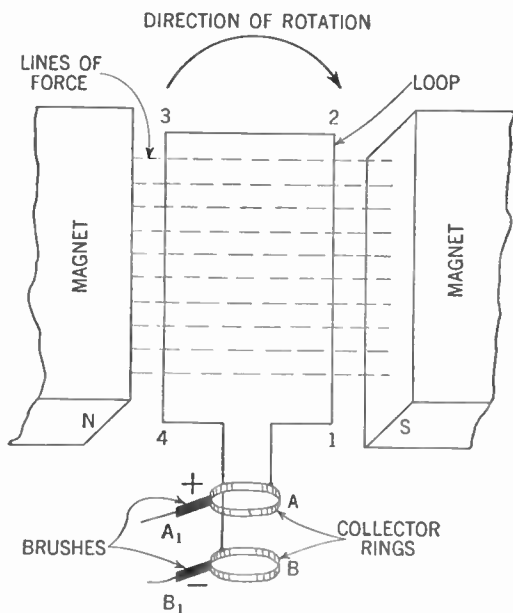

Figure 283. The loop after a three-quarter turn.

Finally, the last quarter of rotation brings the loop back to its original position (Figure 280), during which movement the electromotive force decreases to zero again. As the rotation is continued, the cycle of events is repeated over and over.

### 309. The Alternating-current Cycle

The term *cycle* really means circle—a circle or series of events which recur in the same order. A complete turn of the loop is a cycle. So also is the series of changes of the current. As the loop of the alternating-current generator makes one complete revolution, every point in the conductors describes a circle. Since a circle has 360 degrees ( $360^\circ$ ), a quarter turn would be equal to 90 degrees ( $90^\circ$ ), a half turn equal to 180 degrees ( $180^\circ$ ), a three-

quarter turn 270 degrees ( $270^\circ$ ), and a full turn 360°. The number of degrees measured from the starting point is called the *angle of rotation*.

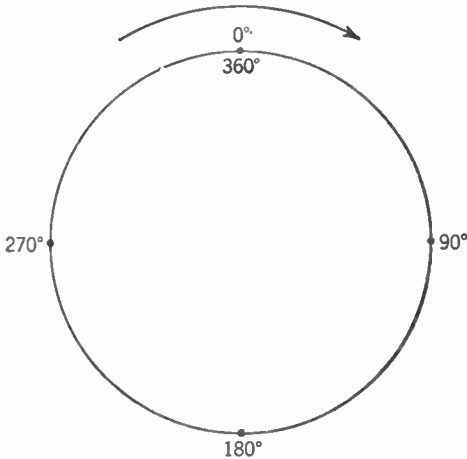

**Figure 284.** Figure showing degrees of a circle. If the complete circle is taken to stand for one revolution, then a quarter turn would amount to  $90^\circ$ , a half turn  $180^\circ$ , a three-quarter turn  $270^\circ$  and a full turn or revolution  $360^\circ$ .

Thus Figure 280 represents the  $0^\circ$  position, Figure 281 the  $90^\circ$  position, Figure 282 the  $180^\circ$  position, Figure 283 the  $270^\circ$  position, and Figure 280 again (after a complete revolution) the  $360^\circ$  position. Of course, positions in between these points may be designated by the corresponding degrees. However, it is customary to use the quadrants (that is, the four quarters of a circle) as the angles of rotation for reference.

Let us assume that the maximum electromotive force generated by this machine is 10 volts. We designate the direction in which the current flows by a plus (+) and minus (-). Now we are able to make a table as in Figure 285 showing the electromotive force being generated during each angle of rotation.

Angle of rotation .....	$0^\circ$	$90^\circ$	$180^\circ$	$270^\circ$	$360^\circ$
Induced E.M.F. (Volts) .....	0	+ 10	0	- 10	0
Time in Seconds .....	0	$\frac{1}{4}$	$\frac{1}{2}$	$\frac{3}{4}$	1

**Figure 285.** Table showing relationship between the degree of rotation of the loop, the induced voltage and the time (assuming the loop makes one revolution in a second).

You will note that in one complete revolution of the loop there are two positions (Figures 280 and 282), at which there is no in-

## 382 ALTERNATING CURRENTS—THEORY AND MEASUREMENT

duced voltage and therefore no current in the external circuit. There are also two positions (Figures 281 and 283), at which the voltage is at maximum value, although in opposite directions. At intermediate positions the voltage has intermediate values.

Assuming that the loop of our generator makes one complete revolution ( $360^\circ$ ) in 1 second, then at  $\frac{1}{4}$  of the second the loop would be at the  $90^\circ$  position, at  $\frac{1}{2}$  of the second the loop would be at the  $180^\circ$  position, and so on. Let us now look at the graph (Figure 286) which shows the induced electromotive force at various intervals in the 1 second required for the loop to make a complete revolution. The graph was made from the data in Figure 285. The time is plotted on the horizontal axis ( $x$ ) and the electromotive force on the vertical axis ( $y$ ).

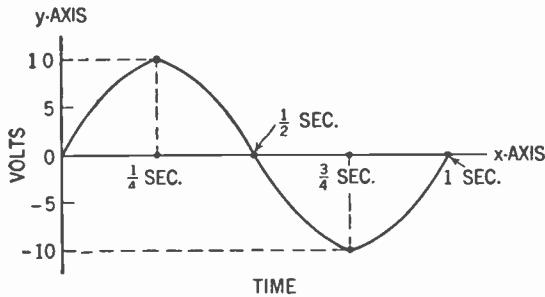

**Figure 286.** Curve showing relationship between time and the induced voltage.

Now you must not get the impression that the electric current is flowing in this scenic-railway type of path. Actually the current is flowing back and forth through the external circuit. What this curve does show, however, is the strength of the induced electromotive force and its direction (+ or -) at any instant during one revolution. So at the  $\frac{1}{4}$ -second mark, the electromotive force is 10 volts and is acting in the direction indicated by plus (+). At the  $\frac{3}{4}$ -second mark, the electromotive force again is 10 volts, but this time it is acting in the opposite direction as indicated by minus (-). In the interval between the  $\frac{1}{4}$ -second mark and the  $\frac{3}{4}$ -second mark the electromotive force changes from + 10 volts to - 10 volts, dropping to zero at the  $\frac{1}{2}$ -second mark, at which instant the electromotive force changes its direction.

We call an electromotive force whose strength and direction varies as indicated by the curve of Figure 286, an *alternating electromotive force*.

THE SINE CURVE

310. What Is a Sine?

We can represent the generation of an alternating electromotive force by means of a *sine curve*. As many of you know, the term "sine" has importance in mathematics. The sine of an angle is one of its trigonometric functions and can be represented very simply in terms of the sides of a right triangle. In Figure 287, the sine of angle *A* is equal to the opposite side of the triangle divided by the hypotenuse.

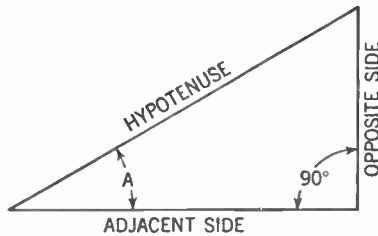

Figure 287. Diagram illustrating what we mean by the sine of an angle. The sine of angle *A* is equal to the value of the opposite side divided by the hypotenuse.

We can make a table to show the value of the sine for any angle. Figure 288 gives the sines of angles from 0° to 360° in 30° steps.

Angle . . . .	0°	30°	60°	90°	120°	150°	180°	210°	240°	270°	300°	330°	360°
Sine . . . . .	0	.50	.866	1.00	.866	.50	0	-.50	-.866	-1.00	-.866	-.50	0

Figure 288. Table showing relationship between angles (in 30° steps) and their respective sines.

If we were to make a graph of the sine of an angle plotted against degrees, we would get the sine curve (Figure 289).

311. Application of the Sine Curve

Note the resemblance of the sine curve to the curve of Figure 286.

The path the sine curve follows during the time the loop of the generator is making one complete revolution (360°) is called a *cycle*. The symbol for the cycle is  The number of



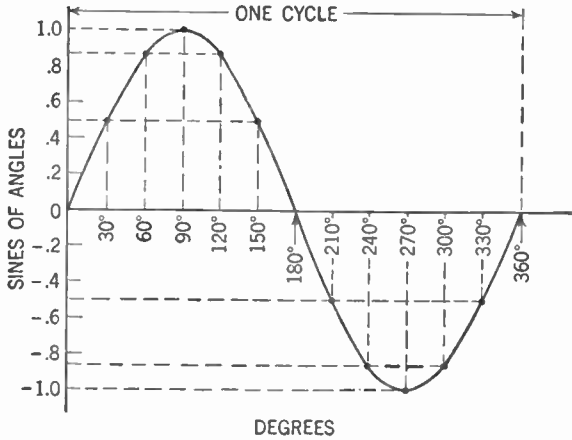

Figure 289. Curve showing relationship between angles (in 30° steps) and their respective sines. Note that this is merely another way of presenting the table in Figure 288.

cycles per second will depend upon the number of revolutions per second of the generator loop. The number of cycles per second is called the *frequency*. The symbol for frequency is *f*.

Since the loop of our generator makes one revolution per second, the induced electromotive force goes through one cycle per second and the frequency of the electromotive force is one cycle per second. The electric current set flowing through the loop by the induced electromotive force will have a frequency of one cycle per second also.

But if the loop were rotated 60 times per second, the induced electromotive force would go through one cycle in  $\frac{1}{60}$  second. The frequency would then be 60 cycles per second. This is the usual frequency of commercial alternating current. Radio-frequency currents have frequencies that may run into tens of thousands or even millions of cycles per second. No generator can be rotated at any such tremendous number of revolutions per second. But we have other means of producing high-frequency currents.

### 312. Maximum Value

As you now know, alternating electromotive force and current are continually changing in magnitude. That is, the instantaneous values are changing. From the sine curve you can see that there are two *maximum* or *instantaneous peak values* for each cycle, a positive maximum and a negative maximum.

**313. Average Value**

If you observe the sine curve of alternating electromotive force or current, you will see that the true average value for a full cycle is zero because there is just as much of the curve above the zero line (+) as there is below it (—). But when we use the *average values* in connection with alternating electromotive force or current we do not refer to the average of the full cycle, but to the average of a half cycle (or alternation, as it is also called).

To get the average it is merely necessary to add the instantaneous values of one alternation as plotted on a curve and divide by the number taken. It can be proved by higher mathematics that the average value of a half-cycle of a sine curve is equal to .636 times the maximum or peak voltage. Thus:

$$\text{average current} = .636 \times \text{maximum current}$$

and

$$\text{average E.M.F.} = .636 \times \text{maximum E.M.F.}$$

**314. Effective or Root Mean Square Value**

In practice we use neither the instantaneous nor average values of the electromotive force or current. To make alternating current compare as nearly to direct current as possible, it is necessary to use an *effective value*. In other words, we must find the value for the sine curve of alternating electromotive force or current which would have the same effect in producing *power* as a corresponding direct-current value. You will recall that the direct-current formulas for power are:

$$W = I^2R \quad \text{and} \quad W = \frac{E^2}{R}$$

From this relation you can see that the power is proportional to the square of the current ( $I \times I$ ) or to the square of the electromotive force ( $E \times E$ ). Thus we must get the average (or mean) of the instantaneous values squared (instantaneous value  $\times$  instantaneous value), and then calculate the square root of this average. To extract the square root of a number means obtaining another number which when multiplied by itself (squared) will give us the original number. Thus the square root of 100 is 10, for  $10 \times 10$  equals 100.

Because of the method used to determine it, the effective value

## 386 ALTERNATING CURRENTS—THEORY AND MEASUREMENT

is known as the *root mean square* (abbreviated to R.M.S.) *value*. By means of mathematics it can be proved that the effective value is equal to .707 times the maximum or peak value and that the peak value is equal to 1.41 times the effective value.

### 315. Method of Plotting a Curve

Before going further, let us be sure we understand the making of a graph. In Part I, Chapter 9, we explained graphs only to the extent necessary at that point. Now we need to be able to make graphs and to read them intelligently. When we make a graph we usually say that we *plot a curve*. We usually plot two sets of values *against* each other. Thus in the graph of Figure 289 we plotted degrees against the sines of angles.

In addition to the curve, the graph has two lines at right angles to each other. The vertical line is called the *Y axis* and the horizontal line the *X axis*. Along one of these axes we lay out, from the point of intersection of the two axes, one set of values and along the other we lay out the other set of values. We usually call all points *above* the *X axis* *positive* (+) values and all points *below* the *X axis* *negative* (—) values.

Thus (Figure 289) along the *X axis* we lay off the degrees and along the *Y axis* we lay off the sines of the angles. If we wish to find the point on the curve corresponding to the sine of  $90^\circ$ , we draw a line *upward*, perpendicular to the *X axis*, from the point on that axis marked " $90^\circ$ ." We draw this line upward because the sine of  $90^\circ$  is a positive value.

Then, from the point on the *Y axis* which corresponds to the sine of  $90^\circ$  (1.0), we draw a line perpendicular to the *Y axis* (and parallel to the *X axis*). Where these two lines meet (that is, at their intersection) is the desired point on the sine curve.

Similarly, we plot a number of such points, and then by connecting all these points with a continuous line we obtain the sine curve.

Sometimes, instead of referring to the *X* and *Y* axes, we designate the axes by the values plotted along them, in this case as the *degree axis* and the *sine of angles axis*.

### 316. Plotting Curves of Current and E.M.F. Together

Now let us see how the use of graphs helps us to understand electric currents. As you know, the electromotive force causes the

## ALTERNATING CURRENTS—THEORY AND MEASUREMENT 387

current to flow. Thus we should expect that when the alternating electromotive force reaches its maximum in one direction, the alternating current also will reach its maximum in that direction. When the electromotive force drops to zero, the current, too, will drop

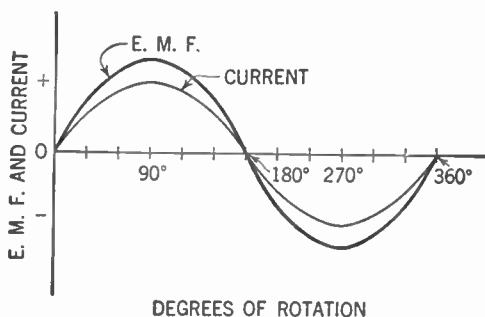

Figure 290. Curves showing the relationships between E.M.F. and current and the degrees of rotation. The two curves here are in phase.

to zero. We may show this relationship graphically by plotting the alternating electromotive force against degrees of rotation and, on the same two axes, plotting the alternating current against degrees of rotation (see Figure 290).

### 317. What Is Meant by Phase?

You will notice in Figure 290 that in both curves the electromotive force and current reach their maximum in the same direc-

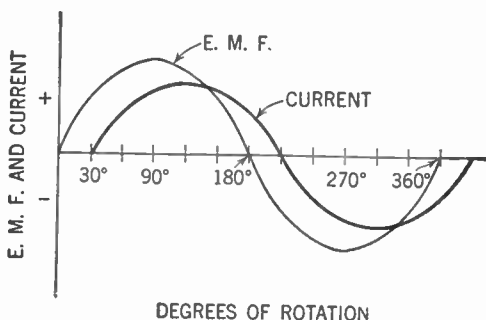

Figure 291. E.M.F. and current curves showing the current lagging  $30^\circ$  behind the E.M.F.

tion at the same time and are likewise at zero at the same time. When the electromotive force and current have this relationship to each other, we say that they are *in phase*.

But in practical circuits, for reasons we will discuss later, the

## 388 ALTERNATING CURRENTS—THEORY AND MEASUREMENT

electromotive force and current may not be in step with each other. The current may either lag behind or lead the electromotive force. We then say that the electromotive force and the current are *out of phase* with each other.

In Figure 291 we show such a condition.

Note that the electromotive-force curve reaches its peak  $30^\circ$  ( $30$  degrees) before the current curve and that it crosses the zero line  $30^\circ$  ahead of the current. We say the electromotive force is *leading* the current by  $30^\circ$  or that the current is *lagging*  $30^\circ$  behind the electromotive force. Another way of describing this condition is to say that the *phase angle* (the difference between the electromotive force and the current) is  $30^\circ$ . The symbol for phase angle is the Greek letter *theta* ( $\theta$ ).

### 318. Vectors

Mathematicians have given us another way of looking at the relationship between an alternating current and its electromotive force. In studying this principle we shall get a clearer understanding of the sine curve.

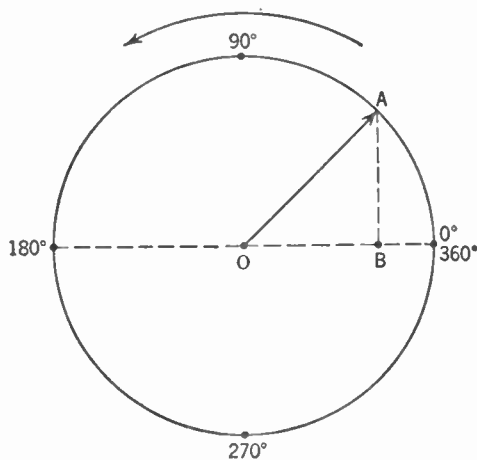
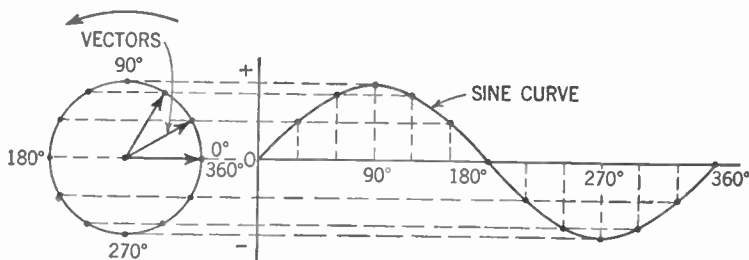

Figure 292. Diagram showing what is meant by a vector.

Let us represent the induced electromotive force by an arrow ( $OA$  in Figure 292) of unit length, fixed at one end to a point ( $O$ ) and free to revolve at a uniform rate about this point as a center, in step with the revolution of the generator. Thus, as the generator makes one complete revolution, the tip of the arrow will describe a circle or  $360^\circ$ .

## ALTERNATING CURRENTS—THEORY AND MEASUREMENT 389

The instantaneous electromotive force produced by the generator may be represented by dropping a line from the tip of the arrow perpendicular to the horizontal diameter of the circle. The length of this line ( $AB$ ) will indicate the instantaneous value of the electromotive force. By plotting these instantaneous values against degrees of rotation, as in Figure 293, we once more obtain our sine curve.



**Figure 293.** Diagram showing the relationship between the vector and sine-curve methods of representing alternating currents and voltages.

The position of the arrow (depending upon the degree of rotation), its direction (as shown by the arrowhead), and its magnitude (as indicated by the length of the line from its tip to the horizontal diameter of the circle) at any instant is called the *vector* of the electromotive force. A vector is the representation of any force or motion by a line. The *direction* of the force or motion is shown by an arrow, while the *magnitude* is shown by the length of the line drawn to some defined scale. Every vector must have definite length and direction. A *vector quantity* is any quantity that can be expressed by a line, such as force, acceleration, or velocity. The magnitude of the electromotive force can be pictured by choosing any convenient scale. Thus a vector 1 in. long may be taken to represent, say, 10 volts. Under these circumstances, a vector 2 in. long would then represent 20 volts; 3 in. would stand for 30 volts; and so on.

Of course, we may have a vector picture for the current as well as for the electromotive force.

### 319. Vector Diagrams May Show Phase Relationship

We can show the phase relationship between electromotive force and current by means of these vector diagrams. We do so by picturing both vectors as connected to the same center. Thus,

## 390 ALTERNATING CURRENTS—THEORY AND MEASUREMENT

if we wish to show the current as lagging  $30^\circ$  behind the electromotive force we picture this relationship as in Figure 294.

The angle between the electromotive force ( $E$ ) vector and the current ( $I$ ) vector is the phase angle. The lengths of the vectors are independent of each other and depend upon the scales selected for each.

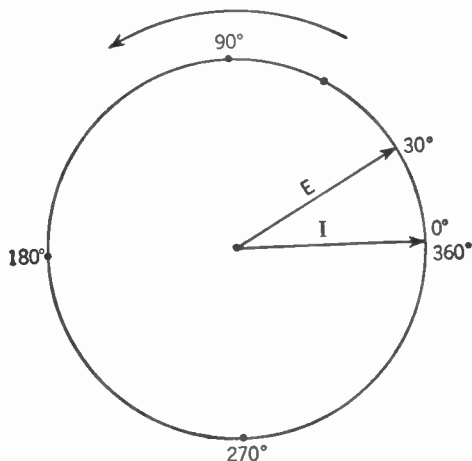

Figure 294. Vector diagram showing the current ( $I$ ) lagging  $30^\circ$  behind the E.M.F. ( $E$ ). Compare this diagram with the curve in Figure 291.

In practice, when we draw our vector diagrams, we omit the circle around them and indicate the phase angle numerically.

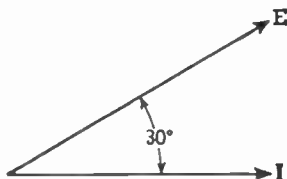

Figure 295. In practice the circle is omitted from the vector diagram. This is analogous to Figure 294.

### 320. Addition of Alternating Electromotive Forces or Currents by Vectors

When we wish to add the electromotive forces from two batteries, the process is a simple problem in addition. The electromotive force from a battery always flows in one direction and is constant in value.

But when we wish to add together two alternating electromotive forces we have a different problem. In an alternating elec-

tromotive force, not only is the direction periodically changed but the value is likewise constantly changing. Moreover, the two electromotive forces may not be in phase.

Since the vector represents the magnitude and direction of an alternating electromotive force at a certain instant, we may use vectors to solve our problem.

Assume that the vector for one electromotive force is represented by line  $OA$  in Figure 296. Assume you wish to add another electromotive force that is twice as great as the first, and the vector of this second is represented by line  $OB$ . Join the two vectors at point  $O$ , making the angle between them equal to the angular difference in phase.

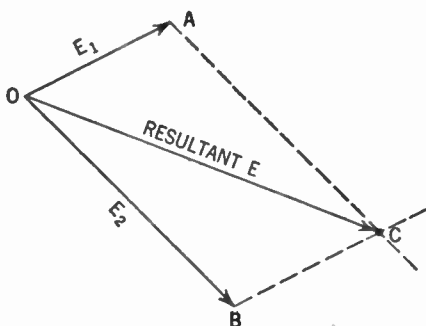

Figure 296. Vector diagram showing how two voltages ( $E_1$  and  $E_2$ ) are added together to give the resultant voltage (Resultant  $E$ ).

Now from point  $A$  draw a line parallel to  $OB$  and from point  $B$  draw a line parallel to  $OA$ . These two lines intersect at point  $C$ , thus completing a parallelogram. Draw line  $OC$  with an arrow-head toward point  $C$ . This line is the vector of the electromotive force resulting from the addition of the other two electromotive forces. In summary, to find the resultant of two electromotive forces we draw vectors to represent the magnitudes and directions (angular difference) of the two electromotive forces. On these lines we construct a parallelogram. The resultant electromotive force is the diagonal of the parallelogram from the point of origin of the two vectors to be added.

We follow the same procedure in adding together two alternating currents.

### 321. Impedance

The rules and formulas that we use in connection with direct-current circuits must be modified in order to apply to alternat-



## 392 ALTERNATING CURRENTS—THEORY AND MEASUREMENT

ing-current circuits. These formulas are intended to compute instantaneous values only. If we are to use effective values of electromotive force and current, we must take into consideration certain factors not present in direct-current problems. For example, if a steady direct current is flowing through a coil, the only resistance encountered by the current is the resistance of the coil itself. But if an alternating current is set flowing through the coil not only is its flow opposed by the resistance of the coil, but moreover the magnetic field set up around the coil, unlike the field set up by the direct current, is constantly expanding and collapsing. Thus the magnetic field is continually cutting across the coil itself, setting up a counter-electromotive force, the effect of which is to further oppose the flow of current.

The total opposition to the flow of alternating current in a circuit is called the *impedance*. Since it is an opposition to the flow of current, it has the same unit of measurement as resistance, that is, the *ohm*. The symbol used to represent impedance is  $Z$ .

Under special conditions where the voltage (electromotive force) and current are in phase, the impedance and the resistance of the circuit are identical. But where the voltage and current are out of phase, the impedance is always *greater* than the resistance. The method for finding how much greater the impedance is for any value of phase angle will be taken up later.

### 322. Ohm's Law for Alternating Currents

If we replace  $R$  in the direct-current Ohm's Law by  $Z$ , it will apply to alternating-current circuits. Thus Ohm's Law for alternating current can be written as follows:

$$I = \frac{E}{Z} \quad \text{or} \quad E = I \times Z \quad \text{or} \quad (\text{Impedance}) \quad Z = \frac{E}{I}$$

### 323. Power Factor

We have seen that in direct-current circuits, the electrical power may be calculated by means of the following formula in which  $W = \text{power}$ :

$$W = E \times I$$

This holds true of alternating-current circuits as well *if* we merely consider *instantaneous* values. Then,

$$W_{\text{instantaneous}} = E_{\text{instantaneous}} \times I_{\text{instantaneous}}$$

Of greater importance to us are the effective values. Thus:

$$W_{\text{effective}} = E_{\text{effective}} \times I_{\text{effective}}$$

The formula for the effective or apparent power holds true only as long as the voltage and current are in phase, that is, as long as they reach their respective peaks at the same instant and reach zero together. When they are out of phase (see Figure 291), there are times during the cycle when the voltage is negative while the current is positive and vice versa. During those intervals when the voltage and current have opposite signs, current is being fed back into the source. This means that there is *less* power in the external circuit than is indicated by the apparent power. Under such conditions, the *true power* is always less than the *apparent power*.

The ratio of the true power to the apparent power is called the *power factor*. Thus:

$$\text{power factor} = \frac{\text{true power}}{\text{apparent power}}$$

This ratio may be expressed either as a fraction or as a percentage. We may say that the power factor is, for example,  $\frac{1}{2}$  or 50%. Where the current and voltage are in phase, the apparent power is equal to the true power. The power factor in this case is unity, that is, 1, or 100%. The power factor can never be greater than unity or 100% (see Paragraph 367).

### 324. Adding Alternating and Direct Current

Alternating and direct currents may be added together. Assume that we have a battery and a generator connected in series, both supplying electric current to an external circuit. We can show the result graphically, as in Figure 297.

The direct current from the battery, having a constant value, may be pictured as a horizontal, straight line above and parallel to the *X* axis. We assume its value to be 1 amp. Let us further assume that the alternating current from the generator has a peak value of 2 amp. Plot the sine curve showing this alternating current on the same axis with the direct-current line.

Now let us suppose that the battery and the generator start furnishing current in the same direction at the same instant. The direct current from the battery rises instantaneously to its maxi-

### 394 ALTERNATING CURRENTS—THEORY AND MEASUREMENT

mum value (+ 1 amp.) and maintains a steady flow at that level as long as the circuit is completed.

Now consider the alternating current during its first half cycle. The current gradually rises until the peak value of + 2 amperes

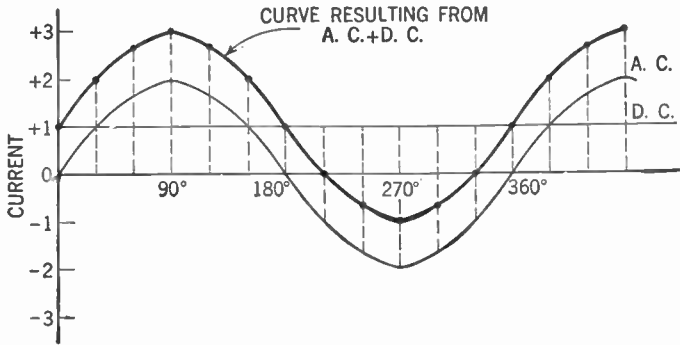

**Figure 297.** Curve showing the result of adding alternating and direct currents.

is reached at the  $90^\circ$  position. Then the current gradually falls off until it reaches zero at the  $180^\circ$  point. During this time the alternating current and direct current are flowing in the same direction and therefore the currents are added to each other. Thus, at the  $90^\circ$  position, the peak of the combined alternating and direct currents reaches + 3 amp.

But when the alternating current reaches zero (at  $180^\circ$ ) the direct current is still + 1 amp. Thus the curve showing the combined alternating and direct current has a value at this point of the sum 0 amp. (from the generator) and + 1 amp. (from the battery) giving a total of + 1 amp. In fact, it is not until the alternating current starts flowing in the opposite direction and reaches a value of - 1 amp., that it is able to neutralize the + 1 amp. of direct current. At that point the total current flow is zero.

As the alternating current increases in its negative value, the combined current becomes more and more negative. At the  $270^\circ$  point the alternating current reaches its negative peak of - 2 amp. If we add to this the + 1 amp. from the battery, we get a total of - 1 amp., which is the current flowing in the circuit at this point ( $270^\circ$ ). As the alternating-current cycle approaches the  $360^\circ$  mark, the negative current decreases and the curve of the combined alternating and direct currents approaches the zero line. When the negative current from the generator drops to - 1 amp.,

the zero line is reached. From that point on, the total current increases until, at the  $360^\circ$  mark, the alternating current being zero and the direct current  $+1$  amp., the total current flowing is  $+1$  amp. Then the cycle repeats itself.

The curve of the combined alternating and direct currents will resemble the one shown in Figure 297 if the peak of the alternating-current curve exceeds the direct-current value. Where the direct current is greater than the peak of the alternating current, the combined curve takes on the form shown in Figure 298.

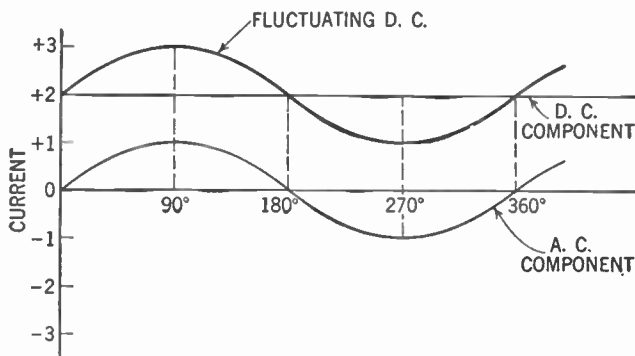

Figure 298. Curves showing how a fluctuating direct current may be broken down to its steady D.C. component and its A.C. component.

### 325. Applications of Combined Currents in Radio

The form of the combined curve will resemble a sine wave, but since the direct current is always greater than the alternating current, at no time will the curve go below the  $X$  axis. The result, then, is a fluctuating direct current.

This curve should be familiar to you. In it you will recognize our friend the fluctuating direct current that we find flowing in the plate circuit of the radio tube. A fluctuating direct current really, then, consists of (at least) two parts or *components*. One component is the steady direct current, while the other component is an alternating current.

We can therefore break up the fluctuating direct current flowing in the plate circuits of the detector and audio-frequency amplifier tubes into the steady direct-current component supplied by the B battery and the alternating-current component supplied by the signal. This alternating current has a frequency that lies in the audio range, that is from 30 to 15,000 cycles per second.

## 396 ALTERNATING CURRENTS—THEORY AND MEASUREMENT

You can now see what we meant when, in discussing the tone control of the radio set (Chap. 25, Vol. I), we said some of the high-frequency current was by-passed by the condenser connected across the primary of the audio-frequency transformer (Fig. 152, Vol. I). Obviously, since the direct current has no frequency, it was the alternating-current component about which we were talking.

We may also see why a pulsating direct current, if fed into the primary of a transformer, will produce alternating current in the secondary, just the same as alternating current fed into the primary (Fig. 37, Vol. I). The alternating-current component of the pulsating direct current does the job.

### 326. Alternating-current Meters

If we were to connect the moving-coil galvanometer used for measurement in direct-current circuits into an alternating-current circuit, the pointer would merely vibrate back and forth. Here is why.

The movement of the pointer depends, you will recall, upon the interaction between the magnetic field of the permanent magnet and that of the armature coil. If alternating current is passed through the armature coil, the field around this coil is expanded and collapsed very rapidly (depending upon the frequency of the current). Before the pointer is able to give us the deflection, the magnetic field begins to collapse and the spring pulls the pointer back. Thus we get a to-and-fro vibration of the pointer.

Of course, we may rectify our alternating current and thus change it to a pulsating direct current (Chap. 18, Vol. I). To do this would necessitate the changing of our scale to take into account the average current.

### 327. The Iron-vane Type of Meter

Another method is to construct a meter as shown in Figure 299. Two soft iron pieces, or vanes, are placed inside of a coil of wire. One of these vanes is fixed while the other is free to move. Attached to the movable vane is a shaft carrying a pointer. As current passes through the coil, the vanes become magnetized. Since they are magnetized in the same way (north pole to north pole and south pole to south pole), even though the direction of the current is changing rapidly, the two vanes repel each other. The movable vane swings away, turning the shaft and the pointer. The force

## ALTERNATING CURRENTS—THEORY AND MEASUREMENT 397

of repulsion is proportional to the current flowing through the coil, a spring (not shown here) pulls the movable vane back.

This meter is called the *moving-vane* or *iron-vane* type of alternating-current meter. A shunt may be connected across the coil

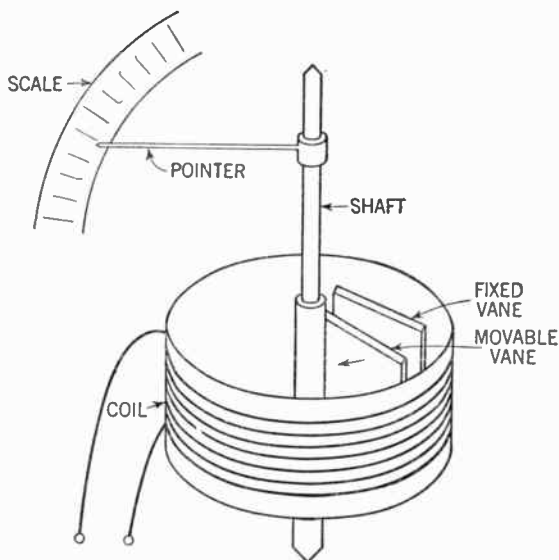

Figure 299. Diagram of the moving-vane A.C. meter.

and the instrument may be used as an alternating-current ammeter, or a multiplier may be connected in series with the coil and the instrument becomes an alternating-current voltmeter.

### 328. The Inclined-coil Meter

Another type of alternating-current meter is the *inclined-coil* meter (Figure 300).

Here a fixed coil is set at an angle to a shaft upon which is mounted a soft iron vane set at right angles to the coil. As current flows through the coil the vane attempts to turn to a position where it will line up with the magnetic lines of force around the coil. As the vane rotates, it turns the shaft, which in turn moves the pointer. The rotation of the vane is opposed by the two springs shown. Since the force of rotation is proportional to the current flowing through the coil, the pointer indicates the force of that current. This type of meter, too, can be used as an ammeter or voltmeter with the appropriate shunts or multipliers.

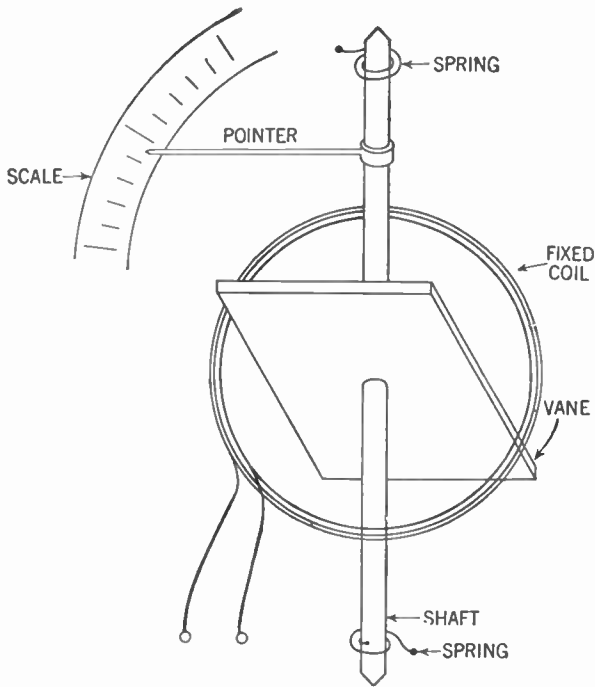

Figure 300. Diagram of the inclined-coil A.C. meter.

### 329. Dynamometer Type of Meter

Another type of alternating-current meter employs the *dynamometer principle*. This meter resembles the direct-current wattmeter, having a fixed field coil and a movable armature coil (Figure 301).

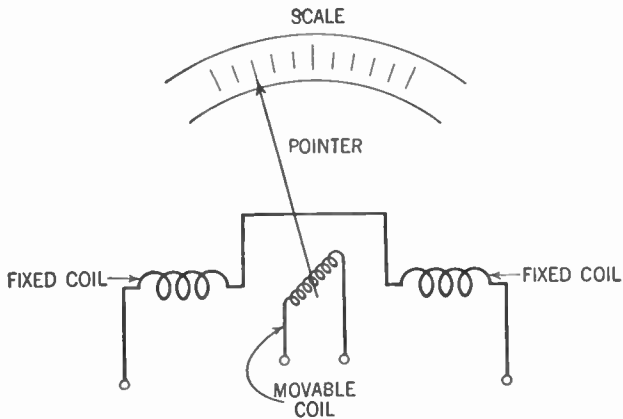

Figure 301. Diagram of the dynamometer principle.

## ALTERNATING CURRENTS—THEORY AND MEASUREMENT 399

If we connect both coils in series and arrange a spring to oppose the tendency of the movable coil to turn, then the pointer attached to the movable coil is deflected in proportion to the cur-

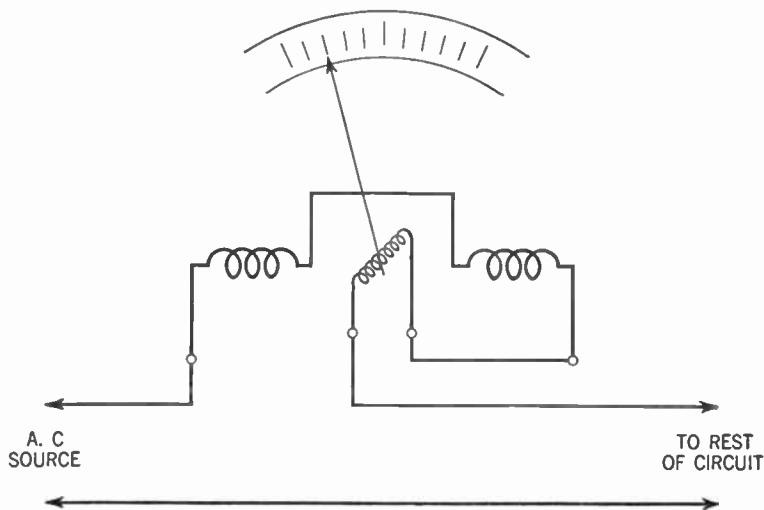

Figure 302. Diagram showing how the dynamometer type of meter is hooked into the circuit to read alternating current.

rent. Note that it makes no difference which way the current is flowing, because the magnetic fields of *both* coils will change together in step with the current. We can use this meter to measure the current.

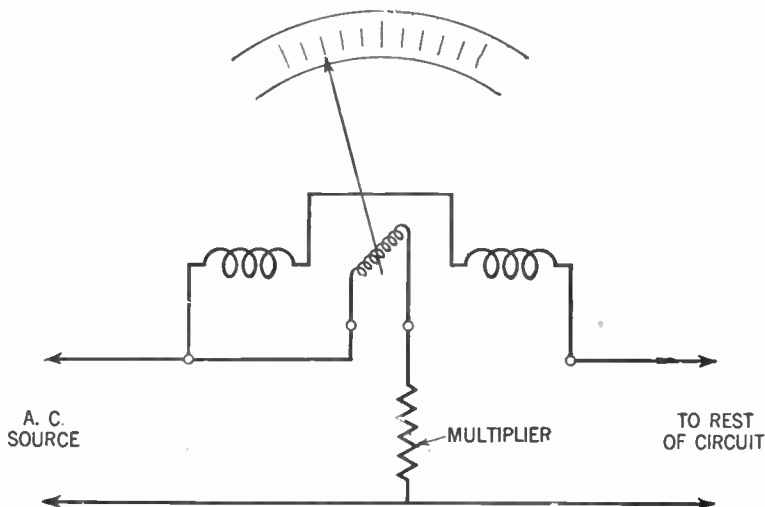

Figure 303. Diagram showing how the dynamometer type of meter is hooked into the circuit to read alternating voltage. (Current must be kept constant.)



## 400 ALTERNATING CURRENTS—THEORY AND MEASUREMENT

If we now connect the fixed coil in series with the line and connect the movable coil in parallel with the line through a multiplier (a resistance in series), then, if the line current is kept at a constant average value, the current flowing through the movable coil (and the resulting deflection of the pointer) will be proportional to the electromotive force.

### 330. The Hot-wire Ammeter

Still another type of instrument is used as an alternating-current ammeter. It is called the *hot-wire ammeter* (Figure 304).

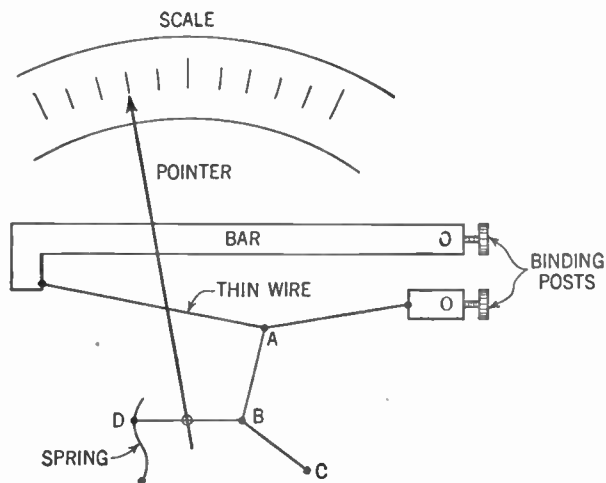

Figure 304. Diagram of a hot-wire ammeter.

Current passes through a fine wire tightly stretched horizontally. From the center of this wire is attached another wire *ABC* which is secured at point *C* and exerts a constant pull on the fine wire. A fine thread *DB*, attached to the spring, exerts a sidewise pull on this second wire. This thread passes over a small roller to which the pointer is attached. Any slight movement of the thread deflects the pointer.

As current flows through the fine wire the heat causes it to expand slightly. This expansion permits the spring to pull the thread and the pointer is deflected. Since the heating effect on the wire (and therefore the amount of expansion) depends upon the current passing through it, the deflection of the pointer shows the value of the current.

## ALTERNATING CURRENTS—THEORY AND MEASUREMENT 401

The hot-wire ammeter is quite commonly employed to measure the small alternating currents of high frequency used in radio.

### 331. The Thermocouple Meter

Still another instrument used for radio-frequency work is the *thermocouple meter*. Here is how it works.

When two wires of dissimilar metals are connected together at one end and the junction is heated, it will be found that a direct-current electromotive force (voltage) is developed between the open ends of the wire. The voltage will be directly proportional to the difference in temperature between the connected (hot) ends and the unconnected (cold) ends.

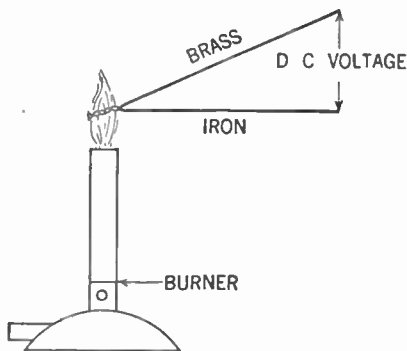

Figure 305. Diagram illustrating the principle of a thermocouple.

The generation of a direct-current electromotive force by heating the junction of two dissimilar metals is known as *electro-thermal action*, and the device that permits this action to take place is known as a *thermocouple*.

If we connect the thermocouple to a sensitive direct-current meter of the Weston type and calibrate the scale in degrees of temperature instead of in units of electric current we have an instrument known as a *pyrometer*, which is used to measure the temperature of heated objects.

Any two dissimilar metals will function as a thermocouple, but it has been found that if we use a wire made of an alloy of bismuth and one made of an alloy of antimony for our thermocouple we get the greatest possible voltage per degree of temperature difference.

Now, we know that an electric current passing through a con-

## 402 ALTERNATING CURRENTS—THEORY AND MEASUREMENT

ductor will heat that conductor in proportion to the square of the current ( $W = I^2R$ ;  $W$  represents heating effect). (Note that this is the same as the power formula.) So if we pass a current through the junction of a thermocouple, that junction will be heated in proportion to the square of the current, and this heat will generate an electromotive force. If we now attach to the cold ends a sensitive galvanometer that is properly calibrated, we can obtain the value of that current. The direction of the external current flow will have no effect upon this instrument; therefore, it can be used to measure either direct or alternating current.

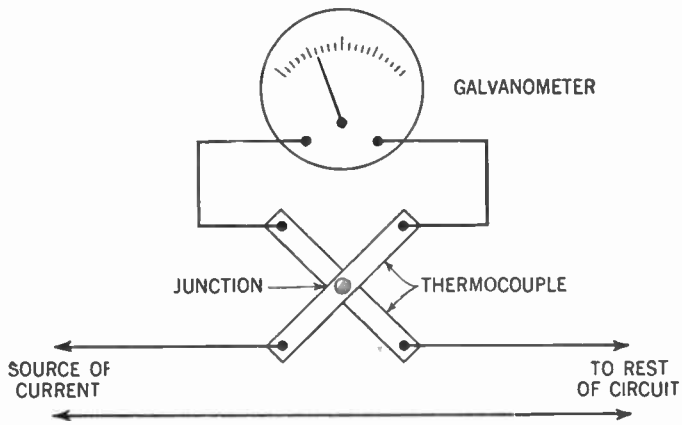

Figure 306. Diagram of the thermocouple ammeter.

This device is called a *thermocouple ammeter*. Since it is operated by the heating effect of the current, this type of meter, as well as the hot-wire ammeter, can be used for radio-frequency measurement.

### SUMMARY

1. (a) An electric current is accompanied by a magnetic field, and, (b) conversely, a changing magnetic field produces a dielectric field and sets up a current in a conductor within the changing magnetic field.
2. An induced current is set up in a conductor in the presence of a magnetic field by any change in their relation which causes magnetic lines of force to cut through the conductor.
3. Alternating-current generators consist of conductors made to pass rapidly in and out of magnetic fields. The current alternates because the electromotive force is set up in one direction when the conductor cuts into the field and in the opposite direction when the conductor cuts out of the field.

## ALTERNATING CURRENTS—THEORY AND MEASUREMENT 403

4. The direction of the current in any conductor or coil is determined by Lenz's Law, which states that the induced current and accompanying magnetic field are in such a direction as to oppose the force which produces them.

5. For measuring alternating currents we use the same units, volt, ampere, and ohm, that are used in direct-current systems. But modification in the definitions of these units is required because of fluctuation, change of direction, and impedance in alternating currents.

6. Impedance means resistance, but includes resistance caused by the counter electromotive force which may be produced by self-induction.

7. Instantaneous values for electromotive force and current in alternating-current circuits are best described by the sine curve, which is a graph plotted from a revolving radius vector or from tabulated data.

8. Both currents and electromotive forces are commonly represented by vectors. When two electromotive forces or two currents that are out of phase are to be added, a parallelogram is constructed on the vectors as sides. The diagonal drawn to scale represents the resultant of the two vectors.

9. The sine curve may be used to show the effects of combined currents or electromotive forces. Alternating current may be added to alternating current or alternating current added to direct current. This principle helps to explain modulated carrier waves in radio.

10. Alternating-current meters must be built on principles different from the principles governing direct-current meters. Several types that work by magnetic effects are practical. However, for radio work, the heating effect of the alternating current is used to operate a sensitive direct-current meter which is not in the alternating-current circuit. The heating effect is utilized by means of (a) a hot wire which expands in proportion to the heat, (b) a thermocouple which sets up a direct current between two dissimilar metals—also in proportion to the temperature.

### GLOSSARY

**Alternating Current:** A current or voltage continually changing in magnitude and periodically reversing its direction.

**Angle of Rotation:** The angle in degrees made by the armature of a generator in rotating from its starting point.

**Cycle:** The voltage variation created as the armature of a generator goes through 1 cycle or  $360^\circ$  of rotation, which may be graphed as a sine curve.

**Direct Current:** A current maintained in one direction through a circuit.

**Electromagnetic Induction:** The production of a voltage in a conductor when it cuts across magnetic lines of force.

**Frequency:** The number of cycles per second of an alternating current.

**Generator:** A device in which a coil rotates in a magnetic field and creates a voltage across its ends.

## 404 ALTERNATING CURRENTS—THEORY AND MEASUREMENT

**Impedance:** The total opposition to the flow of alternating-current in a circuit.

**Phase:** The instantaneous value in degrees of a cycle of alternating voltage or current.

**Phase Angle:** The angle of lead or lag between similar phases of two sine curves.

**Power Factor:** The fraction by which we multiply the apparent power of a circuit to get the true power.

**Sine Curve:** The graph which shows the pattern of any series of events occurring in cycles.

**Vector:** The representation of a quantity by a line that indicates its magnitude and direction.

### QUESTIONS AND PROBLEMS

1. Under what circumstances may a magnetic field produce a voltage?
2. Explain the right-hand rule for direction of the induced voltage.
3. Explain the use of Lenz's Law in determining the polarity of a coil pushed over the end of a bar magnet. State the law.
4. How could we increase the strength of an induced electromotive force in a coil pushed over a bar magnet?
5. What are the characteristics of a direct current? Of an alternating current?
6. Describe the construction of a generator.
7. Explain how a sine wave is generated by an alternating-current generator.
8. Draw a sine wave of alternating-current voltage and explain what its changes mean.
9. What is meant by an alternating-current cycle?
10. At what positions in degrees of an alternating-current cycle are the values zero; at what positions maximum?
11. What is the sine of an angle? How is it related to the sine curve of voltage change produced by an alternating-current generator?
12. In what unit is frequency of an alternating current measured?
13. Explain what is meant by maximum, average, and effective value of an alternating-current voltage. How may they be derived from each other?
14. When is an alternating-current voltage said to be in phase with its current? Indicate this relation by sine curves.
15. What is meant by a vector? What two conditions does it describe?
16. Represent vectorially an alternating-current voltage leading its current by  $90^\circ$ . By  $45^\circ$ . Represent these also by a sine-curve picture.
17. What accounts for the difficulty of adding together the voltages of two alternating-current generators feeding into a single line? How are these difficulties overcome?
18. What is meant by impedance? In what unit is it measured?
19. State Ohm's Law for alternating-current circuits.

## ALTERNATING CURRENTS—THEORY AND MEASUREMENT 405

20. Why can we not always state that Power =  $I_{eff.} \times E_{eff.}$  in alternating-current circuits?
21. How is the power factor of a circuit calculated?
22. When will the apparent and true power of an alternating-current circuit be equal?
23. Derive the result of mixing a direct-current voltage of 10 volts with an alternating-current voltage of 5 volts maximum.
24. What are the components of a fluctuating direct current?
25. Why can't we use direct-current meters in an alternating-current circuit?
26. Describe the iron-vane type of alternating-current meter.
27. Describe the inclined-coil meter.
28. Describe the dynamometer type of alternating-current meter.
29. Describe the operation of the hot-wire ammeter.
30. Describe the thermocouple type of alternating-current meter.

## CHAPTER 32

# Inductance, Inductive Reactance and Impedance

---

- Problem 1:** *What are the factors involved in inductance?*
- Problem 2:** *What are the effects of "self-induction" upon electromotive force, current, and resistance?*
- Problem 3:** *How do we measure self-inductance and mutual inductance?*
- Problem 4:** *How are inductors coupled for various purposes?*
- 

### 332. Induced Currents Obey Lenz's Law

From Lenz's Law we have learned that when an induced current is set up in a moving conductor, the current always flows in such a direction that it forms a magnetic field opposing the motion of the conductor. Let us now see how we must modify this law to take into account a stationary conductor that is cut by a moving magnetic field.

If a current is passed through a coil of wire, a magnetic field is built up around this coil. As this field expands, it cuts across the conductors or turns of the coil itself, inducing a second current in them. Lenz discovered that the direction of this induced current is such that it will oppose the original current. In other words, the direction of the induced current is such that it will tend to reduce the original current and thus tend to oppose the *expansion* of the magnetic field.

When the original current reaches a steady level, the magnetic field becomes stationary and no longer cuts across the turns of the coil. There is no longer an induced current in this coil.

Now let us see what happens when the original current stops flowing. The magnetic field around the coil starts to collapse. In so doing, it cuts across the turns of the coil and once again a second current is induced in the coil. Since the direction of the induced

## 408 INDUCTANCE, INDUCTIVE REACTANCE AND IMPEDANCE

current again opposes the direction of the original current, it tends to keep current flowing in the coil for a time after the original current has ceased. Thus the induced current tends to oppose the *collapse* of the magnetic field.

We can now expand Lenz's Law to state that *an induced current (or the induced voltage which sets the current flowing) is always in such a direction as to oppose the magnetic-field change that is producing it.* For this reason induced voltages are often referred to as *counter-electromotive force* or *back electromotive force*.

### 333. Idea of Inductance

The property of a circuit which opposes any change in the current flowing is called the *inductance*. Since this opposition is caused by voltages induced in the circuit itself by the *changing magnetic field*, anything that affects the amount of magnetic flux must also affect this inductance.

The unit used to measure the inductance of a circuit is called the *henry* (h.). The henry can be defined as being the inductance present when a current change of 1 amp. per second in a circuit produces an induced electromotive force of 1 volt. The symbol used for inductance is *L*.

In radio work, it is often convenient to employ the millihenry (mh.), which is  $\frac{1}{1000}$  of a henry, and the microhenry ( $\mu$ h.), which is  $\frac{1}{1,000,000}$  of a henry.

### 334. Self-inductance May Be Very High

When the effect of inductance is such as to cause an induced voltage in the circuit where the changing current is flowing, the term *self-inductance* is applied to the phenomenon. Except when currents of extremely high frequency are flowing through them, the inductance of straight wires can be neglected. But the self-inductance of coils, especially when wound on magnetic materials, can be very great, the amount being determined by the number of turns, the size, the shape, the type of windings, and other physical factors.

### 335. Selection of Inductors

The inductance of such coils (sometimes called *inductors*) can be calculated in henries (or millihenries or microhenries) from special formulas which you may find in Bulletin 74 of the United States



Bureau of Standards; we need not study or use these formulas here. Inductors used for radio-frequency work generally have cores of air or other nonmetallic materials. Examples are the tuning coil and the radio-frequency choke described in Figures 22 and 136, Vol. I. The tuning coil has an inductance of approximately 300 microhenries and the radio-frequency choke 2.5 millihenries. This radio-frequency choke consists of about 300 turns of No. 36 cotton-covered wire on a ½-in. wooden dowel.

When used for audio-frequency work, the inductors are usually wound on special iron cores which multiply the inductance of the coil many thousands of times. Thus the filter choke described in Figure 96, Vol. I, has an inductance of 30 henries.

**336. Inductors in Series and Parallel**

Inductors, like resistors, can be connected in series, in parallel, or in combinations of series and parallel circuits. The total inductance of several inductors connected in series (provided the magnetic field of one inductor cannot act upon the turns of another) is equal to the sum of the inductances of the individual inductors. In a formula:

$$L_{\text{total}} = L_1 + L_2 + L_3 + \dots + \text{etc.}$$

If two or more inductors are connected in parallel (provided there is no interaction or *coupling* of their magnetic fields), we can find the total inductance from the following formula:

$$\frac{1}{L_{\text{total}}} = \frac{1}{L_1} + \frac{1}{L_2} + \frac{1}{L_3} + \dots \text{etc.}$$

or

$$L_{\text{total}} = \frac{1}{\frac{1}{L_1} + \frac{1}{L_2} + \frac{1}{L_3} + \dots \text{etc.}}$$

Note that this relation is similar to that between resistors in parallel.

As in the case of resistors, the total inductance of inductors connected in a series-parallel circuit may be obtained by first finding the inductance of the inductors in parallel and then adding this inductance to the inductance in series with it as though it were a straight series-inductor circuit.

## 410 INDUCTANCE, INDUCTIVE REACTANCE AND IMPEDANCE

### 337. Inductive Reactance

In Chapter 31 we learned that the impedance of an alternating-current circuit is the total opposition that circuit offers to the flow of current. Where only pure resistance is present in the circuit the impedance is equal to the resistance. But we have seen that the presence of an inductor in the circuit causes a back or counter electromotive force to be built up which further opposes the flow of current. Under such conditions, the impedance of the circuit is greater than the resistance.

The factor which, in an alternating-current circuit, causes the impedance ( $Z$ ) to be larger than the resistance ( $R$ ) is called the reactance ( $X$ ). Since this reactance is due to the presence of inductance, we call it the *inductive reactance*. To show that it is inductive reactance we add the subscript  $L$  to the symbol for reactance ( $X$ ) and we now get  $X_L$  as the symbol for inductive reactance.

This method of adding a subscript to identify an electrical value is commonly used. Thus the current ( $I$ ) flowing through the inductor is shown as  $I_L$ . The voltage ( $E$ ) across the inductor becomes  $E_L$ . This notation is not restricted to inductors. The voltage across a condenser may be designated as  $E_c$ , the resistance of an inductor  $R_L$ , and so on.

Since impedance represents an opposition to the flow of current and has the ohm as its unit, the inductive reactance, which increases the impedance, also has the ohm for its unit.

The inductive reactance depends upon the magnitude of the induced voltage. This magnitude in turn depends upon two factors: the inductance of the circuit ( $L$ ) and the rate or frequency ( $f$ ) at which the current (and therefore the magnetic field) is changing.

The formula for inductive reactance is

$$X_L = 2\pi fL$$

where  $X_L$  is the inductive reactance in ohms,  $f$  is the frequency in cycles per second, and  $L$  is the inductance in henries.

The factor  $2\pi$  is necessary to make the result come out in ohms.  $\pi$  is a constant, equal approximately to 3.14.  $2\pi$  therefore equals 6.28. Notice that the higher the frequency ( $f$ ) the greater the inductive reactance.

## INDUCTANCE, INDUCTIVE REACTANCE AND IMPEDANCE 411

Of course, it is impossible to have a circuit without some resistance in it. Even heavy copper or silver bars have some resistance in them. But for theoretical purposes we may assume such a circuit with inductance only. In such a circuit the impedance will be equal to the inductive reactance.

We know that Ohm's Law for alternating-current circuits is expressed by the following formulas:

$$I = \frac{E}{Z} \quad E = I \times Z \quad Z = \frac{E}{I}$$

$Z$  is the impedance.

Substituting inductive reactance for impedance we get:

$$I = \frac{E}{X_L} \quad E = I \times X_L \quad X_L = \frac{E}{I}$$

### 338. Effect of Inductance on the Phase Relationship of Voltage and Current

We have seen that inductance is the property of a circuit which opposes a change of current. Since in an alternating-current circuit the current and voltage are continually changing, you can see that one of the effects of inductance is to cause the current changes to take place after the voltage changes. We describe this phase

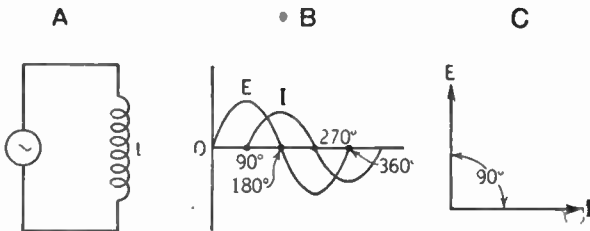

**Figure 307.** A—Circuit containing inductance only.  
 B—Sine curves showing how current ( $I$ ) lags  $90^\circ$  behind the voltage ( $E$ ).  
 C—Vector diagram showing the same thing.

relation of voltage and current in an inductive circuit by saying *the current lags behind the voltage*.

In a pure inductive circuit, that is, a circuit with no resistance ( $R$ ), the current will lag  $90^\circ$  behind the applied voltage. But since there always must be some resistance present, the current may approach but never reach a  $90^\circ$  lag.

## 412 INDUCTANCE, INDUCTIVE REACTANCE AND IMPEDANCE

### 339. Alternating-current Circuits with Inductance and Resistance in Series

In an alternating-current circuit where resistance and inductance are connected in series, the impedance ( $Z$ ) is equal to the combined effect of the resistance ( $R$ ) and the inductive reactance ( $X_L$ ). Since  $R$  and  $X_L$  are both given in ohms, you might suppose that, to get their combined effect in series, the two would merely be added. You would be wrong, however, because not only does inductive reactance oppose the flow of current, but it also causes the current to lag behind the voltage. This relation is shown by graph in Figure 307. Thus the corresponding instantaneous values of voltage and current do not occur at the same time. It is for this reason that the effects of  $R$  and  $X_L$  cannot be added arithmetically. We have devised another method for calculating the impedance, that is, the combined effect of resistance and inductive reactance in series.

### 340. Calculation of Impedance

Draw a right triangle as in Figure 308.

Let the horizontal side represent the value of  $R$  expressed in ohms, and let the vertical side of the triangle represent the value of  $X_L$  in ohms. Both lines are drawn to the same scale. The hy-

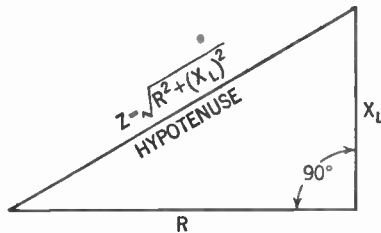

Figure 308. Diagram showing how to add resistance ( $R$ ) and inductive reactance ( $X_L$ ) in series.

potenuse (the side opposite the right or  $90^\circ$  angle) then represents  $Z$ . To find  $Z$ , we square  $R$  (multiply  $R \times R$ ) and  $X_L$  (multiply  $X_L \times X_L$ ). We add these two squares together and then find the square root of the sum. This square root is the value of  $Z$ .

This computation is based upon the well-known formula for a right triangle: *The square of the hypotenuse equals the sum of the squares of the sides.* Using the right-triangle formula, let us work out a problem, based on Figure 308. Assume  $R$  to be equal

## INDUCTANCE, INDUCTIVE REACTANCE AND IMPEDANCE 413

to 8 ohms and  $X_L$  equal to 6 ohms. The square of 8 is 64 ( $8 \times 8 = 64$ ), and the square of 6 is 36 ( $6 \times 6 = 36$ ). Adding these two figures together, we obtain 100. The square root of 100 is 10 ( $10 \times 10 = 100$ ). Thus  $Z$  is equal to 10 ohms.

### 341. Mutual Inductance

Our discussion of inductance, inductive reactance, and impedance has been directed so far chiefly toward a single coil and the effect of changing magnetic fields upon the current, the electromotive force, and the impedance of one coil. When an induced voltage in one circuit is the result of current changes in another circuit, the term *mutual inductance* is used to describe the relationship. The same unit, the henry, that is used for measuring self-inductance is also used for measuring mutual inductance. The symbol for mutual inductance is  $M$ . Like self-inductance, the amount of mutual inductance depends solely upon the physical components that go to make up the circuit. Owing to the fact that mutual inductance represents the effect of one circuit on another circuit, the two circuits are said to be *coupled* together by mutual inductance. The presence of mutual inductance is sometimes indicated by the term *magnetic coupling*, for it is the magnetic field of one circuit that induces a voltage in the other circuit.

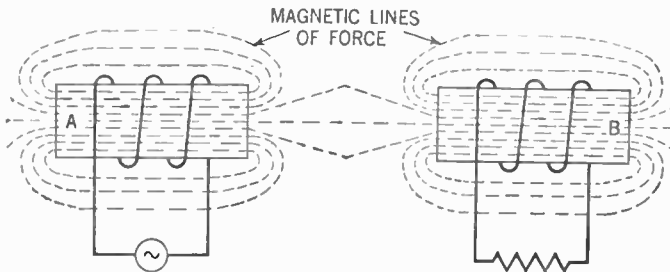

Figure 309. Diagram showing magnetic coupling between two inductors.

### 342. Coupling

Mutual inductance is often employed to transfer electrical energy from one circuit to another. If we have an alternating current flowing in one inductor, a magnetic field that expands and collapses in step with the alternating current is created around that inductor. Assume that this field cuts across the turns of another coil. Then an induced voltage is set up in that coil.

## 414 INDUCTANCE, INDUCTIVE REACTANCE AND IMPEDANCE

If all the lines of force of that magnetic field cut across all the turns of the second coil, we say we have *maximum coupling*. Since this condition can never be obtained in practice, an expression to give the degree of coupling is used. Maximum coupling is considered *100% coupling*, or, as it is often called, *unity coupling*.

If only half the lines of force cut all the turns, or if all the lines of force cut half the number of turns, the degree of coupling is said to be 50%. Only when the two coils are wound on the same iron core does the coupling approach 100%.

### 343. Inductance of Coupled Inductors

We have seen (Par. 336) that the inductance of two inductors in series, whose fields are not coupled, can be expressed by the formula:

$$L_{\text{total}} = L_1 + L_2$$

But when the coils are magnetically coupled, the field of each will have an effect upon the other. Because of this interaction we must take into consideration the mutual inductance ( $M$ ).

Examination will show that there are two ways to connect the inductors in series. Figure 310 shows them connected so that the two magnetic fields aid each other. Since the magnetic fields are

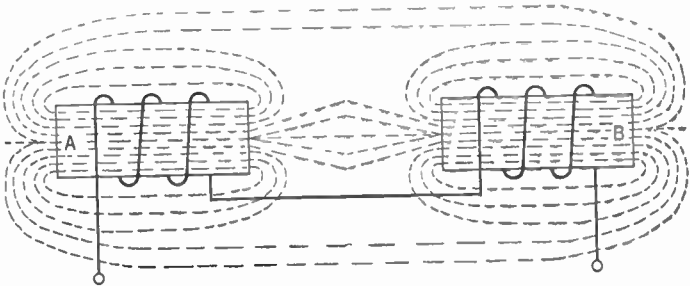

Figure 310. Inductors in series with their magnetic fields aiding each other. Note the windings are in the same direction on both coils.

helping each other the formula for the total inductance becomes:

$$L_{\text{total}} = L_1 + L_2 + 2M$$

From this formula we can see that the effect of mutual inductance is to increase the total inductance.

## INDUCTANCE, INDUCTIVE REACTANCE AND IMPEDANCE 415

The two inductors may also be connected in series in such a way that the magnetic fields oppose each other. Figure 311 shows this circuit. Under such conditions the formula for the total inductance becomes:

$$L_{\text{total}} = L_1 + L_2 - 2M$$

Thus the effect of the mutual inductance is to decrease the total inductance.

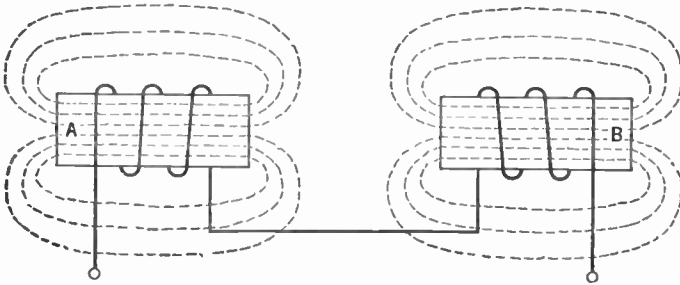

**Figure 311. Inductors in series with their magnetic fields opposing each other. Are the windings here in the same or opposite directions?**

A similar relation holds true for two inductors connected in parallel. If the magnetic fields aid each other, the formula for the total inductance becomes:

$$L_{\text{total}} = \frac{1}{\frac{1}{L_1 + M} + \frac{1}{L_2 + M}}$$

Where the magnetic fields oppose each other, the formula becomes:

$$L_{\text{total}} = \frac{1}{\frac{1}{L_1 - M} + \frac{1}{L_2 - M}}$$

### 344. The Transformer

We have stated that mutual inductance is often employed to transfer electrical energy from one circuit to another. One example of this practice is the antenna coupler in Chapter 10, Vol. I, in which electrical energy flowing in the aerial-ground circuit is transferred to the tuning circuit. Other examples are the radio-frequency transformer employed in the tuned radio-frequency re-

## 416 INDUCTANCE, INDUCTIVE REACTANCE AND IMPEDANCE

ceiver, the intermediate-frequency transformer of the superheterodyne receiver, the audio-frequency transformer used to couple the audio-frequency amplifier stages, and the power transformer used in the B eliminator.

Transformers used for radio-frequency and intermediate-frequency work usually have air cores. Those used for audio-frequency work usually have iron cores. Transformers usually have two windings, a *primary* and a *secondary*. Alternating current (or fluctuating direct current, which as we have seen has an alternating-current component) is fed into the primary winding and we get an alternating electromotive force induced in the secondary by mutual inductance.

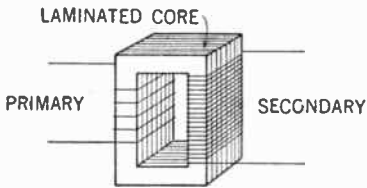

Figure 312. Diagram showing laminated core of a transformer.

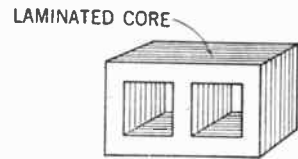

Figure 313. Another form of transformer core which permits closer coupling of the coils wound one over the other on the center arm.

The degree of coupling between the primary and secondary of a transformer wound with a core of air or other nonmagnetic substances is very low. Transformers wound on iron cores, however, have a high degree of coupling, often approaching 100%.

When the primary and secondary are wound on an iron core, the coils are well insulated from the core and from each other. There are several methods of constructing iron-core transformers. One method commonly used is to construct a core which consists of a large number of thin strips or layers, called *laminations* (Figure 312). Another method which gives a somewhat higher degree of coupling is to use a core as shown in Figure 313. Here the primary and secondary are wound one on top of the other on the center arm of the core.

If the number of turns of the secondary is greater than that of the primary, we get a greater number of turns cutting across the lines of force and thus a greater induced electromotive force. We call such a transformer a *step-up* transformer. The ratio between the voltage of the primary ( $E_p$ ) and the voltage of the



## INDUCTANCE, INDUCTIVE REACTANCE AND IMPEDANCE 417

secondary ( $E_s$ ) is equal to the ratio between the number of turns of the primary ( $T_p$ ) and the number of turns of the secondary ( $T_s$ ). This relationship can be expressed as follows:

$$\frac{E_p}{E_s} = \frac{T_p}{T_s}$$

Thus a step-up transformer with a greater number of secondary turns ( $T_s$ ) will have induced in that secondary a greater voltage ( $E_s$ ).

Let us try an example. A power transformer is required to deliver 330 volts alternating current across the secondary winding. Assume that the primary winding of 1,000 turns is connected across the 110-volt alternating-current line. How many turns must we have in the secondary winding?

Substituting our known values in the above formula, we get:

$$\frac{110}{330} = \frac{1,000}{T_s}$$

Cross-multiplying gives us:

$$110 \times T_s = 1,000 \times 330 = 330,000$$

Dividing both sides by 110, we get:

$$T_s = 3,000 \text{ turns}$$

A transformer may have its secondary winding with fewer turns than the primary winding. The voltage across the secondary will be less than that across the primary. We call such a transformer a *step-down* transformer.

Assume we wish to get 11 volts alternating current instead of 330 volts from the transformer described above.

Now substitute our known values in our formula:

$$\frac{110}{11} = \frac{1,000}{T_s}$$

Cross-multiplying and dividing by 110, we get:

$$T_s = 100 \text{ turns}$$

We call the ratio between the voltage across the primary and the voltage across the secondary the *voltage ratio* of the transformer. The ratio between the number of turns in the primary

## 418 INDUCTANCE, INDUCTIVE REACTANCE AND IMPEDANCE

and the number of turns in the secondary winding is known as the *turns ratio*. The voltage ratio is equal to the turns ratio.

### 345. Energy Cannot Be Created or Destroyed

In step-up transformers we obtain a larger voltage output than we put in—but we have to pay for it in terms of current. Theoretically there is no loss or gain of electrical power. The power in the secondary is equal to the power in the primary—practically there are some losses, but the transfer of energy from primary to secondary obeys the law that the power in each is equal to  $E \times I$ . If we increase the *voltage* in the secondary (as in a step-up transformer), the *current* flowing in the secondary will be decreased proportionately. For example, if the voltage in the secondary is stepped up 3 times, the current in the secondary will become  $\frac{1}{3}$  of that flowing in the primary. When the voltage in the secondary is decreased (as in a step-down transformer), the current is increased proportionately. Thus, if the voltage is stepped down to  $\frac{1}{10}$ , the current in the secondary may be 10 times as great as that flowing in the primary.

Since the voltage ratio is equal to the turns ratio, we may substitute currents for voltages and obtain the following formula:

$$\frac{I_p}{I_s} = \frac{T_s}{T_p}$$

$I_p$  is the current in the primary,  $I_s$  is the current in the secondary,  $T_s$  is the number of turns in the secondary, and  $T_p$  is the number of turns in the primary.

### 346. Power Losses

Losses in the transformer are of two kinds. There is a *copper loss* which is due to the resistance of the wire ( $I^2R$ ). The other loss is an *iron loss*, due to the iron in the core.

The iron loss may be divided into two parts. Since the core is in the magnetic field, it is magnetized. But the alternating current causes the iron core to change the polarity of its poles in step with the frequency. A certain amount of energy is required to reverse the alignment of the atoms or molecules of the core. This energy comes from the electrical source and therefore is a

## INDUCTANCE, INDUCTIVE REACTANCE AND IMPEDANCE 419

loss. We call this the *hysteresis loss*. This loss may be partially overcome by using certain alloys of steel (such as an alloy of silicon and steel) that are easy to magnetize and demagnetize.

The other iron loss is due to the fact that an electric current is induced in the iron core by the changing magnetic field of the coils wound upon it. This induced current is called the *eddy current*. Since the eddy current must come from the electrical source, it, too, is a loss. We can reduce the loss due to eddy currents by making the core of the transformer from thin iron sheets, insulated from each other, instead of using a solid piece of iron. These thin sheets are called *laminations*.

### SUMMARY

1. The effects of **induced voltages** are considered in two ways: (a) **effects on the circuit** in which the alternating current is originally introduced; (b) **effects on nearby coils**, or other conductors not in the primary circuit.

2. The **inductance** ( $L$ ) of a conductor (usually a coil) is the property which tends to oppose any change in a current flowing in the conductor, regardless of the origin of this current.

3. Inductance is measured in **henries**. One henry is the inductance possessed by a coil when 1 volt of electromotive force is produced by a current changing at the rate of 1 amp. per second.

4. The inductance of a coil involves voltage, current, time, and a changing magnetic field.

5. **Inductive reactance** ( $X_L$ ) is the name given to the hindrance to a current resulting from the counter-electromotive force of the inductor.

6. The total resistance in ohms of an inductor is called **impedance** ( $Z$ ). This property is the combined resistance of the wire as a conductor ( $R$ ) and of the inductive reactance ( $X_L$ ).

7. In measuring currents and voltages in inductors, instantaneous values must be used because of the rapidly changing magnetic fields. Inductive reactance is found to be measurable in ohms by the formula  $X_L = 2\pi fL$ , which means that the inductive reactance in ohms is 6.28 times ( $2\pi$ ) the frequency times the number of henries of inductance.

8. The effect of the counter-electromotive force or self-inductance of a coil is to make the current **lag**  $90^\circ$  behind the voltage. This relationship may be shown graphically by sine waves and by vectors.

9. The combining of the wire resistance and the inductive reactance is achieved by using the right-triangle formula, that the square of the hypotenuse equals the sum of the squares of the sides. In formula form it appears as:

$$Z = \sqrt{R^2 + X_L^2}$$

$$\text{Impedance} = \sqrt{\text{Resistance (squared)} + \text{Inductive Reactance (squared)}}$$

## 420 INDUCTANCE, INDUCTIVE REACTANCE AND IMPEDANCE

10. **Mutual inductance** means the relation of the induced currents in two coils coupled magnetically.

11. The transfer of energy from primary to secondary in transformers conforms to the law of the conservation of energy. The product  $E \times I$  in the primary is equal to  $E \times I$  in the secondary. It follows that in step-up transformers the current in the secondary will be smaller than in the primary; in step-down transformers the current in the secondary will be greater than in the primary.

12. The **coupling** of two inductors magnetically is increased in proportion to the degree of cutting by the coils of the magnetic lines of force. This coupling is increased by the use of iron cores.

13. **Transformers** are devices for coupling two coils magnetically. Most transformers with iron cores use *laminated cores* to reduce the losses by eddy currents in solid iron cores.

### GLOSSARY

**Copper Losses:** Losses in a transformer due to heat dissipation resulting from ohmic resistance.

**Counter (or Back) Electromotive Force:** The voltage developed in a coil resulting from self-inductance, which is counter or against the impressed voltage.

**Coupling:** The transfer of energy from one circuit to another.

**Coupling, Magnetic:** Another name for mutual inductance.

**Coupling, 100%:** The complete linkage of all the lines of force from one inductor with another.

**Coupling, Unity:** Another name for 100% coupling.

**Eddy Current Losses:** Losses resulting from the inducing of useless currents in the core of a transformer.

**Henry:** The unit of inductance or mutual inductance.

**Hysteresis Loss:** The losses in a transformer due to the reluctance of the molecules of the core to turn around as the current through the coil reverses.

**Inductance:** That property of a coil which makes it resist and oppose any current change through it.

**Inductive Reactance:** The holding back effect of a coil through which a varying current is passing resulting from the development of a counter-electromotive force.

**Inductor:** The name for a coiled conductor.

**Iron Losses:** The losses in a transformer resulting from hysteresis and eddy current losses in the magnetic core.

**Mutual Inductance:** The inductance developed by the magnetic linkage of the field of one coil with a second coil.

**Self-inductance:** The creation of a counter-electromotive force in a coil due to a varying current flowing through it.

**Voltage Ratio:** The ratio between the voltage across the primary and the voltage across the secondary of a transformer.

## INDUCTANCE, INDUCTIVE REACTANCE AND IMPEDANCE 421

### QUESTIONS AND PROBLEMS

1. What effect does a varying current have in passing through a coil? What is the effect called?
2. State Lenz's Law as it applies to a varying current through a coil.
3. Define what is meant by the inductance of a coil. In what units is it measured?
4. What are the subdivisions of the fundamental unit of inductance and what are their magnitudes?
5. What factors determine the amount of self-inductance of a coil?
6. State where inductors are used in radio receivers.
7. What is the total inductance of two inductors connected in series if there is no magnetic linkage?
8. What is the total inductance of inductors connected in parallel if there is no magnetic linkage?
9. Why is the impedance of a circuit with a coil greater than just the ohmic resistance alone of the wires making up the coil?
10. What is the significance of inductive reactance and in what unit is it measured?
11. Upon what two factors does the inductive reactance of a coil in a circuit depend?
12. How is inductive reactance calculated? Give the units of the factors used in your formula.
13. What is Ohm's Law for a purely inductive circuit (that is, a coil assumed to have no ohmic resistance)?
14. What unusual phenomenon occurs between the phase relations of the impressed voltage and impressed current in an inductive circuit? How great will this effect be in an inductive circuit theoretically containing no ohmic resistance?
15. What is the effect of the introduction of ohmic resistance ( $R$ ) in the circuit of latter part of question 14?
16. What is the method of computing the  $Z$  of a circuit containing  $X_L$  and  $R$ ? Why must it be obtained in this way?
17. Under what circumstances will mutual inductance appear? How does it influence the total inductance of the circuit?
18. What is meant by unity coupling between two inductors?
19. What is the formula for the total inductance of two inductors connected in series with mutual inductance  $M$  in the series-aiding condition? In the series-opposing condition?
20. Answer question 19 for two inductors in parallel.
21. Where in the radio receiver are transformers used? Describe the type of each example.
22. Describe the structure of a transformer. What may its input-voltage type be, and what type of voltage is obtained in the output?
23. What is the average degree of magnetic coupling in an efficiently constructed iron-core transformer?
24. What are eddy currents and how are they reduced in a transformer?

## 422 INDUCTANCE, INDUCTIVE REACTANCE AND IMPEDANCE

25. Upon what factors does the step-up or step-down condition of the voltages of a transformer depend? Represent this relationship mathematically.

26. What is meant by the voltage ratio of a transformer?

27. How is the current ratio of a transformer related to the voltage ratio? To the turns ratio?

28. What is the approximate condition of power dissipation in the primary and secondary circuits of a transformer?

29. What are copper losses in transformers?

30. What is meant by hysteresis losses of a transformer?

31. What are the iron losses of a transformer?

## CHAPTER 33

# Capacitance

- 
- Problem 1:** *How are condensers constructed?*
- Problem 2:** *What three conditions determine the electrostatic capacity of condensers?*
- Problem 3:** *What does capacitance mean? How is it measured?*
- Problem 4:** *What is the effect of a condenser in direct-current and alternating-current circuits?*
- 

### 347. The Condenser

A condenser, we have been told, consists of two conductors separated by a dielectric (insulator). The dielectric may be a vacuum, or air, or mica, or wax paper, or oil, or certain chemicals such

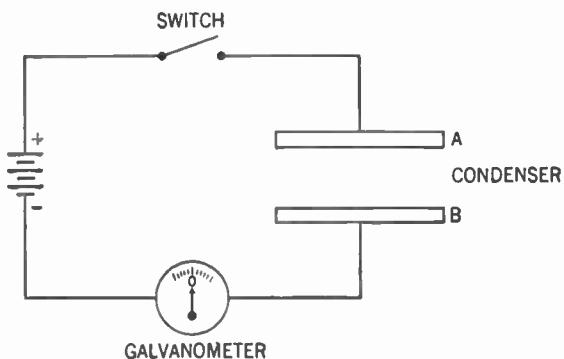

**Figure 314. Condenser ready for charging.**

as aluminum oxide, or, in fact, any material which will not permit electric current to flow through it readily.

Assume we have a condenser consisting of two metal plates separated by a vacuum. Now connect this condenser in series with a battery, a switch, and an ammeter (Figure 314). The ammeter is of a type which has the zero point in the center of the scale.

Thus current flowing through it in one direction causes the pointer to deflect to the right while current in the opposite direction deflects the pointer to the left.

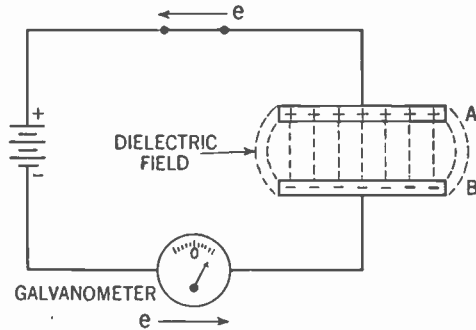

Figure 315. Condenser being charged.

### 348. Charging a Condenser

Now close the switch. The positive pole of the battery, having a deficiency of electrons, pulls electrons off plate A of the condenser, leaving a positive charge on that plate. The negative pole of the battery, having an excess of electrons, forces electrons to flow onto plate B of the condenser, which receives, therefore, a negative charge. The meter shows this flow of electrons by the pointer's deflecting to the right as seen in Figure 315.

The opposing charges on the plates of the condenser set up a dielectric field or electrostatic field between them through the vacuum, as shown by the dotted lines. The electrical energy that flowed through the circuit is stored in this dielectric field and current continues to flow until this field reaches the end of its ability to store electrical energy. When this limit is reached, the pointer of the ammeter drops back to zero, indicating that no more current is flowing, and we say that the condenser is *charged*.

From Figure 315, you see that when the condenser is charged, the electromotive force created by the dielectric field is exactly equal and opposite to the electromotive force of the battery. Hence no current flows. Now remove the battery (Figure 316).

### 349. Discharging

Since we have no closed circuit, no current flows even though the condenser is still charged. If we now complete our circuit by



connecting in a resistor in the place of the battery as in Figure 317, electrons stream from plate B where there is an excess of electrons, through the circuit and onto plate A where a deficiency

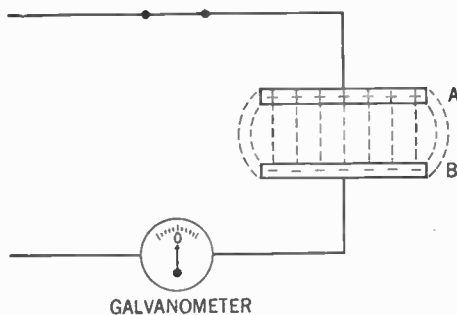

Figure 316. Condenser fully charged. The battery has been removed.

of electrons exists. We say that the condenser is *discharged*. The pointer of the ammeter will indicate that the current is flowing in a direction opposite to that in which it flowed when the condenser was being charged.

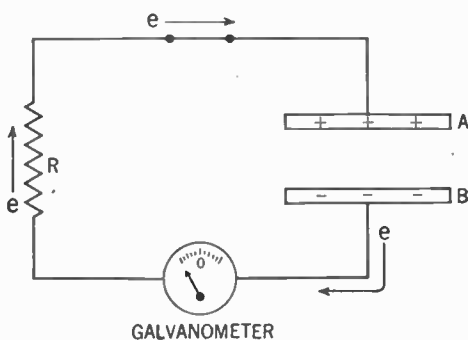

Figure 317. Condenser discharging through resistor (R).

### 350. Conditions Affecting the Storage of Energy by a Condenser

The amount of electrical energy that the dielectric field of this condenser can store depends upon three conditions.

1. The larger the area of the plates facing each other, the more the electrical energy that can be stored in the dielectric field.
2. The closer the plates are to each other, the

more the electrical energy that can be stored in the dielectric field.

3. The nature of the dielectric makes a difference with the amount of energy that can be stored. This principle needs to be demonstrated.

### 351. An Experiment with the Dielectric

Suppose we connect the condenser and the battery in the circuit again as in Figure 315. Now, while the condenser is in this charged condition (Figure 315), let us change the material of the

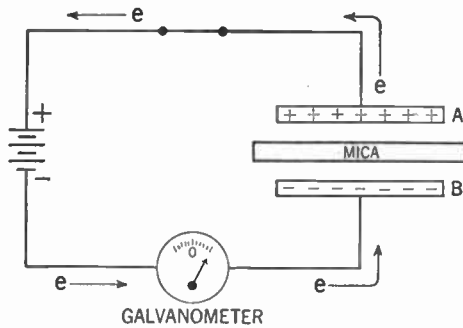

Figure 318. The effect of placing a dielectric (such as mica) between the plates of a fully-charged condenser.

dielectric by inserting a sheet of mica between the plates. The meter indicates that more current flows for a short time in the same direction as before (Figure 318).

Apparently, more electrical energy has been stored in the dielectric field. But where did this increased capacity come from, especially since the electromotive force of the battery remained constant?

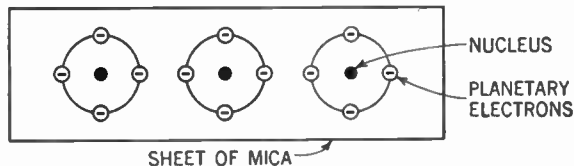
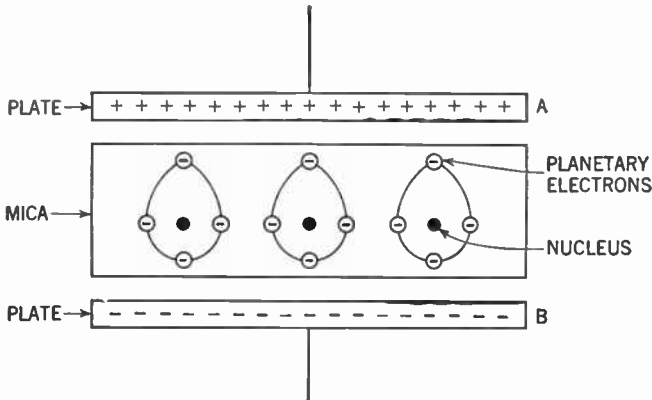

Figure 319. Normal arrangement of the atoms of a sheet of mica.

For the answer we have to go back to our electron theory. One explanation based on this theory is the following: Each atom of

the sheet of mica consists of a nucleus around which are revolving the planetary electrons (Figure 319). When the sheet of mica is placed in the dielectric field between the two plates, the planetary electrons of the atoms tend to move up the field toward the plate with a plus (+) charge. But since the electrons of the atoms of the elements in mica are not readily separated from their nuclei, it is supposed that these electrons rotate in distorted orbits around their nuclei, as shown in Figure 320.



**Figure 320.** Distortion of the orbits of the planetary electrons of the atoms of the mica as a result of charging the condenser plates.

This distortion of the orbits of these electrons changes the dielectric field within the various atoms of the mica, and tends to neutralize the field caused by the charge on the plates of the condenser. Thus, the total dielectric field becomes the field created by the charge on the condenser plates plus the dielectric fields around the atoms of the mica. As a result, the electromotive force created by the charged dielectric field causes more electrons to flow out of plate A and more onto plate B until the original balance is re-established. For these reasons the ammeter showed that more current was flowing.

Another way to state what was just explained is to say that more electrical energy is stored in the distorted orbits of the electrons of the dielectric. So in addition to the size and closeness of the plates of the condenser we have a third condition that determines the amount of electrical energy a condenser can store: namely, the amount of energy that can be stored in the dielectric. This quantity is called the *dielectric constant* and depends upon the material used as a dielectric.

If the dielectric constant for air is taken as 1, mica has a constant of from 3.0 to 7.0, while wax paper has a constant of from 2.0 to 3.2.

### 352. The Variable Condenser

Condensers may be fixed or variable. The *variable condenser*, as used to tune our simple crystal receiver (Figure 13, Vol. I), may have plates of brass or aluminum. These plates may be rotated to vary the area of the plates facing each other, and the capacity of the condenser to store electrical energy is thus varied. Quite often the plates are arranged in two sets of several plates each. The plates in each set are connected together. This gives the same effect as though we had a condenser with larger plates, and thus we get a greater total effect. The stationary set of plates is called the *stator* and the rotary set the *rotor*. Air is usually the dielectric in variable condensers.

### 353. Fixed Condensers

A commonly used type of *fixed condenser* is one with tinfoil or brass plates and with thin sheets of mica for dielectric. A condenser of this type (called a mica condenser) is used in the coupling between stages of resistance-coupled audio-frequency amplifiers (see Fig. 88, Vol. I). This type condenser also is used as the grid condenser in the triode detector circuit (Fig. 73, Vol. I). Such fixed condensers usually are encased in bakelite or other insulating materials to protect them from moisture. To increase the capacity, the plates are arranged in sets just as in the variable condenser.

A fixed condenser of greater capacity can be made by placing a strip of waxed paper between two strips of tinfoil about an inch wide and several feet long. As we know, the large area of the tinfoil plates will permit this condenser to have a large capacity. To save space, the whole is rolled up and encased in cardboard. This is called a *paper condenser*. Such a condenser is used as a by-pass condenser (Figure 135, Vol. I).

### 354. Electrolytic Condensers

The most recent development in the manufacture of fixed condensers is the *electrolytic condenser*. In such a condenser, a sheet of aluminum is kept immersed in a borax solution (called the

*electrolyte*). An extremely thin coating of aluminum oxide and oxygen gas forms on the surface of the aluminum. If we consider the aluminum as one plate of the condenser and the borax solution as the other, the coating of the aluminum oxide and oxygen gas, which will not conduct electricity, becomes the dielectric. The aluminum need not be a straight sheet but may be folded over many times or loosely rolled to give a greater effective area. Because the "plates" are separated by an extremely thin dielectric, the capacity of such a condenser is very high. Care must be taken, however, to connect the aluminum plate to the positive (+) side of the line; otherwise the dielectric will be punctured and the condenser destroyed. A variation of this type of electrolytic condenser (called a "wet" type because of the solution), is the "dry" type. Although this condenser is not strictly dry, it is called so because instead of the liquid electrolyte a gauze saturated with borax solution is used. This "dry" electrolytic condenser has a definite advantage in that the solution cannot spill.

Electrolytic condensers are usually used where large capacities are required, as in the case of the filter system of the B eliminator (Figure 96, Vol. I).

### 355. The Breakdown Voltage of Condensers

In addition to capacity, another factor in the rating of condensers is the *breakdown voltage*. If the electromotive force across the plates becomes great enough, an electron stream may be forced through the dielectric in the form of a spark. This spark burns a hole through the dielectric and thus ruins its insulating property and destroys the condenser. In the case of condensers using paper, mica, or glass as dielectrics, this puncture is fatal to the condensers. If air, borax solution, or oil is used as the dielectric, the breakdown heals itself when the electromotive force is removed. Care must be taken to operate the condenser at a value which will not cause a breakdown. This value usually appears on the label on the condenser.

The breakdown value depends upon the material of the dielectric and upon its thickness. The greater the thickness, the more electromotive force it can stand. But the greater the dielectric thickness, the smaller the capacity. Condensers with thick dielectrics (greater breakdown value) must compensate for this

condition by having a greater plate area if the capacity is to be the same as that of a condenser with a thin dielectric. Thus condensers that can stand greater electromotive forces usually are bulkier.

### 356. How Do Condensers Lose Energy?

Losses of electrical energy in condensers fall into three classes. First, there is the *resistance loss* resulting from the resistance of the plates of the condenser and the wires leading to it. This loss is usually quite low, for the plates of the condenser are large. The wire losses can be kept down by using heavy wire and good joints.

Then there is the *leakage loss*. No matter how good an insulator we have, some electrons are bound to leak through it. This loss can be reduced by choosing material for the dielectric which offers a high resistance to the flow of electrons. Mica is such a substance. Waxed paper is fairly efficient.

Finally, there are the *dielectric losses*. These fall into two groups. When alternating current is applied to a condenser, the orbits of the electrons of the dielectric are constantly being distorted. The energy to perform this work must come from the electrical source and thus represents a loss. We call this the *dielectric hysteresis loss*.

The other dielectric loss arises from the fact that some of the electrical energy remains in the dielectric after the condenser has discharged. This residual loss is called the *dielectric absorption loss*. Certain substances, like mica, if used as dielectrics, will keep these dielectric losses low.

### 357. What Is Capacitance?

From Figure 315 we can see that as we charge a condenser, the dielectric field builds up a back or counter-electromotive force which opposes the original electromotive force. The greater the electromotive force, the stronger the dielectric field and the greater the counter-electromotive force. (We must take care, however, not to exceed the breakdown limit of the condenser.) Thus the condenser acts to oppose any change in the voltage. This property of a circuit which opposes any change in voltage is known as *capacitance*. In direct-current circuits where the voltage is continuous and does not vary, capacitance, therefore, does not en-

ter into their functioning. But in alternating-current circuits the voltage is constantly changing, and here capacitance is just as important as inductance.

### 358. Measurement of Capacitance

The terms *capacity* and *capacitance* are often used interchangeably, but capacitance has better defined meaning. Let us study the measurement of capacitance.

The unit used to measure the capacitance of a circuit is the *farad* (fd.), named in honor of the English scientist Faraday. The farad can be defined as the amount of capacitance present when 1 coulomb of electrical energy ( $6.28 \times 10^{18}$  electrons), is stored in the dielectric field of a circuit when 1 volt of electromotive force is applied. The symbol used for capacitance is  $C$ .

From this definition we can see that

$$C \text{ (in farads)} = \frac{Q \text{ (in coulombs)}}{E \text{ (in volts)}}$$

For practical use the farad is too large a value to be conveniently handled. Accordingly, we use the microfarad ( $\mu$ fd.), which is one one-millionth of a farad, and the micromicrofarad ( $\mu\mu$ fd.), which is one one-millionth of a microfarad.\* Thus the value of the grid condenser used in the triode detector is .00025 microfarad ( $\mu$ fd.) or 250 micromicrofarads ( $\mu\mu$ fd.). The condenser used in the filter circuit of the B eliminator has a capacitance of 8 microfarads ( $\mu$ fd.).

### 359. Calculation of Condenser Capacitance

We have seen that the capacitance of a condenser is directly proportional to the total area of the plates that are exposed to the dielectric, inversely proportional to the thickness of the dielectric, and directly proportional to the dielectric constant.

Scientists have evolved a formula to compute the capacitance of a condenser. It is:

$$C = \frac{0.0885 \times K \times S \times (N - 1)}{t}$$

\*Some manufacturers, in stamping parts, have abbreviated *micro-* by *m* rather than  $\mu$ . This might cause confusion, since 1 mfd. is a millifarad, properly understood. Hence we use  $\mu$  for *micro-*.

$C$  is the capacitance in micromicrofarads ( $\mu\mu\text{fd.}$ ),  $K$  is the dielectric constant,  $S$  is the area in square centimeters of one side of one plate,  $N$  is the total number of plates, and  $t$  is thickness of the dielectric in centimeters.

Let us try an example. Calculate the capacitance of a condenser having two tinfoil plates each 2.5 cm. wide and 250 cm. long. The wax paper which separates these plates has a thickness of .25 cm. and a dielectric constant of 2.

Substituting our values in the above formula, we get:

$$C = \frac{0.0885 \times 2 \times 625 \times 1}{0.25} = 442.5$$

Thus the capacitance of this condenser is 442.5 micromicrofarads ( $\mu\mu\text{fd.}$ ) or 0.0004425 microfarad ( $\mu\text{fd.}$ ).

### 360. Condensers in Series

When two or more condensers are connected in series, the total capacitance is less than that of the smallest condenser in the circuit. Figure 321 shows why. You can see that the effect of

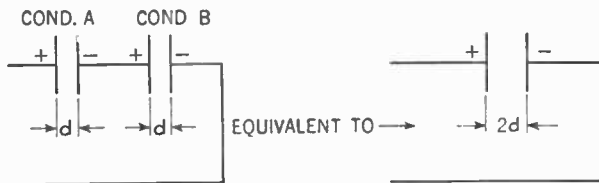

Figure 321. Diagram showing the effect of two condensers in series.

connecting two condensers A and B in series, each with a dielectric thickness of  $d$ , is the equivalent of having one condenser whose dielectric thickness is  $2d$ . The two center plates of the condensers in series really do not add to the capacitance in any way, as the charges produced on them are electrically opposite and therefore neutralize each other. The effect, then, is the same as though the two inner plates were eliminated. Since the effect of connecting condensers in series is to produce the equivalent of one condenser with a thicker dielectric, the total capacitance is less than that of the smallest condenser.

The formula by which we find the total capacitance of condensers connected in series is:



$$C_{\text{total}} = \frac{1}{\frac{1}{C_1} + \frac{1}{C_2} + \frac{1}{C_3} + \dots}$$

Since the effect of connecting condensers in series is to produce the equivalent of one condenser with a thicker dielectric, the breakdown voltage is increased. We must not assume, however, that connecting two condensers, each with a breakdown voltage of 500 volts, will produce a condenser with a breakdown voltage of 1,000 volts. We have seen that in the direct-current circuit the voltage drop across resistors in series depends upon the resistance of each one. Likewise the voltage across each condenser depends upon its impedance. Should a 1,000-volt electromotive force be divided so that the voltage drop across one 500-volt condenser is 300 volts and that across the other 500-volt condenser is 700 volts, the latter will break down. The full 1,000 volts will then be applied to the second condenser which will also break down. Only if the voltage drop across each is equal to that across the other (that is, if the impedances of the two condensers are equal), is it safe to put 1,000 volts across the two in series.

**361. Condensers in Parallel**

Connecting several condensers in parallel is the equivalent of having one condenser whose plate area is equal to the total plate area and whose dielectric thickness is the equivalent of that of one of them. You may see why this is so from Figure 322. The area

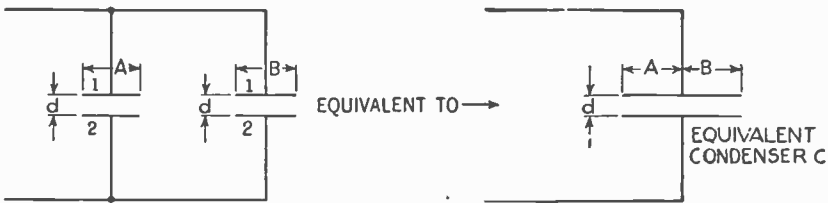

Figure 322. Diagram showing the effect of two condensers in parallel.

of plate 1 of condenser A is added to the area of plate 1 of condenser B. Similarly the area of plate 2 of condenser A is added to the area of plate 2 of condenser B. The dielectric thickness has remained the same. Since the plate areas of condensers A and B have been added and the dielectric thickness has remained the same, the capacitance of the equivalent condenser (C) is equal to

the capacitance of A plus the capacitance of B. This can be expressed in the formula:

$$C_{\text{total}} = C_1 + C_2 + C_3 + \dots$$

The breakdown voltage of condensers in parallel is that of the lowest breakdown voltage of any of them.

### 362. Direct Current Applied to Condensers

A condenser in series with a direct-current circuit will block the current, since in effect there is an insulator inserted in series with the circuit. But the moment the switch is closed there will be a flow of electrons to one plate of the condenser and from the other plate. Thus in effect there will be a flow of current in the direct-current circuit except through the dielectric (see Figure 315). This flow will continue until the back-electromotive force of the condenser is equal to the electromotive force of the battery. This equilibrium comes about very quickly. Then the current flow ceases.

Also, we know that the effect of capacitance is to oppose any change in voltage. Thus, if our voltage is fluctuating, the condenser tends to oppose the rise and fall of this voltage. The effect is thus to produce a steady electromotive force. Now we can understand the smoothing or leveling action of the condensers in the filter circuit of the B eliminator (Figure 96, Vol. I).

Another common use for condensers in a direct-current circuit, although not related to radio, is to protect contact switches of ignition systems in automobiles. An ignition circuit has an inductance in series with a source of direct current. As you know, when the circuit is broken by the switch, inductance tends to keep the current flowing. This current manifests itself in the form of a hot spark across the contact points of the switch. In time, they may be burnt up. We connect a condenser across these contact points; the electrical energy set flowing by the inductance goes to charge the condenser, and no sparking results.

### 363. Condensers in Alternating-current Circuits

As in the case of the direct-current circuit, alternating current cannot flow through the dielectric of a condenser connected in series. But in the alternating-current circuit the voltage and

current are constantly changing and periodically reversing. So just about the time the current has ceased flowing into the plates of the condenser an alternation or half cycle has been completed and the current is ready to reverse anyway, so the electrons that have just entered one plate come back out, go through the external circuit and into the other plate of the condenser. This process continues for each reversal of the alternating current.

Except for the dielectric, then, current is flowing in all parts of the circuit. Meters and lamp bulbs placed in the circuit will indicate this flow. It is common practice to say that alternating current will flow through a condenser.

### 364. Capacitive Reactance

The effect of a condenser is to build up a back-electromotive force which opposes the flow of current. Thus capacitance, like inductance, increases the impedance of an alternating-current circuit. This factor which increases the impedance is called the *capacitive reactance*. Its symbol is  $X_c$  and its unit is the ohm.

The amount of capacitive reactance depends on the value of capacitance and the frequency. The formula for capacitive reactance is:

$$X_c = \frac{1}{2\pi fC} = \frac{1}{6.28fC}$$

$X_c$  is the capacitive reactance in ohms,  $f$  is the frequency in cycles per second,  $C$  is the capacitance in farads, and 2 is the constant necessary to make the result come out in ohms. Since  $\pi$  is approximately equal to 3.14,  $2\pi = 6.28$ . Note here that the higher the frequency, the smaller the capacitive reactance.

If we were to have a circuit which only had capacitance, the impedance ( $Z$ ) would be equal to the capacitive reactance ( $X_c$ ). If we substitute  $X_c$  for  $Z$  in our Ohm's Law for alternating-current circuits (see Paragraph 322) we get:

$$I = \frac{E}{X_c} \quad E = I \times X_c \quad X_c = \frac{E}{I}$$

### 365. Effect of Capacitance on Phase Relationship of Voltage and Current

The effect of capacitance on the phase relation of voltage and

current is opposite to that of inductance; *the voltage lags behind the current*. This lag is due to the counter-electromotive force of the condenser. Thus the current reaches its peak before the voltage.

As in the case of inductance, the maximum phase angle for capacitive circuits is  $90^\circ$ . While this maximum can never be obtained in practice, it can be approached much more closely with condensers than with inductors.

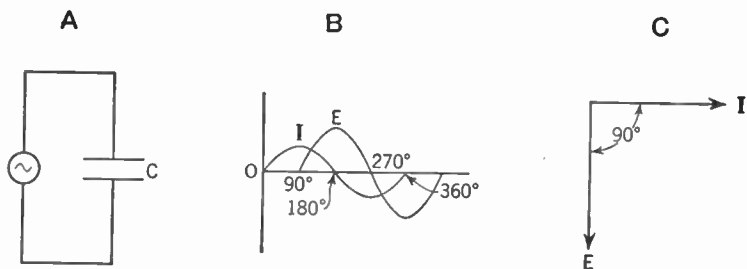
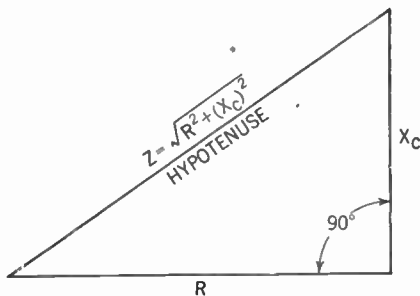

**Figure 323.** A—Circuit containing capacitance only.  
 B—Sine curves showing how voltage (E) lags  $90^\circ$  behind the current (I).  
 C—Vector diagram showing the same thing.

### 366. Alternating-current Circuits with Capacitance and Resistance in Series

As in the case of the alternating-current circuit with inductance and resistance in series, when capacitance and resistance are in series the impedance ( $Z$ ) is equal to the combined effect of the resistance ( $R$ ) and the capacitive reactance ( $X_C$ ). Here, too, you do not simply add  $R$  and  $X_C$  but you must add them by the right-triangle method (see Paragraph 340).

Let  $R$  be one side of a right triangle and  $X_C$  the other. Then



**Figure 324.** Diagram showing how to add resistance ( $R$ ) and capacitive reactance ( $X_C$ ) in series.

$Z$  is equal to the hypotenuse. From this we get the following formula:

$$Z = \sqrt{R^2 + (X_c)^2}$$

### 367. Finding the Value of the Power Factor

We have seen that, in a direct-current circuit:

$$P \text{ (power)} = E \times I$$

We also know that in an alternating-current circuit containing nothing but resistance:

$$P = \text{effective volts} \times \text{effective amperes}$$

But placing a condenser or inductance in the alternating-current circuit causes electrical energy to be stored up in these devices. In the condenser, this energy is stored in the dielectric field. In the inductor it is stored in the magnetic field.

When the applied electromotive force falls to zero, the condenser begins to discharge electrons back through the circuit from the negative plate to the positive plate. As the current falls to zero, the magnetic field around the inductor collapses and a back electromotive force is induced.

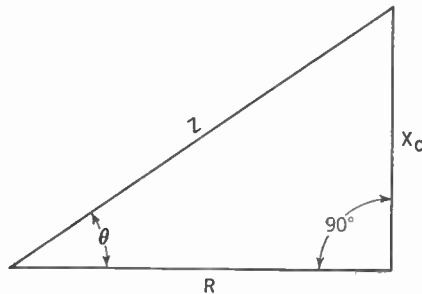

Figure 325. Diagram showing the calculation of the power factor.

In both cases electrical power is sent back into the source. Thus the true power is less than the apparent power. We may describe this condition by saying that:

$$\text{true power} = \text{apparent power} \times \text{power factor}$$

Let us go back to our right-triangle representation of  $Z$  in terms of  $R$  and  $X_c$ . In Figure 325,  $\theta$  is the phase angle. It is the re-

relationship between the resistance ( $R$ ) and the impedance ( $Z$ ) which causes the true power to be less than the apparent power. Thus the power factor is equal to  $\frac{R}{Z}$ . In the above triangle  $R$  is the side adjacent to angle  $\theta$  and  $Z$  is the hypotenuse. From trigonometry we learn that the adjacent side divided by the hypotenuse is known as the *cosine* of the included angle  $\theta$  (abbreviated to  $\cos \theta$ );). Since  $\frac{R}{Z}$  is the power factor, our formula now becomes

$$\text{true power} = \text{apparent power} \times \cos \theta$$

The cosine of  $\theta$  never exceeds 1.

### 368. The Effects of Radio Frequencies

In alternating-current circuits, the frequency of the electric current plays an important part. Household current has frequencies up to 60 cycles per second; audio frequencies go up to 15,000 cycles per second; radio frequencies may run as high as millions of cycles per second.

A study of the formulas indicate that the inductance of a coil or the capacitance of a condenser varies greatly with variations of frequency. Thus a coil which has a low inductive reactance at 60 cycles per second may have an inductive reactance 100 times as great at radio frequencies. A condenser that offers little capacitive reactance at radio frequencies may offer a tremendous capacitive reactance at 60 cycles.

Even the resistance of a straight wire is affected by the frequency of the current flowing through it. It has been found that at high frequencies the electrons traveling through a wire tend to travel near the surface, rather than the center, of the wire. The effect, namely increased resistance, is as though we were using a thinner wire. This effect is called the *skin effect*.

The various losses which we have seen are present in the inductor and condenser, such as the eddy current and hysteresis losses, also are increased as the frequency increases. This is the reason why iron-core inductors are not usually employed for radio-frequency work.

We encounter another difficulty at radio frequencies. A straight wire, carrying a current, has a magnetic field around it and

therefore has a certain amount of inductance. At low frequencies this amount is negligible, but as we approach the higher frequencies, this inductance increases and must be taken into account. We call it the *distributed* or *stray* inductance. A radio set will often fail to function properly owing to the stray inductance of the wires connecting the various parts.

Likewise, two wires running close to each other form a condenser. At low frequencies, the impedance offered by such a condenser is very high and a negligible amount of electrical energy is transferred from one wire to another. But at radio frequencies the impedance becomes smaller and appreciable quantities of electrical energy may thus be transferred to circuits where they do not belong. This effect is called the *distributed* or *stray* capacitance. You will recall that the internal capacitance of the triode, although too small to cause trouble at audio frequencies, is great enough to set up a feedback in the radio-frequency amplifier (see Chapter 23).

#### SUMMARY

1. **Condensers** are devices for storing energy in the form of electrostatic charges.
2. The **capacitance** of a condenser is determined by the area of the plates, the distance between plates and the nature of the dielectric.
3. Condenser types include **fixed**, **variable**, and **electrolytic** condensers.
4. Condensers are rated for their **breakdown voltage**, or the ability to withstand high electromotive forces. This ability is determined by the nature and thickness of the dielectric.
5. The unit of measurement of capacitance is the **farad**. A farad is the amount of capacitance present when 1 coulomb of electrical energy is stored in a dielectric field under the pressure of 1 volt.
6. When condensers are connected *in series* the capacitance is less for the combination than the capacitance of the smallest condenser.
7. Condensers **in parallel** give a combined capacitance equal to the sum of the capacitances of the several condensers.
8. In direct-current circuits no current flows through a condenser, but a momentary current develops until the electromotive force of the condenser equals the applied electromotive force.
9. Strictly speaking no current really goes through a condenser in an alternating-current circuit but since the current on both sides of the condenser is constantly changing, there is at all times a current in all parts of such circuits except in the dielectric itself.
10. The effect of capacitance on phase relationship is to cause the voltage to lag  $90^\circ$  behind the current.

11. Those relationships and problems involving capacitive reactance or power factors may be solved by formulas based on graphs and the right triangle.

#### GLOSSARY

- Breakdown Voltage:** The voltage across a condenser at which a spark will jump through the dielectric.
- Capacitance:** The property of a condenser to store a charge and to oppose any voltage change across it.
- Capacitive Reactance ( $X_C$ ):** The holding back of voltage effect of a condenser.
- Dielectric Constant:** A constant for an insulator telling the relative amount of energy that can be stored in it in the form of a distorted electronic orbit as compared with air.
- Dielectric Field:** The field of energy stored in the dielectric of a charged condenser.
- Dielectric Losses:** Power losses in the dielectric of a condenser.
- Dielectric Hysteresis Loss:** Loss of power in the dielectric of a condenser due to the reluctance of the atomic orbits to change their states of distortion.
- Dielectric Absorption Loss:** Loss of power in the dielectric of a condenser due to the retention of some of the energy of atomic distortion by the dielectric after the condenser has been discharged.
- Electrolytic Condenser:** A condenser with plates of aluminum and borax solution and a dielectric of aluminum oxide and oxygen.
- Electrostatic Field:** Same as the dielectric field.
- Farad:** The unit of capacitance of a condenser.
- Leakage Loss:** Loss of power by electronic leakage through the dielectric of a condenser.
- Mica Condenser:** A condenser with a mica insulator.
- Micro:**  $\frac{1}{1,000,000}$
- Micromicro:**  $\frac{1}{1,000,000,000,000}$
- Paper Condenser:** A condenser with a paper dielectric.
- Resistance Loss:** Power loss in a condenser due to resistance of its plates.
- Skin Effect:** The increase of resistance of a wire over its ohmic resistance with high frequency due to the tendency of current to travel only over the surface or skin of the wire.
- Stray or Distributed Inductance:** The inductance of a straight wire conducting very high-frequency currents.
- Stray or Distributed Capacity:** The capacity between the turns of wire of a coil when the coil is conducting a very high frequency current.

#### QUESTIONS AND PROBLEMS

1. What is the basic structure of all condensers?
2. State the electronic behavior during the charging of a condenser with a battery.



3. What happens to the electrical energy flowing in a circuit as it charges up a condenser?
4. What is the relation between the voltage across a charged condenser and that of the charging battery?
5. Upon what three factors does the amount of energy that can be stored in a charged condenser depend?
6. Explain what is meant by the dielectric constant of the dielectric of a condenser?
7. What is meant by a variable condenser? How is this variation accomplished?
8. What is a mica condenser and where might it be used in receivers?
9. Describe the structure of a paper condenser.
10. Describe the structure of an electrolytic condenser. Account for its high capacity.
11. What care is necessary in the use of an electrolytic condenser?
12. A condenser was ruined when too high a voltage was placed across its plates. Explain what happened internally.
13. Upon what factors does the breakdown voltage of a condenser depend?
14. What are the three classes of losses in a condenser?
15. How does a condenser act to oppose any voltage change across it?
16. Explain the meaning of capacitance of a condenser and give the units in which it is measured.
17. Relate the capacitance, quantity of charge, and charging voltage for any condenser in a formula, and give the units of measurement for each.
18. Calculate the total capacitance of three condensers in parallel, one being 100  $\mu\text{fd.}$ , the other 10  $\mu\text{fd.}$  and the third 800  $\mu\text{fd.}$
19. Calculate the total capacitance of a 10- $\mu\text{fd.}$ , a 20- $\mu\text{fd.}$ , and a 40- $\mu\text{fd.}$  condenser connected in series.
20. What is the effect on breakdown voltage of connecting two condensers of equal capacitance in series?
21. When will current flow from a battery into a condenser cease?
22. Precisely what is meant when we say that alternating current is flowing through a condenser in the circuit?
23. What is the name given to the opposition to flow of current by a condenser and in what unit is it measured?
24. How does the change of frequency affect the reactance of a condenser? How does increasing the capacitance of a condenser affect its reactance when the frequency is kept constant?
25. State Ohm's Law for a purely capacitive circuit supplied with an alternating current.
26. What effect does a condenser in an alternating-current circuit have upon the phase relationship of the voltage and the current? What is the maximum phase difference angle?
27. Calculate the total holding-back effect of an alternating-current circuit containing a condenser whose reactance is 4 ohms and a resistor of 3 ohms.

30 - 71.

28. Why is the true power dissipation of a circuit containing a resistor and condenser different from that of the apparent power? How is the former obtained from the latter?

29. What is meant by power factor? Give two ways in which it may be found.

30. What is the largest power factor possible? Account for this.

31. List the changes in coils wound on iron and condensers as the frequency of the current in the circuit is increased.

## CHAPTER 34

# Resonant Circuits and Tuning Principles

- 
- Problem 1:** *How is resonance shown by vectors?*
- Problem 2:** *How is resonance usually brought about in a receiver?*
- Problem 3:** *What are the characteristics of series and parallel resonant circuits?*
- Problem 4:** *How do we calculate the values for the different factors in a tuning circuit?*
- Problem 5:** *What is the importance of filters for good selectivity?*
- 

### 369. Vector Representation of Resonance

We have already learned that the use of vectors furnishes us with a convenient means for picturing the relationship of currents and voltages in alternating-current circuits. Thus, if an alternating-current circuit has nothing but inductance in it, the vector diagram appears as in Figure 326.

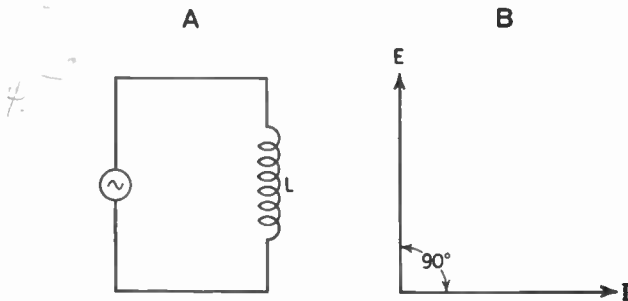

**Figure 326.** A—Circuit containing inductance only.  
B—Vector diagram showing current ( $I$ ) lagging  $90^\circ$  behind voltage ( $E$ ).

We know that the length of the voltage or electromotive-force ( $E$ ) vector is independent of the current ( $I$ ) vector and that the

## 444 RESONANT CIRCUITS AND TUNING PRINCIPLES

length of each vector depends upon the scale selected for each. Thus, if we select a scale of, say, 100 volts per inch for the voltage vector, if this vector is 1 in. long it represents 100 volts. If it is 2 in. long it represents 200 volts.

At the same time we may use a scale of, say, 1 amp. per inch for the current vector. Thus, if this vector is 2 in. long, it represents 2 amp.

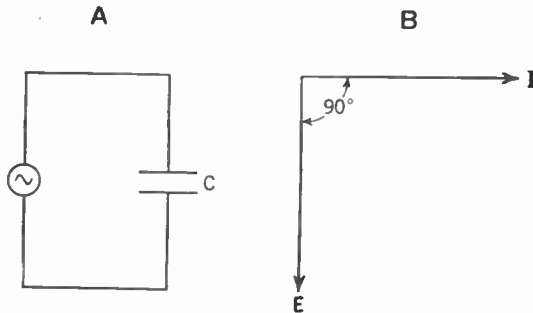

Figure 327. A—Circuit containing capacitance only.  
B—Vector diagram showing voltage (E) lagging  $90^\circ$  behind current (I).

Thus, from Figure 326, we can tell the strength of voltage and current. We can also tell that the voltage leads the current in this circuit. The *angle of lead* (the *phase angle*) is  $90^\circ$ .

If the alternating-current circuit has nothing but capacitance

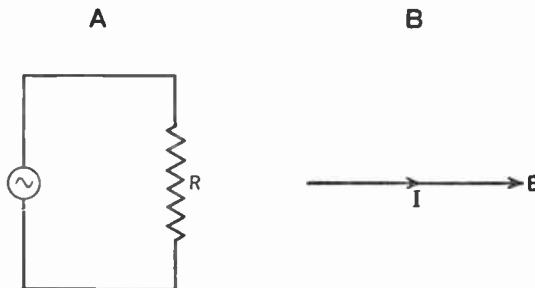

Figure 328. A—Circuit containing resistance only.  
B—Vector diagram showing voltage (E) and current (I) in phase.

in it, the vector diagram appears as in Figure 327. Here, you can see, the current leads the voltage. The phase angle is  $90^\circ$  again.

Pure resistance ( $R$ ), in an alternating-current circuit, has no effect on the phase relationship between current and voltage.

Thus if our circuit has nothing but resistance in it, the vector diagram shows us that the voltage and current are in phase.

Another use of the vector diagram is to enable us to add voltages and currents in alternating-current circuits. If we have two

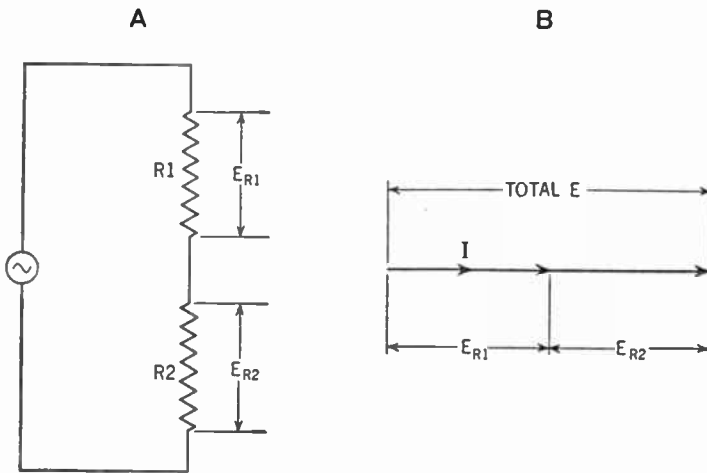

Figure 329. A—Circuit containing two resistors ( $R_1$  and  $R_2$ ) in series. The voltage drop across each ( $E_{R1}$  and  $E_{R2}$ ), when added together, will give the total voltage ( $E$ ) of the circuit.

B—The vector diagram picturing the above.

23  
1.75  
1.0  
150

resistors in series, it is a simple arithmetical problem to add the voltages across each of the resistors in order to calculate the total voltage supplied by the source (see Figure 329). Since the connection in this diagram is a series connection, the current ( $I$ ) is the same throughout the whole circuit.

If, however, we have an inductor and a resistor in series we cannot simply add the voltage across each to give us the total voltage. We must take into consideration the fact that inductance affects the phase relationships. This situation appears in the vector diagram of Figure 330.

To obtain the total voltage supplied by the source, we must make use of the parallelogram method described in Chapter 31. Here, too, the current is the same throughout the whole circuit.

The same procedure can be followed if capacitance and resistance appear in the circuit. The vector diagram appears in Figure 331.

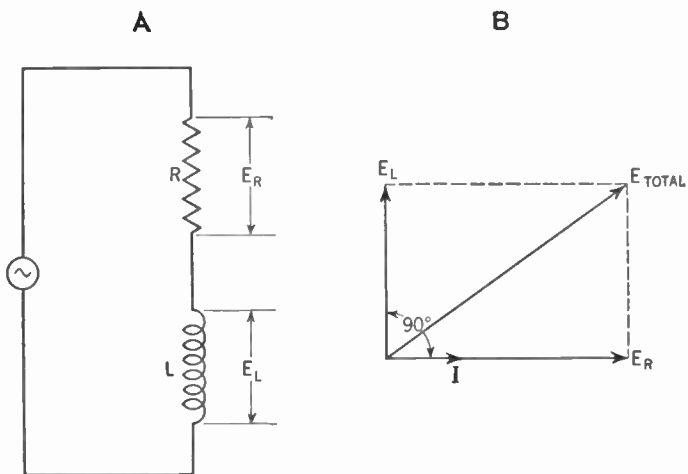

Figure 330. A—Circuit with resistance (R) and inductance (L) in series.  
 B—Vector diagram showing how the voltage drop across the resistor ( $E_R$ ) is added to the voltage drop across the inductance ( $E_L$ ).

### 370. Representing Tuned Circuits by Vectors

When capacitance and inductance both appear in a circuit we call such a hookup a *tuned circuit*. We have encountered such tuned circuits throughout our examination of the radio receiver.

We may use the same procedure as above to show the effect of

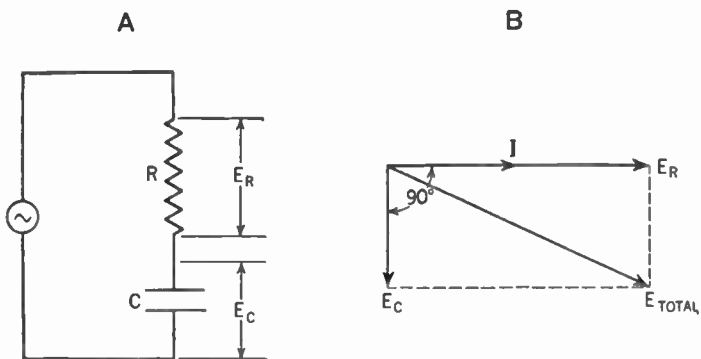

Figure 331. A—Circuit with resistance (R) and capacitance (C) in series.  
 B—Vector diagram showing how the voltage drop across the resistor ( $E_R$ ) is added to the voltage drop across the condenser ( $E_C$ ).

capacitance and inductance in the tuned circuit. The diagrams in Figure 332 picture this.

Since the vector for the voltage across the inductor is  $180^\circ$  from the vector for the voltage across the condenser, they are on

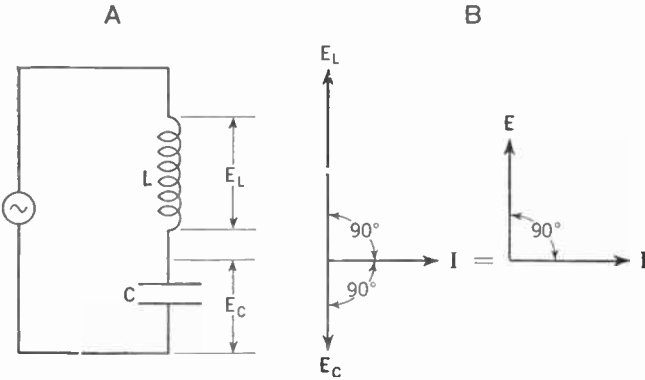

Figure 332. A—Circuit diagram with inductance (L) and capacitance (C) in series. B—Vector diagrams showing  $E_L$  greater than  $E_C$ .

the same straight line. Since they are in opposite directions, we may subtract one from the other to get the total voltage. We may assume for example a vector for  $E_L$  larger than that for  $E_C$ .

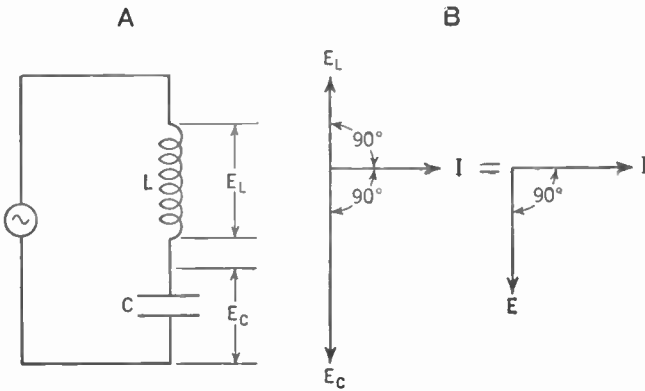

Figure 333. A—Circuit diagram with inductance (L) and capacitance (C) in series. B—Vector diagrams showing  $E_C$  greater than  $E_L$ .

The result then is as if we had nothing in the circuit but an inductor whose voltage vector is the difference between vector  $E_L$  and vector  $E_C$ .

If  $E_C$  is made larger than  $E_L$  the result is as if we had nothing but a condenser in the circuit (Figure 333).

## 448 RESONANT CIRCUITS AND TUNING PRINCIPLES

If  $E_L$  is equal to  $E_C$ , they cancel each other out and the net result is zero. We now have:

$$E_L = E_C \quad E_L + E_C = 0$$

From the formula  $E = I \times X_L$  we may determine that the voltage across the inductor (called here  $E_L$ ) is equal to the product of the current ( $I$ ) and the inductive reactance ( $X_L$ ). Thus  $E_L = I \times X_L$ . Similarly we may determine from the formula  $E = I \times X_C$  that the voltage across the condenser ( $E_C$ ) is equal to  $I \times X_C$ .

Since  $E_L = E_C$ , then  $I \times X_L = I \times X_C$ . The inductor and condenser are connected in series and therefore the current ( $I$ ) flowing through them is the same. We may therefore cancel out  $I$  and we get:

$$X_L = X_C$$

Also, from the formula  $E_L + E_C = 0$ , we get  $(I \times X_L) + (I \times X_C) = 0$ . Dividing through by  $I$  we get:

$$X_L + X_C = \frac{0}{I} = 0$$

So when  $E_L$  is equal to  $E_C$ , the inductive reactance ( $X_L$ ) is equal to the capacitive reactance ( $X_C$ ). These two reactances cancel each other out and the net reactance of the circuit is zero. We call this condition *resonance*.

### 371. Calculating Resonance

Since this circuit contains merely an inductor and a condenser, the impedance ( $Z$ ) of the circuit is equal to the net reactance. Thus  $Z$  becomes equal to zero. Since  $I = \frac{E}{Z}$ , at resonance  $I = \frac{E}{0}$ . Since any number divided by zero is equal to infinity, then  $\frac{E}{0}$  is equal to infinity, and the current flowing through a circuit at resonance is infinitely great. While this ideal does not exist in practice, the current at resonance may reach very large values.

The reason that the current is not equal to infinity at resonance is the presence of a certain amount of resistance in every circuit. Thus, when  $X_L$  and  $X_C$  cancel out,  $Z$  is not equal to zero but actually it is equal to the resistance found in the circuit.



Since the impedance  $Z$  is equal to the square root of the sum of the square of the resistance ( $R$ ) plus the square of reactance ( $X$ ), we can show this formula as follows:

$$Z = \sqrt{R^2 + X^2}$$

Thus, if the reactance is inductive, the formula becomes

$$Z = \sqrt{R^2 + (X_L)^2}$$

and if the reactance is capacitive it becomes

$$Z = \sqrt{R^2 + (X_C)^2}$$

If, however, the reactance is due to inductance and capacity in series, we see that these two reactances tend to oppose each other. Thus the formula becomes

$$Z = \sqrt{R^2 + (X_L - X_C)^2}$$

Note that we subtract  $X_C$  from  $X_L$  because here we assume  $X_L$  to be the larger. If  $X_C$  is the larger, we subtract  $X_L$  from it.

At resonance  $X_L - X_C$  becomes zero. Our formula now is

$$Z = \sqrt{R^2 + 0} \quad \text{or} \quad Z = R$$

This resistance is almost entirely found in the wire that goes to make up the coil or inductor. We can make this resistance very

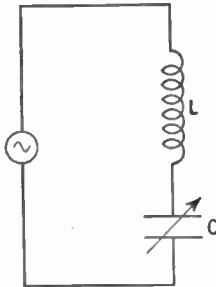

**Figure 334. Use of a variable condenser to vary the resonant frequency of the circuit.**

small by winding our coil with a few turns of heavy wire, but a small amount of resistance still remains. But for our theoretical discussion at this point we assume that there is no resistance in the circuit.

## 450 RESONANT CIRCUITS AND TUNING PRINCIPLES

Assume that the circuit shown in Figure 334 is at resonance and that the frequency of the generator is kept constant. Then  $X_L = X_C$ ,  $X_L + X_C = 0$ ,  $Z = 0$  and the current ( $I$ ) is very great. If we keep the inductance ( $L$ ) constant and vary the condenser ( $C$ ) so that  $X_C$  becomes *larger* or *smaller*, the condition of resonance is destroyed.  $X_L$  no longer equals  $X_C$ .  $X_L + X_C$  no longer equals zero.  $Z$  likewise is no longer equal to zero, but quickly as-

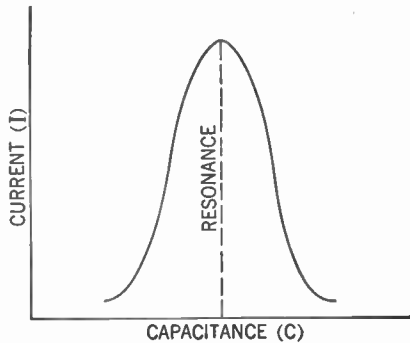

Figure 335. Graph showing the effect on the current ( $I$ ) as the capacitance of the variable condenser of Fig. 334 is changed. The inductance and frequency is kept constant.

sumes sizeable proportions and the current ( $I$ ) is proportionally reduced.

This can be shown by the graph in Figure 335. Note how quickly the current falls at a change in capacitance.

### 372. The Variable Condenser Controls Resonance

We can now understand what happens in our radio receiver as we turn the dial that controls the variable condenser. We say that a certain radio station, say WOR, comes in at a certain "point on the condenser." What we mean is that at this certain "point on the condenser" the capacitance is such that, together with the inductance of a fixed coil or inductor, the tuning circuit is resonant to radio signals of a particular frequency, namely the frequency of station WOR (710 kc. per second). Current set flowing in the tuning circuit by WOR's radio wave will be at its maximum.

Turning the dial (and thereby changing the capacitance) throws the circuit out of resonance. The current quickly dies down and we no longer hear that station. Of course, the same thing would occur if the condenser was kept constant and the in-

ductor varied. While some radio receivers tune by means of changes in inductance, most sets use variable condensers.

**373. How Frequency Affects Resonance**

In addition to being dependent upon the values of  $L$  and  $C$ , the condition of resonance also depends upon the frequency ( $f$ ). We know that  $X_L = 2\pi fL$  and

$$X_c = \frac{1}{2\pi fC}$$

(see Par. 337 and 364). If  $X_L$  equals  $X_c$  (at resonance), then:

$$2\pi fL = \frac{1}{2\pi fC}$$

Multiplying both sides of this equation by  $f$ , we get:

$$f^2 \times (2\pi L) = \frac{1}{2\pi C}$$

Dividing both sides by  $2\pi L$  we get:

$$f^2 = \frac{1}{(2\pi)^2 \times L \times C}$$

Taking the square root of both sides we get:

$$f = \frac{\sqrt{1}}{\sqrt{(2\pi)^2 \times L \times C}} = \frac{1}{2\pi\sqrt{L \times C}}$$

FREQUENCY

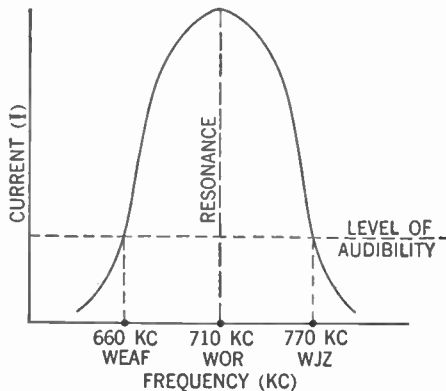

**Figure 336. Curve of a resonant circuit showing the relationship of current (I) to changes in frequency. The inductance and capacitance of the circuit is kept constant.**

## 452 RESONANT CIRCUITS AND TUNING PRINCIPLES

This condition holds at resonance only, and we can see that any change in the frequency will upset this condition.

We can now plot frequency against current to show this relationship (Figure 336). Thus, if our tuning circuit is resonant to a radio signal whose frequency is, say, 710 kc. per second, signals at that frequency will set a large current flowing in the tuner. Signals whose frequencies fall below or above 710 kc. per second will not be able to cause any appreciable currents to flow in the tuning circuit, and thus the signals will not be heard (Chap. 4, Vol. I).

### 574. Voltage Amplification

There is another feature we should note about a resonant circuit. While the voltage drop across the complete circuit ( $E_L + E_C$ ) is equal to zero at resonance, the voltage drop across the inductor ( $E_L$ ) and that across the condenser ( $E_C$ ) are not zero, but may be very large. It is only because they are equal and opposite at resonance that they cancel each other out. In fact,  $E_L$  and  $E_C$  may be many times as great as the voltage delivered by the source. This feature makes it possible to obtain considerable voltage amplification of radio signals of that particular frequency to which the circuit is resonant. You can now understand why a stage of tuned radio-frequency amplification can give more voltage amplification than an untuned stage (Chap. 23, Vol. I).

Examination of the formula

$$f = \frac{1}{2\pi\sqrt{L \times C}}$$

shows us that for a given frequency, the factor  $L \times C$  must be equal to a certain quantity if the circuit is to be resonant to that frequency. Thus  $L$  may be large and  $C$  small or  $C$  large and  $L$  small, provided their product is the same (see Paragraph 30, Vol. I).

### 375. Example: Calculating the Capacitance Needed

Let us try a problem. Assume that the tuner in Chapter 6, Vol. I, consists of an inductor whose inductance is 300 microhenries and a variable condenser whose maximum capacity is .00035  $\mu$ fd. To what value must we set our variable condenser so that our circuit will receive the radio wave broadcast by station WOR (710 kc.)? (In electrical language we mean, at what value

of our condenser will the tuning circuit be in *resonance* with a transmitting station whose frequency is 710 kc.?)

From our formula, we see that at resonance

$$f = \frac{1}{2\pi\sqrt{L \times C}}$$

where  $f$  is in cycles per second,  $L$  is in henries, and  $C$  is in farads. Thus  $f$  is equal to 710 kc. or 710,000 cycles, and  $L$  is equal to 300 microhenries or .0003 henry. Substituting these values, we get:

$$710,000 = \frac{1}{6.28\sqrt{.0003 \times C}}$$

Multiplying both sides by 6.28, we get:

$$710,000 \times 6.28 = \frac{1}{\sqrt{.0003 \times C}}$$

or

$$4,458,800 = \frac{1}{\sqrt{.0003 \times C}}$$

Since the  $\sqrt{.0003}$  is equal to .01732, then:

$$4,458,800 = \frac{1}{.01732 \sqrt{C}}$$

Multiplying both sides by .01732, we get:

$$\frac{1}{\sqrt{C}} = 77,226$$

or

$$\sqrt{C} = \frac{1}{77,226} = .0000129$$

Then  $C = .000000000166$  farad. This magnitude may be expressed more conveniently as .000166  $\mu$ fd. This means, then, that our variable condenser must be set so that its capacity is .000166  $\mu$ fd. to receive station WOR.

### **376. An Example to Show Voltage Amplification**

You will recall it was stated that the tuned circuit at resonance may give us a certain amount of voltage amplification. Let us try another problem to see how this works out.

## 454 RESONANT CIRCUITS AND TUNING PRINCIPLES

Figure 337 shows us the circuit described in the above problem. You recognize the P and S coils as the primary and secondary respectively of the antenna coupler. Across the secondary is placed the input voltage or electromotive force induced in it from the primary by the current produced by the radio wave from station WOR cutting across the aerial-ground system. The output of the tuner is the voltage developed across the condenser (C) which

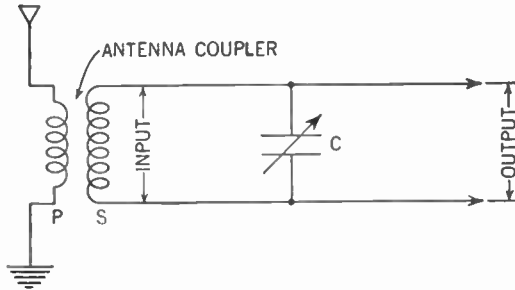

**Figure 337. The tuning circuit of the radio receiver as a resonant circuit.**

places the electrical charges on the grid of the detector tube. The ratio of output to input voltage—that is, the number of times the input voltage must be multiplied to become as great as the output voltage—is the amplification gain of the tuned circuit.

From the previous problem we know that the frequency ( $f$ ) is 710,000 cycles per second and the capacitance ( $C$ ) of the condenser for this station is .000166  $\mu$ fd. (.000000000166 farad). Let us further assume that the input voltage is .001 volt and that the resistance of the secondary is 10 ohms.

The impedance of the condenser can be found from the following formula:

$$X_c = \frac{1}{2\pi \times f \times C}$$

$X_c$  is expressed in ohms,  $f$  is expressed in cycles per second, and  $C$  is expressed in farads.

Substituting our known values we get:

$$X_c = \frac{1}{6.28 \times 710,000 \times .000000000166}$$

$$X_c = \frac{1}{.00074} = 1,351 \text{ ohms}$$

Since at resonance  $X_c$  and  $X_L$  drop out, the current flowing in the tuned circuit may be found by the following formula:

$$I = \frac{E}{R} = \frac{.001}{10} = .0001 \text{ amp.}$$

The voltage across the condenser ( $E_c$ ) is equal to the product of the current ( $I$ ) and the impedance of the condenser ( $X_c$ ). Thus:

$$E_c = I \times X_c = .0001 \times 1,351 = .1351 \text{ volt}$$

But the voltage developed across the condenser is the output voltage of the circuit. Thus you see that we get a voltage amplification of 135 (that is, the voltage across the condenser divided by the input voltage is  $.1351 \div .001 = 135$ ) from this circuit at resonance.

### 377. No Energy Is Created by Voltage Gains

The voltage gain of this circuit is no violation of the principle of the conservation of energy. Electrical energy is alternately exchanged between the inductor and the capacitor. The only power dissipated is that which is converted into heat by the resistance of the circuit. This loss is the only power which the primary is called upon to supply.

If electrical energy is drawn from the tuner, for example, to supply the crystal detector and phones, the voltage across the secondary output will drop to a value consistent with the available input power.

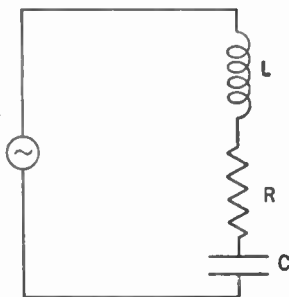

Figure 338. The series resonant circuit showing inductance, resistance and capacitance in series.

### 378. Series Resonant Circuits

We may picture our resonant circuit very simply as in Figure 338. Here the inductor, the resistance of the inductor, and the

## 456 RESONANT CIRCUITS AND TUNING PRINCIPLES

condenser are pictured as being in series with the electrical source. We call such a circuit a *series resonant circuit*.

Let us list some of the things we know about this circuit. At resonance,  $X_L$  is equal and opposite to  $X_C$ . These two reactances cancel each other out. The opposition to the flow of current, or impedance ( $Z$ ), then becomes equal to the resistance ( $R$ ). If  $R$  is small, the current ( $I$ ) flowing through the circuit becomes quite great. *Thus the characteristic effect of a series resonant circuit is to permit to flow through the circuit a large amount of current whose frequency is in resonance with that of the resonant circuit.*

Since the source of electrical energy, here the alternating-current generator, is in series with the circuit, its impedance will help cut down the amount of current in the circuit. It becomes necessary, therefore, to keep the impedance of the source as low as possible.

### 379. How Resistance Reduces Selectivity

In Chapter 10 of Volume I, it was stated that the effect of resistance in the tuner is to reduce the selectivity of the receiving set. Let us see if we can explain how this happens.

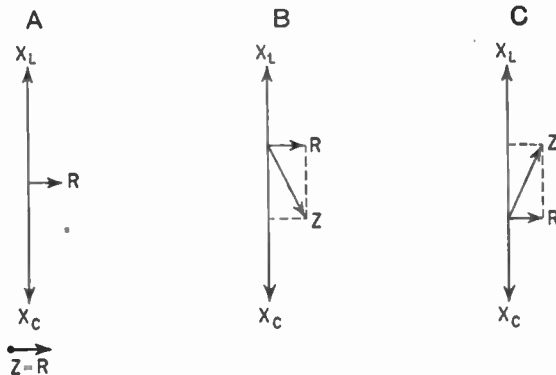

Figure 339. Vector diagrams showing effect of frequency changes on a resonant circuit when the resistance ( $R$ ) is small.

A—Resonance.

B—Frequency reduced. Slightly off resonance.

C—Frequency increased. Slightly off resonance.

We know that at resonance  $X_L$  and  $X_C$  are equal and opposite while  $Z$  is equal to  $R$ . Assume that the value of  $R$  is small and let us draw a vector diagram to picture this condition (Figure 339-A).

Figure 339-B shows what happens as the frequency is reduced.



$X_C$  becomes larger and  $X_L$  smaller. The circuit is now somewhat off resonance. The impedance ( $Z$ ) is increased and therefore the current flowing through the circuit is reduced.

Figure 339-C shows what happens as the frequency is increased.  $X_C$  becomes smaller and  $X_L$  larger. The circuit is somewhat off resonance and the current flowing through the circuit is reduced again.

Now let us see what happens if the resistance is large. Figure 340-A shows the condition of resonance. Note that  $Z$  is larger than it appears in Figure 339-A.

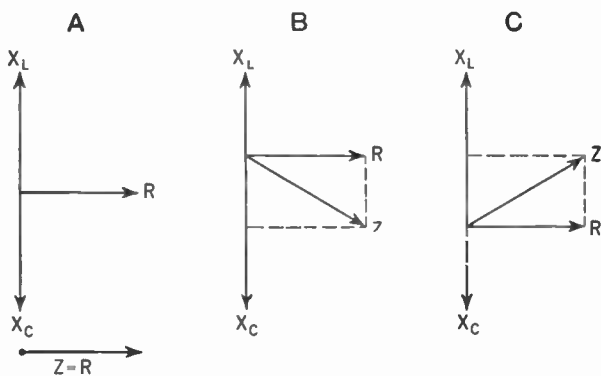

Figure 340. Vector diagrams showing effect of frequency changes on a resonant circuit when the resistance ( $R$ ) is large.  
**A—Resonance.**  
**B—Frequency reduced. Slightly off resonance.**  
**C—Frequency increased. Slightly off resonance.**

Figures 340-B and 340-C show the vector diagram for the circuit made slightly off resonance by reducing the frequency in Figure B and increasing the frequency in Figure C. In both cases  $Z$  appears larger than the  $Z$  at resonance.

But note this. In Figure 339, when the circuit was off resonance, the impedance became *much* larger than was the impedance at resonance. In Figure 340, the impedance when the circuit was off resonance became only *slightly* larger than was the impedance at resonance.

Thus the *difference* between the amounts of current flowing through the circuit in the resonant and off-resonant conditions is much greater when the resistance in the circuit is small than when the resistance is large.

**380. Showing the Effect of Increasing R**

We can now show this relationship in a graph (Figure 341) by plotting the current against the frequency. Here we assume the inductance and capacitance remain the same. These curves

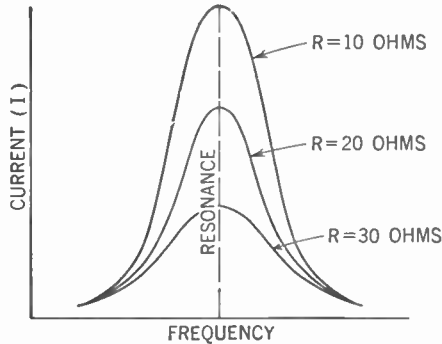
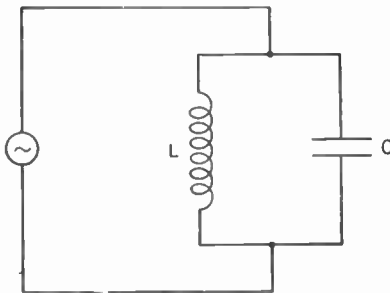

**Figure 341. Resonance curves showing changes produced by changes in resistance (R). Inductance and capacitance are kept constant.**

are called the *resonance curves* and show the effect of resistance in a series resonant circuit. The greater the resistance the less the current, and hence the flatter and broader the curve. Compare these curves with the tuning curves of Figs. 35 and 36, Vol. I.

**381. Parallel Resonant Circuits**

In addition to the series form, the resonant circuit may assume a parallel form. This is shown in Figure 342. We call this a



**Figure 342. The parallel resonant circuit with inductance (L) and capacitance (C) in parallel.**

*parallel resonant circuit.* In a series circuit the current is uniform and the voltages across the circuit elements are added to yield the total potential drop across the circuit. In a parallel circuit, how-

ever, the voltage across each branch is the same, and the separate branch currents are added to yield the total current through the circuit.

The current flowing from the alternating-current generator in Figure 342 divides when it comes to the junction of the two branches of the circuit. Part of the current flows through the inductive branch and part through the capacitive branch. The amount of current that will flow through each branch depends upon the impedance of each. The greater proportion of the current will flow through the branch offering the smaller impedance.

At low frequency the inductive reactance of  $L$  is low, the capacitive reactance of  $C$  is high, and more current tends to flow in the inductive branch. At high frequencies the reverse is true and more current tends to flow in the capacitive branch.

At a certain frequency (resonance) the inductive reactance is equal to the capacitive reactance. The current flowing in each branch is then the same.

But inductance causes the current to lag  $90^\circ$  behind the voltage, while capacitance causes it to lead the voltage by  $90^\circ$ . Thus the currents flowing in each branch are  $180^\circ$  apart ( $90^\circ + 90^\circ$ ). This is the same as to say they are flowing in opposite directions. Since at resonance the currents are thus equal and opposite, they tend to cancel out and the net result for the complete parallel resonant

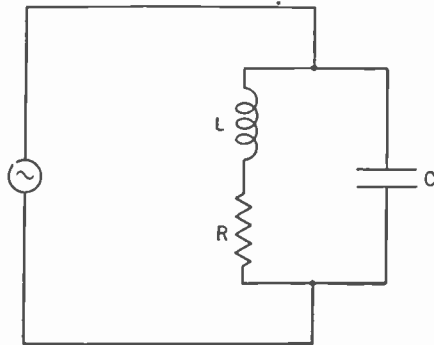

Figure 343. The parallel resonant circuit. The resistance is usually found in the inductive branch of the circuit.

circuit is that there is *no flow of current*. We may also say that the effect of a parallel resonant circuit is the same as if an infinitely great resistance were placed in series with the source of electrical energy. Thus the characteristic effect of a parallel reso-

nant circuit is to offer a tremendous resistance to a current whose frequency is in resonance with that of the resonant circuit.

As in the case of the series resonant circuit, the presence of a small amount of resistance in the circuit causes us to modify our theoretical results. This resistance is almost completely due to the resistance of the wire which goes to make up the inductor. Our circuit for parallel resonance becomes that shown in Figure 343. At resonance the impedance of the  $L$  branch of the circuit is slightly greater than that of the  $C$  branch, and while the net result is equivalent to a very large resistance in series with the source, it is not an infinitely great resistance and a certain small amount of current does actually flow through the circuit.

At resonance, then, the impedance of the parallel resonant circuit becomes very great. As we vary our frequency to a smaller or larger value than the resonant frequency, the impedance of the circuit quickly drops and more and more current flows. We can picture this by plotting *impedance* against *frequency*. The result (Figure 344) is similar to the resonance curve for the series resonant circuit that we obtained when we plotted *current* against *frequency* (Figure 336).

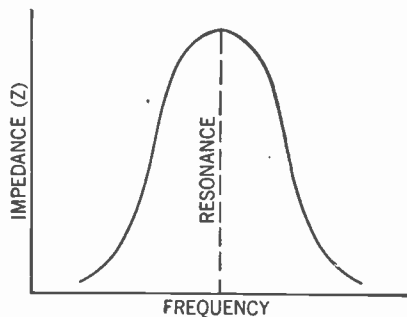

**Figure 344.** Resonance curve for the parallel resonant circuit with impedance ( $Z$ ) plotted against the frequency ( $f$ ).  $C$  and  $L$  are kept constant.

We have seen that the presence of resistance in the inductive branch of the circuit upset the balance and permitted current from the generator to flow in the circuit. The greater this resistance, the more current flows in the circuit. The result of resistance, then, is to flatten and broaden the resonance curve shown in Figure 344.

In the parallel resonant circuit, except for the presence of re-

sistance as noted above, the currents flowing through the branches of the circuit are equal and opposite. Thus we may state that:

$$I_L = I_C \quad I_L + I_C = 0$$

From this relation we may see that, although the net result is that no current flows from the generator, the current flowing from the inductor to the condenser ( $I_L$ ) and back again ( $I_C$ ) may be quite large.

When we discussed the series resonant circuit we stated that at resonance the current flow is at its maximum. But in the case of the parallel resonant circuit we saw that the current flow at resonance is at its minimum. For this reason we often call the parallel resonant circuit the *anti-resonant circuit*.

It has been found that the maximum transfer of power occurs when the impedance of the load (the circuit) matches the impedance of the source (the generator). (See paragraph 452.) Thus, since the impedance of the series resonant circuit is very small, we should keep the impedance of the generator small, too. The impedance of the parallel resonant circuit, however, is very high. It is important, therefore, that the impedance of the source be likewise kept high.

### 382. What Do We Mean by "Q"?

Examination of the resonance curves in Figure 341 show us that the less resistance we have in the circuit, the sharper the curve. This statement means that the difference in current strength at the resonant frequency and current strength at a frequency slightly off resonance is very marked. Another way of saying the same thing is that the *selectivity* is good. The selectivity is thus determined by the amount of resistance in the circuit. The less the resistance, the better the selectivity.

The resistance in a resonant circuit is almost exclusively lodged in the coil. This resistance ( $R$ ) is the effective alternating-current resistance and includes the resistance of the wire, the loss due to distributed capacitance, and the loss due to the skin effect of alternating current. In a well-designed coil  $R$  is due almost entirely to skin effect. The less the resistance of a coil, the better it is.

This "goodness" or merit of the coil may be expressed by the ratio between the inductive reactance ( $X_L$ ) and the resistance ( $R$ ). The symbol for this ratio is the capital letter  $Q$ . It is helpful to associate  $Q$  with quality.

$$Q = \frac{X_L}{R}$$

Since  $X_L$  is equal to  $2\pi fL$ , then:

$$Q = \frac{2\pi fL}{R}$$

The loss in a coil due to distributed capacitance and to the skin effect is roughly proportionate to the frequency. The inductive reactance ( $X_L$ ) is exactly proportionate to the frequency. For these reasons the  $Q$  of a coil remains fairly constant over a wide range of frequencies. Typical radio inductors have  $Q$ 's of the order of 100 to 800, depending upon the nature of the service for which they are designed. The  $Q$  is sometimes called the *figure of merit*.

At resonance in a parallel tuned circuit the net resistance ( $R_0$ ) is  $Q$  times the reactance of either one of the branches. Thus:

$$R_0 = X_C \times Q = X_L \times Q$$

Thus the current through either the inductor or condenser at resonance is  $Q$  times the net line current. In series resonant circuits, the voltage across either the inductor or condenser is equal to  $Q$  times the net voltage across the complete circuit.

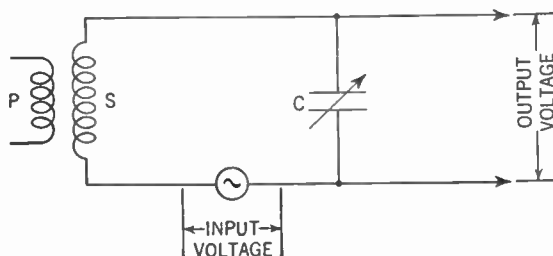
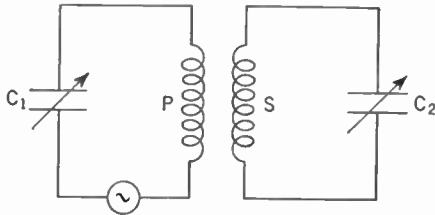

**Figure 345.** Series resonant circuit to show the amplification gain of a tuned circuit.

If we consider the secondary circuit of Figure 337 as a series resonant circuit as shown in Figure 345, we can see that  $Q$  times the net voltage across the complete circuit (the input voltage) is equal to the voltage across the condenser (the output voltage). From this we may infer that  $Q$  is equal to the amplification gain of the tuned circuit.

**383. Coupled Circuits**

In radio work, one tuned circuit is often coupled to another, as in Figure 346. The over-all frequency characteristic—that is,



**Figure 346.** One method of coupling a tuned circuit to another.

the relationship between frequency and current flowing in the secondary for a given voltage across the primary—can be shown by a graph similar to that in Figure 336. If each circuit is independently tuned to the same frequency and then the circuits are *loosely* coupled—that is, if all the lines of force around the primary coil cut across a few of the secondary turns or if a small percentage of the lines of force cut across all the secondary turns—the over-all frequency characteristic assumes the form of curve A in Figure 347.

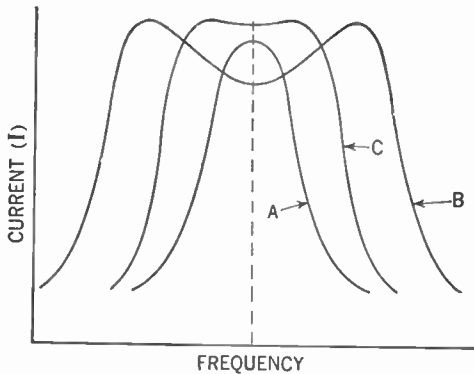

**Figure 347.** Resonant curves showing the effect of coupling.  
 Curve A—Loosely coupled.  
 B—Tightly coupled.  
 C—Compromise between A and B.

However, if the coupling is sufficiently increased so that many lines of force cut across many secondary turns, the over-all reactance and effective resistance are so altered that a double-humped frequency characteristic results, one peak occurring on either side

## 464 RESONANT CIRCUITS AND TUNING PRINCIPLES

of the frequency to which the circuits were individually tuned (Figure 347, curve B).

We call this condition *tight coupling*. One method of achieving it is to wind the secondary coil directly over the primary. You will readily see why such a curve is usually not desired for radio tuning: two frequencies (that is, two radio stations) would come in with equal strength for any one setting of the variable condenser.

In practice a compromise is often struck between very loose and very tight coupling to permit nearly uniform energy transfer over a particular restricted range of frequencies (Figure 347, curve C). You can now see how we eliminated side-band cutting in the superheterodyne receiver (Chapter 26, Figure 164, Vol. I).

As shown in Figure 341, resistance in any circuit tends to flatten out the curve that shows the frequency characteristic and thus tends to reduce the selectivity of our circuit.

### 384. Action of Filters

Electrically, filters are used to separate currents of certain frequencies from those of other frequencies. For our discussion here we may consider direct current as having a zero frequency.

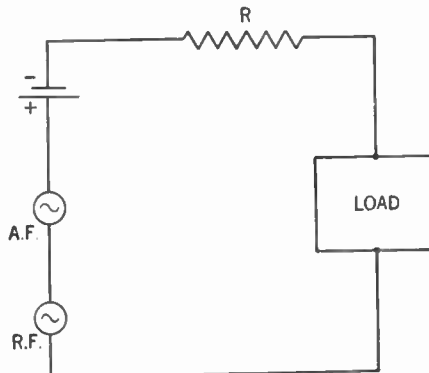

Figure 348. A battery, a low-frequency (A.F.) generator and a high-frequency (R.F.) generator supplying current to a load through a resistor (R).

Assume you have as an electrical source a battery supplying direct current (zero frequency), a generator of alternating current of audio frequency (low frequency) and a generator of radio-



frequency current (high frequency). Assume they are all connected in series and supply current to a load through a resistor connected in series (Figure 348). Let us neglect the impedance of the source.

The resistor will not have any filtering action, for it impedes equally all currents that pass through it, regardless of frequency.

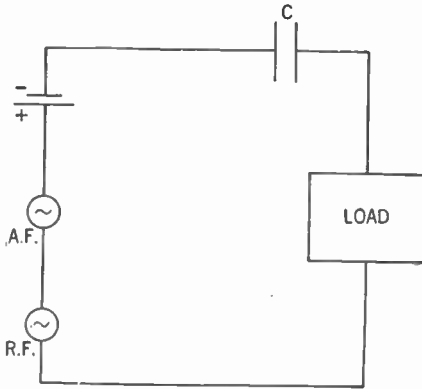

Figure 349. The resistor of Figure 348 has been replaced by a condenser (C).

Now assume you replace the resistor with a condenser (Figure 349). The direct current will be filtered out, for the condenser offers infinite reactance to its passage. Since

$$X_c = \frac{1}{2\pi fC}$$

at low frequencies the condenser offers a definite impedance to the flow of current. Thus it will impede the passage of audio-frequency current considerably. The impedance to the radio-frequency current, however, will be very small, since when  $f$  reaches a large size the value of the fraction becomes very small.

If you now replace the condenser with an inductor (Figure 350), the direct current will be only slightly impeded, owing to the resistance of the coil. Since  $X_L = 2\pi fL$ , the impedance to the audio frequency will be considerably more than that to the direct current. But the impedance to the radio frequency will be so great that most of the radio-frequency current will be held back. We now can understand the action of the radio-frequency choke coil in Fig-

## 466 RESONANT CIRCUITS AND TUNING PRINCIPLES

ure 136, Vol. I, where the radio-frequency currents are held back from the audio-frequency amplifier.

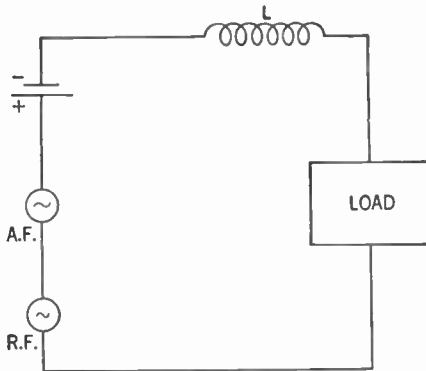

Figure 350. The current is now being fed to the load through an inductor (L).

### 385. Low-pass Filter

Now let us connect the condenser across the load (Figure 351). None of the direct current will flow through the condenser. Since the condenser offers a definite impedance to the audio-frequency current, very little of it will pass through and most of it will flow

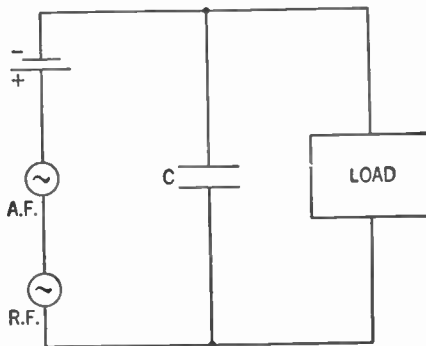

Figure 351. The condenser (C) is now in parallel with the load and acts as a low-pass filter, that is, the low-frequency currents can pass to the load.

into the load. Radio-frequency current, however, will find the condenser offers it an easy path and very little will flow through the load. We call this arrangement a *low-pass filter* since it passes the low frequencies on to the load. Another example of the use of a low-pass filter is shown in the tone control pictured in Figure

152, Vol. I. Stray radio-frequency current is by-passed to the ground through the condenser in Figure 136, Vol. I, by means of this filter system.

### 386. High-pass Filter

In Figure 352 we have replaced the condenser across the load by an inductor. Now the direct current and the audio-frequency

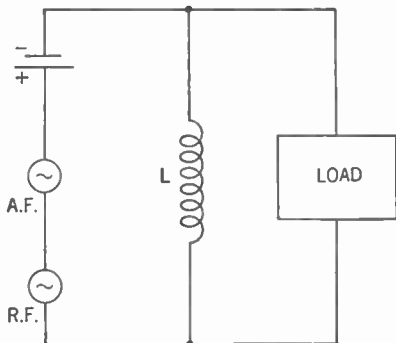

Figure 352. The inductor (L) is now in parallel with the load and acts as a high-pass filter, that is, the high-frequency currents can pass to the load.

current will pass through the inductor, very little going to the load. The radio-frequency current, however, will find that  $L$  offers a very high impedance to its passage and most of the current will flow through the load. We call this arrangement a *high-pass filter*. In Figure 154, Vol. I, arm B of the tone control is an example of such a filter.

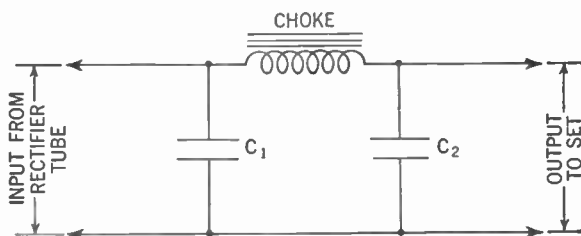
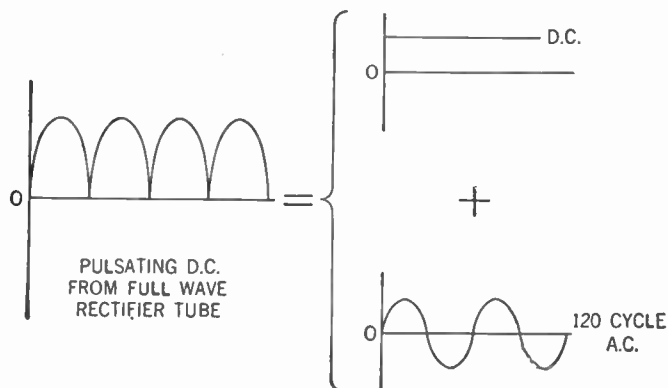

Figure 353. The filter circuit of the power supply.

### 387. Power-supply Filters

Let us see now these principles apply to the filter system of our power supply (Chapter 18, Vol. I). This consists of a choke coil and two condensers connected as in Figure 353. In this circuit the inductor and condensers are very large, the

choke coil being 30 henries and the condensers 8  $\mu$ fd. each. You will also remember that the current flowing into the filter system is a full-wave pulsating direct current delivered by a full-wave rectifier from the 60 cycle alternating-current line. This pulsating direct current may be resolved into its two components, a direct current and a 120-cycle alternating current (Figure 354).



**Figure 354.** Wave-form diagram showing the pulsating direct current from the full-wave rectifier tube broken down into its two components, a steady direct current which goes to the radio set and a 120-cycle alternating current which is filtered out.

As this pulsating direct current enters the filter system, the direct-current component flows through, impeded only by the resistance of the choke coil. The alternating-current component, although at a fairly low frequency, finds the impedance of the 30-henry choke quite high. Most of the alternating current, therefore, is blocked and must pass through  $C_1$ , which, because of its large value, offers a low-impedance path. The current flowing through the choke coil therefore has almost the complete direct-current component and very little of the alternating-current component (Figure 355).

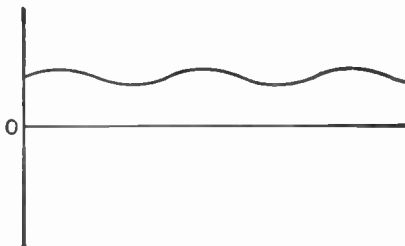

**Figure 355.** Wave form of the pulsating direct current after it passes through half the filter section. The second half of the filter irons out this slight ripple.

The impedance of the load further blocks the alternating-current component, which again finds a path through  $C_2$ . The result is that only a steady direct current flows into the load.

This filter system is an example of a low-pass filter, the current passing in this case having zero frequency.

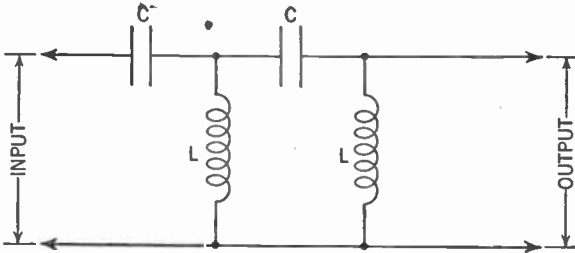
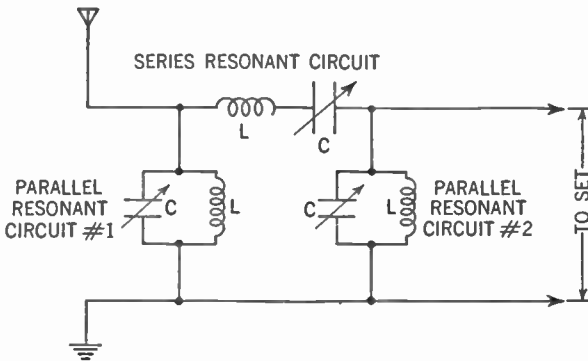

**Figure 356. Circuit of a high-pass filter.**

Figure 356 shows a high-pass filter, having an action opposite to that described above; only currents of high frequency can pass through.

**388. Filter Action of Resonant Circuits**

Resonant circuits can be made to serve as filters in a manner similar to the individual inductors and condensers discussed above. The series resonant circuit offers a very low impedance to currents



**Figure 357. Diagram showing how series and parallel resonant circuits are used to allow signals of only one band of frequencies to pass. The band-pass filter.**

of the particular frequency to which it is tuned and a relatively high impedance to currents of other frequencies.

The parallel resonant circuit, on the other hand, offers a very high impedance to currents of the particular frequency to which

## 470 RESONANT CIRCUITS AND TUNING PRINCIPLES

it is tuned and a relatively low impedance to currents of other frequencies.

Assume the resonant circuits in Figure 357 are tuned to the same frequency, say that of WOR (710 kc.). Currents of all frequencies flow into the filter network from the aerial. As they approach parallel resonant circuit 1, current whose frequency is 710 kc. finds that this circuit offers it a very high impedance. Very little of this current flows through the parallel resonant circuit and most of it flows on to the series resonant circuit. Currents of other frequencies, however, find parallel resonant circuit 1 an easy path and most of these currents flow to the ground.

### 389. The Band-pass Filter

The series resonant circuit offers a low-impedance path to current whose frequency is 710 kc. Currents of other frequencies, however, are stopped and forced to flow back to the ground through parallel resonant circuit 1.

The current that passes through the series resonant circuit is

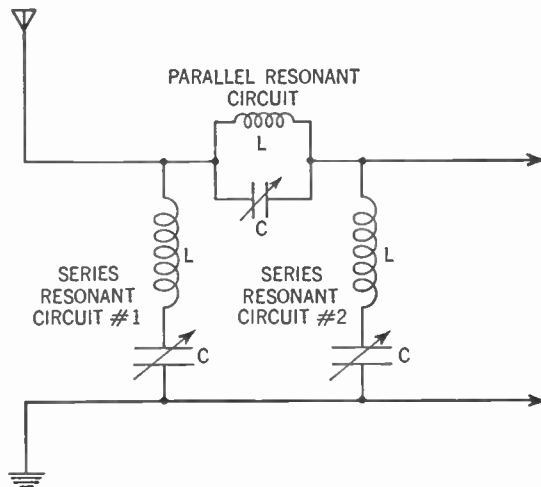

**Figure 358. Diagram showing how series and parallel resonant circuits are used to stop signals of one band of frequencies from passing. The band-stop filter.**

predominantly of the 710-kc. frequency, along with a very small amount of some nearby frequency.

Once again the parallel resonant circuit, now circuit 2, offers a high impedance to the 710-kc. current and forces it to flow on to

the set. The stray currents whose frequencies are not 710 kc. find this circuit an easy path to the ground. The net result is that only currents whose frequency is 710 kc. will find their way to the set.

We call this complete circuit a *band-pass filter*.

### 390. The Band-elimination Filter

The situation shown in Figure 358 is the exact opposite of the one we have just considered. If all three resonant circuits are tuned to, say, 710 kc., any current whose frequency is 710 kc. is stopped from passing through and will be forced to flow to the ground. Currents of all other frequencies will pass through to the set.

We call this a *band-elimination* or *band-stop filter*. It is used under conditions where it is desired to keep a powerful station, such as WOR, from interfering with reception of other stations.

#### SUMMARY

1. **Condensers and inductors** may be connected together to form a circuit that is resonant to a certain frequency.

2. At resonance the voltage drop across the condenser ( $E_C$ ) is equal and opposite to the voltage drop across the inductor ( $E_L$ ). Thus  $E_C = E_L$  and  $E_C + E_L = 0$ .

3. From the above we can see that the **capacitive reactance** ( $X_C$ ), at resonance, is equal to the **inductive reactance** ( $X_L$ ) and that  $X_C + X_L = 0$ .

4. The **series resonant circuit** offers very little impedance to currents of the resonant frequency.

5. The **parallel resonant circuit** offers very high impedance to currents of the resonant frequency.

6. Selectivity in a receiver is improved by the following: (a) Reducing the resistance ( $R$ ) of the tuning circuit. (b) By loose coupling between the primary and secondary of the antenna coupler.

7. The **figure of merit** of an inductor is expressed by the letter  $Q$ , which is the ratio between the inductive reactance ( $X_L$ ) and the resistance ( $R$ ) of the coil. Thus:  $Q = \frac{X_L}{R}$

8. Some of the principles operative in filter systems are: (a) Resistors impede equally the flow of direct and alternating currents, regardless of frequency. (b) Condensers block the flow of direct current completely. The impedance of a condenser is greater for low-frequency currents (A.F.) than for high-frequency currents (R.F.). (c) The impedance offered by inductors to high-frequency currents is greater than to low-frequency currents.

## GLOSSARY

**Anti-resonant Circuit:** A parallel resonant circuit.

**Filter:** A circuit containing inductors and condensers used to separate currents of different frequencies.

**Loose Coupling:** Coupling between coils in which many lines of force from the primary do not cut across the secondary.

**Parallel Resonant Circuit:** A circuit in which the generator is in parallel with a coil and with a condenser.

**Resonance:** That condition of a circuit containing inductance, capacity and resistance in which  $X_L = X_C$  and the total reactance is zero.

**Series Resonant Circuit:** A circuit in which a generator, a condenser, a coil, and a resistance are all in series.

**Tight Coupling:** Coupling between coils in which many lines of force from the primary cut across the secondary.

**Tuned Circuit:** A circuit containing a condenser, a coil, and a resistance in series.

## QUESTIONS AND PROBLEMS

1. State the effect on the current-voltage phase angle of a purely inductive circuit, a purely capacitive circuit, and a purely resistive circuit. Show this vectorially.

2. Show how the impedance is determined vectorially in a circuit containing an inductor and a resistor in series.

3. Do the same for a condenser and a resistor in series as in question 2.

4. Show vectorially how to obtain the impedance of an alternating-current circuit containing a condenser, an inductor, and a resistance in series.

5. When, in the circuit of question 4, the voltage across the coil and condenser are equal, what can be said about their reactances? Give proof.

6. When, in the circuit of question 4, the voltages across the coil and condenser are equal, what is the sum of their reactances? Give proof.

7. What is the magnitude of the current flowing through a circuit containing an inductor and a condenser, and no resistance, when the condition of resonance exists? Give proof.

8. Interpret the resonance curve in Figure 336 from the point of view of tuning for a station.

9. Derive the formula for the resonant frequency and give the units for the various factors.

10. Explain how the voltage across the coil of a circuit containing an alternating-current generator, a condenser, a resistor, and a coil in series at resonance may be many times larger than the voltage of the generator.

11. Describe the characteristics of a series resonant circuit.

12. Explain vectorially why resistance in a series resonant circuit reduces the selectivity of that circuit.

13. Describe the characteristics of a parallel resonant circuit.



## RESONANT CIRCUITS AND TUNING PRINCIPLES 473

14. In a series resonant circuit the source generator must have a very low impedance for maximum power transfer. Explain why.

15. Why must the generator have a high impedance for maximum power transfer in a parallel resonant circuit?

16. What is meant by the  $Q$  of a coil and how is it calculated?

17. What type of coupling is desirable to avoid side-band cutting? Explain why.

18. Illustrate by circuit diagram a low-pass filter.

19. Illustrate by diagram a high-pass filter.

20. Explain how the filter system of a power supply acts as a low-pass filter.

21. Explain the operation of a band-pass filter.

22. Explain the operation of a band-elimination filter.

## CHAPTER 35

# The Electromagnetic Wave

---

- Problem 1:** *What is the nature of an electromagnetic wave?*
- Problem 2:** *How are radio waves produced in a transmitting station?*
- Problem 3:** *How is the radio wave transmitted (a) by ground wave; (b) by sky wave?*
- Problem 4:** *How does the ionosphere affect the sky wave?*
- Problem 5:** *How are "static" and "fading" caused and corrected?*
- 

### 391. How the Radio Wave Is Produced

The term *electromagnetic wave* covers a whole series of phenomena such as radio waves, heat waves, light waves, X rays, gamma rays (the rays emitted by such substances as radium) and, recently discovered, cosmic rays. These waves or rays all may be called forms of radiant energy and seem to differ chiefly in their wave lengths and hence frequencies.

We will deal now only with the radio waves, which, as you will note, comprise a very wide range of frequencies.

Little is known as to just what electromagnetic waves consist of. We know that they represent a form of energy and we have put this energy to use. But the exact nature of these waves or rays is in the realm of theory.

### 392. The Quantum Theory

One school of thought holds that these rays are minute bundles of energy, shot off into space like bullets out of a gun. According to the Planck-Einstein theory, the flow of an alternating current through a conductor tends to force electrons in the outer orbits or rings of the atom to take up positions in the inner orbits. In the

process, bundles of energy, called *quanta*, are emitted. It is these quanta that radiate out into space, producing the radio wave.

While there is considerable evidence to support the quantum theory there are some facts which it does not explain. In the discussion of this book we have used the assumption that the radio wave is a wave motion through the medium of the ether. The student must be warned that all explanations of the radio wave are purely theoretical and that further research may produce new theories. As a matter of fact, many scientists today tend to hold to a theory that combines the quantum explanation with the wave theory.

### 393. How Is an Electromagnetic Wave Produced?

According to the wave theory, this is what happens in a transmitting station which broadcasts radio signals. Assume that you have a generator capable of producing an alternating current whose

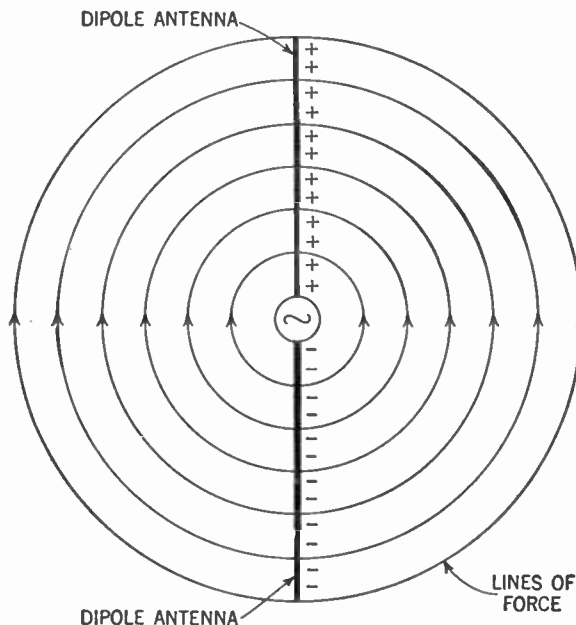

**Figure 359.** Diagram of the dielectric field around a dipole antenna.

frequency is, say, 500,000 cycles per second. Two vertical wires (called a *dipole* antenna) are attached to the brushes of the generator (Figure 359).

During one half cycle, electrons stream into one of the vertical wires (negative charge) and out of the other (positive charge). Since the two wires have opposite electrical charges, we may consider them as the opposite plates of a condenser with the surrounding air as the dielectric. As a result, a dielectric field (also called the *electric* or *electrostatic* field) is set up between them. The lines of force are shown in Figure 359 and the arrowheads indicate the direction of this field, from negative to positive.

As the generator voltage dies down to zero, this dielectric field collapses back into the wires. But before the outermost line of force shown in the drawing can reach the wires, the generator begins to go through the second half-cycle and another dielectric field begins to form. This field is now in the opposite direction.

The line of force remaining from the first field is pushed out by the second field and becomes detached from the wire (Figure 360).

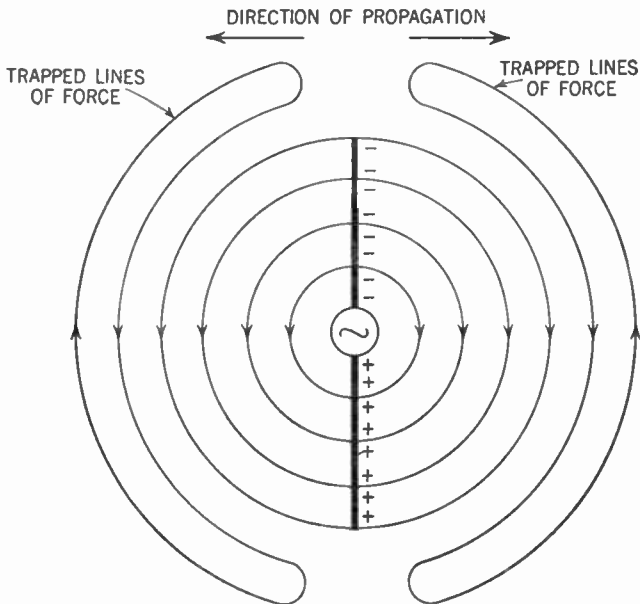

**Figure 360.** Diagram showing how lines of force are prevented from returning to the antenna.

This process repeats itself and the result is a radiating stream of lines of force that move out through space at the rate of 186,000 miles per second (Figure 361).

We have learned earlier in our study that a moving dielectric field produces a magnetic field. This magnetic field is at right angles to the dielectric field. Thus we have a dielectric field, with

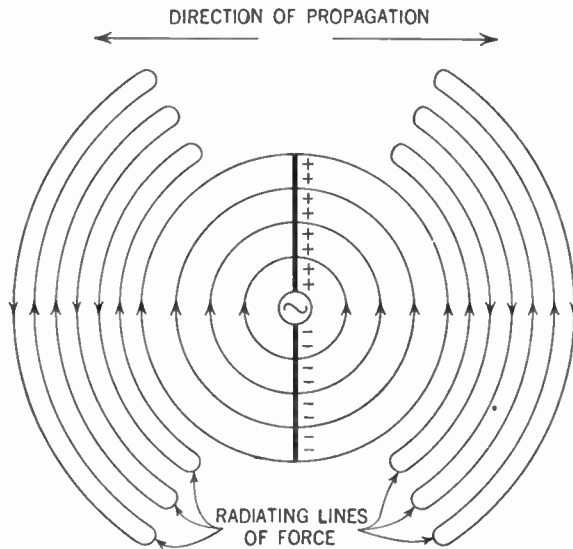

Figure 361. Diagram showing how the trapped lines of force are radiated or propagated.

an accompanying magnetic field, radiating through space. This combined radiation is called the *radio wave*. This radio wave is therefore an electromagnetic wave and, like light, is a form of radiant energy.

### 394. The Induced Field

We must not, however, confuse this *radiation* field with the field around a conductor carrying an electric current. To differentiate between the two we call the latter the *induced* field. The induced field, at a distance of 10 miles from the generator, is only  $\frac{1}{10000}$  as strong as at a distance of 1 mile. But the radiation field is  $\frac{1}{10}$  as strong at 10 miles as it is at 1 mile. We can see why the radiating field is used for long-distance transmission.

### 395. Why Are Signals Weaker as Distance from the Station Increases?

In practice, except in the case of radio waves of very high frequencies, one end of the generator is connected to the ground. The

radiation field then appears as shown in Figure 362. The bottom half of the field may be considered as though it passed through the earth.

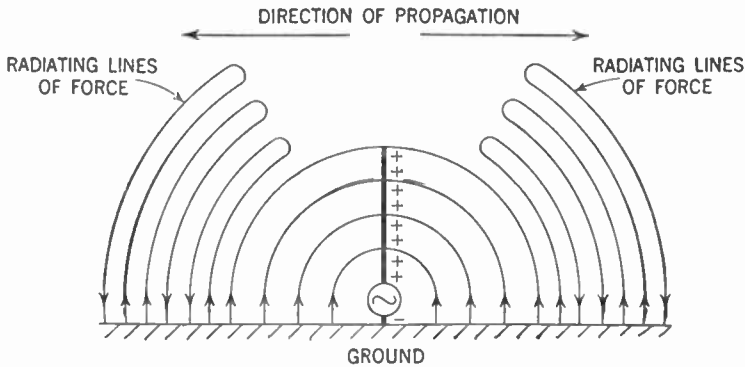

**Figure 362. How lines of force are radiated when one end of the generator is connected to the ground.**

The higher the frequency of the generator, the stronger the radiation field. There is some radiation at frequencies of 25 and 60 cycles per second, but highest efficiency is obtained at 50 kc. or over. Thus, with the ordinary type of transmitting aerial, the radiation field at a given point is about 25,000 times as strong at 1,500 kc. as it would be at 60 cycles per second.

The radiation field spreads out in all directions somewhat like the larger and larger circles formed by ripples in a pond when a stone is thrown in. Since the total energy of the field is constant, the further away the wave gets from the generator, the more it is spread out and the weaker it gets. You will notice that water waves, too, get weaker the further they get from the source of disturbance (the stone in the pond).

Another factor that weakens the radiation field is the absorption of energy by the earth. Eddy currents and dielectric losses cut it down considerably. Thus intervening hills or buildings may prevent a signal from being received strongly.

As the radiation field (that is, the radio wave) sweeps across the receiving antenna, it induces a voltage or electromotive force in the aerial-ground system. This voltage is extremely small. It has been estimated that the electromotive force induced in the average receiving antenna by radiation from a nearby transmitting

station of average power is usually about 50 microvolts (.00005 volt). Signals from distant stations are correspondingly weaker. You can now see the necessity for radio-frequency amplification in our receiver.

### 396. The Radio Wave Is Transmitted by Ground Wave and Sky Wave

When a radio wave leaves the transmitting antenna it spreads out in all directions. One portion travels along the surface of the earth and is accordingly called the *ground wave*. Another portion is radiated out into the sky and is appropriately called the *sky wave* (Figure 363).

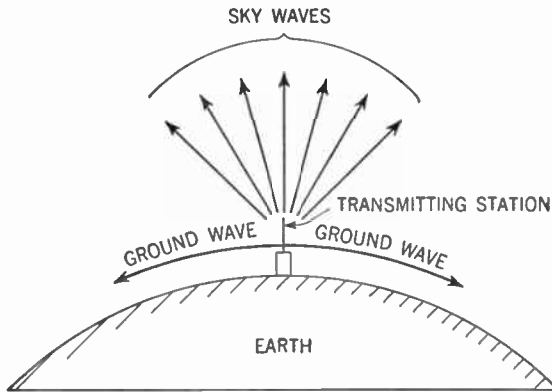

Figure 363. Diagram showing how a transmitting station sends out ground and sky waves.

### 397. The Ground Wave

As the ground wave travels over the surface of the earth, energy is absorbed by the earth and the signal gets weaker and weaker the further it goes. This loss of energy results from the fact that electric currents are induced by the radio wave and set flowing in the earth. Naturally those portions of the earth over which the radio wave travels that are better conductors of electricity require less energy to set these induced currents flowing than portions that are poor conductors. Thus less energy is lost by the radio wave in traveling over good conductors. We can see, therefore, why the ground wave can travel further over ocean water (a relatively good conductor) than over land.

From our study of induction we know that the higher the frequency, the greater the amount of induced voltage. We may therefore expect that radio waves of higher frequencies will lose more power by the absorption of the earth than will radio waves of lower frequencies.

For this reason radio waves of lower frequencies (50 kc. to 550 kc.) are used for ground-wave transmission over distances up to about 1,000 miles. Radio waves whose frequencies lie in the broadcast band (550 kc. to 1,600 kc.) are usually effective over distances of about 50 to 200 miles. Of course, the energy received at any station also depends upon the power of the transmitting station that is sending the signal. At frequencies above 1,600 kc., the ground wave can be received only at distances of about 15 to 20 miles.

### 398. The Sky Wave and the Ionosphere

The sky wave travels outward into the sky and would never return to earth were it not for the *Kennelly-Heaviside Layer*. This layer was named for the two scientists who first studied it. Today this region of the atmosphere beyond the stratosphere is called the *ionosphere* and has been found to consist of several layers of *ionized gases*.

When a gas (such as air) exists under a very low pressure, it is relatively easy to knock out one or more electrons from its molecules. Such a molecule or atom having a deficiency of electrons is called an *ion*. An atom or group of atoms that has lost one or more electrons has a positive charge. Ions can be attracted or repelled by electric forces, just as any other charged bodies are attracted or repelled.

Fast-moving particles, such as electrons, can knock off other electrons from molecules of a gas under low pressure. In addition, certain types of radiations, such as ultraviolet rays from the sun and cosmic rays from outer space, may also knock off these electrons.

Ions tend to lose their charges. They constantly re-combine with free electrons to re-form the original molecules. That is why this ionization is negligible at low altitudes. Below 60 miles any volume of air contains so many molecules of the various gases that any molecule which may have lost an electron almost immediately



recovers it from a neighbor. Moreover, the ultraviolet rays of the sun are absorbed by the upper air and comparatively few get down to a distance less than 60 miles above the surface of the earth.

On the other hand, the further up we go, the rarer the air gets—that is, there are fewer molecules in any volume. Beyond a distance of 200 miles from the earth's surface there probably are so few molecules that ionization is virtually nil.

So we see that the ionosphere is a layer or region beginning at about 60 miles beyond the surface of the earth and extending to about 200 miles beyond the surface of the earth.

The ionosphere is believed to consist of several layers which ionize in different ways. We know that different gases *ionize* at different pressures. Also, the different gases that constitute the air have different densities, and at greater distances from the earth there are more molecules of the lighter gases and fewer of the heavier ones. This condition results in the ions forming lay-

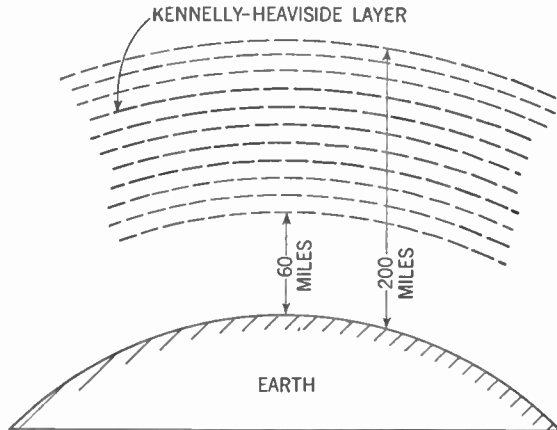

**Figure 364.** Diagram showing the Kennelly-Heaviside layer above the surface of the earth.

ers within the ionosphere at different altitudes, depending upon the gases present (Figure 364). These layers are constantly shifting from day to day, from month to month, and from year to year. The ions also are constantly re-combining with electrons and new ions are being formed. Climatic conditions and solar and stellar disturbances also cause these layers to change position.

In addition to the great mobility of the layers, the absence of ultraviolet rays from the sun at night causes the whole ionosphere to rise. We have seen how this rise affects the night error discussed in the chapter on direction finding (Chap. 28, Vol. I).

### 399. How the Sky Wave Gets Back to Earth

The effect of the ionosphere on the sky wave is threefold. (1) A certain portion of the wave penetrates it and never returns to the earth. (2) A portion of the wave is absorbed by this layer. (3) Another portion is reflected back to the earth, where it may be received.

The angle at which the sky wave must strike the ionosphere to penetrate it depends upon the density of the layer and the frequency of the wave. This angle is known as the *critical angle*. It is the angle between the sky wave and the antenna transmitting it (Figure 365). Waves that strike the ionosphere at angles less

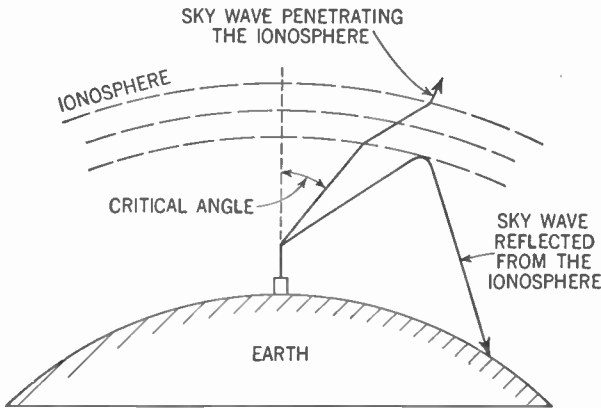

**Figure 365.** Diagram showing the critical angle. Sky waves of a certain frequency, striking the ionosphere at an angle less than the critical angle, penetrate and do not return to earth.

than the critical angle penetrate and never return. Those that strike the ionosphere at angles greater than the critical angle are reflected back to earth, as shown in Figures 365 and 366. The greater the frequency of the sky wave, the greater the critical angle. When the sun is directly overhead, the ionosphere is at its densest. This condition increases the critical angle. For this reason, too, the critical angle is greater in daytime than at night. Seasonal changes

in the ionosphere position and changes in its density resulting from sunspot activity also determine this angle.

The absorption of part of the sky wave depends upon the density of the ionosphere. Increased ionization of the air resulting from sunshine, sunspot activity, and the like, all tend to increase the absorption.

#### 400. Skip Distance and Skip Zones

The portion of the sky wave that is reflected back to the earth does not come straight down, but is reflected at an angle that cor-

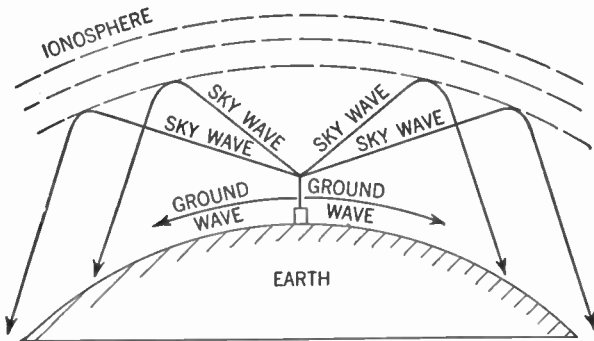

Figure 366. Diagram showing reflection of the sky waves from the ionosphere.

responds to the angle at which that particular wave strikes the ionosphere. Figure 366 illustrates this principle. The wave, after being reflected from the ionosphere, strikes the earth, then bounces back from the earth and is again reflected back toward the earth

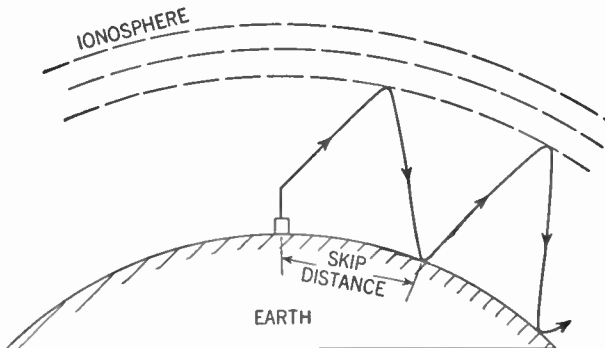

Figure 367. Diagram showing what is meant by skip distance.

from the ionosphere (Figure 367). This process continues until the radio wave is completely absorbed.

The distance between the transmitter and the point where the sky wave first reaches the earth after being reflected from the ionosphere is called the *skip distance*. Skip distances of several hundred miles are common at the higher frequencies.

It is possible that there may be a gap between the furthest point reached by the ground wave and the point where the sky wave is reflected back to earth (Figure 368). This gap is known

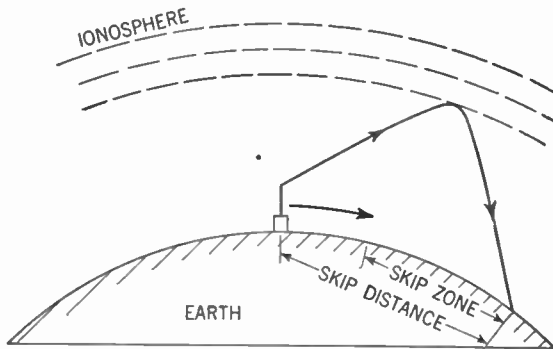

Figure 368. Diagram showing what is meant by skip zone. In this zone no signals are received.

as the *skip zone* and is responsible for the peculiar fact that a signal may be received at a great distance from the transmitting station while an operator whose receiver is nearer to the transmitter may hear nothing.

#### 401. Effect of Frequency on Transmission of the Radio Wave

At low frequencies (50 kc. to 550 kc.) the ground wave is extremely useful for distances up to about 1,000 miles. The energy loss caused in passing over the earth is low, and since we do not depend upon the ionosphere, transmission is stable and practically unaffected by daylight and seasonal changes.

For transmission over distances ranging from 1,000 to about 8,000 miles we must depend upon the sky wave. When the frequency is low, the amount of absorption by the ionosphere is low. However, this absorption increases as we raise the frequency, and

the use of sky waves whose frequencies are about 550 kc. is possible only at night.

At frequencies which lie in the broadcast band (550 kc. to 1,600 kc.), the earth losses of the ground wave limit its use to about 200 miles. Owing to absorption by the ionosphere, sky waves at these frequencies are not effective in daytime. But at night, when this absorption is reduced, transmission up to 3,000 miles is possible. At about 1,400 kc., absorption of the sky wave reaches its maximum. From there on, increases in frequency result in decreases in absorption, until the ultrahigh frequencies are reached (above 30 mc.).

At high frequencies (1,600 kc. to 30 mc.) ground losses become so great that transmission of the ground wave is limited to about 15 miles. The sky wave, however, may reach distances as far away as 12,000 miles from the transmitter. As is the case for all sky waves, however, transmission at these frequencies is unstable as a consequence of constant changes in the ionosphere.

#### 402. The Ultrahigh Frequencies

Frequencies that lie above 30 mc. are called *ultrahigh* frequencies. The ground losses are so high as to completely eliminate the ground wave. At these frequencies the critical angle becomes so

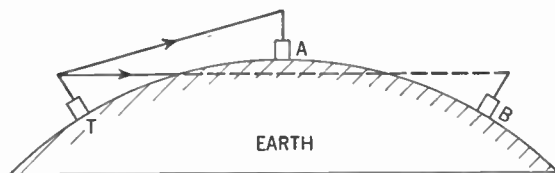

**Figure 369.** Diagram illustrating ultrahigh-frequency transmission. Radio waves from transmitting station (T) can be received at receiving station A but not at B. The curvature of the earth interferes.

great that practically all of the sky wave penetrates the ionosphere and is not reflected back to earth. Under freak conditions of the ionosphere the sky wave may bounce back and then transmission may occur over long distances. But such conditions are rare and do not last very long.

Transmission of the ultrahigh-frequency waves, therefore, is possible normally only in a straight line from the transmitting antenna to the receiving antenna. In this respect, then, ultrahigh-

frequency radio waves resemble light waves. The distance we can transmit in a straight line is limited by the curvature of the earth (Figure 369). Thus transmission is possible between the transmitting station T and receiving station A, but not receiving station B. Of course, if we raise the aerials or place them on top of a hill, greater distances can be covered. Changes in atmospheric conditions, due to changes in temperature, air pressure, and moisture, sometimes seem to increase slightly the distance over which these ultrahigh-frequency waves may be sent, by slightly bending the waves toward the ground. Waves that normally, in straight-line transmission, would pass above the receiving antenna, are bent down to strike it.

Transmission at ultrahigh frequencies is quite stable and signals are affected very little by outside disturbances.

#### 403. Interferences with Reception of Radio Waves

Radio waves suffer from interferences of two types. One such type of interference is called *static* and is manifested as hissing, clicking, and crackling noises heard in the receiver. These noises may become great enough to make transmission impossible. The other type is called *fading* and is manifested in undesirable changes in the intensity or loudness of the signal in the receiver.

#### 404. Preventing Static

Static falls into two categories. There is *man-made static* and *natural static* or *atmospherics*.

Man-made static is generated by most electrical devices. Ignition systems, diathermy machines, sparking brushes on motors and generators, all may cause interference with radio reception. In fact, almost any device that produces an electric spark can generate static. This static may be radiated into space and be picked up by nearby aerials, or may be sent directly into the receiver through a common power supply.

Whenever an electric spark occurs, a train of radio waves is sent out over a fairly wide band of frequencies. For this reason static is difficult to eliminate.

The best method for eliminating man-made static is to kill it at the source. If the brushes of a motor are sparking, cleaning them will eliminate this source of static. Another method of pre-

vention is to place a filter system between the machine that is at fault and the power lines. This filter will by-pass the radio-frequency currents to the ground. Figure 370 shows such a filter.

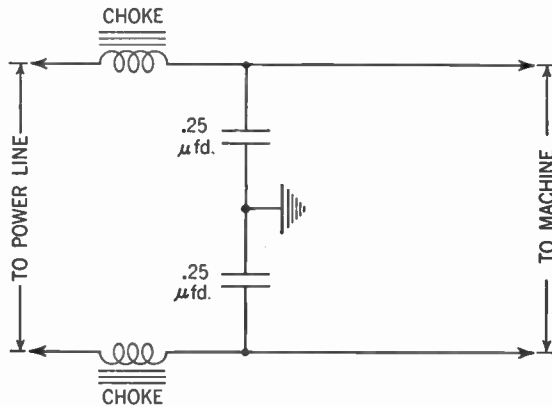

**Figure 370.** Filter circuit to prevent radio-frequency currents set up by sparking machine from traveling back into the power lines.

The radio-frequency currents are prevented from entering the power lines by the choke coils and they take the easy path to the ground through the condensers.

#### 405. Eliminating Static by Changes in the Receiver

Where it is impossible to filter out the static or where the static is radiated into space, other methods of elimination are used. Since static is a form of radio wave, a selective tuner may be of some help in tuning it out. The use of a directional aerial, such as a loop, will eliminate some of the static, provided the source of the noise is not in the same direction as the transmitting station.

Man-made static falls into two classes, the *hiss* type and the *impulse* type. The impulse type consists of separate and distinct pulses of very high amplitude. These pulses are of very short duration. The hiss type consists of a series of pulses, so close together that they overlap to produce the hiss. For the reduction of the hiss type of static we employ the methods outlined above.

The impulse type of static may be eliminated by yet another method. Since the impulses consist of high-amplitude pulses of very short duration, we can get rid of them if the receiver is made to go dead for the extremely short interval that the static impulses

are present. Because this interval is so minute there is no noticeable interference with the signal.

A form of automatic volume control is used. As the loud impulse comes in, the amplification factor of the receiver is reduced to zero and nothing is heard. After the impulse has passed, the set returns to normal (Chap. 24, Vol. I). This automatic volume control must, of necessity, be extremely quick-acting.

Natural static or atmospherics consist of radio waves generated from such natural sources as thunderstorms. Such waves are usually responsible for the crackling and crashing sometimes heard in the receiver. They are present at most of the frequencies and diminish in strength as the frequency increases. For this reason transmission at high frequencies suffers little from this form of interference. At the ultrahigh frequencies static is rarely present except during local thunderstorms.

Static may be transmitted like any other radio wave. At low or broadcast frequencies static from far places is absent in the receiver owing to the absorption of the sky wave. But at night this absorption is diminished and the sky-wave static may cover great distances.

Atmospherics may be reduced by the methods used to reduce the hiss type of man-made static, namely, employment of a selective receiver and a directional antenna.

#### 406. Causes of Fading

Fading, the second source of interference, is caused by the interaction of two parts of the same radio wave. At a certain distance from the transmitter, both the ground wave and the sky wave may be received. Because each wave travels a different path it is possible that they may be received simultaneously or slightly out of step. If they come in together they reinforce each other and the signal is louder. If they are out of step they tend to neutralize each other and the signal dies down (Figure 371).

Another cause of fading is the ionosphere. Because of variations in the sky wave due to changes in the ionosphere, the signal in the receiver may get louder and weaker.

Fading may also be caused by the interaction of two sky waves. One sky wave may reach the receiver in one hop, while the other, hitting the ionosphere at a different angle, may arrive in two hops



(Figure 372). Here, too, fading may or may not occur, depending upon whether or not the two sky waves arrive in step.

Violent changes in the ionosphere, during a condition known as an *ionosphere storm*, cause severe fading especially among fre-

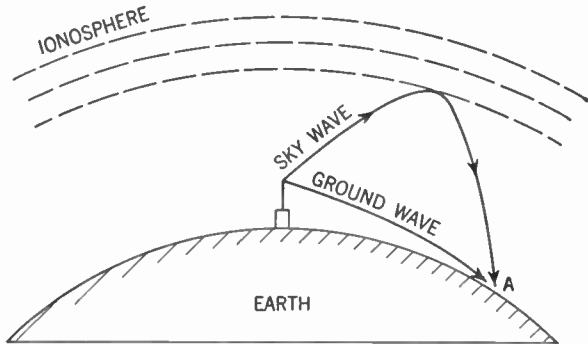

**Figure 371. Diagram showing how fading is produced. The ground wave and the sky wave arrive at the same point (A) out of step (out of phase) and tend to neutralize each other. This condition causes the signal to fade out.**

quencies higher than 1.5 mc. These storms may last as long as several weeks and are believed to be due to vigorous sunspot activity.

The most common means of overcoming fading is the use of automatic volume control. As the signal drops, the amplification

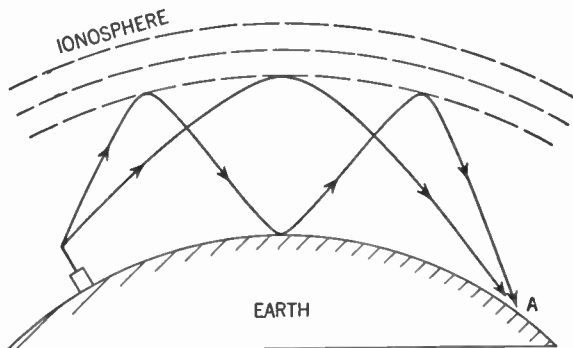

**Figure 372. Another cause of fading. Here two sky waves arrive at the same point (A) out of step.**

factor of the tube is raised and the level of reception is maintained. Automatic volume control is not very effective, however, where the fading is extreme.

Another method used to overcome fading is known as *diversity*

*reception.* It has been found that fading does not usually occur at two different places at exactly the same time. Accordingly, two or more receiving aerials are used, spaced some distance apart. Thus, if fading occurs in one, the other may still receive the loud signal. This method is not yet very practical for home use because a rather complicated type of receiver must be used.

#### SUMMARY

1. Radiant energy is transmitted by **electromagnetic waves**. Heat, light, radio, and cosmic rays are forms of radiant energy differing, as far as we are able to judge, chiefly in frequency and wave length.

2. Radio waves exhibit properties of both electricity and magnetism, or more precisely stated, radio waves have both a dielectric field and a magnetic field at right angles to each other. Also the electric and the magnetic vectors both are at right angles to the direction of propagation.

3. Radio waves may be produced at a transmitting station by alternating-current generators attached to a **dipole antenna**. Electrons are set moving up and down the two arms of the dipole antenna, which may be considered plates of a condenser. A dielectric field is set up between these charged wires. At each alternation the new dielectric field is formed and dies down. The successive waves of lines of dielectric force are sent out into space at the speed of 186,000 miles per second.

4. **Radiation fields** increase in strength in proportion to frequency, but all radio waves lose intensity with distance.

5. The radio wave consists of two parts: a **ground wave** and a **sky wave**.

6. Ground waves travel only comparatively short distances because their energy is absorbed by the earth. Low-frequency radio waves (50-550 kc.) travel up to distances of 1,000 miles under favorable conditions. But frequencies in the broadcast band (550 kc. to 1,600 kc.) are effective as ground waves only for about 50 to 200 miles.

7. Sky waves travel out into space to the ionosphere, which is a region beyond 60 miles from the earth's surface in which are ionized gases. Sky waves are reflected from the ionosphere back to the earth when the angle between the vertical and their direction of propagation is greater than the **critical angle**. The critical angle is the angle below which the waves penetrate the ionosphere.

8. The sky wave is reflected back to earth at varying distances from the transmitting station. For any particular case the distance between the transmitter and the place where the reflected sky wave first reaches the earth is called the **skip distance**.

9. Frequencies above 30 mc. are **ultrahigh** frequencies. Such radio waves are not reflected back from the ionosphere and can be transmitted only in a straight line between the transmitting antennas to the receiving antenna.

10. Static is a form of interference with radio reception due to oscil-

latory discharges from some other source than radio stations. **Man-made** static may come from all kinds of electrical devices which produce sparks. **Natural** static comes from lightning or other electrical disturbances.

11. Man-made static should be controlled at the source by filtering systems, but some help can be provided in receivers by selective tuning or by automatic-volume-control devices.

12. **Fading** is sometimes caused by neutralization of parts of the same wave slightly out of step because received by way of the ground and the sky or by one reflection and two reflections. Sun spots and disturbances in the ionosphere from whatever causes may cause fading.

13. The most common method of correcting fading is by automatic volume control.

#### GLOSSARY

**Critical Angle:** . The angle between a vertical transmitting antenna and the sky wave, which determines whether a radio wave will penetrate the ionosphere or be redirected back to earth.

**Diversity Reception:** Reception with several aerials in different places to overcome fading.

**Fading:** The falling off of intensity of the pickup from the radio wave.

**Ground Wave:** The portion of a radiated field about a transmitter aerial that travels along the ground.

**Induced Field:** The magnetic field around a current-carrying conductor.

**Ionosphere:** A series of layers of ionized air in the upper regions which refract back to earth radiated sky waves.

**Kennelly-Heaviside Layer:** Another name for the ionosphere.

**Quantum:** A unit bundle of energy assumed to be radiated from a transmitting antenna and making up the radio wave.

**Radiated Field:** The field of energy radiated from an antenna consisting of an electrostatic field at right angles to an electromagnetic field.

**Skip Distance:** The distance between a transmitting antenna and the point where the sky wave returns to earth.

**Skip Zone:** The region between the end of the ground wave and the point where the sky wave returns to earth in which no signal for the station is received.

**Static:** Hissing, clicking, cracking noise in receivers which may have a natural or man-made origin.

#### QUESTIONS AND PROBLEMS

1. Name several types of electromagnetic waves.
2. Explain the wave theory of electromagnetic radiation from a dipole antenna.
3. Describe the nature of a radiated radio wave.
4. Differentiate between the radiation field and the induction field around an antenna.

5. How does the radiation field vary with the frequency of its generating current?

6. What accounts for the weakening of the radiation field as it spreads from the source?

7. In what two directions does the radio wave travel from the antenna?

8. How does the earth affect radio waves of high frequencies?

9. Describe the origin of the ionosphere, and its behavior.

10. How does the ionosphere affect the sky wave?

11. What is the relation between the frequency of a sky wave and its critical angle?

12. Illustrate by diagram what is meant by skip distance and skip zone.

13. Explain the fact that a station may be heard by a receiver at a great distance while a receiver closer to the station cannot get that station.

14. Explain the transmission behavior of the following ranges of frequencies: 50 kc. to 550 kc.; 550 kc. to 1600 kc.; 1600 kc. to 30 megacycles; above 30 megacycles.

15. What two conditions serve to interfere with radio reception under normal conditions? How do they arise?

16. Draw a circuit to eliminate man-made static fed in through the power line. Explain how it works.

17. How may a quick-acting automatic-volume-control system eliminate the impulse of man-made static?

18. By what method may natural static effects in the receiver be reduced?

19. What occurs during ionosphere storms and what effect does it have on radio reception?

20. What is the most common means of overcoming fading in modern receivers?

21. What is diversity reception and what is its purpose?

## CHAPTER 36

# Radio Antennas for Transmitters

---

**Problem:** *What principles are involved in adapting antennas for purposes of transmission of radio signals?*

---

### 407. Antenna Characteristics

In our discussion of resonant circuits (Chapter 34) we considered circuits containing concentrated or *lumped* inductance and capacitance as represented by inductors and condensers. There

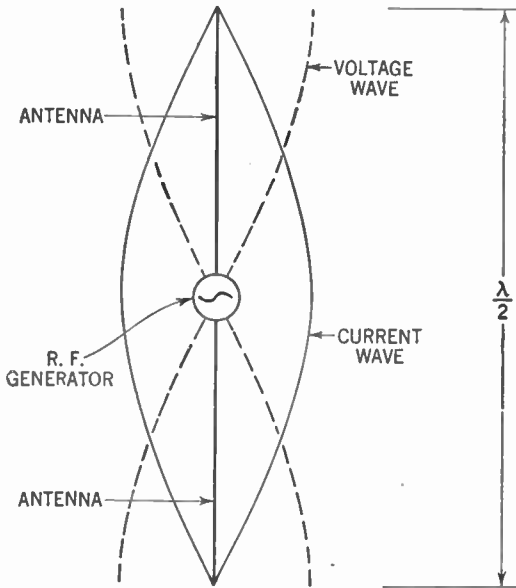

**Figure 373.** The half-wave Hertz (dipole) antenna showing current and voltage waves.

are, however, important tuned circuits where the inductor and condenser do not appear. These circuits utilize the distributed inductance and capacitance which is inevitable even in a circuit containing a single straight wire. An antenna is such a circuit.

A peculiarity of such a circuit is that if we feed into it an alternating current whose frequency is equal to the resonant frequency of the circuit, the current and voltage values will be different at different points. Thus, if our dipole antenna (Figure 373) is connected to a generator, we find that the current is maximum at the center and zero at the ends. On the other hand, the voltage is zero at the center and maximum at the ends.

Here is the explanation. The wave of electric energy travels from the generator out to the ends of the antenna. When it reaches the ends it is reflected back along the wire. The time the wave takes to reach the ends depends upon the length of the aerial. When the aerial is in resonance with the frequency of the generator, the reflected wave is returned so that, as it meets the next oncoming wave, the currents of both waves add or reinforce one another at the center of the antenna and reach zero together at the ends. The opposite is true of the voltages.

#### 408. Standing Waves

Since this condition is the same at all times, if you measure the current at the center you always find it at maximum while the current at the ends is always about zero. This condition is the same as if we had what we might call a *standing wave* instead of waves constantly moving back and forth.

Some radiation occurs if a high-frequency current flows through any conductor. But it has been found that if the antenna is resonant to the frequency of the current, then the radiation is at its maximum. Since the purpose of the transmitting antenna is to achieve maximum radiation of the radio wave, it is desirable to select an antenna whose natural frequency is identical with the frequency of the wave that we wish to transmit.

The presence of standing waves, then, describes the condition of resonance in an antenna. The waves traveling back and forth in the antenna reinforce each other and radiation is at its maximum. When there is no resonance, the waves tend to cancel each other out, thus dissipating their energies in the form of heat rather than utilizing them to radiate the radio wave.

#### 409. Calculating the Length of the Antenna

It is possible, of course, to describe the antenna in terms of its inductance and capacitance. But examination of Figure 373 shows

that, at resonant frequency, the length of the aerial is approximately equal to one half the length of the wave.

Since radio waves travel at the rate of 186,000 miles or 300,000,000 meters per second, we may calculate the frequency of a radio wave of given wave length through the following formula:

$$\text{frequency (in cycles)} = \frac{300,000,000}{\text{wave length (in meters)}}$$

Conversely, we may obtain the wave length of a radio wave of given frequency by means of this formula:

$$\text{wave length (in meters)} = \frac{300,000,000}{\text{frequency (in cycles)}}$$

Thus if, for example, we wish to find the wave length of a radio wave whose frequency is 30 mc. (30,000,000 cycles), we substitute in our formula and get:

$$\text{wave length (in meters)} = \frac{300,000,000}{30,000,000} = 10$$

From this series of formulas we can see that if we use a dipole antenna, such as that in Figure 373, for the transmission of a

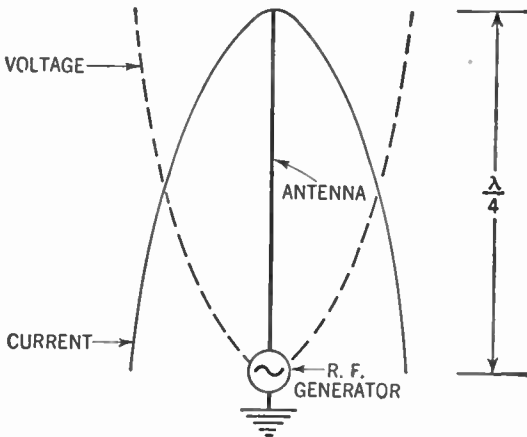

Figure 374. The quarter-wave Marconi antenna showing current and voltage waves.

radio wave whose frequency is 30 mc., we need one whose length is equal to half the wave length, namely, 5 meters (a little more than 5 yards). The symbol for wave length is the Greek letter *lambda* ( $\lambda$ ).

The dipole antenna is called a *half-wave* antenna. It is also called a *Hertz* antenna after the man who first used it.

We have seen that it is possible to eliminate the bottom half of the Hertz antenna by connecting the generator directly to the ground (Chapter 35). Under this condition the length of the antenna becomes one quarter of the wave length of the radio wave (Figure 374). Such an antenna is called a *quarter-wave* or *Marconi* antenna.

Since the standing wave comes into existence when the reflecting wave is returned in step with the oncoming wave, we may see

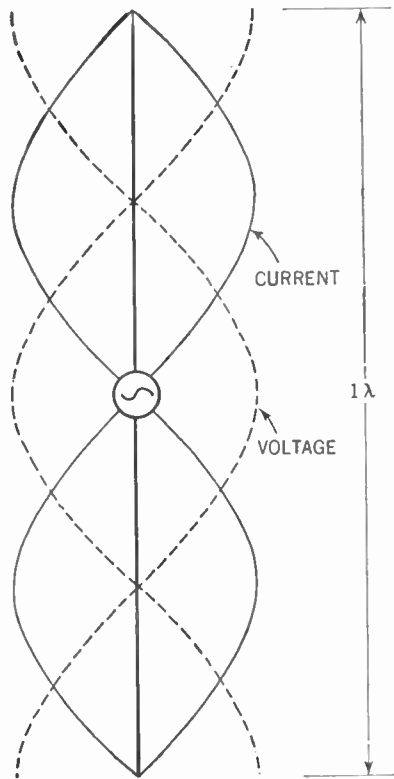

**Figure 375.** Diagram showing standing waves on a full-wave Hertz antenna.

that if the aerial is twice as long (or a full wave length for the Hertz antenna) the same condition of resonance exists (Figure 375). Thus, any multiple of the half wave length ( $\frac{1}{2}\lambda$ ,  $1\lambda$ ,  $1\frac{1}{2}\lambda$ ,  $2\lambda$ , and so on) will produce resonance conditions in the Hertz type



of antenna. Since the bottom of the Marconi antenna is at ground potential, only *odd* multiples of the quarter wave length can be used in this type (Figure 376).

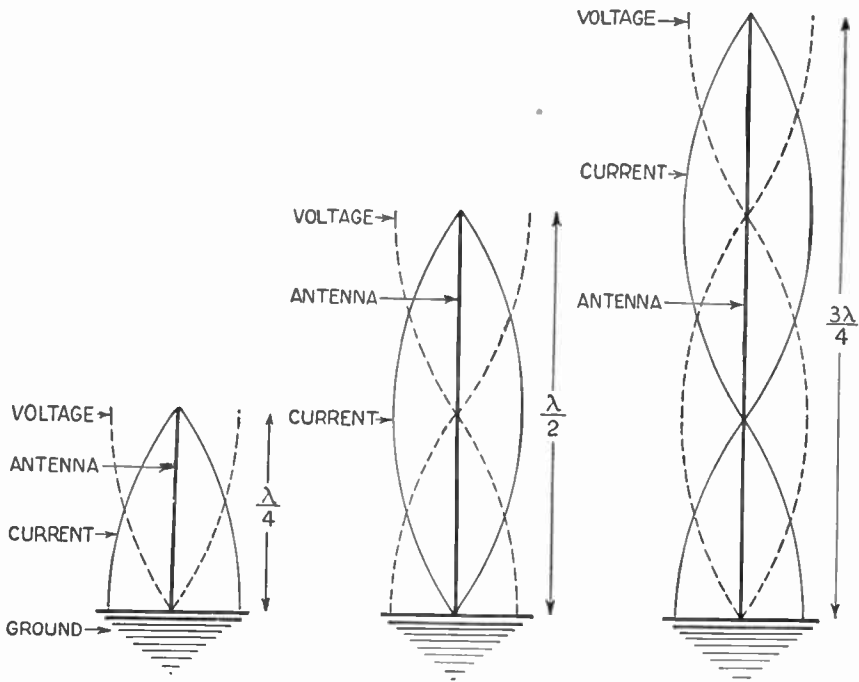

Figure 376. Diagram showing standing waves on a quarter-wave, half-wave, and three-quarter-wave Marconi antenna. (Note that the half-wave antenna cannot be used.)

#### 410. Harmonics and Fundamentals

Although circuits having lumped constants (inductors and condensers) resonate at only one frequency, circuits having distributed inductance and capacitance (such as the antenna) may resonate readily at frequencies that are twice, three times, four times, and other integral multiples of the original frequency to which they were tuned. The original frequency is called the *fundamental* frequency. Since the new frequencies are in *harmonic* relationship to the fundamental frequencies they are called *harmonics*. Thus, an antenna which was designed to resonate at 1,000 kc. may also be used to transmit radio waves whose frequencies are 2,000 kc. (called second harmonic), 3,000 kc. (third harmonic), and so on.

The Hertz antenna may be operated at the fundamental or at any harmonic frequency. In the case of the grounded Marconi

antenna, the voltage is necessarily at a minimum at the ground. This condition exists only on the fundamental and *odd* harmonics (Figure 377). Hence we may use this type of antenna only for transmitting radio waves at their fundamental frequencies and *odd* harmonics (the third, fifth, seventh, and so on).

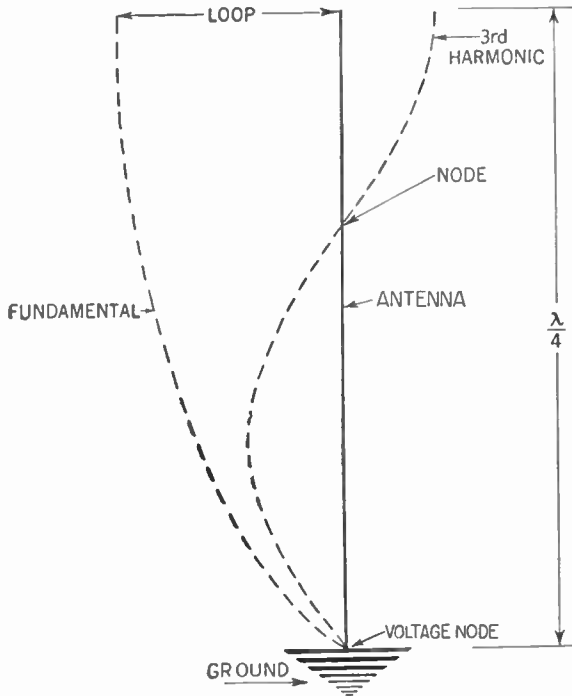
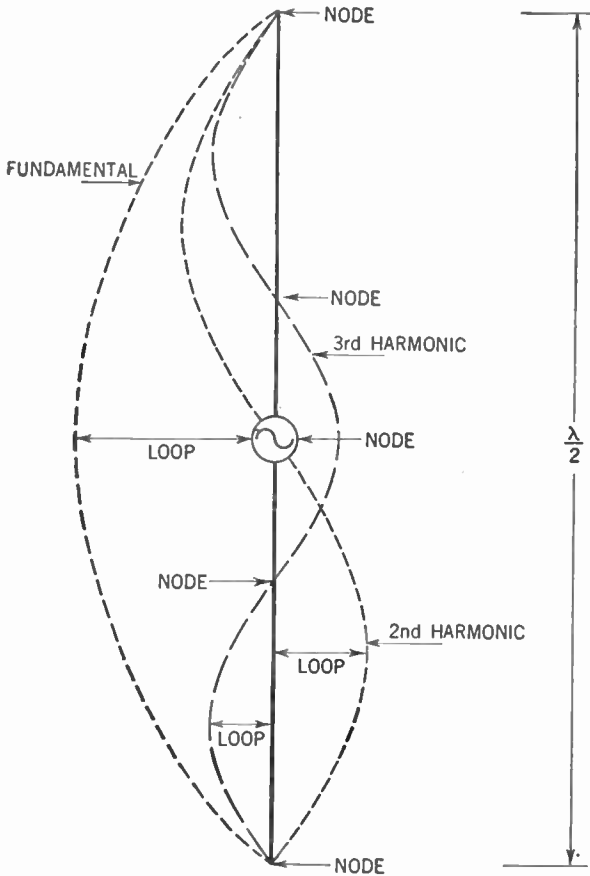

**Figure 377.** Diagram showing fundamental and third harmonics on a quarter-wave Marconi antenna. Here half the voltage waves are shown and the current waves are omitted for simplicity.

In Figure 378 is illustrated the distribution of standing waves on a Hertz antenna for its fundamental, second, and third harmonics. The points where the current is zero are called the *nodes*. The points of maximum current are called *antinodes* or *loops*.

#### 411. Transmission Lines

It is necessary to devise some means for carrying the energy from the transmitter to the antenna. This is accomplished by *transmission* or *feeder* lines. Radiation by these lines is undesirable, for it interferes with the efficient operation of the antenna.



**Figure 378.** Diagram showing relationship between the fundamental frequency, its second and third harmonics on a half-wave Hertz antenna. For the sake of simplicity only the current wave is shown and only half of that.

At the same time it is desirable to keep the impedance of these lines as low as possible to conserve the precious energy.

#### 412. Resonant Transmission Lines

The use of a resonant circuit for a transmission line is suggested by the low-impedance requirement. But we saw that the resonant circuit also is the best radiator. A simple device makes it possible to avoid this radiating characteristic. If we were to fold the half-wave Hertz antenna at its center we would get a pair of wires, one quarter of a wave length long, whose fields along the length of these wires would at all times be *equal* and *opposite*.

Thus they would cancel each other out and no radiation would occur (Figure 379).

Since this circuit with the folded wires has no radiating field and its impedance is practically zero (because it is in resonance with the frequency of the current), it is admirably suited to serve

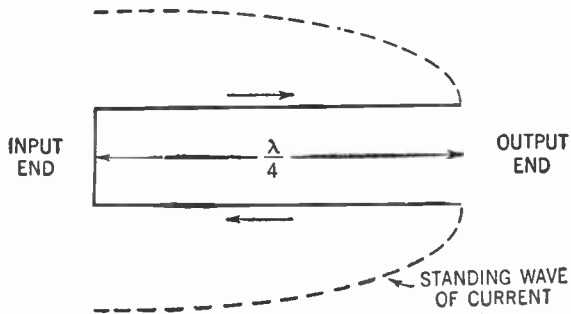

**Figure 379.** Diagram showing how a half-wave antenna is folded to make a quarter-wave resonant transmission line.

as our transmission line. One end is connected to the transmitter while the other end goes to the antenna.

We call this a *resonant transmission line*. For use with a Hertz antenna the effective length of this transmission line may be any multiple of the quarter wave length ( $\frac{1}{4}\lambda$ ,  $\frac{1}{2}\lambda$ ,  $\frac{3}{4}\lambda$ , and so on).

### 413. Nonresonant Transmission Lines

There are two outstanding faults in the resonant transmission line. First of all, it must be of a certain definite length, that is, some multiple of the wave length. Secondly, since there are standing waves along its length, some energy is lost through absorption by nearby objects. Another type of transmission line has been devised to overcome these flaws.

If two parallel lines of infinite length are employed, there can be no reflected waves, hence no standing waves, hence no resonance. In the absence of resonance, radiation is at a minimum.

A line of infinite length is only a theory. But electrically, the condition of an infinite line can be obtained by terminating a finite line (a line with some measurable length) with that impedance which a corresponding infinite line can be calculated to present. This impedance is called the *characteristic impedance* of

the line and is represented by the symbol  $Z_0$ . If  $L$  and  $C$  are the inductance and capacitance per unit length of the line, respectively, then:

$$Z_0 = \sqrt{\frac{L}{C}}$$

We may calculate this characteristic impedance and attach it to the antenna end of a line of *any* length (Figure 380).

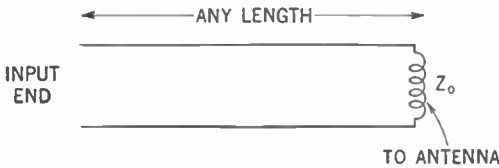

Figure 380. The nonresonant transmission line.

In practice, we may test this line for standing waves by passing over its length a flashlight bulb attached to a loop of wire about 6 in. in diameter. If any standing waves exist along the transmission lines, the loop will absorb some electrical energy, which will light the bulb. Should this occur, the impedance ( $Z_0$ ) may be varied until the bulb fails to light over the full length of the lines (Figure 381).

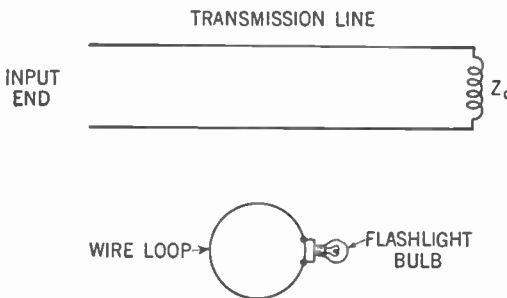

Figure 381. How transmission lines are tested to detect standing waves.

Since there are no standing waves to lose any of the energy, nonresonant transmission lines are somewhat more efficient than are the resonant lines.

#### 414. Connecting the Transmission Lines to the Antenna

There are a number of methods for connecting the transmission lines to the antenna. Let us first consider the resonant lines.

One method is to connect the lines to the center of the dipole antenna in place of the generator shown in Figure 373. The method

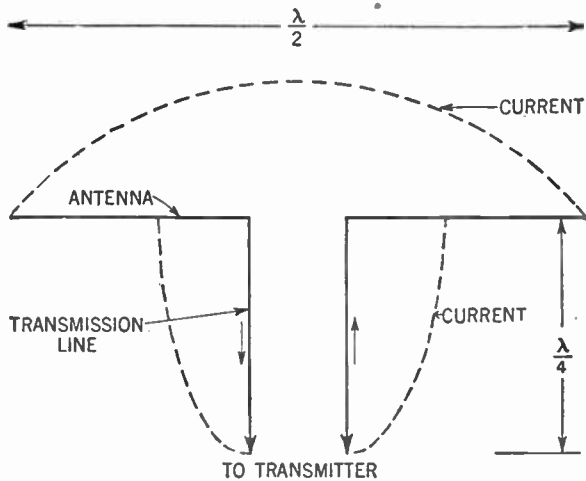

**Figure 382.** How transmission lines are connected to the antenna. This is a center-fed, half-wave Hertz antenna.

of connection appears in Figure 382. This method is the *center-fed* method. Since the current standing wave is at its maximum

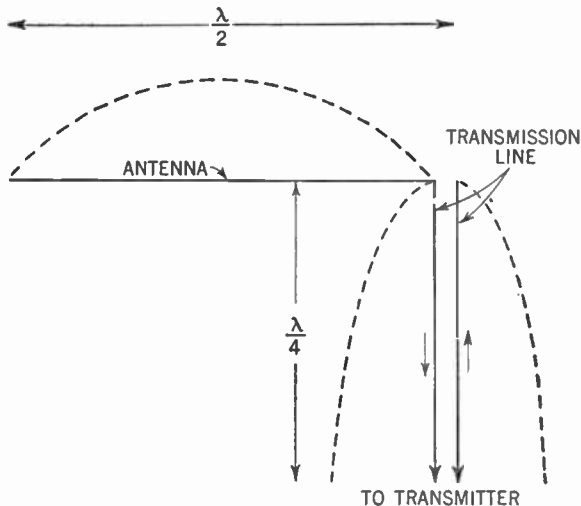

**Figure 383.** The end-fed, half-wave Hertz antenna.

at the points of junction, the center-fed method is also called the *current-fed* method. Another name for it is the *low-impedance*

method. At the point of junction the current is highest and the voltage is nearly zero. Since the impedance is equal to the ratio of voltage to current, that is,

$$Z = \frac{E}{I},$$

the impedance at the antenna center is low (about 72 ohms). Hence the name, *low-impedance*.

Another antenna connection is the *end-fed* method (Figure 383). Here one of the lines is attached to the antenna while the other end is left free. It should be readily understood why

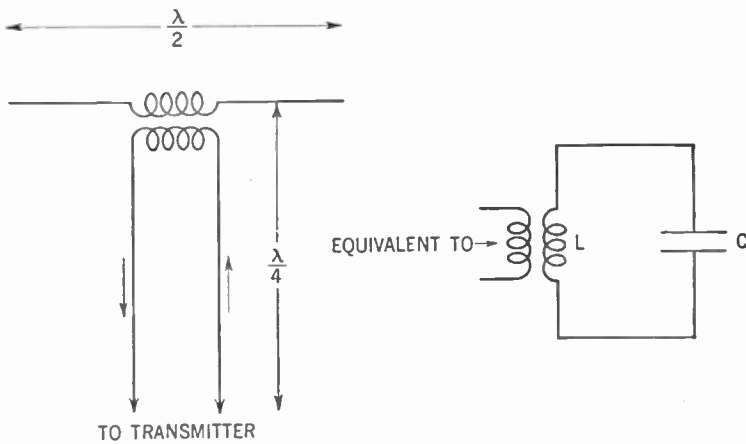

Figure 384. The center-fed, inductively coupled, half-wave Hertz antenna and its equivalent circuit.

this connection is called the *voltage-fed* or *high-impedance* method.

Still another method is to couple the transmission lines to the antenna by means of a transformer (Figure 384). You see that

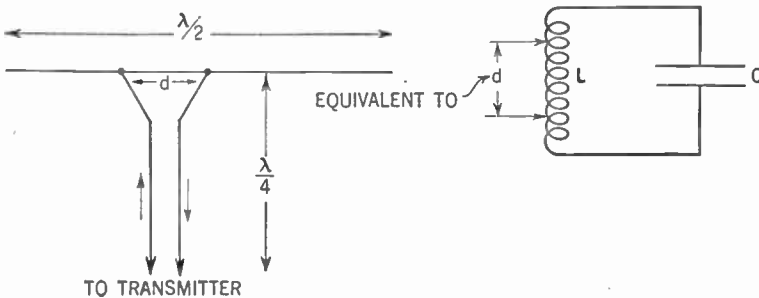
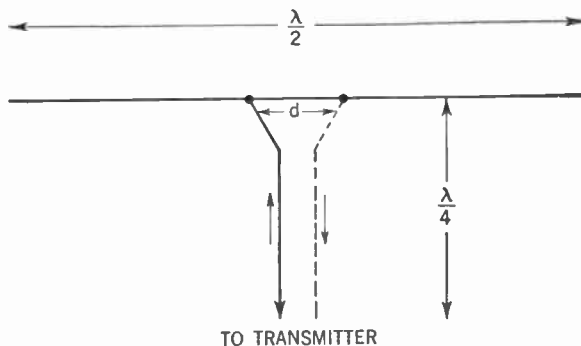

Figure 385. Another type of center-fed, half-wave Hertz antenna with its equivalent circuit.

this coupling hookup is a variation of the center-fed method shown in Figure 382. To the right appears the equivalent circuit with the distributed inductance and capacitance of the antenna appearing as the inductor ( $L$ ) and condenser ( $C$ ).



**Figure 386.** This is the same as shown in Figure 385 except that the antenna-to-ground capacitance gives us the electrical equivalent of the missing wire.

Another method is shown in Figure 385. This plan too is a variation of the center-fed method. If you examine the equivalent circuit at the right you will see that we may consider the portion of the inductor measured by  $d$  the primary and the entire inductor

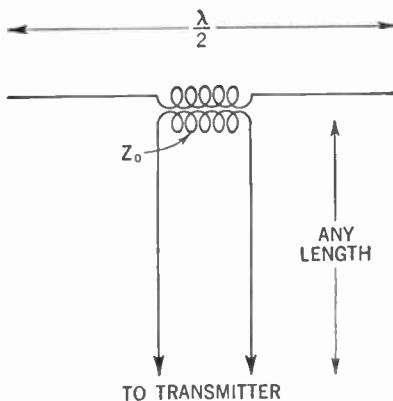

**Figure 387.** How the nonresonant transmission line may be connected to the antenna.

as the secondary of a transformer. Thus, this method is merely a variation of that shown in Figure 384 (the transformer-coupling method). The distance  $d$  is quite critical and the antenna should be tested by the loop-and-bulb method previously described so as



to make its length such as to produce the standing wave which shows resonance.

A further variation of this method is shown in Figure 386. Here only one wire is used. The capacitance of the antenna in relation to the ground, however, gives us the electrical equivalent of the missing wire and therefore it is the same as shown in Figure 385.

The nonresonant transmission line may be connected to the antenna in similar manner. Figure 387 shows the transformer-coupled method. The impedance of the primary is the characteristic impedance ( $Z_0$ ) of the line.

Another method is shown in Figure 388. The procedure for

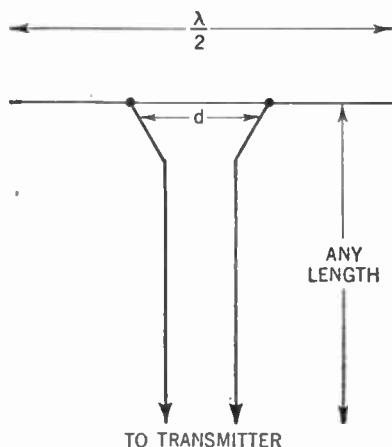

Figure 388. Another method of connecting a nonresonant line to the antenno.

determining  $d$  is the same as in the case of the resonant transmission line. Similarly, one wire may be omitted, the capacitance of the antenna with respect to the ground giving us its electrical equivalent.

There are numerous other methods of connecting the transmission lines to the antenna, but the student should have little difficulty understanding their operation after learning these basic principles.

### 415. Loading

We often desire to use an antenna for transmission of signals of various frequencies. Of course, we may lengthen or shorten

our antenna so that it is always in resonance with the transmitted frequency. But this plan is not very practical.

We may accomplish the same result by inserting an inductor or condenser in series with the antenna. Assume that the antenna

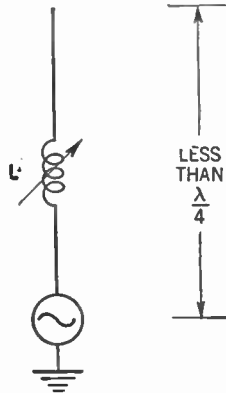

**Figure 389.** Adding inductance to an antenna to increase its effective length.

is too short for the signal frequency. In this situation the natural frequency of the antenna is higher than the signal frequency. When an inductor is inserted in series with the antenna, the total

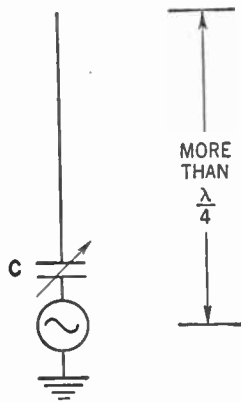

**Figure 390.** Adding capacitance to an antenna to decrease its effective length.

inductance (the distributed inductance of the antenna plus the inductance of the inductor) becomes greater. This increased inductance reduces the natural frequency of the antenna until it is in resonance with the signal frequency (Figure 389).

On the other hand, if the antenna is too long (that is, the natural frequency of the antenna is lower than the signal frequency), a condenser is connected in series with the antenna. Since two capacitances in series (the capacitance of the condenser and that of the distributed capacitance of the antenna) give a total which is smaller than either, the natural frequency of the antenna is increased until once again it is in resonance with the signal frequency (Figure 390).

Refer back to Chapter 34 if you have any difficulty in following the above discussion.

The process of lengthening or shortening the antenna by electrical means is called *loading*.

#### 416. Resistance and Power in the Antenna

Since the antenna is a resonant circuit, the impedance is nearly zero and waves of electrical energy should flow back and forth its length, limited only by the resistance. The electrical energy is dissipated by resistances of two types. One is the *ohmic* or *loss resistance* which is inherent in the wires that go to make up the antenna. This loss can be kept very low by the use of heavy wire or copper tubing and carefully constructed joints. As a matter of fact, this resistance can be kept so low as to be negligible.

But it is the function of the antenna to radiate away as much of the energy as possible. The amount of energy radiated away may be made equivalent to that which would be dissipated by an imaginary resistor placed in the antenna. The resistance of this imaginary resistor is called the *radiation resistance*.

It has been calculated that the radiation resistance of a half-wave, center-fed Hertz antenna, operating at its fundamental frequency, is approximately 72 ohms. The radiation resistance of the quarter-wave Marconi antenna, operating at its fundamental frequency, is about 36 ohms.

In addition to loss of energy due to the loss resistance and radiation resistance there are other losses due to absorption of energy by nearby structures, pipes, and so on. For this reason the antenna should be kept as far as possible from such objects. Other losses occur from slight leakage across insulators supporting an antenna. An attempt should be made to connect the insulators at low-voltage points on the antenna. In the case of the grounded (Marconi) antenna, the resistance of the ground intro-

duces still another loss; hence a good ground connection is essential.

We may calculate the electrical power in the antenna by multiplying the square of the maximum current (at the center of the Hertz antenna) by the assumed radiation resistance:

$$P = I^2 \times R$$

#### 417. Radiation Characteristics

If we erect a vertical antenna and measure the field strength of the wave radiated from it in a circle which has the antenna at its center, we find that this field is equally strong at all points on this circle. Thus we can draw a pattern of the *radiation characteristics* of this antenna by means of a circle (Figure 391-A). This

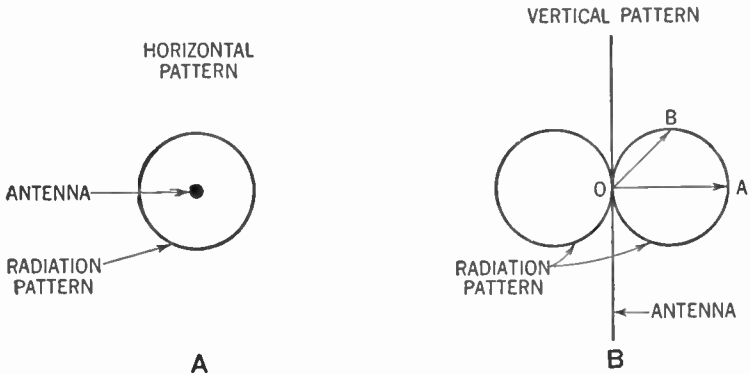

**Figure 391. Radiation pattern of a vertical antenna.**  
**A—The horizontal radiation pattern.**  
**B—The vertical radiation pattern.**

pattern is known as the *radiation pattern*. Since this is the pattern we would draw upon the ground if we were above the antenna looking down, we call it the *horizontal pattern*. It is the pattern of the radio waves radiated parallel to the ground.

If we were to draw the pattern of the radiated waves which are not horizontal to the ground, we would get a pattern as appears in Figure 391-B. This figure is called the *vertical pattern* of radiation. To understand what it means you must assume that the distance from the center of the antenna to the curve, along any particular line, represents the relative field strength in that direction. Thus if line *OA* is twice as long as *OB*, the field strength in the direction of *OA* is twice as strong as in the direction *OB*.

While the pattern shown in Figure 391-B is in two dimensions, the actual pattern is three-dimensional. To get this, you must rotate the figure about the antenna as an axis. You would then get a sort of doughnut with practically no hole and the antenna running through it at the center.

**418. Antennas in Arrays**

These patterns are for a single vertical, half-wave antenna. To obtain radiation which has directional effects, two or more such an-

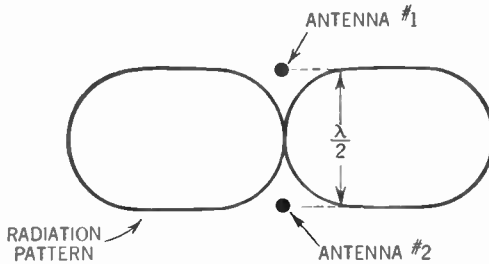

**Figure 392. The horizontal pattern of two vertical half-wave antennas, a half wave apart, with their currents in phase.**

tennas may be combined. The simplest such combination or *array* consists of two vertical, half-wave antennas spaced a half wave length apart. Equal currents are fed into each antenna in step

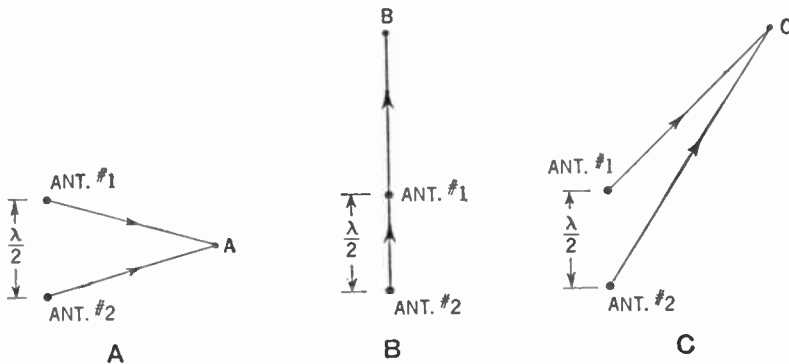

**Figure 393. Diagrams explaining how the radiation pattern of Figure 392 is formed.**

(in phase) with each other so that the currents reach their maximum in the same direction at the same instant. Figure 392 shows the horizontal pattern of such an array.

You may understand how we arrive at this pattern if you examine Figure 393. In Figure 393-A, since the currents in both antennas are in phase and since the distances the two radio waves travel in reaching point *A* are the same, the two waves arrive in step or phase and reinforce each other, giving a strong signal.

In Figure 393-B, the wave from antenna 2, arriving at point *B*, has traveled a half wave length farther than the radio wave from antenna 1. Since a half wave length represents  $180^\circ$ , the currents set flowing by the two radio waves at point *B* are equal, but in opposite directions. Thus they neutralize each other and no signal is heard.

In Figure 393-C, the two radio waves arrive out of phase but at an angle which is less than  $180^\circ$ . They therefore do not completely neutralize each other and the signal is heard, though weaker than at point *A* in Figure 393-A.

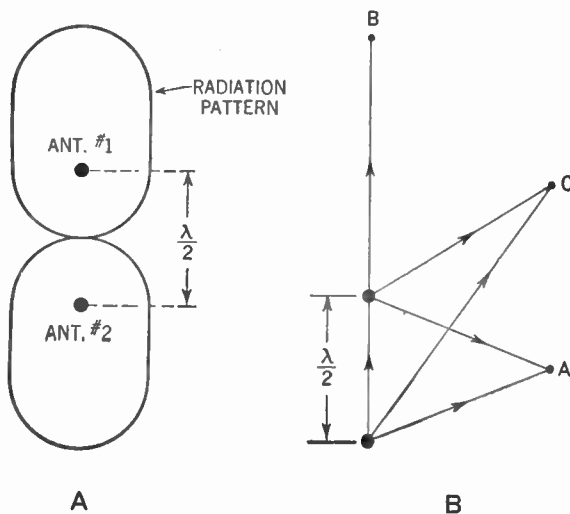

**Figure 394.** A—The horizontal pattern of two vertical half-wave antennas, a half wave apart, with their currents  $180^\circ$  out of phase.  
B—Diagram showing how this pattern is formed.

Of course, if the currents fed into the two antennas are  $180^\circ$  out of phase, the exact opposite of the above results. In Figure 394-B you can see that maximum signal strength will be had at point *B*. At point *A* no signal will be heard, while at point *C* a signal of intermediate strength will be received. Figure 394-A shows the pattern for this array.

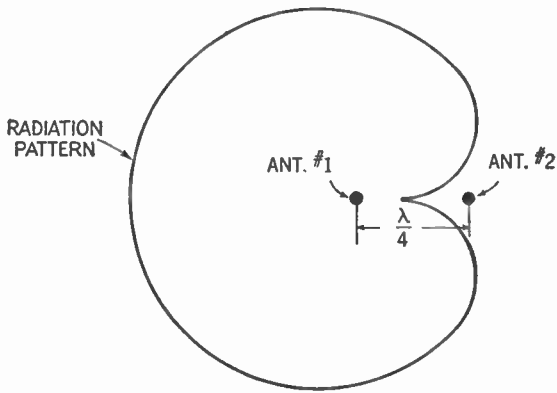

Figure 395. Unidirectional pattern (cardioid) for two vertical, half-wave antennas, a quarter wave apart and with currents 90° out of phase.

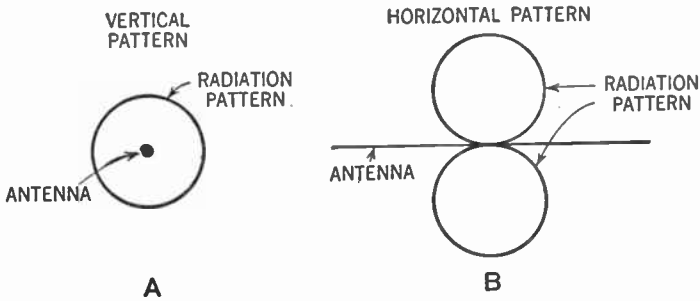

Figure 396. Radiation pattern of a horizontal antenna. Note that it is the opposite of the vertical antenna.  
 A—Vertical pattern.  
 B—Horizontal pattern.

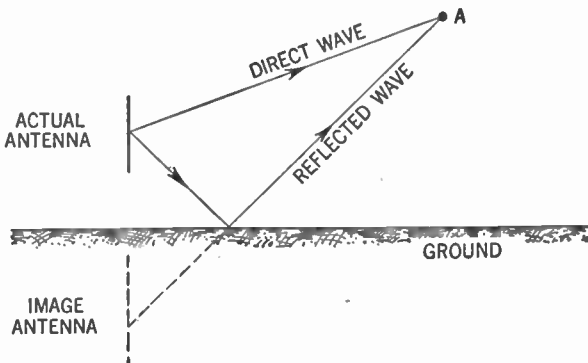
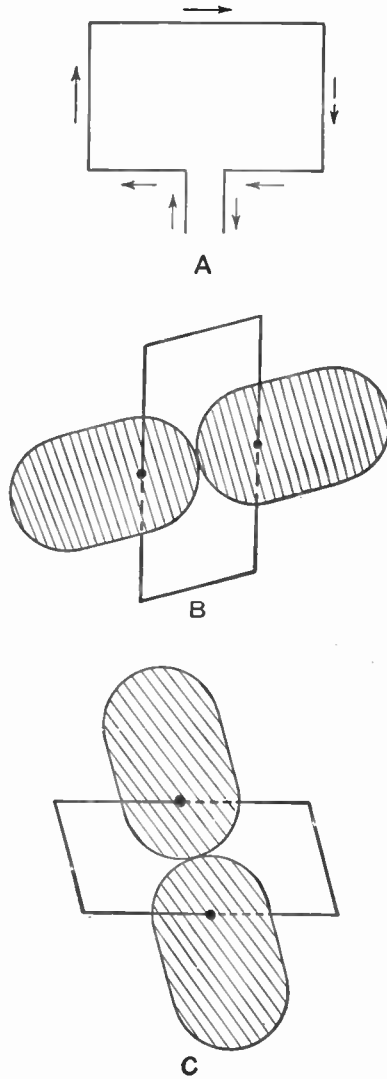

Figure 397. Diagram showing the effect of the ground upon the vertical radiation pattern of an antenna.



**Figure 398.** A—Current flow in a loop antenna.  
 B—Pattern for the vertical arms of the loop.  
 C—Pattern for the horizontal arms of the loop.

Other directional patterns may be obtained by spacing the antennas differently, using currents with different phase differences, and using more antennas in the array. Of particular interest is the array shown in Figure 395. Here the two half-wave antennas are spaced a quarter wave length apart and the current is fed into



them  $90^\circ$  out of phase. The resulting pattern is called the *cardioid* or *unidirectional* pattern because most of the energy is transmitted in one direction.

The half-wave horizontal antenna has characteristics comparable to those of the vertical antenna. But the vertical pattern of the horizontal antenna resembles the horizontal pattern of the vertical antenna and vice versa (Figure 396).

Horizontal antennas may also be arranged in arrays to get a wide variety of directional patterns.

Some of the radio waves radiated by the antenna strike the ground and are reflected upward. This reflected energy affects the vertical pattern of the antenna (see Figure 397). The effect is as if there were an *image* antenna located beneath the surface of the ground and transmitting a simultaneous signal. We may treat the actual antenna and image antenna as though they formed an array and thus determine the resulting pattern.

We studied the pattern of the loop antenna as a receiving antenna in Chapter 28 on radio direction finders in Volume I. Now let us examine the radiation characteristics of the loop as a transmitting antenna. Since the dimensions of the loop usually are small compared to the wave length, we may consider the current at any instant as flowing in one direction (Figure 398-A).

We may therefore regard the two vertical arms as an array of two vertical antennas, less than a wave length apart and with the currents flowing in *opposite phase* to each other (one current is up when the other is down). This gives us the horizontal pattern shown in Figure 398-B.

The top and bottom parts of the loop are equivalent to two horizontal antennas, also  $180^\circ$  out of phase. Their pattern is also a "figure eight," this time vertical (Figure 398-C).

You can now see why the loop will not radiate any signals in directions towards which its flat sides are pointed. This directional characteristic of the loop antenna makes it suitable for the transmission of the radio beam discussed in Chapter 28, Vol. I.

#### SUMMARY

1. **Antennas** constitute circuits in which the inductance and capacitance are properties of the length and pattern of the wire used.

2. In a **half-wave dipole antenna** the current is maximum at the center and nearly zero at the ends; but the voltage is maximum at the ends and nearly zero at the center.

3. Antennas should be made so that their lengths conform to (that is, have the natural frequency of) the wave length which is to be radiated. This is because **standing waves** are set up by the periodic oscillations in an antenna when the antenna is in resonance.

4. The approximate length of the antenna may be calculated from the frequency (number of cycles) and the speed of radio waves. The formula is:

$$\text{Wave length (meters)} = \frac{300,000,000}{\text{frequency (in cycles)}}$$

5. The length of a dipole antenna which is resonant with the wave length ( $\lambda$ ) may be  $\frac{1}{2}\lambda$  or any multiple of  $\frac{1}{2}\lambda$  for the Hertz-type or any odd multiple of  $\frac{1}{4}\lambda$  for the Marconi-type antenna.

6. **Transmission lines** from the transmitter to the antenna are also called **feeder lines**. The principles to be kept in mind are: (1) to avoid radiation, (2) to avoid high impedance.

7. Low radiation may be achieved in the feeder line by calculating its length as if it were a Hertz-type antenna and folding the antenna back on itself so that the tendency to radiate of each fold (half the length of the wire) is just neutralized by the other half, whose fields are at all times equal and opposite to those of the first half. This circuit is called a **resonant type of feeder line**.

8. **Nonresonant feeder lines** make use of the principle that parallel lines of infinite length cannot produce standing waves and hence that their radiation is at a minimum. A practical device to achieve the effect of a transmission line of infinite length is to add impedance, of a calculated amount, to the end of a transmission line of finite length.

9. The transmission lines are connected to the antenna in various ways: **center feed, voltage feed, transformer method**.

10. To adapt an antenna to transmit signals of various frequencies, inductors or condensers may be inserted in series with the antenna to lengthen it (by putting in an inductor) or to shorten it (by putting in a condenser).

11. The **radiation characteristics** of antennas may be shown by drawings which show by lines radiating from the center the strength of the field in any direction. The shape of the periphery of the pattern will be a set of curved lines whose distance at any point from the center varies with the strength of the field.

#### GLOSSARY

**Antinodes:** Regions along an antenna where the current or voltage is maximum.

**Center Feed:** A method of coupling the transmission lines of a transmitter to the center of the half-wave antenna.

**Current-fed Antenna:** Another name for a center-fed antenna.

**Distributed Inductance and Capacitance:** Capacitance and inductance distributed almost uniformly throughout a resonant circuit.

**End Feed:** A method of coupling one transmission line to one end of a

half-wave antenna, allowing the other end of the transmission line to be free.

**Feeder Lines:** The lines connecting a transmitter to an antenna.

**Fundamental Frequency:** The lowest frequency to which an antenna is resonant.

**Harmonics:** Simple whole-number multiples of the fundamental frequency.

**Hertz Antenna:** A simple ungrounded antenna.

**Horizontal Radiation Pattern:** Pattern of radiation from an antenna as viewed from above.

**Loading:** Adding capacitance or inductance to an antenna to make it resonant for various frequencies.

**Loops:** Same as antinodes.

**Lumped Inductances and Capacitances:** Capacitance and inductance concentrated in definite parts of a resonant circuit.

**Marconi Antenna:** A simple grounded antenna.

**Nodes:** Regions along an antenna where the current or voltage is zero.

**Radiation Pattern:** The horizontal and vertical pattern of radiation of radio waves from an antenna.

**Radiation Resistance:** Energy radiated by an antenna is equivalent to energy dissipated in a resistor. The radiation resistance is the value of this equivalent resistance.

**Resonant Transmission Lines:** Transmission lines resonant to the transmitted frequency.

**Standing Wave:** An electrical wave in an antenna, with fixed nodes and loops.

**Transmission Lines:** Lines connecting the transmitter to the antenna, that is, feeder lines.

**Vertical Radiation Pattern:** Pattern of radiation from an antenna as viewed from the ground.

**Voltage-fed Antenna:** Same as an end-fed antenna.

### QUESTIONS AND PROBLEMS

1. Differentiate between lumped inductances and capacitances and distributed inductances and capacitances.

2. What unique effect occurs when a resonant circuit has distributed capacitance and inductance?

3. Explain what occurs in a dipole antenna so far as voltage and current distribution are concerned.

4. What must be the relationship between the antenna and the frequency of current fed into it for maximum radiation?

5. What condition of voltage and current exists when maximum radiation occurs?

6. What is the relationship of size of antenna and wave length of current fed into it for maximum radiation from a simple dipole antenna?

7. State the formula for conversion of frequency into wave length and give the units for each factor.

8. What is the relationship of size of antenna and wave length of current fed into it for maximum radiation from a Marconi antenna?
9. What variations may be made as to length of the Hertz antenna and still obtain maximum radiation? In the Marconi antenna?
10. What group of frequencies may resonate in a resonant circuit with distributed capacity and distributed inductance?
11. In question 10, what portion of the group will resonate in a half-wave antenna? In a quarter-wave antenna?
12. What characteristics are desirable for good transmission lines?
13. What are some defects of a resonant transmission line?
14. What is meant by the characteristic impedance of a nonresonant transmission line?
15. How are good nonresonant transmission lines obtained and tested?
16. Describe with illustration various ways of coupling the transmission line to the antenna.
17. How may an antenna be made, in a practical manner, to be resonant for various frequencies? What is this process called?
18. What is meant by the radiation resistance of an antenna?
19. List several energy losses of an antenna.
20. Illustrate the horizontal and vertical radiation pattern for a single half-wave antenna.
21. Explain how special radiation patterns may be secured.

## CHAPTER 37

# Vacuum-tube Characteristics

- 
- Problem 1:** *How do we show by graphs the characteristics of vacuum tubes?*
- Problem 2:** *How do we use the characteristic curves of tubes to calculate plate current, plate resistance or amplification factors?*
- Problem 3:** *How do we calculate power output and voltage amplification?*
- 

### 419. The Diode in Operation

From our previous studies we have learned that the basic principle of the vacuum tube is simple. A heated filament or cathode shoots off electrons which are attracted to a positively charged plate and made to flow through the plate circuit (Chap. 27, Vol. I).

The simplest type of vacuum tube is the two-electrode *diode*, containing a filament and plate. We have learned before that if the plate is charged positively the electrons will be attracted to

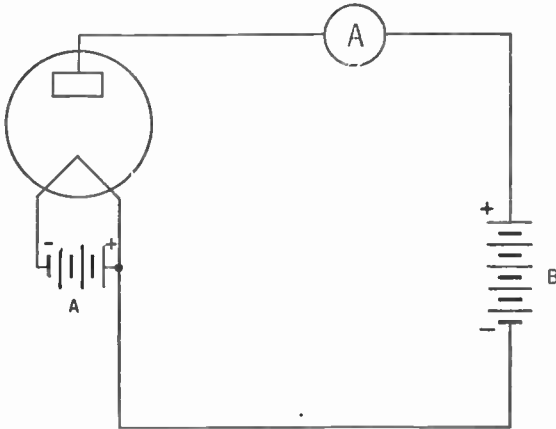

**Figure 399.** Circuit to show relationship between plate current and plate voltage.

it and will flow in the plate circuit. If the plate is charged negatively, the electrons will be repelled and no current will flow in the plate circuit.

If we connect our diode as in Figure 399, and keep the current from the filament battery constant, we are able to see the relationship between changes in the B or plate voltage and the number of electrons attracted to the plate (that is, the amount of plate current as measured by the ammeter).

#### 420. Plotting the Plate Current

If we plot our findings on a graph we get a curve similar to that of Figure 400. This curve is called the *characteristic curve* of the diode.

Arrange the circuit as shown in Figure 399 with a clip on one of the leads to the B battery. Connect a voltmeter across the part

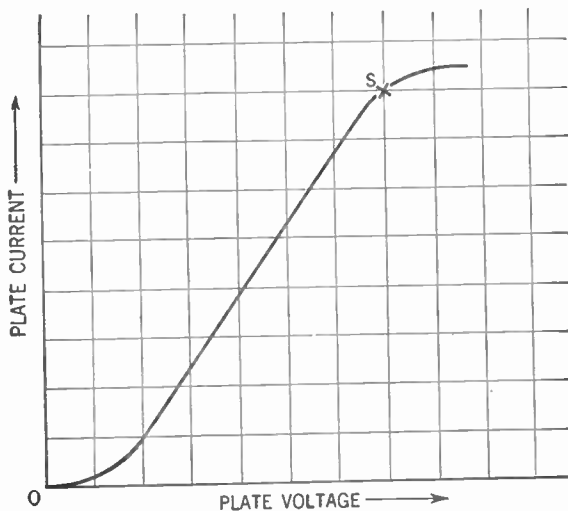

Figure 400. Graph showing the characteristic curve of the diode.

of the B battery which is successively connected to furnish the voltage for the plate. Begin with a low voltage and successively attach the movable clip to higher and higher voltages. Each time that a new voltage is used, record the reading of: (1) the voltmeter; (2) the ammeter. When the table is complete—say with eight or ten readings—transfer the data to the graph as follows. Mark off on the vertical axis (*Y*) the units of current in milliamperes. On the horizontal axis (*X*) mark off units of volts. For

each volt reading put a ruler on the point corresponding to it on the horizontal axis; draw a faint line upward from this point. Now find the point on the *Y* axis that corresponds to the reading of the ammeter taken for the specific voltage and with the ruler draw a faint line horizontally. Where this line of the current level crosses the vertical line indicating the voltage, make a dot. Continue to plot each reading of voltmeter and ammeter in the same way. When all the dots are located on the chart, connect the points by a continuous line. This line is the course or curve of the current under the influence of changing voltage on the plate.

Notice that, except for the bends at the bottom and top, the curve is a straight line bearing upward at about the same rate as it bears to the right. This means that an increase in the plate voltage causes an increase in the number of electrons attracted to the plate and the current set flowing in the plate circuit. That is to say that except for the very low voltages and the very high voltages on the plate, the plate current increases as the plate voltage increases.

When the charge on the plate is low (low plate voltage), a space charge, consisting of a cloud of electrons, gathers around the filament and repels back new electrons being emitted. Thus few electrons reach the plate and the plate current is low. This situation accounts for the bend that is found in the lower end of the curve.

As the plate voltage is increased, the electrons forming the space charge are attracted to the plate and the number of electrons reaching the plate each second is increased. Soon a point is reached (point *S* on the curve) where *all* the electrons being emitted by the filament are immediately attracted to the plate. Increasing the plate voltage beyond this point cannot increase the plate current because the filament is not able to send out electrons any faster. This point is called the *saturation point* of the tube.

The amount of current flowing in the plate circuit when the saturation point is reached is called the *saturation* or *emission* current.

#### 421. Correcting the Space Charge

If the space charge were not present to repel electrons coming from the filament, then the same plate current could be produced at a lower plate voltage. One method for making this space charge

small is to make the distance between the filament and plate small. This method is used in tubes such as type 25Z5.

Another method is to introduce a small amount of mercury, which becomes vaporized when the tube is in use. The space inside the tube is thus filled with mercury atoms. Electrons shot off by the filament collide with these atoms and tear off other electrons from the mercury atoms, thus *ionizing* them. Since these mercury *ions* are positively charged, they neutralize the electrons of the space charge and thus more electrons are made available to the plate. Tubes of this type are called *mercury-vapor rectifiers*. The type 83 tube is an example.

#### 422. The Rectifying Action of the Diode

We can use the characteristic curve to show what happens if the steady direct voltage of the B battery is replaced with an alternating voltage (see Figure 401). In this figure we have combined two graphs into one. First there is the graph for the alternating-voltage input to the diode. Then there is the graph for the characteristic curve of the tube. The action of the alternating

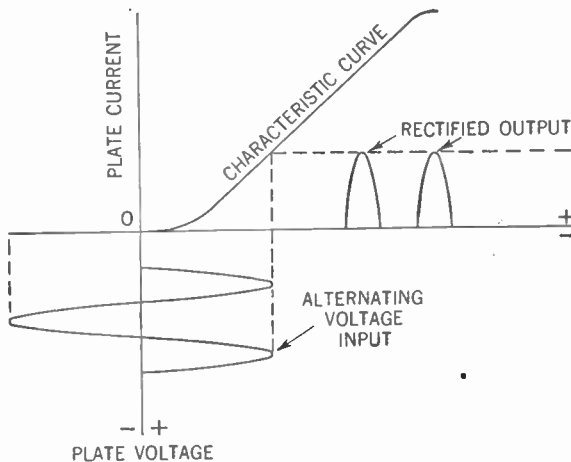

**Figure 401.** How the characteristic curve of the diode is used to show the relationship between the voltage input and the current output.

voltage in the diode produces the rectified output, a series of direct-current pulses. We learned the importance of this phenomenon and explained it in some detail when we discussed the diode detector and the power supply (Chapters 14 and 18, Vol. I).



**423. The Triode Has a Grid**

The *triode* contains a third electrode, the grid, between the filament and the plate (see Chapter 15, Vol. I). This grid acts upon the electron stream as a sort of valve, and small variations in grid voltage cause large variations in plate current.

**424. Subletters on Symbols**

At this point mention should be made of a sort of shorthand used by scientists. We know that the symbol for voltage or potential difference is  $E$ , the symbol for current is  $I$ , and for resistance the symbol  $R$  is used. If we wish to denote the potential difference between the plate and the filament we use the symbol  $E$  with the subscript  $p$ . Thus the new symbol becomes  $E_p$ . Similarly, the plate current becomes  $I_p$ . The filament voltage is  $E_f$  while the filament current is  $I_f$ . Grid voltage becomes  $E_g$  and grid current  $I_g$ . This system is logical and saves a lot of unnecessary words.

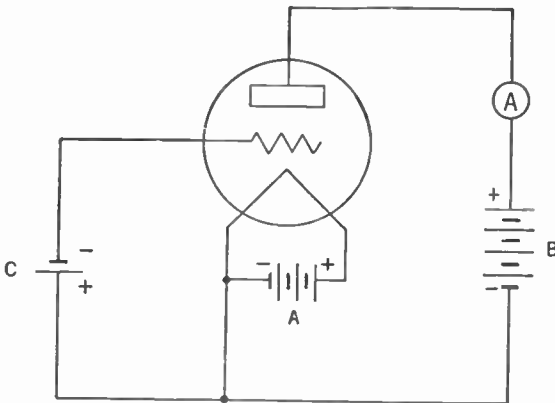

**Figure 402. Hookup for obtaining the characteristic curve of a triode.**

**425. The Characteristic Curve of the Triode**

We may obtain the characteristic curve of the triode by means of a circuit shown in Figure 402. Variations in the voltage of the C battery produce variations in plate current. By plotting one set of values against the other, we may get the characteristic curve shown in Figure 403. From this curve you will notice that a certain amount of current flows in the plate circuit even though the grid may be charged somewhat negatively. We previously

learned the cause of this condition: the stream of electrons to the plate is not cut off completely until an appreciable negative charge is placed on the grid.

You will note also that the bend found in the diode curve at the saturation point toward the top of the curve is missing. The

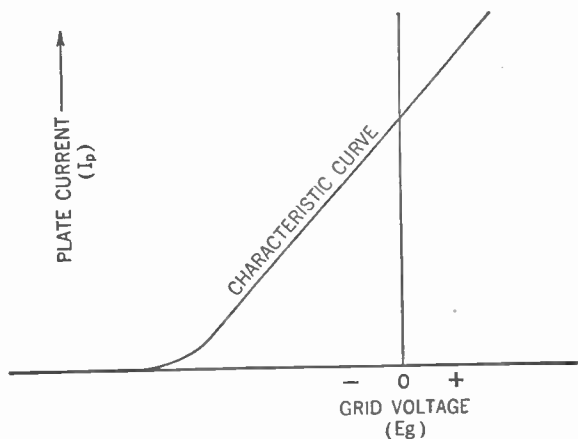

**Figure 403. The grid-voltage-plate-current characteristic curve for a triode.**

reason for this greater linearity is that modern tubes using indirectly heated cathodes as emitters can furnish more electrons than can be conducted away by the plate at the applied potentials, and therefore the plate current continues to mount with increases in the plate voltage (that is, within the limits normally encountered in radio work).

#### 426. The Effect of Grid Bias Shown by a Curve

In Volume I we learned that if the grid ever becomes positive, it will attract some of the electrons shot out by the filament. This electron stream will cause a current to flow in the grid circuit. This current will interfere with the incoming signal and distortion will result. The C battery is used to place a negative charge or bias on the grid to prevent the flowing of any grid current. The incoming signal makes the negative charge on the grid *more negative* or *less negative*. These variations of the negative charge on the grid produce the variations in plate current.

The effect of the grid bias can be shown graphically by use of the characteristic curve of the tube (Figure 404). Figure 404-A shows the effect of having too low a grid bias. Notice that the

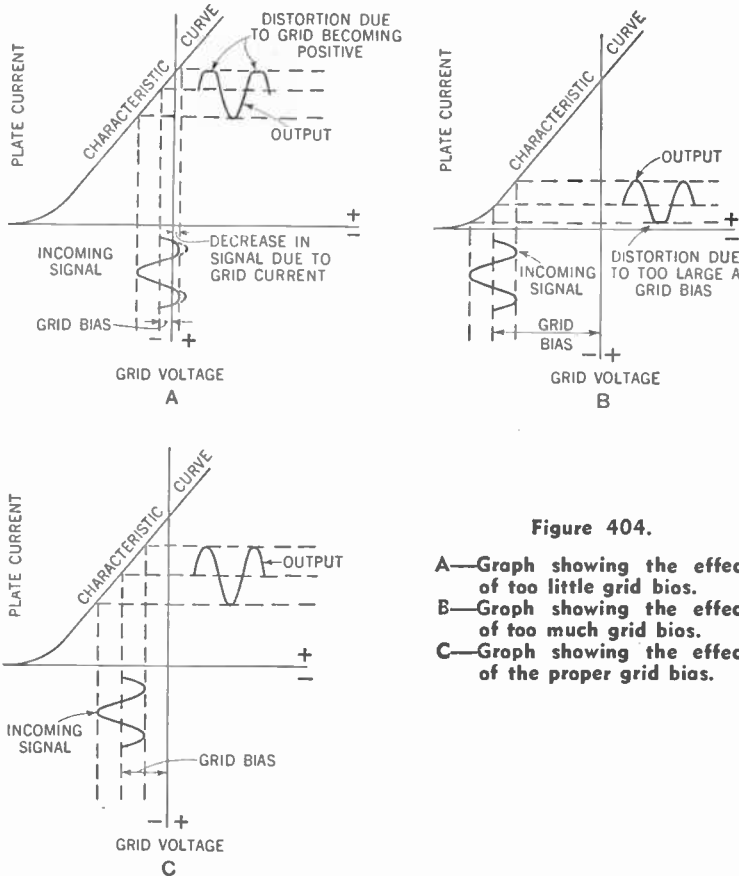

Figure 404.

- A—Graph showing the effect of too little grid bias.
- B—Graph showing the effect of too much grid bias.
- C—Graph showing the effect of the proper grid bias.

output curve differs from the input signal. This difference indicates distortion and is due to the fact that a portion of the positive half cycle of the signal is great enough to overcome the grid bias and the grid becomes positive. The grid bias must be negative enough to be larger than the peak of the positive half cycle of the signal.

Figure 404-B shows the distortion resulting from making the grid bias too large. The signal operates at the bend or *knee* of the characteristic curve and part of the bottom loop is cut off. While this effect is not desirable where we seek to amplify the signal, it is the desirable condition for detection (see Chapter 15, Volume I). You will recall that we strive to remove the bottom loop to give us the result shown in Figure 69, Volume I. The result of having too large a grid bias is *grid-bias detection*.

Figure 404-C shows the correct grid bias to be used for the amplifier tube. It is neither too large nor too small. The output closely resembles the input signal. You will notice that we operate on the straight-line portion of the curve.

#### 427. Transfer Characteristic Curves

In Figure 403 we have the characteristic curve formed when variations of grid voltage ( $E_g$ ) are plotted against corresponding variations of plate current ( $I_p$ ). This curve is called the  $E_g$ - $I_p$  or *transfer-characteristic* curve. You will note that the potential difference between the plate and filament ( $E_p$ ) remained constant. If we change the  $E_p$  and again plot the  $E_g$ - $I_p$  curve, we get a second curve resembling the first and lying nearly parallel to it. If, on the same graph, we plot the curves for a number of different plate

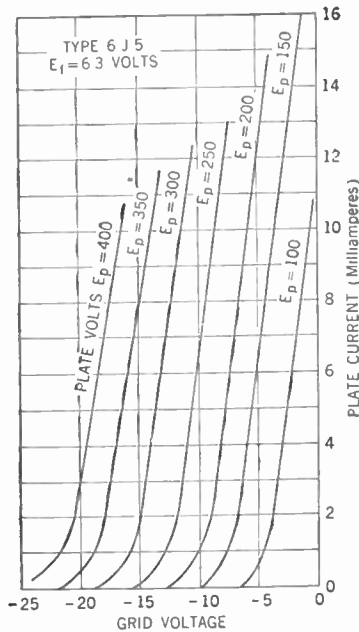

Figure 405. Family of transfer or mutual-characteristic curves for the triode (type 6J5).

voltages, we get a *family* of transfer-characteristic curves. The family of such curves for a triode such as the 6J5 tube is shown in Figure 405.

#### 428. Plate-characteristic Curve

From this family of curves we may obtain the proper grid bias

to be used for a particular tube operating at a particular plate voltage.

There is another tube relationship that may be expressed by a characteristic curve. If we keep the grid voltage ( $E_g$ ) constant and vary the plate voltage ( $E_p$ ), we get corresponding variations of plate current ( $I_p$ ). The curve showing this relationship is called the *plate-characteristic* curve. If we take different values of grid

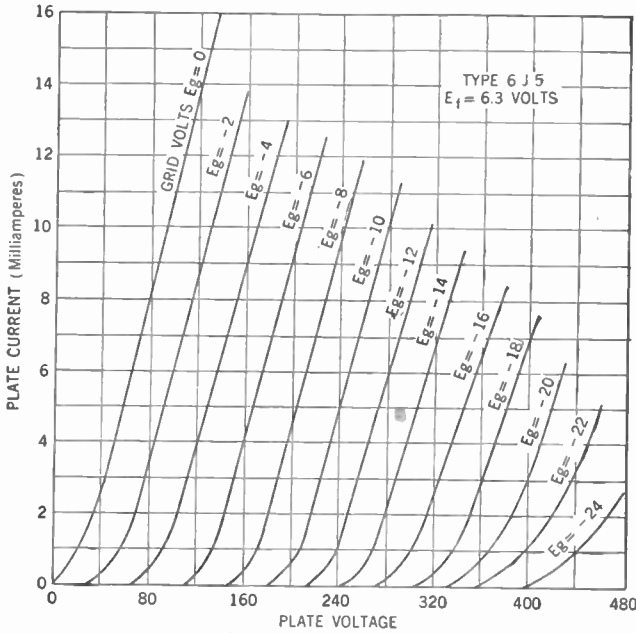

Figure 406. Family of plate characteristic curves for the 6J5 triode.

voltage we are able to obtain a *family* of plate-characteristic curves (Figure 406). The tube used in this illustration is the same as for Figure 405, the 6J5.

### 429. Static and Dynamic Characteristics

So far, in our consideration of the characteristic curves of the tube, we took a tube with no load in the plate circuit, that is, with only the B battery and meter. This is called the *static* condition of the tube and the curves so obtained are called the *static characteristic curves*. But in practice, the output of the tube feeds into a load such as the primary of the coupling transformer. If in our diagram we represent this load by a resistor ( $R$ ) (assumed to be the equivalent of the load) and plot our curves anew, we get characteristic curves that reflect more accurately the operating con-

ditions of the tube. These curves are called the *dynamic characteristic curves*. Figure 407 shows how we obtain these curves.

The dynamic curves differ from the static curves in that their

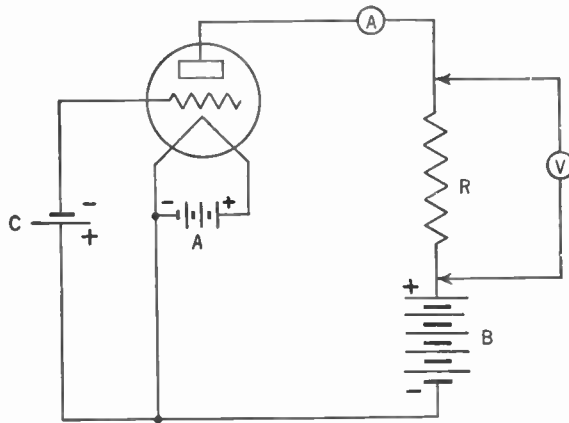

Figure 407. Circuit for obtaining the dynamic characteristic curves of a triode.

slopes are less steep. Figure 408 compares the static with the dynamic curves obtained from the same tube operating with similar voltages on the electrodes.

You will notice that the two curves cross at a point called the *operating point*. When the tube is operating at no load (static)

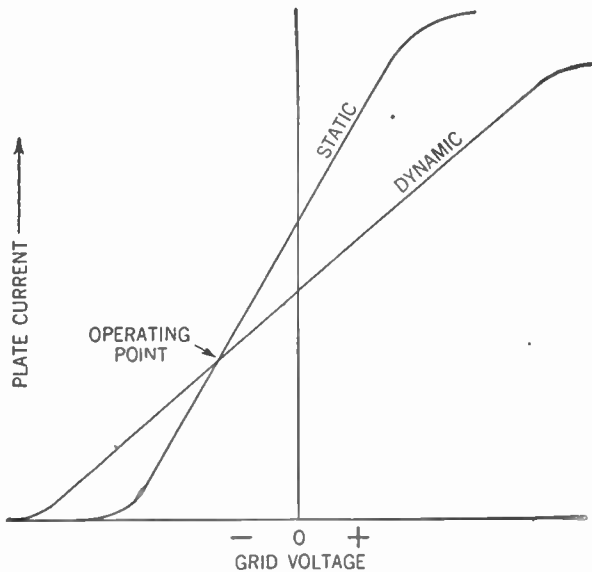

Figure 408. Graph showing the relationship between the static and dynamic curves for the same tube.

the plate-to-cathode potential is constant, regardless of the plate current. But if there is a load ( $R$ ) in the plate circuit there is a drop of potential across the load (as measured by the voltmeter in Figure 407). Thus the plate-to-cathode potential is less by the amount of potential or voltage drop across the load. A changing plate current causes a corresponding change in this potential drop (since  $E = I \times R$ ). Thus a changing plate current causes corresponding changes in the plate-to-cathode potential and our dynamic curves differ from the static curves.

Since the point where the two curves cross indicate a condition where the characteristics are the same under load conditions and under no-load conditions, we take this point as the normal operating point, hence the name. Let us consider these curves around this point (Figure 409).

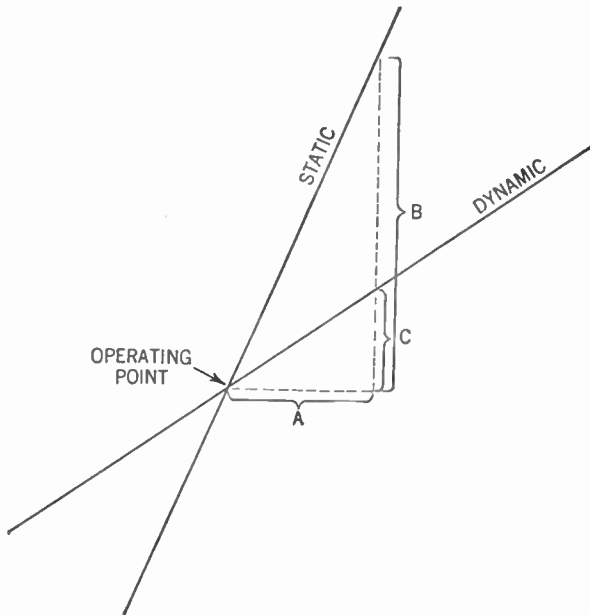

Figure 409. Graph explaining the difference between the static and dynamic characteristic curves.

On the static curve, when the positive half cycle or *swing* of the signal comes in (as measured by distance  $A$ ), the plate current rises by an amount shown as  $B$ . But under load conditions the increase in plate current from the positive swing is in turn accompanied by a potential drop ( $I \times R$ ) across the load. Thus the plate-to-cathode potential within the tube is reduced by this po-

tential drop. The consequent increase in plate current (shown by  $C$ ) is less than it was under no-load conditions.

On the negative swing of the signal fewer electrons are permitted to pass through the grid and the plate current is reduced.

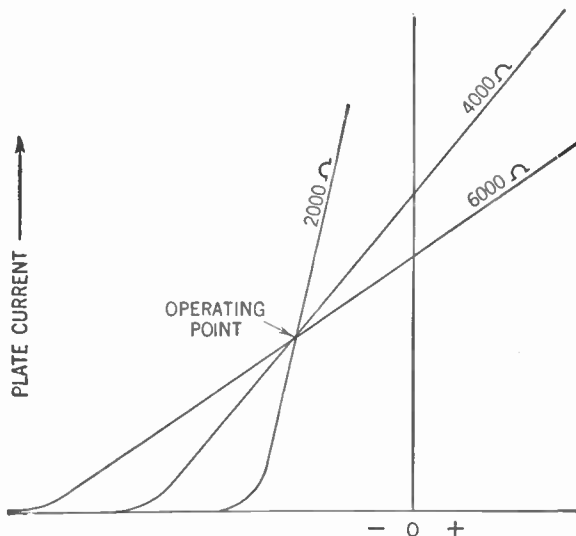

Figure 410. The effect of the resistance of the load upon the dynamic characteristic curves of a triode.

The potential drop across the load is less than it is under zero-signal (operating point) conditions. Thus the plate-to-cathode voltage of the tube rises and therefore more current flows. This behavior accounts for the dynamic curve being less steep than the static curve.

We can show the effect of different resistances of load graphically as in Figure 410. Note that they all intersect in the same operating point and that the less the resistance of the load, the steeper the curve.

### 430. How We Use the Characteristic Curves

An examination of the family of curves shown in Figure 406 shows us the interrelation of the grid-bias voltage, the plate voltage, and the plate current. Knowing any two values will give us the third. Thus, if we know that we are to apply a grid bias of  $-8$  volts to the 6J5 tube (Figure 406) and place 250 volts on the plate, we can determine the plate current that will flow during the maximum signal swing. Here is how.



Along the plate-voltage axis (the horizontal axis) pick out the point representing 250 volts. From this point draw a line vertically upward until it intersects the curve marked " $E_g = -8$ ." This curve is the characteristic curve of the tube for a  $-8$ -volt grid

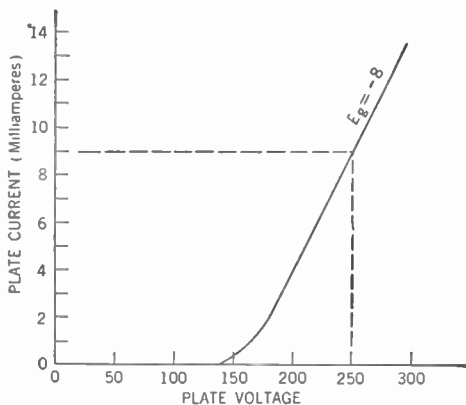

**Figure 411.** Plate-current-plate-voltage characteristic curve for the 6J5 triode. Grid bias is  $-8$  volts.

bias. From the point of intersection draw a horizontal line parallel to the horizontal axis until it reaches the plate-current axis (the vertical axis). At this point of intersection the plate current will read 9 ma., the current that will flow in the plate (Figure 411).

#### 431. Plate Resistance

The *plate resistance* ( $R_p$ ) is the alternating-current internal resistance of a vacuum tube, that is, the resistance of the path between the cathode and the plate. It is the ratio of a small change in plate voltage to the corresponding change in plate current and is expressed in *ohms*, the unit of resistance.

For example, assume that a change of 0.001 amp. is produced by a plate voltage variation of 10 volts. Since  $R = \frac{E}{I}$ , then

$$R_p = \frac{10}{0.001} = 10,000 \text{ ohms.}$$

#### 432. Amplification Factor

We have seen that a small change in the grid potential produces a change in the plate current that is equivalent to a large change

in the plate voltage. Thus an increase of, say, 10 volts in the plate voltage may produce an increase of 0.001 amp. in the plate current. Assume that this same increase of 0.001 amp. in the plate current can be accomplished by increasing the grid potential only 0.1 volt. The ratio, then, between the increase of plate voltage (10 volts) and the increase of grid voltage (0.1 volt) required to produce the same increase in plate current (0.001 amp.) is called the *amplification factor* of the tube. In this case it would be found by dividing the 10 volts by the 0.1 volt. This operation gives us an amplification factor of 100 for this imaginary tube.

The symbol for amplification factor is the Greek letter  $\mu$  ( $\mu$ ). You will recall that we discussed the amplification factor of the tube (Chap. 27, Vol. I). We discovered that it is an indication of the suitability of the tube for voltage-amplification purposes.

### 433. Transconductance

The ratio between a small change in plate current and the change in grid potential producing it, all other voltages remaining constant, is called the *transconductance*. Thus, in the tube taken for our example, the 0.001-amp. increase in plate current was produced by an increase of 0.1 volt in the grid potential. The transconductance of the tube would then be  $\frac{0.001}{0.1}$  or 0.01.

You will recall that by Ohm's Law resistance is equal to the quotient of voltage divided by current. But to compute transconductance, we divide *current* by *voltage*. This is in a sense the converse of the resistance. Accordingly, the unit for transconductance is the *mho*, which is the unit for resistance (ohm) spelled backwards.

Thus the transconductance for our tube becomes 0.01 mho. In practice, the mho is too large for easy handling. Accordingly we use the micromho which is one one-millionth of a mho. Thus our transconductance becomes 10,000 micromhos.

Transconductance is also known as *mutual conductance* and its symbol is  $G_m$ . It is useful as a measure of the suitability of a tube for power-amplification purposes; a tube with a high transconductance produces large plate-current variations corresponding to small variations in grid potential.

The plate resistance, amplification factor, and transconductance

are interrelated. The amplification factor is essentially a product of the other two. Thus:

$$\mu = R_p \times G_m$$

$\mu$  is the amplification factor,  $R_p$  is the plate resistance, and  $G_m$  is the transconductance, in mhos.

**434. Power Output**

We can represent the circuit of the vacuum tube appearing in Figure 412-A by its equivalent circuit shown in Figure 412-B. In Figure 412-A,  $E_g$  is the signal voltage applied to the grid of the tube and  $R$  is the resistance of the load. Since the signal voltage ( $E_g$ ) multiplied by the amplification factor ( $\mu$ ) gives us the corresponding change in the plate voltage, in Figure 412-B the alternating-current generator marked  $\mu E_g$  represents the changing plate voltage.  $R_p$  stands for the plate resistance of the tube and  $R$  for the resistance of the load. Since they both are in series, the total resistance offered to current flowing in the plate circuit is  $R_p + R$ .

We must remember that current *changes* in the plate circuit

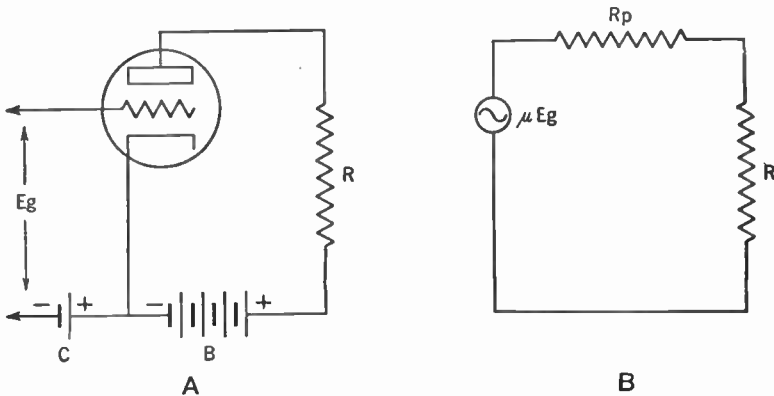

**Figure 412. A—Circuit of the triode as an amplifier. B—The equivalent circuit of A.**

resulting from the signal provide the power in the load. These current changes are caused by the changing plate voltage ( $\mu E_g$ ). Since, from Ohm's Law,  $I = \frac{E}{R}$ , then:

$$I_p = \frac{\mu E_g}{R_p + R}$$

The voltage drop ( $E_R$ ) across the load ( $R$ ) is equal to the resistance times the current flowing through it. Then:

$$E_R = R \times \frac{\mu E_g}{R_p + R}$$

The power in watts is equal to volts times amperes ( $W = E \times I$ ). We therefore get for the power in the load (power output):

$$P = E_R \times I_p$$

Substituting for  $E_R$  and  $I_p$ , we get:

$$P = \frac{R \times \mu E_g}{R_p + R} \times \frac{\mu E_g}{R_p + R} = \frac{R \times \mu^2 E_g^2}{(R_p + R)^2}$$

Later in our study we shall show that the power output for any given signal input voltage is maximum when the plate and load resistance ( $R_p$  and  $R$ ) are equal. The formula for the *maximum power output* then becomes:

$$P = \frac{\mu^2 E_g^2}{4R_p}$$

The above formula applies when we deal with average values of voltage and currents. If we wish to express it in terms of a signal voltage having a *peak* value of  $e_g$ , it becomes:

$$P = \frac{\mu^2 e_g^2}{8R_p}$$

(The use of  $e_g$  instead of  $E_g$  for the peak signal voltage indicates that we are dealing with an *instantaneous* value of voltage, that is, the instant the voltage is at its peak. This instantaneous value is indicated by the use of the small letter.)

Thus for a type 2A3 tube having an amplification factor ( $\mu$ ) of 4.2 and a plate resistance ( $R_p$ ) of 800 ohms, if the peak value of  $e_g$  is 45 volts, the maximum power output may be determined as follows:

$$P = \frac{\mu^2 e_g^2}{8R_p} = \frac{(4.2)^2 \times (45)^2}{8 \times 800} = 5.6 \text{ watts}$$

#### 435. Power Sensitivity

A convenient method for the comparison between tubes is to compare their *power sensitivity*. This is the ratio between the power output and the signal-voltage input. This relationship may be expressed in the following formula:

$$\text{power sensitivity} = \frac{\text{power output}}{(\text{input signal volts})^2}$$

Power sensitivity is expressed in mhos, power output is expressed in watts, and the input signal volts are the root mean square (R.M.S.) values.

#### 436. Plate Dissipation

As electrons emitted by the cathode strike the plate a certain amount of heat is generated. Since this heat energy is taken from the electrical energy of the electrons it represents a loss of power. This loss of power is called *plate dissipation*. It is the difference between the power supplied to the plate of the tube and the power delivered by the tube to the load.

#### 437. Plate Efficiency

It should be remembered that the tube itself does not generate power. It is the B battery that supplies the power fed into the load. The tube acts as a sort of valve in which variations in signal voltage applied to the grid circuit allow more or less power to be drawn from the B battery and expended in the plate circuit.

The ratio, at full signal voltage, of the alternating-current power output to the average direct-current power input is called the *plate efficiency*. Since the average direct-current power input is the product of the average direct-current plate voltage times the average direct-current plate current, then

$$\text{plate efficiency (\%)} = \frac{P}{E_p \times I_p} \times 100$$

where  $E_p$  and  $I_p$  are respectively the average numbers of direct-current plate volts and direct-current plate amperes, and  $P$  is the power output in watts.

#### 438. Voltage Amplification

We have seen that the plate current ( $I_p$ ) flowing through the load resistance ( $R$ ) in Figure 412-A causes a voltage drop in  $R$  that varies directly with the plate current. The ratio of this voltage variation produced in the load resistance to the input signal voltage ( $E_g$ ) is the *voltage amplification* or *gain*, provided by the tube. Thus:

$$\text{voltage amplification} = \frac{E_R}{E_g}$$

But we have seen that

$$E_R = \frac{R \times \mu E_g}{R_p + R}$$

Then:

$$\text{voltage amplification} = \frac{\frac{R \times \mu E_g}{R_p + R}}{E_g} = \frac{\mu \times R}{R_p + R}$$

Thus in our type 2A3 tube, which has a  $\mu = 4.2$  and an  $R_p = 800$  ohms, if we assume a load resistance of 2,500 ohms, then:

$$\text{voltage amplification} = \frac{4.2 \times 2,500}{2,500 + 800} = \frac{10,500}{3,300} = 3.2$$

#### 439. Tetrode

In Chapter 27, Vol. I, it was pointed out to you that as the electrons emitted by the cathode strike the plate, they cause a secondary emission of electrons from the plate owing to the force of impact. The presence of a positively charged screen grid near

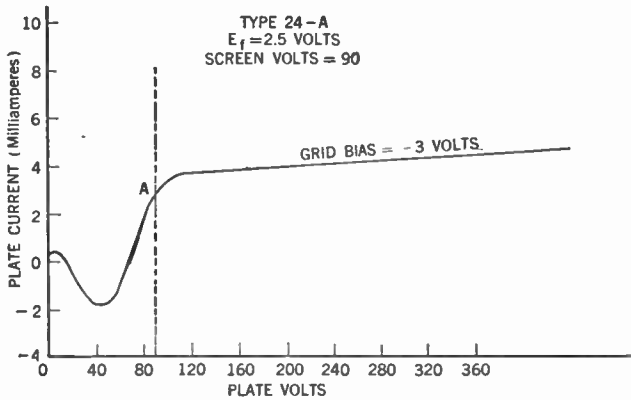

Figure 413. Plate-current-plate-voltage characteristic curve for the tetrode (type 24-A).

the plate causes some of those secondary electrons to be attracted to the screen grid, resulting in a loss for the plate. In Figure 413 we see a graph which illustrates this phenomenon.

The graph is for the type 24-A tube with 90 volts applied to the screen grid. The dip in the graph indicates the fact that when the plate voltage is below that of the screen grid (90 volts), many of the secondary electrons are going to the screen grid. But when the plate voltage is increased above the 90-volt mark (as shown by A on the graph), the greater positive charge on the plate attracts most of these electrons and the graph becomes normal.

**440. Pentode**

One of the effects of the secondary emission from the plate is to limit the available alternating-current output voltage, since true amplifier action does not extend below point A of the graph in Figure 413. This defect is remedied in the pentode by the introduction of the suppressor grid, which herds the secondary electrons back to the plate.

In Figure 414 you will see a family of curves for the type 57 pentode. Note that the dip is not present.

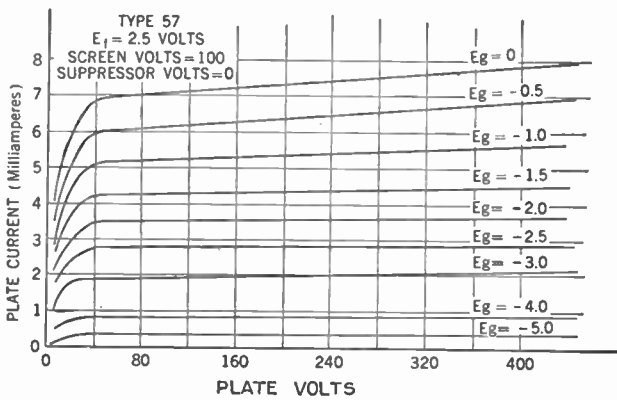

**Figure 414. Family of plate-current-plate-voltage characteristic curves for the pentode (type 57).**

It is suggested that you review the chapter on types of tubes (Chapter 27, Vol. I) and it is suggested that you study the characteristics and curves of various types of tubes as given in the manuals put out by the various tube manufacturers.

**SUMMARY**

1. The characteristic curves of vacuum tubes are graphs showing the relation between two variables plotted on the X and Y axes. The

data for the curve are supplied by the readings of testing meters: voltmeters and ammeters.

2. The characteristic curve of the **diode** shows that as the plate voltage (that is, the positive charge on the plate) is increased the current increases. (a) The flat part of the curve at the bottom shows that the current does not respond to low voltages while (b) the flattening out at the top of the curve shows that beyond a certain point increase in plate voltage does not increase the current.

3. The explanation of the flattened bottom of the curve is that with a low positive charge on the plate, many of the electrons emitted by the filament are not attracted to the plate and hence form a space charge. The explanation of the flattening of the top of the curve is that at a certain voltage, all the electrons possible to be given off by the filament are being attracted to the plate; hence no more electron flow can take place from the filament to plate, regardless of how great a charge is put on the plate.

4. The point on the curve, corresponding to a certain plate voltage and yielding a certain current, above which no increase in plate voltage will increase the current is called the **saturation point** of the diode.

5. The reduction of space charge is aided by (a) reducing the distance between plate and filament and (b) by the use of mercury vapor in the tube.

6. When alternating-current voltages are applied to diodes, the sine curve at the bottom shows the alternating-current voltage input and the characteristic curve for plate current is shown above.

7. For **triodes**, curves may be made to show relations between any two factors when other factors are kept constant. For example, we may plot the relation between the C bias on the grid and the plate current.

8. The characteristic curves of tubes are used for calculations of the various values we sometimes need to know in order to build or repair a radio receiver.

#### GLOSSARY

**Amplification Factor ( $\mu$ ):** The ratio between the change of plate voltage and the change of grid voltage required to give the same plate-current change.

**Characteristic Curve:** A graph showing the relationship between two variables of a tube, when one is made to undergo many changes.

**Dynamic Characteristic Curves:** Characteristic curves obtained under operating conditions of a tube.

**Emission Current:** The current flowing when the saturation point of a tube is reached.

**Ion:** An atom with a positive or negative charge.

**Mercury-vapor Rectifier:** A tube in which mercury vapor fills the inner space instead of its being a vacuum.

**Mutual Conductance:** The ratio between a small change in plate current and the change in grid voltage producing it.



- Operating Point:** The point where the dynamic and static characteristic curves for one condition intersect and where load and no-load result are the same.
- Plate-characteristic Curve:** A characteristic curve whose two variables are plate current and plate voltage.
- Plate Dissipation:** The loss of power in the form of heat at the plate of a tube.
- Plate Efficiency:** The ratio at full signal voltage of alternating-current power output to the average direct-current power input.
- Plate Resistance ( $R_p$ ):** The alternating-current internal resistance of a vacuum tube.
- Power Sensitivity:** A measure of the power controlled in the plate circuit by a given input grid voltage change.
- Saturation Current:** The plate current flowing when the saturation point is reached.
- Saturation Point:** The condition of operation of a tube where further increases of plate voltage cannot produce any greater plate current.
- Space Charge:** The charge produced by the emitted electrons as they fill the space within the tube between cathode and plate.
- Static Characteristic Curves:** Characteristic curves obtained not under operating conditions.
- Transconductance:** Same as mutual conductance.
- Transfer-characteristic Curve:** A graph with two variables: grid voltage and plate current, plate voltage being kept constant.
- Voltage Amplification or Gain:** The ratio of voltage variation across the load resistor to input signal voltage.

### QUESTIONS AND PROBLEMS

1. What is the basic principle of operation of a vacuum tube?
2. What does the characteristic curve of a diode tell us about it?
3. What condition accounts for the lower bend of a diode characteristic curve?
4. What condition accounts for the upper bend of a diode characteristic curve?
5. Explain two ways in which the space charge within a diode might be reduced.
6. What function does the control grid serve in the triode?
7. State the meaning of  $E_p$ ,  $I_p$ ,  $E_f$ ,  $I_f$ ,  $E_a$ ,  $I_g$ .
8. Why is the upper bend of a triode characteristic curve usually not shown for modern tubes?
9. When a negative bias is placed on the grid of a triode audio-frequency amplifier, what is the function of the input signal on the grid? What does it result in?
10. What effect occurs when grid bias is too low? When it is too large?
11. What does the transfer-characteristic curve tell us about a tube?
12. A transfer-characteristic curve is valid only if what condition of the tube is kept constant?

13. What does a plate-characteristic curve tell us about a tube? What condition must be kept constant in securing one such curve?
14. Differentiate between the static and dynamic conditions of a tube.
15. How does a changing plate current affect the plate voltage?
16. What is the significance of the operating point of a tube obtained from a static and dynamic curve?
17. How is the plate resistance of a tube computed?
18. What is the significance of the amplification factor?
19. What may be learned from the transconductance of a tube? In what units is transconductance measured?
20. Relate amplification factor, plate resistance, and transconductance in one formula.
21. When considering a tube as a generator feeding into a load, what is the formula for its voltage?
22. State the general formula for the voltage drop across the load of a tube in the plate circuit, using  $\mu$ ,  $E_g$ ,  $R$ , and  $R_p$ . State it for power dissipated in the load.
23. When will the maximum power output occur for a tube? How may the power output be computed at that time?
24. What is the significance of the power-sensitivity rating of a tube?
25. What is the source of power developed from a tube?
26. What is meant by the voltage amplification or gain of a tube?
27. What effect has secondary emission within the tube?

## CHAPTER 38

# Vacuum-tube Amplifiers

---

- Problem 1:** *What are the general principles governing the use of vacuum-tube amplifiers?*
- Problem 2:** *What are the characteristics of circuits using audio-frequency amplifiers?*
- Problem 3:** *How do radio-frequency amplifiers differ from audio-frequency amplifiers?*
- 

### 441. General Principles

Vacuum-tube amplifiers fall into two broad categories. There are those which are used to amplify currents whose frequencies lie between approximately 30 and 15,000 cycles per second. We call these *audio-frequency amplifiers*. The other group is used to amplify currents whose frequencies lie between about 15 kc. and 300 mc. and more per second. These are the *radio-frequency amplifiers*.

Amplifiers may be designed to serve two functions. One type has as its chief purpose to give a greatly magnified reproduction of the input signal without regard to the power delivered. We call it a *voltage amplifier*. There is another type whose chief purpose it is to deliver a relatively large amount of power to such a load as a loudspeaker or an antenna. An amplifier of this type is called a *power amplifier*.

Generally speaking, the last stage of any amplifier system (whether audio-frequency or radio-frequency) is a power stage, since it is connected to the loudspeaker (in the case of the audio-frequency amplifier) or to the antenna (in the case of the radio-frequency amplifier). The intermediate stages, sometimes called the *driver* stages, are usually voltage amplifiers for audio-frequency work and power amplifiers for radio-frequency amplification in the transmitter. The radio-frequency amplifiers in the receiver are of the voltage type.

#### 442. Audio-frequency Amplifiers

The *audio-frequency amplifier* is one suitable for amplifying signal voltages whose frequencies lie within the audible range, that is, from approximately 30 to 15,000 cycles per second. The amplifier must amplify, without undue discrimination, all the frequencies lying in this range. For this reason we use nonresonant circuits to couple the various stages.

Audio-frequency amplifiers are classified also according to the operating conditions under which the tubes work. The classifications in general use are class A, class AB, and class B. These classes are covered by definitions drawn up by the Institute of Radio Engineers.

A *class A amplifier* is an amplifier in which the grid bias and alternating grid voltages are such that plate current in a specific tube flows at all times.

A *class AB amplifier* is an amplifier in which the grid bias and alternating grid voltages are such that plate current in a specific tube flows for appreciably more than half the electrical cycle but less than the entire cycle.

A *class B amplifier* is an amplifier in which the grid bias is approximately equal to the cutoff value so that the plate current is approximately zero when no exciting grid voltage is applied and so that plate current in a specific tube flows for approximately half of each cycle when an alternating grid voltage is applied.

#### 443. Distortion and Its Remedy

Before going into any further discussion of the various classes of audio-frequency amplifiers, it might be well to consider the problem of *distortion*. Because the aim of the amplifier is to produce an output whose form, as nearly as possible, coincides with that of the signal input, we must strive to cut distortion to a minimum.

First of all there is distortion arising from the inability of the amplifier to amplify equally all frequencies of the audio range. This distortion is especially pronounced at both ends of the audio range and manifests itself by the fact that sounds whose frequencies lie at the low and high ends (low-pitched and high-pitched sounds) are not reproduced with the same relative volume as are

sounds lying in the middle register. Careful selection of the component parts of the amplifier, together with the methods of tone control described in Chapter 25, can reduce this distortion to a point where it is not objectionable. This type of distortion is called *frequency distortion*.

Another form of distortion, called *delay* (or *phase*) *distortion*, results from the effects of transmission of different frequencies at different speeds, giving a relative phase shift over the frequency range in the output. This type of distortion does not concern us here and is important only in cases where ultrahigh-frequency and transmission-line work is considered.

#### 444. Nonlinear Distortion

There is another type of distortion that takes place in the tube itself. It is caused by the improper selection of grid bias, which forces the tube to operate under conditions represented by the curved or *nonlinear* portion of the characteristic curve (see Figure 404). For this reason it is called *nonlinear distortion*. Thus Figure 404-A shows the distortion to the plate-current curve due to too *low* a grid bias, while Figure 404-B shows the distortion due to too *high* a grid bias.

Let us see how this distortion affects the signal. When too low a grid bias is used, the tops of the curve are flattened. When too high a grid bias is used, the bottoms of the curve are flattened. It can be shown, mathematically, that any periodic curve (that is, a curve that periodically repeats itself, as is the case here), regardless of shape, can be reduced to a number of simple sine curves of various amplitudes and phase relationship, but all in harmonic frequency relationship.

Here is what this statement means. Suppose you were to strike middle C of the piano. The frequency of that note is 256 cycles per second. Now assume you were to play the same note on a violin. The frequency is the same, but it sounds different. You are able to distinguish between a note on the piano and the same note on the violin. What makes the difference?

The answer is that the difference is due to *overtones* or *harmonics*. When middle C is played on the piano or violin, we not only get frequencies of 256 cycles per second (called the *fundamental frequency*) but at the same time sounds are produced whose frequencies are two, three, or more times as great. These

sounds are called *overtones* or *harmonics*, and they are said to be in *harmonic relationship* with the fundamental frequency (that is, they are frequencies produced by multiplying the fundamental frequency by a whole number such as 2, 3, 4, 5, and so on).

The harmonic whose frequency is twice the fundamental is called the *second harmonic*; three times the fundamental frequency produces the *third harmonic*; and so forth. The piano and violin differ in that they produce these harmonics in different proportions and strengths. That is why C on the piano sounds different from C on the violin.

When dealing with sound, these harmonics are not considered distortions but are really part of the distinguishing feature or quality of the sound. But in electrical circuits, harmonics are distortions and produce wave forms which are different from the original. Let us see how that occurs.

#### 445. How Harmonics Affect the Curve

Assume we have a sine curve which we will consider the fundamental, and its second harmonic which lies entirely below the X axis.

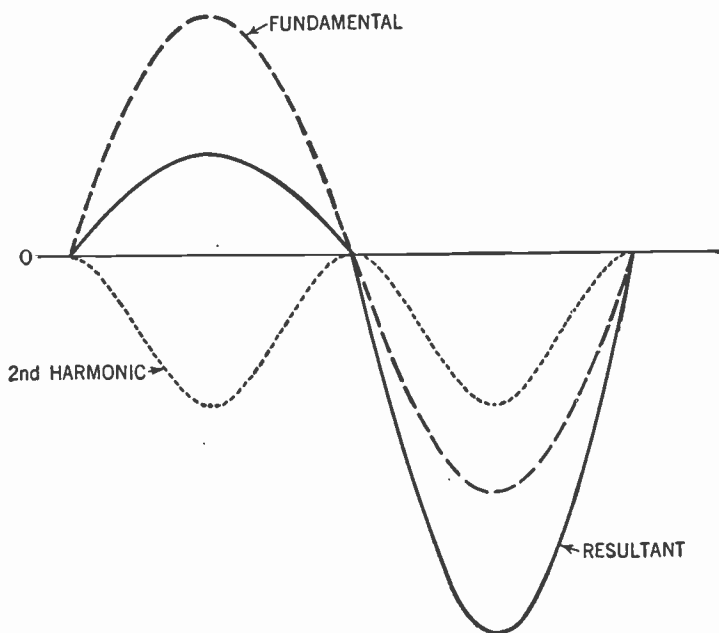
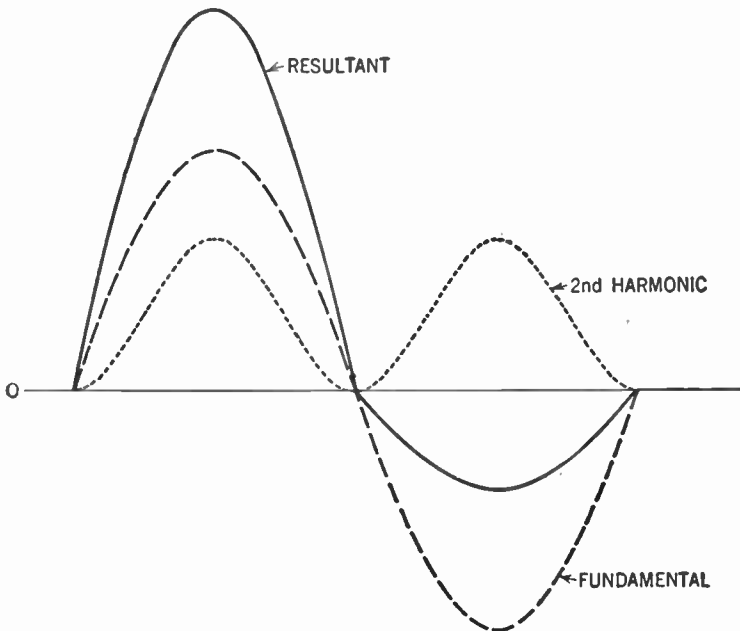

Figure 415. Graph showing the effect of adding the fundamental to the second harmonic which is below the X axis.

zero axis (Figure 415). You can see that by adding the two curves together we get a new curve with the tops flattened. But this new curve resembles the curve of Figure 404-A. Thus we can consider the curve resulting from too low a grid bias as being produced by the fundamental frequency plus its second harmonic. Now you can see how the harmonics cause distortion of the signal.

If we were to take the second harmonic to be entirely above the zero line we would get a curve resembling Figure 404-B (see Figure 416). Here the curve resulting from too high a grid bias is produced by the fundamental frequency plus its second harmonic.



**Figure 416.** Graph showing the effect of adding the fundamental to the second harmonic which is above the X axis.

Similarly, we can break down any distortion to the signal wave form as being due to the presence of harmonics (second and higher) of the fundamental. These harmonics rapidly decrease in strength as their frequencies differ from the fundamental. Thus the second harmonic may be strong enough to cause distortion in the audio-frequency amplifier and steps must be taken to eliminate it, but harmonics of the order of the third or higher usually are negligible.

Sometimes, as we shall see later when we consider the transmitter, we deliberately seek to generate these harmonics.

#### 446. Correcting Nonlinear Distortion

The remedy for nonlinear distortion is to choose correct grid-bias and plate-voltage values so that the tube may be operated on the straight portion of the curve. The *push-pull amplifier* (see Par. 205, Vol. I) also serves to reduce nonlinear distortion, especially second-harmonic distortion. You will recall that each tube in the push-pull arrangement operated on different half cycles of the signal; while one tube was handling the positive half cycle, the other was handling the negative half cycle.

You will also recall that both tubes simultaneously delivered their outputs to the center-tapped primary of the output transformer (Fig. 169, Vol. I). These two outputs were added together to give the total output of the stage of amplification.

Now let us see how the second-harmonic distortion is removed (Figure 417). From Figure 417-A you can see that during the

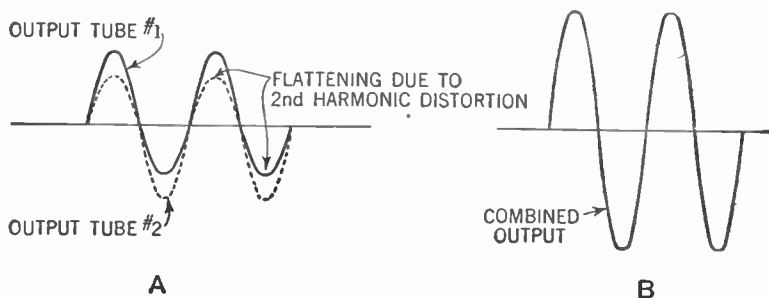

**Figure 417. How the push-pull amplifier eliminates second-harmonic distortion.**

**A—Graph showing output of each tube.**

**B—Graph showing combined output of the output transformer. Note that the distortion has been eliminated.**

first half cycle the output from tube 1 is the undistorted signal while that from tube 2 is the distorted signal. During the next half cycle this condition is reversed. But since the two outputs are added together, the *total* output for each half cycle is the same and therefore the over-all effect is to produce an output signal whose wave form closely resembles that of the input signal.

Of course, this method eliminates only second-harmonic (and other *even*-harmonic) distortion. But as we have seen, harmonics beyond the second are so weak as to have little effect.



#### 447. Overloading Causes Distortion

There is another form of distortion caused by *overloading* the tube. We may select the proper grid bias for our tube but if a signal comes in that produces too great a swing of the grid potential, the grid may be driven positive on the positive half cycle and to the point of *cutoff* (the point where the negative charge on the grid gets so great as to stop entirely the flow of electrons from the cathode to the plate) on the negative half cycle (see Figure 418). This condition results in a flattening of the tops and bot-

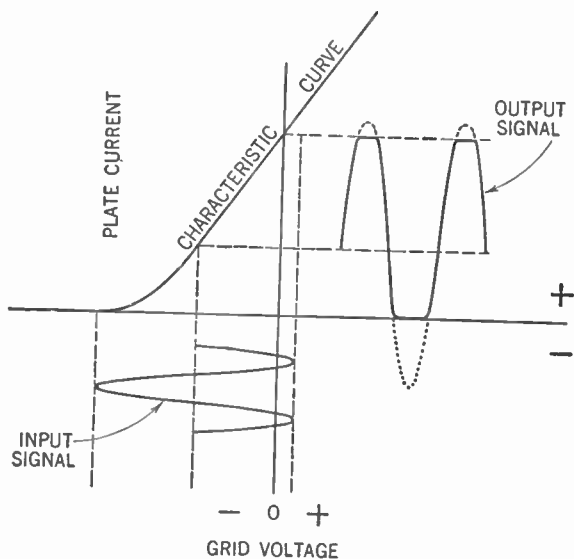

Figure 418. Distortion of the signal due to overloading.

toms of the output curve. The remedy is to choose a tube which has a longer straight-line characteristic or else to use an input signal without so great a swing.

Still another form of distortion arises through the use of a load in the plate circuit whose resistance is too low. If you turn back to Figure 410 you will see that the less the load resistance, the more the characteristic curve is bent. This condition in turn reduces the length of the straight-line portion of the curve and thus a nonlinear distortion may be introduced. The remedy for the difficulty, obviously, is to use a load whose resistance is suited to the tube.

#### 448. The Class A Amplifier

In the *class A amplifier*, a radio tube is used to reproduce grid-voltage variations across a load in the plate circuit. These variations closely resemble in form the input-signal voltage impressed on the grid, but are of greater amplitude. The reproduction is accomplished by using a suitable grid bias so that the tube operates on the straight-line or linear portion of the characteristic curve. At no time does the grid go positive (Figure 419).

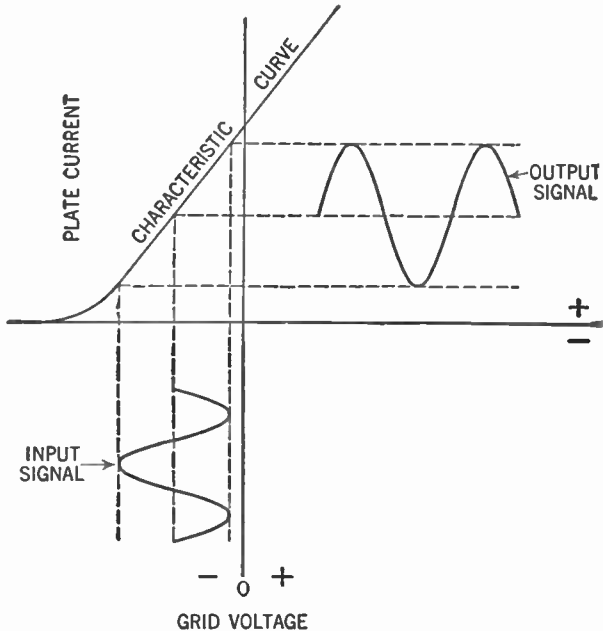
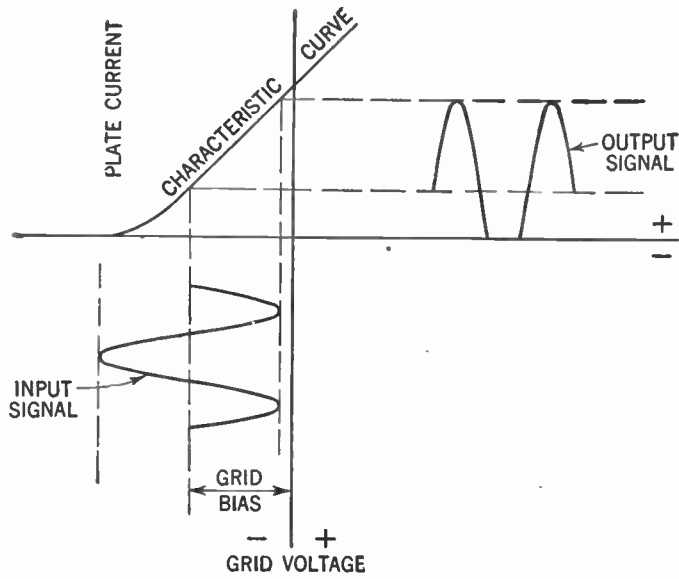

Figure 419. Graph showing relationship between the input and output signals in a class A amplifier.

The class A amplifier produces high-fidelity amplification. As a voltage amplifier it may be used to provide the high-voltage grid swing necessary to operate the power stage.

As a power amplifier, it sacrifices high voltage gain for relatively large power output (Chap. 27, Vol. I). Power tubes of the triode type in class A service are characterized by low power sensitivity, low plate efficiency, and low distortion. Pentodes in class A are characterized by high power sensitivity, high plate efficiency, and relatively high distortion.



A

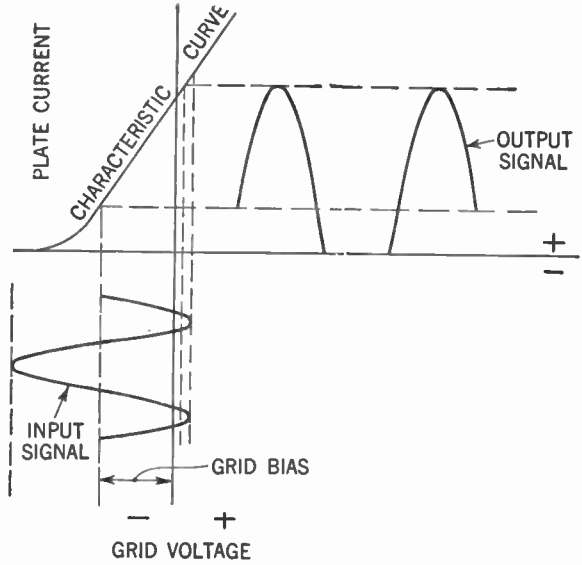

B

Figure 420.

A—Graph showing relationship between input and output signals in a class AB<sub>1</sub> amplifier.

B—Graph showing relationship between input and output signals in a class AB<sub>2</sub> amplifier.

Faithful reproduction may be obtained by using a single class A tube in the output stage. Greater power may be obtained by hooking two such tubes in parallel or push-pull (Chap. 27, Vol. I). The push-pull arrangement has the added advantage of eliminating any second-harmonic distortion that may be present.

#### 449. The Class AB Amplifier

A class AB amplifier employs two tubes connected in push-pull with a higher negative grid bias than is used in a class A stage. Class AB amplifiers are subdivided into two classes: *class AB<sub>1</sub>*, wherein the peak signal voltage applied to each grid is not greater than the negative grid-bias voltage, wherefore there is no flow of

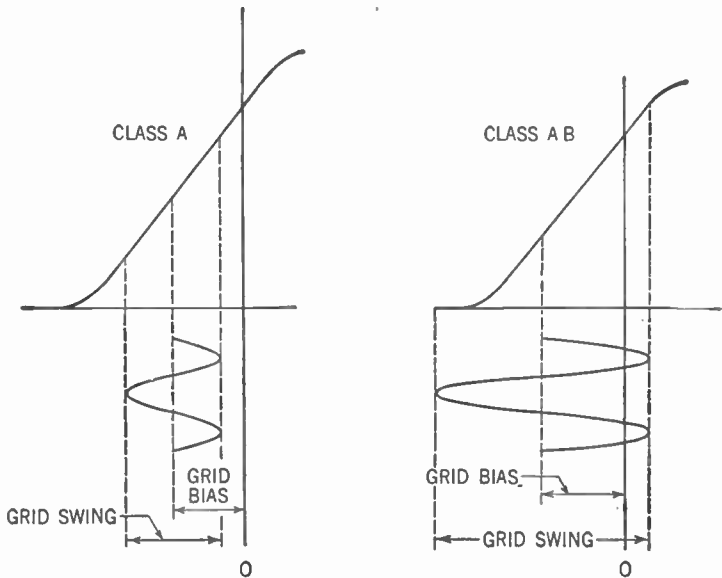

Figure 421. Graphs showing how a greater grid swing is possible with the class AB amplifier.

grid current, and *class AB<sub>2</sub>*, wherein the peak signal voltage slightly exceeds the negative grid-bias voltage and wherefore there is a flow of grid current during a small portion of the cycle (Figure 420).

More power output can be obtained from the class AB amplifier than from the class A amplifier. The reason is that a greater grid swing is possible with the class AB than with the class A amplifier. The operating point is shifted to the low end of the

characteristic curve and a greater grid swing is possible with class AB before the grid goes positive or the top bend of the curve is reached (Figure 421).

Since we can use larger grid potentials ( $e_g$ ) in the class AB amplifier, the power output is increased, for:

$$\text{power output} = \frac{\mu^2 e_g^2}{8R_p}$$

Examination of the output signal curves (Figure 420) shows that part of the bottom loops has been cut off. If a single tube were used this would create a great deal of distortion (especially of the second-harmonic type). But we have already seen (Figure 417) how two tubes in push-pull eliminate this distortion.

In the case of class AB<sub>2</sub> amplification, the grid goes positive for a small portion of the cycle (Figure 420-B). This condition causes a loss of power due to the flow of grid current. This power loss, plus the power consumed by the input transformer, must be furnished by the preceding stage of amplification (the driver

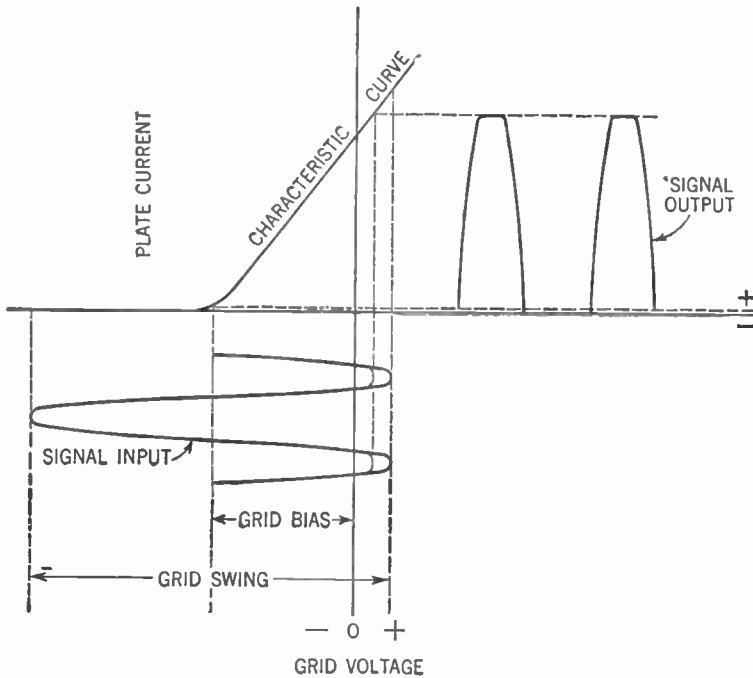

Figure 422. Graph showing relationship between the input and output signals in a class B amplifier.

stage). In practice, the driver stage is a class A amplifier designed to furnish considerably more than the necessary power and the input transformer has a step-down turn ratio.

#### 450. The Class B Amplifier

By increasing the negative grid bias to the point where there is practically no flow of plate current at zero-signal voltage (point of cutoff), we obtain our *class B amplifier* (Figure 422).

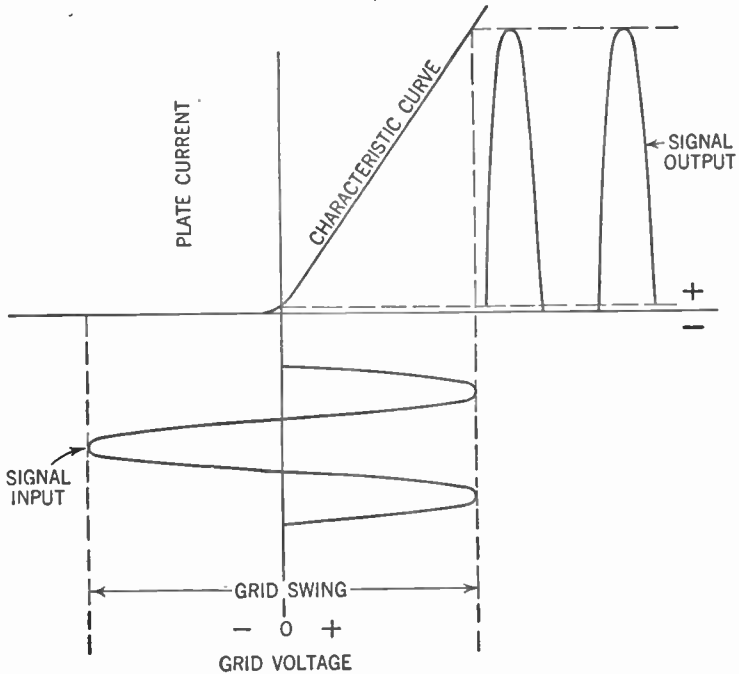

Figure 423. Graph showing how the special class B tubes operate on zero grid bias.

You will note that the curves for class B resemble those for class  $AB_2$ , except that a larger power output may be obtained because of the larger grid swing ( $e_g$ ).

There are specially designed class B tubes whose characteristic curves have been shifted to the right (Figure 423). Thus when the grid bias is zero, we still have the class B condition where there is no flow of plate current at zero-signal voltage. This arrangement eliminates the necessity of using a grid bias.

Examples of tubes of this type are the 19, 6N7, and 6A6. You will notice that the grid is positive for practically a half cycle.

Thus a great deal of power is lost owing to the flow of grid current. As in the case of the  $AB_2$  amplifier, the driver stage must supply more than enough power to make up for this loss if distortion is to be avoided. Of course, the greater grid swing permissible enables the class B amplifier to deliver a greater power output. Again, like class AB, the class B amplifier can only be operated in a push-pull circuit.

#### 451. Grid-bias Voltage

It might be well to say a few words here about how we obtain the *grid-bias voltage* which is so important in determining how the amplifier tube will operate. One method is the *cathode-resistor bias method* (Figure 424). Here a resistor, shunted by a fixed

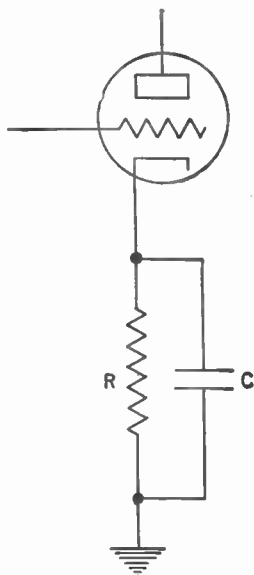

Figure 424. The cathode-resistor method for obtaining grid bias.

condenser, is connected to the cathode of the tube. The voltage drop across the resistor supplies the necessary grid-bias voltage (see Paragraph 134 in Volume I).

This method is used extensively in both the audio- and radio-frequency amplifiers of the radio receiver. It is also employed in low- and medium-powered public-address systems and low-powered transmitters.

Another method for obtaining the grid-bias voltage is the use

of *batteries* or a separate *rectifier and filter system*. This method has the advantage that it can furnish a steady, constant bias under all conditions of operation. It is not usually employed in receivers that obtain their power from the house power lines, since the cathode-resistor bias method is more convenient. But portable receivers, high-power audio amplifiers, and powerful transmitters make extensive use of this method for obtaining the necessary grid bias.

You should recall that certain types of class B tubes (such as the 19, 6N7, and the like) are designed to operate at zero bias. This practice, of course, eliminates the necessity for any of the above methods.

#### 452. Power Transfer

We have seen that the function of the radio tube is to amplify the signal and to transfer the electrical energy on to a load. Since this energy is quite small in most radio circuits, this transfer must be accomplished with maximum efficiency.

Figure 425 shows the equivalent circuit for the amplifier.

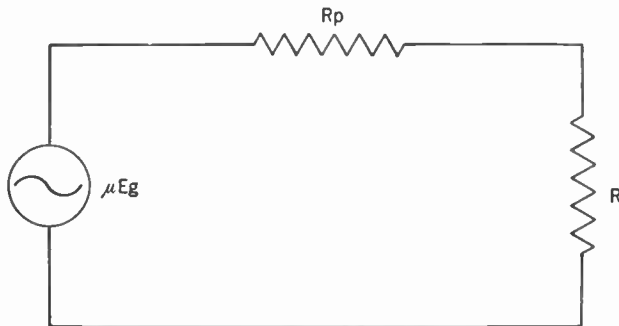

Figure 425. The equivalent circuit for an amplifier.

Assume the voltage ( $\mu E_g$ ) to be equal to 100 volts and the plate resistance of the tube ( $R_p$ ) to be 10 ohms. If we assume the load resistance ( $R$ ) to be 1 ohm, then the total resistance of the circuit ( $R_p + R$ ) is equal to 11 ohms. From Ohm's Law we can determine the current ( $I$ ) flowing through the circuit.

$$I = \frac{E}{R} = \frac{100}{11} = 9.09 \text{ amp.}$$

The voltage drop across the load resistor ( $R$ ) can be determined as follows:



$$E_R = I \times R = 9.09 \times 1 = 9.09 \text{ volts}$$

The power in the load then becomes:

$$P_R = I^2 R = (9.09)^2 \times 1 = 82.62 \text{ watts}$$

$\mu E_g$ (volts)	$R_p$ (ohms)	$R$ (ohms)	$I$ (amperes)	$E_R$ (volts)	$P_R$ (watts)
100	10	1	9.09	9.09	82.62
100	10	5	6.66	33.30	221.77
100	10	10	5.00	50.00	250.00
100	10	20	3.33	66.60	221.77
100	10	100	.90	90.00	81.00

Figure 426. Table showing power and voltage relationships as the load resistor (R) is changed.

If we assume different values for the load resistance we can draw up the table shown in Figure 426. From this table we can draw the following conclusions:

1. The higher the load resistance ( $R$ ) the greater the voltage drop across the load ( $E_R$ ). Thus, if we are operating the amplifier as a *voltage* amplifier, we should have the load resistance as high as is feasible.
2. If we are interested in the *power* output, the maximum transfer of power occurs when the load resistance ( $R$ ) is equal to the resistance of the source ( $R_p$ ). We shall see later that there are some modifications of this rule.

These rules apply not only to radio tubes, but also to any circuits where electrical power is transferred from one circuit to another.

### 453. Impedance Matching in Audio-frequency Circuits

So far, we have considered the load as if it were a pure resistance. But this is not always the case. The load may be the primary of the coupling transformer or the voice coil of the speaker. Accordingly, the load may present an impedance rather than a resistance.

Since the impedance varies with variations of frequency, distortion may appear if the impedance of the load is made equal to the impedance of the source. It has been found that making the load impedance twice as great as the plate resistance ( $R_p$ ) gives us an output that contains less than 5% of second-harmonic distortion.

Careful tests have shown that second-harmonic distortions of 5% or less cannot be detected by the human ear and so we call the value corresponding to this the *maximum undistorted power output*. An examination of the table in Figure 426 shows that the effect of making the load twice the resistance of the plate drops the power output about 10%. Since variations of power output which are less than 25% cannot be detected by the human ear, this power loss is negligible. Thus manufacturers of radio tubes specify that a load impedance about twice as great as the plate resistance be used for maximum undistorted power output.

#### 454. Example: Type 10 Tube

The principles of impedance matching must be used in every circuit where electrical energy is transferred. Assume that we have a type 10 tube acting as a class A power amplifier and that we wish to deliver the output to the voice coil of a dynamic speaker. The plate resistance of the type 10 tube is 6,000 ohms and the impedance of the voice coil is, say, 8 ohms (Figure 427).

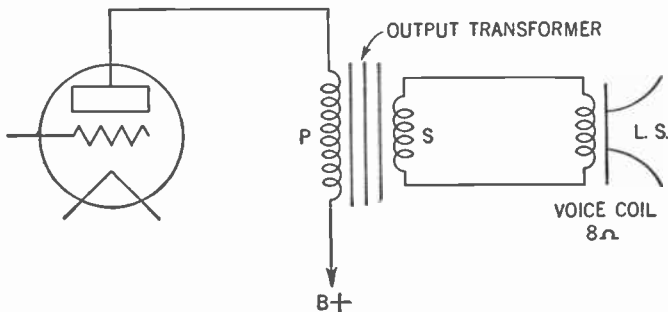

**Figure 427.** How the output transformer is used to match the impedance of the voice coil to the resistance of the tube.

As we now know, for the maximum undistorted power output, the impedance of the load must be about twice the plate resistance or about 12,000 ohms. Obviously, the 8-ohm voice coil cannot be coupled directly to the tube.

Use is made here of an output transformer. The primary of this transformer supplies the load to the tube and its impedance, therefore, is made to equal about 12,000 ohms, the necessary value to insure the maximum undistorted power output.

The power is transferred to the secondary of the transformer by mutual inductance. This secondary now becomes the source of electrical power to the voice coil of the speaker. Since maximum power transfer is achieved when the impedance of the source equals the impedance of the load, the impedance of the secondary is made the same as that of the voice coil, namely, 8 ohms.

The same principle is employed wherever an audio-frequency transformer is used to couple the output of one tube to the input of another (Figure 428). The impedance of the primary is two

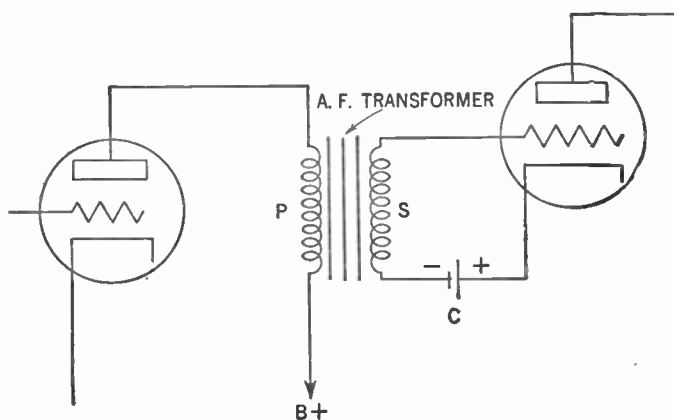

**Figure 428.** How the audio-frequency transformer is used to match the output of one tube with the input of the next.

or more times the plate resistance. If the first tube is used as a voltage amplifier we want this impedance to be as high as possible. But the higher the primary impedance, the more it cuts down the charge from the B+ that can be put on the plate. Some compromise value is chosen.

The impedance of the secondary must match the input impedance of the second tube. If this tube is used as a class A amplifier, there is no flow of grid current and therefore the impedance of the grid (input) circuit is very high. Thus the impedance of the secondary of the audio-frequency transformer must be very high, too.

### 455. Coupling of Audio-frequency Amplifier Stages

To pass the signal from one stage of amplification to another, means of *coupling* must be devised. In general, there are three methods of coupling: *resistance* coupling, *impedance* coupling, and *transformer* coupling.

In Chapter 17 of Volume I we discussed *resistance coupling*. The coupling device consisted of a *plate resistor* (this is the load resistor and not to be confused with the plate resistance  $R_p$ , which is the internal resistance of the tube itself), a *coupling condenser*, and a *grid-leak resistor* (Figure 429).

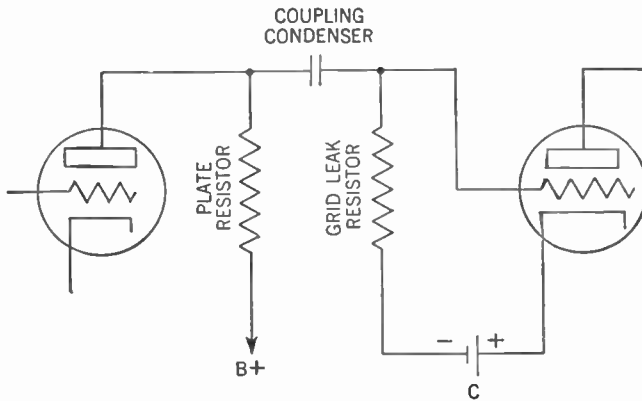

Figure 429. Resistance coupling for audio-frequency amplification.

When the tube is operating as a voltage amplifier, the plate resistor should be as large as possible. But this resistance cuts down the plate charge. A compromise figure is arrived at whereby a plate resistor is used whose resistance is up to ten times as great as the plate resistance of the tube ( $R_p$ ).

The coupling condenser must keep the large positive charge from the B battery off the grid of the second tube and, at the same time, offer a minimum impedance to the signal voltage. This requirement calls for a large value for this condenser, usually about  $.004 \mu\text{fd}$ . If the condenser is made too large, the charge on the grid will take too long a time to leak off through the grid-leak resistor. The coupling condenser must keep direct-current leakage to a minimum. For this reason condensers with mica dielectric are usually used here.

The grid-leak resistor helps keep the signal voltage charges on

the grid of the tube. For this reason it must be made as large as possible. But too large a resistance will prevent the charges from leaking off the grid fast enough. A value of 1,000,000 ohms (1 megohm) is usually chosen for the grid-leak resistor.

At low frequencies (about 50 cycles per second) the amplification for a resistance-coupled audio-frequency amplifier falls off because of the high reactance offered by the coupling condenser. At high frequencies the amplification falls off, too, because the capacitance between the grid and cathode of the second tube offers a low reactance. Since the grid-and-cathode circuit is in parallel (or shunt) with the signal input, a good deal of the signal is lost through this path. For intermediate frequencies the response is fairly uniform.

Resistance-coupled audio-frequency amplification has the advantage of low cost and relative freedom from distortion. Its chief disadvantage is that a high B voltage is needed to overcome the high resistance of the plate resistor.

#### 456. Impedance Coupling

The *impedance-coupled* audio-frequency amplifier is an attempt to overcome this disadvantage. A large inductance (called a *choke coil*) is used instead of the plate resistor. This coil gives the high impedance load needed by the voltage amplifier and at the same time the low direct-current resistance needed to place a large positive charge on the plate.

The rest of the circuit is similar to that of the resistance-coupled amplifier. The frequency response, too, is similar to that of the resistance-coupled amplifier, though using an inductor instead of a resistor introduces a slightly greater distortion of the signal.

#### 457. Coupling by a Transformer

The *transformer-coupled* audio-frequency amplifier has been discussed (Chap. 17, Vol. I). Amplification falls off at low frequencies because the impedance of the primary (the load) decreases with the frequency. The low grid-cathode capacitive reactance causes a falling off of amplification at the high frequencies.

#### 458. Inverse Feedback

In Chap. 16, Vol. I, we saw how some of the output voltage was fed back to the input circuit of the tube to be reamplified and thus

give us a greater output. We called this *regenerative feedback*. Now it is possible to feed this voltage back in such a way that it does not aid but tends to cancel the signal input. The feedback is then out of step ( $180^\circ$  out of phase) with the incoming signal. We call this *degenerative* or *inverse feedback* (also known as *negative feedback*). Such feedback is of no value to us in the regenerative detector, but it is frequently used in audio-frequency amplifiers to reduce distortion. Figure 430 shows such a circuit.

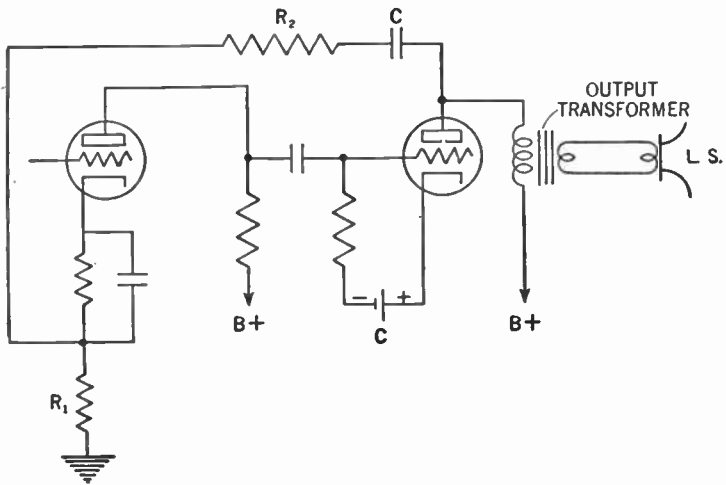

**Figure 430. Circuit showing inverse feedback in the audio-frequency amplifier. The values of  $R_1$  and  $R_2$  determine the amount of feedback.**

You will notice that this is the circuit for an ordinary resistance-coupled audio-frequency amplifier. The inverse feedback is obtained from the plate of the last tube and is fed back to the cathode of the first tube through a network consisting of the coupling condenser ( $C$ ) and two resistors ( $R_1$  and  $R_2$ ). The values of these resistors determine how much of the output signal voltage is fed back.

If distortion is present owing to the presence of unwanted frequencies in the output, the inverse feedback tends to repress these unwanted frequencies in the input signal and thus they are not present (at least in so great a degree as otherwise) in the final output signal. Again, if distortion is present owing to the fact that the amplifier had amplified some frequencies more than others, the inverse feedback represses to a greater degree, in the

input signal, those frequencies that were overamplified. Thus the final output signal shows a more even frequency range.

Of course, the effect of inverse feedback is to reduce the overall amplification, but modern high-mu tubes can compensate for this defect.

#### 459. The Radio-frequency Amplifier

The *audio-frequency* amplifier differs from the *radio-frequency* amplifier in a number of ways. First of all, the range of frequencies that must be covered by the audio-frequency amplifier lies between about 30 and 15,000 cycles per second. The radio-frequency amplifier amplifies signals whose frequencies may lie between 15 kc. and upward of 300 mc. per second.

But whereas the audio-frequency amplifier must handle its full frequency range at one time, the radio-frequency amplifier is called upon to handle only one frequency at a time (or at most, a very narrow band of frequencies). For this reason we deal with nonresonant or untuned circuits when we consider the audio-frequency amplifier, whereas we deal with resonant or tuned circuits when we consider the radio-frequency amplifier (see Chapters 23 and 26 in Volume I).

#### 460. Harmonics Do Not Distort in Radio-frequency Amplifiers

Another difference is that the chief bugaboo of the audio-frequency amplifier is harmonic frequency distortion. Because of this we can operate a single tube only in class A. Tubes must be operated in push-pull for class AB and class B. In the case of the radio-frequency amplifier, however, harmonic distortion has very little effect because of the filter action of the tuned circuit. The second harmonic of a 500-kc. signal, for example, is 1,000 kc. It would have to be a poorly tuned circuit, indeed, to pass both the fundamental (500 kc.) and the second harmonic (1,000 kc.).

#### 461. "Flywheel" Effect

There is still another difference. In the case of the audio-frequency amplifier, the *whole* input signal must be faithfully reproduced in amplified form. This requirement means that the tube must amplify the whole input signal curve or else two tubes must be used in push-pull, each tube operating on half the curve, both halves being added together in the output transformer.

In the case of the radio-frequency amplifier, we have the cur-

rent oscillating in the tuned circuit. It is not necessary that power be supplied to this oscillating current during its complete cycle of oscillation. It is enough that a short pulse, in step with the oscillation of course, be given to the oscillating current. The effect is the same as if you push a child in a swing. You do not have to push during the whole swing. It is enough to give a slight push during a small portion of the swing to keep the child going. This effect is known as the *flywheel effect*.

Thus we need not have plate current flowing during the whole cycle. All we need are short pulses of plate current in resonance with the oscillations of the tuned circuit (see Figure 431). This is

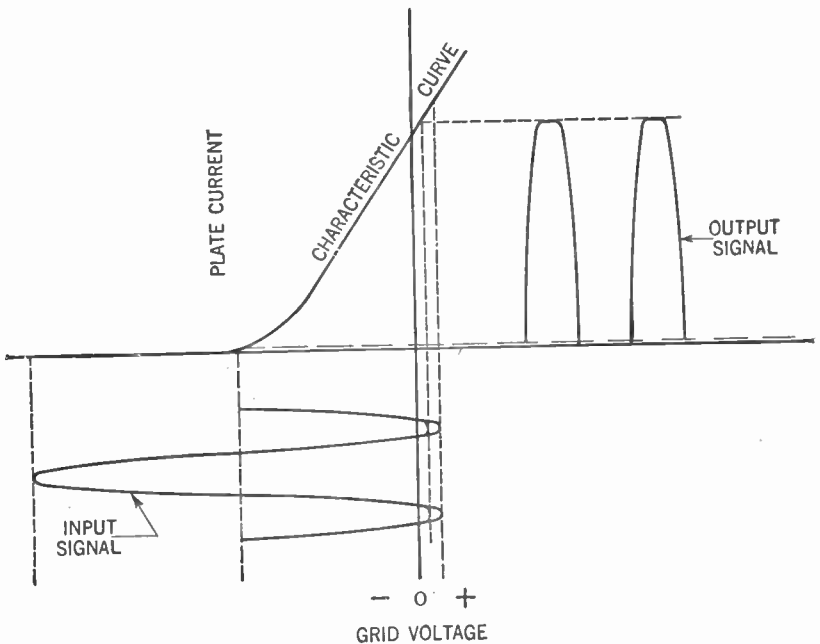

**Figure 431** Distortion of the output signal in a class B amplifier. While this distortion would prevent us from using a single tube in class B as an audio-frequency amplifier, we can do so in the radio-frequency amplifier because of the "flywheel" effect.

another reason why a single tube can be operated as a radio-frequency amplifier of any class.

#### 462. The Class C Amplifier

We have classified our amplifiers by the amount of grid bias placed on the tube. This amount in turn determined the portion



of the characteristic curve upon which the tube operated. Accordingly, there is still another class of amplifier to be considered.

According to standards set by the Institute of Radio Engineers, a *class C amplifier* is an amplifier in which the grid bias is appreciably greater than the cutoff value, so that the plate current in each tube is zero when no alternating grid voltage is applied, and so that plate current in a specific tube flows for appreciably less than half of each cycle when an alternating grid voltage is applied. Figure 432 shows this graphically.

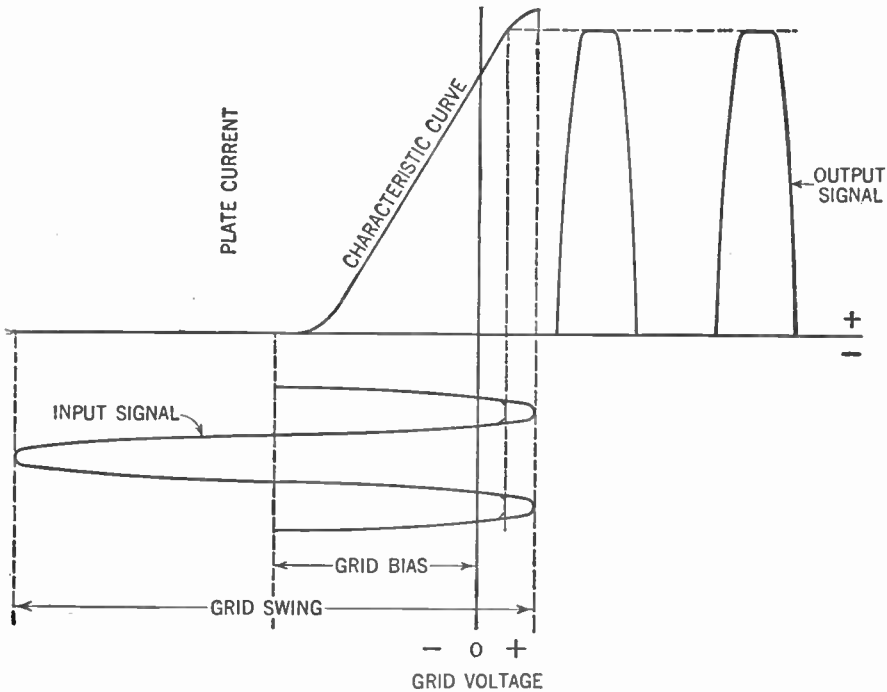

Figure 432. Graph showing relationship between the input and output signals in a class C amplifier.

Here you see why class C amplification is not suitable for audio-frequency work. Not even the push-pull hookup can overcome the distortion, because the output-signal curve represents less than half the input-signal wave form. But in the radio-frequency amplifier the "flywheel" effect of the tuned circuit supplies the missing portions of the cycle. The high efficiency and high power output ( $e_o$  is very large) of this class of amplifier make it suitable for certain types of radio transmitters.

The grid swing is great enough to drive the grid to such a positive condition that the saturation point of the characteristic curve is reached. The plate current then is limited by this point. But the saturation point is controlled by the emission of electrons from the cathode and the plate voltage applied to the tube. Modern transmitting tubes are constructed to supply adequate electronic emission. We may therefore use extremely high plate voltages and the plate current will be proportional to the plate voltage.

#### 463. The Radio-frequency Amplifier in the Receiver

In the receiver, radio-frequency amplifiers are employed to produce the tremendous voltage amplification needed to transform the minute voltages induced in the aerial-ground system by the passing radio wave into signals of sufficient strength to pass through the detector and audio-frequency stages of the system. Thus the radio-frequency amplifier in the receiver is a *voltage amplifier*.

If we examine the circuit of a stage of radio-frequency amplification (Figure 433), we notice that the resistance between the grid and cathode of the tube is in parallel (or shunt) with the tuned circuit which feeds into the input of the tube.

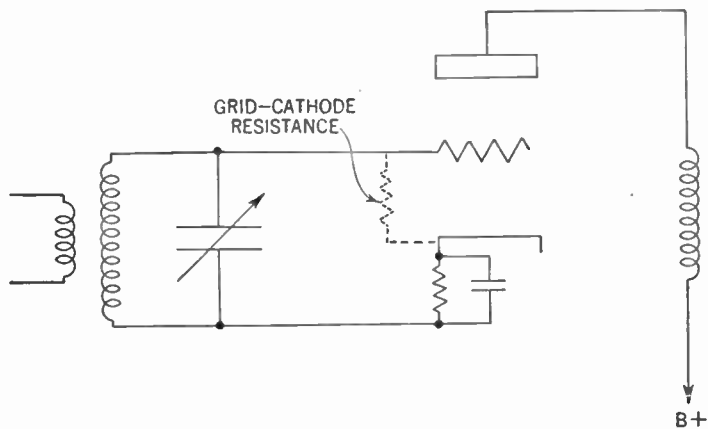

Figure 433. Diagram showing that the grid-cathode resistance of the tube is in parallel with the tuned circuit.

In our study of resonant circuits (Chapter 34), we saw that the effect of a resistance across such a circuit is to destroy the *selectivity* of the tuned circuit. We may consider a tube that draws grid current as equivalent to a resistor across the input

circuit: the higher the current, the lower the resistance. If the grid draws no current the tube then presents an infinite input resistance. Since this condition is desirable, we must operate our tube so that the grid draws no current, namely, in class A operation.

#### 464. The Radio-frequency Amplifier in the Transmitter

Because efficiency and large power output are desirable in radio transmitters, class B and C amplifiers are usually employed. Harmonic distortions are filtered out by the tuned circuits and the flywheel effect of the oscillating currents supplies the portions of the cycle that are missing as the result of the large grid bias used in class C.

The radio-frequency amplifier may consist of a single-tube stage (called a single-ended stage) or may consist of stages where the tubes are connected in parallel or push-pull for greater power output. As we have seen, the single-tube stage is not confined to class A operation, as in the case of the audio-frequency amplifier, but may be operated in any class.

When the tube is operated as a class B amplifier, the signal-voltage swing is such that during the positive half of the swing (the time during which plate current flows) the tube operates over the whole linear section of the characteristic curve (see Figure 422). For this reason the class B amplifier is often called a *linear amplifier*. The output current is proportional to the input voltage.

The final stage of the transmitter is called upon to deliver power to the antenna. Thus this stage is always a *power* stage. Since this final stage is a class B or C amplifier, there is a loss of power due to the grid being driven positive with the accompanying flow of grid current. This power loss must be made up in the intermediate or driver stages. For this reason the driver stages, too, are usually operated as *power* amplifiers.

#### 465. Grid Bias for the Radio-frequency Amplifier

Grid-bias voltage for the radio-frequency amplifiers used in radio receivers is usually obtained by means of the *cathode-resistor bias* method (Figure 424), described in Chapter 20, Vol. I.

In the transmitter, a favorite method for obtaining the grid-bias voltage is the *grid leak-condenser* method (Fig. 434-A), described in Chap. 15, Vol. I. This method is used only for class B or C

amplifiers, that is, only where there is a flow of grid current owing to the fact that the grid has been driven positive. Current flowing through the resistor  $R$  causes a voltage drop, and it is this that biases the grid of the tube. Condenser  $C$  acts as a blocking condenser to keep the bias on the grid of the tube. Figure 434-A shows the *series* arrangement of such a system.

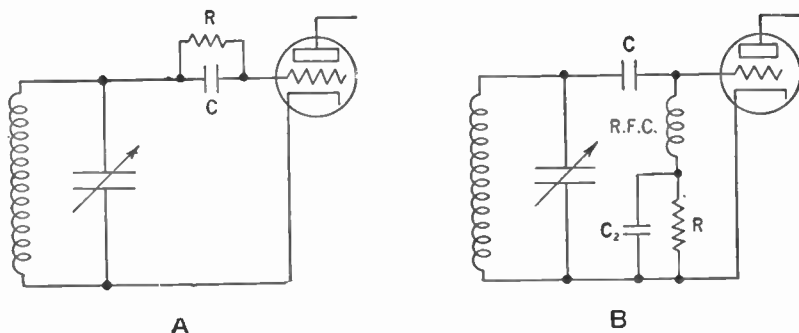

**Figure 434.** Methods of obtaining grid bias by the voltage drop across a resistor.  
**A**—Series method.  
**B**—Shunt or parallel method.

In Figure 434-B is shown the *parallel* arrangement of such a system. Current flowing through  $R$  creates the voltage drop that places the bias on the grid of the tube. Condenser  $C$  is a blocking condenser. The radio-frequency choke coil (R.F.C.) and the condenser ( $C_2$ ) connected across the grid-leak resistor ( $R$ ) are used to filter out variations of voltage and thus a steady bias voltage is applied to the grid.

This grid leak-condenser method for obtaining grid bias suffers from one serious drawback. The bias voltage is obtained only when there is a flow of grid current. When the grid current flow stops the grid bias of the tube is reduced to zero. An examination of Figure 432 shows what happens to the plate current when the grid bias becomes zero. The plate current shoots right up and may reach a very high value. This in turn causes the plate to be bombarded heavily by the electron stream from the cathode. If this condition continues for any considerable period of time the plate turns red hot and may even burn up.

Because of this danger, transmitters (especially high-power ones) often use *batteries* or a separate *rectifier and filter system* to supply the necessary grid-bias voltage to the tubes. This plan

has the advantage that a steady bias voltage is delivered under all conditions of operation and thus the danger of too great a plate current is removed. Many transmitters use both batteries and the grid-leak method. The batteries furnish an irreducible minimum of bias voltage, thus insuring the safety of the tubes. The grid-leak supplies the voltage needed in excess of this minimum amount.

**466. Coupling Radio-frequency Amplifiers**

As in the case of audio-frequency amplifiers, radio-frequency amplifiers may be resistance-coupled, impedance-coupled, and transformer coupled. The fact that we are able to use tuned circuits in the radio-frequency amplifiers, however, is a distinct advantage and we accordingly modify our circuits to this end. Figure 435 shows a typical stage of resistance-coupled audio-frequency amplification. Condenser *C* is the blocking condenser which prevents

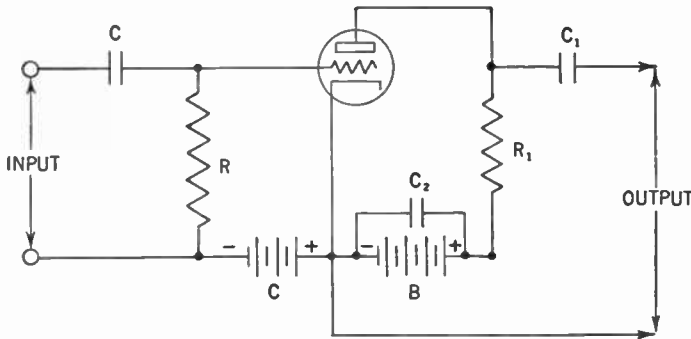

**Figure 435. A stage of resistance-coupled audio-frequency amplification.**

direct-current plate voltage from the previous stage from flowing onto the grid. *R* prevents the input signal from being shorted through the bias supply. *R*<sub>1</sub> is the load resistor and *C*<sub>1</sub> is the coupling condenser which passes on the alternating-current signal voltage, but keeps the direct-current plate voltage off the grid of the following tube. *C*<sub>2</sub> is a by-pass condenser.

Figure 436 shows changes made to operate the amplifier as a radio-frequency amplifier using tuned circuits. (It should be noted that the stage of amplification shown in Figure 435 could be operated as a radio-frequency amplifier as well as an audio-frequency amplifier). In place of *R* a radio-frequency choke coil

(R.F.C.) has been inserted. At high frequencies the impedance of this choke coil becomes quite high. In place of the load resistor ( $R_1$ ) a *parallel-resonant tuned circuit* (often called a *tank*) is inserted. From our studies of resonant circuits (Chapter 34) we

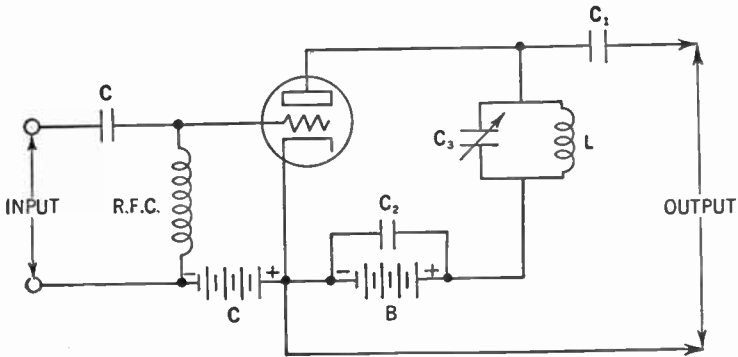

Figure 436. A stage of radio-frequency amplification. Note the resemblance to the audio-frequency stage in Figure 435.

learned that the impedance of such a resonant circuit is very high. By matching the impedance of the tank circuit to the plate resistance ( $R_p$ ) of the tube, we are able to get the maximum power output. But if any unwanted frequencies come through, the impedance of the tank circuit falls off rapidly and the power output at these unwanted frequencies dies down. Thus harmonic distortion is eliminated.

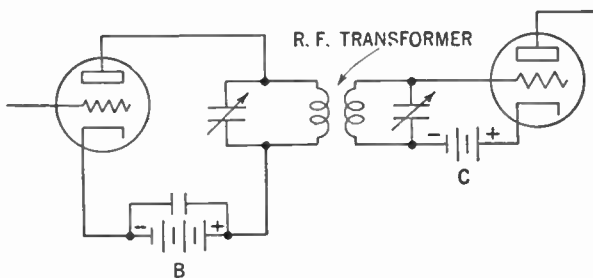

Figure 437. Circuit of a transformer-coupled radio-frequency amplifier.

Transformer coupling may also be employed, using tuned circuits for the primary and secondary of the transformer. Transformers for radio-frequency currents are usually made with cores of air to avoid large losses of electrical power because of hysteresis and eddy currents (see Chapter 32). In the receiver, it should be

noted, successful use has been made of a radio-frequency transformer having a core of finely divided iron powder.

Figure 437 shows the circuit for a transformer-coupled radio-frequency amplifier. The tank circuit comprising the primary of the radio-frequency transformer is a *parallel-resonant* circuit providing the high impedance needed for the load for the first tube. The tuned circuit comprising the secondary of the transformer is a *series-resonant* circuit (see Chapter 34). The impedance of such a circuit is very low and thus very little of the signal voltage is lost.

Other methods of coupling, variations of the above two, will be discussed when we consider the radio transmitter.

### 467. Neutralization

Studying the radio-frequency amplifier for the receiver (Chap. 23, Vol. I), we saw how *neutralization* was needed to overcome undesired feedback arising out of the interelectrode capacitance between the grid and plate of the triode. The capacitance between the grid and plate of the tube sets up a voltage which feeds back some of the electrical energy from the plate to the grid, setting up oscillations and other disturbances. If we send into the grid a voltage that is equal and opposite in direction or phase ( $180^\circ$  out of phase) to the voltage set up by the interelectrode capaci-

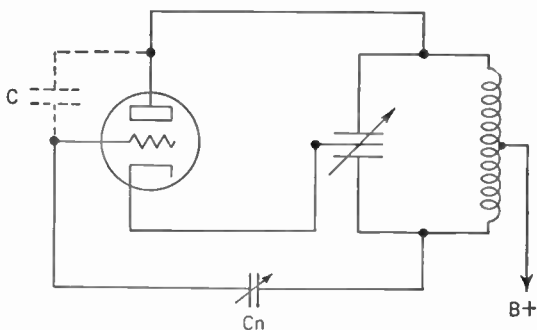

Figure 438. Circuit of a radio-frequency amplifier showing the neutralizing condenser ( $C_n$ ). This is an example of plate neutralization.

tance, the two voltages cancel each other out and no feedback results. This suppression illustrates the principle of *neutralization*.

Figure 438 shows how it is accomplished.

Note that the variable condenser in the tank circuit has a

peculiar form. In reality it is two variable condensers in series with their center going to the cathode of the tube. Note also that the B+ goes to the center tap of the coil. The net effect of this hookup is to produce a condition similar to that which exists across the center-tapped primary of the output transformer of a push-pull audio-frequency stage of amplification (Fig. 169, Vol. I). The voltages at both ends of the tank coil are opposite in direction ( $180^\circ$  out of phase).

If some of the voltage from the bottom end of the coil is fed through a small variable condenser ( $C_n$ ), called a *neutralizing condenser*, on to the grid of the tube, neutralization is achieved. The neutralizing condenser controls the amount of voltage so fed to insure that it is just enough to neutralize that arising from the capacitance of the electrodes. Since this neutralizing voltage comes from the plate circuit, this method is called *plate neutralization*.

Neutralizing voltage may also be drawn from the grid circuit and deposited on the plate. Such a method is shown in Figure 439. This method is called *grid neutralization* and operates the same as plate neutralization.

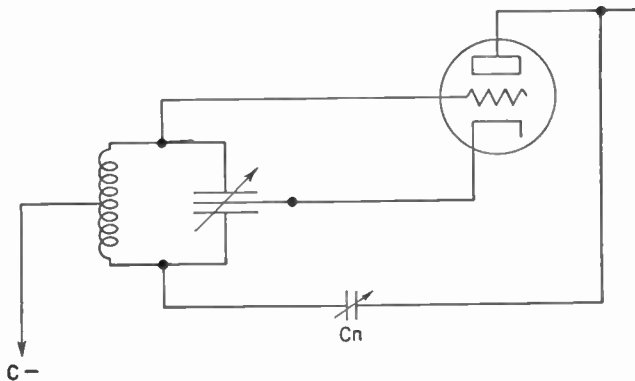

Figure 439. Circuit showing grid neutralization.

There is another method which is called *direct plate-to-grid neutralization*. Here use is made of the fact that the voltage drop across an inductance is  $180^\circ$  out of phase with the drop across a condenser in that same circuit (see Par. 370). If an inductance ( $L$ ) is placed across the plate and grid of the tube, the voltage drop across it will be exactly *opposite* to the voltage drop across the grid



and plate of the tube. This is so because of the condenser effect of plate and grid. If the inductance is carefully chosen, the voltage drop across it will also be *equal* to the voltage drop across the grid and plate. Thus the two voltages will cancel each other out and no feedback will result (Figure 440).

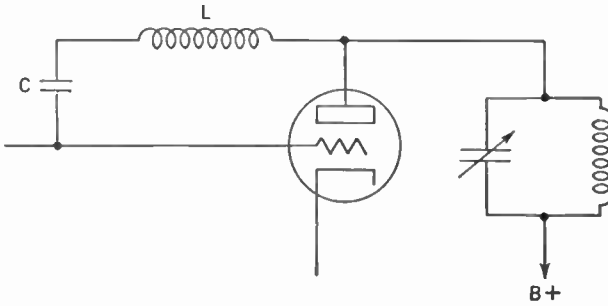

Figure 440. Circuit using direct plate-to-grid neutralization.

The condenser (C) in series with the inductance (L) is used to keep the B+ off the grid of the tube.

In modern practice, however, as you already know, radio-frequency amplifiers using screen-grid tubes do not have to be neutralized. At radio frequencies the grid-to-plate capacitance of the screen-grid tube is negligible.

SUMMARY

1. Vacuum-tube amplifiers may be classified under two headings: (1) audio-frequency and (2) radio-frequency.
2. Another classification is based on their function: (a) voltage amplifiers magnify the input signal without regard to the power delivered; (b) power amplifiers deliver a large amount of power to a load—usually loudspeakers or aerials.
3. Audio-frequencies lie between 30 and 15,000 cycles while radio frequencies range from 15 kc. to 300 mc.
4. Amplifying tubes are classified by the Institute of Radio Engineers as A, AB, B, and C, according to the operating conditions for which they are adapted.
5. Briefly, these types are defined in terms of grid bias, alternating grid voltages, and plate current as follows:

A class A amplifier is a tube in which some plate current flows at all times.

A class AB amplifier is a tube in which plate current flows

during less than the entire cycle but during more than half of it.

A **class B amplifier** is a tube such that plate current is approximately zero when no exciting grid voltage is applied; hence plate current flows only during half of each cycle.

A **class C amplifier** is one in which the grid bias is greater than the cutoff value, so that plate current is not only zero when no alternating grid voltage is applied, but also so that when an alternating grid voltage is applied, plate current flows for less than half of each cycle.

6. Class C amplifiers are used in certain types of transmitters but not in audio-frequency work.

7. The general principle of the rating and use of amplifying tubes is that of providing such a negative charge on the grid (that is, grid bias) that the current in the plate circuit may be controlled and directed for specific purposes.

8. The relation of grid bias to plate current is as follows: (1) The smaller the negative charge on the grid the more readily do electrons pass through to the plate. (2) The larger the negative charge, the less readily do electrons pass through to the plate. (3) When the grid bias is small, the alternating voltages from the signal impressed on the grid make it easy for electrons to flow during the positive half of the cycle and may even permit some current to flow during the negative half of the cycle.

9. In general, when using an amplifier as a *voltage* amplifier we should have the resistance of the load as high as feasible; when *power* amplification is desired the load resistance should be about twice the plate resistance ( $R_p$ ) of the tube.

#### GLOSSARY

**Audio-frequency Amplifier:** A tube amplifying frequencies from about 30 to 15,000 cycles per second.

**Class A Amplifier:** A tube amplifier so biased that plate current flows at all times during an input voltage.

**Class AB Amplifier:** A tube amplifier so biased that plate current flows for more than half but not all of the input voltage cycles.

**Class B Amplifier:** A tube amplifier so biased that plate current flows for only half of the input voltage cycle.

**Class C Amplifier:** A tube amplifier so biased that plate current flows for less than half of the input voltage cycle.

**Degenerative Feedback:** Feedback of energy from the plate circuit to the grid circuit in such phase relationship as to weaken the input signal.

**Delay Distortion:** Distortion due to transmission of different frequencies at different speeds resulting in phase shifting.

- Distortion:** Change of wave form in the output of a tube as compared with the input.
- Frequency Distortion:** Unequal amplification of different frequencies by a tube.
- Impedance Matching:** Adjusting load impedance to generator impedance to get maximum power output.
- Inverse Feedback:** Same as degenerative feedback.
- Negative Feedback:** Same as inverse feedback.
- Nonlinear Distortion:** Distortion due to tube operation on the bends of a characteristic curve.
- Overloading:** Allowing too large a signal voltage swing on the grid, resulting in distortion.
- Phase Distortion:** Same as delay distortion.
- Power Amplifier:** An amplifier designed primarily to get the maximum power output from a tube.
- Radio-frequency Amplifier:** An amplifier designed to amplify frequencies above 15,000 cycles per second.
- Second Harmonic:** A frequency twice the fundamental frequency.
- Third Harmonic:** A frequency three times the fundamental frequency.
- Voltage Amplifier:** An amplifier designed primarily to get a maximum voltage amplification from voltage on grid to voltage across plate load.

#### QUESTIONS AND PROBLEMS

1. What are the two broad categories of tube amplifiers? Explain each.
2. What two functions might a tube amplifier serve at audio frequencies?
3. Driver stages are usually amplifiers of what type? What type of tube amplifier do they usually feed into?
4. What types of amplifiers are the radio-frequency stages of a tuned radio-frequency receiver?
5. Why are audio amplifier stages coupled together with nonresonant circuits?
6. Differentiate by diagram between a class A, a class AB, and a class B audio amplifier.
7. List and describe the different forms of tube amplifier distortion.
8. What distortion results when grid bias is too low?
9. What type of distortion is remedied by use of a push-pull amplifier? How is this accomplished?
10. What distortion effect results from overloading an amplifier?
11. What distortion effect results from using too low a plate resistor?
12. Describe the characteristics of a class A amplifier.
13. Describe the characteristics of a class AB amplifier.
14. Differentiate between a class AB<sub>1</sub> and a class AB<sub>2</sub> amplifier.
15. Describe the characteristics of a class B amplifier.
16. How is the distortion resulting from flow of grid current overcome in the class AB<sub>2</sub> amplifier? In the class B amplifier?

17. What practical methods are used to obtain grid bias?
18. What determines whether a tube will operate as a class A, AB<sub>1</sub>, AB<sub>2</sub>, or B amplifier?
19. Complete the following statements: The higher the load resistance of a tube amplifier, the greater the \_\_\_\_\_ of the tube. The greatest power transfer from a tube to a load occurs when \_\_\_\_\_.
20. To obtain less than five per cent second-harmonic distortion with maximum undistorted power output, how large must the plate resistance be as compared with the load impedance?
21. From the point of view of maximum undistorted power output, what is the function of an output transformer?
22. List and describe three methods of coupling circuits. Give the advantages and disadvantages of each method.
23. Explain the operation and purpose of a degenerative amplifier.
24. Differentiate a radio-frequency amplifier from an audio-frequency amplifier from the point of view of function.
25. Why are resonant circuits used with radio-frequency amplifiers?
26. Why is harmonic distortion a negligible problem with radio-frequency amplifiers?
27. What are the characteristics of a class C amplifier and where is it used?
28. A radio-frequency amplifier whose grid draws current corresponds to what condition in a radio receiver?
29. What class of amplifiers are usually used in radio-frequency stages of amplifiers?
30. Why are driver stages in a transmitter coupled to the final power stage? Why power amplifiers?
31. What danger is met in using grid leak and condenser grid bias in a transmitter?
32. In place of a load resistor, what might be used in the plate circuits of radio-frequency stages in a transmitter?
33. What is the purpose of neutralization of a triode radio-frequency amplifier?
34. List and describe the methods of neutralization of a triode radio-frequency amplifier.

## CHAPTER 39

# Vacuum-tube Oscillators

---

**Problem:** *How are triode vacuum tubes made to serve as oscillators in transmitters?*

---

### 468. Why Is an Oscillator Important?

In addition to serving as rectifiers, detectors and amplifiers, vacuum tubes may serve as *oscillators*. As such they set flowing an alternating current of radio frequency and of equal amplitude for each cycle. We call this type of current a *continuous radio-frequency* or *carrier* current. It is this current which when amplified and *modulated* by voice currents originating in the microphone forms the *modulated radio-frequency current*. This current in turn produces the *modulated radio wave* that is radiated by the transmitting antenna and received in the receiving set (Chap. 9, Vol. I). In short, vacuum tubes, when supplied with power and when connected in properly tuned circuits, become the transmitters for modern radio broadcasting.

### 469. Oscillators in the Superheterodyne and Regenerative Receiver

We made the acquaintance of the vacuum-tube oscillator in our discussion of the superheterodyne receiver (Chap. 26, Vol. I). Here it was used to generate the continuous radio-frequency current which was used to beat against the incoming signal to produce the intermediate beat-frequency current which was fed into the intermediate-frequency amplifiers.

Before we studied the superheterodyne receiver we met the vacuum-tube oscillator (in a somewhat disguised form) as the regenerative detector (Chap. 16, Vol. I). Here plate current was fed back to the tuning circuit, by means of a tickler coil, to be re-amplified and thus to produce a louder signal. You will recall that

unless this feedback was carefully controlled, the tube would start to *oscillate* and transmit a signal that could be received over a distance of several blocks.

#### 470. The Simple Oscillator Circuit

In its essence, the oscillator consists of a coil and condenser hooked together (Figure 441). Assume that the condenser is



Figure 441. A simple oscillatory circuit.

charged. Electrical energy is contained in the *dielectric* or *electrostatic* field of the condenser. The condenser starts to discharge. Electrons flowing through the coil set up a *magnetic* field. The energy of the dielectric field is then converted into the energy of the magnetic field. The current continues flowing and the energy of the magnetic field is changed into dielectric-field energy as the condenser is charged again, this time in the opposite direction.

The back and forth swings of the electrons (called oscillations) continue at an extremely rapid rate and, were it not for the presence of resistance in the circuit, these oscillations would continue indefinitely. Thus an alternating current of extremely high frequency circulates through the circuit and this frequency is determined by the value of the inductance and capacitance. As we have seen:

$$f = \frac{1}{2\pi\sqrt{L \times C}}$$

$f$  signifies frequency. The frequencies considered here are *radio frequencies* (15 kc. to 300 mc. and more per second). We can vary the frequency of this alternating current by changing the values of  $L$  or  $C$ . In practice we usually use a variable condenser to give us our frequency changes.

471. Using the Oscillator

The next step is to amplify this alternating current. A class C amplifier (see Paragraph 462) is hooked across the condenser (Figure 442).

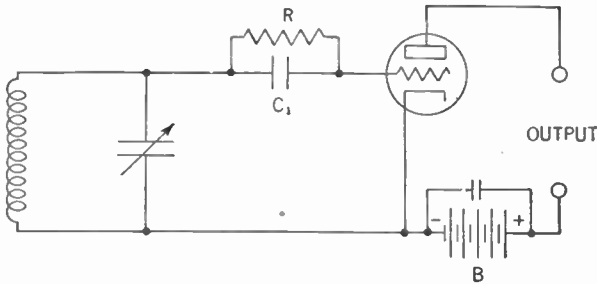

Figure 442. A class C amplifier is hooked across the simple oscillatory circuit.

The oscillating radio-frequency current in the coil-condenser circuit (called the *tank*) causes a radio-frequency voltage (the *signal* or *excitation* voltage) to be placed across the input of the tube. Grid bias is furnished by the voltage drop across the grid leak (*R*). As a result, the signal, in greatly amplified form, appears at the output of the tube (see Chapter 38).

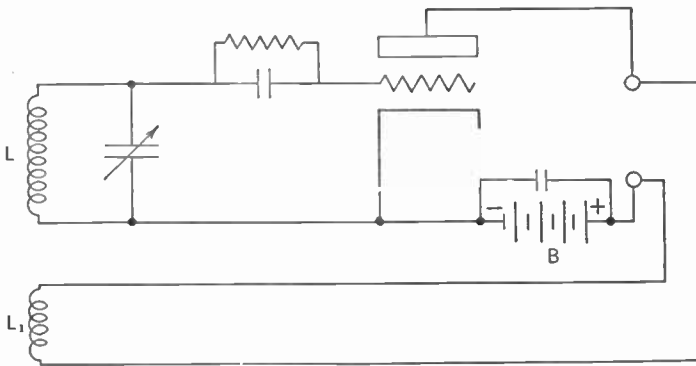

Figure 443. The output is fed back into the oscillatory circuit by means of an inductor (*L<sub>1</sub>*).

A question now arises. Since some resistance is always present in every circuit, and since energy is dissipated in overcoming this resistance, what keeps the oscillations going? The answer to our question is *feedback*. You will recall that in the case of the regen-

erative detector (Chap. 16, Vol. I) some of the plate current was fed back to the tuning circuit by mutual inductance. The same principle is used here (Figure 443).

Coil  $L_1$  corresponds to the tickler coil of the regenerative detector feeding back energy from the output, which overcomes the effect of resistance and keeps the oscillations going. Since this is a class C amplifier, plate current flows only during a small portion of the cycle. But it is not necessary that energy be fed into the tank during the *complete* cycle of oscillation. It is enough that *short pulses*, in step with the oscillations, be fed in. (See "*fly-wheel*" effect, Paragraph 461.)

Merely setting a current oscillating in the tank circuit does not make a transmitter. The signal so set up must be passed on, amplified, and ultimately radiated out as a radio wave. In other words, the oscillator must be coupled to the rest of the transmitter. We will discuss this matter of transmitters later in Chapters 40 and 41. But keep in mind that electrical energy will be drained off the oscillator for this purpose. Because of this drain, feedback from the plate must not only provide for losses resulting from resistance, but also for power handed on by the oscillator to the rest of the transmitter.

The next question that arises is, what makes the oscillator *self-starting*? In the case of the regenerative detector, the incoming signal started a current flowing in the tuning circuit. But there is no incoming signal here. The *grid-leak bias* does the trick for us. Since, at the start, there is no grid current flowing, the voltage drop across the grid leak is zero. Hence the grid bias, also, is zero. If you examine the characteristic curve for the Class C amplifier (Figure 432) you will notice that when grid bias goes to zero, the plate current becomes quite great. This current, flowing through the feedback coil ( $L_1$ ) of Figure 443, induces a current in the tank circuit which starts the oscillations. Once started, these oscillations are kept going as we have seen above.

Another question is, what makes the peak amplitude of each cycle of this oscillating current equal to its neighbor? Well, let us see what happens if the amplitude of the radio-frequency current oscillating in the tank circuits starts to die down. Look at Figure 444 (page 579). The signal voltage across the input of the tube starts to drop and the grid bias (because of the voltage drop across the grid leak  $R$ ) also goes down. But as the grid bias ap-



proaches zero, the plate current goes up. Thus more current is fed back to the tank through coil  $L_1$  and the radio-frequency current rises back to its normal level.

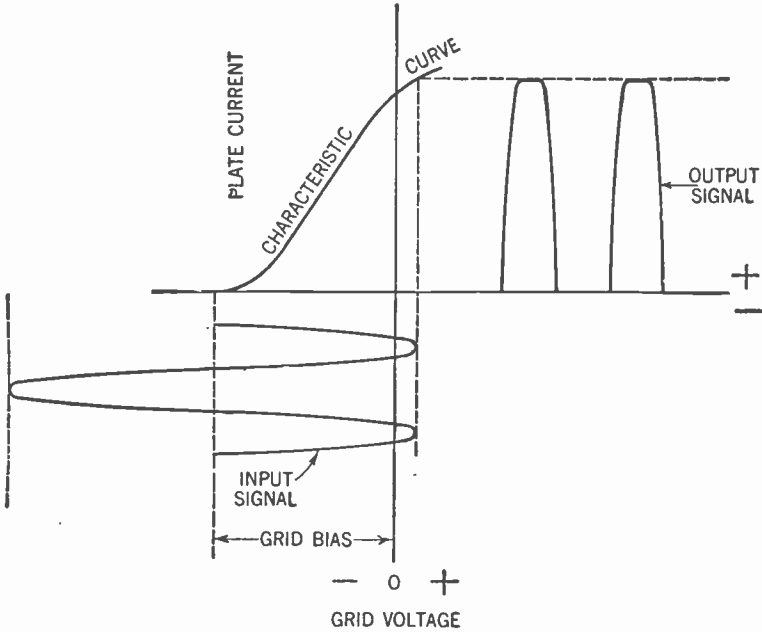

Figure 444. Graph showing how plate current goes up as the grid bias approaches zero.

The amplitude of the radio-frequency current cannot go up because the plate current in the output is limited as shown by the top bend of the curve in Figure 444. Since the feedback depends upon the plate current, the feedback, too, is limited, as shown by the same bend of the curve. So, if the radio-frequency current in the tank circuit rises, its losses rise, too, but the feedback cannot go beyond its maximum value. The mounting losses quickly reduce the radio-frequency current to its original value.

You can see now why the amplitudes of the peaks of the radio-frequency current oscillating in the tank circuit are all of the same value.

We have stated that the frequency of this oscillating radio-frequency current depends upon the values of inductance ( $L$ ) and capacitance ( $C$ ) in the tank circuit and is determined by the following formula:

$$f = \frac{1}{2\pi \sqrt{L \times C}}$$

Actually, this formula is not strictly true. If we consider the plate resistance of the tube ( $R_p$ ) and the resistance ( $R$ ) of the tank circuit, including the resistance introduced into the tank circuit when it is coupled to a load, the formula for frequency becomes:

$$f = \frac{1}{2\pi} \sqrt{\frac{1 + \frac{R}{R_p}}{L \times C}}$$

$\frac{R}{R_p}$  values are very small, usually much less than unity; nevertheless, in the interest of frequency stability, we should seek to keep the value of  $R$  as low as possible. Quite obviously, the load should be kept as low as possible. For this reason the oscillator should not be coupled directly to a radiating system such as an antenna.

For a particular frequency (which fixes the product of  $L \times C$ ) and for a given  $Q$  (Paragraph 382), the value of  $R$  can be reduced and stability thus increased by using a low  $L$  (that is, a low  $L$ -to- $C$  ratio). The smaller the inductance, the smaller the dimensions of the coil, and the lower the inherent resistance.

#### 472. Types of Oscillator Circuits

Although vacuum-tube oscillators may take many forms, they fall into two general types depending upon how feedback is accomplished. One type depends upon the inductive coupling between

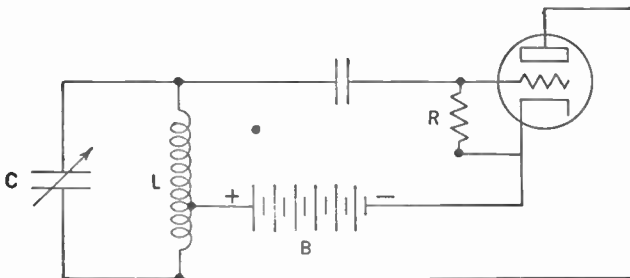

Figure 445. The Hartley oscillator.

two inductances to give us the required feedback. The simple oscillator shown in Figure 443 is of this type. A variation of this

simple oscillator that is in wide use is the *Hartley* oscillator shown in Figure 445.

The novelty of this circuit lies in the fact that coil  $L$  is, in reality, two coils in one. Thus the whole coil is the inductance of the tank circuit, while the bottom half of coil  $L$  may be considered as the feedback coil corresponding to coil  $L_1$  of Figure 443. The frequency of the oscillating current is determined by the values of  $L$  and  $C$ .

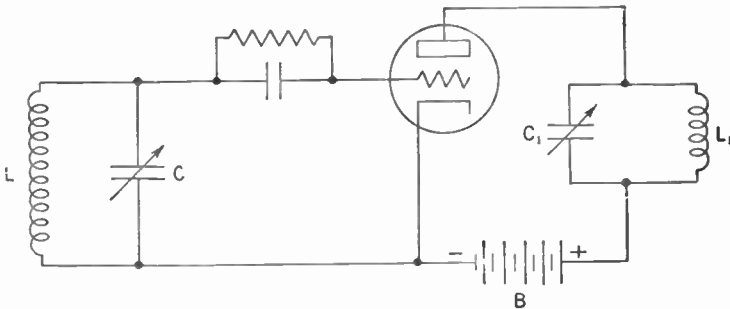

Figure 446. The tuned-grid tuned-plate oscillator.

The second type of oscillator depends upon the capacitance between the grid and plate of the tube to couple the feedback to the tank circuit. An example of this type is the *tuned-grid tuned-plate* oscillator shown in Figure 446.

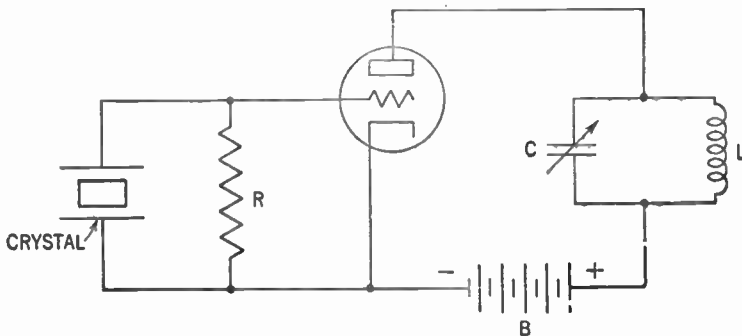

Figure 447. The crystal oscillator.

In this circuit, the frequency of the oscillating current is determined jointly by the  $L \times C$  of the grid circuit and the  $L_1 \times C_1$  of the plate circuit. Hence its name: *tuned-grid tuned-plate*. The plate circuit should be tuned to the same resonant frequency as the grid circuit and feedback is accomplished through the elec-

trodes of the tube. At high radio frequencies the grid-to-plate capacitance of the tube provides sufficient coupling, but at lower radio frequencies a small condenser may be needed across these two electrodes of the tube to provide the necessary feedback coupling.

The *crystal oscillator* shown in Figure 447 is a variation of the tuned-grid tuned-plate oscillator. Certain crystalline substances possess the property of converting electrical energy to mechanical energy and vice versa. We already have met such a crystal in the Rochelle-salt phonograph pickup (see Par. 115, Vol. I). The quartz crystal is another. If a mechanical stress is applied to the crystal, a dielectric field appears between its faces. Conversely, when a voltage is applied to electrodes on two parallel faces of the crystal, a mechanical strain occurs in the crystal. As you already know, we call this the *piezoelectric* effect.

Thus electrical energy applied to two parallel faces of the crystal produces a mechanical strain in the crystal. This strain in turn produces a dielectric field which in turn again produces a strain. This process goes on. At the natural period of the mechanical vibrations of the crystal, the two actions may be made mutually self-sustaining by feeding back a sufficient portion of electrical energy to replenish the energy which is lost as heat during each cycle.

The effect in the crystal circuit then is that we have an oscillating current whose frequency is determined by the natural frequency of the crystal. This frequency, in turn, is determined by the mechanical structure of the crystal. Quartz crystals can be cut whose natural frequency may be hundreds of thousands and even millions of cycles per second.

Since we may consider the quartz crystal as a tuned circuit, you can now see the resemblance between the crystal oscillator and the tuned-grid tuned-plate oscillator. Quartz-crystal oscillators are noteworthy for their remarkably steady frequency output.

#### SUMMARY

1. An **oscillator** is a device for setting electrons in a to-and-fro motion in a conductor.
2. Oscillations are started in a circuit by a strong plate current fed back to and setting up induced voltages in a **tank**, or tuned oscillator circuit.
3. Once started, oscillations of electrons would continue indefinitely except for resistance.

4. The supply of energy to keep the oscillations going is furnished by the feedback circuit.

5. A class C amplifier is used with this so-called tank, or oscillating circuit.

6. In all cases the frequency ( $f$ ) of the oscillating current depends upon the inductance ( $L$ ) and the capacitance ( $C$ ) of the tank circuit as expressed by the formula

$$f = \frac{1}{2\pi} \sqrt{\frac{1 + \frac{R}{R_p}}{L \times C}}$$

7. Three types of oscillator circuits are in practical use: (1) the **Hartley** oscillator, whose principle is that one tapped coil serves both as the inductance for the tank circuit and as a feedback coil from the plate circuit. (2) The **tuned-grid tuned-plate** oscillator. (3) The **quartz-crystal** oscillator, which depends on the piezoelectric effect.

#### GLOSSARY

**Carrier:** An alternating current of radio frequency and equal amplitude.

**Continuous Radio Frequency:** Same as the carrier.

**Feedback:** Coupling of energy from the plate circuit to the input or grid circuit of a tube.

**Hartley Oscillator:** An oscillator in which feedback is accomplished by mutual inductance.

**Oscillator:** A circuit used to generate alternating currents, usually of high frequency.

**Piezoelectric Effect:** The effect whereby certain crystals develop a voltage across their faces when mechanically stressed and become mechanically stressed when a voltage is placed across them.

**Tank:** An  $L \times C$  circuit, usually in the plate circuit of a tube.

**Tune-grid Tune-plate Oscillator:** An oscillator in which feedback is by plate-to-grid capacitance.

#### QUESTIONS AND PROBLEMS

1. Describe the behavior of a tube as an oscillator.
2. What is the function of a tube oscillator in the superheterodyne receiver?
3. How may a regenerative receiver be made to oscillate?
4. In essence, what is an oscillator? Why must energy be fed into it continually?
5. What is it that determines the oscillation frequency of a resonant circuit?
6. What function does feedback perform in an oscillator?
7. Explain how the simple regenerative oscillator is made self-starting and how oscillations of equal amplitude are maintained.

8. Why shouldn't an oscillator be coupled directly to a radiating system such as an antenna?
9. What condition varies in the different types of oscillators?
10. Draw a simple Hartley oscillator.
11. Describe the behavior of a tuned-grid tuned-plate oscillator and draw the diagram of one.
12. What is the principle of operation of a crystal oscillator?
13. Draw the circuit of a crystal oscillator.

## CHAPTER 40

# The Continuous-wave (C.W.) Transmitter

**Problem 1:** *How are telegraph code signals produced by radio transmitters?*

**Problem 2:** *What new principles are involved in continuous-wave transmitters?*

### RADIOTELEGRAPHY

#### 473. Kinds of Waves in Modern Transmitters

Modern radio transmitters radiate waves which may be of two general types. One type is the *continuous* or *unmodulated* radio wave whose wave form resembles the radio-frequency current oscillating in the tank of the oscillator discussed in Chapter 39. The peaks of all the cycles are even and there is nothing to distinguish one cycle from the next (see Figure 28, Vol. I).

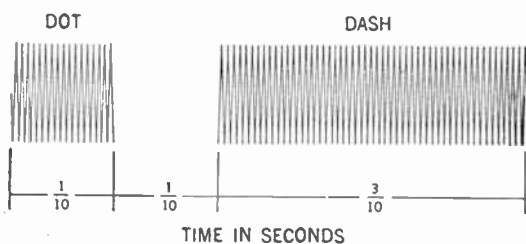

**Figure 448.** Diagram showing the relative duration of dots and dashes. The letter illustrated here is A (dot-spocce-dash or . —).

The other type of radio wave is the *modulated* wave. In this type the amplitudes of the peaks vary from cycle to cycle. Transmitters of the modulated radio wave will be discussed in the next chapter.

**474. The Dot-dash Signals**

The continuous radio wave is used only for *radiotelegraphy*, that is, for the transmission of short and long pulses or trains of waves to form the dots and dashes of a telegraphic code (see Appendix). As the operator presses the key down (closes the key) a train of these continuous waves radiates from the antenna. When the key is raised (opened) the train of waves ceases. By keeping the key closed for a shorter or longer period of time, a *dot* (short train) or *dash* (long train) is radiated out. Thus if it is desired to send the letter "A" (dot-space-dash or • —) the operator closes the key for a fraction of a second, opens it for the same length of time, and then closes it for a period three times as long as the first time (see Figure 448).

We should not forget that the frequency of the radio waves is *radio frequency*; the train forming the dot, although of  $\frac{1}{16}$ -second duration, may contain thousands or even millions of cycles.

**475. Why We Need an Amplifier**

We may, of course, connect the oscillator directly to the antenna and radiate the radio wave. This, however, is rarely done. First of all, since the radio-frequency currents in the oscillator are relatively weak, very little power can be delivered to the antenna and the radiated wave, therefore, would be quite weak. Furthermore, as we learned in Chapter 39, putting a heavy load on the oscillator varies the frequency to which it is tuned. The antenna is such a heavy load. For these two reasons, then, it becomes important to feed the oscillations into a radio-frequency amplifier before we send the signal into the antenna. As we have learned in Chapter 38, the radio-frequency amplifier usually employed in the transmitter is of class C.

**476. Methods of Coupling—Capacity Coupling**

There are a number of methods for coupling the oscillator to the radio-frequency amplifier. Simplest is the *direct* or *capacity-couple* method (Figure 449). The *signal* or *excitation* is fed from the tank circuit of the oscillator, through the coupling condenser (*C*), to the grid of the amplifier tube. The coupling condenser also serves to keep the direct current of the oscillator off the grid of the amplifier tube



Bias is supplied to the amplifier by means of the C battery feeding through the radio-frequency choke (R.F.C.). The purpose of the choke coil is to supply a high resistance to the radio-frequency excitation and thus to keep it from leaking off the grid of the tube. Condenser  $C_1$  across the B batteries is used to offer an easy path for the radio-frequency current, which can therefore avoid traveling through the B battery to the cathode in order to complete the plate circuit.

You will notice that the connection between the coupling condenser ( $C$ ) and the coil of the oscillator tank is an adjustable one.

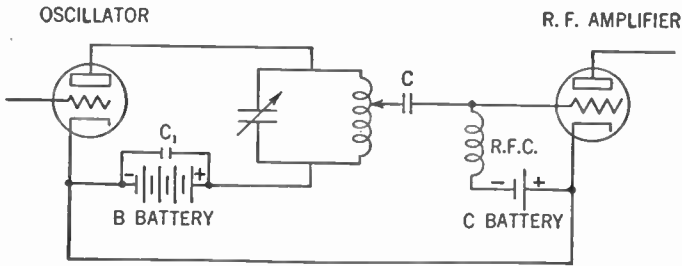

Figure 449. The direct or capacity method of coupling the oscillator to the radio-frequency amplifier.

By changing the point on the coil where contact is made, the amount of excitation fed into the grid of the amplifier tube may be varied. This variation controls the grid swing of the tube. The adjustment should be varied until maximum operation is achieved. (We shall see how to test for this maximum a little later.)

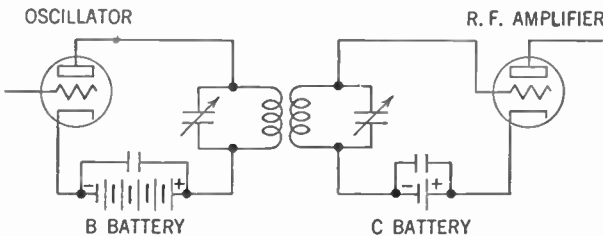

Figure 450. The inductive method of coupling the oscillator to the radio-frequency amplifier.

### 477. Inductive Coupling

Another method for coupling the oscillator to the radio-frequency amplifier is the *inductive method* (Figure 450). Both tank circuits are tuned to the same frequency. Coupling takes place

## 588 THE CONTINUOUS-WAVE (C.W.) TRANSMITTER

by mutual inductance. The coupling can be varied by moving the coils nearer together or further apart or by rotating one in relation to the other (Par. 98, Vol. I). The degree of coupling will help determine the amount of excitation fed into the amplifier.

The inductive method of coupling introduces a difficulty. The distributed capacitance of the coils may produce an unwanted cou-

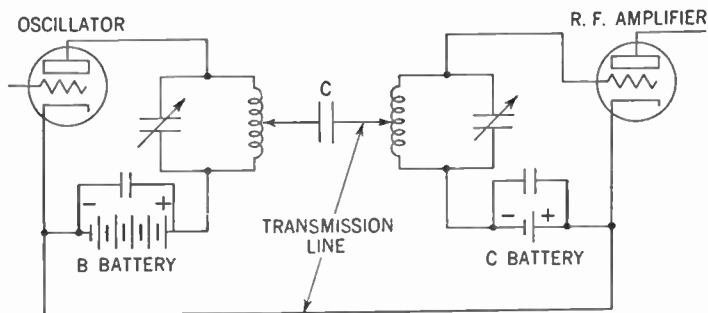

**Figure 451.** The matched-impedance transmission-line method of coupling.

pling effect upon each other. This undesirable feature may be reduced by placing the coils further apart, but doing this cuts down the efficiency of the transfer of excitation. However, by the use of *transmission lines* the two coils may be kept a considerable distance apart and yet be able to transfer the excitation from the oscillator to the radio-frequency amplifier. Figure 451 shows one type of such a transmission line.

The condenser (*C*) is for the purpose of keeping the B-battery current off the grid of the amplifier and not for coupling. The

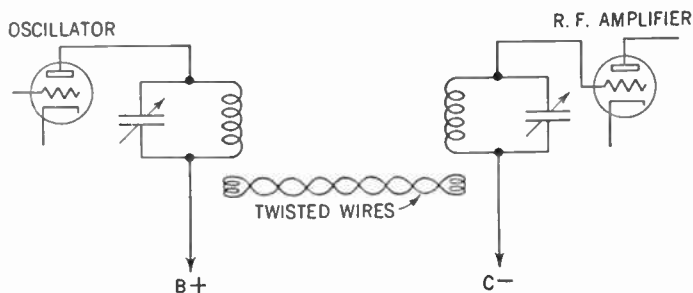

**Figure 452.** The link-coupled transmission line.

connection to each coil is adjustable and should be varied until the proper excitation is achieved. Care should also be taken to adjust these connections (or *taps*) so that the impedances at each

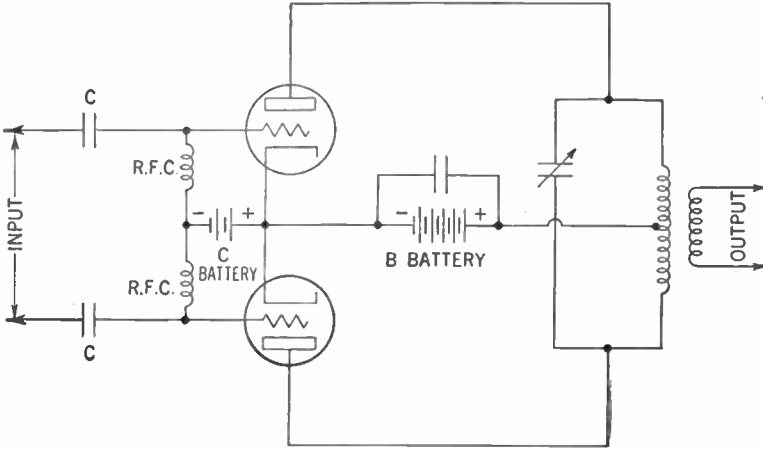

Figure 453. The push-pull radio-frequency amplifier.

end of the transmission line are equal for the maximum transfer of power (see Par. 452). This method is called *matched-impedance coupling*.

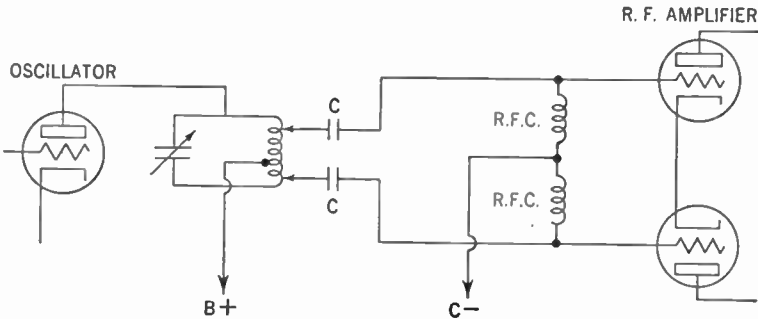

Figure 454. Direct or capacity coupling for the push-pull radio-frequency amplifier.

Another type of transmission line is shown in Figure 452. Here use is made of a link between the two tank circuits. This link consists of a twisted pair of wires with a loop or two at each end wound around the bottoms of the tank coils. Since the connecting wires are twisted, the magnetic fields around them cancel out and therefore do not interfere with the transmitter. The amount of

## 590 THE CONTINUOUS-WAVE (C.W.) TRANSMITTER

excitation fed into the amplifier may be varied by varying the number of loops at each end of the link and by varying the coupling between these loops and their respective tank coils. This type of coupling is called *link coupling*.

### 478. The Push-Pull Amplifier

As in the case of the audio-frequency amplifier, the radio-frequency amplifier may be operated in *push-pull* for greater power output. Figure 453 shows a typical circuit.

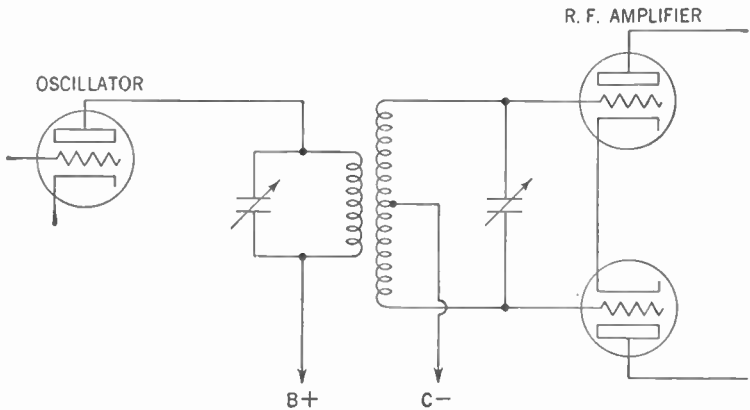

Figure 455. The inductive method of coupling a push-pull radio-frequency amplifier to the oscillator.

The push-pull amplifier may be coupled to the oscillator or driver amplifier in the same manner as the single-ended amplifier. Figure 454 shows the *direct* or *capacity-couple* method. Figure 455 shows the *inductive* method of coupling.

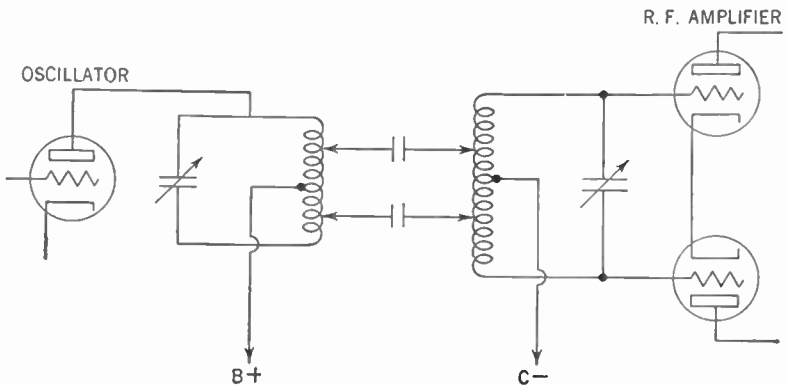
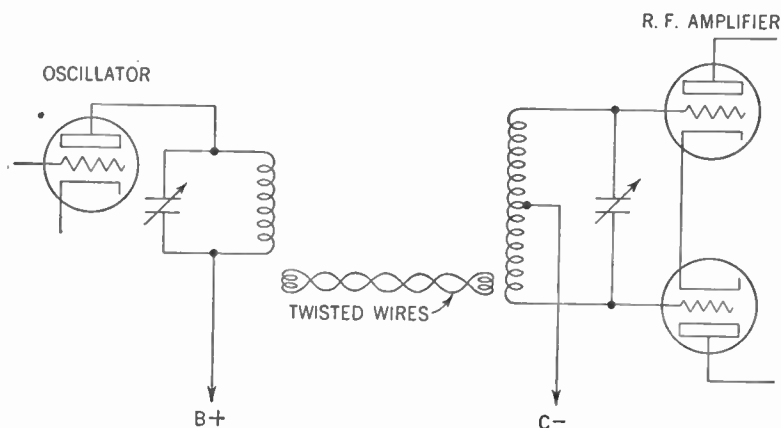

Figure 456. The matched-impedance transmission line method of coupling an oscillator to a push-pull radio-frequency amplifier.

## THE CONTINUOUS-WAVE (C.W.) TRANSMITTER 591

Transmission lines, too, can be employed for coupling. Figure 456 shows the *matched-impedance* method of coupling. In Figure 457 is shown the *link coupling* method.



**Figure 457.** Method of coupling the oscillator to the push-pull radio-frequency amplifier by means of a link-coupled transmission line.

Like the single-ended radio-frequency amplifier, the push-pull radio-frequency amplifier employing triodes must be neutralized to prevent feedback. Two neutralizing condensers are employed, connecting the grid of one tube with the plate of the other (Figure 458).

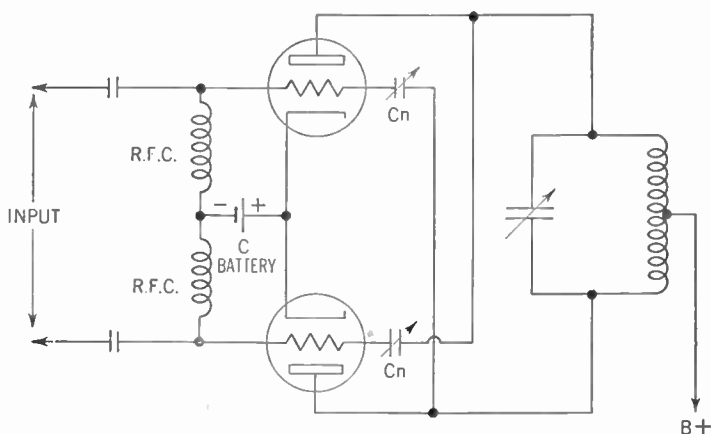

**Figure 458.** Circuit showing how neutralizing condensers ( $C_n$ ) are hooked up to neutralize a push-pull radio-frequency amplifier.

### 479. Frequency Multipliers

Oscillators using a tuned tank in the grid circuit are called *self-excited oscillators*. An example of such an oscillator is the

## 592 THE CONTINUOUS-WAVE (C.W.) TRANSMITTER

Hartley type shown in Figure 445. Oscillators using crystals in the grid circuits are called *crystal oscillators* (Figure 447). The frequency of the self-excited oscillator can be changed by varying the value of the coil or the condenser or of both. But crystals oscillate only at their natural frequencies. The higher the frequency, the thinner the crystal must be.

To avoid the need for changing coils, condensers, or crystals in the oscillator when change of frequency is desired, use is made of *frequency multipliers*. In the frequency multiplier, the harmonics of the fundamental frequency are deliberately produced. This practice is in contrast with the procedure of eliminating harmonics discussed in Par. 445. Thus if the oscillator frequency (the fundamental frequency) is, say, 3.5 mc., the second-harmonic output is 7 mc., and the third-harmonic output is 10.5 mc., and so on. Since harmonics drop off sharply in amplitude the further they are from the fundamental frequency, harmonics above the second are rarely used. For this reason frequency multipliers are sometimes called *doublers*. Figure 459 shows a typical circuit.

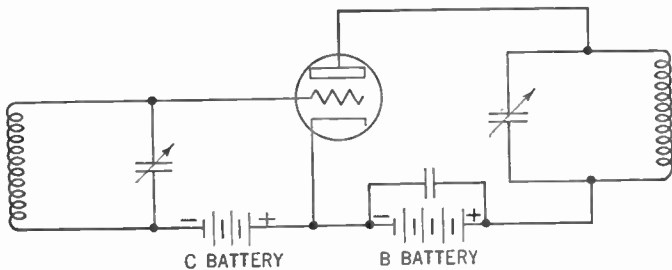

**Figure 459.** Circuit of the frequency multiplier. The plate tank circuit is tuned to a harmonic of the frequency to which the grid tank is tuned.

You see, the circuit of the frequency multiplier looks the same as that of the ordinary radio-frequency amplifier. There are several important differences, however. While the tank in the grid circuit is tuned to the same frequency as is the oscillator (the fundamental frequency), the tank in the plate circuit is tuned to the harmonic of that frequency (usually the second harmonic). To obtain a rich harmonic output, we need a high negative grid bias on the tube, considerably more than double the cutoff value. The excitation voltage must be quite high. (It is suggested that you review the chapter on amplifiers, Chapter 38.)

If harmonics greater than the second are desired, the doubler stage may be followed by another doubler, thus producing the fourth harmonic of the fundamental frequency. The push-pull amplifier is not suitable for second-harmonic output because this type of amplifier suppresses the second harmonic. However, the push-pull circuit may be used to produce the third and other odd harmonics.

Because the frequency of the plate circuit differs from the frequency of the grid circuit, frequency multipliers, even those employing triodes, do not have to be neutralized. In practice, since the output of the frequency multiplier is quite low, a final amplifier is used between it and the antenna.

**480. Coupling the Transmitter to the Antenna**

The method of coupling the antenna to the transmitter depends upon the type of antenna used. While types of coupling are many and varied, the simple examples given here will illustrate the method.

Figure 460 illustrates the method of coupling a Marconi antenna to the transmitter. Coupling coil *L* consists of a few turns

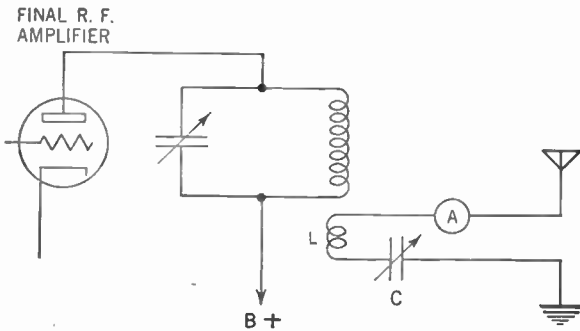

**Figure 460.** Method of coupling the final radio-frequency amplifier to a Marconi antenna.

of wire inductively coupled to the bottom of the tank coil. Since its inductance will increase the effective length of the antenna, the variable condenser *C* (about .00025  $\mu$ fd.) is used to bring the effective length of the antenna down again until it is in resonance with the transmitter. Maximum operating conditions may be achieved by varying the coupling between coil *L* and the tank coil of the transmitter.

## 594 THE CONTINUOUS-WAVE (C.W.) TRANSMITTER

Since variations in the load will change the resonant frequency of the plate tank of the transmitter, this tank must be returned to resonance after every change of coupling or of variable condenser  $C$ . The ammeter is a radio-frequency type and indicates the current flowing into the antenna.

Coupling to a Hertz antenna depends upon whether it is center-fed (current-fed) or end-fed (voltage-fed). Figure 461 shows the method of coupling a center-fed antenna.

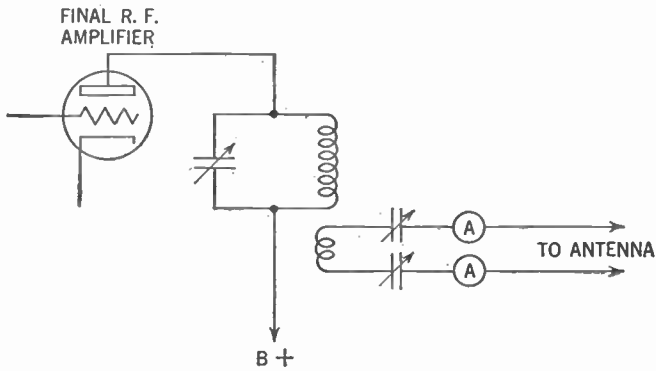

Figure 461. Method of coupling the final radio-frequency amplifier to a center-fed Hertz antenna.

quency ammeters show similar readings it indicates that the transmission line and antenna are being fed properly.

The circuit for coupling to an end-fed antenna is shown in Figure 462.

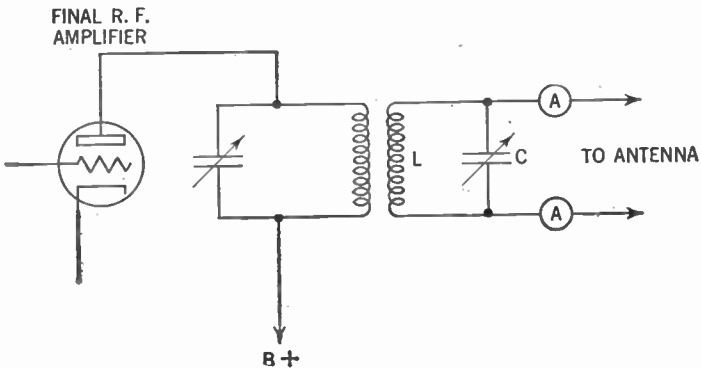

Figure 462. Method of coupling the final radio-frequency amplifier to an end-fed Hertz antenna.



In this case  $L$  and  $C$  are adjusted so that the circuit is in resonance with the transmitter.

**481. Keying the Transmitter**

Since we are discussing continuous-wave transmitters, which send dot-dash messages, we need a key in the circuit. The key is only a device for closing and opening a circuit. But in radio transmitters the key must be connected in the circuit with regard for certain precautions. A good keying system must fulfill three general objectives.

1. When the key is open, there must be no radiation from the antenna.
2. When the key is closed, there must be full power output from the transmitter into the antenna.
3. Keying should not cause clicks which may interfere with nearby stations.

Radiation occurring when the key is open comes from two general sources. If the final amplifier of the transmitter is improperly neutralized, some energy may leak across from the grid to the plate of the tube, because of the capacitance between these two electrodes, and thus into the antenna. This creates a background signal and the dots and dashes appear simply as louder portions of the continuous wave. The obvious remedy is proper neutralization.

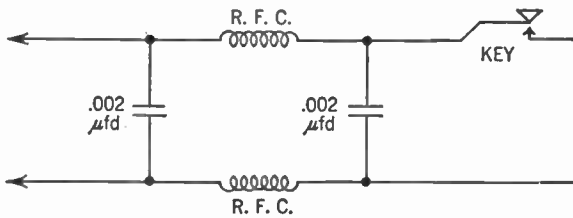

Figure 463. A filter used to eliminate key clicks.

Another source of this difficulty is the magnetic coupling that may exist between the final tank coil and other parts of the transmitter. The remedies here are proper spacing of parts and shielding.

*Key clicks* occur because of sudden surges of electrical energy that may accompany the opening and closing of the key. There are numerous ways of eliminating them. Figure 463 shows one

## 596 THE CONTINUOUS-WAVE (C.W.) TRANSMITTER

method. Since these surges are of radio frequency, the filter circuit shown above will filter them out.

Another method of preventing key clicks is shown in Figure 464. The choke coil  $L$  (several henries) causes a slight current lag

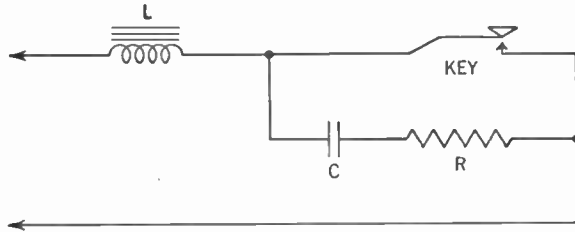

**Figure 464.** Another method used to eliminate key clicks. The lag circuit.

which is enough to eliminate the surges. The energy due to the self-inductance of  $L$  is absorbed by the condenser  $C$  (about .25  $\mu$ fd.). The discharge of the condenser  $C$ , in turn, is dissipated in the resistor  $R$  (about 100 ohms).

Keying in general may take place in the *plate* or *grid* circuits of the amplifier. Thus keying in the plate circuit turns the plate voltage on and off. This method generally is not preferred be-

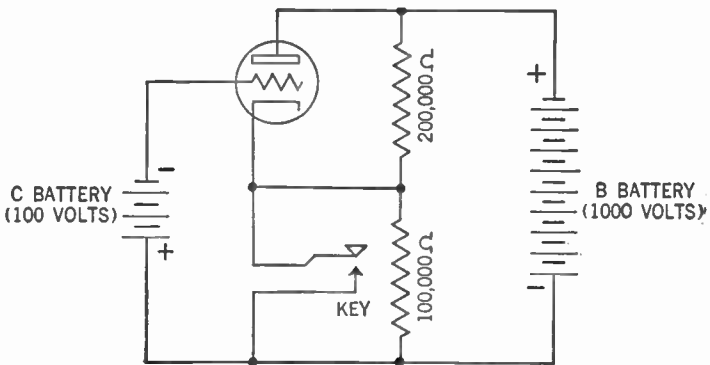

**Figure 465.** The blocked-grid method of keying.

cause of the large voltages handled by the key. Keying in the grid circuit controls the excitation to the grid of the tube. Since the voltages involved in this circuit are relatively low, this method of keying is preferred.

Figure 465 shows such a method. Assume the circuit shown here. When the key is up, two thirds of the B voltage (1,000 volts) or 667

volts is across the 200,000-ohm resistor. This statement means that 667 volts are on the plate of the tube. One third of the B voltage or 333 volts is across the 100,000-ohm resistor. Thus the C-battery voltage (100 volts) plus the 333 volts supplies a negative bias of 433 volts to the grid of the tube. This bias is more than enough to cut off all plate current.

When the key is closed the 100,000-ohm resistor is short-circuited. The full 1,000 volts is now applied to the plate of the tube. The negative grid bias drops to 100 volts (which we have assumed is the normal bias for the tube). Plate current now flows. This type of keying is known as the *grid-blocking* method.

**482. Neutralizing the Radio-frequency Amplifier**

When the radio-frequency amplifier tube is a triode, we must neutralize the feedback that occurs through the capacitance between the grid and plate of the tube. We encountered this problem in the study of receivers (Par. 161, Vol. I). Figure 466 shows the circuit employed to neutralize the amplifier tube in a transmitter.

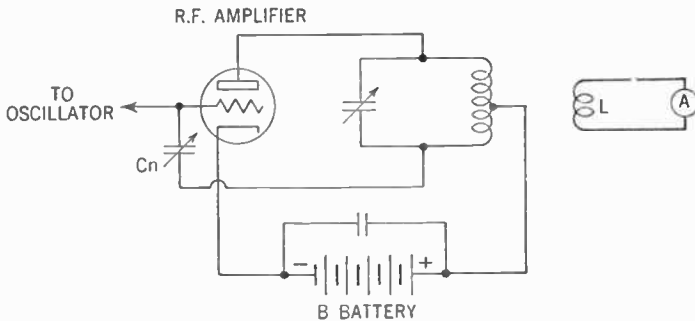

Figure 466. Circuit showing how a radio-frequency amplifier is neutralized.

While the circuit shown here is for *plate neutralization*, the procedure about to be described applies to all types of neutralization.

First, operate the oscillator and amplifier normally. Next, remove the B voltage from the amplifier. Now adjust the neutralizing condenser ( $C_n$ ) until the radio-frequency milliammeter coupled to the plate tank coil of the amplifier through coil  $L$  gives a minimum reading. At this point the capacitance of  $C_n$  and that between the grid and plate of the tube are such that potential varia-

## 598 THE CONTINUOUS-WAVE (C.W.) TRANSMITTER

tions coupled through them from the grid circuit into the plate tank circuit are equal and opposite.

Thus, with direct-current voltage applied to the plate of the amplifier, feedback from the plate circuit to the grid circuit through the tube is exactly counterbalanced by that through  $C_n$ . The amplifier now is nonoscillatory. You may therefore replace the B voltage and the transmitter is ready for operation.

In the case of a push-pull amplifier, each tube is neutralized separately.

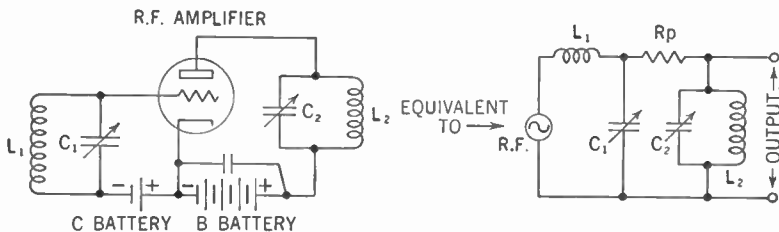

**Figure 467.** Diagram showing the equivalent circuit of a radio-frequency amplifier.  $R_p$  is the internal resistance of the tube.

### 483. Testing for Resonance

The principle of resonance must be applied to continuous-wave transmitters. Let us investigate this problem now. In Figure 467 we have a diagram of the radio-frequency amplifier with its equivalent circuit. Note that the grid tank circuit ( $L_1$  and  $C_1$ ) is a *series* resonant circuit while the plate tank circuit ( $L_2$  and  $C_2$ ) is a *parallel* resonant circuit. Both of these tank circuits may be tested for resonance by connecting milliammeters in the grid and plate circuits as shown in Figure 468.

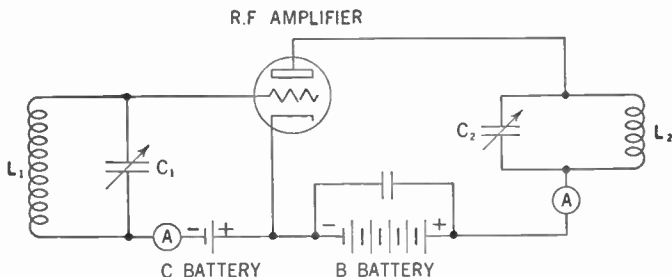

**Figure 468.** Diagram showing how direct-current milliammeters are hooked into the grid and plate circuits of the radio-frequency amplifier to test for resonance.

Since the grid tank circuit is a series resonant circuit, its impedance is lowest at resonance. Thus when the *maximum* current flow occurs in the grid circuit (as shown by the milliammeter), the grid tank is at resonance.

On the other hand, the plate tank circuit is a parallel resonant circuit. At resonance its impedance is at maximum. Thus when

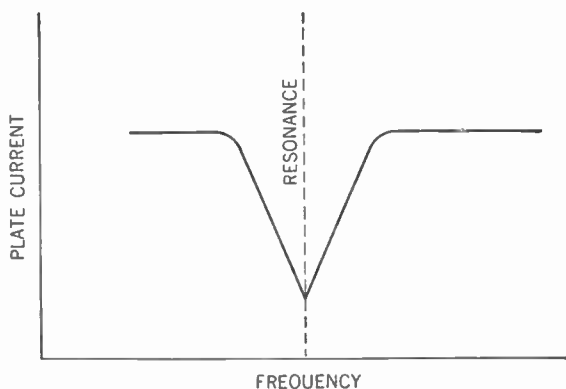

Figure 469. Graph showing the dip in plate current which indicates that the plate tank circuit is at resonance.

the *minimum* current flow occurs in the plate circuit (as shown by its milliammeter), the plate tank is at resonance. The point of resonance is shown by a sharp dip in the plate current (see Figure 469).

#### 484. The Absorption Frequency Meter

It is very important that the transmitter should operate only at that frequency for which it was designed. We may calculate the values of all the parts needed for that particular frequency, but practice shows variations between the theoretical frequency and the actual frequency of the radiated waves. Variations of coupling and loading, as well as many other factors, all tend to create variations of frequency.

You can see, therefore, that an instrument which can check the frequency of the transmitter is an essential part of the transmitting station. Such an instrument is the *absorption frequency meter*, a simple example of which appears in Figure 470.

This meter consists of a coil ( $L$ ) and a variable condenser ( $C$ ), tunable over the frequency range of the transmitter. The coil

## 600 THE CONTINUOUS-WAVE (C.W.) TRANSMITTER

is loosely coupled to the plate tank coil of the amplifier and when this meter is tuned to the frequency of the transmitter, a small amount of energy will be extracted from the tank.

This energy can be used to light the small flashlight lamp shown in Figure 470. When the frequency meter is tuned exactly to the

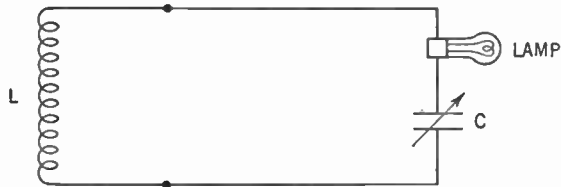

Figure 470. Circuit of the absorption frequency meter.

transmitter frequency, maximum current will flow in the lamp. Thus the brightness of the lamp indicates resonance.

The frequency meter is calibrated so that for the particular coil used, settings of the variable condenser can be read directly as frequency. The frequency (as shown by the frequency meter) at which the lamp burns brightest is the frequency of the transmitter.

### 485. The Dummy Antenna to Measure Power Output

It is quite essential also to know the power output of a transmitter. The current flowing in the feeder lines (as shown by am-

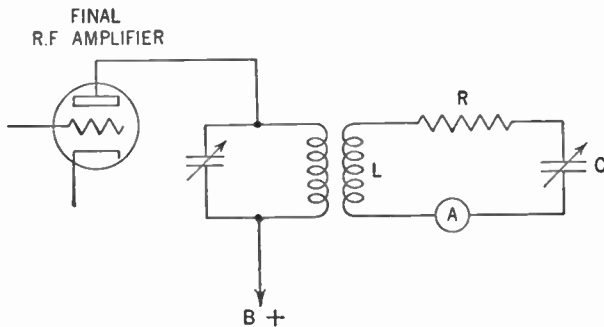

Figure 471. Circuit of the dummy antenno.

meter in Figure 460) cannot give us this information because the resistance of the antenna at the point measured is rarely known. Use, therefore, is made of a device known as a *dummy antenna* (Figure 471).

This dummy antenna consists of a coil ( $L$ ) which is coupled to the plate tank coil of the final amplifier of the transmitter, a variable condenser ( $C$ ), a known resistor ( $R$ ) of about 25 ohms, and a radio-frequency ammeter. The dummy antenna is tuned to the same frequency as is the transmitter. If we now take the reading of the radio-frequency ammeter, we can calculate the power in the dummy antenna from the following formula:

$$\text{Power} = I^2 \times R$$

Power is expressed in watts,  $I$  is the current as shown by the radio-frequency ammeter, and  $R$  is the resistance (about 25 ohms). Since the power in the dummy antenna can come only from the transmitter, this calculated value is the power output of the set.

### 486. The Continuous-wave Receiver

In concluding the discussion of the continuous-wave transmitter something must be said about the reception of telegraph signals. The receiver for continuous-wave radiotelegraphy presents a special problem. Since the carrier wave is at radio frequency, the impulses coming through the detector, too, will be at radio frequency. This is above the audio range and cannot be heard. The receiver, therefore, must have incorporated in it a local radio-frequency oscillator, similar to the type used in the superheterodyne receiver (Chap. 26, Vol. I). This oscillator produces a radio-frequency current which beats against the incoming signal to produce a beat note whose frequency lies in the audio range.

Assume the signal frequency to be 1,000 kc. If the local oscillator produces a current whose frequency is 1,001 kc. and the two currents are mixed, we will get two beat frequencies, one the sum of the two or 2,001 kc. and the other the difference between the two, or 1 kc. The 2,001-kc. note cannot be heard because it lies above the audio range, but the 1-kc. note can actuate the ear-phones or loudspeaker and thus be heard.

### SUMMARY

1. Radio waves sent out by transmitting stations may be either of two types: continuous (unmodulated) or modulated.
2. A continuous-wave transmitter is used to send the dot and dash signals of radiotelegraphy.
3. The signals are produced by a key momentarily closing an open circuit bearing radio-frequency current.

## 602 THE CONTINUOUS-WAVE (C.W.) TRANSMITTER

4. Both the dot and the dash consist of pulses or trains of many waves, but the dash is noticeably longer than the dot.

5. A radio-frequency amplifier must be coupled to the oscillator to produce enough energy for the antenna. This amplifier may be coupled by capacity coupling or inductive coupling.

6. Change of frequency may be produced by a **frequency multiplier**, a system in which the tank in the grid circuit is tuned to the fundamental frequency while the tank in the plate circuit is tuned to a harmonic—usually the second harmonic.

7. The method of coupling the transmitter to the antenna depends upon whether the antenna is the Marconi or Hertz type.

8. The key for sending must be connected so as to prevent radiation, or clicks, and yet so as to provide full power when the key is momentarily closed.

9. In continuous-wave transmitting, feedback grid-to-plate capacitance is usually prevented by neutralizing carefully each tube.

10. The frequency of the transmitter is checked by a circuit consisting of a coil, a small lamp, and a variable condenser calibrated to read in frequencies. This coil is coupled inductively to the plate tank coil and is tuned by means of the variable condenser. The light is at its brightest when tuned to resonance.

11. Power output is measured by a dummy antenna coupled to the transmitter. In the circuit is a known resistance and a radio-frequency ammeter.

$$\text{Power} = I^2 \times R$$

### GLOSSARY

**Absorption Frequency Meter:** A resonant circuit calibrated to check the transmitter frequency.

**Continuous Radio Wave:** A radio wave capable of inducing in a receiving antenna a radio-frequency alternating current of uniform amplitude.

**Crystal Oscillator:** An oscillator using a crystal in the grid circuit.

**Doubler:** A frequency multiplier generating the second harmonic.

**Dummy Antenna:** A non-radiating load, coupled to a transmitter, used to measure the power output of the transmitter.

**Frequency Multiplier:** An amplifier whose output is some harmonic of the fundamental oscillator frequency.

**Key Clicks:** Radiations of noise due to surges of energy across the key as it is opened and closed.

**Link Coupling:** Coupling between two coils through the agency of two other coupling coils.

**Self-excited Oscillator:** An oscillator using a tuned tank ( $L \times C$  circuit) in the grid circuit.

**Single-ended Amplifier:** A one-tube amplifier stage.



## QUESTIONS AND PROBLEMS

1. What two general types of waves are radiated by transmitters and where is each used?
2. How are dots and dashes produced in a radiated continuous radio wave?
3. Why don't we merely couple the oscillator to the antenna and send out a continuous radio wave?
4. Explain with the use of a diagram the operation of a radio-frequency amplifier coupled capacitively to an oscillator.
5. Substitute inductive coupling instead of capacitive coupling in question 4 and answer.
6. What difficulty arises with inductive coupling and how is it remedied?
7. Explain with the use of a diagram the operation of a radio-frequency amplifier coupled to an oscillator by means of link coupling.
8. Show by diagrams a push-pull radio-frequency amplifier coupled to an oscillator by various coupling methods.
9. How may the frequency of the self-excited oscillator be varied?
10. What is the purpose of the frequency multiplier? Explain its operation.
11. Why may the push-pull frequency amplifier not be used as a frequency doubler?
12. Why is it not necessary to neutralize a frequency-multiplier stage?
13. Describe several methods of coupling the transmitter to the antenna.
14. List the three prime requirements for a good keying system.
15. What are the causes of and remedies for radiation from a continuous-wave transmitter when the key is open?
16. Illustrate one method of eliminating key clicks.
17. Why is keying in the plate circuit not very desirable?
18. Describe the grid-blocking method of keying.
19. Describe the step-by-step procedure in neutralizing a triode radio-frequency amplifier in a transmitter.
20. Describe the structure and use of an absorption frequency meter.
21. Describe the structure and use of a dummy antenna.
22. What special problem must the continuous-wave radiotelegraph receiver solve? How does it meet this problem?

## CHAPTER 41

# The Modulated-wave Transmitter

---

**Problem 1:** *How is the carrier wave of a transmitter modified to transmit telephone messages and music?*

**Problem 2:** *What are the principles of transmission by amplitude modulation (A.M.) and frequency modulation (F.M.)?*

---

### 487. Two Methods of Modulation

We must not lose sight of the fact that the primary purpose of radio transmission is to convey ideas or intelligible signals from the sender to the receiver. Thus, merely to generate and radiate a continuous wave is meaningless, as meaningless as sending a letter that contains a blank sheet of paper. Something must be done to the radio wave if it is to convey a message.

In Chapter 40 we saw that if we break up the continuous wave into a series of short and long trains (dots and dashes) we can devise a code which will convey ideas to the person receiving the wave signal. In this chapter we will deal with another method of saddling intelligence onto our winged carrier.

The continuous radio wave has two inherent characteristics which lend themselves to our purpose. These are the *frequency* and *amplitude* of the wave. Varying either of these characteristics according to a prearranged plan will permit us to "write" on the "blank sheet," the continuous radio wave.

This process of varying either the frequency or amplitude of the continuous carrier wave is called *modulation*. *Frequency modulation* is a comparative newcomer to the radio field, and since it involves principles beyond the elementary stage, no attempt will be made here to go into details concerning its operation. At the end of this chapter, however, some of its basic principles will be discussed.

This chapter will deal primarily with *amplitude modulation*. In essence, it is a process whereby audio-frequency fluctuations are impressed on the continuous radio wave in order to cause corresponding variations in the amplitude of this wave. Changing the wave in this manner is called *modulation* and the changed radio wave is called a *modulated radio wave*.

This modulated radio wave produced at the transmitting station is radiated by the transmitting antenna and received in the radio receiver. The detector in the receiver separates the audio-frequency variations from the carrier and passes on these audio-frequency variations to the audio-frequency amplifier, where they are built up to sufficient strength to operate the loudspeaker, thus giving back to us the original message delivered into the microphone at the transmitting station (see Chapter 9, Volume I).

In general, there are two types of audio-frequency variations used to modulate the carrier wave. One is a steady audio-frequency note (such as a 1,000-cycle note) (see Figure 472).

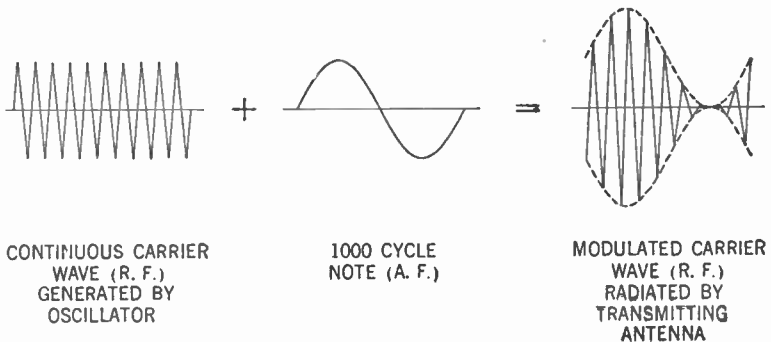
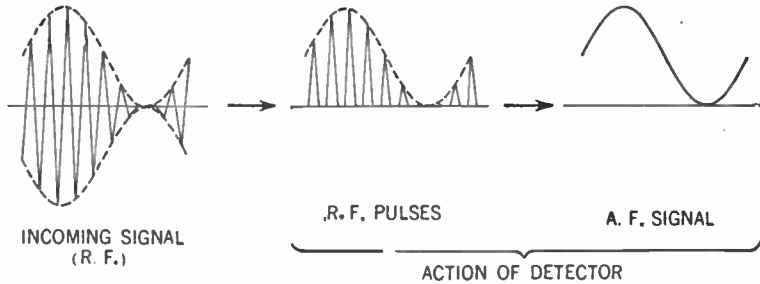

**Figure 472.** How the continuous carrier wave is modulated by the audio-frequency note.

In the receiver, the detector removes the bottom half of the incoming signal, removes the radio-frequency carrier wave (demodulation) and leaves the original 1,000-cycle audio-frequency note (see Figure 473).

From the transmitting antenna, short and long trains of this modulated wave (corresponding to the dots and dashes of the code mentioned in Chapter 40) are radiated. This radiation results in short and long sounds coming from the loudspeaker of the receiving set. These sounds are the 1,000-cycle note or whistle. This method of radio communication is called *interrupted continu-*

ous-wave (I.C.W.) radio telegraphy. Note that no local oscillator is needed in the receiver in order to hear the signals.



**Figure 473.** How the detector demodulates the incoming radio-frequency signal.

You can see that other audio-frequency variations may be impressed on the carrier wave. Thus the audio-frequency fluctuations caused by speech or music may be used to modulate the carrier wave (see Figure 474).

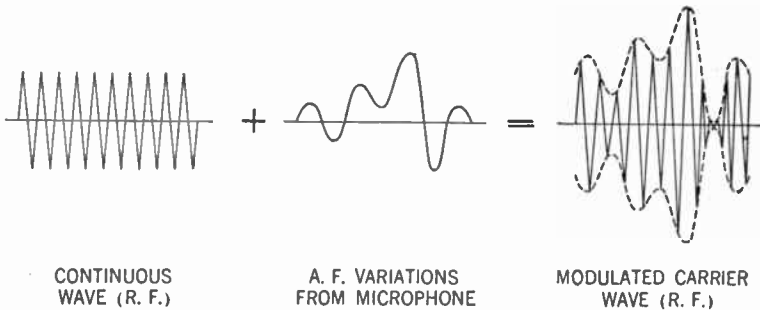

**Figure 474.** How the voice currents in the microphone circuit modulate the carrier wave.

Demodulation in the detector causes the reproduction of the original audio-frequency variations. This method of radio communication is known as *radio telephony*.

**488. The Modulator: How We Get the Audio-frequency Variations**

To modulate the continuous carrier wave in the transmitter for interrupted continuous-wave radio telegraphy, a number of different devices are used. Since we need a constant audio frequency (say a 1,000-cycle note) any device which vibrates at that frequency, a tuning fork for example, can be made to vibrate at its

natural frequency in a magnetic field. As it cuts across this magnetic field, it will cause to be set up an alternating current whose frequency is 1,000 cycles. This alternating current may then be amplified by an audio-frequency amplifier and the output used to modulate the carrier wave.

Of greater interest to us is the process of modulating the carrier wave by means of audio-frequency currents whose variations conform to speech and music—that is, radio telephony. Refer to Par. 23, Vol. I, and you will recall that sound waves, striking the telephone transmitter, cause corresponding variations in the electric current flowing in the transmitter circuit. It is this fluctuating electric current which we amplify in the audio-frequency amplifier and use to modulate the carrier wave. The audio-frequency amplifier used for this purpose is called the *modulator*. Except for certain variations which we will discuss later in this chapter, it is identical with the audio-frequency amplifier discussed in Chapter 17, Volume I.

#### 489. Side Bands

The combination of audio-frequency currents with the radio-frequency carrier current is, in essence, a heterodyne process similar to that which takes place in the mixer tube of the superheterodyne receiver (Chap. 27, Vol. I). We therefore get beat frequencies equal to the *sum* and the *difference* of the audio frequencies and the radio frequencies involved. Thus, for each audio frequency appearing in the modulating signal two new radio frequencies appear, one equal to the carrier frequency *plus* the audio frequency, the other equal to the carrier frequency *minus* the audio frequency. These new frequencies are called *side frequencies*, since they appear on each side of the carrier. The groups of side frequencies representing a band or group of modulation frequencies are called *side bands*.

Let us assume the oscillator of the transmitting set produces a carrier current whose frequency is 1,000,000 cycles per second. If we were to modulate this carrier by an audio-frequency current whose frequency is 1,000 cycles per second, we would get two new radio frequencies, 1,000,000 plus 1,000 or 1,001,000 cycles per second and 1,000,000 minus 1,000 or 999,000 cycles per second. These two new frequencies are the side frequencies.

If instead of using a 1,000-cycle note to modulate our carrier

current, we were to use audio-frequency currents created by sound waves whose frequencies range up to, say, 5,000 cycles per second, we would get, not two single side frequencies, but two whole bands of side frequencies. One band would lie between 1,000,000 cycles and 1,005,000 cycles, while the other would lie between 1,000,000 cycles and 995,000 cycles.

Thus a modulated signal occupies a group of radio frequencies, or *channel*, rather than a single frequency as in the case of the unmodulated carrier. The *channel width* is twice the highest modulation frequency. In the example given here, the channel width would be twice 5,000 cycles or 10,000 cycles.

#### 490. Percentage of Modulation

In the radio receiver, the audible output depends entirely upon the *amount of variation* in the carrier wave and not upon the strength of the carrier alone. We therefore seek to obtain the largest permissible variations in the carrier wave. Let us see how we do so.

Examine Figure 475. You will note that the amplitude of the the

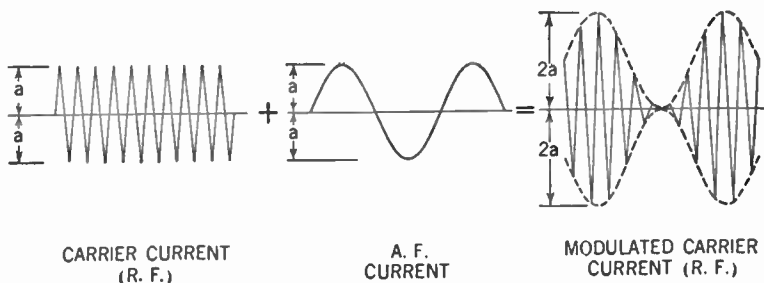

Figure 475. 100% modulation.

carrier current is measured by the distance  $a$ . The amplitude of the audio-frequency current is assumed here to be the same value ( $a$ ). Now consider the positive half (above the X axis) of the carrier current. If the audio-frequency current is added to it, the positive half cycles of audio-frequency current will be added to the carrier current to produce the peaks in the modulated current curve. These peaks will be equal to *twice* the amplitude of the carrier current.

The negative half cycle of the audio-frequency current will cancel out the carrier current (since the amplitudes are equal

and opposite) to produce the valley in the modulated current curve. At this point the resulting current is zero. The same thing happens to the negative half (below the  $X$  axis) of the carrier current.

This condition, where the carrier amplitude during modulation is at times reduced to zero and at other times increased to twice its unmodulated value, is called *100% modulation*. It occurs when the peak amplitude of the audio-frequency current equals the amplitude of the unmodulated carrier current. The proportion between the amplitude of the carrier and the peak amplitude of the audio-frequency current is called the *degree of modulation* and can be measured in percentages.

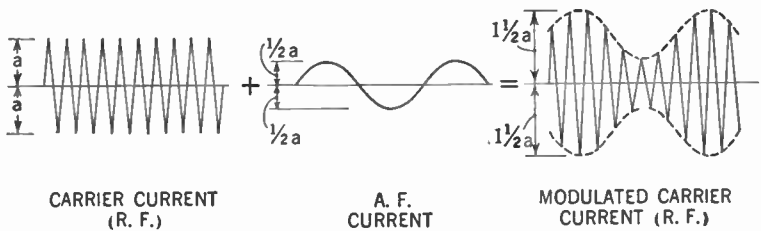

Figure 476. Undermodulation. 50% modulation.

Thus, if the peak amplitude of the audio-frequency current is equal to *half* the amplitude of the carrier current, we say we have *50% modulation* (see Figure 476).

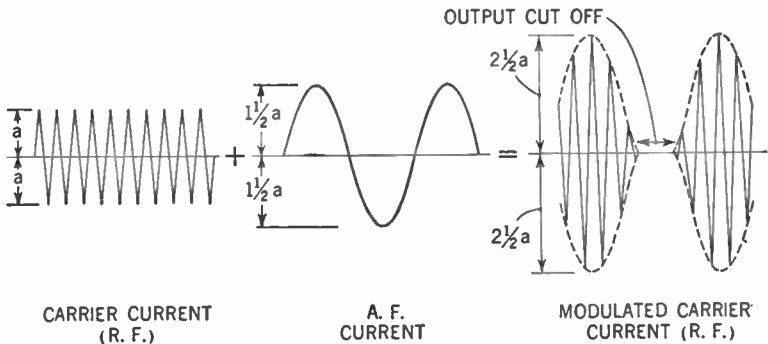

Figure 477. Overmodulation. 150% modulation.

If, on the other hand, the peak amplitude of the audio-frequency current exceeds the amplitude of the carrier current, we have a condition of *more than 100% modulation*. We say we have *overmodulated* the carrier current (Figure 477). You see that dur-

ing a considerable period of time the output is completely cut off. The wave form of the signal heard in the loudspeaker of the receiver will not be equal to that of the original. In consequence we have distortion.

Since we are seeking the greatest amount of variation, modulation less than 100% means a loss of power. On the other hand, overmodulation produces distortion. It can be readily seen that 100% modulation is desirable.

#### 491. Power Relations in the Modulated Transmitter

The amount of power required to modulate a transmitter depends on the percentage and type of modulation. To modulate a carrier 100% with a single tone (as in Figure 475) requires an audio-frequency power equal to one half of the radio-frequency carrier power. Here is how it is calculated.

The peak amplitude of the modulated carrier current is twice that of the unmodulated carrier current. Since the power ( $P$ ) =  $I^2 \times R$ , then if we assume the resistance ( $R$ ) to be constant, the power of the peaks of the modulated carrier is *four times* ( $2^2$ ) that of the unmodulated carrier. However, this value holds only for the peaks. It can be calculated mathematically that the overall power of the modulated carrier is *one and one half times* that of the unmodulated carrier. Since this 50% increase in power must come from the modulator, the audio-frequency power must be equal to one half the unmodulated carrier power.

With voice modulation (Figure 474), the greater portion of the audio-frequency components will not modulate the carrier 100%, so that the power increase is considerably less than for single-tone modulation.

#### 492. Methods of Modulation

There are various methods of modulation. Perhaps the most common type is the method whereby the audio-frequency current is applied to the plate of one of the radio-frequency amplifiers to cause the output of the transmitter to vary in accordance with the audio-frequency variations. This method is known as *plate modulation*. Application of the audio-frequency voltage to the control grid of the radio-frequency amplifier is referred to as *grid*. or *grid-bias modulation*. The audio-frequency voltage may be applied also to the cathode of the radio-frequency amplifier. This method



## 612 THE MODULATED-WAVE TRANSMITTER

is a combination of plate and grid modulation and is known as *cathode modulation*.

When a tetrode is used as a radio-frequency amplifier, modulation may be applied to the screen grid as well as to the plate. This method is a variation of plate modulation. Where a pentode is employed, modulation may be applied to the suppressor grid of the tube. This method is a variation of grid modulation.

### 493. Plate Modulation

Figure 478 illustrates plate modulation. The modulator consists of a stage of audio-frequency push-pull amplification. The tubes are operated in class A, AB, or B (see Chapter 38). The only difference between the modulator stage and an ordinary audio-fre-

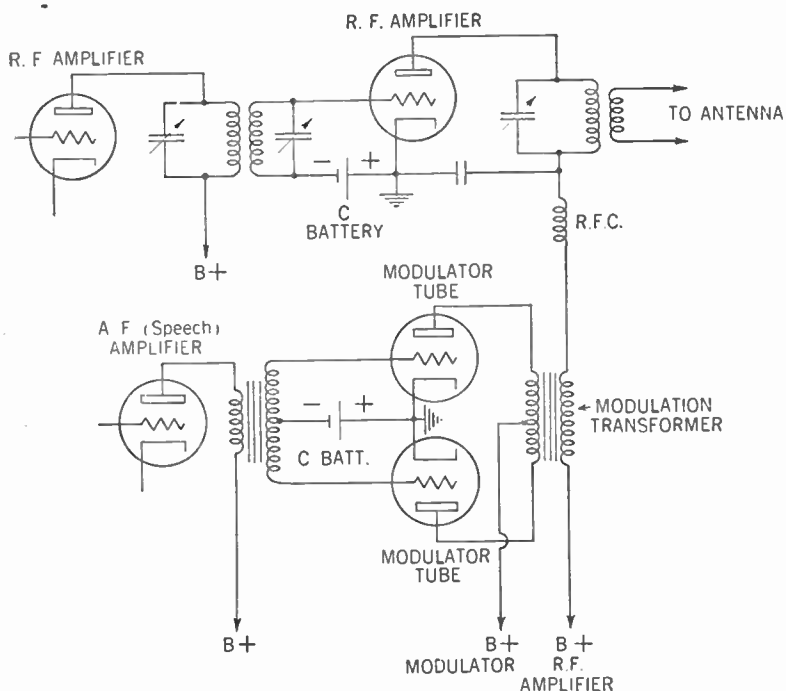

Figure 478. Plate modulation, transformer coupling.

quency stage of amplification lies in the fact that whereas the audio-frequency amplifier feeds into an *output transformer* which, in turn, couples the loudspeaker to the amplifier, the modulator tubes feed into a *modulation transformer* that couples the audio-frequency variations to the plate circuit of the radio-frequency amplifier.

Note that the plate voltage to the radio-frequency amplifier must pass through the secondary of the modulation transformer. The audio-frequency voltages in this secondary vary this direct-current plate voltage and the result is that a varying direct-current voltage (varying in step with the audio-frequency variations) is applied to the plate of the radio-frequency amplifier. This variation causes the power fed into the antenna to vary with the audio-frequency variations and hence a modulated wave is radiated.

The radio-frequency choke between the secondary of the modulation transformer and the plate tank of the radio-frequency amplifier is used to offer a high impedance to the radio-frequency currents and thus keep them from flowing down into the plate voltage supply. Note that separate plate-voltage supplies are indicated for the modulator and the radio-frequency amplifier. This practice is followed where powerful transmitters are employed. For low or medium power the same plate-voltage supply may be used for both.

The audio-frequency amplifier driving the tubes of the modulator is an ordinary amplifier, such as, for example, the one illustrated in Figure 93, Volume I.

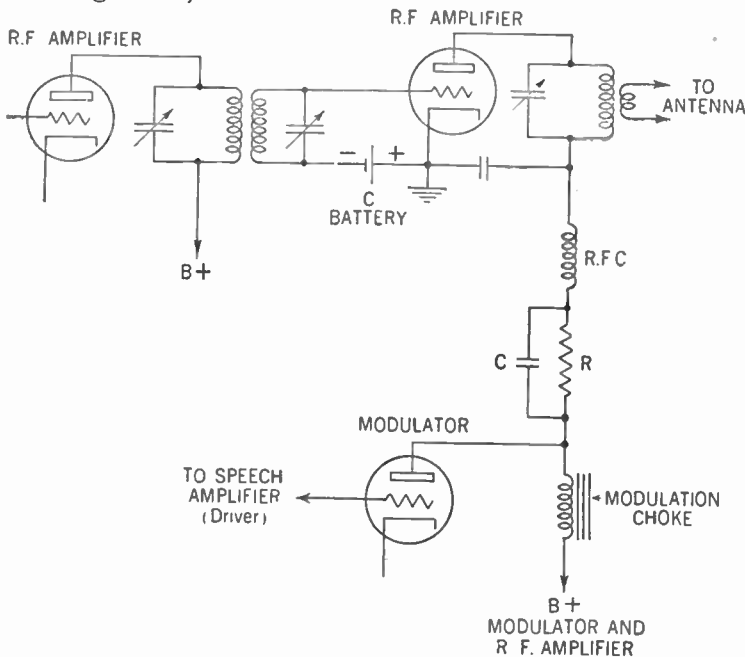

Figure 479. Plate modulation, choke coupling.

This method of coupling the audio-frequency variations to the carrier is called *transformer coupling*. In Figure 479 is illustrated another method of coupling which may be used in plate modulation. Note that here the modulator consists of a single tube. To prevent distortion, this tube must be a class A audio-frequency amplifier. Note also that the same plate-voltage supply feeds both the modulator and the radio-frequency amplifier. The choke coil offers a high impedance to the audio-frequency output of the modulator and thus prevents it from going down to the plate supply.

For 100% modulation the audio-frequency voltage applied to the radio-frequency amplifier plate circuit must have a peak value equal to the direct-current voltage on the modulated amplifier (see Figure 475). To obtain this without distortion, the radio-frequency amplifier must be operated at a direct-current plate voltage *less* than the modulator plate voltage. The extent of the voltage difference is determined by the type of modulator tube used. To obtain this drop in voltage the resistor  $R$  is employed. The condenser  $C$  permits audio-frequency voltages to flow around this resistor. This method of modulation is called *choke-coupled plate modulation*.

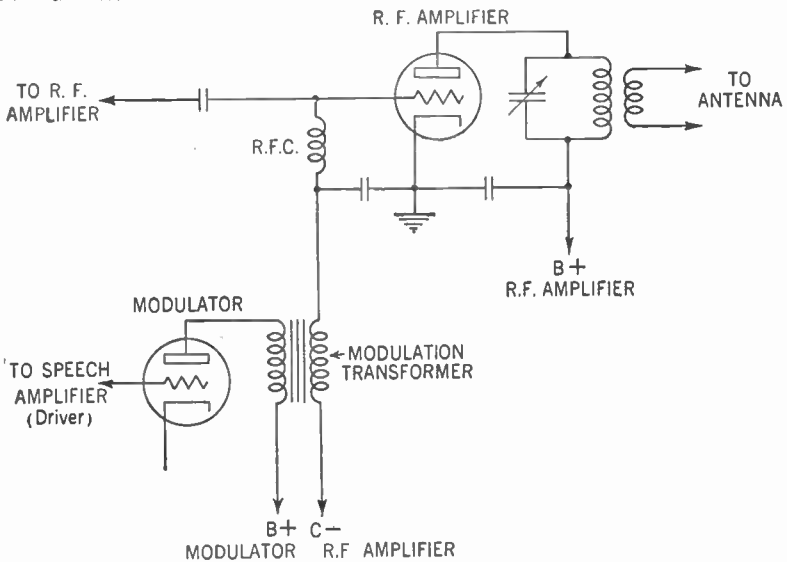

Figure 480. Grid modulation, transformer coupling.

#### 494. Grid-bias Modulation

In Figure 480 is shown the circuit for *grid-bias modulation*. Here the audio-frequency voltages vary the grid-bias supply to the radio-frequency amplifier. This variation in turn varies the power output of this amplifier, which causes a modulated wave to be radiated. Best results are obtained when the source of grid bias comes from batteries.

The modulator tube must be operated as a class A audio-frequency amplifier. Since we are varying the grid bias of the radio-frequency amplifier we do not need as much power as is needed for plate modulation. The comparatively low power output of the class A audio-frequency amplifier is usually sufficient for our purpose. On the other hand, the carrier output of the transmitter that is grid-modulated is about one quarter that of the plate-modulated transmitter.

#### 495. In What Part of the Transmitter Is Modulation Impressed?

We have seen that the purpose of the modulator is to impress the audio-frequency variations upon the carrier. We must decide where, between the oscillator and the antenna, this coupling is to take place.

The oscillator should never be modulated because, as we have seen, change in load will seriously affect the frequency. Thus modulation of the oscillator will cause the signal to wobble, spoiling the reception and causing interference with neighboring stations. As a matter of fact, in the interest of frequency stability, the transmitter should be modulated as far away from the oscillator as possible.

This requirement indicates that the final radio-frequency amplifier should be modulated. This final amplifier may be a class C amplifier with the advantage of greatest efficiency.

There is, however, a drawback to this procedure. Since the carrier is being modulated at the point of its greatest power, the audio-frequency power used to modulate it, too, must be at its maximum. Often a compromise is made by modulating that radio-frequency stage next to the final amplifier. Thus less audio-frequency power is needed.

As the final radio-frequency stage then amplifies the *modulated* carrier, it must be a *linear amplifier* (class B). If it were a class C

amplifier, too much distortion would creep in. Thus the advantage of the greater efficiency of class C amplification would be sacrificed. We would save in audio-frequency power at the cost of output power.

If we modulate the final radio-frequency amplifier we call the modulation *high-level* modulation. Modulating in any other stage is called *low-level* modulation.

It is in the interest of good frequency stability to insert at least one stage of radio-frequency amplification between the oscillator and the tube being modulated. Such a stage is called a *buffer amplifier*. Figure 481 shows the block diagram for a radio-telephone transmitter.

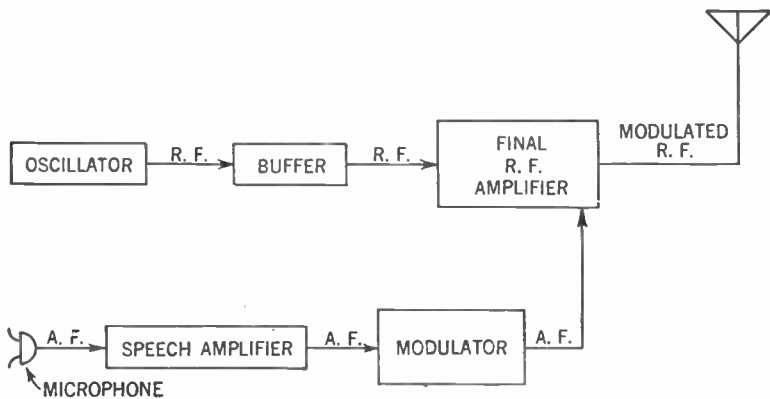

Figure 481. Block diagram showing the relationship of the components of a radio-telephone transmitter.

#### 496. The Microphone Changes Sound Waves into Electrical Impulses

As the radio-frequency portion of the radio-telephone transmitter starts with the oscillator, the audio-frequency portion starts with the *microphone*. This is a device used to change sound waves into the fluctuating audio-frequency currents that are amplified and used to modulate the carrier.

Five types of microphones are in general use. The *carbon-grain microphone* consists of two carbon disks, one fastened securely to the back of the microphone and the other to a diaphragm. The space between these two disks is partly filled with carbon granules. As the sound waves strike the diaphragm these carbon granules are pressed together with a varying pressure, depending

upon the sound waves. This varying pressure on the granules changes the electrical resistance between the two disks. If this device is hooked up in a circuit such as that in Figure 482, the sound waves cause a fluctuating current to flow in the circuit.

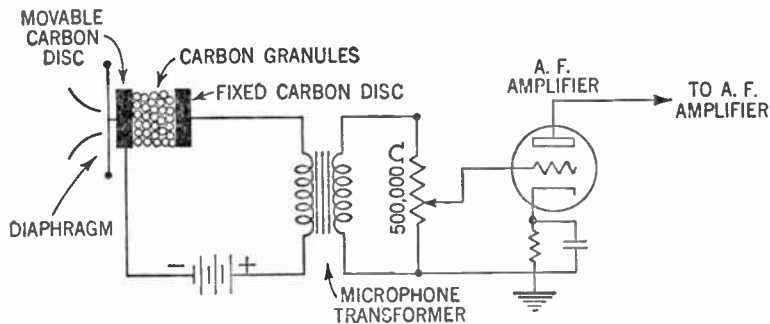

Figure 482. Hookup for the carbon-grain microphone.

This fluctuating current varies in step with the sound waves, that is, at audio frequency. By means of the transformer this audio-frequency current places a fluctuating charge upon the grid of the amplifier tube. The 500,000-ohm potentiometer acts as a volume control (see Paragraph 114 in Volume I).

Another type of microphone is the *piezoelectric crystal* type. We have already met this crystal in a phonograph pickup in Chapter 17 (Fig. 94, Vol. I). If for the needle holder we substitute a diaphragm, then sound waves striking this diaphragm set up a fluctuating alternating voltage across the faces of the crystal. These voltage variations are amplified by the audio-frequency amplifier.

Still another type of microphone is the *condenser* type. If a small air-spaced condenser, consisting of two metallic plates separated by about .001 in., is fixed so that one plate is stationary while the other is movable, sound waves striking the movable plate vary the capacitance of this condenser. These variations are in step with the sound waves. If this condenser is hooked up as in Figure 483, these variations place a varying charge upon the grid of the amplifier tube.

Still another type of microphone is the *ribbon* or *velocity* type. Here a thin metallic ribbon (usually made of duralumin, an aluminum alloy) is suspended between the poles of a powerful permanent magnet. Sound waves striking this ribbon cause it to vi-

brate back and forth, cutting the magnetic field and setting up an alternating current in the ribbon. This ribbon is coupled to the tube of the audio-frequency amplifier by means of a transformer.

The *dynamic* microphone is a variant of the velocity type. In-

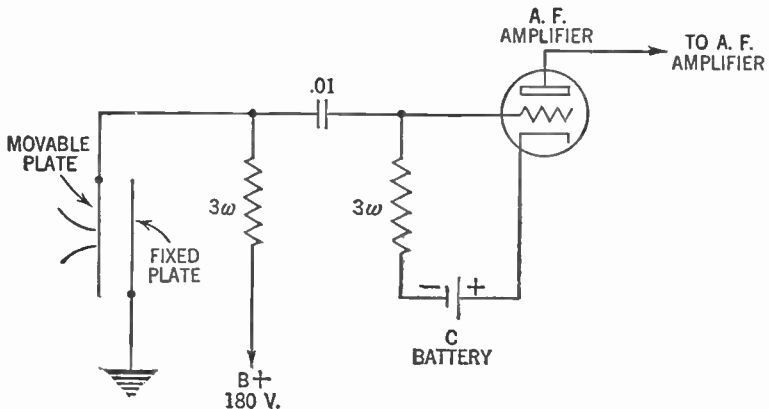

Figure 483. Hookup for the condenser microphone.

stead of a metallic ribbon, a small, light coil of wire moves across the magnetic field. In fact, if you were to speak into the cone of a small permanent-magnet dynamic speaker (Fig. 121, Vol. I) you would have a dynamic microphone.

#### 497. Frequency Modulation (F.M.)

As stated earlier in this chapter, messages may be conveyed by varying the frequency of the carrier wave in step with audio-frequency variations caused by speech or music. This method of radio communication is called *frequency modulation*. While it is beyond the scope of this book to go into the procedure in detail, we will attempt to outline the basic principles.

Assume that you have a radio-frequency oscillator as shown in Figure 484. You will recognize this as the regenerative oscillator with a condenser microphone across the grid tank circuit. As sound strikes the condenser microphone the capacitance varies with the frequency of the sound. This capacitance variation in turn varies the capacitance of the tank circuit, thus varying the frequency of the oscillator.

If you examine Figure 485 you will see how the frequency-modulated carrier wave differs from the amplitude-modulated carrier wave. Note that whereas in the amplitude-modulated car-

rier the frequency is constant and the amplitude is varied by the audio frequency, in the frequency-modulated carrier the amplitude is constant and the frequency is varied by the audio frequency.

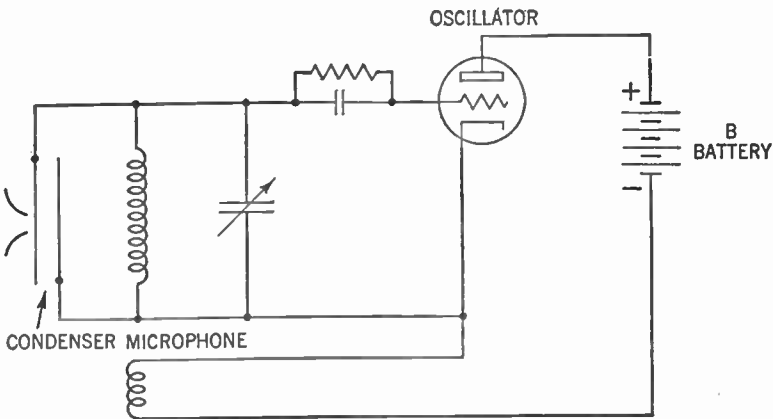

Figure 484. Theoretical hookup of the frequency-modulation transmitter.

Another important difference lies in the matter of side bands. In the amplitude-modulated wave the width of the side bands is equal to twice the highest frequency of the audio frequencies; hence the greatest width of the side bands may be about 30 kc.

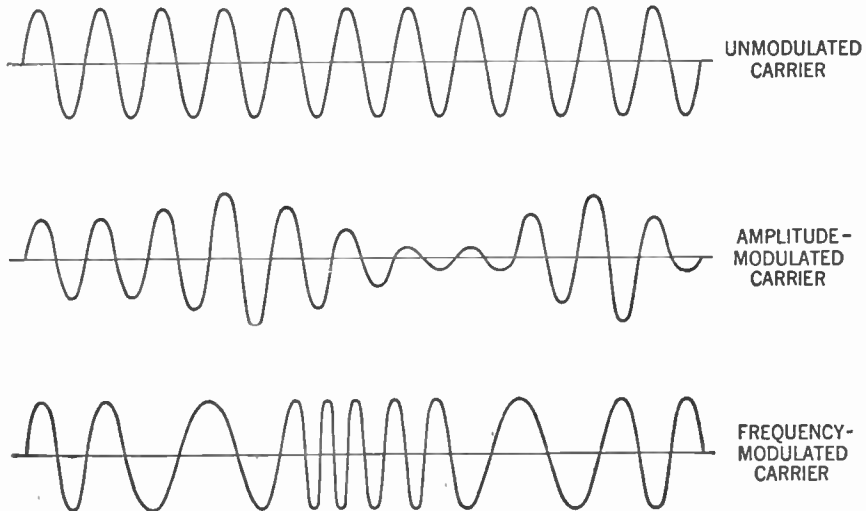

Figure 485. Comparison between the amplitude-modulated and frequency-modulated carrier.



In the frequency-modulated carrier the side bands may extend over a width of 50 kc. to 150 kc. Broadcasting stations usually employ a width of 75 kc. To get the necessary wide channels and prevent one station from interfering with another, extremely high frequencies are employed, usually around 40 mc. This high frequency makes it necessary to transmit in a direct line rather than in accordance with the ordinary broadcasting procedure (see Paragraph 402).

To receive the frequency-modulated wave we may employ the ordinary superheterodyne receiver, but with a number of important changes. In the amplitude-modulated (A.M.) receiver the resistance of the tuning circuits of the radio-frequency and intermediate-frequency amplifiers is kept very low to increase the selectivity. But in the frequency-modulated (F.M.) receiver, since we wish to pass a broad band of frequencies, resistance is deliberately added to broaden the tuning curve. Following the intermediate-frequency amplifier is a *limiter* circuit which removes any amplitude modulation which may have crept in. The signal is then fed into a *frequency discriminator* which acts as a second detector to demodulate the signal. The audio-frequency currents are then fed into an ordinary audio-frequency amplifier.

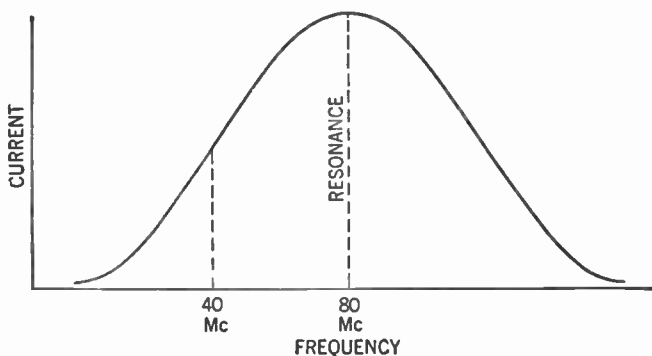

Figure 486. Diagram to show the theoretical concept of the frequency-modulation receiver.

To understand how the frequency-modulation receiver acts, consider the tuning curve shown in Figure 486. Assume that the frequency of the unmodulated carrier wave is 40 mc. The receiver is tuned to resonance at 80 mc. Thus the unmodulated carrier does not come in at the point of resonance on the curve, but rather to one side of this point. Any shift in frequency of the

carrier will cause a variation in the strength of the current flowing in the receiver.

Frequency modulation of the carrier causes such frequency shifts in step with the audio frequency. Thus the current flowing in the receiver varies in step with the audio frequency.

One great advantage of the frequency-modulation system is the comparative absence of static. The effect of static, generally, is to cause changes in the amplitudes of the signal. Since these amplitude changes are removed in the limiter circuit, static is not troublesome in frequency-modulated receivers.

#### 498. Modulation by the Effects of Light—Facsimile

The frequency-modulation transmitter may be affected by audio-frequency currents modified by light as well as by sound. If a beam of light, say about .01 in. in diameter, is passed over a picture or photograph, this beam of light will be reflected back with a varying intensity according to whether the spot on the picture is light or dark. If the spot is light, much light will be reflected back; if the spot is dark, little light will be reflected back. This reflected light is caused to fall upon a *photoelectric cell*, a device which changes light waves into electric current. The brighter the light striking this photoelectric cell, the greater the current output of the cell.

As the beam of light traverses (or scans) the picture, the reflected light varies in intensity with the light and dark spots on the picture. The result is a fluctuating current output from the cell.

If this fluctuating current is used to modulate the frequency of the carrier, the wave will then contain frequency variations in step with the fluctuating current.

At the receiving end the fluctuating current operates a stylus that passes over a special chemically treated paper in step with the movements of the beam of light at the transmitting station. The effect of the current is to cause a black spot to appear on the paper, the density of the spot varying with the strength of the current. Thus the picture is reproduced at the receiver. This process is called *facsimile transmission*.

## SUMMARY

1. The continuous wave of a transmitter must be modified in some way to convey intelligible signals.

2. Two methods of modulation (modifying the continuous wave) are used: (a) amplitude modulation (A.M.) and (b) frequency modulation (F.M.).

3. The common method used by broadcasting stations was, up to a few years ago, amplitude modulation. This method continues to be the practice generally, but a few stations transmit also by frequency modulation.

4. In amplitude modulation, the carrier wave is maintained at a constant frequency, and the sound waves are impressed on the carrier wave so as to modify the amplitude. The pattern of such waves shows an envelope on the carrier wave having fluctuations corresponding to the variations of the sound waves.

5. The process of amplitude modulation consists of using in the transmitter the principles of audio-frequency amplifier and the beat system of the superheterodyne receiver.

6. The ideal condition for amplitude modulation is to have the peak amplitude of the audio-frequency current equal the normal amplitude of the carrier current. In this case the total amplitude at the peak will be two times the amplitude of the carrier wave, or 100% modulation.

7. The power of the audio-frequency current will bring about this ideal condition when it is one half the unmodulated carrier power.

8. The modulation may be applied as audio-frequency voltage to the plate, to the grid, or to the cathode of the radio-frequency amplifier. For plate modulation, which is most common, the modulator is essentially a stage of push-pull amplification that feeds into a modulation transformer. This transformer couples the audio-frequency variation to the plate circuit of the radio-frequency amplifier.

9. The modulator must be as far away from the oscillator as possible. When the final radio-frequency amplifier is modulated, the system is called high-level modulation. Modulation at any other point is called low-level modulation.

10. Microphones have the function of impressing the energy of sound waves upon electric currents. This function is the reverse of the functions of loudspeakers. The principles used in microphones are: (1) to vary the resistance of the electrical circuit (carbon-granule type); (2) to vary the charge on the grid of a tube (condenser type); or (3) to vary the magnetic field (ribbon type or dynamic type).

11. In the frequency-modulation system of transmission the carrier wave is maintained at a constant amplitude while the frequency is varied.

12. One method of producing frequency modulation is to connect a condenser microphone across the grid tank circuit of a regenerative oscillator. Here the capacitance of the microphone varies the capacitance of the tank circuit, which in turn varies the frequency of the oscillator.

13. Frequency-modulated waves are usually transmitted in straight lines to receivers, and transmission is limited therefore to short distances.

#### GLOSSARY

- Amplitude Modulation:** Varying the amplitude of a carrier wave with an audio-frequency signal.
- Carbon Microphone:** A microphone operating on the principle of varying the resistance of a container of carbon granules by means of sound waves.
- Cathode Modulation:** A form of modulation wherein the audio signal is fed into the cathode circuit of a radio-frequency amplifier.
- Channel:** A band of radio frequencies.
- Condenser Microphone:** A microphone operating on the principle of varying the thickness of the dielectric of a condenser, thereby changing its capacitance and producing a varying voltage output.
- Crystal Microphone:** A microphone operating on the principle of making sound waves vary the compression on a crystal, thereby producing a varying voltage across the faces of the crystal.
- Discriminator:** A detector in a frequency-modulation receiver which changes variations in the received carrier frequency into audio-frequency changes.
- Facsimile Transmission:** Transmission of pictures by radio.
- Frequency Modulation:** Varying the frequency of the carrier wave in accordance with an audio-frequency signal.
- Grid Modulation:** A form of carrier modulation wherein the audio-frequency signal is fed into the grid circuit of a radio-frequency amplifier.
- High-level Modulation:** Modulation of the final radio-frequency amplifier stage.
- Interrupted Continuous Wave (I.C.W.):** Dots and dashes produced by intermittent transmitting of a carrier modulated continually by a single audio-frequency signal.
- Limiter:** A stage in a frequency-modulation receiver which limits all signals to the same amplitude.
- Low-level Modulation:** Modulation of a radio-frequency amplifier stage before the last stage.
- Microphone:** A device to change sound into fluctuating audio-frequency currents.
- Modulation:** Variation of the frequency or amplitude of a continuous carrier by means of an audio-frequency signal.
- Modulator:** An audio-frequency amplifier used to modulate a continuous radio-frequency current.
- Per Cent Modulation:** The percentage of increase or decrease of peak amplitude of the unmodulated carrier.
- Plate Modulation:** A form of modulation wherein the audio-frequency signal is fed into the plate circuit of a radio-frequency amplifier.
- Overmodulation:** A condition of modulation wherein the amplitude of

the modulator wave is greater than the amplitude of the continuous carrier, resulting in distortion.

**Side Bands:** The range of frequencies on each side of the carrier frequency produced by audio-frequency amplitude modulation.

#### QUESTIONS AND PROBLEMS

1. By what two alterations of a continuous carrier wave may modulation be effected?
2. What two types of audio-frequency variations are used to modulate a carrier wave?
3. What is the interrupted continuous-wave method of radio transmission?
4. What is meant by radio telegraphy? By radio telephony?
5. In its fundamental form, what is a modulator?
6. How do side bands arise when a radio-frequency current is modulated in radio telephony?
7. What is the channel width when a radio-frequency current is modulated in radio telephony by audio-frequency signals up to 4,000 cycles per second? Show how you derived this.
8. What factor, in addition to the strength of the carrier from the transmitter, determines what the strength of the signal from the transmitter shall be?
9. Draw a diagram showing a radio-frequency carrier 100% modulated, 50% modulated, overmodulated. Which is most desirable?
10. Describe several methods of transmitter modulation.
11. Describe, with the aid of a diagram, two methods of plate modulation.
12. Compare plate modulation and grid modulation as to advantages and disadvantages.
13. Generally speaking, to what stage is it best to couple an audio modulator?
14. What is a buffer amplifier, and what is its purpose?
15. What is the originating source of the radio-frequency portion of a radio-telephone transmitter? Of the audio-frequency portion?
16. Explain the operating principles of the five types of microphones in general use.
17. Give a short description of the form of a frequency-modulated wave.
18. Compare band widths provided for amplitude-modulated stations and frequency-modulated stations.
19. What is the function of the limiter in the frequency-modulated receiver?
20. In what manner does static affect the radio wave? How does the frequency-modulated receiver eliminate the effects of static?
21. Briefly explain the operation of facsimile transmission.

## CHAPTER 42

# The Cathode-ray Tube and Its Applications

---

**Problem 1:** *What are the principles of the cathode-ray tube?*

**Problem 2:** *How is the cathode ray used in the oscillograph to show pictures of currents in radio circuits?*

**Problem 3:** *How are television pictures produced?*

---

### 499. Geissler Tubes

Up to now we have been considering such applications of the radio tube as the amplifier, the rectifier, and the oscillator. In this chapter we will consider yet another application of this marvelous device: the cathode-ray tube.

In about the year 1874, an English scientist, Sir William Crookes, was experimenting with some Geissler tubes. These are simply long glass tubes into each end of which a metal electrode is sealed. The air inside these tubes is pumped out and in its place a very small amount of some such gas as neon is inserted. When a large voltage is placed across the electrodes this gas glows similarly to our present-day neon tubes.

When the charge on the positive electrode gets great enough, one of the planetary electrons of the gas atom near it is torn away. The gas atom then becomes a positively charged *ion*. As such, it is repelled from the positive electrode (like charges repel) and it rushes towards the negative electrode (unlike charges attract).

As it strikes the negative electrode the ion regains its missing electron from the great mass of them piled up on this electrode. Thus the gas ion again becomes an atom. In the process of changing from an ion to an atom, energy is given off in the form of light. The color of this light depends upon the kind of gas present in the tube; neon tubes give an orange light

## 626 THE CATHODE-RAY TUBE AND ITS APPLICATIONS

### 500. Crookes Tubes and Cathode Rays

Sir William Crookes did not know all this, but he noticed that if the tube was exhausted to a very high vacuum, the glow of the gas disappeared and instead the inside walls of the tube would start to glow with a strange light.

Mysterious rays seemed to shoot out of the negative electrode (the cathode) toward the positive electrode (the anode). If the cathode was made concave these rays could be focused to a point, just as light is focused to a point by the concave reflector of an automobile headlight (Figure 487).

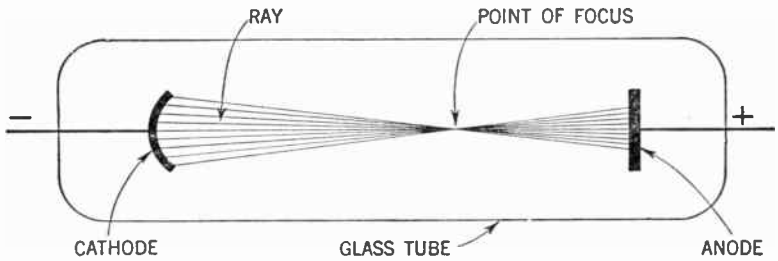

Figure 487. The cathode rays may be focused like light rays.

These rays themselves are invisible, but if a piece of platinum foil is placed at the point of focus, the concentrated energy of the rays is great enough to melt the metal—just as sunlight, focused through a lens, will burn a hole in a piece of paper held at the point of focus.

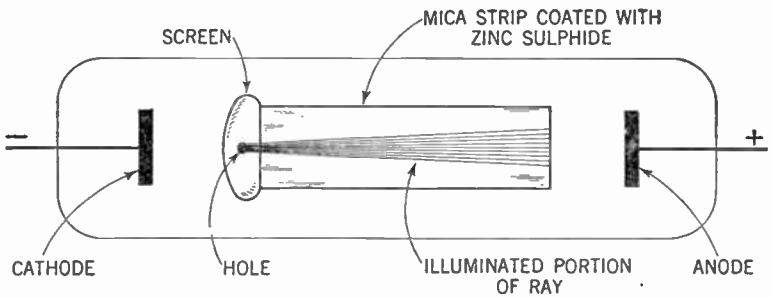

Figure 488. How the path of the cathode ray is made visible.

About 1892, Sir J. J. Thomson, another English scientist, proved that these rays coming from the cathode (and therefore called *cathode rays*) are in reality a stream of free electrons. He was able to make the path of this stream visible by placing in the tube,

parallel to the electron stream, a strip of mica whose surface was coated with zinc sulphide. This chemical has the property of glowing when struck by electrons. As the electron stream swept past this mica strip, the electrons struck against the zinc sulphide. Thus the path of these electrons was shown clearly (Figure 488).

**501 Deflection of Cathode Rays by a Charged Plate**

Thomson discovered another curious thing about these cathode rays. He held a magnet near the glass tube. The path of the rays, as shown on the mica strip, was deflected by the magnet.

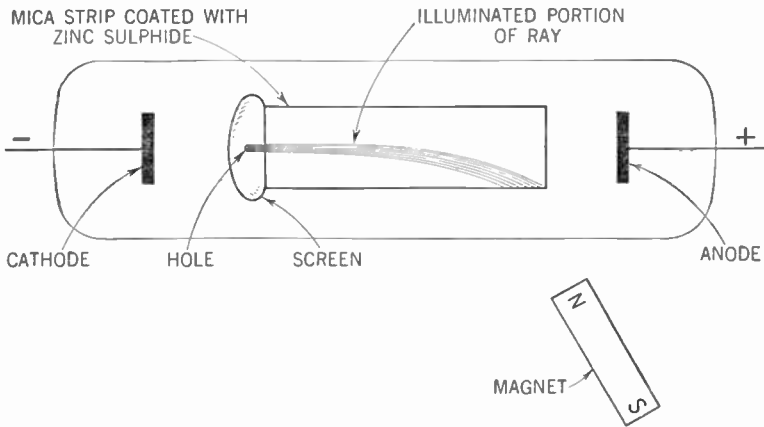

**Figure 489.** How the electron stream is deflected by a magnet.

The stream of electrons was deflected by the magnet and the stronger the magnet, the more the electrons were deflected (Figure 489).

It also proved possible to deflect the cathode rays by electrically charged plates. Since the cathode ray consists of a stream of elec-

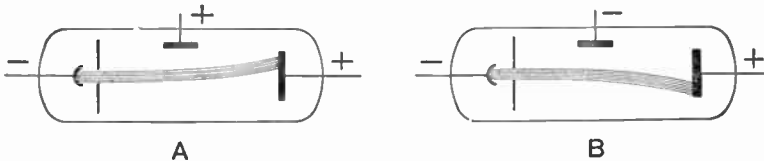

**Figure 490.** A—The effect on the electron stream of a positive charge. B—The effect on the electron stream of a negative charge.

trons, then if a plate carrying positive charge is placed parallel to the stream, the ray will be attracted toward that plate. Similarly, if the plate has a negative charge on it, the ray will be repelled



## 628 THE CATHODE-RAY TUBE AND ITS APPLICATIONS

away from it (Figure 490). Thus, by varying the charge on a third plate other than the cathode and anode, the cathode ray can be bent up or down. This third plate is known as a *deflector plate*.

### 502. Putting the Cathode Ray to Work

The next step in the direction of making the cathode ray useful was to replace the *cold* cathode described above with a heated filament similar to that used in a radio tube. This *hot* cathode, as we have learned in studying radio tubes, is a more efficient emitter of electrons than a cold metal plate charged negatively. With such a hot cathode a smaller positive charge is used on the anode than with the tube devised by Crookes.

### 503. The Tuning-eye Tube

An ingenious application of the cathode-ray (or electron-ray) tube has been developed to aid us to tune our radio receiver. In a glass bulb, from which the air is evacuated, a cathode is mounted in a vertical position. Around it is placed a funnel-shaped anode, tapering down. The inner surface of the anode is coated with a chemical that glows when struck by an electron stream. Electrons streaming off the heated cathode strike the inner surface of the anode (or target), producing a ring of light (Figure 491).

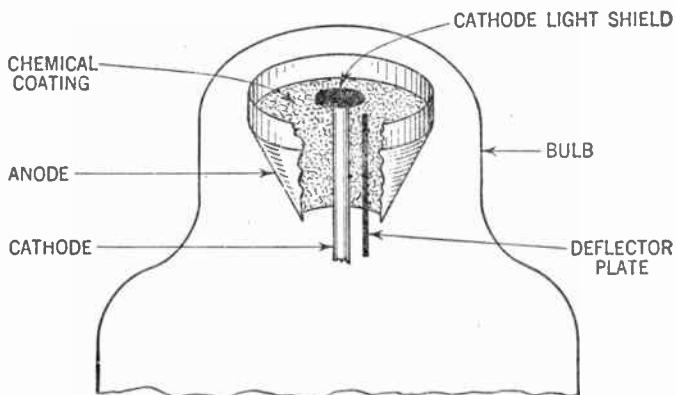

Figure 491. The tuning-eye tube.

Between the cathode and the anode a vertical deflector plate consisting of a thin wire, is inserted. If this plate is at the same potential as the anode it will have little effect on the electron stream and the glow will be an uninterrupted ring. But if the

charge on this deflector plate is less positive than that on the anode, a dielectric field will be set up between it and the anode. This field will repel electrons flowing toward the anode and thus the portion of the anode in line with the deflector plate will be dark. The greater the potential difference between the anode and the deflector plate, the greater the dark portion of the anode (Figure 492).

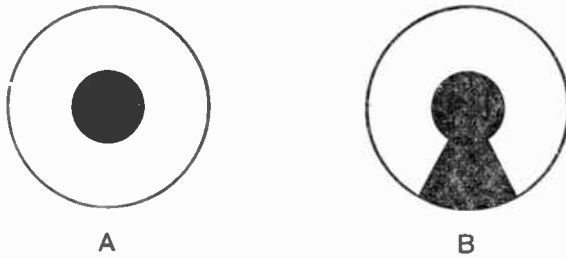

Figure 492. Top view of tuning-eye tube.  
 A—Deflector plate of same potential as the anode.  
 B—Deflector plate of lower potential than the anode.

The dark round spot in the center of this ring of light in most tuning-eye tubes is caused by a cathode light shield so placed as to make the amount of deflection more noticeable.

Now turn back to the circuit of the automatic volume control (Figure 148, Vol. I). As you know, the greater the signal strength in the detector circuit, the greater the negative voltage in the automatic-volume-control system. Thus, when a given station is tuned in at its maximum volume, the automatic-volume-control voltage for that particular station will be at its maximum.

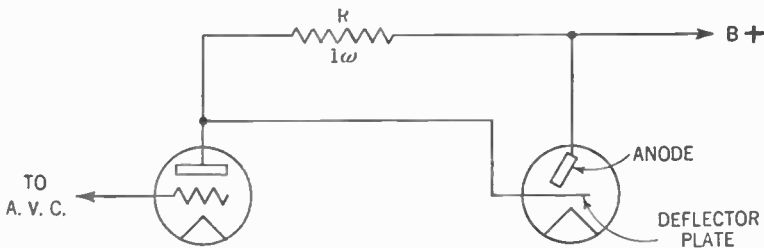

Figure 493. Circuit showing how the tuning-eye tube is connected to the automatic-volume-control line.

If the deflector plate of our electron-ray tube is connected to this source of automatic-volume-control voltage, the negative charge on this plate will be greatest when the signal is tuned in at

## 630 THE CATHODE-RAY TUBE AND ITS APPLICATIONS

its maximum. The dark portion of the ring then will be at its maximum width.

In practice, the reverse of this action is used. The negative automatic-volume-control voltage is placed on the grid of a triode connected to the electron-ray tube, as shown in Figure 493. As the grid of the triode becomes more negative (station tuned in at maximum volume), the plate current of the triode gets smaller. The voltage drop across resistor  $R$  becomes less ( $E = I \times R$ ), and thus the positive charge on the deflector plate of the electron-ray tube gets nearer to that of the anode. Thus the dark section of the ring becomes smallest as the station is tuned in to its maximum volume.

This gives us a device for actually "seeing" when the receiver is properly tuned. In modern practice both the triode and the electron-ray tube are placed in one envelope (Figure 494). Such a

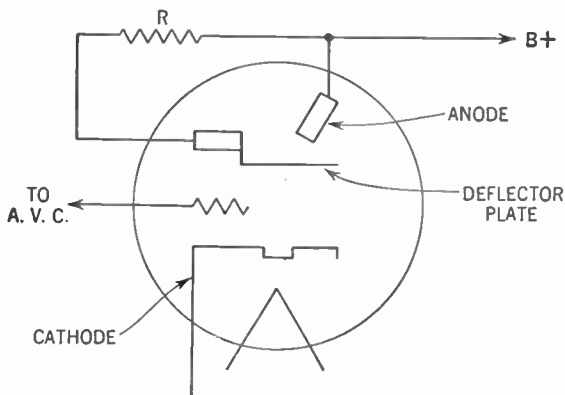

Figure 494. How the triode and tuning eye are connected in one envelope.

tube is called a *tuning-eye* tube. Examples are the 6E5 and 6U5/6G5 types.

### 504. Modern Cathode-ray Tubes

Now let us go back to the cathode-ray tube shown in Figure 488. We have already learned that if the stream of electrons strikes certain chemicals, such as zinc sulphide, it makes them glow. If we erect a screen coated with these chemicals, and focus a beam of cathode rays upon it we can see where the electrons strike it from the point of light which appears. By observing the motion of this point of light toward and away from the deflector plate, we can visualize the varying charges on the deflector plate.

## THE CATHODE-RAY TUBE AND ITS APPLICATIONS 631

Such a screen may be made by coating the inner side of the end of the tube behind the anode with these chemicals (called *fluorescent chemicals* or *phosphors*). To enable the electron stream to strike this screen, a hole is cut in the anode plate and this plate is moved closer to the cathode (Figure 495). Between the cathode

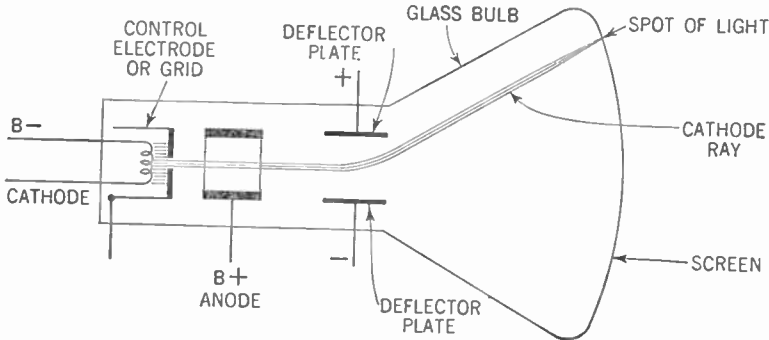

Figure 495. The basic diagram of the cathode-ray tube.

and the anode is a control electrode, a tube which is slipped over the cathode. The stream of electrons must pass through the small hole at the end of this electrode. A negative charge on this control electrode will narrow the electron stream passing through this hole and thus will reduce the beam density or current. Two deflector plates are inserted, one above the stream and one below. Since one plate is positively charged and the other negatively charged, the deflection of the ray is twice as great as with one plate.

### 505. The Electron Gun

It was found that cathode rays may be focused to a sharp point in somewhat the same way as a light beam may be focused with a lens. The focusing device consists of a second hollow anode inserted between the control electrode and the original anode. The positive charge on this second anode is usually about one-fifth of the charge on the original anode. At this value the cathode ray is focused so that it appears as a pinpoint of light on the screen. The voltage on this second anode is made variable to provide a means of focusing (Figure 496).

The original anode is called the *accelerating anode*, since its function is to speed up or accelerate the electron stream from the cathode to the screen or target. The second anode is called the

## 532 THE CATHODE-RAY TUBE AND ITS APPLICATIONS

*focusing electrode* for obvious reasons. Varying the voltage on this electrode varies the size of the spot of light appearing on the screen. Sometimes a second accelerating anode is inserted between

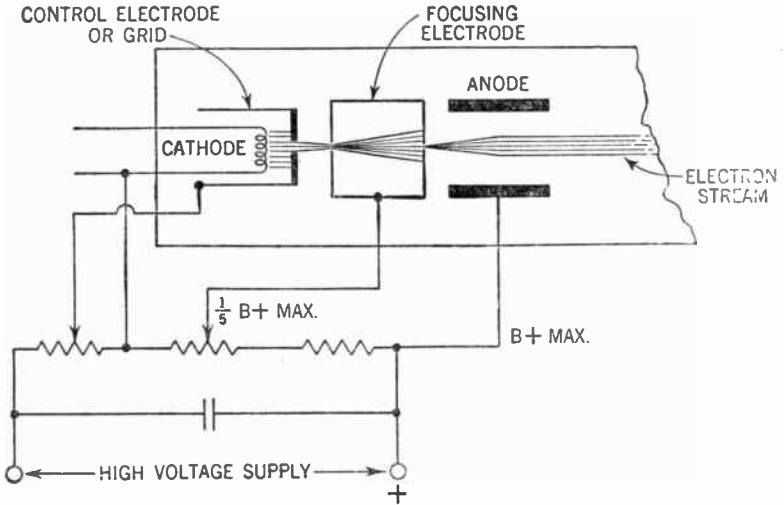

**Figure 496.** Voltage relationship between the various portions of the electron gun.

the control electrode and the focusing electrode. The complete assembly of cathode, control electrode, focusing electrode, and accelerating anode is called the *electron gun*.

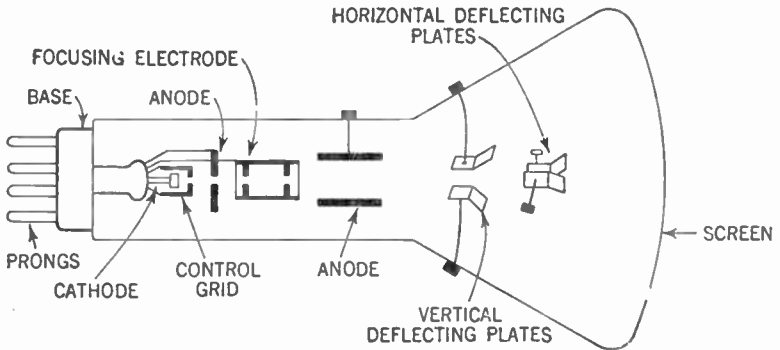

**Figure 497.** The cathode-ray tube.

Placing opposite charges on the deflector plates creates a dielectric or electrostatic field between these plates which tends to deflect the electron stream passing between them toward the positively charged plate. By varying the charges on these plates (and

thereby varying the strength of the electrostatic field) the electron beam is moved toward one or the other and the luminous spot on the screen moves likewise. When they are placed so that the luminous spot moves in a vertical plane (up and down), these plates are called the *vertical deflecting plates*.

By placing two similar plates at the sides of the tube, that is, to the right and left of the electron beam, the luminous spot is also made to move in a horizontal direction or plane. These two plates are called the *horizontal deflecting plates* (Figure 497).

**506. The Cathode-ray Oscillograph**

We are now ready to understand how an electric current can be made to draw its picture on the screen of a cathode-ray tube. The machine which pictures the movement of the electric current is called a *cathode-ray oscillograph* or *oscilloscope*. Assume there is no charge on any of the deflecting plates. The electron stream will be focused to a pinpoint of light appearing in the center of the screen (Figure 498-A).

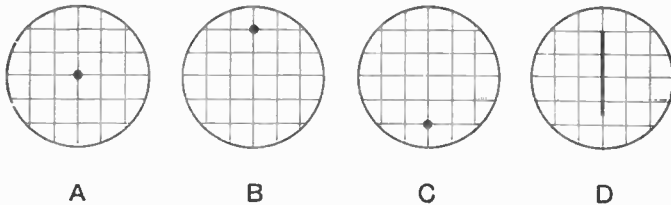

**Figure 498. View of screen of the cathode-ray tube showing the positions of the spot of light.**

If a voltage is placed on the vertical deflecting plates so that the upper plate is positive and the lower is negative, the point of light appears above the center of the tube (Figure 498-B). The distance the point of light is moved above the center of the screen depends upon the voltage on the vertical plates. The *sensitivity* of the tube (that is, the number of volts required to deflect the spot of light 1 in.) is given by the tube manufacturer. Thus with a tube that has a deflection sensitivity of 50 volts per inch, if the spot of light has moved, say, an inch and a half above the center position, we know the voltage across the plates is 75 volts. You see that we may use this tube as a voltmeter. For convenience of measurement a cross-ruled piece of celluloid may be mounted over the screen of the tube.

## 634 THE CATHODE-RAY TUBE AND ITS APPLICATIONS

If our connections are reversed so that the bottom vertical deflecting plate is positive, the spot moves below the center of the tube (Figure 498-C). If an alternating voltage is placed on the plates the spot of light will move up and down in step with the alternations of voltage.

If the frequency of the alternating voltage is low enough we can actually see the spot move up and down. But if the frequency is too high for our eye to follow, say 60 cycles or more per second, the moving spot will appear as a continuous vertical line (Figure 498-D).

Of course, a corresponding effect can be had by using the horizontal deflecting plates. Our spot then moves from left to right or vice versa.

Assume that we have placed a 60-cycle alternating voltage on the vertical plates. In  $\frac{1}{60}$  second the spot will have moved from the center of the screen, up to the top of its path, down to the center again, down to the bottom of its path and up again to the center. You know, of course, that this sequence represents one complete cycle. Assume that at the same time a constantly increasing voltage is placed on the horizontal plates, which tends to drive the spot from the extreme left of the screen to the right in

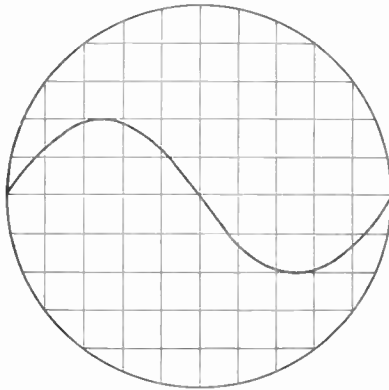

Figure 499. Trace described by a sine wave.

$\frac{1}{60}$  second. As a result of these two voltages the spot describes a sine curve (Figure 499).

If at the instant the spot reaches the extreme right of the screen, the voltage on the horizontal deflecting plates drops to zero and starts over again, another sine curve is traced over the

original one. This continues and the effect is as if the curve stood still, enabling us to inspect it.

**507. The Sweep Circuit**

The horizontal component of the movement of the spot of light is a continuous, even, left-to-right motion until the extreme right of the screen is reached. At that instant the spot is returned to its original position at the extreme left of the screen. This motion is described as the *linear sweep* of the cathode-ray tube. The voltage wave form on the horizontal deflecting plates to accomplish this sweep is shown in Figure 500. Because of the shape of this

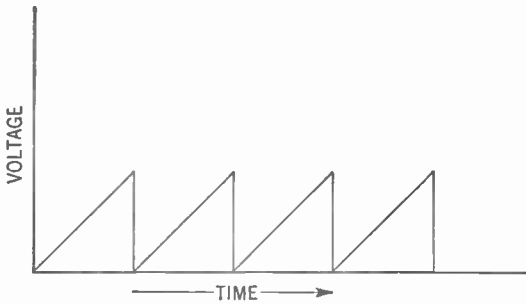

Figure 500. Wave form of the output of a sawtooth oscillator.

wave form the device that produces it is called a *sawtooth* oscillator. Another name for it is the *linear timing axis* oscillator.

**508. Neon-bulb Oscillators**

A simple sawtooth oscillator is shown in Figure 501. Here direct current flowing through a resistor ( $R$ ) charges a fixed condenser ( $C$ ). Across this condenser is a neon bulb ( $N$ ). This bulb has no effect on the condenser until a voltage high enough to flash the bulb (about 60 volts) is built up across the plates of the condenser. When this voltage is reached, the gas within the bulb ionizes. The bulb becomes a conductor, instantly discharging condenser  $C$ .

As the voltage across the condenser drops to almost zero, the neon gas in the bulb deionizes. This suddenly makes the bulb an insulator, and another cycle begins as the condenser starts charging up again.

The frequency of these cycles is determined by the length of time it takes to charge the condenser to the flashing point of the



## 636 THE CATHODE-RAY TUBE AND ITS APPLICATIONS

neon bulb. By selecting proper values of capacitance and by making  $R$  variable, a sweep of any frequency from a few cycles up to many thousands may be obtained.

In Figure 502 is shown an improvement over the simple neon-bulb oscillator. Substituted for the neon bulb is a tube that

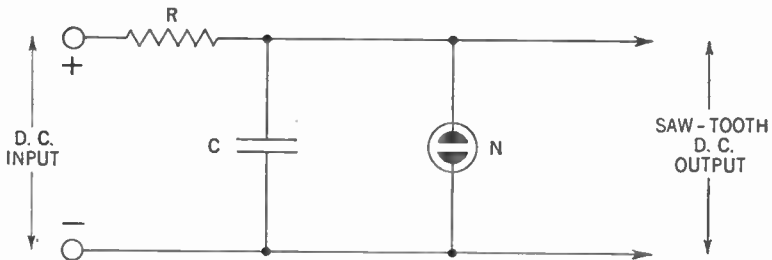

Figure 501. A sawtooth oscillator using a neon bulb.

looks like an ordinary triode. In this tube, however, a small amount of some such gas as neon is introduced. The action of this tube (which is called a *thyatron*) is similar to that of the neon bulb, except that its flashing voltage may be set to any predetermined value by using the proper value of grid-bias voltage. Two

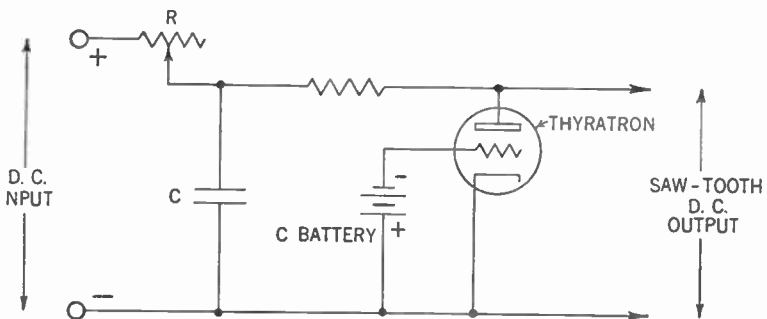

Figure 502. A sawtooth oscillator using a thyatron tube.

tubes of this type are the 884 and 885. In these tubes the discharges will occur when the plate voltage reaches about seven times the grid-bias voltage.

In practice, oscillographs are sold in compact units with knobs for control and with means of connecting to radio circuits. Amplifiers are usually provided in commercial oscillographs to amplify the input voltages to the vertical and horizontal deflecting plates. Our complete oscillograph then consists of the following parts:

1. Cathode-ray tube
2. Vertical amplifier
3. Horizontal amplifier
4. Timing-axis oscillator
5. Power-supply unit

### 509. Using the Cathode-ray Oscillograph

It is not the purpose of this book to enter into a discussion of all the tests which can be made with the cathode-ray oscillograph. Such a discussion is suited to a more advanced text. Indeed, whole volumes have been written about this subject alone. We will try here to present some simple principles encountered as we operate this marvelous device.

We already know that we can use the oscillograph to measure alternating and direct voltages. Note that it is the *peak* alternating voltage we measure here, not the root-mean-square voltage (as measured by an alternating-current voltmeter).

We may examine the wave form of an alternating voltage by impressing this voltage on the vertical deflecting plates and impressing the voltage obtained from the sawtooth oscillator on the horizontal plates. If we make the frequency of the horizontal voltage equal to the frequency of the alternating voltage under test, we get the picture of a single cycle of that alternating voltage. This picture or *trace* seems to stand still, thus permitting close inspection. Deviations from the true sine curve can be clearly seen.

You can see that if we know the frequency of the sawtooth voltage we can tell the frequency of the alternating voltage. If the frequency of the voltage on the horizontal plates is a *sub-multiple* of the alternating voltage under test (that is,  $\frac{1}{2}$ ,  $\frac{1}{3}$ ,  $\frac{1}{4}$ , or the like), we get 2, 3, 4, or a corresponding number of cycles appearing on the screen. As an example, assume we apply a 60-cycle alternating voltage on the vertical plates. If the sawtooth voltage applied to the horizontal plates also has a frequency of 60 cycles per second, we get 1 cycle on the screen. If it has a frequency of 30 cycles per second ( $\frac{1}{2}$ ), we get two cycles on the screen; 20 cycles per second produces 3 cycles, and so forth.

Although the use of the linear timing axis (the sawtooth voltage) is fairly general, there are some applications of the oscillograph where it is not used. Thus, if we wish to see the phase

## 638 THE CATHODE-RAY TUBE AND ITS APPLICATIONS

shift in an electrical device, we can show it pictorially by impressing the input voltage to this device on one set of plates and the output voltage upon the other set of plates.

Graphic pictures of sound waves also may be traced on the screen by using the linear timing axis and connecting the output of a microphone to the vertical plates.

As stated, these are but a few of the many applications of the cathode-ray oscillograph.

### 510. Television

The fairy tales of all nations have had some tale of men who could see what was happening at a great distance, far beyond the range of human sight. The twentieth century has seen this tale come true. The invention of television has been one of mankind's greatest achievements.

Although the details of television are beyond the scope of an elementary radio text, the principles are quite simple and we shall present them briefly here.

The eye sees objects by the light reflected from them. If an object did not reflect light it would be invisible. Assume we have a spot that is illuminated by a bright light. If this spot is light in color, it will reflect a good deal of the light falling on it. If it is dark, it will reflect but little of the light falling on it.

Further, assume that we have a device such as a photoelectric cell which can convert light energy into electrical energy. If all the reflected light from the light-colored spot falls upon this device, a large current will flow. If all the reflected light from the dark-colored spot strikes this device, less current will flow.

A picture can be broken down into spots of color of varying degrees of light and dark shades. If the device that changes light energy into electrical energy (the *photoelectric* cell) moves from spot to spot successively (we call this *scanning* the picture), the current set flowing in the photoelectric device will vary in step with the light and dark spots.

If this varying current is sent finally into a device whose action is the reverse of the photoelectric device—that is, a device whereby electrical energy is changed into light energy—and if this reproducing device moves in step with the photoelectric device, the picture may be reconstructed on a screen (Figure 503).

This explanation covers the principle of television. The vary-

## THE CATHODE-RAY TUBE AND ITS APPLICATIONS 639

ing current may be sent over wires, it may be used to modulate a radio wave and send the variations many miles through space. If the scanning is rapid enough, pictures of moving objects may

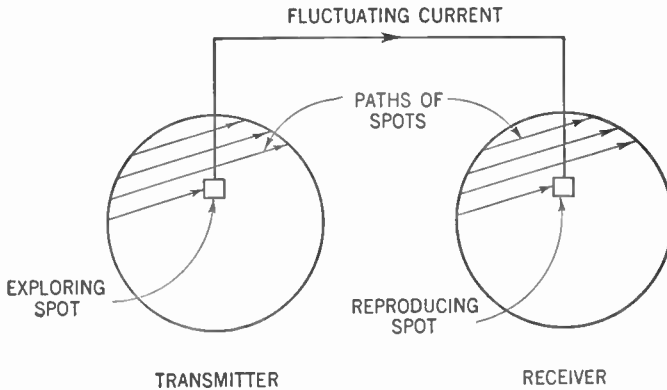

**Figure 503. The basic principle of television. The two spots keep in step with each other.**

be shown in rapid succession on the screen of the television receiver, thus giving the illusion of motion just as motion pictures do.

### 511. The Iconoscope

There are a number of methods for producing the varying current at the television transmitter. The most modern employs our old friend, the cathode ray, in a device called the *iconoscope*.

There are certain materials, such as the metal *caesium*, which have the peculiar property of shooting off electrons when exposed to light. We call such materials *photoelectric* materials. The electrons thus discharged are called *photoelectrons*. The greater the intensity of the light, the greater the number of photoelectrons discharged.

In the iconoscope a fine-mesh metal screen is coated with some insulating material, care being taken to leave the openings of the mesh free. These openings are filled with silver plugs coated with the photoelectric metal caesium. Each space so filled with the photoelectric plug is called an *element*. This screen (called a *mosaic*) is mounted in a glass bulb from which the air has been exhausted (Figure 504).

The coated side of the mosaic (the *photosensitized* side) faces

## 640 THE CATHODE-RAY TUBE AND ITS APPLICATIONS

the front of the bulb and the rear side faces an *electron gun* of the type previously described. In front of the mosaic is mounted a metal ring called the *collecting element*.

When light strikes an element of the mosaic, photoelectrons are emitted. The greater the intensity of the light the more elec-

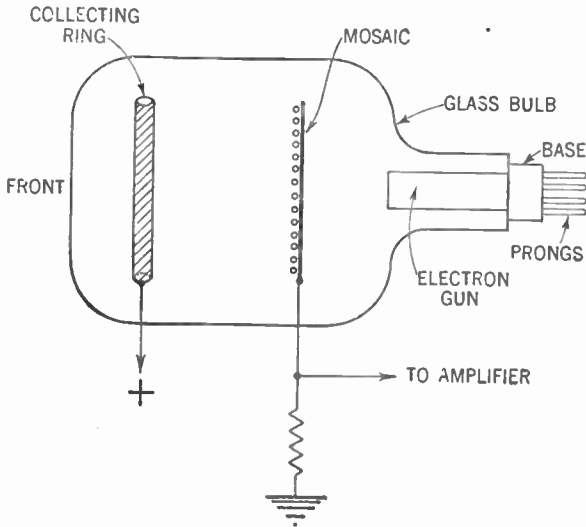

Figure 504. The iconoscope

trons are shot off. This illuminated element of the mosaic thus receives a positive charge, the value of this charge depending upon the intensity of the light. The function of the collecting ring or element is to collect the free photoelectrons and drain them out of the bulb.

Light reflected from a picture, striking the mosaic, will cause varying positive charges to appear on the elements of this mosaic. The positive charge on a particular element will depend upon the intensity of the light reflected from that portion of the picture which reaches that particular element.

The mosaic is swept from the rear by a thin stream of electrons emitted by the electron gun. As this electron stream strikes a particular element it supplies the missing electrons and thus the positive charge is neutralized.

Each element is coupled by capacitance to the screen. Any change in the charge on the element, therefore, will set electrons flowing (set up an electric current) in the screen. This current

is fed into an amplifier and is used to modulate a carrier current which in turn causes a modulated radio wave to be radiated.

The electron stream from the electron gun sweeps across the charged elements in a horizontal direction, traversing one horizontal row after another. Modern iconoscopes utilize a beam which can sweep or scan 441 rows of elements per second.

### 512. The Television Reproducer

In the television receiver the cathode-ray tube, shown in Figure 497, is used as a reproducer. The tube is adjusted so that the electron beam sweeps across the surface of the screen in step with the beam in the iconoscope. After the modulated wave has been received, amplified, and demodulated, the varying current is fed to the control electrode or grid of the tube. This electrode, you will recall, varies the density of the beam, thus varying the intensity of the light produced on the screen.

For example, if at one instant the beam of the iconoscope discharges an element which has received a large positive charge due to the fact that a bright light had fallen on it, a large current flows from the screen to the modulator of the transmitter. At the receiving end the beam of the cathode-ray tube is at a position on the screen corresponding to the position of the beam in the iconoscope. The large current flowing into the control grid causes a bright spot to appear on the screen. Thus dark and bright spots appear on the cathode-ray screen in step with the dark and bright spots of the picture at the transmitting studio. Since these spots constitute the picture, the picture is reproduced on the receiving screen.

These spots merge to produce the picture because of two factors. One is the persistence of human vision. The eye sees a light for a fraction of a second after the light has disappeared. Thus we get an overlapping of spots which blend to give us the picture. Similar to this is the persistence of glow which the chemicals on the cathode-ray screen possess. The glow persists for a fraction of a second after the electron stream has moved to the next spot. Once again the spots merge to produce the picture. If successive pictures are produced rapidly enough we get the illusion of motion pictures.

## 642 THE CATHODE-RAY TUBE AND ITS APPLICATIONS

### SUMMARY

1. The **Crookes tube** is known as a **cathode tube** because electrons are given off from the cathode pole of the tube. The tube is made by having two metal poles protrude into a sealed tube from which most of the air has been pumped out. When the ends of the metal electrodes are charged oppositely (by connecting them to a static electric machine or an induction coil) with a high voltage, electrons stream from the cathode.

2. The deflection of the stream of particles both by magnetic fields and by dielectric fields is evidence that the particles given off by the cathode are electrons.

3. When the cathode is made hot, the principle of the Crookes tube is used as a modern **cathode-ray tube** for radio work.

4. The most important uses in radio for this cathode tube are for the **tuning eye** and for the **cathode-ray oscillograph**.

5. The principles of the cathode-ray oscillograph are that (1) a screen coated with fluorescent material glows when bombarded with electrons of the cathode rays. (2) When the cathode rays are focused to a cone-shaped beam a single point of light is formed on the screen. (3) The beam may be deflected both vertically and horizontally by properly placed **deflecting plates**. (4) When these plates are charged by the varying voltages of radio circuits the screen may be used to show pictures of the sine curve, of the current in a radio tube, and of other characteristics.

6. **Television** or the transmission of pictures through space is a modern application of several principles connected with radio and with electrons: In brief, television depends upon (1) the fact that light causes certain substances to emit electrons proportional to the intensity of the light; (2) the electron impulses can be amplified and transmitted as electromagnetic waves; (3) electromagnetic waves can be detected, amplified and transformed into light varying in intensity just as did the original light.

### GLOSSARY

**Accelerating Electrode:** The electrode in the cathode-ray tube which speeds up the stream of electrons from the cathode to the plate.

**Cathode Ray:** A stream of free electrons.

**Cathode-ray Oscillograph:** A device which traces out a graph on a fluorescent screen, which graph may be used to interpret the nature of a wave.

**Cathode-ray Tube:** A tube in which a stream of electrons is deflected in various directions under the influence of a set of nearby charged plates.

**Collecting Element:** A metal ring which collects the electrons emitted by the caesium elements in the iconoscope.

## THE CATHODE-RAY TUBE AND ITS APPLICATIONS 643

**Control Electrode:** A tube with a hole at the end of it placed between the anode and cathode which controls the beam density in a cathode-ray tube.

**Deflector Plate:** A plate in a cathode-ray tube which, by receiving a charge, deflects the cathode ray.

**Electron Gun:** The complete assembly of cathode, control electrode, focusing electrode, and accelerating electrode in a cathode-ray tube.

**Focusing Electrode:** An electrode in a cathode-ray tube, used to focus the cathode-ray beam on the screen.

**Horizontal Deflecting Plates:** Electrodes in a cathode-ray tube which serve to move the focused points from left to right across the screen.

**Iconoscope:** A tube used in television transmission to pick up light-image impulses and change them into electrical impulses.

**Linear Sweep:** Movement of the focused point from left to right and back.

**Linear Timing-axis Oscillator:** An oscillator which sweeps the focused dot of an oscillograph periodically across the screen from left to right.

**Mosaic Screen:** A screen in which are imbedded photoelectric particles insulated from each other and which change light energy into electrical energy.

**Oscilloscope:** Same as the cathode-ray oscillograph.

**Photoelectric Materials:** Materials which convert light energy into electrical energy.

**Sawtooth Oscillator:** Same as a linear timing-axis oscillator.

**Television:** The process of sending scenes via radio waves.

**Thyratron:** A tube used in the oscillograph to give sawtooth oscillations.

**Tuning-eye Tube:** A cathode-ray tube used for aiding in the tuning of a receiver.

**Vertical Deflection Plates:** Electrodes in a cathode-ray tube which serve to move the focused dot up and down on the screen.

### QUESTIONS AND PROBLEMS

1. What is the nature of the cathode ray in a Crookes tube?
2. Explain the structure and operation of the tuning-eye tube.
3. Explain, with the aid of a diagram, how the tuning-eye tube is connected in a radio receiver to aid in tuning.
4. Why is a triode amplifier used in conjunction with a tuning-eye tube?
5. How are the parts of cathode rays made visible in a cathode-ray tube?
6. How are electrons made to move up and down in a cathode-ray tube? To the right and left?



## 644 THE CATHODE-RAY TUBE AND ITS APPLICATIONS

7. Draw the screen of a cathode-ray oscillograph and locate the visible point for the conditions represented by charges on the deflecting plates:



NO CHARGE ON ANY PLATE



CHARGES ONLY ON THE VERTICAL PLATES

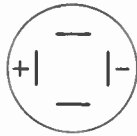

CHARGES ONLY ON THE HORIZONTAL PLATES

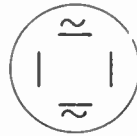

A.C. ON THE VERTICAL PLATES

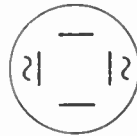

A.C. ON THE HORIZONTAL PLATES

8. How may the cathode-ray oscillograph be used as a voltmeter?
9. Explain the type of oscillogram (wave picture) that would be obtained if an alternating sine voltage were placed on the vertical plates while an ever-increasing voltage acted to drive the focused light point from left to right under the influence of the horizontal deflecting plates.
10. What is the purpose of a sawtooth oscillator in the oscillograph?
11. Make the diagram of a simple sawtooth oscillator using a neon tube and explain how it works. How is its timing controlled?
12. List the five essential functional parts of a complete oscillograph.
13. List several uses to which an oscillograph may be put.
14. State the general principle of television.
15. Describe the structure of an iconoscope and explain how it works.
16. How many rows of elements are swept per second in modern iconoscopes?
17. Explain how the cathode-ray tube is used in a television receiver to reproduce a scene.
18. How does a series of dots on the cathode-ray tube screen form a total picture as well as show motion?

# Demonstrations

# Demonstrations for Volume I

## Chapter 2

**Demonstration 1:** *To show how energy is handed on by wave motion.* Set up a row of dominoes, so spaced that when one falls it upsets its neighbor. Tip the first and note how energy is handed down the line without any domino moving more than a small distance. (See Figure 4).

## Chapter 3

**Demonstration 1:** Light a carbon-vacuum electric bulb. Note that heat and light waves pass through the vacuum.

**Demonstration 2:** Demonstrate the apparatus shown in Figure 9.

**Demonstration 3:** Obtain a number of soft iron rods about  $\frac{1}{4}$  in. in diameter and 12 in. long. Make a bundle of them about  $1\frac{1}{2}$  in. in diameter. Wrap a layer of tape over them. Wind upon this core about 3 lbs. of bell wire (No. 18 double cotton covered) making a winding about 6 in. wide. Attach the ends of this coil to the 110-volt alternating-current line. Wind another coil of bell wire consisting of about 30 turns having a diameter of 2 in. Attach a telephone receiver to the ends of this coil. Slip the small coil over the iron core. Note the pickup of the 60-cycle note. Move the small coil further and further away from the large coil. Note that the note falls off.

## Chapter 4

**Demonstration 1:** *To show the need for an aerial.* Set up the following apparatus:

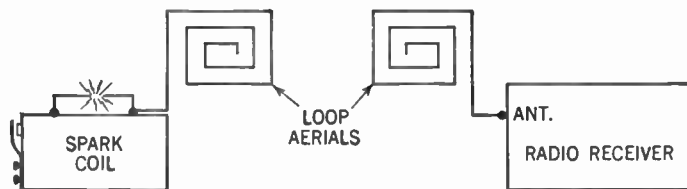

The loop aerials or antennas may be made by winding about 15 turns of bell wire on dowel sticks, spacing the turns about 1 in. apart. Place the spark coil in a felt-lined box to absorb the spark noise. The radio receiver will pick up the spark over a fairly large distance.

Disconnect the transmitting antenna. Note that the pickup drops off. Disconnect the receiving antenna. The pickup drops off still more and disappears.

**Demonstration 2:** *To illustrate the natural period of a wave or vibration.*

(a) Suspend two pendulums, one 2 ft. long and the other 3 ft. long. Count the number of swings of each in one minute.

(b) Strike various tuning forks of different sizes. Note the different notes characteristic of each fork.

**Demonstration 3:** *To demonstrate the principle of tuning.* Obtain four tuning blocks having the following frequencies: two of 512 vibrations per second and two of 256 vibrations per second. Strike one 512-v.p.s. block. Note that only the other 512-v.p.s. block picks up the vibrations. Then strike one 256-v.p.s. block. Only the other 256-v.p.s. block will pick up these vibrations.

**Demonstration 4:** Demonstrate the apparatus shown in Figure 11 to show how the reproducer changes fluctuating electrical currents into sound.

**Demonstration 5:** *To show how the detector works.* Connect up a crystal receiver as shown in Figure 22. Short out the crystal. Note how the signal disappears.

## Chapter 5

**Demonstration 1:** *To illustrate the behavior of conductors and insulators.*

Arrange the following circuit:

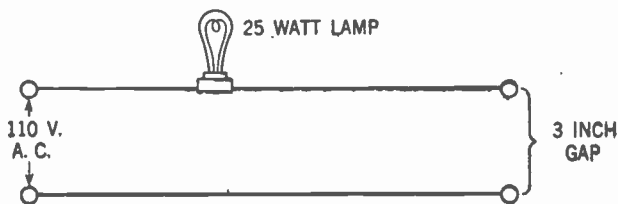

Across the gap in the circuit place in turn rods of the following materials: glass, iron, brass, copper, porcelain, carbon, zinc, wood, and the like. The 25-watt lamp lights up when a conductor is placed across the gap.

**Demonstration 2:** *To construct an aerial.* If the school building is not of the steel-frame type, run a 50-ft. piece of bell wire around the molding of the room. Another method of construction is to run a 100-ft. length of bell wire from the window to a nearby tree or flag pole. Failing either of these possibilities, the wire may be dropped out the window and permitted to hang down, or else run up the side of the building to the roof. Care should be taken that the bare end of the wire does not touch the ground or the side of the building.

Chapter 6

**Demonstration 1:** Show the students various tuning coils from commercial receivers, explaining methods of connecting the windings into the circuit.

**Demonstration 2:** (a) Open up various fixed condensers and show their construction. Show the ratings on these condensers.

(b) Show various variable tuning condensers. Point out the rotor and stator plates and show their connections.

**Demonstration 3:** Repeat Demonstration 3, Chapter 4.

**Demonstration 4:** *To exhibit a mechanical analogy of the fact that for resonance or tuning the transmitter and receiver need not be physically the same.* Take two tuning forks mounted on resonance boxes, one of 320 vibrations per second and the other of 384 vibrations per second. Strike one and show that there is no resonance. Then load one or more pinch clamps on the 384-v.p.s. fork. By trial and error find the condition where striking the 320-v.p.s. fork results in resonance with the 384-v.p.s. fork and its load.

Chapter 7

**Demonstration 1:** Perform the experiment described in Figure 14.

**Demonstration 2:** Demonstrate the construction of a telephone receiver, of a pair of earphones, and of a magnetic loudspeaker.

**Demonstration 3:** *To show that a reproducer will respond to a varying but not a steady current.* Connect a battery, an ammeter, a magnetic loudspeaker, a file, and a screwdriver as follows:

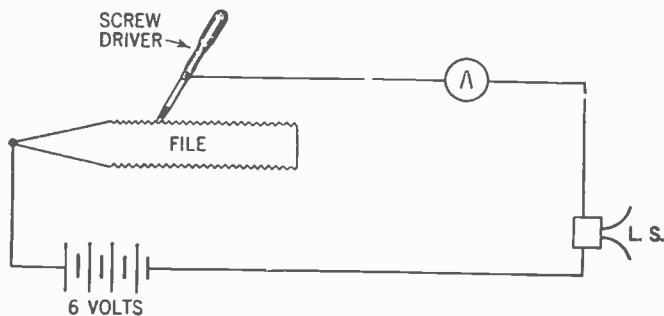

When the screwdriver is in resting contact with the file, a steady current flows through the ammeter, but no sound results. But as the screwdriver slides over the file a fluctuating current flows through the ammeter and a sound is heard coming from the loudspeaker.

Chapter 8

**Demonstration 1:** Show the students various crystals, of fixed and adjustable type.

**Demonstration 2:** Connect a crystal detector, 1,000-ohm resistor, a single dry cell, and a sensitive milliammeter in series. Record the milliammeter reading. Now reverse the dry cell. Compare the milliammeter reading with the previous recording.

**Demonstration 3:** Construct the crystal set shown in Figure 22.

### Chapter 9

**Demonstration 1:** Show a barograph chart and explain it.

**Demonstration 2:** Construct a graph on the basis of the time it takes the students to work five problems.

**Demonstration 3:** If a cathode-ray oscillograph is available, show an alternating-current sine curve, a direct-current voltage, and an audio-frequency (voice) wave. Interpret them.

### Chapter 10

**Demonstration 1:** On a large nail wind a coil of bell wire consisting of about 25 turns (primary). To the ends of this coil connect a key and dry cell in series. On the same nail wind a second coil (secondary) of the same number of turns. Connect a galvanometer to the ends of this coil. Closing the key of the primary coil will send a current flowing in the secondary coil (as shown by the deflection of the galvanometer).

**Demonstration 2:** *To demonstrate a step-down transformer.* Obtain a bell transformer. Place 110 volts of alternating current on the primary. Attach an electric bell to the secondary.

**Demonstration 3:** *To demonstrate a step-up transformer.*

(a) Place 6 volts on the primary of a spark coil and notice the high-voltage spark across the secondary.

(b) Put 110 volts alternating current on the primary of a neon-sign transformer. Note the high-voltage spark across the secondary (from 5,000 to 15,000 volts).

**Demonstration 4:** Construct set shown in Figure 40.

### Chapter 11

**Demonstration 1:** Cut an old dry cell in half. Point out the carbon rod, the zinc shell, and the electrolyte.

**Demonstration 2:** *To study the law of electric charges.*

(a) Suspend two pith balls from silk strings. Charge them both negatively by touching each with a hard rubber rod that has been stroked on a piece of fur. Now bring the two pith balls near each other. They repel each other.

(b) Charge one pith ball negatively as above. Charge the other positively by touching it to a glass rod that has been rubbed on silk. Now bring the two pith balls near each other. They attract each other.

**Demonstration 3:** *To distinguish between alternating current and direct current.* Connect a dry cell to a center-zero ammeter through a 30-ohm resistor. The needle moves to one side and remains stationary.

Now replace the dry cell with a magneto or a Brownlee generator connected for alternating current. Slowly rotate the handle and note how the needle of the meter fluctuates to either side of the center zero.

**Chapter 12**

**Demonstration 1:** Inspect the structure of a Leyden jar. Charge it up with an electrostatic machine. Then show the spark as it is discharged with a pair of discharging tongs.

**Demonstration 2:** Connect a 90-volt battery across a 1- $\mu$ fd. condenser. Disconnect and discharge with a piece of wire, showing the spark.

**Demonstration 3:** *To exhibit an analogy to the oscillatory discharge of a condenser.* Suspend a ball from a string about a yard long. Raise the ball to one side and release it. Note that the ball overshoots the center position and swings to the opposite side. Note how long it takes the ball to come to rest.

**Demonstration 4:** *To note the effect of self-inductance.* Connect a 90-volt battery in series with a 30-henry choke and a key switch. Close the switch. Now open it and note the spark that jumps across the gap, indicating that current is still flowing for an instant after the key switch is opened.

**Chapter 13**

**Demonstration 1:** Arrange electric light bulbs in series and parallel circuits and trace the paths of current flow for the students.

**Demonstration 2:** Repeat Demonstration 4, Chapter 10, placing a .006- $\mu$ fd. condenser across the phones.

**Chapter 14**

**Demonstration 1:** Demonstrate the apparatus shown in Figure 56. The tube may be any triode with the grid left free. The meter should be an 0-100 microammeter.

**Demonstration 2:** Demonstrate the apparatus shown in Figures 57, 58, and 59. The tube may be a type 01A with the grid left free. The meter should be 0-10 milliammeter. The B battery should be from 45 to 90 volts. A small hand magneto, turned slowly, will give the alternating-current voltage.

**Demonstration 3:** *To show how the diode acts as a rectifier.* Arrange the following apparatus:

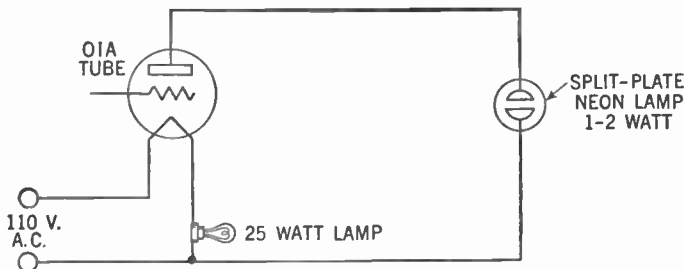

Place the neon lamp in a 110-volt alternating-current socket. Show how both plates are illuminated. Set the neon lamp in a 110-volt direct-current socket. Show that only one plate (the negative) is illuminated. The 25-watt lamp is merely a dropping resistor to reduce the 110 volts to a value suitable for lighting the 01A tube filament. Now attach apparatus to the 110-volt alternating-current line. Only one of the neon plates lights up, showing that the alternating current has been rectified to direct current by the diode.

**Demonstration 4:** *To exhibit a working diode detector.* Set up the following apparatus:

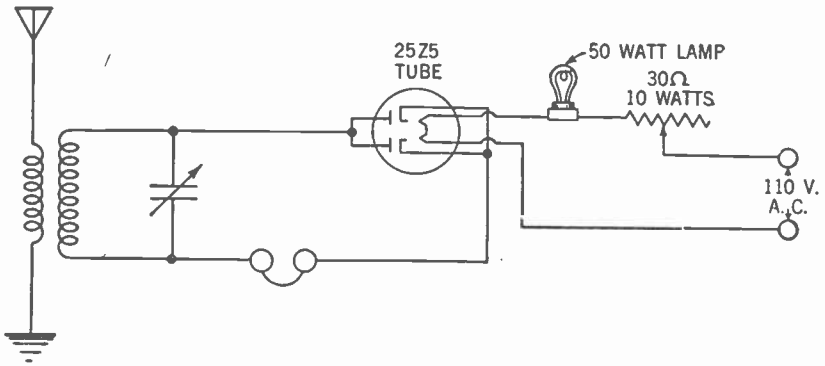

The tuner is the one shown in Figure 40 except that the crystal detector has been replaced by a diode (the 25Z5 tube). The 50-watt lamp and the 30-ohm 10-watt rheostat are used to drop the 110-volt line current to the proper value to operate the filament of the tube. The rheostat must be carefully adjusted for proper results.

If desired, the 25Z5 tube may be replaced by a 6H6 tube operating from a 6-volt source. The 50-watt lamp must then be omitted.

## Chapter 15

**Demonstration 1:** *To show how the grid voltage controls plate current.* In the set-up of Demonstration 3, Chapter 14, connect a dry cell between the grid and the filament so as to place a positive charge on the grid. Attach more and more cells in series so as to make the grid more and more positive. Note how the plate of the neon lamp glows brighter and brighter, indicating more plate current. Now reverse the cells to place a negative charge on the grid. Note how the brightness of the plate of the neon lamp diminishes and disappears when the grid becomes negative enough.

**Demonstration 2:** *To compare control of plate current by the plate voltage and by the grid voltage.* Hook up apparatus as shown in Figure 64. The tube may be a type 30. The filament may be lighted by a single dry cell. The B battery is 90 volts and should be variable. The



meter is a direct-current 0-10 milliammeter. Place the charges on the grid by connecting dry cells between the grid and the filament. Vary the grid charges and note the change in plate current for every volt change in grid voltage.

Keep the grid voltage constant and vary the plate voltage. Note the change in plate current for every volt change in plate voltage. Compare the effect on the plate current of the grid voltage and plate voltage. Make graphs.

**Demonstration 3:** Construct the receiver shown in Figure 73. Keep all leads as short as possible. Tune in a station. Remove the grid condenser. Note the effect. Replace the grid condenser and remove the grid leak. Note the effect.

**Demonstration 4:** *To study how a filament rheostat acts as a volume control.* Repeat Demonstration 2, Chapter 15, but include a 30-ohm rheostat in series with the filament and the A battery. Study the effect of changes in rheostat settings upon the plate current.

## Chapter 16

**Demonstration 1:** *To show how a varying direct current may operate a transformer.* Obtain a 1:1 or 1:2 audio-frequency transformer. Connect the primary in series with a 6-volt battery and a 30-ohm rheostat. Connect the secondary to a center-zero voltmeter. Move the rheostat arm back and forth and note the variations on the voltmeter. Note that the voltage output of the secondary is alternating in character. Also note that when there is no current variation in the primary, no voltage is produced across the secondary.

**Demonstration 2:** Repeat Demonstration 3, Chapter 3, holding the smaller coil with its axis the same as the large coil and then with its axis at right angles to the large coil. Note difference.

**Demonstration 3:** Build the regenerative receiver shown in Figure 76. It may be necessary to reverse the tickler-coil terminals if the set fails to operate.

## Chapter 17

**Demonstration 1:** Construct the set shown in Figure 92. Short out the C battery to show why the grid bias is necessary.

**Demonstration 2:** Build a public-address system as shown in Figure 93.

**Demonstration 3:** Build an electrical phonograph as shown in Figure 94.

**Demonstration 4:** *To study an analogy of the carbon microphone.* Cut into five pieces the carbon of a dry cell. Line them up in a grooved board. Connect the original ends of the carbon in series with a 6-volt battery and a 6-volt 15-watt lamp. Squeeze the carbon pieces together firmly and note the brilliance of the light. Slowly relax the compression and note how the intensity drops off.

## Chapter 18

**Demonstration 1:** To show how a tube acts as a rectifier. Repeat Demonstration 3, Chapter 14.

**Demonstration 2:** To explain the component parts of a power transformer. Repeat Demonstrations 2 and 3, Chapter 10.

**Demonstration 3:** To demonstrate the principle of a voltage divider. Connect a 500-ohm potentiometer in series with a 90-volt battery. Connect a direct-current 0-100 voltmeter to one end of the potentiometer and to the sliding arm. Move the sliding arm across the potentiometer and note how the reading of the voltmeter varies.

**Demonstration 4:** Construct the following apparatus:

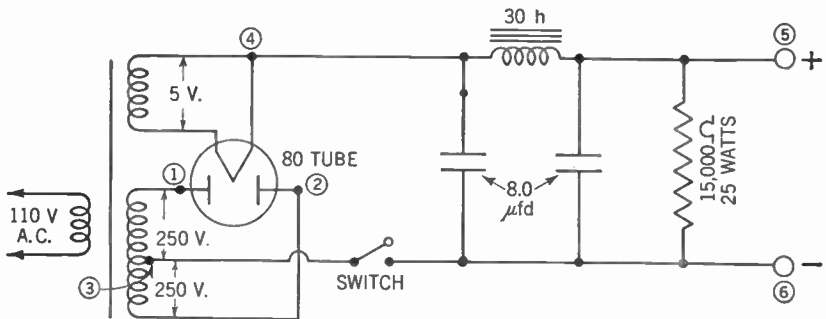

The power transformer should be able to deliver about 250 volts on either side of the center tap. The rectifier tube is a type 80. The filter condensers are  $8.0 \mu\text{fd}$ . at 450 volts direct current working voltage. The choke is an ordinary 30-henry choke coil. The voltage divider is 15,000 ohms rated at 25 watts. Connect a 2-watt split-plate neon lamp in series with a magnetic speaker and test as follows:

1. Open switch. (a) Test from point 3 to point 1. Both plates light up, indicating alternating current. 60-cycle hum is heard in the loudspeaker. (b) Test from point 3 to point 2. Both plates light up, as above. (c) Test from point 3 to point 4. One plate lights, indicating direct current. 60-cycle hum is heard in the loudspeaker.

2. Close switch. (a) Test from point 5 to point 6. One plate lights, indicating direct current. No hum is heard in the loudspeaker.

**Demonstration 5:** Repeat above with a cathode-ray oscillograph.

## Chapter 19

**Demonstration 1:** Hook up the apparatus in the upper illustration, page 655. Note the 60-cycle hum in the earphones.

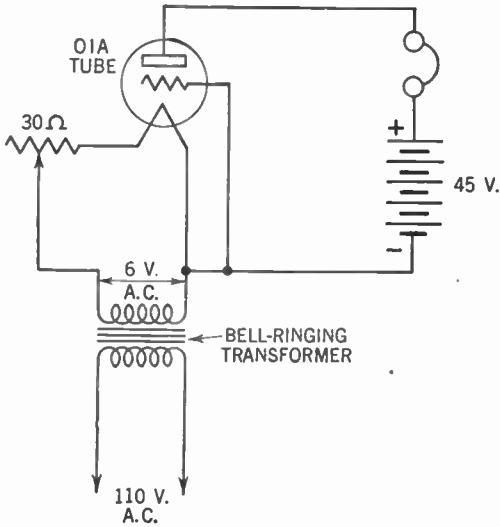

Demonstration 2: Hook up the following apparatus:

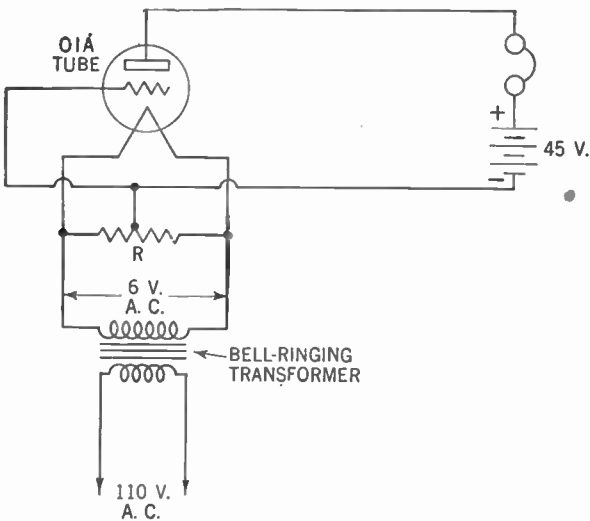

*R* is a 20 to 40 ohm center-tapped resistor. The hum is nearly gone.

Demonstration 3: Hook up the following apparatus. The hum disappears.

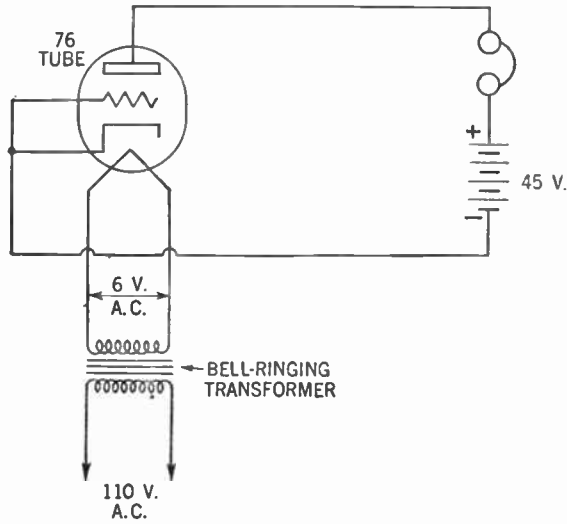

**Chapter 20**

**Demonstration 1:** Repeat Demonstration 3, Chapter 18, using a center-zero voltmeter. Leave the slider arm of the potentiometer in one position and switch the other lead of the voltmeter from one end of the potentiometer to the other. Note that one side of the potentiometer is negative and the other is positive.

**Chapter 21**

**Demonstration 1:** Construct the below A.C.-D.C. power supply. The tube is a type 117Z6GT. The condensers are 12- $\mu$ fd. 150-volt working voltage. The resistor is of 10,000 ohms and 25 watts. The choke coil is of 15 henries. When using on direct current reverse the plug to the wall outlet if the power supply fails to work.

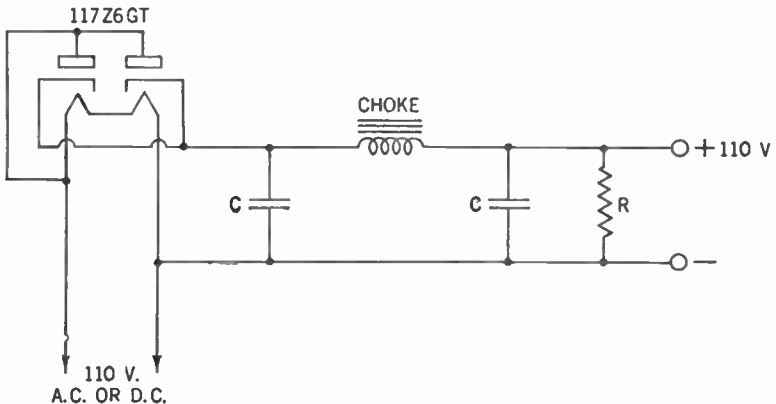

### Chapter 22

**Demonstration 1:** Construct the following apparatus:

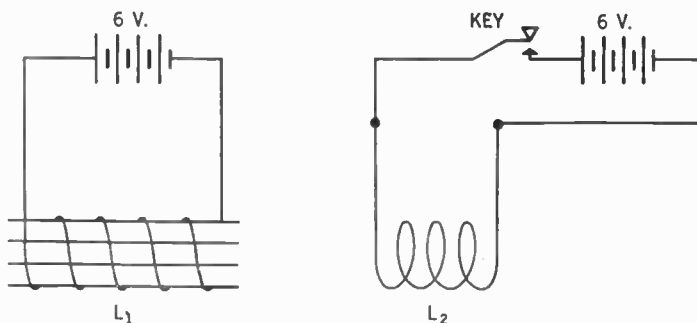

$L_1$  corresponds to the field coil of the dynamic speaker. It consists of about 300 turns of bell wire wound on a soft iron core and it is held in a fixed position.  $L_2$  corresponds to the voice coil of the dynamic speaker. It consists of about 30 turns, air wound, with a diameter of about 1 in. It is suspended so that it is free to move.

Close the key. The voice coil moves violently.

**Demonstration 2:** Obtain an old electromagnetic dynamic speaker. Open it up to show the field coil, voice coil, and spider.

### Chapter 23

**Demonstration 1:** Examine a three-gang variable condenser. Notice how each condenser moves an equal amount with the rotation of the shaft. Examine the trimmer on each condenser.

**Demonstration 2:** Construct the tuned radio-frequency receiver shown in Figure 139.

### Chapter 24

**Demonstration 1:** Repeat Demonstration 4, Chapter 15.

**Demonstration 2:** Replace the 2,000-ohm grid-bias resistor in the second radio-frequency stage in the set shown in Figure 139 by a 5,000-ohm rheostat. Note the effect on the volume of the set at different settings of this rheostat.

### Chapter 25

**Demonstration 1:** *To show that different sounds may have different pitches.* Strike different types and shapes of materials and note the pitch of each sound produced.

**Demonstration 2:** *To show how mechanical filters may remove high or low tones.* Talk through a cardboard tube, a megaphone, the cupped hands, and the like.

**Demonstration 3:** *To show how sounds of different pitches may produce currents of different frequencies.* Connect a telephone receiver to a cathode-ray oscillograph. Talk into the receiver and notice the wave picture.

## Chapter 26

**Demonstration 1:** *To show the principle of beats.* Obtain two tuning forks whose frequencies are close together (such as 320 vibrations per second and 384 vibrations per second). Strike both and hold them close to each other. Note the beats.

**Demonstration 2:** Operate ordinary radio receiver. Near-by, operate a regenerative receiver as shown in Figure 76. Tune both receivers to the same station. Now adjust the regenerative control until the regenerative receiver oscillates. The second receiver will pick up the radio wave transmitted by the regenerative receiver as a squeal or whistle.

## Chapter 27

**Demonstration 1:** Obtain as many different types of burnt-out tubes as possible. Break the glass envelopes and study the electrodes.

**Demonstration 2:** Build this push-pull audio-frequency amplifier:  $T_1$  is a push-pull input transformer;  $T_2$  is a push-pull output transformer;  $T_3$  is a 2.5-volt filament transformer;  $R_1$  is 400-ohm, 5 watts;  $R_2$  is a 20- to 40-ohm center-tapped resistor; the power tubes are type 45.

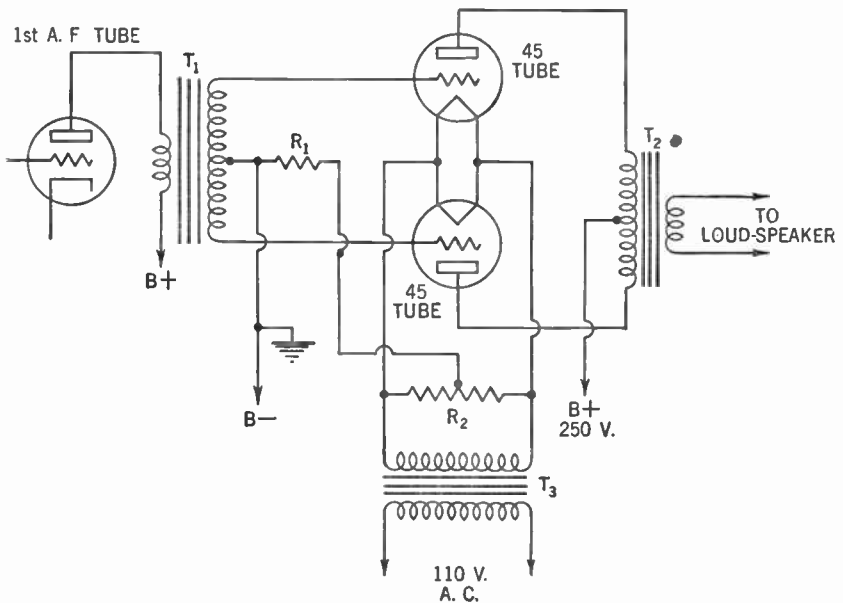

## Chapter 28

**Demonstration 1:** *To show the directional property of a loop aerial.* Obtain a portable radio receiver with a built-in loop aerial. Tune in a station. Rotate the receiver. Note how the station dies away and comes in again as the set is rotated.

# Demonstrations for Volume II

## Chapter 29

**Demonstration 1:** *To show the law of electric charges.* Repeat Demonstration 2, Chapter 11, Vol. I.

**Demonstration 2:** *To construct an electroscope.* Obtain a small cardboard or wooden box; a chalk box is ideal. Replace the top cover with a sheet of cellophane or celluloid. Place the box on end. In the top end cut a small hole and insert a one-hole rubber stopper. Through the hole in the stopper insert a screwdriver from which the handle has been removed so that the working end goes down into the box. Place a piece of gold leaf (or any light metal foil) between two sheets of paper. With a razor blade, cut through the paper two strips about  $\frac{3}{8}$  in. wide and  $1\frac{1}{4}$  in. long. Attach the gold leaf to opposite sides of the screwdriver blade by use of a little saliva. For use, follow the directions in the text.

If the cellophane is replaced by a piece of chart cloth and a square hole is cut in the bottom of the box, shining an electric light through this hole will cast a shadow of the leaves on the chart-cloth screen.

**Demonstration 3:** *To show the difference between insulators and conductors.* Repeat Demonstration 1, Chapter 5, Vol. I.

**Demonstration 4:** *To show the relative resistance of similar wires of different materials.* Connect, in series, a dry cell, a direct-current 0-30 ammeter and, in turn, each of the following: 10 ft. of No. 36 copper wire, 10 ft. of No. 36 German silver wire, 10 ft. of No. 36 soft iron wire, 10 ft. of No. 36 nichrome wire. Note the reading of the ammeter with each different wire.

**Demonstration 5:** *To show the effect of temperature on resistance.* Connect in series a 6-volt battery, a 6-volt 15-watt lamp, and about 13 in. of No. 28 nichrome wire. The lamp burns faintly. Heat the nichrome wire with a bunsen flame. The lamp goes out. When the wire cools, the lamp lights up again.

**Demonstration 6:** *To show how resistance varies with the cross-section area of a conductor.* Repeat Demonstration 4 using 10 ft. of No. 36 nichrome wire. Note the ammeter reading. Now repeat using 10 ft. of No. 18 nichrome wire. Note the ammeter reading.

**Demonstration 7:** *To show how resistance varies with the length of a conductor.* Repeat Demonstration 4, using 10 ft. of No. 36 ni-

chrome wire. Repeat, using 5 ft. of wire of the same size. Use 20 ft. of wire. Note the ammeter reading in each case.

**Demonstration 8:** *To show the heating effect of an electric current.* Pass 110 volts through a heater coil and note the temperature change.

**Demonstration 9:** *To show how a fuse works.* Connect in series with the 110-volt line a 25-watt lamp and about 2 in. of fuse wire rated at 2 amp. Short out the lamp with a piece of wire. The fuse "pops."

**Caution!** Place the fuse wire on a piece of asbestos board and use a glass screen around it to avoid being sprayed by the molten metal.

**Demonstration 10:** *To illustrate the concept of "voltage drop."*

(a) Connect in series a 45-volt battery, a 1,000-ohm resistor, a 2,000-ohm resistor, and a 3,000-ohm resistor. Test the voltage across each resistor with a direct-current 0-50 voltmeter.

(b) Substitute for the resistors a 25-watt lamp, a 50-watt lamp, and a 100-watt lamp. For the battery, substitute the 110-volt alternating-current line. Test across the lamps with an alternating-current 0-150 voltmeter.

**Demonstration 11:** *To show the total resistance of resistors in series and parallel.* Hook up the following apparatus:

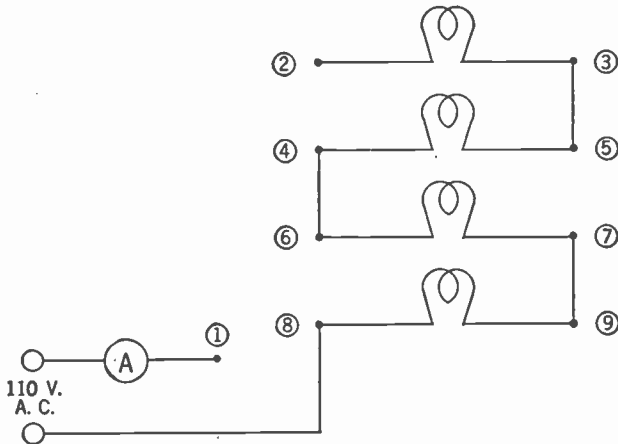

The lamps are each 110-volt, 50-watt lamps. The ammeter is an alternating-current 0-5 ammeter.

**Series connections:**

To get current through 1 lamp, connect a wire from 1 to 9. To get current through 2 lamps, connect a wire from 1 to 6. To get current through 3 lamps, connect a wire from 1 to 5. To get current through 4 lamps, connect a wire from 1 to 2. Observe the ammeter reading in each case.

**Parallel connections:**

Connect wires from 6 to 8, 5 to 7, 2 to 4 and 1 to 9. Remove all



the lamps and reinsert them one at a time, taking ammeter readings with each lamp inserted.

**Demonstration 12:** *To construct a Voltaic cell.* Place a strip of zinc and copper in a sulphuric acid solution (1 part acid to 20 parts water). Connect a voltmeter across the two strips.

**Caution!** In mixing acid with water, use an earthenware or pyrex vessel and always pour the acid *slowly* into the water. If any of the acid spills, neutralize with bicarbonate of soda.

**Demonstration 13:** *To construct a storage cell.* Place two lead strips in sulphuric acid (one part acid to five parts water). Connect a 6-volt storage battery across the lead strips for about five minutes. Remove the battery and connect a bell or direct-current voltmeter across the lead strips.

### Chapter 30

**Demonstration 1:** *To show the magnetic field around a magnet.*

(a) Place a piece of cardboard over a bar magnet. Sprinkle iron filings on the cardboard. Tap gently. The iron filings line up along the lines of force.

(b) Place a piece of magnetized watch spring between two glass plates, then lay them all on an upright delinescope and project on a screen. Sprinkle the top plate with iron filings and tap it gently. This demonstration is good for a classroom.

**Demonstration 2:** *To illustrate the molecular theory of magnetism.* Magnetize a piece of watch spring. Test its polarity with a compass. Cut the spring in half and test the polarity of each piece. Note that the ends formed by the break at the center have opposite polarity.

**Demonstration 3:** *To illustrate the Oersted effect.* Hook up the following apparatus:

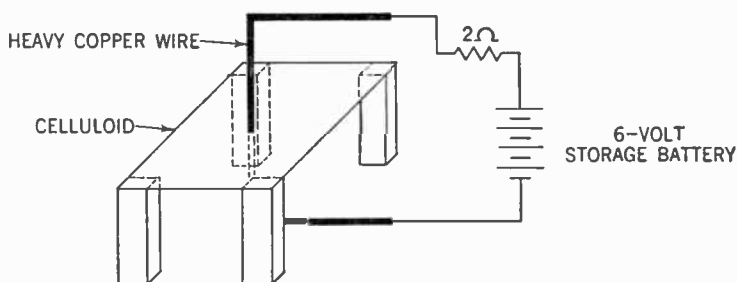

(a) Trace the magnetic lines of force by a small compass moved around on the sheet of celluloid.

(b) Place the whole device on an upright delinescope, sprinkle with iron filings, and tap gently. Be sure to focus on the plane of the celluloid sheet.

**Demonstration 4:** *To show the relationship between polarity and*

*direction of current through an electromagnet.* Send direct current through a coil of wire wound on a nail. Test for north and south poles. Reverse the battery and retest for polarity.

**Demonstration 5:** *To show the effect of an iron core on the strength of an electromagnet.* Wind 50 turns of bell wire on a cardboard tube about 1 in. in diameter. Connect the coil to a battery of four dry cells in series. See if it will pick up any small brads. Now place a soft iron core in the tube. See how many brads can be picked up now.

**Demonstration 6:** *To show how the strength of an electromagnet depends upon the ampere-turns.* Wind 25 turns of bell wire on a soft iron bar. Send 6 volts through it and weigh the number of brads that can be picked up. Now rewind the coil with 50 turns of wire. Compare the weight of the brads lifted by the electromagnet. Repeat, using 3 volts. Compare the results. If a scale is not available the number of brads lifted in each case may be counted. Care should be taken that all the brads are of the same size.

**Demonstration 7:** *To show the principle of the motor.* Place two smooth bar magnets with like poles together, one on top of the other. The upper magnet will spin around so that the opposite poles are together.

**Demonstration 8:** *To illustrate the principle of the electric motor and galvanometer.* Arrange the following apparatus:

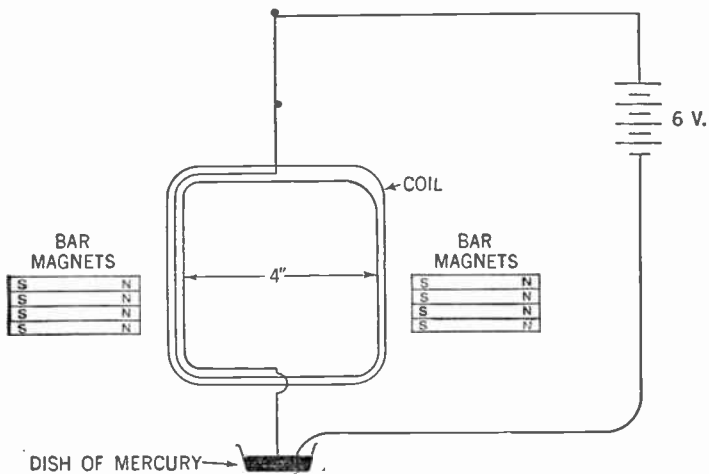

The coil consists of about 25 turns of bell wire. Both ends are bared. One end is connected to a piece of thin copper wire (No. 30 or finer) which suspends the coil. The other end dips into a small dish of mercury. A 6-volt battery is connected to the coil through the thin wire at one end and the mercury at the other.

The field magnets are made up of two sets of four bar magnets arranged as shown. As the current flows through the coil it makes a

half-turn. A light wooden splint stuck in the coil may simulate the pointer of the galvanometer. Reversing the battery will swing the coil the other way.

**Demonstrate 9:** *To observe how a voltmeter and ammeter are used to determine the wattage of an electrical device.* Connect a lamp of unknown wattage to the 110-volt line. In series with it connect an ammeter. Across the lamp connect a voltmeter. Determine the wattage of the lamp from the following formula:

$$\text{watts} = E \times I$$

### Chapter 31

**Demonstration 1:** Wind 50 turns of bell wire on a cardboard tube 1 in. wide and 1 in. in diameter. Connect a sensitive galvanometer to the ends of the coil. Mount a bar magnet in a vertical position. Slip the coil over the magnet. Note the deflection of the meter pointer.

**Demonstration 2:** Replace the galvanometer in the above demonstration with a center-zero galvanometer. Now move the coil up and down the bar magnet. Observe the movement of the pointer.

**Demonstration 3:** (a) In the set-up for Demonstration 2 use first a weak bar magnet and then a strong bar magnet. Note the difference in the amount of deflection.

(b) Move the coil slowly over the bar magnet. Now move the coil rapidly. Note the greater deflection.

(c) Increase the number of turns of the coil to 100. Now note the greater deflection.

**Demonstration 4:** *To calculate the power factor.* Connect up the following apparatus:

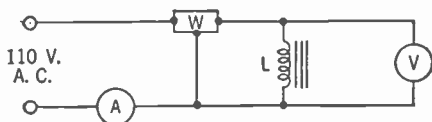

W is a wattmeter, L is a 15-henry choke, A is an alternating-current ammeter, V is alternating-current voltmeter.

If we multiply the voltage by the current we get the apparent power. The wattmeter gives us the true power. We can obtain the power factor from the following formula:

$$\text{power factor} = \frac{\text{true power}}{\text{apparent power}}$$

**Demonstration 5:** *To illustrate the thermocouple principle.* Connect a demonstration thermocouple (which may be obtained from any scientific supply house) to a direct-current millivoltmeter. Heat the junction point of the thermocouple and note the voltage developed.

## Chapter 32

**Demonstration 1:** *To illustrate self-inductance.* Connect up the following apparatus:

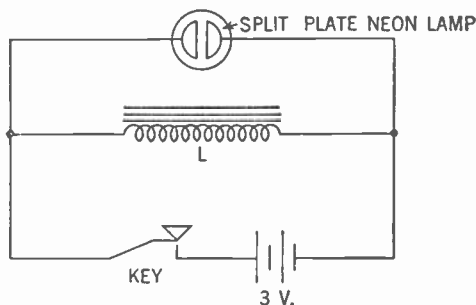

$L$  is a 15- to 30-henry choke. Close the key. Since the neon lamp requires about 70 volts before it lights up, no light appears. Now open the key quickly. The neon lamp flashes.

**Demonstration 2:** *To indicate the operation of inductive reactance.* Connect a 1-henry choke in series with the 110-volt direct-current line, a 25-watt lamp and a 0-5-amp. direct-current ammeter. (If the choke is not available, the primary of a power transformer may be substituted.) Note the reading of the ammeter. Now replace the direct-current ammeter with an alternating-current ammeter and the 110-volt direct-current line by a 110-volt alternating-current line. Note the difference in ammeter reading.

**Demonstration 3:** *To show the effect of an iron core on inductive reactance.* Wind about 400 turns of bell wire on a cardboard tube 6 in. long and  $1\frac{1}{2}$  in. in diameter. Connect this coil in series with the 110-volt alternating-current line and a 500-watt lamp. Observe the brightness of the lamp. Now place a bundle of soft iron rods into the core space of the coil. Note how the brightness of the lamp diminishes.

## Chapter 33

**Demonstration 1:** *To show the nature of the charge on the plates of a condenser.* Connect in series a 45-volt battery, a 1- $\mu$ fd. condenser, and a center-zero ammeter.

(a) Note that the ammeter pointer is deflected at the moment the circuit is completed and then quickly falls back to zero. This indicates that the condenser does not pass direct current.

(b) Remove the 45-volt battery and touch together the two wires that formerly went to its terminals. Note the spark. Note how the ammeter pointer is deflected.

**Demonstration 2:** *To show how a condenser blocks direct current but passes alternating current.* Connect a 10- $\mu$ fd. 200-volt paper condenser in series with a 25-watt lamp and the 110-volt direct-current

line. Note the lamp does not light. Now replace the 110-volt direct current with 110-volt alternating current. The lamp lights up.

**Demonstration 3:** *To illustrate capacitive reactance.* Connect a 25-watt lamp, an alternating-current ammeter, and a .1- $\mu\text{fd.}$ , 200-volt paper condenser in series with the 110-volt alternating-current line. Note the ammeter reading. Now replace the .1- $\mu\text{fd.}$  condenser with condensers whose values are .5  $\mu\text{fd.}$ , 1  $\mu\text{fd.}$ , 2  $\mu\text{fd.}$ , 4  $\mu\text{fd.}$ , 8  $\mu\text{fd.}$ , 12  $\mu\text{fd.}$  Note the ammeter reading for each condenser.

**Chapter 34**

**Demonstration 1:** *To observe the series resonant circuit.* Connect a 30-henry choke, a 10-watt lamp, and an alternating-current ammeter in series with the 110-volt 60-cycle alternating-current line. Note the reading on the ammeter. Replace the choke with a .25- $\mu\text{fd.}$  paper condenser rated at 600 volts working voltage. Note the reading of the ammeter. Now connect the lamp, ammeter, choke, and condenser in series with the 110-volt alternating-current line. Note the ammeter reading.

**Caution!** The choke should be able to pass safely 200 ma.

**Demonstration 2:** *To study the parallel resonant circuit.* Hook up the following apparatus:

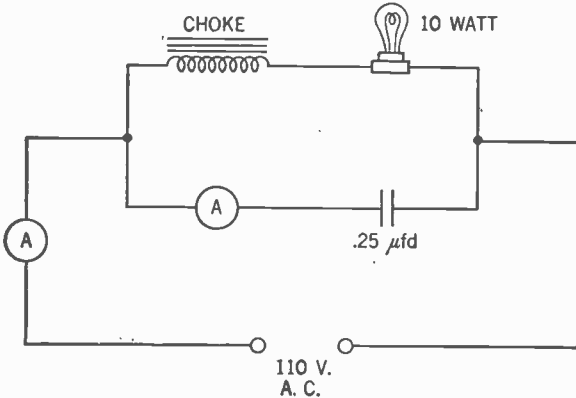

The value of the choke is 30 henries at 200 ma. The condenser is rated at 600 volts working voltage. The ammeters are alternating-current meters. Note the readings of the two ammeters.

**Demonstration 3:** *To derive a resonance curve.* Repeat Demonstration 1, using one at a time condensers of the following values: .01  $\mu\text{fd.}$ ; .05  $\mu\text{fd.}$ , .1  $\mu\text{fd.}$ , .25  $\mu\text{fd.}$ , .5  $\mu\text{fd.}$ , 1  $\mu\text{fd.}$ , 2  $\mu\text{fd.}$ , 4  $\mu\text{fd.}$  Note the ammeter reading in each case and plot a graph of the amount of current flow (on the Y axis) against the capacitance (on the X axis).

**Caution!** All of the above condensers should be rated at 600 volts working voltage.

## Chapter 35

**Demonstration 1:** *To illustrate man-made static.* Spark an induction coil near an operating radio receiver and note the noise pickup.

**Demonstration 2:** *To filter line noises.* Obtain a small motor and place a little grease on the commutator to cause sparking. Connect an electric radio receiver to the same line and note the noise pickup. Now connect up a filter system as shown in figure 370. Note the diminishing of the noise.

## Chapter 36

**Demonstration 1:** *To show the node and loop points on an antenna.* Construct a 2½ meter oscillator as follows:

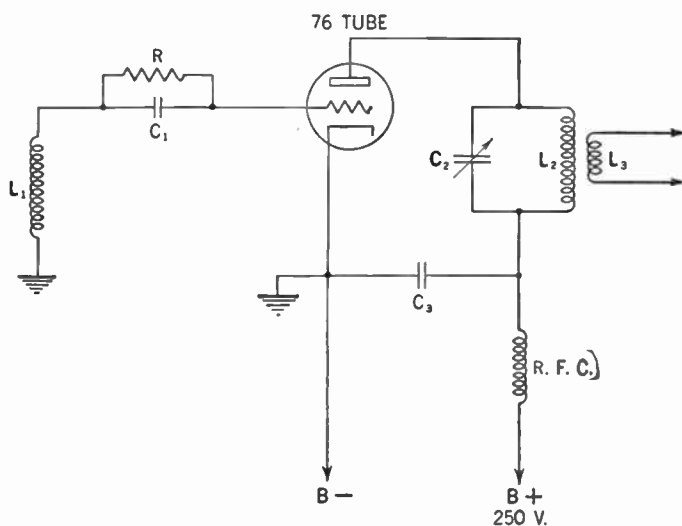

In this oscillator diagram,  $C_1$  is a .0001- $\mu$ fd. mica condenser,  $C_2$  is a 15- $\mu$ fd. variable condenser,  $C_3$  is a .0005- $\mu$ fd. mica condenser;  $R$  is 10,000 to 50,000 ohms;  $L_1$  and  $L_2$  are made of four turns of No. 14 copper wire wound to make a coil  $\frac{3}{8}$  in. in diameter and spaced to be  $\frac{5}{8}$  in. long;  $L_3$  is made of one or two turns of No. 14 copper wire wound to make a coil  $\frac{3}{8}$  inch in diameter and coupled to the bottom of  $L_2$ ; R.F.C. is approximately 30 turns of No. 30 wire on a  $\frac{1}{4}$ -in. dowel stick.

**Note carefully!** *It is unlawful for anyone but a licensed operator to transmit a radio signal. In time of war even licensed amateurs may not transmit. This oscillator is a transmitting set and care should be taken not to connect it to an aerial.*

Having constructed the oscillator, set up the following apparatus (called a Lecher system):

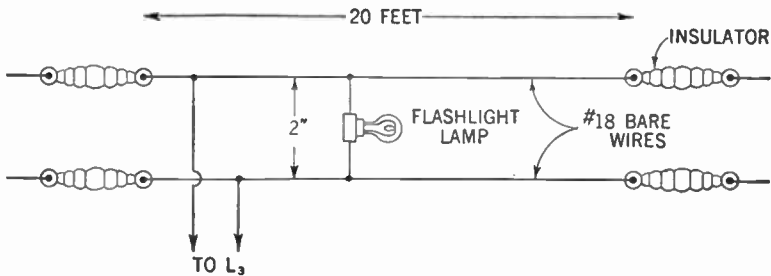

The terminals of the flashlight lamp are soldered to two bare copper wires that slide on the Lecher wires. As the lamp is moved over the wires it glows brightly at some points and goes out at others, depending upon whether it is passing a loop or node of the standing wave.

**Caution!** Mount the Lecher wires clear of obstructions. Keep the hands clear of the wires when in use.

### Chapter 37

**Demonstration 1:** To determine the characteristics of a vacuum tube. Connect up the following apparatus:

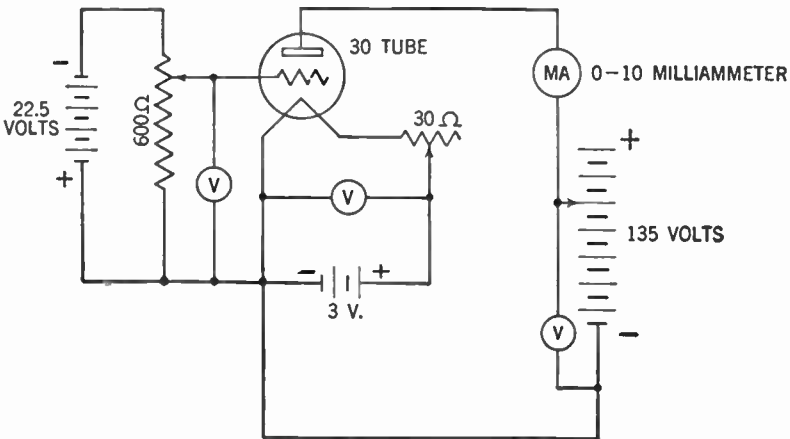

(a) Keeping the grid bias fixed, vary the plate voltage and draw the  $I_p-E_p$  characteristic curve.

(b) Keeping the plate voltage fixed, vary the grid bias and draw the  $E_g-I_p$  characteristic curve.

(c) Determine the amplification factor of the tube by seeing how great an  $E_g$  change is necessary to produce the same  $I_p$  change as a change in  $E_p$ .

Chapter 38

**Demonstration 1:** To show conditions for maximum transfer of power. Calculate the data required from the data given in the following table (do not write in the book!):

Generator resistance	Generator voltage	External resistance	Current	Power dissipated externally	Voltage across the external resistor
2Ω	10	2Ω			
2Ω	10	.5Ω			
2Ω	10	1Ω			
2Ω	10	2Ω			
2Ω	10	4Ω			
2Ω	10	6Ω			
2Ω	10	8Ω			
2Ω	10	10Ω			

Note when the power dissipated externally is greatest. Note when the voltage across the external resistor is greatest.

Chapter 39

**Demonstration 1:** To build an oscillator for audio frequencies  
Build an oscillator according to the following diagram:

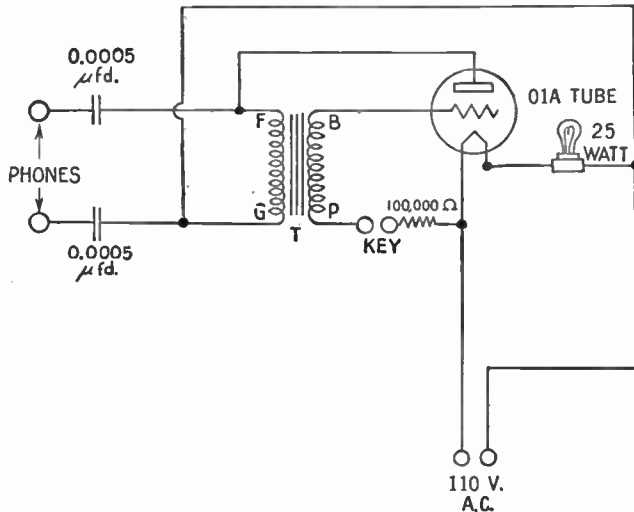

*T* is an ordinary 3:1 audio-frequency transformer.

This oscillator is suitable for code practice work.

**Demonstration 2:** To build a low-power Hartley oscillator for the broadcast frequencies. Build the set shown at the top of p. 669.



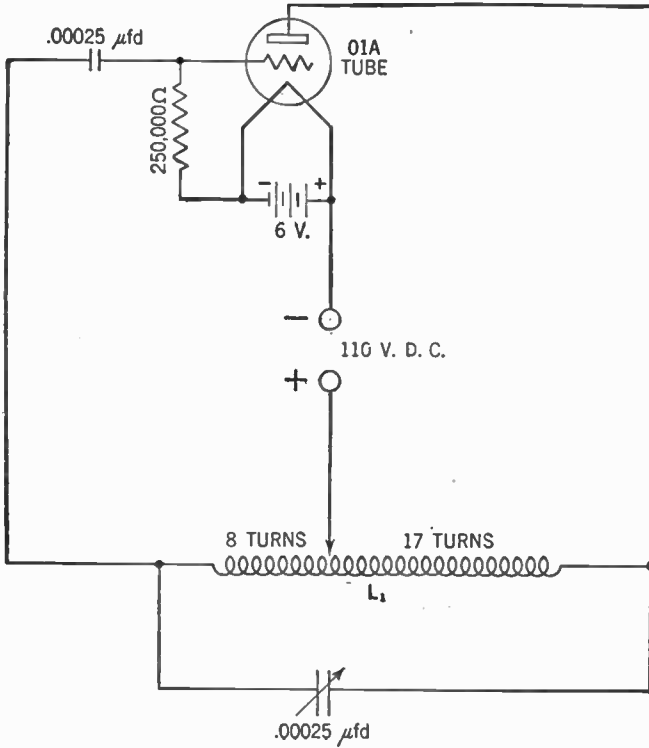

$L_1$  is 25 turns of No. 14 double-cotton-covered wire on a cardboard tube 3 in. in diameter.

To modulate, wind one turn of No. 14 double-cotton-covered wire over the grid end of  $L_1$ . Connect a dry cell and a telephone microphone in series with this one turn. The signal may be picked up on a standard broadcast receiver. Remember the caution (page 666) against connecting this oscillator to an antenna!

### Chapter 40

**Demonstration 1:** To construct a simple continuous-wave transmitter for 80 meters. Build the set shown at the top of page 670.

$C_1$  is a .0001-μfd. variable condenser,  $C$  is a 0.1-μfd. 600-volt fixed condenser;  $R_1$  is 10,000 ohms, 2 watts,  $R_2$  is 200 ohms, 1 watt,  $R_3$  is 20,000 ohms, 5 watts; R.F.C. is 2.5 millihenries;  $L_1$  is 29 turns of No. 18 double-cotton-covered wire on a 1½-in. form,  $L_2$  is 1 turn of No. 18 double-cotton-covered wire; the crystal is an 80-meter crystal.

Close the key. The transmitter is now oscillating. This condition is indicated by the drop in plate current as shown on the milliammeter. If a 2-watt neon lamp is touched to the plate-circuit tank coil, the lamp will glow. Observe the caution against connecting this set to an antenna.

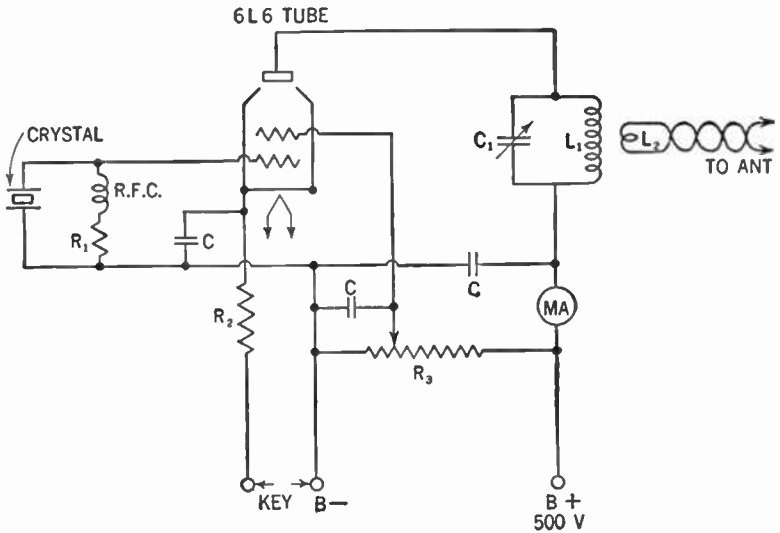

**Demonstration 2:** To show the use of the dummy antenna. Wind a coil similar to  $L_1$  of Demonstration 1. Connect this coil in series with a .0001- $\mu$ fd. variable condenser, a radio-frequency milliammeter, and a 10-ohm resistor. Couple this coil to  $L_1$  in the above set-up and adjust the variable condenser until resonance is reached. (This condition is shown by the greatest current reading of the milliammeter.) Then calculate the power by the formula  $P = I^2 \times R$  where  $I$  is the current indicated by the radio-frequency milliammeter and  $R$  is 10 ohms.

### Chapter 41

**Demonstration 1:** To construct a simple radiotelephone on the broadcast band. Construct the following apparatus:

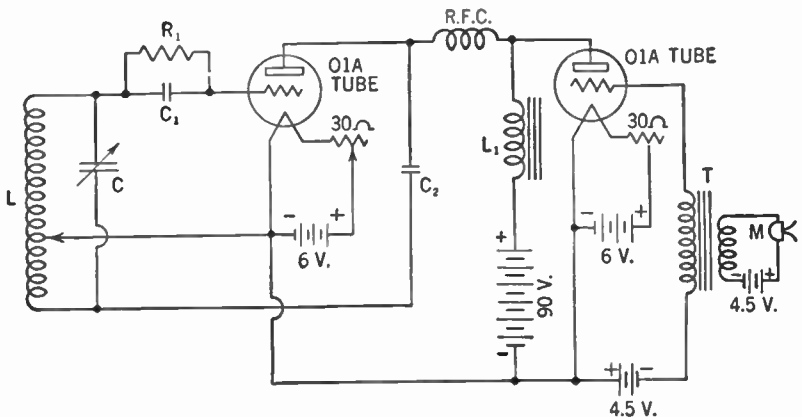

$C$  is a .00035- $\mu$ fd. variable condenser,  $C_1$  is a .00025- $\mu$ fd. fixed condenser,  $C_2$  is a .002- $\mu$ fd. fixed condenser;  $R_1$  is 50,000 ohms; R.F.C. is 33 turns No. 32 double-cotton-covered wire on a  $\frac{1}{2}$  in. dowel;  $L$  is a broadcast-band coil,  $L_1$  is a 30-henry choke;  $T$  is the microphone transformer.

Test for oscillation by touching a neon lamp to coil  $L$ .

Talk into the microphone and tune a nearby broadcast receiver for the signal. Adjust the tap on coil  $L$  for best results.

*Caution!* Avoid connecting this transmitter to an antenna.

Chapter 42

**Demonstration 1:** *To show magnetic deflection of a cathode ray.* Connect a Crookes tube with a fluorescent screen to the secondary of an induction coil. Connect the primary of the coil to a 6-volt battery. Observe the path of the cathode ray on the screen. Now bring the north pole of a magnet to the top of the tube. Note the deflection of the ray. Bring the south pole of the magnet to the top of the tube. Note the deflection of the ray.

**Demonstration 2:** *To operate the cathode-ray oscillograph.* Plug the oscillograph into a 110-volt alternating-current outlet and turn on the main power switch. Wait several seconds for the dot to appear on the screen. Keep the intensity control low so that the screen will not be damaged. If the dot is not sharp, adjust the focus control knob. By adjusting the vertical and horizontal centering knobs, get the dot to appear at the center of the screen. You are now ready to make various tests. The general method of employing an oscillograph is to impress the voltage to be observed on the vertical input and to apply the sweep circuit on the horizontal plates of the cathode-ray tube.

**Demonstration 3:** *To observe a direct-current voltage on the oscillograph.* Connect the following hookup to the vertical input of the oscillograph:

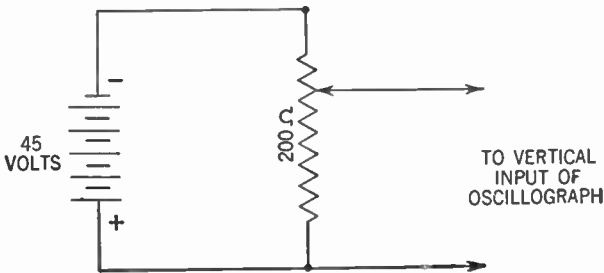

Adjust the oscillograph to place a 60-cycle sweep on the horizontal plates. Observe the location of the horizontal line. Move the potentiometer arm and notice changes of the image on the screen.

Reverse the battery terminals and note the effect on the position of the image.

**Demonstration 4:** *To observe an alternating-current voltage on*

*the oscillograph.* Set the horizontal control on the 60-cycle sweep. Connect the primary of a bell transformer to the 110-volt alternating-current line and connect the output to the vertical input of the oscillograph. Observe the wave form produced. Note the results when the horizontal and vertical gain controls are turned up. Note the results when the frequency and range controls are varied. The wave form will be a sine curve.

**Demonstration 5:** Connect the output of an audio-frequency amplifier, shown in Figure 93, Volume I, to the vertical input of the oscillograph. Set the horizontal sweep at 60 cycles. Speak into the microphone. Observe the wave forms produced.

**Demonstration 6:** Replace the phones of the diagram shown in Dem. 1, Chapter 39, Vol. I, by the vertical input terminals of the oscillograph. Set the horizontal sweep at 60 cycles. Close the key and observe the wave forms produced. Observe the results obtained by varying the frequency of the horizontal sweep.

**Demonstration 7:** Substitute the vertical input posts of the oscillograph for the neon lamp and speaker in Dem. 4, Chapter 18, Vol. I. Set the horizontal sweep for 60 cycles and observe the wave forms at different portions of the power supply.

# Appendix



# Appendix

## THE EVENTFUL DATES IN RADIO DEVELOPMENT

- 1727 Cuneus and Musschenbroek (Dutch) discovered the principle of the condenser.
- 1842 Joseph Henry (U. S.) experimented with induced voltages.
- 1850 Faraday (English) performed experiments similar to those of Joseph Henry.
- 1867 Clerk Maxwell (Scotch) showed mathematically that light is an electromagnetic wave and predicted that there must be other electromagnetic waves of different frequencies.
- 1874 Ferdinand Braun (German) discovered the rectifying action of some crystals.
- 1879 Hughes (English) heard wireless waves but could not explain them to the Royal Society.
- 1884 Edison (U. S.) observed the "Edison effect."
- 1887-9 Heinrich Hertz (German) developed a spark transmitter using a condenser with plates fairly wide apart. He developed the first wireless detector.
- 1889 Sir Oliver Lodge (English) developed the principle of tuning based on the previous work of Michael Pupin (American).
- 1890 Branly (French) developed the Branly coherer, a form of detector, based on the earlier work of Guitard (French).
- 1894 Marconi (Italian) developed an aerial and ground system, using the Branly coherer. He radiotelegraphed over a distance of two miles.
- 1902 Fessenden (U. S.) developed the continuous-wave system with radio-frequency alternators. Poulsen (Denmark) worked out another continuous wave system with an arc.
- 1901 Marconi sent a signal from England to Newfoundland, using a detector invented by Lieutenant Solari (Italian).
- 1904 J. A. Fleming (English) developed the Fleming valve.
- 1906 General Dunwoody (American) devised a crystal detector.
- 1907 Lee De Forest (U. S.) developed the triode with a control grid.
- 1907 E. H. Armstrong (U. S.) developed the regeneration principle for receivers and transmitters.
- 1909 The steamship *Republic* sank, January 23. People were rescued for the first time because of radio. Radio was popularized.
- Recent Hazeltine (U. S.) developed the neutrodyne receiver.
- Recent Armstrong (U. S.) developed the superheterodyne and frequency-modulation receiver.

SCHMATIC SYMBOLS USED IN CIRCUIT DIAGRAMS



Antenna



Ground

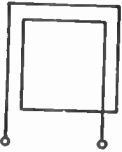

Loop Aerial

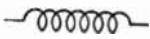

Air-core Inductance

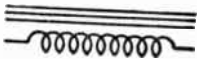

Iron-core Inductance

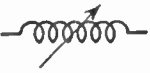

Variable Inductance

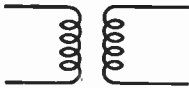

Air-core Transformer

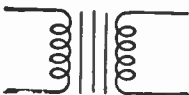

Iron-core Transformer



Resistor



Variable Resistor (Rheostat)



Variable Resistor (Potentiometer)



Fixed Condenser



Variable Condenser

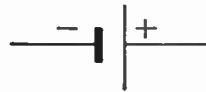

Single Cell

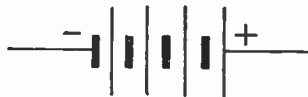

Battery



Wires Connected



Wires Not Connected





Headphones

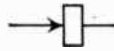

Crystal Rectifier

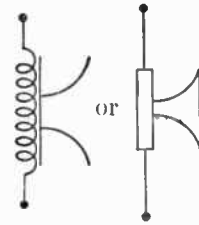

Loudspeaker



Crystal Pickup

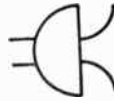

Microphone

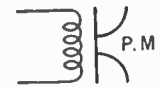

Permanent-magnet  
Dynamic Speaker

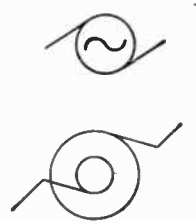

A. C.  
Generator

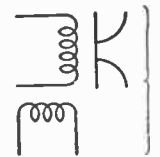

Electromagnetic  
Dynamic Speaker



Fuse



Galva-  
nometer



Shielding



Ammeter

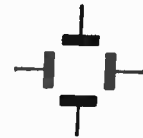

Cathode-ray Tube  
Deflecting plates



Voltmeter



Wattmeter



Tube filament



Key



Tube grid



Switch



Tube plate



Crystal



Tube cathode



Diode

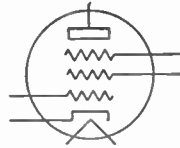

Pentode



OR



Triode

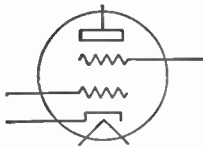

Tetrode

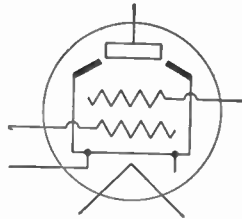

Beam-Power Tube

ABBREVIATIONS AND SYMBOLS

Alternating current	A.C.	Intermediate frequency	I.F.
Ampere	a., amp.	Interrupted continuous waves	I.C.W.
Amplitude modulation	A.M.	Kilocycles (per second)	kc.
Antenna	Ant.	Kilowatt	kw.
Audio frequency	A.F.	Mega (million)	M or m
Automatic volume control	A.V.C.	Megacycles (per second)	Mc. or mc.
Beat frequency	B.F.	Megohm	MΩ or ω
Beat-frequency oscillator	B.F.O.	Meter (measure of length)	m.
Capacitance	C	Micro $\frac{1}{1,000,000}$	μ
Capacitive reactance	$X_C$	Microampere	μa. or μamp.
Cathode ray	c.r.	Microfarad	μfd.
Centimeter	cm.	Microhenry	μh.
Continuous waves	C.W.	Micromicro $\frac{1}{1,000,000,000,000}$	μμ
Crystal	Xtal.	Micromicrofarad	μμfd.
Current	I	Microvolt	μvolt
Cycles per second	c.p.s.	Microwatt	μw.
Direct current	D.C.	Milli $\frac{1}{1,000}$	m
Electromotive force	E.M.F.	Milliampere	ma.
Farad	fd.	Millihenry	mh.
Frequency	f	Millivolt	mv.
Frequency modulation	F.M.	Milliwatt	mw.
Ground	gnd.	Modulated continuous waves	M.C.W.
Henry	h	Ohm	Ω
High frequency	H.F.		
Impedance	Z		
Inductance	L		
Inductive reactance	$X_L$		

## ABBREVIATIONS AND SYMBOLS—Continued

Power	$P$	Tuned radio frequency	T.R.F.
Power factor	p.f.	Ultrahigh frequency	U.H.F.
Radio frequency	R.F.	Volt	v.
Resistance	$R$	Watt	w.

## ELECTRICAL UNITS

Capacitance	farad	Phase	degree
Capacitive reactance	ohm	Power	watt
Current	ampere	Resistance	ohm
Frequency	cycles per second	Voltage (potential difference, E.M.F.)	volt
Impedance	ohm	Wave length	meter
Inductance	henry		
Inductive reactance	ohm		

## R.M.A. COLOR CODE

To identify the various connections and values of standard radio components, the Radio Manufacturers Association (R.M.A.) has adopted a color code.

## R.M.A. Color Code for Resistors

Numbers are represented by the following colors:

0 — black	5 — green
1 — brown	6 — blue
2 — red	7 — violet
3 — orange	8 — gray
4 — yellow	9 — white

Three colors are used on each resistor to identify its value. The *body* color represents the first figure of the resistance value. One *end* or *tip* is colored to represent the second figure. A colored *band* or *dot* near the center of the resistor gives the number of zeros following the first two figures.

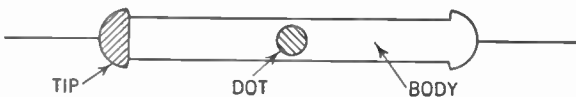

Here is an example. Assume a resistor whose body is yellow, tip blue, and dot red. We thus get yellow, blue, red—which, translated into the code, stands for

$$4 - 6 - 00 \quad \text{or} \quad 4600 \text{ ohms.}$$

Some resistors are marked with three bands of color. The band nearest the end is the body color, the next band the tip color and the third band is the dot color.

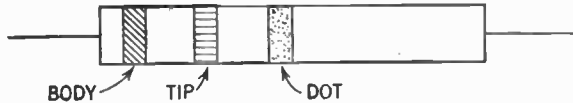

### R.M.A. Color Code for Condensers

Small mica condensers may be marked with three color dots, with an arrow or other symbol indicating the sequence of numbers. The color code is the same as for resistors except that the readings are in micromicrofarads instead of ohms.

Thus, if the condenser were marked as follows:

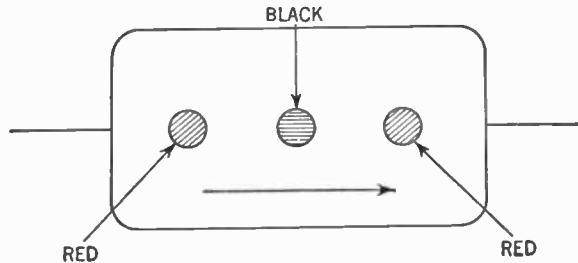

the value of this condenser would be:

$$2-0-00 \quad \text{or} \quad 2,000 \mu\text{fd.} \quad (.002 \mu\text{fd.})$$

### R.M.A. Color Code for Power Transformers

To identify the various leads the following color code has been adopted:

1. Primary leads—black. If tapped: common—black; tap—black and yellow striped; finish—black and red striped.
2. High-voltage plate winding—red. Center tap—red and yellow striped.
3. Rectifier filament winding—yellow. Center tap—yellow and blue striped.
4. Filament winding No. 1—green. Center tap—green and yellow striped.
5. Filament winding No. 2—brown. Center tap—brown and yellow striped.
6. Filament winding No. 3—slate. Center tap—slate and yellow striped.

### R.M.A. Color Code for Audio-frequency Transformers

Blue—Plate (finish) lead of the primary.

Red—B+ lead (this applies whether the primary is plain or center tapped.)

Brown—Plate (start) lead on center-tapped primaries. (Blue may be used for this lead if polarity is not important.)

Green—Grid (finish) lead of secondary.

Black—Grid return (this applies whether the secondary is plain or center tapped).

Yellow—Grid (start) lead on center-tapped secondaries. (Green may be used for this lead if polarity is not important.)

*Note:* These markings apply also to line-to-grid, and tube-to-line transformers.

### R.M.A. Color Code for Intermediate-frequency Transformers

Blue—Plate lead.

Red—B+ lead.

Green—Grid (or diode) lead.

Black—Grid (or diode) return.

*Note:* If the secondary of the intermediate-frequency transformer is center-tapped, the second diode plate lead is green and black striped, and black is used for the center-tap lead.

### R.M.A. Color Code for Loudspeaker Voice Coils

Green—finish      Black—start

### R.M.A. Color Code for Loudspeaker Field Coils

Black and red striped—start

Yellow and red striped—finish

Slate and red striped—tap (if any)

## WAVE-LENGTH-FREQUENCY CONVERSIONS

$$\text{wave length (in meters)} = \frac{300,000,000}{\text{frequency (in cycles per second)}}$$

Station	Location	Frequency (cycles per second)	Wave length (meters)
WSYR	Syracuse	570,000	526
WEAF	New York	660,000	454.3
KPO	San Francisco	680,000	440.9
WGN	Chicago	720,000	416.4
WJR	Detroit	760,000	394.5
WCCO	Minneapolis	830,000	361.2
WWL	New Orleans	870,000	344.6
KHJ	Los Angeles	930,000	322.4
WAAT	Jersey City	970,000	309.1
KJR	Seattle	1,000,000	299.8
WHO	Des Moines	1,040,000	288.3
WBAL	Baltimore	1,090,000	275.1
KSL	Salt Lake City	1,160,000	258.5
WOAI	San Antonio	1,200,000	249.9
WLAC	Nashville	1,510,000	199.1

velocity of a radio wave = 300,000,000 meters per second

**The Resonant Wave Length**

$$\text{wave length (in meters)} = 1,885 \sqrt{L \times C}$$

*L* is in microhenries; *C* is in microfarads.

**INTERNATIONAL MORSE CODE TABLE**

A . —	J . — — —	S ...
B — ...	K — . —	T —
C — . — .	L . — ..	U .. — —
D — ..	M — — —	V ... — —
E .	N — .	W . — — —
F .. — .	O — — — —	X — . — .
G — — — .	P . — — .	Y . — . — —
H ....	Q — — . —	Z — — . ..
I ..	R . — .	

1 . — — — — —
2 .. — — — —
3 ... — — —
4. .... —
5 .....

6 — ....
7 — — ...
8 — — — ..
9 — — — .
0 — — — — —

Period . . . . .  
 Interrogation .. — — — . . .  
 Break — . . . .

Wait . — . . .  
 End of message . . . — . . .  
 End of transmission . . . — . — —

**Construction of an Oscillator and Wavemeter**

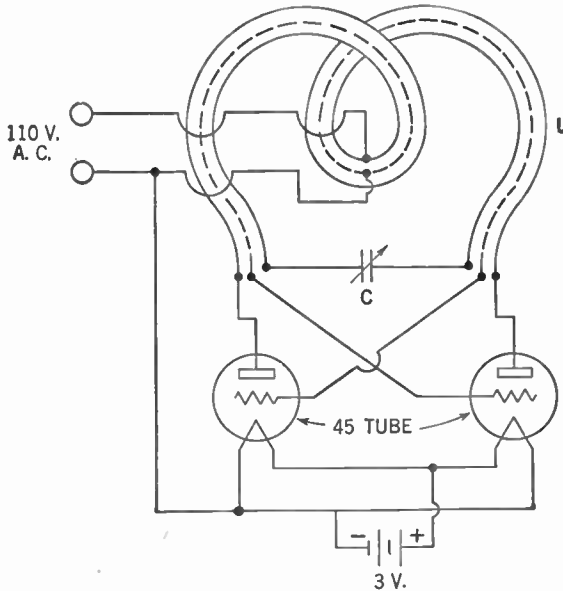

$C$  is a  $140 \mu\text{fd.}$  variable condenser.  $L$  is 3 turns  $\frac{1}{8}$ -in. copper tubing, 3 in. in diameter. An insulated wire runs through the tubing and is

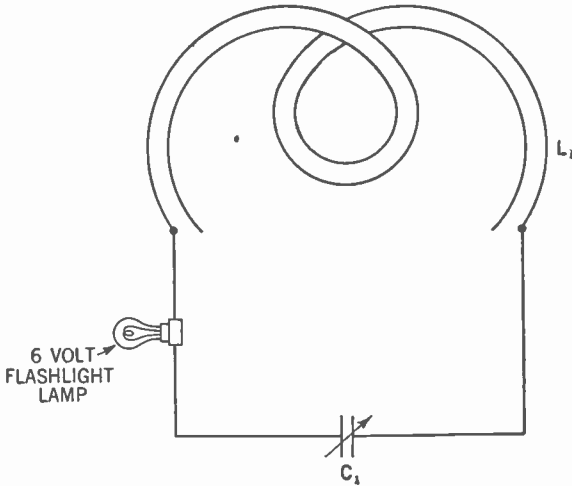

connected to the grids of the tubes.  $L_1$  is the same as  $L$ , except that there is no wire running through the tubing.  $C_1$  is the same as  $C$ .

When the oscillator is connected up, bring the wavemeter close so that the plane of  $L_1$  is parallel to that of  $L$ . Then turn  $C_1$  slowly until the flashlight lamp lights up. The wavemeter is now in resonance with the oscillator. Change  $C$  to vary the frequency of the oscillator. The flashlight lamp goes out and  $C_1$  must be adjusted again before the lamp lights up again.

### HOW TO SOLDER

There are three essentials to successful soldering: cleanliness, flux, and heat.

1. *Cleanliness.* Be sure that the surfaces to be soldered are perfectly clean. Scrape the surfaces with a knife or rub with sandpaper or steel wool wherever possible.

2. *Flux.* Use a rosin flux. An acid flux may corrode the wires. Use flux sparingly, enough to flow thinly over the surfaces, not to drown them. After soldering, wipe off any excess flux.

3. *Heat.* Heat the surfaces to be soldered until the solder flows over them. If possible, keep the hot iron on the joint even after the solder has flowed so as to be sure there is enough heat. For ordinary radio work a 65- to 75-watt soldering iron is sufficient. Greater soldered surfaces require greater heat.

4. Keep the soldering iron clean by removing any oxide that may form on it. Tin the iron by scraping it clean, dipping the point into the flux and then applying solder to the tip.

**PRACTICAL DATA**

1. Make connections as short as possible.
2. Shield as many grid leads as you can.
3. The rotor of a variable condenser is usually grounded to eliminate body capacitance.
4. Pushback wire will be found convenient for wiring.
5. In electrolytic condensers, the black wire is usually the negative wire, and the red wire usually the positive wire.
6. For shielding purposes, in using paper condensers, the end which is marked by a black band is usually the grounded or negative end.
7. To calculate a line-cord resistance:

$$R \text{ (ohms)} = \frac{110 - \text{sum of all the filament voltages of the tubes in series}}{\text{current through the tube filaments}}$$



# Index

[Page references in *italic* refer to Volume II]

## A

- A battery, 105, 118  
eliminating, 161-166
- Abbreviations, glossary of, 678-679
- Absorption frequency meter, 599-600, 602
- Absorption loss, dielectric, 430, 440
- Accelerating electrode, 642
- Adcock aerial, 297  
symbol, 299
- A eliminator, 161-165  
action, 165  
defined, 166
- Aerial, 29  
construction, 28  
demonstration, 647  
function, 19-20  
loop, 284-286, 290, 299  
symbol, 29, 30, 299  
(*See also* Antenna)
- Aerial-ground system, 24  
construction, 27-30  
electron flow in, 73-78, 281-287  
purpose, 19-20  
wave form in, 57-58, 61  
in wiring diagrams, 110
- Aerial trimmer, defined, 201-204
- Air core, symbol, 32
- Aligning, 201, 204  
selectivity and, 242
- Alternating current:  
adding to direct current, 393-394  
in aerial-ground system, 76  
average, 385  
capacitance and voltage, 435-436  
carriers twisted, 173  
in condensers, 434-435  
defined, 44, 48, 76, 78, 377, 403  
demonstration, 650-651, 663  
diode characteristic, 522  
electromotive force and, 411-412  
electronic definition, 76  
in Fleming valve, 100-102  
formula for, 392  
graphs, 54-61  
measurement, 392-403  
radio-frequency, 44, 48, 76, 78  
60-cycle, 44, 48, 76, 78
- Alternating current (*Cont.*)  
theory, 373-392  
in tuning circuit, 81-89  
types, 45  
voltage and, 386-387  
wave forms, 54-61
- Alternating E.M.F., average, 385  
current and, 386, 411-412  
defined, 382  
formula for, 392
- Ammeters, 362-363  
for alternating current, 397-402  
defined, 370  
hot-wire, 400-401  
symbol, 363
- Ampere, defined, 318, 336
- Ampere-turns, defined, 350
- Amplification, audio-frequency (*see also* Audio amplification)  
power, 555  
radio-frequency (*see* Radio amplification)  
stage of, 145, 252-253  
defined, 132  
transformer, 252-253  
in triode, 250  
tuned radio-frequency, 192-195  
voltage, 452-455, 535-536, 539, 555
- Amplification factor, 531-532, 533  
defined, 250, 277, 538  
determination, 252  
in power tubes, 254-255  
screen-grid tubes, 259  
tetrode, 259  
variable, 261-263
- Amplifier:  
audio-frequency (*see* Audio amplifier)  
class A, 572  
class AB, 572  
class B, 572  
class C, 572  
classes, 571-572  
driver stages, 541  
general principles, 541  
power (*see* Power amplifiers)  
radio-frequency (*see* Radio amplifiers)

- Amplifier (*Cont.*)  
 in radiotelegraph transmitter, 586  
 single-ended, 602  
 vacuum-tube, 541-572  
 voltage, 541, 573
- Amplifier tube, defined, 132  
 variable-*mu*, 261-263
- Amplitude, defined, 11, 62, 323, 336
- Antenna coupler, 61-72  
 defined, 71  
 induction in, 81-83  
 symbol, 71
- Antennas (*see also* Aerial)  
 arrays, 511-515  
 center-fed, 503-505, 516  
 coupling to transmitter, 593-595  
 current-fed, 504, 516  
 defined, 27, 29  
 dipole, 476-478, 495, 498  
 directional, 281-299, 511-515  
 directional qualities, 290-293, 297  
 dummy, 600-602  
   demonstration, 670  
 end-fed, 504-506, 516  
 feeder connection, 503-507  
 frequency and length, 497  
 full-wave, 498  
 half-wave, 495, 498, 499, 517  
 Hertz, 495, 498, 517, 594  
 image, 515  
 length, 496-499  
 loading, 507-509  
 loop, 284-286, 290, 514  
   symbol, 299  
 low-impedance connection, 504-505  
 Marconi, 497-500, 517, 593-594  
 quarter-wave, 497-500, 517  
 radiation characteristics, 510-515  
 resonance in, 496-498  
 transformer feed, 505-506  
 for transmitters, 495-515  
   as tuned circuits, 495  
   voltage-fed, 517  
   waves in, 495-500
- Antinodes, defined, 501, 516
- Antiresonant circuit, 461  
 defined, 472
- Appendix, 675-684
- Armature, defined, 354
- Armature-commutator assembly, symbol, 356
- Array, defined, 511
- Atmospherics, 487
- Atoms:  
 amphoteric, 312  
 charging process, 310-311  
 defined, 309, 336  
 structure, 311-312
- Audio amplification:  
 demonstration, 653  
 power stage, 254  
 radio amplification and, 201-202  
 second detector and, 243
- Audio amplifier, 131-145  
 action of, 131-133  
 class A, 548-550  
   defined, 542, 572  
 class AB, 549-552  
   defined, 542, 572  
 class B, 552-553  
   defined, 542, 572  
 classes, 542  
 coupling, 133-141  
 defined, 133, 145, 541, 572  
 function, 144  
 grid bias in, 553-554  
 interstage coupling, 553-559  
 plate current graph, 133  
 push-pull, demonstration, 658  
 unit, 141-142  
 uses of, 145, 542
- Audio frequency, defined, 145
- Aurora, 482
- Automatic volume control, 214-220  
 defined, 220  
 fading control, 490  
 multielement tubes in, 220  
 static elimination, 489
- B
- Back electromotive force (*see* Counter E.M.F.)
- Band width, defined, 241, 245
- Base tone, defined, 223, 229  
 false, 225
- Batteries, 327-335  
 B (*see* B battery)  
 defined, 329-330, 336  
 demonstration, 650  
 storage, 334-336
- Battery sets, volume control in, 210
- B battery:  
 defined, 105, 118, 332  
 eliminating, 147-158  
 faults, 147
- Beacon, radio, 297-298
- Beam power tube, 265-268  
 defined, 277
- Beat current, defined, 233
- Beat frequency, 233-234
- Beat note, 232, 245
- Beats, 232, 246  
 demonstration, 658  
 production of, 234-235

- B eliminator, 158  
 action, 156-157  
 C-eliminator connections, 171-173  
 field-coil power from, 185-186
- Bias resistor, 171  
 cathode, 174  
 volume control, 213-214
- Breakdown voltage, 429, 440  
 series and parallel, 433, 434
- Brush, defined, 353
- By-pass condenser, 174, 204  
 in C eliminator, 171-172  
 in radio amplifiers, 198-199
- C
- Cable, Atlantic telegraph, 4
- Caesium, 639
- Capacitance, 423-440  
 in antennas, 507-509  
 calculation of, 431-432  
 defined, 31, 430, 440  
 demonstrations, 651, 664  
 dielectric and, 426-428  
 distributed, 439, 440, 516  
 interelectrode, 195-198  
 lumped, 499, 517  
 measurement of, 431  
 resistance added to, 436-437  
 resonance and, 450-453  
 stray, 439, 440  
 symbol (*C*), 33  
 tube (see Capacitance, interelectrode)  
 in a tuner, 31-33
- Capacitive reactance, 435, 440  
 demonstration, 665  
 formulas, 435  
 unit of, 435
- Capacity (see Capacitance)
- Carbon microphone, 616-617, 623
- Carborundum, detector crystal, 46
- Cardioid, 514, 515
- Carrier, 62, 583  
 form, 56  
 frequency modulated, 619  
 generation, 575  
 graph, 57  
 power in, 611  
 in radiotelegraphy, 585-592  
 symbol, 63
- Cathode, 166, 328  
 symbol, 165, 167  
 in triode, 164-165, 167  
 volume control, 213-214
- Cathode ray, 642  
 demonstrations, 671  
 discovery, 626
- Cathode-ray oscillograph, 633-641  
 constituent units, 637  
 defined, 642  
 demonstration, 650  
 uses, 637-641
- Cathode-ray tube, 625-643  
 defined, 642  
 structure, 630-633
- Cathode-resistor bias, 553
- Cathode sleeve, 164-165  
 defined, 166
- Catwhisker, defined, 47, 48, 102
- C battery:  
 in audio amplifier, 135-137  
 defined, 113, 118  
 elimination of, 169-174  
 in A.C.-D.C. sets, 178  
 function, 111-115, 118
- C eliminators, 169-174  
 B-eliminator connection, 171-173
- Cells, 78  
 charging and discharging, 334  
 demonstration, 650  
 dry, 330-331  
 in parallel, 330  
 primary, 326-328  
 defined, 332, 336  
 in series, 329-330  
 storage, 332-333  
 defined, 336  
 symbol, 78
- Centi-, defined, 14
- Channel, defined, 609, 623
- Characteristic curves, 520, 537, 538  
 dynamic, 527-530, 533  
 families, 526, 527  
 mutual, 526  
 plate, 526-527, 539  
 static, 527-530, 539  
 transfer, 526, 539  
 use of, 530-531
- Characteristics, graphic representation,  
 519-537
- Charging, 334  
 condenser, 424
- Choke, filter (see Filter choke)
- Choke coil:  
 in filter, 149-150  
 radio-frequency (see Radio-frequency  
 choke coil)
- Circuit, defined, 323
- Code, 536, 682
- Coil:  
 condenser action, 95  
 shielded, symbol, 206  
 symbol, 32, 35  
 in a tuner, 31

- Coil (*Cont.*)  
 variable, 32, 36  
 voice (*see* Voice coil)
- Collecting element, 640, 642
- Collector rings, 377
- Color codes, 679-681
- Communication, history of, 3-5, 675
- Commutator, defined, 351
- Compass, magnetic, 343-344
- Compass, radio, 294-295
- Components, defined, 395
- Condenser microphone, 617, 623
- Condenser, 83-85  
 alternating current and, 664  
 by-pass (*see* By-pass condenser)
- C battery replaced by, 113-115
- charging, 83-85, 424  
 coil as, 95  
 construction, 423-428  
 coupling, 138-141  
   defined, 35, 89, 145  
 demonstration, 649, 651, 657  
 direct current on, 434  
 discharging, 83-85, 425  
 electrolytic, 157, 428-429  
   defined, 158, 440  
 electron behavior in, 83-84  
 filter, 157  
   defined, 158  
 fixed, 428  
   defined, 35  
   feedback controlled by, 125  
 ganged, 205  
   symbol, 206  
 in grid circuit, 113-115  
 mica, 428, 440  
 neutralizing, 197-198  
   defined, 205  
 operation of, 424-428  
 paper, 428, 440  
 in parallel, 433-434  
 phones parallel to, 93-94  
 in series, 432-433  
 symbols, 32-33, 36  
 trimmer (*see* Trimmer condensers)  
 in a tuner, 32-33  
 variable, 33, 428  
   defined, 35  
   feedback controlled by, 125  
   symbols, 32-33, 36
- Conductance, mutual, 532, 538
- Conductors:  
 compared, 316  
 defined, 29, 308, 336  
 demonstration, 648, 659
- Continuous radio-frequency current (*see* Carrier)
- Control electrode, defined, 642
- Control grid, 257-259  
 defined, 277
- Copper, resistance, 316, 318
- Copper loss, defined, 418, 420
- Cores:  
 demonstration, 664  
 symbols, 32, 35
- Coulomb, defined, 317, 336
- Counter E.M.F., 408  
 defined, 420  
 self-induction and, 86
- Coupling:  
 audio amplifier, 133-141, 558-559  
 capacitive, defined, 238, 246, 586, 589  
 defined, 128  
 electron, 239  
   defined, 277  
 electronic, 271  
 impedance, 559  
   matched, 589-591  
 inductive, 587-591  
   defined, 238, 246  
 between inductors, 409  
 link, 588-591, 602  
 loose, 463, 472  
 magnetic, 413  
   defined, 420  
 modulator, 614  
 100%, defined, 414, 420  
 oscillator-amplifier, 586-591  
 radio amplifiers, 190-191, 567  
 resistance, 138-141  
   defined, 145, 558  
 theory of, 413-414  
 tight, 464, 472  
 transformer, 134-138, 141, 145, 559  
 tuned circuits, 463-464  
 unity, defined, 414, 420  
 variation of, 125
- Crest, 10
- Critical angle, defined, 483, 492
- Crookes, W., 625-627
- Crystal detectors, 24, 46-47  
 demonstration, 648, 649, 650  
 electron flow in, 91-95  
 faults, 97  
 in parallel circuit, 92  
 rectifying action, 47, 59  
 symbol, 47, 48
- Crystal microphone, 617, 623
- Crystal phonograph pickup, 144, 146
- Current:  
 in A.C. cycle, 378-380  
 defined, 48  
 eddy, 419  
 electromagnetism and, 37-39  
 electron theory, 313  
 emission, 521, 538

- Current (*Cont.*)  
 factors of, 314-317  
 formula for, 321  
 heating effect, 321-323  
 induced (*see* Induced current)  
 measurement of, 317-318  
 through parallel resistors, 326  
 rectified, defined, 158  
 saturation, defined, 521, 539  
 through series resistors, 324
- Curve, plotting, 386
- Cycle, defined, 11, 45, 380-381, 403  
 symbol, 383
- D
- Damped wave, 56, 62, 63
- Deci-, defined, 14
- Deflector plate, 628, 633  
 defined, 642
- De Forest, Lee, 105-109, 117, 257
- Deka-, defined, 14
- Demodulator tube, defined, 235
- Demonstrations, 647-672
- Detection, grid-bias, 525
- Detector, 19  
 crystal (*see* Crystal detectors)  
 defined, 24, 48  
 diode, 101-102  
   demonstration, 652  
 function, 24, 46, 47  
 gate function, 46-47, 58-59  
 regenerative, 121-128  
 tetrode, 260-261  
 theory and principle, 43  
 vacuum-tube (*see* Vacuum-tube detector)  
 wave form in, 58-61
- Diaphragm, 42  
 in phones, 38-40
- Dielectric, 35  
 capacitance and, 426-428  
 in a condenser, 32-33, 424-428
- Dielectric constant, defined, 427, 440
- Dielectric field, 340, 370, 440  
 dipole antenna, 477
- Dielectric losses, 430, 440
- Diode detector, with automatic volume control, 217-219
- Diodes, 250  
 characteristics, 520-522  
 defined, 101-102  
 De Forest's experiments, 105-107  
 operation, 519-522  
 as rectifier, 148  
 symbol, 102, 103
- Direct current, 44, 48, 377, 403  
 adding to alternating current, 393-394
- Direct current (*Cont.*)  
 condensers and, 434  
 demonstration, 650-651  
 electron flow, 75  
 fluctuating, 53  
   defined, 62  
   graph symbol, 62  
   wave form, 57  
 graphs and graph symbols, 52-54, 62  
 pulsating, 46, 48  
   graphs, 59-60, 62  
 steady, 62  
   wave form, 52  
 theory of, 305-336
- Direction, line and sense, defined, 299
- Directional, defined, 299
- Direction finders, 281-299  
 demonstration, 659  
 electron flow in, 281-287  
 sense and line, 287-289
- Discharge, oscillatory, 85
- Discharging, 334  
 condenser, 425
- Discriminator, 620, 623
- Distortion, 542-544  
 in audio amplifiers, 135-140, 145  
 defined, 573  
 delay, 543, 572  
 frequency, 543, 573  
 nonlinear, 543-546, 573  
 overloading, 547  
 phase, 543, 573  
 push-pull correction, 546
- Doubler, defined, 592, 602
- Dropping resistor, 158  
 in A.C.-D.C. sets, 177  
 in B eliminator, 155
- Dry cell, 73-75  
 electron flow in, 74
- "DX," defined, 121
- Dynamic microphone, 618
- Dynamic speaker, 181-186  
 defined, 186  
 demonstration, 657  
 electromagnetic, 183-185  
 defined, 186  
 symbol, 184, 187  
 permanent-magnet, 181-182  
 defined, 186  
 symbol, 182, 187  
 in portable receivers, 186
- Dynamometer meter, 398-400
- E
- Earphones (*see* Phones)
- Eddy current losses, 419, 420

- Edison, Thomas A., 97, 102  
 Edison cell, 334-336  
 Edison effect, 97-98  
   demonstration, 651  
 Electrical units, 679  
 Electricity:  
   current, 308  
   defined, 336  
   definition efforts, 43  
   fluid concepts, 308  
   nature of, 305-337  
   static, 305-308  
     demonstration, 650, 659  
 Electrified, defined, 336  
 Electrode, dry cell, 74, 78  
 Electrolyte, defined, 329, 336  
 Electromagnet, 41  
   defined, 37, 350, 370  
   polarity, 351-352  
 Electromagnetic waves, 17, 475, 492  
   defined, 475  
   production of, 476-480  
 Electromagnetism, 349-352  
   current changes and, 37  
   demonstrations, 649, 661-662  
   in reproducer, 37-41  
 Electromotive force, 74-75, 319, 336  
   alternating (*see* Alternating E.M.F.)  
   formula for, 321  
   induced (*see* Induced E.M.F.)  
   nature of, 314-315  
   in series, 75  
   unit of, 319  
 Electron flow, 313  
   in cathode-ray tube, 627-643  
   in condensers, 426-428  
   direction, 74-75  
   in direction finders, 282  
   electromotive force, and, 73-75  
   symbol, 76  
   in tuning circuit, 81-89  
   in wiring diagrams, 110  
 Electron gun, 631-633  
   defined, 642  
   in iconoscope, 640  
 Electrons, 44, 48, 310, 336  
   capacitance and, 426-428  
   lending and borrowing, 312-313  
   planetary, 311  
   theory of, 309-313  
 Electron theory, 44-45, 48  
 Element, chemical definition, 309  
 Electrostatic field, 306-308  
   defined, 336  
   demonstration, 659  
 Electrostatic field (*see* Dielectric field)
- Electrothermal action, 401  
 Energy:  
   conservation of, 418, 455  
   storage in condenser, 425-426  
   wave transmission of, 9-10  
 Energy, radiation, demonstration, 647  
 Envelope:  
   illustrated and defined, 60-62  
   phone current, 94  
 Ether, 13-14, 17  
   waves in, 13-18  
 Ether wave, defined, 17  
 Exponents, use of, 317
- F
- Facsimiles, 621-623  
 Fading, 214  
   causes of, 489-491  
   defined, 220, 487, 492  
 Farad, defined, 32, 35, 431, 440  
 Faraday, M., 373  
 Feedback, 128  
   defined, 205, 583  
   degenerative, 560-561, 572  
   eliminating, 195  
   inverse, 559-561, 573  
   negative, 573  
   in oscillators, 577-578  
   in radio amplifiers, 195-198  
 Feedback circuit, action of, 121-123  
 Feeder lines, 500-507  
   defined, 517  
 Field coil:  
   dynamic speaker, 184-186  
   motor, 356  
 Field magnets, 352  
   symbol, 356  
 Filament battery (*see* A battery)  
 Filament circuit, 118  
   in wiring diagram, 110  
 Filament current, in A.C.-D.C. sets, 176  
 Filaments:  
   alternating current on, 161-162  
   ribbon type, 162  
   in series, 176-177  
 Filament transformer, 158, 165-166  
   in B eliminator, 151-152  
   defined, 158  
   for rectifier, 151  
 Filter choke, defined, 158  
 Filters, 464-471  
   action, 149-150  
   band stops, 471  
   band-pass, 470-471  
   defined, 158, 472

- Filters (*Cont.*)  
 demonstration, 654-656  
 function, 149-150  
 high-pass, 467  
 low-pass, 466-467  
 power supply, 467-469
- Filter system, defined, 157
- First detector tube, 236  
 defined, 245  
 radio amplification and, 243
- Fleming, J. Ambrose, 98-102, 105
- Fleming valve, 98-102  
 alternating current in, 100-102  
 defined, 102  
 demonstration, 651  
 electron flow in, 100-102
- Fluorescence, in cathode-ray tube, 631
- Flywheel effect, 561-562
- Focusing electrode, defined, 642
- Franklin, Benjamin, 306-308
- Frequency, 11, 45, 384, 403  
 antenna length and, 497  
 classified, 45  
 formula for oscillators, 580, 583  
 multipliers, 591-592  
 natural, 24  
 demonstration, 648  
 resonance and, 20-22  
 pitch and, 223, 229  
 resonance and, 451-452  
 tests for, 599-600  
 tone and, 223, 229  
 wave-length conversion, 681  
 wave transmission and, 485-487
- Frequency meter, absorption type, 599-600
- Frequency modulation, 605, 618-621  
 defined, 623  
 transmitter, 619
- Fundamentals, 499-501  
 defined, 517  
 distortion and, 543
- Fuses, 323  
 defined, 336  
 demonstration, 660
- G**
- Galena, 24, 46-48
- Galvanometers, 359-369  
 defined, 370  
 demonstration, 662  
 moving coil, 359-362  
 symbol, 361
- Geissler tubes, 625
- Generators, alternating-current, 76  
 defined, 377, 403  
 operation, 378-380  
 symbol, 100, 103
- Gilbert, defined, 348, 370
- Gilbert, William, 305-306
- Graphs, 51-52, 62  
 conventions, 53  
 demonstration, 650  
 wave-form, 51-63
- Grid, 118  
 action of, 107-110  
 control, 257, 277  
 discovery of, 107  
 function, 117  
 screen, 257, 277  
 suppressor, 264
- Grid bias, 118  
 in audio amplifier, 135-137, 553-554  
 automatic volume control, 214-216  
 without battery, 169-174  
 in characteristic curve, 524-525  
 in radio amplifiers, 566-567  
 sources of, 111-115
- Grid-bias battery (*see* C battery)
- Grid circuit, 118  
 in wiring diagrams, 110
- Grid coil, defined, 128
- Grid condenser, 118  
 action of, 113-115  
 function, 431
- Grid-leak, 117-118  
 function of, 115-118  
 resistor, 558-559
- Grid resistor, 145  
 in audio amplifiers, 140
- Grid return, defined, 128
- Grid swing, 254  
 defined, 277
- Grid voltage, demonstration of, 652-653
- Ground, 27 *n.*, 29  
 in aerial construction, 28-29  
 symbol, 29, 30
- Ground wave, 480-481  
 defined, 492
- H**
- Harmonics, 499-501  
 defined, 517  
 distortion and, 543-546  
 higher, 573  
 in radio amplifiers, 561
- Hartley oscillator, 580-581  
 defined, 583  
 self-excited, 592
- Headphones (*see* Phones)
- Heat, formula for, 322
- Heat wave, 14  
 defined, 17  
 frequency, length, and speed, 14
- Heaviside layer (*see* Ionosphere)

- Hecto-, defined, 14  
 Henry, defined, 32, 35, 408, 420  
 Hertz, Heinrich Rudolph, 4-5  
 Heterodyning, defined, 234, 246  
 Homing device, 299  
   defined, 295  
 Hum, alternating-current, 161-165  
 Huygens, Christian, 13 n.  
 Hydrometer, 334  
   defined, 336  
 Hypothesis, defined, 44  
 Hysteresis loss, defined, 418-420  
   dielectric, 430, 440
- I
- Iconoscope, 639-641  
   defined, 643  
 Image frequencies, 245  
   defined, 246  
 Impedance, 392, 404, 412  
   calculation of, 412-413  
   characteristic, 502-503, 507  
   formula for, 392  
   matching, 555-557, 573  
   resonance and, 449  
   unit of, 392  
 Inclined-coil meter, 397-398  
 Induced current, 375-380  
   direction, 376  
 Induced E.M.F., 373  
   strength, 376-377  
 Induced field, 478  
   defined, 492  
 Inductance-capacitance tuning, 33-34  
 Inductances, 407-410  
   in antennas, 507-509  
   defined, 408, 420  
   distributed, 439, 440, 516  
   formulas for, 414-415  
   lumped, 499, 517  
   mutual, 82, 413, 420  
   phase relations and, 411-412  
   resistance in series with, 412  
   stray, 439, 440  
   symbol (*L*), 32  
   in a tuner, 31-32  
 Induction:  
   in antenna coupler, 81-83  
   coupling, 587-591  
   demonstration, 647  
   electromagnetic, 373-380  
     defined, 403  
     mutual, 89  
   self (see Self-induction)  
 Inductive reactance, 420  
   demonstration, 664  
   formulas, 410-411
- Inductors, 39, 420  
   in parallel, 408-409  
   selection of, 408-409  
   in series, 409  
   symbols, 32, 35-36  
   variable, 32  
     symbols, 32, 36  
 Insulators, 27, 29, 308, 336  
   antenna, 27, 29  
   compared, 316  
   demonstration, 648, 659  
 Intermediate frequency, 239, 246  
 Intermediate-frequency amplifiers, 239-241  
 Ionosphere, 492  
   direction finders and, 296-298  
   transmission and, 481-491  
 Ions, 481, 538  
   in Geissler tubes, 625  
   in rectifier tubes, 522  
 Iron core, symbol, 32  
 Iron loss, defined, 418, 420  
 Iron-vane meter, 396-397
- K
- Kennelly-Heaviside layer, defined, 220  
   (see also Ionosphere)  
 Key clicks, 595-596  
   defined, 595, 602  
 Keying, transmitter, 595  
 Kilo-, defined, 14  
 Knee, defined, 525
- L
- Lagging, defined, 388  
 Laminations, transformer, 416, 419  
 Law, defined, 44  
 Lead-in, 29  
   construction, 28-29  
   symbol, 30  
 Leading, defined, 388  
 Leakage loss, defined, 430, 440  
 Lecher system, 667  
 Left-hand rule, 351, 370, 375  
 Lenz's law, 376  
   for induced currents, 407-408  
 Light waves, 13-14  
   defined, 17  
   frequency, length, and speed, 14  
 Limiter, 620  
 Lines of force, magnetic, behavior, 341-342  
   defined, 340, 370  
 Loading, 517  
   for antennas, 507-509



- Local oscillator, 233, 246  
 coupling, 237-238  
 principle of, 236-237
- Lodestone, defined, 370
- Loops=antinodes (*see* Antinodes)
- Loudspeaker (*see* Speaker)
- Luminiferous ether, 13
- M
- Magnes, 339
- Magnetic field, 16, 41  
 defined, 342, 370  
 direction, 346  
 pattern of, 345-348
- Magnetic flux, defined, 343, 370
- Magnetic waves, 15-16
- Magnetism, 339-352  
 cause of, 344-345  
 demonstrations, 661-662  
 in reproducer, 37-41
- Magnetomotive force, 343, 370  
 formula for, 350
- Magnets, 18  
 law of, 343, 369  
 permanent, 186, 348, 371  
 poles of, 342-343  
 temporary, 348, 371
- Marconi, Guglielmo, 5
- Maxwell, defined, 348, 370
- Maxwell, James Clerk, 4
- Measurement, units of, 317-319
- Measuring instruments, 359-369
- Medium, in wave motion, 9-11
- Meg-, defined, 14, 117, 118
- Merit, figure of, 462
- Meters:  
 alternating current, 396-402  
 direct current, 359-369  
 symbol, 119
- Metric system, 14-15
- Mho, defined, 532
- Micro-, defined, 35, 440
- Micromicro-, defined, 35, 440
- Microphones, 145, 623  
 demonstration, 653  
 modulating function, 616-618  
 symbol, 146  
 types, 616-617
- Middle-register tone, defined, 223, 229
- Milli-, defined, 14, 35
- Mixer tube, defined, 236
- Modulated wave, 62  
 form, 56  
 graphs, 56, 57, 63  
 production of, 56-57
- Modulation, 62, 605  
 amplitude, 606, 623
- Modulation (*Cont.*)  
 cathode, 623  
 cross, 262  
 defined, 277, 623  
 50%, 610  
 frequency (*see* Frequency modulation)  
 graph explaining, 57  
 grid, 623  
 grid-bias, 615  
 high-level, 616, 623  
 low-level, 616, 623  
 methods, 605-607, 611-615  
 100%, 609-610  
 150%, 610  
 optical, 621  
 percentage of, 609-611, 623  
 place, 615  
 plate, 612-613, 623  
 power and, 611
- Modulator, 607-608  
 defined, 623
- Molecule, defined, 309, 336
- Morse, S. F. B., 3-4, 351-352
- Morse code, 682
- Mosaic screen, 639, 643
- Motors, 352-359  
 compound, 359  
 defined, 370  
 demonstration, 662  
 four-poled, 358  
 parallel (*see* Motors, shunt-wound)  
 series wound, 357-358  
 shunt-wound, 356-357
- Moving-vane meter, 396-397
- Mu ( $\mu$ ), defined, 32, 251  
 (*see also* Amplification factor)
- Multielectrode tubes, 268-269  
 defined, 276, 277
- Multiplier, 602  
 defined, 364  
 frequency, 591-592
- Multiunit tubes, 271-276  
 defined, 277
- N
- Negative, graphic representation, 53
- Negative charge, electronic definition, 75, 78
- Negative post, defined, 323
- Negative terminal, electrons and, 328
- Neutralization, 195-198  
 defined, 205  
 radio amplifiers, 569-571  
 in transmitter amplifiers, 597-598
- Newton, Isaac, 13 *n.*
- Nicander, 339

Night error, 295-297  
 defined, 299  
 Nodes, 500, 517  
 demonstration, 666  
 Nonconductors (*see* Insulators)  
 Normal tone, defined, 223, 229  
 North-seeking pole, defined, 343, 370  
 Null position, defined, 299

## O

Oersted, defined, 348, 370  
 Oersted, H. C., 349, 352, 373  
 Oersted effect, demonstration, 661  
 Ohm, 117, 118, 319, 336, 392  
 symbol, 319  
 Ohm, G. S., 319-320  
 Ohmmeters, 366-367  
 defined, 370  
 Ohm's Law, 319-321, 366, 435  
 for alternating currents, 392  
 Operating point, defined, 528, 538  
 Oscillation, control of, 123-128  
 Oscillations, 33, 35, 89, 123, 128  
 demonstration, 658  
 feedback and, 121-128  
 in regenerative circuit, 123-127  
 in tuning circuit, 87  
 Oscillator, 583  
 crystal, 581-582, 602  
 self-excited, 592  
 demonstrations, 668-669  
 Hartley (*see* Hartley oscillators)  
 local (*see* Local oscillator)  
 neon-bulb, 635-637  
 sawtooth, 635-637  
 self-excited, 602-602  
 simple circuit, 576  
 timing axis (*see* Oscillator, sawtooth)  
 tuned-plate-tuned-grid, 581-583  
 types of, 580-582  
 unmodulated, 682-683  
 vacuum tube, 675-683  
 Oscillatory discharge, 85  
 Oscillograms, demonstration, 672  
 Oscilloscope (*see* Cathode-ray oscillograph)  
 Output transformer, 186  
 dynamic speaker, and, 182-183  
 Overloading, defined, 573  
 Overmodulation, defined, 633  
 Overtones (*see* Harmonics)

## P

Parallel circuits, 95, 324-325  
 alternating current in, 91  
 crystal detector in, 92

Parallel circuits (*Cont.*)  
 electron flow in, 91-92  
 resistors in, 660-661  
 resonant, 458-461, 472  
 Parallel connection, demonstration, 651-652  
 Pattern, 290, 299  
 radiation, 510-515, 517  
 Pendulum:  
 demonstration, 648  
 resonance and, 20-22  
 Pentagrid converter, 268-271  
 defined, 277  
 Pentode, 277  
 characteristics, 537  
 power, 264-265  
 radio-frequency, 263-264  
 symbol, 278  
 Permeability, defined, 349, 371  
 Permeance, defined, 348, 371  
 Phase, 387-388, 404  
 capacitance and, 435  
 inductance and, 411  
 vector representation, 389-391  
 Phase angle, 388, 390, 404  
 symbol, 388  
 Phones, 40-41  
 condenser parallel to, 93-94  
 defined, 42  
 electron flow in, 91-95  
 symbol, 41, 42  
 wave form in, 61  
 Phonograph, audio amplifier in, 143-144  
 Phonograph pickup, 145  
 action, 143-144  
 demonstration, 653  
 symbol, 144, 146  
 Phosphor, 631  
 Photoelectric cell, 621, 638-639  
 Photoelectrons, 630-640  
 Piezoelectrical effect, 143-145, 582-583, 617  
 Pitch, 223, 229  
 demonstration, 657  
 separation, 225-227  
 Planck-Einstein theory, 475  
 Plate battery (*see* B battery)  
 Plate circuit, 105, 118  
 electron flow in, 251  
 in wiring diagrams, 110  
 Plate coil (*see* Tickler coil), 122  
 Plate current:  
 in audio amplifiers, 133  
 demonstration, 652-653  
 Plate dissipation, 536, 639  
 Plate efficiency, defined, 535, 539  
 Plate resistor, 145  
 in audio amplifiers, 139  
 Plates, in a condenser, 32-33

- Plate voltage, demonstration, *652-653*  
 Plotting curves, *386*  
 Polarity, in A.C.-D.C. sets, *178-179*  
 Pole:  
   dry cell, *74, 78*  
   magnetic, *343-344, 347-348*  
 Positive, graphic representation, *53*  
 Positive post, defined, *323*  
 Positive terminal, electrons and, *323*  
 Potential, at negative and positive terminals, *323*  
 Potential difference, defined, *315*  
 Potential drop:  
   demonstration, *660*  
   formula for, *534*  
   measurement, *365*  
 Potentiometers, *145, 157*  
   symbol, *143, 145*  
   as voltage divider, *153-155*  
   volume control, *211, 212*  
 Power, *319*  
   alternating-current formula, *393*  
   in antennas, *509*  
   formula, *322, 392-393*  
   measurement of, *368-369*  
   modulation and, *611*  
   output formulas, *533-534*  
   unit of, *319*  
 Power amplifiers, *541, 573*  
   class A, *548*  
   class AB, *550*  
 Power factor, *392-393, 404*  
   in alternating-current circuits, *392-393*  
   computation of, *437*  
   demonstration, *663*  
   formula for, *393*  
 Power losses, in transformers, *418-419*  
 Power output, transmitter, *600-601*  
 Power supply, A.C.-D.C., *175-179, 656-657*  
   filters for, *467-469*  
 Power transfer, *554-555*  
   demonstration, *668*  
 Power transformer, *158*  
   in B eliminator, *150-151*  
   faults, *175*  
   symbol, *159*  
 Power tubes, *253-257, 265-268*  
   in parallel, *255*  
   pentodes, *264-265*  
   push-pull connection, *255-257*  
 Pressure, electrical, *314*  
 Primary transformer, *416*  
   defined, *68, 71*  
 Proton, defined, *309-310, 336*  
 Public-address systems:  
   audio amplifiers in, *142-143*  
   demonstration, *653*  
 Pulsating currents, *46, 48*  
 Push-pull, *277*  
   distortion correction, *546*  
   power tubes, *255-257*  
   in transmitter amplifiers, *589-591*  
 Pyrometer, *401*
- Q
- Q, defined, *461-462*  
 Quanta, *467, 492*  
 Quantum theory, *475-476*
- R
- Radiation characteristics, defined, *510*  
 Radiation field, *473*  
   defined, *492*  
 Radio, history, *4-5, 675*  
 Radio amplification:  
   audio amplification and, *201-202*  
   first detector and, *243*  
   tuned, *192-195*  
 Radio amplifiers, *189-205, 561-571*  
   class AB, *562*  
   class B, *562*  
   class C, *562-564*  
   coupling, *190-191, 567-569*  
   defined, *190, 205, 541, 573*  
   grid bias, *566, 567*  
   harmonics in, *561*  
   neutralization, *569-571, 597-598*  
   in receivers, *564*  
   super-control, *263, 277*  
   in transmitters, *565*  
   tuned, *192-195, 204*  
 Radio frequency, *45, 205*  
   effects, *438-439*  
   range, *55*  
 Radio-frequency choke coil, *199-200, 205*  
   symbol, *205*  
 Radio-frequency current, generation, *575-576*  
 Radiotelegraphy, modulation in, *607*  
 Radiotelephone, demonstration, *670*  
 Radio waves, *16-17, 475*  
   defined, *18*  
   form, *55-61*  
   frequency, length, and speed, *17*  
   speed, *681*  
   production, *476-478*  
 Reactance (*see* Capacitive reactance, Inductive reactance)

- Receiver:
- aligning, 201
  - A.C.-D.C., 175-179
  - battery (*see* Battery sets)
  - batteryless, 172-173
  - continuous-wave, 601
  - crystal, 47, 61, 70-71
    - demonstration, 650
  - essential parts, 19
  - five-tube, 204
  - radio amplifiers in, 564
  - regenerative (*see* Regenerative receiver)
  - simple, 19-24
  - superheterodyne (*see* Superheterodyne set)
  - telephone, 38-40, 42
  - triode detector, 116
    - demonstration, 653, 657
  - tuned radio-frequency (*see* Tuned R. F. sets)
- Reception:
- diversity, 491, 492
  - interference with, 487
- Rectification, 158
- full-wave, 152-153
  - half-wave, 148-149, 152-153
    - defined, 158
- Rectifiers:
- chemical, 162
  - copper oxide, 162
  - demonstration, 654
  - diode, 148
  - full wave, 250
  - half wave, in A.C.-D.C. sets, 175
  - for heating current, 162
  - mercury-vapor, 522, 538
- Rectifier tubes, 178
- defined, 148, 158
  - demonstration, 651-652
  - full-wave, 157
- Regeneration, 129
- control of, 128
  - demonstration, 658
- Regenerative circuit, action of, 121-123
- Regenerative receiver:
- building of, 126-128
  - demonstration, 653
  - operation, 128
  - oscillators in, 575
- Reluctance, defined, 348, 371
- Reproducer, 19
- defined, 23, 24
  - demonstration, 648, 649
  - function of, 22-24
  - telephone, 23-24
  - television, 641
  - theory and principle, 37-42
  - wave form in, 60-61
- Resistance, 71
- in antennas, 509
  - capacitance added to, 436-437
  - demonstration, 659-660
  - factors causing, 318-319
  - formula for, 320-321, 366
  - inductance in series with, 412
  - loss, 509
  - measurement of, 365-367
  - nature of, 315-317
  - ohmic, 509
  - in parallel, 325
  - plate, 531
  - radiation, 509
  - selectivity and, 456-458
  - in series, 324
  - symbol, 116
  - temperature and, 318-319
  - tuning and, 67
  - unit of, 117, 118, 319
- Resistance loss, defined, 430, 440
- Resistances:
- fixed, symbol, 119
  - grid, in audio amplifiers, 139-140
  - grid leak (*see* Grid leak)
- Resistor, bias (*see* Bias resistor)
- Resistor, dropping (*see* Dropping resistor), 158
- Resistor, limiting (*see* Multiplier)
- Resistor, line-cord, 177
- definition and symbol, 177, 179
  - plate, in audio amplifiers, 138-139
  - variable, symbol, 119
  - wattage rating, 155
- Resonance, 20-22, 443-470
- calculating, 448-450
  - capacitance and, 450-453
  - coupling and, 463
  - defined, 22, 24, 472
  - demonstration, 649
  - frequency and, 451-452
  - impedance and, 449
  - sound, 20-22
  - standing waves and, 496
  - test for, 598-599
  - in transmission lines, 501-503
  - in tuning circuit, 88-89
  - vector representation, 443-446
  - wave length, 682
- Resonance curves, 458, 460
- demonstration, 665
- Resonant circuit, 443-470
- demonstrations, 665
  - filter action, 469-470
  - parallel, 458-461, 472
  - series, 455-456, 472
- Rheostat, 118
- feedback controlled by, 125
  - potentiometer as, 153

- Rheostat (*Cont.*)  
 symbol, 117, 119  
 in tone control, 226  
 volume control, 117, 118, 209-210, 212-214
- Ribbon microphone, 617
- Rochelle salts, 143
- Root mean square, defined, 385-386
- Rotation, angle of, 381, 403
- S
- Saturation point, defined, 521, 539
- Screen grid, 257-259  
 defined, 277
- Secondary emission, 264, 277
- Secondary transformer, 68, 71, 416
- Second detector tube, 236  
 audio amplification and, 243
- Selectivity, 118  
 alignment and, 243  
 antenna coupler and, 117  
 excessive, 241-242  
 resistance and, 456-458
- Self-inductance, demonstration, 651, 664
- Self-induction, 85-86  
 defined, 86, 89, 408, 420
- Sense aerial, defined, 293, 299
- Sensitivity, 118  
 power, 254, 277, 534-535, 539  
 triode detector and, 117
- Series, 38  
 cells in, symbol, 78  
 dry cells in, 73  
 resistors in, demonstration, 660
- Series circuit, 95, 323, 336  
 resonant, 455-456, 472
- Series connection:  
 cells, 38  
 demonstration, 651  
 phones, 40
- Series-parallel circuit, resistance in, 326-327
- Shielding, 205  
 symbol, 195, 206  
 transformers, 194-195
- Shunt, 92, 95, 371  
 in ammeter, 362
- Side bands, 608-609  
 cutting, 242  
 defined, 242, 247, 624
- Sight signals, 3
- Signals:  
 strength, 478-480  
 types of, 3-5
- Silver, resistance, 316, 318
- Sine, defined, 383
- Sine curve, 54-61, 383-388  
 defined, 62, 404
- Sine curve (*Cont.*)  
 graph symbol, 62  
 vectors and, 389
- Sine wave, in oscilloscope, 634
- Skin effect, defined, 438
- Skip distance, 484-485  
 defined, 492
- Skip zones, 484-485  
 defined, 492
- Sky wave, 299  
 behavior, 481-486  
 direction finders and, 296  
 fading and, 489-491
- Soldering, 683
- Sound:  
 reproduction of, 38-40  
 resonance in, 20-22
- Sound signals, 3, 5
- South-seeking pole, defined, 343-371
- Space charge, 539  
 amplification and, 252  
 correcting, 521-522  
 defined, 539
- Speaker, 42  
 dynamic (*see* Dynamic speaker)  
 magnetic, 41  
 paper cone, 181  
 symbol, 42
- Spider, 181, 186
- Static, 487, 492  
 demonstrations, 666  
 eliminating, 487-489  
 hiss, 488  
 impulse, 488  
 sources, 487
- Storage cell, demonstration, 661
- Subletters, 523
- Superheterodyne set, 231-247  
 circuit diagram, 244  
 oscillators in, 575-576  
 tuning curve, 240
- Suppressor grid, 264
- Symbols:  
 glossary of, 676-678  
 subletters on, 523
- T
- Tank circuit, 533  
 in oscillators, 577  
 in radio amplifiers, 568
- Telegraph, history of, 3-5
- Telephone:  
 history of, 4  
 reproducer in, 23-24
- Telephone-receiver, 38-40, 42
- Television, 638-641
- Temperature, resistance and, 318-319
- Tetrode, 257-260  
 characteristics, 536-537

- Tetrode (*Cont.*)  
 defined, 277  
 symbol, 278
- Theory, defined, 44
- Thermal effect, demonstration, 660
- Thermionic effect, defined, 98, 102
- Thermocouple, 401
- Thermocouple meter, 401-402
- Thermocouple principle, demonstration, 663
- Thomson, J. J., 626-628
- Three-circuit-tuner, definition and symbol, 129
- Thyratron, 636, 643
- Tickler coil, 128  
 action, 122-127  
 defined, 129  
 feedback controlled by, 123-125
- Tone, defined, 223, 229
- Tone control, 223-229  
 defined, 229  
 demonstration, 657  
 methods, 225-228
- Transconductance, 532-533  
 defined 539
- Transformers, 67-68, 71  
 air-core, 71  
 amplification by, 252-253  
 antenna coupler, 69-71  
 audio amplifier coupling, 135-138, 141  
 audio-frequency, 137-138, 145  
 symbol, 145  
 demonstration, 650, 653, 654  
 filament (*see* Filament transformer)  
 formulas concerning, 417-418  
 inductance in, 415-416  
 intermediate-frequency, 246  
 symbol, 247  
 iron core, symbol, 72  
 losses in, 418-419  
 magnetic fields, interaction of, 192-195  
 output (*see* Output transformer)  
 power (*see* Power transformer)  
 radio-frequency, 205  
 symbol, 205  
 shielding, 194-195  
 step-down, 69, 71  
 symbol, 72  
 as output transformer, 183  
 step-up, 416  
 defined, 69, 71  
 symbol, 72  
 symbols, 71-72, 135  
 tuned radio-frequency, 191-195  
 in superheterodyne sets, 233  
 symbol, 205
- Transmission lines, 500-507  
 antenna connection, 503-507  
 for coupling, 588-591  
 nonresonant, 502-503  
 resonant, 501-302, 517
- Transmitters:  
 amplifier in, 586  
 antenna coupling, 593-595  
 antennas for, 495-515  
 continuous-wave, 585-601  
 demonstrations, 669-670  
 frequency modulation, 619  
 modulated wave, 605-623  
 oscillators in, 575-583  
 power output, 600-601  
 radio amplifier in, 565  
 radiotelegraph, 585-601
- Treble tone, 223, 229  
 false, 225
- Trimmer condensers, 205  
 in aerial circuits, 201  
 with ganged condensers, 200
- Triodes, 250-257  
 characteristics, 523-527  
 defined, 118  
 electron flow in, 107-111  
 symbol, 110, 119
- Trough, 10
- Tuned circuits, 446, 472  
 antennas as, 495  
 coupled, 463-464  
 vector representation, 446-448
- Tuned R. F. sets, 204  
 defined, 205  
 diagram, 203  
 faults, 231-232  
 tuning curve, 240
- Tuner, 19  
 construction of, 34  
 defined, 24  
 faults, 65-67  
 function, 20-22  
 inductance in, 31-32  
 inductor in, 32-33  
 resistance in, 67  
 theory and principle, 31-35  
 three-circuit, 123-127  
 wave form in, 58, 61
- Tuning:  
 broad, defined, 67, 71  
 demonstration, 648, 649  
 principles of, 443-470  
 sharp, defined, 67, 71
- Tuning blocks, resonance and, 21
- Tuning circuit:  
 electron flow in, 81-89  
 illustration and diagram, 33

- Tuning circuit (*Cant.*)  
 resonance in, 88-89  
 symbol and diagram, 33, 36  
 in wiring diagrams, 110
- Tuning coils, demonstration, 649
- Tuning curves, 65-67
- Tuning-eye tube, 628-630, 643
- Turns ratio, in transformers, 418
- U
- Ultrahigh frequencies, 486-487
- V
- Vacuum-tube detector:  
 diode, 97-102  
 triode, 105-119
- Vacuum tubes:  
 alternating current and, 76  
 characteristics, 519-533, 667  
 demonstration, 653  
 general principles, 249  
 multielectrode, 277  
 multiunit, 274, 277  
 types of, 249-278  
 variable- $\mu$ , 278  
 voltages, 250
- Value:  
 average, 385  
 effective, 385  
 instantaneous, 384  
 maximum, 384  
 peak, 384  
 root mean square, 385
- Valve, radio, defined, 103
- Vectors, 388-392  
 defined, 404  
 resonance represented by, 443-446  
 sine curves and, 389
- Velocity microphone, 617
- Voice coil, 186  
 in dynamic speaker, 181-182
- Volt, defined, 319, 336
- Volta, A., 328
- Voltage, defined, 48  
 (*see also* Electromotive force)
- Voltage divider, 158  
 in C eliminator, 170  
 demonstration, 654  
 potentiometer as, 153-155
- Voltage drop, defined, 324  
 (*see also* Potential drop)
- Voltage ratio, defined, 420
- Voltaic cell, 328, 337  
 demonstration, 661
- Voltmeters, 363-365  
 for alternating current, 397-402  
 defined, 371  
 symbol, 364
- Volume control, 117, 209-220 (*see also*  
 Automatic volume control)  
 automatic (*see* Automatic volume control)  
 defined, 118  
 demonstration, 653  
 manual, 209-214, 220
- W
- Water waves, 7-8
- Watt, defined, 155, 158, 319, 337
- Wattage (*see* Power)
- Wattmeter, 368-369  
 defined, 371  
 demonstration, 663
- Wave form, 51-63  
 defined, 62  
 demonstration, 650  
 radio, 55-61
- Wave length, 10-11  
 frequency conversion, 631
- Wavemeter, 682-683
- Wave motion:  
 demonstration, 647  
 nature of, 7-12
- Waves:  
 in antennas and conductors, 495-515  
 defined in terms of energy, 10  
 energy transmission by, 9-10  
 ether, 13-18  
 heat, 14, 17  
 light, 13-14, 17  
 radio, 17, 18  
 standing, 496, 503, 517  
 demonstration, 666-667  
 water, 7-8
- Weston movement, 360
- Wiring diagrams, electron flow in, 110

