

HOW TO BUILD 78 RADIO AND TELEVISION SETS



EVERYTHING YOU WANT TO KNOW
ABOUT RADIO AND TELEVISION
REPAIR AND CONSTRUCTION

HOW TO BUILD

78

RADIO AND TELEVISION SETS

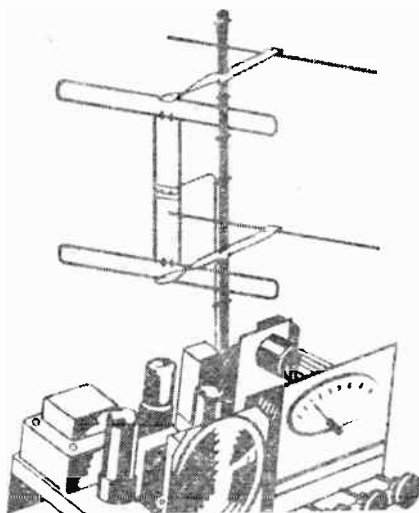

Everything You Want to Know
About Radio and Television
Repair and Construction



POPULAR SCIENCE PUBLISHING CO., INC.

353 Fourth Avenue • New York 10, N. Y.

COPYRIGHT, 1950
POPULAR SCIENCE PUBLISHING COMPANY, INC.

ALL RIGHTS RESERVED

PRINTED IN THE UNITED STATES OF AMERICA

HOW TO BUILD
78 RADIO AND
TELEVISION SETS

Table of Contents

How to Buy Radio Parts	8	Old Tubes Salvaged as Rectifiers	73
Radio-Building Hints for the Beginner	14	Rectifier Gives Bias Voltage	73
The Last Word in Crystal Sets	18	Standard Symbols for Circuit Elements	73
Beginner's Radio Grows by Stages	22	Testing with Resistor Bridges	74
Intercoms Save You Steps	26	Repairing Noisy Potentiometers	74
Amplifier Fits on Headphone	31	Heavy-Duty Choke-Input Power Pack	75
Radio Parts from Your Scrap Box	32	Hidden Brackets Hold Radio on Wall	76
A Superhet the Beginner Can Build	36	Terminal Strips Help Test Circuits	76
Completing the Beginner's Set	40	What to Do About Intermittent Reception	77
How to Stop Appliance Static	44	Improving Low-Cost Record Players	78
Relaxation Oscillator for Code Practice	45	Filter Improves Crystal Pick-Ups	81
Testing for Burned-Out Tube Filaments	45	What Tube Can I use?	82
Meet Mr. Mike	46	Glow Lamp Shows Tube Cutoff Action	85
Wiring Puzzlers	51	Adapting Auto Radios to Home Use	86
Filters . . . Radio's Most Important Networks	52	Tuning In Those Off-the-Dial Stations	88
Wireless Record Player Broadcasts	56	Arrow on Knob Gauges Volume	89
Personal Radio with a Bedside Manner	58	Clip on Portable Lid Holds Data	89
T.R.F. Receiver Has A.V.C.	60	Electronic Print Timer	90
Seeing Eye of Electronics	62	Eliminating Speaker Hum	91
Building a Cathode-Ray Oscilloscope	66	Homemade Wand Helps Alignment	91
Measuring Impedances	71	Loudspeaker Adjustments	92
Signal Booster Brings in Weak Stations	72	Circuit Tester Uses Standard Parts	93

Permissible Voltage Drop	93	Playing Records with One Tube	164
Multipurpose Test Instrument & Amplifier	94	Pocket Radio Doubles as Hearing Aid	168
Listen in on This 10-Meter Receiver	96	External Speaker Adds Uses to Auto Radio	172
Short-Wave Converter Brings in the World	98	One-Tube Radio Can Be Mailed	173
Midget 80-Meter Code Transmitter	102	One-Tube Radio Is Matchbox Size	174
Two-Meter Handie Talkie	104	You Can't Sneak Past This Robot Watchman	176
Low-Cost Parts Test Radios	107	Two-Band Superhet	178
Circuit Tester Uses Tuning Eye as Meter	111	More Power to You	182
Capacity Bridge for Testing Condensers	112	Businessman's Radio Fits in Briefcase	186
Output Meter Uses 1½-Volt Tube	115	Bring Out High Notes with a Tweeter	190
Meters Clock Electricity's Flow	116	Portable Phono-Radio Combination	192
Building a Multimeter	120	Three-Pound Radio Is on the Ball	196
Completing Your Multimeter	124	RF Booster Stretches Radio's Range	200
Midget Volt-Ohmmeter	127	B Supply Cuts Battery Cost	202
Push-Button Selector Keeps Test Values Handy	129	Converting AC-DC Sets to Portables	204
Vacuum-Tube Meters Read Voltage Right	130	Oscillator-Amplifier Is Master Music System	208
Pocket Set Has Permeability Tuning	135	Armchair Tuner Reaches to Your Radio	212
High Fidelity with Two Tubes	136	Tuning Eye Makes Old Radios Look Up	217
De Luxe Vacation Portable Rivals Console	140	Wireless Mike Puts You on the Air	222
Boy's Radio Lets Dad Enjoy His	145	Getting Big-Set Quality from a Midget	224
Simple Guard Protects Needle	146	Preamplifier Serves Mike or Pickup	227
Tagging Wires Saves Time	146	How Good Is Your TV Picture?	229
4-Way Portable Stretches Battery Life	147	Taking Care of a TV Set	231
Battery Phono-Radio Portable	152	I Assembled My TV Set from a Kit	234
Dry-Disk Rectifier Replaces Tubes	155	Antennas for FM and Television	240
Tune In on High Fidelity	156	Improving Quality of TV Sound	245
Hi-Fi Amplifier Gets ALL the Music	160	How to Rotate TV Antennas	248
		Glossary of Television Terms	252
		Index	254

How to Buy Radio Parts

By Frank Tobin



Knowing what to buy and why is the first step to successful shopping, and the key to building electronic gadgets that work.

SHOULD you ask a radio-parts salesman for a "double-o-one-mike condenser," he could put out a counterful of parts—all different, yet all .001-mfd. capacitors. "Which do you want?" he might ask. "Paper, mica, or ceramic—and what voltage and tolerance?"

If your first impulse is to say that it makes no difference so long as the capacity is right, you've probably never seen the wax melt out of a paper condenser used where a mica should have been. Sometimes, to be sure, identically rated parts may be used interchangeably. But don't overlook the many cases where an improper part may cause a short, burnout, or open circuit, or simply become defective in a hurry.

Some of the things that are worth knowing about condensers, coils, resistors, output transformers, and tubes are dealt with in this article. You may find them helpful next time you shop for radio parts.

Condensers—Fixed and Variable

Mica condensers (Fig. 1) are easily recognized by their molded-plastic cases. They are commonly used in by-pass and coupling circuits and as grid condensers in grid-leak detectors. Their working-voltage rating is generally about 500 volts DC but the cases are rarely marked. Mica condensers are used mostly at high frequencies, and therefore capacities are low, ranging from about 50 mmf. to 6,000 mmf. (.006 mfd.). You'll find micas in demand wherever low capacities with

low loss at high frequencies are required.

Incidentally, in case condenser arithmetic has you stumped, the basic unit of capacity is the *farad*. As radio components go, this unit is enormous, so it's divided by a million. This gives the *microfarad* (mfd.) and can be expressed as .000001 farad, (one millionth farad) but would normally be written 1 mfd. Even that's big in radio work, so the microfarad is further divided by a million to give the *micromicrofarad* (mmf.) which can be written .000001 mfd. or, more simply, 1 mmf. To translate mfd. to mmf., simply move the decimal six places to the right (in effect, multiply by a million). Thus .0001 mfd. is the same as 100 mmf., and .005 mfd. becomes 5000 mmf.

One of the war-developed ceramic capacitors will often do when specifications call for mica. Ceramics have high stability and compactness; they come in the form of small disks or tiny cylinders resembling fixed resistors (Fig. 1). They are also primarily for use in radio-frequency (RF) circuits.

Paper condensers can be found in every stage of a modern receiver. They have such varied functions as by-passing stray signal voltages, coupling two stages, bass boosting (in tone-control circuits), and filtering in certain rectifier applications.

Working voltages are usually indicated for paper condensers, and it is important that the rating be adequate. When in doubt always take a larger voltage. In AC-DC or

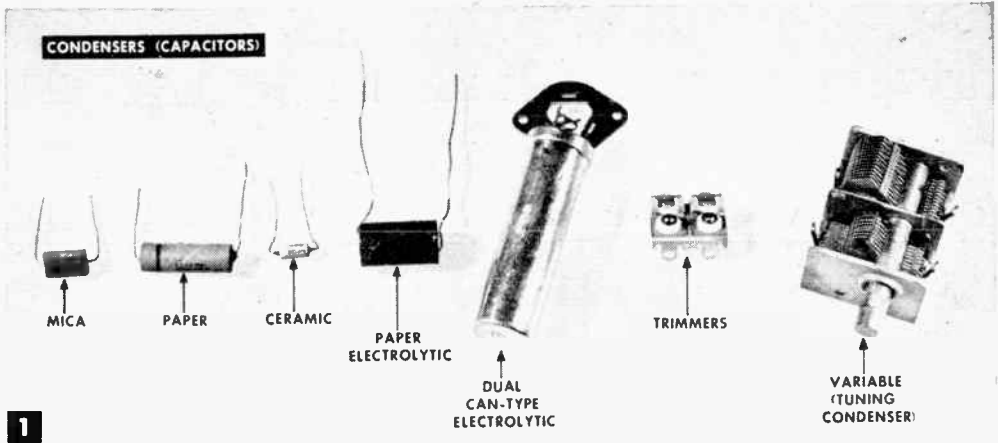

1

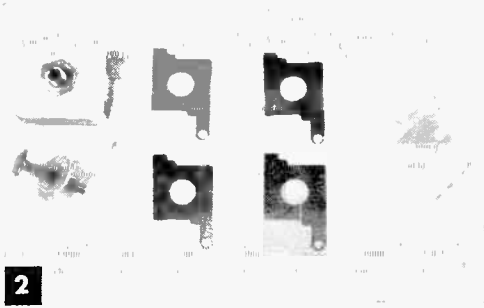

2

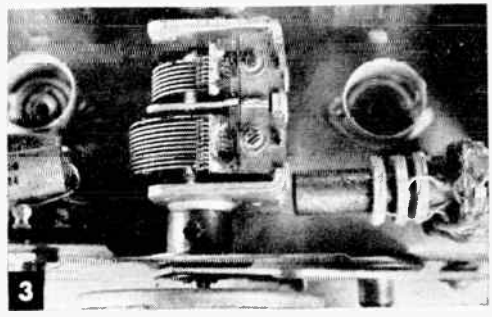

3

battery-operated receivers a condenser rated at 400 volts allows a safe margin. You might get by with these even in an AC set or amplifier that delivers 250 to 350 volts of B plus, but a few pennies more can buy greater safety in the form of 600-volt condensers. Sometimes heat generated by tubes may melt the wax in which a condenser is sealed. Where this seems likely, try to get capacitors sealed in plastic.

There is still another type of fixed condenser that crops up in practically every

piece of radio or electronic equipment—the electrolytic. This is used in all filter circuits and in many special applications. Electrolytic condensers come in aluminum cans or cardboard containers. In order to save space (and cost), two or more units are often put in one container with separate leads brought out. A single can containing two units is called a dual electrolytic; multiple electrolytics with up to four sections are common. Polarity must be observed for electrolytics, so make sure the leads are color-coded or

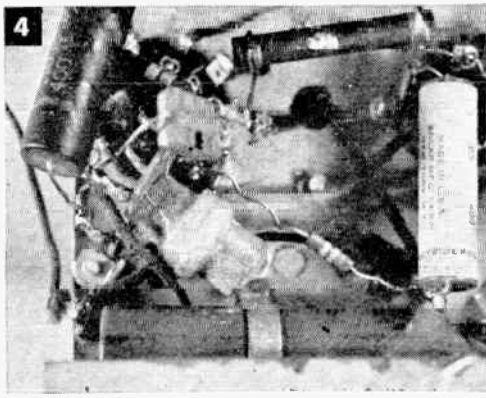

4

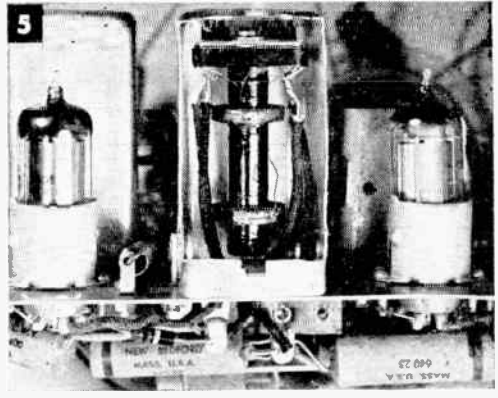

5

RESISTORS



UNINSULATED
CARBON



INSULATED
CARBON



WIRE-WOUND



ADJUSTABLE
WIRE-WOUND



VARIABLE
(POTENTIOMETER)

6

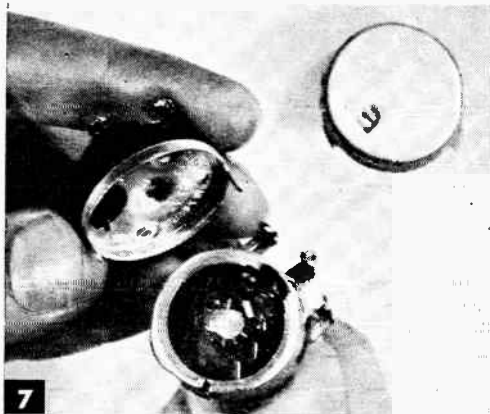

7

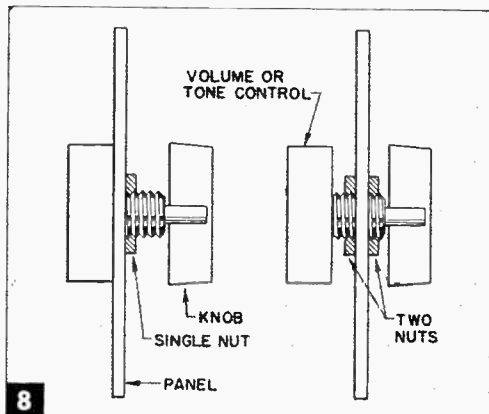

8

otherwise marked. Standard codes use red for the positive and black for the negative terminals.

Fixed condensers sometimes vary from rated value by as much as 20 percent plus or minus. Except for test equipment or the like you can usually allow an extra margin of up to 20 percent when you can't find a condenser of the right size. If the parts list calls for .005 mfd., you can get by with .006 or .004 mfd. But for very exacting equipment it is frequently wise to pay more for condensers guaranteed within 5 percent of stated capacity.

The variable condensers used for tuning short-wave or broadcast receivers are usually .00014 mfd. (140 mmf.) or .000365 mfd. (365 mmf.). They're available either as single units or ganged into two or three sections. The type to buy depends on the number of tuned circuits in the set. Ganging of two condensers of unequal size is common in superhets to tune the antenna and the oscillator circuits to different frequencies.

Experimenters almost always find it wise to purchase variable condensers with built-in trimmers. These are sandwiches of metal

and mica (Fig. 2). A setscrew squeezes the metal plates more tightly when you have to increase capacity, or relieves the pressure to reduce capacity. Fig. 3 shows trimmers mounted directly above the variable plates.

Trimmers are built into most IF transformers to enable you to make minor adjustments. They also come separately for use in coupling an antenna to an antenna coil, as padders in oscillator circuits, and even as tuning condensers in midget receivers.

Coils

Coils constitute another large and often bewildering category to the man who sets out to buy radio parts. Under this head you will find plug-in, antenna, RF, oscillator, and IF transformer coils. Some are shielded, some aren't.

Plug-in coils, found in simple crystal and regenerative receivers, are generally sold in matched sets to cover broadcast and short-wave bands. In most cases the tuning condenser is of 140-mmf. capacity. Four-prong coils are used when the circuit calls for two windings, while six-prong coils are needed for three windings.

Antenna and RF coils are employed in small TRF receivers. They are available either shielded or unshielded. When using unshielded coils, it is best to mount the antenna coil above the chassis and the RF coil underneath so the chassis will serve as a shield. Wherever it is necessary to mount all coils on one side of the chassis, or where there's more than one tuned RF stage, only shielded units should be used. In buying receiver coils, ask for a matched set. This will assure accurate gauging between coils as well as with the condensers.

Most superheterodyne circuits call for an antenna coil, and they always require an oscillator coil, and at least two intermediate-frequency (IF) transformers. Shielding problems are the same as in the TRF set. In the lower foreground of Fig. 4 an unshielded oscillator coil is mounted underneath the chassis.

The transformers used to couple IF stages are basically coils tuned to a fixed frequency—in broadcast receivers 456 kc. They are in aluminum cans (Fig. 5 shows one cut away) with lugs, clips, or feet by which they can be mounted.

Some IF transformers are brought to peak frequency by trimmers, and some by adjusting an iron core. The latter respond over a much broader tuning range and are therefore easier to align without a signal generator.

One final point to bear in mind when buying coils: If you are building a receiver with only a single stage of RF or IF, you need maximum amplification in each stage. You will get this plus greater selectivity by using coils with iron cores.

Fixed and Variable Resistors

You'd have to look hard for an electronic circuit that doesn't use a fixed or variable

resistor of some kind. Fixed carbon resistors constitute the bulk of all resistance units. They are inexpensive, reasonably accurate, and come in a large variety of sizes and ratings. Some are encased in plastic, which makes them impervious to moisture and less likely to short against other components. Uninsulated resistors (Fig. 6) dissipate heat a little more readily but shouldn't be used in cramped quarters.

All fixed resistors are rated in *ohms* (the unit of resistance) and *watts* (current rating). As with voltage ratings in condensers, a larger wattage is safer when there's doubt.

For AC-DC receivers and amplifiers, $\frac{1}{2}$ -watt units are generally adequate in the control-grid circuits of amplifier tubes. Plate and screen circuits should get 1-watt resistors, and cathode and filter circuits 2 watts or more. Battery-operated equipment can generally get by with ratings half as large.

Wire-wound resistors are employed where current drain is high and where stability and accuracy are paramount. On adjustable wire-wound resistors part of the winding is left bare so that a movable metal band can tap off any resistance between zero and the maximum.

Variable resistors, now found chiefly in the form of potentiometers, have a fixed carbon or wire-wound element and a moving contact turned by a shaft. If you want resistance to increase evenly in proportion to shaft movement, specify a linear-taper pot. Because of tube characteristics, nonlinear pots usually give more gradual control over volume, tone, and bias. In logarithmic pots, usually used for tone and volume controls, resistance increases at a definite but uneven rate. In end-tapered pots, used for varying tube bias, resistance "thins out" at one end.

For the convenience of radio builders, the

9

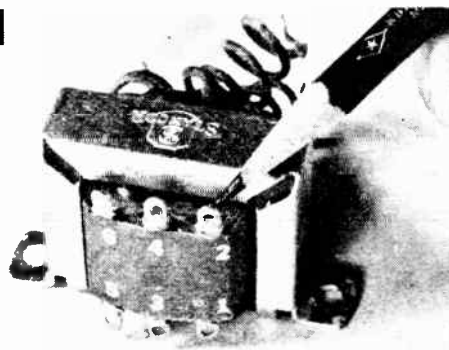

10

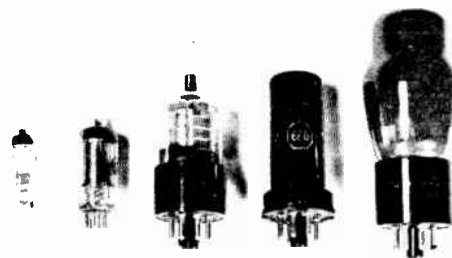

makers of potentiometers provide switches that can be slipped onto the back of the unit (Fig. 7). The switch is actuated by the first few degrees of shaft turn.

A potentiometer is usually fastened to a panel by means of a gripping nut screwed on a threaded shaft. Since there is a good deal of variation in shaft nuts, you can often do yourself a favor by purchasing an extra one at the time you buy the potentiometer. With two nuts you can exactly regulate the projection of the shaft in front of the panel as shown in Fig. 8.

Output Transformers

In purchasing an output transformer for a small set, it is best to look for the universal type. Taps on the secondary winding of the transformer (Fig. 9) allow matching of any tube impedance from 1,500 to 20,000 ohms to any voice-coil impedance from .1 to 24 ohms. These figures vary somewhat with different makes.

Impedance matching is probably the leading consideration in the selection of an output transformer, but there is one other that must never be overlooked. If the transformer can't handle all the plate current that will be delivered to it, it cannot transfer that power to the speaker. Output transformers are rated in watts. For most battery and small AC-DC receivers, 4 to 5 watts is suitable; for AC receivers and high-powered audio amplifiers you will usually want a transformer rated at 8 watts or more.

Tubes and Pilot Lights

Some people feel that radio tubes offer the largest variety of radio components. Several catalogs list upward of 400 types. This, however, need rarely worry the builder who works from a parts list. The specifica-

tions always designate tubes by numbers.

One puzzling element is the lettering that follows the tube number. A metal 6K7, for example, has the same electrical characteristics as the glass-dome 6K7-G or the bantam 6K7-GT (the latter is sometimes listed as GT/G). The only differences are in their physical dimensions (Fig. 10) and in the method of shielding. The first of these tubes is encased in metal, the other two in glass envelopes of different sizes (G being considerably larger than the GT). The 6K7 requires no separate shielding, while the others must be covered with a metal shield (Fig. 11) to suppress undesirable coupling. Only tubes used in the high-frequency circuits—RF, converter, IF, and sometimes detector stages—need shielding; others such as power output tubes and rectifiers don't require it. Fig. 10 shows the most common types of receiving tubes, being, from left to right, sub-miniature, miniature, bantam (GT), metal, and glass dome (G).

Sometimes you want to duplicate a particular circuit in a smaller size. This is becoming increasingly possible with miniature components. For example, the 50L6 beam-power amplifier can be replaced with a 50B5 miniature.

Dial pilot bulbs become critical in AC-DC sets, because they're in series with the tubes and must match them in current rating, since current is equal in all parts of a series circuit. The bulb ratings are marked by a colored glass bead in the bulb. For example, a set using tubes with heaters drawing .15 amp at 6.3 volts calls for a brown-bead pilot bulb. A white bead means .5 amp. at 2.5 volts, a blue .3 amp. at 6 to 8 volts, and a pink one .06 amp. at 2 volts. All types come with both bayonet and screw bases to suit the two socket types (Fig. 12).



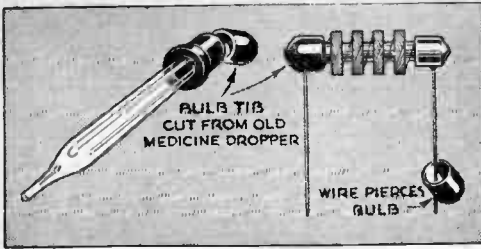

Rubber Tips Insulate Chokes

WHEN crowding radio parts close together to make a compact job, here's a method for protecting the bare metal ends of an RF choke against accidental contacts. For each end, cut the rubber tip from an old medicine dropper and place it over the end as shown.—*Alfred H. Fortier, Orono, Me.*

Vent Holes Prolong Tube Life

A FEW $\frac{1}{8}$ " holes drilled around the socket of the rectifier tube of a large receiver, amplifier, or transmitter will keep the tube cooler and thus help to increase its life. Other nearby components are also benefited because the increased air circulation carries away much of the damaging heat.—*D. J. Bachner, Jackson Heights, N. Y.*

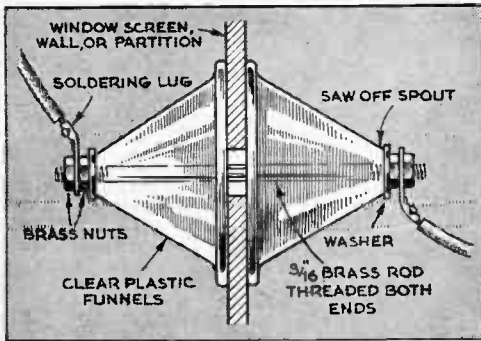

Insulators Made From Funnel

I MADE some swell cone-type feed-through insulators from the small plastic funnels sold in dime stores. Comparable commercial insulators would have cost me a lot more. Two of the funnels, with the tips cut off, are used for each insulator as shown in the sketch above.—*Arthur Trauffer, Council Bluffs, Iowa.*

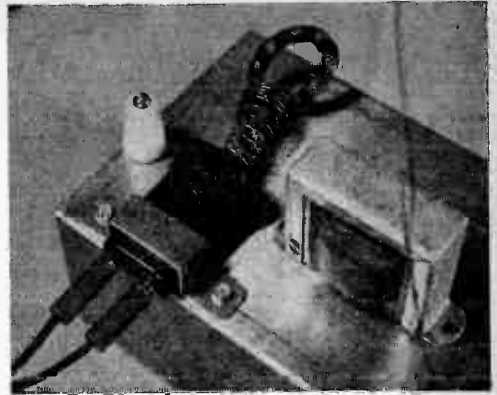

Iron Plug Is Phone Terminal

AN OLD electric-iron plug can be converted into a handy terminal for a mike or phono input or used for an output connection to speaker or phones. Its own cable can be brought under the chassis to the appropriate connections. Incoming leads are fitted with banana plugs, which are in most cases a good fit in the holes. Either bolts and nuts or self-tapping screws can be used to hold the clamp. Being built with heavy-duty insulation, the plugs can be attached directly to the chassis as shown.



Pointer Filed on Plain Knob

IT IS often convenient to have a reference point on the knob of a volume, tone, or other control so that a setting can be noted for future use. If you don't have a pointer knob on hand or want one that matches the others as closely as possible, you can convert an ordinary round knob to your purposes as shown. File two small flats on the rim, leaving a small portion between them. Then file this portion sharp to form the pointer.

A spot of paint or nail polish on the point will make it easier to read.

Radio-Building Hints for the Beginner



The best way to learn radio building is by building radios, but these tips may smooth your first steps.

By Frank Tobin

MANY craftsmen who have been bitten by the radio bug have discovered that the hardest thing about getting started in radio is—getting started. Right at the outset you have to answer a hundred practical questions that crop up even in the simplest project. Common sense can answer most of them, but a few pointers may help you past the first bottleneck.

Quite literally, the chassis is the foundation of any electronic gadget. It's the place where you hang all the parts. You can bend it up out of tomato cans, cut it from a breadboard, or use the orthodox kind that you buy in radio stores. Most of the latter are made of either aluminum or steel, generally about 1/16" thick. They come in a variety of sizes and finishes.

Aluminum, of course, is easier to work with than steel, particularly if you have only

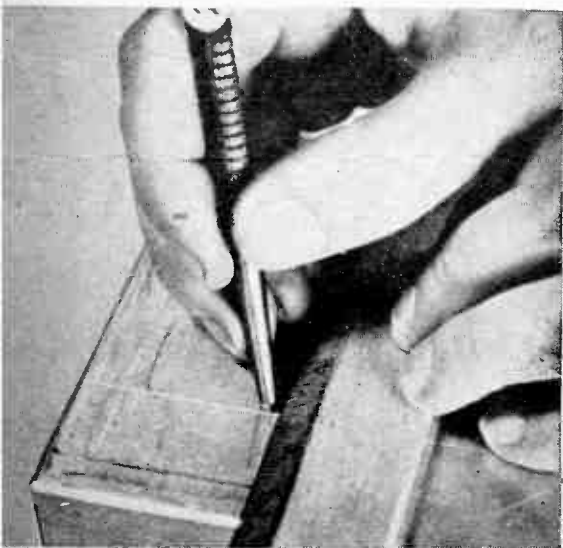

A ruler and a sharp punch are used to mark a chassis. For experimental layouts that may have to be erased, use soft or colored pencil.

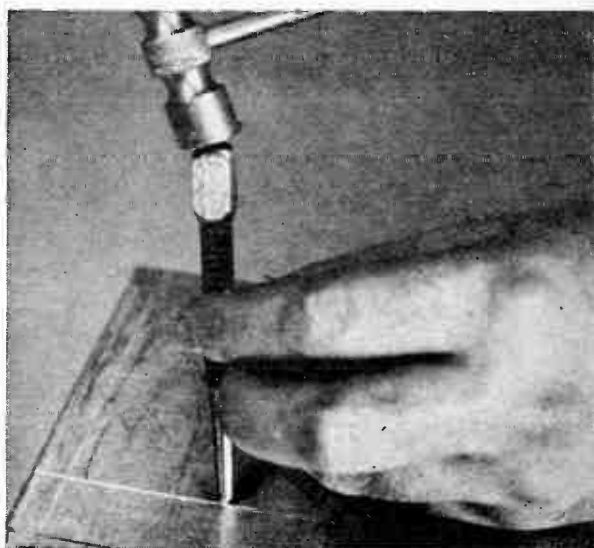

Where a hole is to be made, hit the punch a sharp hammer blow. The indentation guides the drill, helps get the hole exactly on center.

a hand drill. With an electric drill the difference isn't very great. You can use carbon-steel bits with a hand drill, but high-speed drills will last longer if you have a heavy-duty electric drill.

Drilling the holes is an easier matter than deciding *where* to drill them. Tube sockets and coils especially must never be placed haphazardly. They have to be located and oriented so as to keep the leads as short as possible. Not all wires can be short, of course, but they aren't all equally important. The critical ones are those going to plates and grids. From the diagram or a tube manual you can easily figure which way to turn a socket or IF transformer so that the leads will remain short. Screen-grid and B-plus wires are next in importance. Keep them short if you can, but don't worry if they have to stretch a bit. Heater, ground, and AVC leads practically don't count in the shortness sweepstakes.

Should you find that the grid leads in an audio or output stage have to be long, use shielded wire and ground the braid to the chassis at some point. Good examples are the connections to volume or tone controls. Do not use shielded wire in radio-frequency stages, as the added capacity of the shield may easily throw off the alignment of the coils and tuning condenser. And if any grid wire has to cross one that goes to a plate, make sure they do so at right angles.

Wherever possible, group components which perform similar functions. The RF and IF parts can go on one section of a chassis, the audio and output stages are gathered in another, and the rectifier and power-supply pieces occupy still a different corner.

Once you've decided where each of the parts is to go, mark the chassis for drilling with a soft pencil or a sharp-pointed tool. At the spot where a hole is to be drilled, make a punch mark that can serve as a pilot for the drill. Since the three holes for a tube socket (two hold-down screws and that for the socket opening) must line up exactly, marking and drilling require care.

Small holes are easy. All you have to do is select a drill of the proper size. Larger ones for tube sockets and the like are another matter. There are three common methods for making such holes.

You can either enlarge a smaller opening with a rat-tail file, use an adjustable hole cutter in a drill press, or employ a chassis punch. Punches are made in all the common socket sizes; the three that take care of most work are $\frac{3}{8}$ ", $1\frac{1}{16}$ " and $1\frac{1}{4}$ ".

It is difficult to visualize in advance all the holes that may be needed, but drilling others after some parts are mounted may endanger those parts. Why not drill a few extra holes, especially in strategic locations?

Remember, for example, that leads from

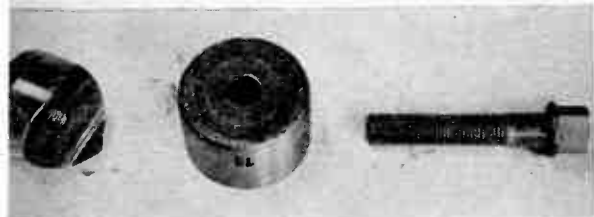

A chassis punch consists of a two-jaw cutter, left, a die, and a machine bolt. A separate punch is needed for each different hole size.



Drawing up the bolt with a wrench brings the cutter and die in contact with the chassis and shears out a clean, precise socket opening.

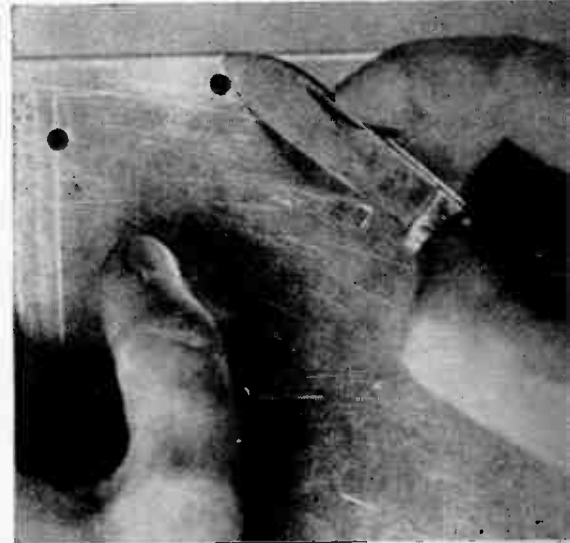

Any burred edges that are left after drilling—especially in aluminum—should be removed with a file or a heavy knife blade.



Copper wire solders best when it is tinned. Best bet is to buy it that way, but you can tin the ends yourself by scraping them clean



and dipping them into rosin flux paste. Put an end on a metal plate and run a thin coat of solder over it. Melt off any excess.

a transformer or choke can't get to the underside of a chassis through solid metal. A $5/32''$ or $3/16''$ hole is about right for passing a wire through the chassis. You need an opening, also, when you use a tube that has a grid connection brought to a metal cap on top. And for each gang of a tuning condenser there has to be some way to get to the stator (fixed) plate terminals. If the condenser has lugs on the bottom, drill over-

size holes—say $1/2''$ to $3/8''$ —so that neither the lug nor the connecting wire can touch the chassis.

Once you have all the holes drilled and the parts mounted, you can get down to the serious business of wiring the set. It is usually advisable to make all filament or heater connection first. Take care of the cathodes next, then go back to the RF stage and work along, in order, to the rectifier.

In AC receivers where heater voltage is obtained from a filament winding on the power transformer, twist the leads and ground the centertap of the winding. This helps to reduce hum pickup. If the winding has no centertap, ground one of its two leads and one of the heater pins on each tube socket directly to the chassis. The other transformer lead then goes to the remaining heater prongs. Always use stranded wire with good insulation; it withstands twisting and bending a good deal better than solid wire.

While stranded wire is recommended for heater connections, a solid wire—preferably with insulation of the "push-back" type—has advantages for B-plus and plate leads. Being less flexible, this wire can be bent up out of the way and will stay where it is put.

In actual practice you will find that you don't need very much wire to hook up a set. Many components are sold with their own leads, which are almost always ample for the connections that have to be made. If they aren't, the chances are that something is wrong with the placement of the parts. Most often it will be necessary to cut these

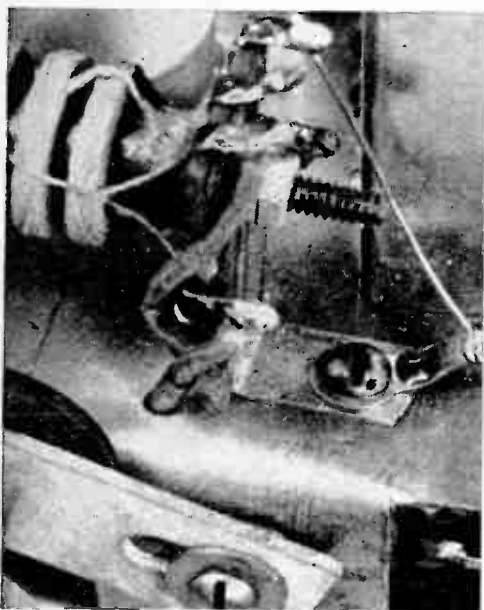

A soldering lug, held down by a screw that is used to fasten some other part to the chassis, provides an excellent ground connection.

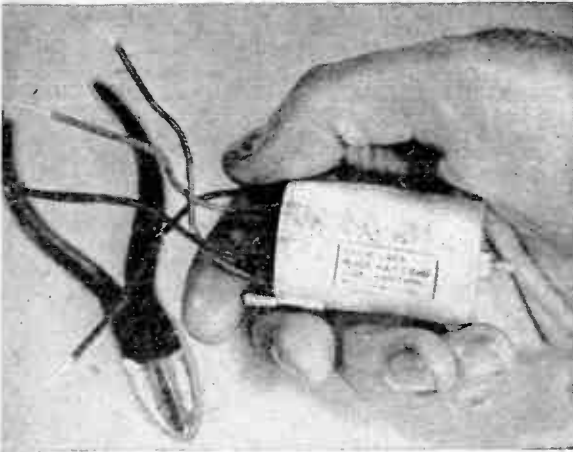

Many components can be purchased with tinned wire leads, all ready to solder into the set. Push about $\frac{1}{8}$ " of insulation back from end.

leads down to size. When one isn't needed at all, cut it off short.

Much the same facts apply to small parts such as resistors, mica and paper condensers, and plate chokes. These usually come with "pigtail" leads which are stiff enough to support their weight. If a pigtail lead has to come near or cross a bare wire, or is in any other danger of grounding or shorting, slip a length of "spaghetti" tubing over it for insulation.

To provide anchoring points for a wire that goes to ground or for two or more leads that come together, use soldering lugs and terminal strips. The soldering lug is a little metal tab with a hole at each end. Slip one hole over a machine screw that is being used

to hold down some large part, and clamp it with an extra nut. Wires that are soldered to the other hole will then be in good electrical contact with the chassis.

When joining unground wires—as several B-plus connections that come together—use a terminal strip or lug. These consist of one or more eyelets mounted on a fiber strip. A leg is provided for bolting the strip to the chassis, but the eyelets to which connections are made are insulated from all other points.

Copper wire that has been "tinned" (that is, cleaned and finely coated with solder) is best for radio work as it allows faster and more secure soldering. Try to buy tinned wire and parts with tinned leads, but if you can't, here's how to fix them up yourself. Cut off or push back the insulation to a distance of about $\frac{3}{8}$ " from the end, and clean the copper with a piece of emery cloth. Stick the cleaned tip into a can of rosin flux paste and place it on a small metal plate. Bring a hot iron and a strip of solder into contact with the end. A thin coat should adhere to the wire. Run off any excess with the hot iron.

Never use acid-core solder in radio work. Acid can corrode the connections, and if any should remain between socket prongs or other critical points, it could act as a leakage path for the busy electrons. Plain and rosin-core solders are fine, and a can of rosin paste is handy since even the cored solders can stand some extra flux. Excess paste on a joint need not be wiped off as it can't do any harm. In making soldered connections, heat the joint and let the *joint* melt the solder.

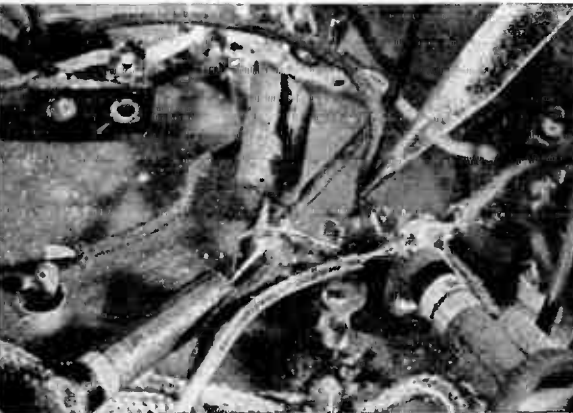

Terminal strips make fine anchored meeting points for ungrounded wires. The pencil points to one; another one is in the background.

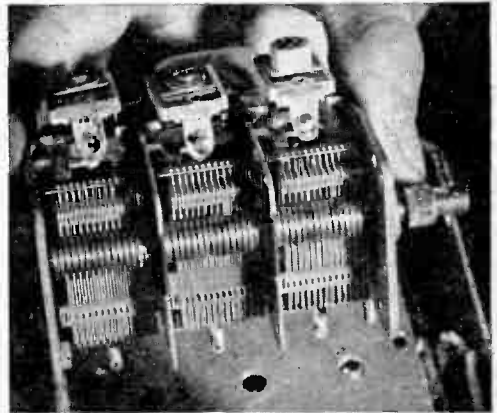

Try to visualize all necessary holes and drill them in advance. One is needed to clear the stator lug on each unit of a ganged condenser.

Still the beginner's choice, crystal receivers refuse to die out. These four de luxe versions will surprise you with the things galena can do.

By FRANK TOBIN

CRYSTAL receivers occupy a unique and honorable position in the history of modern science. Almost to a man, the present generation of engineers and technicians grew up on crystals, and it is this generation that has made electronics a synonym for progress and achievement.

With the rapid advance of the radio art, crystal detectors were forced to give way to vacuum tubes. But as much as they've been shoved into the background, these perennial favorites have never passed out of the radio picture. Beginners and experimenters who like to do a lot with a little still find their simple circuits inviting, especially since new developments in crystals have given a boost to the old-fashioned sets.

Take, for example, the novel radio phonograph shown on the next page. The output of the pickup (which employs a piezoelectric rather than a detector crystal) is sufficient to drive one or two pairs of headphones at full strength and with excellent quality. By using a spring-wound motor in place of the one shown, you can make the outfit independent of a power supply as well as of an amplifier.

Most of the space in the standard 4" by 10" by 12" cabinet is occupied by the phonograph. One of the newer fixed crystals (type 1N34) is used in the radio. An antenna coil of the type commonly used in A.C. - D.C. sets and a .00036-mfd. variable condenser are employed for tuning. Connected between the primary and secondary windings of the coil, a midget .00005-mfd. trimmer adjusts the coupling. The looser the coupling (i.e., the more out of mesh the rotor plates are) the greater will be the selectivity and the weaker the volume. Once it is set for any particular locality and antenna, the trimmer need not be altered.

A pickup with as little as .5-volt output will serve, but one rated at 1.5 volts or more is preferable because the output of the phono crystal is fed directly into the headphones without amplification. To vary the volume, use different needles. Soft needles give less headphone volume than hard ones.



The last word in

CRYSTAL SETS

...the first word in radio

Too much power can sometimes be as bad as too little. Standard crystal receivers used close to several high-powered transmitters often fail to separate the stations, and it is to overcome this weakness that two separate tuned circuits are employed in the super-selective receiver illustrated at the top of page 20. Coils L1 and L2, together with a .00036-mfd. variable condenser (C1) form the first tuned circuit; L3 and C2 form the second. Selectivity is obtained in this fashion without sacrificing signal strength.

All the coils are wound on a 2½" tube 6½" long. Use No. 24 enameled wire throughout, winding 50 turns for L1, 25 turns for L2, and 60 turns for L3. When a long outdoor antenna is available, better results can be obtained by connecting it to the midpoint of L1.

Closest in design to the conventional crystal set that has been popular since the begin-



Radio-phonograph combinations strike a new note in crystal-set construction. The complete yet extremely simple unit shown at the right depends upon two relatively recent developments. First is a high-output pickup that can operate headphones directly without amplification; the second is a preset, fixed-crystal detector. Because this crystal requires no manual adjustment of its cat's whisker, the entire radio can be tucked out of sight inside the cabinet.

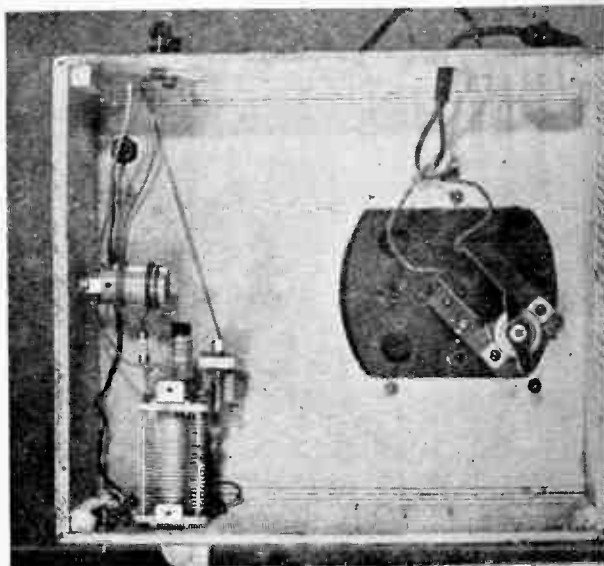
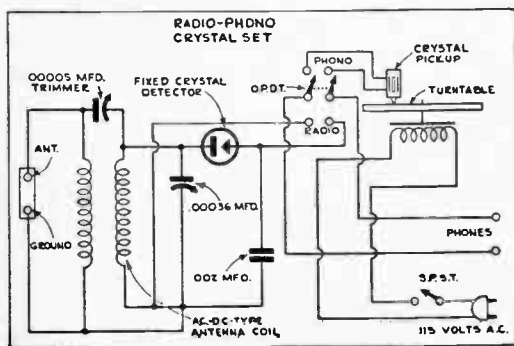

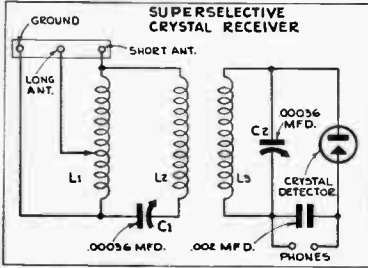
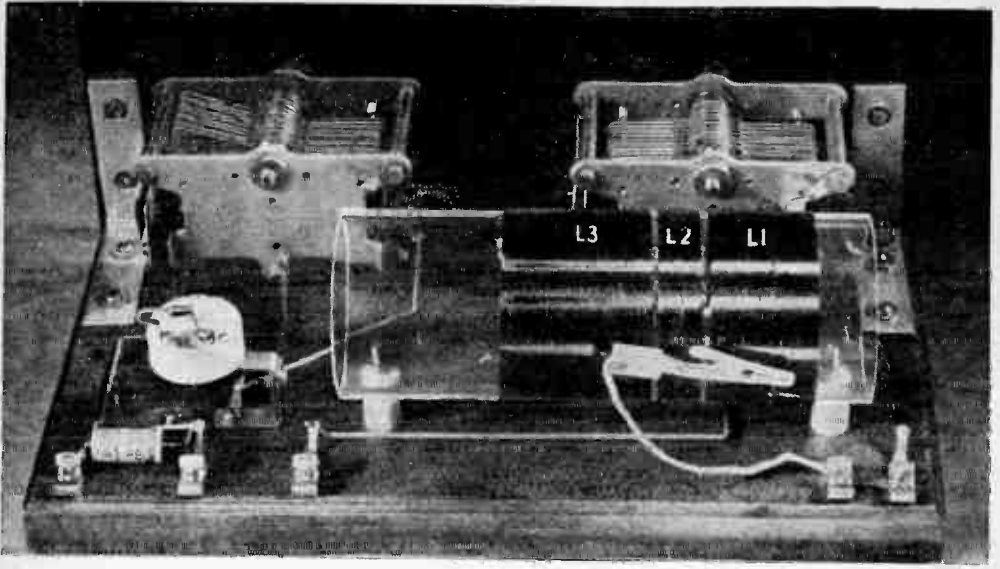

Two separate tuned circuits enable this receiver to distinguish between two or more powerful signals. The alligator clip is used to centertap the antenna coil, L1, when a long aerial is available.

ning of radio is the compact portable shown below. To cover the entire broadcast band with its .00014-mfd. condenser, two sets of coils are needed. These can be made interchangeable by winding them on a pair of 4-prong, 1/4" plastic forms. For use between 200 and 350 meters, L2 should consist of 100 turns of 32-gauge wire, and L1 of 40 turns of No. 36. Leave 1/16" to 1/8" space between the two windings. Stations operating in the 350 to 550-meter range can be tuned in with a coil that consists of 170 turns of No. 34 (L2), and 60 turns of No. 36 (L1). As before, enameled wire is used

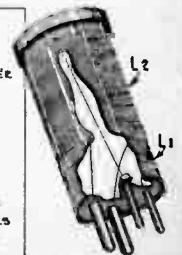
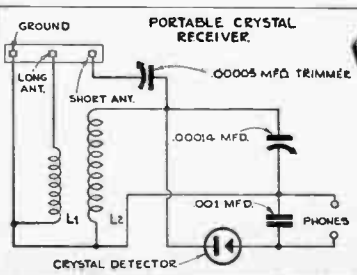
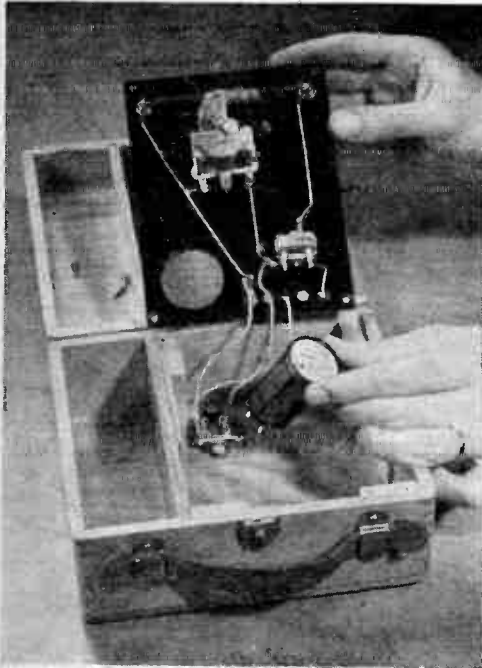

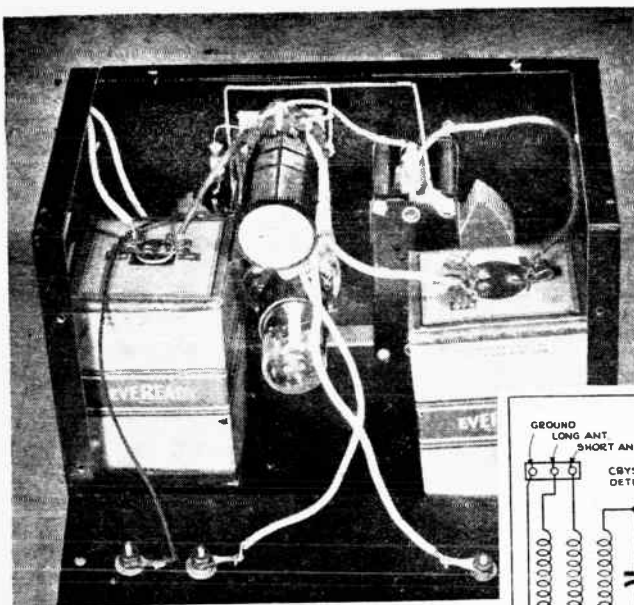

Departing from conventional crystal-set design, this model employs one stage of amplification. With 90 volts on the plate, it will operate a loudspeaker or pull in distant stations.

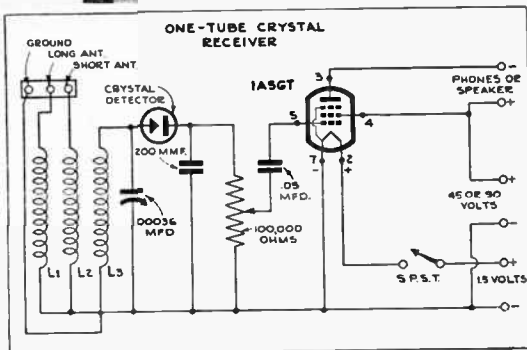
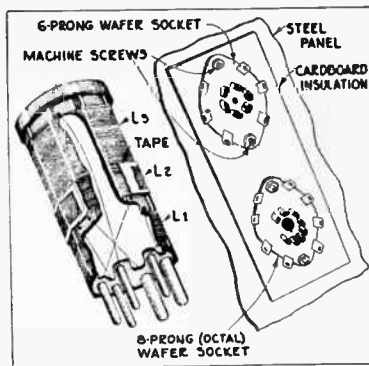

for all windings. The small left-hand compartment in the 4" by 7" by 8" cabinet will hold a single headphone, the extra coil, a hank of antenna wire, and a ground connection. A stock cabinet is illustrated in the photo, but one like it can easily be glued up out of thin wood stock.

Because crystals can only detect a signal without amplifying it, they rarely give satisfactory performance when used at a distance of 50 miles or more from the transmitter. If you want to double the radius of useful reception, however, you can add an amplifier tube as is done in the circuit pictured above. For phone reception, 45 volts on the plate of the 1A5GT should be sufficient. In addition, local broadcasts may often be picked up with a loudspeaker connected in place of the phones. For speaker operation, plate voltage should be increased to 90. A separate A battery supplies the 1.5 volts needed by the filament.

For the sake of simplicity, all the parts are mounted on the front panel of the metal cabinet. As the chassis panel is grounded, and it is necessary to keep the tube and coil sockets from making contact with it, a cardboard insert is placed between the panel and the sockets as shown in the drawing.

Windings L1, L2, and L3 consist of 40, 70, and 110 turns respectively. For the first pair use No. 36 enameled wire, and for L3 use No. 32. Wrap a strip of tape around the lower end of L3 and wind L2 over the tape. When tuned by a .00036-mfd. variable condenser, this coil will cover the entire broadcast band. The close coupling of L2 is intended to increase signal strength when the set is used with a short antenna.

Several types of crystal detectors may be purchased from radio supply stores, and three different ones have been employed in these four circuits. As far as performance is concerned, any of them may be used in any of the sets, but a fixed, preset crystal is suggested wherever the layout requires that it be placed in some inaccessible spot.

When using an adjustable crystal, move the cat's whisker carefully over the surface while turning the condenser slowly backward and forward until a sensitive spot is found. Don't bear heavily on the contact, and try to avoid touching the crystal with the finger tips as any oily film on its face will reduce the number of sensitive spots.

For maximum performance with any crystal set, use a long outdoor antenna and a good, clean connection to ground.

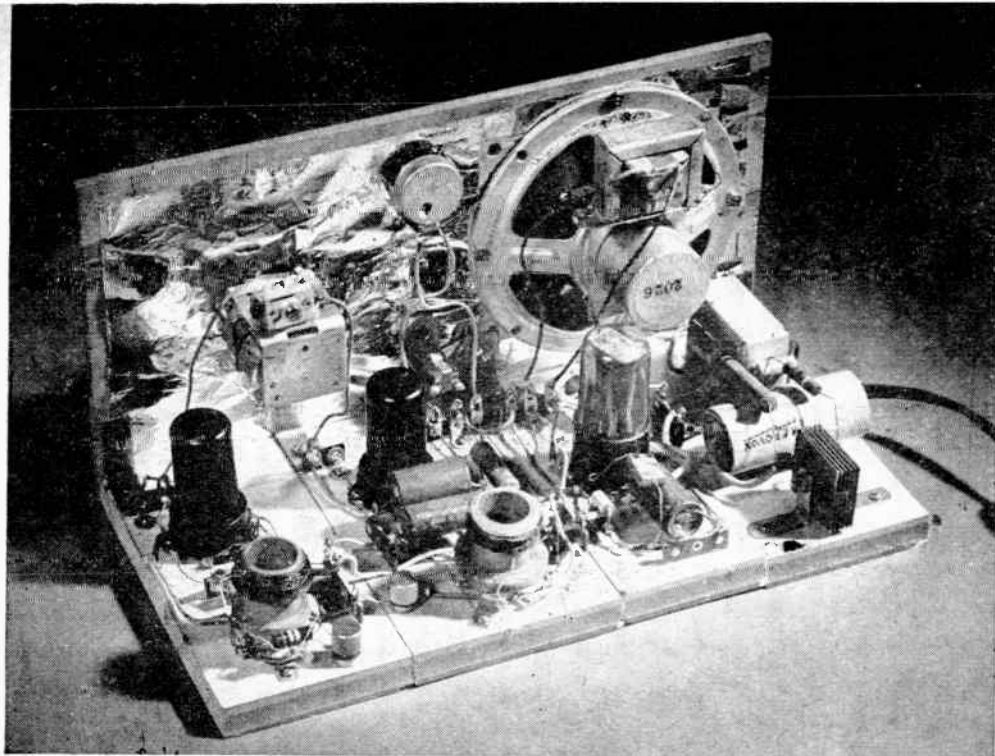

Start with a one-tube receiver and add stages. This set gets better as it gets bigger.

Beginner's Radio Grows by Stages

By *Albert Rowley*

HAVE you ever thought of budgeting a radio? That is, investing small quantities of money, time, and study until they add up to the finished job you want? If you now have a nodding acquaintance with the electronic art, you'll learn a great deal more by watching this radio work as it grows. For a few dollars and even fewer evenings you

can build yourself a one-tube-plus-rectifier receiver that will bring in most of the local stations at comfortable headphone volume.

Later, at your leisure, you can add another tube to increase the range and selectivity of the set. Then—like building with blocks—you can add a third tube to complete the job. You'll have a three-tube loud-speaker radio that makes a fine extra set for the workshop or even a fill-in upstairs.

As can be seen from the photos, the building-block idea is an actual method of construction. Each of the four stages is built on a slab of wood $\frac{1}{2}$ " thick and 6" long. They vary slightly in width, the detector stage being $3\frac{1}{2}$ " and the audio $2\frac{1}{2}$ ", while the rectifier and RF units are each 3" wide. This adds up to 12", which is the width of the front panel to which all four units are ultimately attached.

The first set to make is the one-tube regenerative receiver consisting of units 1 and 2—the detector and rectifier stages. If you want to see what the schematic of this set looks like, fold page 25 down the center. Now fold up the left-hand column along its center. This covers up unit 4 and brings units 1 and 2 together.

On the detector block, drill or saw out a $\frac{3}{8}$ " hole centered about 2" from the front edge.

Mount an octal wafer socket with the prongs fitting into the hole and the base of the socket flush with the board. The lugs to which connections are soldered can be bent over to rest flat on the board. Wood screws hold down the socket, coil L1, and the half dozen terminal strips that are used to anchor the fixed resistors and condensers. Predrilling the screw holes makes the assembly easier.

An air-core RF coil is used in this stage as the antenna coil. The plate lead (A) is connected to an external antenna and the B-Plus terminal (B) goes to the point marked C in the diagram. The other two leads are wired in the usual fashion to grid and ground.

Before you do any wiring on the detector stage, wind 15 to 20 turns of No. 34 D.C.C. wire around the ground end of the secondary or grid winding. This will become the tickler coil (L2) and will serve to feed back some of the signal to the grid in order to build up amplification. The amount of feedback is controlled by the 5,000-ohm potentiometer, R2, which makes it, in effect, the volume control.

Ground connections are brought to a 1" angle bracket mounted flush with the front edge of the block. A soldering lug under the wood screw that fastens the bracket collects the ground leads. No connection is made to the phone jack terminal marked D in the diagram.

When the detector block is assembled, start on the rectifier. A feed-through switch is cut into the line cord to turn the power on and off. The two leads coming from the switch are anchored to a 2-lug terminal strip. Solder the pigtails of a .01-mfd. condenser (C9) across the same two lugs.

A filament transformer for the 6-volt tube heaters and a dry-disk selenium rectifier are the principal components of the rectifier stage. Output of the dry disk, as filtered by

The coils in both the detector and RF stages must be altered. Nail polish is an effective coil dope for sealing new turns in place.

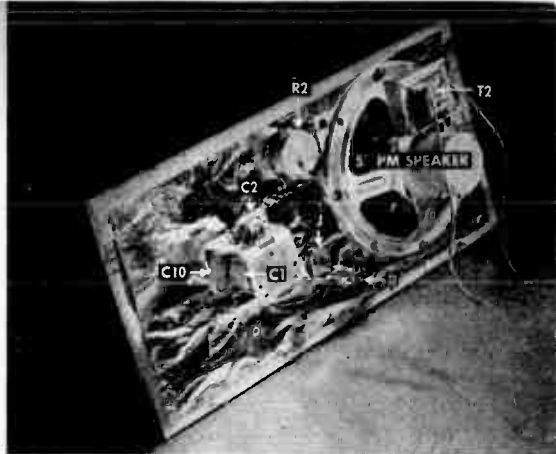

Aluminum foil stapled to the front panel acts as a common ground or chassis and also provides shielding for the variable condenser.

R5, and the dual electrolytic, C7, C8, feeds about 100 volts of direct current to the B-plus line going to the other stage or stages.

One leg of the angle bracket on each block is bolted to the front panel. This panel is backed by a sheet of aluminum foil or tinfoil stapled or tacked to the board. The foil serves as a shield for the tuning condenser and also as a common ground return.

If you plan to build all four stages of the receiver in time, you can save yourself some work by completing the front panel right at the start. It is a 1/4" by 6" by 12" board on which are mounted a two-gang tuning condenser, closed-circuit phone jack, and 5,000-ohm potentiometer. A trimmer might be included in this list although it is actually attached directly to the frame of C1. The only parts that will have to be added later are the 5" PM speaker and output transformer. A grille for the speaker is made by drilling seven or eight rows of 1/8" holes spaced 1/2" apart. If you don't have an electric drill or drill press, you may find it easier to jigsaw an opening and cover it with a cloth.

In this one-tube set, impulses that reach the external antenna are brought down into

First of three sets you can make with your building-block receiver. It's a regenerative detector employing one tube plus rectifier.

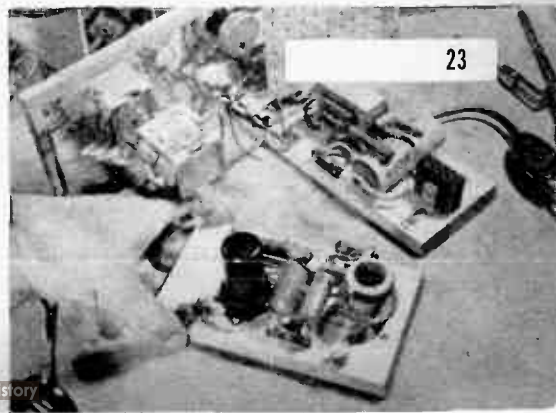
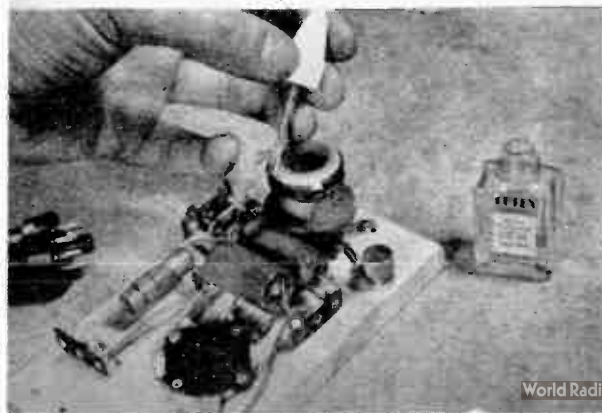

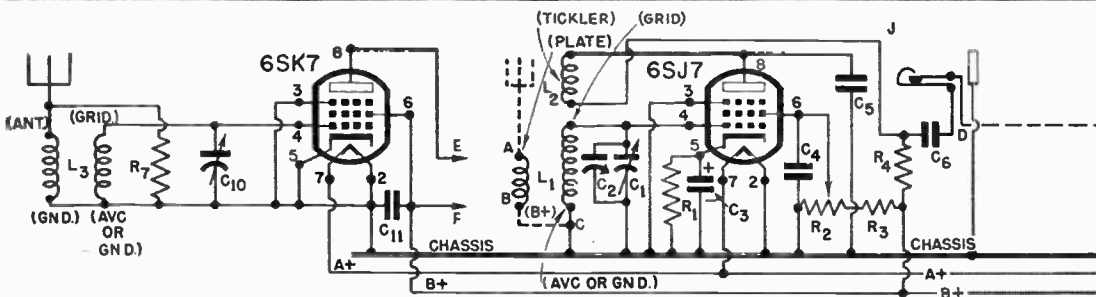
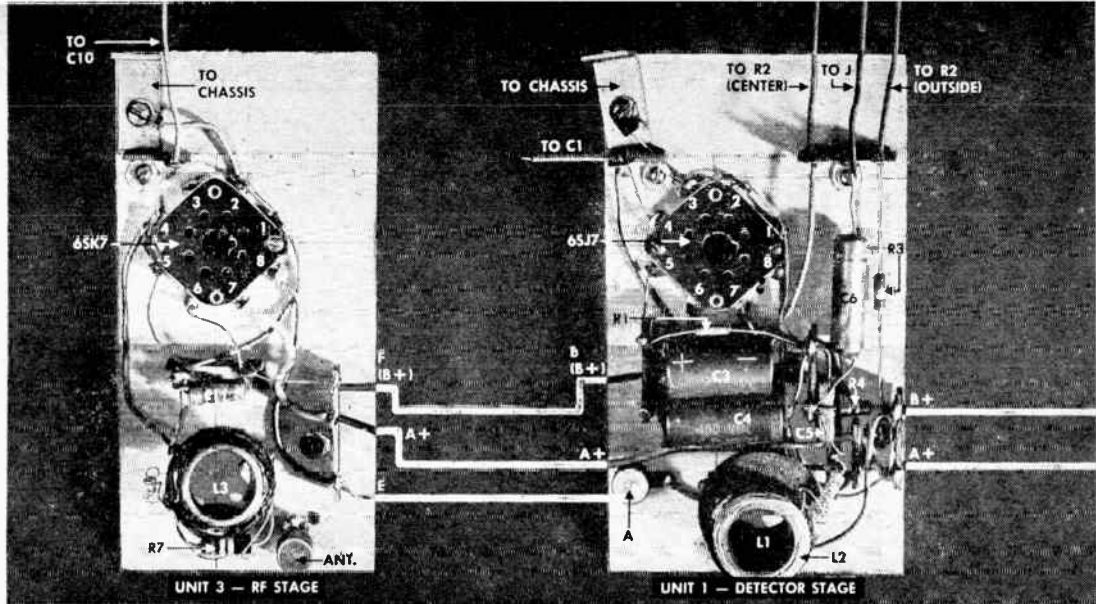

the primary winding of the RF coil. By induction the coil transfers them to the secondary winding where the tuning condenser (in parallel with this part of the coil) selects one particular signal from the jumble.

This selected signal goes to the control grid of the 6SJ7 detector tube. It is then demodulated—that is, the radio-frequency component or carrier wave is rectified and filtered out, leaving only the audio-frequency voltage to energize the headphones.

In order to increase the amount of am-

plication that can normally be obtained from a single tube, part of the signal is fed back from the plate to the grid through the tickler winding.

If you'd like to add pep to the headphone signals, bring in weak ones with greater strength, and capture some new ones that you can't get at all, try adding a stage of radio-frequency amplification. Unit 3, the RF stage, is assembled in much the same way as the detector. Antenna coil L3 should be of the same manufacture as L1.

LIST OF PARTS

UNIT 1 (DETECTOR)

- R1: 33,000-ohm, $\frac{1}{2}$ -watt carbon.
- R2: 5,000-ohm potentiometer.
- R3: 50,000-ohm $\frac{1}{2}$ -watt carbon
- R4: 100,000-ohm $\frac{1}{2}$ -watt carbon
- C1: Second section of 2-gang tuning condenser .00041 mfd. each section.
- C2: 4-80 muf variable trimmer.
- C3: 4-mfd. 150-volt electrolytic.
- C4: .05-mfd 400-volt paper.
- C5: .0001-mfd mica
- C6: .01-mfd 400-volt paper
- L1: Air-core RF coil
- L2: Tickler coil (see text)
- J: Closed-circuit phone jack.
- Octal wafer socket and 6SJ7 pentode.

UNIT 2 (RECTIFIER)

- R5: 1,000-ohm, 2-watt carbon.
- R6: 15-ohm, 1-watt carbon
- C7: 50-mfd. $\frac{1}{2}$ 150-volt dual electrolytic.
- C8: 30-mfd. $\frac{1}{2}$ 150-volt dual electrolytic.
- C9: .01-mfd 400-volt paper
- T1: On-off feed-through switch.
- T2: 6.3-volt, 1.2-amp. filament transformer.
- SR: 100-ma. selenium rect.
- Line cord and plug

UNIT 3 (RF)

- R7: 27,000-ohm, $\frac{1}{2}$ -watt carbon
- C10: Front half of 2-gang tuning

- condenser (See C1).
- C11: .01-mfd., 400-volt paper.
- L3: Air-core Ant. coil. (See text).
- Octal wafer socket and 6SK7 pentode.

UNIT 4 (AUDIO)

- R8: 1-meg. $\frac{1}{2}$ -watt carbon.
- R9: 200-ohm $\frac{1}{2}$ -watt carbon.
- C12: 50 to 100 muf ceramic or mica (see text)
- C13: .0033-mfd. 400-volt paper.
- C14: 4-mfd. 150-volt electrolytic.
- T2: Output trans. (see text).
- 5" PM speaker, octal wafer socket and 6K6-GT pentode.

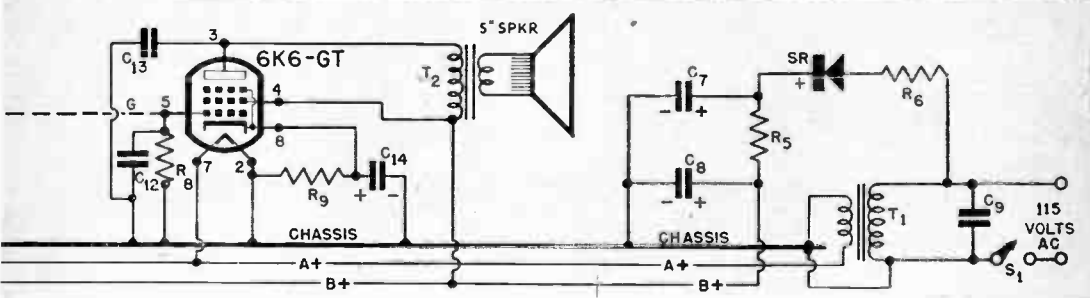
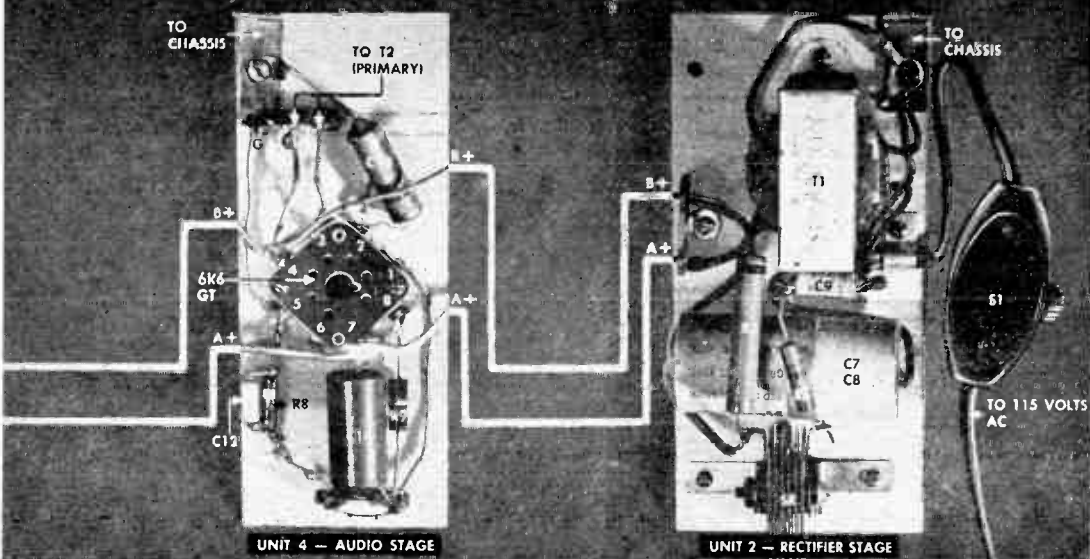

Matching the coils is important, or the two sections of the tuning condenser won't align correctly. Even buying a pair, however, won't insure matching in this case, because the addition of the tickler winding tends to upset the balance. To remedy this condition, remove about ten turns of wire from both the primary and secondary windings of the antenna coil.

When the RF block is finished, connect the grid of the 6SK7 to the front section of the two-gang tuning condenser (C10). Remove the external antenna from point A and connect it to the antenna terminal of L3. Break the connection from B to C and connect A to E and B to F.

In this setup, incoming signals are first tuned by C10, the variable condenser across the secondary of the antenna coil. The selected signal is amplified in the 6SK7 and coupled to the detector by means of the RF coil, which has been restored to its proper function. Having a stronger signal to start with, the detector stage can now produce greater output.

Although this two-tube will get more

than the one-tube job, it is still a headphone receiver. If you want to strengthen the signal enough to get loudspeaker volume, add a stage of audio amplification (Unit 4). Connect point D on the phone jack to G, the grid pin of the 6K6.

In order to obtain the correct match between the plate of the 6K6 and the speaker, you need an output transformer with a primary impedance of 10,000 to 12,000 ohms and a secondary of the proper rating for the voice coil of the speaker you will use.

Note the 50-mmf. ceramic condenser (C12) across the grid resistor. The capacity of this condenser is far too low for it to have any effect on the tone of the set. It is used to increase the amount of feedback getting to the grid of the detector tube when the audio stage is added. Although it is wired to the grid of the 6K6, it is effectively located between the plate of the 6SJ7 and ground. This capacity must be kept low in order to prevent oscillation. However if 50 mmf. doesn't provide enough feedback, try raising the value of C12 to a maximum of 100 or 150 mmf.

Intercoms Save You Steps in Home, Office, Shop

Take your pick of a minimum tubeless circuit, an instant-heating battery job, or a heavy-duty AC-DC unit.

IF YOU live or work in more than a couple of rooms, the question you may well ask yourself is not *whether* you need an intercom but *what kind* of intercom you need. These tireless servants run your errands faithfully to save you countless steps. At home they make it unnecessary to shout from cellar to attic; at work they lighten the load on telephone extensions and get your message through fast.

But granting their usefulness, it must still be admitted that no one type of intercom is suited to every job. If you have to make only one or two calls a day, you wouldn't want a set that draws current while it's idle. A battery set will give you the advantages of instant heating, and uses no stand-by power. On the other hand the cost of battery replacements may make it unwise to use this type of circuit when the intercom must be left on for long periods.

To solve a variety of intercom problems, POPULAR SCIENCE has rounded up the three

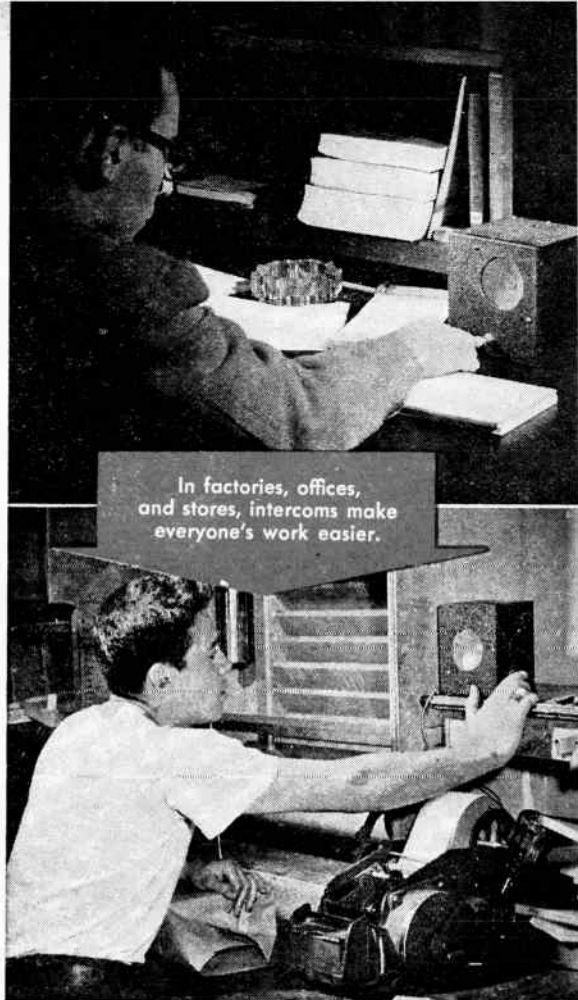

pairs of squawk boxes pictured above and on the following pages. The first, built by Tracy Diers, of Richmond Hill, N. Y., is a three-tube, battery-powered unit. It requires no warm-up period, so calls can be made instantly from either end. Because no current is used unless a call is being made, the batteries will have long life.

The second pair, devised by William Norton, Manhattan, N. Y., consists of two identical units. It would be hard to find a simpler circuit, for each box contains only a war-surplus carbon mike, a speaker, and a battery. No tubes are used.

Henry C. Martin, also of Manhattan, built the third set. It operates from an AC or DC house line and is ideal for service in which it will be turned on in the morning and off at night. After it has warmed up, calls can be made from either end just by pressing a button. In the photo at the right, above, the remote unit is shown in service as a baby tender. The master set in the shop enables



Homemaking is big business, too. Intercoms skip stairs from kitchen to study.

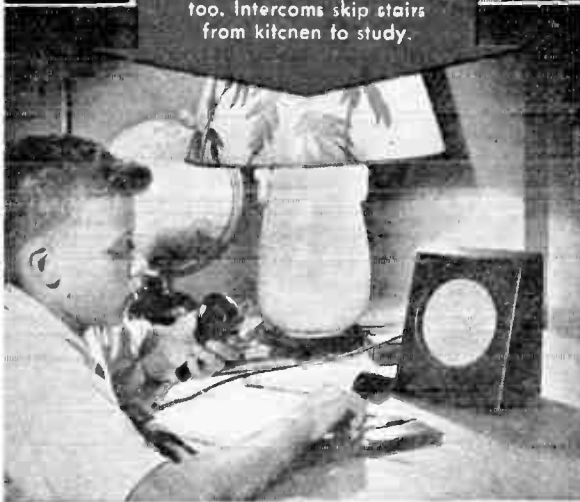

No need to run up to see if baby's awake. A speaker listens for you.



you to keep tabs on a sleeping child upstairs. Note the clock placed next to the listening box. So long as its ticking can be heard downstairs, you know the intercom is functioning.

Battery-operated Intercom

In the three-tube circuit shown in photos and diagram on the following page, two small permanent-magnet speakers double as microphones. Power is obtained from a 67½-volt B battery and a 1½-volt hearing-aid cell.

Build the amplifier first. The model pictured was assembled on a 3¾" by 4½" chassis. Three tubes and two transformers are mounted on top of the chassis, as can be seen in the photos. An 8-contact terminal strip is also placed on top to facilitate connections to batteries and the remote unit.

The amplifier should present no special wiring problems. Short leads are always desirable: all of these were made with push-back wire. Ground connections are soldered

to lugs bolted to the chassis. Use solder sparingly; a blob of it could easily short-circuit the closely spaced prongs of the miniature tube sockets.

When you have completed the wiring, you can test the amplifier by connecting the voice-coil terminals of the remote speaker to terminals 3 and 4. Press S1 down to turn on the filaments. The amplifier should start operating immediately. Since the speakers are close together in this test, you will probably also hear a loud feedback howl. Moving the speakers farther apart reduces it.

Both the local and remote units were placed in metal boxes. The former measures 5½" by 5½" by 6¼", and has two removable covers. The back cover was discarded and a piece of wire screening was fastened in its place. The front panel is then drilled to clear the shafts of S1 and R7, and a speaker hole is cut out.

The remote box is simplicity itself. It contains only speaker, switch, and a four-

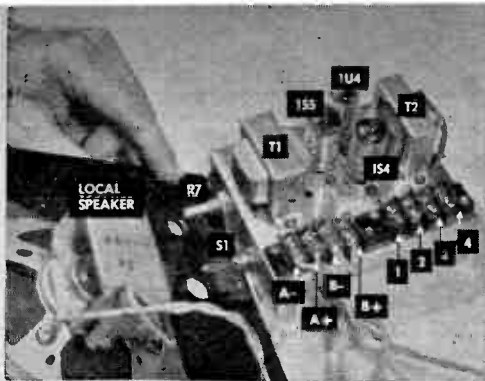

Local station is assembled on a 3 3/4" by 4 1/2" chassis; transformers, tubes, and terminal strips go on top. Controls are on front edge.



Front panel of metal box is cut for speaker and control shafts; the back cover is removed and replaced with a piece of wire screening.

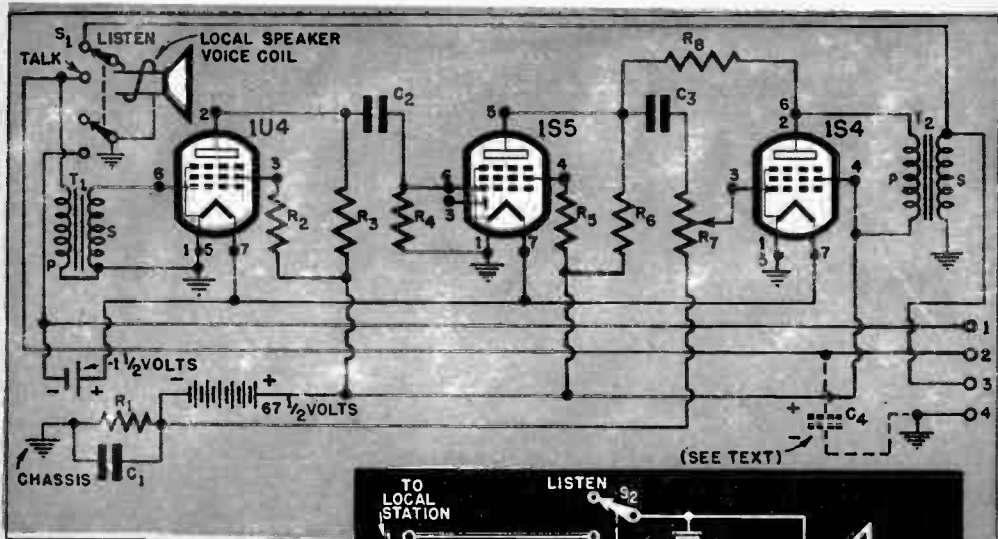

LIST OF PARTS

All fixed resistors 1/2-watt carbon.
 R1: 700 ohms.
 R2, R6: 22,000 ohms.
 R3, R5, R8: 47,000 ohms.
 R4: 250,000 ohms.
 R7: 1-meg. volume control.
 C1: 1-mfd., 400-volt paper.
 C2, C3: .005-mfd., 400-volt paper.
 C4: 8-mfd., 450-volt electrolytic (optional, see text).
 S1, S2: DPDT toggle, spring return.
 T1: Intercom input transformer, 25,000 ohms on grid side to 4 ohms on speaker side. (If other than 4-

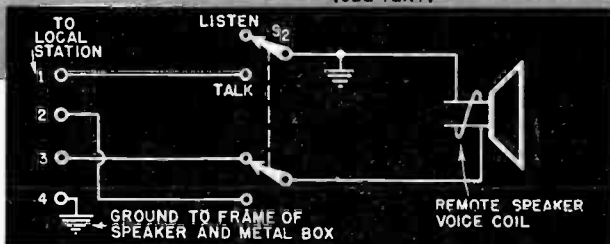

ohm speaker is used, transformer should match).
 T2: Midget output transformer, 5,000 to 8,000-ohm plate to 4-ohm voice coil.

4" Permanent-magnet speakers (2) with 4-ohm voice coils.
 Tubes (1U4, 1S5, 1S4) with miniature sockets, cabinets, 4-wire cable, batteries, misc. hardware.

When planning parts layout leave space for batteries; they go in cabinet with amplifier.

Bottom view shows location of most of the small parts. Position isn't critical in this circuit but it's good to keep leads short.

Remote station contains speaker and switch. Grommet mounting of speaker helps reduce bass tone that often occurs at the end of a long line.

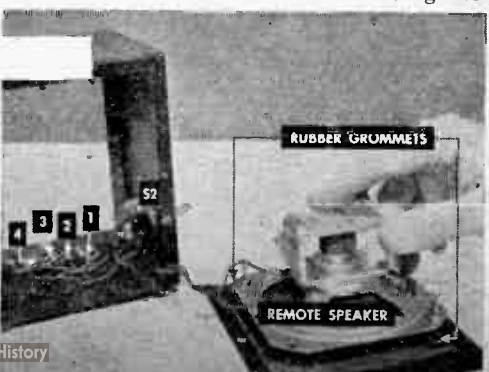

contact terminal strip housed in a 4" by 5" by 6" metal box. Stack a couple of rubber grommets or washers on the screws that hold the speaker to space it back of the panel.

Connections between the two units are best made with four-conductor intercom cable, but you can use two lengths of lamp cord. The latter, however, may cause some oscillation. Should this happen, add an 8-mfd. electrolytic condenser (C4) from terminal 2 to ground on the local unit. It's essential, of course, to connect the local-station terminals to the corresponding ones on the remote unit. With four-wire cable, the job is made easy by color-coded wires; if you use un-coded lamp cord, test each lead for continuity.

Tubeless Intercom

There are many cases, especially around the home, where an intercom would come in handy, yet the use you can get out of it doesn't justify the cost or work involved in building a high-powered job. For such light service, take a crack at the tubeless unit pictured above. It will work at distances from 50 to 100 feet. Though it isn't loud, it is clear and audible.

Two Army-surplus T-17B microphones were purchased for about a dollar apiece; each of the 6" speakers cost just a bit more than that. These items plus a pair of batteries are all you need. If you make your own cabinets, total cost won't go much above \$3 a unit. Should you have trouble obtaining the surplus mikes, use standard carbon microphones. In this case, however, reduce battery voltage to 6 to 8 volts. The army mikes have three color-coded leads. Use only the black and red ones; cut off the white. This takes advantage of the press-to-talk switches in the mikes; no other switches are needed. Connect the units together with two-conductor wire attached to the terminal clips indicated in the diagram.

AC-DC Unit

An amplifier circuit similar to that used in small record players provides the muscle for this two-tube squawk box. Special coupling transformers and a switching arrangement again allow ordinary permanent-magnet speakers to double as microphones. The speaker-to-grid matching transformer, T1, couples the Alnico speakers to the input of the amplifier. Primary impedance matches that of the voice coils (in this case, 4 ohms). Secondary impedance should be as high as

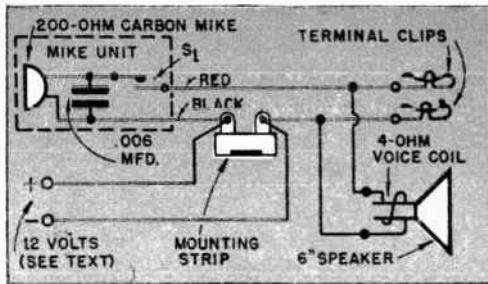
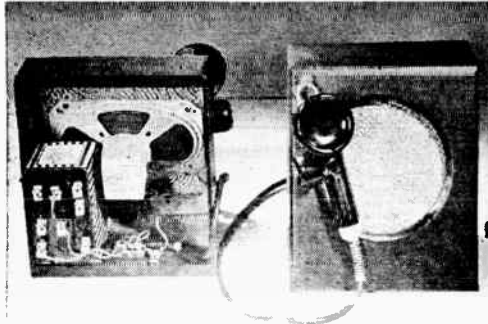

Simple intercom needs only mike, speaker, and battery. Parts enclosed in dotted line in diagram are included in surplus T-17B mike.

possible. In the unit shown it is 106,000 ohms.

The other transformer, T2, matches the output of the 30B5 (about 2,000 to 2,500 ohms) to the speaker voice coils. Note the tap on the primary; this is a hum-reduction tap. Although it isn't essential, it will improve the performance of the circuit. If you use a transformer without this tap, connect the points marked X together.

Parts are mounted on a 1½" by 4½" by 5" metal chassis and on a clear plastic panel bolted to the chassis front. The controls that go on the panel are the on-off switch, S1, the 250,000-ohm volume control, R2, and the press-to-talk switch, S2. A 3-contact strip is mounted on the rear chassis edge.

After mounting the parts—preferably in the approximate locations indicated in the photos—proceed with the wiring. First make connections to the secondary of T2 and the primary of T1, then wire S1 and the terminal strip. Now follow the wiring diagram, reading from left to right. Leave the rectifier circuit to the last. When you get to it, be sure that both leads are connected to the rectifier before wiring C6 on top of it.

Three-conductor cable wires the master and remote units together. Connections from one terminal strip must be made to the corresponding numbers on the other.

Once you have an intercom installed, you'll find many extra uses for it. It's possible, for example, to pipe music from room to room by placing the master

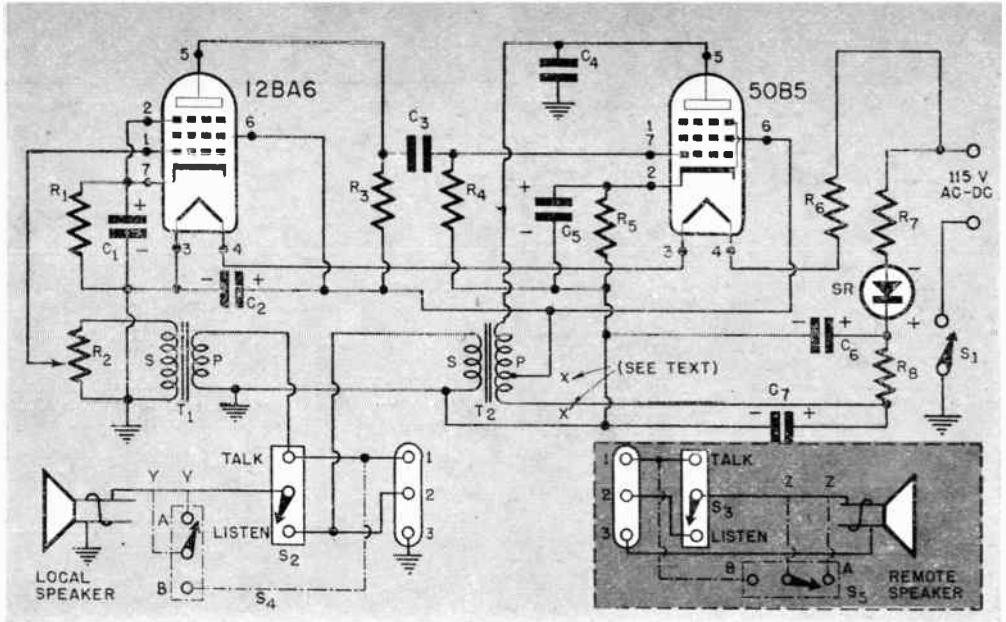

LIST OF PARTS

- | | | |
|--|---|--|
| <p>R1: 33 000-ohm 1/2-watt carbon.
 R2: 250 000-ohm volume control.
 R3: 180 000-ohm 1/2-watt carbon.
 R4: 680 000-ohm 1/2-watt carbon.
 R5: 200-ohm 1-watt carbon.
 R6: 390-ohm line-cord resistor.
 R7: 36-ohm 1-watt carbon.
 R8: 1 000-ohm 5-watt wire-wound.
 C1: 1-mfd. 150-volt electrolytic.
 C2: 4-mfd 150-volt electrolytic.</p> | <p>C3: 05-mfd. 400-volt paper.
 C4: 001-mfd. 600-volt paper
 C5: 8-mfd. 150-volt electrolytic.
 C6: 40-mid. 150-volt electrolytic.
 C7: 50-mid 150-volt electrolytic.
 S1: SPST toggle
 S2 S3: SPDT spring-return switches.
 S4, S5: SPDT (optional).
 T1: Intercom input trans. 106,000-ohm grid to 4-ohm speaker.</p> | <p>T2: Output trans. for 50B5; 2,000-ohm plate to 4-ohm voice coil.
 SR: 100-ma selenium rectifier.
 5" Permanent-magnet speakers (2) with 4-ohm voice coils (If other than 4-ohm speakers are used, transformers should match.)
 Tubes (12BA6, 50B5) miniature sockets, cabinets, 3-wire cable, misc. hardware.</p> |
|--|---|--|

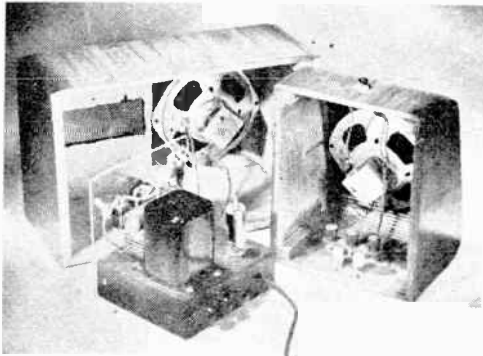

AC-DC unit uses speaker and two-tube amplifier in master or local station. Remote box, right, contains only speaker and switch.

Clear plastic front panel is attached directly to amplifier. No pilot light is needed since plastic window shows when tubes are lit.

unit in front of the radio. Since S2 is a spring-action switch and normally in the "listen" position you either have to replace it with an ordinary SPDT switch, or, better still add S4. Break the original connection at the points marked Y-Y and wire in the new switch. When S4 is in position a, intercom operations remains unchanged; when it's flipped to b, the master unit is locked in "talk" position.

The same considerations apply to the remote unit. Adding S5—and breaking the original lead at Z-Z—readies the small box to act as a baby tender. Place it next to the baby's crib and if the youngster cries, you can hear it at the master unit.

The output transformer was placed under the chassis in this set. If you use a shallow chassis, it can be moved to the top.

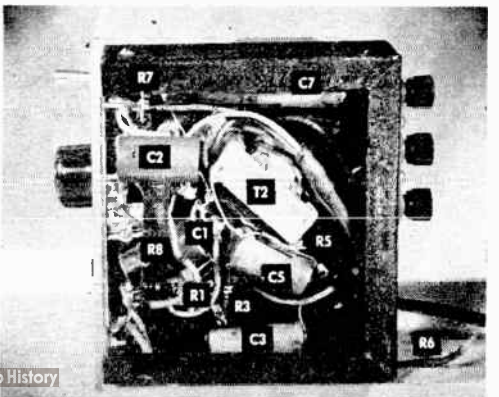
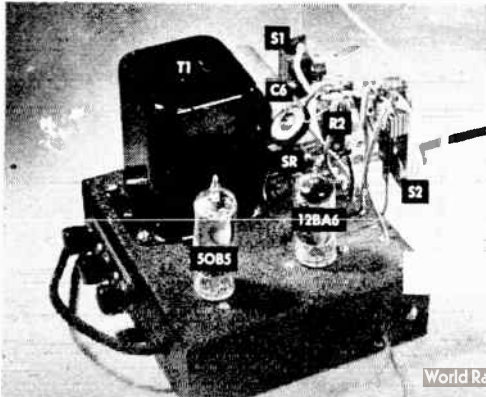

Amplifier Fits On Headphone

YOU'LL listen more comfortably to your crystal and one-tube receivers with a pair of amplifying headphones. And you'll also find them helpful for signal tracing, checking phono cartridges, and the like.

This amplifier, built on a ordinary pair of 2,000-ohm phones (each phone is 1,000 ohms) will work with any type of set. The whole amplifier, less batteries, fits into a metal bottle cap measuring $1\frac{1}{2}$ " across by only $\frac{1}{2}$ " deep. This bottle-cap chassis is bolted to the back of one phone. Since the cap is in effect grounded, you'll lessen the chance of shorts if you line it with cellulose tape. Also tape the bolts and spacers.

Initially the two sides of a pair of headphones are wired in series, with the common wire running down to the yoke and back up the other side. To connect the amplifier, remove the leads from the phone carrying the bottle cap and connect them to the points marked X in the diagram. The two phone terminals are then wired to pins 4 and 5 of the tube, which is a subminiature one, type 2E36.

Get more stations at better volume on your crystal and one-tube receivers by using amplifying phones. They'll work with any set.

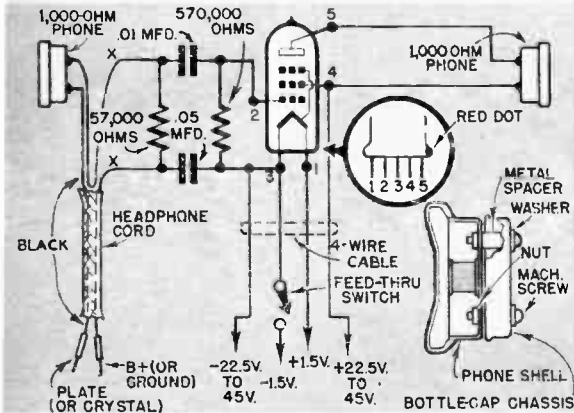

Tube connections are soldered directly to the pins. Use a small iron and try to solder each joint quickly; too much heat may cause damage.

All parts, including tube, are mounted inside the bottle cap. Battery and phone wires are taped together to keep them from snarling.

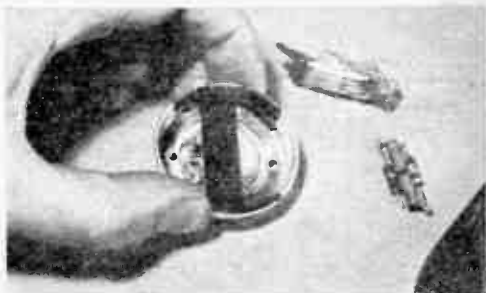

Insulate the bottle-cap chassis with tape. The holes in back are for mounting; drill two more in the rim to clear battery and phone cables.

Amplifying headphones complete except for the batteries. Use a 1.5-volt flashlight cell and a 22½- or 45-volt hearing-aid B battery.

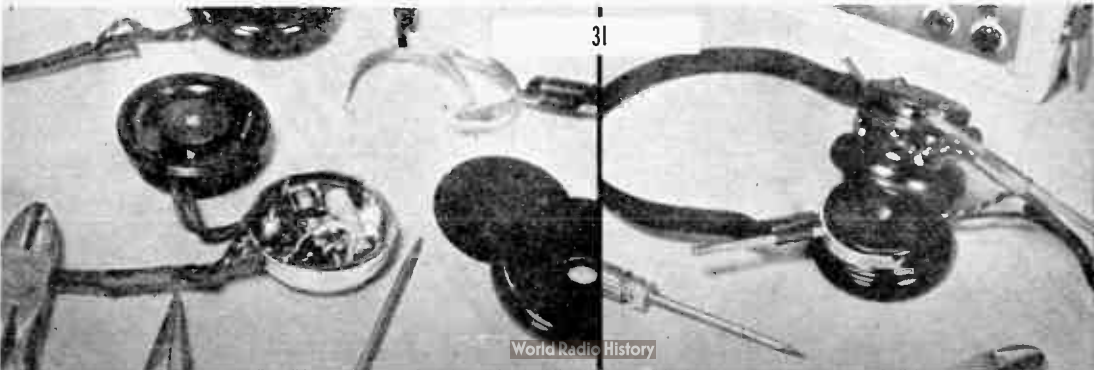

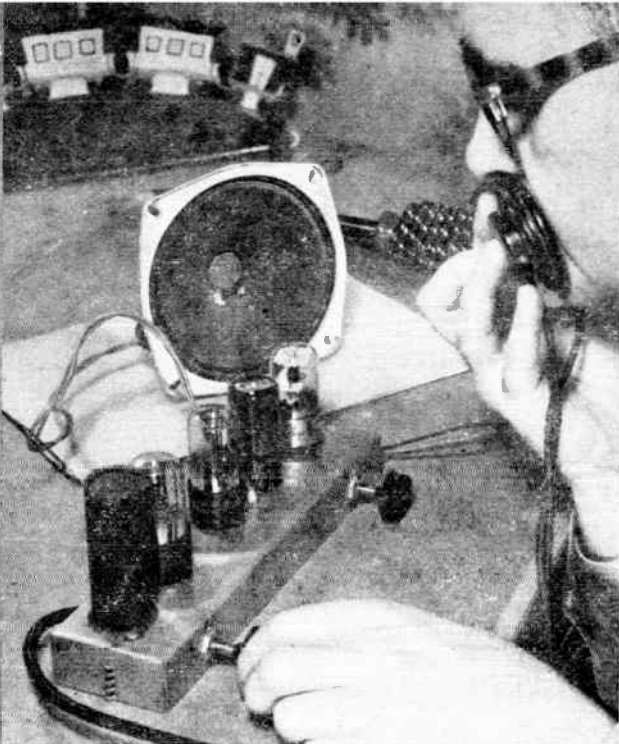
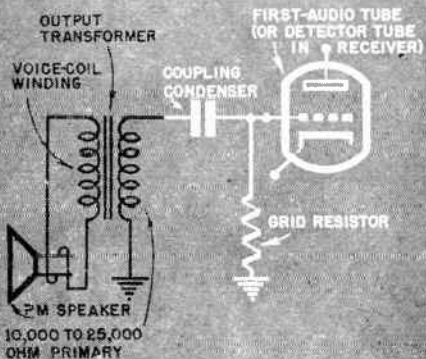
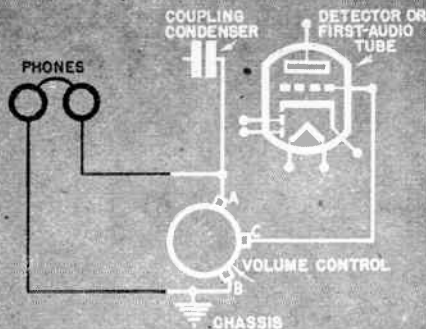

1. Headphones or even a loudspeaker will often replace a crystal microphone. Drawings at

the left show connection to common radio circuits. Above, phone is used to test amplifier.

Radio Parts from Your Scrap Box

Though most components are designed for particular jobs, you can make many of them double up in a pinch.

By Frank Tobin

IF YOU'RE a typical radio experimenter, you know what it means to be stuck for a vital part when the stores are closed. Since many amateurs do their work nights and holidays, it happens to a lot of people. Next time you run into that situation, take a look in your spare-parts box. You may not see what you're looking for, but perhaps you'll find at least a temporary substitute for the part you need.

The first rule for making spare parts work for you is to keep them in good order. Separate components by type and value, and never, never toss in a defective part without marking it. If you know a condenser is shorted or open, throw it away. A transformer with one winding open is worth saving,

however, if you tape on a note that tells what's wrong with it.

With a fair selection of resistors you should never be too badly stuck for a particular value. Connect smaller ones in series to add up to the total you want, or in parallel to get a lower value. The same is true of condensers, but in reverse.

Headphones and loudspeakers are usually thought of as reproducers but they will also operate as microphones in a pinch. A single phone will give fair volume with two stages of amplification, as in an AC-DC receiver; both phones will do even better. For such use, connect it as shown in the upper sketch. In some cases it may be necessary to make the connection at terminal C of the volume control instead of terminal A. If the amplifier has a microphone-input jack, you'll use that, of course. As you can see in the diagram, no special coupling is needed; the condenser and volume control are already in the set.

To use a permanent-magnet speaker as a microphone you need a transformer to match the voice-coil impedance to that of the amplifier grid. The best bet is to use a regular intercom transformer which has a secondary winding in the neighborhood of 70,000 ohms. Lacking this, try an ordinary output transformer, selecting the highest primary impedance available. Wire them as shown in the lower sketch of Fig. 1; black lines represent the parts added to those already in the set.

The humble wafer socket has the makings of a test-point adapter (Fig. 2). The wafer socket must be of the same base type as the tube to be checked. Invert the socket, push in the tube, and plug both tube and test socket into the socket on the chassis. It may be necessary to clip the prong sleeves on the wafer socket to allow the tube pins to extend through. Bend back the soldering lugs.

You may find yourself short of test prods at a bad time. That's nothing to worry about if you have two mechanical pencils around the shop. These pencils make good substitutes for prods (Fig. 3). They should have plastic barrels, or you may find yourself holding a piece of high voltage. Make sure that a good contact exists between the metal ferrule on top of the pencil and the metal tip. Wedge the wire from the meter under the eraser cap or solder it on.

Coil Forms from Spools

An ordinary wooden pencil, by the way, will make a fine core for a high-frequency choke. Such chokes are widely used in FM and TV receivers and in other high-frequency equipment. Leave the graphite in the pencil; it takes the place of a powdered metal core. Saw off a 1" piece and wind the coil around it.

Other substitute coil forms can be salvaged from flashlight batteries or a sewing box (Fig. 4). In the former case, slip the cardboard sleeve off the cell; in the latter, use a wooden spool from which the thread has been removed. Finished coils will stay neat longer if they are coated with liquid coil dope.

Have you ever thought of employing a power transformer as an output transformer? Even a defective unit can be used at times. In Fig. 5 a fairly common transformer type is shown in this unconventional application. Using half the high-voltage winding between the plate and B plus, and em-

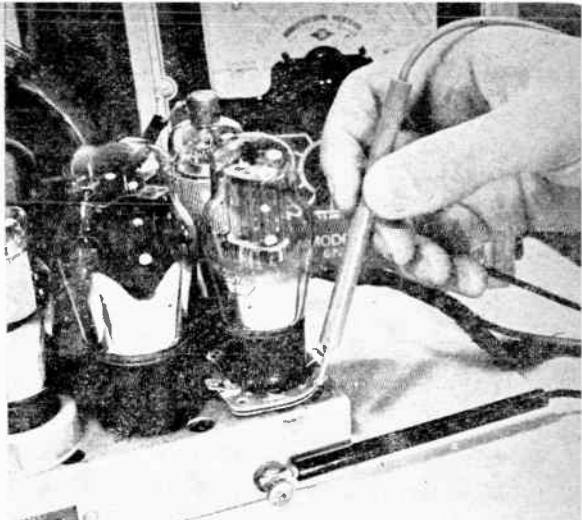

2. Test-point adapter, easily made from wafer tube socket, allows you to check voltages at the tube instead of turning chassis over.

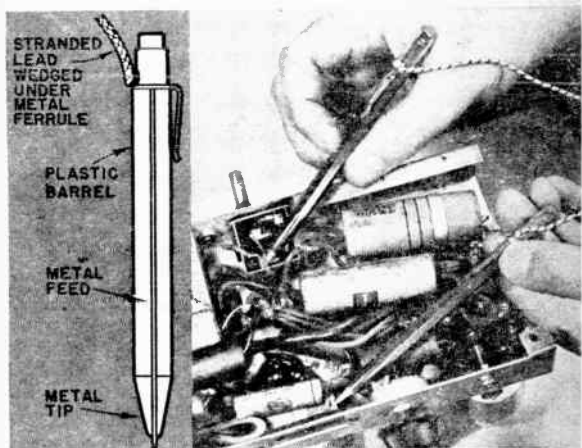

3. Need a pair of test prods? Try using mechanical pencils. Be sure they have plastic barrels, for the metal parts may be "hot."



4. Coil forms can be improvised from many common objects. Windings must, of course, be figured in relation to diameter of the form. ▶

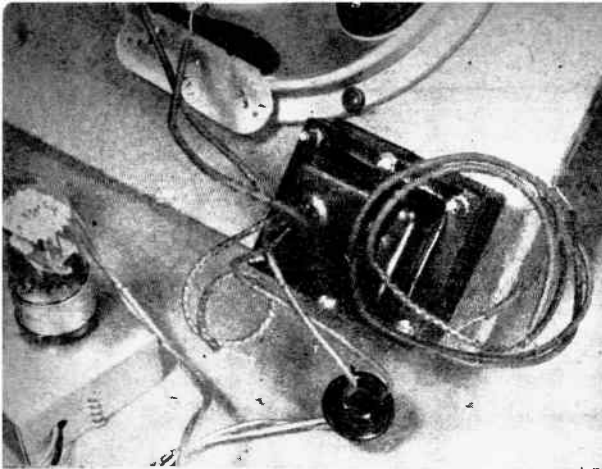

5. A power transformer can be used in place of an output transformer. It's an expensive sub-

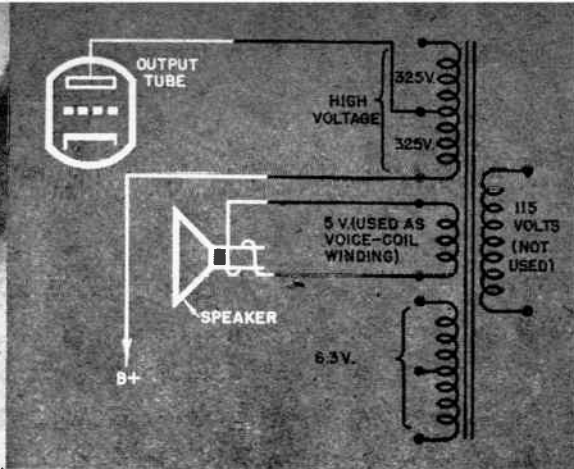

stitute, but it will work nicely until you get a chance to put in the correct replacement unit.

ploying the 5-volt rectifier winding for the voice coil gave a surprisingly good match between a 35L6 power tube and the speaker. For other tubes and speakers you can try a number of other combinations. The 6.3-volt secondary, for example may be used in place of the 5-volt one. Also try the entire high-voltage side, or half the 6.3-volt winding.

A push-pull audio transformer can be made from two single-tube transformers if they're wired in series as shown in Fig. 6. First try connecting one grid and one ground lead together at the center tap. This may not be the best arrangement, however, so experiment with others.

By juggling the filament windings on an old power transformer made for 5-volt and 2.5-volt tubes, you can obtain 6.25 volts. This means you can use the transformer in a circuit employing modern 6.3-volt tubes. Note, however, that you no longer have a 5-volt tap for the rectifier, so you'll have to use a 6X5 or similar 6.3-volt rectifier, heating all tubes off one winding.

Subs for Filter Chokes

It often happens that a serviceman or experimenter is stuck for a filter choke. It may occur when you replace a field-coil speaker with a permanent-magnet one, for the field coil frequently doubles up as a choke. In a pinch you'll find a filament transformer is a pretty good substitute. Lacking a filament transformer, try using the primary winding of an output transformer in place of the missing choke. Both applications are pictured in Fig. 8.

Figure 9 illustrates another possible transformer dodge. The photo shows a universal output transformer being used to feed

6.3-volt tube heaters. This won't work in all cases, but by trying the various taps on both primary and secondary you may be able to find a combination that steps down 115 volts to a value very close to 6.3. Test the voltage on an AC meter before risking the tubes. The transformer should be rated at 8 to 10 watts or higher; smaller ones will overheat. The voice-coil winding goes to the tube filaments while the primary is connected to the 115-volt line.

Selector Switches

If it's a low-voltage switch you want, you don't have to hunt very far. A few nickel-plated wood or machine screws will do the job nicely, as pictured in Fig. 10. The setup shown is a test circuit in which a universal output transformer is used to feed a number of different speakers. Instead of soldering and unsoldering a number of connections to find the best match, make a selector switch by driving the required number of screws into a scrap of wood. Place them in an arc arrangement so that the moving arm—which can be a flat brass or plated bracket about 1½" long—will make contact with each screw head. A small wooden knob can be attached at the end opposite the pivot screw.

Parts substitution of the kind described above may not save you much money, but it will save a lot of time and energy. Obviously it doesn't make sense to buy a \$3 power transformer in order to replace a filament transformer that costs half as much. But if you happen to have the more expensive unit gathering dust, you won't lose anything by putting it to work. If this makes it possible to finish the building or repair job you're doing, it will often put you ahead of the game.

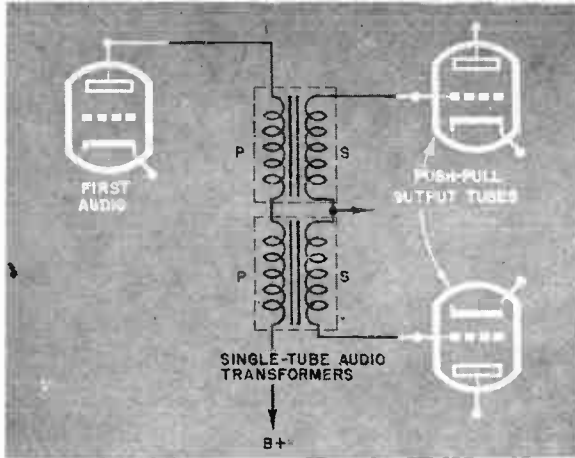

6. Two single-tube audio transformers make a neat replacement for a push-pull transformer.

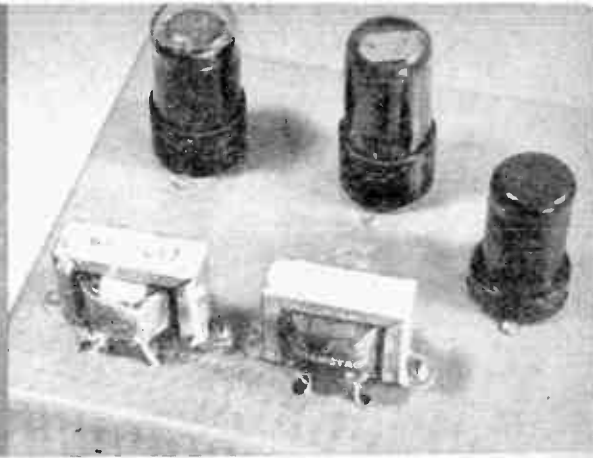

Depending on transformer make, method of connection may vary; try different combinations.

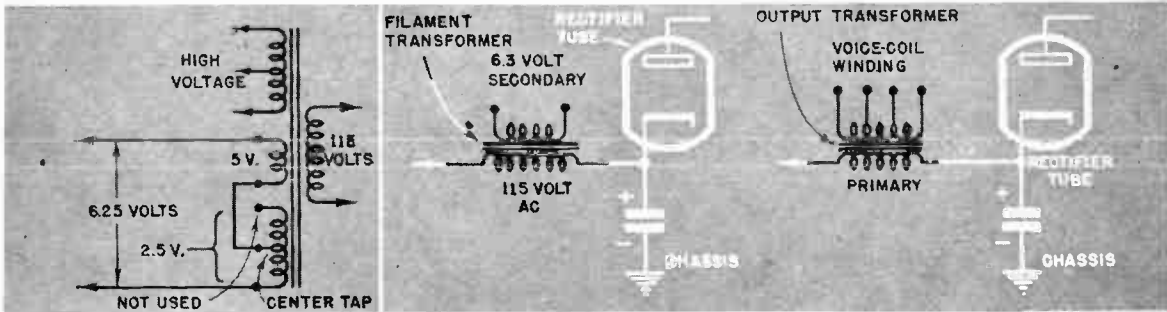

7. Old transformers for 2.5 and 5-volt tubes can be used in modern circuits with 6.3-volt heaters. This arrangement gives 6.25 volts.

8. Filter chokes may be improvised from either filament or output transformers. One winding isn't used; it can even be open or shorted.

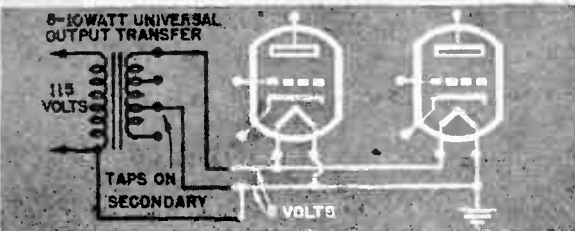
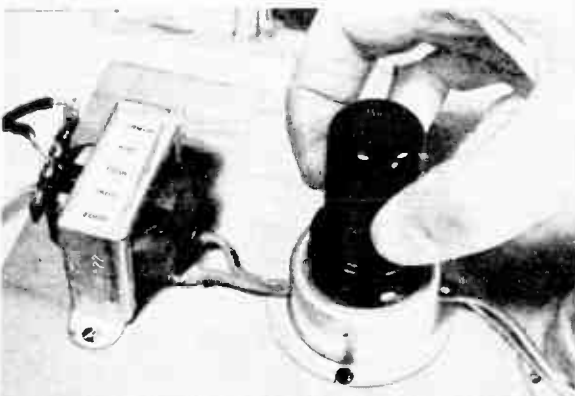

9. Heater voltage can be furnished in many ways; one of the more unusual ones is to use an output transformer. Test tap combinations.

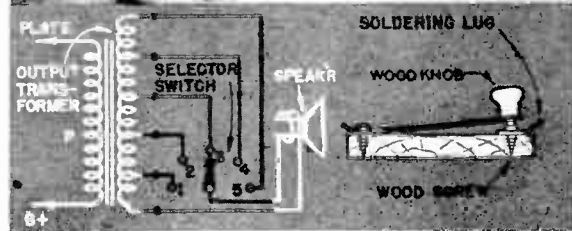

10. Selector switches are a cinch to make. A couple of screws and a flat metal arm the trick. Use soldering lugs for the contacts.

A Superhet the Beginner Can Build

Never built a radio? Tune in on this hobby now with these plans for a five-tuber anyone can make.

*By a High-School
Shop Teacher*



DO VOLTS scare you? Are you *sure* you can't get to first base with radio? Your answer to these questions should be a thumping "No!" If it isn't, someone's kidding you.

I'm not guessing about it. As a shop instructor, I've met hundreds of beginners who were so scared of an ohm they'd hide under a table whenever one crawled out of a circuit. Yet within a few weeks the most timid of them was sporting a receiver he'd built from scratch.

When I say they made receivers, I mean the same 5 tube AC-DC superhet you see here. But isn't it wiser, you may ask, to start off with a simple one-tuber? I don't think so. It's no harder to hook up five tubes than two—you just work a bit longer. And when you've finished, you'll have a sweet little

set with plenty of power and sensitivity. It's even got automatic volume control, something you won't always find on small sets.

The superhet circuit is a highly efficient one used in scores of commercial designs. It has a few more parts than some others, but they're standard and easily obtained. If you're remote from radio shops, the mail-order radio houses have all you'll need. Your parts cost may be as little as \$12, and your time investment will probably run from four to seven evenings.

What this radio—and any other—has to do is to select the signal of a station you want to listen to, separate the audio modulation (electric vibrations at sound frequencies) from the high frequencies that have carried them through space, and then fatten them

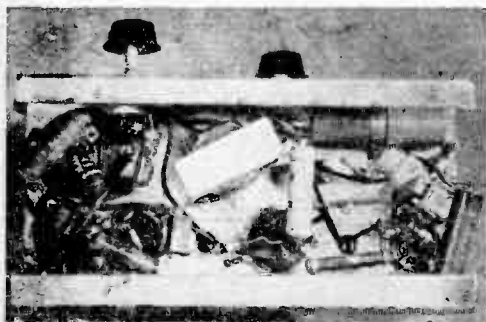

Bottom of the completed set. Follow this and the pictorial diagram in laying out the parts.

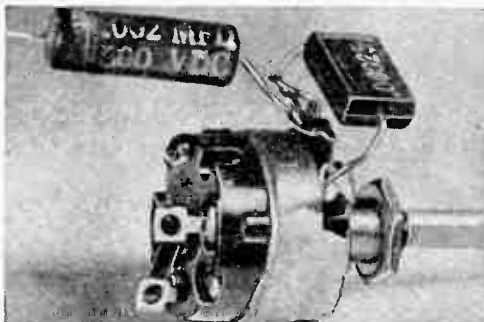

Soldering can be simplified by making all convenient connections before mounting parts.

up to loudspeaker volume. A superhet has a baby transmitter of its own, consisting of an oscillator coil and a mixer tube, which generates a radio signal that's used to convert *any* broadcast signal to a standard frequency of 456 kc. This is lower than the broadcast range but not yet in the audible range. It's intermediate, so the transformers and amplifiers that boost it are called intermediate-frequency (IF) transformers and stages. What skims off the low audio frequencies is the detector (part of the 12SQ7 tube in the diagrams), and they are then beefed up by a husky beam-power tube, the 50L6.

Sure, the schematic circuit at the top of page 39 looks complicated. But you've only got to follow one line at a time! Here each part is shown by a symbol—fixed condensers by two thick parallel lines, trimmer condensers by one line and a thick curved arrow, and variable tuning condensers by a straight arrow through a straight and curved line. The letter C refers to condensers that are numbered with the parts list; and R identifies resistors, which are zigzags in the circuit. The springlike symbols are coils or (when paired) transformers.

Those heavy ovals are tube symbols; inside, from the bottom up, are the cathode, one or more grids (thick dotted lines), and the plate. But all you really need to remember is to make the connections to the proper pins on the sockets. Looking at the *bottom* of the socket, these are always numbered clockwise from the little notch or key in the center hole. Connections to the heaters, which make the tubes glow, are separate from other wiring, so they're shown at the bottom of the diagram with just the pin numbers for each of the tubes.

Schematics are drawn in a kind of elec-

tronic shorthand that you'll pick up fast. Meanwhile, a pictorial diagram of the same set may prove a help, since it suggests what the parts look like and where to put them. It's at the bottom of page 39.

In buying parts, be cautious about accepting substitutions, even if a salesman tells you that the exact value of a part isn't important. Don't use paper condensers where mica ones are specified, or resistors of lower wattage rating than called for. Be sure you buy an oscillator coil with four leads. The IF transformers should have trimmer condensers attached inside the can. I recommend using Bakelite octal sockets having a metal frame with ground connections next to prongs 1 and 5, rather than the cheaper wafer sockets.

The tuning condenser is a two-gang cut-plate type; that is, it has one 27-plate section and one 19-plate section. It should also have built-in trimmer condensers—tiny screw-adjusted ones used in aligning later.

Either a permanent-magnet or a dynamic speaker can be used. The latter has an electromagnet, the field coil of which will serve as the filter choke (L3), while with a PM speaker you'll need a separate choke. Some builders use a 1,000-ohm 5-watt resistor in place of the choke, since it costs less and takes less space, but a choke cuts hum and gives better tone.

While we're on the subject of choices, there's another that you may want to consider in building the set. The lower left part of the schematic diagram shows an alternative to the 35Z5 rectifier tube. Selenium rectifiers are gaining popularity as rectifier-tube replacements because they give trouble-free service, don't have to warm up as tubes do, and need no heater supply. Since the heaters in this set are connected in series,

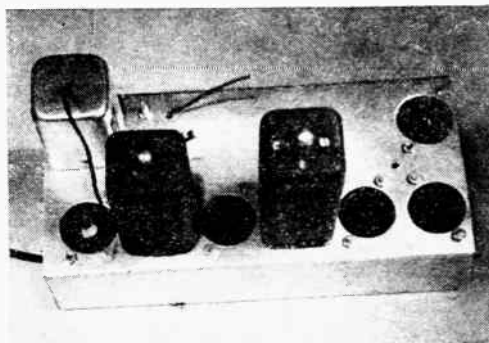

Top of the chassis with sockets and coil cans mounted as called for by the template, right.

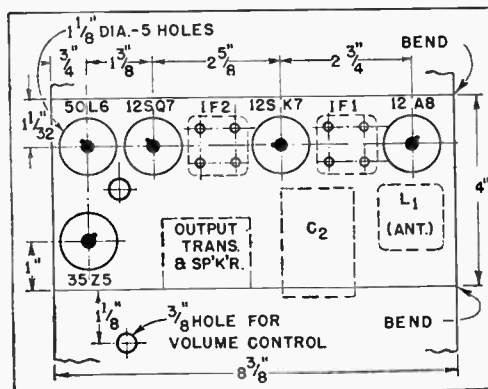



Arrow points to the plate (blue) lead of the oscillator coil, soldered to pin 6 of the 12A8.

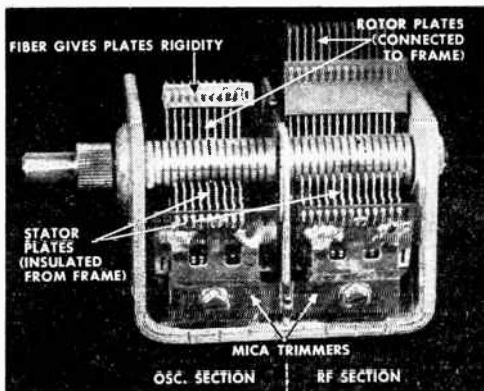

Cut-plate, two-gang tuning condenser, showing basic elements. Make sure yours has trimmers.

you'll have to insert the additional resistors R11 and R12 if you omit the rectifier tube.

And now let's get down to building. For a neat chassis arrangement, draw a full-size chassis template, paste it on a flat piece of aluminum, and punch and drill all holes. A No. 28 drill is right to clear the 6-32 screws used to mount all parts. Take pains in making the holes for the tube sockets, since the big central hole and the two mounting ones must be in line. While the 1 $\frac{1}{8}$ " socket holes can be cut on the drill press with a hole cutter, a chassis punch is much easier. Bend in the sides and letter on the tube numbers for each socket. Many radio supply houses sell prepunched chassis that'll do nicely.

Don't mount the tuning condenser and speaker right away, since they're both fairly delicate and might be damaged during work. Inasmuch as you're using a 12A8 tube in which the signal-grid comes out to a cap at the top, use an antenna coil that has a hole in the top of the shield can for this grid lead. When installing the IF transformers, orient them so that the plate and grid leads are as short as possible. Follow the color coding; the blue one goes to plate, red to B plus, green to grid, and black to the AVC line.

Note the four holes to be drilled through the chassis under each IF can; they allow the leads to be brought out singly for maximum separation. Grid and plate leads of IF transformers must be cut as short as possible, and kept away from each other and close to the chassis. If they *must* cross, see to it that they cross at right angles.

Construction will go most smoothly if you complete all chassis drilling and punching first, and have all parts at hand before you

begin. Many parts can be wired before they're mounted on the chassis. For example, mica condenser C7 is shunted across the outside terminals of the volume control (R5) before the latter is mounted. One end of C6 is similarly attached. Making connections out where you have plenty of room renders assembly easier. Make all leads as short as possible, and don't be afraid to crowd parts together.

It's also a good plan to wire each separate part of the circuit with different colored wire. Circuits are commonly coded like the IF leads—blue for plate, and so on, plus yellow for the filament and brown for cathode circuits. Pushback wire, the kind most convenient to use, comes in these colors. The logical wiring sequence is: heaters, cathodes, screen grids, control grids and diode plates (pins 4 and 5 of the 12SQ7), AVC leads, and the B-plus circuits.

Note the location of the dual electrolytic condenser C11 and C12 in the pictorial diagram—as far as possible from the 35Z5 and the 50L6 tubes. These are the ones that generate most heat, and heat is bad for electrolytics. These condensers must be connected with the correct polarity; they're ruined by reversed polarity. Run the black lead to ground and the red one to the plus side. If the leads aren't colored, the ground lead comes from the end with a heavy black line. The value of this dual electrolytic isn't critical; anything from a 16-16 mfd. to a 40-40 mfd. one will do. With paper condensers, the lead attached to the outer foil is the one to be grounded if either one is. In the case of the tuning condenser, it's the terminals of the rotor section that go to ground.

TURN TO PAGE 40.

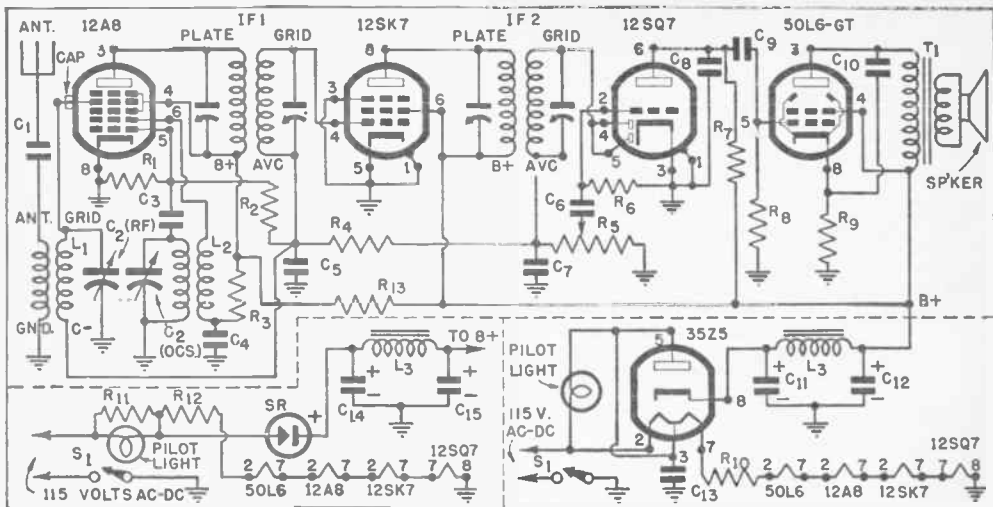

LIST OF PARTS

All resistors $\frac{1}{2}$ -watt carbon unless otherwise specified.

R1: 50,000-ohm. This is critical.

R2: 15-meg.

R3: 20,000-ohm.

R4: 3-meg.

R5: 500,000-ohm pot (with switch).

R7: R8: 500,000-ohm.

R9: 150-ohm.

R10: 30 to 50-ohm, 10-watt wire-wound.

R11: 22-ohm, 10-watt wire-wound.

R12: 200-ohm, 10-watt wire-wound.

R13: 50,000-ohm.

All paper condensers 400 volt unless otherwise specified.

C1, C7, C8: .00025-mfd. mica.

C2: two-gang, cut-plate variable condenser for broadcast band and 456 kc. IF.

C3: .0001-mfd. mica.

C4: 1 mfd. paper.

C5, C13: .05-mfd. paper.

C6: .002-mfd. 600-volt paper.

C9, C10: .02-mfd. paper.

C11, C12: 20-20-mfd., 150 volt dual electrolytic.

C14, C15: 40-40-mfd., 150 volt dual electrolytic.

L1: Shielded ant. coil with trans. windings. Grid lead should come out at top of shield can.

L2: Four-lead, 455-6 kc. osc. coil.

L3: 400-ohm, 15 to 30-henry, 75-ma.

choke coil, or 450-ohm field coil on dynamic spkr.

IF 1, IF 2: Input and output shielded intermediate-frequency transformers for 455-6 kc.

T1: Output trans. to match 50L6.

S1: SPST switch on R5.

SR: 100-ma. selenium rectifier.

Speaker: 6" PM or dynamic.

Pilot light (6-8 volt, .15-amp., No. 47) and bayonet socket; prepunched chassis or 8" x 9" sheet aluminum; line cord; tubes; octal sockets; nuts; bolts; misc. hardware.

Note: With 35Z5 rect., omit R11, R12, C14, C15, SR, with selenium rect., omit R10, C11, C12.

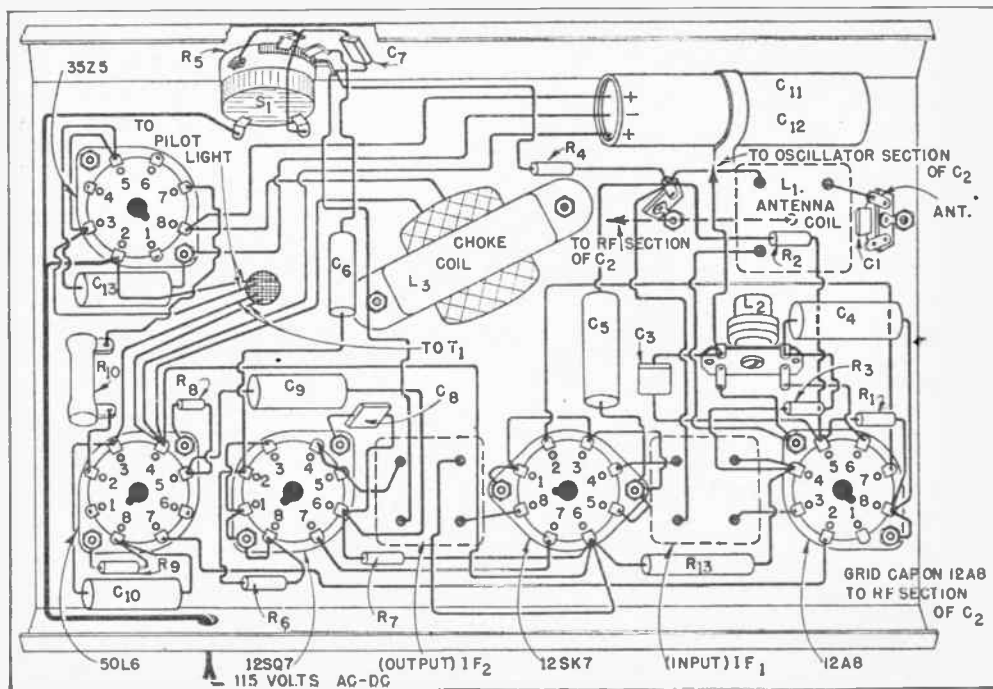

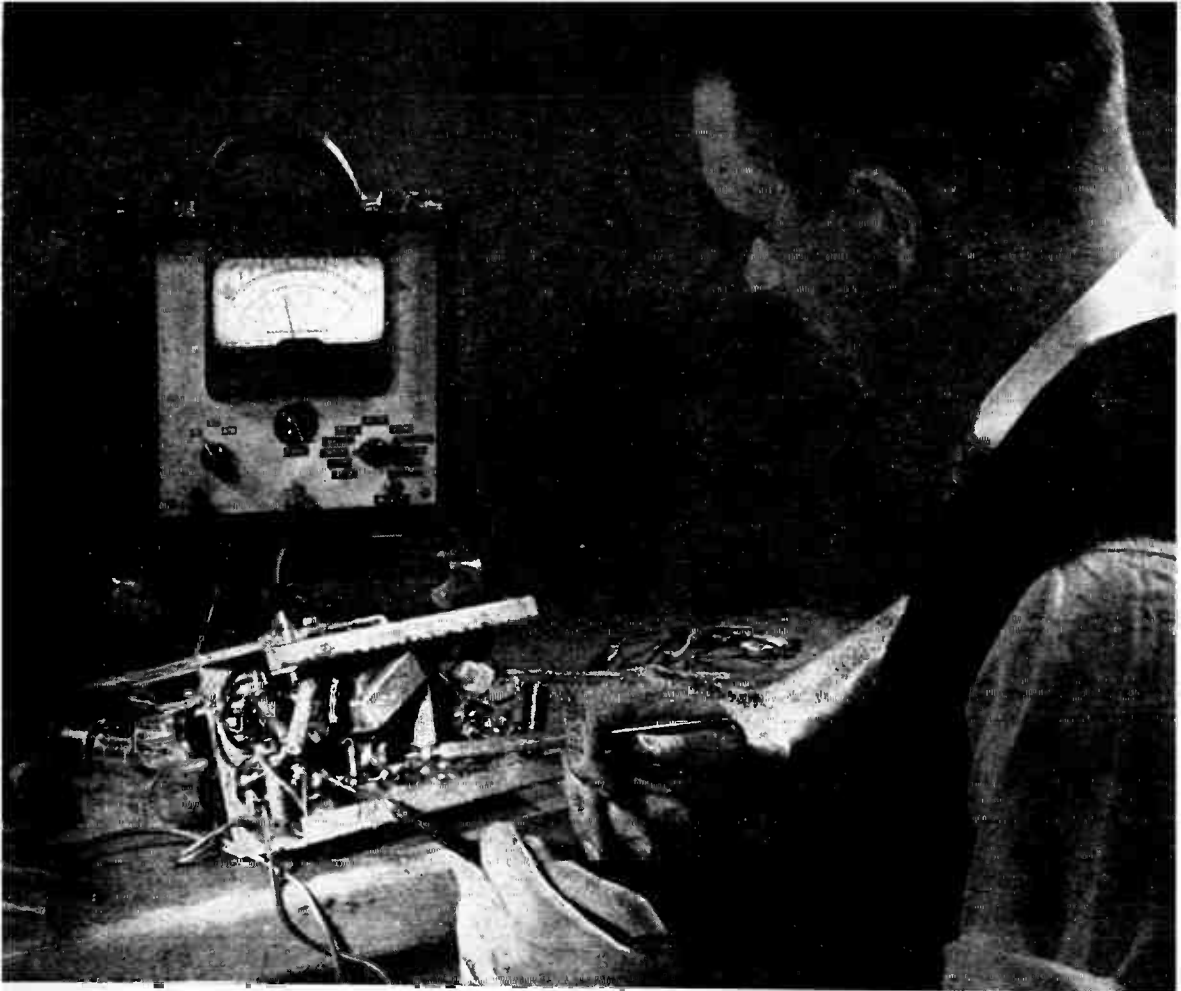

A voltmeter check of a receiver is the most efficient method of locating causes of trouble.

Completing the Beginner's Set

Here are further pointers on wiring, aligning, and checking a superhet that anyone can build.

By a High-School Shop Teacher

ONCE you get to know your way around radio you'll find that there are only two things you really need to complete any building project: a schematic diagram and a parts list. Photographs, description, and pictorial diagrams are "extras" like a radio and heater in a car. You can get where you're going without them, but they sometimes make the trip more comfortable.

Since all the essential information was

given in the first part of this article last month, you may have completed your five-tube superhet. Assuming that you have, and that it's working to your complete satisfaction, you need only file this installment for future reference. Radios do break down, and when they do it is comforting to know the most likely places to look for trouble.

If on the other hand you have waited to become thoroughly familiar with the project before heating up your soldering iron, you may be interested in more construction tips.

Most connections in a radio circuit end up at the tube sockets, so it seems reasonable—for the beginner at least—to start with the five octal sockets and make them the heart

of the wiring schedule. It may be helpful to indicate the manner in which connections are made to a typical socket. Let's take the 12A8, because it is probably the most difficult of the lot.

Remember that pin numbers are counted clockwise from the keyway in the center when you are looking at the underside of the socket. Prong 1 is a shield pin and it can either be left alone or grounded to a mounting screw and used as a lug for nearby ground leads.

Pins 2 and 7 are the filament connections. These are shown separately in the schematic diagram. Solder a piece of yellow wire to one of these—say pin 2—but don't make any connection to the other one. If you follow the same system with the remaining tubes you will simply connect the yellow lead from pin 2 of the 12SK7 to pin 7 of the 12A8 after all sockets are in place.

The oscillator coil (L2) is a rather small unit with four lugs. Solder the plate lug (usually indicated by a blue dot) directly to prong 6.

The critical 50,000-ohm resistor, R1, is connected across pins 5 and 8. Try to get a very small resistor that will fit neatly between these pins and be entirely out of the way. Hook it in place, but don't flow in the solder until you have made the remaining connections to these pins. You can usually get a better joint when you avoid cluttering it up with too much solder. In the case of prong 8 the additional connection is only a ground lead; pin 5 isn't finished until you have brought to it one end of R2 (a 15-meg. resistor) and of C3 (a .0001-mfd. mica condenser). The other end of C3 can be soldered to the grid (green) lug of the oscillator coil at the same time. One end of a 20,000-ohm resistor (R3) goes to pin 4. Hold off the solder on this one, too, as another connection will be made later.

All these connections can be made before the 12A8 socket is attached to the chassis. After the socket is in you will be able to bring the plate (blue) lead of IF1 (the input IF transformer) to pin 3; the B-plus (red) wire from the same transformer to pin 4; and the lead from filament pin 2 of the 12SK7 to prong 7. The connection to the grid cap at the top of the tube consists of a short jumper from the RF section of the variable condenser, C2.

For all of the tubes except the 35Z5 rectifier, the filament connections may be reversed without causing any harm. But on



Tubes are fragile, so install them only after all the wiring is completed. The jumper lead from the RF section of C2 must be clipped to the grid cap of the 12A8 mixer tube.

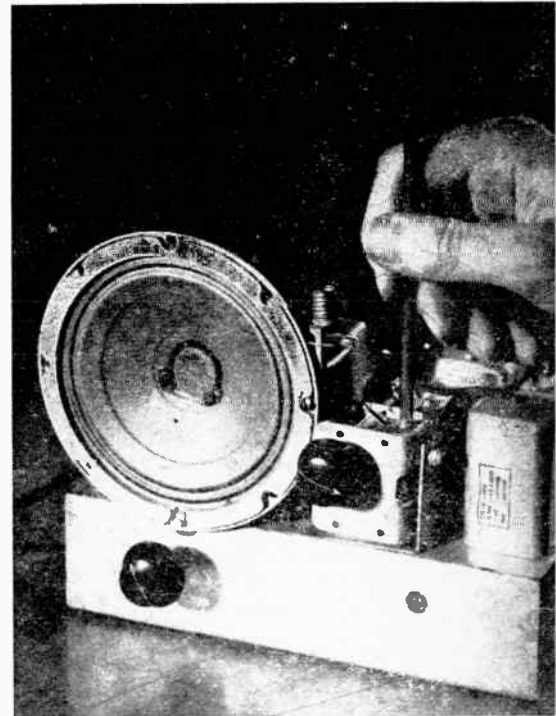

An alignment tool should be used for adjusting trimmers. Being nonmetallic, it can't short B-plus to ground. It also keeps hand capacitance from changing any of the circuit constants.

the 35Z5 it makes a great deal of difference. If the line lead is brought to pin 7 instead of pin 2, the No. 47 pilot light will burn out. There will also be a voltage drop of about 35 volts due to the resistance of the filament. This will be reflected in decreased B-plus and plate voltages in other parts of the circuit. Make absolutely certain, therefore, that the live line lead comes to prong 2 of the rectifier.

With pin 8 of the 12SQ7 and one leg of the switch grounded, the filament circuit is complete. A break anywhere in this line will kill the operation of the set completely. That's the reason servicemen always suspect a tube-filament burnout first whenever an AC-DC set fails to light up.

Using the chassis as the power-line ground connection has some desirable shielding effect, but it is important to note that it also produces a "hot" chassis. *Never* let the chassis come in contact with a radiator, water pipe, or any other metal that leads to an earth ground, and don't touch it yourself when the line plug is connected. Felt or rubber-covered bumper feet in the bottom of the cabinet, and plastic or similar insulating knobs on the volume-control and tuning-condenser shafts are desirable. The .00025-mfd, mica condenser, C1, is inserted in the circuit principally to guard against accidental shorts through the antenna. A built-in loop could be used instead of the antenna coil, L1. In this case, simply omit C1 and L1 and wire in the loop in place of the antenna-coil secondary—i.e., between the points marked "C" and "Grid." All grounds shown in the diagram are to the chassis itself. *Never* use an external ground.

For systematic service checking—and even for effective building—one of the most useful instruments you can have is a multimeter or AC-DC volt-ohm-milliammeter. This will measure the ohmic value of most of the resistors and coils (depending on the meter's range) and will enable you to check voltages at any point in the set.

If you have the use of a meter, it is a good idea to take as many readings as possible on the individual parts before you actually wire them into the circuit. This can frequently give you a clue to trouble in a completed set.

In taking voltage readings it is considered good practice to clip the negative voltmeter terminal to the chassis or ground, then touch the positive lead to the various tube pins. Voltages exist at many other points, but

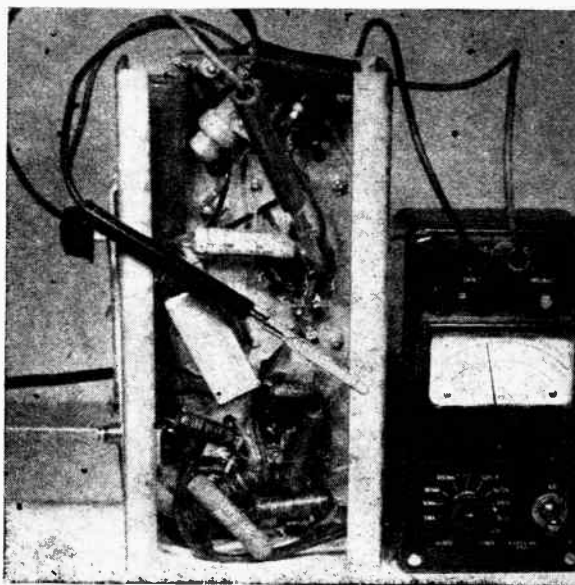

Clip the negative prod of a voltmeter to the chassis; touch each tube pin with the other.

what you can't read directly by this method you can usually get by subtraction. For example, if you subtract the voltage at pin 3 of the 12A8 from that at pin 4, you have the voltage drop across the primary of IF1.

As an aid to ready checking, a table of voltage readings is given on page 43. These were taken with a 1,000-ohm-per-volt meter. An instrument of greater or lesser sensitivity will give different readings in many cases because of the "loading" effect of a meter on a circuit. Greatest accuracy is obtained with a vacuum-tube voltmeter because of its high internal resistance. If you have one of these instruments you will probably be able to observe a slight negative voltage at the points marked in the table 0.^o On the low-resistance meters used in these tests, no needle deflection was noted. Values shown in color on the table represent filament voltages; when the set is used on AC, these will have to be read on the AC meter scale. Above the table is a reprint of the schematic diagram with each voltage related to its proper pin.

Your readings may vary slightly, and if they do, don't worry about it. Remember that voltage checks are used primarily as guides to trouble *when trouble appears*. To scramble a metaphor, the proof of the pudding is in the listening. If the set sounds good, you can forget about almost everything else. If it doesn't, or if it fails to operate entirely, an incorrect voltage may give

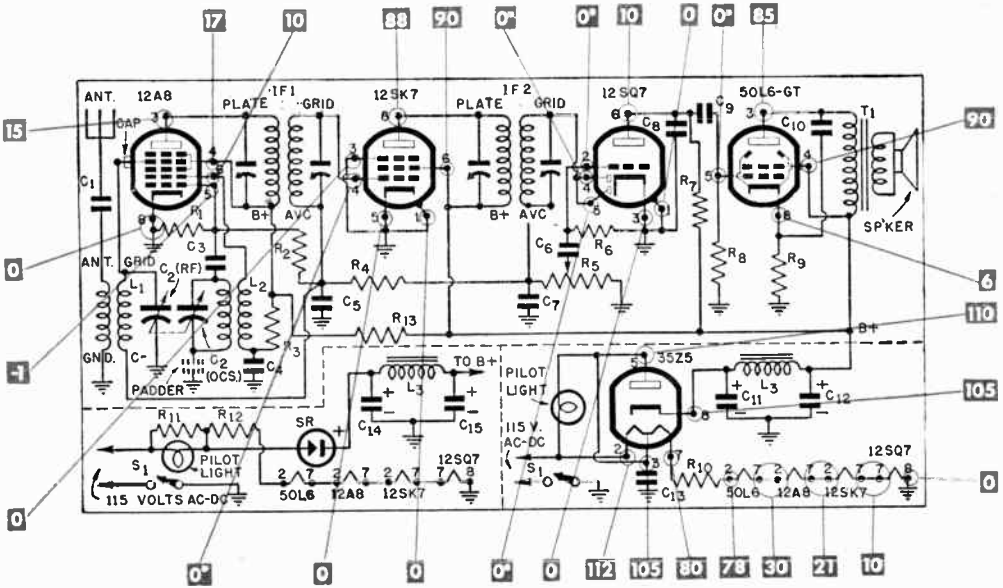

Taking a reading from each of these points to ground will show whether voltages are present

at the places where they should be and whether they are large enough to do their job properly.

you the clue you need to find the trouble.

The big bugaboo in superhets—and the thing that has made many experts feel that the circuit is too complicated for the beginner—is alignment. This consists of integrating the various circuits so that they are in harmony with each other. Fortunately it is rarely necessary to do the job entirely on your own. Manufacturers generally align their IF transformers pretty well at the factory. You only have to make small adjustments. Whatever you do, *don't tamper with the trimmers on these transformers until the set is finished.*

Automatic volume control—AVC—uses part of the rectified signal present at the detector to vary the grid bias on the 12SK7 and 12A8. When a strong signal comes through, the amount of voltage available for biasing goes up and this automatically decreases the amplification of the tube. On a weak signal the reverse occurs. Now, for aligning you want to know when you are getting a station at maximum strength, and this automatic compensation for weak signals would only throw you off. The first step, then, is to ground the AVC by running a jumper from the black lead of the input IF transformer to ground.

Set the manual volume control (R5) at maximum, and tune in the strongest local station. Working back from the output end, and using a fiber wand or other insulated

TUBE	PRONG							
	1	2	3	4	5	6	7	8
12A8	0	30	15	17	-1	10	21	0
12SK7	0	21	0	0*	0	90	10	88
12SQ7	0	0*	0	0*	0*	10	10	0
50L6	NC	78	85	90	0*	NC	30	6
35Z5	NC	112	105	NC	110	NC	80	105

For a negative reading, polarity of the voltmeter terminals must be reversed. A vacuum-tube voltmeter should read slightly negative at the points marked with an asterisk (*).

screwdriver, adjust the trimmers for maximum output in the following order: the secondary of IF2, then the primary; the secondary of IF1, and again the primary. Now tune in a station somewhere around 1400 kc—the variable-condenser plates are almost fully open at this point—and adjust the oscillator section of the tuning condenser, and, last, the RF section of C2. Bear in mind that it is seldom necessary to make much of an adjustment in the IF trimmers. Don't touch them at all until you have tuned in a station.

Should the signal become quite loud during the adjustment, it is advisable to get a weaker station. When you have the high end of the band lined up, tune in a station at the other end and make whatever slight adjustments may still be necessary.

HOW TO STOP APPLIANCE STATIC

Servicing Your Radio

FEW people realize how much of the static heard on a radio receiver may come from electric appliances in the home. Especially noisy are the older types of appliances, for much of the later equipment is provided

with some sort of built-in filter. Simple remedies can be effected by the amateur serviceman. Those described below call for noise filters put into the appliance circuit itself and will prove highly efficient.

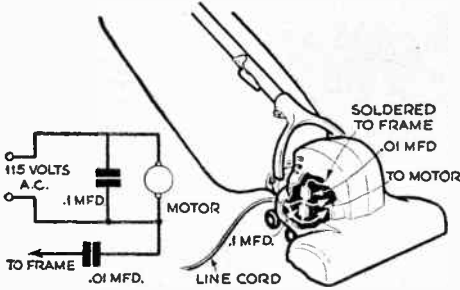

VACUUM CLEANER. Two paper tubular condensers are required. Each is rated at 400 volts, but one should have a capacity of .1 mfd. and the other of .01 mfd. It is important to have these values correct both for this and other filters. The .1-mfd. condenser is connected across the motor, while the other is connected from one side of the line cord to the metal frame of the vacuum cleaner. Sometimes static caused by the machine can be reduced still further by reversing the plug in the wall socket.

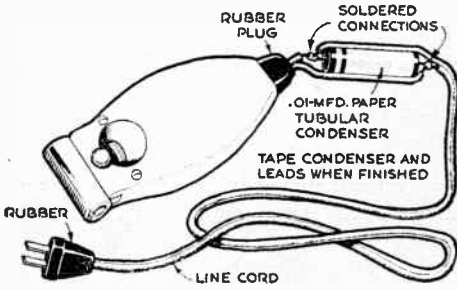

ELECTRIC RAZOR. This is a noisy trouble-maker that will interfere with reception out of all proportion to the size of its tiny motor. It is, however, the simplest of the appliances to filter. Connect a 400-volt, .01-mfd. paper tubular condenser across the cord at a point near the A.C. motor plug, soldering one lead of the condenser to one wire and the other lead to the other wire, as shown in the drawing at the left. Both the condenser and the exposed wire can be covered with rubber tape. So secured, the filter will not be in the way during use.

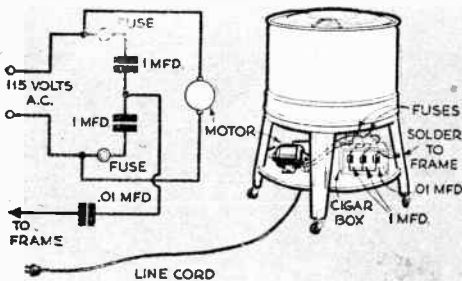

WASHING MACHINE. Two 1-mfd. condensers, one .01-mfd. condenser, and two 10-amp. fuses will filter a washing-machine or home workshop motor. Connect the fuses with the two 1-mfd. condensers across the input of the motor as in the diagram. Then connect one lead of the small condenser to a wire put in the circuit between the 1-mfd. condensers and ground the other lead to the metal frame of the machine. The fuses guard against a short circuit. This whole setup can be mounted in a wooden box near the motor.

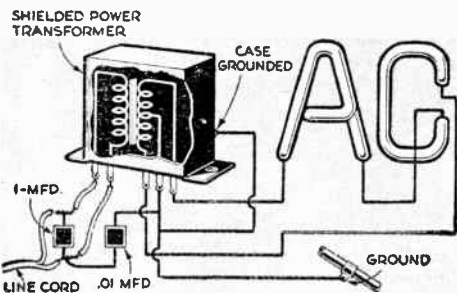

NEON SIGN. Store owners and apartment dwellers in buildings having stores on the street floor are often troubled with static caused by neon signs. The owner of the sign can keep most of this static from entering the electric lines by inserting two paper condensers in the A.C. transformer circuit, as shown in the diagram. A 1-mfd. condenser is connected across the transformer, and a .01-mfd. condenser is connected between one side of the primary and the metal casing of the transformer, which is connected to ground.

Relaxation Oscillator Makes Portable Code Practice Set

LEARNING the dot-and-dash alphabet is only a preliminary step in code mastery, for the knack of fast operation really depends upon getting acquainted with the sound of the incoming signal. This compact practice oscillator has the advantage of being adjustable through a variety of sound frequencies and tones. The capacity of the condenser connected in series with the headphones determines the fundamental frequency of the oscillator; if a higher pitch is wanted, it may be necessary to use a smaller condenser. Some tone control can also be obtained by adjusting the potentiometer. Many types of small neon tubes will work satisfactorily in this circuit. A miniature 90-volt B battery can be used safely as the current drain is slight.—WALTER F. POWELL, JR.

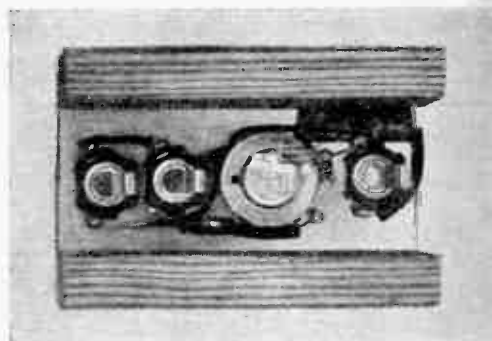
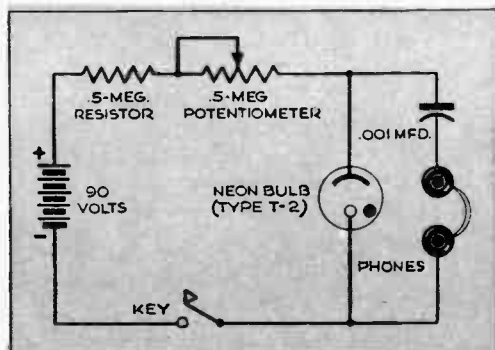
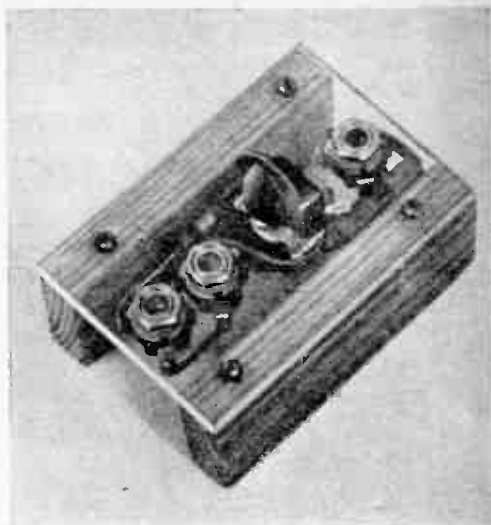

Home Test Gives Quick Check on Burned-Out Tube Filaments

BURNED-OUT tube filaments account for a great percentage of radio failures and are worth looking for when a radio goes dead. When filaments are connected in parallel, allow the set to cool, turn it on, and touch all the tubes. If you find one that stays cool, you're hot.

In an A.C.-D.C., series-wired radio, none of the tubes will light, but an A.C. voltmeter will point out the guilty one when held across each pair of heater terminals. The meter completes the circuit and

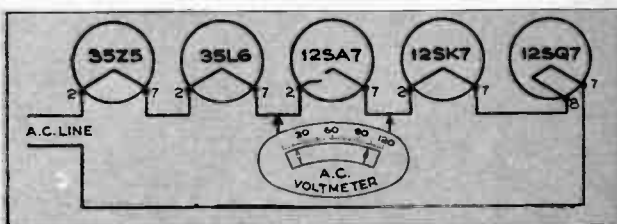

gives a reading of about 110 volts. If the filament should close during the test, the voltage will drop to its normal value for the tube.—G. BOLTON.

High-Temperature Solder Found to Shorten Life of Fine Wire

MOLTEN solders have been found to reduce the diameter of copper wire and cause some embrittlement of the parts subjected to high temperatures. In tests conducted by engineers of the Fairchild Camera & Instru-

ment Corp., of New York, it was shown that destructiveness was greatest in fine wires and increased with the tin content of the solder. For delicate work, therefore, solders of low melting point should be used.

Meet Mr.

—the conversion of sound energy into electrical energy. David Edward Hughes stumbled on his microphone while experimenting with imperfect electrical contacts. You can duplicate his experiment by hooking up three large iron nails as shown in Figs. 1 and 2. Two are tacked down tight on a $\frac{1}{2}$ " by 3" by 5" block of wood and hooked in circuit. The third merely lies across the other two. Small strips of sponge rubber insulate the mike from the table.

When there is no sound to strike in waves, a smooth flow of current circulates; but sound waves shake the loose nail, and this varies the resistance of the contacts, interrupting the current flow and causing sound in the headphones.

Low-resistance headphones are best. A long line may be used. By listening to a

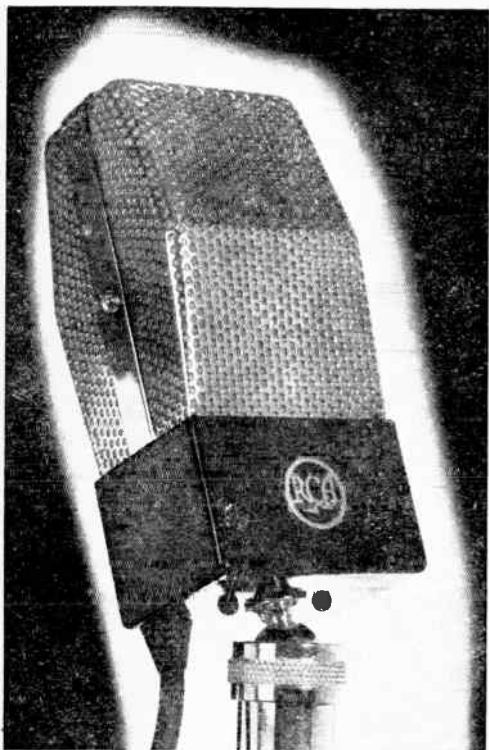

The history of the microphone is closely linked to the story of broadcasting. A series of fascinating experiments will show you how radio developed its high-fidelity ears.

By TRACY DIERS

ON JUNE 19, 1878, a routine performance of Donizetti's opera "Don Pasquale" was given in the Swiss town of Bellinzona. Neither the date nor the event would be remembered had it not been for a telegraphic engineer named Patocchi. Patocchi installed a newly invented Hughes microphone on the stage and several Bell telephone receivers in another part of the building. Thus "Don Pasquale" became the first broadcast opera and Patocchi the first studio engineer. There was no sponsor.

Since then science has devoted much effort toward developing a microphone that would reproduce all it heard. You can get an idea of the difficulties if you build and study some experimental "mikes."

Every microphone performs one basic job

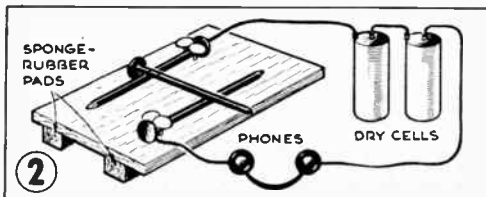

Mike

metronome, you can adjust the cross nail until it is in a sensitive spot and reproduces speech understandably.

Many unstable-contact microphones were developed. One with a loose carbon rod (Fig. 3) was used for the "Don Pasquale" broadcast. It would be useless in radio. One blast from a symphony orchestra, and you had to readjust it to a sensitive position.

A microphone employing a button containing carbon granules was invented by Edison in 1876. You can make one with a $\frac{1}{2}$ " by 5" by 5" wood block having a hole over which you cement a diaphragm from a headphone or a 3" iron diaphragm no thicker than .006". Have the hole $1\frac{3}{4}$ " in diameter for a $2\frac{1}{8}$ " headphone diaphragm or $2\frac{1}{2}$ " for the 3" diaphragm.

Solder No. 30 wire to the diaphragm and solder wire to the top of a metal screw cap from a solvent can or ketchup bottle. Half fill the cap, or "button," with microphone-carbon granules or crushed battery carbon and cement it to the diaphragm with a paper washer under it for insulation, as in Fig. 4. The hookup is shown in Fig. 5.

Normally current flows smoothly through the carbon and headphone, but the pressure of sound waves on the diaphragm presses and releases the granules, changing resistance and the current flow to the headphone and thus producing sound.

There are disadvantages, as you will find if you listen to the continuous hiss of the

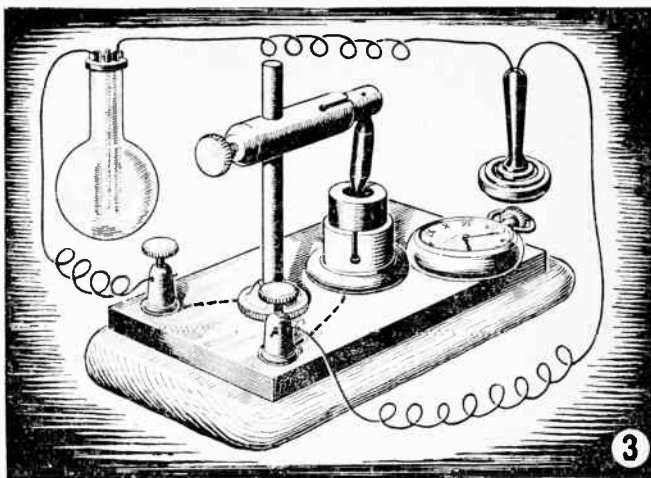

granules in a quiet room. Note, too, how they react to different letters in the alphabet. Such a mike is erratic at various frequencies and is hardly of high fidelity. Held in different positions, it varies in sensitivity, and frequently its granules pack. But in spite of drawbacks, the carbon mike has reached a good stage of development in telephones, walkie-talkies, and tank and plane radios.

The double-button carbon mike, having buttons on opposite sides of the diaphragm, saw us through the early days of broadcasting. It was connected through a center-tapped input transformer. Finally the demand for a higher-fidelity mike tough enough to stand a little manhandling resulted in the condenser microphone. And from it radio got its first high-fidelity ears.

You can build a condenser mike from scrap items. Cut a $2\frac{1}{2}$ " diameter hole in a $\frac{1}{2}$ " by 5" by 5" piece of wood and sand one face smooth. Cover the hole on the sanded face with a 4" square of thin tin foil or aluminum foil, as in Fig. 6, inserting a 6" length of No. 30 wire under the foil for a

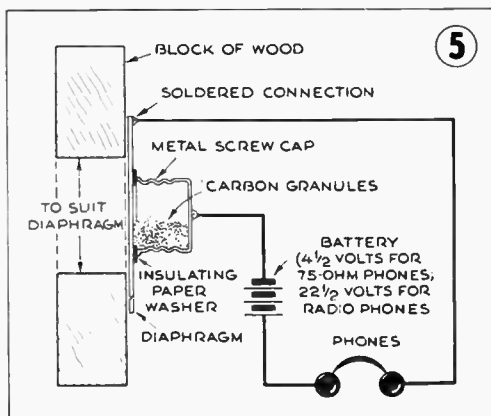
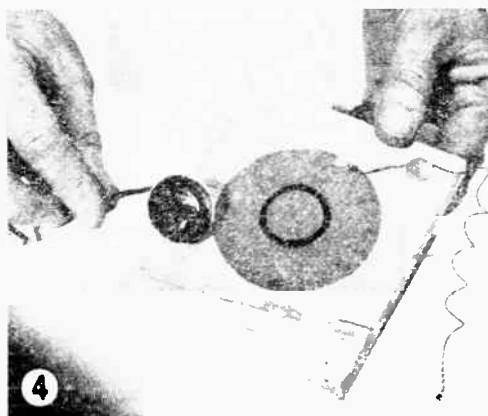

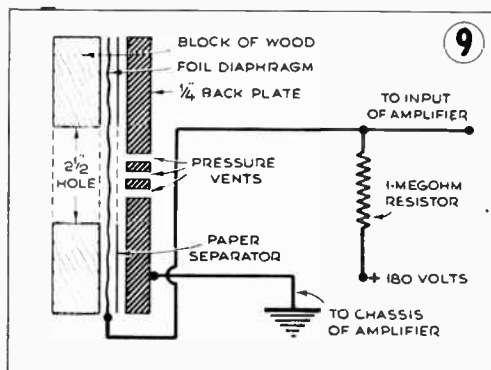
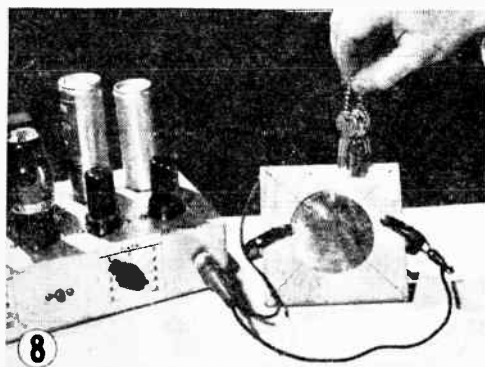
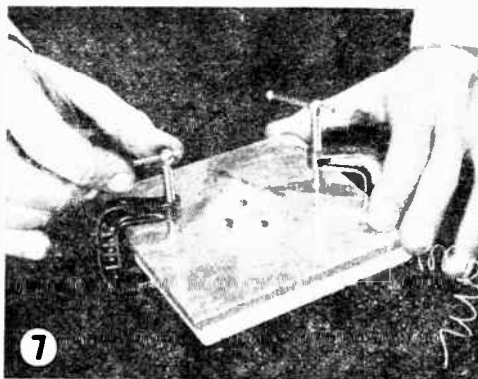
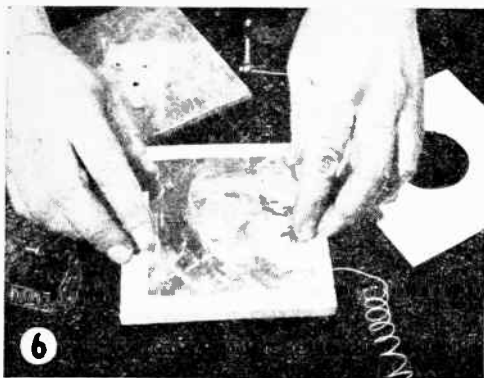

connection. Cut a $2\frac{1}{2}$ " hole in a thin sheet of paper 5" square, lay it on the foil, and put on top of that an absolutely flat $\frac{1}{4}$ " by 5" by 5" sheet of aluminum or brass in which two or three $\frac{1}{4}$ " holes have been drilled near the center. Clamp the pieces, as in Fig. 7, and the mike is ready for action (Fig. 8). The wiring diagram is shown in Fig. 9.

Since the output will be too low for headphones, connect the condenser mike directly to an amplifier by means of the ungrounded mike lead. The phonograph input of a radio may be used if it has sufficient stages of amplification, but a high-gain audio amplifier is more satisfactory.

The required 180 volts for charging the mike is obtained with least hum from separate batteries. If voltage must be taken from the amplifier power supply itself, tap the voltage divider at the 180-volt point or, if there is no divider, tap at the filtered high-voltage point with a resistance in series to drop the voltage to 180. A separate small B eliminator can also be used. The foil diaphragm and backplate act as the plates of a condenser. Pressure from sound waves moves the diaphragm and changes the capacity of the condenser, producing across the 1-megohm resistor a voltage that is fed into the grid of the first amplifying stage.

Condenser mikes were essential to radio and talkies for years. Their chief disadvantage was the need of a small amplifier tagging along or in the same case. Then a fact that had been known for 100 years was utilized to make a microphone that was light in weight, was high in fidelity, and could be separated from the amplifier—the dynamic mike.

You can build a moving-coil dynamic microphone on a $1\frac{1}{2}$ " by 5" by 5" block of wood having a hole $2\frac{1}{2}$ " in diameter. Cement a very thin iron or mica diaphragm over the hole, and then to the center of the diaphragm cement a voice coil. Use a coil from an old dynamic speaker or make one with No. 36 enameled wire wound in one layer for $3\frac{1}{4}$ " around the circumference of a light paper form 1" in diameter. Bring out the ends of the wire to the terminals on the board (Fig. 10).

Use two small permanent horseshoe magnets to surround the coil with a strong magnetic field, attaching each with a screw passed through $\frac{1}{4}$ " wood shims, as in Fig. 11, so that the magnet does not touch the diaphragm. Opposite poles face each other so the field flows through the coil.

An amplifier makes audible the sounds picked up. But since the impedance (A.C. resistance) of the voice coil is very low,

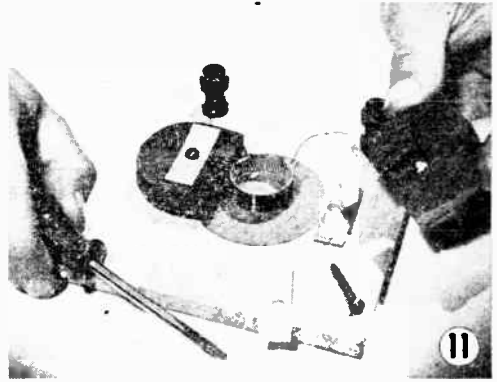
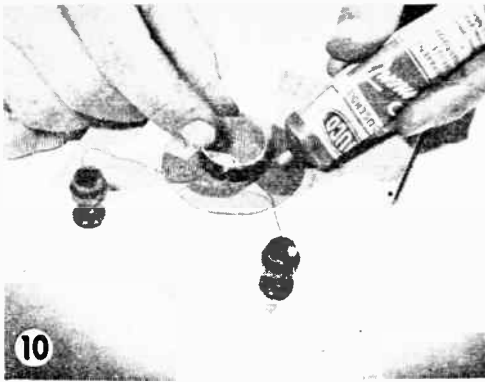

couple the mike to the amplifier through a matching transformer, such as a push-pull output transformer, as shown in Fig. 12. When sound waves strike the diaphragm, the coil moves in the magnetic field. A tiny voltage is thus induced in the coil and flows into the transformer. A secondary voltage is induced in the other side of the transformer, and this enters the amplifier.

Modern dynamic mikes reproduce sounds ranging from 35 to 10,000 cycles per second and are still widely used.

Another type, a ribbon or velocity mike, is operated by changes in the velocity of the surrounding air instead of by pressure. In contrast to the diaphragm, which tends to resist sound waves, the ribbon is so light it bobs up and down as the waves approach and offers so little resistance that they pass on unaltered.

To make a ribbon microphone, cut a $\frac{7}{16}$ " by $4\frac{3}{4}$ " slot in a $\frac{1}{4}$ " by 3" by 9" piece of plywood and screw a $\frac{1}{2}$ " by $4\frac{1}{2}$ " angle iron at each edge of the slot. The ribbon may be very thin aluminum foil—the thinner the better. Cut a strip $\frac{1}{4}$ " wide and $5\frac{1}{2}$ " in length and corrugate it by pressing it against a piece of corrugated cardboard. Then suspend it over the slot by a screw at each end, as shown in Fig. 13. Place horseshoe magnets at the ends with polarities arranged for attraction. Connections to the ribbon are made through the screws.

Hook a transformer between the mike and amplifier (Fig. 14). Any transformer having 2 ohms or less impedance on one side and 2,000 ohms or more on the other works well. Turn the amplifier gain up high and test the mike. The velocity of sounds in the vicinity starts a slight motion in the ribbon, and since the motion is in a strong field, voltage is generated and current flows to the transformer.

Your ribbon mike will work whether you speak in front of or behind it, but if you move a sound producer such as a music box or bell around it, as in Fig. 15, you will

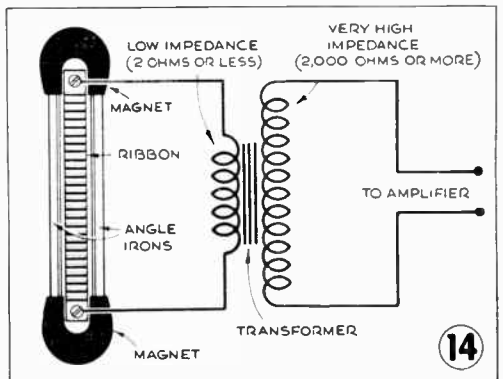
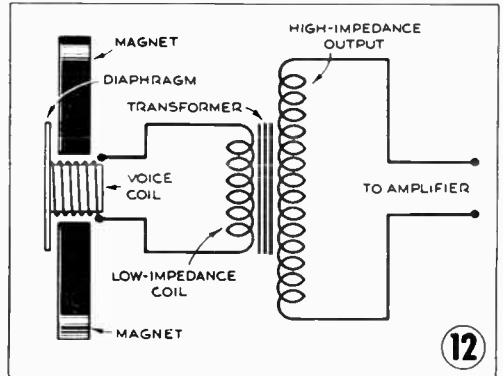

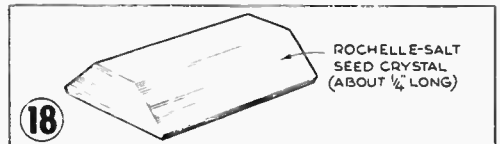
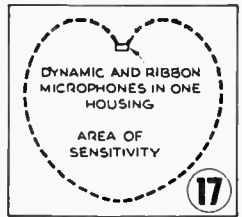
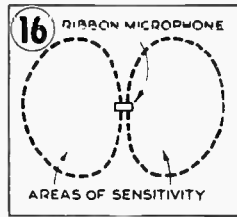
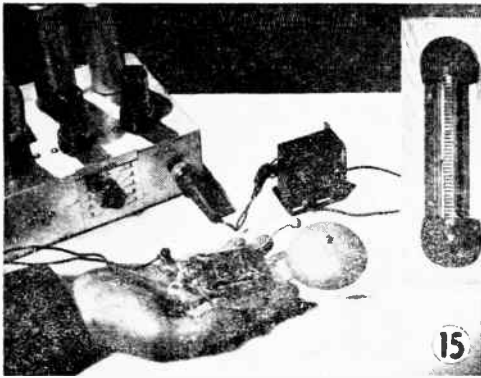

find spots of greater and less sensitivity. Figure 16 shows the field of sensitivity of a typical ribbon mike.

If you could cut off one of the loops in Fig. 16, you would have a directional mike that would "select" sound from a given area. This is done with a cardioid mike (named for the shape of the field, as shown in Fig. 17) which usually combines in one housing a ribbon mike and a dynamic mike, the latter "phased" to cancel one loop. Opera is broadcast by such a cardioid mike with the live side facing the performers.

A very new addition is the crystal mike, depending for its operation on what is known as the piezoelectric effect. When a crystal held between metal plates vibrates under slight pressure, a measurable voltage is produced in it. You can make the active element, a crystal sound cell.

Make a supersaturated solution by dissolving 6 oz. Rochelle salt in 4 oz. water at about 200 deg. F. As the solution cools slowly, crystals about $\frac{1}{4}$ " long form. When one resembles that in Fig. 18, remove it and let it dry. This is your seed crystal.

Bring 16 oz. water to the boiling point, dissolve in it as much Rochelle salt as can be held in solution, and let it cool slowly, being sure to keep out dust. Then hang the seed crystal in the solution on a thread. Growth takes place in a few hours. Remove

the crystal when it measures about 1" in any direction, and put it in alcohol for 24 hours. If your first attempt doesn't turn out well, try again.

Make a sound cell by wrapping a $\frac{1}{4}$ " strip of tin foil around a perimeter of the crystal and clamping any two opposite surfaces between two metal plates, as in Fig. 19; then hook the cell to the amplifier as shown in Fig. 20. Move the crystal to a different position in the holder if it doesn't show good sensitivity at first.

There are two types of crystal mikes. In one, two small plates of Rochelle salt are cemented together to make a "bimorph" unit of extreme fidelity that will respond to from 30 to 20,000 cycles a second. The pressure of sound waves causes the flat crystal plates to generate voltage. A more popular, cheaper type has a diaphragm connected to a light driving rod that transmits the pressures to the bimorph unit.

"Don Pasquale" is still very much alive, but the methods of broadcasting it have changed greatly. Instead of simple rods delicately adjusted, we now have slick chromium-plated cardioid mikes with directional selectivity and high fidelity. Such innovations as frequency modulation have put Mr. Mike on the spot, but moving coils, vibrating ribbons, and sensitive crystals have met the challenge.

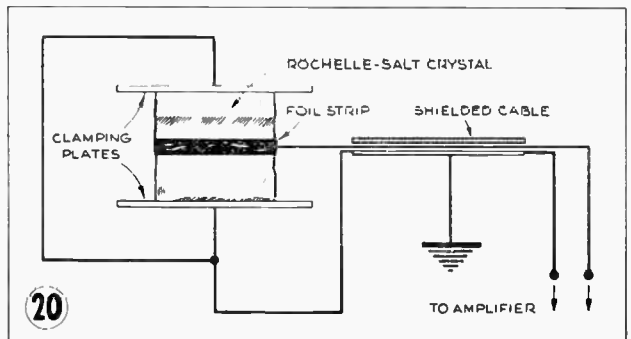
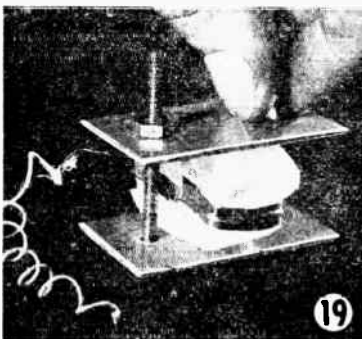

Wiring Puzzlers to Test Your Electrical I.Q.

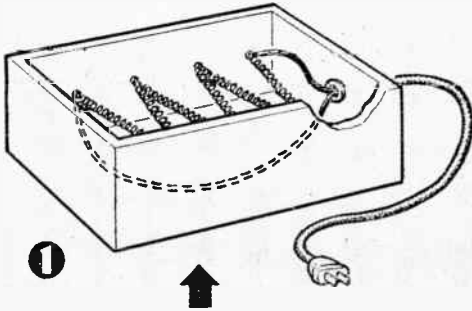

TO MAKE a photographic dryer, Smith used a 600-watt replacement coil sold for use in toasters and stretched it over a series of hooks inside an asbestos-lined box. But he found the wire heated to redness, scorched the prints, and threatened to burn the box itself. To halve the amount of heat, should he cut the resistance wire in half, add a second element in series, or connect another in parallel?

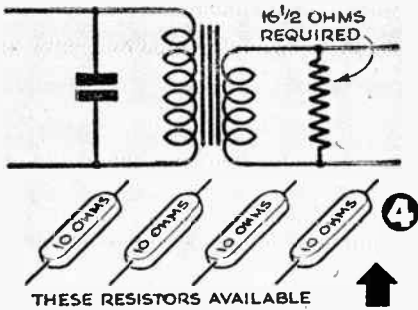

A RADIO engineer, needing a 16½-ohm resistance across an amplifier transformer for testing purposes, found he had nothing but four 10-ohm resistors in his parts drawer, which therefore had to serve. How did he connect them?

two of them with the fourth. The formula for parallel resistances is:

$$\frac{R_1 \times R_2}{R_1 + R_2}$$

Substituting known values:

$$\frac{20 \times 10}{20 + 10} = 6.6 \text{ ohms.}$$

Added to the unshunted resistance, this gives a total of 16.6 ohms.

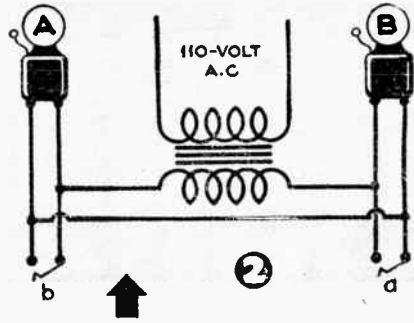

WISHING to save wire, Jones hooked up two bells this way. Button *a* was to ring bell *A*, and button *b* bell *B*. Although pushing both buttons at once would cause a short circuit, Jones thought this would be of too short duration to harm the transformer, and he expected no trouble. He had trouble anyway. Why?

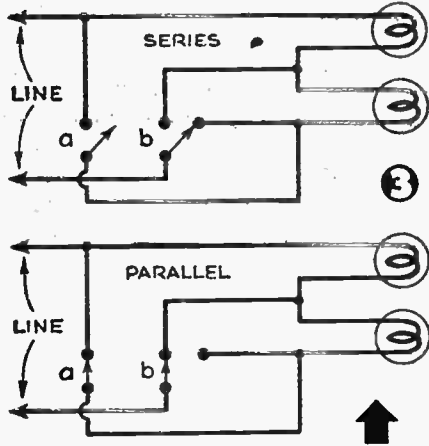

NOT having a double-pole, double-throw switch on hand, a photographer connected a S.P.S.T. switch *a* and a S.P.D.T. switch *b* as above to throw two flood lamps from series to parallel or vice versa. As all worked well in the positions shown, he considered himself lucky. Why was he even luckier than he thought?

1. Add a second element in series with the first, thus halving the current.
 2. The bells will ring continuously even when neither button is pressed.
 3. If switch *a* is closed while switch *b* is thrown to the right, a short circuit results and fuses will be blown. But it is possible to connect these switches in a satisfactory way. Can you do it?
 4. Put three resistors in series and shunt

Filters...radio's most

How ingenious combinations of
censors in your receiver to

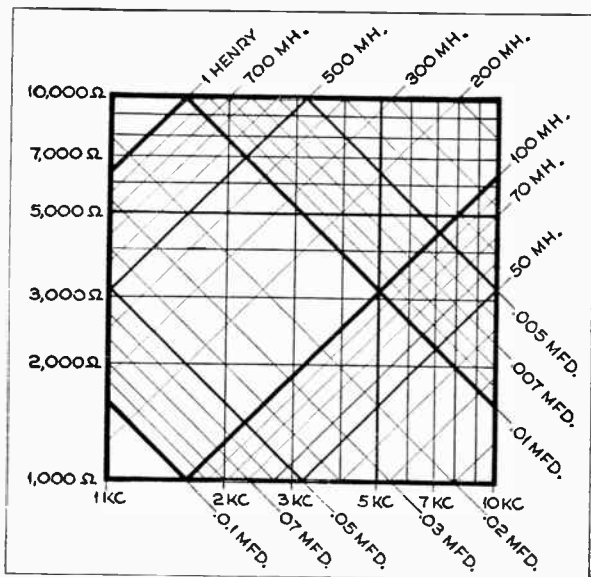

A reactance-frequency graph, of which this is a section, gives direct values in ohms for any frequency up to 1,000 kilocycles.

By GEORGE O. SMITH

FILTERS are electronic circuits that have frequency selectivity. At the will of the designer, they can be made to pass or block frequencies below, above, between, or around certain specified limits. The names of the four major types are self-explanatory; they are low-pass, high-pass, band-pass, and band-elimination filters. Taken together they make possible two important things: the first is radio reception; the second is good radio reception.

The ability of filters to discriminate against certain frequencies is due to the fact that the resistance of capacitors and inductors to alternating-current changes with frequency. Alternating-current resistance is called *reactance*, and is symbolized by the letter X. Like direct-current (or pure) resistance, it is measured in ohms.

In the case of a choke coil labeled, say, 300 henries, 200 ohms, the 200 ohms stands for the resistance of the wire that is wound on the coil. This is a constant minimum, regardless of frequency; it would still measure 200 ohms if a D. C. potential were ap-

plied, or if the wire were stretched out straight. Reactance is another matter. It increases as frequency increases. In addition to the resistance of the wire, a 30-henry choke has a reactance of about 11,300 ohms at 60 cycles. At 600 cycles, the reactance has grown to 113,000 ohms. The way in which the reactance of a coil varies with frequency is expressed by the formula: $X_L = 2 \pi f L$, where X_L stands for inductive reactance, 2π is the constant 6.28, f equals frequency in cycles per second, and L represents inductance in henries.

A good capacitor, on the other hand, has infinite resistance to direct current, but will pass alternating current more or less readily, depending on frequency. Unlike the choke coil, the reactance of a capacitor goes down as the frequency goes up. In mathematical terms, $X_C = \frac{1}{2 \pi f C}$. Here, X_C stands for capacitive reactance, and C is a measure of capacity in farads. A .01-microfarad capacitor

would have a reactance of about 265,000 ohms at 60 cycles, but only 26,500 ohms at 600 cycles. The total opposition that inductive reactance, capacitive reactance, and resistance offer to the flow of an electric current is called *impedance*.

Between them, capacitors and inductors can hold any alternating current at their mercy. Used in various combinations—series, parallel, and series-parallel—coils and condensers serve varied functions in radio transmission and reception. They polish off rectified A. C. so as to provide a smooth D. C. power supply; in the form of tuning circuits they enable you to select a station at the twist of a condenser.

This article makes no attempt to deal with all filtering actions. While filters are integral in the basic radio circuit, they may also be added to existing amplifiers as tone-corrective devices. One of the simplest types is that shown at the right. This is a form of high-pass filter, and it operates in precisely the same way as a voltage divider, except that the resistance of one leg automatically varies with frequency. Let us say that the components of the circuit are

important networks

resistors and condensers can be made to act as electronic screen out unwanted frequencies or boost fading ones.

a 50,000-ohm resistor, and a .01-mfd. capacitor. Then at 320 cycles, X_C equals 50,000 ohms, and the output voltage at the tap between the two elements is one half the input across the divider. This is just what you'd get if both R and X_C were 50,000-ohm resistors. But at 640 cycles, X_C has fallen to 25,000 ohms, which gives a voltage division of one-to-two. The output is then two thirds of the input.

Now, if both 320 and 640-cycle signals are put into the circuit simultaneously at equal voltages, two thirds of the 640-cycle signal will come through, but only half of the 320-cycle note. Conversely, if the 320-cycle input were, say, 12 volts, and the 640-cycle signal were 9 volts, both signals would come out as 6 volts A. C.

The first effect is useful in boosting high frequencies, while the second helps to level off the response of an amplifier that favors the lows. Carrying the calculation higher and lower than the figures given will demonstrate the high-pass effect of the filter. The graph at the bottom of this page shows the output response of a typical high-pass, tone-corrective filter. At 100 cycles the output may be about one fourth of the input, while at 10,000 cycles almost the entire voltage drop is across the resistor.

In order to design a resistor-capacitor filter to suit your own needs, you will have to determine the reactance of any given

condenser within the limiting frequencies. These values may be obtained either by calculation, or through the use of a reactance-frequency graph which can be purchased at any drafting-supply house. The figure on page 52 is one small segment of such a graph, twice enlarged. To find the reactance of any condenser, locate the condenser's capacity along the right-hand edge of the chart. (In the section reproduced, capacities are carried around to the bottom of the sheet.) Follow the sloping line up until it intersects the vertical line that represents, say, the lowest frequency you are interested in filtering. Where these two lines cross, read straight over to the left-hand margin where capacitive reactance is indicated directly in ohms.

From this chart, get the reactance of the condenser for a number of frequencies in the passband of your filter. Assuming a standard load resistance, you can then figure how the voltage will divide for each frequency, and draw a graph representing the output of this particular filter. Percentage of output is obtained by dividing the sum of reactance and resistance into the resistance. If the resulting curve doesn't suit your needs, try another capacity.

In constructing a filter, remember that a large capacitor and a large resistor give quite different results than a small capacitor and a small resistor. For example, a .2-mfd.

If your receiver tends to cut off or distort the high notes, this tone-corrective filter may be just what it needs. It acts like a voltage divider in which the ratio of output to input rises with frequency.

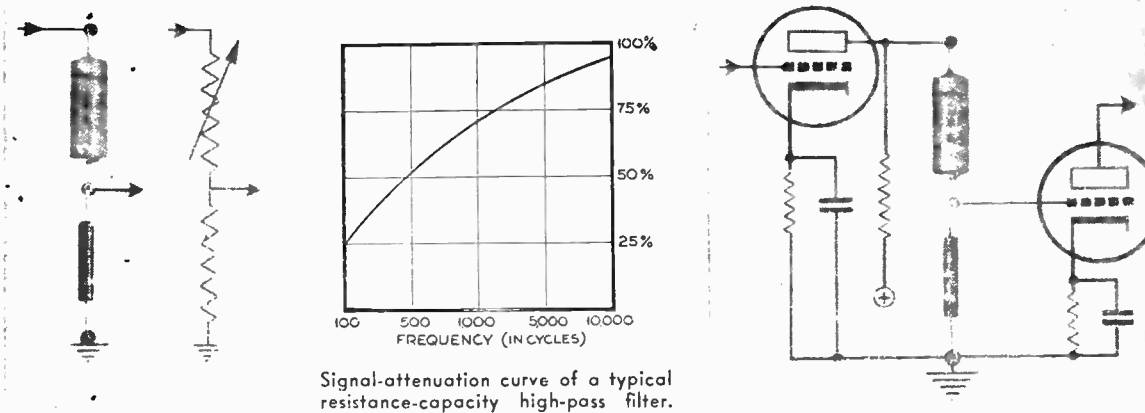

Signal-attenuation curve of a typical resistance-capacity high-pass filter.

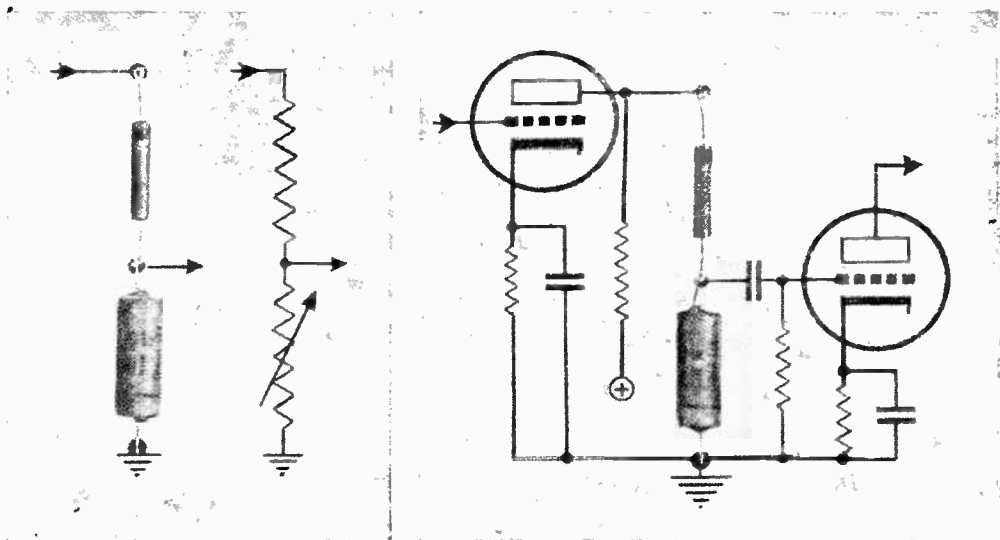

Tapping the output voltage off the capacitor will tend to favor the low notes.

Used between amplifier stages, this type of filter requires an extra condenser-resistor arrangement in the coupling circuit.

condenser and a 2-megohm resistor show less than 1 percent response difference between 80 and 8,000 cycles, while .001 mfd. and 20,000 ohms will cause about 40 percent difference in the same range.

This type of filter may be connected between the audio stages of an average amplifier as shown in the hookup schematic on page 53. While calculated values give you a good starting point, the final test of any filter is in its effect on the entire amplifier. Because of distributed effects, calculated values are at best approximate, and it may be necessary to juggle values a little until you get a result that is pleasing to the ear. A voltmeter placed across the amplifier output will help you to check the real effect of a filter. Used in conjunction with an audio-frequency generator, or a frequency-test record, the voltmeter will show how output voltage varies as the input frequency is changed.

While resistor-condenser combinations are often favored for tone correction in audio circuits, there are times when a more level response is desirable. Let us say, for example, that you want to give equal emphasis to all notes between 10 and 1,000 cycles. The response curve shown on the previous page would then not be satisfactory. At 1,000 cycles, this filter has almost three times the output it has at 100 cycles, whereas the graph we now want should be level between the two extremes of our pass-band.

To obtain this effect it is necessary to replace the resistor with a choke coil, thus giving your voltage divider two variable

arms instead of one. When the reactance of one arm increases, that of the other decreases correspondingly.

The use of inductance-capacity filters, however, involves a number of other critical considerations which are outside the scope of this article. Getting back to our first circuit, let's see what happens when we make a few changes.

Reversing the positions of the filter components produces, reasonably enough, an opposite effect. The illustrations above show how this is done to produce a low-pass filter that will attenuate the higher frequencies. In this case the output voltage is tapped off the variable leg of the divider. As frequency goes up, the reactance of the capacitor decreases, giving a lower voltage drop for the higher frequencies.

Using a filter of this type between amplifier stages requires certain precautions that are not needed with the high-pass unit. By themselves, the filter components would put part of the high plate voltage on the grid, and the condenser would block the grid return to ground. The schematic diagram above shows the additional circuit elements that must be used when this kind of low-pass filter is inserted between stages. In this hookup, the filtering is done between the plate connection and ground, and the grid is coupled to the filter terminal through a condenser-resistor arrangement. This, however, constitutes another high-pass filter; if the components of both sets were alike, they would merely nullify each other.

To offset this possibility, the coupling components are made large, thus reducing

their frequency selectivity, and allowing the desired filter to do most of the frequency selection. The coupling condenser for this circuit should be about .1 mfd., and the grid resistor about 2 megohms.

Among the "built-in" defects of many existing amplifiers is an auditory effect known as "loss of bass." Most often this is noted when the volume control is turned to a low position. A tone-corrective filter that often succeeds in eliminating this fault consists of a tapped volume control with a condenser connected between the tap and ground. When the volume control is turned down near the tap or below, the condenser causes it to act as a type of low-pass filter. As volume decreases, the low notes are increasingly favored, thus compensating for the loss of bass.

To prevent overemphasis of the bass, a limiting resistor should be used in series with the condenser from tap to ground, as shown at the left, below. At high frequencies the capacitive reactance may drop to just a few ohms, yet the series resistor maintains the total shunting effect above the level of its own resistance. At low frequencies, the higher capacitive reactance adds its ohmage to that of the resistor, raising the shunting effect.

In order to reverse this effect, the limit-resistor should be connected in parallel with the condenser, as shown at the lower right. Below the so-called "cross-over frequency"—that frequency where the capacitive reactance equals the pure resistance—the incoming signal sees mainly the pure resistance shunting the line. Above this frequency, the line is shunted by the resistor and the lowered reactance in parallel.

Connected in series, the impedance of this filter tends to level off to the limiting resistance above the cross-over frequency, while in the parallel hookup the total impedance is level for frequencies below the cross-over level, and the impedance drops as the frequency rises above the critical value.

As before, the final test of these filters is in the listening. Using a .01-mfd. condenser and a 30,000-ohm resistor as a starter, this tone compensator can be adjusted to suit your taste. Set the volume-control arm to the point that gives the lowest ohmmeter reading between tap and arm, and leave it at that value while making changes.

Some increase in high-frequency response can be obtained with this filter by connecting a small condenser—say 50 mmf. to 250 mmf.—between the top of the control and the tap. The over-all response will then be low in the middle-frequency ranges, and have broad peaks at both the low and the high ends. This type of response curve is generally considered to be the most pleasing.

The thing to remember about resistance-capacity filters is that the use of a frequency-selective element (the capacitor), in conjunction with a nonselective element will produce all manner of curves in the audio response of an amplifier. Whether high or low frequencies will be passed or blocked depends upon the position of the components, while the range of any filter is governed by the size of the parts. Doubling or adding filter after filter will steepen the response curve. In one combination or another, filters will permit you to do just about anything you want with just about any alternating-current signal.

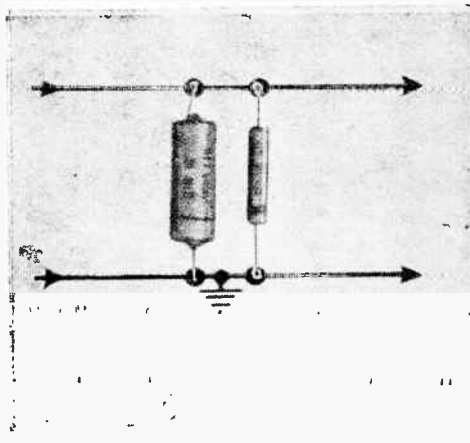
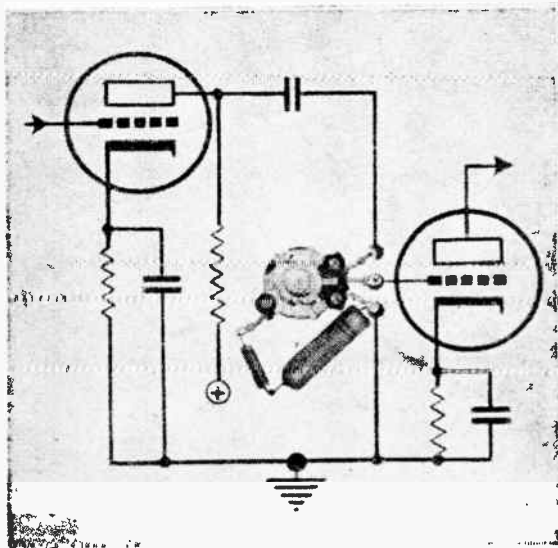

If turning the volume control low produces a "loss of bass" in your receiver, inserting a condenser between volume-control top and ground may give the foiling low notes a boost.

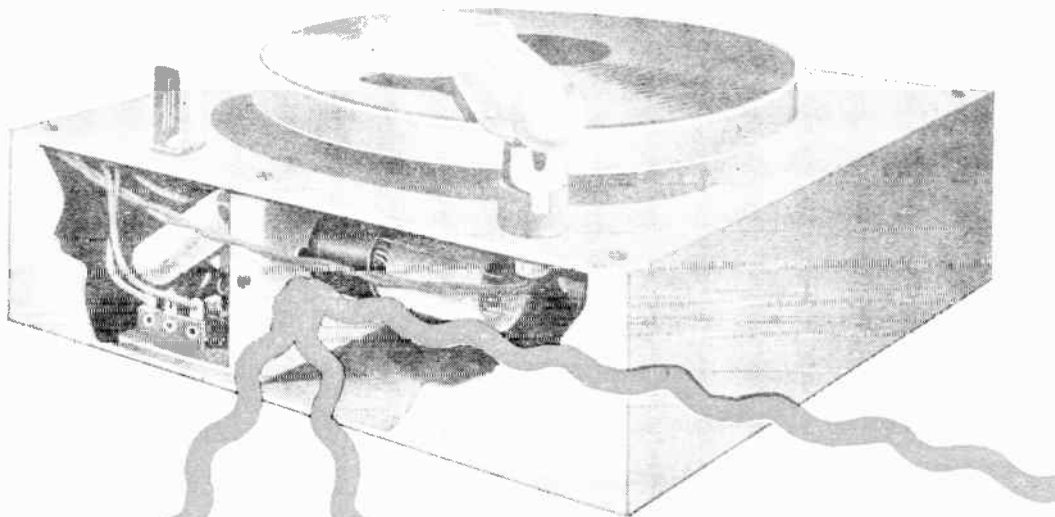

Wireless Record Player

BROADCASTS THROUGH YOUR RADIO

By Albert W. Hellenthal



HAVE you banished your old hand-wound phonograph to the attic because radio has spoiled your ear for its tinny sound? If so, here's your chance to modernize the forgotten antique, and for a few dollars give it a tone as good as that of your radio. Exactly the same

tone, in fact, for it will play records through your radio. From basement to attic, any radio in the house can be tuned to pick up records played on the unit, so the entire family can enjoy favorite selections even though not gathered in one room.

The heart of the record player, a one-tube oscillator small enough to fit into the palm of your hand, is actually a tiny broadcasting station. It emits a radio-frequency carrier wave on which are impressed the audio frequencies comprising the recording.

Assuming that you have none of the necessary parts in your scrap box, total cost for the oscillator should be about \$5. Add to this the cost of a crystal pickup—say another \$5—and you're all set. If you want to save yourself the bother of cranking up an old spring-wound clockwork drive, a phono motor and turntable can be picked up for only a few dollars more.

Compactness and simplicity of design are obtained chiefly through the use of a single multipurpose tube designed for use on 115-volt house current. A 117N7 tube is shown in the diagram, but a 117L7, 117M7, or 117P7 can be used equally well with a few minor changes in the socket connections. The diode section of the tube rectifies A.C. into a D.C. power supply which is filtered through R5, R6, C7, and C8. As with any A.C.-D.C. circuit, direct current goes through the rectifier relatively unchanged.

Radio-frequency (R.F.) currents are set up in the tank circuit, which consists of a small trimmer condenser (C2), and one winding of an adjustable iron-core oscillator or antenna coil (L). Some experimenting may be necessary to find the correct connections. Varying either the core or trimmer or both will change the oscillator frequency.

Transferred to the secondary of the coil and applied to the control grid of the amplifier section, this R.F. constitutes the "carrier wave" of your transmitter.

Vibration in the needle of the pickup causes a varying pressure to be exerted on the crystal. Through an effect known as piezoelectricity, these mechanical vibrations are converted into alternating voltages that vary at audio frequencies. When this audio signal is applied to the screen grid, it alters the carrier wave, and it is the modulated wave that



reaches the plate. From here the combined wave goes directly to the antenna and out into space. In principle, pretty much the same thing takes place in a large transmitter.

Any kind of cloth-covered wire may be used for the antenna, but it should be kept under 5' in length to prevent the signal from radiating beyond the house. This is important, since regulations of the Federal Communications Commission prohibit unlicensed broadcasting beyond a very limited range. To insure further against radio interference either for yourself or your immediate neighbors, tune the oscillator to a frequency that is not used by any local station.

The oscillator will have to be tuned experimentally. Put a record on the phonograph, turn up the volume of both the record player (R4) and the radio, and tune the radio through its entire range. If the signal is not picked up, vary the trimmer condenser or the iron core of the coil until it is. Now select an unused frequency and keep adjusting the oscillator until the record comes through with maximum strength just at that point on the dial of your radio.

While an old spring motor is perfectly satisfactory in this unit—provided, of course, that both the spring drive and speed regulator are in good condition—it isn't necessary to use this type if you have or can get an electric turntable. With the latter you eliminate the need for hand winding, which is a troublesome and unpopular feature of the older phonographs. To install an electric motor, wire it into the circuit as shown by the dotted lines in the diagram; all the other wiring remains the same.

Any box or cabinet will serve to house your new record player; the tiny oscillator requires very little space and may be mounted in any position without affecting its operation. If you put the player in the original phonograph cabinet, it will be necessary to remove the acoustical pickup. This will leave a large hole which may be covered with a piece of composition board or plywood that becomes a mounting place for the new pickup arm.

On D.C., the unit may not work as it is first plugged in. Take out the power-line plug and reverse it. You may wish to mark it for future use.

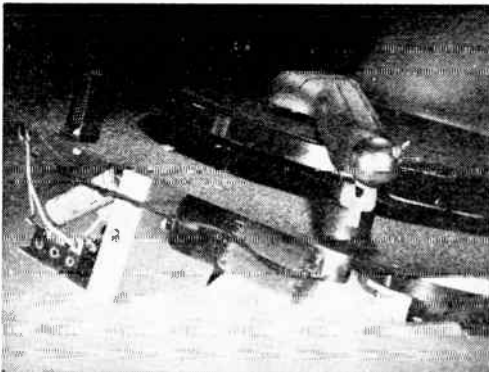

List of Parts

- | | |
|--------------------------------|--------------------------------------|
| C1: 110 mmfd. | R4: 250,000-ohm potentiometer. |
| C2: Trimmer condenser. | R5: 10,000 ohms, 1 watt. |
| C3: 250 mmfd. | R6: 1,000 ohms, 1 watt. |
| C4: C5: .05 mfd. | L: Iron-core osc. or ant. coil. |
| C6, C9: .1 mfd. | S1, S2: S.P.S.T. switches. |
| C7, C8: 20-20 mfd., 150 volts. | Crystal pickup. |
| R1, R3: 65,000 ohms. | Electric or spring-driven turntable. |
| R2: 3.5 meg. | |

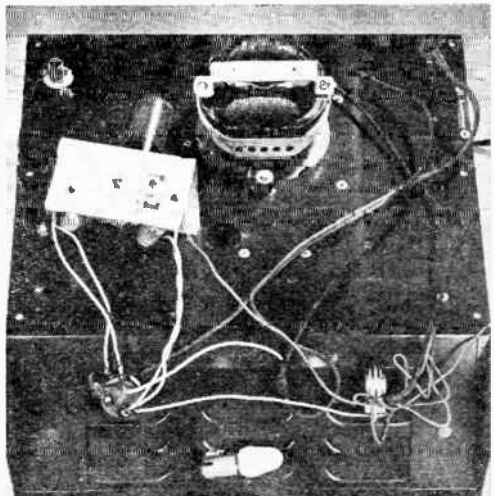
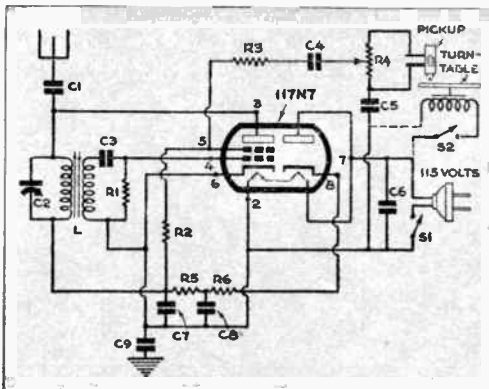



PERSONAL RADIO

WITH A BEDSIDE MANNER

By Albert W. Hellenthal

INSTEAD of thinking harsh thoughts about members of your family who frown on your radio listening when they want to read or sleep, try one of these compact personal radios that make the entertainment of the airwaves your private business.

This set can practically be built out of the

spare-parts box, for with the exception of the resistance in series with the heaters, none of the specified values is critical. In selecting both condensers and resistors, a tolerance of about 20 percent is permissible. The set can be used on A.C. or D.C.

Lay out your parts before cutting the chassis. The one shown here measures 1½" by 3½" by 4", but some variation may

Since the wires are stored inside the cabinet, exposed parts are carefully shielded and secured.

Compactness is achieved through design rather than through the use of small parts. Note the odd sizes.

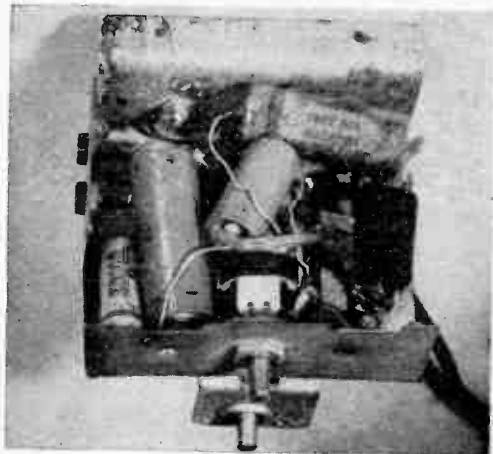
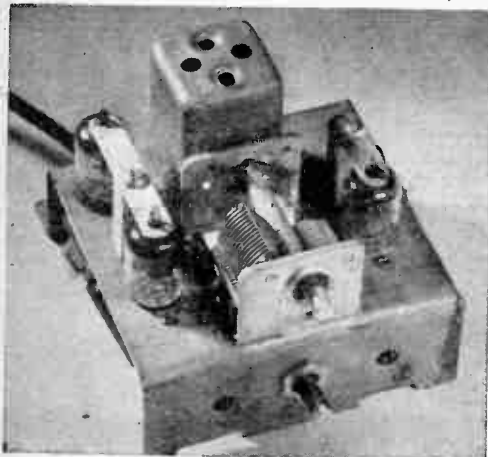

be necessary, depending on the parts you can obtain. One 9002 tube is used as an A.F. amplifier; another, with its plate and grid tied together, serves as a diode half-wave rectifier for the power supply. The third tube, a 9003, acts as detector and R.F. amplifier. Regenerative oscillation, used to get added selectivity and gain, is controlled by putting the volume control (R2) in the screen-grid circuit.

With all tube heaters connected in series, a 600-ohm voltage-dropping resistor must be inserted in the line. Any combination of line cords adding up to 600 ohms will serve.

One of the last steps in the wiring consists of winding the feedback, or tickler winding. This goes next to the grid section of a standard iron-core adjustable antenna coil. Two to 10 turns of 30-gauge enameled or D.S.C. wire will be needed. Turn the set on and find the exact number of turns by experimenting. If no effect is noticed while making the adjustment, try reversing the leads.

Hard composition-board sides and an aluminum front were used for the cabinet shown, which measures 4½" by 4¾" by 6¼". To prevent the tubes from working loose in their sockets, two 1¼" wood posts were fastened to the chassis. Small metal crossarms have holes drilled to fit over the glass tips.

A 25' length of covered-wire antenna, dropped out the window or fastened to a bedspring, will bring in the local stations. As the power line goes to chassis, use no ground and keep the set away from radiators.

Although this set is designed for personal listening, it has enough power to drive a small speaker. Should you want to add one to yours, follow the inset shown in the diagram below. The extra parts that are needed are marked "optional."

List of Parts

- L1, L2: Standard adjustable iron-core antenna coil.
- L3: Tickler coil.
- C1: 365-mmfd. midjet tuning condenser.
- C2: .0025 mfd., mica. ←
- C3, C6: .5 mfd.
- C4: .0005 mfd., mica. ←
- C5: .03 mfd. ←
- C7, C8: 20-20 mfd., 150 volts, electrolytic. ←
- C9: .05 mfd., 400 volts. ←
- R1: 2 meg., ½ watt.
- R2: 15,000-ohm potentiometer.
- R3: 50,000 ohms, ½ watt.
- R4: 45,000 ohms, ½ watt.
- R5: 100,000 ohms, ½ watt.
- R6: 800 ohms, 1 watt.
- R7: 800 ohms, 2 watts.
- R8, R9: 300-ohm line cords.
- S1: S.P.S.T. switch.
- S2: S.P.D.T. switch (opt.).
- T: 10,000-ohm midjet output transformer (opt.).
- 2" Permanent-magnet speaker (opt.).

The extra space inside the cabinet will hold either the line cord and coiled antenna, or a 2" speaker.

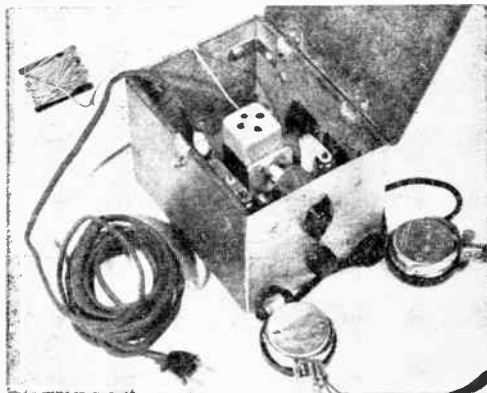

Angle irons and small bolts hold together a composition-board box.

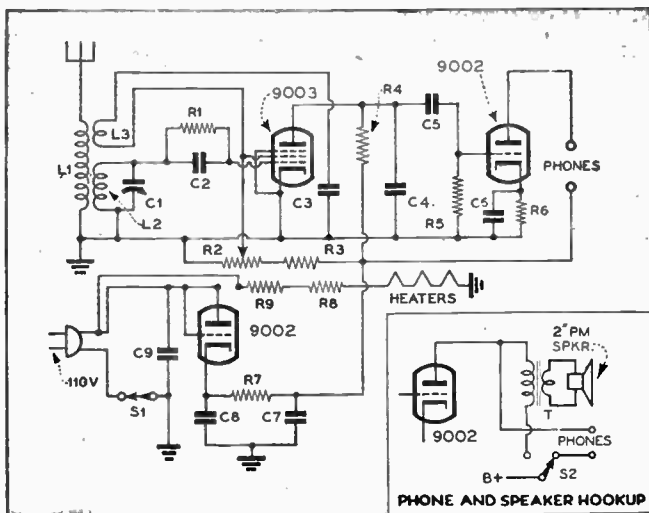
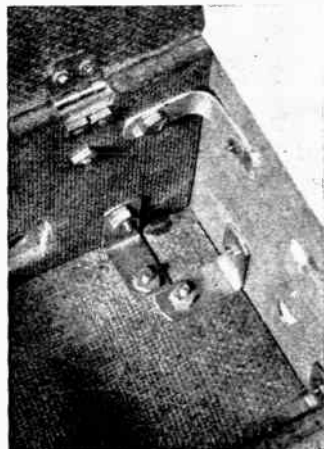

T. R. F. RECEIVER HAS

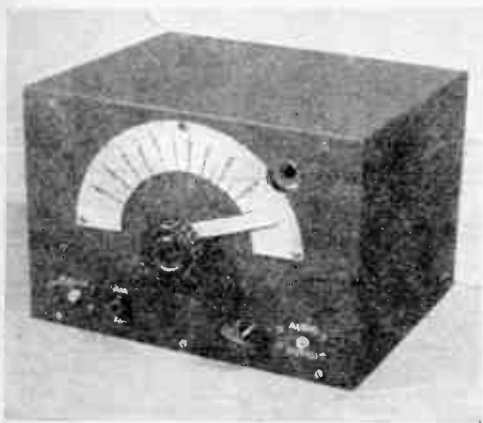

Housed in a trim cabinet, the original receiver had an extra input enabling it to be used with an FM tuner. A tuning eye is located beside the dial

COMBINING automatic volume control and a tuning eye with excellent fidelity, this tuned-radio-frequency receiver will give top-notch local reception when connected to a good amplifier. It will not tune with the critical sharpness of a superheterodyne, but is selective enough for all ordinary purposes. For use with a high-quality A.F. amplifier, or a high-fidelity woofer-tweeter system, the T.R.F. circuit is hard to beat. Whereas superheterodyne receivers can be made to give high fidelity only by elaborate and critical adjustments,

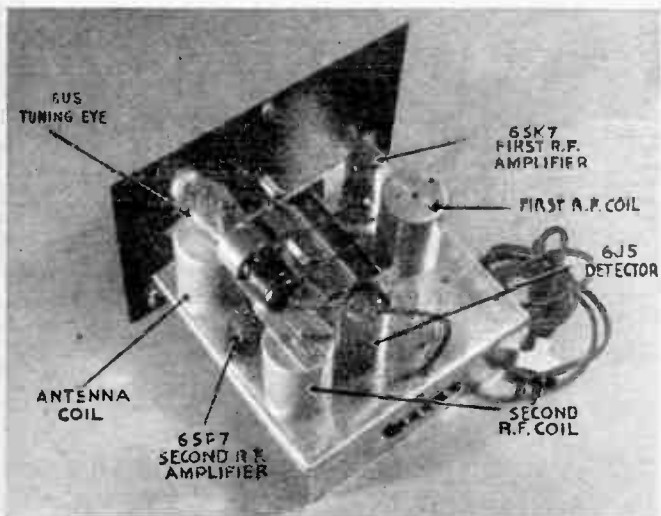

this T.R.F. circuit is simple enough for the beginner to assemble.

Aside from the tuning eye, the circuit requires only three tubes. It can be connected to draw its power from the audio amplifier used with it, or may be built with a separate power pack. The hookup shown uses standard 6-volt tubes; if others are substituted, condenser and resistance values may have to be revised to suit.

A straightforward two-stage T.R.F. amplifier is followed by an infinite-impedance detector, which gives excellent quality without loading the tuned circuits. The 6SF7 tube used as the second amplifier is essentially a pentode identical to the 6SK7, plus a detector diode. This diode is condenser-coupled to the plate of the pentode section to generate the A.V.C. voltage. Since the plate coil section of an R.F. transformer is not tuned, the diode load does not appear on the tuned circuits.

As shown in one of the photographs, the antenna coil, which feeds into the grid of the 6SK7, is across the chassis from it. The first R.F. coil, which feeds into the 6SF7 grid, is across the chassis from this tube, but next to the 6SK7, the plate of which feeds into it. This is sound layout practice. The grid of the 6SK7, as shown in the drawing, is connected to the stator plates of the tuning condenser. Gang condensers have connecting lugs on both sides of the stator frame, so the grid end of the antenna coil is connected by a very short lead to the stator lug on that side, and the 6SK7 by another short lead to the stator lug on its side of the chassis. The same is done with

the first R.F. coil and the 6SF7. Thus the stator plates constitute most of the grid leads. Because the coil associated with each plate circuit is near the tube involved, plate leads also can be kept to minimum length.

Keep all other R.F. leads as short as possible and well protected from each other to avoid excessive feed-back. It's a good trick to use bright-red hookup wire for them, and to place the various by-pass condensers so that they will help block feed-back.

Parts are laid out to minimize R.F. feed-back. All coils are shielded. Both plate and heater current is drawn from the A.F. amplifier used with this tuner

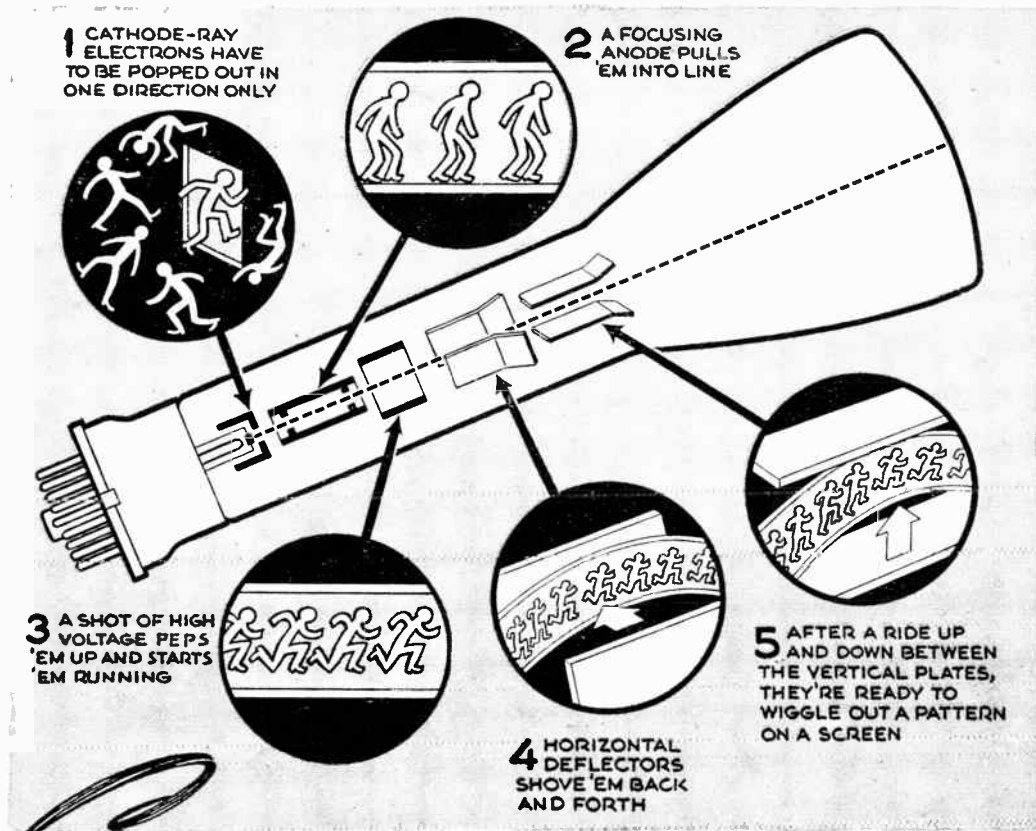

Seeing Eye of Electronics

MOST USEFUL AND VERSATILE OF ALL SERVICING TOOLS, THE CATHODE-RAY TUBE TRACES THE PATHS OF ELECTRONS FOR US

SOME inventions become famous overnight while others seem to lie in storage for years on end, waiting for a chain of pioneers to push them upward into the light.

Cathode-ray oscillography, and, more particularly, the tube that is its eye and brain, falls into this class. Although it was invented nearly fifty years ago, at the outbreak of World War II the cathode-ray tube was still something of a rarity. Of course, the handful of oscilloscopes and television receivers in use all featured the miracle tube, but it remained for a mechanized war to teach us that the seeing eye of elec-

tronics is the practically indispensable gauge of electronic movement—an almost pluperfect meter that can register everything that's measurable and even some things that aren't.

In 1897 Karl Braun, a German physicist, channeled the discoveries and inventions of a number of other scientists by producing an electrostatically controlled tube inside of which electrons could be made to trace a pattern on a fluorescent screen.

It didn't create much of a general stir except among the pioneers in radio, television, and electronics. How did scientists regard Braun's tube? The tip-off is that

in 1909 Braun shared the Nobel physics prize with Marconi.

Considered in only one of its aspects—as a servicing tool—the jobs that a cathode-ray tube can perform are almost endless.

Essentially the cathode-ray tube is a meter. Either as a voltmeter—the more usual test-device form—or as a milliammeter, it uses a practically weightless pointer capable of being deflected with enormous rapidity. The “pointer” can faithfully follow voltage fluctuations at frequencies as high as 200,000,000 cycles a second or react to direct-current potentials.

The “pointer,” of course, is a beam of electrons; it is made visible when the electrons strike the fluorescent coating at the end of the tube. Electrostatic focusing and deflection of the electron beam is common in the test-instrument type of cathode-ray tube, while television tubes employ magnetic focusing and deflection because a somewhat sharper focus can be obtained. When deflection is obtained by the magnetic field of a coil, however, there is an inductance load which tends to limit frequency response. Electrostatic deflectors represent a more nearly pure resistance load and can more readily be driven to very high frequencies. This article deals chiefly with the latter type.

An electron-emitting cathode, surrounded by a metal sleeve with a small opening, is the heart of the cathode-ray tube. The hole serves to define the electron beam and acts as an intensity-controlling grid. Two ring-shaped anodes draw out the electrons, accelerating them to high velocity. Because of the shape of the electrostatic fields between the control electrode and the focusing anode, and between the focusing and high-voltage anodes, the electron beam is drawn, as if shot from a gun, to a pin-point of light at the fluorescent screen, as shown in Fig. 1 on page 64.

Leaving the gun, the electrons move toward the screen at great speed. En route, however, they are pushed and pulled by the deflecting apparatus, causing the spot to move on the screen.



Size isn't everything in cathode-ray television tubes. The smaller one on the right here is far more serviceable than the old-style large tube.

Just beyond the high-voltage anode the deflectors take over. The diagram shows the construction of a tube operated by electrostatic deflection. Two pairs of plates, mounted inside the tube, control the beam. One pair is mounted in a horizontal plane and deflects the beam vertically; the other plates lie in a vertical plane and deflect horizontally. If one plate of a pair is charged positive and the other negative, the beam will bend toward the positive plate—since the negatively charged electrons will be attracted to it—and away from the negative plate. By putting an alternating voltage on the plates they can be made to change from positive to negative and back again as often as the voltage alternates. If the charge is weak, the electrons will be moved back and forth only a short distance; if it is strong, they will swing across the screen from end to end. An alternating voltage applied to the horizontal-deflecting plates, then, will sweep the beam right and left at a rate equivalent to the frequency. The trace of this beam on the screen, however, will appear only as a straight horizontal line (Fig. 2) since each side motion only covers the trace of the preceding electrons.

When a signal is applied to the vertical-deflecting plates, exactly the same effect takes place except that the trace is perpendicular to the horizontal trace, as shown in Fig. 3. If, however, alternating voltages

Sweep voltage generators used in oscilloscopes produce sawtooth waves that build up to a peak and then drop to zero almost instantaneously.



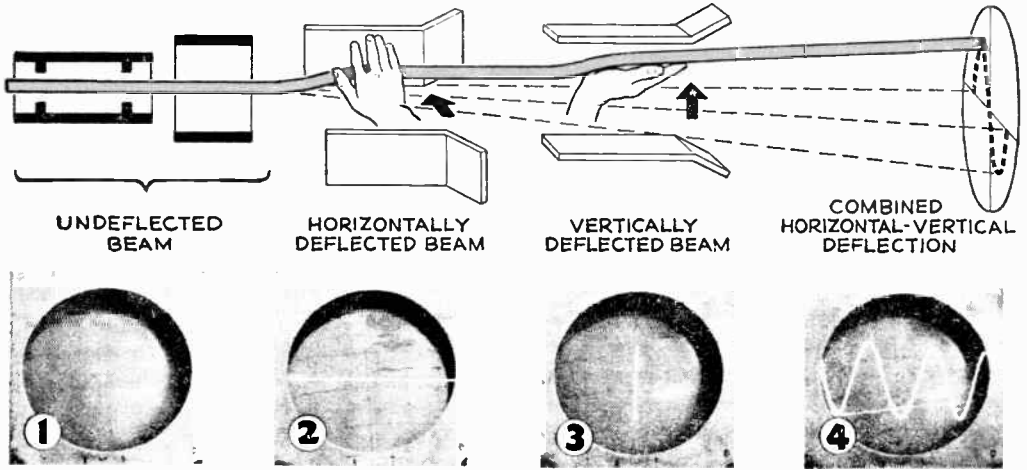
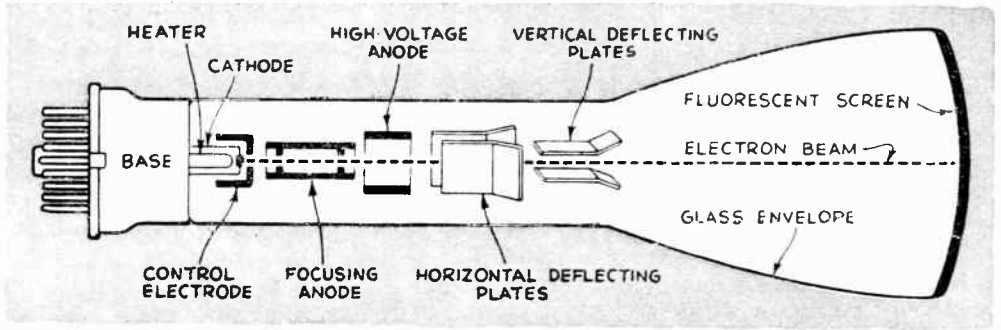

are simultaneously applied to both pairs of plates, so that as the spot moves across the screen it also moves up and down, then the electron beam will trace out a visible pattern (Fig. 4) representing the relationship of the two voltages applied.

The cathode-ray tube itself is rather insensitive. Some with screens 5" in diameter operate with 1,200 to 1,500 volts between cathode and high-voltage anode. When electrons are accelerated by such high voltages, they move with enormous speed. Fairly heavy potentials are therefore needed on the plates to cause adequate deflection. For a standard 5" tube, about 400 volts swing is needed to drive the spot completely across the screen. In checking the performance of a radio transmitter or the power stage of an audio amplifier, sufficiently large voltages are normally available and the tube can be directly connected. But for most work deflection voltages must be amplified, and amplifiers are therefore built into test instruments such as the oscilloscope.

An oscilloscope is a test instrument built around a cathode-ray tube. By means of it you can amplify and feed a signal onto

either the horizontal or vertical deflectors.

Usually the test signal is applied only to the vertical-deflecting plates of an oscilloscope, while horizontal movement is obtained by means of a sweep-frequency generator, which usually operates in direct proportion to elapsed time. At the bottom of page 63 is a picture of a sweep voltage as recorded by the cathode-ray tube; it is obtained by means of an accumulation of a charge on the plates of a condenser connected across a control tube. This charge builds up at a uniform rate, reaches a peak, and discharges almost instantaneously. The "almost" is important because the very slight time required for the spot to return to its starting point introduces some distortion. For most practical uses, however, the fly-back time can be discounted.

Three basic factors account for the immense utility and adaptability of the cathode-ray tube as a test instrument: first, it is a double vacuum-tube voltmeter which gives a direct, visual indication of *instantaneous* voltage. Second, being double, it can indicate the instantaneous value of one voltage while simultaneously indicating the instantaneous value of a second, separate

voltage. Third, comparatively simple electronic circuits can be devised to measure any given quantity, quality, or property in terms of voltage.

This last factor may not look impressive, but its importance is almost beyond estimate. A photoelectric cell readily converts light intensity into voltage; a microphone converts sound-wave pressure into voltage; a Rochelle salt or quartz crystal converts mechanical pressure into voltage; a mechanical setup of a rocking prism, a small motor, and a motor-driven variable resistor can produce a voltage proportional to the color of light allowed to fall on a surface; two small coils and a bar of metal will produce a voltage characteristic of the magnetic properties of the bar of metal, and those magnetic properties are dependent upon the alloy content of the metal, its past history of heat treatment, mechanical treatment, and temperature. The list could be continued indefinitely—in fact, there is no known quantity that cannot be measured in terms of voltage. Humidity, X-rays, oxygen, hydrogen, nitrogen, or the gas content of any sample can be measured electrically. Even the intensity of human emotions can be measured in terms of voltages!

But the cathode-ray tube paints a visible picture of how one voltage varies with respect to another. If the sweep voltage—the one causing the horizontal deflections—is generated by a relaxation oscillator, the spot will move from left to right at a steady rate. The horizontal axis, then, will represent time. If an audio-frequency signal is applied so as to cause vertical deflection, the resultant trace on the screen will be a graph of instantaneous voltage vs. time. This very capacity to compare any two things expressed in terms of volts makes the cathode-ray tube the most universally applicable, the most adaptable, of all servicing tools. Since it is inherently a vacuum-tube voltmeter, it is ideal as an output meter. But since it can both measure the

amplitude of a wave and determine the shape of that wave, unlike ordinary output meters, it can also act as a distortion meter.

By using the cathode-ray tube in conjunction with a frequency-modulated signal generator, set alignment of an accuracy otherwise impossible becomes simple. The horizontal sweep (time) is tied to the frequency modulator in such a way that the horizontal displacement of the spot represents frequency. The vertical sweep is supplied by the output of the audio system of the set under test. If you were aligning the 456-kc. intermediate frequency, the frequency-modulated signal generator would be set to generate 456 kc. plus and minus about 15 kc.

In a properly aligned set, maximum audio-frequency output would appear as the signal passes through 456 kc. In any case, the resultant pattern on the screen is an accurately plotted response curve. Where alignment is incorrect, there may be two, three, or more minor humps. As the trimmers are adjusted, these minor humps are seen to slide along, coalesce, and finally build the properly peaked curve of exact alignment.

An output meter and ordinary signal generator can do fairly well on this job with an ordinary set, but when double-peaked intermediate frequencies are used in broad-band, high-fidelity superheterodynes, the output meter won't do the job. An oscilloscope and F.M. generator are the only team that can properly align an F.M. set.

For tracking down and curing distortion in an audio amplifier, the cathode-ray oscilloscope is the instrument of final authority. With it you can see the distortion. It draws its own portrait, and by its type and form tells you where to look and what type of correction to make.

There is a simplified, small, green-glowing type of cathode-ray tube familiar to most people as the "magic eye." But it's the cathode-ray oscilloscope tube that is the real magic eye. It sees all, knows all, and tells all!

Here's the life story of an electric wave as told by a cathode-ray oscilloscope. Left, the harmonic-rich, highly distorted output of a 50-kc. multivibrator; when filtered, the signal becomes an almost pure sine wave. The greater number of peaks means a slower sweep voltage. When the sweep is lowered still further, we see a filtered but unmodulated R.F. carrier. Last, a 400-cycle signal is impressed on the carrier.

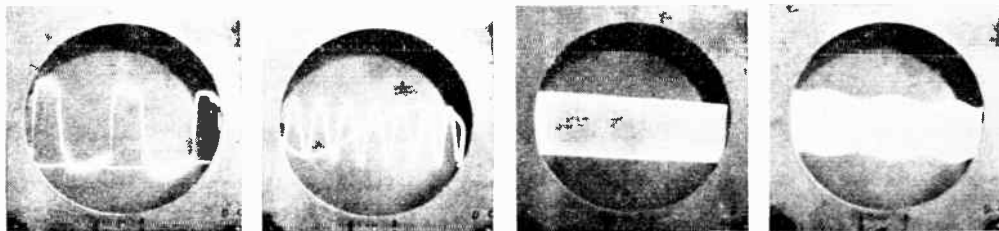

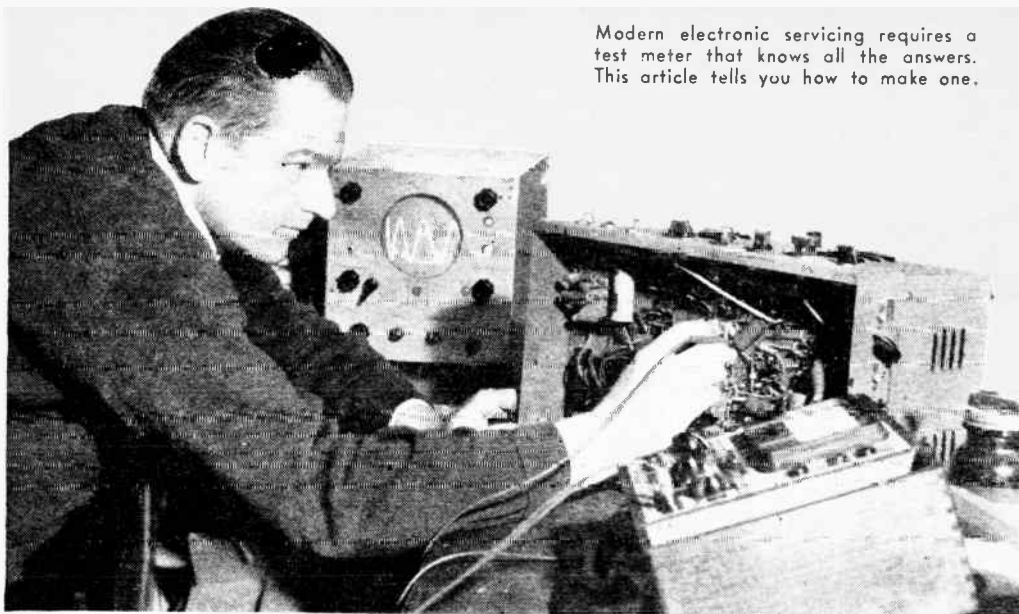

Modern electronic servicing requires a test meter that knows all the answers. This article tells you how to make one.

Building a Cathode-Ray Oscilloscope

THE ONE-INSTRUMENT LAB FOR RADIO SERVICING

NOT long ago, radio servicemen could troubleshoot almost any ailment just by listening to the symptoms. Circuits were —by present standards— relatively simple, and in nine cases out of ten a little sound judgment would quickly suggest the cause of the trouble.

Those days aren't dead yet, but they're dying fast, for two closely connected reasons. The first is that radio engineering has advanced into regions hardly dreamed of a decade ago. Infinitely more complicated circuits offer so many potential trouble spots that it is almost impossible to guess at the cause of poor operation.

Secondly, as an offshoot of better radio design, the public has come to expect quality reception. The old feeling that a radio is all right as long as it plays is giving way to the more critical attitude that a radio should reproduce sound faithfully and well. From a servicing standpoint this means that a cathode-ray oscilloscope has become the key-stone of a good radio lab.

An earlier section of this book (see pages 62-65) discussed some of the jobs that an oscilloscope takes in its stride. Despite the almost superstitious belief that it is a myste-

rious and fearfully complicated thing, a 'scope is easier to set up than a standard all-wave receiver of comparable quality, and costs about as much to make.

As can be seen from the diagrams on the following pages, the complete oscilloscope involves, essentially, five units: horizontal and vertical amplifiers, sawtooth oscillator, power supply, and cathode-ray tube circuit. The cathode follower which helps stabilize the amplifiers need not be counted as a separate part.

Horizontal and vertical amplifiers are simple repetitions of the same basic circuit. Each is essentially a phase-inverter, push-pull power amplifier such as might be used in any radio receiver. But it is simpler, uses fewer parts, has higher gain, and a type of "high-fidelity" response that is completely beyond the ordinary concept of high fidelity. These amplifiers respond equally to *any* frequency from 20 cycles per second right through the short-wave spectrum at 2,500,000 cycles. The 2.5-megacycle band is handled on a flat characteristic; at 10 megacycles the gain has fallen off somewhat, but still shows considerable amplification.

Blocking condensers C1 and C2 are used

to allow study of A.C. waves on a D.C. line. A composite voltage divider, R1, reduces the effect of stray capacitance. The first half of the 6SN7 is used as a cathode follower to minimize loading of the circuit under test; the other half of the tube is a phase splitter of the cathode-follower type, R5 and R6 being equal. Any value between 1,800 and 2,500 ohms will do, but the two resistors should be accurately matched by ohmmeter tests. This setup assures that the plate and cathode will follow accurately any frequency impressed on the grid, yet never impose a load on the input circuit.

The amplifier stage also follows pretty conventional lines for Class A push-pull, except for one feature. It takes voltage to swing the cathode-ray beam, but almost no power. Instead of using a push-pull output coupling transformer, therefore, resistance loads R10 and R11 are used instead. The 6AG7 is a special type of video power amplifier designed for cathode-ray use. It is unique in that it gives high gain although working into a low load resistance.

Low load resistance, here and in the phase splitter, is essential to broad band response because of the unavoidable capacity from wiring to ground. Leads, socket pins—everything associated with the circuit—has some unwanted capacity that acts to shunt high frequencies to ground. It's a small capacity—perhaps only 15 mmfd.—but even that becomes important at 2 megacycles, since it represents an impedance of only a few thousand ohms. If we were to use, say, a 50,000-ohm load resistor from plate to ground, much of the high-frequency signal would be shunted by the capacitance. But with a high-power signal developed across 6,000 ohms or less, the slight shunting is simply swamped, and the desired signal blasts through to the cathode-ray tube.

Similar considerations lead to the need for the unusual gain-control system. The full signal is applied to the grid of the first half of the 6SN7, and the potentiometer R3 in the cathode-follower circuit. All potentiometers have some shunting capacity, so low resistance (2,000 ohms in this case) is used

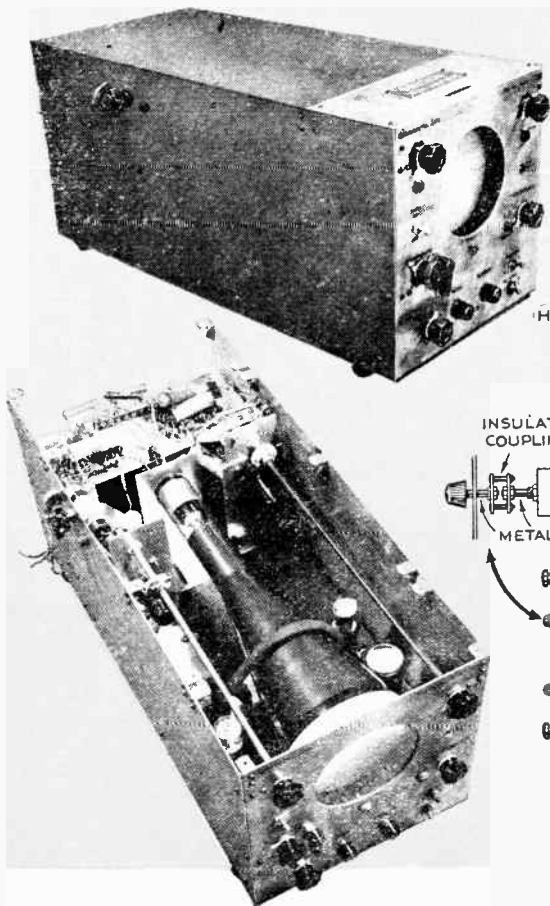

Layout is important on all high-frequency equipment. In order to keep wiring to a minimum, it is necessary to place related parts close together. The drawing shows a recommended arrangement of tube sockets on the subpanel. Note that it differs from the original model shown in the photograph.

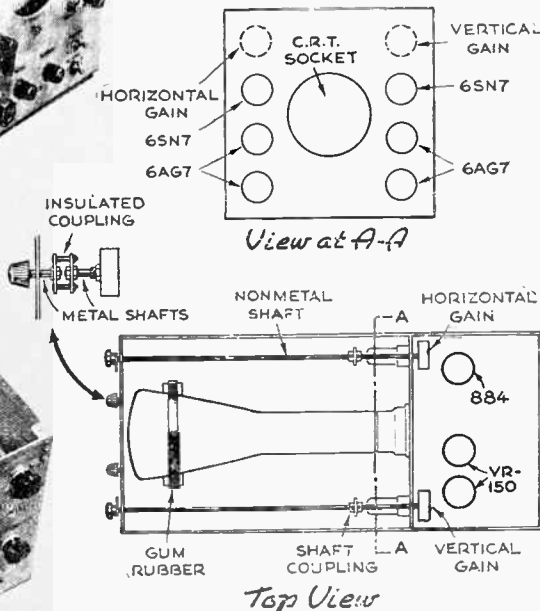

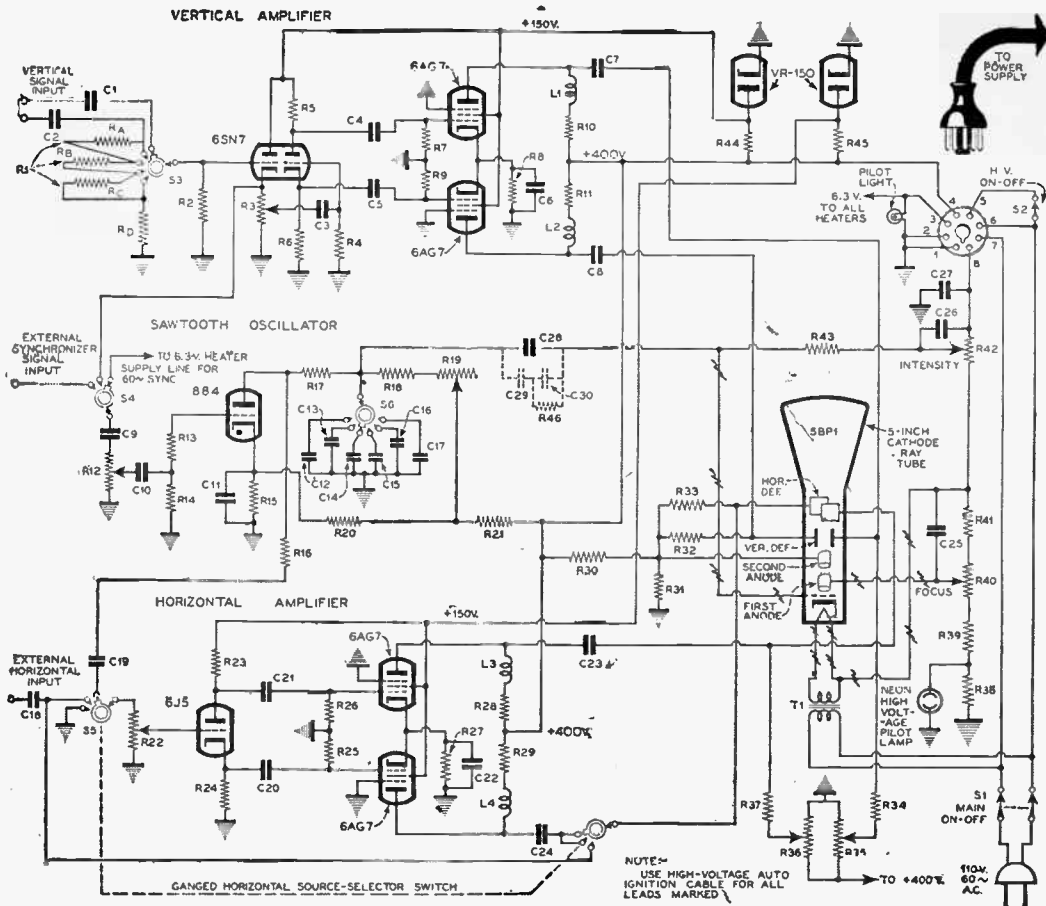

to prevent attenuation of high-frequency signals. But this also means that the cathode follower can't follow signals in excess of about 20 volts. It is in order to boost this range up to about 600 volts that the special voltage divider R1 is used.

The familiar sine wave represents a graph of voltage plotted against time. To reproduce it on an oscilloscope, we must make the horizontal beam move across the screen at a constant rate. Without this horizontal timing movement, any signal that causes a repeated vertical traces, appearing to the viewer as a straight vertical line.

To give visible motion to the cathode-ray beam, therefore, it is necessary to produce a voltage that will rise at a steady rate, causing the spot to move steadily from left to right, and return from maximum to zero almost instantaneously. A circuit producing such a wave is called a sawtooth oscillator.

In this oscillator, voltage is fed into one of the condensers in the bank C12—C17 through the high resistance of R18 and R19. This voltage gradually builds up across the condenser, and also across the gas-type triode 884. When the voltage reaches a critical value, the gas in the tube breaks down

and suddenly becomes an excellent conductor. The full potential discharges through the 884, whereupon the tube relapses into a nonconducting state, and the charge again begins to build up across the condenser.

The frequency with which this trip-hammer discharge takes place depends on several factors: how large a condenser is used (which is why five choices are given), how fast voltage is fed into the selected condenser by varying R19, and how many volts must be developed across the tube before it fires. This last factor is controlled by the tube's grid bias, which is supplied by the voltage divider consisting of R15, R20, and R21, and by signal voltage through S4.

Keeping the beam visible on the fluorescent screen requires that horizontal and vertical movements be synchronized. The trace moves from left to right, jumps back, and starts again from the left. Since the same trace moves both ways, it will be visible on its return trip unless a blanking circuit is used. This consists of R43 and C28; because a 50-mmfd., 2,000-volt capacitor may be hard to get, an alternative circuit is indicated by the dotted lines. In this setup, substitute C30 for C28, and connect it in series with C29 and in parallel with R46.

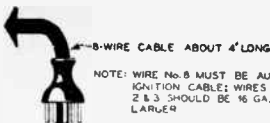

NOTE: WIRE No. 8 MUST BE AUTO IGNITION CABLE; WIRES Nos. 2 & 3 SHOULD BE 16 GA. OR LARGER

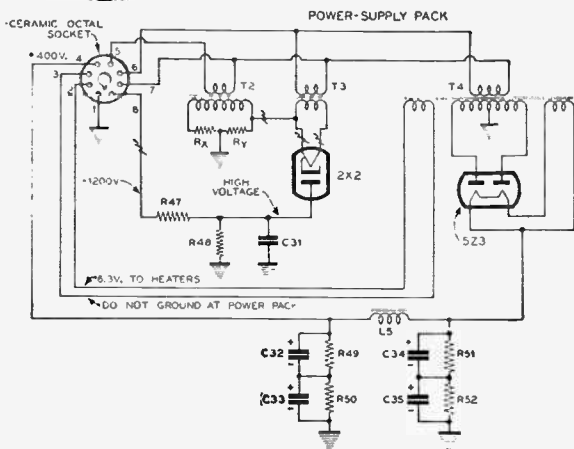

LIST OF PARTS

All condensers 600 volts unless otherwise noted.

- C1, C3, C7, C8, C18, C19, C23, C24, C25, C26: .1 mfd.
- C2: 2 mfd., 2,000 volts or highest voltage available.
- C4, C5, C10, C20, C21: .25 mfd.
- C6, C22: 20 mfd., 25 volts, electrolytic.
- C9: 5 mfd.
- C11: 25 mfd., 25 volts, electrolytic.
- C12: .25 mfd., 400 volts.

- C13: .05 mfd., 400 volts.
 - C14: .005 mfd., 400 volts.
 - C15: 1.500 mmfd., 400 volts.
 - C16: 250 mmfd., 400 volts.
 - C17, C30: 50 mmfd., 400 volts.
 - C27, C31: 1 mfd., 1,500 volts, oil-filled paper.
 - C28: 50 mmfd., 2,000 volts.
 - C29: .001 mfd., 2,000 volts.
 - C32, C33, C34, C35: 16-mfd., 450-volt, electrolytic filter condensers.
- All resistors 1 watt unless otherwise noted.

R1: composite voltage divider, consisting of 3-watt resistors: R_a, 10,000 ohms; R_b, 2,500 ohms; R_c, 1,200 ohms; R_d, 500 ohms.

- R2, R4: 2 meg.
- R3: 2,000-ohm pot.
- R5, R6, R13, R23, R24: 2,000 ohms.
- R7, R9, R25, R26, R30, R31, R38: 250,000 ohms.
- R8, R27: 50 ohms, 2 watts.
- R10, R11, R28, R29: 6,000 ohms, 10 watts.
- R12: 5,000-ohm pot.
- R14: 40,000 ohms.
- R15: 1,500 ohms.
- R16, R32, R33, R34, R37: 1 meg.
- R17: 25 ohms.
- R18: 400,000 ohms.
- R19: 5-meg. pot.
- R20: 80,000 ohms.
- R21: 60,000 ohms.
- R22: 2-meg. pot.
- R35, R36: 1-meg. pot.
- R39: 700,000 ohms, 2 watts (two 350,000 ohms, 1 watt in series).
- R40: 500,000 ohms, 2-watt pot.
- R41, R43, R49, R50, R51, R52: 100,000 ohms.
- R42: 250,000-ohm pot.
- R44, R45: 8,000 ohms, 10 watts.
- R46: 10 meg.
- R47: 20,000 ohms.
- R48: 5 meg.

R_r, R_v: To be determined by trial; see text. If T2 is a standard 3,000-volt neon-tube trans., R_r equals 100,000 ohms, 8 watts, and R_v equals 1 meg., 2 watts.

L1, L2, L3, L4: one pie from standard four-pie, 2.5-mh. R.F. choke.

L5: power filter choke, 200 ma., 10 h., or larger.

T1: 115-to-6.3 volt trans.; 5,000-volt insulation.

T2: 115-to-1,000 volts or more.

T3: 115-to-2.5 volt trans.; 5,000-volt insulation.

T4: standard 200-ma. power trans.; 115 to 6.3, 50, and 425-0-425.

S1: D.P.S.T. tumbler.

S2: S.P.S.T. toggle.

S3: 5-position selector; preferably low-loss ceramic.

S4: 3-position selector.

S5: 3-position D.P. selector.

S6: 6-position S.P. selector.

Tubes, sockets, and accessories as noted.

Healthy voltages are needed to drive the spot across the screen, and call for a 200-milliamp. power supply capable of delivering a full 400 volts under load. If you can get transmitter-type filament transformers with 3,000-volt insulation you can save yourself the job of rewinding heater transformers for the 2X2 and cathode-ray tube.

This can be done, however, in a single evening's work on two small, standard 6.3-volt transformers. Taking out the core stack you will find the 6.3-volt winding outermost. Remove this winding, counting the turns. Wind two layers of 5,000-volt insulating cambric over the primary, and, for T1, replace the 6.3-volt secondary. Put another

Block Diagram of Cathode-Ray Oscilloscope

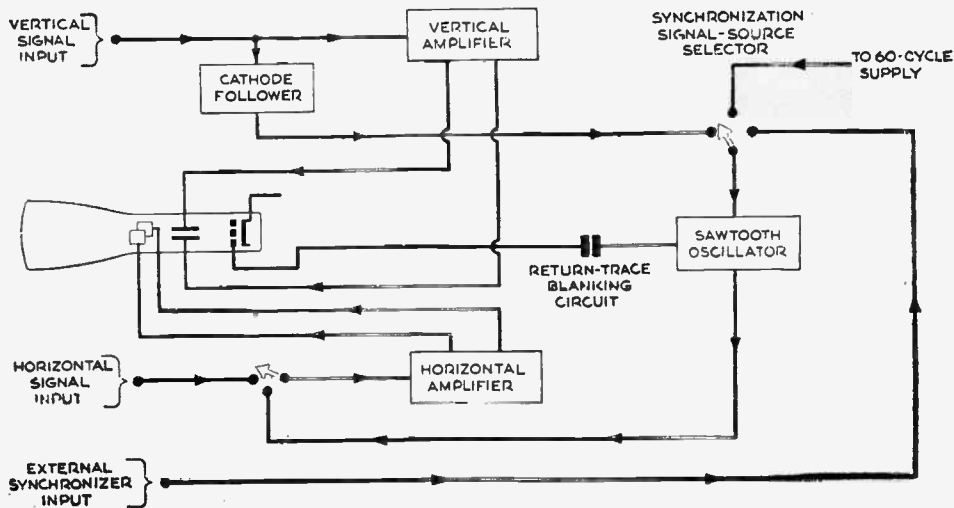

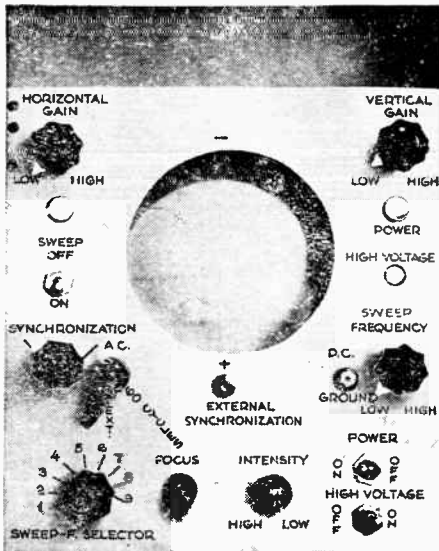

A focused beam without amplification.

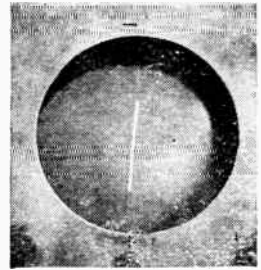
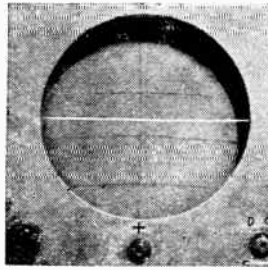

Since the oscilloscope is an enormously sensitive test instrument, it needs many controls. A useful panel arrangement is indicated at the left. The three views at the right illustrate the operation of the three amplifiers. Horizontal and vertical signals are shown above; the lower picture shows a vertical signal timed by a horizontal sweep.

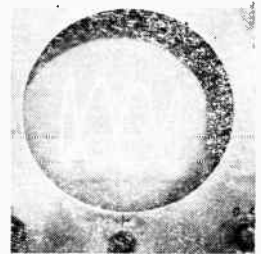

double layer of cambric over this, and replace the core stack. The 2X2 transformer (T3) is processed in the same way except that only 25/63 times the number of turns is replaced in the secondary.

The high-voltage transformer can be any convenient one giving 1,000 volts R.M.S. or better. A small neon-sign transformer is likely to be the cheapest and easiest to obtain; it will work nicely in conjunction with a voltage-divider system Rx and Ry as shown. Values of the resistors will have to be determined by trial measurement on the finished oscilloscope. Use different resistors until an output voltage of 1,200 volts negative to ground is obtained across C31 with the high-voltage neon pilot light removed.

Since the busy end of the cathode-ray tube is nearly 18" behind the front panel, the amplifier circuits should be located at the back. Horizontal and vertical-gain potentiometers should be mounted on the subpanel carrying the amplifiers and cathode-ray tube socket. Use long plastic rods to drive the potentiometers from the front panel. Horizontal and vertical input jacks should be placed on the side of the oscilloscope, and the selector switch (S5) for horizontal inputs should also be placed at the side rear.

If the 6AG's are mounted horizontally as suggested by the drawing on page 67, care

should be taken to install the sockets so that pins 2 and 7 are in a vertical plane.

Note that the focusing and intensity control potentiometers (R40, R42) run nearly 1,200 volts negative to ground. But these potentiometers aren't ordinarily insulated to withstand thousand-volt strains—and neither are you. Mount them on a bakelite sub-panel and join the shafts with insulated couplings. While the insulation stands up, both you and the oscilloscope are safe. But if it should break down, the metal shaft will cause the cathode to short out to the chassis. It will be an expensive breakdown, to be sure, but at least you'll still be around to make the repair.

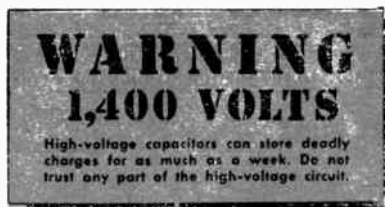

Condensers C25 and C26 also run at very high potentials. Make sure they are supported where

they can't touch ground. Use high-voltage auto ignition cable for all leads marked with a spark symbol in the diagram.

When working on the oscilloscope, its power supply, and especially the high-voltage supply, remember that you are handling sudden death. Electrons are quicker on the draw than you are, so don't depend on your agility to make adjustments with the power on. Engineers, radio hams, and power-line workers live with the stuff because they respect it and never trust it.

They've got the right idea.

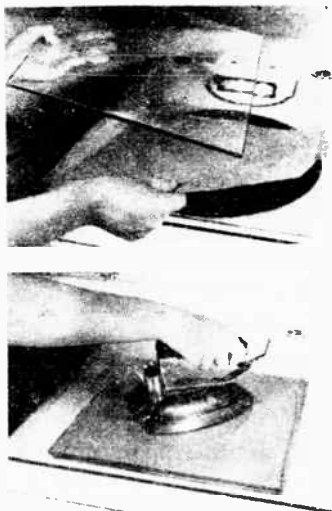

WARPED PHONOGRAPH RECORDS that slip against other records on an automatic changer can often be straightened simply by placing them between glass and leaving them in a warm place for a few hours. Use two scrap pieces of plate glass at least 12" square and lay a sheet of paper between each surface of the record and a glass to avoid damaging the grooves. Put a weight, such as an electric iron, on top. A shelf over the kitchen range, or some similar spot, should provide sufficient warmth to take out the bend.

Occasionally a record so straightened will retain a slight curve that permits the convex surface to slip. This can be corrected by repeating the straightening operation with a 4" circle of heavy paper or thin cardboard on the center of the convex side.

Slipping usually occurs when a record is so warped that the drag of the needle is greater than the drag of the record on the one below it on the automatic changer. Two adjacent records in a set may be warped and still fit together in such a way that they do not slip. In such a case straightening is unnecessary.—WILLARD ALLPHIN.

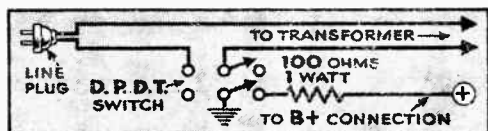

SAFETY CAN BE ASSURED in working with experimental high-voltage electronic equipment by incorporating a double-pole double-throw switch in the circuit, as shown in the diagram above, instead of the customary line switch. This acts on the same principle as the more expensive and hard-to-obtain interlock switches, permitting the condensers to discharge automatically when the switch is thrown over. The resistor is added to prevent excessive sparking at the contacts. Since the discharge takes place in a matter of milliseconds, a 1-watt resistor is adequate.—GEORGE O. SMITH.

SHORTS IN A CONDENSER, such as are apparent when a radio goes dead over part of the dial, can be traced quickly by rigging up a homemade tester consisting of two dry cells and a door buzzer. Disconnect the stator leads and connect the cells and buzzer in series with one section of the condenser at a time, as shown below. Then slowly rotate the condenser back and forth, watching the segments closely. A short will show up as sparks between the plates, which can then be straightened.—OTTO H. MILLER.

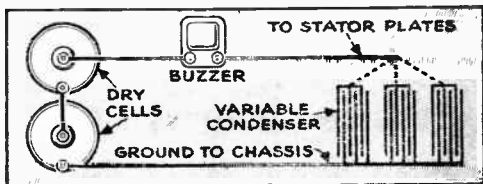

MEASURING IMPEDANCES

[ELECTRICAL]

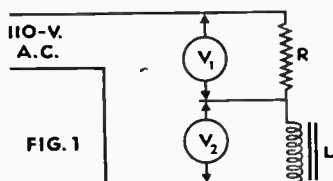

FIG. 1

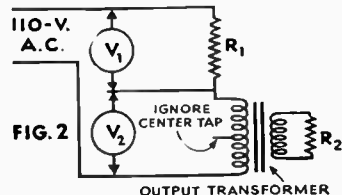

FIG. 2

With the aid of an ordinary A.C. voltmeter, it is fairly easy to measure the actual impedance value of chokes, output transformers, and large paper condensers. If you have an inductance-capacitance-impedance frequency chart, the impedance measurements so determined can be converted to henries or microfarads.

In Fig. 1, R is a known resistor approximately equal to the impedance of the inductance but, to prevent overheating, not less than 2,500 ohms, while L is the element to be measured. Read V_1 and V_2 with the A.C. voltmeter; then use the following formula:

$$\text{Impedance of L in ohms} = \frac{R \times V_2}{V_1}$$

If R is 4,000 ohms, V_1 is 88 volts, and V_2 is 22 volts, then $L = \frac{4,000 \times 22}{88} = 1,000$ ohms.

When impedance readings are to be on a transformer, the secondary must be loaded with a resistor of the value of the speaker voice coil normally used. The correct pair of secondary taps to match an 8-ohm speaker to a required output can be determined by measuring the impedance of the transformer with an 8-ohm resistor across different secondary taps.

In Fig. 2, R_1 is a known resistor approximately equal to the impedance of the transformer but, to prevent overheating, not less than 2,500 ohms, and R_2 is a resistor equal to the impedance of the normally used speaker voice coil. For push-pull transformers, use the two plate taps and ignore the center tap. Then, as with chokes, read V_1 and V_2 and use the following formula:

$$\text{Impedance in ohms} = \frac{R \times V_2}{V_1}$$

If R_1 is 8,000 ohms, R_2 is 8 ohms, V_1 is 60 volts, and V_2 is 50 volts, then impedance = $\frac{8,000 \times 50}{60} = 6,666$ ohms.

Worn-Out Tubes Are Salvaged As Rectifiers with Few Changes

RADIO tubes that drop off in efficiency or introduce unwanted noises into the receiver may have to be replaced even though they are not actually burned out.

Many such tubes can be reused as rectifiers by reducing the effective number of circuit elements to the two found in a simple diode.

Some tube types, illustrated at the right, can be converted by means of the changes shown. The beam-forming plates of the L6 series of amplifiers have been omitted since they are not affected by the changes. In some cases it may be necessary to insert a voltage-dropping resistor in series with the filament.—WALTER ANDERSON.

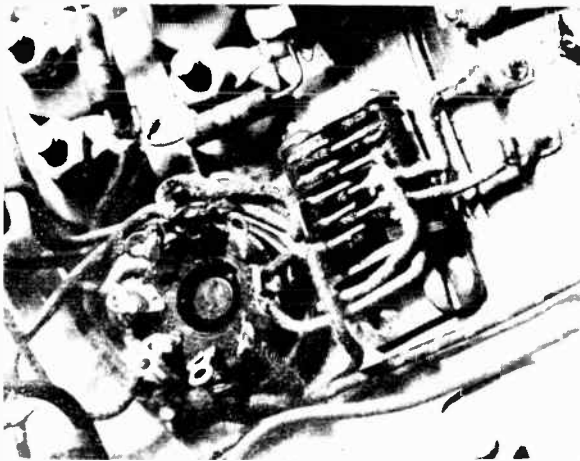
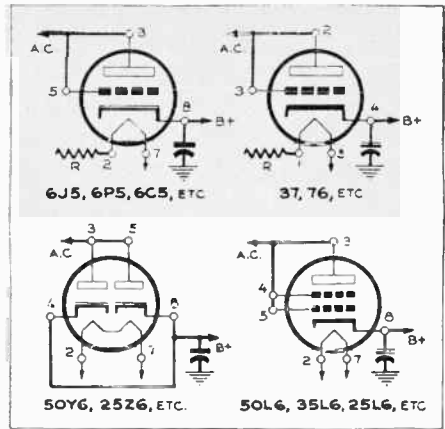

Copper-Oxide Rectifier Used for Bias Voltage

BIAS voltage may be obtained in certain types of equipment by lifting the filament line from ground and installing a copper-oxide rectifier. Conventional cathode-resistor bias is ineffective in circuits where plate current either doesn't flow or is intermittent—for example, relay or photocell hookups—and a voltage divider may cut the plate current. A rectifier across the filament is, in effect, a small power-supply bias that does away with the need for an extra D.C. source to serve this purpose.—GEORGE O. SMITH.

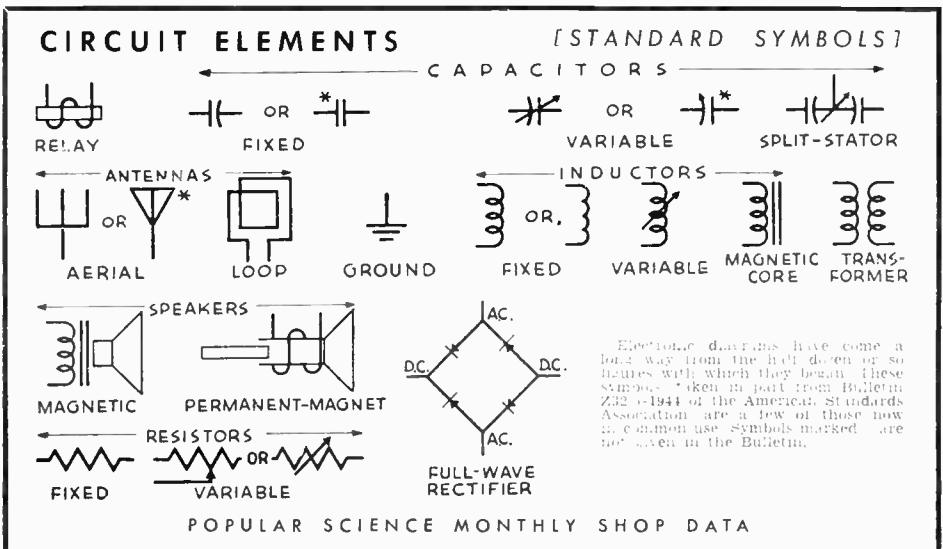

Servicing Your Radio

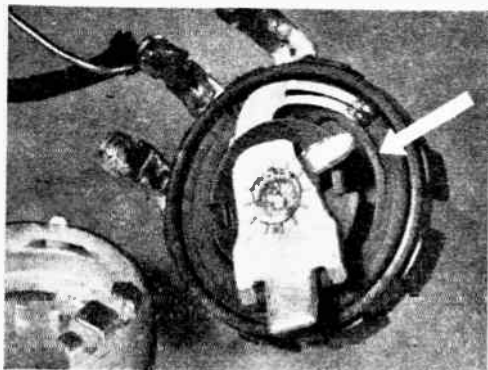

NOISY OR ERRATIC performance may result if there is pitting in the resistance element of a carbon-strip potentiometer, above, often used as a volume or tone control. The pitting, which develops after use or where the unit must carry appreciable current, occurs directly under the curved path of the movable contact finger. A satisfactory repair can be effected by bending the movable contact radially, either in or out, so that it travels along a fresh track on the carbon strip. Controls having two or more contact fingers will work for a time with only one, so if a new path cannot be obtained, remove the finger that rides along the pitted path.—GILBERT R. SONBERGH.

HIGH-VOLTAGE LEAKS within a condenser can be quickly located with just an ohmmeter or voltmeter and a B-battery. The same method will measure unknown high resistances on the order of 10,000 megohms.

To test the resistance of a condenser, connect it as at A, close the circuit for an instant, and then open it. The meter will kick. If the condenser were perfect, remaking the circuit would not cause the meter to budge. In practice, a .02-mfd mica condenser in good shape won't show a second meter kick after a delay of a minute, though a good paper condenser may lose its charge in a few seconds. Comparative tests with similar condensers known to be good will tell whether a specific condenser is good, fair, or poor.

RESISTOR BRIDGES, or chains of fixed carbon resistors, have numerous test uses. Below is shown how five 1-megohm resistors were connected to measure a 10,000-volt power supply with a 5,000-volt voltmeter. They were connected across the power supply to simulate its normal load and the voltmeter was then connected across one of the resistors. The true voltage was somewhat more than five times the reading because of the voltmeter draw, but this factor can be neglected with most testing meters.

Another use for this improvised voltage divider is for securing accurate low A.C. test voltages sometimes required as a signal input. To obtain .1 volt, for example, use 10 resistors of equal value across a 1-volt 60-cycle source.—G. R. S.

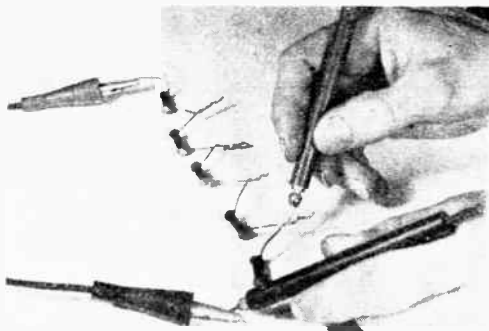

Approximate values of resistors can be determined as at B. By comparing the meter deflection after a timed wait when the condenser is shunted across an unknown resistor with that obtained from a known one, you can gauge the unknown value.

Insulation resistance can be checked by the method illustrated at C. A 1 or 2-mfd. oil-filled condenser may show a substantial charge after eight hours if in good condition. Give one of this type a charge of several hundred volts from a B power supply, and connect it across the insulation to be checked. If the condenser alone gives a healthy meter kick after eight hours, but in the circuit loses its charge in five minutes, the insulation leaks badly.—J. W. C. JR.

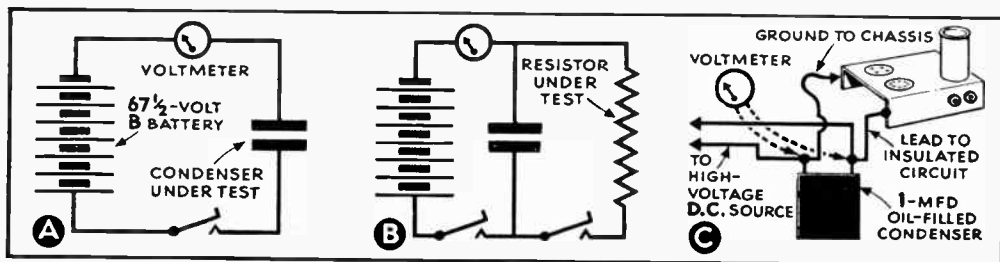

HEAVY-DUTY CHOKE-INPUT POWER PACK

Servicing Your Radio

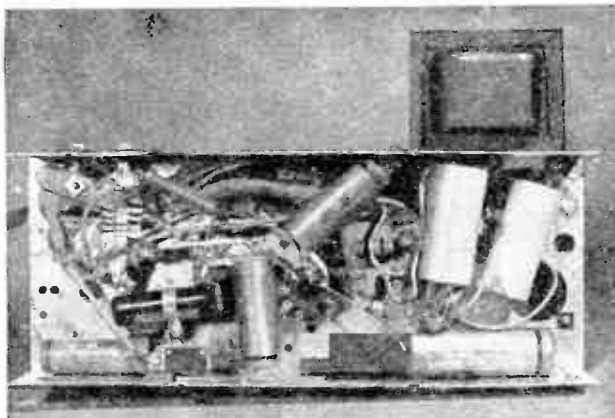
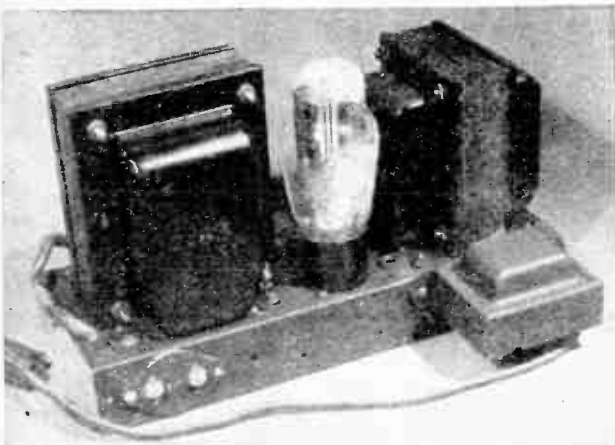

In the rear view of the power pack, the transformer is at left and the two chokes at right, the second being the one on the side. Wiring is shown in the view from the bottom.

mercury-vapor rectifier tube is used. This type of filter gives better voltage regulation than those of the condenser-input type, showing less voltage drop when a heavy current demand is placed on it.

Two .01-mfd. condensers from the plates to ground cancel the annoying hums that are sometimes caused when the R.F. circuits are modulated by the power supply at certain frequency settings while the detector is oscillating. If A. C. hums are encountered, add .25-mfd. condensers across each side of the power line and from the 6.3-volt heater leads to ground.

If the speaker you use is one of the many of the electrodynamic type employing a powerful electromagnet instead of a permanent magnet, you may connect its field coil for use as one of the choke coils in the power pack. This expedient permits the coil to function in two ways, since it will also provide the necessary magnetic field for the speaker. For use on other sets, the power pack will require two chokes.

The parts are arranged on a metal chassis with the second choke screwed on one side to allow for greater compactness. An octal socket is used for the outlet connections, while a discarded octal-tube base makes an excellent plug for the outlet cord for the receiver-tube filament voltages and high-voltage taps. Less flash back on starting, but poorer voltage regulation, is possible with a 5Z3 or 5U4 tube.

WHERE you find replacement of a power pack difficult, or have trouble with blowouts on a condenser-input filter, this rugged power pack, constructed of salvaged parts and capable of delivering 300 watts at 250 milliamp., will give excellent service. It will also provide a well-filtered source of power for a short-wave receiver. The unusually high current rating provides plenty of current for power stages.

Good voltage regulation is assured by the choke-input filtering feature, which also will prevent the high peak voltages that sometimes blow out even 450-volt condensers when a

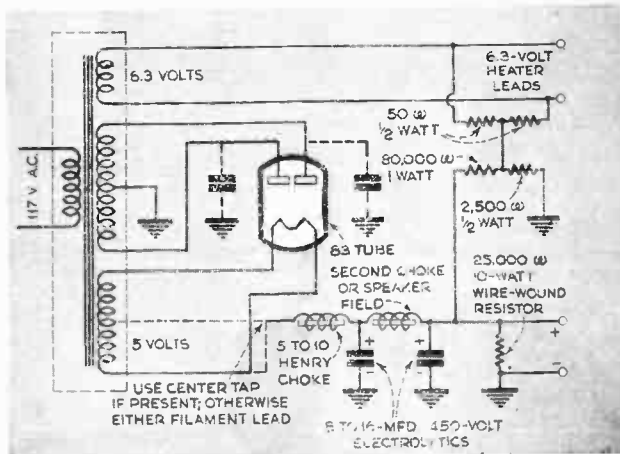

Hidden Mounting Brackets Fasten Small Radio to Wall

ALL too often a small radio ends up at the wrong side of a room because there's no table space available where you want it. This problem can be overcome by the hidden wall bracket shown here, which also helps to give little radios a modern, "built-in" look. Its cost is negligible.

Before hanging your radio, be sure that the cabinet is sound and the joints are in good condition. Screw two angle brackets to the wall as shown. Finishing nails or small wood screws driven through the top of the cabinet will keep it from sliding off without preventing you from lifting it off when desired. Cut off the ends of the nails. H. D. POST.

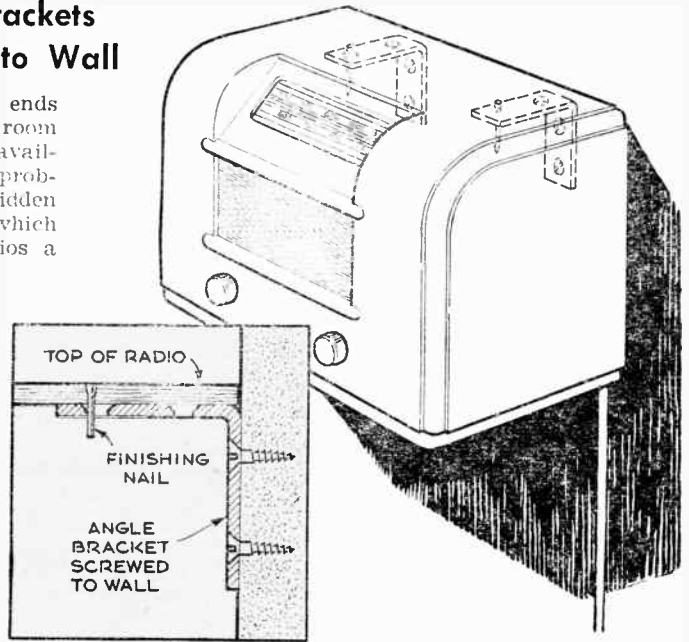

Terminal Strip Helps Experimenters in Testing New Circuits

RADIO experimenters who have to stretch available equipment can adapt a home radio set to supply current at different potentials for a variety of test instruments or "add-on" circuits. Six connections brought out to a terminal mounting strip at the back of the chassis will make it unnecessary to remove the set for every new experiment.

Connect the terminal points to the circuit element indicated in the drawing. Shield the No. 4 connection and hook it to the un-

grounded side of the volume control that connects with the A.F. input to the audio amplifier. Check your radio before making this connection, since not all volume controls are suitable for this use. For a handy continuity and condenser tester, attach a pair of prods in series with a neon lamp as shown. A record player may be connected to Nos. 1 and 4, or a complete crystal-microphone preamplifier can be fed directly into the power output stage.—E. E. YOUNGKIN.

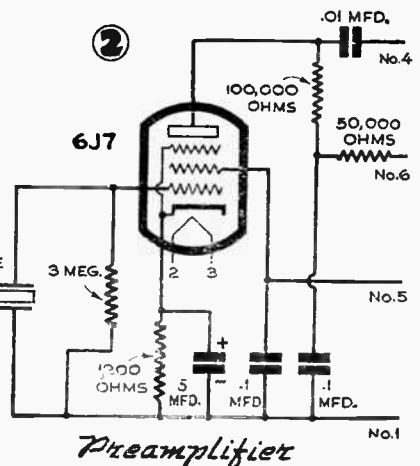
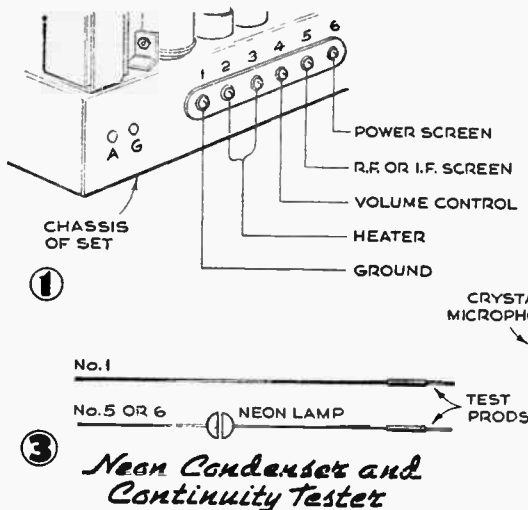

WHAT TO DO ABOUT INTERMITTENT RECEPTION

"Servicing Your Radio"

RADIO servicemen and home mechanics are often hard put to find the cause of intermittent or fading radio reception. A receiver working perfectly one minute may drop in volume or fade away completely the next, perplexing the repair man no less than it exasperates listeners. Banging the cabinet, flicking the switch, or simply walking heavily across the room will often jar the radio back to life, but this is only a temporary expedient, and the reception is sure to fade again later on. In the following instances several of the more common manifestations of such trouble were traced to their source, and lasting remedies were applied.

A small A.C.-D.C. five-tube superheterodyne was afflicted with abrupt increases and decreases in volume. The fluctuations usually occurred when house lights were turned on or off. It was found that the .05-mfd., 400-volt tubular condensers in the grid returns of the A.V.C. tubes (Fig. 1) were faulty. These had to be replaced.

Similar trouble was experienced by the owner of a set that could be stirred into renewed operation only by snapping the on-off switch or turning on a house light. After all tubes were checked, it was discovered that reception could be restored by touching the plate leads of the first detector or converter tube, or the IF leads or oscillator-tube leads. This led to the trouble being traced to a defective detector-cathode by-pass condenser (Fig. 2).

Frequently intermittent reception is due to a faulty coupling condenser in the grid circuit of a power-pentode tube (Fig. 3), such as a 50L6 or a 43. This causes a radio to lose volume suddenly. The fault can be corrected only by replacing the condenser, which usually has a value of .05 mfd., 400 volts.

Intermittent reception is also often caused by dirty wave-band switches. Hardened flux or grease may accumulate on the contact points, which can be easily cleaned with carbon tetrachloride and a small cloth or toothbrush, as shown in the photo. Even if a switch tests O.K. on 110 volts, it will still cause intermittence if the contacts are not clean.

Radios with weak or noisy reception may owe their eccentricity to corrosion of R.F. or I.F. grid-return leads at the chassis. These points should be carefully inspected. Usually it is best to install a common ground wire and connect grid returns to it.



Dirty wave-band switches often cause intermittent reception. Clean them with carbon tetrachloride.

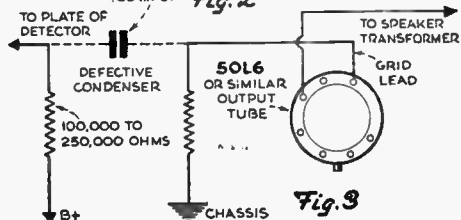
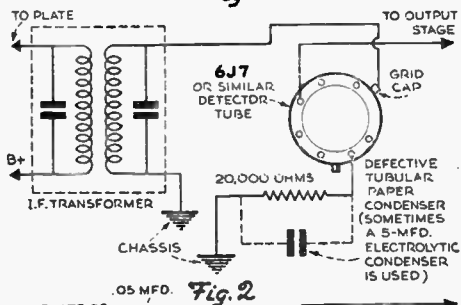
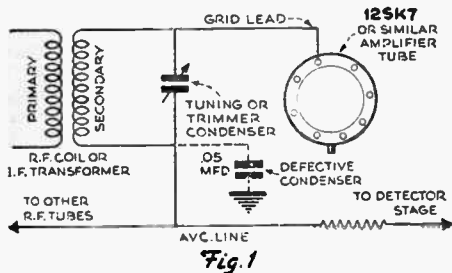



Improving

SMALL THINGS CAN MAKE

By Tracy Diers

OWNERS of inexpensive record players often content themselves with lower standards of performance than they would like because of the belief that price and quality have to go hand in hand. Generally speaking, that's a sound rule, but it doesn't mean that the performance of such phonographs can't be improved.

Defects inherent in many players can be corrected at least in part. Among the most

common faults are A. C. hum, motor vibrations, "wows," and distortion of high-volume passages.

While this article deals only with adjustments that can be made in the record player, a few things should be known about the amplifier with which it is used—in most cases the output stage of a home radio. Most important, of course, is the question of whether it is the radio that is causing the disturbing background hum. If your radio doesn't have a separate ground lead, it is probably of the voltage-doubler type and should not be grounded. In most cases, however, an amplifier or radio will be used that has a ground connection, and this should be securely connected



Before attempting to eliminate background hum from the record player, be sure that the trouble doesn't originate in the radio amplifier. A 100,000-ohm resistance will simulate the pickup impedance.

Good grounding is important to humless reception. If an ohmmeter test of the pickup case shows an imperfect ground, solder one end of a piece of wire to the holding nut, the other to the cable shield.

Hum may be caused by the A.C. field put out by the motor line cord. Separate it from the pickup cable.

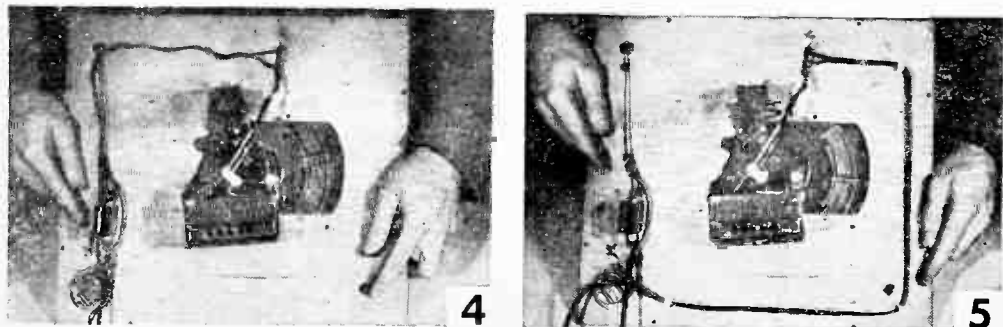

Low-Cost Record Players

A BIG DIFFERENCE IN THE QUALITY OF YOUR PHONOGRAPH

to a water pipe, steam radiator, or the like.

Remove the phonograph plug and replace it with a 100,000-ohm resistor to serve as a dummy load. Turn the volume up to the usual point and note the hum level. If it is very pronounced, then you must seek the trouble in your radio; if not, remove the resistor and reconnect the record player. With the motor turned off, but the volume up to its customary level, listen again for hum. Whatever increase you now hear may be put down to the record player. The trouble may be of either inductive or mechanical origin.

Connections between pickup and amplifier are one source of induced hum. If ordinary wire was used, replace it with shielded cable

and ground the shield. To make sure that the pickup case is effectively grounded, touch one prod of an ohmmeter to the ground pipe and the other side to the pickup case (Fig. 2). A perfect ground will give a meter reading close to zero ohms; if it is higher, ground the case as shown in Fig. 3.

Now listen again for hum in the speaker, first with the motor off. As you turn it on, you should hear a click in the speaker, but no hum. If you do hear hum, reverse the line-cord plug.

Still no improvement? Perhaps the motor is putting out an A.C. field that is being picked up by the shielded cable. A motor line cord that runs parallel to the pickup cable (Fig. 4), should be separated as shown

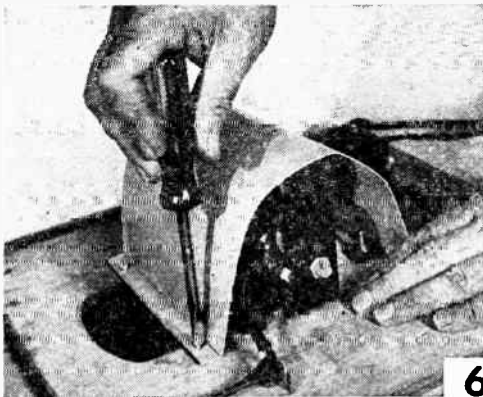

Sometimes the magnetic field set up by the motor persists even with all leads properly grounded. Should this happen, shield the motor with a thin sheet of any magnetic metal and ground the shield.

To eliminate mechanically caused hum, vibrations transmitted from the motor to the record must be damped somewhere along the line of travel. A piece of heavy felt glued to the turntable may help.

Used with the bolts that hold the motor to the mounting board, rubber sleeves will absorb some vibration.

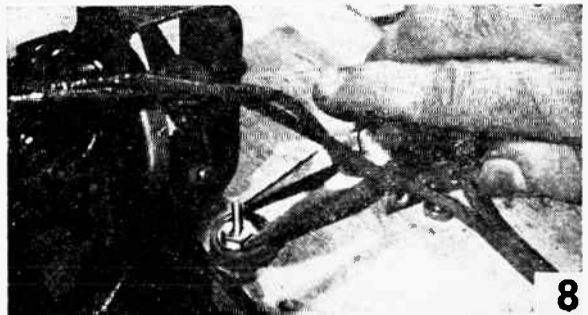
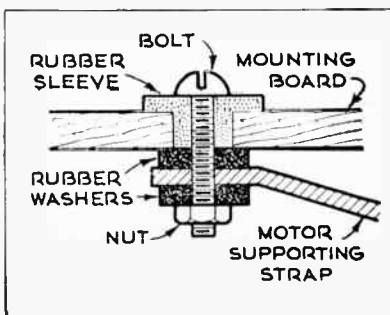

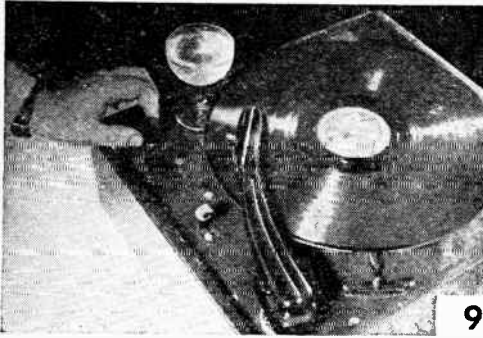

9
The water test, above, shows if motor vibrations are still being transmitted to the pickup. One common cause of "wows" is fluctuation in the line voltage. A voltmeter across the line (right) will show a dip or rise at the time the music quavers.

in Fig. 5. Better still, replace the line cord with a shielded two-conductor cable, and ground the shield.

Despite all these precautions, induced hum may still continue to ride through. One measure that still remains is to bend a sheet of iron or similar magnetic material around the motor as shown in Fig. 6.

There seems to be a perverse force in life that always manages to put the thing we're looking for at the bottom of the pile. So don't be too surprised if none of these improvements quite turns the trick. There's a pretty good chance that the trouble is not inductive at all, but mechanical.

Mechanically caused hum usually originates within the laminations of the motor itself, and works upward through the shaft to the spindle and turntable. Once in a while it is possible to eliminate the trouble by tightening the laminations. More often, it

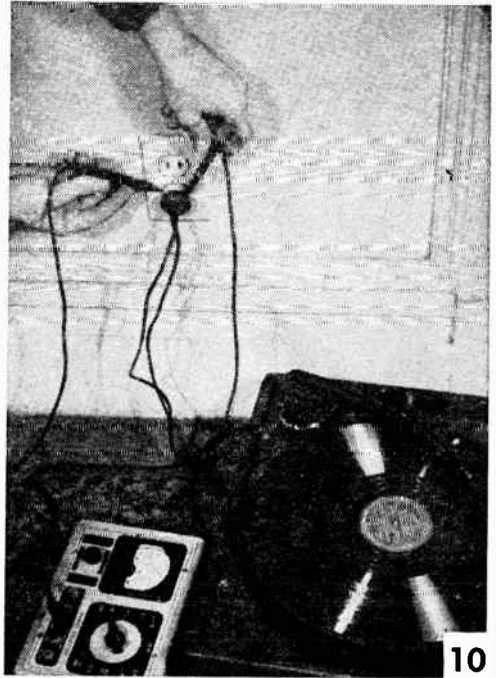

will require that the record be physically isolated from the vibrating motor and shaft.

Cement a piece of heavy felt over the turntable (Fig. 7), and place on it a record having a quiet or unmodulated section. With the needle in the quiet grooves, turn the gain up high. Any hum that can now be heard in addition to needle scratch may indicate that vibrations are being transmitted. Replacing the metal spindle with a rubber one should lessen this distortion. If it doesn't, you will have to sound-insulate the motor from the mounting board.

Use live-rubber sleeves and washers for the sound insulation. Discard old hardened washers, if any, and insert sleeves of at least $\frac{1}{2}$ " o.d. (Fig. 8). Do not draw the nuts so tight as to cancel the springiness of the rubber. To test for motor vibrations, use a glass of water as shown in Fig. 9; with the motor running, no ripples should appear on the surface.

Another common trouble found in inexpensive players is a malady known as "wows," caused when the turntable speed changes and introduces unpleasant quavers into sustained musical notes. Rooting out this defect completely might require a major rebuilding job, but the nuisance can be minimized if it happens to be caused by overloading of the line. Using the record player on a circuit on which you already have a refrigerator, oil burner, or other fair-sized load may mean that the player is subjected

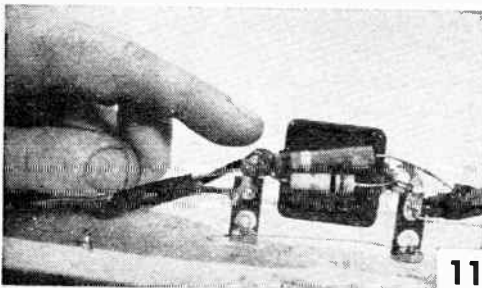
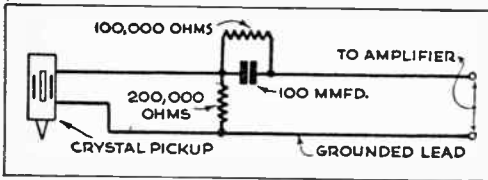

to voltage fluctuations introduced into the line when this equipment is turned on and off by regular service demands.

To check line fluctuations, connect a voltmeter across the record-player plug at the point where it enters the wall receptacle (Fig. 10). At the instant a "wow" occurs, the voltage may show a marked variation.

Filter Increases Tonal Range of High-Fidelity Crystal Pickups

SOME of the newer phonographs feature pickups with excellent crystals and extremely light needle pressure. Used in conjunction with the vinylite-type records that practically eliminate needle scratch, it is possible to get the full tonal range actually recorded on the disks.

But because recordings are made with magnetic cutters and played back with crystal, a filter should be inserted in the pickup circuit to compensate for inherent differences in frequency characteristics between magnetic and crystal devices. The shunt is

used to disconnect the filter when old-style records—still the most common—are being played.—JOHN W. CAMPBELL, JR.

Should this happen, try the record player on a less heavily loaded circuit. Distortion of high-frequency sound passages results when a crystal pickup generates too high a voltage for the amplifier with which it is used. This defect, known as "blasting," can be remedied by the simple filter circuit shown with Fig. 11.

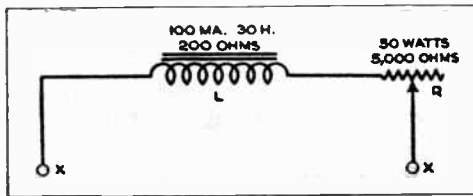
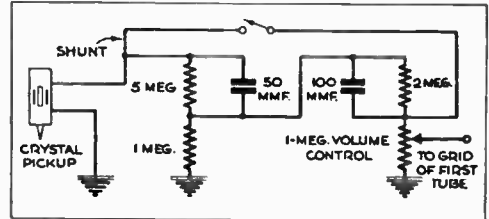

Test Gives Field-Coil Resistance

WHEN the resistance of a burned-out loudspeaker field coil is not marked on the original—as often happens—finding a replacement poses a problem for the serviceman. Connect a resistance in series with coil L, as shown above, across the field-coil terminals, and vary R until proper plate and screen voltages are observed. Turn off the power, and measure resistance *x-x*. Install a coil with the same value.—JACK KING.

Surgical Instrument Serves as "Third Hand" for Serviceman

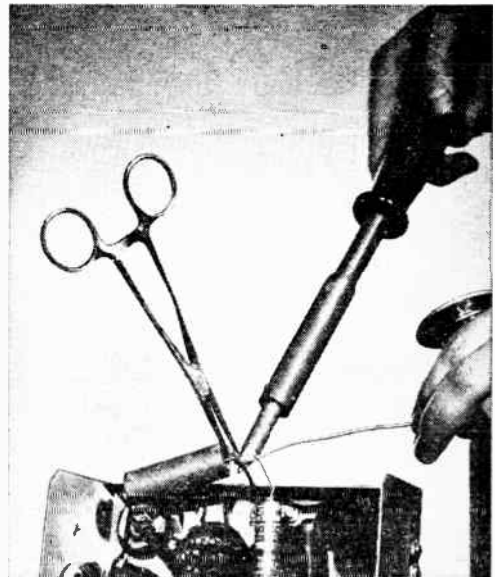

TEMPERED steel forceps that can be made to lock in one of several positions are particularly useful for holding wires or small parts in place while both hands are used for soldering. Slightly damaged or worn hemostatic forceps of the type illustrated above are available at many secondhand stores. Metal shims may be soldered to the blades to allow the right pressure for frequently repeated operations.—H. LEEPER.

Knobs Protected by Recessing

FLUSH knobs on a portable radio or phonograph case can be fitted by cutting suitably sized holes in a thick panel and mounting the controls on composition-board sheets screwed on behind. Knobs in this position cannot interfere with the closing of tight-fitting covers.—G. O. S.

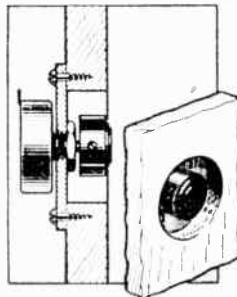

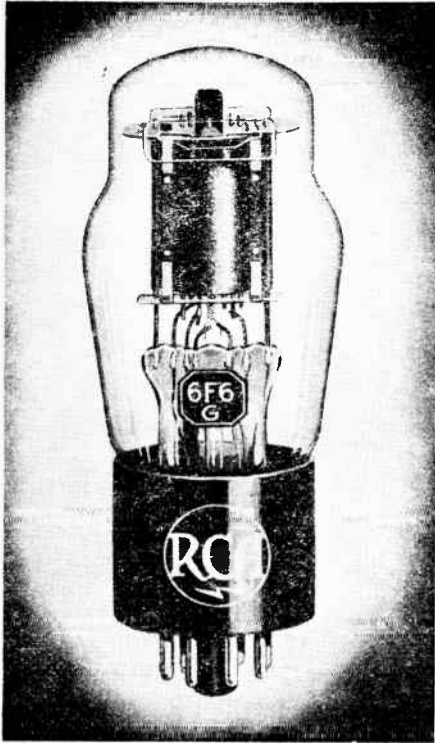

WHAT TUBE

**6SJ7-CONTROL-GRID
WIRES EVENLY SPACED**

**6SK7-CONTROL-GRID
WIRES NOT EVENLY SPACED**

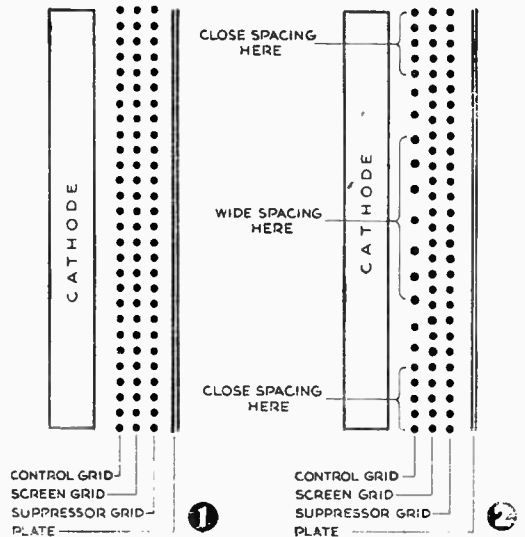

Knowing Six Basic Types Will Enable You to Adopt Salvaged Tubes to Almost Any Circuit

FACED with a new circuit he wishes to build and a collection of salvaged tubes, the electronic experimenter may find it hard to decide which will serve his purpose. Tube manuals are full of information, but after studying the bewildering array of tubes listed in them, the beginner may find himself as badly off as before. The way out of this confusion is to understand the six basic tube types. It will be simple then to classify the tubes on hand and make full use of the data in the manuals.

"Triode," "pentode," and "tetrode" are simply general classifications, each covering several subdivisions. These subdivisions are based upon the operating characteristics of the tube and the use for which it is intended. The steady progress of research has constantly added new tubes in each category, yet to keep older equipment in use, it has also been necessary to keep available the older types of tubes. This results in the plenitude we find in the manuals.

Another reason for the large variety of

tubes is that different filament-heater voltages are used in various radio receivers, and each of the basic tube types must, therefore, be available in different heater ratings. Thus a 12SK7 and a 6SK7 are identical save for the heater voltage—12 for the former and six for the latter. Portable radio receivers designed to use flashlight cells as a source of heater current also need pentodes such as the 6SK7. The 1T4 was designed for them.

Most standard electron tubes have been designed for use in radio receivers simply because these have offered the greatest market for them. However, radio tubes will serve admirably in many other applications. Most radio and laboratory needs can be met with six basic types: the 6SJ7, 6SK7, 6SA7, 6SQ7, 6J5, and 6L6. Almost any tube listed in the manuals can be understood by comparing it to one or the other of these six basic types.

The 6J5 is a triode. So is the 6SQ7, but this tube has two small detector diodes as well. Frequently these are ignored and the tube is used simply as a high-gain triode. Both are modern tubes. It must not be supposed that because the triode was the first developed it is an inferior tube. It is not an extremely high-gain tube, but for many purposes it is the best choice never-

CAN I USE?

BY JOHN W. CAMPBELL, JR.

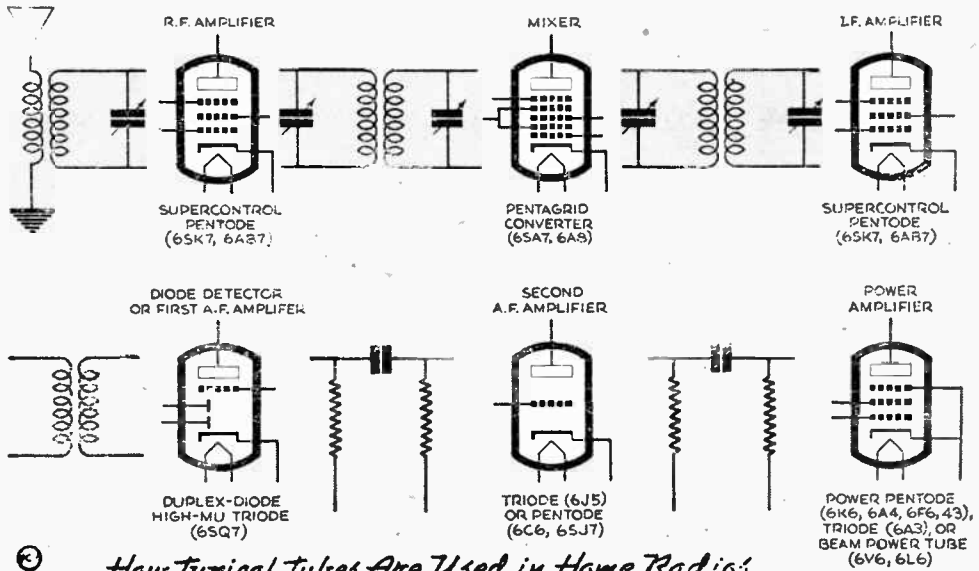

theless. The biggest transmitter power tubes 100,000-watt giants—are triodes.

Tube manuals list two kinds of triodes—voltage amplifiers and power amplifiers. Each of these is in turn subdivided into two classes—the voltage amplifiers as medium-mu and high-mu, and power tubes as low-mu and high-mu, *mu* standing for the amplification factor. The designation of voltage or power amplifier indicates what kind of gain the tube provides. Each has advantages in certain applications.

One type of gain does not exclude the other; a voltage amplifier steps up the power (current) to some extent, and a high-mu power amplifier amplifies the voltage swing somewhat, but the order of amplification is very different for the two types. For example, a 6A3 power-amplifier triode can deliver as much as 200 milliamperes, while the 6SQ7 voltage-amplifier triode is rated at 0.9 milliamperes. The 6A3, a low-gain power tube, passes much more current than a high-mu power tube, while the 6SQ7 is a high-mu voltage amplifier that sacrifices current gain. Between these there is the 6J5, a medium-mu triode rated at 9 milliamperes and capable of an amplification of about 20 times.

In general, power-amplifier tubes require a fairly strong grid signal, but they deliver

a powerful punch at the output. A low-mu triode power tube may require a grid variation of 60 volts and have a plate-voltage swing of only 100 volts, so that its voltage amplification is small. But the current, which on the grid may be less than .01 milliamperes, may be stepped up several thousand times at the output.

High-mu power tubes such as the 6AC5 require smaller grid voltages, but they give less power gain. High-gain voltage-amplifier tubes, on the other hand, may deliver up to 100 times as much voltage as is impressed on their grids, but with small current output.

The distinction between voltage and power amplifiers holds for tetrodes and pentodes as well as for triodes. However, the tetrode power amplifier becomes the beam power tube, which in effect acts as a pentode. Pentode and beam power amplifiers require much smaller grid voltages than do triodes; their great gain makes them more efficient for small apparatus such as radio receivers and public address systems. Two 6L6 beam power tubes can supply 15 to 30 watts of audio power, or, in a special hookup, as much as 80 watts—enough to be heard two miles away. Amateur short-wave transmitters using two 6L6's can communicate across the continent. The 6V6 is a slightly

smaller beam power tube that can be used in the same way.

Tetrode and pentode voltage amplifiers are divided into remote-cutoff and sharp-cutoff types, the later also being called a variable-mu or supercontrol pentode. The difference between these lies in the structure of the control grid.

So far as electrons are concerned, the grid wires can be "inflated" by impressing on them a negative potential until, in effect, they overlap and block the tube. Closely spaced grid wires will be so inflated when a charge of only a few volts is applied. Widely spaced wires will be individually inflated as much with the same charge, but because of their greater separation, they will not block the tube.

Two pentodes among the six basic tube types illustrate this. In the 6SJ7, the control-grid wires are closely and uniformly spaced (Fig. 1). With a negative charge of 3 volts on the grid, a change of 1 volt will cause a change in plate current of 2.5 milliamperes. In the 6SK7, the change in plate current would be about 2 milliamperes under the same conditions, and both tubes would have about the same amplification.

The 6SK7 has grid wires that are not uniformly spaced. As shown in Fig. 2, those at the top and bottom are spaced like the grid wires of the 6SJ7, and at a potential of -3 volts they act in much the same way. But the entire grid of the 6SJ7 "overlaps" at -9 volts; the tube is blocked and stops conducting at that point, whereas the 6SK7 is still strongly conductive at a grid charge of -19 or even 29 volts, because its grid wires are widely spaced in the middle. This wide spacing permits the tube to pass current, but it also makes it less responsive to changes in grid potential. For example, with a charge of -35 volts on the grid, a 1-volt signal will alter the plate current by only .01 milliamperes. Thus, at high grid potentials, amplification is very low.

This feature characterizing the super-control pentode is very useful. With ordinary tubes, volume control is gained only by varying the strength of the signal impressed on the grid with a potentiometer or a similar device. With supercontrol pentodes such as the 6SK7, the entire signal can be fed into the grid, and amplification control can be gained simply by varying the grid



Shown full size, these tiny acorn triodes work at 500,000,000 cycles and more. In the socket is a 6-volt tube; the other is a 1 1/2-volt type.

bias. This is purely an electronic control, involving no mechanical parts, and therefore it can be readily incorporated into an electronic circuit. It is this automatic volume control that permits you to tune from a near-by 50,000-watt station to a 5,000-watt one in another city without touching the manual volume control.

The 6SK7 differs from the 6K7 chiefly in being provided with internal shielding and having the control-grid lead come to a prong in the base instead of to a grid cap.

Sharp-cutoff pentodes like the 6SJ7 and 6J7 are used in high-gain audio amplifiers, detectors, oscillators, and D.C. amplifiers. Frequently they are hooked up as triodes.

Heater rating is indicated by the figure preceding the letter or letters in a tube designation. For each heater voltage there is, in general, a high-gain pentode like the 6J7, a supercontrol pentode corresponding to the 6K7, a pentagrid converter similar to the 6SA7 or 6A8, a general-purpose triode like the 6J5, a high-mu triode such as the 6F5, and a duplex-diode high-mu triode equivalent to the 6SQ7. There will also be power-amplifier triodes corresponding to the 6A3 or 6AC5.

If a circuit diagram calls for a 6SJ7, a little adjustment of resistance and condenser values will permit you to use a 6J7, a 6AC7, a 6C6, a 12J7, or any of several other pentodes. A few 6-volt tubes, however, and some of the battery-type pentodes, have the suppressor grid con-

ned to the cathode within the tube. Usually 6SJ7 circuits call for this connection anyway; if the one in question does not, internally-connected pentodes can't be used.

Both pentodes and triodes can be used as triodes. Simply connect the extra grid or grids to the plate. Some tube handbooks include data for using pentodes in triode connection in resistance-coupled amplifiers.

Among the things you *cannot* do is to use a voltage amplifier (6SJ7) to replace a

power amplifier like the 6K6, or vice versa.

The suffix "G" or "GT" indicates the tube type designated in a glass envelope instead of a metal one, the tube being otherwise identical.

With the advent of multielectrode tubes, the four-prong socket gave way to others until today the octal (eight-prong) socket is standard. It is wired differently for various tubes. Diagrams always show socket connections as seen from beneath the chassis.

Glow Lamp Demonstrates Cutoff Action of Various Tubes

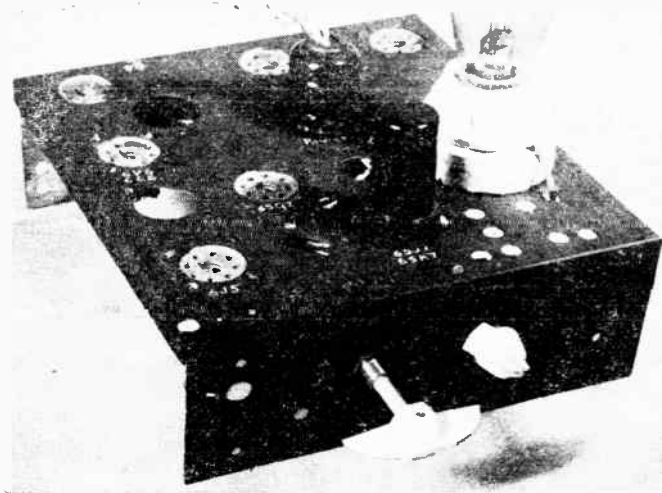

Extra sockets can be added. This chassis has one for testing 6SQ7's

Between .01 and .1 milliampere, the character of the glow changes: from .1 to 5 milliamperes the area of glow increases; and above 5 milliamperes the brilliance of the glow increases.

The circuit can be assembled on an old radio chassis. Three sockets are used to facilitate the testing of different tubes. If available, old sockets will do satisfactorily, or three octal sockets can be utilized by wiring them as shown, the unused terminals being disregarded.

One 5,000-ohm fixed resistor and two potentiometers are required. The 5,000-ohm potentiometer makes it possible to vary the control-grid voltage, while the other permits variation of the screen-grid voltage. The screens of

beam power tubes frequently operate at full plate-supply voltage, being connected directly to the plus side while the plate is connected through the load. The switch shown permits this hookup.

A voltmeter is optional. It will show exactly what grid bias is being applied. A milliammeter, if available, may be used in place of the argon bulb for better comparison of the plate current passed.—J. W. C.

beam power tubes frequently operate at full plate-supply voltage, being connected directly to the plus side while the plate is connected through the load. The switch shown permits this hookup.

A voltmeter is optional. It will show exactly what grid bias is being applied. A milliammeter, if available, may be used in place of the argon bulb for better comparison of the plate current passed.—J. W. C.

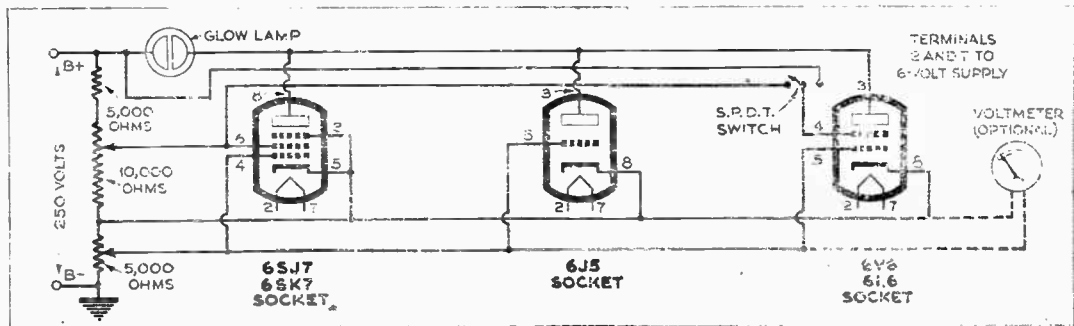

ADAPTING AUTO RADIOS TO HOME USE

Servicing Your Radio

WITH a few basic changes an automobile receiver can be adapted for use in the home on standard house current. Some of the parts do not work on 115-volt A.C., but substitution of parts that will result in conversion of the entire set.

First, get a new speaker—a permanent-magnet type. Most automobile speakers use a 6-volt D.C. field, and you will need one that uses no current for the field. Merely connect the voice coil to the leads that were connected to the voice coil of the original speaker. In some cases, a plug arrangement may permit returning the set to the car.

The power supply must also be changed. There are two types commonly used in auto receivers. For that employing a tube rectifier (Fig. 1), obtain a 110-volt power transformer that will deliver 150 milliamp. at 250 to 350 volts and 6.3 volts for tube heaters. Use the same rectifier, hooking the high-voltage leads to the two plates as shown. These are the same connections used for the old transformer.

After this, remove the input-line and ignition fil-

ter and add an on-off switch to break the 115-volt A.C. circuit. Run the filaments of the tubes from the 6.3-volt A.C. winding of the transformer, hooking the transformer lead to any convenient filament prongs in the set and grounding the other end of the transformer winding. The circuit is shown in Fig. 2.

In an automobile receiver with a power supply utilizing a synchronous-type vibrator, the high-voltage input comes from the center tap of the car transformer. Use a new power transformer with a center tap to connect to the filament of an 80, 5Y3, 5Y4, or similar-type rectifier tube, and use the 5-volt winding to drive the rectifier filaments. This, of course, requires the addition of a tube and socket as well as the power transformer.

A long antenna is not necessary since automobile receivers are made to operate on very short whip antennas. A short piece of wire about 20'—will serve very well. The speaker may be mounted on the panel of a cabinet or in any way suited to its use. Insert the shut-off switch, which should be a 110-volt type, in one lead to the transformer primary.—G. O. SMITH.

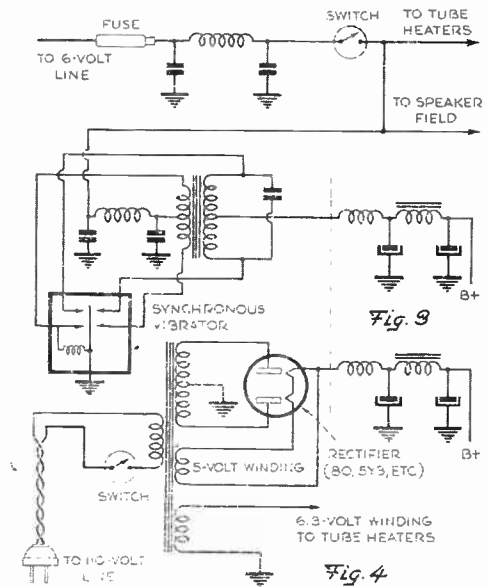
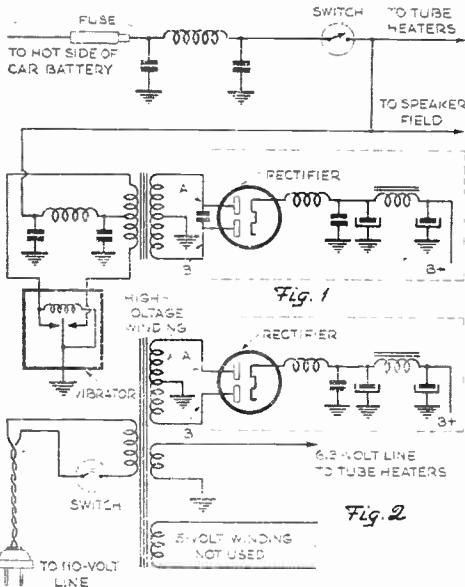

RADIO SERVICING

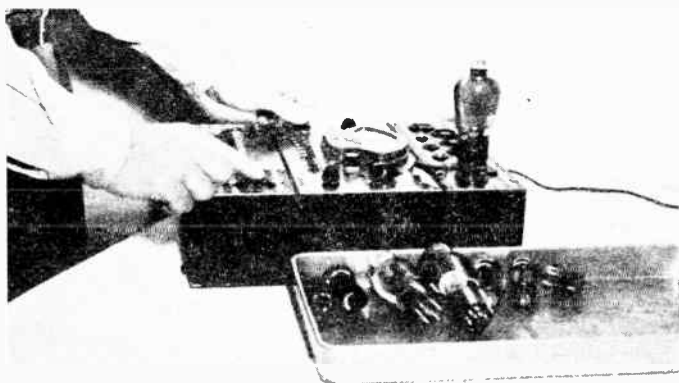

FROZEN MUSIC used to be a constant cold-weather problem because our automatic phonograph, located next to an outside wall, refused to warm up.

We gave our sluggish turntable a boost by mounting a 5,000-ohm resistor in a space between the motor and record-changer mechanism. A separate cord and plug assembly, which can be removed in the spring, connects with the 115-volt line. The heat dissipated by the resistor keeps the phonograph at operating temperature. Power consumption, even under continuous operation, is less than two kilowatt-hours a month.—W. ALLPIN.

WEAK RADIO TUBES often show new signs of life when subjected to the healing effects of heat. You may have noticed that tubes that were relegated to the spare-parts shelf for a "rest" worked perfectly a year or so later. Heat merely speeds up this self-healing process. To reactivate tubes having no defects other than low electron emission, place them in a tray or shallow pan and bake them for four to five hours in an oven that is kept between 350 and 400 deg. F. Allow the tubes to cool in the oven, and test them after they are cool. Some tubes will show no improvement until they have been in operation for a few hours. The process is usable only on tubes with oxide-coated cathodes, but this class embraces practically all modern receiving tubes. No tube can be successfully reactivated more than once, so those so treated should be plainly marked.—W. H. BLANKMEYER.

SPAGHETTI with nail-polish "sauce" doesn't make a very appetizing dish, but your radio won't be able to tell the difference. If you have trouble obtaining spaghetti tubing, use ordinary soda-pop straws. After fitting the straw around the wire, cover it with nail polish or shellac. Be sure to apply the latter generously around the ends to prevent slipping.

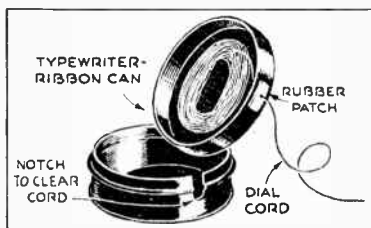

DIAL CORD won't snarl up in a serviceman's kit if it is carried in a dispenser such as that shown above. Drill a hole about $\frac{1}{8}$ " diameter in the upper part of a typewriter-ribbon can and cut a corresponding notch in the lower piece. Cement a small rubber patch over the hole, and when the cement has dried, punch a pinhole and draw the cord through. The patch acts to prevent the cord from slipping back inside.—R. P. TURNER.



BURNED FINGERS sometimes result when tubes that have become uncomfortably hot are removed or switched around. Rectifiers, power-output tubes, and high-current television amplifiers such as the 6AC7 shown often dissipate enough watts to become painful to the touch. A pair of rubber fingertips of the sort used by many bank tellers will protect your fingers against heat, and will provide a safe and sure grip on the tube as well.—G. S.

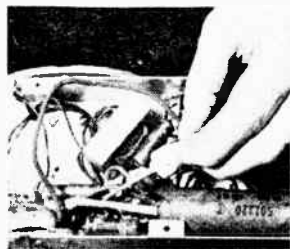

TUNING IN THOSE

Servicing Your Radio

LD radio receivers that can't be tuned in clearly on stations at the high-frequency end of the dial can be adjusted more or less simply. How this is done is of particular interest because of the addition of stations at this end of the dial when all frequencies were changed not so long ago.

In making the adjustment, however, a compensating loss is to be expected at the low-frequency end. Those who prefer stations at the low end of the dial may be better pleased, therefore, to leave the adjustment as it is, though in many cases it is possible to get satisfactory reception at both ends.

Usually the radio will have to be lifted from the cabinet to make the adjustment. This is done by first removing the tuning knobs and then taking out the small bolts at the bottom. Often the chassis will bear a label telling

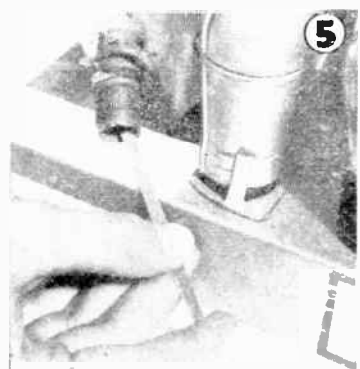
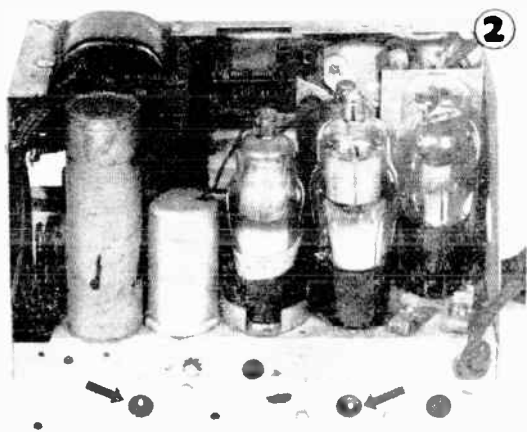
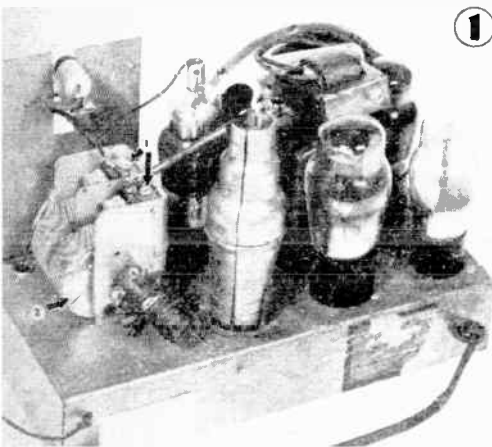

OFF-THE-DIAL STATIONS

whether the circuit is superheterodyne or tuned radio frequency (T.R.F.). These two general types require slightly different treatment, but if you can't find out which yours is, handle it first as a superheterodyne.

The tuning condensers of many superheterodynes are located on the chassis in the position shown in Fig. 1, and are shunted with small trimmer condensers, indicated by the two arrows marked 1. These trimmers are not always located on the main tuning condenser, however. Some may be placed underneath the chassis and can be reached from the rear as indicated by the two arrows in Fig. 2.

Mark on the trimmers the position of the slot in the holding screw, and open one of the screws a one-eighth turn (Fig. 3). Have the antenna attached and the radio turned on so any change in reception can be noted. When the oscillator trimmer is opened up in this way, all stations on the dial will be moved up several points. The screw can then be turned back slightly, or opened up still further, until satisfactory reception of the high-frequency stations is obtained. Test stations at both ends of the dial, and insulate the handle of the screwdriver so reception will be as nearly as possible the same as you will get when the set is returned to the cabinet. If nothing happens when the screw is turned, the trimmer should be closed up again by returning the screw slot to its original position, and the same opening turn should then be given to the other trimmer screw. After the adjustment has been completed, the trimmer should be sealed with a drop of sealing wax so vibration will not open it further.

T.R.F. adjustment is a little more complicated. Mark the trimmers as before, and open them for a test one after the other until the detector stage is reached and the stations shift on the dial as in the case of the superheterodyne. If no single trimmer causes this, open the trimmers in groups of two so as to cause a greater capacity change, choosing any two and opening them up equal-

ly. Should this still not produce the desired change, try bending the outside plates (shown at 2 in Fig. 1) of the main tuning condensers with a pair of long-nosed pliers, as in Fig. 4. Make the test on one condenser in the gang at a time.

When all these capacity-changing methods fail, the value of one or more of the inductances may be lowered in order to achieve the desired result. Insert a 1/16" by 1/4" by 4" piece of copper in the center of any one of the inductances, as in Fig. 5, while the main tuning gang condenser is turned to its highest setting. At some definite point of insertion, the high-frequency stations will begin to come in, and a little tuning will sharpen them. Insertions may be tried in all the inductances to determine which produces the best results, after which the copper piece can be attached permanently to the coil with a small screw or a drop of sealing wax.—TRACY DIERS.

Arrow on Control Knob Will Gauge Volume

A SMALL arrow painted on the volume-control knob, as shown at right, will enable you to turn the radio to nearly the volume desired without waiting for the tubes to warm up. On occasion it may also indicate a weakening battery or other loss of volume that might not otherwise be noticed until serious trouble occurs.—BLANCHE PORTER.

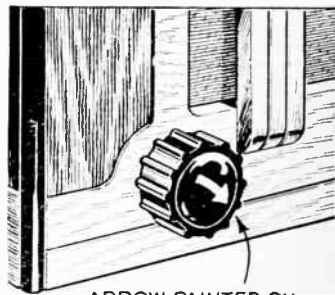

ARROW PAINTED ON VOLUME-CONTROL KNOB

Clip on Lid of Portable Holds Radio Data

SPACE behind the lid or door that protects control knobs of some portable radios can be utilized by attaching a strip of springy metal, bamboo, or wood. Round the free end of the clip so program lists, other papers, or booklets will slip under it easily, and mount where it won't interfere with the knobs.—W. E. B.

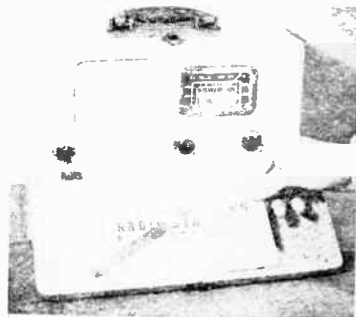

ELECTRONIC PRINT TIMER



Any lighttight box can be used for this timer, but the fruit can is big enough if the parts are properly laid out. The drawing, right, shows a practical arrangement.

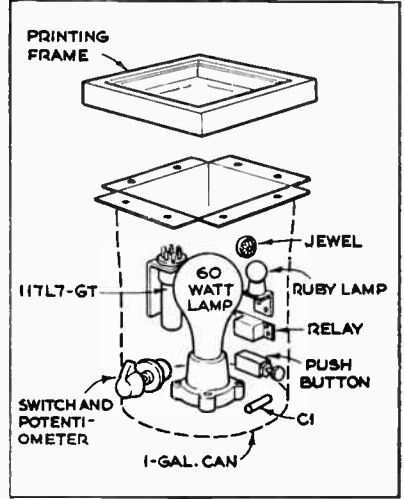

THOSE who go for canned fruit in a big way, or can get a 1-gal. fruit can from a boarding house, have a good photo accessory at hand. Such a can is lighttight and just the right size to hold this electronically controlled contact printer.

Bend the opening into a rectangular shape and mount a standard 3 $\frac{1}{4}$ " by 5 $\frac{1}{2}$ " printing frame as shown. A hinge between the frame and pressure plate completes the photographic part of the job. Chief components of the timer are a 117L7GT vacuum tube, a linear .5-meg. potentiometer with switch, a double-pole, double-throw pushbutton switch, and any fairly sensitive, normally energized relay rated at around 10 milliamp. and 2,000 to 3,000 ohms.

Mount and wire the parts as shown. To calibrate the timer, turn the potentiometer clockwise until you hear the snap of the

power switch. Both bulbs will light, but after the tube starts to warm up it activates the relay and cuts out the exposure light. Allow a few more minutes for the tube to get into proper operation, set the potentiometer about half way, and press the pushbutton switch for one second.

The exposure lamp should go on and then turn off automatically. Using a stop watch, time the length of exposure for various settings. Each time you get an even-second exposure, scribe the position of the knob on the can. The maximum time of this unit is about 15 seconds; for a longer maximum, increase the capacitance of C1 or the resistance of the potentiometer.

By plugging the line cord of your enlarger into the exposure-lamp socket, you can make the timer keep watch over your larger prints as well.—KARL GREIF.

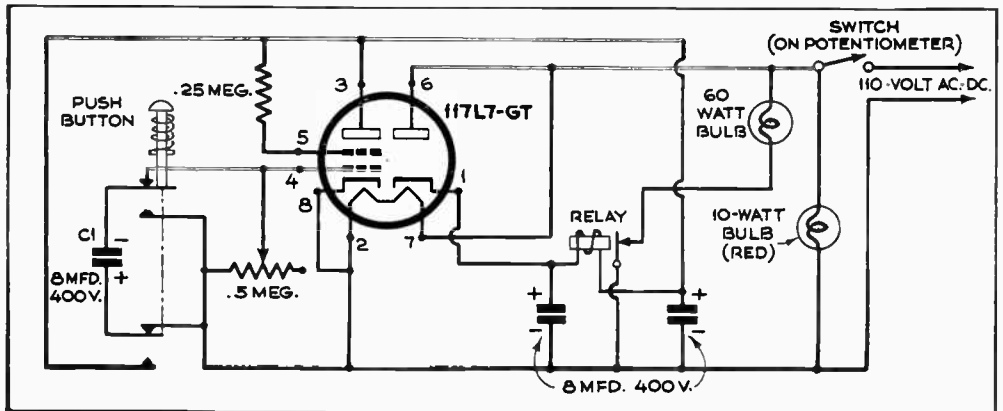

ELIMINATING SPEAKER HUM

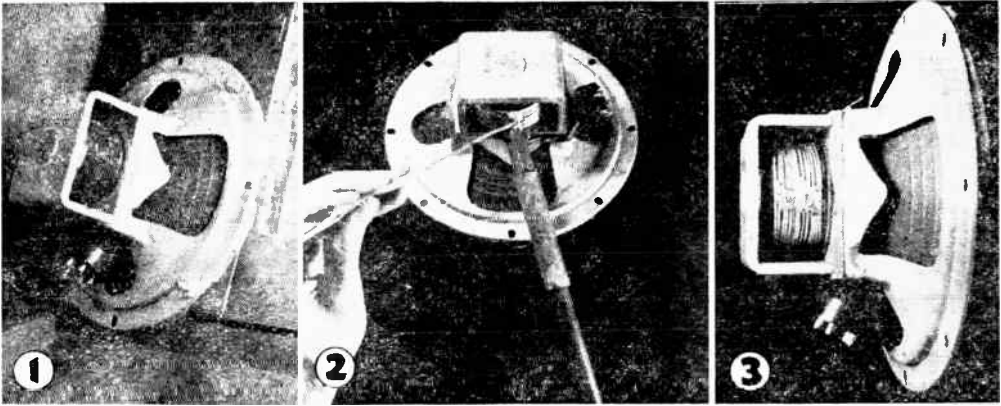

Servicing Your Radio

RESIDUAL or "field" hum in a small speaker is caused by ripple voltage on the field winding. In an automobile receiver it comes from the transients on the field-supply line caused by the vibrator in the power supply. This hum cannot be filtered, and although in some cases it may be possible to readjust the "hum-bucking" coil that is wired in series with the voice coil, it may be more convenient to smooth the field ripple in the following manner:

Wind a number of turns of heavy, tinned wire about the field coil. The size of the wire is not important except that it should be as large as is convenient to handle. Put on as many turns as possible, being careful not to break through the paper insulation that covers the field coil, as this may cause a field short. It is not necessary to insulate

the auxiliary coil from the frame of the speaker (Fig. 1). Solder the turns together, as shown in Fig. 2, thus creating an effective single shorted turn (Fig. 3).

This shorted turn acts as a shading ring, which decreases the inductance of the field while increasing its reluctance. It behaves similarly to a shorted turn in a power transformer and tends to resist the collapse of a magnetic field as the ripple current passes through a cycle. This maintenance of a constant field will reduce ripple hum, and the lower the resistance of the shorted turn, the less the fluctuation of the field current will be observed.

The method is not a cure-all, nor a substitute for filtering. Although it works on an automobile speaker as well as on a home set, the effect is more noticeable on the bench than when the speaker is back in the car.—GEORGE O. SMITH.

Homemade Tuning Wand Helps in Aligning Receiver Oscillator

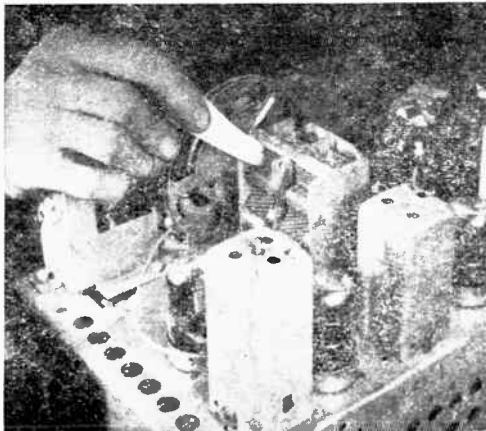

IN RECEIVERS where the oscillator and R.F. coils are not readily accessible for inserting a tuning wand, a strip of photographic film, old pyralin dial, celluloid, or similar material will serve handily. It should be thin enough to pass between rotor and stator plates without bending them.

When alignment is considered good, insert the strip between the plates of the antenna and R.F. section. If response increases, the antenna and R.F. tuning is high, and the padding condenser should be decreased. Should response fall off immediately, insert $\frac{1}{4}$ " of the strip in the oscillator section and turn the gang condenser to full resonance. If this gives more output, the oscillator tuning is high, and the padder should be increased slightly.—G. O. S.

LOUDSPEAKER ADJUSTMENTS

Servicing Your Radio

MANY radio owners will put up with a certain amount of distortion in their loudspeakers rather than tackle a repair because they realize how delicate such work is. Loudspeakers have air gaps of only .005". If care is exercised, however, a competent serviceman or home mechanic should be able to do an effective job.

The most common fault is an off-center cone. This usually causes a fuzziness in the reproduction, especially when the volume is turned low. To recenter the cone, obtain colored-paper shims at a radio store, or cut shims from stiff paper such as that used for calling cards.

Three strips are required for proper centering, and they are placed at 120-deg. angles from each other in the center of the cone, as shown in the photograph at top. The cone is loosened slightly to receive them by means of its centering screw and then is retightened.

This centering screw is usually behind the speaker magnet or in front in the middle of the cone; but if the speaker has no such screw, the whole cone and voice-coil assembly can be loosened by applying a cement solvent or lacquer thinner to the cement holding the rim of the cone to the frame of the speaker, as in one of the photos. Use the three shims the same way, and then cement the cone back to the speaker frame and let it dry thoroughly.

Many loudspeakers have a "papery" sound that mars the reproduction. This is sometimes caused by an off-center cone, but more often it is due to an open seam in a cone that has not been pressed or molded from a single piece. Cement in the seam dries out after a time, and the loose edges touch while the cone is vibrating, thus causing the objectionable sound. This trouble can be remedied easily by putting new cement in the open places along the seam. Tears in a cone may be similarly cemented, as shown in the bottom photograph.

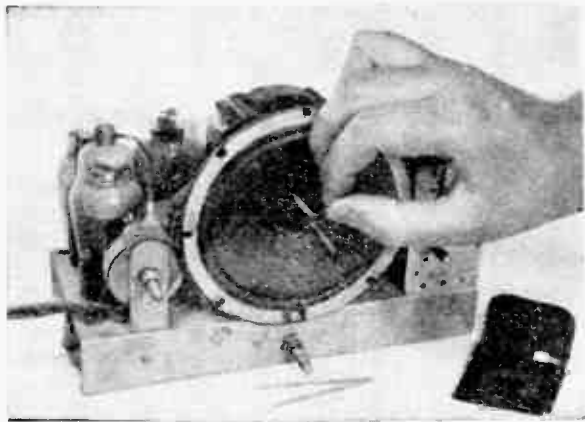

Three paper shims are inserted to center a loudspeaker cone

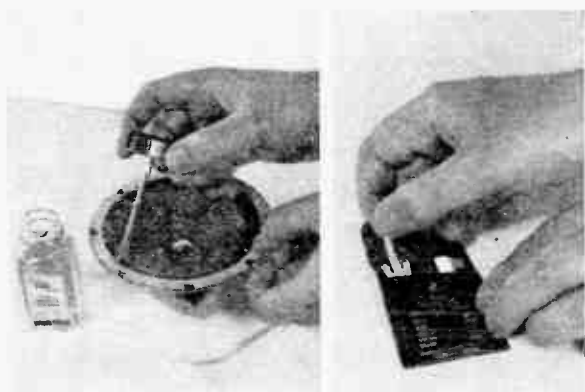

Loosen the cement at the rim of the frame to remove a cone that has no centering screw. Paper centering shims of different thicknesses can be obtained in a small kit

Tears in a cone are easily mended by an application of cement



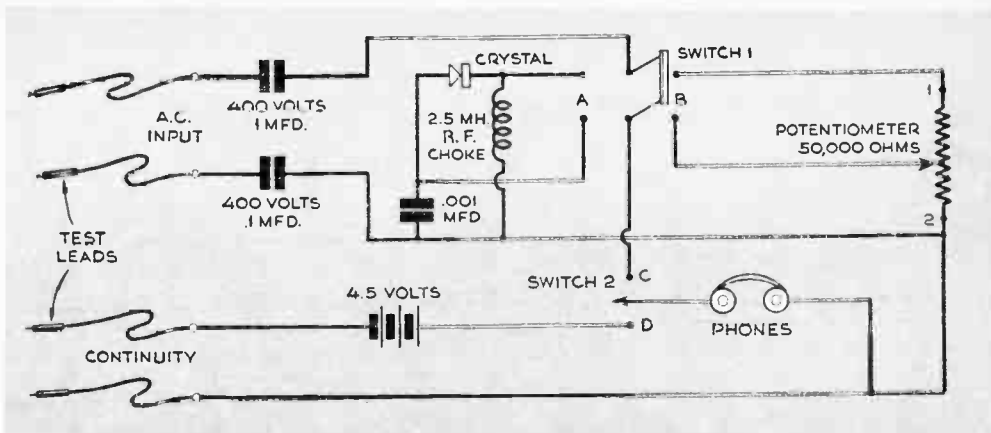

Radio Circuit Tester Uses Headphones and Standard Parts

THIS simple test circuit will prove useful to the student of electronics or the experimenter, and will often track down trouble that can't be located by guesswork.

To check audio signals, use the A.C. input leads with switch 1 at B and switch 2 at C. For example, if distortion is to be localized, put the leads first across the plate and cathode of an output tube, then across the grid and cathode. If the signal is clear at the grid but not at the plate, the distortion is in that output stage or tube.

For radio-frequency tests, set switch 1 at A and switch 2 at C. Place the prods on the plate of the tube and the positive side of the plate supply. The signal should be heard, rectified by the crystal detector. Shift the lead from the plate to the grid. If the signal

is not much weaker, the gain of the stage is low and some defect exists.

For continuity tests, disregard switch 1 and set switch 2 at D. To test a fixed condenser, touch the prods to its terminals. A click should be heard. Remove the prods, wait a few seconds, and again apply them. The click should be much weaker, showing that the condenser has held the charge.

Coils, resistors, and tube filaments may be tested on the same circuit. No click means an open circuit. Tuning condensers can be tested by first disconnecting the leads to prevent shorting through other parts. No click should be heard when the rotor is turned. Never use the continuity leads on a receiver unless the line cord or batteries are disconnected.—WILLARD MOODY.

PERMISSIBLE VOLTAGE DROP

[ELECTRICAL]

WHAT must be the rated capacity of a 10,000-ohm resistor across which the voltage drop is to be 125 volts? The table below shows instantly that the permissible voltage drop across a 1-watt, 10,000-ohm resistor is 100 volts, which is too small. The drop across a 2-watt resistor may safely be 140 volts. A 2-watt unit is therefore required. As another example, if a 500-ohm resistor rated at 3 watts is at hand, it may safely be used to create a potential drop of 38 volts or less.

Ohms	1-watt size	2-watt size	3-watt size	10-watt size	Ohms	1-watt size	2-watt size	3-watt size	10-watt size
100	10	14	17	30	10,000	100	140	170	310
200	14	20	21	45	20,000	140	200	245	445
300	17	24	30	55	30,000	170	245	300	550
500	22	31	38	70	40,000	200	280	345	
700	26	38	45	85	50,000	225	310	385	
1,000	30	45	55	100	70,000	265	375	460	
2,000	45	65	80	140	100,000	310	450	550	
5,000	70	100	125	225	200,000	450	500		
7,000	85	120	145	265	300,000	500			
8,000	90	125	155	280	400,000				
					500,000	over 500	over 500	over 550	over 550 volts

POPULAR SCIENCE MONTHLY SHOP DATA

MULTIPURPOSE TEST INSTRUMENT

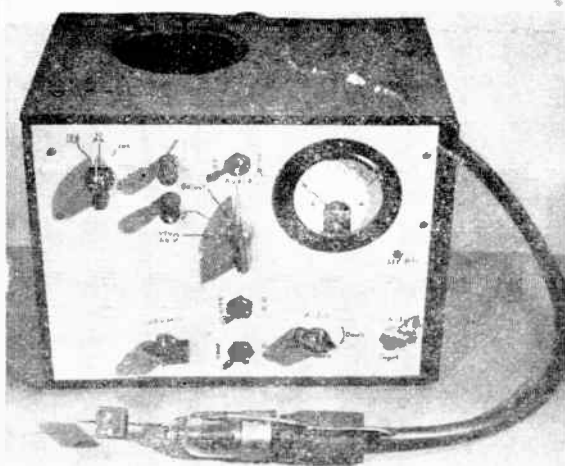
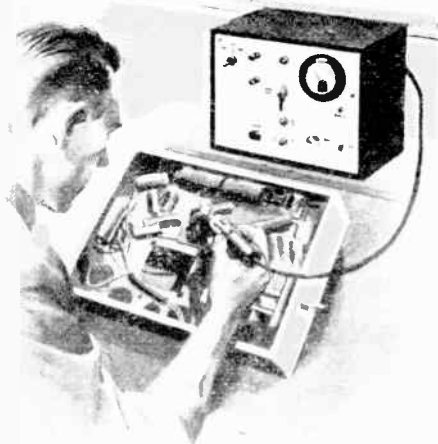

TRACING receiver troubles is a routine job with this multipurpose tester, for it has the "know how" to pick out even carefully hidden sore spots in most sets. Turning the selector switch converts the gadget from a cathode-follower tube vacuum-tube voltmeter with two voltage ranges to a very tricky and equally useful sort of detector-and-audio system: another flick and it becomes a simple audio amplifier with speaker.

Touch the grid-cap lead of the 6F5 tube to any point of any circuit carrying amplitude modulation at audio frequencies, and the speaker will tell whether that modulation is clear or distorted. Acting as an infinite-impedance detector, the 6F5 adds very little capacitance and almost no load to the circuit being tested.

Do you want to trace the I.F. signal? The infinite-impedance detector can pick it up anywhere down the line. It is also quite capable of isolating audio distortion no matter at what stage it originates, from the output right back to the antenna.

The fact that the tester can pick out modulation at the antenna stage itself permits you to determine the frequency to which the antenna stage is tuned independently of the oscillator tuning.

Switching from an infinite-impedance detector to a cathode-follower vacuum-tube voltmeter, you have an extremely sensitive instrument that can be used as an output meter at power levels where the loading

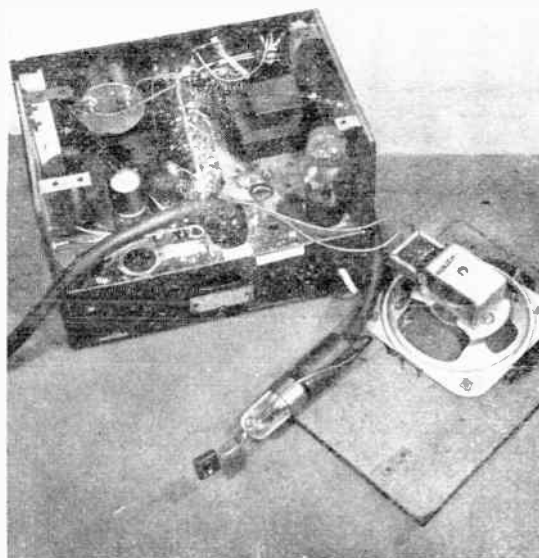

imposed by a standard meter would be ruinous. When no signal is applied to the vacuum-tube voltmeter circuit, the cathode tends to bias itself upward to near cutoff, due to plate-current flow through the cathode resistor. If a positive signal is applied to the grid of the 6F5, the tube is no longer biased to cutoff, but the increase in plate-current flow tends to cause a larger drop across the cathode resistor, till the cathode is again biased up to nearly match the grid voltage. Since the cathode will always remain slightly negative with respect to the grid, grid current never flows.

DOUBLES AS AUDIO AMPLIFIER

The filter arrangements R-C and R-C hold the cathode at the highest voltage attained during any voltage wave cycle, so the instrument becomes a peak-reading voltmeter. To obtain a root-mean-square voltage, you will have to adjust the reading. For a sine wave, r.m.s. voltage equals 0.707 times peak voltage.

Shunting the grid condenser of the 6F5 will cause the instrument to record D.C. volts, the grid lead becoming positive.

Potentiometer R₁ is used to adjust the millimeter to zero so that the initial plate current that must flow to bias the cathode can be balanced out of the meter.

To minimize grid emission in the 6F5, the heaters are operated at less-than-rated voltage via the 5-volt filament winding, and a 6X5 rectifier is employed in place of the usual rectifier circuit. If a 6X5 is not available, but you happen to have a 5Y3 or similar tube, the 5-volt transformer winding can be diverted to its use. In this case, insert a 5-ohm resistor in series with the 6.3-volt tap and the 6F5 filament.

KEY TO MULTITESTER PARTS

- C₁: 1,000 mmfd. mica
- C₂: .8 mfd. electrolytic, 100 v.
- C₃: C₄: .25 mfd. electrolytic, 25 v.
- C₅: .8 mfd. electrolytic, 200 v.
- C₆: 500 mmfd. mica
- C₇: .01 mfd.
- C₈: C₉: .1 mfd., 25 v.
- C₁₀: C₁₁: .1 mfd.
- C₁₂: .01 mfd.
- C₁₃: C₁₄: .8 mfd., 150 v.
- C₁₅: .01 mfd. mica
- R₁: 10,000 ohms
- R₂: R₃: 200,000 ohms
- R₄: 1-megohm pot.
- R₅: 1,100 ohms
- R₆: 22 meg.
- R₇: 0.5 meg.
- R₈: 350 ohms
- R₉: 1 meg.
- R₁₀: 30,000 ohms, 10 watt
- R₁₁: 5,000 ohms, 2 watt
- R₁₂: 25,000 ohms
- R₁₃: 25,000-ohm pot
- R₁₄: 25,000 ohms, 3 watt
- R₁₅: 20 to 50 meg.
- T₁: 250 volt, 50 ma. power trans.
- T₂: 8.500 ohm output trans.
- L₁: 19-henry filter choke

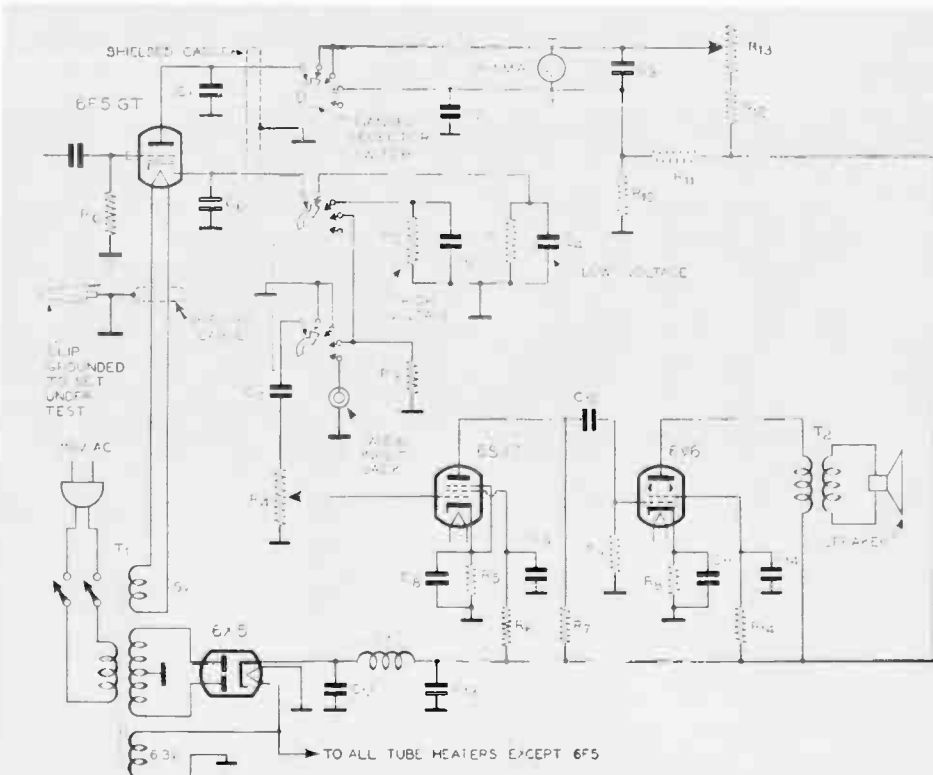

*Listen in on
the hams with this*

10-METER BAND RECEIVER

By Clinton Clark

TEN METER phone reception and transmission have long been popular with radio hams because this channel is good for both long-distance and local communication. When the end of the war made it possible for communications authorities to turn on the green light, amateurs all over the world reopened ten-meter transmitters, and lost little time in contacting old friends, far and near.

If you tune in tonight, there's a good chance that you can pick up Algeria, England, or the Philippines. Yes—you can tune in tonight, for this receiver, reduced to bare essentials, will take very little of your time to build. It is intended to open the door of a fascinating spectrum to the beginner, and invites experimentation on other short-wave bands through the use of easily made, interchangeable coils.

First step in construction is the base which, in this case, is a $\frac{3}{4}$ " by 7" by 7" pine board, sanded and coated with clear varnish. Details of the condenser-tube-coil assembly in the photographs is suggested because it allows for short connections. Low-loss insulation and direct wiring are very important in all high-frequency circuits.

The tube upright is a 2 $\frac{1}{2}$ " by 4" strip of composition board. Bore a 1 $\frac{1}{4}$ " hole to take a five-prong ceramic tube socket. Another piece of composition board, 3" by 5 $\frac{1}{2}$ ", is used as an upright for the coil-and-condenser assembly. In the center of this panel mount a midget 15-mmf. tuning condenser. Bolt a $\frac{1}{2}$ " strip of bakelite or other low-loss material to the edge of the upright, and drill three holes for tip jacks. When fastened into place, these jacks form a socket for the coil ends and tap.

Arrange the two uprights at a 90-deg.

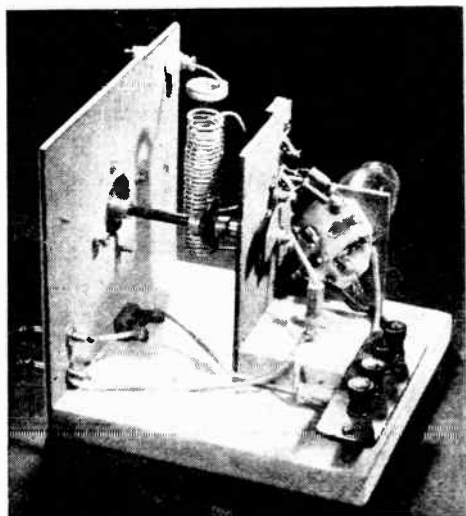

Fewer than a dozen electrical parts went into this short-wave receiver. It takes very little space, although no special attempt was made to keep it compact.

Skip-distance effects are very marked on the 10-meter band. Don't be surprised if your set pulls in stations 5,000 miles away more readily than those only 500 miles from you.

angle to each other by screwing them to a square wooden subbase. This is later screwed to the larger base. Now make the short connections from the coil terminals to the condenser and tube socket. Attach the radio-frequency choke to the smaller square. The choke may be purchased, or hand wound on a $\frac{3}{8}$ " dowel. If you prefer the latter, drill a $\frac{3}{8}$ " hole in the subbase to receive the dowel, and wind it with 100 turns of No. 34 D.S.C. wire.

For the front panel, a 7" square of composition board is screwed to the base. Drill holes for the dial, switch, antenna binding post, and phone jacks. Make sure that the hole for the dial is aligned with the condenser shaft. Since approximately 3" is allowed between the front panel and the condenser subpanel, a coupling will probably be needed to connect the knob and the condenser. The distance, plus a fiber or plastic coupling shaft, helps to prevent the introduction of hand capacitance.

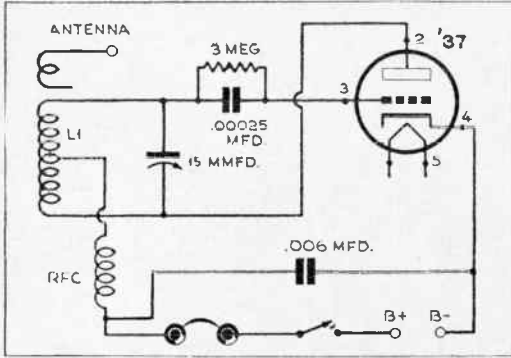

To make the coil, L1, wind 30 turns of No. 14 solid copper wire on a $\frac{1}{2}$ " form. When the form is removed, you have a self-supporting, low-loss coil. Solder the coil ends into phone tips to fit the jacks used as sockets on the subpanel. The tap may be of flexible wire soldered approximately a quarter of the distance from the plate end of the coil. Phone tips and jacks make a good coil-mounting combination; a dozen or so tips cost but a few cents, and will enable you to make additional coils for trial on other bands. Some experimentation may be necessary to locate the best spot for the tap, because of the individual characteristics of many high-frequency elements.

A type 37 tube is used, requiring a 6-volt A.C. or D.C. filament supply. If it is more convenient to operate the heater off a $2\frac{1}{2}$ -volt supply, substitute a type 27 tube.

When wiring is completed, apply the filament voltage, then turn on the switch in the plate circuit. Either a 90 or 135-volt B

supply may be used, the higher voltage, of course, providing greater output.

A loud, hissing noise, characteristic of all superregenerative receivers, should be heard in the earphones. As a station is tuned in, this hiss will be blocked out or recede into the background.

A good high-frequency antenna is recommended for best results. It may be coupled into the circuit by placing two turns of stiff, insulated wire near the grid end of the tuning coil, as shown. Alternatively, a hairpin loop of wire from the antenna binding post may be inserted directly into the grid end of the coil.

For convenience, the battery connections are grouped in a single terminal strip, illustrated in the photograph at the upper left, but omitted from the diagram.

Best reception on the ten-meter band can be expected during daylight hours. It is, however, subject to strong interference due to seasonal and atmospheric changes.

Short-Wave Converter Brings in the World

Operated with your regular broadcast receiver, this one-tuber will cover the major foreign wavelengths.

By S. T. Van Esen, W2OXD

LONDON is calling. Lima, Sydney, and Johannesburg, are on the air too. There's a wealth of news, information, and entertainment pouring out of foreign skies, just waiting for you to listen in. If you've been wanting to do just that but have hesitated because of the difficulty of building a short-wave receiver from scratch, here is your answer. It's as simple as one tube and a few coils. The rest is already built into your regular radio.

A superheterodyne will give best results, but most radios are of this type. These as well as most other kinds of receivers have everything you need for short-wave reception except that their antenna circuits are designed for a lower frequency. All you have to do is change the short waves into longer ones that can be detected by the broadcast receiver.

A converter that will do this job consists of a single tube of the pentagrid type operated in conjunction with suitable coils and capacitors. Two things should be noted about this tube: first, it is actually two tubes in one, and second, it has five grids. For

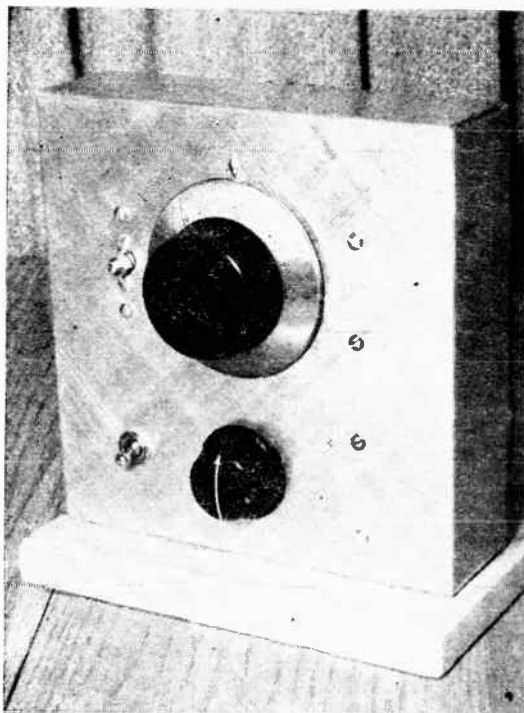

Standing on end, the chassis becomes the front panel. The larger knob governs the oscillator condenser; the small one the mixer. Finish is obtained by drawing steel wool along a rule.

simplicity, only three of them are shown in the diagram; the suppressor and one of the screen grids are omitted since their connections are made internally.

One section of this tube is called the "mixer" because the incoming or short-wave signal applied to its grid or input circuit is changed to broadcast frequency in the plate or output circuit. The other section, the "oscillator," may be visualized as a miniature transmitter. It produces a signal voltage of its own that is applied to the mixer circuit simultaneously with the desired short-wave signal.

Now let us say that the broadcast receiver is tuned to 1,500 kc. (1.5 mc.). We will then want the mixer to operate only at this frequency—that is, we want it to convert every short-wave signal within its range to 1,500 kc. To do this the oscillator must be tuned 1,500 kc. higher or lower than the incoming programs. For example, to get a foreign station broadcasting on the 6 mc. channel, we tune the oscillator to 6 plus 1.5, or 7.5 mc. By combining or "beating" the two signals together, we obtain the 1.5 mc.

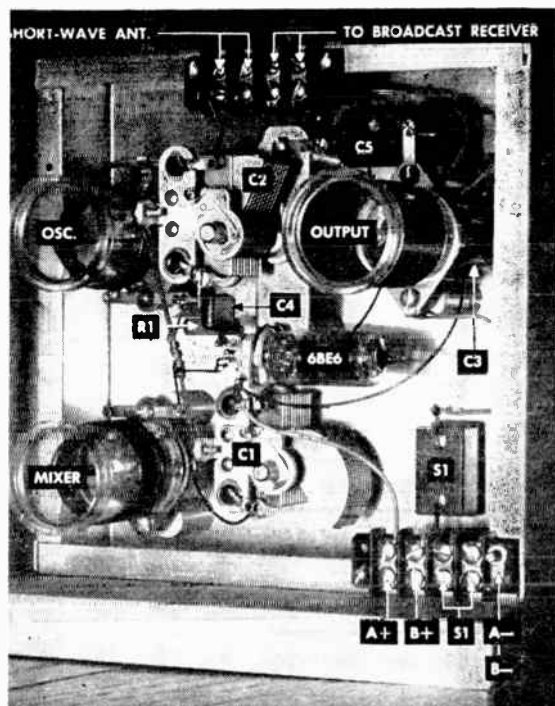

Coil sockets and the oscillator capacitor are raised from the chassis by insulated spacers. Solder all leads that go beneath these parts before you actually fasten them into position.

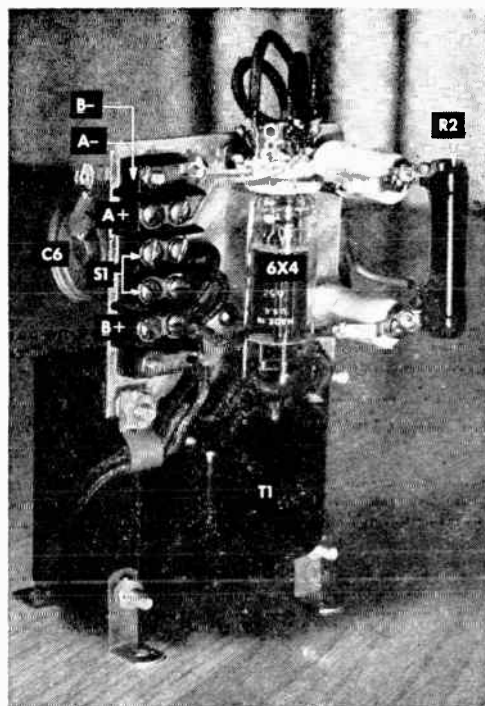

If a separate power supply is used, the only connections to the receiver will be those for antenna and ground. Alternatively, plate and filament voltages can be tapped off an AC set.

difference that can then be applied directly to the input circuit of the broadcast receiver.

In this converter the critical tuning is done by the oscillator capacitor, C2. As we rotate the dial through its range of frequencies, any signal that is *lower* than the oscillator setting by exactly 1.5 mc. will be heard in the loud-speaker of the broadcast receiver. Strictly speaking, "image" signals exactly 1.5 mc. *higher* should also be heard, but since the mixer tuned circuits are adjusted for best response to the lower frequency, the latter will probably come in much stronger.

A 2" by 7" by 7" aluminum chassis doubles as the front panel. Aluminum is a good choice because it can be worked without special tools. If reasonable care is taken to keep from scratching the face, it will be possible to apply an attractive cross-grain finish by pulling a small wad of steel wool against a straightedge.

Sockets for the three plug-in coils are mounted 1 $\frac{3}{8}$ " off the chassis. Common ceramic stand-off insulators 1" long were used. (They are $\frac{1}{2}$ " in diameter and tapped at both ends for 6-32 machine screws.) The

extra spacing was obtained by adding lengths of $\frac{1}{4}$ " aluminum tubing to the end of each insulator.

Because the type of vernier dial used has a protruding hub, the main oscillator tuning condenser also had to be spaced away from the chassis. Ceramic insulators were used here too with a metal strip bridged across them to support and ground the rotor. Details of this construction are shown in the closeup photo on page 100. The holes through which this bridge strip is fastened to the insulators are slightly elongated so that the tuning shaft can be aligned, and a flexible coupling is used to link it to the dial hub.

The tube socket, mounted to hold the 6BE6 horizontally, has a metal ring that allows it to be attached to one of the ceramic supports by means of a 6-32 spade bolt. A midget variable capacitor, used to tune the output coil, is placed directly beneath the coil socket. If there is not enough clearance between socket and capacitor, use longer aluminum spacers. Bear in mind that while the capacitor mounts directly on the chassis,

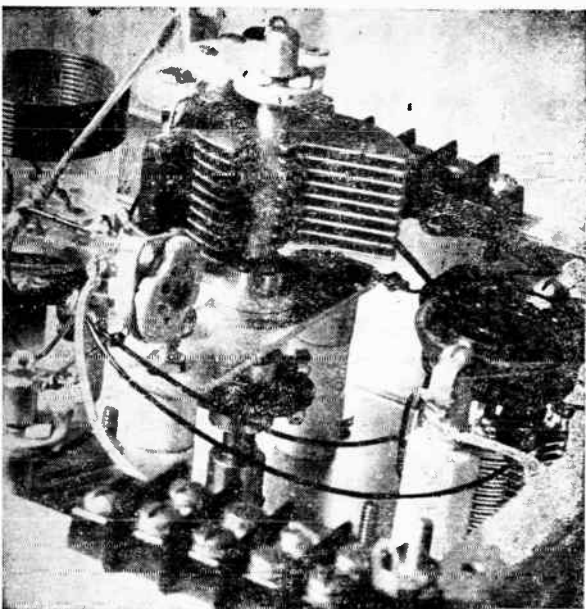

Ceramic insulators, bridged by a metal strip, hold the oscillator condenser off the chassis. The midget tuning capacitor, C3, may be seen at the right, under the output-coil socket.

it has a high voltage at both ends and therefore must be electrically separated from the chassis. Mounting inserts are insulated, and the hole through which the shaft projects must give adequate clearance.

Input and output signal leads are brought to a terminal strip on the rear top edge of the chassis; power connections center in another block at the lower edge. Power for the converter can readily be taken from most AC receivers, but where proper voltages are not available (on some AC and all AC-DC sets) it is advisable to construct a separate power supply. This will have the additional advantage of making the unit completely self-contained.

The photo of the power supply shows how the long bolts that hold the transformer-core laminations are used to support an aluminum panel upon which the rectifier tube (6X4), the filter capacitor, and the filter resistor are mounted. The switch could have been mounted here rather than on the converter, but the arrangement shown was found more convenient in use, and it also lessens the danger of shock by making it unnecessary to handle the high-voltage supply once it is connected.

While considerable leeway is possible in the arrangement of wiring and components,

LIST OF PARTS

- C1, C2: 140-mmf. variable capacitor (Hammarlund type MC-140M).
- C3: 75-mmf. midget variable (Hammarlund type APC-75).
- C4: 50-mmf. midget mica.
- C5: .01-mfd., 400-volt paper.
- C6: 18-18 mfd., 450-volt dual electrolytic.
- R1: 20,000-ohm, ½-watt carbon.
- R2: 30,000-ohm, 10-watt wire-wound.
- S1: SPST toggle.
- T1: power trans., primary: 115 volts; secondary: 700 volts (at 50 ma.) center-tapped, and 6 volts (at 2 amp.).
- Coil forms (3) 5-prong, 1½"-dia, polystyrene (Amphenol type 24-5P).
- Coil sockets (3) 5-prong.
- Tubes, 7-prong miniature sockets, chassis, knobs, misc. hardware.

the coils *must* be as specified if proper results are to be obtained. They are worked out so that, when tuned with the capacitors specified, they will operate properly over a frequency band ranging from approximately 6 to 16 mc.

Connect the antenna terminal of the broadcast receiver to the converter; if no ground connection is provided on the receiver, wire the other end of the output-coil secondary to the chassis of the receiver through a .01-mfd. condenser. Remember that on some sets the chassis is "hot." Now set the dial of the broadcast receiver to 1,500 kc. If you get interference at this point, turn the dial slightly (toward the high-frequency end, if possible) until you have tuned out the interfering station.

For good long-distance reception, an outdoor antenna about 40' long should be used, although in actual tests this converter gave good results with a short indoor aerial. Connect it to the proper input post, leaving the ground lead open for the moment. Turn on the power for both sets and adjust the receiver volume control for maximum gain. Starting at the lowest frequency on the oscillator dial (plates completely in mesh), slowly rotate the knob until some signal is heard. It doesn't make any difference what the

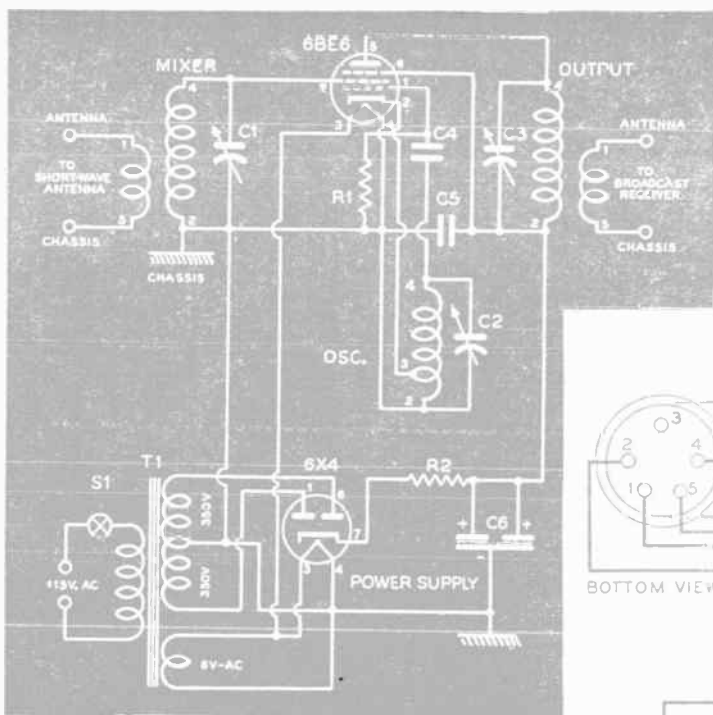

Schematic diagram shows how to wire the simple one-tube converter and its power supply. If possible, follow the parts layout shown in photos, keeping all signal leads short.

Coils are critical. Make sure that the forms are the right size and that wire and number of turns are exactly as specified. They are calculated to cover the 6 to 16 mc. bands.

signal is so long as it is steady enough so that you can use it to peak the converter. With a fiber wand, carefully rotate the midjet capacitor C3 until the signal reaches maximum strength. Now rotate the mixer control, C1, until the test signal is again brought to maximum. The ground lug adjacent to the antenna input terminal should now be touched to the chassis to see whether this increases volume; if it does, make a permanent connection.

Once these preliminary adjustments have been made, do not touch C3 or the dial of the broadcast receiver. Change stations by rotating the oscillator capacitor, and then peak the signal by careful adjustment of the mixer control.

Image signals may cause the converter to bring in the same station at two different settings of the oscillator dial. To tell which is the correct position, look at the plates of the oscillator and mixer capacitors. They should be in or out of mesh to about the same extent. However there's no harm done if you peak up on an image rather than a true signal except that dial settings will be out of proper sequence.

The range of the converter includes a majority of the international broadcast bands as well as many amateur transmissions.

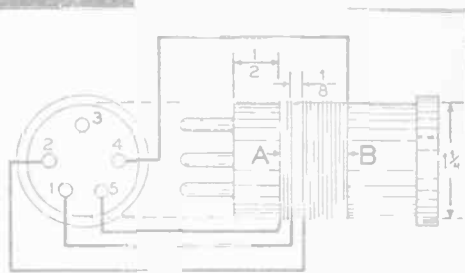

BOTTOM VIEW OF FORM
MIXER COIL

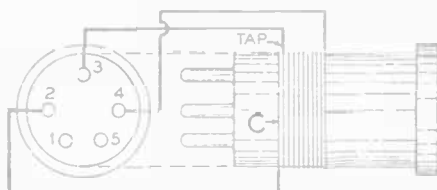

BOTTOM VIEW OF FORM
OSCILLATOR COIL

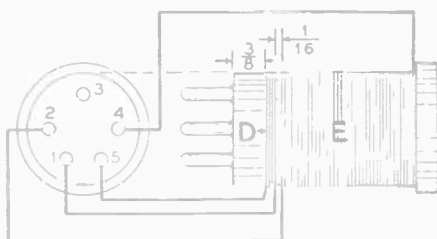

BOTTOM VIEW OF FORM
OUTPUT COIL

COIL DATA

All turns close wound with plain enameled copper wire; sizes as given below.

Mixer Coil:

- A: 3 turns, No. 18.
- B: 11 turns, No. 18.

Oscillator Coil:

- C: 10 turns, No. 18; tap 1 complete turn up from bottom end.

Output Coil:

- D: 5 turns, No. 26.
- E: 87 turns, No. 26.



To check the frequency of your signal, separate your receiver and transmitter, and listen in on yourself.

GET STARTED IN HAM RADIO WITH THIS

Midget 80-Meter Code Transmitter

By CLINTON E. CLARK

A RADIO "station" hardly bigger than a shoe box is an ideal rig in many respects. If you've just obtained your license, you can use it to get on the air at the cost of a few dollars and even fewer hours. On the other hand, if you're an old timer operating a more elaborate phone transmitter, here's a quick and inexpensive way to renew your acquaintance with the fast-fingered hams who keep the code hands clicking.

Despite its size, this transmitter is capable of real performance. Just bear in mind that the 80-meter band is crowded with high-powered outfits, so you'll have the best chance of getting through during the relatively quiet hours.

For the baseboard, take a piece of $\frac{3}{4}$ " by 5" by 7" wood and center the tube socket and six-prong crystal holder on a line $2\frac{1}{2}$ " from the rear. Raise the socket on $\frac{1}{8}$ " sleeves or small insulators, and drill a $\frac{3}{8}$ " hole under

it to pass the filament and cathode wires. Fasten a six-lug terminal strip along the rear edge of the wood.

To make the plate coil, L3, wind 38 turns of No. 20 D.C.C. wire on a 2" dia. form, spacing the turns to a length of 3". This coil is center tapped, as indicated in the diagram, and has a two-turn coupling coil wound over it. The antenna coil, L4, is made in the same way except for the omission of the center tap. Mount the plate coil alongside the tube socket on a pair of standoff insulators.

The antenna tuning unit is the electrical counterpart of the coil-condenser circuit in the transmitter. Front and rear panels are made of $\frac{1}{4}$ " by 6" by 6" composition board separated by $\frac{1}{4}$ " dowels 3" long.

When the wiring is completed, connect the transmitter to a power supply capable of delivering 250 to 300 volts to the plate, and 6.3 volts to the filament. Shunt a 0-to-200 milliammeter across the keying circuit as shown in the diagram, and, with the tube

lit, apply plate power by closing the key. The meter needle should rise sharply, but as the plate circuit is tuned to the operating frequency of the crystal, the meter will register a downward dip.

The next step is commonly called "loading the antenna." Connect twisted lamp cord between terminals *y-u* of the transmitter and antenna unit, hook up the antenna and ground, and rotate the antenna-tuning condenser. With the key closed, the meter needle will rise when the antenna is in resonance with the transmitter. After loading the antenna, it is sometimes necessary to retune the transmitter slightly. Another method is shown at the right. The bulb should be brightest when the transmitter is tuned to resonance, but the light decreases as the antenna is closed.

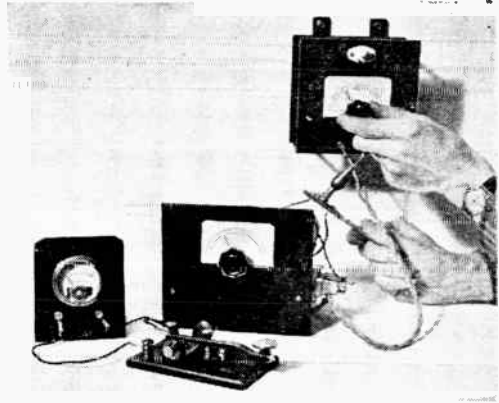

An alternative antenna-tuning method consists of connecting a loop of wire to a neon or Christmas-tree bulb, and holding the loop near either end of the plate coil. Energy in the coil lights the bulb.

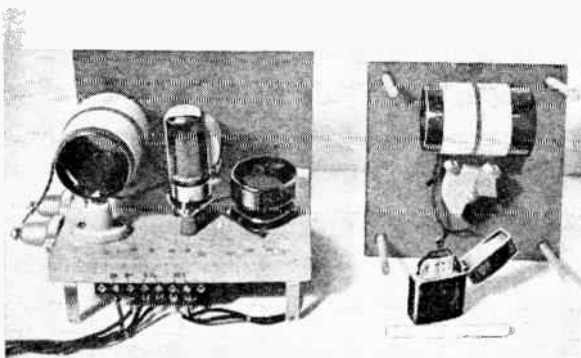
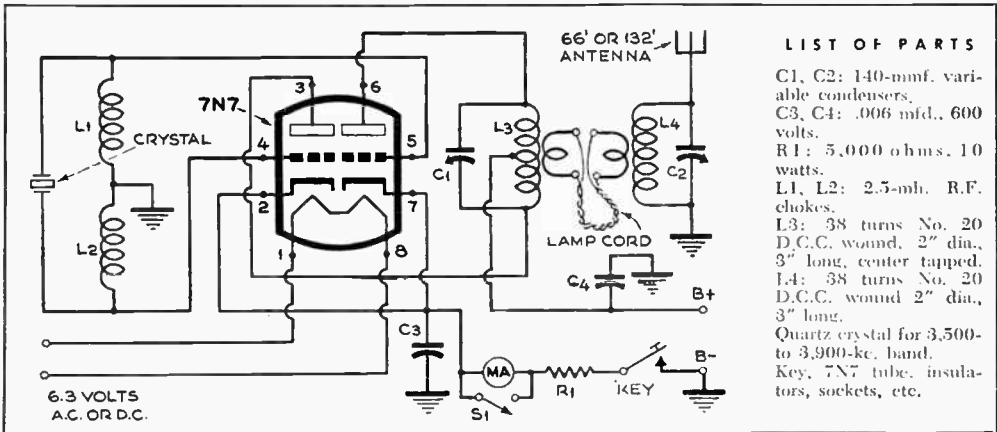

Legs for the transmitter are formed by two metal angles in back, and the bottom of the panel in front. The two stand-off insulators at the far left support the link-coupling coil, which is made of two turns of insulated wire around the center of the plate coil. Underneath the baseboard, mount the two R.F. chokes, the two by-pass condensers, and the 5,000-ohm cathode resistor, as shown at the right.

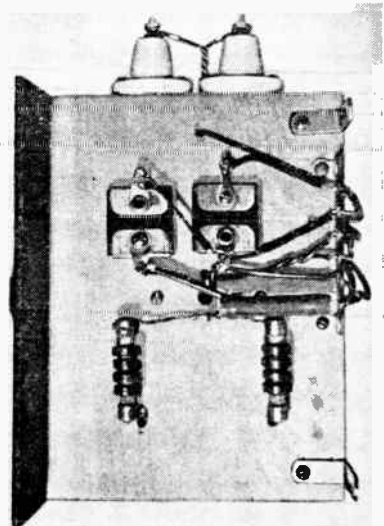

Two-Meter Handie Talkie

ADD THIS PORTABLE TRANSCEIVER TO YOUR LICENSED EQUIPMENT

By Harry R. Hyder

UNDER favorable conditions, a range of up to 30 miles is possible with this compact, self-contained transceiver, modeled on the handie talkie of the armed forces. It is designed for use on the new 144-148-mc. amateur band, and, in common with all high- and ultrahigh-frequency apparatus, its effective range depends on altitude. The farther the horizon, the greater the distance you can cover. But the power is all there—packed into a 5" by 6" by 9" case. Licensed amateurs will find this portable rig a handy addition to their present stations.

The circuit itself is simple; a 958A acts as a detector when receiving, and an oscillator when transmitting, and a 3Q4 doubles as an amplifier and a modulator in the same order. A single dry cell constitutes the filament supply of both tubes. For reliable operation on very-high frequencies, the familiar ultradion detector-oscillator circuit is used.

Lead lengths are particularly important on these frequencies; in the oscillator, the terminals of one component are soldered directly to the terminals of another. The antenna is capacitively coupled to the grid end of the oscillator tank coil.

It is important that the stator of the tuning condenser go directly to the plate of the 958A, and the rotor to the grid, since the ultradion oscillator depends for its feedback on the ratio of plate-to-filament and grid-to-filament capacities. With the condenser connected as shown, these capacities are just about right. All but one rotor and one stator plate were removed from a midget 6-plate 15-mmf. tuning condenser. The condenser and the acorn-tube socket are spaced from the chassis on $\frac{1}{2}$ " ceramic pillars, and the shaft of the condenser is joined to the dial by a flexible coupling.

To make the two chokes (L2, L3) shown in the oscillator circuit, wind 25 turns of No. 22 enameled wire on 5-megohm, 1-watt resistors, and solder the ends of the wire to the resistor pigtailed. Coat the coils with cellulose cement. For the oscillator coil (L1), wind 6 turns of No. 18 tinned wire to $\frac{3}{8}$ " inside diameter, spacing them to a total length of $\frac{1}{2}$ ". A transceiver transformer of the "microphone and plate-to-grid" type is used to couple the detector-oscillator to the amplifier-modulator.

Bias for the 3Q4 is supplied by a 350-ohm resistor in the negative B return; this reduces the total plate potential to 85 volts.

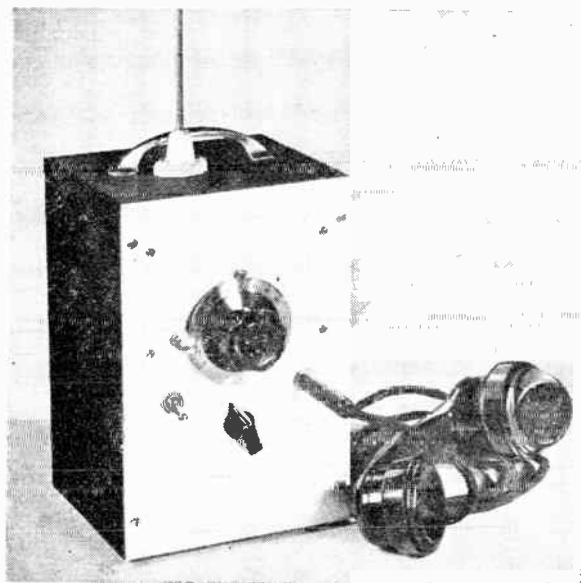

The complete transceiver, left, can be carried about conveniently. Careful placement of the parts is important both for compactness and to keep leads short.

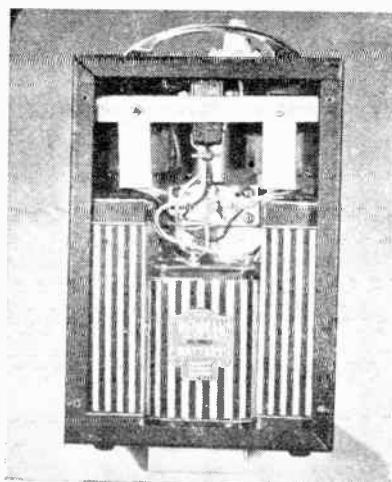

but does away with the C battery; the filaments of the tubes are wired for 1.4-volt operation. Place a small shield over the tube to reduce R.F. pickup from the tank coil.

In transmitting, only the primary of the speaker output transformer is used, while in receiving half the primary is used, and the 2,000-ohm phone is connected to the voice-coil winding. This isn't good matching, but since the gain and output of the 3Q4 are rather high, enough power is delivered to the phones to give comfortable volume.

Current for the microphone is taken from a 1.5-volt dry-cell A battery. The handset contains a 200-ohm carbon microphone in addition to the 2,000-ohm receiver. A three-way jack on the front panel takes the matching plug on the handset.

Part sizes must be kept to a minimum if the entire assembly is to fit properly into the container used for this model. Two 45-volt B batteries and a small 1½-volt A cell make a compact package, as can be be seen in the right-hand photo on page 104. A 4-prong plug and socket assembly is used to connect the batteries to the set terminals, and facilitates removal of the batteries for checking



Try to get above nearby buildings when operating in a city.

and replacement. Screw four small rubber bumpers to the bottom of the can, and place over them a 5" by 6" sheet of ¼" composition board with holes drilled in the corners to clear the bumpers. This board serves as a floor under the batteries.

Mount the chassis, inverted, at the top of the

Brass spacers ¼" long are used to separate the chassis from the front panel. Both switches are mounted directly on the panel. The tuning condenser is built on a ceramic plate and spaced off on ½" pillars.

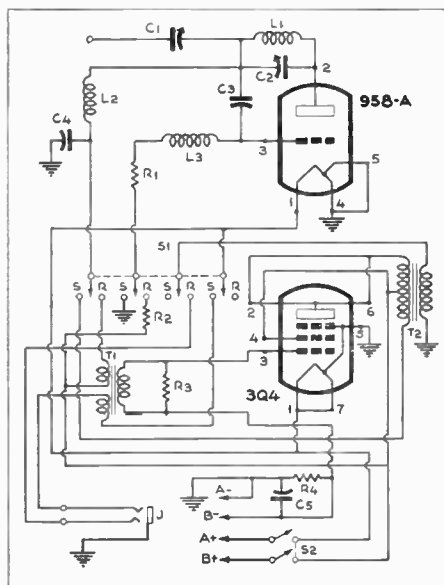
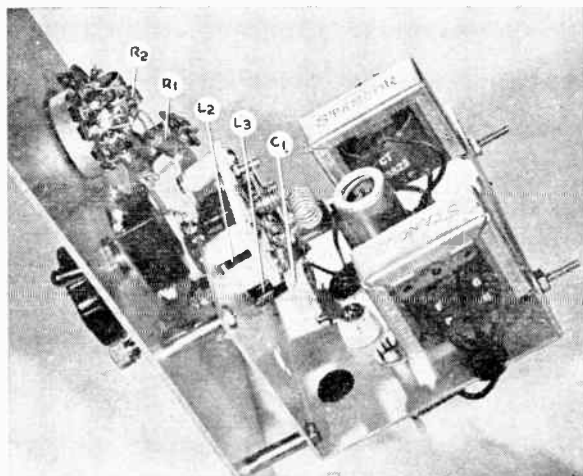

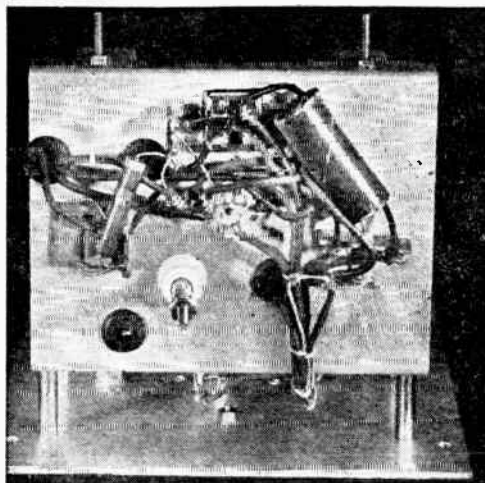
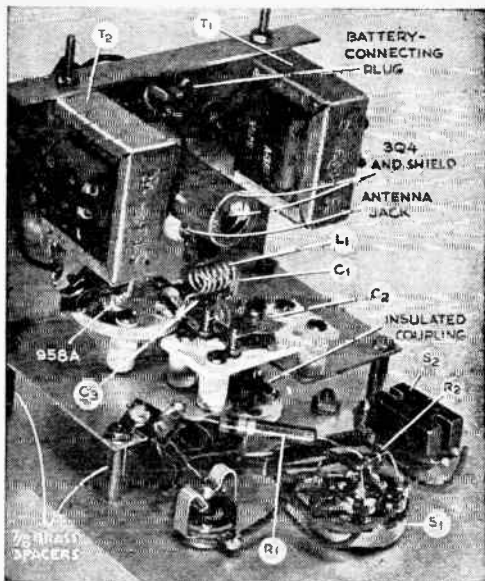

Most of the leads are brought around to the under side of the chassis, which becomes the top when the set is fitted in place. The antenna jack protrudes straight upward through the top of the case.

the front panel, spacing it from the panel with $\frac{3}{8}$ " brass collars. The screw for the antenna insulator projects through the hole at the top of the case. Two extra-length screws were used in mounting the transformers; these come out through holes drilled in the back cover. Resting in the holes, these screws help take up the weight of the chassis. Since it is not always possible to obtain the right part in the right size, you may find it preferable to wait until you have the entire unit assembled before determining the dimensions of the case.

A 27" length of $\frac{3}{16}$ " brass tubing is used for the antenna. Tap one end to fit the antenna insulator screw; this will probably require a 6-32 tap. While this holds the antenna in place, it does not provide much protection against vibration and movement. This deficiency can be corrected by bolting a 1" ceramic standoff insulator directly over the antenna clearance hole, and drilling out the core of the insulator to a diameter that will make it a close-fitting sleeve around the antenna rod.

If the transceiver has been wired correctly, it should work without additional adjustments. A rushing noise will be heard when the handset is plugged in and the change-over switch is turned to "receive" position. Rotate the dial slowly, and listen for signals. If the rushing stops at any point on the dial, the antenna is probably coupled too tightly, and the capacity of the coupling

condenser, C1, should be reduced to the point where smooth superregeneration is obtained over the entire band. This is important in transmitting as well as in receiving.

The 144-148-mc. band covers about 25 divisions on the dial. Most of the stations operating on these frequencies are broad, modulated oscillators, and extremely sharp tuning is therefore unnecessary. If the band is not quite centered on the dial, compress or expand the tank coil until it is.

For easy portability, bolt a handle to the top of the case. Center the handle as nearly as possible, allowing clearance for the fingers around the antenna insulator.

LIST OF PARTS

- C1: 1.5 to 7 mmf. ceramic trimmer.
- C2: modified 15-mmf. midjet tuning cond., .017" air gap. See text.
- C3: 50-mmf. mica.
- C4: .003-mfd. mica.
- C5: 20-mfd., 25-volt dry electrolytic.
- R1: 20,000-ohm, $\frac{1}{2}$ -watt carbon.
- R2: 4.7-meg., $\frac{1}{4}$ -watt carbon.
- R3: 470,000-ohm, $\frac{1}{4}$ -watt carbon.
- R4: 350-ohm, $\frac{1}{2}$ -watt carbon.
- T1: Single-button microphone and plate-to-grid transformer.
- T2: Universal speaker output transformer.
- S1: Four-pole, two-position rotary switch.
- S2: D.P.S.T. toggle switch.
- J: Three-way jack.
- L1: Tank coil. See text.
- L2, L3: R-F. chokes. See text.
- Handset, 200-ohm carbon microphone and 2,000-ohm receiver.
- Tubes, sockets, insulators, misc. accessories.

Low-Cost Parts Test Radios



Most radio breakdowns are due to the failure of some one part. Here are some simple tests to help you find the trouble.

By Frank Tobin

THERE'S no denying that radio servicing can be a complicated business. At its best it calls for a nice combination of theoretical knowledge and practical experience. But it also has its simple side, and here's why: when a radio that was playing well yesterday just stops operating or drops off in quality, the overwhelming probability is that some

one thing has gone wrong. Moreover, some parts break down much more frequently than others. With a little basic knowledge and a lot of common sense you can usually find the guilty component pretty quickly.

This doesn't mean that you're all set to go into the radio-repair business. It does mean that you're probably better than you may think at fixing your own or your friends' receivers. The miniature servicing "labora-

Nine separate servicing tests are possible with the parts crammed into this wooden box. The tests cover most common radio ailments.

Complete pocket laboratory. Extra equipment includes headphones and test prods. Auxiliary tips and clips for the prods are helpful.

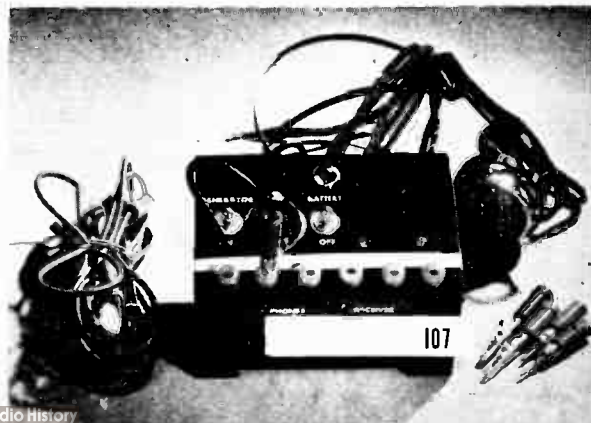
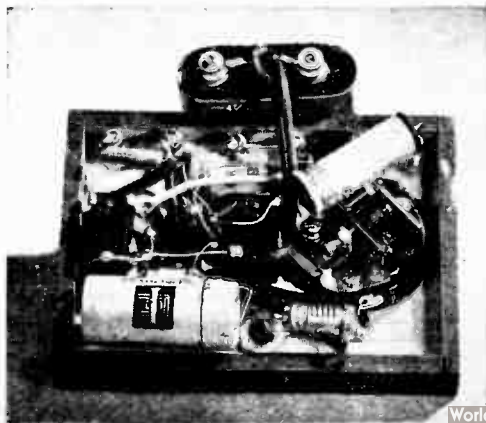

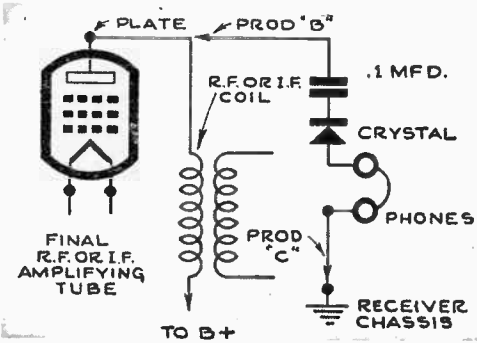
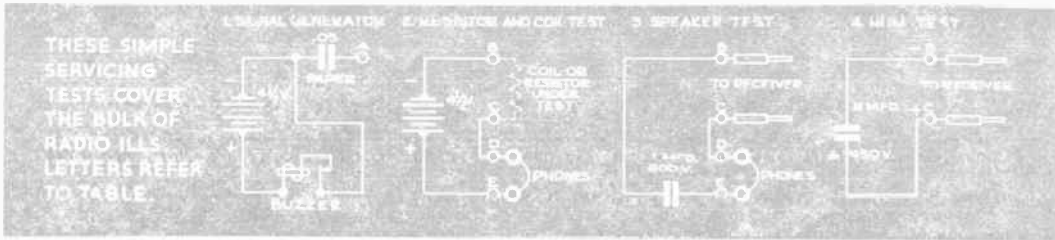

RF test No. 5 connects a crystal detector to the RF or IF plate. The circuit is shown above.

...tory" shown in these photos cost only a few dollars to build. It is simply a collection of inexpensive parts that combine in one unit the various test setups shown in the diagrams across the top of these pages. Each test is complete in itself and requires only the parts indicated by the individual drawing.

For example, to inject an audible signal

into a radio receiver, you need only a small buzzer, a battery, a .05-mfd. paper condenser, and a test prod. Put the prod on the grid pin of a tube—starting with the output stage and working back. If the signal is heard in the loudspeaker, you know that the stage being tested (and all those following it) are working. When it stops being heard, you have probably found the offending stage.

With the complete pocket laboratory you can carry this test one step further. The table describes the first part. To this setup add a pair of headphones by plugging them in at Jacks D and E, and another set of test prods at jacks C and F. With prod A on the grid of an audio tube (or the plate of the same tube (or the grid of the following one) and prod F grounded to chassis, you should be able to pick up the signal in the phones. Note, however, that it applies only to detector and audio tubes.

Common sense enters the picture in helping you select the order of the tests and de-

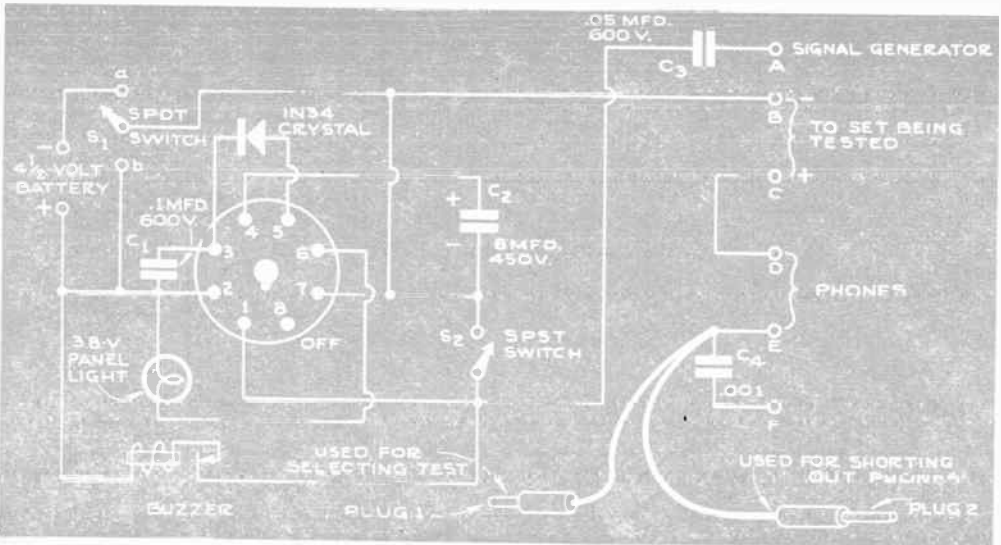

An octal tube socket is used for pin connections; jacks A to F are set in front of panel.

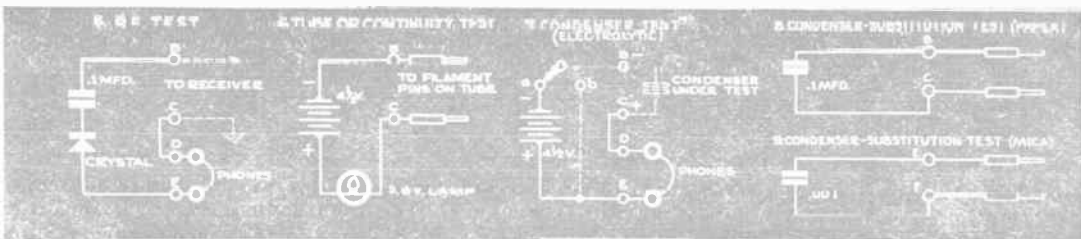

cluding which ones will be useful. If a set, for example, is not working at all and the tubes don't light up, the signal-generator test simply doesn't apply. In an AC-DC receiver, there's a good likelihood that these symptoms point to a burnt-out tube heater. Filaments are connected in series in sets of this kind, and when one goes the whole set stops working. Where a tube failure is suspected, check the filaments first. For this use test 2 or 6. Both are continuity tests, but the former will register (by a click in the headphones) even across a high resistance.

The latter gives an indication (lighting up the pilot lamp) only if there is comparatively little resistance. If test 6 fails to indicate, always try test 2 before discarding a tube as burned out. The low-resistance test is also useful for straight continuity checks, while test 2 is invaluable for revealing open circuits across coils and resistors.

If the tubes light up but the set fails to play, there are a number of things to consider. An ordinary neon tester will tell you whether B-plus voltage is getting through from the rectifier. Use it carefully to avoid

HOW TO USE THE POCKET LABORATORY

TEST	PLUGS	JACKS	APPLICATION	S1	S2
1	Plugs not used	Test prod in Jack A	Signal-generator buzz is heard in speaker if tested stage is operating.	<i>a</i>	On
2	Plug 1 in Pin 2; Plug 2 not used	Phones in Jacks D and E; prods in B and C	Resistor and coil test. Click in phones indicates continuity through coil or resistor.	<i>a</i>	Off
3	Plug 1 in Pin 3; Plug 2 not used	Same as above	Speaker test used when no sound is heard and speaker, output tube, or transformer is suspected. (See text.)	<i>b</i>	Off
4	Plug 1 in Pin 4; Plug 2 in D	Test prods in Jacks B (-) and C (+)	Where hum or whistling is caused by defective filter condenser, placing prods across suspected unit diminishes hum.	<i>a</i> or <i>b</i>	Off
5	Plug 1 in Pin 5; Plug 2 not used	Phones in D and E; prods in B and C	Touch Prod B to plate of RF or IF tube, and C to chassis. If these stages work, phones give reception.	<i>b</i>	Off
6	Plug 1 in Pin 6; Plug 2 in D	Test prods in B and C	Continuity test; may also be used for checking burnt-out tube filaments.	<i>a</i>	Either
7	Plug 1 in Pin 2; Plug 2 not used	Phones in D and E; prods in B and C	Charge large electrolytics with S1 at <i>a</i> ; throw to <i>b</i> and tap one prod against terminal. Phones should click as condenser discharges. (See text.)	<i>a</i> and <i>b</i>	Off
8	Plug 1 in Pin 3; Plug 2 in D	Test prods in B and C	Touch prods across terminals of suspected paper condenser. If condenser is faulty, operation should improve.	<i>b</i>	Off
9	Plugs not used	Test prods in E and F	Same as No. 8, but for mica and ceramic condensers.	<i>a</i> or <i>b</i>	Either



The pocket laboratory quickly tracked down the fault in this receiver. Used for stage-by-stage checking, it's a valuable service tool.

shocks. Put one terminal on the chassis or ground and the other on a screen-grid or plate pin of a tube. If the neon lamp glows, the voltage is probably adequate.

But let us assume that you are getting the necessary voltage and none of the tubes is burned out. This could suggest that the receiver itself is functioning but that the speaker or output transformer isn't. Test 3 will tell you whether this is so. Touch one test prod to the plate of the output tube and the other to chassis and see if you can pick up a signal in the earphones. If you do, look for speaker trouble. It may be an open winding in the transformer or voice coil, in which case the defective unit will have to be replaced. The same test can be used at the plate of the detector tube. Should you get no signal in the phones, the trouble probably lies further back in the circuit. Use the signal-generator test, working back from the output until the faulty stage shows up.

Or you can start from the "front end" of the receiver with RF test No. 5. This test, in effect, constitutes an untuned crystal set. By adding it to the tuned RF portion of a set you can get headphone reception, provided the RF circuits are operating.

Hum in a receiver is frequently caused by a faulty electrolytic condenser in the filter circuit or in the cathode-bias of a tube. Test 4 puts an 8-mfd. electrolytic in parallel with the suspected condenser. If hum is reduced, the condenser in the set should be replaced. Observe polarity in making the test. Prod C goes to the positive side of the electrolytic and prod B goes to the negative side or chassis.

When you suspect a paper condenser of being shorted, make continuity test No. 6. If the pilot lamp glows, double-check by

unsoldering one lead of the condenser and repeating the test on it alone. With one lead open, use test 8 to put a good condenser in the circuit.

Test 7 applies to the larger electrolytics used in filter circuits. The index of a good electrolytic is its ability to store a charge. With the set turned off put prods B and C across the condenser, observing polarity. Throw S1 to position *a* to put the battery in series with the condenser. Change S1 to position *b*, then lift either one of the prods for a fraction of a second. This is almost a rubbing or a tapping motion. As the stored charge leaks off, you should hear rapidly diminishing clicks in the headphones. With smaller electrolytics the 4½-volt battery won't store enough of a charge to click the phones.

There are some additional rule-of-thumb tests you can make when you want to find out the condition of a condenser. These are based on the observation that when you put a good condenser in parallel with a bad one, part of the trouble caused by the defective unit should clear up. A leaky or open condenser (as distinct from one that is shorted) may cause loss of volume, distortion, or other symptoms. Tests 4, 8, and 9 are substitution tests for electrolytic, paper, and mica condensers respectively. They put a condenser that is known to be good across one that is suspected. If the suspicion is correct, the test should produce a marked improvement in set performance. Replace the faulty unit.

Make all tests with caution. Be sure the power is off when it isn't actually needed for the check you are making.

Building the pocket laboratory consists simply of putting the components used in the individual tests into a single box. A wooden box measuring 1¾" by 3¼" by 4½" was used here. The dimensions aren't critical. Neither are the parts, except that they must be dependable and of good quality. A high-frequency buzzer, capable of operating on a 4½-volt C battery is another requirement. The jeweled panel lamp was purchased as a complete assembly with socket and mounting bracket; the 1N34 crystal is a germanium diode.

Since connections must be interchangeable, all contacts should be uniform in size. Phone tips are convenient, since headphones come equipped with them and test prods may be so purchased or the original tips can be replaced. They also allow the use of an octal tube socket to permit selection of pin positions.

Circuit Tester

USES TUNING EYE AS METER

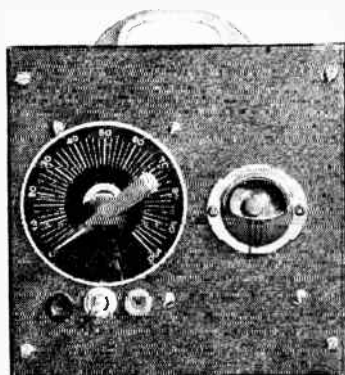
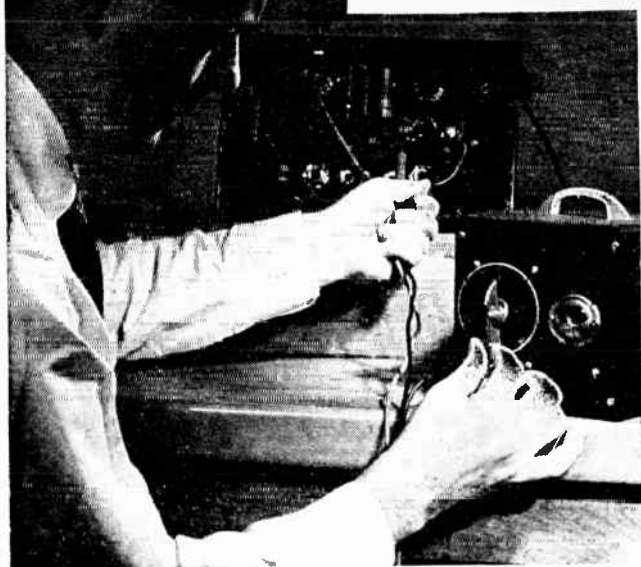

When correctly calibrated by the builder, this circuit tester will give accurate readings between 1.5 and 45 volts. The range can be extended by putting extra resistors in series with the potentiometer.

WITH a 6E5 tube serving as an indicator, this vacuum-tube voltmeter gives accurate readings from 1.5 to 45 volts, and will safely handle up to 90 volts, enabling the serviceman to check for moderate screen and plate voltages. A detector circuit rectifies signal voltages, making it possible to trace and test A. C. as well as D. C. Although it has the no-load advantages of more expensive vacuum-tube meters, this tester can be built at moderate cost.

The entire assembly is mounted on the front panel of a 6" by 6" by 6" metal cabinet. A standard 6.3-volt filament transformer delivering 1 amp. in the secondary heats the 6E5 tube, and an audio transformer is pressed into service as a power transformer. With a fixed crystal detector and a protective .05-mfd., 600-volt condenser, the tester is able to detect an A. C. signal.

To calibrate the scale, apply several known voltages, and adjust the potentiometer for each one until the angle of the eye is at minimum. With a straight-line potentiometer it is only necessary to obtain a few

typical readings from which intermediate values can be calculated. To increase the range of the meter, add a 250,000-ohm resistor between the potentiometer and ground.—N. C. HEKIMIAN.

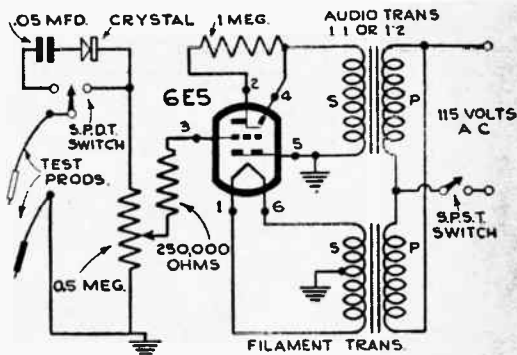

The S.P.D.T. switch on the input side cuts in a fixed crystal detector for testing A.C. circuits.

Capacity Bridge for Testing

By **GEORGE O. SMITH**

TO MOST casual radio experimenters, condensers are a bit like electric-light bulbs: either they're good, or they're bad, and it's not hard to tell which. In a majority of cases this rule-of-thumb works out pretty well. An ohmmeter or a simple neon tester tells you all you need to know for a quick decision.

One vital fact about a capacitor, however, is neglected by these oversimplified tests—its capacity. This useful instrument fills the gap, and makes possible many refinements in radio testing and construction. It does it by telling you the value of an unknown condenser.

No provision is made for testing shorted condensers, as these may be readily checked with an ohmmeter. "Open" condensers show up, however, since they have only a small fraction of their rated capacity.

The theory of the bridge is simple. Figure 1, below, shows a basic form of Wheatstone-bridge circuit, with all resistors equal. Current flowing through the members of the bridge divides equally, and no voltage difference exists across the meter. Lowering one resistance, say R1, produces the unbalanced condition illustrated in Fig. 2. The division across the lower pair remains the same, since these resistors are unchanged, but the altered proportions in the upper half cause a voltage increase at the junction. The meter reads the difference between the two junction voltages. If R2, the corresponding resistor in the lower pair, is reduced proportionately, the junction

voltage will again be equal, although not necessarily at half the input.

Combining the lower divider into a single potentiometer makes possible a wide variation in division ratios. That is the basis of the capacity bridge. Since, however, capacitors will not pass direct current, the batteries represented in Fig. 1 and 2 are replaced in Fig. 3 by an alternating-current source. Any A. C. voltmeter could, theoretically, be used to complete the bridge, but in practice few would prove sensitive enough for the job. This is particularly true since voltage difference becomes extremely small near the balance point. Therefore the meter is replaced by an amplifier that drives the 6E5 indicator tube.

In the schematic diagram on page 114, the bridge circuit may be traced out, although its configuration is not very clear. Potentiometer R1 obviously replaces R2 and R3 of Fig. 3, and the "standard" impedance, Z1, corresponds to the condenser selected by switch S1. This switch allows the use of three continuous ranges from 10 micromicrofarads to 10 microfarads, covering all the condensers used in most receivers. It is possible to calibrate the dial for still broader coverage, but this will result in decreased accuracy.

The "unknown" side, Z2, consists of any capacitor connected across the test terminals. A 5-volt winding of a power transformer is used as the A. C. source.

One side of the 6SL7 is connected as a high-gain amplifier, the other side as a rectifying diode. To give good sensitivity on the low-capacity range, R4 is made quite

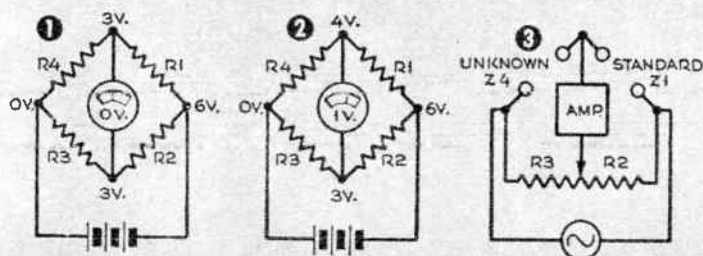

When all resistors are equal (Fig. 1), the voltage across the Wheatstone bridge divides so that the meter reads zero. An unequal division obtains when R1 is reduced (Fig. 2). Lowering R2 or R4, or raising R3, will tend to re-balance the bridge, since

$$\frac{R1}{R4} = \frac{R2}{R3}$$

Condensers

large. Output from the amplifier is coupled to the diode through C4. This value is not critical. A 1-mfd. condenser is specified, but anything from .25 mfd. to 4 mfd. may be substituted.

When the unknown capacity is out of balance with the known, the available A. C. is amplified in the first section and rectified in the second, placing a positive voltage on the grid of the 6E5 indicator. Potentiometer R2 is used to adjust the eye of the tube to an almost-closed position, since this is the most sensitive part of the 6E5 operation curve.

Most of the components are noncritical, but the three bridge condensers, C1, C2, and C3, should be as accurate as possible. The additional cost of capacitors having close tolerance will pay off in increased accuracy.

A standard small transformer is used for the conventional power supply. By using a 6X5 rectifier that will operate off the 6.3-volt winding, the 5-volt section is left free for the bridge supply. All three tubes share the same heater power; do not ground them at the sockets, but run a twisted filament line through the chassis and ground the entire circuit at pin 8 of the 6SL7.

The center arm of R1, and the "adjust" position of the range-selector switch are grounded at the same spot on the chassis, along with a number of other parts. This practice minimizes chassis currents, which are capable of causing trouble in the balance of the bridge. Filter C5, C6, and R6 is used to smooth the rectified output of the detector diode so that the grid of the indicator will be furnished with D. C. proportional to the unbalance of the bridge.

Range selection is accomplished by means of a two-pole, five-position switch, but the line-switch portion may be replaced with a simple toggle, and a single-pole selector used instead. The line by-pass condenser, C11, is connected to the chassis at this point to help prevent the 115-volt A. C. from interfering with the other sections.

In operation the switch is turned first to the "adjust" position (between C3 and "off"), and left until illumination of the eye shows that the circuit is operating. The "adjust-eye" potentiometer, R2, is then

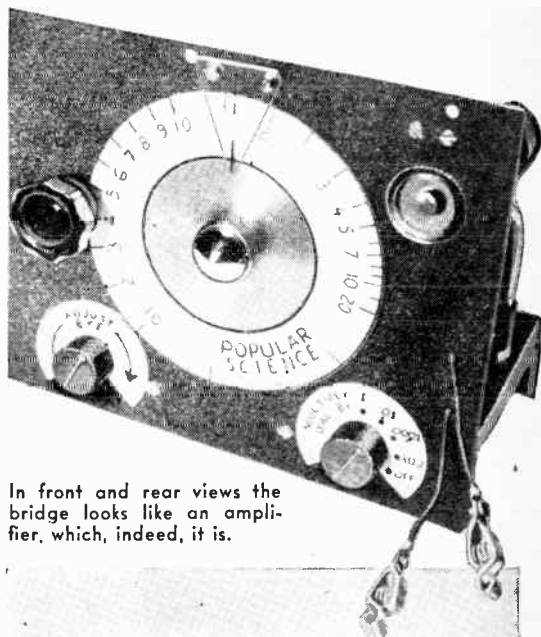

In front and rear views the bridge looks like an amplifier, which, indeed, it is.



turned until the eye is almost closed. Now connect the unknown capacity across the test leads, and turn the selector to the range most likely to cover. If, for some reason, you have no indication at all of the value of the unknown, work down from the highest range. Potentiometer R1 is rocked until the eye closes again. There may be a slight time delay.

To calibrate the dial, you will need seven condensers of known value and very close tolerance. These should be of the following values, in microfarads: .001, .002, .003, .004, .02, .03, and .04. Paste a circle of

LIST OF PARTS

- R1: 400-ohm wire-wound linear potentiometer.
 R2: 200-ohm wire-wound linear potentiometer.
 R3, R12: ± 2 ohms, close tolerance.
 R4: 10 meg.
 R5, R7: 1 meg.
 R6, R8: 500,000 ohms.
 R9: 20,000 ohms.
 R10: 2 meg. (in socket assembly).
 R11: 10,000 ohms, 10 watts.
 C1: 1 mfd. close tolerance.
 C2: .01 mfd. close tolerance.
 C3: 100 mmf. close tolerance.
 C4: 1 mfd. 400 volts.
 C5, C6: .1 mfd. 100 volts (dual).
 C7, C8, C9: 10 mfd., 350 volts electrolytic. (Triple-capacity unit, if available.)
 C10: 25 mfd., 25 volts.
 C11: .05 to .1 mfd., 400 volts.
 L1: A. C.-D. C.-type choke.
 T1: Small power transformer, 200 to 250 volts (at 30 ma.), 6.3, and 5 volts.
 S1a,b: Two-pole, five-position selector switch.
 Sockets, tubes, indicator-eye assembly.

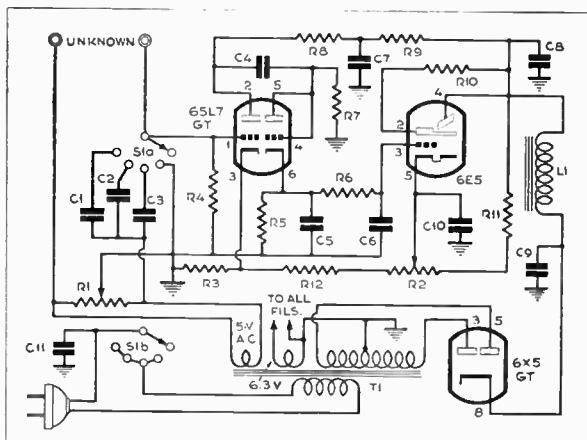

This circuit is an expanded version of Fig. 3 on page 112. Balance is obtained when the voltage division across the known and unknown condensers equals that across R1.

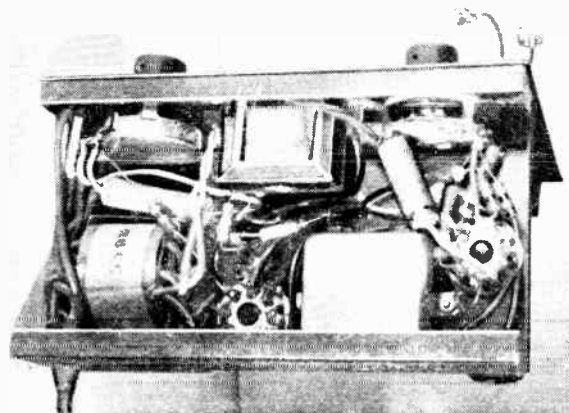

paper over the dial, and set the switch to the middle range. Starting with .001 mfd., adjust the eye for the null, and mark the dial at each step. Other values are obtained by adding the smaller units in parallel. For example, .005 is composed of .001 and .004; and the sum of the first four values equals .01. By adding condensers in parallel, the dial may be calibrated from .001 mfd. to .1 mfd.

Since C1 is 100 times greater than C2, setting the range switch up to this point will multiply the scale by 100, and give readings from .1 mfd. to 10 mfd. At the other extreme, C3 effectively divides the calibrations by 100, covering the span from 10 mmf. to .001 mfd.

Electrolytic capacitors can be measured by the bridge since 5 volts of A.C. is not enough to damage them. The average electrolytic has some inherent resistance and inductance which tend to decrease the eye angle, but the true value will be indicated at the null despite the fact that the eye may not be completely closed.

This incomplete eye closure, by the way, may be taken as an index of the condenser's quality. Balance any good condenser, then connect, say, a 50,000-ohm resistor across it. Note that the eye will open slightly. The effect is equivalent to measuring a condenser with an internal leakage of 50,000 ohms. Connecting the resistor in series also

widens the eye, being comparable to the internal resistance of an electrolytic.

The values given assume a total high voltage of 200 volts D. C. across C8. If this voltage is incorrect, R11 may be replaced by an adjustable power resistor of about 15,000 ohms. This will permit adjustment of the total voltage across the divider so that the eye angle may be set properly with potentiometer R2. Approximately 1.5 to 2 volts maximum is required at the cathode of the amplifier section of the 6SL7.

Test clips were used instead of insulated binding posts since this offered an easy way of connecting unknown condensers.

If a complete indicator-eye assembly cable is available, use it by all means. And don't bother changing the internally connected resistor, R10; it will be correct.

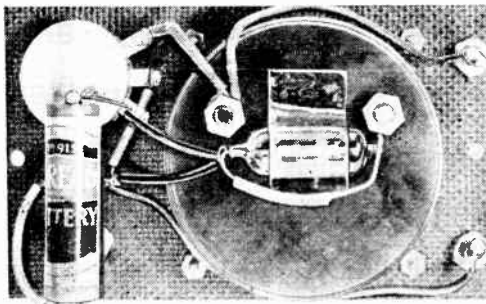
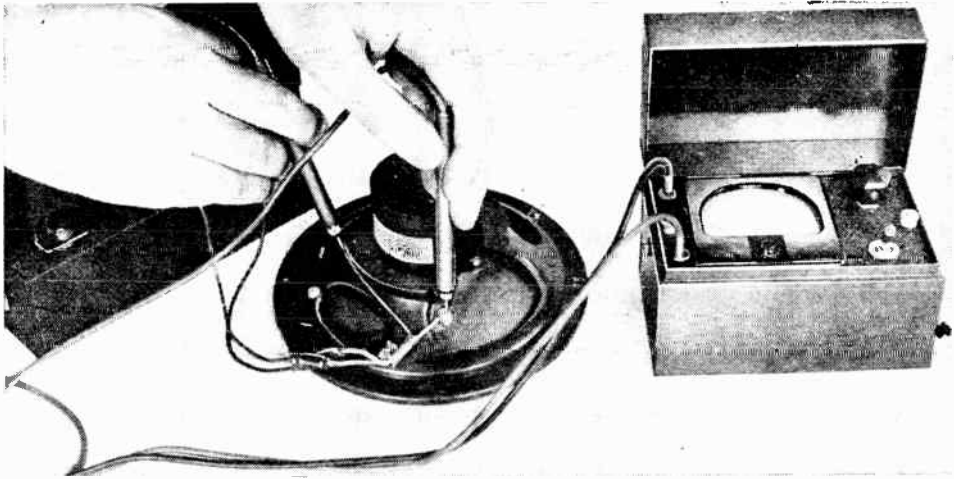

Connections on the underside of the meter. The midget triode used was taped to the milliammeter.

OUTPUT METER

Uses 1½-Volt Tube

FOR accurate alignment of the stages of a Superhet or TRF receiver, where the ear can't catch minute variations, an output meter is an inexpensive aid. Such a meter is also valuable when hooked up in a public-address system or with a home recorder for regulating output level during operation.

A midget war-surplus triode having a 1.4-volt filament was used as a diode detector in the meter shown, being secured with tape to the back of the 0-1 ma. D.C. milliammeter. A more readily available R.F. pentode, the 1T4, may be substituted by tying its grids and plate together. This tube will fit a button-base socket. Tape holds the 1.5-volt battery filament supply. A 3,000-ohm variable resistor across the meter input prevents overloading and keeps the needle on the scale. The housing is a card-file box.

In use the meter is connected across the secondary of the speaker transformer, in parallel with the voice coil (as in the photo above), or directly across the plate of the output tube and ground through a condenser (as in the drawing). The last increases sensitivity tenfold for weak signals. Adjust receiver trimmers for maximum scale deflection. If noise is objectionable in aligning I.F. transformers, disconnect the speaker.

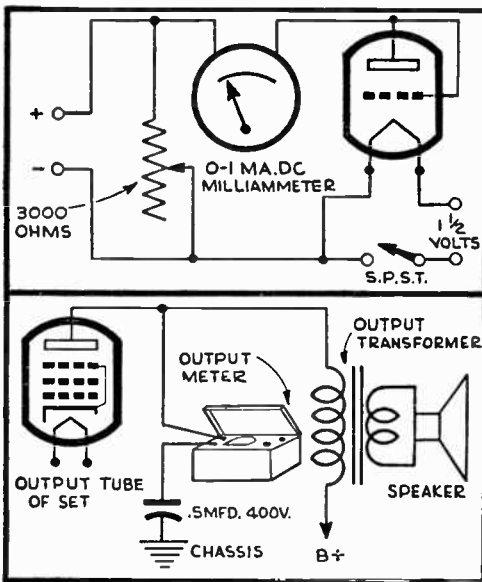

Maximum sensitivity of the needle is obtained by connecting across the output plate to a ground.

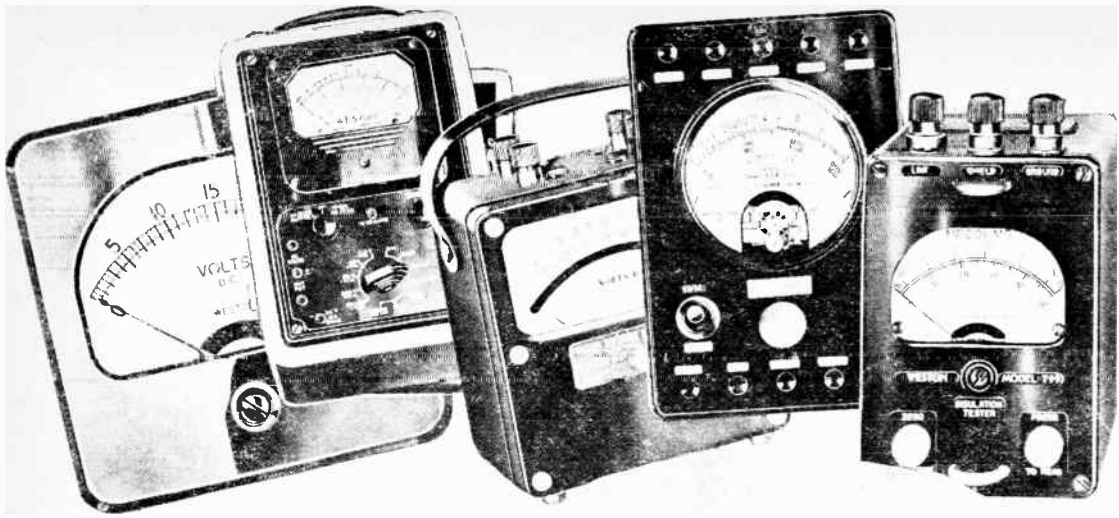

Meters Clock Electricity's Flow

By *Gilbert Soubergh*

FOR THE electronic experimenter, there's one tool that's just about as essential as a soldering iron—a wide-range AC-DC volt-ohm-milliammeter. If you work or play with electricity and have graduated out of the doorbell-and-dry-cell stage, you'll use such a meter to find accurate values of voltage, current, and resistance. Beyond these basic applications, your meter will also tell you a lot about the impedance, inductance, and capacitance of coils and condensers; it will help test tubes and do general troubleshooting; it will serve as an easy way of measuring output in voltage, decibels, or watts; and it will permit accurate determination of input to amplifiers and other apparatus.

Once you have a good understanding of the relation between volts, amperes, and ohms, you can build yourself one of these almost indispensable tools around any fairly

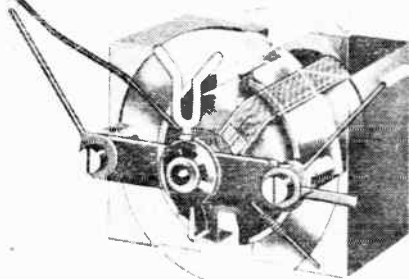

A D'Arsonval movement, shown here in phantom, indicates DC when the coil is energized.

sensitive D'Arsonval movement. To the beginner, it may seem to be asking a lot of one meter to measure such different things, but actually it has to measure only one to tell you all three. The ironclad magic of Ohm's Law does the rest. This law specifies that a current of 1 ampere will flow when a potential of 1 volt is applied across a resistance of 1 ohm. If the meter can measure any one of these, a second one being known, the third always pops up as the answer.

Heart of the standard DC meter, the current-measuring D'Arsonval movement consists of a lightweight pointer attached to a pivoted coil of fine copper wire. Mounted between jewel bearings, the coil is free to rotate in the field of a permanent magnet,

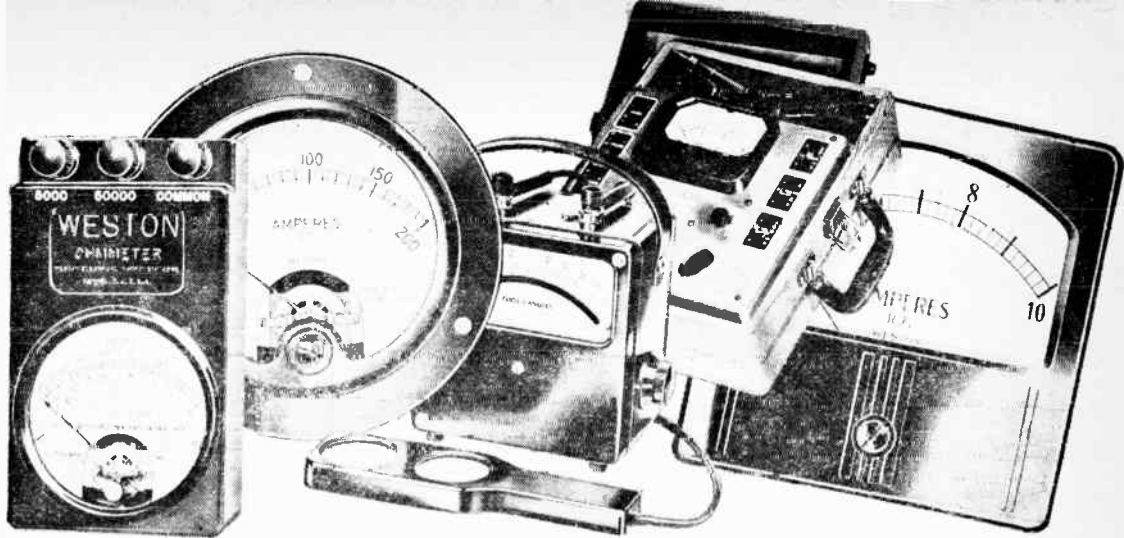

Two delicate hairsprings carry current to the coil and also serve to position it so that the pointer is normally at zero on the scale. When current flows in the coil, interaction of the lines of force produces a torque. This torque rotates the coil and its pointer to a position where it balances the opposing torque of the springs.

For greatest versatility, multimeter movements are usually designed to react to very low values of current, but it's a simple matter to increase the current range of such a meter. Let's say it has an internal resistance (R_m) of 100 ohms—that is, the moving coil itself offers this resistance to the flow of current—and that 1 milliamperere (.001 amp.) will deflect the needle all the way across the scale.

In order to double the range of such a meter, all you need to do is put a 100-ohm resistor in parallel with the meter to by-pass half the current, and multiply the reading by two. Shunts of lower resistance increase the current-handling capacity still more.

Volt and Ohmmeters

Milliammeters plus Ohm's law also add up to volt and ohmmeters. By measuring current, the former tells you how much voltage is being applied to a circuit of known resistance. Take the same 0-to-1 ma. movement with an R_m of 100 ohms. You want to convert it into a 0-to-10 volt meter. This means merely that 1 ma. must flow through the coil when you put 10 volts across the meter. But its own resistance is far too low and will pass too much current, so extra resistance is added. We know from Ohm's law that a potential of 10 volts will send a current of .001 amp. through a resistance

of 10,000 ohms. To the 100 ohms of the meter itself, 9,900 ohms must therefore be added in series. For measuring AC voltages, a D'Arsonval meter must also be equipped with some sort of rectifier that will serve to convert to DC that portion of the current needed for the operation of the meter.

The conventional ohmmeter, as has been said, is also an ammeter in disguise. A suitable voltage is applied to meter and resistor which permits, say, 1 ma. to flow when the circuit is completed. Thus, if you short the test prods the needle goes all the way across the dial to zero ohms. But when you put additional resistance in series with this circuit, you decrease the current. The higher the resistance that you're measuring, the lower the current that gets through. Unlike other values, resistance is lowest at the right, highest at the left end of the dial.

A variation of the usual resistance meter is the shunt ohmmeter used to measure low ohmic values. This is a milliammeter of known internal resistance that is energized to read full scale. When the unknown resistance is shunted across the circuit, current through the meter coil drops in proportion to the ratio between the fixed and unknown resistances.

Measuring a Meter

In order to build a multimeter, it is first necessary to know the characteristics of the movement you plan to use. The easiest way to determine the current required for full-scale deflection is to connect the unknown meter in series with a meter of known accuracy, a variable resistor, and a voltage source. This is illustrated by the closed circuit shown on page 118. Since the cur-

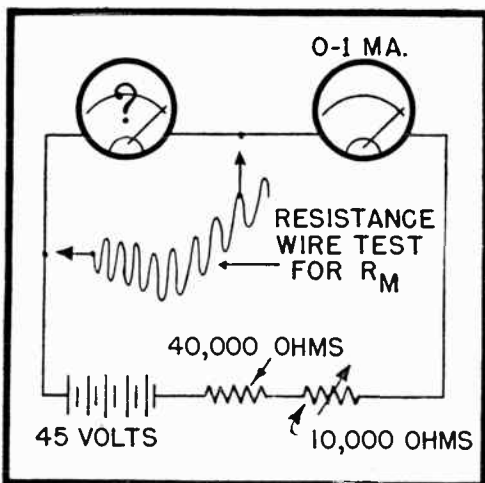

The internal resistance of a meter movement and the current required for full-scale deflection can be determined with this setup.

rent is the same in all parts of a series circuit, all you need do is adjust the variable resistor until the unknown meter reads full scale. The amount of current required to produce this deflection may then be read directly on the known meter.

Using the same setup, you can determine the internal resistance of the movement. With the variable resistor adjusted to make the meter read full scale, shunt the meter with fine resistance wire of, say, 10 ohms per foot as indicated by the wavy line. Add wire until the meter reads half scale, and

reset the variable resistor as needed to keep the total current (shown on the second meter) constant. When the wire shunt and the unknown R_m are equal, half the current goes through the meter and the other half through the wire. Measuring the length of the wire then tells you the R_m of the meter. Use accurately labeled resistance wire.

Sensitivity, another characteristic of the movement, may become important in some applications of multimeters. A meter that yields full-scale deflection with a current of 1 ma. is said to have a sensitivity of 1,000 ohms per volt, because 1 volt will give full scale reading when the total series resistance equals 1,000 ohms. This ratio will apply for all other ranges, that is, 100 volts full scale will require resistance totaling 100,000 ohms.

For electronic work, meters should have at least 1,000 ohms per volt sensitivity to avoid "loading" circuits under test.

When building a multimeter, it is usually a good idea to complete the ohmmeter section first so that it can be used in the selection of other resistors. The accuracy of a series ohmmeter depends primarily upon the accuracy with which the total circuit resistance is known. Since the voltage of batteries, even when new, varies widely, some means of zero adjustment is always provided. With the test leads shorted together, zero ohms, or full-scale deflection, is adjusted by means of the variable resistor shunted across the meter.

Bear in mind that any series ohmmeter,

FORMULAS FOR MULTIMETERS [ELECTRICITY]

General Forms for Ohm's law

$$(1) I = \frac{E}{R}$$

$$(2) R = \frac{E}{I}$$

$$(3) E = IR$$

$$(4) P = IE = I^2R = \frac{E^2}{R}$$

Where I is current in amperes.

R is resistance in ohms.

E is potential in volts.

P is power in watts.

To Calculate Milliammeter Shunts

$$(5) R = \frac{R_m}{n-1}$$

R_m is internal resistance of meter (plus resistance of series-connected fuse)

n is range-multiplication factor (to convert from 1 ma full scale to 10 ma, $n-1=10-1=9$).

To Calculate Voltmeter Multipliers

$$(6) R = R_m(n-1)$$

Series-Ohmmeter Operation

$$(7) R = \frac{R_s I_s}{I_m} - R_s$$

R_s is total fixed resistance in meter circuit (including R_m).

I_s is meter's full-scale current.

I_m is reduced current during test.

Shunt-Ohmmeter Operation

$$(8) R = \frac{I_m R_m}{I_s - I_m}$$

(approximation)

POPULAR SCIENCE MONTHLY SHOP DATA

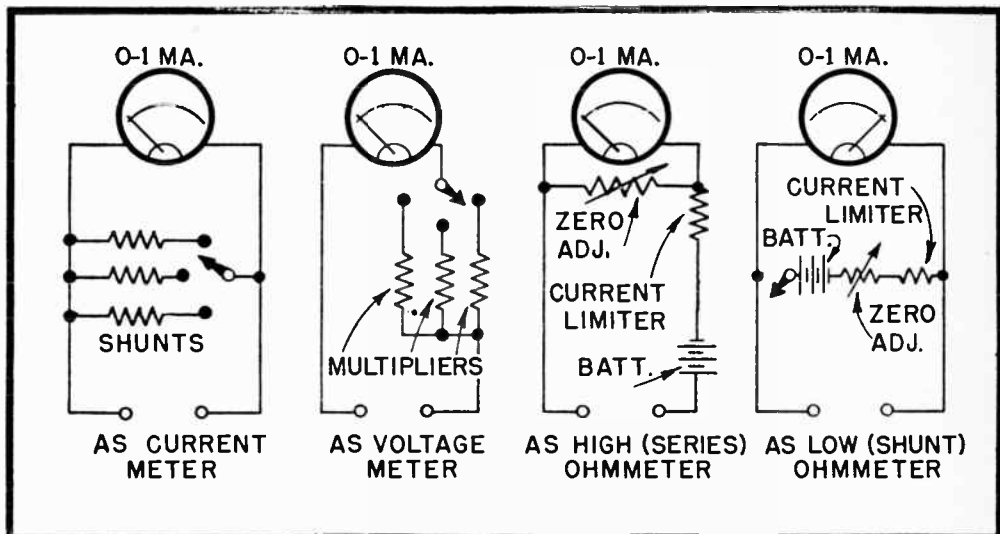

Basic Principles of V-O-M meters. Any fairly sensitive current meter will register higher values of current as well as volts and ohms if

the proper resistors and energizing voltages are connected. One meter and a switching arrangement combines them into a multimeter.

whether its scale is 0-100 or 0-100,000, effectively covers the enormous range from zero to infinity. This being so, the upper end of the scale—which is the lower end of the milliammeter scale—is bound to be very hard to read and increasingly inaccurate as it crowds in toward infinity. Series ohmmeters therefore, are usually peaked at the center of the dial. For a 0-1 ma. movement, standard series-ohms ranges are 45,000 ohms center scale (using a 45-volt battery

and a total of 45,000 ohms fixed resistance); 4,500 ohms center scale (4.5 volts and 4,500 ohms); and 450 ohms center scale, using a total circuit resistance of 450 ohms. To calibrate or graph the dial of a milliammeter so that ohms may be read directly, use the table below; the figures are based upon these standard resistance-voltage values.

Construction notes on several multimeters of different characteristics will be found on the pages immediately following.

OHMMETER TABLE

[ELECTRICITY]

	Ohms	ma.	Ohms	ma.
	Zero	1.0	5,000	.474
	100	.978	6,000	.429
	200	.957	7,000	.391
	300	.937	8,000	.36
	400	.918	9,000	.333
	500	.9	10,000	.31
	600	.883	12,000	.273
	700	.865	15,000	.231
	1,000	.818	20,000	.184
	1,500	.75	25,000	.152
	2,000	.692	30,000	.13
	2,500	.643	40,000	.101
	3,000	.6	50,000	.083
	3,500	.563	60,000	.07
	4,000	.53	100,000	.043
	4,500	.5		

*For calibration of meter dial
or graph sheet*

Meter scale readings resulting from various values of resistance in circuit of conventional series-type ohmmeter using 0-1 ma. meter with 4.5-volt battery and enough resistance (4,500 ohms) in series to make meter read full scale for zero ohms. The ohmic values for the given meter readings may be divided by ten by using 0-10 ma. meter with 450 ohms, or multiplied by ten by using 45-volt battery and 45,000 ohms in series.

POPULAR SCIENCE MONTHLY SHOP DATA

Building a Multimeter

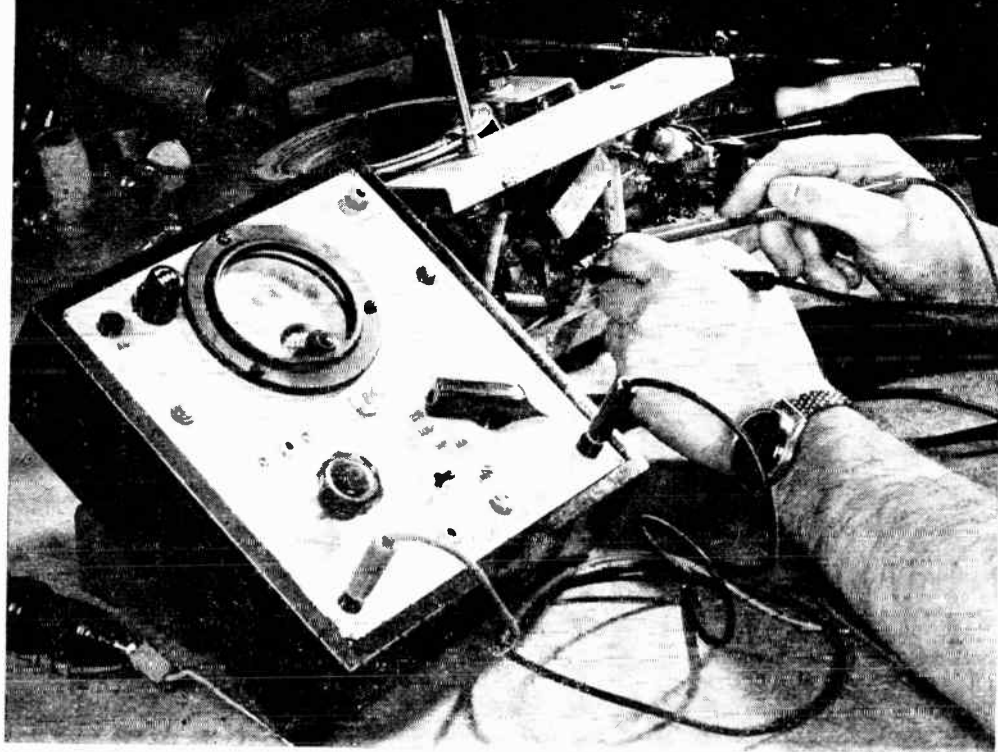

The multimeter above, diagrammed on page 122, is a wide-range, general-purpose unit.

By Gilbert Soubergh

BEFORE you start to build your own multimeter, look over the fundamental data on the relationship between volts, ohms, and amperes given in the previous installment. With this information you can design a meter for any special purpose, adapt spare parts to suit your circuit, or build a general-utility multimeter for radio and electrical checking. To make use of spare parts, you must design your circuit around them, for you can't substitute values that are nearly but not quite correct. Resistors must be calculated with great precision. Wherever possible, use wire-wound resistors that are guaranteed accurate to 1 percent. Carbon resistors, costing much less than the wire-wound type, may be used in some cases, although they are less likely to be stable over a long period of time. They do, however, have one advantage in that

they can be adjusted upward in resistance value. To do this, file a small flat on one side. Check the resistor on an accurate ohmmeter as you file it, and when you have exactly the right value, coat the scored part with wax or varnish to keep out moisture.

The photos here and the diagram on page 122 show a V-O-M meter designed to get the most measuring power in a relatively simple one-meter unit at moderate cost. With the aid of a few calibration graphs, this tester can cover more than 24 ranges of ohms, microfarads, henrys, AC and DC volts and milliamperes.

Suggested diagrams for simpler and less costly meters are given on page 123. Both of these models use standard O-I ma. meters and simplified switching systems. In the diagram at the left, toggle or pushbutton station-selector switches are employed; note that the 10- and 100-ma., as well as the

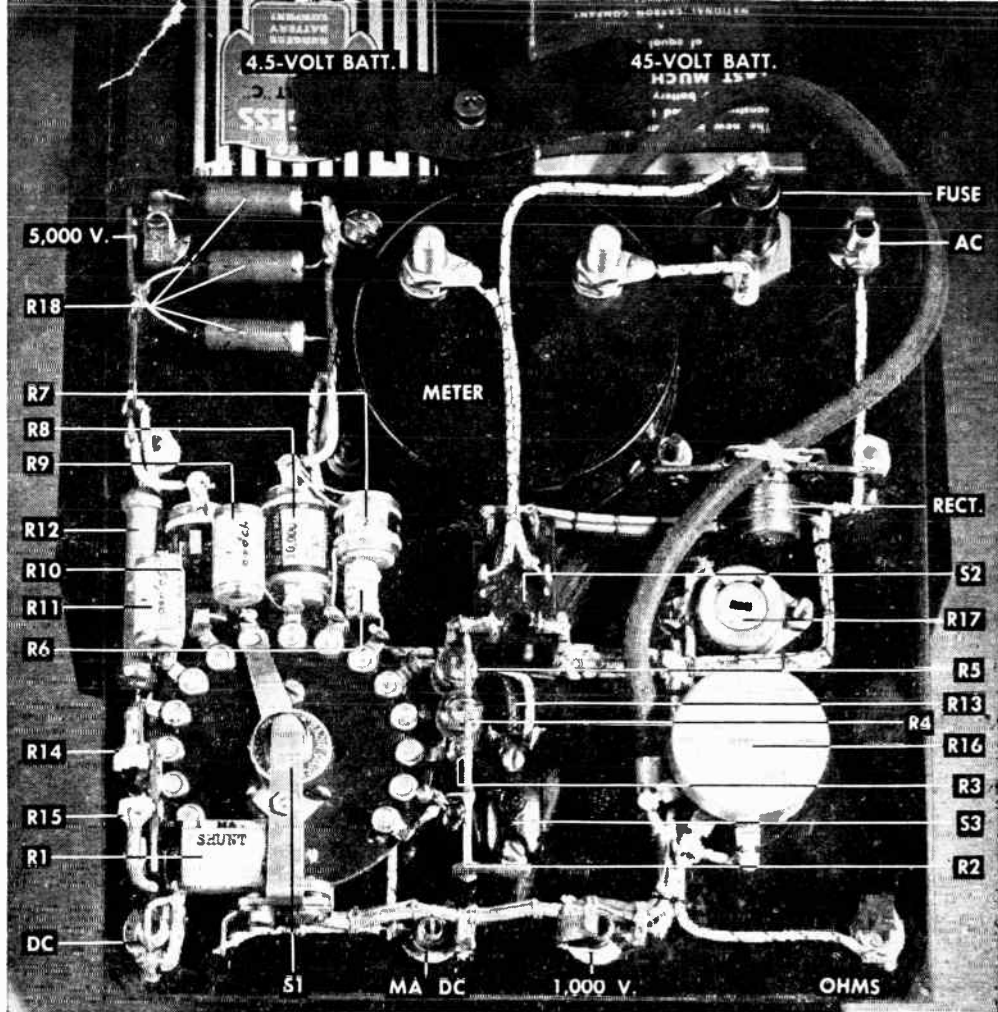

All parts except the batteries are mounted on a bakelite panel, shown here from beneath.

ohms-divided-by-ten ranges call for double-pole arrangements. If pushbutton switches are used, depress two buttons simultaneously. The companion drawing calls for only one switch, and this is on R16 so that the 10,000-ohm resistor can be cut out of the circuit for readings other than ohms.

No matter what meter you elect to build, two general precautions should be observed. First, avoid meter overloads, especially in switching. Second, make certain that components are satisfactorily outside the circuit or isolated when the meter is positioned on a range not calling for them. For example, the meter in our principal circuit would be seriously overloaded if you switched from one milliamperere range to another while making a measurement except for the fact that the rotor of S1 touches one contact before leaving the previous one.

Despite all precautions, accidents do happen, which is why all circuits display fuses.

The type of fuse to use is one that will "let go" quickly on currents 10 to 25 times greater than the meter's normal full-scale capacity. The resistance of the fuse, however becomes part of the circuit and must be taken into account in all calculations. Make sure you can get replacements of exactly the same resistance. A good procedure is to pick some identical fuses from your dealer's stock with the aid of a low-range ohmmeter.

Our major circuit contains a feature that is well worth considering in the design of your own multimeter: it has equal sensitivity of 1,000-ohms-per-volt on both the AC and DC ranges, making it possible to use the same set of multipliers and main selector switch for both currents. This arrangement cannot be achieved with an ordinary O-1 ma. movement, but calls for a meter that will give full-scale deflection on .89 to .9 ma. for use with the full-wave rectifier connec-

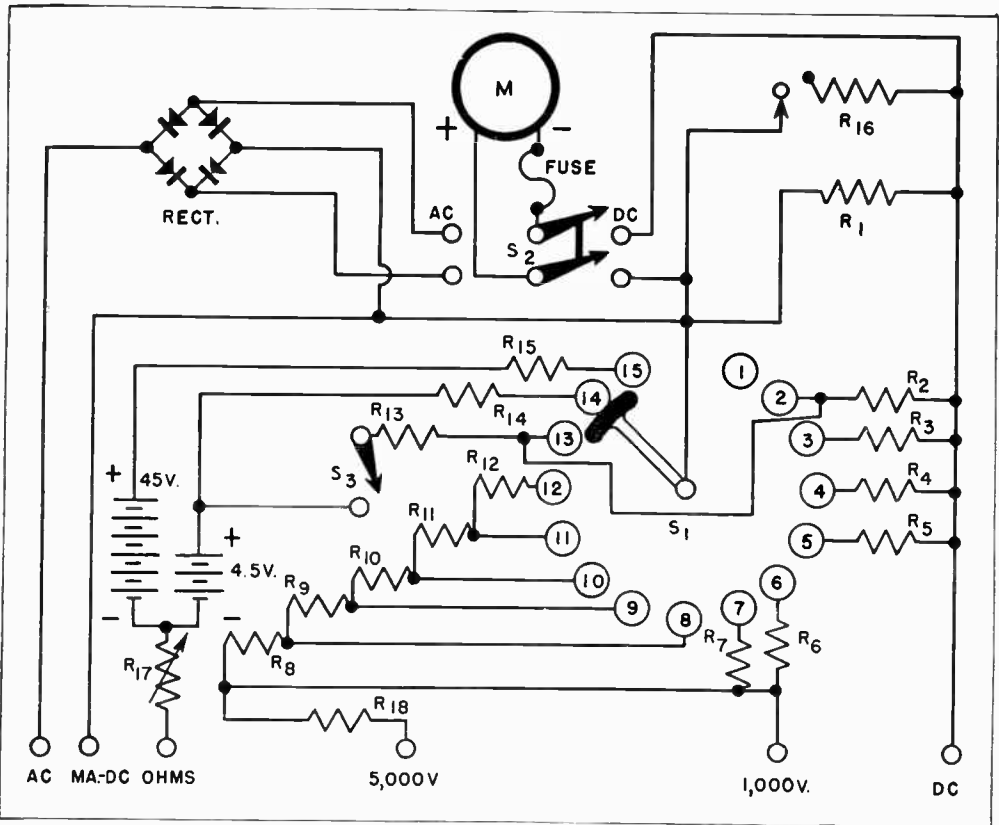

LIST OF PARTS

M: DC milliammeter with full-scale sensitivity of 0 to .89 ma. and internal resistance of 105 ohms.
 Fuse: 1/32 amp., tested at exactly 20 ohms.
 S1: 15-position, meter type rotary.
 S2: DPDT toggle (AC-DC).
 S3: SPST (ohms-divided-by-ten).
 Rect.: full-wave meter rectifier.
 R1: 1,011 ohms (1-ma. DC shunt).
 R2: 12.36 ohms, wire (10-ma. shunt).
 R3: 2.27 ohms, wire (50-ma. shunt).
 R4: 1,121 ohms, wire (100-ma. shunt).
 R5: 0.447 ohms, wire (250-ma. shunt).
 R6: 890 ohms (1-volt multiplier).
 R7: 4,900 ohms (5-volt multiplier).

R8: 9,900 ohms (10-volt multiplier).
 R9: 40,000 ohms (for 50-volt range with R8).
 R10: 50,000 ohms (for 100-volt range with R8-9).
 R11: 150,000 ohms (for 250-volt range with R8-10).
 R12: .75 meg. (for 1,000-volt range with R8-11).
 R13: 439 ohms (450 ohms center scale).
 R14: 4,100 ohms (4,500 ohms center scale).
 R15: 45,000 ohms (45,000 ohms center scale).
 R16: 10,000-ohm wire-wound rheostat with "off" or open position (series ohmmeter zero adjustment).
 R17: 500-ohm wire-wound rheostat (shunt ohmmeter zero adjustment).
 R18: 1-watt carbon resistors in series, totaling 4 meg. (5,000-volt multiplier with R8-12).

tion shown. Most meter manufacturers either stock meters of this description or will supply them on special order. For DC ranges, sensitivity is reduced to 1 ma. by means of shunt R1.

Alternating currents and voltages are rather elusive things to peg since their actual values are constantly changing. That quantity of AC that we mean when we say one ampere actually hits a *peak value* of 1.41 amp. both sides of zero. We call it one ampere because it has the same heating effect as that amount of DC. In other words, 1 amp. is its *effective value*, also known as *root-mean-square*, or *r.m.s.*

But that's not all. If an AC current of

1.41 ma. peak value is rectified and sent one way through a DC meter, we get a deflection of only .9 ma. This is the *average value* of the pulsating current. Hence, in order to get our meter to read full scale with 1 ma. of *r.m.s.* AC going through the rectifier, we want a meter with DC sensitivity of about .9 ma. Theoretically, .89 ma. will give greater accuracy because rectifiers are not in actual practice strictly unidirectional in their conductivity.

All this applies only to a full-wave rectifier used with a .89 ma. meter as in our main diagram. The other schematics show half-wave rectifiers and 1-ma. movements. To compensate for the difference between

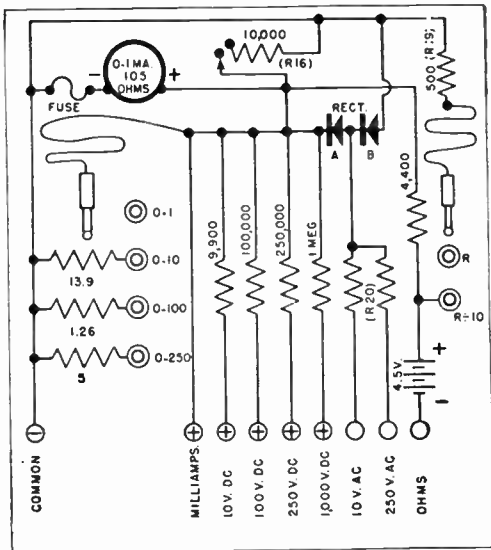
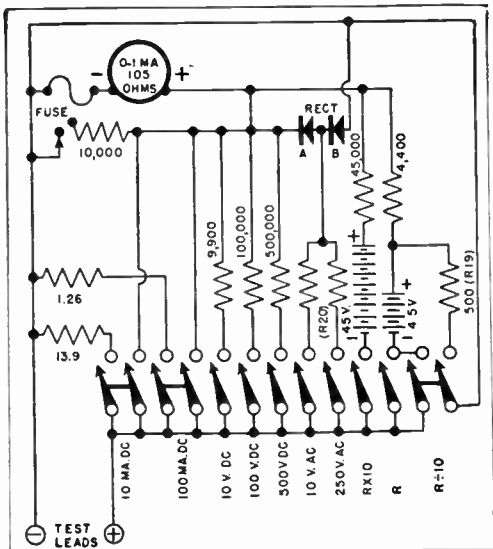

Pushbutton selector switches or individual toggles are used here to simplify switching.

For portability the high-ohms range has been omitted, doing away with the 45-volt battery.

average and r.m.s. values, the AC multipliers (R20 in both circuits shown above) are made smaller than the comparable DC multipliers. Using half-wave rectification, R20 will be approximately 445 ohms-per-volt (4,000 ohms for the 10-volt, and 110,000 ohms for the 250-volt scale). With a four-element full-wave rectifier these values are doubled. As a check on operation, apply known DC voltages across the AC terminals; the indication should be about 11 per cent too high.

As was noted in the previous discussion, ohmmeters are usually peaked at center scale, common ranges being 45,000 ohms, 4,500 ohms and 450 ohms. Using a 0-1 ma. meter, the former calls for a 45-volt battery and total series resistance of 45,000 ohms. For the second, both values are divided by ten. To divide again by ten in order to achieve the third range would seemingly call for a .45-volt battery. Since there is no

reliable means for obtaining such a battery voltage, we must use a higher voltage and a higher full-scale current in order to maintain total series resistance of 450 ohms. Two methods of accomplishing this are shown in the diagrams.

In the one on page 122 the meter is shunted to read 10 ma. full scale. Note the jumper from the 10 ma. shunt, R2, to position 13 on selector switch S1. When S3 is closed, a current of 10 ma. flows from the 4.5-volt battery through R13 and the shunted meter. For measurements on the series-ohm ranges, R17 is set at zero and can therefore be disregarded.

The second method for obtaining the lowest series-ohms range requires the addition of just one resistor to the 4,500-ohm center-scale circuit. This is R19 in the two smaller diagrams; the 500-ohm unit shunts the 4,500-ohm resistance that is made up by adding 4,400 ohms to the approximately 100-ohm meter. Two things are accomplished by R19: the reduction of the total circuit resistance from 4,500 to 450 ohms. and the by-passing around the meter of nine-tenths of the resulting increased current.

If still lower ohms ranges are desired, the shunt ohmmeter is recommended in place of the series type. It is incorporated in the major diagram on the facing page, and its special advantages are considered on the pages immediately following.

COPPER WIRE TABLE			
No. SIZE	OHMS PER FOOT		MAXIMUM CURRENT MA.
	68°F	77°F	
22	.01615	.01646	1300
24	.02568	.02617	800
26	.04082	.04162	500
28	.0649	.06617	300
30	.1032	.1052	200
32	.1641	.1673	120
34	.2609	.266	80
36	.4148	.423	50
38	.6596	.6726	30
40	1.05	1.069	20

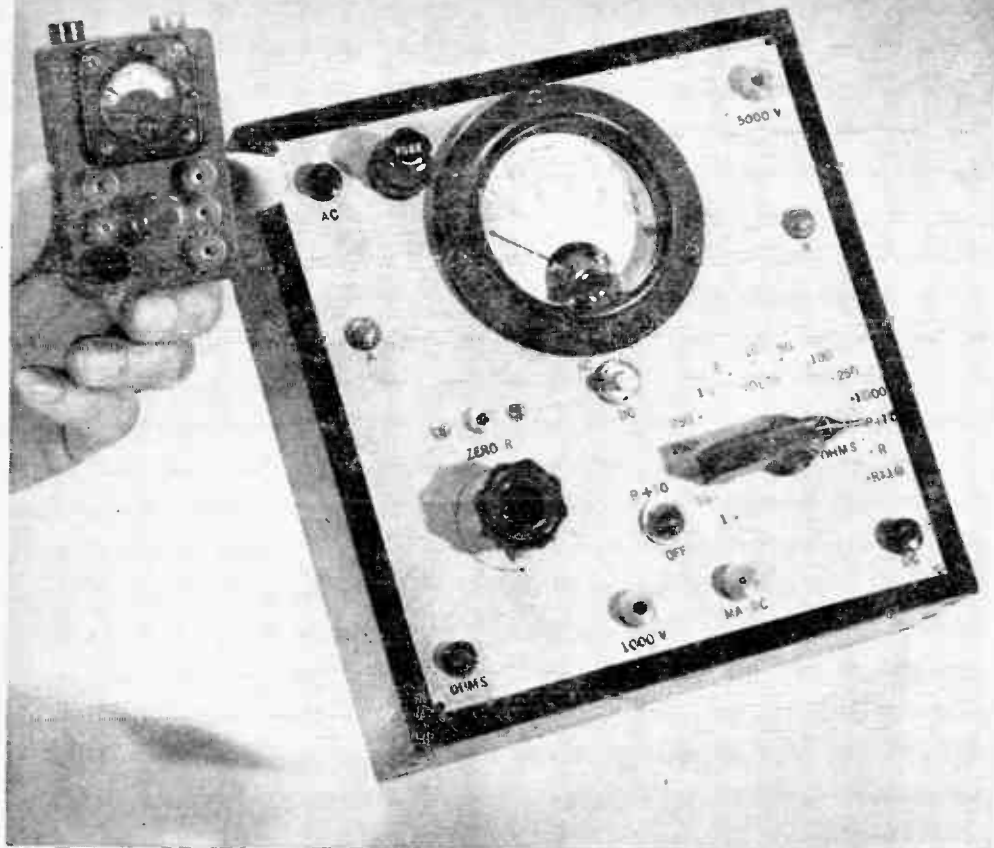

Bench instrument or pocket-size midget, a multimeter is a must in every electrical shop.

Completing Your Multimeter

If you built the tester described on page 120, you will want these further pointers on its use.

By Gilbert Soubergh

SINCE all the essential information needed for building three types of multimeter was given on the previous eight pages, you probably have your tester pretty well under construction. The two smaller units illustrated on page 123 offer no special problems. Most of this discussion, therefore, concerns the featured instrument.

It was stated that the range of a series ohmmeter cannot readily be lowered

enough to measure very small resistances. To do that a shunt ohmmeter was recommended. The principle of the shunt ohmmeter will be recognized as the same one used to determine the internal resistance of a meter with the aid of a known value of shunting resistor (see page 118). If we use a 0 to 1-ma. meter with internal resistance of 105 ohms, and shunt it with an equal resistor while energizing the circuit, a half-scale reading of 105 ohms results. Unlike series-ohms readings, infinite resistance is at full scale and zero is at zero on the dial.

A reading of 105 ohms center scale (higher if a fuse is used in the circuit) is not, however, sufficiently lower than the 450-ohm range to be of great value. In our

circuit, therefore, the meter and fuse are shunted to read 10 ma. in order to provide a center-scale reading of 11.4 ohms. Switch positions are the same as for the lowest series-ohms range, but a test lead is used to short the DC and OHMS terminals. The unknown resistor is then inserted between this jumper and MA-DC. Since accuracy is dependent primarily upon current value, rheostat R16 is turned to "off" position, and current is regulated to full scale—precisely 10 ma.—by R17. This is being done by the screwdriver adjustment illustrated at the upper right.

The resistor under test then shunts the whole circuit, and its value may be calculated from formula 8 (See page 118). It must be remembered that this formula is only an approximation, and its accuracy decreases as the circuit current is raised. The graph at the right was plotted by calculating a number of points from a more exact formula, and it should hold reasonably well for any meter constructed with the same values as the one shown.

If the graph should prove inaccurate for your meter, you can plot another one with the help of a few feet of resistance or fine-copper wire. Measure a dozen or so lengths of wire and calculate the resistance of each from the ohms-per-foot rating of the wire. Then check the wire on the meter and plot scale deflection against known ohmic value. Shunt ohms are represented by the numbers in the left hand margin of the graph; a companion curve for a series ohmmeter crosses it from upper left to lower right and is read against the figures in the right-hand column. The chart is drawn on logarithmically scaled paper, available at most stationers.

As has been pointed out, the reason that ohmmeters are peaked at center scale is that all ranges cover the area from zero to infinity, and therefore both ends of the scale are bound to be inaccurate. The problem of measuring low resistances may be met by the shunt ohmmeter. But what about very high ohmic values? Of what use is a meter that reads, say, 90,000 ohms when you want to measure a resistance of several megohms? The answer seems to be that you can't make these measurements, but in fact the problem is easily solved. All you need is a voltmeter and a source of high voltage, such as the power-supply circuit of an AC receiver.

Measure this voltage—preferably several hundred volts—and then make a second



Adjusting the meter to read on the lowest ohm range. Scale divisions are graphed as below.

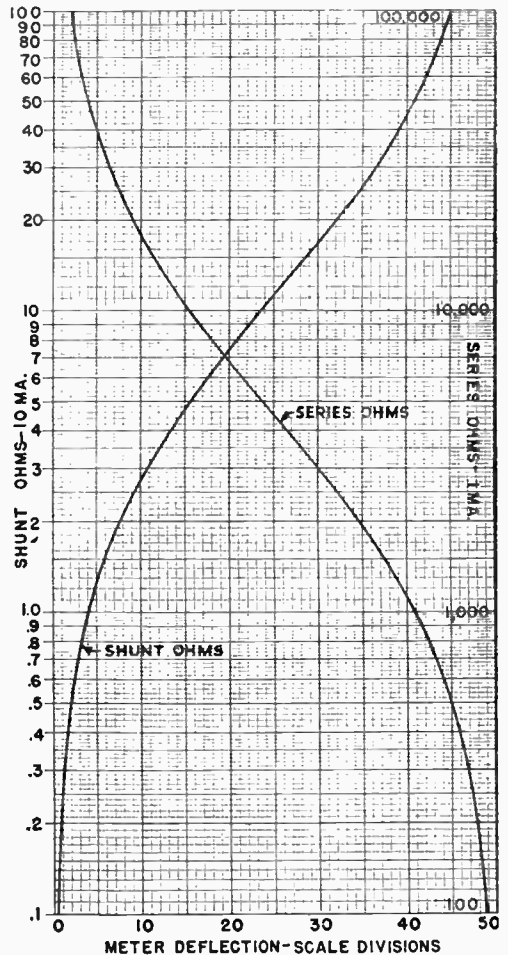

A graph of this type will help you interpret nonlinear shunt and series ohmmeter readings. It should hold for meters built like the one above, or it can be plotted from known values.

reading with the unknown resistor in series with the meter. The unknown value may then be calculated from formula 9, below.

Your AC voltmeter may also be used to measure capacitance, inductance, and impedance with sufficient accuracy for most purposes. An AC power line will serve very well, provided that you take adequate precautions to prevent electrocution. First measure the line voltage; then take a second reading with the unknown element in series with the voltmeter.

Capacitance of condensers is figured from formula 10. Again it may be wise—if any considerable number of readings is to be made—to draw a logarithmic graph in which the voltage readings of your meter are plotted against capacitance. The graph will be useful wherever the same meter is used on the same line voltage. Use a dozen or so accurately known condensers to plot this graph. Capacitance measurements may be multiplied by ten or a hundred if the voltmeter leads are shunted by suitable resistors to reduce the effective voltmeter resistance (R_v in the formula) to a tenth or a hundredth of its normal value. Alternatively the high ranges may be obtained by using a stepdown transformer (and a lower voltmeter range) to reduce the values of E_m and E_l .

Inductance is calculated approximately from formula 11. A graph of inductance values against meter readings would be accurate only for high "Q" inductances—those

in which DC resistance is small compared to AC inductive reactance.

Impedance is expressed in ohms, and is the tendency of capacitors or inductors to resist the flow of alternating current of any given frequency. When needed, the impedance of a coil or condenser may be obtained with the help of formula 12.

An AC rectifier-type voltmeter makes an excellent output meter for receiver alignment, power-output measurements, measurements of gains or losses of amplifiers, and the like; it may be calibrated in volts or decibels. If any direct current is present in the circuit under test, it should be kept from the meter by a good quality paper condenser of from .5 to 2 mfd. The AC component or "ripple voltage" of power supplies is measured in this manner.

If your meter is built according to all the specifications given in the previous installment, the face of the instrument, including switches and test jacks, will probably resemble that of the larger unit shown on page 124. To read DC milliamperes, then, insert test leads into the DC and MA-DC pin jacks. Note that a narrow pin and adapter is shown in the photos for the latter jack. This is used to lessen the possibility of applying a high voltage to the milliammeter by accident. When making current measurements, always start out with the selector switch indexed to the highest range and back down until an accurate reading can be made. Insertion of a milliammeter into a circuit that

FORMULAS FOR MULTIMETERS [ELECTRICITY]

To Use Voltmeter as Ohmmeter

$$(9) R = \frac{E_b R_v}{E_m} - R_s$$

AC Voltmeter as Capacitance Meter

$$(10) C = \frac{E_m}{2\pi f R_v \sqrt{E_l^2 - E_m^2}}$$

AC Voltmeter as Inductance Meter

$$(11) L = \frac{R_v \sqrt{E_l^2 - E_m^2}}{2\pi f E_m}$$

AC Voltmeter as Impedance Meter

$$(12) Z = \frac{R_v \sqrt{E_l^2 - E_m^2}}{E_m}$$

where R_s is total fixed resistance in meter circuit.
 E_b is battery or power-supply voltage.
 E_m is reduced voltage reading during test.

C is unknown capacitance (in microfarads).
 E_l is full voltage of AC line.
 f is AC frequency ($2\pi f = 377$ on 60 cycles).
 R_v is total voltmeter resistance (in megohms).

L is unknown inductance in henrys.
 R_v is total voltmeter resistance in ohms.

Z is unknown impedance in ohms (may be capacitive or inductive).

POPULAR SCIENCE MONTHLY SHOP DATA

has low resistance and high current will cause a change in the normal current flow. Such measurements should therefore be made on the highest range that will still provide a readable pointer deflection. For greatest accuracy on DC current and voltage ranges, turn R16 to its "off" position in order to keep the 10,000-ohm rheostat from slanting the meter.

Voltages are read by inserting the test leads into the DC (or AC) and 1,000-volt

jacks. The AC-DC switch is also thrown to correspond to the character of the voltage being measured. Index the selector to the appropriate range. When measuring voltages in excess of 1,000, move the test lead from the 1,000 to the 5,000-volt jack, and leave the selector on 1,000. Exercise caution when measuring high voltages. One good practice is to keep one hand in your pocket and perform all necessary manipulations with the other.

Midget Volt - Ohmmeter

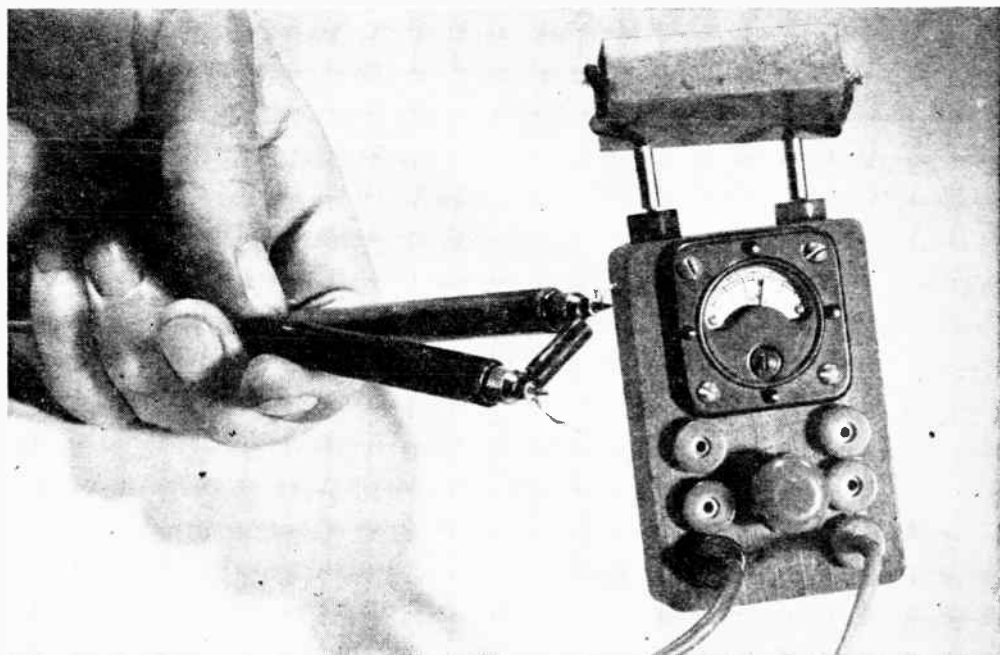

With external battery the pocket-size tester measures two ranges of resistance. Three pen-

light cells in series, wrapped in cardboard or cellulose tape, make a compact voltage source.

WHETHER or not you have built, bought, or borrowed a general-purpose multimeter, you will find a place in your electronic tool kit for a midget meter that measures the things you most frequently need to know. If you are a beginner, building it will teach you the principles and uses of multimeters; if you are an experimenter or service man you will find unlimited applications for an auxiliary, pocket-sized instrument both in and out of the shop.

Compact as the meter is, all the components are standard. When buying the resistors or selecting them from your spare-

parts box, you will want to check them for accuracy on a reliable ohmmeter. All resistors are connected in series with the positive side of the midget meter.

The meter itself, a 0 to 1-ma. unit with internal resistance of approximately 25 ohms, is of the type developed during the war for use in aircraft equipment. It measures only 1" in diameter and has a mounting flange 1 3/8" square. Together with all the auxiliary parts, it is built into a 1" by 2" by 3" wooden box. Near the top of the box panel, drill a hole slightly over 1" in diameter. Aside from the meter, six di-

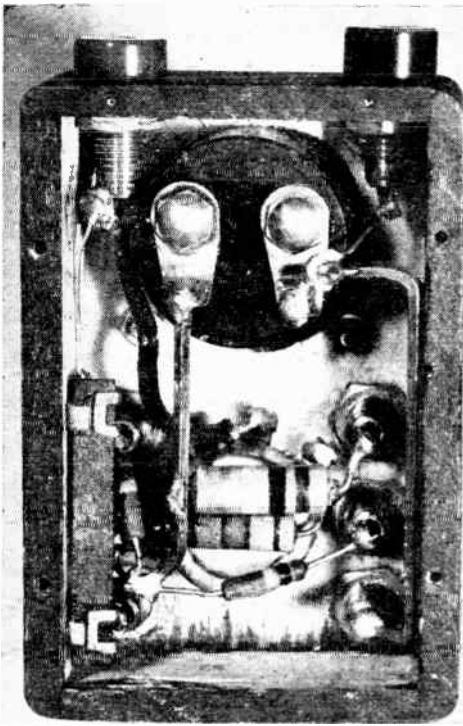

Even inside the 1" by 2" by 3" case, there is plenty of room for the handful of components.

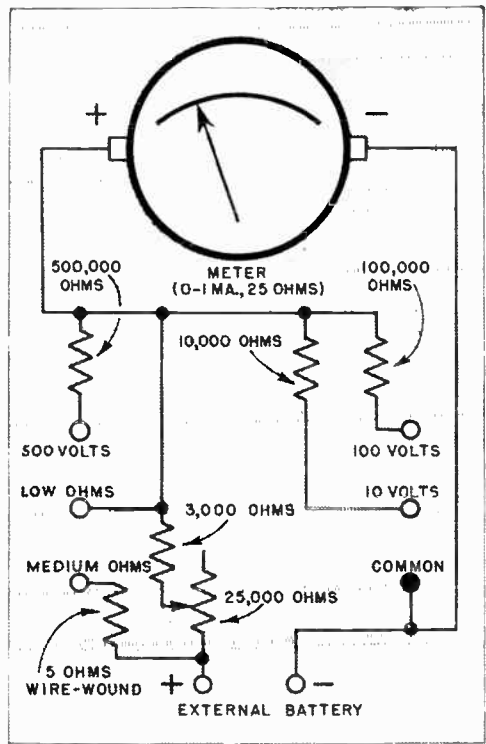

In most respects placement of the parts can follow the layout shown in the diagram above.

tip jacks and a midget 25,000-ohm rheostat are mounted on the face. In the edge of the box above the meter place two more jacks for the external battery. This will be in series with the rheostat and a 3,000-ohm fixed resistor.

For both the low and medium-ohms ranges an external battery is required. Use a 4½-volt supply; three pen-light cells in series are suggested because they will not add very much to the size and weight of the equipment.

The five scales chosen offer a wide variety of uses in radio servicing. The 0 to 10 and 0 to 100-volt ranges will enable you to check all sizes of A and B batteries, and the 0 to 500-volt scale will come in handy when you want to know the potential across the plate or screen of most receiver tubes.

Each of the ohms ranges has its own particular advantage. All antenna, RF, and IF coil windings, as well as filter chokes and power transformers, can be tested on the low scale, and this range is also useful as a continuity tester. By touching the two prods to the heater pins on a tube, you can deter-

mine whether the filament is open. If it is, there will be no deflection of the needle. About 80 percent of set failures can be traced to burned-out tubes, and in AC-DC receivers, where tubes are connected in series, it is impossible to tell which is causing the trouble unless the filaments can be checked.

With the medium-ohm meter you can tell whether the high-resistance windings of such parts as high-impedance chokes, output and audio transformers are open or shorted. Higher resistors, such as may be found in plate, screen, or coupling circuits, can't be measured directly, but defects can easily be spotted by checking the voltage reaching the tubes. Both ohms scales can be used to detect shorts in paper-tubular condensers and leakage in electrolytics.

You can read volts directly by multiplying scale markings by 10, 100, or 500, depending upon the range. The ohmmeter is service checking rather than for accurate measurement. To get approximate values, measure a dozen known resistors and graph pointer positions.—ALBERT ROWLEY.

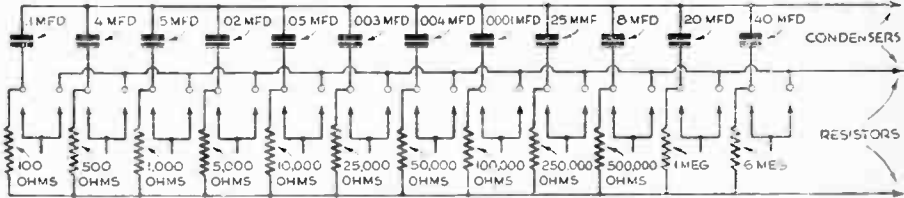
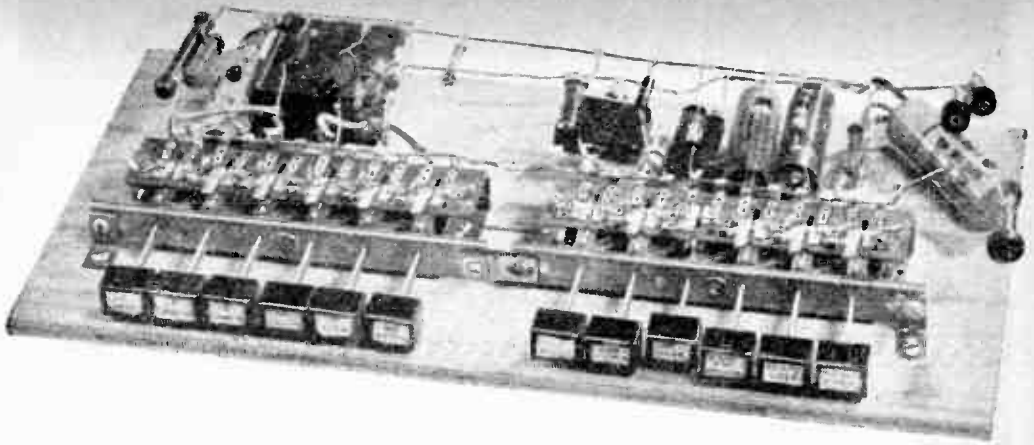

Push-Button Selector Keeps Range of Test Values Handy on Bench

RADIO experimenters who like to try a variety of condensers or resistors in a working circuit before soldering one in will find this bench panel a useful workshop tool. It is built around two discarded push-button selector switches, and employs a group of close-tolerance condensers and resistors. When condensers are used in parallel, their

total capacity is equal to the sum of the individual capacities. Adding resistors in parallel gives a total resistance smaller than any of the components; it may be calculated by adding reciprocals. The builder may substitute values in geometrical progression in place of those shown in the diagram.—ANDREW VALENTINO.

Cement in Wrench Holds Nuts

TO REPLACE a nut in some inaccessible part of a radio chassis, put a drop of speaker cement, or other thin, liquid adhesive, in the opening of a socket wrench. Just a slight amount of tackiness is needed to keep the nut in place while you place the wrench over the bolt and engage the first couple of turns.—H. LEPPER.

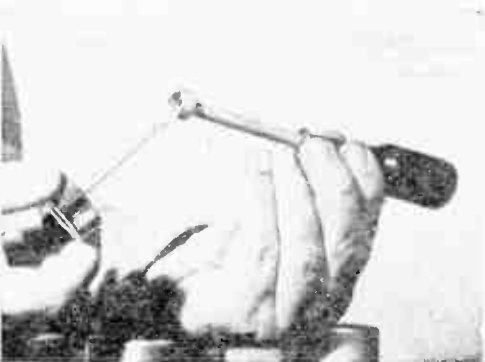
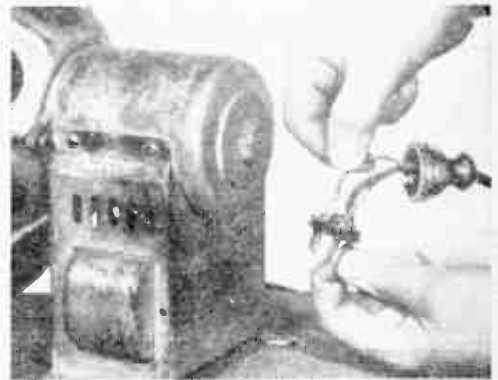

Check Speaker-Plug Connection

Noise, hum, or similar trouble in a radio receiver is often due to loose connections at the speaker plug. When checking these wires, turn off the set, remove the plug from the socket, and pull on the individual strands as shown above. Resolder loose wires to the plug prongs.—H. L.

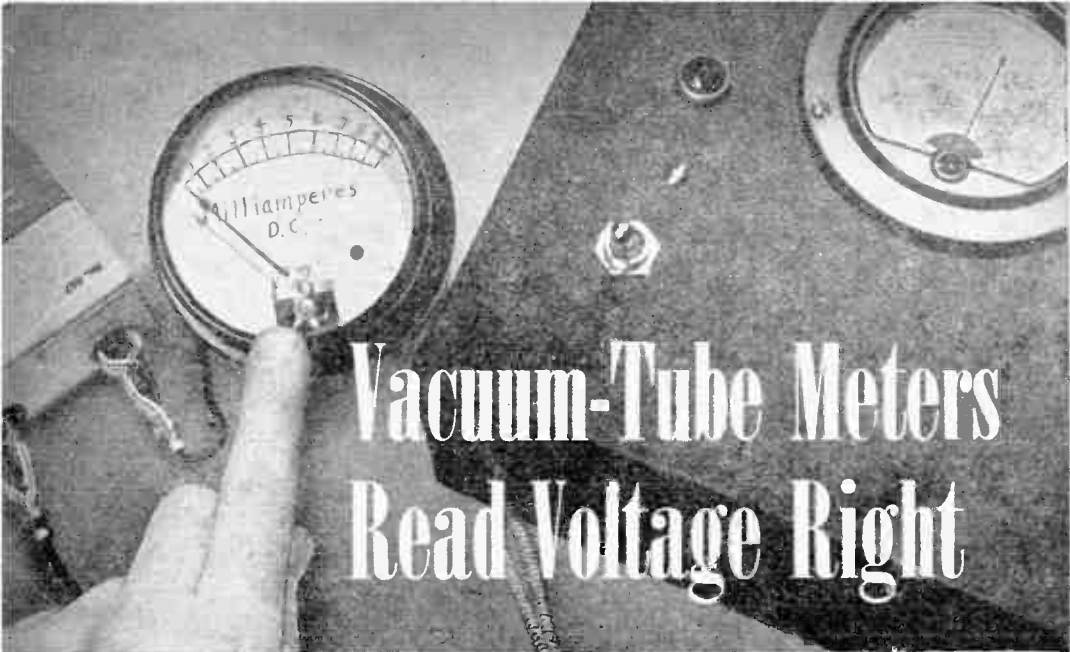

Vacuum-Tube Meters Read Voltage Right

Does a VTVM draw current from the circuit under test? The milliammeter gives the answer.

IF YOU'VE ever tried servicing a radio, you don't have to be told that a voltmeter is like an extra right arm. It's the tool that often tells you what the trouble is, and when it can't do that, tells you where to look for it.

Voltmeters can be roughly divided into three classes. Low-resistance meters are the commonest. They are usually rated for sensitivity in the neighborhood of 1,000-ohms-per-volt and require 1 ma. of current to deflect the pointer full scale. High-resistance meters of the 20,000-ohms-per-volt class are distinctly better and will give accurate results under most conditions. They need only .05 ma. to drive the needle across the dial. The third type is the vacuum-tube voltmeter, or VTVM. It has almost infinite resistance and takes practically no current for its operation. If you bear in mind that any current required by the meter must be

taken from the circuit being tested—which tends to "load" the circuit—you can see why it is often important to keep drain to a minimum.

None of this should be read as a criticism of the first two types of meter. Both have numerous applications if you understand their limits. But take the situation diagramed in Fig. 1. The tube is receiving its plate current through R1 and R2. Now if you try to measure the voltage at the plate with a 1,000-ohms-per-volt meter, you introduce another current-drawing element into the circuit, the meter itself. The extra drain may be very little (say a half or quarter milli-ampere); but since it must also flow through R1 and R2, it introduces an extra voltage drop. Thus the very presence of the meter changes the circuit you are trying to measure.

Another way of viewing the same problem

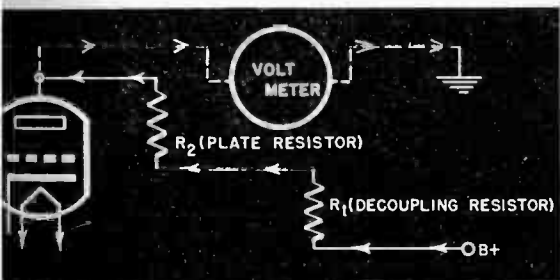

1. Here's where the current goes. The meter "loads" the circuit by drawing extra current.

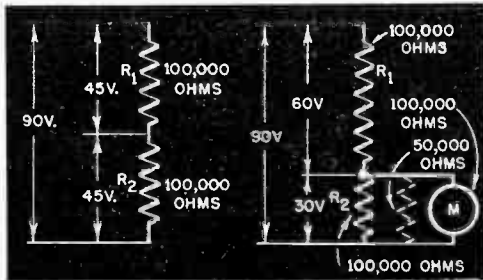

2. There should be 45 volts across R2, but an ordinary meter will give a reading of only 30.

is illustrated in Fig. 2. The left-hand sketch shows a 90-volt source across which two identical resistors have been connected in series. Basic electrical theory tells you that the voltage will divide equally across the resistors. Now connect a low-resistance meter across R2. A 1,000-ohms-per-volt meter used on the 100-volt scale would have a resistance of 100,000 ohms. This gives you the effective circuit shown in the right-hand sketch. The net resistance of the meter and R2 is only 50,000 ohms. Voltage drop across this part of the circuit, therefore, is no longer 45 volts but 30.

The more we increase the resistance of the meter and the less current is needed to drive it, the more accurate will the reading become. That's a job for vacuum tubes. Tubes are able to amplify because a small change in current at the grid produces a much larger change at the plate. Thus if you feed an unknown voltage to the grid and place a reasonably accurate milliammeter in the plate circuit, you can obtain a meter in which the minutest amount of current will be sufficient to operate the meter movement.

The photos and drawings on the following pages show two vacuum-tube voltmeters. The larger one, diagramed in Fig. 6, was built by Tracy Diers, of Richmond Hill, N. Y. The smaller one (Fig. 14) made by Albert Rowley, Manhattan, N. Y., is a less versatile unit but easier to build.

Mr. Diers' unit will measure both alternating and direct voltages and has four ranges from 0 to 1, 10, 100, and 500 volts. A 6SQ7 was selected for the meter tube because in addition to the triode it contains diodes for rectifying AC. The grid of the triode is given a fixed bias of 1½ volts by a bias cell of the type used in some amplifiers.

For the meter itself you may use any surplus or standard unit provided it has a basic movement of 0.1 ma.—that is, 1 milli-

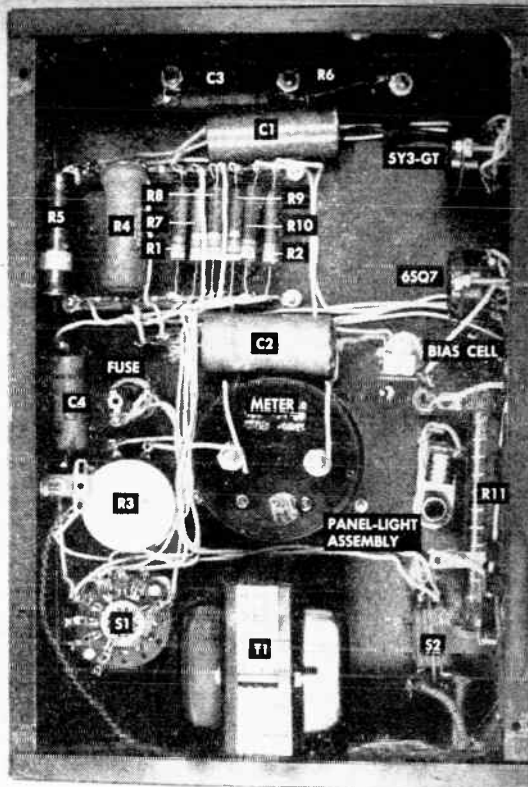

3. A combined chassis and cabinet is used for assembling the parts. Layout isn't very critical.

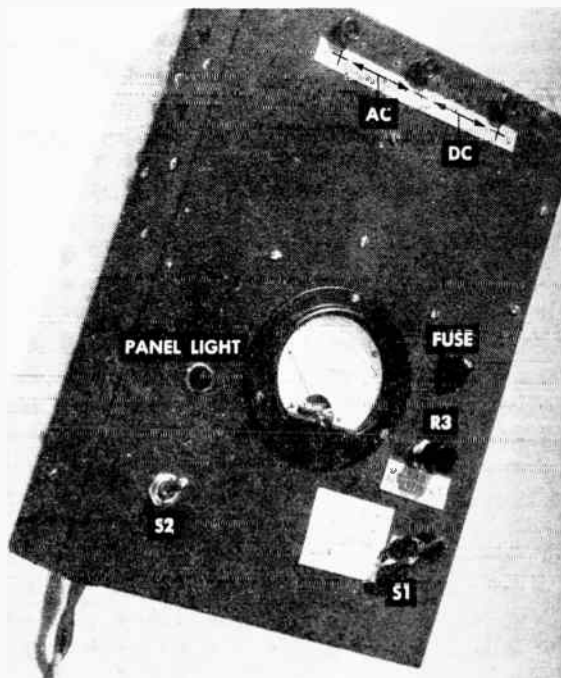

5. Range switch, test-prod jacks, and zero adjustment must be located on top of the panel.



4. If a meter is altered to read 0.1 ma. by removing a shunt, the scale must be re-marked.

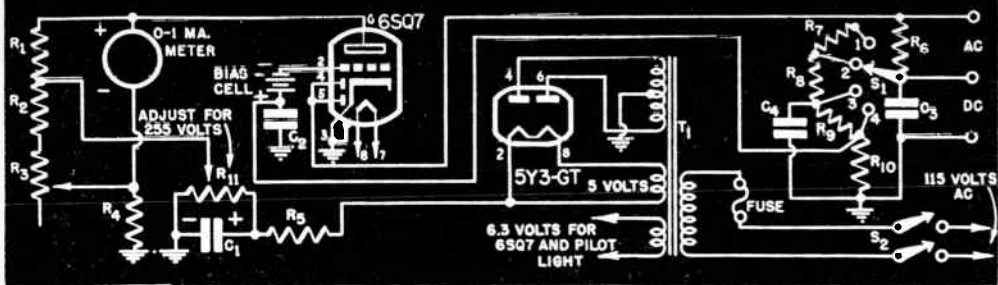

6. Parts used in building the VTVM must be of close tolerance, but the wiring is simple.

LIST OF PARTS

- R1: 10,000-ohm, 1-watt carbon.
- R2: 1,500-ohm, 2-watt carbon.
- R3: 2,000-ohm wire-wound potentiometer.
- R4: 10,000-ohm, 20-watt adjustable wire-wound. Set slide for 36,000 ohms. See text.
- R5: 2,500-ohm, 5-watt wire-wound.
- R6: 1-meg., 1-watt carbon.

- R7: 40-meg., 1-watt carbon (2% tolerance).
- R8: 9-meg., 1-watt carbon (2% tolerance).
- R9: 900,000-ohm, 1-watt carbon (2% tolerance).
- R10: 100,000-ohm, 1-watt carbon.
- R11: 15,000-ohm, 50-watt, adjustable wire-wound.
- C1: 8-mfd., 150-volt electrolytic.

- C2: .5-mfd., 150-volt paper.
 - C3: .05-mfd., 600-volt paper.
 - C4: 1-mfd., 600-volt paper.
 - S1: 4-contact rotary switch.
 - S2: DPST toggle.
 - T1: 600 to 650-volt power trans.
- Meter (0-1 ma, DC), 1 1/2-volt bias cell and holder, panel-light assembly, tubes and sockets, misc. hardware.

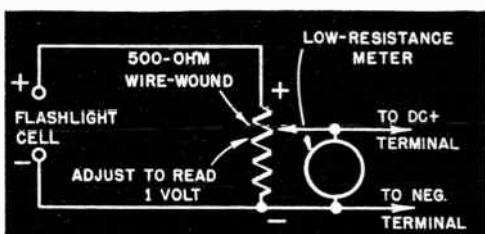

7. Calibrate the meter with this setup. Leave the low-resistance meter connected throughout.

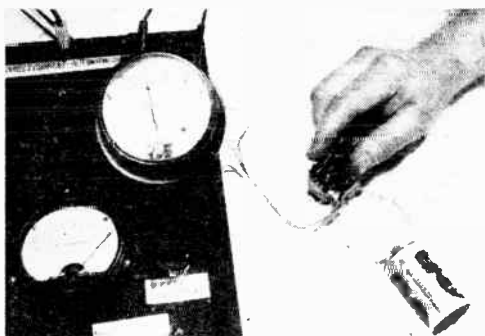

8. The VTVM should give the same reading as the calibration meter. Zero the VTVM first.

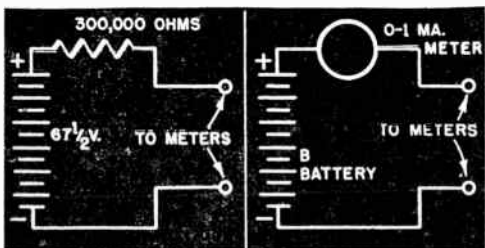

9. In each of these circuits try first a low-resistance meter and a VTVM; compare results.

ampere causes full-scale deflection. It may be necessary to remove shunts or multipliers that are used to give the meter a different scale. If you do, re-mark the dial as in Fig. 4. Figures 3, 5, and 6 show the location of the parts and the method of connection. Scrape every contact and tin those that need it before soldering. This is important if you want clean, firm joints.

The unit is built into a chassis measuring 3" by 10" by 12". Tube sockets are mounted along an inner chassis edge by means of bolts and spacers. Some of the resistors called for may be hard to come by. If you have trouble finding any, remember you can always make up the right resistance by adding two or more smaller units in series. A higher wattage than specified will do no harm.

To obtain the proper operating voltage, a power transformer, T1, and a 5Y3 rectifier are used. The sliding arm on R11 has to be adjusted to 255 volts from slide to ground.

Scale selection is accomplished by means of a single-pole four-position rotary switch. With the slider on contact 1, the meter reads from 0 to 500 volts full scale (which means that you multiply the meter scale by 500). Contact 2 gives the 0-to-100 range (multiply by 100). Contacts 3 and 4 are for the 10- and 1-volt scales.

The meter is calibrated for DC. Note, however, that a separate terminal is provided for measuring alternating voltages. These are rectified in the diode portion of the 6SQ7. The meter registers *peak* voltage. Alternating current or voltage changes its value every instant, ranging from zero to

peak. The thing you usually want to know about it is the *effective value*, which is known also as *root mean square*, or *r.m.s.* To convert the voltage indicated on the meter dial to r.m.s., multiply the peak value by .707. In most cases multiplying by $\sqrt{2}$ gives a sufficiently close answer.

When you have completed the wiring, check the VTVM for accuracy of calibration. Turn it on and allow it to warm up. The meter needle will swing off scale, and then gradually fall toward zero. Insert one test lead in the common terminal and another in the DC jack. After about five minutes, short the prods by touching them together. Adjust R3 until you obtain a zero reading. These adjustments should be made with the selector switch on the 1-volt scale. When the prods are not touching the needle may swing away from zero, but the important thing is to have the pointer at zero when the prods are shorted.

If the meter fails to zero properly, you may have to readjust R4 slightly. The initial value of this resistor was figured as 36,000 ohms, but it may be necessary to raise or lower it a little by shifting the sliding contact. A 40,000-ohm adjustable resistor is suggested for R4. Note however, that it is shown in the diagram as a fixed resistor because once the proper value is found no further adjustment should be needed.

Hook up a flashlight cell and a 500-ohm potentiometer as shown in Fig. 7. An ordinary but accurate voltmeter may be used for the calibration. Vary the resistor until the meter reads exactly 1 volt. Connect the terminals of the VTVM to the points shown. The meter should read 1 milliamperere—or, if you have re-marked the scale—1 volt.

If R7, R8, and R9 are known to be within 2-percent tolerance, it should not be necessary to calibrate for the higher ranges. However you may do so by adapting the setup of Fig. 7, using a higher voltage source, a 1-meg. potentiometer, and a multi-range voltmeter. Check full- and half-scale deflection on each range.

To demonstrate the superiority of a VTVM over ordinary meters, duplicate the circuit shown at the left in Fig. 9. With a low-resistance meter the probable reading will be about 25 volts; the VTVM will indicate very close to $67\frac{1}{2}$ volts.

As a second step, check the current needed by each of the meters by inserting a 0-1 ma. meter in place of the 300,000-ohm resistor. Make a voltage reading across the

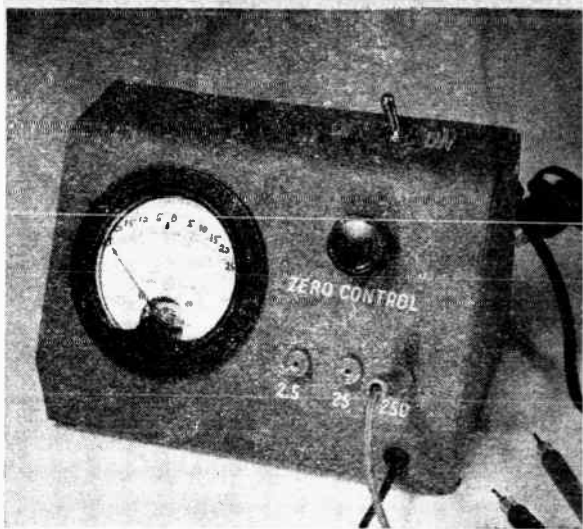

10. This simplified VTVM uses one tube. Scale divisions, from 0 to 25, are marked on glass.

terminals with a low-resistance meter and the VTVM. The milliammeter in series shows how much current is taken by each of the voltmeters. It will probably be something like .6 ma. for the low-resistance unit. How much does the VTVM draw? You can read the answer yourself at the top of page 130.

Compact One-Tuber

Everything that has been said about vacuum-tube voltmeters applies equally to the simplified model shown above and on the following page. Mr. Rowley's meter uses one tube and reads DC voltages only. It has three ranges, from 0 to 2.5, 25, and 250 volts. Selector switch and bias cell have been omitted, and one half of the 7N7 dual triode is used as a power rectifier by tying the grid and plate together.

Again, any good 0-1 ma. meter may be used; one with a fairly large scale is desirable since this hookup causes the meter to zero at midscale. A small meter would make the divisions hard to read.

The power transformer has a high-voltage secondary of 240 volts on either side of the center-tap. One of the outer leads is cut off and taped, as are both leads of the 5-volt secondary, which is not used.

Tube, calibration control, and most of the small parts are mounted on a $2\frac{1}{2}$ " by $4\frac{1}{2}$ " aluminum chassis. This unit, in turn, is installed in a larger cabinet on which are placed the meter, zero control, selector terminals, and switch.

Like the other meter, this one has to be calibrated before it can be used. After completing the wiring, turn on the switch and let the tube warm up. After a few seconds

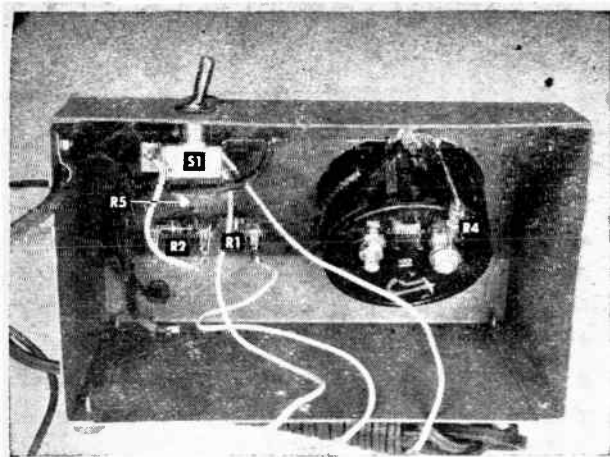

11. A few of the parts are attached directly to the front and top of a small metal cabinet.

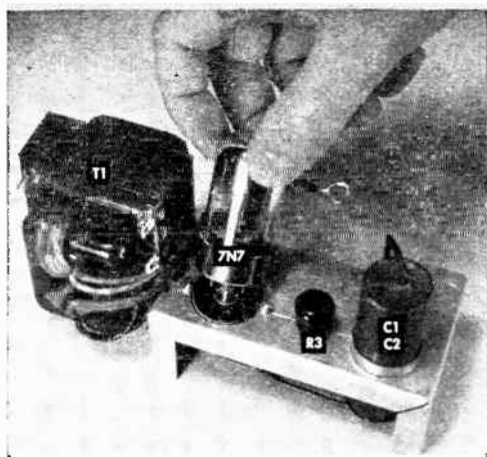

12. The transformer is bolted to the chassis. Calibration control and the tube go on top.

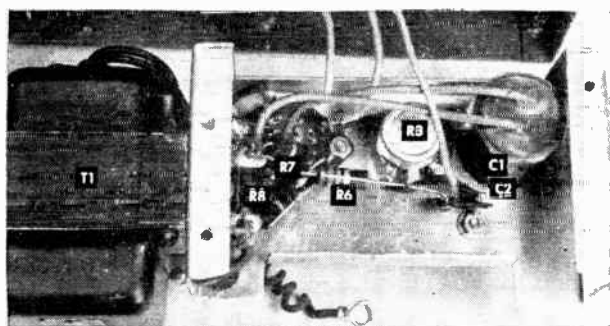

13. Remaining parts are wired underneath the chassis, which is then placed in the cabinet.

the needle will start climbing to the center of the scale. Use the zero control to bring the needle to exact center. Repeat the setup shown in Fig. 7. Plug a positive test lead into the 2.5-volt jack and connect the leads to

take a reading. Adjust the calibration control so that the needle swings exactly one division when the low-resistance meter shows 1 volt. Reverse the polarity of the test prods and check the swing in the opposite direction.

Should the reading be inaccurate, readjust the zero control until the swing is exactly one division either way. Disconnect the test prods and make a sharp mark on the glass dial face at the point where the needle rests. Re-mark—on the glass—this new zero position and use it whenever you are testing on the 2.5-volt scale. Use the normal zero—i.e., dead center—on the 25 and 250-volt ranges. The meter reads both ways from center, so you don't have to worry about polarizing the test prods. This is handy in checking bias voltages where you'd usually have to reverse the prods.

LIST OF PARTS

All fixed resistors 1-watt carbon.
 R1: 10 meg.
 R2: 820,000 ohms.
 R3: 250,000-ohm potentiometer.
 R4: 2,700 ohms.

R5: 25,000-ohm potentiometer.
 R6: 68,000 ohms.
 R7: 1,000 ohms.
 R8: 2,200 ohms.
 C1, C2: 8-8-mfd., 450-volt dual

electrolytic.
 S1: SPST toggle.
 T1: 480-volt power transformer.
 Meter (0-1 ma. DC), 7N7 tube and lock-in socket, test prods.

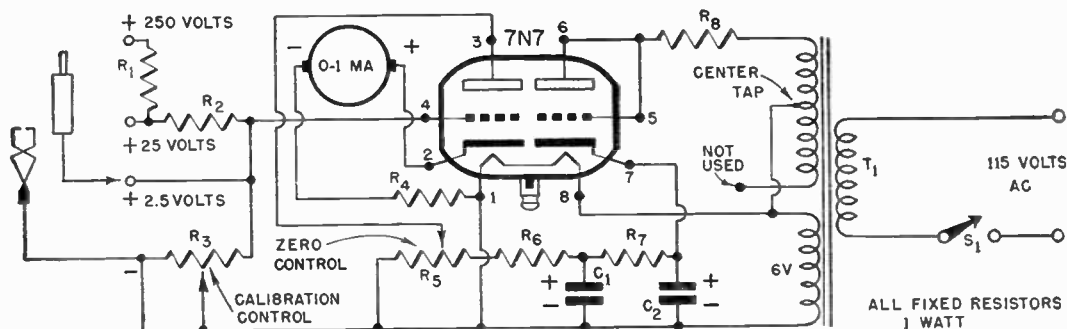

14. Half of the dual triode serves as a power rectifier, the other half as the meter tube.



The dial plate on which the slug-tuning unit is mounted makes up the face of the receiver.

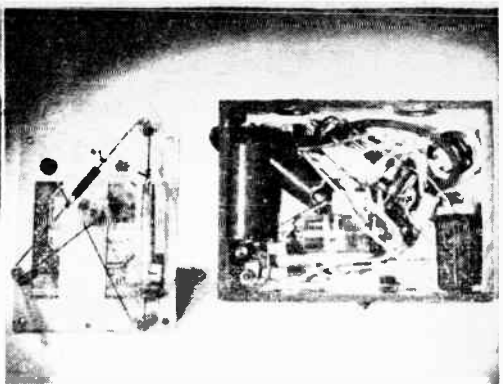

The back of the tuner is shown at left. Next to it is a rear view of the complete receiver.

Pocket Set Has Permeability Tuning

COMPACTNESS in radio receiver design has been achieved in many ways, but when really tiny sets are made they will probably employ permeability tuning. In this regenerative circuit the usual variable condenser and the coil with primary, secondary, and tickler windings are replaced by a thin plastic form 5/16" in diameter around which is wound a special low-resistance coil. An iron slug moves inside the form to vary its inductance and tune to any frequency in the broadcast band. The tuning unit used comes mounted on a 3 1/2" by 5" metal plate; dial and pointer are on the reverse side.

The single coil of the tuner serves for both antenna and tickler windings; the latter acts as a feed-back path between plate and grid. Regeneration is obtained by varying the interelectrode capacity of the 12BA6 detector through the 100,000-ohm potentiometer, R3. When this capacity is high, the circuit breaks into oscillation. As the plate voltage is decreased, the plate-to-grid capacity decreases and the tube becomes less sensitive to incoming signals. Best reception is obtained when the potentiometer is set just below the point where oscillation begins.

Four 3/8" wire-mesh ventilators are let into the sides of the 1 3/16" by 3 1/2" by 5 3/8" wooden box. Slats for the switch and regeneration control are brought out through the panel and holes are drilled for mounting the earphone jacks and the antenna binding post. Post and jacks must be of the insulated type and should not make contact with the metal panel.

No chassis is needed since heavy bus bar is sufficiently rigid to support the tube sockets and other light components. When wiring the set, leave the tubes in their sockets

to insure proper spacing of the parts. Adjust C2, the .001-mfd. trimmer that is brought out through the side of the box, until stations come in at their proper dial settings. Do not use an external ground, since this connection is already made through the 115-volt AC or DC line. A bank of wire will serve as an antenna, or you may connect the set to an outdoor aerial.—EDWARD BLANTON.

LIST OF PARTS

- R1: 5-meg. 1/2-watt carbon.
- R2: 150,000-ohms, 1/2-watt carbon.
- R3: 100,000-ohm potentiometer.
- R4: 50,000-ohms, 1/2-watt carbon.
- R5: 10,000-ohms, 5-watts ribbon-wound or carbon.
- R6: 130-ohm line cord resistor.
- C1, C5, C9: .005 mfd., 400 volts midget tubular.
- C2: .001 mfd. (var.) trimmer.
- C3: .0002 mfd. mica.
- C4: 1 mfd., 100 volts, paper.
- C6: .002 mfd. mica.
- C7: 16-mfd., 150 volt electrolytic.
- C8: 20-mfd., 150 volt electrolytic.
- PF: permeability-tuning unit for regenerative circuit.
- S1: SPST rotary.
- Tubes, sockets, insulated phone tips, binding post, steel-mesh ventilators, noise, hardware.

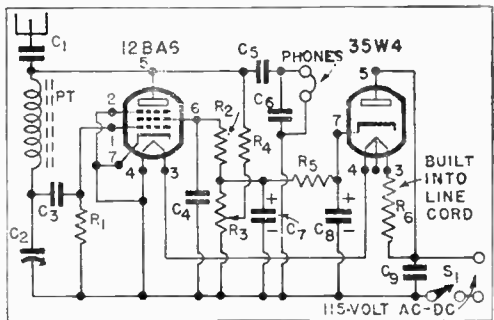

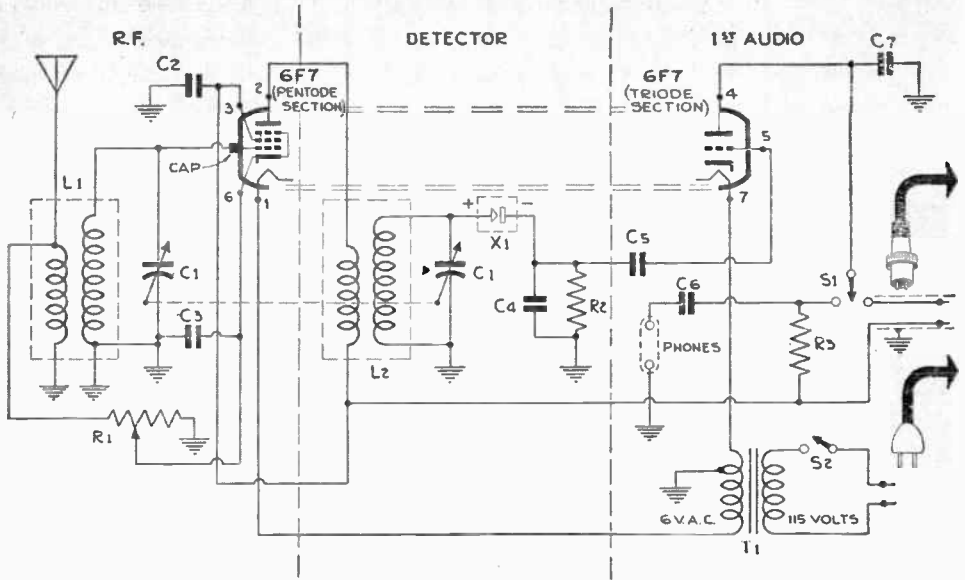

The cathode-regenerative circuit employed in this one-tube tuner is free of whistles and haws, and causes no interference with other radios. A tiny new crystal used in wartime radar equipment acts as the detector, replacing the more conventional diode.

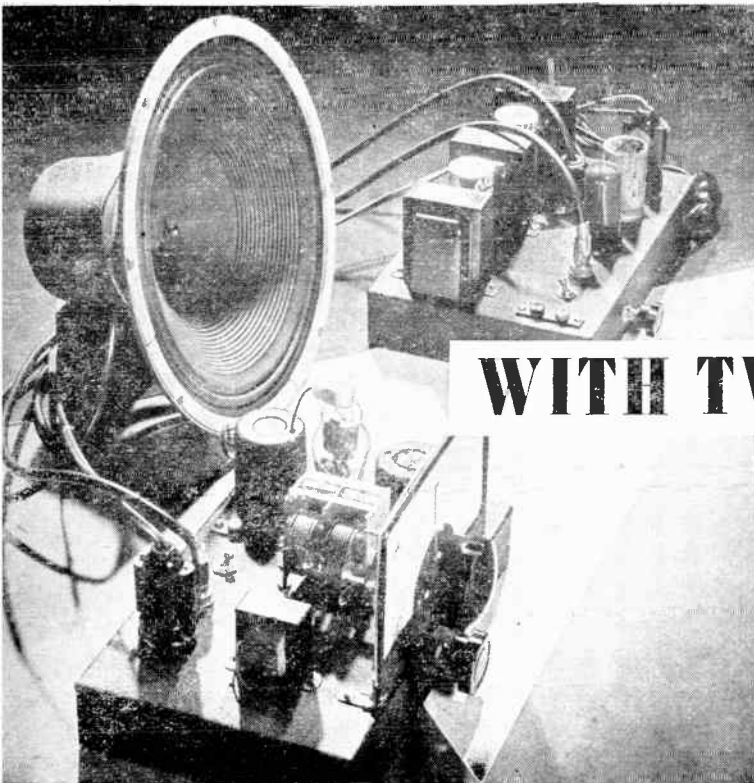

High Fidelity

WITH TWO TUBES

Neatly laid out and with all internal wiring below the two metal chassis, the rig can be housed vertically or horizontally in a cabinet. The speaker should be fitted to a baffle for best tone quality.

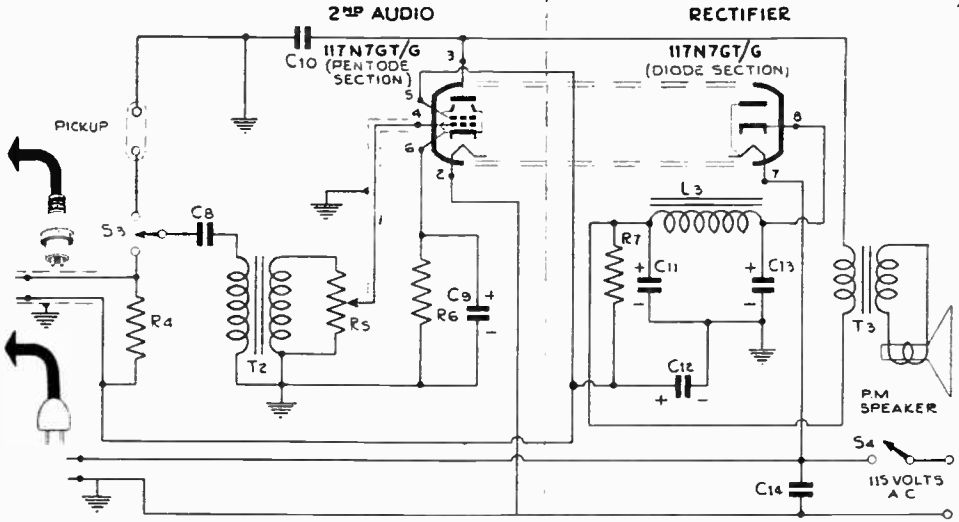

One stage of amplification is enough to drive a 12" speaker at comfortable volume, but a smaller unit can be used if preferred. When operating with a phonograph, the amplifier gives best results if coupled to a crystal pickup of the high-output type.

Dual-Purpose Tubes Provide Five Stages in Unusual Circuit

By WILLIAM NORTON

A CIRCUIT design that makes most of the components double up or perform some extra function is largely responsible for the high quality of reception possible with this two-tube receiver. Each of the tubes actually contains two separate sections within its glass envelope, and a war-born development replaces the detector tube, adding up to five stages in all.

About the size of a small resistor, the new part, X1 in the diagram, is actually the old familiar crystal detector in a new dress. Engineered for use in compact radar equipment, the midget crystal is now being offered to radio builders as a replacement for all types of diode-detector circuits. Available with pigtail leads for wiring into the set, it not only saves space but eliminates the need for a filament current, result-

ing in cooler operation with no sacrifice—and possibly some gain—in performance. The crystal is factory adjusted, and its "cat's whisker" is imbedded in wax for uniform shock-resistant service.

Also contributing to the set's high fidelity is the use of an audio transformer, employed here in a somewhat unconventional circuit. The transformer, T2, has a ratio of 3.5 to 1 and, as used with both B-plus and C-minus leads soldered to the chassis, carries no plate voltage in its primary winding. This tends to give a flatter response curve—that is, more uniform amplification of signal voltage and reproduction of the musical and voice ranges.

The elaborate filter circuit adds its share to smooth performance. Output from the half-wave rectifier is first filtered through the heavy-duty choke, L3, and electrolytic condensers C11 and C13. It is then further

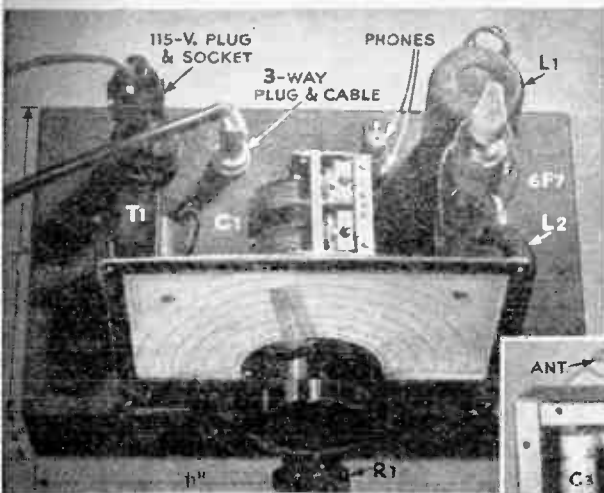

Tuning and regeneration controls are both placed on the front of the first chassis. The regeneration control also acts as one of the two volume controls on the radio. To align the set, adjust the trimmers on top of C1. Ink the call letters of local stations on the dial for easy reference after you have logged all of them.

The size of the metal chassis allows ample room for neat wiring. Note the tiny fixed crystal detector X1; it takes the place of an extra tube, but is no larger than a 1/2-watt resistor.

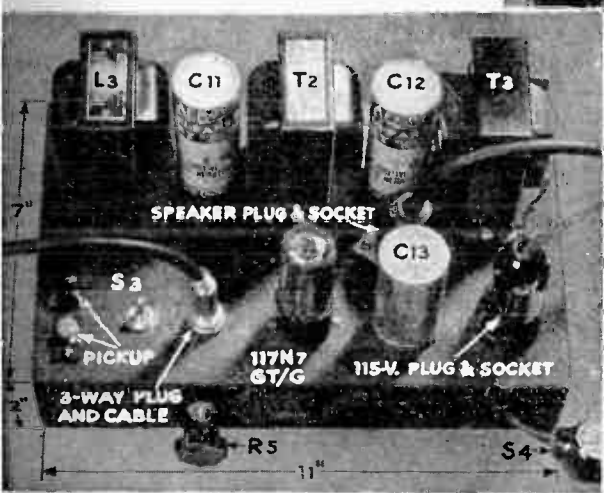
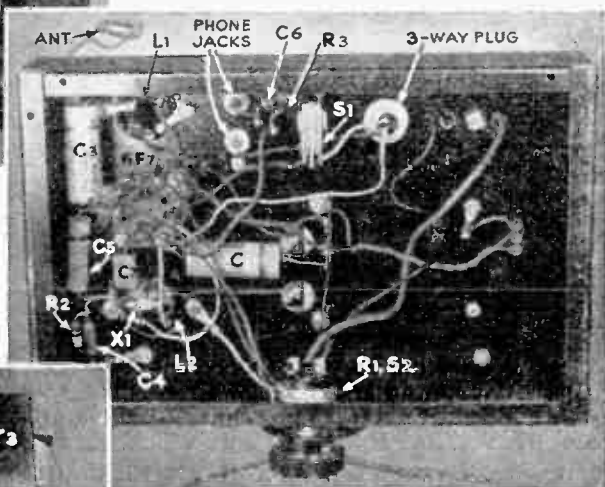

Large transformers and electrolytic condensers contribute to the over-all efficiency and tone of the finished receiver. They also give the set a handsome, professional appearance.

Note the shielded wire used between the grid of the 117N7 and the volume control, R5. The latter shunts the secondary of the audio transformer. The feed-through switch, S4, can be combined with the potentiometer or replaced by a separate panel switch.

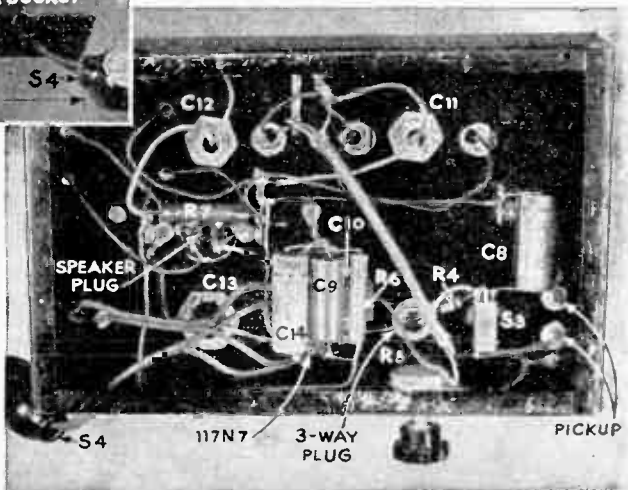

filtered through R7 and C12. Tapped off the choke, the voltage that reaches the plate of the 117N7 is higher than the one that gets to the screen.

Fidelity of sound reproduction generally requires that the plate impedance of the output tube be matched to the impedance of the speaker. This is done with an output transformer that has several taps in the secondary winding. By selecting the right ones, any speaker can be matched to the tube through the simple trial-and-error system of testing various taps until the most pleasing tone reproduction is obtained. There is enough power in this set to drive a 12" speaker, but if the full bass rendition of a large speaker is not required, an 8" or 10" unit may be used instead.

To make the tuner and audio amplifier sections independent of each other, two metal chassis blanks were used. The first 2" by 7" by 11" unit contains the radio-frequency, detector, and first-audio stages; the other holds the second-audio amplifier and the rectifier. A black crackle finish on the metal enhances the appearance of the work and lends a professional touch to the equipment. Used alone, the tuner will give excellent reception on headphones; alternatively, the amplifier can be used with either a microphone or a phonograph pickup. Switches S1 and S3 allow individual operation.

As only one stage of audio amplification is provided for a phonograph, a high-output pickup is needed to obtain high volume. For most satisfactory performance, one of the new crystal pickups with a signal output of about 4.5 volts should be used.

Air-core coils are used in the R.F. stage, but shielded iron-core coils may be substituted if they are easier to obtain locally. The coils are tuned by a two-gang .000365-mfd. variable condenser against a dial that can be marked with the call letters of local stations. Dials of this type are furnished with several blanks so that new station letters can be written in if the set is returned or moved to a new location.

Extremely stable regeneration, free of whistles, hoots, and howls, is provided by the cathode-regenerative circuit, and controlled by R1. This type of regeneration boosts the power of the receiver but does not interfere with neighboring radios. By using external line switch S4, and a second volume control, R5, it is possible to leave the regeneration control set at the point

where reception is best. No ground is needed, but if one is used it should be connected to the chassis through a .1-mfd., 600-volt condenser to prevent any possibility of shorting the 115-volt line. In some neighborhoods the receiver will give adequate volume with a very small antenna, or even none at all; in others anything from a 20' indoor line to an outdoor antenna of 100' or more may be needed.

Because this set is capable of quality sound reproduction, it deserves a cabinet that will help rather than hinder its tone. The speaker should be mounted on a baffle

LIST OF PARTS

- R1: 50,000-ohm potentiometer, with switch.
- R2, R3, R4: 100,000 ohms, ½ watt.
- R5: 500,000-ohm pot.
- R6: 600 ohms, 2 watts.
- R7: 500 ohms, 10 watts.
- C1: .000365-mfd. two-gang tuning condenser.
- C2, C3, C8, C14: .1-mfd., 600 volts.
- C4: .0002-mfd. mica.
- C5, C6: .05-mfd., 600 volts.
- C7: .00025-mfd., mica.
- C9: 25-mfd., 50-volt electrolytic.
- C10: .003-mfd., mica.
- C11, C12: 8-mfd., 450-volt electrolytic.
- C13: 20-mfd., 450-volt electrolytic.
- L1: Shielded air-core antenna coil.
- L2: Shielded air-core R.F. coil.
- L3: Shielded filter choke, 10 to 20 henries, 200 to 600 ohms.
- T1: Filament trans. 6.3-volt, 1-amp. secondary.
- T2: Shielded audio trans., 3.5 to 1 ratio.
- T3: Output trans., tapped secondary.
- X1: 1N34 midget crystal detector.
- S1, S3: S.P.D.T. toggle switches.
- S2: S.P.S.T. See R1.
- S4: S.P.S.T.
- Tubes, sockets, P.M. speaker, dial, cable, plugs, misc. hardware.

to prevent loss of low notes and an over-all tinny sound. The cabinet should be chosen with an eye to the versatility of the two units that make up the receiver. If you plan to use a phonograph with the amplifier, some provision should be made to house it. The changeover switch, S3, may be moved if necessary to make it easily accessible outside a closed cabinet. Similarly, the head-phone attachment on the tuner and switch S1 may be shifted so that phones can be plugged in with the least difficulty. If the set is destined to remain in your workshop, the metal chassis can be mounted at any angle on the walls or bench.

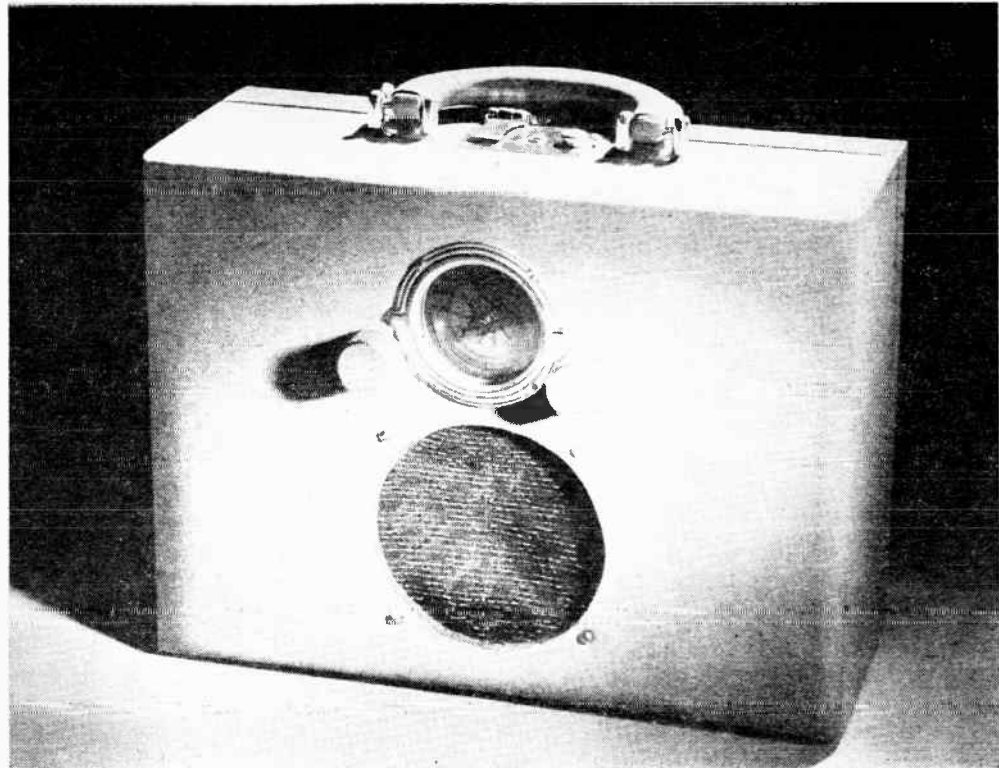

De Luxe Vacation Portable Rivals Console in Tone

By Henry C. Martin

PORTABILITY in radios suggests the great outdoors, yet few manufactured receivers allow for the different requirements of out-of-door as against indoor listening. With the exception of more expensive models, many commercial portables are either incapable of delivering comfortable outdoor volume or else overload to the point of distortion when they are turned up to an adequate level.

These were the chief factors that were kept in mind in the design of this portable. In tone it is equal to many large consoles, while the output level of undistorted volume is high enough to flood a good-sized room. Even where surrounding noise would normally drown out the sound of a radio, you won't have to cock your ear to the loud-

speaker of this set. For all its power, it is small enough in size and weight to be easily carried on picnics, beach and boat trips, and the like.

Two 1S4 pentodes are wired in parallel in the output stage and matched to a light permanent-magnet speaker to produce the unusually good tone. The tubes feed into a universal output transformer that has several taps on the voice-coil (or secondary) winding. A transformer with an input capable of matching load impedances up to 4,000 ohms is desirable since that is the theoretical resistance of two 1S4's in parallel. In the original receiver the 2,000-ohm tap was used because it produced the most pleasing tone. The transformer matches this tube impedance to the voice-coil impedance of the speaker which, in this case, is 4 to 6 ohms. The speaker itself is one of the light-

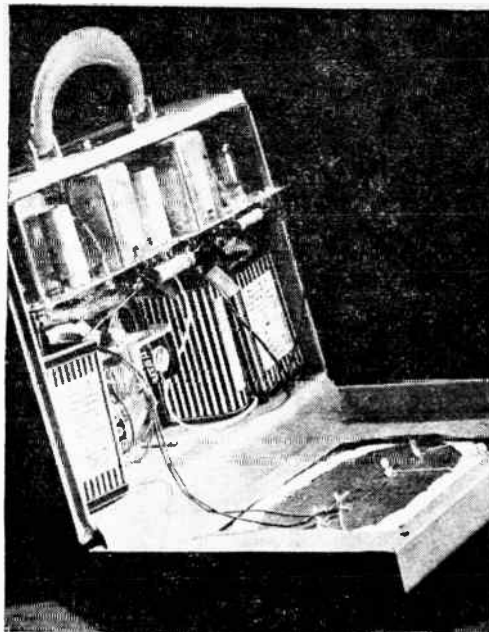

A piece of flat brass, cut to fit snugly across the upper part of the case, is used as a chassis. The lower portion of the cabinet is given over to the speaker and batteries. One 1.5-volt A and two 45-volt B batteries supply the set with power. The loop antenna slips under the lid of the case.

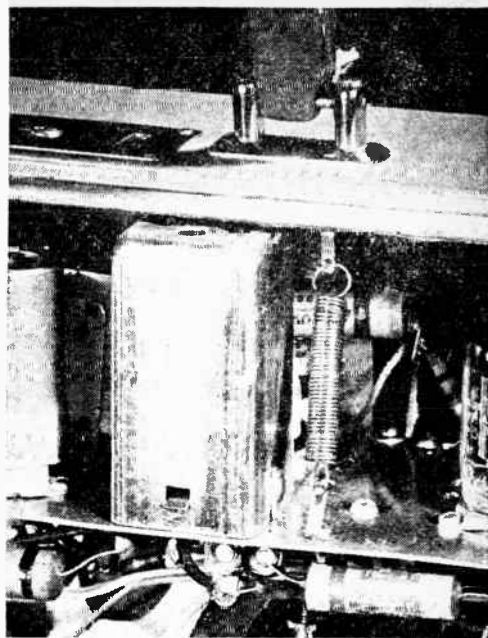

Here's part of the spring-suspension system that helps protect this set from the jolts and bumps that shorten the life of most portables. Anchored between soldering lugs on the chassis and case, two tension springs provide a "floating" or shock-absorbing support for one edge of the chassis.

est 5" units that can now be purchased; its alnico magnet is about as large as a thimble. Weight, of course, is correspondingly small.

The chassis consists of a 3½" by 11" strip of brass approximately 1/16" thick. This piece has no sides but a 2" flange is formed in front to support the dial assembly. By keeping chassis dimensions to a minimum and eliminating the sides, weight is reduced and wiring is made easier. Before cutting the chassis, measure the inside dimensions of the carrying case you intend to use.

Both sensitivity and selectivity are extremely good, the former because two stages of IF are employed, and the latter because in all, eight tuned circuits are used. Tuning is accomplished by means of a midget two-gang tuning condenser. As may be seen in the top photograph on page 143, the plates of the oscillator tracking section are considerably smaller than those of the antenna section. This is because the oscillator automatically tunes to a beat frequency 456 kc. higher than the antenna. As usual, all the IF transformers are adjusted to this fixed 456 kc. intermediate frequency. Incoming signals go directly to the 1R5 which acts both as first detector and local oscillator.

A pair of 1T's is utilized for IF amplifiers. Ground return leads of both the inter-stage and output IF transformers (L4, L5)

are wired into the automatic volume control circuit. Manual control of volume is obtained through a 1-meg. variable resistor (R11) in series with the control grid of the 1S5. Detection, or more correctly rectification, is performed by the diode plate within the envelope of the 1S5. The pentode section of the tube acts as the first audio amplifier and is coupled to the detector through R11 and C12. Resistance and condenser coupling is also employed between the first and second audio stages. The latter consists of the pair of 1S4 power pentodes which, in combination, boost the audio signal to the high output level that makes this set so satisfactory.

Final choice of a cabinet will be made on the basis of personal taste, price, and availability. The handsome leather-covered bag shown here is on the expensive side, and many less costly but equally satisfactory substitutes can be found in any luggage store. A small overnight bag will do provided that it is approximately the right size and sturdy enough to stand the wear that portables are subject to. This case measures 4½" by 8½" by 11½" outside; a smaller one is not advisable. Before cutting the case, make cardboard templates of the chassis, speaker, and batteries, and decide on the best position for each of them. Mark the

positions of the volume control and tuning shafts and the openings for the speaker and dial on the outside of the case. Score the leather with a sharp knife, drill the shaft holes, and cut or saw the circular speaker and dial apertures. The edges of the cuts can be concealed by suitable escutcheon plates.

Most overnight bags are fitted with mirrors, and if yours has one it should be removed and the loop antenna slipped under the cover lining. Instead of being mounted rigidly inside the case, the chassis is sprung to absorb jolts and shocks. Two soldering lugs are screwed to the top of the case and another two lugs are bolted to the edge of the chassis. Between the anchor points thus formed, small tension springs are installed to support the rear edge. The front is held only by the shafts, which project through the face of the bag and are gripped by the knobs on the outside.

Since, in common with all portables, this

set is dependent entirely on its loop antenna for station pickup, it should not be expected to perform any remarkable feats of long-distance reception. It will, however, easily pick up and separate all local stations, and its performance can be improved by using the antenna to best advantage. One way of doing this is to turn the set as you tune it until the position of the antenna favors the station you are trying to get. Reception can also be improved in many cases by leaving the cover of the case slightly ajar. Most loop antennas, in addition, have an extra connection that permits the attachment of an outside aerial when conditions permit.

In order to keep battery drain to a minimum, no pilot light was used in this circuit. This makes it all the more important that you remember to turn off the switch when the set is not in use. If you can't trust your memory, insert a 1.5-volt .06 amp (60 ma.) pilot light behind the dial and wire it in parallel with the tube filaments.

LIST OF PARTS

All resistors $\frac{1}{2}$ watt carbon unless otherwise noted.
 R1: 100,000 ohms.
 R2: 2 meg.
 R3: 10,000 ohms.
 R4: 2,000 ohms.
 R5: 5,000 ohms.
 R6, R9: 5 meg.
 R7: 15,000 ohms.
 R8: 1,000 ohms.

R10: 3 meg.
 R11: 1 meg. with switch pot.
 R12: 10 meg.
 R13, R14: 1 meg.
 R15: 180 ohms, 1 watt.
 C1: Two-gang tuning condenser.
 C2, C11: .1-mfd., 450-volt paper tubular cond.
 C3, C13: .0001 mfd. mica.
 C4, C5, C6, C7, C8, C9, C10, C12, C15: .05-mfd., 450-volt paper tubular.

C14: .0002 mfd. mica.
 C16: .0005-mfd., 450-volt paper tubular.
 L1: Loop antenna.
 L2: Iron-core oscillator coil.
 L3, L4, L5: input, interstage, and output IF transformers.
 T1: Midget universal output trans.
 S1: D.P.S.T. switch on R11.
 Speaker, tubes, case, tube sockets, shields, batteries, hardware.

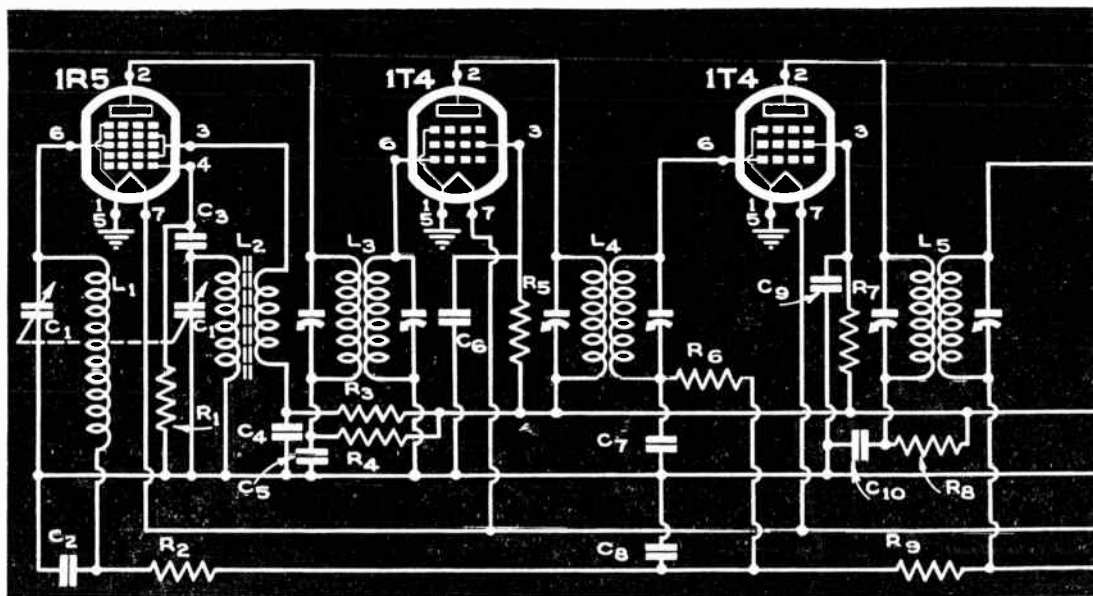

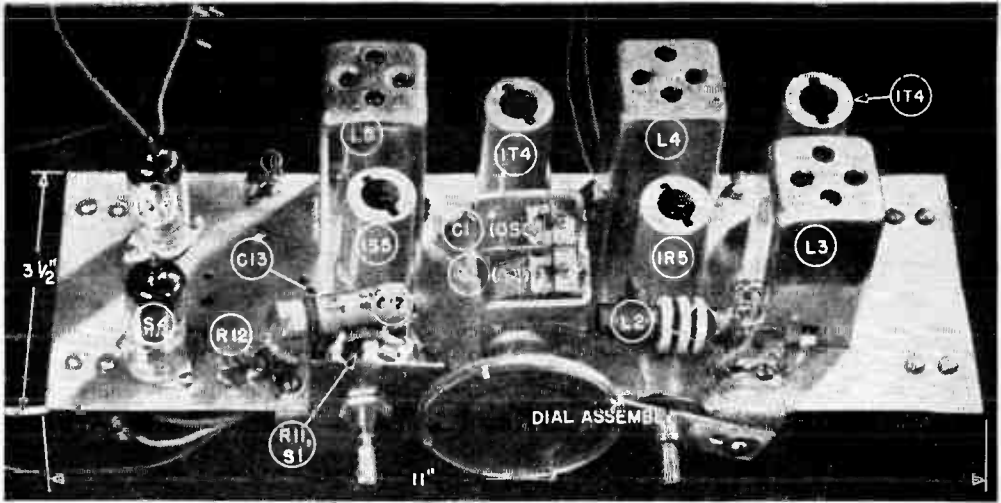

Labeled photograph shows where major parts are placed on top of the chassis for most effective separation.

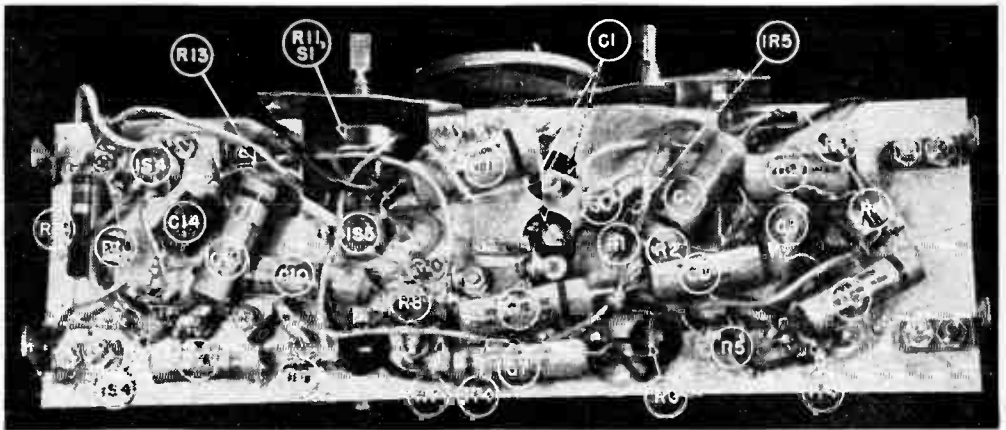

Most of the wiring is done below the chassis. Use the new tiny resistors and condensers to save space.

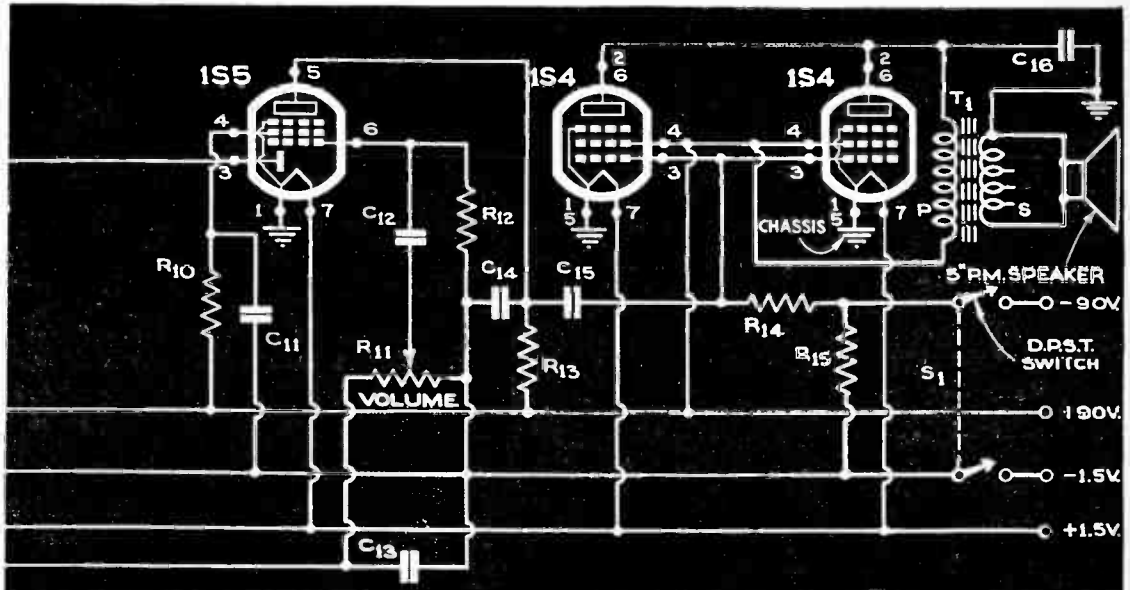

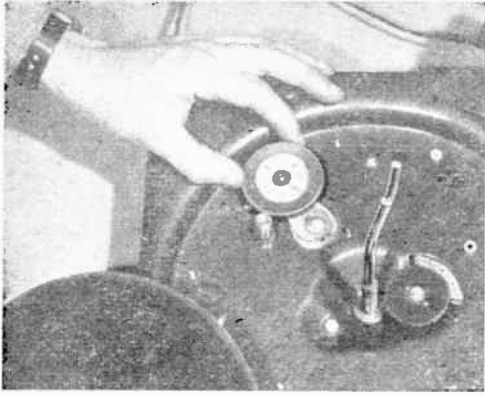

Flat on Idler Bumps Turntable

RUBBER-COVERED idler wheels used between the driver and turntable rim on rim-driven phono motors may develop a flat if left standing in one position. Flats cause an audible bump at every revolution of the turntable: they are most likely to develop during the hot summer months. Before going away for the summer, unseat the turntable to relieve pressure on the idler. And if the trouble should develop, you can replace the idler or turn it down carefully on a lathe to restore perfect roundness.

Troubles Traced to Condensers

DISTORTION, loss of volume, and squealing in a radio can often be traced to a faulty electrolytic condenser in the cathode of the power output tube. A typical value of this condenser is 25 mfd., 50 volts.

When a set suddenly loses volume but can be brought back by banging the cabinet or flicking a light switch in the room, the electrolytic in the cathode of the second detector (57, 6C6, 6J7, etc.) may be leaky. Its value is 5 mfd., 25 volts.

In replacing either of these bias condensers, connect the positive terminal to the cathode and the negative lead to the chassis or other ground.—*Frank Tobin, Manhattan, N. Y.*

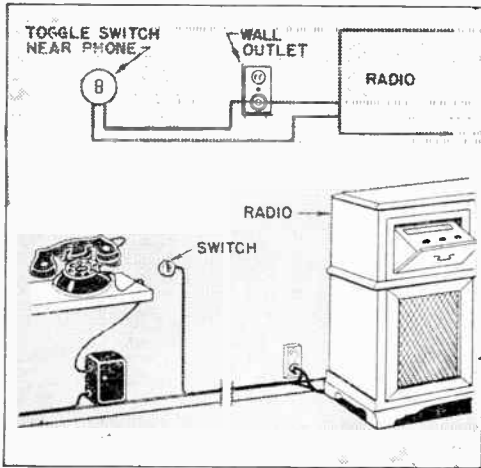
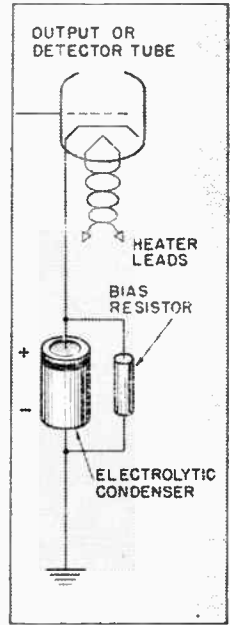

Switch Near Phone Cuts Radio

TIRED of running to reduce radio volume every time the phone rang, we mounted a toggle switch near the telephone. By connecting it in series with the radio line cord, we can now turn the set off right at the phone. The wire leading from switch to radio is stapled to the baseboard.—*Arthur Trauffer, Council Bluffs, Iowa.*

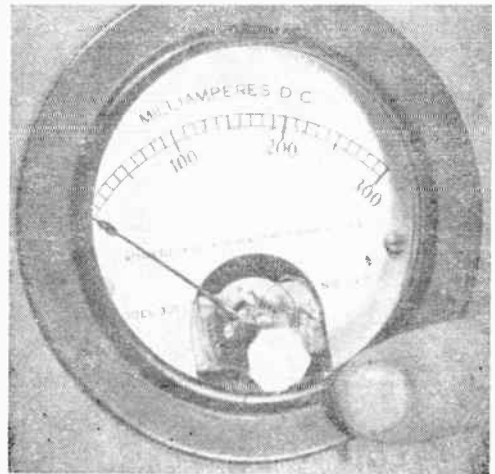

Tape Reduces Shock Hazard

THE tiny zeroing screw on the face of a 0-300-ma. plate meter on a transmitter proved to be loaded with high voltage. An accidental touch produced a painful and unexpected shock. To prevent recurrence, I covered the head with adhesive tape. It is easily removed when adjustment is necessary.—*D. J. Bachner, Queens, N. Y.*

Boy's Radio Lets Dad Enjoy His



By Clinton E. Clark

EVERYONE in the family will enjoy this little two-tube headphone set. Junior can listen to all the programs especially meant for him, and Pop and Mom will escape the nerve-shattering tommy guns and thundering herds. Pretuning makes things easy, for any young listener can turn on the switch and set the pointer knob to his choice of three stations. A four-position switch and one extra trimmer would adapt the set to cover all four major networks. Although the circuit is regenerative, pretuning eliminates the usual squeals.

Begin work on the chassis by drilling or punching two $1\frac{1}{8}$ " holes for the tube sockets. Then drill holes for mounting the line-dropping resistor $1\frac{1}{2}$ " in front of the 12J5GT tube. This resistor must be above the chassis because it creates considerable heat.

In the back of the chassis, drill three holes

for the phone jacks and line cord, protecting the latter with a rubber grommet. In the front, drill three evenly spaced holes for the switch, pilot light, and regeneration control. Drill three corresponding holes in the panel, plus a fourth for the selector switch.

After the sockets, filter choke, and selenium rectifier have been mounted, the subchassis wiring may be started, taking the power-supply section first. If you have a meter, the DC voltage here should test approximately 100. Then install the filament circuit, and determine the 580-ohm setting of the adjustable slide with an ohm meter.

Mount two $1\frac{1}{2}$ " high standoff insulators 2" apart on the left rear of the chassis top. These support the coil and tuning capacitors, a soldering lug being used on the top of each to attach a length of stiff wire to which the condensers are soldered. The other ends of the condensers are brought to

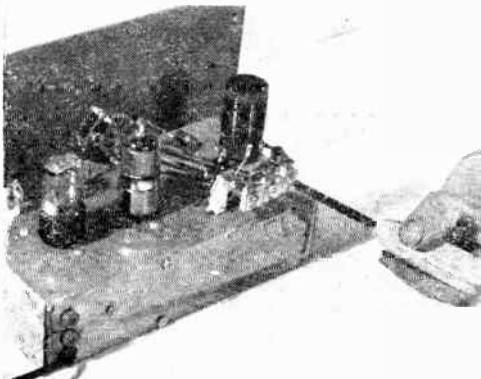

Pretune the set with a neutralizing tool or a bakelite shaft ground to a screwdriver tip.

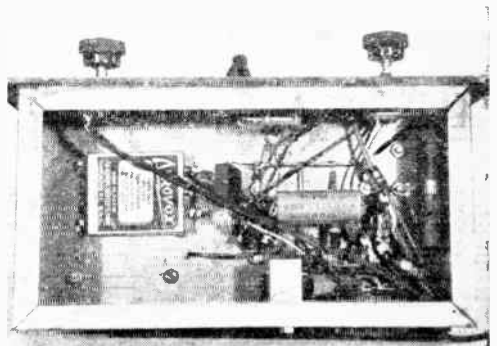

Subchassis wiring is comparatively simple. Test the various sections as you go along.

their respective positions on the tap switch. For this receiver, the coil is the type commonly used on small TRF sets, the winding being a single layer. Remove the primary winding entirely.

Experimentation generally will show that the best position for making the cathode connection is near the bottom or ground end of the coil. To locate the exact position, probe with a needle or pin stuck into the eraser on the end of a pencil until you find where regeneration control R2 operates smoothly. Then make a soldered connection. To adjust the tuning condensers, use a serviceman's neutralizing tool, or, lacking

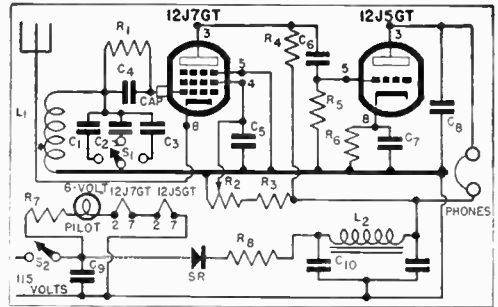

this, a 4" length of bakelite shafting ground to a screwdriver tip. An outside antenna is desirable but not absolutely necessary.

LIST OF PARTS

- | | |
|---|---|
| L1: TRF coil. | R2: 50,000-ohm pot. |
| L2: 10-hy., 50-ma. choke. | R3: 100,000 ohms. |
| C1, C2, C3: 100-mmf. trimmers. | R4, R5: 250,000 ohms. |
| C4: .0001 mfd. mica. | R6: 2,000 ohms. |
| C5: 1 mfd. | R7: 600-ohm wire-wound, 20-watts; adjustable to 580 ohms. |
| C6, C9: .01 mfd. | R8: 100 ohms. |
| C7: 4 mfd. | SR: 75-ma. selenium rectifier. |
| C8: .005 mfd. | S1: Single-pole, 3-position selector switch. |
| C10: dual 20-20-mfd., 150-volt, electrolytic. | S2: SPST rotary switch. |
| R1: 5 meg. | |

Simple Guard Protects Needle

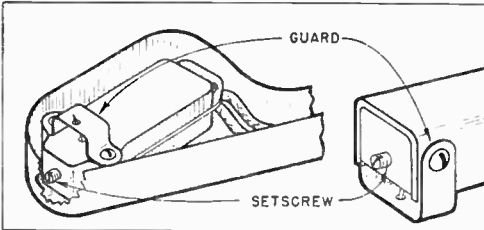

Physical abuse is a frequent cause of crystal-pickup failure. This may be avoided by installing a permanent-needle type of cartridge with a guard or by building a guard for your present pickup.

An effective guard may be made from a 1/2" by 1 1/2" strip of shim brass .005" thick. Drill a 3/8" hole in the center for the needle. Then bend the ends of the strip upward parallel to the needle, and finally, if the arm is the type at the left above, outward so that the ends may be fastened to the bolts that hold the cartridge in place. Drill holes to suit these bolts. Form the guard so the needle projects about 1/16".

Install a jeweled or other permanent needle and replace the thumbscrew with a setscrew. The arm need not be rebalanced as the weight of the brass strip is not sufficient to warrant it. MAX ALLEN.

Tagging Wires Saves Time

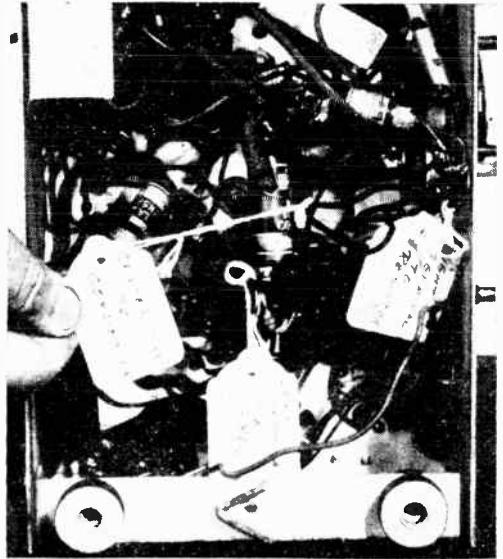

CONSIDERABLE time may be saved and possible errors eliminated by using price tags to mark the wires when making replacement of radio parts. During reassembly, the tags will show exactly where each wire goes. By erasing the pencil marks, the tags may be used many times. Such tags are available at office supply stores.



1-Way Portable Stretches Battery Life

Getting ready for summer afternoons? A radio is almost as important as sunshine and water.

High and low battery positions as well as AC and DC operation give this versatile set surprising economy.

By Henry C. Martin

Plan the parts layout and drill the necessary holes. Rub down the chassis with steel wool to clean it up and smooth rough-cut edges.

TWO resistors can make a big difference in a radio circuit. In the little set pictured here, they make a whopping difference in economy and battery life. You've seen standard three-way portables that operate on 90 volts of B battery or from an AC or

Save space by joining small parts that go together—such as condensers and resistors in parallel—before soldering them into the set.

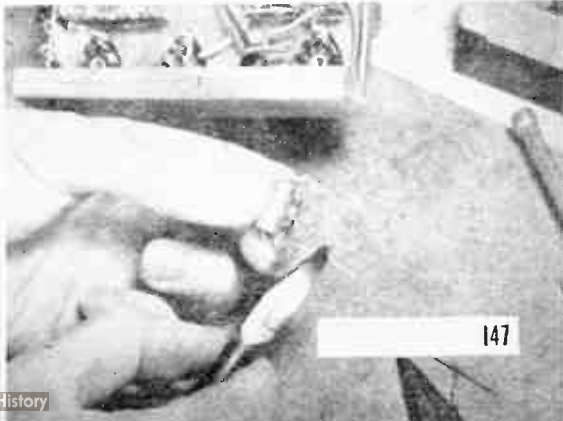
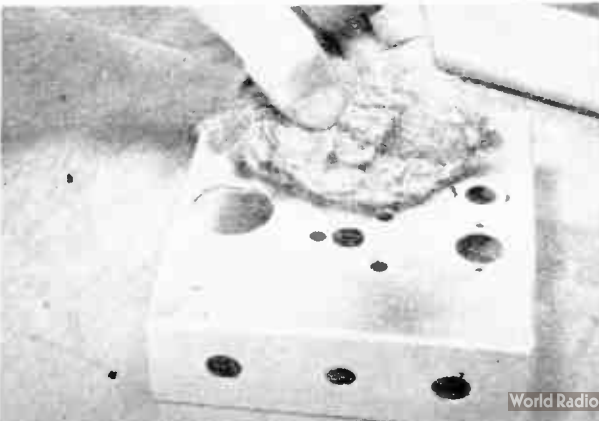

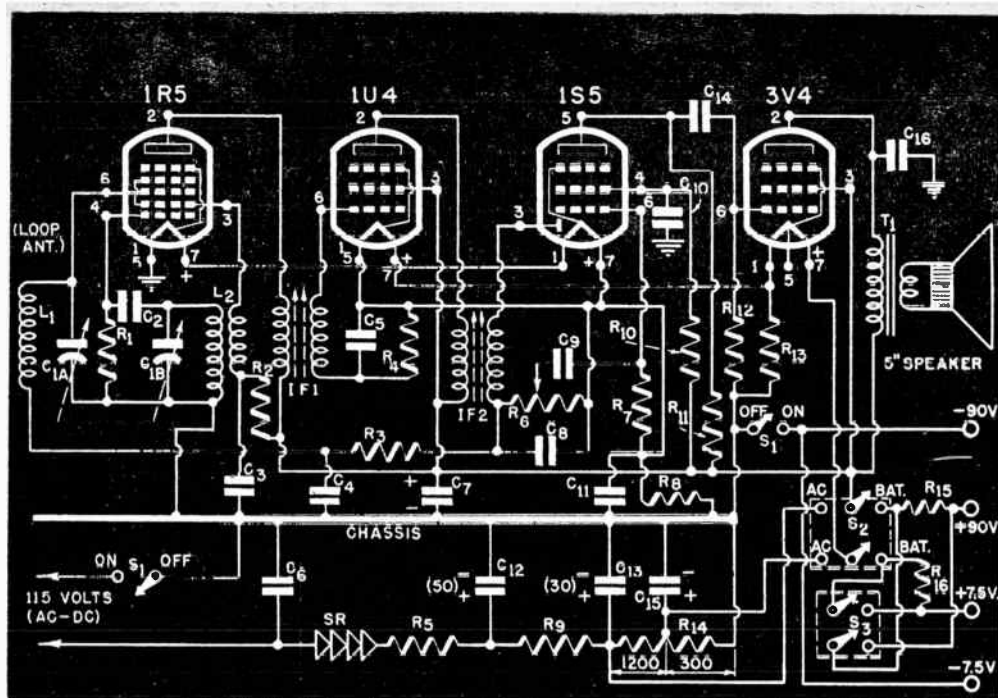

LIST OF PARTS

All resistors $\frac{1}{2}$ -watt carbon unless otherwise specified.

R1: 50,000 ohms.
 R2: 6,800 ohms.
 R3, R12: 2.2 meg.
 R1, R7: 10 meg.
 R5: 50 ohm, 10-watt wire-wound.
 R6: $\frac{1}{2}$ meg. potentiometer (volumen control).
 R8: 2,200 ohms.
 R9: 200-ohm, 10 watt wire-wound.
 R10: 3 meg.
 R11: 1 meg.
 R13: 150 ohms.
 R14: 1,500 ohm, 25-watt adjustable wire-wound.

R15: 2,500 ohms.
 R16: 20 ohms.
 C1 A, B: Two-gang tuning condenser with cut-plate section for 455 kc. IF.
 C2: 50-mfd. mica or ceramic.
 C3, C5, C6, C9, C10, C11, C14: .01-mfd., 200-volt midget paper.
 C4: .05-mfd., 200-volt midget paper.
 C7: 20-mfd., 150-volt electrolytic.
 C8: 100-mfd. mica.
 C12, C13: 50-30-mfd., 150-volt dual electrolytic.
 C15: 100-mfd., 50-volt electrolytic.

C16: .01-mfd., 200-volt midget paper.
 S1: DPST switch on R6.
 S2: DPDT toggle.
 S3: DPST toggle.
 T1: Midget output trans. (see text).
 SR: 100-ma. selenium rectifier.
 L1: Loop antenna.
 L2: Air-core osc. coil.
 IF1, IF2: Iron-core intermediate-frequency transformers.
 Batteries (90 volts B; 7 $\frac{1}{2}$ volts A).
 5" PM speaker, tubes, sockets, cabinet, back panel, chassis, dial, line cord and plug.

DC line. Another common design is the "personal" radio that generally uses a 67 $\frac{1}{2}$ -volt battery to save space. Compactness is achieved, but at the cost of lowered sensitivity and volume.

Here, for the first time, both circuits are incorporated in one set. Indoors you'll run this receiver off the house lines. When you get out of range of an extension cord, however, you'll find that packaged power not only delivers the goods but does so at a considerable saving.

The whole trick is in the addition of two dropping resistors and an economy switch. Using 90 volts of B battery and 7 $\frac{1}{2}$ volts of A, the receiver performs with maximum sensitivity and volume. That's fine for a noisy beach or ball park, or when you want to listen to a far-off station. But most of the time you can get away with less power without noticing the difference. Flicking a switch reduces the potential from 90 volts to about 60, and from 7 $\frac{1}{2}$ volts to 6. Current drain

from the B battery is cut from 18 milliamperes to 7, while A current goes down from 55 to 45 milliamperes.

All of this means long, long battery life, for even after the cells have run down by a third, the set will continue to give first-rate performance if the economy switch is set up to maximum. To reduce battery drain, R15, a 2,500-ohm resistor is inserted in the B-plus line, and R16, a 20-ohm unit, is placed in the filament lead. When full power is needed, the DPST switch, S3, shorts out the dropping resistors.

A small 90-volt battery was used in this set in order to hold down size and weight. If you don't mind a slightly heavier package, you can get even greater economy by using two of the huskier 45-volt batteries in series.

Another feature of this set is a simplified rectifier circuit for AC-DC operation. It consists of a 100-ma. selenium rectifier, three electrolytic condensers, and three resistors.

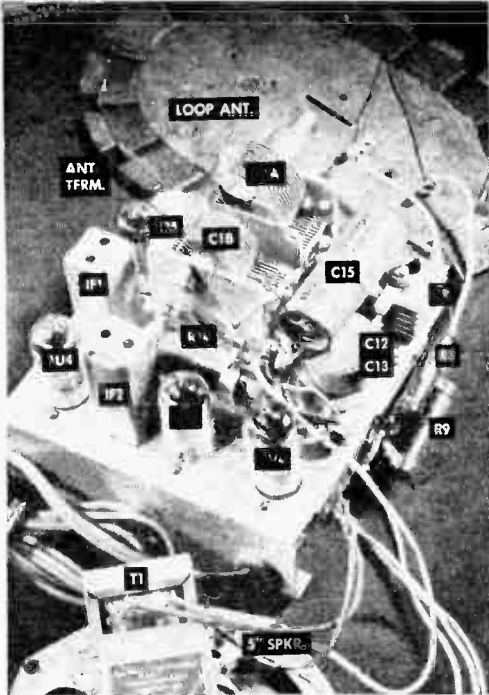

Wire-wound resistors are mounted outside the chassis for better heat dissipation. One machine screw holds the selenium rectifier.

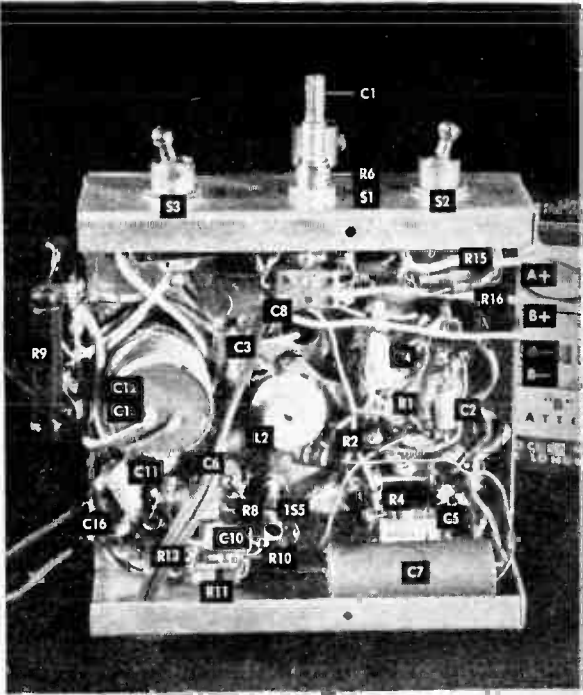

The dual-electrolytic condenser projects partly below and partly above the chassis. It is fastened on top by its mounting collar.

One of the latter, R14, is a 1,500-ohm, 25-watt unit with an adjustable tap. Setting the tap varies the filament voltage. It should be adjusted so that the tubes get about 7 volts—or even slightly less—when the set is being operated on house current. For testing, fix the tap to give a division of about 1,200 ohms to 300.

The balance of the circuit follows standard practice pretty closely. There are four miniature tubes in addition to the dry-disk rectifier, making this the equivalent of a five-tube superhet. The first tube, a 1R5, is a pentagrid converter that acts as an RF amplifier and local oscillator. The incoming signal is tuned by one section of the two-gang tuning condenser, C1; the other gang tunes the oscillator. Try to buy a condenser that has cut plates for the oscillator section, and built-in trimmers on both gangs.

The IF amplifier, a 1U4, operates at the fixed frequency of 455-6 kc. Two IF transformers, tuned to the same frequency, are also employed. Midget transformers with powdered iron cores were selected as iron cores give higher gain. It makes relatively little difference whether fine adjustment is made by means of air-spaced trimmers or by moving the iron cores. The diagram indicates a movable-core transformer, but the trimmer type may be more generally available and will work as well.

A diode detector and pentode amplifier are combined in the 1S5. The former demodulates the RF signal, the latter acts as a first audio amplifier. The 3V4 tube used in the output stage is a relatively new development; it was selected because of its effectiveness in amplifying weak signals and bringing them up to loudspeaker volume. Although this tube has a plate impedance of 10,000 ohms, it was found that an output transformer with an 8,000-ohm primary and 3.5 to 4-ohm secondary gave satisfactory matching. Transformers of the latter type are more readily available in small sizes.

An aluminum chassis measuring 1½" by 4¾" by 5" provided ample space. However it is always a good idea to assemble the parts for a set before finally determining the chassis size and arrangement. Aluminum is first choice for the chassis as it can be drilled and cut easily. Seven large holes had to be made for the tube sockets, the dual-electrolytic condenser, and the IF transformers. Socket holes are ⅜" in diameter, those for passing the IF leads through the chassis are ½". The 50-30 dual electrolytic used here required a 1⅛" hole in order to be mounted, as shown, partly above and partly below the chassis. If you don't have chassis punches in the right sizes, drill smaller holes and file or ream them to the required diameters.

Solid pushback wire is the easiest to use

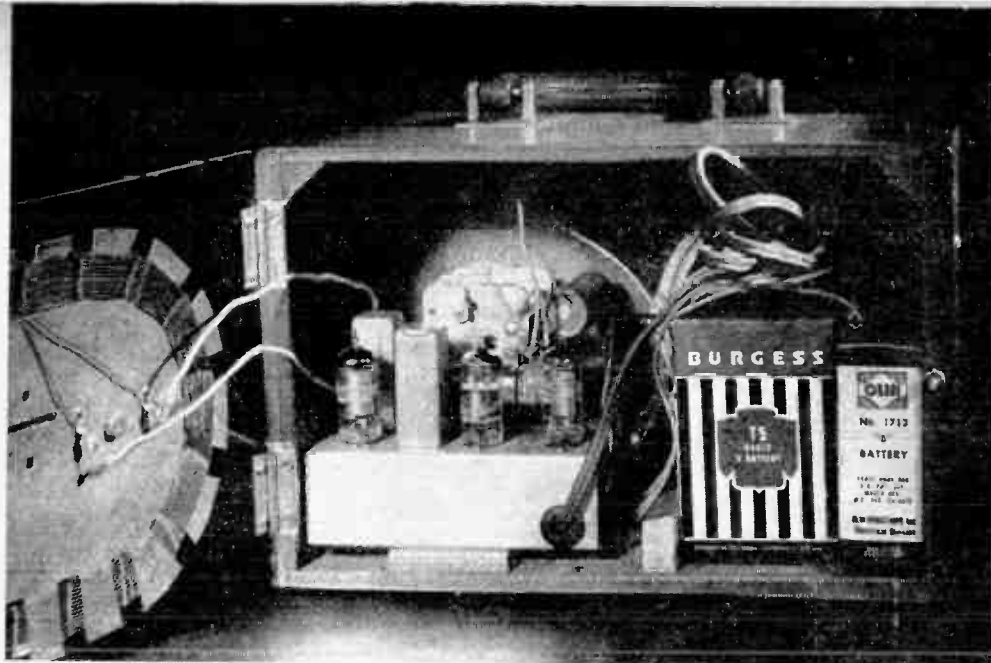

A small wooden cleat behind the chassis keeps it from sliding back in the cabinet. Cleats are

also used to keep the batteries in place. For carrying, a leather handle is screwed on top.

for wiring the parts, and is suitable for all except the battery leads and those to R14. Cotton-covered stranded wire has the inside track for these connections where extra flexibility and current-handling capacity are important. Note that R5, R9, and R14 are all mounted above or outside the chassis. This is done because these resistors—all of the wire-wound type—generate more heat than could be readily dissipated if they were confined under the chassis. They only come into operation when the set is used on a 115-volt line. Should they appear to get too hot, it might be well to open the back cover when the set is kept on for long.

Although IF transformers are preset at the factory, wiring them into a set may throw them slightly out of adjustment. When the assembly is completed, tune in a station at the high end of the broadcast band (the plates of the tuning condenser are out of mesh at the high end) and rock the trimmers on the IF transformers very slightly to peak the signal. Use a small screwdriver for this adjustment, or, preferably, an insulated tuning wand. Make any similar adjustment that may be necessary on the trimmer alongside the oscillator section of C1. Rock the tuning dial back and forth while adjusting this trimmer, and then make a final check on a station at the low end of the band.

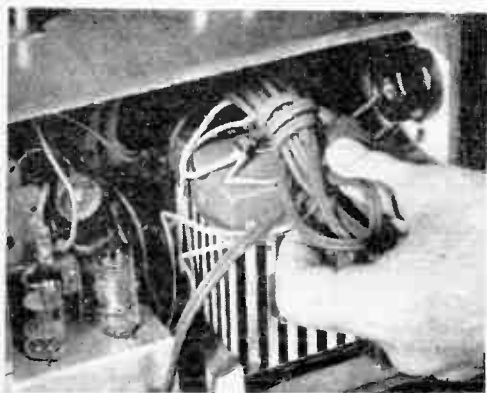

A dummy wall outlet is screwed to the side of the cabinet to provide an anchor for the AC-DC cord when the set is operated on batteries.

An inexpensive solution to the cabinet problem is to use one of the replacement cabinets for AC-DC receivers available at many supply houses. It isn't likely that any of them will come with carrying handles, but an attachable luggage handle takes care of that. Cut a plywood, plastic, or similar back to the proper size and hinge it to the cabinet along one edge. A loop antenna can be fastened to the back with a couple of screws. The speaker is attached directly to the front panel behind the grille, and the chassis is held by the two toggle switches, the volume control, and the tuning condenser. If necessary, tack in wooden cleats to keep the batteries from shifting inside the box.

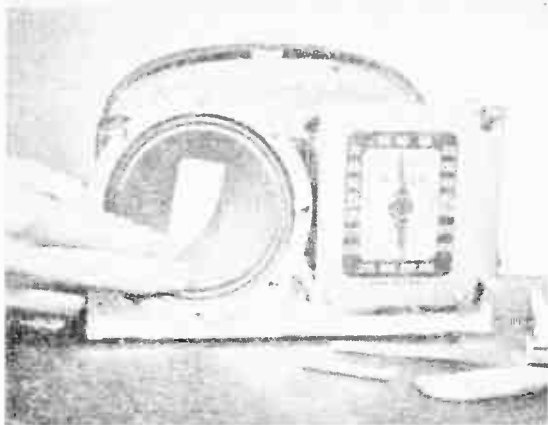

Tape Shields Speaker Magnet

Should you have to saw or file control shafts or other metal parts of a radio while making repairs or replacements, see that no filings are permitted to enter the speaker cone, where they may cause distortion and rattling. You can protect the speaker by keeping a strip of adhesive tape over the opening while you work.—H. LEEPER.



Braid Grounds Condenser

Noisy and erratic tuning is sometimes caused by a poor connection between a tuning-condenser rotor and ground. It is especially common in portables where the condenser has been mounted on rubber to absorb vibrations. A short piece of timed braid soldered between the condenser frame and chassis cures it.—FRANK TOWN.

Markers Make Tuning Easier

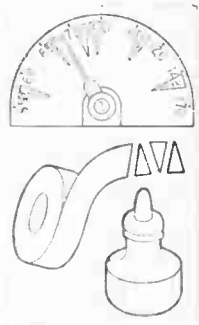

WEDGE-SHAPED bits of cellulose tape make station settings easy to locate. Lettered with India ink and placed in appropriate spots on the dial, they help you tune in where the light is poor without having to remember wavelengths of favorite stations.—G. E. HARRINGTON.

Rifle Shells Used as Wire Caps

NEAT ends for shielded wire can be made from used .22-cal. rifle shells. Drill or punch a hole in the end, slip the conductor through, and solder the braid inside the shell. Empty shells are also useful as grid caps. Spread or pinch the side of the shell to fit.—RICHARD SAIZER.

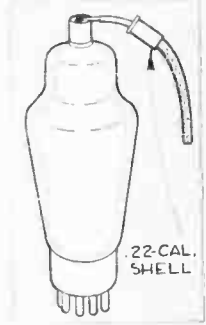

Extra Speaker Converts Receiver to an Intercom

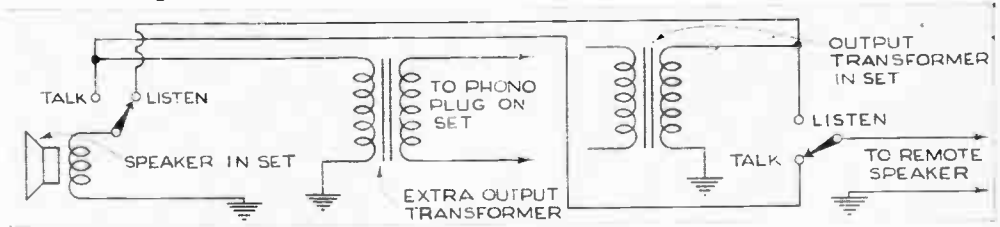

Radio receivers having sufficiently high audio gain will double as intercoms with the addition of an extra speaker and transformer. A single wired connection to the remote speaker is sufficient, since the re-

turn can be made to a common ground. When the switches are turned to "Talk," the speakers act as microphones. A single DPDT switch may be substituted for the two SPDT units shown in the drawing. LES JONES.

Battery Phono-Radio Portable



Music where you like it with this spring-driven, battery-powered record player and receiver.

By WILLIAM NORTON

Built into a small carrying case, this one-tube radio-phonograph can be played anywhere. To suppress surface noises, close the lid while records are playing.

PORTABILITY in a radio-phonograph usually means little more than that the unit is built into a carrying case and provided with a handle. Such a set can be carried around easily enough, but can only be played where the right current is available. If you don't want to be tied down by the power lines, and are willing to sacrifice the convenience of an electric motor for the advantages of complete mobility, this one-tube combination will reward you by playing anywhere so long as it is supplied with batteries and you remember to wind its spring-driven turntable motor.

The amplifier is a straightforward one-tube circuit in which the single tube—a 1DS GT—acts as a two-stage amplifier. Output from the pickup or from a fixed crystal detector is fed into the grid of the triode section which is resistance-capacity coupled to the power pentode. A variable 250,000-ohm resistor between ground and the grid of the first audio stage acts as a volume control for both the phonograph and radio.

Small as it is, the amplifier delivers enough power from the pickup to overload the 5" speaker.

Radio strength is not nearly as great, but local stations can be picked up with good loudspeaker volume. An external antenna and ground will usually be required for clear reception.

The primary winding of a standard shielded antenna coil is connected to the antenna post and inductively coupled to the secondary winding; capacitive coupling between the two coils is provided by C1, a 10-mmf. air-spaced trimmer. The combination of inductive and capacitive coupling increases selectivity without sacrificing volume.

For the tuning condenser, C2, a midget 360-mmf. variable capacitor was used. Small dimensions for this part are important if the condenser is to clear the speaker frame when the chassis is mounted in the cabinet.

The signal taken from the plate of the power pentode is matched to the speaker through a midget universal output trans-

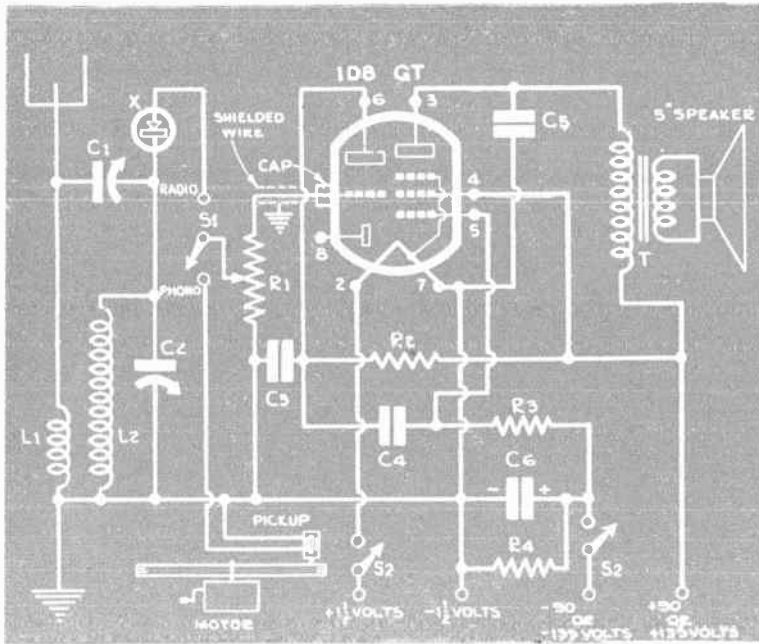

This one-tube circuit actually includes a two-stage amplifier fed either by the pickup or by the tuned circuit and detector. Parts are keyed to the list at the bottom of the next page.

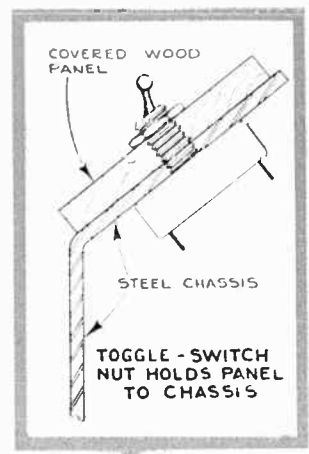

The chassis is a 6" by 6" metal sheet bent to conform with the slope of the wood panel. The cabinet is covered with artificial leather both inside and out.

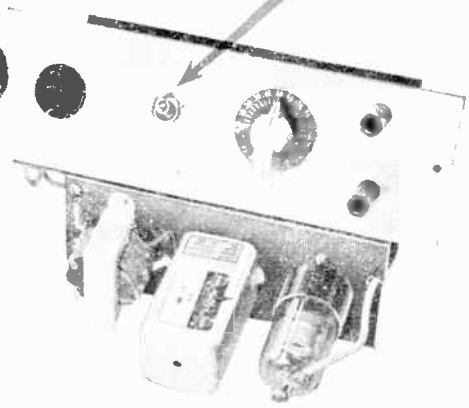

former. Taps on the secondary winding of the transformer permit selection of the most pleasing tone.

An automatic bias circuit consisting of R1 and C6 makes it unnecessary to carry a separate "C" battery to bias the grid of the pentode. Bias voltage is taken from the drop across the 600-ohm resistor.

Two midsize 67½-volt "B" batteries are connected in series to give a total of 135 plate volts, but anything from that down to 90 volts would serve. Higher plate voltage, of course, gives higher volume output, but for most purposes the lower voltage will be sufficient. A 1½-volt "A" battery supplies the

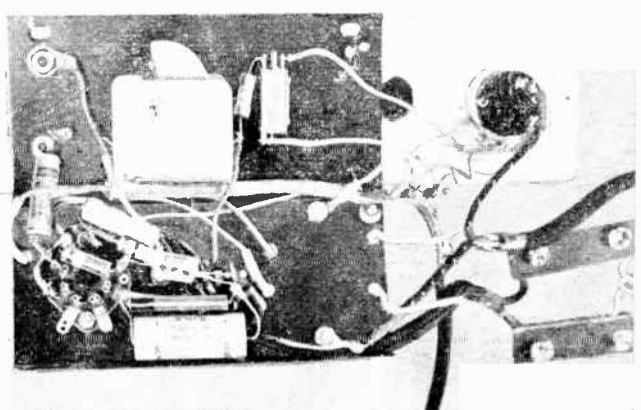

Wiring must be kept reasonably compact, but if small parts are used, no special crowding is necessary. Note the small 360-mmf. tuning condenser, and the miniature fixed crystal detector on its right.

At right, an inside view of the case with the phonograph motor board removed. Note the position of the batteries, which are clamped clear of the motor.

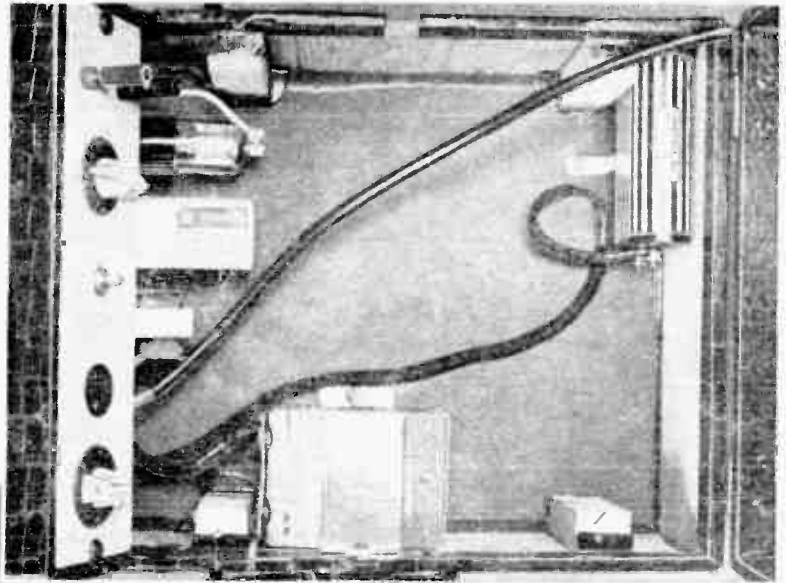

The control panel is shown below in close up. The knob on the left governs R1 and S2, the volume control and switch. To keep from draining batteries, turn off the switch when the set is not in use.

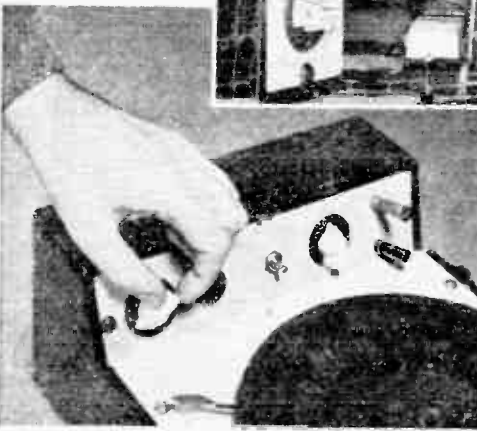

tube's filament. The entire chassis is mounted on a 6" by 6" steel sheet which is bent to fit below and in front of the control panel. To mount the chassis to the panel, bolt the toggle switch through both pieces, as shown in the drawing on page 153. Follow the same procedure with the antenna and ground jacks.

Phonograph cases are now available in a wide selection of attractive luggage styles, and you can almost certainly find one to suit your taste and price. One factor that must be taken into account is the size of the records that you intend to play. Only 10" records can be played on the model shown here, and a larger case will be needed if you want your combination to handle 12" disks as well.

Single spring phonograph motors require about 50 turns for a full wind, and they will then play two 10"-record sides. Don't overwind the motor or use force in handling it.

Bearings should be oiled occasionally, and the gear teeth lubricated with petroleum jelly about once a year.

If the motor has a speed regulator, set the pointer at 80, or midway between "S" and "F". Accurate adjustment of turntable speed may be made with stroboscopic record, but if you don't have one of these, insert a slip of paper between the turntable and a record so that it projects at one point. Then count the number of times the paper passes a given spot in a minute. Increase or decrease the speed until you get a count of 80 r.p.m. Actual playing speed, allowing for the weight of the pickup on the record, will then be very close to 78 r.p.m., the speed for which many popular recordings are cut.

LIST OF PARTS

- C1: 10-mmf. air-spaced trimmer.
- C2: 360-mmf. midget tuning condenser.
- C3: 200-mmf. mica.
- C4: .01-mfd., 600 volts.
- C5: .02-mfd., 600 volts.
- C6: 8-mfd., 150-volt electrolytic.
- R1: 250,000-ohm volume control, with switch.
See S2.
- R2: 100,000-ohm, 1/2-watt carbon.
- R3: 1-meg., 1/2-watt carbon.
- R4: 600-ohm, 2-watt carbon.
- S1: S.P.D.T. toggle switch, with long neck.
- S2: D.P.S.T. switch on volume control.
- X: 1N34 fixed crystal.
- L1, L2: shielded antenna coil.
- T: Midget output transformer.
- Cr: Midget pickup, spring-wound motor, batteries, 5" P.M. speaker, cabinet, dial, knobs, etc.

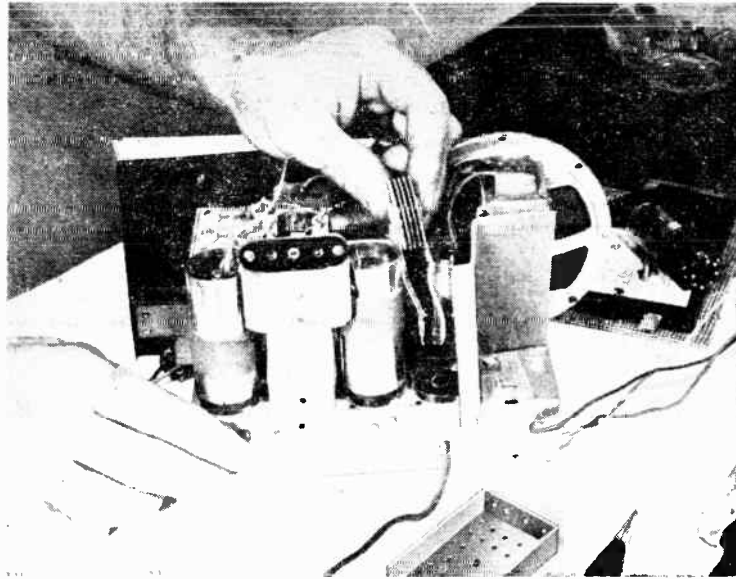

Dry-Disk RECTIFIER

REPLACES
BURNED-OUT TUBES

If the rectifier stack doesn't fit conveniently beneath the chassis, solder two extension leads to its terminals and install the disk over the empty tube socket.

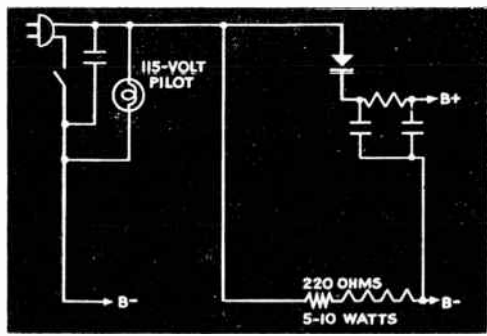
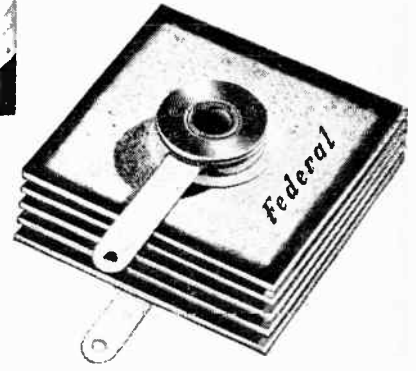

PRACTICALLY all commonly used rectifier tubes are now replaceable by dry-disk selenium rectifiers. They not only take the place of hard-to-get tubes, but are also smaller, cooler and quicker in operation (because they have no filaments to warm up), and they won't burn out or break under conditions that generally damage tubes.

Details of the replacement vary from set to set; the diagrams on this page show two typical installations. One involves a 35Z5 tube and the other a 117Z6. In the former case tube filaments are in series, requiring a 200-ohm, 5- to 10-watt resistor to be inserted in the line to provide continuity for the other heaters. Since the pilot light is generally operated off the center tap of the 35Z5, some changes are called for in that circuit as well. One of the simpler solutions to the pilot-light problem is shown at the upper left. The original pilot connections are shunted, and a 115-volt bulb is connected between the cold side of the power switch and the old tube's plate prong.

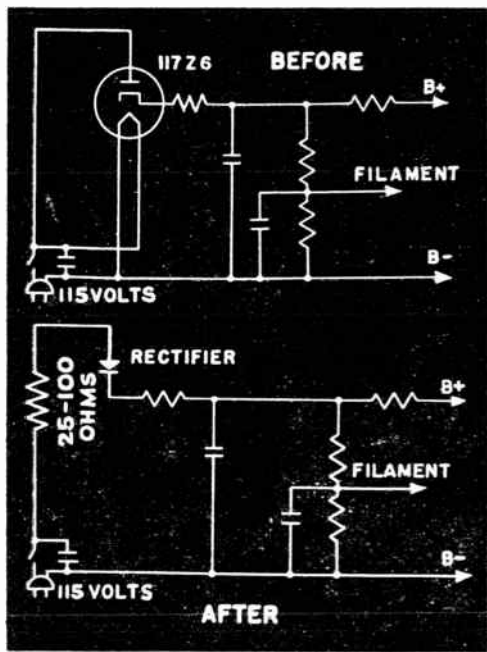

Where a tube of the 117-volt type is being replaced, a series resistor of between 25 and 100 ohms is needed (as shown in the bottom drawing) to compensate for the lower internal resistance of the dry disk. The filament connections, however, may be removed without affecting the other tubes.

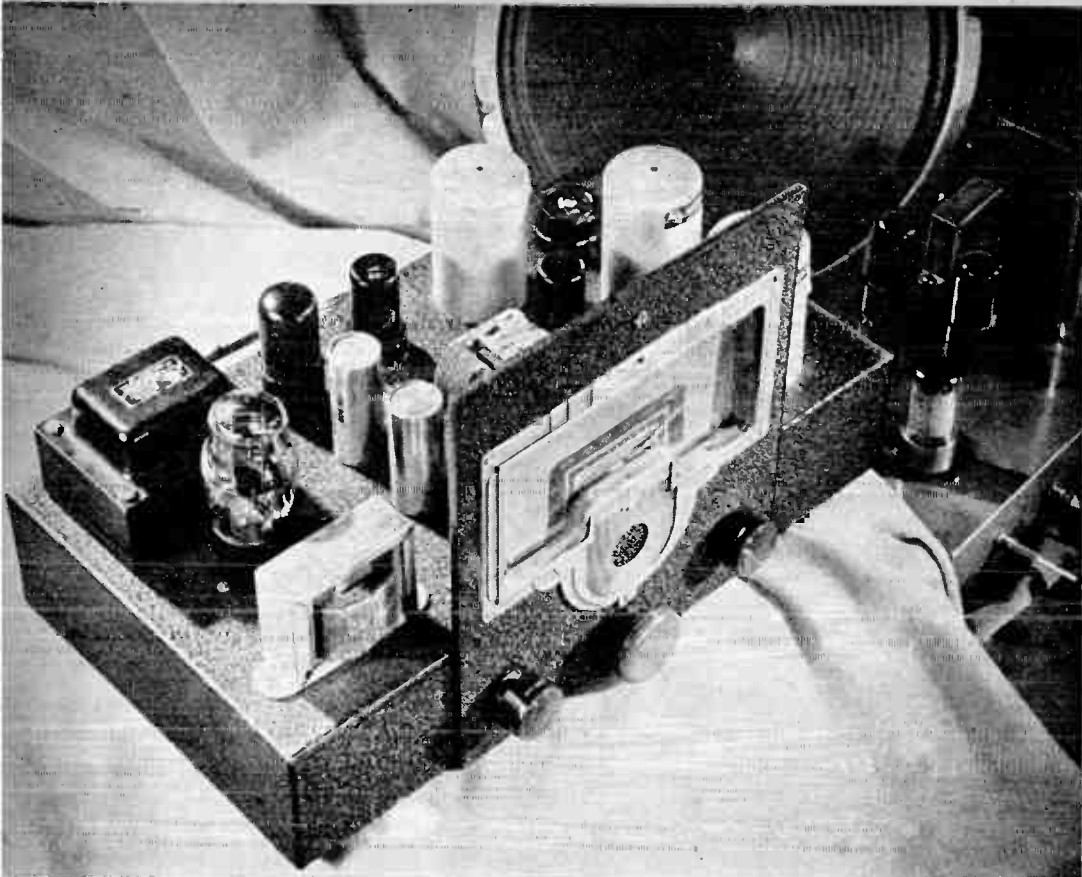

The versatile tuner-receiver. In the background is PSM's hi-fi amplifier, which is described on page 160.

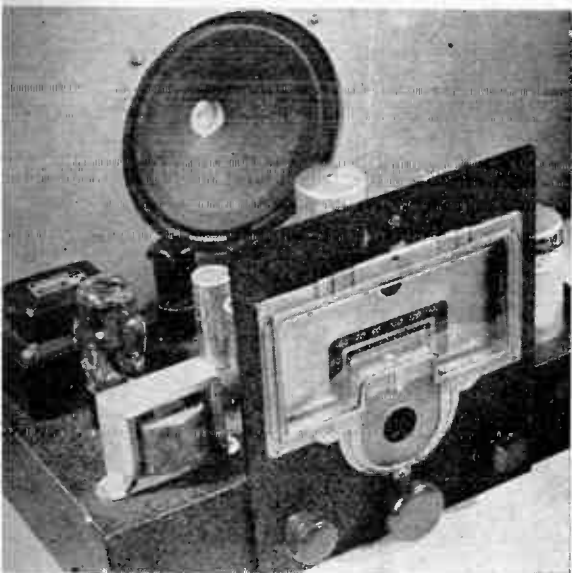

Working into a single dynamic speaker, the tuner becomes a complete, better-than-average receiver. It separates stations sharply, has ample room volume, and its fidelity and tone are excellent.

PSM photos by HUBERT LUCKETT

LIST OF PARTS

- R1: 10,000-ohm volume control.
- R2: 750-ohm, 1-watt carbon.
- R3: 15,000-ohm, 2-watt carbon.
- R4: 5,000-ohm, 2-watt carbon.
- R5: 10,000-ohm, 10-watt wire-wound.
- R6: 20,000-ohm, 2-watt carbon.
- R7, R11, 150,000-ohm, 2-watt carbon.
- R8: 240,000-ohm, 2-watt carbon.
- R9: 350,000-ohm tone control, with switch, S3.
- R10: 40,000-ohm, 2-watt carbon.
- R12: 2,000-ohm, 10-watt wire-wound.
- R13: 125,000-ohm, 1-watt carbon.
- R14, 1-meg., 1-watt carbon.
- C1, C4, C16: .25-mfd., 600-volt paper.
- C2a, b, c: Three-gang, 365-mmfd. tuning condenser.
- C3, C10: .1-mfd., 600-volt paper.
- C5, C6, C7: .0001-mfd. mica.
- C8, C11, C12: .02-mfd., 600-volt paper.
- C9: 8-mfd., 450-volt dry-electrolytic.
- C12, C14, C15: 8-ufd., 450-volt em-type electrolytic.
- L1, L2, L3: Matched set shielded TRF coils, powdered-iron core.
- L4: 2.5-mh., air-core RF plate choke.
- L5: 15-h., 75-ma. filter choke, 400 ohms DC res.
- T1: 90-ma. power transformer, 350 volts each side of center-tap, 6.3-volt filament, 5-volt rectifier windings.
- S1: DPDT toggle.
- S2: SPDT toggle.
- S3: SPST switch on R9.
- Electrodynamic speaker with output trans. and 1,500-ohm field coil; tubes, sockets, dial, misc. hardware.

Tune In on High Fidelity

This TRF unit can be used with an amplifier or as a self-sufficient high-quality radio receiver.

By Edward Blanton

SOUND systems, like chains, are only as good as their weakest parts. Here is a really strong beginning for that high-quality, high-fidelity system you've been planning to build—a tuner or receiver that will give you perfect, undistorted reception of every note sent out on the air by your local broadcasting stations. The set pictured at the left is a complete radio receiver. Used alone, it will give excellent frequency coverage and ample room volume. It may also be used with an amplifier as part of a more powerful and elaborate setup. **The following article gives a circuit for an amplifier that will do full justice to the pure sound of this tuner.**

But before you start, note the phrase "local broadcasting stations." A tuned radio frequency (TRF) circuit such as is employed here allows the full signal to come through to the detector stage. It does not have the tendency of the superheterodyne to clip the side bands of broadcast signals, often eliminating the high-frequency response. The disadvantage of TRF is that it lacks the ability to pull in and sharply separate distant stations. What this adds up to is simply that this tuner is recommended for those who live in or near metropolitan areas and who do most of their listening to nearby transmitters. For remote, rural listeners, a superhet tuner will prove more advantageous. However, if the stations are close by, you needn't worry about the selectivity of this set. Its three tuned circuits give plenty of separation between stations even in radio-crowded areas.

Primary and secondary windings of the antenna and RF coils are inductively coupled, and, in addition, the windings of the two RF coils are coupled through small-capacity condensers built into the units. This construction allows a flat band of

frequencies to pass through to the detector stage. All coils are shielded.

To do justice to the full-frequency response, an infinite-impedance detector circuit is employed. As can be seen in the diagram, the output from the 6SF5 detector is taken from the cathode rather than the plate of the tube. This design, better known as a cathode follower, requires no plate bypass condensers, which usually dampen the high notes; linearity of such a detector is straight from the lowest to the highest tones.

But again, the increase in fidelity is not achieved without cost. While a cathode follower passes a signal faithfully, it adds nothing to its strength, and another stage of amplification is therefore needed. This stage is built around the 6V6-GT.

When the set is connected as an independent receiver, the 6V6 acts as a pentode. Flicking two switches changes the unit to a tuner and modifies the tube connections to those of a triode. This reduces the output, all of which is not now needed, and which might overload the amplifier. As a receiver, provision is made for the use of a dynamic speaker with a 1,500-ohm field. In order to change over to tuner position, it is necessary to make contact across the field-coil terminals and also to achieve a compensating voltage drop. This is accomplished by R12 and S2 when the latter is in position B. Still another change is needed: when the set is used as a receiver, two terminals of the four-prong speaker socket are connected to the output transformer of the dynamic speaker. As a tuner the set feeds directly into an amplifier, so the transformer terminals must be shorted to complete the circuit. The shorting connection is made by a jumper plug (indicated by the broken lines in the socket diagram) in which the corresponding prongs have been wired together.

In order to keep the unit self-sufficient, separate power supply and filter systems are employed in this tuner and the forthcoming amplifier. This results in slightly higher parts cost but makes the units completely independent for all future uses.

Layout isn't critical, but you will note

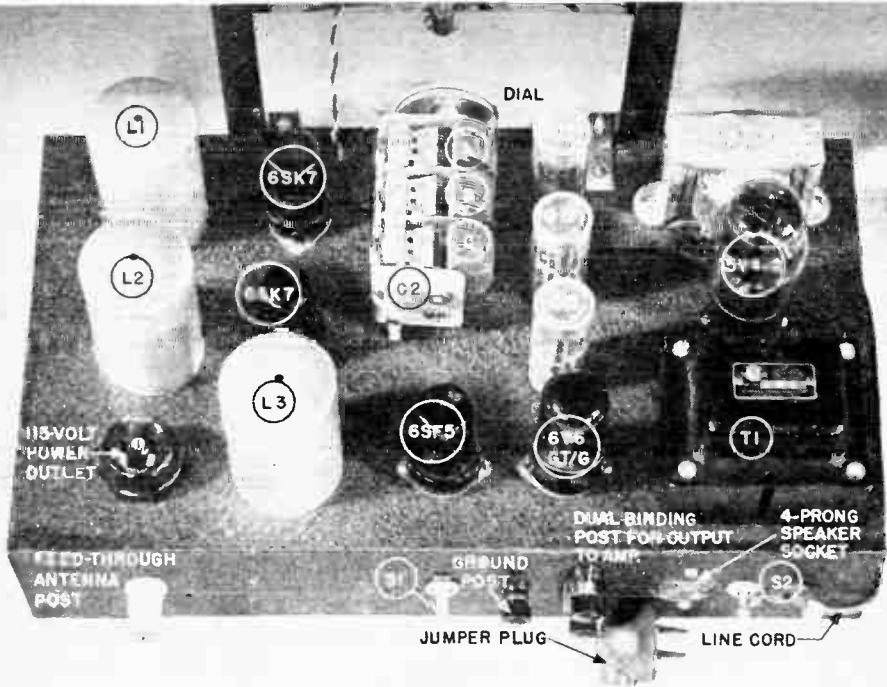

Top view of the chassis. Jumper plug replaces the dynamic-speaker plug when the set is used as a tuner.

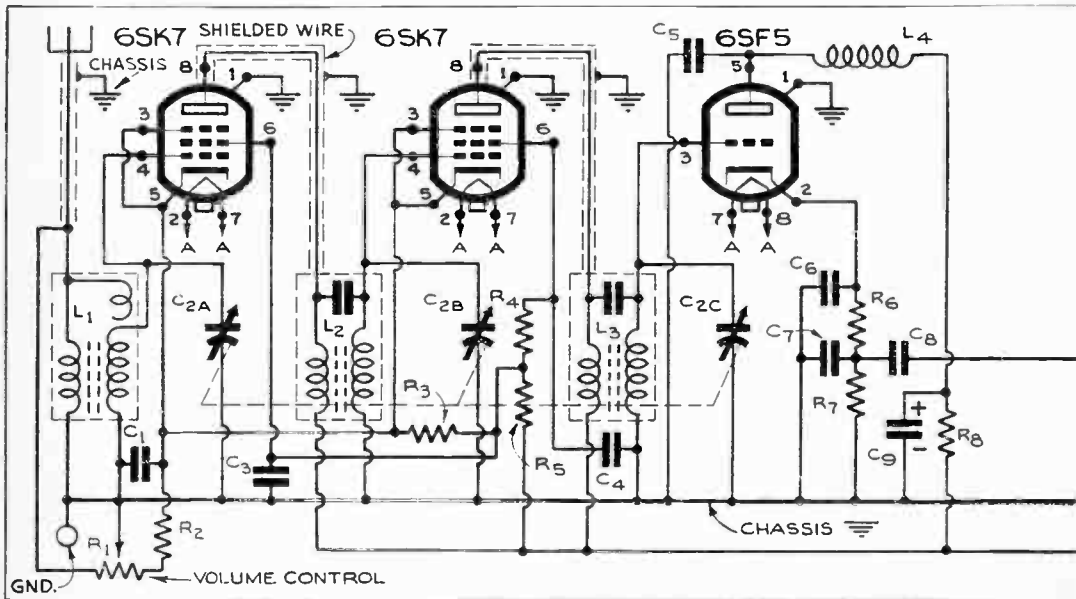

in the photographs that the three basic sets of components—RF, power supply, and detector-audio—are grouped and placed at maximum distance from each other. Especially in a circuit of this sort where detection and amplification give such faithful reproduction of the signal that passes the RF stages, it is important that stray pickups be held to a minimum. In addition to spacing, therefore, shielded conductors are used

in the antenna lead and in the plate connections of both 6SK7 tubes as well as in the grid lead of the 6V6.

To use the set as a receiver, plug in a dynamic speaker having a 1,500-ohm field coil, turn S1 to the position marked "receiver," and S2 to position A. Connect an outside antenna to the insulated jack, and ground the chassis to a water pipe.

Should you want the set to feed an am-

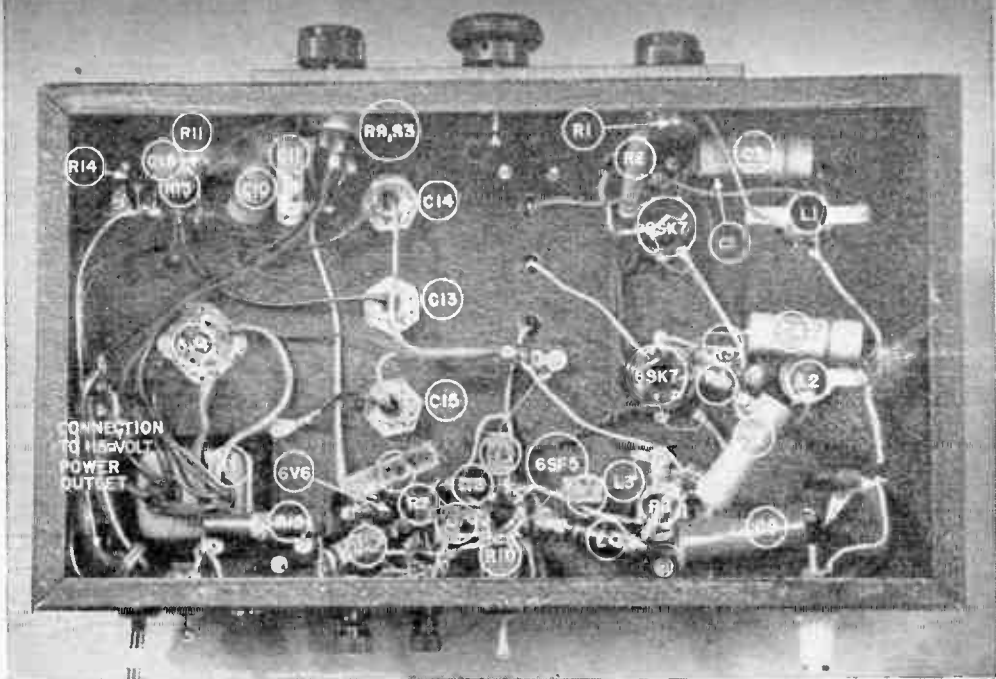

Parts placement isn't critical, but try to keep space between components that might cause interference.

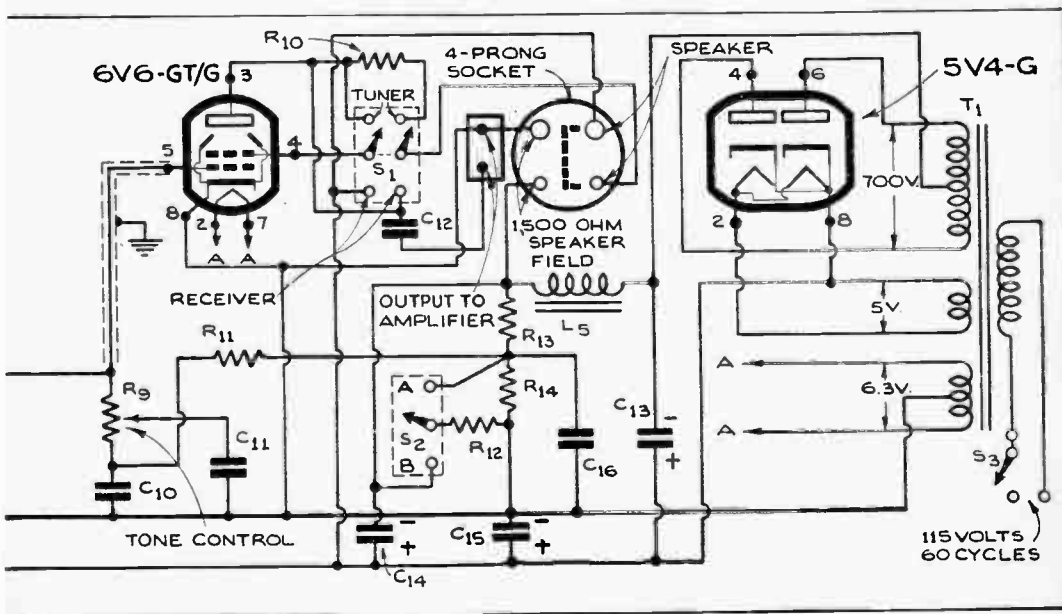

plifier, reverse the positions of both S1 and S2 and replace the speaker plug with the jumper described above. Run a single-conductor cable with a braided external shield from the binding posts to the input connections of the amplifier. The braided shield of the cable, of course, goes to the grounded terminals at tuner and amplifier.

A parallel line from the 115-volt supply is brought out to a separate socket on the

chassis. By connecting it at a point beyond S3, in parallel with the transformer primary, S3 will then serve as a master switch. An amplifier may be plugged into this socket and turned on or off by the switch mounted on the tone control of the tuner. This arrangement will facilitate housing of the multiple units in a cabinet, since all controls on the amplifier can then be preset and left in fixed positions.

Hi-Fi Amplifier Gets ALL the Music

It has power and quality, and will faithfully reproduce the output of pickup, mike, or radio tuner.

By Harry R. Hyder

MANY amplifiers claim the flattering title of high fidelity, but relatively few satisfy the major requirements of accurate record reproduction. It is true, of course, that there is a good deal of argument as to just what is meant by the term, but all definitions agree on at least two things.

Minimum Distortion

The first requirement is low distortion. This means that each stage must have a reserve of gain so that it is worked well within its maximum ratings at all volume levels. Tubes and other components tend to distort a signal when driven at or near their theoretical limits. While the reserve is important for all parts of an amplifier, it is particularly needed in the power-output stage. For good volume in an average room, only one watt of power is required, but occasional sound peaks may call for several times as much, and the amplifier should be able to deliver these peaks faithfully and without overloading. A high-fidelity amplifier, then, needs at least five watts of undistorted output power.

Frequency Coverage

Wide frequency range is the second important requirement. Practically all fundamental musical notes are below 5,000 cycles per second, but the overtones—the harmonics or multiples of the fundamental—that give musical instruments their characteristic sounds extend beyond the range of the human ear to about 15,000 cycles. At the present state of the recording art, the highest audio frequencies cannot be put on commercial disks, but the best new records exceed 10,000 cycles, and your amplifier should be capable of reaching this level without any falling off in output. At the lower end, the

limit is set at about 50 cycles. Good bass reproduction, however, is easier to achieve than good treble.

Test Results

How does this amplifier meet high-fidelity requirements? Actual tests were made on several units built from the same plans with similar but not identical parts. In each case the output was measured at 9 watts or more before distortion became audible; at 5 watts distortion read less than 2 percent. Frequency response proved virtually flat from 50 to 10,000 cycles—that is, all notes between these limits were amplified about equally.

Because the amplifier has power as well as quality, it can be used not only with a radio tuner and record player as a complete radio-phonograph combination, but also with a microphone to make a public-address system.

Construction Notes

The first, or phono-input terminal, II, is followed by an equalizing network, R1 and C1, and then by a 6SJ7 input amplifier. When this tube is wired as a pentode, the gain of the stage is more than 100. Since this is much greater than will normally be needed, an alternative circuit is given in the drawing. Tying screen and suppressor grids to the plate changes the tube to triode operation, and makes it possible to omit several components. As a rule, triodes give lower output than pentodes, but also have less tendency to produce distortion. Unless you intend to use the amplifier for public address, you will find the triode circuit completely satisfactory. To find where the wires go, simply lay the shaded portion of the diagram over that part of the original which is drawn inside the broken-line box, so that the connections V, Y, and Z coincide.

For the second stage a 6N7 is used as a phase inverter in a self-balancing degenerative circuit. Part of the output of the first triode inside the tube envelope is fed back to the grid of the second triode in opposite phase to the original signal. This produces the out-of-phase signals that are fed to the

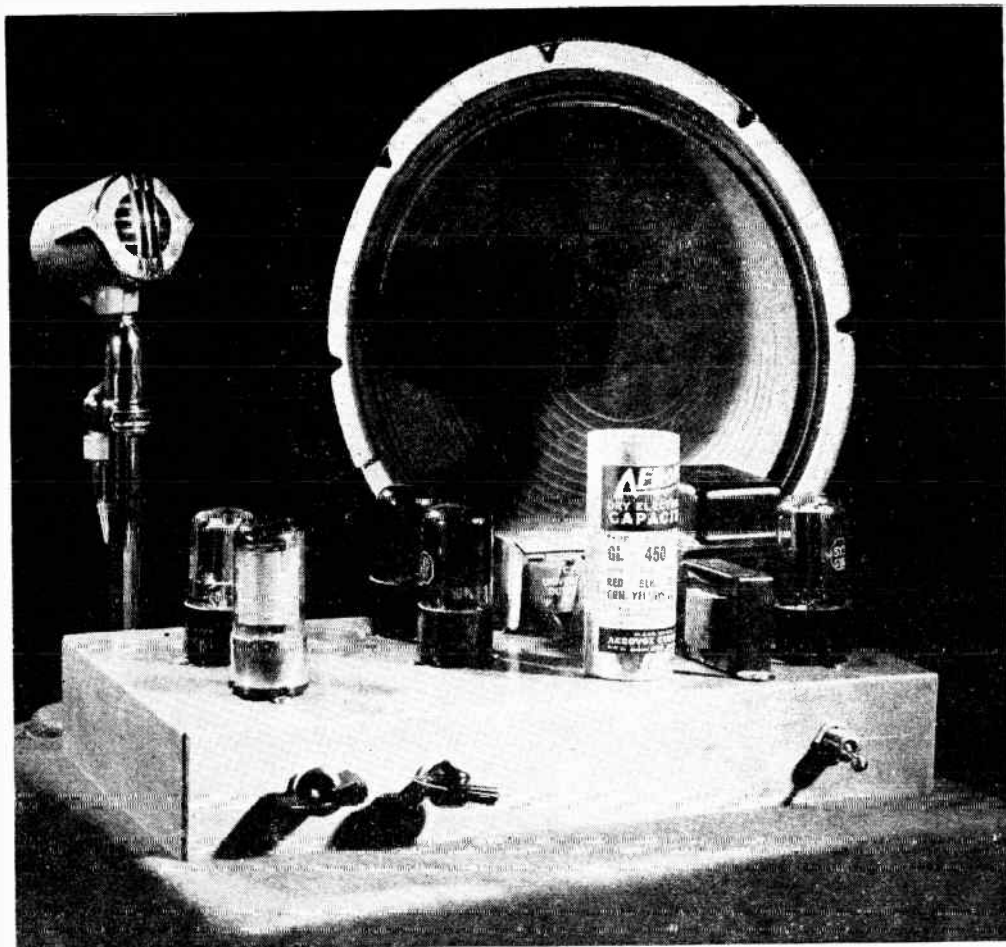

These three units and a carrying case in which the speaker is baffled make a complete portable PA system.

push-pull grids of the 6F6s. Strong signals from a microphone or tuner may be fed directly to the 6N7 through input terminal I2, thus by-passing the equalizing network and first amplifier as well as the volume (R2) and tone (R7) controls. Since microphones and tuners vary, try both inputs and use the one that gives best results.

Tone control, in itself, is usually a compromise with high fidelity. A condenser and variable resistor silence upper-frequency noise merely by shunting these frequencies to ground. But while this gets rid of the noise, it also loses the notes with which it is mingled. Many high-fidelity enthusiasts feel that a small amount of noise is preferable to tone-controlled music. To satisfy both sides of the argument, R7 has been connected directly to switch S1, making it possible to cut it out of the circuit entirely.

Two 6F6s in push-pull form the heart of the power-output stage. They are connected as triodes in the interest of low distortion and high speaker damping. A 5Y3-GT is used as the full-wave rectifier in the power-supply circuit.

The entire amplifier is mounted on a standard 2" by 7" by 13" metal chassis. As can be seen in the photographs, the space is not used tightly and a smaller chassis may be substituted if cabinet dimensions demand it. Power-supply components are placed at one end and the input stage at the other, while the phase inverter, output tubes, and output transformer occupy the center of the chassis. The principal precaution to be observed in wiring is to keep the AC filament leads spaced as far as possible from the grid leads, especially in the sensitive input stage. It is also suggested that the 6SJ7 socket be

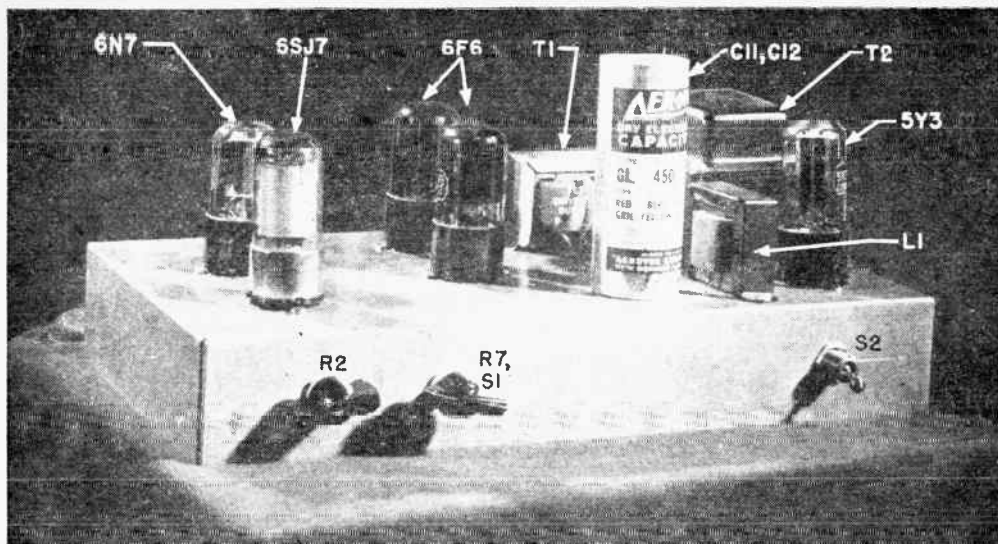

The input stage at one end of the chassis is isolated from the heavy-duty power and filter components.

mounted on live-rubber grommets to reduce any tendency toward microphonics.

Pickup and Speaker

So far as actual sound quality is concerned, a high-fidelity phonograph amplifier is no better than its pickup and speaker, so a few words on these may be in order. Crystal pickups are used almost universally today because of their low cost, high output, and generally good performance. As a rule, pickups of low output voltage have slightly better quality than the high-output types. Since this amplifier has such an abundance of power, the choice of a pickup should be made for quality rather than output. Better pickups are also noted for light weight; many different ones are now available with a needle pressure of about 1 oz. With most records, crystal pickups have higher output at low frequencies than at high. Therefore some form of equalization is needed to boost the treble. In this amplifier it is accomplished by R1 and C1. Note that these are in the circuit only if the pickup is connected at 11.

The speaker selected should be capable of handling the full power of the amplifier without overloading and distorting. Mount it in a solid baffle of adequate size. For best bass reproduction, a speaker of at least 12" diameter is recommended. Speakers of the coaxial type, consisting of a small high-frequency cone, a large low-frequency unit, and a dividing network, give maximum coverage but are quite costly. The better permanent-mag-

net speakers now on the market give very satisfactory response and are priced much lower. For public-address work, two or even three speakers may be used. If they are identical, connect similar terminals together; if they are not, experiment with the connections until you get the speakers in proper phase. See that the units are at least five feet from the mike, pickup, and amplifier. When they are grouped too closely, acoustic feedback or "howls" may occur at high volume levels.

LIST OF PARTS

R1: 2.2 meg., ½ watt.	volts, dry electro-
R2: 1-meg. volume	lytic.
control.	C5, C8, C9: .1 mfd.,
R3: 1,500 ohms,	400 volts, paper.
½ watt.	C6: .005 mfd., 400
R4: 1 meg., ½ watt.	volts, paper (if 6SJ7
R5, R14: 270,000	is pentode), or .01
ohms, ½ watt.	mfd. (if used
R6: 47,000 ohms,	as triode).
½ watt.	C7: .02 mfd., 400
R7: 100,000-ohm	volts, paper.
potentiometer.	C11, C12: 20-20 mfd.,
R8, R12, R13: 470,-	450 volts, can type,
000 ohms, ½ watt.	dual electrolytic.
R9: 3,300 ohms,	T1: 10-watt universal
½ watt.	output transformer.
R10, R11: 100,000	T2: Power transformer,
ohms, ½ watt.	350-0-350 volts,
R15: 800 ohms,	100 ma.; 6.3 volts,
5 watts.	3 amp.; 5 volts,
R16: 2,000 ohms,	2 amp.
5 watts.	L1: 10-hy, 100-ma.
C1: 750 mmf., mica.	filter choke.
C2: 25 mfd., 25 volts,	S1: SPST on R7.
dry electrolytic.	S2: SPST toggle.
C3: .05 mfd., 400	Speaker, chassis, tubes,
volts, paper.	sockets, misc.
C4, C10: 8 mfd., 450	hardware.

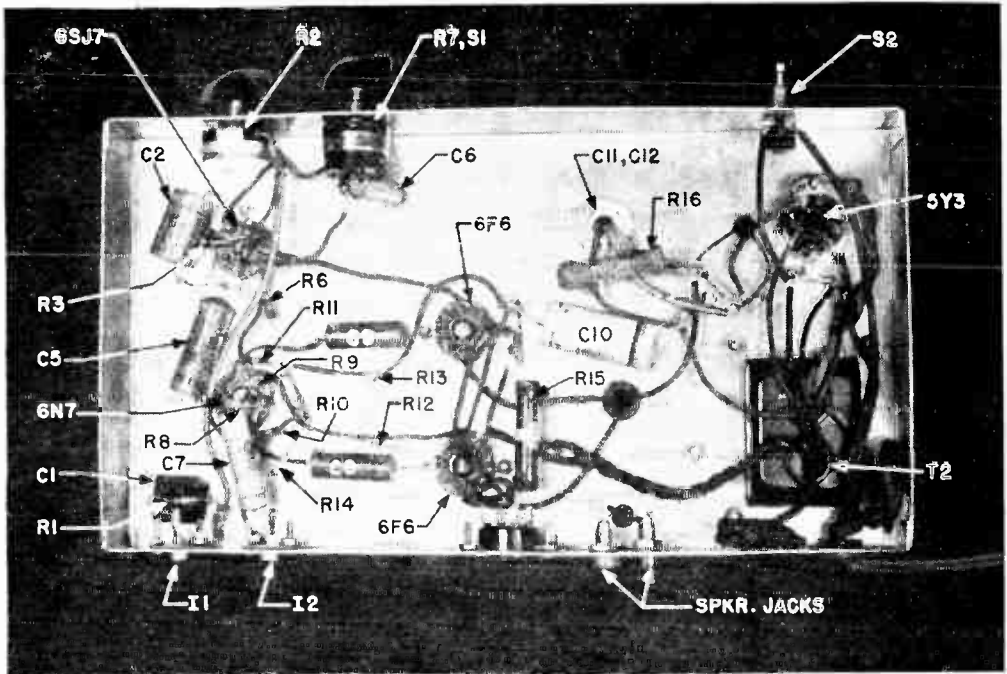

Above, the 6SJ7 amplifier is wired as a triode, and C3, C4, R4, and R5 have been omitted from the circuit.

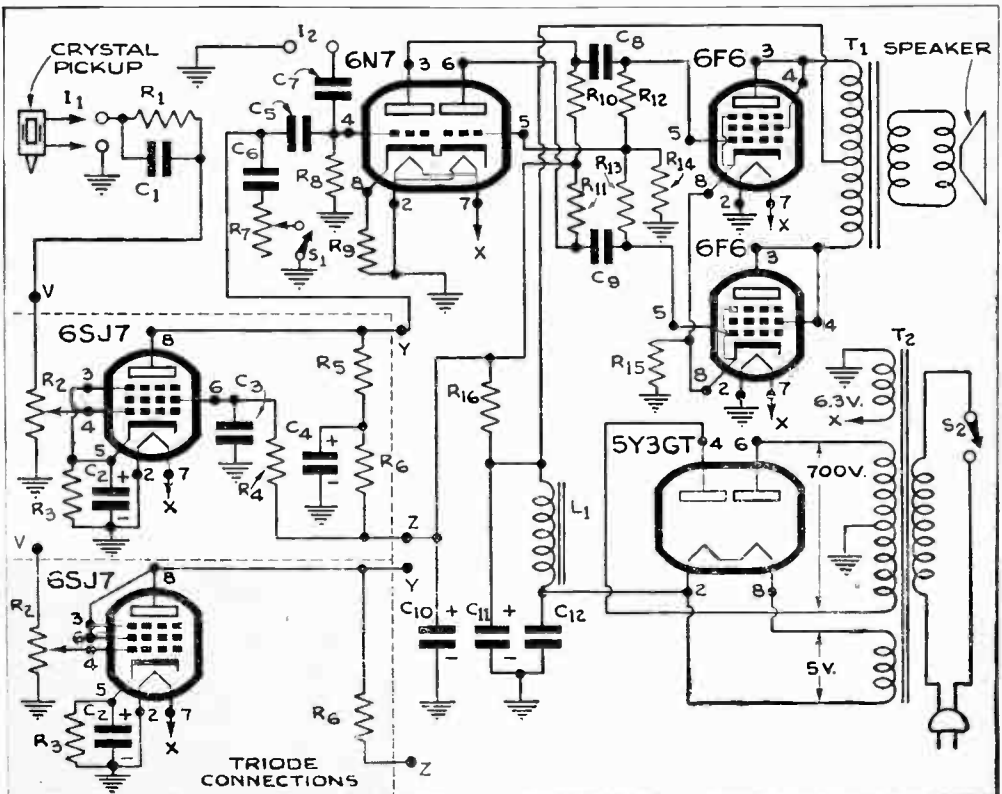

Two input circuits make it possible to leave both pickup and tuner permanently connected to the amplifier.

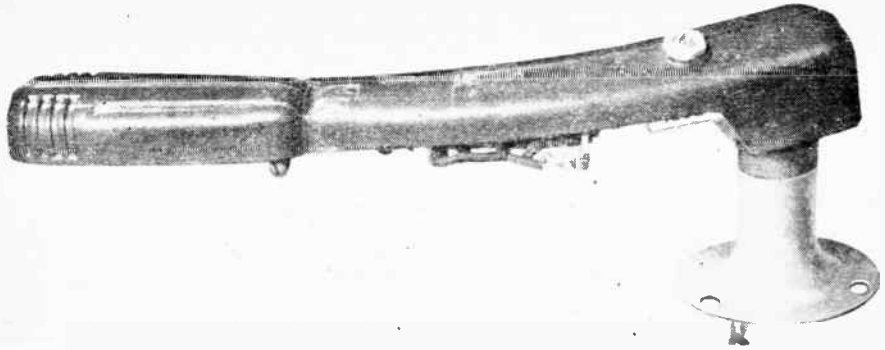

Complete phono oscillator, built into the arm of a pickup, plays records through any nearby

radio. Screw or clamp the flange so that the needle will track on a turntable, and tune in.

Playing Records with One Tube

Want an extra phonograph for den or shop? Take your pick of these three one-tube music makers.

MOST people who live in large households know the advantages of having one or more small radios scattered around the house. If you want to listen in while you work, play, or rest, or if you just want to hear a different program from the one that's coming in over the living-room console, you can go off and tune in on your own private set. It's different with phonographs, but it doesn't have to be. Here are three different models that can be built easily and inexpensively, each around a single tube.

Pictured on this and the facing page is a novelty design by Frank Tobin; it may be

used with any phono motor to play records through a radio. If you have an odd turntable around, or a portable phonograph that doesn't sound too well, just clamp on this pickup and tune in through a nearby radio. Inside the tone arm you have a complete miniature broadcasting station.

Oscillator Built in Pickup

A subminiature tube, the 2G22, acts in this circuit as a pentode modulator and triode oscillator. Designed for pocket receivers, it requires a plate potential of only 22½ volts. Output from the crystal is fed through pin 3 to the control grid of the pentode modulator. The triode oscillator, shown to the left of the common filament in the diagram, creates a carrier wave somewhere in the

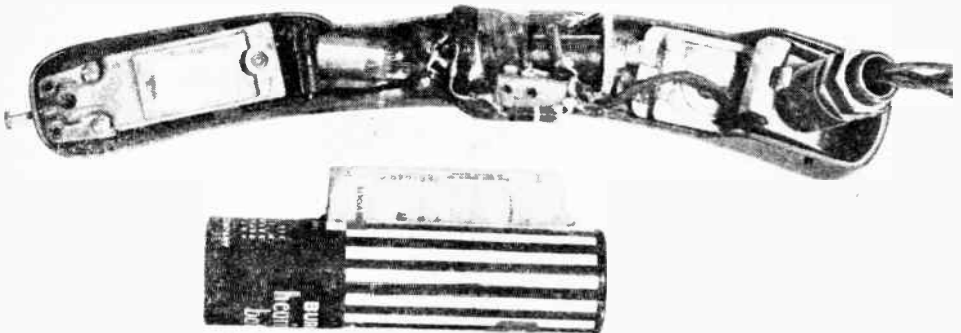

Here's the miniature transmitter, including its power supply. The larger battery, bottom,

provides 1½ volts for the heater; the smaller unit above it is the tiny 22½-volt plate supply.

broadcast band. This wave, modulated by the output of the crystal, is radiated to a nearby receiver and there tuned in as if it were a regular broadcast signal.

Across the crystal cartridge is soldered a $\frac{1}{2}$ -watt 20,000-ohm carbon resistor. This relatively low value was found to be necessary because the output of the crystal was so great that it overmodulated the tube and caused considerable distortion. Depending upon the pickup used, you may find that you get better results with a higher or lower resistor value.

No socket is required for the tube since it is small and light enough to be supported by its own wiring. Place it directly behind the crystal cartridge, and make sure that it does not touch either the cartridge or the sides of the arm, since needle vibration might cause the tube to become microphonic. Tuning of the transmitter is accomplished by C2 and the secondary, or grid-to-ground, winding of L1. The former is a small padder condenser with a range of approximately 300 to 1,000 mmf., and the latter is a standard midjet iron-core antenna coil, mounted directly behind the tube.

Oscillation within the tube is developed by the feedback coupling between the two windings of the coil. Just to preclude the possibility of any wiring touching the metal of the arm, line the inside with two or three layers of cellulose tape before you start.

The padder is mounted through a hole in the arm so that the capacity-adjustment screw is accessible through the top. This allows you to vary the frequency until the signal comes in at a blank spot on the radio dial. For the antenna lead, use a 20' hank of wire. Bring it close to the antenna lead-in of the radio, but do not connect them electrically.

Phono Strip Amplifier

For beginners in electronics, Homer L. Davidson has worked out this one-evening project. You'll be surprised at the results you can get from a pint-sized amplifier that uses only five condensers and four resistors, yet gives you independent control of both volume and tone.

Again the tube selected serves a dual purpose. The 117L7-GT is both amplifier and power rectifier. Constructed on a thin strip of composition board, the amplifier can be mounted in any position inside the box that houses the phono motor and turntable. First drill a 1K" hole to receive the octal



A painted radio chassis holds the phono motor and batteries; the rest is under the tone arm.

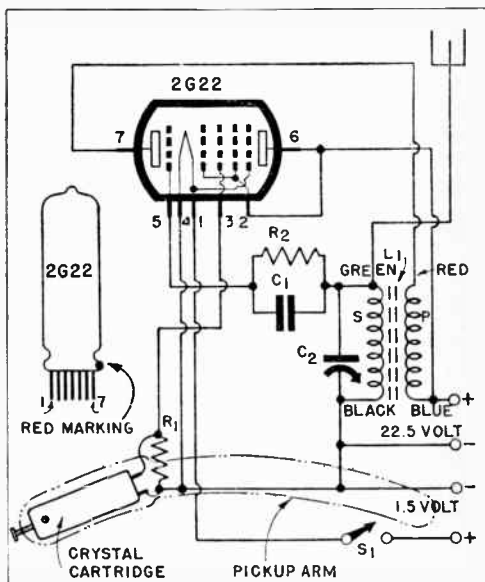

LIST OF PARTS

- R1: 20,000-ohm, $\frac{1}{2}$ -watt carbon.
- R2: 150,000-ohm, $\frac{1}{2}$ -watt carbon.
- C1: 100-mmf. mica.
- C2: 300 to 1,000-mmf. padder.
- L1: Unshielded iron-core antenna coil.
- S1: SPST toggle (or DPST to connect phono motor simultaneously).

Crystal pickup, 2G22 subminiature tube, 20' hank of antenna wire, 22 $\frac{1}{2}$ -volt B battery, 1 $\frac{1}{2}$ -volt A battery, misc. hardware.

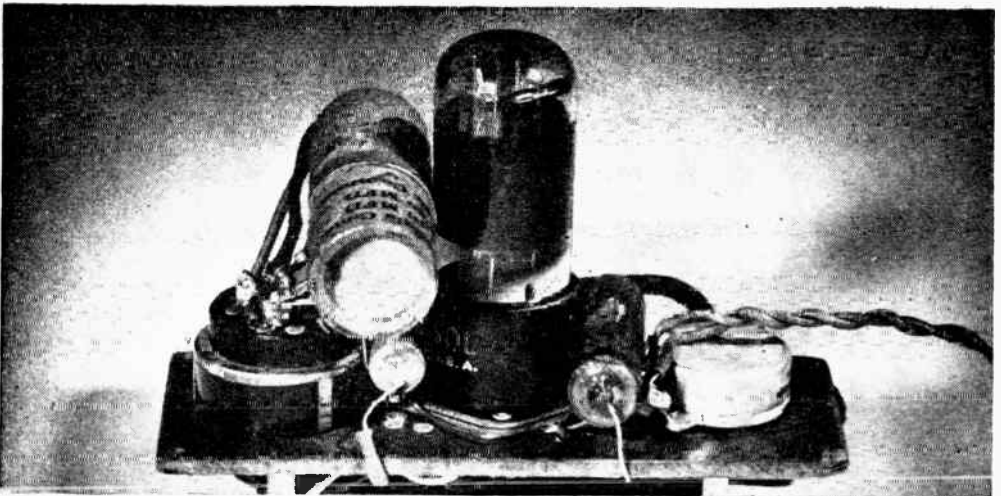

A dual-purpose rectifier and beam-power tube makes this compact amplifier possible. A strip

of nonmetallic material such as bakelite, plywood, or composition board serves as chassis.

socket. If you don't have the right size drill, make smaller holes and file out the opening. Install the two variable resistors, one on each side of the socket, with their shafts facing in the opposite direction from the tube. Using spacer washers, you will then be able to screw the strip to the inside of a cabinet or panel so that the controls will be easily accessible.

A dynamic speaker was used, and its field coil became the filter choke. In addition to this coil, the filter employs a dual

40-mfd. electrolytic condenser or two separate condensers of equal value. If you have a 5" permanent-magnet speaker, you can use that instead of a dynamic unit by substituting a 3,000-ohm resistor in place of the field coil. Filtering action, however, will not be as smooth.

High Input Yields High Output

With one of the new pickups that give between four and five volts of signal strength, you can get very substantial room



Control shafts project through panel bottom and can be brought through front of cabinet.

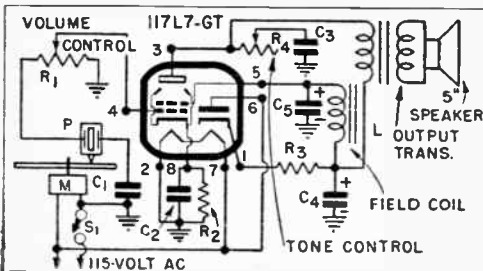

LIST OF PARTS

- R1: 1-meg. potentiometer.
 - R2: 150-ohm. 1/2-watt carbon.
 - R3: 25-ohm. 5-watt wire wound.
 - R4: 50,000-ohm pot.
 - C1, C3: .05-mfd., 400-volt paper.
 - C2: 10-mfd., 25-volt electrolytic.
 - C4, C5: 40-40 mfd., 150-volt dual electrolytic.
 - L: 2,750-ohm field coil on 5" electrodynamic speaker.
 - S1: SPST rotary on R1.
- Output trans., 117L7-GT tube, crystal pickup, phono motor, misc. hardware.



A simple cabinet, made of composition board, completes this one-evening phonograph project.

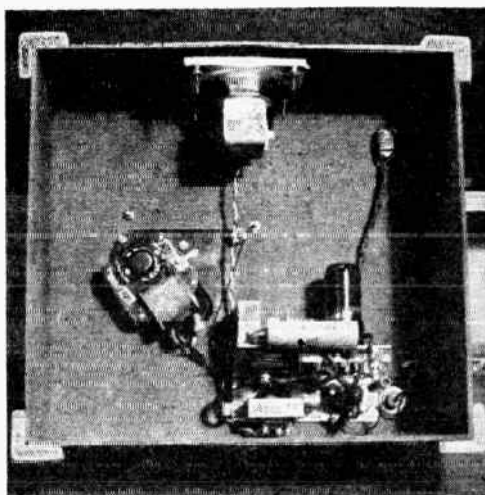

Position of components is optional. Drill one or two holes under turntable for ventilation.

volume from this one-tube amplifier built by Clinton E. Clark. As shown in the diagram at the right, the output of the crystal is fed directly to the control grid of a 50L6-GT beam-power pentode. Filament voltage for the tube is taken from the 115-volt line through dropping resistor R3, and in place of a separate rectifier tube, a new selenium stack is used in the power supply. The cabinet is built up from composition board.

Assemble the parts on an aluminum or steel chassis about 5" by 6". All ground connections in the unit shown were brought to a single point on a terminal strip, but the chassis can be used for ground if that should prove more convenient. Either way, ground is connected to one side of the 115-volt line. The yellow or black terminal of the rectifier goes to one side of the line switch. S1; the red side to the input of filter choke L.

When you have determined the position of the chassis but have not yet mounted it in the cabinet, drill one or two ventilation holes to carry off the heat generated in the tube. If properly placed, these holes will be concealed by the turntable. To avoid any possible damage to the pickup, install it after all other parts are in place.

The miniature oscillator is battery powered, but the other two circuits will work equally well on AC or DC. Although AC input is specified in the diagrams, this is only because the motors are connected to the same line. If you have DC, you can substitute a suitable electric or spring-wound motor.

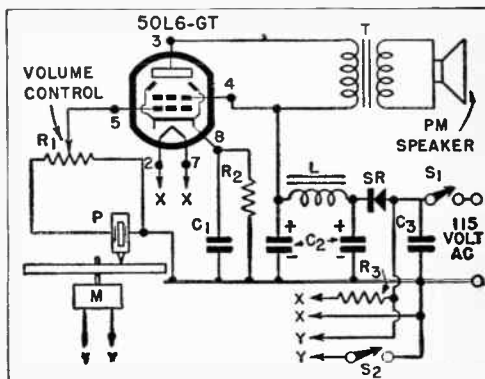

LIST OF PARTS

- R1: 500,000-ohm linear-taper potentiometer.
- R2: 200-ohm, 1-watt carbon.
- R3: 500-ohm, 20-watt wire wound.
- C1: 25-mfd., 25-volt electrolytic.
- C2: 20-20 mfd., 150-volt dual electrolytic.
- C3: .01-mfd., 400-volt paper.
- SR: 100-ma. selenium rectifier.
- L: 15-hy., 40-ma. midget AC-DC choke.
- T: Midget universal output trans.
- S1: SPST rotary on R1.
- S2: SPST toggle.
- Phono motor, high-output (4-5 volts) pickup, 50L6-GT tube, PM speaker, misc. hardware.

Pocket Radio Doubles as Hearing Aid

By *Albert Rowley*

GUIDED by wartime needs and the ingenuity of parts designers, electronic components are getting to be so tiny that even electrons may soon feel cramped. Elsewhere in this book you can see what manufacturers have in store in the way of miniature radios, hearing aids, and the like. For the experimenter who must work with standard parts, much of this is still out of reach. But if you can't quite compete with mass-production techniques, you can come pretty close with some of the pint-size parts that are now available.

The pocket radio and hearing aid described in these pages uses only four sub-miniature tubes in a dual circuit arrangement. When the switches are in one position, all four are incorporated in a super-heterodyne receiver. With two of the switches reversed, three tubes form a sensitive audio amplifier.

In the radio circuit the 2G22 acts as a



A crystal cartridge, together with its rubber cushion, is removed from a microphone housing.



Cut a hole that will make a press fit for the rubber lip and cement the cartridge in place.

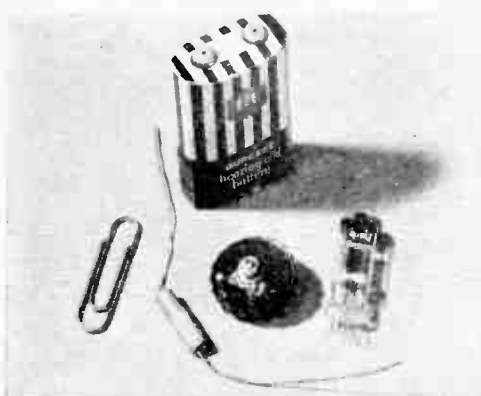

A few of the tiny components. Note the small condenser, volume control, tube, and battery.

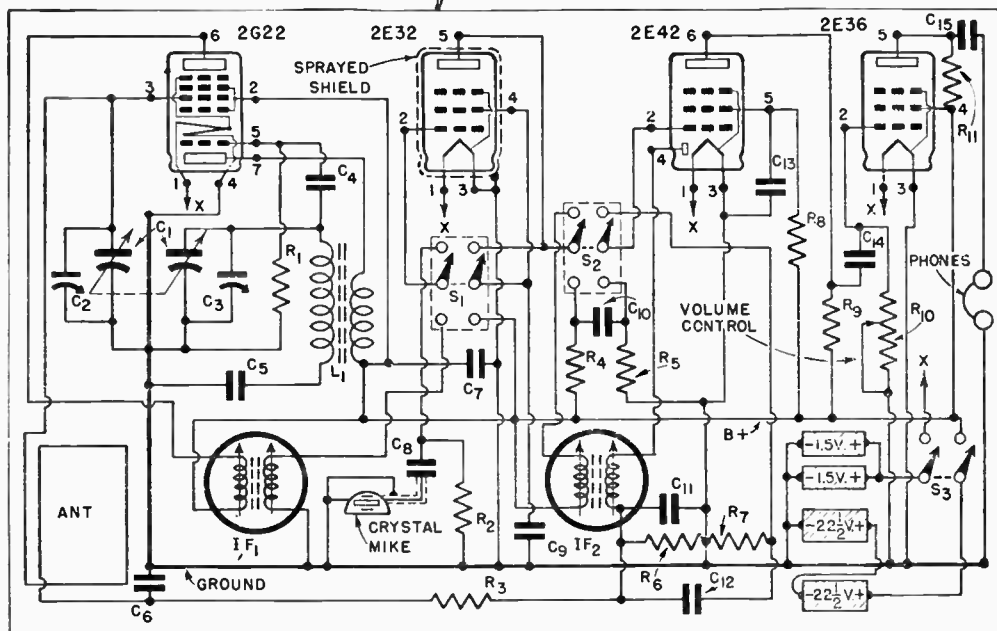

Tube-pin numbers are counted from the left when the red dot is at the right.

triode-heptode frequency converter; it is replaced by the microphone in the hearing-aid application. A shielded pentode RF amplifier, the 2E32 is used alternately as IF amplifier and first-audio tube. Next comes the 2E42, a diode-pentode which doubles as second detector and second audio amplifier. The 2E36 pentode is the output amplifier in both applications.

Proper assistance for the hard of hearing is something that may require the individual attention of a physician as well as the electronic designer. No attempt has been made here to correct for varying con-

ditions of deafness. All this hearing aid will do is amplify sounds at the microphone so that they reach the ear with far greater intensity. Many persons who are hard of hearing can use this instrument with advantage as an auxiliary—not as a substitute—for an expertly fitted device.

For those with normal hearing who fancy a pocket-size radio without the extra feature, it is a simple matter to omit the microphone and switches S1 and S2, making the

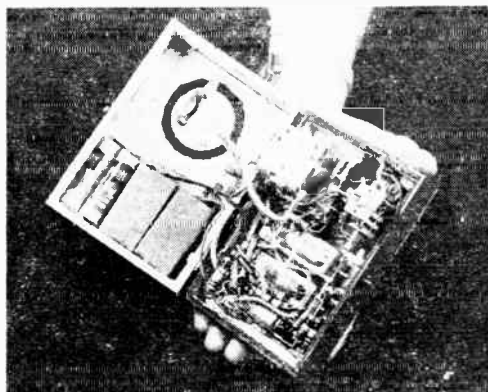
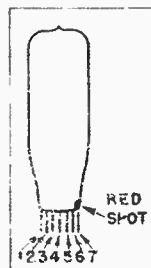

Interior of completed set. All parts except batteries, mike, and C2 are on the front panel.

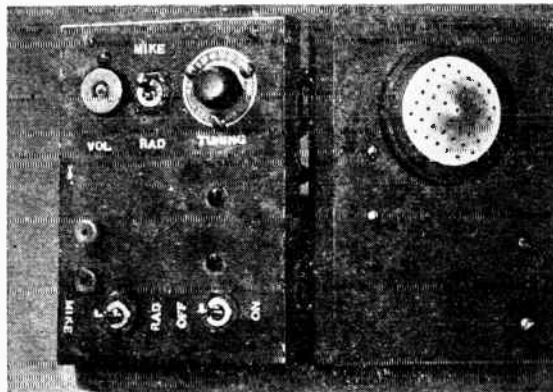

Opened out, front and back look as above. Controls are on the front, mike on the back.

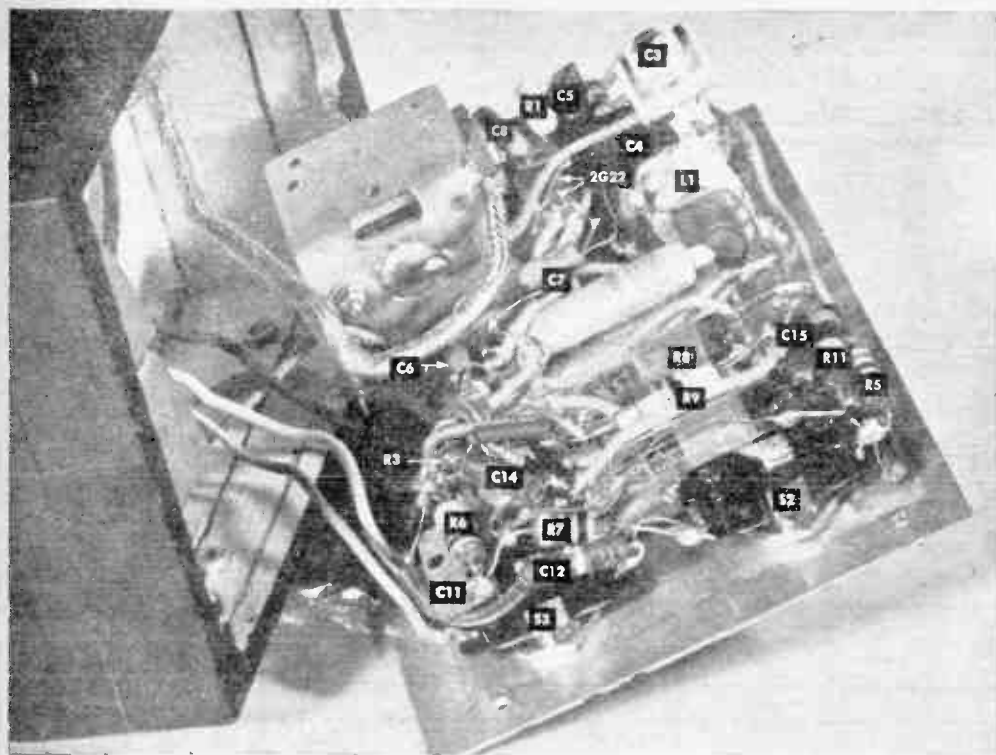

Placement of the parts is important for reasons of space economy rather than of function.

connections permanently in the radio position. The associated resistors and condensers can also be left out, thus making it possible to reduce the size of the case below the 1½" by 3½" by 5½" box needed to house the present components.

Two 1.5-volt penlight cells in parallel supply the filament voltage for the tubes. As these must be changed quite often, a clip bent from aluminum or other metal should be used to permit easy insertion of replacements. The pair of 22.5-volt batteries that furnish the 45 volts of B-plus last longer and can be soldered in. Other miniature parts used in this set include paper tubular condensers about the size of a ½-watt resistor, IF-transformer cans ¾" square, and a volume control in which the carbonized element is contained inside the tiny knob.

A loop antenna consisting of 30 turns of No. 28 enameled wire is wound around the case and held in place by a layer of cloth tape. One side of the loop is connected to pin 3 of the 2G22 converter and to the antenna section of the two-gang tuning condenser, C1. The other side of the loop goes to the chassis through a condenser. The in-

coming signal is mixed with a frequency generated by the oscillator circuit to create an intermediate frequency of 456 kc. This is amplified by the 2E32 IF tube. Coupling between the converter, IF, and second-detector stages is accomplished by the IF transformers.

The larger of the two oscillator-coil windings is connected in series with C5, a .0004-mfd. fixed mica condenser that acts as a padder. This condenser, plus the proper adjustment of the iron core of the oscillator coil, permits this circuit to track at the proper frequency above that to which the antenna circuit is tuned.

Two midget IF transformers, mounted in cans measuring only ¾" square by 2" long, are fastened directly to the chassis—which is the reverse side of the front panel—by means of small machine screws. Like the oscillator coil, the IF transformers are tuned by adjustable iron cores. Since the tuning of these transformers is extremely broad, it is not necessary to use a signal generator in aligning the set. Once a station is tuned in, the cores can be adjusted by ear to maximum volume.

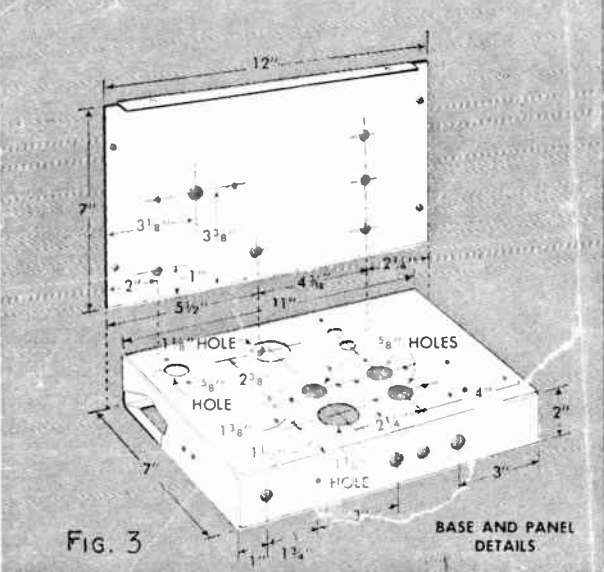

the important short-wave bands. There are 10 plug-in coils, and two of them are used for each band covered. Each pair is made up in the same way although different sizes of coil forms and windings are employed. The completed receiver fits into a standard hinged-lid metal cabinet which is available from all large radio-parts houses. All parts specified are standard and easily obtained. Having the small speaker as a separate unit eliminates microphonic troubles, and also makes it possible to plug in headphones. The speaker and its output transformer can be mounted in any small wood or metal case. In order to keep the coil winding simple, no effort was made to gang the tuning of the larger variable condensers C1-A and C1-B. Therefore, on the broadcast band, stations should be selected by rotating C1-B and then peaking the station up with C1-A, the R.F. peaking control indicated in photos A and E. The regeneration control is advanced far enough to hear the whistle as the station is tuned in, then is backed off until the signal is clear. The other two controls are audio and R.F. gain. Be sure to use the shields indicated in photo B, and also use tube shields on tubes 1U4 and 3V4 as shown in the top-view photos G and H.

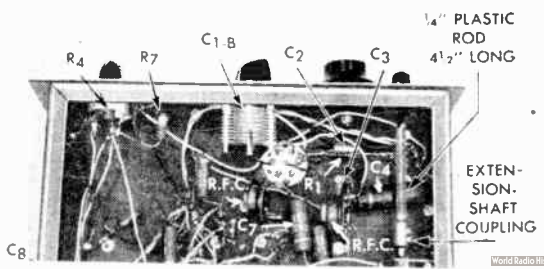

Tuning on the short-wave bands is easy. Set the bandsetting condenser to about the center of the band that is to be covered,

FOR EXPERIMENTERS

bandsread tuning. Photos D, G and H show these condensers mounted on a small metal strip on top of the chassis base. This bracket strip, indicated in photo D, raises them clear of the chassis and places them in the proper position. The bandsread dial is a vernier type, which simplifies tuning on the short-wave bands. Wiring is not difficult but should be done very carefully, keeping all leads as short as possible. The audio choke is the same as the one used in the first set; it can be any 500-hy. type such as the UTC S-23 or a similar unit. Any standard 3 to 1 ratio audio transformer can be substituted by connecting the primary and secondary windings in series.

All of the plug-in coils are clearly detailed in Fig. 1: they cover all bands from .55 megacycles to 15 megacycles, thus including the standard broadcast band and



RESISTORS	
R1	= 2-megohm, 1/2-watt carbon
R2	= 5-megohm, 1/2-watt carbon
R3	= 470-ohm, 1/2-watt carbon
R4	= 50,000-ohm volume control, linear taper, with D.P.S.T. switch cover
R5	= 50,000-ohm, R.F. gain control, linear taper
R6	= 100,000-ohm, 1/2-watt carbon

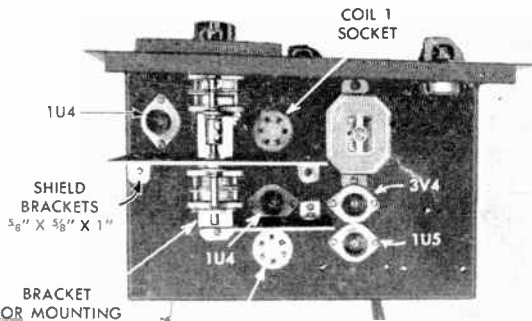

BATTERY-OPERATED FIVE-BAND RECEIVER

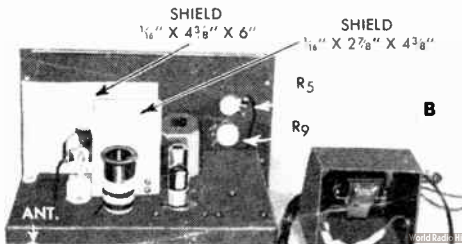

THIS MULTIBAND battery-operated receiver is set No. 2 in the progressive series for experimenters that began in the May 1951 issue. Practically all of the same parts can be employed, with additions. This final No. 2 receiver is a complete unit in every detail. Therefore, it is not necessary to build the first set unless you wish to do so as a student project.

Battery-operated radio receivers are in demand today. The main reason, of course, is the fact that battery sets are independent of power lines, a necessary factor stressed by those planning civil-defense programs. This receiver is especially designed for advancing experimenters and purposely employs hand-wound plug-in coils for this reason. Plug-in coils are highly efficient in short-wave receivers, and they are not difficult to wind. This is an excellent DX short-wave student set and can be used almost anywhere as the 1½-volt A-battery and 90-volt B-batteries are self-contained.

If you built the May 1951 two-tube set, R-400 in this series, remove all previous wiring and drill the new holes required for mounting the additional tubes and parts. Complete chassis-base and front-panel details are shown in Fig. 3. Note that the

Radio Television Electronics

CAR-HOP ORDERS SPEEDED BY WALKIE-TALKIE

SHORT ORDERS by short wave enables two girl car hops in Milwaukee to do the work formerly done by five girls taking orders with pad and pencil. Equipped with 8-lb. walkie-talkie radios, these girls circulate among the customers in a 136-car drive-in parking lot. The drive-in customer makes selections from an attractive walkie-talkie menu; the car hop writes the order on a special order blank, gives the customer a copy and then broadcasts the order to a girl dispatcher in the firm's kitchen, as illustrated in photos A, B and C. She then places a key car number on the customer's windshield, corresponding to the order number broadcast.

The dispatcher in the kitchen writes down the order, tears off a slip at the bottom, noting the car number, price of order, etc. Three delivery girls who take the



order slip for payment. Meanwhile the car hops are busy taking orders from other customers. The Federal Communications Commission has designated station KA 8931 for the Ace Foods, Inc. This broadcasting system includes two mobile sets and a control dispatcher.

Up to 950 customers are served nightly from 5:00 p.m. to midnight on the drive-in parking lot, photo D. This is about a 30-percent increase over the old system.

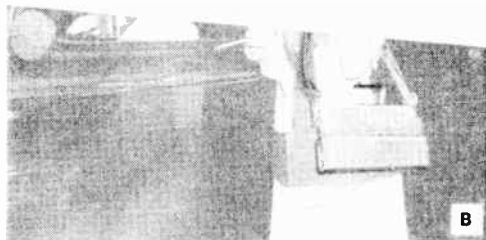

NOVEMBER 1951

227

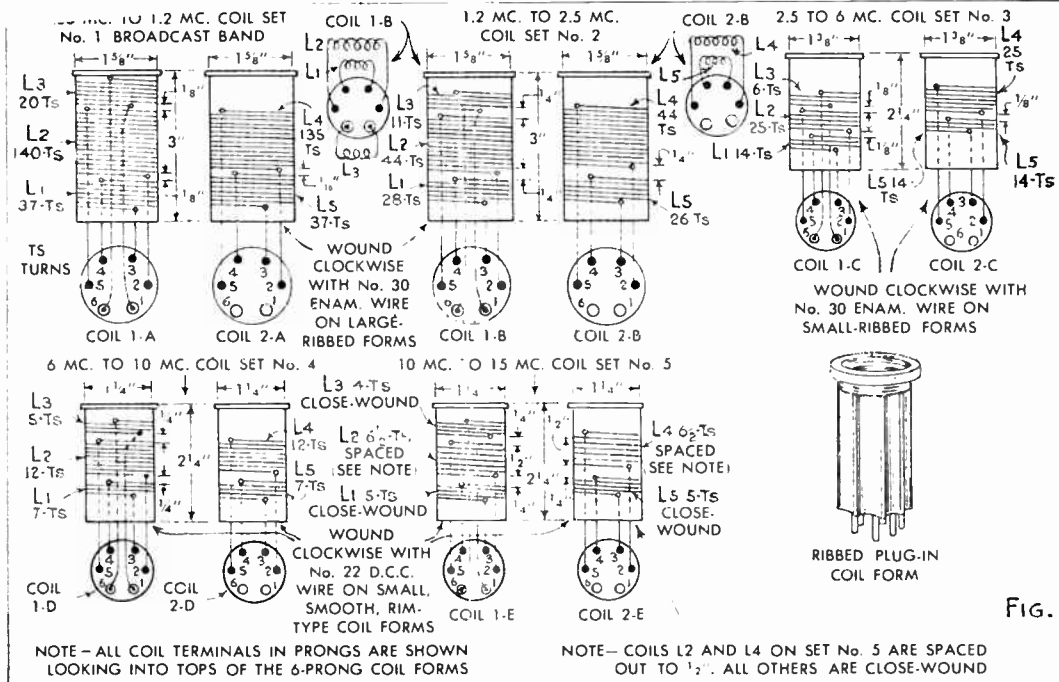
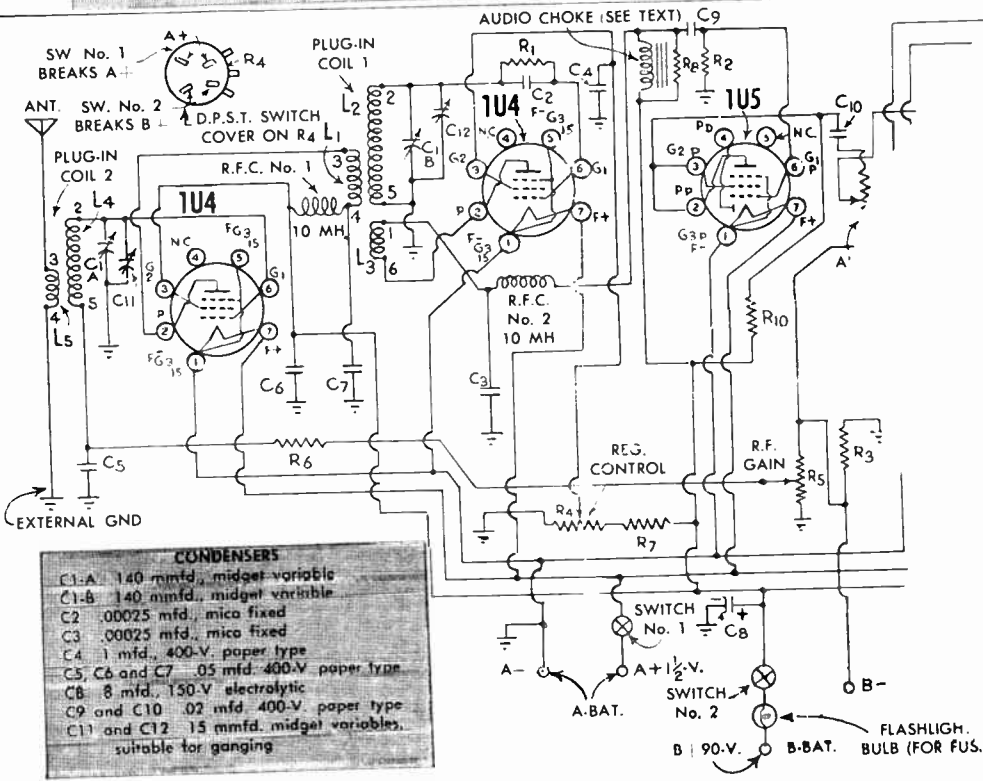

FIG.



CONDENSERS

- C1-A 140 mmfd., midgel variable
- C1-B 140 mmfd., midgel variable
- C2 .00025 mfd., mica fixed
- C3 .00025 mfd., mica fixed
- C4 1 mfd., 400-V. paper type
- C5, C6 and C7 .05 mfd., 400-V paper type
- C8 8 mfd., 150-V electrolytic
- C9 and C10 .02 mfd., 400-V paper type
- C11 and C12 15 mmfd., midgel variables, suitable for ganging

E

F

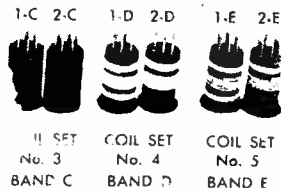

...tuning dial. Once the band has been set, only a slight adjustment of the regeneration control is required. The R.F. gain control is useful if you have strong stations near by. It can be backed off to prevent overloading. Use a short indoor antenna for local broadcast-band reception, then shift to a high outdoor antenna for short wave. The use of the external ground will depend upon local conditions. It will increase sensitivity but will reduce selectivity in the broadcast band. The ground clip is mounted directly on the chassis base at rear. Detailed student material list R-105 is available from Popular Mechanics Radio and Electronics department upon receipt of ordinary letter postage.

G

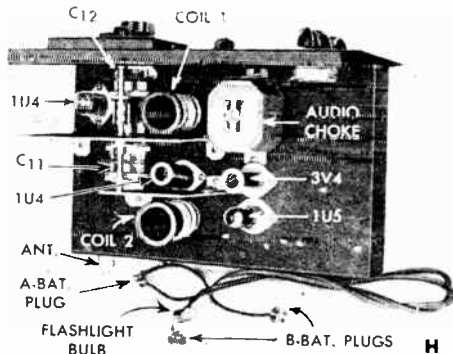
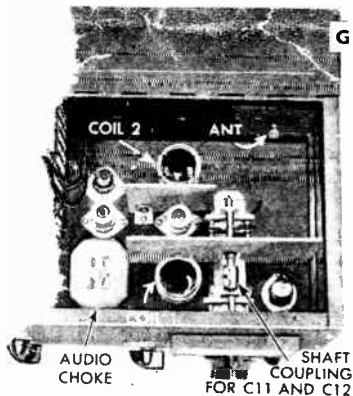

H

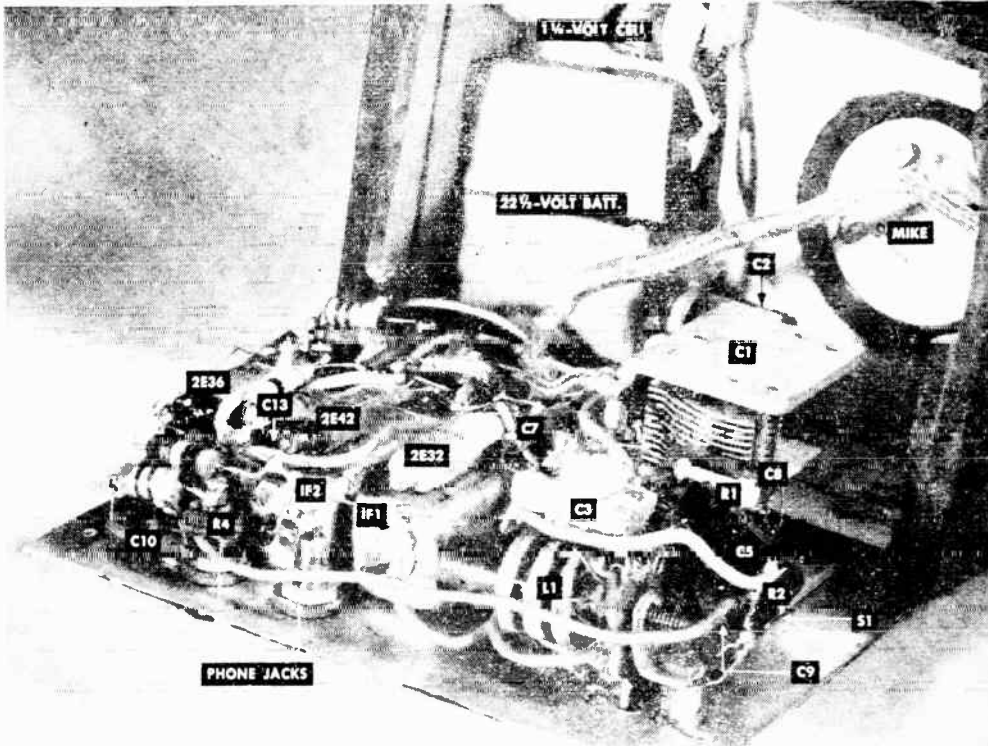

The general layout shown is recommended; if you must vary it, plan your changes carefully.

To get all the necessary parts into the small space allowed, it is important that you plan the layout with care. The photographs indicate the location selected for most of the items; where you deviate from this it is a good idea to try out the major units before making permanent connections.

Another consideration in building this set is that some of the components are placed directly on top of others. It is therefore necessary to complete all soldering on the

first layer before placing the next one on top. Switch S1, for example, is mounted between C1 and the oscillator coil, and wiring to it must be completed before the 2G22 is placed above it. The same holds true for the volume control, R10, since the oscillator coil and padding condenser are mounted on top of it. Wiring to the other two switches must be completed before the 2E36 is put in place.

Since they are so small and light, no sock-

LIST OF PARTS

C1: Two-gang midget tuning condenser, .00036 mfd, each section.
 C2, C3: 0 to 50 mmf. trimmers.
 C4: .0002 mfd, mica.
 C5: .0001 mfd, mica (used as padding).
 C6, C7, C8, C9, C10, C12, C13, C14, C15: .005 mfd, paper tubular, very small.
 C11: .0001 mfd, mica.
 R1: 100,000-ohm, 1/2-watt carbon.
 R2, R9: 1/2-meg., 1/2-watt carbon.
 R3, R5, R6, R7, R8: 1-meg., 1/2-watt carbon.
 R4: 200,000-ohm, 1/2-watt carbon.
 R10: hearing-aid volume control (carbon element enclosed in knob) 1/2 meg.

R11: 10,000-ohm, 1/2-watt carbon.
 Ant: 30 turns No. 28 enameled wire wound around case.
 IF1, IF2: Iron-core, 156-ke, IF trans, mounted in cans 3/4" square.
 L1: Adjustable iron-core oscillator coil.
 S1, S2: DPDT toggle.
 S3: DPST toggle.
 Crystal microphone (lapel type, or cartridge removed from housing); headphones (crystal or magnetic); four subminiature tubes (one each, 2G22, 2E32, 2E12, 2E36); penlight A cells, miniature 22 1/2-volt batteries, misc. hardware.

FIG. 2
 NOTE—
 FIL. MID-TAP
 N 3V4 TUBE
 TUBE SOCKETS
 BOTTOM VIEW
 DYNAMIC
 SPEAKER
 TRANS
 OUTPUT
 UNIVERSAL
 ON
 SPEAKER
 TAP
 2 1/2



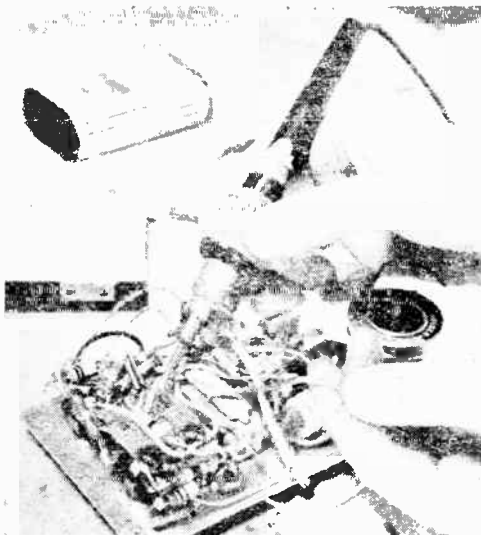

One of the newer pen-size soldering irons is almost essential for work on this midget set.

ets are required for the tubes. They are held in position by strips of cellulose tape plus the soldered connections to the pins.

A high-impedance lapel microphone would probably be most satisfactory for use in the hearing-aid portion of this set, but a very suitable—and much less expensive—substitute can be found inside an ordinary crys-

tal-mike housing. The photos show how the cartridge was removed from its bullet-like shell and fastened inside a hole in one side of the box that holds the set. The rubber cushion around the crystal unit must be left on to protect the microphone from vibration. It is fastened with rubber cement.

For other applications you may find it more desirable to keep the mike entirely separate so that it can be placed in a desk stand or worn on the clothing. Either way, the cable should be shielded.

At the other end of the circuit, ordinary high-impedance headphones of the crystal or magnetic type may be used. A single phone gives adequate results.

While there is nothing intrinsically difficult about the construction of this set, it cannot be built to size unless you are careful to obtain the very smallest parts. Also, it will take all your skill and experience with a soldering iron and the best workmanship you can put into it.

To make the unit completely self-contained, the external antenna and ground are omitted in favor of the case-wound loop. An antenna coil and aerial can be substituted if the conditions of use permit. Pick-up will, of course, be improved. Using only the loop shown, however, stations as far off as 100 miles were brought in clearly.

External Speaker Adds Uses to Your Auto Radio

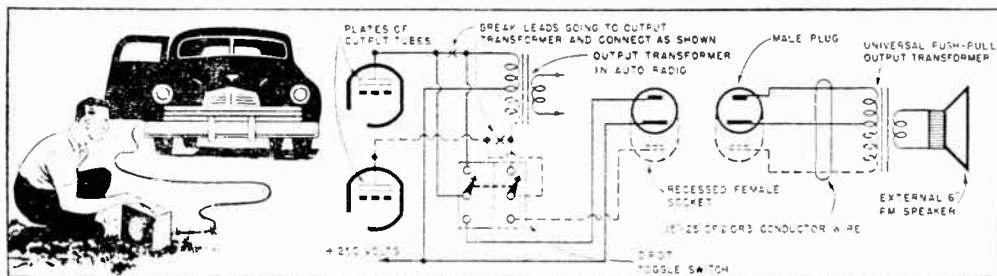

Give a loudspeaker enough cord and you can hang it on a nearby limb or simply place it on the ground beside you when you get out of an auto to loll in the shade. For those many times when you are just far enough away from a car for its radio to be of no use, this extension speaker is the perfect answer.

The toggle switch makes it possible to change instantly from the internal to external sound. Just plug in the connector,

lick the switch, and carry the boxed speaker anywhere within the 15' to 25' range of the extension wire. The solid lines in the diagram show what must be done if the radio has a single output tube; for push-pull output make the changes shown by the broken lines as well. With single-tube output you'll need only a SPDT switch. A two- or three-way polarized plug and socket and two- or three-conductor wire make the connection.

One-Tube Radio Can Be Mailed

SUBMINIATURE tubes measuring less than $\frac{1}{2}$ " in diameter will make it possible to redesign radio circuits to almost any shape and size. This novelty receiver is as flat as the tube itself and can therefore be inserted in a 6" by 9" envelope and sent through the mails as a letter. The two pieces of $\frac{1}{8}$ " cardboard that form the chassis are held together by the same nuts and bolts that hold the phone, battery, antenna and ground terminals in place. Slots are cut in the cardboard to clear the components.

Fitting parts into slots in the cardboard chassis makes the set flat and also guards the components.

The tiny 2E32 tube is a shielded pentode and operates with a plate voltage of $22\frac{1}{2}$ and a filament voltage of 1 $\frac{1}{2}$. For the latter, a small flashlight cell will give several hours of useful life. One of the miniature 22 $\frac{1}{2}$ - or 30-volt batteries will supply both the plate and the screen.

To keep the receiver flat, the coil is wound on a cardboard disk 4" in diameter. Cut 13 slots at intervals of approximately 1" as shown in the sketch below; then interlace the form with 92 turns of No. 30 enameled wire. At every twelfth turn, make a tap by scraping the enamel and letting a drop of solder adhere to the spot.

Although the circuit doesn't employ regeneration, it has sufficient power to pull in local stations. By selecting the right antenna and ground taps and adjusting the trimmer in the antenna lead, it should be possible to cover the entire broadcast band. The trimmer specified in the drawing is intended for use with a short indoor antenna; if used with a long antenna, a trimmer of lower capacity—say 125 to 350 mmf.—should be substituted.—ALBERT ROWLEY.

Small crocodile clips soldered to the various detachable leads permit quick and easy connection.

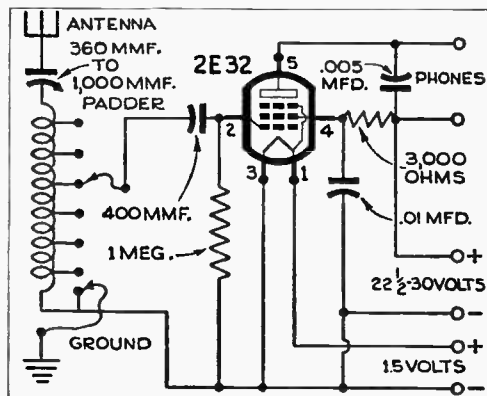

Resistors are $\frac{1}{4}$ watt, and the tubular condensers 200 volts; phone impedance should be 2,000 ohms.

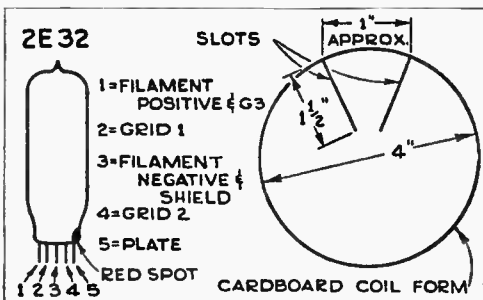

Tube leads may be identified by the position of the red spot. The coil is wound on a cardboard circle.



A shaft is soldered to the top of the trimmer condenser so that a tuning knob may be added.

One-Tube Radio Is Matchbox Size

SQUEEZING a complete radio receiver down to the dimensions of a matchbox is no more than a leisurely evening's work. This set, which will readily fit in your vest pocket, is built on a $\frac{3}{8}$ " by $1\frac{7}{16}$ " by $2\frac{1}{4}$ " chassis made from $\frac{1}{16}$ " aluminum.

A small trimmer condenser used for tuning, two phone jacks, and a 7-prong miniature socket are mounted on top of the chassis. Underneath are the 1-meg. grid

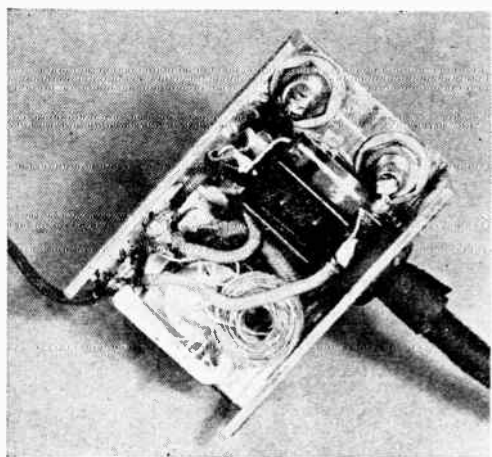

The turns of the antenna coil have been bunched together to take as little space as possible. An antenna lead and 4-way battery cable are brought out from under the chassis.

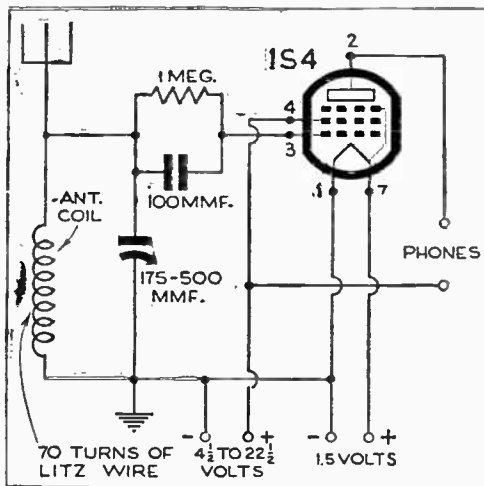

The average spare-parts box will produce most of the components used in this simple circuit.

resistor, the 100-mmf. mica condenser, and an antenna coil that is made by winding approximately 70 turns of litz wire around a pencil. Slip the coil off the pencil and impregnate it with coil dope.

Since the 175-500-mmf. trimmer will tune only a portion of the band with this coil, you may want to make other coils with more or fewer turns in order to increase the coverage of the set. The 1S4 pentode used as a detector requires $1\frac{1}{2}$ volts for the filament, and will operate with a B battery that supplies anywhere from $4\frac{1}{2}$ to $22\frac{1}{2}$ volts. For best results use a good ground and antenna.—ALBERT ROWLEY.

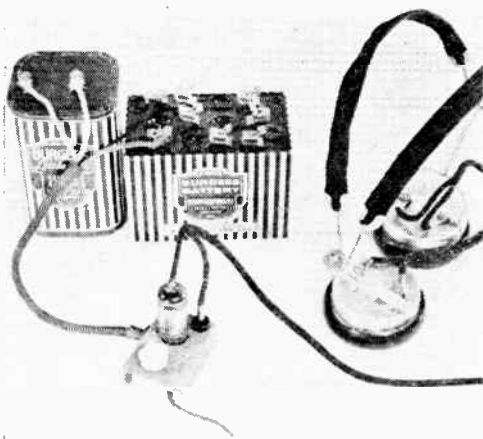

For test purposes standard $1\frac{1}{2}$ and $22\frac{1}{2}$ -volt batteries were used, but a penlight cell and a miniature B battery would provide a power supply hardly larger than the radio itself.



You can listen to your best radio from any room with this system.

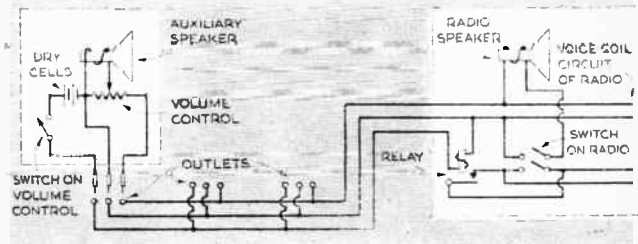

PIPED PROGRAMS. You can listen to your console radio in any room in the house with the remote pickup and control system shown below. A portable speaker, plugged into the circuit whenever convenient, has a volume control and an on-off switch that controls the radio.

The only changes necessary in the radio itself are the installation of a new power switch with an extra pole, and a relay for remote on-off control. This relay, of about 1,000 ohms resistance, should operate on two or three flashlight cells. Low-voltage conductors such as bell or magnet wire will do for the house circuit. The portable speaker—more than one could be used—is a permanent-magnet type; mount it in a housing with a combined power switch and volume control of 1,000 to 5,000 ohms resistance. This adjusts the remote speaker without affecting the radio.—WILLARD ALLPHEX.

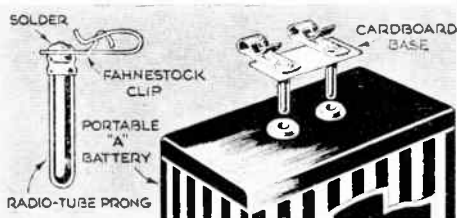

PLUG-IN ADAPTERS. Prongs from burned-out radio tubes secured to a cardboard base enable you to connect plug-in type portable radio batteries anywhere. Three prongs are needed for a "B" battery having a 22-volt terminal. Make sure the leads can't be accidentally shorted. C. E. WARD III.

INSULATING GROMMETS are quickly made from slip-on pencil erasers. Drill the hole right through and round off corners on an emery wheel. Cement will hold it on the wire.—AL. M. LINDNER, JR.



LEST YOU FORGET which part of a complicated wiring job has been finished, run a colored pencil over the lines on the circuit diagram as you wire in each one. Then there is no need to trace wiring to learn what is left to do. It's also a help in preventing wiring mistakes.—JOHN BORODICH.

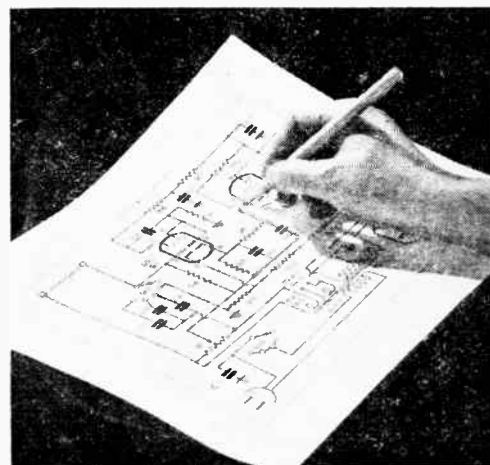

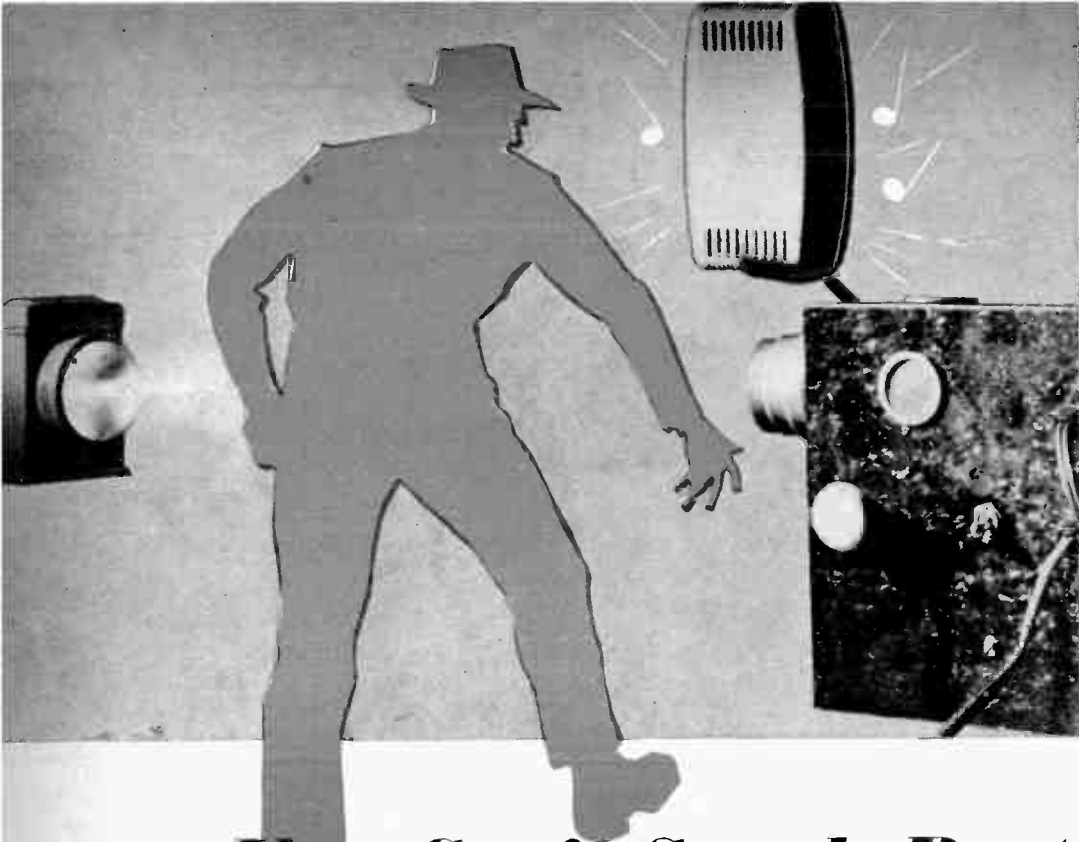

You Can't Sneak Past This Robot Watchman

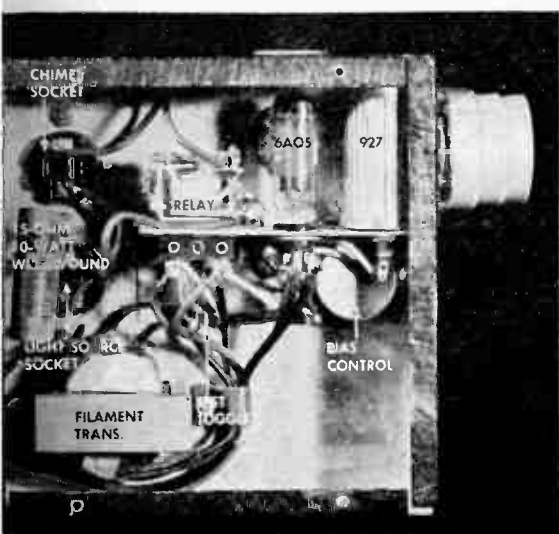

For a cabinet, a 2" by 7" radio chassis is used. The 6-volt transformer and sockets for chimes and light source are fastened to it; other parts are on a separate subchassis.

ARE you allergic to sneak thieves? Would you like a little advance warning when visitors cross your lawn? Want your car's headlights to open garage doors? Maybe you need an electric eye to help you keep watch. There's no end to the chores that a suitably rigged phototube will perform. The setting sun, for example, can be made to turn on the lights in the chicken house, and sunrise will turn them off. A photoelectric unit has few rivals for fire alarms, motor shutoffs, emergency control units, switches that illumine the front door or driveway at the approach of a caller or a car . . . the list can be extended to the limit of your imagination.

In the setup shown here, the 6-volt output of the photocell-and-relay box is used to sound a door chime when any person or object breaks the beam. By improvising a few parts—such as the light source—it should be possible to keep the cost low. In this case a flat flashlight was converted into an electric

unit. A 3.8-volt bulb is powered by the same 6-volt filament transformer that is used for the heaters of the 6AQ5 amplifier pentode. Any flashlight with a strong light spot can be similarly used. One with a diffused beam is not suitable.

A piece of aluminum bent to a right angle $1\frac{1}{2}$ " high and measuring $1\frac{3}{4}$ " by $4\frac{1}{2}$ " on top is used as a chassis. The relay, 6AQ5, and 927 phototube are mounted on top of it. Make sure that the 3-prong socket for the 927 is oriented so that light strikes the sensitive face of the tube. A shield (snipped to size from an ordinary tube shield) is recommended. Punch a hole through the shield and the front edge of the cabinet in a direct line with the face of the phototube.

Even though a focused beam is used, the light must be refocused directly ahead of the photoelectric tube. Two dime-store magnifying glasses proved adequate for this purpose. They are set into a plastic flashlight head which is reversed and cemented over the light passage in the cabinet. An alternative method of mounting the lenses is illustrated in the lower right-hand drawing below.

Some ventilation is needed for the 6AQ5. To provide it, three 1" holes were punched in the cabinet around it and the holes were covered with screen plugs.

Actual resistance of this relay is 3,800 ohms; one measuring from 3,000 to 4,000 should be satisfactory. Contacts must be at least single pole, double throw for most photocell applications.

When the assembly is complete, plug the chimes and flashlight into the connectors provided for them (recessed sockets set into the side of the cabinet), turn on the switch, and watch the operation of the relay. As the amplifier tube warms up, the relay should pull in; if not, adjust the bias control until it does. Focus the light and the concentrating lenses. When the spot strikes correctly, the relay should release or pull up. Breaking the beam will then cause the relay to pull back in and complete the 6-volt circuit that energizes the chimes.

With this light source, maximum operating distance of the unit is about 8'—ample for most applications. Should greater range be required, substitute a stronger light.—
Frank Tobin, Manhattan, N. Y.

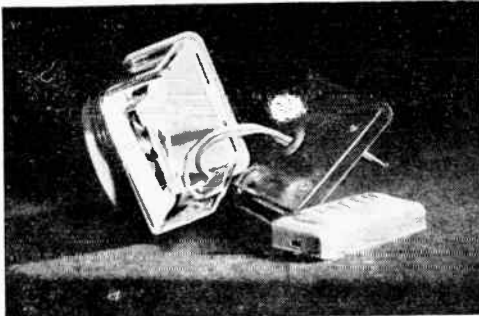

Wires soldered to the contacts electrify this flashlight. Power is taken from the filament transformer. A 15-ohm adjustable resistor drops the voltage from 6 to about 4.5.

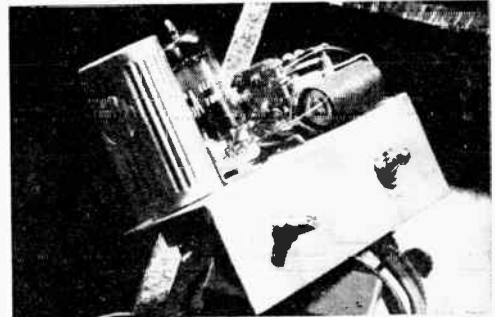

Inside the shield is the phototube with the 6AQ5 and relay lined up behind it. The small chassis is held in the cabinet by the shaft nuts of the switch and bias potentiometer.

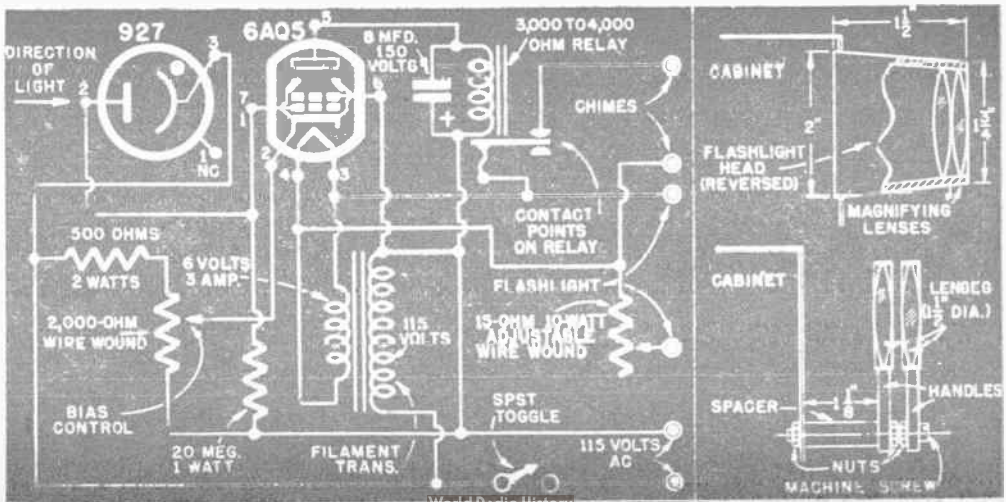



Elusive short-wave signals often come in best at night, so headphones are built into this two-band superheterodyne for midnight DX listening. Flicking a couple of switches, however, brings in the full broadcast band at loudspeaker volume.

By FRANK TOBIN

THREE tubes for a two-band superhet doesn't suggest much power, but there's plenty of pickup and drive in this circuit to pull in the 20 and 40-meter ham-band transmitters as well as short-wave broadcasts from Europe and Australia. Reception on the broadcast band is clear and loud: a 10-foot hank of antenna wire strung out along the floor will usually be sufficient to get local stations at full loudspeaker volume, and an external ground can be omitted altogether. For remote locations or good DX listening, of course, you'll want a more substantial antenna and a good ground.

Being battery operated, this set is ideal for camp, hunting lodge, or week-end cabin as well as for the den. The use of only three tubes allows economical operation on dry batteries.

Considerations of size played practically no part in the selection of the midget 3S4 power tube; what is important about the

tube is that it will maintain good and undistorted output at plate potentials down to 65 volts. Most battery-operated power pentodes work well enough with a fresh battery supply, but when the cells age and voltage starts to drop, considerable distortion occurs at normal output levels. The 3S4, however, is built to work in personal radios that normally use 67½-volt batteries, and is therefore capable of distortion-free performance from 90 volts down to 65.

It is possible that you may have difficulty in locating the 3AS-CT tube called for, since some manufacturers have discontinued production of it. However, it's simple enough to substitute two separate tubes for the combination triode-pentode-diode. Use a 114 in place of the pentode section and a 1S5 in place of the triode-diode portion. As the 1S5 is a pentode-diode, tie the plate and G2 (screen grid) together, and connect them to C10, C11, and R7. The control grid (G1) of the 1S5 is wired to R5 and C9. The filaments of the 1S5 are connected to the

Two-Band SUPERHET

**THREE-TUBE CIRCUIT PERMITS
COMMUNICATIONS RECEIVER
TO OPERATE UP TO 1,000 HOURS
ON BATTERY PACK**

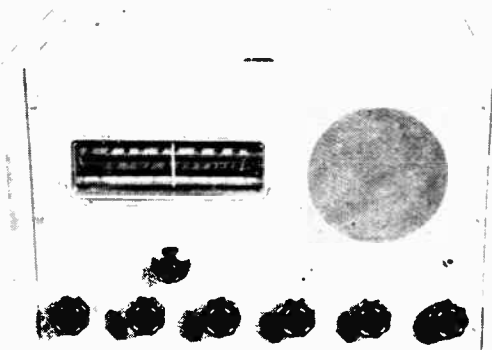

same points as the pins 1 and 7 of the 3A8-GT.

Connections for the 1T4 substitute are made in a similar manner. Its plate is wired to the same point as pin 3 of the 3A8-GT, G2 of the 1T4 as if it were pin 4 of the 3A8-GT, and G1 to the same connection as the cap on the 3A8-GT. The filament leads are wired to pins 1 and 2.

If you happen to find a 3A8-GT, it is probably simpler not to make this change in the circuit diagram. Bear in mind, however, that future replacement of the 3A8-GT may not be easy as stocks lessen.

For night-time listening or when signals are weak, a headphone jack has been included. By taking the phone-jack connections from the voice-coil winding of the output transformer, the phones can be switched in at any time, regardless of volume, without danger of blasting or overloading. Use the transformer tap that gives the most comfortable volume, and be sure that the grounded side of the phones cor-

responds to the grounded side of the speaker. This connection is shockproof since none of the high voltage flows through the phone circuit.

A variable tone control, consisting of a .1-mfd. tubular condenser (C12) in series with R10, a 75,000-ohm potentiometer, operates on both speaker and phones. By reducing the audibility of higher sound frequencies, this control serves to relieve heavy static conditions. High-pitched code signals can also be changed to more pleasing notes by means of the tone control, and musical programs can be tuned to suit the ear.

When a signal is picked up by the antenna, it is fed into the fourth grid of the 1A7 converter, where it is mixed with a signal generated by the local oscillator to create an intermediate frequency of 456 kc. After passing through the I.F. amplifier, this signal is rectified by the diode detector, then further amplified by the first audio tube. All three functions—I.F. amplifier, diode detector, and first audio—are performed by the single 3A8 tube. Building a pentode amplifier, diode rectifier, and high- μ triode into one glass envelope not only saves space, parts and work for the builder, but also cuts down filament current drain.

The output of the 3A8 amplifier triode is resistance coupled to the control grid of the 3S4 power pentode through a 75,000-ohm plate resistor, a .05-mfd. coupling condenser, and a 1-meg. grid resistor. A mica condenser of 100-mmf. capacity in the plate circuit of the first audio stage by-passes any unrectified R.F. current to ground, preventing it from weakening or distorting the desired signal.

Through an output transformer, the audio-frequency currents flowing in the plate circuit of the 3S4 are fed into a 6" P.M. speaker. Load resistance of the tube is about 5,000 ohms; a selection of taps on the secondary of the transformer permits matching of this resistance to the speaker's voice-coil impedance.

Grid bias for the 3S4 is obtained by means of a 600-ohm resistor, R9, in series with the negative 90-volt lead and ground. The voltage drop across this resistor is impressed on the grid of the tube through the 1-meg. grid leak, R8. As the B voltage drops, so does the negative bias on the tube, resulting in a compensating increase in amplification. Automatically regulated bias permits the power tube to function efficiently even though the output voltage of the B battery

falls by as much as a third.

To protect the loudspeaker cone from damage, a wire screen is placed over the speaker frame. The screen is covered by a grille cloth before the speaker is bolted to the front panel.

The number of knobs in use could have been reduced if space had demanded, but it will probably prove convenient to have the full number. From left to right, these knobs control: sensitivity (R1, for local-distance tuning), wave band (S1), volume (R6), tone (R10), power (S3, on-off switch), and speaker or headphone output (S2).

Although the volume control and power switch might easily have been combined, the latter is also useful as a quick-action stand-by switch because the battery circuit requires practically no warm-up time. When the set is played through the loudspeaker, the speaker-headphone switch will provide even more instantaneous stand-by control.

Three-scale slide-rule dials of the type shown may be obtained with all the neces-

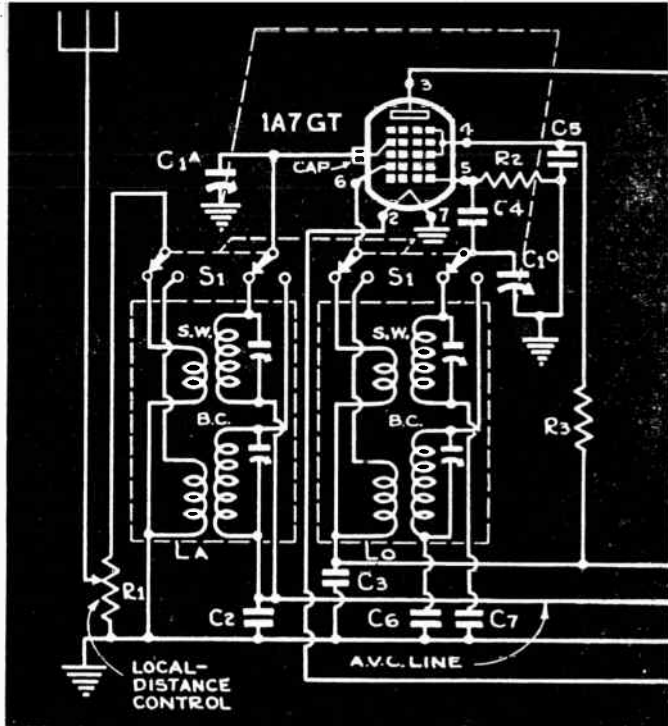

LIST OF PARTS

- C1: 360-mmf. two-gang tuning condenser.
- C2, C3, C5, C12: .1-mfd., 600-volt paper tubular.
- C4: 250-mmf. mica.
- C6: 400-mmf. mica, close tolerance.
- C7: .01-mfd. mica, close tolerance.
- C8, C10: 100-mmf. mica.
- C9, C11: .05-mfd., 600-volt paper tubular.
- C13: 16 mfd., 200-volt electrolytic.
- R1: 250,000-ohm potentiometer.
- R2: 50,000-ohm, 1/2-watt carbon.
- R3: 10,000-ohm, 1-watt carbon.
- R4, R5: 2-meg., 1-watt carbon.
- R6: 1-meg. pot.
- R7: 75,000-ohm, 1/2-watt carbon.
- R8: 1-meg., 1-watt carbon.
- R9: 600-ohm, 1-watt carbon.
- R10: 75,000-ohm pot.
- S1: 4-pole D.T. rotary band switch.
- S2: D.P.D.T. rotary.
- S3: D.P.S.T. rotary.
- LA: Shielded antenna coil, 540-1,500 kc., and 5,500-18,000 kc.
- LO: Shielded oscillator coil, same bands.
- I.F.1: Iron-core I.F. input transformer, 456 kc.
- I.F.2: Iron-core I.F. output transformer, 456 kc.
- T: Universal output transformer.
- J: Headphone jack and plug.
- Tubes, chassis, cabinet, 6" P.M. speaker, sockets, knobs, hardware, etc.

sary calibrations for both broadcast and short-wave bands, plus a 0-100 scale for logging purposes.

To align the set a modulated signal generator is, of course, desirable. If one is available, ground the shielded cable to the chassis and clip the live conductor to the grid of the 3AS pentode. Tune the generator to 456 kc. and adjust the secondary and then the primary of I.F.2 for maximum sound at the speaker. Work backward through the first I.F. transformer. Tune the R.F. stage by removing the screws on the condenser (C1) trimmer and aligning the trimmers first on the oscillator and then on the antenna coils. Broadcast and short-wave bands will have to be tuned separately. Use a 1,500-ke. R.F. signal for the former and 15 or 16 mc. for the latter.

If you don't have a signal generator, you can tune by ear by first getting the strongest station you can find, and working backward in the sequence described above until the signal comes through with the greatest volume. It may be necessary to do the aligning of the short-wave band at night when strong stations are easier to find. Most I.F. transformers are factory tuned with sufficient precision to allow a strong signal to get through.

Cabinet size will depend largely on your individual requirements. The one shown was

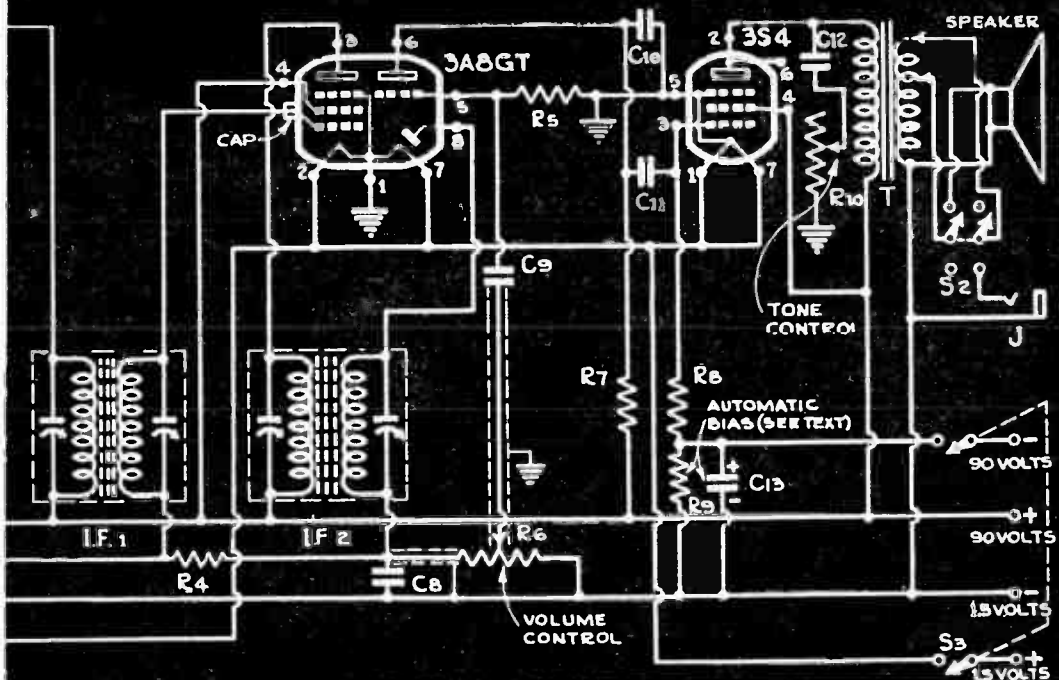

selected because it has room for a 1,000-hour power supply. Battery packs that deliver 1.5 volts for the filaments and 90 volts for the plates are now available in a variety of sizes and shapes. Where portability is a factor, a small pack may be used, in which case the cabinet can be much reduced in size. The larger of the so-called "lamm" packs are estimated to be good for a full year of service with this low-drain circuit, based on average daily use of about three hours.

For extra usefulness the set may be readily converted to 115-volt A.C. or D.C. operation. An article on the next page describes a suitable dry-disk rectifier unit that will enable the builder to install a complete three-way power supply.

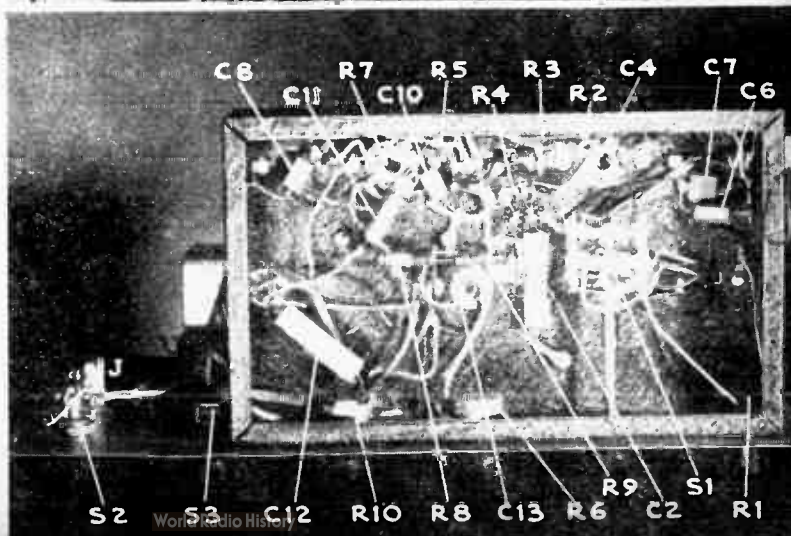
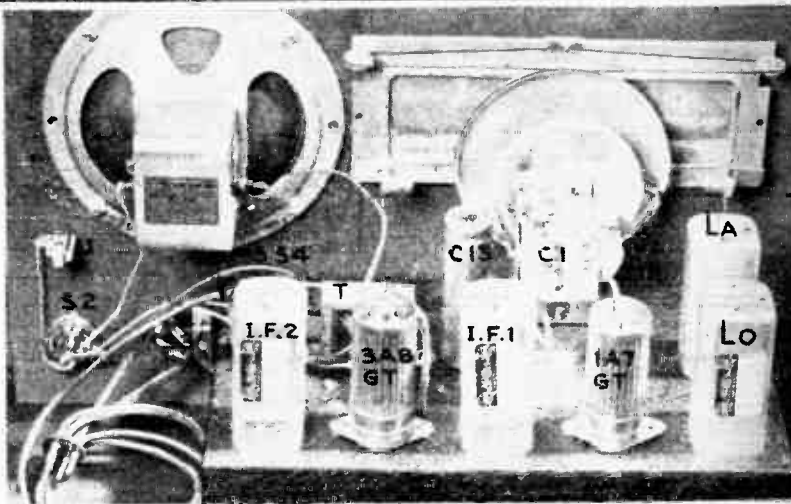

More Power to You

Here are three designs for D.C. power supplies that will furnish rectified voltages for receivers, transmitters, test equipment, and other uses.

S MALL power supplies capable of furnishing filtered and reasonably pure direct current always have a place on the experimenter's workbench. For some equipment, of course, power packs must be designed to give specific currents and voltages, but for the majority of applications one or more of the three units described here can be used. They will conserve battery life in portable apparatus, balance a Wheatstone bridge, extend the range of an ohmmeter, or provide bias or power voltage for experimental amplifiers, receivers, and transmitters.

Dry-disk rectifiers, recently made available to experimenters, replace rectifier tubes in many circuits. The selenium disks require only two soldered connections. They have no filaments and therefore require no separate filament supply. Because of their rugged metallic construction they are also able to withstand a lot of knocks. Two of the three circuits given below employ these new rectifiers; all three are made of easily obtainable and standard parts.

Selenium rectifiers are color-coded to in-

dicate polarity. The positive side, indicated by a red dot or some similar marking, is equivalent to the cathode of a rectifier tube; the negative side, marked with black, functions as the plate. The position of the red dot in relation to the other circuit elements is shown in the diagrams.

Battery Eliminator

The dry-disk battery eliminator shown on these two pages was built by Frank Tobin as a companion piece for his three-tube superheterodyne receiver (See page 178). It is shaped to fit the battery compartment of his and other radios and can be used with practically any receiver that requires approximately 90 and 7.5 volts of B and A supply respectively.

In order to use the eliminator with the three-tube receiver, it is necessary to connect the tubes in series so that the current drain will not exceed 50 ma. Many battery tubes have their filaments arranged so that they may be connected either in series or in parallel. As originally built, the set placed all the tubes in parallel to operate on a 1.5-volt battery. The diagram on the facing page shows the changes that must be made if the set is to run on the higher filament voltage. Simply putting the tubes in series without modifying the associated circuit shown by the blue lines would also have the effect of raising the A.V.C. voltage to 7.5 volts—equal to the sum of the tube voltages. In

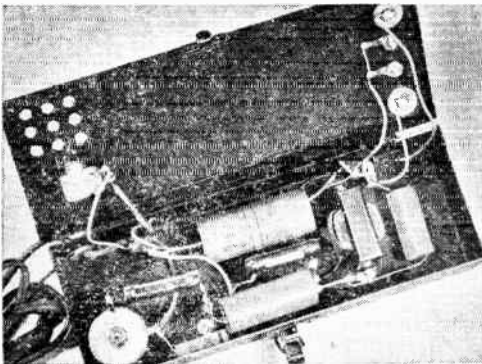

An oblong metal tool box that will fit readily into the battery compartment of most receivers is both the chassis and cabinet of this power supply.

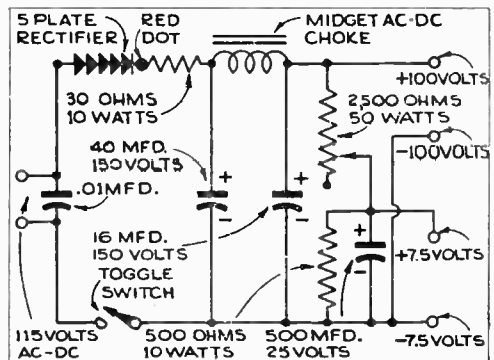

The parts used in this simple rectifier unit may be purchased for a couple of dollars. They will save many times their cost in battery replacements.

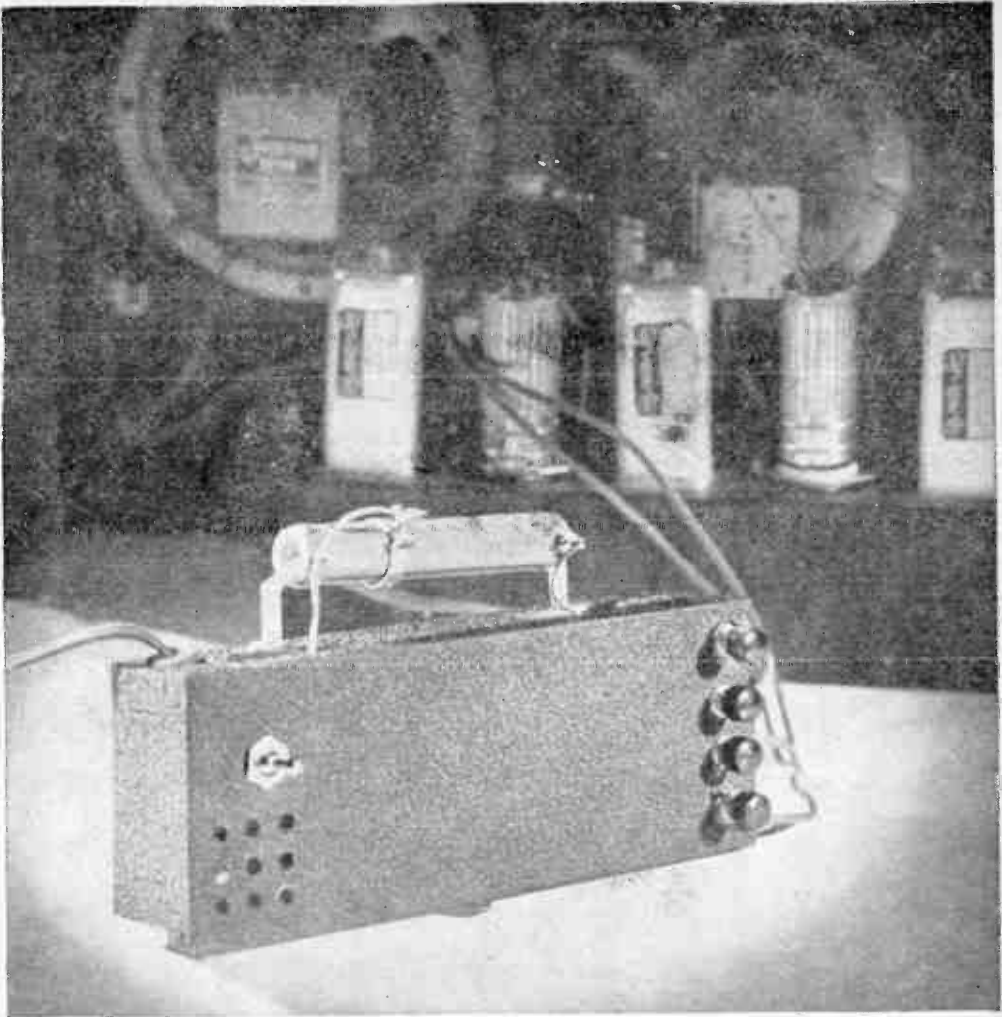

When used with the rectifier, the superhet circuit must be altered as shown by the modified diagram, below.

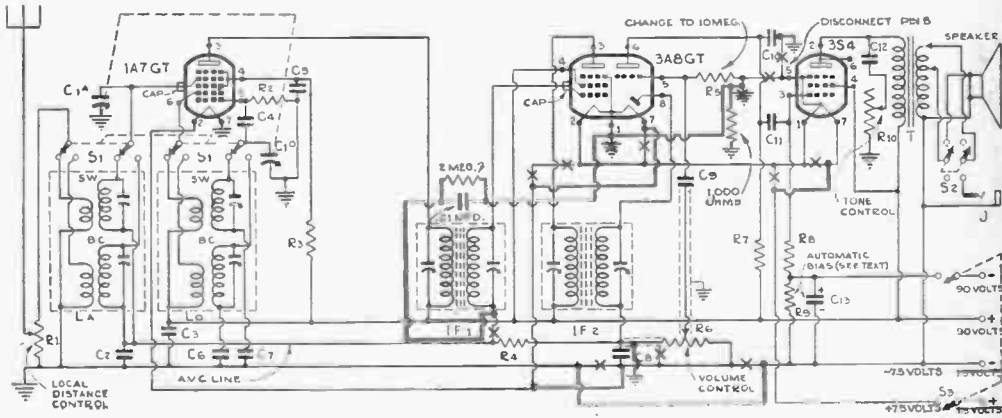

New connections in the filament circuit are indicated by lines in color; remove leads marked with an X.



A small bakelite box houses the midget rectifier. The voltage control, pilot light, and output jacks are conveniently placed on top of the cabinet.

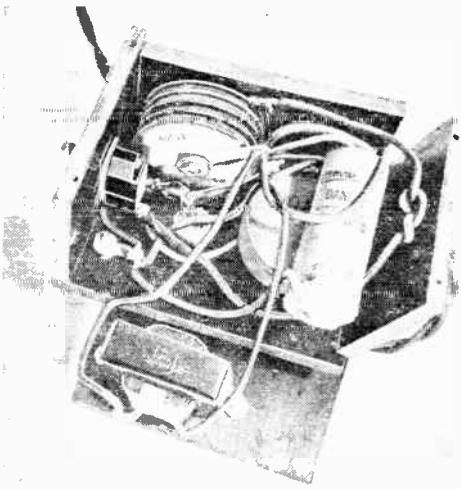

Position of the parts is not critical but it is desirable to allow as much space and ventilation as possible around the dry-disk rectifier stack.

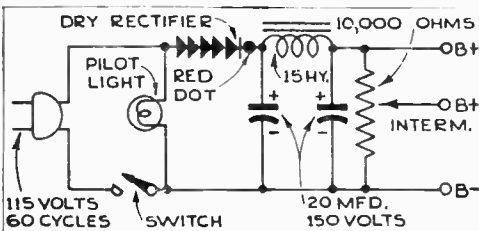

Output of this power supply is variable from 70 to 140 volts. If the ripple is objectionable, increase the size of the first condenser to 40 mfd.

other words, the set would have to receive a signal of 7.5 volts before it could operate. Since received signals are generally on the order of microvolts, it is evident that no sound will reach the loudspeaker unless these other changes are made. The alterations in the circuit indicated by the red lines in the diagram, should not take more than half an hour to accomplish.

Because a considerable amount of heat is dissipated through the 2,500-ohm dropping resistor, a unit with a rated value of 50 watts was selected. The high wattage gives a safe margin against overheating, but a 25-watt resistor of equal ohmage may be substituted provided that it is used outside the cabinet and is otherwise well ventilated. The variable tap on this resistor allows for accurate adjustment of the A voltage.

A small metal tool box is used as both chassis and cabinet of the battery eliminator. The metal box also serves as a shield around the rectifier, cutting down the induced hum. Holes are drilled in the cover just above the dry-disk rectifier to provide the necessary ventilation. The wire-wound resistor is placed outside the box.

Midget Power Pack

In the operation of battery radios, the major item of cost is the B battery. Regardless of filament requirements, therefore, an appreciable saving can be made by using a rectifier for the B supply whenever house current is available. This midget power supply, made by R. L. Parmenter, provides such a variable B voltage and can be used in conjunction with a dry-cell A supply. Output is variable from 75 to 140 volts. As can be seen from the photos, the complete assembly is hardly larger than a cigarette package.

A bakelite box was fabricated from $\frac{1}{4}$ " stock and has inside dimensions of 2" by 2 $\frac{1}{2}$ " by 3 $\frac{1}{2}$ ". Placement of parts is not critical, but it is desirable to leave as much "breathing space" as possible around the rectifier. The 10,000-ohm wire-wound potentiometer which is used as a voltage divider to vary the output potential is mounted on the top panel. Also on this panel are the pilot light and the banana jacks to which the output leads may be connected. The pilot light consists of a midget fuse indicator cemented into a ruby jewel. The limiting resistor that comes with such a light should be left attached and wired into the circuit. A $\frac{1}{2}$ -watt neon bulb may be even more satisfactory for this purpose.

Limits on the amount of current that can be passed by a power supply circuit are set by the rectifier that is selected. The dry disks are available in several current ratings from 75 to 200 ma.; 100 ma. is adequate for most uses to which the supply is likely to be put. To eliminate the ripple that is present after half-wave rectification, a filter choke must be used in conjunction with at least one, and preferably two, filter condensers. The larger the capacity of the input condenser, the higher the output voltage. Also, within certain limits, higher capacity usually results in better filtering. A choke capable of handling from 70 to 100 ma. is desirable in order to make the most efficient use of the rectifier.

The imaginative builder will find many applications for this power supply. Used to provide plate potential for small short-wave regenerative receivers, the variable resistor acts as an auxiliary regeneration control. If the device is to be used with a volt-ohmmeter to increase the range of resistance readings, it may be worthwhile to incorporate some method for checking the available voltage. A voltmeter of 1,000-ohms-per-volt sensitivity connected across the terminals through a switch will allow for continuous checking of the booster voltage.

400-Volt Supply

Carl Andresen built this third power supply from his spare-parts box: most of the necessary components can probably be found in the average electrical or radio home workshop. A 2" by 4" by 8" sheet-metal chassis painted with a dark wrinkle-finish enamel was used. Neither the chassis size nor the position of the parts is critical.

The power transformer, which came out of an old radio, has a high-voltage winding of approximately 500 volts with 250 volts at the center tap. It also has two filament windings of which only the 5-volt section is used. The 5T4 tube was chosen because it happened to be handy; several other full-wave rectifiers would work as well. For the filter choke the author removed a 500-ohm field coil from a small speaker; the coil and a dual 16-16 mfd., 450-volt electrolytic condenser make up the filter system. A 50,000-ohm, 50-watt bleeder resistance is put across the output to improve voltage regulation. Different voltages may be tapped off the adjustable slide of this resistor. Plugged into a 115-volt 60-cycle line, it should deliver about 400 volts of ripple-free D.C.

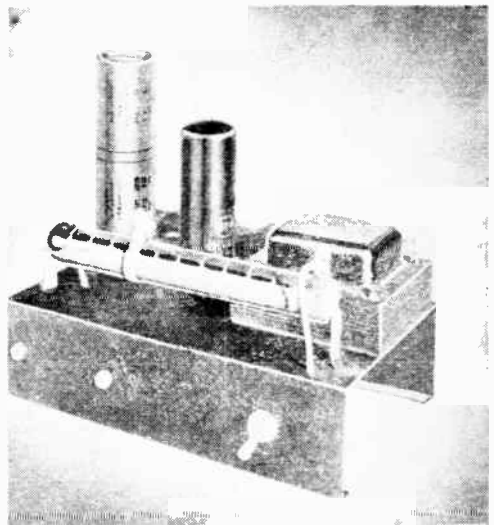

The power transformer, full-wave rectifier, dual electrolytic, and bleeder resistor are mounted on top of the 2" by 4" by 8" sheet-metal chassis.

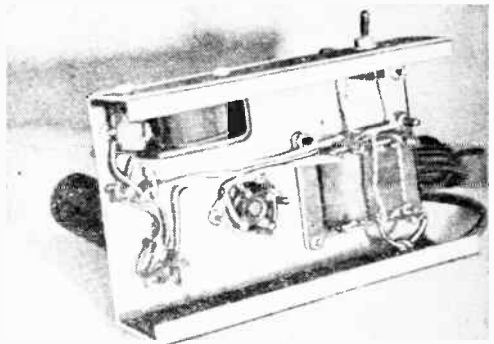

Wiring is done on the underside of the chassis of the 400-volt power supply. The 500-ohm field coil used as a filter choke is also mounted underneath.

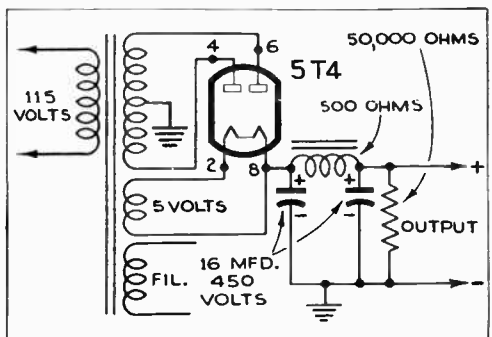

One of the filament windings of the power transformer is left unconnected. The switch shown in the photos is inserted in the transformer primary.

Businessman's Radio

By EDWARD BLANTON

FOR THE businessman who has to travel and likes to travel light, here is a handy radio that manages to be a constant companion without becoming an extra piece of luggage. Flat enough to fit into a briefcase or overnight suitcase without crowding out the other things you want to take along, this four-tube receiver operates on either AC or DC at 115 volts.

The resistance of the four tube filaments in series is such that no line-cord resistor is needed to drop the voltage. Therefore an ordinary two-conductor cord can be used, as long or as short as you like. A little extra length is all to the good, since in some of the older hotels electric outlets aren't placed as close as you might like to the desk or night table.

All the tubes are midgets; leads from inside are brought out to miniature metal prongs embedded in the glass envelopes. Connections are made to miniature 7-prong

sockets that are fastened to the chassis.

The chassis consists of a $5\frac{1}{2}$ " by 8" sheet of thin aluminum bent to form a 90-degree angle about 2" from one of the longer edges. Most of the parts are fastened to the 2" leg so formed.

The first tube, a 12BA6, is a radio-frequency amplifier pentode with remote cut-off characteristics. The control grid of the tube is connected to the secondary winding of the antenna coil (L1) and the stator plates of one section of the two-gang tuning condenser (C1). From the plate of the 12BA6, the amplified radio-frequency signal is fed into the primary winding of the RF coil, L2, which is coupled to a second tank circuit composed of the secondary of the RF coil and the other half of C1.

The unshielded antenna coil is placed beneath the bend in the chassis; the RF coil is placed above the chassis and must be shielded to prevent oscillation and distortion due to stray couplings between the coil windings and the other circuit components.

To cover the coil, a portion of an old tube shield was cut off and bolted to the chassis as illustrated on page 189.

Output from the RF tank circuit is fed to the grid of the 12AT6, used as an anode detector and amplifier. Bias is provided by a 2,700-ohm resistor and a 10-mfd., 25-volt electrolytic condenser (R1, C4). A small mica condenser



An average-size briefcase holds the radio and plenty of books, papers, and other articles as well. The case is a leather-covered jewel box or accessory case.

Fits in a Briefcase

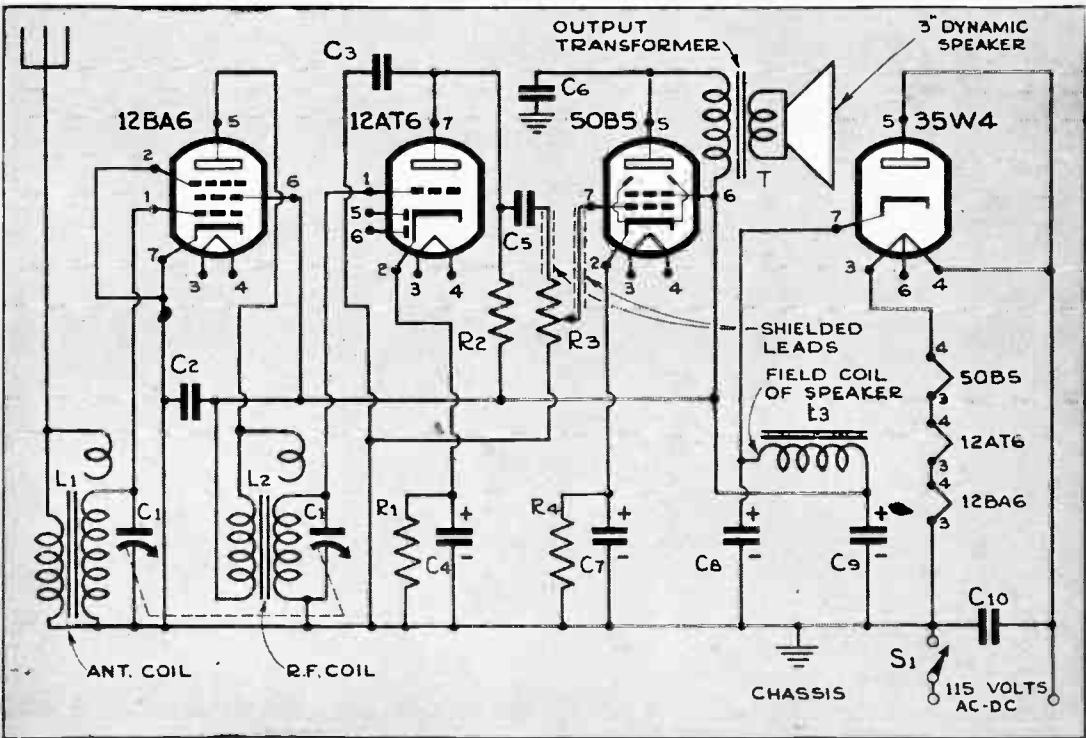
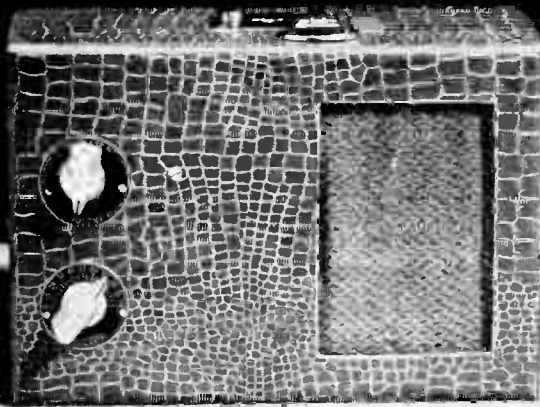

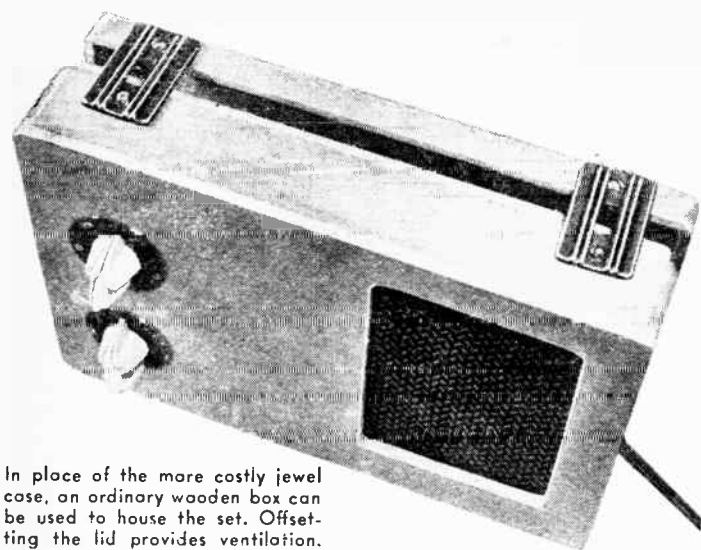

In place of the more costly jewel case, an ordinary wooden box can be used to house the set. Offsetting the lid provides ventilation.

(C3) in the plate circuit of the tube bypasses stray RF signals to ground before they can get into the audio system and introduce unwanted noise.

Resistance coupling is employed between the detector and audio stages. For the latter, a 50B5 beam-power pentode is used. A 1-meg. variable resistor (R3) in the grid circuit of the tube acts as a volume control. For bias, a 270-ohm resistor and another 10-mfd. electrolytic (R1, C7) are used.

All of the electrolytics in this set are of the dry type, encased in tubular aluminum shells and wrapped in heavy paper. These electrolytics require no mounting brackets as they are small and light enough to be supported by their own pigtail leads. Polarity is important in wiring electrolytic condensers. The "plus" and "minus" leads must be connected as indicated in the diagram. Should the leads of an electrolytic be reversed, it may start to "boil" and will quickly short or otherwise become inoperative.

The midget output transformer, mounted on the underside of the speaker frame and projecting through an opening cut in the chassis, couples the output from the plate of the 50B5 with the 3" dynamic speaker. To match the impedance of the tube to that of the voice coil, the transformer should have a primary impedance of 2,000 to 3,000 ohms and an impedance in the secondary winding of about 4 ohms.

For the filter choke, L3, the 500-ohm field coil of the speaker is used. This value isn't critical; any field coil from 500 to 1,500

ohms will serve. Small 16-mfd. electrolytic condensers are connected to both sides of the coil.

A rectangular speaker opening approximately 3" by 4" is cut in the front panel of the case and covered on the inside with a suitable grille cloth. Since the speaker is mounted on the aluminum chassis, it is not necessary to bolt it to the cabinet. Two 1/2" dia. holes are drilled in the front of the cabinet to clear the tuning-condenser and volume-control shafts. These two shafts, supplemented by one nut and bolt, should be

sufficient to hold the aluminum chassis firmly against the front of the cabinet.

The cabinet itself consists of an imitation-leather covered jewel box measuring 3" by 6" by 9" which allows slight clearance for the chassis on all sides. A rectangular opening is cut in the back of the box and covered on the inside with wire mesh. This is necessary to provide adequate ventilation for the set. With a case of this size, both the line cord and a 25' length of antenna wire can be coiled inside for easy transportation.

The photo on this page shows an alternative and less expensive cabinet made of a small wooden box purchased at a crafts

LIST OF PARTS

- C1: 360-mmf. two-gang tuning condenser.
 - C2, C10: .01-mfd. paper tubular, 400 volts.
 - C3: 250-mmf. mica.
 - C4, C7: 10-mfd., 25-volt electrolytic.
 - C5: .02-mfd. paper tubular, 400 volts.
 - C6: .005-mfd. paper tubular, 400 volts.
 - C8, C9: 16-mfd., 150-volt electrolytic.
 - R1: 2,700-ohm, 2-watt carbon.
 - R2: 150,000-ohm, 1-watt carbon.
 - R3: 1-meg. volume control with switch. See S1.
 - R4: 270-ohm, 2-watt carbon.
 - L1: Adjustable iron-core antenna coil.
 - L2: Adjustable iron-core RF coil.
 - L3: Field coil of speaker used as filter choke.
 - S1: S.P.S.T. on volume control R3.
 - T: Output transformer.
- Tubes, wafer sockets, 3" electrodynamic speaker, dial plates, knobs, misc. hardware.

store for less than a dollar. The lid of this box is mounted on the body with metal brackets, providing a 1/2" wide air space to allow ventilation for the tubes on all sides. With such all-around cooling, the set may be played while it is lying on its back or on any of its sides. Although somewhat less handsome, a cigar box with a ventilation slot will be as serviceable.

In common with most AC-DC sets, the chassis of this receiver is grounded to one side of the power line. Therefore no external ground should be used. A hank of antenna wire thrown out the window or strung along the floor is sufficient to pick up most local stations. It must be noted, however, that this is a TRF circuit and its selectivity is not as great as that of a superheterodyne. Nevertheless, it should be sufficient to separate transmitters in most localities. When using the set on DC, remember to reverse the plug if the radio fails to play on the first try.

If you like radio novelties, you may want to try putting this compact circuit, perhaps rearranged on a more suitable chassis, into a banjo clock, a table lamp, a book cover, a night table, or even a ship model.

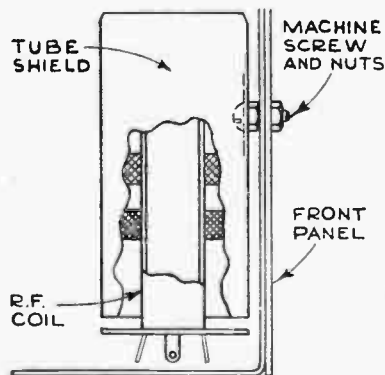

To prevent oscillation and distortion due to stray coupling, the RF coil must be shielded. A suggested method for isolating the coil is to enclose it in an old tube shield which is attached to the chassis as shown above.

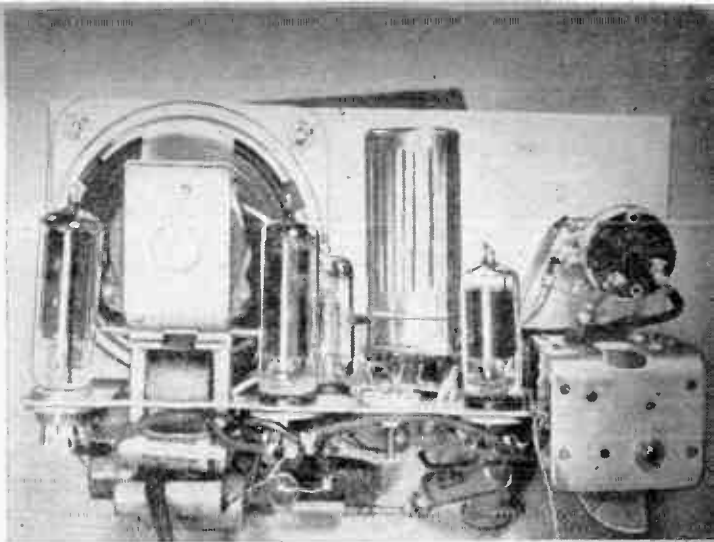

The chassis is a sheet of aluminum bent to the shape of a long "L." Most of the parts are attached to the projecting ledge.

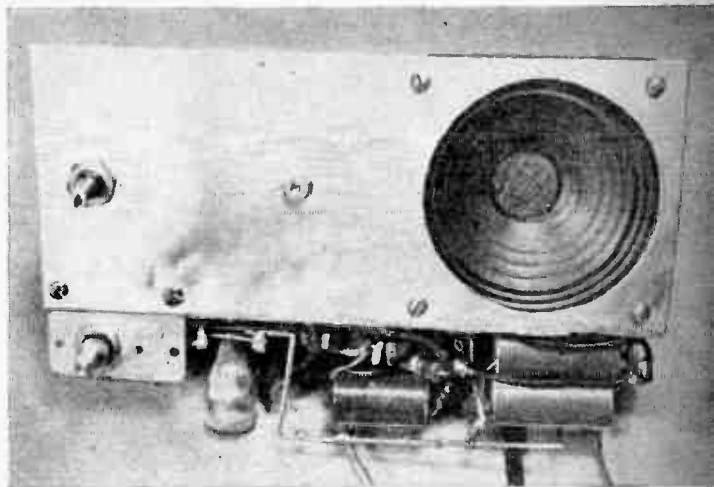

Front view of the chassis. Matching holes are cut in the cabinet for the speaker and volume-control and condenser shafts.

Aside from the tubes and speaker, most of the parts are mounted below the bend in the chassis, as shown in the photograph below.

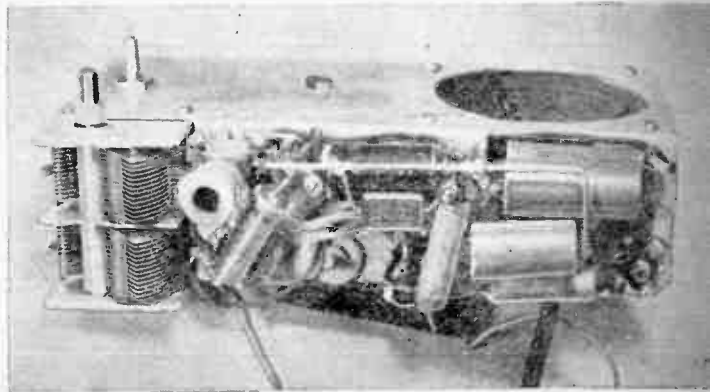

Bring Out High Notes with a Tweeter

IS THE loudspeaker bottlenecking your radio-phonograph? It is if you have a good audio system feeding into a single speaker. For no matter how much sound quality reaches the plate of the output tube, you'll only hear what the speaker can reproduce.

Single speakers are found in the overwhelming bulk of all radios and phonographs. For the most part they give adequate sound reproduction, but in many cases they do not deliver the full potential of the rest of the equipment—particularly with FM and the new wide-range records and pickups. The larger speakers—those



Dual speakers give you the full benefit of a well designed cabinet and a quality amplifier.

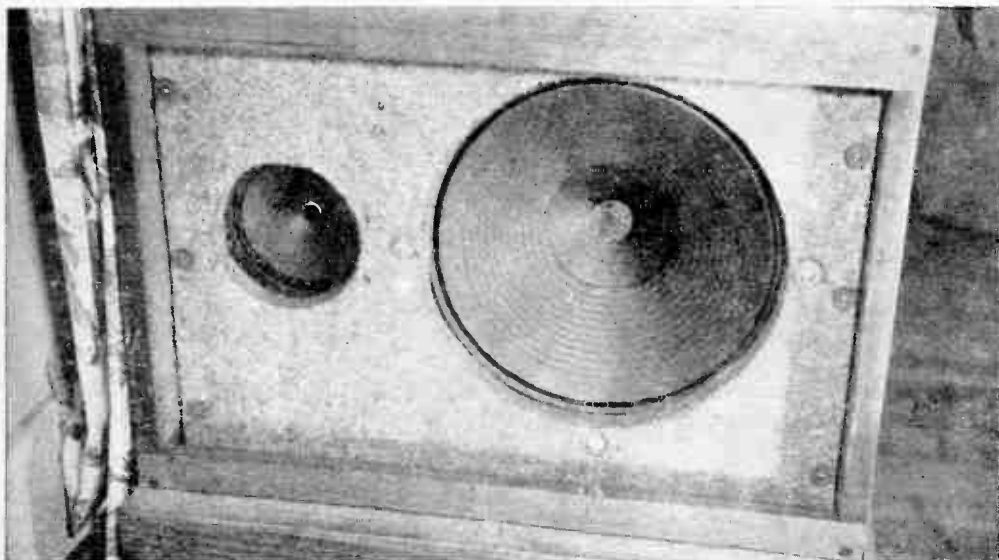

Speakers are mounted behind openings cut in a baffle made of soft fiber board. They are then

covered by a grille cloth. The tweeter may be placed on either side or above the large unit.

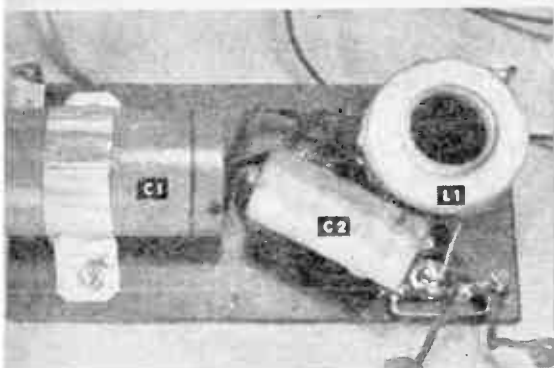

The divider network consists of two condensers and an RF choke, mounted on an insulating strip.

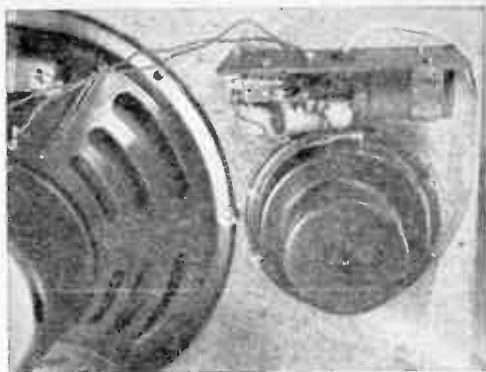

Place the speakers side by side on the baffle. The filter network is attached near the tweeter.

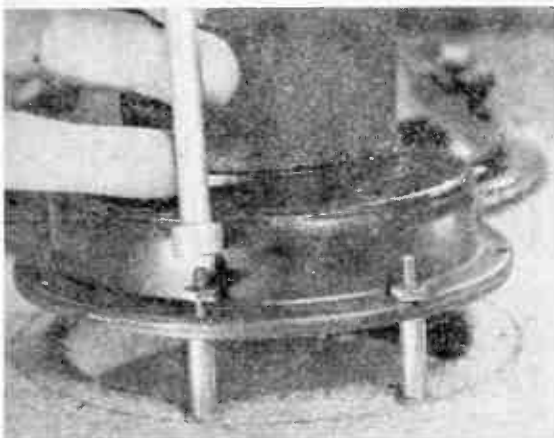

Spacing the tweeter on four 1" metal collars minimizes reproduction of low-frequency notes.

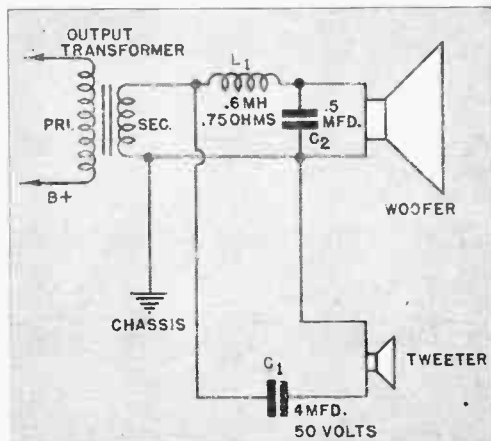

Filter circuits for tweeters may be purchased prewired, or you can make one as shown above.

with frame diameters of 8", 10", 12" or larger—are particularly good for reproducing low notes. However, while their large, free-moving cones boom out the bass well enough, they tend to muffle the high notes. To reproduce the latter sounds with fidelity, you need a tweeter.

Tweeters are small, rigid-cone speakers of about 3" to 6" diameter especially designed to reproduce all or part of the sound spectrum between 2,000 and 15,000 cycles. When combined with a large speaker—or "woofer"—and a dividing network, a tweeter will give greater faithfulness and brilliance to any music. In addition to increasing the range of your sound system, it will also improve the balance between high and low notes and separate individual instruments.

You can spend from \$2 to \$25 or more on a tweeter. The one in the photos cost about \$8. It has a voice-coil impedance of

16 ohms, but in this circuit it works perfectly in combination with a standard 12" speaker having an impedance of 6-8 ohms.

The dividing network includes a .6-milli-henry, .75-ohm RF filter choke whose function is to keep high frequencies from the woofer. Low notes take an opposite path, since C1 blocks them from the tweeter while L1 passes them readily. Condenser C2 filters any stray highs that may have gotten past the choke. Note that C1 is a paper condenser, not an electrolytic.

Mount the two speakers on a fiber-board baffle. The tweeter should not be placed below the woofer; it is spaced off the board on four 1" collars to discourage the reproduction of low frequencies. To obtain fullest emphasis of low notes you may wish to try a bass-reflex cabinet. Construction details will be found in the drawing at the lower right corner of page 225.



With the latest disks and even later music off the airwaves, you're equipped for any party—anywhere.

Portable Phono-Radio Combination

By **GEORGE O. SMITH**

FOR CANNED or current entertainment, here's an all-around music box that will keep you in the swing. Built into a small case that usually holds only a phonograph, this set contains a five-tube superheterodyne receiver that can be used alone or as an amplifier for the record player. The radio operates on A.C. or D.C., making the unit useful wherever 115-volt current is available. A universal motor would give the record player an equal amount of flexibility, but since one may be hard to come by, either an A.C. or D.C. motor can be used in its place. In this event, of course, you will have to see that the phonograph part is not used on the wrong current.

To get the radio into a small cabinet, the tubes and intermediate-frequency transformers are mounted on one edge of the chassis. This "in-line" layout fits below the phonograph motor and tends to isolate several of the oscillation-producing components. A standard 1½" by 5" by 9" blank is used for the chassis, but a satisfactory substitute can be formed from 20-gauge steel or aluminum. Aluminum may be better if heavier stock is used, and it should offer no soldering difficulties since connections to the

chassis are made with lugs. The complement of tubes and transformers will fill the edge of the chassis with no room to spare, so, as a step in space conservation, use spring-type tube bases; these fit into mounting holes of approximately 1 5/32" diameter and are secured by retaining clips.

The rest of the layout will depend upon the space available in your cabinet. In mounting the gang condenser, don't forget to allow for the swing of the rotor plates. It may be possible to make a direct coupling in some cases; in others, a flexible coupling or flexible shaft must be used. The latter will allow the condenser to be mounted at some distance from the dial. If none of these methods is feasible, you may have to resort to the dial-cable system shown in the photograph at the top of page 194. Cut the condenser shaft short of the front panel, and fasten over it a knob with straight sides. Build up the hub of the dial assembly with tape or a metal bushing, and wrap the cable around it. To secure the cable ends, replace the knob setscrew with a longer screw of the same thread, slotted at one end. Tighten the knob with this screw, pull the cable firmly through the slot, and solder it fast.

When cutting the board for the phono-

graph motor and turntable, it is necessary to place the disk over to one side in order to leave enough room for the pickup arm. Try out the position of both units with the largest record you expect to use before drilling the board.

The recessed-control panel eliminates the protruding knobs that may either become damaged or do damage during transit. Separate rectangles are cut out of the cabinet front, and the panels holding the dial and control knobs are fastened behind the openings. If you have a large sheet of bakelite or other material suitable for use as a panel, you may prefer to cut a single rectangle long enough for the speaker and both control sections. Whichever way you do it, be sure to leave finger clearance around the knobs.

Remove the crystal cartridge from the pickup arm by taking out the two screws

on the sides. The cartridge probably has two lugs used in making connections to the amplifier, and a third, grounded lug which is usually riveted to the case and soldered to one of the connecting lugs. Unsolder this connection. Using two-conductor shielded cable, run the shield to the cartridge-case lug, and the two wires to the crystal-element lugs. These connections will isolate the circuit from the chassis and pickup arm.

With great good luck you may be able to find a manufactured loop that will fit your cabinet. In the more likely event that you can't, a plan for the loop is shown in the photo and drawing at the bottom of the next page. Follow the pattern as closely as possible; if you must revise it to fit your carrying case, alter the internal dimensions proportionately. Cut the form from heavy cardboard or medium fiber, making an uneven number of slots so that the alternate turns will cross above and below each tongue. Wind the loop with No. 22 silk-covered wire; be sure there is an enamel coating on the wire, for the thin silk insulation may part where the wires cross, and an uncoated wire would cause shorted turns. After winding, either paint the loop liberally with coil dope or immerse it in melted paraffin to keep moisture out.

The three-position, four-pole rotary switch turns on the radio in one position, turns everything off in another, and in its third slot operates the phono amplifier and the motor. Pilot lights illuminate the radio dial or the turntable area, depending upon which part is in use. Hum pickup is min-

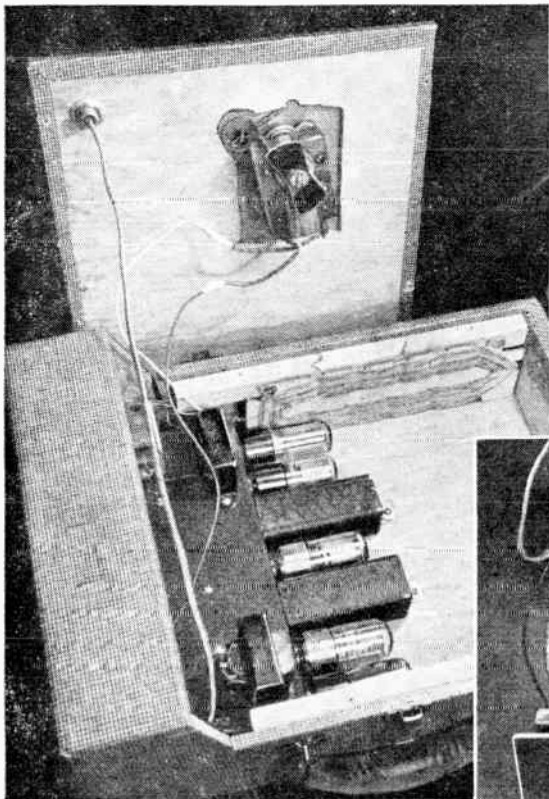

The "in-line" radio-amplifier layout utilizes the normally wasted space in front and below the phonograph motor. Tubes are mounted along one edge of the chassis, with the speaker and control panels fixed along the opposite edge.

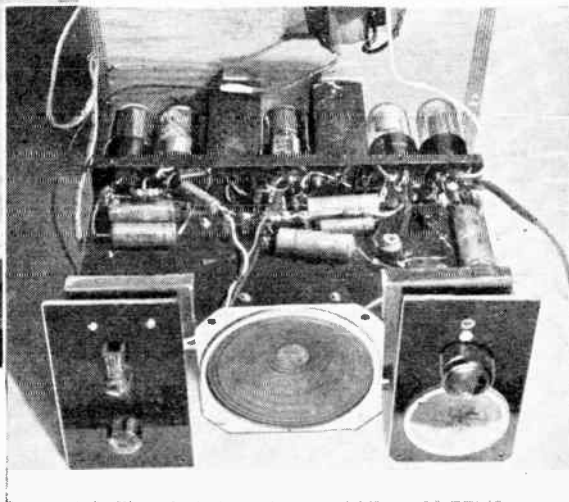

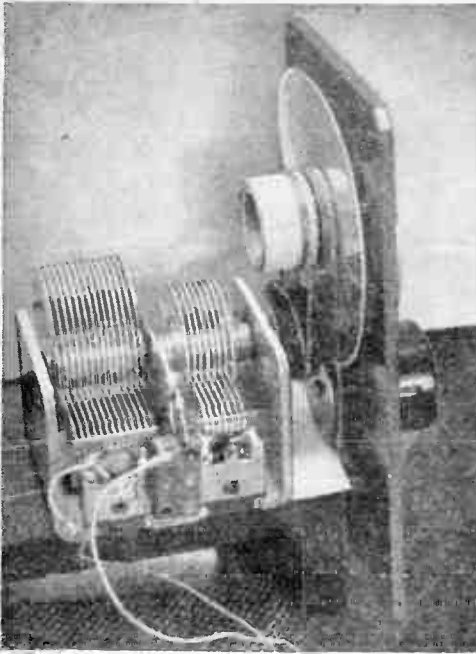

imized by breaking the 115-volt line at the B-minus side of the switch. This side is directly connected to the audio return circuit, where little hum voltage exists.

Alignment and adjustment of the set follow the usual procedure. If a signal generator is available, trace the signal through

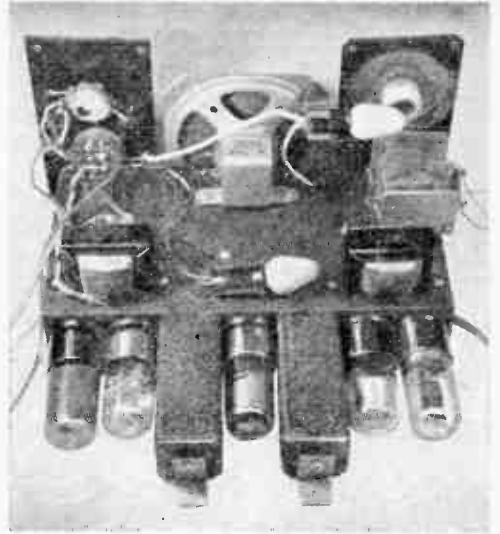
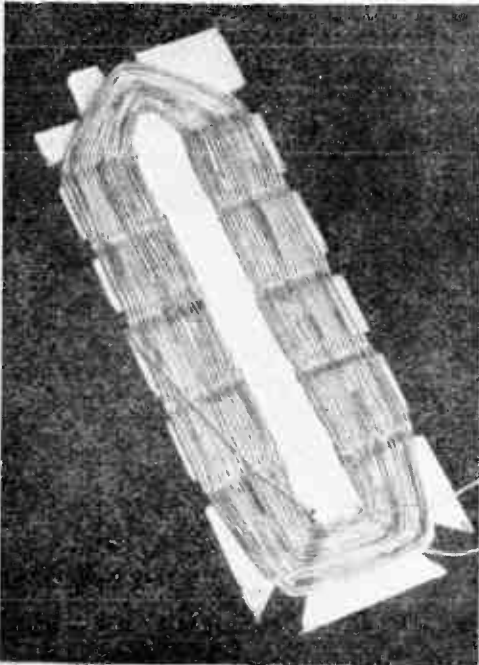

At left, the dial-cable assembly, showing the knob on the condenser shaft and the built-up bushing on the dial hub. Above, note the angle brackets atop the I. F. transformers for fastening to the case.

the I. F. transformers, and adjust for maximum output. Without a generator, the adjustment can be made on the air. Intermediate-frequency transformers are generally tested at the factory and set approximately to operating frequency. It is only necessary for you to compensate for the difference between the manufacturer's test equipment and your circuit by tuning in a strong local station (which should come through the factory-set transformers) and adjusting for maximum strength.

If a high-resistance voltmeter is handy, clip it directly across the outside terminals of the volume control. Use a meter scale that includes at least .5 megohm (on a 1,000-ohms-per-volt instrument, this would be the 500-volt scale) and align the I. F. trimmers for maximum voltage.

On the oscillator section of the gang con-

If it is necessary to alter the dimensions of the antenna, try to maintain the proportions as shown.

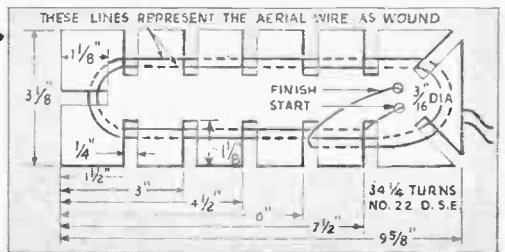

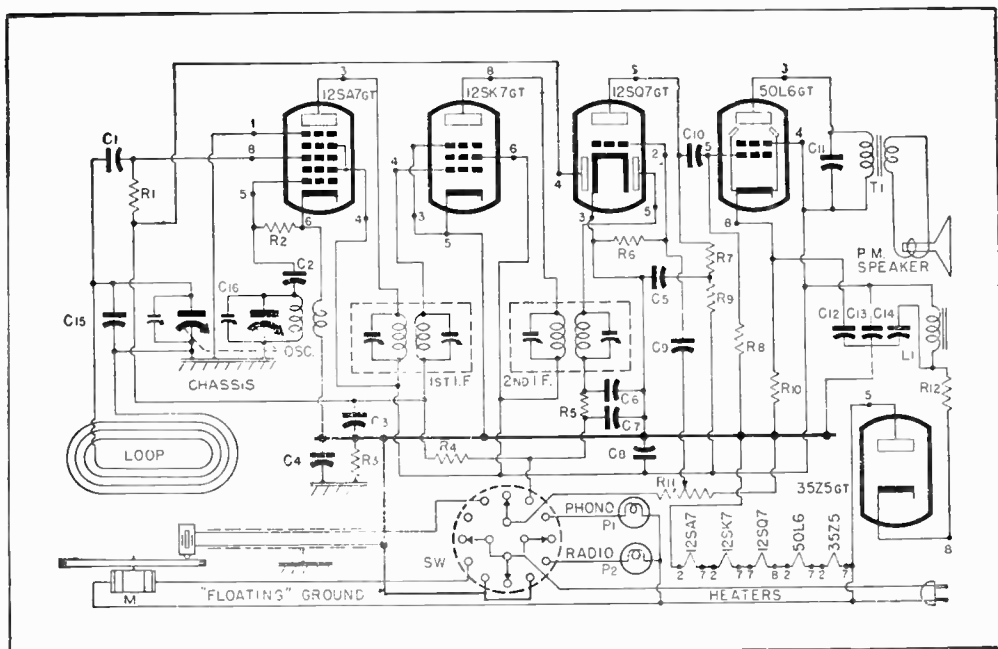

denser, C 16, the trimmer should be set to about one full turn out from the "tight" position. It may be necessary to alter this setting later if the frequency coverage of the receiver is incorrect, but use this as a starter. Tune the set to a station near the high end of the band (i.e., with the condenser almost fully open), and adjust the trimmer on the antenna section of the condenser for greatest signal volume. If the peak volume is not passed by the time the trimmer is fully tightened, add a 10-mmf. or 20-mmf. mica condenser (C 15) across the gang-condenser section. Use whichever value is needed to peak the trimmer.

Now tune in a station at the low end of the dial, and see if the signal strength can be improved by altering the setting of the trimmer. If more capacity—tightening of the trimmer—is needed, add about a half turn to the antenna loop, and repeat the tuning procedure, starting at the high end. Continue adding wire, a half turn at a time, until no trimmer change is needed at the low end of the dial. The set is then properly tracked. If less capacity is needed on the first trial at the low end, remove a half loop of the antenna and continue removing turns until tracking is right.

The set is held in the cabinet by two L-brackets placed under the hold-down nuts on top of the I. F. transformers, and by screws connecting the panels and cabinet.

LIST OF PARTS

- C1, C2: 50 mmf. mica.
- C3: .05 mfd., 250 volts.
- C4, C5, C8: .25 mfd., 250 volts.
- C6, C7: 100 mmf. mica.
- C9: .002 mfd., 250 volts.
- C10: .02 mfd., 250 volts.
- C11: .01 mfd., 450 volts.
- C12, C13, C14: triple-capacity electrolytic. C12, 20 mfd. 25 volts; C13, C14, 20 mfd. 150 volts.
- C15: 10 or 20 mfd. See text.
- C16: Two-gang tuning condenser with trimmers.
- R1, R8: 1 meg.
- R2: 35,000 ohms.
- R3: 250,000 ohms.
- R4: 2 meg.
- R5: 50,000 ohms.
- R6: 10 to 20 meg.
- R7, R9: 500,000 ohms.
- R10: 170 ohms, ½ watt.
- R11: 500,000-ohm pot.
- R12: 25 ohms, ½ watt.
- (Resistors ¼ watt unless otherwise specified.)
- T1: Output transformer.
- L1: Filter choke.
- Osc.: Oscillator coil.
- Sw: 4-pole, 3-position rotary switch.
- P1, P2: 115-volt pilot lights.
- M: Phonograph motor.
- Permanent-magnet speaker, 2 intermediate-frequency transformers, crystal pickup, tubes, sockets, knobs, dial, misc. accessories.

Three-Pound Radio Is on the Ball



Housed in a cut-down file box, this little personal portable really drags in stations.

By Albert Rowley

HOW much radio can you stuff into a portable, and how small can you make it? POPULAR SCIENCE asked these two questions, and here are my answers. The first is "plenty." The second is that with standard, easily available parts, you can boil it down to a three-pound package 3½" by 5½" by 6".

Smaller sets can be made, but they'll probably offer less radio. Here's a honey of a compromise between size and performance. It gives you a four-tube superhet circuit, good loudspeaker volume, and enough sensitivity to pull in practically everything on the air. In tryouts the signal-grabbing qualities of this midget put several table-model radios to shame.

It's a natural to take along to the ball park—easier to carry than your best girl's handbag. Your favorite sports announcer

can feed you the statistics on the game while you watch, and if leather-lunged fans around you get too noisy, all you have to do is plug in the earphone jack and listen in quiet and privacy. And don't worry about having to tote extra batteries to keep the set alive. This model went through two ball games on the same single-cell A supply.

Your first job is to assemble the parts, and that means careful shopping and selection. Chances are the spare-parts box won't be of much help in this case because you have to make sure, before using any part, that no smaller one is available. Be sure to specify ½-watt fixed resistors, and get the smallest paper tubular condensers you can. They don't have to be rated higher than 200 volts as they won't have anything over 70 volts to cope with. Mica condensers don't have to be any larger than 7/16" by 11/16". You may find a volume control even smaller than

the one used here, as some new midget units have recently been announced.

The midget two-gang tuning condenser measures only $1\frac{1}{8}$ " behind the panel; this one has a cut-plate section to tune the oscillator of the 1N5 converter tube. Should you be unable to find a midget condenser with an oscillator section, a small standard unit with two equal gangs can be used instead. In this case, however, a paddler will have to be inserted in series with the ground lead of the oscillator coil.

The oscillator coil itself should have an adjustable iron core. This makes it easier to align the two sections of the variable condenser. Turn the core about three fourths of the way out of the coil; final adjustment can be made after the set is working.

Probably the most important components in terms of size are the intermediate-frequency transformers and the loudspeaker. Your best bet in both cases is to try to pick up replacement parts for commercial personal radios. Surplus permeability-tuned IF transformers also are available in the proper size, and some new IF's are to be had within the $\frac{3}{4}$ " by $\frac{3}{4}$ " by 2" dimensions of the ones I used. Slug-tuned IF's, incidentally, have the additional advantage of broad-tuning, which means that you can align the circuits easily without a signal generator. Those who have built superhets with ordinary IF transformers know what this can mean with limited equipment. Should you settle on surplus transformers, make sure that they are designed for the 456-kc. intermediate frequency.

Both the output transformer and the speaker are replacement parts for midget sets. The speaker is of an oval shape, and its cone measures only $1\frac{3}{8}$ " by $2\frac{1}{2}$ ". It's rated for 1 watt of output, which is ample for the set.

When you get through with your purchases at the radio store, drop into a stationery store and buy the cabinet. Just ask for an ordinary wooden file box of the extra-deep (6") type, made to hold 500 $3\frac{1}{2}$ " by 5" cards. Don't use a metal case if you hope to get reception with a loop antenna. The old cover is glued down and a new one sawed off near the back. Make another cut at the same time to reduce the over-all height of the box to $3\frac{3}{4}$ ". A $\frac{1}{4}$ " plywood shelf is glued and nailed in $1\frac{1}{8}$ " above the bottom to provide a base for the chassis and a compartment for the batteries. The top of the case becomes the front of the radio.

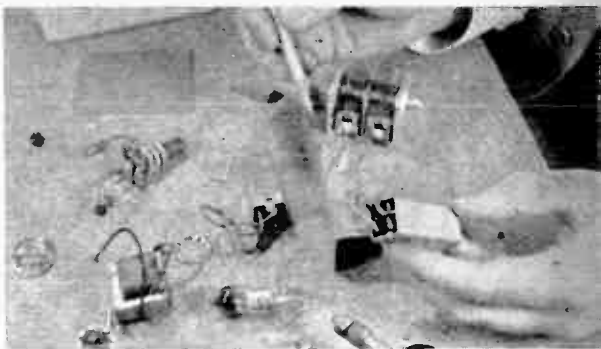

Make trial layouts of the chassis-mounted components before you drill all of the mounting holes. The chassis area is only $2\frac{3}{4}$ " by 5".

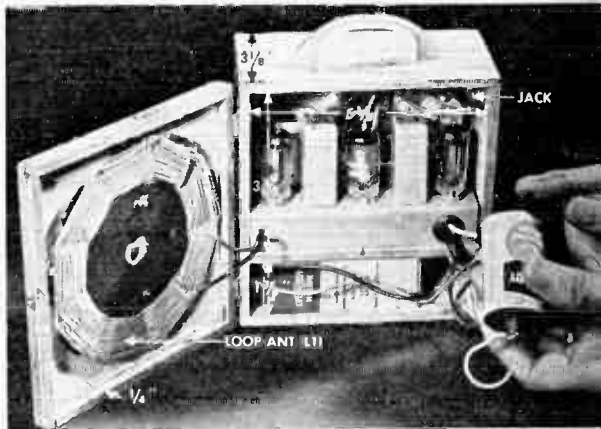

A grid cap snaps on the positive contact of the single A cell. Slid between cardboard tube and case, a split paper clip takes the other lead.

These photos show the chassis layout used; some of the parts can be shifted around to suit your own design, but for short leads try to maintain the relative positions shown. Cut a piece of sheet aluminum $4\frac{1}{2}$ " by 5" and bend a $\frac{3}{8}$ " leg along each of the shorter sides. The resulting chassis will measure $2\frac{3}{4}$ " by 5". Since all the larger parts except the oscillator coil go on top of the chassis, this is the side to consider most carefully. Spread the parts out as shown in one photo, and mark the position of each one carefully. The two-gang tuning condenser, four miniature-tube sockets, two IF transformers, volume control and switch, output transformer, small PM speaker, and the plate by-pass condenser for the 1S4 go above the chassis; all except the by-pass condenser need separate house room on the small plate.

While you have to allow room for the volume control and switch, you won't be able to mount them on the chassis. For this you

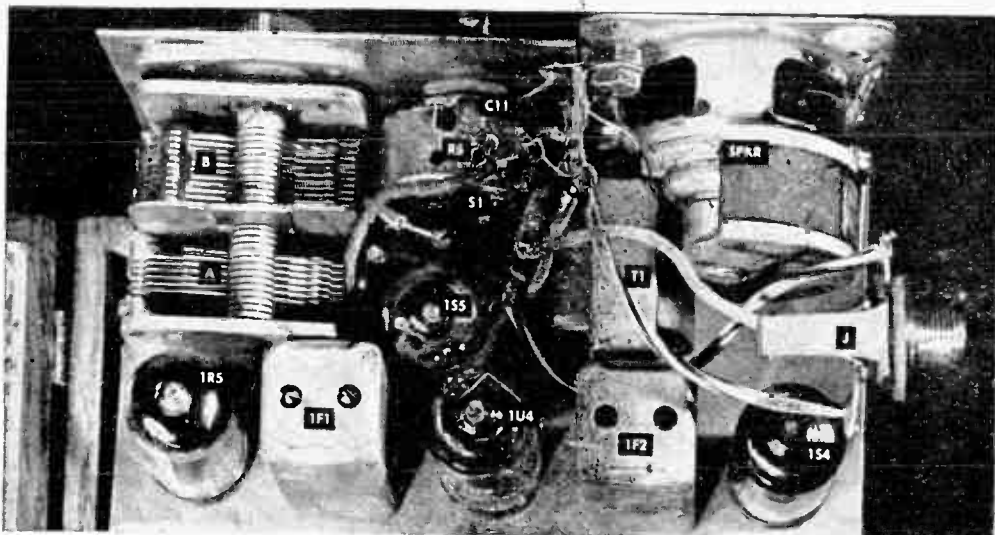

Compact but not overcrowded, the chassis top has little waste space. Note the midget output

transformer next to the speaker, which is a miniature 2½" PM that has an oval-shaped cone.

need a front panel—a 3" aluminum square bolted to the chassis. Drill a hole through the same panel to clear the shaft of the tuning condenser.

Leave the wiring of the loop antenna and

the batteries for the last. Begin with the connections to the 1R5 converter stage, then go on to the IF stage and the 1U4 RF pentode. Next make the connections to the diode of the 1S5 detector. Instead of follow-

PARTS LIST

All fixed resistors ¼ watt

insulated carbon

R1: 220,000 ohms

R2: 10,000 ohms

R3, R6: 3.3 meg

R4: 82,000 ohms

R5: 1-meg. volume control with

DPST switch

R7: 10 meg

R8: 1 meg

R9: 2.2 meg

R10: 200 ohms (This value is

critical within 5%)

All paper condensers 200 volts.

C1 A, B: Midget two-gang tuning

condenser with cut-plate

oscillator section.

C2, C5, C8: .0001-mfd. mica

C3, C4, C9: .01-mfd. paper

C6: 8-mfd., 150-volt electrolytic.

C7, C10, C11: .005-mfd. paper.

L1: Loop antenna

L2: Adjustable iron-core OSC. coil.

IF1, IF2: Midget intermediate-

frequency transformers, preferably

permeability tuned.

S1: DPST switch on R5

J: Normally closed phone jack

PM speaker, 2½" oval cone; tubes,

batteries (1 67½ -volt B and 1

1½ -volt A); four miniature-

tube sockets; aluminum chassis

and panel, misc hardware

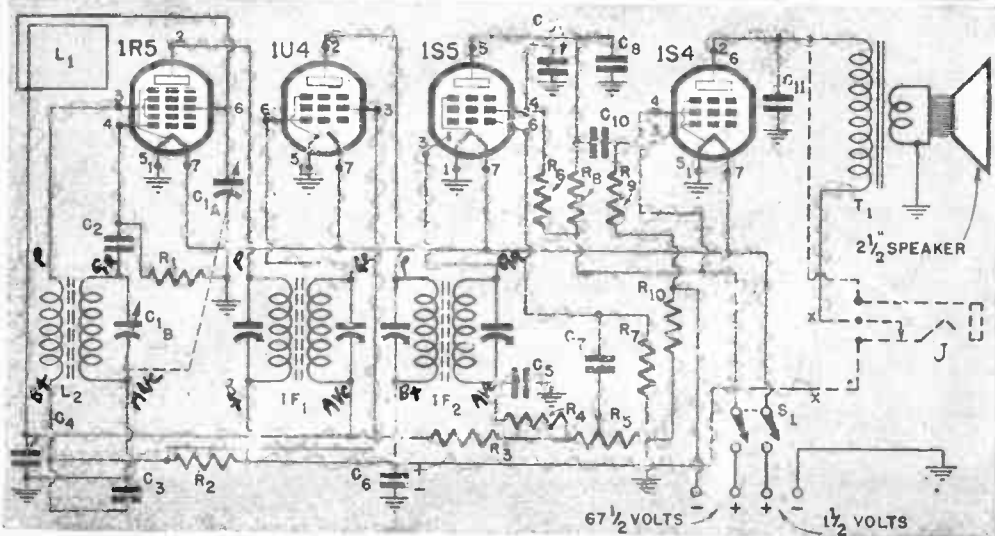

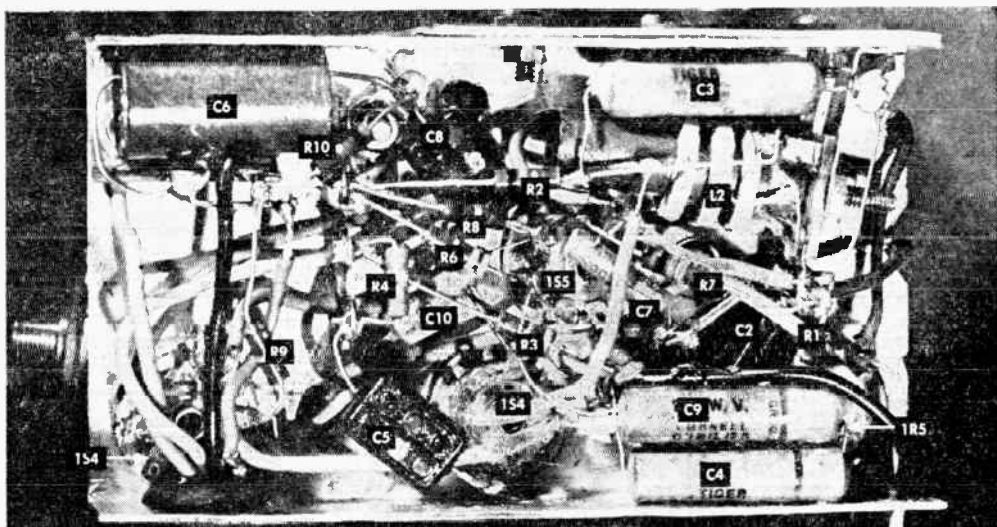

No rat's nest, the underside of the chassis is no tougher to wire than many larger sets. How-

ever, a planned wiring sequence will help to prevent you from getting badly in your own way.

ing the usual sequence right through, it may be better to stop at this point and commence wiring the speaker. Work backward from here to the pentode portion of the 1S5. The network of resistors and condensers that go to the grid, screen and plate of this tube and to the grid of the 1S4 output tube are the last of the small parts to be connected. This wiring sequence isn't essential, but it will help you find soldering room.

Headphones aren't necessary with this set but there are times when you will find them handy, so an optional phone jack is shown in the diagram. The jack to use is a normally closed unit that completes the loudspeaker circuit when the phones are not being used. Plugging in the phones automatically breaks the connection to the speaker.

For noisy spots, weak stations, or private listening, earphones are nice extra equipment. But if you should decide to pass them by, all you have to do is omit the portion shown by broken lines and connect the two wires marked "x" in the schematic drawing.

Drill a hole through the rear flange of the chassis and insert a rubber grommet. Through it you can bring four leads—preferably color coded—to the batteries. The coding is only to help you until the connections are made, since two of the leads are soldered to a standard, polarized clip that is used on 67½-volt batteries. The wire going to the positive (center) terminal of the flashlight cell is soldered to a grid-cap clip. For the negative connection a paper fastener is

soldered to the lead and inserted between the metal shell of the battery and its cardboard sleeve. Cells of the sleeveless type will require a different connection.

When the chassis is completely wired, connect the batteries and loop antenna and tune the circuits for maximum volume and sensitivity. Start with the secondary of 1F2, and work back to the primary of 1F1. Bring in a station at the high end of the dial (with the tuning-condenser plates out of mesh) and adjust the trimmers on the side of the variable condenser. Take care of the oscillator trimmer first.

You'll find that you can strengthen weak stations a little by opening the back cover and allowing the antenna to swing about two or three inches away from the metal chassis.

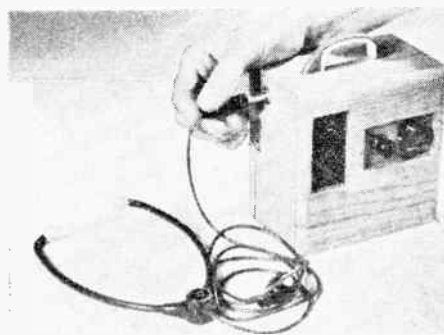

Plugging in the phones automatically cuts off the speaker. Phones are good in noisy locations.



Plugging in an extra stage of amplification can improve the performance of small portables.

By Albert Rowley

I LIKE my portable radios small. It makes sense to me to have a little set that I can lug around without effort, rather than one that threatens to pull my arm off at the shoulder.

At the same time I know my compact portable doesn't have as much pick-up power built into it as one of the larger, more expensive sets. It works fine close to a small station and up to 50 miles from a high-powered transmitter; but when I take it on a long ride, performance definitely falls off.

To overcome this defect, I built an RF booster for my set. It consists of an untuned RF stage packed in a plastic cigarette case. It can be plugged into the portable when and if it's needed. The booster increases the signal pickup of the portable, converting its four-tube circuit into a five-tuber on

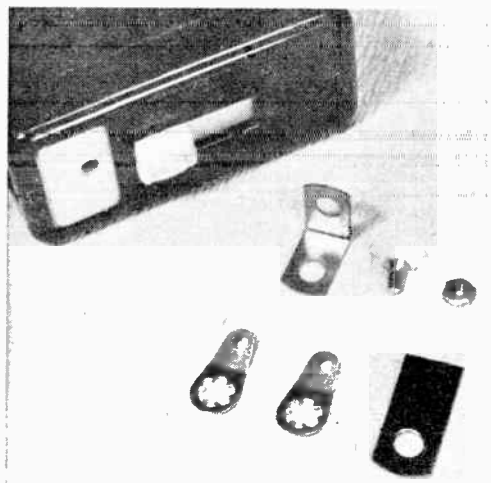

Making a switch out of the slide top of a cigarette case calls for a $\frac{1}{2}$ " angle bracket, a flat mending plate, soldering lugs, and hardware.

Assembly of the switch can be seen here. The view is through a $1\frac{1}{2}$ " by 2" rectangular cut-out made in the side of the cigarette case.

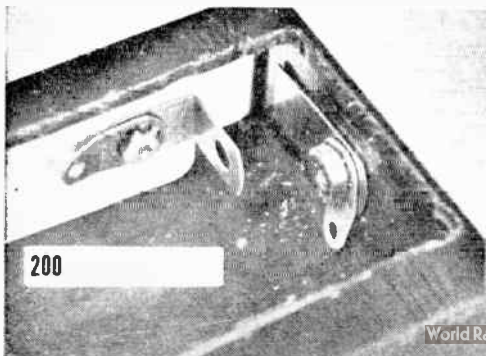

A 5-prong wafer socket mounted in the back of the cabinet supplies both electrical contact and mechanical support for the booster.

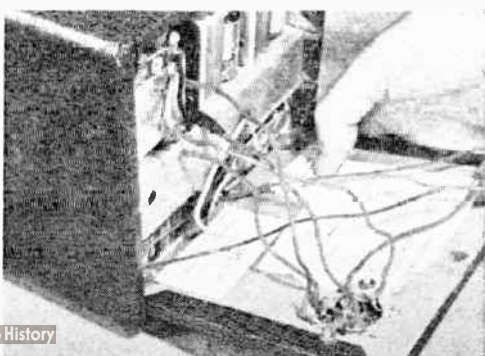

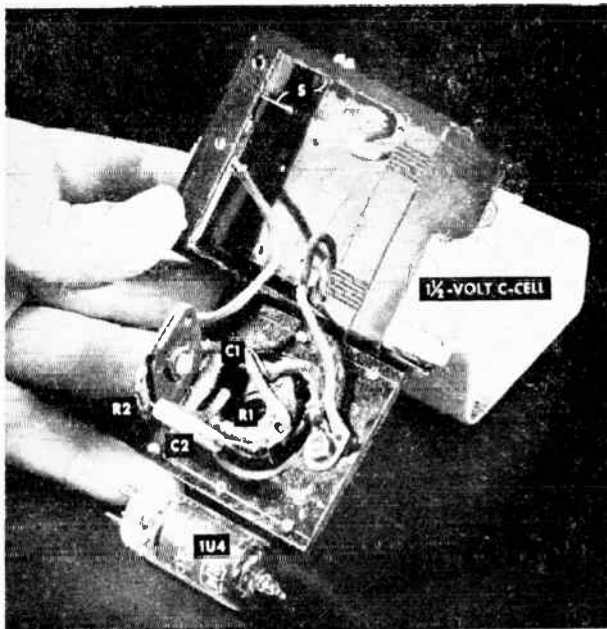

Layout and wiring of the parts is simple. The thing to watch for is clearance of the tube and socket in the 2"-wide opening in the case.

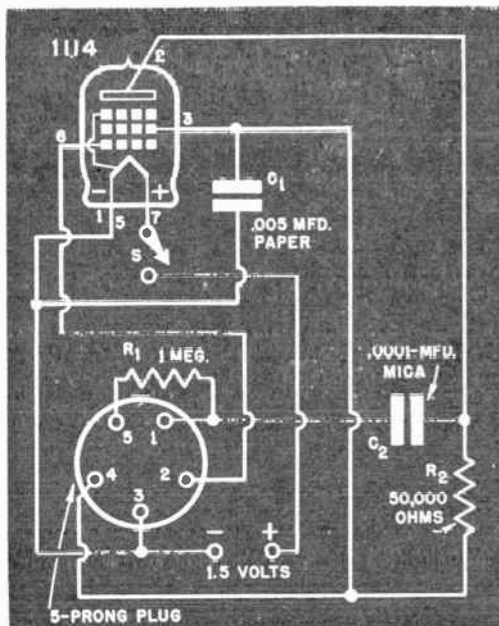

The small parts used can be soldered directly to the 5-prong mounting plug and the 7-pin miniature wafer socket that holds the tube.

demand. With it the set can reach out reliably for hard-to-get stations.

A booster like this will improve a great many portables, but there are many more on which it would be wasted. Sets that already have a stage of RF amplification or two stages of IF won't benefit by the addition. To find out how yours stacks up, remove the back cover and take a peek inside. A 3-gang tuning condenser is a sure indication that you *don't* need this booster. Less certain but a good clue is the number of tubes. Five or more—not counting the rectifier, if any—mean the set already has enough RF or IF gain. As a final check, look at the tube-type numbers. More than one of any of the following tubes indicates that you don't need a booster: 1T4, 1U4, 1N5-GT, or 1LN5.

If examination shows that your set can benefit from some additional radio-frequency amplification, your first step should be to purchase the little "cabinet." I used a plastic cigarette case with a slide opening on top through which the smokes can be popped out. The slide is useful because it's a cinch to convert it into an on-off switch.

In the side of the case near the top, cut out a rectangular opening. Make a cover for the opening from a piece of plastic about

2" by 2 1/4". It can be fastened to the case by drilling undersize holes and using small machine screws that will tap their own threads.

Drill and file a hole in the center of the plastic rectangle for a 5-prong plug that has a metal ring for flush mounting. Two machine screws and nuts secure it to the plastic panel. Inside and at right angles to the plastic attach a 7-pin miniature wafer socket by soldering its pin 5 to one of the machine screws. Make a strong mechanical bond to hold the miniature socket rigidly. A couple of resistors and condensers as well as leads for the switch and the A battery are then soldered in to complete the wiring.

The filament supply comes from a size C flashlight cell that fits nicely in the width of the case; connections can be made by clips or bars bolted to the inside of the case. B-plus voltage is tapped off the set.

To make connections to the set, I drilled a hole in the back of the radio cabinet and mounted a 5-prong wafer socket. Connections to this socket are made as follows:

Prong 1 goes to the grid of the converter tube. This is found at the fixed-plate terminal of the antenna tuning condenser (the larger plates of a two-gang tuning unit). The original connection is unsoldered. If

there are two connections at this point, don't touch the one that goes to the loop antenna. Prong 2 goes to the wire you have just unsoldered from the tuning condenser. Prong 3 runs to the chassis of the set. Prong 4 leads to the positive terminal of the B battery. If you have a 3-way portable, it may go either here or to a B-plus point inside the set. Prong 5 can go either to the chassis

of the set or to the AVC line (the black lead from either of the IF transformers). Try both of these connections and solder it permanently to the one that gives best results.

For those times when the booster isn't going to be used, buy an extra 5-prong plug and solder a jumper lead between prongs 1 and 2. Plugging in the jumper in place of the booster restores the original circuit.

B Supply Cuts Battery Cost



HAVING discovered how easy it is to make my small portable behave like a bigger set, I decided to get rid of another sore spot in its operation—the high cost of B batteries. It's no fun to shell out a couple of bucks every few weeks to replace the weakened battery. For very little more than the price of a replacement battery I built this perpetual B supply that works off any 115-volt AC or DC line. I still use flashlight cells for the A supply, but their cost is insignificant.

Like the RF booster described above, this device is independent of the set and doesn't impair its usefulness as a portable. While my set uses a 67½-volt battery, the same eliminator will serve other sets requiring up to 90 volts. It would be useless, naturally, on 3-way portables.

Instant warm-up is retained by using a 100-ma. selenium rectifier. This and all other parts are assembled inside a steel first-aid box measuring 1½" by 4½" by 7½". You'll find a cabinet of about this size convenient, since it forms a platform on which to rest the set.

Listen all you want without draining those expensive batteries. The little box supplies B voltage; weight of the portable turns it on.

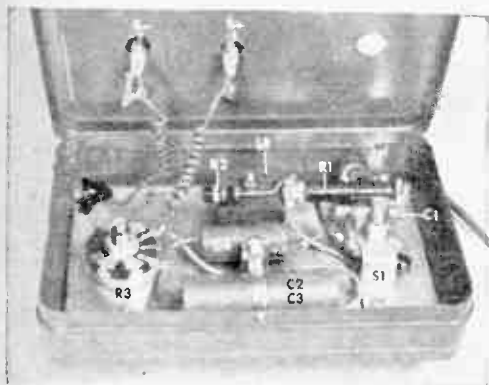

Parts are mounted on a flat chassis that is fastened inside the steel box by machine screws slipped through the rubber feet.

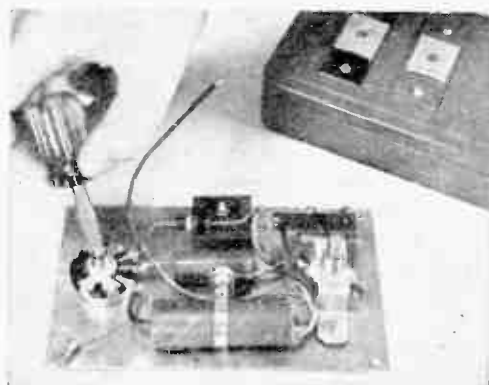

The shaft of the voltage-regulating potentiometer is sawed off to fit inside the box. Slot the shaft to permit screwdriver adjustment.

On top of the box and insulated from it by pieces of fiber are two 1" by 1 1/2" aluminum contact plates. The remaining parts are mounted on a flat chassis inside that is secured by four mounting screws through the bottom. Use rubber insulating feet on the bottom and never set the box on a grounded metal surface like a radiator or sink. Better still, use a plastic chassis panel to insulate all components from the box, wiring together the grounded points in the diagram, and put in a two-pole switch instead of a single-pole one. This will open both sides of the power line. You could still get a shock by pushing the switch and touching the terminal plates, or one plate and an outside ground, so keep the gadget away from kids.

One side of the line cord is connected to the negative terminal of the selenium rectifier through a 30-ohm wire-wound resistor. The other side goes to the chassis through a push-type switch (S1). An aluminum strap holds this switch upright, permitting the plunger to project through a hole in the top of the cabinet. The switch is of the normally-off type. It is turned on by the weight of the radio and goes off automatically when the set is lifted off. It's a good idea to remove the set when you are through listening, for current will continue to flow through R3 even with the set turned off.

Voltage output is regulated by a wire-wound potentiometer rated at 2 watts or more and having a resistance of 10,000 ohms. You can adjust this to any value from about 60 to 100 volts. Set it 10 to 15 percent above the nominal rating of the battery used in your portable. The higher voltage will make the set more sensitive than it usually is on batteries alone, and it won't do any harm to the circuit components.

You'll have to make a few minor changes in the receiver. The first is to make some arrangement for disconnecting the battery when the eliminator is used. To do this, simply cut the lead to the plus terminal of the B battery and connect it to the center arm of a SPDT toggle switch. Wire one side of the switch to the battery and the remaining switch terminal to an aluminum contact on the bottom of the cabinet. The circuit and suggested method of attachment are shown at the lower right. Make sure that the contacts on the set line up with those on the eliminator. The switch can be placed in the back panel of the radio.—*Albert Rowley, Manhattan, N. Y.*

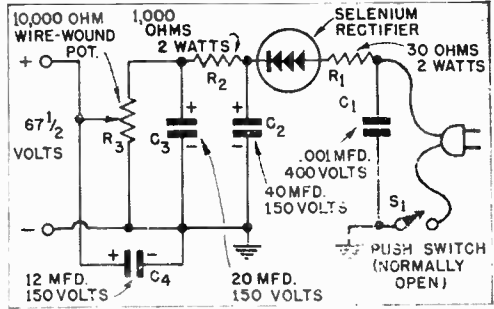

Wiring shown is for a metal chassis. To make the unit still safer, use a plastic panel, a DPDT switch, and connect all grounds together.

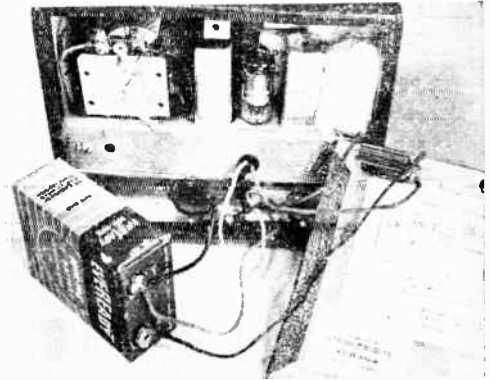

Connections to the portable are made directly to the battery terminals. The B-plus line is cut and rewired through a toggle switch.

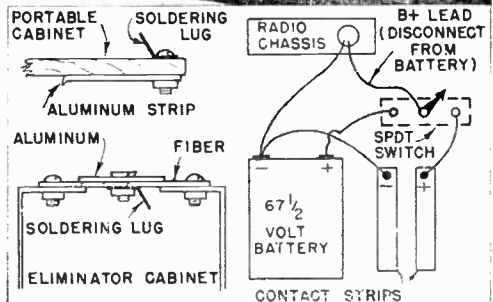
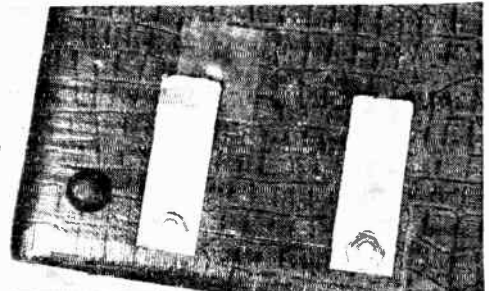

Contact strips are added to the bottom of the radio. These must line up with the contacts on the eliminator. The outer one is negative.

Converting AC-DC Sets to Portables

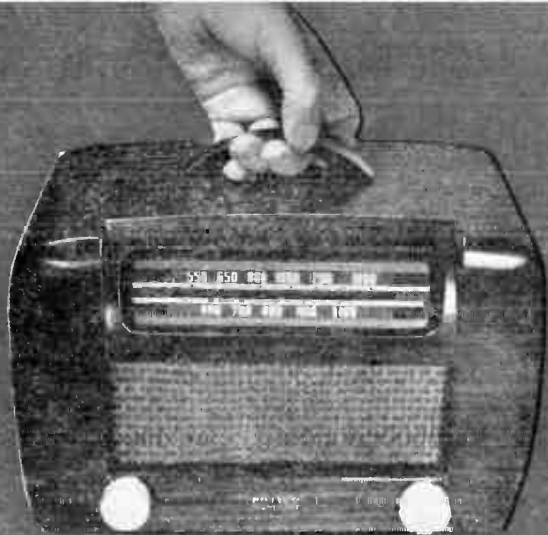

New tubes and some minor changes turn this midgot radio into a self-powered portable—and back again.

Need a portable? Switch your AC-DC midget to battery power. It costs little and doesn't harm the set.

By William Norton

SUMMER months are outdoor months, and radios that can't get out into the open with you don't fit into the picture very well. But if you already own a number of household receivers, you may have some objection to buying or building still another set. You don't have to. One of those AC-DC midgets has the makings of a good battery portable. It isn't even necessary to make any

permanent changes in the circuit. To restore the portable to AC-DC operation, you need only replace the original tubes and throw a switch.

The main consideration is tube substitution. The table on page 207 covers the commoner tube lineups. It is impossible to show all variations, but the chances are that if the set uses standard-size tubes and was manufactured in the last dozen years, it will fall into one or another of the main groups listed. The more recent midgets employing miniature tubes are not included since these can't readily be converted by the method described. In some cases you may also find a set that overlaps two groups.

Many of the tubes in the chart offer the possibility of simple plug-in substitution. All you have to do with a 7AS converter, for example, is lift it out of its socket and slip in a 1LA6. Pin connections are the same.

Some problems arise, however, when it comes to changing the detector tube. Most AC-DC sets use dual diode triodes in this stage while battery detectors are generally single diode triodes or pentodes. For the first two groups the 1S5 miniature diode pentode is suggested. In the third group you have a choice of this tube or the 1H5. Since the latter tube is a triode, it may not give as much amplification. However, it can be plugged in in place of the 6Q7, while for the 1S5 you'll have to make an adapter socket.

The adapter socket for a 1S5 consists of a

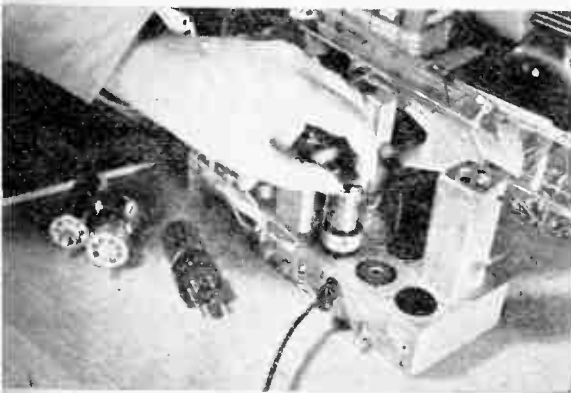

Remove all tubes before starting to work on the set. Mark each socket with the number of the original tube and its battery replacement.

7-pin miniature wafer socket mounted on top of an octal or lock-in base—whichever matches the socket in the set. For the adapter base use a burnt-out tube. If you don't have the right kind in your workshop, you can pick one up for a few cents from a local repairman. Place the tube in a paper bag and give it a sharp hammer blow to break the glass. Using pliers and cutters, remove the loosened elements and break off any remaining glass.

Octal bases are easier to work with since the prongs are hollow on the inside. Remove the old connections by melting the solder and make new ones by inserting wires into the hollow prongs and flowing in solder. Use solid tinned wire of fairly heavy gauge—No. 18 is about right—making sure that the wire is well insulated. Bare wire can be covered with plastic spaghetti.

If your set uses lock-in tubes, file the part of the pin that protrudes inside the base. Filing cleans the metal and allows the added wires to be soldered on firmly.

Where the 1S5 pentode is used to replace a triode, some provision must be made for the screen grid. This is connected to B-plus through a 680,000-ohm, $\frac{1}{2}$ -watt resistor. A midget .01-mfd., 200-volt paper tubular condenser provides a bypass path to ground. Both these parts are mounted directly on the miniature socket. In the chart, one side of the resistor is shown connected to pin 2, a dead prong used as an anchor point.

If you plan to reconvert the set to AC-DC use at any future time, it is advisable to use phone tips and jacks for B-plus and other connections so that the original circuit can be easily restored. Find a B-plus point in the receiver—usually at the screen grid of the power output tube—install an insulated phone jack on the chassis, and wire the two together. The lead from pin 2 of the 1S5 socket can terminate in a phone tip and be plugged in whenever the tube is inserted.

A second lead from the adapter socket goes to another phone jack on the chassis. This connects the second diode plate in the original circuit to A-plus through a 1-meg. resistor. The reason for this connection is that the single-diode 1S5 is being used in place of a dual-diode detector in the original set. In some sets this wiring isn't necessary so if you like you can try the set first before inserting it.

All AC-DC receivers have tube heaters connected in series. By leaving them that way it is possible to avoid rewiring. Make

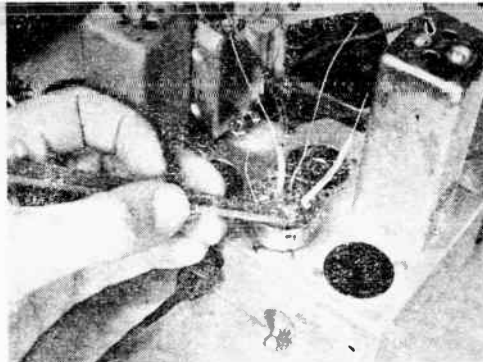

To make an adapter socket, select a tube with the right base and break off the glass. File the pins that protrude inside a lock-in base.

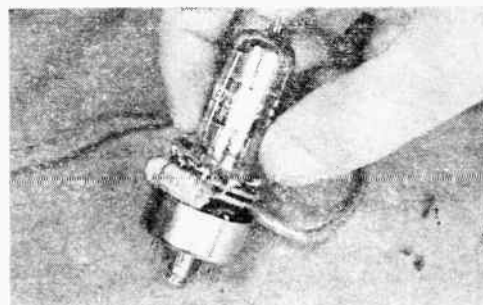

This adapter allows the battery tube to be plugged in in place of the original tube. New wiring is made at the socket, not in the set.

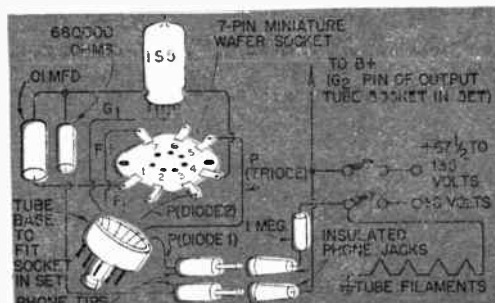

A 7-pin miniature wafer socket, used upside down, and the base of a burnt-out tube are wired together to make the adapter socket.

sure there are no resistors in series with the heaters. If there are, they will have to be shorted out with a switch. One end of the filament string is usually grounded at the detector stage. Connect the negative A-battery lead at this point. The B battery is *not* grounded to the chassis directly; instead it goes through a bias resistor. The installation of this resistor—which should be between 330 and 680 ohms—is shown in one of the drawings. One side of the output tube's grid resistor must be disconnected from chassis or ground and wired to B-minus. When the set is restored to AC-DC operation, the small

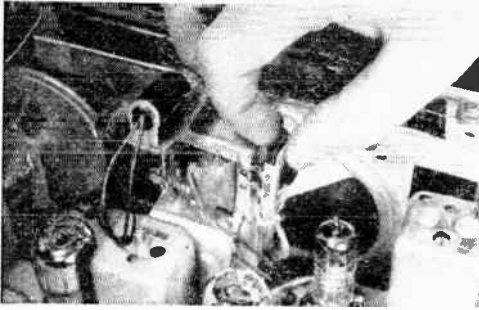

A slide switch soldered to the frame of the output transformer changes the impedance of the transformer to match the new output tube.

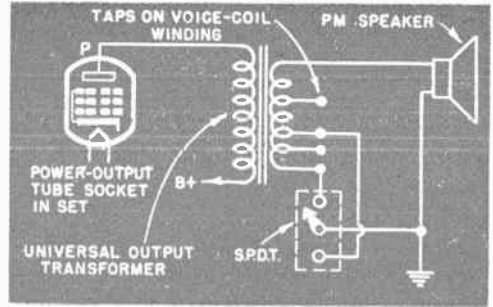

The switch shown at the left is wired across two taps of a universal output transformer. Select the best tap for each output tube.

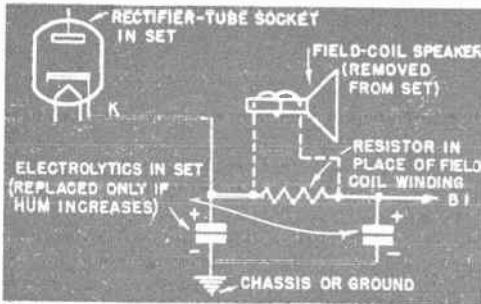

Field-coil windings are usually used as filter chokes. When replacing such a speaker with a PM unit, insert a filter resistor as shown.

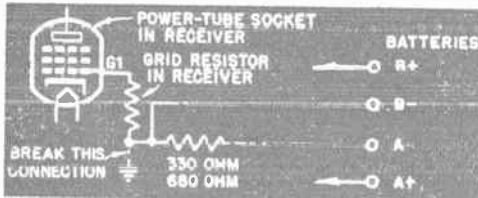

Lift the grid resistor of the output tube from ground and connect it to B-minus. Insert a bias resistor between this junction and A-minus.

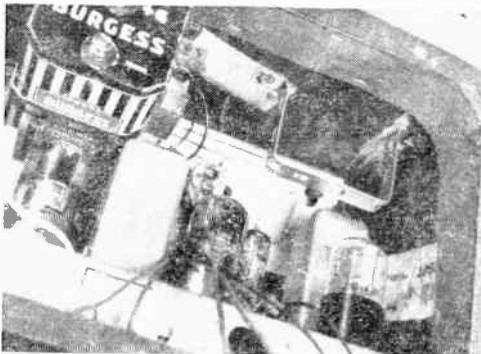

Batteries are held in place by metal strips. For 4-tube lineups, use a 6-volt A battery; B voltage can range from about 67½ to 135.

bias resistor, in series with the much larger grid resistor, has virtually no effect.

The A-plus connection from the battery is soldered to whichever heater lug on the power-tube socket goes to the rectifier-tube socket. The rectifier is omitted from the circuit. Wire the plus side of the B battery to any B-plus point in the receiver. Both the A and B connections are made through a DPST toggle switch. This becomes the on-off switch for battery operation.

Another important point in battery operation concerns the speaker. Check the one in your set to see whether it is energized by a permanent magnet or a field coil. If it is of the latter type, you will have to replace it with a PM speaker. Select one of the same size so it will fit the cabinet.

If your speaker has a field coil, the chances are that the coil also acts as a filter choke. A 2,200-ohm, 2-watt resistor has to be installed between the two wires that are disconnected from the field coil. Since a resistor doesn't give as much filtering action as a coil, there may be an increase of hum when the set is used on AC. Try it out, and if you find there is too much hum, replace the filter condensers with two 40-mfd. capacitors or a dual unit containing two such condensers in one shell. They should have a rating of 150 volts or more.

Another point relating to the speaker—whether you have to change yours or not—concerns the output transformer. Battery tubes generally have higher load impedances than the output tubes used in AC-DC sets. As a result the original transformer may not give proper matching. Should you find this to be the case, replace the transformer with one of the universal type and select the output taps that sound best on each service. When you have picked the right ones, wire

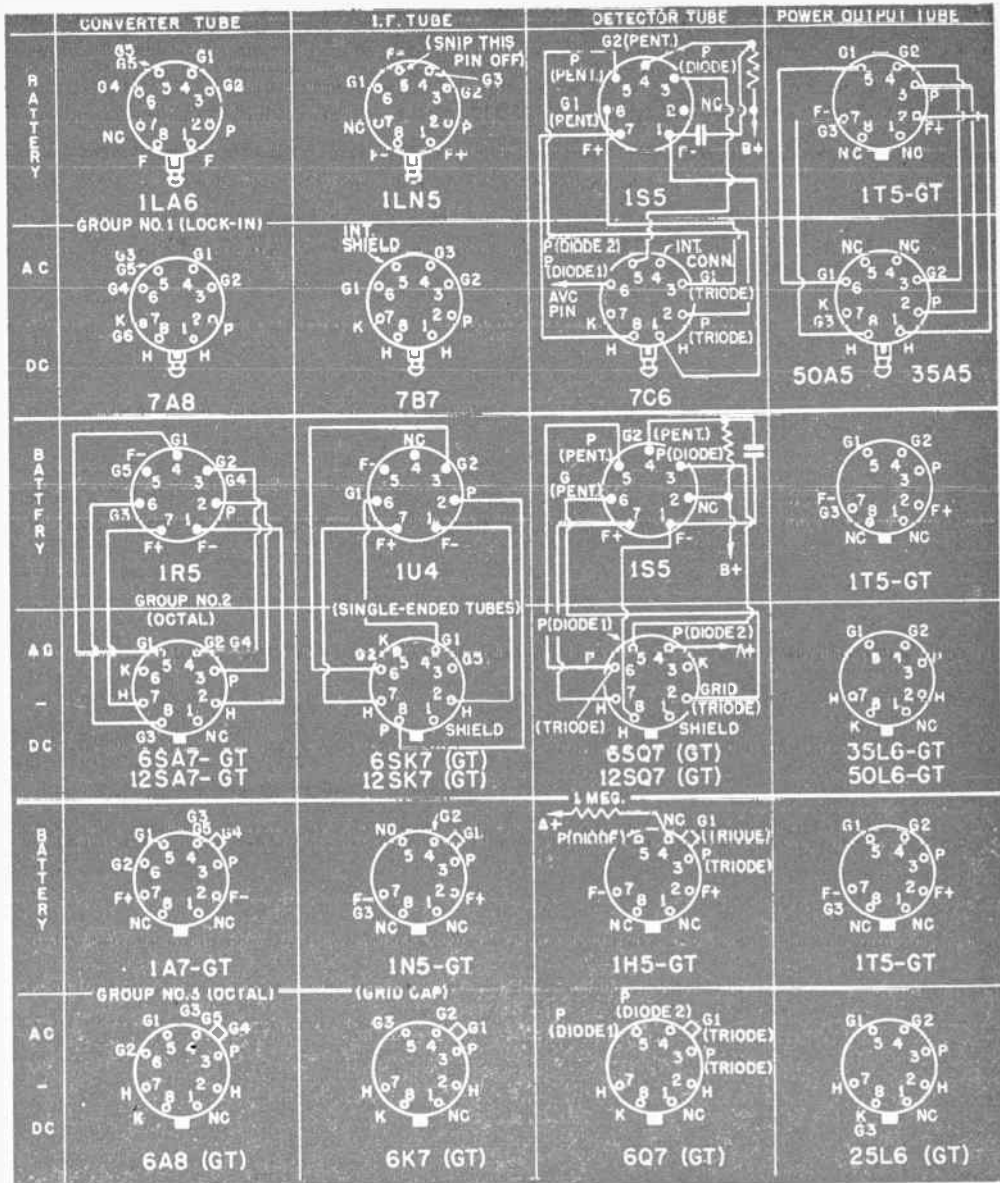

Pick your tube lineup. Battery substitutes or adapter sockets are given. All are top views.

them across a SPDT switch as shown in one of the drawings. The switch allows you to select the correct match for either battery or house-line operation. Like many of the other alterations, this one won't be needed in all cases. If you already have a PM speaker in your set, try the battery conversion with the original transformer before investing in a new one.

Batteries can be held in place by metal straps. Fasten the straps with wood screws,

or with nuts and bolts if you have a plastic cabinet. For series filaments, a 6-volt A battery is about right for a 4-tube circuit, omitting the rectifier; B voltage can vary more. Depending on the space in the cabinet, you can use one or two 67½-volt batteries in series to give a total of 135 volts, or two 45-volts totaling 90 volts. This gives you a choice of 67½, 90, or 135 volts. The set should work with any of these arrangements, but more voltage usually gives higher output.

Oscillator-Amplifier Is Your Master Music System



Recorded music or your own voice goes over the airwaves at the mere flick of a switch.

You can play it through its own speaker, any nearby radio, or you can combine both at the same time.

By Henry C. Martin

LARGE households can get the most out of this centralized control system that pipes music anywhere in the house, but you'll also find it handy if you have any-

thing larger than a one-room apartment. Here's a unit that combines two types of record player—a direct amplifier and an oscillator that broadcasts through any nearby radio. The features may be used together, or either one will work by itself. While your wife enjoys a stack of records in the living room, you can have the same music in your basement shop. Those little radios in the kitchen or an upstairs bedroom can also pick up the program. And if you have a few radios strategically located around the house, the microphone and oscillator become a handy one-way intercom to summon you to the telephone or to dinner. All this and a hundred other uses of your own devising are controlled from the single switch panel on your master music system.

Connections for speaker, phono motor, pickup, and mike are made by means of plugs and jacks.

An automatic record changer was used in this model and is recommended, but a separate motor and crystal pickup would operate just as well on a one-record-at-a-time basis. Also, if you are in an experimental

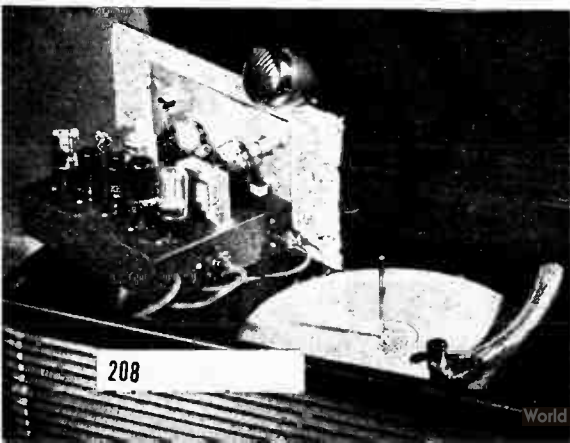

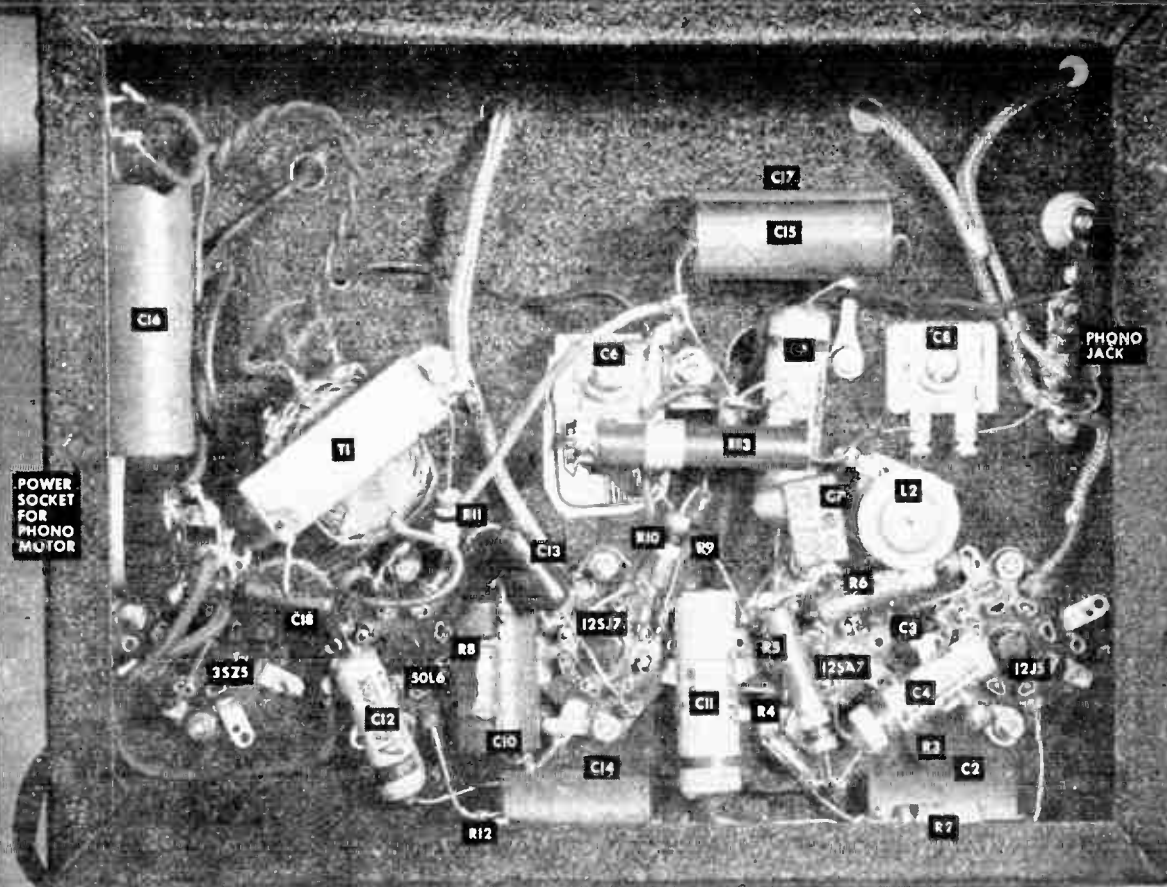

Although there is ample room on both sides of the chassis, parts should be closely grouped.

mood, you can ring in such changes as installing a 33 1/2 r.p.m. turntable with a special lightweight pickup to use with long-playing records, or you can add a magnetic pickup and preamplifier by adapting the circuit shown on page 227.

In all cases the basic oscillator-amplifier circuit remains the same. It is built around five tubes. Two of them (the 12J5 and 12SA7) are used in the oscillator section to broadcast sound from the microphone or pickup; two more (the 12S7 and 50L6) amplify the same signal and feed it out—on demand—through the built-in speaker. The fifth tube, a 35Z5, rectifies the AC power and supplies the required DC voltages to the other four stages.

With a 5-meg. variable resistor (R1) acting as a volume control in the oscillator part, you can "ride the gain" on the transmitter. Volume can also be regulated at the receiving set. A separate potentiometer, R7, controls the volume of the two-tube audio amplifier.

Both the antenna and oscillator coils are tuned by means of small ceramic padder condensers (C6 and C8): one is mounted on the chassis on each side of the shielded antenna coil (L1). The padder that tunes this coil is connected across the larger of the two windings—usually considered as the secondary. A tapped coil, L2, in this electron-coupled oscillator circuit, is tuned by

The chassis is bolted to a metal panel which, in turn, is inset into a larger wooden front.



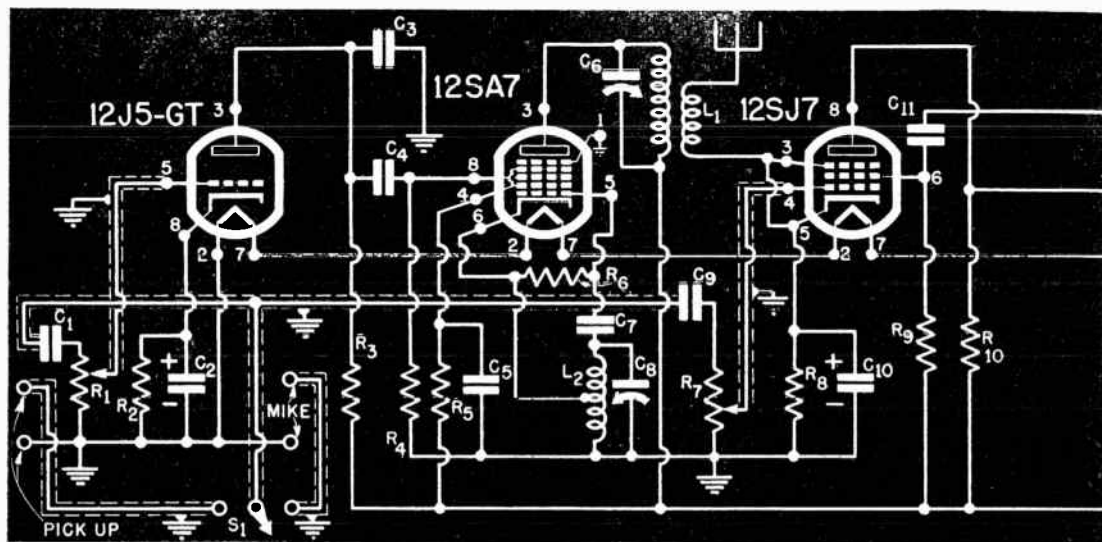

the second padder. Once the padders have been correctly set (by means of a small screwdriver adjustment) they should need no further attention unless you decide to change the frequency of the little transmitter. It is important to insulate both padders from the chassis; this can be done by means of fiber washers as shown in the drawing below. The bottom washer should have a slight shoulder to make the insulation positive and prevent the shaft from sliding sideways into contact with the metal.

As can be seen in the photos, the standard 2" by 7" by 9" chassis that was used is more than ample for all the necessary parts. It can be made smaller, but since the chassis takes a relatively small portion of the total space in any phonograph, the saving will not be great. Five octal sockets for the tubes are mounted in a line along the rear of the chassis. The filter choke and antenna coil are placed in front of the tubes, and padder condensers peer up from underneath on both sides of L1. Almost directly underneath the

choke and at right angles to it is a small universal output transformer. The photo of the underside of the chassis shows two leads coming from the secondary of this transformer and terminating at a recessed two-connection socket in the side of the chassis. This was done for convenience in assembling the unit in a cabinet. The two leads coming from the voice coil of the speaker plug into the socket and can readily be disconnected when the chassis has to be removed for any reason.

With the same idea of making the chassis as independent as possible of external connections, all other contacts are made by jacks or sockets. This arrangement, of course, is optional with the builder. The feed-through, 115-volt line into which the phono motor can be plugged is brought to a recessed socket. This connection is tapped off the line ahead of the power switch (S2). Most automatic record changers have their own switches so they can be stopped (for changing records or when the microphone is to be used) without cutting off the current going to the oscillator-amplifier. If your changer hasn't such a switch, or if you are using a plain motor, insert a SPST switch in series with one side of the motor's line cord.

A two-connection jack on the chassis receives the "hot" and grounded leads from the crystal pickup. This jack is not accessible when the unit is in a cabinet, but there's no need to get at it since switch S1 changes over the input circuit from phonograph to microphone. Because the mike need not be

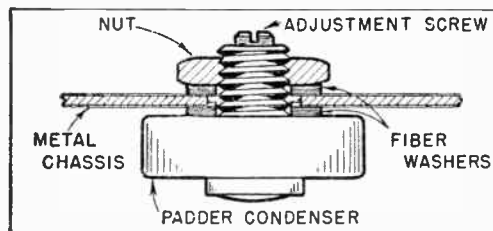

The padder condensers must be insulated from the chassis. Use two fiber washers as shown.

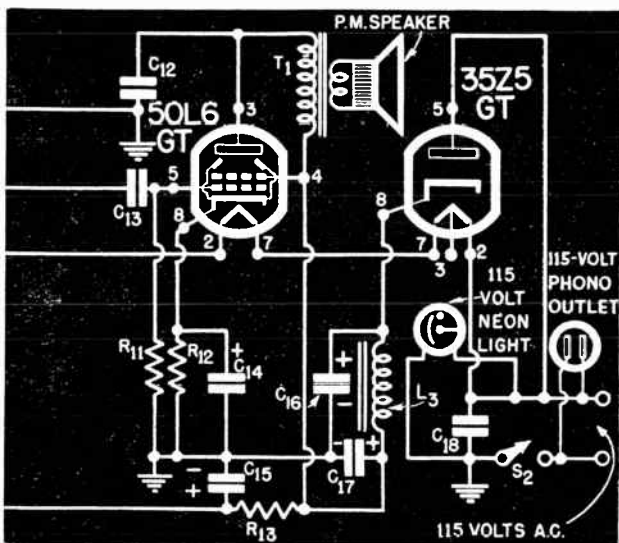

LIST OF PARTS

- R1, R7: 5-meg. potentiometer.
- R2: 1,800-ohm, 1-watt carbon.
- R3: 68,000-ohm, 1/2-watt carbon.
- R4: 100,000-ohm, 1/2-watt carbon.
- R5, R6, R10: 51,000-ohm, 1/2-watt carbon.
- R8: 22,000-ohm, 1-watt carbon.
- R9: 1-meg., 1/2-watt carbon.
- R11: 680,000-ohm, 1/2-watt carbon.
- R12: 390-ohm, 1-watt carbon.
- R13: 1,000-ohm, 10-watt wire-wound.
- C1, C9, C13, C18: .01-mfd., 400-volt paper.
- C2: 5-mfd., 25-volt dry electrolytic.
- C3: .0002-mfd. ceramic.
- C4, C12: .006-mfd., 400-volt paper.
- C5, C11: .05-mfd., 400-volt paper.
- C6, C8: 175 to 500-mmf. ceramic padder.
- C7: .0001-mfd. mica.
- C10, C14: 10-mfd., 25-volt dry electrolytic.
- C15, C17: 16-mfd., 150-volt dry electrolytic.
- C16: 24 mfd., 150 volt dry electrolytic.
- L1: Shielded iron-core ant. coil for broadcast band.
- L2: Tapped osc. coil, air-core, unshielded, 456 kc.
- T1: Universal output transformer.
- S1: SPDT toggle.
- S2: SPST toggle.
- P.M. speaker, 115-volt neon pilot lamp, record changer or phono motor and pickup, tubes sockets, two connector jacks (2) and plugs, recessed feed-through socket, misc. hardware.

a permanent part of the assembly, its jack is placed on the front panel.

In the diagram above, some of the input leads are represented as being made with shielded wire. If you trace the same portions of the circuit in the photos, you will find that some of these leads are unshielded. This was done because it was found convenient to keep these leads short, near the chassis, and out of the way of other wires. When the layout allows this you may omit the shield, but otherwise it is a good idea to provide for it.

Cabineting the oscillator-amplifier is a matter for individual taste. For convenience, a purchased cabinet designed to hold a record changer, amplifier and speaker was used in the model illustrated. Although it was relatively inexpensive, it did add about \$10 to the cost of the item—an amount you may be able to save by constructing your own cabinet or building the unit into a bookcase or other piece of furniture. Total cost, incidentally, ran to about \$45, including the cabinet and record changer but not counting a microphone. This changer cost something over \$20. Other models are available at half or twice this price. Since the components are all standard, your spare-parts box may make a big dent in the cost figure.

When you have completed and double checked the wiring, connect the speaker, phono motor, and pickup, turn on S2 and throw S1 to "phono" position. Give the amplifier a few seconds to warm up, then check for sound by scraping a finger across

the pickup needle. There are no tuning adjustments to be made on the amplifier section.

In order to transmit, however, you must first align the oscillator padders. Tune a nearby radio to a dead spot near the *low* end of the broadcast band—around 600 kc. on the dial. Adjust the padder across the oscillator coil first. This one is critical and should be tuned by turning the setscrew slowly until the test signal is heard on the radio. For a test signal you can either continue the needle scraping or play some records with the amplifier volume turned way down.

When you have the oscillator padder set to its best position, adjust C6 for maximum volume. Once the signal starts coming through the radio receiver, lower the volume adjustment (R1) to keep from overloading the transmitter and distorting the sound. Keep this resistor at about the half-way setting for the phonograph but turn it up for the mike. When either the oscillator or amplifier is wanted by itself, set the control of the other all the way down.

This two-tube oscillator has a husky output and with a long antenna is capable of radiating signals further than the maximum allowed by the Federal Communications Commission. To avoid trouble, keep the antenna short. A 5' or 6' piece of insulated copper wire left dangling behind the cabinet should be adequate.

Armchair Tuner Reaches to Your Radio

Sit back and relax . . . this two-tube remote control puts the pick of the programs at your fingertips.

By Edward Blanton

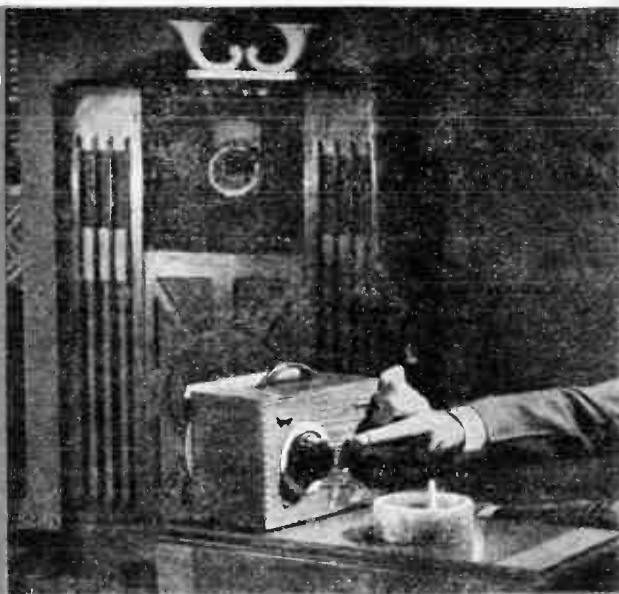

HOW do you measure the distance from your favorite armchair to the control knobs on a radio? You can count inches, centimeters, or the seconds it takes you to get across the room, but they won't tell you much. The real test is the effort you have to spend when you're settled down comfortably. That's when you are apt to find it too much trouble to pull yourself up in order to adjust volume or select a new program.

If you'd like to combine the tone and quality of your console with the portability of a midget that you can always keep at your elbow, here's a perfect answer. It's a little box that can be carried anywhere

around the room. You can place it on an end table or on the arm of a chair and let it reach out to mastermind your radio dial. One of its two knobs serves to tune in any station in the broadcast band; the other adjusts volume and turns the remote tuner on and off.

The unit might be described as a little less than half a radio—a two-tube superhet that stops short at the intermediate-frequency stage. Instead of being set to the usual 456 kc., the IF transformers are moved up to around 550 kc. The tuner then converts any incoming radio signal to this frequency and broadcasts it across the room. Like a relay runner, the regular radio takes

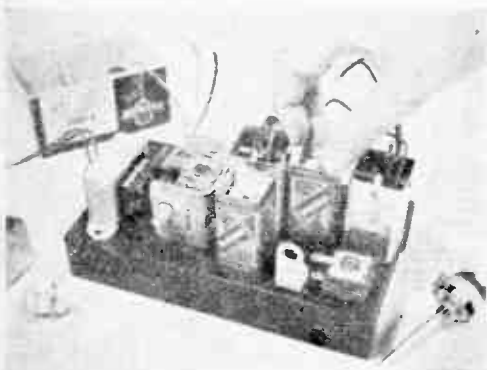

An experimental layout will help you determine the best arrangement of parts. It's a good way to achieve compactness without crowding.



Punch and drill all holes before assembly. An electric vibrating tool easily marks a crackle finish, and lets you identify tube sockets.

over at this point. When its dial is set to the same frequency as the tuner's IF's (say 550 kc.) it will pick up whatever program is being radiated by the little box.

Being half a radio, the tuner has half as many components as a comparable small set. Two 7-pin miniature tubes plus a dry-disk selenium rectifier do the electronic work. The tubes are a 6BE6 oscillator and first detector, and a 6BA6 IF amplifier.

For portability and general convenience it is desirable to keep the tuner reasonably compact. In assembling the tuner shown, the topside parts were arranged on a $1\frac{1}{2}$ " by $4\frac{1}{2}$ " by 8" chassis, occupying a width of $3\frac{1}{4}$ ". After all holes were drilled and punched, the extra $1\frac{1}{4}$ " of chassis width was hacksawed off.

Once the major parts are mounted you are ready to start wiring. The AC line cord is brought in under the chassis and held down with a cable clamp. The two wires from this cord are soldered to a two-lug terminal strip. One side of the power line is grounded to the chassis through SPST switch S1. (Caution: This makes the chassis 'hot'; don't let it come in contact with an external ground and don't touch it when the power is on.)

One side of each of the transformer windings is also grounded. The ungrounded side of the secondary—6.3-volt—winding goes to pin 3 on both tube sockets. Both pins 4 are then soldered to a chassis terminal to complete the heater connections.

The negative side of the selenium rectifier is wired to the ungrounded side of the 115-volt primary winding of T1. Polarity is important here. The positive side of the rectifier goes to the filter circuit through R6.

Most manufacturers mark this side with a red dot or a plus sign.

If you'll recall what was said earlier about resetting the IF transformers, you will see why it is necessary to take special pains in the selection and use of these transformers. Most commercial units are limited in range to from 400 to 500 kc., and these are no good at all here. What's needed is a pair of *wide-range* IF's that are tunable to about 600 kc. The bottom limit will probably be about 380 kc., but this is less important. Be sure to mention these frequencies when ordering the transformers, and also add the specification "iron core."

An old file cabinet measuring $4\frac{1}{2}$ " by $6\frac{3}{8}$ " by $8\frac{3}{8}$ " serves to house the tuner. The hinged side becomes the front and an opening is cut in the back to allow free ventilation for the tubes. This hole is concealed by the loop antenna, which is mounted on the back of the box with $\frac{1}{2}$ " brass spacers and 1" machine screws. A cover or protective backing for the loop may be made from any thin, nonmetallic sheet.

The opening in the back of the cabinet is also used to bring out the line cord and a 25' hank of wire that serves as the transmitting antenna (the loop is the receiving aerial). Fasten these leads with a cable clamp to keep them from pushing out on the loop. The transmitter antenna is tossed out on the floor when the tuner is in use.

Adjusting the tuner is not difficult but it takes a little patience. First turn on your radio and set the dial to a quiet spot around 550 kc. Put the tuner antenna (the transmitter hank) close to that of the receiver but without making direct contact. Now start raising the frequency of the IF

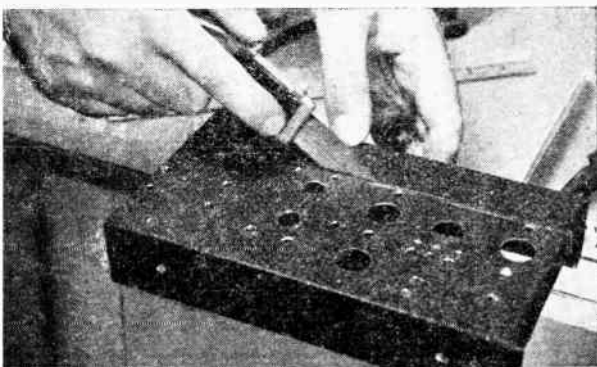

To save space, a strip $1\frac{1}{4}$ " wide was hacksawed from the standard $1\frac{1}{2}$ " by $4\frac{1}{2}$ " by 8" chassis. This was done after layout, drilling, and punching.

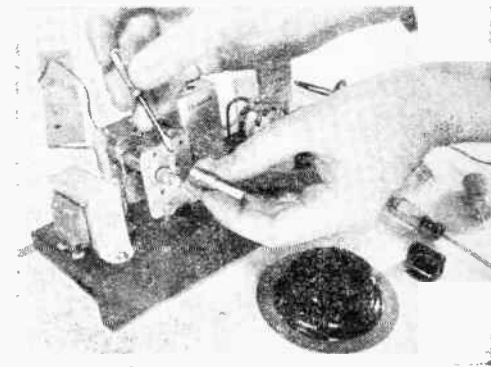

The stubby shaft on the two-gang tuning condenser used in this set didn't clear the panel, so a shaft extension was attached as shown.

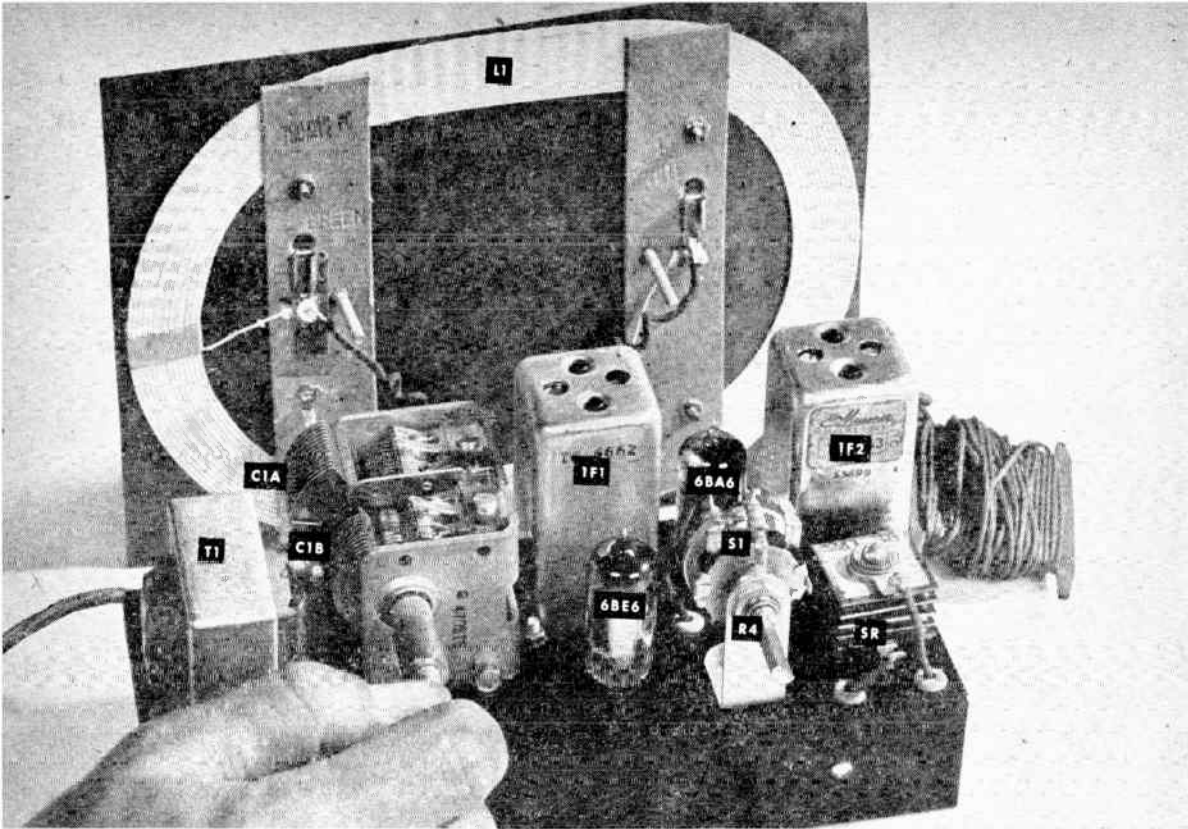

Try to follow this arrangement of the major components for short leads and easy wiring.

transformers from their preset value of about 456 ke. to about 550 ke. Do this by decreasing the capacity of the trimmers—turning them counterclockwise—a little at a time. Adjust all four trimmers more or less simultaneously by taking a half turn on each one and then going on to the next. While you are doing this, keep rocking the dial of the remote tuner so that the plates of the variable condenser are moving from about half mesh to fully open (the upper half of the broadcast band). Continue the adjustments until the tuner begins to pull in stations on the radio. The first sign of success may be a squeal or a whistle.

Once you've reached this point, make careful adjustments on the trimmers until stations come in with maximum volume. Align the trimmers on the tuning condenser (chiefly on the oscillator section) until a station around the middle of the broadcast band (850-900 ke.) comes in near the middle of the remote-tuner dial. Now make a final check to be sure that the highest local station can still be brought in.

You'll probably find that the tuner compresses the broadcast band from 10 to 30 percent—that is it will cover the entire

band while traveling only 70 to 90 percent of its full sweep. The reason for this is that the oscillator is still working at a lower frequency than the IF's. You will therefore have to log stations a little bit differently on the tuner dial, but their relative positions should remain about the same. If you should happen to be using an adjustable oscillator coil—which was not done in the unit shown—you may be able to raise the coil frequency by changing the position of the iron core. This should somewhat reduce the compression of the tuning range.

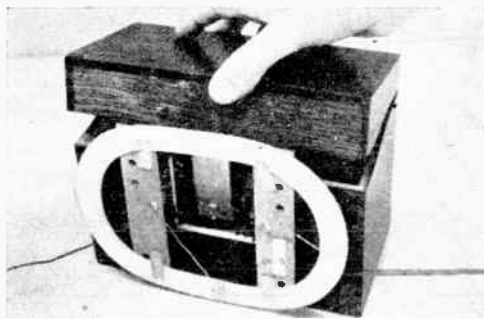

Here the tuner has been mounted in the filing box. Note the large ventilating hole at rear.

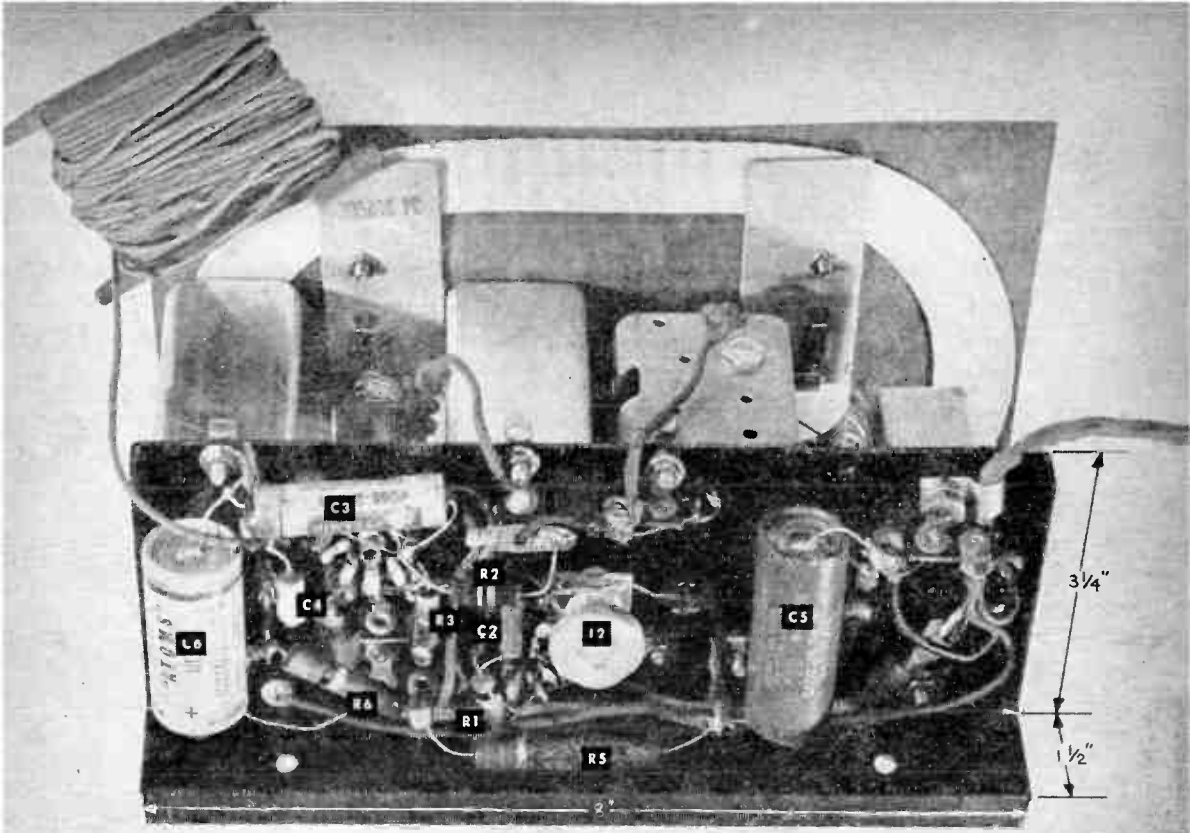

Bottom view of the completed chassis. It's "hot," so see that it isn't externally grounded.

LIST OF PARTS

R1: 10,000-ohm, $\frac{1}{2}$ -watt carbon.
 R2: 22,000-ohm, $\frac{1}{2}$ -watt carbon.
 R3: 330-ohm, $\frac{1}{2}$ -watt carbon.
 R4: 15,000-ohm potentiometer with switch (S1).
 R5: 2,200-ohm, 2-watt carbon.
 R6: 51-ohm, 1-watt carbon.
 C1: A, B: 2-gang variable condenser with cut-plate osc. section

C2: .0005-mfd. mica.
 C3: .05-mfd., 400-volt paper.
 C4: 50-mmf. ceramic.
 C5: 30-mfd., 150-volt dry electrolytic.
 C6: 40-mfd., 150-volt dry electrolytic.
 S1: SPST rotary switch on R4.
 T1: Filament trans. with 6.3-volt secondary.

L1: Loop antenna.
 L2: Tapped oscillator coil.
 IF1, IF2: Input and output wide-range (380-600 kc.) iron-core IF transformers.
 SR: 100-ma. selenium rectifier.
 Miniature tubes and sockets, .25" bank of antenna wire, tuning dial, chassis, cabinet, misc. hardware.

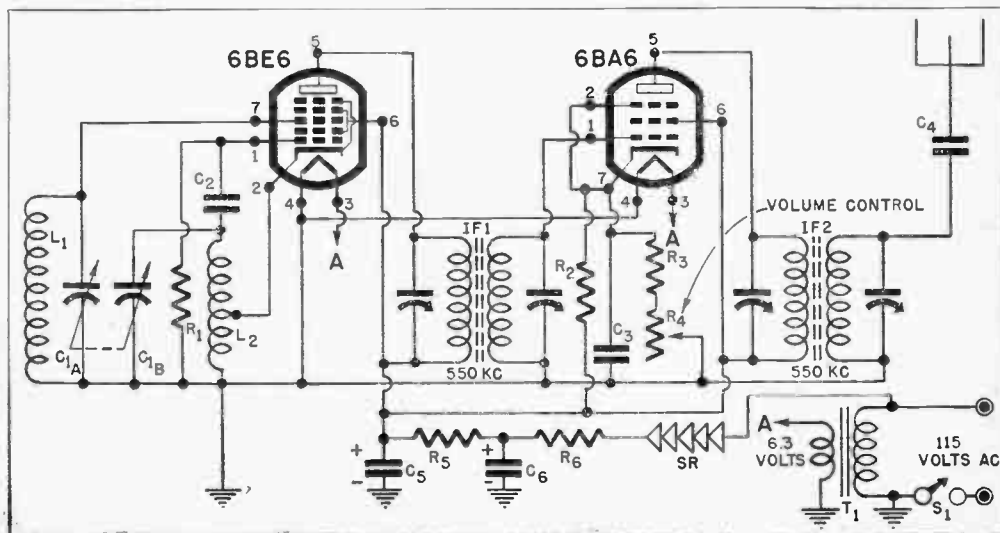

Pillow Phone Mutes Late Music

If you like to let that last musical night-cap rock you off to sleep like one of mother's lullabies, try this way of doing your mid-night listening. It's as comfortable for you as it is for the other members of the family who have already succumbed to the sandman. A suitable pillow can be made with tightly packed cotton. Wire any good-quality headphone to the output of your radio as shown, and stitch the phone into a depression formed in the pillow. When used with large consoles, the headphone should come off the second detector instead of the last audio stage.—W. E. DANNEGAN.

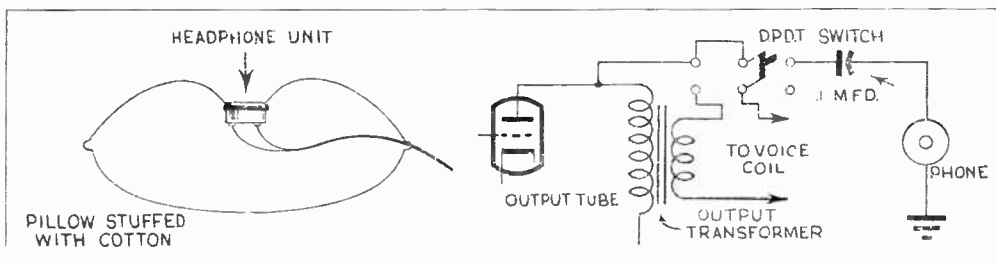

Reinforcements Stop Record Slipping



STACKED phonograph records sometimes skid over the records underneath, resulting in musical distortion. One frequently effective method of preventing this slippage consists of gumming three or four loose-leaf reinforcements on each record to increase the friction between the disks.—G. O. S.

Doorstop Pegs Radio

WHEN you stand a radio on end for servicing, slip a wedge-shaped doorstop under some solid part to keep the weight of the set off tubes and coils and prevent the chassis from tipping. Flexible stops of the type illustrated below can be purchased at hardware, novelty or dime stores.—H. LEEBEE.

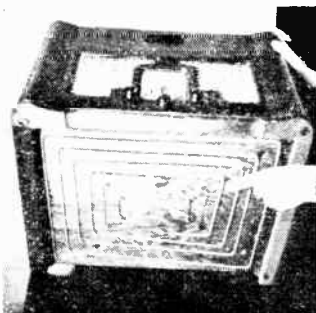
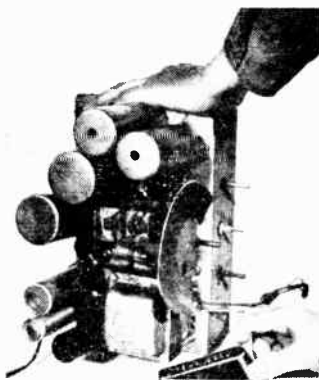

Concealed Antenna

SHORT antennas need not consist of wires dangled out the window or bunched up behind the furniture. Screws driven into the bottom of the radio cabinet diagonally from each corner make convenient pegs for antenna wire as shown at the left.—ROBERT H. DALTON.



Tuning Eye Makes Old Radios Look Up



Bring your radio up to date

by giving it

eye-sharp tuning plus freedom from blasting. Here's how for most receivers.

By William Norton

HARSH background noises that come through when a radio dial isn't properly set won't spoil your listening if you tune by eye. Sounds may fool the ear, but there's no deceiving an electron-ray indicator tube. When the eye squints down to its narrowest angle, you know you're on the beam.

Perhaps you already enjoy the advantages of eye tuning in your living-room console. It's easier than you think to add the same feature to those extra sets in the kitchen, bedroom, and workshop. The two main exceptions are midget TRF receivers and some

pre-1930 radios employing triode RF amplifiers. In the former case there is usually not sufficient gain to operate the indicator, while the neutralizing circuits of the latter do not lend themselves to diode detection and AVC. If your radio is not much over ten years old, the chances are that it will be a relatively simple matter to add the eye. On some older sets it will first be necessary to switch over to a diode detector before an eye can be made to operate. This procedure will be described below.

Note the words diode detection and AVC. They are the key to the whole job. Automatic volume control—AVC—consists of a condenser-resistor network connecting the

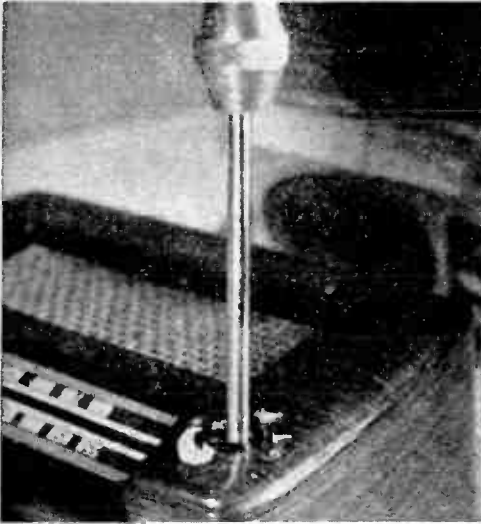

An opening for the indicator tube is made with an expansive bit. For the 6AL7-GT it should be $\frac{3}{8}$ "; most other tubes need a 1 $\frac{3}{16}$ " hole.

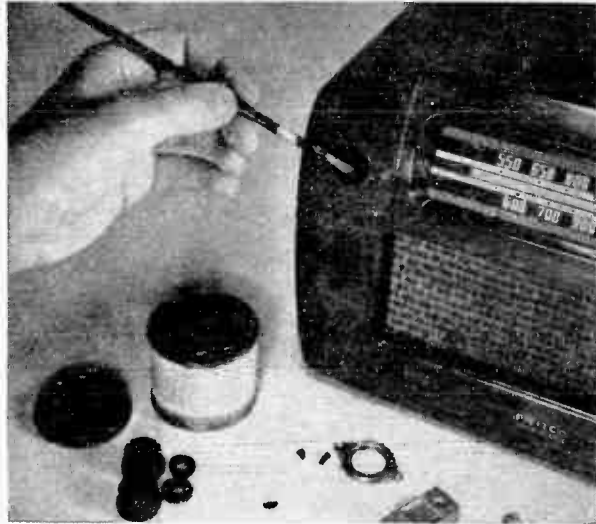

Paint the inside of the opening black to give greatest definition to the tube pattern. The decorative bezel (foreground) goes on last.

various grid-return leads of each RF or IF stage with the diode detector. The voltage developed across this network controls the deflection of the indicator eye.

How can you tell whether your set has AVC? Sets that don't have it are usually guilty of "blasting"—a sudden increase in volume as you tune from a weak station to a strong one. The reverse is also true, of course, and you'll be able to tell these older receivers by the fact that they require constant adjustment of the volume. To make doubly sure, tune in a local station and listen for background noise when the station is silent for a moment. Now turn off the station. Sets that *have* AVC generally show an in-

crease in background noise when the pointer is set between stations.

Take a look, also, at the table on page 221. If your detector tube is listed in Col. 1, the set probably has AVC. If you find it in Col. 2 instead, the answer is no.

Let's assume for the moment that we're dealing with one of the more modern sets. It may be an AC-DC midget or a straight AC job. If it is a midget, make sure it is also a superhet. It isn't advisable to try the conversion on AC-DC TRF's.

Now find your detector tube in Col. 1 of the table mentioned above and read straight across to the last column to find a suitable indicator tube. For some of these tubes the

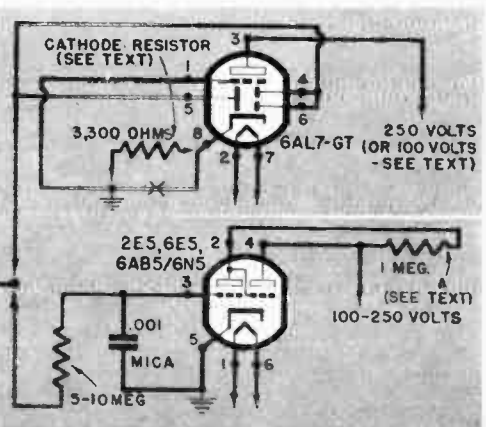
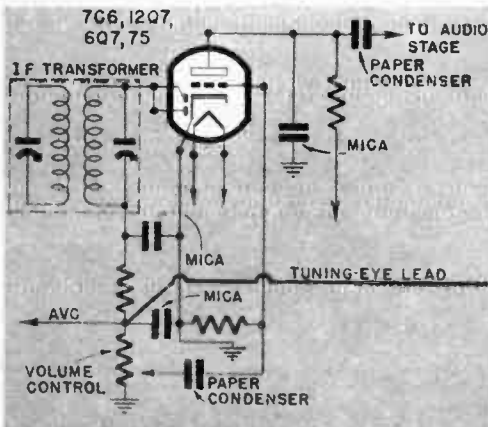

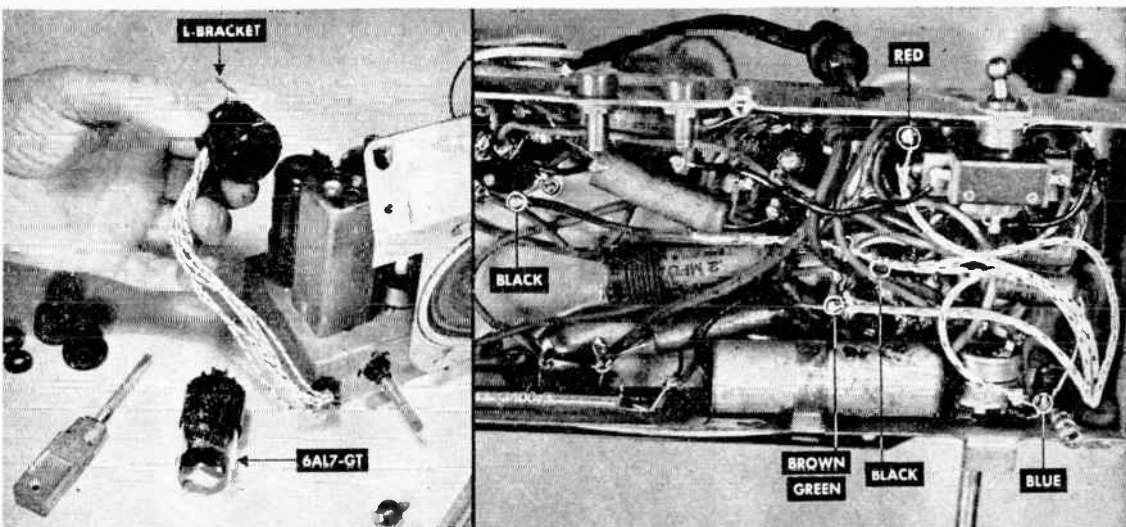

An indicator-eye assembly consists of a wired socket and mounting hardware. The L-bracket was used here instead to save cabinet space.

Solder the six leads as shown in the diagrams on the facing page. This 1942 AC-DC superhet already had AVC and diode detection.

recommended plate potential is 250 volts, but they will still glow—less brightly, to be sure—on the 110 volts available from the average AC-DC circuit.

The necessary parts for a tuning-eye assembly are generally sold in kit form. Those marketed by Amphenol come with additional information and circuit data. Use the 6-prong MEA6 for a 2E5, 6E5, or 6AB5/6N5; kit MEA8 will be needed for the 8-prong 6AL7-GT.

The new 6AL7-GT can be used wherever the older 6AB5/6N5 is called for. In midget cabinets the smaller size of the new tube may prove a real convenience. Should you wish to use it, the first step will be to remove the socket shield and solder together pins 4, 5, and 6. The reason for this is that the tube was engineered as an FM indicator and the deflection plates must be tied together when it's used on AM. Unlike most other indicators, the 6AL7-GT shows a flat band of light on its translucent screen. The band is at minimum width when a station is timed in.

Only six of the eight prongs on the assembly socket are wired, and these may not be the right ones for the 6AL7-GT. If you find this to be the case, remove the extra lead from pin 4 or 5 and solder it to pin 1. Note the color coding of the remaining leads before replacing the socket cover.

Wire the socket into the set as shown at the bottom of page 218. When working on

an AC-DC receiver it will be necessary to open the series-filament string at some convenient point and wire the black leads from the tuning-eye socket in series with the others. On an AC set the heaters are put in parallel.

The two schematics shown at the right-hand side of the diagram should apply to most receivers, but it would be well to study your receiver for any possible variation in the AVC circuit. For example, should the eye fail to operate when connected to the hot side of the volume control, it may be necessary to try other points in the detector circuit such as the black or AVC lead of the output IF transformer.

On AC-DC sets you'll need all the voltage you can get, so run the lead from pin 3 to the cathode (usually pin 8) of the rectifier tube. Where higher voltages are available—as on AC sets—this lead may be wired to the output of the power filter. Best place to locate this is at the screen grid (usually pin 4) of the power output tube.

Unless the receiver uses a floating ground, the grid lead of the 6AL7-GT (pin 1) will be connected to the chassis. However, when the chassis is not grounded, make this connection to the cathode of the detector tube. The cathode of the 6AL7-GT (pin 8) will be anchored to the same point if the set has a plate voltage of 125 volts or less—i.e., if it is an AC-DC receiver. For sets of higher voltage, use a 3,300-ohm cathode resistor and



This 1931 model, 2-stage, TRF receiver first had to be altered for AVC and diode detection before a tuning eye could be made to operate.



Bottom view of the converted receiver. Note position of the 2E5 indicator and new volume control. The old control is left at maximum.

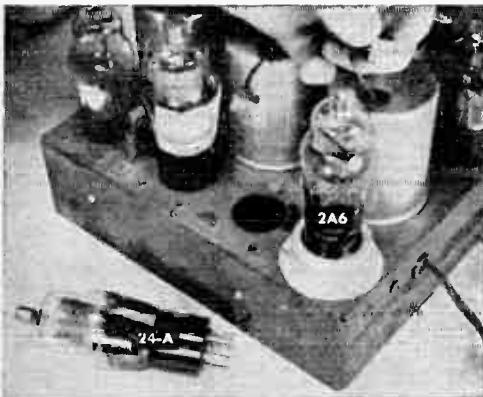

The new 2A6 diode-triode detector replaces the 24A. Its socket goes on top of the old one.

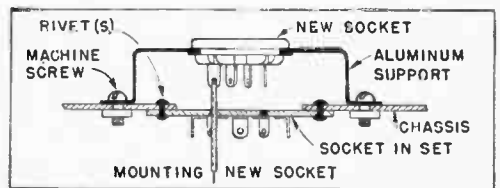

omit the direct connection to ground (the lead marked X in the upper-right diagram on page 218).

Pins 2 and 4 of the 2E5, 6E5, or 6AB5, 6N5 must be connected through a 1-meg. resistor (marked A in the lower right-hand diagram, page 218). If you use a kit you may find this resistor already included in the socket.

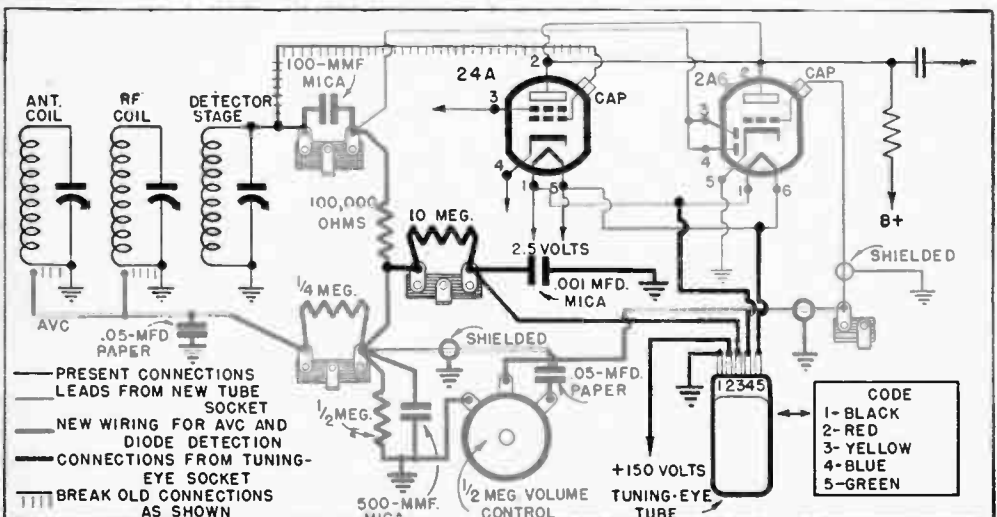

Fewer than a dozen wired connections are needed to add an eye to a set that has AVC. But what about the other ones? Here the job is slightly more complex, but it is even more worth while in terms of improved performance. Adding a diode detector and tuning eye should reap dividends in improving tone quality as well as ending blasting and off-station tuning.

The converted set shown here is an antique (1931), two-stage TRF receiver. It used a 24A for a detector, and this first had to be replaced with a 2A6 diode-triode. A new 6-prong socket was placed on top of the old 5-prong one by means of a flanged aluminum support. Wood or metal spacers about 1" long could have been used instead. Five wire leads, each 6" to 8" long, are soldered to the contacts on the new socket (pins 3 and 4 are joined and require only one lead). These are pushed down through the holes in the old socket and wired into the circuit as shown by the light red lines in the diagram.

Unsolder the clip from the old grid lead and pull the wire through the shielding can to the underside of the chassis. Bolt three or four fiber mounting strips to the chassis to serve as tie points for the new wiring and add the extra resistors, condensers, and volume control as shown. The new grid lead must be shielded; this can be done by using braided wire or by bringing it up through the shield can of the detector coil. Color coding for the tuning-eye socket refers to the MEA6 assembly as used with the 2E5 tube. The grounded lead, 1, is the cathode; 2 is the B-plus lead from prongs 2 and 4 which combines the target, plate, and ray-control electrode; 3 is the grid connection, and 4 and 5 supply current for the heaters.

With three or more shield cans on top of a TRF chassis you may have some trouble

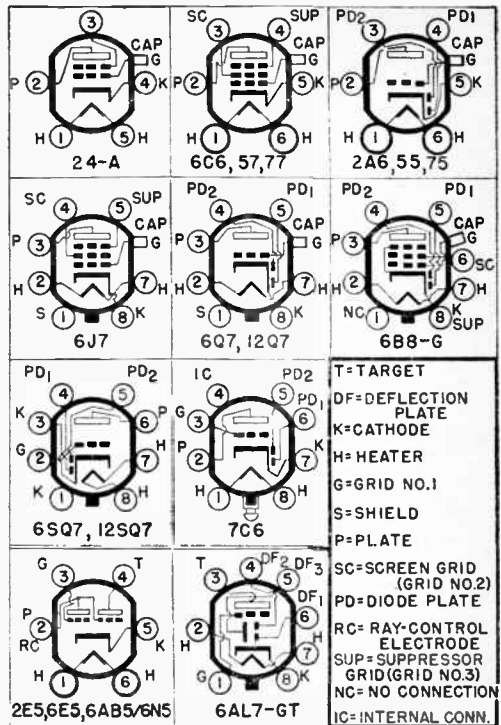

For convenience the base connections (bottom view) of most detector tubes are shown above.

identifying the various coils. The job isn't made any easier by the fact that the same tetrode was often used in the first and second RF stages as well as the detector. This set, for example, had three 24A's.

Some tracing is therefore necessary. Life will be made simpler if you can find a circuit diagram of the set, but it isn't imperative. To find the antenna coil trace the antenna lead-in wire under the chassis. It will probably go—either directly or through a volume control—to one section of a ganged tuning condenser. A wire connects this condenser section to the antenna coil, and this coil is linked to the grid cap of the first RF tube.

The second section of the ganged tuning condenser will most likely be joined to the second RF tube in the same manner. That leaves only the detector stage to account for. This may be further checked by looking for a fixed resistor and condenser (in parallel) from the cathode of this tube to ground. The detector tube is also coupled through a condenser to the first audio tube, which will in all likelihood be of a different style—type 27 or a similar tube.

Receivers with these diode detectors probably have AVC	Receivers using these tubes as detectors do not have AVC	Replate tubes in Column 2 with these diodes	Det tube heater voltage	Det tube heater current (amps)	Use for indicator tube
2A6			2.5	0.8	2E5
6Q7			6.3	0.3	6E5
6SQ7			6.3	0.3	6E5
7C6			7.0	0.15	6AB5, 6NS*
12Q7			12.6	0.15	6AB5/6NS*
12SQ7			12.6	0.15	6AB5/6NS*
55			2.5	1.0	2E5
75			6.3	0.3	6E5
	24A	2A6	2.5	0.8	2E5
	6C6, 77	6B8	6.3	0.3	6E5
	6J7	6SQ7	6.3	0.3	6E5
	57	2A6	2.5	1.0	2E5

*The new 6AL7-GT can be used in place of the 6AB5/6NS

Wireless Mike Puts You on the Air



This complete miniature broadcasting station will fit comfortably in the palm of your hand.

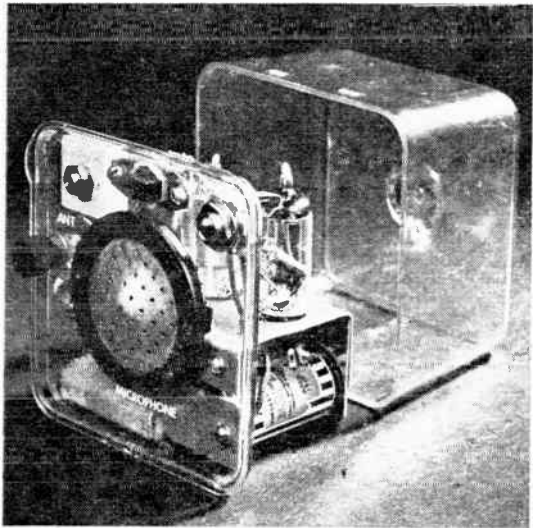

The cartridge from a crystal mike, with the rubber cushion left on, is set into the panel.

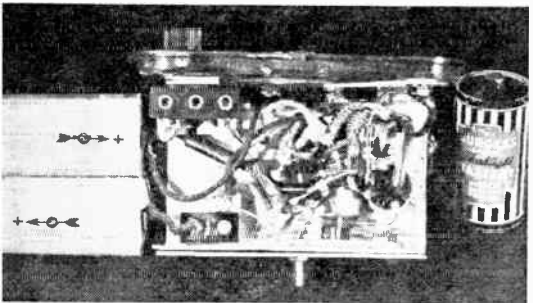

Wiring shouldn't be difficult. Just don't let it spread out. Batteries fit under the chassis.

TALK into this tiny handful of radio transmitter, and your voice will come out of the nearest radio. It can be tuned to any quiet spot near the high end of the band. When held a few feet away from a receiver, this wireless microphone works without an antenna. For greater distance a hank of wire is needed to radiate the signal. If you arrange it right, your party guests don't even have to know that the voice-and-music program that's coming over your radio originates in the next room.

The complete miniature broadcasting station, including batteries, is housed in a tapered plastic refrigerator box measuring 2" deep and 4" square across the front. On the lid of the box, which becomes the front panel, are mounted the crystal unit taken from an inexpensive microphone, an on-off switch, a closed-circuit phono jack, an antenna binding post, and a ceramic trimmer. The latter is used to tune to the best frequency between about 1,200 and 1,600 kc. A chassis cut from 1/16" aluminum to the size and shape shown in the drawing holds the remainder of the parts. It is bolted to the back of the same panel.

There is nothing difficult about the wiring, but this is a miniature circuit and calls for a little extra care to keep the parts from getting in their own way. Use tiny resistors—the 1/2-watt type is husky enough—and the smallest paper and mica condensers.

For the A battery, a flashlight cell intermediate in size between the regular and penlight (type C) is used. It measures just under 2" long and so can be clipped into place between the rear leg of the chassis (which acts as the negative terminal) and a separate tab of aluminum bolted to the front panel. The B-voltage supply is obtained

from two 22½-volt hearing-aid batteries wired in series. Taped together, these fit the space alongside the A cell. A 45-, 67½-, or 90-volt B battery could be used for greater economy and increased output but it will not fit inside the case. By clipping rather than soldering the B-supply leads, you can easily arrange to switch from the miniature to the larger batteries, depending upon the conditions of use.

As can be seen in the bottom-view photo at the lower left on the facing page, two terminal strips are used as meeting points for some of the connecting wires. By bolting these to the chassis as shown—opposite each other and at the same height—they can be made into a convenient shelf or ledge for the B batteries.

Since the output of a crystal pickup is considerably greater than that of a microphone, only one stage of amplification is used to broadcast records. The pickup jack by-passes the mike preamplifier (1U4 or 1T4) and is coupled directly to the grid of the oscillator-RF amplifier tube (1R5) through a .005-mfd. condenser (C2). As a precaution against overloading this tube, reduce the output of the pickup by wiring

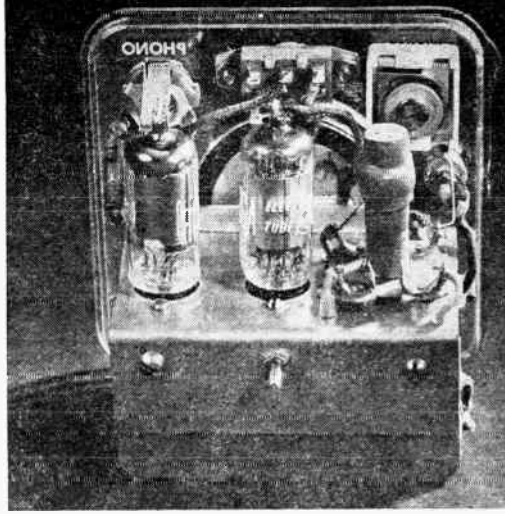

The plastic cover (removed in this view) is held to the chassis by the protruding screw.

a 50-mmf. mica or ceramic condenser (C6) in series with the "hot" lead from the pickup.

A slightly more elaborate circuit, but one that may give greater fidelity, is shown in inset "A" of the wiring diagram. With this setup volume can be controlled at the phonograph, while with the simpler one it is done at the set.—Albert Rowley, Manhattan, N. Y.

LIST OF PARTS

R1: 3.3-meg., ½-watt carbon.
 R2: 2.2-meg., ¼-watt carbon.
 R3: 820,000-ohm, ¼-watt carbon.
 R4: 1-meg., ¼-watt carbon.
 R5: 150,000-ohm, ¼-watt carbon.
 R6: 75,000-ohm, ½-watt carbon.
 R7: ½-meg. volume control.
 C1: .02-mfd., 200-volt paper.

C2: .005-mfd., 200-volt paper.
 C3: C5: .0001-mfd. mica.
 C4: 75-225 mmf. ceramic trimmer.
 C6: 50-mmf. ceramic or mica.
 C7: .001-mfd. ceramic or mica.
 L1: 456-ke. adjustable iron-core osc. coil.

S1: DPST slide-lever switch.
 J: closed-circuit phone jack.
 Two 22½-volt hearing-aid batteries, one "C" size flashlight cell, tubes and sockets, crystal-mike cartridge or lapel mike, phone pickup, 25' hank ant. wire, misc. hardware.

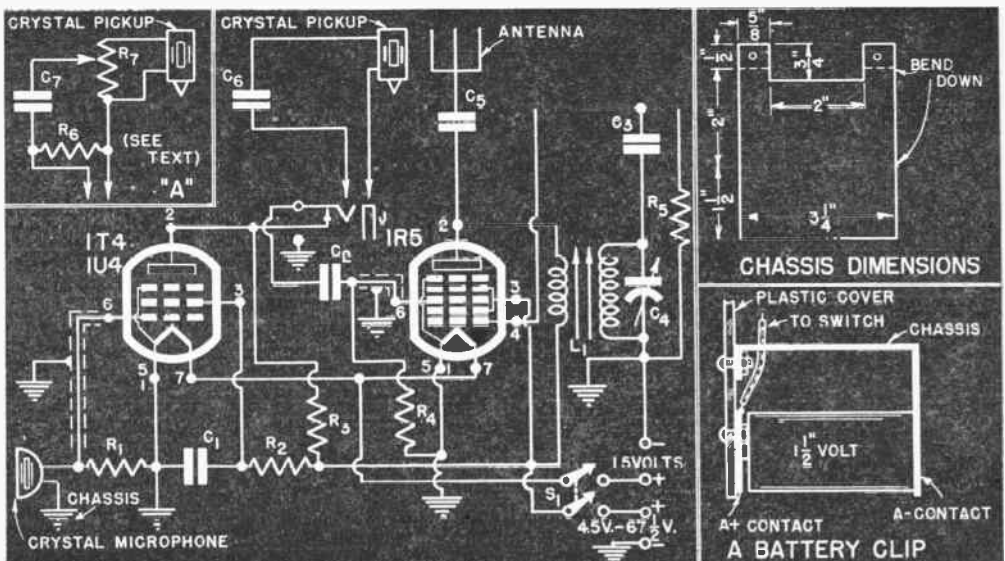

Getting Big-Set Quality from a Midget

By Joseph Saldana

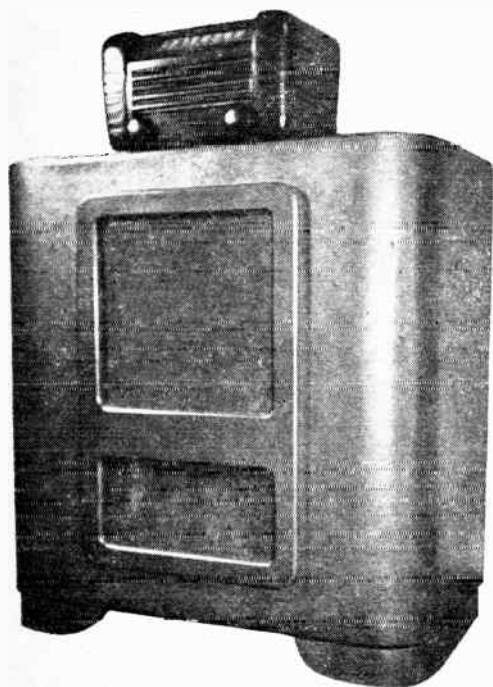

A speaker cabinet helps you get full console sound quality from the modified midget on top.

LIKE the legendary cobbler whose children went without shoes, I'm a radio engineer who has never owned a good receiver. A few months ago I grew tired of listening to the tinny squawks that came out of my little AC-DC midget, and decided that I wanted something better. That could have meant an investment of a couple of hundred dollars in a high-fidelity console or the expenditure of a lot of time—and money—in building an equivalent set from scratch.

I decided against both courses. Instead I modified my small set for better reception. Since then I have made similar changes in several other superhet midgets, always with remarkable improvement in tone. Deep bass notes which had been almost inaudible can now be heard in correct balance; high flute and triangle sounds come alive during symphonic broadcasts; and the entire response is smoother and has no harsh peaks.

Feeling that I could work better if I attacked the problem systematically, I broke the receiver into four sections. Ignoring the RF stage in each case, I began with the IF. The objective here is to increase the band-pass characteristics of the intermediate-frequency transformers and thus bring up the high-frequency response. There are at least three approaches to this, and which one you choose is a matter of convenience and cost:

1. Replace the IF transformers in the set with a pair of broad-band units. These may be purchased for about \$3.

2. Load the secondary windings of both transformers with 50,000-ohm, ¼-watt resistors. These are connected from the grid to ground or AVC terminals as shown in Fig. 1.

3. If it is convenient to open the IF cans, move the windings about ¼" closer together, as illustrated in Fig. 2. This increases the

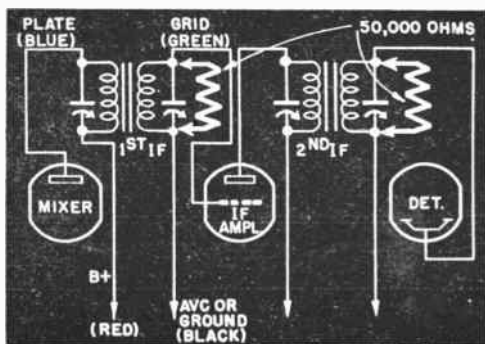

1. Loading the secondary of an IF transformer with a resistor helps to broaden its response.

coupling and broaden the resonance peak. Take great pains not to damage the delicate wires. Heating the coil to soften the wax coating makes it easier and less hazardous to move the windings.

The next portion of the set to consider is the audio amplifier. Because manufacturers are anxious to keep hum level low, they usually use low values of coupling condensers in midset sets. These, in turn, limit the low-frequency response of the audio section. I substituted .05-mfd. coupling condensers in this section. A typical position for one of these capacitors is diagrammed in Fig. 3. In sets using single pentode or beam-power output tubes, an R-C (resistance-capacitance) filter can be used to advantage to smooth the high-frequency end. A resistor and condenser in series are connected across the primary of the output transformer (Fig. 4). This puts a more constant load on the output tube in the middle and upper frequencies, and thus improves the response. The resistor should be 1.3 times the value of the output tube's rated load resistance. You can check this figure by looking up your particular tube in a tube manual. The condenser may vary from .05 to 1 mfd.

The third section to be attended to is the speaker system. Most midsets have 4" to 6" speakers that can't do much in the way of bringing out low notes but which can be used as tweeters or high-frequency reproducers. By purchasing a 12" speaker and connecting it in parallel with the one in the set, I had an effective woofer-tweeter combination. There are many more elaborate

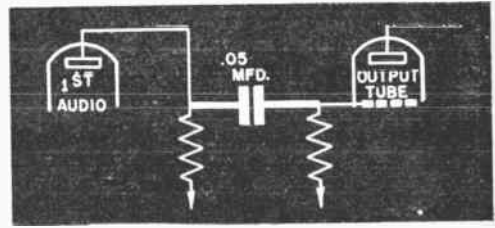

3. Bass is increased by changing the coupling condensers to .05 mfd. in the audio section.

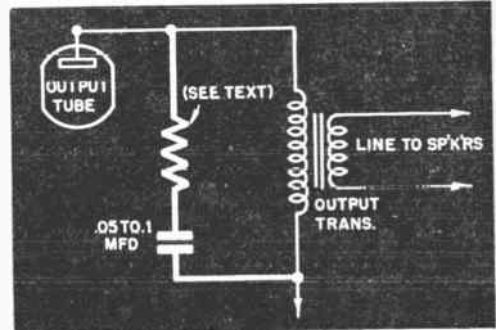

4. An R-C filter shunted across the primary of the output transformer smooths the response.

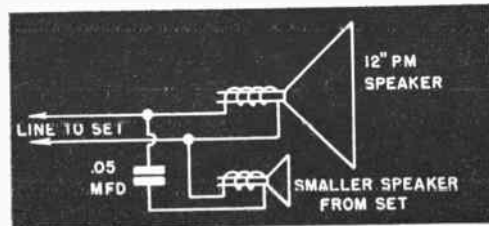

5. Use the original speaker as a tweeter and add a 12" woofer. A condenser divides the two.

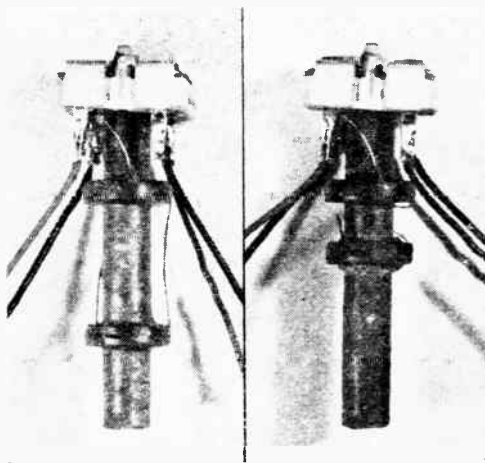

2. The original IF coil (left, can removed) can be modified by moving the windings closer.

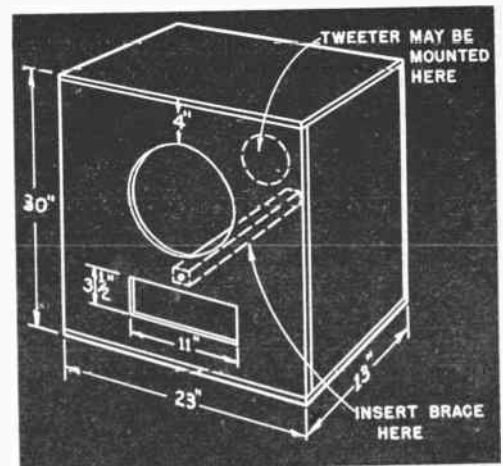

6. A bass-reflex cabinet for a 12" speaker may be made to these dimensions. Use 3/4" plywood.

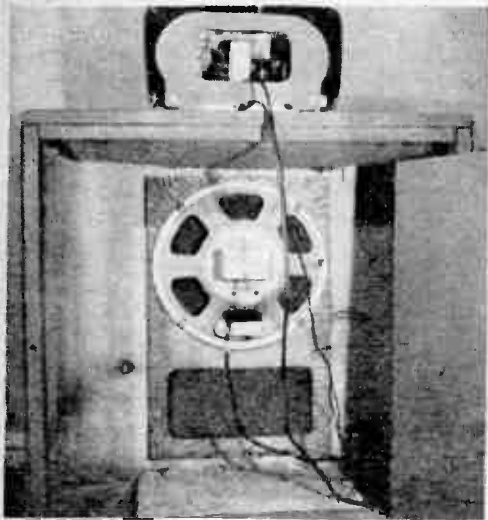

7. A commercial speaker cabinet seen from the rear. Set and small speaker are used near it.

divider networks and speaker systems possible (one is described on page 190) but for my setup I found it sufficient to insert a single .05-mfd. condenser as shown in Fig. 5 to keep low frequencies from getting through to the tweeter.

Cost is an important factor in the next decision. I purchased a bass-reflex cabinet to house my new 12" speaker. You can do likewise, or build one to the measurements shown in Fig. 6. There are decided advantages to such a cabinet, since it gives extended bass reproduction without the annoying booming often encountered in other types of baffle. But also bear in mind that there are some very good sets that do not use speaker cabinets.

The tweeter may be mounted inside the speaker cabinet at approximately the point

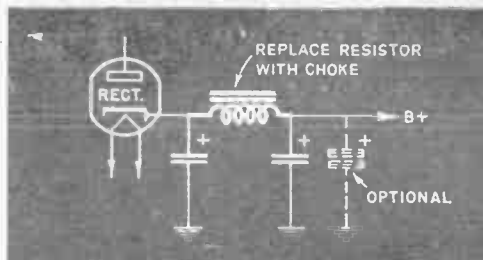

8. Hum level is raised by some of the changes, so a new choke is inserted in the filter circuit.

shown in the drawing, or it may be left in the original cabinet if the two units are going to be kept fairly close together during operation (Fig. 7). Bass-reflex cabinets must be thoroughly enclosed on all sides. To prevent the back from rattling due to sound pressure inside the box, attach a sturdy brace to front and back as indicated by the dotted lines in Fig. 6. Line the cabinet with cotton batting or other sound-absorbing material.

Having completed the modification of the signal circuits, I found that I had worked myself into an additional job. By bringing up low-frequency response, I had also brought up the AC hum, which is in the same portion of the spectrum. In some sets I worked on, this was curable by the addition of extra filtering capacitors, but in most cases a small choke proved more useful. Remove the filter resistor (usually a 1,000-ohm, 2-watt unit) connected between the two positive terminals of the dual electrolytic, and replace it with a filter choke rated from 8 to 16 henries and 400 to 600 ohms. The higher the inductance the more thorough the hum filtering. If some hum remains, add a 20-mfd. electrolytic—rated at 150 volts or up—as shown by the broken lines in Fig. 8. END

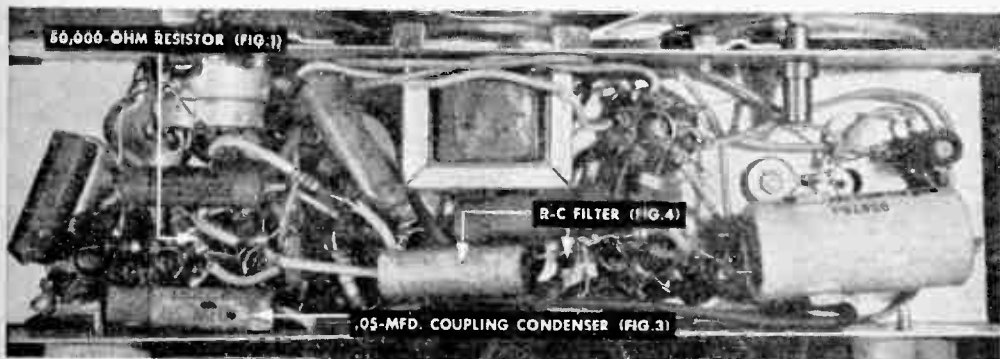

A typical superhet midset looks like this. Some of the modifications are shown by arrows.

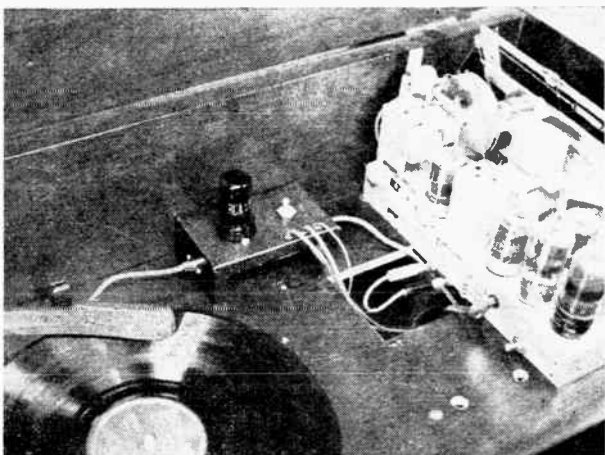

In a test setup, the preamplifier is used with an ordinary AC-DC radio. The better the amplifier and speaker, the better the results.

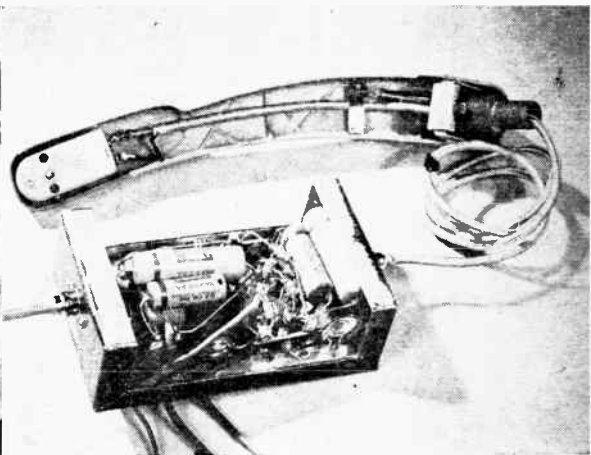

The tone arm has been fitted with a GE reluctance cartridge. This pickup needs frequency equalization as well as preamplification.

Preamplifier Serves Mike or Magnetic Pickup

EVEN a little radio or amplifier can do more jobs than you usually give it credit for. If its tone is good—that is, if its loudspeaker and output stages are up to snuff—it can be used as an audio amplifier for microphone or phono pickup.

The one or two audio stages in a small set, however, frequently aren't enough to get comfortable volume. They are also unsuitable for the new magnetic or reluctance pickups. Magnetic reproducers have excellent fidelity and they cut noise to the bone, but for this they sacrifice power. To use one, therefore, you have to give it a boost. Also, its frequency-response characteristics aren't suited to commercial recordings. It must be equalized as well as preamplified.

Maybe that sounds like a lot, but you can get it all with one tube and a few resistors and condensers. The little unit shown above and on the next page is truly universal in its performance. For a mike or crystal pickup, it gives all the preamplification you need; with a magnetic pickup it gives this plus proper equalization. For the latter feature alone it can be used even with a high-powered amplifier.

Universality is achieved in still another way, for it is designed to operate with either of two tubes, depending on the re-

quirement of the radio or amplifier with which it is to be combined. Use the 6SC7 with practically all AC radios and amplifiers. It will also suit AC-DC receivers using tubes with filament ratings of .3 amp. such as 6D6 or 6K7. Most of the newer AC-DC sets use .15-amp. heater-current tubes (e.g. 12SK7, 12K7 and 12BA6) and call for the 12SC7 in the preamp circuit. Generally the extra tube won't underpower the filaments.

If the preamplifier is coupled with an AC-DC receiver, break one of the series filament connections in the set, and insert the two heater leads so that they form part of the series circuit. With AC amplifiers or receivers, the heaters are in parallel and the appropriate leads on this unit can be connected to the heater terminals on any one of the other tube sockets. These are usually pins 2 and 7, but it is worth while to check your tubes with a manual.

The third lead from the preamplifier must be tapped into the B-plus line of the radio at some point. In small sets this is most convenient to find at the screen-grid pin of the output tube.

Many receivers and all amplifiers have jacks or terminal lugs for the phono input. Connect the two output leads to this jack;

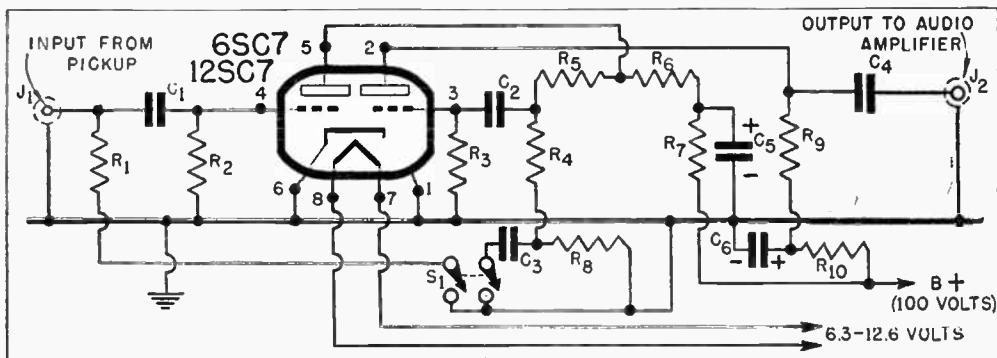

LIST OF PARTS

All resistors $\frac{1}{2}$ watt carbon.
 R1: 6,800 ohms.
 R2, R3: 3.3 meg.
 R4: 27,000 ohms.
 R5: 220,000 ohms.
 R6, R7: 68,000 ohms.
 R8: 180,000 ohms.

R9, R10: 33,000 ohms.
 All paper tubular condensers 400 volts.
 C1, C4: .05-mfd paper
 C2, C3: .01-mfd paper
 C5, C6: 16-mfd., 150-volt dry electrolytic.

J1, J2: phono jacks and tip plugs.
 S1: DPST toggle.
 Aluminum chassis, $1\frac{1}{2}$ " by $2\frac{1}{2}$ " by $4\frac{1}{2}$ " or equivalent; 6SC7 or 12SC7 twin triode (see text); octal socket, misc. hardware.

if your set doesn't provide for such a connection, bring the lead from C4 to the "hot" side of the volume control (the outside lug that is not grounded) and connect the shielded lead to the chassis of the radio. A SPST switch in series with the ungrounded lead will enable you to cut out the preamp when listening to the radio.

When using a magnetic pickup, switch S1 should be on so that the unit acts as an equalizer. For mike or crystal pickup, turn the switch off. In using a mike it is impor-

tant to maintain adequate separation between it and the amplifier and speaker. If the mike and speaker are too close together you will get a lot of feedback howl.

Inexpensive magnetic pickups are now widely distributed. The one used here is a GE cartridge. Solder a single conductor shielded wire to either one of the terminals and connect the shield to the other terminal. The shield should be grounded to the preamplifier chassis. *Edward Blanton, Manhattan, N. Y.*

FM Dipole Hidden Behind Sofa

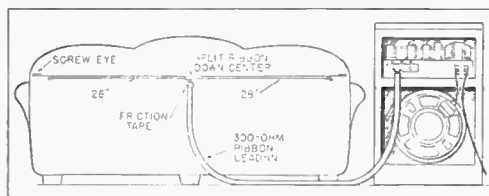

If either you or the landlord objects to your hanging an FM antenna on the roof, this indoor rig may help you get reception. Antenna and lead in are of one-piece construction, consisting of a length of 300-ohm ribbon lead-in. Wrap a few turns of tape around the wire 25" from one end and split it down the center. Drive hooks or screw eyes into the frame of a davenport and fasten the ends of the ribbon to them. The other ends go to the antenna terminals on the receiver.

Extra Loop Helps Small Radios

PORTABLES and small radios that many travelers take along often meet their match in steel-girder hotels and office buildings. Where radio reception is poor due to location, an extra length of wire may improve matters. If it is attached to a loop antenna it reduces directional sensitivity; also the extra length gives a little more pickup, which may be all the set needs to improve its reception.

Four suction cups used as pictured above offer a convenient means of spreading out the wire around a window. The cups come with molded-in bolts or clips that allow the antenna to be hooked on.—*Arthur Trauffer, Council Bluffs, Iowa.*

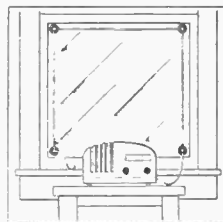

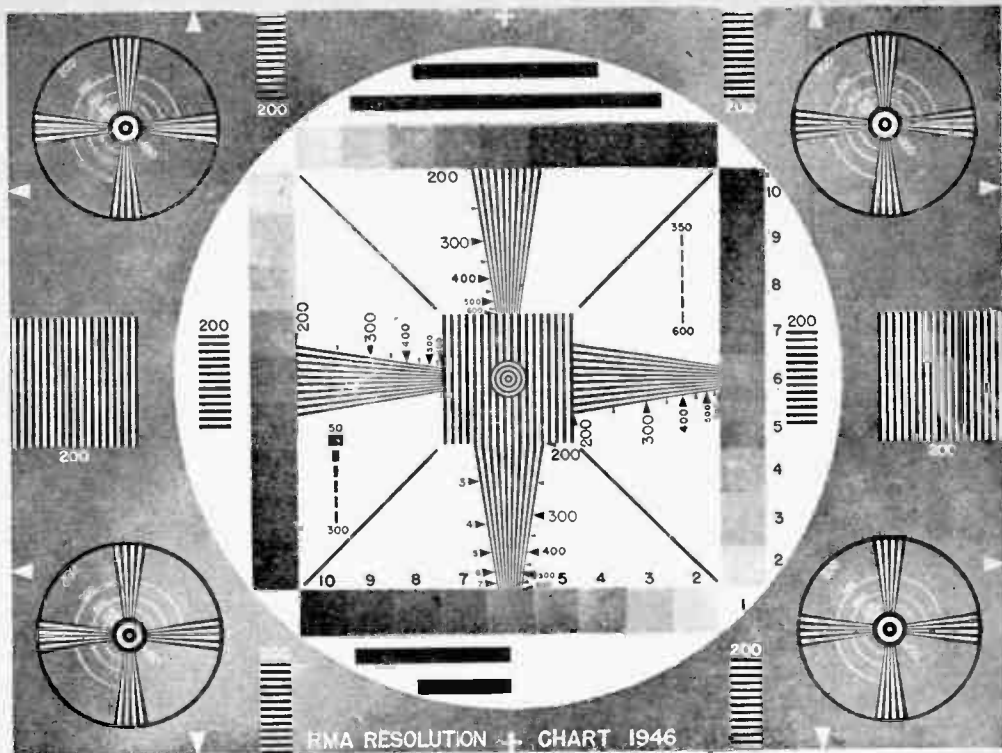

RMA RESOLUTION CHART 1946

How Good Is Your TV Picture?

IN TELEVISION it is no exaggeration to say that the picture tells everything. And the one picture that tells more than any other is the test pattern used by all stations. It is transmitted for some part of every broadcast day as a service to set owners, technicians, and station engineers.

An elaborate form of test pattern—more accurately known as a “Resolution Chart”—is shown above. It was designed by the Radio Manufacturers Association to standardize resolution measurements—that is, the

amount of detail that can be seen on the screen.

You’ll recognize many elements of this chart in the more common test pattern pictured below. The basic structure of both is made up of horizontal and vertical wedges in which the lines get thicker as they fan outward. Wedge lines in the pattern are so drawn that the lines and spaces tend to blur if the picture is being improperly transmitted or received. This gives you an immediate visual check of your receiver.

Another important element in the test pattern is the gradation of tones. In the resolution chart, this is shown in squares ranging from almost white to black; the simpler form uses a series of concentric circles.

All patterns have some circular element. These should appear as true circles on the receiving screen if the picture is to be free of distortion.

By watching these three elements on your test pattern, you can tell how well your picture is coming in. A poor picture often indicates poor adjustment of controls. The photos on the next page show the more common misadjustment patterns.

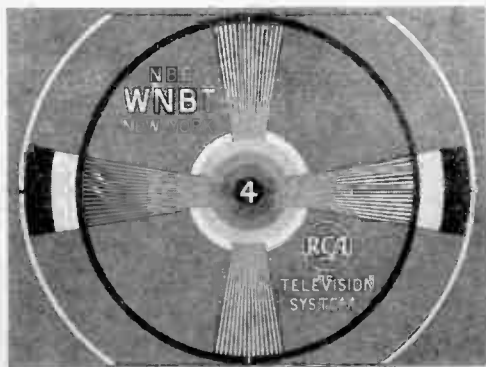

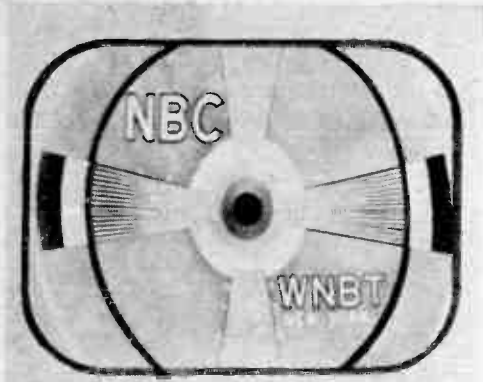

Height control is misadjusted. Notice the elongated circle showing that the picture is stretched out vertically. The adjustment is one of the "fixed controls" at the back of set.

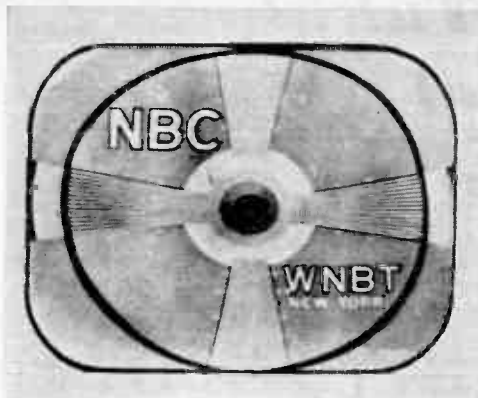

Width control is set wrong here. The squashed appearance of the picture tells the story. This control is also in back. They're put there because they only have to be set once.

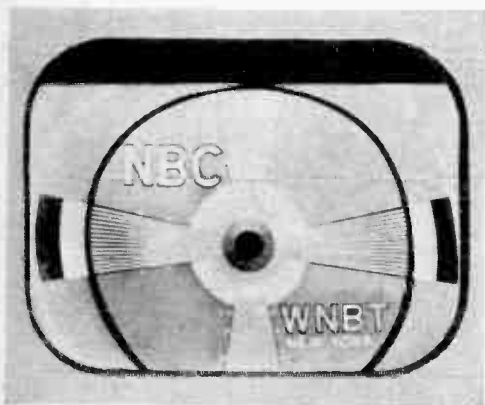

Vertical centering here just isn't centered. It would be the same if the picture went off screen at the top. This is also a rear control but is not made accessible on all types of receiver.

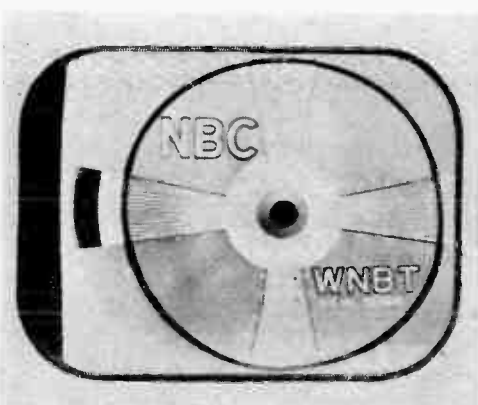

Horizontal centering, like the vertical, brings the picture frame inside the limits of the mask. Misadjustment of this control could also push the picture to the left. Usually a rear adjustment.



Focus is important to a good picture. A clear picture is obtained by sharpening the cathode-ray spot. Most sets have a variable focus adjustment. Sometimes it's in front, often in back.



Sound bars break up a picture as shown. They are particularly common on sets using the same intermediate-frequency circuit for sound and picture. Fine-tuning adjustment clears it up.

Taking Care of a TV Set

These basic servicing procedures you can do yourself will improve image quality and prevent breakdowns.

YOUR television set is a complicated machine, but that doesn't mean it has to be a mysterious one. The more you know about how it operates and why, the more you can save in needless service calls. Even when there's nothing wrong with the set, you'll often find that a few careful adjustments will make it perform better than it did before.

This doesn't mean that you ought to go barging into the set's innards with a blowtorch and electric drill. But so long as you know what you're doing and do it carefully, there's a good chance that you can raise the television standards in your house.

If you plan to do any work on your set at all, the first thing you should know is how to handle the picture tube—especially if it's an all-glass tube. There's a high vacuum inside the shell, and if anything damages the glass, the tube is liable to shatter with explosive force. (What happens is actually an "implosion", not an explosion, but the flying glass fragments are just as dangerous either way.)

It doesn't happen often, to be sure, but tubes do blow up. So play it safe and handle the tube with that possibility in mind. That means, first, that you ought to wear shatterproof goggles and heavy gloves. It means, also, that you must always handle the tube by the bulb—never by the neck. If your set is so constructed that the face of the tube is not supported when the chassis is out of the cabinet, make sure that the bulb is propped up when you're doing out-of-cabinet servicing. One or two books will support the tube face and keep the neck from straining inside the deflection and focus yokes.

The correct method of handling the tube is shown above. There's one other important point to consider. When you remove a tube from a set, you have to disconnect the base socket *and* the high-voltage lead. The latter is a small plug, usually enclosed in a rubber cup. It is attached to the tube at the lower part of the bulb. This lead carries

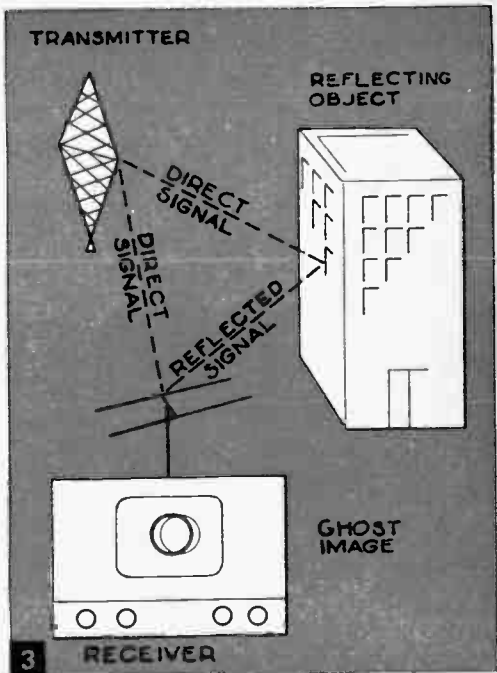
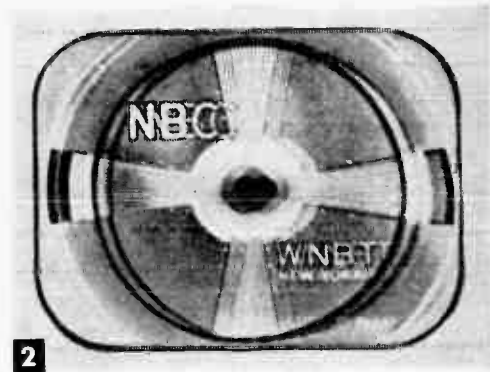

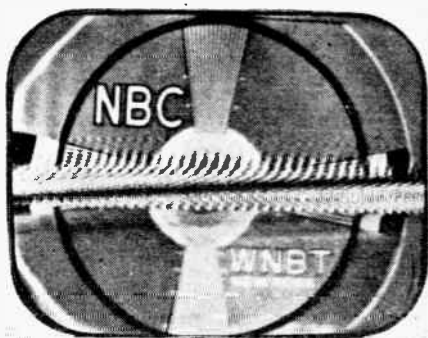
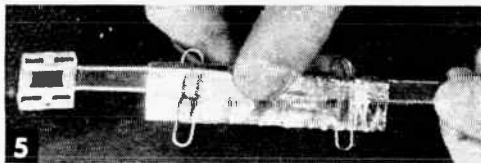
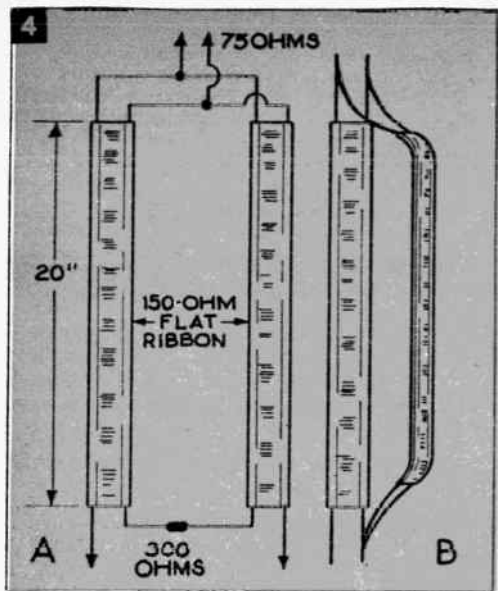

many thousands of volts when the set is on. It may also carry a whopping voltage even after the power is off.

Be safe! Before you do anything with the picture tube, disconnect this lead—touching only the rubber part—and ground the metal contact to the chassis.

The picture tube does an enormous amount of work, but it is not the most over-worked tube in the set. The horizontal sweep tube that regulates the voltage used to pull the electron beam across the face of the picture tube has to do more work.

It's not surprising, therefore, that this tube gives out more frequently than most others. When this tube goes bad, the picture shrinks to a single vertical line running up and down the tube face.

A little foresight can keep you from missing out on an exciting program. Keep a replacement for the horizontal sweep tube on hand. Best way to find out which it is in your set is to consult the manufacturer's service manual. Usually it is a dual triode or power pentode such as a 12SN7 or 6K6.

The antenna is another thing that deserves your attention. It can cause trouble at many points between the roof and the picture. Ghosts or double images are pretty sure indications of antenna trouble. In most cases ghosts show up on one or two channels only. The rest come in clearly.

A common variety of ghost is shown in Fig. 2. It is actually caused by a subsidiary image that reaches your set a few micro-

seconds (millionths of a second) after the true image.

Ghosts are produced as shown in Fig. 3. The signal from the transmitter goes in all directions. Part of it goes straight to your set; another part first hits a building or other object that reflects it toward your receiver. The second, or reflected image has to travel further, and therefore arrives later. Sometimes there are a number of reflecting surfaces, and therefore a number of distinct, displaced images.

For ghosts caused by this type of reflection, the practical cure is to reorient your antenna. A more directional array may be needed to cut out reflected signals coming from an angle. Adding a reflector behind the dipole sharpens the response of the antenna in the favored direction.

Ghosts, however, often creep in *below* the antenna. The usual complaint of set owners is that the signal doesn't come in strongly enough. There are cases, however, where the trouble is caused by too much signal. One of the symptoms of this trouble is a ghost image.

In the ordinary type of ghost, the weaker image is seen to the right of the true image. But strong signal may cause a "leading" ghost in which the false image is displaced to the left.

This trouble sometimes occurs when the set is located close to the transmitter and has a long lead-in from the roof. If the RF or detector circuits of the receiver pick up

the signal directly, this false image will come in ahead of the main one.

Aside from the left-hand displacement, you can often tell a leading ghost from the fact that the picture changes when someone walks near the receiver. If your set displays this fault, check your transmission line to make sure that the signal isn't losing too much strength coming down from the antenna. A fairly sure cure, also, is to shield the chassis with a grounded metal sheet.

Losses in the transmission line may be due to many factors. The most prevalent one is mismatching. Proper matching between antenna, transmission line, and receiver is important if you want to transfer all the energy possible from the antenna to the set.

A simple dipole usually has a radiation resistance of 72 ohms at the center. Your receiver input is also designed with a certain characteristic impedance. It may be 50 ohms, 72 ohms, or 300 ohms. The same is true of the transmission line. Coaxial cable, flat-ribbon lead-in, or twisted pair should be selected so that its impedance will be as close as possible to both set and antenna.

If your line is poorly matched, there are several things you can do about it. First try a simple matching transformer made from a few inches of 150-ohm flat-ribbon lead. Connect two lengths as shown in Fig. 4. Try method A, and then method B.

Another device is shown in Fig. 5. Wrap the foil from a cigarette package around the transmission line near the set. Secure it with a paper clip, and slide the wrapper slowly away from the antenna terminals on the receiver. Watch the picture carefully as you do so. At some point the picture will probably brighten up if the line is badly matched. Leave the wrapper clipped at the point of greatest improvement.

Some interference, such as that shown in Fig. 6, is caused by "transmitters" that just send out noise instead of pictures. Motors, auto-ignition systems, and the like, are common offenders. The pattern illustrated is caused by diathermy interference.

There's very little you can do about this type of interference if it is strong. Try changing the orientation of the antenna. Or if you are using an indoor antenna, switch to a rooftop rig. A stronger signal often helps to overcome the interfering one.

Noise signals, fortunately, are usually of limited range. It may be, for example, that

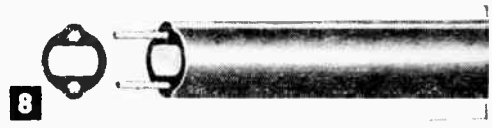
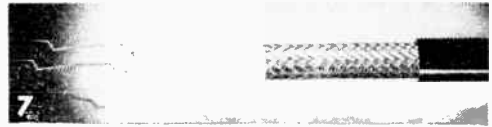

they do not reach clear up to the antenna at all. Instead they may be picked up by the transmission line at some point below the roof. In cases like this a shielded coaxial cable or twin lead will help. Shielded 300-ohm line is shown in Fig. 7.

Deterioration of lead-in due to ageing, moisture, dirt, and the like (especially in salt-air localities) may cause a gradual worsening of reception. A weatherproof type, shown in Fig. 8, is relatively immune to the elements. Try it if your reception falls off in bad weather.

In strong-signal areas it is often possible to do away with an outdoor antenna altogether. If you use an indoor dipole, you may find it possible to improve reception by adjusting the length and plane of the arms. Usually indoor aerials of the type pictured in Fig. 9 are used with the arms arranged symmetrically. This isn't always the best way. Unequal arms may help clear up ghosts. Correct rotation also makes a big difference.





Fifty hours, from carton to cabinet, was the building time for this set.

I Assembled My Own TV Set from a Kit

You don't have to be an expert to wire up a television kit, but knowing a little about radio is a big help.

By Robert Gorman

PS photos by Hubert Luckett

LIKE everybody, I had been hearing about TV kits. I've spoken to people who have built them and asked lots of questions. Adding up the answers, it seemed to me that one man's experience cancelled out another's. "Anyone can wire up a kit," said some. Others cautioned, "Don't try it unless you know some electrons by their first name."

"How are the instructions?" I asked. "They're a cinch." I was told, "if you're a graduate engineer with radar experience." But the other side also had its say: "The diagrams are clear. You can understand them even if you don't know the difference between a 1-meg. pot and a drip pan for grid leaks."

The only sure fact I had to go on was that in every case that came to my attention the

kit builder was either an expert radioman, or he had an expert standing at his elbow.

I'm no expert. I've built a couple of simple receivers and phono amplifiers. I know how to read diagrams, and because I can count from one to eight I can distinguish the prong connections on a tube socket.

I assembled a TV kit. It works fine.

When I decided to try TV kit building, my first problem was to select the kit. Conceivably I could have made a study of the different types on the market, but a comparison of their fine points would have put a strain on my technical knowledge. I had heard good reports on the RCA 630 TS receiver—a 30-tube job—so arbitrarily I fixed on one of the kits embodying this circuit. There are several such kits, so I had to be arbitrary again. I picked the one that was then the lowest in price and had the most parts mounted. It's the RCA-type kit marketed by Lafayette-Concord Radio, a large mail-order supplier. Complete with all tubes including a 10" picture tube, it sold for \$195.50. A cabinet to house it is also available for \$42.50.



1. Here's the kit unpacked from its cartons. There are a lot of loose parts despite the fact that all the major ones are mounted.



2. Emptying the envelopes shown at the left reveals this bewildering array. There are 108 resistors, 77 capacitors, and 11 coils.

As I tumbled the parts and packages you see in photo 1 out of the shipping cartons I couldn't help feeling how nice it would be to forget the whole thing. That feeling didn't diminish when I unpacked the eight or ten envelopes and got a look at the hundreds of resistors, capacitors, and coils, plus miscellaneous wires, knobs, hardware, and many mysterious parts. There's no organiza-

tion of the components—they're all there, but separating the pieces and relating them to the circuit is the builder's job.

The instructions that are provided also give a minimum of orientation. You get an RCA service manual and a couple of mimeographed sheets of parts lists, color-code information, and instructions for connecting the previred tuner section. Most

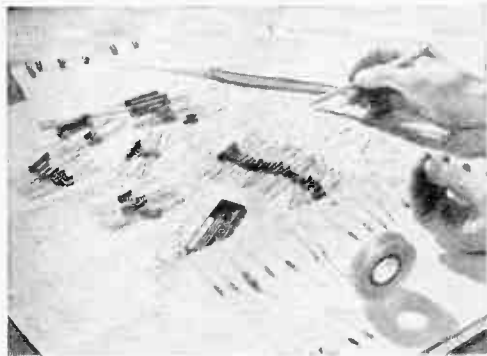

3. Organizing the items is a chore. I marked the value of each one on the diagram and taped the parts down in order on separate sheets.

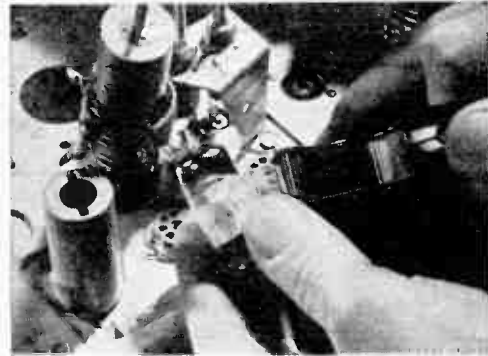

4. Removing the tubes isn't necessary, but I thought it was safer. In the tuner each must be marked for return to the identical socket.

5. Chassis layouts in the service manual give much useful information, including the function and location of each of the 30 tubes.

6. As an aid in wiring, I marked the parts on the underside of the chassis as well. It was helpful in locating terminals quickly.

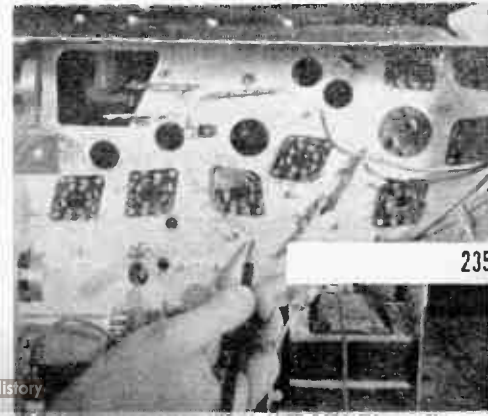

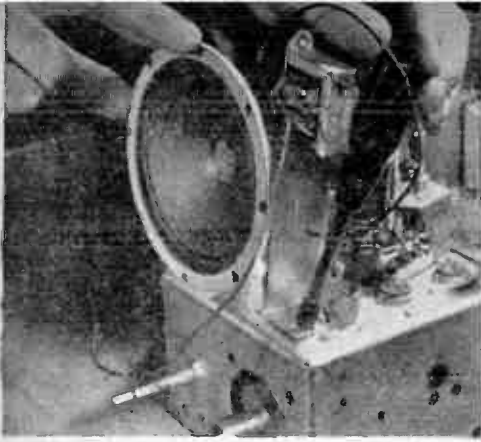

7. Speakers are fragile. This one has four leads which can be soldered in at the very end. I removed it for safety during the main job.

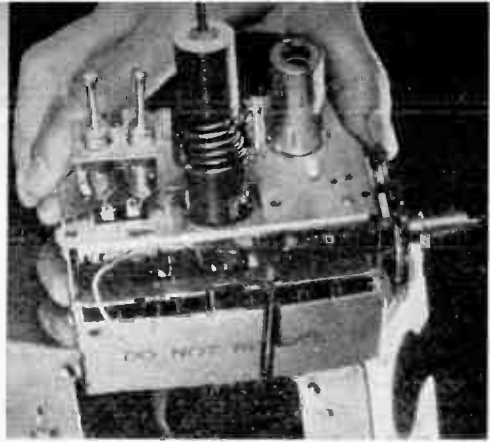

8. Do not remove is what it says, but I could not complete the wiring in this crowded corner without first unbolting the tuner.

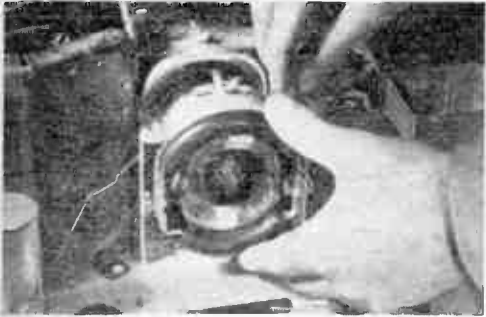

9. The deflection yoke is held in a U-bracket by two wing bolts. They have to be taken out to complete internal wiring on the yoke.

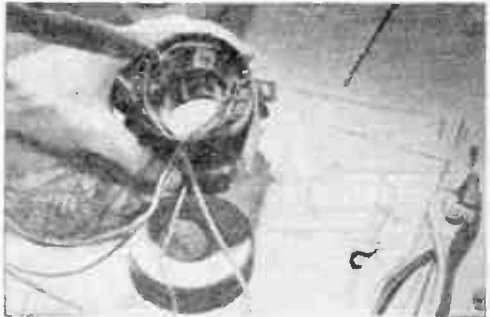

10. Two resistors, a condenser, and four wires are soldered into the back of the yoke. Details are furnished in a corner of the diagram.

important, there are six full-size pictorial diagrams showing the mounted parts in black and the wiring overprinted in red. Each of these sheets has a different set of connections, broken down for wiring convenience. Because of their size and the red overprinting, they are easy to read and follow. The RCA book has a good deal of

11. As a precaution against burning out the high-voltage transformer should one tube go bad, I wired in a No. 47 pilot light as a fuse.

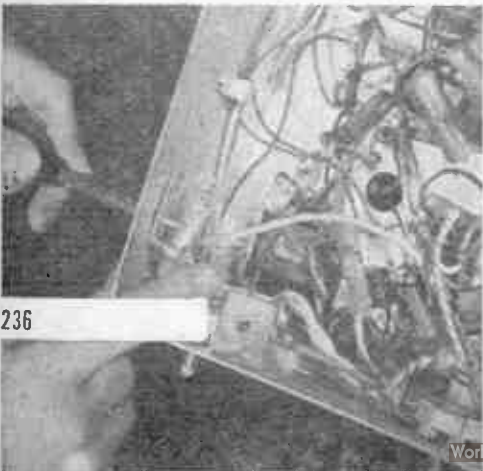

additional information. I found a couple of minor changes from the RCA diagram; there are also one or two errors that had been corrected in pencil on the sheets.

By way of getting started, my first step was to arrange the small components according to wiring sheets. The experienced man may scoff at my system, but I found it helpful. I went through each diagram and the parts lists, marking the value of each part next to the code number printed in red. At the same time I picked out that part and taped it to a sheet of plain paper, marking the code number alongside it (photo 3). By first separating the resistors into piles according to the first band of color, I was able to pick out the proper one fairly quickly. For example, if I was looking for a 6,800-ohm resistor, I had only to glance through the pile containing those with blue bands, meanwhile looking for a gray second band, and so on. With the parts taped to sheets, I didn't have to hunt for a single piece while doing the actual wiring.

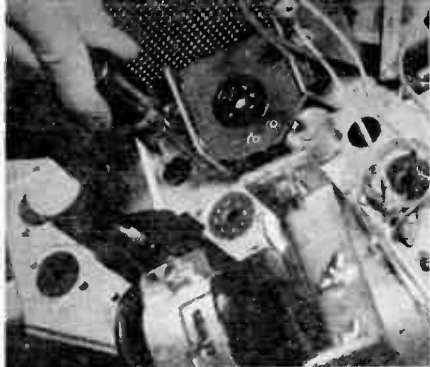

12. The high-voltage rectifier is placed on an insulated platform inside a shielded compartment. Remove the platform to wire the socket.



13. Corona—a kind of electron halo that occurs at high voltages—is minimized by removing the unused rectifier-socket prongs. One twist and they drop out.



14. After mounting the parts and soldering in the corona ring, I dabbed the terminals with cellulose cement for extra insulation.

To minimize the risk of breakage in handling the cumbersome chassis, I removed all the tubes. A band of transparent tape over the number on the glass insured against it rubbing off in handling. The front end or tuner section, which comes completely wired and aligned, uses three 6J6 miniatures. It's essential that each tube be restored to its original socket. Photos 4 and 5 show how I marked each tube and socket with precise identification.

With these preliminary details attended to, I just had to buckle down to the serious business of wiring the chassis and soldering in a couple of hundred loose pieces. On this subject, too, I had heard all sorts of conflicting reports. The best time estimate I got was eight hours, but most of the people who quoted this figure had it at second hand. Reliably and at first hand I got approximately this time from two people—both experts who had wired a number of kits. One of them had a helper read off the diagrams while he worked.

However fast others may be, I have to report that my wiring time exceeded four times the estimated eight hours. I'll tip my hat twice to anyone who builds his first kit, alone, between sunup and sunup. There are about 400 pigtail leads to solder on the loose components alone, and another couple of hundred on the wiring and ground connections. Going strictly by the book, I tried clinching every lead before soldering it. That makes a big difference in time—the fast radiomen I spoke to didn't clinch the wires; they merely pasted them to the lugs with solder.

Incidentally, most of the lugs to which connections are made in the early sheets get additional leads in the later ones. On tube sockets it is therefore advisable to make

the initial connections to the lower of the two holes, saving the top one in case another wire has to be brought to it. It's also important to keep leads as short as possible in any high-frequency radio work. I aimed at this but didn't succeed too well, as you can see in the close-up photos of my chassis. While we're on the subject of soldering, remember that rosin flux is conductive at high frequencies. If you decide to build a TV kit, use as little rosin as you can get away with and wash off any excess with alcohol. Rosin-core solder is okay; it eases the work

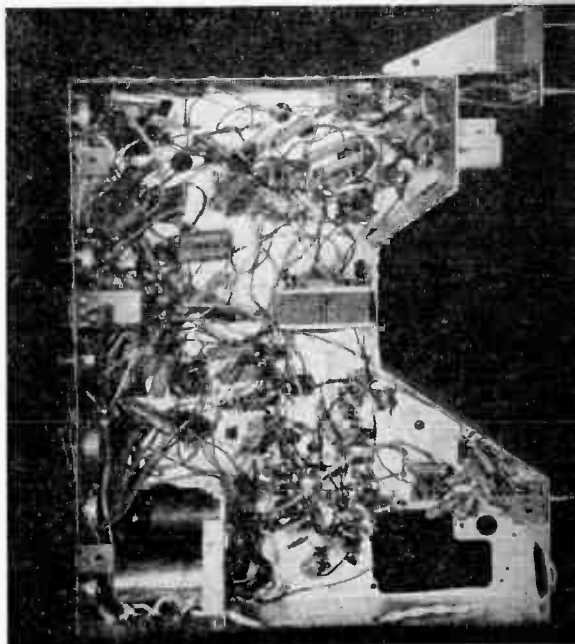

15. Wiring took a long time and was a tedious job. Professionals will scoff at these long leads. They should have been kept shorter.

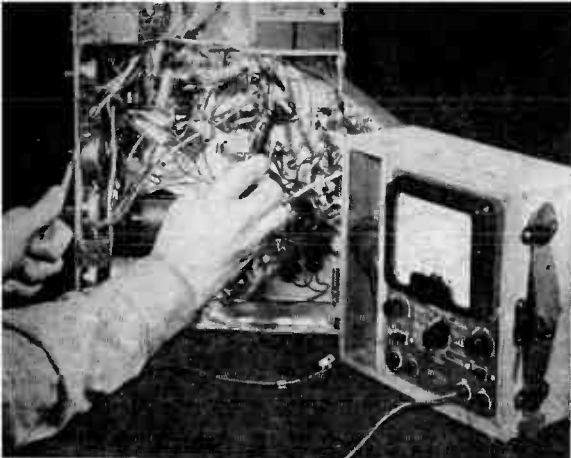

16. Checking for shorts is an important precaution. Test from B-plus to ground, AC to B-plus, and from both AC leads to ground.

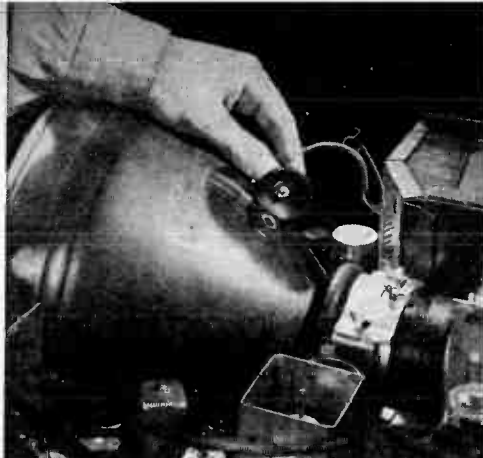

17. Danger! 9,000 volts of it! The anode cap is the hot spot on top of the chassis. It holds a charge long after the power is turned off.

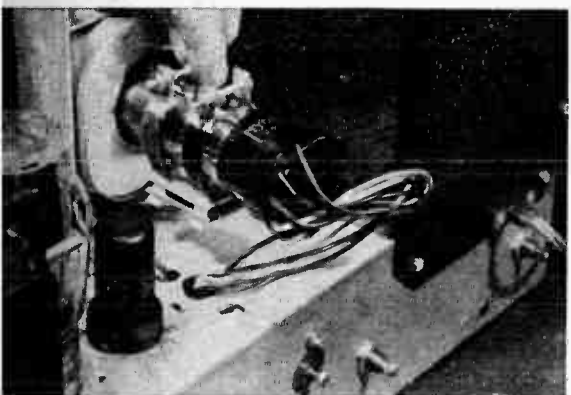

18. The ion trap on the neck of the tube is adjusted for brightness. Six other controls at the back are also set to get the best picture.

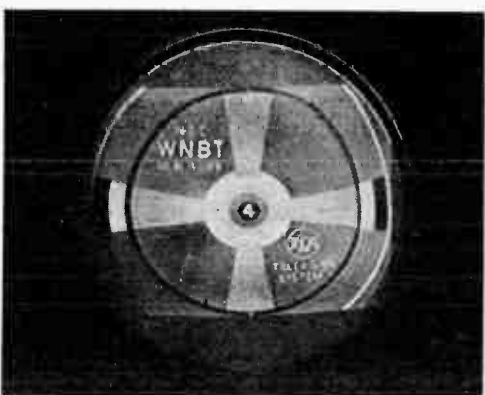

19. Success! A lot of work and worry went into assembling this kit, but that clear, sharp test pattern made it all seem worth while.

and doesn't contain enough paste to do much harm. No shielded wire is needed in the hookup. I started with a full-size 100-watt soldering iron. Along about the middle, as the chassis started to crowd up, I switched to a pencil-size iron and used it almost exclusively in the tight corners.

The deflection yoke through which the neck of the picture tube passes has to be removed from the top of the chassis. Two wing bolts are all that hold it. The back, which is a cardboard cover, slips off so that two resistors, a condenser, and four wires may be soldered in.

Discussing the construction of this kit with some men who know it well, I picked up a couple of tips that may be worth passing along. Servicemen have encountered some trouble with sets and kits of this type because the 6BG6-G horizontal-sweep output tube sometimes becomes defective and starts to draw excessive current. Since the

plate of the tube is in series with one winding of the high-voltage transformer, the extra current also flows through the transformer. In most cases this results in a burnt-out transformer—and an expensive repair job. To reduce this hazard, I inserted a No. 47 pilot light in series with the transformer lead to act as a fuse. Photo 11 shows how I attached the bracket beneath the chassis. The lead from terminal 1 on the transformer to pin 6 (a dummy pin) on the 6K6-GT horizontal sweep oscillator is opened and the lamp wired in. Excess current burns out the bulb.

Another useful trick—although less generally known and applied—concerns the mounting of the 1B3/8016 high-voltage rectifier. This tube puts out better than 9,000 volts. As a result, the socket connections around the base are subject to a high-voltage discharge known as "corona." One method of minimizing corona is to remove

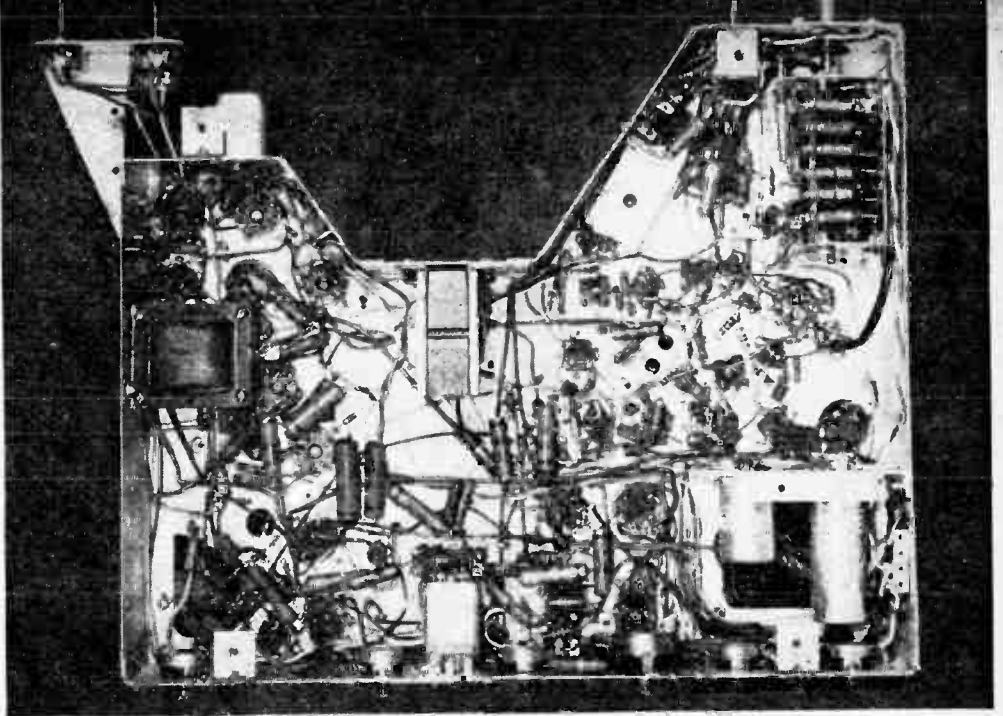

20. This isn't my set. I wish it were, not because it works better than mine but because I'd be proud of the wiring. It was assembled by

Melvin Pollack, Lafayette's chief service engineer. Note short, neatly dressed leads and compact arrangement of small parts.

the extra lugs from the bottom of the tube socket. Only three of them are needed, so the others can be twisted slightly and pushed out through the top of the socket (photo 13). The necessary parts and wires are then soldered in, and the corona ring is sweated into the two anchor points on the mounting plate. Excess solder and rosin is scraped out and the anchor lugs are coated with cellulose cement.

When I finally finished the wiring I had to agree with the most enthusiastic kit builders. It's not hard. It was, for me, a long and tiring job, but it's certainly possible for a semiskilled experimenter to get it done.

After checking the wiring carefully, I made a couple of safety tests before plugging in the set. To check for shorts you need an ohmmeter (photo 16) or a continuity tester. The main points to test are B-plus shorts (touching one meter prod to the chassis and the other to two or three electrolytic-capacitor terminals), shorts from AC to ground, and from AC to B-plus. If you get no reading at these points, it is reasonably safe to plug in the set. It may not work, but the chances are that no serious trouble will result.

Handling the picture tube calls for spe-

cial precautions. Hold it only by the large bulb, never by the neck, and don't try to move the set while the tube is in. When using the tube out of a cabinet, prop a medium-size book under the face end to support the weight (in a cabinet it is held by cushioned brackets). When the set is turned right side up and all the shields are in place, the main danger spot is the second anode cap (photo 17). There's over 9,000 volts there, so keep clear of it if you value your health. Make sure the power is off when handling the cap—but even that isn't enough. The high-voltage capacitors store a charge and can give you a jolt long after the switch is turned off. After removing the cap from the tube, hold it a half inch from some piece of grounded metal to draw a spark if any energy remains. Bring it closer until it touches the metal. Make sure that the cap is either in the tube or clear of any possible ground when the power is on.

The ion trap, being adjusted in photo 18, and the six controls along the rear edge of the chassis must be set for the best image. Once they are tuned for your antenna and location, nothing has to be done to them. All further tuning is done by the seven controls in front.

Antennas for FM and Television

Signal strength may be good on the rooftops, but for good sound and video reception you have to pull it in and get it downstairs.

THE TWO most important parts of your television picture are your antenna and receiver—in that order.

Sure, there are differences in set design and construction. Some are better than others. But any modern set is capable of putting together a good image. All it needs is enough broadcast signal to work on. It's the job of the antenna to provide the signal.

Even if you have a professionally installed rig on your roof, it will pay you to know a few basic facts about FM and TV antennas. They will help you to add to or modify your existing arrangement to improve your set's

operation and bring in difficult stations.

Electromagnetic waves are basically alternating currents that travel through space at the uniform speed of 984,000,000 feet a second. The thing that distinguishes them is their *frequency*, or the rate at which they alternate.

The distance that a wave travels in one complete alternation—or cycle—is called its wavelength. It follows that the more rapidly a current alternates—that is, the higher the frequency—the shorter its wavelength will be.

Now, the reason wavelengths are so important is simply this: as a radio signal is broadcast into space, it showers its energy all about. Any rod, wire, or other conductor it meets absorbs some of that energy. But maximum energy is transferred when the length of the conductor corresponds to the length of the transmitted wave.

It is known that the most practical and efficient length for an antenna is half the length of the wave. In practice antennas are made 5 to 7 percent shorter than a half wave to compensate for certain undesirable effects.

From the above figure you can derive a handy formula for calculating proper antenna length. The one commonly used is:

$$\text{Length (feet)} = \frac{468}{\text{frequency (megacycles)}}$$



For best results the half-wave dipole should extend as high as possible above the building. A simple dipole and coaxial-cable transmission line is shown in Fig. 1. You can use other types of low-loss feeders in place of coax. Dipoles are directional; they favor signals coming from the direction of blocked arrows.

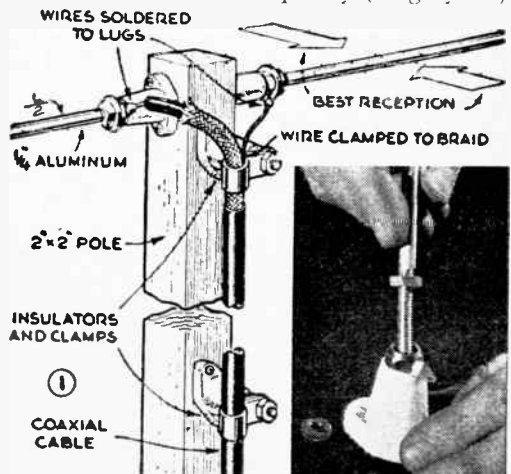

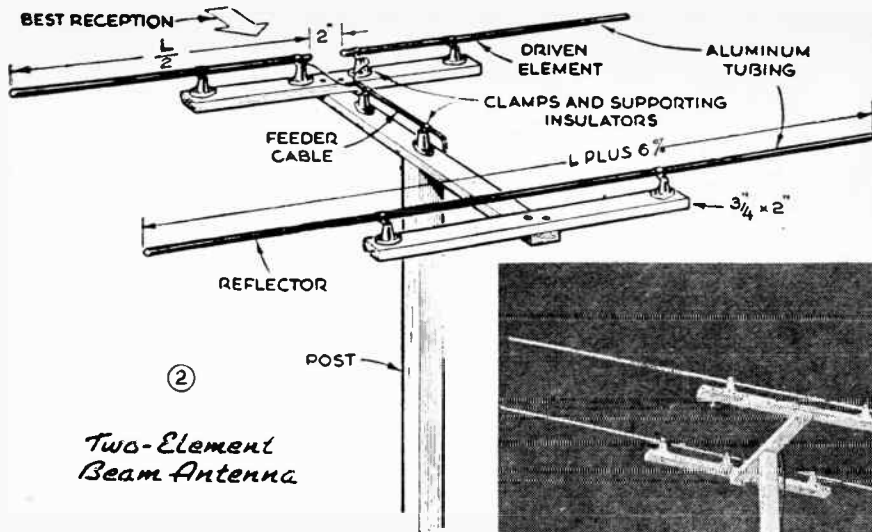

Two-Element Beam Antenna

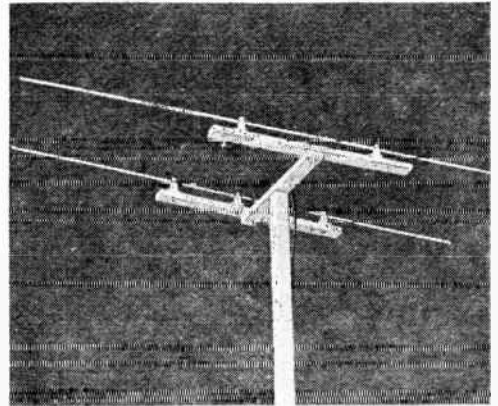

As can be seen in the drawing above, the two-element beam antenna consists of a half-wave dipole, now called the driven element, and a reflector. The latter isn't connected.

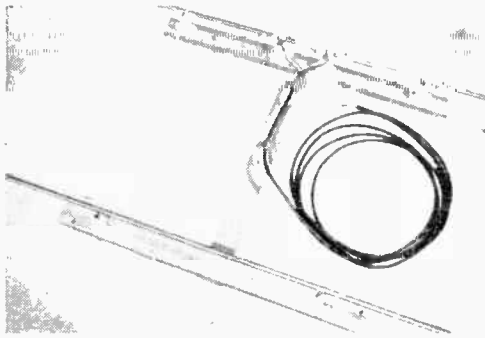

A two-conductor feeder cable is illustrated at the left. One conductor is soldered to each half of the dipole; the other ends go to set.

The basic form of the TV and FM antenna is the half-wave dipole shown at the left. As you can see, the half wavelength is made up of two equal arms extending outward from the center. Each arm, then, is equal to the corrected half wave divided by 2. The table at the right gives the length for various channels: "L" represents the total length of both arms.

It is convenient to use the total length in the table because other elements of an antenna, such as reflectors and directors (which will be discussed below) can also be calculated as fractions of "L".

Proper length is one key factor in antenna construction. Another is the way in which high-frequency waves travel. They move in straight lines and are reflected by flat surfaces. When it comes to building an antenna, you also want to take into account such things as elevation, neighboring buildings, distance from transmitters, and strength of the signal in your location. If you live

Channel or band	Frequency (mc.)	"L" (Total length of both rods of dipole — inches)
2	54-60	98
3	60-66	88
4	66-72	80
5	76-82	70
6	82-88	65
7	174-180	31
8	180-186	30
9	186-192	29
10	192-198	28
11	198-204	27
12	204-210	26
13	210-216	25
low band (2-6)	54-88	78
high band (7-13)	174-216	28
all band (2-13)	54-216	60-65
FM	88-108	56

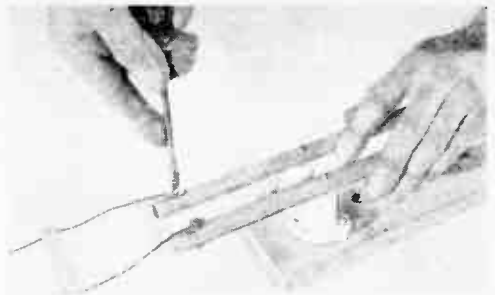
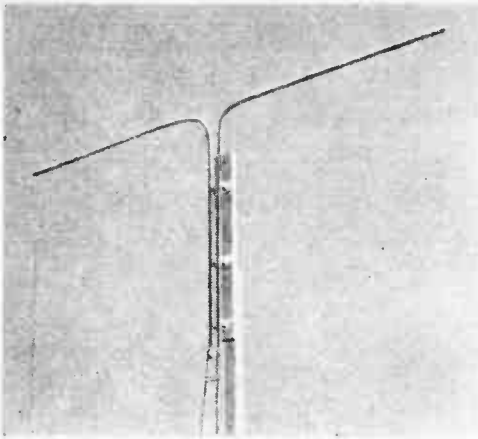

The half-wave open-wire antenna is constructed from two lengths of $\frac{1}{2}$ " to $\frac{3}{4}$ " aluminum tubing. Make a 90° bend at the midpoint of each tube to form the Q-matching transformer.

Space the open-wire line with a sufficient number of 2" plastic spreaders. Use insulators to keep the wire from touching the building.

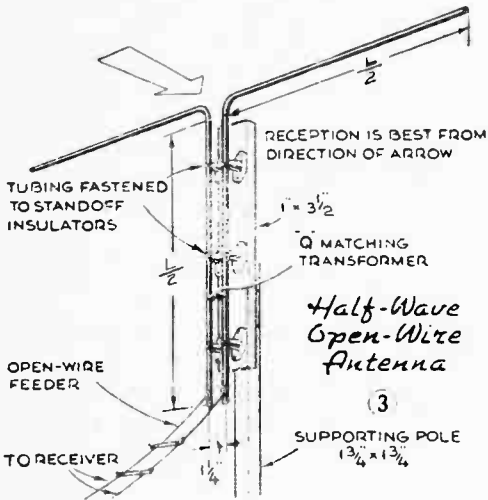
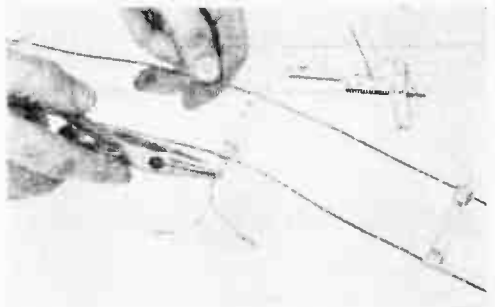

close to a broadcasting station you'll find the easily constructed half-wave dipole efficient.

The dipoles are made of $\frac{1}{2}$ " aluminum rod. After cutting them to length, thread one end of each $\frac{1}{2}$ "-20. Use two nuts to clamp the end into an insulator as shown in the inset of Fig. 1. Mount the insulators on opposite sides of a 2"-square wooden pole. Several types of feeders, or connecting wires, may be used between roof and receiver.

Most high-frequency antennas must be correctly aimed for best performance. To position your antenna, rotate it slowly while a helper tunes the receiver and signals to you when all stations come in best.

Farther from the center of a service area the antenna must be more sensitive to signals coming from the chosen direction and capable of cutting off noises from the rear. The two-element antenna of Fig. 2 is designed for that job. The addition of a re-

flector behind the dipole gives a much higher ratio in the favored direction. It can be made of aluminum rod or tubing from $\frac{1}{2}$ " to $\frac{3}{4}$ " in diameter.

Transmission lines from antenna to set generally drop off in efficiency as a result of age and weather. While coaxial cable is quite durable, it may prove to be a bit expensive, especially if the receiver is located at any great distance from the roof.

You can make a low-cost, long-lasting feeder line of ordinary No. 14 enameled copper wire, but to link it to the antenna you will need a simple Q-matching transformer. This is nothing more than two vertical legs. The combination is the half-wave antenna, open-wire line shown in Fig. 3. Bend two aluminum tubes and bolt them to standoff insulators through $\frac{3}{16}$ " holes drilled in the tube walls. The vertical portions of the tubes must be perfectly parallel and spaced 1 $\frac{1}{2}$ " from center to center.

Another popular and efficient transmission line is the flat ribbon-type lead. For difficult reception, the choice is almost always between this and coaxial cable.

It isn't always easy to know what feeder

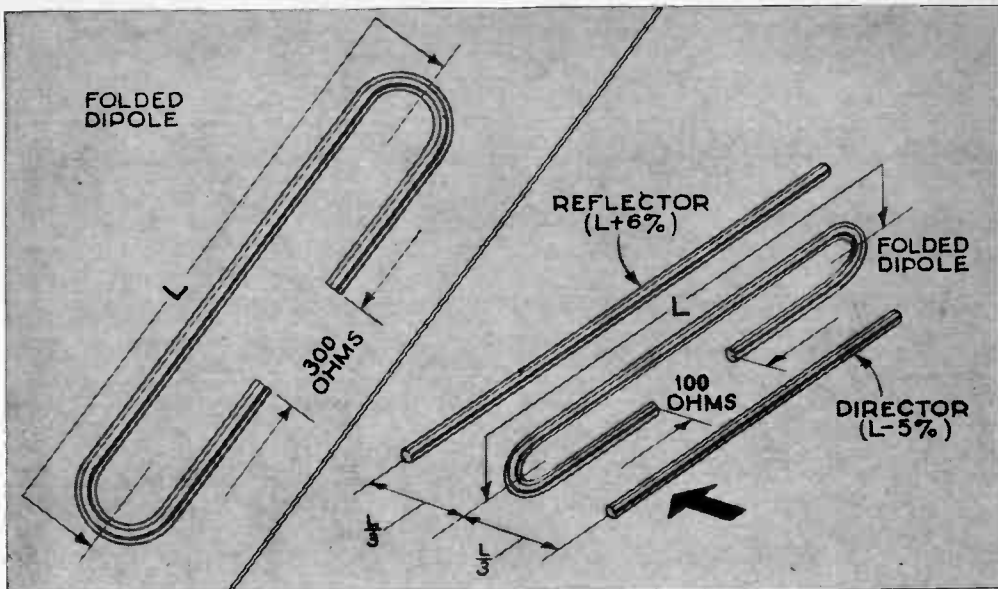

The folded dipole has a broad directional pattern, which is desirable in localities that have

several stations. The terminal impedance is higher than that of a conventional dipole.

to select, but the first things to consider are the input impedance of the receiver and the radiation resistance of the antenna.

A properly made antenna is essentially a tuned circuit. That is, it is *resonant* at the particular frequency for which it is cut. For its own frequency, a dipole almost always has an impedance of 72 ohms at the center.

Now, if a receiver has an input circuit matched for 72 ohms and it is connected to a properly tuned antenna by 72-ohm coaxial cable, you will obtain the most efficient transfer of energy from the roof to the set. Impedance matching thus becomes a vital consideration when you're dealing with such elusive things as television waves.

The most common receiver input circuits are matched for 72 or 300-ohm lines. You should know which yours is.

In virtually all cases you can get by with a certain amount of mismatch—say up to 100 percent. Beyond that you begin to pay for it in weaker signals.

Coaxial or flat-ribbon transmission lines are available in a number of ratings from about 50 to 300 ohms, with stops at 72 and 150 ohms. The higher values are usually ribbon types.

Now consider a dipole that is cut to half wavelength of television channel 2. Under ideal conditions it will have an impedance of 72 ohms—for the signal of channel 2.

The same dipole has quite a different value when it is receiving channel 6. Thus, even though you may match your transmission line correctly, it will remain correct only under specific conditions.

The terminal impedance of an antenna is affected also by its design. For example, a folded dipole (Fig. 4) broadens the response of the antenna, and also raises its impedance to about 300 ohms. Adding a reflector to a dipole, as in Fig. 2, sharpens its directional sensitivity and simultaneously lowers the radiation resistance. Using a reflector in back and a director in front (Fig. 5) drops the terminal impedance to a still lower figure (20 to 30 ohms for a plain dipole; about 100 for a folded type) while giving very high gain in the favored direction.

Directional sensitivity is an important consideration in antenna design. Let's assume there are three stations in your locality. Your present antenna may be bringing in two of these very well but giving only poor results on the third. It could then be well worth your while to erect a separate antenna for the single hard-to-get station. In this case the more directional you can make it the better it will be, since you can point it straight at the desired transmitter. You can also cut it to correspond exactly with the wavelength of the station.

Additional or special-purpose antennas

such as this may be mounted on the same mast as the existing ones. Bring the feed line down separately and connect it to the receiver through a selector switch, as shown in Fig. 6.

Until you've tried it you won't know how much or what kind of antenna you need. The unpredictable factors such as natural and man-made obstructions, radiated interference, as well as the considerations discussed above, make it practically impossible to know in advance what your reception is going to be like.

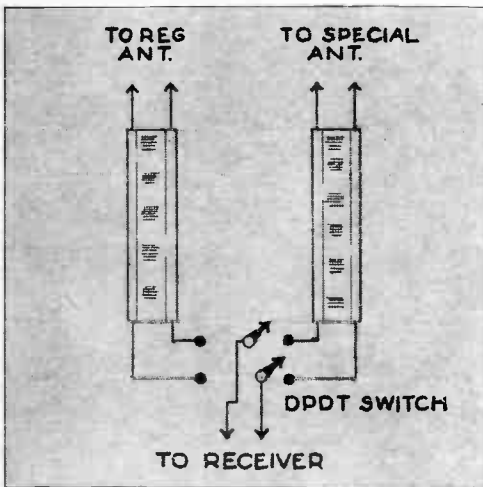

Where an extra antenna is used to bring in a weak station, use a separate transmission line and connect it to the receiver as shown. The antennas below and at right are indoor types for use in strong-signal localities.

You can, however, make certain guesses. Look into the experience of your close neighbors, ask the broadcasting stations about field strength in your location, and find out about the direction and distance of the transmitters.

All this information will provide you with a starting point. Then, whether you build or buy your equipment, start with the minimum reasonable amount. Try it out, and if necessary you can always add to it.

This applies even to commercial antennas, for most of them are so constructed that you can add additional elements as needed.

If you are located close to the broadcasting stations you may find that an indoor antenna gives adequate receptions. This can be important if you are an apartment dweller, for landlords are often reluctant to permit antennas to blossom out all over the roof.

One of the most satisfactory indoor antennas is the half-wave directional loop, (Fig. 7), since it can easily be turned to favor any station. Drill a hole 3" in one end of a dowel. Make the hole large enough to permit a free fit on top of a music or lamp stand. Twisted lamp cord or flat ribbon feeder is clamped to the ends of the aluminum semicircles. If twisted cord is used, keep the length under 12".

Where home decoration calls for a less conspicuous type of indoor aerial, the fixed-position half-wave antenna (Fig. 8) may do the trick. The flat wire can be concealed behind a bookcase, under drapes, or in a closet. If any choice of position is possible, make tests to determine which is the best.

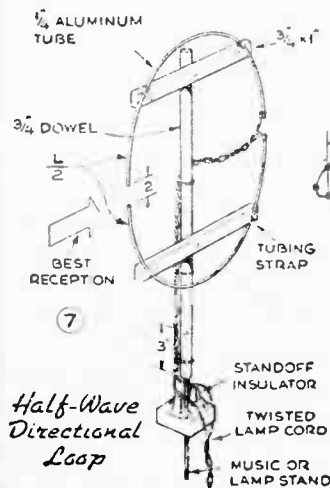
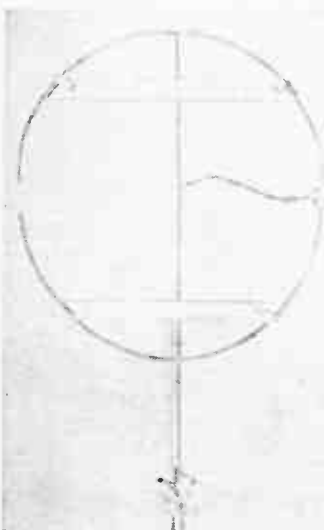

Half-Wave Directional Loop

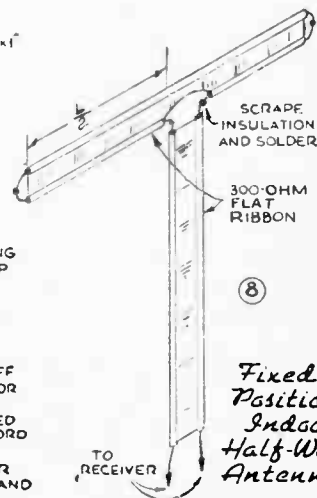

Fixed Position Indoor Half-Wave Antenna

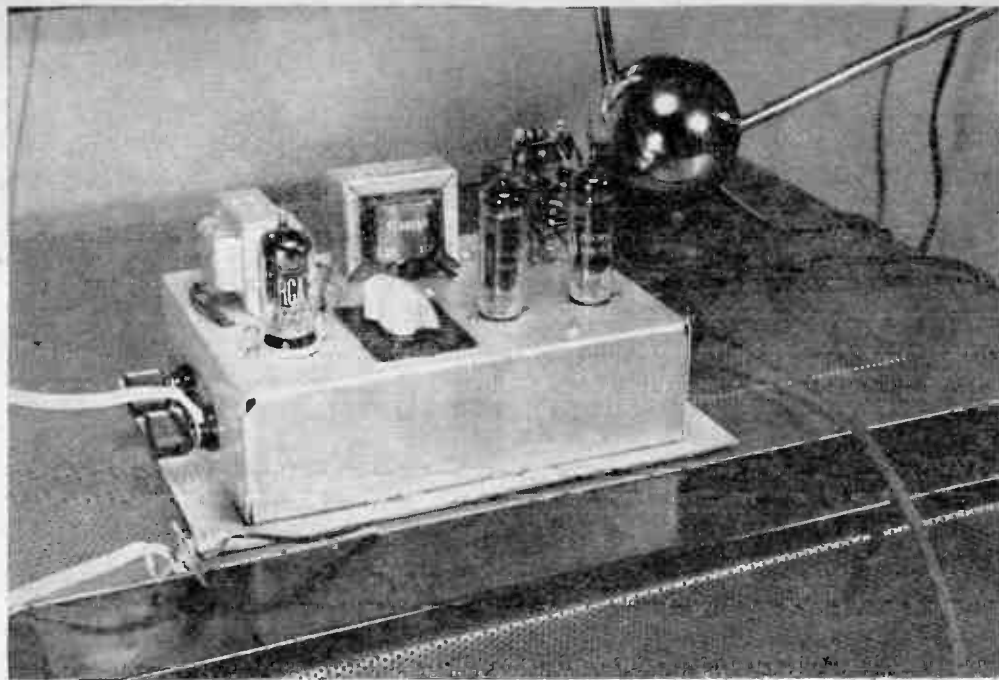

Amplifier is placed on top of TV set for tryout before being placed in its separate cabinet.

Improving Sound on TV Sets

Special audio amplifier lets you get maximum FM quality from the sound part of a television signal.

MOST television sets are bought on the basis of picture rather than sound, and both buyers and sellers have paid surprisingly little attention to the quality of the audio-output circuits. In the average set the sound is heard through an output tube and speaker such as you'd find in a small AC-DC receiver.

The sound part of a video show is broadcast and received by frequency modulation. That means it is capable of noise-free, full-frequency reproduction. All you need is a good speaker and a little extra power to drive it.

Works with All Sets

The audio unit shown here, consisting of a phase inverter and two output tubes in push-pull, can be attached to any TV set without touching the under-chassis wiring.

It has a tone control for reducing some of the objectionable high notes that you sometimes get on the sound track of old-time movies.

Parts for this 3-tube push-pull amplifier are mounted on a 2" by 5" by 7" chassis. As the photos show, there is ample room on top for the three miniature tubes, two transformers, and two selenium rectifiers. The under side is a little more cluttered chiefly because the half dozen electrolytic condensers are a trifle bulky. You may be able to save a little space and cost by using a dual unit for C8 and C9.

Mount Parts Carefully

The input transformer is the type used in intercoms. It is a shielded unit and has a primary of 4 ohms and a secondary of 25,000 ohms. A good place to mount it is right behind the 12AU7 phase inverter. The filter choke beneath the chassis is mounted directly below the input transformer. In fact the same two screws are used to hold both

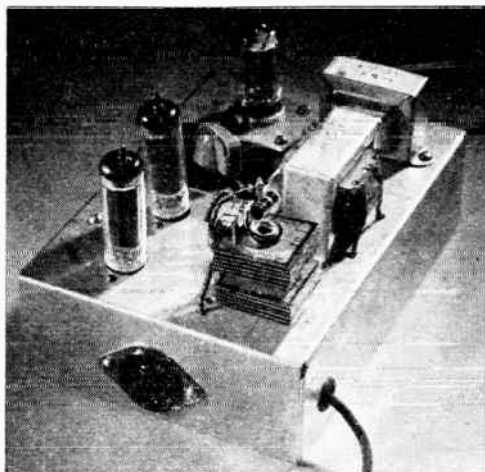

Top view of chassis shows placement of parts. Note how selenium rectifiers are mounted on a single screw that also holds terminal strip.

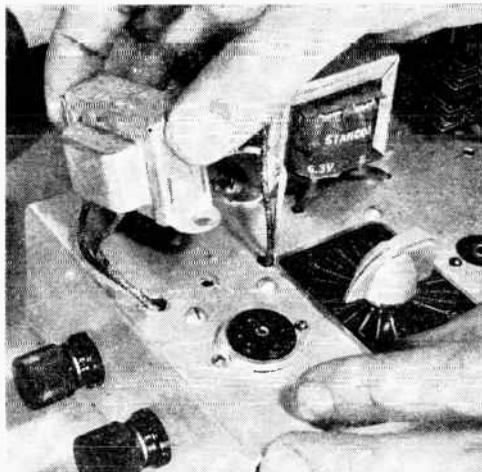

Mounting shielded intercom transformer used for input. It's placed behind 12AU7 socket. Leads are pushed through a hole in chassis.

units. It is only possible to do this if the mounting holes of the two units are spaced equal distances. It's not vital, though: if the units you purchase have different mounting centers, you'll merely have to drill two more holes.

To attach the two selenium rectifiers, you need a 2" long screw, preferably 6-32. First pass the screw through a 2-lug terminal strip, and then through the center hole in both dry disks. Put on a nut after this, and tighten up on the stack. You can even solder R13 and R14 in place before installing the rectifier unit. To do this, drill a hole in the chassis and fit another nut underneath. It's important to observe polarity when wiring the dry-disk units.

Electrolytics Go on Last

Leave the electrolytic condensers for the last so that you'll have plenty of room to complete the small amount of wiring that has to be done under the chassis. Fit the filter condensers in anywhere that you find space. They can be supported by their own leads, so no additional anchoring should be necessary.

The 25,000-ohm tone control, R5, is optional, and can be omitted if you choose. Should you decide to leave it out, also omit C3.

One important component that is not shown in the diagram is the push-pull output transformer. Mount this on the frame of the loudspeaker you will use with this unit and connect it to the amplifier by means of a

four-prong speaker plug. The 4-prong socket that receives it is flush mounted in one end of the chassis. Connections to the speaker transformer should be made as shown in the socket diagram.

Only two connections have to be made to the TV set itself. These go to the voice-coil—that is, the secondary—winding of the output transformer. They can be wired directly into the amplifier chassis or, as shown, to a pair of binding posts placed on the side. It is also necessary to disconnect the same two voice-coil wires from the speaker inside the TV receiver.

The 1,800-ohm resistor, R1, was placed across the secondary winding of the input transformer because the high sensitivity of the amplifier caused too much hum. This resistor actually reduces the input and thereby eliminates hum. The exact value for this resistor may vary from set to set. It can vary from 300 to 12,000 ohms. Start with the larger value and reduce it in small units until hum disappears. The lower the value, the lower the volume will be, but you'll still have enough sound power to fill a small hall.

Use Good PM Speaker

To get the maximum benefit from this unit, use as large a speaker as possible. It shouldn't be under 10". A good cabinet or baffle for the speaker will also help the tone. In combination with a good permanent-magnet speaker, this amplifier will give you lots of sound—and what you get will sound good.

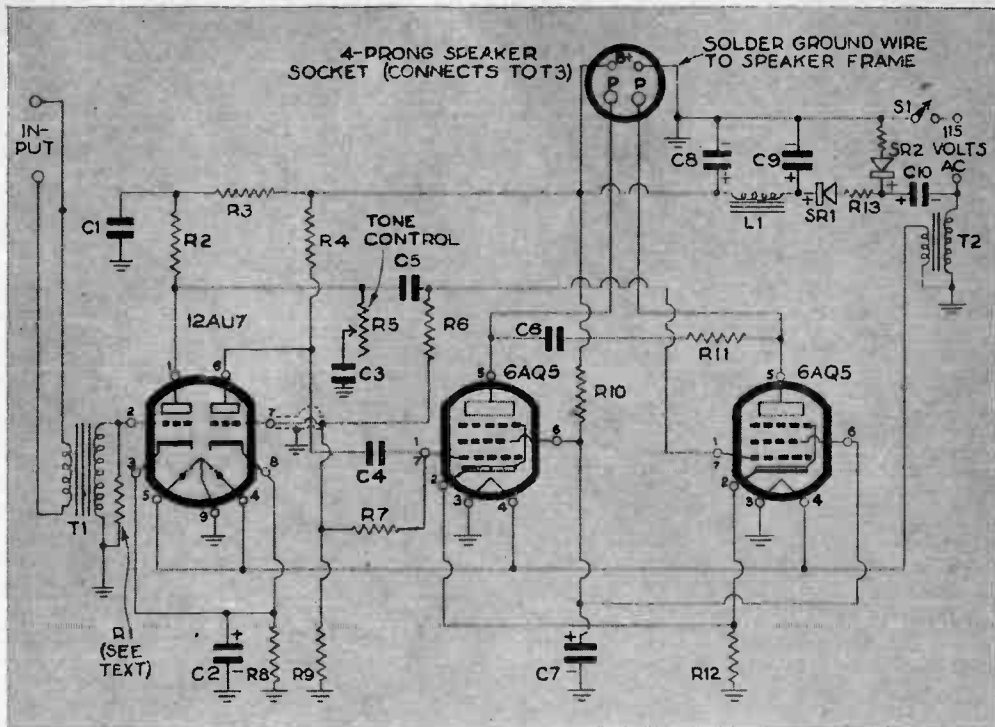

LIST OF PARTS

All fixed resistors 1-watt carbon.
 R1, R8: 1,800 ohms.
 R2, R4, R9: 100,000 ohms.
 R3: 56,000 ohms.
 R5: 250,000-ohm variable tone control with switch (see S1).
 R6, R7: 270,000 ohms.
 R10: 5,600 ohms.
 R11: 12,000 ohms.
 R12: 150 ohms.
 R13, R14: 47 ohms.
 C1, C7: 8-mfd., 450-volt electrolytic.

C2: 10-mfd. 25-volt elect.
 C3, C4, C5, C6: .05-mfd., 400-volt paper.
 C8: 40-mfd., 450-volt elect.
 C9: 20-mfd., 450-volt elect.
 C10: 30-mfd., 450-volt elect.
 SR1, SR2: 100-ma. selenium rectifier.
 L1: 8.5-hy., 50-ma., 400-ohm filter choke.
 T1: Shielded intercom trans., 4-ohm primary, 25,000-ohm secondary.

T2: Filament trans., 6.3 volts, 1.2 amp.
 T3: Push-pull output transformer (not shown in diagram; this is mounted on speaker frame.)
 S1: SPST switch on R5.
 Speaker plug and socket (4-prong), tubes, miniature sockets (two 7-prong, one 9-prong), large P.M. speaker (at least 10"), chassis, binding posts, misc. hardware.

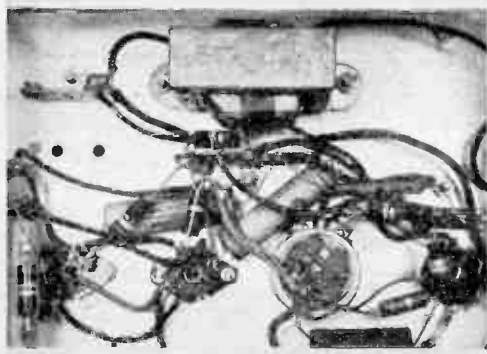

Partially wired chassis seen from below. Filter choke is held in place by the same two screws that fasten the filament transformer on top.

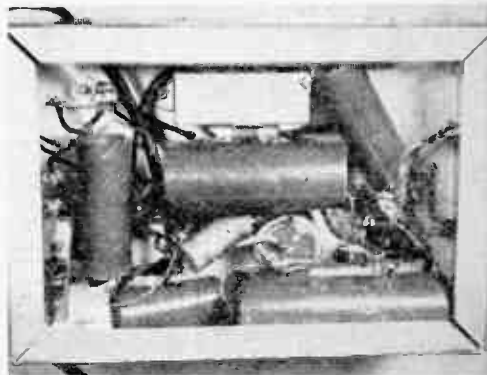

Electrolytic condensers have been installed. This is done last since the bulky paper tubes would otherwise interfere with socket wiring.



Placing the outside pulley near the roof peak allows the mast to be cut to a short stub.

3 Ways To Rotate TV Antennas

Cables run down to identical pulley in the basement; the shaft goes up through floor.

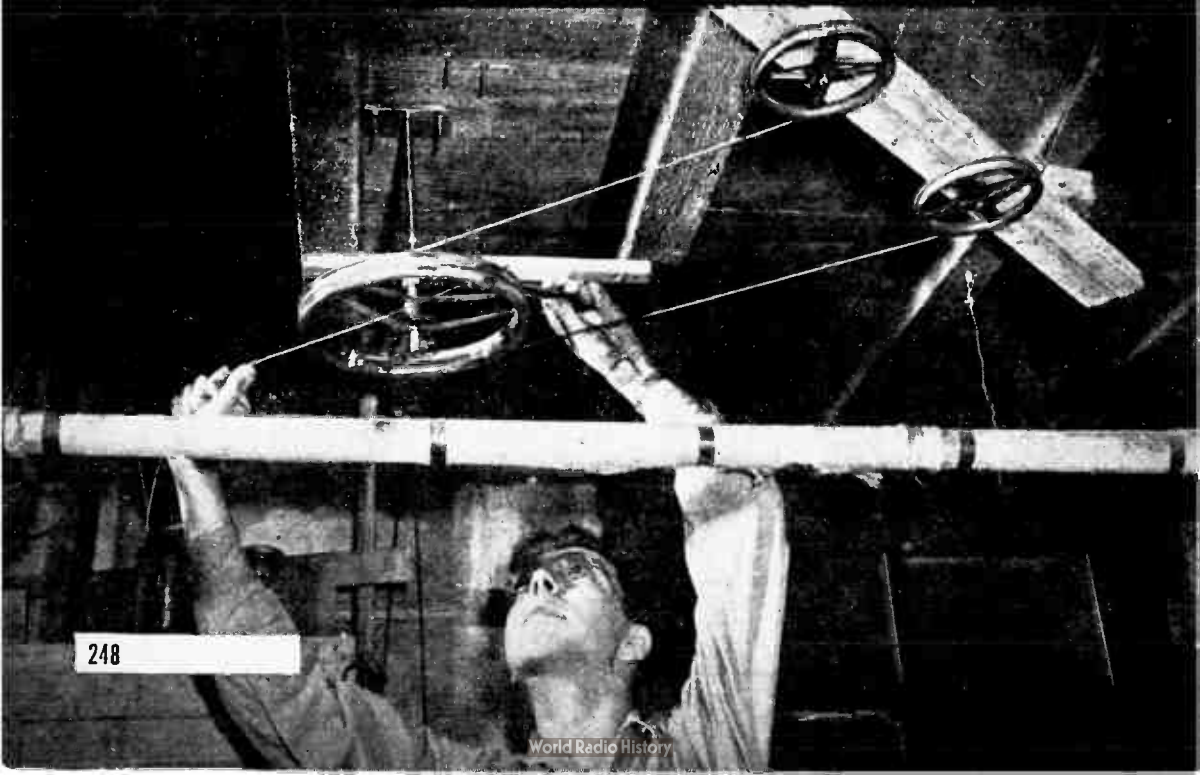

Clever craftsmen improve reception by devising ways to swing dipoles.

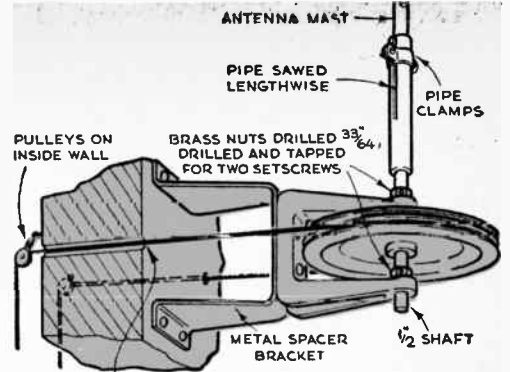
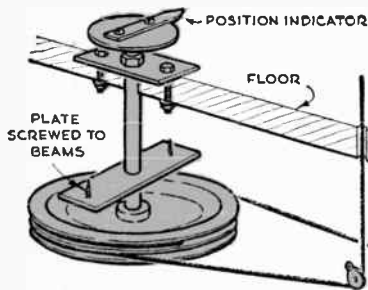

Moving the position indicator shifts the roof antenna in any desired direction. Equal pulley diameters give a 1-to-1 ratio of pointer to mast.

By Robert Gorman

IS YOUR television antenna doing the best job it can? An array that does wonders in one location may be all wrong in another.

Why? Because all TV dipoles are directional. They pick up signals best when they are oriented broadside to the transmitter. To catch a weak signal it is often necessary to increase the gain of an antenna, especially when you live on the fringes of a signal area. You can do this by adding reflectors, directors, and other gimmicks, but increasing an antenna's sensitivity automatically narrows its directional pattern. It then becomes more necessary to line up your antenna squarely at right angles to the direction of the station you want to receive.

If there is only one station in your locality, this may not be difficult. But let's assume that there are two or more on one band—for example, channels 2 and 4 at the low-frequency end—and that they come from different directions. You could orient your antenna to a compromise position half-way between them, but this might sacrifice the quality of your reception of either or both stations. Or you could use two or more separate antennas, each one favoring a particular station.

There's a third choice, which is often the easiest and best: to rotate your antenna. By making it movable you can "tune" the antenna every time you switch to a new channel.

In building a rotator, you have to consider three main elements:

- A mounting that will support the mast and permit it to turn.
- A control unit near the receiver that will permit you to move the antenna at

will. An indexing arrangement on the control to locate station positions is also desirable.

● A link between the inside control and the antenna outside. This may be either mechanical or electrical.

You will, of course, also want to provide enough slack in the transmission line or lead-in wire to let the array turn freely. A mechanical stop to keep the antenna from turning more than 360° will keep you from twisting the wires off.

Mechanical Rotator

The rig pictured above and on the facing page was built by Edward Zafian, of Bayonne, N. J. His design was largely suggested by available materials and equipment—a drill press, lathe, and a welding outfit—but it can be adapted to your requirements.

The bracket that spaces the pulley out from the house wall, for example, is actually bent up from 1/2" metal, but it could just as readily be made of wood. Similarly, the wheel-bearing assembly is a war-surplus bronze casting with the ends drilled for a 1/2" shaft. But this, too, could be wood, though metal bushings would then be needed.

Pulley wheels are the double-groove type. The wire in each groove enters a hole in the groove and is secured by a clamp. In similar installations, baby-carriage wheels could be made to serve nicely. The wheel can be brazed to the shaft, or the hub can be drilled and tapped for setscrews. Brass nuts or collars are used as bearings on the two arms of the supporting fork. All parts of the roof-top rig should be rustproof.

Stainless-steel cable is attached to the pulley wheel, looped around 180°, and



Adding a rotator required very few changes in the installation above. The control unit, made from a spring phono motor, is pictured below.



brought into the building. Tight rubber fittings help weatherproof the entrance holes on the outside.

Inside the building the cables are turned downward over two pulleys. In this installation the wires are brought into the basement, across the ceiling, and then up to the floor of a closet near the receiver, where the control handle and indexing pointer are located. The pulley wheel in the basement is the same size as that on the roof.

Phono-Motor Control

An odd assortment of junk-yard salvage is used in the second rig, shown at the left and below. Fred Henkel, of Hollis, N. Y., built it. He used an old spring-wound phono motor and part of a Model-A Ford generator.

The springs of the phono motor were removed and the wind-up shaft used to drive four cables. The cables operate in pairs, one pair reeling in as the other reels out.

As you can see in the drawing, one wire from each pair goes outward, through pulleys, to the leverage bar clamped to the antenna. The other two cables are brought to a shaft and worm gear that drive a pointer on the turntable. Channels are marked off on the turntable for quick and easy selection.

The end plate and bearing of a Model-A generator are used as a pivot for the antenna mast. The bearing plate supports the bottom

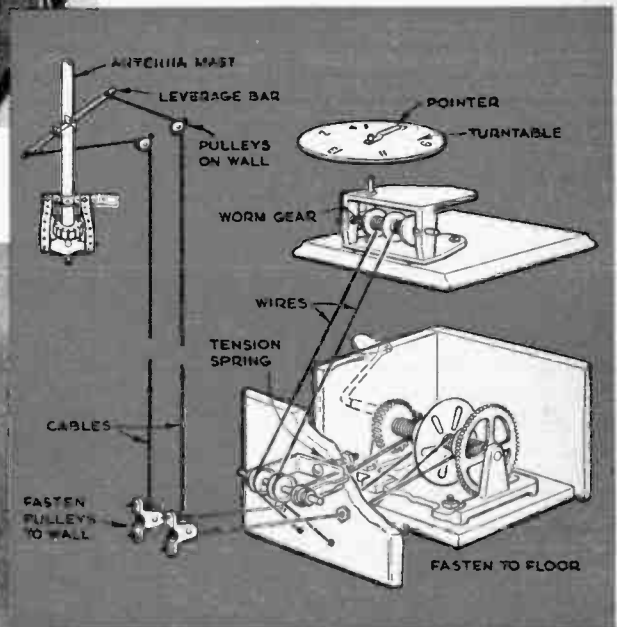

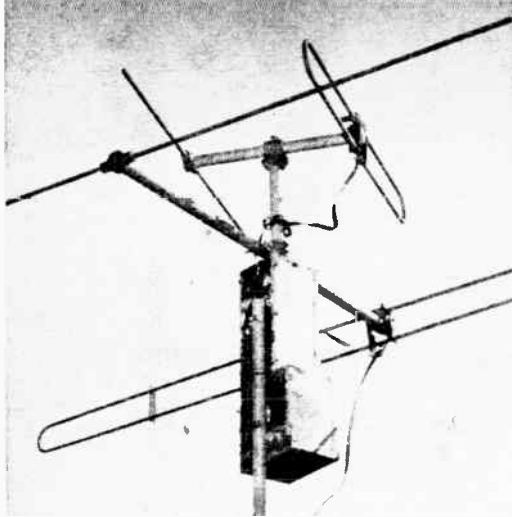

Motor-driven antenna is governed by a switch located at the receiver. A three-wire cable brings power to the roof; the rest of the mechanism is sealed inside a weathertight box.

end of the armature shaft, while the mast is slipped over the top end and rests on the core.

A housing for the shaft is bent from steel straps and bolted to one of the supporting arms of the antenna. Bolt clamps on the mast itself are loosened a turn or two—just enough to allow rotation without permitting sway or side movement.

Motorized Antenna

The electrified system, above, is the work of George Basler, Hoboken, N. J. He has a surplus 24-volt motor arranged so that he can turn his antenna simply by throwing a switch at the receiver. Aside from the switch and transformer, the entire mechanism is on the mast.

The motor is mounted on a 5" by 12" piece of weatherproof composition board and attached by screws from the back. In this case the motor housing had tapped holes for the screws; lacking them, a metal strap might be used to secure the motor.

Two 5" by 5" squares of the same composition board are drilled to line up with the motor shaft, and one is counterbored for a standard thrust bearing. The drive shaft can be turned from steel or bronze. One end is a tight fit inside a piece of 1" aluminum pipe, while the slotted end fits over the drive pin on the motor shaft. The collar resting on the thrust bearing is positioned to take the weight of the antenna off the motor.

Both high- and low-band antennas are fastened to the aluminum pipe and the back board of the assembly is held on a supporting mast by pipe clamps.

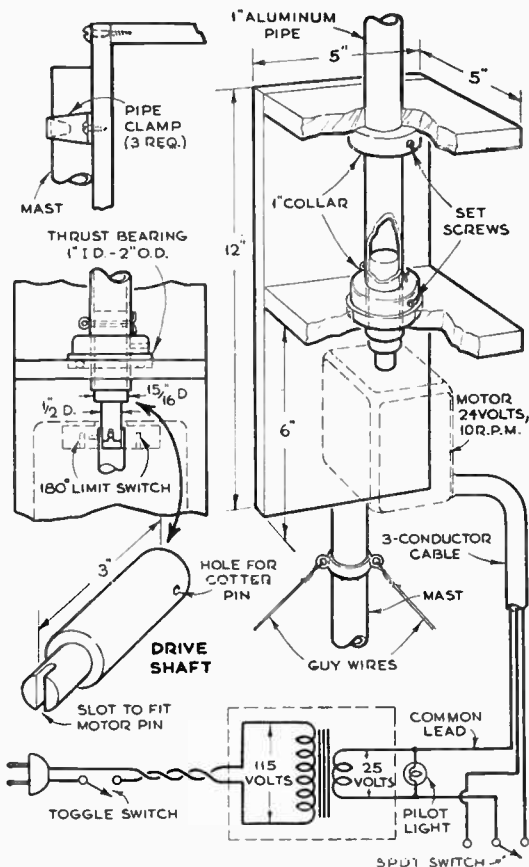

Electrical controls, consisting of an on-off switch, an SPDT reversing switch, a pilot light, and a 25-volt transformer, are incorporated in a box. Outdoor parts are boxed in with sheet copper for protection against the weather.

A standard 115-volt motor could be substituted for the one shown. It would have to be a 1 or 2 r.p.m. type and would probably require the addition of limit switches. These switches were built into the aircraft motor that was used.

Condenser Parts Salvaged. In need of a short length of $\frac{1}{8}$ " steel rod, I remembered an old radio stored away in the attic. The three-gang tuning condenser not only supplied the desired rod, but many other useful items as well.

Included in the parts I salvaged are two dozen 6-32 brass machine screws, six 8-32 setscrews, two dozen special washers, eight lock washers, and numerous brass plates.
—A. C. Porter, South Bend, Ind.

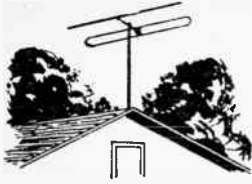

Television Glossary

ACTIVE LINES: Horizontal lines which contribute to the picture, as distinguished from retrace lines which are blanked out, or inactive.

ARRAY: An arrangement of two or more antenna elements in a single system.

ASPECT RATIO: The ratio of picture width to height. The television standard is 4:3, although many receiving sets use pictures of different shape.

AUTOMATIC GAIN CONTROL (AGC): Electronic regulation of amplification of a receiver to produce pictures of equal contrast despite variations in signal strength.

BEAM: A stream of electrons moving in a uniform path. Also applied to response pattern of directional antenna array.

BLANKING: Interruption of electron beam in a picture tube between scanning lines; i.e., during retrace of scanning voltage.

BOOSTER: An amplifier, usually broadband, used to amplify weak radio or television signals before they reach the receiver.

CAMERA TUBE: A pickup tube used at television studios and elsewhere that "photographs" a scene and converts the picture into varying voltages that can be used to modulate a video carrier wave.

CHANNEL: A portion of the frequency spectrum assigned for the transmission of a complete television signal.

CHARACTERISTIC IMPEDANCE: A ratio of voltage to current in any circuit. Often used as descriptive of antenna or transmission line. In the latter it describes the voltage-to-current ratio at every point along the length of the line.

COAXIAL CABLE (COAX): A cable used for high-frequency transmission. It is usual-

ly circular and consists of a central conductor, an outer shield, and insulating material.

DEFLECTION YOKE: A unit placed around the neck of magnetic picture tubes to bend the electron beam across the tube face and up and down. This produces the scanning lines.

DIPOLE: An antenna that is resonant to a half wavelength. Usually divided at the center.

DIRECTOR: A rod placed between a dipole and transmitter to increase sensitivity in one direction.

DISCRIMINATOR: A circuit that detects or demodulates an FM signal, i.e., that separates the message portion (modulation) from the high-frequency carrier wave.

ELECTRON: A tiny portion of matter that has a negative electrical charge.

ELECTROSTATIC FIELD: A field existing in space between two charged bodies that exerts a force on electrons.

FIELD: A complete tracing of an image on a television tube. Under U. S. standards, this contains only half the information transmitted and is accomplished in 1/60 sec. A second field, traced in the succeeding 1/60 sec, contains the remaining picture information. Two fields constitute a frame.

FLUORESCENT SCREEN: A phosphor coating applied to the inside face of a picture tube. It lights up when struck by an electron beam, thus producing a picture.

FOLDED DIPOLE: An arrangement of an antenna in which two half-wave dipoles are made parallel and continuous. One of the dipoles remains open at the center for connection.

FRAME: One complete picture of a tele-

vision image, consisting of two fields. A frame lasts 1/30 sec. before being replaced on the screen by the following one.

FRONT-TO-BACK RATIO: The ratio of increased sensitivity of an antenna for signals received from the desired direction and rejection of those coming from the opposite side.

GHOST: A subsidiary image seen alongside the desired image on a television screen.

HALATION: A broadening of light on a television screen caused by excessive brilliance or reflection of light from inside the tube or through the glass. The effect resembles that of a crown or halo.

ICONOSCOPE: A type of pickup tube used in television cameras.

IMAGE ORTHICON: A television pickup tube with high sensitivity to light.

IMPLODE: Bursting of a television picture tube. It is distinguished from "explode" in that the high vacuum inside the bulb causes the glass fragments to fly inward rather than outward.

INTERCARRIER SOUND: A design of a television receiver in which a single intermediate frequency amplifier is used for both picture and sound signals.

INTERLACING: A system of tracing a television image in successive fields, each carrying half the information.

ION: A charged particle. Ions are emitted by the cathode of TV picture tubes; if permitted to reach the screen, they would cause spots or discolorations of the phosphor. In electromagnetic tubes they are removed from the electron beam by ion traps.

LIMITER: An electronic circuit used to remove noise and amplitude variations from an FM signal.

LINEARITY: Distribution of the elements of a picture in either the horizontal or vertical planes.

MAGNETIC DEFLECTION: A system

used for bending the electron by means of coils placed outside the picture tube.

NOISE: Distortion or deterioration of a television picture due to atmospheric conditions, interference, and the like. Usually identified by a "snow" pattern.

PERSISTENCE: The ability of the eye to retain the impression of an image after the light producing the picture is extinguished.

RASTER: Scanning lines on a television screen, usually without picture information.

REFLECTOR: A rod placed parallel to a dipole and on the side away from the transmitter.

RETRACE: The travel of an electron beam from the end of one scanned line to the beginning of the succeeding one. Also called Flyback.

SCANNING: The system of breaking down any picture into successive lines, each subdivided into areas of light and shadow. The combination of scanned lines reproduces the picture.

SNOW: An impression of rapidly moving white spots caused by certain types of television interference.

SYNCHRONIZING PULSES: Electrical impulses sent out by the transmitter for the purpose of controlling those portions of a receiver circuit which govern the timing action of horizontal and vertical oscillators.

TEARING: The appearance of a torn picture caused by failure of synchronization that groups scanning lines improperly.

TRANSMISSION LINE: Cable or wire used to carry electrical signals from antenna to receiver.

VESTIGIAL SIDEBAND TRANSMISSION: A method of picture modulation in which the carrier is modulated by all of the upper sideband and a portion (vestige) of the lower sideband.

YAGI: An antenna array in which one element is used as a dipole for one band and as a reflector or director for another dipole in the same array.

INDEX

A		D	
Amplifier and oscillator	208	D'Arsonval meter	116
Amplifier and tester	94	E	
Amplifier, reluctance pickup	227	Electric-razor static	44
Amplifier, headphone	31	Electrolytic fault	144
Amplifier, high fidelity	160	F	
Amplifier, phono	165, 167	Field-coil resistance	81
Antenna concealed	216	Filament transformer	34
Appliance static	44	Filter-choke substitutes	34
Auto receiver modifications	86	Filter for crystal pickup	81
Auto speaker	172	Filter, high-pass	53
AVC added	217	Filter, low-pass	54
B		FM antennas	240
Battery adapters	175	Forceps as aid	81
Battery eliminator	182	H	
Battery eliminator, for portable	202	Headphone as microphone	32
B supply for portable	202	Hearing-aid amplifier	169
C		Hidden mounting bracket	76
Capacity bridge	112	High-fidelity amplifier	160
Cathode-ray tubes	62	High-fidelity TRF receiver	156
Chassis drilling	15	High-fidelity two-tube receiver	136
Choke-input power supply	75	High-voltage safety	70, 238
Choke insulated	13	High-voltage safety switch	71
Circuit symbols	73	Hum elimination	91
Coil forms	33	I	
Concealing FM antenna	228	Impedances, measuring	71
Condenser, faulty electrolytic	144	Improving record players	78
Condenser, grounded	151	Induced AC hum	78
Condenser, leaky	74	Insulating grommets	175
Condenser tester	112	Insulation, high voltage	70
Condenser types and ratings	8	Insulators, from funnels	13
Condenser, variable, shorted	71	Intercom, AC-DC	29
Converter, short-wave	98		
Crystal receivers	18		

Intercom, battery-operated	27	Phone terminal from plug	13
Intercom, from receiver	151	Phono amplifier	165, 167
Intercom, tubeless	29	Phono needle guard	146
Intermittent reception	77	Phono oscillator, midget	164
K			
Knob arrow	89	Phono-radio portable	152, 192
Knob made pointer	13	Phono records, warped	71
Knobs recessed	81	Phono thump prevented	144
M			
Meter formulas	118, 126	Photoelectric relay	176
Meter, output	115	Piped programs	175
Meters	116	Pocket laboratory	107
Meter shock hazard	144	Portable, booster for	200
Meter, tuning-eye	111	Portable, converted from AC-DC	204
Microphone, carbon	47	Portable, de luxe	140
Microphone, condenser	47	Portable lid clip	89
Microphone, crystal	50	Portable, three-pound	196
Microphone, dynamic	48	Potentiometer servicing	74
Microphone, ribbon	49	Power pack, 400-volt	185
Microphone, unstable-contact	46	Power pack, midget	184
Multimeter calibration	125	Power supply, heavy duty	75
Multimeter construction	120	Preamplifier	227
Multimeter fusing	121	Progressive receiver	22
Multimeter, portable	123	Push-button test values	129
Multimeter, principles	119	Push-pull transformer	34
Multimeter, push-button	123	Punches	15
N			
Neon sign static	44	R	
Noisy potentiometers	74	Receiver, AC-DC, converted to portable	204
O			
Ohmmeter table	119	Receiver as intercom	151
Oscillator and amplifier	208	Receiver, boy's	145
Oscillator, microphone	222	Receiver, businessman's	186
Oscillator, phono	56, 208	Receiver, communications	178
Oscillator, phono, midget	164	Receiver, crystal	18
Oscillator, relaxation	45	Receiver, de luxe portable	140
Oscilloscope, cathode-ray	66	Receiver, four-way portable	147
Output meter	115	Receiver, high-fidelity	156
Output transformer	33	Receiver, high-fidelity two-tube	136
Output transformer rating	12	Receiver, improving quality	224
I			
Permeability-tuned receiver	135	Receiver, one-tube mailable	173
Pillow phone	216	Receiver, matchbox-size	174
		Receiver, midget	196
		Receiver, permeability-tuned	135
		Receiver, personal	58
		Receiver, phono-radio portable	152, 192
		Receiver, pocket	168
		Receiver, progressive	22

